



*Files are in Adobe format.
Download the newest version from Adobe.*

48th Annual Targets, UAVS & Range Operations Symposium & Exhibition

“Moving Forward: Next Generation Targets and Ranges”

New Orleans, LA

19 – 21 October 2010

Agenda

Wednesday, October 20, 2010

Keynote Address

- Maj Gen James A. Whitmore, USAF, Director of Intelligence, Operations and Nuclear Integration, HQ Air Education and Training Command, Randolph AFB

SESSION I: RANGES AND RANGE OPERATIONS

- **Sustainability Challenges of the “GREEN RANGE”**, Mr. Anthony (Tony) Parisi, Head, NAVAIR Ranges Sustainability Office
- **Range Sustainment and Modernization to Meet Customer Needs**, Mr. Robert Arnold, Senior Executive Service 3, AFMC, 46th Test Wing, Eglin AFB
- **Central Test and Evaluation Investment Program (CTEIP)**, Mr. Gerald Christeson, Deputy, ATL Defense Test Resource Management Center, Office of the Secretary of Defense, Wright Patterson AFB
- **Combat Hammer**, Lt Col Michael Neeman, USAF, Commander, 86th FWS
- **21st Century Target Control System**, Mr. Steve Gonzales, Team Leader, Target Control Systems Development, Systems Engineering Directorate, White Sands Missile Range
- **Testing the Test Range: No Flights Required**, Mr. Steve Williams, Business Area Manager, Signal Instrumentation, RT Logic, Inc.
- **Holographic Radar: A Universal Solution for High Clutter Environments, Collision Avoidance, Wind Farms and Scoring**, Mr. Gary Kemp, Programme Director, Missile Scoring, Cambridge Consultants - England
- **Moving Forward: Responding to the Fast Attack Threat**, Mr. Jeffrey Blume, Head, Seaborne Targets IPT, Threat/ Target Systems Department, NAWCWD, Point Mugu
- **Directed Energy T&E at NAVAIR Weapons Division**, Mr. Brian Krinsley, Chief Engineer, Sea Range, NAWCWD, Point Mugu
- **Office of the Secretary of Defense: Operational Test Assessment of Current Target Capability**, Mr. Dennis Mischel, DOT&E, OSD

SESSION II: NEW TECHNOLOGY

- **Multi Stage Supersonic Target**, Mr. Michael Stuart, Director, Missiles Int'l Programs, ATK - Advanced Weapons Division
- **Target Transformation**, Mr. Thomas Dowd, Director, Threat/Target Systems Department (Air 5.3), NAWCWD, Point Mugu
- **Hugh Harris Scholarship Update and Willis Howard Award Presentation**, Mr. Cort Proctor, Consultant, Micro Systems, Inc.
- **Miniature Air Launched Decoy (MALD)**, Mr. Jerry Rutt, Director, Advanced Strike Systems, Raytheon

Thursday, October 21, 2010

SESSION III: CURRENT DEVELOPMENTS

- **QF-16 Program**, Mr. Robert Insinna, QF-16 Program Manager, Boeing
- **Target Management Initiative: Status Update**, Mr. James Maybury, Senior Programmer, Applied Resources, Inc.
- **F-35 Joint Strike Fighter**, Maj Michael Ebner, USAF, 58th FS, Eglin AFB
- **MQM-171 BroadSword in Support of Test Missions**, Mr. Larry French, CEO/CTO, Griffon Aerospace

- **Information Assurance: Impacts on Army Target Programs**, Mr. Barry Hatchet, Lead Project Director, Targets Management Office, Redstone Arsenal, Huntsville
- **Common Range Integrated Instrumentation System (CRIIS) Update**, Mr. Alan Massing, Systems Development Lead, CRIIS Program Office, Eglin AFB
- **Hammerhead Attack Boat Swarm: A World First in Naval Target Technology**, Mr. Spencer Fraser, President and General Manager, Meggitt Training Systems, Inc. - Canada

SESSION IV: MILITARY PROGRAMS AND REQUIREMENTS

- **U.S. Air Force**, Ms. Holly Reedy, Full-Scale Aerial Target IPT Lead, Eglin AFB
- **U.S. Army**, Mr. Alvin Brown, Director, Targets Management Office, Redstone Arsenal, Huntsville
- **U.S. Navy**, CAPT Daniel McNamara, USN, Program Manager, Aerial Target and Decoy Systems, PMA-208, Patuxent River

48th ANNUAL
TARGETS, UAVS & RANGE OPERATIONS
SYMPOSIUM & EXHIBITION

“Moving Forward: Next Generation Targets and Ranges”



OCTOBER 19-21, 2010

HILTON NEW ORLEANS ► NEW ORLEANS, LA

WWW.NDIA.ORG/MEETINGS/1410

EVENT #1410

LOCATION & LODGING

Hilton New Orleans Riverside
Two Poydras St.
New Orleans, LA 70130
(504) 561-0500

SYMPOSIUM THEME

The 2010 Symposium brings together recognized experts from government, military and industry to showcase the latest developments in Targets, UAVs and Range Operations. As threats and weapons systems evolve and robotics become ever more prominent in warfare, training and testing for these advanced scenarios becomes increasingly critical. Questions of threat replication and fidelity versus the realities of cost and funds availability make the planner's role in product selection difficult.

This symposium addresses these realities through presentations on such cutting edge developments as diverse as naval targets and control systems that can deal with swarm threats in a credible way, to testing of directed energy weapons systems and the challenges of making these systems affordable for the end user. Included in this symposium are presentations from high-ranking OSD officials concerning the big picture as to way ahead, and from international experts concerning their perspectives in these areas.

WILLIS HOWARD AWARD

The Willis Howard Award is presented annually at the symposium to the person, either corporate or military, who in the view of the Executive Board, has demonstrated both sustained superior service within the communities now represented by the NDIA Targets Division, as well as active service to the Division.

Named after Mr. Willis Howard, one of the founding owners of Cartwright Electronics (now a division of Meggitt Defense Systems, Inc.), it is the highest award presented within the targets community. Willis was also one of the founding corporate members of the NDIA Targets Division, which was originally the Aerial Targets Division of the American Ordnance Association. He was an extremely active member of the Division who presented papers, chaired Sessions and was Chairman of the Annual Symposium on two occasions.

Willis was killed in an auto accident while working with the USAF Weapons Evaluation Group at Tyndall Air Force Base. He was so well respected throughout the targets community that the Division implemented an award in his honor.

HUGH HARRIS MEMORIAL SCHOLARSHIP

The Hubert D. Harris Scholarship Program was established in 1991 to memorialize Mr. Hugh Harris for his many contributions to the targets community in both government and industry. The NDIA Targets Division has been joined by NDIA's Gulf Coast Chapter as a co-sponsor of the scholarship program.

Hugh was a longtime member and leader in various professional organizations including IEEE, AOC and ADPA (forerunner of NDIA). He served two years as the National Chairman for the Aerial Targets and RPV Section, working closely with all three military services. Subsequent to his death on June 9, 1991, Hugh was the posthumous winner of the Division's Willis Howard Award for outstanding service.

The Scholarship is presented annually to a deserving high school senior who will be entering an accredited four-year university in pursuit of a math, engineering or hard science degree.

TUESDAY, OCTOBER 19, 2010

- 12:00 PM - 6:30 PM** **Registration Open**
Ballroom Foyer - 3rd Floor
- 5:00 PM - 6:30 PM** **Opening Reception (Hosted Beer and Wine)**
Napoleon Ballroom - Exhibit Hall
- 6:30 PM** **Adjourn for the Day**

WEDNESDAY, OCTOBER 20, 2010

- 7:00 AM - 5:45 PM** **Registration Open**
Ballroom Foyer - 3rd Floor
- 7:00 AM - 8:00 AM** **Continental Breakfast**
Napoleon Ballroom - Exhibit Hall
- 8:00 AM - 8:10 AM** **Welcome Remarks and Keynote Speaker Introduction
by Symposium Co-Chairmen**
Versailles Ballroom
- Lt Gen Lawrence P. Farrell, Jr., USAF (Ret), President & CEO, NDIA
Mr. David Laird, Director of Programs, Micro Systems, Inc.
Mr. Craig Tangedal, Vice President, 5-D Systems, Inc.
- 8:10 AM - 8:50 AM** **Keynote Address**
Versailles Ballroom
- Maj Gen James A. Whitmore, USAF, Director of Intelligence, Operations and Nuclear Integration, HQ Air Education and Training Command, Randolph AFB

SESSION I: RANGES AND RANGE OPERATIONS

- 8:50 AM - 9:00 AM** **Introduction by Session Chair**
Versailles Ballroom
- Ms. Karen Draper, Deputy, Test Management Division, NAVAIR Ranges Department, Point Mugu
- 9:00 AM - 9:20 AM** **Sustainability Challenges of the "GREEN RANGE"**
Versailles Ballroom
- Mr. Anthony (Tony) Parisi, Head, NAVAIR Ranges Sustainability Office
- 9:20 AM - 9:40 AM** **Range Sustainment and Modernization to Meet Customer Needs**
Versailles Ballroom
- Mr. Robert Arnold, Senior Technical Advisor, AFMC, 46th Test Wing, Eglin AFB

KEYNOTE ADDRESS

Maj Gen James A. Whitmore, USAF



REGISTRATION

Ballroom Foyer - 3rd Floor

GENERAL SESSION

Versailles Ballroom - 3rd Floor

EXHIBIT HALL

Napoleon Ballroom - 3rd Floor

ATTIRE

Appropriate dress for the symposium is business casual for civilians and Class B uniform or uniform of the day for military personnel.

ID BADGES

During symposium registration and check-in, each attendee will be issued an identification badge. Please be prepared to present a valid picture ID. Badges must be worn at all symposium functions.

DONATION

In lieu of Speaker gifts, a donation will be made to the Hubert D. Harris Scholarship Program.

| | |
|---------------------|--|
| 9:40 AM - 10:00 AM | Central Test and Evaluation Investment Program (CTEIP) <i>Versailles Ballroom</i> Mr. Gerald Christeson, CTEIP Program Manager, Defense Test Resource Management Center |
| 10:00 AM - 10:30 AM | Networking Break <i>Napoleon Ballroom - Exhibit Hall</i> |
| 10:30 AM - 10:50 AM | Combat Hammer <i>Versailles Ballroom</i> Lt Col Michael Neeman, USAF, Commander, 86th Fighter Weapons Squadron |
| 10:50 AM - 11:10 AM | 21st Century Target Control System <i>Versailles Ballroom</i> Mr. Steve Gonzales, Team Leader, Target Control Systems Development, Systems Engineering Directorate, White Sands Missile Range |
| 11:10 AM - 11:30 AM | Testing the Test Range: No Flights Required <i>Versailles Ballroom</i> Mr. Steve Williams, Business Area Manager, Signal Instrumentation, RT Logic, Inc. |
| 11:30 AM - 11:50 AM | Holographic Radar: A Universal Solution for High Clutter Environments, Collision Avoidance, Wind Farms and Scoring <i>Versailles Ballroom</i> Mr. Gary Kemp, Programme Director, Missile Scoring, Cambridge Consultants - England |
| 11:50 AM - 12:10 PM | Moving Forward: Responding to the Fast Attack Threat <i>Versailles Ballroom</i> Mr. Jeffrey Blume, Head, Seaborne Targets IPT, Threat/Target Systems Department, NAWCWD, Point Mugu |
| 12:10 PM - 12:30 PM | Directed Energy T&E at NAVAIR Weapons Division <i>Versailles Ballroom</i> Mr. Brian Krinsley, Chief Engineer, Sea Range, NAWCWD, Point Mugu |
| 12:30 PM - 1:45 PM | Networking Lunch <i>Napoleon Ballroom - Exhibit Hall</i> |
| 1:45 PM - 1:55 PM | Office of the Secretary of Defense: Operational Test Assessment of Current Target Capability <i>Versailles Ballroom</i> Mr. Dennis Mischel, DOT&E, OSD |

SESSION II: NEW TECHNOLOGY

- 1:55 PM - 2:05 PM** **Introduction by Session Chair**
Versailles Ballroom
- Mr. Gary Freudenberger, North American Business Development Manager, CEI
- 2:05 PM - 2:25 PM** **Multi Stage Supersonic Target**
Versailles Ballroom
- Mr. Michael Stuart, Director, Missiles Int'l Programs, ATK - Advanced Weapons Division
- 2:25 PM - 2:45 PM** **Target Transformation**
Versailles Ballroom
- Mr. Thomas Dowd, Director, Threat/Target Systems Department (Air 5.3), NAWCWD, Point Mugu
- 2:45 PM - 3:15 PM** **Networking Break**
Napoleon Ballroom - Exhibit Hall
- 3:15 PM - 3:35 PM** **Hugh Harris Scholarship Update and Willis Howard Award Presentation**
Versailles Ballroom
- Mr. Cort Proctor, Consultant, Micro Systems, Inc.
Mr. David Miller, Business Development, Meggitt Defense Systems, Inc.; NDIA Division Chairman
- 3:35 PM - 3:55 PM** **Miniature Air Launched Decoy (MALD)**
Versailles Ballroom
- Mr. Jerry Rutt, Director, Advanced Strike Systems, Raytheon Company
- 4:00 PM - 5:30 PM** **Networking Reception (Cash Bar)**
Napoleon Ballroom - Exhibit Hall
- 5:30 PM** **Adjourn for the Day**

NDIA EVENTS

Thank you for joining us at the Targets Symposium! We hope to see you at a future NDIA event. Please visit the NDIA website for a complete listing of the events we offer.

NDIA website:

<http://www.ndia.org>

Select:

Meetings & Events

Schedule of Events

ADVERTISING

Advertise in *National Defense* magazine and increase your organization's exposure. *National Defense* will be distributed to attendees of this event, as well as other NDIA events. For more information, please contact Mr. Dino Pignotti, NDIA, at (703) 247-2541 or dpignotti@ndia.org.

SURVEY

A survey will be e-mailed to you after the event. NDIA would greatly appreciate your time in completing the survey to help make our event even more successful in the future.

THURSDAY, OCTOBER 21, 2010

7:00 AM - 2:10 PM

Registration Open

Ballroom Foyer - 3rd Floor

7:00 AM - 8:00 AM

Continental Breakfast

Napoleon Ballroom - Exhibit Hall

8:00 AM - 8:10 AM

Welcome Remarks by Symposium Co-Chairmen

Versailles Ballroom

Mr. David Laird, Director of Programs, Micro Systems, Inc.
Mr. Craig Tangedal, Vice President, 5-D Systems, Inc.

SESSION III: CURRENT DEVELOPMENTS

8:10 AM - 8:20 AM

Introduction by Session Chair

Versailles Ballroom

Mr. Jack Chancellor, Business Development, Meggitt Defense Systems, Inc.

8:20 AM - 8:40 AM

QF-16 Program

Versailles Ballroom

Mr. Robert Insinna, QF-16 Program Manager, The Boeing Company

8:40 AM - 9:00 AM

Target Management Initiative: Status Update

Versailles Ballroom

Mr. James Maybury, Senior Programmer, Applied Resources, Inc.

9:00 AM - 9:20 AM

F-35 Joint Strike Fighter

Versailles Ballroom

Maj Michael Ebner, USAF, 58th FS, Eglin AFB

9:20 AM - 9:50 AM

Networking Break

Napoleon Ballroom - Exhibit Hall

9:50 AM - 10:10 AM

MQM-171 BroadSword in Support of Test Missions

Versailles Ballroom

Mr. Larry French, CEO/CTO, Griffon Aerospace

10:10 AM - 10:30 AM

UK Aerial Target Programmes

Versailles Ballroom

Mr. John Childs, Aerial Targets Business Development Leader, QinetiQ, Ltd.

10:30 AM - 10:50 AM

Information Assurance: Impacts on Army Target Programs

Versailles Ballroom

Mr. Barry Hatchett, Lead Project Director, Targets Management Office, Redstone Arsenal, Huntsville

10:50 AM - 11:10 AM **Common Range Integrated Instrumentation System (CRIIS) Update**
Versailles Ballroom

Mr. Alan Massing, Systems Development Lead, CRIIS Program Office, Eglin AFB

11:10 AM - 11:30 AM **Hammerhead Attack Boat Swarm: A World First in Naval Target Technology**
Versailles Ballroom

Mr. Spencer Fraser, President and General Manager, Meggitt Training Systems, Inc. - Canada

11:30 AM - 12:45 PM **Networking Lunch**
Napoleon Ballroom - Exhibit Hall

SESSION IV: MILITARY PROGRAMS AND REQUIREMENTS

12:45 PM - 12:55 PM **Introduction by Session Chair**
Versailles Ballroom

Mr. Ken Hislop, QF-16 Program Manager, Eglin AFB

12:55 PM - 1:15 PM **U.S. Air Force**
Versailles Ballroom

Ms. Holly Reedy, Full-Scale Aerial Target IPT Lead, AAC/EBYA, Eglin AFB

1:15 PM - 1:35 PM **U.S. Army**
Versailles Ballroom

Mr. Alvin Brown, Director, Targets Management Office, Redstone Arsenal, Huntsville

1:35 PM - 1:55 PM **U.S. Navy**
Versailles Ballroom

CAPT Daniel McNamara, USN, Program Manager, Aerial Target and Decoy Systems, PMA-208, Patuxent River

1:55 PM - 2:15 PM **Concluding Remarks by Symposium Co-Chairmen**
Versailles Ballroom

Mr. David Laird, Director of Programs, Micro Systems, Inc.
Mr. Craig Tangedal, Vice President, 5-D Systems, Inc.

2:00 PM **Exhibit Hall to Close**

2:15 PM **Symposium Adjourned**

SYMPOSIUM CONTACT

Ms. Meredith Geary, CMP
Associate Director, NDIA
(703) 247-9476
mgeary@ndia.org

EXHIBITS CONTACT

Mr. Dennis W. Tharp, CEM
Exhibits Manager, NDIA
(703) 247-2584
dtharp@ndia.org

EXHIBITING COMPANIES

BOOTH

EXHIBITING AS

| | |
|-----|---------------------------|
| 102 | Targets Management Office |
| 103 | SA-TECH |
| 107 | Northrop Grumman |
| 111 | Griffon Aerospace |
| 116 | Cambridge Consultants |
| 202 | Composite Engineering |
| 216 | NAVAIR Test & Evaluation |
| 302 | EADS North America |
| 312 | Meggitt Defense Systems |
| 315 | RT Logic |
| 316 | Micro Systems, Inc. |

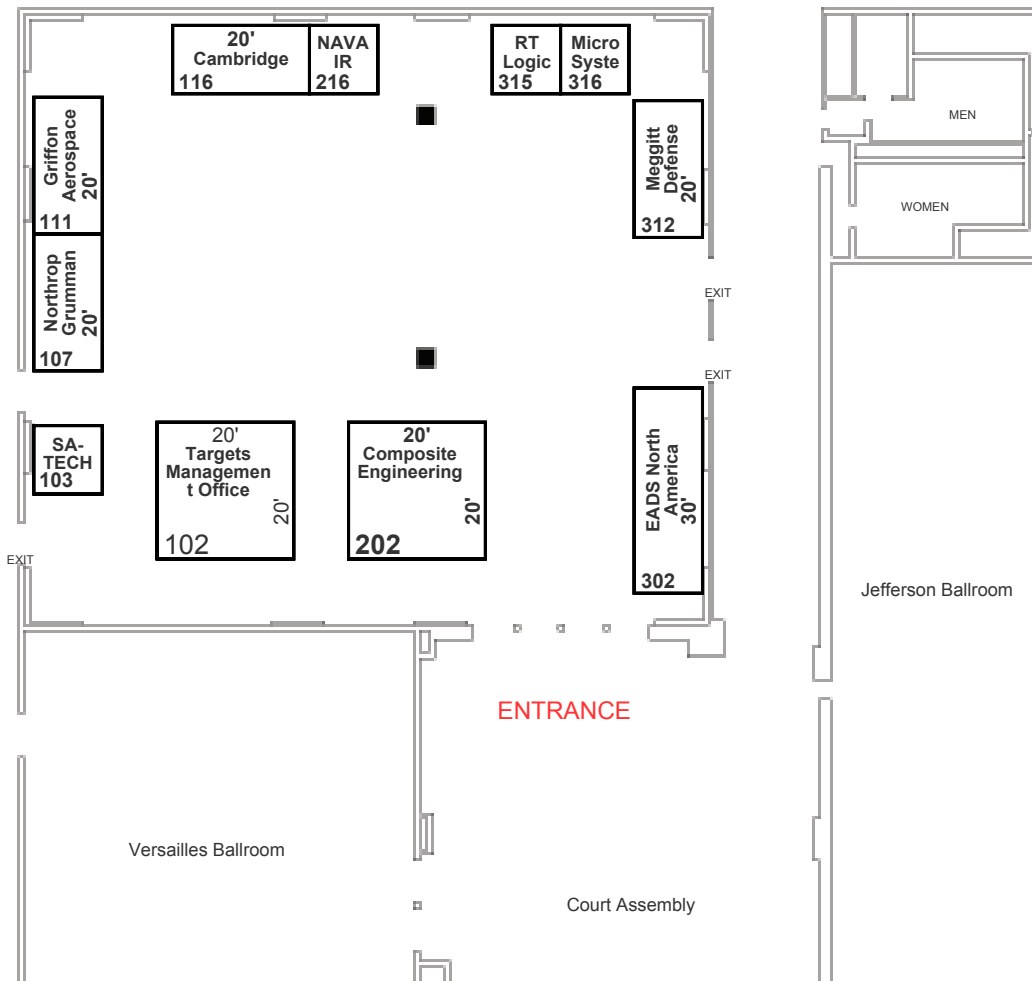

116

Cambridge Consultants

Anna Hervey-Murray

Cambridge Consultants develops world-leading products and systems, creates and licenses IP and provides technology consultancy. We work across a range of industries including defense, medical technology, industrial & consumer products and wireless.

202

Composite Engineering

Jeff Herro

Composite Engineering Incorporated, headquartered in Roseville, California is a full service provider of aerial targets and services. CEI is the sole source provider of Sub-scale aerial to the United States Air Force. Our proven capabilities include target design, integration, prototyping, production and full service field support. With a suite of high fidelity targets, CEI stands ready to fill the war fighters aerial targets needs anytime and anywhere in the free world.

302

EADS North America

Peter Altmann

EADS North America is a major provider of advanced solutions for U.S. defense and homeland security, and is a recognized leader in the design, production, and operation of aerial targets. EADS North America and its parent company, EADS, contribute \$11 billion to the U.S. economy and support 200,000 American jobs.

111

Griffon Aerospace

Gary Tuttle

Griffon is the prime contractor for Air Defense Targets for the U.S. Army Targets Management Office (TMO) and the manufacturer of the MQM-170A Outlaw and MQM-171 BroadSword.

312

Meggitt Defense Systems

Judy Smith

Meggitt Defense Systems (MDS) is a world leading designer and producer of free flying and towed targets. MDS also designs and produces a wide variety of Acoustic and Doppler radar based scoring systems for both scalar and vector.

316

Micro Systems, Inc.

Dale Gates

Micro Systems, Inc. offers turn-key solutions for command/control, instrumentation systems and components for airborne and ground based target applications. The company's capabilities encompass all aspects of system development including Systems Engineering, benign and severe environment hardware engineering, high performance, real-time software engineering, and field engineering support. www.gomicrosystems.com

216

NAVAIR Test & Evaluation

Theresa Hopkins

NAVAIR Range assets include the Atlantic Test Ranges at Patuxent River, MD; the Sea Range at Point Mugu, CA; and the Land Ranges & Electronic Combat Range (ECR) at China Lake, CA. <http://www.navair.navy.mil/tande>

107

Northrop Grumman

Gail Thompson

Northrop Grumman Corporation is a leading global security company whose 120,000 employees provide innovative systems, products, and solutions in aerospace, electronics, information systems, shipbuilding and technical services to government and commercial customers worldwide. Please visit www.northropgrumman.com for more information.

315

RT Logic

Michael Reising

RT Logic designs, develops, and delivers innovative signal processing systems for the space, flight test and range communications industry.

103

SA-TECH

Karen Chergoski

Over two decades supporting the warfighter, SA-TECH is a progressive and steadily growing professional services firm. We strive to provide exceptional customer service by using right person, leading-edge technologies and latest automated tools.

102

Targets Management Office

Jason Guthrie

The Targets Management Office provides technically advanced target system development, procurement, life-cycle operations and sustainment support in live and virtual environments for U.S. and allied clients. Domains include: Aerial, Ground and Virtual.

ATTENDEE ROSTER *(As of 10/14/10)*

Mr. Ken Adams
Targets Management Office

Mr. Tim Adams
Systems Applications & Technologies, Inc.

Mr. Sami Adlay
U.S. Navy

Mr. Mike Amspacker
AAC/EBYC

Dr. KP Ananth
Idaho National Laboratory

Lt Col Rod Apgar, USAF (Ret)
U.S. Air Force

Mr. Robert Arnold
AFMC, 46th Test Wing

Mr. Paul Baiter
Analytical Services, Inc.

Mr. Tim Barnes
NAVAIR PEO

Mr. Bobby Barreto
Airborne Threat Simulation

Mr. Scott Belanger
DRS Defense Solutions, LLC

Mr. Steve Berkel
Naval Air Warfare Center, Weapons Division

CDR Mike Bertin, USN (Ret)
Science Applications Int'l Corporation

Mr. Jeff Blume
Naval Air Warfare Center, Weapons Division

Mr. Robert Brannon
780th Test Squadron

Ms. Michele Brazel
691st Armament Systems Squadron

Mr. Joe Briganti
46th Test Wing

1st Lt AJ Brinker, USAF
U.S. Air Force

Mr. Alvin Brown
Targets Management Office

Ms. Donna Brown
A Box 4 U

Mr. Lowell Buchholz
Rockwell Collins

Mr. John Buck
QinetiQ, Ltd.

Ms. Angel Burke
U.S. Air Force

CAPT Ed Caffrey, USN (Ret)
Engineered Arresting Systems Corp.

Mr. Steve Carlson
Atlantic Targets & Marine Operations, Norfolk Det.

Ms. Katie Carr
NASA

Mr. Pete Castrilli
Raytheon Technical Services Company, LLC

Mr. Paul Cejas
The Boeing Company

Mr. Jack Chancellor
Meggitt Defense Systems

Col Mark Chapin, USAF (Ret)
The Charles Stark Draper Laboratory, Inc.

Mr. John Childs
QinetiQ, Ltd.

Mr. Gerry Christeson
Defense Test Resource Management Center

Mr. Dan Clapp
U.S. Air Force

Mrs. Debbie Clegg
Argon ST

Mr. Gifford Clegg, III
Raytheon Company

Ms. Margie Coleman
Alliant Techsystems

Mr. Jim Cornwell
691st Armament Systems Squadron

Mr. Jim Cotter
KRATOS Defense and Security Solutions, Inc.

Ms. Linda Culliton
AAC/EBYA

SGM Larry DeRoche, USA (Ret)
Vectronix, Inc.

Mr. Thomas Dowd
Naval Air Warfare Center, Weapons Division

Mr. David Dowley
Bechtel National, Inc.

Ms. Karen Draper
NAVAIR

Mr. Scott Duffy
TASC

Mr. Jim Duncan
Raytheon Company

Maj Jeb Ebner, USAF
58th FS

SGM Mark Englert, USA (Ret)
EOD Technology, Inc.

Mr. Dik Farhall
Airborne Systems N.A.

Lt Gen Larry Farrell, Jr., USAF (Ret)
National Defense Industrial Association

Mr. Don Ferguson, Jr.
U.S. Army Missile Command

Mr. Kevin Ferguson
Micro Systems, Inc. - A subsidiary of Herley Industries

Mr. Michael Francis
Targets Management Office

Mr. Spencer Fraser
Meggitt Training Systems, Inc., Canada

Mr. Dobie Frazier
Raytheon Company

Mr. Larry French
Griffon Aerospace

Ms. Kathy Fuszner
USAF AAC/WMRA

Mr. Ron Glockner, Jr.
Atlantic Targets & Marine Operations

Mr. Ron Godlewski
Cobham Sensor Systems

Dr. Bill Golbitz

Mr. Steve Gonzales
White Sands Missile Range

Mr. Michael Griffin
Culmen International, LLC

Mr. Sam Griffith
Atlantic Targets & Marine Operations

Col Michael Guidry, USAF
AAC/SE

Col Pete Guter, USAF (Ret)
AFOTEC Det 2

Lt Col Mark Handrop, USAF
Air Force Research Laboratory

Maj Gen George Harrison, USAF (Ret)
GA Tech Research Institute

Mr. Barry Hatchett
Targets Management Office

Mrs. Teri Higgs
NAVAIR

Lt Col Ken Hislop, USAF (Ret)
AAC/EBYA

Mr. Jim Hobson
Argon ST

Ms. Katie Hodges
AAC/EBY

Mr. Bob Insinna
The Boeing Company

Mr. Randy Jeffreys
ONR

Mr. Gary Kemp
Cambridge Consultants

Mr. Bob Kenny
Conley & Associates, Inc.

Mr. Sundeep Kharey
CDL Systems, Inc.

Mr. Steve Kimmel
Alion Science and Technology

Mr. Larry KinCannon
EADS North America

Mr. Dave Kitchen
308th Armament Systems Wing

Mr. Joel Knight
AAC/EBYC

Mr. Don Koch
EOD Technology, Inc.

Mr. Brian Krinsley
Naval Air Warfare Center, Weapons Division

Mr. Andy Kristovich
OSD/DOT&E

Mr. Todd Kustom
Micro Systems, Inc. - A subsidiary of Herley Industries

Mr. David Laird
Micro Systems, Inc. - A subsidiary of Herley Industries

Mr. Ken Laird
328 ARSW Air-to-Air Missile Systems Wing

Mr. Patrick Laney
CDL Systems, Inc.

Mr. John Latimer
Lockheed Martin Technical Services

Ms. Karen Lawson

Mr. Marty Lawson
OPNAV N433 Targets

Capt Ian Layugan, USAF
U.S. Air Force

Mr. Jim Lewis
Systems Application & Technologies, Inc.

Ms. Sharon Lovelace
AAC/EBYA

Mr. Ken Lyle
Target Consulting Services

Mr. Michael Marlow
Aerojet

Mr. Alan Massing
AAC/EBYC

Mr. James Maybury
Applied Resources, Inc.

Mr. Dave McClure
Rockwell Collins

Mr. George McCullough
Martin Electronics, Inc. dba Chemring Ordnance

Mr. Rod McLaury
Systems Application & Technologies, Inc.

CAPT Dan McNamara, USN
PMA-208 Navy Aerial Targets & Decoy Systems

Mr. Bob McNiel
Lockheed Martin Corporation

Mr. Richard Meiners
Naval Air Warfare Center, Weapons Division

Mr. John Mendes
Targets Management Office

Mr. Doug Meyer
CEI

Mr. Dave Miller
Meggitt Defense Systems

Mr. Josh Miller
Air Force Materiel Command (AFML/A5J)

Mr. Matt Milligan
Southern California Offshore Range

Mr. Dennis Mischel
DOT&E/LEW

Mr. Walter Monteith, Jr.
AAC/SE

Lt Col Boosh Neeman, USAF
86th Fighter Weapons Squadron

Ms. Roshelle Orgusaar
AAC/ENY

Mr. John Ota
NAVAIR Threat/Target Systems

Mr. Tony Parisi
NAVAIR Ranges Sustainability Office

Mr. Yogeshkumar Patel
NAVAIR Threat/Target Systems

MAJ Bernie Peters, USA
Camp Grayling Joint Maneuver Training Center

Maj Greg Pixley, USAF (Ret)
691st Armament Systems Squadron

Mr. Matt Poff
780th Test Squadron

Mr. Karl Poulsen
Microturbo, Inc.

Mr. Cort Proctor
Micro Systems, Inc. - A subsidiary of Herley Industries

Mr. Ben Rasnick
NAVAIR

Ms. Holly Reedy
AAC/EBYA

Mr. Leo Rose
Air Force Armament Laboratory

Lt Col Jerry Rutt, USAF (Ret)
Raytheon Company

Mr. Sandy Sanford, Jr.
Applied Resources, Inc.

Mr. Glenn Schaffer
Targets Management Office

Mr. Dan Schoenborn
USA Yuma Proving Ground

Mr. Henry Schoenborn
Surface Combat Systems Center

SSG Steve Schwandt, USA (Ret)
DPTMS Fort AP Hill

Mr. Dave Sheehan
Northrop Grumman Corporation

CAPT Steve Shegrud, USN (Ret)
Whitney, Bradley & Brown

Ms. Veronica Sherard
Ensco, Inc.

Mr. Bruce Simon
Science Applications Int'l Corporation

Col Mark Simpson, USAF (Ret)
Oasis Systems, Inc.

Mr. Chuck Sleeper
UBC, Inc.

Mr. Brent Smith
Jacobs Engineering Group, Inc.

Ms. Alexis Smollok
TSA-Federal Air Marshal Service

Mr. Mike Sorial
AAC/EBYC

Mr. Pat Speake
Raytheon Company

Mr. Walt Spence
Honeywell Corp.

Mr. Mike Spencer
Raytheon Company

Mr. Steve Streightiff
Computer Sciences Corporation

Mr. Michael Stuart
ATK - Advanced Weapons Division

Mr. Eddy Sutton
Jacobs Sverdrup

Mr. Dennis Tackett
Modern Technology Solutions, Inc.

Mr. Craig Tangedal
5-D Systems, Inc.

Ms. Michelle Tibbitts
IBM Federal Software

Mr. Stan Ulkoski
J.F. Taylor, Inc.

Mr. Eric Underwood
Lockheed Martin Aeronautics Company

Mr. Joe Valenzuela
DRS Technologies C3 Systems

Mr. Michael VandenBoom
691st Armament Systems Squadron

Mr. David Walthall
USAF AFMC AAC/EBYE

Mr. James Webb
AAC/EBAD

Mr. Daniel Whealton
Surface Combat Systems Center

Maj Gen James Whitmore, USAF
HQ AETC/A2/3/10

Col Rae Williams, USAF (Ret)

Mr. Steve Williams
RT Logic, Inc.

Mr. Billy Wilson
Naval Air Warfare Center, Weapons Division

Ms. Sue Wood
Atlantic Test Ranges

Mr. Harold Woodfin
Applied Geo Technologies, Inc.

THANK YOU TO OUR LUNCH SPONSOR



Nearly a century of expertise and continuing innovation make Boeing the leader in the aerospace and defense industry. Boeing combines global resources and a spirit of innovation to provide best-of-industry, network-enabled solutions to military, government and commercial customers around the world.

From battle-proven aircraft to space systems and beyond, Boeing is the world's leading space and defense business and the world's largest and most versatile manufacturer of military aircraft. Boeing is also the world's largest satellite manufacturer, an emerging leader in support systems and services, and a leading global supplier of human space exploration systems and services.

THANK YOU TO OUR OPENING RECEPTION SPONSOR



Meggitt Defense Systems (MDS) is proud to sponsor the NDIA Targets Symposium. MDS is a world leading designer and producer of sub-scale free flying and towed targets with well over 140,000 targets delivered to the U.S. and allied forces over our company's history. Our products range from the 180-300 knot class Banshee and Voodoo powered targets, to the 400 knot class GT-400 glide target, and a wide portfolio of towed targets and highly reliable reeling machines and tow lines. Our targets can be modified with signature augmentation devices to match training threats in the visible IR and radar spectrums. MDS also designs and produces a wide variety of Acoustic and Doppler radar based scoring systems for both scalar and vector applications along with associated ground stations for rapid feedback during engagements. We have also developed and fielded the Aerial Weapon Scoring System (AWSS) that has become the U.S. Army's standard for objective weapons evaluation during Apache crew qualification gunnery tables.

MDS' other technologies include airborne countermeasure systems, ammunition handling systems, and environmental control systems. Our Training Systems group in Atlanta, Georgia specializes in live-fire range Targetry, control and instrumentation for various weapon types ranging from small arms through full tank rounds and virtual training ranges utilizing the latest in computer generated graphics for full immersion scenarios from individual weapons to full combat unit engagements including calls for fire and air strikes.

Our company's goal is to support our armed forces with the best training and combat systems possible so the soldiers can train like they fight and fight like they train. We take pride in our combat systems' reliability from towed countermeasures to ammunition handling systems – all proven in combat in the harshest environments in the world. Our motto, "Smart engineering for extreme environments," means we take great pride that our equipment will work the first time and every time, wherever deployed.

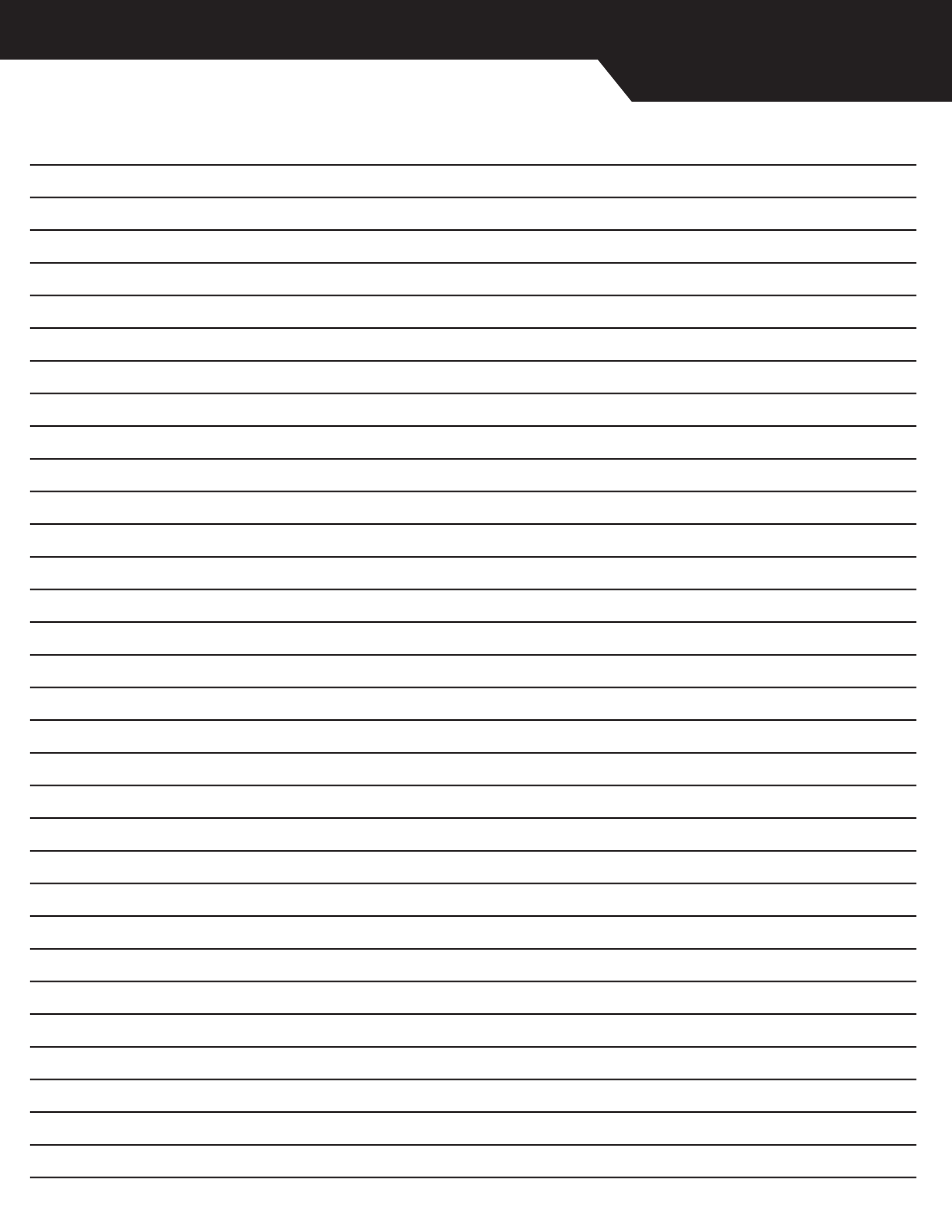

2111 WILSON BOULEVARD
SUITE 400
ARLINGTON, VA 22201-3061
(703) 522-1820
(703) 522-1885 FAX
WWW.NDIA.ORG

Thank You for Attending!
We'll See You in 2011!

SAVE THE DATE

October 25-27, 2011
Emerald Coast Conference Center
Fort Walton Beach, FL
<http://www.ndia.org/meetings/2410>

**48th ANNUAL
TARGETS, UAVS &
RANGE OPERATIONS
SYMPOSIUM & EXHIBITION**



Range Sustainment and Modernization to Meet Customer Needs

*Targets, UAVs & Range Operations Symposium
New Orleans, LA*

**Mr. Robert J. Arnold
Technical Advisor, 46th Test Wing
Eglin Air Force Base, Florida**

20 October 2010

Integrity - Service - Excellence



KEY TAKE-AWAY





VIDEO





URBAN WARFARE: FUTURE WEAPONS

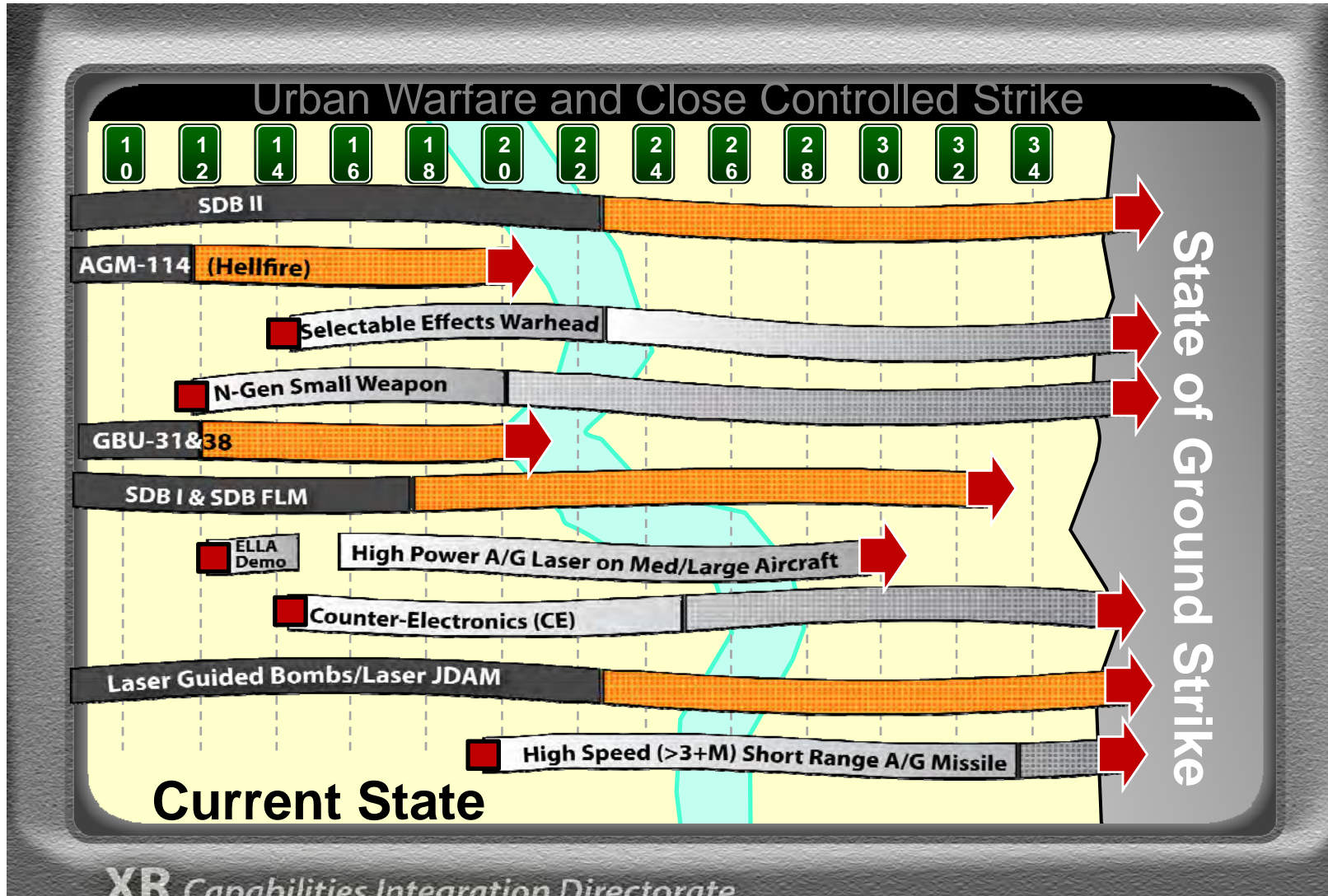



TEST HIERARCHY

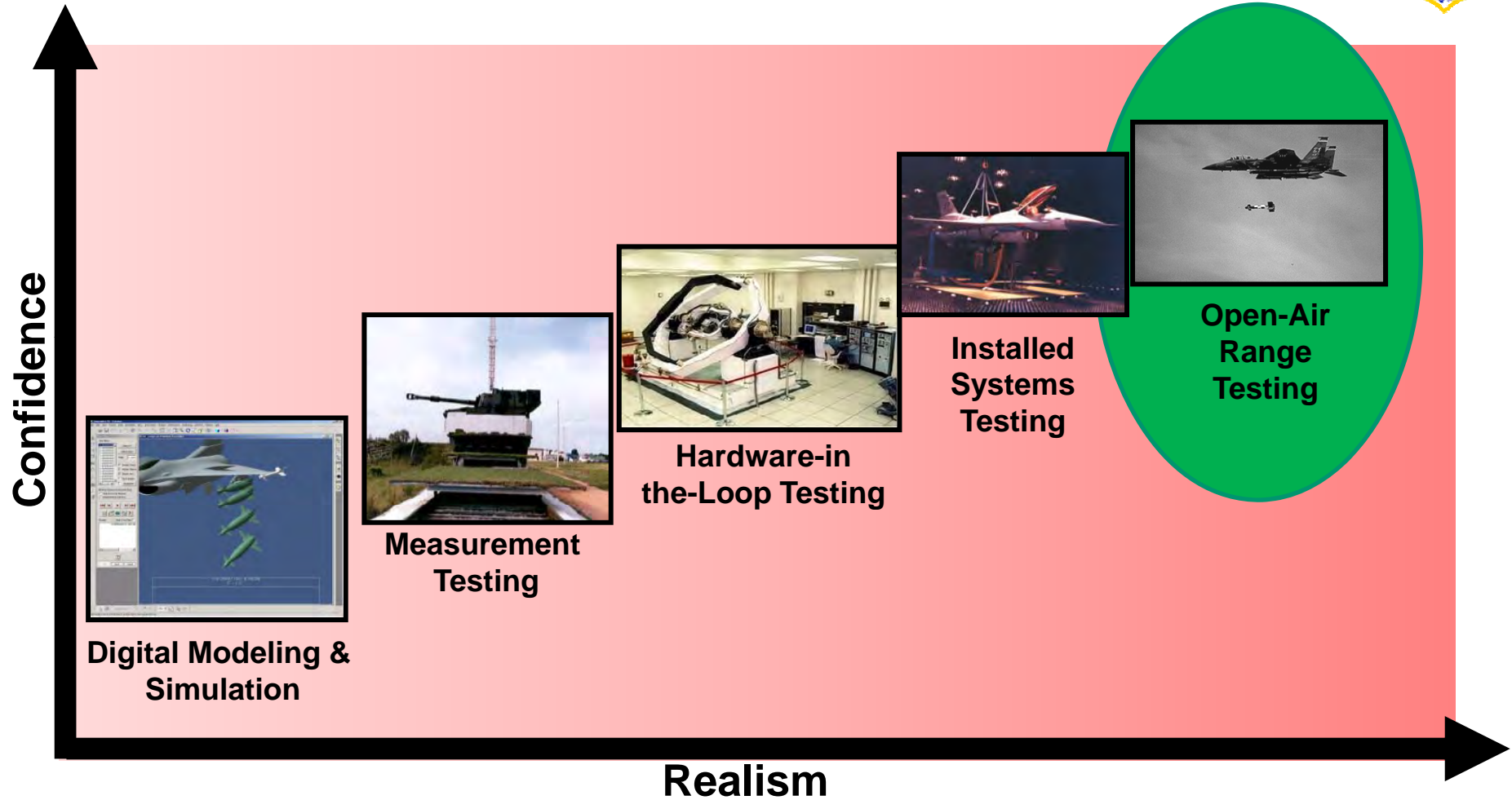

There Is No Substitute For Open-Air Testing!



KEY CHALLENGES



- **Range Constraints**
- **Encroachment**
- **Congestion**



HISTORICAL SAFETY FOOTPRINTS

AFMCO

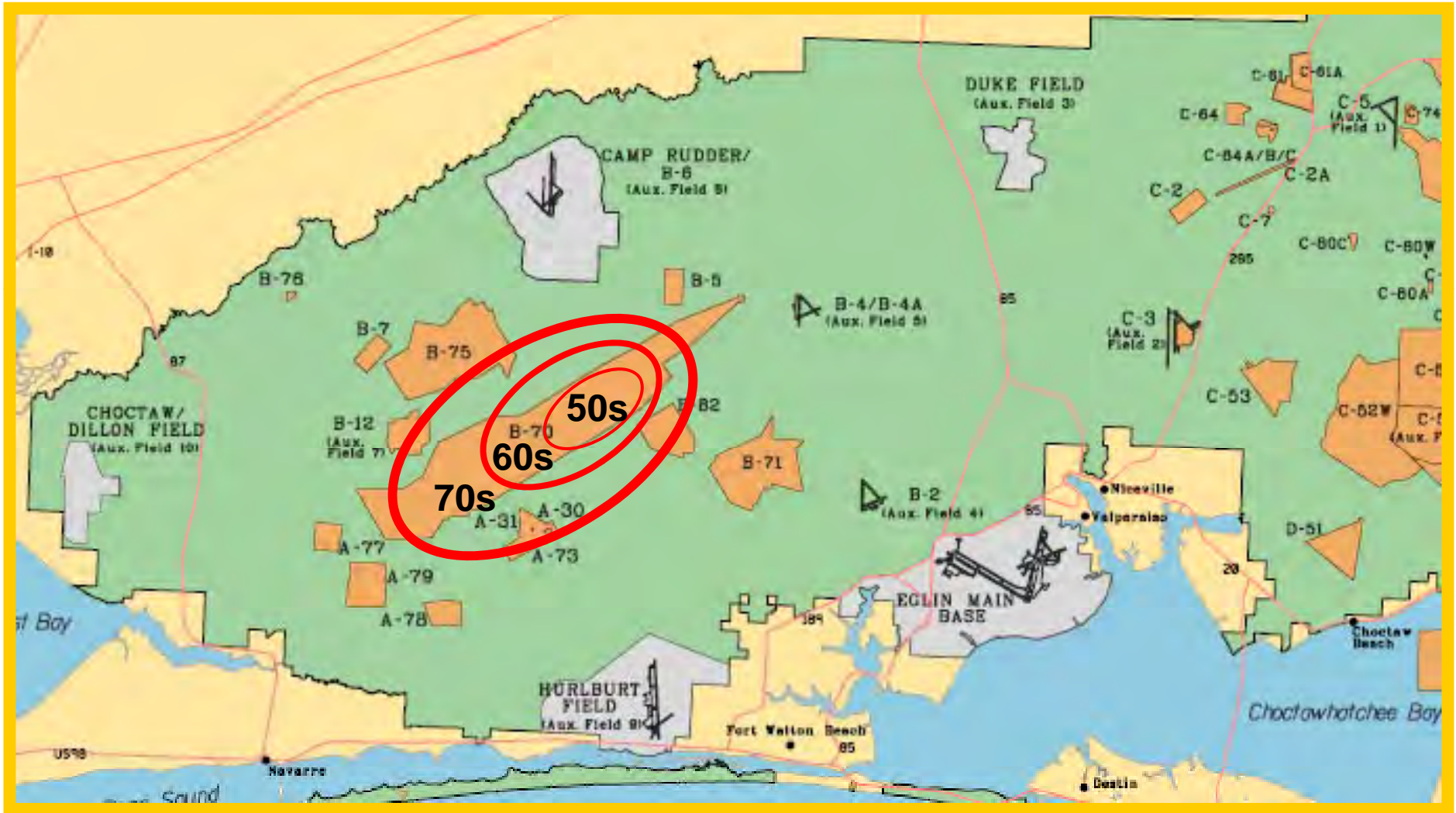



CURRENT SAFETY FOOTPRINTS

AFMCG

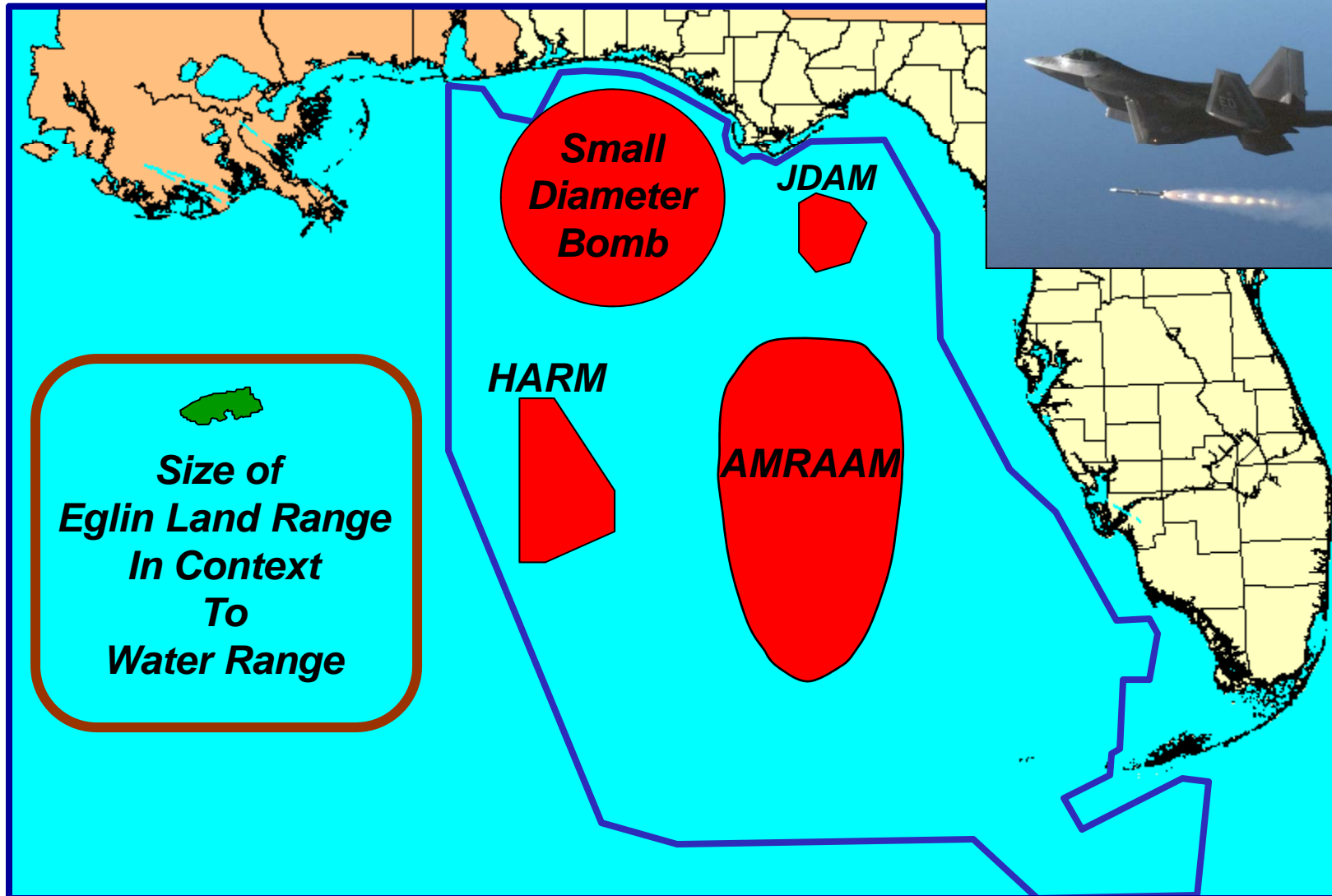



URBAN GROWTH



**Urban Development Has Marched To The Gates Of
Once Remote Military Training Installations**



AIRSPACE

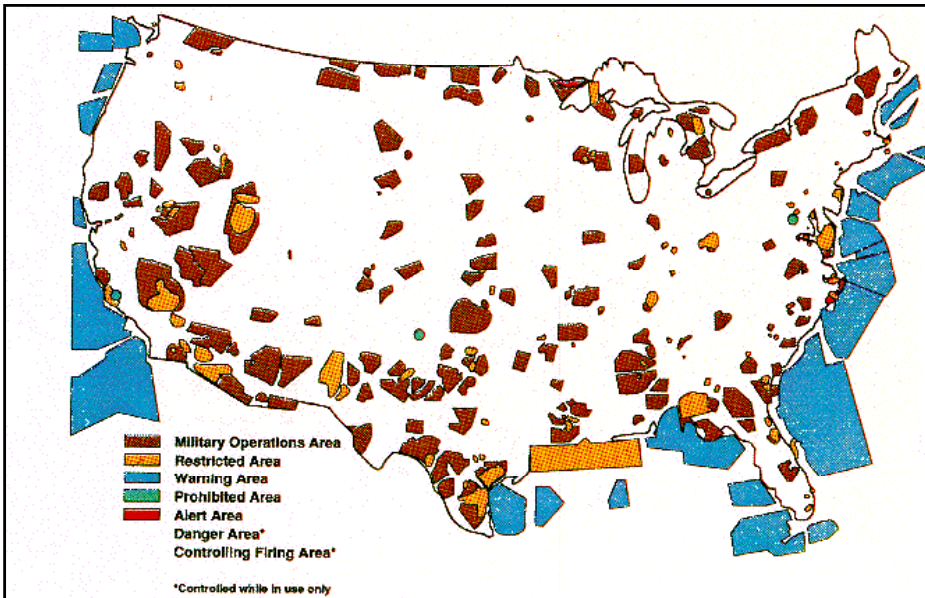

Special Use Airspace

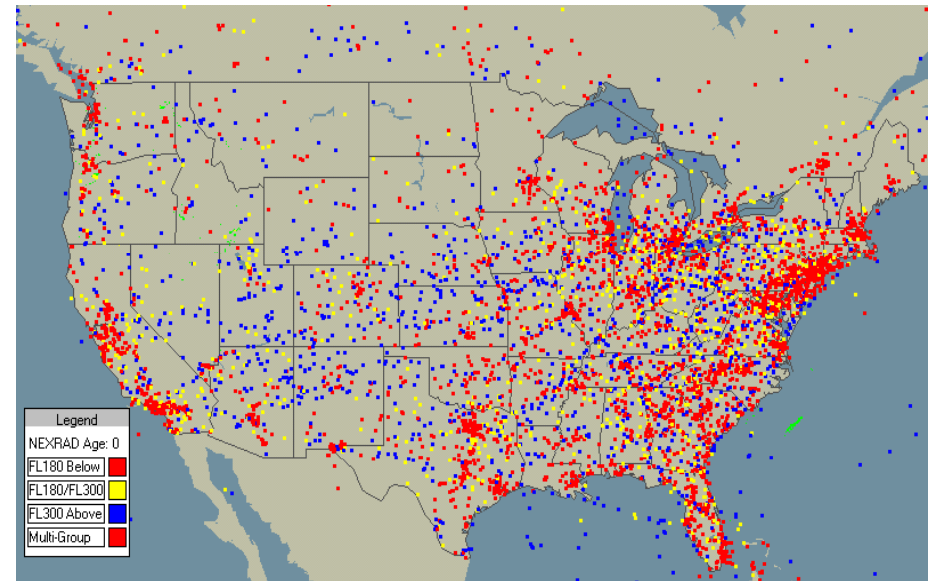

Commercial Air Traffic

Airspace Competition From Both Within And Outside Of DoD



AVIATION GROWTH





ENDANGERED SPECIES

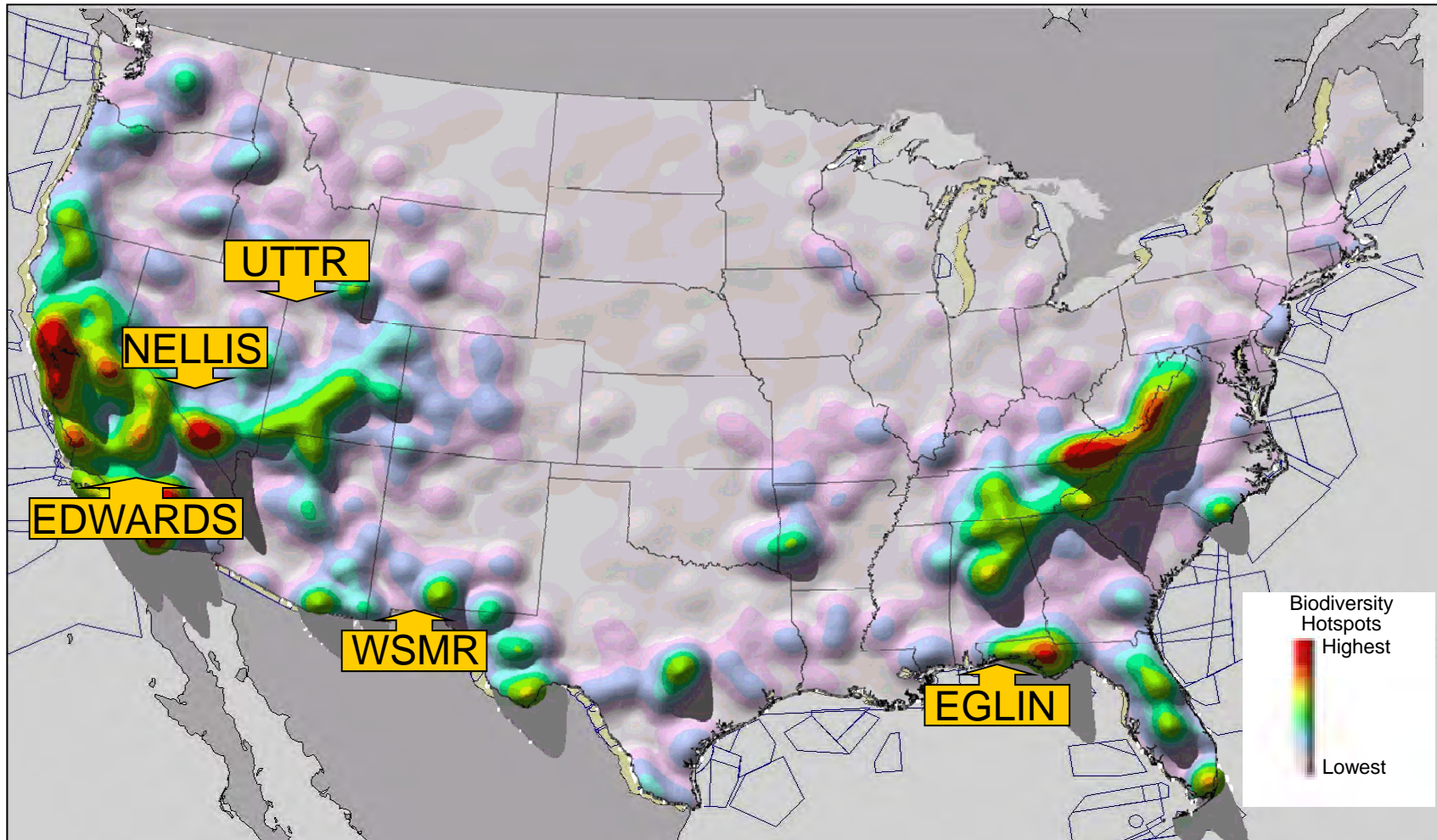

Ranges Are Environmental Hot Spots



LOSS OF SPECTRUM



TSPI & Telemetry Application

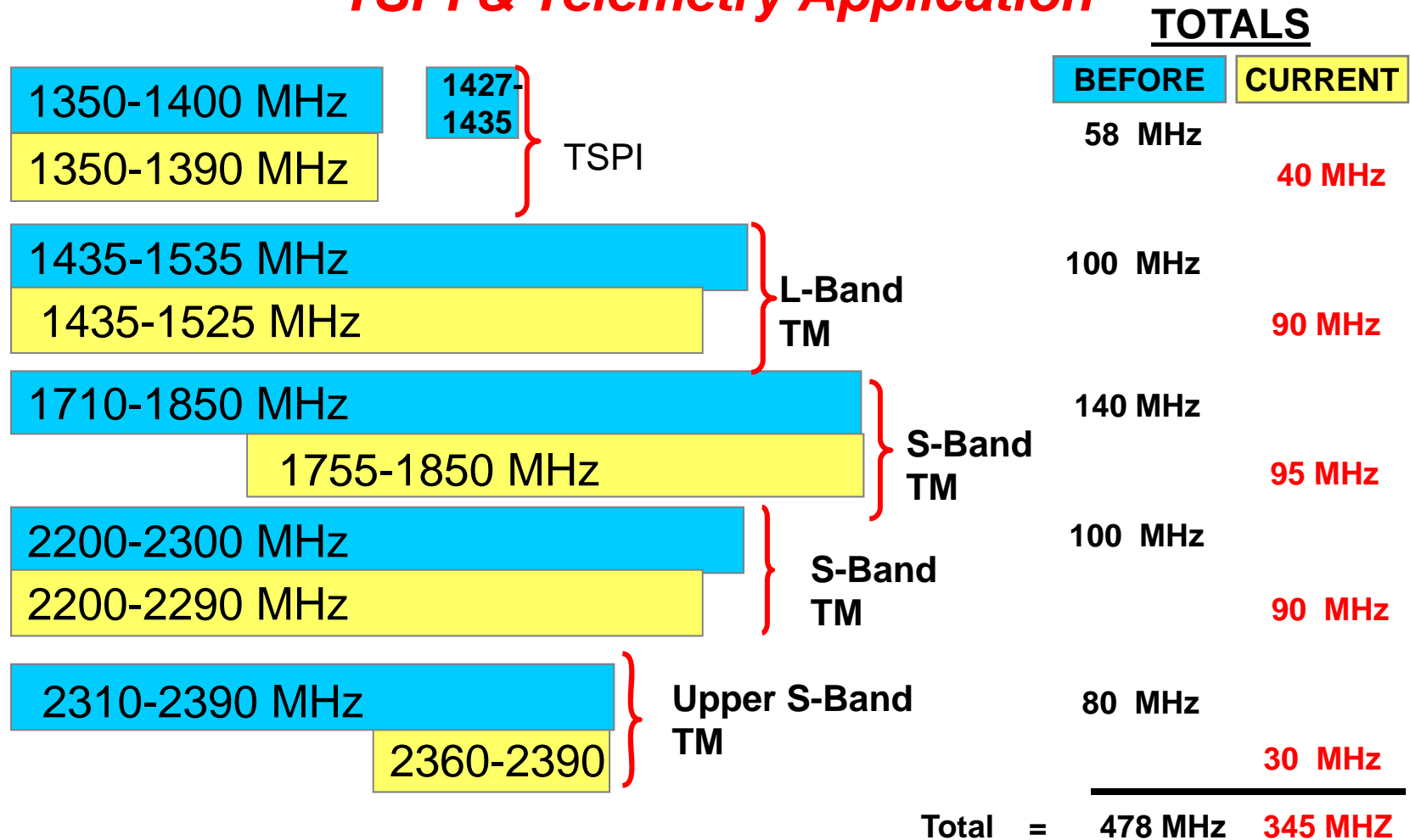

Loss Of 133 Mhz Of Spectrum Since WRC 92



BRAC 2005

ADDITIONAL DEMANDS ON RANGE USE

AFMCG



7th Special Forces Group (Airborne)



~2200 Personnel - Arriving FY11
~\$400M MILCON - Began FY09
Location - West of Duke Field

F-35 Integrated Training Center (ITC)



~2000 Personnel - Arriving FY09-FY15
~\$400M MILCON - Began FY09
Location - 33 FW Area



BRAC 2005 New Missions For Eglin

~800M MILCON
~4200 Mil/Civ/Ctr
~6000 Dependents



2005 Base Realignment And Closure (BRAC)



TESTING & TRAINING



*Testing
Modernization
For Tomorrow*



**Scheduling
Throttles**

D
O
D

R
A
N
G
E
S

*Sustainment
Mission*



*Training
Readiness
For Today*

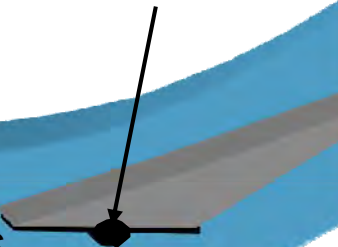

Balancing Testing And Training



TRAINING REQUIREMENTS LAND SEGMENTATION

AFMCG

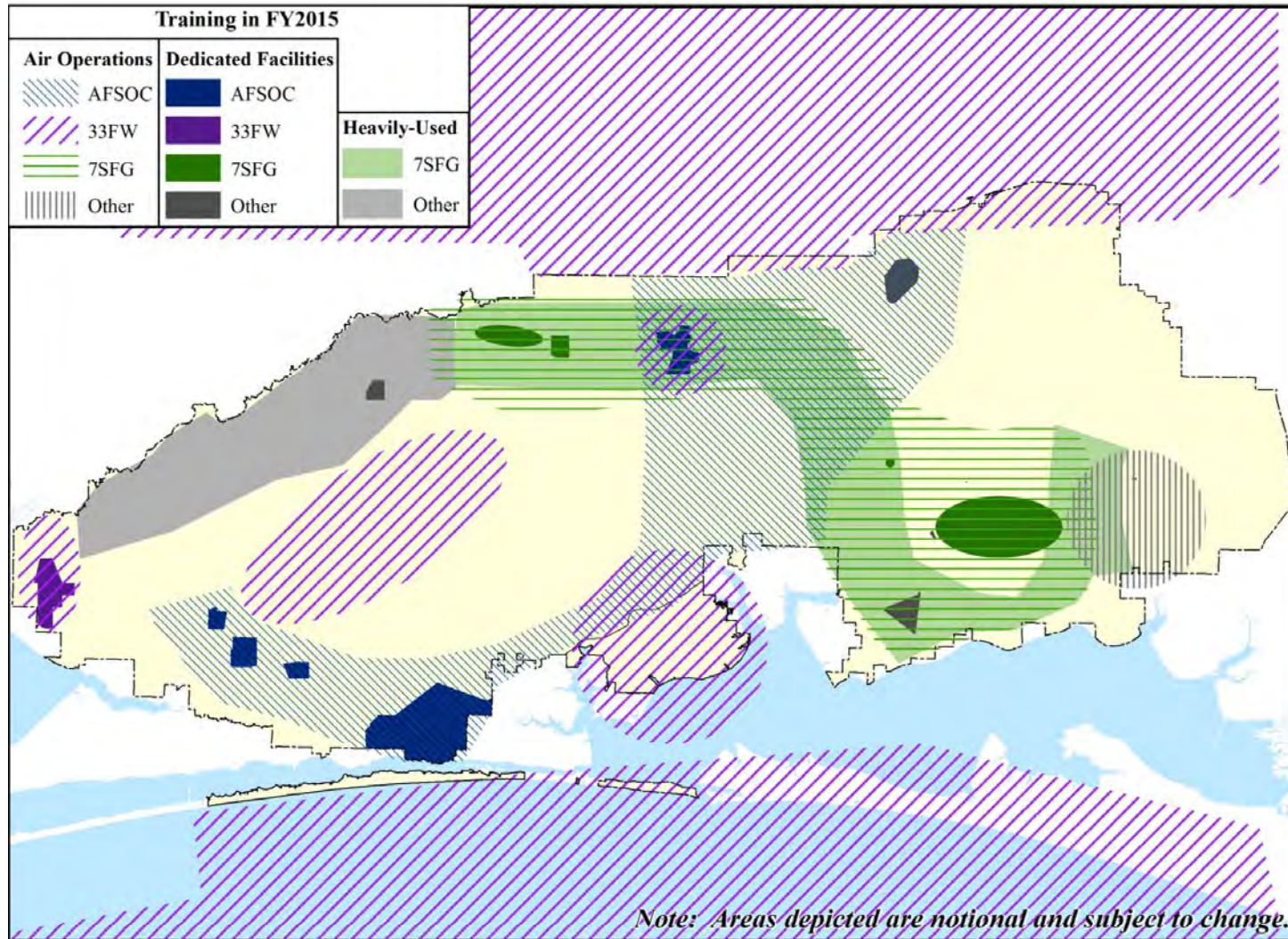

New Paradigm For A Traditional Test Range



RANGE COMPARTMENTALIZATION

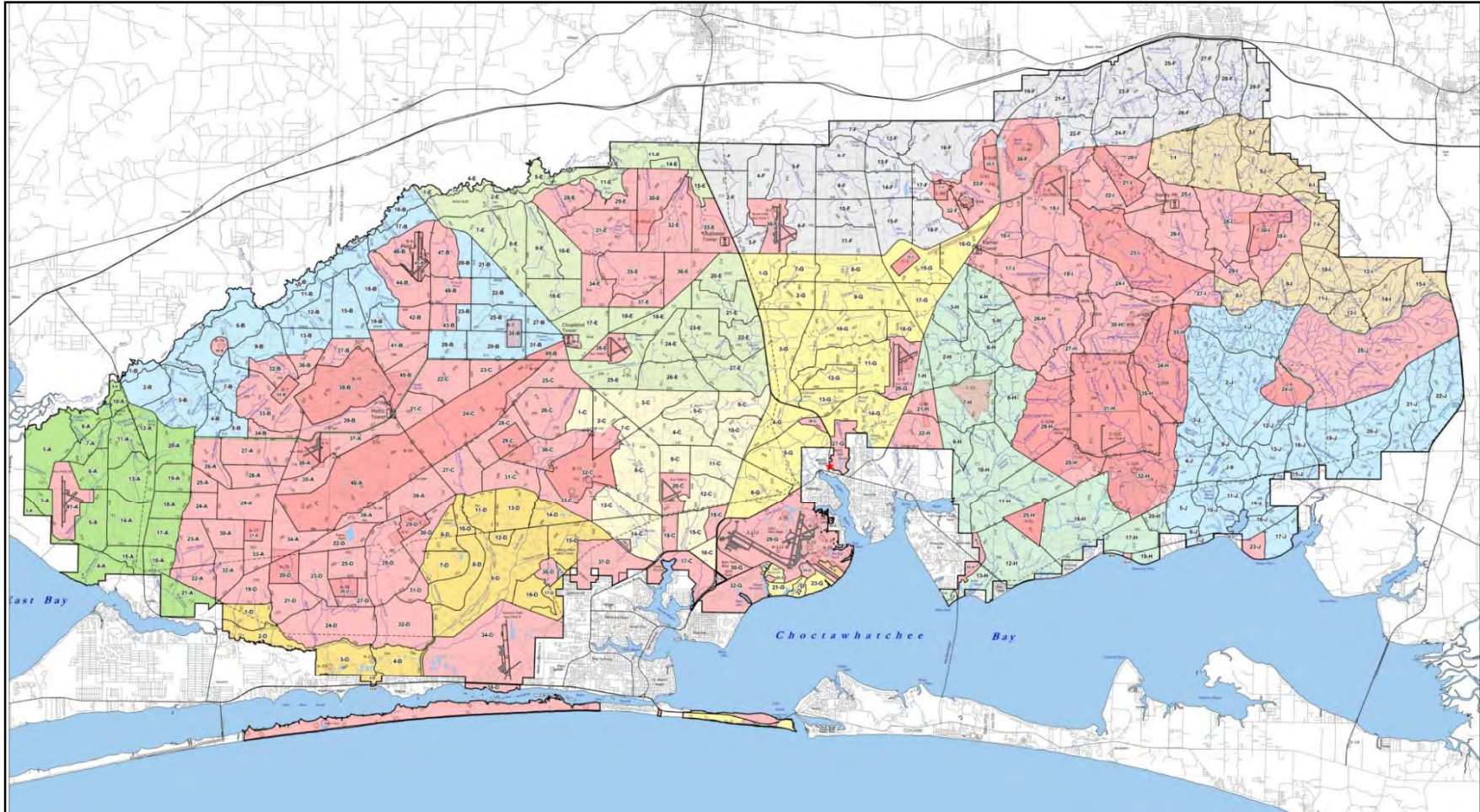

Deconflicts Land Use By Trainers



MISSION SCHEDULING

AFMOC

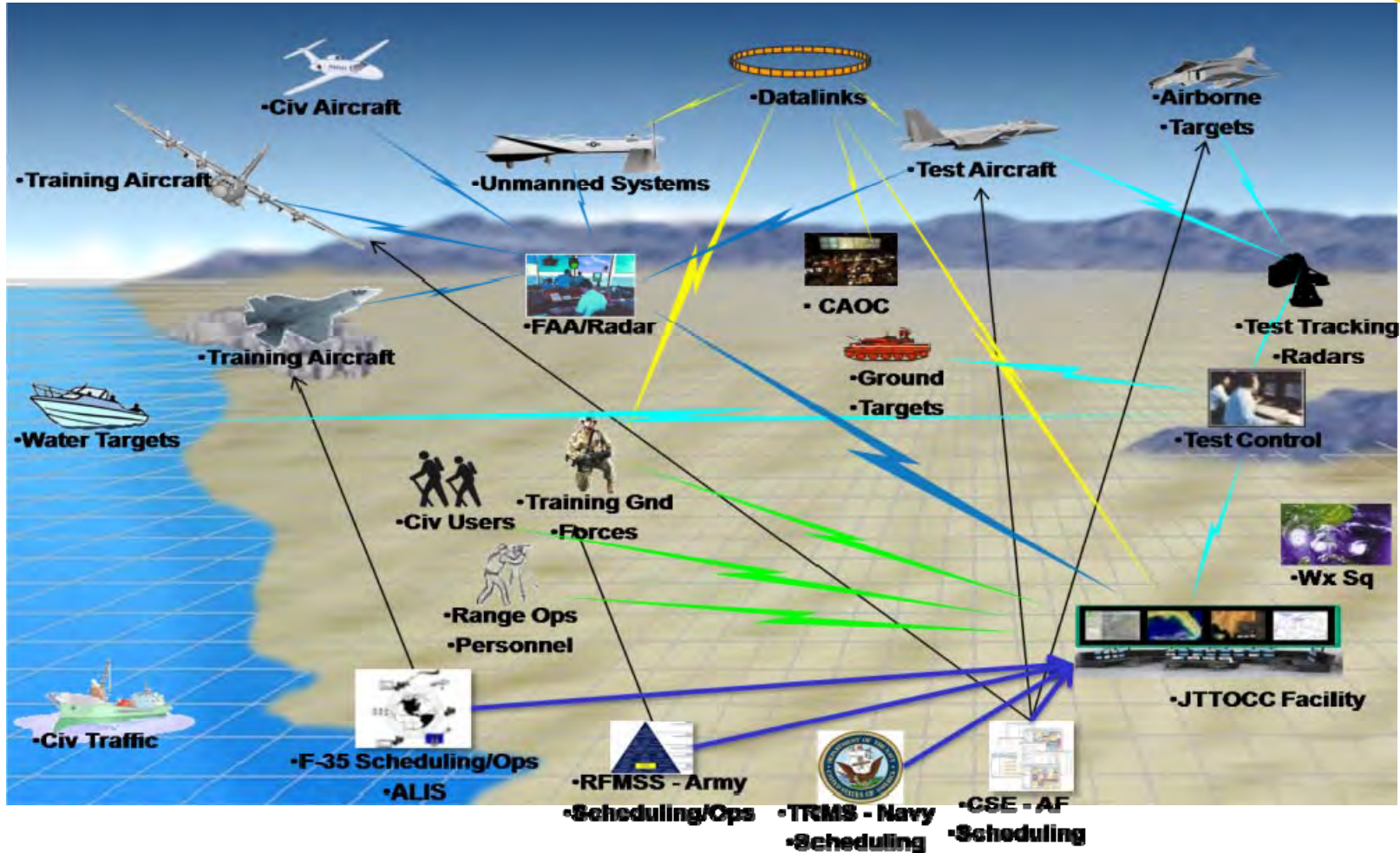

Establishing New Joint Test & Training Operations Control Capability



STRATEGIC BUFFERING

AFMCO

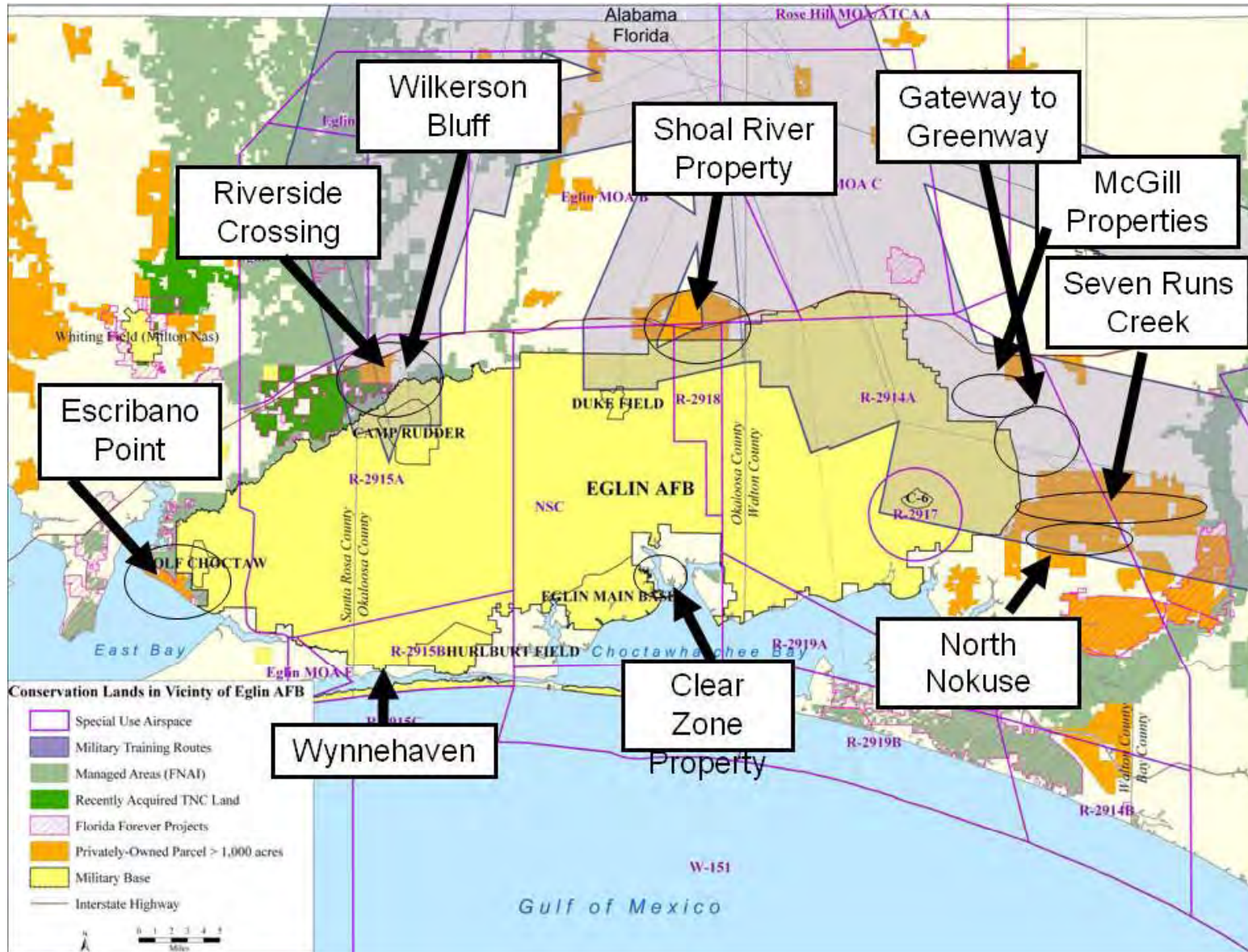



EGLIN WATER RANGE

AFMCG

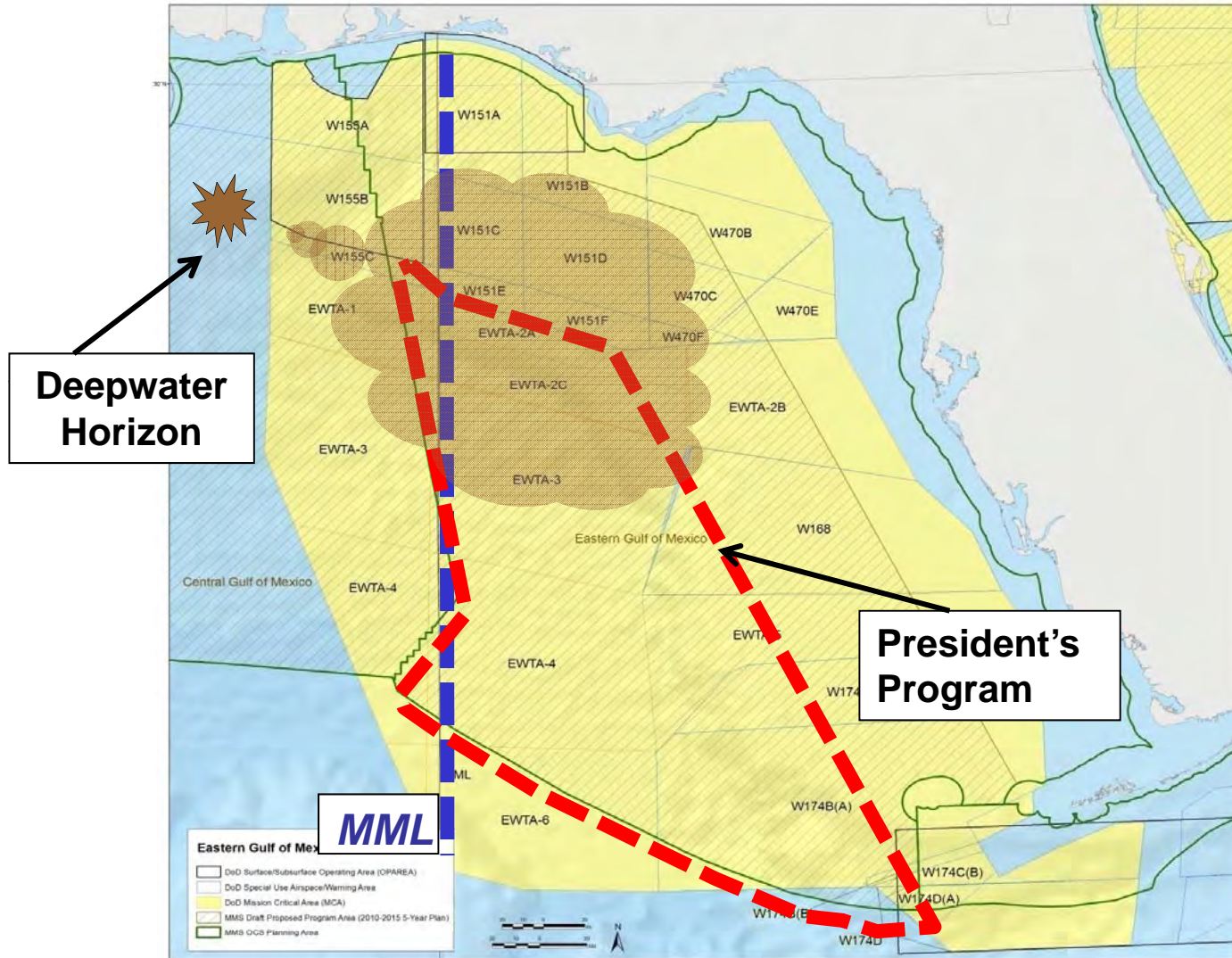

Balancing DoD Missions With National Energy Needs



GULF RANGE AIRSPACE STRATEGIC INITIATIVE

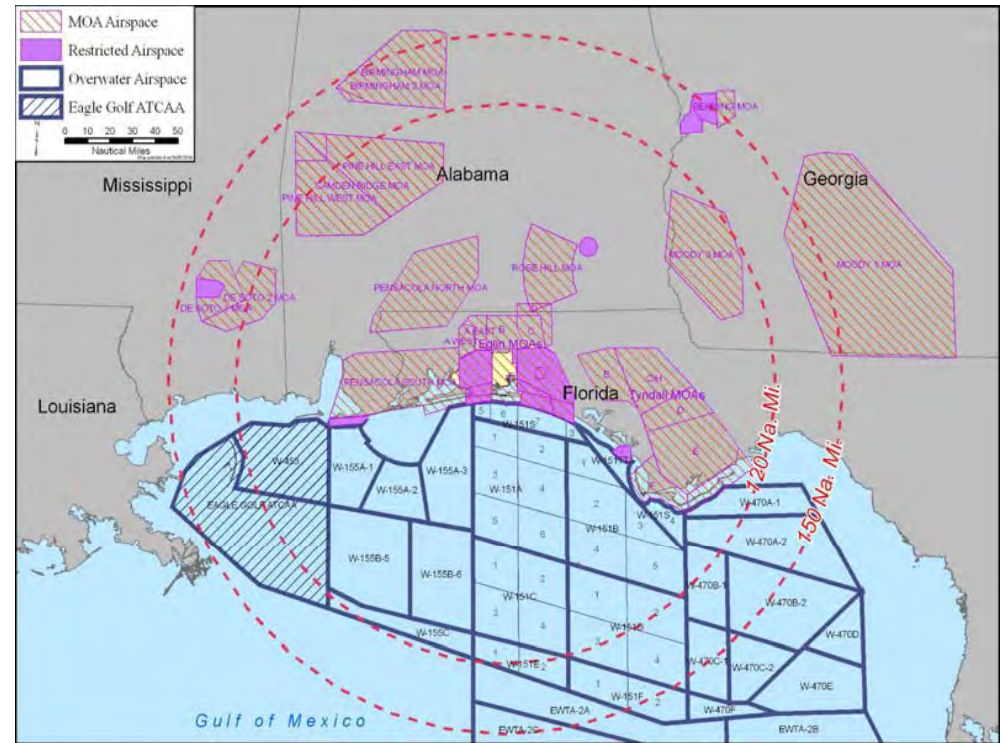
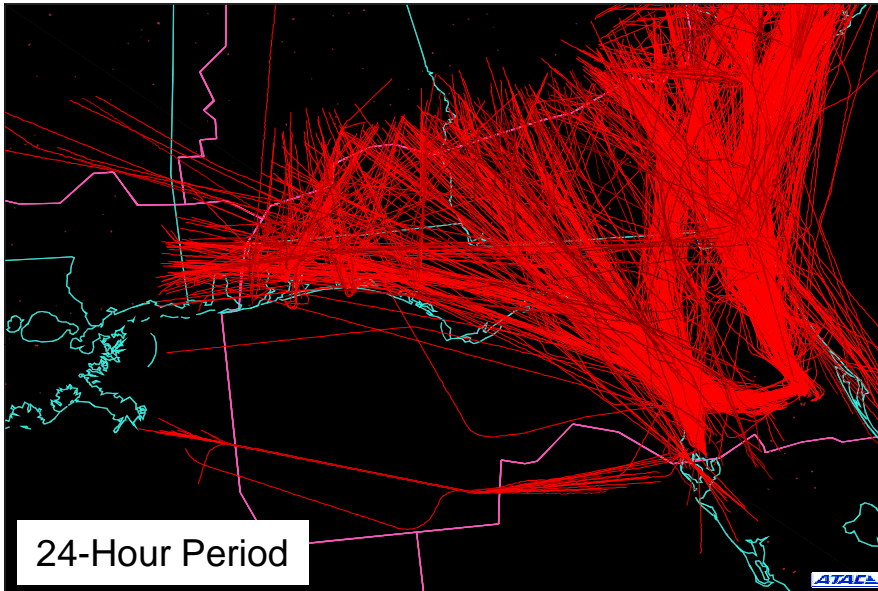

Increasing Airspace Demands From Both DoD And Civilian Operators

Gulf Regional Airspace Is A National Asset



SUMMARY



Air-Land-Sea Ranges are critical for testing weapon systems for tomorrow and training readiness for today



U. S. NAVY SEABORNE TARGETS

Moving Forward
Responding to the Fast Attack Threat

Head, Surface Targets Team
NAVAIR 5.3

Threat/Target Systems Department
Pt. Mugu, California



48th Annual NDIA
Targets, UAV's & Range Operations
Symposium and Exhibition



Unclassified



New Challenges = New Capabilities



Overview

- Organization / mission
- Current targets
- Fast Inshore Attack Craft – HSMST evolution
- Fast Attack Craft - FACT evolution
- Control Systems
- Enhanced realism
- Expanded role



Seaborne Targets Structure

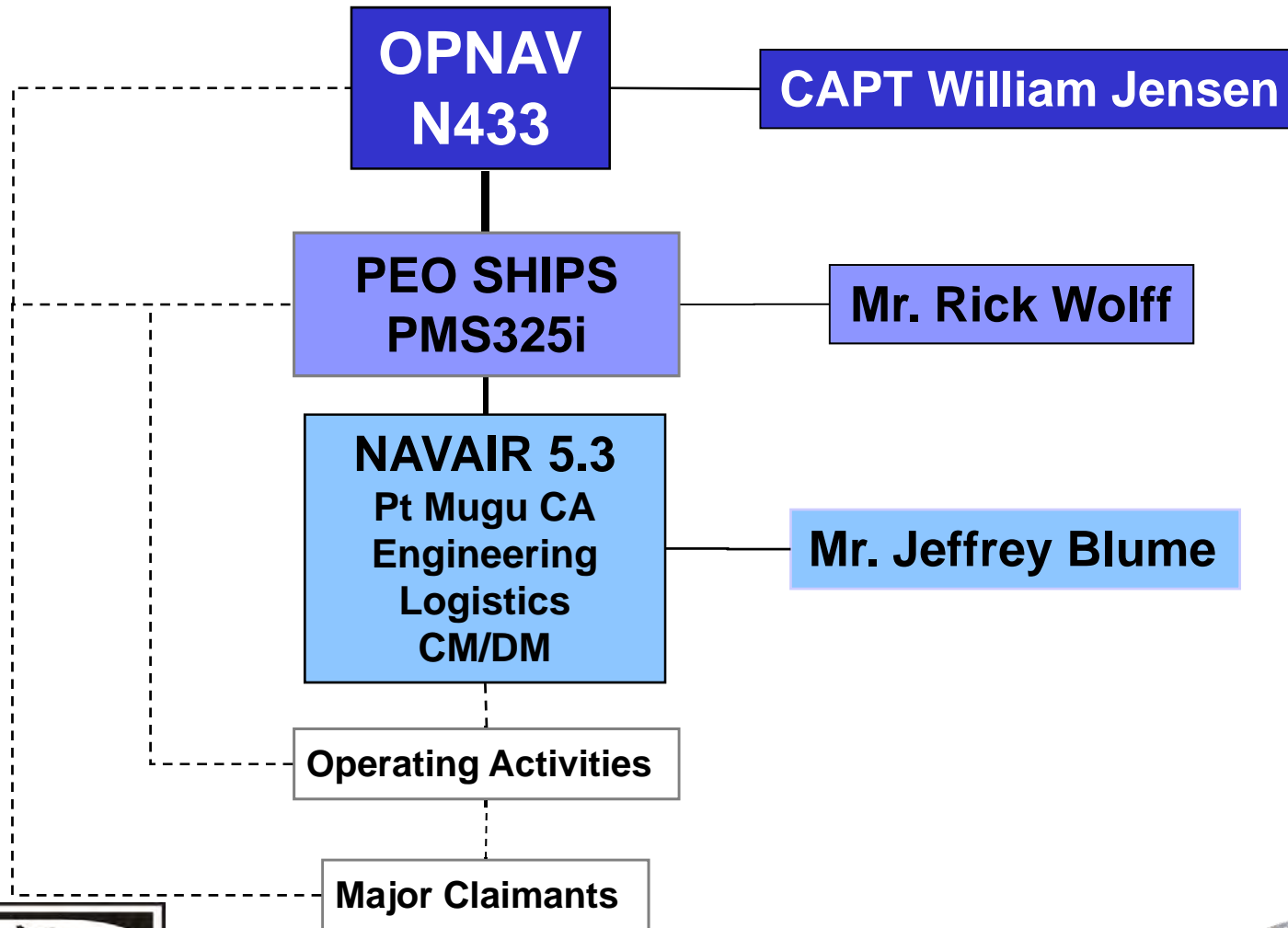

Surface Targets Team

Mission

- Navy life-cycle lead for Seaborne Targets and augmentation systems
- Tri-Service Lead for Seaborne Targets
- Seaborne target services to the Fleet, DoD, and Foreign Military Customers in support of weapon system T&E and Fleet Training



Seaborne Target Resources

Powered Targets



Fast-Attack Craft Target



High-speed threat



Ship deployable for at-sea training.



Generic threat. Also tow tractor



Self-propelled ship simulator

Seaborne Target Resources

Towed Targets



Low-Cost Modular Target



Small low-cost tow for use with HSMST & SDST



Multi-purpose tow used with QST-35 or HSMST

Fast Inshore Attack Craft Evolution

- Requirement
 - 5” gun - High Speed Maneuvering Surface Target test requirements
 - Multiple maneuvering targets capable of 35 knots in Sea State 3

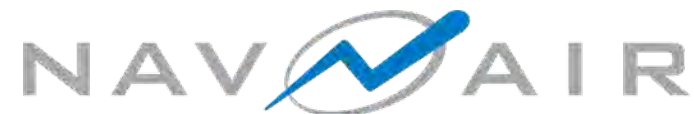

Fast Inshore Attack Craft Target QST-33

- **Characteristics**
 - 18 feet long
 - 7' 4" beam
 - 330 Hp
 - 3650 Lb
 - Deficient performance in established seas

- **Requirement**
 - 35 Kts SS3
- **Capability**
 - 20 Kts SS2

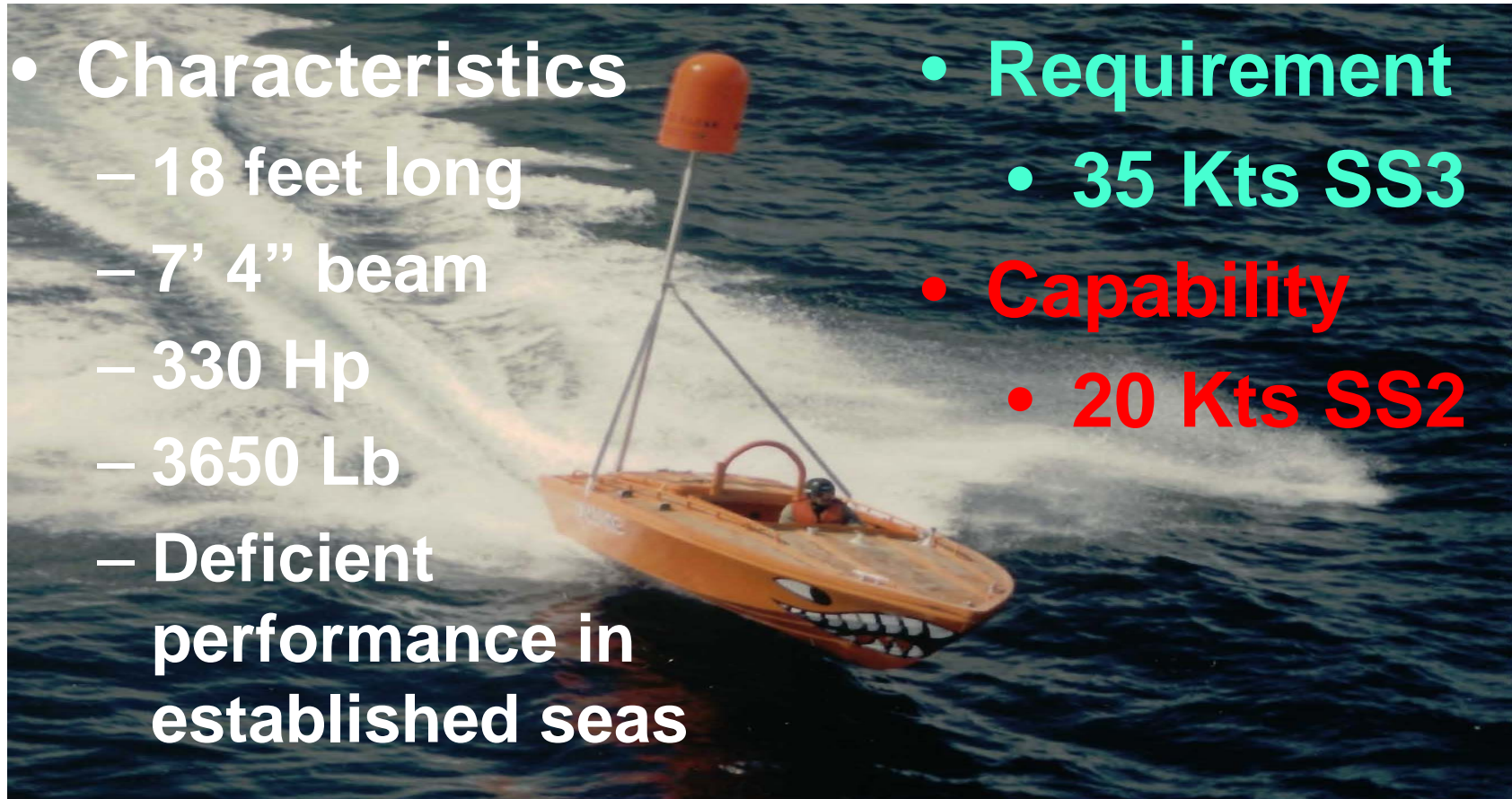

Fast Inshore Attack Craft Target HSMST-1

- **Characteristics**

- 7 meters long

- 9.5 ft beam

- 300 Hp

- 5000 Lb

- Substantial improvement over QST-33 attributed to size

- **Requirement**

- 35 Kts SS3

- **Capability**

- 35 Kts SS3

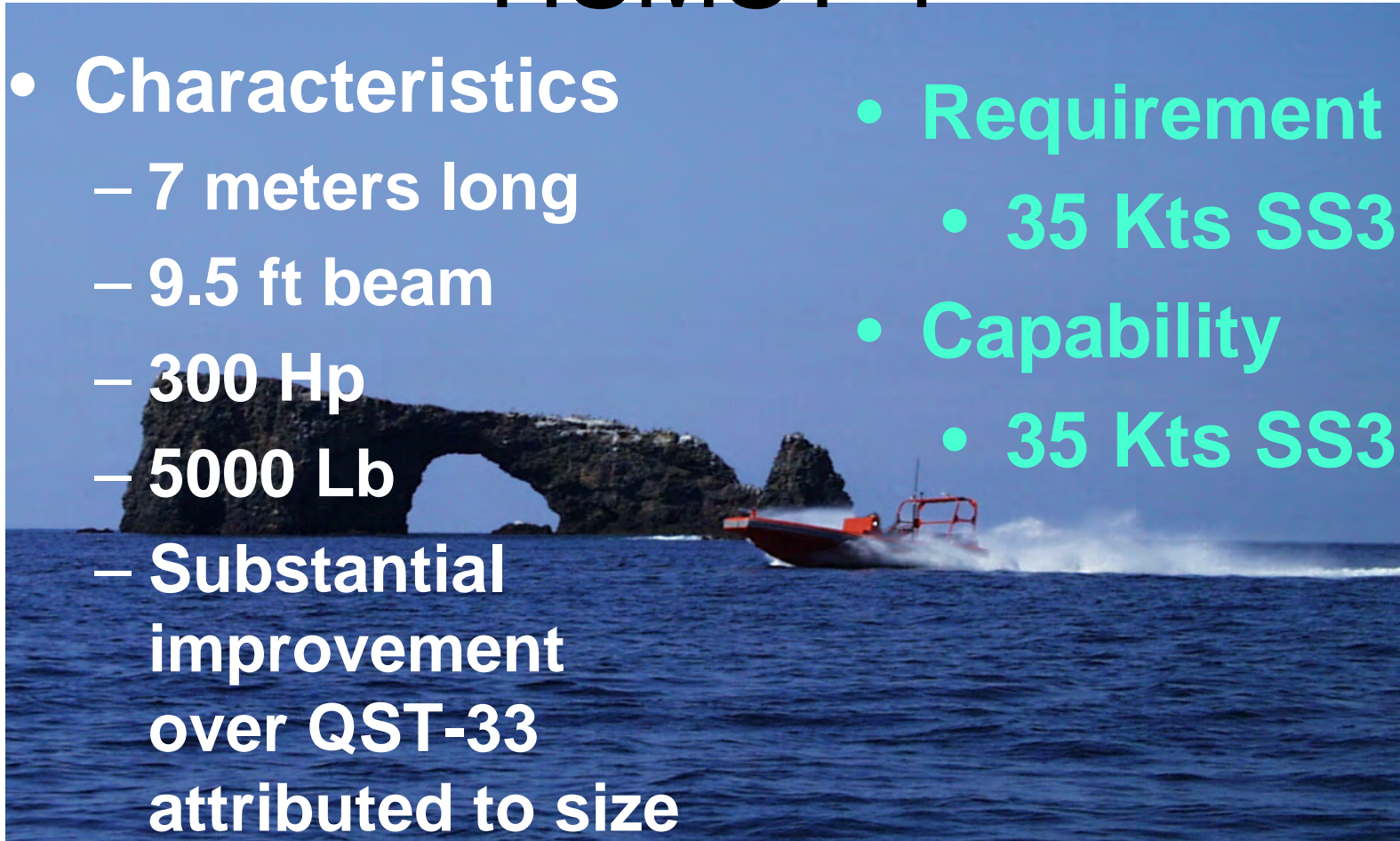

Fast Inshore Attack Craft Target HSMST

- **Characteristics**

- 8 meters long
- 7.5 ft beam
- 400 Hp
- 5700 Lb
- Additional size contributed to performance

- **Requirement**

- 35 Kts SS3

- **Capability**

- 46+ Kts
- 35 Kts SS3

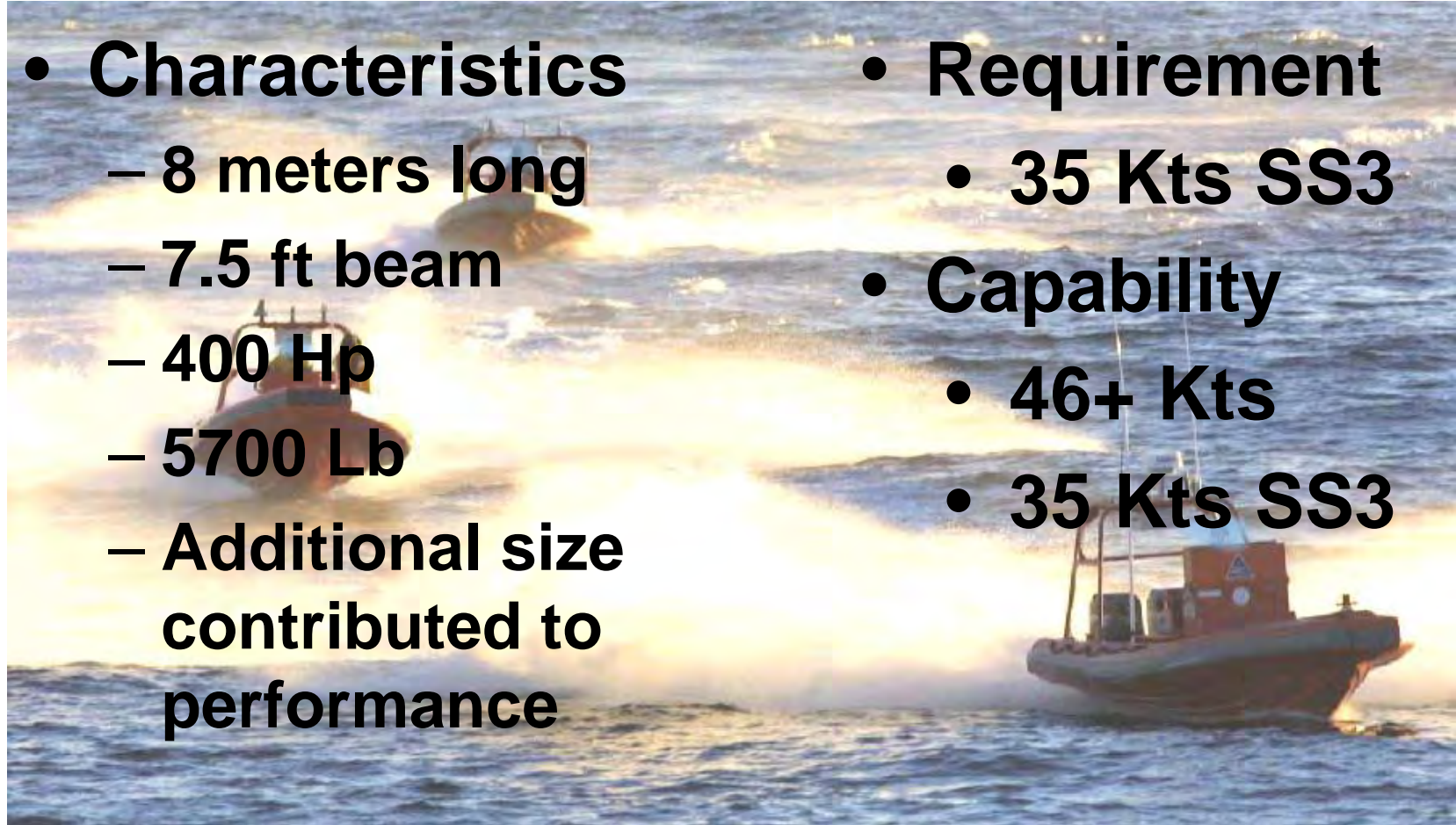

Fast Attack Craft Target

FACT Requirements

- 50+ feet
- 50+ Knots SS2
- Survivability
- High-speed towing
- Realistic signatures

• QST-35 Deficiencies

- Marginal IR and RF signature representation
- Inadequate speed in developed seaway
 - 15 knot capability
 - 50 knots required
- Survivability
 - High amortized cost/impact



Fast-Attack Craft Target FACT

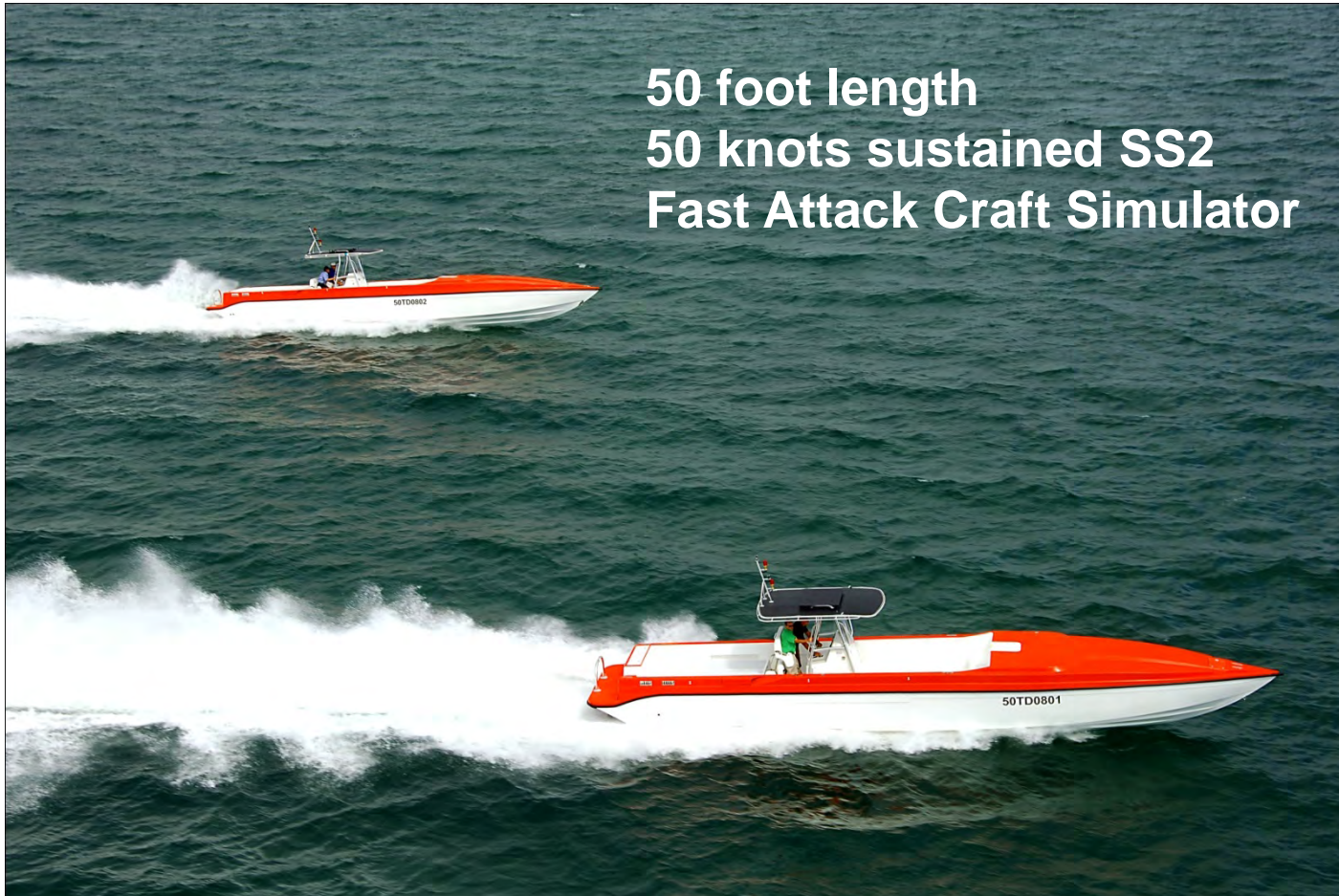

Control Systems

- Seaborne Controller Area Network (SeaCAN)
 - A singular solution
 - Common architecture and hardware for **ALL** Seaborne powered targets
 - Operates with **ALL** Navy command links
 - Portable Command Control Unit (PCCU) is primary command link



Multi-Target Control

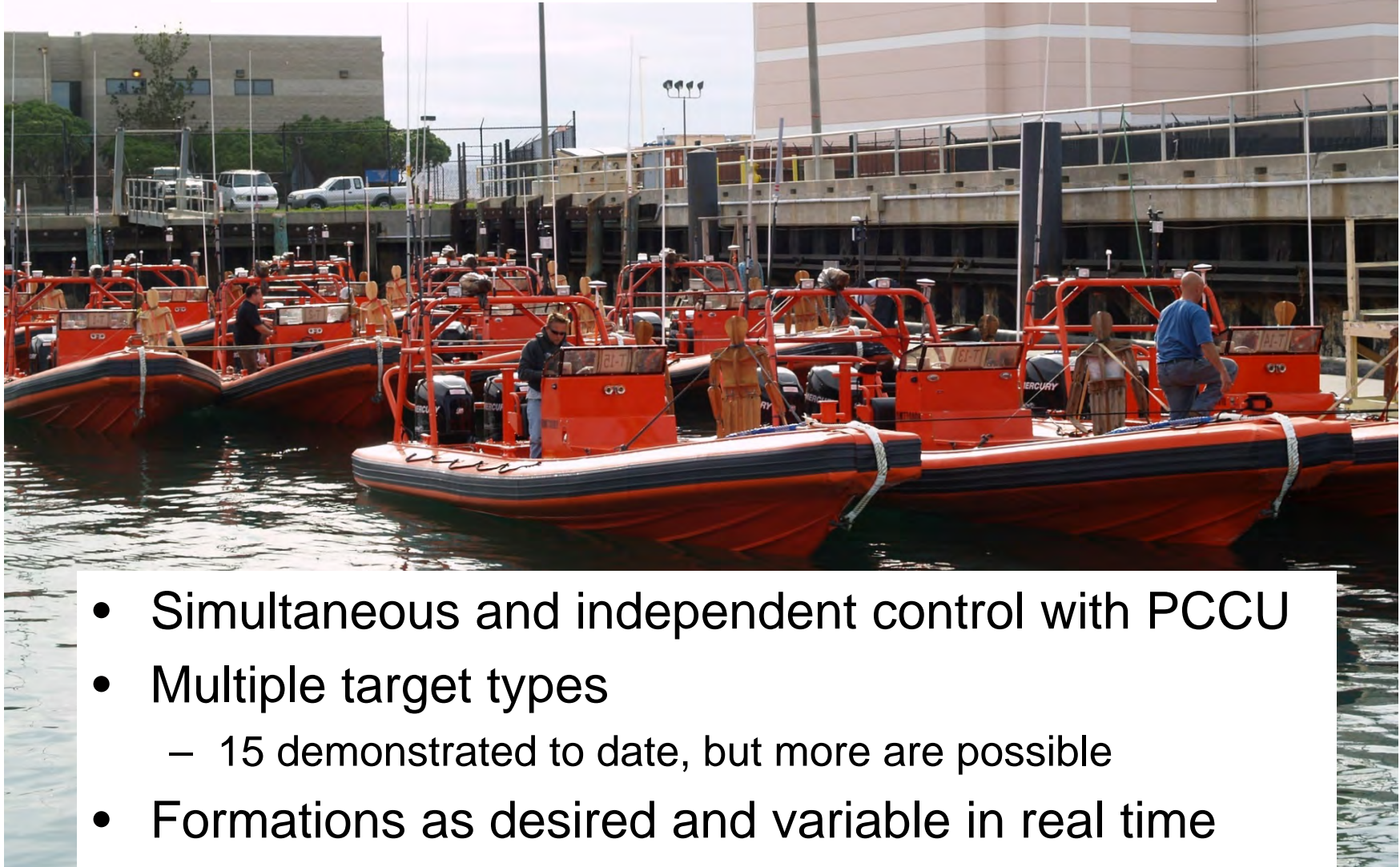

- Simultaneous and independent control with PCCU
- Multiple target types
 - 15 demonstrated to date, but more are possible
- Formations as desired and variable in real time

Augmentation

- Focus on realistic and repeatable IR and RF signatures
 - Developing compendium of signature data for all Program-of-Record targets
- Signature management
 - Users may assess signatures and request modifications



Humannequin

- Threat surface craft can be disabled by rendering either propulsion systems or the craft operator inoperative. Currently there is no real-time means to assess whether operator has been incapacitated.
- Commercial mannequins will be outfitted with heat sources and sensors to provide realistic human signatures and vulnerability measurements.



New Roles

- Seaborne targets as USV
 - Targets can be configured to execute other USV missions either operationally or as developmental prototypes
- Seaborne targets as UAV surrogate test beds
 - Good payload test beds
 - Impervious to traditional flight risks
 - Long endurance



Operating Sites and Resources

| U. S. Navy Seaborne Targets | | | | | | | | | |
|-----------------------------|---------|--------|------|-------|------|------|---------------|------|------|
| Operating Activity | Powered | | | | | | Towed Targets | | |
| | MST | QST-35 | FACT | HSMST | SDST | ATLS | ISTT | LCTT | LCMT |
| NAWCWD, Point Mugu, CA | X | X | X | X | X | X | X | X | X |
| NAWCAD, Pax River, MD | | X | | X | X | | X | X | |
| NAWCAD Det, Norfolk, VA | | X | | X | X | | X | X | X |
| CFAO, Okinawa | | | | X | X | | X | X | X |
| PMRF, Kauai, HI | | X | | X | X | | X | X | X |
| SCORE, San Diego, CA | | | | X | X | | X | X | X |
| MCAS, Cherry Point, NC | | X | | X | | | | X | |
| ATGL, Norfolk. VA | | | | | X | | | X | |
| ATGM, Mayport, FL | | | | | X | | | X | |



Summary

- US Navy has a robust inventory of threat-representative targets including Fast Attack Craft simulators available at many locations worldwide.
- These targets are deployable.

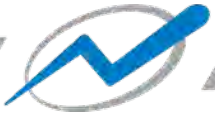

Questions?

NAV  AIR

THREAT/TARGET SYSTEMS DEPARTMENT





Purpose:

**Provide NDIA Symposium An Overview Of
U.S. Army, PEO STRI, PM ITTS
TMO Activities**

Briefed by:

Mr. Al Brown

TMO Director, PM ITTS, PEO STRI

256-876-4077 DSN: 746-4077

e-mail: alvin.brown@us.army.mil



FALSE IMPRESSION CAVEAT



It should be explicitly noted that the U.S. Government makes no official commitment nor obligation to provide any additional detailed information or an agreement of sale on any of the systems/capabilities portrayed during this presentation that have not been authorized for release.



OUTLINE



- **Who We Are**
- **Mission**
- **Activities**
- **Organization (Tie-in with Testing & Training)**
- **Recently Developed Products**
- **Future Efforts**
- **Summary**

ORGANIZATION

PM ITTS

PM: COL Michael E. Zarbo
Project Manager for Instrumentation, Targets,
and Threat Simulators

ATTN: SFAE-STRI-PMITTS
12350 Research Parkway, Orlando, FL 32826-3276
(407) 384-5250 DSN 970-5250
e-mail: michael.zarbo@us.army.mil
DPM: Mr. Jerry Sirmans
(407) 384-5251 DSN 970-5251
e-mail: jerry.sirmans@us.army.mil

IMO

Mr. J. Russell Longenbach
Instrumentation Mgmt Office
ATTN: SFAE-STRI-PMITTS-I
12350 Research Parkway
Orlando, FL 32826-3276
(407) 384-5230 / DSN 970-5230
e-mail:
J.Russ.Longenbach@us.army.mil



TMO

Mr. Al Brown
Targets Mgmt Office
ATTN: SFAE-STRI-PMITTS-Q
Redstone Arsenal, AL 35898-7458
(256) 876-4077/7764
DSN 746-4077/7764
e-mail:
Alvin.Brown@us.army.mil



TSMO

Mr. Mark C. Tutten
Threat Systems Mgmt Office
ATTN: SFAE-STRI-PMITTS-S
Redstone Arsenal, AL 35898-4761
(256) 876-9656 x200
DSN 746-9656 x200
e-mail:
Mark.Tutten@us.army.mil



Visit our website at <http://www.peostri.army.mil/PM-ITTS>



TMO MISSION



- **MANAGE TOTAL LIFE CYCLE OF TARGETS, OPERATIONAL THREAT VEHICLES, TARGET CONTROL SYSTEMS AND GROUND RANGE SYSTEMS USED IN LIVE AND VIRTUAL TESTING AND TRAINING.**
- **PROVIDE BEST VALUE ACQUISITION, SUPERIOR LIFE CYCLE SUSTAINMENT AND OPERATION FOR THE U.S. ARMY, DoD AND INTERNATIONAL CUSTOMER.**
- **EXECUTE MISSIONS AS ASSIGNED OR DIRECTED BY PEO STRI AND PM ITTS.**



PRIMARY ACTIVITIES



Based on Customer Target Requirements

- Aerial – Fixed and Rotary Wing
- Mobile Ground / Foreign Materiel (both conventional and unconventional)
 - “Real Deal Steel”
 - Surrogates
- Virtual – Models and Simulations
- Precision Targetry Systems
- Auxiliary / Ancillary Equipment



MQM-107

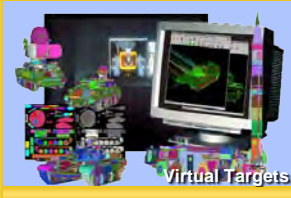

Virtual Targets



Precision Targetry System

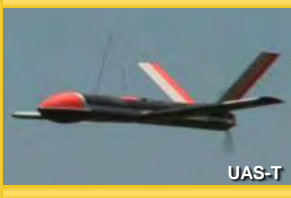

UAS-T



SMERCH



QUH-1



T-72



Towed Target



MSAT



BMP-2



RPVT



Technical Vehicle



WHAT WE DO



Develop products

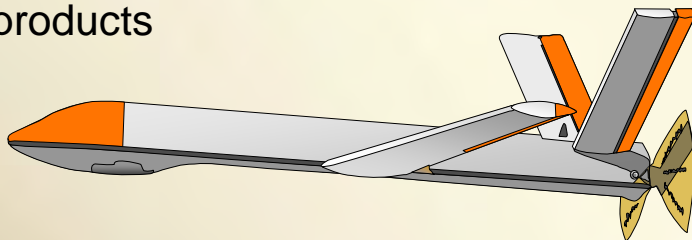

Buy products



AND we



Fly



Drive



Sustain



AERIAL TARGETS



- Turnkey Operations
- Target Systems Flight Services Supporting Army and Tri-service Test, Training and FMS Requirements
- Low Cost



*Aerial Target Flight Services

Simulate Aerial Threats World-Wide in Live and Virtual Domains



MOBILE GROUND TARGETS



Centrally Manage and Execute:

- Over 480 assets
- Mobile Ground Targets for development and operational testing
- Multiple usage options:
 - Rent
 - Lease
 - Buy
- Provide accreditation support

Range Targetry

- Design
- Procurement
- Fielding
- Support



Threat Representative Targets in Live and Virtual Domains



VIRTUAL TARGETS

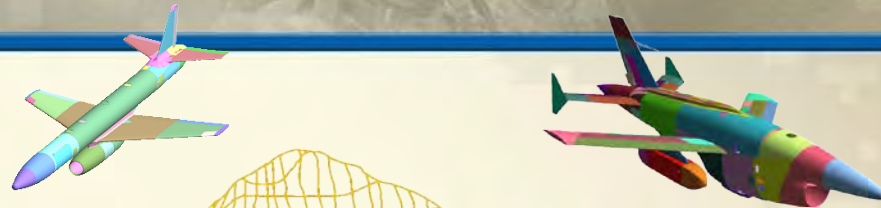

- **Virtual Targets Project:** Building simulation target models capable of being used in synthetic signature prediction analysis software programs
- **Target Generation Laboratory:** Transitioning CAD models into simulation compliant visual, infrared, and radar frequency simulation target models
- **Army Model Exchange:** Distributing simulation target models to simulation developers throughout the Army T&E community

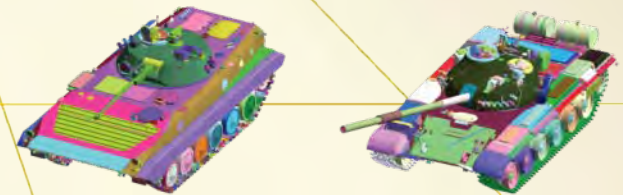



WHAT WE HAVE DEVELOPED/ PURCHASED RECENTLY



Precision Target Signature

URAL 375



T-72



BMP-2



UAS-T



Virtual Targets



JCHAAT



FIVE YEAR FORECAST TO DEVELOP/PURCHASE



Medium Speed Aerial Targets

High Speed Aerial Targets

Precision Targets - Mobility



**Looking at
technology areas to
enhance current
capabilities**



Rotary Wing Targets

Fully Mission Capable Threat Targets



Technical Vehicle w/crew representation



Common Control System



SUMMARY



TMO:

- ALWAYS LOOKING FOR A BETTER, FASTER, CHEAPER PRODUCT FOR OUR CUSTOMERS
- RECOGNIZED LEADER OF AERIAL AND GROUND TARGETS
- READY TO RESPONSIVELY AND RESPONSIBLY SUPPORT T&E AND SPECIAL TRAINING REQUIREMENTS

NEED INDUSTRY TO CONTINUE PROVIDING STATE OF THE ART TECHNOLOGIES FOR ADAPTATION AND INCORPORATION INTO TARGETRY



PROVIDING/OPERATING AERIAL, GROUND & VIRTUAL TARGETS

AERIAL TARGETS

| Target ID: 1 | |
|--------------|------|
| 1 | 2000 |
| 2 | 1000 |
| 3 | 500 |
| 4 | 250 |
| 5 | 125 |
| 6 | 62.5 |



VIRTUAL TARGETS

GROUND TARGETS





“Building Next Generation Range Capabilities”

Central Test and Evaluation Investment Program (CTEIP)

Gerry Christeson
Test Resource Management Center
20 October 2010



Test Resource Management Center (TRMC)



NDAA 2003
Established
TRMC

- DoD Field Activity
 - Direct Report to USD(AT&L)
- ☆☆☆ SES Director

Oversee
T&E Budgets

Major Range & Test Facility Base
(MRTFB);
Other T&E Facilities
Within & Outside DoD

Biennial 10-Year
Strategic Plan for
DoD T&E Resources

Administer
Centrally-Funded T&E
Investment Programs

Annual T&E Budget
Certification
Military Departments
& Defense Agencies



T&E Investment Planning Process

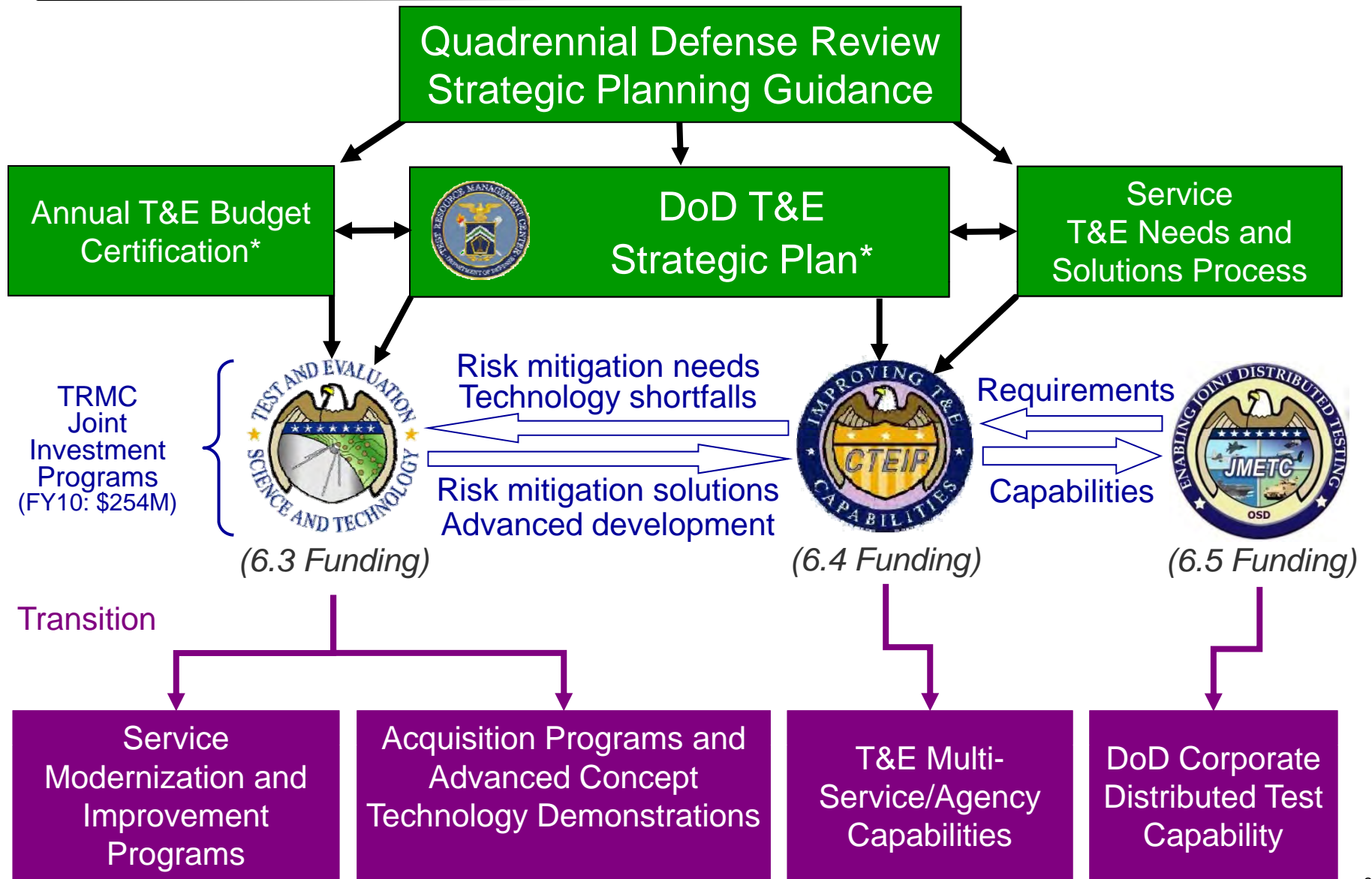



Central Test & Evaluation Investment Program (CTEIP)



Mission: Develop or Improve Major Test Capabilities that have Multi-Service Utility

- Initiated DEPSECDEF – 9 November 1988
- Established in FY91 by Congress
- 6.4 RDT&E funds
- Purpose
 - Have multi-Service utility
 - Be developmental
 - Be non-procurement

47 Active Projects

T&E Master Plans (TEMP) References

Precision Portable Underwater Tracking System

- SSN-774 “Virginia Class” Attack Submarine mine warfare testing

Multi-Spectral Anti-Radiation Missile Air Defense Array

- AGM-88E Advanced Anti-radiation guided missile testing

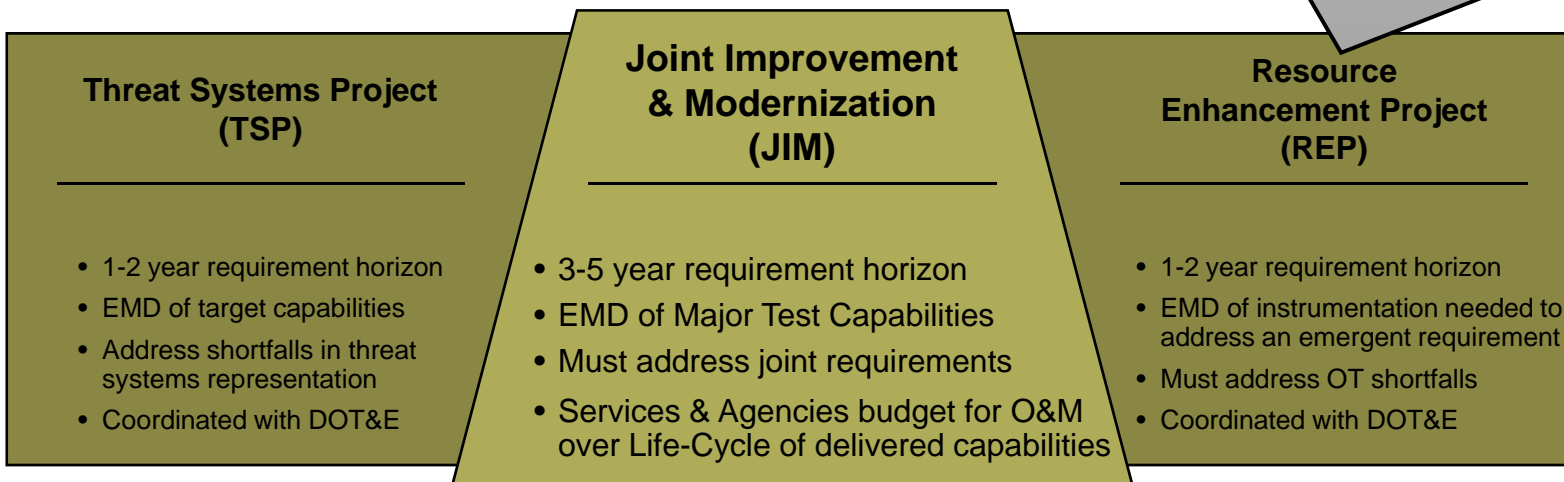

25 JIM, 9 Threat, 13 REP – 47 projects / subprojects



CTEIP - JIM Funding Criteria



- Support multi-Service/Agency test capability need
 - Traceable to DoD Strategic Plan for T&E Resources
 - Promotes interoperability & standardization across DoD
- Developmental in nature (not procurement)
- Does not duplicate existing capability
- Technology Readiness Level 6 or better
- Executable considering technical, cost, and schedule risk
- Service/Agency agree to life cycle support



Enhancing Range Capabilities

Key CTEIP Projects



Challenges

Initiatives

| | |
|--|---|
| Spectrum efficient telemetry network that is adaptable and robust | iNET – integrated Network Enhanced Telemetry |
| Safe-realistic testing of Large Footprint Weapons | SFSS – Subminiature Flight Safety System |
| Real-time TSPI for Systems Under Test | CRIS – Common Range Integrated Instrumentation System |
| Aircraft Survivability – Advanced Infra-Red Countermeasure (IRCM) Testing | JMITS - Joint Mobile IRCM Test System TAPS - Towed Airborne Plume Simulator MSALTS - Multi-Spectral Sea and Land Target Simulator JDIGS -Joint Distributed IRCM Ground Test System |
| Testing in an Urban Environment | JUTC -Joint Urban Test Capability Project |
| Systems of systems testing of interconnected network enabled weapons systems | InterTEC – Interoperability Test and Evaluation Capability |
| Testing of revolutionary warfighter capabilities | DETEC – Directed Energy T&E Capability |
| | |



Spectrum Efficient Technology



Drivers

Spectrum and Data Rates Trends

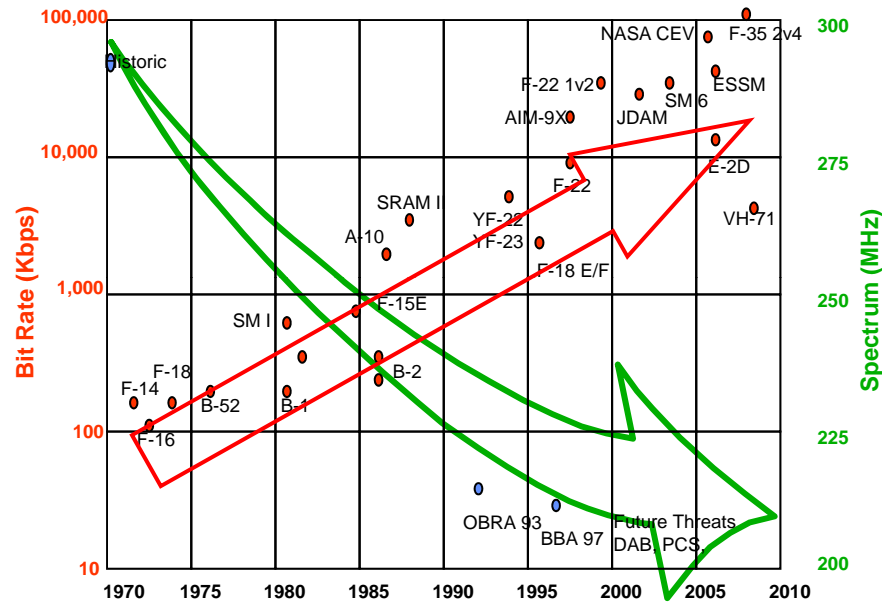

Challenge

- Develop a T&E capability that:
 - Uses available spectrum more efficiently by dynamically changing bandwidth during test events.
 - Reduces test and re-test time by fixing data drop-outs and enabling data selection during tests.

Programs

- **Integrated Network Enhanced Telemetry (iNET) Block 1 Project**
 - Enhances current 1-way Serial Streaming Telemetry (SST) systems with a 2-way network capability
- Develop and field equipment to effectively use WRC2007 allocated C-band spectrum

Goals

- IOC for C-Band Serial Stream Telemetry at AFFTC and NAWC-AD in FY12
- Test initial iNET Block 1 prototype capability at Edwards Air Force Base and Naval Air Station Patuxent River in FY13.



Safe Realistic Testing of Large Footprint Weapons



Challenge

- Range safety constraints limit testing of longer range (large footprint) standoff weapons without flight termination systems (FTS).
- Limited unused space inside modern weapons requires flight termination systems to be subminiature in size (10 to 16 inch³).

Programs

- Subminiature Flight Safety System (SFSS)
- Leverages completed CTEIP projects
 - Joint Advanced Missile Instrumentation (JAMI) provides GPS-based TSPI and real time post flight data processing.
 - Enhanced Flight Termination System (EFTS) provides new digital and encrypted flight termination link.

Goals

- Fewer operational and range safety constraints on flight test of long range weapons.
- Test/Demonstrate modularized SFSS (FTS) design on MALD in FY12.



Real Time Time Space Position Information (TSPI) for Systems Under Test



Drivers

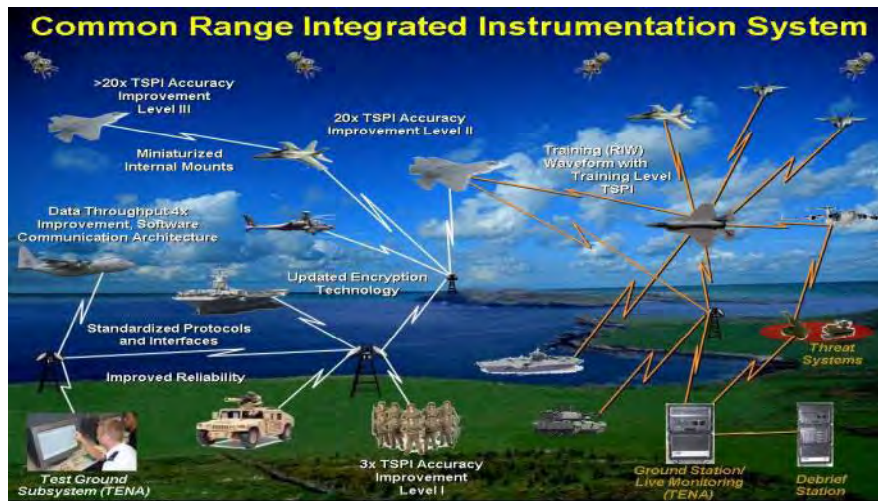

Challenge

Greater TSPI accuracy to evaluate future high accuracy platforms.

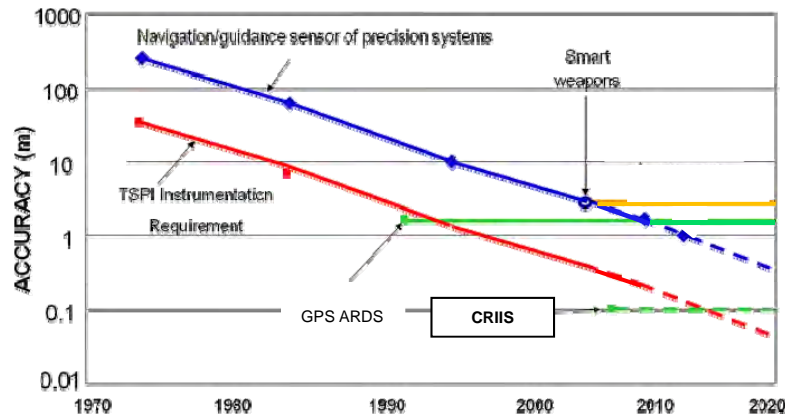

Programs



- **Common Range Integrated Instrumentation System (CRIIS)** - First real-time, high-precision (sub-meter) TSPI range system
- **Joint Advanced Missile Instrumentation (JAMI)** - First hybrid GPS engine able to track in 100G environment.

Goals

- **Sub-meter TSPI for Air/land/Sea Applications**
- **Field systems that replace current ARDS inventory starting in 2014.**



Infra-Red Countermeasure (IRCM) T&E



Drivers

- Advanced IR Missiles
- Advanced IRCM Systems

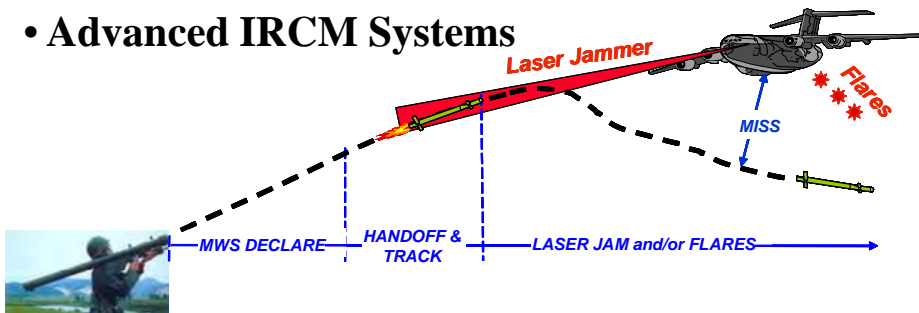

Not feasible to fire missiles at manned aircraft to test IRCM system effectiveness

Programs

- **Ground Based Missile Simulators**
 - JMITS - Joint Mobile IRCM Test System
 - MSALTS- Multi-Spectral Sea and Land Target Simulator
- **Airborne Missile Simulator**
 - TAPS - Towed Airborne Plume Simulator
- **Installed System Environments**
 - Joint Distributed IRCM Ground Test System (JDIGS)

Challenge

Present IRCM system-under-test with a realistic representation of an incoming missile



Ground Based (JMITS)

Missile Simulators



Airborne (TAPS)

Successes

- **Two JMITS Units Delivered and Operational**
 - Included in Navy and Air Force IRCM TEMP's
 - Initial deployments include CH-53 and CV-22
- **TAPS Flight Testing Completed Aug 2010**
 - Ready for LAIRCM NextGen Operational Test
- **IRCM Test Resource Requirements Study Complete**
 - DoD Investment road-map for test resource needs
- **Development of Advanced Simulation Tools**
 - Distributed testing (ISTF, HITL, Open Air)



T&E in an Urban Environment



Drivers



Challenge

- **Develop operationally realistic, technically relevant, Brigade and below urban environment DT and OT capabilities**
- **Geographically representative physical, electro-magnetic and population effects.**
- **Measure both the effects of UE on systems under test (SUT) and SUT effects on UE domains (e.g. collateral damage) .**

Programs

- **Joint Urban Test Capability (JUTC) Project**
 - FY2010 New Start
- **Planning to leverage JMETC/InterTEC /TENA network, tools, and capabilities to integrate virtual and constructive urban environment events with live urban tests.**

Successes

- **Urban Environment Test Capability (UETC Study)**
 - Army led, Joint/ Interagency analysis of UE requirements, current capabilities and possible solutions
 - Precursor to JUTC project
 - Final Report due Oct 2010
- **Next Generation TSPI Study complete**
 - Identifies technologies for use in GPS-Denied urban environment



Net-Centric Warfare Testing

Net Enabled Weapons Testing



Drivers

- Interoperability testing of systems of systems
- Testing of Net Enabled Weapons
- T&E must exploit networks ,e.g., the Global Information Grid
- Joint service test & training exercises are increasing in frequency and complexity



Programs

- **Test and Training Enabling Architecture (TENA)** – Enables interoperability among Live, Virtual, and Constructive (LVC) test facilities.
- **InterTEC** – Tools to construct, control, instrument, capture data from operationally relevant distributed test
- **Joint Gulf Range Complex Upgrade** - Integrate and extend test environment for net enabled weapons at Eglin AFB.

Challenge

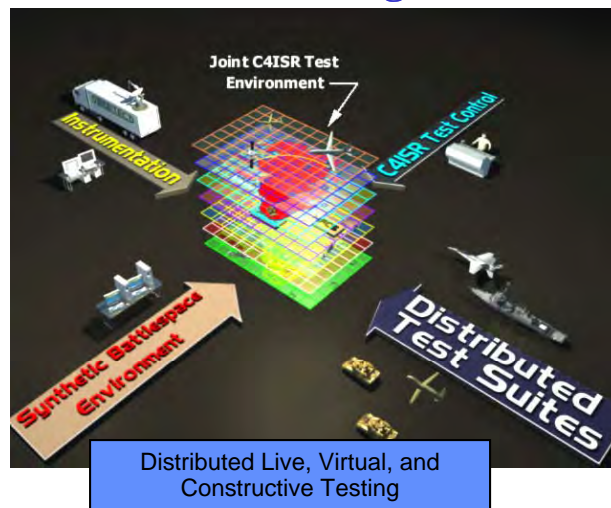

Successes

- **InterTEC:** Spiral 1&2 provide s 24 test tool applications at 23 DoD sites. Spiral 3, to be fielded in FY11/12 enhances system reliability and adds the NR KPP certification process.
- **Joint Gulf Range Complex:** Demonstrated the ability to exchange all essential Link-16 messages and tested the system with live moving targets on the range.



Testing of Revolutionary Warfighter Capabilities



Drivers



Challenge

- Revolutionary new High Energy Laser (HEL) and High Power Microwave (HPM) systems and technologies are being developed to defend against a variety of threats (rockets, artillery, mortars, ballistic missiles, IEDs, UAVs, C4ISR, seekers, and electronics systems).
- The DoD T&E community needs measurement systems, tools, and threat simulators to test them.

Programs

- Directed Energy T&E Capability (DETEC) developed 12 T&E capabilities
- DETEC II Roadmap for Service use in nominating new projects.

Successes

- HEL, 5 capabilities fielded at the High Energy Laser Test Facility (HELSTF) at WSMR, NM addressing:
 - Airborne and Ground Target Irradiance Measurement
 - Target Reflected Energy Measurement
- HPM, 7 capabilities fielded at both Naval Air Warfare Center Weapons Division at Pt. Mugu, CA and WSMR, NM addressing:
 - Narrowband and Wideband Threat Simulators
 - HPM Sensor Suite
 - HPM Propagation Measurement



Questions?



**CTEIP: An effective multi-Service
partnership providing
essential T&E capabilities**



Unclassified

Targets Transformation NAVAIR 5.3 Threat / Target Systems Department

**Director, Threat/Target Systems Department, AIR 5.3
Naval Air Warfare Center Weapons Division, Point Mugu, CA
805-989-8474**



Outline

- **TTSD Mission**
- **TTSD History**
- **Where we work and Scope of Work**
- **Overview of major target systems**
- **2 specific examples of “Making it real”**
- **Where we are going & why**



TTSD Mission

OUR MISSION IS TO EMULATE THREATS FOR WEAPONS AND EW SYSTEMS TEST AND EVALUATION AND TO SUPPORT EXPERIMENTATION AND FLEET TRAINING



*UNDERSTANDING THE CRITICAL MASS
Generic/Surrogate/Validated/Replica
(Cost Effective Fidelity For T&E & Training)*



Point Mugu – Over 65 Years as the Navy’s First Target Operating Site

1945 CNO establishes requirement for missile test center. Navy pilotless aircraft unit based in Mojave, CA.

1946 PAU moves to Point Mugu. December 13, 1952 first direct hit intercept of Navy Sparrow missile against QB-17 on Sea Range.

1991 NAVAIR consolidates target development / test at WD.





TTSD Operating Sites

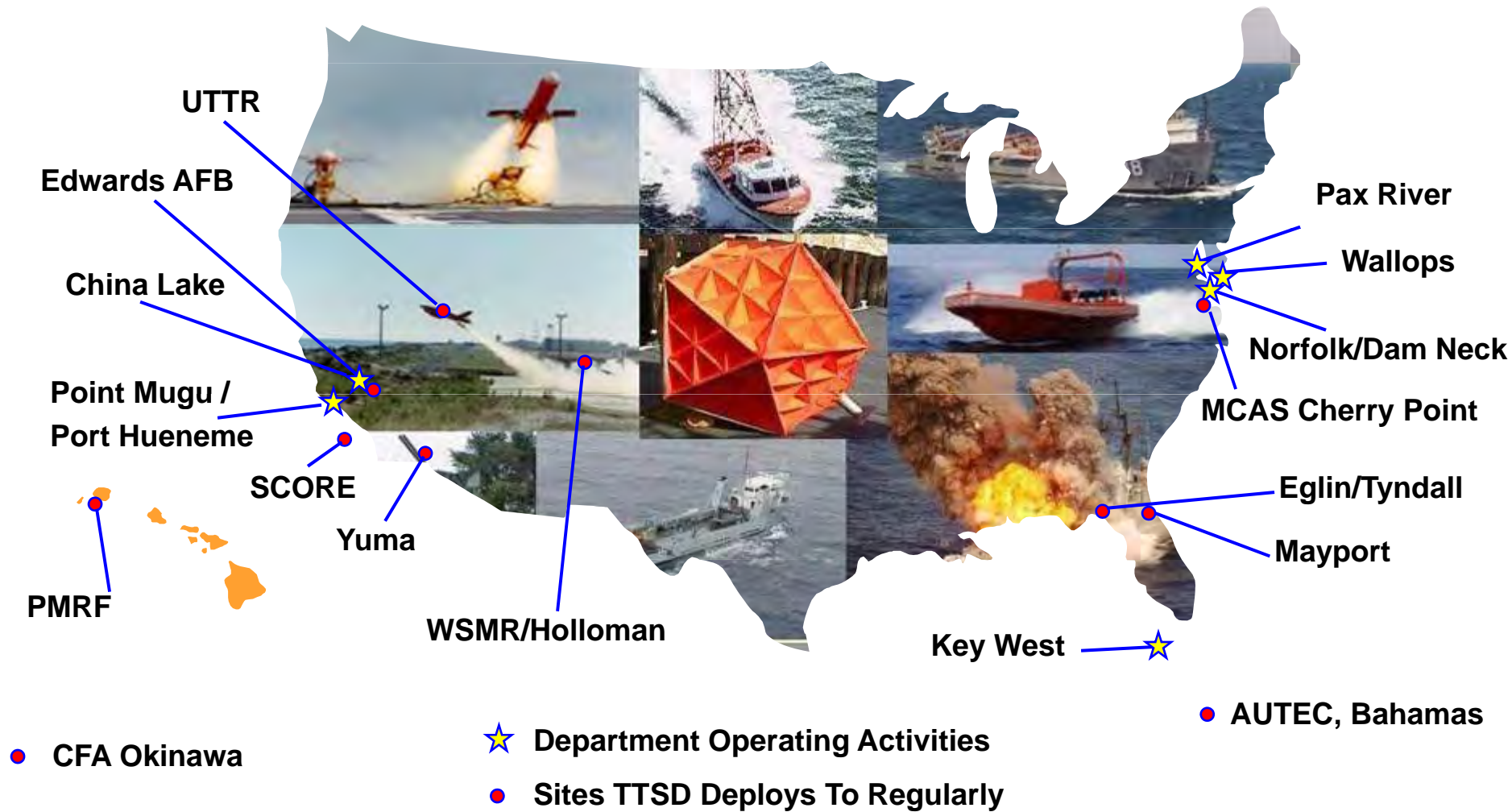

Aerial Targets





Seaborne Targets

Seaborne Powered Targets





Public Release

Shoot-able Remote Threat Ground Target



SRTGT towing a Jeep shape



Threat EW & Radar Simulation

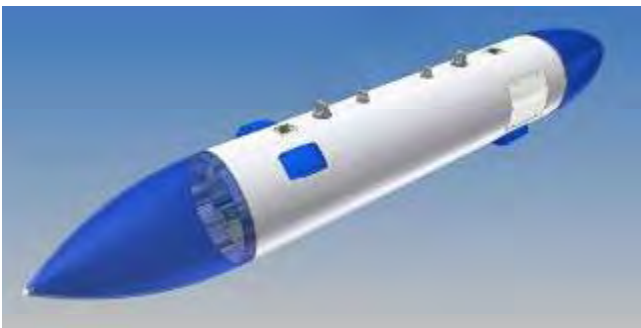



Target Transformation



**AOB
System on
BQM-34**





TTSD Employment of Swarming Tactics



- **East Coast – 12 manned vessels in multiple groups/waves**
 - Currently working toward 15+ vessels both manned and unmanned
- **West Coast – 15+ unmanned vessels in multiple groups/waves**



Seaborne Swarming Operations



- **Sept 28 – Iran announces deployment of 3 squadrons of Bavar-2**
 - Emphasizes comm suite, payload capacity and mounted machine gun...and manned operation.

Bavar-2 (Confidence-2)



<http://www.kansascity.com/2010/09/28/2257242/irans-guard-gets-first-squadrons.html>

Approved for Public Release



Coordinated &/or Autonomous Swarming

- **Expect to see an increased need to conduct T&E of systems that need to Find, Fix, Track and Engage swarms of small, relatively slow, air, surface and subsurface vehicles.**
- **Also expect to see an increased desire to train the warfighter in the same kind of threat environment.**
- **These threats will most likely be a combination of manned and unmanned and will work together in a coordinated fashion with varying degrees of autonomy.**



Coordinated &/or Autonomous Swarming

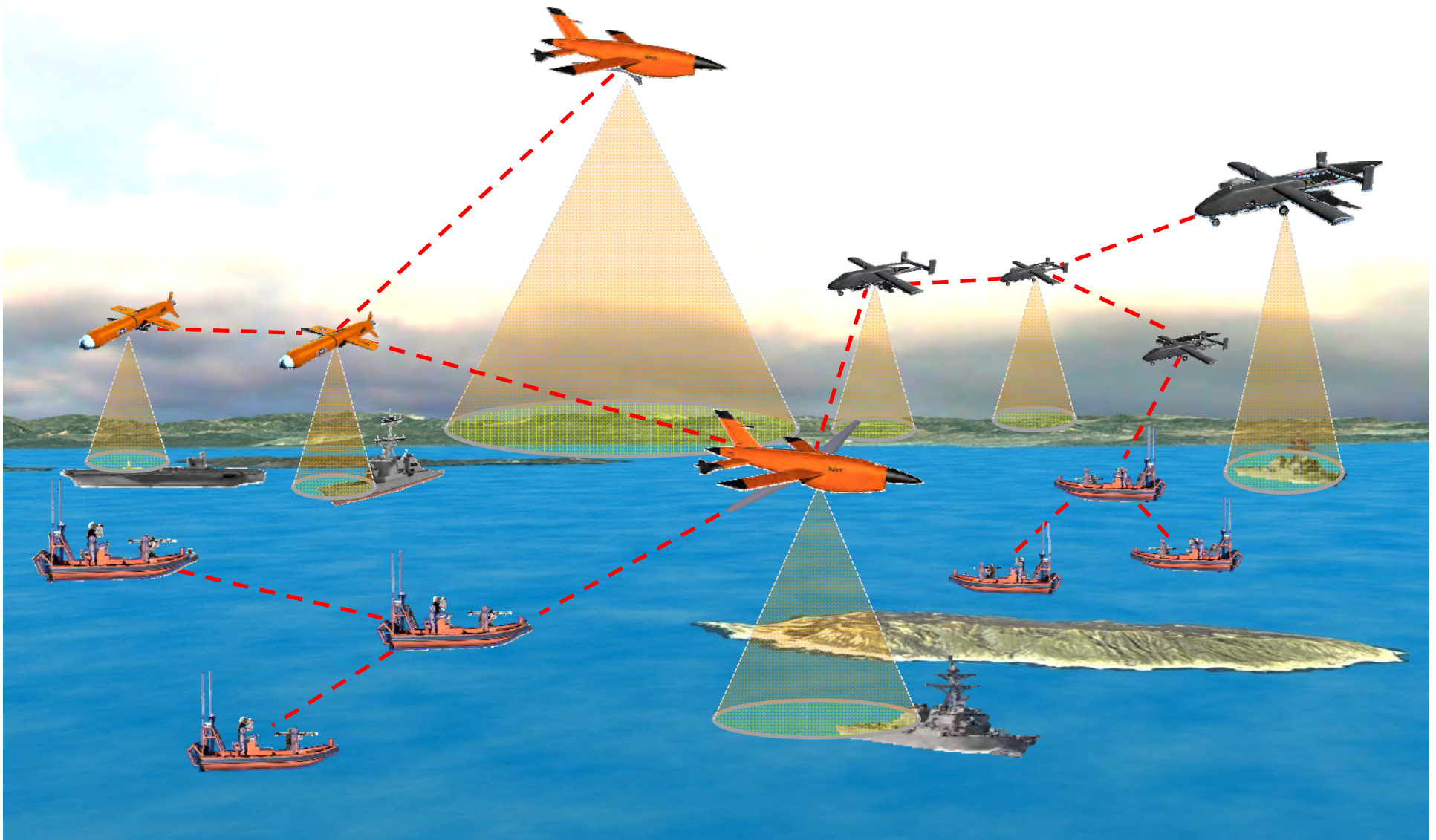



Test Infrastructure Required for Representation of Threat Systems and Tactics

- **Target control systems will need to enable autonomous activity while providing test safety**
- **POR Target surrogates can meet these roles today, except for low, slow flyer UAS...**
- **However, industry has group 2/3 class UAS that can meet many of the vehicle requirements**
- **We bring the know how and ability to modify signatures, integrate threat EW payloads, and operate the vehicles in a complex environment.**





Questions?





33d Fighter Wing F-35 Brief



**Maj Michael “Jeb” Ebner,
58 FS, USAF**





Overview



- Team Eglin
- Integrated Training Center
- Facilities
- Planning & timelines
- F-35 Info
- Key Take Aways





Team Eglin

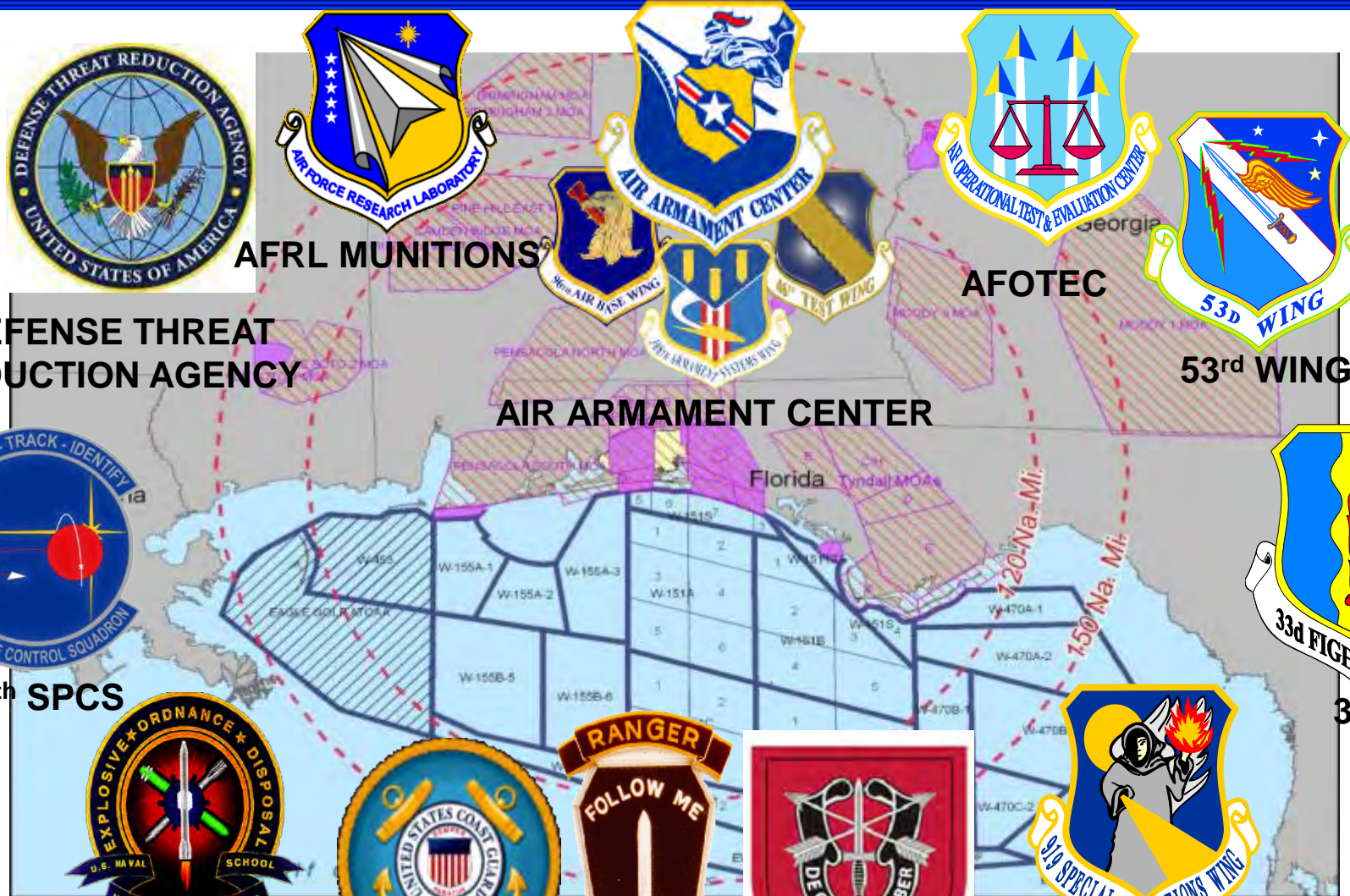

DEFENSE THREAT REDUCTION AGENCY



AFRL MUNITIONS



AIR ARMAMENT CENTER



AFOTEC



53rd WING



20th SPCS



33d FW

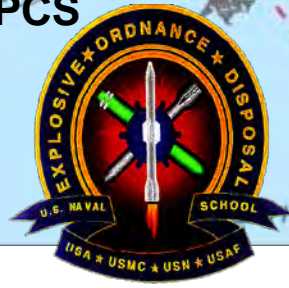

NAVY EOD SCHOOL



COAST GUARD



ARMY RANGERS



ARMY 7th SFG



919th SPECIAL OPS WING





Integrated Training Center



- Joint ITC - BRAC directed
 - “ This recommendation establishes Eglin Air Force Base, FL, as an Initial Joint Training Site that teaches entry-level aviators and maintenance technicians how to safely operate and maintain the new Joint Strike Fighter (JSF) (F-35) aircraft”
 - \$400M+ in MILCON and upgrades
 - 1600+ military, DoD civilian & contractor personnel
- Involves “shared resources”
 - Airspace
 - Facilities
 - CLS





F-35 Integrated Training Center (Eglin AFB) Command Relationships

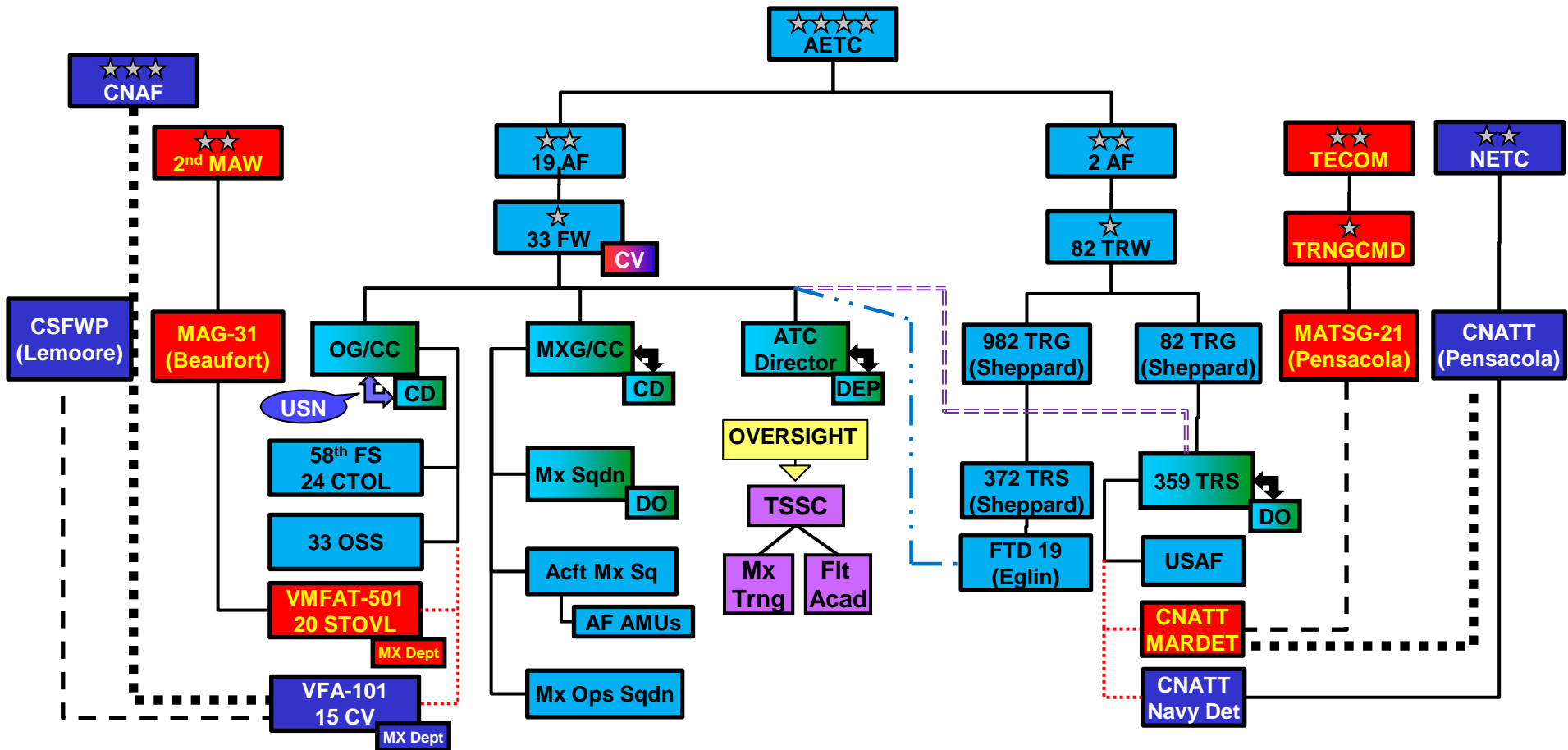

——— OPCON/ADCON
 - - - - - OPCON
 ADCON
 TACON (limited)
 - - - - - Attached/Other
 - Host Support

USAF
 USMC
 USN/USMC
 USN
 LM
 USAF/DoN





Integrated Training Center Campus

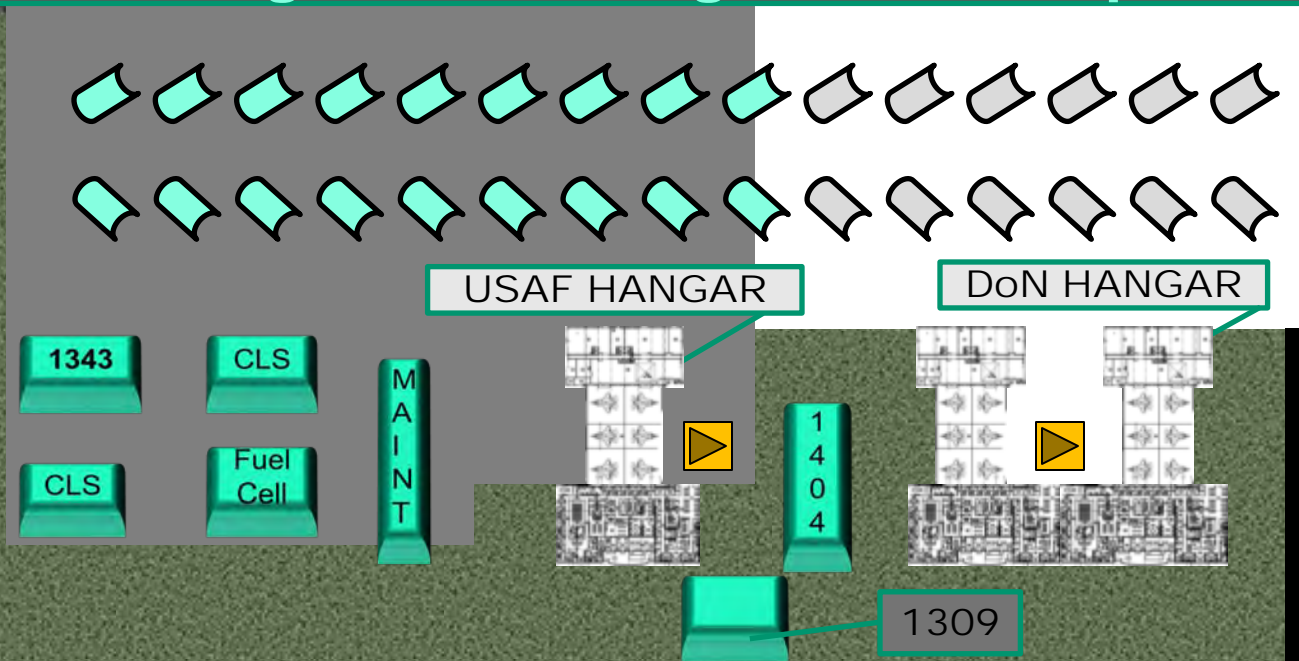

NOMAD WAY

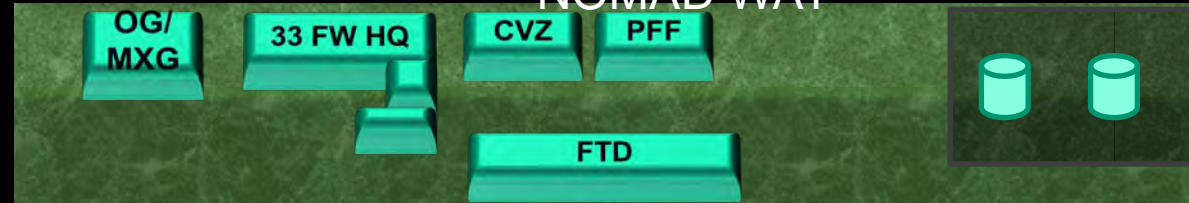

Track & USMC CFT

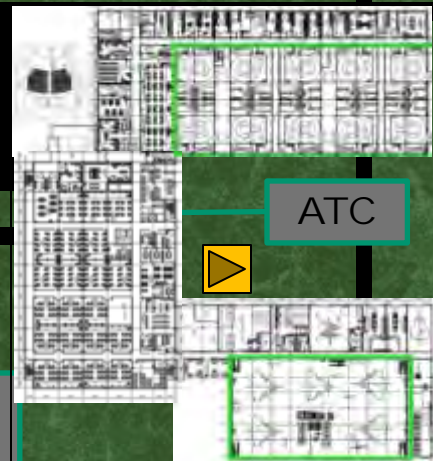



Eglin & Duke Upgrades

Eglin AFB



 New Concrete

Duke Field





33 FW Focus

Current Planning Dates

~ **Summer 2011**
Pilot Training

~ **Mar 2011**
Maint Training

Ready For
Training

Stand Up
Capabilities

Sustained
Production

OT

33 FW Core Cadre

USMC
Ops
Req

USAF
Ops
Req

USN
Ops
Req

INTL
Ops
Req

USMC
Annual
Req

USAF
Annual
Req

USN
Annual
Req

INTL
Annual
Req

- Facilities
- Equipment
- People
- Processes
- Small Group Tryouts
- Day In the Life (DITL) Exercises

- Required number of Pilots and Maintainers Trained to support Instructors, OT, 33 FW Core Cadre, Service Initial OPS Squadron IOC/RFO

- Meet Annual Service/Partner Requirements for Pilots Trained
- Meet Annual Service/Partner Requirements for Maintainers Trained



F-35 Training

Pilot Simulators

Maintenance Simulators



Electronic



Software, Tech Data,
Configurations

JSF Aircraft

PTA
Pilot Training Aircraft

MRT

Mission Rehearsal

FMS

Full Mission Simulator

ASMT

Aircraft Systems
Maintenance Trainer

ESMT

Ejection System
Maintenance Trainer

WLT

Weapons Loading
Trainer





F-35 Partnership

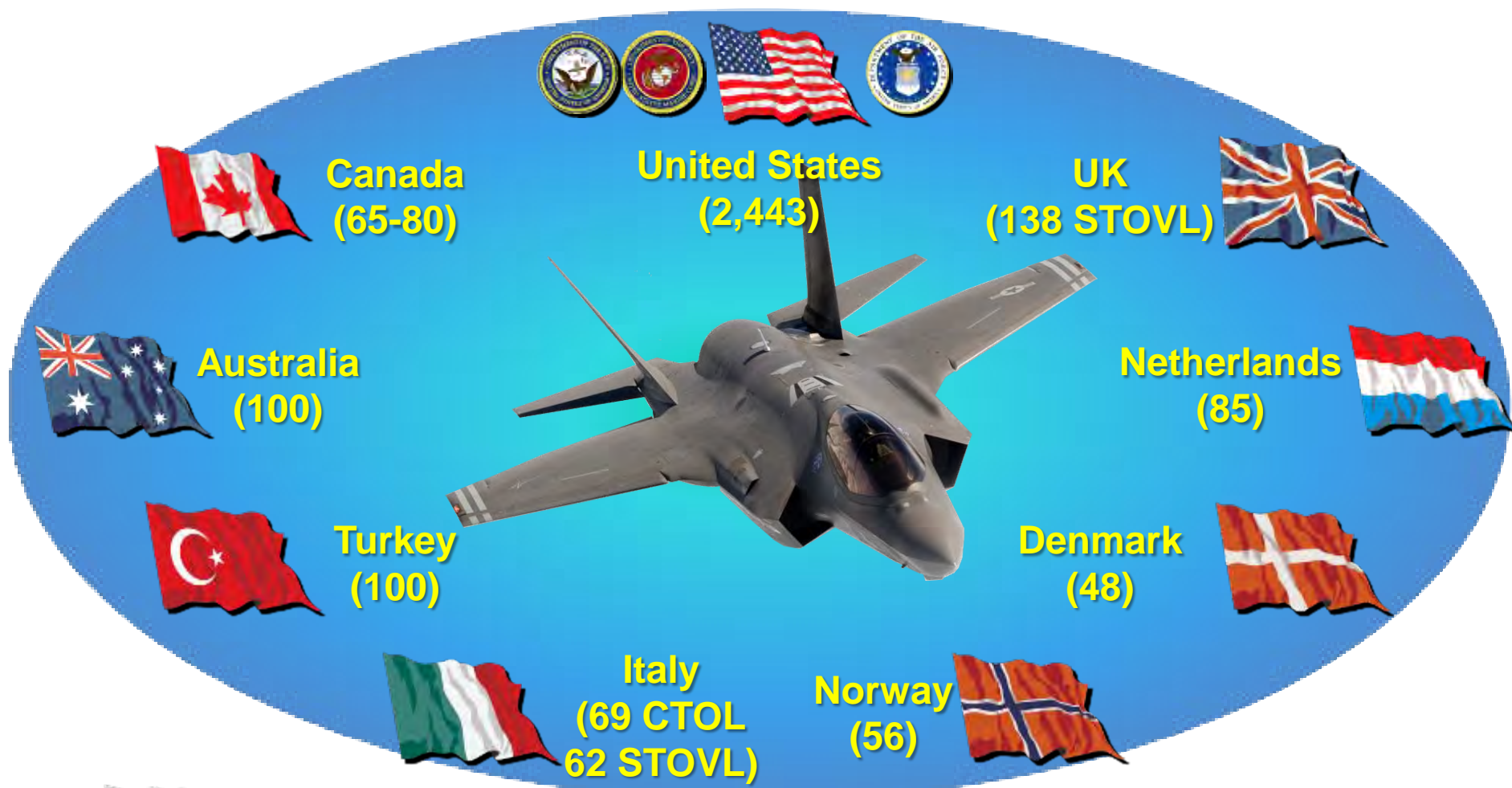

Potential FMS

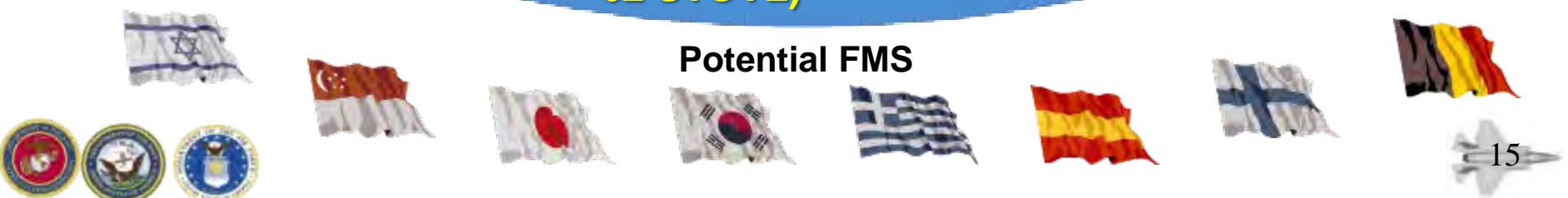



Fleets F-35 Will Replace



Domestic and UK

International

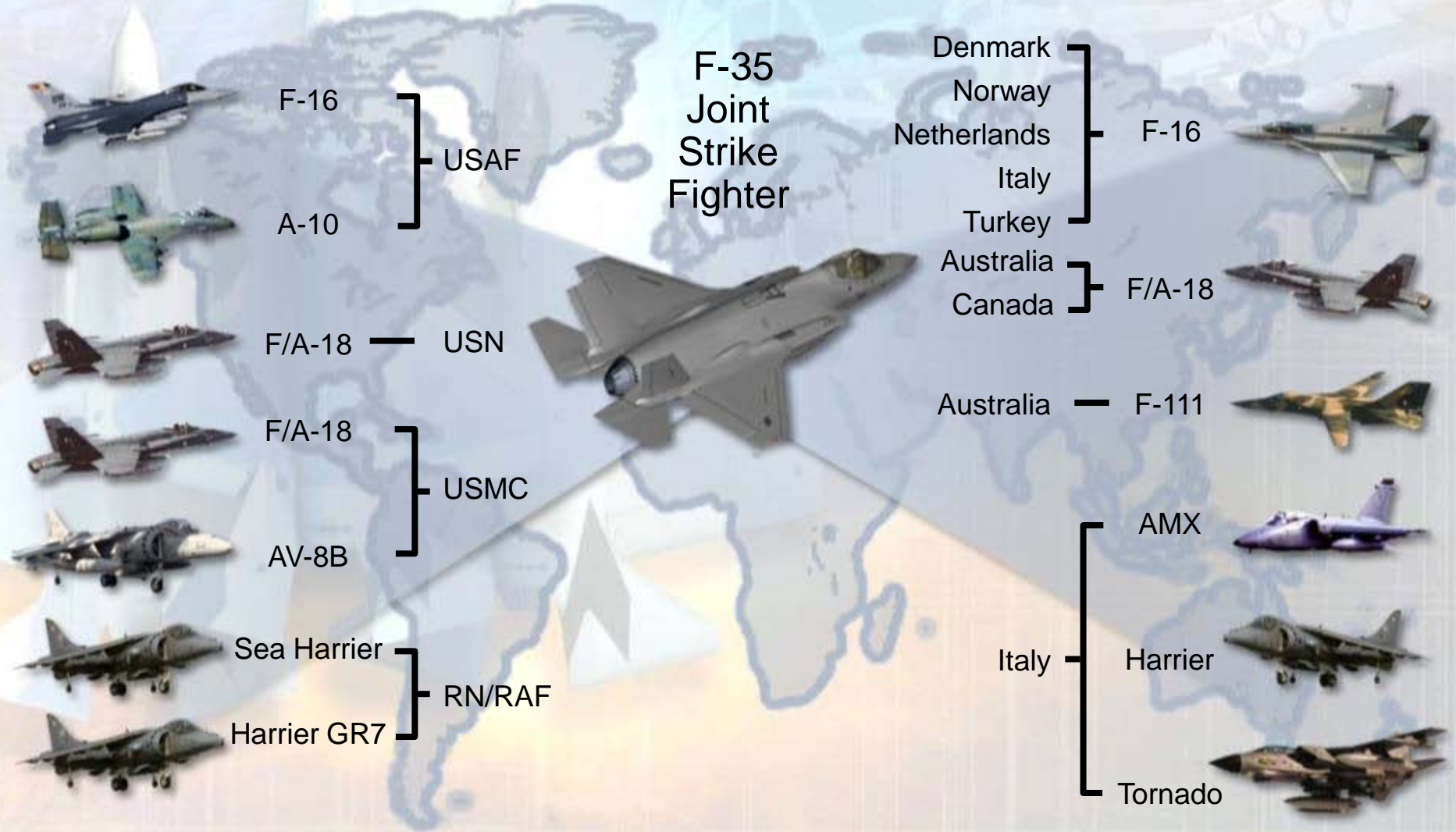



JSF Family Of Aircraft

One Program -- Three Variants
Meeting Service and International Needs

F-35A
Conventional
Take-Off and
Landing
(CTOL)



In-Flight Refueling
Door (Boom)

Internal
25mm 4-Barrel
Gatling Gun

F-35C
Carrier Variant
(CV)



Larger Wing and
Horizontal Tail Area

Probe and Drogue
Refueling (Basket)

Strengthened
Landing Gear
and Tailhook

Centerline
Gun Pod
with 25mm Gun

F-35B
Short Take-Off and
Vertical Landing
(STOVL)

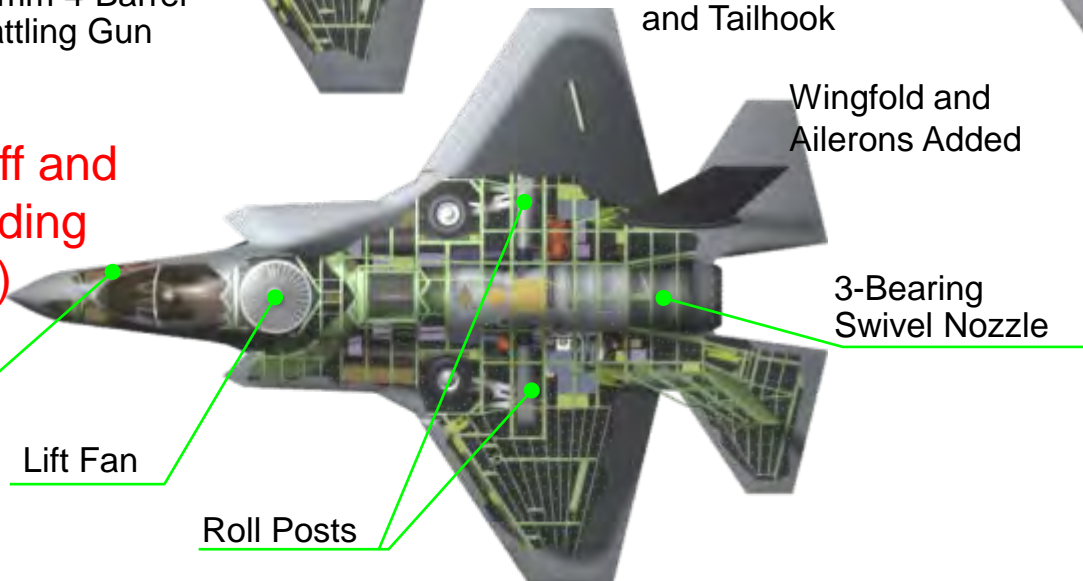

Wingfold and
Ailerons Added

3-Bearing
Swivel Nozzle

Probe and Drogue
Refueling (Basket)

Lift Fan

Roll Posts











Multi-Mission Capability



- Very Low Observable Stealth
- Fighter Performance
- Integrated Sensor Fusion
- Net-Enabled Operations
- Peace Keeping Capabilities
- Advanced Sustainment



Intelligence, Surveillance, Reconnaissance

Electronic Attack

Command & Control

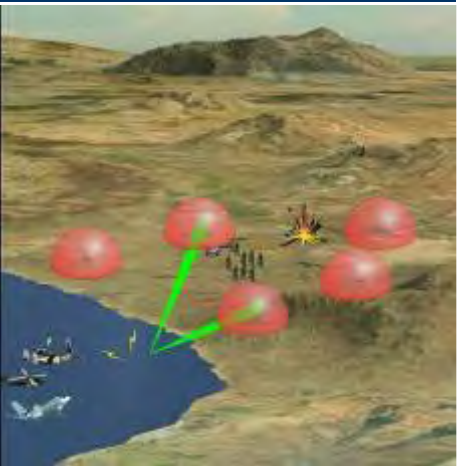
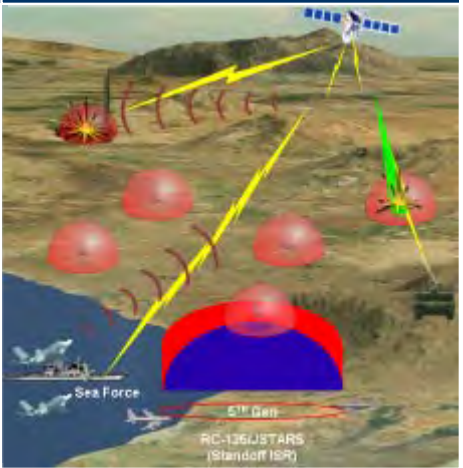



Fully Integrated Avionics & Sensors

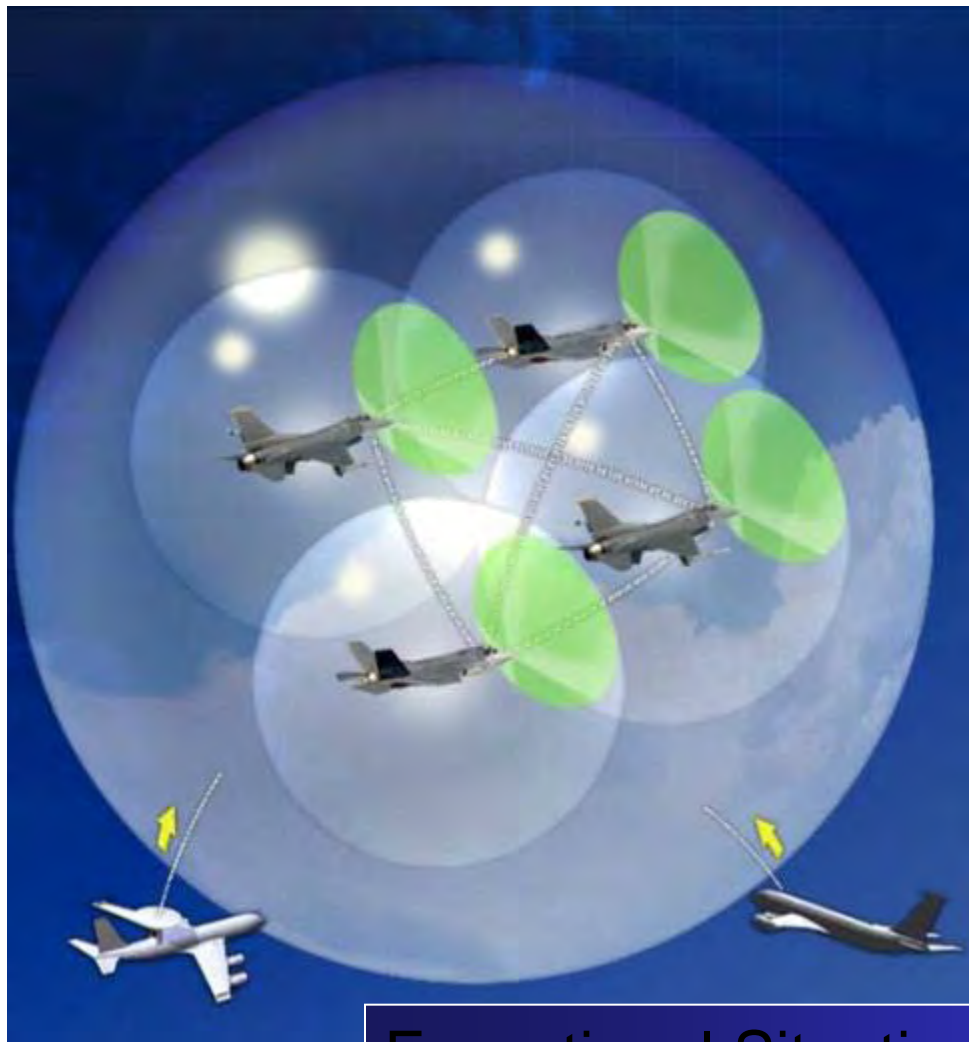

Exceptional Situational Awareness





Weapons Carriage Requirements

Non-Technical Data



CTOL Internal Gun

Store Fully Certified During SDD

EXTERNAL WEAPONS

INTERNAL

EXTERNAL WEAPONS



426 -Gallon Wing Tank

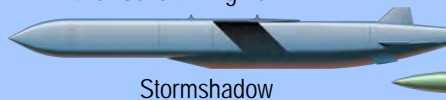

Stormshadow



GBU-38 JDAM 500-lb (MK-82 Warhead)



AGM-158 JASSM



MXU-648/CNU-88 Baggage Pod

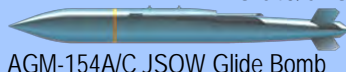

AGM-154A/C JSOW Glide Bomb

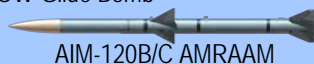

AIM-120B/C AMRAAM



GBU-31 JDAM 2,000-lb (MK-84 Warhead)



AIM-9X Sidewinder

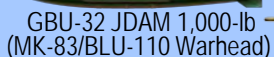

GBU-32 JDAM 1,000-lb (MK-83/BLU-110 Warhead)

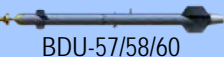

BDU-57/58/60 Laser-Guided Training Round



GBU-31 JDAM 2,000-lb (BLU-109 Warhead)

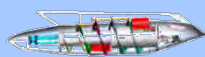

Missionized Gun



Brimstone/Joint Common Missile

MK-76/MK-58/BDU-48

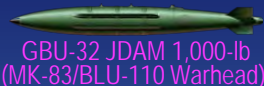

GBU-32 JDAM 1,000-lb (MK-83/BLU-110 Warhead)



GBU-12 Paveway II 500-lb LGB (MK-82 Warhead)



GBU-31 JDAM 2,000-lb (MK-84 Warhead)



AGM-154A/C JSOW Glide Bomb



GBU-31 JDAM 2,000-lb (BLU-109 Warhead)



Brimstone/Joint Common Missile

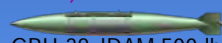

GBU-38 JDAM 500-lb (MK-82 Warhead)



AIM-120C AMRAAM



AIM-132 ASRAAM

Weapons Currently Under Development



UK 500# PGB



Phase I SDB



GBU-10 Paveway II 2,000-lb LGB (MK-84 Warhead)

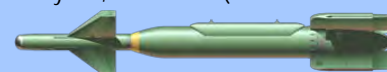

GBU-24A/B Paveway III 2,000-lb LGB (MK-84 / BLU-109 Warhead)



GBU-16 Paveway II 1,000-lb LGB (MK-83 Warhead)



MK-83 BLU-110 LDGP 1,000-lb LDGP



MK-83 BSU-85 HDGP



MK-84 2,000-lb LD/HDGP



MK-84 BSU-50 Ballute 2,000-lb HDGP



GBU-12 Paveway II 500-lb LGB (MK-82 Warhead)

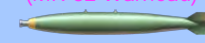

MK-82 500-lb LD & HD

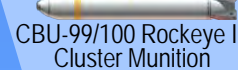

CBU-99/100 Rockeye II Cluster Munition

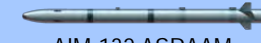

AIM-132 ASRAAM



Key Take Aways

- **Eglin F-35 ITC is Unique**
 - **Only joint site for pilot and maintainer training on all three variants for all US Services and Coalition Partners.**
- **ITC training success tied to:**
 - **Aircraft utilization/Availability**
 - **Effective use of shared resources**
- **F-35 will have a huge footprint across the U.S.**
 - **Ranges, Targets and EW emitters will be key to effective training**
 - **High-fidelity targets key for advanced sensors**





- Questions
- Briefer Info: Maj Michael Ebner, 58 FS, michael.ebner@us.af.mil





Backup Slides





AF Ops/AMU Hangar

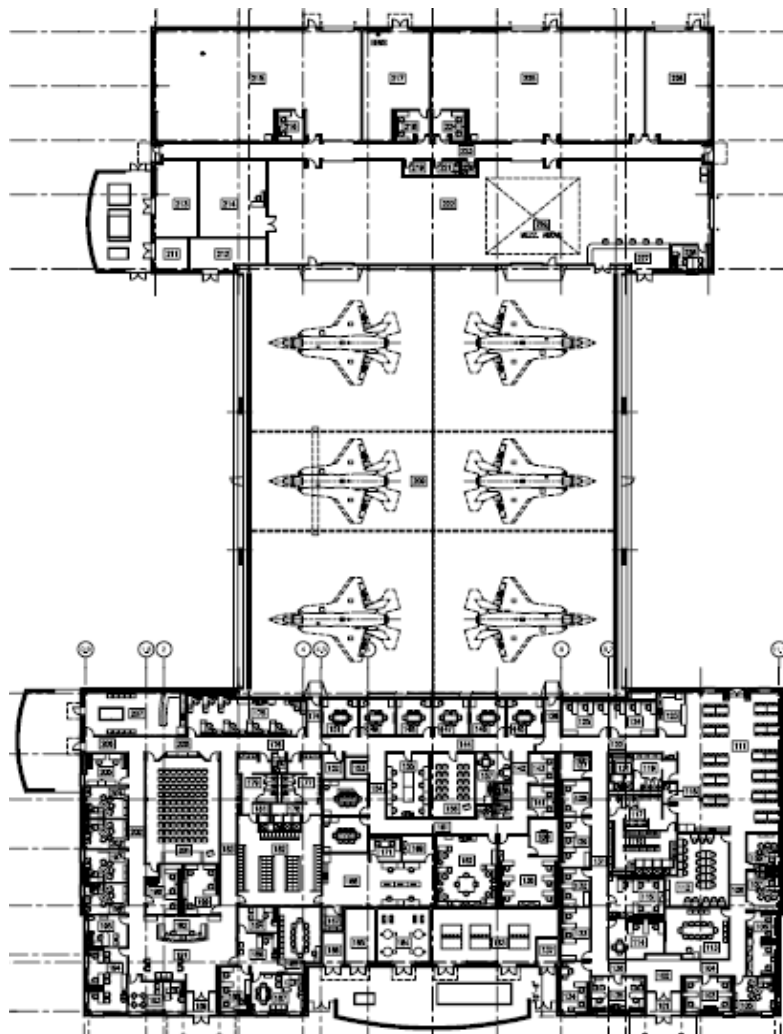

58 FS
'Gorillas'
24 x F-35A

270 ft x 400 ft
77,000 sq-ft

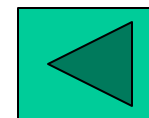



DoN Hangar

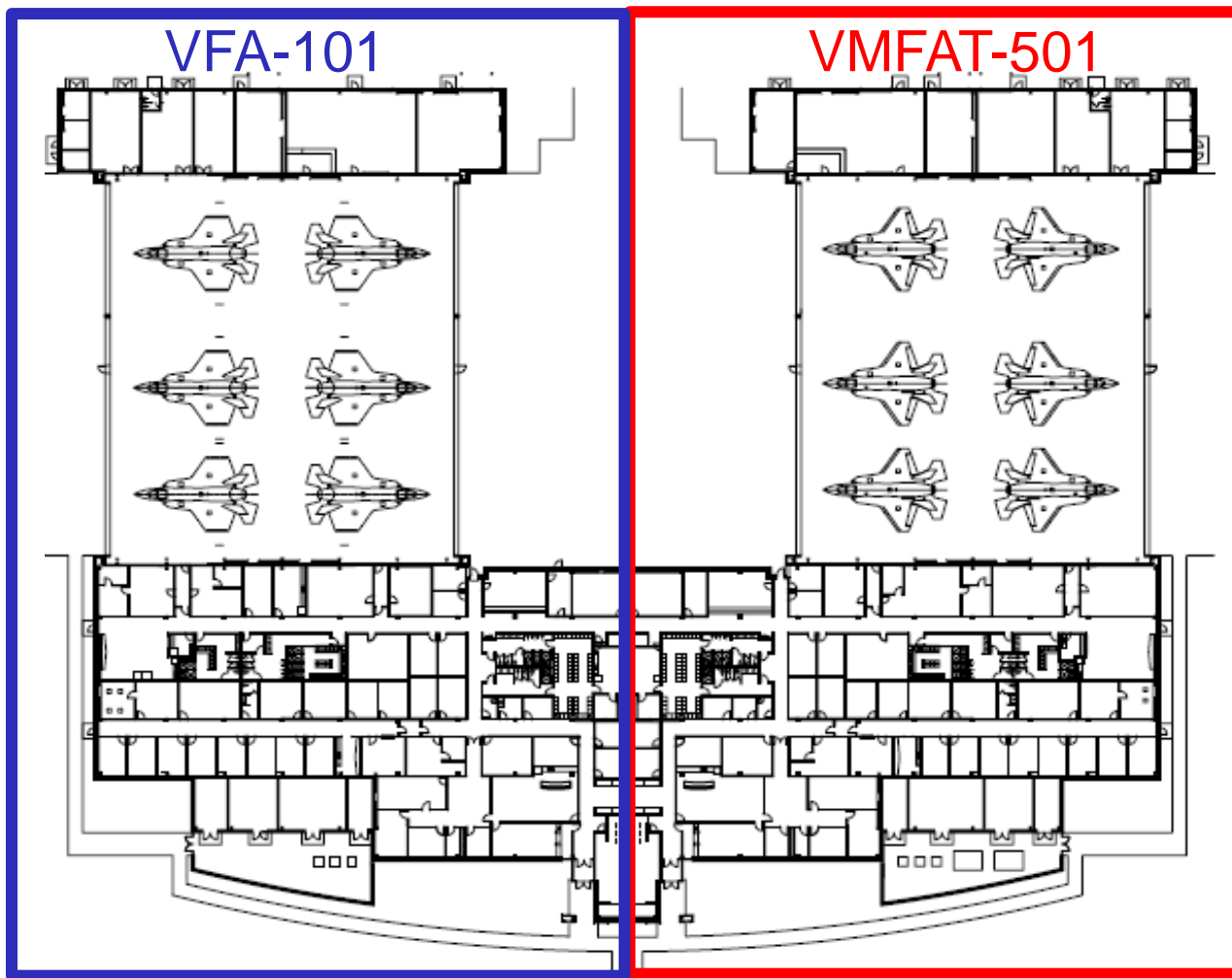

VMFAT-501

'Warlords'

- Apr 2010
- 20 x F-35B
- UK 6 jets

VFA-101

'Grim Reapers'

- Oct 2011
- 15 x F-35C

450 ft x 400 ft
110,000 sq-ft

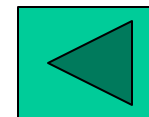



Academic Training Center

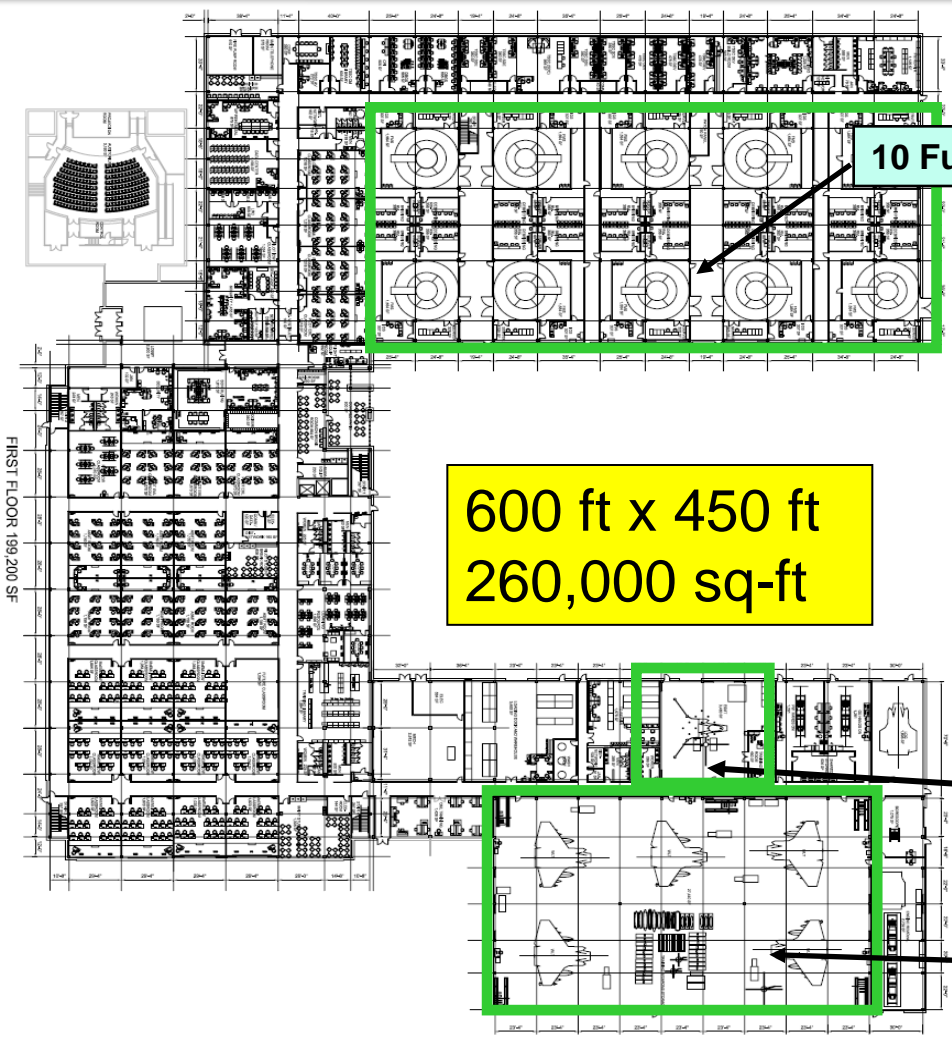

600 ft x 450 ft
260,000 sq-ft

10 Full Mission Sims

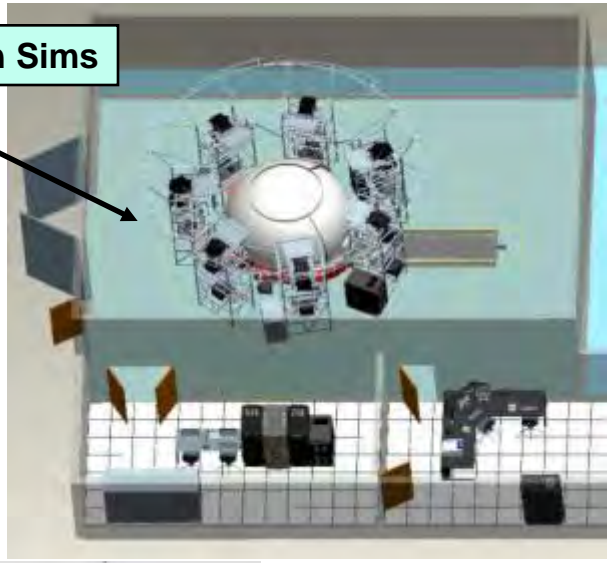

Ejection seat trainer

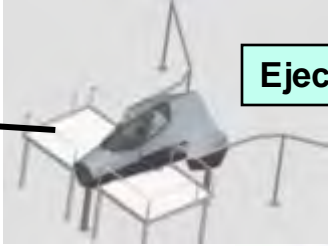

MX Weapons Load Trainer Area

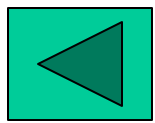
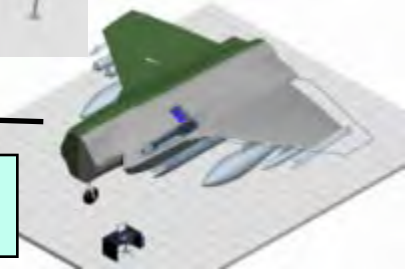

LHA DECK – STOVL Training

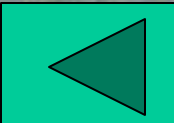

MQM-171 BROADSWORD IN SUPPORT OF TEST MISSIONS



2010 NDIA Targets Conference

Presenter: Larry French

Title: CEO/CTO



GRIFFON
AEROSPACE

MQM-171 BroadSword Program Overview



- **BroadSword is the result of the Army's need for a threat representative tactical class UAV target.**
- **The emerging threat on the battlefield requires the Army to test and evaluate means of mitigating enemy tactical UAVs.**
- **A 1998 Army Study resulted in a "Statistical" tactical UAV which became BroadSword's size and performance requirements.**
- **Key Milestones:**
 - **Design/Development Start** **March 2004**
 - **CDR** **October 2004**
 - **First Flight** **March 2006**
 - **Quals Complete** **August 2007**
 - **First Customer Mission** **April 2008**
 - **Production/Ops Contract** **August 2009**
 - **First Production MQM-171** **March 2010**

UAS-T Physical Requirements



Propulsion – Pusher Prop

Length – 4M +/-5% (13.8 Ft)

Wing Span – 5M +/-5% (17.2 Ft)

Fuselage Diameter - >.5M (1.6 Ft)

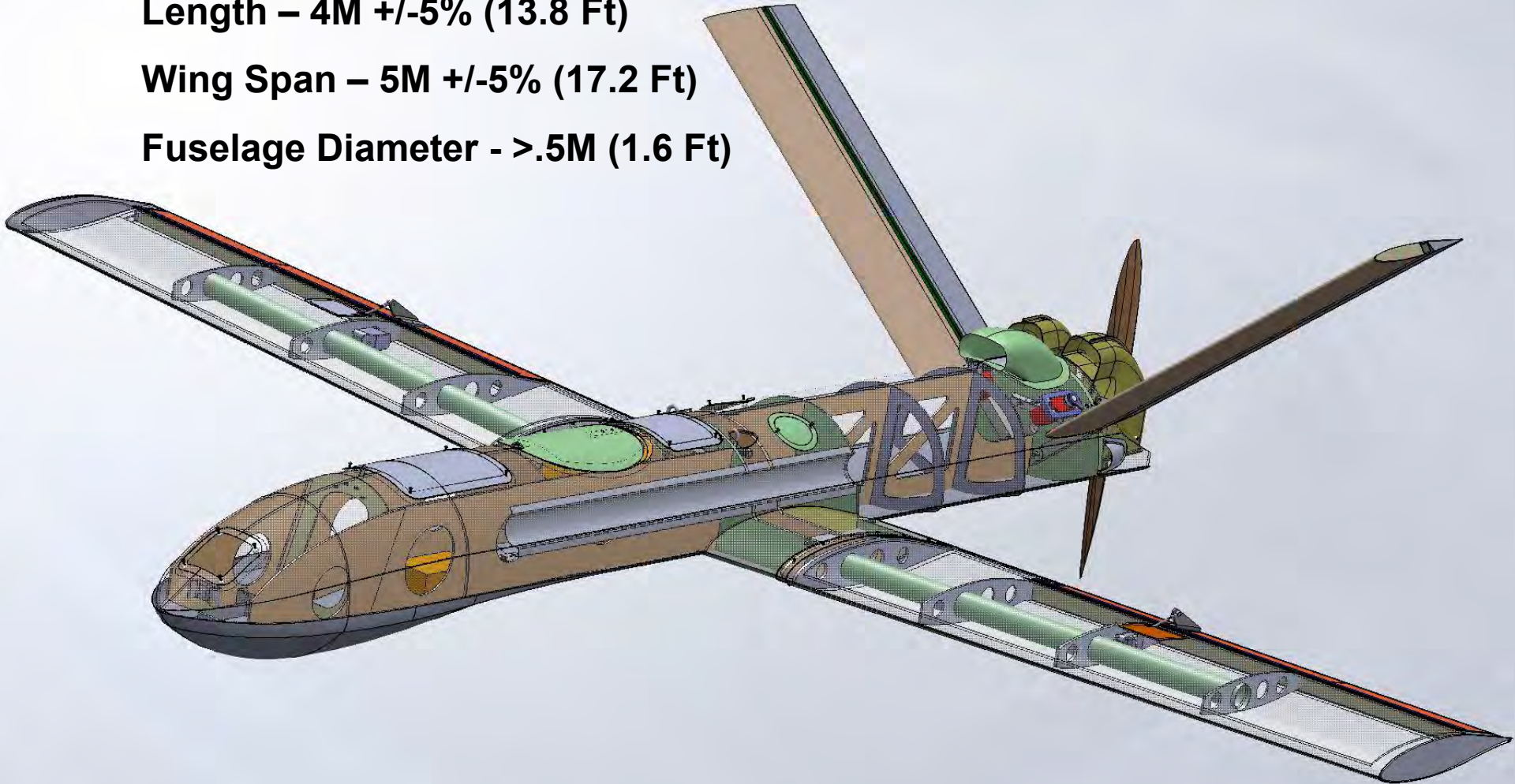

UAS-T Performance Requirements



| Parameter | Requirement | Demonstrated |
|-------------------|---------------|-----------------|
| Max Cruise | 115 KTAS | 115 KTAS |
| Min Cruise | 60 KTAS | 55 KTAS |
| Min Ceiling | 12,000 ft MSL | 18,000 ft MSL |
| Min Control Range | 25 Km | +25 Km & Satcom |
| Loiter Endurance | 1 hr | 2.5 hr |



Avionics/Command Link



Qualified Command and Control Systems

- CloudCap Piccolo Autopilot and Ground Station
- CapLite with TTCS-U Command Link
 - CapLite and datalink implementation by Micro Systems

| Autopilot | Command Link | Demonstrated | Range |
|--------------|--------------|----------------------------|--------------|
| Piccolo Plus | CloudCap | 400 Mhz | 25-30 Km |
| CapLite | TTCS-U | 400 Mhz | 25-30 Km |
| Piccolo II | CloudCap | 400 Mhz and Iridium Satcom | Fuel Limited |



Mission Ready GSE



BroadSword Ground Support Equipment (GSE)

- Launcher with Shipping Container
- Portable Ground Control Stations and Mobile TTCS-U Control
- Conex Shipping, Handling, and Operations Containers
- Lift/Recovery Road Dollies
- Aircraft Handling Equipment
- Fueling and Charging Systems
- System Spares



SLAMRAAM



Program: Surface Launched Advanced Medium Range Air-to-Air Missile Air Defense System (SLAMRAAM) - mobile, day/night adverse weather, non-line of sight weapon system for countering cruise missiles, fixed wing and UAVs.

Program Lead: PEO Missiles and Space, Cruise Missile Defense Systems

BroadSword Flight Ops: BroadSword has flown four (4) missions for the SLAMRAAM program. Each mission consisted of 3-4 flights. These flights have included tracking and livefire.



IMG_1093.mov Launch video



Counter Rockets, Mortars, and Artillery (C-RAM)



Program: Provide forces with real-time air situational awareness and protection from Rocket Artillery and Mortar (RAM). C-RAM consists of multiple COTS systems integrated to provide area defense.

Program Lead: PEO C3T, C-RAM Program Directorate

BroadSword Flights: BroadSword flew the first mission for C-RAM this year. Three (3) flights were flown at various altitudes, and speeds. The BroadSword was used to represent both friend and foe flight profiles.



NAVY Littoral Ship Program



Program: Littoral Combat Ships are small surface vessels intended for operations close to shore (littorals). They will be an agile, stealthy surface combatant capable of defeating anti-access and unconventional threats.

Program Lead: U.S. Navy

BroadSword Flights: BroadSword flew a one-way mission via satellite control to engage a Littoral Ship 70+ miles off shore. The aircraft was launched from the shore and flown via satcom link to perform multiple engagements/sorties on the ship until destroyed by intentional livefire.



BlackDart



Program: Black Dart is a joint agency demonstration focusing on rapid development and implementation of UAV technology from readily-available COTS products to develop anti-UAV systems. BlackDart demonstrates the ability to detect, track and shoot down small drones.

Program Lead: Joint Integrated Air and Missile Defense Org (JIAMDO)

BroadSword Flights: New customer for 2011. BroadSword will serve as a surrogate UAS for tracking and weapon system engagements. BroadSword is being added after many years of successful Outlaw mission support.



JLENS



Program: Joint Land Attack Cruise Missile Defense Elevated Netted Sensors System (JLENS) is a tethered early warning and surveillance medium altitude aerostat. JLENS provides over-the-horizon detection and tracking of aircraft, helicopters, UAVs and cruise missiles.

Program Lead: Aerostat Joint Project Office of the U.S. Army Space and Strategic Defense Command.

BroadSword Flights: New customer for 2011. BroadSword will serve as a surrogate UAS for tracking and sensor evaluations.



BroadSword is the Army Target Management Office's newest target system for test and evaluation of systems requiring threat representative tactical class UAS tracking and engagements.

BroadSword has successfully flown on numerous Army and Navy test ranges.

The MQM-171 BroadSword is operational and available for research and development, test and evaluation, and training applications.

ATEC



21st Century Target Control System (21st Century TCS)

Steve M. Gonzales
Systems Engineering Directorate
Network & Control Division

575-678-4930

20 Oct 2010

*Army Proven
Battle Ready*



Outline



- Requirement
- History
- Description and Highlights
 - Overview
 - Ground
 - Aerial
- Future Enhancements
- Questions



Requirement



- WSMR requires a remote control system for controlling both aerial and ground targets
- The existing control system, Drone Formation Control System (DFCS) developed in the early 70's using 70's technology
- Existing WSMR legacy remote ground control system was obsolete
- Upgrade to modular control system utilizing state-of-the-art technology



HISTORY



- **MSTCS restructure Jan, 2002 led the Army to develop new TCS as replacement for aging DFCS.**
- **IBM to adopt LINUX as OS of choice starting in 2004**
- **Future support of AIX by IBM not predictable**
- **Initial 21st Century TCS tied to legacy AIX in DFCS**
- **Port of datalink network function to TCS**
- **Need to eliminate multiple computers and port system into a single multiprocessor computer**



HISTORY

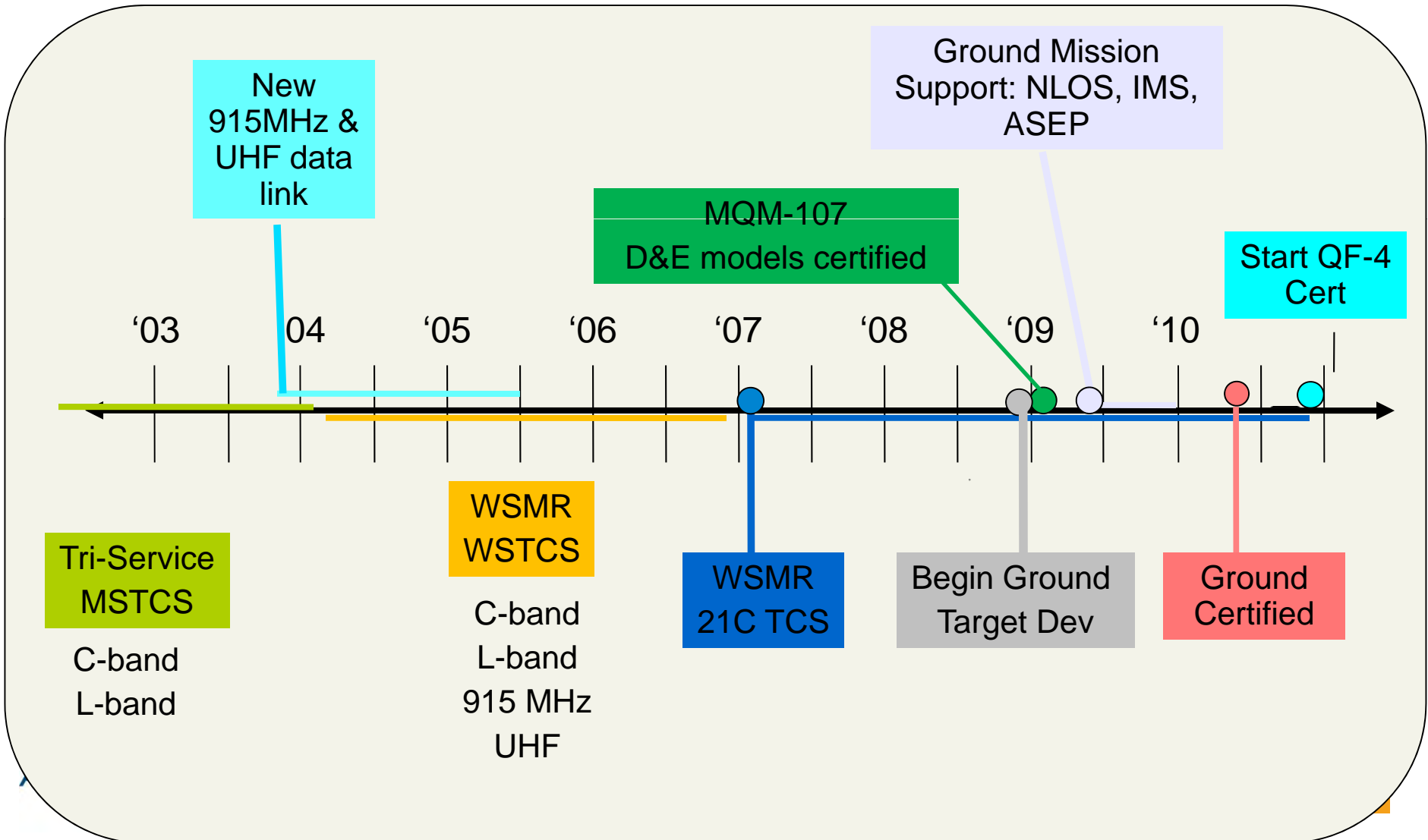

Description

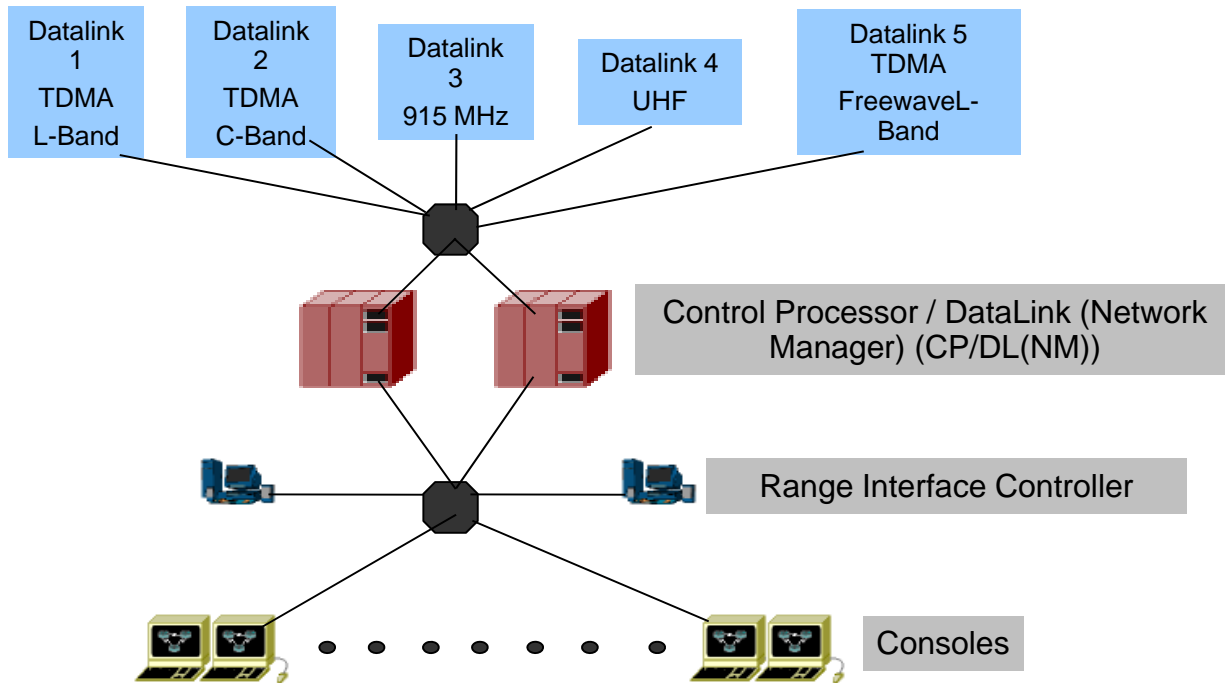



Qt Based GUI



WSTCS

Config Mission DFCS

Cons 7 Cons 8 Cons 9 Cons 10 Cons 11 Cons 12 Cons 13 Cons 14

BMP ID: 9 Address: 211

BMP ID: 10 Address: 212

TRUCK ID: 11 Address: 113

L-Band GV L-Band UHF 915 MHz C-Band Sim L-Band Sim GV L-Band Sim 915

09 Incorrect Auto Segment
09 Incorrect Auto Segment
09 Incorrect Auto Segment
09 Incorrect Auto Segment
09 Incorrect Auto Segment
09 Incorrect Auto Segment
09 Incorrect Auto Segment
09 Incorrect Auto Segment
09 Incorrect Auto Segment
09 Incorrect Auto Segment
09 Incorrect Auto Segment

Ground Targets
Aerial Targets

TRUCK

T72



TCS HDD Console



Arr
Battle Ready

e

Description: *Ground Target Control*

Compact Design



New Control System Architecture



Vehicle Telemetry Information Display

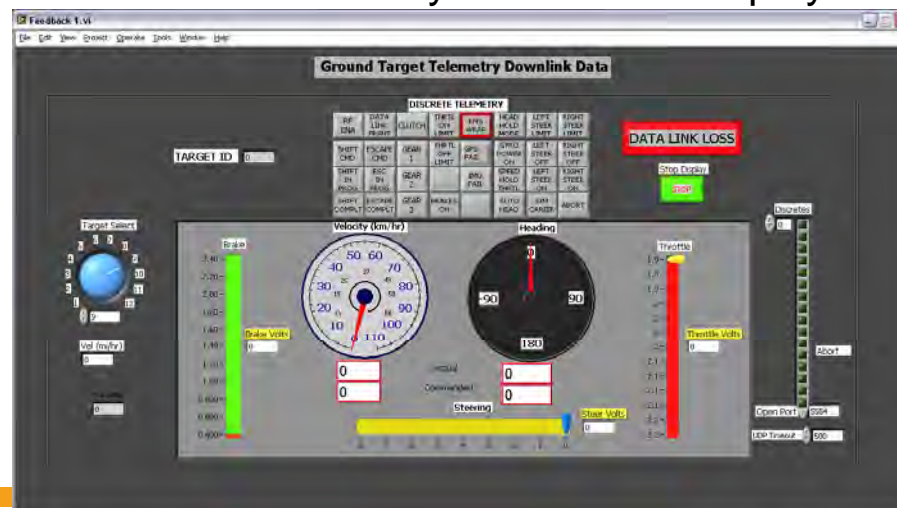

Description: *Ground Target Control*

Vehicles Currently Configured





21st Century TCS Mobile Van



Army Proven
Battle Ready

US Army White Sands Missile Range



Highlights: *Ground Target Control*

Intelligent Munitions System (IMS)-Support Fort Devens, MA, Feb 2009.

- Team support at Fort Devens, MA 17 -27 Feb 2009. Conditions of track Sat 7 Feb 2009.



- Track was approximately 626 meter long and 10 feet wide.
- Ice and Snow made for poor traction of two 1997 black Nissan trucks

Two vehicle convoy mission @ Zumwalt Track 7 July 2009 using 21st Century TCS from B312 (95 mi. from test site)



Automated Analysis Environment

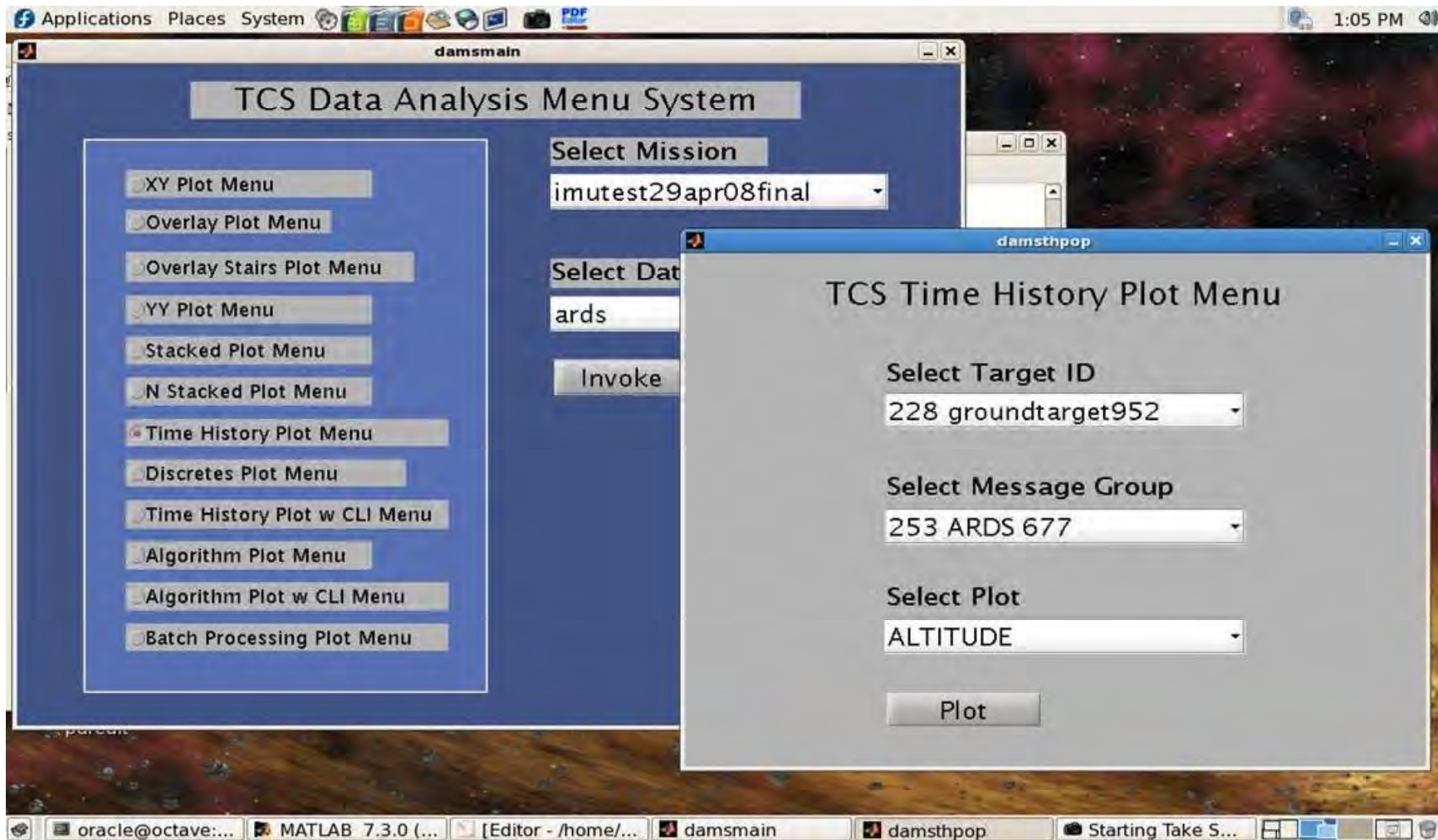



Innovations and Milestones



- **Dynamic Speed Control (5 – 65 mph)**
- **Auto vehicle spacing (30 – 100 m)**
- **Formation control of different vehicle permutations**
- **Multiple formation support**
- **Auto launch of formation**
- **Multiple Safety Options**
 - **Collision Avoidance**
 - **Remote Abort**
 - **Master Stop (Mission Pause)**
 - **Automatic slot allocation**



Innovations and Milestones



- Sub-meter (60 cm) GPS accuracy
- Automatic generation of ground path based on GPS data
- Over-the-air modifications of vehicle configurations
- Health of systems display capability
- Logging and state of the art analysis capability
- Ability to change segment velocities in real time
- Mobile systems capability

Description: *Aerial Target Control*

Targets to be certified for control

MQM-107



Models: D*, E*, IAP
Datalink: UHF

QF-4



Datalink: 915MHz

* MQM-107 D and MQM-107 E have been certified



Highlights: *Aerial Target Control*

- Certified UHF MQM-107 D & E Fall of '08*
- Scheduled UHF MQM-107 Integrated Avionics Package (IAP) flights within next 6 months
- QF-4 testing FY11



Future Enhancements

- Touchscreen (Haptic feedback) user interface
- New actuator control
- Integration of surrogate targets
- UAV integration
- Threat management system capability
- New kill switches
- More efficient vehicle instrumentation



*Army Proven
Battle Ready*



US Army White Sands Missile Range



Questions??



**PEO
STRI**

Information Assurance: Impacts on Army Target Programs

Barry Hatchett
Lead Project Director
Targets Management Office (TMO)
COM 256-842-6797,
DSN 788-6797
Barry.Hatchett@us.army.mil



Targets Management Office



Outline

- **What is DOD Information Assurance Certification and Accreditation Process (DIACAP)?**
- **Why do Information Assurance?**
- **Process for DIACAP Compliance**
- **What impacts does DIACAP have on target programs**



Targets Management Office



What is DIACAP?

It is the process by which information systems are *certified* for compliance with DoD security requirements and *accredited* for operation by a designated official. It is the standard process under which all DoD information systems will achieve and maintain their Authority To Operate (ATO).





Targets Management Office



Why do Information Assurance?

It is the Law! –

Clinger-Cohen Act, 1996

Federal Information Security Management Act (FISMA), 2002

DODI 5000.02 - “Operation of the Defense Acquisition System”

DODI 8580.1 – “IA in the Defense Acquisition System”

AR 25-2 – “Information Assurance”

***Military, Federal Civilian & Contractor* personnel may be subject to administrative &/or judicial sanctions if they knowingly, willfully , or negligently compromise, damage or place Army information systems at risk by not ensuring implementation of DOD & Army policies & procedures.**



Targets Management Office



Process for DIACAP Compliance

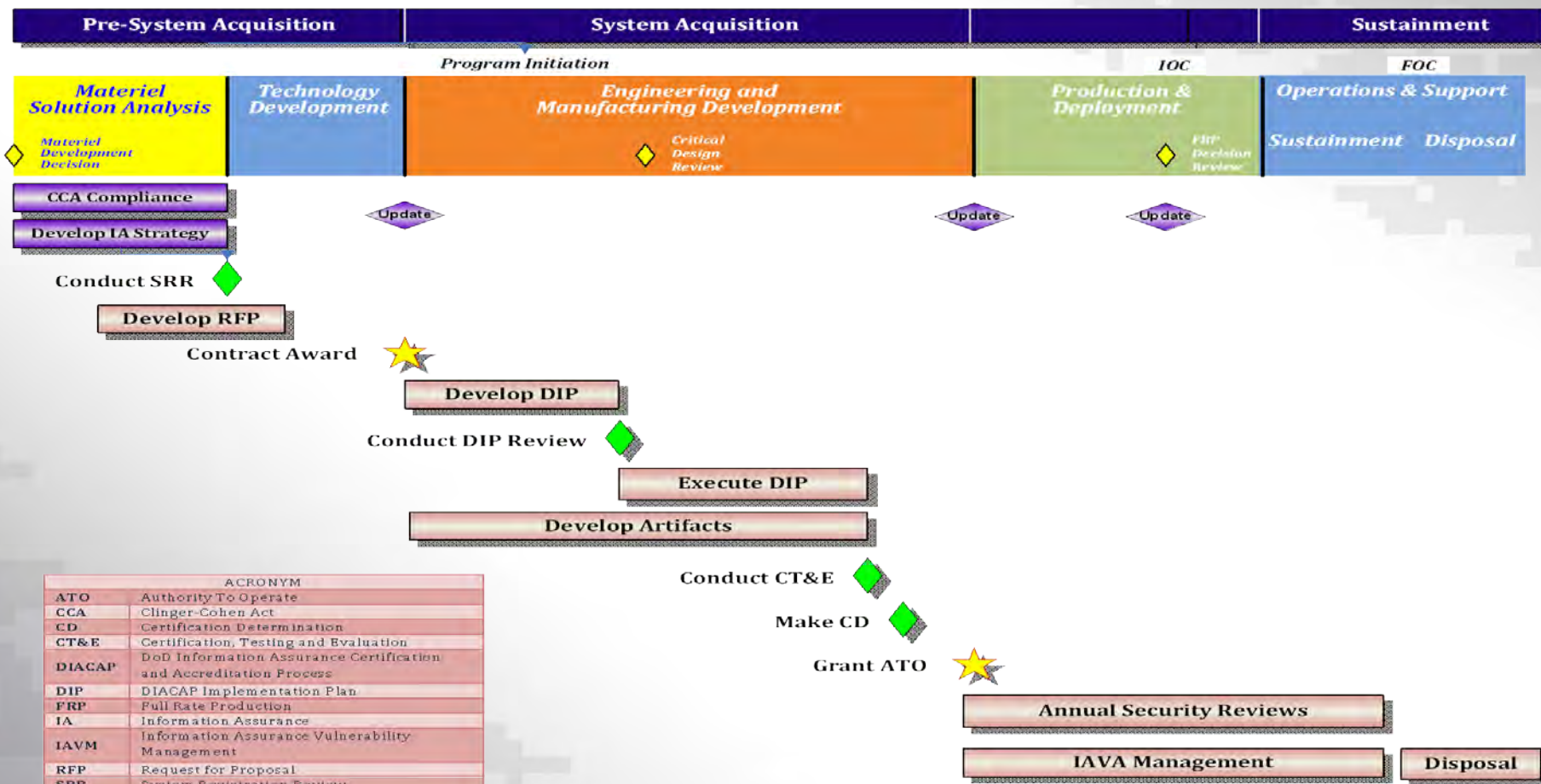

IA Milestone Schedule



Targets Management Office



Target Control System (TCS)

- **The Army's primary Subscale and Rotary Wing aerial target control system**
- **Current TCS began development in 2001**
- **System Configurations: Fixed Site, S280 Shelter, Portable**





Targets Management Office



TTCS-U
Engineering Flight Test
20 May 2010



IA Issues with TCS

- **Legacy System**
 - Some IA controls cannot be implemented
 - Hardware could not support IA tools
- **Certain IA controls could add risk to mission**
- **Funding to support DIACAP**
- **Each computer in the system must be configured separately**
- **Overall process is time consuming as it is manually intensive**





Targets Management Office



Impacts to TCS

- **Additional training is required for operators**
- **Manuals need to be updated**
- **Increases sustainment cost**
- **Increase time of regression testing**
- **Additional personnel needed to support IA needs**
 - Review and storage of audit records
 - Updating DIACAP documentation and yearly IA recertifying scans





Targets Management Office



TCS Open Vulnerabilities

| | Before | After |
|-----------------------------|--------|-------|
| Subsystem Control Console | 339 | 114 |
| Command Telemetry Subsystem | 338 | 119 |
| Position Display Subsystem | 338 | 124 |
| STEALTH | 356 | 135 |

* Windows XP Service Pack 3 accounts for ~ 90% of remaining Vulnerabilities



Aerial Weapon Scoring System (AWSS)

- An integrated group of computer-controlled sensors used to score live-fire helicopter gunnery exercises at designated gunnery ranges





Targets Management Office





Targets Management Office



IA Issues with AWSS

- **Separate scan required for each computer hardware configuration**
- **Full licensed version of Retina required to resolve vulnerabilities**
- **AWSS is not connected to internet to receive security updates**
- **Overall process is time consuming as it is manually intensive**

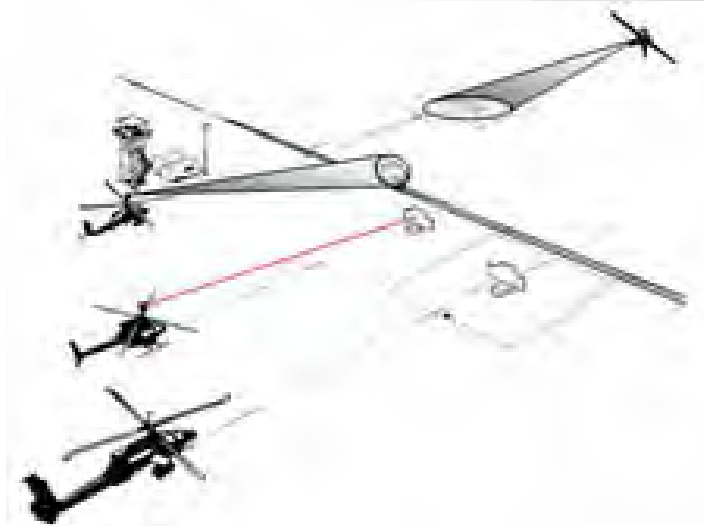



Targets Management Office



Impacts to AWSS

- **Virtual Network Connection not authorized thus preventing communication from tower**
- **User login with password protection (14 characters)**
- **System response performance was degraded**





Targets Management Office



AWSS Open Vulnerabilities

| | Before | After |
|-----------|--------|-------|
| Gold Disk | 732 | 3 |
| Retina | 43 | 34 |

- 3 Open Vulnerabilities with Gold Disk were considered acceptable for accreditation
- Most Open Vulnerabilities with Retina were low risk

Summary

- IA is law and here to stay
- Plan and prepare early in the acquisition of system
- Continue to support mission requirements





48th Annual NDIA Conference Targets, UAVs & Range Operations Symposium & Exhibition

Boeing QF-16 Program



QF-16 Full Scale Aerial Target
Boeing Global Services and Support
Maintenance, Modifications, & Upgrades
Aircraft Sustainment & Maintenance

Mr. Robert Insinna
QF-16 Program Manager
October 21, 2010

Boeing Targets / Decoys



- Cost Effectively Converting Highly Reliable, NDI Air Vehicles
- Providing Foundation for New Development Programs
- Boeing's Systems Integration Expertise and Teaming
- Application of Boeing Critical Technologies
- Synergy Among Our Targets, Unmanned Systems, and Weapons Programs



Demonstrated Performance on Non-OEM Platforms



- **T-38 Avionics Upgrade Program**
 - Cockpit digital conversion on Non-Boeing platform
 - 100% on-time production delivery (465 units)
 - System Design Exceeding Mean Time Between Failure Key Performance Metric
- **C-130 Avionics Modernization Program**
 - Cockpit digital conversion design and installation on Non-Boeing platform
- **A-10 Wing Replacement Program**
 - Structural Design and Interface to Non-Boeing Platform
 - Experience Working with Non-Boeing Engineering Documentation
- **MA-31 Target System**
 - Russian KH31 Missile Conversion to US Target System
 - Upgraded to Precision Guidance with Boeing Developed Hardware/Software



QF-16 Overview

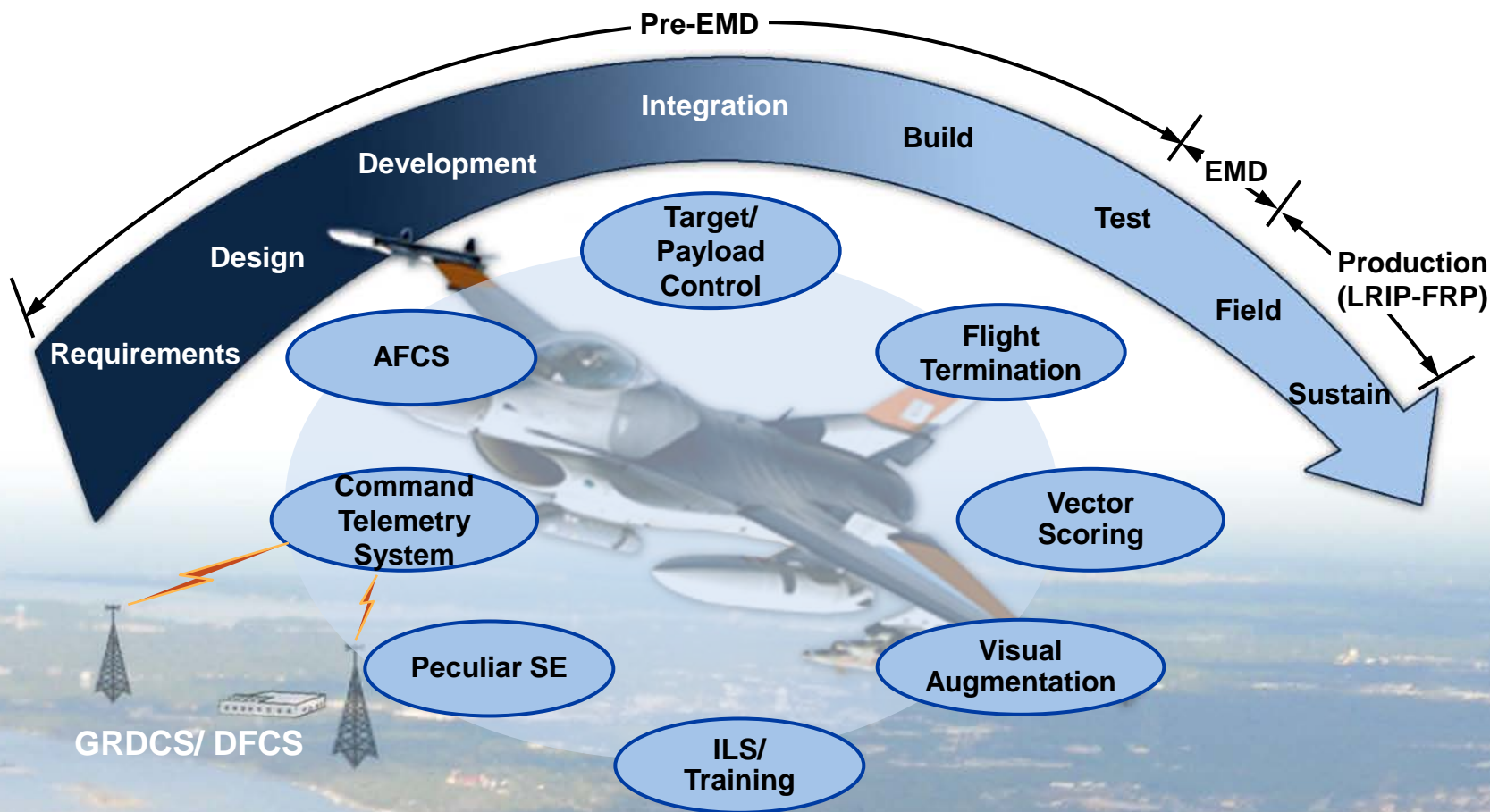

Key Features

- Follow on for QF-4 Program: Supersonic, High-G, Heavy Payload Capability
- Satisfies Title 10 "Live Fire/Lethality"
- Provides 4th Generation Threat Representation

QF-16 Program Key Sites

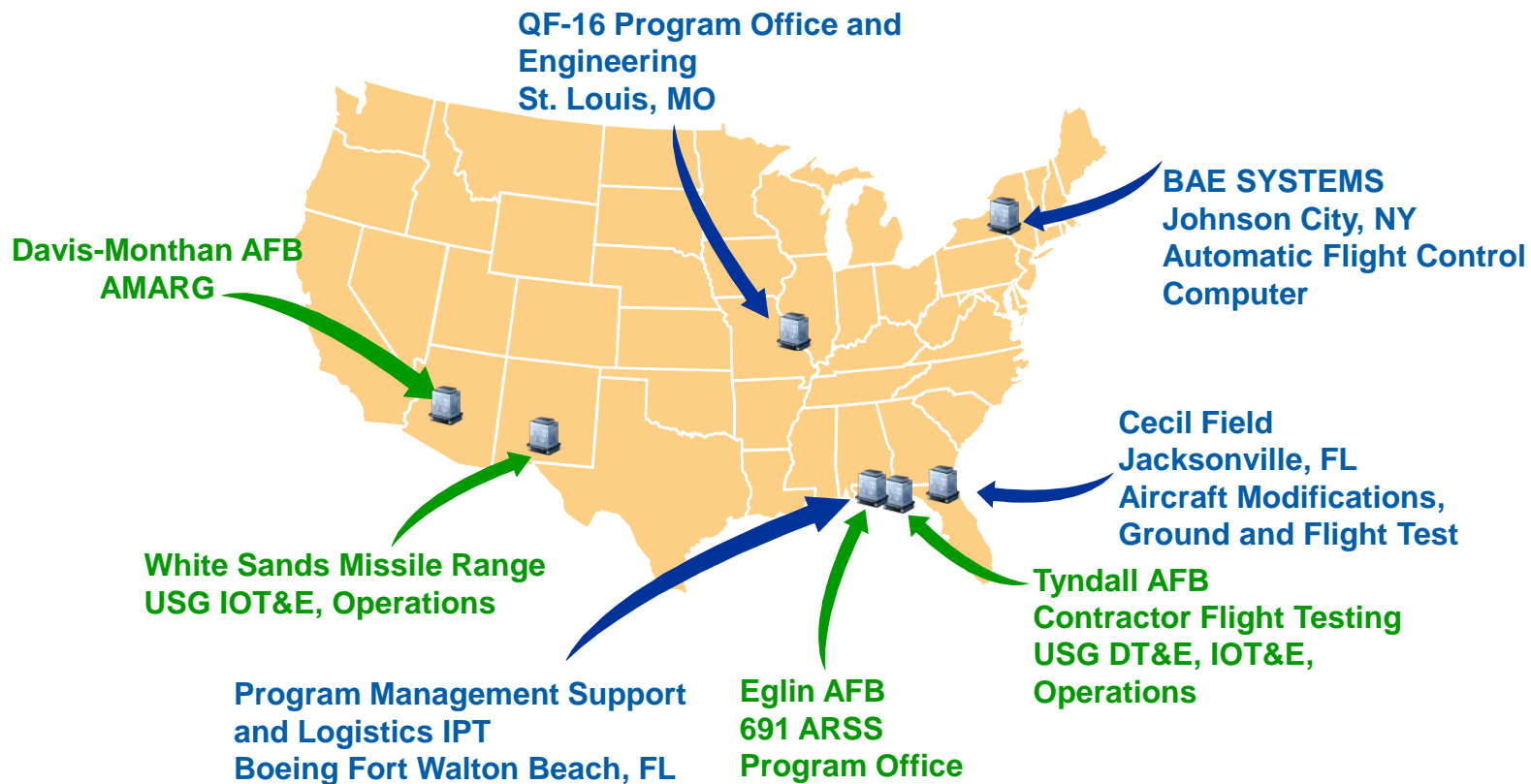

Leveraging the Best of Industry to meet Customer needs

QF-16 FSAT Roadmap Meets All Government Milestones

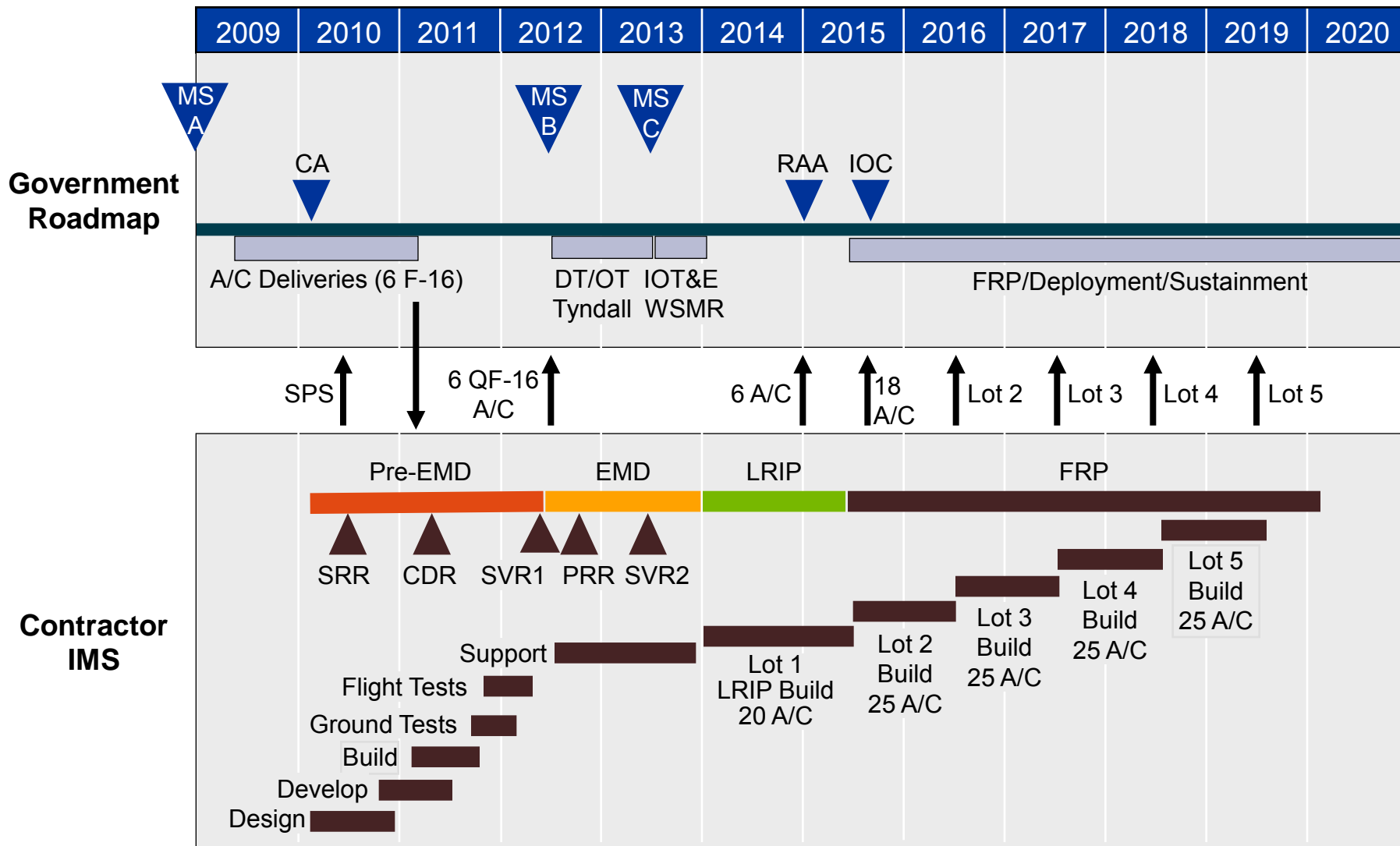

Functional Baseline - DPE



- **Drone Peculiar Equipment (DPE) refers to the unique airborne equipment developed to remotely command and control the QF-16 aircraft and provide scoring data for end game mission analysis.**
 - Target Control System integration
 - Launch and Recovery
 - Full F-16 flight envelope performance and maneuvers
 - Payload control and deployment
 - Commanded or Automatic Flight Termination
 - Visual Augmentation
 - End game scoring
- **DPE consists of multiple subsystems with Top Level functions:**
 - Automatic Flight Control System (AFCS)
 - Take-off and Landing
 - Programmed Maneuvers & Automatic Sequences
 - Throttle Control
 - Air vehicle command and control
 - Command Telemetry System (CTS)
 - Target Control System to AFCS interface
 - Payload Control System (PCS)
 - Payload control and deployment
 - Flight Termination System (FTS)
 - Commanded or automatic immediate termination of aerodynamic flight
 - Vector Scoring System (VSS)
 - End game projectile miss distance
 - Visual Augmentation System (VAS)
 - Commanded Pulsed smoke trail for visual acquisition

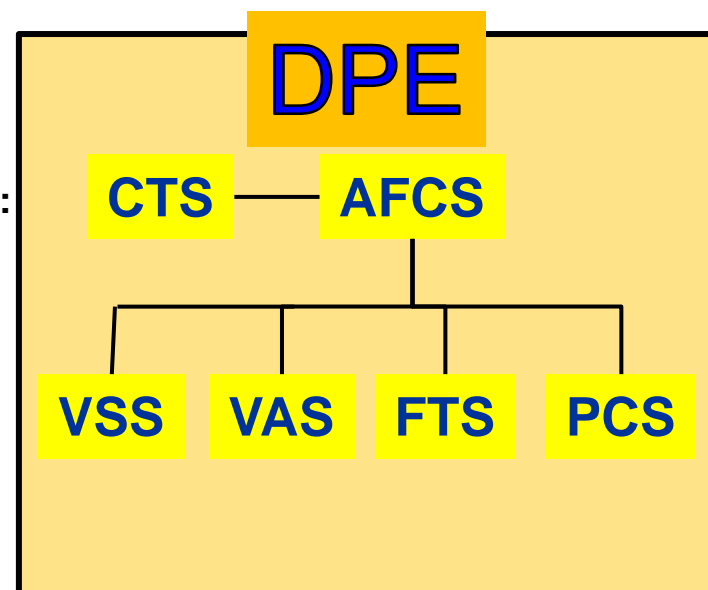

Functional Baseline - PSE



- **Peculiar Support Equipment (PSE) refers to the unique support equipment developed to test and troubleshoot the QF-16 Drone Peculiar Equipment (DPE)**
 - Acceptance test of QF-16 modifications at Cecil Field
 - Pre-Mission Test of QF-16s at Tyndall and Holloman AFB
 - Diagnosis and Isolation of DPE anomalies
- **PSE consists of an Automated System Test Set (ASTS) and a Portable Flight Line (PFLT) Tester.**
 - ASTS Top Level Functions
 - Perform full QF-16 system level Acceptance Test Procedures (ATP) to verify that the DPE drone modifications are installed correctly
 - Perform NULLO (Not Under Live Local Operation) Pre-Mission system level validation Test (PMT)
 - Fault isolate to the QF-16 DPE major Line Replaceable Unit (LRU) level
 - PFLT Top Level Functions
 - Test and troubleshoot the QF-16 system to the DPE LRU level
 - Load Operation Flight Programs (OFPs) for DPE systems with flight-line loadable OFPs
 - Program levels for payloads signals



QF-16 Architecture Block Diagram

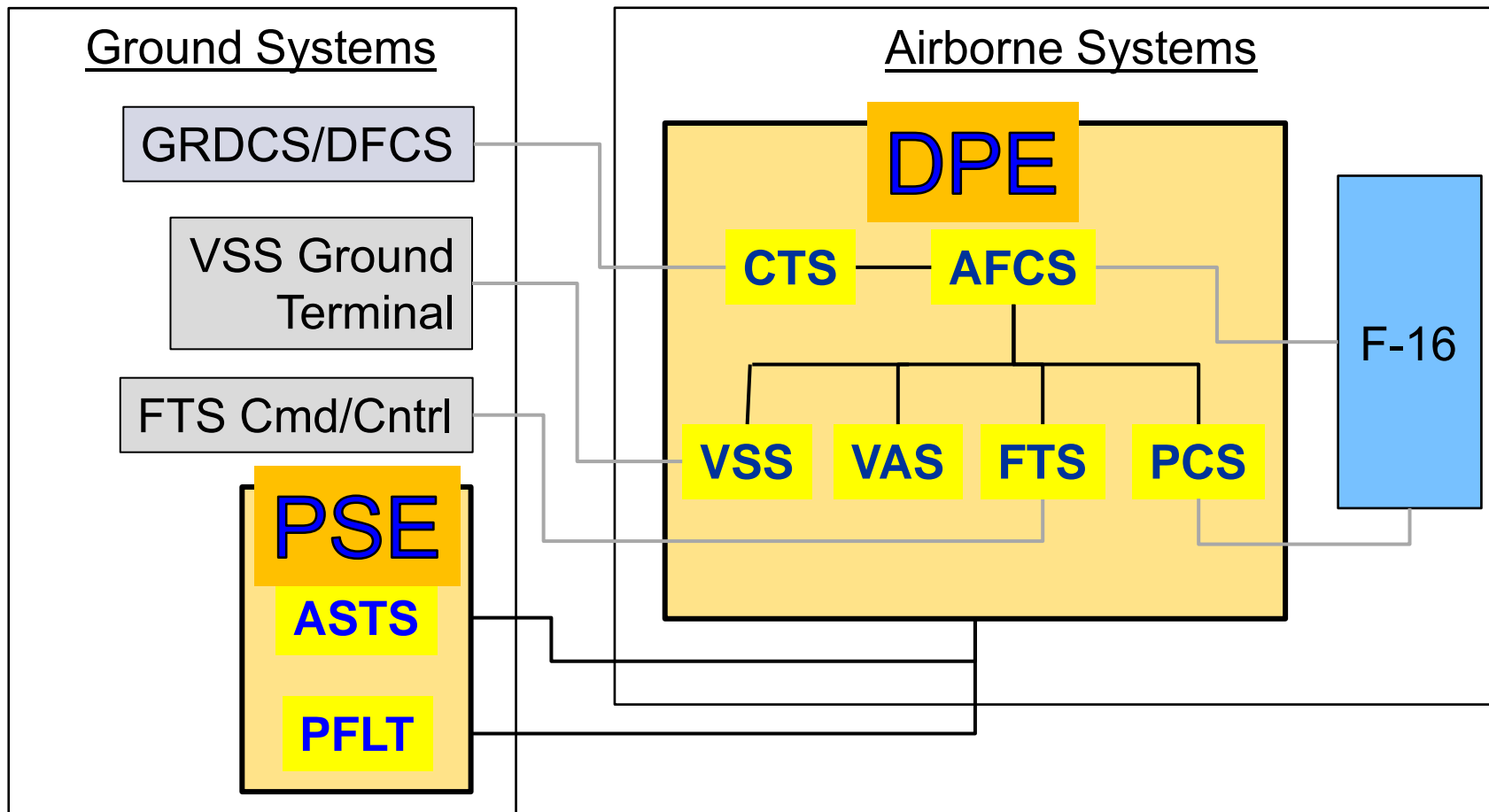

Synthesis and Integration



- Architecture has been defined and the suppliers selected
 - Alternative concepts defined and analyzed
 - Physical interface definition started

Drone Peculiar Equipment (DPE)

PCS – Payload Control System

AFCS_ Automatic Flight Control System

VAS – Visual Augmentation System

Peculiar Support Equipment (PSE)

ASTS



VSS – Vector Scoring System w/ Encryption

PFLT



FTS – Flight Termination system

CTS – Command Telemetry System

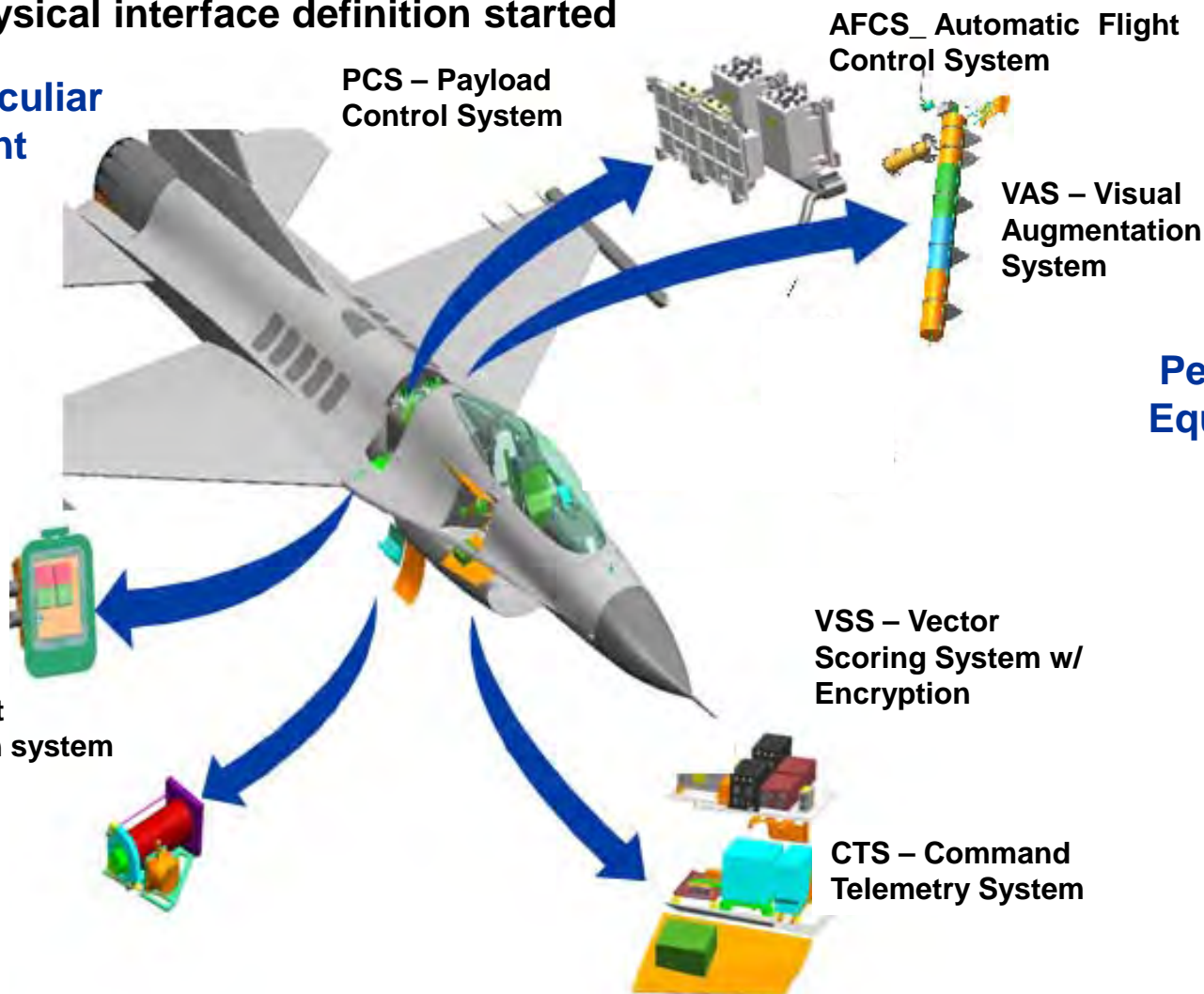

Advanced Engineering Applied to QF-16



- Use of X-ray and Laser Scanning Technology
 - Rapid prototyping of risk reduction articles
 - 3D modeling of equipment installation

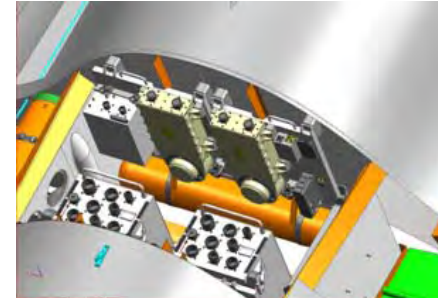

3D Modeling of Equipment Installation in Gun Ammo Bay



Rapid Prototype of FTS Pallet Installation on Block 25 F-16



- Rapid Prototype of F-16 Structure for Visual Augmentation Equipment Installation

Static Destruct Test



- Testing supports QF-16 Flight Termination System Warhead Placement
- Static Destruct Test Successfully Completed at Eglin AFB - August 2010
- Test Results show FTS warhead detonation will terminate QF-16 flight



Antenna Testing



- **Completed Testing in Boeing Near Field Test Facility**
 - Determined RCS contribution of QF-16 unique antennas
 - Antennas installed on F-16 Test Asset
- **Antenna Pattern Testing at Boeing's Antenna Test Range, planned for January 2011.**



Near Field Testing



Antenna Pattern Testing

Test and Evaluation



- A dedicated QF-16 System Integration Lab (SIL) will be used to support integration of DPE/PSE, to develop SW for DPE, and to support Flight Testing
 - Hardware in loop testing, GRDCS Simulations and GRDCS Data Link Testing (GDLT)
- Contractor Aircraft Ground and Flight Testing - Cecil Field
 - Mobile GRDCS and GRDCS Portable Towers



GDLT



SIL



Mobile GRDCS



GRDCS Portable Towers

- EMD Phase - DT/OT at Tyndall and at Holloman (White Sands Missile Range)



Ready to Support Drone Conversions

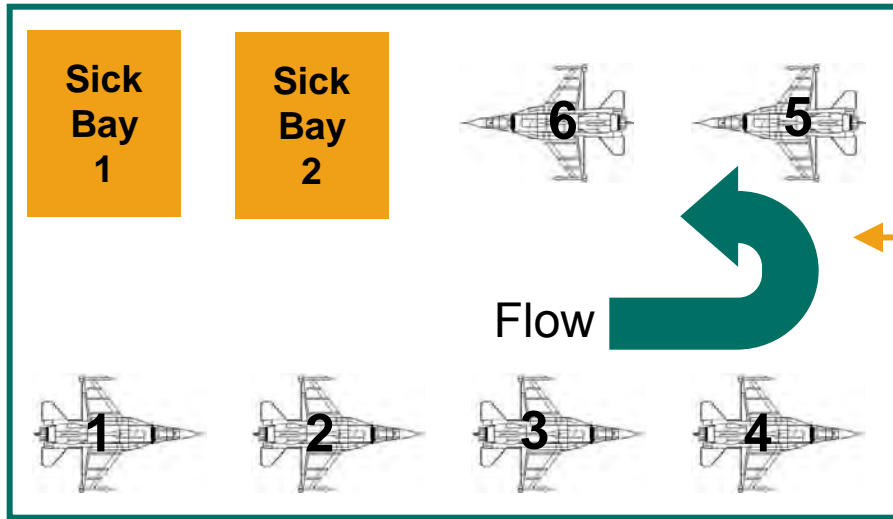

- **Cecil Field Recovery of first F-16**
 - On time readiness
 - Trained and experienced support personnel

Lean cellular production supports affordable, high quality, on time performance

Program Summary



- The Boeing QF-16 Program leverages QF-4 supply base and maximizes the use of existing hardware and software capabilities to provide a low risk drone peculiar equipment solution.
- The program has progressed through the startup phase, completed a system requirements review (SRR), the integrated baseline review (IBR), and the system functional review (SFR). PDR is on schedule for October 2010.
- Boeing systems engineering processes and program management best practices are in place to provide successful execution of the program requirements.

Non-OEM Experience



System Integration Experience



Unmanned Experience





Holographic Radar – a universal solution

Collision avoidance, wind farms and scoring!



NDIA targets and ranges conference

Gary Kemp

- 1 Short introduction to Cambridge Consultants**
- 2 What is holographic radar?**
- 3 Applications of holographic radar**
- 4 Questions**

- 1 Short introduction to Cambridge Consultants
- 2 **What is holographic radar?**
- 3 Applications of holographic radar
- 4 Questions

Holographic radar implements Skolnik's vision of Ubiquitous Radar

- Holographic Radar looks continuously at a whole volume of space (rather than scanning).
- It acquires fully sampled amplitude and phase information from every object within the volume.
- It provides range, azimuth, elevation and Doppler information for every detected object.
- Tracking algorithms discriminate moving targets and clutter.
- Clutter is removed without loss of sensitivity.

- Practical holographic radar is possible in the modern day due to the availability of high-power processor devices at reasonable cost.

Holographic radar

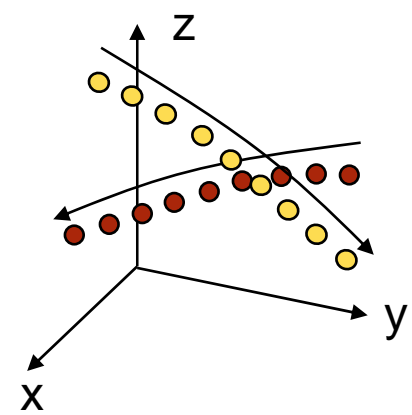
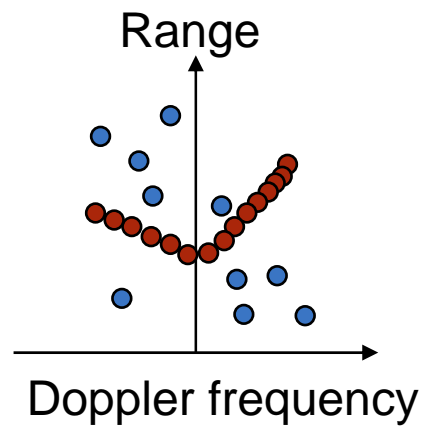
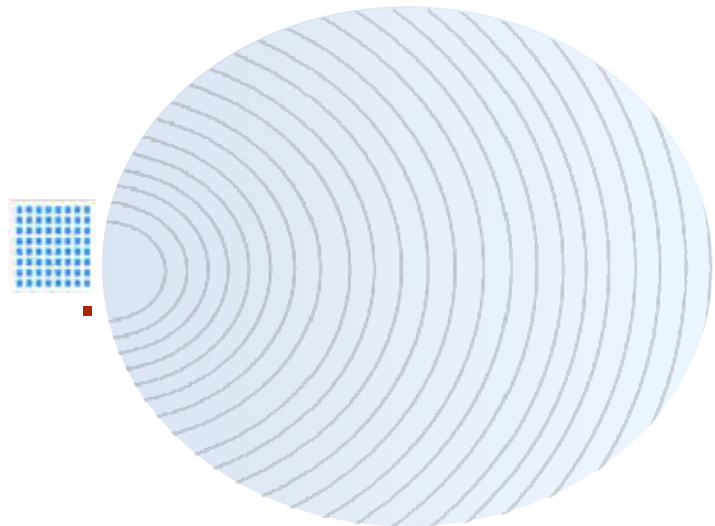
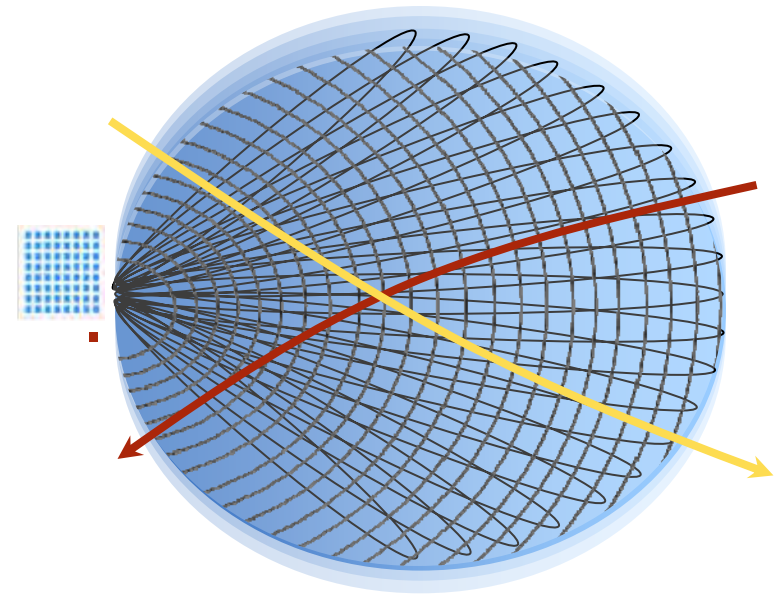
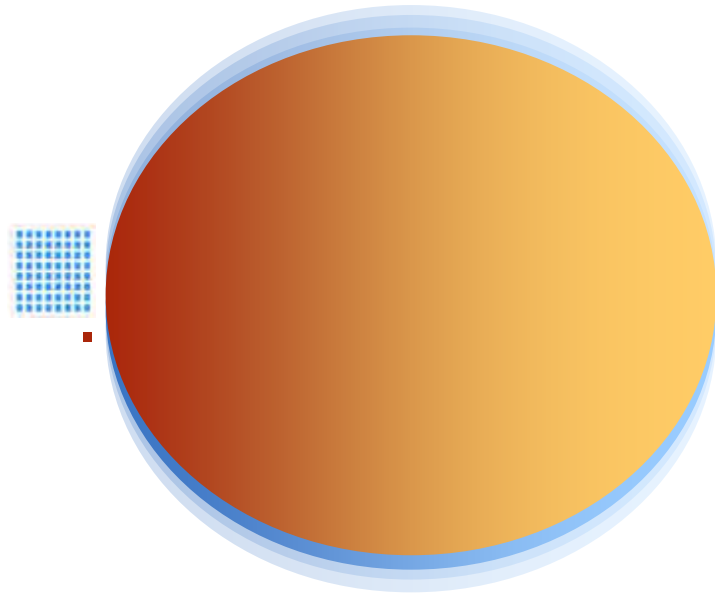

- 1 Short introduction to Cambridge Consultants
- 2 What is holographic radar?
- 3 Applications of holographic radar
- 4 Questions

Collision warning radar

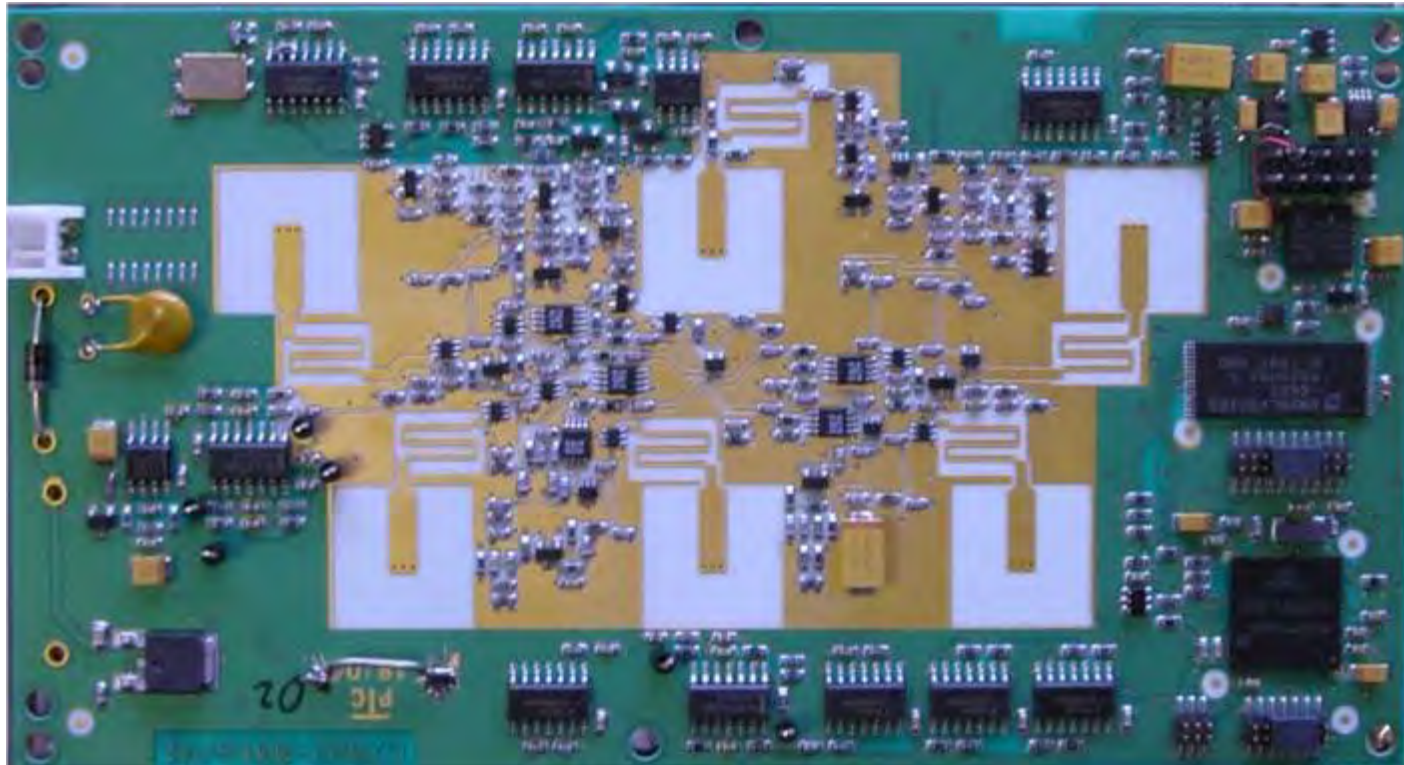

5-channel array for automotive pre-crash sensing – a minimum holographic array

Collision warning radar



Many wind farm planning applications are stalled

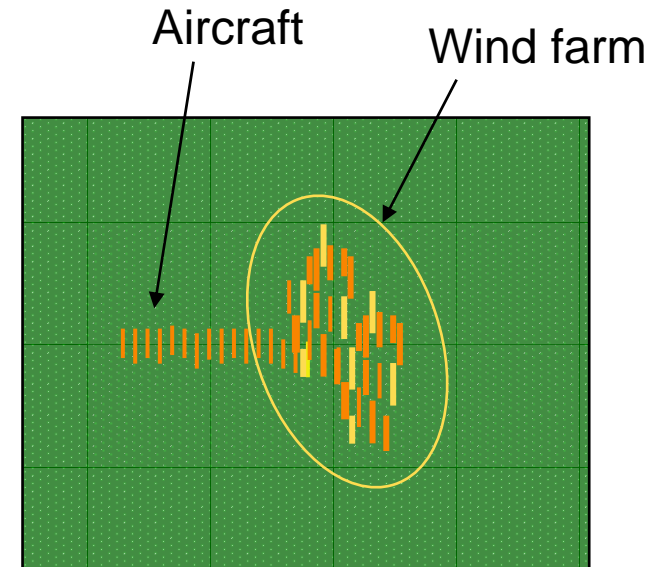

Absence of vertical discrimination combined with scan aliasing makes it impossible for a PSR to separate the track from the clutter.

Holographic radar provides the solution.

Wind farm infill radar

CH-InFill is a holographic radar located at or near a wind farm to generate local, high-resolution, 3D infill data

- The sensor is located in or near the wind farm
- It sees through and around the turbines without disruption
- Nothing else has been shown to do this
- Range up to 13km / 43,000ft
- Reporting rate 3-10Hz

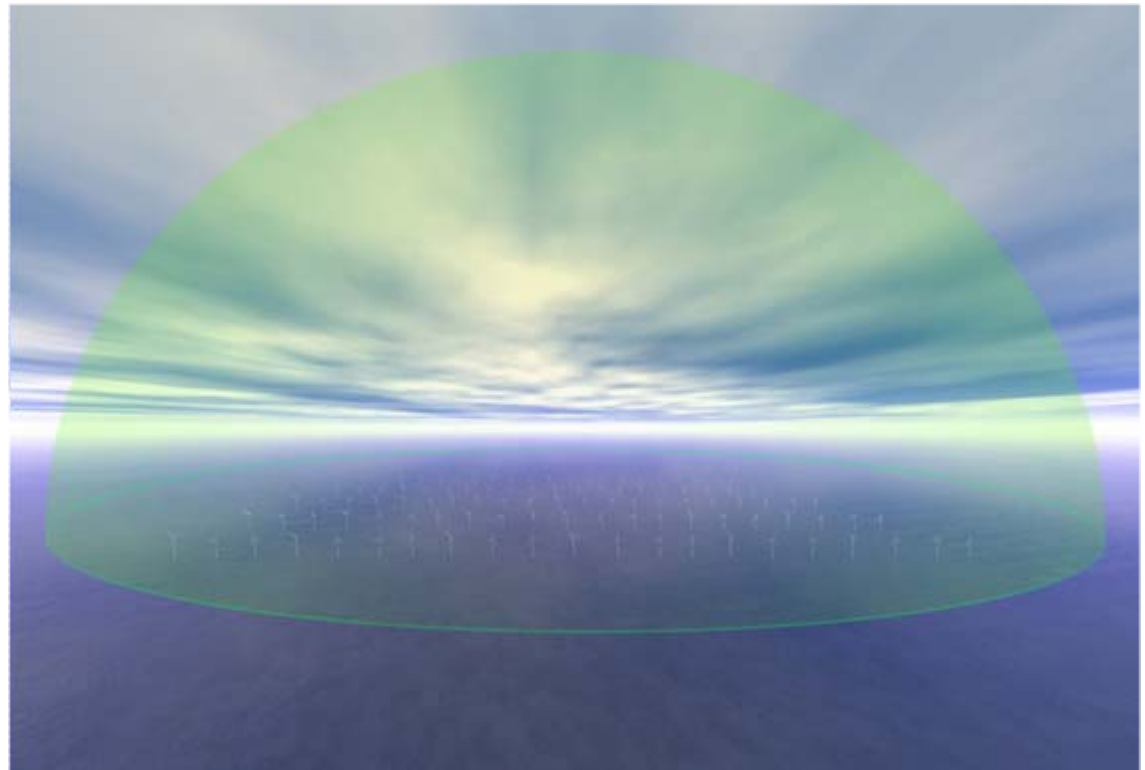
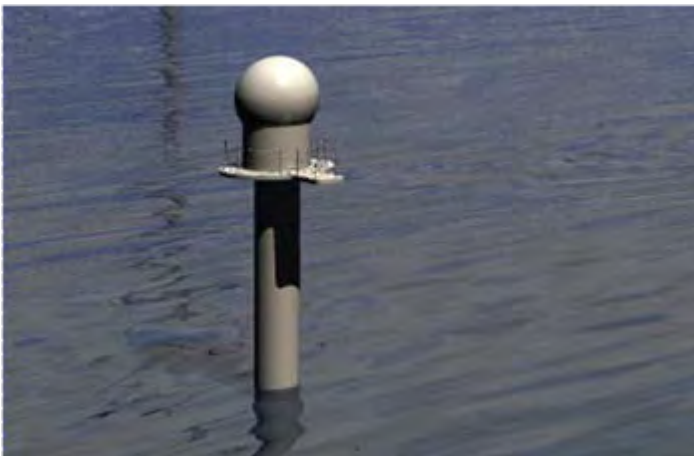

Wind farm infill radar - testing

66m diameter wind turbine



Remote-controlled
helicopter with 2.2m² radar
reflector



LSTS

Land and Surface Target Scorer (LSTS) system – in development

- The Land and Surface Target Scorer is a real-time vector scoring system for highly mobile targets operating in very cluttered environments.
- LSTS application of the CH radar is funded by the OSD Target Management Initiative program, sponsored and managed by NAWC-WD, Point Mugu, Target Systems Division, 5.3.1

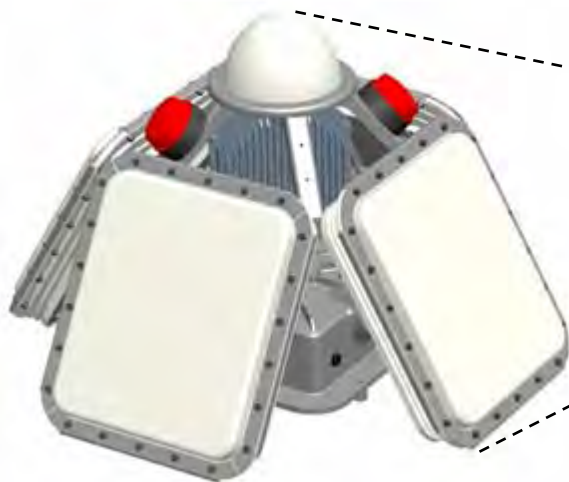

LSTS sensor head

HSMST

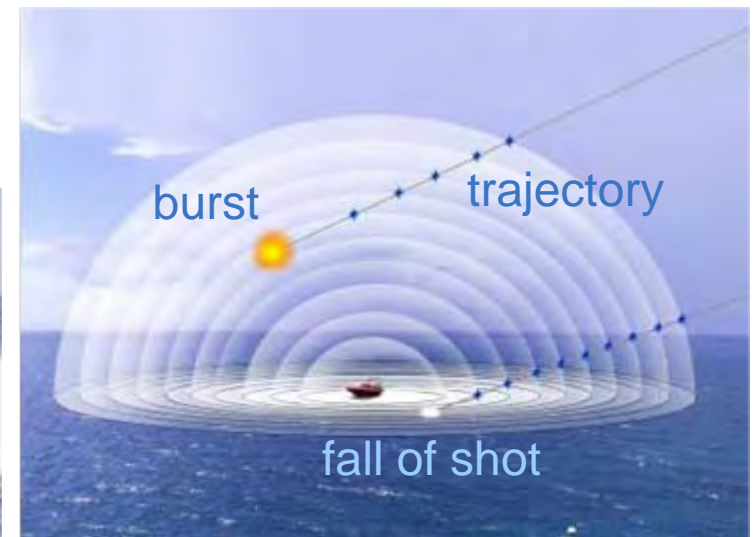

1000ft scoring volume

LSTS

Two views of how LSTS will perform:

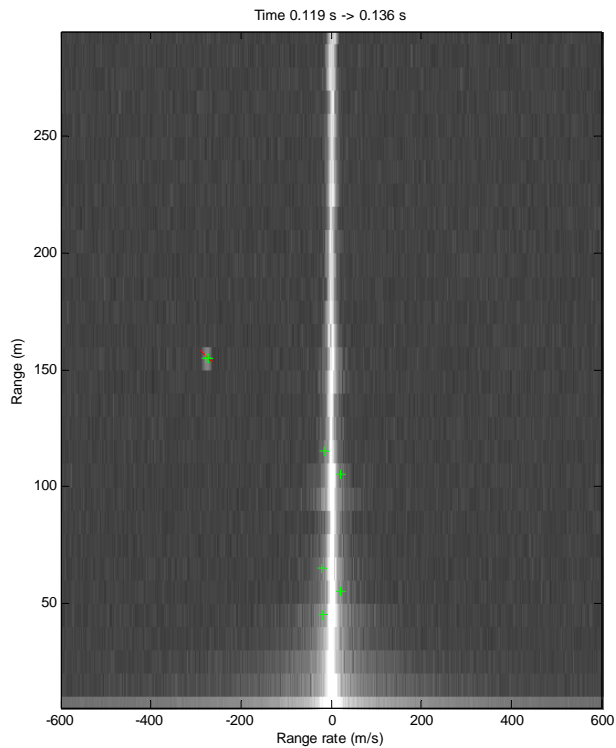

Migration process rejects clutter

Accuracy and throughput

| | |
|-------------------------------|---|
| Range (5" Shell) | 50ft - 1000ft |
| Firing rate | Up to 20 rounds / minute |
| Along-track position accuracy | 13ft / 5% at longer range |
| Target speed | Up to 46kts (at SS3) Up to 100mph (land) |
| Sea state | Up to sea state 3 |
| Trajectory reporting | Within 3 seconds of projectile arrival |

LSTS program

Proof of Concept Phase (system design and single face build)

- Start date: Jan 2010 ✓
- System Requirements Review: April 2010 ✓
- Preliminary Design Review: June 2010 ✓
- Critical Design Review: September 2010 ✓
- Test Readiness review: November 2010
- Proof of Concept System trials with 5" shell: December 2010

Beta-prototype phase (complete system build and test)

- Start date: Jan 2011
- Trials with 50 cal rounds: March 2011
- Sea trials on HSMST: September 2011

Conclusions

Holographic radar is the best you can do in very cluttered environments

- **Target and clutter separation**
 - Continuously gather signals from a large volume of space
 - Fully sampled amplitude and phase data from every target
 - Separate targets of interest from clutter through tracking processes
- **Applications** in collision avoidance, PSR infill, scoring, through-wall, asset protection, border monitoring, other...
- **LSTS system** under development
 - 5" and 50 cal projectiles
 - Land and sea surface targets
 - Proof of Concept sea trials in December 2010

- 1 Short introduction to Cambridge Consultants
- 2 What is holographic radar?
- 3 Applications of holographic radar
- 4 Questions

Contact details:

Cambridge Consultants Ltd

Science Park, Milton Road
Cambridge, CB4 0DW
England

Tel: +44(0)1223 420024
Fax: +44(0)1223 423373

Registered No. 1036298 England

info@CambridgeConsultants.com
www.CambridgeConsultants.com

Cambridge Consultants Inc

101 Main Street
Cambridge MA 02142
USA

Tel: +1 617 532 4700
Fax: +1 617 737 9889

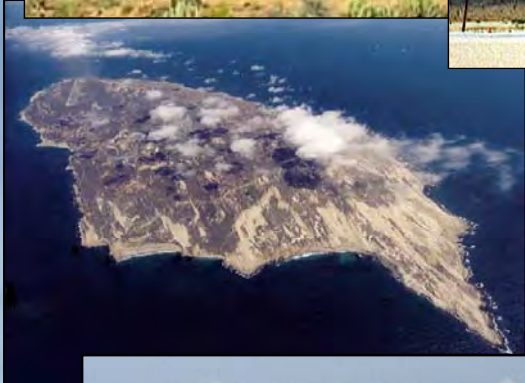

NAV  AIR RANGES
Leaders in providing decision-quality data

Directed Energy T&E at Weapons Division



Approved for
Public Release
NAVAIR Public Affairs Office

06 Aug 2009

Take - Aways

- **NAVAIR operates full-service, highly instrumented ranges in realistic environments**
- **Customers are supported from all of the Services, many Agencies & beyond ...**
- **Risks are managed for a broad array of high hazard testing & training events**
- **Land & Sea Ranges have the experience & unique resources for HEL & HPM T&E**

Approved for
Public Release
NAVAIR Public Affairs Office

NAVAIR Ranges

Weapons Division



Aircraft Division

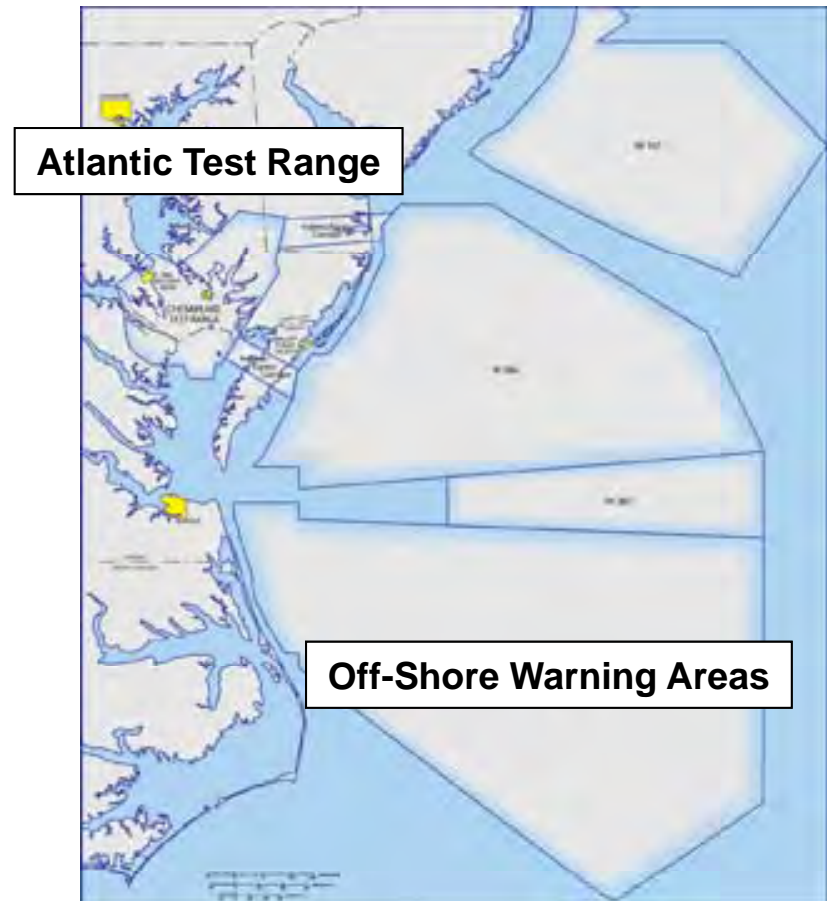

Approved for
Public Release
NAVAIR Public Affairs Office

Weapons Division Mission Support



Surface-to-Surface

Land attack: launch occurs on the Sea Range with impact at SCI, China Lake, or further inland



Satellite and Strategic Missile Launch Support



Surface-to-Air



Air-to-Air



Air-to-Surface



Electronic Warfare



DE Weapons

Approved for
Public Release
NAVAIR Public Affairs Office

We have a diverse customer base ...

Sea Range

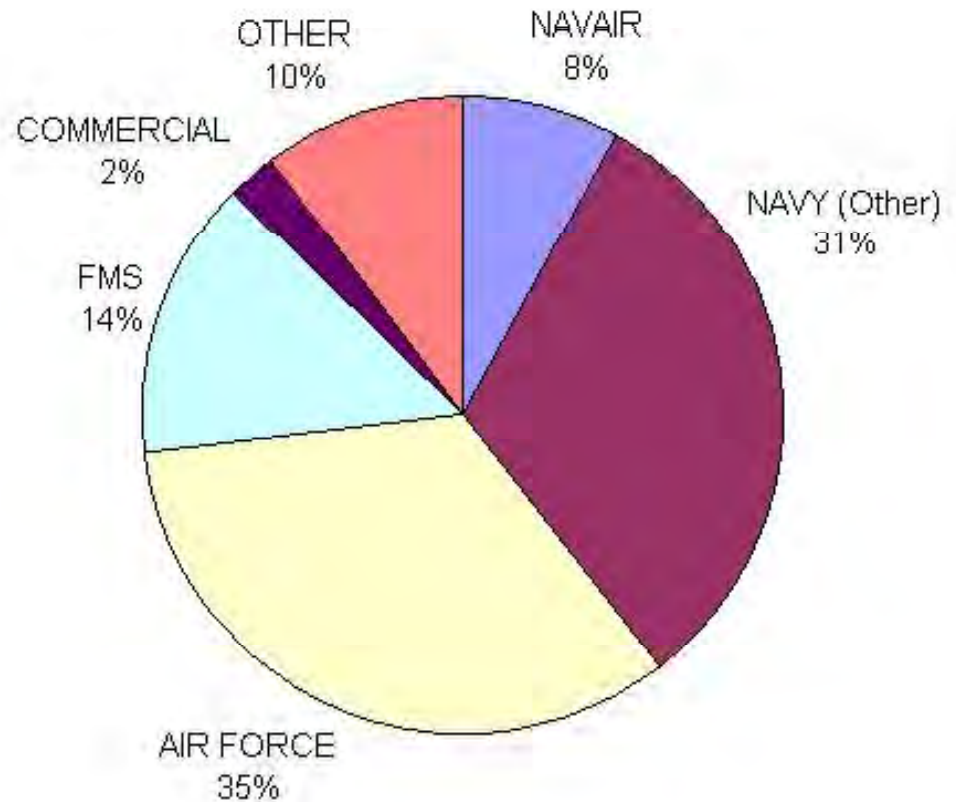

Land Range*

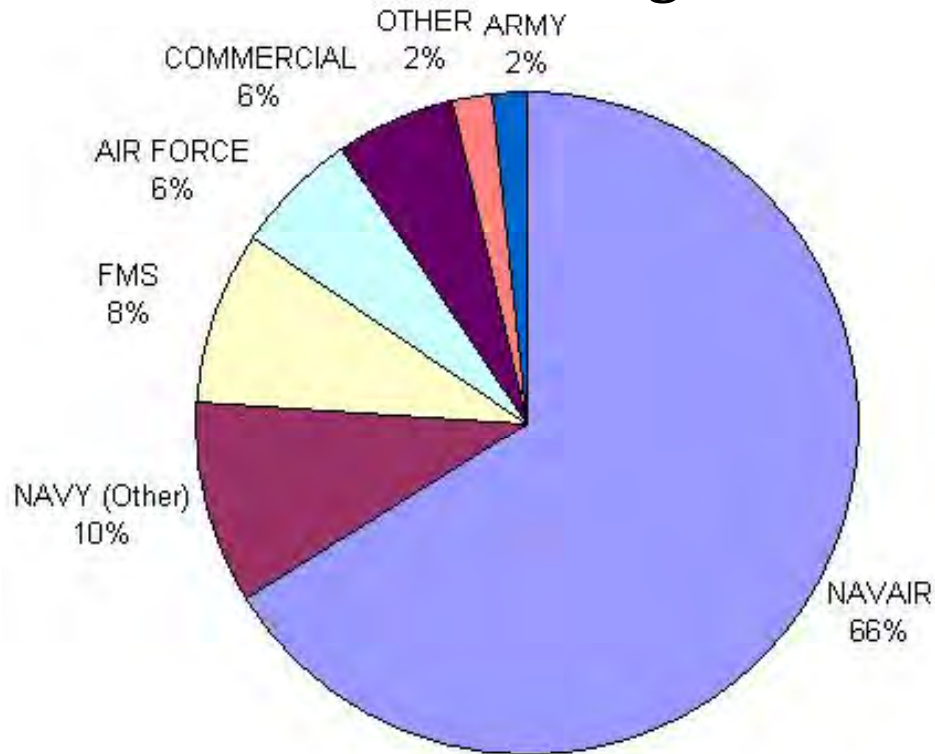

Customer Base (FY07)

* Does not include the Electronic Combat Range

Land Range Complex, China Lake



- Realistic air, land & electronic operational environment
- 1,722 sq mi of land space
- 20,000 sq mi of controlled airspace
- Comprehensive instrumentation set includes TSPI, telemetry, optical, communications, ...
- Air, land, & ARM targets
- Ordnance storage, handling, and assembly facilities
- Range safety, security, and environmental support
- Two major EOD groups for IED RDT&E support and training
- Proximity to Ft. Irwin, 29 Palms, Nellis AFB

Approved for
Public Release
NAVAIR Public Affairs Office

Airspace Control - R2508

**Secured
airspace
in R-2505
and
R-2524
from
ground
level
up**

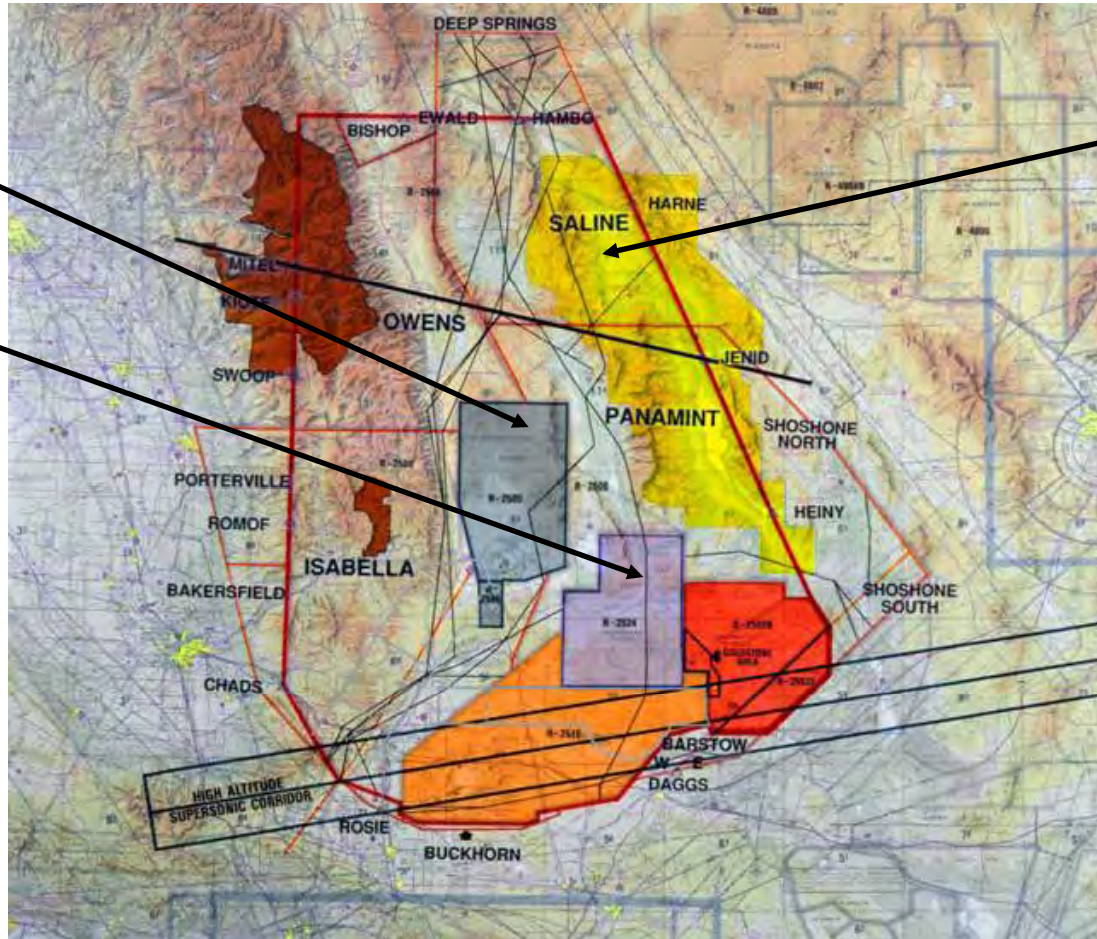

**Restricted
airspace in
R-2508
from 20K ft
and up**

Approved for
Public Release
NAVAIR Public Affairs Office

Land Range Role

- **Weapons & weapons system RDT&E**
- **Have tested most of the U.S. air-to-air & air-to-ground tactical weapon systems & many from our Allies**
- **Heavily involved in air vehicle mission systems testing** (e.g., testing associated with the F-18 weapons sys S/W support lab)
- **Also test ground-launched systems including guns, artillery, & missiles**
- **Accomplish component level testing: rocket motors, fuzes, sensors, & warheads**

DE Testing at Land Range

- **Environmental documentation is in place to support HEL & HPM testing**
- **HPM Experience**
 - RF weapon survivability testing for OSD Live Fire T&E Office
 - Non-lethal HPM
 - Commercial infrastructure RF susceptibility testing
 - Counter IED Interoperability/Compatibility test site
- **HEL Experience**
 - Airborne Laser Lab & high energy laser damage effects testing
 - Demonstrated above-horizon laser engagement capability

Darwin Wash
Explosive-driven HPM T&E &
Combat Mobility & Small Unit
Tactics Training Range



*Land Range
Complex
DE T&E
Venues*



Etcharren Valley Range
High Power Microwave, GPS Anti-
Jamming/Jamming, & Radar
Cross Section T&E

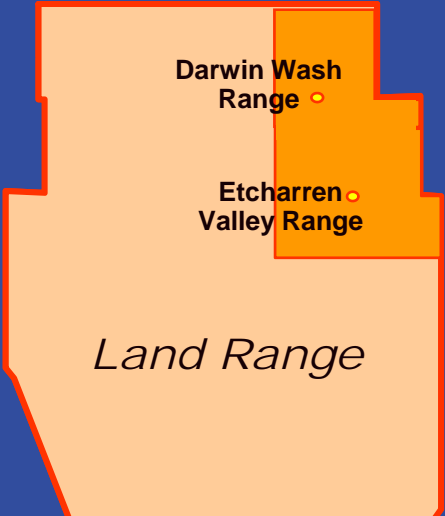

Land Range
Aircraft Systems
Integration, UAS,
Kinetic Weapons,
Laser T&E



Approved for
Public Release
NAVAIR Public Affairs Office

Look Down Facility at over 8200 MSL

North 40



Approved for
Public Release
NAVAIR Public Affairs Office

Target Facilities at 5400 MSL



Sea Range, Point Mugu



- Realistic maritime operational environment
- 36,000 sq mi of controlled sea / airspace
- Over 220,000 sq mi instrumented sea & airspace
 - TSPI, telemetry, communications, geophysics ...
- Operations & range control
- Data processing & display system
- Air, sea, littoral targets
- Ordnance storage, handling, and assembly facilities
- Range safety, security, & environmental support
- Aircraft support
- Adjacent to Port Hueneme & NAVSEA Self Defense Test Ship

Approved for
Public Release
NAVAIR Public Affairs Office



Airspace Control

- **NAVAIR WD is scheduling authority for Sea Range airspace, including Restricted Airspace over SNI**
- **Can close CAE-1177 for continuous air & sea operations between Sea Range and SCORE Range**

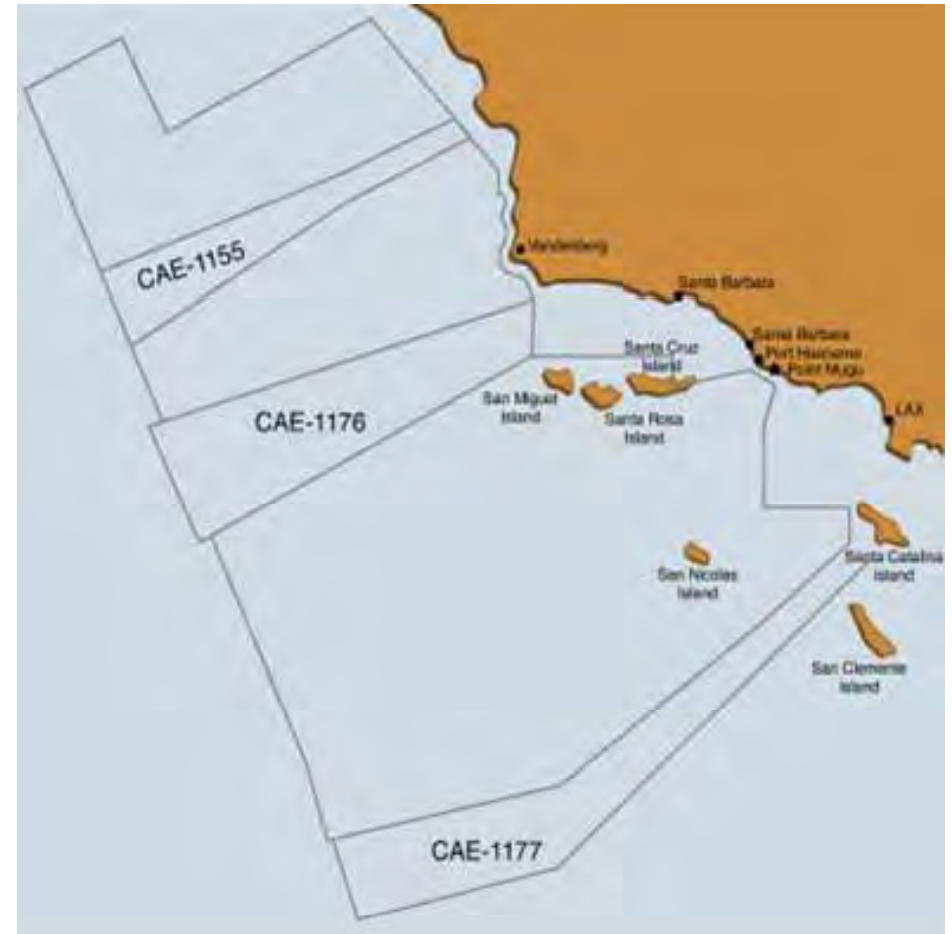

An aerial photograph of the Pacific Northwest coast of the United States, showing the coastline from the Columbia River down to the Gulf of the Farallones. The land is shown in shades of green and brown, while the ocean is dark blue. Several overlapping, semi-transparent colored polygons (yellow, blue, purple, and orange) are overlaid on the map, primarily in the coastal waters, representing operational areas. The text 'Sea Range operational footprint expands to meet program needs' is written in white, italicized font across the upper left portion of the map. The text 'Demonstrated Operational Areas' is written in white, italicized font in the lower left. A white box with black text is in the bottom left, and the NAVAIR RANGES logo is in the bottom right.

Sea Range operational footprint expands to meet program needs

Demonstrated Operational Areas

Approved for
Public Release
NAVAIR Public Affairs Office

NAVAIR RANGES

Approved for
Public Release
NAVAIR Public Affairs Office

San Nicolas Island

"Cornerstone of the Sea Range"



- Under Navy ownership since 1933
- 3.6 miles wide X 9 miles long
- Highest point = 907 ft
- 65 miles from Pt Mugu, 85 miles from L.A.
- 10,000 foot airfield with daily passenger & logistics flights
- High Bandwidth fiber optic comm to Pt Mugu & other DoD ranges



- Secure facility / hanger
- Inert impact area
- Beach landing areas
- Nearing completion of an Environmental Assessment for conducting HEL ops
- SNI can be used as a backstop for laser energy



Sea Range Role

- **Support the T&E of a wide variety of weapons, ships, aircraft & specialized systems for a broad spectrum of military, Homeland Defense, NASA, foreign Allies, & private sector programs**
- **Almost every weapon system in the Navy's inventory has been tested or used at the Sea Range, including those launched from aircraft, surface vessels, & submarines**
- **Coordinated air, surface, & submarine operations including carrier strike group exercises**
- **Long-range, large hazard pattern weapons T&E & experimental vehicle testing**
- **Support ICBM, missile defense, & Polar-orbit satellite launches**
- **Multi-service, multinational T&E & training exercises**

Approved for
Public Release
NAVAIR Public Affairs Office

DE Testing at Sea Range

- **An Environmental Assessment is nearing completion that will permit laser testing/training in general**
 - Will be able to execute a wide variety of events, including surface-to-surface, surface-to-air, air-to-air, & air-to-surface
 - Broad range of wavelengths, & power levels to 1 mega watt, supported
- **Airborne Laser is testing under their own EIS, including target launches from San Nicolas Island**
- **What's unique?**
 - Maritime/Littoral environment
 - Ability to use San Nicolas Island, as a test venue & as a backstop for laser energy to help mitigate safety issues
 - NAVSEA's Self Defense Test Ship (SDTS) can host laser systems & can provide an at-sea, remotely controlled, T&E platform for the conduct of advanced self defense combat systems & weapons evaluation without risk to personnel

SNI Altitude Contours



Laser Target Site

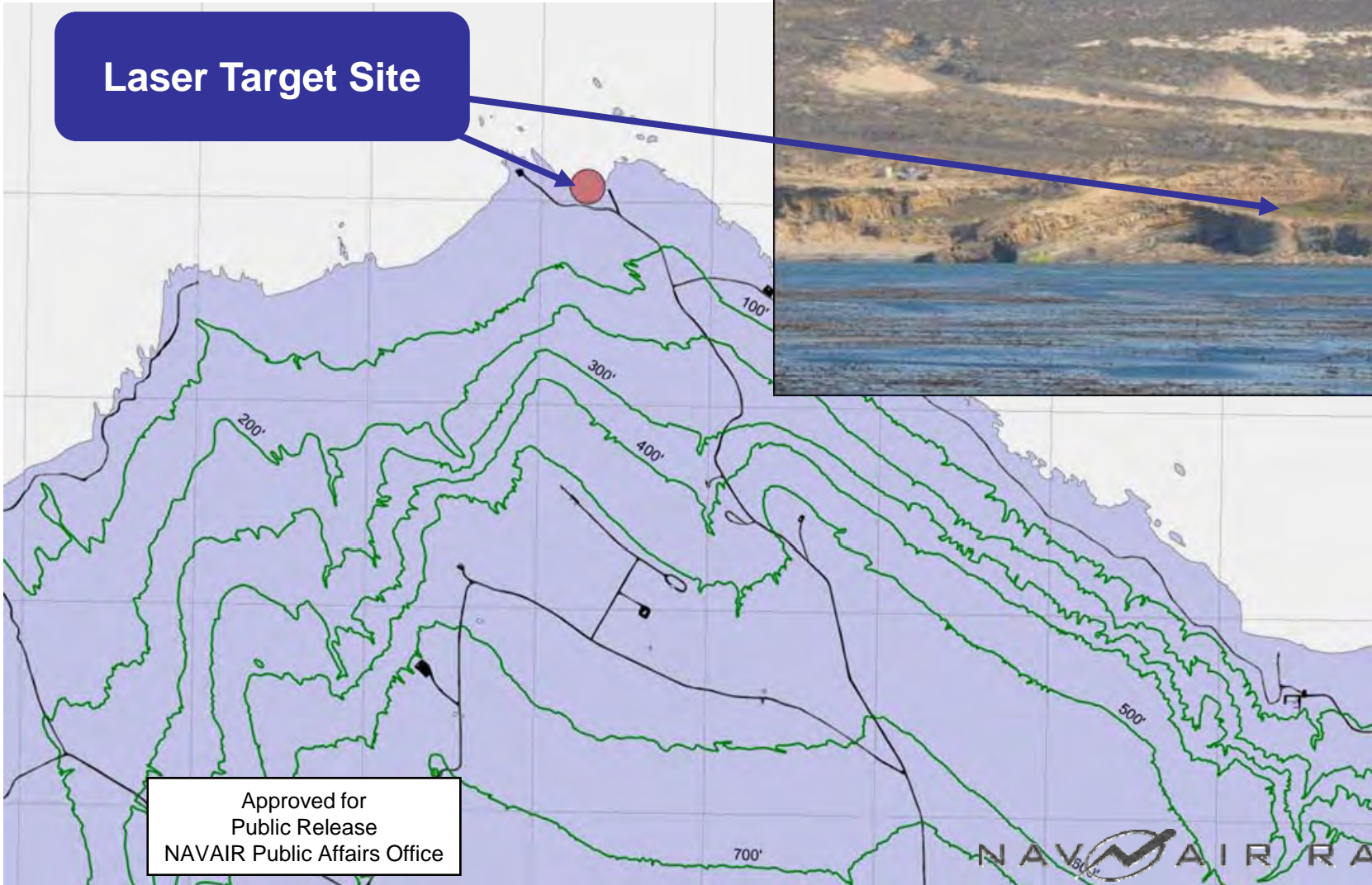

Approved for
Public Release
NAVAIR Public Affairs Office

Self Defense Test Ship



Formerly the
USS PAUL F. FOSTER
(DDH 964)

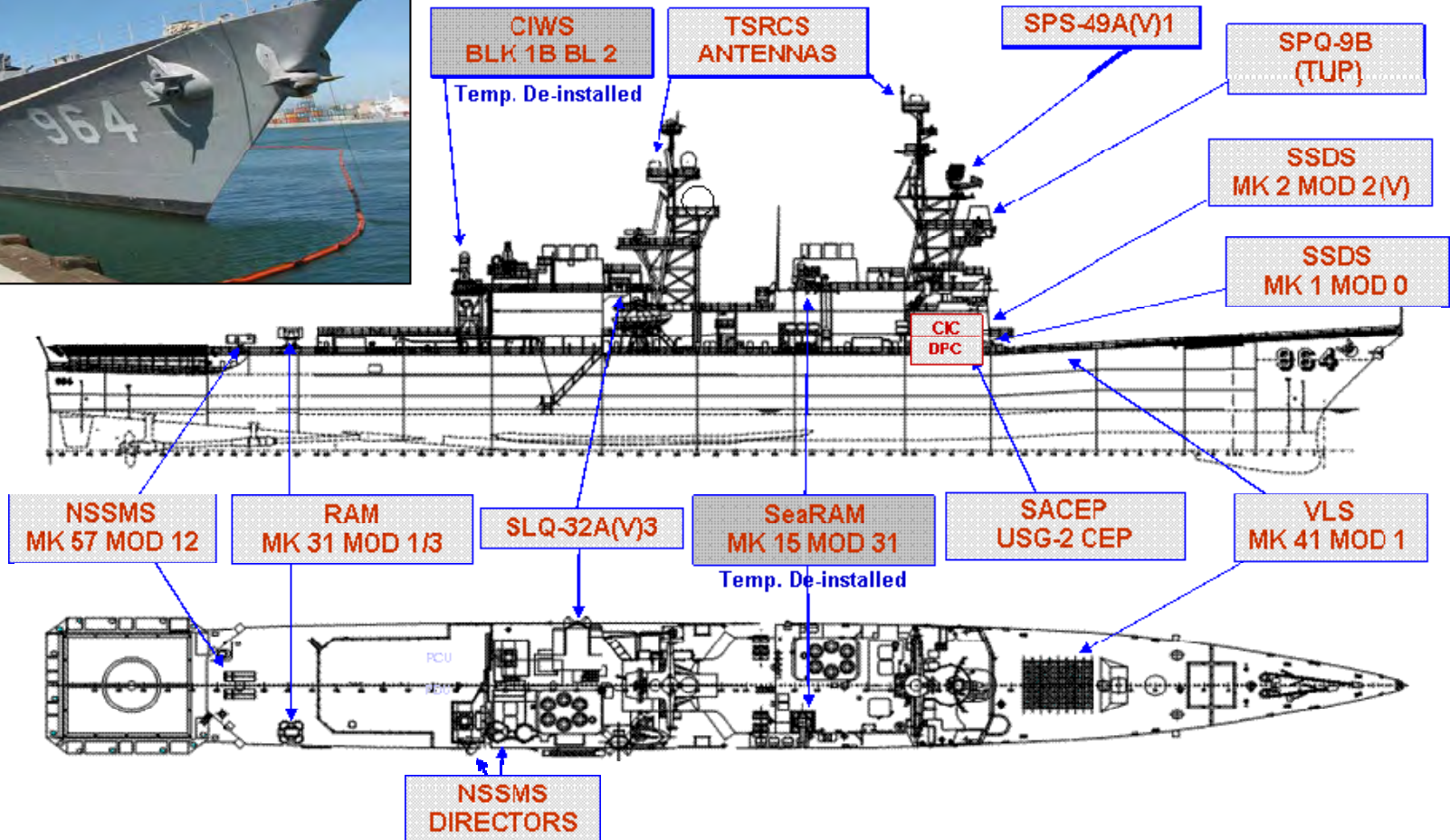



Self Defense Test Ship



- **Ample shipboard real estate**
- **Manned or unmanned operations at-sea and/or in-port operations**
- **Speed: Capable of 33 Knots (typically < 15 Knots to conserve fuel)**
- **Sea State: No Limits**
- **Electric Power**
 - 8,000kW/440V/60Hz
 - 450kW/440V/400Hz
- **Chilled Water**
 - Three Chilled Water Plants x 500 GPM
- **Ordnance handling & storage, Secure operations**
- **At-Sea passenger embarkation/disembarkation**
- **Berthing/messing/laundry, 100 ship-riders (34 crew)**



Environmental Stewardship



- 1.1 million acres
- 4,500 acres of coastline and wetlands
- 650 species of plants
- 340 species of animals
- 40 species of marine mammals
- Coso Rock Art National Historic Landmark
- San Nicolas Island historic sites
- Point Mugu lagoon and estuary



Approved for
Public Release
NAVAIR Public Affairs Office

Take - Aways

- **NAVAIR operates full-service, highly instrumented ranges in realistic environments**
- **Customers are supported from all of the Services, many Agencies & beyond ...**
- **Risks are managed for a broad array of high hazard testing & training events**
- **Land & Sea Ranges have the experience & unique resources for HEL & HPM T&E**



Common Range Integrated Instrumentation System (CRIIS)

National Defense Industrial Association
*48th Annual Targets, UAVs & Range Operations
Symposium & Exhibition*



CRIIS Program Overview **October 2010**

Mr. Alan Massing, CRIIS Program
Email: alan.massing@eglin.af.mil

Distribution Statement A: Approved for public release. Distribution unlimited.



Outline



- **Background**
- **Strategy**
- **Achievements**
- **Summary**



Background

- **Primary Function: Test Data Collection**
 - Land, Sea, and Airborne Platforms (Including F-22A and F-35)
 - Requires Equipment More Accurate than System Under Test (SUT)
- **CRIIS Provides:**
 - High Accuracy Time, Space, Position Information (TSPI) of SUT
 - Secure Datalink(s) Transmit Real Time TSPI and Aircraft Data
 - Avionics
 - Weapons Targeting and Status Data
 - Aircraft Status
- **CRIIS Maximizes Interoperability Among T&E Ranges**
- **Potential Use on Training Ranges**
- **CRIIS Development Funded by Central Test & Evaluation Investment Program**
 - CRIIS Production and Sustainment Funded by Individual Services

***CRIIS is A Test Range Replacement of the Existing GPS Based ARDS
With Advanced Datalink, TSPI, Security Features***

CRIS Overview

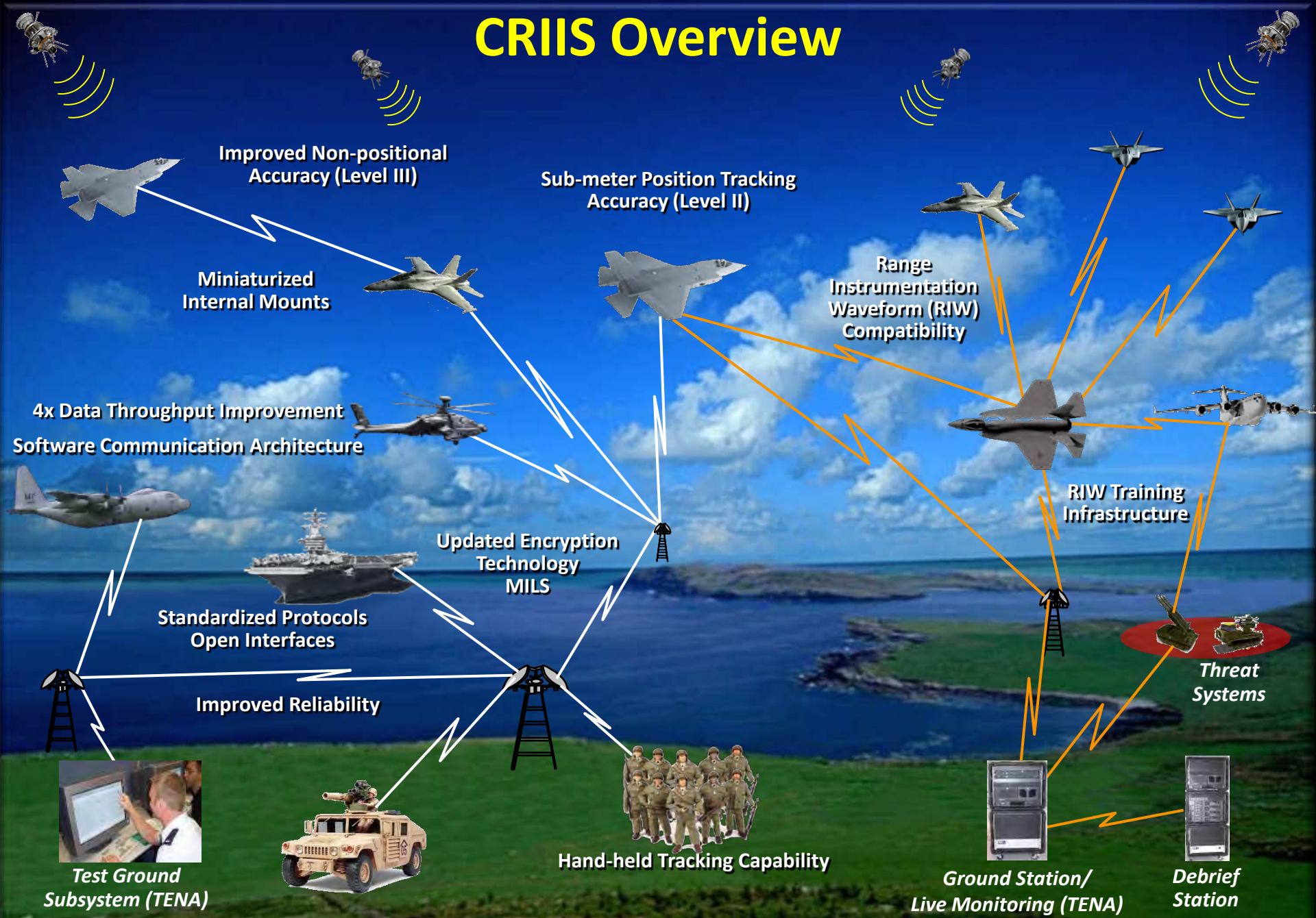

Test Package Directive (TPD) Issued 7 Jul 10



Functional Configurations

INCREMENT 1

Configurations 1, 2, 3



Level IA TSPI
Short Range DL

*Config. 1
Dismounted Soldier*

Level IB TSPI
Mid Range DL
Encryption



*Config. 2
Low Dynamic Vehicles*



*Config. 3
Ship-to-Shore*

Level IB TSPI
Extended Range DL

INCREMENT 2

Configurations 4, 5, 6

Level II TSPI
High Throughput DL
Encryption



Config. 4 Pod



*Config. 5 Moderate Accuracy
Multi-Package Internal Mount*



*Config. 6 Moderate Accuracy
Single Package Internal Mount*

INCREMENT 3

Configurations 7, 8



*Config. 7 High Accuracy
Multiple-Package Internal Mount*

Level III TSPI
High Throughput DL
Encryption



*Config. 8 High Accuracy
Single Package Internal Mount*

Capability to Run RIW Ground Subsystem

| | | | | | | | | | |
|-------------------|-----|-----|----|-----|----|----|----|----|----|
| Configuration | 1 | 2 | 3 | 4 | 5 | 6 | 7 | 8 | GS |
| Most Probable Qty | 300 | 460 | 65 | 102 | 94 | 32 | 28 | 11 | 8 |



Major Range and Test Facility Base (MRTFB) and Initial Beddown Locations

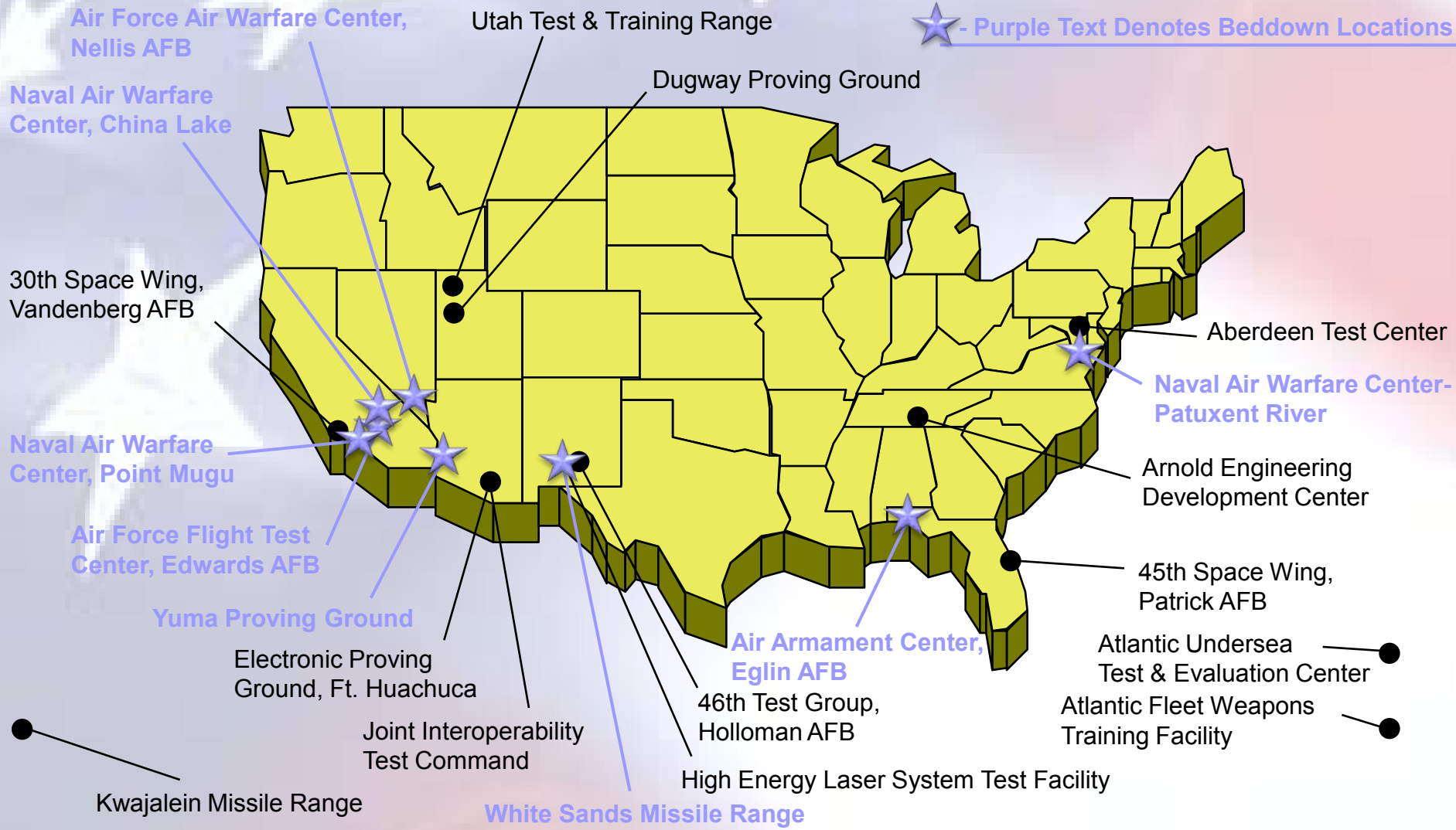



Key Performance Parameters



| Configuration | Requirement |
|---------------------|--|
| Dismounted Soldier | <ul style="list-style-type: none"> • Man-carriable • Less than or equal to 2.5 lbs |
| Low Dynamic Vehicle | <ul style="list-style-type: none"> • Less than or equal to 1 m Horizontal RMS TSPI accuracy on ground vehicles |
| Ship-to-Shore | <ul style="list-style-type: none"> • 250 nmi datalink range |
| Moderate Accuracy | <ul style="list-style-type: none"> • 0.5 meter horizontal RMS accuracy on fighter aircraft • Top Secret (TS) encryption capability • Datalink throughput greater than or equal to 400 kbps per frequency within ARDS occupied bandwidth |
| Pod | <ul style="list-style-type: none"> • Mass properties consistent with ARDS, within constraints |
| 1-box IM | <ul style="list-style-type: none"> • Fits on F-18 6L Bay Door |
| 1 or 2-box IM | <ul style="list-style-type: none"> • Fits internally in F-35 and F-22 |
| High Accuracy | <ul style="list-style-type: none"> • 0.5 -meter horizontal RMS accuracy on fighter aircraft with non-positional accuracies better than the Level II requirements |
| 1-box IM | <ul style="list-style-type: none"> • Fits on F-18 6L Bay Door |
| 1 or 2-box IM | <ul style="list-style-type: none"> • Fits internally in F-35 and F-22 |
| Net Ready | <ul style="list-style-type: none"> • The capability, system, and/or service must support Net-Centric military operations. The capability, system and/or service must be able to enter and be managed in the network, and exchange data in a secure manner to enhance mission effectiveness. The capability, system, and/or service must continuously provide survivable, interoperable, secure and operationally effective information exchanges to enable a Net-Centric military capability. |



Acquisition Strategy

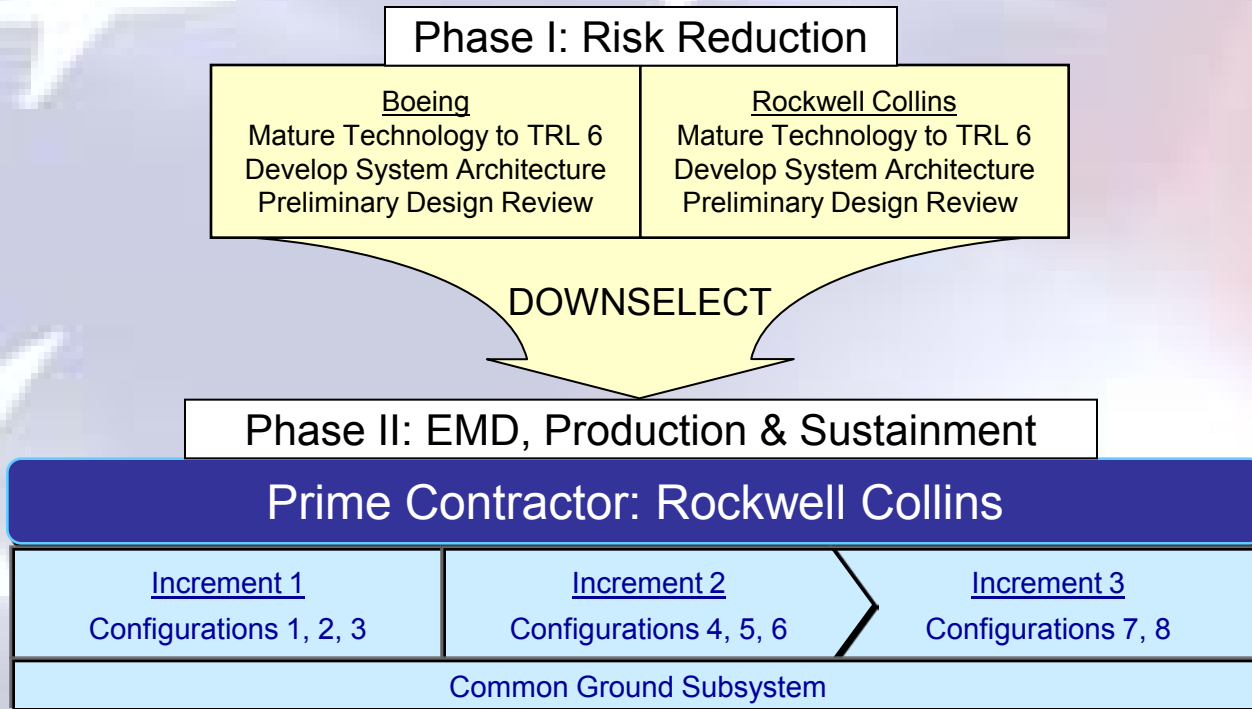

- Risk Reduction and EMD Funded by CTEIP
- Production and Sustainment Funded by Services
- CRIIS Program Executes All Phases



Phase I Accomplishments



- ✓ Matured and Demonstrated TSPI Technology
- ✓ Reduced Risk, Demonstrated High Throughput Datalink Capabilities
- ✓ Developed System Architecture and Preliminary Design
- ✓ Developed Life Cycle Support Concept
- ✓ Updated Test Capabilities Requirement Document to Match Demonstrated Capabilities and Synthesized System Performance Specification
- ✓ Completed Phase II Source Selection and Awarded Phase II EMD Contract
- ✓ Obtained Affordable Fixed Prices for Prototypes, Production, and Sustainment



Rockwell Risk Reduction/Technology Maturity PDR Complete 26 Feb 10



TSPI

- Global Differential Corrections
- RTK Algorithms for Position Accuracy
- Rockwell 24 Channel SAASM Receiver
- UTC Kalman Filter for Non-Positional TSPI
- Honeywell's HG1700 and HG9900 IMU

Datalink

- Modified Rockwell Quint Network Technology (QNT) Radio
 - Time Division Multiple Access (TDMA)
 - Modulation: Modified BEAM

Security

- Rockwell JANUS Encryption Chip

Demonstration

- Independent TSPI and Datalink Testing

TSPI Demo

| Flight | 29 Oct, Flight | Rqmt (m) |
|-----------------------|------------------|----------|
| Maneuver Type | 360 ° 5g turn | |
| RT Horiz Pos Acc (m) | 0.1 | 0.3 |
| RT Vert Pos Acc | 0.1 | 0.3 |
| PM Horiz Pos Accuracy | 0.05 | 0.1 |
| PM Vert Pos Acc | 0.1 | 0.1 |

Datalink Demo:

- 90% Message Reliability
- 130 nmi Range

Security:

- JANUS Type 1 Encrypt
- Viable MILS Approach

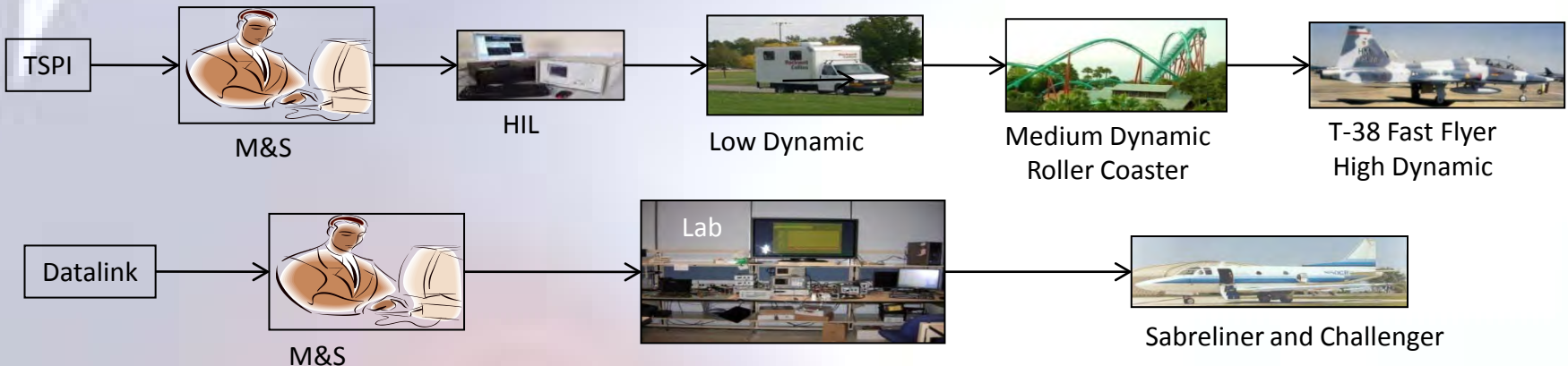



CRIIS TRA Assessment (Post Risk Reduction)

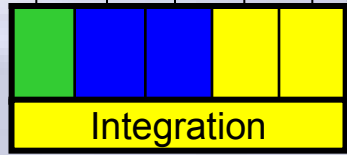
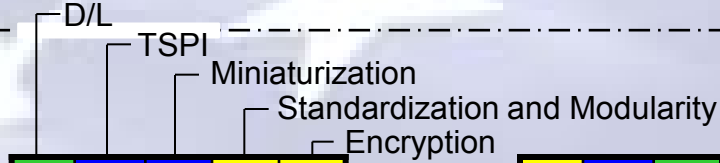

Config 1

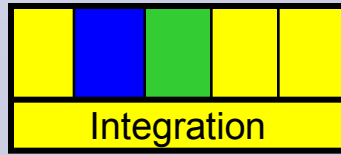

Config 2

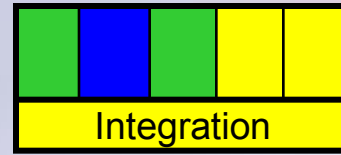

Config 3

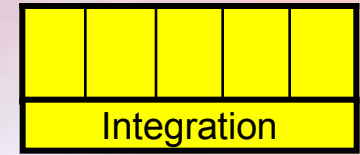

Config 4

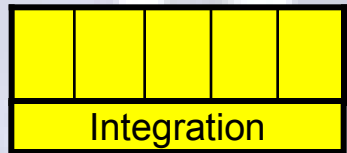

Config 5

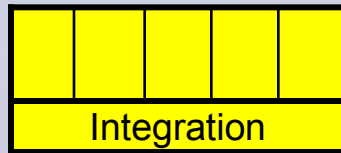

Config 6

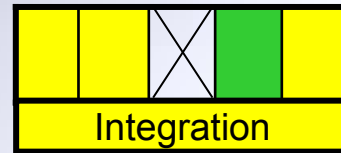

Ground Subsystem

Increment 1 & 2 EMD

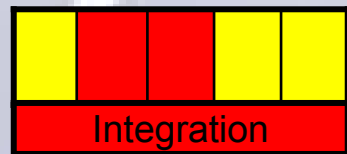

Config 7

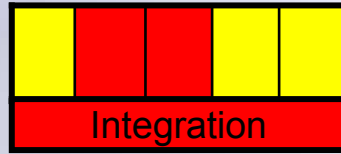

Config 8

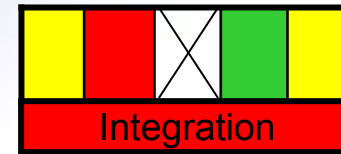

Inc 3 Ground Subsystem

**Increment 3
Maturation**

Blue TRL = 9 Program Completed

Yellow TRL = 6 - 7 Appropriate EMD-Level Integration

Green TRL = 8 Demonstrated on Similar System

Red TRL = 1 - 5 Requires Risk Reduction Prior to EMD



CRIIS Phase II Project Schedule



FY: 2007 2008 2009 2010 2011 2012 2013 2014 2015 2016 2017 2018 2019 2020 2021 2022

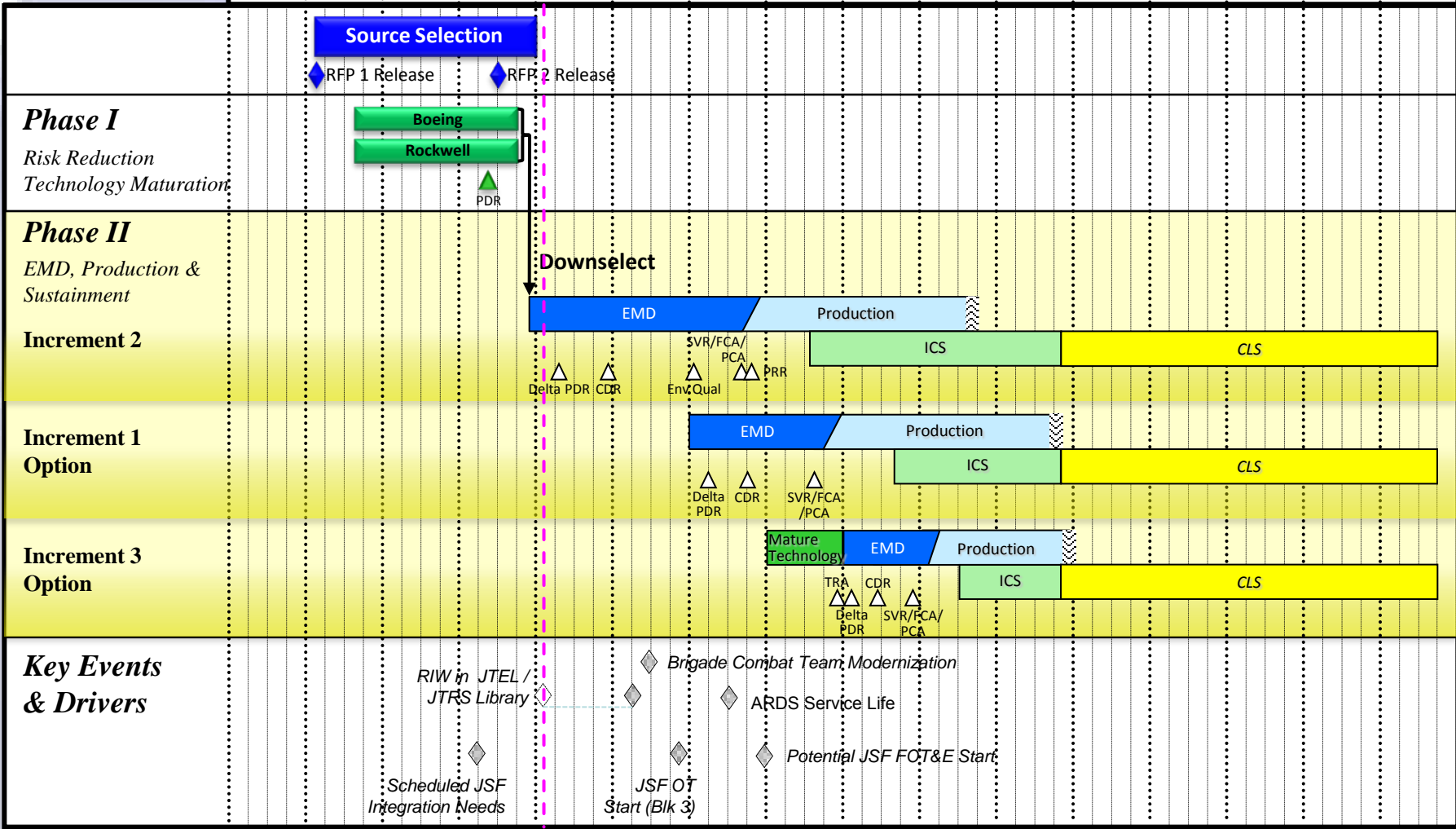



Common Test and Training Instrumentation Still in Play



■ Challenges

- Bridging the Community Gap – Great Strides Achieved
- Bridging the Technical Gap – We Have the ‘Know-How’
 - Common Set of Airborne Equipment is Feasible
 - Closure of Ground Infrastructure Gaps are Feasible
- Quantifying the Efficiencies – We Have to Prove its Worth

■ Time Frame

- Leverage CRIIS Development in the Future
 - Preserve Baseline CRIIS Schedule
 - Incorporate Training when Appropriate

The Window is Open



Summary

- **CRIIS is Funded and Executing Phase II**
- **CRIIS Technologies are Leading Edge**
 - **TSPI Pushing GPS Boundaries**
 - **Secure High Throughput, High Spectrally Efficient Datalink**
- **CRIIS is a Future Enabler**
 - **Conducive to Live, Virtual, Constructive Applications**
 - **Potential Operational Use**
- **CRIIS is Taking First Steps in Bringing Test and Training Together**



TARGET MANAGEMENT INITIATIVE

OSD, Director of Operational Test and Evaluation (DOT&E) TMI Status Update

James Maybury - DOT&E TMI Support

*“Moving Forward:
Next Gen Targets”*

48th Annual NDIA
Targets, UAVs &
Range Operations Symposium
New Orleans, LA
October 19-21, 2010



Outline

- Org Chart within DOT&E
- Supporting DOT&E's Mission
- The Target Management Initiative
- Submitting Proposals
- FY10 Recap
- FY11 Program
- FY12 Focus Areas

DOT&E's Target Resources Staff:

- Dennis Mischel: TMI Program Manager / Targets Lead
- Pat Burris: 5th Gen. FSAT Project Manager / Aerial Targets
- James Maybury: Target Control Systems / C² Interfaces
- Josh Messner: TMI Execution Manager / Mobile Ground Targets



Org Chart within DOT&E

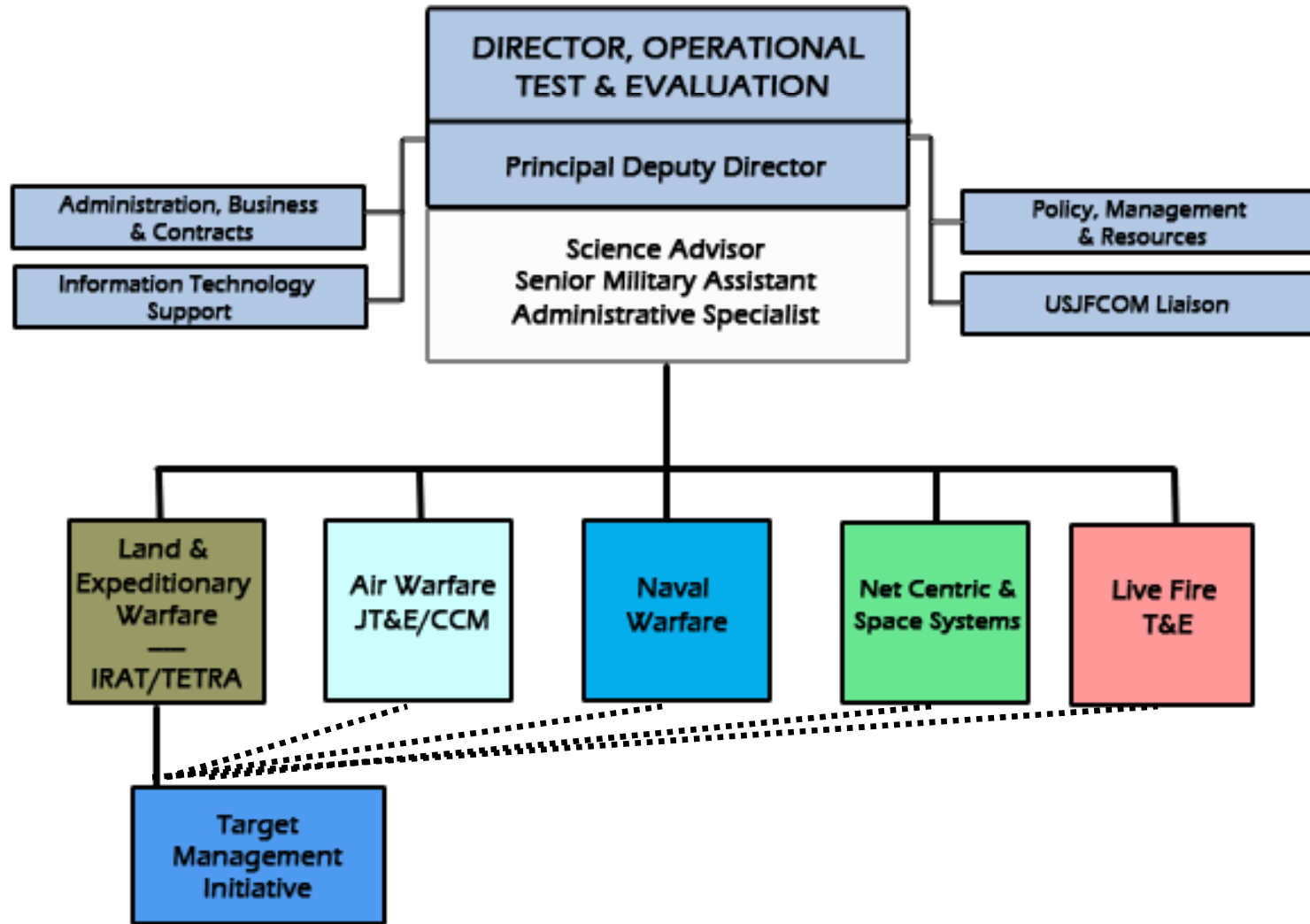



Supporting DOT&E's Mission

<http://www.dote.osd.mil/about.html>

“The Director, Operational Test & Evaluation (DOT&E) ... making **budgetary and financial recommendations to the SecDef regarding OT&E**; and **oversight to ensure OT&E for major DoD acquisition programs is adequate to confirm operational effectiveness and suitability of the defense system in combat use.**”

Targets Staff supports DOT&E by:

- Annual monitoring of Services targets budgets for potential impacts to OT&E
- Making investments that:
 - Help to ensure Targets are Threat Representative and Cost Effective
 - Help promote interoperability between Services and Ranges
 - Help to ensure Target Systems (C², Scoring, Launch) are adequate to support Testing



The Target Management Initiative

Objective

- Improve threat realism, increase interoperability, and reduce test costs.

Projects

- TMI projects include *studies, standards developments, target system prototypes, and proof of concept demonstrations.*

Selection

- Supported by Target Investment Working Group (TIWG)
- Criteria Include: Importance to Operational Testing, Improvement to the Threat Realism, Benefit vs. Cost, Multi-Program Applicability, Potential for Successful Execution
- DOT&E Deputies are briefed on prioritized project list

Execution

- Projects are typically 1-3 years in length
- \$50K Studies to \$3M Prototypes
- Project Execution is Managed by the Services
- Minimum deliverables include: Monthly reporting, Bi-annual briefings, Final Report

Prime consideration is given to projects that address Operational Testing (OT) requirements and DOT&E resource concerns.



Notional Upcoming Dates

- **Week of 1 Nov** – Release Call for Proposals & FY12 Focus Areas
 - Initial proposal format will be a 1-2 page white paper
- **Week of 6 Dec** – White paper proposals due
- **Week of 20 Dec** – TMI response to white papers released and detailed proposals requested.
- **Week of 24 Jan** – Detailed proposals due.
- **Week of 1 Feb** – TMI response to proposal authors released.
- **Late February** – New Start Reviews



Project Selection Timeline

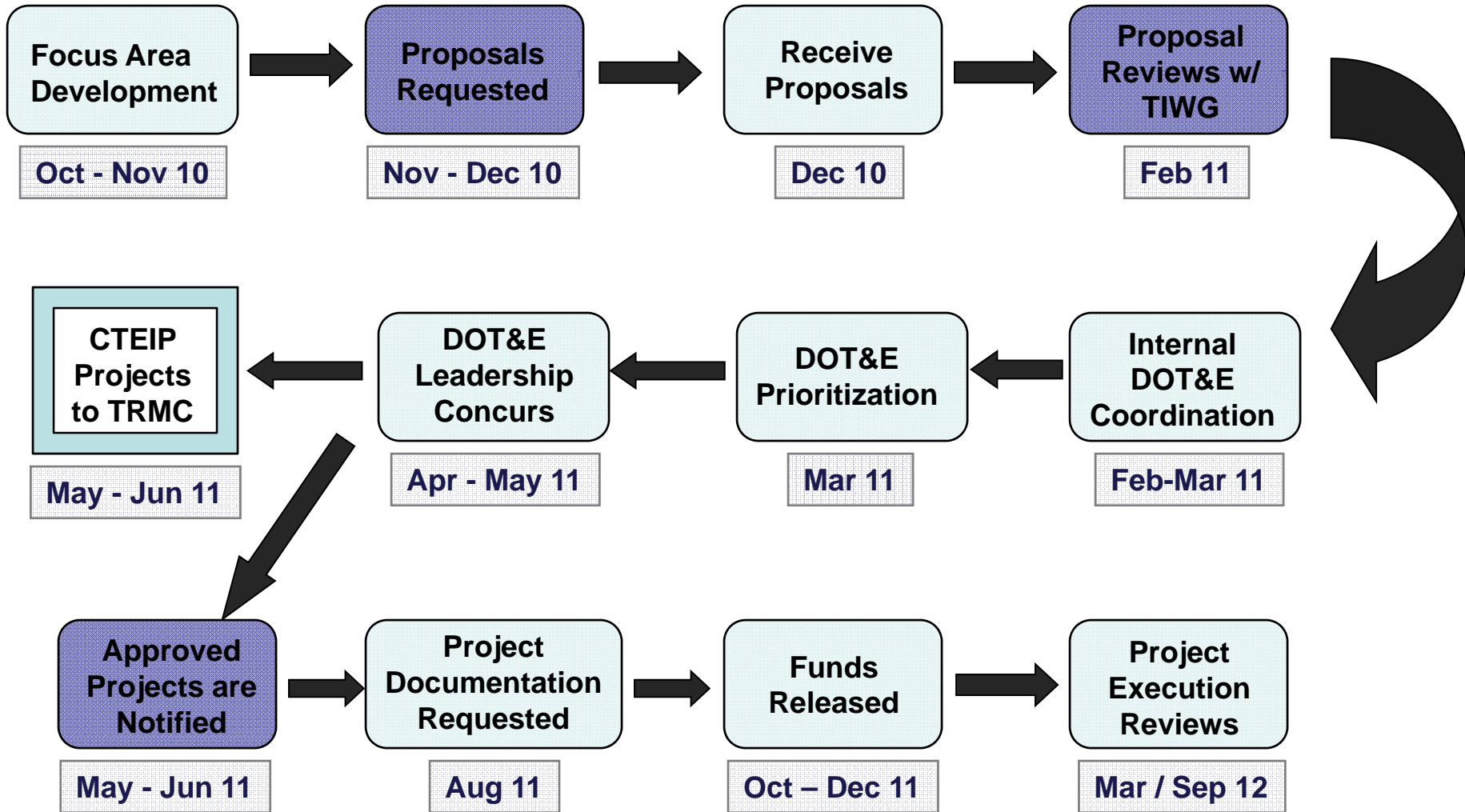



Submitting Proposals

- Project proposals may be submitted via the TMI website: www.tmi.osd.mil
- We recommend industry and academia work with Service partners when submitting proposals.
- Please follow-up submittals with a call to 703-681-5502

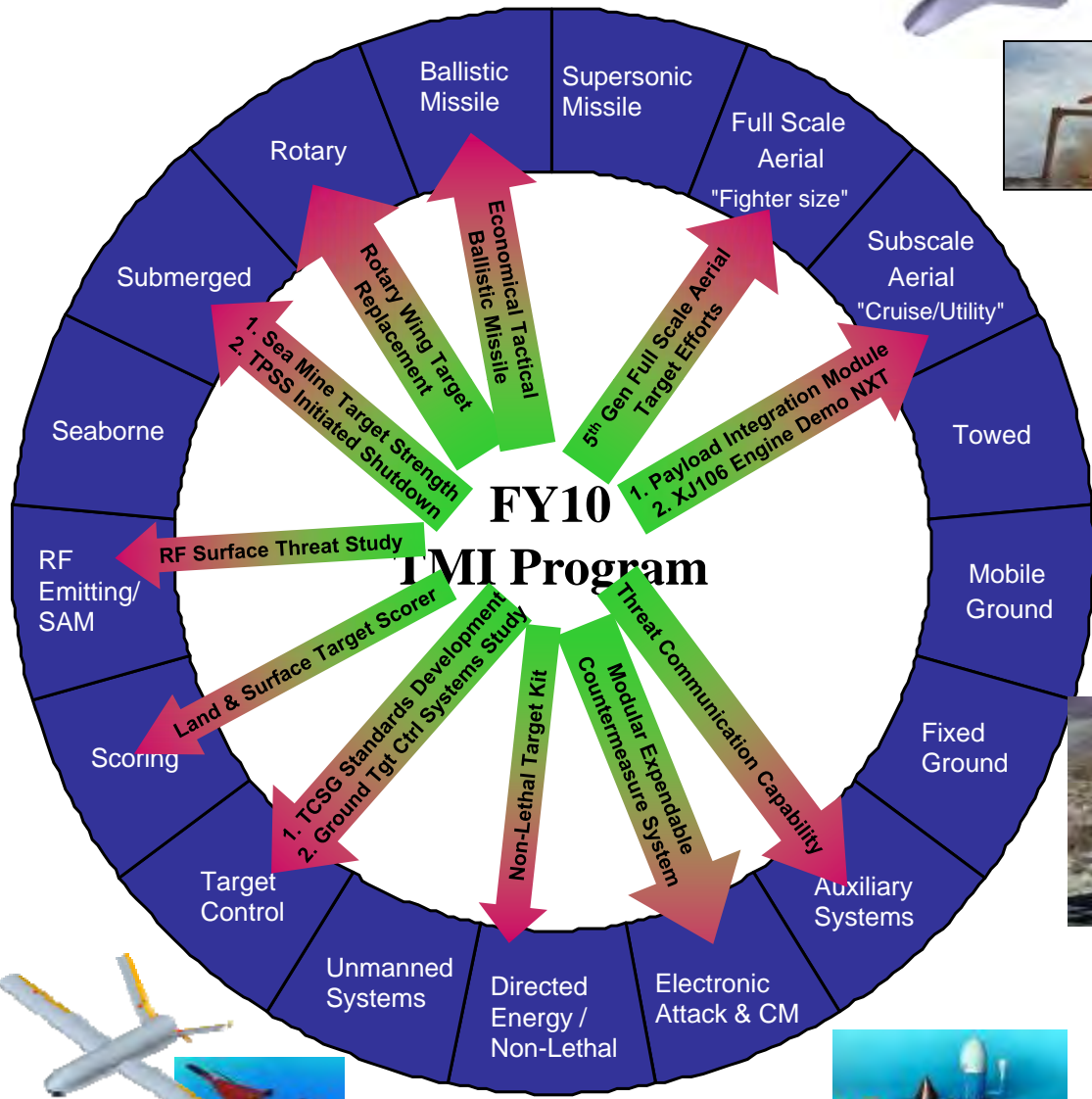
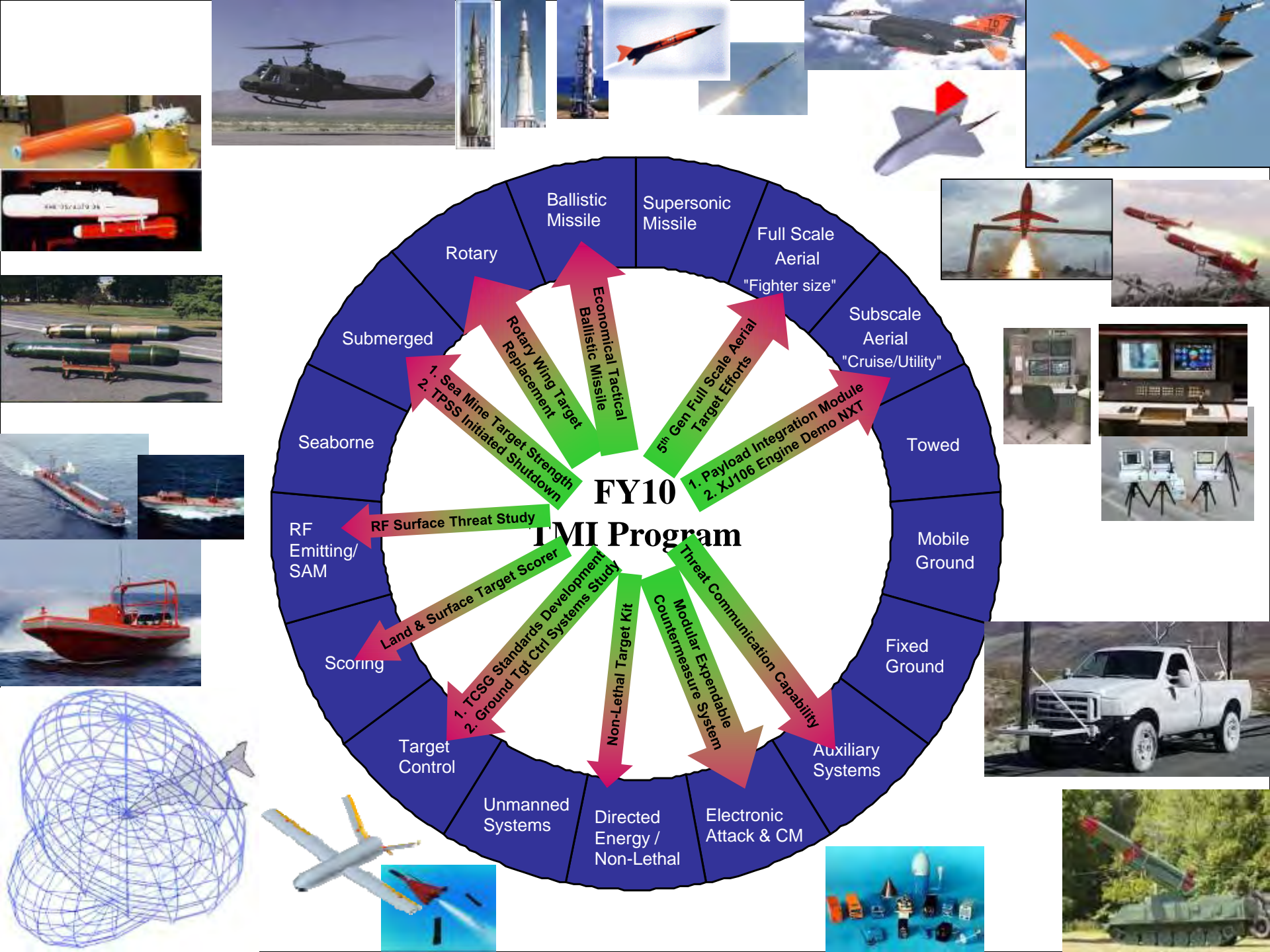



FY11 TMI Program

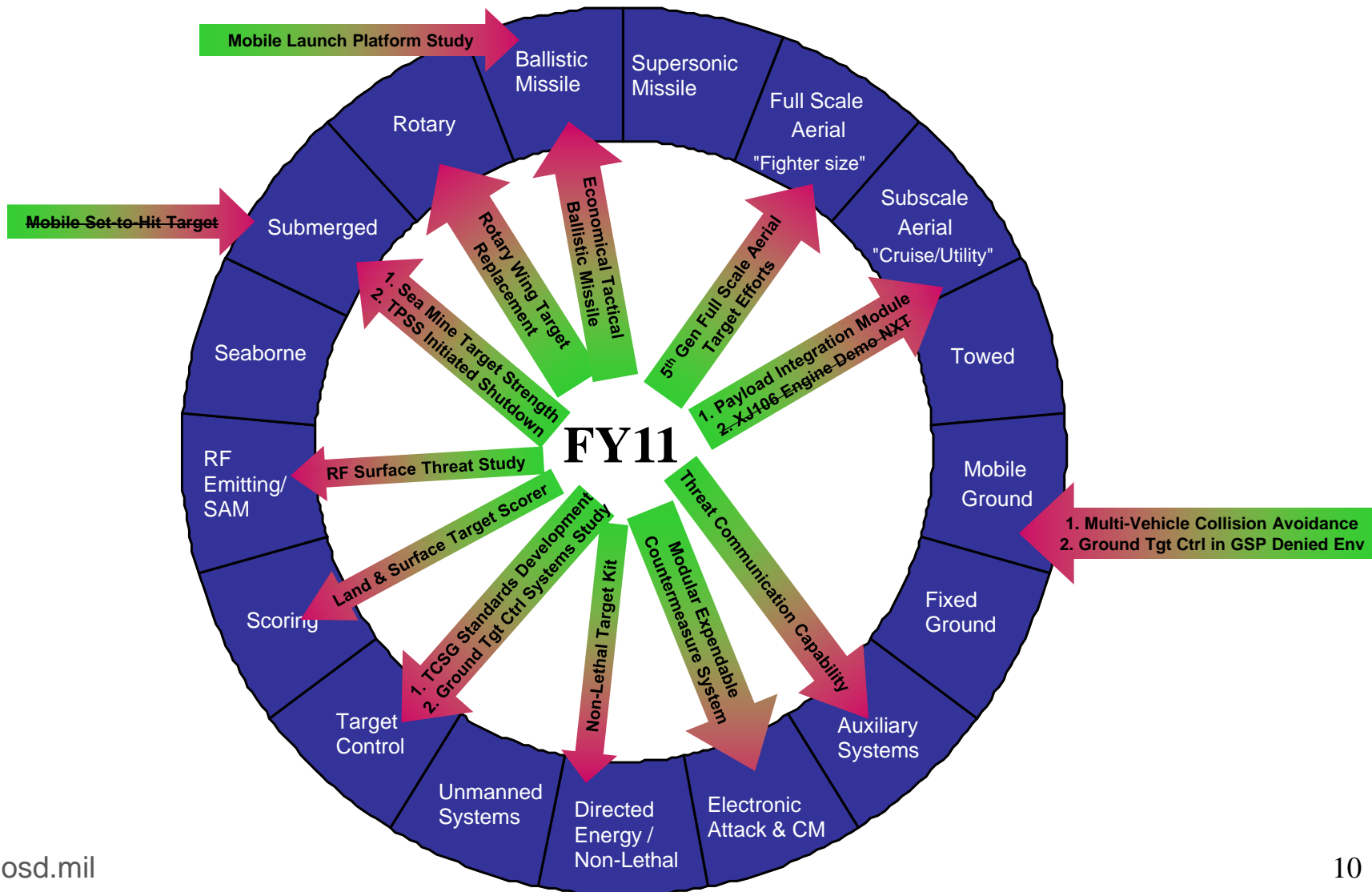



FY12 TMI Focus Areas

- In the process of developing
- For reference, the FY11-FY08 focus areas are on the TMI website
- Additional references:
 - The DoD Strategic Plan for T&E Resources (TRMC)
 - Service target resource needs (citing any references or documents will strengthen a proposal)
 - The DOT&E Annual Report “T&E Resources Appendix”



TARGET MANAGEMENT INITIATIVE

Thanks!

www.tmi.osd.mil



U.S. Navy Aerial Target Systems

Presented to 48th Annual NDIA Symposium

20 October 2010

New Orleans, LA

Captain Dan McNamara
Program Manager
PMA-208, Navy Aerial Target & Decoy Systems

Mr. Tim Barnes
Principal Deputy Program Manager
PMA-208A, Navy Aerial Target & Decoy Systems



Outline



- Product Line
- Operating Sites
- Supersonic Targets
- Subsonic Targets
- Full Scale Targets
- Target Control System
- Foreign Military Sales
- Challenges





PMA-208 Target Product Lines



Supersonic



GQM-163A



AQM-37C



ZGQM-173A Multi-Stage Supersonic Target (MSST) (development)

Subsonic



BQM-34S



BQM-74E



Sub-Sonic Aerial Target (SSAT) (development)

Full Scale



QF-4



QF-16

Mobile Land Target (MLT) (New Program)



Other/Support



Tactical Air Launched Decoys



Common Equipment / Augmentation



Threat Simulation



Banners



System for Naval Target Control (SNTC)



Operating Sites

✦ GQM-163 capability at the following ranges:

- Stood up Pacific Missile Range Facility Hawaii in 2010
- Plan to stand up Levant Island France (via FMS case) in 2011



Air Launch:

- BQM-34
- AQM-37
- BQM-74



Ground Launch:

- BQM-34
- BQM-74
- SSAT (threshold)
- GQM-163



Ship Launch:

- BQM-34
- BQM-74
- SSAT (threshold)



SSAT (objective)

ZGQM-173 (threshold)



GQM-163A Supersonic Sea Skimming Target



- Prime Contractor: Orbital Sciences Corporation
- Operations to date: 6 (Targets Expended: 10)
 - 6 October 2005 (1)
 - 12 and 13 June 2007 (2)
 - 12 December 2007 (2 as stream raid)
 - 3 December 2008 (1)
 - 18 December 2008 (2 as stream raid)
 - 9 Dec 2009 (2 as stream raid)
- Demonstrations to date: 2 (Targets Expended: 2)
 - 8 June 2010 (1 as Engine-Power-Off-Demo)
 - 9 July 2010 (1 as High Diver)



*** Preparing for Orbital Front End Subsystem (OFES) DEMO in November 2010

- First Pacific Missile Range Facility (PMRF) launch capability May 2010
- First launch out of U.S., planned at Mediterranean range in FY 11

GQM-163A meets most Supersonic Sea Skimming test requirements



GQM-163A

High Diver Demonstration



Successfully Completed High Diver (HD) Demonstration on 08 July 2010
on the Point Mugu Sea Test Range

- Threat Representative ASCM
- Cruise Altitude of 35,000 feet
- Cruise Speed of Mach 3.3
- 40 Degree Unpowered Dive
- Range of 110 nautical miles
- End-Point Accuracy of 6 feet
- Developing one threat representative trajectory for each launch site

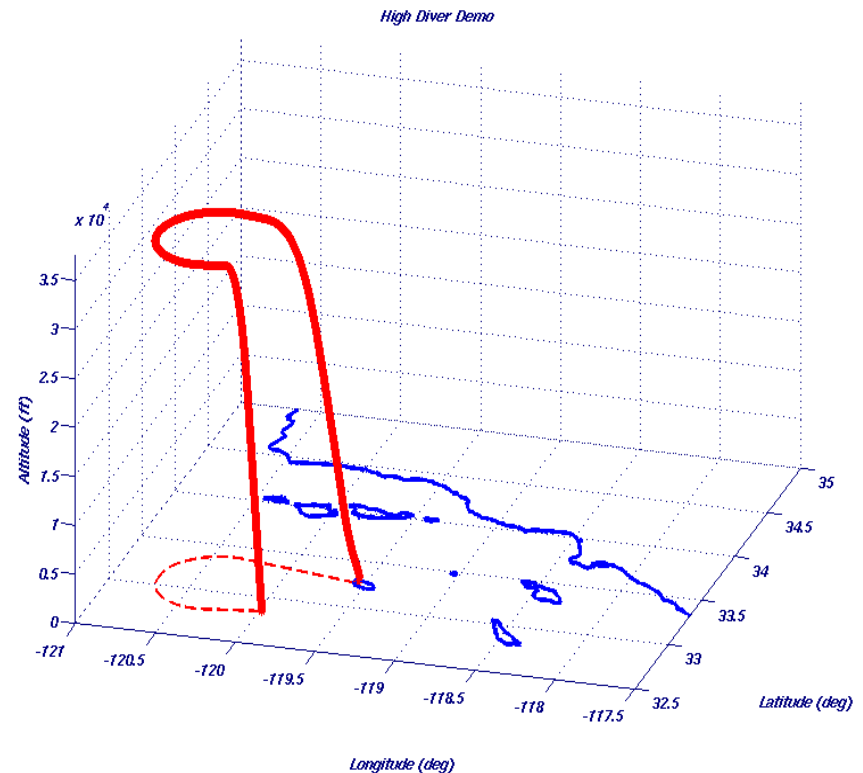



AQM-37



- **Medium to high altitude supersonic cruise with dive capability**
 - Mach 2.0 – 4.0
 - Range 100 mi
 - Altitude 1000 ft – 100 Kft
 - Demonstrated TBM profiles (300 Kft, 120 nmi downrange)
 - F-16 launch platform (some challenges)
- **Out of production system**
 - Last Delivery Dec 2001
 - 56 AQM-37C in inventory; 30 AQM-37D (USAF flight clearance needed – FY11 schedule)
 - New GPS range tracking capability added this year (JAMI)
 - New trajectories added this year
- **Historically have conducted approximately 10-15 operations per year (~ half FMS)**
- **Low fidelity high-diver**





ZGQM-173A Multi-Stage Supersonic Target (MSST)



- Replicates a family of multi-stage supersonic ASCM Threats
 - Subsonic cruise with transition to supersonic terminal phase
- Program in Engineering & Manufacturing Development phase (EMD)
 - MS B completed August 2008
 - EMD contract awarded to Alliant Techsystems Incorporated (ATK), Woodland Hills, CA
 - EMD effort planned at 4.5 years
 - Planned Initial Operational Capability in FY14
- Program Status
 - Program designated nomenclature ZGQM-173A
 - Activities completed
 - System Requirements Review (SRR) Jun 09
 - Integrate Baseline Review (IBR) Jul 09
 - System Functional Review (SFR) Dec 09
 - Software Specification Review (SSR) Mar 10
 - Preliminary Design Review (PDR) Apr 10
 - Activities planned
 - Contractor prototype (EEU#2) Flight Nov 10
 - Critical Design Review (CDR) Feb 11





BQM-34S



- Prime contractor – Northrop Grumman
- Sustainment
- Missions
 - Low fidelity A/C simulator
 - T&E workhorse – special configurations
 - Open Loop Seeker (OLS) integration
 - Launch: ground, ship, air
- Product Improvements
 - Integrated Avionics Unit (UIAU) integration fielded Oct 09:
 - Replace existing autopilots with UIAU from BQM-74
 - Common avionics, radar altimeter, Support Equipment with current production BQM-74E
 - Address obsolescence issues
 - Reduced logistics
 - Allows for performance growth if required
 - 25 retrofits planned to support expected operations

Current Inventory ~ 204

FY06 Ops/Expenditures - 19/2

FY07 Ops/Expenditures - 14/3

FY08 Ops/Expenditures - 12/0

FY09 Ops/Expenditures - 4/1

FY10 Ops/Expenditures – 12/1



Great T&E “Truck” but does not adequately represent many of today’s threat ASCMs



BQM-74E



- Prime Contractor: – Northrop Grumman
- Production
 - Training and T&E workhorse
 - Final delivery **Dec 10**
- Missions:
 - High fidelity Anti-Ship Cruise Missile (ASCM) Surrogate
 - Low-fidelity A/C simulator
 - Launch: ground, ship, air
- Product improvements
 - Programmable semi-autonomous navigation
 - Selectable Lost Carrier Sensitivity from waypoint to waypoint
 - Return to Recovery Area
 - Planned fielding FY11

Current Inventory ~ 339

FY06 Ops/Expenditures - 235/62

FY07 Ops/Expenditures - 158/52

FY08 Ops/Expenditures - 231/68

FY09 Ops/Expenditures - 207/46

FY10 Ops/Expenditures - 181/44



Target still adequately represents many but not all threat ASCMs



Requirement for New Subsonic Target



- BQM-34 and BQM-74 no longer represent all modern subsonic threats
- Previous attempts to replace were unsuccessful (1999-2007)
- AOA / Sensitivity Study completed Apr 2008
 - Identified key performance attributes required for combat systems testing
 - Determined threat equivalency boundaries for key performance attributes
 - Determined that existing Navy subsonic targets could not be modified to achieve needed performance attributes
 - Study accepted by stakeholders (OSD(DOT&E), ASN(IWS), PEO(IWS), and OPNAV N43/N91 sponsors as Analysis of Alternatives (AoA)
- Navy decision to proceed with a new acquisition program called Subsonic Aerial Target (SSAT)



Subsonic Aerial Target (SSAT) Acquisition Approach



- Acquisition Strategy is to have industry modify an existing subsonic target to achieve Navy SSAT requirements rather than develop from scratch
- Contract Strategy is full and open competition including:
 - Cost-Plus Incentive Fee (CPIF) contract for Engineering and Manufacturing Development (EMD) phase
 - Two Firm, Fixed Price (FFP) production options
 - Two Cost-Plus Fixed Fee (CPFF) Contractor Logistics Support (CLS) options
- RFP released Dec 2009
- Proposals received Mar 2010
- Contract award expected 1st quarter 2011

Currently in Source Selection

Potential subsonic target inventory gap as SSAT transitions to production



QF-4/QF-16 Full Scale Aerial Targets



- Provides Threat Representative Target capabilities to meet Title 10 Live Fire T&E for weapons systems
- QF-4 Full Scale Aerial Target
 - A/F led procurement
 - A/F provides operational services at Tyndall & WSMR
 - Navy procurements from USAF began FY03
 - 5 targets to be delivered in Oct from FY08 buy
 - 5 targets to be delivered in FY11 from FY09 buy
 - FY10 last Navy buy of 2 targets to be delivered in FY12
 - Navy trading QF-4's for BQM-167's to support (N)WSEP
 - 1 QF-4 Traded for 4 BQM-167's in FY08
 - 3 QF-4's traded for 10 BQM-167's in FY10
- QF-16 Follow-on
 - Air Force led development with Army/Navy participation
 - Air Force awarded EMD contract to Boeing St.Louis 8 Mar10
 - Low Rate Initial Production buy 3QFY13
 - Full Rate Production 1QFY14
 - Planned Initial Operational Capability in FY15



- Current QF-4 Inventory 11
S/K
- FY07 Ops/Expenditures - 4/2
- FY08 Ops/Expenditures - 2/2
- FY09 Ops/Expenditures - 1/1
- FY10 Ops/Expenditures - 1/0





Navy Moving Land Target (MLT)



- Navy identified need for a threat representative training MLT to replace QLT-1C
- MLT program transferred from PMA-205 to PMA-208 2007
- Navy leveraged the Shootable Remote Threat Ground Target (SRTGT) OSD T&E demonstration initiative to refine requirements, prototypes filling gap until MLTs procured competitively
- MLT acquisition approach:
 - Planning for full and open competition to purchase commercial system
 - Completed a requirements study Jun 09
 - RFI released Aug 09 (solicitation #N00019-09-RFI-0235)
 - Requirement defined in Target Capability Document (TCD) signed Sep 09
 - Designated as Abbreviated Acquisition Program (AAP) in Sep 09
 - RFP released May 2010

Currently in Source Selection



System for Naval Target Control (SNTC)



- SNTC
 - Prime Micro Systems, Inc
 - Controls BQM-74/34 aerial targets & seaborne targets
 - UHF 435–450 & 358-380 MHz
 - 200 nm line of sight
 - 330 nm via Relay
 - Supports Training and T&E

- Several hardware and software upgrades scheduled due to:
 - new target types
 - frequency limitations and interference
 - Information assurance requirements
 - hardware obsolescence















Foreign Military Sales (FMS)



FMS Cases managed by PMA-208

| | | | |
|--|--|--|---|
|  Australia |  Canada |  UK |  Germany |
|  France |  Netherlands |  Norway |  Portugal |

Other international funding of target operations

| | | |
|--|--|---|
|  Japan |  Spain |  Taiwan |
|--|--|---|

Description

PMA-208 Hardware Case

- USN is reimbursed for Targets & TAAS expended from USN inventory in support of international operations on US ranges

Range Services Case

- Separate FMS Case to fund target presentation at US Range

Presentations on OCONUS Ranges

- Target presentations performed on foreign range

Background

PMA-208 manages 8 active cases / 1 Lease Agreement

- 6 countries / Case Values Total: \$ 32M

Typical FMS Range Sites

- NAWCWD Pt. Mugu/China Lake, CA
- PMRF Barking Sands, HI
- NAWCAD Wallops Island, VA



Target System Challenges



- Keep pace with evolution of threats
 - Electronic emission, vehicle capability, other characteristics
- Develop and/or acquire new targets
 - MSST, SSAT, MLT, QF-16
- New capabilities to existing targets
 - GQM-163 high diver and OFES, AQM-37 guidance, BQM-34/74 waypoints
- Evolve target control systems
- Manage target production
- Maintain out of production targets
- Support test and training presentations
- Control cost of acquisition, maintenance, and operations
- Inventory and obsolescence management

A critical enabler to the successful development & fielding of future Naval combatants and their associated defensive weapons systems . . .

“Just Targets”



Questions?

U.S. Navy Aerial Target Systems

Contact:

Captain Dan McNamara

Program Manager

PMA-208, Navy Aerial Target & Decoy Systems

301-757-6129

Mr. Tim Barnes

Principal Deputy Program Manager

PMA-208A, Navy Aerial Target & Decoy Systems

301-757-5798



DOT&E Targets Perspective

Dennis Mischel

Target Systems Office

d.mischel@osd.mil

703-681-5505 (D) or 703-244-0515 (C)



Office of the Secretary of Defense

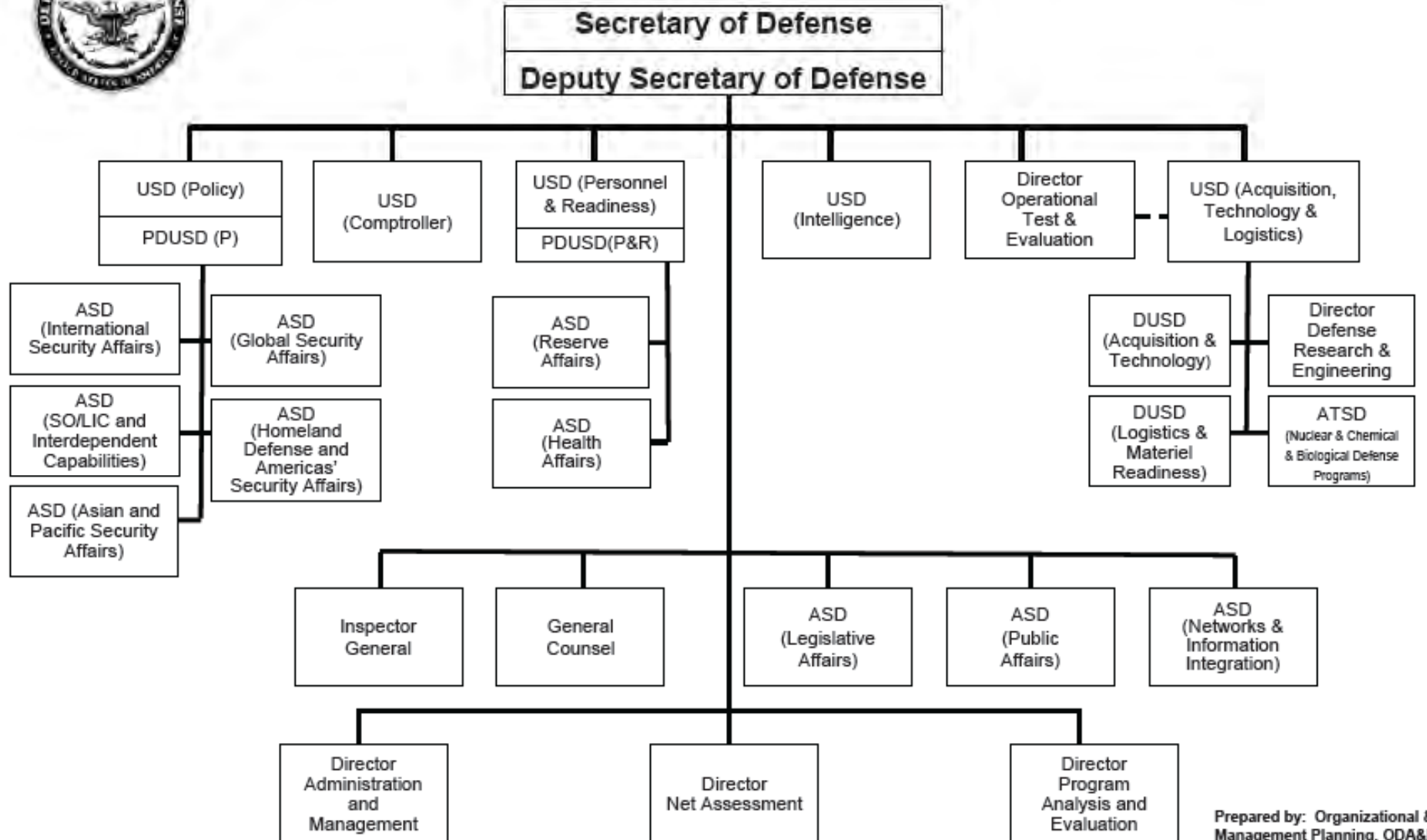

Chart reflects PAS officials and those reporting directly to the Secretary and Deputy Secretary of Defense

Prepared by: Organizational & Management Planning, ODA&M, OSD
Date: January 2008

So what has changed?

Office of the Secretary of Defense



Secretary of Defense

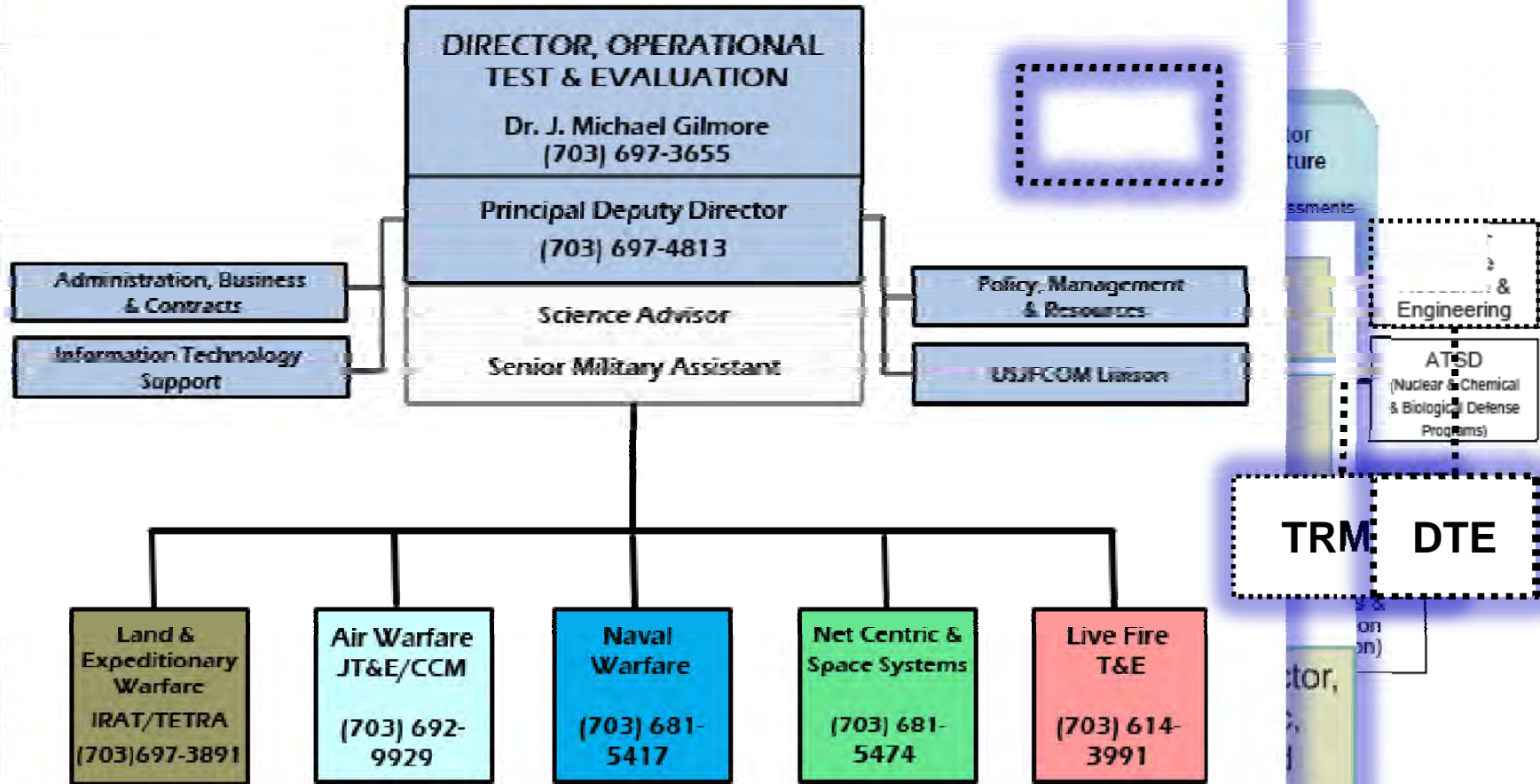
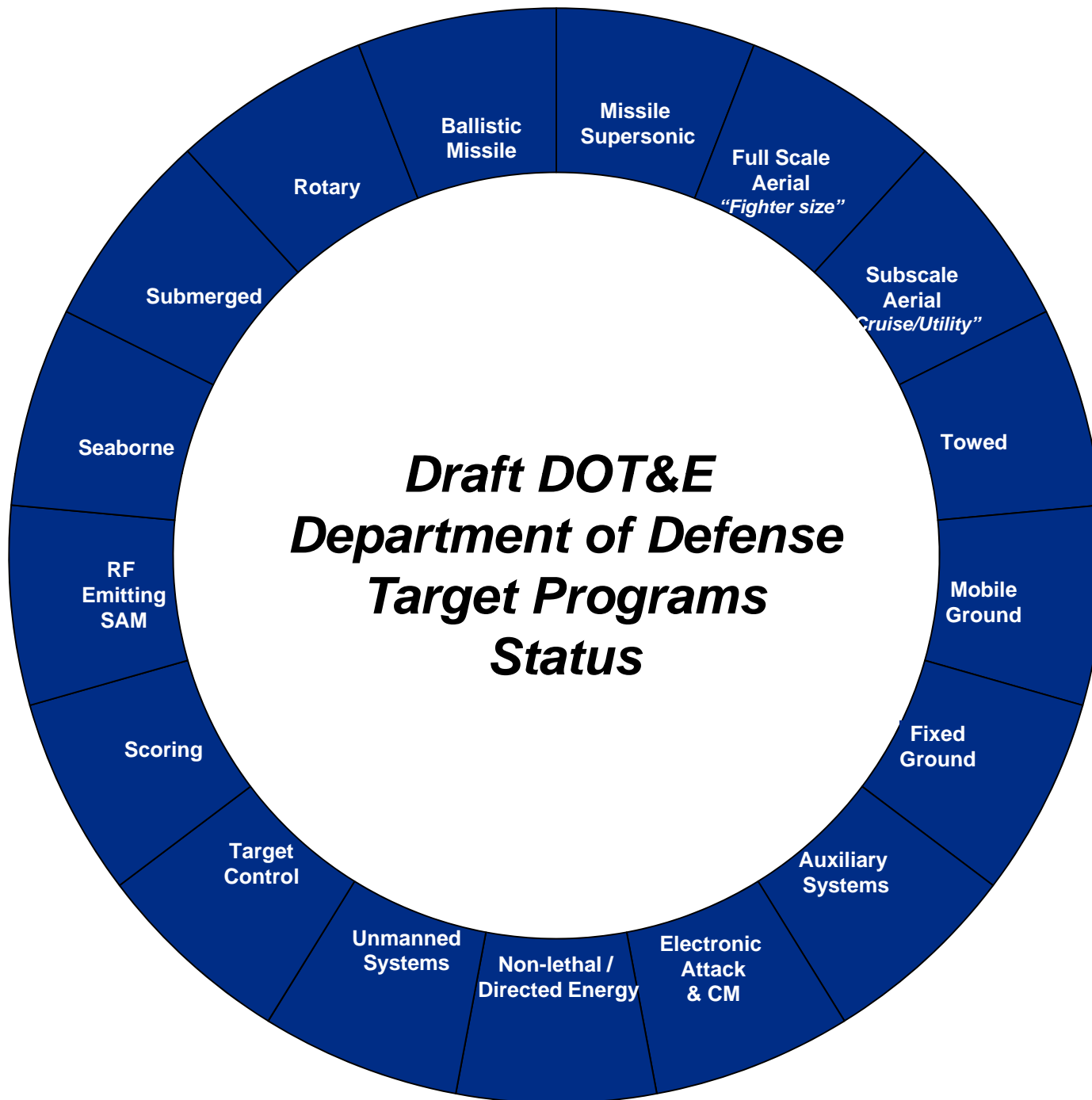
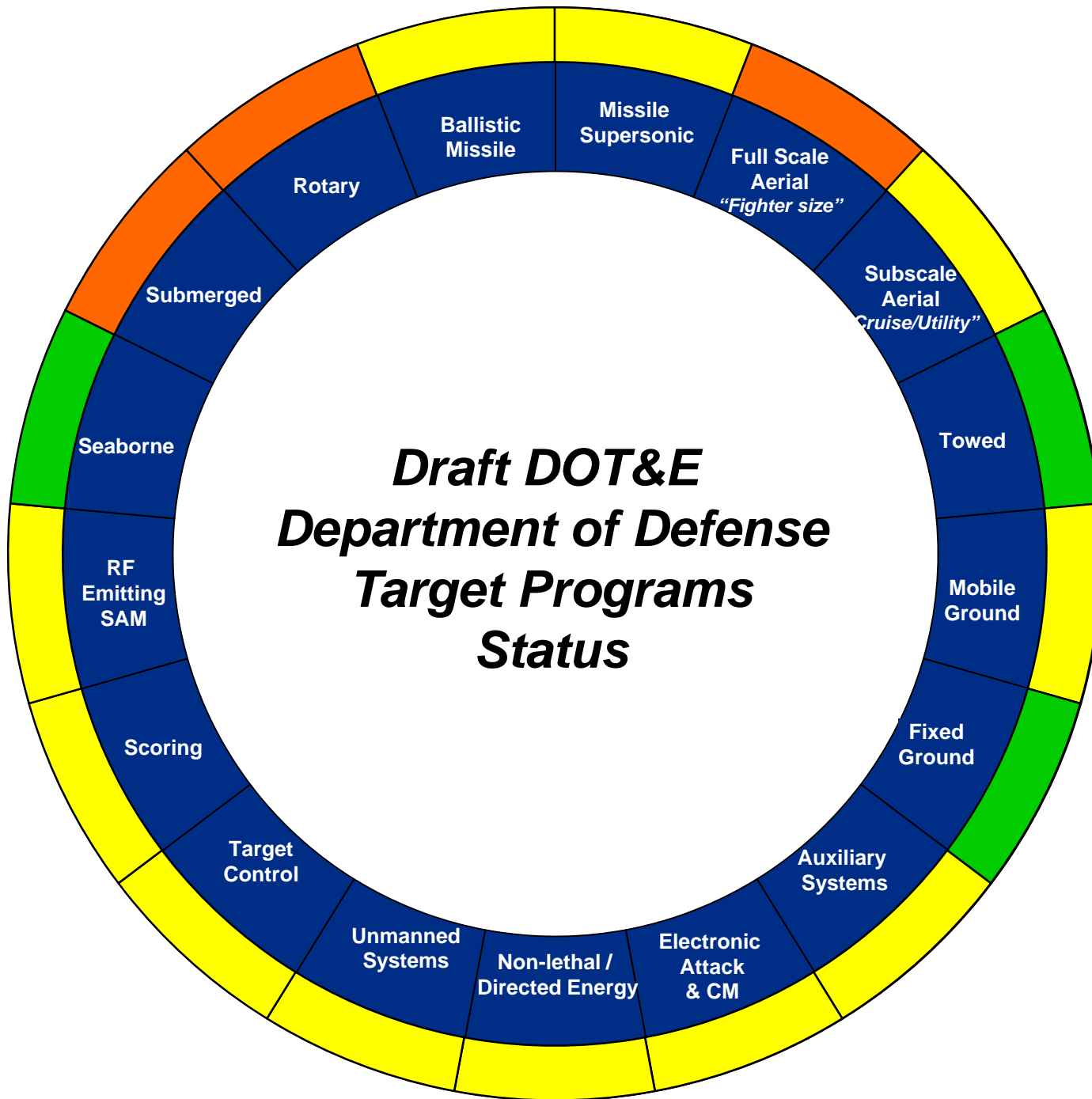
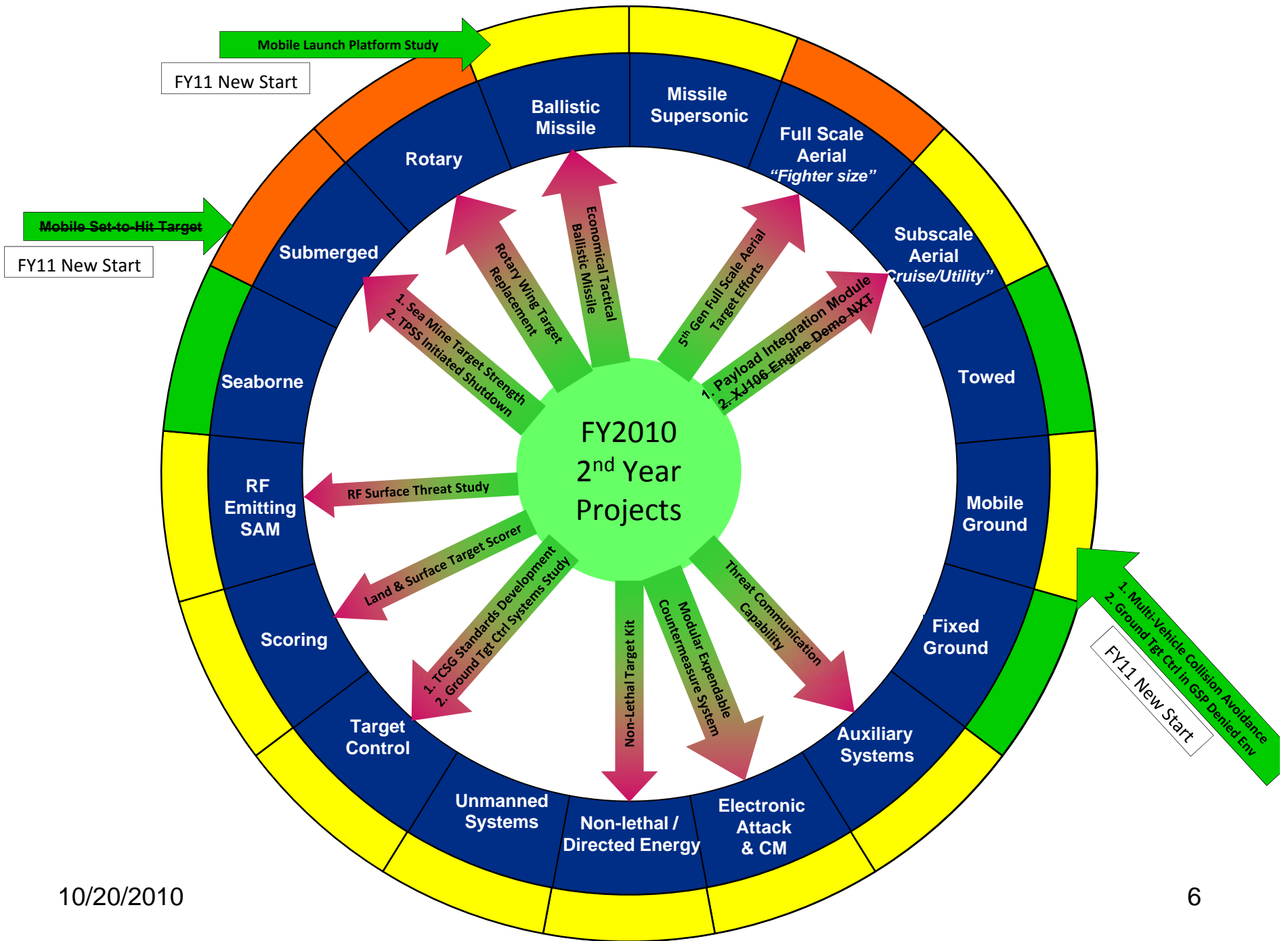

Chart ref

Prepared by: Organizational & Management Planning, ODA&M, OSD
Date: January 2008









Director, Operational Test & Evaluation

Target Systems Office

The Future of Targets



Next Generation Targets

Headquarters USAF Warfare Center

Air-to-Ground Weapons System Evaluation Program (WSEP)



Lt Col Michael Neeman
86 FWS/CC



UNCLASSIFIED

Perfecting Lethality



Overview

- 86 FWS Program
- Ranges and Targets
- Instrumentation / Data Collection
- Challenges





86th FWS

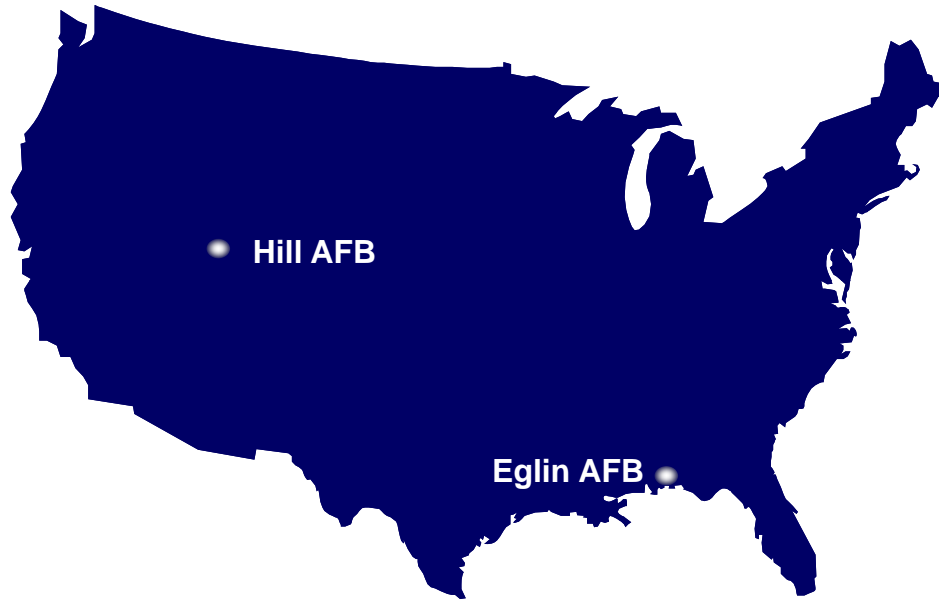

Perfecting Lethality

Perfecting Lethality

UNCLASSIFIED



53 WEG MISSION



- **Conduct Follow-on Test and Evaluation for air-to-air missiles and precision-guided air-to-ground munitions under the USAF's Weapon System Evaluation Program**

Perfecting Lethality



Mission Statement



COMBAT

HAMMER

“Evaluate the effectiveness, maintainability, suitability, and accuracy of precision guided munitions and high technology A/G munitions from tactical deliveries against realistic targets with realistic enemy defenses.”



A/G WSEP Mission

- End-to-end evaluation
- Integral part of AF / DOD life cycle acquisition and sustainment program
- Not just ACC...evaluations support AFMC / DOD WRM considerations
 - Extensive Program Office liaison
 - Symbiotic relationship (Hardware & Software)



1986 - 2010

- Initial charter 1986 - *COMACC PLAN 90, “Air-to-Ground Weapon Systems Evaluation Program”*
- 1986: 9 units / 50 weapons
- 2010: 17 units / 374 weapons
- We own a growth industry
 - Annual program resource requirements (infrastructure, funding, manpower) increasing in scope commensurate with rapid rise in CAF PGM capabilities
 - Sustained requirement is 20 WSEPs annually with a 22-24 WSEP “surge” capacity in any given year employing 350 weapons



CAF Air-to-Ground Arsenal

- | | | |
|---|--|--|
| <ul style="list-style-type: none">■ B-1B<ul style="list-style-type: none">■ GBU-31/38■ CBU-103/4/5■ AGM-158■ B-2A<ul style="list-style-type: none">■ GBU-28/31/38■ AGM-154A■ AGM-158■ B-52H<ul style="list-style-type: none">■ AGM-86C/D■ GBU-31/38■ GBU-12■ CBU-103/4/5■ AGM-154A■ AGM-158■ MQ-1 Predator<ul style="list-style-type: none">■ AGM-114■ MQ-9 Reaper<ul style="list-style-type: none">■ AGM-114■ GBU-12 | <ul style="list-style-type: none">■ A/OA-10<ul style="list-style-type: none">■ AGM-65D/G/G2/H/K■ GBU-10/12■ A/OA-10C<ul style="list-style-type: none">■ AGM-65D/G/G2/H/K■ GBU-10/12■ GBU-31/38/54■ CBU-103■ F-15E<ul style="list-style-type: none">■ EGBU-15■ AGM-130■ GBU-10/12/24/28■ GBU-31/38/54■ CBU-103/4/5■ GBU-39■ F-22A<ul style="list-style-type: none">■ GBU-32 | <ul style="list-style-type: none">■ F-16C<ul style="list-style-type: none">■ AGM-65D/G/G2/H/K/E■ AGM-88■ GBU-10/12/24■ GBU-31/38/54■ CBU-103■ F-16CG<ul style="list-style-type: none">■ AGM-65D/G/G2/H/K/E■ GBU-10/12/24■ GBU-31/38/54■ CBU-103/4/5■ F-16CJ<ul style="list-style-type: none">■ AGM-65D/G/G2/H/K/E■ AGM-88■ AGM-154A■ GBU-10/12/24■ GBU-31/38/54■ CBU-103/4/5■ AGM-158 |
|---|--|--|

**Today – 12 Platforms
103 weapon system combinations**



CAF Air-to-Ground Arsenal

- | | | |
|---|---|--|
| <ul style="list-style-type: none">■ B-1B<ul style="list-style-type: none">■ GBU-31/38/54■ GBU-154A■ CBU-103/4/5■ AGM-158■ GBU-39■ B-2A<ul style="list-style-type: none">■ GBU-28/31/38■ AGM-154A■ AGM-158■ GBU-28■ GBU-39■ B-52H<ul style="list-style-type: none">■ AGM-86C/D■ GBU-31/38/54 (FY10)■ GBU-12■ CBU-103/4/5■ AGM-154A■ AGM-158■ GBU-39■ MQ-1 Predator<ul style="list-style-type: none">■ AGM-114■ MQ-9 Reaper<ul style="list-style-type: none">■ AGM-114■ GBU-12■ GBU-38■ GBU-39 | <ul style="list-style-type: none">■ A/OA-10<ul style="list-style-type: none">■ AGM-65D/G/G2/H/K■ GBU-10/12■ A/OA-10C<ul style="list-style-type: none">■ AGM-65D/G/G2/H/K■ GBU-10/12■ GBU-31/38/54■ CBU-103/4/5■ F-15E<ul style="list-style-type: none">■ EGBU-15■ AGM-130■ GBU-10/12/24/28■ GBU-31/38/54■ CBU-103/4/5■ GBU-39■ F-22A<ul style="list-style-type: none">■ GBU-32■ GBU-39■ F-35<ul style="list-style-type: none">■ GBU-31/32/38/39■ AGM-154■ AGM-158■ CBU-103/4/5 | <ul style="list-style-type: none">■ F-16C<ul style="list-style-type: none">■ AGM-65D/G/G2/H/K/E■ AGM-88■ GBU-10/12/24■ GBU-31/38/54■ CBU-103■ F-16CG<ul style="list-style-type: none">■ AGM-65D/G/G2/H/K/E■ GBU-10/12/24■ GBU-31/38/54■ CBU-103/4/5■ AGM-154A■ F-16CJ<ul style="list-style-type: none">■ AGM-65D/G/G2/H/K/E■ AGM-88■ AGM-154A■ GBU-10/12/24■ GBU-31/38/54■ CBU-103/4/5■ AGM-158 |
|---|---|--|

**Future – 13 Platforms
124 weapon system combinations**



A/G WSEP Mission Execution

- **Fighter squadrons deploy to Eglin and Hill AFB**
 - 8-12 jets; one and two week evaluation deployments
 - Typical unit 12-18 aircrews; 100-150 people deployed
 - Ammo troops up front (2 wks early)
- **Bomber / RPA squadrons execute from home station**
- **Hammer constructs realistic scenarios**
- **Weapons, platforms, and targets “instrumented”**
- **Hammer collects data, conducts analysis, and determines weapon system effectiveness**



Ranges and Targets

- **Eglin (35%)**

- High humidity / green environment
- Shoot cones more restrictive / limited airspace
- High / slow speed moving targets
- Urban CAS villages

- **UTTR (65%)**

- Desert / barren environment
- Permissive shoot cones / high altitude
- Urban CAS village
- High / slow speed moving targets



Ranges and Targets



UNCLASSIFIED

Perfecting Lethality



Ranges and Targets

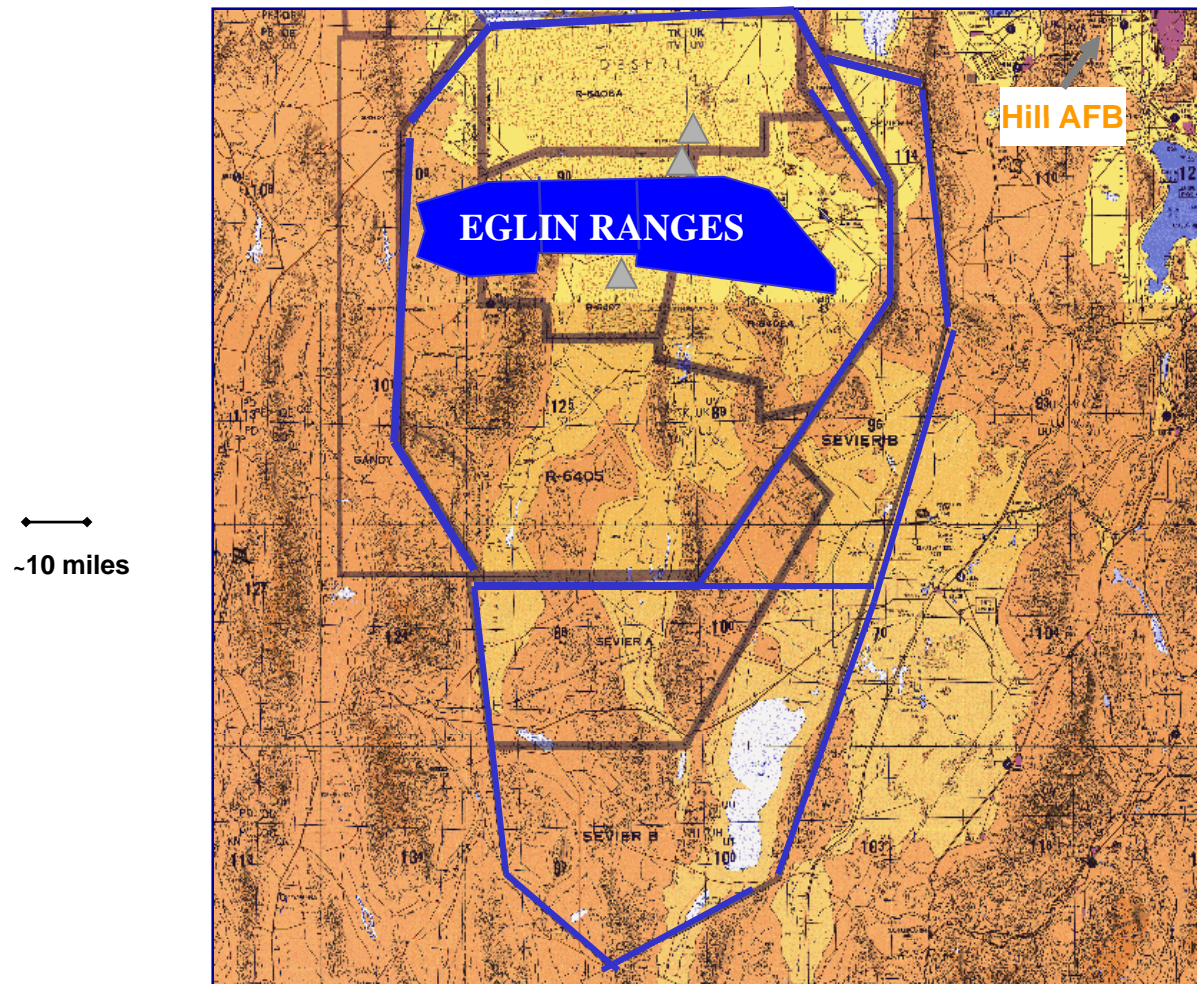

UNCLASSIFIED

Perfecting Lethality



Ranges and Targets

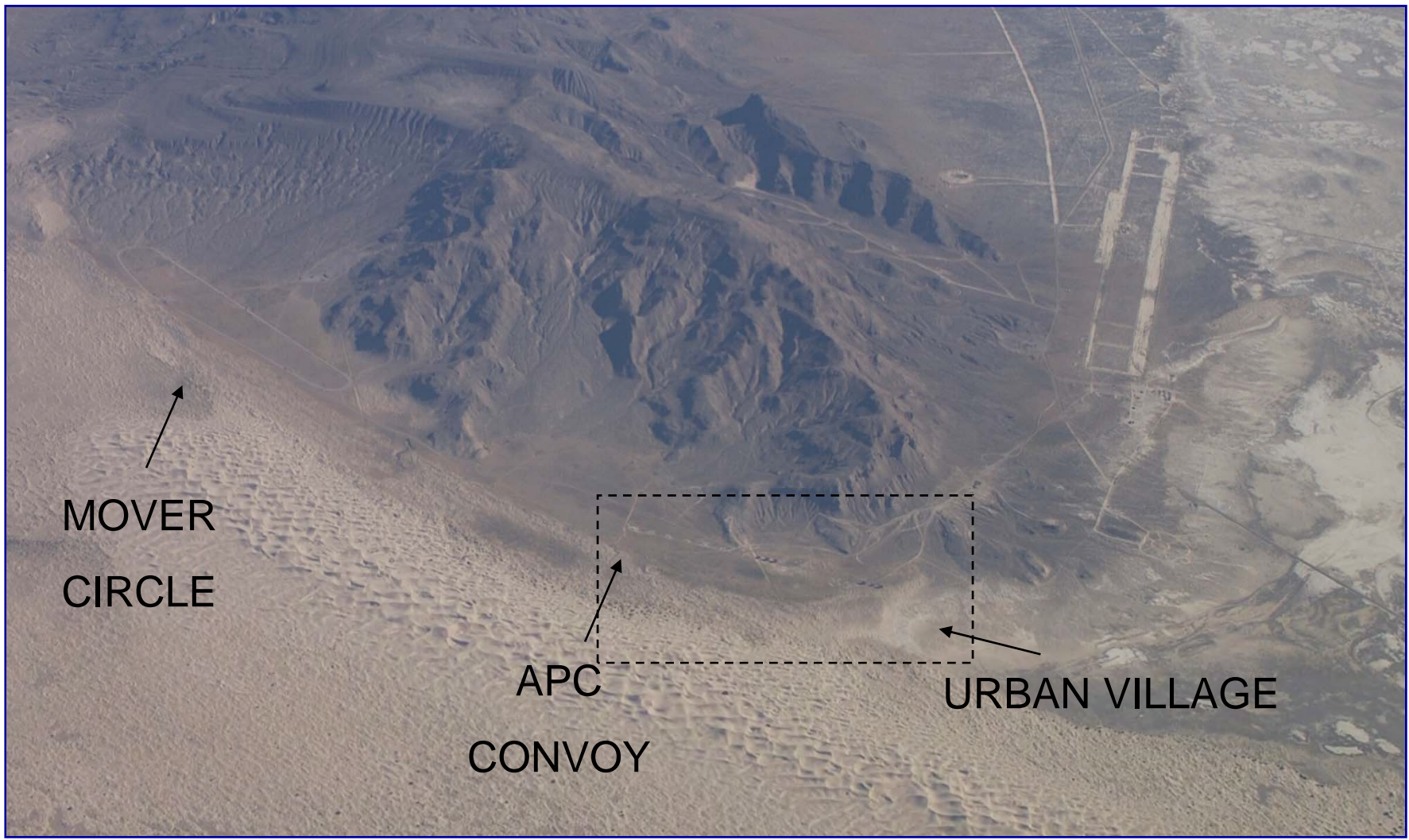

UNCLASSIFIED

Perfecting Lethality



Ranges and Targets (Caves)

A/G WSEP 10-12
366 FW / 391 FS

Hammer 15A
Day 1
GBU-15V1 C/B (TV)



Ranges and Targets



UNCLASSIFIED

Perfecting Lethality



Ranges and Targets (Geckostan)

A/G WSEP 10-11
355 FW / 354 FS

Hammer 22A
Day 2
AGM-65G2



Ranges and Targets



UNCLASSIFIED

Perfecting Lethality



Ranges and Targets (Hammer Pads)

A/G WSEP 10-15
20FW / 79FS

Hammer 13A
Day 3
GBU-10



Ranges and Targets



UNCLASSIFIED

Perfecting Lethality



Ranges and Targets (Mover Track)

A/G WSEP 10-11
355 FW / 354 FS

Hammer 21
Day 2
Strafe



Ranges and Targets (High Speed Mover)



UNCLASSIFIED

Perfecting Lethality



Ranges and Targets (HARM)

**A/G WSEP 10-15
20FW / 79FS**

**Hammer 13A
Day 1
AGM-88**



Instrumentation / Data Collection

- **Time / Space / Position / Information (TSPI)**
 - Radar Tracking
 - Global Positioning System (GPS)
 - A/C AVTR / DVS

- **Telemetry**
 - Used to the maximum extent possible
 - Assess weapon performance--launch to impact
 - Paveway / AGM-130 exceptions

- **Improve Laser Tracker (ILAST)**
 - Measures Laser Designator Performance
 - Power Output, Spot Stability, And Spot Position
 - Boresight Check



Instrumentation / Data Collection

- **Videometric Analysis System (VMAS)**
 - Measures weapon impact conditions
 - Impact angle, bomb body yaw, and impact position

- **Effects (LPA)**
 - Video record of target condition - before / after
 - Video record of munitions impacts relative to DPI / DMPI

- **Chase Aircraft**
 - Assess tactics and weapon performance post release
 - Ensures range safety
 - Fills in where no telemetry available
 - Desired - not required



Challenges

- **Realistic Targets**
 - 5th Gen sensor integration needs emitting / CCD / jamming
- **Air to ground range encroachment**
 - Airspace availability
 - Frequency conflicts
 - UTTR viability / funding
- **Weapons**
 - Large footprint
 - Limited quantities of several wpns
 - Telemetry availability (\$)
- **Funding**



53^D Weapons Evaluation Group

Integrity - Service - Excellence



UNCLASSIFIED

Perfecting Lethality



A/G WSEP Overview

- Formed in 1985 by TAC/CV
 - No capability to operationally assess PGMs
 - Verify combat capability on annual schedule

- Objectives
 - Evaluate the total A/G weapons system
 - Reliability, maintainability, accuracy
 - Deficiencies and causes
 - Provide recommendations to CAF and HHQ
 - Enhance operational training - 50% 1st time shooters

- Evaluation Results
 - PGM Probability of Success (P_s) & Probability of Hit (P_h)
 - Storage-to-Impact
 - Data collection



Statistical Analysis

- **8 Evaluation Phases**
 - Munitions Buildup
 - Ground, Enroute
 - Employment, Guidance, Fuzing, Warhead, Target Damage
- **Probability Of Success**
 - Encompasses All Phases Except Munitions Buildup
- **Probability Of Hit**
 - Encompasses Last 5 Phases
 - Probability Of Target Damage Given The Opportunity To Employ
- **Non-chargeable Interruptions**
 - Weather, Range Closure, TM Failure



Statistical Analysis

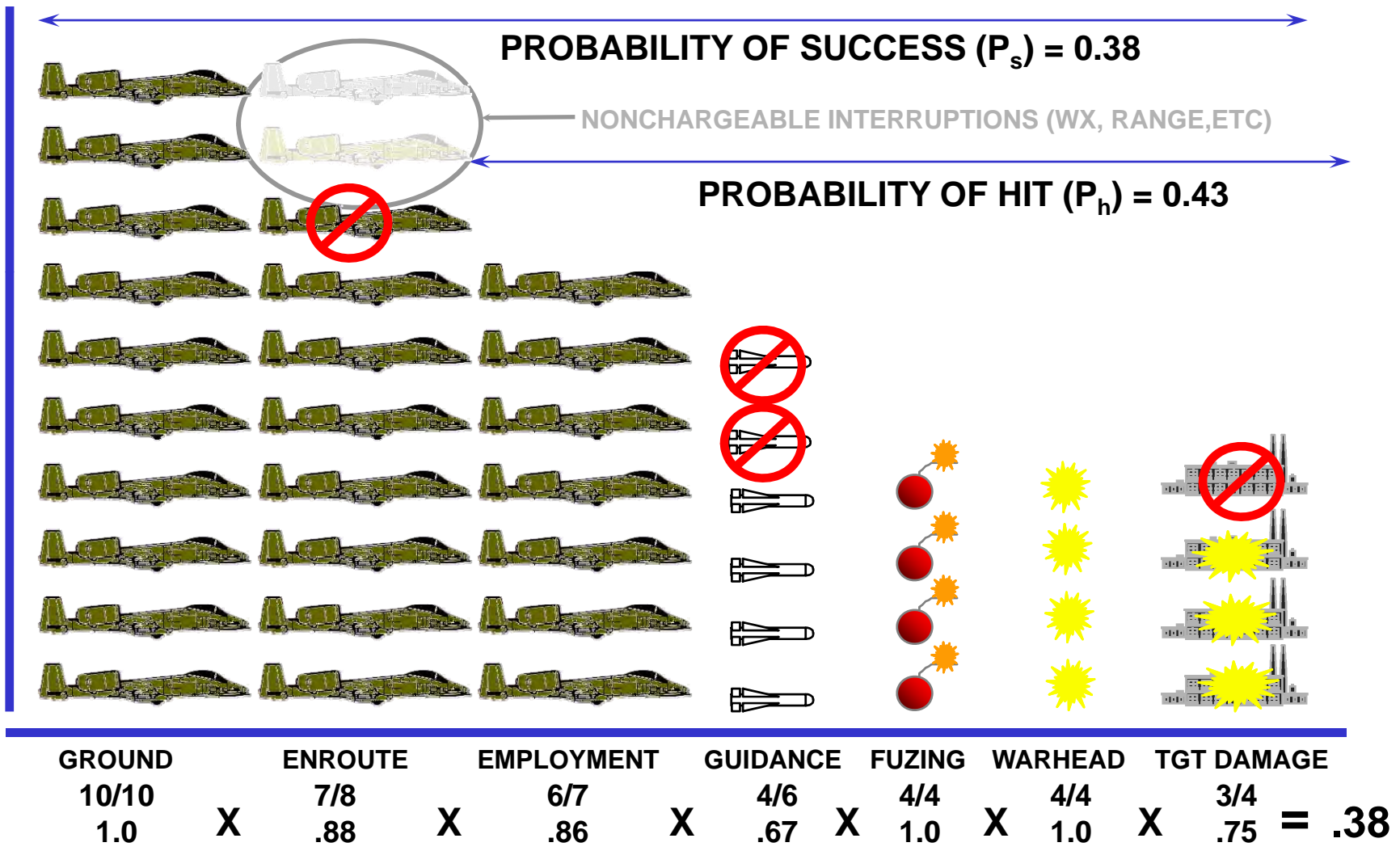

UNCLASSIFIED

Perfecting Lethality



Statistical Analysis

- **As defined by COMACC Plan 90:**
 - **80% Confidence Level**
 - **10% Accuracy Level**
 - **80% chance Hammer probabilities will be replicated in the real world (± 10%)**



Statistical Analysis

- **Can't meet statistical significance all the time**
 - **Currently 103 Different Weapons System Combinations**
 - **Goal Achievable Over 5 Year Period (7-10 Wpns per Yr)**

- **Confidence Level Does Not Differentiate Between:**
 - **Different Delivery Parameters**
 - **Environmental Factors**
 - **OFP Changes**
 - **Scenario**



Combat Hammer Charter

- **EMPLOY** A/G PGMs and High Technology Weapons
 - A/G WSEP “COMBAT HAMMER”
 - Investigative Firing Program

- **ASSESS/VALIDATE** Combat Capabilities
 - Total Weapons System
 - “Storage through impact”
 - Ops units, combat realistic scenarios, and realistic threat replication

- **IMPROVE** A/G PGM Effects
 - Telemetry
 - Recommend changes
 - Maintain comprehensive database

- **PROVIDE** PGM expertise on demand
 - “ON-CALL” capability



Sustainability Challenges of the “GREEN RANGE”

NAV  AIR

**Tony Parisi
Head, Sustainability Office
NAVAIR Ranges
20 October 2010**

Overview

- NAVAIR Ranges & Sustainability Office
- Urban Development
- OCS Energy Development
- Renewable Energy Development
- California Low-Sulfur Fuel Regulation

NAVAIR Ranges

Pacific Ranges

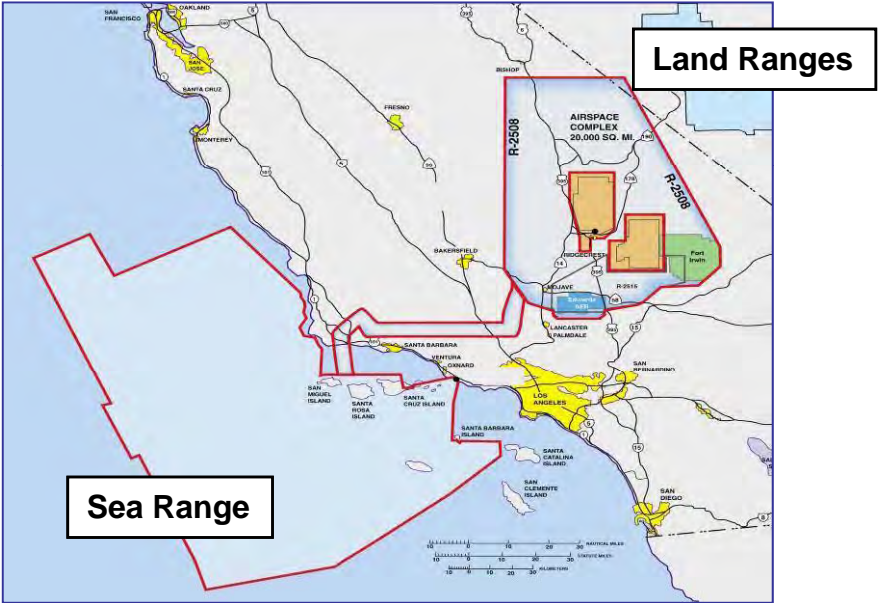

Atlantic Ranges

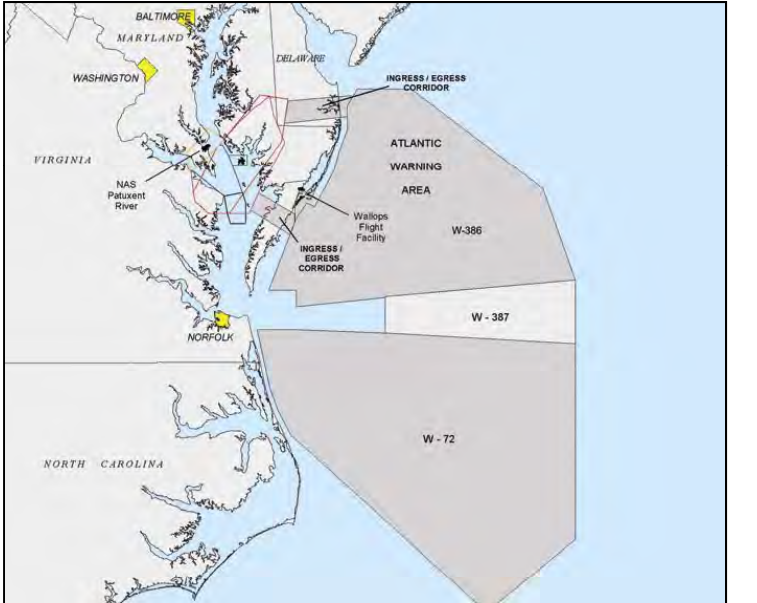

- Chesapeake Test Range
- Atlantic (Off-Shore) Warning Areas

Sustainability Office

- Mission: Support the fleet's sustainable readiness by ensuring the NAVAIR Team has access to ranges, facilities, resources and public support for its test, training, evaluation and experimentation mission.
- What Do We Do?
 - Environmental planning for ranges
 - Encroachment prevention & management
- Approach
 - External engagement/outreach
 - Coordination with Installations, Fleet, Other Services, Regions, RECs and others
 - Enhanced Readiness Teams
- Senior leadership involvement & support is critical

Urban Development

Atlantic Test Range

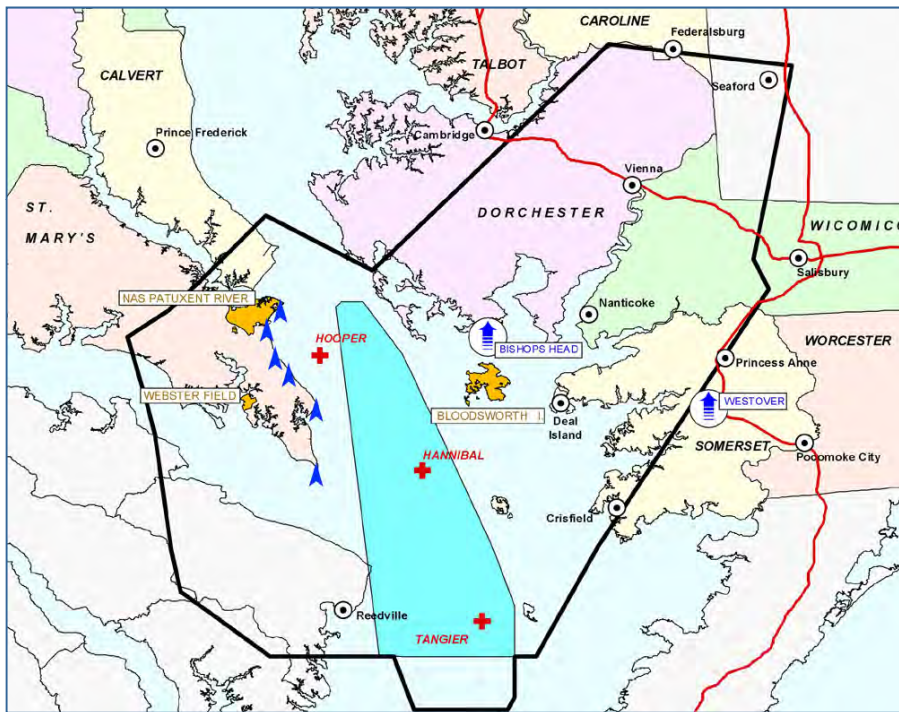

- Increased development in Lexington Park, MD Eastern Shore, & VA Northern Neck
- Substantial outreach/engagement
- Encroachment partnering/REPI project for easements to prevent incompatible development

OCS Energy Development

Atlantic Test Range

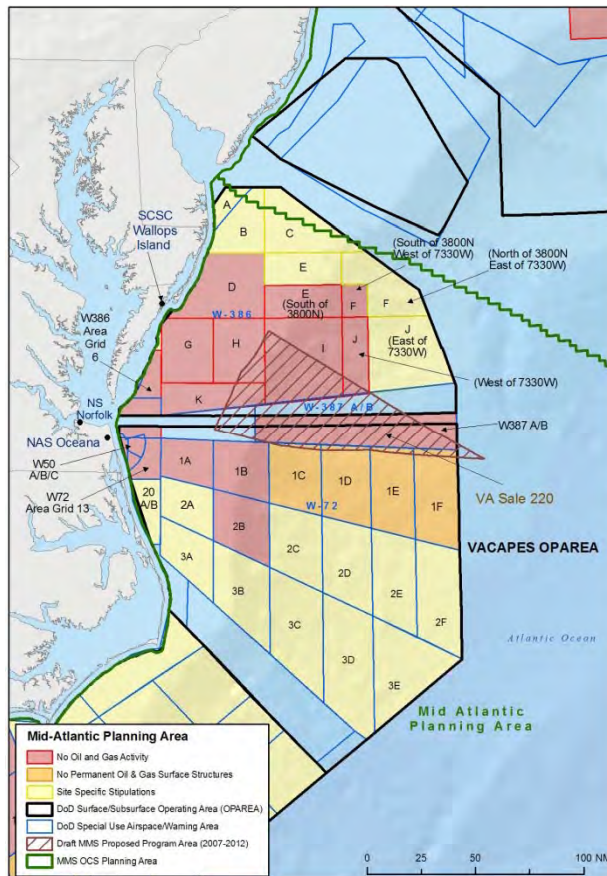

- Oil & gas
- Wind energy
- Engagement with USFF & OSD tiger team to identify areas of incompatible development
- Engagement/outreach with Maryland & Virginia

Existing & Proposed Wind & Solar Energy Projects

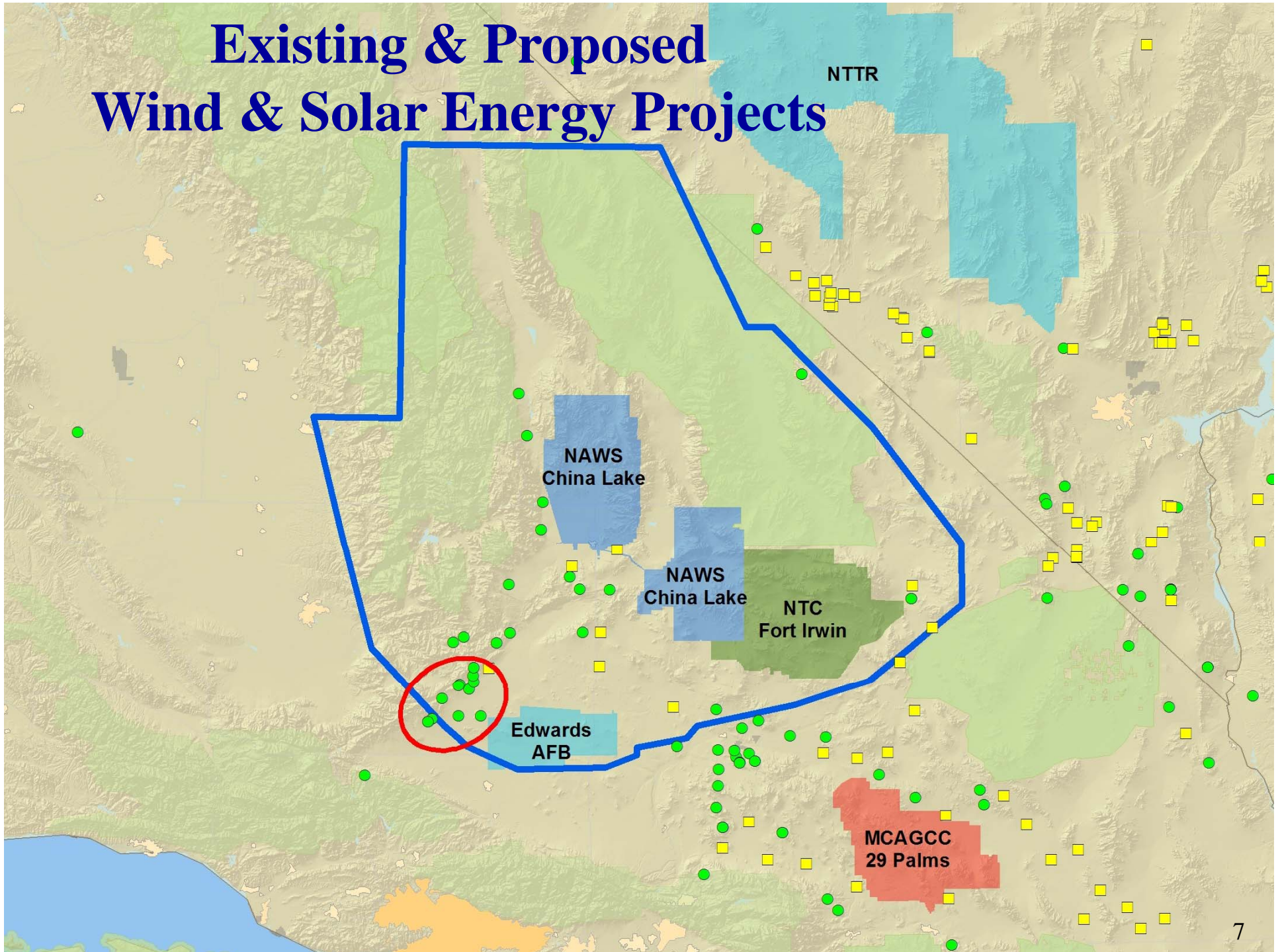

Renewable Energy Mission Impacts

- Wind Energy
 - Low-level airspace
 - Ground based radars/telemetry
 - Airborne radars
- Solar Energy
 - Glint/glare
 - Affect on infrared sensors
 - Habitat destruction (secondary effect)

NAVAIR Airborne Radar/Wind Turbine Testing

- Tested airborne RADAR Implications Against Wind Turbine Installations in Region
- Assessed Impacts of Turbines on Current & Future Test Capabilities
 - Conducted Open Air Testing in Various Flight Scenarios
 - Actual Wind Turbine Truth Data Utilized for all Testing

State of the Art Wind Turbine

- Tower Height: ~328 ft
- Rotor Diameter: ~ 361 ft
- Rated Capacity: ~ 3 MW
- Cut-in wind speed: ~6.8 kts
- Cut-out wind speed: ~52 kts
- Rated wind speed: 27 kts
- Rotor speed: 8.5 – 15.3 rpm
- Blade tip speed: ~170 kts



Radar Test Results

- Increased Processing Time
 - Busy Processing False Targets Vice Actual Targets
- Inability to Acquire Targets
 - Too Many Targets or too Much Noise to see Targets
- Detailed Results Available in Classified Brief
- Implications
 - Airborne RADAR “Laboratory” Would be Destroyed by Turbines
 - Inability to Field Weapons Systems to Warfighter
 - Training???
- No current mitigation
- Additional testing planned

California Low-Sulfur Fuel Regulation

Point Mugu Sea Range

- Most shipping uses Traffic Separation Scheme (Santa Barbara Channel)
 - Exceptions: Supertankers
 - Average of 2 ships/day on range
 - Minimal impact on Sea Range operations
- California regulation requires low-sulfur fuel within 24 nm of mainland – effective 1 JUL 2009
 - Significant Navy involvement/objection
- Since regulation went into effect, traffic avoiding the Santa Barbara Channel has increased to over 14 ships/day

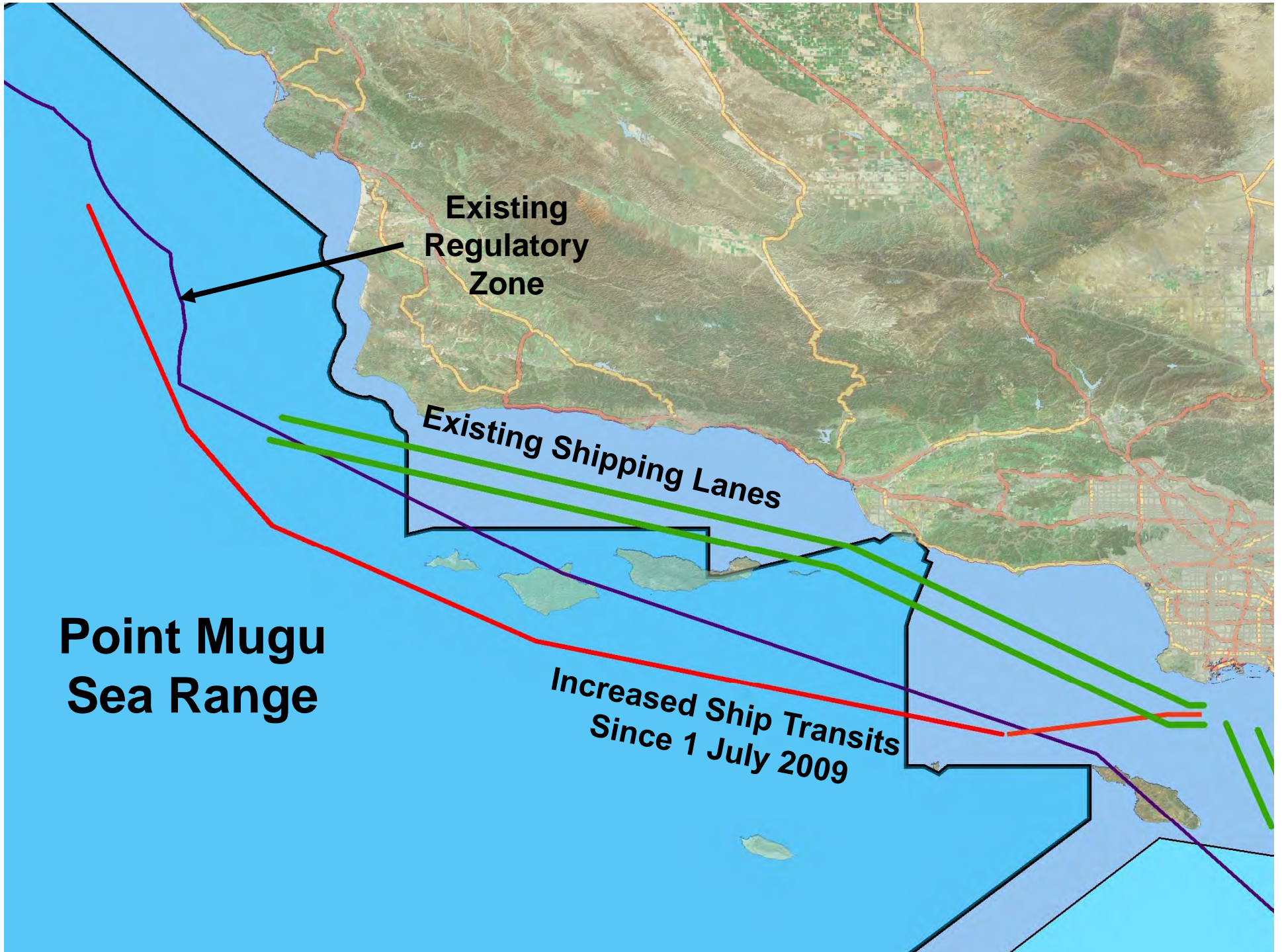

Sea Range Ship Traffic

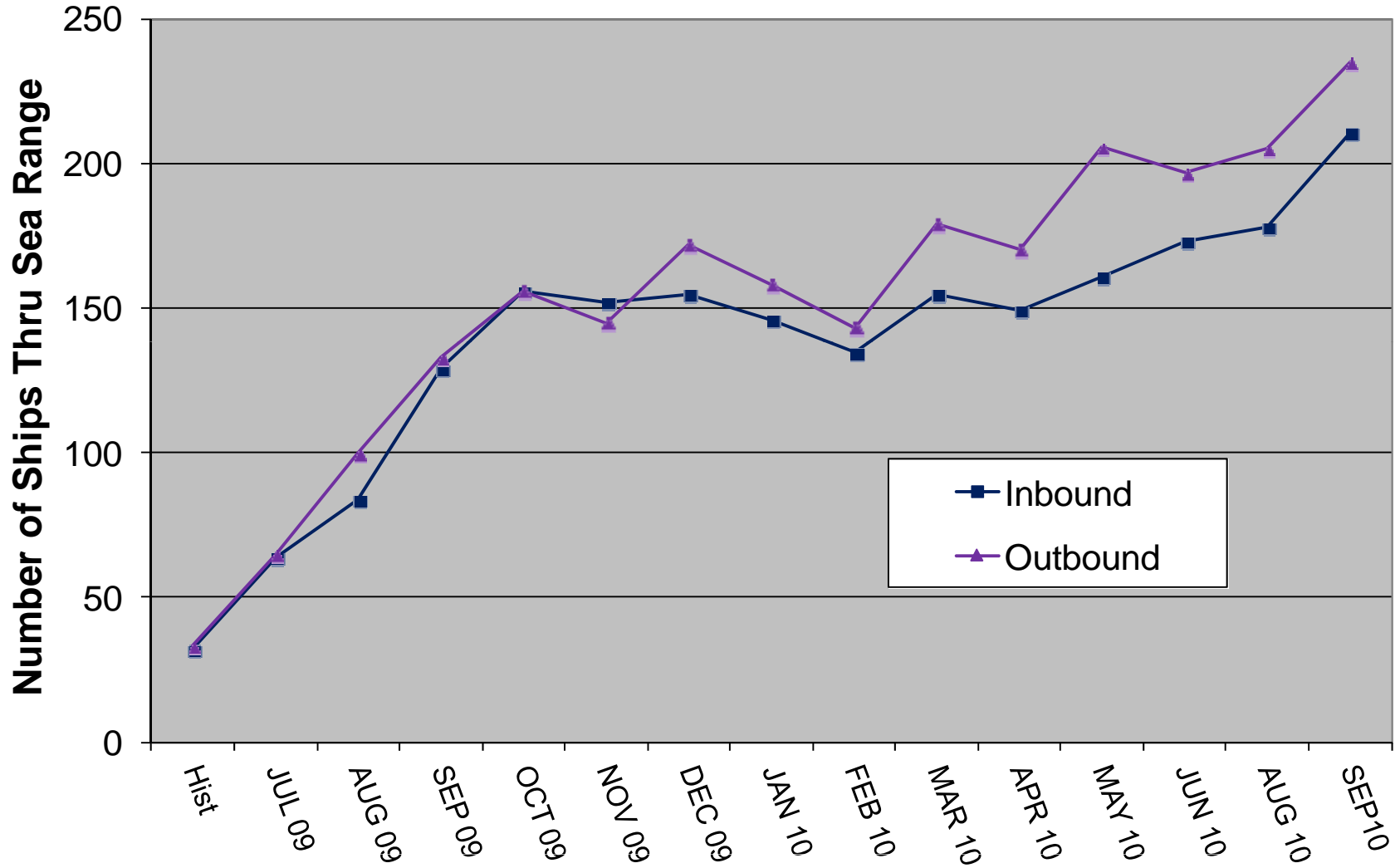

California Low-Sulfur Fuel Regulation

What Are We Doing?

- Established communications with shipping industry through LA/LB Marine Exchange
- Monitoring impacts
 - Minimal operational delays
 - Redirecting significant number of ships
- Engaged with CA Air Resources Board
 - CARB is modifying regulation to remove financial incentive to leave the Santa Barbara Channel
 - Unclear if change will be enough

California Low-Sulfur Fuel Regulation

Operational Impacts

- Minimal until recently
- CSSQT delay
- Two tests cancelled but unclear if unrelated to low-sulfur reg
 - Ships well beyond 24 nm
 - 9 APR 10: F-22 Small Diameter Bomb
 - 25 MAY 10: X-51A Test

California Low-Sulfur Fuel Regulation

What's Next?

- USCG studying formal shipping lanes through Sea Range
 - NAVAIR engaged
- CA Air Resources Board has considered formal regulation to reduce vessel speeds in existing channel, up to 100 nm from ports within 24 nm or 40 nm from mainland
 - Now saying speed reduction can't be limited to SB Channel
- Whale strikes: Proposals to reduce speed to 10 knots in SB Channel
 - No good species data outside SB Channel
- US EPA Emissions Control Area (ECA) off the West Coast
 - Will supersede CA regulation in 2015 but not speed reduction

Summary

- Significant external encroachment issues but no major impacts – yet
- Significant resources required

Hugh Harris Scholarship



◆ My Purpose

- ◆ Provide annual update to the membership
- ◆ Review/Inform membership on application procedures
- ◆ Solicit your continued support by
 - ◆ Identifying qualified applicants
 - ◆ Providing continued financial support

Purpose of Scholarship



- ◆ Memorialize Hugh Harris
- ◆ Provide Financial Assistance to Eligible Students
- ◆ Encourage Interest in:
Science/Engineering/Technology/Mathematics
(STEM)

Educational Crisis



- ◆ In 30 Years US Public Education Dropped from No. 1 in the World to No. 29
- ◆ All-STEM Degrees (% of total awarded)
 - ◆ S. Korea: 37.8%
 - ◆ Mexico: 28.1%
 - ◆ US: 17.6% (Engineering 6.7%)

Scholarship Status



- ◆ Established in 1991: Goal \$50K, to be self sustaining
 - ◆ Funds Administered by NDIA HQ.
- ◆ First Scholarship Awarded in 1992
 - ◆ One \$1000 Award in '92
 - ◆ Awarded \$59K to date
- ◆ This year's winners
 - ◆ Mark Barrett: Univ. of FL, Civil Engineering
 - ◆ Lauren Myers: Univ. of FL, Pre-Med
 - ◆ Elizabeth Gallagher: Auburn, Civil Engineering
 - ◆ Benjamin Piburn: Vanderbilt, Math/Computer Science
 - ◆ Jordan Colclasure: Yale, BioMed Engineering

Scholarship Schedule



- ◆ 20 January: Members identify applicants
- ◆ 1 February: Mail info packets to applicants
- ◆ 15 March: Applications to Scholarship Committee
- ◆ 1 April: Scholarship Committee ranks applicants
- ◆ 10 April: Executive Committee determines number/amount of scholarships
- ◆ Early August: NDIA issues scholarship grants

Eligibility



- ◆ Be a US Citizen
- ◆ High school senior or graduate
- ◆ Applied to/enrolled in accredited 4 year college
- ◆ Pursuing STEM career
 - ◆ Science
 - ◆ Technical: Physics, Chemistry
 - ◆ Engineering: Aerospace, Chemical, Civil, Computer, Electrical, Industrial, Mechanical, Software
 - ◆ Mathematics

Eligibility (continued)



- ◆ Sponsored by Targets/Ranges/UAV Division member (individual or corporate)
- ◆ Sponsored by Gulf Coast Chapter
- ◆ Recipients of full scholarships (military academy, ROTC, etc.) are ineligible
- ◆ Enrollments in 2-year community colleges are ineligible
- ◆ Complete by-laws are available upon request

Your Responsibilities



- ◆ Identify Potential Applicants
- ◆ Notify Scholarship Committee
 - Cort Proctor
 - 1542 Glenlake Circle
 - Niceville FL 32578
 - email: cortp@aol.com
- ◆ Ensure continued tax deductible donations (corporate/individual)

2009 Contributors

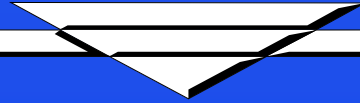

NDIA's Gulf Coast Chapter: \$3000

THANKS

Questions

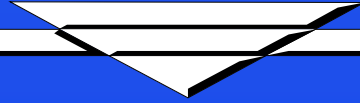

?



MEGGITT

smart engineering for
extreme environments

Hammerhead SwarmEx

NDIA

48th Annual Targets, UAVs & Range Operations Symposium & Exhibition 2010

Mr Spencer Fraser
President & General Manager
Meggitt Training Systems Canada
21 October 2010

© Meggitt Training Systems Canada. This document and the information in it is proprietary and is the property of Meggitt Training Systems Canada. It may not be copied or disclosed to a third party or used for any purpose other than that for which it is supplied without the express written consent of Meggitt Training Systems Canada.

Information contained in this document is subject to certain Export Control regulations, specifically of Canada, the United Kingdom, European Union, other national jurisdiction and / or the United States International Traffic in Arms Regulations and / or Export Administration Regulations. Each recipient of this document is responsible for ensuring that transfer or use of any information contained in this document complies with all relevant Export Control Regulations.

MEGGITT



Agenda

- Genesis of Hammerhead
- Hammerhead Solution
- Swarm Ex Results



Presentation Take Aways

- ▶ Hammerhead USV-T is a proven & cost-effective training target available today, and
- ▶ Large Swarm Training Exercises can be accomplished today, no development required



Genesis of Hammerhead USV-T



**2010 – 10th year since the attack on the USS Cole
A catalytic event for Allied Navies**



Genesis of Hammerhead USV-T

***“...well trained crews remain
the key to survival”***

**Admiral Vern Clark
Chief of Naval Operations
Investigation of USS Cole
United States Department of Defense
January 19, 2001**

Equipment Centric Response

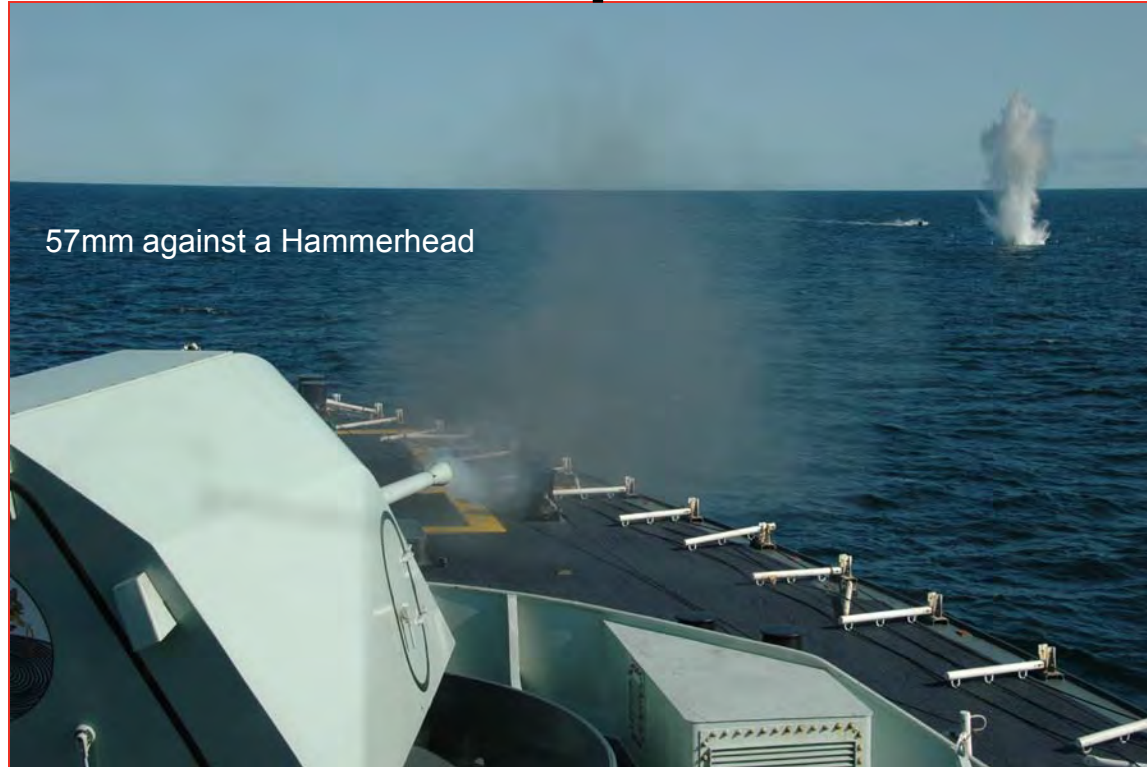

- **Rapid Fire Guns** - some with Air Burst Munitions (ABMs),
- **Stabilized Mounts** - (preferably with operator out of harms way), and
- **Exploit EO/IR sights for better fire-control and situational awareness** (as attacks are probably more likely at night).

Genesis of Hammerhead USV-T

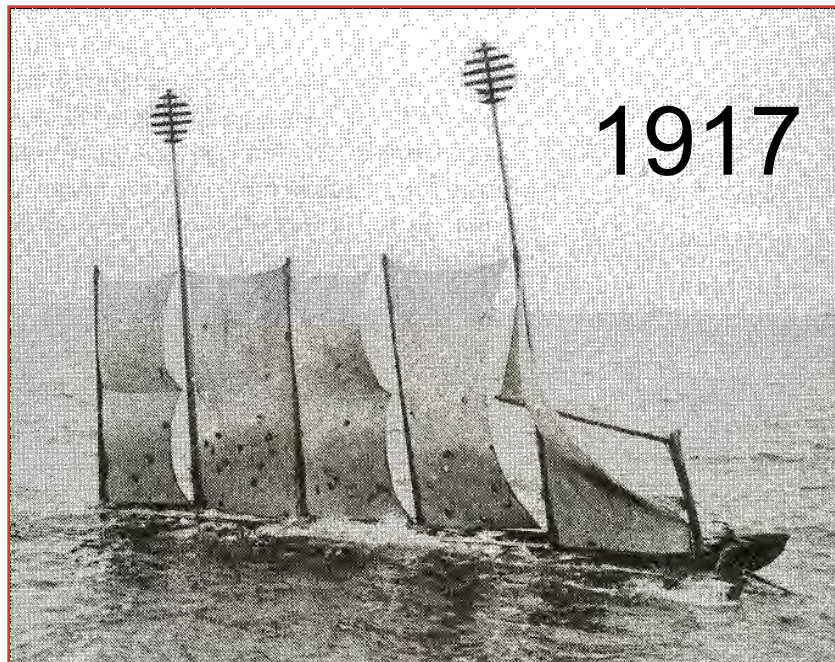

Surface targets over the years – threat replication?



BARRACUDA USV-T

SwarmEx Lessons Learned





Hammerhead Solution

- **Capable & Cost Effective Platform**
 - **Proven (>35knots in SS3)**
- **Ability to control at least 16 vehicles**
 - **Proven**
- **Ability to organize and execute a safe Swarm Ex live fire training event**
 - **Proven**





MEGGITT
smart engineering for
extreme environments



Presentation Take Aways

- ▶ Hammerhead USV-T is a proven & cost-effective training target available today, and
- ▶ Large Swarm Training Exercises can be accomplished today, no development required

MEGGITT
smart engineering for extreme environments

FIAC CHALLENGE

Your Ship's **DEFENSES** VS Our Hammerhead **SWARM**

Can the Swarm be stopped?

Don't wait until it happens again.
Properly train your sailors against the FIAC threat.

On 18 May 2010, Meggitt achieved a world first in live fire naval training. We demonstrated that a large swarm of Hammerhead Unmanned Surface Vehicle Targets can be efficiently and effectively controlled at sea and showed that a large anti-FIAC exercise can be executed in a cost-effective manner.

See "Meggitt Swarm Ex" on [YouTube](#)

Meggitt Training Systems
E-mail: MTSCanada@Meggitt.com



Questions & Discussion?



The information contained in this document is the property of Meggitt Training Systems Canada and is proprietary and/or copyright material. This information and this document may not be used or disclosed without the express authorization of Meggitt Training Systems Canada. Any unauthorized use or disclosure may be unlawful.

The information contained in this document may be subject to the provisions of the trade compliance regulations (including those regulations governing transfer to a dual national or third country national, export and re-export) of various countries; see the first page for specific requirements. The recipient acknowledges that licences from the applicable regulatory agency or agencies may be required before the recipient may further disclose such information to others, and that such licences may impose restrictions on further disclosure of such information. The recipient agrees to comply with all applicable governmental regulations as they relate to the transfer, export and re-export of information disclosed in this document.'



MEGGITT

smart engineering for
extreme environments



UNITED STATES AIR FORCE



Air Force Aerial Targets

October 2010 NDIA Brief

New Orleans, LA

Ms. Holly Reedy
Chief, Full-Scale Targets
Aerial Targets Branch (AAC/EBYA)
Eglin AFB, FL



Overview



- **Purpose**
- System Description
- Organizational Structure
- Product Groups
 - Subscale Aerial Targets
 - Full-Scale Aerial Targets
 - Target Control Systems (TCS)
- Summary



Purpose



- **Provide “Presentations” of Realistic Threat Representative Systems in Support of the Following Joint Requirements:**
 - **Lethality Testing Required for New or Improved Weapon Systems Prior to Production (10 USC 2366)**
 - **USAF Air-to-Air Weapon System Evaluation Program**
- **Validate Performance Of DoD Surface-to-Air and Air-to-Air Missiles and Aircraft Systems**
 - **Emulates Performance, Signatures and Countermeasures (Infrared and Electronic Attack)**



Overview



- Purpose
- **System Description**
- Organizational Structure
- Product Groups
 - Subscale Aerial Targets
 - Full-Scale Aerial Targets
 - Target Control Systems (TCS)
- Summary



System Description



- **Aerial Target “Presentations” Include:**
 - **The Target Itself**
 - **Threat Representative EA/IR Payloads**
 - **Target Control System (TCS)**
 - **Gulf Range Drone Control System (GRDCS)**
 - **Missile Scoring**
 - **Launch, Recovery, Maintenance & Repair of Target**



Overview



- Purpose
- System Description
- **Organizational Structure**
- Product Groups
 - Subscale Aerial Targets
 - Full-Scale Aerial Targets
 - Target Control Systems (TCS)
- Summary



Aerial Targets Branch (AAC/EBYA)

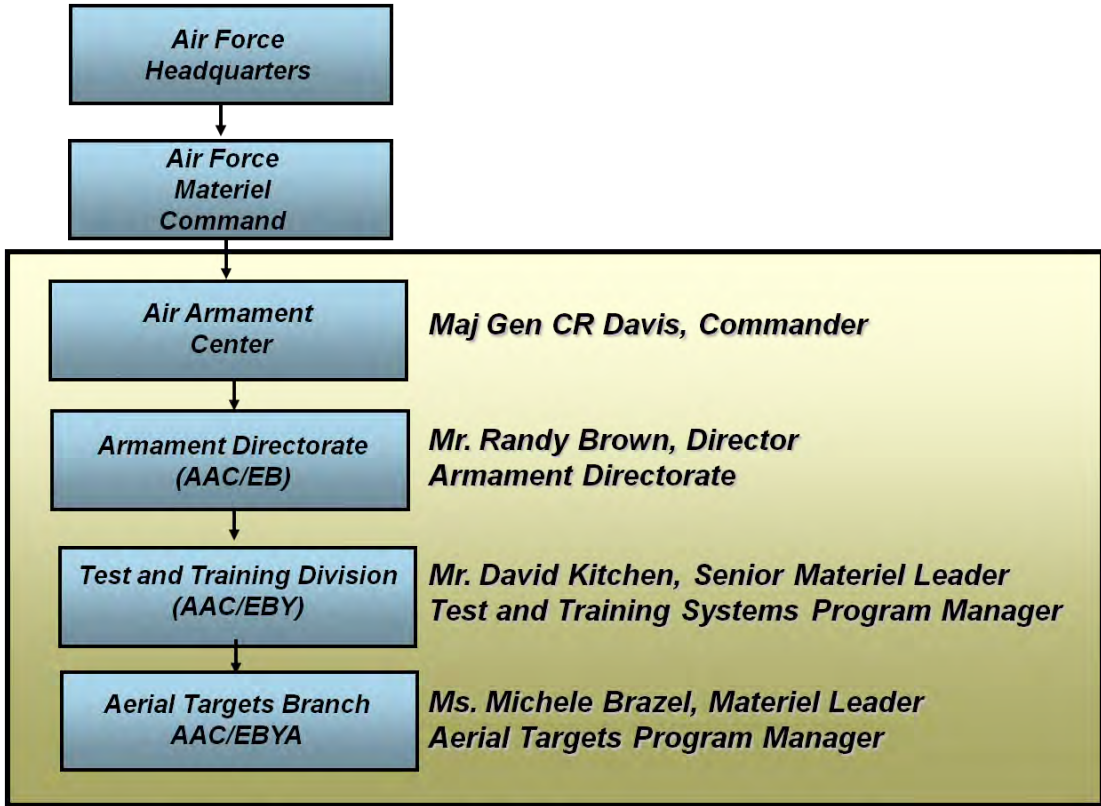

*Ms. Michele Brazel
Materiel Leader*



*Mr. Greg Pixley
Chief Engineer*



*Mr. Jim Cornwell
Chief, Subscale Targets & TCS Section*



*Ms. Holly Reedy
Chief, Full-Scale Targets Section*



USAF Aerial Targets Stakeholders

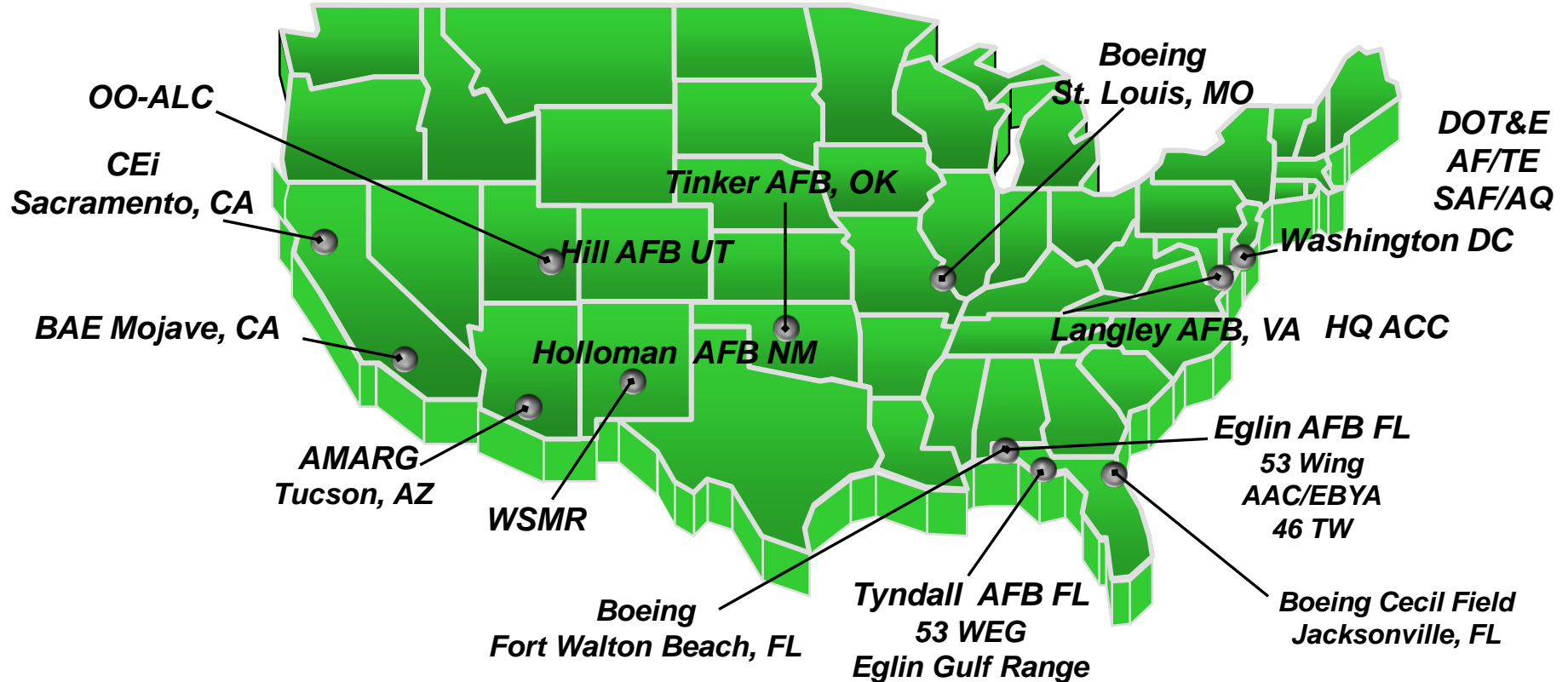



Aerial Targets Schedule

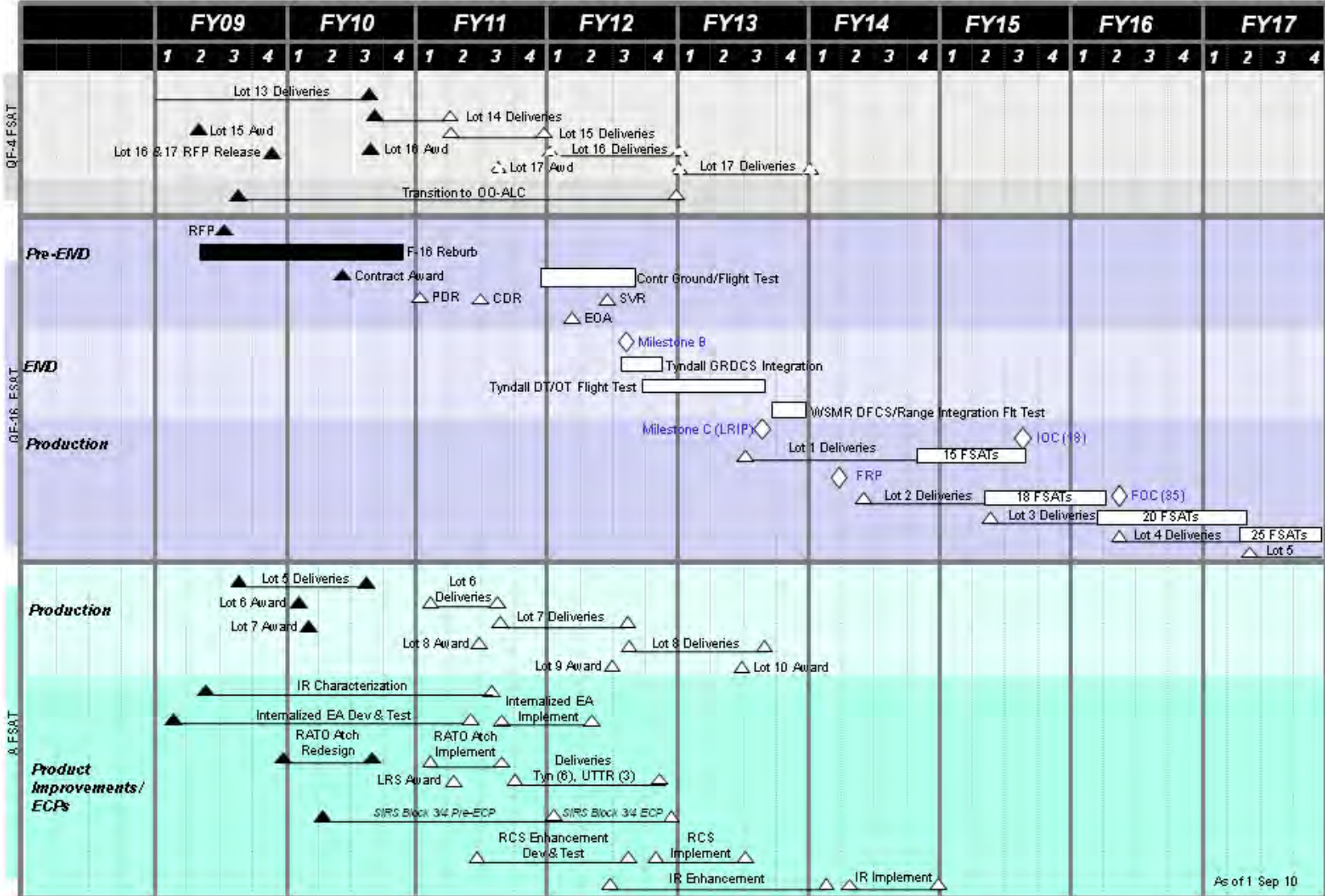

As of 1 Sep 10



Overview



- Purpose
- System Description
- Organizational Structure
- **Product Groups**
 - **Subscale Aerial Targets**
 - Full-Scale Aerial Targets
 - Target Control Systems (TCS)
- Summary



AFSAT Subscale Aerial Target

Ms. Linda Culliton, Program Manager



Prime Contractor: Composite Engineering, Inc. (CEi)

Description

- **An Affordable, All-Composite Airframe**
- **Flies Faster/Slower, Higher/Lower, and Provides 3x+ More Presentations Than Legacy Subscale Targets**
- **Program in Production Phase**
- **Operates via Ground Based Target Control System**
- **Subsonic, Relatively Heavy Payload Capability**





AFSAT FY10 Accomplishments



- **Current Program Focus**
 - Resume Production Deliveries in Nov 10
 - System Improvements (e.g., Internal EA, Selectable Munitions)
 - Sustainment Planning Through 2020
- **164 Targets Delivered to Date**
- **150 WEG Operational “Hot” Missions Supported Since Fielding**

| | <u>FY10</u> | <u>Since Fielding (FY08)</u> |
|---------------|-------------|------------------------------|
| Launches | 114 | 285 |
| Presentations | 457 | 1054 |
| Missile Shots | 356 | 797 |

- **Procuring Nine New Launch Rails**
 - Six for Tyndall
 - Three for Utah Test & Training Range (UTTR)
- **Supported 1st Operational Archer/Hammer at UTTR Aug 10**
 - Follow-on to Successful Nov 08 & Aug 09 UTTR Demonstrations



Overview



- Purpose
- System Description
- Organizational Structure
- **Product Groups**
 - Subscale Aerial Targets
 - **Full-Scale Aerial Targets**
 - Target Control Systems (TCS)
- Summary



QF-4 Full-Scale Aerial Target

Capt Briana Mack, Program Manager



Prime Contractor: BAE Systems, CA

Description

- **Full-Scale Aerial Target for Threat- Representative Weapon System Evaluation**
- **Meets USAF, USA, USN, Allied Test Requirements**
- **Droned, Refurbished F-4 Aircraft Out of AMARG**
- **Program in Full Rate Production**
- **Operates via Ground-Based Target Control System**
- **Supersonic, High-G, Heavy Payload Capability**
- **Provides 3rd Generation Threat Representation**





QF-4 2010 Accomplishments



- **Key Focus – Bridging the Gap Until QF-16 IOC**
 - **Completing Production**
 - **Sustainment Planning Through 2017**
- **Awarded Lot 16; Lot 17 Award Planned 2QFY11**
 - **Total of 273 QF-4s Delivered to Date**
- **Regen/Repair Challenges With Older QRF-4C Aircraft**
- **FY10 Operations**
 - **790 Missions**
 - **27 NULLO**
 - **10 Kills**



The Future of QF-4



- **Last QF-4 Delivery Planned FY13**
- **Sufficient Inventory Through FY15**
 - **Assumes 16 to 20 QF-4 Kills Per Year**
 - **Assumes Current Production Plan**
 - **Maintains Full-Scale Operational Capability Until Planned QF-16 Deliveries**



QF-16 Full-Scale Aerial Target

Mr. Kenneth Hislop, Program Manager



Prime Contractor: Boeing Company, St. Louis, MO

Description

- **Next Generation Full-Scale Target for Threat-Representative Testing & Weapon System Evaluation**
- **Provides 4th Generation Threat Representation**
- **Meets USAF, USA, USN, Allied Test Requirements**
- **Refurbished F-16 Aircraft With Drone Mod Installed**
- **Supersonic, High-G, Heavy Payload Capability**
- **Operations Via Ground Based Target Control System**
- **Program in Pre-MS B Phase**





QF-16 Program Snapshot





- **ACAT Level: II**
- **Production Quantity - 210 QF-16s**
- **Completed Source Selection 8 Mar 10**
 - **Awarded Pre-EMD Contract: The Boeing Co, St Louis MO**
 - **Contract Type - FPIF/FFP**
 - **Pre-EMD Period of Performance Through 21 Jun 12**
 - **Options for EMD, LRIP and 4 FRP Lots**
- **Major Milestones**
 - **MS B – 3QFY12**
 - **MS C – 3QFY13**
 - **IOC – 3QFY13**

First Cecil Field Delivery – Blk 25 84-1260

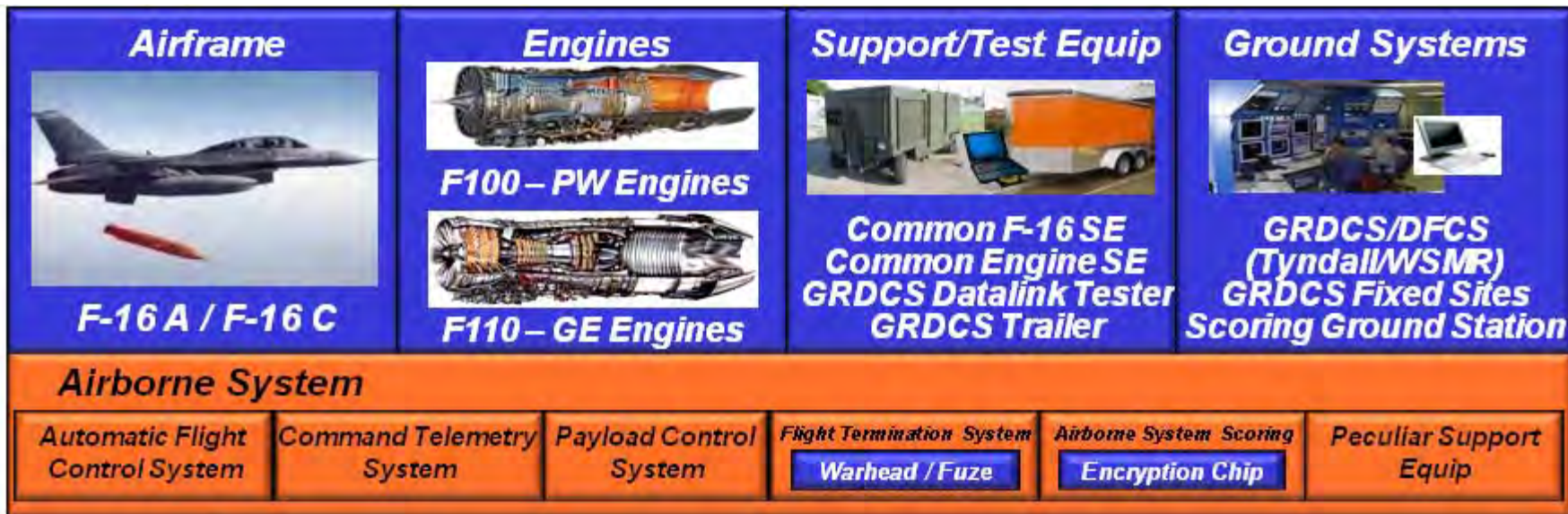

QF-16 System



 **Government Furnished**
(67% of \$)

 **Contractor Developed**
(33% of \$)

**QF-16 System Integration:
Contractor Drone Peculiar Equipment w/ GFP**



QF-16 Support Equipment

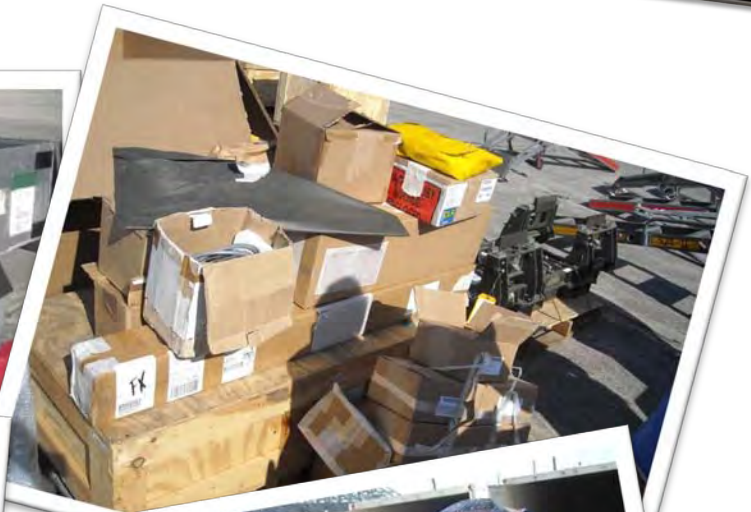



From Desert Floor to Contractor



A/C DELIVERIES TO CECIL FIELD



AMARG REGENERATION



STATIC DESTRUCT TEST



PRE-TEST



QF-16 TEAM



Overview



- Purpose
- System Description
- Organizational Structure
- **Product Groups**
 - Subscale Aerial Targets
 - Full-Scale Aerial Targets
 - **Target Control Systems (TCS)**
- Summary



Gulf Range Drone Control System (GRDCS)

Ms. Kathy Fuszner, TCS Program Manager

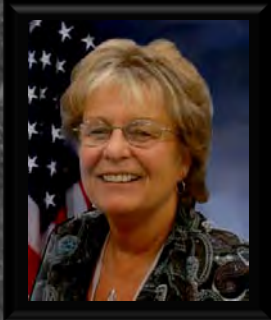

Description

- **Developed in Early 1980s to Support AMRAAM**
- **System Developed with “In-House” Technical Expertise**
- **Eglin CCF Real Time System**
- **Track/Control Any Mix of Drones**
- **Track Shooters, Track and Terminate Missiles**
- **Track High Fliers, Track Other Aircraft**
- **DME TSPI , Z-Aiding – Aircraft Telemetry**
- **Over the Horizon Tracking**



QF-16 Operational View

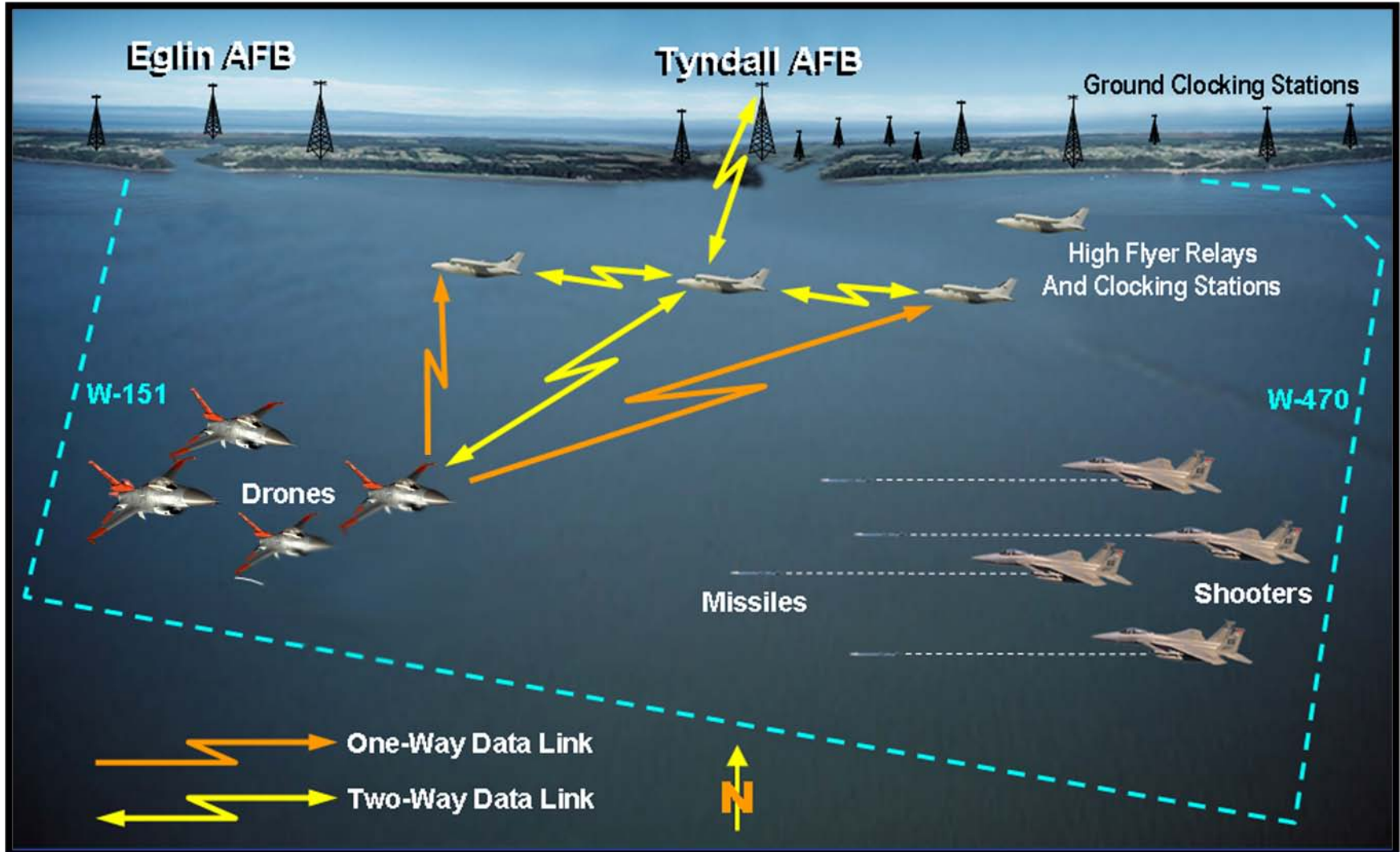



Ranges

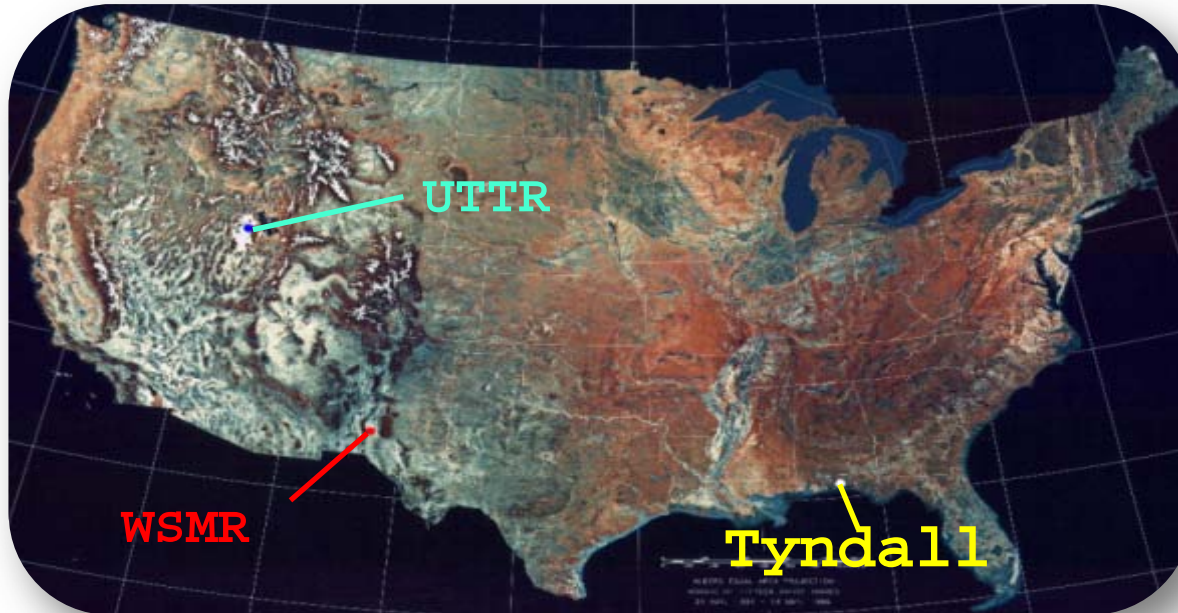

Tyndall AFB / Eglin AFB

- Main Mission Ops (53 WEG)
- GRDCS Sustainment & Dev (46 TW)
- Target & Target Control Acq (AAC/EBYA)

Holloman AFB / WSMR, NM

- Support FSAT Ops (53 DET)

Utah Test & Training

- Support Combined Combat Archer and Combat Hammer Evaluation (53 WEG)



GRDCS Improvements



Console

- Widescreen Monitors
- COTS Touch Screen
- Integrated Connection Programmable LCD Pushbuttons with Standard Serial Interface
- USB Joystick



Display

- Modern Open Standard OpenGL
- COTS PCs
- Linux Based OS
- Modern Display Technology



Linux Server



Overview



- Purpose
- System Description
- Organizational Structure
- Product Groups
 - Subscale Aerial Targets
 - Full-Scale Aerial Targets
 - Target Control Systems (TCS)
- **Summary**



Summary



- **AFSAT – Workhorse for Warfighter**
 - Supported a Record 60 Operational Missions in FY10
 - Next Step to Award Lot 8 in FY11
- **QF-4 Production Planned Through FY13**
 - FSAT Inventory to Bridge Gap Until QF-16 IOC
- **QF-16 Pre-EMD Underway**
 - Contract Awarded to Boeing
 - First Production Delivery Late FY14
- **TCS**
 - HW & SW Modernization

Click Middle of Screen to Start Movie

Miniature Air Launched Decoy (MALD[®]) & Future Concepts

Presented at the NDIA

48th Annual Targets, UAVs & Range
Operations Symposium & Exhibition

10/20/2010



Raytheon Missile Systems

®MALD is a registered trademark of Raytheon Company

Cleared For Public Release 5 May 2010, 96ABW-2010-0286

DSER 163378

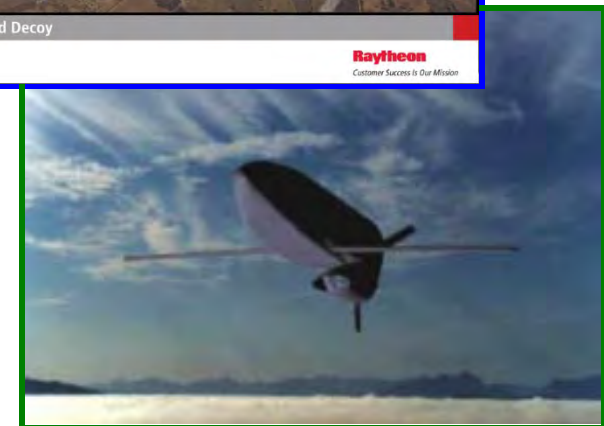

Miniature Air Launched Decoy

- Low-Cost, Air-Launched Programmable Craft
- Duplicates the Combat Flight Profiles Signatures of U.S. and Allied Aircraft
- Deceives Air Defense Systems that Pose a Threat to U.S. and Allied Pilots
- Modular Flexible System Capable of Delivering a Spectrum of Effects



- Modularity—Same Production Line
- Affordable—Swiss Army Knife Design
- Flexibility—Spectrum of Effects



MALD[®]

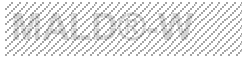
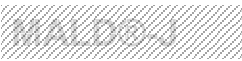

MALD[®]-V



USAF Programs
USAF Study

Raytheon Growth Initiatives



"MALD[®]... Spectrum of Effects"

MALD® Vehicle B-52 and F-16 Threshold A/C

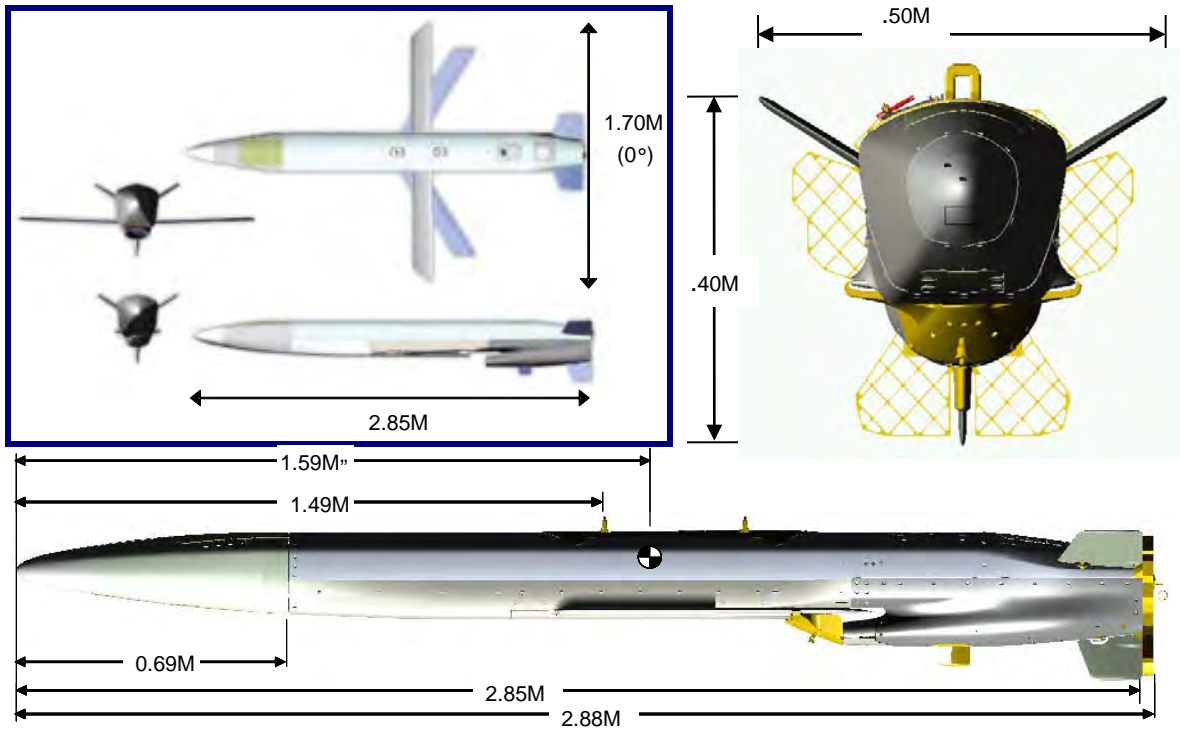

MALD® Air Vehicle Overview

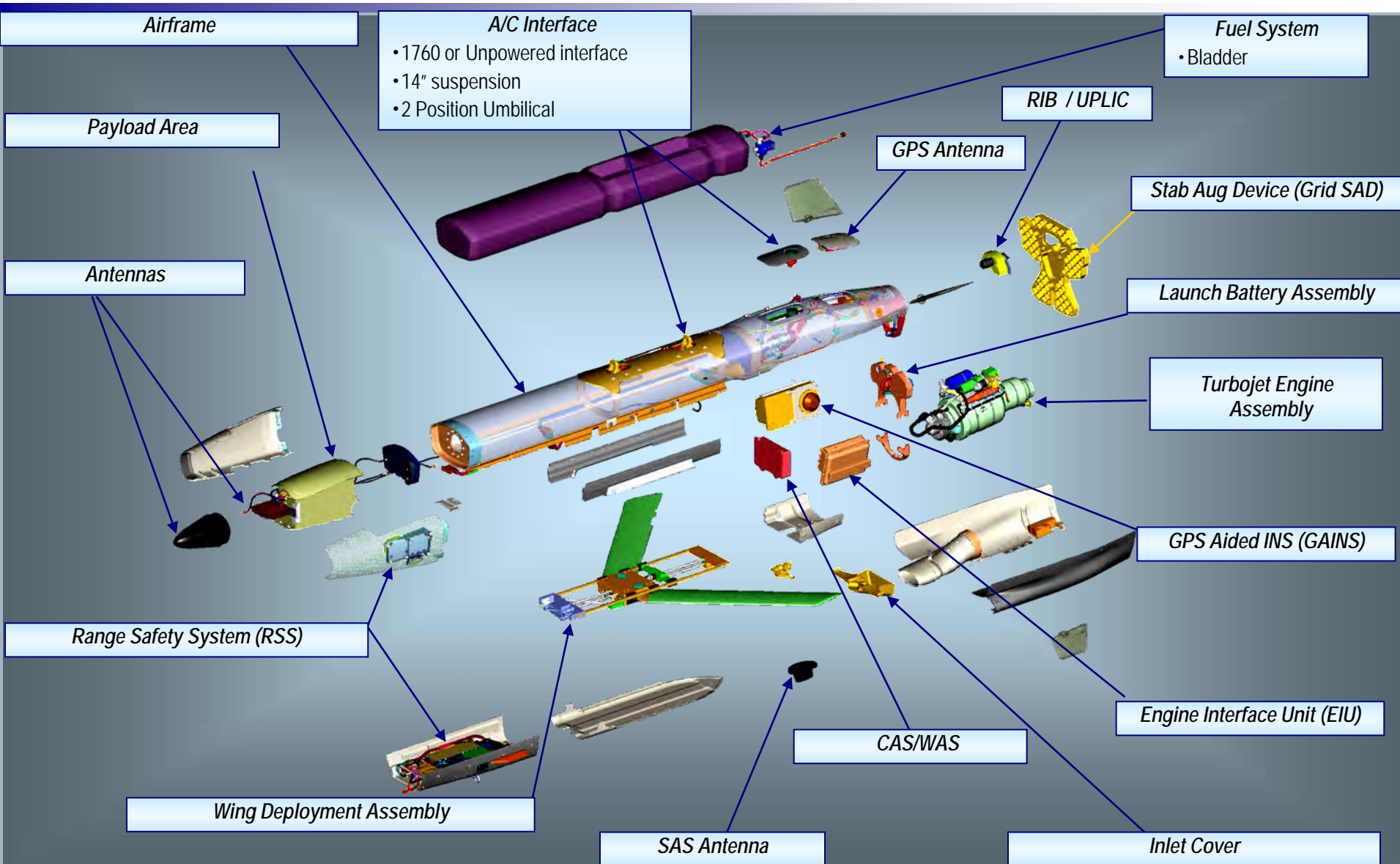

- **Specifications**

- System Weight: ~ 280 Pounds
- Payload Weight ~ 40 Pounds
- Payload Power ~ 1 KVA



- **Flexible Aircraft Interface**

- 1760 Interface or Unpowered
- 14 Inch (35.56 cm) Suspension Lugs
- Pull Lanyard

- **GPS-Aided Inertial Navigation Systems (GAINS)**

- Precise Preprogrammed Navigation

- **Signature Augmentation System (SAS)**

- Contains Various Active Radar Enhancers with a Range of Frequencies
- Simulates Range of Relative Aircraft Sizes

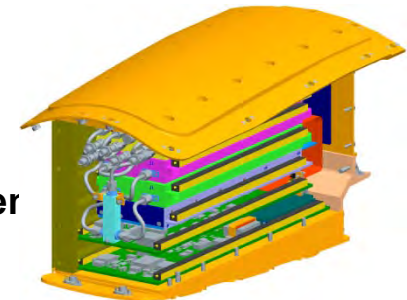

- **Missions Preprogrammed Prior to Launch**

- **Operating Altitudes:**

- T/O to 35K' MSL
- Launched 6K' AGL to 25K' MSL
- Post Launch 2K' AGL to 35K' MSL

- **Rate of Climb:**

- 1500 fpm @ 25K' MSL
- 4000 fpm @ 3K' MSL

- **Launch:**

- Envelope 1G (± 0.5 G) Level flight
- 6K' AGL to 25K' MSL
- 220K to 450KCAS, NTE 0.90M

- **Jettison:**

- No Restriction to Aircraft Jettison Envelopes (T=O)
 - Certified F-16 and B-52

- **Turn Maneuverability:**

- Represent Aircraft Turn Maneuvers of 2Gs @
2K' MSL to 19K' MSL

- **Temperature:**

- +71 °Centigrade (°C) to -46 °C
- 0.35M to 0.9M @ 3K' MSL

- **Materiel Reliability:**

- .93

- **Service Life:**

- 60 Days Cum if Sheltered
- 30 Days Not Sheltered

- **Shelf Minimum**

- 15 Year Shelf Life in Container

- **Storage Reliability:**

- 0.95, Allowed Degrade to 0.80 Over 15 yrs

- **Carriage Life:**

- Minimum of 60 hours

- **Built-in-Test (BIT) Reprogramming:**

- Not to Exceed 5 min

- **Near Perfect DT, Delivering to USAF Now...Completing IOT&E**
 - Over 300 MALD[®]'s on Contract...Working Fourth Production Contract Now
- **MALD[®]-J in EMD, 4th Production Contract Postures for J IOT&E**
 - FRP Decision & Release Policy Follows...MALD[®] Aerial Target Ready Now
- Recognized by *Aviation Week* for Program Excellence in 2009

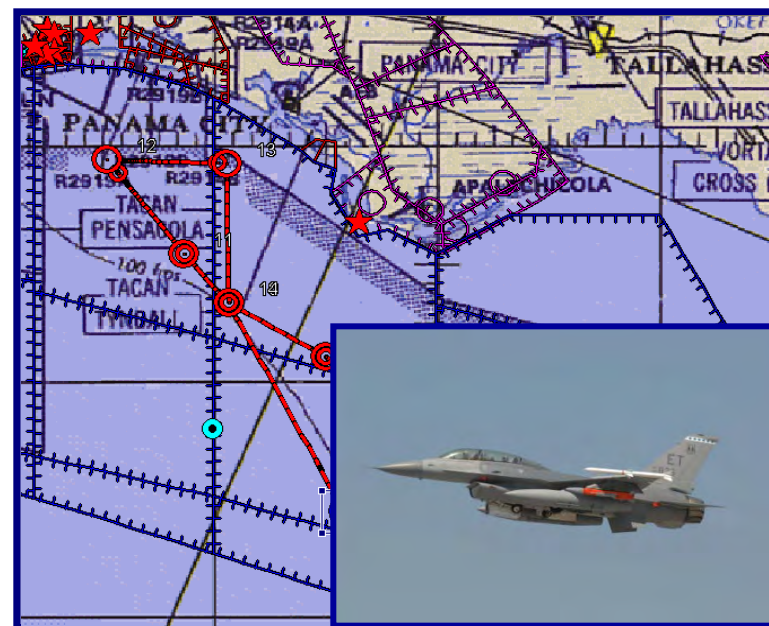

- Modularity—Same Production Line
- Affordable—Swiss Army Knife Design
- Flexibility—Spectrum of Effects



MALD®

MALD®-J

MALD®-J Inc II

MALD®-W

MALD®-V

MALD®-A

MALD®-TL



**Raytheon
Growth Initiatives**



"MALD®... Delivering a Spectrum of Effects"

- **MALD® Less the Payload--Use Indigenous Payload or as Aerial Target**
 - Maximizes Scarce R&D Dollars for Payload Development
 - Reduces Development Risks Using a *Proven Solution*
 - Compresses Development Schedules
 - Easily Integrated/Employed From Multiple Aircraft
- **International Interest Increasing...**



MALD-VTM “Truck”

Raytheon
Missile Systems

Payload Area

- User Integrates Own Payload
 - Jamming Equipment
 - Seeker
 - Data Link
 - Surveillance Equipment
 - Warhead

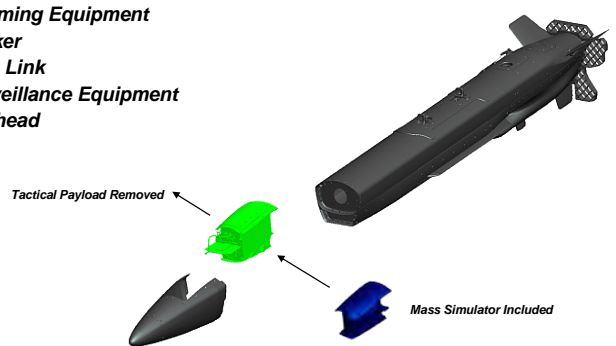

4/3/2009 | Page 12



Affordable Miniature Aerial Target (AMAT)

Raytheon
Missile Systems

- Maximize Aerial Engagement Opportunities Within Budgets
- Can Replicate the Size of Multiple Different Aircraft for Beyond Visual Range Training Engagements
- Easily Launched from Military, Non-Military Aircraft, or Container Launched



Page 1

- Maximize Aerial Engagement Opportunities Within Budgets
 - Replicate Multiple Different Aircraft for BVR Training
 - Use to Deplete Shelf-Life Expired Air-to-Air Radar and/or IR Missiles
- Easily Launched from Military or Non-Military Aircraft



- **Fit Checks Accomplished**

- F-18
- Harrier

- **Preliminary Studies**

- JSF
 - Initial Discussions with Lockheed Held 12-09
 - A MALDTM fit into Weapons Bay Planned
 - Fit Check with JSF Launch Rack Planned
- Eurofighter
 - Fit Check Planned



- Only Sub-300 Pound, Low Cost System With an Extended Range
- In Production
- Flexible Aircraft Interface
 - Flight Certified on F-16, Low Entry Costs
 - 1760 Interface or Unpowered (Pull Lanyard)
 - 14 Inch (35.56 cm) Suspension Lugs
 - Transferable to Other Aircraft
- Spectrum of Effects
 - Reduces Logistics Foot Print
 - Multiple Systems Leverage from Single Design
- “Truck” Accommodates Different Avionics & Communication Goals
- Unprecedented Flight Test Box Score
- Award Winning R&D Team

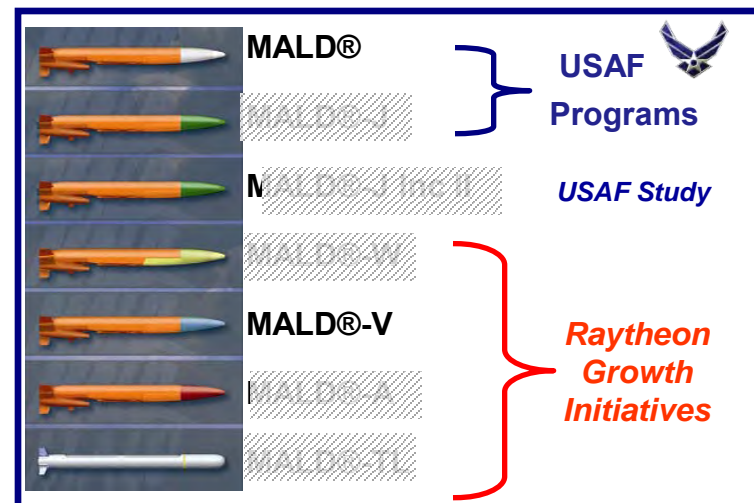

MALD® ... A Low-Cost Aerial Target Alternative



Back Ups

Raytheon
Missile Systems

- ✓ **Increases Survivability in Defense of Airspace**
 - Entice the Enemy to Expend Resources on Decoys
 - Creates an Advantage in the Air to Air Arena
- ✓ **Force Multiplier for Gaining Air Superiority**
 - Makes You Appear to Have More Aircraft
 - Responsive, Persistent, Cost-effective
- ✓ **Stimulate Integrated Air Defense Systems (IADS)**
 - Deceive/Confuse IADS Commanders
 - Forces Difficult Engagements Using Scarce Resources
- ✓ **Reduce Reliance on Manned Aircraft for SEAD**
 - Persistent, Flexible, Expendable, and Affordable
- ✓ **Simple, Modular, Cost-Efficient**
 - Versatile Airframe
 - Interoperable



Increases Survivability...

- Continuous Operation

- 18 Hours

- Navigation System – Dynamics

- Angular Displacements, Rates, Accelerations
- Linear Acceleration and Velocities

- Navigation – Horizontal

- <30M With GPS
- <2NM After 5 min Without GPS

- Navigation Systems – Vertical

- <30 m GPS
- <1000 ft After 5 Min Without GPS

- Time of Arrival Control

- +/- 20 Seconds at Waypoint

- GPS Acquisition Performance

- Cold Start – 60 Seconds
- Warm Start – 15 Seconds
- Hot Start – 5 Seconds

- Waypoint Capacity

- 100 Waypoints

- Growth Potential/Activities

- Anti-Jam
- Thermal Conditioning
- Data Link Interface

- GPS

- L1 and L2
- SAASM Compliant

MALD[®] Guidance Scheme

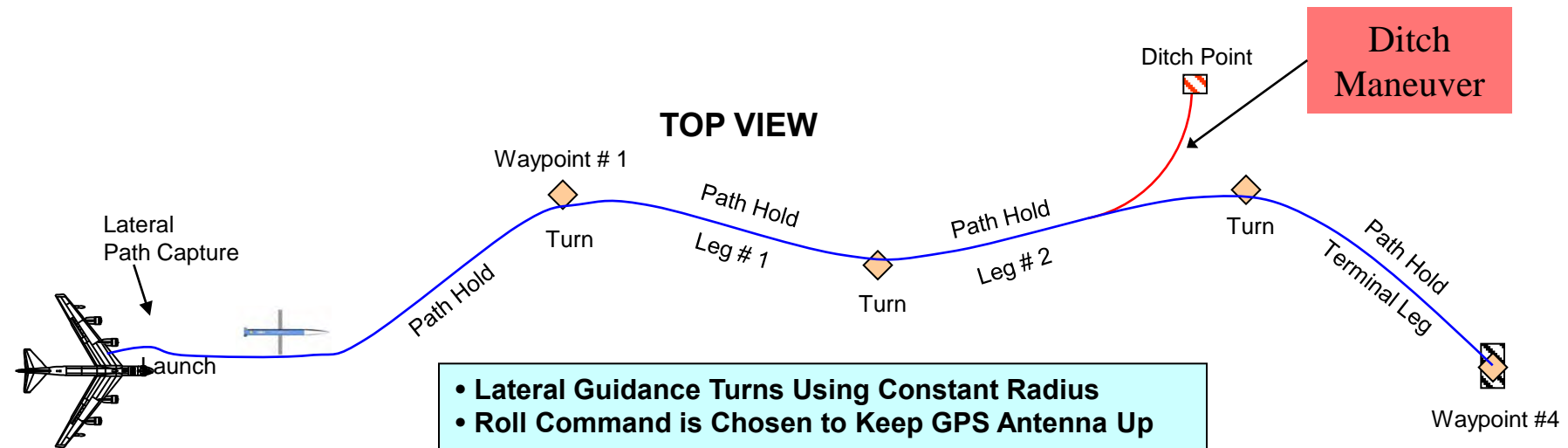
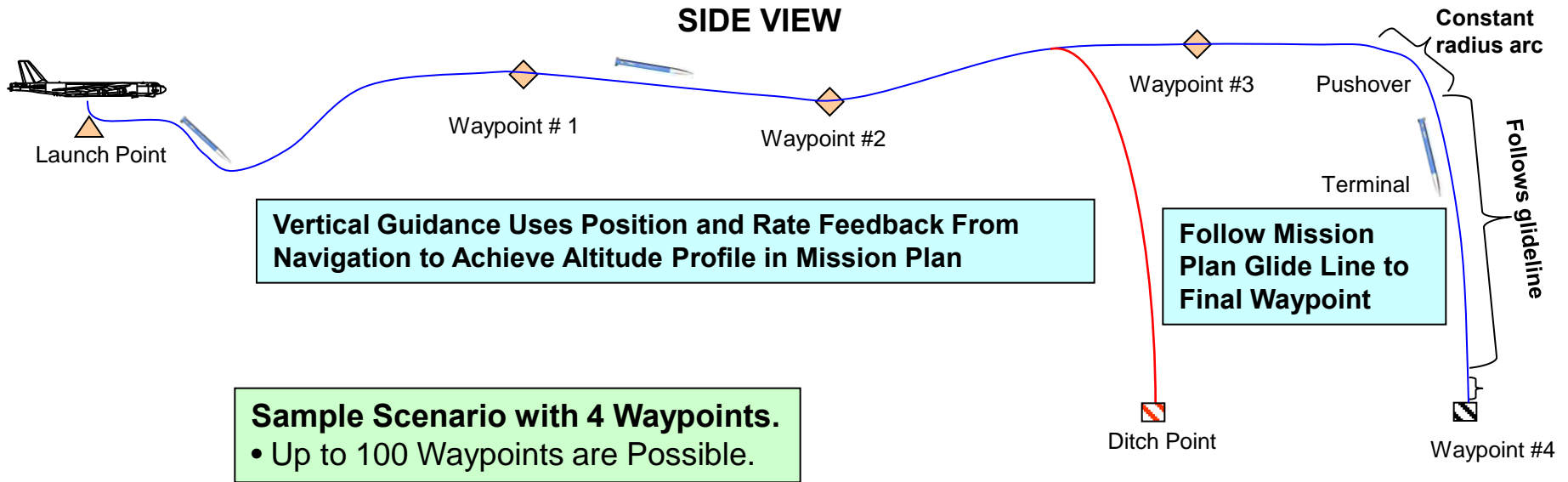

Launch - Separation - Transition to Cruise

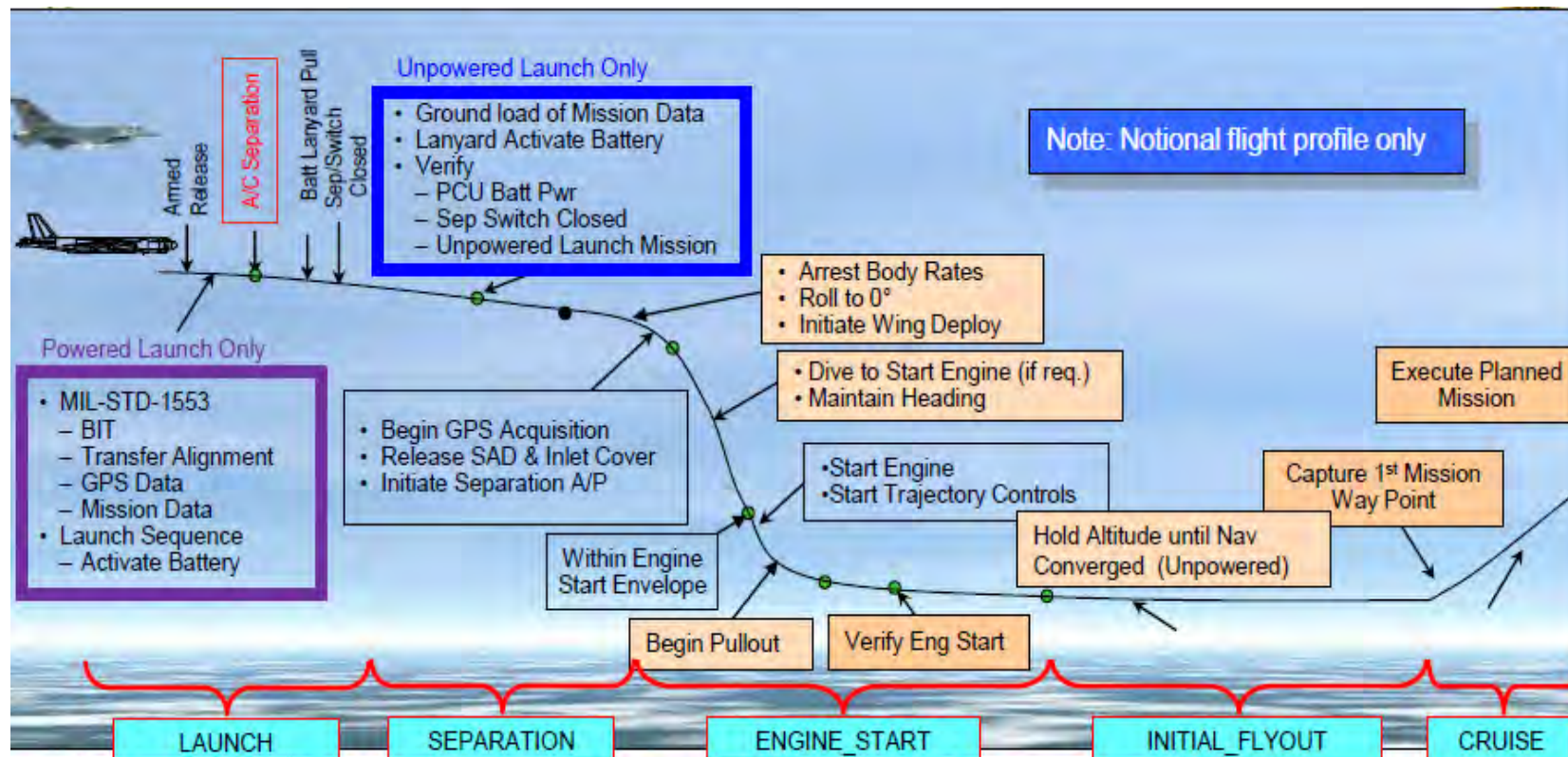

MALD[®] Payload System

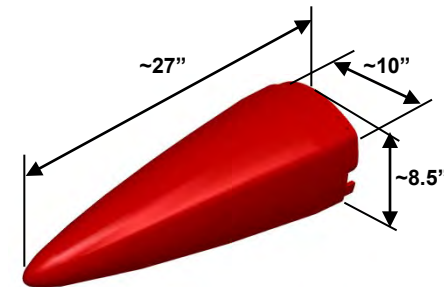
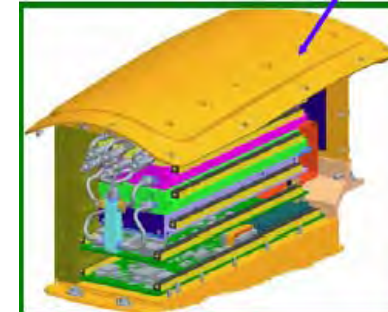
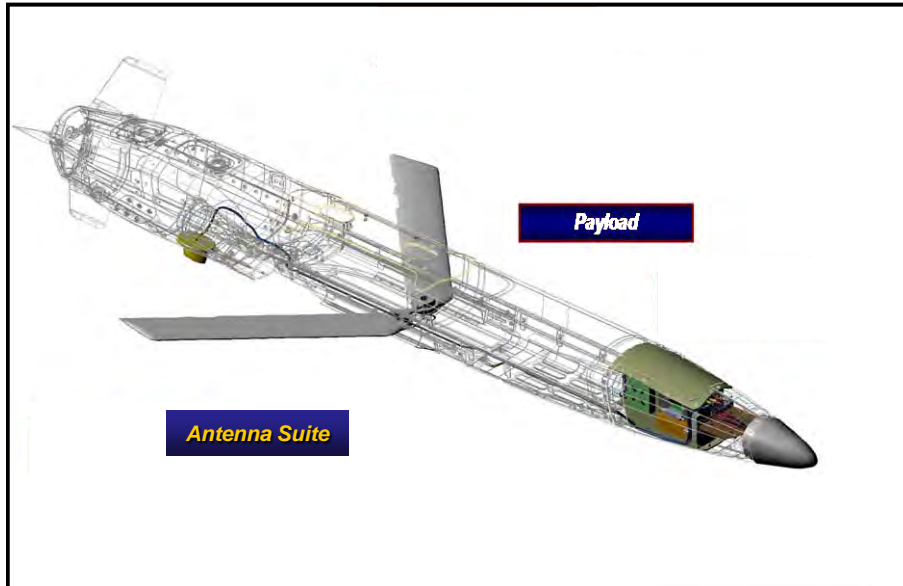

Power Requirements:
Voltage: +28 VDC Nominal, 19.4 VDC Minimum, and 33.0 Maximum
Standby Power: 28 Watts Maximum
In-rush Current: Peak Amplitude No Greater Than 25 Amps and Duration Less Than 1 Millisecond

- Flexible Aircraft Interface
 - Compatible with an MIL-8591 14 Inch Suspension Lugs
 - **Un powered Interface**
 - No Umbilical
 - Lanyard Squibbed Battery
 - Smart Data Interface (1760)

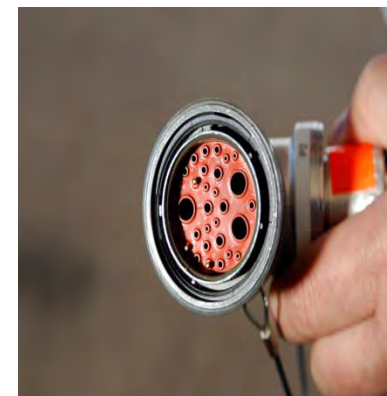

- Mission Planning
 - JMPS Compatible

- Un powered Interface
 - Missions Loaded via RIB on the Ground with CMBRE*
 - Maximum of 8 Missions
 - Ground Crew or Pilots Selects Mission Prior to Take Off
 - Cannot Be Changed Once Aircraft Takes Off

- Smart Data Interface (1760)
 - Mission Data Loaded onto Aircraft – Multiple Missions
 - Pilot Loads a Single Mission onto MALD[™] Prior to Launch
 - Mission Can be Changed Prior to Launch

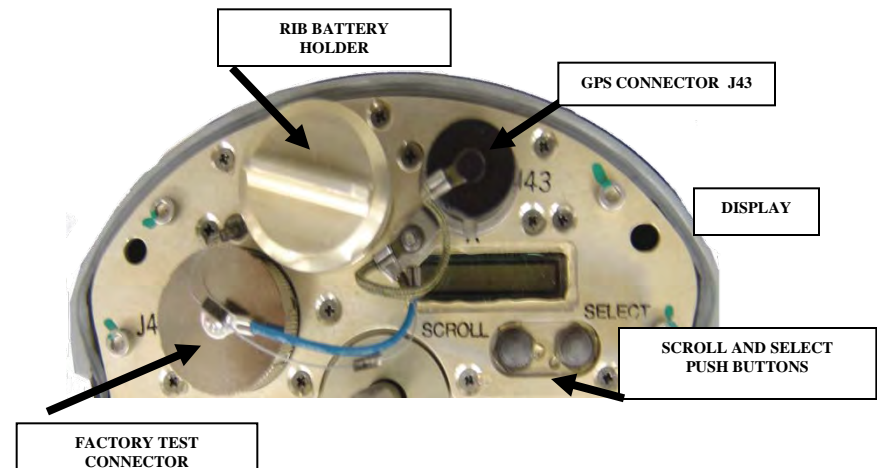
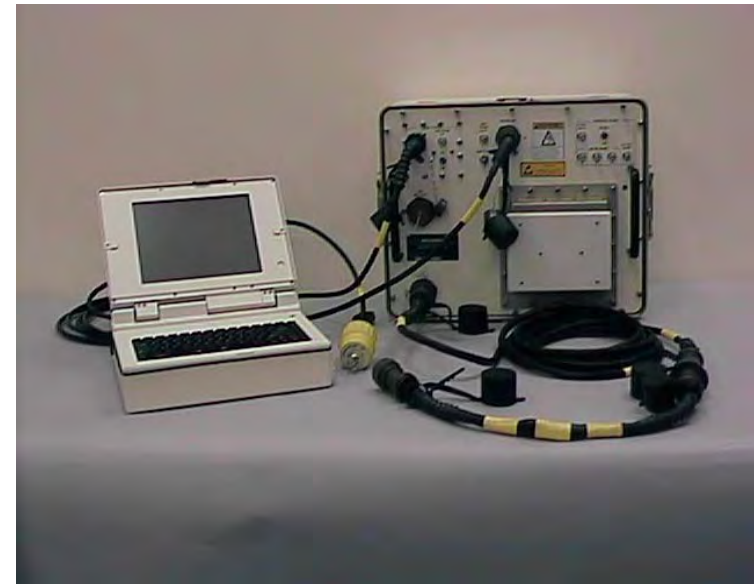

* Common Munitions Bit/Re Programming Equipment

The background is a composite image. At the top, a dark space scene shows a fighter jet with glowing orange lights along its fuselage. Below this, a rocket is shown launching from a launch pad, with a large plume of white and orange smoke and fire at its base. In the bottom left corner, a soldier is shown from the chest up, holding an M4-style rifle. The overall color palette is dominated by blues, oranges, and greys.

Innovation ... Delivered.

Multi-Stage Supersonic Target (MSST)

Mike Stuart
ATK Defense Electronics Systems
Director, Missiles Business Development

NAVAIR Public Release 10-1294
Approved for public release; distribution is unlimited.

- Requirement
- Preliminary Design Review (PDR)
- Engineering Evaluation (EEU) #2
- Critical Design Review (CDR)
- Flight Test Program
- MSST Profile
- Growth Opportunities



- MSST is system designed to represent a family of threat systems with an extremely wide variety of flight parameters and representations
 - A two-stage unmanned aerial target, launcher and associated support equipment
 - Subsonic bus stage followed by a supersonic sprint stage
 - Maximum range in excess of 100 NM
 - Minimum cruise altitude approximately 50 feet
 - Separation event at altitudes below 3000 feet
- MSST will provide unparalleled threat representation for developmental and operational testing of major DoD and international weapon systems

Multi-Stage Supersonic Target Requirement



A premier aerospace and defense company

- MSST is designed to emulate advanced two-stage Anti-Ship Cruise Missiles in support of Air Defense Weapons/Combat Systems T&E events for major acquisition programs
- Prime Contractor: Alliant Techsystems Inc. (ATK)
- Development effort will lead to follow-on contract for Low-Rate Initial Production and Full- Rate Production
- Initial Operational Capability planned for 2014
- ACAT IVM Program that directly impacts ACAT I Programs

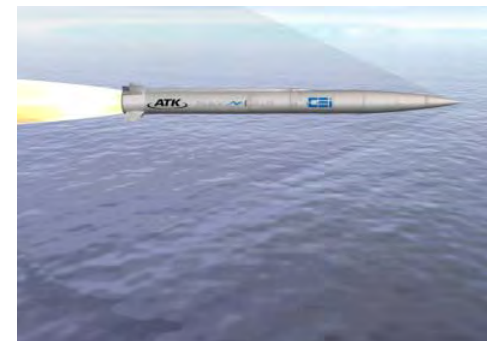

- Completed 2nd Quarter 2010
- Due to impending Pre-CDR flight test in November 2010, the maturity of both the hardware and software designs were well ahead of most programs at the PDR stage
- Rocket motor technology was adapted from a well proven VLA design
- The bus system was adapted from the well proven BQM-167x design used by Composite Engineering Inc (CEi)
- Successful passing of the PDR was accomplished by closing some RFAs required for CDR and within 90 days of PDR conclusion



Prototype
MSST
Vehicle for
PDR

- A risk-reduction Engineering Evaluation Unit (EEU) #2 flight is scheduled prior to the Critical Design Review (CDR)
- This flight test requires a significant amount of the required CDR design be completed prior to this flight.
- Fidelity of both hardware and software is well ahead of most programs due to this flight test (HW 95%, SW 85%)
- Flight test scheduled for 17 Nov 2010
- EEU#2 will significantly reduce the engineering development cycle following CDR

- Currently planned for 1st Quarter 2011
- 80% of critical Design will be completed by EEU#2 Flight Test
- Subsystem CDRs scheduled to be completed by the end of 2010
- With successful completion of EEU#2 risk-reduction flight, CDR is anticipated to go extremely well
- Scheduled closure of CDR is April 2011

Flight Test Program (FTP)



A premier aerospace and defense company

- FTP is scheduled to be initiated during the 1st quarter of 2012
- FTP consists of 6 flight tests scheduled to complete the design requirements matrix
- 7 EDM vehicles are scheduled to be deployed during FTP
- One flight test includes 2 units fired in close proximity of each other and at the same ship
- FTP scheduled to conclude in early 2013

MSST Profile



A premier aerospace and defense company

ATK MSST Mission Sequence

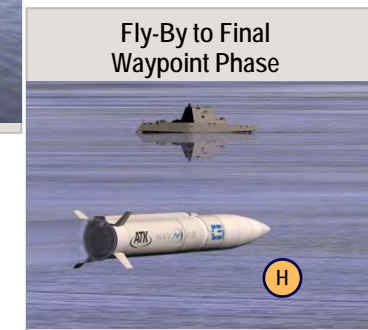
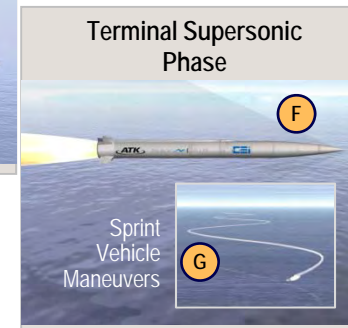
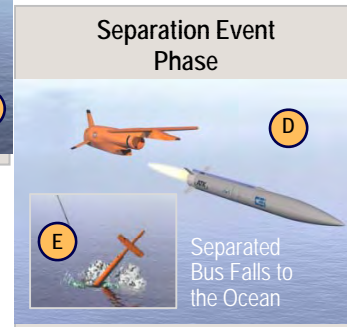
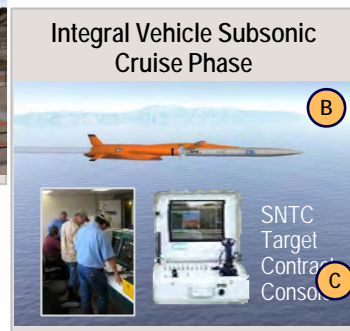
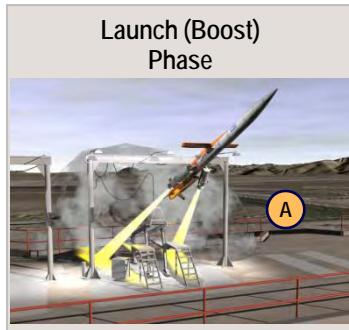

Designed with Low Cost and Efficient Target Representation as the Priority

Launch Boost Phase

- Ground launched by dual Rocket Assisted Take Off (RATO) bottles providing ~ 26,000 lbs of total thrust
- RATOs separate from Integral Vehicle ~2.5 seconds after launch
- Autopilot stabilizes vehicle

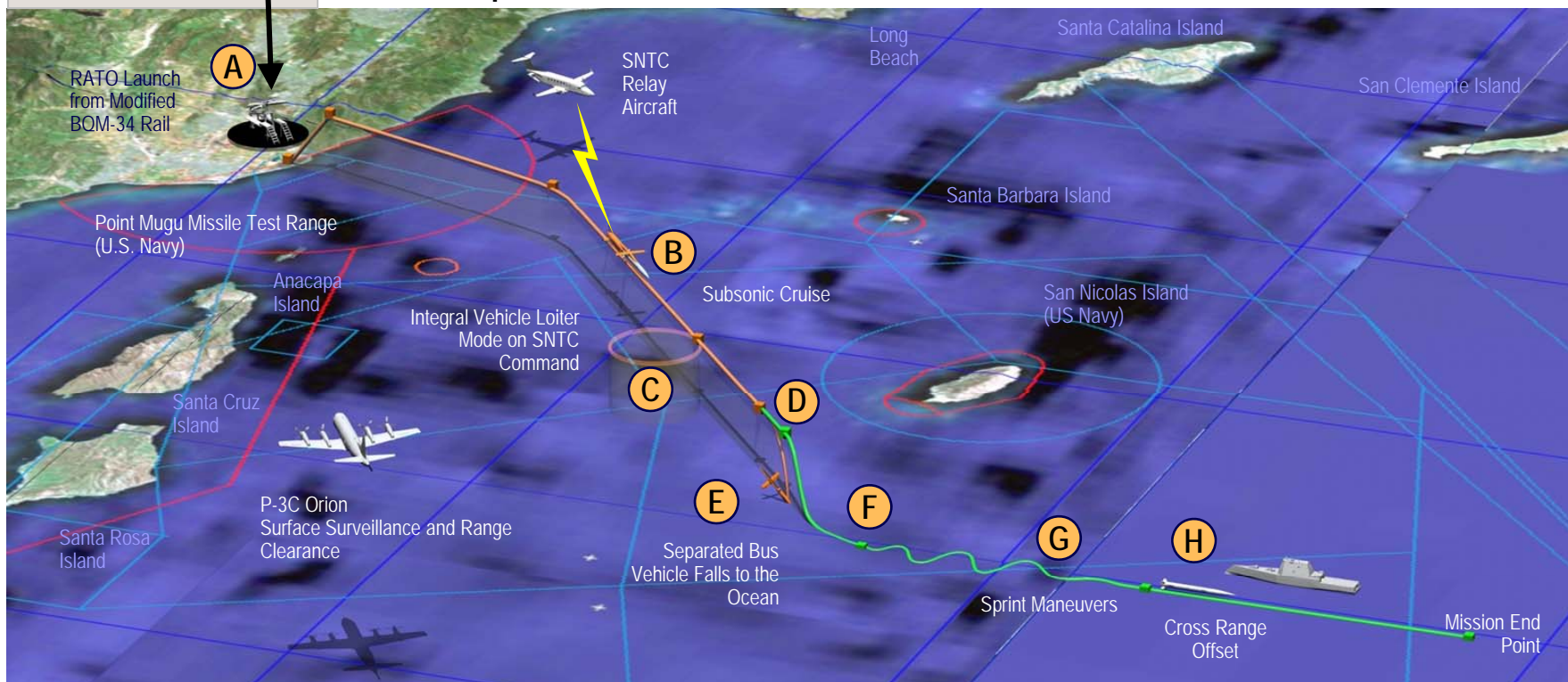
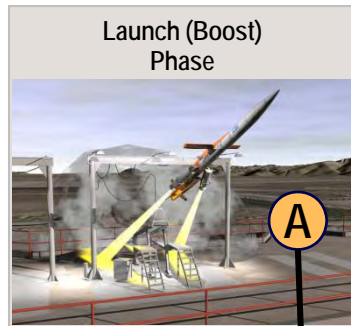

MSST EEU2 on Launch Rail - 01 October 2010



A premier aerospace and defense company



MSST EEU2 on Launch Rail - 01 October 2010



A premier aerospace and defense company



Integral Vehicle Subsonic Cruise Phase

- After the Integral Vehicle is stabilized, waypoint guidance is initiated based on pre-programmed mission events
- A turbojet engine provides thrust for subsonic cruise up to Mach .8

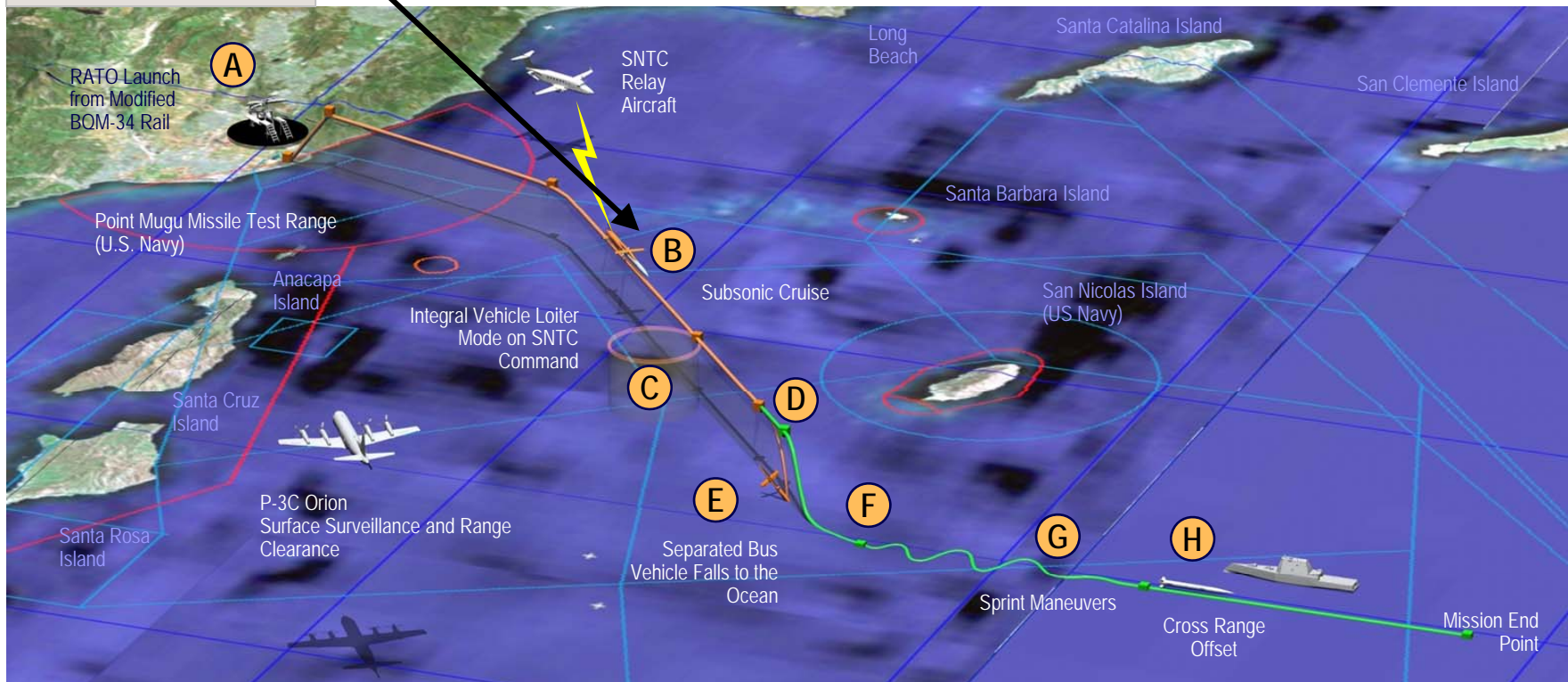
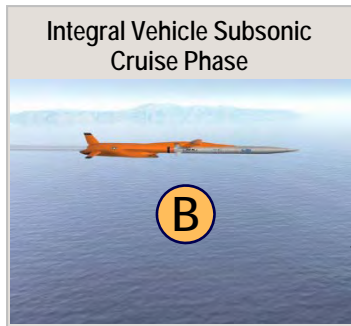

Integral Vehicle Subsonic Cruise Phase Loiter Mode

- The System for Naval Target Control (SNTC) can be used to modify pre-programmed missions or takeover vehicle control
- The SNTC operator can control the vehicle to avoid unforeseen obstacles and initiate the separation sequence

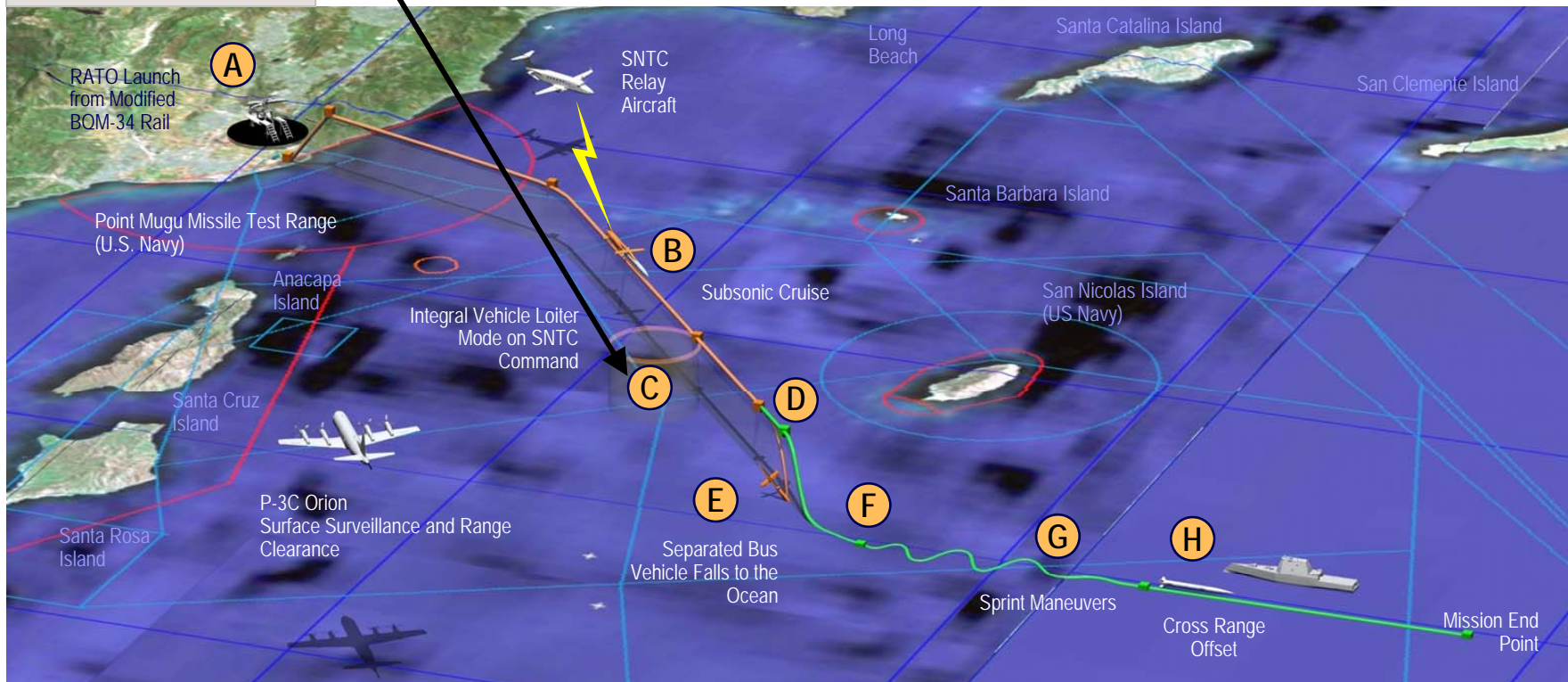

Separation Event Phase

- The Integral Vehicle separates into the aft Bus and Sprint vehicles when the separation waypoint is achieved or separation is initiated by SNTC

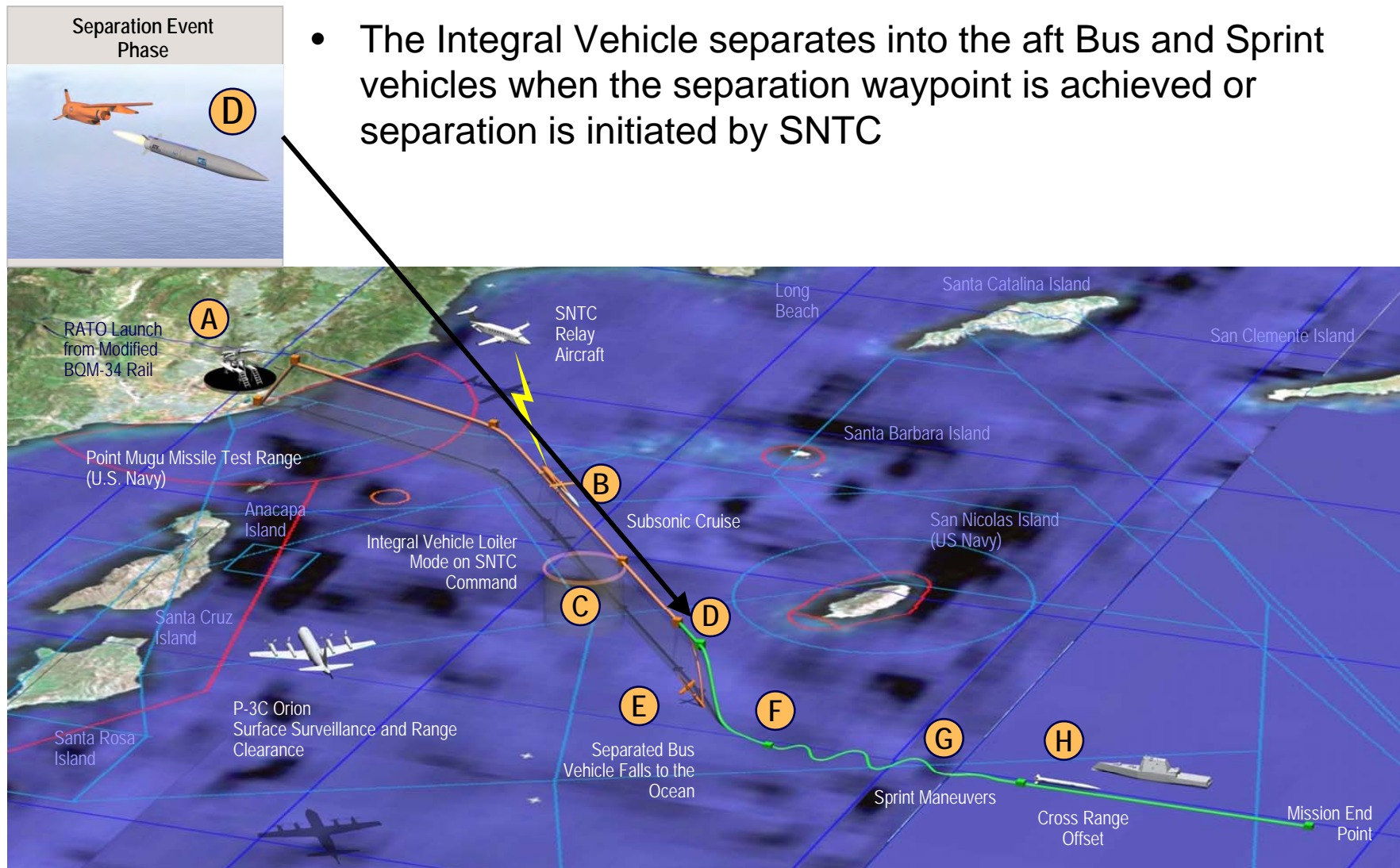

Separation Event Phase Bus Falls Into Ocean

- After separation, the aerodynamically unstable Bus tumbles and falls into the ocean

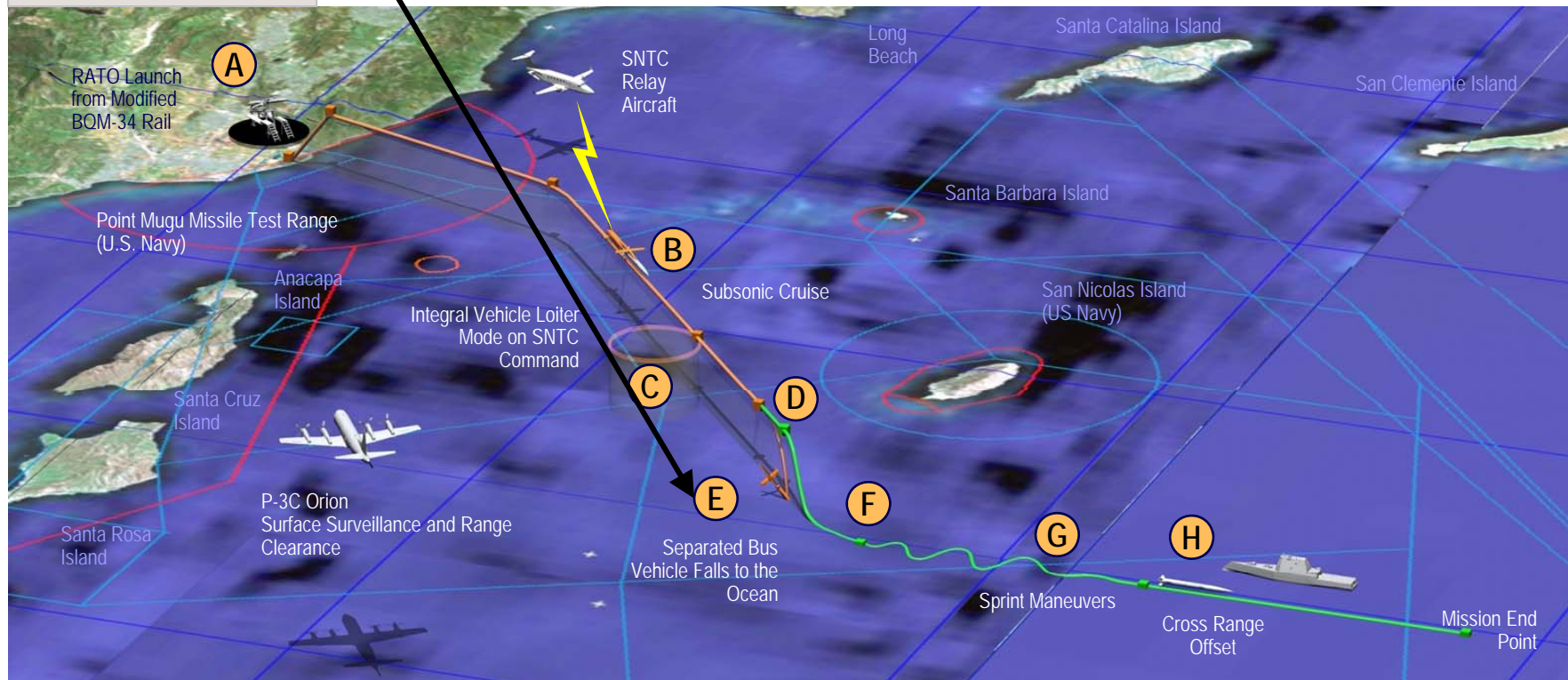
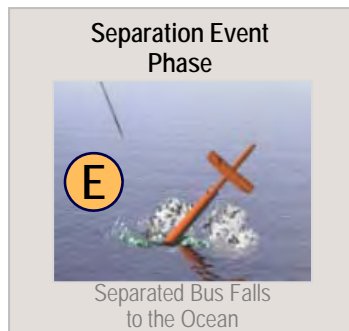

Terminal Supersonic Phase

- The Sprint Vehicle ignites a solid rocket motor after separation and accelerates the vehicle up to Mach 3.5
- Waypoint guidance based on mission events controls the vehicle and initiates climbs, dives or maneuvers

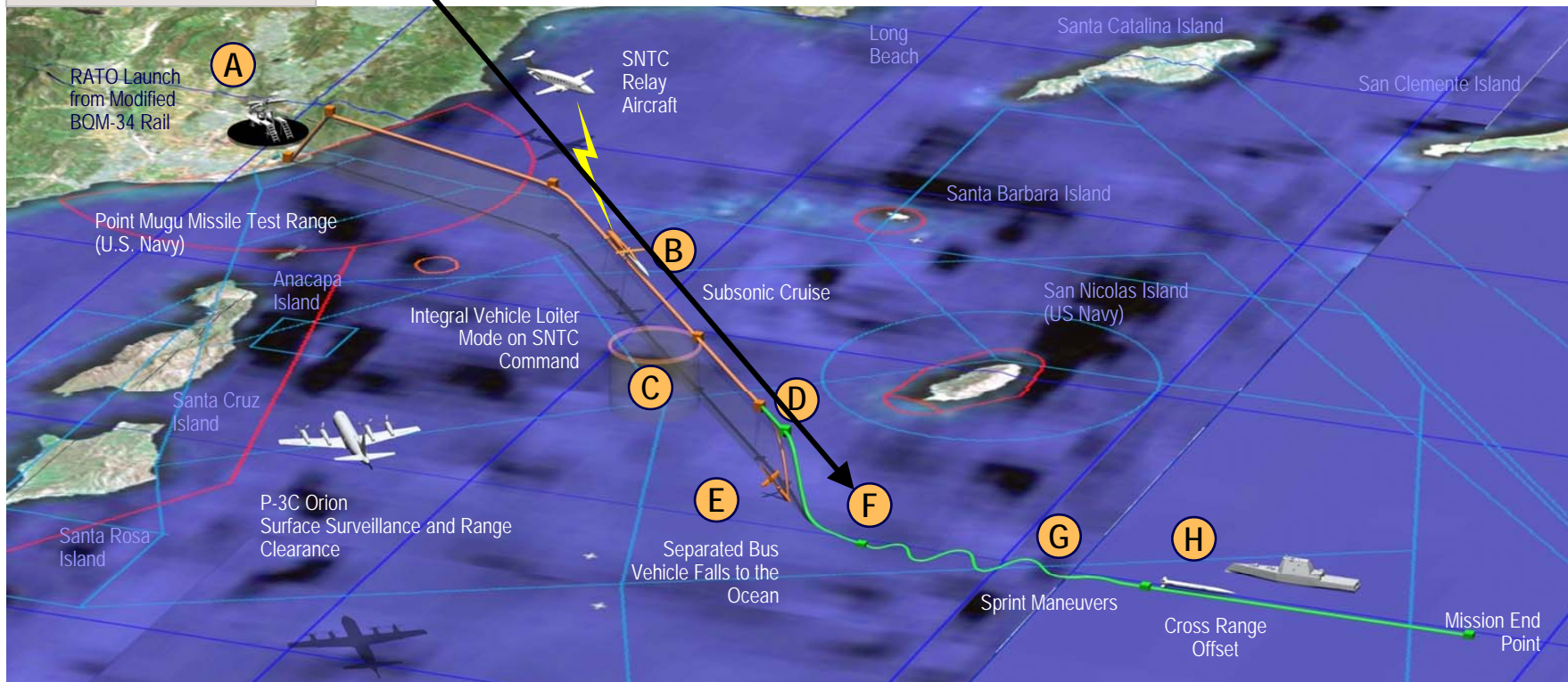
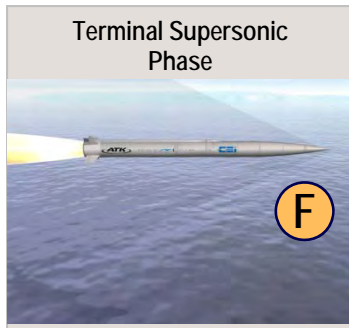

Terminal Supersonic Phase Sprint Vehicle Maneuvers

- Vertical, horizontal or composite weave maneuvers are initiated based on the pre-programmed plan
- Altitude can be controlled to just above the mean wave height

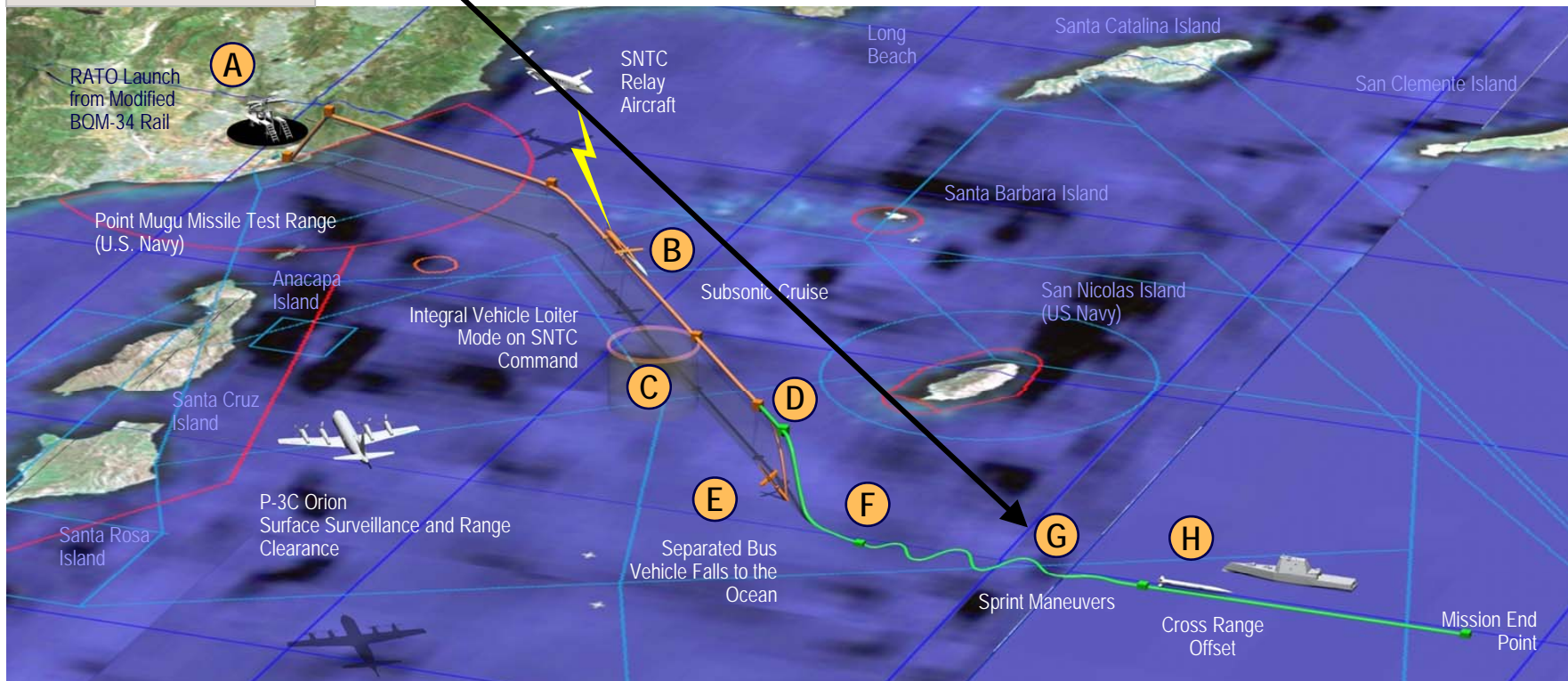
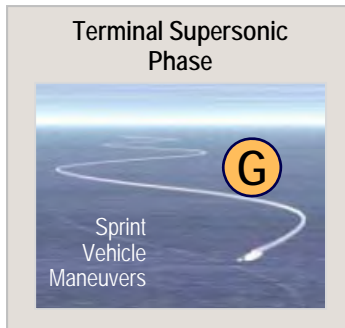

Fly-By to Final Waypoint Phase

- Terminal guidance performs a fly-by of the operating ship to within nominal offset objective location

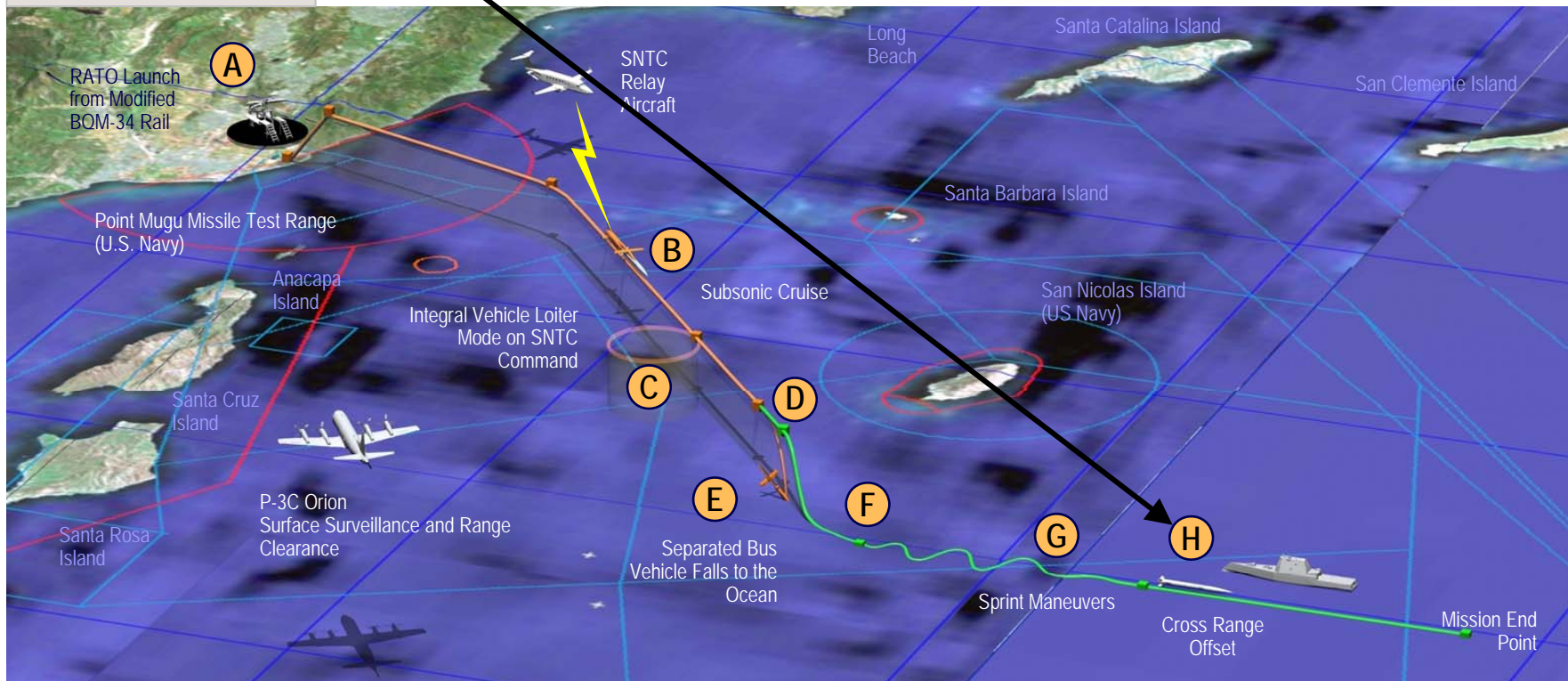
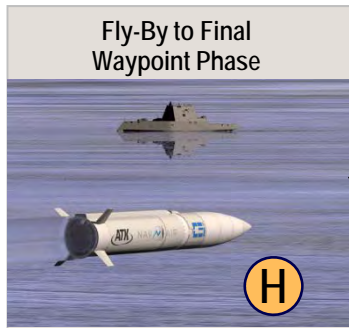

MSST EEU2 on Launch Rail - 01 October 2010



A premier aerospace and defense company



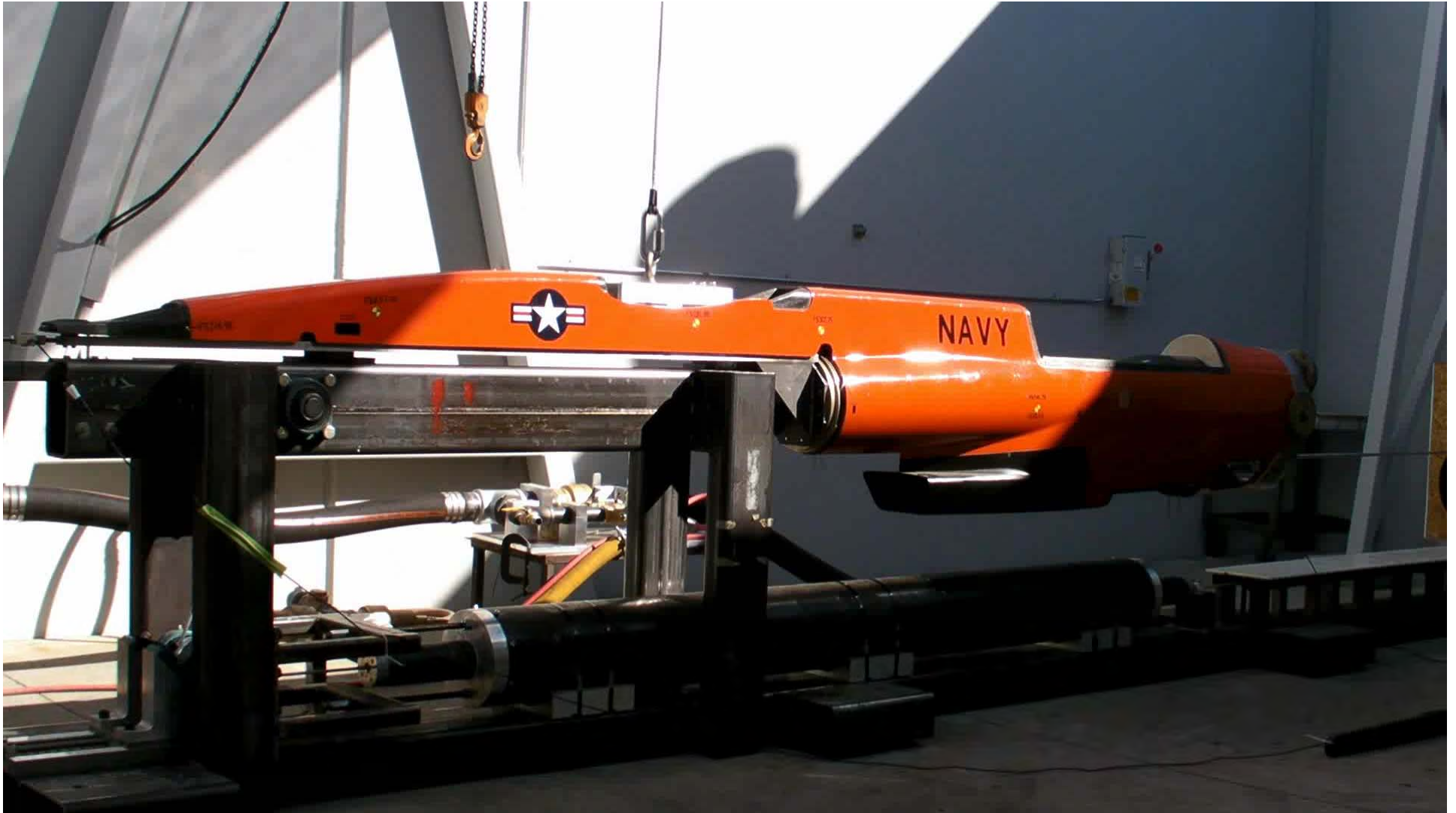

MSST 50 PSI Separation Test.avi



[MSST 70 PSI Separation Test.avi](#)

- Introduction of MSST system to additional domestic and international markets
- Replace higher cost supersonic threat simulators with lower cost MSST
- Growth of MSST from the T&E requirement to a more robust operational target
- The MSST program performance is projected to meet or exceed all U.S. Navy objective values
- ATK, working with the US Government, is planning to make MSST available for export on a case by case basis
 - International customer requirements align with the US Navy
 - Specific customer requirements can be incorporated into the MSST flight profile
 - Additional MSST quantities favor follow on customers
 - Reduced Risk
 - In production pricing
- Expansion of launch locations beyond Pt. Mugu
 - Better serves DoD & international customers

Questions



A premier aerospace and defense company





Develop America's Airmen Today ... for Tomorrow

Moving Forward: The Next Generation of Combat Aviators

Major General James A. Whitmore

Director of Intelligence, Operations and Nuclear Integration
Air Education and Training Command

The First Command



Overview



Develop America's Airmen Today ... for Tomorrow

- AETC Philosophy
- Future Requirements
- Combat Systems Officer Training
- Remotely Piloted Aircraft Training
- Future of Pilot Training



The First Command



AETC



Develop America's Airmen Today ... for Tomorrow

Mission: Develop America's Airmen today . . . for tomorrow

Vision: Deliver unrivaled air, space and cyberspace education and training to America's Air Force

What we do: *Recruit, Train, Educate, Innovate* – AETC trains & educates over 400K personnel annually for the Joint Team, US agencies and 150 partner nations

Annual budget: \$8.8 billion

Personnel: Almost 70,000 military, civilian and contractor

Locations worldwide: Over 1,300

Aircraft: 1450, 29 diverse airframes...World's 4th largest air force!

**AETC prepares the warfighters of today
for the challenges of tomorrow**

INNOVATE • EDUCATE • TRAIN • RECRUIT • EDUCATE • INNOVATE

Warfighter Requirements Drive Our Mission



Develop America's Airmen Today ... for Tomorrow

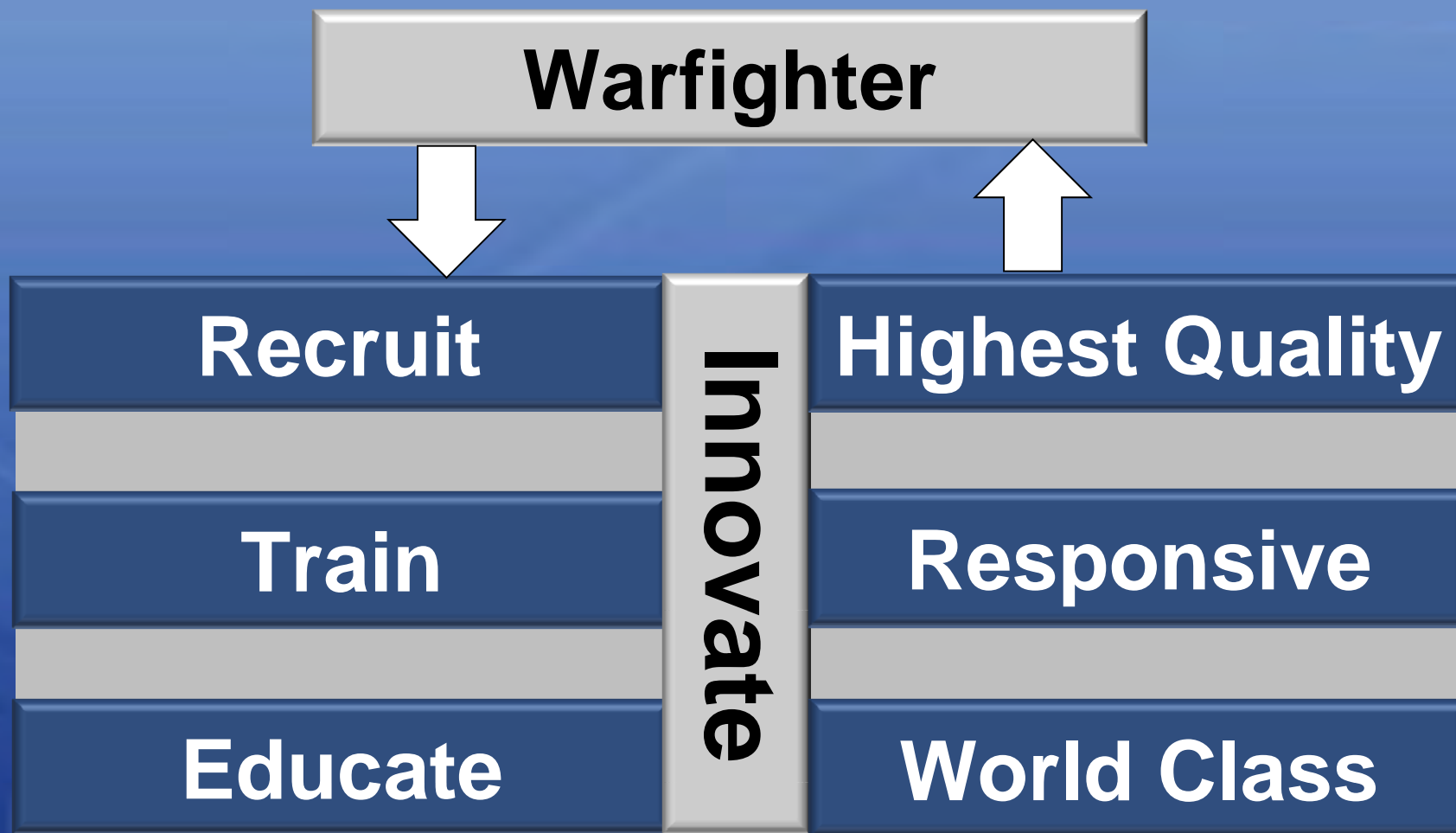

**The decisions made today must strike a balance
between present and future requirements**



Training System Balance

Develop America's Airmen Today ... for Tomorrow

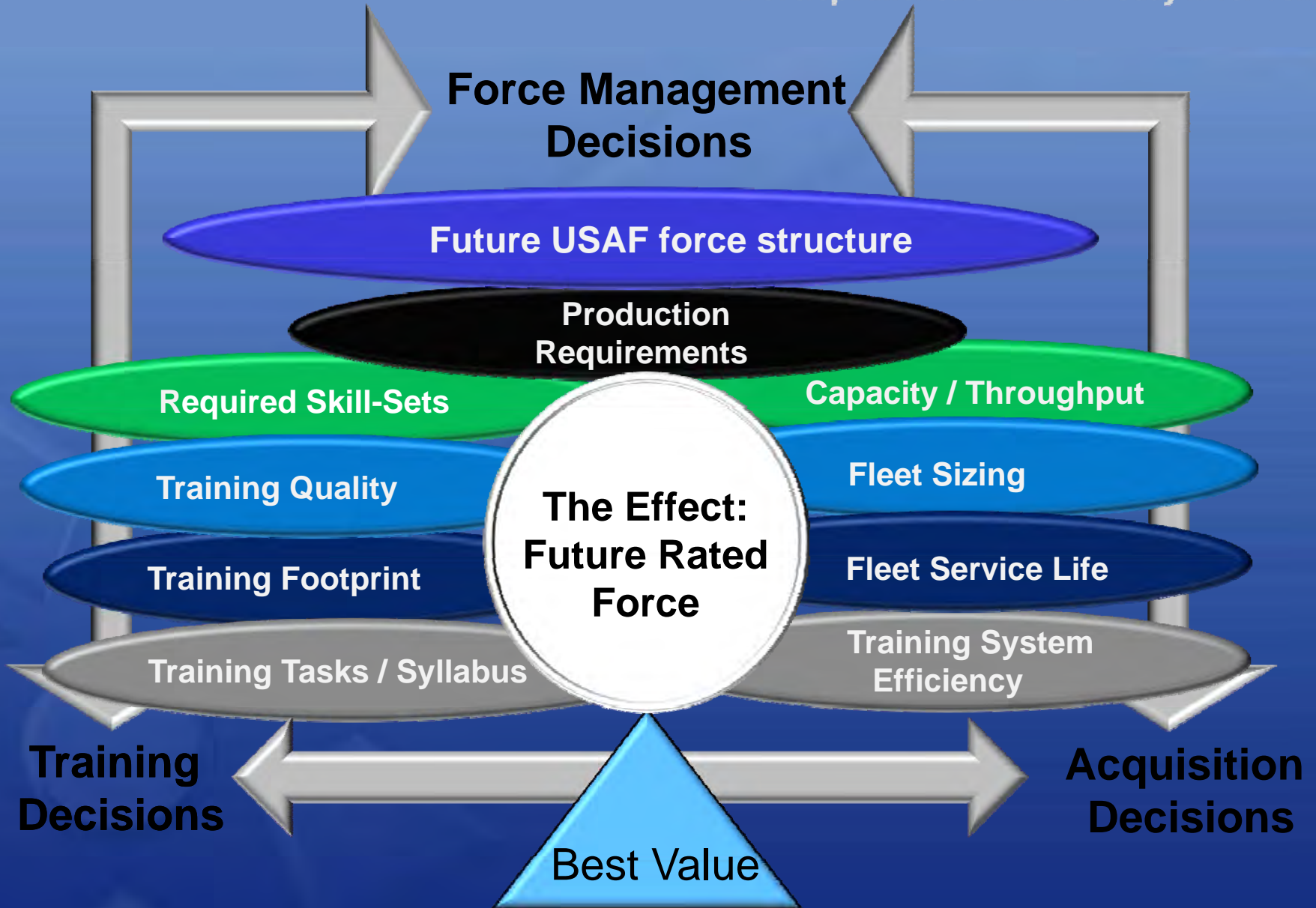

The First Command

RECRUIT • TRAIN • EDUCATE • INNOVATE • RECRUIT • TRAIN • EDUCATE • INNOVATE



New Combat System Officer (CSO) Pipeline



Develop America's Airmen Today ... for Tomorrow

- Consolidates NAV, EWO & WSO training into 1 pipeline
- Centralizes training at one location – NAS Pensacola, FL.
- Program uses a combination of the DA-20, T-25 Simulators, T-6A, and T-1M in the training program
- First class started 5 May 2010 and we expect to graduate 108 new CSOs by the end of FY11



The First Command

TE • INNOVATE • RECRUIT • TRAIN • EDUCATE • INNOVATE

R

CSO Training Program

Develop America's Airmen Today ... for Tomorrow



TRAIN • EDUCATE • INNOVATE • RECRUIT • TRAIN • EDUCATE • INNOVATE

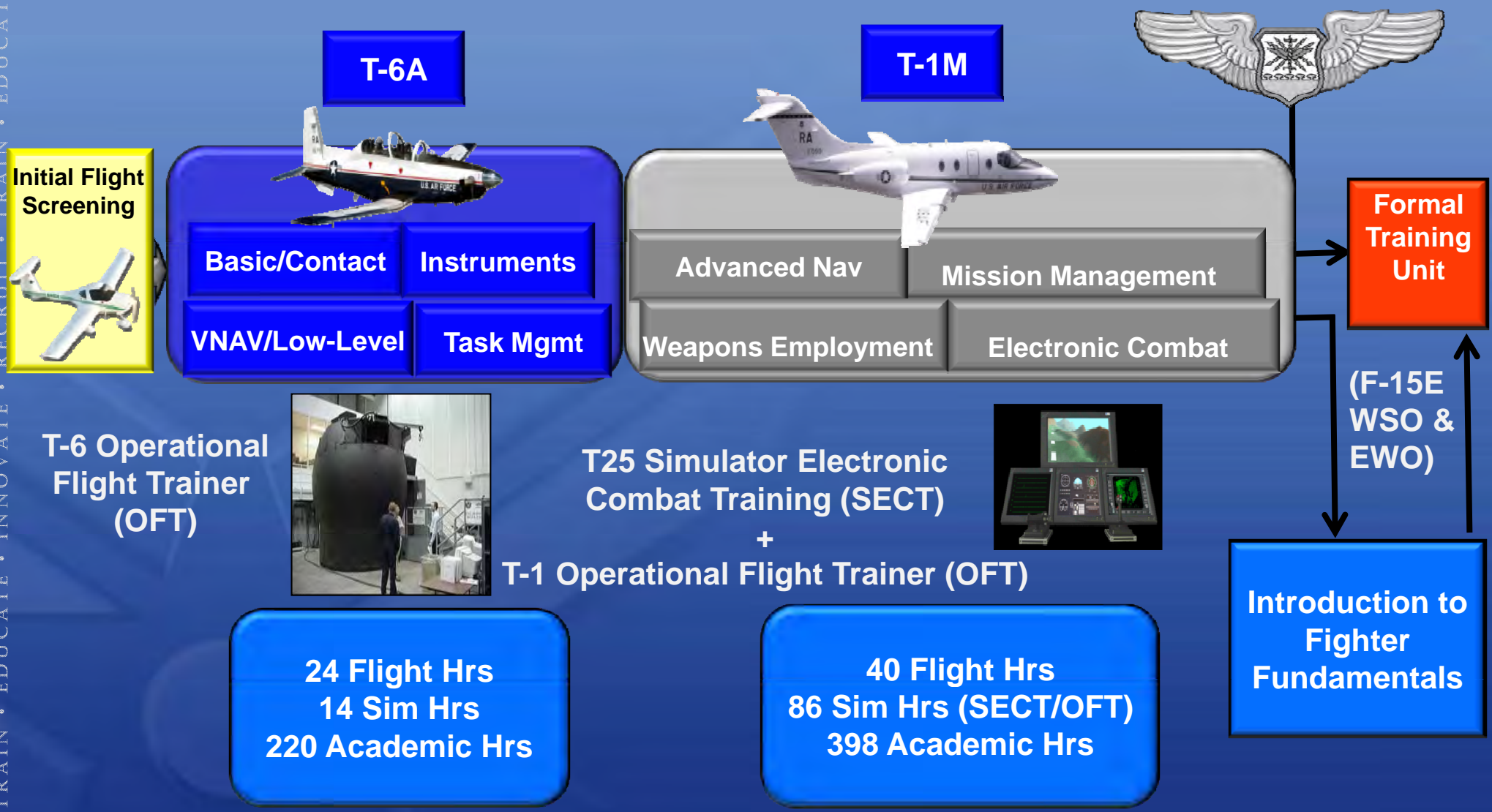

This innovative program will provide every new CSO a common set of 21st century warfighter skills.



Remotely Piloted Aircraft Training



Develop America's Airmen Today ... for Tomorrow

- CSAF chartered AETC to institutionalize the RPA pilot & sensor operator training courses March 2009
 - Went from concept to classroom in **Six Weeks**
- Graduates from this program are flying Predator and Reaper combat missions today and are ready for instructor upgrade!
- New RPA Desktop Simulator built to train tomorrow's force
- Planned production
 - FY11: 60 Pilots/ 353 Sensors
 - FY12: 146 Pilots/ 305 Sensors
 - FY13: 250 Pilots/ 305 Sensors



The First Command



Pilot Training of the Future



Develop America's Airmen Today ... for Tomorrow

- In the 1980s the Air Force developed the multiple track Specialized Undergraduate Pilot Training (SUPT) program
- Today, with a smaller fighter force, anywhere from 30 - 50% of our T-38 graduates are assigned to non-fighter aircraft
- Given the changing circumstances, we need to determine how training will evolve in the next 20 to 30 years



History tells us that a smaller, resource constrained AF needs a flexible, responsive training pipeline



SUPT 2000: The Past



Develop America's Airmen Today ... for Tomorrow

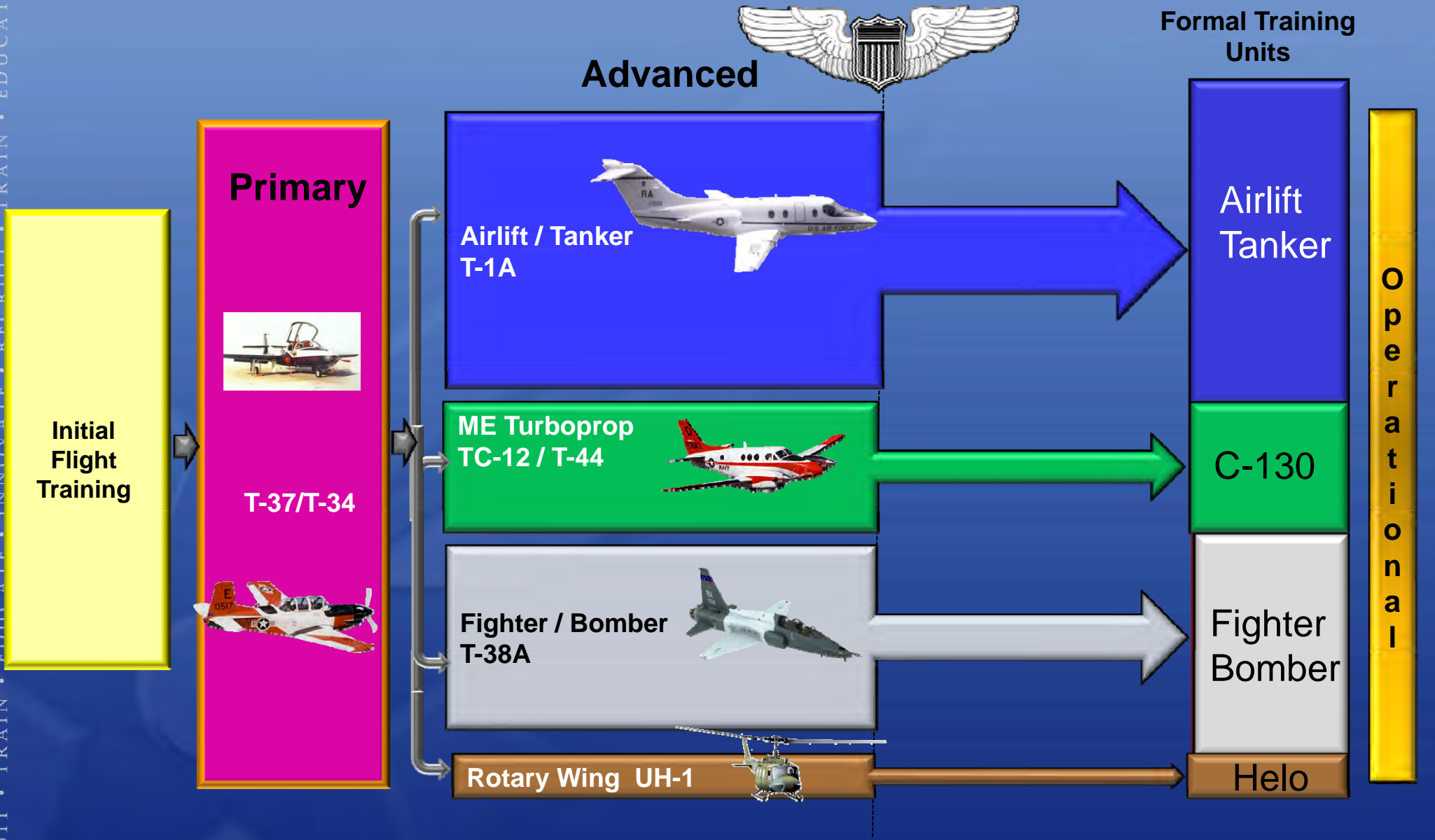

The First Command



SUPT 2010: The Present



Develop America's Airmen Today ... for Tomorrow

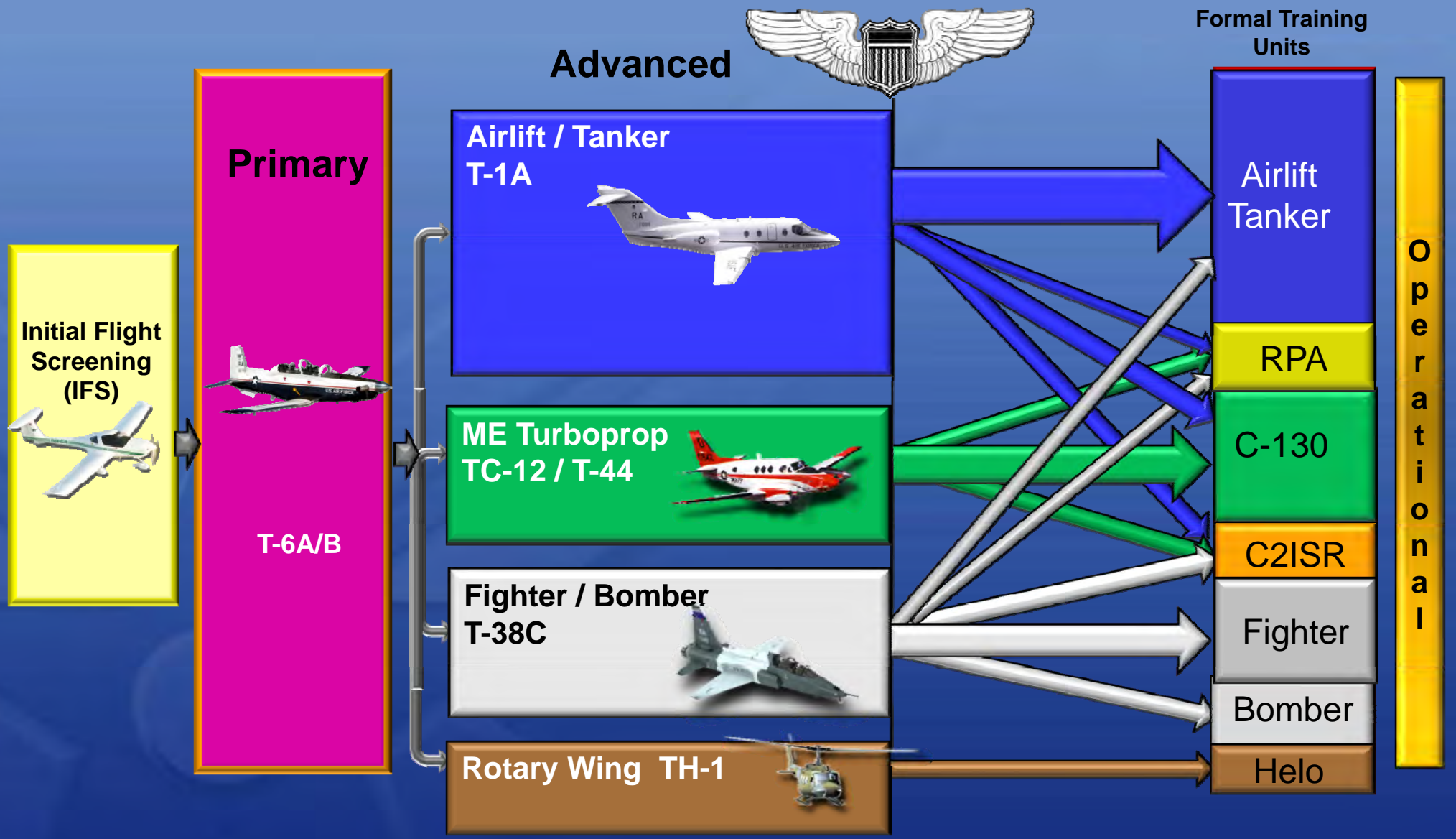

The First Command



SUPT 20??: Uncertain Future



Develop America's Airmen Today ... for Tomorrow

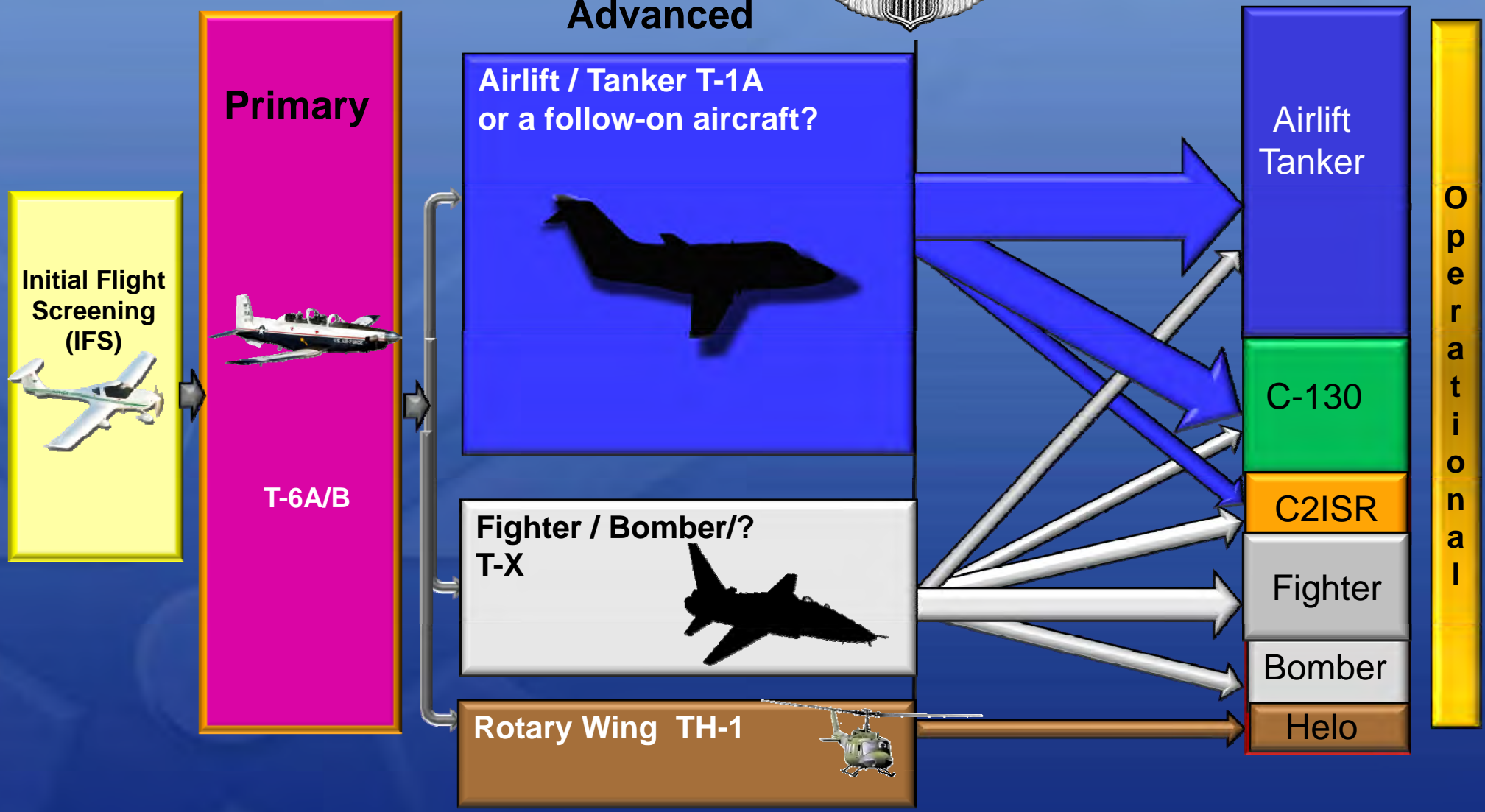

The First Command



sUPT 20??: Uncertain Future



Develop America's Airmen Today ... for Tomorrow

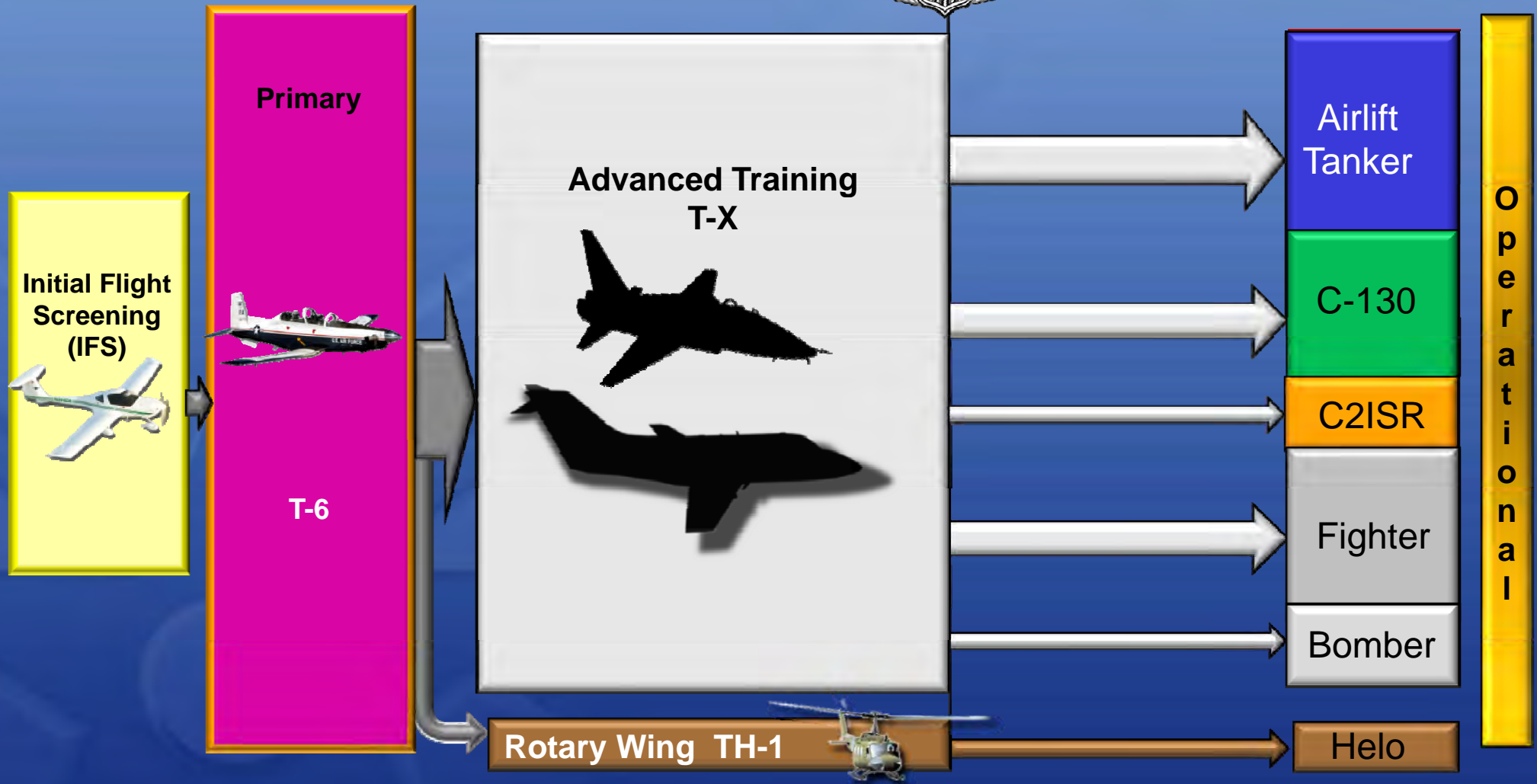

**Regardless of the structure we choose...
we need a new trainer!**



Future Trainer (T-X)



Develop America's Airmen Today ... for Tomorrow

- The average age of the T-38 fleet is 43.5 years old
- The Air Force is in the process of conducting an Analysis of Alternatives (AOA)
- The T-X must be economically viable, bridge the gap between 4th and 5th generation aircraft and prepare our aviators for the demands of the modern cockpit and battlespace



**“We’re following DOD acquisition procedures so that someday soon the AF will be able to procure a new trainer ... because this will be a 50-year decision”
- General Stephen R. Lorenz, Air Force Times 31 Aug 10**



The Certain Future



Develop America's Airmen Today ... for Tomorrow



Pilot



Manned Platforms

CSO

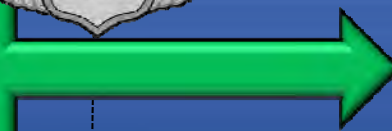

Manned Platforms

RPA

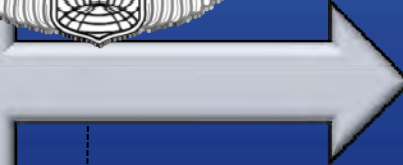

RPA

O
p
e
r
a
t
i
o
n
a
l

Each of these programs is critical in maintaining the combat capability of the Air Force



Summary



Develop America's Airmen Today ... for Tomorrow

- AETC is a dynamic Total Force team providing training & education to over 400K people each year
- We are focused on partnering with the warfighter to ensure we deliver innovative training solutions
- The AF is taking a holistic approach to rated force training, production and weapon system acquisition
- AETC is leveraging our greatest assets, our people, to ensure we Develop America's Airmen Today...For Tomorrow

Unrivaled Air, Space and Cyberspace Training in the future...

RAIN • EDUCATE • INNOVATE • RECRUIT • TRAIN • EDUCATE • INNOVATE



Develop America's Airmen Today ... for Tomorrow

Questions?

The First Command



Testing the Test Range without Flights

Progress Update



RT Logic, Steve Williams
48th Annual Targets, UAVs and Range
Operations Symposium & Exhibition
20 October, 2010



Whenever transmitters and receivers are in motion with respect to each other, RF link perturbations occur.

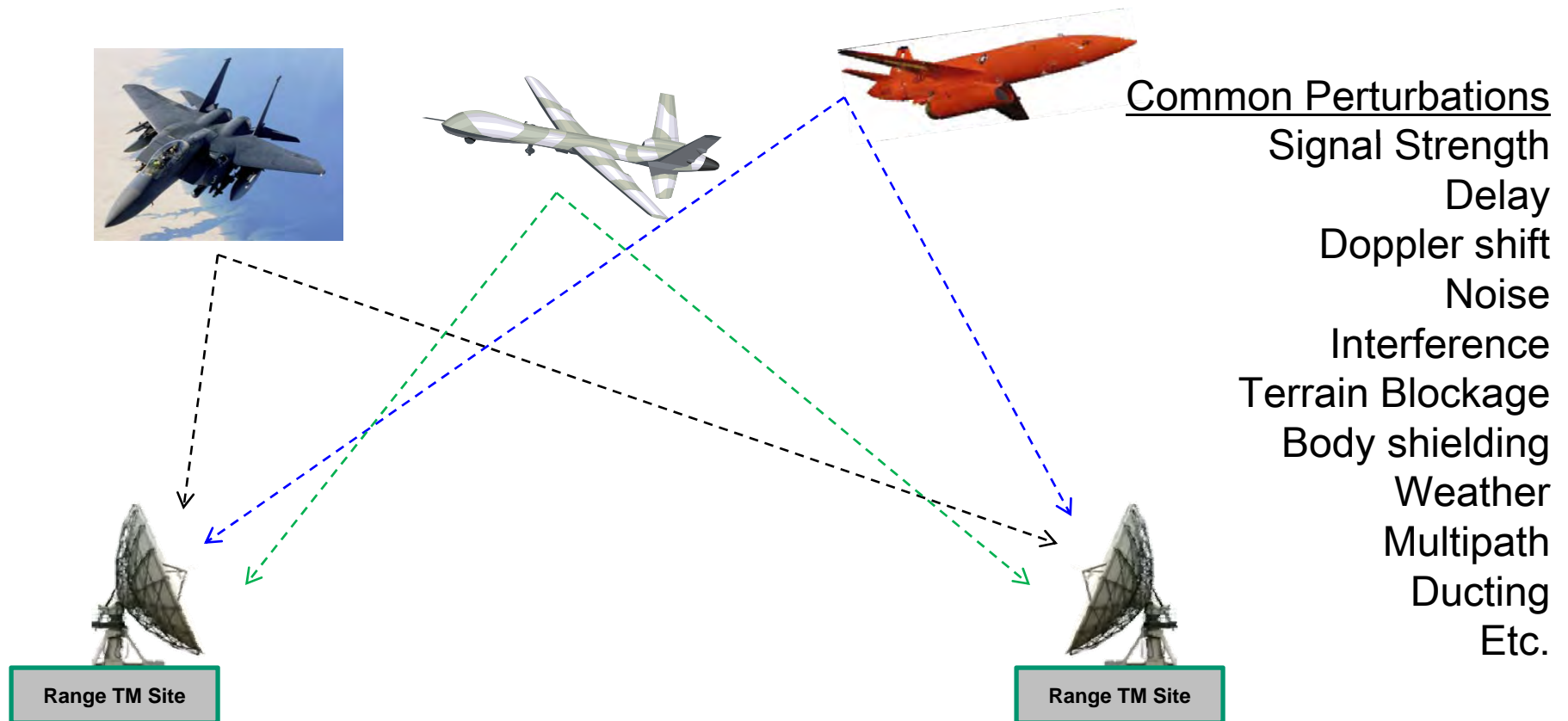

Signals TM1 and TM2 are transmitted from the same transmitter, so the data on each is the same, but the signals can look dramatically different from each other at receiving TM sites.

Examples

- TM1 delay shorter than TM2
- TM1 signal strength higher than TM2
- TM1 affected by more Doppler shift than TM2
- TM1 affected by different terrain than TM2
- TM1 antenna angles different than for TM2
- Etc.

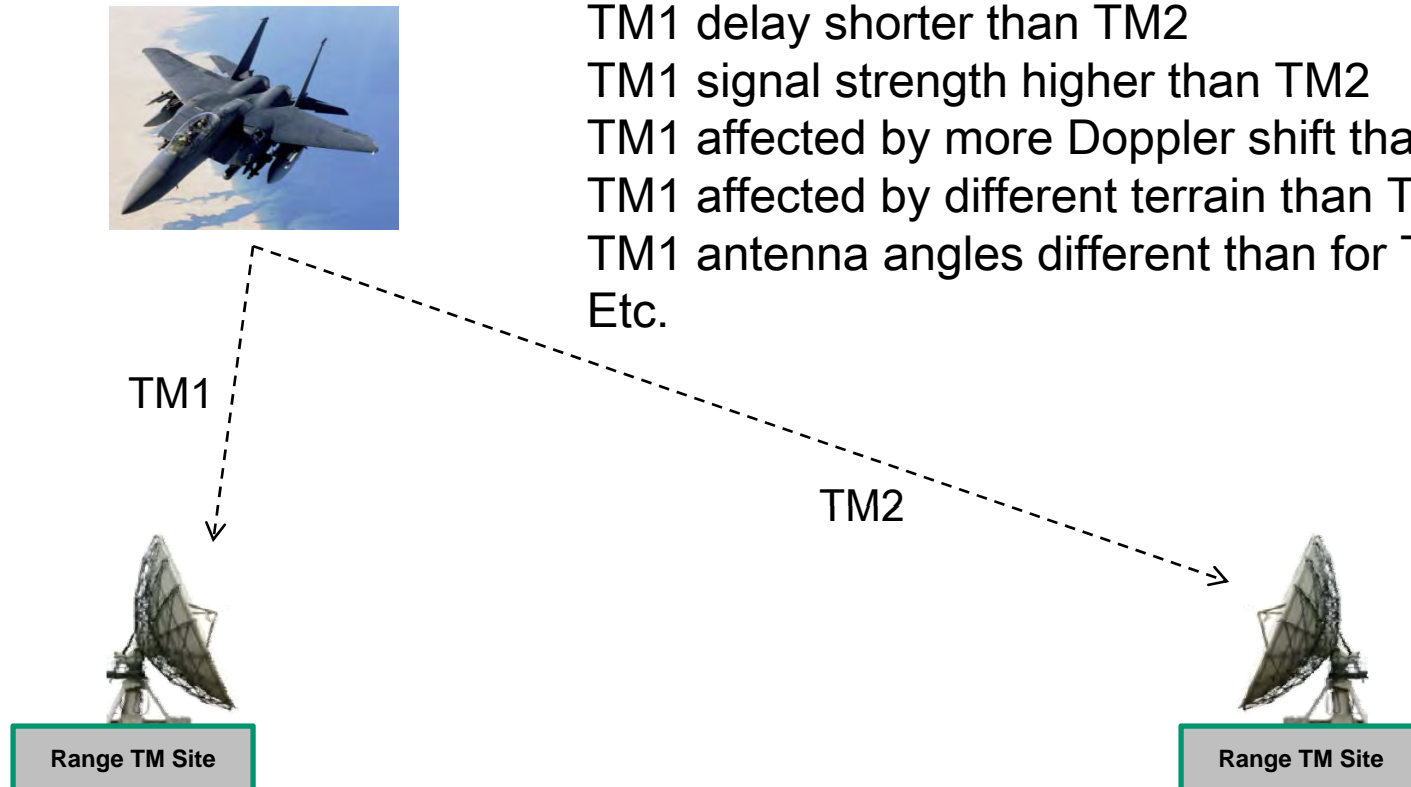

A method for testing the Test Range without flights is to supply signals from a central fixed location to the TM sites that have these same signal characteristics.

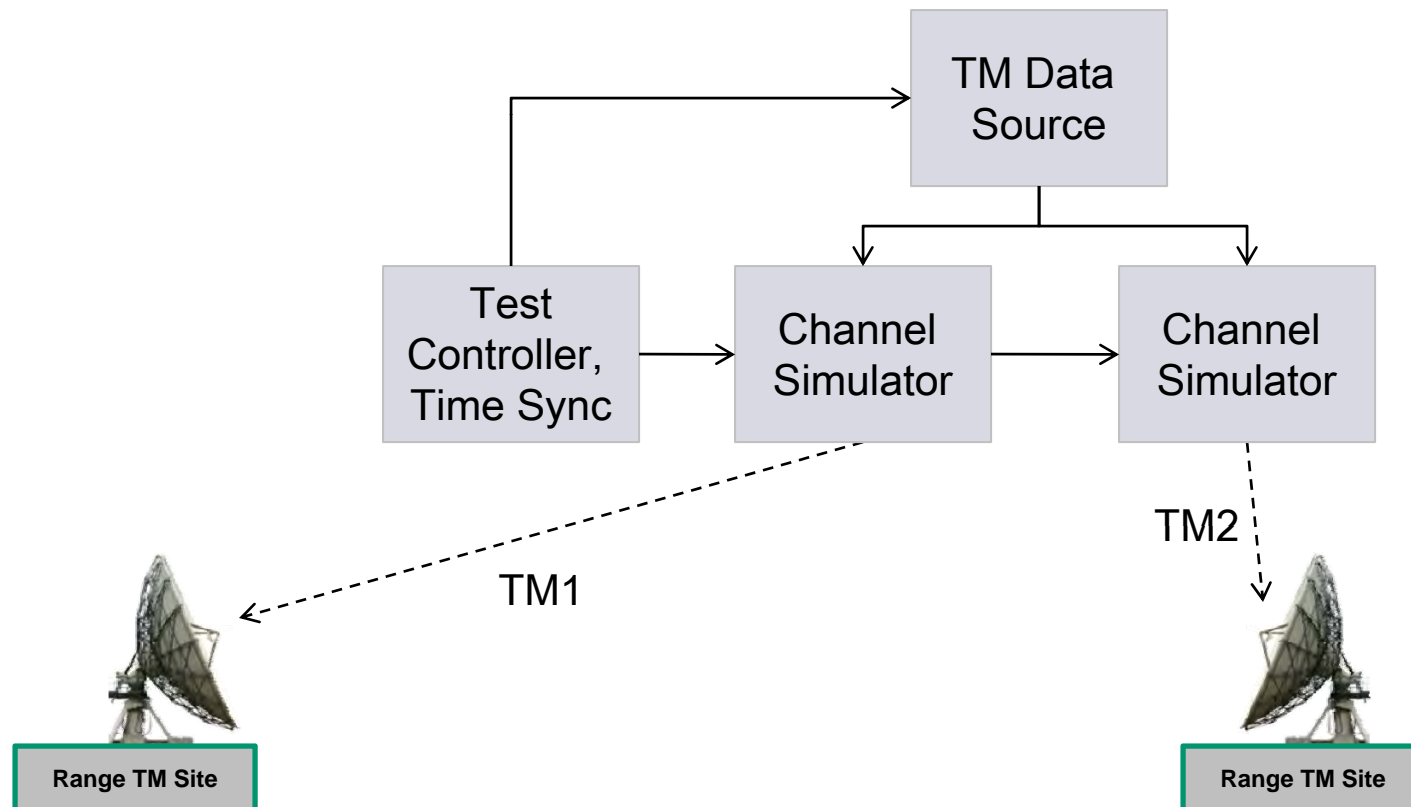

Examples

- TM1 delay shorter than TM2
- TM1 signal strength higher than TM2
- TM1 affected by more Doppler shift than TM2
- TM1 affected by different terrain than TM2
- TM1 antenna angles different than for TM2
- Etc...

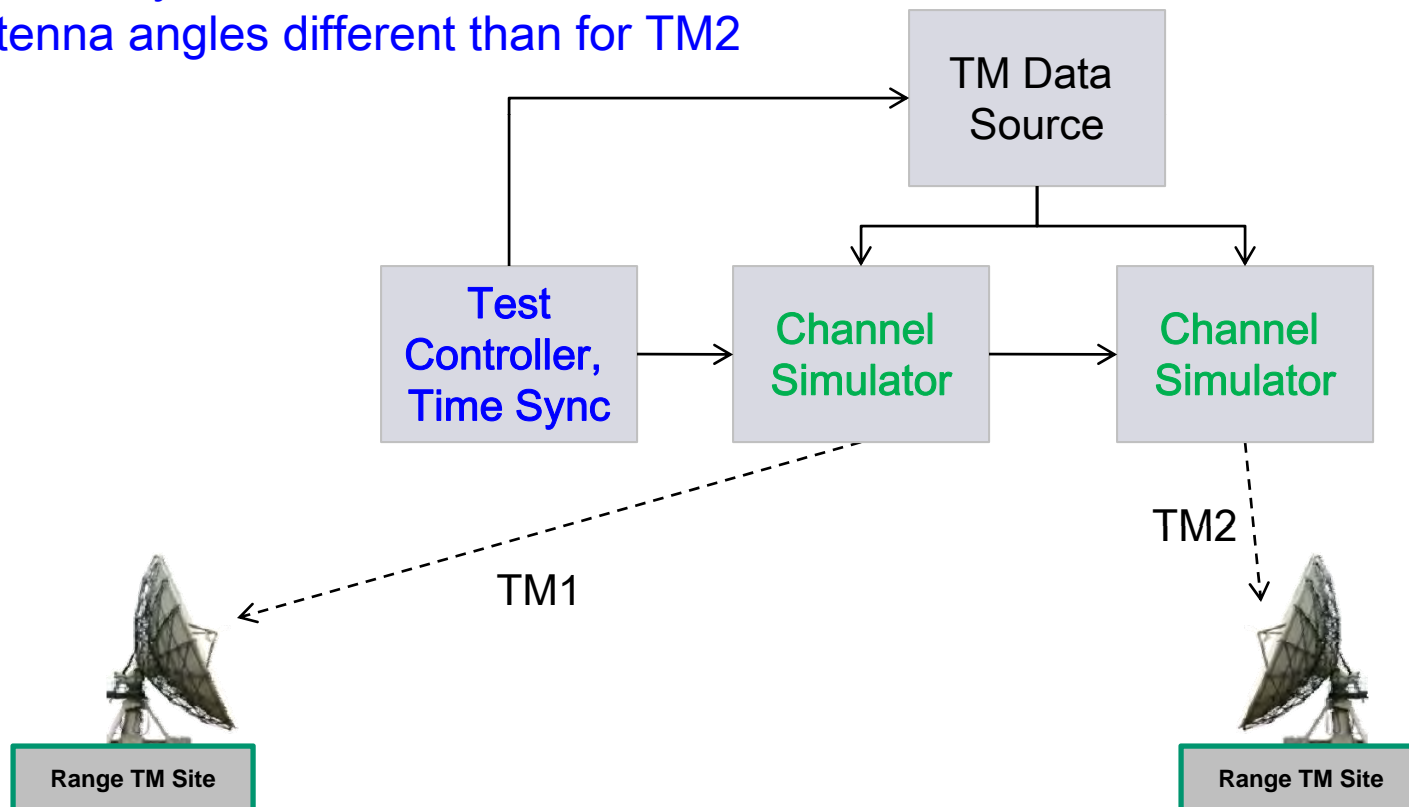

Signal Delay Variance Through Flight

Gaps are terrain, link budget, and/or body shielding drop-outs

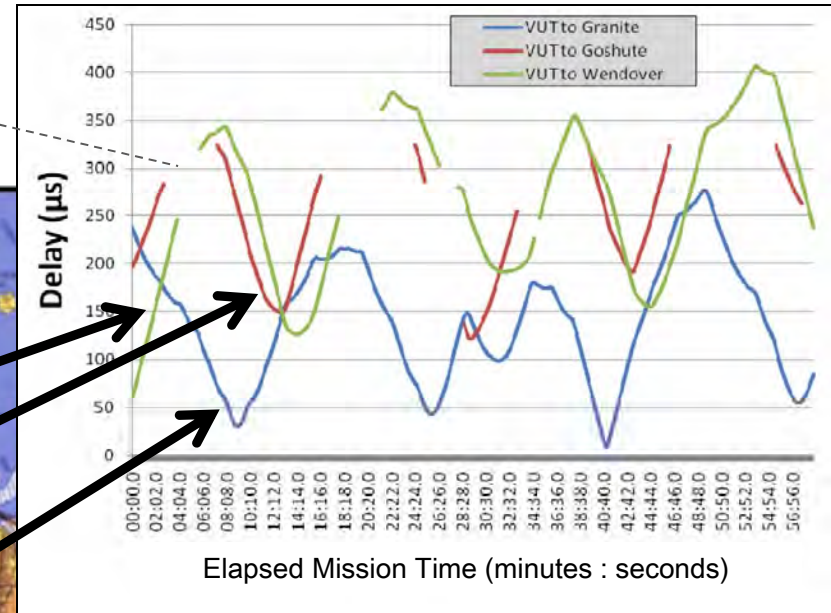
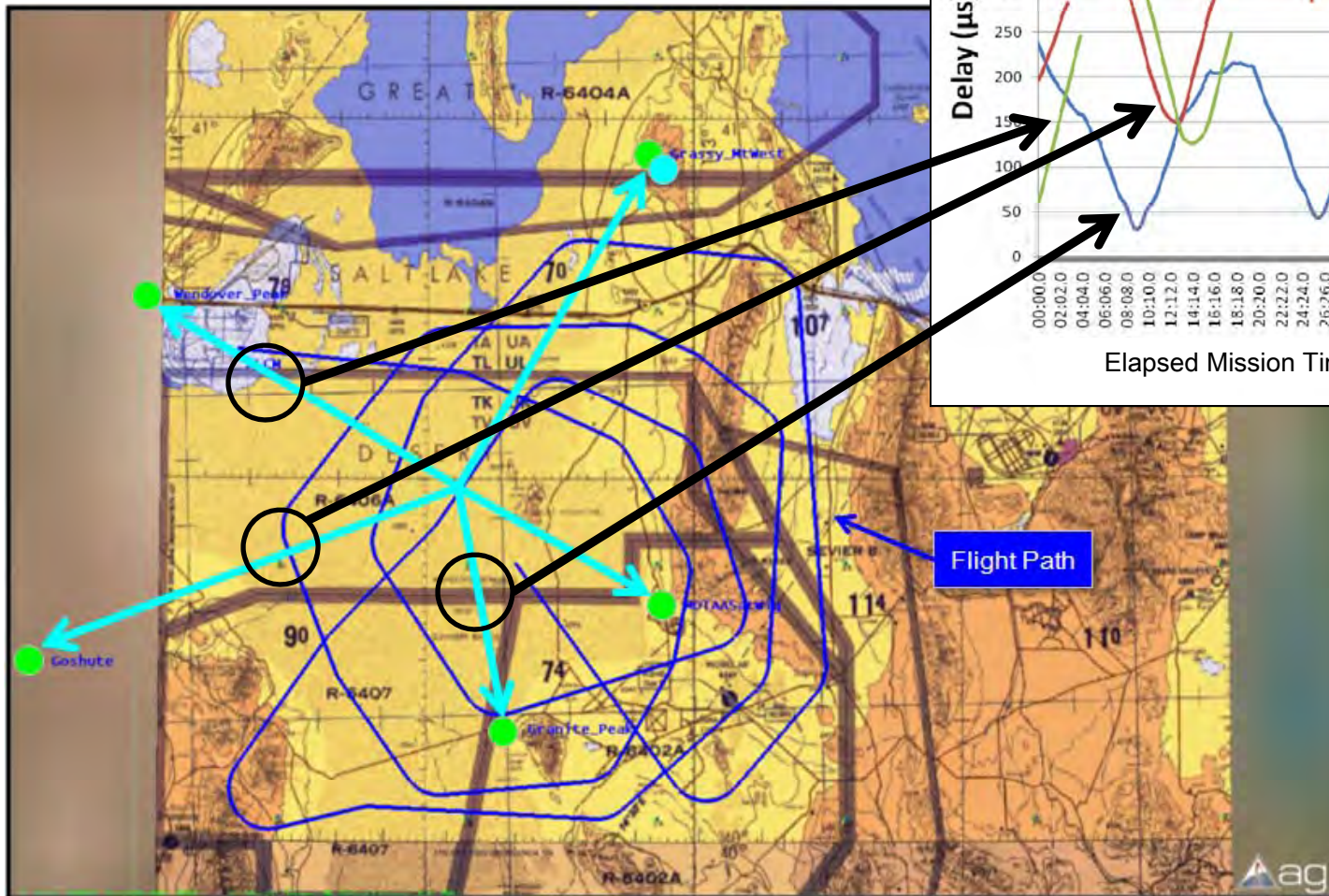

RF signals are received at each TM site at slightly different times due to the dynamic distance between the flight platform and the TM site location.

Attenuation (Loss) Variance Through Flight

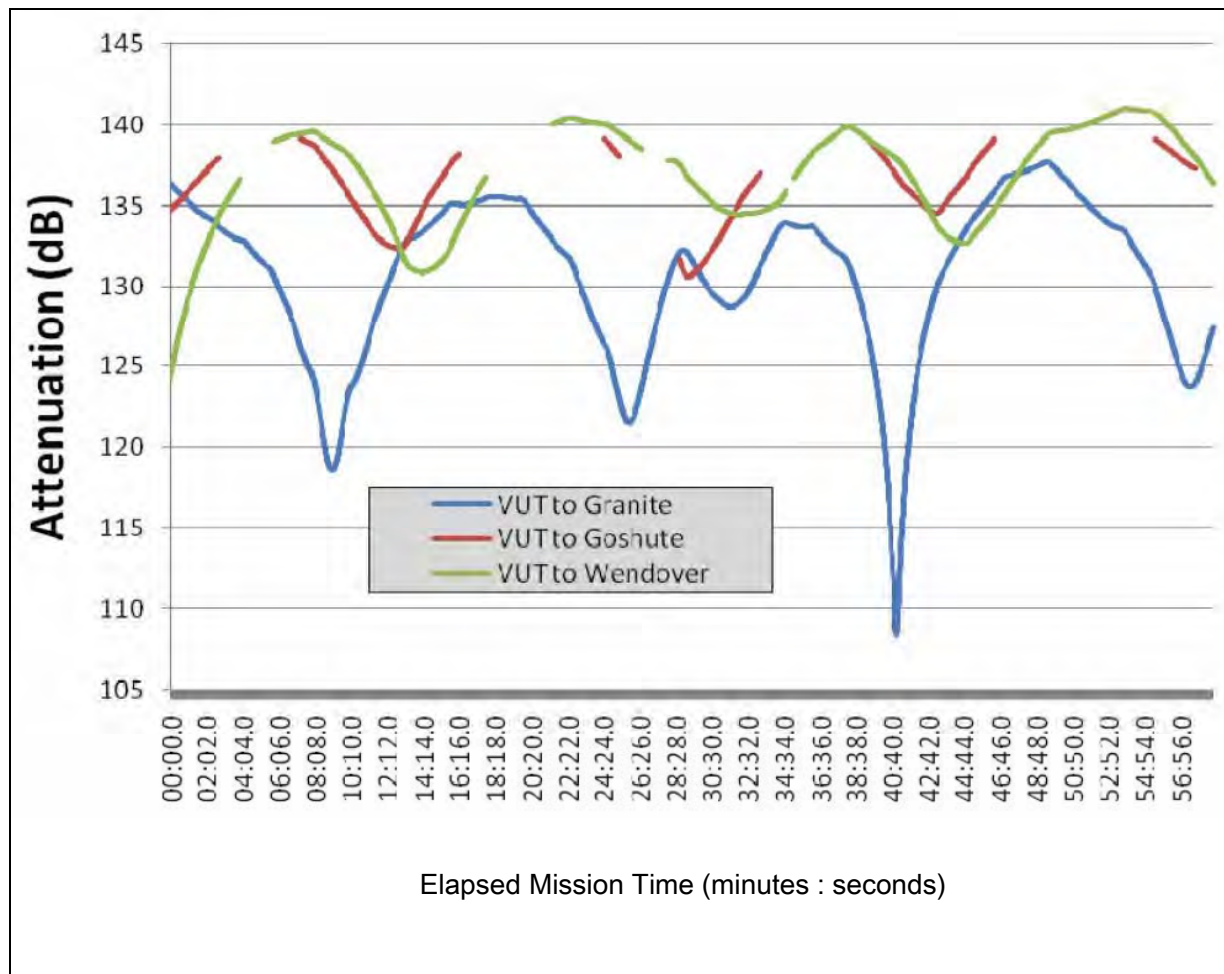

RF signals are received with differing power levels at each TM site at due to the dynamic distance between the flight platform and the TM site location.

Other dynamic attenuation factors include antenna patterns, body shielding, foliage, frequency selection, etc.

- Testing possibilities
 - TM Site as a whole
 - TM Site RF hardware elements
 - TM Site signal processing hardware elements
 - TM Site firmware, software, algorithms or processes
 - Entire Test Range, including BSS, Range Control Center Displays and final data creation/processing
- Training possibilities
 - TM Site Operators } Nominal conditions
 - Range Operators } Worst-case conditions
- Up-front range capability proof to customer
- Range mission readiness proof to range personnel and customer

- Theory is sound
- And, Channel Simulators do exist
 - But usually used in the lab for testing flight/ground hardware, SW, FW, etc.
 - Flight/Ground systems: Satellites, UAVs, Targets, Aircraft, Missiles, etc.

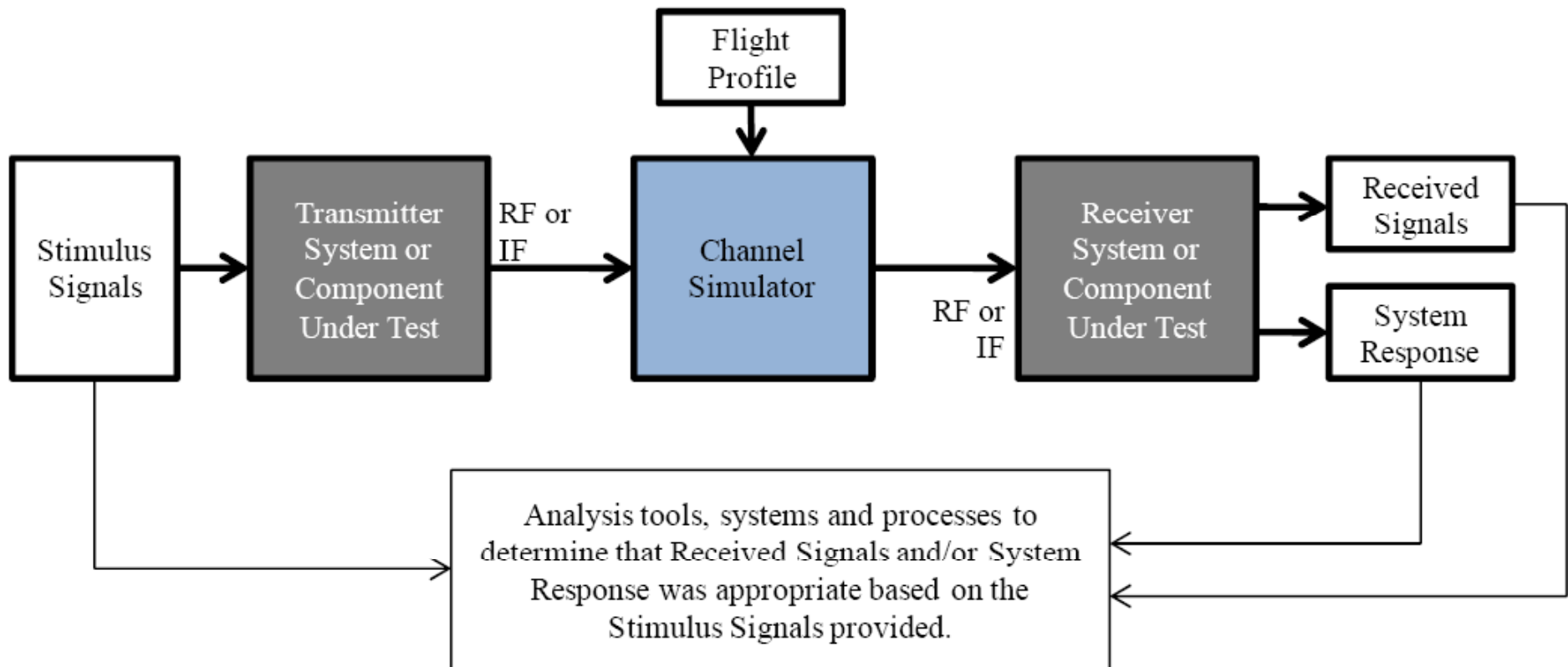

- Channel Simulators haven't been used in this manner in the past. Will they be useful for Range Testing?
 - With high power amplifiers and antennas
 - With complex flight profiles and flight/ground antenna models
- Needed to find a Test Range and a flight capability that was interested in helping validate the concept.
 - UTTR, Summer, 2009
 - Use of a Channel Simulator to pre-distort signals and transmit at RF to a TM site to validate received signal quality and Doppler, delay, loss and noise expectations.
 - Pax River and Airtec, Sept 28-29, 2010
 - Expanded test of entire concept...

- Test Process utilized at Pax River
 - 1. Perform Test Flight
 - Transmitting simple, known, unclassified BER TM
 - Close range and long range → signal fading, BER
 - High speed, close passes → Doppler shift
 - Various turn maneuvers → body shielding
 - Horizon → terrain masking
 - Record as-transmitted TM and TSPI on aircraft (truth data)
 - Also captured at Pax TM sites
 - Record TM & and signal characteristics at two TM sites
 - St. Mary's Airport
 - On Pax River

2. Process flight TSPI data to create Channel Simulator control model that mirrored the actual flight.

- Latitude, Longitude, Altitude, Yaw, Pitch and Roll
 - Incorporate previously constructed
 - Aircraft body model
 - Aircraft antenna/transmitter model
 - TM site antenna/receiver model
- } RF Model

3. Use Channel Simulators to transmit to 2 TM sites.

- Input signal = BER TM pattern as recorded on aircraft during flight
- Use TSPI and RF model constructed in #2 above
- Record TM & signal characteristics at two TM sites

4. Compare TM & signal characteristics from actual flight (step #1) and the simulated (step #3) flight.



Airtec Beach A-100 King Air

On board equipment rack
GPS / IRIG Time
BER / TM Data Generator
S-Band Transmitter





Novatel ARDS Pod
For acquiring
recording and
transmitting TSPI
data



S-Band Antenna
This was used
for transmitting
our test BER TM.

A separate
antenna was
used for
transmitting from
the ARDS pod.

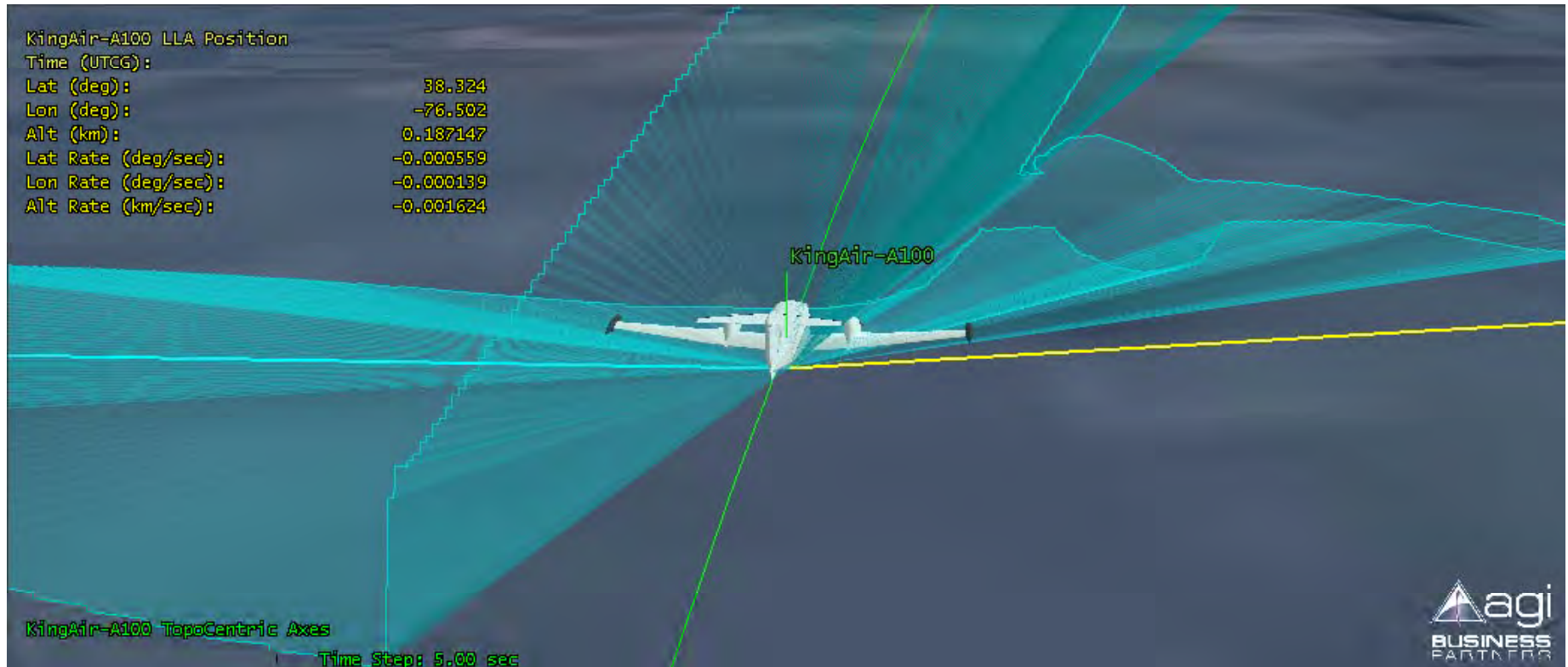

Antenna Body Shielding Mask

Based on mounting location of antenna. Modeled in AGI STK, which is used for Channel Simulator control.

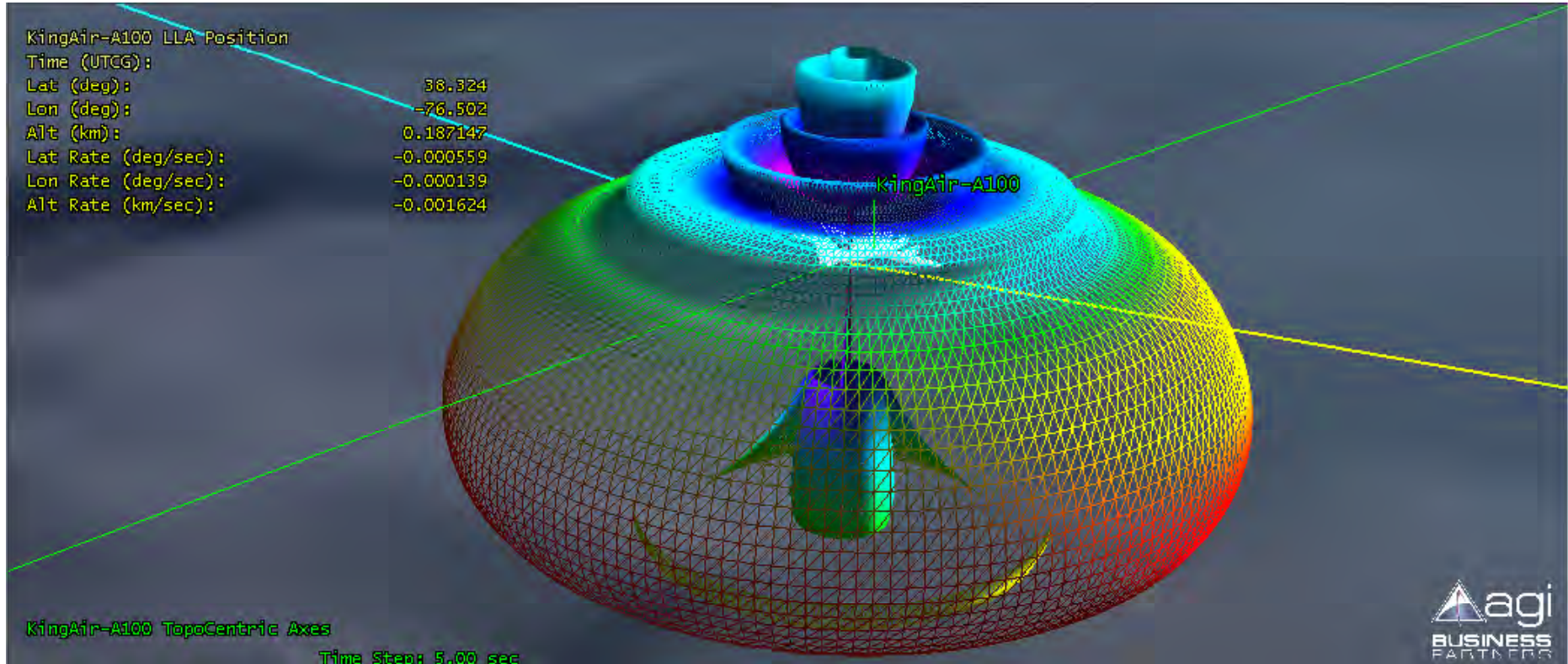

Antenna Radiation Pattern
Based on antenna characteristics.

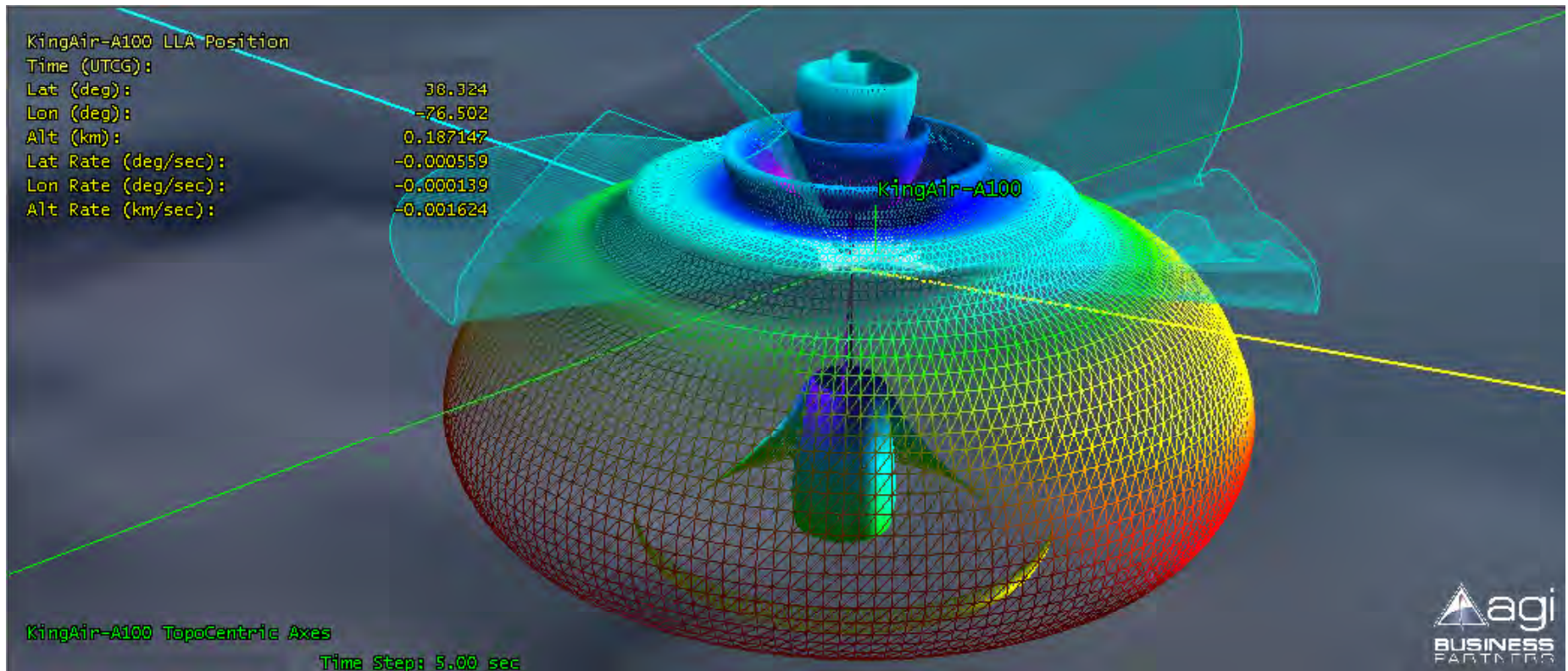

Antenna Radiation Pattern and Body Shielding Mask
Based on antenna characteristics and mounting location.



TM Sites
This was the
mobile site used
at St. Mary's
Airport

Very similar
system used at
Pax River site.

- TM Site locations for test flight

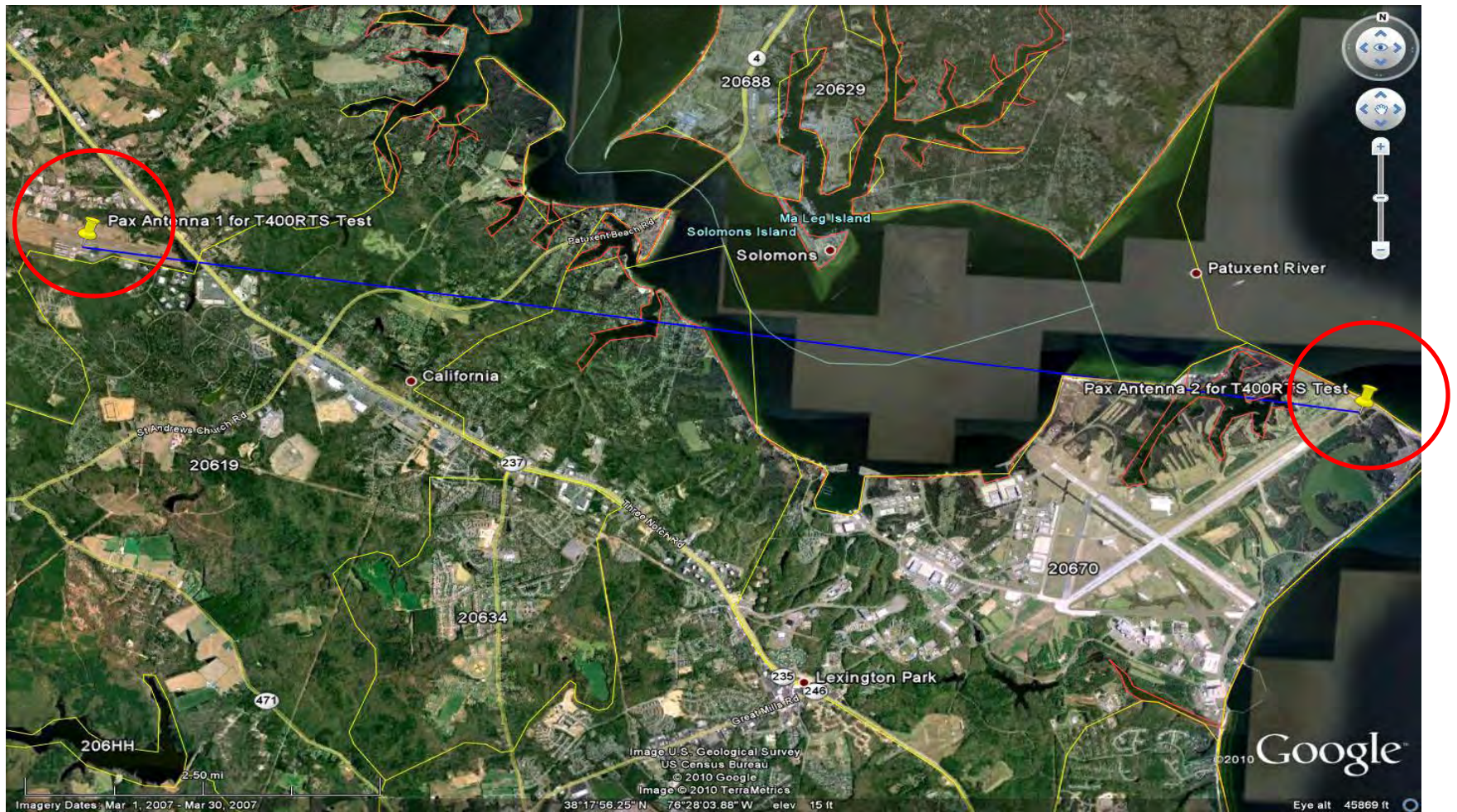

- Test Flight, Pax River, 28 Sept, 2010



- Flight Simulation, Pax River, 29 Sept, 2010

Primary Channel
Simulation Equipment



Telemetry Van
Channel Simulators,
Amplifiers and control
elements.
Two S-Band cone
antennas pointed at 2
TM sites.

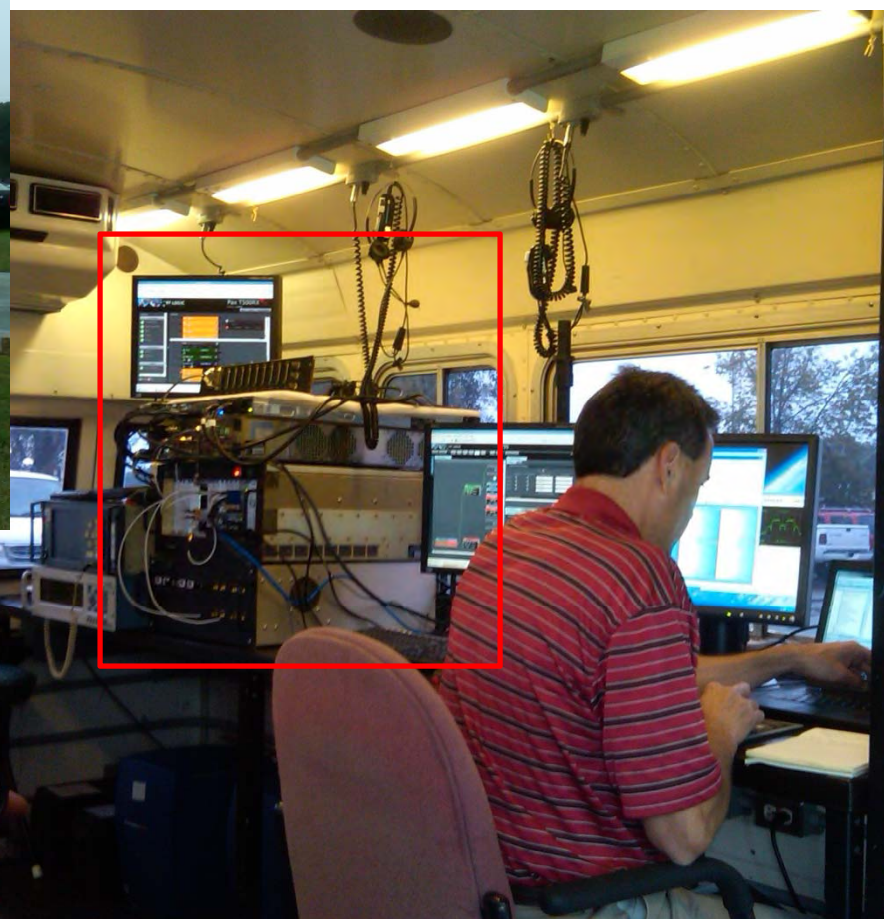

- Very Preliminary Sample Data

Altitude (meters)

Scaled Relative Power (dBm)

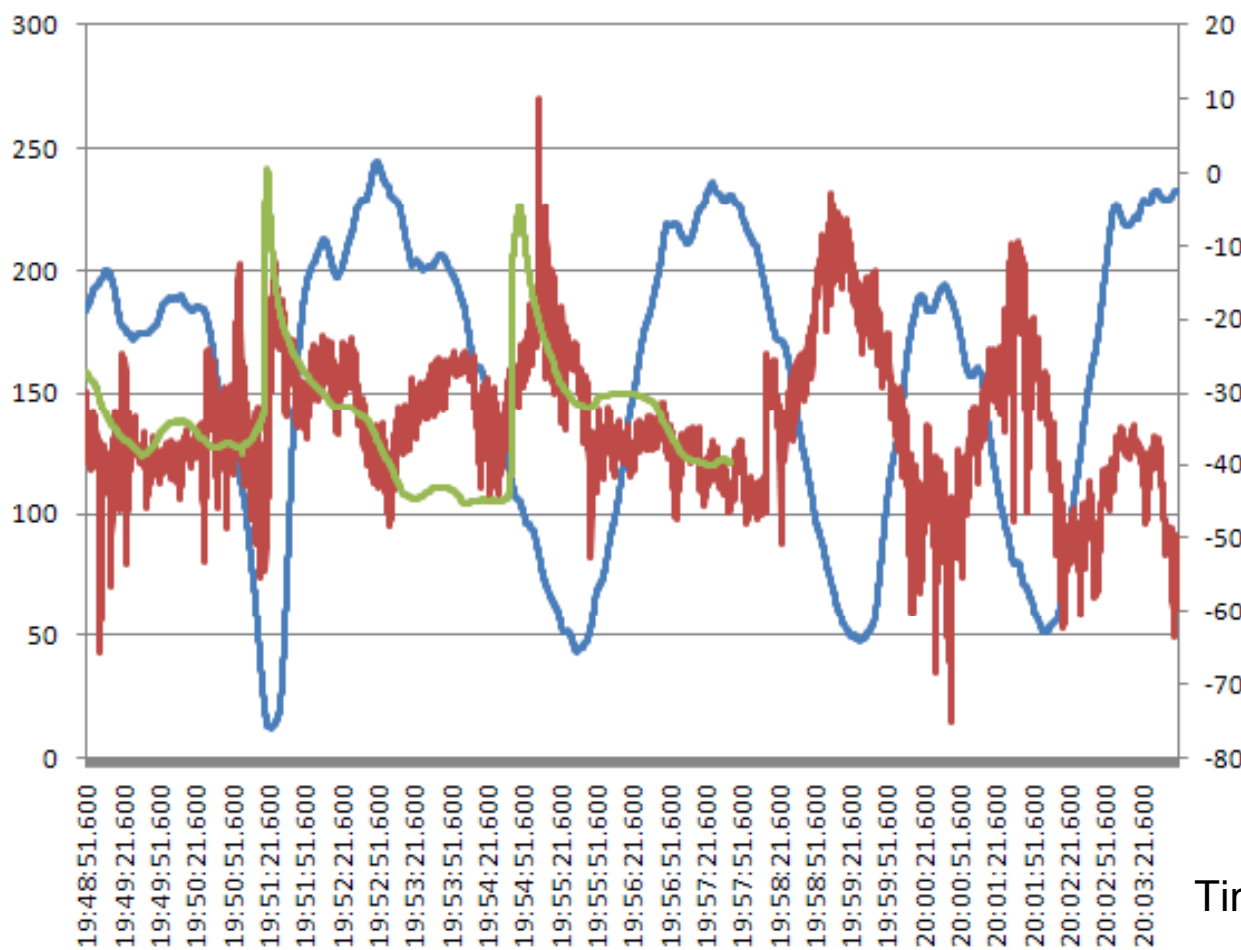

Without :
 -Antenna models
 -Body shielding
 -Antenna pointing error factoring
 -Time alignment
 -Etc...

— Novatel Height
 — StMary's LS35 RSSI_1
 — Calculated Recv Power ←

Time (first ~15 minutes)

- Near term next steps

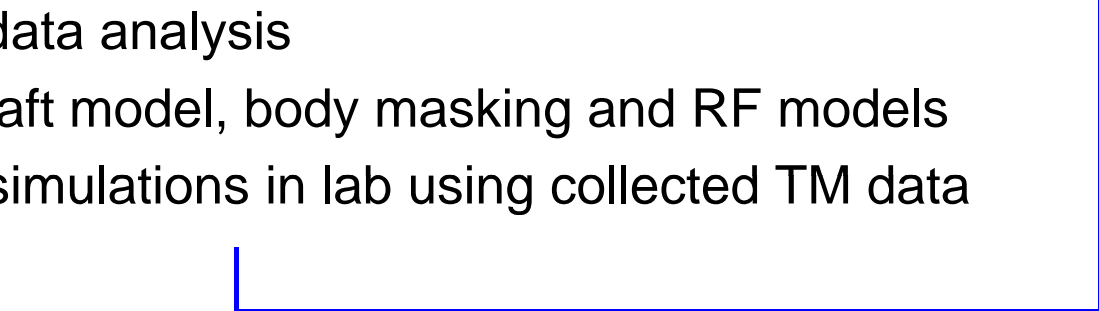
- 
- Continued data analysis
 - Refine aircraft model, body masking and RF models
 - Rerun test simulations in lab using collected TM data
-
- In-depth review of final results with Pax River
 - Develop and implement recommendations
 - Another test flight
 - Retransmit to Pax TM sites
 - Channel Simulator functionality modifications (e.g. multipath)
 - Etc.

- Summary
 - Verification efforts continue, but...
 - Channel Simulators can be used to verify Test Range operation as a whole, or in part, and can be dual-purposed for Test Range operations training.
 - Such testing/training is faster, more economical and more complete than testing/training with actual flights, since the limits of scenario development are virtually boundless.
- Acknowledgement
 - RT Logic would like to express it's sincere gratitude to Mr. Bob Myers and his NAVAIR team at Pax River for their enthusiastic support and valued assistance in conducting these tests.
- For further information and/or a copy of the final report
 - Steve Williams, RT Logic, 719-884-6269, swilliams@rtlogic.com.
 - Booth #315, NDIA Targets, UAVs and Range Operations Symposium.