



*Files are in Adobe format.
Download the newest version from Adobe.*

2011 WOMEN IN DEFENSE (WID) NATIONAL FALL CONFERENCE

“Growing and Giving: Significant Issues Facing the National Security Community”

Washington, DC

19 October 2011

Agenda

Wednesday, October 19, 2011

“BUDGET CRISIS”

- Ms. Jenness B. Simler, Professional Staff, Committee on Armed Services, U.S. House of Representatives

PANEL: “RECENT DEVELOPMENTS IN ACQUISITION: NEW LAWS, REGULATIONS AND DIRECTIVES”

Moderator: Ms. Susan Ebner, Counsel, Buchanan Ingersoll & Rooney PC

Panelists:

- Ms. Jennifer Schaus, Principal & Founder, Jennifer Schaus Associates
- Ms. Hazel Scalia, Senior Attorney, KBR North American Government and Defense
- Ms. Sherri L. Schornstein, Senior Assistant U.S. Attorney, Fraud & Public Corruption Section, U.S. Attorney’s Office, District of Columbia

PANEL: “GOVERNMENT AND INDUSTRY PARTNERING FOR SECURITY BUDGETING”

Moderator: Ms. Eileen Giglio, Consultant, National Defense Business Institute, University of Tennessee

Panelists:

- Ms. Kristina Tanasichuk, Chief Executive Officer, Government Technology & Services Coalition; President & Founder, Women in Homeland Security
- Ms. Trish Culbreth, Small Business Advocate/Mentor-Protegee Program Manager, Office of Small and Disadvantaged Business Utilization (OSDBU), U.S. Department of State
- Ms. Laurie Schive, Director of Outreach, Office of the Director of National Intelligence (ODNI), Office of the National Counterintelligence Executive (ONCIX)
- Ms. Pamela R. McFarland, Consulting Property Manager, Supply Chain Management Compliance, Raytheon Technical Services Company

“DEFENSE IN TRANSITION - LESSONS LEARNED”

- RADM Kathleen M. Dussault, USN, Director, Supply, Ordnance and Logistics Operations Division (OPNAV N41)

“CYBER RESILIENCY OF DEFENSE SYSTEMS”

- Ms. Kristen J. Baldwin, Principal Deputy, Office of the Deputy Assistant Secretary of Defense for Systems Engineering; Acting Director, Systems Analysis

“TYING THE RIBBON: SCIENCE, TECHNOLOGY, ENGINEERING, MATHEMATICS AND THE FUTURE OF THE INDUSTRIAL BASE”

- Dr. Patricia Falcone, Assistant Director, National Security and International Affairs Division, Office of Science and Technology Policy (OSTP), White House
-



WOMEN IN DEFENSE
A NATIONAL SECURITY ORGANIZATION

CONFERENCE BROCHURE

2011 WID NATIONAL FALL CONFERENCE

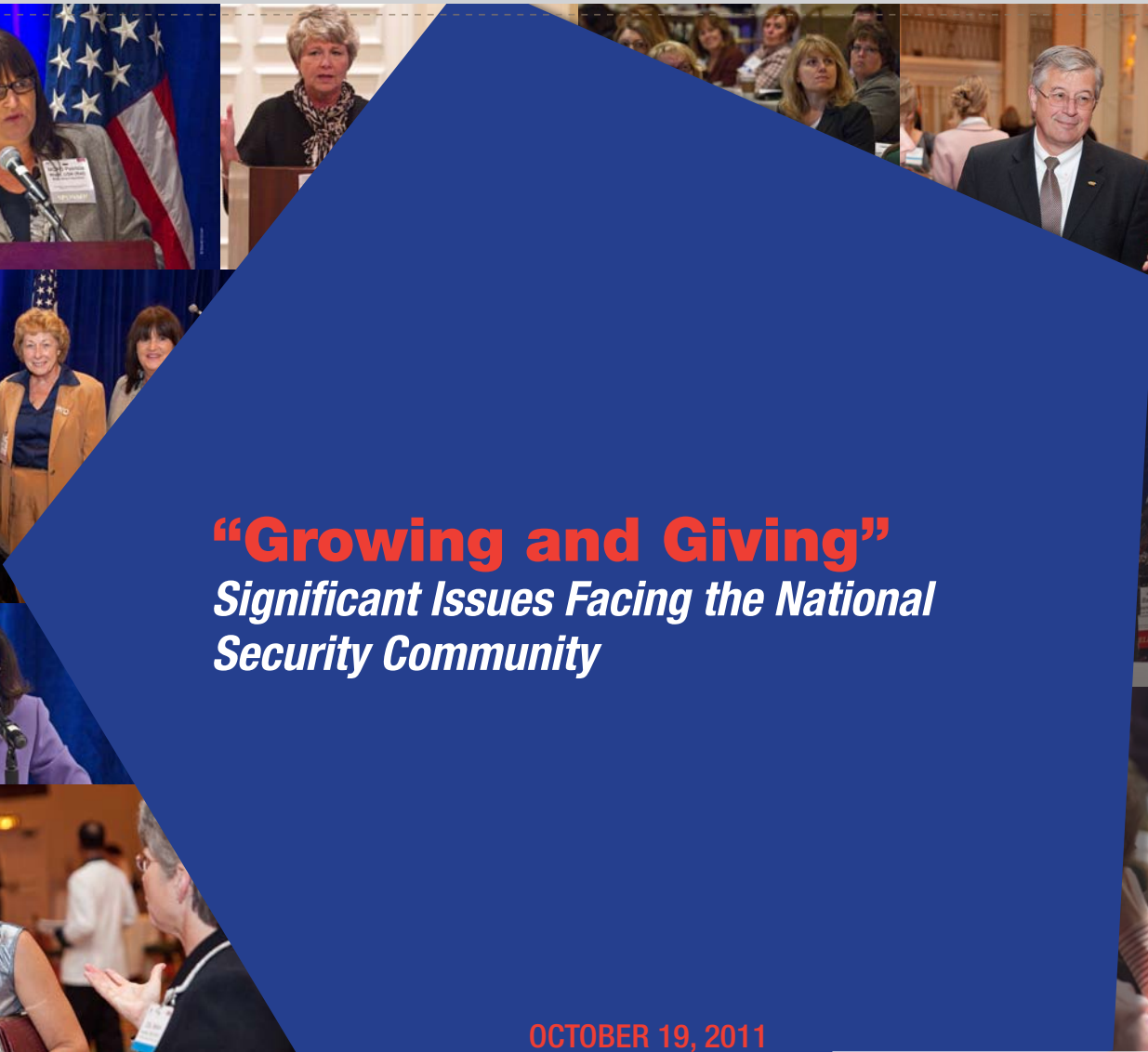

“Growing and Giving”
Significant Issues Facing the National Security Community

OCTOBER 19, 2011

MAYFLOWER HOTEL ▶ WASHINGTON, DC

EVENT #2WID

A Proud Affiliate Of



WEDNESDAY OCTOBER 19 2011



7:00 am - 5:15 pm
REGISTRATION OPEN — PROMENADE

7:00 am - 8:00 am
CONTINENTAL BREAKFAST — PROMENADE

8:00 am - 8:15 am
WELCOME AND OPENING REMARKS — STATE BALLROOM

- ▶ Ms. Tricia Ward, *Senior Associate, Booz Allen Hamilton; National President, Women In Defense*

8:15 am - 9:15 am
KEYNOTE SPEAKER: "ACQUISITION AGILITY"

- ▶ Ms. Heidi Shyu, *Acting Assistant Secretary of the Army (Acquisition, Logistics and Technology) and Army Acquisition Executive; Principal Deputy*

9:15 am - 10:15 am
"BUDGET CRISIS"

- ▶ Ms. Jenness B. Simler, *Professional Staff, Committee on Armed Services, U.S. House of Representatives*

10:15 am - 10:30 am
NETWORKING BREAK — PROMENADE

10:30 am - 11:30 am
PANEL: "RECENT DEVELOPMENTS IN ACQUISITION: NEW LAWS, REGULATIONS AND DIRECTIVES"

Moderator:

- ▶ Ms. Susan Ebner, *Counsel, Buchanan Ingersoll & Rooney PC*

Panelists:

- ▶ Ms. Jennifer Schaus, *Principal & Founder, Jennifer Schaus Associates*
- ▶ Ms. Hazel Scalia, *Senior Attorney, KBR North American Government and Defense*
- ▶ Ms. Sherri L. Schornstein, *Senior Assistant U.S. Attorney, Fraud & Public Corruption Section, U.S. Attorney's Office, District of Columbia*

11:30 am - 12:30 pm
THE HORIZONS LUNCHEON — EAST BALLROOM

"SUSTAINING MILITARY READINESS AND THE ROLE OF WOMEN IN CONFLICT"

Moderator:

- ▶ Ms. Brenda McKinney, *District Manager, Kelly Government Solutions; HORIZONS Scholarship Director, Women In Defense*

Speaker:

- ▶ Ms. Jennifer Griffin, *National Security Correspondent, FOX News Channel*



WEDNESDAY OCTOBER 19 2011

12:45 pm - 1:45 pm

PANEL: "GOVERNMENT AND INDUSTRY PARTNERING FOR SECURITY BUDGETING"

Moderator:

- ▶ Ms. Eileen Giglio, *Consultant, National Defense Business Institute, University of Tennessee*

Panelists:

- ▶ Ms. Kristina Tanasichuk, *Chief Executive Officer, Government Technology & Services Coalition; President & Founder, Women in Homeland Security*
- ▶ Ms. Trish Culbreth, *Small Business Advocate/Mentor-Protegee Program Manager, Office of Small and Disadvantaged Business Utilization (OSDBU), U.S. Department of State*
- ▶ Ms. Laurie Schive, *Director of Outreach, Office of the Director of National Intelligence (ODNI), Office of the National Counterintelligence Executive (ONCIX)*
- ▶ Ms. Pamela R. McFarland, *Consulting Property Manager, Supply Chain Management Compliance, Raytheon Technical Services Company*

1:45 pm - 2:30 pm

"DEFENSE IN TRANSITION - LESSONS LEARNED"

- ▶ RADM Kathleen M. Dussault, USN, *Director, Supply, Ordnance and Logistics Operations Division (OPNAV N41)*

2:30 pm - 2:45 pm

NETWORKING BREAK — PROMENADE

2:45 pm - 3:30 pm

PANEL: "SUSTAINING MILITARY READINESS AND THE ROLE OF WOMEN IN CONFLICT"

Panelists: Marine Female Engagement Team

- ▶ LtCol Julie Nethercot, USMC, *Former Battalion Commander; Currently at the National War College*
- ▶ Sgt Sara Bryant, USMC, *Wounded Warrior Battalion*
- ▶ Capt Sherwood, USMC, *Watch Officer, Marine Corps Network Operations Center*

3:30 pm - 4:15 pm

"CYBER RESILIENCY OF DEFENSE SYSTEMS"

- ▶ Ms. Kristen J. Baldwin, *Principal Deputy, Office of the Deputy Assistant Secretary of Defense for Systems Engineering; Acting Director, Systems Analysis*

4:15 pm - 5:00 pm

"TYING THE RIBBON: SCIENCE, TECHNOLOGY, ENGINEERING, MATHEMATICS AND THE FUTURE OF THE INDUSTRIAL BASE"

- ▶ Dr. Patricia Falcone, *Assistant Director, National Security and International Affairs Division, Office of Science and Technology Policy (OSTP), White House*

5:00 pm - 5:15 pm

CLOSING REMARKS

- ▶ Ms. Tricia Ward, *Senior Associate, Booz Allen Hamilton; National President, Women In Defense*

5:15 pm - 6:15 pm

RECEPTION — EAST BALLROOM



Bloomberg GOVERNMENT

Bloomberg Government is the single source for professionals who need to understand the business impacts of government actions. This comprehensive, online tool collects best-in-class data, provides high-end analysis and analytic tools, and delivers reliable and unbiased reporting from a team of more than

2,300 journalists and multimedia specialists worldwide, including former congressional staffers, veterans, economists, and financial analysts, covering key industry sectors (healthcare, energy, defense, infrastructure, finance, and tech/telecom) and trade, taxation, and labor. Linking the reporting and analysis of our teams to a customizable console of tools and resources, Bloomberg Government helps everyone do their jobs better.

Booz | Allen | Hamilton

Booz Allen Hamilton has been at the forefront of strategy and technology consulting for nearly

a century. Today, Booz Allen is a leading provider of management and technology consulting services to the US government in defense, intelligence, and civil markets, and to major corporations, institutions, and not-for-profit organizations. In the commercial sector, the firm focuses on leveraging its existing expertise for clients in the financial services, healthcare, and energy markets, and to international clients in the Middle East. Booz Allen offers clients deep functional knowledge spanning strategy and organization, engineering and operations, technology, and analytics—which it combines with specialized expertise in clients' mission and domain areas to help solve their toughest problems.

The firm's management consulting heritage is the basis for its unique collaborative culture and operating model, enabling Booz Allen to anticipate needs and opportunities, rapidly deploy talent and resources, and deliver enduring results. By combining a consultant's problem-solving orientation with deep technical knowledge and strong execution, Booz Allen helps clients achieve success in their most critical missions—as evidenced by the firm's many client relationships that span decades. Booz Allen helps shape thinking and prepare for future developments in areas of national importance, including cybersecurity, homeland security, healthcare, and information technology.

Booz Allen is headquartered in McLean, Virginia, employs more than 25,000 people, and had revenue of \$5.59 billion for the 12 months ended March 31, 2011. Fortune has named Booz Allen one of its "100 Best Companies to Work For" for seven consecutive years. Working Mother has ranked the firm among its "100 Best Companies for Working Mothers" annually since 1999. More information is available at www.boozallen.com. (NYSE: BAH).



Concurrent Technologies Corporation

Concurrent Technologies Corporation (CTC) is an independent, nonprofit, applied scientific research and development professional services organization providing innovative management and technology-based solutions to government and industry. CTC identifies and creates breakthrough technologies and applies them through an

integrated business and technical approach to produce transformative solutions. CTC is results-motivated, not profit-motivated. As a nonprofit organization, CTC conducts impartial, in-depth assessments and delivers reliable, unbiased solutions that emphasize increased quality, enhanced effectiveness, and rapid technology transition and deployment. The company's bottom line is helping every client achieve its mission. For more information, visit www.ctc.com.

GENERAL DYNAMICS Information Technology

(IT), systems engineering, professional services and simulation and training to customers in the defense, federal civilian government, health, homeland security, intelligence, state and local government and commercial sectors. With approximately 24,000 professionals worldwide, the company delivers IT enterprise solutions, manages large-scale, mission-critical programs and provides mission support services. General Dynamics Information Technology is one of four business units of the General Dynamics Information Systems and Technology business segment. Headquartered in Fairfax, Va., General Dynamics Information Technology has major offices worldwide.”

“As a trusted systems integrator for more than 50 years, General Dynamics Information Technology provides information technology

www.ndbi.utk.edu



MS. KRISTEN J. BALDWIN

Principal Deputy, Office of the Deputy Assistant Secretary of Defense for Systems Engineering; Acting Director, Systems Analysis

Kristen Baldwin is the Principal Deputy in the Office of the Deputy Assistant Secretary of Defense for Systems Engineering (ODASD(SE)). Ms. Baldwin acts on behalf of the DASD and is responsible for engineering and technical workforce, policy, and acquisition program implementation across the Department of Defense (DoD). This includes concept engineering and analysis, design, development and manufacturing, and independent program review and assessment for all DoD major weapon system acquisition programs. She supports ODASD(SE) in its role as the systems engineering workforce leader with responsibility for more than 40,000 DoD acquisition professionals. She is also overseeing the DoD's Strategies for Engineering Resilient Systems and Trusted Systems Design. A member of the Senior Executive Service, Ms. Baldwin is also the acting Director for Systems Analysis and oversees development planning and modeling and simulation activities across DoD. She leads cyber and system assurance, program protection, systems engineering for systems of systems, and research and development initiatives. She oversees the DoD Systems Engineering Research Center, a University Affiliated Research Center, dedicated to advancing systems engineering methods, processes, and tools. Ms. Baldwin has been with OSD since 1998, where she has led the application of capabilities-based planning in the acquisition process, with a focus on the integration of requirements, acquisition, and programming processes; served as Deputy Director, Software Intensive Systems; and managed the Tri-Service Assessment Initiative. Before working with OSD, Ms. Baldwin served as a Science and Technology Advisor in the Army's Office of the Deputy Chief of Staff for Operations and Plans, and at the Dismounted Battlespace Battle Lab, Fort Benning, GA. Ms. Baldwin began her career at the U.S. Army's Armament Research, Development, and Engineering Center, Picatinny Arsenal, where she was responsible for infantry weapons and ammunition design and production. Ms. Baldwin received a bachelor's degree in mechanical engineering from the Virginia Polytechnic Institute and a master's degree in systems management from the Florida Institute of Technology.

SGT SARA BRYANT, USMC

Wounded Warrior Battalion

Sgt Sara Bryant enlisted into the United States Marine Corps in December 2004 during her senior year at Tunstall High School in Danville, Virginia. She reported to Marine Corps Recruit Depot, Parris Island, South Carolina, in June 2005 for basic training. Upon graduating from basic training, Bryant attended Marine Combat Training at Camp Lejeune, North Carolina, and was subsequently assigned to Marine Corps Air Ground Combat Center, Twentynine Palms, California, and attended Field Radio Operators Course. Bryant was later assigned to 9th Communication Battalion, Camp Pendleton, California. Bryant deployed to Fallujah, Iraq in the Al Anbar province in January 2009 where she participated in the Marine Corps' Lioness Program with Regimental Combat Team 5. The Lioness Program attached female Marines and corpsmen to ground elements to search Iraqi women and children at security checkpoints. The lionesses also trained Iraqi women how to conduct proper searches on other women and children. Bryant's after action reports were used by ground commanders to mold the Lioness Program into a more effective program. Bryant returned to Camp Pendleton and held several billets usually reserved for Marines of higher rank such as battalion security manager and career retention specialist. During this time, Bryant assisted commanders in developing the Female Engagement Team program which is now in effect in Afghanistan. The Female Engagement Teams were comprised of four-and-five member units that accompanied male Marines on patrols in Helmand province to try to win over the rural Afghan women who are culturally off limits to outside men. Bryant deployed in 2010 with I Marine Expeditionary Force (FWD) and served on the Female Engagement Team with 3rd Battalion, 7th Marine Regiment, where she participated in the push into Sangin, a Taliban stronghold. She is now stationed at the Wounded Warrior Battalion, Camp Pendleton, where she is recovering from injuries sustained in combat.

MS. TRISH CULBRETH

Small Business Advocate/Mentor-Protegee Program Manager, Office of Small and Disadvantaged Business Utilization (OSDBU), U.S. Department of State

Trish Culbreth has been with the Department of State since 2001. She is a Senior Procurement Analyst and the Mentor-Protege Program Manager for the Office of Small and Disadvantaged Business Utilization. She is an advocate for small business and has considerable knowledge of small and disadvantaged business utilization, business development and community outreach programs. Ms. Culbreth's career in the Federal Government began at the Department of

Defense. Prior to her government service, Ms. Culbreth spent six years in non-profit business development. She holds a Masters Degree in Business from Webster University and a Bachelors Degree in Art from the University of South Carolina.

RADM KATHLEEN M. DUSSAULT, USN

Director, Supply, Ordnance and Logistics Operations Division (OPNAV N41)

RADM Kathleen Dussault assumed duties as the Director of Supply, Ordnance and Logistics Operations in the Office of Chief of Naval Operations (OPNAV N41) in March 2009. Dussault comes to OPNAV from her most recent assignment as Commander of the Joint Contracting Command Iraq/Afghanistan, headquartered in Baghdad, Iraq, with 18 regional offices throughout both theaters. Dussault graduated from the University of Virginia in 1977 with a Bachelor of Arts in American Government, received her commission through Officer Candidate School in Newport, R.I., in November 1979, and graduated from Navy Supply Corps School in May 1980. Dussault has served in USS Point Loma (AGDS-2) in the Pacific Area Launch Support Ship for the Trident missile program as Supply Officer, USS Concord (AFS-5) as the Assistant Supply Officer during Operations Desert Shield and Desert Storm, and as Supply Officer Aboard USS Seattle (AOE-3) where she served as Afloat Logistics Coordinator while deployed to the 5th Fleet operating area. Dussault's shore tours include: Assistant Supply Officer and Disbursing Officer to the Navy Communications Station, Nea Makri, Greece, Defense Contract Administration Services Region (DCASR), Los Angeles, a Negotiator and Contracting Officer at Naval Supply Center, Oakland, California, Procuring Contracting Officer for the Sidewinder and Deputy for Missile Systems Acquisition at Naval Air Systems Command (NAVAIR), Business and Financial Manager for programs managed by the Space and Naval Warfare Command and Executive Assistant to the Deputy Assistant Secretary of the Navy for Acquisition Management within the office of the Assistant Secretary of the Navy for Research Development and Acquisition. In May 2001, Dussault assumed command of Defense Distribution Depot San Diego, and in April 2003 she assumed command of the Office of Special Projects, Arlington, Virginia. She then served as Deputy Director of Acquisition Management at Defense Logistics Agency, Ft. Belvoir, Virginia. Prior to her combat assignment, she was assigned as Deputy Assistant Secretary of the Navy for Acquisition and Logistics Management in Washington. Dussault has earned a Master's degree (with honors) in Procurement Management from Saint Mary's College in Moraga, California, and a Master's degree in National Resource Strategy from the Industrial College of the Armed Forces. She has achieved the highest levels of accreditation in Acquisition, Financial and Supply Chain Management and Joint Professional Military Education. Dussault is certified in production and inventory management through APICS, the educational society for resource management. She has completed the Executive Education Program at Columbia Business School. Her decorations include the Defense Superior Service Medal, Legion of Merit, Bronze Star, Navy Meritorious Service Medal with two gold stars, Joint Service Commendation Medal, Navy Commendation Medal, Navy Achievement Medal with gold star and various unit citations, campaign medals and service medals.

MS. SUSAN EBNER

Counsel, Buchanan Ingersoll & Rooney PC

Susan Warsaw Ebner focuses on advising and representing clients on a broad spectrum of government procurement matters, including strategic alliances, contract acquisition and performance, business ethics and compliance, research and development, intellectual property rights, audits, investigations, protests, claims, and litigation and alternative dispute resolution. Susan advises and represents clients on a full range of government contracts matters involving traditional areas of federal government contracting, as well as less traditional areas such as other transaction agreements, technology investment agreements, cooperative agreements, and grants. Her work includes handling audits, bid protests, contract changes, claims and disputes, internal compliance program development and implementation matters, federal, state and local procurement issues, such as Buy American Act, Trade Agreements Act, Specialty Metals, Berry Amendment, American Reinvestment And Recovery Act, Pennsylvania Steel Procurement Act issues, intellectual property rights,

R&D contracting, small business size matters, and strategic alliances (including prime and subcontract agreements). She works to resolve issues at the lowest possible level. Her dispute resolution experience includes handling matters informally and formally, including REAs, claims, disclosures, informal negotiation and alternative dispute resolution, agency and GAO bid protests, and formal litigation at the U.S. Court of Federal Claims. Susan has practiced before the United States Court of Federal Claims, the Government Accountability Office, various Boards of Contract Appeal, United States District and Appellate Courts, as well as state courts. Her government contracts experience includes working on matters involving a variety of federal agencies, bodies and grant institutions, such as the Department of Agriculture, Department of Defense (Army, Navy, Air Force and Marine Corps), General Services Administration, Department of Transportation, Department of Treasury, USAID/Host Nation, and the Iraq CPA. Early in her career, she served as a government attorney representing the Department of the Navy, the Department of Defense, and the Office of Personnel Management in complex litigation before Federal district and appellate courts, administrative boards and the United States Court of Federal Claims. Susan was also appointed as a Special Assistant United States Attorney for the Northern District of Florida. As a private practitioner, Susan was an associate in government contracts with one of Washington, D.C.'s largest government contract law firms and of counsel at a small boutique law firm. As a private practitioner, she advised and represented clients on government contracts matters including bid protests, civil investigations, claims, computer software and technical data rights issues, contract disputes, due diligence investigations, FOIA requests, small business size disputes and terminations. For a number of years after her large firm experience, she served as in-house counsel first at Cincinnati Bell Incorporated and later at its spin-off, Convergys Corporation. Susan also served as Chief Counsel at NCR Government Systems Corporation. In these positions, she handled a broad spectrum of federal, state and local government contracts and corporate compliance matters. Susan has experience handling "buy American" issues relating to the acquisition and use of commercial and non-commercial supplies, construction equipment and materials, and specialty metals under the Buy American Act, Trade Agreements Act, Specialty Metals, Berry Amendment, as well as the American Investment and Recovery Act and Pennsylvania Steel Procurement Act. In 2006, Susan was named to the BTI Client Service All-Star Team for Law Firms. In June 2008, the D.C. Bar Government Contracts and Litigation Section was awarded the D.C. Bar Best Section Community Outreach Project Award for its March 2008 community outreach project. Susan led this project, organizing and working with government officials, private practitioners and corporate counsel, to conduct training for D.C. government procurement personnel, contractors, potential contractors and practitioners regarding D.C. Government procurement and the handling of protests, claims and other disputes. In 2010, Susan received the Life Service Award from the Boards of Contract Appeals Bar Association, Inc. She has held several positions on the WID National Board.

DR. PATRICIA FALCONE

Assistant Director, National Security & International Affairs Division, Office of Science and Technology Policy (OSTP), White House

Dr. Patricia Falcone is Assistant Director for National Security in the Office of Science and Technology Policy (OSTP) within the Executive Office of the President. Her work in the National Security and International Affairs Division of OSTP includes advanced technologies and innovation, nuclear security and nonproliferation, and science and technology strategies for national and homeland security. Previously, she was a Senior Policy Analyst at OSTP. Prior to that, Falcone was a Senior Manager at Sandia National Laboratories in Livermore, California where she was responsible for Systems Analysis and Engineering; earlier, she was named a Distinguished Member of the Technical Staff at Sandia. She has worked on a variety of research topics, including technologies associated with countering weapons of mass destruction; assessments of the nation's nuclear weapons stockpile and infrastructure; and advanced and renewable energy technologies. She served on the Board on Army Science and Technology of the National Academies, the Nuclear Deterrent Transformation Panel of the DoD Threat Reduction Advisory Committee, and continues to serve on an advisory committee at Princeton University. Falcone holds a B.S.E. in Aerospace and Mechanical Sciences from Princeton, and M.S. and Ph.D. degrees in Mechanical Engineering from Stanford University. She and her husband have two grown children.

MS. EILEEN GIGLIO

Consultant, National Defense Business Institute, University of Tennessee

Ms. Giglio is currently serving as a Consultant with the National Defense Business Institute at the University of Tennessee in Knoxville and as a Consultant to a defense small business firm, Loch Harbour Group. After 30 years of government service, she retired from the Department of Defense as Assistant Deputy Under Secretary of Defense for Strategic Plans and Initiatives, Acquisition Transformation for the Under Secretary of Defense (USD), Acquisition, Technology and Logistics (AT&L). She was responsible for the management of biannual reports to Congress regarding implementation of defense-wide reforms of the Acquisition System. She provided incentives to affect transformation of the Acquisition System and collected data and established a system to track current initiatives. She provided leadership to socialize the concepts and to generate greater consistency and transparency regarding reforms related to the workforce, organization, budget, requirements, industry and the acquisition processes. She formerly served as the Deputy Director of the Defense Acquisition Performance Assessment Project for the Deputy Secretary of Defense. Prior to that assignment, she was a Special Assistant to the Deputy Under Secretary of Defense for International Technology Security. She was responsible for a variety of projects, to include technology security acquisition policy, the Militarily Critical Technologies Program, the Wisconsin Project, a nano-technology initiative, high performance computer control parameters, outreach to industry, and budgeting and funding for these activities. Prior to this assignment, she served as a Dual-Use Licensing Technology Security Analyst in USD Policy in the Defense Technology Security Administration (DTSA) and managed the outreach to industry program for export controls. In DTSA she also served as Director of External Affairs in the Technology Security Directorate of the Defense Threat Reduction Agency (DTRA) where she was the liaison with congress, industry, and the offices of the Department of Defense Inspector General and General Accounting Office. She has served as Deputy Director to the Threat Reduction Advisory Committee (TRAC), a Federal Advisory Committee of senior executives reporting to the Secretary of Defense, with responsibility for analyzing national security matters and the threat of weapons of mass destruction. Before reporting to DTRA, she was Special Assistant for Communications in the Defense Reform Office in the OSD, where she formulated and directed public relations and legislative strategy for reform initiatives throughout the department. The Defense Reform Initiative of 1997 included the consolidation of three defense agencies into DTRA. As the External Affairs Advisor to the DTRA Transition Team, she devised communication strategy and initiated congressional and media consultations related to the consolidation. For five years, she served as Special Assistant to the Assistant to the Secretary of Defense for Nuclear, Chemical and Biological Defense Programs. During the course of her career, Ms. Giglio has served at the White House, State Department, the Arms Control and Disarmament Agency and as a Defense Legislative Assistant to Representative Hal Daub (R-Nebraska). She was one of the original employees at the On-Site Inspection Agency, serving as Chief of Congressional Affairs and an Intermediate-range Nuclear Forces (INF) Treaty Inspector. Her career has been dedicated to national security policy issues serving as a government liaison with the press, the Congress and industry. In addition, Ms. Giglio has been a volunteer to political campaigns for over 25 years. Ms. Giglio is a Senior Executive Fellow of Harvard University's JFK School of Government. She graduated from the University of Nebraska with a major in Political Science and a minor in German. She was born in the Bronx, N.Y. and resides in Alexandria, Virginia with her husband Michael A. Giglio (Colonel, USAF ret.). She has held several positions on the WID National Board.

MS. JENNIFER GRIFFIN

National Security Correspondent, FOX News

Jennifer Griffin is the National Security Correspondent for FOX News Channel (FNC). She has been based at the Pentagon covering military and intelligence matters since March 2007. Griffin joined FNC in October 1999 as a correspondent for the Jerusalem bureau providing coverage of the Middle East, including the Israeli-Palestinian conflict, countless suicide bombings, military incursions and failed peace deals. She provided on site coverage of Israel's withdrawal from Lebanon in 2000, its withdrawal from the Gaza strip and Yasser Arafat's funeral. Also, Griffin is credited with conducting a rare interview with Ariel Sharon, Prime Minister of Israel. During her tenure at FNC, she

has covered Operation Enduring Freedom from Israel and the ongoing Israeli/Palestinian conflict in the Middle East. In 2004, Griffin provided extensive on-site coverage in the wake of the South-East Asia tsunami tragedy from Phuket, Thailand. Prior to joining FNC, Griffin covered the Middle East region for several American media organizations, including the Associated Press, National Public Radio and U.S. News and World Report. Previously, she reported for The Sowetan newspaper in Johannesburg, South Africa, where she covered Nelson Mandela's prison release and numerous other historic moments in South Africa's transition away from apartheid. A graduate of Harvard University in 1992, Griffin received a Bachelor's degree in comparative politics. She and her husband, Greg Myre, recently wrote a book, "This Burning Land: Lessons from the Frontlines of the Transformed Israeli-Palestinian Conflict," about their time in Israel. Griffin and her husband have two daughters and a son. Read more: <http://www.foxnews.com/on-air/personalities/jennifer-griffin/bio/#ixzz1Vu4sUBEs>.

MS. PAMELA MCFARLAND

Consulting Property Manager, Supply Chain Management Compliance, Raytheon Technical Services Company

Pamela McFarland has been recognized as a Certified Professional Property Manager (CPPM) and Consulting Fellow (CF), by the National Property Management Association (NPMA), and is currently working as a Consulting Property Manager with Raytheon Technical Services Company in Supply Chain Management Compliance. Her career spans over 30 years with experience in Government/Corporate asset management and is considered an expert in subcontractor property management solutions. Her diverse work experience includes management of Government property accountable to all types of contracts for commercial, DoD, NASA, and other Government agencies. Pam is the corporate property management representative for Raytheon on the Aerospace Industry Association's Property Management Committee. Pam has won numerous literary awards for her articles titled, "The FAR Re-write and Its Effects on Contractors," "Contract Closeout Standardization – The Good, The Bad, and The Ugly," and "Contractor Risk Assessments – Risky Business" awarded by the NPMA at their annual National Educational Seminars in 2008, 2009 and 2011. She has published several articles in the National Property Management Association's "Property Professional: Leaders in Asset Management," magazine. Raytheon has recognized her talents with several "outstanding performance" awards for her work to implement compliant systems that result in streamlined solutions that dramatically reduce cost.

MS. BRENDA MCKINNEY

District Manager, Kelly Government Solutions, Kelly Services, Inc.

Ms. McKinney is the District Manager for Kelly Government Solutions, a specialized division of Kelly Services, Inc., focused primarily on security cleared staffing support requirements. She has worked with Government Solutions for over seven years and has extensive experience working with many of the Federal agencies. Ms. McKinney has significant personnel management, coaching and development, budget management and quality control management experience. Her career with Kelly Services, a Fortune 500 company, spans twelve years with a beginning in Houston, TX. Prior to joining Kelly Services, Ms. McKinney worked in the staffing industry for over ten years holding positions in marketing, resource development and business development. She regularly participates in events for the USO, MS Foundation, breast cancer prevention and the Wounded Warrior's program. Ms. McKinney serves on the Women In Defense National Board as HORIZONS Scholarship Director.

LTCOL JULIE NETHERCOT, USMC

Former Battalion Commander; Currently at the National War College

Lieutenant Colonel Julie Nethercot was commissioned in May of 1993 following her graduation from Midland University with a Bachelor of Science Degree in Biology, Natural Science and Chemistry. Upon graduation from The Basic School and Communication Officers School in 1994, Lieutenant Colonel Nethercot reported for duty at Marine

Corps Air Station Cherry Point. From 1995-1997, she served with Bravo Company, Marine Wing Communications Squadron-28. Her positions within MWCS-28 included assignments as Platoon Commander for three different platoons: Wire Platoon, Data Communications Platoon, and Multi-Channel Radio Platoon. She went on to serve as the Company Executive Officer and Operations Officer before subsequently taking command of Bravo Company in 1997. From 1997-2000, Lieutenant Colonel Nethercot was assigned as a Tactics Instructor at The Basic School in Quantico, Virginia. There she served as a Staff Platoon Commander for three companies before taking command of Mike Company. From 2000-2001, Lieutenant Colonel Nethercot attended Command and Control Systems School. She graduated in the spring of 2001 and then spent that summer as a Platoon Commander at Officer Candidate School for Charlie Company, 1st Platoon. In August of 2001, Lieutenant Colonel Nethercot moved to Camp LeJeune, North Carolina to serve as the Company Commander for Alpha Company, 8th Communication Battalion. Following that command tour she was assigned as the Battalion Operations Officer and deployed with the battalion in February of 2003 in support of Operation Iraqi Freedom I, returning in June. After returning from Iraq, Lieutenant Colonel Nethercot deployed from July 2003 to March 2004 to support Operation Enduring Freedom as the Communications Officer for Marine Corps Central Command-Djibouti in Africa. From 2004-2007, she served as the Commanding Officer of Recruiting Station Frederick, Maryland and then spent the next year at the Naval Command and Staff College in Newport, Rhode Island. From August of 2008 to May 2009, she has served as a Regional Plans Officer on the staffs of 5th FLEET and U.S. Navy Central Command in Bahrain as well as serving as the Chief of Plans (G-5) of I Marine Expeditionary Force. From May 2009-June 2011, LtCol Nethercot served as the Battalion Commander for 9th Communications Battalion, Camp Pendleton. Her battalion was deployed to Helmand Province, Afghanistan from January 2010 through February 2011. Following her command tour, she was selected to attend the National War College in Washington, D.C. Lieutenant Colonel Nethercot is a graduate of the Weapons and Tactics Instructor Course, Command and Control Systems School, Naval Command and Staff College and the Maritime Advanced Warfighting School. She holds a Master of Arts degree in National Security and Strategic Studies from the Naval War College. Lieutenant Colonel Nethercot's personal decorations include the Bronze Star, Defense Meritorious Service Medal, Meritorious Service Medal (Gold star in lieu of second award), Navy and Marine Corps Commendation Medal (Gold stars in lieu of fourth award) and the Navy Achievement Medal. She was the recipient of the 2010 Major Megan McClung award for Visionary Leadership.

MS. HAZEL SCALIA

Senior Attorney, KBR North American Government and Defense

Ms. Scalia is a Senior Attorney in KBR's North American Government and Defense line of business. In that capacity, she is part of the team working on contracts with the U.S. federal government, as well as state and local institutions. She is involved from initial Request for Proposal to final contract close out, and beyond. This includes potential protests, requests for equitable adjustment, and other contractual, legal and regulatory disputes for CONUS and OCONUS-based Indefinite Delivery, Indefinite Quantity Task Order contracts, among others. She is experienced in working with operating units to find solutions to business challenges. Prior to KBR, she was part of the materials management team for the then Hoechst-Celanese Chemical Company, specializing in innovative Supply-Chain solutions involving integrated vendor/purchaser Enterprise Resource Planning and/or Materials Requirements Planning systems, Just-In-Time and TQM. She holds a B.A. from the University of New Mexico, a J.D. from Catholic University of America, Columbus School of Law, and is admitted to the practice of law in the Commonwealth of Virginia.

MS. JENNIFER SCHAUS

Principal & Founder, Jennifer Schaus & Associates

Ms. Jennifer Schaus is Principal and Founder of Jennifer Schaus & Associates, a Washington, DC boutique consulting firm. The organization works with domestic and European firms, including small, mid-size and Fortune 500 companies interested in B2G and B2B commerce. Service offerings include both social media marketing services and government

contract assistance (GSA Schedule proposals). Additionally, Ms. Schaus hosts a gratis Government Contractors Networking Event at The John F. Kennedy Center in Washington, DC. This monthly event allows contractors to exchange best practices and to team with partners for larger opportunities. Prior to establishing her own practice, Ms. Schaus worked for Dun & Bradstreet's (D&B) Government Sales Division where she sold financial and business data to contracting officers. Post D&B, Ms. Schaus sold products and services directly to the U.S. Government, including the CIA, FBI, DEA, Secret Service and DoD. She has worked with international clients, including companies and/or embassies from The Netherlands, Canada, Latvia, Belgium, France and Italy. Ms. Schaus holds a B.A. from Towson University. She works in Washington, DC and Rome, Italy.

MS. LAURIE SCHIVE

Director of Outreach, Office of the Director of National Intelligence (ODNI), Office of the National Counterintelligence Executive (ONCIX)

Ms. Schive assumed her duties as the Director of Outreach for ONCIX in September, 2010. In this role, Ms. Schive directs the CI and security outreach and foreign intelligence threat awareness programs for the ODNI's Office of the National Counterintelligence Executive (ONCIX). She is a member of the Senior National Intelligence Service and has over 22 years of experience in the Intelligence Community. From 1988 to 2006, Ms. Schive served in the CIA's National Clandestine Service, working both in Washington, DC and in the field on counterproliferation and economic security issues. Prior to joining ONCIX, she worked in the private sector for 4 years, managing projects for the ODNI, CIA and FBI. Ms. Schive holds an MS in Technology Management from the University of Maryland and a BA in Political Science from the George Washington University. She is married and has two children.

MS. SHERRI SCHORNSTEIN

Senior Assistant U.S. Attorney, Fraud & Public Corruption Section, U.S. Attorney's Office, District of Columbia

Ms. Schornstein is a Senior Assistant U.S. Attorney in the Fraud & Public Corruption Section of the U.S. Attorney's Office for the District of Columbia. She is also the senior member of the Computer Hacking & Intellectual Property (CHIP) Unit. She leads the D.C. Counterfeit Microelectronics Working Group, a public-private partnership consisting of attorneys, law enforcement, the military, scientists, engineers, quality control and security professionals, academics, trade groups, and private industry semiconductor companies and defense contractors. Prior to her tenure at the U.S. Attorney's office, Ms. Schornstein was a trial attorney for the U.S. Department of Justice, Tax Division, Criminal Section in the Honors Program. Ms. Schornstein earned her undergraduate degree in Business Administration from the University of Iowa's College of Business and her J.D., cum laude, from California Western School of Law. Ms. Schornstein has prosecuted a wide variety of Intellectual Property Crimes and other complex, multi-jurisdictional, multi-agency fraud schemes. She works closely with U.S. Immigration and Customs Enforcement (ICE), the Federal Bureau of Investigation (FBI), and other law enforcement agencies, including Naval Criminal Investigative Service (NCIS). She led the investigations and prosecuted the cases arising from VisionTech Components (United States v. Shannon L. Wren, et. al.) and MVP Micro (United States v. Mustafa Abdul Aljaff, et. al.) - the first such prosecutions ever, involving the sales of counterfeit integrated circuits to the U.S. Military and other industries. Ms. Schornstein holds a number of leadership positions with the American Bar Association (ABA). She Co-Chairs the ABA's committee on Ethics, Gideon and Professionalism, she is a member of the editorial board of the ABA's Criminal Justice magazine, and she serves on the ABA Criminal Justice Section Council - one of the ABA's policy making bodies. She is a former Co-Chair of the ABA's White Collar Crime Committee, D.C. Regional Subcommittee and a former Co-Chair of the ABA's Annual National Institute on Criminal Enforcement of Intellectual Property Rights. She has also served as Co-Executive Director of the Division on Communications, Membership and Services. She formerly served as Co-Chair of the ABA's Subcommittee on Computer Crime, Intellectual Property and Trade Secrets. She has also served as Vice Chair of American Intellectual Property Law Association's (AIPLA's) Anti-Counterfeiting & Anti-Piracy Committee, where she Chaired the Enforcement Subcommittee. Ms. Schornstein serves as a faculty member for the INTERPOL/EUROPOL International Law Enforcement Intellectual Property Crime Conference which attracts members of law

enforcement and private industry from 187 different countries. Her book, *Criminal Enforcement of Intellectual Property Rights*, will be published in Spring 2012 by Oxford University Press.

CAPT SHERWOOD, USMC

Watch Officer, Marine Corps Network Operations Center

Captain Sherwood graduated from Wells College in 2006. She attended Officer Candidate School Officer Candidate Class 195 in Quantico, VA and was commissioned in August of 2007. Capt Sherwood attended The Basic School following OCS and was designated a communications officer. She reported to the Marine Corps Network Operations and Security Center in March of 2008 and served in the S-5 planning department prior to attending The Basic Communications Officer Course in the fall of 2008. In January of 2009 Capt Sherwood was assigned to Marine Wing Support Squadron 371 in Yuma, AZ to serve as the primary staff communications officer and communications platoon commander. She deployed in support of Operation Enduring Freedom with Marine Expeditionary Brigade-A in March of 2009 as squadron communications officer and as team leader Female Engagement Team 001. In May of 2011 Capt Sherwood was assigned to Officer Candidate School Quantico, VA as an Academics instructor. In August of 2011 she reported to the Marine Corps Network Operations and Security Center where she currently serves as operations manager.

MS. HEIDI SHYU

Ms. Heidi Shyu, Acting Assistant Secretary of the Army (Acquisition, Logistics and Technology) and Army Acquisition Executive; Principal Deputy

Heidi Shyu, a member of the Senior Executive Service, was named the Acting Assistant Secretary of the Army for Acquisition, Logistics and Technology [ASA(ALT)] on June 4, 2011. She also continues to serve as the Principal Deputy, a position to which she was appointed on November 8, 2010. As the Acting ASA (ALT), Ms. Shyu serves as the Army Acquisition Executive, the Senior Procurement Executive, the Science Advisor to the Secretary of the Army, and the Army's Senior Research and Development official. She also has principal responsibility for all Department of the Army matters related to logistics. Ms. Shyu leads the execution of the Army's acquisition function and the acquisition management system. Her responsibilities include providing oversight for the life cycle management and sustainment of Army weapons systems and equipment from research and development through test and evaluation, acquisition, logistics, fielding, and disposition. Ms. Shyu also oversees the Elimination of Chemical Weapons Program. In addition, she is responsible for appointing, managing, and evaluating program executive officers and managing the Army Acquisition Corps and the Army Acquisition Workforce. Prior to this position, Ms. Shyu was the Vice President of Technology Strategy for Raytheon Company's Space and Airborne Systems. She also held several senior leadership positions there, including Vice President of Technology and Research, Vice President and Technical Director of Space and Airborne Systems, Vice President of Unmanned and Reconnaissance Systems, Senior Director of Unmanned Combat Vehicles, Senior Director of Joint Strike Fighter (JSF), and Director of JSF Integrated Radar/Electronic Warfare Sensors. As Director of JSF Antenna Technologies at Raytheon, Ms. Shyu was responsible for the development of lightweight, low-cost, Tile Active Electronically Scanned Antenna technologies. She also served as the Laboratory Manager for Electromagnetic Systems. In addition to her extensive experience at Raytheon, Ms. Shyu served as a Project Manager at Litton Industries and was the Principal Engineer for the Joint STARS Self Defense Study at Grumman. She began her career at the Hughes Aircraft Company. Ms. Shyu holds a Bachelor of Science Degree in Mathematics from the University of New Brunswick, a Master of Science Degree in Mathematics from the University of Toronto, and a Master of Science Degree in Electrical Engineering from the University of California, Los Angeles (UCLA) and an Engineer's Degree from UCLA. She is also a graduate of the UCLA Executive Management Course and the University of Chicago Business Leadership Program. A member of the Air Force Scientific Advisory Board from 2000 to 2010, Ms. Shyu served as the Vice Chairman from 2003 to 2005 and as Chairman from 2005 to 2008.

MS. JENNESS B. SIMLER

Professional Staff, Committee on Armed Services, U.S. House of Representatives

Ms. Jenness B. Simler is a member of the professional staff on the Committee on Armed Services of the U.S. House of Representatives.

She joined the committee on October 1, 2005 and serves as the policy staff lead for the committee. In this role she serves as the senior advisor to the Chairman of the committee on all matters within the full committee's jurisdiction, including regional security issues, nonproliferation, cooperative threat reduction, acquisition policy, export control, the defense industrial base, industrial security, counternarcotics, strategic documents, and the organization and functions of the Department of Defense. Previously, Ms. Simler served as the Republican lead staff for the subcommittee with oversight of Navy and Marine Corps procurement and research and development programs and has also had responsibility for defense science and technology issues. Prior to joining the HASC, Ms. Simler served as the deputy to the Chairman, Combating Terrorism Technology Task Force within the Office of the Secretary of Defense. She worked closely with multiple Defense laboratories and agencies, National Labs, combatant commands, and the joint task force established to defeat Improvised Explosive Devices in identifying promising technologies and developing counter-terrorism/counter-insurgency concepts. Ms. Simler's previous experience also includes several years as a program officer at the Office of Naval Research (ONR) and as an engineer working within private industry. At ONR, Ms. Simler was responsible for the Navy's Manufacturing Technology programs in the areas of advanced composite materials and joining technologies. Ms. Simler holds a Master of Business Administration, awarded by the University of Maryland-College Park and a Bachelor of Science in Mathematics, with a pre-medical concentration, from Millsaps College in Jackson, MS.

MS. KRISTINA TANASICHUK

Chief Executive Officer, Government Technology & Services Coalition; President & Founder, Women in Homeland Security

Kristina Tanasichuk founded the Government & Services Technology Coalition in 2011 after several small business CEOs in the Federal homeland/security market approached her about how they could band together to face an increasingly competitive market. She is responsible for the growth, content, strategy and manages the day-to-day operations of the Coalition. She has nearly 20 years of lobbying and advocacy experience on the Hill, on behalf of non-profit associations and coalitions. Tanasichuk is also the President and Founder of Women in Homeland Security, a professional development organization for women in the field of homeland security that has grown to nearly 1000 members in 2 years. She also founded and served for two years as Executive Director of the American Security Challenge, an event that awards monetary and contractual awards in excess of \$3.5 million to emerging security technology firms. Prior to founding the Government Technology & Services Coalition she was Vice President of the Homeland Security & Defense Business Council (HSDBC), the premier organization for the leading large corporations in the federal homeland security market. She was responsible for thought leadership and programs, strategic partnerships, internal and external communications, marketing and public affairs. She managed the Council's Executive Brief Series and strategic alliances, as well as the organization's Thought Leadership Committee and Board of Advisors. Before joining HSDBC, Tanasichuk was the event director for the largest homeland security conference and exposition in the country where she created and managed three Boards of Advisors representing physical and IT security, first responders, Federal, State and local law enforcement, and public health. She determined conference curriculum, established all of the strategic partnerships, and managed the communications and media relations. Tanasichuk began her career in homeland security shortly after September 11, 2001, while at the American Public Works Association, where she managed homeland security and emergency management issues before Congress and the Administration on first responder issues, water, transportation, utility and public building security. Prior to that, she worked on electric utility deregulation and domestic energy issues for a boutique lobbying firm and as professional staff for the Chairman of the U.S. House Committee on Energy & Commerce. Tanasichuk has also worked at the American Enterprise Institute, several Washington, D.C. associations representing both the public and private sectors, and the White House under President George H.W. Bush. She is a graduate of St. Olaf College and earned her Masters in Public Administration from George Mason University. Recently, she was honored by the National Association of Woman Owned Businesses as a Distinguished Woman of the Year Finalist. Tanasichuk serves on the U.S. Coast Guard Mutual Assistance Board, as an Advisor to the Chesapeake Innovation Center (CIC) Business to Government CEO Roundtable and is currently attending the FBI's Citizens Academy.

MS. PATRICIA WARD

Senior Associate, Booz Allen Hamilton; National President, Women In Defense

Patricia Ward was born and raised in Philadelphia, Pennsylvania. She is a 1999 graduate of San Diego State University with a Bachelor of Arts in Adult Education and Instructional System Design. She earned certifications in Total Quality Management and Statistical Process Control from the University of California, San Diego and a certification in Quality and Productivity from the University of San Diego. Ms. Ward's active duty tours include: Tech Control Supervisor for Naval Communications Area Master Station Mediterranean Region, Tech Control Supervisor for Naval Communications Area Master Station Eastern Pacific, Senior Facilitator / Curriculum Quality Assurance at Naval Training Center San Diego (Qualified as Master Training Specialist), Officer in Charge of Communication Security Advice and Assistance Team, Communication Security Systems Manager for Space and Naval Warfare Systems Center San Diego, and Command Senior Chief for Space and Naval Warfare Systems Center San Diego. Ms. Ward retired at the rank of Senior Chief, after 20 years Navy service. Her personal decorations include Navy and Marine Corps Commendation Medal (5 Awards), Navy Marine Corps Achievement Medal (4 Awards) and selected as the Department of the Navy Instructor of the Year and the Navy League Enlisted Women of the Year. Upon retirement from active duty service in January of 2000, Ms. Ward went to work for Booz Allen Hamilton. Currently a Senior Associate with over 25 years of Navy C4I experience, she manages a multi-million dollar account at SPAWAR Headquarters and provides direct support to clients such as the Global Broadcast Service (GBS) Project Office, the Program Executive Office, C4I and Space, PMW 176, Navy SATCOM Systems Engineer, the Commander of Space and Naval Warfare Systems Center Chief Engineer and the Commander / Deputy Commander of Space and Naval Warfare Systems Center. To each of her clients she provided expert program management, strategic planning and consulting services, valued thought leadership and support to key initiatives. Ms. Ward is active in the community and dedicates a significant amount of her time in leadership roles for non-profits such as the Children's Organ Transplant Association and San Diego City Schools. She was awarded the "Women who mean business" Award by the San Diego Business Journal and the YWCA "Tribute to Women in Industry" Award. She served as Vice President of the San Diego Chapter of Women In Defense and Chairperson for the chapter's first and second Annual Symposium. She was co-chair of the 2010 and 2011 WID National Fall Conferences. After serving as WID National Vice President for 2009-2011, she became 2011-2013 President of the National Board of Women In Defense.



LTC Steve M. Alexander, USA (Ret)
MacAulay Brown, Inc.

Mrs. Blossom B. Baker
JB Technologies, Inc.

Nada Bakos
Glass Global Consulting

Miss Jamila Baraka
Africa Center for Strategic Studies

Ms. Cathy Benson
SAP Public Services, Inc.

Ms. Debbie L. Berry
Lockheed Martin GTL

Ms. Mickie D. Bolduc
Booz Allen Hamilton

Lt Col Marlene Ann Brake, USAF (Ret)

Ms. Laura Breslin
PriceWaterhouseCoopers

Ms. Lauren K. Brickley
IBM Global Business Services

Ms. Kathy E. Broad
QTEC, Inc.

Ms. Kimberly Bruce
Crystal Group, Inc.

Ms. Amy C. Bruins
DCMO

Sgt Sara Bryant, USMC
Marine Female Engagement Team

Ms. Shelia Burgess
Azos AI, LLC.

Ms. Nicole A. Byrd
Defense Security Cooperation Agency

Mr. Robert Cable
Concurrent Technologies Corporation

Ms. Alena M. Calm
U.S. Army Edgewood Chemical Biological Center

Miss Sarah P. Campbell
Defense Threat Reduction Agency

Ms. Alison A. Carter
PriceWaterhouseCoopers

Ms. Christine Christine Chase
Booz Allen Hamilton

Ms. Teresa Clark
ISYS Technologies

Ms. Jill Cohen
DuPont

Ms. Amy S. Courter
U.S. Air Force Civil Air Patrol

Mrs. Townley Cozad
Lockheed Martin Corporation

Ms. Linda Cramer
Q10 Contracting, LLC

Dr. Nancy Crews
Custom Manufacturing & Engineering, Inc.

Ms. Trish Culbreth
OSDBU, U.S. Department of State

Ms. Maryam Darvish
NetApp

Ms. Cindy DeCarlo
Cisco Systems, Inc.

COL Deb Deville, USA (Ret)
LMI Government Consulting

Ms. Julie Disandro
Booz Allen Hamilton

Ms. Margaret DiVirgilio
Concurrent Technologies Corporation

RADM Kathleen Dussault, USN
OPNAV N41

Ms. Susan Warshaw Ebner
Buchanan Ingersoll & Rooney PC

Col Karen A. Esaias, USAF (Ret)
Concurrent Technologies Corporation

Ms. Shelly Evans
Booz Allen Hamilton

Dr. Patricia Falcone
Office of Science and Technology Policy (OSTP), White House

Ms. Melinda Fall
Crystal Group, Inc.

Ms. Jeanne Lynn Farmer
Defense Security Cooperation Agency

Ms. Beth A. Ferrell
McKenna Long & Aldridge, LLP

Ms. Nicole S. Finch
SCITOR Corporation

CDR Jennifer Flather, USN

Ms. Joy D. Fleming
DFAS-Rock Island

Ms. Jody Fuller
Network Appliance Federal Systems, Inc.

Ms. Nicole A. Funk
Booz Allen Hamilton

Ms. Kelley Gapen
Thales Communications, Inc.

Mrs. Ivania A Garcia
General Dynamics Electric Boat

Ms. Becca Gaspard
Lockheed Martin Information Systems & Global Solutions

Miss Cassie Gettman
Lockheed Martin Information Systems & Global Solutions

Ms. Traci Gholson
BMI Defense Systems

Ms. Eileen Giglio
National Defense Business Institute, University of Tennessee

Mrs. Beverly Greenwood
BMI Defense Systems

Ms. Jennifer Griffin
FOX News Channel

Ms. Marina Gurbanov
General Dynamics Electric Boat

Maj Gary Hall, USMC (Ret)
Immediate Response Technologies,
Inc.

SSG Debra Jean Hallgren, USA (Ret)
National Geospatial-Intelligence
Agency

Ms. Tania W. Hanna
Harris Corporation

Mrs. Julie E. Harris McCrey
RTD Embedded Technologies, Inc.

Mrs. Sarah D. Hassinger
Remploy Frontline

Mrs. Holly Haverstick
Defense Security Cooperation
Agency

Ms. Rebecca Henley
General Dynamics Information
Technology

Ms. Barbara Hennessy
Command Decisions Systems and
Solutions

Ms. Rebecca Hodkin
Penn State

Ms. Lynne A. Hood
Concurrent Technologies Corporation

Ms. Kristen Kessler
Hillmer, Inc.

Mr. Jack A. Kinsey

Ms. Kirstin J. Knott
FedEx

Ms. Kate Bonner Kronmiller
Orbital Sciences Corporation

Ms. Cindy Marie Kurt
United Space Alliance

Ms. Nina Laserson-Dunn
Finmeccanica, Inc.

Ms. Meaghan Maureen Lawrence
Northrop Grumman Corporation

Ms. Heidi N Lindelof

Ms. Joanne Longo
Barry University

Ms. Bobbi Markley
PriceWaterhouseCoopers

Ms. Phylliss Clark Marshall
Defense Security Cooperation
Agency

Ms. Dana Lynn Mascali
Africa Center for Strategic Studies

Ms. Maura McCarthy
KMI Media Group

Mrs. Kelly R. McDonald
NAVAIR

Ms. Pamela McFarland
Raytheon Technical Services
Company

Ms. Brenda K. McKinney
Kelly Government Solutions / Kelly
Services, Inc.

Ms. Brooke A. McNierney
NEK Advanced Securities Group, Inc.

Ms. Nisa Mehta
Lockheed Martin Corporation

Ms. Susan A Michalski
Cox Communications Hampton
Roads, LLC

Mrs. Diane Gronkiewicz Miller
Northrop Grumman Corporation

Ms. Edwina Sherer Musante
Irving Burton Associates, Inc.

Ms. Jovanna O. Nelson
Good 2 Go Event Management, Inc.

LtCol Julie Nethercot, USMC
9th Communication Battalion

Ms. Jolie Hoang-Lan Nguyen
PriceWaterhouseCoopers

Ms. Catherine Nicholas
PriceWaterhouseCoopers

Mrs. Rose M. Oxley
Software Synergy, Inc.

Mrs. Maria E Patterson
Defense Security Cooperation
Agency

Ms. Marie Payne
CSC

Mrs. Beth G. Pershing
Bloomberg Government

Ms. Leslie Ann Pope
Lutron Electronics

Ms. Patty S. Popour
Analytical Services, Inc.

Ms. Teresa Porter
ISYS Technologies

Ms. Jack Powell
General Dynamics Information
Technology

Miss Sheri Profant
General Dynamics Land Systems

**LTC Suellen Binder Raycraft, USA
(Ret)**
Defense Security Cooperation
Agency

Ms. Emily Renard
Africa Center for Strategic Studies

Ms. Kecia Reyes
Thales Communications, Inc.

Ms. Meg Rhodes
Booz Allen Hamilton

Ms. Carol J. Robert
BAE Systems Information Technology

Ms. Rebecca J. Robertson
INFICON

Ms. Ann Elise Sauer

Ms. Debbie C Saunders

Ms. Rita M. Savage
CECOM

Ms. Hazel Scalia
KBR North American Government
and Defense

Ms. Jennifer Schaus
Jennifer Schaus & Associates

Ms. Kathy G. Scheessele
MBDi

Ms. Laurie A Schive
Office of the National
Counterintelligence Executive

Ms. Sherri Schornstein
U.S. Attorney's Office, District of
Columbia

Ms. Robin Schulze
Baker Tilly

Ms. Joanna Shapiro
The Bank of New York Mellon

Ms. Kristi Shauger
Supercircuits

Ms. Beth A. Shepard-Savery
Cox Communications Hampton
Roads, LLC

Ms. Erin B. Sheppard
McKenna Long & Aldridge, LLP

Ms. Heidi L Shyu
ASAALT

Ms. Dottie Simeona
Booz Allen Hamilton

Ms. Terri Smith
C4 Advanced Tactical Systems, LLC

Mrs. Jane L. Smith Krueger
Picatinny Arsenal

Mrs. Holly L. Snyder
Booz Allen Hamilton

Ms. Stephanie Spano
Engility Corporation

Ms. Kristina Tanasichuk
Government Technology & Services
Coalition

Mrs. Charlie Teague
Defense Threat Reduction Agency

Ms. Sarah C. Thomas
Rylander Technology Group, Inc.

Ms. Rene Thomas-Rizzo
Assistant Secretary of the Navy for
Research & Development

Ms. Melissa Trace
Crystal Group, Inc.

Mrs. Hillary Waldron
MLM International

Ms. Tricia M. Ward
Booz Allen Hamilton

Ms. Christine Weatherspoon
DFAS

Ms. Jane Marie Weddleton
General Dynamics Electric Boat

Ms. Bridgette White
General Dynamics Information
Technology

Ms. Erin Wilkerson
Berkeley Research Group

Dr. Marta C. Wilson
Transformation Systems, Inc.

Ms. Matice Wright
OSD/AT

Miss Jill Elizabeth Wyman
Aeroflex Incorporated

Ms. Karin Zielinski
U.S. Army PEO STRI

Ms. Suzan Zimmerman
QinetiQ North America

Ms. Cara Zwerling
Diversity in Defense

**DOCUMENTS WILL BE AVAILABLE
FOR DOWNLOADING 1 to 2 WEEKS
AFTER THE CONFERENCE AT**

**[www.dtic.mil/ndia/2011WID/2011WID.
html](http://www.dtic.mil/ndia/2011WID/2011WID.html)**

Thank You to Our Sponsors!

PLATINUM SPONSOR

Booz | Allen | Hamilton

SILVER SPONSOR



*Concurrent
Technologies
Corporation*

SILVER SPONSOR

GENERAL DYNAMICS

Information Technology

BRONZE SPONSOR

Bloomberg
GOVERNMENT

SMALL BUSINESS SPONSOR



DEFENSE IN TRANSITION

***Adapting To The New Budget
Environment While Keeping The
Warfighter Supplied***

2011 WOMEN IN DEFENSE



***RADM Kathleen M. Dussault
Director
Supply, Ordnance and Logistics
Operations Division (OPNAV N41)***



Agenda

- **This Time It's Different**
- Closing the Maintenance Gap
- Contracting for the Long Haul
- Optimizing Joint Logistics Engagement
- Navy Energy Improvements
- The Path Forward...



“We have gone through a decade of war in which the defense budget has more than doubled, and now we have to look at a decade where we have to prevent war but be able to fight wars and win wars, if we have to, recognizing we have less resources. That’s the challenge that we face as we confront this budget issue.”

***Secretary of Defense Leon Panetta
Testimony before the SASC
22 September 2011***



Navy Challenge

- Always deployed
- Across 5 oceans
- All Resources are precious commodities
- Capital intensive, long service life Force

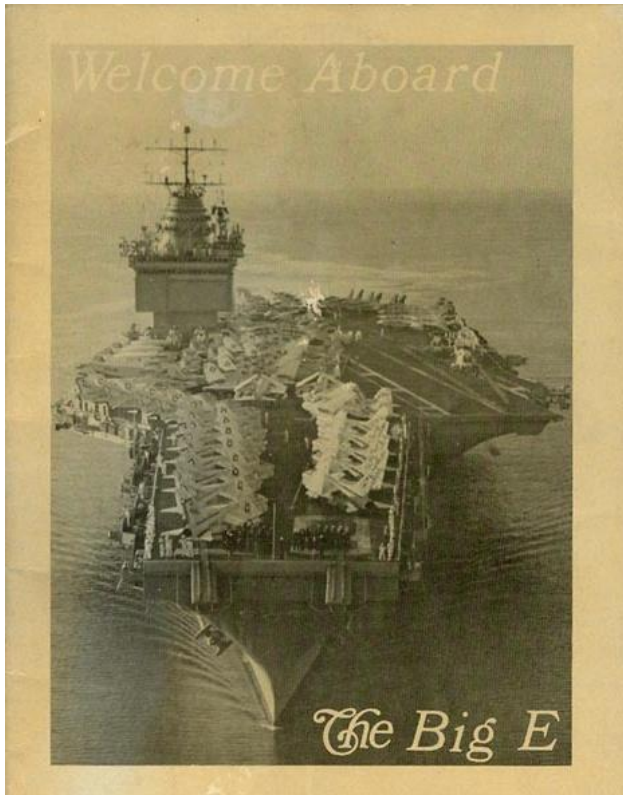



Challenge of Today: Fiscal & Logistical

- Always deployed
- Across 5 oceans
- All Resources are precious commodities
- Capital intensive, long service life Force

And...

- **Two Theaters of Operation**
- **Majority of 2020 Battle Force exists today**
 - Older ships / Increasing Sustainment Cost
- **Cost to own & operate our Fleet growing faster than inflation**
- **Pressurized Budget**





Future Fiscal Environment

DoN TOA Trend FY1950 - 2021

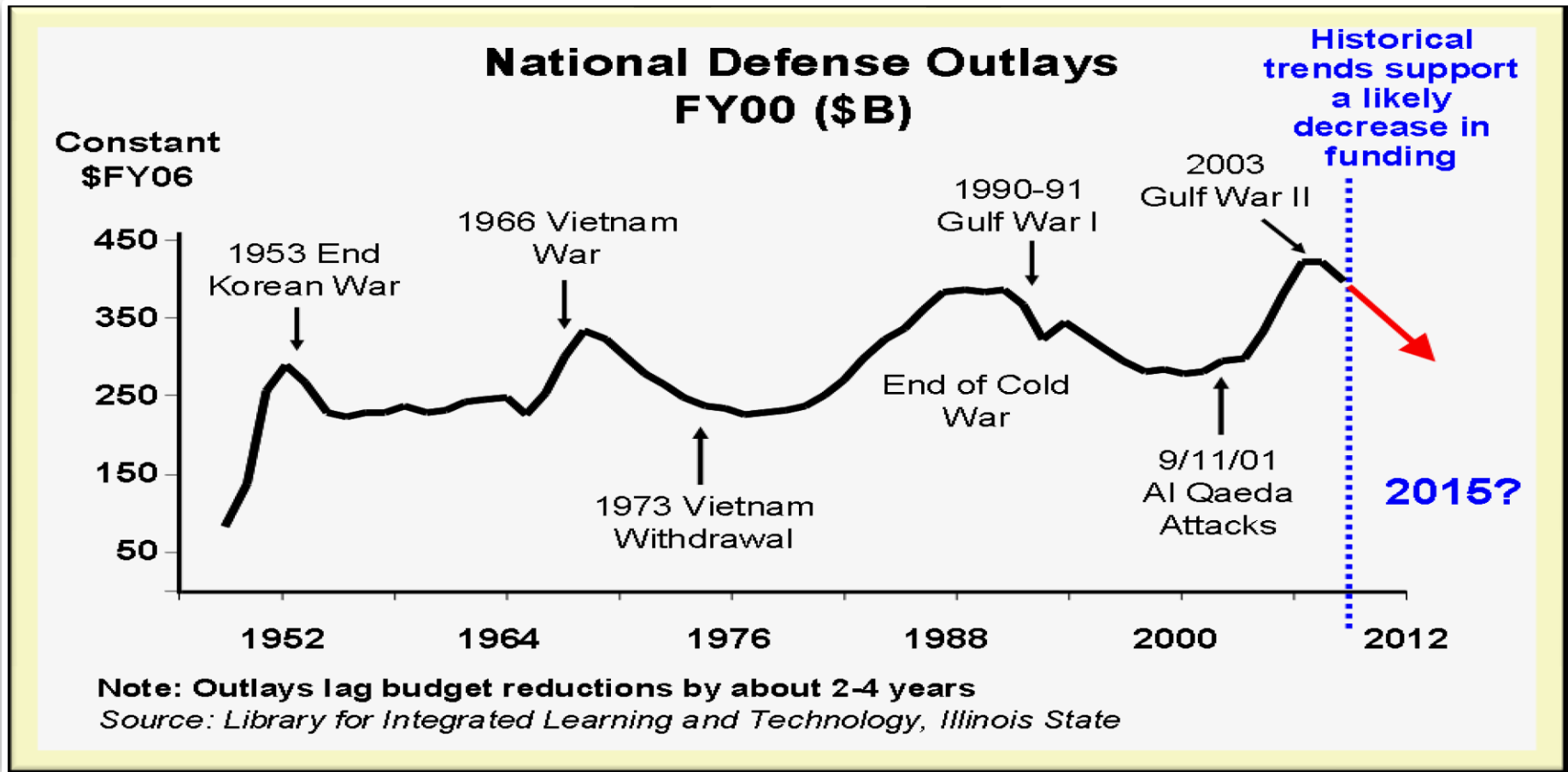

**DoD budgets are cyclical & due for a down turn.
Procurement suffers disproportionately during down turns.**



Two Perspectives

DOD Needs

- Force structure
- People
- Repositioning
- “Reset”
- Modernization
- Industrial base
- R&D

Fiscal Climate

- Mandatory Funding Growth
- Debt at Historic Levels
- “No Growth” DOD Budget
- Weak Economy
- Fuel Cost Fluctuations
- Non-DOD Spending Priorities

What alternatives do you see?

How do you reconcile these two perspectives?



The Environment We Face

Program vs Budget ...



If you agree the status quo will not get us through this...

... what's the solution?



Logistics Efficiencies

Strategic Network Optimization

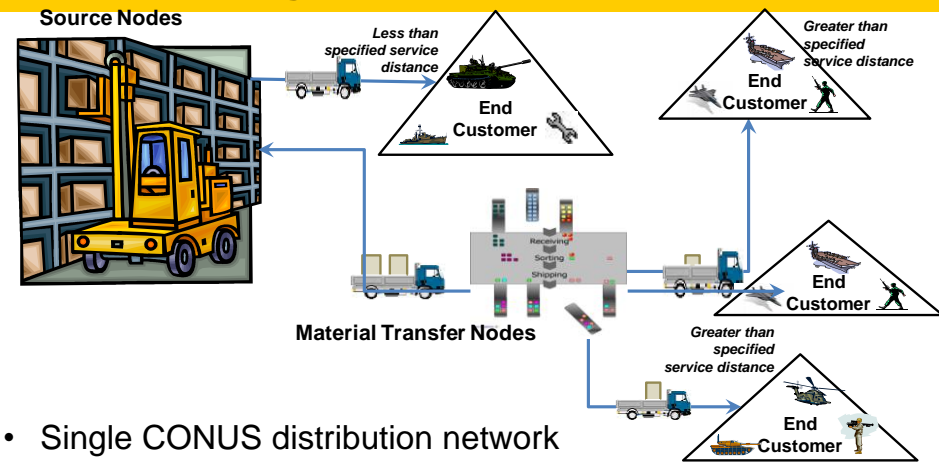

- Single CONUS distribution network
- Aggregate materiel from multiple source nodes & deliver to end customers

Defense Trans. Coordination Initiative

DoD Domestic Freight Management Today:



DoD Domestic Freight Management Tomorrow:

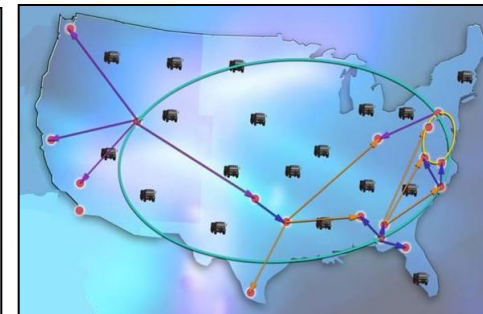

Chemical Management Services (CMS)

- Single inventory manager/provider of chemical management services
- 3PL performs procurement, inventory management, storage, distribution, hazardous waste removal, and disposal
- Uniform policy & practices implemented at all sites
- Savings through efficiencies in buying and managing HAZMAT



Improve Inventory Management

- Improve overall DoD inventory management
- Reduce excess inventory on-hand
- Decrease excess inventory on-order
- Specific objectives and targets to improve forecasting and reduce/terminate orders

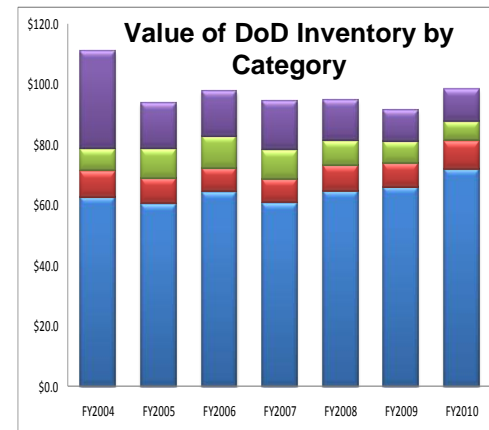



Agenda

- This Time It's Different
- **Closing the Maintenance Gap**
- Contracting for the Long Haul
- Optimizing Joint Logistics Engagement
- Navy Energy Improvements
- The Path Forward...



Depot Cost, Age, Operational Tempo

Surface

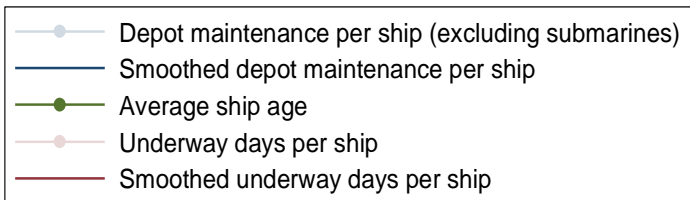
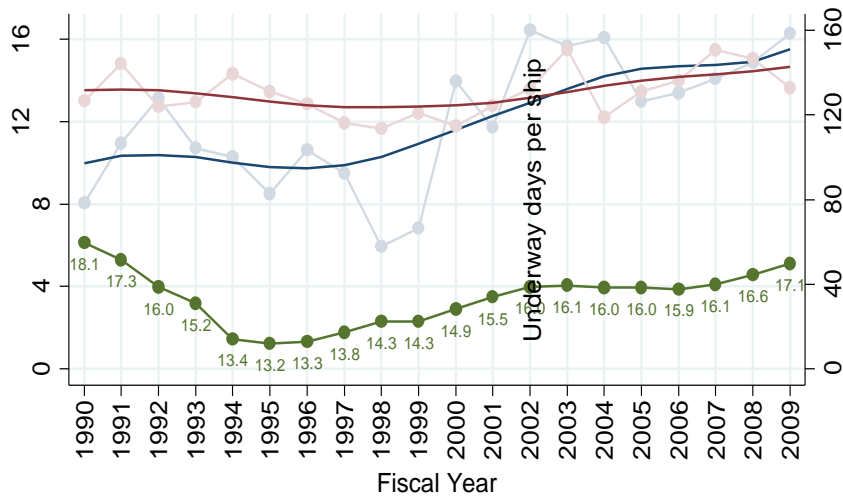

Aviation

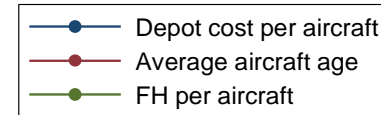
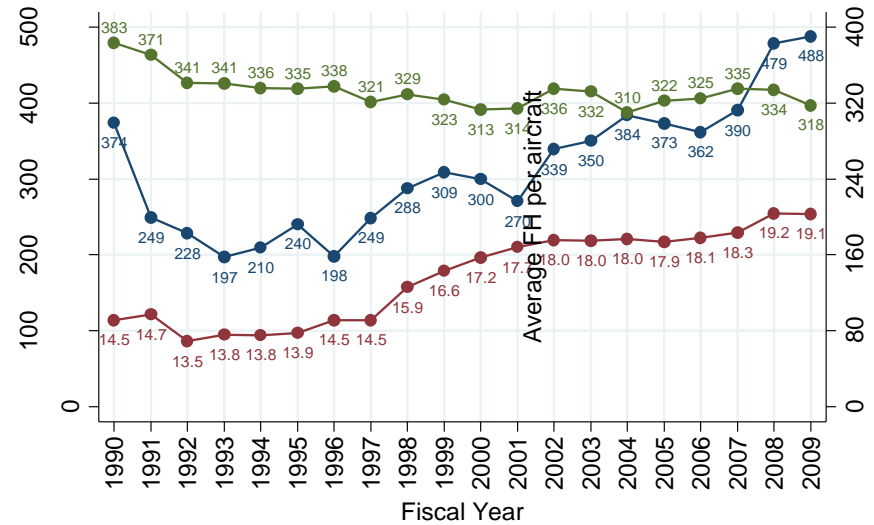



Maritime Opportunities

Class Maintenance Plans

- Scheduled maintenance actions
- Ensure ship and installed equipment perform as designed
- Reach expected service lives

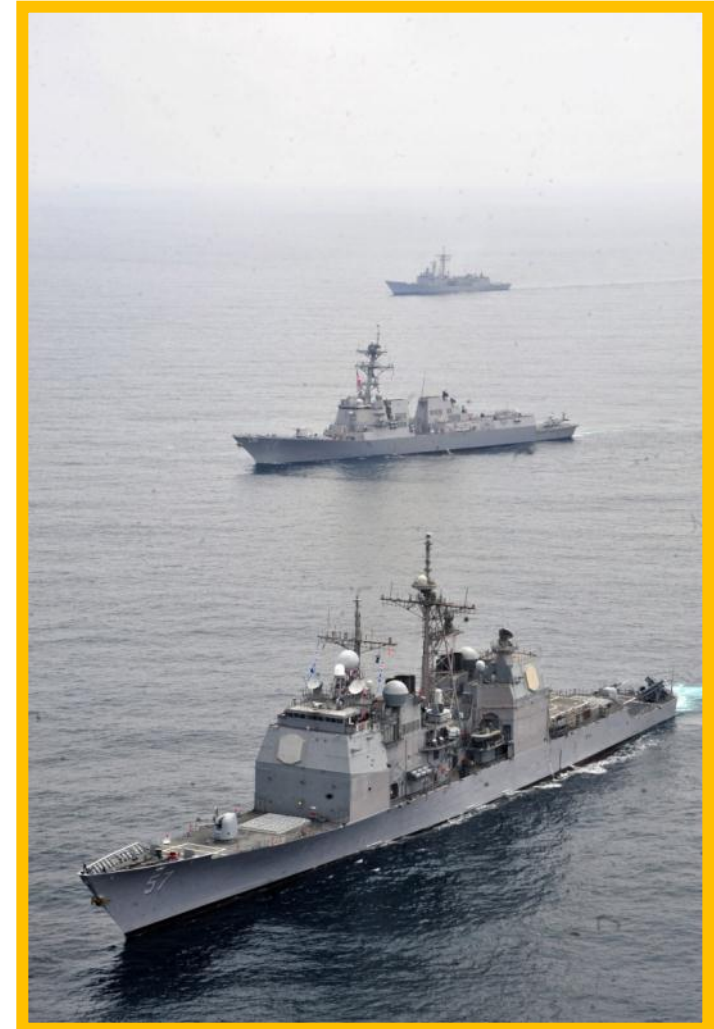



Leveraging Simulator Capability

Current Use

USN FA-18 A-F	7%
USN EA-6B	2%
EA-18G	4%
E-2C	11%
MH-60R	19%
MH-60S	25%
P-3	11%

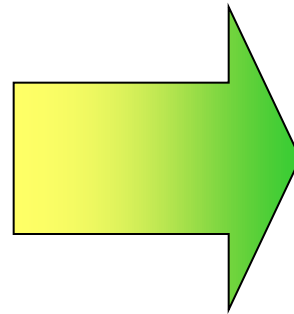

Future

- Maximize use of simulators for all warfare communities
- Effective training requires efficient balance of live and synthetic approaches
- Type Commanders working Fleet simulator guidance



JSF Opportunities and Challenges

➤ Opportunities

- Fifth-Generation Logistics Information Technology
- Leverage of advanced simulator capability
- Cost efficiencies due to variant commonality



➤ Challenges

- Sustainment Affordability
- Cost-effectiveness & detail of Performance Based Logistics (PBL) Sustainment Strategy
- Fleet integration, e.g. engine replenishment at sea, first/last mile supply chain



Agenda

- This Time It's Different
- Closing the Maintenance Gap
- **Contracting for the Long Haul**
- Optimizing Joint Logistics Engagement
- Navy Energy Improvements
- The Path Forward...



Money as a Weapon System

Goals

- Assist Host Nations transition to vibrant self-sustaining economies
- Employ Iraqi and Afghan citizens
- Reconstruction / contracting with local businesses

Focus – positive impact on local economies

- Host Nation ownership
- Host Nation participation
- Direct contracting to companies

Results

- NDA 2008 Set Aside Authority
- FY06 – Present
- \$9.5B awarded to Host Nation firms
- Over 4,200 vendors registered
- Set asides for targeted groups
 - *Historically underrepresented*
 - *Cognizant of the 'very local' industrial base*

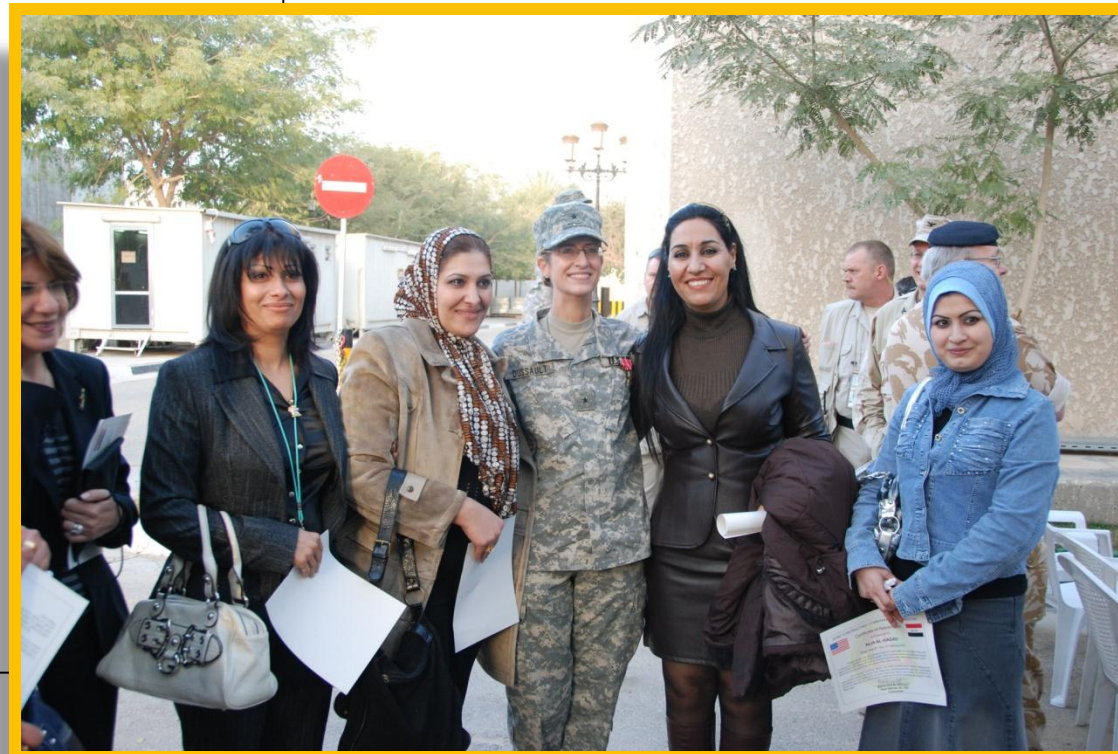



Kuwait / Iraq Contracting Lessons Learned

➤ What We're Improving

- Desperate need for better requirements development process (automated)
- Acquisition strategies moving us toward more fixed price, competitive awards
- Ensure “life cycle” contracting (including post-award through closeout)
- Execute Procurement Management Reviews (PMR) (ensuring we're doing things right)
- Oversight at Contracting Officer Rep (COR) and CO levels needs improvement
- Strategic sourcing – fully utilize Joint Logistics Procurement Support Board
- Leverage reachback
- Adequate resourcing/manpower—still a critical shortage of qualified KO's



Operational Approach

Observed State

Insufficient synchronization of contracting in theater

Contracting processes often lack transparency and accountability

Contracting corruption is degrading COIN

Insufficient attention paid to enduring economic prosperity

Lines of Effort

Synchronize Contracting Activities

- Stand up regional command contract review boards
- Conduct contracting network analysis (synthesize existing information and validate)

Increase Transparency And Accountability In Contracting Process

- Price PSC services separately in all contracts
- Require primes to submit names of all subcontractors

Reduce Contracting Corruption

- Work with USG and int'l agencies to properly vet and, when appropriate, restrict companies
- Invigorate and extend theater business clearance authority

Promote Economic Development

- Analyze and recommend viable EFT destinations for contracting organizations
- Direct set-asides (Section 886) to traditionally under-represented tribes

Effects

Increased contracting oversight & coordination

Improved reputation of our contracting

Contracting linked to a winning COIN strategy

Increased long term effectiveness of aid

Desired State

Earn trust & collaboration of the Afghan People by conducting synchronized and transparent contracting practices that support COIN and promote sustainable economic growth for Afghanistan.



TOC Principles in Contracting

Navy Portfolio

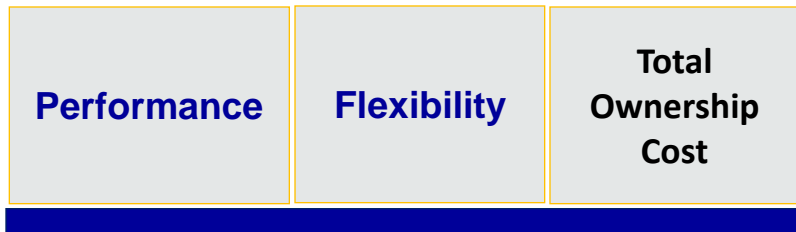

Contracting Tools to Optimize TOC

- Multi-year Procurement
- Contract Type (e.g., Fixed Price vs. Cost Plus)
- Performance Based Logistics and Contractor Logistics Services
- Commonality and Strategic Sourcing

Navy Utilizes Several Contracting Tools to Balance Optimal Total Ownership Cost with Performance and Flexibility Goals



Leadership Provides Tactics



**Deputy Secretary of Defense
Dr. Ashton Carter
14 Sept 2010
Memo to Acquisition Professionals**

-as Undersecretary of Defense (Acquisition,
Technology & Logistics)

- **Get the Requirements Right**
- **Make Every Dollar Count**
- **Perform to Plan**
- **Mind the Health of the Industrial Base**
- **Strengthen the Acquisition Workforce**

Do More Without More



Agenda

- This Time It's Different
- Closing the Maintenance Gap
- Contracting for the Long Haul
- **Optimizing Joint Logistics Engagement**
- Navy Energy Improvements
- The Path Forward...



Developing the Joint Logistics Enterprise (Optimizing Joint Logistics Engagement)

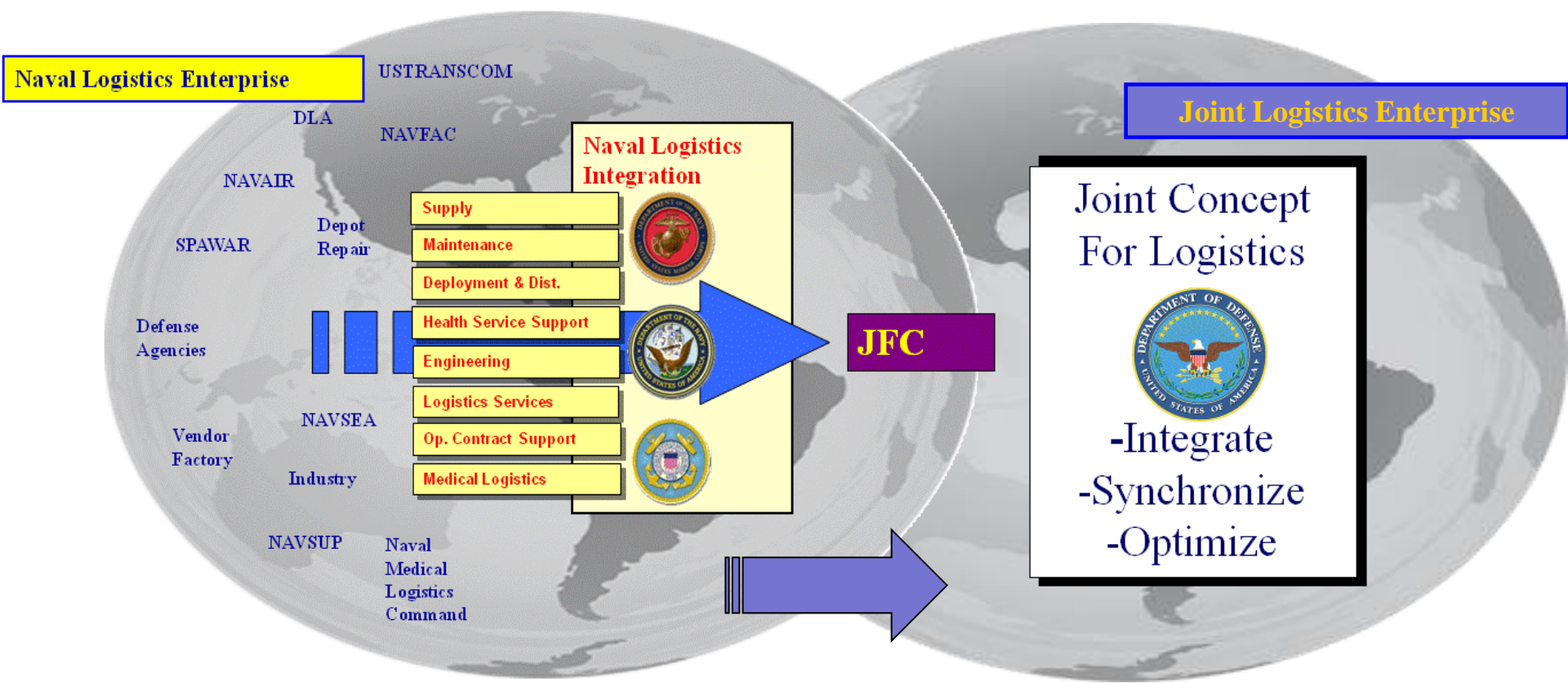

A template for success...



Agenda

- This Time It's Different
- Closing the Maintenance Gap
- Contracting for the Long Haul
- Optimizing Joint Logistics Engagement
- **Navy Energy Improvements**
- The Path Forward...



SECNAV Energy Goals

Naval Energy Forum in 2009 - Secretary of the Navy announced five Energy Goals:

Increase Alternatives Afloat

By 2020, 50% of total DON energy consumption will come from alternative sources

Increase Alternatives Ashore

By 2020, DON will produce at least 50% of shore-based energy requirements from alternative sources; 50% of DON installations will be net-zero

Sail the “Great Green Fleet”

DON will demonstrate a Green Strike Group in local operations by 2012 and sail it by 2016

Reduce Non-Tactical Petroleum Use

By 2015, DON will reduce petroleum use in the commercial vehicle fleet by 50%

Energy Efficient Acquisition

Evaluation of energy factors will be mandatory when awarding contracts for systems and buildings

The Navy is moving forward on these aggressive targets



Opportunity – Energy Investment

Alternatives

Efficiency

Afloat

- Hybrid Electric Drive
- Propeller coatings
- Stern flaps
- Solid state lighting
- Combustion trim loop
- Efficient HVAC systems, generators
- Fleet scheduler planning tool
- Hull coatings
- Alternative fuels (multiple platforms)
- Online water wash

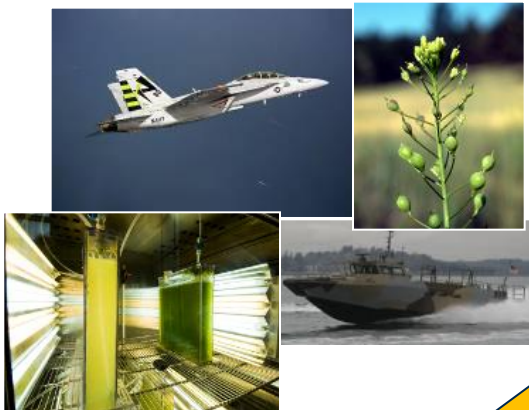
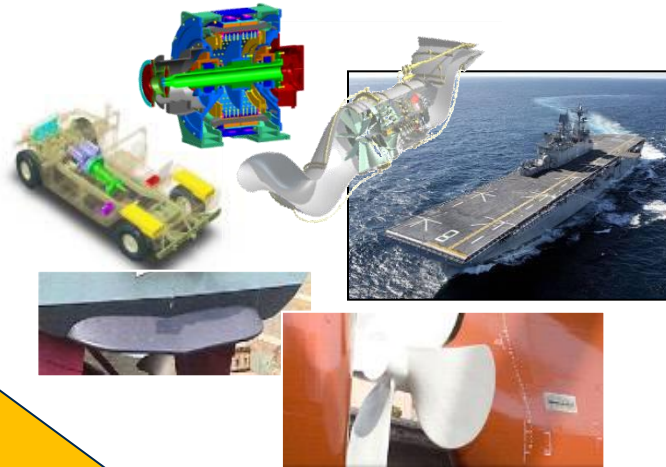

Energy Security

Ashore

- Hybrid non-tactical vehicles
- Renewable energy sources
- LEED building standards
- Smart meters and auditing
- Micro grid
- Solid state lighting



Afloat

Ashore



2012 and Beyond

- Focus remains on efficiency technologies for legacy assets
- Culture Change
 - Critical to create energy awareness
 - Maritime Incentivized Energy Conservation Program Success
 - Aviation community instituting similar program
- Continue to work with public and private entities to spur alternative fuel development



Agenda

- This Time It's Different
- Closing the Maintenance Gap
- Contracting for the Long Haul
- Optimizing Joint Logistics Engagement
- Navy Energy Improvements
- **The Path Forward...**



The Path Forward



- Imperative: The Navy remains a ready force that is meeting all commitments in support of the Maritime Strategy
- Reality: Fiscal pressures and the need to grow the future force pose significant challenges
- Solution: We must find ways to more efficiently buy, own and operate the force
- Assessment: Department of Defense logistics is fertile with opportunities



Leadership Thoughts

The role of a leader is to:

- *develop the 'big idea'*
- *communicate that to the team*
- *and then guide the execution*







Tying the Ribbon:
**Science, Technology, Engineering,
Mathematics (STEM) and the
Future of the Defense Industrial Base**

Dr. Patricia Falcone
Assistant Director, National Security
Office of Science and Technology Policy

October 19, 2011



Office of Science and Technology Policy



- Science and technology for policy
- Policy for science and technology

Innovation for National Security is a Presidential Priority



“Reaffirming America’s role as the global engine of scientific discovery and technological innovation has never been more critical ... Our renewed commitment to science and technology ... will help us protect our citizens and advance U.S. national security priorities.”

National Security Strategy, May 2010



Elements of Innovation

“How then is America to maintain, or preferably enhance, the future standard of living of its citizenry? The answer (and seemingly the only answer) is through innovation.

Innovation commonly consists of being **first to acquire** new knowledge through leading edge research; being **first to apply** that knowledge to create sought-after products and services, often through world-class engineering; and being **first to introduce** those products and services into the marketplace through extraordinary entrepreneurship. “

*Rising Above the Gathering Storm, Revisited –
Rapidly Approaching Category 5 (2010)*

Innovation and National Security

A track record of success....

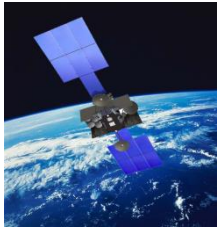
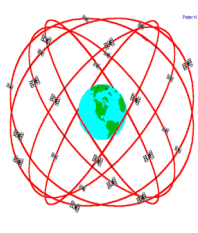
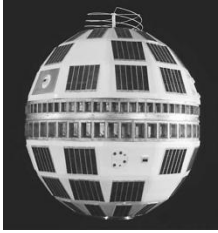

40s	50s	60s	70s	80s	90s	00s
-----	-----	-----	-----	-----	-----	-----

... new challenges and threats in the future





“We know what it takes to compete for the jobs and industries of our time. We need to out-innovate, out-educate, and out-build the rest of the world.”

*President Obama
January 25, 2011*

President's Strategy for American Innovation

*Innovation for
Sustainable Growth
and Quality Jobs*

- Unleash a clean energy revolution
- Accelerate biotechnology, nanotechnology, and advanced manufacturing

Catalyze
Breakthroughs for
National Priorities

- Encourage high-growth and innovation-based entrepreneurship
- Promote innovative, open, and competitive markets

- Educate Americans with 21st century skills and create a world-class workforce
- Strengthen and broaden American leadership in fundamental research

Spur Productive
Entrepreneurship and Promote
Efficiency

Invest in the Building Blocks of American Innovation

① Focusing on Strategy Elements

②

Catalyze
Breakthroughs for
National Security

Spur Productive
Entrepreneurship and Promote
Efficiency

- Educate Americans with 21st century skills and create **a world-class workforce**
- Strengthen and broaden American leadership in fundamental research

① Invest in the Building Blocks of American Innovation

A world class workforce

- Scientifically literate public
- Adept in the modern global economy
- Plenty of scientists and engineers



First university degrees in natural sciences and engineering, selected countries

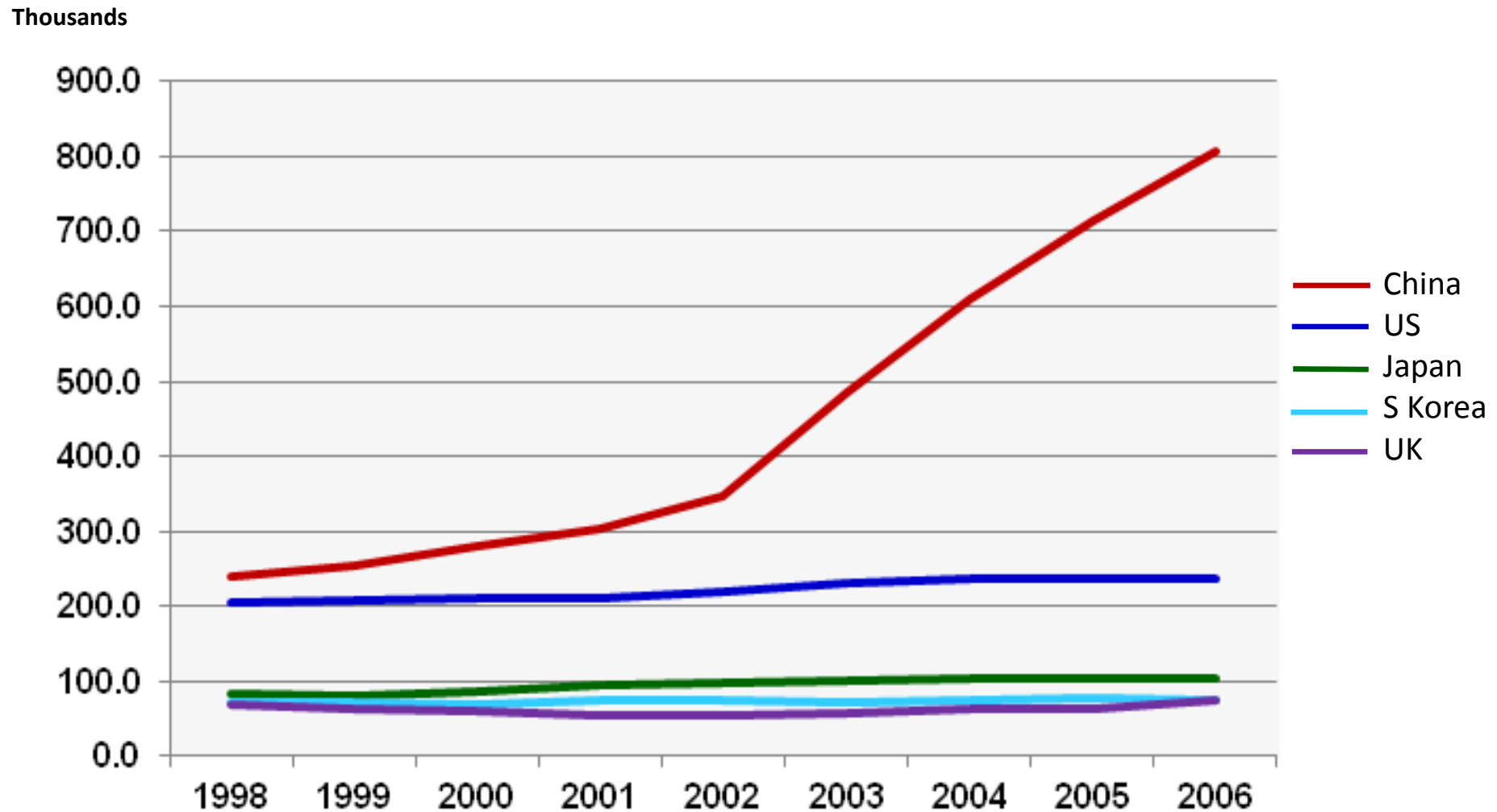

STEM Doctoral Degrees Awarded to Foreign Students (2007)

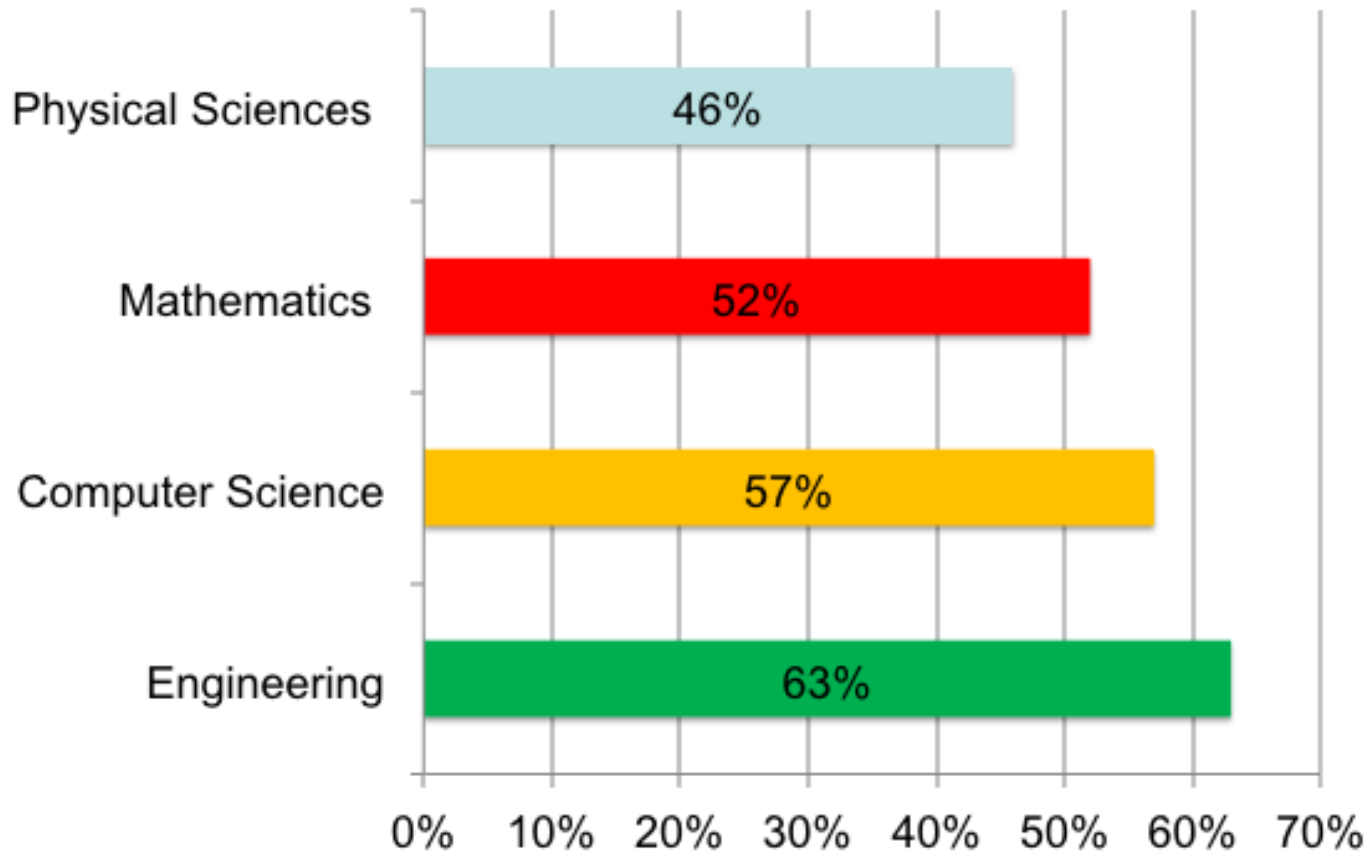

Science and Engineering Degrees Awarded to US Citizens & Permanent Residents

By Type, Ethnicity, and Gender-- 2006

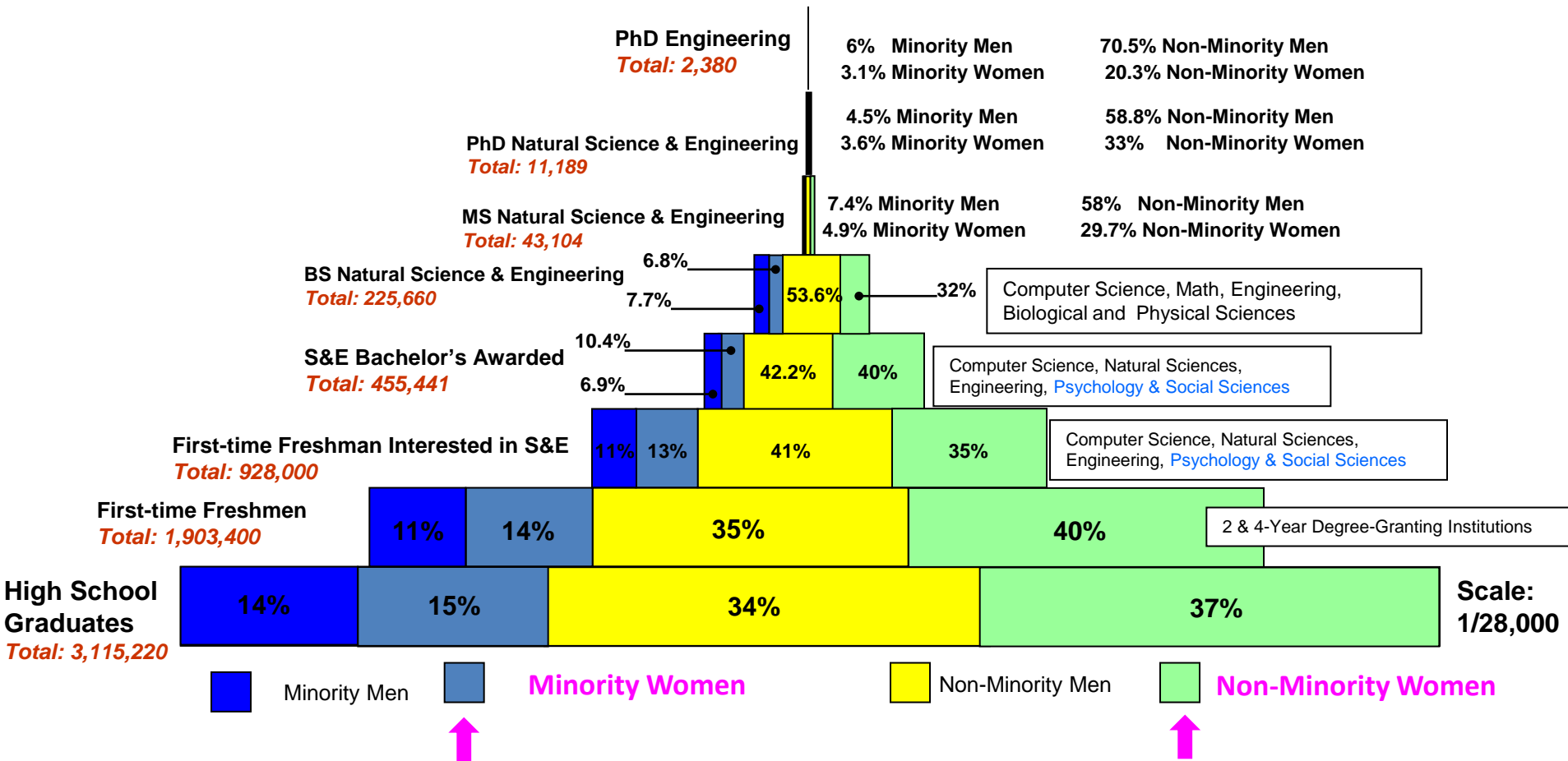

Minority = Black/African American, Hispanic, and Native American

Non-Minority = White & Asian

Demographics at the top of the pyramid

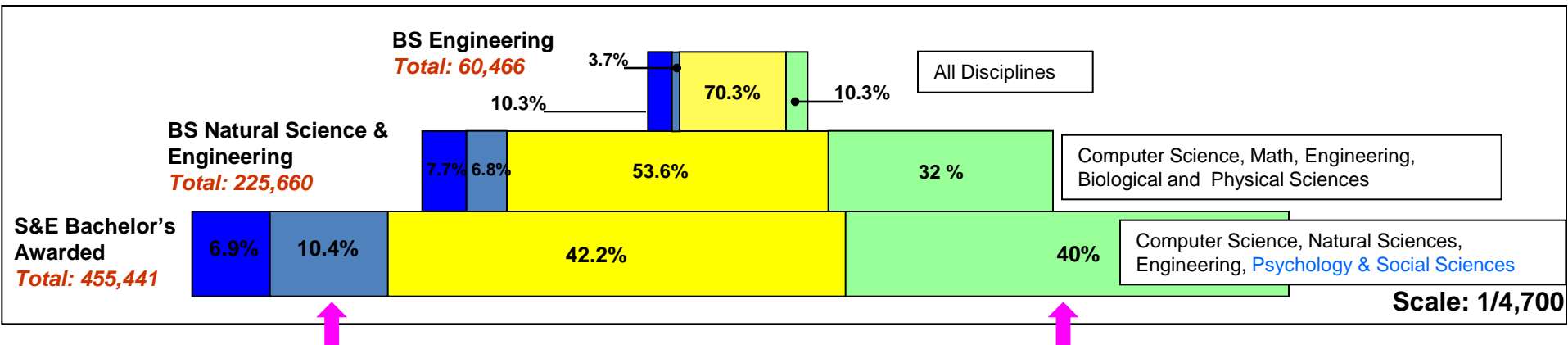
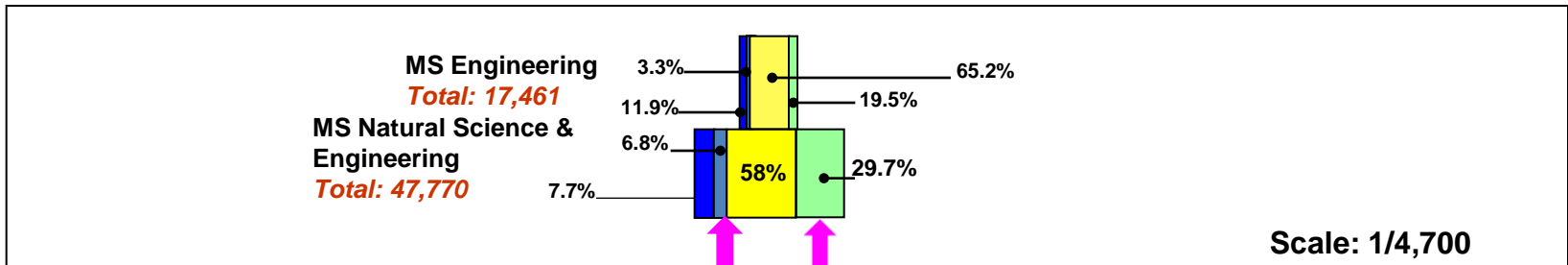
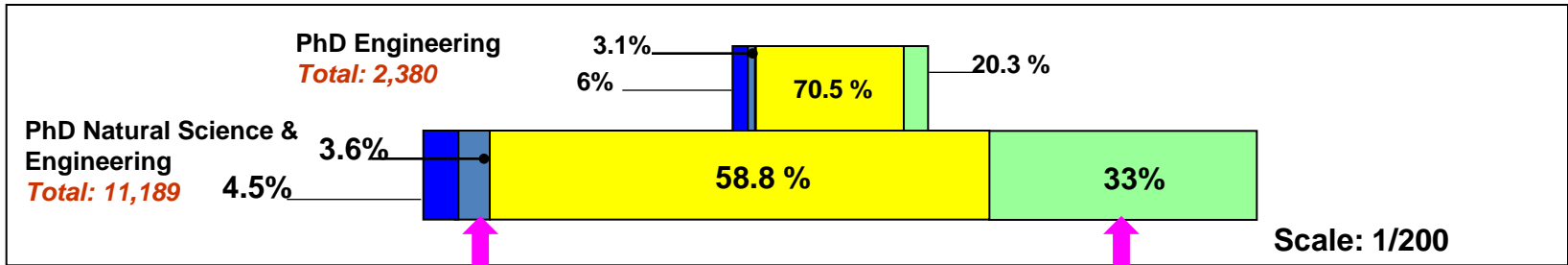

Figure courtesy of the Office of Naval Research

Our STEM priorities

- Increasing STEM literacy so all students can think critically
- Improving the quality of math and science teaching from kindergarten through college based on new knowledge about learning and brain function
- Expanding educational success and representation in all parts of the science and engineering workforce of underrepresented groups, including women and minorities

Expanding best practices



Informal Science



*Design and test of paper bag kites
at the White House Easter Egg Roll
Instructions at HowToSmile.org*

AP Training and Incentive Programs
U Teach Program
Young Leaders
Initiative for Military Families



Great Teaching; Inspired
Learners; A Committed Nation
A Public-Private Partnership

Improving teaching

“Major advances have yielded a consistent picture of how to best learn to think like a scientist or engineer”

Carl Wieman – Nobel Prize winner; college science teaching innovator; OSTP Associate Director for Science

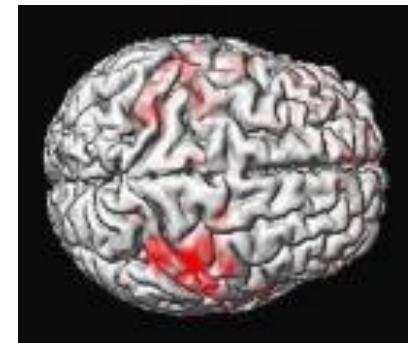
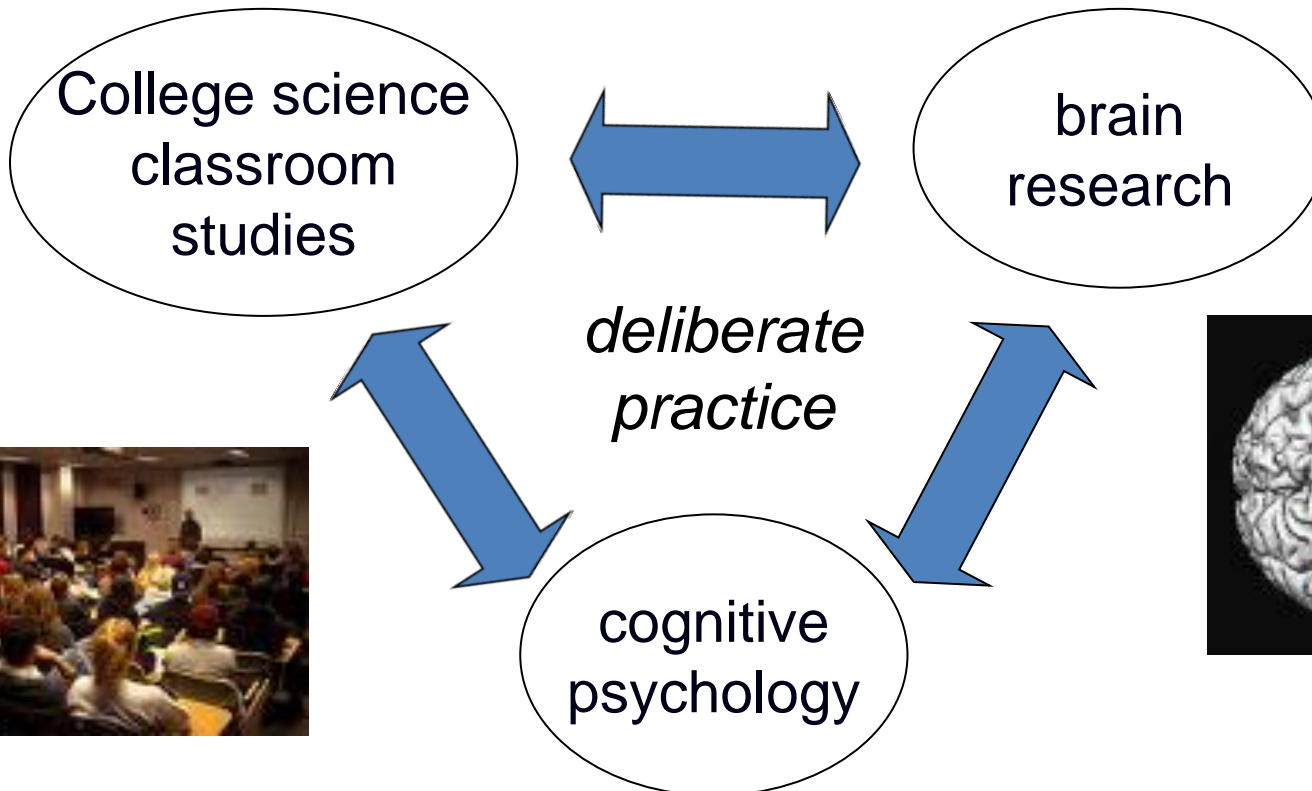

Increasing numbers and representation



First Lady at National Science Foundation
Family-Friendly-Policies Event
September 26, 2011



President with Google Science Fair Winners
October 7, 2011

② Focusing on Strategy Elements

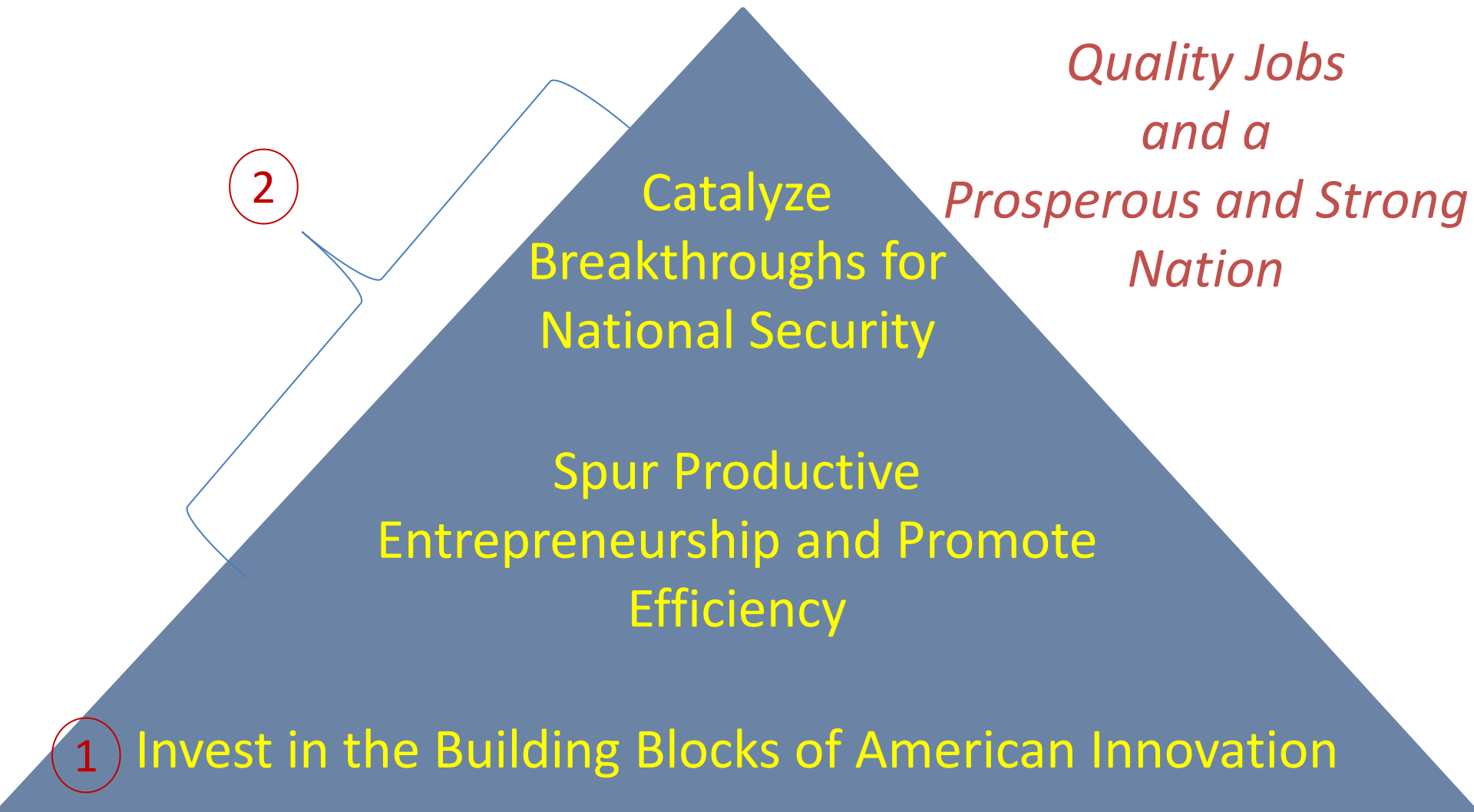

Our competitors are investing

Globalization of R&D and emerging centers-of-excellence around the world



Gross domestic expenditure on R&D (in billions of yuan)

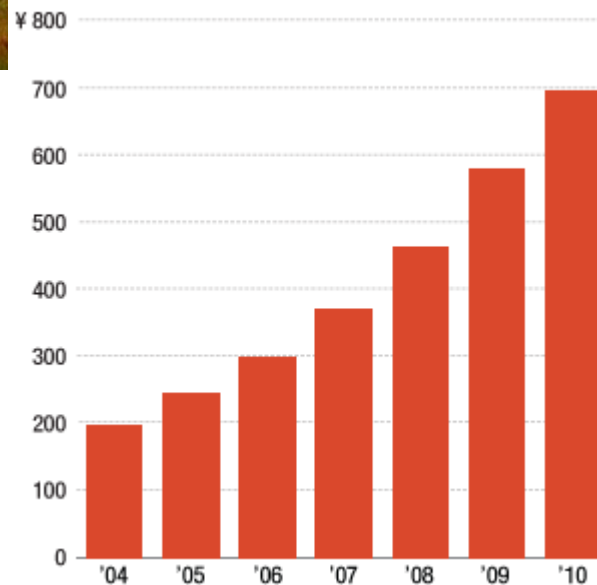

698 billion yuan equals \$108 billion U.S..

Source: China Science & Technology Statistics Data Book

Credit: Christina Baird/NPR

Figure O-13
S&E journal articles produced by selected regions/countries: 1988–2008

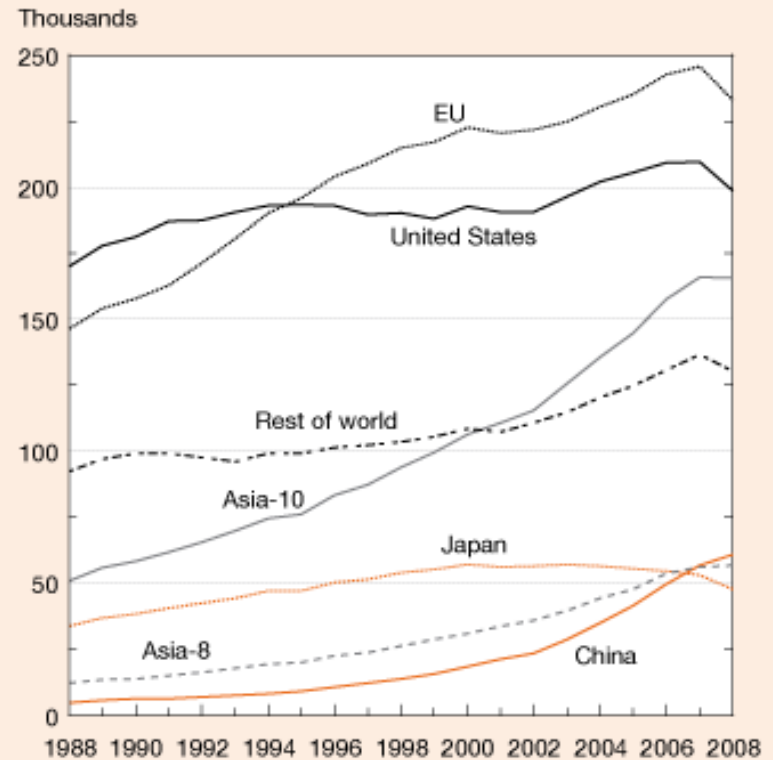

From NSF, Science and Engineering Indicators, 2010

Between Invention and Commercialization

Innovation Program to Bridge the Valley of Death

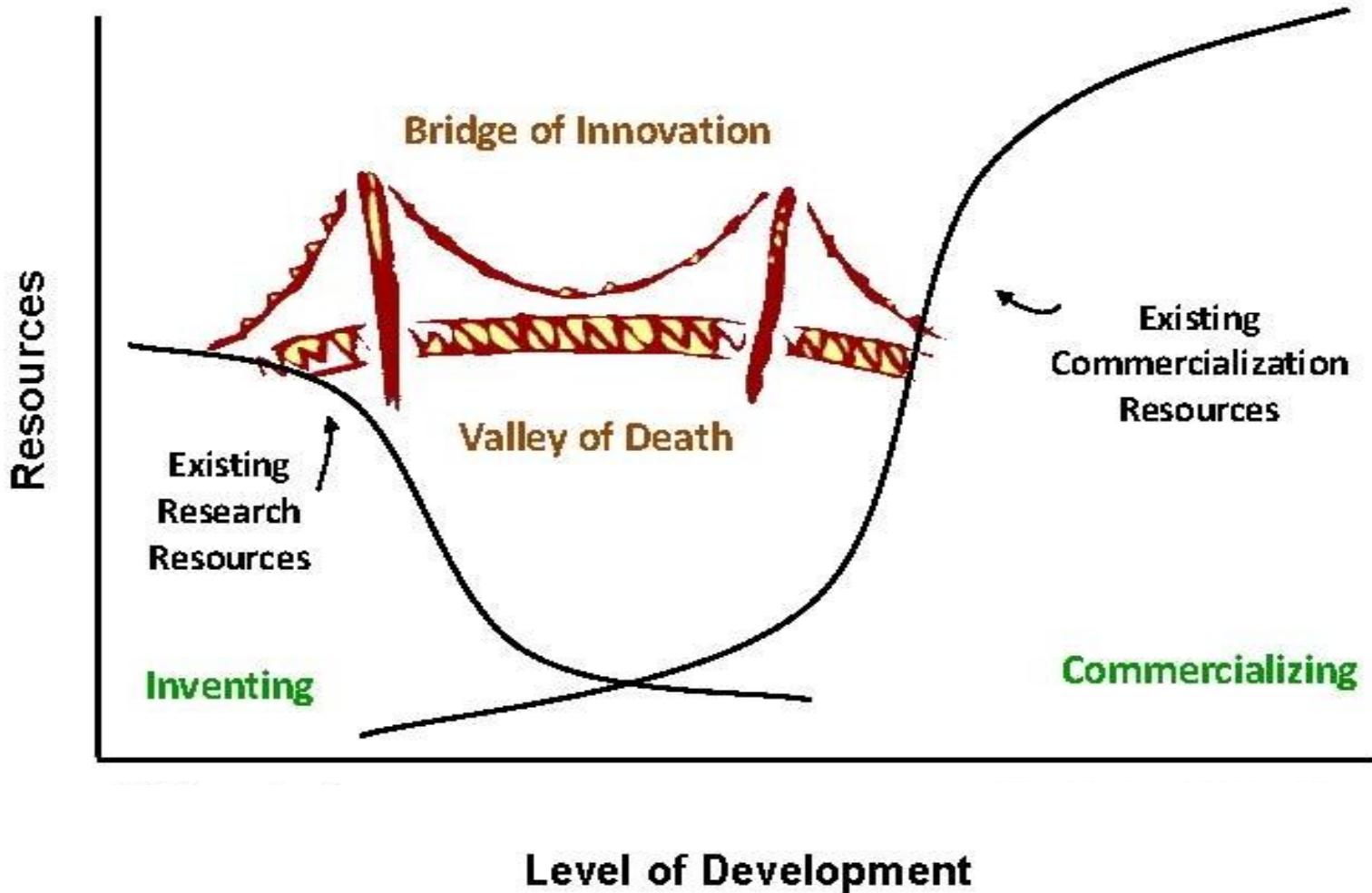

Bridging the *Missing Middle*

The *Missing Middle* – a gap in access to capital or other key resources at a crucial step in the development of new businesses or new technology.

The gap often occurs at the stage of development where opportunity and uncertainty are both high, or where there is little marketplace interest such as for capabilities exclusively for national security applications

Currently, research and invention occurs in a rich science and technology (S&T) ecosystem of performers

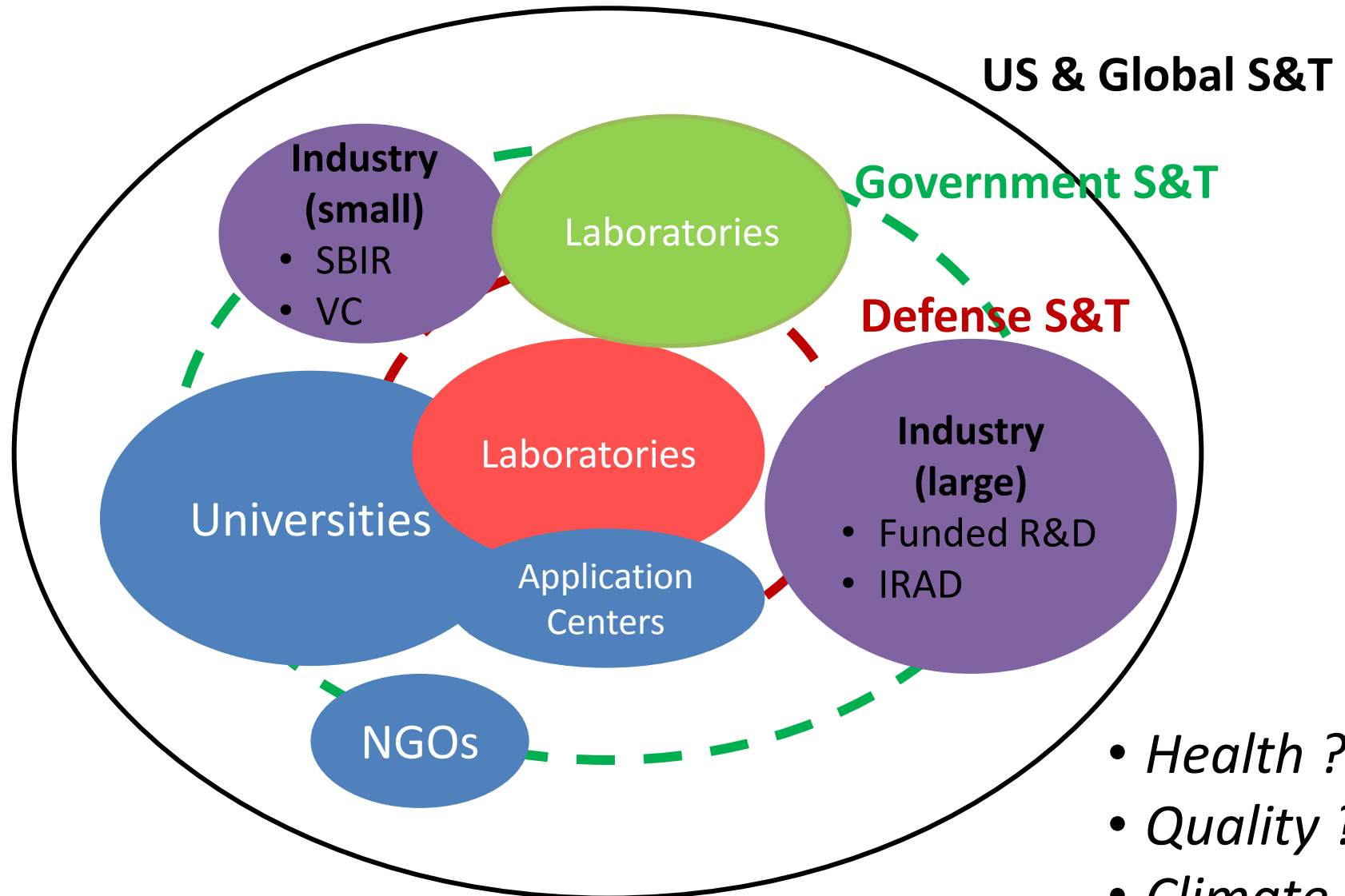

The Role of Young, High-Growth Firms

Young Firms Account for the largest Share of Job Creation

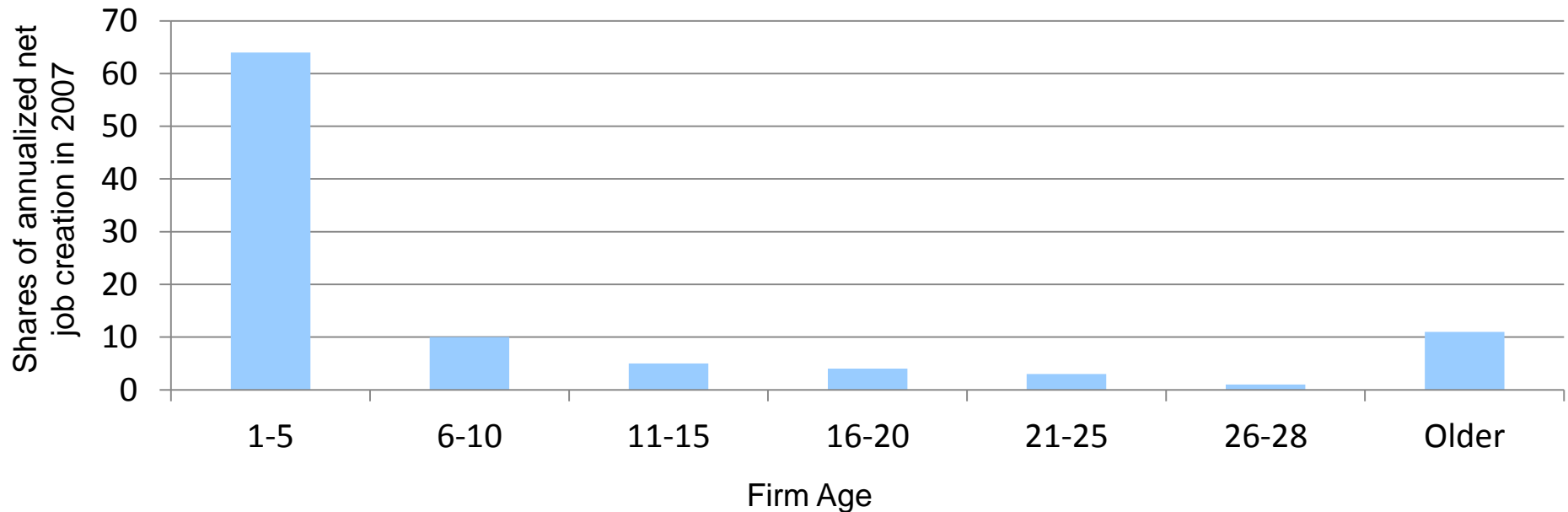

What to Do?

- focus on creating new firms
- remove barriers to emergence of high-growth companies
- target areas that are resources for high-growth firms:
immigrants and universities

Net Job Creation within Startups and without Startups

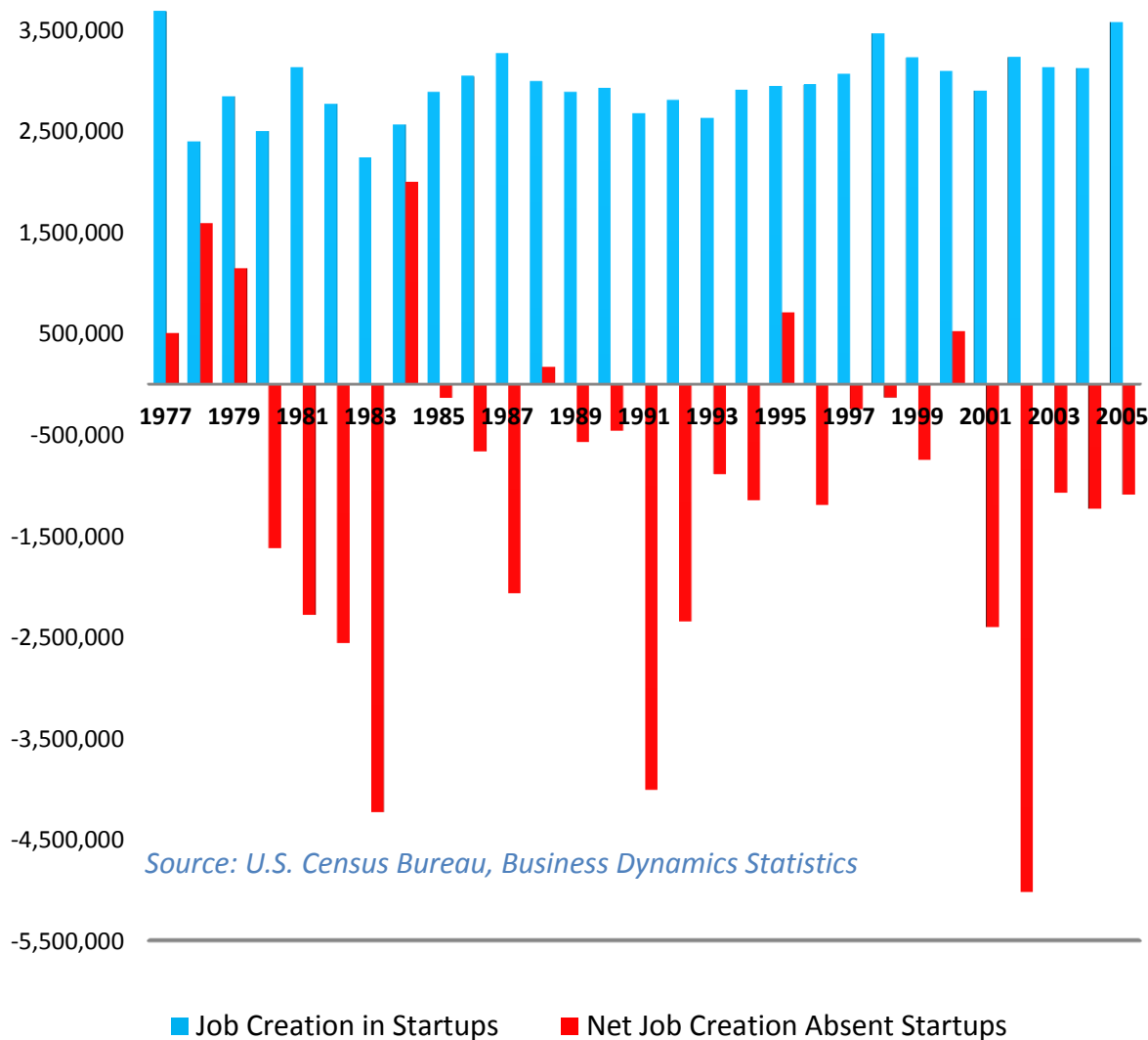

- High-growth firms or “gazelles” account for a disproportionate share of job creation in any given year, generating roughly 40 percent of new jobs in any given year.
- The fastest-growing young firms (between the ages of three and five) account for less than 1 percent of all companies in the economy, yet generate 10 percent of new jobs each year.

Source: Kauffman Foundation
Research Series: Firm Formation and Economic Growth High-Growth Firms and the Future of the American Economy, March 2010.

Revitalizing American Manufacturing

Advanced Manufacturing Partnership:

- National Robotics Initiative
- Materials Genome Initiative
- PCAST Report on Advanced Manufacturing
- Public-Private Partnerships in Manufacturing
- Defense Manufacturing and Industrial Base Investments



Government Procurement as a Catalyst

US Semiconductor Market Price and Military Use, 1962-1968

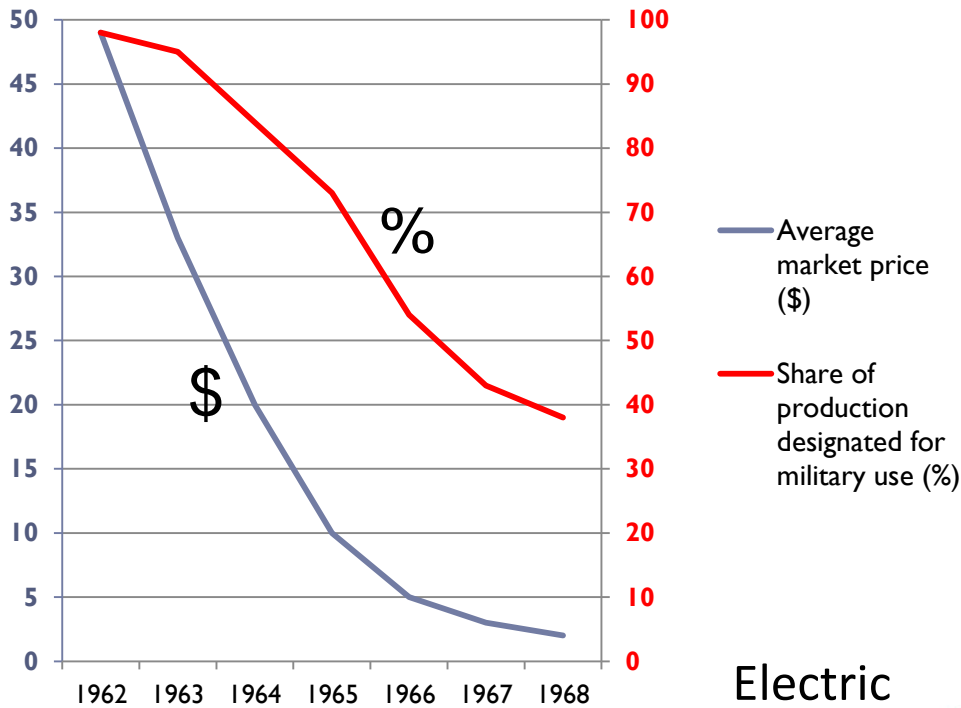

Source: ¹Morris, Peter Robin. *A history of the world semiconductor industry*. 1990, pg 75; ²Defense Science Board, "High Performance Microchip Supply", 2005.



Prosthetics

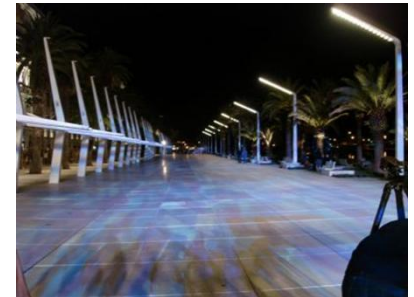

Solid State Lighting

Electric Vehicles



BioFuels



Strengthening the Defense Industrial Base

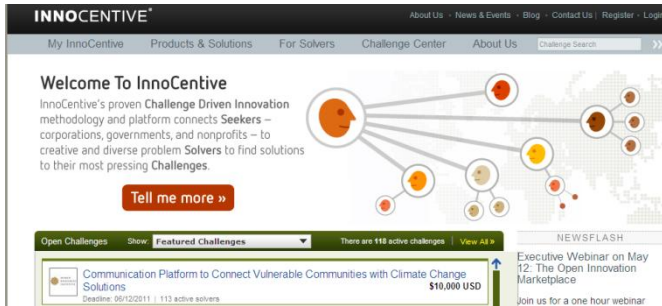

Shrinking the Missing Middle for Prosperity and Strength

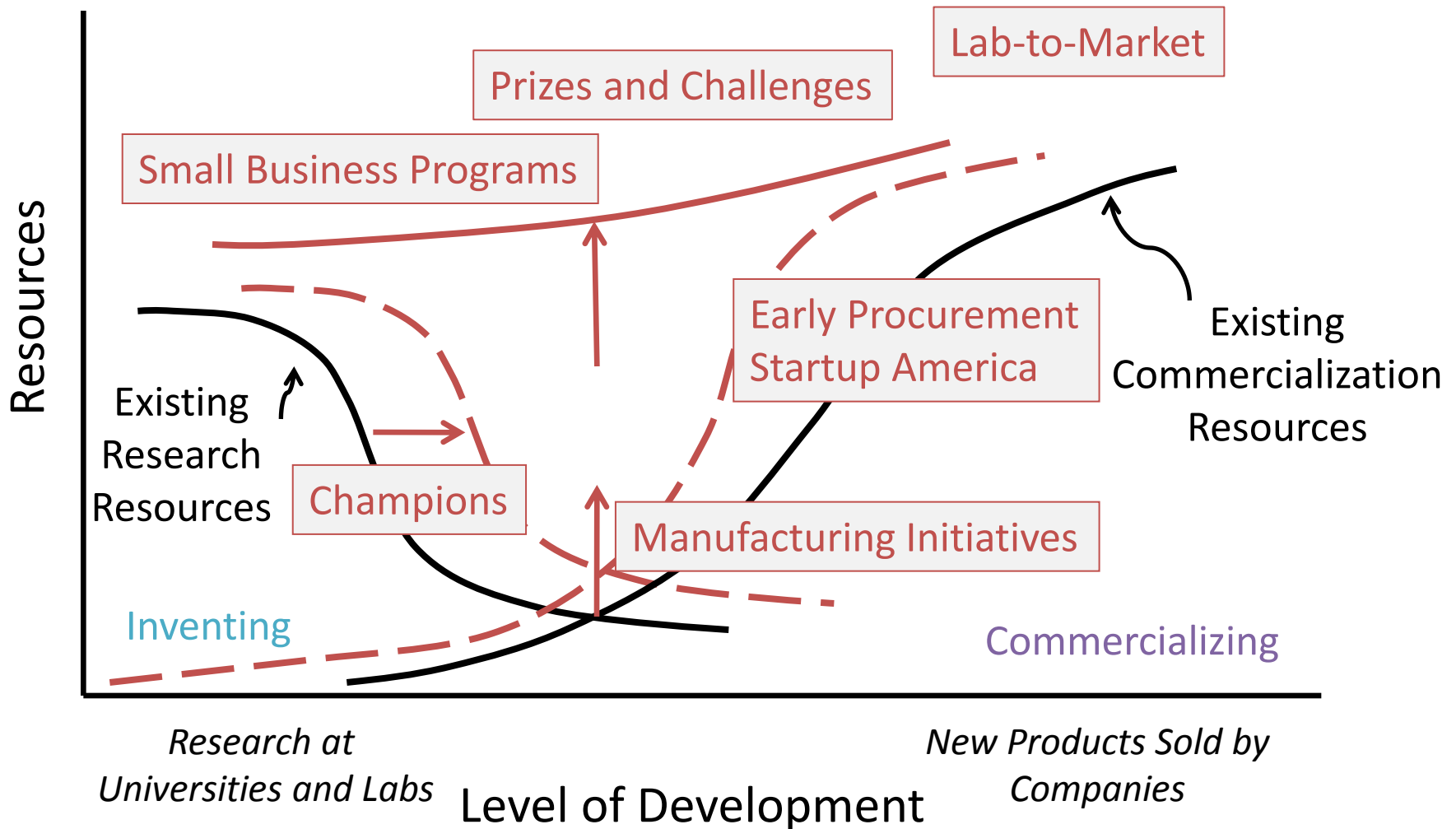

Many Challenges Remain

1999-2008 Mean Temperatures

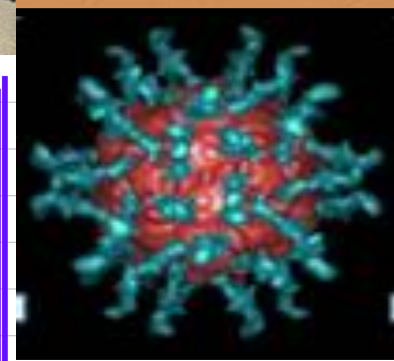
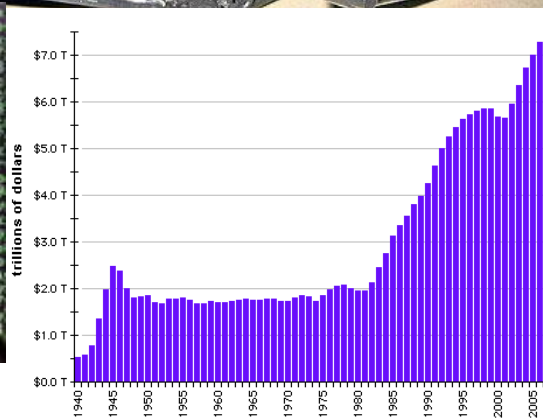
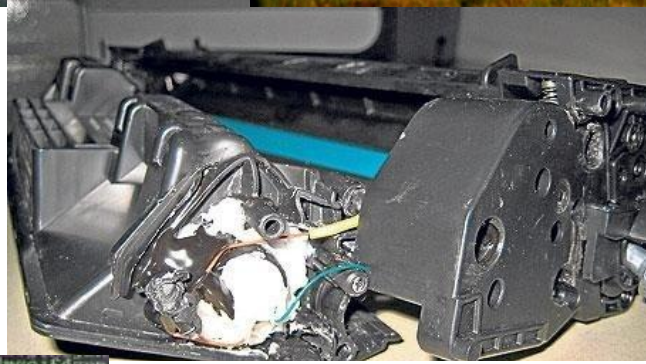
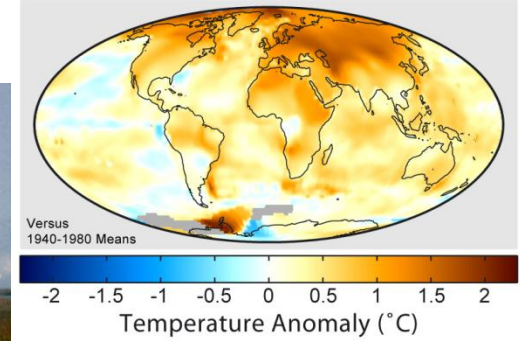

Source: U.S. National Debt Clock



**Acquisition with Shrinking
Resources**
“Giving *More* & Growing *Less*?”

Jenness B. Simler

**U.S. House of Representatives
Committee on Armed Services**

Summary of National Defense Fiscal Scenarios

Analysis over 10-year period FY 2012 – FY 2021

(Totals in Billions of Dollars)

National Defense Budget Function (\$B)	Cumulative Total FY2012 - FY2021	Change From FY11 Request	Change From FY12 Request
February 2010 - FY 2011 Administration Projection (FY 2011 Budget Submission)	6,703		
February 2011 - FY 2012 Administration Projection (FY 2012 Budget Submission - includes efficiencies)	6,414	-289	
July 2011 - FY 2012 House Appropriation Position (Current appropriation bills with CBO inflation – no real growth)	6,264	-439	-150
** Budget Control Act (Specifies new Security category to include DHS, IA, and VA)	5,949	-754	-465
If Joint Select Committee fails, additional decrease FY13-21	5,385	-1,318	-1,029

April 2011, President Obama announces goal to reduce defense by \$400B and examine roles & missions

** - HASC estimate

Budget Control Act - Title I

- Defines “Security Category” for first time
- Sets caps for discretionary spending for FY12 and FY13.

- \$684B for FY12

- \$686 B for FY13

(\$B)	H.R. 1	FY12 House APPN	Spread
Defense	513.0	530.0	504.4
MILCON/VA	73.3	72.5	72.1
Homeland Security	41.7	40.9	41.0
NNSA	10.6	10.6	10.4
Foreign Ops	50.2	41.6	49.4
Total Security	688.8	695.6	684.0

- National Defense

- \$596B request for FY13

- Likely to remain at FY11 levels: \$553B

Budget Control Act – Sequestration

- The Budget Control Act established a Joint Select Committee for Deficit Reduction.
 - \$1.2 trillion mandate
 - Deadlines
- Should the Joint Select Committee fail, or the House or Senate fail to adopt the Select Committee's recommendations, sequestration takes effect.
 - Amount of sequestration may vary
- New caps immediately take effect for national defense ONLY in FY13.
 - \$546B for FY13
 - Baseline for further cuts
- Full sequestration is an effective cut of 18% - 24%
 - President has the authority to hold military pay and benefits exempt.
- Overseas Contingency Operations accounts are not required to be sequestered.

National Defense Base Budget Topline

January 2012 – Implementation of Budget Control Act (BCA) Sequestration

FY 2009 – FY 2021

Constant FY 2012 Dollars

Base Budget

(In Billions of Dollars)

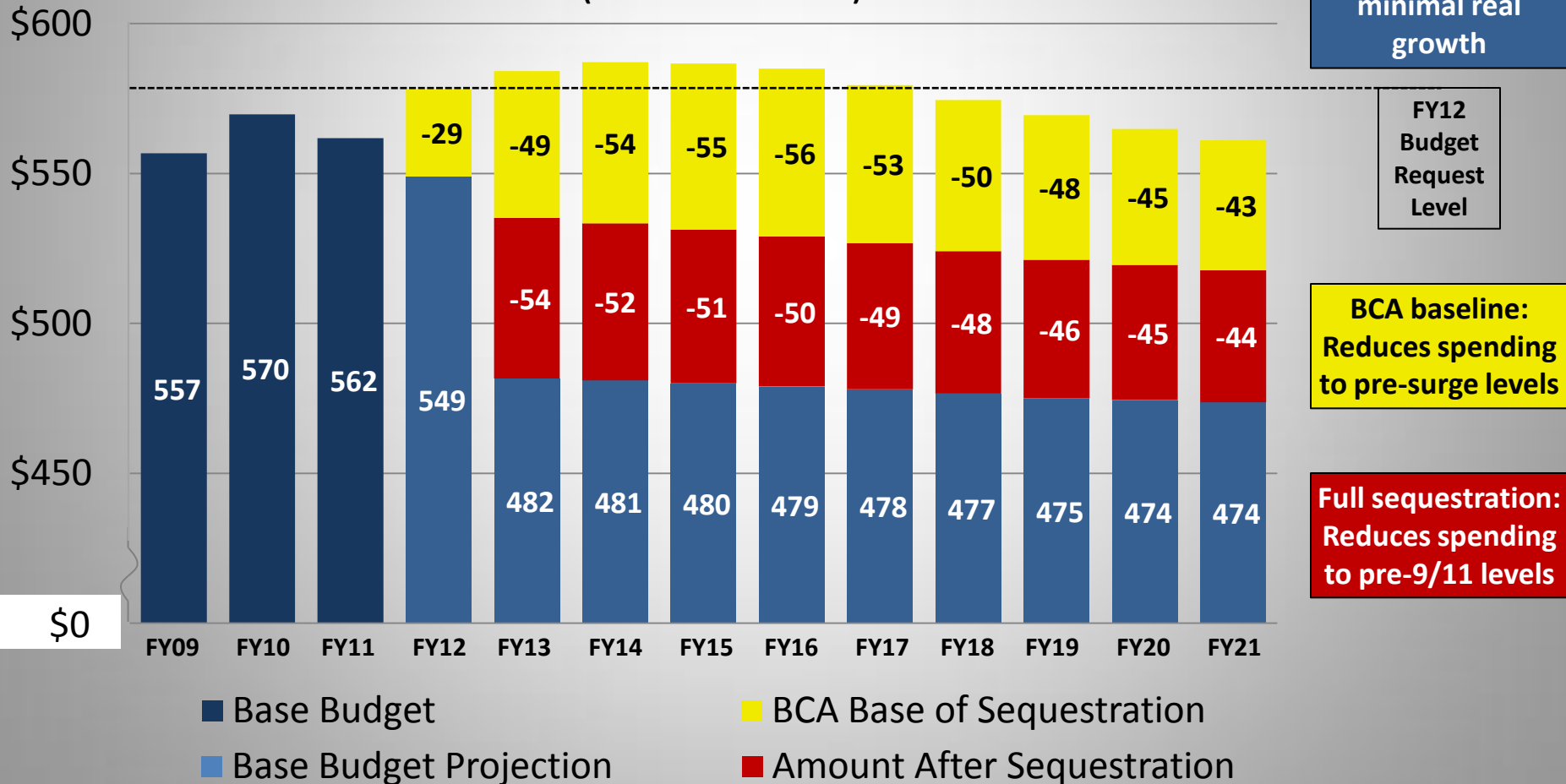

Defense Department Funding as a Percentage of Total Budget Authority FY1976 – FY2021

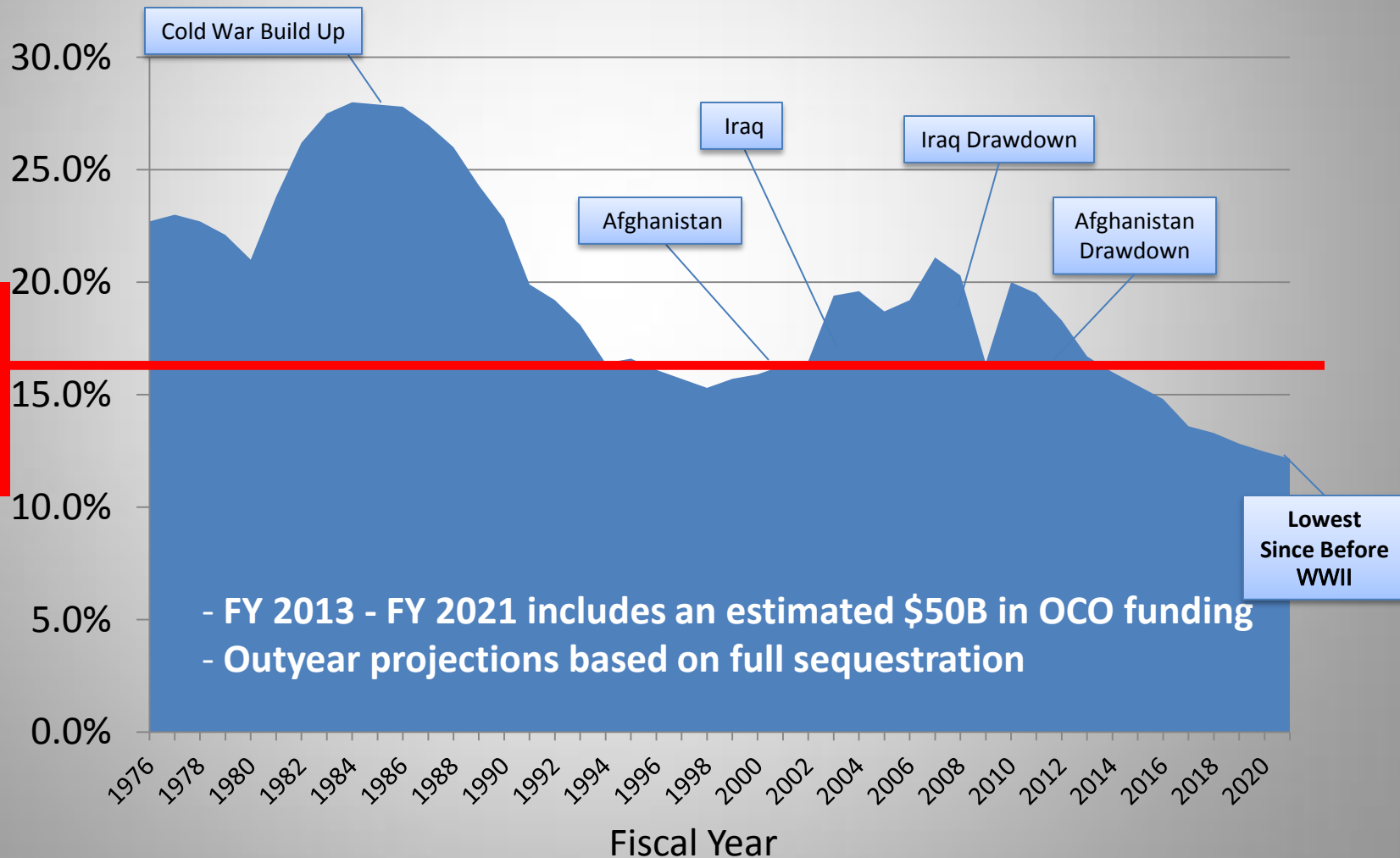

Bush 41 / Clinton-Era Defense Levels

Cuts to Military End Strength

	Today	Estimated Force Based on <u>Current Funding</u>	If Super-Committee Fails
Army	569,400	481,000	426,000
Marine Corps	202,000	173,000	145,000
Total	771,400	654,000	571,000

- Savings as a result of reductions to end strength is minimal in the near term, increases in out-years
- CBO - returning to pre 9/11 levels yields only \$4.1B in FY 2013
 - Only \$2.6B is in military personnel accounts
- Procurement and research and development accounts likely be reduced disproportionately

Aging Platforms – No Relief in Operations & Maintenance

	Average Age (years)
Amphibious Assault Vehicle	35
Light Attack Vehicle	20
Navy Ships	19
Army CH-47 Helicopters	16
Strategic Bombers	34
Tanker Aircraft	47
Airlift Aircraft	19

“There is increased operational tempo for a force that is much smaller than it was during the years of the Cold War. In addition, the age of major military systems has increased within all the services, and that age has been magnified by wear and tear through intensified use.”

-The QDR in Perspective: Meeting America’s National Security Needs in the 21st Century. Final Report of the Quadrennial Defense Review Independent Panel. Stephen J. Hadley and William J. Perry, Co-Chairs. Washington, DC, 2010

Declining Force Structure

	1990	2000	Today	Estimate Based on <u>Current Funding</u>	If Super-Committee Fails
Army Maneuver Battalions	172	98	100	78	60 - 70
Navy Ships	546	316	288	263	238
USAF Fighters	4355	3602	1990	1739	1512
Strategic Bombers	282	153	135	118	101
Strategic and Tactical Air Lift	872	743	651	572	494

“The general trend has been to replace more with fewer more-capable systems. We are concerned that, beyond a certain point, quality cannot substitute for quantity.”

Broad Impacts

- Mission risk and force planning construct
- U.S. Marine Corps
- Deterrence
- Breaking Faith with All Volunteer Force
- Shipbuilding

Consequences for Acquisition

- Reductions to civilian workforce follow reductions in military end strength
 - Growth in acquisition workforce limited
 - Loss of seasoned professionals
- Modernization programs at risk
- Services prioritize core capabilities
- Renewed emphasis on incremental capability versus transformational leaps
- Impacts on R&D and small business

A Few Myths

- Defense funding can be “fixed” next year
 - Irrevocable changes
- Diminished forward presence can save money
 - Little cost savings and opportunity cost
- Negotiated deal is better than sequestration
 - Devil is in the details.
- OCO is safe

Thank you!

Questions?

Yearly Breakdown of Scenarios

Budget Function 050

National Defense Budget Function (\$B)	FY10	FY11	FY12	FY13	FY14	FY15	FY16	FY17	FY18	FY19	FY20	FY21	Total FY12-21
February 2010 - FY 2011 Administration Projection (FY 2011 Budget Submission)	* 552	574	591	607	624	643	659	677	696	715	735	756	6,703
February 2011 - FY 2012 Administration Projection (FY 2012 Budget Submission)	* 552	* 553	578	596	612	625	638	649	661	673	685	698	6,414
** Budget Control Act Specifies new Security category to include DHS, IA, and VA	* 552	* 553	553	553	563	574	585	597	611	624	638	652	5,949
If Joint Select Committee stalemates, additional decrease FY13-21			549	491	501	511	521	535	548	561	575	589	5,385

* - FY10 and FY11 appropriation figures entered for reference only

** - HASC estimate



Cyber Resiliency of Defense Systems

Ms. Kristen Baldwin

Principal Deputy, Systems Engineering

Office of the Assistant Secretary of Defense, Research and Engineering

Women In Defense National Fall Conference

October 19, 2011



Trusted Defense Systems Strategy



Drivers/Enablers

- National Cybersecurity Strategies
- Congressional Interest
- DoD Policy and Directives
- Globalization Challenges
- Increasing System Complexity

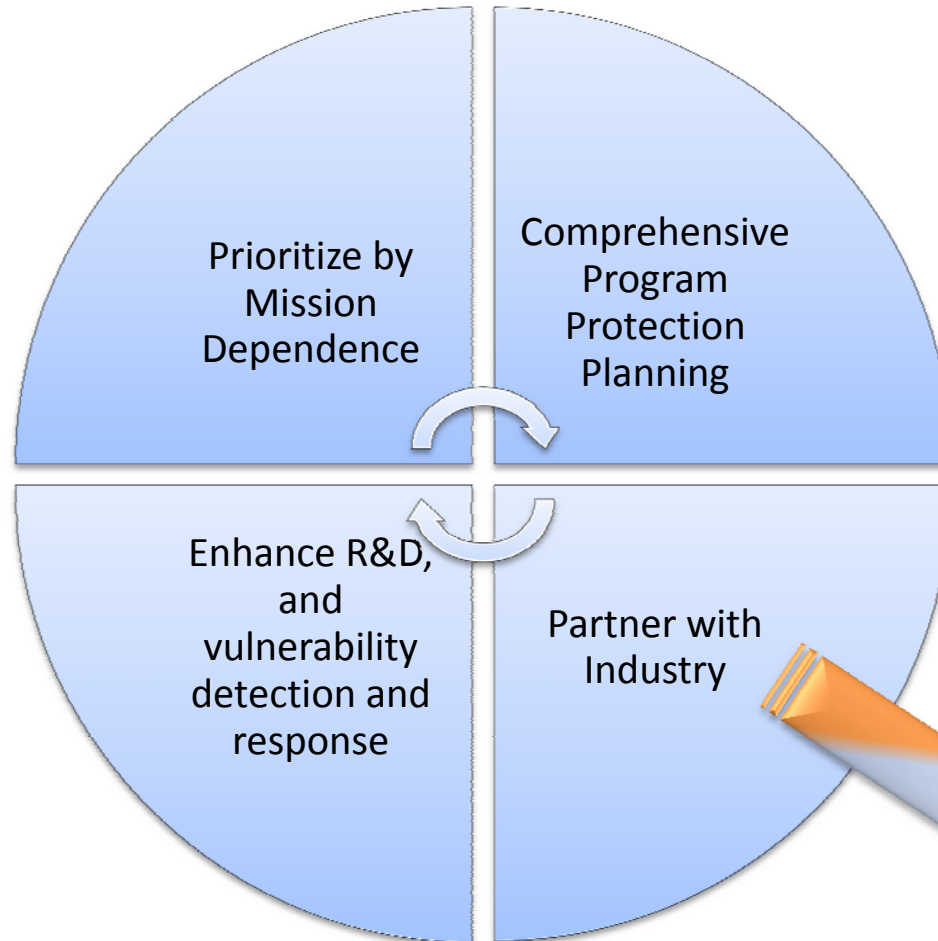

Delivering Trusted Systems

Report on Trusted Defense Systems

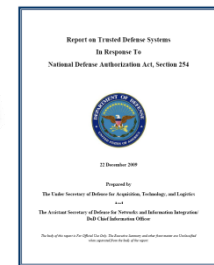

USD(AT&L)
ASD(NII)/DoD CIO



Trusted Defense Systems Strategy Basic Tenants



- **Prioritization:**
 - Focus security requirements on mission critical systems
 - Within systems, identify and protect critical components, technology, information
- **Comprehensive Program Protection Planning**
 - Early lifecycle identification of critical components
 - Provide PMs with intelligence analysis of supply chain risk
 - Protect critical components through trusted suppliers, or secure systems design
 - Assure systems through advanced vulnerability detection, test and evaluation
 - Manage counterfeit risk through sustainment
- **Partner with Industry**
 - Develop commercial standards for secure products
- **Enhance capability through R&D**
 - Leverage and enhance vulnerability detection tools and capabilities
 - Technology investment to advance secure software, hardware, and system design methods

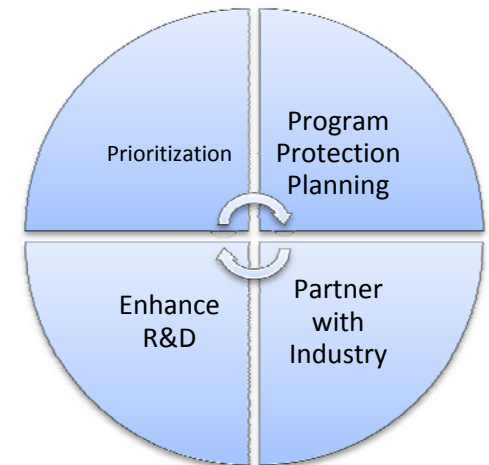



Threats

- **Threats: Nation-state, terrorist, criminal, rogue developer who:**
 - Gain control of systems through supply chain opportunities
 - Exploit vulnerabilities remotely
- **Vulnerabilities: All systems, networks, applications**
 - Intentionally implanted logic (e.g., back doors, logic bombs, spyware)
 - Unintentional vulnerabilities maliciously exploited (e.g., poor quality or fragile code)
- **Consequences: Stolen critical data & technology; corruption, denial of critical warfighting capability**

Today's acquisition environment drives the increased emphasis:

<u>Then</u>		<u>Now</u>
Standalone systems	>>>	Networked systems
Some software functions	>>>	Software-intensive
Known supply base	>>>	Prime Integrator, hundreds of suppliers



What We Are Protecting

Program Protection Planning

DoDI 5000.02 Update

DoDI 5200.39
Change 1, dtd Dec 10

DTM 09-016
DoDI 5200.cc, TBD

DoDI 5200.39
DTM 09-016

Technology

What: Leading-edge research and technology

Who Identifies: Technologists, System Engineers

ID Process: CPI Identification

Threat Assessment: TTRA, M/D-CITA

Countermeasures: AT, Classification, Export Controls, Security, etc.

Focus: "Keep secret stuff in" by protecting any form of technology

Components

What: Mission-critical elements and components

Who Identifies: System Engineers, Logisticians

ID Process: Criticality Analysis

Threat Assessment: DIA SCRM TAC

Countermeasures: SCRM, SSE, Anti-counterfeits, software assurance, Trusted Foundry, etc.

Focus: "Keep malicious stuff out" by protecting key mission components

Information*

What: Information about applications, processes, capabilities and end-items

Who Identifies: All

ID Process: Various

Threat Assessment: Various

Countermeasures: Information Assurance, Classification, Export Controls, Security, etc.

Focus: Keep critical information from getting out by protecting data

Protecting Warfighting Capability Throughout the Lifecycle

* Program Protection Planning Includes DoDI 8500 series



Program Protection Plan Outline and Guidance as “Expected Business Practice”



 DEPARTMENT OF DEFENSE
 ACQUISITION, TECHNOLOGY AND LOGISTICS

PRINCIPAL DEPUTY UNDER SECRETARY OF DEFENSE
 3015 DEFENSE PENTAGON
 WASHINGTON, DC 20301-3015

JUL 18 2011

MEMORANDUM FOR SECRETARIES OF THE MILITARY DEPARTMENTS
 DIRECTORS OF THE DEFENSE AGENCIES

SUBJECT: Document Streamlining – Program Protection Plan (PPP)

The September 14, 2010, Better Buying Power memorandum directed a review of the documentation required by Department of Defense Instruction (DoDI) 5000.02 in support of the acquisition process. This is the second in a series of document streamlining memoranda, following my April 20, 2011, direction on the streamlined Technology Development Strategy/Acquisition Strategy (TDS/AS) and Systems Engineering Plan outlines. I am directing the following actions for the PPP:

Document Streamlining: The PPP will be streamlined consistent with the attached annotated outline. The outline is designed to guide both program protection management and document preparation. It increases emphasis on early-phase planning activity and is specifically focused on information central to the purpose of the document. The new PPP reflects the integration of the Acquisition Information Assurance (IA) Strategy and recognizes Program Protection as the Department’s holistic approach for delivering trusted systems.

PPP Review and Approval: Every acquisition program shall submit a PPP for Milestone Decision Authority review and approval at Milestone A and shall update the PPP at each subsequent milestone and the Full-Rate Production decision. While some programs may not have Critical Program Information, every program, including those with special access content, shall address mission-critical functions and components requiring risk management to protect warfighting capabilities. Per the TDS/AS outline described above, Program Protection information is no longer included in the TDS. The Acquisition IA Strategy shall continue to be reviewed and approved in accordance with DoDI 8500.1 and shall be included as an appendix to the PPP.

These actions constitute expected business practice and are effective immediately. The revised outline will be documented in the Defense Acquisition Guidebook and referenced in the next update to DoDI 5000.02. My point of contact is the Mr. Stephen Welby, Deputy Assistant Secretary of Defense for Systems Engineering, at 703-695-7417.

 Frank Kendall

cc:
 All CAEs
 DCMA
 DCAA
 DCMO
 DASD(PSA)

Program Protection Plan
 Outline & Guidance

• VERSION 1.0 •
 • July 2011 •



Deputy Assistant Secretary of Defense
 Systems Engineering

<http://www.acq.osd.mil/se/pg/index.html#PPP>



Program Protection Plan (PPP) Streamlining



- **Vision: PPP is the consolidated security perspective for the program throughout the lifecycle**
- **Streamlined PPP content and format**
 - Moved to tables/bullets instead of essay paragraphs
 - Reduced boilerplate and front matter
 - Removed duplication across PPP annexes (Anti-Tamper Plan, Technology Assessment/Control Plan)
- **Coordinated disciplines to improve system security**
 - Supply Chain Risk Mitigation, Anti-Tamper, Security, Counterintelligence, Intelligence, System Security Engineering, Countering-Counterfeits, Information Assurance
 - Comprehensive PPP review/approval process
 - Coordination between USD(I), USD(AT&L), ASD(NII), Services, Anti-Tamper Executive Agent

*July 2011 PPP Outline and Guidance sets
expected business practice for all DoD programs*



Systems Security Engineering (SSE): Early Engineering Emphasis



- **Identify components that need protection**
 - Perform criticality analysis based on mission context and system function
 - Evaluate CONOPS, threat information, notional system architecture to identify critical components (hardware, software and firmware)
 - Identify rationale for inclusion or exclusion from candidate CPI list
 - Perform trade-offs of design concepts and potential countermeasures to minimize vulnerabilities, weaknesses, and implementation costs
- **Establish Systems Security Engineering Criteria**
 - Ensure preferred concept has preliminary level security requirements derived from candidate CPI countermeasures
 - Ensure system security is addressed as part of Systems Engineering Technical Reviews
- **We have begun to apply these practices with major acquisition programs**
 - In support of risk-based Program Protection Plan development
 - In preparation for MS B and MS C Defense Acquisition Board reviews



Risk Assessment Methodology



Input Analysis Results:

Criticality Analysis Results

Mission	Critical Functions	Logic-Bearing Components (HW, SW, Firmware)	System Impact (I, II, III, IV)	Rationale
Mission 1	CF 1	Processor X	II	Redundancy
	CF 2	SW Module Y	I	Performance
Mission 2	CF 3	SW Algorithm A	II	Accuracy
	CF 4	FPGA 123	I	Performance

Vulnerability Assessment Results

Critical Components (HW, SW, Firmware)	Identified Vulnerabilities	Exploitability	System Impact (I, II, III, IV)	Exposure
Processor X	Vulnerability 1 Vulnerability 4	Low Medium	II	Low Low
SW Module Y	Vulnerability 1 Vulnerability 2 Vulnerability 3 Vulnerability 6	High Low Medium High	I	High Low Medium Low
SW Algorithm A	None	Very Low	II	Very Low
FPGA 123	Vulnerability 1 Vulnerability 23	Low Low	I	High High

Supply Chain Threat Analysis Results

Supplier	Critical Components (HW, SW, Firmware)	TAC Findings
Supplier 1	Processor X	Potential Foreign Influence
	FPGA 123	Potential Foreign Influence
Supplier 2	SW Algorithm A	Cleared Personnel
	SW Module Y	Cleared Personnel

Risk Mitigation and Countermeasure Options

Consequence of Losing Mission Capability
Very High
High
Moderate
Low
Very Low

Likelihood of Losing Mission Capability
Near Certainty (VH)
Highly Likely (H)
Likely (M)
Low Likelihood (L)
Not Likely (VL)

Initial Risk Posture

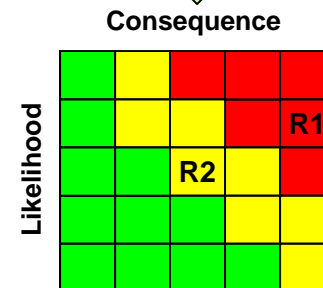

Risk Mitigation Decisions

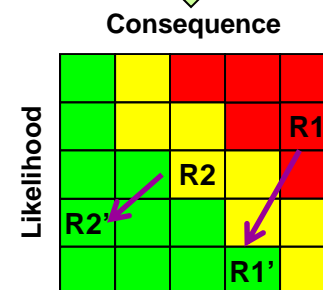



In Summary



- **Holistic approach to security is critical**
 - To focus attention on the threat
 - To avoid risk exposure from gaps and seams
- **Program Protection Policy provides overarching framework for trusted systems**
 - Common implementation processes are beneficial
- **Stakeholder integration is key to success**
 - Acquisition, Intelligence, Engineering, Industry, Research Communities are all stakeholders
- **Systems engineering brings these stakeholders, risk trades, policy, and design decisions together**
 - Informing leadership early; providing programs with risk-based options



Vision of Success

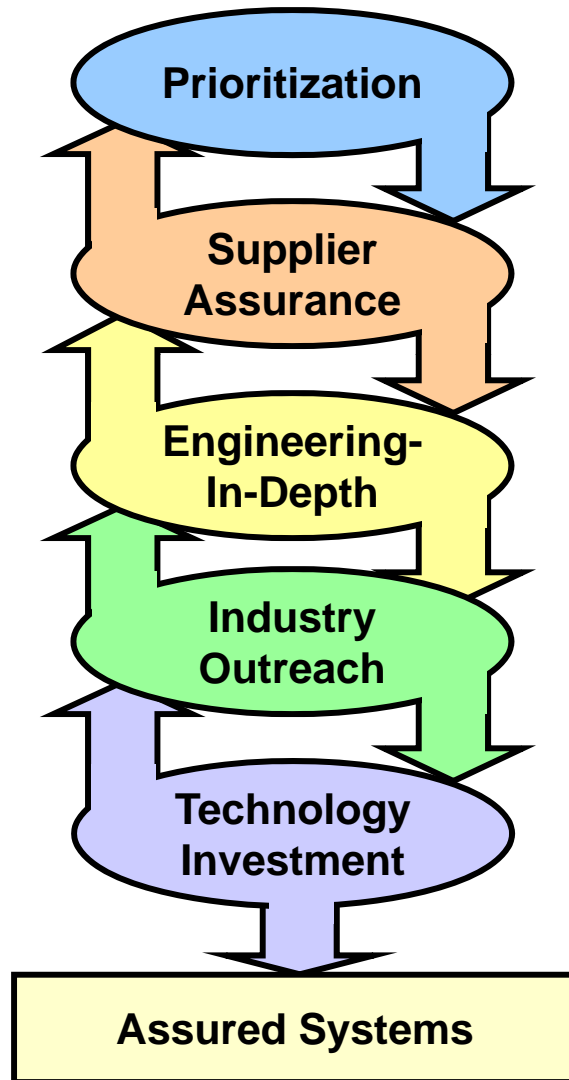

- The requirement for assurance is allocated among the right systems and their critical components
- DoD understands its supply chain risks
- DoD systems are designed and sustained at a known level of assurance
- Commercial sector shares ownership and builds assured products
- Technology investment transforms the ability to detect and mitigate system vulnerabilities

***Reference: DoD System Assurance CONOPS, 2004**



Questions?



Criticality Analysis Methodology

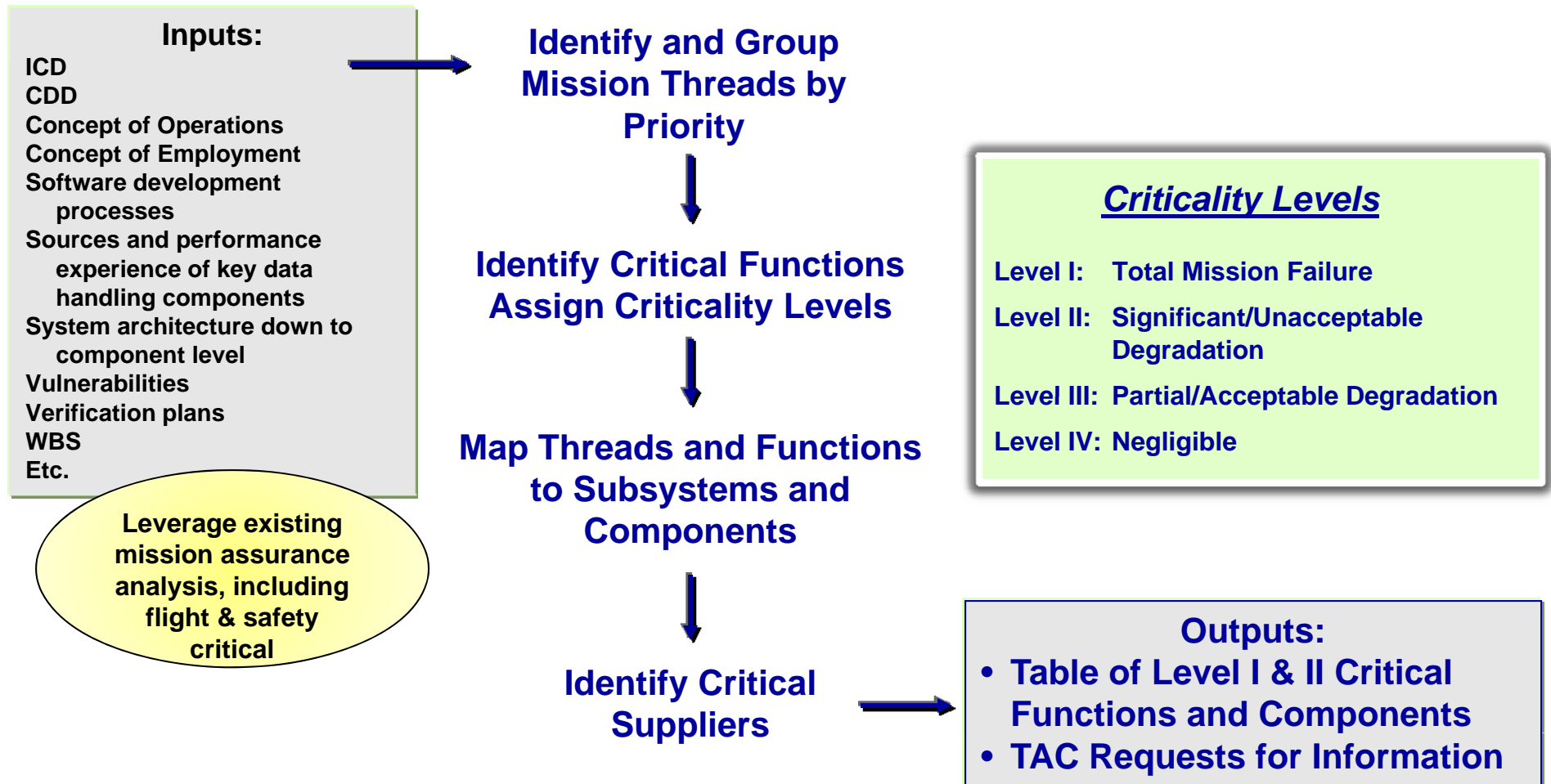



Vulnerability Assessment Methodology



- **Inputs**

- System architecture
- Critical functions and components
- Design, development, integration and test processes
- Manufacturing processes
- Software development processes
- Update, configuration, and maintenance processes

- **Processes**

- Review all stages of the inputs to identify access opportunities for introducing and exploiting vulnerabilities

- **Outputs**

- Risks due to vulnerabilities of the system, critical functions, and critical components
- Countermeasure and mitigation suggestions



Tiered Supply Chain (Notional Example)

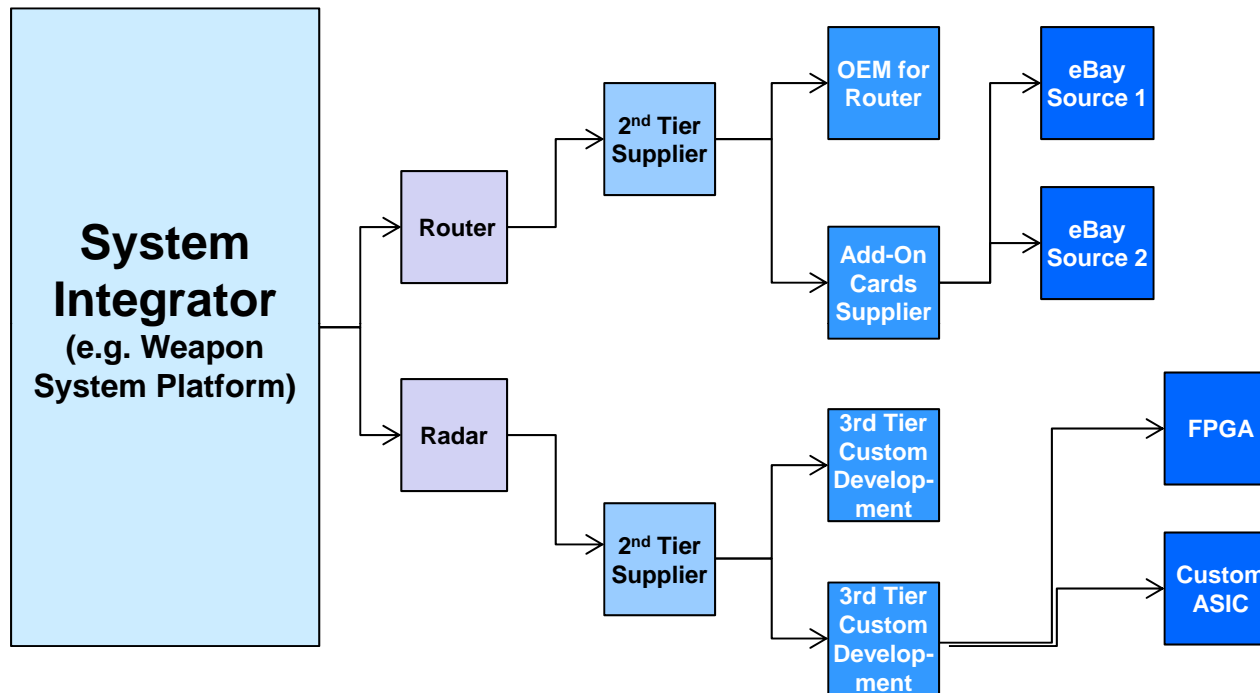

Supplier Threat can reside several layers down from System Integrator

How is it shipped?
 How is it verified and validated ?
 How is it physically protected?
 Do you execute a Blind Buy?
 ...

Manage Risks

Criticality
Schedule
Cost

- 1st Tier Supplier
- 2nd Tier Supplier
- 3rd Tier Supplier
- 4th Tier Supplier



Key Elements of the PPP

Key Sections	Rationale
3.0 CPI and Critical Components (CC) <ul style="list-style-type: none"> Documents output of Research & Tech. Protect and Criticality Analysis Distinguishes between inherited and organic elements 	Focus protection on critical technology, information, and components
4.0 Horizontal Protection <ul style="list-style-type: none"> Assessment of similar CPI on other DoD programs, ASDB status 	Protect technologies across the DoD
5.0 Threats <ul style="list-style-type: none"> Identifies foreign collection, supply chain, and battlefield threats 	Acknowledge advanced, persistent threat
6.0 Vulnerabilities and Countermeasures <ul style="list-style-type: none"> Documents assessment of vulnerability to threats and mitigating actions 	Assess weaknesses to documented threats and use risk-based mitigations
7.0 Other Plans <ul style="list-style-type: none"> Pointers to related documents (CI Support Plan, TEMP, etc.) 	Reference, not duplicate, key documents
8.0 Residual Risk Assessment <ul style="list-style-type: none"> Document unmitigated risks to CPI and CC compromise 	Document risks program is assuming
9.0 Foreign Involvement <ul style="list-style-type: none"> Identify known and potential co-development, foreign military sales, and direct commercial sales 	Drive export realism and prepare for export-specific countermeasures early
10.0 Processes for PM Oversight & Implementation	PM Resources and Implementation Reviews
11.0 Processes for Monitoring & Reporting Loss of CPI and CC <ul style="list-style-type: none"> Monitor open source and intelligence sources for loss 	Assess effectiveness of implemented countermeasures
12.0 Costs <ul style="list-style-type: none"> Estimate of implementation costs for CPI and CC protection 	Support cost/benefit assessment of risk mitigations

The PPP contains the information a PM needs to effectively secure the system



WID Annual Conference 2011

Government and Industry ~ Security Budget Panel

INTRODUCTIONS

K. Eileen Giglio, Government Liaison

~ National Defense Business Institute, University of Tennessee ~

Pamela R. McFarland, Consulting Property Manager

~ Supply Chain Management Compliance ~ Raytheon Technical Services Co ~

Kristina Tanasichuk, President & CEO

**~ Government Technology & Services Coalition , Founder & President,
Women In Homeland Security~**

Patricia (Trish) Culbreth, Manager

**~Small Business Advocate/Mentor Protégé Program ~ Department of
State~**

Laurie A. Schive, Director Outreach

~ Office of National Counterintelligence Executive ~



WID Annual Conference 2011

Government and Industry Panel ~ Security Budget

CAREER

Briefly describe your current professional position

What motivated you to bring you to this Career field



WID Annual Conference 2011

Government and Industry ~ Security Budget Panel

Roles & Missions

Provide an Overview of your Organization

Describe Relationships with other Government Organizations in the Security Communities

What capabilities do your organization contribute to the Security Community



WID Annual Conference 2011

Government and Industry ~ Security Budget Panel

RESOURCE CONSTRAINTS

Workforce – Staffing, Training

Regulations – helpful, minimal or extraordinary

Mission Relationships – internal and external

Funding – Plans & Programs



WID Annual Conference 2011

Government and Industry ~ Security Budget Panel

QUESTIONS

K. Eileen Giglio – www.ndbi,utk.edu/defense

Pamela R. McFarland www.raytheon.com/businesses/rts

Kristina Tanasichuk – www.GTSCoalition.com

Patricia (Trish) Culbreth www.state.gov/M/A/SDBU

Laurie A. Schive www.ncix.gov

WID Annual Conference:

Recent Developments in Acquisition:

New Laws, Regulations, Directives

Susan Warshaw Ebner

Hazel Scalia

Jennifer Schaus

Sherri L. Schornstein

4-1-1 On Laws, Rules, Regs:

- :: Budget Deficit and Ceiling**
- :: FAPIIS Reporting**
- :: Conflicts of Interest**
- :: Information Security and Export**
- :: Technical Data and Patent Reform**
- :: Audit**

Counterfeit Parts

- :: Video Clip**
- :: The Counterfeit Parts Task Force**
- :: Impact On Government And Industry**

Social Media

:: Is It A Revolution

- In Communicating?
- In Contracting?

:: How Can It Be Used?

:: Potential Risk Areas

Questions???

:: Susan Warshaw Ebner

- susan.ebner@bipc.com

:: Hazel Scalia

- hazel.scalia@kbr.com

:: Jennifer Schaus

- jschaus@jenniferschaus.com

:: Sherri Schornstein

- sherri.schornstein@usdoj.gov