

Image Cover Sheet

98 - 01223

CLASSIFICATION

SYSTEM NUMBER

508031

UNCLASSIFIED



TITLE

HUMAN FACTORS OF CC-130 OPERATIONS. VOLUME 5: HUMAN FACTORS IN DECISION MAKING

System Number:

Patron Number:

Requester:

Notes:

DSIS Use only:

Deliver to:



Human Factors of CC-130 Operations

Volume 5:

Human factors in decision making



K.C. Hendy
G. Ho

Defence and Civil
INSTITUTE OF ENVIRONMENTAL MEDICINE

Canada 



February 1998

DCIEM No. 98-R-18

**HUMAN FACTORS OF CC-130
OPERATIONS**

**VOLUME 5: HUMAN FACTORS IN
DECISION MAKING**

K.C. Hendy
G. Ho

Defence and Civil Institute of Environmental Medicine
1133 Sheppard Avenue West, P.O. Box 2000
Toronto, Ontario
Canada M3M 3B9

- © HER MAJESTY THE QUEEN IN RIGHT OF CANADA (1998)
as represented by the Minister of National Defence
- © SA MAJESTE LA REINE EN DROIT DU CANADA (1998)
Défense Nationale Canada

DEPARTMENT OF NATIONAL DEFENCE – CANADA

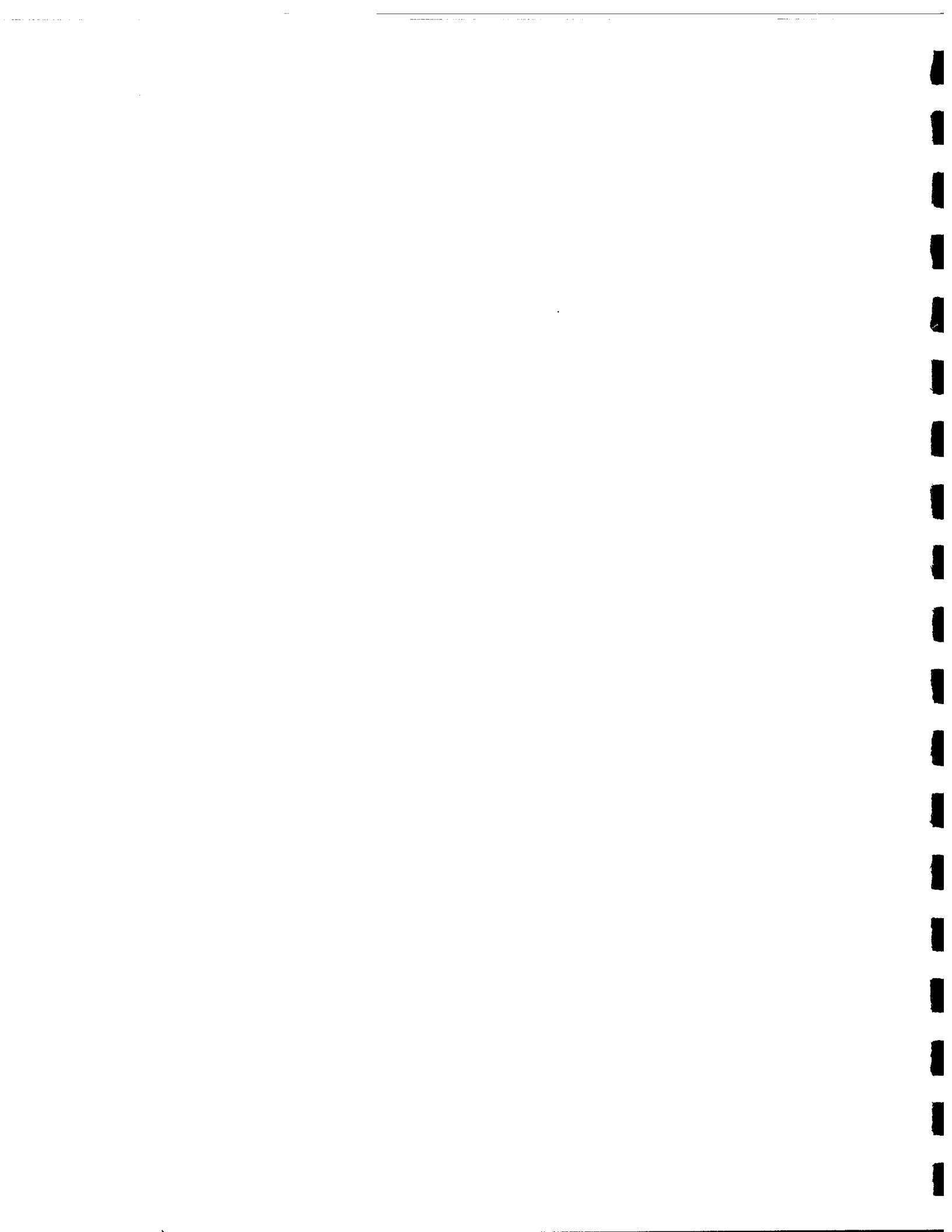

EXECUTIVE SUMMARY

Volume 5 of the Report of the Defence and Civil Institute of Environmental Medicine/Air Transport Group (DCIEM/ATG) study team describes the development of a proposed new training programme devoted to *Human Factors in Decision Making* (HFDM). It is envisaged that the HFDM training syllabus would replace existing *Aircrew Co-ordination Training* (ACT) within the CC-130 community. The proposed training can be distinguished from other approaches with similar goals (either explicit or implicit) by its base within a theoretical framework of human information processing. The differences lie less in the content than in the way the material is organised and shaped by theory.

The proposed HFDM training is based on two related models of the human information processor. They are.

The Information Processing (IP) Model. The IP model claims that all factors that determine operator workload can be reduced to their effect on the **amount of information** that has to be processed, or their effect on the **time available** before a decision has to be implemented. Under the assertion that humans are limited in the rate at which they can process information, operator workload, performance and error production can all be shown to be functions of the *time pressure* or the ratio of *time to process* the information to the *time available*.

The Perceptual Control Theory (PCT) Model. The PCT model is based on the assertion that all living organisms operate as a multi-layered closed loop control system. The set points for the control loops are the organism's goals (or how you want to *see* the state of the world). PCT asserts that all observable behaviours are intended to operate on the external world so that the perceived world state matches a desired state (the goal). This model provides a coherent framework for integrating the concepts of workload, situation awareness, mental models and decision making performance. It establishes the absolute necessity of feedback in goal directed activity.

The models are complementary, as the IP model sits within the PCT framework. Together they integrate much of what is known about human information processing and decision making.

Topics for HFDM training come directly from this theoretical framework. The proposed syllabus is made up of 11 related modules covering the following topics: an introduction to the decision making loop; leadership and followership; the emergence of communication and captaincy in teams and groups; sensation/perception; goal setting; action selection; management of control, attention, time and knowledge; and finally communication. Each module is anchored in the theoretical framework and its effect on decision making. The core knowledge and skill set that are expected to come from each module are described for the purposes of assessing the efficacy of training.

A clear distinction has been made between the knowledge development phase of training and skill development. In the proposed training programme, skill development would be done in a hands-on team environment using a variety of situations such as: role playing and team

exercises; case study analysis; low and high fidelity simulation; instructional rides; and on-the-job-training (OJT). It is at this level that there exists the greatest potential for tailoring the training to the trainee's position on the aircraft, and making the training relevant to each individual's stage of development (upgrade training, recurrency training, etc.).

A programme such as the one outlined in this Volume requires the following additions to the current CC-130 training commitment:

- 1 extra classroom day added to the current ACT course;
- 2 extra days devoted to hands-on team decision making training for all positions (as preparation for simulator sessions in the case of the Aircraft Commanders [ACs], Co-pilots [CPs] and Flight Engineers [FEs]);
- 2 days per year of HFDM refresher training within the Squadrons (this could be in conjunction with a safety stand-down); and
- 3 extra days for all those going through AC upgrade training or re-qualification training.

Manning levels within the training Squadron, to accomplish this task, have not been assessed. Overall these are modest additions to a training programme that is currently devoted almost entirely to technical issues. Considering that human factors (HF) failures are assigned to somewhere between 70% and 80% of the accidents and incidents around the world, the proposed amount of time spent in HF training is not excessive.

CONTENTS

EXECUTIVE SUMMARY	i
INTRODUCTION	1
TRAINING MODEL	7
THEORETICAL FRAMEWORK	11
SUPERPILOT, DREAMTEAM AND HERCCREW	14
CAPTAINCY	17
PROPOSED SYLLABUS	21
FROM KNOWLEDGE TO PRACTICE	23
KNOWLEDGE DEVELOPMENT	23
SKILL DEVELOPMENT	25
ACHIEVING SAFE FLIGHT PERFORMANCE	26
A BASIS FOR ASSESSMENT	28
CONCLUSIONS	33
REFERENCES	35
ACKNOWLEDGEMENTS	39
APPENDIX 1: DRAFT SYLLABUS FOR <i>HUMAN FACTORS IN DECISION MAKING TRAINING</i>	41
APPENDIX 2: REPERTORY GRID PROCEDURE FOR ELICITING OBSERVABLE CAPTAINCY BEHAVIOURS	69
APPENDIX 3: BEHAVIOURALLY ANCHORED RATING SCALES FOR HFDM EVALUATION	85

INTRODUCTION

This volume is the fifth in a six part series describing a human factors study for the Canadian Forces CC-130 aircraft (see References [1-5] for details of the remaining documents in this series). This volume deals with the issue of Crew Resource Management (CRM), specifically as it relates to decision making in multi-crew cockpits.

CRM programmes, were born in the aftermath of the 1978 United Airlines (Flight 173) accident at Portland, Oregon, although the ideas had been around for some time prior to that. In the succeeding years, as CRM has matured, it sometimes seems to take on a chameleon character as it reflects an ever increasing domain of interest. It has reached the point where some people use the term *CRM training* and *human factors training* synonymously. As the specifics of individual CRM programmes differ from one another, it is essential to look at the core topics covered and the overall training objectives before drawing conclusions about the effectiveness of a specific programme. Robert Helmreich, of the University of Texas' Aerospace Research Project, argues that 4 generations of CRM programmes have been implemented to date [6]. He characterises them as follows:

- Generation 1 (1981-1986)
 - derived from corporate management development training
 - focus on individual management style/interpersonal skills
 - intended to fix the 'Wrong Stuff' captains with a subsidiary goal of making First Officers/Co-pilots (FOs/CPs) more assertive;

- Generation 2 (1986-present)
 - more team based
 - team building
 - focus on concepts
 - situation awareness
 - stress management
 - modular
 - error chain
 - individual decision making (DM) models;

- Generation 3 (1986-present)
 - systems approach
 - focus on specific skills/behaviours
 - integration with technical performance
 - emphasis on evaluating human factors
 - special training for check airmen/instructors

- broadened perspective
 - include flight attendants, dispatchers and maintenance;
- Generation 4 (1994-present)
 - performance data guide training
 - integration of CRM into technical training
 - proceduralisation of CRM
 - CRM aspects added to checklists
 - specialised curriculum topics
 - automation, etc.
 - Evaluation of human factors in full mission simulation.

Helmreich and his colleagues have recently argued for a further change in focus, one that is intended to return CRM training to its original goal of error management [6]. Helmreich et al. present the following recipe for a fifth generation CRM.

- Generation 5 (199? - future)
 - Focus on managing human error
 - Training in the limitations of human performance
 - ubiquity of human error
 - use of accident and incident data to illustrate these limitations
 - Continuation of earlier generation training topics under an error management format.

Over these years, CRM has gained widespread acceptance amongst civilian and military organisations alike. All major western operators of multi-place aircraft have some sort of CRM programme in place. Many certifying bodies mandate CRM training. Considering the dearth of hard evidence showing the benefits of CRM training, the enthusiasm for these programmes may be perceived to be based largely on faith. This situation has fuelled an often lively debate, exacerbated by the current climate of fiscal restraint and the requirement to justify any resources devoted to safety-related programmes. While few would argue that safety is not important, the question "...how much must be spent on safety..." is a legitimate question to ask in what is otherwise an open-ended situation. Unless CRM is delivering expected improvements in safe flight performance, dollars spent on CRM might be spent more effectively elsewhere (more conventional training time, etc.). This is not to say that CRM is only a safety related issue. An argument can be made to show that CRM potentially increases **both** the **efficiency** and **safety** of an operation. In fact the United States Air Force (USAF) puts "...Maximise operational effectiveness and combat capability..." as number one in a list of three objectives for their CRM programme [7].

Alan Unit (in 1978 he was the National Transportation Safety Board [NTSB] Human Factors Group Co-Chairman for the UA 173 accident, now the Technical Advisor for Human Performance in the USAF Safety Agency) quoted a 1997 study by Jensen and Benal for the US Department of Transportation/Federal Aviation Authority (DoT/FAA) in which the authors claimed that all aircrew errors could be classified according to three major categories [8], namely

- procedural errors;
- perceptual motor errors; and

- decisional errors.

Diehl used this classification to analyse a selection of US general aviation accidents, airline and USAF Class A mishaps. For each class of aviation, decisional errors were implicated in over half of the accidents. Therefore, to the extent that CRM programmes emphasise decision making, there is an expectation that they will have a positive impact on safety. However, for the purposes of interpreting the following studies, it cannot be assumed that CRM and Aeronautical Decision Making (ADM) are identical.

As a long time advocate of both CRM and ADM programmes, Diehl addresses the evidence for the benefits of this type of training. He points to six world-wide government sponsored evaluations of the efficacy of ADM training (1 Australian, 2 Canadian and 3 US). Diehl describes these studies as examining errors made during "...short, seemingly routine, cross country observational flights." Specially trained observers placed subjects in a series of decision making situations and, it is claimed, surreptitiously recorded judgmental errors. These experiments were double blind (the observers did not know who had been given ADM training and the subjects did not know the true purpose of the experiment). Those subjects who had received ADM training performed, on average, better than those who had not. Mean average error rates were reduced by a factor that ranged from 8% to 46%. In general those programmes that included ADM in simulator and flight training did better than those based on manuals and lectures alone. Each of these studies dealt with the general aviation fleet, but used quite rigorous methods that give credence to the results obtained.

Diehl also describes a number of longitudinal studies of: major rotorcraft organisations; the US Navy; and Air Force Airlift Command (MAC). It is difficult to draw conclusions from longitudinal studies as many factors might change over time in addition to the variable of interest (in this case the provision of ADM or CRM training). However, Diehl claims that the one major difference between MAC training and that of other commands in the two five-year periods investigated (1981-1985 for the *before* data; 1986-1990 for the *after* data) was the addition of a CRM programme. If the differences in these studies can really be attributed to ADM/CRM training the numbers are impressive, with accident rates reducing by a factor of 28 to 81%.

We are now entering an era where it is almost certain that crews involved in accidents will have been exposed to some sort of CRM training. This doesn't mean that CRM is necessarily failing as nobody has claimed CRM training would eliminate all human factors related accidents. Yet many argue that CRM must involve more than awareness training if it is to have the expected effects. This quote from the accident investigation board of AA965 near Cali, Columbia in 1995 makes the point most poignantly [9].

"...This accident demonstrates that merely informing crews of the hazards of over reliance on automation and advising them to turn off the automation is insufficient and may not affect pilot procedures when it is needed most.

This accident also demonstrates that even superior CRM programs, as evidenced at AA, cannot assure that under times of stress or high workload, when it is most critically needed, effective CRM will be manifest. In this accident, the CRM of the crew was deficient as neither pilot was able to recognize the following:

- *The use of the FMS was confusing and did not clarify the situation.*
- *Neither understood the steps necessary to execute the approach, even while trying to execute it.*
- *Numerous cues were available that illustrated that the initial decision to accept runway 19 was ill advised and should be changed.*

- *They were encountering numerous parallels with an accident scenario they had reviewed in recent CRM training.*
- *The flight path was not monitored for over a minute just before the accident.*

Although the accident flightcrew articulated misgivings several times during the approach, neither pilot displayed the objectivity necessary to recognize that they had lost situation awareness and effective CRM.

The FAA has encouraged airlines to implement effective CRM programs and has mandated it as a fundamental part of the advanced qualification program (AQP), an innovative method of training airline pilots. The FAA has issued an advisory circular..., No. 120-51A, that provides guidance to airlines on elements needed for a [sic] effective CRM program. The [advisory circular] identifies topics that should be included in a CRM program. These include: communications processes and decision behavior; briefings; inquiry/advocacy/assertion, crew self-critique; conflict resolution; communications and decision making; team building and maintenance; and individual factors/stress reduction. Within the topic of team building, the [advisory circular] suggests that workload management and situational awareness be addressed, so that ‘... the importance of maintaining awareness of the operational environment and anticipating contingencies ...’ is addressed.

Aeronautica Civil believes that this accident demonstrates the difficulty in training for enhanced pilot situational awareness. The crew of AA965 was trained in a CRM program that adhered to the guidance of [advisory circular] 120-51A, and that had added additional information on hazards unique to the South American operating environment. The evidence indicates that this crew was given background material and information necessary to avoid this accident, but during a stressful situation, when it was most needed, the information was not applied, most likely because the critical situation was not recognized.

Offering further guidance on training in situation awareness does not address the fact that pilots who have lost or not achieved situation awareness cannot be expected to recognize that they have lost or not achieved it. More importantly, these pilots cannot be expected to develop a mechanism to efficiently achieve it.”
(pp. 46-47)

The archives of the CRM-Developers forum on the internet (<http://www.caar.db.erau.edu/crm/>) provide further evidence that not everyone is fully convinced that CRM training is hitting the mark. Some contributors have made the case that CRM (and human factors) has become a *buzz* word that has lost its impact [10]. The lack of a convincing theoretical position has only muddied the waters. In a recent book chapter the question “Why Crew Resource Management?...” was asked [11]. In the discussion that followed, the authors traced some of the history of CRM programmes within airline and military operations; provided a number of case histories where crews apparently did not draw on all the resources available to them — usually with tragic consequences; and presented some of the experimental evidence in support of the current team training approach to CRM. While the empirical/anecdotal evidence is often compelling, little is presented that would qualify as providing a theoretical justification for CRM.

This report describes an approach to human factors training with the explicit goal of improved decision making. It is proposed that training based on this approach would replace the current Aircrew Co-ordination Training the CC-130 community. The proposed training can be distinguished from other approaches with similar goals (either explicit or implicit) mainly by its

base within a theoretical framework of human information processing. The differences lie less in the content of the course than in the way the material is organised and shaped by theory.

TRAINING MODEL

The objective of training is to establish, within each individual, a behaviour that did not formerly exist, to re-enforce a behaviour that is already present, or to align an existing behaviour with some target behaviour. This process usually follows a progression which starts with a general awareness of the topic and ends with a set of target behaviours that are robust and reliable. The model of learning that has guided the development of the Human Factors in Decision Making (HFDM) package, presented in this Volume, can be represented as follows [12]:

theory → through instruction/case studies/examples → **knowledge**

knowledge → through exercises/role plays → **skills**

skills → through organisational reinforcement → **everyday practice.**

Rasmussen [13] argues that human decision making is based on three types of problem solving strategies. He terms these strategies *knowledge-based*, *rule-based*, and *skill-based* (K-R-S). Knowledge-based problem solving is the most information processing intensive strategy of the three. It involves deductive reasoning, what is sometimes called algorithmic problem solving, and makes heavy demands on working memory (a recognised bottle-neck in human information processing). Knowledge-based problem solving characterises our behaviours in the early days of any new activity. It is also the type of strategy we generally use in unforeseen or novel situations (e.g., the crew of the United DC-10 Flight 232 at Sioux City, Iowa). These circumstances are related by the novelty of the situation. Knowledge-based problem solving can be very precise, but it is also slow due to the amount of uncertainty (information) that must be resolved.

Less demanding at the cognitive level is rule-based problem solving. As the name suggests, rule-based problem solving can be used when an appropriate behaviour is linked to an initiating condition (the need to act) by some form of rule (e.g., in the form of an IF *this* THEN *that* statement) or rule of thumb (also called a heuristic [14]). A heuristic is a problem solving strategy that yields an adequate solution to the problem in a reasonable amount of time (e.g., the 1 in 60 rule for correcting off-track navigational error). The information processing involved in this type of decision making is less than that for knowledge-based problem solving, as it is generally sufficient to link the need to act with one of a small set of rules. This type of problem solving is often less precise than knowledge-based solutions, but is more timely. This represents the type of speed accuracy trade-off that is built into one of the models that forms the theoretical framework for the HFDM training (the Information Processing or IP model¹).

Finally there is skill-based problem solving, sometimes called automatic [15, 16]. This represents the most refined level of skill acquisition, where stimulus and response appear to be linked directly by a process of pattern recognition. Skill-based problem solving is the fastest form of decision making, as little working memory or conscious processing appears to be

¹ The IP model is described later in this Volume.

involved. This type of information processing strategy can be associated with Klein's recognition-primed (R-primed) decision model [17].

A skilled aviator must be practised in all of the complex aviation tasks, and will be required to exercise all three types of decision making strategies. The ability to exercise each type of decision making strategy appropriately can therefore be considered a *skill* in its own right, in the sense of the learning model presented at the beginning of this Section. The role of training is to push the decision making associated with each target behaviour as far down in Rasmussen's hierarchy as is possible and appropriate (i.e., K→R→S), acknowledging that the ability to do this will depend on the activity being trained. Note that the ability to generalise each strategy reduces as one goes from K→R→S. It is the objective of the training system that crews operate largely at the skill-based level so far as the mechanics of flying the aircraft, and operating all the on-board equipment during routine operations, is concerned. As the situation departs from the normal, rule- and knowledge-based behaviours will tend to assume greater importance.

The tenets of Ecological Interface Design (EID) argue that equipment design should support problem solving at each of the levels of Rasmussen's hierarchy [18]. Training needs to provide similar support. The ideas behind EID came largely from the design of interfaces for the nuclear power industry and are intended to promote better decision making particularly in fault finding activities and the diagnosis of abnormal situations. Skill and rule-based problem solving relies on being able to retrieve from memory the specifics of a response. If memory fails there is usually little from which the correct response can be derived at this level. One can either retrieve the correct behaviour or not. Having higher level knowledge, that allows the appropriate response to be deduced, can compensate for this initial failure of retrieval. For example, in a typical emergency undercarriage extension procedure, the undercarriage handle can be *up* or *down* and the circuit breaker can be *in* or *out*. If one practices this procedure many times over the appropriate responses (put handle down, pull circuit breaker) are likely to exist at the skill-based level. At the next level up, the response might be coded in the form of a rule (before manual extension put handle in the **down** position and **pull** the circuit breaker — the arguments **down** and **up** have to be correctly retrieved from memory whenever the rule is fired). If one has learnt the causal relationships between likely undercarriage failures and the subsequent behaviour of the system then one can deduce the appropriate response (e.g., if an intermittent electrical or hydraulic failure has prevented the undercarriage from extending then the gear will retract — and override the manual extension — if the fault clears and the handle remains up with the circuit breaker in; therefore the appropriate action is handle **down** and circuit breaker **pulled**). At this higher level a strategy can be deduced that will probably apply to all, or at least most, airframes.

The development of the proposed HFDM course syllabus presented in this Volume was guided by the following principles:

Principal	Purpose
1. Provide a clear focus for the training — in this case it is decision making .	<ul style="list-style-type: none">• To place all training material in the context of a final objective.• To provide a bench mark for assessing the relevance of all training material.• Emphasise the product (decision making) rather than the process.

2. Provide a high level theoretical framework of human performance and decision making.
 - By constantly returning to the framework learning will be facilitated by repetition.
 - To provide a framework which establishes the inter-dependence between individual course items.
 - Establish a connection between the product and the process.
 - Establishes causality which aids knowledge-based problem solving.

3. Use a multi-tiered approach to training that develops deeper knowledge as aircrew progress from initial training through the various phases of recurrent training and upgrades. Training should also be distributed throughout
 - *ab initio* training (eventually)
 - initial conversion training
 - upgrade training
 - recurrent training
 - coursework
 - simulator and role playing
 - on-the-job-training (OJT).
 - To present the knowledge as required (*just-in-time-training*). A new right-seater will not need to have the depth of knowledge that a left-seater should have — particularly at the level of strategic decision making (indeed the existence of OJT implies that a new right-seater is an apprentice in training).
 - Maintains the freshness and relevance of recurrent training.
 - Provides *undergraduate* through to *post graduate* level training.

4. Re-use the theoretical framework at all stages of development.
 - Repetition promotes learning.
 - The framework provides the scaffolding on which all the individual knowledge is hung.

5. Provide a consistent mapping between training materials and the desired outcome.
 - To facilitate retention of knowledge and the retrieval of that knowledge when action is required.

6. Provide examples of desirable behaviours rather than just what-not-to-do.
 - To present positive role models rather than negative ones.
 - Provide example behaviours that can be modelled.
 - To speed the acquisition of target behaviours.

7. Support all levels of the learning model so that theory promotes knowledge, knowledge is turned into demonstrable skills, and these skills are made everyday practice by the imposition of organisational standards and values.
 - To achieve the highest possible level of safe flight performance and mission effectiveness.

8. Required core knowledge should be identified.
9. Skill acquisition should be demonstrated through observable behaviours.

- To provide a means of assessment.
- To provide a means of assessment.
- To provide a model for students.

THEORETICAL FRAMEWORK

The proposed HFDM training is based on two related models of the human information processor. They are.

The Information Processing (IP) Model. The IP model claims that all factors that determine operator workload can be reduced to their effect on the **amount of information** that has to be processed, or their effect on the **time available** before a decision has to be implemented [19, 20]. Under the assertion that humans are limited in the rate at which they can process information, operator workload, performance and error production can all be shown to be functions of the *time pressure* or the ratio of *time to process* the information to the *time available*.

The Perceptual Control Theory (PCT) Model. The PCT model is based on the assertion that all living organisms operate as a multi-layered closed loop control system [21, 22]. The set points for the control loops are the organism's goals (or how you want to *see* the state of the world). PCT asserts that all observable behaviours are intended to operate on the external world so that the perceived world state matches a desired state (the goal). This model provides a coherent framework for integrating the concepts of workload, situation awareness, mental models and decision making performance. It establishes the absolute necessity of feedback in goal directed activity.

The models are complementary as the IP model sits within the PCT framework. Together they integrate much of what is known about human information processing and decision making.

To put these models into context, suppose we start with something that is familiar — a household air-conditioning system (see Figure 1). Most air-conditioning systems operate in a closed loop fashion, sensing the temperature of the air, comparing the temperature value sensed with the thermostat set point, and controlling the compressor according to the difference between the desired value and the sensed value. But the compressor is capacity limited and can only provide a certain amount of cooling power. This fixes the rate at which temperature changes can be corrected, as doors are opened or shut, or pieces of heat producing equipment are turned on or off. The IP/PCT model asserts that human decision making occurs in an analogous fashion (Figure 1). The following equivalencies apply.

Air Conditioning System	Human Decision Maker
<ul style="list-style-type: none">• Thermostat set point• Temperature and humidity sensors• Valves, compressor, heat exchanger properties• Rated compressor power (BTU)• Physical limits on cooling capacity (size of compressor, heat exchanger, wear, etc.)	<ul style="list-style-type: none">• Goals• Eyes, ears, sense of smell and touch• Mental models of action selection• Internal processing rate (bits per second)• Various physiological and psychological stressors (fatigue, motivation, anxiety, etc.)

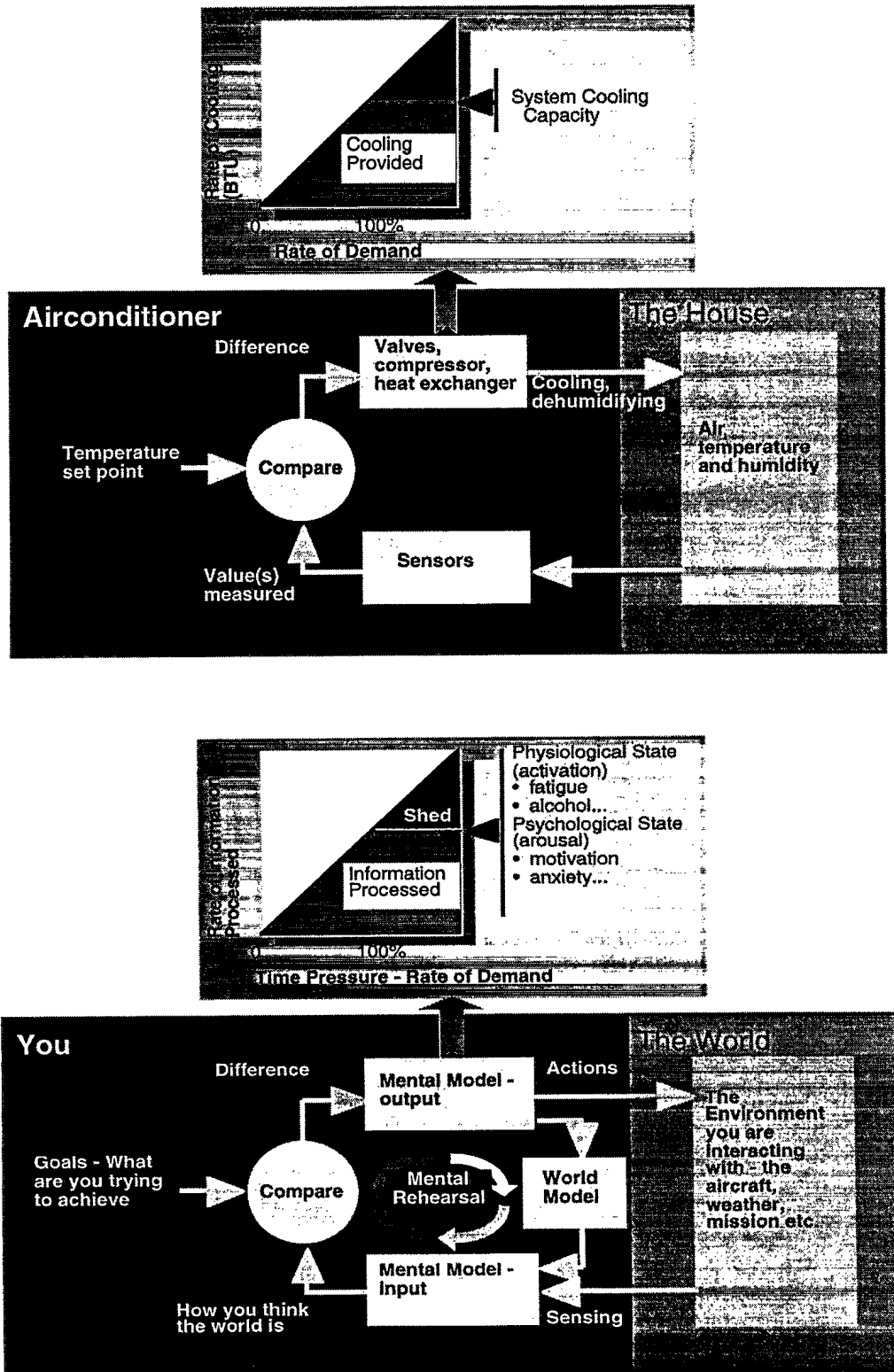

Figure 1: Closed loop control of room temperature and the IP/PCT model.

Unlike the typical air-conditioner unit, the human has many set points (goals) and therefore many loops under control at any point in time. Also, the human can be processing information even when there are no observable behaviours (thinking, reasoning, deducing, etc.). Often multi-loop control is not simultaneous but relies on attention switching from loop to loop. Using the IP/PCT model framework of Figure 1, a number of subject headings emerge for a HFDM syllabus. For example:

- sensation/perception;
- goal setting;
- action selection;
- resource management;
 - management of control and attention;
 - management of time pressure;
 - management of knowledge;

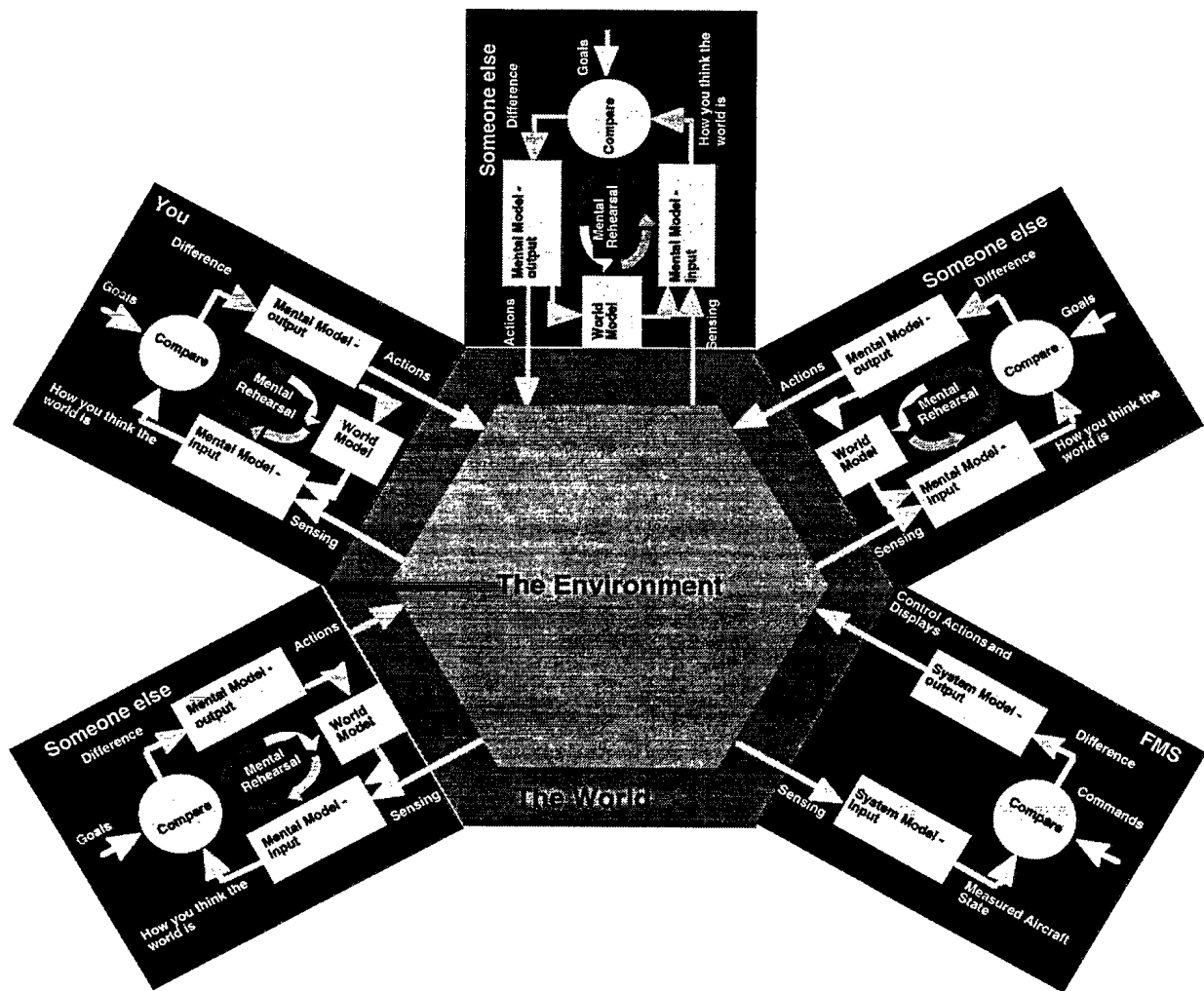

Figure 2. Multiple-controller systems of humans and machines (e.g., a Flight Management System or FMS).

The IP/PCT model can be extended to situations where multiple controllers are acting on the same world variables. This is the team or group situation. Note that the other team members may be human or machine (see Figure 2). The general principles remain the same for human-human and human-machine interaction under this framework — it is just that machines are generally far more limited in the numbers and types of ‘behaviours’ they exhibit.

It should also be stressed that the IP/PCT model indicates that superior team performance starts with superior performance from each of the individuals that compose the team, that is, team performance is built on top of the highest levels of individual skill. Good team processes might compensate for a weak team member, but will not make a superior team. Further, the team member(s) that has the greatest influence on overall performance might be mission or mission segment specific [23]. However, as we see in the following, certain emergent properties must be supported if the team is to be effective — individual skill is a necessary but not sufficient requirement for superior team performance.

From what is known about the behaviour of multiple controller systems and the conditions under which stable control can be realised, it becomes evident that there are certain requirements for the allocation of responsibilities and the calibration of all participant’s mental models and goal states [24]. As is shown in the following material, leadership/captaincy issues and the need for communication are properties that emerge from the IP/PCT model when multiple controllers are involved.

SUPERPILOT, DREAMTEAM AND HERCCREW

In the following discussion, three hypothetical types of aircrew are defined. They are *SuperPilot*, *DreamTeam* and *HercCrew*. Many of the properties ascribed to *SuperPilot*, *DreamTeam* and *HercCrew* come from the two theoretical models presented at the beginning of this Section. The concept of a *SuperPilot* and the *DreamTeam* came from an attempt to understand the fundamental functions of crew communication and Captaincy/Leadership issues in a multiple controller environment. It starts with the premise of an all capable individual and traces the emergence of communication and leadership functions as one moves to an idealised team and then the truths of the real world. Although we might automatically think of a team in purely human terms, note that the team also includes advanced automation systems.

Imagine an ideal flight deck that is run by a single individual — the *SuperPilot*. What does this *SuperPilot* do?

SuperPilots are decision makers, establishing goals, forming perceptions about the world, comparing these perceptions with their goals and acting to correct discrepancies. *SuperPilots* ensure that the most important information processing loops are always controlled by prioritising. Results from lower level loops are fed to higher level loops by relatively high speed neural communication. These pilots are super proficient, so their mental models always contain the knowledge required to form the appropriate actions. Actions are always consistent with *SuperPilot*’s overall state of knowledge (what we might call their mental models and situation awareness) and are goal driven with no slips, lapses, omissions, etc. The only resource managed is *SuperPilot*’s attentional resources — that is, what loops are to be controlled, at what level of precision, at any point of time. Resource management is entirely internal.

But *SuperPilots* are rare, so the next best thing is the *DreamTeam*. *DreamTeam* crews have exactly the same life experiences and share entirely common mental models and goals. Because each team member takes a little longer to process information and make the mechanical actions needed to operate all the systems on board, two members are required on the flight deck.

So what does the *DreamTeam* do? The functions are exactly the same as for *SuperPilot*, but now there is a requirement for communication between the flight crew. What might this communication be about?

Because these team members share the same goals, priorities and mental models, anything attended to in the external environment will be perceived identically by the members of the *DreamTeam* — their actions in all circumstances will be identical and indistinguishable. Therefore, the *DreamTeam* would communicate in order to:

- Allocate responsibilities (otherwise both members of the *DreamTeam* will be reaching for the same controls at the same time in response to changes in the external environment). The only way the *DreamTeam* can approach the performance of *SuperPilot* is by dividing the task load and not competing for control.
- Pass the results of internal processes (i.e., thinking without observable action) so that the internal mental models of both team members remain the same as the mission unfolds.
- Provide feedback on system states that are not within the common locus of attention (because of the division of duties, each member of the *DreamTeam* might be attending to different things).
- Direct attention i.e., inviting direct observation rather than using verbal descriptions to convey information.

The *DreamTeam* will operate at a slightly lower level of precision than *SuperPilot*. This is a direct function of the time lost in external (voice, gesture, etc.) versus internal (neural) communication speeds. The only new functions for *DreamTeam* are the requirements to allocate responsibilities and to replicate the complete mental model in the other crew member at all times. This suggests a Captaincy or Leadership role for one of the *DreamTeam* members (because the *DreamTeam* are entirely in tune with each other, each will come up with the same division of duties for the other — this needs to be resolved!). There is no need to assign a principle decision maker or leader as each member will make the same decisions given a common state of situational knowledge. Each knows what the other will do in a given situation. However, the role of splitting the load should be assigned to one of the *DreamTeam* crew in order to avoid the need for conflict resolution.

But most of our crews are made up by the *HercCrew* variety of aviators. These crews come to the job with different life experiences and some common training for the task. They have different levels of proficiency as measured by their state of knowledge (mental models) of the environment. Their decision and action times are such that they cannot accomplish all the tasks to the same level of precision that *SuperPilot* and the *DreamTeam* can. Therefore, they have to shed more tasks than their more proficient peers and prioritisation (what they choose to attend to) assumes greater importance.

Time management is the critical issue at all levels of proficiency from *SuperPilot* down to *HercCrew*. It is a constant trade-off between speed and precision of performance. A hub (principle decision maker or PDM — say the Aircraft Commander [AC], Mission Commander [MC], etc.) and spoke (secondary decision makers or supporting crew) arrangement of the team is appropriate in this situation. Where there is the possibility of more than one outcome in a given situation someone has to choose. Pre-assignment of this responsibility resolves uncertainty and saves time. And time is the critical resource.

The mental models of the *HercCrew* members can not be assumed to be identical and therefore their decisions/actions will not be the same. The PDM must assume that certain assigned

activities will be completed by the team members. This allows the PDM to delegate responsibility and switch attention to other tasks. Confirmation of final results may be all that is necessary. Only through this type of off-loading can the PDM free up **time** to control the high level loops that are essential to the executive role of the PDM, for example, strategic goal setting, and risk management. This can not be done at the expense of overloading the secondary decision maker(s), however, as this can adversely effect the outcomes of the delegated tasks! Note that the role assigned to the PDM is an executive role of risk management, related to the control of strategic goals. It does not undermine the delegation of tactical decision making roles to other crewmembers (e.g., in a pilot-flying, pilot-not-flying situation).

The following communication functions for the *DreamTeam* can be added:

- Establish common goals. If team members are trying to accomplish conflicting goals the system will go unstable particularly if both are controlling identical variables in the environment. This is a fundamental property of multiple controller systems.
- Build common mental models of system states. **This pertains only to the mental models that each member of the team might call on to control the loops for which they are responsible** . Not every one needs to know everything, and in a time pressured environment this is a luxury that can not be afforded. However, as time permits, the alignment of mental models should be a goal.

When there is human-human interaction, a secondary communication role emerges related to:

- Establishing and maintaining effective external communications. This involves:
 - establishing leadership,
 - establishing the level of trust,
 - establishing the authority gradient,
 - establishing receptiveness, attentiveness, co-operativeness, assertiveness, etc.

Therefore, the roles of communication in a flight deck of *HercCrew* can be summarised as follows.

- Allocation of responsibilities (AC, MC).
- Establishing common goals (AC, MC).
- Building common mental models of system states (All).
- Providing feedback on system states and directing attention (All).
- Establishing and maintaining communication channels (All).

From this list of functions, together with the theoretical framework provided by the IP and PCT models, it is possible to formulate a list of topics that might be included in a *Human Factors in Decision Making* course. From these topics a skill set can be derived that will also form the basis for an assessment system. A course structure might be.

- Introduction to the Decision Making Loop.
- Leadership and Followership.
- SuperPilot, DreamTeam and You.

- Sensation/Perception.
- Goal Setting.
- Action Selection.
- Resource Management.
 - Management of Control and Attention.
 - Management of Time Pressure.
 - Management of Knowledge.
- Communication.

CAPTAINCY

From the preceding discussion, Captaincy is seen to be a property emerging from the need to establish stable control in a multi-controller environment, and to exercise the functions of the executive role of primary decision maker. The concepts of Captaincy and Leadership seem to go together, but leadership is not necessarily isolated in the Captain. Transport Canada promotes leadership as a responsibility for all crew members [25]. Pettitt and Dunlap [26] suggest that “...*leadership is a general systematic and relational process that emphasises the ability to exercise skill in the movement towards goal achievement.*” They further suggest that “...*leadership is proactive rather than reactive, and necessarily takes into account other members of the group.*” But although the term ‘leadership’ has been with us for nearly 200 years [26], and despite a huge literature on the topic, a concise, unambiguous, definition has not been established. Captaincy is best seen as a role (this is consistent with the *SuperPilot* analysis in the preceding Section) with leadership as one of the traits that Captains amongst others should exhibit — what will be unique to Captains are the goals in which they take leadership.

The presence of leadership suggests the existence of the complimentary attribute of followership. There should be no stigma attached to the term *followership* as it does not imply passiveness or submissiveness. Pettitt and Dunlap conclude [26]

“followership...[is]...the ability to contribute to task and goal accomplishment through supportive technical, interpersonal, and cognitive skills. Followership is not a challenge to the Captain’s authority, but neither is it unthinking compliance with directives, especially if those directives endanger the safety of the operation. Further our research suggests that the concept of followership in flight operations is in every way similar to the view advocated by Hollander and Offerman (1990): ‘being a follower can be an active role that holds the potential for leadership...behaviors seen to represent effective leadership include attributes of good followership’ (p. 180).”

Leadership and followership skills are important contributors to overall crew effectiveness. Pettitt and Dunlap [26] found overall crew effectiveness was generally higher when leadership/followership skills were present in the Captain than in the First Officer. That is, the Captain’s skills have a large effect on overall crew effectiveness. This parallels the results of the Phase I CC-130 study where AC’s behaviours² were seen to have a dominant effect on rated crew proficiency [27].

² Note that in certain missions or mission segments, the major influence on overall crew performance could change from crewmember to crewmember: For example, while the AC may well exert the dominant influence in a strategic mission, the Navigator may assume a prime role in a tactical mission etc.

Pettitt and Dunlap identify the following 6 leadership/followership skills and observable behaviours in the civilian airline environment.

Skill	Observable behaviour
<i>Envisioning</i>	Crewmember develops and articulates a picture of the future or desired state.
<i>Modelling</i>	Crewmember's conduct with other employees and passengers is consistent with the Company's highest standards.
<i>Receptiveness</i>	Crewmember gives attention to other crewmember's ideas, concerns or questions.
<i>Influence</i>	Crewmember obtains a commitment from others to ideas or actions using a variety of interpersonal skills.
<i>Adaptability</i>	Crewmember states the need to make adjustments to changing environments and abnormal situations.
<i>Initiative</i>	Crewmember begins an action, without external direction, to respond to an operational deficiency.

But what are the other attributes associated with the concept of Captaincy and how are these attributes demonstrated? It is not enough to say "...we know it when we see it..." Those who have it are not the concern. It is those who do not currently demonstrate adequate Captaincy skills that need guidance and development. For them, one needs to present a role model that can be imitated.

In an effort to define the observable behaviours associated with *good* versus *bad* Captaincy skills, a formal knowledge elicitation procedure — the repertory grid — was used. A contractor from the study team visited 424, 426, 429 and 436 Squadrons during the period April to September 1997 to administer the procedure. 102 CC-130 crewmembers (21 ACs, 12 CPs, 18 Navigators [NAVs], 22 FEs, 21 Loadmasters [LMs], plus 2 Search and Rescue Technicians [SARTECHs], 2 Aeromedical Evacuation Officers [AEOs] + 4 non-completions due to the priority of duty) have participated in this exercise at the time of writing this report. For the purposes of analysis the SARTECHs and AEOs were absorbed into the LM group as non-cockpit crew. A detailed set of instructions for conducting the knowledge elicitation process is included at Appendix 2 to this Volume.

A summary of the process follows. All participants were advised that they were free to leave at any time and that their participation was voluntary. Two took this option. Each participant was asked to name the three best Captains they knew, and the three worst. This information remained in the possession of the respondent at all times, with the contractor always unaware of the Captains named. The sheet containing the names was taken by the participant at the end of the session. This was done to ensure confidentiality. A mythical 'ideal' AC was added to the pool of candidates making 7 in all.

Each participant in the knowledge elicitation process was asked to describe how one of a randomly selected triad of the 7 ACs was different, in terms of observable Captaincy behaviours, from the other two. They were then asked how the remaining pair were similar, relative to the first selected AC. Rating scales are formed during this procedure, and each of the 7 ACs (3 good, 3 less good and the ideal) is placed on the scale according to how much of behaviour in

question they display. A new triad is formed and the process repeated until the participants can no longer generate similarities and differences between members of the triads.

Only preliminary data analyses have been conducted so far. Detailed analysis has been held over until all data are gathered. Using a principle component analysis, the three main factors that appear to characterise each individual's concept of Captaincy were abstracted from the data for the first 25 respondents. Nine main categories of Captaincy behaviours are emerging. They are listed below with Pettitt and Dunlap's leadership/followership skills for comparison.

CC-130 Study of Captaincy Behaviours/Skills	Pettitt and Dunlap's Leadership/Followership Skills
Sees and communicates the big picture	Envisioning
Receptiveness	Receptiveness
Technical and procedural skill	(Influence)
Functions well under pressure	Adaptability
Can re-focus crew's attention and re-delegate tasks in a timely fashion	Adaptability, Influence
Establishes trust and respect	Influence
Professional conduct	Modelling
Crew development skills	Initiative
Attends to crew welfare	Initiative.

To the original list of 9 categories, 3 additions were made as a result of subsequent analysis. They are:

- sociability
- patience
- decisiveness in decision making.

There are no corresponding skills in Pettitt and Dunlap's list for these additions.

As postulated, there were differences in the perception of good Captaincy behaviours from seat to seat. It appears that:

- ACs favour *technical and procedural skill, functions well under pressure, and ability to focus crew's attention and delegate tasks*;
- CPs favour *sees and communicates the big picture, functions well under pressure, and crew development skill*;
- FEs favour *technical and procedural skill, receptiveness, and sociability*;
- NAVs favour *ability to focus crew's attention and delegate tasks, professional conduct and patience*; and

- LMs favour *attends to crew welfare, receptiveness, sociability*.

A more detailed analysis is in preparation. The information will provide teaching material for the HFDM syllabus and guide an assessment package by which Captaincy behaviours may be scored. Because behaviours are generally observable, measurement is made easier. An external observer (a trainer or Standards Officer) can look for and score the presence or absence of target behaviours.

PROPOSED SYLLABUS

In Appendix 1 to this Volume, a draft syllabus is presented which is intended to provide a plan for the future. Eleven modules make up the syllabus. The topics are derived from the theoretical basis presented previously. Appendix 1 presents brief course notes and a first attempt at developing graphical representations which illustrate some of the core concepts. The syllabus was developed to this level of detail to facilitate discussion with 8 Wing, Trenton, training personnel. It is a prototype to be shaped, edited, or recast according to 8 Wing requirements. Sufficient detail is included to show how such a syllabus can be developed into a full training programme — it is not currently complete, as this would be inappropriate until 8 Wing have had full input. Incomplete skill sets are presented for the modules, and examples of appropriate exercises, case studies and videos are given for demonstration purposes.

A summary of the 11 modules appears below.

MODULE 1: INTRODUCTION TO THE DECISION MAKING LOOP

Summary: Accidents statistics; majority of accidents attributed to human factors issues; decision making is implicated in most of these; review of CC-130 accident history, Reason's model³ of organisational issues in safety; active and latent failures; course outline - focus on decision making. Introduce the PCT and IP models. Show how time pressure determines performance, errors, and perceptions of workload. Introduce decision making strategies, and the speed accuracy trade-off. Show how chronic physiological and psychological stressors can effect performance.

MODULE 2: LEADERSHIP AND FOLLOWERSHIP

Summary: Teams and groups, the aviation team, leadership, followership (opportunities to demonstrate these behaviours will occur in all the aspects covered in this training programme). Authority gradient gives control priority in a team environment. Leadership and Followership issues will be addressed in each module as appropriate.

MODULE 3: SUPERPILOT, DREAMTEAM AND HERCCREW

Summary: Introduce SuperPilot (an all capable individual), DreamTeam (the perfect team) and HercCrew (the 'real world'). These stereotypes trace the emergence of communication and Captaincy as one goes from an all capable individual, to teams of people from different backgrounds, with differing levels of experience, etc.

MODULE 4: SENSATION/PERCEPTION

Summary: A primer on how the world is perceived and how perceptions can be distorted by illusions or expectations. This will be related to aviation, and examples will be chosen to represent the types of illusions and other perceptual distortions that aircrew may encounter.

MODULE 5: GOAL SETTING

³ James Reason's risk management model is discussed in some detail in Volume 1 of this Report. It will not be elaborated here.

Summary: Goals are the set point of perceptual control loops (compare this idea with setting room temperature on a thermostat); they are how the human wants to perceive ('see') the world. Actions are driven by the human's goals and shaped by their state of knowledge or mental models.

MODULE 6: ACTION SELECTION

Summary: Actions are the manifestation of a decision, actions are intended to change the state of the world so that perception matches goal; this is usually the point of obvious departure from safe operations (unsafe acts). Actions are shaped by the mental model (compare with reaching down into a [mental model] toolbox and making a selection), make the distinction between knowing and doing (confidence, attitudes, high level goals — wishing to impress, etc. — all effect which tool is pulled out of the box). Action selection is the second last line of defence in risk management. Look at retrieving information from memory and what can go wrong (slips, lapses errors).

MODULE 7: RESOURCE MANAGEMENT

Summary: An overview of what resource is being managed (attention, time and knowledge). Review of SuperPilot, DreamTeam and HercCrew — the reason for multi-place aircraft is that the task load is too much for one. This is a lead in to the next three modules which deal with each resource to be managed separately.

MODULE 8: MANAGEMENT OF CONTROL AND ATTENTION

Summary: Review the idea of a hierarchical system with control switching from loop to loop; loops not attended to are not under control; there is a need to sample at a rate determined by how quickly things can change.

MODULE 9: MANAGEMENT OF TIME PRESSURE

Summary: Review of the IP model and the effects of time pressure on performance, workload, and errors.

MODULE 10: MANAGEMENT OF KNOWLEDGE

Summary: Review how the mental model shapes actions, and that decision time and time pressure depend on the highest level of individual skills. The quality of a decision depends on the state of knowledge, managing knowledge is largely managing the locus of attention. Having access to all relevant available knowledge results in better decisions. There is a time penalty associated with gathering this knowledge.

MODULE 11: COMMUNICATION

Summary: Review the functions of communication (allocate responsibilities [AC], establish common goals [AC], build common mental models of system states [All], provide feedback on system states and direct attention [All], establish and maintain communication channels [All]). Communication is more than the words: how is the information coded; draws on common mental models; both verbal and non-verbal communication are involved; and there are barriers to communication.

A *You are here* button is shown on each of the graphical representations of the IP and PCT models. It latches each module to the theoretical framework and repeatedly returns the student to the underlying structure as an aid to comprehension and retention. It formally makes the connection between the content of each module and the theoretical framework. It justifies the claim that each module derives directly from the underlying theory.

FROM KNOWLEDGE TO PRACTICE

In a previous Section, a theoretical basis for HFDM training was presented. This framework assembled and integrated a large body of knowledge from the human factors arena. It should be possible to develop skills for improving safe flight performance, by the appropriate mix of training interventions, from this framework. This assertion can, and should, be tested empirically by some form of assessment system. Strategies for assessing the effects of various human factors interventions is the subject of Volume 2 of this report, and will not be dealt with in detail here. However, an attempt has been made to identify observable behaviours associated with the core skills that this training is expected to build (see Appendix 1 of this Volume for more details). The presence or absence of these behaviours, or the degree to which they are present, provides a basis for assessment.

KNOWLEDGE DEVELOPMENT

theory → through instruction/case studies/examples → knowledge

The first stage of the educational process is the building of a body of knowledge in each student from which skills can be developed. Traditionally this is done through formal classroom training backed up with directed or self-directed study of books or manuals. The knowledge built at this stage should facilitate later KRS-based problem solving — when knowledge has been developed into skills and skills are being exercised in an operational setting. As this is also the first exposure to this material, the focus should be on presenting core concepts that can be expanded on, mainly in terms of skill development, during upgrade and continuation training.

To support this phase, detailed course notes and teaching materials are required. They must present the core material in a concise and understandable fashion. This is a challenge for material that comes from the psychological and human performance field of research — a field that might be treated with some suspicion by crews steeped in the more tangible world of the physical scientist and engineer. As the IP and PCT models are derived from engineering concepts, it is expected that they will provide a bridge between these two worlds.

The knowledge development phase should cover all topics presented in the draft syllabus. The level of detail covered in each module ideally should be tailored to the training cycle, making each module relevant to the crewmember's current stage of development (*just-in-time* training). With traditional CRM, it has been generally accepted that all crew positions should be represented during training exercises. This would limit the approach to a two tiered programme, that is, an introductory level course during *ab initio* training (in conjunction with AC upgrades) with the second tier coming during operational/conversion training. As the implementation plans do not extend outside the CC-130 community at the present time, the total knowledge base shown in the draft syllabus must be presented to crews at their first exposure under such a two tiered system. Upgrade and recurrent training would build on this existing knowledge base (reviewing and elaborating on previously presented material as appropriate) with further skill development, case studies and examples.

However, if the knowledge building and skill development phases of training are clearly separated, a more reasonable attempt at a multi-tiered and tailored system can be made (see Figure 3 as an example of a multi-tiered system). Figure 3 is presented for discussion only, and does not represent the only configuration for a tailored HFDM training programme.

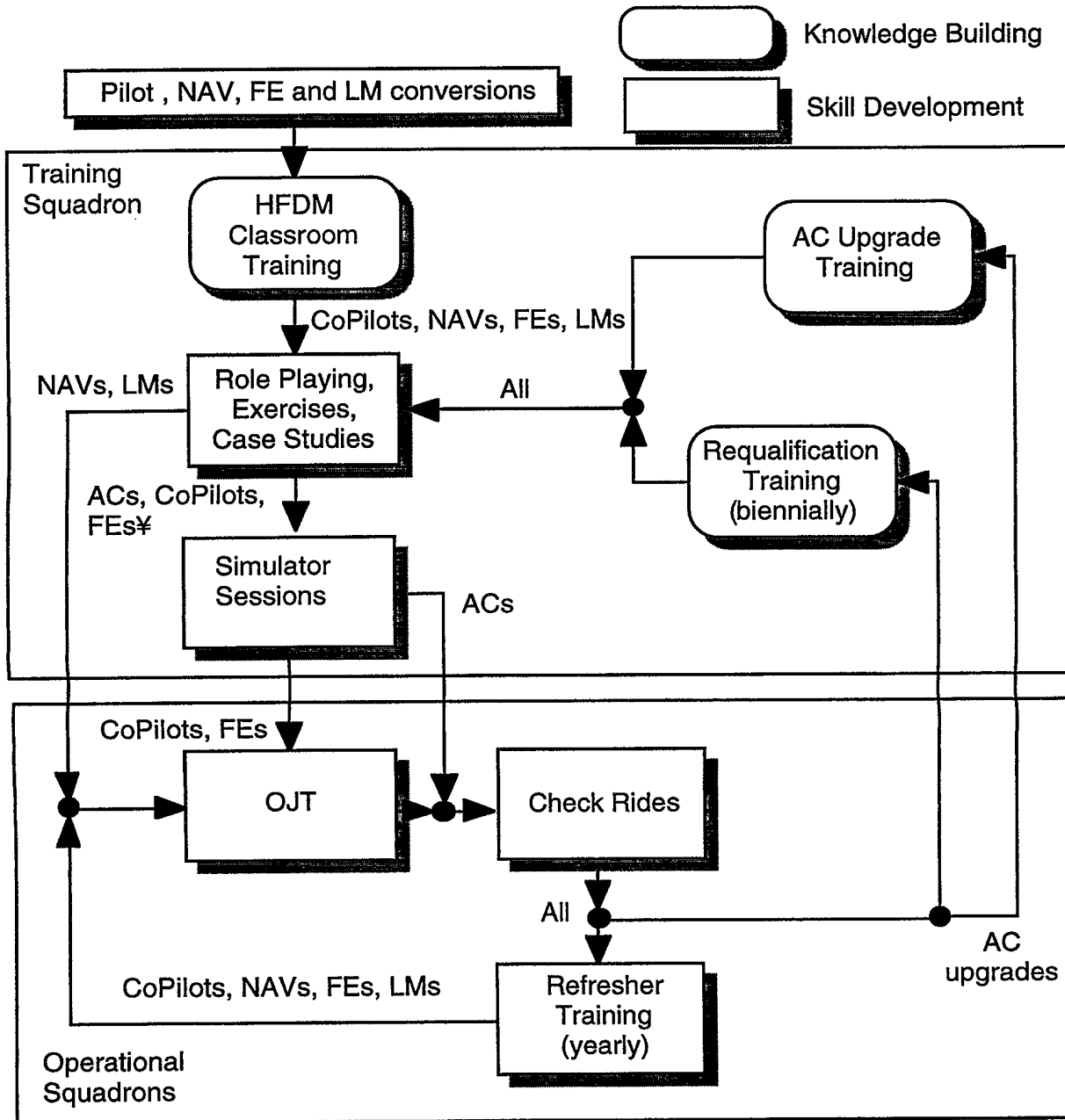

¥ Due to current limitations with the CC-130 simulator

Figure 3. A multi-tiered approach to HFDM training.

In the approach suggested by Figure 3, the detailed core knowledge is presented once only as part of conversion training for pilots, navigators, FEs, and LMs. This core knowledge is

reviewed and elaborated during AC upgrade training, and biennial crew re-qualification training. Little skill development is undertaken during the classroom sessions. Skill development will be left to hands-on training.

SKILL DEVELOPMENT

knowledge → through exercises/role plays → skills

Skills are built through the exercise of higher level knowledge. In PCT terms, processing loops adapt (learn) **only** when control is exercised and attention is allocated. Skills allow us to *do* things as distinct from just *knowing about* things. Skill acquisition is demonstrated by the occurrence of target behaviours. Feedback is an essential part of this process because feedback closes the loop and allows the adaptation to take place. The word *skill* is again used in the colloquial sense rather than the more specific sense of Rasmussen's KRS-hierarchy. Skills can be developed in a variety of hands-on environments. For example:

- role playing and team exercises;
- analysis of case studies;
- low and high fidelity simulation;
- instructional rides; or
- OJT.

The success of each method depends on the particular skill being developed. Because each crew member controls slightly different decision making loops, it is at the level of skill development where there exists the greatest opportunity for tailoring training to the individual. Individual training, by position, would concentrate on those areas where skill sets do not overlap. For example:

Position	Training should emphasise
AC	<ul style="list-style-type: none"> • Strategic DM. • Risk management. • Application of rules and regulations. • Appropriate use of authority. • Allocation of responsibilities — maximising team performance. • Establishing and achieving common goals. • Team building. • Crew expectations.
CP, NAV, FE, LM	<ul style="list-style-type: none"> • Tactical DM. • Establishing and achieving tactical goals. • Providing supportive technical, interpersonal and cognitive support to other team members and the AC. • Contribution to the team. • Appropriate assertiveness. • AC expectations.

This will require additional knowledge building for ACs, which is shown in Figure 3 under the label *AC Upgrade Training*. While the knowledge building phase is shown in Figure 3 as occurring in isolation (AC upgrade course only) from other team members, the skill development/assessment is shown as occurring in a team environment (role playing, exercises, case studies). It is during the *doing* phase that it is essential to have all positions present. One can not build team skills effectively away from a team environment.

In the article titled "CRM and the Emperor's New Clothes", John Wise attempts to make the CRM community take stock and collectively ask some probing questions about programme evaluation [28]. Intended to be controversial, the paper argues that the only way to be sure that behaviour has indeed changed, is by direct measure of the behaviours in question. This is the theme of many contemporary writers on CRM and in fact underlies Helmreich's fifth generation of CRM training [6]. A complementary argument has been pursued in the situation awareness literature (e.g., see Ref. [29]) that if you want to know a person's situation awareness or state of knowledge, make them do something that draws on that knowledge and results in a observable (and therefore testable) response. In a parallel argument it is possible to take the position that if you want to test to see if a skill is present, then invoke situations that draw on that skill and focus on the presence or absence of associated behaviours. In the draft HFDM syllabus presented in Appendix 1 to this Volume, an attempt has been made to identify a subset of potentially observable behaviours for each module. The presence or absence of these behaviours could be used to evaluate the acquisition of skill. A more global approach to assessment is described in a companion Volume (see Volume 2 to this report).

ACHIEVING SAFE FLIGHT PERFORMANCE

skills → through organisational reinforcement → everyday practice

The assumption of any aircrew training system is that safe and effective flight performance will be achieved when crews reliably and regularly use the target behaviours instilled by the training. Given that the human has a large toolkit of behaviours to chose from on any given occasion, some form of organisational re-enforcement is needed to ensure that target behaviours are consistently used in preference to non-target or even undesirable behaviours. Organisations can provide re-enforcement in a variety of ways, for example, by calling for general flying stand-downs, grounding specific fleets, or by mounting sporadic safety seminars and programmes. Such interventions are often initiated by a run of incidents or accidents in a condensed period of time (e.g., the USAF called a brief flying stand-down after a series of major losses during a one week period in September 1997).

While this type of intervention may have the desired effect in the short term, it is likely that its benefits will be short-lived. To have long-term effects, there must be a permanent change in the organisation and safety related behaviours of those within the culture. More enduring organisational interventions include.

- The establishment of rules and regulations (sometimes only as good as the last accident).
- A clearly stated set of organisational values (these establish high level goals and therefore shape and direct behaviour), for example:
 - operational requirements are not to take precedence over safe operations during peacetime;
 - building technical excellence and professionalism are goals of the organisation.

- An organisation that is seen to act in accordance with their stated values, for example by:
 - providing resources for training and technical development;
 - rewarding those that display excellence and professionalism and not rewarding those who do not;
- Establishment of, and assessment against, standards.
- Monitoring how the organisation is performing against those standards and the provision of regular *howgozit* feedback.

As one of the organisational support mechanisms listed above is based on the commitment to the training system, an attempt was made to estimate the resources required to implement the type of programme outlined in Figure 3. The following contains the suggested duration and frequency for each stage of training.

Stage	Requirements (Frequency)	Objectives
HFDN Classroom Training	3 days (on initial conversion)	Develop an understanding of core knowledge on human decision making and information processing.
Role Playing, Exercises and Case Studies	2 days (on initial conversion, then on biennial re-qualification, and AC upgrade)	Develop high level skills in situation assessment and analysis. This stage should immediately follow the classroom training. For the first day, apply core knowledge to case studies. Each team member to analyse the situation from the perspective of their own crew position if represented. If their position is not represented they should pick one that is. On the second day exercises will focus on team DM in time pressured, uncertain environments.
Simulator Sessions	2 LOS / LOE type scenarios (initial conversion, biennial re-qualification, and AC upgrade)	ACs, CPs and FEs to run through at least 2 LOS/LOE type simulations, with full audio/video debrief. These scenarios should emphasise DM and the need to process information at each of the <i>awareness, consider the implications and make a plan</i> stages of the Awareness Implications Plan (AIP) decision model.
OJT	Ongoing	During OJT ACs should take opportunities to vocalise their decisions in AIP form and test other crewmembers against this template.
Check Rides	As required	Check rides should test DM skills as well as technical skills.

Refresher Training	2 days (annually)	Refresher training should review the HFDM theoretical framework and expand one or more aspects that have relevance to the Squadron's operations (e.g., perhaps there have been some incidences where visual illusions have played a part, or a number of decisions have been made that showed the confirmation bias at work). Case studies and exercises will be used to refresh situation assessment skills.
Re-qualification Training	1 day§ (biennially)	Re-qualification training should have similar objectives to refresher training. The topics for deeper study may be chosen by the training squadron on the basis of deficiencies they have seen in simulator and classroom settings.
AC Upgrade Training	1 day§ (in conjunction with AC upgrade course)	This will review the theoretical framework and expand on topics related to strategic DM, risk management, allocation of responsibilities, etc.

Notes:

§ Followed by role playing, exercises, case study analysis in a team environment and LOS/LOE scenarios in the simulator with detailed debriefing playing the key role.

Figure 3 represents one of at least several ways of dividing up the HFDM training budget, therefore the preceding outline is for discussion purposes only. A programme such as the one outlined in Figure 3 would make the following additions to current CC-130 training requirements:

- 1 extra classroom day added to the current ACT training course;
- 2 extra days devoted to hands-on team DM training for all positions (as preparation for simulator sessions in the case of the ACs, CPs and FEs);
- 2 days per year of HFDM refresher training within the Squadrons (this could be in conjunction with a safety stand-down); and
- 3 extra days for all those going through AC upgrade training or re-qualification training.

Manning levels within the training Squadron to accomplish this task have not been assessed. Overall these are modest additions to a training programme that is currently devoted almost entirely to technical issues. Considering that human factors (HF) failures are assigned to somewhere between 70% and 80% of the accidents and incidents around the world, the proposed amount of time spent in HF training is not excessive.

A BASIS FOR ASSESSMENT

While the issue of programme assessment is addressed in more detail in Volume 2 of this report, the implications of the theoretical framework offered by the IP/PCT model, to the development

of assessment instruments, is worthy of comment. The causal chain from the IP/PCT model is argued to be as follows.

- Decisions are the end point. Their timeliness and appropriateness sets the gold standard against which crew system performance is always judged.
- If an individual has an appropriate goal and the necessary base knowledge, given time to process all the available information, an appropriate decision is expected.
- Once the conditions for goals and knowledge are established, it is the timeliness of the information processing that is at issue. Timeliness (through its effect on time pressure) of decision making becomes the driver of performance, errors, and perceived workload when externally paced.
- Timeliness depends on the state of the pre-existing mental model (level of proficiency/skill) and the management of attention (situation assessment).

Failures to make timely and appropriate decisions under high time pressure can be traced to: inappropriate goal setting; the lack of pre-requisite or base knowledge (forcing the use of R and K instead of S processing); or poor situation assessment due to a restricted locus of control arising from the time pressure. Failures under low time pressure can usually be traced to deficiencies in the locus of control/attention due to complacency or vigilance effects.

A framework for a measurement system might look something like the following (the assessment criteria listed below are a subset of the skills presented in Appendix 1).

TYPE OF MEASURE	FUNCTIONAL AREA	ASSESSMENT CRITERIA
Outcome	Decision Making	<u>Individual</u> <ul style="list-style-type: none"> • Were the decisions/actions appropriate? • Did the decisions/actions occur within the time available?
Process	Time Management	<u>Individual</u> <ul style="list-style-type: none"> • Did each crewmember appear calm or rushed? • Did each crewmember prioritise, delegate, delay, shed, buy time appropriately? • Is each crewmember using the appropriate level of KRS processing for the task in hand? • Did each crewmember act to relieve the loads of other crewmembers. <u>Crew</u> <ul style="list-style-type: none"> • Was a balance achieved in the imposed time pressure of all crewmembers?

Knowledge Management

Individual

- Did each crewmember actively seek and correctly perceive (was Aware of) all important information?
- Did each crewmember consider the Implications of the situation?
- Did each crewmember form Plans to cope with the situation and its implications, appropriate to their role?
- Did each crewmember set appropriate goals and communicate them as required (e.g., by briefing)?
- Did each crewmember share their knowledge (i.e., establish a common mental model) as appropriate?
- Did each crewmember resolve conflicts appropriately?
- Did each crewmember consider all the information they were aware of in making their decisions?

Crew

- Were the crew working from common goals and mental models?

Attention Management

Individual

- Did each crewmember attend to (control) the variables within their domain of responsibility?
- Did each crewmember direct attention when appropriate?

Crew

- Did the crew ensure that goals were achieved by monitoring, acknowledging, cross-checking, backing up, etc?

Team Process

Individual

- Did each crewmember provide appropriate supportive technical, interpersonal and cognitive skills?

Crew

- Was the crew cohesive?
- Was an environment established that was open, receptive, supportive, non-threatening?

A variety of assessment instruments can be developed from this framework. Behaviourally Anchored Rating Scales (BARS) have a history in CRM evaluation [23]. BARS contain written descriptions of the behaviours associated with each of the rating scale values. This is said to aid evaluators in applying the scales, and to result in improved inter- and intra-rater reliability. The US Army has used BARS extensively in the evaluation of their ACT training programme, and the USAF is planning to use BARS in a large scale research programme to evaluate MC-130P

team performance in combat mission training [23]. BARS can evaluate on multiple levels (say 1-5) or on a simple YES/NO basis.

A series of BARS could be developed from the framework presented above, for each crew position (AC, CP, FE, etc.), to be administered on a segment by segment basis or for the mission as a whole. These might range from a simple 5 factor instrument (Decision Making, Time Management, Knowledge Management, Attention Management, Team Process) to a detailed 21 factor instrument that rates each criterion behaviour separately. The 5 factor instrument would be appropriate for operational people (trainers, check pilots, standards officers, etc.) while the 21 factor instrument would most likely be used by researchers. When done on a segment by segment basis, the specific tasks, required knowledge, implications, plans and locus of control could be listed for that segment thus adding to the potential diagnosticity of the instrument.

In Appendix 3, an example 5 factor BARS is presented to demonstrate the concept. This instrument has not been validated and is presented merely to show how the complexity of the IP/PCT model can be distilled down to an instrument for use in real-time operational evaluation. The development of such an instrument completes the sequence from theory → course syllabus → evaluation, all within the IP/PCT paradigm. The behavioural anchors that are used in this example are notional at this point, and should have operator input to make them more relevant to the CC-130 community's needs for standards and evaluation. Critical to this process will be the development of definitions for the minimum required skill levels.

It should be noted that the dimensions of this scale are conceptually independent. For example:

- the appropriateness of a decision can be judged independently of the timeliness in most cases (one can have an appropriate decision that is either timely or late, etc.);
- outcome and process can be separated (a timely and appropriate decision might result from either good situation assessment — good locus of control, etc. — or from serendipitously attending to a critical piece of information); and finally
- time management, knowledge management and attention are separate entities.

In practice, and over many observations, ratings on the scales are likely to be correlated as time, knowledge and attention management trade-off, one against the other. However, the notional independence of the underlying concepts should make the scale easier to use and be more powerful from a diagnostic point of view.

In contrast to the categories arising from the IP/PCT model (see above), the USAF proposed the following five functional areas (dimensions) for measuring CRM performance in their MC-130P operations [23].

1. **Time Management (TM):** Involves the ability of the combat mission team to employ and manage limited time resources, so that all tasks receive sufficient time to be performed correctly and critical tasks are not omitted.
2. **Tactics Employment (TE):** Includes all analytic activities necessary to avoid or minimise threat detection or exposure, and to successfully co-ordinate complex mission events and multiple mission objectives.
3. **Function allocation (FA):** Includes the division of crew responsibilities so that workload is distributed among the crew, avoiding redundant tasking, task overload, and crewmember disinterest or non-involvement. Tasks should be allocated in such a manner so that crewmembers are able to share information and co-ordinate activities.
4. **Situation Awareness (SA):** Entails maintaining an accurate mental picture of mission events and objectives as they unfold over time and space. Emphasis and analysis are placed on the

three levels of SA (perception, integration, and generation) and their impact on team co-ordination.

5. **Command, Control and Communication (C³):** Encompasses those activities required to involve external parties in the mission, and to maintain communications with those external team members, communication within the crew, and controlling the sequence of mission events according to the mission execution plan.

Here the domains seem to be inherently related. TM, FA, and the command and control parts of C³, all have concepts of timeline management associated with them. FA and SA also overlap in the area of mental model building, particularly the shared mental model. TE and C³ both have command or co-ordination aspects built into them. There appears to be a mixture of measurements at what might be conceived to be both the *crewness* and the individual level, within and across scales. Yet there is no particular structure to aid in diagnosis. This would make it difficult to debrief the individuals that make up the crew — note that we can only change crew performance by changing the behaviours of those individuals within the crew.

CONCLUSIONS

This Volume describes a proposed syllabus for a course in *Human Factors in Decision Making*. The proposed course attempts to address some of the criticisms levelled at early generation CRM programmes — such as their emphasis on process rather than observable product. Its scope is on one hand broader than traditional CRM training, but on the other hand more focused by the specific emphasis on decision making. The draft syllabus is made up of 11 modules covering a variety of topics, each one critical to the understanding of human decision making. These modules are titled: an introduction to the decision making loop; leadership and followership; the emergence of communication and captaincy in teams and groups; sensation/perception; goal setting; action selection; management of control, attention, time, and knowledge; and finally human-human and human-machine communication.

The distinction between the proposed training and other similar endeavours lies in its foundation in theory. Two strong information processing-based models (the Information Processing [IP] model and the Perceptual Control Theory [PCT] model) form the theoretical framework for the proposed programme. This provides a consistency that permeates through all course modules and is expected to aid understanding and retention. Both the course syllabus and the potential for developing assessment instruments derive directly from the IP/PCT paradigm.

REFERENCES

1. Hendy, K.C., Thompson, M.M., Fraser, W.D., Jamieson, D.W., Comeau, P., Mack, C.I., Paul, M.A., and Brooks, C.J. (1998). Human factors of CC-130 operations — Volume 1: Final report of the DCIEM/ATG study team (DCIEM 98-R-14). Toronto, Ontario, Canada: Defence and Civil Institute of Environmental Medicine.
2. Thompson, M.M. (1998). Human factors of CC-130 operations — Volume 2: Crew performance measures (DCIEM 98-R-15). Toronto, Ontario, Canada: Defence and Civil Institute of Environmental Medicine.
3. Fraser, W.D. (1998). Human factors of CC-130 operations — Volume 3: Future aircraft performance measures (DCIEM 98-R-16). Toronto, Ontario, Canada: Defence and Civil Institute of Environmental Medicine.
4. Jamieson, D.W. (1998). Human factors of CC-130 operations — Volume 4: Training systems knowledge (DCIEM 98-R-17). Toronto, Ontario, Canada: Defence and Civil Institute of Environmental Medicine.
5. Paul, M.A. and Pigeau, R.A., Weinberg, H. (1998). Human factors of CC-130 operations — Volume 6: Fatigue in long-haul re-supply missions (DCIEM 98-R-19). Toronto, Ontario, Canada: Defence and Civil Institute of Environmental Medicine.
6. Helmreich, R.L. (1996). The evolution of Crew Resource Management. (<http://www.psy.utexas.edu/psy/helmreich/main.htm#new>). Paper presented to the IATA Human Factors Seminar, Warsaw, Poland.
7. Anon. (1994). Cockpit/crew resource management program (Air Force Instruction AFI 36-2243). Washington, DC, USA: Department of the Air Force.
8. Diehl, A.E. (1991). Does cockpit management training reduce aircrew error? Paper Presented at the 22nd International Seminar International Society of Air Safety Investigators, Canberra Australia,.
9. Anon. (1996). Controlled Flight Into Terrain — American Airlines Flight 965, Boeing 757-223, N651AA near Cali, Columbia, December 20, 1965 (Aircraft Accident Report). Santafe de Bogota, D.C. Columbia: Aeronautica Civil of the Republic of Columbia.
10. Wilson, D. (1997). CRM metrics: a recap. (<http://www.caar.db.erau.edu/crm/>). CRM Developers Forum: Industry CRM Developers group.
11. Helmreich, R.L. and Fourshee, H.C. (1993). Why crew resource management? Empirical and theoretical bases of human factors training in aviation. In, E.L. Wiener, B.G. Kanki, and R.L. Helmreich (Eds.), *Cockpit Resource Management*. San Diego, CA, USA: Academic Press, Inc., Harcourt Brace Jovanovich, Publishers. 3-45.

12. Bonner, M.C. (1996). Crew resource management. In, *Minutes of Technical Panel 7, Sub Group U, of The Technical Cooperation Program*. Monterey, CA, USA: The Technical Cooperation Program, Washington, DC, USA. 63-68.
13. Rasmussen, J. (1983). Skills, rules and knowledge; signals, signs and symbols and other distinctions in human performance models. *IEEE Transactions on Systems, Man and Cybernetics*, SMC-13(3), 257-266.
14. Anderson, B.F., Deane, D.H., Hammond, K.R., and McClelland, G.H. (1981). *Concepts in Judgement and Decision Research*. New York, NY, USA: Praeger Publishers.
15. Kihlstrom, J.F. (1987). The cognitive unconscious. *Science*, 237, 1445-1452.
16. Logan, G. (1988). Automaticity, resources, and memory: theoretical controversies and practical limitations. *Human Factors*, 30(5), 583-598.
17. Klein, G.A. (1993). A recognition-primed decision (RPD) model for rapid decision making. In, G.A. Klein, J. Orasanu, R. Calderwood, and C.E. Zsombok (Eds.), *Decision Making in Action: Models and Methods*. New Jersey, New York, USA: Ablex Publishing Corporation. 138-147.
18. Vincente, K.J., Flach, J.M., and Sanderson, P.M. (1989). Ecological interface design: creating a window to the world of complex work domains. In, J. Dalton and C. Thornton (Eds.), *Proceedings of the 22nd Annual Conference of the Human Factors Association of Canada*. Mississauga, Ontario, Canada: Human Factors Association of Canada. 151-155.
19. Hendy, K.C., Liao, J., and Milgram, P. (1997). Combining time and intensity effects in assessing operator information processing load. *Human Factors*, 39(1), 30-47.
20. Hendy, K.C. and Farrell, P.S. (1997). Implementing a model of human information processing in a task network simulation environment (DCIEM 97-R-71). North York, Ontario, Canada: Defence and Civil Institute of Environmental Medicine.
21. Powers, W.T. (1973). Feedback: beyond behaviorism. *Science*, 179(4071), 351-356.
22. Powers, W.T. (1992). CT psychology and social organizations. In, G. Williams (Ed.), *Living Control Systems II — Selected Papers of William T. Powers*. Gravel Switch, Kentucky, USA: The Control Systems Group, Inc. 91-127.
23. Spiker, A., Tourville, S.J., Silverman, D.R., and Nullmeyer, R.T. (1996). Team performance during combat mission training: a conceptual model and measurement framework (Final Report AL/HR-TR-1996-0092). Mesa, AZ, USA: Aircrew Training Research Division, Human Resources Directorate, Armstrong Laboratory.
24. Hendy, K.C. (1997). An information processing approach to workload and situation awareness. In, R.S. Jensen and L.A. Rakovan (Eds.), *Proceedings of the 9th International Symposium on Aviation Psychology*. Columbus, OH, USA: The Aviation Psychology Laboratory, The Ohio State University. (in press).
25. Anon. (1997). Command, leadership resource management (System Safety Report). North York, Ontario, Canada: Transport Canada Aviation, System Safety.

26. Pettitt, M.A. and Dunlap, J.H. (1997). Understanding leadership/followership skills. In, *Proceedings of the 9th International Symposium on Aviation Psychology*. Columbus, OH, USA: The Aviation Psychology Laboratory, The Ohio State University. (in press).
27. Banks, R.D., Hendy, K.C., Fraser, W.D., Thompson, M.M., Jamieson, D., Wright, H., Gee, T., Mack, C.I., Latulip, J., Davis, B., and Cole, M. (1996). Human factors study of CC-130 operations (DCIEM 96-R-66). North York, Ontario, Canada: Defence and Civil Institute of Environmental Medicine.
28. Wise, J.A. (1996). CRM and the Emperor's new clothes. Presentation to the Third Global Flight Safety and Human Factors Symposium, Auckland, New Zealand.
29. Pritchett, A.R., Hansman, R.J., and Johnson, E.N. (1996). Use of testable responses for performance-based measurement of situation awareness. In, D. Garland and M. Endsley (Eds.), *International Conference on Experimental Analysis and Measurement of Situation Awareness*. Daytona Beach, FL, USA: Embry-Riddle Aeronautical University.

ACKNOWLEDGEMENTS

The concept of SuperPilot and the DreamTeam commenced with an idea by Jason Lawrence, now at Transport Canada, while a Master's student at York University and under the supervision of one of the authors. The authors would also like to thank Meagan Thompson and Ronald Ebbers for their many helpful comments during the drafting of this Volume.

APPENDIX 1: DRAFT SYLLABUS FOR *HUMAN FACTORS IN DECISION MAKING* TRAINING

INTRODUCTION TO THE DECISION MAKING LOOP

Introduction: accidents statistics, majority of accidents attributed to human factors issues, decision making implicated in most of these, review of CC-130 accident history, Reason's model, active and latent failures, course outline — focus on decision making.

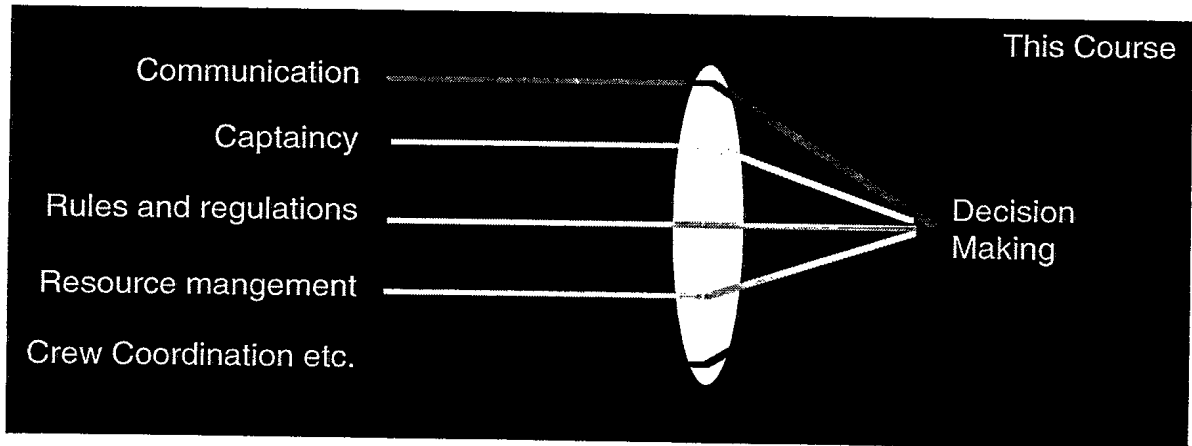

The PCT Model and the Decision Making Loop: introduction to the thermostat and closed loop control of temperature (temperature set point, etc.) leading to the PCT model, goals, mental models, situation awareness and the shaping of decisions, essential requirement for feedback in goal directed activity. Relate the components of the air-conditioning control system (something that is familiar) to the components of the perceptual control loop (a new concept).

Air Conditioning System

- Thermostat set point
- Temperature and humidity sensors
- Valves, compressor, heat exchanger properties
- Rated compressor power (BTU)
- Physical limits on cooling capacity (size of compressor, heat exchanger, wear, etc.)

Human Decision Maker

- Goals
- Eyes, ears, sense of smell and touch
- Mental models of action selection
- Internal processing rate (bits per second)
- Various physiological and psychological stressors (fatigue, motivation, anxiety, etc.)

You are here

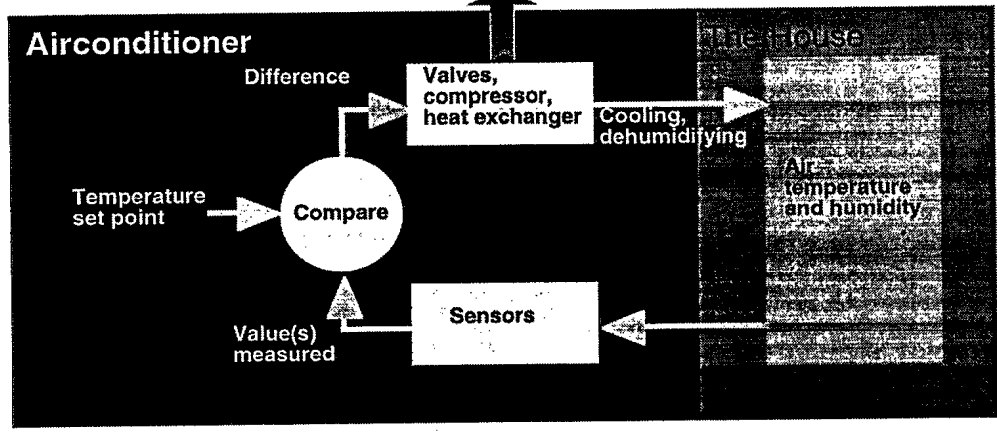
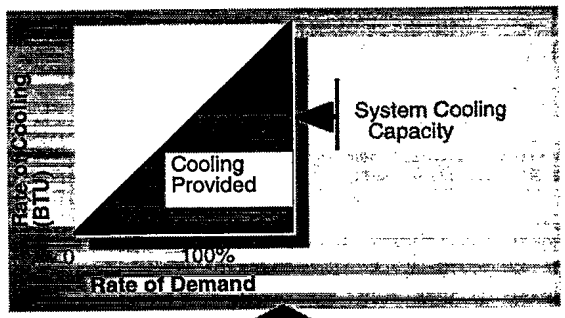

You are here

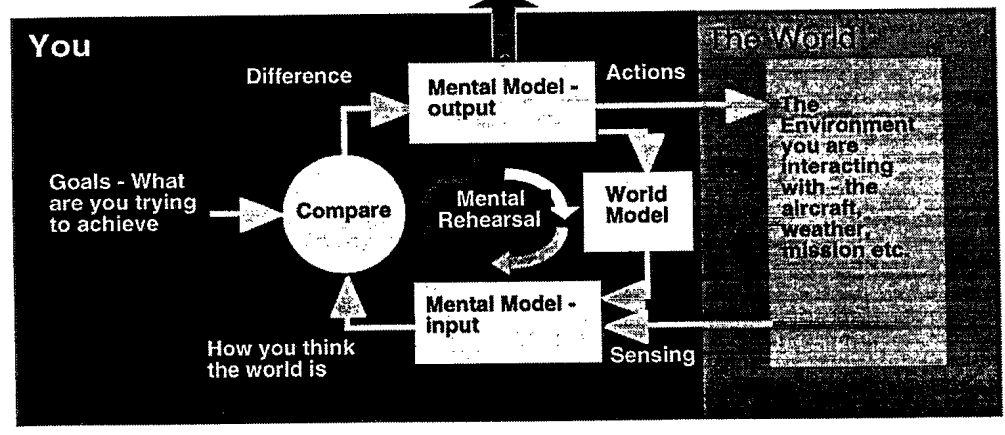
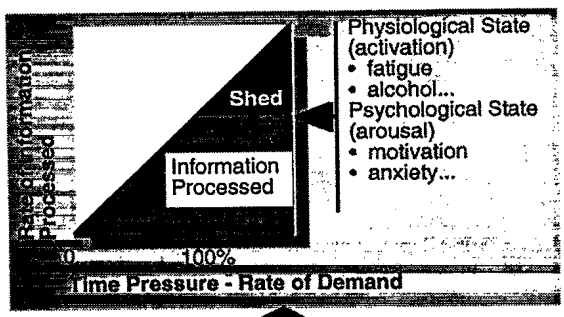

The IP Model: introduction to the IP model, effects of time pressure on performance and errors, strategies and the speed accuracy trade off, errors of omission, skills rules and knowledge based behaviours, recognition primed decision making. Introduce the integration of PCT and the IP model, time pressure and the bandwidth of the loop, knowing the goals and mental model, behaviour is predictable.

Introduction

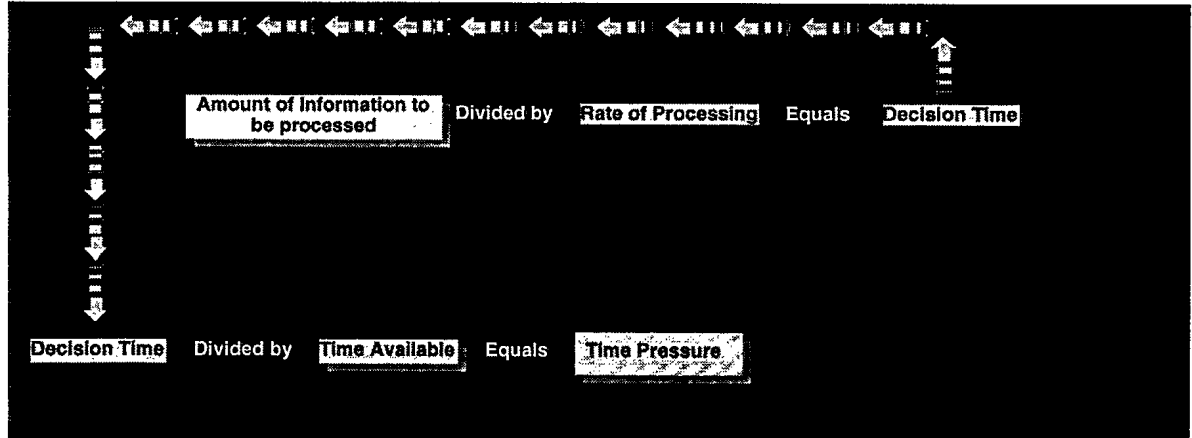

Adaptation to Excessive Time Pressure

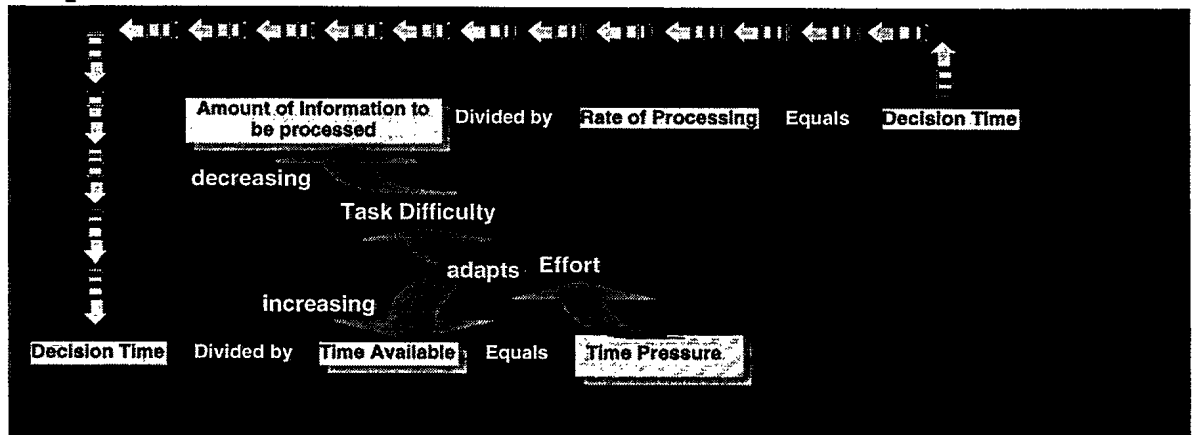

Time Pressure and Errors

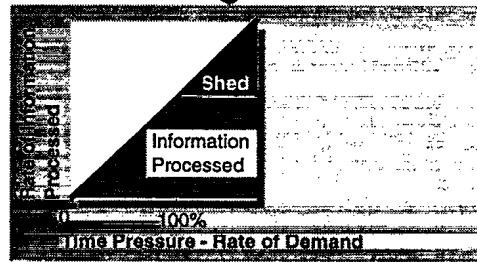
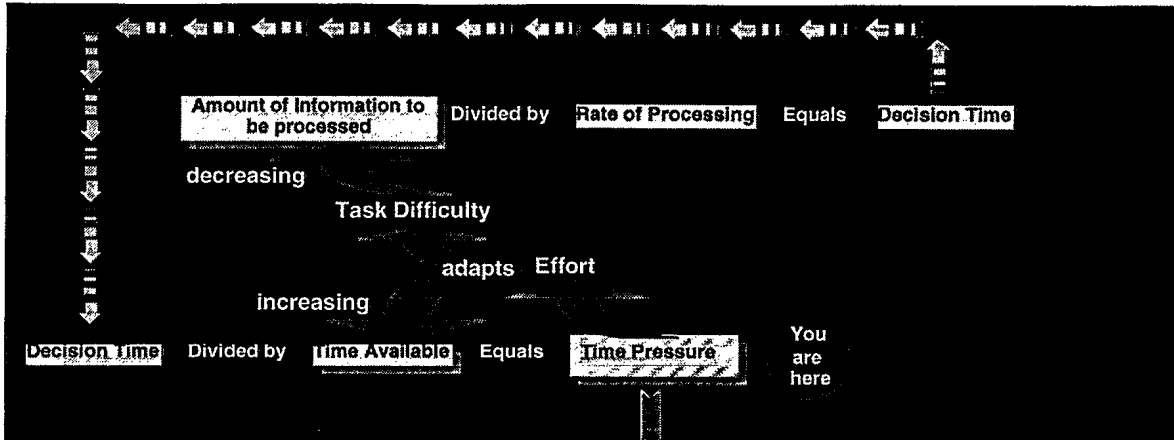

Time Pressure and the Speed/Accuracy Trade Off

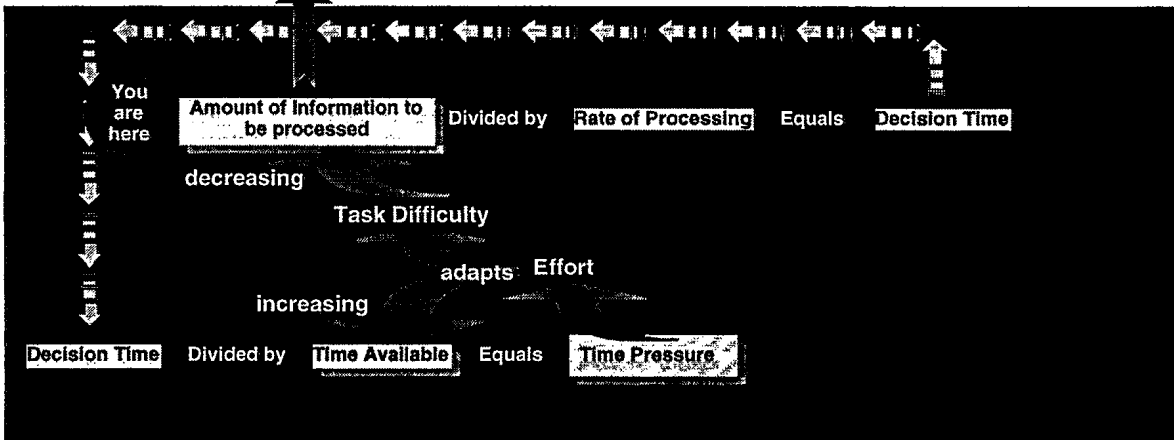
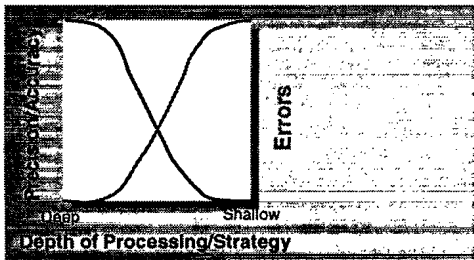

Effects of Physiological and Psychological Stressors

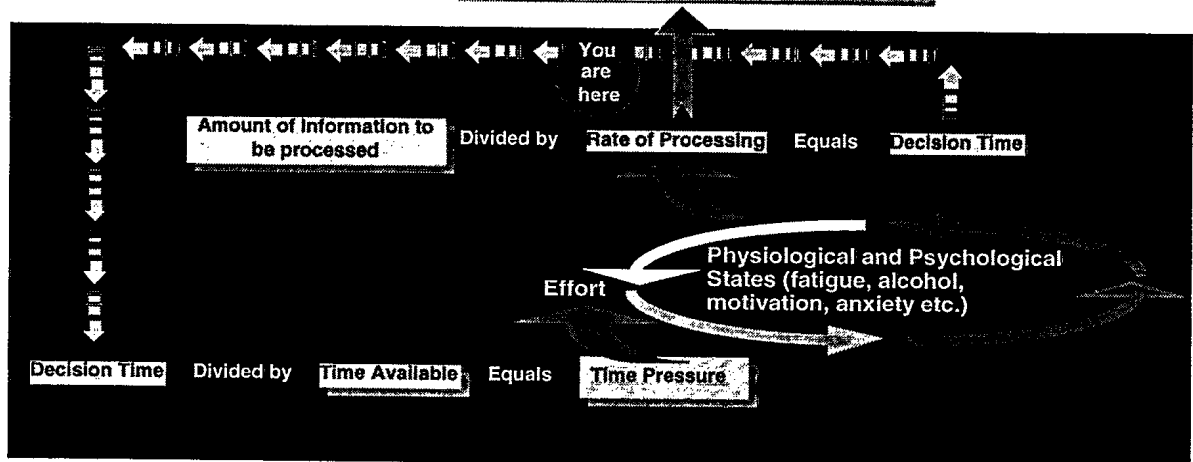
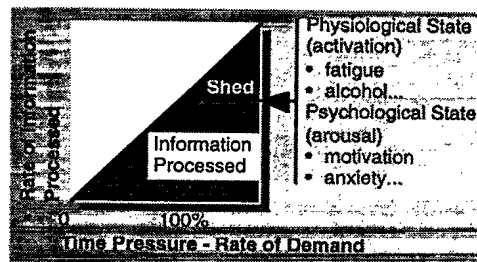
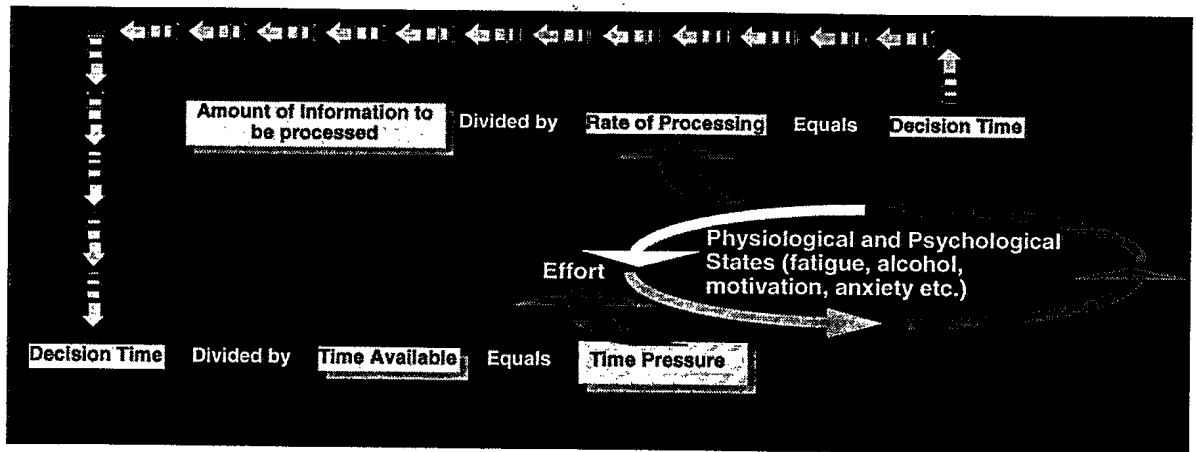

Teams: multi-person PCT, requirements for stability, need for compatible goals and mental models, authority gradients, emergence of role and task allocation.

Introduction

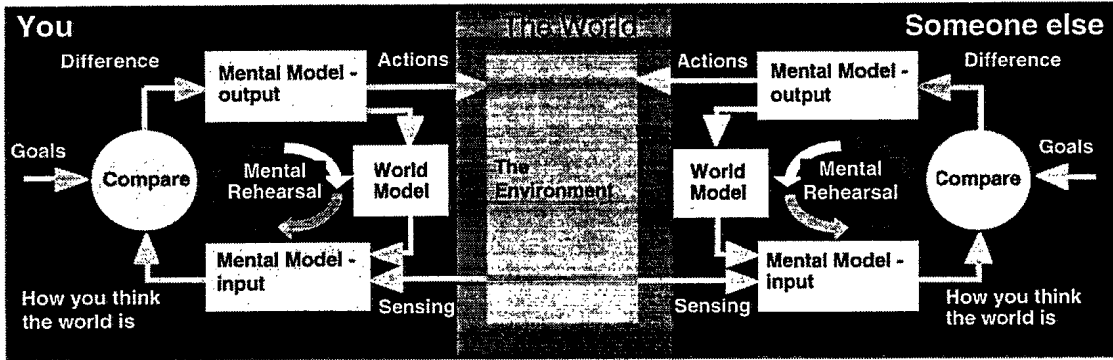

Multiple Controllers (Human and Machines)

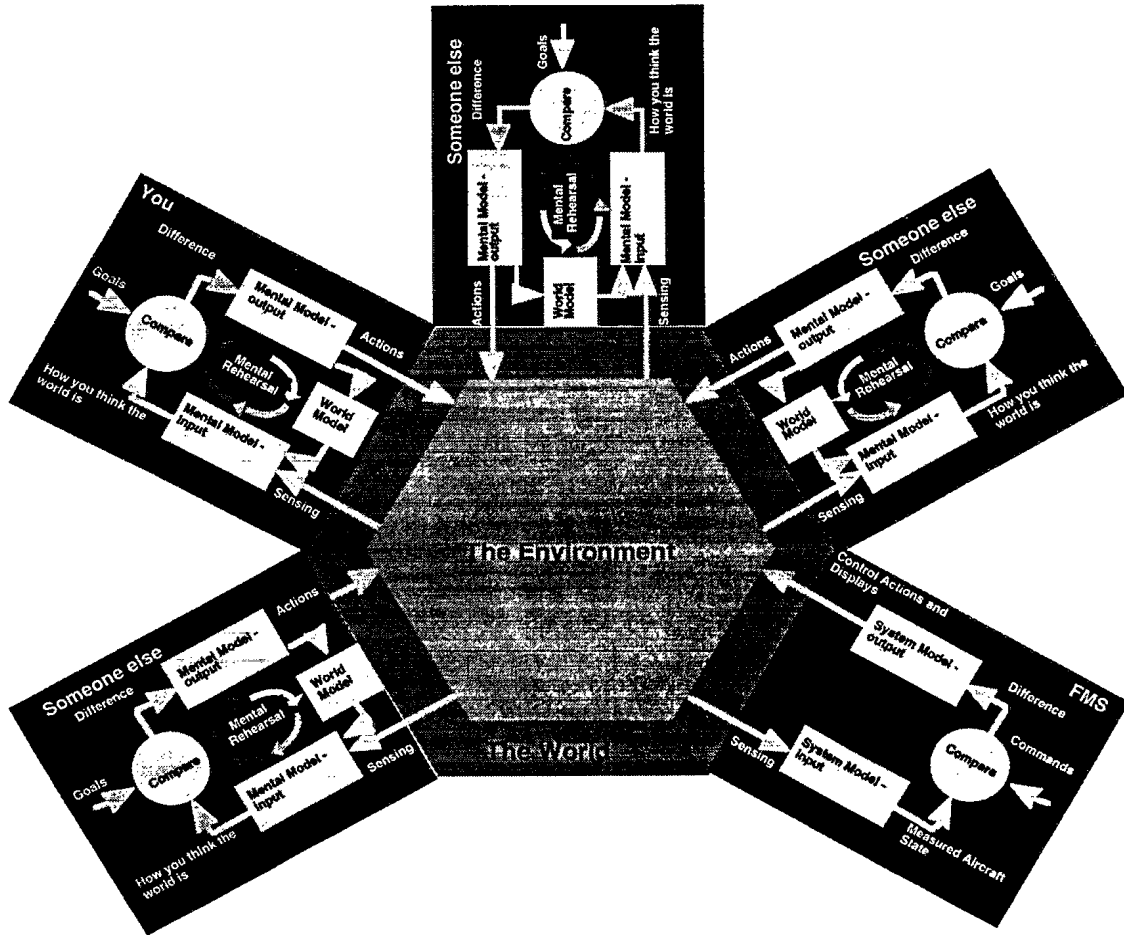

Living with Error: living with error ('error' is inevitable), breaking the chain, monitoring/feedback, closed loop behaviour allows us to be successful without perfect

mental models, open loop behaviours lack error checking, you as the aircrew are the last line of defence in the accident chain, managing error.

Summary:

Knowledge: Basic understanding of

1. effects of time pressure on workload, performance, and errors,
2. strategies for managing time pressure,
3. the concept of closed loop control and the importance of feedback,
4. requirements for stable team performance; and
5. the concept of goals and mental models.

Skills: NA.

Assessment:

1. core knowledge.

Resources:

Exercises

1. Dynamically demonstrate a multivariate control loop with different goals, models and loop gains.

Case Studies

Positive

1. Most CC-130 operations - get personal experiences
2. Horizon 2658, Seattle WA
3. Pan Am 543, Boston,
4. United 232, Sioux City, IA

Negative

1. Discuss the Challenger accident in Ottawa as an example of multi-controller instability.

Videos

Positive

1. Use a high performing crew from the CC-130 study to demonstrate timeline management, building common goals and mental models, closing feedback loops.

Negative

1. NA

LEADERSHIP AND FOLLOWERSHIP

Introduction: teams and groups, the aviation team, leadership, followership (opportunities to demonstrate these behaviours will occur in all the aspects covered in this course), authority gradient gives control priority in a team environment.

Responsibility: legal responsibility for the safety of the operation vested in AC, responsibility of the AC and the crew.

Authority: origins of power, authority gradients (flat, negative and positive) and effects on the team.

Leadership: ability to influence others, differences between leadership and authority, leadership styles, situational leadership, maturity models.

Followership: followership doesn't imply subservience, responsibility to support AC's decision as long as safety is not jeopardised, when to dispute non-safety related decisions, proactive followership, can all lead?

Dimensions of Captaincy: From the Captaincy study.

Summary:

Knowledge: Understanding of

1. the Captain's role and responsibility
2. the crew's role and responsibility.

Skills:

1. Leadership.
2. Followership.

Assessment:

1. Core knowledge.
2. Acts in accordance with responsibilities.
3. Appropriate exercise of authority.
4. Demonstration of Captaincy behaviours.
5. Ability to resolve conflict.
6. Proactive support of AC's decisions through technical, interpersonal and cognitive skills.
7. Appropriate challenge— demonstrating when to challenge and when to demure.

Resources:

Exercises

1. Discuss leadership and followership.
2. Have each class do a mini-version of generating Captaincy dimensions for themselves (as individuals or as groups — clearly should be done prior to a presentation of results — and see how they match up

Case Studies

Core Knowledge

1. The rep grid study of Captaincy.
2. CC-130 study results.

Positive

1. BA Indonesia
2. Horizon 2658, Seattle, WA
3. United 811, Honolulu, HI

Negative

1. HTI CC-130 example.
2. Jackson's Hole CC-130.
3. AA 965, Cali, Columbia.
4. Tiger 66, Kuala Lumpur, Malaysia.
5. FAA, Front Royal, VA.

Videos

Positive

1. CC-130 example of AC dealing with strategic DM and crew backing up with pro-active tactical decision making.

Negative

1. Northwest 1451, Detroit,

SUPERPILOT, DREAMTEAM AND HERCCREW

Introduction: introduce SuperPilot, DreamTeam and HercCrew.

Emergence of CRM and Communication: trace the emergence of CRM and communication as one progresses from SP to DT to HercCrew, functions of communication, information and uncertainty.

Summary:

Knowledge: An understanding of the following concepts

1. Functions of Captaincy.
2. Functions of communication.

Skills: NA.

Assessment:

1. Core knowledge.

SENSATION/PERCEPTION

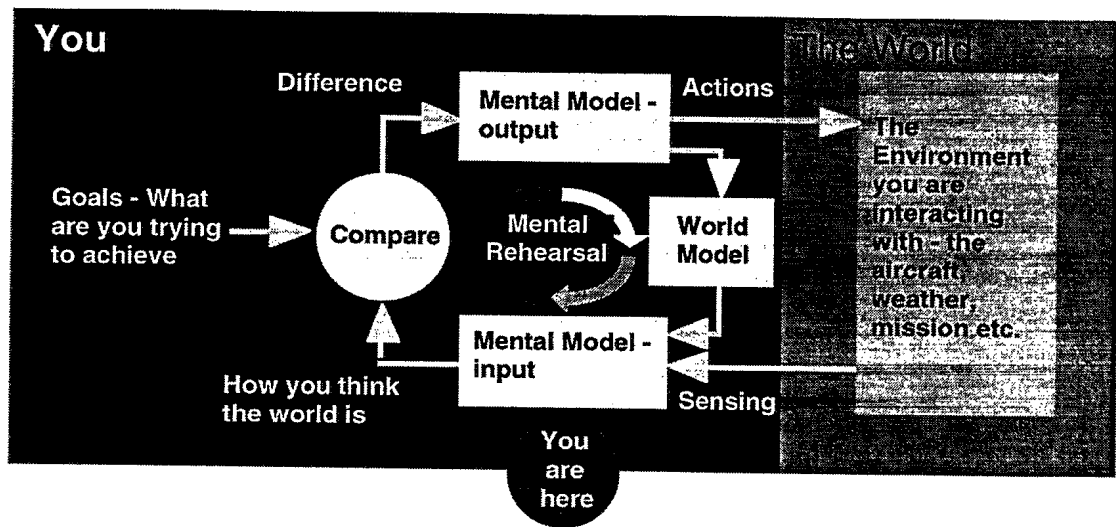

Introduction: perception is the result of passing the incoming sensory information (light, sound, force, texture, etc.) through a transformation process (some hard wired, some learned at an early age, some acquired over time), how you perceive the world may not be how it is (illusions), the same stimulus can elicit different sensations depending on set, expectation, etc.

Miss-perceptions: when the perception may not match the 'reality', visual illusions, errors in sound localisation, aviation related illusions and effects on control, spatial disorientation, leans, somogravic effects, miss-perception of auditory information, effects of displays (moving aircraft versus moving horizon AI, moving scale versus moving pointer and control reversals, radar reversal, etc.).

Leadership/Followership Issues: be aware of the potential for misleading sensations, brief/warn cross check as appropriate if someone is not reacting to your perception of the world (either they or you may be operating under the wrong mental model — wrong model = wrong action).

Summary:

Knowledge: An understanding of

1. Common aviation related miss-perceptions.
2. Review of disorientation effects.

Skills:

1. Ability to recognise the circumstances that may result in ambiguous perceptions.
2. Ability to maintain control under conflicting somogravic stimuli.

Assessment:

1. Core knowledge.
2. Demonstrates an awareness of the potential for ambiguous sensory cues, by warning, briefing or checking.
3. Responds to the actions of other crew members when seem inappropriate to the situation (may be indicative of a miss-perception).

Resources:

Exercises

1. Generate a list of potential situations that may lead to miss-perceptions.
2. Use slides to show effects of runway widths, slopes on perceived approach angle.

Case Studies

Positive

1. tba

Negative

1. Wainwright AK.
2. Box Top 22, Alert, NWT
3. The tall fireman.
4. USAir 105, Kansas City, MO

Videos

1. tba

GOAL SETTING

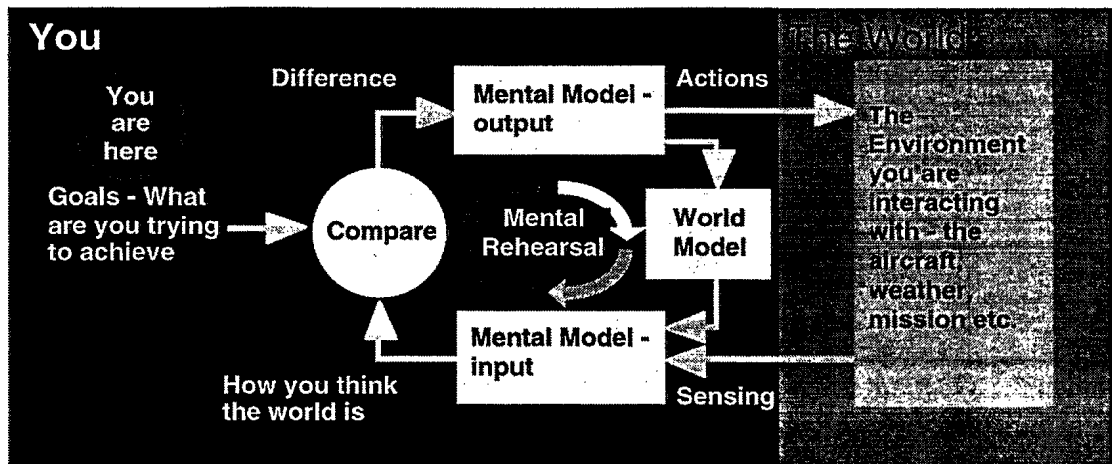

Introduction: review — goals are the set point of your perceptual control loops (compare with setting room temperature on a thermostat), they are how you want to perceive ('see') the world, your actions are driven by your goals and shaped by your mental model.

Goals: tactical and strategic goals, need for appropriate goals, goals should match the capability of the crew, your goals are your first line of defence in risk management, need to communicate and gain agreement on goals (stable multi-loop control), monitoring (loop closure) requires an awareness of goals.

Rules and Regulations: ask the question "...is this legal?" (push down below MDA, take off in low RVR, etc.).

Leadership/Followership Issues: authority and responsibility, who sets, AC's role - crew's role, maturity model of leadership revisited in this context.

Summary:

Knowledge:

1. Concept of strategic and tactical goals and how they relate to risk management.
2. Roles and responsibilities of all positions.
3. Knows the rules that are appropriate to their position.

Skills:

1. Ability to set and communicate appropriate goals.

Assessment:

1. Core knowledge.
2. Demonstrates appropriate goal setting (strategic and tactical).
3. Communicates and gains acceptance of goals.
4. Acts in accordance with the rules and regulations that govern the operation.

Resources:

Exercises

1. Have all participants list some of the tactical and strategic goals they might set in an operational setting - discuss.
2. Groups should analyse case studies, or additional scenarios, in terms of (1) initial goal setting and (2) changing goals as the scenario unfolds – if goals change or start to conflict this exercise introduces the notions of task prioritisation/offloading/workload management, etc.

Case Studies

Positive

1. tba

Negative

1. Jackson's Hole CC-130 accident.
2. Box Top 22, Alert, NWT.
3. Bud Holland.
4. Avianca 052, New York, NY.
5. Eastern L-1011, Miami, FL.

Videos

Positive

1. CC-130 crew showing changing goals as the situation changes.

Negative

1. tba

ACTION SELECTION

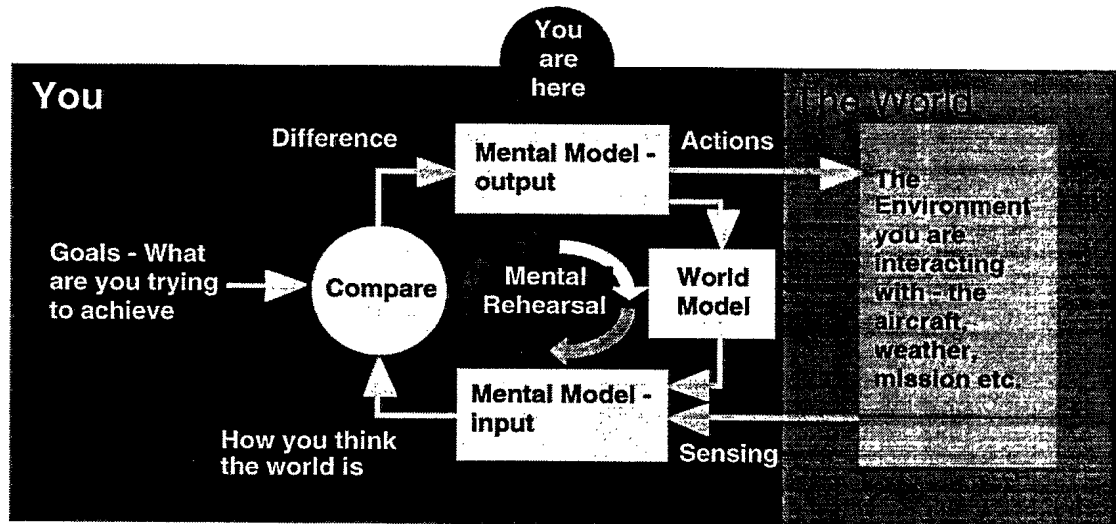

Introduction: the task is not done until the goal is 'seen' to be achieved. This means we must act on the world.

Action Selection: manifestation of a decision, your action is intended to change the state of the world so that your perception matches your goal, this is usually the point of obvious departure from safe operations, actions are shaped by the mental model (this is like reaching down into the mental model toolbox and making a selection), difference between knowing and doing (your confidence, attitudes, high level goals — wishing to impress, peer pressure, etc. — all effect which tool you pull out of the box), second last line of defence in risk management, retrieving information from memory, what can go wrong.

Memory: types and limitations of memory, associative model of memory, slips, errors of commission, memory aids (check lists, etc.), need to confirm and resolve discrepancies, spatial and verbal encoders.

Risk Management: every decision involves risk management, risk management is based on goals, the state of knowledge and further shaped by attitudinal factors, safe and unsafe attitudes (over confidence, complacency, get-home-itis, macho, etc.), attitudes and changing attitudes, knowledge versus experience, compensation for lack of experience, many tactical goals and mental models may achieve the same strategic goals, rules and regulations, risk management is about bounding behaviour - works when regulations don't cover the situation, danger signs (departure from SOPs, etc.), use of the most conservative response, use of the veto for ACs, effects on your decision others — the big picture (e.g., in formation).

AIP Model: before you select an action have you gone through the process of Awareness-Implications-Plan?

Goal Achievement: timeliness and appropriateness of the outcome relative to your goal.

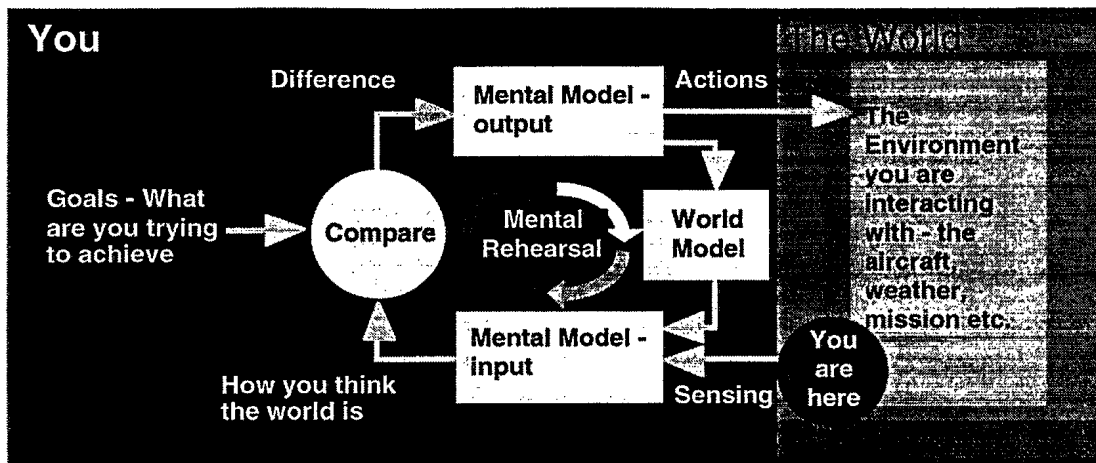

Feedback: must close loops, essential to ensure goal achievement, feedback allows the use of less than perfect mental models (try controlling the aircraft with your eyes shut), last line of defence in error management.

Leadership/Followership Issues: responsibilities for risk management, all have the responsibility to monitor the situation and see that collectively you are moving towards the goal (particularly with respect to safe operations).

Summary:

Knowledge:

1. Types of memory lapses and aids to recall.
2. Signs that risk management is breaking down.
3. The requirement for feedback and monitoring.
4. The AIP model.

Skills:

1. The ability to detect the symptoms of risk management breakdown.
2. Ability to use the AIP model in a number of exercises.

Assessment:

1. Core knowledge.
2. Acts when risk management is breaking down, by calling attention to the situation and offering solutions.
3. Demonstrates the use of the AIP model in decision making.

Resources:

Exercises

1. Use AIP in a scenario.
2. Use of feedback.

Case Studies

Positive

1. Pan Am 543, Boston
2. United 232, Sioux City, IA
3. Aloha 1712 Maui, Hawaii

Negative

1. CC-130 mid air.
2. British Midlands, Manchester, UK
3. Air Inter, Strasbourg, France.
4. Delta 1141, Dallas Fort Worth, TX
5. Air Bus A310 Vancouver, BC.
6. Avianca 052, New York, NY.
7. Eastern L-1011, Miami, FL.

Videos

Positive

1. CC-130 crew using an AIP approach during system failures.

Negative

1. tba

RESOURCE MANAGEMENT

Introduction: review of SuperPilot, DreamTeam and HercCrew, reason for multi-place aircraft is that the task load is too much for one. This module introduces the 3 following modules therefore no specific uses of exercises, case studies or videos are required.

Resources Available: time, knowledge and attention, starts with the prime decision maker and their resources, and flows outward → other crew members → aircraft systems → ATC → other aircraft → ATOC, etc., all crewmembers have external resources to draw on. Management of time, attention and knowledge are all related. It all gets down to the trade-offs.

Managing Time and Attention: two sides of the same coin, making sure that the team locus of control covers all the critical variables (e.g., FFA: first fly-the-aircraft), managing the timeline.

Managing Knowledge: your internal knowledge state shapes the decisions you make, quality of the decision depends on your knowledge state, what you don't know CAN hurt you.

Leadership/Followership Issues: management doesn't just happen - it is an active process, leadership, followership revisited, all can provide leadership in resource management.

Summary:

Knowledge:

1. What are the available resources?
2. What is being managed?

Skills: NA.

Assessment:

1. Core knowledge.

MANAGEMENT OF CONTROL AND ATTENTION

Introduction: review the idea of a hierarchical system with control switching from loop to loop, loops not attended to are not under control, need to sample at a rate determined by how quickly things can change.

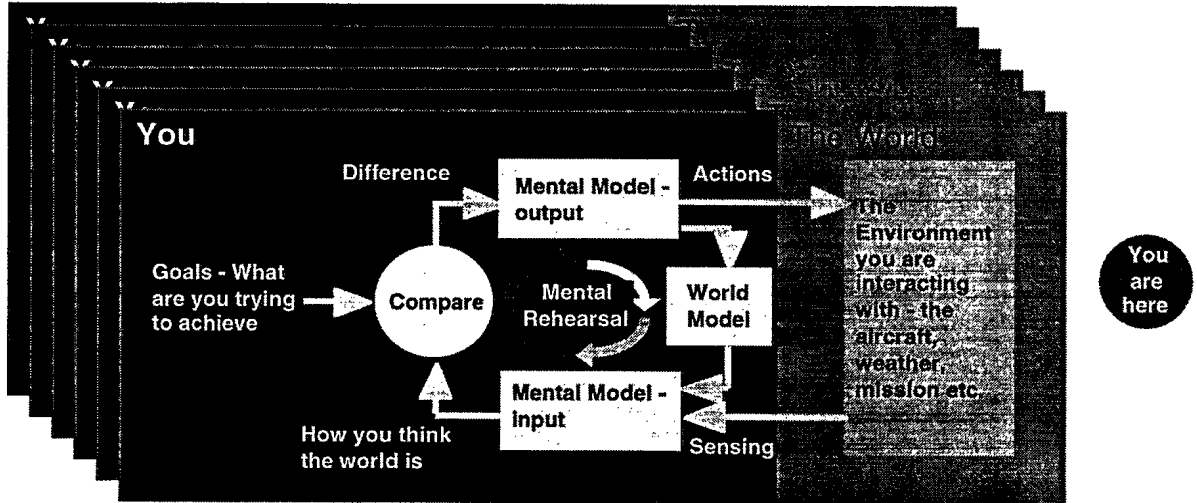

Adaptation and Learning: control is necessary for adaptation (learning) and the building of situation awareness.

Locus of Control: depth and breadth of processing, depth and breadth of control - AIP revisited, individual and team locus of control, backing up, critical loops.

Control and Arousal: active control involves incoming information to the brain which drives the body's state of activation and arousal, adaptation to constant stimuli, arousal decays in the absence of stimuli.

Vigilance: passive control, monitoring and vigilance effects, attention wanes when out-of-the-loop.

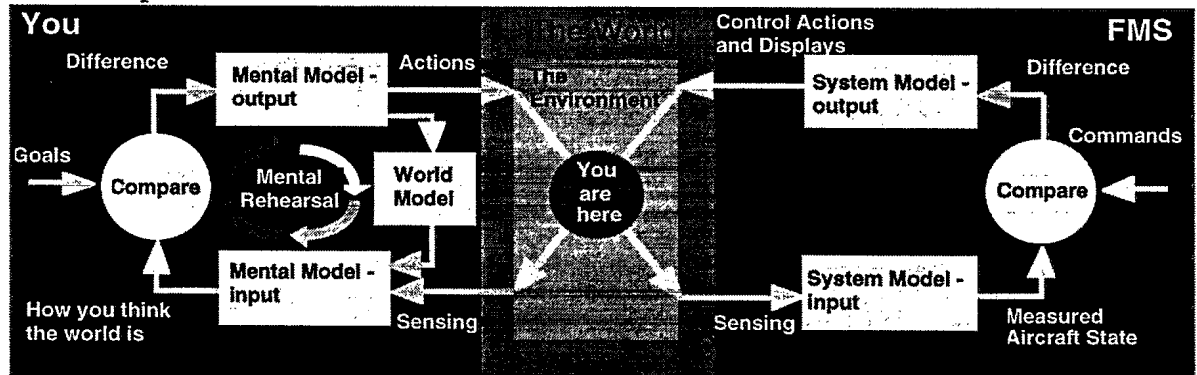

Control and Automation: who is in control, complacency, trust, in-the-loop versus out-of-the-loop, timeline management versus knowledge management, what does automation do for you, automation failures, lack of good mental models.

Leadership/Followership Issues: AC's responsibility for the assignment of roles, acceptance of responsibility that goes with this allocation, all play an active role in achieving team locus of control.

Summary:

Knowledge:

1. Control means 'attending to'.
2. When out-of-the-loop you are not gaining knowledge.
3. Automation traps.

Skills:

1. Ability to manage the loops under control (depends on goals and responsibilities).
2. Ability to maintain depth (and breadth) of processing when under load (AIP revisited).
3. Knowing when to use, and using, alerting (attention capture) and backing up (closing loops) behaviours.

Assessment:

1. Core knowledge.
2. Demonstrates control of all critical variables.
3. Demonstrates the use of alerting and backing up behaviours as appropriate.

Resources:

Exercises

1. tba

Case Studies

Positive

1. BA Indonesia.
2. United 811, Honolulu, HI
3. United 232, Sioux City, KA
4. Aloha 1712, Maui, HI.
5. Pan Am 543, Boston.

Negative

1. United 173, Portland, OR
2. Eastern 401, Florida Everglades, Miami FL.
3. China Air 012, enroute SF to Taipei.
4. Markair 3087, Unalakeet.
5. Mohawk, Albany, NY.
6. Northwest 255 Detroit, MI

Videos

Positive

1. CC-130 crew managing locus of attention and control.

Negative

1. tba

MANAGEMENT OF TIME PRESSURE

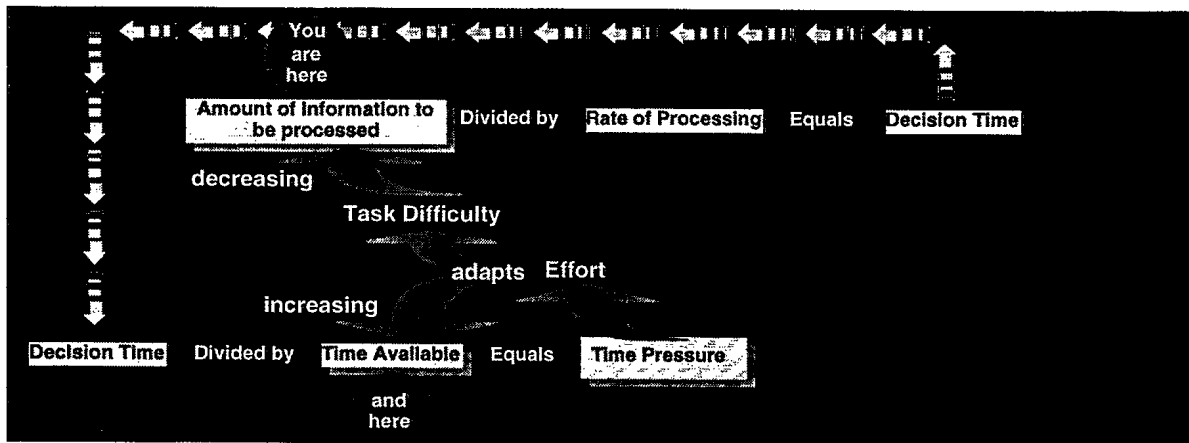
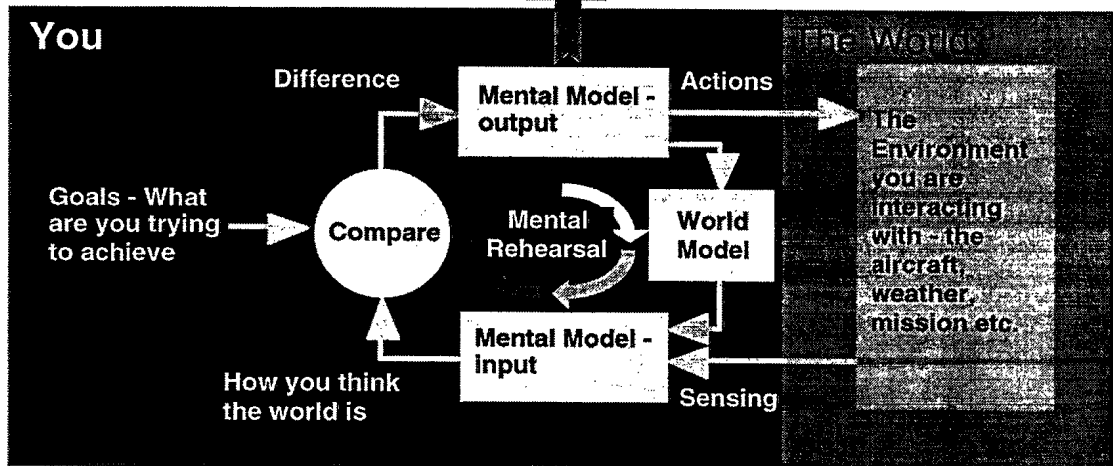
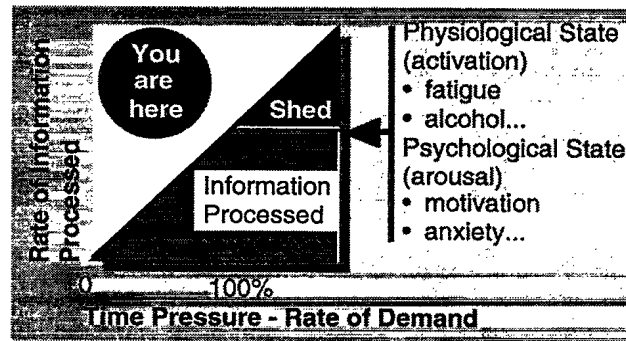

Introduction: review of the IP model and the effects of time pressure on performance, workload and errors.

Coping with TP: IP strategies (recognition primed decisions, move from Knowledge-Rule-Skill based processing, speed accuracy trade-off and errors of omission, rules of thumb), task loading strategies (prioritisation, shedding and controlling input, delegation, need for common mental models, role of briefing, postponement, pre-planning) reduced locus of attention (tunnelling).

Stressors: low arousal states, high arousal states, time pressure, chronic and acute stress, stressors, effects on channel capacity and locus of attention, recognising stress in yourself and others, what to do about it, responsibilities of AC and crew.

Leadership/Followership Issues: each crewmember has the responsibility to manage their own time pressure by the use of appropriate strategies and calling on all available resources, be sensitive to task loadings of others and **do something** about it if you can.

Summary:

Knowledge:

1. Effects of time pressure on performance and errors.
2. Strategies for coping with high time pressure.
3. Effects of stress and recognition of the symptoms of stress.
4. Responsibilities for managing stress.

Skills:

1. Ability to recognise situations of excessive time stress.
2. Ability to manage the timeline by
 - prioritisation,
 - delegation,
 - postponement,
 - pre-planning.

Assessment:

1. Core knowledge.
2. Recognises the symptoms and situations associated with excessive time pressure.
3. Demonstrates timeline management skills.

Resources:

- | | |
|---------------------|---|
| Exercises | 1. Have groups work through a scenario emphasising elements each team member brings to the situation and issues of timelines - what information is timely when. |
| Case Studies | <u>Positive</u>
1. Pan Am 543, Boston.
<u>Negative</u>
1. MD-180 incident, Austin TX.
2. Mohawk, Albany, NY.
3. Markair 3087, Unalakeet. |
| Videos | <u>Positive</u>
1. CC-130 crew actively managing the timeline.
<u>Negative</u>
1. tba |

MANAGEMENT OF KNOWLEDGE

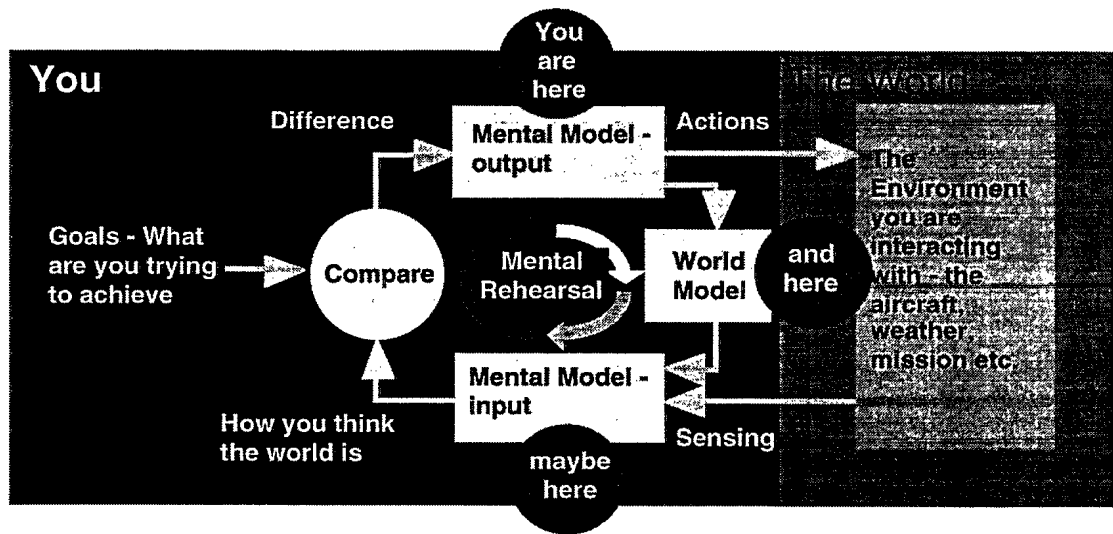

Introduction: review how the mental model shapes actions and that decision time and time pressure depend on the highest levels of individual skills, quality of your decisions depend on your state of knowledge, managing knowledge is largely managing your locus of attention, managing attention and managing knowledge are complementary.

The Mental Model: consists both of the long term declarative knowledge and short term situation specific knowledge, individual knowledge and shared knowledge.

Situation Assessment: Situation awareness depends on situation assessment which requires the active control of relevant loops, active control is more effective than passive control, depth and breadth of the mental model (situation awareness is not a single entity that you either have or don't have), high time pressure results in reduced locus of control and situation awareness, offload the housekeeping duties and focus on the most important strategic and tactical goals depending on your role. Seamster's studies that show that many cases of 'lack of assertiveness' are due to inadequate situation assessment.

Decision Making: decision making and the knowledge we draw on, decision biases (confirmation, primacy, recency, expectancies, weighting of *a priori* probabilities, order of presentation, etc.) and how you ask the question might determine the information you receive, satisficing, knowledge management, role of feedback in adaptation and learning.

Team Decision Making and Team Performance: differences between team performance and team decision making (in a hierarchical team not everyone needs to participate in every decision), the relevant cumulative knowledge of the team usually exceeds that of any one individual (synergy versus antagonistic), when this knowledge is shared a better decision is often made as one is drawing on the pooled knowledge (c.f. two people pushing a heavy load), trade-off between the timeliness of the decision and the quality of that decision, styles for high and low time pressure ("...what do you suggest?" versus "...I suggest...any problems?"), need to make a decision (team decision making is not an excuse for the AC not to make a decision), need to manage the shared knowledge (what, when and how).

Leadership/Followership Issues: pro-actively seeking and offering knowledge when appropriate. Ensuring each stage of the AIP model is exercised.

Summary:

Knowledge:

1. Situation assessment depends on the locus of control (AIP again).
2. Decision biases and what to do about them.

3. Asking questions and considering the options.
4. The role of the team in this process.
5. Differences between teams and groups.

Skills:

1. Situation assessment, managing the locus of control.
2. Ability to prioritise and focus on the most important strategic and tactical goals.
3. Ability to generate and evaluate options.
4. Ability to process at all stages of the AIP model.
5. Ability to use all available resources.
6. Ability to take input and make an appropriate decision.

Assessment:

1. Core knowledge.
2. Seeks all appropriate sources of knowledge to support decision.
3. Tests mental models against all appropriate knowledge sources.
4. Offers knowledge appropriate to the level of decision being made.
5. Resolves conflicting data (ACs).
6. Exercises the AIP model.

Resources:

Exercises

1. Various examples demonstrating decision biases (e.g., the green taxi⁴).
2. Systems knowledge exercise of the type used in the AS Army course⁵ (similar to the survival exercise but made operationally relevant).
3. Set up a situation in which team members have different pieces of the puzzle, some conflicting and some congruent. The object is to see how the knowledge is managed.

Case Studies

Positive

1. United 232, Sioux City, KA

Negative

1. HTI's CC-130 example.
2. AA 965, Cali, Columbia.
3. Tiger 66, Kuala Lumpur, Malaysia.

Videos

1. tba

⁴ An example used by Tversky and Kahneman to demonstrate that human decision makers do not use prior probabilities in their judgements appropriate to a Bayesian decision making model. See Tversky, A. and Kahneman, D. (1974). Judgment under uncertainty: Heuristics and biases. *Science*, 185, 1124-1131.

⁵ Bonner, M.C. (1996). Crew resource management. In, *Minutes of Technical Panel 7, Sub Group U, of The Technical Cooperation Program*. Monterey, CA, USA: The Technical Cooperation Program, Washington, DC, USA. 63-68

COMMUNICATION

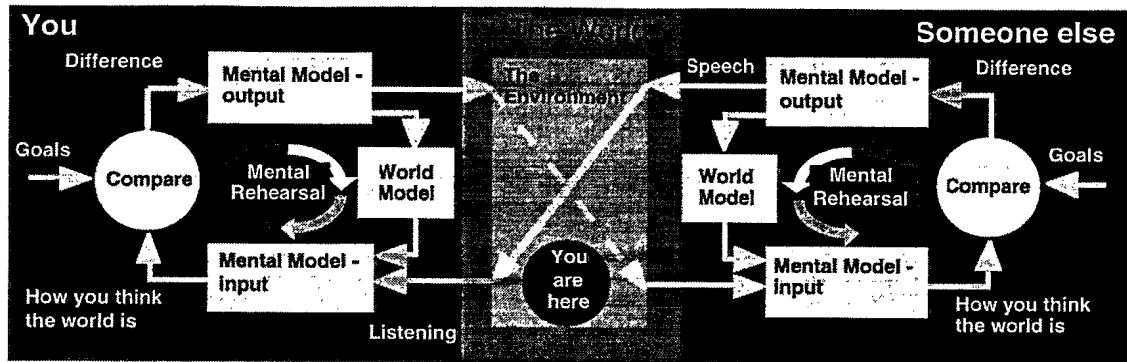

Introduction: review of the functions of communication, need to open and maintain communication channels, communication is more than the words, how is the information coded, draws on common mental models (e.g., Who's on first?), verbal and non-verbal communication.

Communication Loop: Sender, encoding, receiver, decoding, feedback.

Barriers to Communication: physical, cognitive, physiology, interpersonal (styles), organisational, cultural.

When, Why and How: when and why do you need to build common mental models, when is it better to stay quiet, the sterile cockpit (“...cheer up...”, “...off you go...”) and when to speak up, a Captain’s brief, monitoring other’s workload, timing of input, how to open communication channels and maintain them, how to increase your loop gain (active listening, levels of assertiveness, advocacy, body language, key phrases), breaking down the barriers, say what you mean, listen beyond the words — listen to the message, famous last words.

What was said

“...we have a slight problem...”

“...we would like to expedite our arrival...”

“...please amend our ETA XYZ from 1300 to 1330Z...”

“...Tower this is ABC — tell the aircraft following we are experiencing a slight windshear on finals...”

“...Houston we have a problem...”

What was meant

“...we have an uncontrollable engine fire and the main spar is about to fail...”

“...we are 10 miles out and #4 has just flamed out due to fuel starvation...”

“...we have no idea of our current position...”

“...our airspeed is fluctuating + and - 30 knots and we are showing full deflection on the glideslope...”

Apollo 13

Open Loop Communication: must receive closure, acknowledgements, high proficiency crews are characterised by a low proportion of open loop communications.

Effective Communication: common communication errors, promoting effective communication.

Leadership/Followership Issues: exercising responsibility for opening and maintaining communication channels.

Summary:

Knowledge:

1. Roles of communication.
2. The communication loop.
3. Ways of opening and maintaining communication channels.
4. Barriers to communication and what can be done about it.
5. How to increase your loop gain.

Skills:

1. Ability to establish and maintain communication channels.
2. Ability to communicate clearly and concisely.

Assessment:

1. Core knowledge.
2. Sets the tone for open communication channels.
3. Maintains information flow.
4. Uses language appropriate to the situation (names items, doesn't use slang or non-standard terms).
5. Conveys meaning (loop closure) in minimum number of iterations.

Resources:

Exercises

1. tba

Case Studies

Positive

1. BA 747, Indonesia.
2. UK Tornado crew.

Negative

1. Cheer up.
2. Off you go.

Videos

Positive

1. tba

Negative

1. Who's on first.

**APPENDIX 2: REPERTORY GRID PROCEDURE FOR ELICITING
OBSERVABLE CAPTAINCY BEHAVIOURS**

USING *REPGRID* TO ELICIT CAPTAINCY CONSTRUCTS

For the purposes of interpreting these instructions note that the *Administrator* is the person administrating the elicitation process, while the *Subject* is the person providing the Captaincy constructs.

There are three phases in this exercise.

PHASE 1

General

In the first phase, the *Administrator* will assure the *Subject* that all information provided in this exercise is strictly confidential. For example:

Administrator: "Hello, (Subject's Name), I am (Administrator's Name). I would like to welcome you and thank you for participating in the Captaincy Constructs Elicitation exercise. In this exercise, you will be using the interactive RepGrid computer program to unravel behaviours that you identify with the notion of Captaincy. I will guide you through all necessary steps in order for you to complete this process on the computer. I assure you that all information provided is strictly confidential. Let us start by having you fill out Form A and Form B."

Form A consists of the following items that the *Subject* is required to provide information on:

Name (Optional but highly recommended)
Current Position (e.g.: Aircraft Commander)
Rank (e.g.: Major)
Date of Birth (*day, month, year*)
Flying History
 Total Hours
 Total On Type
 Number of hours in present position
 Aircraft Commander (all multi-crew types)
 Co-pilot (all multi-crew types)
Completed CRM course
 Yes/No (when)
 Refreshers (when)

Form B is written in a self explanatory format and guarantees the confidentiality of the information given by the *Subject*. In fact the *Subject* will take this Form from the testing venue at the end of the exercise.

Form B requires the *Subject* to reflect upon, and choose by name or other identifier, a total of 6 captains that they have flown with. The *Administrator* needs only to ask that the form be completed, and to answer any questions the *Subject* might have. **The *Administrator* does not see this form!** For example:

Administrator: "Now that you have completed Form A, let us introduce Form B which you get to keep at the end of this exercise. I will not need to see what you have written on it. It is merely a tool to help you with the exercise."

Although, Form B is self explanatory, please do not hesitate to ask me if you have any questions regarding the Form. There is no rush, so please take all the time you need for completion.”

While the *Subject* is working on Form B, it is a good time for the *Administrator* to prepare the *RepGrid* computer program, instead of looking at what the *Subject* is doing. This way, the *Subject* will be tend to feel less hurried and can concentrate on the task of choosing the 6 captains. However, the *Administrator* may choose to prepare the computer program before the arrival of the *Subject*. If so, the *Administrator* will merely need to double check the preparation process, while the *Subject* is filling out forms A and B.

Preparing the RepGrid

We start the program by clicking on the *RepGrid* icon. The “Welcome to RepGrid” window will appear. In this window, it reads “Please enter your name and a session description.” The *Administrator* will need to type in the *Subject* number in the “Name and description” field (e.g., Subject1) and click on “Done”. Each *Subject* should be given a different Subject number.

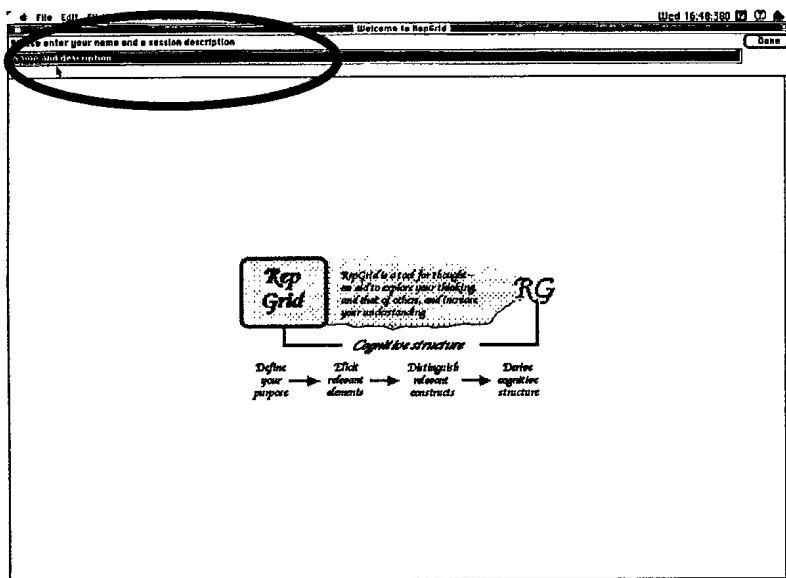

The “Grids” window should appear next The *Administrator* will continue by clicking on “New Grid.”

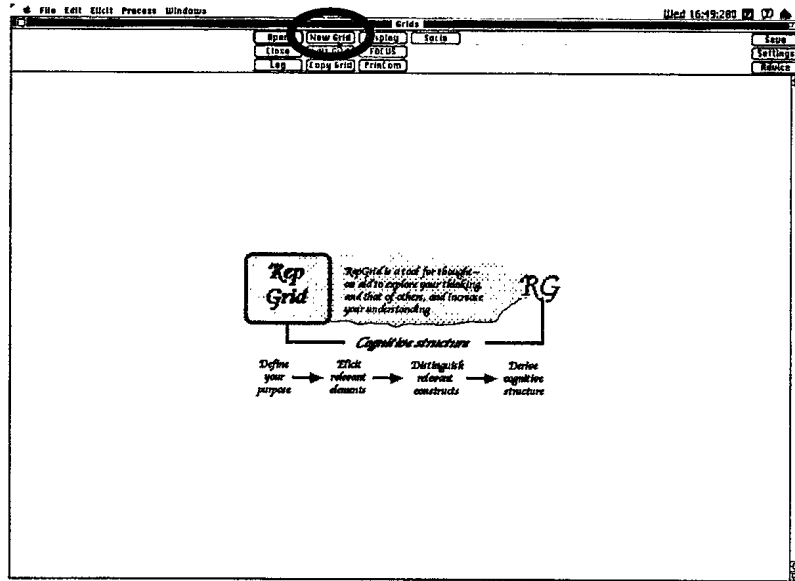

A small window will appear asking for a file name to save the session. Here, the *Administrator* should type in the *Subject* number (e.g. Subject1), and click on “OK”.

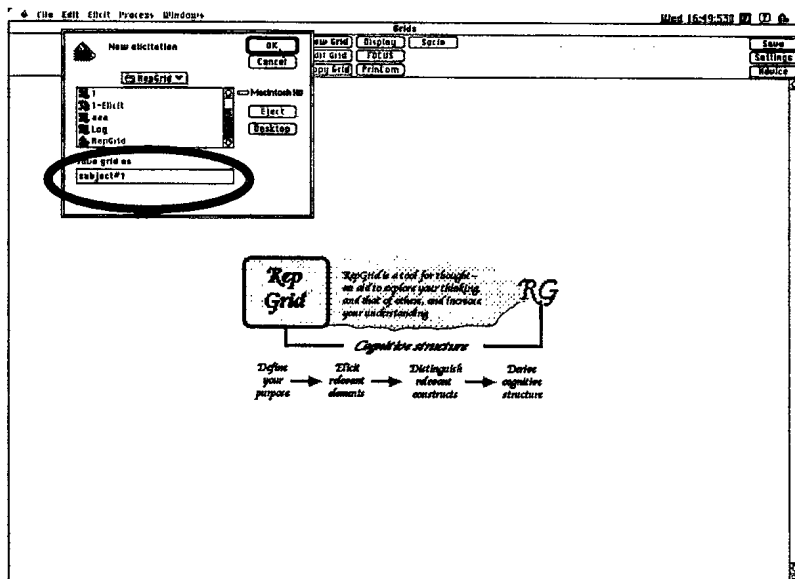

The “Subject?-Elicit” window will then appear. The blocked field **anonymous** will appear in the box situated below the *Showing elicitation status* statement. The *Administrator* should now type the *Subject* number (e.g., Subject1) follow by clicking on “Done”.

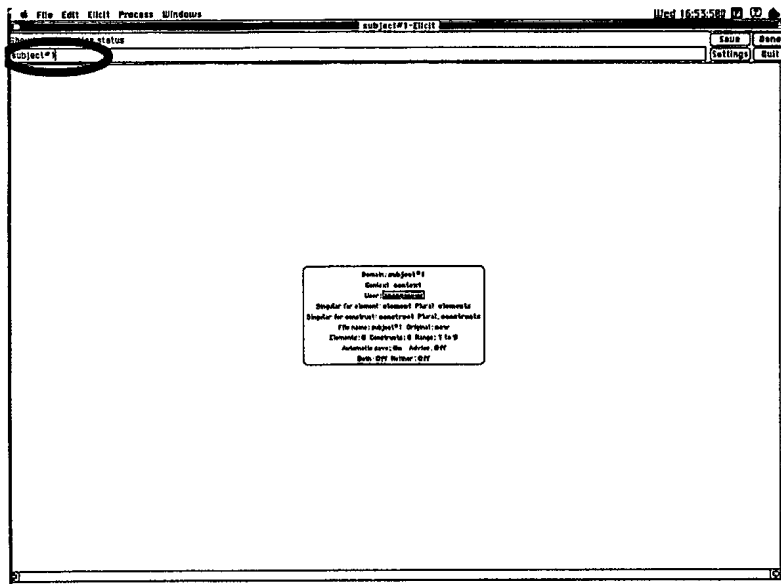

The blocked field **context** will appear next inside the box. The *Administrator* continues by typing in “to explore Identifiable Captaincy Behaviour (ICB)”, follow by clicking on “Done” *three* times.

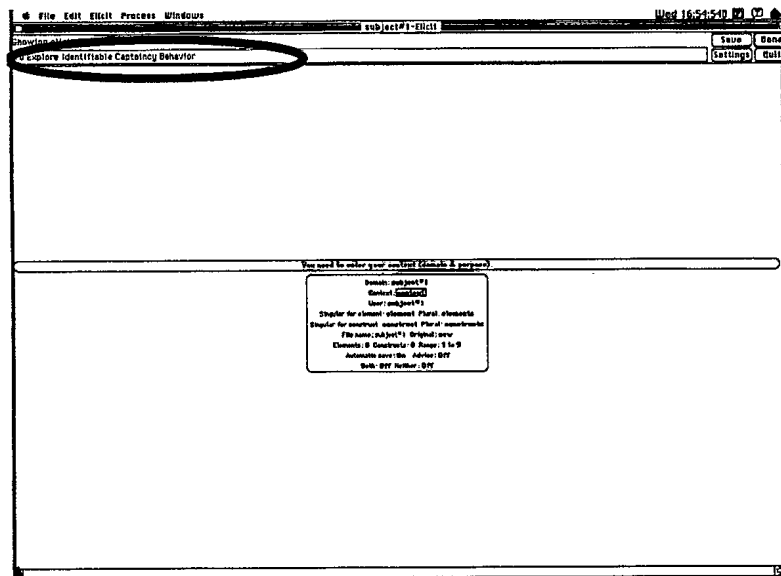

Next to appear inside the box is the blocked field **New element**. The *Administrator* should type in the following Elements, one at a time, clicking on “More” after each entry (except the last element — Captain G).

- Captain A (More)
- Captain B (More)
- Captain C (More)
- Captain D (More)

Captain E (More)
Captain F (More)
Captain G (Done)

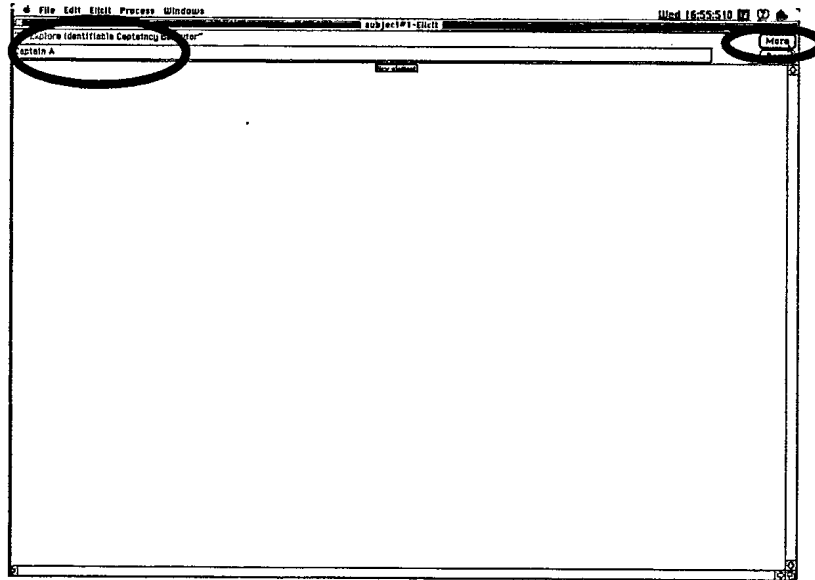

After entering the last element (Captain G), the *Administrator* will click on “Done” to return to the “Subject?-Elicit” window. The Grid is now ready for testing the *Subject*.

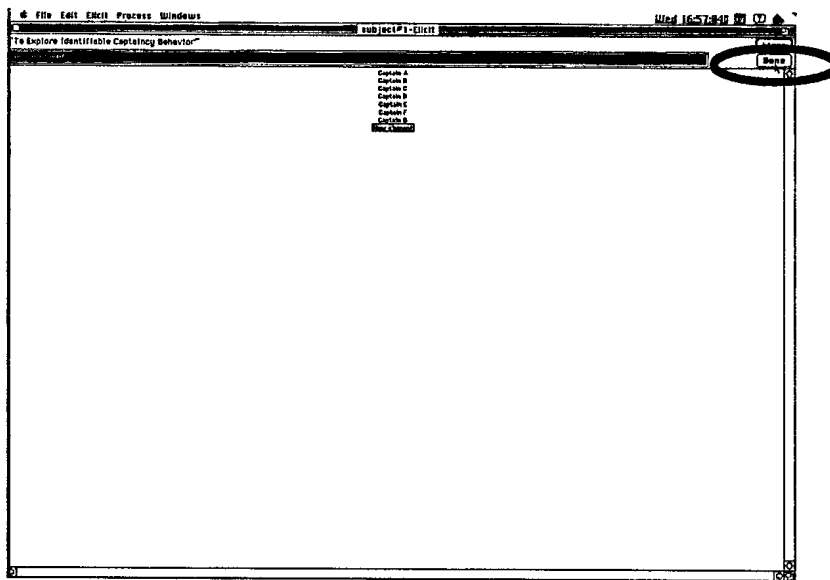

PHASE 2

When the *Subject* signals that Form B has been completed, the *Administrator* will place the computer in front of the *Subject*, and inform them that **reference should always be made to**

Form B when relating Captain's names to the Elements A-G.

Construct Elicitation

The elicitation process will be presented as cycles. Each cycle will elicit one bi-polar construct under the context of *Identifiable Captaincy Behaviours*.

The cycle starts by clicking on "Triad". Three elements should be presented, and at the top of the window it should read "In what way are two of the situations alike and different from the third?"

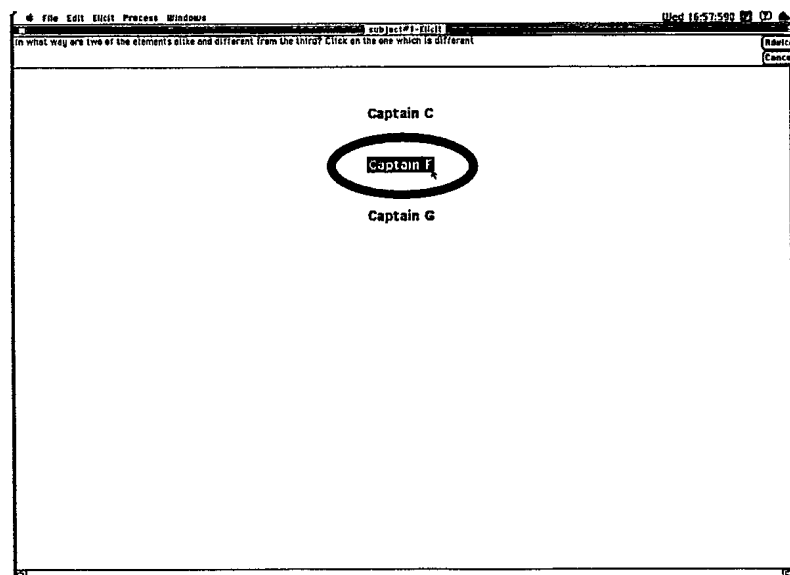
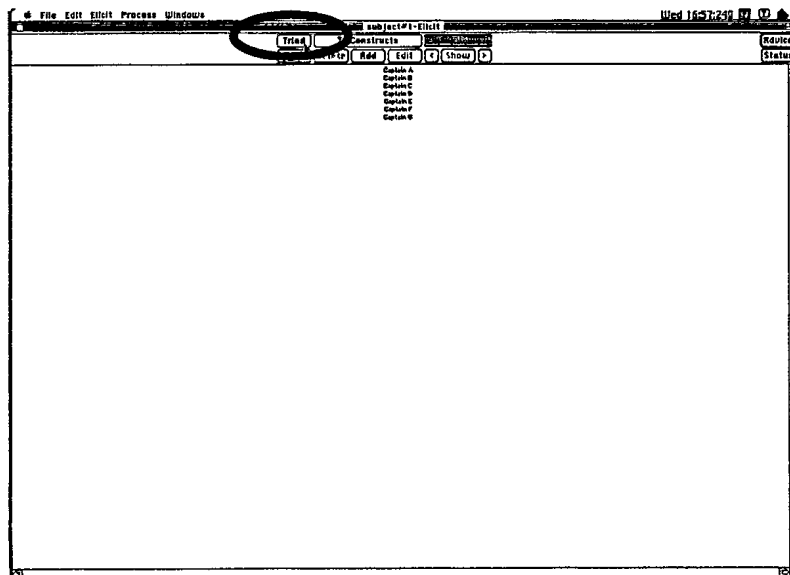

The *Subject* should click on the field that contains the identifier (Captain A, Captain B, Captain C, etc.) of the Captain that they consider to be **different** from the other two (they should refer to Form B to assist them in this task). It will be highlighted to indicate which of the three has been selected. After the *Subject* has made a choice, a new window should appear.

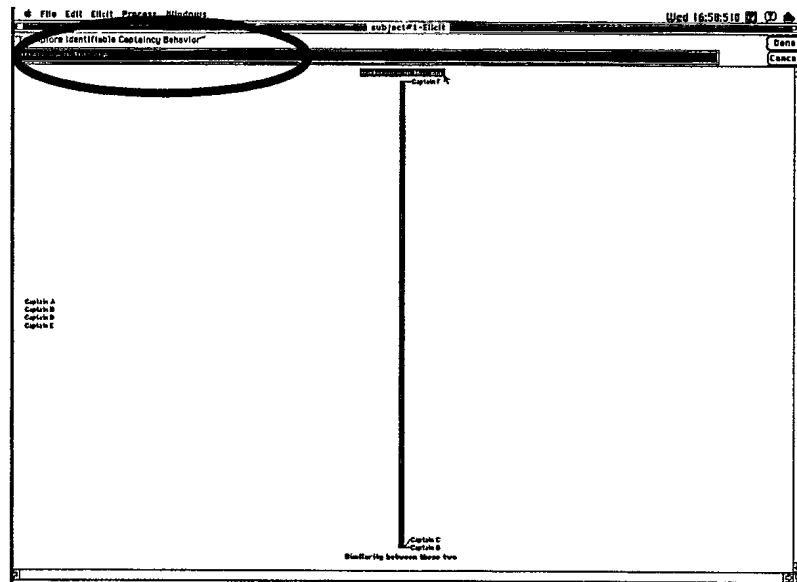

In this new window, the *Subject* is required to perform a series of tasks.

- First the *Subject* will be prompted to enter in “The difference in this one” field, what they think is the difference between this captain and the other pair, in term of an **identifiable captaincy behaviour** (e.g., “Doesn’t invite input from his crew”).
- Secondly, the *Subject* should double click on the “Similarity between these two” field, , and enter in this field what they think is the similarity between this pair of captains, relative to the captain that is different (e.g., “incorporates crew’s inputs to their decisions”). Note that these same and difference categories are by nature opposites.
- **Finally, the *Subject* will adjust the position of the elements (the Captains) on the newly formed bi-polar scale, so as to reflect best the *Subject*’s judgement of where each Captain should fit on the scale relative to the others.** The adjustment is done by selecting (clicking and holding) the element to be repositioned and dragging it to a new position on the scale.

The *Subject* should reposition the elements, along the newly formed bi-polar scale, **starting with the pair of captains who are similar**. This will force the *Subject* to further differentiate between the Captains who are similar. As mentioned before, this can be done by clicking and holding on the element to be moved and dragging it to a new position on the scale. Now the **remaining** Captains, whose labels (Captain A, Captain B, etc.) appear on the left side of the window, are positioned on the scale. The *Subject* should click and hold on these elements, one at a time, and drag them to a position along the scale that represents the degree to which their behaviour is characterised by the statements at the end of the scale. The *Subject* is free to reposition any existing elements on the scale at any time. **Note that reference should always be made to Form B regarding the correspondence between**

name and elements.

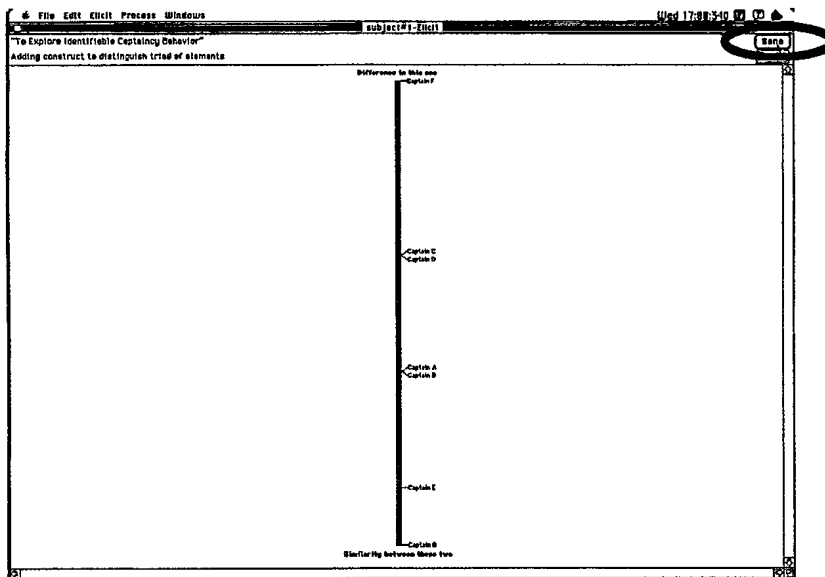
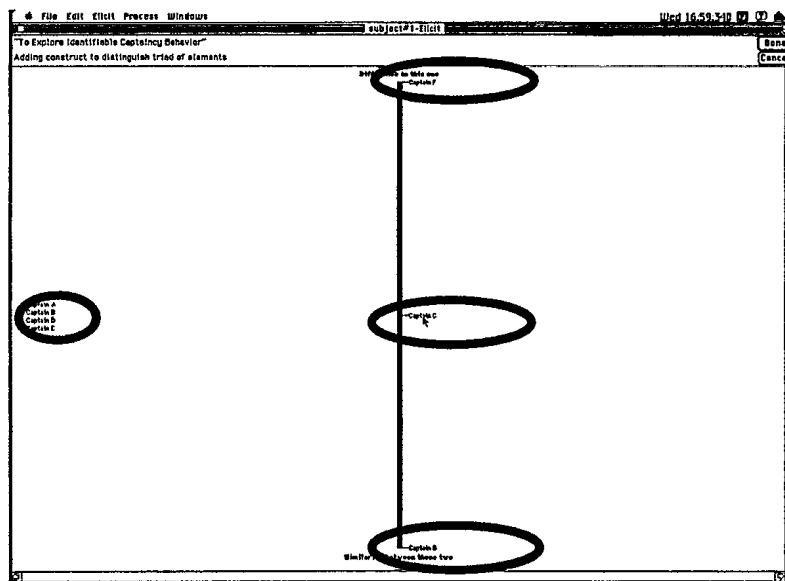

When all the elements are place, the *Subject* can continue to another Triad by clicking “Done” and then “Triad”. A new cycle of the elicitation process will begin. The *Administrator* should stay with the *Subject* for at least three cycles of the process, and then leave the *Subject* alone to complete the exercise. The elicitation process will end when the *Subject* cannot think of any further way of making distinctions between triads.

The subject may try several triads to see if any grouping elicits further ideas. If a particular triad doesn’t trigger any thoughts the *Subject* can use the cancel button and try again. When the subject has exhausted all possibilities they should call the *Administrator* for the final Phase of the exercise.

PHASE 3

The *Administrator* will rejoin the *Subject* at the end of the elicitation process.

The *Administrator* will click on the “To constructs” button, if it is showing, to obtain a listing of the bi-polar constructs elicited at phase 2. Here, the *Administrator* will need to align the bi-polar constructs in the same direction, starting from left to right, **the least desired pole to the highly desired pole** (e.g., Lazy ↔ Industrious). The *Administrator* can polarise the constructs by using the “Flip” feature. Clicking on the Flip icon button after selecting the bi-polar construct, will reverse the polarity for this construct.

Furthermore, clarification notes describing the concise meaning of each pair of constructs should also be included. The *Administrator* can enter and add clarification text by double clicking on the bi-polar construct and editing the entry, or the *Administrator* can add clarification notes in the space provided in Form C. This process will ensure the co-directional property and descriptive content accuracy of all the constructs elicited.

The *Subject* will continue to rate the importance of each bi-polar construct in determining their overall perception of *Captaincy*, using a 9 point scale. These ratings should be noted by the *Administrator* using Form C. If there are any constructs that share the same ratings, the *Administrator* should further require the *Subjects* to rank these equal rated constructs by their relative importance in determining identifiable captaincy behaviour.

Finally, the *Subject* will rate themselves on each of the elicited bi-polar constructs, using a nine point bi-polar scale. This is to determine how “Self” is being judged on each bi-polar construct by the *Subject*. The *Administrator* should record these ratings using Form D.

When this is done, the *Administrator* should debrief the *Subject* on the exercise, ensuring confidentiality, and, attend to questions and suggestions from the *Subject*.

The *Administrator* should make a copy of the elicited file on a separate diskette.

Annexes: Forms A, B, C and D

Annex A

Form A: Captaincy Elicitation Study

Subject Name (Optional): _____

Subject Number: _____

Position: _____

Rank: _____

Age (day, month, year): _____

Flying History:

(a) Total Hours: _____

(b) Total Hours On Type: _____

(c) Number of Hours in Present Position: _____

CRM Course Completed: Yes/No
If yes, date of completion: _____

CRM Refresher Course: Yes/No
If yes, date of course: _____

Annex B

Form B: Captaincy Elicitation Study

The information provided by you in this form is strictly confidential. **You are the only person that will know its content. You will take this form with you at the end of this session. We will have no record of this document.**

1. Take a moment to reflect upon the captains whom you have served with in your flying career.
2. Reflect on and choose the three best captains, and list them below (use real names, nicknames, initials, etc.):

3. Reflect on and choose the three worst captains, and list them below:

4. Rank order your three best captains below.

Best of Best: (A) _____

Second Best: (B) _____

Third Best: (C) _____

5. Rank order your three worst captains below.

Worst of Worst: (F) _____

Second Worst: (E) _____

Third Worst: (D) _____

6. Please turn the page.

Form B (Continued): Captaincy Elicitation Study

7. With reference to the ordering of your Captains as they appear in steps 4 and 5, please rewrite the names of your selections in the corresponding boxes below:

- Captain A (A) _____
- Captain (B) _____
- Captain (C) _____
- Captain D (D) _____
- Captain E (E) _____
- Captain F (F) _____
- Captain G (G) The "IDEAL" captain

Keep this page handy for ready reference during the remaining part of this exercise.

8. When you have completed this step, please notify the *Administrator*.

Annex C

Form C: Captaincy Elicitation Study

Date: _____
 Administrator: _____
 Subject Number: _____
 Number of Constructs: _____

On a scale of 1 to 9, rank order the importance of each construct in determining identifiable captaincy behaviour.

1	2	3	4	5	6	7	8	9
least important		quite important		fairly important		very important		most important

	Construct	1 to 9 Rating	Further ranking, if any two or more ratings are equal
1.	_____	_____	_____
2.	_____	_____	_____
3.	_____	_____	_____
4.	_____	_____	_____
5.	_____	_____	_____
6.	_____	_____	_____
7.	_____	_____	_____
8.	_____	_____	_____
9.	_____	_____	_____
10.	_____	_____	_____
11.	_____	_____	_____
12.	_____	_____	_____
13.	_____	_____	_____
14.	_____	_____	_____
15.	_____	_____	_____
16.	_____	_____	_____
17.	_____	_____	_____
18.	_____	_____	_____
19.	_____	_____	_____
20.	_____	_____	_____

Annex D

Form D: Captaincy Elicitation Study

Date: _____
Administrator: _____
Subject Number: _____
Number of Constructs: _____

Rate "Self" on each of the elicited bi-polar constructs.

	1	2	3	4	5	6	7	8	9
	least desired pole								most desired pole
	Construct								1 to 9 "Self" Rating
1.	_____	_____	_____	_____	_____	_____	_____	_____	_____
2.	_____	_____	_____	_____	_____	_____	_____	_____	_____
3.	_____	_____	_____	_____	_____	_____	_____	_____	_____
4.	_____	_____	_____	_____	_____	_____	_____	_____	_____
5.	_____	_____	_____	_____	_____	_____	_____	_____	_____
6.	_____	_____	_____	_____	_____	_____	_____	_____	_____
7.	_____	_____	_____	_____	_____	_____	_____	_____	_____
8.	_____	_____	_____	_____	_____	_____	_____	_____	_____
9.	_____	_____	_____	_____	_____	_____	_____	_____	_____
10.	_____	_____	_____	_____	_____	_____	_____	_____	_____
11.	_____	_____	_____	_____	_____	_____	_____	_____	_____
12.	_____	_____	_____	_____	_____	_____	_____	_____	_____
13.	_____	_____	_____	_____	_____	_____	_____	_____	_____
14.	_____	_____	_____	_____	_____	_____	_____	_____	_____
15.	_____	_____	_____	_____	_____	_____	_____	_____	_____
16.	_____	_____	_____	_____	_____	_____	_____	_____	_____
17.	_____	_____	_____	_____	_____	_____	_____	_____	_____
18.	_____	_____	_____	_____	_____	_____	_____	_____	_____
19.	_____	_____	_____	_____	_____	_____	_____	_____	_____
20.	_____	_____	_____	_____	_____	_____	_____	_____	_____

**APPENDIX 3: BEHAVIOURALLY ANCHORED RATING SCALES FOR
HFDM EVALUATION**

DECISION MAKING

The result of a decision can be seen in an observable action or utterance and can sometimes be inferred by the absence of an action.

Criterion: Were the decisions/actions appropriate?

Scale	Rating	Definition	AC	CP	FE	NAV	LM
0	Not observed	No opportunities for the target behaviours to be observed.					
1	Poor	No decision or incorrect for the circumstances, does not accomplish task objectives, does not bound risk.					
2	Min. Required	Bounds risk but compromises task objectives.					
3	Standard	Accomplishes prime task objectives with an acceptable level of risk.					
4	Outstanding	Accomplishes all task objectives with superior risk management.					
5	Exceptional	Completely satisfies all task objectives, adds to mission goals, with lowest levels of risk achievable.					

DECISION MAKING

The result of a decision can be seen in an observable action or utterance and can sometimes be inferred by the absence of an action.

Criterion: Did the decisions/actions occur within the time available?

Scale	Rating	Definition	AC	CP	FE	NAV	LM
0	Not observed	No opportunities for the target behaviours to be observed.					
1	Poor	Did not accomplish all essential tasks in the available time.					
2	Min. Required	Accomplished all essential tasks in the available time.					
3	Standard	Accomplished all tasks in the available time.					
4	Outstanding	Accomplished all tasks easily within the available time.					
5	Exceptional	Accomplished all tasks, brought forward tasks, took on additional discretionary tasks.					

TIME MANAGEMENT

Criteria

Individual

- Did each crewmember appear calm or rushed?
- Did each crewmember prioritise, delegate, delay, shed, buy time appropriately?
- Is each crewmember using the appropriate level of KRS processing for the task in hand?
- Did each crewmember act to relieve the loads of other crewmembers.

Scale	Rating	Definition	AC	CP	FE	NAV	LM
0	Not observed	No opportunities for the target behaviours to be observed.					
1	Poor	Very rushed. Did not routinely employ time management strategies or optimal processing strategies.					
2	Min. Required	Was rushed with little capacity for additional time load, used less than optimal processing strategies and did not use best available time management methods.					
3	Standard	Can handle additional load, generally used best processing strategies and appropriate time management methods.					
4	Outstanding	Calm. Demonstrated the routine use of appropriate time management strategies, always used optimal processing strategies, monitored the load of others.					
5	Exceptional	Calm. Always used best available time management methods and optimal strategies. Brought forward tasks, took on additional tasks, relieved others.					

TIME MANAGEMENT

Criteria

Crew

- Was a balance achieved in the imposed time pressure of all crewmembers?

Scale	Rating	Definition	Crew
0	Not observed	No opportunities for the target behaviours to be observed.	
1	Poor	Gross discrepancies between the time pressures with some crewmembers overloaded.	
2	Min. Required	Uneven time pressures between crew members, but no-one overloaded.	
3	Standard	Crew busy, the load is evenly distributed, no one overloaded.	
4	Outstanding	No crewmember was obviously rushed.	
5	Exceptional	An air of calm was seen with time available to take on additional tasks and bring activities forward.	

KNOWLEDGE MANAGEMENT

Criterion

Individual

- Did each crewmember
 - actively seek and correctly perceive (was Aware of) all important information?
 - consider the Implications of the situation?
 - form Plans to cope with the situation and its implications, appropriate to their role?
- Did each crewmember set appropriate goals and communicate them as required (e.g., by briefing)?
- Did each crewmember share their knowledge (i.e., establish a common mental model) as appropriate?
- Did each crewmember resolve conflicts appropriately?
- Did each crewmember consider all the information they were aware of in making their decisions?

Scale	Rating	Definition	AC	CP	FE	NAV	LM
0	Not observed	No opportunities for the target behaviours to be observed.					
1	Poor	Did not plan in depth (AIP), poor goal setting and communication of goals, sometimes left conflicting information unresolved, did not always share knowledge or use all knowledge in decisions.					
2	Min. Required	Generally planned in depth, occasionally did not clearly communicate goals and knowledge and left conflicting information unresolved. Generally used most of the available knowledge in decision making.					
3	Standard	Generally planned in depth, formed and communicated appropriate goals, resolved most conflicts and used most of the available knowledge.					
4	Outstanding	Almost always planned in depth, with clearly formed and communicated goals. Most times built common mental models and resolved conflicting information. Used the most important information in decision making.					
5	Exceptional	Always planned in depth, set and communicated clear goals, used superior methods for building common mental models (thinking aloud, briefing), actively sought and used information from all applicable sources always resolving conflicting information.					

KNOWLEDGE MANAGEMENT

Criterion

Crew

- Were the crew working from common goals and mental models?

Scale	Rating	Definition	Crew
0	Not observed	No opportunities for the target behaviours to be observed.	
1	Poor	Instances occurred where crewmembers were working towards different goals or had conflicting mental models that were left unresolved until their consequences were noted in mission performance.	
2	Min. Required	When discrepancies occurred between crewmember's goals or mental models they were resolved with some delay but before their consequences on satisfactory mission performance were observed.	
3	Standard	Crew were always working towards common goals at the level their role dictated. Mental models were shared to enable tactical goals to be met. Conflicting knowledge was resolved when noted with minimal delay.	
4	Outstanding	Crew were always working towards common goals at the tactical level and had some appreciation of the broader issues. Mental models were shared at the tactical level, and at the strategic level to some extent. Conflicts were resolved immediately.	
5	Exceptional	All crewmembers had a common understanding of all goals that effected the mission at both strategic and tactical levels. Mental Models were widely shared. Conflicts were resolved immediately they were noted.	

ATTENTION MANAGEMENT

Criterion

Individual

- Did each crewmember attend to (control) the variables within their domain of responsibility?
- Did each crewmember direct attention when appropriate?

Scale	Rating	Definition	AC	CP	FE	NAV	LM
0	Not observed	No opportunities for the target behaviours to be observed.					
1	Poor	Loops within the crewmember's domain of responsibility were left unattended until their consequences (deviations) were seen in mission performance. Failures in their own, and other's, goal achievement were left uncorrected until they impacted the mission.					
2	Min. Required	All critical variables were controlled so that there was no impact on satisfactory mission performance. Failures in their own, and other's, goal achievement were corrected before they impacted the satisfactory performance of the mission.					
3	Standard	All critical variables were controlled within acceptable limits. Generally directed attention to variables that deviated from set goals well before there was a negative impact on mission performance.					
4	Outstanding	All critical variables within the crewmembers domain of responsibility were controlled with minimum deviation from goals states. Crewmember directed their own and other's attention to variables that were deviating from goals states before they impacted the mission.					
5	Exceptional	All variables within the crewmembers domain of responsibility were controlled with minimum deviation from goals states. Crewmember always directed their own and other's attention to variables that were deviating from goals states, well before limits were exceeded.					

ATTENTION MANAGEMENT

Criterion

Crew

- Did the crew ensure that goals were achieved by monitoring, acknowledging, cross-checking, backing up, etc?

Scale	Rating	Definition	Crew
0	Not observed	No opportunities for the target behaviours to be observed.	
1	Poor	Many instances of open loop communication, little evidence of monitoring or cross-checking behaviour. No attempts to back up inattentive or overloaded crewmembers. Easily distracted, cases of narrow locus of control.	
2	Min. Required	Crew achieved closure on all critical goals, with the essential variables under sufficient control to prevent deviations from impacting the mission.	
3	Standard	Crew achieved closure on all critical goals, with the essential variables under tight control so that no impact would be expected on mission performance. Crew resistant to distraction with broad locus of control.	
4	Outstanding	Crew achieved closure on all critical goals. Crew routinely monitored all variables at the tactical and strategic levels and cross checked when their was doubt about current state or goal closure. All communications were responded to. Crew did not lose focus in the face of distractions.	
5	Exceptional	Crew achieved closure on all critical goals. Crew monitored all variables at the tactical and strategic levels and cross checked when their was doubt about current state or goal closure. All communications were responded to with minimal delay. Crew did not lose focus in the face of distractions.	

UNCLASSIFIED

SECURITY CLASSIFICATION OF FORM
(Highest classification of Title, Abstract, Keywords)

DOCUMENT CONTROL DATA

(Security classification of title, body of abstract and indexing annotation must be entered when the overall document is classified)

1. ORIGINATOR (the name and address of the organization preparing the document. Organizations for whom the document was prepared, e.g., Establishment sponsoring a contractor's report, or tasking agency, are entered in section 12.) DCIEM PO Box 2000 North York, ON CANADA		2. DOCUMENT SECURITY CLASSIFICATION (overall security classification of the document including special warning terms if applicable) Unclassified	
3. DOCUMENT TITLE (the complete document title as indicated on the title page. Its classification should be indicated by the appropriate abbreviation (S,C,R or U) in parentheses after the title.) Human factors of CC-130 operations. Volume 5: Human factors in decision making (U)			
4. DESCRIPTIVE NOTES (the category of the document, e.g., technical report, technical note or memorandum. If appropriate, enter the type of report, e.g. interim, progress, summary, annual or final. Give the inclusive dates when a specific reporting period is covered.) Final Report			
5. AUTHOR(S) (Last name, first name, middle initial. If military, show rank, e.g. Burns, Maj. Frank E.) K.C. Hendy, G. Ho			
6. DOCUMENT DATE (month and year of publication of document) December 1997		7.a. NO. OF PAGES (total containing information. Include Annexes, Appendices, etc.) 90	7.b. NO. OF REFS. (total cited in document) 23
8.a. PROJECT OR GRANT NO. (if appropriate, the applicable research and development project or grant number under which the document was written. Please specify whether project or grant) Project 3fa11		8.b. CONTRACT NO. (if appropriate, the applicable number under which the document was written)	
9.a. ORIGINATOR'S DOCUMENT NUMBER (the official document number by which the document is identified by the originating activity. This number must be unique to this document.) DCIEM No. 98-R-18		9.b. OTHER DOCUMENT NO.(S) (any other numbers which may be assigned this document either by the originator or by the sponsor.)	
10. DOCUMENT AVAILABILITY (any limitation on further dissemination of the document, other than those imposed by security classification)			
<input checked="" type="checkbox"/> Unlimited distribution			
<input type="checkbox"/> Distribution limited to defence departments and defence contractors; further distribution only as approved			
<input type="checkbox"/> Distribution limited to defence departments and Canadian defence contractors; further distribution only as approved			
<input type="checkbox"/> Distribution limited to government departments and agencies; further distribution only as approved			
<input type="checkbox"/> Distribution limited to defence departments; further distribution only as approved			
<input type="checkbox"/> Other			
11. ANNOUNCEMENT AVAILABILITY (any limitation to the bibliographic announcement of this document. This will normally correspond to the Document Availability (10.) However, where further distribution (beyond the audience specified in 10) is possible, a wider announcement audience may be selected.) Unlimited			
12. SPONSORING ACTIVITY (the name of the department project office or laboratory sponsoring the research and development. Include the address.) DCIEM PO Box 2000, North York, ON CANADA			

DSIS DCD03
HFD 09/94SECURITY CLASSIFICATION OF FORM
(Highest classification of Title, Abstract, Keywords)
UNCLASSIFIED

UNCLASSIFIED
SECURITY CLASSIFICATION OF FORM
(Highest classification of Title, Abstract, Keywords)

13. **ABSTRACT** (a brief and factual summary of the document. It may also appear elsewhere in the body of the document itself. It is highly desirable that the abstract of classified documents be unclassified. Each paragraph of the abstract shall begin with an indication of the security classification of the information in the paragraph (unless the document itself is unclassified) represented as (S), (C), (R), or (U). It is not necessary to include here abstracts in both official languages unless the text is bilingual).

Volume 5 of the Report of the DCIEM/ATG study team describes the development of a proposed new training programme devoted to *Human Factors in Decision Making* (HFDM). It is envisaged that the HFDM training syllabus would replace existing *Aircrew Co-ordination Training* (ACT) within the CC-130 community. The proposed training can be distinguished from other approaches with similar goals (either explicit or implicit) by its base within a theoretical framework of human information processing. The differences lie less in the content than in the way the material is organised and shaped by theory.

The proposed HFDM training is based on two related models of the human information processor. They are the *Information Processing* (IP) model., and the *Perceptual Control Theory* (PCT) model. The models are complementary as the IP model sits within the PCT framework. Together they integrate much of what is known about human information processing and decision making.

Topics for HFDM training come directly from this theoretical framework. The proposed syllabus is made up of 11 related modules covering the following topics: an introduction to the decision making loop; leadership and followership; the emergence of communication and captaincy in teams and groups; sensation/perception; goal setting; action selection; management of control, attention, time and knowledge; and finally communication. Each module is anchored in the theoretical framework and its effect on decision making. The core knowledge and skill set that are expected to come from each module are described for assessment purposes.

A clear distinction has been made between the knowledge development phase of training and skill development. In the proposed training programme, skill development would be done in a hands-on team environment using a variety of situations such as: role playing and team exercises; case study analysis; low and high fidelity simulation; instructional rides; and on-the-job-training. It is at this level that there exists the greatest potential for tailoring the training to aircraft position and making the training relevant to each individual's stage of development (upgrade training, recurrency training etc.).

14. **KEYWORDS, DESCRIPTORS or IDENTIFIERS** (technically meaningful terms or short phrases that characterize a document and could be helpful in cataloguing the document. They should be selected so that no security classification is required. Identifiers, such as equipment model designation, trade name, military project code name, geographic location may also be included. If possible, keywords should be selected from a published thesaurus, e.g. Thesaurus of Engineering and Scientific Terms (TEST) and that thesaurus identified. If it is not possible to select indexing terms which are Unclassified, the classification of each should be indicated as with the title.)

aviation safety
flight training
decision making
IP model
PCT
crew resource management

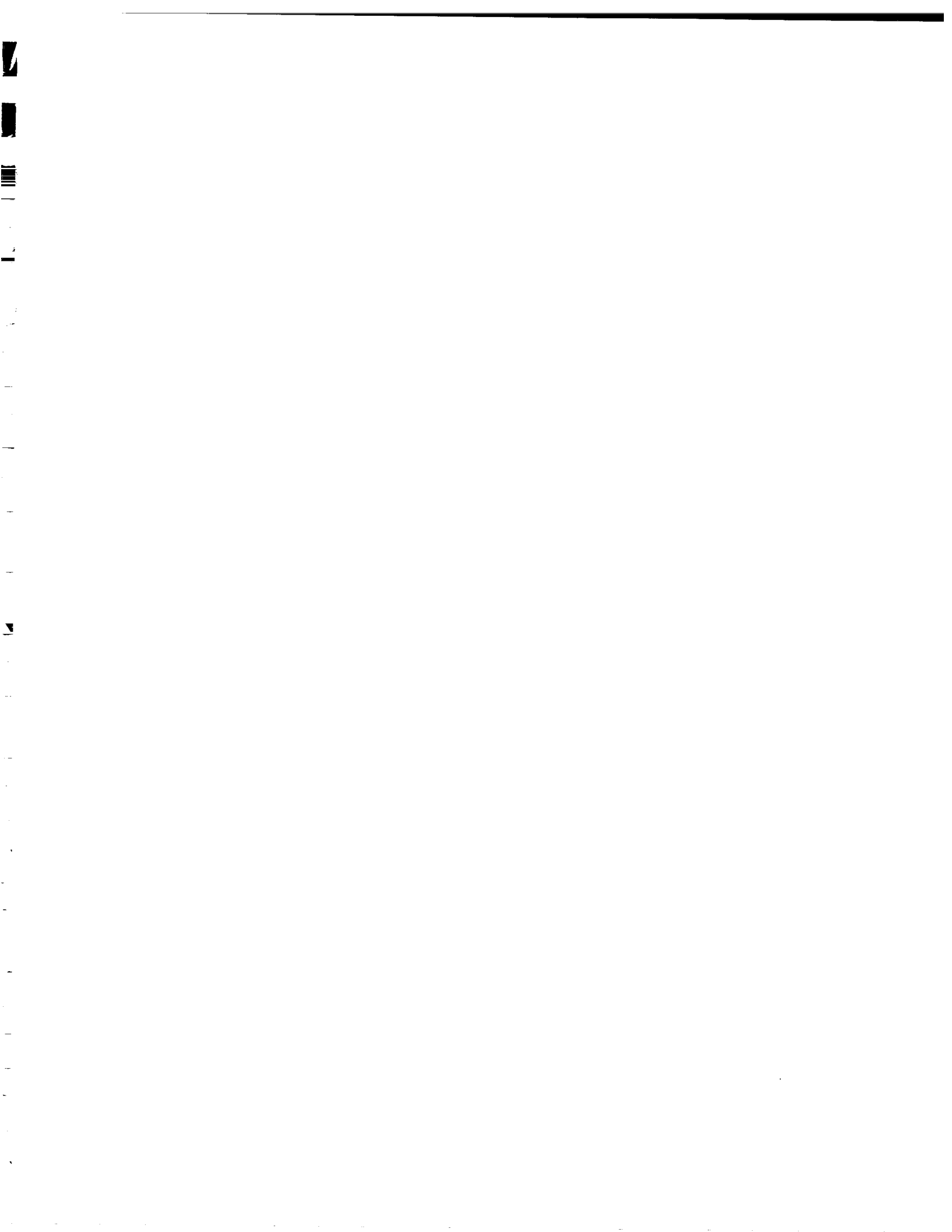

#508031

98-01223