

# Image Cover Sheet

**CLASSIFICATION**

**SYSTEM NUMBER**

511555

UNCLASSIFIED



**TITLE**

Detail Analysis of Ship Structures

**System Number:**

**Patron Number:**

**Requester:**

**Notes:**

**DSIS Use only:**

**Deliver to:**



# Detail Analysis of Ship Structures

By David Heath, Neil Pegg

Defence Research Establishment Atlantic, Dartmouth, Nova Scotia, Canada  
and

Aaron Dinovitzer, Robert Walker

Fleet Technology Limited, Kanata, Ontario, Canada

## Abstract

This paper describes an improved approach to finite element modeling of ship structural details for design and in-service assessment. Specialized meshing algorithms have been developed which create finite element meshes of three-dimensional detail structure from predefined templates of the detail boundaries and associated meshing parameters. The ship structural details are divided into classes such as stiffener intersections, brackets, bulkhead-stiffener intersections or cut-outs, which have common meshing parameters. Classes can be identified from lists of standard ship structural details produced by classification societies or for a specific ship type. Parametric stress analyses have been undertaken for these classes in advance to determine suitable finite element size distributions which are stored in a database and used to quickly generate the selected detail meshes when required. A relational object oriented global ship model is currently being developed from which users can graphically select a connection. The connection is checked against the predefined templates and the geometric parameters describing the detail are collected to direct the mesh development. Early use of this approach shows that it has the potential to reduce the overall time to produce a ship detail mesh from several days, using general-purpose finite element model generators, to under an hour. This improved detail meshing approach is being incorporated into an overall finite element based ship structural analysis program that uses global ship displacement results in a semi-automated top-down analysis of structural details. Overall, this approach will significantly reduce the time necessary to undertake complex analysis of ship structural details.

## Introduction

There has been considerable effort in the past decade by classification societies and Navies towards the development of 'first-principles' rational assessment methods for ship structures [1,2,3,4]. Finite element analysis (FEA) has become the standard method to obtain reasonable estimates of the hull girder structural response and of the complex stress patterns occurring in structural details such as cut-outs and connections. The top-down finite element (FE) approach, which uses coarser mesh models of the complete ship hull structure to provide boundary loads to fine mesh models of structural details, has become an accepted approach in many of the rational ship structural analysis tools.

While the computation time for large FE models has become acceptable, there remain some major drawbacks to applying the finite element method (FEM) to routine design and analysis of ship structure. One of these is the amount of time required to create the FE models. Even the more advanced general purpose FE mesh generators require significant time and skill to produce models of complex three dimensional shell structures. This paper discusses an approach to FE meshing of ship structural details which will significantly decrease the time required to undertake FEA to the point where it can be undertaken in a routine and timely manner. The topic of ship structural detail meshing classes is discussed followed by a description of a specialised FE mesher that can be used to create FE meshes of the detail classes. Application of this approach to the Halifax Class frigate for the Improved Ship Structures Maintenance Management (ISSMM) [5] project is discussed.

## Top-Down Ship Structural Detail Analysis

The modelling and analysis of ship structural details referred to in this paper uses the top-down FE method. The 'top' level analysis is of the global ship model, such as may be provided by the program Maestro [6]. Loads are applied as pressure and inertia forces from three-dimensional sea load codes, and/or as sectional bending moments and shear forces. The 'down' level analysis is done with the general purpose FE code VAST [7]. The program MGDSA (Maestro Graphics Detail Stress Analysis) [8], which facilitates the interface between the two levels of modelling and the FEA, has been used to undertake the top-down analysis. The top-down interface is undertaken by automatically identifying nodes that are common to the Maestro global model and the detail VAST model. These become master nodes on the boundaries between the two models. Other nodes, which may be created on the boundary of the detail model, are automatically slaved to the master nodes to give the correct translation of displacement boundary conditions between the two models. In addition to creating the detail meshes and the top-down analysis data, the MGDSA code also has facilities to verify the models and plot displacement and stress results. Figure 1 shows a global and detail model being used in a top-down analysis. This paper is concerned with the topic of efficiently producing the FE meshes of the structural details that can be used in a top-down FEA. Further discussion of the top-down approach and detail meshing can be found in [9] and [10].

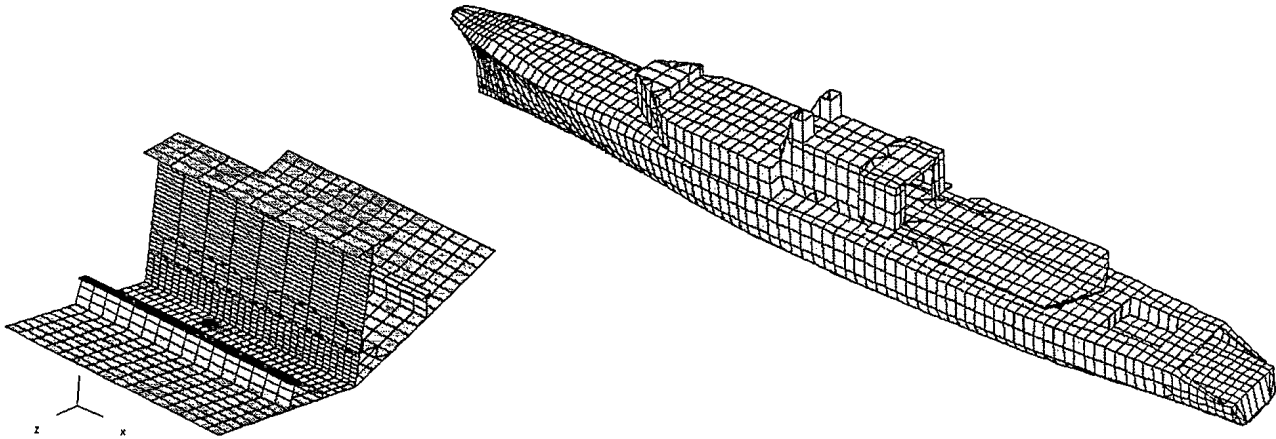

Figure 1: Top-down analysis example showing detail of keel structure and the global model

## The DASS Structural Detail Meshing System

In order to improve the efficiency of creating FE models of ship structural details, which is required for the ISSMM project, DREA developed the DASS (Detail Analysis of Ship Structure) system. The DASS system produces FE models for a predefined set of ship details by using a data management system and a structural component risk-based assessment method that determines the optimal element distribution for a given structural detail.

Ships are usually built with a defined set of details which are documented by classification societies, owners (such as Navies), or the builders. Details include stringer and frame intersections, bulkhead and stiffener connections (watertight and non-watertight), penetrations, cut-outs, etc. The defined detail may vary in component dimensions (plate thickness, web height, etc.) and possibly have minor variations such as the inclusion of tripping brackets. Details can be defined by a set of 2D surfaces which are defined by boundary lines (this approach uses interior as well as exterior boundary lines to include cut-outs and crack lines) and connected together at common boundaries to form the 3D detail. The 2D patches are meshed based on a description of the node distribution on the boundary lines consistent with a special purpose FE mesher (discussed below). Parametric stress analysis of the detail classes is undertaken to produce the best predefined set of nodal distributions for meshing the details. The nodal distributions

may be defined by characteristics of the detail geometry as opposed to fixed values (eg. a function of plate thickness or cut-out dimension). Development of the detail classes and the parametric analysis takes considerable time, and is to be done before use in a specific ship analysis. The detail class descriptions and meshing parameters are stored in a database that can be called during a ship analysis to quickly generate the detail FE mesh of interest. As the object-oriented database management system is developed, the specific detail classes will be identified at their locations in the global ship model and include the actual scantling information for that detail. The overall approach to the DASS detail meshing is illustrated in the flowchart of Figure 2.

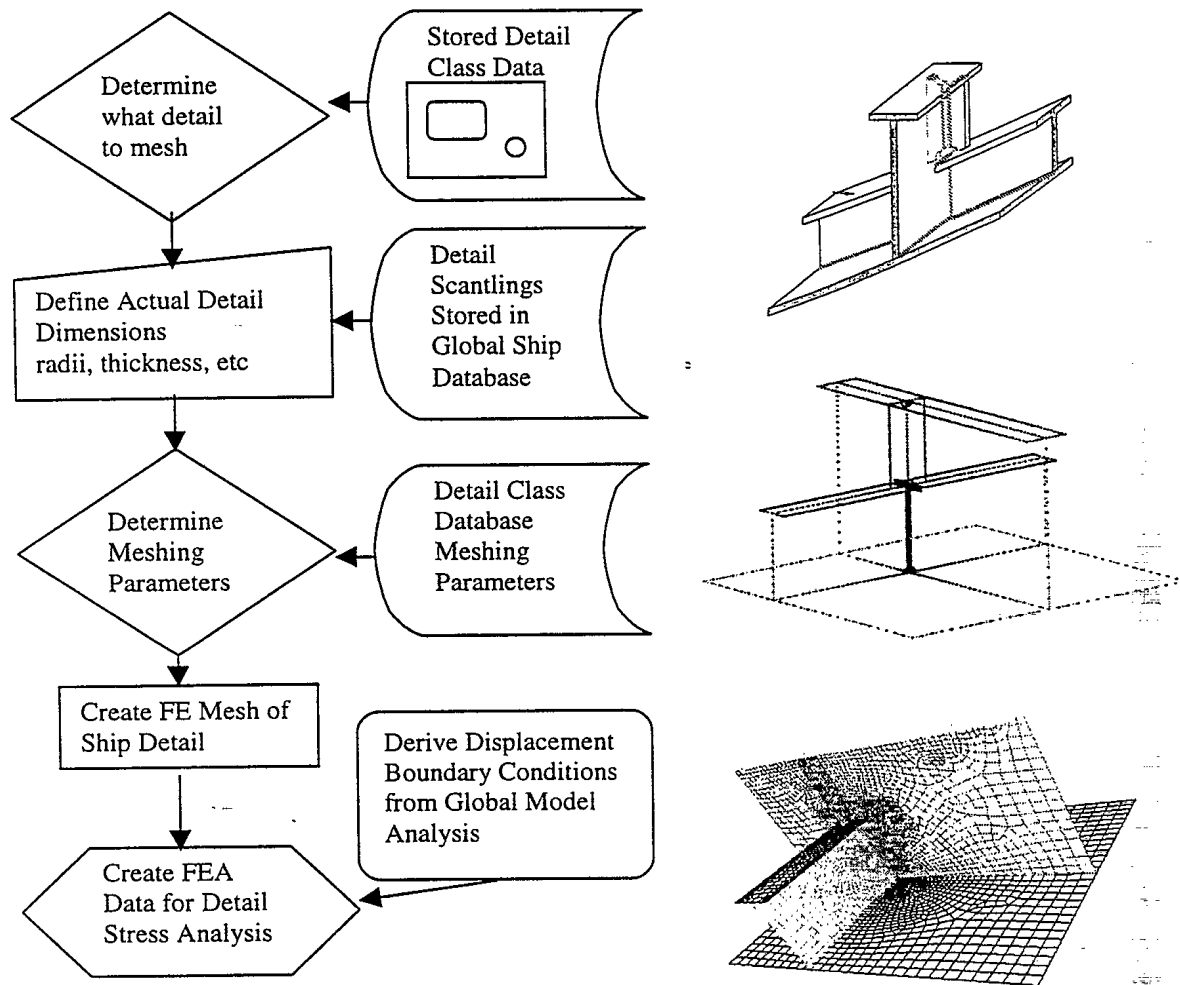

Figure 2: Schematic of DASS structural detail FE meshing system

### Ship Structural Detail Classes for the Halifax Class

A structural component risk-based assessment was used to rationally identify the 100 most critical structural detail types (openings and connections) in the Halifax Class [11]. The risk index system used to identify the criticality of details considered:

- probability of damage accumulation,

- damage consequence with respect to vessel integrity, and
- the ability to inspect or know the condition of the detail.

Data for the risk ranking of the CPF structural details was taken from drawings and a previous fatigue susceptibility study [12]. The review was confined to the main deck, hull shell, and longitudinal transverse bulkheads through the midbody of the ship. Initially, a list of all connection and opening details used for the Halifax Class was sorted using the risk rating to identify the most critical details. The top 100 critical details from this list were then sorted into 30 detail classes; a class having similar configurations but varying in overall dimensions (i.e. size of opening, plate thickness and frame size and spacing). Figure 3 below shows two connection details with similar topology but different dimensions which would have been considered to belong to the same class. The first 22 detail classes were used to represent connections, with the remaining eight used to represent opening details.

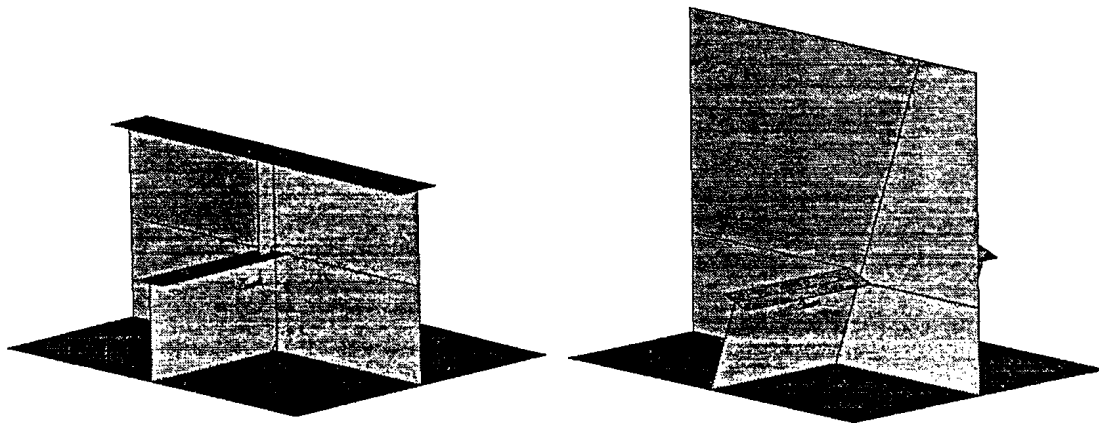

Figure 3: Connection details included in a common class

The extent of structure for each detail in the top-down analysis is shown in Figure 4. The generic geometry of each connection detail class consisted of four plating panels bounded by, but not including longitudinals, frames or bulkheads. The generic geometry of each opening detail model was selected to include a single panel as shown in Figure 4. The shape, position and size of the opening and attached coaming are model parameters.

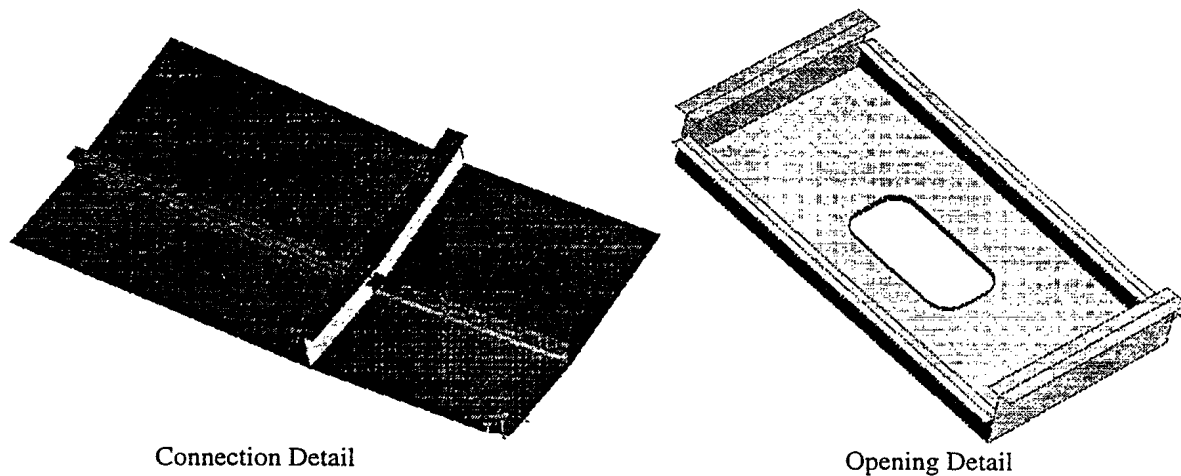

Figure 4: Generic structural detail extents

## Parameterization of Halifax Class Details

Each generic detail group was described in terms of the geometric parameters defining its configuration. A sample detail group parametric description is shown in Figure 5. Each detail group parametric description is intended to represent many structural configurations with similar topology. Alternative structural configurations or topologies are specified by changing the detail's geometric parameters, which are identified using the following pattern:

- Group (GROUP) - indicates which detail class is being described
- Angles ( $A_i$ ) - define the angle between two surfaces
- Lengths ( $L_i$ ,  $W_i$ ) - specify lengths or widths of a chock (e.g.  $CL_i$ ), flange ( $FL_i$ ), plate or web.
- Radii ( $R_i$ ) - describe cut-outs and scallops
- Thickness ( $T_i$ ) - plate thickness.
  - where  $i$  is the number of the part of the detail.

Detail entities, such as flanges or scallops, may be omitted from the detail by setting their thickness or radii, respectively, to zero.

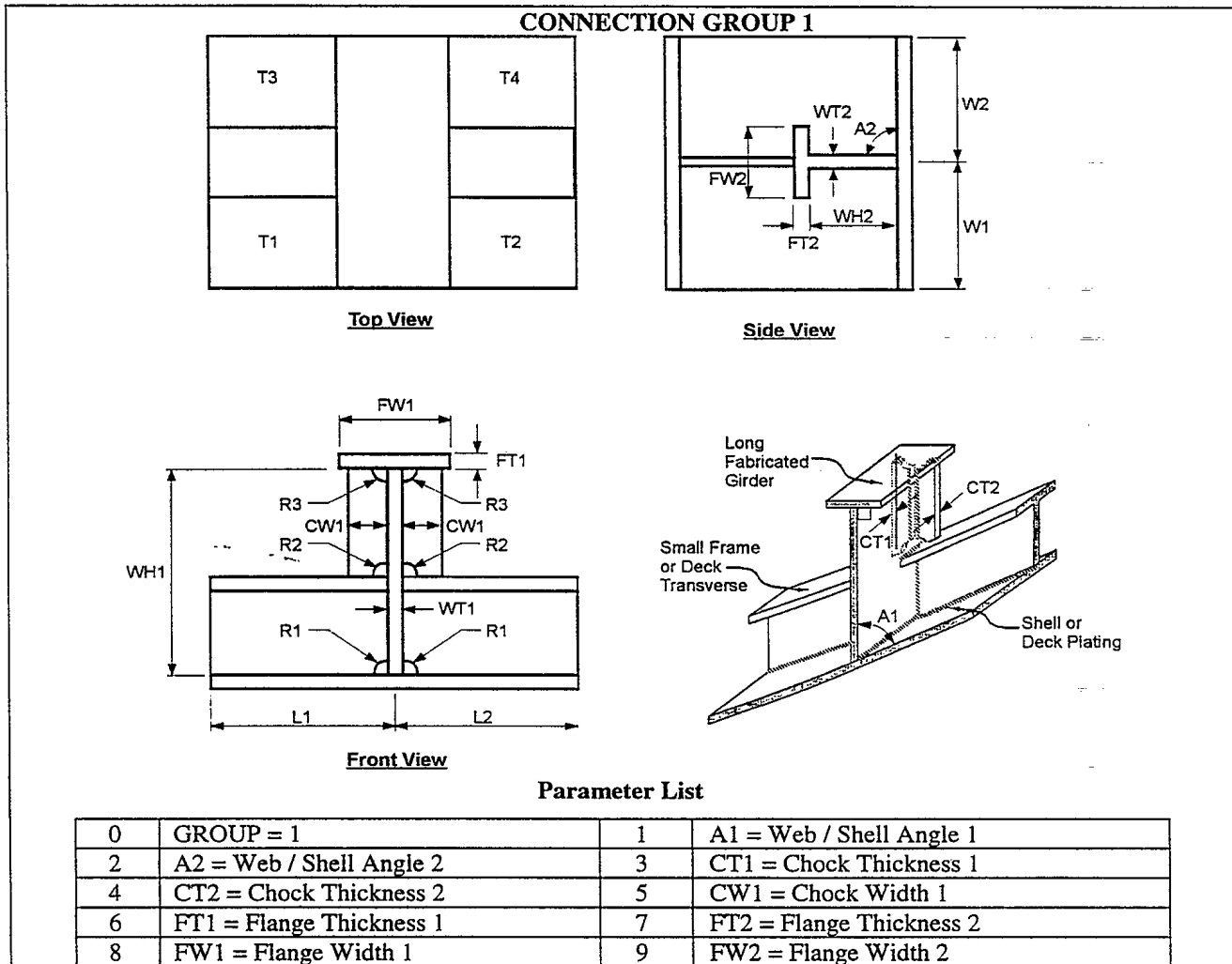

10	L1 = Shell Length 1	11	L2 = Shell Length 2
12	R1 = Scallop Radius 1	13	R2 = Scallop Radius 2
14	R3 = Scallop Radius 3	15	T1 = Shell Plate Thickness 1
16	T2 = Shell Plate Thickness 2	17	T3 = Shell Plate Thickness 3
18	T4 = Shell Plate Thickness 4	19	W1 = Shell Width 1
20	W2 = Shell Width 2	21	WH1 = Web Height 1
22	WH2 = Web Height 2	23	WO = Weld Toe Offset
24	WT1 = Web Thickness 1	25	WT2 = Web Thickness 2

Figure 5: Sample parametric detail group description

The geometric information for each detail is used to define points, connectivity and element sizes for the specialized detail FEA mesher described below.

### Specialised Detail Finite Element Mesher

A meshing algorithm has been developed which uses a paving method to produce a mesh of quad elements on any two-dimensional surface made up of any number of boundary lines. This includes interior (multiple cut-outs and/or crack lines) as well as exterior boundaries. The boundary lines are described by both geometric primitive shapes and node distribution algorithms. Each two-dimensional surface describes one part of a detail class. Figure 6 shows some examples of meshes created by the detail finite element mesher. Special features to control symmetry and limit element size as a function of their location in the mesh domain are being developed and implemented. Assembling the two dimensional planes together produces the three-dimensional models. Compatibility between the planes is ensured by using the same boundary line definition at the common boundaries in the meshing process. Curved surfaces are handled by first mapping the curved surface on to a flat surface for meshing and then mapping the element and node distribution back to the curved surface.

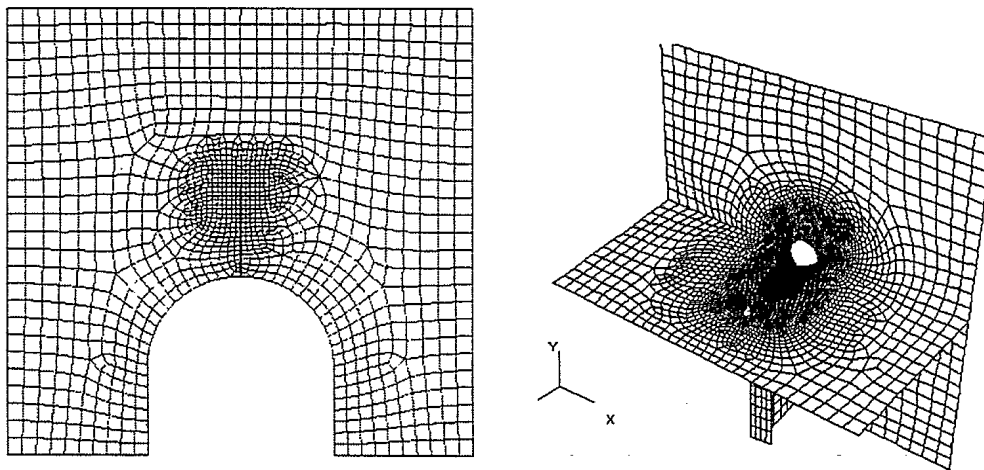

Figure 6: Examples of meshes created by the specialised detail mesher (a single 2D surface of a hatch cut-out containing a crack propagating upwards and a complete 3D detail)



## Global Geometric Relational Data Management System

The DASS system is one part of a much larger effort in developing a new data and modelling system for ship structures. Most codes used for structural analysis have been in existence for some time and have been developed by 'older' methods of programming. Modern object-oriented methods of programming offer some advantages in developing complex analysis packages which use large databases. DREA is developing an object-oriented data management system called HOOD (Hierarchical Object-Oriented Data manager) specifically for ship structures. HOOD describes the ship by its component objects such as decks, bulkheads, stiffeners and connection types. Each of these 'smart' component objects is programmed to have certain attributes which define what structure it is related to, how it is to be meshed, what scantling dimensions and materials are associated with it and so on. The HOOD data structure exists at a higher level than what would be provided by a finite element model such as Maestro, which could be derived from the HOOD data for a specific ship. The HOOD system has the following advantages over traditional data management:

- Extensive re-use of developed objects in producing code,
- The ability to interface with supporting software applications in a modular fashion,
- A consistent and flexible data structure which helps eliminate extensive re-coding when different data requirements arise,
- A relational system which helps to propagate modelling changes through to lower or higher level objects, and
- The introduction of 'domain engineering' concepts which allow for a common set of reusable object through out the domain of ship structural analysis applications.

The DASS system is at the lowest level of the HOOD smart object modelling hierarchy as it is used to develop FE models of structural details. When the complete HOOD system is developed, the user will be able to identify the location of interest in the global HOOD database, all global and detail structure at that location will be identified by the HOOD system and appropriate FE models for top-down analysis will be automatically developed.

## Conclusions

This paper has presented an overview of a new method of creating finite element models for ship structural details. The DASS method potentially provides considerable time savings over conventional methods, possibly providing a means to make FEA of ship structural details a routine part of ship design. The method has been discussed in reference to the work that is underway for the Halifax Class frigate but could easily be extended to other ship types. Once the detail class system has been set up for a ship type, the user of the system does not have to be an expert in FEA. This again increases the use of a more comprehensive analysis of ship structure which could lead to improved fatigue performance and a more rational assessment of the effects of damage on structure.

## References

1. 'Veristar, Integrating Design And Analysis And Ship Management', Bureau Veritas program documentation, 1997.
2. 'Safehull, Technical Information', American Bureau of Shipping, 1997.
3. 'Nauticus, The Classification Information Highway', Det Norske Veritas Classification AS, 1995.
4. 'Shipright, Design, Construction And Lifetime Ship Care Procedures', Lloyd's Register Report 95/50/3.11, 1998.
5. Pegg, N.G., Gibson S., "Application of Advanced Analysis Methods to the Life Cycle Management of Ship Structures", Advances in Marine Structures III, DERA, Scotland, 1997.
6. MAESTRO - Method for Analysis Evaluation and Structural Optimization, User's Manual - Version 7.0', distributed by Proteus Engineering Ltd, Annapolis, MD, July 1992.
7. VAST - Vibration and Strength Finite Element Code, User's Manual - Version 7.0, Martec Ltd., 1996.
8. 'MAESTRO/DSA', Martec Ltd., DREA CR in review, October 1998.

9. Kumar R., Pegg N.G., Heath D., Stone K., 'A Computerized Method for the Rapid Global and Local Analysis of Ship Structure', RINA Warships 98 Proceedings, London, June 1998.
10. Pegg N.G., Heath D., Norwood M.E., 'Improved Ship Detail Finite Element Stress Analysis', Proceedings of PRADS 98, The Hague, September 1998.
11. 'Development of Specifications and Algorithms for Finite Element Meshes of Ship Structural Details', Fleet Technology Ltd., DREA CR in review, December, 1998.
12. "Halifax Class Structural Fatigue Analysis", Saint John Ship Building and Fleet Technology Limited, ETSS Task ES950010 Final Report, 1996.

#511555