



DEPARTMENT OF THE NAVY
OFFICE OF NAVAL RESEARCH
875 NORTH RANDOLPH STREET
SUITE 1425
ARLINGTON, VA 22203-1995

IN REPLY REFER TO:
Ser 32LASW/011/16
12 February 2016

Mr. Robert B. Stokes, CIV DTIC EM (US)
Defense Technical Information Center
8725 John J. Kingman Rd, Suite 0828
Ft. Belvoir, VA 22060-6218

Dear Mr. Stokes:

I am the sponsor of work performed by John G. Shannon and Paul M. Moser of Rite-Solutions, Inc. in preparing two documents: (1) a technical paper by John G. Shannon entitled "A History of U.S. Navy Airborne and Shipboard Periscope Detection Radar Design and Development" that was published in the U.S. Navy Journal of Underwater Acoustics Volume 62, Issue 2, in January 2014, and (2) a still-unpublished expansion of this paper in the form of a monograph by John G. Shannon and Paul M. Moser entitled "A History of U.S. Navy Periscope Detection Radar, Sensor Design and Development." The first of these is already in the possession of DTIC under the accession number ADA618106.

Both of these documents are UNCLASSIFIED and are approved for public release, distribution unlimited.

Respectfully yours,

David H. Johnson, PhD
Team Leader, LASW

Copy to:

David L. Bradley, PhD
Journal of Underwater Acoustics (JUA)
Marine and Physical Acoustics Department
The Pennsylvania State University
Applied Research Laboratory
P.O. Box 30, Mail Stop 3230G
State College, PA 16804

John G. Shannon
1151 Lightstreet Road
Bloomsburg, PA 17815

**A History of U.S. Navy
Periscope Detection Radar
Sensor Design and Development**

**John G. Shannon
Paul M. Moser**

Rite-Solutions, Inc.

Sponsored by the Office of Naval Research

Contract N00178-04-D-4115

31 December 2014

REPORT DOCUMENTATION PAGE

*Form Approved
OMB No. 0704-0188*

The public reporting burden for this collection of information is estimated to average 1 hour per response, including the time for reviewing instructions, searching existing data sources, gathering and maintaining the data needed, and completing and reviewing the collection of information. Send comments regarding this burden estimate or any other aspect of this collection of information, including suggestions for reducing the burden, to Department of Defense, Washington Headquarters Services, Directorate for Information Operations and Reports (0704-0188), 1215 Jefferson Davis Highway, Suite 1204, Arlington, VA 22202-4302. Respondents should be aware that notwithstanding any other provision of law, no person shall be subject to any penalty for failing to comply with a collection of information if it does not display a currently valid OMB control number.
PLEASE DO NOT RETURN YOUR FORM TO THE ABOVE ADDRESS.

1. REPORT DATE (DD-MM-YYYY) 31-12-2014	2. REPORT TYPE Monograph	3. DATES COVERED (From - To) 2008 - 2014
--	------------------------------------	--

4. TITLE AND SUBTITLE A History of U.S. Navy Periscope Detection Radar Sensor Design and Development	5a. CONTRACT NUMBER N00178-04-D-4115
	5b. GRANT NUMBER
	5c. PROGRAM ELEMENT NUMBER

6. AUTHOR(S) Shannon, John G. Moser, Paul M.	5d. PROJECT NUMBER
	5e. TASK NUMBER
	5f. WORK UNIT NUMBER

7. PERFORMING ORGANIZATION NAME(S) AND ADDRESS(ES) Rite-Solutions, Inc. 1 Corporate Place, 2nd Floor Middletown, RI 02842	8. PERFORMING ORGANIZATION REPORT NUMBER
---	---

9. SPONSORING/MONITORING AGENCY NAME(S) AND ADDRESS(ES) Office of Naval Research Code 32ASW Arlington, VA	10. SPONSOR/MONITOR'S ACRONYM(S)
	11. SPONSOR/MONITOR'S REPORT NUMBER(S)

12. DISTRIBUTION/AVAILABILITY STATEMENT
Approved for public release, distribution unlimited

13. SUPPLEMENTARY NOTES

14. ABSTRACT
This monograph traces the history of periscope detection radar (PDR) from the origin of radar in World War II to 2008. During this period, PDR sensors have evolved substantially, owing primarily to notable changes in the threat, missions, requirements, measures, countermeasures, environment, and advances in technology. Today, it is necessary to detect relatively frequent, but fleeting, periscope exposures of acoustically quiet diesel-electric submarines against a background of numerous target-like objects in high-clutter littoral environments. State-of-the-art signal processing has transformed a labor-intensive false-alarm-ridden endeavor into an automatic radar periscope detection and discrimination system.

15. SUBJECT TERMS
Submarine, Periscope, Detection, Radar, History, Nonacoustic, Aircraft, Shipboard, Signal Processing, High Clutter

16. SECURITY CLASSIFICATION OF:			17. LIMITATION OF ABSTRACT	18. NUMBER OF PAGES	19a. NAME OF RESPONSIBLE PERSON	
a. REPORT	b. ABSTRACT	c. THIS PAGE			19b. TELEPHONE NUMBER (Include area code)	
unclassified	unclassified	unclassified	unlimited	154		

ACKNOWLEDGEMENTS

This monograph was prepared under the sponsorship of Dr. David Johnson (ONR 32ASW) of the Office of Naval Research in Arlington, Virginia. We are deeply indebted to Dr. Johnson for his encouragement, guidance and financial support.

We wish to extend sincere thanks to our Rite-Solutions colleagues: Ms. Heidi Gervais for manuscript preparation, Ms. Rebecca Hosch for editorial support, Ms. Melanie Wilson for publication planning support, and Mr. Juergen Keil for general oversight and guidance. Finally, we wish to extend a special note of thanks to Ms. Barbara White, Paul Moser's daughter, for proofreading and formatting the manuscript. Without all of their dedicated help and support, this book would have never been completed.

PREFACE

From the humble beginnings of the use of radar to detect surfaced German U-boats during the Battle of the Atlantic in World War II (WWII) to today's state-of-the-art airborne Anti-Submarine Warfare (ASW) surveillance applications, radar has played a vital role in achieving and maintaining U.S. Navy ASW superiority through the years.

Highly effective radar sensors used for military applications were originally large ground-based units designed, developed and employed by the British for detecting inbound German aircraft during the Battle of Britain early in WWII. As early as 1940, British radars were also designed compact enough to fit into combat aircraft, as well as mast-mounted on ships, for detecting surfaced German U-boats. However, none of these WWII radars had the appropriate design and performance characteristics to detect small radar-cross-section targets such as exposed periscopes.

It was not until the early 1970s that the first tactical radar designed specifically for periscope detection, the U.S. Navy's AN/APS-116 radar on S-3A ASW aircraft, arrived on the scene. Furthermore, it was not until the early 1990s that the U.S. Navy established a formal requirement for automatic periscope detection and classification, and subsequently initiated the technology development for detecting and classifying periscope targets automatically. Until very recently, all fleet operational periscope detection radar (PDR) sensor systems have required a skilled and alert human operator to perform their detection function. However, the introduction, during the 1990s, of the Office of Naval Research (ONR)-sponsored technology to automate the target detection and classification process, particularly for challenging littoral operational environments, has transformed a manual, operator-intensive PDR process into a robust automatic target detection and classification capability for both airborne and shipboard ASW applications.

Over the years, Research, Development, Test and Evaluation (RDT&E) and the operational employment of PDR has involved a rich and proud history of military endeavor. This history is embodied in the knowledge base, technical expertise, innovations and accomplishments of a cadre of highly talented and dedicated scientists, engineers, managers, program sponsors and war fighters within the U.S. Navy and industry. Unfortunately, as the years pass and these technical experts continue to retire from the military and civilian workforce, their knowledge base, their memory and the lessons learned are becoming lost to subsequent generations. Accordingly, this monograph is intended to capture and preserve the fleeting and fragile memory and, particularly, the technical challenges and accomplishments of these dedicated men and women who designed and developed the Navy's state-of-the-art PDRs.

TABLE OF CONTENTS

ACKNOWLEDGEMENTS.....	3
PREFACE.....	4
TABLE OF CONTENTS.....	5
LIST OF FIGURES	7
LIST OF TABLES.....	8
I. INTRODUCTION.....	9
Background.....	9
Scope of this Document	10
Why Focus on Nonacoustic ASW Sensors?	11
Why Focus on PDR?.....	12
II. REQUIREMENT AND TECHNOLOGY DRIVERS	13
Requirement Drivers.....	13
Technology Drivers	16
III. PDR SENSOR FUNDAMENTALS	18
The Electromagnetic Spectrum and Radar.....	18
Periscope Target Characteristics	19
Sea Background Characteristics.....	20
Man-Made Clutter.....	21
Polarization	21
Radar Horizon and Ducting	22
Propagation and Attenuation of Radar Energy in Atmosphere	22
PDR Design Considerations	24
PDR Range Performance Predictions	26
PDR Countermeasures.....	27
IV. EXPLOITABLE TARGETS.....	29

V.	HISTORY OF AIRBORNE PDR SENSOR DESIGN AND DEVELOPMENT	32
	The Beginnings—WWII Airborne Radars.....	32
	Cold War Airborne PDR Sensors	34
	Post-Cold War Airborne PDR Sensors	42
VI.	HISTORY OF SHIPBOARD PDR SENSOR DESIGN AND DEVELOPMENT	47
	Introduction.....	47
	Early Shipboard Periscope Detection Techniques	47
	Shipboard Periscope and Mast Detection Challenges.....	48
	Existing Shipboard Surface-Search Radars That May Have Application to Periscope/Mast Detection	50
	Advanced Technology Development for Surface Ship Periscope Detection	52
	Shipboard ARPDD	52
VII.	POST-COLD WAR ARPDD SYSTEM DEVELOPMENT FOR AIR AND SHIP APPLICATIONS.....	54
	Post-Cold War PDR Sensor Requirements	54
	Automatic Radar Periscope Detection and Discrimination (ARPDD) Program	57
VIII.	LESSONS LEARNED.....	67
	Lessons Learned in PDR Technology Improvements.....	67
	Lessons Learned in PDR Operations	67
IX.	SUMMARY	69
	ABOUT THE AUTHORS	70
	REFERENCES	72

APPENDICES

Appendix A - Chronology of Periscope Detection Radar Research Efforts	A-1
Appendix B - Chronology of Radar Developments.....	B-1
Appendix C - Chronology of Submarine Developments	C-1
Appendix D - Bibliography	D-1

LIST OF FIGURES

Figure 1. The <i>target</i> for periscope detecting radar.....	9
Figure 2. The electromagnetic (EM) radiation spectrum	18
Figure 3. The microwave region and its standard band designations	19
Figure 4. Radar cross-section of a sphere as a function of wavelength	23
Figure 5. Microwave attenuation in the atmosphere	24
Figure 6. AN/APS-137 Radar Components	25
Figure 7. Calculated minimum detectable radar cross section.....	27
Figure 8. Type U-214 diesel-electric submarine with raised periscopes and masts..	29
Figure 9. Search and attack periscopes	30
Figure 10. Kollmorgen low-RCS photonic mast	30
Figure 11. Photonics mast array on a Virginia-Class submarine	31
Figure 12. P2V-7 aircraft with AN/APS-20 radome on its underside.....	34
Figure 13. P-3B aircraft	35
Figure 14. P-3C aircraft	36
Figure 15. S-3A aircraft	37
Figure 16. S-3B Aircraft	38
Figure 17. AN/APS-137 antenna in nose of P-3C Update III Aircraft	39
Figure 18. SH-60B aircraft	41
Figure 19. MH-60R aircraft.....	42
Figure 20. E-2C aircraft.....	44
Figure 21. Brassboard ARPDD signal processing system	61
Figure 22. Locations of brassboard ARPDD testing	63
Figure 23. ARPDD program timeline	63

LIST OF TABLES

Table 1. Historical Evolution of ASW Target and Airborne ASW Radar	16
Table 2. Major Milestones in Airborne PDR Design and Development.....	46
Table 3. Major Milestones in Shipboard PDR Design and Development.....	53
Table 4. Major Milestones in ARPDD System Concept Formulation, Design and Development.....	64

I. INTRODUCTION

Background

From the humble beginnings of the use of radio detection and ranging (i.e., *radar*) to detect surfaced German U-boats during the Battle of the Atlantic in World War II, to today's state-of-the-art airborne Anti-Submarine Warfare (ASW) radar surveillance applications, radar has evolved into playing a vital role in achieving and maintaining U.S. Navy ASW superiority through the years. Since radar energy cannot effectively penetrate seawater, ASW radars are used primarily for detecting the submarine's periscopes and masts exposed above the sea surface, as shown in Figure 1.



Figure 1. The *target* for periscope detecting radar

A modern periscope detection radar (PDR) is essentially one *mode* of operation of a multi-function, multi-platform maritime surveillance radar, rather than a sensor dedicated exclusively to ASW. Employed primarily on aircraft, but also on ships and on land, it is used for detecting small radar cross-section (RCS) targets such as the “hard target” exposures of submarine periscopes, masts and snorkels. When employed on aircraft, PDR is used offensively in the surveillance and area-search phases of ASW prosecution. When employed on ships, PDR is used defensively for detecting the torpedo-firing threat submarine (which often exposes its periscopes for final targeting during approach and attack) prior to weapon launch.

Until very recently, ASW detection and classification with a fleet-operational PDR has been a manual, operator-intensive process. Fortunately, the recent development of modern digital signal processors, with their high computational power and speed, along with sophisticated target discrimination algorithms, has made possible real-time PDR signal processing capable of automatic detection and classification of targets in high-clutter littoral environments. This technology development was pursued during the 1990s under the Automatic Radar Periscope Detection and Discrimination (ARPDD) program sponsored by the Office of Naval Research (ONR), and is transforming the Fleet's manual, operator-intensive PDR procedures into a robust automatic target detection and classification process. More recently, the ARPDD program has evolved into acquisition programs for both airborne and shipboard ASW applications.

Over the years, Research, Development, Test and Evaluation (RDT&E) and the operational employment of PDR have involved a rich and proud history of military endeavor. This history is embodied in the knowledge base, technical expertise, innovations and accomplishments of a cadre of highly talented and dedicated scientists, engineers, managers, program sponsors and war fighters within the U.S. Navy and industry. Unfortunately, as the years pass and these technical experts continue to retire from the military and civilian workforce, their knowledge base, their memory, and the lessons learned become lost to subsequent generations.

In 2008, ONR initiated and sponsored the preparation of a two-volume monograph, (one unclassified and the second classified) to capture and document the rich history of the design, development and operational performance of PDR sensors. This monograph is intended to preserve the fleeting and fragile memory and, particularly, the technical challenges and accomplishments of these dedicated men and women who designed and developed the Navy's state-of-the-art PDRs.

Scope of this Document

This monograph documents historical highlights in the research, design and development of PDR sensors, for both airborne and shipboard applications. The historical period covered includes the sensor's WWII beginnings, through the Cold War, and into the early 21st century. This monograph is a greatly expanded version of a technical paper on the same topic that was published in a recent issue of the *Journal of Underwater Acoustics*.¹

Emphasis in this monograph is placed on the design and development of late-Cold War and post-Cold War PDRs. The scope is limited to PDRs used for U.S. Navy ASW applications, specifically for detecting small *hard targets* such as submarine periscopes and masts, and does not include investigations into nonacoustic phenomenology and target detectability performed under the U.S. Navy's Submarine Security Program (SSP). However, the SSP investigations have made extensive and notable contributions to the understanding of the physics of various nonacoustic

detection techniques, which in turn, have provided an excellent technical background for developing design guidelines for such ASW sensors.

Both airborne PDRs used for ASW surface surveillance and shipboard PDRs used for surface ship torpedo defense are addressed herein. Emphasis is placed on those PDR sensors (predominantly airborne) that have been deployed operationally in the fleet, i.e., that have reached Initial Operational Capability (IOC). Also included are promising developmental PDR sensors that have matured to the Category 6.3 Program Element phase of Advanced Development, or beyond, and are considered by ONR to be promising transition products.

There exists a rich history of relevant research that was conducted by U.S. Navy laboratories such as the Naval Research Laboratory (NRL) and the former Naval Air Development Center (NADC), by academia such as the Georgia Tech Research Institute (GTRI) and by industry such as Raytheon Texas Instruments Systems. These research efforts, which are summarized in Appendix A (Chronology of Periscope Detection Radar Research Efforts), have provided the technical foundation for the subsequent design and development of PDR.

Also included herein are Appendix B (Chronology of Radar Developments) and Appendix C (Chronology of Submarine Developments), which provide the interested reader a broader historical perspective on radar and submarine developments. Finally, Appendix D provides a bibliography of supplemental source documents.

Why Focus on Nonacoustic ASW Sensors?

Historically, ASW detection of threat submarines has been accomplished primarily using passive and/or active acoustic means. Even before the advent of acoustic ASW during WW I, however, the human eye (a *nonacoustic* sensor), aided by search lights and binoculars, was used as a primary means for detection of submarines operating on the surface or at periscope depth. Starting in WWII, throughout the Cold War, and during the modern post-Cold War era, a variety of other nonacoustic technologies (some of them quite esoteric), which span much of the electromagnetic (EM) spectrum, were proposed and investigated. Some of the most promising of these technologies have been further developed, and a few of them have been operationally deployed, particularly for airborne ASW applications. The most common of these nonacoustic ASW (NAASW) technologies that have become operational and/or are under development, include the following:

- Magnetic anomaly detection sensors (operating in low-frequency EM region)
- Radar sensors (operating in microwave region)
- Infrared sensors (operating in infrared region)
- Laser (lidar) sensors (operating in blue/green visible region).

Since no single sensor is sufficient for detection of the submarine target throughout its full operating envelope, countering enemy submarines requires a robust capability having as its foundation an integrated mix of complementary acoustic and nonacoustic sensors. Such an integrated suite provides better coverage of the submarine's full operating envelope, exploits multiple submarine signature vulnerabilities in a variety of environments, and enhances target detection and classification probabilities. NAASW technologies are particularly applicable for ASW detection of exposed submarine periscopes and masts, or for detection of submarines operating at relatively shallow depths in littoral waters. As a complement and/or alternative to acoustics, NAASW sensors offer a significant capability for detecting, localizing and accurately classifying submarines.

In the modern post-Cold War era, ASW emphasis has notably shifted towards detecting the acoustically quiet diesel-electric submarine (SS) [sometimes referred to as a diesel-electric attack submarine (SSK)] operating primarily in acoustically harsh, shallow-water, littoral environments. In such environments, nonacoustic sensors play a particularly effective and increasingly important role in ASW detection and prosecution.

Why Focus on PDR?

During the post-Cold War years, ASW operational emphasis has shifted from Soviet nuclear submarines operating predominantly in open-ocean *blue waters* to modern *rest-of-the-world* SSs operating primarily in acoustically harsh, shallow-water, littoral environments. The SS must frequently operate at periscope depth to fulfill its primary assigned mission, Anti-Surface Warfare (ASUW). Among other things, it must expose a periscope and/or other masts for situational awareness, to communicate, and to recharge its batteries. Furthermore, most of them (except for the most modern SS units manned by the most proficient crews) must expose their periscopes in order to perform ASUW approach and attack effectively. Since the SS frequently exposes its periscopes and masts in the performance of its missions, it can be readily detected and exploited by a modern PDR.

In recent years, the U.S. Navy has developed an increasingly keen interest in developing and fielding a highly effective PDR capability for both airborne and shipboard applications. The primary reason for this increased interest is the fact that PDR provides a cost-effective complement and/or alternative to relatively poor acoustic area-search performance against the modern, quiet SS operating (typically at or near the surface) in littoral ASW environments.

II. REQUIREMENT AND TECHNOLOGY DRIVERS

This section paints the strategic landscape and identifies those key, historical change drivers, including both requirements and technology, that have had a notable impact on shaping the design and development of PDRs beginning during WWII.

Requirement Drivers

As with most military systems, the primary forcing functions that have shaped PDR technology developments through the years have been the operational requirements generated by the fleet, particularly during wartime. The most significant advancements in PDR technologies have been those driven by operational necessity (requirements *pull*) rather than by technology opportunities (technology *push*).

Although early radar technology was originally investigated for potential military applications by a number of nations during the mid-1930s, it was the exigencies of war with Germany, starting in September 1939, that drove the British to develop radar for various air-, sea-, and land-based military applications. Without radar, the British would not have prevailed during the Battle of Britain in the autumn of 1940, during the Allied strategic bombing campaign of Germany, and during the Battle of the Atlantic against the German diesel-electric U-boat threat.

During the Battle of the Atlantic, the German U-boat, which aggressively attacked the Allied supply convoys from North America, was a major threat to Britain's survival. Until mid-1943, the majority of U-boat attacks against Allied shipping were performed at night, mostly while the submarines were operating on the surface. Thus, until that time, the primary requirement for airborne surveillance radars at sea was to detect German surface ships and surfaced U-boats, not exposed submarine periscopes and masts. It was fortunate that radar technology, which was still in its infancy throughout WWII, was not required for the detection of submarine periscopes and masts until late in the war when the introduction of the snorkel allowed U-boats to remain submerged for a greater percentage of the time.

The 1954 launch of the first nuclear-powered submarine, the *USS Nautilus*, was the harbinger of a major paradigm shift in submarine warfare, as well as in ASW. Starting in the late 1950s, the shift from diesel-electric submarines to nuclear-powered submarines eliminated the need to snorkel and, thereby, reduced the ASW opportunities to detect the enemy's submarines.

During the Cold War (circa 1948-1989), the Soviet Union developed, by the early 1960s, a blue-water navy spearheaded by a vast nuclear submarine fleet consisting of guided-missile-firing submarines (SSGNs), attack submarines (SSNs), and ballistic-missile submarines (SSBNs). The primary mission of the Soviet SSGNs, and to some extent the SSNs, was ASUW consisting of interdiction of U.S. sea lines of communication and, most importantly, countering the potent American aircraft-carrier battle group. Among others, the Soviet Echo II-Class SSGNs were first

deployed in 1962, and Charlie-Class SSGNs in 1969.² The U.S. Navy's counter to this formidable SSGN threat was a sea-based air-ASW capability provided by ASW helicopters equipped with dipping sonar to protect the carrier's inner zone, and S-3 fixed-wing aircraft equipped with sonobuoys and modern ASW radar to cover the middle zone.

The early Soviet SSGNs had to be surfaced to fire their anti-ship cruise missiles. Therefore, a good surface surveillance radar was adequate for detecting such an attack. However, later in the Cold War, the newer SSGNs could fire their cruise missiles while submerged. This capability minimized their vulnerability to airborne surveillance radar since they had to expose their periscopes and masts for only relatively short periods for communications and stand-off targeting. Additionally, finding a periscope in the background of sea clutter was a difficult task. This change in the Soviet submarine's operating profile forced a fundamental change in the operational requirements of U.S. airborne ASW radars. Specifically, in 1974, the U.S. Navy introduced the S-3A carrier-based ASW aircraft with the AN/APS-116 state-of-the-art surface surveillance radar, which was designed particularly for reliable detection of fleetingly exposed submarine periscopes and masts.

During the Cold War, ASW consisted primarily of open-ocean operations using mostly passive acoustic sensor systems that, at the time, were deemed more than adequate. Therefore, radar detection of periscopes was not a priority, and there was minimal PDR system development during much of this period. Furthermore, in open ocean operations there was little concern about clutter from man-made objects. Therefore, interpretation of fairly raw radar data by human operators was deemed adequate.

The Cold War necessitated changes in United States ASW policy and the formulation of requirement documents. A formalized requirement-generation process evolved through which fleet operational requirements were forwarded to the Pentagon and translated into technical procurement requirements.² To this day, fleet operators typically provide their inputs on ASW requirements to fleet commanders who, in turn, forward these requirements to the Office of the Chief of Naval Operations (OPNAV). Subsequently, OPNAV reviews, approves and formalizes general and specific operational requirements, and coordinates their translation into procurement requirements addressed to the RDT&E and acquisition communities.²

It is of interest to note the relative differences in the research and development (R&D) horizons between the fleet and the R&D community as they pertain to defining operational requirements and the time expectations for achieving the corresponding R&D solutions. In general, the fleet tends to be primarily concerned with maximizing near-term readiness, defining the requirements for solving the problems of *today*. In contrast, the R&D community addresses readiness not only for the near term, but also for the far term, focusing on the R&D necessary for solving the problems of *tomorrow*.

During the 1990s, ASW operational emphasis shifted (1) from Cold War Soviet nuclear submarines operating primarily in blue waters, to non-nuclear diesel-electric (SS) submarines operating primarily in relatively shallow, acoustically noisy, cluttered, littoral waters, and (2) from countering relatively noisy Soviet submarines by use of passive acoustic ASW sensors, to countering the acoustically quiet littoral SS submarine threat primarily with nonacoustic and active acoustic sensors.

The primary role of the enemy SS is to deny freedom of the seas, in particular, to deny access by U.S. forces in selected littoral areas of interest. Their primary mission is ASUW against U.S. forces. However, they have also been known to undertake such missions as Intelligence, Surveillance and Reconnaissance (ISR), insertion of special operating forces, smuggling of contraband and supporting state-sponsored terrorism. When operating submerged on their batteries, SSs are extremely quiet. Because many of these submarines originate in Russia or Western countries, they may have high-end sensor and weapon systems. Some of them also have air-independent propulsion that substantially extends their underwater endurance from a few days to a few weeks.

Nevertheless, the SS must frequently operate at periscope depth to execute its missions. It must expose periscopes and/or masts to communicate and to recharge its batteries. Also, most of them must expose their periscopes to perform ASUW approach and to attack effectively. The modern SS operating in littoral waters is considered to be an extremely formidable threat, much more difficult to detect acoustically than former Soviet nuclear submarines. However, in the performance of its missions, the SS frequently exposes its periscopes and masts, which can be detected by airborne and shipboard PDRs.

A summary of the historical evolution of the threat submarine, its operating profile while attacking, and the airborne radar deployed to counter this threat, is provided in Table 1.

Through the years, the requirements for shipboard detection of submarine periscopes followed a somewhat different historical path than that for airborne detection. During WWII, shipboard radars were developed and used for detecting aircraft, surface ships and surfaced submarines, but not periscopes or snorkels, since these radars were incapable of detecting small RCS targets. During most of the Cold War, shipboard surface surveillance radars were optimized to counter surface and sea-skimming air threats, not submarines. During this era, search and detection of periscopes from a ship were performed primarily by visual lookouts. It was not until the post-Cold War shift to ASW operations in the high-clutter littorals that a formal requirement developed for shipboard detection of submarine periscopes, particularly for surface-ship torpedo-defense applications.





Era →						
Item ↻	1940-43		1944-45	1950s & 1960s	1970s & 1980s	1990s →
Predominant ASUW Submarine Threat	German U-Boat		German U-Boat	Soviet SSGN	Soviet SSGN	Threat SS
Predominant Operating Posture of ASUW Threat Submarine when Attacking	Attacking and recharging batteries on surface at night 		Attacking at PD with torpedoes, and using snorkel to recharge batteries 	On surface to fire ASUW cruise missiles 	At shallow depths to fire sub-surface ASUW cruise missiles 	Attacking at PD with torpedoes 
Predominant Operating Environment	Open Ocean		Littoral	Open Ocean (with little/no clutter)	Open Ocean (with little/no clutter)	Littoral (with high clutter)
Primary USN ASW Radar (Fixed Wing A/C)	1940-42 ASV-1, 2 (UK)	1943 ASV-3 (UK) APS-2 (US)	APS-2	APS-20 APS-80 APS-115	APS-116 APS-137	APS-137 ARPDD (under development)
Radar Frequency Band	214 MHz, 176 MHz VHF-band	3 GHz S-band (Centimetric)	3 GHz S-band (Centimetric)	Multiple Frequencies L-, S-, and X-band	9.5 GHz X-band	9.5 GHz X-band
Periscope Detection Capability	No		No	Minimal	Yes	Yes
Target Detection and Classification Process	Manual		Manual	Manual	Manual	• Manual (in Fleet) • Automatic (under development)

Table 1. Historical Evolution of ASW Target and Airborne ASW Radar

Technology Drivers

In addition to operational requirement drivers, emerging technologies have had a significant impact on shaping PDR design and development over the years. These include the following:

- **During WWII:** development of S-band (3-GHz) radar, which enabled fitting airborne radar equipment into combat aircraft
- **During the Cold War:** development of X-band (10-GHz) radar with characteristics suitable for detecting targets of small radar cross section such as periscopes in high sea states
- **During the post-Cold War era:** development of modern digital signal processors with high computational power and speed, enabling real-time signal processing with sophisticated algorithms capable of automatic target detection and classification in a high-clutter littoral environment.

Also, throughout the entire history of PDR developments, the miniaturization of sensor system components and electronics has significantly reduced their size and weight, making them suitable for airborne and mast-mounted shipboard applications.

PDR developments, shaped by various requirement and technology drivers, have undergone a fascinating history since early in WWII. Furthermore, the introduction of new sensors, weapons and tactics has led to a continued evolutionary interplay of measures, countermeasures and counter-countermeasures.

III. PDR SENSOR FUNDAMENTALS

The Electromagnetic Spectrum and Radar

The frequencies used by radars occupy the microwave portion of the electromagnetic (EM) spectrum between the radio frequencies and the infrared region. Figure 2 depicts the EM radiation spectrum and some of the commonly used frequency and wavelength regions therein.

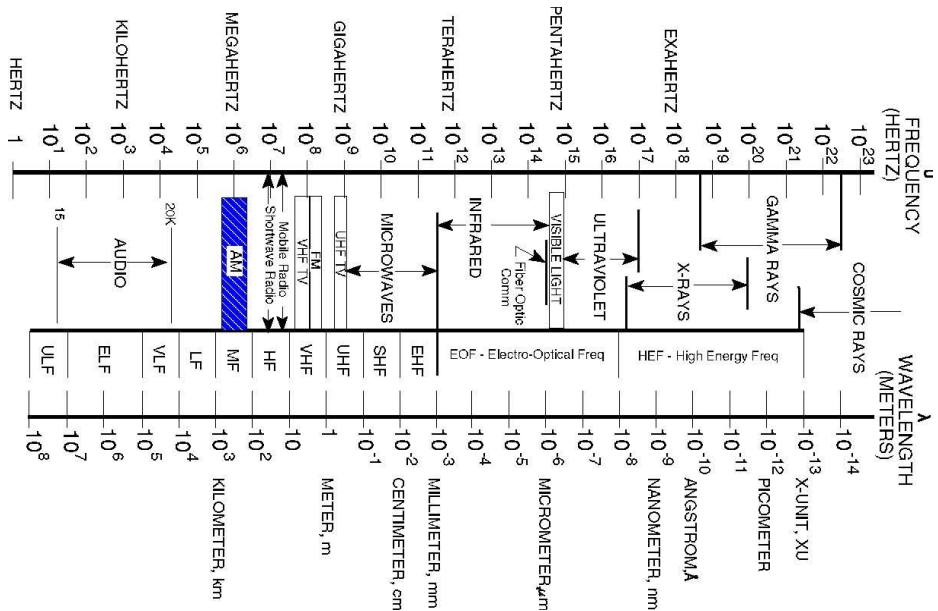

Figure 2. The electromagnetic (EM) radiation spectrum

Figure 3 depicts the microwave region of the EM spectrum, ranging from megahertz (MHz) through gigahertz (GHz) frequencies, which are frequently referred to by band designations rather than by frequency. These include the U.S. standard Institute of Electrical and Electronics Engineers (IEEE) band, the International standard band, and the Military standard band. Military operators primarily use the Military band designations, whereas radar design engineers primarily use the IEEE band designations. In terms of the IEEE band designations, most U.S. Navy surveillance radars operate within the UHF (300-1000 MHz) to X-band (8-12 GHz) regions. For security reasons the IEEE standard bands were named cryptically and not in logical alphabetical order.

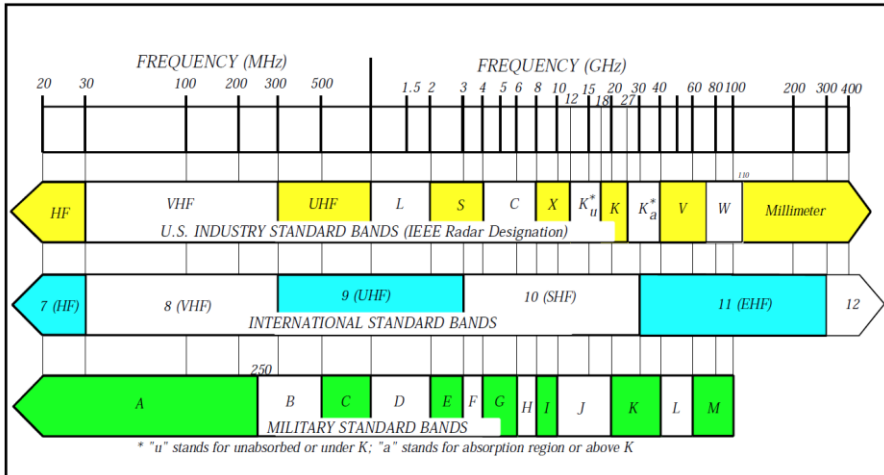

Figure 3. The microwave region and its standard band designations

Periscope Target Characteristics

To enable it to maintain contact with the above-surface world, a submarine has a complement of as many as eight “masts” which can be raised through the air-water interface. Included among these masts are optical and electro-optical periscopes and various antennas, all of which, when exposed, are potentially detectable by a PDR.

Detection of an exposed submarine periscope by an airborne or ship-mounted radar involves many interrelated factors, including the characteristics of the target and its background, the properties of the intervening path, and the characteristics of the sensor itself.

The detectability of a radar target is described in terms of its radar cross section (RCS). For a metallic sphere that is much larger in circumference than the radar wavelength, the RCS is equal to its cross-sectional or projected area. Thus, a 1.13-meter-diameter conducting sphere would have an RCS of one square meter. This is not as large a target for a radar as one might suspect in that most of the radiation impinging on it is reflected in directions other than back toward the radar receiver. Indeed, only the glint or radiation reflected off the portion of the spherical surface that is nearly normal to the direction of the incoming beam has a chance of being intercepted by the radar antenna. However, radiation reflected off the surface of the water before and after reflection off a periscope can increase its effective RCS. The wake of a periscope and water displaced by it can also contribute to its effective cross section.

A favorably oriented flat conducting surface could exhibit a very large RCS, much larger than its actual area, which would drop off drastically if its orientation was changed, even slightly. On the other hand, the RCS of a trihedral corner reflector would remain large, relatively independent of its orientation. Periscopes are designed to present a low RCS. They are made as small as possible and may be covered with a radar-absorbing coating. They may also incorporate stealth (shaping) techniques such as having flat surfaces oriented such that they would reflect incoming microwaves away from their incoming path.

The maximum RCS of a right circular cylinder is given by $RCS_{\max} = 2ab^2/\lambda$. As an example, if the exposed portion of a submarine periscope can be approximated as a cylinder of radius $a = 0.1$ m and length $b = 1.0$ m, and the X-band wavelength λ is 3 cm = 0.03 m, its RCS, when viewed normal to its axis, will be 6.7 m². However, it is very improbable that the periscope will be viewed exactly normal to its axis and the RCS decreases dramatically as the angle of incidence departs from the normal.

For purposes of calculation, the nominal RCS value of an exposed submarine periscope is often taken as one square meter.

Sea Background Characteristics

Because microwave radiation from a PDR is incident upon the sea surface at a glancing angle, most of its energy is forward-scattered and very little penetrates the surface. The very small fraction that enters the water is quickly attenuated; for example, at a frequency of 10 GHz, the attenuation is about 3000 dB/m. Accordingly, seawater is essentially opaque to microwave radiation, and subsurface objects are invisible to radar.

Because the sea surface is uneven, a small but not inconsequential amount of the incident radiation is backscattered incoherently by surface waves and ripples as *clutter* toward its source. This clutter is a significant limiter to system performance, particularly for airborne radars. Waves, swell, whitecaps and debris create a background of clutter against which the periscope must be detected. In addition, nearby land masses and birds may contribute to background clutter.

For small grazing angles, the sea-clutter radar cross section is proportional to the radar altitude, i.e., doubling the radar altitude doubles the clutter cross section and reduces the signal-to-clutter ratio by half. Finding a periscope in the sea-clutter background is a difficult task. For moderate to high sea states, the range at which a periscope can be detected by a current airborne PDR is limited, by both clutter and receiver noise, to about 20 nautical miles (nmi). Sea clutter masks the periscope signal at near range but decreases as the grazing angle gets smaller. At longer ranges, receiver noise dominates and limits the maximum range at which a periscope can be detected.

Sea-clutter samples tend to de-correlate or become unrelated to each other for sampling periods greater than about 0.2 second. However, some sea-clutter spikes may persist for several seconds, making simple integration over time inadequate as a means of suppression when considered in the light that the clutter de-correlation time may be of the same order of magnitude as a fleeting periscope exposure. Thus, the discrimination problem is made more difficult because the clutter time constant may be of the same order of magnitude as a fleeting periscope exposure.

Sea clutter increases with sea state, with sea state five being a practical upper limit for periscope detection. Sea clutter also varies with polarization and with wind, sea, and swell directions relative to the sensor.

Man-Made Clutter

Man-made sources of interference (false targets) include items such as small boats, buoys, flotsam and debris. All of these man-made clutter sources, which often exhibit high densities in littoral regions, can produce competing signals that have characteristics similar to those of exposed periscopes and masts.

Polarization

The effect of polarization on clutter has been the subject of considerable study over many years. The direction of the electric vector of the electromagnetic radiation is taken as the direction of polarization. Experiments have been performed in which the emitted radiation is polarized either horizontally (H) or vertically (V) and the return radiation received as horizontally or vertically polarized in various combinations: HH, VV, and cross-polarizations HV, and VH. Circularly polarized radiation, in which the electric vector is caused to rotate either clockwise or counterclockwise about the direction of propagation, has also been tried.

For low grazing angles, the forward reflection coefficient of sea water is greater for horizontal polarization than for vertical polarization. Thus, for low and moderate sea states, horizontal polarization yields a smaller amount of clutter than vertical polarization because a larger portion of the radiation reflected from the sea surface is forward-scattered and does not return to the receiver. An additional benefit of horizontal polarization is that the return from a periscope may be enhanced because of the multipath effect, that is, radiation reflected from the sea surface may then impinge on the periscope and contribute to the return signal. At higher sea states, the clutter from horizontal and vertical polarization is about equal.³ On the negative side, clutter from horizontally polarized radiation tends to be more *spikey* than that from vertically polarized radiation and more likely to interfere with a target signature.

Significant controversy still exists in the scientific community as to the type of polarization that is optimum for PDR operational performance.

Radar Horizon and Ducting

Microwaves are primarily line-of-sight limited. However, diffraction and refraction extend the radar horizon beyond the geometrical horizon. Diffraction is the wavelength-dependent bending of radiation around obstacles, such as the horizon, although such bending is not, in general, sufficient to overcome obscuration from the curvature of the earth. Refraction enters in because the density of the atmosphere decreases with increasing altitude, with a concomitant decrease in refractive index. Consequently, the speed of propagation of microwaves increases with increasing altitude, resulting in a downward curving of the beam over the horizon. In addition, if a layer of humid air is capped by a layer of drier air, or if a temperature inversion exists, radiation entering the lower layer may be refracted and reflected back and forth between the upper air layer and the ocean surface and propagate well beyond the normal radar horizon – a phenomenon known as ducting. Ducting can yield increased detection ranges; however, multiple reflections off the sea surface can cause increased clutter.

Not surprisingly, the radius of the earth enters into calculations of the geometrical range to the horizon; calculations of the range to the radar horizon account for refraction by assuming that the radius of the earth is $4/3$ as great as its actual value. For sensor altitudes small in comparison with the radius of the earth, the distance to the radar horizon in nautical miles is 1.23 times the square root of the altitude in feet. Thus, for a typical airborne PDR altitude of 500 feet, the range to the radar horizon is 27.5 nmi, and for a nominal mast-mounted shipboard antenna height of 70 ft, it is about 10 nmi. Note that common surveillance radar heights for a U.S. cruiser or destroyer are 100-120 ft, and, for an aircraft carrier, 150-180 ft.

Propagation and Attenuation of Radar Energy in Atmosphere

En route to the target, microwave radiation may be attenuated by intervening rain, clouds, fog and aerosols, and by molecular absorbers water vapor and oxygen. One must contend with the fact that droplets in the atmosphere exhibit an RCS that competes with the RCS of the target. Figure 4 illustrates, in parametric form, the variation of the radar cross section σ of spherical scatterers as a function of wavelength λ . The abscissa may be thought of as the number of wavelengths of the radiation that it takes to circumscribe a droplet. The ordinate is the ratio of the RCS to the actual projected area of the droplet. It is seen that, in the region of *Rayleigh* scattering, where the size of the scatterers is small compared to the wavelength, the RCS is a small fraction of the actual cross section. Thus we would expect small droplets, such as haze and clouds, which are much smaller than a wavelength, to cause minimal attenuation.

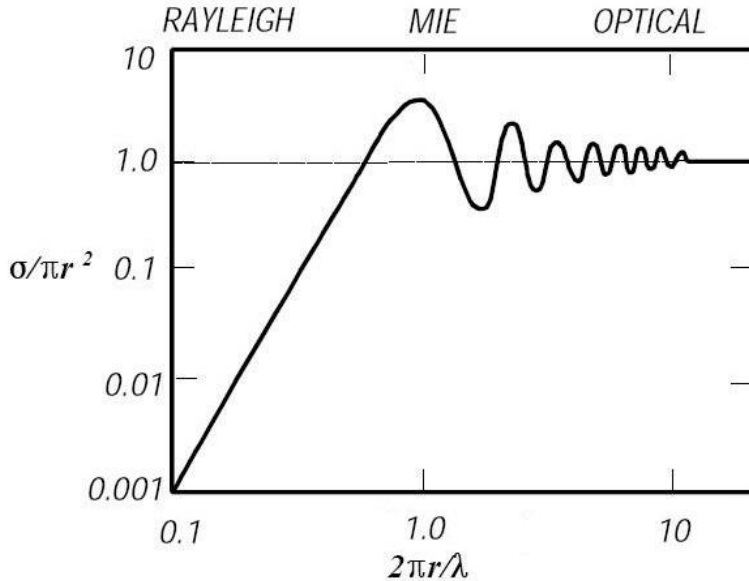

Figure 4. Radar cross section of a sphere as a function of wavelength

In the *optical* regime, where the size of the scattering object is much larger than a wavelength, the RCS equals the projected area of a spherical object. This indeed is the regime in which periscope-sized targets exist, provided that a wavelength has been chosen that is significantly smaller than the dimensions of the exposed periscope. Therefore, the small size of the exposed periscope is one of the considerations for the selection of the wavelength at which the radar is to operate. The intermediate *Mie* scattering region, where the size of the scattering object is approximately equal to the wavelength, is one in which roughly one to ten wavelengths can wrap around a scatterer and in which resonance occurs.

The effect of droplets in the atmosphere is further illustrated in Figure 5. It is seen that the smallest attenuation is achieved at the longer wavelengths (lower frequencies), which, unfortunately, conflicts with the desideratum for shorter wavelengths to enhance detection of small targets.

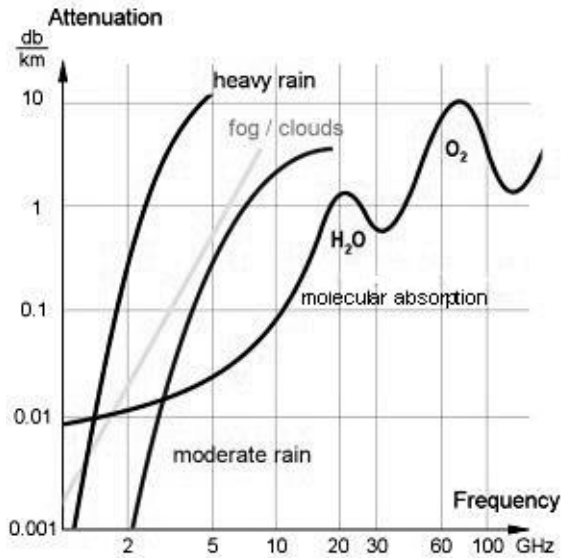

Figure 5. Microwave attenuation in the atmosphere

For frequencies above about 10 GHz, or a wavelength of 3 cm, molecular absorption by water vapor and oxygen increases significantly. Molecules of water in the vapor state have permanent electric dipole moments, which are seized by the alternating electric field of the microwave radiation and caused to take on rotational or vibrational energy at the expense of the microwave field. This energy is then reradiated in various directions or dissipated as heat. Similarly, the oxygen molecule has a magnetic dipole moment, which allows it to drain energy from the magnetic component of the radiation field in the form of increased rotational energy.

For wavelengths that are large in comparison to the dimensions of droplets of rain, clouds and fog, scattering losses are small. Rain interferes with target detection by introducing signal losses in the radar-to-target transmission path and by backscattering radiation to the receiver, where it appears as increased noise.

PDR Design Considerations

As indicated in the foregoing, the wavelength selected for a PDR should be small compared to the dimensions of the intended target but large compared to attenuating scatterers such as raindrops. The higher frequencies are to be avoided, particularly for long-range airborne applications, because at frequencies of 20 GHz and above the

atmosphere becomes increasingly opaque owing to molecular absorption. Since the range to the radar horizon for a typical mast-mounted shipboard radar is about half that of an airborne radar operating at a typical altitude, atmospheric attenuation is a less dominant factor for a shipboard PDR, and use of a shorter wavelength may be more appropriate than for the airborne case. A further argument for the use of the shorter wavelengths, which is particularly applicable to airborne radars, is that the size of components, particularly the antenna, scales downward as wavelength is reduced. Another design consideration is the relative availability of applicable components operating in the various frequency bands.

The current standard of performance for an airborne PDR is the multimode AN/APS-137 radar, which was developed in the early 1980s. In its periscope detection mode, it operates in the X-band frequency range of 9.5 to 10 GHz, corresponding to a wavelength of about 3 cm. The APS-137 comprises the components shown in Figure 6.



Figure 6. AN/APS-137 Radar Components

The major components of a PDR are the transmitter, duplexer, mechanically scanned antenna, receiver, and display. The transmitter employs a magnetron to generate microwave power, which is then further amplified before being fed into the antenna. Because the same antenna is used for receiving as well as transmitting, a duplexer is used to switch off the receiver during pulse transmission to avoid overloading the sensitive receiver.

As with all types of wave phenomena, the ratio of wavelength to aperture dimensions determines the angular spread of the projected beam. For a radar, the beam width is taken as the angle between points off the axis of the beam where the power density is 3 dB below the peak. The beam width (in radians) is equal approximately to 1.5 times the ratio of wavelength-to-aperture dimension. Because of aircraft platform constraints, the aperture dimensions of the APS-137 radar are limited to 42 inches by 26 inches to yield a beam width of 2.4° in azimuth by 4.0° in elevation. The antenna gain is 35 dB. At a range of 10 nmi, the projected beam has dimensions of about 2500 ft in azimuth and a much greater altitude-dependent dimension in the forward direction because the PDR irradiates the surface at a grazing angle. The resulting “spot size” is orders of magnitude greater than the dimensions of the intended target, thereby diluting the signal. This handicap is somewhat overcome by the fact that many independent looks at the target and clutter are presented, over which scan-to-scan integration can take place.

To avoid range ambiguity, the return from a given pulse must be received before the next pulse is emitted. Because the cycle time between successive 500-ns pulses is 500,000 ns, the time available for pulses to travel the two-way distance between the

sensor and a target is 499,500 ns. Thus the maximum unambiguous range is about 40 nmi.

The antenna is a parabolic reflector that scans 360° in azimuth every 0.2 second or at a rate of 1800° per second, yielding a dwell time of 1.33 ms on a point target and a revisit time of 0.2 s, during which sea clutter is partially correlated. The pulse duration of 500 ns corresponds to a linear dimension of 492 ft. However, the returned pulse is compressed in the receiver by a factor of 200, providing an equivalent linear dimension of 2.5 ft and a range resolution of 1.25 ft. Pulse compression is achieved by frequency modulating the individual outgoing pulses in such a way that frequency increases linearly with time. In the receiver, these pulses are passed through a dispersive delay line in which the transit time varies inversely with frequency, allowing the end of the pulse to “catch up” to the beginning and produce a narrower pulse of increased amplitude.

For moderate to high sea states, the detection range of a periscope is limited by clutter at ranges up to about 20 nmi and by receiver noise at somewhat longer ranges. The latter is partly a consequence of an inverse-fourth-power drop-off in returned signal power as a function of range.

The processing of signals and clutter to improve detection probability and to achieve acceptable false alarm rates represents a key emphasis area for present and future PDR improvements. Since the initial development of the APS-137, tremendous advances have been made in the storage of data and the speed of processing which better enable exploiting the distinct temporal and spatial characteristics of periscopes against the sea background in efforts to automate the detection and classification process.

The output of the APS-137 is presented on a multi-purpose display driven by a scan converter.

Since surface scattering decreases with decreasing grazing angle, the center of a PDR beam is aimed close to the horizon. To obtain this low grazing angle, the airborne radar, which has a limited range against a target as small as a periscope, should be operated at altitudes below 1500 feet, with 500 feet generally regarded as the optimum altitude. Performance at sea state 5 and above is degraded significantly owing to increases in sea clutter from breaking waves and shadowing of the periscope by the larger waves.

PDR Range Performance Predictions

Models exist for computing the range performance of PDRs in terms of minimum detectable radar cross section and sea state. An example of such a performance prediction is given in Figure 7 for the APS-137 at an altitude of 500 ft. The distance to the radar horizon is shown by the vertical dotted line at a range of 27.5 nmi. Values are plotted for sea states 3, 4, and 5. The boundary for noise-limited

performance is shown by the curve increasing monotonically to the right. If one assumes a nominal RCS of one square meter for a periscope, it is seen that, for sea state 4, detection is achievable for ranges out almost to the radar horizon. For sea state 5, detection is possible in two zones: for ranges out to about 3.5 nmi and from about 21 nmi out almost to the radar horizon.

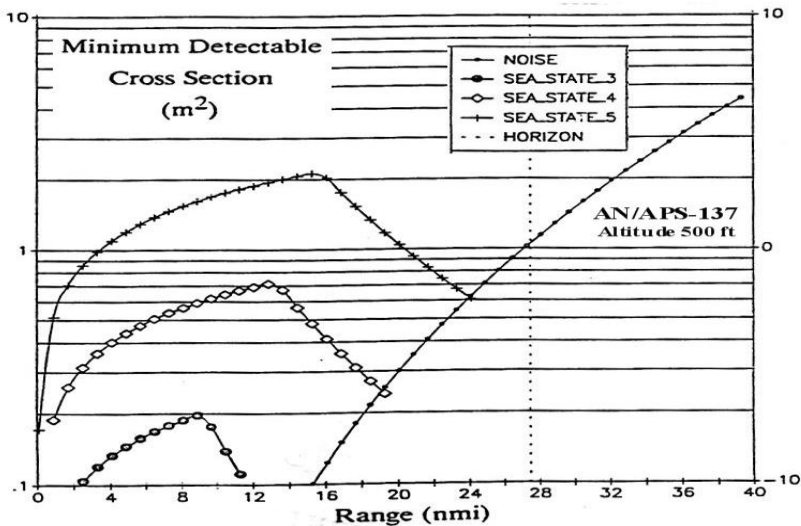

Figure 7. Calculated minimum detectable radar cross section

PDR Countermeasures

As with most military systems, for every *measure* there is usually a *countermeasure*, and in some cases even a *counter-countermeasure* to reduce the enemy's effectiveness. The submarine target can counter or reduce the effectiveness of a PDR system through a variety of operational and/or technical means, including the following:

- Employ Electronic Support Measures (ESM) gear to serve as a radar warning receiver. Its range should substantially exceed the detection range of the PDR
- Employ stealth techniques on the periscope/mast, including the use of radar-absorbing or radar-transparent materials, and shaping facets of the periscope to reflect radiation away from the incoming path
- Quickly retract the periscopes/masts and/or submerge.

Although the principal advantage of a submerged submarine is stealth, it is possible that, in an unusual tactical situation in which it might be necessary to have periscopes and/or masts exposed, a submarine could employ active radar countermeasures (although most may be a dead giveaway), including these:

- Use radar jamming
- Use “inverse gain jamming” to fool the PDR by transmitting modified copies of signals received by a radar warning receiver
- Eject a cloud of metallic chaff
- Deploy many floating metal corner reflectors as decoys.

IV. EXPLOITABLE TARGETS

Since microwave radiation does not penetrate (in a practical sense) into sea water, the PDR's *target* for a periscope-depth submarine is only that portion of a periscope or mast that is exposed above the sea surface. Included among the masts are optical and electro-optical periscopes and various communication and ESM antennas, all of which, when exposed, are potentially detectable by a PDR.

Figure 8 shows a modern German Type U-214 diesel-electric submarine (which had been exported to Pakistan) transiting on the surface with several periscopes and masts extended above its sail.



Figure 8. Type U-214 diesel-electric submarine with raised periscopes and masts

Aside from various environmental and operational conditions, the primary factors governing PDR target delectability are the strength of the reflected radar signal from the target (a function of the target's RCS), and the frequency and duration of the target's exposure. Radar detection of an exposed periscope is made difficult because of its relatively small size and RCS, brief exposure times, competing sea clutter, and false targets.

An older version of a U.S. submarine with its raised search and attack periscopes is shown in Figure 9. From this illustration, one can infer the relatively small size and small degree of exposure (and corresponding low RCS) these periscopes present when only approximately one meter of mast is exposed above the surface.

The fleeting exposure of a periscope (sometimes on the order of only a few seconds) makes it a very difficult and technically challenging target to detect. This is particularly true for a modern periscope that is coupled with advanced ESM capabilities (that can counter-detect the PDR well before it can detect the periscope) and the use of sophisticated radar-absorbent materials and fabrications to minimize its RCS.

To enhance its capabilities in missions such as ASUW and ISR, a modern submarine may also be equipped with a state-of-the-art *optronic* or *photonic* mast containing

electro-optical sensors such as high-resolution imaging cameras, a television camera, a passive infrared imaging sensor and a laser range finder, all connected to onboard displays and recording devices. The photonic mast might be raised, scanned through 360°, and lowered, all within a few seconds, even though its output can be viewed over an extended period of time. The use of electro-optics implies that the imaging sensor doesn't necessarily have to be mounted on a traditional retractable hull-penetrating mast whose output is viewed by an operator standing in a control room located directly below. Instead, the output can be displayed anywhere throughout the submarine. Some photonic masts have multiple optical systems which provide an instantaneous 360° field of view. For such masts, the exposure time might be determined principally by the time required for seawater to be shed from the exposed optics, rather than the time needed to acquire a 360° field of view. The relatively low RCS of a photonic mast is achieved through a combination of external shaping and the use of radar absorbing material.



Figure 10. Kollmorgen low-RCS photonic mast

An example of a photonic mast designed and manufactured by Calzoni, a subsidiary of Kollmorgen Electro-Optical, is illustrated in Figure 10. Its relatively low RCS is achieved through a combination of external shaping and the use of radar-absorbent material.



Figure 9. Search and attack periscopes

Although the U.S. Navy was among the first to deploy photonic masts operationally in its Virginia-Class submarine, as shown in Figure 11, this type of modern periscope technology has proliferated extensively in recent years via a lucrative export market. For example, Kollmorgen completed delivery of its Model 86 photonic masts to the Egyptian navy in 2002 for use in its Chinese-built Romeo-Class submarines.⁴



Figure 11. Photonics mast array on a Virginia-Class submarine

Another primary manufacturer and exporter of modern photonic/optronic masts is Thales, a French multi-national defense contractor. Thales optronic masts have been widely exported to countries such as Egypt, Saudi Arabia, South Africa, and Pakistan, in addition to Japan and some of our more traditional allies.^{4,5}

During the Cold War, which was characterized mostly by blue-water ASW operations at depth against Soviet nuclear submarines, the opportunities for periscope detection with radar were relatively infrequent. However, in the successful performance of its primary missions in the littorals (e.g., ASUW, ISR), post-Cold War acoustically quiet SSs operate predominantly at periscope depth, frequently exposing periscopes and masts. For example, the North Atlantic Treaty Organization (NATO) Supreme Allied Commander Atlantic Undersea Research Center database indicates that a mast is often exposed more than half the time a diesel submarine is underway.⁶ Therefore, PDR is a primary sensor of choice to exploit the relatively high exposure rates of SS periscopes and masts.

V. HISTORY OF AIRBORNE PDR SENSOR DESIGN AND DEVELOPMENT

This section traces the history of the design and development of airborne radar used for ASW applications, from its WWII beginnings, through the Cold War and into the post-Cold War era.

The Beginnings—WWII Airborne Radars

The use of radio-wave technology for target ranging was investigated by researchers in several nations as early as the 1920s. However, it was the British who, in the mid-1930s, first used radio detection and ranging (radar) technology in a practical sense for potential military applications. Radar saw its first military applications during WWII, particularly during the Battle of Britain in the summer and autumn of 1940, during the Allied strategic bombing campaign of Germany, and during the Battle of the Atlantic against German U-boats. Initial experimental radars were ground-based for potential use against enemy aircraft. Subsequently, radar was investigated for airborne applications. Because of the interdependence of wavelength, beam width and antenna size, the wavelength of airborne radar had to be considerably shorter than that used for ground-based sets, since the transmitter and antenna had to be small enough to fit into a tactical aircraft.

By late 1939, the British undertook trials with an experimental airborne radar device, operating in the VHF band at a frequency of 214 MHz, or a wavelength of 1.40 m, which was designated as Air to Surface Vessels Mk I, or ASV-1. By January 1940, the British had outfitted 12 Hudson aircraft with production ASV-1 radar sets for detecting surface ships and surfaced submarines. Although the ASV-1 was only marginally effective in locating surfaced submarines to a maximum range of a few nautical miles at best, it could detect coastlines out to approximately 20 nmi.⁷

By August 1940, the British deployed an updated ASV-1 VHF-band radar, operating at a frequency of 176 MHz, or 1.70 m, designated ASV-2. The ASV-2 had a more powerful transmitter and a more sensitive receiver, which enabled improved detection ranges against surfaced U-boats.⁷ In response, the Germans developed and deployed the Metox radar warning receiver on its submarines as a countermeasure to the British VHF radar.

By far the most notable and exciting new advance in radar technology, which far overshadowed all others during WWII, was the British adaptation and improvement in 1940 of a multi-cavity resonant magnetron, one of a long series of inventions by scientists in a number of countries. The first magnetron was invented by an American in 1920. One of many multi-cavity magnetrons was invented in Germany in 1935. The operating frequency (3 GHz) of the British third-generation device corresponded to a much shorter wavelength of approximately 10 cm and, for that reason, it was commonly referred to as *centimetric* radar. The initial British airborne

centimetric radars, designated ASV-3, could detect a surfaced submarine's conning tower at approximately 4 nmi, depending upon weather conditions, but as the power of the magnetron increased, the detection range steadily increased.⁷ Although the S-band centimetric radar was invented in 1940, it was not operationally deployed in significant quantities by the British until late 1942.⁸

Airborne centimetric radar gave the British two advantages: (1) it depicted objects such as coastlines and buildings on a radar screen, which the older radars could not do, and (2) the U-boat's radar warning receivers such as the Metox,⁹ which were tuned to the longer VHF wavelengths of the older ASV-1 and ASV-2 radars, could not detect it. Accordingly, with the new centimetric radar, British aircraft could locate surfaced U-boats from a distance without alerting them, and thus attack by surprise.⁹

British centimetric radar technology was first introduced to the U.S. scientific community in August 1940, after which scientists at the Massachusetts Institute of Technology began working with the magnetron in its newly established Radiation Laboratory. The introduction of the S-band magnetron to the U.S. was so significant that one U.S. historian later commented that the magnetron was "...the most valuable cargo ever brought to our shores."⁷ By late 1942, the U.S. Navy introduced the first of its own centimetric radars, designated the AN/APS-2 (alternatively referred to by the U.S. Army Air Corps as the SCR517).⁸

The Battle of the Atlantic was eventually won by the Allies owing to a variety of operational, tactical and technological factors. These factors included *Operation Ultra* deciphering of intercepted *Enigma*-machine encrypted German messages to U-boats; escorted convoys; shipboard direction-finding; surface-ship active sonar; long-range patrol aircraft with radar; the U.S. Navy's Tenth Fleet (*Phantom Fleet*); operational research; and escort aircraft carriers. Of these, one of the most significant was the operational employment of airborne radar, particularly the use of 10-cm wavelength S-band radar that was used with a high degree of success to detect and attack surfaced German U-boats during the summer of 1943.⁹

Throughout WWII, British and U.S. airborne radars were effective only in detecting surface ships and surfaced U-boats, not small-RCS targets such as exposed periscopes. The Allied radar's effectiveness against surfaced U-boats stimulated a cycle of tactical and electronic measures, countermeasures, and counter-countermeasures, which represented the earliest examples of modern electronic warfare. The most significant German countermeasures to Allied radars were as follows: (1) the development of intercept receivers, which today would be called ESM gear, (2) the development of the U-boat *Schnorchel* (or snout) to allow battery recharging without requiring the submarine to surface and be exposed to Allied radar detection, and (3) the development of radar-absorbing material to serve as camouflage.⁸ Germany developed ESM receivers to counter the ASV-2 VHF radar deployed in 1940, but took until well into 1943 to figure out the Allied switch to 3-GHz radar during late 1942. In fact, it was the Allied forces' great success with

centimetric radar in detecting surfaced U-boats during the summer of 1943 that compelled Germany to counter with the development and deployment of the Dutch-invented snorkel.⁸

Allied experience with ASW radar during the Battle of the Atlantic provided a number of general lessons that are significant and still applicable, as identified in Section VIII.

Cold War Airborne PDR Sensors

The earliest U.S. Navy radars for surface surveillance appeared near the end of WWII, when radar suites were placed on land-based sites, selected seaplanes and some carrier-based aircraft to detect low-flying aircraft, surface ships, and surfaced submarines. These radar systems were extremely big, power-hungry, and operator-intensive, and were prone to frequent operational failures.¹⁰ Furthermore, they were incapable of detecting relatively small RCS targets such as exposed periscopes and masts.

AN/APS-20 Airborne Radar (on P-2)

One of the earliest U.S. Navy airborne radar suites with good surface surveillance capability was the AN/APS-20, which was initially developed during WWII but did not enter operational service until 1946. The APS-20 was deployed operationally in 1953 on Lockheed's maritime patrol aircraft, the P-2 Neptune, shown in Figure 12. The APS-20 operated at L-band, S-band, and X-band, had selectable Pulse Repetition Frequencies (PRFs) in each band, as well as a wide selection of pulse widths in each band. It also provided a host of other features and operator tools such as automatic target indicator, plan position indicator, three choices of heading reference and stabilization, and selectable azimuth and elevation beam widths.



Figure 12. P2V-7 aircraft with AN/APS-20 radome on its underside

Furthermore, it included selectable output-radiated gain, selectable receiver-radiated gain, selectable antenna gain, automatic gain control low and high settings, plus a wide assortment of display and strobe-light control selections, all of which could be employed by a highly-trained operator. (Perhaps there were too many operator-selectable controls that could be set non-optimally.) It was a powerful radar that could radiate up to 1 megawatt in L-band, and could detect large surface ships beyond 200 nmi on a good refracting day. On a good day, a highly trained operator could determine approximate target size, heading and speed within three or four sweeps. The S-band was significantly better at discrimination and resolution of targets at 100 to 150 nmi. The X-band was even better at detection ranges of 75 to 100 nmi, and was especially effective at detecting low-flying aircraft. But like all of these early radars, the APS-20 was very large, heavy, power-hungry, and operator-intensive, and was ineffective at detecting small RCS surface targets such as exposed periscopes and masts.¹⁰

AN/APS-80 Airborne Radar (on P-3A and P-3B)

Many of the APS-20's features and operator controls were subsequently included in the AN/APS-80 surveillance radar suites which were delivered with Lockheed's P-2 follow-on aircraft, namely the P-3A and P-3B Orion long-range maritime patrol aircraft, in 1962 and 1965, respectively. A photo of a P-3B appears in Figure 13. The performance capabilities of the APS-80 were similar to those of the APS-20.¹⁰ Among other things, the APS-80 was the first airborne surveillance radar that had dual mechanically scanned antennas, forward- and aft-looking, to provide continuous 360° area search coverage.¹¹



Figure 13. P-3B aircraft

AN/APS-115 (on Older P-3Cs)

The AN/APS-115B radar set, used in the P-3C aircraft (see Figure 14) beginning in 1969, is an X-band air and surface surveillance radar system that provides surveillance and detection of surface vessels, submarine snorkels and aircraft. It consists of two radar receiver-transmitters, two antennas (located in the nose and aft section of the aircraft, providing 360° azimuth coverage), associated radar system controls, and a radar interface unit. The APS-115 is a frequency-agile system, meaning that the transmitter carrier frequency is changed between pulses or groups of pulses to reduce the probability of intercept and alerting of a target submarine using ESM equipment. The APS-115 is still currently deployed on the majority of P-3C aircraft in the U.S. fleet. Although excellent for surface surveillance, the APS-115 has a limited capability for detecting exposed periscopes.



Figure 14. P-3C aircraft

AN/APS-116 Radar (on S-3A)

After the Cuban Missile Crisis in October 1962, and during the mid/late 1960s, U.S. Navy carrier battle groups began facing an increasingly menacing Soviet nuclear submarine cruise-missile-firing SSGN threat. In response, the Navy developed and deployed, in 1974, the Lockheed S-3A Viking high-bypass fanjet aircraft, shown in

Figure 15. The S-3A was a follow-on to the older Grumman S-2 Tracker to provide aircraft carriers with a highly capable organic ASW capability, out to ranges in excess of 200 nmi. The S-3A aircraft incorporated the new multi-function AN/APS-116 radar, which had three modes of operation: (1) periscope and small target detection, (2) long-range search and navigation, and (3) maritime surveillance. It was the first airborne surveillance radar designed specifically for the detection of small RCS targets on the sea surface, such as exposed submarine periscopes and masts, and was the U.S. Navy's first airborne radar with a demonstrated periscope detection capability.¹² The APS-116, which is a derivative of the APS-115 but with only one (forward-looking) radar antenna, was manufactured by Texas Instruments Inc. (TI).



Figure 15. S-3A aircraft

Although the APS-116 had an excellent periscope detection capability, the detection and target declaration process was not automated and thus still required a highly skilled human operator to maximize operational effectiveness. The 500-MHz bandwidth of this radar was exceptional for the period in which it was developed and the APS-116 long remained the airborne surveillance radar with the highest range resolution in the U.S. inventory. The system spun the antenna at a very high rate to provide scan-to-scan de-correlation of the sea clutter, enabling the stable periscope return to stand out from the variable sea clutter. Development of this radar was done in collaboration with the Naval Air Development Center, Warminster, PA. Much of the early testing by the government was conducted on the sea cliffs overlooking the Kalaupapa Peninsula on the Hawaiian island of Molokai. This cliff setting, which overlooked an unsheltered, deep, uncontaminated ocean with a variety of sea state environments, allowed the radar to be tested at altitudes comparable to S-3 operational altitudes.

For its three modes of operation, the characteristics of the APS-116 were the same as those of the follow-on AN/APS-137.

AN/APS-137 Radar (on S-3B and selected P-3Cs)

The S-3B aircraft followed the S-3A in the mid-1980s. The S-3B, shown in Figure 16, incorporated a new multi-mode radar, derived from the APS-116 radar, and designated the AN/APS-137. The APS-137 radar was developed in the early 1980s by TI by modifying and upgrading the APS-116 to add an inverse synthetic aperture radar (ISAR) mode developed by NRL, while retaining the original three modes of the APS-116.¹² This fourth operating mode enabled better and longer-range target identification (albeit still requiring interpretation by a human operator) of Soviet sea-based threats, particularly the cruise-missile-firing SSGN. ISAR provides relatively crude two-dimensional radar images of moving surface targets that extend over many range cells. It relies on roll, pitch and yaw motions of the target vessel to produce Doppler shifts in the return signals, which vary as a function of position along the length and height of the ship. In addition to being used on the S-3B, the APS-137 has also been deployed on selected P-3C aircraft, replacing the older APS-115 radar.



Figure 16. S-3B Aircraft

An installation of the AN/APS-137 antenna in the nose of a P-3C Update III aircraft is shown in Figure 17.

The parameters of the periscope detection mode for the APS-137 and APS-116 are essentially the same, as given in Section III. Their common design philosophy was based on three very challenging operational and environmental characteristics: (1) the exposed periscope is physically small, with a small RCS, (2) during attack by the submarine, periscope exposures are typically very brief, and (3) the surrounding sea clutter de-correlates in time frames that are comparable to the shortest expected periscope exposure times. These characteristics led to a design that incorporated the

following: (1) high range resolution of 1.25 feet to enhance the signal-to-clutter ratio, (2) a 5- to 15-second scan-to-scan signal-processing integration time matched to expected exposure times and relatively long compared to clutter de-correlation times, (3) a rapid 300-rpm antenna scan rate to yield many independent samples during the nominal sea clutter de-correlation time, and (4) automatic-gain-control loops to maintain a constant false-alarm rate.¹²



Figure 17. AN/APS-137 antenna in nose of P-3C Update III Aircraft

Operationally, periscope detection is best at low altitudes of about 500 feet and small grazing angles of about 1 degree because sea backscatter is lower at the lower altitudes with smaller grazing angles.¹²

The nominal performance of the APS-137 in the periscope detection mode, operating at an altitude of 500 ft, is described as detection of a small RCS ($\sim 1 \text{ m}^2$) attack periscope at a range of 19 nmi in sea state 3, with a probability of detection of 0.5, and a very low probability of false alarm, corresponding to approximately one false alarm per hour. Actual real-world detection is variable, depending on particular operational and environmental conditions, including sea state, wind direction, sea and swell direction, height and duration of periscope exposure, platform altitude, system-processing settings such as threshold and gain, and perhaps most importantly, operator training, proficiency and alertness.¹²

Air ASW Effectiveness Measurement (AIREM) exercises during the early 1990s, in which the APS-116 served as a surrogate for the APS-137, had produced highly variable PDR performance results, particularly in *free-play* exercises. These variable results suggested problems in the scan converter and in operator training involving the selection of threshold, gain and system default settings, antenna tilt, and in-flight

profiles. The best performance was achieved at low altitudes/small grazing angles, but this imperative conflicts with the higher altitudes desired for simultaneously monitoring large fields of sonobuoys. In addition, perhaps the most serious shortfalls of the early APS-137's operational performance included the following:

- Automation was lacking in detection, and the operator-intensive detection process was highly dependent upon operator training, experience, attentiveness, and alertness.
- An automatic target discrimination or classification process was lacking.

Given the post-Cold War policy changes in ASW during the early 1990s, these concerns persuaded the Navy to issue, in April 1992, a formal requirements document (Mission Needs Statement) for airborne automatic periscope detection and discrimination, and subsequently to initiate an Enhanced Advanced Technology Demonstration (EATD) Category 6.3 program, starting in Fiscal Year 1993, to address these shortfalls.¹² These efforts are discussed in greater detail in Section VII.

The APS-137 radar was designed to meet the Cold War ASW threat of the 1980s and, in its ISAR mode, to provide a stand-off surface ship classification capability for the S-3B aircraft. Unfortunately, technology limitations during this period limited the full potential of the APS-137. For example, bandwidth reduction processes had to be incorporated into the radar to reduce the high data rates prior to digital processing, thereby reducing the resolution below its inherent capability. However, by the 1990s, advances in radar-sensor and signal-processing technology enabled TI to recommend changes to the APS-137 that would enhance its ability to detect and classify smaller RCS targets at longer detection ranges in higher sea states. Accordingly, by the early 1990s, TI proposed to improve the periscope detection capability of the APS-137 and provide for auto-classification of exposed periscopes and masts.³ These proposed sensor enhancements included the following:

- Processing the radar data at the radar's full range resolution (1.25 ft), increasing the radar's gain against clutter by as much as 19 dB
- Increasing the range at which target detection becomes noise-limited by about 40%, by increasing the two-way system gain by a factor of four, through increases in the transmitter's power and antenna gain
- Adding an automatic ship detection and classification capability for the manually operated ISAR mode and then adapting these algorithms to periscope/mast detection
- Adapting the radar's Doppler and spatial processing capability for ship classification and large/small target discrimination to short-exposure periscope/mast detection
- Using the radar to cue secondary sensors such as a forward-looking infrared imaging device and/or secondary radars.³

AN/APS-124 Radar (on SH-60B)

The AN/APS-124 maritime surveillance radar was developed by TI for use in the SH-60B Seahawk Light Airborne Multi-Purpose System (LAMPS) Mark III helicopter, shown in Figure 18. LAMPS was designed for use on Spruance-Class destroyers and serves as a direct extension of its host surface vessel rather than as a stand-alone system. Because the helicopter can operate at altitude, the APS-124 provides a greatly extended range to the radar horizon than that afforded by a ship's mast-mounted radar. The antenna is mounted under the fuselage and provides 360° coverage. A remote radar operator aboard the ship can control the APS-124 and receive its output via a data link. The APS-124 operates in three modes for (1) long range search, (2) medium range search, and (3) fast-scan surveillance. The third mode, which is applicable to periscope detection, uses 0.5- μ s pulses at a rate of 1880/s and a scan rate of 120 rpm. These features, coupled with high transmit pulse energy and digital scan-to-scan signal integration, enable sea clutter de-correlation and the detection of small surface targets in high sea states. The false-alarm rate can be adjusted to suit conditions.¹³



Figure 18. SH-60B aircraft

Post-Cold War Airborne PDR Sensors

AN/APS-147 Multi-Mode Radar (for MH-60R)

During the mid-1990s, the Navy's program manager for maritime helicopters, PEO(A)/PMA-299, motivated by a need for improved periscope detection capability on LAMPS helicopters, chose Telephonics to develop a new lightweight multi-mode radar, the AN/APS-147, for the new multi-mission MH-60R, shown in Figure 19. Primarily because of weight limitations on the helicopter, the proven fixed-wing APS-137 ASW radar was not selected. At approximately 260 pounds, the APS-147 is about half the weight of the APS-137 radar used on fixed-wing aircraft.¹⁴ The missions of the MH-60R include ASW, ASUW, strike, and search and rescue. The APS-147 provides six modes of operation: (1) long-range search, (2) low-probability-of-intercept search, (3) short-range search, (4) small-RCS periscope detection, (5) target designation for the Penguin, Harpoon and Tomahawk missiles, and (6) inverse synthetic aperture radar (ISAR).



Figure 19. MH-60R aircraft

The primary operational and technical requirements driving the design of the periscope detection mode in the APS-147 were less stringent than those associated with the new APS-137-oriented Automatic Radar Periscope Detection and Discrimination (ARPDD) program, which was concurrently in development during the 1990's. (The ARPDD program is discussed in detail in Section VII.) The general requirements included small target RCS, short exposure time, and automatic detection with low false-alarm rate, even in high sea states. To accommodate these ASW requirements, the APS-147 radar's design features included wide bandwidth, high average power, fast scan rate (108/minute), frequency agility, scan-to-scan integration over nine scans, and a track-before-detect capability.¹⁴

Based on in-house modeling and analyses conducted during the mid-1990s, Telephonics felt that the periscope detection performance of the APS-147 would be comparable to that of the APS-137.¹⁵ Initially, the different signal and clutter processing approaches used by the two radar types did not allow the ready incorporation of ARPDD's more stringent signal-processing algorithms and software for automatic target discrimination into the APS-147. Instead, it was expected that *lessons learned* from ARPDD development would be applicable only to a future upgrade of the APS-147.¹⁵ However, by taking advantage of recent technology breakthroughs in processor miniaturization and processing power, Telephonics developed the AN/APS-153, an upgrade of the APS-147, to include an "ARPDD-like" capability in its periscope detection mode. This involved replacing the APS-147's signal processor with a much more powerful, high-speed, high-data-rate, automatic-discrimination processor that was designed by the Naval Air Warfare Center Weapons Division, China Lake, California, with the capability of handling the unique ARPDD periscope detection and discrimination algorithms.¹⁶

Investigating Feasibility of Using UHF Radar (on E-2C) for ASW Applications

The Grumman E-2C Hawkeye is a carrier-based aircraft that employs the AN/APS-145 high-power UHF Doppler surveillance radar for the fleet defense mission. The E-2C, shown in Figure 20, is a derivative of the Grumman S-2F Tracker carrier-based ASW aircraft and the E-1 Tracer ("Stoof with a Roof") airborne early-warning aircraft, and is characterized by a 26-ft dish-shaped radome mounted atop the aircraft. This radar is the latest in a long line of carrier-based airborne early-warning (AEW) radar systems (AN/APS-120, AN/APS-125, and AN/APS-138) from General Electric Aerospace. It uses a rotating antenna, covering 360° within its circular radome. Typically flown at an altitude of 15,000 to 25,000 feet, the radar system can simultaneously and automatically detect and track multiple targets on the sea, in the air, over land, and at the critical land-sea interface.³

The APS-145 AEW radar has demonstrated an in-flight capability to detect and track thousands of targets at ranges in excess of 200 nmi over several million cubic miles of volume. Its highly sophisticated signal-processing capabilities, including pulse compression, coherent integration, constant false-alarm rate (CFAR) processing, non-coherent integration, and scan-to-scan auto tracking, enable it to discriminate relatively small and large RCS targets under widely varying environmental conditions. The radar continuously monitors and adapts to the environment while its six parallel processors maintain potentially thousands of tracks in its AEW surveillance volume.³



Figure 20. E-2C aircraft

The characteristics of the APS-145 are essentially identical to those of the earlier APS-125 and APS-138. These are horizontally polarized radars that operate in 10 channels in the frequency band of 406 to 446 MHz with a pulse width of 12.8 μ s compressed to 270 ns, a PRF of 300 Hz, and a scan rate of 5 to 6 rpm.

Although there were no formal requirements to use this AEW radar for ASW applications, anecdotal information, as well as flight- and ground-based test data, has indicated the possibility that the APS-145 is able to detect and track targets as small as periscopes at extended ranges, which are much greater than those of X-band radars such as the APS-137. The potential advantages of using UHF for the ASW surveillance mission include the following:³

- There were some indications that target radar cross sections are larger at lower frequencies and that radar-absorption materials surrounding periscopes are less effective at the lower UHF frequencies than at X-band.
- Sea backscatter is smaller at UHF frequencies. Thus, relatively stationary objects such as periscopes, which compete against the sea clutter, appear stronger relative to background clutter.

- Weather-related effects are minimal since this all-weather radar operates at wavelengths that are very large compared to the size of rain and fog droplets.

However, because the APS-145's scan rate is only 5 to 6 rpm, or one scan every 10 to 12 seconds, it is not well suited for detecting fleeting periscope exposures.

In 1990, NADC under the sponsorship of ONR, started investigating the feasibility of employing high-altitude UHF radar for detecting exposed periscopes at very long ranges, as suggested by previous anecdotal evidence and flight tests. E-2C flight tests with an APS-145 radar, conducted in the Bahamas in June 1990 under highly controlled operational conditions, were successful in validating this assertion. However, at that time, the mechanisms responsible for radar backscatter from the sea surface at low (and mid-) grazing angles were not well understood. Therefore, the E-2C flight tests were followed by further ONR-sponsored investigations to develop a better understanding of the phenomenology of periscope and mast detection from high altitudes, and to develop design guidelines for high-altitude PDR sensors. Among other investigations by NADC, a series of low-grazing-angle (LOGAN) radar experiments was conducted from the Chesapeake Light Tower, near Norfolk, Virginia, to measure sea clutter and its Doppler properties and the radar characteristics of periscopes. These measurements served to expand the knowledge base for low-grazing-angle periscope detection.¹⁷

However, owing to operational and technical challenges associated with periscope detection from high altitudes and to new evolving mission requirements imposed upon the E-2C operational community to support *strike* operations, as well as to the post-Cold War decline in ASW emphasis, the potential application of the E-2C's APS-145 UHF radar to long-range periscope detection was not pursued further.

Airborne ARPDD

By far the most exciting and technically challenging new effort that has substantially advanced the state of the art in PDR technology was the ONR-sponsored Automatic Radar Periscope Detection and Discrimination (ARPDD) program. This advanced technology development transformed a manual, operator-intensive PDR process into a robust, automatic periscope-detection and classification capability, even in high-clutter littoral environments. Although the Navy initiated separate programs in FY93 to address both airborne and shipboard periscope detection applications, these two programs were subsequently merged into a single program, ARPDD, beginning in FY94. This topic is discussed in detail in Section VII.

The major milestones in airborne PDR design and development from WWII to the early 1990s are summarized in Table 2.

IOC Date	Radar Type	Platform	Significance	Ops Requirement	PD Design Features	PD Performance
Early 1940	ASV-1	U.K. Aircraft	U.K. introduced first military airborne radar	Surface surveillance to detect German ships and surfaced U-boats	<ul style="list-style-type: none"> Pulsed microwave radar 214 MHz (VHF band) 1.5-m wavelength Fits into combat A/C 	<ul style="list-style-type: none"> Detect surfaced sub at 2 to 3 nmi (in calm seas) No PD capability
Late 1940 (U.K.; limited IOC)	Centimetric (S-band)	U.K. Aircraft	<ul style="list-style-type: none"> U.K. introduced first centimetric radar Compelled Germans to develop/deploy snorkel 	Surface surveillance to detect German ships and surfaced U-boats	<ul style="list-style-type: none"> 10-cm cavity resonator magnetron at 3 GHz High resolution, compact 	<ul style="list-style-type: none"> Reliably detect surfaced sub at < 4 nmi No PD capability
Late 1942 (U.S.)	<ul style="list-style-type: none"> ASV-3 (U.K.) APS-2 (USN) SCR-517 (USA) 	U.S. Aircraft	develop/deploy snorkel			
1946	APS-20	P-2 (in 1953)	First U.S. AEW and surface surveillance radar	Detect ships and surfaced subs and low-flying A/C	L, S, & X-band; 4 PRFs; variable pulse width, etc., but large, heavy, operator-intensive	<ul style="list-style-type: none"> Good surface surveillance No PD capability
Mid-1960s	APS-80	P-3A, P-3B	First radar with dual antennas (fore & aft looking) and digital circuitry	Surface surveillance	X-band	<ul style="list-style-type: none"> Similar to APS-20 No PD capability
Late-1960s	APS-115	Older P-3Cs		Surface surveillance	X-band	<ul style="list-style-type: none"> Excellent surface surveillance Minimal PD capability
1974	APS-116	S-3A	First multi-mode radar designed specifically for low RCS periscope detection	Surface surveillance plus detect fleeting periscope/mast of Soviet ASUW threat	<ul style="list-style-type: none"> X-Band (9.5 GHz) High range resolution (1.25 ft) Rapid scan antenna (300 RPM) High PRF (2000) 	<ul style="list-style-type: none"> Reliable manual detection of 1-m² RCS@ 20 nmi in SS3, with P_r = 0.5 and PFA=10⁻⁵
Mid-1980s	APS-137	S-3B Selected P-3Cs	Added ISAR capability to APS-116	Same as APS-116; plus surface ship classification for HARPOON targeting		
1980s	APS-124	SH-60B	Helicopter multi-mode surveillance radar without PD capability	Surface surveillance		<ul style="list-style-type: none"> Good surface surveillance Minimal PD capability
Early-1990s (Investigations)	UHF Radar	E-2C	Potential for using high-altitude AEW radar for ASW	PD capability an opportunity, but not a requirement	<ul style="list-style-type: none"> High-power UHF yields: <ul style="list-style-type: none"> Larger target RCS Smaller sea back scatter Smaller weather effects 	<ul style="list-style-type: none"> Significantly longer PD ranges than X-band radar; High altitude ops
Mid-1990s (Start Development)	APS-147	MH-60R	Helicopter multi-mode surveillance radar w/ISAR and PD capability	Littoral ASW, ASUW and strike missions	Lightweight, compact design = 1/2 weight of fixed wing APS-137	
1993 (Start Development)	Air ARPDD	MH-60R (First Candidate)	First airborne PD capability with automatic detection & classification	Air MNS, 21 April 1992	See Table 4 for details	See Table 4 for details

Table 2. Major Milestones in Airborne PDR Design and Development

VI. HISTORY OF SHIPBOARD PDR SENSOR DESIGN AND DEVELOPMENT

Introduction

Like their airborne counterparts, shipboard radars were developed and used during WWII to detect aircraft, surface ships and surfaced submarines. However, as with their airborne counterparts, WWII shipboard radars were incapable of detecting small RCS targets such as periscopes. The earliest S-band shipboard radar was the Type 271 fitted on British corvettes in 1942.⁸ To defend against German U-boats during convoy routing and protection operations, the British had to be able to find them. ASDIC, the newly developed British underwater active acoustic ranging system, could detect submerged, but not surfaced, submarines within a half mile on average, whereas shipboard radar could detect surfaced submarines to several miles, particularly if the weather was calm.⁹

Early Shipboard Periscope Detection Techniques

During WWII, shipboard radar was used primarily to detect large RCS targets, including aircraft, surface ships and surfaced submarines. Since, at that time, radar was unable to detect small RCS targets, search and detection of periscopes from a ship was performed primarily by visual lookouts. Although there was some interest in U.S. Navy shipboard PDR developments during the 1950s and 1960s, this interest declined with the switch from diesel-electric to nuclear submarines. The practice of using lookouts continued during the Cold War, when most detections of Soviet nuclear submarines were performed by the long-range sea-floor-mounted passive acoustic Sound Surveillance System (SOSUS) arrays in blue waters, which, in turn, cued tactical maritime patrol aircraft using passive sonobuoys. Accordingly, there was relatively little interest in, or a requirement for, shipboard detection of exposed periscopes, particularly by nonacoustic means.

However, by the mid-1980s, the U.S. Navy and the Defense Advanced Research Projects Agency showed interest in exploring industry proposals for developing technology for the shipboard detection of exposed periscopes using various types of nonacoustic sensing techniques. These proposals included the following:

- *Sea Star*: A concept that was sponsored and pursued by the Navy's Directed Energy Office (PMW-145) from fiscal years 1984 through 1988. It involved active illumination of periscopes using a scanning laser and detection of the retro-reflection from the periscope optics. However, this technique is limited in that it works only when the periscope is looking directly at the ship's sensor.¹⁸
- *Passive Coherent Location*: A concept for exploiting VHF and UHF signals of opportunity from TV and FM broadcast stations and reflected from targets, such as exposed periscopes, using Doppler processing.¹⁹

Beyond exploratory investigations, however, most of these nonacoustic sensing techniques were never further developed, owing primarily to significant operational and technical challenges, as well as the lack of a rigorous formal requirement for shipboard periscope detection.

However, by the early 1990s, after the end of the Cold War and the subsequent shift in ASW emphasis toward SSs operating in the littorals, the Navy began to take a much more serious interest in periscope detection for ship self-defense. At that time, the only Navy technology efforts focused on ASW radar were the NRL testing of the APS-137 airborne radar aboard a ship and the Office of Naval Technology's (ONT) Nonacoustic ASW Block Program (Block OR3A), which focused specifically on airborne radar.

During the summer of 1991, under the ONT's Nonacoustic ASW Block Program manager sponsorship, NADC prepared a task plan for a ship-based periscope and mast (P&M) detection technology development effort, scheduled to start in FY92. This plan addressed the background, operational requirement, technical status and issues associated with ship-based P&M detection. The task focused on the respective operational and technical challenges of lidar technology versus radar technology, and on investigating which is more suitable for meeting the operational requirements of shipboard P&M detection.²⁰

Up to that point, shipboard P&M detection in the fleet was still performed visually by lookouts, with additional lookouts posted when the ship was in high-threat areas. Existing shipboard surface-search radars, such as AN/SPS-10, -55, and -67, were deemed unsuitable since their technical characteristics (operating frequency, power, pulse width, scan rate, and PRF) were not optimized for P&M detection. Therefore, they exhibited low detection probabilities and high false-alarm rates against P&M targets. Likewise, existing fire-control radars, such as the AN/SPQ-9 used for controlling the ship's five-inch gun and the Phalanx Close-in Weapon System (CWIS) used for terminal point defense against air and sea-skimming threats, were similarly deemed not suitable for P&M detection.²⁰

Shipboard Periscope and Mast Detection Challenges

The most challenging operational problems to overcome in shipboard P&M detection include the following:²⁰

- The threat submarine must be detected and acted upon during the short time period between initial periscope exposure and possible torpedo launch.
- P&M exposure durations are often very short.
- The radar and optical cross sections of the exposed P&M are relatively small.

The most challenging technical issues for a shipboard radar P&M detection system are as follows:²⁰

- What is the detection phenomenology? Periscope/mast hard target? Wake? Other?
- What are the optimum radar parameters for short range (<10 nmi) detection? Frequency? Polarization? Range resolution? Antenna scan rate? Waveform?
- What is the clutter at low grazing angles at the frequencies of interest?
- What determines the RCS? Periscope/mast hard target? Wake? Periscope-generated clutter?
- What is the optimum signal processing for target detection and discrimination?
- What are the effects of environmental factors? Ducting? Multi-path? Air-sea interaction?

Most, if not all, of these questions were resolved under the shipboard portion of the ONR-sponsored ARPDD program, which is discussed in detail in Section VII.

The advantages of using an ASW radar appropriate for shipboard P&M detection, having characteristics similar to those of the airborne APS-137, include the following:²⁰

- Day/night all-weather capability
- Proven technology, able to detect periscopes at ranges >20 nmi (from aircraft altitudes)
- Ability with ISAR to discriminate a periscope from floating debris
- Low two-way transmission losses at 10 GHz for nominal 10-nmi range

The disadvantages of an APS-137-like radar for shipboard P&M detection include the inability to detect targets which are closer than about

- 400 ft away from the ship, because of the transmitted pulse width and receiver saturation
- 240 ft away from the ship, because of antenna-tilt limitations, for an assumed antenna height of 70 ft

As an alternative to radar, the use of lidar technology has been considered for shipboard P&M detection. However, the use of a shipboard lidar system for P&M detection has its own set of operational and technical issues, the most challenging of which include the following:²⁰

- What is the optimum wavelength? Atmospheric penetration and scintillation? Available equipment? Eye safety? Target reflectivity?
- What is the background noise? Filter bandpass during daylight? Clutter from sea surface?

- What is the optimum system architecture? Direct vs. heterodyne detection? Imaging vs. non-imaging?

Following is a list of the potential advantages of a shipboard lidar P&M detection capability:²⁰

- Accurate range and bearing information
- Target velocity information via Doppler
- Low probability of intercept
- No RF radiation in emission control situations
- Target/false-target discrimination

However, there are also disadvantages of a shipboard lidar P&M detection capability:²⁰

- Performance is highly weather-dependent
- Technical maturity is limited

Existing Shipboard Surface-Search Radars That May Have Application to Periscope/Mast Detection

As discussed in Section VII, the National Security Industrial Association conducted an ad hoc study in the summer of 1992 to assess the capabilities of available commercial and military radars to perform submarine mast detection. The study group identified three candidate radars as potential shipboard PDRs: (1) the AN/SPS-70 shipboard radar, (2) the Phalanx Close-In Weapon System (CIWS) radar, and (3) a proposed combination of the AN/BPS-16 submarine radar and the commercial RASCAR radar.³ Of these three radars, the SPS-70 has the characteristics most suitable for periscope detection.

The AN/SPS-70 Radar

The AN/SPS-70 is a high-performance ASW/ASUW surveillance radar built by Texas Instruments Inc. and is the shipboard counterpart to the airborne APS-137 in that the two share identical performance characteristics. Shipboard weight, volume and power constraints are not as stringent as for airborne equipment, but other requirements, such as ruggedness and salt-spray resistance, are more demanding. Thus, the SPS-70 weighs 1000 pounds compared to 500 pounds for the airborne APS-137; its volume is 50 ft³ compared to 33 ft³ for the APS-137; and it draws 6500 W of electrical power compared to 5000 W for its airborne counterpart. The SPS-70 uses mast-detecting concepts developed at the former NADC, and classification concepts and algorithms developed by NRL. It has been deployed on a number of classes of ships.

The Phalanx CIWS Radar

The Phalanx CIWS radar is a shipboard system for protection against anti-ship missiles. It was designed and manufactured by the General Dynamics Corporation and is used on every class of U.S. Navy surface combat ship. Phalanx, considered the last defense for Navy ships against high-speed cruise missiles, is an autonomous system consisting of a search radar, track radar, a 6-barrel 20-mm Gatling gun, and a computer. Phalanx performs search, target declaration, track, gun slew, open-fire and cease-fire automatically for quick reaction. The gun can fire up to 4500 rounds per minute. Because of their distinctive barrel-shaped radomes and their automated nature of operation, Phalanx CIWS units are sometimes nicknamed “R2-D2s.”

Phalanx operates in the K_u band and uses one klystron tube, which is switched to either the search antenna or the track antenna. The antenna system rotates in azimuth at 90 rpm. In a periscope detection mode the radar would operate at an average transmitted power of 800 W, a peak power of 30 kW, and a PRF of 10 to 20 kHz. The antenna gain is 31.4 dB, and the radiation emitted is vertically polarized. The beam width is 2.5° in azimuth and 10° in elevation.

Phalanx has a quick reaction time because it was designed to engage fast, low-flying cruise missiles, a feature relevant and useful for detecting fleeting periscope targets. Because it operates automatically, without human intervention, Phalanx reacts quickly to a threat. In high-threat areas, the Phalanx system could presumably not only detect the periscope of a hostile submarine, but, if sufficiently close, may also be able to destroy it automatically. However, because the Phalanx radar operates in the K_u band, at a short wavelength of about 2 cm, it performs poorly against periscopes in rain squalls or in high sea states. Although CIWS may be capable of P&M detection, operationally it would not be implemented unless it is on a not-to-interfere-basis with its primary duty of anti-ship missile defense.

The Proposed Hybrid AN/BPS-16 / RASCAR Radar

The AN/BPS-16 is an X-band radar providing surfaced submarines with capabilities of navigation, surface surveillance and limited detection of low-flying aircraft. It is carried on the later Ohio-Class and on Virginia-Class submarines. The RASCAR radar is a widely used commercial shipboard navigation system, with tracking capabilities for channel navigation and collision avoidance. The BPS-16 and RASCAR are both supplied by Sperry Marine Inc. The proposed system would be a hybrid system consisting of a BPS-16 transceiver, a RASCAR antenna, and processing components from both. The transceiver provides a 60-kW peak power output, a 1000-Hz PRF, and a 700-ns pulse width, compressible to 10 ns. The proposed antenna is a 9-ft linear array rotating at 60 rpm and providing a gain of 32.5 dB, an elevation beam width of 30° , and an azimuth beam width of 0.8° . This very narrow azimuth beam width would reduce the clutter area seen by the radar and is achievable because such a wide-aperture antenna is feasible on a shipboard system.

Advanced Technology Development for Surface Ship Periscope Detection

After a Mission Need Statement (MNS) for shipboard periscope detection was issued in April 1992 (along with an MNS for airborne periscope detection), the U.S. Navy began a shipboard Enhanced Advanced Technology Demonstration (EATD) program (similar to the airborne EATD program) to identify and assess key technologies applicable to shipboard periscope detection in support of surface ship torpedo defense. In December 1992, the Naval Surface Warfare Center Dahlgren Division (NSWCDD) issued a Broad Agency Announcement (BAA) for a “Surface Ship ASW–Periscope Detection EATD” to meet the shipboard periscope detection requirements.²¹ After an industry brief on this BAA in January 1993, NSWC started a full-scale EATD program whose objective was to explore various sensor concepts such as radar, lidar, and infrared for reliable automatic detection and classification of submarine periscopes/masts.²²

Throughout the 1990s, NSWCDD, under ONR sponsorship, was actively involved in the design, development and testing of a prototype periscope detection sensor system which exploited the optical augmentation technique using a ship-based laser cued by a ship-based PDR. The objectives of this effort included the development of an improved capability to detect and classify periscopes from a surface ship at tactically useful ranges, and to reduce the false-alarm rate from a radar-only solution. The ultimate goal was to improve surface-ship torpedo defense capabilities through reliable periscope detection. However, owing to certain operational issues and the absence of a formal requirement to augment a surface-ship PDR with a lidar system for reducing false alarms to acceptable levels, this program was eventually discontinued.

Shipboard ARPDD

As indicated previously, the U.S. Navy initiated separate EATD programs in FY93 to address both airborne and shipboard periscope detection. Subsequently, these two programs were merged into a single ARPDD program beginning in early FY94. Although the airborne APS-137 was chosen as the host radar for RDT&E purposes under the ARPDD program, both airborne and shipboard PDRs were addressed on equal footings. The ARPDD program is discussed in more detail in Section VII.

The major milestones in shipboard PDR design and development from WWII to the early 1990s are summarized in Table 3.

Era	Radar Type	Platform	Significance	Ops Requirement	PD Design Features	PD Performance
Early in WWII	Surface Search Radars	Surface combatants and escorts	U.K. introduced first military shipboard radars	Detect low-flying aircraft, ships and surfaced U-Boats	Not designed for periscope detection	No PD capability
Cold War Years	Surface Search Radars (e.g., SPS-10, SPS-55, SPS-67)	Surface combatants	Designed for detecting surface vessels, not periscopes	Detect ships and sea-skimming aircraft and cruise missiles	Not designed for periscope detection	Very limited PD capability
	Fire Control Radars (e.g., SPQ-9, Phalanx)	Surface combatants	Designed for AEW fire control support, not for detecting periscopes	Detect / engage sea-skimming aircraft and cruise missiles	Not designed for periscope detection	Very limited PD capability
Late-Cold War Years (1980s)	Shipboard applications of airborne APS-137	Surface combatants	Harness best airborne PDR for ships	Reliable detection of threat sub periscope prior to torpedo attack	Same as airborne APS-137, but operated at smaller grazing angles	Reliable manual detection of periscopes similar to APS-137
	Nonacoustic alternative/ adjunct concepts to PDR (e.g., optical augmentation)	Surface combatants	Investigate nonacoustic alternatives to shipboard PDR	Reliable detection of threat sub periscope prior to torpedo attack	Potential application to periscope detection	Optical PD capability limited by weather, target/sensor alignment, etc.
1993 (Start Development)	Ship ARPDD	HVU surface combatants	First shipboard PD capability with automatic detection & classification	Ship MNS, 21 April 1992	See Table 4 for details	See Table 4 for details

Table 3. Major Milestones in Shipboard PDR Design and Development

VII. POST-COLD WAR ARPDD SYSTEM DEVELOPMENT FOR AIR AND SHIP APPLICATIONS

As discussed previously, the APS-116 and the follow-on APS-137 were the first U.S. Navy airborne radars designed specifically for detecting small RCS periscopes at tactically significant ranges in relatively high sea states. Although effective in detecting periscopes, target classification with these radars remains an operator-intensive process. However, the post-Cold War paradigm shift in the ASW operational environment caused a dramatic shift in PDR requirements and in the Navy's technology developments for meeting those requirements. This redirection precipitated the formulation and execution of what is considered by many to be the most exciting and technically challenging new effort to advance substantially the state of the art in PDR development – the ONR-sponsored Automatic Radar Periscope Detection and Discrimination (ARPDD) program. ARPDD focused on developing the technology for an automatic periscope detection and classification capability for both airborne and shipboard applications, particularly in high-clutter littoral ASW environments. This program is discussed in detail herein.

Post-Cold War PDR Sensor Requirements

During the Cold War years, when passive acoustic ASW sensors were the sensors of choice against Soviet nuclear submarines operating primarily in open ocean waters, the opportunities and need for airborne detection of exposed submarine periscopes and masts were limited. Therefore, the fleet's requirements for PDR were not compelling; there were no formalized OPNAV requirement documents for PDR; and, with the exception of the new periscope detection mode of the 1970s-developed multi-function APS-116 radar, the pace of advancement in PDR sensor technology was mostly incremental during much of this era.

Mission Need Statement, April 1992

During the post-Cold War 1990s, the U.S. Navy's ASW focus changed significantly in terms of mission priority, threat submarine type, and operating environment. In particular, the Navy shifted its mission priorities toward expeditionary force operations in support of regional conflicts, primarily in the littoral environment. The new ASW threat became the acoustically quiet, elusive SS, whose primary mission was anti-access, area-denial ASUW. Operating in a high-clutter littoral environment, the SS posed a particularly difficult detection and classification challenge for the manual, operator-intensive PDRs of the day.

As a result, the specific requirements for developing and fielding a robust automatic periscope detection and discrimination capability became very compelling. At that time, the formal Department of Defense (DoD) requirement for developing and fielding such a capability was an official requirements document called a Mission Need Statement (MNS). Specifically, to meet the challenges of proliferating

acoustically quiet diesel-electric submarines operating in an area-denial role in the shallow-water littorals, the OPNAV Anti-Submarine Warfare Division (OP-71) issued, on 21 April 1992, two separate MNSs for the development of a robust capability to detect and classify exposed periscopes automatically. These two MNSs documented the following requirements, respectively: (1) an airborne periscope-detection capability for offensive ASW applications and (2) a shipboard periscope-detection capability for own-ship self-defense against a torpedo-launching submarine. Because of their distinct, unique operational natures, separate MNS performance specifications were issued for each application.³

These MNSs specified only the following generic requirements for periscope detection, as opposed to stipulating a particular ASW sensor solution:

- Day/night, all-weather operation
- High area search rate
- High detection rate, even for short duration exposures
- Low false-alarm rate, independent of sea state
- The ability to classify targets while maintaining search volume
- The ability to detect and to classify automatically

The first of these two requirements (day/night, all-weather operation, and high area search rate) tended to favor radar strongly over optical devices as the sensor type of choice. By far the biggest technical challenges for any MNS sensor solution were the requirements for responding to very short exposure times and for automatic detection and classification.

National Security Industrial Association Quick Reaction PDR Study, Summer 1992

Immediately after the MNSs for airborne and shipboard periscope detection capability were issued in April 1992, OP-71 engaged key radar experts in industry through the National Security Industrial Association (NSIA) to assess the capabilities of available commercial and military radars to satisfy the requirements specified in the MNSs. An ad hoc study was performed over approximately 90 days to address two specific questions: (1) Are there any commercial-off-the-shelf (COTS) products that could help solve the problem? and (2) What processing improvements would enable existing shipboard or airborne radar systems to meet Navy requirements?³

Three previously described representative commercial/military shipboard radars and two airborne radars were selected as potential solution candidates: (1) the AN/SPS-70 (shipboard version of the AN/APS-137), (2) the Close-In-Weapons-System K_u-band radar used in the Phalanx ship defense system, (3) a hybrid system combining components of the RASCAR commercial radar system with the

AN/BPS-16 submarine radar, (4) the X-band AN/APS-137 radar used on S-3B and some P-3C aircraft, and (5) the UHF AN/APS-145 radar used on E-2C aircraft.³

In response to the two key questions, the ad hoc study group reached the following conclusions:

- (1) There were no airborne or shipboard COTS products that could, without substantial and costly modifications, satisfy the MNS requirements. Moreover, none of the military radars could fully meet all MNS requirements. The best military candidates were the airborne APS-137 and its shipboard counterpart, the SPS-70. However, neither could meet the challenging MNS requirement of automatic detection and classification. The main limiting factors were the following: (a) very short target exposure times, (b) high potential false alarms from sea clutter, and (c) difficulty in discriminating real from false targets.³
- (2) There was sufficient evidence that existing radars could be modified to meet the MNS requirements through processing improvements, although with great difficulty. The group also concluded that employing more than one radar type, and/or employing and fusing data from other sensor types, (e.g., lidar or a passive optical sensor) may be useful, especially for a shipboard system.³

Based on these study results, the NSIA committee recommended that the Navy initiate advanced development programs as soon as possible to develop and field a radar with an automatic periscope detection and discrimination capability, for both airborne and shipboard applications. Specifically, the programs should focus on the following:

- employing and upgrading the detection capability of an existing, highly capable small-RCS-detecting radar such as the APS-137.
- investigating and developing algorithms and processing techniques for automatic target classification/discrimination, that is, developing techniques to aid in false-track rejection and for accelerating the target-declaration process. Such techniques might include Doppler interrogation, spatial filtering, frequency correlation, and interferometry. An investigation of the polarimetric qualities of masts was also recommended.
- conducting operational evaluations and improving the database of mast signatures and ocean clutter.

The primary conclusion of this NSIA study was that the recommended upgrade of an existing military radar system, such as the APS-137, for automatic detection and classification is based on sound science and engineering, and should be pursued vigorously by the U.S. Navy.³

Automatic Radar Periscope Detection and Discrimination (ARPDD) Program

Introduction

Based on the formal requirements for reliable periscope detection, as documented in the Airborne and Shipboard MNSs of April 1992, and the recommendations and impetus provided by the NSIA quick-reaction study in July 1992, the Navy initiated, in October 1992, two separate periscope detection EATD programs, one for airborne and one for shipboard applications. These programs were to be executed by the Naval Air Systems Command (NAVAIR) and the Naval Sea Systems Command (NAVSEA), respectively.

The initial NAVAIR approach was to develop test plans, and to use the APS-137 radar to perform tests and collect data, early in 1993, against submarine periscopes and other small targets in a variety of sea states. The basic question to be answered was as follows: Are the fundamental characteristics and range resolution of the APS-137 sufficient for discrimination of periscopes from small “confusion” targets? Following the establishment of the feasibility of an APS-137-based approach, system architecture plans and data analyses were begun to develop a prototype ARPDD system.

The initial NAVSEA approach was to develop, during the first year, an extensive plan for collecting data relevant to radar, passive mid-/long-wave infrared, and near-infrared lidar sensors, followed by the actual data collection and analysis and shipboard system architecture definition and design in the second year.

At the request of the Office of the Assistant Secretary of the Navy for Research, Development & Acquisition (ASN RDA), the Naval Studies Board of the National Academy of Sciences reviewed both EATD programs during the summer of 1993. Following this review, ASN RDA directed, in September 1993, that the Airborne and Shipboard Periscope Detection EATDs be combined into a single new advanced technology demonstration program, primarily to reduce costs by leveraging PDR technology developments common to both applications. Sponsorship of the combined program, called ARPDD, was assigned to ONR, and management responsibility was assigned to NAVAIR. Subsequently, an APS-137-based common system architecture (with variations) was defined for both the airborne and shipboard applications, to be implemented by NAVAIR and NAVSEA, respectively.

ARPDD Requirements and Technical Challenges

The primary requirement for the ARPDD program was to develop a radar that fully satisfies the Navy’s Airborne and Shipboard Periscope Detection MNSs of April 1992. In particular, the radar should:²³

- detect periscopes with short-duration exposures reliably and automatically at operationally significant ranges
- discriminate, with a low false-alarm rate (FAR), periscopes from false targets, reliably and automatically
- have capabilities suitable for both aircraft and ships operating in littoral areas.

Detection of such fleeting targets requires, among other things, a radar system with a sensitive detection threshold, a high PRF, and high range resolution. Modern airborne ASW radars such as the APS-137 are designed to provide such a capability over open ocean waters where there are few false targets. In such benign waters, an alert operator viewing a radar display can readily detect and classify a *pop-up* periscope. However, in littoral environments with large numbers of false targets, the operator of such a system may be overwhelmed by returns from confusion targets such as debris, buoys, and small boats. This false-alarm problem became the focus of the ARPDD program's goal of automating target detection and classification.

During its first year, the ARPDD program's technical team, consisting of members from NAVAIR, the Naval Air Warfare Center Weapons Division/China Lake, CA (NAWC WD), the Naval Air Warfare Center Aircraft Division/Patuxent River, MD (NAWC AD), NRL, the Johns Hopkins University Applied Physics Laboratory (JHU/APL), and Raytheon TI Systems, formulated a comprehensive RDT&E program to address and resolve these technical issues. The ARPDD program was divided into three major development phases:

1. Develop and gather data with a *breadboard* ARPDD system
2. Develop and test a land-based *brassboard* ARPDD system
3. Develop and test shipboard and airborne ARPDD Fleet Demonstration Units (FDUs)

The unique algorithms and signal-processing software developed under the ARPDD program were intended to be forward- and back-fit into (1) surface-search radar replacements on surface combatants and (2) upgrades to air ASW radar systems such as the APS-137 (on selected P-3Cs) and the APS-147 (on MH-60R).

ARPDD Basic Concepts

Since the development of the APS-116 and APS-137 radars in the 1970s and 1980s, respectively, there have been tremendous advances in technology, particularly in sensor post-processing. To this day, computer-processing speed and data-storage capacity continue to expand exponentially. Advances in navigation aids such as the Global Positioning System, in conjunction with advances in computer technology, make possible improvements in the performance and post-processing of data from these radars that could not have been anticipated at the times of their initial development. On the other hand, the detection of submarine periscopes is anticipated

to be more difficult in the future through the widespread introduction and use of photonic masts, which can function with minimal exposure times.

The goal of the ARPDD program was to automate the detection of very-short-duration transient periscope exposures with a very low false-alarm rate. The approach was to exploit the spatial and temporal characteristics of signals obtained by a PDR in conjunction with other knowledge of target and background characteristics. Target characteristics include small size, moving linearly at reasonable submarine speeds, and not bobbing about. Background characteristics include natural clutter (from waves, swell, whitecaps) and man-made clutter (e.g., boats, buoys, debris). Other useful knowledge is that the speed of a diesel-electric submarine operating with its periscope up is unlikely to exceed 10 knots. In general, submarines must maintain a minimum speed of about two knots or more for steerage, depth control and trim. *A priori* knowledge of the limits of submarine behavior can be applied to distinguishing between submarine and non-submarine. For example, if a small target is observed to be moving at a constant radial speed of 5 knots over a 5-second period, as determined by a tracker and/or by the Doppler shift of its radar return, it would be a candidate for declaration as a target. On the other hand, a small object that exhibits no significant translational motion but yields a radar return whose Doppler frequency fluctuates or is broadened, is likely to be a floating object being moved only by wave motion.

The ARPDD program chose to use the APS-137 radar as a starting point. As mentioned previously, this radar did not originally operate at its full-potential range resolution of 1.25 feet because of limitations in data processing at the time of its development. That is, the bandwidth of the received signals had to be reduced prior to digital processing, thereby reducing the radar's effective resolution. However, after the initial development of the APS-137 in the early 1980s, major advances in digital-processing speeds by the mid-1990s enabled ARPDD to process signals to the full 1.25-ft resolution. This is important for several reasons. First, clutter is reduced as the size of a resolution cell is reduced. Second, it is desirable for the target to fill a resolution cell as completely as possible to achieve the greatest contrast relative to adjacent resolution cells, thereby reducing "dilution" of the signal over a large volume of space. (Even at that, with an azimuth beam width of 2.4° and elevation beam width of 4.0° , the cross section of a resolution cell at a low grazing angle and distance of 10 nmi would be over 2500 ft by 4200 ft.)

The processing technique used originally in the APS-137 avoided the need to compensate for target and platform motion since, during an integration period of, say 5 seconds, the target is likely to remain in the same window. However, what appears to be an advantage means that no information on short-term target movement is gained. On the other hand, the full 1.25-ft resolution obtainable with an ARPDD-augmented radar operating on a platform whose motion is compensated over an integration period to that same tolerance enables acquiring precise real-time information on target movement. ARPDD effectively plots the tracks of potential

targets and discards those that do not correspond to pre-established velocity templates. ARPDD employs a *retrospective* processor which uses all contacts or plots from a number of past radar scans, taking into account all possible target trajectories formed from stored contacts for each input detection. The processor eliminates many false alarms, while retaining those contacts describing reasonable trajectories. Therefore, employment of a retrospective processor makes it possible to obtain large improvements in detection sensitivity in certain important clutter environments.

A numerical example will serve to illustrate the process. Suppose a submarine periscope is moving with a velocity component of 5 knots radially toward or away from the radar scanning at a rate of 300 rpm. If an integration period of 5 seconds is selected, the periscope will have moved radially 42 feet during 25 scans of the radar. If a detectable return is obtained for, say, 13 of these 25 “looks” at the target and a comparison with a velocity template covering the range of possible target-velocity vectors indicates the target is moving at some reasonable speed for the situation, a detection may be declared. In contrast, an anchored fishing boat or buoy would be ignored. Compared to the processing technique used previously in the APS-137, retrospective detection with 1.25-ft range resolution requires compensation of sensor platform motion to better than 1.25 feet during the integration period. This is achieved by use of data from the Global Positioning System and an inertial navigation system with a Kalman filter to compensate the radar data before detection processing.

The sensitivity required to detect submarine masts reliably also results in the detection of many persistent clutter spikes, such as from breaking waves, which may persist for several seconds. In general, these will not satisfy the spatial and temporal criteria for submarine masts and will be disregarded.

Breadboard ARPDD System

The first phase of the ARPDD program, which began in FY94, focused on building a *breadboard* test radar system to investigate and evaluate processing schemes, to validate the motion-compensation algorithm, to validate target-discrimination feasibility, to develop target-discrimination algorithms, and to enhance the detector design. The breadboard system consisted of an APS-137 host radar from NRL, a limited-coverage automatic detector prototype, and data recorders. To achieve automatic detection and discrimination, the high-resolution APS-137 radar was coupled to a two-stage periscope-declaration processor that performed the following functions: (1) conventional target detection with a moderate FAR, followed by (2) signature discrimination to reduce false alarms. The ARPDD program’s approach to discriminate real periscopes from false targets and ocean-clutter spikes was to identify and then eliminate the false targets by their spatial and temporal characteristics, enabled by the retrospective temporal processing scheme. Among

other things, the breadboard-development phase successfully demonstrated the application of retrospective processing to the periscope-detection problem.²⁴

Brassboard ARPDD System

The second phase of the ARPDD program began in 1995 and involved development of a *brassboard* radar system. This prototype engineering system, which extended the limited-coverage breadboard retrospective processor to full area coverage, was quite large and occupied ten 72- by 19-inch equipment racks, as shown in Figure 21.

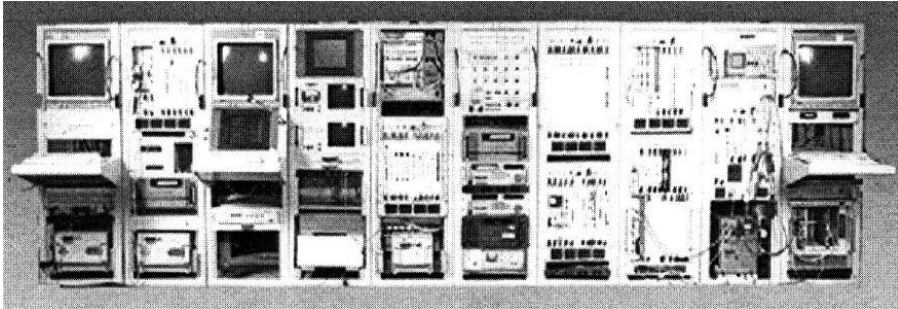

Figure 21. Brassboard ARPDD signal processing system

The brassboard system incorporated additional capabilities including automatic detection, direct discrimination, tracking and indirect discrimination. It also incorporated extensive data recording capabilities that were used for land-based field-testing in Hawaii in 1997. The brassboard system was used successfully to determine the performance of individual system components, the sensitivity of performance to various system parameters, and total system performance.²⁴

Ship Tests of Brassboard ARPDD System (1998)

The third phase of the ARPDD program was to involve testing both shipboard and airborne fleet demonstration units (FDUs) of the developmental system by fleet personnel to demonstrate its operational capabilities and utility. However, because of funding limitations, the FDUs were not built and instead, follow-on testing was performed with modified versions of the brassboard system.

In the summer and fall of 1998, a series of field trials was conducted on the *USS Stump* (DD-978) with the brassboard ARPDD system replacing the ship's AN/SPS-55 surface search radar. During work-up exercises with a carrier battle group and its subsequent deployment, as well as during Ship Antisubmarine Readiness and Evaluation Measurement (SHAREM) exercises in the Mediterranean, the shipboard brassboard system underwent extensive testing with numerous submarine interactions. Among other things, ARPDD's sea-clutter rejection algorithms were validated under way, with performance equal to that experienced

during the land-based tests with the brassboard system the previous year. In terms of operational capability against submarine periscopes, the brassboard ARPDD on the *USS Stump* demonstrated such a high probability of detection and low probability of false alarms that fleet operators developed a high degree of confidence in its ability to detect and accurately declare targets automatically.²⁵

The highly successful performance of the brassboard ARPDD during its Mediterranean deployment prompted several laudatory messages and comments from fleet commanders. For example, in post-test discussions between the commanding officer of the *USS Stump* and the ONR program sponsor, the sponsor stated: “The CO personally told me that ARPDD accounted for the majority of detections during the SHAREM. He said that he soon came to depend on ARPDD more than [on] acoustics, and began to plan his [ASW] tactics around the ARPDD range of the day.”²⁶

Airborne Tests of Brassboard ARPDD System (1999 & 2001)

After completion of the brassboard ARPDD tests on the *USS Stump* in late 1998, the brassboard system was modified and re-installed in an NRL P-3 aircraft in March 1999 to collect target-discrimination data and to perform flight evaluations of the system. During the summer of 1999, a series of P-3 flight tests of the brassboard ARPDD was conducted in various types of littoral waters to develop and evaluate target-discrimination algorithms and to obtain system-optimization data under various environmental and operational conditions. In addition, the P-3 brassboard ARPDD was used in operational exercises in the Western Pacific during the fall of 1999 to quantify the density of detected objects in high-clutter littoral regions of interest and to assess target-discrimination performance.²⁷

The SHAREM flight tests revealed some unanticipated technical issues. Specifically, under certain sea-state conditions, the false alarms (periscope declarations with no target present) were significantly higher than expected.²⁸ Sea-clutter detections were found to be a much greater problem for ARPDD than man-made clutter. To gain a thorough understanding of the relationship between the observed ARPDD false-alarm rate and the littoral environmental conditions during these SHAREM tests, it was necessary to obtain a much larger statistical sample of false alarms under a variety of environmental and operational conditions. Therefore, a second series of P-3 flight tests was conducted with the brassboard ARPDD system, in the summer of 2001, to obtain the necessary data. These flight tests were successful in resolving the technical issues uncovered during the 1999 SHAREM flight tests.²⁹

The map of Figure 22 shows the test locations of the brassboard ARPDD system.³⁰

Upon completion of the second series of P-3 flight tests in the summer of 2001, and upon the successful accomplishment of all of the ARPDD program’s major technical objectives, ARPDD formally ended as an ATD program on 30 September 2001.

Subsequently, ARPDD undertook a series of follow-on engineering development activities in preparation for the acquisition of airborne and shipboard PDR systems.

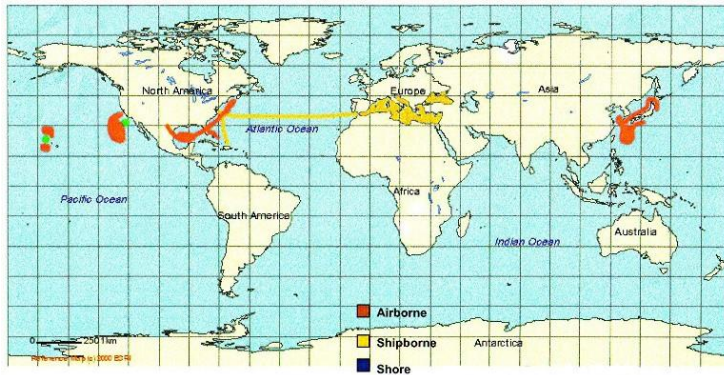

Figure 22. Locations of brassboard ARPDD testing

The timeline for the ARPDD Advanced Technology Demonstration program is illustrated in Figure 23.³¹

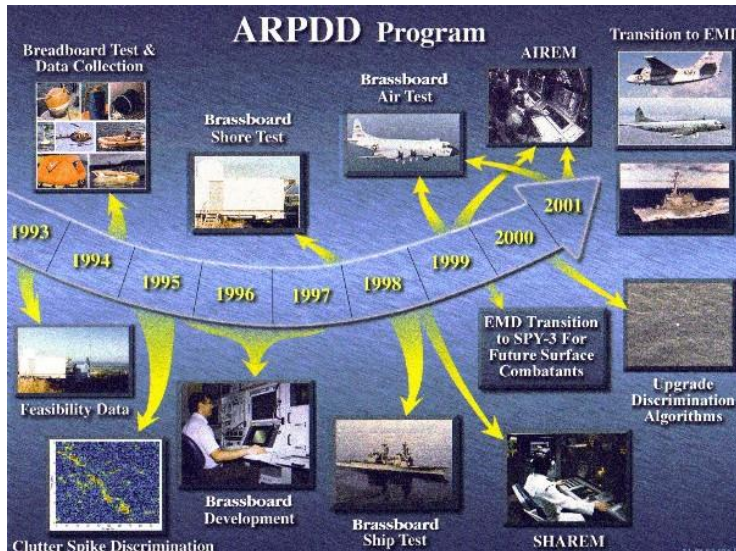

Figure 23. ARPDD program timeline

The major milestones in ARPDD system concept formulation, design, and development are summarized in Table 4.

Date	Major Milestone	Significance	Program Sponsor & Manager	Technical Team	Comments
21 Apr 1992	MNS issued for: • Airborne PD • Shipboard PD	First formal OPNAV requirement for automatic airborne and shipboard PD in high-clutter littorals	OP-71	Navy and Industry	Specified: • Day/night all-weather ops • High-detection rate against short exposures • Automatic detect and classify with low FAR
Summer 1992	National Security Industrial Association Quick-Reaction PDR Study	Industry investigation into existing air and ship radar systems that could, if modified, meet MNS	National Security Industrial Association	National Security Industrial Association	Concluded that: • No existing COTS or military radars could fully meet MNS requirements without major modifications • APS-137 is best candidate
Oct 1992	Start EATDs for: • Air PD • Shipboard Capability • Ship PD • Shipboard Capability	First Navy program to develop air and ship PD capability, responsive to MNS	Air: PMA-264 Ship: PEO-NSWC/STO	Air: NAWC AD, NAWC WD, APL, NRL & TI Ship: NSWC/Dahlgren	
1 Oct 1993 (Start ARPDD Prg)	Merge both EATDs into single ARPDD Program	Programmatic decision to focus common PDR technology developments and reduce costs	ONR Sponsor & PMA-264 Manager	N/A	Most stressing technical challenges for ARPDD: • Detect short transient low-RCS target • Automatically discriminate target in high-clutter with low FAR
1994–1995	Develop Broadboard ARPDD system	Successfully demonstrated automatic retrospective processing	ONR Sponsor & PMA-264 Manager	NAWC WD, JHU/APL, NRL, TI	• Leverage high-resolution APS-137 as ARPDD baseline • Collect data to develop 2-stage target discriminator
1996–1997	Develop Brassboard ARPDD system	• Engineering asset which incorporates all elements of ARPDD design • Additional capabilities plus extensive data recording	ONR Sponsor & PMA-264 Manager	NAWC WD, JHU/APL, NRL, TI	Data collection and testing at low- and high-elevation shore sites in Hawaii
1998	Fleet Demo (Ship) Tests on USS Stump	First shipboard test of brassboard system by fleet operators	ONR Sponsor & PMA-264 Manager	NAWC WD, JHU/APL, NRL, TI	SHAREM 125 and other tests in Mediterranean
1999	Fleet Demo (Air) (1 st Air Test on NRL P-3C)	• First airborne test of brassboard system by fleet operators • Identified littoral FAR issues	ONR Sponsor & PMA-264 Manager	NAWC WD, JHU/APL, NRL, TI	SHAREM 138 tests in WESTPAC
2001	Fleet Demo (Air) (2 nd Air Test on NRL P-3C)	• Second airborne test of brassboard system by fleet operators • Resolved littoral FAR issues	ONR Sponsor & PMA-264 Manager	NAWC WD, JHU/APL, NRL, TI	
30 Sep 2001	Completed ARPDD ATD Program	Successful completion of ATD prior to follow-on activities in support of transition to air and ship programs	N/A	N/A	Assessments and strong Navy endorsements recommended full-scale air and ship PDR programs

Table 4. Major Milestones in ARPDD System Concept Formulation, Design and Development

Assessment Activities and Endorsements for ARPDD

In 2001, the ASW Requirements Division (OPNAV N74) conducted several major ASW technology assessments to develop an investment strategy applicable to ASW operations in contested littorals. OPNAV engaged several blue-ribbon panels, including the *Littoral ASW Future Naval Capability Integrated Product Team (IPT)*, the *Sensor Systems IPT*, and the *Nonacoustic Sensors Sub-Committee* of the OPNAV *Planning and Steering Advisory Committee (PSAC)*, to assess promising ASW Science and Technology (S&T) efforts and to help define, select and recommend the best ASW sensor system candidates for near-term development and transition into operational capability.

Among other things, these study panels concluded the following:³²

- Both airborne and shipboard ARPDD had a high warfighting priority that should be transitioned into the fleet as soon as practical. (*Littoral ASW Future Naval Capability IPT*)
- ARPDD is one of the most promising ASW technologies to be pursued. (*Littoral ASW Future Naval Capability IPT*)
- The most critical issue and the most difficult technical challenge to overcome is the false-alarm rate, which is driven by the short-exposure-time requirement in PDR. ARPDD is the most promising research and development approach, and it is strongly recommended that both airborne and shipboard ARPDD acquisition programs be pursued. (*Nonacoustic Sensors Sub-Committee of PSAC*)

Following the OPNAV N74 ASW sensor assessments of 2001, there were several less formal, but no less compelling, endorsements for ARPDD from the fleet and from high-level Navy leadership. Examples of these endorsements, which strongly advocated the near-term development and fielding of both Air and Ship ARPDD, included the following:³³

- A recommendation for development and deployment, made by the Fleet ASW Improvement Program's (FLTASWIP) 2002 World-Wide ASW Assessment
- A recommendation for immediate acquisition, made by the following:
 - FLTASWIP leadership – msg 271300Z Feb 02
 - Program Executive Officer (Mine Undersea Warfare) (PEO (MUW)) – December 2001
 - Commander-in-Chief, U.S. Pacific Command (CINCPAC) – msg 141953Z Feb 02
 - Commander Fleet Forces Command (COMFLTFORCOM) – msg 041400Z Feb 02

The combination of a highly successful ATD program coupled with strong fleet and Navy leadership endorsements has made the ARPDD program one of ONR's most

successful candidates for transition to further development, acquisition and fielding in the fleet. Having been fully responsive in meeting OPNAV and fleet requirements, ARPDD is expected to enhance fleet ASW capabilities significantly. Therefore, subsequent to the formal ending of ONR's ARPDD ATD program in September 2001, the Navy undertook a series of ARPDD follow-on activities in pursuit of engineering development and acquisition of both airborne and shipboard PDR systems.

Air ARPDD Status and Plans

In May 2002, the Chief of Naval Operations directed OPNAV N78 to fund an Air ARPDD acquisition program. As a result, Air ARPDD was funded in Program Objective Memorandum 2004 (POM-04), with funding starting in Fiscal Year 2005.³⁴ The airborne version of ARPDD was originally targeted for deployment on P-3C aircraft. However, upon the decision to twilight the decades-old P-3C's in favor of the new P-8A, ARPDD was redirected to the MH-60R.³⁵

Ship ARPDD Status and Plans

Similar to air ARPDD, U.S. Navy leadership has provided strong endorsements for the development, acquisition and fielding of a shipboard ARPDD capability. Along with the further brassboard demonstration of an upgraded shipboard ARPDD in fleet exercises on an aircraft carrier during 2003 and 2004, these endorsements have led to subsequent CNO direction and Navy plans to develop and incorporate automatic periscope detection and discrimination technology into a suitable mast-mounted radar, with an *APS-137-like* capability, on selected high-value unit surface ships and surface combatants.³⁶

VIII. LESSONS LEARNED

While there is no guarantee that successful technology improvements and measures of the past are accurate predictors for success in the future, some fundamental, enduring lessons learned can be gleaned from the historical evolution of the design, development and employment of PDR sensors. These include the following:

Lessons Learned in PDR Technology Improvements

- Significant historical advancements in PDR technology have been driven primarily by operational necessity (requirements pull), particularly during wartime, rather than via technological opportunities (technology push). Just as with the development of sonar, the military operational requirements during WWII were the primary stimulus for the introduction, rapid technology advances and combat applications of radar.
- During peacetime, affordability and vetted requirements issued formally by Navy leadership are the principal drivers for PDR RDT&E programming and funding.
- The size and weight restrictions for airborne radars, particularly for highly weight-sensitive helicopter and unmanned air vehicle systems, are among the biggest drivers in the choice of the PDR's wavelength, power, PRF, and scan rate.
- The paradigm shift from Cold War ASW in blue waters to post-Cold War ASW in the cluttered littorals has resulted in a corresponding shift in emphasis from PDR target detection to the much more difficult problem of automatic target classification (discrimination). Accurate target classification has been, and continues to be, the most difficult operational and technical challenge for PDR.
- When fully fielded, the technology development pursued under the ONR-sponsored ARPDD program during the 1990s will transform a manual, operator-intensive PDR process into a robust automatic target detection and classification capability, for both airborne and shipboard ASW applications.
- Successful employment of new PDR technology is, to a high degree, a function of tactics, and operator training, proficiency and alertness.
- The introduction of new sensors, weapons and tactics leads to a continued evolutionary interplay of measures, countermeasures and counter-countermeasures.

Lessons Learned in PDR Operations

- The primary stimuli for the introduction, rapid technology advances and combat applications of radar during WWII were military operational requirements.

- Historically, and until very recently, PDR operations in the fleet have been manual, operator-intensive processes.
- Air superiority is effective in suppressing SS ASUW operational effectiveness since the SS's need for periscope exposures during final ASUW targeting (except for the most proficient, advanced SS crews) is readily exploitable by an effective airborne PDR.
- Maintaining radar surveillance in the vicinity of threat submarines not only may lead to a significant number of periscope detections but also may force submariners to minimize their periscope exposures (indiscretion rate), particularly during ASUW submarine approach and attack. This *hold-down* tactic restricts the submarine's maneuver and mission options, often resulting in a *soft kill*.
- PDR utility is, and will continue to be, relatively high against most SS submarines, even those with the longer submerged endurance capability provided by air-independent propulsion, since (with the exception of high-end-crewed SSs) they typically require one or more periscope *looks* to satisfy torpedo attack criteria against a surface ship.

IX. SUMMARY

The intent of this monograph is to trace and summarize the historical development and technical design issues of U.S. Navy airborne and shipboard radar used for the detection of exposed submarine periscopes. Over the years, periscope detection radar (PDR) sensors have evolved with a concurrent interplay of changes in the threat, missions, requirements, measures, countermeasures, environment, and advances in technology.

Early during World War II, the first airborne radars operated at wavelengths of 1 to 2 m in the VHF band and required large arrays of dipoles as antennas. During the Battle of the Atlantic, they were effective in detecting only surfaced German U-boats, not their periscopes. Later in the war, S-band (10-cm wavelength) technology advancements, such as the development of the cavity magnetron, yielded higher resolution with smaller antennas more suitable for fitting into military aircraft.

During the Cold War, the switch to X-band (3-cm wavelength) in the U.S. Navy's AN/APS-116 and APS-137 airborne ASW radars enabled resolution sufficient for detecting periscopes of low radar cross section in high sea states at tactically significant ranges. However, because of a lack of formal operational requirements, radar detection and classification of rarely exposed periscopes of Soviet nuclear submarines, which operated primarily in relatively benign open-ocean waters, remained a manual, operator-intensive process.

In contrast, during the post-Cold War era, it became necessary to detect relatively frequent, but fleeting, exposures of periscopes of acoustically quiet diesel-electric submarines against a background of numerous target-like objects in acoustically challenging littoral environments. This provided the impetus for automating the periscope detection and discrimination process for airborne PDR, and for adapting PDR to Navy ships, thereby endowing shipboard surface-surveillance radars with a periscope-detecting capability in support of self-defense against torpedo-firing submarines.

The recent development of modern digital signal processors, with their high computational power and speed, has enabled significant improvements in both airborne and shipboard radars. These advances made possible real-time signal processing with sophisticated algorithms capable of automatic detection and classification of exposed periscope targets in high-clutter littoral environments. This technology development, pursued under the ONR-sponsored Automatic Radar Periscope Detection and Discrimination program during the 1990s, has transformed a manual, operator-intensive PDR process into a robust automatic target detection and classification capability for both airborne and shipboard ASW applications.

ABOUT THE AUTHORS

John G. Shannon is a recognized technical expert in the field of airborne non-acoustic Anti-submarine Warfare (NAASW) technology and systems development, as well as in Undersea Warfare (USW) operations analysis. He has authored and/or co-authored numerous technical articles and reports in the field, including a Navy-wide NAASW Master Plan and several technical papers in the peer-reviewed U.S. Navy Journal of Underwater Acoustics. Mr. Shannon holds the M.E. degree in mechanical engineering from Cornell University, Ithaca, New York (1968); the B.E. degree in mechanical engineering from Villanova University, Villanova, Pennsylvania (1967); and a certificate degree from the U.S. Naval War College, Newport, Rhode Island (1977).

From 1971 to 1993, he was employed as an electronics engineer at the former Naval Air Development Center (NADC), Warminster, Pennsylvania, where he specialized in the development of airborne NAASW sensor systems, including ASW lidars, magnetic anomaly detection sensors, infrared sensors and periscope detection radars. While at NADC, he also served as the project engineer for the P-3C Update IV avionics program and the deputy block manager (Airborne) of the Office of Naval Research's NAASW Block.

From 1993 to 2005, Mr. Shannon was employed as a senior engineer and operations research analyst at the Naval Undersea Warfare Center (NUWC), Newport, Rhode Island, specializing in USW and network-centric warfare analysis. Among other things, he was an active participant in the Fleet ASW Improvement Program, serving as conference "recorder" from 1999 to 2005. He also served as the U.S. National Leader for an Action Group within the international organization The Technical Cooperation Program, which investigated the merits of coalition network-centric warfare. Mr. Shannon retired from NUWC in 2005, after 34 years of distinguished Civil Service, for which he received the Navy Meritorious Civilian Service Award.

Mr. Shannon is also a retired Captain, Aerospace Engineering Duty Officer, after almost 30 years of distinguished service in the U.S. Naval Reserve. Since 2005, he has been employed part-time as a senior engineer at Rite-Solutions, Inc., Middletown, Rhode Island.

Paul M. Moser received his B.A. in physics from La Salle University and his M.S. in physics from the University of Delaware. He performed research in microwave spectroscopy at Delaware and at Duke University in which he determined the molecular structure of several chemical compounds and studied the broadening of microwave absorption lines of gases with increasing pressure and decreasing temperature.

At the DuPont Experimental Station he developed instrumentation and performed low-resolution nuclear magnetic resonance spectroscopy of polymers, clathrates, and adsorbed organic molecules.

Over a 34-year period at the Naval Air Development Center (NADC), Mr. Moser performed studies on the nonacoustic detection of submarines, developed sensors, and conducted airborne experiments with high-sensitivity passive infrared imaging sensors in thermal wake detection studies with cooperating submarines at sea. His comprehensive report "Notebook on Nonacoustic Detection of Submarines" has been used as a text in the ASW curriculum at the Naval Postgraduate School. During the Viet Nam conflict, his experience with infrared imaging sensors was applied to the development and fleet introduction of the first passive infrared imaging devices to be used successfully in combat missions. The team he led was responsible for the in-house development and installation of the AN/AAR-35 infrared detecting set in nine RA-3B aircraft of Heavy Photographic Squadron Sixty-One (VAP-61) stationed in Guam. His mathematical model of the operational performance of Forward Looking Infrared (FLIR) imaging sensors and associated studies of absolute humidity probabilities and ship-to-background temperature differences are widely cited in the works of others. He has published over 100 technical articles, reports and papers and holds three patents on inventions. While at NADC he served, in several cases as chairman, on many Navy-wide, Department of Defense, and international technical coordinating groups including panels under The Technical Cooperation Program and the North Atlantic Treaty Organization. He has received numerous awards and commendations including Department of the Navy awards for Meritorious Civilian Service and Superior Civilian Service and the Naval Air Development Center Award for Scientific Achievement.

While an NADC employee, he also served on the faculty of La Salle University for 28 years, teaching undergraduate physics courses in the school's evening degree program.

After retiring from NADC he worked for Pacific Sierra Research Corporation (PSR) for a period of seven years and taught two 16/17-week courses on Infrared Imaging Technology for NAVAIRSYSCOM and NADC engineers. At PSR he continued his modeling studies related to infrared imaging and the nonacoustic detection of submarines. The latter included sensor operational performance modeling and/or phenomenology modeling of long-standoff-range infrared imaging sensors, air-to-subsurface lidar, magnetic anomaly detection, FLIR, radar, and gravitational detection of submarines.

In December 2008, Mr. Moser began work as a part-time Senior Technical Advisor at Rite-Solutions Inc. in support of an ONR program to document the history of periscope detection radar.

Mr. Moser is a senior member of the American Physical Society.

REFERENCES

1. J. G. Shannon, "A History of U.S. Navy Airborne and Shipboard Periscope Detection Radar Design and Developments," *U.S. Navy Journal of Underwater Acoustics*, JUA_2014_019_W, January 2014.
2. R. C. Manke, "Overview of U.S. Navy Antisubmarine Warfare (ASW) Organization during the Cold War Era," NUWC-NPT Technical Report 11,890, Naval Undersea Warfare Center, Newport, RI, 12 August 2008.
3. Detection and Classification Subcommittee, ASW Committee, "Radar Detection of Submarine Masts; Final Report," (Ad Hoc Study), Technical Brief, National Security Industrial Association (NSIA), 1 May 1993.
4. N. Friedman, *The Naval Institute Guide to World Naval Weapon Systems*, US Naval Institute Press, 5th Edition, 30 September 2006.
5. "Japan Orders Thales Optronic Submarine Masts," *Defense Industry Daily*, 1 July 2005.
6. P. Stevens, "Can Radar Help to Defeat the Diesel-Electric Sub?" in *Proceedings*, U.S. Naval Institute, August 1999, p. 58.
7. A. Price, *Aircraft versus Submarines in Two World Wars* (Pen & Sword Books Ltd, South Yorkshire, England, 2004).
8. C. M. Sternhell and A. M. Thorndike, "Antisubmarine Warfare in WWII," Operations Evaluation Group Report No. 51, Office of the Chief of Naval Operations (OPNAV), Washington, DC, 10 April 1946.
9. D. Kahn, *Seizing the Enigma: The Race to Break the German U-Boat Codes, 1939-1943* (Barnes & Noble Books, 2001).
10. D. Weisbrod, private communication with author, Whidbey Island, WA, 8 July 2008.
11. E. M. Brittingham, *Sub Chaser: The Story of a Navy VP NFO* (ASW Press, Richmond, VA, 2004), p. 283.
12. E. A. Mebus, "Periscope Detection Radar," Technical Brief, Code 50BX, Naval Air Warfare Center Warminster, PA, 10 June 1992.
13. "AN/APS-124 Search Radar (United States), Airborne Radar Systems," *Jane's Avionics* (Jane's Information Group 2008), 2 December 2008, <http://www.janes.com/articles/Janes-Avionics/AN-APS-124-search-radar-United-States.html>.
14. P. Ryan, "MMR Overview Data," Technical Brief, Loral Federal Systems, Manassas, VA, 24 May 1995.

15. P. Ryan, private communication with author, Loral Federal Systems, Manassas, VA, 23 April 1996.
16. J. W. Glass, "Periscope Pursuit - New Breed of U.S. Navy Radars Would Reveal Stealthy Subs," *Defense News*, 17 November 2008.
17. A. R. Ochadlick, Jr., O. Shemdin, J. Duke, C. Rino, A.C. Schultheis, H. Kritikos, and J. Kraus, "Measuring Sea Clutter and Doppler Properties with Low Grazing Angle Radars," in IEEE International Geoscience and Remote Sensing Symposium, 2, 1444-1447 (1992).
18. R. Rud, "Sea Star Development Status," Technical Brief, Naval Air Development Center, Code 501, Warminster, PA, March 1991.
19. E. Mihalak, private communication with author, Defense Advanced Research Projects Agency, Arlington, VA, April 1991.
20. "Shipboard Periscope and Mast Detection Technology Development," Technical Brief, Naval Air Warfare Center, Code 50, Warminster, PA, August 1991.
21. "Shipboard Periscope Detection EATD BAA," Naval Surface Warfare Center, 28 December 1992.
22. "Surface Ship ASW – Periscope Detection EATD Industry Brief," Naval Surface Warfare Center, 13 January 1993.
23. G. Snider, "Automatic Radar Periscope Detection and Discrimination," Technical Brief, Naval Air Systems Command, Patuxent River, MD, 3 August, 1998.
24. J. J. Osborne, D. Griffith, and R.W. Yuan, "A Periscope Detection Radar," Johns Hopkins APL Technical Digest, 18, 125-133 (1997), <http://www.jhuapl.edu/techdigest/TD/td1801/ousbourn.pdf>.
25. P. Stevens, "Radars Can Detect the Periscope," in Proceedings, U.S. Naval Institute, September 1999, Vol. 125, Issue 9, p. 62.
26. D. Johnson, "ARPDD Performance in SHAREM-125," e-mail, Arlington, VA, 3 August 1998.
27. J. J. Osborne, "ARPDD P-3 Flight Test Plan," Johns Hopkins APL, STS-99-110, 27 May 1999.
28. P. Stevens, "ARPDD – Air Mid Term Report," e-mail, 14 October 1999.
29. G. Snider, private communications with author, PSAC PDR Workshop, Washington, DC, 27 August 2001.
30. O. McNeil, "ARPDD Periscope Discrimination Algorithm History and Status," Technical Brief, National Defense Industrial Association, 18 March 2004.

31. T. Porter, "Automatic Radar Periscope Detection and Discrimination (ARPDD)," Technical Brief, Naval Air Systems Command, PMA-264D, 30 October 2003.
32. R. Oh, "Naval Undersea Warfare Center Representative Status Report," Chief of Naval Operations (N74), September 2001.
33. T. Porter, "Automatic Radar Periscope Detection and Discrimination (ARPDD)," 30 October 2003.
34. T. Porter, Technical Brief, Naval Air Systems Command, PMA-264D, 19 November 2003.
35. O. Allen, private communication with author, Naval Air Systems Command, Patuxent River, MD, 24 July 2008.
36. PEO IWS Broad Agency Announcement, "Periscope Detection and Discrimination (PDD) for Surface Ships," 20 October 2005.

APPENDIX A

CHRONOLOGY OF PERISCOPE DETECTION RADAR RESEARCH EFFORTS

Introduction

The development of effective periscope detection radar (PDR) hardware and software would not have been possible without the underlying research performed by many Navy laboratories and contractors. Gaining basic knowledge of radar propagation through the atmosphere, backscatter from the sea surface, and characteristics of periscope-like targets and false targets such as small boats, buoys and flotsam under a wide range of environmental conditions has been critical to PDR development. The largest part of the research effort was devoted to the study, characterization, and modeling of small RCS targets against a background of sea clutter. This appendix provides brief chronological summaries of various PDR research efforts performed over the years.

Chronology

Naval Research Laboratory

In 1947-48, NRL investigated the feasibility of detecting periscopes by radar, using an existing S-band APS-20 in field tests.¹

Philco Corporation

In 1950, Philco Corporation used a frequency-agile X-band radar to investigate the effect of varying frequency on clutter. Sea clutter was found to decorrelate with a 110-MHz frequency separation.¹

Naval Electronics Laboratory

Circa 1951, the Naval Electronics Laboratory investigated the use of an S-band continuous-wave radar for periscope detection and found that the CW radar was not satisfactory for detecting small moving targets in sea clutter.¹

Georgia Tech Research Institute

Over the period 1953-56, GTRI used C-band and K_a-band multi-polarization radars at Boca Raton, Florida, to measure clutter and mast signatures as functions of frequency and polarization and found that sea spikes were more problematic for HH polarization than for VV.¹

Naval Research Laboratory

From 1955 to 1958, NRL conducted shore-based tests of a radar operating at a PRF of 1800 pps at Boca Raton, Florida to evaluate the effectiveness of short-pulse X-band radar for detecting periscopes in clutter. It was found that the use of short pulses reduced clutter sufficiently to detect attack periscopes. Extensive measurements showed target detection ranges were often twice as great against a background of downwind clutter as for upwind clutter.¹

Naval Research Laboratory

In 1958, NRL collected data with a 300-rpm, 4500-pps, 10-ns-pulse-width, X-band radar to investigate the possible benefits of using a high-scan-rate radar for periscope detection. Signal-to-clutter ratios and target probability of detection improved with high resolution and high scan rate.¹

Naval Research Laboratory

Over the period 1961-64, NRL used radars from Raytheon Company and Hughes Aircraft Company in a data collection program to investigate the use of Doppler for detection and discrimination of submarine periscopes. Findings included the following: periscopes and snorkels exhibited a very narrow steady Doppler return whereas buoys and boats showed rapid shifts in Doppler. The clutter spectral width is narrow at low sea states but broadens above sea state 2. HH polarization produces less clutter at low sea states but HH and VV are similar at higher sea states.¹

Naval Air Development Center

In the 1960s, NADC conducted land-based radar experiments from Cadillac Mountain on Mount Desert Island, Maine, with a submarine operating in the Gulf of Maine.²

Naval Air Development Center

In 1962, NADC performed field tests with a radar capable of transmitting and receiving microwave radiation with various combinations of linear and circular polarization to determine the best polarization for periscope detection. It was found that linear polarization provided the best target signal-to-clutter ratio and that horizontal polarization provided a 0- to 20-dB improvement over vertical polarization at grazing angles less than 4°, with smaller differences at higher sea states. The RCS of a periscope exhibited large amounts of scintillation.³

Grumman Aircraft Engineering Corporation

In 1965, GAEC used an AN/APS-96 radar on an E-2 airborne early warning aircraft to evaluate a UHF air surveillance radar for periscope detection. It was reported that a snorkeling submarine was detected at long ranges in sea state 5 to 6 from a sensor altitude of 15,000 ft.³

Georgia Tech Research Institute

During the period 1965-69, GTRI used an X-band, 3600-pps, 250-ns, radar with horizontal, vertical, and right- and left-circular polarization to collect target signatures and clutter data in field tests at Boca Raton as part of an effort to develop a shipboard radar providing improved performance in clutter. Clutter characteristics were determined and studied. The RCS of a mast was found to be a strong function of its exposed height but relatively independent of polarization at X-band.³

Naval Research Laboratory / Westinghouse Electric Company / Raytheon Company

In 1967, NRL, Westinghouse, and Raytheon collaborated in conducting comparative sea tests of radars employing different technologies as part of an effort to develop a shipboard radar for periscope detection and to compare performance to that of the AN/SPS-10 surface search radar. It was found that the Raytheon X-band pulse Doppler radar outperformed a Westinghouse K_a-band (35-GHz) fast-scan system at long ranges.³

Naval Research Laboratory

In 1969, NRL generated *sea clutter* in the NRL swimming pool and measured the X-band magnitude of radar cross section per unit area σ_0 at various grazing angles using nanosecond radar techniques. The σ_0 curves for both horizontal and vertical polarization were measured and fell near open-ocean observed values in the range of 8° to 80°. Below 8° the open-ocean values were higher, and above 80° they were lower. Some statistical properties of small-wave sea clutter were determined. Cross section σ_0 as a function of wind velocity was measured. The combination of nanosecond radar techniques and the carefully controllable environment of the swimming pool permitted unique measurements of properties of targets and sea clutter over water.⁴

Naval Research Laboratory

In 1969, NRL investigated Doppler spectra of radar sea echo theoretically and experimentally. Electromagnetic scattering models were developed with composite rough surfaces, i.e., Bragg-resonant water waves superimposed on a carrier water wave; and basic concepts in hydrodynamics were developed for gravity waves of finite height. Experimental results were obtained at four frequencies (428 MHz, 1,228 MHz, 4,455 MHz, and 8,910 MHz), for sea conditions ranging from 1- to 2-ft waves and 1- to 2-kn winds to 26-ft waves and 46- to 48-kn winds. The results showed that the bandwidth of radar sea echo is polarization and frequency dependent, and the differential Doppler (between horizontal and vertical polarization) is frequency- and depression-angle dependent. Both the “noisiness” of the spectra and the greater spectral width of the horizontally polarized return indicated spray over the sea might be the mechanism responsible for the dependencies observed.⁵

Naval Air Development Center / Texas Instruments

In 1969-70, NADC and TI collaborated on the development of the AN/APS-116 PDR for the S-3 aircraft. Related research activities included shore tests at Molokai, Hawaii in 1969, and P-3 flight tests in 1969-70. It was found that high-resolution clutter followed a log normal distribution and that its decorrelation exhibited a bimodal distribution involving two mechanisms: (1) short term, of the order of 10 ms, and (2) longer term, of the order of a few seconds from ocean swell. For an attack periscope, decorrelation times of 2-3 seconds were measured.⁶

Naval Research Laboratory

In 1972, NRL measured backscatter from rough water surfaces using 20- and 100-ns X-band radar pulses. The emphasis was on airborne open-ocean measurements but low-grazing-angle, shore-based data were also obtained. The results were expressed in the form of cumulative probability distribution functions and autocorrelation functions.⁷

Georgia Tech Research Institute

In 1974, GTRI conducted tests at S- and X-band to measure radar forward scattering and propagation over water. It was found that the previously assumed value of surface roughness factor (3) was too large.⁸

Applied Physics Laboratory/Johns Hopkins University

In 1976, to develop and test a mast RCS model that incorporated mast tilt, APL/JHU measured the RCS of tilt-controlled cylinders and masts viewed at grazing angles of 1.7° and 7° using an X-band, 4-ns-pulse-width radar mounted at Calvert Cliffs, Maryland, overlooking low-sea-state Chesapeake Bay. Measurements and model were found to be in good agreement, especially with VV polarization.⁸

Naval Air Development Center

Over the period 1979–1985, NADC modified X-band and L-band radars and used them to acquire shore-based data, which were analyzed by NADC and by its contractors. Specifically, in 1981, NADC operated from a base on Molokai Island, using a modified APS-116, and again in 1985, used APS-116 and SPS-58 radars modified for polarimetric studies. The resulting data were analyzed by Teledyne Micronetics, Computer Sciences Corporation, and Global Analytics, Inc. in addition to NADC. Based on these studies, in 1986, NADC developed a polarimetric signal processor and compensation matrices.⁹

Global Analytics, Inc.

In 1984, Global Analytics, Inc., using data collected by NADC at the Molokai test site in 1981, completed a study of sea clutter discriminants based on the polarization properties of sea clutter and ship targets. Six classes of discriminants were investigated. Of the 184 discriminants evaluated, the coherent spectrum consistently

outperformed the single parameter SIG(HH) discriminant, which, in turn, outperformed the other single parameter discriminants under quiet sea conditions and at low elevation angles.¹⁰

Naval Research Laboratory

In March 1989, NRL reported the results of an upwind-illumination, low-grazing-angle marine radar sea scatter experiment in the Pacific Ocean. A wide range of wind speeds and directions resulted in nonequilibrium sea conditions, in contrast to a previous Atlantic Ocean experiment in which ocean waves were fully developed. Statistical properties of the radar echoes were parameterized by a dual-Weibull model versus wind speed and were compared with the North Atlantic data. It was concluded that the Pacific results can be regarded as a lower limit case, appropriate to random seas, whereas the North Atlantic results can be regarded as an upper limit for well-developed seas.¹¹

Admiralty Research Establishment

In 1990, the Admiralty Research Establishment and Smith Associates Ltd. published a paper on *Sea Surface Effects on the Radar Return from a Periscope* in which wave shadowing, effects of periscope motion, specular multipath effects, and periscope tilt were taken into account in a mathematical model.¹²

Office of Naval Research / Naval Air Development Center

In 1990, NADC, under the sponsorship of ONR, investigated the feasibility of employing high-altitude UHF radar for detecting exposed periscopes at very long ranges, as suggested by previous anecdotal evidence and flight tests. E-2C flight tests with an APS-145 radar, conducted in the Bahamas in June 1990 under highly controlled operational conditions, were successful in validating this assertion. However, at that time, the mechanisms responsible for radar backscatter from the sea surface at low grazing angles were not well understood.

ONR sought to sponsor further investigations to develop a better understanding of the phenomenology of periscope and mast detections from high altitudes, and to develop design guidelines for high-altitude PDR sensors. Specific technical issues to be investigated included: (1) What is the optimum frequency (between UHF and X-band) for long range periscope detection and target discrimination by use of a real-aperture radar operated at high altitudes and low grazing angles? (2) What is the predominant detection mechanism (i.e., mast or wake)? (3) What is the RCS of sea clutter and of the hard target? and (4) Can synthetic aperture radar (SAR), operated at higher grazing angles, be used for periscope detection?

However, owing primarily to operational and technical challenges associated with periscope detection from high altitudes, because of stressing organic airborne early warning mission requirements on the E-2C operational community, and because of the general post-Cold War decline in ASW emphasis, the potential application of the

E-2C's APS-145 UHF radar to long range periscope detection was not pursued further by ONR. Likewise, owing to prospective high cost estimates for experimentation, the ONR investigations into using SAR for periscope detection were discontinued.¹³

Naval Air Development Center / Naval Air Test Center / Grumman Aircraft Engineering Corporation

Over the period 1990-95, to evaluate the periscope detection and discrimination capabilities of the APS-145 radar, NADC, NATC, and GAEC modified an APS-145 UHF radar for recording and off-line processing of data for detecting and discriminating low-speed targets. Flight tests were conducted at sea in an E-2C aircraft. It was reported that periscopes could be detected at ranges greater than 100 nmi. It was concluded that the Doppler width and mean Doppler shift might provide a discriminating feature.¹⁴

International Business Machines Corporation

In 1991, IBM proposed applying *passive coherent location* to the detection of submarine periscopes. This covert technique exploits the use of VHF and UHF emissions from radio and television stations. The sensor detects direct signals from the transmitter(s) and signals reflected from the periscope. Doppler processing is used to determine range and bearing to the target. This approach is applicable to littoral warfare and has the benefit of not alerting the target. The concept of passive coherent location evoked Defense Advanced Research Projects Agency (DARPA) interest.

Vista Research, Inc.

In the 1991 time frame, Vista Research, Inc. developed a systems-level predictive model for exposed periscope detection. The *Mutual Interaction Method* is a technique which provides a rigorous framework for modeling the surface interaction that dominates the RCS structure at low grazing angles. Model predictions were tested against real data.¹⁵

Naval Surface Warfare Center, Carderock Division, Santa Cruz Island Facility

In 1991-92, periscope RCSs were measured at various polarizations over the frequency range from UHF to K_u band at grazing angles of 1° to 3° at the Naval Surface Warfare Center, Carderock Division facility on Santa Cruz Island, California, to determine periscope radar cross sections as a function of frequency, polarization and grazing angle. It was found that mast returns decorrelated over shorter times at the higher frequencies. The frequency at which the RCS was largest depended upon the grazing angle. Radar cross sections and decorrelation times were similar for HH and VV polarizations at X-band, and Doppler spectra were narrow.¹⁶

Science Applications International Corporation

In the 1992 to 1994 time frame, SAIC, under DARPA sponsorship, developed and performed sea trials of the *Periscope Optical Detection System* (PODS) which used a laser and the phenomenon of optical augmentation for detecting periscope optical systems. A laser radar, or lidar, offers advantages over microwave radar in that the wavelengths employed are about four orders of magnitude shorter, allowing extremely high azimuth and elevation resolution in addition to high range resolution, from a very compact equipment. However, the short wavelengths employed by lidar result in a lack of all-weather capability insofar as the wavelengths are small compared to the sizes of fog and rain droplets, resulting in significant scattering losses in the atmosphere under adverse weather conditions. Lidar can provide a significant advantage in detecting a periscope because of retroreflection from the periscope's optics. If the periscope is looking toward the lidar, light will be transmitted through the optical system of the periscope, strike a reticle, and be reflected back over the same path to its origin. This is similar to the "red-eye" effect that occurs in flash photography if the camera lens and the flash are in close proximity. A concern about the use of lidar is the issue of eye safety.¹⁷

Dynamics Technology, Inc.

In the 1993 time frame, DTI acquired a number of databases on targets and sea clutter and established empirical predictive models for clutter spikiness, target characterization, shipboard performance in ducted and unducted environments, and constant-false-alarm processing.¹⁸

Princeton University / JASON

PDRs such as the APS-116 and -137 offer high range resolution of about one foot but azimuth and elevation resolutions of 2.4° and 4.0° , respectively, which, if projected at a flat normal surface at a range of ten nautical miles, would correspond to an area of about 2500 by 4200 ft., a huge mismatch in dimensions compared to those of a periscope. Because these radars, operating in the periscope detecting mode, view the ocean surface at grazing incidence, this latter number is greatly increased. Thus, the radar cross section of the clutter patch is many orders of magnitude greater than the RCS of a periscope. This vast disparity in resolution in the three dimensions stems from the practical limitation of the ratio of antenna dimensions to wavelength in a practical radar, particularly one designed for airborne use. Use of a synthetic aperture many orders of magnitude larger than any practical real aperture could provide a huge improvement in spatial resolution and a significant decrease in the amount of clutter received. Clutter would be reduced in two ways: (1) by reducing the size of the clutter patch, and (2) by integrating out clutter over times that are large compared to clutter decorrelation times.

In 1993, Dr. Francis Perkins, of Princeton University and a member of JASON, proposed to increase the azimuthal antenna beamwidth of the APS-137 radar to 5.7° and to operate it at a low scan rate of 6 rpm to enable illuminating a periscope target

coherently over an extended period of time of about 0.16 s while the carrying aircraft moves through a distance that would represent a large aperture of length 25 m. This would yield an azimuthal resolution of 20 m at a nominal range of 30 km. (The scan rate of the APS-137 in its long range search and navigation mode is 6 rpm.) This approach would accept 2% as many looks at the target as provided by the APS-137 in its conventional periscope detection mode in exchange for fewer higher-quality looks. In this synthetic aperture mode, the radar would yield greatly enhanced resolution and an improved signal-to-clutter ratio.¹⁹

Applied Physics Laboratory/Johns Hopkins University

In 1993, to acquire field test data for validating a mathematical shadowing model, APL/JHU used optical means to measure shadowing of a rigid target at a range of 700 meters in the ocean at grazing angles of 0.1° to 1.4° from an oil tower at heights from 8 to 100 ft. Measurements agreed well with model computations.²⁰

Naval Air Warfare Center, Aircraft Division, Warminster

During the summer of 1993, NAWCADWAR (formerly NADC), System Planning Corporation, Vista Research, and ERIM, Inc., conducted the LOGAN (low-grazing angle) experiments on the Chesapeake Light Tower, about 16 miles east of Virginia Beach, Virginia. The purpose was to measure, at low grazing angles, multi-band ocean clutter and periscope/periscope-like signatures, and the Doppler properties of both. Calibrated radar measurements were made on an attack periscope, a search periscope, and aluminum cylinders mounted on pilings; a towed target and its wake; floating debris; a small boat; and sea clutter viewed at grazing angles of 1° and 2°. Frequencies of 0.35 to 18 GHz; HH, VV, and HV polarizations; and a range of resolutions were used to emulate the APS-137 and APS-145 radars. Directional wind and wave data were collected throughout to characterize environmental conditions. To enable isolating causes of signal fluctuation, periscope exposure measurements were made concurrent with the radar measurements. Periscope RCS fluctuations were found to be large. Target Doppler widths were narrow, e.g., 2 to 4 Hz at X-band and target wake Doppler widths were broad (20 – 50 Hz).^{20, 21, 22, 23, 24}

Naval Research and Development Division of the Naval Command, Control, and Ocean Surveillance Center

In 1993-94, NRAd/NCCOSC, San Diego, California, under sponsorship of DARPA, investigated *Resonant Radar Periscope Detection (rPDR)* and conducted sea tests from Point Loma, California, to evaluate the performance of an ultra-wideband radar system that would excite VHF resonances in exposed submarine periscopes and re-emit the incident radiation. If a periscope can be approximated as a long thin metal object on a conducting plane, it would resonate at a wavelength equal to four times its height, resulting in an increase in RCS between 10 and 23 dB. Ocean clutter does not resonate and the narrow-band resonance should stand out clearly over this wide-band sea clutter return. The movement of the periscope through swells will change its exposed length periodically and the resulting amplitude modulation of the

resonance frequency should allow the rejection of false alarms. In tests, the detection range against small targets was found to be disappointingly small.^{25, 26}

Naval Air Warfare Center Aircraft Division Warminster

In 1994, NAWCADWAR reported using a small sample of the LOGAN data to illustrate a processing scheme in which significant improvements in periscope target-to-clutter ratios were achieved by discriminating against returns that arose from more than one range cell. By rejecting everything other than *point* targets, the periscope-like signals were made to stand out prominently. (It is interesting to note that the signals were reduced when the return from a wave in the vicinity of the periscope contrived to make the periscope appear larger than a point and thus be discriminated against.) A countervailing aspect of this type of processing is that if a submarine has more than one mast exposed, ironically the probability of detection would be reduced. A countermeasure that a submarine could employ would be to come to a shallower depth to make its sail appear.²⁷

Dynamics Technology, Inc.

In 1994, DTI applied its clutter model and target model to predict the performance of the APS-137 in land-based tests at San Clemente Island, California, relevant to shipborne applications. In 1994-95, these models were applied by DTI as part of the Cost and Operational Effectiveness Assessment (COEA) for the proposed new attack submarine (NSSN).^{28, 29}

Naval Research Laboratory

In 1995, NRL reported conducting shipboard radar experiments on radar scatter from submesoscale ocean surface features, such as internal gravity waves and surface convergence frontal rips. An X-band dual polarized radar was scanned each minute, collecting successive images over 360° in azimuth while the ship was underway. The results showed striking differences between horizontal and vertical scatter from the submesoscale surface features versus the ambient sea echo, and suggested a new scattering model based on Brewster angle damping to explain the results.³⁰

Dynamics Technology, Inc.

In 1996, DTI developed an end-to-end PDR model that integrates previously independent models to enable computation of signal-to-noise ratio and clutter-to-noise ratio as a function of sensor-to-target range for a wide variety of environmental parameters, radar system parameters, and detection process parameters.³¹

Dynamics Technology, Inc. / Lambda Science, Inc. /Naval Air Warfare Center Aircraft Division Warminster / Naval Research and Development Division of the Naval Command, Control, and Ocean Surveillance Center

In 1998 DTI, Lambda Science, Inc., NAWCADWAR, and NRaD initiated a *High Altitude Periscope Detection Radar* investigation to enable simultaneous PDR search and sonobuoy monitoring and increase area search rate using an electronically scanned array antenna. Two approaches “pulse agile” and “dwell agile” were proposed. For various technical and budgetary reasons, the effort was discontinued.³²

REFERENCES

- ¹ J. J. Ousbourne, (JHU/APL), “A History of U.S. Periscope Detection Efforts,” Proceedings of the UK-US Periscope Detection Memorandum of Understanding Meeting, Defense Evaluation and Research Agency, Great Malvern, UK, 11-13 March 1997.
- ² P. M. Moser, Personal visit to the Naval Air Development Center radar test site on Mount Cadillac, Acadia National Park, Maine, 23 May 1961.
- ³ J. J. Ousbourne, 11-13 March 1997.
- ⁴ G.F. Myers and I.W. Fuller, Jr., “Nanosecond Radar Observations of Sea Clutter Cross Section Vs Grazing Angle,” NRL Interim Report, 8 October 1969, <http://oai.dtic.mil/oai/oai?verb=getRecord&metadataPrefix=html&identifier=AD0861321>.
- ⁵ G. R. Valenzuela and M. B. Laing, “Study of Doppler Spectra of Radar Sea Echo,” NRL Report 0711896,3 November 1969, <http://www.stormingmedia.us/71/7118/0711896.html>.
- ⁶ J. J. Ousbourne, 11-13 March 1997.
- ⁷ K. R. Schmidt, P. M. Thiebaud, and S. J. Weller, “Statistical Functions of Short-Pulse Radar Sea Return,” NRL Interim Report, 26 July 1972, <http://oai.dtic.mil/oai/oai?verb=getRecord&metadataPrefix=html&identifier=AD0747949>.
- ⁸ J. J. Ousbourne, 11-13 March 1997.
- ⁹ R. Dalton, “Clutter Measurement Program,” Naval Air Warfare Center, Aircraft Division, Warminster Presentation, undated.
- ¹⁰ L. A. Morgan, S. Weisbrod, and C. R. Acquista, “Analysis of Sea Clutter Discriminants,” Naval Air Development Center Report NADC-85046-30, 26 March 1984.
- ¹¹ D. B. Trizna, “Results of a marine radar sea clutter experiment for non-equilibrium seas,” Proceedings of the 1989 IEEE National Radar Conference, 29-30 March 1989,

http://ieeexplore.ieee.org/xpl/freeabs_all.jsp?reload=true&tp=&arnumber=47640&isnumber=1796.

- ¹² S. P. Tonkin and D. L. Dolman, "Sea surface effects on the radar return from a periscope," IEEE Proceedings 137, April 1990.
- ¹³ D. Johnson, Technical Brief to Director, Office of Naval Technology, "Periscope and Mast Detection Project," Office of Naval Research, 16 October 1991.
- ¹⁴ J. J. Ousbourne, 11-13 March 1997.
- ¹⁵ C. L. Rino and H. Guthart, "Radar Detection of Exposed Periscopes," Presentation to ONR, 19 July 1991.
- ¹⁶ J. J. Ousbourne, 11-13 March 1997.
- ¹⁷ DDR&E Science & Technology Thrust Advanced Technology Demonstration Program Plan, Surface Ship Based Periscope Detection, 19 March 1992.
- ¹⁸ S. R. Borchardt, Presentation "Periscope Detection Radar Knowledge Base & Test Recommendations," December 1993.
- ¹⁹ F. Perkins, "Periscope Radars: The Case for an Azimuthal-Scan SAR," JSR-93-170-02, 23 July 1993.
- ²⁰ J. J. Ousbourne, 11-13 March 1997.
- ²¹ A. R. Ochadlick, O. Shemdin, J. Duke, C. Rino, A. C. Schultheis, H. Kritikos, and J. Kraus, "Measuring Sea Clutter and Doppler Properties with Low Grazing Angle Radars," Geoscience and Remote Sensing Symposium, IGARSS '92, 1992.
- ²² A. D. Siegel, T. T. Webster, A. C. Schultheis, A. R. Ochadlick, E. A. Mebus, and W. C. Everett, "Signal Processing of LOGAN Data to Support APS-137 ASW Enhancements," June 1993.
- ²³ J. Davis, M. Rankin, A. Ochadlick, W. Everett, J. Kraus, A. Siegel, T. Webster, C. Rino, and J. Lyden, "Sea Spikes: The Empirical Dependence of K-Distribution Parameters on System and Environmental Parameters," Geoscience and Remote Sensing Symposium, 1994, 8-12 August 1994.
- ²⁴ A. D. Siegel, A. R. Ochadlick, J. Davis, W. Everett, J. Kraus, M. Rankin, and J. Lyden, "Spatial and Temporal Correlation of LOGAN-1 High-Resolution Radar Sea Clutter Data," Geoscience and Remote Sensing Symposium, 1994, 8-12 August 1994.
- ²⁵ J. J. Ousbourne, 11-13 March 1997.
- ²⁶ DDR&E, 19 March 1992.
- ²⁷ A. Ochadlick, J. Davis, M. Rankin, W. Everett, J. Kraus, A. D. Siegel, Report No. NAWCADWAR-94117-50 "Sea Clutter Spatial Editor for Transition to the 6.3 PDR ATD," 30 April 1994.
- ²⁸ J. Kraiman, "APS-137 Performance Predictions for San Clemente Island," DTI Memo DTM-9234-94101, 24 March 1994.

-
- ²⁹ J. B. Kraiman, T. F. Press, “DTI Periscope Detection Radar Model Calculations for NSSN COEA (U),” 1 May 1995.
- ³⁰ D. Trizna, “Dual polarized low grazing angle radar sea scatter results from the High-Res ARI experiment,” Geoscience and Remote Sensing Symposium, 1995. IGARSS '95, 10-14 July 1995,
http://ieeexplore.ieee.org/xpl/freeabs_all.jsp?tp=&arnumber=521148&isnumber=11410.
- ³¹ T. Press and M. Webb, Dynamics Technology, Inc. Presentation, “DTI PDR Model v1.1: Technical Description,” 8 January 1997.
- ³² S. R. Borchardt, Dynamics Technology, Inc. Presentation “High Altitude Periscope Detection Radar,” January 1998.

APPENDIX B

CHRONOLOGY OF RADAR DEVELOPMENTS

Introduction

The development of periscope detection radar (PDR) over many decades by and for the U.S. Navy could not proceed in isolation from the many other developments of radar and its underlying science and technology. PDR is only one mode of operation of an airborne surveillance radar or of a shipboard surface search radar. In this monograph, the specialized field of PDR is viewed under a magnifying glass; in this appendix, however, an attempt is made to put PDR developments into the perspective of radar developments in a much broader context of time and space.

In the preparation of this chronology it became quite clear that credit for the development of radar cannot be claimed by any single nation or person but that radar is an evolutionary product that resulted from the efforts of many. No single person can rightfully claim to be the *inventor of radar* or the *father of radar*. Indeed, one's suspicions are aroused when such claims are made by the inventor himself or by someone bearing the same surname as the supposed inventor.

In this document, attempts were made to determine the priority of inventions by noting the dates on which patent applications were filed and the patents issued. In many cases, especially during the WWII era, the issuance of patents was delayed for more than a decade for security reasons. Compounding the problem, the name by which an invention is commonly known often does not appear in the patent. In some cases, it appears that inventors in one country were unaware of inventions patented in other countries, resulting in their reinvention.

The British appear to have been the most secretive in describing inventions whereas the Germans were still publishing technical articles in the open literature and applying for and having U.S. patents issued even when WWII was under way. U. S. patents can be searched at United States Patent and Trademark Office¹ and at Google search page for patents.²

This appendix provides a chronological summary of radar developments through the years. In this chronology, many references are cited to allow the interested reader to pursue a topic further.

Chronology

~600 B.C. Thales of Miletus observes that a rubbed piece of amber (*elektron*) attracts small pieces of straw.^{3,4}

~210 B.C. In Magnesia, which is part of the southeastern area of Thessaly in central Greece, naturally occurring lodestones (magnetite) are observed to attract pieces of iron ore. The word magnet comes from the Greek "magnítis líthos" (μαγνήτης λίθος), which means "magnesian stone."⁵

1100s Chinese observe that when a lodestone is able to rotate freely, it orients itself relative to the earth and serves as a compass.^{6,7,8}

Note: The studies of electricity and magnetism develop independently with different sets of units such as statvolts and abvolts, respectively.

1820 Hans Christian Oersted observes that an *electric* current can deflect a *magnetic* compass needle.⁹

1831 Michael Faraday and Joseph Henry observe independently that a changing *magnetic* field can produce an *electric* current.^{10, 11, 12}

1865 James Clerk Maxwell summarizes the laws of electromagnetism in the four "Maxwell's Equations," expressing in a compact, consistent form (1) Gauss's law for electricity, (2) Gauss's law for magnetism, (3) Faraday's law of magnetic induction and (4) an extension of Ampère's law. The speed of light is related to purely electric and magnetic quantities, suggesting that light is only one form of electromagnetic radiation and that other forms remained to be discovered. A charge at rest produces an electric field; a charge in motion produces a magnetic field (in addition); an accelerated charge produces electromagnetic radiation. Electromagnetic radiation is found to consist of electric and magnetic fields alternating perpendicular to each other and to the direction of propagation. Application of Maxwell's equations shows that electromagnetic oscillations can resonate in a metallic cavity.¹³

1880 William J. Hammer, a laboratory assistant to Thomas Alva Edison in charge of testing early light globes, notes a blue glow around the positive pole in a vacuum bulb and a blackening of the wire and the bulb at the negative pole. (Edison was a believer in direct current rather than alternating current.) This discovery became the basis of electron tube theory, which was the foundation for the entire electronics industry. Trying to discover the reason for breakage of lamp filaments and uneven blackening of the bulbs in his incandescent lamps, Edison built several

(No Model.)

T. A. EDISON.
ELECTRICAL INDICATOR.

No. 307,031.

Patented Oct. 21, 1884.

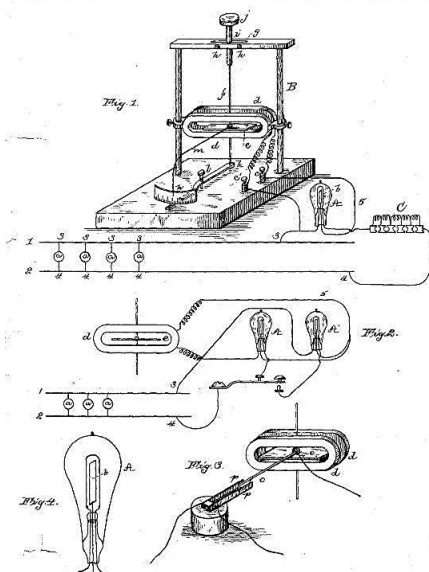

experimental bulbs, some with an extra wire, a metal plate, or foil inside the bulb which was electrically separate from the filament. He connected the extra metal electrode to the lamp filament through a galvanometer and found that a current would flow. When a battery was connected between the foil and the filament, and the foil was made negative relative to the filament, no current flowed through the galvanometer between the foil and the filament. However, when the foil was connected to the positive terminal of the battery and made more positive than the filament, a current did flow. He found that the current emitted by the hot filament increased rapidly with increasing voltage, and filed a patent application for a voltage-regulating device using the effect (U.S. Patent 307,031, the first U.S. patent for an

electronic device). He found that sufficient current would pass through the device to operate a telegraph sounder. This was exhibited at the International Electrical Exposition in Philadelphia in September 1884. William Preece, a British scientist took back with him several of the bulbs, and presented a paper on them in 1885, in which he referred to *thermionic* emission as the “Edison Effect.” Edison had only a minor interest in this eponymous effect and did not envision that his discovery would mark the birth of the electronics industry. Indeed, the *electron* was not “discovered” and recognized as a charged particle until 1897 and even today, streams of electrons are referred to as “cathode rays.”^{14,15}

1886 Heinrich Rudolf Hertz uses electric sparks in a resonant circuit to produce electromagnetic “Maxwellian waves” having a wavelength of about four meters that would be called VHF radio waves today. His receiver was a resonant circuit tuned to the transmitter’s

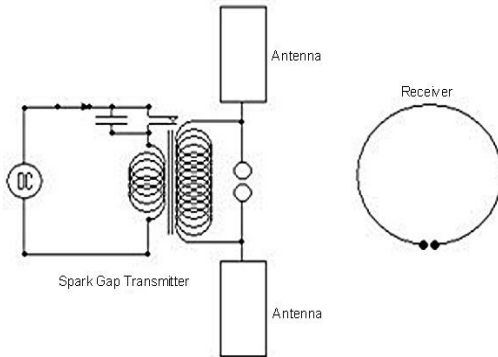

frequency in which sparks were produced across a gap. He invented the dipole antenna and demonstrated that these waves exhibit the same properties as light and are reflected by conducting materials, transmitted through non-conductive materials, and focused by concave reflectors. He demonstrated standing waves, polarization, and the propagation of electromagnetic

waves over distances. He foresaw no use for these electromagnetic waves.^{16,17}

1897 The first cathode ray tube scanning device was invented by the German scientist Karl Ferdinand Braun in 1897. Braun introduced a CRT with a fluorescent screen, known as the cathode ray oscilloscope. The screen emitted visible

light when struck by a beam of electrons. It was a cold-cathode diode, a modification of the Crookes tube with a phosphor-coated screen. Braun shared the 1909 Nobel Prize for Physics with Guglielmo Marconi. The first version to use a hot cathode was developed by John B. Johnson (whose



name was applied to the term *Johnson noise*) and Harry Weiner Weinhart of Western Electric, and became a commercial product in 1922.¹⁸

1897 German physicist Emil Wiechert and British scientist J. J. Thomson independently discover the electron. Using a cathode ray tube, Thomson measured the ratio of charge to mass of the electron (e/m) by observing its deflection in combined magnetic and electric fields. What were previously thought of as cathode rays were shown to be streams of particles called electrons.^{19,20,21,22,23}

1904 Christian Hülsmeier invents the “Telemobiloskop” for ship traffic control, using a spark-gap transmitter. Operating from a tower, he scanned vertically from the horizon, measured the angle between the horizon and a ship and, by

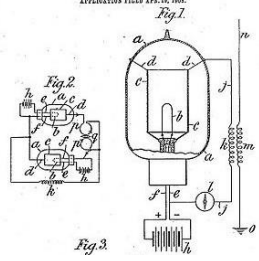

Fig. 1 - Drawing from Ch. Hülsmeier's patent of April 1904, showing what application he had mainly in mind

triangulation, he determined the distances to the ship. This was the first practical test of a radar. Hülsmeier patented his invention in Germany and in the United Kingdom. Hülsmeier was motivated to develop his device after one of his friends was killed in a ship collision. With his device, which was to be installed on ships, he was able to detect other ships in fog and to measure the range to them. Successful demonstrations of his device aroused little attention from the German Navy and the commercial shipping lines.²⁴

1904 British physicist John Ambrose Fleming discovers that an Edison-

No. 803,684. J. A. FLEMING. PATENTED NOV. 7, 1905. INSTRUMENT FOR CONVERTING ALTERNATING ELECTRIC CURRENTS INTO CONTINUOUS CURRENTS. APPLICATION FILED APR. 10, 1905.



Effect tube can be used to detect radio waves because it allowed the electric current to pass through it in only one direction, rendering the output detectable by a galvanometer. That is, it served as a *rectifier*. Fleming went on to develop the two-element vacuum tube, which became known, in British parlance, as the *Fleming Valve*. The Fleming Valve consisted essentially of a heated filament (cathode) and a plate (anode) in an evacuated bulb. He patented the device, which later became known as a *diode* (U.S. Patent 803,684).²⁵

1906

American inventor Lee de Forest modifies the Fleming Valve by adding a third element, a *grid*, between the filament and the plate, to control and amplify

No. 879,532.

L. DE FOREST.
SPACE TELEGRAPH.
APPLICATION FILED MAR. 19, 1907.

PATENTED FEB. 10, 1908.

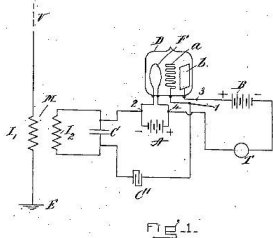

FIG. 1.

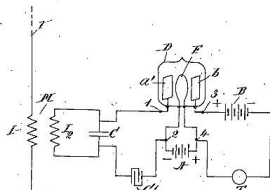
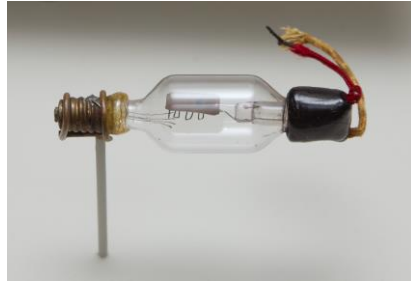

FIG. 2.

WITNESSES:
E. B. Thompson
Patrick J. Conroy

INVENTOR:
Lee de Forest



signals, and calls his device the *Audion* (U.S. Patent 879,532). Applying a signal voltage to the grid controlled the amount of current flowing between the filament and the plate. The Audion was used not only as a detector of radio signals, but also as an amplifier and an oscillator for generating radio waves. (De Forest disliked the term “wireless” and adopted the name “radio” instead.) The name

triode appeared later, when it became necessary to distinguish it from other generic kinds of vacuum tubes with more or fewer elements.^{26,27}

1906 Guglielmo Marconi invents his “Wireless Signaling System” incorporating an improved antenna. (U.S. Patent 924,560).²⁸

G. MARCONI.
WIRELESS SIGNALING SYSTEM.
APPLICATION FILED AUG. 9, 1902.

924,560.

Patented June 8, 1909.

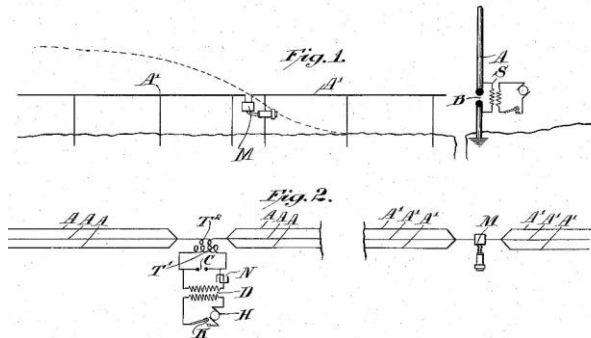

1917 Nicola Tesla, a Croatian born of Serbian parents, and a U.S. naturalized citizen, proposes concepts of radar through the use of standing electromagnetic waves along with pulsed reflected waves to determine the relative position, speed, and course of a moving object.²⁹

1920 Albert Wallace Hull of the General Electric Research Laboratory invents the two-pole *magnetron* as a means for circumventing the vacuum tube triode patents of Lee de Forest and Edwin Armstrong. The magnetron used magnetic control of the movement of electrons whereas the triode used electrostatic control. A magnetic field applied along the axis of the magnetron's concentric cylindrical cathode and anode caused electrons to follow spiraling paths. By varying the magnetic field, the flow of electrons to the anode could be controlled and amplification

Nov. 23, 1926. A. W. HULL 1,608,316
METHOD OF AND MEANS FOR PRODUCING ALTERNATING CURRENTS
Filed Jan. 29, 1920

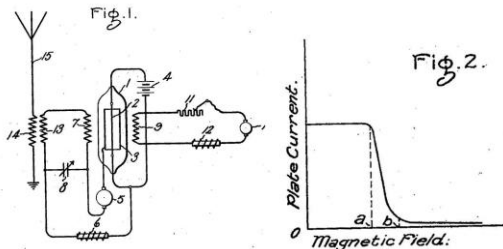

achieved. The device could serve as an oscillator by feeding back current from the output circuit to the coil that produced the varying input magnetic field. (U.S. Patent 1,608,316).^{30,31}

1922 Guglielmo Marconi recognizes the potential of using short wave radio waves for the detection of metallic objects. Marconi envisaged the use of radio for ship-to-ship detection at night or in fog. However, he did not appear to receive the support or have the resources to carry these ideas further at the time.³²

1922 The Naval Research Laboratory is established and Albert H. Taylor heads the Radio Division.³³



1922 Albert H. Taylor and Leo C. Young of the Naval Research Laboratory radio-locate a wooden ship for the first time. They were conducting communication experiments when they noticed that a wooden ship in the Potomac River was interfering with their signals; in effect, they had demonstrated the first continuous wave (CW) interference radar with separated transmitting and receiving antennas.^{34,35}

1923 In the U.K., Robert Watson-Watt develops the use of radio signals generated by lightning strikes to map out the position of thunderstorms. Pinpointing the direction of these fleeting signals led to the use of rotating directional antennas, and the use of oscilloscopes to display them. At this point the only missing part of a functioning radar was the transmitter.^{36,37}



1924 A British physicist, Sir Edward Victor Appleton uses radio echoes from continuous radio waves that cause interference patterns to determine the height of the ionosphere.^{38,39}

1925 In the first use of pulsed radio waves for ranging, Merle Anthony Tuve and Gregory Breit measure the altitude of the earth's ionosphere by bouncing short-pulse radio waves off its ionized layers of air and determining the amount of time taken by the echoes to return.^{40,41}

1925 A magnetron is built at GE that could produce a power output of 15 kW at a frequency of 20 kHz.⁴²

1926 Hidetsugu Yagi and Shintaro Uta of Japan patent the Yagi directional antenna, which was used as a radar antenna by the Allies during WWII and as a rooftop television receiving antenna beginning in the 1950s. A Yagi antenna consists of a dipole, a reflector behind the dipole and a number of parallel elements called directors located in front of the dipole. The antenna gain is proportional to the



Jan. 26, 1930. H. YAGI 1,745,342
 DERIVATIVE PROGRESSIVE SYSTEM OF ELECTRIC WAVES
 Filed Sept. 3, 1926

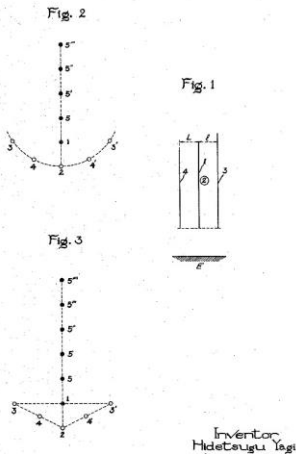

number of elements. The Yagi was first widely used during World War II for airborne radar sets because of its simplicity and directionality. Despite its being invented in Japan, many Japanese radar engineers were unaware of the design until very late in the war. Ironically, the Japanese military authorities were unaware of this technology until after the Battle of Singapore when they captured the notes of a British radar technician that mentioned “yagi antenna.” Japanese intelligence officers did not even recognize that Yagi was a Japanese name in this context. When questioned, the technician said it was an antenna named after a Japanese professor. U.S. Patent 1,745,342 was granted in 1930.^{43,44}

1927 French engineers Camille Gutton and Pierret experiment with wavelengths down to 16 cm.⁴⁵

1930 Lawrence A. Hyland of the Naval Research Laboratory radio-locates an aircraft for the first time with a continuous wave interference radar operating at a frequency of 33 MHz.^{46,46,47,48}

1931 French engineers Mesny and David notice repeatedly that aircraft flying between a transmitter and a receiver disturb radio communications.⁴⁹

Early 1930s The idea of pulse radar occurred to Taylor and Young, as it had to German and British scientists. Taylor instructed an assistant, Robert M. Page, to construct a working prototype, which was achieved by 1934. By 1937 his team had developed a practical shipboard radar that became known as the CXAM radar - a technology very similar to that of Britain's Chain Home radar system.^{50,51,52}

1930s Hundreds of U.S. and foreign patents are applied for and issued for magnetron inventions.^{53,54,55,56,57}

1931 A ship is equipped with radar. Parabolic dishes with horn radiators were used as antennas.⁵⁸

1931 George C. Southworth of AT&T begins a study of wave propagation in dielectric rods, although the project did not yet have official authorization.⁵⁹

1933 Using high-frequency vacuum tubes imported from France, George Southworth transmits waves through air-filled copper pipes up to 20 feet long. He later recalled that the first message sent through a waveguide was “Send money.” He receives authorization to construct a 5-inch-diameter guide with a length of 875 ft for further tests.⁵⁹

1933 Albert H. Taylor, Lawrence A. Hyland, and Leo C. Young of the Naval Research Laboratory apply for a patent on a continuous-wave, bistatic system for detecting objects by radio. (U.S. Patent 1,981,884).⁶⁰

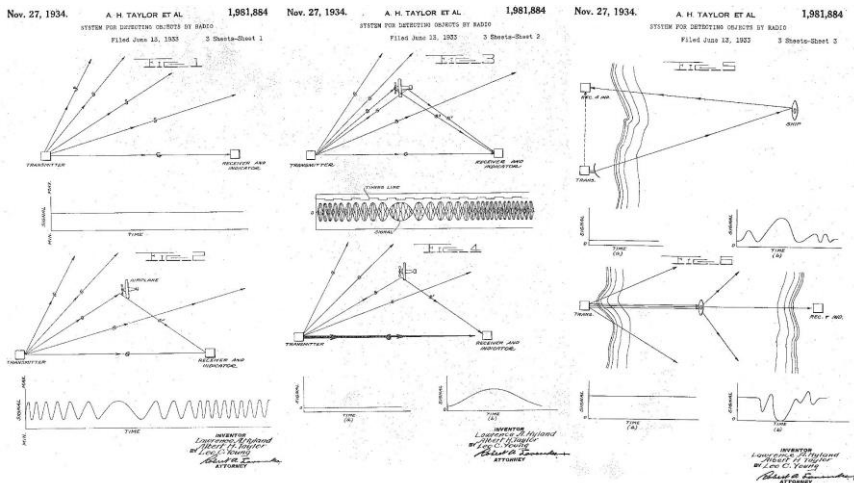

1933 Robert M. Page of NRL constructs a working prototype of a pulse radar operating at a frequency of 25 MHz and producing pulses of 5- μ s width. It used an *A-scope* display in which a sawtooth wave is applied to the horizontal deflection plates of a cathode-ray tube and the return signal pulse is applied to the vertical deflection plates. The horizontal scan is started when a pulse is emitted and continues, for perhaps 100 μ s, as return signals are received. Targets appear as pips on the scan line, with their horizontal positions corresponding to target range and their amplitudes corresponding to target strength.^{61,62,63}



1934-35 Robert Page conducts experiments with pulse radar at NRL.⁶⁴

1934 The invention of electronic pulse generation and pulse timing circuitry makes pulsed radar possible. Robert Page uses a pulsed radar demonstration system to detect a small airplane flying up and down the Potomac River.⁶⁵

1934 Hans E. Hollmann and two associates found the German company GEMA (Gesellschaft für Elektroakustische und Mechanische Apparate), which became the birthplace of the Freya air-warning and Seetakt ocean-surveillance radars.⁶⁶

1934 GEMA builds the first radar transmitter for detecting ships. The radar operated at a wavelength of 50 cm and could find ships up to 10 km away.⁶⁷

1934 Robert M. Page invents the *Antenna Duplexer*, a gas discharge transmit-receive (T-R) tube duplexer switch, which permits the use of just one send-receive antenna, rather than two separate units. This allowed a pulse transmitter and receiver to share the same antenna without destabilizing the sensitive receiver. (U.S. Patent 2,512,673) The combination of the magnetron, the duplexer switch, small antennas and high resolution allowed small high quality radars to be installed in aircraft.^{68,69}

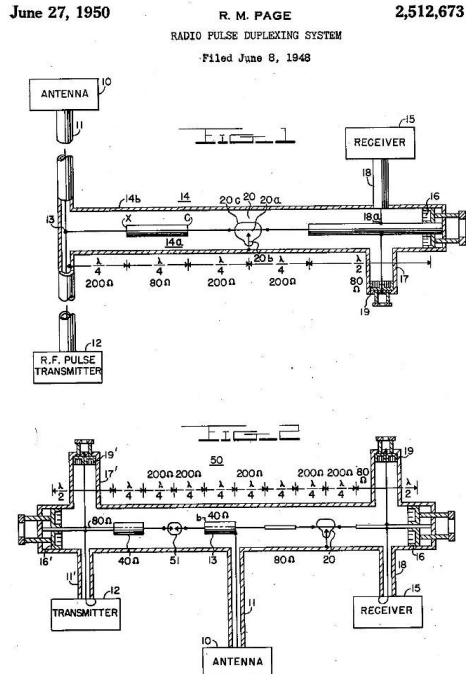

1934-38 At the Bell Telephone Laboratories in Holmdel, NJ, George Southworth directs a small team of two other engineers and a technician in the development of waveguide technology, including instrumentation.⁷⁰

1935 Based on the 1927 work of Gutton and Pierret, the Compagnie Générale de Télégraphie Sans Fil puts equipment for detecting airplanes flying over a given area into operational use.⁷¹

1935 Henri Gutton patents an invention, “New system of location of obstacles and its applications,” French Patent 788,795, for detecting obstacles (icebergs, ships, planes) using pulses of ultra-short wavelength produced by a magnetron. This was the first patent for an operational radar using *centimetric* wavelengths. The radar was tested from November to December 1934 aboard the

cargo ship *l'Oregon*, with two transmitters working at 80- and 16-cm wavelengths. Coastlines were detected from a range of 10 to 12 nautical miles. The shorter wavelength was chosen for the final design, which was installed for operational use on the liner *Normandie* as early as mid-1935.^{72,73}

1935 Robert Watson-Watt and Arnold Wilkins demonstrate the detection of an aircraft at ranges up to 8 miles using reflected radio waves. The source of the radio waves was a nearby BBC short wave radio transmitter which operated at a wavelength of 49 m. This demonstration led to the development of radar in the UK.⁷⁴

1935 In Berlin, Hans Erich Hollmann develops a multi-cavity resonant magnetron to generate microwave radiation. Electrons are made to circulate past slots in cylindrical cavities, thereby exciting electromagnetic resonance within the cavities analogous to blowing air across the mouth of a bottle to excite acoustical resonance. (U.S. Patent 2,123,728) Because of frequency drift, however, it was later put aside.⁷⁵

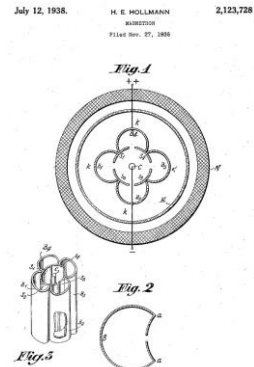

1935 Hans Hollmann and GEMA develop a pulse radar with which they could spot the light cruiser *Königsberg* 8 km away. This radar unit used cathode ray tubes invented by Karl Ferdinand Braun (Braunsche Röhre) and had an accuracy of 50 m. A magnetron had been tried but its frequency was not stable, and therefore conventional vacuum tubes were used. A wavelength of 60 to 80 cm was used. An airplane at an altitude of 500 m and a distance of 28 km could be seen.⁷⁶

1935 GEMA builds its first successful radar units: the land-based *Freya*, named after a Norse warrior goddess, and the *Seetakt* shipboard radar. Both were basically similar except the early *Seetakt* operated at a wavelength of 50 cm whereas the longer range *Freya* operated at about 2.5 m.⁷⁷

1936 In Britain, after many improvements, aircraft are detected at ranges of up to 100 miles. This caused work to be started on a chain of radar stations (*Chain Home* or *CH*), initially just covering the approaches to London.⁷⁸

1936 George F. Metcalf and William C. Hahn of General Electric invent the *klystron*. This became an important component in radar units as an amplifier and as a local oscillator in a heterodyne receiver.⁷⁹

1936 In spite of its receiving low priority and limited support from the U.S. Navy administration, Robert Page successfully demonstrates NRL's first pulse radar

at a range of 2.5 miles against a small airplane flying up and down the Potomac in April. Later in the year, the range is extended to 25 miles. Page's radar was based on low frequency signals, at least by today's standards, and thus required large antennas, making it impractical for ship or aircraft mounting.^{80,81,82}

1936 Telefunken develops the *Würzburg* radar with a rotating parabolic antenna of 3-m diameter. The first unit had a range of 10 km (later increased to 35 km) with a range accuracy of 100 m and an azimuth and elevation accuracy of 0.25 deg. The new radar was demonstrated to Commander Ernst Udet, the chief of the Luftwaffe's Technical Office, and he commented, "If you introduce that thing, you'll take all the fun out of flying."^{83,84}

1936 Welsh scientist Edward George Bowen develops the *Airborne Interception (AI)* set, a miniaturized radar system suitable for aircraft. Installing radar



in an aircraft was difficult because of the size and weight of the equipment and of the antenna. Furthermore the equipment had to operate in a vibrating and cold environment. At the same time Bowen developed radar sets for aircraft to detect submarines, the *Air to Surface Vessel (ASV)* set, making a significant contribution to the defeat of the German U-boats.⁸⁵

1937 Robert Page tests a 200-MHz *breadboard* radar successfully at sea aboard the destroyer *USS Leary*, detecting planes at distances up to 17 miles.⁸⁶

1937 Robert Page's team begins development of the prototype XAF shipboard radar that evolved into the CXAM radar.⁸⁷

1937 Edward George Bowen gives a dramatic and unexpected demonstration of the application of radar by searching for the British fleet in the North Sea in poor visibility, detecting three capital ships. Bowen's airborne radar group now had two major projects, one for the detection of ships and the other for interception of aircraft. Bowen also experimented briefly with the use of airborne radar to detect features on the ground such as towns and coastlines to aid in navigation.⁸⁸

1937 Germany deploys Seetakt radars on four ships: the light cruiser *Königsberg*, torpedo boat *G10*, battleship *Admiral Graf Spee*, and the *Strahl*. The *Admiral Graf Spee* used this radar successfully against shipping in the Atlantic.⁸⁹

1937 The first British airborne radar, the *Air to Surface Vessel Mk I (ASV-1)* is flown. It generated 100 watts of power at a wavelength of 1.25 meters, and was later improved by increasing the wavelength to 1.5 meters. Installed in Avro Anson K6260, this radar proved that it was capable of tracking the aircraft carrier *HMS Courageous*, the battleship *HMS Rodney*, and the cruiser *HMS Southampton*, in weather conditions that would have made conventional reconnaissance impossible. It even detected aircraft taking off from *HMS Courageous*.⁹⁰



1938 Robert Page demonstrates detection of aircraft at a range of 25 miles. Page's radar operated at a low frequency (long wavelength) compared to current radars and thus required a large antenna, making it impractical for ship or aircraft mounting.⁹¹

1938 Following tests of the breadboard radar aboard the *USS Leary*, NRL installs a more formalized prototype, called the XAF, on the battleship *USS New York*. This 200-MHz set produced 15-kW pulses, each 5 μ s wide. It had a large 20.5-

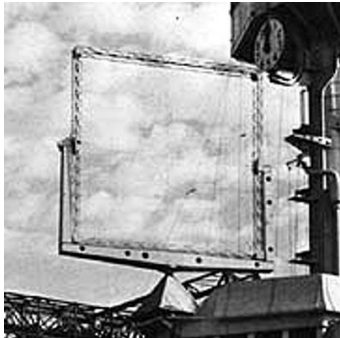

by 23.5-ft planar antenna, dubbed the "flying mattress." It detected planes up to 48 miles away. It was used very successfully as a search radar on large ships throughout WWII. Performance was so good that 20 more sets, called CXAM, were built and put into service on battleships, cruisers, aircraft carriers and a seaplane tender. The CXAM radar system was the first production radar system deployed on U.S. Navy ships. XAF-derived Navy programs moved on to 200-MHz air search prototypes with 330-kW pulse outputs, very sensitive receivers and planar "bedspring"

antennas. They picked up aircraft at previously unheard-of ranges of up to 150 miles.^{92,93}

1938 The first British ship-based radar system, fitted to *HMS Sheffield*, becomes operational in August. The Type 79 air-warning radar operated at a wavelength of 7 m, had a power output of 70 kW, and a range of 60 nmi.⁹⁴

1939 The ASV-1, flying at 1000 feet, with a fully alerted crew, detects a submarine broadside at 3 miles. Further tests revealed that when flying at 6000 feet, the range was increased to 6 miles. By the end of 1940 about 200 sets were produced and installed in about 50 aircraft.

A notable improvement in resolution was achieved with a large side-looking antenna configuration called “Long Range ASV.” The transmitting antenna

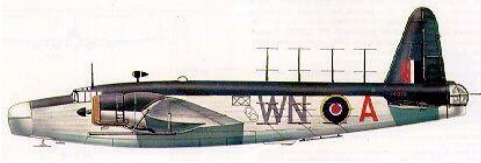

was an array of ten dipoles, installed in five (later reduced to four) pairs on top of the fuselage of the aircraft. The receiving antennas were fitted to the sides of the fuselage. Because the transmitter array was a dipole array 18 feet long and the two receivers were arrays 12 feet long, a much better resolution and range could be achieved. The first installation was on a Whitley bomber, in late 1939. Later, Wellington aircraft were used. LRASV had a range 2.5 times better than the forward-looking system; it could detect submarines at 10 to 15 miles.^{95,96,97}

1939 In December 1939, after heavy fighting, the *Admiral Graf Spee* was severely damaged and the captain scuttled the ship in the neutral harbor off Montevideo, Uruguay. The ship sank in shallow water such that its radar antenna was still visible. British photos taken of the ship showed the mattress radar antenna of the Seetakt radar. This is the first time that the British had seen radar being used by the Kriegsmarine.⁹⁸

1939 GEMA begins delivery of 31 Seetakt radar sets operating on a wavelength of 81.5 cm (368 MHz).⁹⁸

1939–1945 During WWII, the Freya and the Würzburg were paired so that the Freya would spot and track incoming aircraft and the Würzburg would determine the exact range and height when the aircraft came closer. The *Würzburg-Riese* (Giant *Würzburg*) was used to direct fighter aircraft against the incoming bombers. These radars were very effective. By the end of the war an estimated 12,000 bombers had been shot down out of 50,000 built by the Allies during the war. However as WWII continued, the Allies began to use *chaff* (U.S.) or *windows* (U.K.) and other radar countermeasures were developed and used to jam these radars. Allied aircraft would dispense a cloud of small, thin pieces of electrically conducting material such as aluminum or metalized paper, cut to one-half wavelength of the German radar to obscure the attacking bombers. In response, the Germans devised counter-countermeasures such as changing frequencies, thus ushering in the age of electronic warfare.^{98,99}

1940 Dutch scientists J. von Weiler and S. Gratema build four working prototypes of centimetric gunlaying radars operating at a wavelength of 50 cm and providing a practical range of 20 km. Technically far more sophisticated than British early warning radar of the time, it was not operationally integrated into the armed

forces. As the Luftwaffe destroyed the Dutch air force on its airfields, landed thousands of airborne troops on the seat of government, and laid waste to the city of Rotterdam, radar operators could only track their planes. Dutch radar engineer, Max Staal said, “frustratingly, we had nothing to shoot at them with.” Some scientists escaped to Britain before the Dutch capitulation on May 14, 1940, taking with them prototypes that aided the development of the British-American centimetric radar.¹⁰⁰

1940 At the University of Birmingham in the United Kingdom, John Randall and Harry Boot produce a more stable liquid-cooled cavity magnetron similar to Hollmann’s and devise means for tolerating the remaining instability by having the receiver track the transmitter in frequency. (U.S. Patent 2,542,966) Because of the magnetron’s instability, the Germans had chosen the more stable klystron, which limited the power output of their radars to about ten watts. By 1940 the British had built microwave magnetrons with outputs of 6 kW. Today, microwave ovens using magnetrons producing output powers of about 1000 watts at a frequency of 2.45 GHz are ubiquitous.¹⁰¹

Feb. 20, 1951 J. T. RANDALL ET AL. 2,542,966
HIGH-FREQUENCY ELECTRICAL OSCILLATOR
Filed Aug. 20, 1941 3 Sheets-Sheet 1

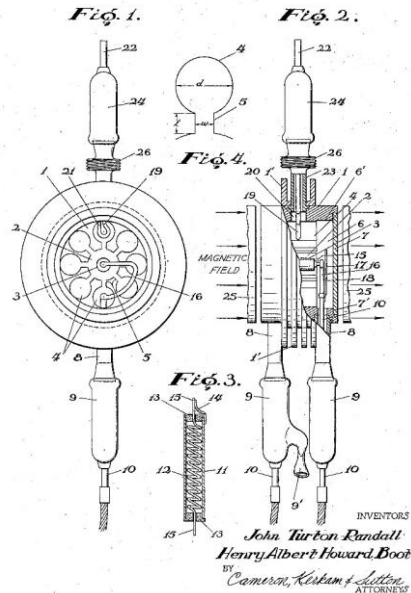

1940 The ASV-2 radar is developed in both forward-looking and side-looking configurations, operating at a frequency of 176 MHz (1.70 m). Several thousand sets were built, and installed in numerous aircraft types. Only the LRASV was useful against submarines. In November 1940, an aircraft equipped with ASV-2 damaged a German U-boat in the Bay of Biscay. By mid-1941 the ASV-2 had increased daytime attacks on U-boats and made nightly attacks possible. However, night attacks were generally ineffective because the aircraft crew could not see the submarine. The radar guided them to within a mile of the submarine, but not closer. Flares dropped from the aircraft did not enhance success significantly.^{102,103}

1940 Sir Henry Tizard leads a mission to the U.S. to share British war-related technology, including a greatly improved multi-cavity magnetron.¹⁰⁴

1940 The Massachusetts Institute of Technology Radiation Laboratory is established shortly after the Tizard mission.¹⁰⁵

1940 Military radars are developed in the USA, Russia, Germany, France and Japan.¹⁰⁶

1940 A radar with a “Panorama” display is built by GEMA in 1940 at Tremmen near Berlin. Its 20-m large antenna was located on the top of the concrete tower and it rotated through 360 degrees at 6 rpm. Its maximum range was 120 km. The radar display station was located in the base of the tower and a PPI-type display was used. The PPI radar was invented and developed by GEMA in 1937 and patented by Hollmann in 1940. Because its frequency could be varied over the range of 158 to 240 MHz, it could not be jammed by chaff. Sixty-two units were built and it was operational up to the end of WWII.¹⁰⁷

1941 The XAS aircraft-warning radar for submarines, another descendant of Navy’s XAF breadboard, is tested aboard the submarine *USS Gar* in June 1941. It becomes the SD, the submariner’s air-search workhorse radar. It operated at 114 MHz, with 140-kW output pulses.¹⁰⁸

1941 As soon as Bell Labs engineered a producible American magnetron, Western Electric set up to build them. NRL and the MIT Radiation Laboratory developed a prototype 3000-MHz surface search radar and tested it on the *USS Semmes* in the spring of 1941. They then worked closely with Raytheon to produce the first American microwave surface search radar, the model SG. This radar produced 50-kW pulses, 1.3- to 2- μ s wide, at 3000 MHz. It was highly successful, with nearly 1000 being manufactured in 1942-43. Many were still in operation some 20 years later.^{109,110}

1941 Humphrey de Verd Leigh develops a powerful (22 million candela) airborne searchlight which was installed on patrol bombers and integrated with the radar to help spot surfaced German U-boats at night. This use of integrated nonacoustic sensors enabled detections by radar to be handed-off to visual means for localization, final classification and attack. This combination became so effective in surprising U-boat crews that by August 1942 they preferred to take their chances in daytime when they at least had some warning.^{111,112}



1941 The United States enters World War II with only 79 radar sets installed on the Navy's approximately 2,000 vessels. These radars, and those that followed, were credited with providing the U.S. Navy a significant advantage over the Japanese Navy in the Pacific.¹¹³

1942 In an example of the development of radar countermeasures, the Germans adopt *Metox*, which was named after the French electronics company, Metox Grandin that developed it. Metox operated in the 1.3- to 2.6-m band which included the 1.4-m and 1.7-m wavelengths of the British ASV-1 and ASV-2 radars, respectively. Metox rendered the Leigh light completely ineffective. The Metox sets received the transmitted pulses from the ASV and presented them as audible beeps over the U-boat's speaker system. It enjoyed the usual advantage of radar detectors over radar in that the signal is direct and had to travel only one way, whereas the radar has to detect the very weak reflection from the submarine. Most radars increase the number of pulses and decrease the width of the pulses when switched to a shorter range; the shorter pulse widths allow the radar to look at closer objects. The Metox exploited the fact that once the radar operator changed the range indication from 36 miles to 9 miles, the pulse repetition frequency of the radar's transmitter doubled. Radar cannot detect any reflections returned earlier than half a pulse width so when the U-boat was closer than 9 miles the operator would change to the shorter scale. If the Metox set started beeping at twice the rate, the U-boat crew knew that they had been detected. By the time the aircraft approached the U-boat's position close enough to energize the Leigh light, the U-boat was well under the water. As a bonus, the Metox set would also provide warning in excess of visual range in daylight.¹¹⁴



1942 Metox radar warning receivers are installed on all German submarines as countermeasures to the British ASV-1 and ASV-2 radars. The antenna consisted of a coil of wire wrapped around a simple wooden cross and nicknamed *Biscay Cross*. The antenna was turned by hand and had to be withdrawn into the boat when diving. Its official name was *FuMB-1 Funkmessbeobachtungsgerät* (radar observation apparatus). This reduced the efficiency of the ASV-equipped aircraft considerably, and shipping losses increased again.^{115,116}

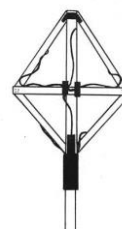

1942 The Royal Navy develops and installs on convoy-escort ships the *High Frequency Direction Finder* (HF/DF or *huff-duff*) for obtaining bearings and, through triangulation involving receivers on several ships, approximate locations of German U-boats operating in *wolfpacks* awaiting convoys, by intercepting their radio communications. This enabled convoys to change course to avoid the U-boats.^{117,118,119}

1942 Robert M. Page invents the *Plan Position Indicator (PPI)* which provides the location and direction of a target on a map-like presentation that is easy to interpret. In the PPI, a scan line, which is intensity-modulated on a long-persistence cathode-ray tube, rotates in synchronism with a rotating radar antenna.

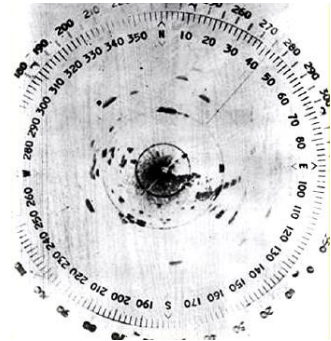
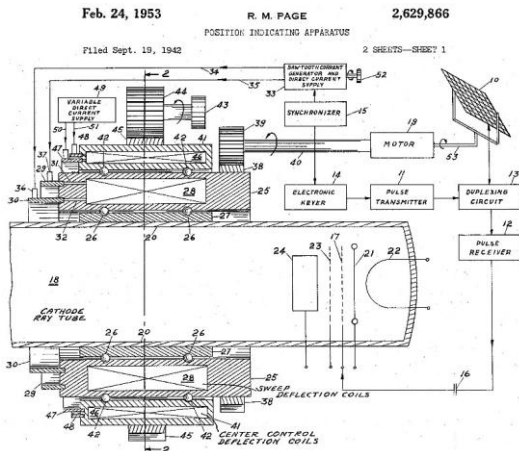

Targets are displayed with their ranges proportional to the radial distance from the center and their bearings by their angular positions. (U.S. Patent 2,629,866).^{120,121}

1943 The British switch to the *ASV-3* radar which operated at a wavelength of 10 cm against which the Metox warning receivers were useless. German submarines were attacked so often, usually without a chance to take countermeasures and sometimes on totally dark nights, that losses became catastrophic. Initially the Germans suspected that the Metox was emitting radio frequency radiation that allowed British aircraft to home in on the U-boats.¹²²

1943 After Metox had entered service, U-boat crews found that allied aircraft had appeared even more frequently. By early 1943, it was apparent that despite the widespread use of Metox, allied aircraft were appearing too often, and were forcing U-boats to submerge and travel underwater. The German technical intelligence sought to find the reason behind the strange phenomenon, and found that the device itself emitted a signal that could be picked up for miles around. This led to suspicions that the allies used the emissions as a means of homing in on U-boats and on July 31st 1943, Admiral Dönitz issued a directive to use the Metox sparingly.¹²²

The British were indeed trying to home in on the signals, but had abandoned all efforts as it proved too difficult. Unknown to the Germans, the real reason behind the increase in aircraft appearance was the introduction of the new British *ASV MkIII* radar.¹²³

1943 Later on August 13, a British prisoner of war under interrogation deceived the Germans by informing that the British were indeed homing in on Metox signals. This led to the order to ban the use of Metox altogether.¹²³

1943 Metox was countered by a version of the 10-cm *H2S* radar which Metox could not detect and, once again, the Leigh light forced U-boat crews to remain submerged at night. Even during the day, the new radar could detect the U-boat's periscope.¹²³

1943 The development of the British H2S ten-centimeter radar, (actually 9.1 cm) was possible owing to the development of the cavity magnetron. Later versions of H2S reduced the wavelength, first to 3 cm and then 1.5 cm at which wavelength the system was capable of detecting rain clouds.¹²⁴

1943 On a raid to Cologne on February 2/3, 1943, a Stirling *Pathfinder* is shot down over the Netherlands. The H2S set it was carrying was damaged but not beyond repair (fortunately for the Germans it was only the second operational use of H2S). Known as the *Rotterdam Gerät* (Rotterdam apparatus), Telefunken was able to reassemble it, with the exception of the PPI display that had been destroyed. Eventually this led to the development of the Naxos radar detector, which enabled Luftwaffe night fighters to home on the transmissions of H2S.¹²⁴

1943 The FuMB-9 *Wanze* (short for *Wellenanzeiger* or *waves indicator*) radar warning receiver, replaces the Metox. It scanned the radar wavelengths from 120 to 180 cm automatically, covering the ASV-1 and ASV-2. *Wanze* entered service on August 1943, but, because of its ineffectiveness in preventing surprise attacks by allied aircraft on U-boats equipped with it, led to its use being discontinued in November 1943.¹²⁵

1943 The Germans replace the ineffective *Wanze* with the FuMB-10 *Borkum* radar warning device, named after a resort island in the North Sea. It was intended as a simple stop-gap measure until a more reliable device could become available. It was a very simple device with a crystal detector attached to a radio receiver. When allied radars were detected, it gave an audible warning on the boat's loudspeakers. It had very limited range and could not indicate the direction of the approaching aircraft. In addition, it could not detect the new ASV-3 centimetric radar. Nevertheless, *Borkum* continued to be used up to the end of the war.¹²⁵

1943 The British anticipate that the Germans would develop a warning detector for the 10-cm ASV, as they had done for the 1.5-meter ASV but, nevertheless, developed the 10-cm ASV-6 airborne radar. It had an attenuator to reduce the power transmitted after detection to give the false impression to the operator of a radar warning receiver that it was not approaching the target U-boat.¹²⁶

1943 The British develop the ASV-7 airborne radar. It operated in the 3-cm waveband and was commissioned in anticipation of the German *Naxos* radar warning receiver.¹²⁶

1943 Robert M. Page at NRL studies means for reducing or avoiding a radar's vulnerability to jamming, to reduce effects of pulse-to-pulse variations in microwave power output, and to improve its boresight accuracy. He devised a technique for providing multiple lobes about the antenna axis that could be compared simultaneously to sense target displacement from the axis of the antenna. This technique called "Simultaneous Lobe Comparison, Pulse Echo Location System" was invented and documented by Page in 1943 and for which a patent was applied for in 1947. U.S. Patent No. 2,929,056 was granted but not issued until 1960 because of security considerations. This technique was later given the more convenient but somewhat confusing name "monopulse tracking radar" even though it did not need pulse operation and performed equally effectively with CW radiation.¹²⁷

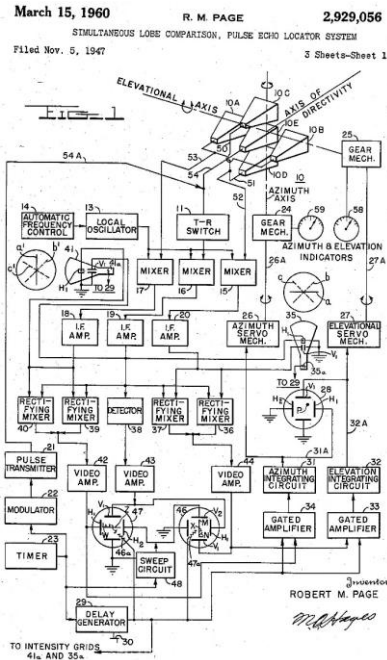

Whereas classical conical scan systems generate pointing accuracy on the order of 0.1 degree, monopulse radars generally improve this by a factor of 10, and advanced tracking radars like the AN/FPS-16 are accurate to 0.006 degree. This is an accuracy of about 10 m at a distance of 100 km. Jamming resistance is greatly improved over conical scanning. Monopulse radar is an adaptation of conical scanning radar which transmits additional information in the radar signal to avoid problems caused by rapid changes in signal strength. The system also makes jamming more difficult. Most radars designed since the 1960s are monopulse systems.¹²⁸

1943 The Germans begin development of the FuMB-7 *Naxos* radar warning receiver, named after a Greek Island, to counter the British ASV-3 centimetric radar. German scientists had considered the use of such short wavelengths impractical. However, in early 1942, the wreckage of an RAF Stirling bomber was examined and the new British 10-cm H2S radar was discovered. This information apparently did not reach the Kriegsmarine (German Navy) until December 1943. *Naxos* covered the 8- to 12-cm wavelength band. Later versions of *Naxos* were capable of indicating the direction of approaching aircraft, but its short detection range of 5 km meant that U-boats had only one minute's warning. The *Naxos* was a reliable unit, but the

British quickly became aware of the Germans' new capability, and as newer generations of British radars were developed to counter the Naxos, the Germans continued to improve the device. (Another radar warning receiver was the FuMB-28 *Naxos ZM*. It was essentially the same as the FuMB-7, except for the antenna, which rotated at 1300 rpm, with its output displayed on a cathode ray tube, providing a 360° visual coverage. This was still under development when the war ended.)¹²⁹

1943 The U-58 is the first Kriegsmarine submarine to be fitted with a snorkel and experiments are performed with it in the Baltic Sea during the summer of 1943. U-boats began to use it operationally in early 1944, and by June 1944 about half of the boats stationed at French bases had snorkels fitted.¹³⁰

1944 The Germans develop the FuMB-26 *Tunis*, a more advanced radar warning device, covering the 3-cm band used by U.S. radar. The antenna was horn shaped, as was that of the FuMB-24 *Fliege (Fly)*, and it covered a wide horizontal arc and a narrow vertical area. To save bridge space, *Fliege* and the *Tunis*'s antenna were mounted back-to-back on a single pole. The watch crew still had to rotate the antenna periodically and it had to be taken below deck every time the boat submerged. *Tunis* entered service in May 1944.¹³¹

1944 The Germans develop the FuMB-29 *Bali*, a watertight, multi-directional antenna which could be permanently mounted on a bracket atop the bridge of a U-boat. It consisted of a polarized pole enclosed in a cylindrical wire mesh frame. It could be used with a number of radar warning receivers including the FuMB-10 Borkum signal detector. The signals were fed through an amplifier to an oscillograph, where they could be viewed and interpreted by the operator.^{131,132}

1944 Germany installs radar-absorbing material on submarine periscopes and snorkels because allied radar was sensitive enough to detect an object as small as a snorkel head. Although this was much more difficult compared to a surfaced U-boat, allied reports indicated that a surfaced U-boat could be detected up to a distance of 10 km, whereas a snorkel head could be detected at only about 5 km. Later, snorkel heads were coated with radar absorbing materials known as *Tarnmatte* (camouflage mat). It consisted of BUNA synthetic rubber that contained iron oxide powder and was claimed to have 90 percent effectiveness in reducing radar signature, although there were no definitive tests. However, it probably afforded little benefit because radar waves could reflect off the film of conductive saltwater coating the mast without penetrating into the absorbing material.^{133,134,135}

1945 The FuMB-35 *Athos* was the final German radar warning receiver set developed during WWII. The electronics were much more sophisticated with the output being displayed on a cathode ray tube. A further advantage was that the antenna was watertight. This was installed on several Type XXI U-boats just before the war ended.¹³⁶

1946 The AN/APS-20 radar enters operational service in P-2 aircraft after being developed during WWII.^{137,138}

Late 1940s Robert Page conceives and initiates the first successful demonstration of high-frequency over-the-horizon (HF OTH) radar, whose propagating waves are refracted by the Earth's ionosphere. The detection of ships, aircraft, and ballistic missiles was thereby extended out to about 2,000 miles, approximately 10 times the range of microwave radars, which are limited to the line of sight by the horizon.^{139,140,141}

1962 The AN/APS-80 radar is incorporated into P-3A aircraft.¹⁴²

1965 The AN/APS-80 radar is incorporated into P-3B aircraft.¹⁴²

1969 The AN/APS-115 radar is incorporated into P-3C aircraft.¹⁴²

1974 The AN/APS-116 radar is incorporated into S-3A aircraft.¹⁴³

1979 The AN/APS-124 radar is incorporated into SH-60B helicopters.¹⁴⁴

Mid-1980s The AN/APS-137 radar is incorporated into S-3B aircraft.¹⁴⁵

Early 1990s Flight tests of the AN/APS-145 radar in E-3C aircraft are conducted to investigate the potential use of UHF radar for long range detection of periscopes.¹⁴⁶

Mid-1990s Development of the AN/APS-147 radar is initiated for eventual incorporation into MH-60R helicopters.¹⁴⁷

1992 OPNAV issues separate Mission Need Statements for periscope detection and discrimination from aircraft and ships.¹⁴⁸

1992 Periscope detection Enhanced Advanced Technology Demonstration (EATD) programs are initiated for airborne and shipboard applications.¹⁴⁹

1993 Airborne and shipboard EATD programs are merged to form the ARPDD program.¹⁴⁹

1993 Breadboard phase of the ARPDD program begins.¹⁵⁰

1994 Brassboard phase of the ARPDD program begins.¹⁵⁰

1997 Shore-based tests of the ARPDD brassboard system are conducted in Hawaii.¹⁵⁰

1997 The ARPDD brassboard system is installed on the *USS Stump* (DD-978). It participated successfully in exercises off the east coast of the U.S. and in exercises in the Mediterranean Sea during a 6-month deployment.¹⁵¹

1998 After removal from the *USS Stump*, the ARPDD brassboard is installed in an NRL P-3 aircraft for (1) flight tests off San Diego against the small-displacement (950-ton) submarine *USS Dolphin* (AGSS-555), (2) system optimization and mast detection performance tests in Hawaiian waters, and (3) flight tests in far-east littoral waters to determine ARPDD's ability to discriminate against large numbers of non-periscope targets.¹⁵²

2001 A second series of flight tests of ARPDD in the NRL P-3 aircraft is conducted.¹⁵³

2001 The ARPDD program is concluded.¹⁵³

REFERENCES

- ¹ United States Patent and Trademark Office, United States Department of Commerce, 4 December 2009, Retrieved from <http://patft.uspto.gov/>.
- ² Google/patents/beta, 2010, Retrieved from <http://www.google.com/patents>.
- ³ Physics Evolution, IOP Institute of Physics, Retrieved from <http://www.physics.org/interact/physics-evolution/text-only/index.html>.
- ⁴ The Only Stupid Questions Are the Ones Left Unasked, Retrieved from <http://unasked.com/question/view/id/26122>.
- ⁵ "Permanent Magnet," Nationmaster.com. Retrieved from <http://www.statemaster.com/encyclopedia/Permanent-magnet>.
- ⁶ S. Silverman AC, "Compass, China, 220 BCE," Retrieved from http://www.smith.edu/hsc/museum/ancient_inventions/compass2.html.
- ⁷ Oracle ThinkQuest Education Foundation, "Knowing Your Way- Compass," Retrieved from <http://library.thinkquest.org/23062/compass.html>.
- ⁸ J.B. Carlson, "Lodestone Compass: Chinese or Olmec Primacy? Multidisciplinary Analysis of an Olmec Hematite Artifact from San Lorenzo, Veracruz, Mexico," "Science 5," Vol 189. no. 4205, September 1975, Retrieved from <http://www.sciencemag.org/cgi/content/abstract/189/4205/753>.
- ⁹ "Hans Christian Ørsted," Retrieved from http://en.wikipedia.org/wiki/Hans_Christian_%C3%98rsted.
- ¹⁰ "Faraday's law of induction," Wikipedia, Retrieved from http://en.wikipedia.org/wiki/Faraday%27s_law_of_induction.
- ¹¹ Molecular Expressions™, "Electricity and Magnetism, Introduction," 28 January 2003, Retrieved from <http://micro.magnet.fsu.edu/electromag/electricity/inductance.html>.

-
- ¹² “Joseph Henry,” Answers.com, Retrieved from <http://www.answers.com/topic/joseph-henry>.
- ¹³ “Milestones: Maxwell’s Equations, 1860-1871,” IEEE Global History Network, Retrieved from http://www.ieeeahn.org/wiki/index.php/Milestones:Maxwell%27s_Equations,_1860-1871.
- ¹⁴ G. Wilson, “William J. Hammer,” Retrieved from <http://www.drbronsontours.com/bronsonwilliamhammer.html>.
- ¹⁵ “Thermionic Emission,” Wikipedia, Retrieved from http://en.wikipedia.org/wiki/Thermionic_emission.
- ¹⁶ “Heinrich Rudolph Hertz (1857 – 1894),” Corrosion Doctors, Retrieved from <http://www.corrosion-doctors.org/Biographies/HertzBio.htm>.
- ¹⁷ “Heinrich Hertz,” Wikipedia, Retrieved from http://en.wikipedia.org/wiki/Heinrich_Hertz.
- ¹⁸ “Karl Ferdinand Braun,” Wikipedia, Retrieved from http://en.wikipedia.org/wiki/Karl_Ferdinand_Braun.
- ¹⁹ L. Lederman and D. Teresi, “The God Particle: If the Universe Is the Answer, What Is the Question?” Delta, 1 January 1994, Retrieved from <http://www.amazon.com/God-Particle-Universe-Answer-Question/dp/0385312113>.
- ²⁰ “J. J. Thomson,” Wikipedia, Retrieved from http://en.wikipedia.org/wiki/J._J._Thomson.
- ²¹ “A Look Inside the Atom,” American Institute of Physics, March 1997, Retrieved from <http://www.aip.org/history/electron/jjhome.htm>.
- ²² “Classic Chemistry: Elements and Atoms, Chapter 16: Discovery of the Electron: J. J. Thomson,” Department of Chemistry, LeMoyne College, Retrieved from <http://web.lemoyne.edu/~giunta/ea/THOMSONann.HTML>.
- ²³ L. Lederman and D. Teresi, 1 January 1994.
- ²⁴ “Christian Huelsmeyer, the inventor,” Radar World, 2007, Retrieved from <http://www.radarworld.org/huelsmeyer.html>.
- ²⁵ “Fleming Valve,” Wikipedia, Retrieved from http://en.wikipedia.org/wiki/Fleming_valve.
- ²⁶ “Lee’s Audion,” The Complete Lee de Forest, Retrieved from <http://www.leedeforest.org/inventor.html>.
- ²⁷ “Lee De Forest,” Wikipedia, Retrieved from http://en.wikipedia.org/wiki/Lee_De_Forest.
- ²⁸ J. Bieberich, “The Complete Guglielmo Marconi,” U.S. Patent Collection, (25 April 1874 – 20 July 1937), 1998 - 2008 Mall USA, Inc. <http://www.uspat.com/marconi/>.

-
- ²⁹ “History of radar,” Wikipedia, 15 December 2004, Retrieved from http://en.wikipedia.org/wiki/History_of_radar.
- ³⁰ “Albert W. Hull,” IEEE Global History Network, 15 September 2008, Retrieved from http://www.ieeeahn.com/wiki/index.php/Albert_W._Hull.
- ³¹ “Albert Hull,” Wikipedia, Retrieved from http://en.wikipedia.org/wiki/Albert_Hull.
- ³² P. Devine, “Radar level measurement; The user’s guide,” 2000, Retrieved from http://www.vega.com/downloads/Radar_book_chapter1.pdf.
- ³³ “Albert H. Taylor,” IEEE Global History Network, 12 September 2008, Retrieved from http://www.ieeeahn.com/wiki/index.php/Albert_H._Taylor.
- ³⁴ “Wiki: History of Radar,” Wapedia, Retrieved from http://wapedia.mobi/en/History_of_radar.
- ³⁵ “Albert H. Taylor,” Wikipedia, Retrieved from http://en.wikipedia.org/wiki/Albert_H._Taylor.
- ³⁶ “Robert Watson-Watt,” ECONOMICexpert.com, Retrieved from <http://www.economicexpert.com/a/Robert:Watson:Watt.htm>.
- ³⁷ “Robert Watson-Watt,” Wikipedia, Retrieved from http://en.wikipedia.org/wiki/Robert_Watson-Watt.
- ³⁸ C. Drentea, “Who Invented Radar,” RF Café, Retrieved from <http://www.rfcafe.com/references/articles/who-invented-radar.htm>.
- ³⁹ J. Chiles, “The Road to Radar,” Invention & Technology Magazine, Spring 1987, Vol. 2, Issue 3, Retrieved from http://www.americanheritage.com/articles/magazine/it/1987/3/1987_3_24.shtml.
- ⁴⁰ “Merle Antony Tuve,” Answers.com, Retrieved from <http://www.answers.com/topic/merle-antony-tuve>.
- ⁴¹ P.H. Abelson, “Merle Antony Tuve,” Norwegian Hall of Fame, Retrieved from <http://www.lawzone.com/half-nor/tuve.html>.
- ⁴² “Microwave Amplifier & Oscillator Tubes,” The Vintage Technology Association, Retrieved from <http://www.decadecounter.com/vta/tubepage.php?item=20>.
- ⁴³ “Yagi Antenna,” Absolute Astronomy, Retrieved from http://www.absoluteastronomy.com/topics/Yagi_antenna.
- ⁴⁴ J.E. Brittain, “Hidetsugu Yagi Antenna,” School of History, Technology, and Society, Retrieved from http://www.oelcwj.com/literature/hidetsugu_yagi_yagi_antenna.htm.
- ⁴⁵ “Wiki: History of radar,” Wapedia.
- ⁴⁶ “Lawrence A. Hyland,” IEEE Global History Network, 3 October 2008, Retrieved from http://www.ieeeahn.com/wiki/index.php/Lawrence_A._Hyland.
- ⁴⁷ “History of radar,” 15 December 2004.

-
- 48 L. Brown, "A Radar History of World War 2 - Technical and Military Imperatives," Institute of Physics Publishing, Bristol & Philadelphia, ISBN 0-7503-0659-9, 1999, p. 43.
- 49 "Wiki: History of radar," Wapedia.
- 50 G. Goebel, "The British Invention of Radar," In the Public Domain, 1 May 2009, Retrieved from http://www.vectorsite.net/ttwiz_01.html.
- 51 "Albert Hoyt Taylor," New World Encyclopedia, Retrieved from http://www.newworldencyclopedia.org/entry/Albert_Hoyt_Taylor.
- 52 N. J. Willis and H.D. Griffith, "Advances in Bistatic Radar," Scitech Pub Inc., ISBN-13: 978-1891121487 17 August 2007, p. 24.
- 53 Google patents, Retrieved from <http://www.google.com/patents?q=magnetron>.
- 54 www.pat2pdf.org - A FREE patent search tool, Retrieved from <http://www.pat2pdf.org/>.
- 55 Freepatentsonline: all the inventions of mankind, Retrieved from <http://www.freepatentsonline.com/>.
- 56 United States Patent and Trademark Office, Retrieved from <http://patft.uspto.gov/>.
- 57 "Magnetron," Freepatentsonline: all the inventions of mankind, Retrieved from http://www.freepatentsonline.com/result.html?p=15&query_txt=magnetron&sort=relevance&srch=top.
- 58 "Radartutorial," Retrieved from <http://www.radartutorial.eu/druck/Book1.pdf>.
- 59 "George Clark Southworth," Wikipedia, Retrieved from http://en.wikipedia.org/wiki/George_Clark_Southworth.
- 60 United States Patent US1981884, free patents online, <http://www.freepatentsonline.com/1981884.pdf>.
- 61 J.R. Chiles, "The Road to Radar," Invention and Technology Magazine, Spring 1987, Vol. 2, Issue 3, Retrieved from http://www.americanheritage.com/articles/magazine/it/1987/3/1987_3_24.shtml.
- 62 "History of radar," Absolute Astronomy, Retrieved from http://www.absoluteastronomy.com/topics/History_of_radar#encyclopedia.
- 63 "Invention and Initial Development of Monopulse Radar," IEEE Global History Network, 2 February 2009, Retrieved from http://www.ieeeahn.org/wiki/index.php/Invention_and_Initial_Development_of_Monopulse_Radar.
- 64 "History of radar," 15 December 2004.
- 65 G. Goebel, 1 May 2009.
- 66 "Wurzburg Radar," Absolute Astronomy, Retrieved from http://www.absoluteastronomy.com/topics/W%C3%BCrzburg_radar.

-
- 67 M. Hollman, "Radar Development in Germany," Radar World, 2007, <http://www.radarworld.org/germany.html>.
- 68 J.R. Page, "The Development of Radar," chuckhawks.com, Retrieved from http://www.chuckhawks.com/monopulse_radar.htm.
- 69 "History of radar," 15 December 2004.
- 70 "George C. Southworth," IEEE Global History Network, 11 September 2008, http://www.ieeeahn.org/wiki/index.php/George_C._Southworth.
- 71 "Wiki: History of radar," Wapedia.
- 72 "Information on History of radar," Retrieved from http://www.reachinformation.com/define/History_of_radar.aspx.
- 73 "History of radar," Welcome to the Cyprus Turkish Air Traffic Controllers Association Web page, Retrieved from <http://www.ctatca.org/radarhistory1.html>.
- 74 "Robert Watson-Watt," Undiscovered Scotland, Retrieved from <http://www.undiscoveredscotland.co.uk/usbiography/w/robertwatsonwatt.html>.
- 75 "Cavity Magnetron," Absolute Astronomy, Retrieved from http://www.absoluteastronomy.com/topics/Cavity_magnetron.
- 76 M. Hollman, 2007.
- 77 "Seetakt radar," Wikipedia, Retrieved from http://en.wikipedia.org/wiki/Seetakt_radar.
- 78 Edward George Bowen, Wikipedia, Retrieved from http://en.wikipedia.org/wiki/Edward_George_Bowen.
- 79 C. Wolff, "Historical Overview," Radartutorial.eu, Retrieved from <http://www.radartutorial.eu/04.history/hi04.en.html>.
- 80 "Robert Morris Page," Encyclopædia Britannica Online, 2010, Retrieved from <http://www.britannica.com/EBchecked/topic/438225/Robert-Morris-Page>.
- 81 "History of radar," 15 December 2004.
- 82 "Wiki: History of radar," Wapedia.
- 83 M. Hollman, Radar World, 2001.
- 84 D. Caldwell and R. Miller, "The Luftwaffe Over Germany: Defense of the Reich," London: Greenhill Books, 2007, ISBN 978-1-85367-712-0, p. 26.
- 85 "History of radar," Absolute Astronomy.
- 86 J.R. Page, "The Development of Radar."
- 87 L. Brown, "A radar history of World War II: technical and military imperatives," Taylor & Francis, ISBN-10: 0750306599, p. 67, Retrieved on 3 March 2010 from http://books.google.com/books?id=wpFMWeLmp4cC&pg=PA67&lpg=PA67&dq=1937+XAF+radar+Page&source=bl&ots=fpA5RPdyWn&sig=W0RtaRM_AonJrnMFbvhRaX9HIo0&hl=en&ei=UO2WSvqwCNUmAfjOmqBQ&sa=X&oi=book_result&ct=result&resnum=1#v=onepage&q=1937%20XAF%20radar%20Page&f=false.

-
- 88 Edward George Bowen, Wikipedia.
- 89 M. Hollman, Radar World, 2001.
- 90 E. Gustin, "British ASV radars," uboat.net, Retrieved from http://uboat.net/allies/technical/uk_radars.htm.
- 91 "History of radar," http://en.wikipedia.org/wiki/History_of_radar.
- 92 U.S. Navy Shipboard Radars – XAF," Department of the Navy -- Naval Historical Center, 9 June 2008, Retrieved from <http://www.history.navy.mil/photos/weap-sen/radar/us/xaf.htm>.
- 93 E.A. Sharpe, "Morgan McMahon and Radar," McMahon's Radars!, 2001, Retrieved from http://www.smecc.org/mcmahon%27s_radars!.htm.
- 94 "British Naval Radar Equipment of World War II," Retrieved from http://www.navweaps.com/Weapons/WNBR_Radar.htm.
- 95 E. Gustin, uboat.net.
- 96 "Peter Cattley," Retrieved from <http://mckechnies.net/family/cattley/peter/index.htm>.
- 97 "Biographical Memoirs: Edward George Bowen: 1911-1991," Australia Academy of Science, Retrieved from <http://www.science.org.au/academy/memoirs/bowen.htm>.
- 98 M. Hollman, Radar World, 2001.
- 99 "Freya radar," Wikipedia, Retrieved from http://en.wikipedia.org/wiki/Freya_radar.
- 100 "History of radar," 15 December 2004.
- 101 "Cavity Magnetron," Absolute Astronomy.
- 102 "Air to Surface Vessel Radar ASV Mk II," Retrieved from <http://website.lineone.net/~norman.groom/ASVMKII.htm>.
- 103 "British ASV Radars," Retrieved from <http://www.mckechnies.net/family/cattley/peter/asv-radars.htm>.
- 104 "Henry Tizard," Wikipedia, Retrieved from http://en.wikipedia.org/wiki/Henry_Tizard.
- 105 A.G. Levine, "MIT Radiation Laboratory," APS Physics, 2010, Retrieved from <http://www.aps.org/programs/outreach/history/historicsites/mit.cfm>.
- 106 "History of radar: Early Experiments," Retrieved from <http://www.britannica.com/EBchecked/topic/488278/radar/28735/History-of-radar>.
- 107 R. Arndt, "Gema Kristall Flugzeug DFS-468 Schwarz Diamant," Retrieved from <http://discircraft.greyfalcon.us/Gema.htm>.
- 108 "Morgan McMahon and Radar," 2001.

-
- ¹⁰⁹ G. Goebel, "Microwave Radar & The MIT Rad Lab," In the Public Domain, 1 May 2009, Retrieved from http://www.vectorsite.net/ttwiz_03.html.
- ¹¹⁰ "Morgan McMahon and Radar," 2001.
- ¹¹¹ "Leigh light," Absolute Astronomy, Retrieved from http://www.absoluteastronomy.com/topics/Leigh_light.
- ¹¹² "Wiki: Leigh light," Wapedia, Retrieved from http://wapedia.mobi/en/Leigh_light.
- ¹¹³ R. Watson, Jr., "Solving the Naval Radar Crisis," Trafford Publishing, ISBN: 9781425161736, February 2008, Retrieved from <http://www.trafford.com/Bookstore/BookDetail.aspx?Book=183435>.
- ¹¹⁴ "Metox," Wikipedia, Retrieved from <http://en.wikipedia.org/wiki/Metox>.
- ¹¹⁵ "Radar Warning Receivers," German U-Boats and Battle of the Atlantic, Retrieved from <http://www.uboataces.com/radar-warning.shtml>.
- ¹¹⁶ "British ASV Radars," mckechnies.net.
- ¹¹⁷ "HF/DF: The High Frequency Direction Finder," German U-Boats and Battle of the Atlantic, Retrieved from <http://uboat.net/allies/technical/hfdf.htm>.
- ¹¹⁸ "High frequency direction finding," Wikipedia, Retrieved from <http://en.wikipedia.org/wiki/Huff-Duff>.
- ¹¹⁹ G.F. Mason, Lt. Cmdr, RN (Rtd), "HF/DF or HUFF DUFF - High Frequency Radio Direction Finding in Royal Navy Warships in World War 2," 1992, Retrieved from <http://www.naval-history.net/xGM-Tech-HFDF.htm>.
- ¹²⁰ T.D. Calderwood, "Highlights of NRL's First 75 Years," Naval Research Laboratory, Retrieved from <http://www.nrl.navy.mil/NewsRoom/images/75highlights.pdf>.
- ¹²¹ J.R. Page, "The Development of Radar," Naval, Aviation and Military History, Retrieved from http://www.chuckhawks.com/monopulse_radar.htm.
- ¹²² E. Gustin, uboat.net.
- ¹²³ "Radar Warning Receivers," German U-Boats and Battle of the Atlantic.
- ¹²⁴ "H2S radar," Wikipedia, Retrieved from http://en.wikipedia.org/wiki/H2S_radar.
- ¹²⁵ "Radar Warning Receivers," German U-Boats and Battle of the Atlantic.
- ¹²⁶ "British ASV Radars," mckechnies.net.
- ¹²⁷ "Invention and Initial Development of Monopulse Radar," 2 February 2009.
- ¹²⁸ "Monopulse radar," Absolute Astronomy, Retrieved from http://www.absoluteastronomy.com/topics/Monopulse_radar#encyclopedia.
- ¹²⁹ "Radar Warning Receivers," German U-Boats and Battle of the Atlantic.
- ¹³⁰ "Dutch inventions and discoveries," Wikipedia, Retrieved from http://en.wikipedia.org/wiki/Dutch_inventions_and_discoveries.
- ¹³¹ "Radar Warning Receivers," German U-Boats and Battle of the Atlantic.

-
- ¹³² “Radio & Signals,” Schnellboot, Retrieved from <http://www.prinzeugen.com/SchnellSignals.htm>.
- ¹³³ “Snorkel,” German U-Boats and Battle of the Atlantic, Retrieved from <http://www.uboataces.com/snorkel.shtml>.
- ¹³⁴ “Anti Sonar Coating,” German U-Boats and Battle of the Atlantic, Retrieved from <http://www.uboataces.com/sonar-coating.shtml>.
- ¹³⁵ J. Brandt, “rf absorbent,” Online posting, 25 May 2000, Retrieved from <http://www.uboat.net/forums/read.php?20,58738,58742,quote=1>.
- ¹³⁶ “Radar Warning Receivers,” German U-Boats and Battle of the Atlantic.
- ¹³⁷ G. Goebel, “Microwave Radar At War,” In The Public Domain, v2.0.3, 1 May 2009, Retrieved from http://www.vectorsite.net/ttwiz_06.html.
- ¹³⁸ “P2V (P-2) Neptune,” Retrieved from <http://www.globalsecurity.org/military/systems/aircraft/p-2.htm>.
- ¹³⁹ “Over-the-Horizon Radar,” Naval Research Laboratory, Retrieved from <http://www.nrl.navy.mil/content.php?P=HORIZONRADAR>.
- ¹⁴⁰ “Over-the-Horizon Radar,” In Encyclopædia Britannica. Retrieved from Encyclopædia Britannica Online: <http://www.britannica.com/EBchecked/topic/435869/over-the-horizon-radar>.
- ¹⁴¹ “Robert Morris Page,” 2010.
- ¹⁴² J. G. Shannon, Private communications with D. Weisbrod, Whidbey Island, WA, 8 July 2008.
- ¹⁴³ E.A. Mebus, Technical Brief, “Airborne Periscope Detection Radar,” Code 50BX, NADC, Naval Air Development Center, Warminster, PA, 1993.
- ¹⁴⁴ “SH-60B Seahawk, Maritime Light Airborne Multi-Purpose System (LAMPS) multipurpose helicopter,” Military.com entertainment, <http://tech.military.com/equipment/view/152549/sh-60b-seahawk.html>.
- ¹⁴⁵ “AN/APS-137B(V)5 Radar System,” Retrieved from <http://www.raytheon.com/capabilities/products/aps137b/>.
- ¹⁴⁶ A.R. Ochadlick, Jr., O. Shemdin, J. Duke, C. Rino, A.C. Schultheis, H. Kritikos, and J. Kraus, “Measuring Sea Clutter and Doppler Properties with Low Grazing Angle Radars,” IGARSS ’92.
- ¹⁴⁷ “AN/APS-147 Multi-Mode Radar,” Telephonics Radar Systems Division, 2008, <http://www.telephonics.com/products/AN-APS-147.pdf>.
- ¹⁴⁸ “Radar Detection of Submarine Masts; Final Report,” Ad Hoc Study, Detection and Classification Subcommittee, ASW Committee, National Security Industrial Association, 1 May 1993.
- ¹⁴⁹ G. Snider, Technical Brief, “Automatic Radar Periscope Detection and Discrimination,” 3 August 1998.

-
- ¹⁵⁰ J.J. Ousbourne, D. Griffith, and R. W. Yuan, “A Periscope Detection Radar,” Johns Hopkins APL Technical Digest, Vol. 18, No. 1, 1997, Retrieved from <http://www.jhuapl.edu/techdigest/td1801/ousbourn.pdf>.
- ¹⁵¹ F.D. Kennedy, Jr., “U.S. naval aircraft and weapon developments,” U.S. Naval Institute, Proceedings of the US Naval Institute, ISSN: 0041-798X, 1999, Retrieved from <http://www.faqs.org/abstracts/Business/US-naval-aircraft-and-weapon-developments-Radars-can-detect-the-periscope.html>.
- ¹⁵² J.J. Osborne, “ARPDD P-3 Flight Test Plan,” Johns Hopkins APL, STS-99-110, 27 May 1999.
- ¹⁵³ J. G. Shannon, Private communications with G. Snider, PSAC PDR Workshop, Washington, DC, 27 August 2001.

APPENDIX C

CHRONOLOGY OF SUBMARINE DEVELOPMENTS

Leonardo da Vinci on the Submarine

To the Editor of The New York Times:

Leonardo da Vinci's conviction that submarines should not be used because of the impossibility of using them properly gains emphasis from the fact that he invented a "sub." His opinion after five hundred years still has timeliness. We read in Dr. J. P. Richter's "The Literary Works of Leonardo da Vinci," Paragraph 1:

"How by a certain machine many may stay some time under water. And how and wherefore I do not describe my method of remaining under water. * * * And I do not publish nor divulge these, by reason of the evil nature of men, who would use them for assassinations at the bottom of the sea by destroying ships and sinking them, together with the men in them."

Here as elsewhere Leonardo's prophetic vision is remarkable.

FRANK JEWETT MATHER,
Princeton, N. J., Dec. 16, 1921.

Introduction

Around the year 1500, Leonardo da Vinci sketched a submarine in one of his notebooks; however, because he believed a submarine would be used only for destructive rather than constructive purposes, he declined to provide any design details.

The submarine is unique among means of transportation, whether by air, sea surface or land, in that it has been designed, developed and used almost exclusively for war fighting. The few exceptions are a small number of research vessels, some submarines developed by Simon Lake (1897), and a German civilian cargo submarine (1916).

During World War II, the Germans sank 5,150 allied merchant ships displacing 21.57 million tons. Of this, the U-boats were responsible for 2,828 ships of 14.69 million tons. To place this in perspective, the Germans sank the equivalent of the entire British merchant fleet at the start of the war. Additionally, German submarines destroyed 187 warships, including 6 aircraft carriers and 2 battleships; however, this

tremendous destruction came at a heavy price: the Germans lost 785 submarines of 1,158 constructed.

The Japanese merchant marine lost 8.1 million tons of vessels during the war, with submarines accounting for 4.9 million tons (60%) of the losses. Additionally, U.S. submarines sank 700,000 tons of naval ships (about 30% of the total lost) including 8 aircraft carriers, 1 battleship and 11 cruisers. Of the total 288 U.S. submarines deployed throughout the war (including those stationed in the Atlantic), 52 submarines were lost, with 48 destroyed in the war zones of the Pacific. American submariners, who comprised only 1.6% of the Navy, suffered the highest loss rate in the U.S. Armed Forces, with 22% killed.

History has shown Leonardo's concerns to be well-founded.

Just as periscope detection radar was not developed in isolation from radars developed for other purposes, so also, periscopes and other masts were developed along with other features of submarines.¹

This appendix provides a chronological summary of submarine developments through the years.

Chronology

360 BC Aristotle notes the use of a diving bell by Greek sponge gatherers.²

332 BC According to tradition, Alexander the Great descends in a sealed waterproof container off the island of Tyre.²

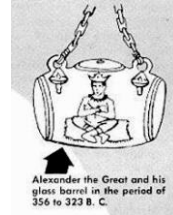

1430s Johann Gutenberg, better known for his contribution to printing technology, markets a periscope to enable pilgrims to see over the heads of the crowd at a religious festival in Aachen.³

~1500 Leonardo da Vinci makes sketches of a submarine. It was simply a shell with room enough for one person to sit inside. It was topped with a conning tower which had a lid and predated the true submarine by over one hundred years. Leonardo was to describe it as a 'ship to sink another ship.' Leonardo considered that the best way to defend against underwater attack by ships similar in design to his 'submarine' was to have double-hulled boats. This would not only solve the problem of ramming, but also that of divers interfering with the vessel. By this time he had already devised a method by which divers could separate the planks of ships.⁴

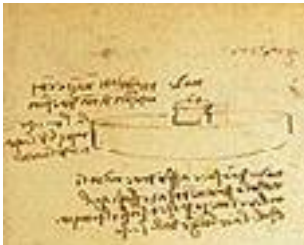

1535 Guglielmo de Lorena creates and uses what is considered to be the first modern diving bell.⁵

1578 English innkeeper William Bourne, in a book entitled "Inventions and Devices," describes in detail a device capable of diving. Its design, fully waterproof, had the ability to go beneath the surface using rowing as a means of propulsion. To submerge, large screws were used to adjust the volume of the vessel, causing the hull to shrink or enlarge, thus varying the amount of water it displaced and, accordingly, its buoyancy. There is no evidence that Bourne actually constructed a submarine.⁶

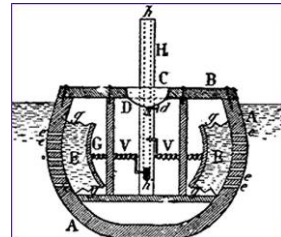

1620 Cornelius van Drebbel, a Dutch physicist and inventor living in England, builds a submarine. Drebbel's submarine design was the first to address the problem



of air replenishment while submerged, using air tubes, supported on the surface by floats, to bring oxygen down to the submerged boat. It was the first successful underwater craft, best described as a wooden rowboat tightly encased in waterproofed leather. Oars penetrated the hull through flexible leather gaskets. It was said to be based on design sketches of da Vinci. In 1620 he demonstrated the operation of the submarine

in a series of trips in the River Thames with twelve oarsmen and several passengers - remaining submerged for as much as three hours.⁷

1653 A Frenchman, known only as De Son, designs and builds the 72-foot-long *Rotterdam Boat*, probably the first underwater vessel specifically built (by Belgians) to attack an enemy (the English Navy).

De Son meant for his almost-submarine—a semi-submerged ram—to sneak up unobserved and punch a hole in an enemy ship. He boasted that it could cross the English Channel and back in a day, and sink a hundred ships along the way. Its propulsion system was a spring-driven clockwork device that turned a central paddle wheel. The device was so underpowered, however, that when the boat was finally launched, it went nowhere.⁸

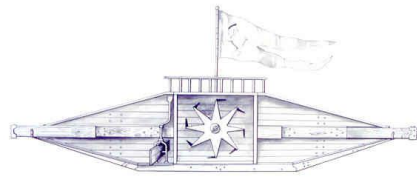

*De Son's Submersible
Catamaran of 1653*

1680 Giovanni Borelli proposes a boat with goatskins in the hull, each being connected to an opening. The boat would submerge by letting water into the goatskins and surface by forcing water out by a twisting rod. This seems to be the first approach to the modern ballast tank.^{9,10}

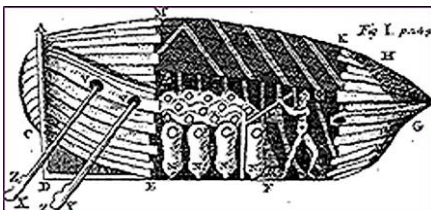

1690 Edmund Halley (of comet fame) completes plans for a diving bell capable of remaining submerged for extended periods of time, and fitted with a window for the purpose of undersea exploration. In Halley's diving bell, the atmosphere was replenished by sending weighted barrels of air down from the surface.¹¹

1692 Denis Papin, a mathematics professor, builds two submarines. He used an air pump to balance internal pressure with external water pressure, thus controlling buoyancy through the in-and-out flow of water into the hull. For propulsion he used sails on the surface and oars below. Papin tested his first boat, but his patron lost interest and the second boat was never finished. Illustrations of this submarine look like a steam kettle. Papin was also the inventor of the pressure cooker.¹²



1775 After about four years of work, David Bushnell, a Yale medical student, completes work on a small submarine. This first warfare submarine, named the *Turtle*, was described by Bushnell as having “some

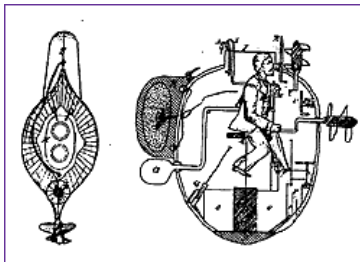

resemblance to two upper tortoise shells of equal size, joined together...” It was 7.5 feet deep, and under ideal conditions had a maximum speed of 3 knots. The *Turtle* was a wooden submarine



powered by hand-turned propellers. Its single operator could remain submerged for 30 minutes. The *Turtle* was armed with an oak casing filled with 150 pounds of explosives. This charge could be attached to the bottom of an enemy ship where it was intended to remain until detonated by a simple clockwork mechanism. After completing the submarine, Bushnell took it for several dives to prove its seaworthiness.¹³

1776 In September Bushnell is ready to try the *Turtle* against the British in New York harbor. Sergeant Ezra Lee, a volunteer from the Connecticut militia, maneuvers the *Turtle* through the use of hand-driven screw propellers. His mission was to attach a time-fuse charge of gunpowder to the hull of *HMS Eagle*. However, the mission was aborted when the auger failed to penetrate the copper sheathing of the *Eagle*. Bushnell made a few more attempts to use the *Turtle* against the British in the Delaware River. He attached mines to the *Turtle* and floated the mines against ships. These attempts failed. The submarine was finally sunk by the British in New York harbor—the first recorded instance of an antisubmarine attack.^{13,14}

iron rod. The accompanying photograph shows a cutaway model that is displayed in a Dresden museum.^{20,21,22}

On a subsequent submerged run, however, the sliding weight slid too far forward, and the vessel plunged to the bottom, getting stuck in mud at 60 feet. Bauer and his



two companions could not open the hatch because of the water pressure; they had to wait until a leak had sufficiently filled the interior with seawater that the pressure inside matched the exterior pressure. After an unimaginable six hours in the claustrophobic darkness, they opened the hatch and were swept to the surface in a bubble of escaping air.²³

Brandtaucher was recovered in 1887 and is now on display at the Militärhistorisches Museum der Bundeswehr (German Army Museum of Military History) in Dresden.^{24,25}

1852 Lodner D. Phillips is granted U.S. Patent 9,389 for a “Steering Submarine Propeller,” whose main innovation was a hand-cranked propeller on a swivel joint that would allow the operator to steer the vessel and control its up and down movement.²⁶

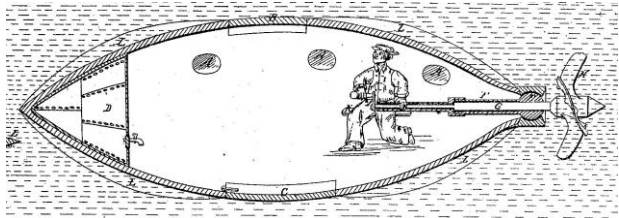

1855 Wilhelm Bauer builds the 52-foot *Diable Marin* (Sea Devil) for Russia. The submarine made as many as 134 dives, the most spectacular of which celebrated the coronation of Tsar Alexander II. Of the 16 men the boat took underwater, four formed a brass band, whose underwater rendition of the national anthem could be heard clearly by listeners on the surface.²⁷

1859 French designer Brutus de Villeroi builds a 33-foot-long treasure-hunting submarine for Philadelphia financier Stephen Girard. Its target was the wreck of the British warship *De Braak*, lost near the mouth of the Delaware River in



1780. The salvage method consisted of divers operating out of an airlock. The boat made at least one three-hour dive to 20 feet but no other details are known.^{28,29}

1859 Narcís Monturiol i Estarriol of Spain demonstrates his human-powered *Ictineo* [from the Greek *ichthys* (fish) and *naus* (boat)] submarine in over 20 test dives of 20 minutes or more. To provide oxygen for his 16-man crew to breathe, Monturiol figured that if his boat was to look like a fish, it might as well breathe like a fish.

Therefore, he studied the gills of fish to learn how they extract oxygen from the water. Upon further consideration, however, he concluded that most fish spend their time close to the surface and, therefore, the ocean's oxygen must be concentrated there. And

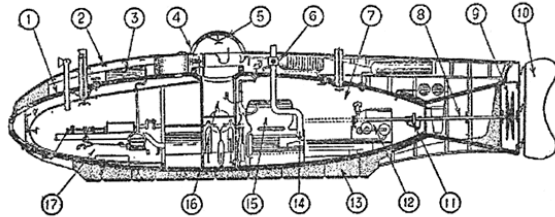

since his was to be a deep-diving submarine, he abandoned the gills concept. He did manage to develop a way to cleanse the interior chamber of carbon dioxide by pumping air through a container of slaked lime (calcium hydroxide). The carbon dioxide and calcium hydroxide would react to form solid calcium carbonate, leaving behind air free of carbon dioxide. However, his solution to produce oxygen proved unfeasible because it produced sulfuric acid – not something to be desired in the confined, submerged spaces of a submarine.³⁰

1861 The American Civil War provides an impetus for the development of submarines and for practical experiments in torpedo attack, particularly in the Confederate States. While U.S. Federal development efforts were burdened with conventional naval bureaucratic processes of contracting and evaluation, the Confederate efforts were able to benefit from a quick application of private initiative, which was in turn met with swift support from a government unburdened with the traditional bureaucracy of the type existing in the North.^{31,32}

1861 During the American Civil War, Confederate lawyer and inventor Horace Lawson Hunley converts a steam boiler into a submarine called the *Pioneer*. This submarine could be propelled at four knots by a hand-driven screw. Unfortunately, the submarine sank twice during trials in Charleston, South Carolina. These accidental sinkings in Charleston harbor cost the lives of two crews. In the second accident the submarine was stranded on the bottom and Hunley himself was asphyxiated with eight other crew members.³³

1862 The United States Federal Navy purchases and tests its first prototype submarine, the French-designed *USS Alligator*. It was the first to feature compressed

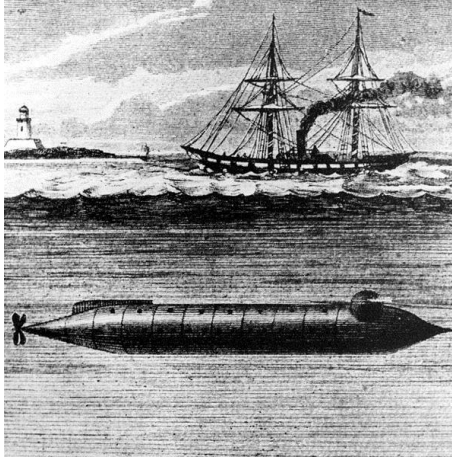

air for breathing and an air filtration system. It contained two crude air purifiers: a chemical-based system for producing oxygen and a bellows to force air through lime. It had a diver lock which allowed a diver to plant electrically detonated mines on enemy ships. Initially hand-powered by oars, it was converted after 6 months to a screw propeller powered by a hand crank. With a crew of 20, it was larger than Confederate submarines. *Alligator* was 47 feet (14.3 m) long and about 4 feet (1.2 m) in diameter. The *Alligator* was intended for operations in the James River below Richmond, Virginia.

However, it proved too large for diving in the river's shallow waters. It was lost in a storm off Cape Hatteras on April 1, 1863 while under tow to its first combat deployment at Charleston.^{34,35}

1863 Hunley's submarine is raised and renamed the *CSS Hunley*. In 1864, armed with a 90-pound charge of powder on a long pole, the *Hunley* attacked and

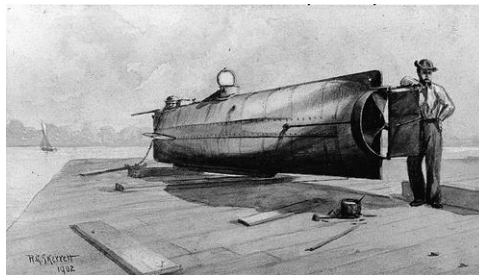
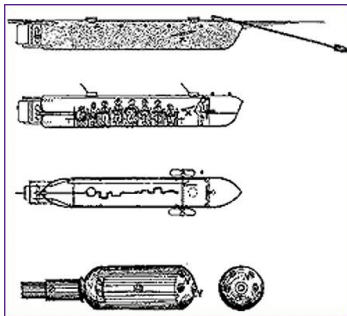

sank a new Federal steam sloop, *USS Housatonic*, at the entrance to Charleston Harbor.

After her successful attack on *Housatonic*, the *Hunley* disappeared and her fate remained unknown for 131 years. In 1995 the wreck of the *Hunley* was located 4 miles off Sullivans Island, South Carolina and recovered on 8 August 2000. Even though she sank, the *Hunley* proved that the submarine could be a valuable weapon in time of war.³⁶

1867 Narcís Monturiol designs, builds and successfully operates his *Ictíneo II* submarine employing a new early form of air-independent propulsion chemical steam engine. His plans to build a much larger boat built entirely of metal were precluded because of a lack of funds. Instead, he installed two engines on his earlier

wooden *Ictineo*. The 14-meter (46-ft) craft was designed for a crew of two, could dive to 30 meters (96 ft), and demonstrated dives of two hours. On the surface it ran on a steam engine, but underwater such an engine would quickly consume the submarine's oxygen, so Monturiol developed his most important invention, an *anaerobic* engine. The engine employed a chemical mix of magnesium peroxide, zinc, and potassium chlorate that reacted to generate the heat needed to produce steam for the engine. Its product of reaction was oxygen which was collected and used for breathing and illumination purposes. The beauty of this method was that while the engine drove the screw, it also released oxygen which was used for the crew to breathe and to enable operation of an auxiliary steam engine. On 22 October 1867, the *Ictineo II* made its first surface journey under steam power. The submarine averaged 3.5 knots with a top speed of 4.5 knots, enough for Monturiol's minimum requirements. On 14 December, he took the boat under the waves and ran the chemical steam engine, but didn't attempt to go anywhere. Two weeks later, on 23 December, Monturiol's submarine association went completely bankrupt, having finally exhausted all of its funds. The main creditor called in his debt, and, unable to pay, Monturiol was forced to surrender his only asset, the *Ictineo II*. The creditor subsequently sold the submarine to a business man whom Monturiol hoped would use the vessel for its original purpose of harvesting coral. But even this was not to be, as the authorities, who taxed all marine vessels, decided that the *Ictineo II* fit that description and issued its new owner a tax bill. Rather than pay, he dismantled the entire submarine and sold it for scrap. A reconstruction of *Ictineo II* is exhibited in Barcelona.^{37,38,39}



1870 Jules Verne publishes the novel “20,000 Leagues under the Sea,” which serves as inspiration for submarine designers John P. Holland and Simon Lake.⁴⁰

1872 The U.S. Navy tests the *Intelligent Whale*, another hand-crank-powered submarine that failed. After the *Intelligent Whale's* failure as a submarine, inventors realized that until a propulsion method better than manpower could be developed for underwater use, submarines were not going to be worth the effort.⁴¹

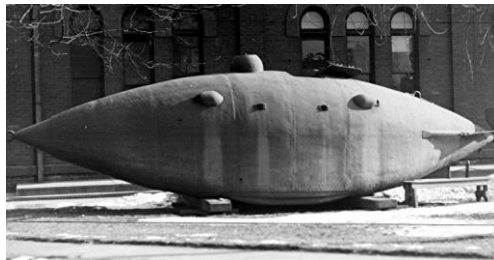

1874 John P. Holland designs his first submarine, a one-man, 15.5-foot-long pedal-propelled craft. Its treadle was to drive not only the propeller, but also to control the one-cubic-foot ballast tank and to discharge “used” air. Holland, who was born in Ireland in 1841 and emigrated to the United States in 1873, joined a militant group called the Fenians that was dedicated to the overthrow of British rule of Ireland. He was motivated

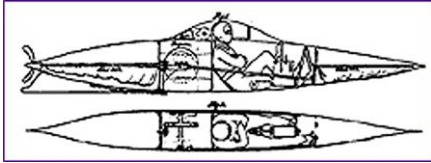

to develop a submarine that could sink British warships.^{42,43}

1877 With funding from the Fenians, John Holland builds and tests his first engine-driven submarine, the Holland No. 1, in the Passaic River. It was 14 feet long, was powered by a primitive 4-horsepower engine, and carried one man. Holland made several successful dives. The Fenians were impressed and voted more money to develop a boat “suitable for war.” Holland removed the useful parts from No. 1 and scuttled her, figuring that it was cheaper to start afresh rather than take her out of the water and put her in storage. Fifty years later, the little sub was salvaged from the Passaic River and, together with Holland’s papers, is now preserved in the Paterson town museum.⁴⁴

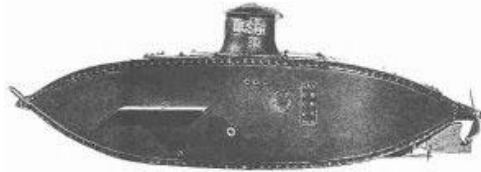

1890s Simon Lake and John Philip Holland, rival inventors, develop the first



Simon Lake

true submarines in the 1890s. The U.S. Navy purchased submarines built by Holland, while Russia and Japan opted for the designs of Lake. Their submarines used gasoline or steam engines for surface cruising and electric motors for underwater travel. They also

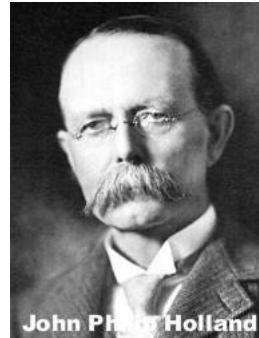

John Philip Holland

invented torpedoes which were propelled by small electric motors, thereby introducing one of the most dangerous weapons in the world.^{45,46}

1893 Simon Lake designs a submarine with a periscope that can be folded flush with the submarine when under way and submits his design to the U.S. Department of the Navy.⁴⁷

1894 Simon Lake builds his first submarine, the *Argonaut Junior*, in response to an 1893 request from the Navy for a submarine torpedo boat. The *Argonaut Junior* was built of pitch pine, as an inexpensive way to demonstrate his principles of submergence that would ultimately change the development of submarine technology. When the craft was submerged to a shallow seafloor, a door could be opened and a diver could retrieve articles or exit and re-enter the little 14-foot submarine by maintaining a pressurized compartment. A novel feature of Lake's early submarines was the use of wheels to provide mobility by the use of interior hand cranks. The success of the demonstration amazed on-lookers at Atlantic Highlands, New



Jersey, and inspired investors to support the establishment of The Lake Submarine Company in 1895 and to build a proper steel submarine vessel, the *Argonaut I*, by 1898.⁴⁸

1896 The U.S. Navy contracts with John Holland to develop a submarine and, despite Holland's objections to steam power on submarines, specifies that it use a steam engine for surface propulsion because the Navy was replacing sail power with steam power in its ships. Nevertheless, Holland built the submarine, named the *Plunger*, with three steam engines to meet the Navy's prescribed surface speed. During dock trials of the *Plunger*, the temperature in the fire room became intolerably high and the effort was discontinued.^{49,50}

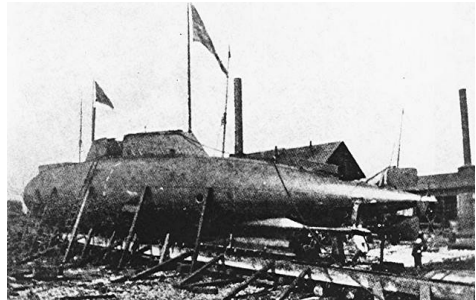

1897 The newly developed internal combustion engine offers speed and comparative endurance on the surface, but its deadly carbon monoxide exhaust fumes and high oxygen consumption were obstacles to life beneath the surface.⁵¹

1897 Simon Lake builds the *Argonaut* submarine. It was 36 feet long with a 9-foot beam, and powered by a 30-horsepower gasoline engine.⁵²

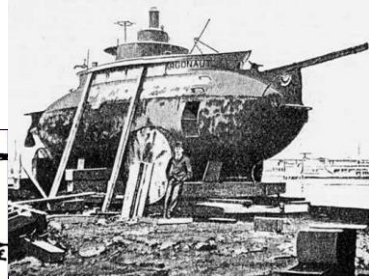
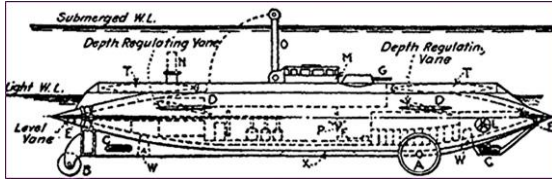

1898 According to his biographers, Simon Lake sets out with a crew of four men on a 2000-mile journey in Chesapeake Bay and along the Atlantic coast, traveling both on the surface and submerged, and over all kinds of bottoms, putting the *Argonaut* to the test. Like a true-to-life Captain Nemo, Lake and his crew gathered fish, clams and oysters through the dive compartment to demonstrate the practicality of living and traveling underwater. By traveling through the peaceful waters below, they survived violent storms in which over 200 surface vessels were lost. By the end of 1898, Lake and his *Argonaut* achieved worldwide acclaim, which was further complimented by a telegram sent by Jules Verne congratulating Lake in bringing the submarine dream to reality.⁵²

1898 Lake brings his little *Argonaut* to New York to be enlarged and refitted with a variety of improvements including greater buoyancy, deck space, fuel capacity, a 60-horsepower engine and living quarters for a crew of eight. A searchlight was added in the bow to illuminate its path. Telephones were installed throughout, so that conversation could be conducted between the divers and their tenders, with crew members stationed at different parts of the boat, and with persons on the surface and the shore.⁵²

1898 The U.S. Navy begins a two-year trial period of the *Holland VI*.⁵³

1900 *Argonaut II* is reconstructed to 66 feet in length and designed to be capable of making a non-stop sea voyage of 3000 miles and submerging for 48 hours. The new *Argonaut* looked quite different than the original one with the new raised deck that made the vessel appear more like a surface boat than a submarine.⁵⁴



1900 After rigorous tests, the *Holland VI* is purchased for \$160,000 by the U.S. Navy (on 11 April) and renamed the USS *Holland (SS-1)*, marking the beginning of the U.S. Navy Submarine Service. It was the sixth submarine that had been designed and built by Holland using his own funds. This 64-ton submarine was equipped with an Otto-cycle gasoline internal combustion engine for surface running and electric motors for submerged operations. The *Holland* achieved the “amazing speed” of seven knots surfaced, made possible by her 45-horsepower engine. She also had an endurance of several hours submerged when running on rechargeable storage batteries. Six more of her type were ordered and built.^{55,56,57}



The *Holland* was armed with a single torpedo tube and a pneumatic dynamite gun that fired through an opening in the bow. It carried three torpedoes, each with a pressure-sensitive piston that controlled the depth of the torpedo run. The torpedo’s stability was controlled by a pendulum, while direction was controlled by a gyroscope. A number of modern torpedoes use similar principles.⁵⁸

1900 Simon Lake experiments with boats that descend and ascend vertically according to negative or positive buoyancy controlled by pumps and tanks. In addition, for traveling between the surface and the bottom, he made use of “four big hydroplanes, two on each side that steer the boat either down or up.” Similar hydroplanes, or horizontal rudders, appeared in the later Holland boats, and are now in common use in all submarine types.⁵⁹

1900 The U.S. Navy considers, but decides not to accept Simon Lake’s *Argonaut*, an advanced version of his *Argonaut Junior*. Lake’s *Argonauts* had wheels with which to crawl along shallow bottoms and air locks to permit divers to enter and leave the craft while it was submerged.^{59,60}

1901 Neither *Argonaut* nor Lake’s following submarine, *Protector*, built in 1901, were accepted by the Navy. *Protector* was the first submarine to have diving planes mounted forward of the conning tower and a flat keel. Four diving planes allowed *Protector* to maintain depth without changing ballast levels. *Protector* also had a lock-out chamber for divers to leave the submarine. Lake is credited with the following design aspects of the



modern submarine: escape trunk, conning tower, diving planes, control room, and the rotating, retractable periscope.⁶¹

1901 An Italian engineer, Signor Triulzi, is said to have devised a special instrument, the “cleptoscope,” whereby it is possible for the crew of a submarine boat to ascertain what is progressing on the surface while submerged. It comprised a tube fitted with crystal prisms. Experiments were carried out on board the submarine *Il Delphino* in the presence of the Italian Minister of the Marine. Photographs of objects on the surface were successfully obtained.⁶²

1901 John Holland's boats develop neutral buoyancy by admitting water to balance the weight of the boat with the weight of water it displaces. With diving planes and a constant source of power, Holland's boats could dive and surface on diagonal lines.⁶³

1901 For all its innovations, the *USS Holland* had a major deficiency, namely, lack of vision when submerged. The submarine had to broach the surface so the crew could look out through windows in the conning tower. Broaching deprived the *Holland* of its greatest advantage, stealth.⁶⁴

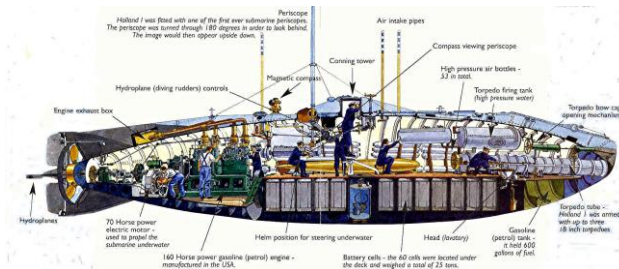

1901 After a falling out with the Fenians, John Holland designs a submarine for the British Royal Navy. *HM Submarine Torpedo Boat No 1* (or *Holland 1*) is the first submarine commissioned by the

Royal Navy, the first in a six-boat batch of the *Holland-Class* submarine. Constructed at Barrow-in-Furness, it was fitted with one of the first submarine periscopes. However, as the periscope was rotated through 180 degrees, the image would also rotate such that, when viewing aft, the image appeared upside down.⁶⁵



1902 Lack of clear vision when submerged is eventually corrected when Simon Lake uses prisms and lenses to develop the *omniscopes*, forerunner of the periscope,

an optical device for conducting observations from a concealed or protected position. Simple periscopes consist of reflecting mirrors and/or prisms at opposite ends of a tubular container. The reflecting surfaces are parallel to each other and at a 45° angle to the axis of the tube. The U.S. Navy attributes the invention of the submarine periscope to Simon Lake and its perfection of design during World War I to Sir Howard Grubb, a designer of astronomical instruments.^{66,67}

1903 The first German submarine, the *Forelle*, is built by Krupp but is sold to Russia.^{68,69}

1904 The French submarine *Aigette* is the first submarine built with a diesel engine for surface propulsion and an electric motor for submerged operations. Diesel fuel is less volatile than gasoline and becomes the preferred fuel for current and future conventionally-powered submarines.⁷⁰

1904 Lake, lacking Holland's financial backing, is unable to continue building submarines in the United States. He sold *Protector* to Imperial Russia and spent the next seven years in Europe designing submarines for the Austro-Hungarian Navy, the Kaiserliche Marine, and Imperial Russian Navy.⁷¹

1905 The first Unterseeboot (U-boat) for the German Navy is completed.⁷²

1908 The Imperial Russian Navy launches the submarine *Pochtovy* which used an air-independent-propulsion gasoline engine fed with compressed air and exhausted under water.⁷³

1909 American submarine designers adopt the French practice of using the diesel engine, beginning with the Electric Boat Company's *F-Class* submarines (SS-20 through 23).⁷⁴

1912 Simon Lake founds the Lake Torpedo Boat Company, which built 24 submarines for the U.S. Navy during and after World War I. Lake's first submarine for the U.S. Navy, *USS G-1 (SS-19½)*, set a depth record of 256 feet in November 1912.⁷⁵

1912 The U.S. Navy replaces its submarine gasoline engines with safer and more efficient diesel engines. The oil-burning diesel engine required no complicated ignition system, and it produced fewer noxious fumes. The *USS Skipjack (SS-24)* and the *USS Sturgeon (SS-25)* were the first diesel-propelled U.S. submarines.⁷⁶

~1915 Sir Howard Grubb, designer of astronomical instruments, develops the modern periscope that was first used on Holland-designed British Royal Navy submarines.⁷⁷

1916 The *Deutschland* was a blockade-breaking German cargo submarine used during World War I. Developed with private funds and operated by the North German Lloyd Line, it was one of the first *UA-Class* boats built but was unarmed, with a wide beam to provide space for cargo. The capacity was 700 tons, relatively small compared to surface ships. The boat was 213 feet long with a top speed of 15 knots on the surface and 7 knots while submerged. The *Deutschland* was used for high-value trans-Atlantic commerce, submerging to avoid British patrols. On its first trip, the submarine carried dyes, medicinals and gemstones to the U.S. The



payload was worth \$1.5 million. On 9 July 1916, after four weeks at sea, it arrived in Baltimore harbor as shown in the accompanying photograph. It returned to Germany with strategic war materials including nickel, tin and rubber, much of it stored outside the pressure hull.⁷⁸



1916 The U.S. Navy's first real effort as a submarine design organization results in plans for the *S-Class* boats. The Navy followed up by building *USS S-3 (SS-107)* at the Portsmouth Navy Yard to display its skill to the private sector.⁷⁹

1917 On 31 January, Germany declares that all sea traffic within certain zones around the British Isles, France and Italy will “be prevented by all weapons” and resorts to submarines to carry out the threat.⁸⁰

1917 On 6 April, the United States enters World War I with a total of 24 diesel-powered submarines. U.S. Navy subs patrolled the waters off the U.S. East Coast and deployed overseas to the Azores and Ireland. The American submarines' primary missions were to escort Allied shipping and counter the German U-boat threat. Though there were no confirmed sinkings of U-boats by American submarines, the number of German attacks repulsed by near misses showed the submarine to be an effective anti-submarine weapon. However, it was Germany's use of the U-boat in World War I that demonstrated the vital role the submarine would play in the next global conflict.⁸¹

1919 In Article 181 of the Treaty of Versailles, Germany is banned from possessing submarines.⁸²

1920s Various new submarine designs are developed during the interwar years. Among the most notorious ones were submarine aircraft carriers, equipped

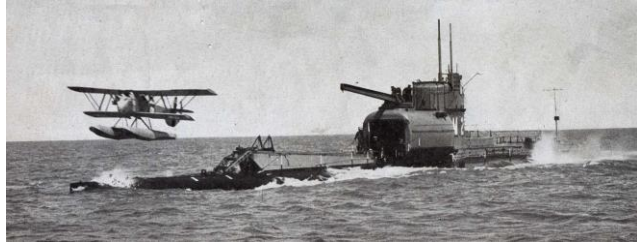

with waterproof hangars and steam catapults, which could launch and recover one or more small seaplanes. The submarine and her plane could then act as a reconnaissance unit ahead of the fleet, an essential role at a time when radar still did not exist. The first example was the British *HMS M2*, followed by the French *Surcouf*, and numerous aircraft-carrying submarines in the Imperial Japanese Navy.⁸³

1925 Captain Pericle Ferretti of the technical corps of the Italian Navy runs tests with a ventilation pipe installed on board the ex-US *H-3* submarine received by the Regia Marina during World War I; the tests were largely successful and a similar system was designed for the *Sirena-Class*. Subsequent snorkel systems, however, were not based on Ferretti's design.⁸⁴

1925 In Germany, Professor Hellmuth Walter's experience with marine engines stimulates his interest in overcoming some of the limitations of the internal combustion engine. He reasoned that an engine powered by a fuel source already rich with oxygen would not require an external supply of oxygen (from the atmosphere or from storage tanks) and would have obvious advantages for powering submarines and torpedoes.

Research suggested that hydrogen peroxide was a suitable fuel – in the presence of a suitable catalyst (such as sodium permanganate, calcium permanganate, silver wire or platinum sponge) it would break down into oxygen and steam at high temperature. The heat of the reaction would cause the oxygen and steam to expand, and this could be used as a source of pressure to drive a turbine. Walter also realized that a hydrocarbon such as diesel fuel could be injected into this hot mixture of gases to provide combustion and therefore more power. He patented this idea in 1925.^{85,86}

1935 *Unterseeboot 1* or *U-1* is the first submarine (or U-boat) built for the Kriegsmarine (Navy) following Adolf Hitler's abrogation of the terms

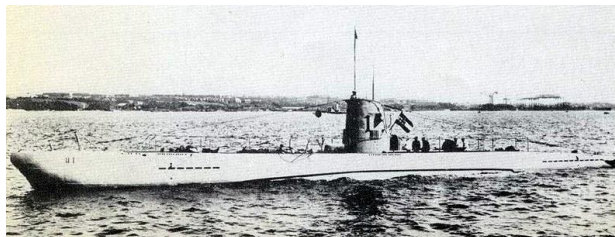

of the Treaty of Versailles, which banned Germany from possessing a submarine force.⁸⁷

1940 From the time of Narcís Monturiol in 1867, no other submarine employs an anaerobic propulsion system until 1940 when the German Navy tests a system employing the same principles, the Walter turbine, on the experimental *V.80* submarine and later on the naval *U.791* submarines. (The problem of anaerobic propulsion was finally solved with the invention of the first nuclear submarine, the *USS Nautilus*.)

By the early 1940s, Hellmuth Walter's research with hydrogen peroxide had progressed to the point where he was able to convince the Kriegsmarine to build some prototype submarines. By 1943, a Walter hydrogen peroxide turbine had been used to power an unarmed test U-boat to a submerged speed of 26 knots. This was some 18 knots faster than the fastest conventional submarine of the period, and actually about 5 knots faster than the most common Allied escort vessels.^{88,89,90}

1940 The defeat of the Netherlands by the Wehrmacht (Army), and the capture of Dutch submarines *O-25* and *O-26* is a stroke of luck for the German Kriegsmarine. The Dutch had been working on a device that they had named the "snuiver" (sniffer) and had been experimenting as early as 1938 with a simple pipe system on the submarines *O-19* and *O-20* that enabled them to travel at periscope depth operating under diesel power with almost unlimited underwater range while charging the propulsion batteries.⁹¹

1941 Gesellschaft für Elektroakustische Mechanische Apparate (GEMA) constructs a version of the Seetakt radar small enough to be fitted into the conning tower of a U-boat. Its antenna system consisted of two horizontal rows of vertical dipoles installed in a half-circle, following the curve of the conning tower. It had a maximum range of about 7 km, with a field of view of 60°. To scan a full 360°, the submarine had to execute a circular turn. It was generally unsuccessful. In 1942 the antenna array was replaced with one fitted on a retractable, rotating mast.⁹²

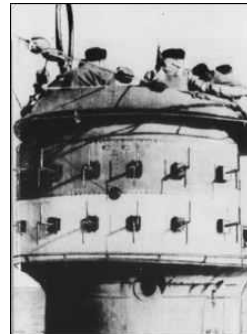

~1941 To extend the range of view of U-boats, the Germans experiment with demountable lookout masts.⁹³



1942 To further extend an observer's range of view, the Germans develop and deploy the Focke Achgeles Fa-330 "Bachstelze." (The Bachstelze is a small fluttering bird known in Britain as "Wagtail.") The Fa-330 was a small motorless, 3-bladed, 180-lb autogyro that was towed on a 60- to 150-meter long cable and flown as a manned kite by surface-running U-boats. It could maintain an altitude of 400 feet and extend the range of vision to surface vessels and aircraft to about 25 nmi. It was a collapsible assembly of small dimensions that enabled its components to be taken through a hatch on the U-boat and to be assembled on the deck. After use, it was pulled in by a winch. About 200 were built by the



end of WWII during which it saw service in the South Atlantic and Indian Oceans.^{94,95}

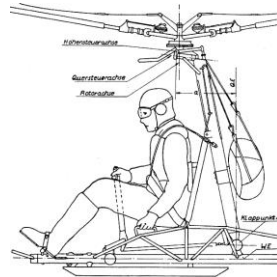

1943 The Kriegsmarine considers the snorkel as a means to take fresh air into the U-boats but sees no need to run the diesel engines underwater. In 1943, however, as German submarine losses increased sharply as radar-equipped Allied aircraft attacked U-boats running on the surface recharging their batteries, snorkels were retrofitted to the *VIIIC* and *IXC* classes and designed into the new *XXI* and *XXIII* types.

The first Kriegsmarine boat to be fitted with a snorkel was *U-58*, which was used experimentally in the Baltic Sea during the summer of 1943. Boats began using it operationally with *U-264* in early 1944 and, by June 1944, about half of the boats stationed in the French bases had snorkels fitted. To some extent the snorkel reduced

vulnerability to detection and attack, but it protruded above the surface and could be detected by radar. The Germans introduced the snorkel too late in the war to make a difference.^{96,97,98}

1944 The German submarine *U-791* uses hydrogen peroxide as a source of oxygen for its diesel power plant.⁹⁹

1945 The Japanese make extensive use of suicide and midget submarines and submarine-launched, human-guided torpedoes.¹⁰⁰



1945 The U.S. Navy submarine force begins experimenting with high speed, sophisticated silencing techniques, sensitive sonic detection, and deeper diving. The result took the shape of the greater underwater propulsive power, or GUPPY, conversions that changed the configuration of wartime submersibles to enhance submerged speed and hydrodynamic efficiency. The *Tang-Class*, the first truly new postwar construction, represented an initial step on a new road toward greater speed and endurance below the surface.¹⁰¹

1947 The U.S. Navy develops and successfully launches the KUV-1 “Loon,” a submarine-launched version of the German V-1 “Buzz Bomb.”



These missiles were carried in watertight containers on the aft deck. The first submarine to employ them was the SS-348 *Cusk*. The missile “hangar” appears aft of the Loon.^{102,103}

1953 The U.S. Navy commissions the experimental *USS Albacore* with a “tear drop” hull design to reduce underwater drag and allow greater submerged speed and maneuverability. The first submarine class to use this new hull design is the *USS Skipjack*. It is interesting to note that many of the submarines of the 1800s had round



cross-sections but such shapes were largely abandoned in later models in favor of more conventional surface vessel shapes. This reflected the fact that submarines of the first half of the 20th century spent most of their time on the surface and their superior surface sea-keeping properties were preferred.^{104,105}

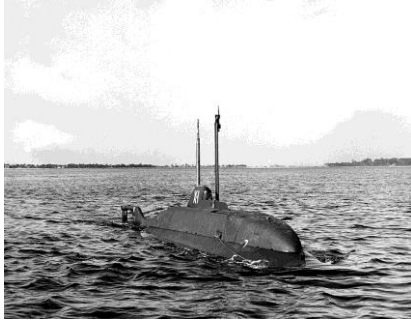

platform suspended beneath the Bay Bridge.¹⁰⁶

1954 The U.S. Navy begins construction of its only midget submarine, the USS X-1, which was powered by a hydrogen peroxide/diesel engine and battery system. An explosion of her hydrogen peroxide supply in 1957 resulted in the craft's modification to diesel-electric drive. She was used subsequently for research purposes in wake detection in which she operated in Chesapeake Bay, passing under an NRL instrumented

1954 Led by Captain Hyman G. Rickover, the U.S. Navy develops and launches the *USS Nautilus* - the world's first nuclear powered submarine. Nuclear power enabled submarines to become true "submersibles," that is, able to operate underwater for extended indefinite periods of time. Not only was the goal of anaerobic propulsion achieved but also the objectives of obtaining fresh water from the distillation of sea water and oxygen for the crew to breathe by the electrolysis of sea water. The development of the naval nuclear propulsion plant was the work of a team of Navy, government and contractor engineers.¹⁰⁷



1957 The *Leninsky Komsomol* is the first Soviet nuclear submarine.¹⁰⁸



1958 The *USS Skipjack* (SSN 585) is launched, combining features of the long-endurance nuclear propulsion system of the *Nautilus* and the high-speed tear-drop hull design of the *Albacore*.^{109,110,111}

1958 The *USS Nautilus* is the first submarine to reach the North Pole.¹¹²

1959 The *USS George Washington* is commissioned as the world's first nuclear powered ballistic missile firing submarine.¹¹³

1960 In July, while submerged off the coast of Cape Canaveral, Florida, the *USS George Washington* fires a Polaris A-1 missile which strikes the impact area 1,100 miles down range. Shakedown for the crew ended at Groton, Connecticut, on 30 August and the boat got underway from that port 28 October for the Naval Weapons Station Charleston, to load her full complement of 16 Polaris missiles.^{113,114}

1962 The *Leninsky Komsomol* is the first Soviet nuclear submarine to reach the North Pole.¹¹⁵

~1968 With the advent of the *Los Angeles-Class* fast attack submarine design, the Navy develops a new attack periscope, the Type 18, providing 18-times magnification, as opposed to its predecessor's eight. This design eventually permitted the use of television cameras, whose images can be displayed throughout the submarine and recorded. The Type 18 periscope is one of the primary hull-penetrating periscopes in the fleet today, used on all *Los Angeles-* and *Seawolf-Class* submarines. Important features of the Type 18 include multiple magnification levels, single-axis stabilization, digital photography, low-light image intensification, color television, and day-and-night viewing capabilities. The Type 18 periscope was upgraded for a video package known as SUBIS (Submarine Imaging Subsystem), a set of analog video and digital still cameras that record the view from the periscope and provide image enhancement software for image analysis. The photograph shows the Type 2 attack periscope (port side) and the Type 18 periscope (starboard) on the *USS Pittsburgh*.^{116,117}



~2004 Although the Type 18 represents the state-of-the-art in U.S. submarine periscopes, the Navy's new *USS Virginia (SSN-774)-Class* submarine has a completely new set of eyes. *Virginia's* AN/BVS-1 Photonics Mast has replaced the



traditional optical lenses and prisms of conventional periscopes with electronic imaging equipment. There are two problems with conventional optical periscopes. First, a periscope well runs the entire height of the ship to house the periscope, and its size restricts the arrangement of the sail and interior compartments. The second problem is that

periscopes can accommodate only one person at a time. Each *Virginia-Class* submarine will have two photonics masts that do not require physical penetration of the ship's hull, but instead "telescope" out of the sail. Importantly, this allows *Virginia's* control room to be moved from the cramped first deck to the more spacious second deck. Additionally, there will be no "gray lady" to dance with – or take up valuable control-room space – since the customary periscope in its below-deck well gives way to a fiber optic system that carries images from the photonics masts to two workstations and a commander's control console, each equipped with two flat-panel displays and a keyboard, trackball, and joystick. The masts are equipped with three cameras – color, high-resolution black-and-white, and infrared – in addition to a mission-critical control camera in a separate, pressure-proof and shock-hardened housing and a laser range finder that will provide accurate ranges to targets and aids to navigation. All of these sensors are housed in the mast's rotating head.^{118,119,120}

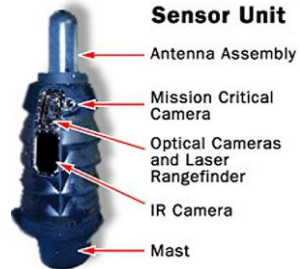

2008 The U.S. Navy begins sea trials of an advanced camera system to enhance safety and situational awareness for submarines with Type 18 periscopes, used on all *Los Angeles-* and *Seawolf-Class* submarines. Instead of the traditional submarine surface-viewing operation that might take several seconds to complete a 360-degree scan of surrounding waters, the RemoteReality camera system gives an instantaneous omni-directional view. It captures, in an instant, a full 360-degree view of activity on the surface, through the use of a very high-resolution 12-megapixel visible-light omni camera and an uncooled (640 x 480 pixels) thermal infrared omni camera for nighttime use.¹²¹

REFERENCES

- ¹ M.T. Poirier, Cmdr, USN, “Results of the German and American Submarine Campaigns of World War II,” Office of the Chief of Naval Operations, Submarine Warfare Divisions, 20 October 1999, <http://www.navy.mil/navydata/cno/n87/history/wwii-campaigns.html>.
- ² R.F. Marx and J. Marx, “Treasure lost at sea: diving to the world’s great shipwrecks,” Firefly Books, 7 February 2004, p. 8.
- ³ “Periscope,” Wikipedia: <http://en.wikipedia.org/wiki/Periscope>.
- ⁴ “Battleships,” Leonardo da Vinci, The Man & the Inventor, <http://www.lairweb.org.nz/leonardo/ships.html>.
- ⁵ S. Wood, PE, “Diving Bells,” Important Events in Ocean Engineering History, http://my.fit.edu/~swood/History_pg4.html.
- ⁶ “William Bourne (mathematician),” Wikipedia: http://en.wikipedia.org/wiki/William_Bourne_%28mathematician%29.
- ⁷ “The First Submarine,” Cornelius Drebbel, Inventor of the Submarine, http://www.dutchsubmarines.com/specials/special_drebbel.htm.
- ⁸ “400 Years of Subs,” Hitler’s Lost Sub, November 2000, <http://www.pbs.org/wgbh/nova/lostsub/hist1580.html>.
- ⁹ “The Saga of the Submarine,” Office of the Chief of Naval Operations, Submarine Warfare Divisions, 20 October 1999, <http://www.navy.mil/navydata/cno/n87/history/subsaga.html>.
- ¹⁰ “History of submarines,” Wikipedia: http://en.wikipedia.org/wiki/History_of_submarines.
- ¹¹ “Diving bell,” Wikipedia: http://en.wikipedia.org/wiki/Diving_bell.
- ¹² B. Harris, CAPT USN (Ret.), “World Submarine History Timeline, Part One: 1580-1869,” The Navy Times Book of Submarines: A Political, Social and Military History, 31 January 2010, <http://www.submarine-history.com/NOVAone.htm>.
- ¹³ Nonresident Training Courses (NRTCs), Defense Policy, Globalsecurity.org, http://www.globalsecurity.org/military/library/policy/navy/nrtc/12018_ch5a.pdf.
- ¹⁴ M. Bellis, “History of the Submarine - David Bushnell 1742-1824,” 2010, http://inventors.about.com/od/sstartinventions/a/Submarines_3.htm.
- ¹⁵ M. Bellis, “Timeline - Evolution of Submarine Design,” 2010, <http://inventors.about.com/od/timelines/tp/SubmarineTimeline.htm>.
- ¹⁶ “Nautilus (1800) Submarine,” Wikipedia: http://en.wikipedia.org/wiki/Nautilus_%281800_submarine%29.
- ¹⁷ M. Bellis, “History of the Submarine,” Robert Fulton and the Nautilus Submarine, http://inventors.about.com/od/sstartinventions/a/Submarines_4.htm.
- ¹⁸ “400 Years of Subs,” November 2000.

-
- 19 “Lodner Darvontis Phillips (1825 – 1869),” Rebreathers Worldwide, http://www.therebreathersite.nl/12_Atmospheric%20Diving%20Suits/1856_Phillips/1856_Phillips.htm.
- 20 “Wilhelm Bauer,” Wikipedia: http://en.wikipedia.org/wiki/Wilhelm_Bauer.
- 21 M. Williamson, “Brandtaucher,” Message posted to War and Game, 25 February 2008, <http://warandgame.blogspot.com/2008/02/brandtaucher.html>.
- 22 “Brandtaucher,” Wikipedia: <http://en.wikipedia.org/wiki/Brandtaucher>.
- 23 “400 Years of Subs,” NOVA, <http://www.pbs.org/wgbh/nova/lostsub/hist1580.html>.
- 24 “Wilhelm Bauer,” Bookrags, http://www.bookrags.com/wiki/Wilhelm_Bauer.
- 25 “Brandtaucher,” Wikipedia.
- 26 “1856 Lodner D Phillips,” http://www.therebreathersite.nl/12_Atmospheric%20Diving%20Suits/1856_Phillips/1856_Phillips.htm.
- 27 B. Harris, CAPT USN (Ret.), 7 August 2001.
- 28 “400 Years of Subs,” November 2000.
- 29 “Brutus de Villeroi,” Wikipedia: http://en.wikipedia.org/wiki/Brutus_de_Villeroi.
- 30 T. Holian, “Monturiol, The Forgotten Submariner,” Undersea Warfare, Spring 2005, Vol. 7, No. 3, http://www.navy.mil/navydata/cno/n87/usw/issue_26/monturiol.html.
- 31 J. Pike, “Submarine History – Civil War,” Globalsecurity.org, 27 April 2005, <http://www.globalsecurity.org/military/systems/ship/sub-history3.htm>.
- 32 Sir H. Newbolt, “A note on the history of submarine war,” 10 September 2007, http://www.archive.org/stream/noteonhistoryofs00newbuoft/noteonhistoryofs00newbuoft_djvu.txt.
- 33 M. Bellis, “History of the Submarine – Horace Lawson Hunley.”
- 34 M. Bellis, “History of the Submarine – The USS Holland Submarine – John Holland,” <http://inventors.about.com/od/hstartinventors/a/JohnHolland.htm>.
- 35 “History of submarines,” Wikipedia.
- 36 M. Bellis, “History of the Submarine – Horace Lawson Hunley.”
- 37 “Monturiol,” Undersea Warfare, Spring 2005, Vol. 7, No. 3, http://www.navy.mil/navydata/cno/n87/usw/issue_26/monturiol2.html.
- 38 “Early history of submarines and the first submersibles,” http://www.statemaster.com/encyclopedia/Submarine#Early_history_of_submarines_and_the_first_submersibles.
- 39 “Narcis Monturiol i Estarriol,” Statemaster.com, <http://www.statemaster.com/encyclopedia/Narcis-Monturiol-i-Estarriol>.

-
- ⁴⁰ E.C. Whitman, “The Submarine Technology of Jules Verne,” Undersea Warfare, Winter 2004, http://www.navy.mil/navydata/cno/n87/usw/issue_21/verne.htm.
- ⁴¹ M. Bellis, “History of the Submarine – The USS Holland Submarine – John Holland.”
- ⁴² “John P. Holland (1841 – 1914), The Liscannor Man who invented the Sub,” Clare County Library, <http://www.clarelibrary.ie/eolas/coclare/people/holland.htm>.
- ⁴³ B. Harris, CAPT, USN (Ret.), 7 August 2001.
- ⁴⁴ “John P. Holland (1841 – 1914), The Liscannor Man who invented the Sub,” Clare County Library.
- ⁴⁵ “John Phillip Holland,” Answers.com, <http://www.answers.com/topic/john-philip-holland>.
- ⁴⁶ S. Ditmire, “Simon Lake of Pleasantville, NJ,” Atlantic County, New Jersey, 6 May 2006, <http://www.usgennet.org/usa/nj/county/atlantic/Simon%20Lake.htm>.
- ⁴⁷ “Eyes from the Deep—A History of U.S. Navy Submarine Periscopes,” Undersea Warfare, Fall 2004, http://www.navy.mil/navydata/cno/n87/usw/issue_24/eyes.htm.
- ⁴⁸ “Argonauts,” The Simon Lake Story Is Just Below the Surface, <http://www.simonlake.com/html/argonauts.html>.
- ⁴⁹ M. Bellis, “History of the Submarine – The USS Holland Submarine – John Holland.”
- ⁵⁰ “Submarine Plunger on a slipway, circa the later 1890s,” Navsource.org, NavSource Online: Submarine Photo Archive, <http://www.navsource.org/archives/08/0844502.jpg>.
- ⁵¹ M. Bellis, “History of the Submarine – The USS Holland Submarine – John Holland.”
- ⁵² “Argonauts,” The Simon Lake Story Is Just Below the Surface.
- ⁵³ “400 Years of Subs,” November 2000.
- ⁵⁴ “Argonauts,” The Simon Lake Story Is Just Below the Surface.
- ⁵⁵ G.E. Weir, Ph.D., “Silent Defense: One Hundred Years of the American Submarine Force,” Submarine Force History, CNO, Submarine, Warfare Division, 27 April 1999, <http://www.navy.mil/navydata/cno/n87/history/fullhist.html>.
- ⁵⁶ “John Philip Holland,” Wikipedia: http://en.wikipedia.org/wiki/John_Philip_Holland.
- ⁵⁷ E.C. Whitman, “John Holland, Father of the Modern Submarine,” Undersea Warfare, Summer 2003, http://www.navy.mil/navydata/cno/n87/usw/issue_19/holland.htm.

-
- 58 M. Bellis, "History of the Submarine – The USS Holland Submarine – John Holland."
- 59 Sir H. Newbolt, 10 September 2007.
- 60 M. Bellis, "History of the Submarine – The USS Holland Submarine – John Holland."
- 61 "Argonauts," The Simon Lake Story Is Just Below the Surface.
- 62 S. Wood, Ph.D, PE, "Submarines, How Submarines Work," Important Events in Ocean Engineering History, http://my.fit.edu/~swood/History_pg2.html.
- 63 M. Bellis, "History of the Submarine – John Holland and Simon Lake were at odds in developing their submarine concepts," http://inventors.about.com/od/hstartinventors/a/JohnHolland_2.htm.
- 64 "History of the Periscope," Scout Sniper Periscope, <http://www.swatscope.com/History.htm>.
- 65 S. Wood, Ph.D, PE, "Submarines, How Submarines Work," Important Events in Ocean Engineering History.
- 66 "History of the Periscope," Scout Sniper Periscope.
- 67 "Periscope," Wikipedia.
- 68 "History of submarines," Wikipedia.
- 69 "Forelle (U-Boat)," Wikipedia: [http://de.wikipedia.org/wiki/Forelle %28U-Boot%29](http://de.wikipedia.org/wiki/Forelle_%28U-Boot%29).
- 70 M. Bellis, 2010.
- 71 "Simon Lake," Wikipedia: http://en.wikipedia.org/wiki/Simon_Lake.
- 72 "History of submarines," Wikipedia.
- 73 N. Polmar and J. Noot, "Submarines of the Russian and Soviet Navies, 1718-1900," US Naval Institute Press, April 1991.
- 74 G.E. Weir, Ph.D., 27 April 1999.
- 75 "Simon Lake," Absolute Astronomy, http://www.absoluteastronomy.com/topics/Simon_Lake.
- 76 P. Wittmer, "U.S. Submarine Engines," <http://www.subvetpaul.com/Engines.htm>.
- 77 M. Bellis, "Periscope," Inventors Guide, <http://inventors.about.com/library/inventors/blperiscope.htm>.
- 78 "The Submarine Deutschland," ColorantsHistory.org, 2005, <http://www.colorantshistory.org/SubmarineDeutschland.html>.
- 79 G.E. Weir, "The Demise Of The Lake Torpedo Boat Company," Building American Submarines, University Press of the Pacific, ISBN-10: 0898750660, 1 April 2000, [http://diodon349.com/Stories/Story_of_Demise %20of Laketorp.htm](http://diodon349.com/Stories/Story_of_Demise_%20of_Laketorp.htm).

-
- 80 M. Duffy, "Germany's Policy of Unrestricted Submarine Warfare, 31 January 1917," firstworldwar.com, 22 August, 2009, http://www.firstworldwar.com/source/uboaat_bernstorff.htm.
- 81 M. Bellis, "History of the Submarine—Military Application Submarines," http://inventors.about.com/od/militaryhistoryinventions/a/Military_Sub.htm.
- 82 M. Duffy, "Treaty of Versailles: Articles 159-213," firstworldwar.com, 22 August 2009, <http://www.firstworldwar.com/source/versailles159-213.htm>.
- 83 "History of submarines," Wikipedia.
- 84 "Wiki: Dutch inventions and discoveries," Wapedia: http://wapedia.mobi/en/Dutch_inventions_and_discoveries.
- 85 "Hellmuth Walter," Wikipedia: http://en.wikipedia.org/wiki/Hellmuth_Walter.
- 86 Google patents: Hellmuth Walter, <http://www.google.com/patents?q=Hellmuth+Walter&spell=1&oi=spell>.
- 87 "German submarine U-1 (1935)," Wikipedia: http://en.wikipedia.org/wiki/German_submarine_U-1_%281935%29.
- 88 J.T. McDaniel, "The Walter Submarine Turbine – Basic Submarine Tactics in World War II," J.T. McDaniel Official Website, http://jtmcdaniel.com/walter_turbine.html.
- 89 "Narcis Monturiol i Estarriol," Statemaster.com.
- 90 "The Walter System," The Boats, http://www.dataphone.se/~ms/ubootw/boats_walter-system.htm.
- 91 "Dutch inventions and discoveries," Wikipedia: http://en.wikipedia.org/wiki/Dutch_inventions_and_discoveries.
- 92 E. Gustin, "U-boat Radars," <http://www.uboaat.net/technical/radar.htm>.
- 93 "Final Report – G/Serial 25, Report on the Interrogation of Survivors from U-boat 662 Sunk 21 July 1943," U-boat Archive, <http://www.uboaatarchive.net/U-662INT.htm>.
- 94 C. Eger, "The Fa-330 Bachstelze U-boat Kite, Primitive WWII Nazi Towed Helicopter," suite101[®].com, 21 August 2008, http://ww2history.suite101.com/article.cfm/the_fa330_bachstelze_uboaat_kite.
- 95 "Focke-Achgelis Fa-330 Backstelze, 1942," aviastar.org, http://www.aviastar.org/helicopters_eng/focke_330.php.
- 96 "Dutch inventions and discoveries," Wikipedia.
- 97 M. Bellis, 2010.
- 98 M. Bellis, "History of the submarine – World War II Submarines," http://inventors.about.com/od/militaryhistoryinventions/a/Military_Sub_2.htm.
- 99 M. Bellis, 2010.
- 100 "World War II in the Pacific: Japanese Suicide Attacks at Sea," 23 January 2009, <http://www.ww2pacific.com/suicide.html>.

-
- ¹⁰¹ G.E. Weir, Ph.D., 27 April 1999.
- ¹⁰² “The Loon Missile, a.k.a., the V-1 ‘Buzz Bomb’,” The United States Ship Cusk – World’s First Missile Submarine, 12 February 2009, <http://www.usscusk.com/loon.htm>.
- ¹⁰³ “Republic-Ford JB-2,” Wikipedia: http://en.wikipedia.org/wiki/Republic-Ford_JB-2.
- ¹⁰⁴ “USS Albacore (AGSS-569),” Wikipedia: http://en.wikipedia.org/wiki/USS_Albacore_%28AGSS-569%29.
- ¹⁰⁵ “The Albacore Story – Concept to Mothballs,” USS Albacore, http://www.ussalbacore.org/html/albacore_story.html.
- ¹⁰⁶ “X-1 Submarine,” Wikipedia: http://en.wikipedia.org/wiki/X-1_Submarine.
- ¹⁰⁷ “The Cold War,” Official Website of the United States Navy, <http://www.navy.mil/navydata/cno/n87/images/coldwar.pdf>.
- ¹⁰⁸ S. Wood, Ph.D, PE, “Submarines, How Submarines Work,” Important Events in Ocean Engineering History.
- ¹⁰⁹ G.E. Weir, Ph.D., 27 April 1999.
- ¹¹⁰ “USS Skipjack (SSN-585),” Wikipedia: http://en.wikipedia.org/wiki/USS_Skipjack_%28SSN-585%29.
- ¹¹¹ “USS Skipjack (SSN-585),” 2010, Retrieved from: NavSource Online: Submarine Photo Archive, <http://www.navsource.org/archives/08/0858515.jpg>.
- ¹¹² S. Wood, Ph.D, PE, “Submarines, How Submarines Work,” Important Events in Ocean Engineering History.
- ¹¹³ “Submarine Chronology,” Submarine Force History, CNO, Submarine, Warfare Division, <http://www.navy.mil/navydata/cno/n87/history/chrono.html>.
- ¹¹⁴ “USS George Washington (SSBN-598),” Knowledgerush.com, http://www.knowledgerush.com/kr/encyclopedia/USS_George_Washington_%28SSBN-598%29/.
- ¹¹⁵ S. Wood, Ph.D, PE, “Submarines, How Submarines Work,” Important Events in Ocean Engineering History.
- ¹¹⁶ “Eyes from the Deep: A History of U.S. Navy Submarine Periscopes,” Undersea Warfare, Fall 2004.
- ¹¹⁷ G. Priolo, “Pittsburgh (SSN 720),” 2010, Retrieved from: NavSource Online: Submarine Photo Archive, <http://www.navsource.org/archives/08/08720.htm>.
- ¹¹⁸ “Eyes from the Deep: A History of U.S. Navy Submarine Periscopes,” Fall 2004.
- ¹¹⁹ K. Bonsor, “How Photonics Masts Will Work,” 21 June 2001, Retrieved from: howstuffworks.com, <http://science.howstuffworks.com/photonic-mast2.htm>.
- ¹²⁰ “NSSN Virginia Class Attack Submarine, USA,” Retrieved from: navaltechnology.com, <http://www.naval-technology.com/projects/nssn/nssn3.html>.

¹²¹ M. Zwolinski, "U.S. Navy To Test Advanced Submarine Periscope Camera System from RemoteReality for Total Horizon View, Enhanced Situational Awareness," 11 Apr. 2008, Retrieved from: RemoteReality <http://www.remotereality.com/submarine-periscope-press-release>.

APPENDIX D

BIBLIOGRAPHY

Allison, D.K. (23 September 1981). New Eye for the Navy: The Origin of Radar at the Naval Research Laboratory.

<http://oai.dtic.mil/oai/oai?verb=getRecord&metadataPrefix=html&identifier=ADA110586>

Amato, I. (1998). Pushing the Horizon, Seventy-Five Years of High-Stakes Science and Technology at the Naval Research Laboratory.

<http://www.nrl.navy.mil/NewsRoom/images/horizon.pdf>

Bellis, M. "n.d." History of the Submarine.

http://inventors.about.com/od/sstartinventions/a/Submarines_2.htm

Launius, R.D. (1 May 1999). Paths for Flight, Innovation and the Origin of Radar, in Innovation and the development of flight.

http://books.google.com/books?id=yEzkXqHLF48C&dq=Roger+D.+Launius,+Innovation+and+the+development+of+flight&printsec=frontcover&source=bl&ots=JbXbMxxzHN&sig=M4g7dVB4REI9EsOOon2O7Pr2tlrc&hl=en&ei=0evkSZjCJD_tlQe_19ngDg&sa=X&oi=book_result&ct=result&resnum=1#PPA188,M1

Brown, L. (1 January 1999). A Radar History of World War II.

http://books.google.com/books?id=uYgsr3exvS4C&dq=Louis+Brown+%22+A+Radar+History+of+World+War+II%22&printsec=frontcover&source=bl&ots=AILGObpIJG&sig=mixgFJbpYgVPRbOVfvPBoCr4ZA0&hl=en&ei=3TfISaqZO4vnnQfe9fSiCQ&sa=X&oi=book_result&ct=result&resnum=4#PPR5,M1

Chief of Naval Operations. "n.d." Submarine Warfare Division, Submarine History.

<http://www.navy.mil/navydata/cno/n87/history.html>

Chief of Naval Operations. "n.d." Submarine Warfare Division, Submarine Centennial Log Sheets.

<http://www.navy.mil/navydata/cno/n87/history/log%20sheets.html>

Friedman, N. (30 September 2006). The Naval Institute Guide to World Naval Weapon Systems.

http://books.google.com/books?id=4S3h8j_NEmkC&dq=Norman+Friedman,+The+Naval+Institute+Guide+to+World+Naval+Weapon+Systems&printsec=frontcover&source=bl&ots=hHUzPT_X8U&sig=NgQ14QcNMXyLGDFXfMzBiR6Y3vQ&hl=en&ei=kCnLSZqgLI7wMrKjwJII&sa=X&oi=book_result&ct=result&resnum=1

Goebel, G. (1 August 2008). The Invention Of The Submarine. In the Public Domain. v1.1.2. <http://www.vectorsite.net/twsub1.html>

Goebel, G. (1 August 2008). The Submarine In WWI. In the Public Domain. v1.0.5. <http://www.vectorsite.net/twsub2.html>

Goebel, G. (1 November 2009). Early Radar Technology. In the Public Domain. v2.1.3. http://www.vectorsite.net/ttradar_2.html#m5

Goebel, G. (1 May 2009). Microwave Radar At War. Chapter 4. In the Public Domain. v2.0.3. http://www.vectorsite.net/ttwiz_04.html

Goebel, G. (1 May 2009). Microwave Radar At War. Chapter 5. In the Public Domain. v2.0.3. http://www.vectorsite.net/ttwiz_05.html

Goebel, G. (1 May 2009). Microwave Radar At War. Chapter 6. In the Public Domain. v2.0.3. http://www.vectorsite.net/ttwiz_06.html

Harris, B. CAPT, USN (Ret.) (November 2000). 400 Years of Subs, Hitler's Lost Sub. www.pbs.org/wgbh/nova/lostsub/history.html

Harris, B. CAPT, USN (Ret.) (January 2010). Submarine History. <http://www.submarine-history.com>

Harris, B. CAPT, USN (Ret.) (7 August 2001). Navy Times Book of Submarines: A Political Social, and Military History. <http://www.submarine-history.com/subreviews.htm>

Hepcke, G. "n.d." The Radar War. <http://www.radarworld.org/radarwar.pdf>

"n.d." The History of Flight, History of Aviation. <http://www.century-of-flight.net/index.htm>

Holler, R. A., Horbach, A.W., and McEachern, J.F. (2008) The Ears of Air ASW, A History of U.S. Navy Sonobuoys. Navmar Applied Sciences Corporation. <http://www.navmar.com/earsofair.php>

Hollmann, M. (2001). Radar World. <http://www.radarworld.org>

Holpp, W. "n.d." The Century of Radar. www.100-jahre-radar.de/vortraege/Holpp-The_Century_of_Radar.pdf

Howeth, L.S., CAPT, USN (Ret.). (1963). History of Communications-Electronics in the United States Navy, Chapter XXXVIII, Radar (1963). <http://earlyradiohistory.us/1963hw.htm>

Keane, J.F. and Easterling, C. A. (2003). Maritime Patrol Aviation: 90 Years of Continuing Innovation. Johns Hopkins APL Technical Digest, Volume 24, Number 3. www.jhuapl.edu/techdigest/td2403/Keane.pdf

Lederman, L.M. and Teresi, D. (1994). The God Particle: If the Universe Is the Answer, What Is the Question? Dell Publishing. p. 135.
http://books.google.com/books?id=-v84Bp-LNNIC&pg=PA135&lpg=PA135&dq=Emil+Weichert&source=bl&ots=thfgqXaq9Z&sig=9ub5saPztK5eIfk59LnBxJkDEVg&hl=en&ei=RuC7SpvbMY_hlAfeybG6DQ&sa=X&oi=book_result&ct=result&resnum=3#v=onepage&q=Emil%20Weichert&f=false

McCue, G. "n.d." John Philip Holland (1841-1914). and His Submarines.
<http://www.maidenvoyagebooksellers.com/shop/maiden/70136.html>.

McMahon, M. (2007). McMahon's Radars! www.smecc.org/mcmahon's_radars!.htm

"n.d." Microwave Encyclopedia.
<http://www.microwaves101.com/encyclopedia/index.cfm>

Morris, R. K. (1998). John P. Holland: Inventor of the Modern Submarine. Annapolis: U.S. Naval Institute, 1966; 2nd ed., Univ. S.C. Press.

Mullane, P., LCDR. (May 1970). ASW Aircraft. Naval Aviation News. p. 28-39.
<http://www.history.navy.mil/nan/backissues/1970s/1970/may70.pdf>

Naval Air Warfare Center Weapons Division. (1 April 1999). Electronic Warfare and Radar Systems Engineering Handbook.
www.microwaves101.com/encyclopedia/Navy%20handbook/EW_Radar_Handbook.pdf

Naval Air Warfare Center Weapons Division. (25 April 2008). Electronic Warfare and Radar Systems Engineering Handbook.
http://www.microwaves101.com/encyclopedia/Navy_Handbook.cfm

Navy Department Library. (1 August 1943). U.S. Radar.
<http://www.history.navy.mil/library/online/radar.htm>

Ousborne, J.J., Griffith, D. and. Yuan, R.W. (1997). A Periscope Detection Radar. Johns Hopkins APL Technical Digest, 18, p. 125-133.
<http://www.jhuapl.edu/techdigest/td1801/ousbourn.pdf>

Page, J.R. (2005). The Development of Radar.
http://www.chuckhawks.com/monopulse_radar.htm

Parsch, A. (25 June 2009). Designation-Systems.Net. <http://www.designation-systems.net/>

Proc, J. (27 July 2008). ASDIC, RADAR and IFF SYSTEMS used by the RCN - WWII and Post War. <http://jproc.ca/sari/index.html>

Schneider, J. (2 September 2003). Opportunities in Industry! History of Radar. Lockheed Martin. http://math.la.asu.edu/~kuang/LM/030902-Radar_History10.pdf

Skolnik, M. (1990). Radar Handbook. McGraw-Hill. http://books.google.com/books?id=m_rvUQswj3sC&pg=PA1&lpg=PA1&dq=Merril+I.+Skolnik+Radar&source=bl&ots=ShFTEl17HQ&sig=jvh_lbadac1Jsl0nMQoZZAOs2ww&hl=en&ei=pPvlSeTgGpnKMprAsf8I&sa=X&oi=book_result&ct=result&resnum=4#PPP1,M1

Stimson, G.W. (1 January 1998). Introduction to Airborne Radar, 2nd Edition. SciTech Publishing. <http://www.chipsbooks.com/introair.htm>

Tait, P. (17 January 2006). Introduction to Radar Target Recognition. Institution of Engineering and Technology. http://books.google.com/books?id=hrp_QP-vz4sC&dq=Peter+Tait,+Introduction+to+Radar+Target+Recognition&printsec=frontcover&source=bl&ots=xteQPVVNfC&sig=i-Le1vDtsCBuHD0zIlrJ9C_0sV8&hl=en&ei=v80OS7SCLtC9IAfG4eiaBA&sa=X&oi=book_result&ct=result&resnum=1&ved=0CAgQ6AEwAA#v=onepage&q=&f=false

navy.mil. "n.d." Official Website of the United States Navy. <http://www.navy.mil/navydata/infoIndex.asp>

[uboaat.net](http://www.uboaat.net). (1995-2010). www.uboaat.net

Wittenberg, P., et al. (1997). Introduction to Airborne Radar, Problems, Solutions, and Programs. <http://radarproblems.com>