



AFCEC-CX-TY-TR-2016-0004

## **Development and Evaluation of a Prototype Wheeled Ultra-High Pressure Extinguisher System with Novec 1230**

---

Dr. Mark Enlow  
Applied Research Associates  
430 West 5<sup>th</sup> Street, Suite 700  
Panama City, FL 32401

John R. Hawk, III  
Air Force Civil Engineer Center  
Readiness Directorate  
Requirements and Acquisition Division  
139 Barnes Drive, Suite 1  
Tyndall Air Force Base, FL 32403-5323

Contract No. FA8051-14-P-0010

January 2016

**DISTRIBUTION A.** Approved for public release; distribution unlimited. AFCEC-201602,  
20 January 2016

**AIR FORCE CIVIL ENGINEER CENTER  
READINESS DIRECTORATE**

## **DISCLAIMER**

**Reference herein to any specific commercial product, process, or service by trade name, trademark, manufacturer, or otherwise does not constitute or imply its endorsement, recommendation, or approval by the United States Air Force. The views and opinions of authors expressed herein do not necessarily state or reflect those of the United States Air Force.**

**This report was prepared as an account of work sponsored by the United States Air Force. Neither the United States Air Force, nor any of its employees, makes any warranty, expressed or implied, or assumes any legal liability or responsibility for the accuracy, completeness, or usefulness of any information, apparatus, product, or process disclosed, or represents that its use would not infringe privately owned rights.**

## NOTICE AND SIGNATURE PAGE

Using Government drawings, specifications, or other data included in this document for any purpose other than Government procurement does not in any way obligate the U.S. Government. The fact that the Government formulated or supplied the drawings, specifications, or other data does not license the holder or any other person or corporation; or convey any rights or permission to manufacture, use, or sell any patented invention that may relate to them.

This report was cleared for public release by the AFCEC Public Affairs Office at Joint Base San Antonio-Lackland Air Force Base, Texas available to the general public, including foreign nationals. Copies may be obtained from the Defense Technical Information Center (DTIC) (<http://www.dtic.mil>).

AFCEC-CX-TY-TR-2016-0004 HAS BEEN REVIEWED AND IS APPROVED FOR PUBLICATION IN ACCORDANCE WITH ASSIGNED DISTRIBUTION STATEMENT.

//SIGNED//

---

John Hawk  
Contracting Officer Representative

//SIGNED//

---

Alessandra Bianchini  
Technical Advisor

This report is published in the interest of scientific and technical information exchange, and its publication does not constitute the Government's approval or disapproval of its ideas or findings.

**REPORT DOCUMENTATION PAGE**

*Form Approved  
OMB No. 0704-0188*

The public reporting burden for this collection of information is estimated to average 1 hour per response, including the time for reviewing instructions, searching existing data sources, gathering and maintaining the data needed, and completing and reviewing the collection of information. Send comments regarding this burden estimate or any other aspect of this collection of information, including suggestions for reducing the burden, to Department of Defense, Washington Headquarters Services, Directorate for Information Operations and Reports (0704-0188), 1215 Jefferson Davis Highway, Suite 1204, Arlington, VA 22202-4302. Respondents should be aware that notwithstanding any other provision of law, no person shall be subject to any penalty for failing to comply with a collection of information if it does not display a currently valid OMB control number.

**PLEASE DO NOT RETURN YOUR FORM TO THE ABOVE ADDRESS.**

<b>1. REPORT DATE (DD-MM-YYYY)</b> 20 January 2016		<b>2. REPORT TYPE</b> Technical Report		<b>3. DATES COVERED (From - To)</b> 1 Nov 2014 -- 1 Jul 2015	
<b>4. TITLE AND SUBTITLE</b> Development and Evaluation of a Prototype Wheeled Ultra-High Pressure Extinguisher System With Novec 1230				<b>5a. CONTRACT NUMBER</b> FA8051-14-P-0010	
				<b>5b. GRANT NUMBER</b>	
				<b>5c. PROGRAM ELEMENT NUMBER</b>	
<b>6. AUTHOR(S)</b> Mark A. Enlow*, John R. Hawk%				<b>5d. PROJECT NUMBER</b>	
				<b>5e. TASK NUMBER</b>	
				<b>5f. WORK UNIT NUMBER</b> X14PL001	
<b>7. PERFORMING ORGANIZATION NAME(S) AND ADDRESS(ES)</b> *Applied Research Associates 430 West 5th Street, Suite 700 Panama City, FL 32401				<b>8. PERFORMING ORGANIZATION REPORT NUMBER</b>  AFCEC-CX-TY-TR-2016-0004	
<b>9. SPONSORING/MONITORING AGENCY NAME(S) AND ADDRESS(ES)</b> %Air Force Civil Engineer Center Readiness Directorate Requirements and Acquisition Division 139 Barnes Drive, Suite 2 Tyndall Air Force Base, FL 32403-5323				<b>10. SPONSOR/MONITOR'S ACRONYM(S)</b> AFCEC/CXA	
				<b>11. SPONSOR/MONITOR'S REPORT NUMBER(S)</b>	
<b>12. DISTRIBUTION/AVAILABILITY STATEMENT</b> Distribution A: Approved for public release; distribution unlimited. AFCEC-201602, 20 January 2016					
<b>13. SUPPLEMENTARY NOTES</b> Ref Public Affairs Case #AFCEC-201602, 20 January 2016. Document contains color images.					
<b>14. ABSTRACT</b> As part of an ongoing effort to identify a replacement for the Department of Defense (DOD) Halon 1211 flightline extinguisher, the Air Force Civil Engineer Center (AFCEC) developed and evaluated a prototype wheeled ultra-high pressure extinguisher containing the Novec 1230 firefighting agent manufactured by 3M. This effort expanded upon a previous evaluation of the Amerex Corporation model 775 wheeled low pressure (125 psi) extinguisher containing the Novec 1230 firefighting agent, and past projects in which AFCEC demonstrated the effectiveness of ultra-high pressure (UHP) systems using the water based Aqueous Film Forming Foam (AFFF) firefighting agent. Several ultra-high pressure hardware configurations were evaluated at pressures ranging from 550 to 2100 psi against F-100 rear engine fire tests. No combination of pressure, discharge rate, and nozzle spray pattern evaluated was effective at extinguishing both the pool fire and the nacelle fire portions of the F-100 rear engine fire test.					
<b>15. SUBJECT TERMS</b> Flightline Extinguisher, Halon 1211, Novec 1230, Ultra-High Pressure.					
<b>16. SECURITY CLASSIFICATION OF:</b>			<b>17. LIMITATION OF ABSTRACT</b>  SAR	<b>18. NUMBER OF PAGES</b>  29	<b>19a. NAME OF RESPONSIBLE PERSON</b> John R. Hawk
<b>a. REPORT</b>  U	<b>b. ABSTRACT</b>  U	<b>c. THIS PAGE</b>  U			<b>19b. TELEPHONE NUMBER (Include area code)</b> 850-283-3736

Reset

## TABLE OF CONTENTS

LIST OF FIGURES .....	ii
LIST OF TABLES .....	ii
1. SUMMARY .....	1
2. INTRODUCTION .....	2
2.1. The DoD Halon 1211 Flightline Extinguisher .....	2
2.2. The Amerex model 775 Extinguisher .....	3
2.3. UHP Technology .....	4
3. METHODS, ASSUMPTIONS, AND PROCEDURES .....	5
3.1. Design of the Prototype UHP Extinguisher .....	5
3.2. Nozzle Selection .....	7
3.3. Water Discharge Tests .....	8
3.4. Fire Suppression Tests .....	10
3.4.1. Pool Fire Tests .....	11
3.4.2. Rear Engine Fire Tests .....	12
3.5. Estimation of Discharge Rates .....	14
4. RESULTS AND DISCUSSION .....	16
4.1. Evaluations of the StoneAge Attack Nozzle .....	16
4.2. Evaluation of the Rosenbauer Nozzle .....	21
5. CONCLUSIONS .....	24
6. RECOMMENDATIONS .....	25
7. REFERENCES .....	26
LIST OF SYMBOLS, ABBREVIATIONS, AND ACRONYMS .....	27

## LIST OF FIGURES

	<b>Page</b>
Figure 1. Amerex Model 600 DoD Halon 1211 Flightline Extinguisher .....	2
Figure 2. Amerex Model 775 Wheeled Fire Extinguisher.....	3
Figure 3. Prototype UHP Extinguisher .....	6
Figure 4. The Prototype UHP Extinguisher Resting on a Scale .....	9
Figure 5. F-100 Engine Nacelle Mock-Up .....	10
Figure 6. F-100 Nacelle Mockup during Pre-Burn Phase of a Rear Engine Fire Test .....	12
Figure 7. Firefighter Applying Agent during a Rear Engine Fire Test.....	13
Figure 8. Estimation of Discharge Rate Using the Linear Fit Method for Test 2015-05-27-b....	14
Figure 9. Estimation of Discharge Rate Using the Exponential Fit Method for Test 2015-05-27-b .....	15
Figure 10. StoneAge Attack Tip Nozzle.....	16
Figure 11. Spiral Insert Constructed for the StoneAge Attack Nozzle.....	17
Figure 12. Sleeve Attachment Constructed for the StoneAge Attack Nozzle .....	18
Figure 13. Rear Engine Fire Using a 0.165-in Stoneage Nozzle at 2100 psi .....	19
Figure 14. Pool Fire Using a 0.243-in StoneAge Nozzle at 1500 psi.....	20
Figure 15. Rosenbauer Nozzle and Trigger Gun with Custom-made Sleeve Attachment .....	21
Figure 16. Extinguishing a Pool Fire Fire Using a 0.230-in Rosenbauer Nozzle at 1050 psi .....	22
Figure 17. Rear Engine Fire Using a 0.230-in Rosenbauer Nozzle at 1050 psi .....	23

## LIST OF TABLES

	<b>Page</b>
Table 1. Water Discharge Times Necessary to Produce Desired Novec 1230 Discharge Times.....	9
Table 2. Summary of Fire Suppression Tests Performed with the StoneAge Nozzle .....	20
Table 3. Summary of Fire Suppression Tests Performed with the Rosenbauer Nozzle .....	23

## 1. SUMMARY

In 2014, as part of an ongoing effort to identify a replacement for the Department of Defense (DoD) Halon 1211 flightline extinguisher, the Air Force Civil Engineer Center (AFCEC) performed a series of tests to evaluate the performance of the Amerex Corporation model 775 wheeled extinguisher containing 150 lb of the Novec 1230 firefighting agent manufactured by 3M. This test series consisted of ten rear engine fire tests, ten access panel fire tests, and one stream reach test. The Amerex extinguisher had satisfactory performance during this test series, extinguishing nine of ten rear engine fires, nine of ten access panel fires, and meeting stream reach requirements established in an earlier joint Air Force–Navy project. However, Novec 1230 is a relatively expensive agent. At the time of this report, current GSA pricing for Novec 1230 is \$16.77 per lb, bringing the total cost for agent to \$2,515.50 per Amerex model 775 extinguisher.

In the past, AFCEC/CXA (Requirements and Acquisition Division) evaluations have demonstrated the effectiveness of ultra-high-pressure (UHP) systems using the water-based Aqueous Film Forming Foam (AFFF) firefighting agent. In particular, UHP systems have been shown to reduce the amount of agent required to extinguish a given fire scenario in many cases. It is believed that UHP increases the effectiveness of water based agents by generating smaller droplets with larger overall surface area in the discharge stream, and it was thought that Novec 1230, which extinguishes fires primarily by cooling, could benefit from this effect as well. If an alternative to the Amerex extinguisher could be developed using UHP technology that had equal performance while requiring less Novec 1230 agent, then considerable savings could be achieved by the Air Force.

To evaluate this possibility, a prototype UHP extinguisher using the Novec 1230 firefighting agent was constructed and evaluated. This prototype extinguisher contained 100 lb of the Novec 1230 firefighting agent, which would result in a saving of \$838.50 per extinguisher charge compared with the Amerex extinguisher at current agent costs. It was originally envisioned that this extinguisher would be subject to the same test series used to evaluate the Amerex model 75 extinguisher—ten rear engine fire tests, ten access panel fire tests, and one stream reach test.

To evaluate the prototype UHP extinguisher, several pool fire and F-100 rear engine fire tests were performed with a variety of nozzle configurations based upon nozzles available from StoneAge Tools and Rosenbauer Firefighting Systems. Nozzles were evaluated at system pressures ranging from 550 to 2100 psi, sufficient to produce total discharge times of 30 and 20 s and average flow rates of 3.33 and 5 lb/s respectively. No combination of pressure, discharge rate, and nozzle spray pattern evaluated was effective at extinguishing both the pool fire and the nacelle fire portions of the full F-100 rear engine fire scenario. The system did not reach the level of effectiveness required to justify access panel or stream reach testing.

## 2. INTRODUCTION

### 2.1. The DoD Halon 1211 Flightline Extinguisher

It has been estimated that there are 20,000 flightline fire extinguishers at DoD installations, primarily at airfields operated by the U.S. Air Force (USAF), Navy and Marine Corps. The current DoD flightline extinguisher uses Halon 1211, an ozone-depleting substance (ODS). Under the terms of the Montreal Protocol and the U.S. Clean Air Act, the production of Halon 1211 ceased in 1993. DoD maintains a stockpile of Halon 1211 under the Defense Logistics Agency (DLA) Defense Reserve. Annual consumption of Halon 1211 for flightline applications is estimated to be as high as 200,000 lb. Based on the size of the DLA reserve, the stockpile could be depleted in less than ten years (1). Planned restrictions on the use of Halon 1211 in other countries may require an USAF alternative agent/extinguisher sooner.

The existing Halon 1211 flightline extinguishers were procured by DoD using a purchase description prepared by Warner Robins ALC (2). Figure 1 shows the current unit.



**Figure 1. Amerex Model 600 DoD Halon 1211 Flightline Extinguisher**

The extinguisher holds 150 lb of Halon 1211, which is discharged through a hand-held nozzle connected to 50 ft of  $\frac{3}{4}$ -in hose. The agent container is of the stored pressure type, using nitrogen as the pressurizing medium. The overall discharge time is approximately 48 s, yielding an average flow rate over the entire discharge of 3.1 lb/s. The unit has a 30A:240B:C rating from Underwriters Laboratory (UL) based on UL Standard 711 (3).

AFCEC desires to identify and select an alternative agent and/or a dispensing system to replace the existing 150-lb Halon 1211 flightline units.



## 2.2. The Amerex model 775 Extinguisher

Amerex Defense recently began marketing the Amerex model 775 extinguisher, a wheeled fire extinguisher containing the Novec 1230 agent manufactured by 3M, as a replacement for the Halon flightline extinguisher to meet the requirements of *National Fire Protection Association (NFPA) Standards 407: Standard for Aircraft Fuel Servicing* and *410: Standard on Aircraft Maintenance* (4), (5). The Amerex Model 775 wheeled fire extinguisher is shown in Figure 2.



**Figure 2. Amerex Model 775 Wheeled Fire Extinguisher**

The model 775 is 3 in taller, 4 in deeper and 40 lb heavier than the model 600. Both extinguishers hold 150 lb of their respective agent, pressurized with nitrogen to expel their extinguishing agent, the model 775 operating at 125 psi compared to the Halon 1211 extinguisher operating at 200 psi. The model 775 has a 40-ft long, 1-in hose, shorter in length and larger in diameter than the hose on the Halon 1211 extinguisher. The listed discharge range for the model 775 is 30 ft, whereas the Halon 1211 extinguisher range is given as being 30–40 ft. The listed discharge time for the model 775 is 22 s, giving it an average discharge rate of 6.8 lb/s (compared to 40 s and 3.1 lb/s for the Halon 1211 extinguisher). The model 775 extinguisher has a 3A:80B:C rating from UL based on UL Standard 711 (3).

In 2014, AFCEC performed a series of tests to evaluate the Amerex model 775 extinguisher. The test series was based upon the established Air Force performance test protocol described in AFRL-ML-TY-TR-02-4540 (6), and consisted of ten access panel tests, ten rear engine tests, and one stream reach test. The Amerex extinguisher successfully extinguished nine of ten F-100 rear engine fire tests, nine of ten F-100 access panel fire tests, and successfully met the stream reach requirement. Details of this test series are presented in AFCEC-CX-TY-TR-2014-0033 (7).

### 2.3. UHP Technology

Although test performance of the Amerex model 775 extinguisher was superior to all alternative extinguisher-and-agent combinations evaluated to date at AFCEC, one serious disadvantage of the extinguisher is the relatively high cost of the Novec 1230 firefighting agent. At the time of this report, current GSA pricing for Novec 1230 is \$16.77 per lb, bringing the total cost for agent to \$2,515.50 per extinguisher. Current GSA pricing for a fully charged Amerex model 775 extinguisher is \$6,375.82 each.

In the past, AFCEC/CXA evaluations have demonstrated the effectiveness of UHP systems using the water-based AFFF firefighting agent (8). In particular, UHP systems have been shown to reduce the amount of agent required to extinguish a given fire scenario in many cases. It is believed that UHP increases the effectiveness of water-based agents by generating smaller droplets and increasing overall surface area in the discharge stream. The Novec 1230 agent, which extinguishes fires primarily by cooling, could be expected to benefit from this effect as well. It is of interest then to determine if UHP technology can offer similar improvements in agent efficiency to extinguisher systems using the Novec 1230 firefighting agent. If an alternative to the Amerex extinguisher could be developed using UHP technology that had equal performance while requiring less Novec 1230 agent, considerable savings could be achieved by the Air Force.

To evaluate this possibility, a prototype UHP extinguisher using the Novec 1230 firefighting agent was constructed and evaluated. This prototype extinguisher contained 100 lb of Novec 1230 firefighting agent, which would result in a saving of \$838.50 per extinguisher charge compared with the Amerex extinguisher at current agent costs. The initial cost for the UHP extinguisher system itself would be higher than for a low-pressure system such as the Amerex 775, but the initial expense would be offset by the lower cost of servicing and refilling the extinguishers and could be less expensive over the life-cycle of the extinguishers.

It was originally envisioned that this extinguisher would be subject to the same test series used to evaluate the Amerex model 775 extinguisher—ten rear engine fire tests, ten access panel fire tests, and one stream reach test. However, as section 4 of this report describes, initial rear engine fires tests results were unsatisfactory. Despite attempts to improve the extinguisher performance, the extinguisher never reached the level of effectiveness to warrant access panel fire tests or stream reach tests.

### 3. METHODS, ASSUMPTIONS, AND PROCEDURES

#### 3.1. Design of the Prototype UHP Extinguisher

A prototype stored-pressure extinguisher that was previously used for evaluating UHP water/foam application on flightline fire scenarios was modified for this project. A Fathom steady-state fluid dynamics model<sup>1</sup> was created to calculate pressure drop and to assist with design changes to this extinguisher for discharging Novec 1230 or water at ultra-high pressures. Unnecessary and/or overly restrictive components were removed so that the UHP extinguisher could discharge up to 25 gal/min with no more than 250-psi loss from the cylinder to the nozzle. It was also decided to remove the extinguisher dip tube to reduce system complexity which then required the extinguisher to be vertical for gravity flow from the cylinder when discharging. The final extinguisher components selected and assembled included:

- Lincoln Composites 19-gal composite cylinder
- 8 ft of ½-in tubing
- ½-in ball valve
- 40 ft of 5/8-in hose
- High-flow shutoff spray gun (valve) with a flow coefficient of approximately 3.0 (manufactured by P.A. SpA (aka PA), part# RL204)<sup>2</sup>
- 10 in of ½-in pipe between the spray gun and the nozzle

The final assembled extinguisher is shown in Figure 3. All extinguisher components were rated to at least 2,500 psi.

The filling procedure for the extinguisher included pumping 7.5 gal of liquid agent into the cylinder, closing the fill port, and then adding nitrogen to the head space for the desired fill pressure. No additional nitrogen was added during discharge; all the potential energy to drive the agent discharge was stored in the cylinder; therefore, working pressure and flow rate dropped during the course of discharge.

When the ball valve was opened to charge the handline, the working pressure in the cylinder decreased from the initial fill pressure. This was documented as the initial pressure and was determined experimentally to be 93 percent of fill pressure. It was expected that initial pressure could be calculated using ideal gas laws, but calculations did not match experimental results.

Discharging the contents of the extinguisher eventually resulted in a sputter at the nozzle as the gaseous nitrogen made its way out of the handline along with the liquid agent. The cylinder pressure at the onset of the sputtering sound was documented as the final pressure. The final pressure was determined experimentally to be 45 percent of fill pressure.

Initially pressure transducers were installed just downstream of the cylinder and upstream of the nozzle. Water was tested at various pressures and flow rates to determine a complete extinguisher

---

<sup>1</sup> <http://www.aft.com/products/fathom>

<sup>2</sup> <http://www.pa-etl.it/en/catalogo/spray-guns-up-to-22mpa-3130-psi/rl-204.html>



**Figure 3. Prototype UHP Extinguisher**

flow coefficient  $(C_v)_e$  of 1.65, from:

$$C_v = Q \sqrt{\frac{SG}{\Delta psi}}$$

where:

$Q$  = flow rate in gal/min

$SG$  = specific gravity of the fluid

$\Delta psi$  = pressure differential in psi

For instance, a flow rate of 20 gal/min of water ( $SG = 1.0$ ) requires a pressure drop of 147 psi between the cylinder and the nozzle for this extinguisher. A cylinder pressure of 1500 psi will therefore result in a nozzle pressure of 1353 psi. The extinguisher flow coefficient was constant because the same cylinder, fittings, and discharge hose were used for all tests. The nozzle, however, can change from test to test, but is still bound by the above general equation and definition of flow coefficient. It is the nozzle pressure, along with physical characteristics such as orifice diameter of the nozzle tested, that determine the flow rate through the nozzle.

### 3.2. Nozzle Selection

The extinguisher was initially designed to have a total discharge time of 30 s at an initial cylinder pressure of 2000 psi. A ¼- in NPT AP4 Attack Tip Nozzle with 0.165-in orifice manufactured by StoneAge Tools was selected that was expected to meet these parameters. After initial testing revealed that this configuration had unsatisfactory firefighting performance, several alternative nozzle designs were considered. Evaluations were conducted using modified StoneAge nozzles as well as a nozzle manufactured by Rosenbauer Firefighting Systems. Both nozzles were evaluated and improved in parallel. Further discussion of the various nozzle configurations evaluated can be found in section 4.

StoneAge AP4 nozzles are commercially available in a variety of orifice sizes. Published data on the characteristic performance of these nozzles were curve fitted to reveal the relationship between orifice diameter and nozzle flow coefficient  $(C_v)_n$ :

$$(C_v)_n = 27.65 \times (\phi)^{2.079}$$

where:

$\phi$  = orifice diameter in inches

With the performance of the extinguisher and the nozzle characterized, and given the fact that both components must have the same flow rate at any given time, nozzle pressure ( $psi_n$ ) can be calculated from the extinguisher working pressure:

$$Q = \left( \frac{C_v}{\sqrt{\frac{SG}{\Delta psi}}} \right)_e = \left( \frac{C_v}{\sqrt{\frac{SG}{\Delta psi}}} \right)_n$$

$$\frac{(C_v)_e^2}{\left( \frac{SG}{psi_e - psi_n} \right)} = \frac{(C_v)_n^2}{\left( \frac{SG}{psi_n} \right)}$$

$$psi_n = \frac{(C_v)_e^2 \times psi_e}{(C_v)_e^2 + (C_v)_n^2}$$

where:

$psi_e$  = the working pressure in the cylinder at the beginning or the end of discharge, previously defined as initial pressure or final pressure.

With the nozzle parameters quantified, discharge rate ( $gpm$ ) in gal/min can be estimated at both the beginning and end of discharge:

$$gpm = \left( \frac{C_v}{\sqrt{\frac{SG}{psi}}} \right)_n$$

Ultimately, effective discharge time (in seconds) can be estimated from the extinguisher volume (7.5 gal), average flow (determined using extinguisher fill pressure and nozzle orifice diameter), and a constant (0.96) that was determined experimentally:

$$\text{effective discharge time} = \frac{7.5 \times 60}{0.96 \times Q_{\text{avg}}}$$

where:

$Q_{\text{avg}}$  = the average of the initial and final flow rates, in gal/min

In an effort to not design a nozzle that is difficult for a single firefighter to control, net nozzle force (pounds) was derived from the time rate change of momentum of the flow through the nozzle:

$$\text{nozzle Reaction Force} = 0.0182 \times Q \times \sqrt{8.32 \times SG \times \text{nozzle Pressure}}$$

### 3.3. Water Discharge Tests

Although the pressure required to achieve a desired discharge time could be calculated for some nozzle configurations, it was necessary to confirm the optimal pressures experimentally prior to testing the configuration in a fire suppression test. During these preliminary tests, the extinguisher pressure could be increased or decreased on a trial-and-error basis to determine the exact pressure necessary to obtain a desired discharge time. In addition, the spray pattern of the particular nozzle could be observed and adjusted prior to use in an actual fire test.

Because of the relatively high cost of Novec 1230, these preliminary tests were conducted using water instead of Novec 1230. The prototype UHP extinguisher was designed to hold 100 lb (45.4 kg) of Novec 1230, which occupies a volume of 7.49 gal (28.3 L). To maintain the same ratio of liquid agent volume to nitrogen propellant head space volume, the same volume of water was used, 7.49 gal (28.3 L), which corresponds to a mass of 62.5 lb (28.4 kg) of water.

During this test series, it was desired that various nozzle configurations be evaluated at extinguisher pressures that would result in complete discharge of Novec 1230 in either 20 s or 30 s. Because water has lower density (1.0 g/mL) than Novec 1230 (1.6 g/mL), the expected discharge time for the two liquids will be different and proportional to the square root of their densities:

$$t_{\text{water}} = t_{\text{novec}} \times \sqrt{\frac{D_{\text{water}}}{D_{\text{novec}}}}$$

Where  $t_{\text{water}}$  and  $t_{\text{novec}}$  represent the discharge times with water and Novec 1230, and  $D_{\text{water}}$  and  $D_{\text{novec}}$  represent their respective densities. Using this relationship the discharge time with water necessary to produce a desired discharge time when using Novec 1230 at the same pressure was calculated (Table 1).

**Table 1. Water Discharge Times Necessary to Produce Desired Novec 1230 Discharge Times**

Desired Discharge Time with Novec 1230	Corresponding Discharge Time with Water
20 s	15.8 s
30 s	23.7 s

To have a discharge time of 20 s delivering Novec 1230, the extinguisher would need to discharge water in 15.8 s. To have a discharge time of 30 s delivering Novec 1230, the extinguisher would need to discharge water in 23.7 s. Thus, the UHP extinguisher pressure was adjusted up or down until the discharge time with water equaled the above target values. This system pressure was then used for subsequent fire suppression tests with Novec 1230.

Water discharge tests were conducted at building 9443 at the Silver Flag Test site on Tyndall Air Force Base. The extinguisher was positioned inside the building, while the firefighter operating the nozzle stood just inside a bay door and directed the flow of water onto a nearby open space. In this way the effects of wind or weather on the discharge stream pattern were minimized.

During the water discharge tests, the prototype UHP extinguisher was positioned on a scale so mass could be monitored during the tests (Figure 4). A computer and data acquisition system



**Figure 4. The Prototype UHP Extinguisher Resting on a Scale**



coupled to the scale recorded mass data at a rate of two data points per second. This was done to facilitate filling the extinguisher with the proper amount of agent before each test, and to allow calculation of the mass of agent used and discharge rate of agent during each test. The scale accuracy was  $\pm 1$  lb.

A single tripod-mounted video camera was used to record water discharge tests to facilitate comparisons between nozzle configurations.

### 3.4. Fire Suppression Tests

Fire suppression tests were performed using the F-100 nacelle test fixture located at the Silver Flag test site (Figure 5). The fixture is a cylinder 16 ft long that contains an inner cylinder (the space between the cylinders is termed the annulus) and three baffles positioned along the inside of the inner cylinder. The fixture is equipped with three spray nozzles that allow fuel to flow into different regions of the nacelle to simulate different fire scenarios. The nacelle sits atop a concave concrete pad that can collect an 11-ft diameter pool of jet fuel as part of the fire scenario. Design details and test protocol using this fixture are described in AFRL-ML-TY-TR-02-4540 (6) and AFRL-ML-TY-TR-2002-4604 (9).



**Figure 5. F-100 Engine Nacelle Mock-Up (In This Photo, Fuel Is Flowing through the Nacelle in Preparation for a Rear Engine Test.)**

During the fire suppression scenarios, the prototype UHP extinguisher was positioned on a scale so mass could be monitored as described in Section 3.3.



Two tripod-mounted video cameras were set up to record each test from two different angles. A tripod-mounted Kestrel weather meter was also used to monitor the ambient temperature, humidity, and wind speed and direction. The extinguisher and nacelle were positioned so that the wind direction was from the firefighter's back and towards the nacelle, plus or minus 30 degrees. To minimize the impact of wind on the extinguisher's performance, testing was performed only when wind speed was 8 mph or less. In addition, testing was performed only when the ambient temperature was 60 °F or above.

It was initially envisioned that the prototype UHP extinguisher would be evaluated using the same test protocols as were used to evaluate the Amerex model 775 extinguisher: ten rear engine fire tests, followed by ten access panel fire tests, and one stream reach evaluation. The Amerex model 775 extinguisher had been very effective at extinguishing these fire scenarios, and it was expected that the UHP extinguisher would be similarly effective after a small number of practice fire suppression tests were conducted to familiarize the firefighter with the equipment. However, initial tests revealed that although the prototype UHP extinguisher appeared effective at extinguishing fire present in the nacelle, it had difficulty extinguishing the ground fire portion of the scenario. Several alternate nozzle designs were selected for evaluation to overcome this shortcoming. After several rear engine tests were performed without successful extinguishment, it was decided to evaluate these prospective nozzle configurations using a less difficult fire scenario consisting of a pool fire only. If a nozzle configuration was effective extinguishing the ground fire, then it was planned to return to the original test series. Although revisions to the nozzle design improved the system's effectiveness against ground fires, the extinguisher effectiveness was not sufficiently increased to warrant access panel testing or stream reach testing by the project end date.

### **3.4.1. Pool Fire Tests**

Pool fire tests were conducted as outlined below, and consisted of a pretest phase, in which the F-100 engine nacelle was first preheated to a specified temperature, and then a certain amount of fuel was allowed to flow into the nacelle and onto the concrete pad (Figure 5), followed by test phase, in which the fuel on the ground was ignited and the firefighter attempted to extinguish the fire. Ideally, no fuel would remain in the nacelle during the test phase.

#### **Pretest Phase**

- Determine and record extinguisher full weight.
- Initiate flow of jet fuel through the afterburner nozzle (nozzle 3) at a flow rate of 2 gal/min.
- Ignite fuel.
- Heat tail pipe to  $550 \pm 25$  °F.
- Shut off fuel.
- Allow fuel to self-extinguish, or extinguish any remaining fires manually with an auxiliary extinguisher.
- Allow metal to cool to  $475 \pm 25$  °F.
- Initiate fuel flow through nozzles 2 (2 gal/min) and 3 (2 gal/min) at a total flow rate of 4 gal/min.
- Flow 25 gal of jet fuel through the fixture into the concrete pan.

- If spontaneous ignition occurs, shut off fuel and allow metal to cool to a lower temperature; then resume flowing jet fuel.
- Allow sufficient time for any residual fuel in the nacelle to stop flowing out of the nacelle onto the concrete pad.

#### Test Phase

- Ignite fuel on the ground with a suitable torch.
- Allow the fuel to burn for 15 s.
- Apply fire extinguisher according to manufacturer's instructions.
- Record
  - Time to extinguish,
  - Weight of agent used,
  - Weight of extinguisher after test.

### 3.4.2. Rear Engine Fire Tests

Rear engine fire tests were conducted as outlined below, and consisted of a pretest phase, in which the F-100 engine nacelle was first preheated to a specified temperature (Figure 6), and then a certain amount of fuel was allowed to flow into the nacelle and onto the concrete pad (Figure 5), followed by test phase, in which the fuel in the nacelle and on the ground was ignited and the firefighter attempted to extinguish the fire (Figure 7). Unlike the pool fire described above, fuel continued to flow into the nacelle and onto the ground during the test phase.



**Figure 6. F-100 Nacelle Mockup during Pre-Burn Phase of a Rear Engine Fire Test**



**Figure 7. Firefighter Applying Agent during a Rear Engine Fire Test**

#### Pretest Phase

- Determine and record extinguisher full weight.
- Initiate flow of jet fuel through the afterburner nozzle (nozzle 3) at a flow rate of 2 gal/min.
- Ignite fuel.
- Heat tail pipe to  $550 \pm 25$  °F.
- Shut off fuel.
- Allow fuel to self-extinguish, or extinguish any remaining fires manually with an auxiliary extinguisher.
- Allow metal to cool to  $475 \pm 25$  °F.
- Initiate fuel flow through nozzles 2 (2 gal/min) and 3 (2 gal/min) at a total flow rate of 4 gal/min.
- Flow 25 gal of jet fuel through the fixture into the concrete pan.
- If spontaneous ignition occurs, shut off fuel and allow metal to cool to a lower temperature; then resume flowing jet fuel.

#### Test Phase

- Ignite low-pressure turbine and afterburner fuel sprays with a suitable torch applied through the ignition port.
- Ignite fuel on the ground with a suitable torch.
- Allow the fuel to burn for 15 s.
- Apply fire extinguisher according to manufacturer's instructions.
- Record
  - Time to extinguish,
  - Weight of agent used,
  - Weight of extinguisher after test.

### 3.5. Estimation of Discharge Rates

The time-resolved weight data recorded by the digital scale that the extinguisher sat on during the fire suppression tests was used to calculate the discharge time of the extinguisher during the test. The simplest method involved performing a least squares line fit to the weight data for the discharge period. This was done to obtain the average discharge rate data presented in Table 2 and Table 3. An example of this process is presented in Figure 8, where the average discharge rate for test 2015-05-27-b is calculated. The weight data was first plotted versus time (dotted red line), and then the discharge period was determined visually from the plot of the data (solid red line). A line was fit to this data segment using the least squares method (dashed red line). The average discharge rate is the slope (derivative) of this line. For test 2015-05-27-b, the average discharge rate was determined to be 3.19 lb/s by this method. The average discharge rate is also displayed in Figure 8 by the solid green line. The discharge rate outside the discharge period is set to zero for simplicity.

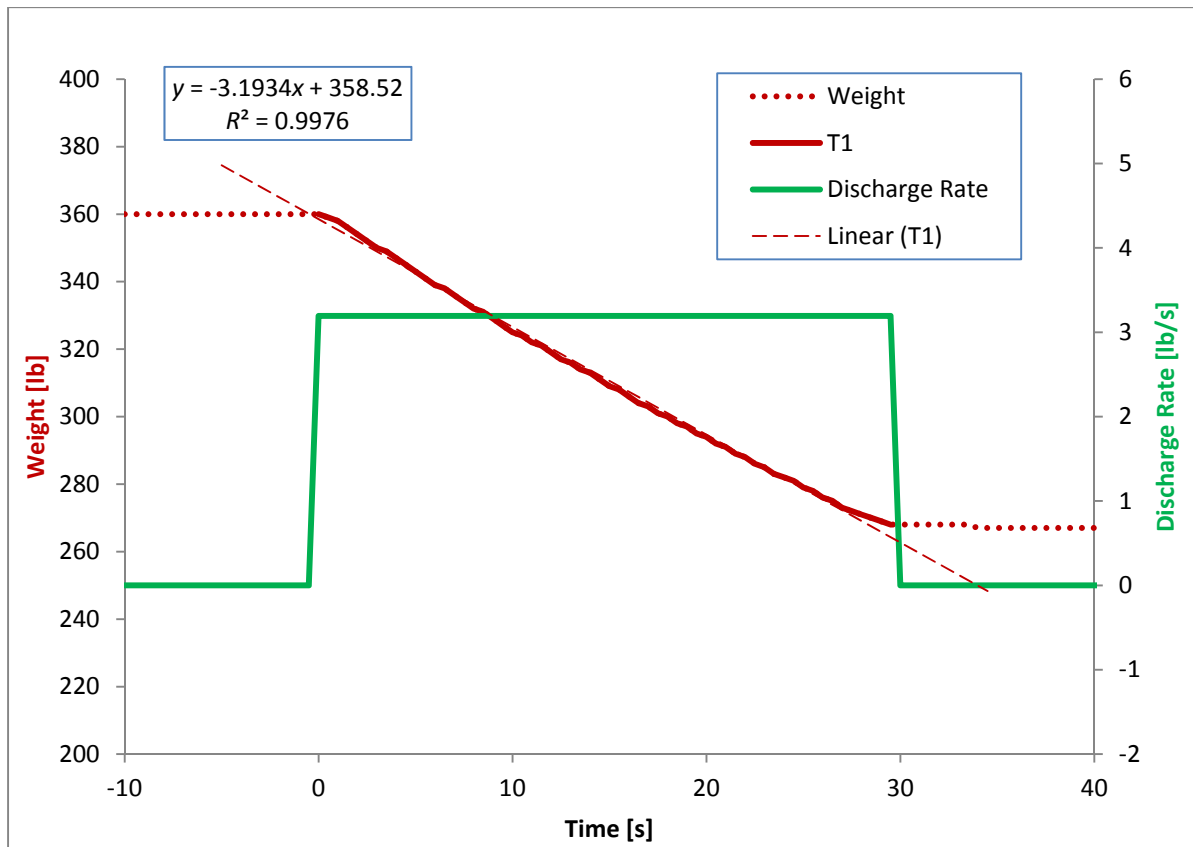
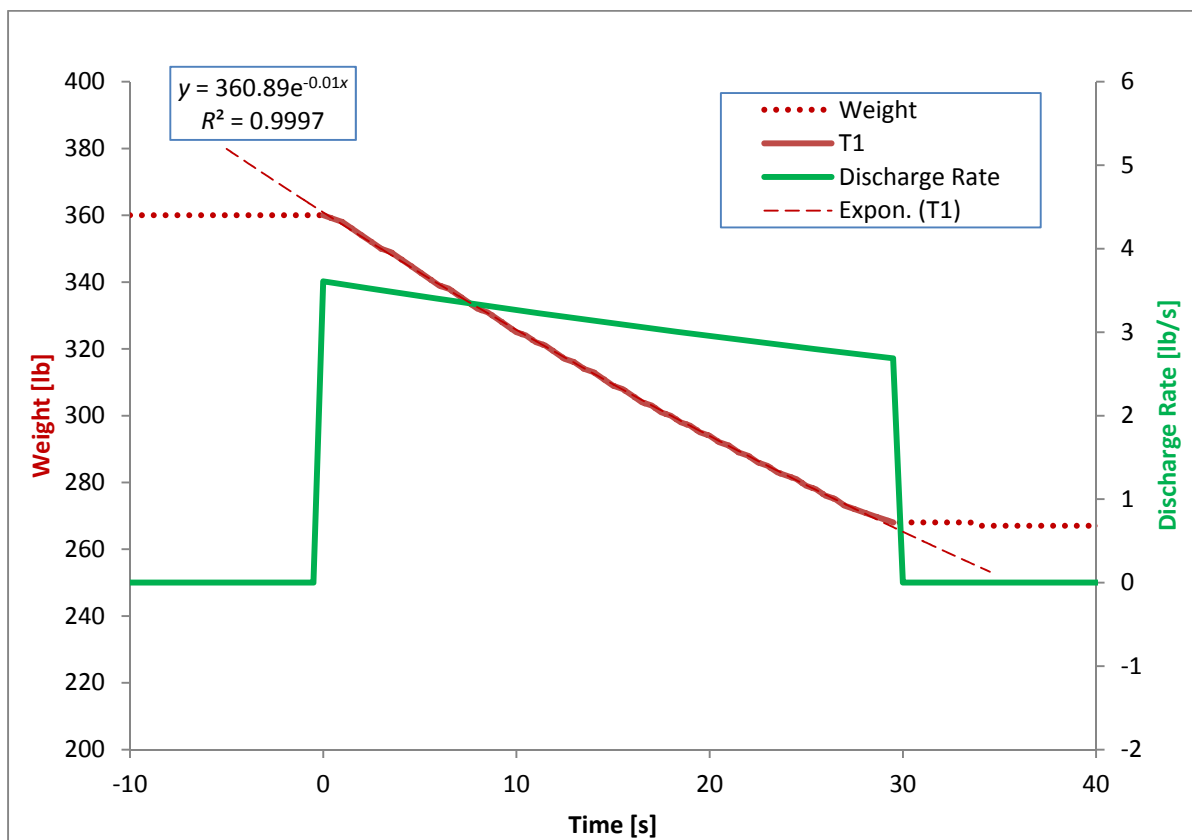

Figure 8. Estimation of Discharge Rate Using the Linear Fit Method for Test 2015-05-27-b

In reality the discharge rate is not constant over the discharge period. As agent is expelled from the extinguisher reservoir the propellant gas occupies a progressively larger volume, which causes the internal pressure to drop, thereby causing the discharge rate to drop over time. A better estimate of discharge rate can be obtained by taking the stepwise derivative of the weight data. Calculation of discharge rate by this method indicates that the discharge rate varies from 4 lb/s to 2 lb/s. However, the discharge rate is poorly resolved, and a plot of discharge rate over time (not shown) has a jagged stepwise appearance. This is a consequence of the limited resolution of the

scale (1 lb) and limited collection rate (2/s). Collection of weight data at a higher rate with a more accurate scale would result in better resolution with this method.

An alternate method of estimating the discharge rate over time involves performing an exponential line fit to the weight data during the discharge period. An example of this process is presented in Figure 9, where the average discharge rate for test 2015-05-27-b is calculated. The weight data are first plotted versus time (dotted red line), whence the discharge period was determined visually from the plot of the data (solid red line). An exponential function is then fit to this data segment (dashed red line). Note that the exponential fit has a slightly larger coefficient of determination (0.9997) than that for the linear fit performed above (0.9976), indicating that the exponential function fit the weight data more accurately. The discharge rate is the slope (derivative) of this exponential function. For test 2015-05-27-b, the discharge rate determined by this method dropped from an initial value of 3.6 lb/s to a final value of 2.6 lb/s, and the calculated discharge rate is displayed in Figure 9 by the solid green line. The discharge rate outside the discharge period is set to zero for simplicity.



**Figure 9. Estimation of Discharge Rate Using the Exponential Fit Method for Test 2015-05-27-b**

The exponential fit method appears to be the more accurate method for estimating the discharge rate with data of this quality. If the prototype extinguisher had been more successful, accurate determination of the discharge rate may have aided in optimizing the volume required for the propellant gas and may have been a useful point of comparison with similar data obtained from evaluation of the Amerex model 775 extinguisher.



## 4. RESULTS AND DISCUSSION

### 4.1. Evaluations of the StoneAge Attack Nozzle

The initial nozzle tested in the prototype UHP extinguisher was a ¼-in NPT StoneAge AP4 Attack Tip Nozzle with a 0.165-in orifice. An orifice of this diameter was predicted to produce the desired discharge time of 30 s at the desired pressure of 2000 psi. This nozzle is presented in Figure 10.



**Figure 10. StoneAge Attack Tip Nozzle (Left- illustration of the StoneAge Attack Tip nozzle. Right- Photograph of a StoneAge Attack Tip nozzle attached to a trigger gun.)**

Evaluations with this nozzle revealed several deficiencies:

- Initial testing at the designed pressure of 2000 psi revealed that the discharge time was too long, indicating that the nozzle orifice size was too small. Increasing the initial pressure above 2,000 psi did lower the discharge time to the desired level. However, the necessary pressure approached the safety limit of 2,500 psi for the valves used in the prototype UHP extinguisher. In addition, the nozzle had relatively high recoil at pressures above 2000 psi, making it difficult for the firefighter to control.
- It was determined that this nozzle had unsatisfactory firefighting performance. The forceful straight stream of agent produced by this configuration resulted in considerable splashing when directed at the pool of fuel on the ground, making suppression of the ground fire very difficult for the firefighter.
- It was also of interest to evaluate the extinguisher at a discharge time of 20 s rather than 30 s. However, that would have required very high pressures using the 0.165-in orifice nozzle.

To address these issues, a number of modifications were made to the nozzle followed by water and Novec 1230 tests to evaluate the effect of each subsequent modification.

StoneAge Tools sells the Attack Tip Nozzle family of nozzles with orifices ranging in diameter from 0.018 to 0.165 in. Thus it was not possible to purchase a nozzle with a larger orifice from StoneAge. Two nozzles with 0.165-in orifices were purchased and their orifices enlarged to 0.182 in and 0.243 in, the maximum orifice size that the ¼-in NPT Attack Tip Nozzle body can accommodate.

A spiral insert for the StoneAge nozzle was constructed to modify the discharge pattern and improve the performance of the extinguisher. This insert was constructed from two intersecting rectangular sheets of metal that were twisted into a shape somewhat similar to a propeller. A schematic of the insert is presented in Figure 11 (dimensions shown are inches). When inserted into the nozzle tip, the insert disrupted the flow of agent and introduced a slightly conical discharge pattern.

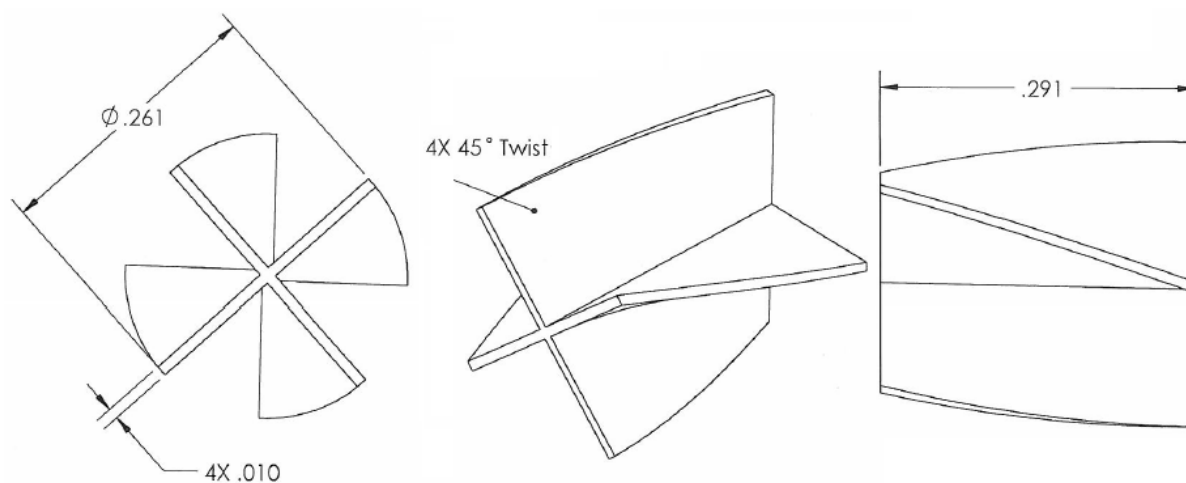

**Figure 11. Spiral Insert Constructed for the StoneAge Attack Nozzle**

After evaluations were conducted with the Rosenbauer nozzle (see Section 4.2) it was decided to construct a sleeve attachment for the StoneAge nozzle similar to the one present in the Rosenbauer nozzle. This attachment consisted of an approximately 11- by 1.5-in hollow aluminum cylinder that slid over the end of the StoneAge nozzle and trigger gun assembly. The sleeve also had two bolts intersecting the interior of the sleeve, arranged in a cross or plus configuration. The bolts served to partially break up the stream of agent emitted by the nozzle, while the sleeve confined the resulting flow into a limited cone. An illustration of the sleeve assembly is presented in Figure 12 (dimensions shown are inches).

After receiving the sleeve from the machine shop, it was noted that the machinist had mistakenly included much larger cross bolts than were requested. Initial evaluation of the nozzle and sleeve configuration with water revealed that the large bolts disrupted the liquid flow excessively, resulting in a very poor discharge pattern. After removing the bolts, the discharge pattern appeared promising. It was therefore decided to evaluate the sleeve without cross bolts initially, and to have the proper sized cross bolts added for further evaluation at a later date. Although several tests were performed using the sleeve attachment without cross bolts, it was not possible to evaluate the sleeve attachment with properly sized bolts prior to the project end date.

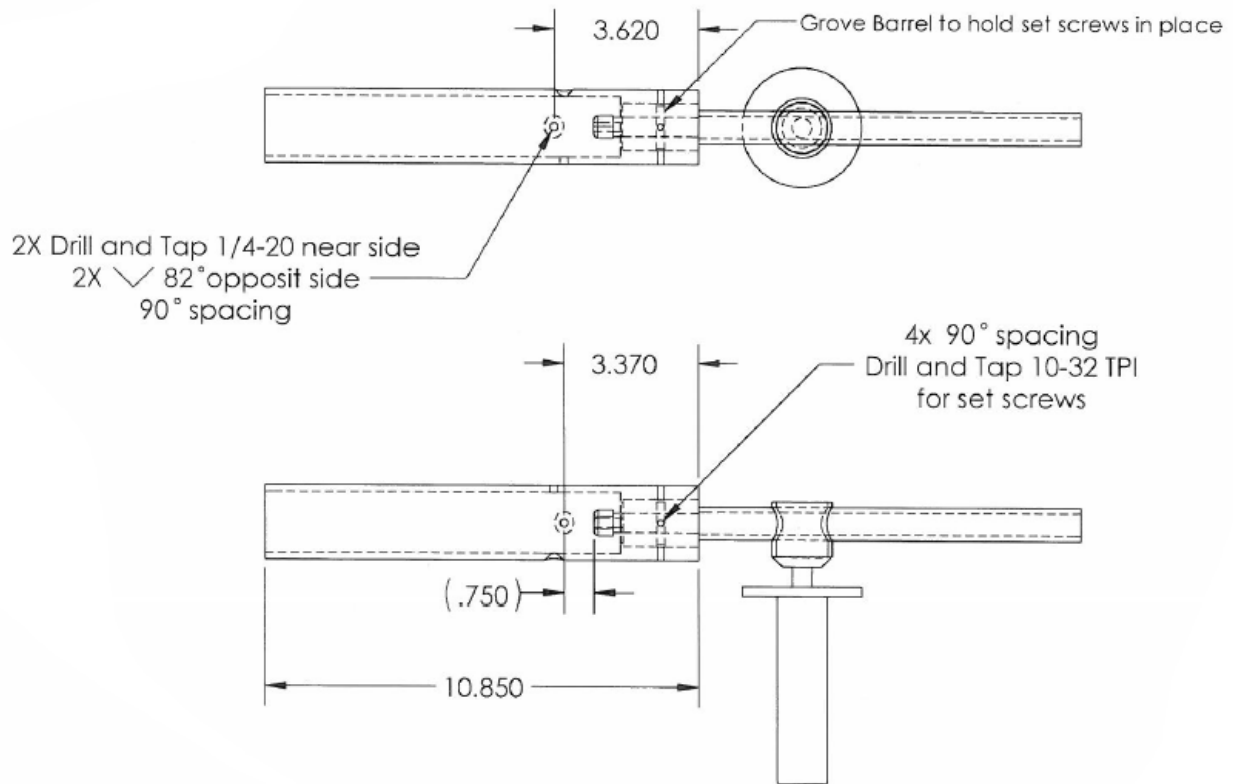

**Figure 12. Sleeve Attachment Constructed for the StoneAge Attack Nozzle (Note that part of the trigger gun assembly is also shown.)**

A total of eleven discharges of Novec 1230 in fire suppression tests were performed using the StoneAge nozzles:

- Two rear engine fire tests were performed using the 0.165-in nozzle at a pressure of 2100 psi. Previous evaluations with water indicated that this configuration would result in the desired total discharge time of 30 s and an average flow rate of 3.33 lb/s. This nozzle was again determined to have unsatisfactory firefighting performance. Although the nozzle appeared effective at suppressing the nacelle portion of the fire scenario, the forceful straight stream of agent produced by this configuration resulted in considerable splashing when directed at the pool of fuel on the ground, making suppression of the ground fire very difficult for the firefighter (see Figure 13) . At this point it was decided to construct a spiral insert for the StoneAge nozzle to disrupt the flow and modify the discharge pattern in an attempt to improve performance against the ground fire.
- One rear engine fire test was performed using the 0.165-in nozzle with the spiral insert at a pressure of 2100 psi. The insert appeared to modify the discharge pattern as desired. However, the high pressure still produced significant splashing in the pool fire.
- Two rear engine fire tests were performed using a 0.182-in nozzle with the spiral insert at pressures of 1300 and 1000 psi. The lower pressure discharge appeared to be more effective at extinguishing the ground fire, but still failed to successfully extinguish the combined pool and nacelle fire.





**Figure 13. Rear Engine Fire Using a 0.165-in Stoneage Nozzle at 2100 psi (Note the burning fuel being pushed towards the rear of the test structure by the force of the agent stream.)**

- Two rear engine fire tests were performed using a 0.243-in nozzle with the spiral insert at a pressure of 550 psi. The lower pressure discharge appeared to be more effective at extinguishing the ground fire, but still failed to successfully extinguish the combined pool and nacelle fire. After this test it was decided to perform subsequent tests using a 25-gallon pool fire rather than the full rear engine fire scenario until the nozzle performance against the pool fire had been optimized.
- One pool fire test was performed using a 0.243-in nozzle with the spiral insert at a pressure of 1500 psi. Previous evaluations with water indicated that this configuration would result in a total discharge time of 20 s and an average flow rate of 5 lb/s. The higher flow rate appeared to improve the performance against the ground fire (see Figure 14). It was therefore decided to construct a nozzle with sufficient orifice size to permit a similar flow rate at lower pressure (see section 4.2).
- Two pool fire tests were performed using a 0.243-in nozzle with the spiral insert and a new sleeve attachment. This attachment was based upon a sleeve attachment for the Rosenbauer nozzle system (see section 4.2), which appeared to improve performance with that nozzle. Although the firefighter failed to extinguish the pool fire, this configuration appeared to have the best performance of the StoneAge configurations tested to date.



**Figure 14. Pool Fire Using a 0.243-in StoneAge Nozzle at 1500 psi (Notice that the ground fire is largely suppressed; however, the extinguisher ran out of agent before the fire was completely extinguished.)**

Table 2 summarizes the fire suppression tests performed with the various StoneAge nozzle configurations.

**Table 2. Summary of Fire Suppression Tests Performed with the StoneAge Nozzle**

Test Code	Orifice Diameter (in)	Nozzle Modifications	Pressure (psi)	Fire Scenario	Discharge Time (s)	Average Discharge Rate (lb/s)	Successfully Extinguished?
2014-11-20-a	0.165		2100	Rear Engine	26	3.58	No
2014-12-02-a	0.165		2100	Rear Engine	27	3.76	No
2015-01-20-a	0.165	spiral insert	2100	Rear Engine	26.5	3.58	No
2015-03-02-a	0.182	spiral insert	1300	Rear Engine	28	3.36	No
2015-03-11-a	0.182	spiral insert	1000	Rear Engine	30	3.11	No
2015-04-08-a	0.243	spiral insert	550	Rear Engine	30	3.20	No
2015-04-08-b	0.243	spiral insert	550	Rear Engine	27.5	3.39	No
2015-04-10-a	0.243	spiral insert	1500	Pool Fire	20	4.92	No
2015-05-06-a	0.243	spiral insert and sleeve	600	Pool Fire	28.5	3.26	No
2015-05-08-c	0.243	spiral insert and sleeve	600	Pool Fire	29	3.18	No



## 4.2. Evaluation of the Rosenbauer Nozzle

A Rosenbauer trigger gun assembly and nozzle was also evaluated. This assembly included a trigger gun with an internal valve that can be adjusted between a straight stream and a fog discharge pattern. The Rosenbauer assembly was also equipped with a sleeve attachment that had been custom built for a previous experiment. This sleeve consisted of an approximately 11- by 1.5-in hollow aluminum cylinder that slid over the end of the Rosenbauer nozzle and trigger gun assembly. The sleeve had two bolts in the interior of the sleeve arranged in a cross or plus configuration to partially break up the stream of agent emitted by the nozzle while the sleeve confined the resulting flow into a limited cone. Although the sleeve was designed to increase the generation of foam when used with AFFF firefighting agent, it was theorized that the sleeve might improve the spray pattern when used with the UHP extinguisher as well. The Rosenbauer nozzle was evaluated with and without this sleeve. A picture of the Rosenbauer nozzle is presented in Figure 15.



**Figure 15. Rosenbauer Nozzle and Trigger Gun with Custom-made Sleeve Attachment**

Several Rosenbauer nozzles were available for use with the gun assembly. Nozzles with orifice sizes of 0.093 in, 0.217 in, and 0.230 in were tested with and without the sleeve attachment.

A total of nine fire suppression discharge tests of Novec 1230 were performed using the Rosenbauer nozzles:

- One rear engine fire test was performed with a 0.217-in Rosenbauer nozzle on the fog pattern setting at 2100 psi. Previous water discharge tests indicated that this pressure would result in a total discharge time of 30 s and an average flow rate of 3.33 lb/s. The fog setting produced a very wide discharge pattern that appeared ineffective at both the nacelle and the ground fire portion of the fire scenario.

- One rear engine fire test was inadvertently performed using a 0.093-in nozzle on the straight stream setting with the sleeve attachment at a pressure of 2100 psi. As would be expected, use of a nozzle with a very small orifice resulted in a very long discharge time and very poor firefighting performance.
- One rear engine fire test was performed using a 0.230-in nozzle on the straight stream setting with the sleeve attachment at a pressure of 2100 psi. Previous evaluations with water indicated that this configuration would result in a total discharge time of 20 s and an average flow rate of 5 lb/s. The higher flow rate appeared to marginally improve the performance against the ground fire. After this test it was decided to perform subsequent tests using a 25-gal pool fire, rather than the full rear engine fire scenario, until the nozzle performance against the pool fire had sufficiently improved.
- One pool fire test was performed using a 0.230-in nozzle on the straight stream setting with the sleeve attachment at a pressure of 2100 psi. The firefighter was able to extinguish the fire in 19 s. After approximately three seconds, re-ignition of the pool fire occurred. The firefighter was unable to re-extinguish the fire with the agent remaining in the extinguisher.
- Two pool fire tests were performed with a 0.230-in nozzle on the straight stream setting with the sleeve attachment at 1050 psi. Previous water discharge tests indicated that this pressure would result in a total discharge time of 30 s and an average flow rate of 3.33 lb/s. The firefighter was able to extinguish the fires in 13 s and 9 s, respectively (Figure 16).



**Figure 16. Extinguishing a Pool Fire Fire Using a 0.230-in Rosenbauer Nozzle at 1050 psi**

- One full rear engine fire test was performed with a 0.230-in nozzle on the straight stream setting with the sleeve attachment at 1050 psi. The firefighter was able to extinguish the fire in 19 s. However, it was later determined that during this test jet fuel was flowing through the nacelle at less than the 4-gal/min flow rate required by procedure.
- Two rear engine fire tests were performed with a 0.230-in nozzle on the straight stream setting with the sleeve attachment at 1050 psi. The firefighter was unable to extinguish these fires. This configuration appeared effective at extinguishing the ground fire portion of the fire scenario, but agent did not sufficiently penetrate the baffles in the nacelle to suppress the nacelle portion of the fire scenario (see Figure 17).



**Figure 17. Rear Engine Fire Using a 0.230-in Rosenbauer Nozzle at 1050 psi**

Table 3 summarizes the fire suppression tests performed with the various Rosenbauer nozzle configurations.

**Table 3. Summary of Fire Suppression Tests Performed with the Rosenbauer Nozzle**

Test Code 2015-	Orifice Diameter (in)	Nozzle Modifications	Stream Setting	Pressure (psi)	Fire Scenario	Discharge Time (s)	Average Discharge Rate (lb/s)	Successfully Extinguished ?	Extinguish Time (s)
02-11-a	0.217		Fog Pattern	2100	Rear Engine	28	3.36	No	
04-08-c	0.093	sleeve	Straight Stream	2100		80	1.15	No	
04-09-a	0.230			2100		21.5	4.42	No	
04-10-b	0.230			2100	20	4.55	Yes <sup>[2]</sup>	19	
05-07-a	0.230			1050	14 <sup>[1]</sup>	3.61	Yes	13	
05-08-a	0.230			1050	8.5 <sup>[1]</sup>	3.75	Yes	9	
05-08-b	0.230			1050	17.5 <sup>[1]</sup>	3.45	Yes <sup>[3]</sup>	19	
05-27-a	0.230			1050	Rear Engine	29	3.22	No	
05-27-b	0.230			1050		29.5	3.19	No	

<sup>[1]</sup> The extinguisher was not fully discharged during these tests.

<sup>[2]</sup> The fire was successfully extinguished. Reignition occurred after approximately three seconds. The firefighter was unable to re-extinguish the resulting fire with the agent left in the extinguisher.

<sup>[3]</sup> Fuel was flowing through the nacelle at less than the desired flow rate of 4 gal/min during this test.

## 5. CONCLUSIONS

It was thought that a UHP system would increase the effectiveness of Novec 1230 by atomizing small droplets with much greater total surface area, and so a prototype UHP extinguisher using the Novec 1230 firefighting agent was constructed and evaluated as an alternative to the Amerex model 775 extinguisher for the replacement of the Air Force Halon 1211 flight line extinguisher. This prototype extinguisher contained 100 lb of Novec 1230 firefighting agent. If successful, this UHP extinguisher might have been a cost effective alternative to the Amerex model 775 extinguisher, which contains 150 lb of Novec 1230 firefighting agent.

Several pool fire and F-100 rear engine fire tests were performed to evaluate the prototype UHP extinguisher with a variety of nozzle configurations based upon nozzles available from StoneAge Tools and Rosenbauer Firefighting Systems. Nozzles were evaluated at system pressures ranging from 550 to 2100 psi, sufficient to produce total discharge times of 30 and 20 s, equivalent to average flow rates of 3.33 and 5 lb/s respectively. No combination of pressure, discharge rate, and nozzle spray pattern evaluated was effective at extinguishing both the pool fire and the nacelle fire portions of the full F-100 rear engine fire scenario.

The most effective nozzle evaluated during the test series was a Rosenbauer nozzle assembly set to the straight stream setting utilizing a nozzle with a 0.240-in orifice and a custom-built sleeve attachment. This nozzle was most effective when the extinguisher was charged to an initial pressure of 1050 psi, which resulted in a total discharge time of 30 s and an average flow rate of 3.33 lb/s. Lessons learned from the Rosenbauer system were used to construct and evaluate alternative systems using currently available hardware from StoneAge tools and other sources, but none were successful.



## 6. RECOMMENDATIONS

Based upon the observations of the pressure and nozzle configurations examined in this work, it appears that extinguisher effectiveness vs. the F-100 nacelle fire scenario was strongly affected by the extinguisher pressure. Configurations with pressure of 2000 psi or above resulted in a forceful agent stream that produced excessive splashing of burning jet fuel when directed at the pool fire portion of the fire scenario. Configurations with pressure of 500 psi or less were not effective at suppressing the fire within the interior of the F-100 nacelle structure. Any future work on a UHP extinguisher should concentrate on configurations with system intermediate pressure in the range of 1000 to 1500 psi, which appear to have the most promise in extinguishing both components of the fire scenario.

Although configurations including the Rosenbauer nozzle were the most effective configurations evaluated in this test series, these nozzles are no longer commercially available. Lessons learned from the Rosenbauer nozzle were used to construct and evaluate the effectiveness of alternative systems using nozzles from StoneAge tools. Future work should continue these refinements to the StoneAge nozzle configuration. The next logical step would be addition of cross bolts in the sleeve attachment, with or without the spiral insert, which should improve performance against a pool fire by disrupting the agent stream.

The majority of configurations evaluated in this test series had a discharge time of 30 s, resulting in an application rate of 3.3 lb/s. It was also of interest to evaluate configurations with a discharge time of 20 s, which result in an application rate of 5 lb/s. Although the firefighter would have less time to suppress the fire, the increased agent flow rate may have resulted in improved effectiveness, allowing the firefighter to extinguish the full F-100 fire scenario. To produce discharge times of 20 s with the Rosenbauer and StoneAge nozzles used in this test series, it was necessary to utilize system pressures of 2100 and 1500 psi, respectively, due to the orifice diameter of these nozzles. As described above, this relatively high pressure reduced the effectiveness against the pool portion of the F-100 fire scenario. We recommend that future investigators purchase or construct a UHP nozzle with an orifice diameter sufficient to permit discharge times of 20 s at pressures in the range of 500 to 1500 psi.

The Rosenbauer and StoneAge nozzle configurations evaluated in this work contained a cylindrical interior cross section. However, many commercial extinguishers include nozzles with conical rather than cylindrical interior cross-sections. We recommend that future investigators purchase or construct a UHP nozzle with this interior geometry. Such a configuration may result in a more dispersed discharge pattern that would improve performance against the pool fire portion of the F-100 fire scenario.

## 7. REFERENCES

1. Department of Defense Environmental Security Technology Certification Program, "Qualification of an Acceptable Alternative to Halon 1211 DoD Flightline Extinguishers", ESTCP Project WP-0618, NAWCWD TP 8572 (available online at [www.serdp.org](http://www.serdp.org)).
2. Warner Robins Air Logistics Center, Purchase Description PD 99LECF02, "Extinguisher, Fire Liquefied Gas (Halon 1211) 150 Pound, Wheeled", dated 19 Feb 1999.
3. Underwriters Laboratory Standard 711, *Rating and Fire Testing of Fire Extinguishers*, dated 17 December, 2004.
4. NFPA 407: *Standard for Aircraft Fuel Servicing*, National Fire Protection Association (2007).
5. NFPA 410: *Standard on Aircraft Maintenance*, National Fire Protection Association (2010).
6. *Minimum Performance Requirements for Air Force Flightline Fire Extinguishers: Extinguishing Performance Against 3-Dimensional and Hidden Fires*, AFRL-ML-TY-02-4540, May 2002.
7. *Evaluation of the AMEREX Model 775 Wheeled Extinguisher with Novec*, AFCEC-CX-TY-TR-2014-0033, November 2014.
8. *Fire Extinguishing Effectiveness Tests*, McDonald, Michael J. et al. Defense Technical Information Center. AFRL-ML-TY-TR-2004-4554, October 2005.
9. *F100 Engine Nacelle Firefighting Test Mockup Drawings*, AFRL-ML-TY-TR-2002-4604, July 2002.



## LIST OF SYMBOLS, ABBREVIATIONS, AND ACRONYMS

°F	degrees Fahrenheit
AFCEC	Air Force Civil Engineering Center
AFFF	Aqueous Film Forming Foam
AFRL	Air Force Research Laboratory
ALC	Air Logistics Center
DLA	Defense Logistics Agency
DoD	Department of Defense
ESTCP	Environmental Security Technology Certification Program
ft	feet
g	gram
gal	gallon(s)
gal/min	gallons per minute
GSA	General Services Administration
L	liter(s)
lb	pound
lb/s	pounds per second
mph	miles per hour
NFPA	National Fire Protection Association
NPT	National Pipe Thread
ODS	ozone depleting substance
psi	pounds per square inch
s	second
UHP	ultra-high-pressure
UL	Underwriters Laboratories
USAF	United States Air Force