



ARL-TN-0728 • DEC 2015



# Aircraft Enroute Command and Control Comms Redesign Mechanical Documentation

by Steven P Callaway

Approved for public release; distribution unlimited.

## **NOTICES**

### **Disclaimers**

The findings in this report are not to be construed as an official Department of the Army position unless so designated by other authorized documents.

Citation of manufacturer's or trade names does not constitute an official endorsement or approval of the use thereof.

Destroy this report when it is no longer needed. Do not return it to the originator.



# **Aircraft Enroute Command and Control Comms Redesign Mechanical Documentation**

**by Steven P Callaway**

*Computational and Information Sciences Directorate, ARL*

**REPORT DOCUMENTATION PAGE**

Form Approved  
OMB No. 0704-0188

Public reporting burden for this collection of information is estimated to average 1 hour per response, including the time for reviewing instructions, searching existing data sources, gathering and maintaining the data needed, and completing and reviewing the collection information. Send comments regarding this burden estimate or any other aspect of this collection of information, including suggestions for reducing the burden, to Department of Defense, Washington Headquarters Services, Directorate for Information Operations and Reports (0704-0188), 1215 Jefferson Davis Highway, Suite 1204, Arlington, VA 22202-4302. Respondents should be aware that notwithstanding any other provision of law, no person shall be subject to any penalty for failing to comply with a collection of information if it does not display a currently valid OMB control number.

**PLEASE DO NOT RETURN YOUR FORM TO THE ABOVE ADDRESS.**

<b>1. REPORT DATE (DD-MM-YYYY)</b> December 2015		<b>2. REPORT TYPE</b> Technical Note		<b>3. DATES COVERED (From - To)</b> 04/2015	
<b>4. TITLE AND SUBTITLE</b> Aircraft Enroute Command and Control Comms Redesign Mechanical Documentation				<b>5a. CONTRACT NUMBER</b>	
				<b>5b. GRANT NUMBER</b>	
				<b>5c. PROGRAM ELEMENT NUMBER</b>	
<b>6. AUTHOR(S)</b> Steven P Callaway				<b>5d. PROJECT NUMBER</b> R.0013587.1	
				<b>5e. TASK NUMBER</b>	
				<b>5f. WORK UNIT NUMBER</b>	
<b>7. PERFORMING ORGANIZATION NAME(S) AND ADDRESS(ES)</b> US Army Research Laboratory ATTN: RDRL-CII-B 2800 Powder Mill Road Adelphi, MD 20783-1138				<b>8. PERFORMING ORGANIZATION REPORT NUMBER</b> ARL-TN-0728	
<b>9. SPONSORING/MONITORING AGENCY NAME(S) AND ADDRESS(ES)</b> SOCOM				<b>10. SPONSOR/MONITOR'S ACRONYM(S)</b>	
				<b>11. SPONSOR/MONITOR'S REPORT NUMBER(S)</b>	
<b>12. DISTRIBUTION/AVAILABILITY STATEMENT</b> Approved for public release; distribution unlimited.					
<b>13. SUPPLEMENTARY NOTES</b>					
<b>14. ABSTRACT</b> The Next Generation Joint Command and Control System pallet systems serves as an enroute command center, stowed in the rear of a C-17 or C-130 aircraft. They original system, designed by the US Army Research Laboratory had been used extensively and required updating. Based on customer specified requirements the uninterrupted power supply, frequency converter, DC power supply, and monitor mount were updated.					
<b>15. SUBJECT TERMS</b> JC2S, NG-JC2S, en route, comms, command, 463L, aircraft, pallet, C-17, C-130					
<b>16. SECURITY CLASSIFICATION OF:</b>			<b>17. LIMITATION OF ABSTRACT</b> UU	<b>18. NUMBER OF PAGES</b> 62	<b>19a. NAME OF RESPONSIBLE PERSON</b> Steven P Callaway
<b>a. REPORT</b> Unclassified	<b>b. ABSTRACT</b> Unclassified	<b>c. THIS PAGE</b> Unclassified			<b>19b. TELEPHONE NUMBER (Include area code)</b> (301) 394-1152



## **Contents**

---

---

<b>List of Tables</b>	<b>iv</b>
<b>1. Introduction</b>	<b>1</b>
<b>2. Mechanical Requirements</b>	<b>1</b>
<b>3. Drawing Package</b>	<b>2</b>
<b>4. Conclusion</b>	<b>3</b>
<b>Appendix. NG-JC2S Comms System Drawings</b>	<b>5</b>
<b>Distribution List</b>	<b>55</b>

## List of Tables

---

---

Table 1	NG-JC2S COMMS System drawing package .....	2
---------	--	---

## **1. Introduction**

---

---

Joint Command and Control System (JC2S) pallets serve as a mobile command system for commanders. A single system is comprised of 3 463L aircraft pallets, loaded into the rear cargo area of a C-17 and C-130 aircraft. Two of the pallets, deemed planner's pallets, feature 6 opposing desk stations on each pallet, for a total of 12 user stations in each system. Each desk station includes network, communications (comms), and power interfaces for each user to be able to conduct battle command while en route.

The third pallet, the comms pallet, is where all of the necessary comms and power equipment is secured. Custom racks, with 8 server rack bays, are mounted to the pallet, with 2 desk stations for equipment operators, responsible for keeping the comms equipment running as necessary during the mission.

The initial system, designed and fabricated at the US Army Research Laboratory (ARL), has served thousands of hours on hundreds of missions. After a long period of service, the customer wanted to update to newer equipment and eliminate unnecessary features, evident after the extensive field experience.

## **2. Mechanical Requirements**

---

---

Three main mechanical subsystems were redesigned in the Next Generation JC2S (NG-JC2S) COMMS System: the uninterrupted power supply (UPS) and frequency converter, the DC power supplies, and the flat panel displays.

The UPS and frequency converter act as a battery backup and power conditioning for the network equipment. The frequency converter converts 115/200 V AC, 400-Hz, 3-phase aircraft power to 120 V AC, 60-Hz, single-phase power so that it can be used by conventional rack equipment. Equipment in the original system was larger and heavier than the new equipment selected for the NG-JC2S. Battery backup was required by the customer for specific network equipment in the event of a power interruption. The UPS and frequency converter were required to be mounted so that they could be easily removed by the user in the case of equipment failure.

The DC power supply sub system supplies 24 V DC power to the necessary equipment. The wiring for these power supplies needed to be shielded to protect the user, but also easily accessible for maintenance purposes. The equipment also needed to be easily removable in the event of equipment failure. Surplus rack space available in the NG-JC2S system allowed for a new power supply mounting

approach, making the equipment more easily serviceable and lowering the center of gravity of the system.

The flat panel displays, positioned off of the end of the comms pallet facing the Planner's pallets, were upgraded in the NG-JC2S COMMS System from four 23 inch flat panel displays to two 26 inch flat panel displays and one 32 inch flat panel display. The displays needed to be mounted with an overall height no greater than 108 inches and inside the outer envelope of the pallet.

### **3. Drawing Package**

The following drawing package (Table 1) was used for the fabrication of parts for the NG-JC2S COMMS System. The package was also consulted by ARL technicians for system assembly. The individual drawings are provided in the Appendix.

**Table 1 NG-JC2S COMMS System drawing package**

<b>SK549241 Falcon UPS Frequency Converter Bottom Mount</b>	
<b>Dash No.</b>	<b>Drawing Title</b>
-11001	UPS Bottom Mount, Tray
-11002	UPS Bottom Mount, Rail Guide
-11003	UPS Bottom Mount, Crossmember
-11004	UPS Bottom Mount, Rear Block 2.1
-11005	UPS Bottom Mount, Rear Block 2.2
-11006	UPS Bottom Mount, Retainer Shim
-11007	Battery Hawker Bracket, Right
-11008	Battery Hawker Bracket, Left
-11009	Battery Hawker Bracket, Rear
<b>SK549243 DC P/S Mount</b>	
<b>Dash No.</b>	<b>Drawing Title</b>
-1001	D/C PS Mount - Tray
-11002	D/C PS Mount - Crossmember
-11003	D/C PS Mount - Power Supply Plate
-11004	D/C PS Mount - Power Supply Plate Retainer
-11005	D/C PS Mount - Top Brace
-11006	D/C PS Mount - Finger Guard

**Table 1 NG-JC2S COMMS System drawing package (continued)**

**SK549265 Installation, Flat Panel Display**

---

<b>Dash No.</b>	<b>Drawing Title</b>
-11001	Monitor Mount - Rack U Channel Crossmember
-11002	Monitor Mount - Strut, Tab End
-11003	Monitor Mount - Strut, Clevis End
-11004	Monitor Mount - Strut, Eye Bolt
-12001	26 Inch Monitor Mount - Crossmember, Screen Display Mounting
-12002	26 Inch Monitor Mount - Frame, Left
-12003	26 Inch Monitor Mount - Frame, Right
-12004	26 Inch Monitor Mount - Lower Crossmember
-12005	26 Inch Monitor Mount - Bracket, Crossmember Pin
-12006	26 Inch Monitor Mount - Lower Vertical Support
-12007	26 Inch Monitor Mount - Strut, Tube
-13001	32 Inch Monitor Mount - Crossmember, Screen Display Mounting
-13002	32 Inch Monitor Mount - Frame, Left
-13003	32 Inch Monitor Mount - Frame, Right
-13004	32 Inch Monitor Mount - Lower Crossmember
-13005	32 Inch Monitor Mount - Bracket, Crossmember Pin
-13006	32 Inch Monitor Mount - Lower Vertical Support
-13007	32 Inch Monitor Mount - Strut, Tube
-13008	32 Inch Monitor Mount - Strut Block
-13009	32 Inch Monitor Mount - Lower Crossmember Spacer
-13010	32 Inch Monitor Mount - Top Crossmember Spacer

---

#### **4. Conclusion**

---

---

After extensive use, the JC2S pallet required updating. The NG-JC2S system was developed at ARL based on new requirements and specifications from the customer. Capabilities and equipment were either updated or eliminated based on the customers experience with the system. The UPS, frequency converter, DC power supply mount, and monitor mount were redesigned and updated. Initial system deployment is ongoing.

INTENTIONALLY LEFT BLANK.

## **Appendix. NG-JC2S Comms System Drawings**

---

---

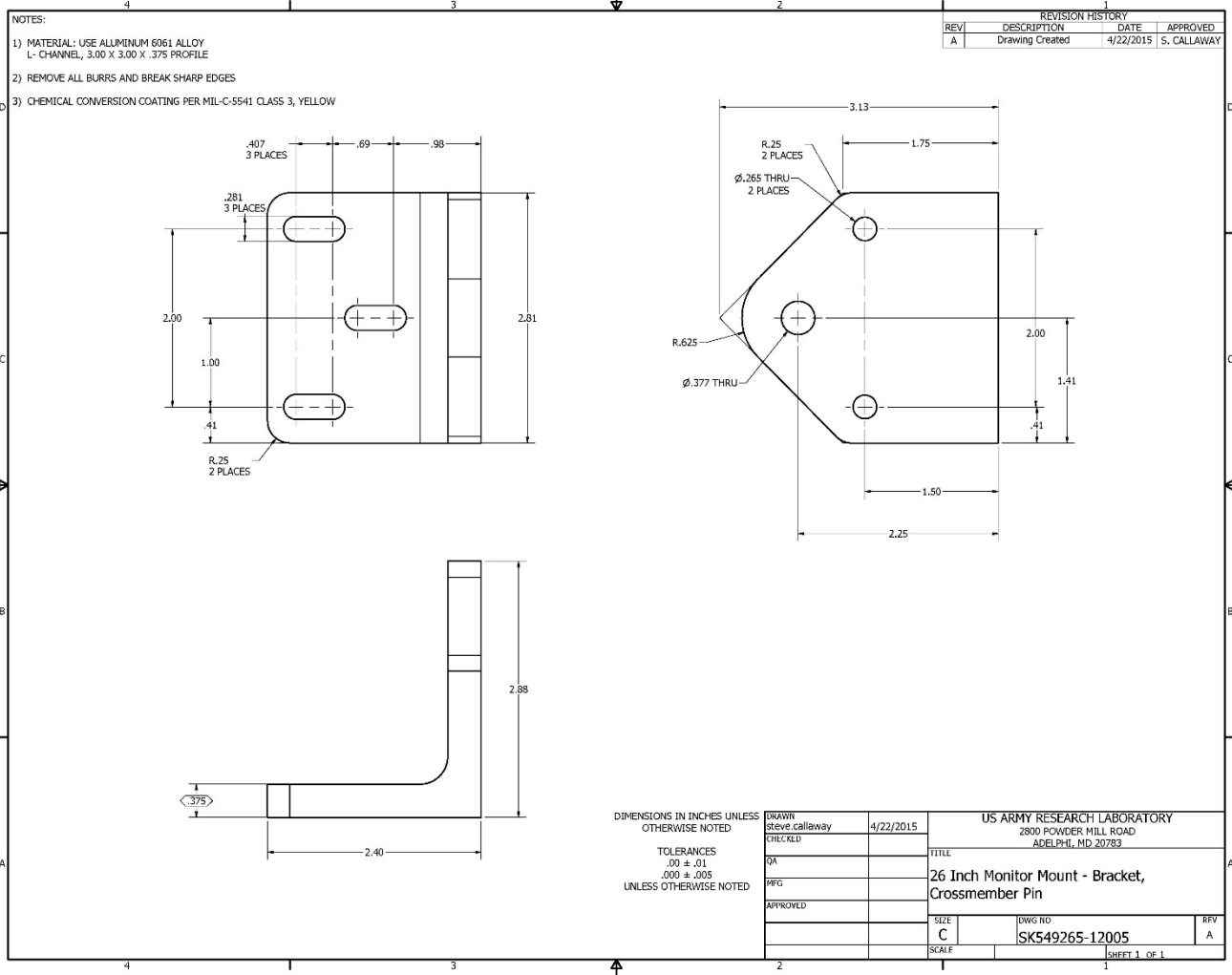



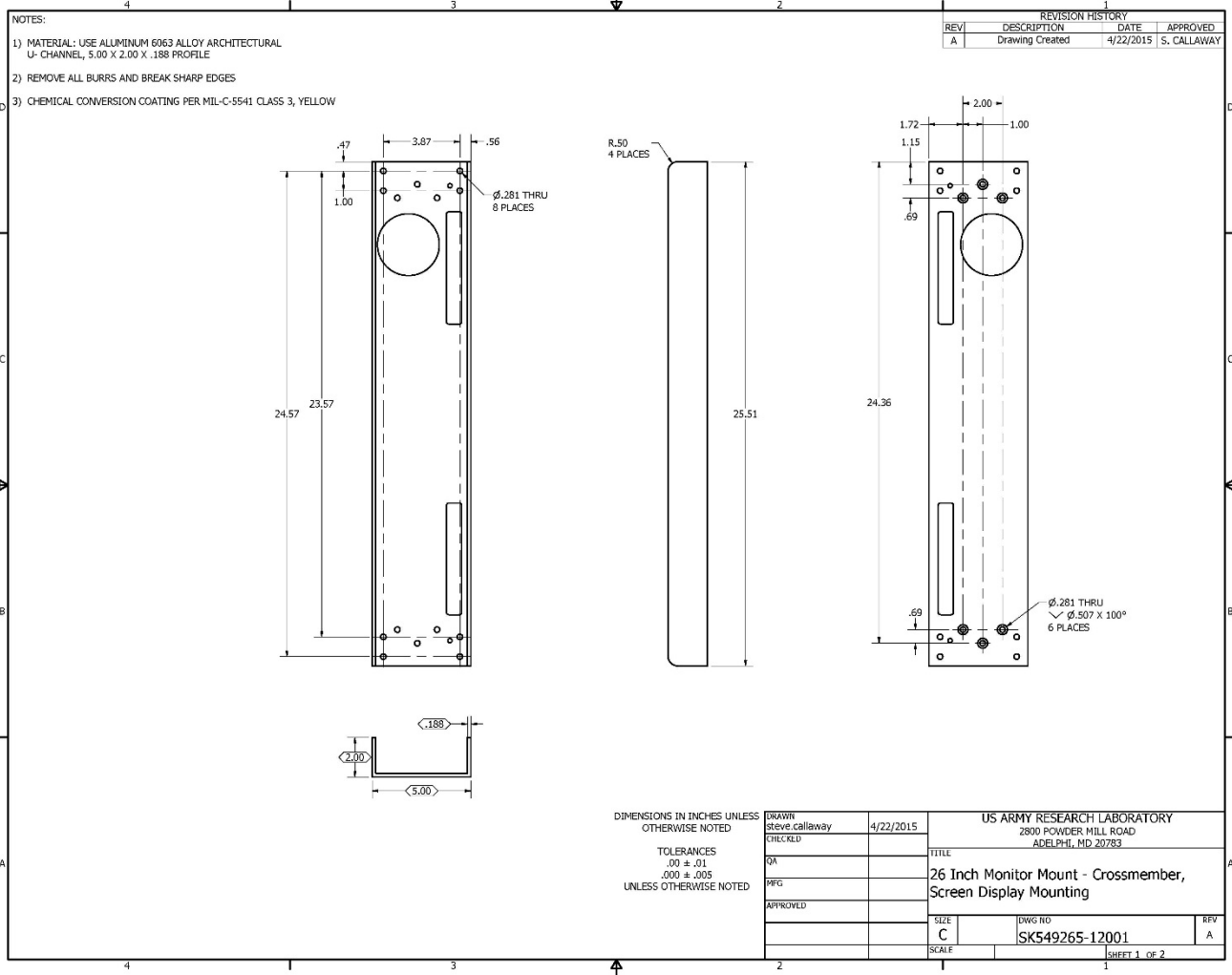

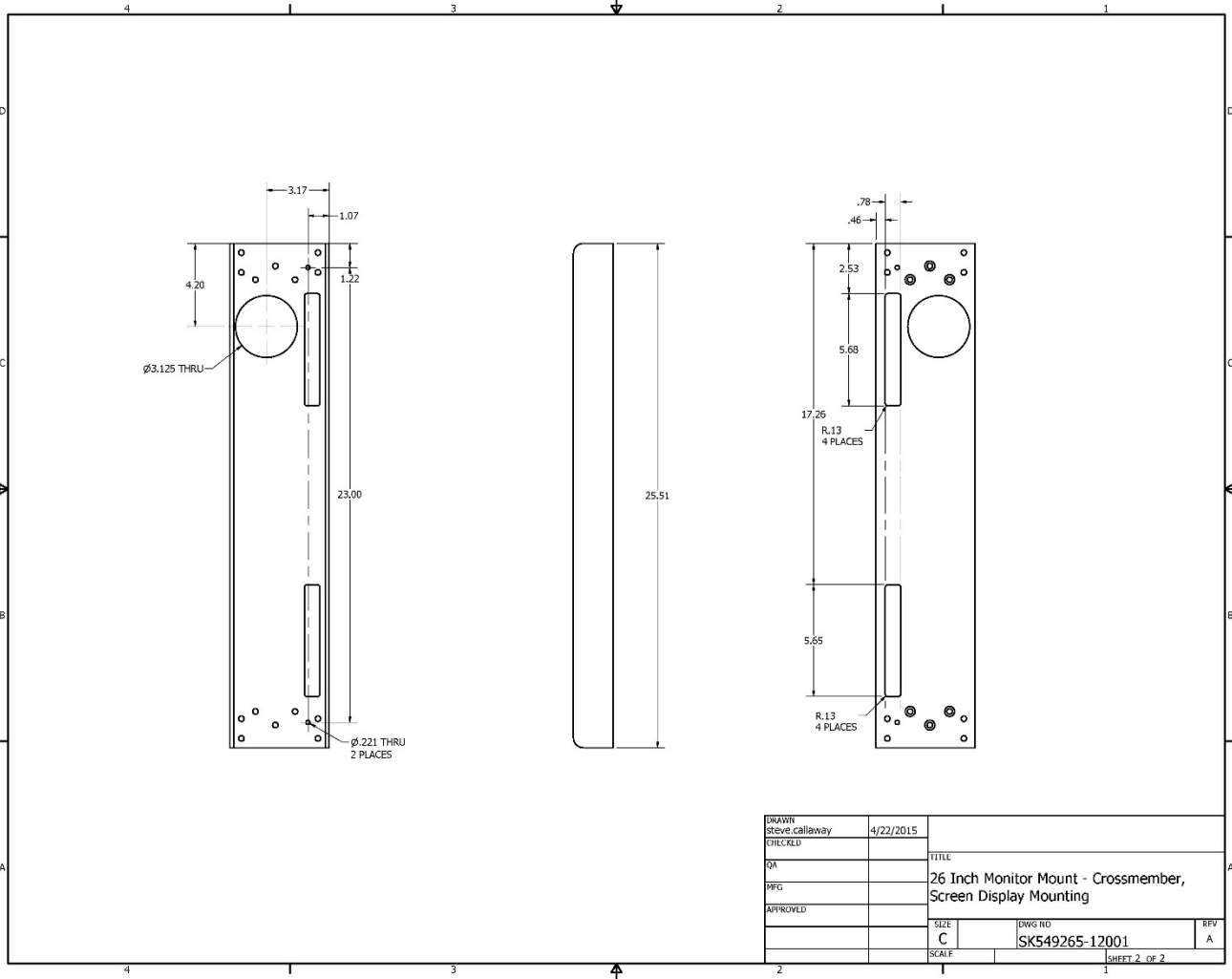

DRAWN	steve.callaway	4/22/2015		
CHECKED			TITLE	
QA			26 Inch Monitor Mount - Crossmember, Screen Display Mounting	
PFG			SIZE	DWG NO
APPROVED			C	SK549265-12001
			SCALE	REV A
				SHEET 2 OF 2

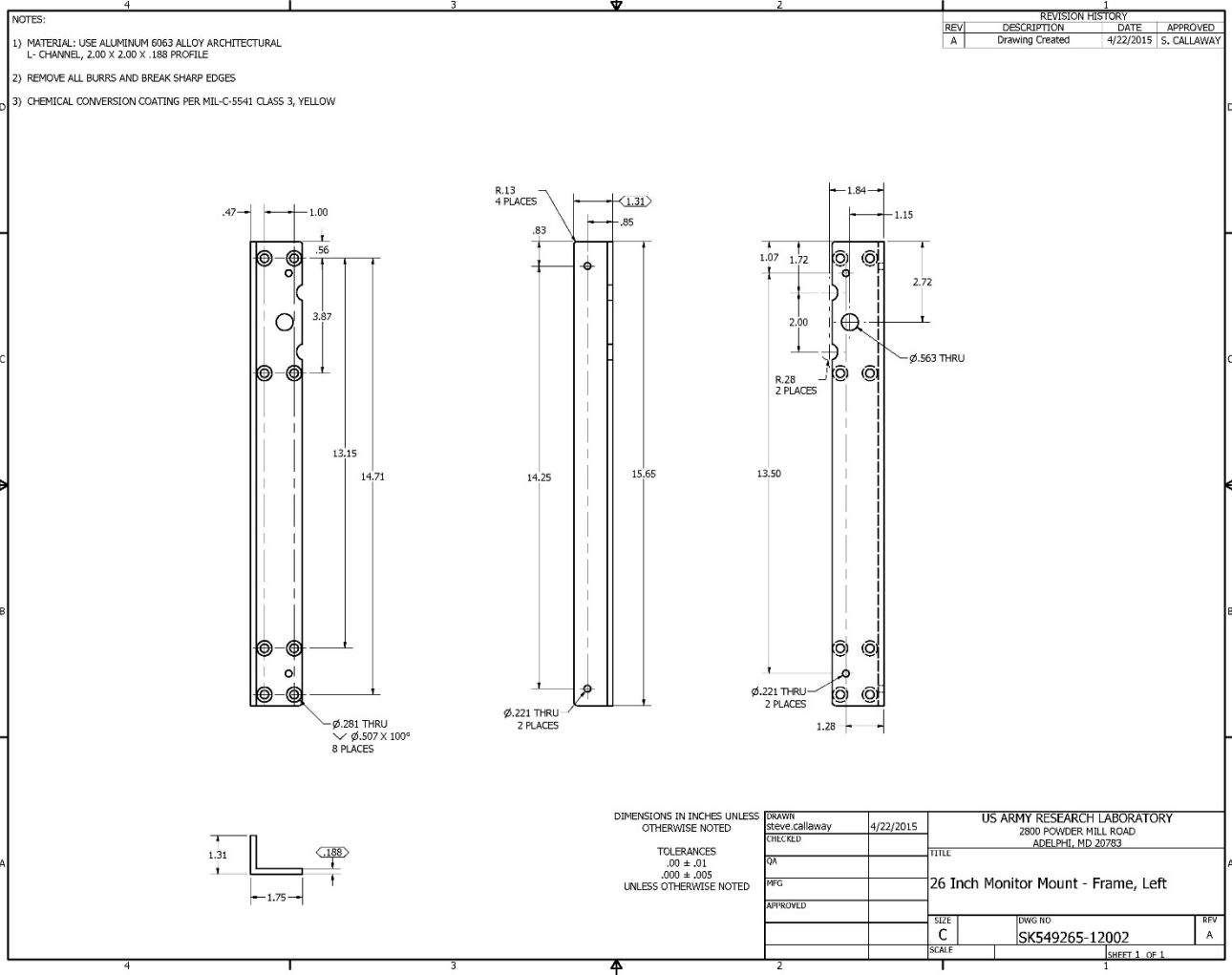

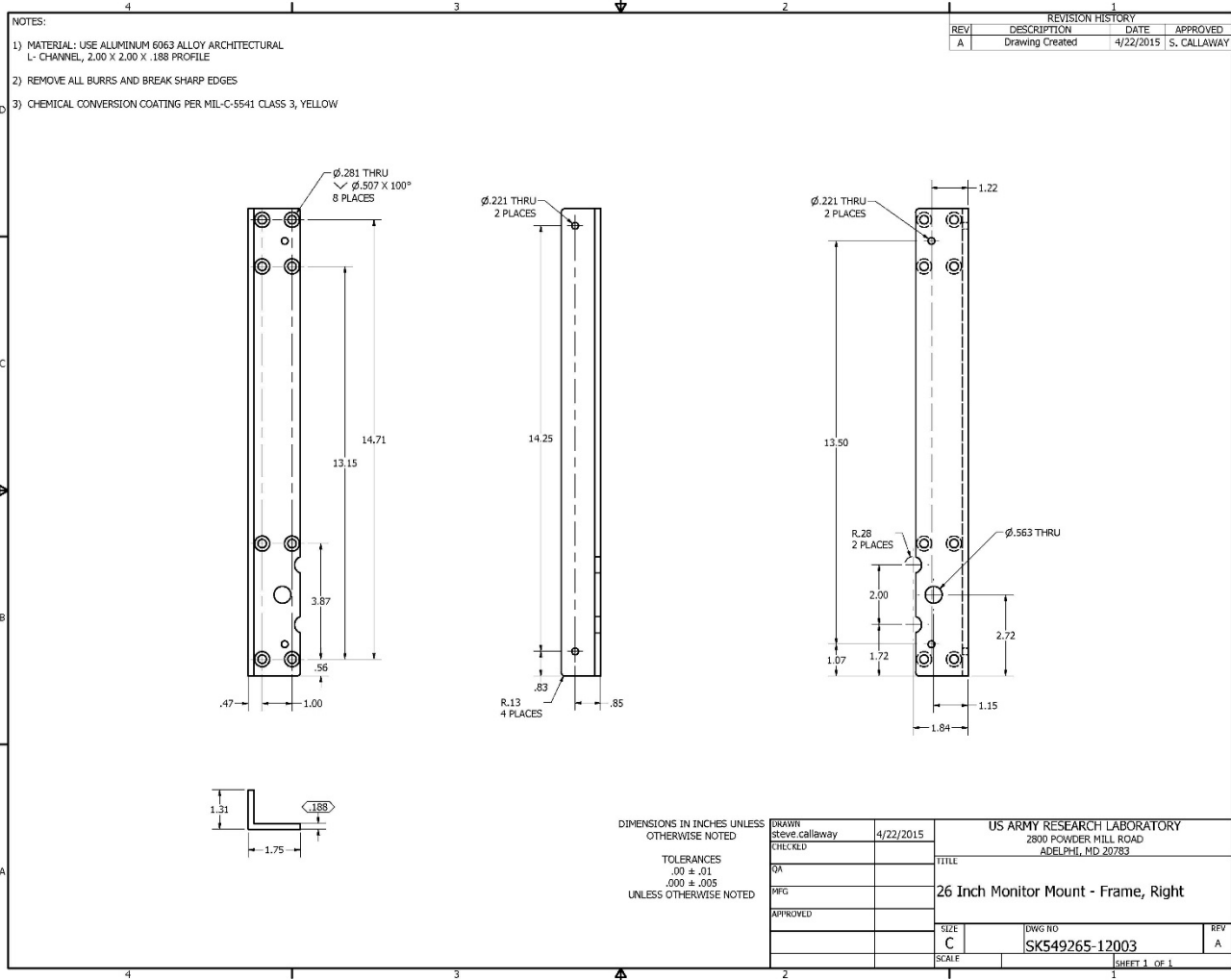

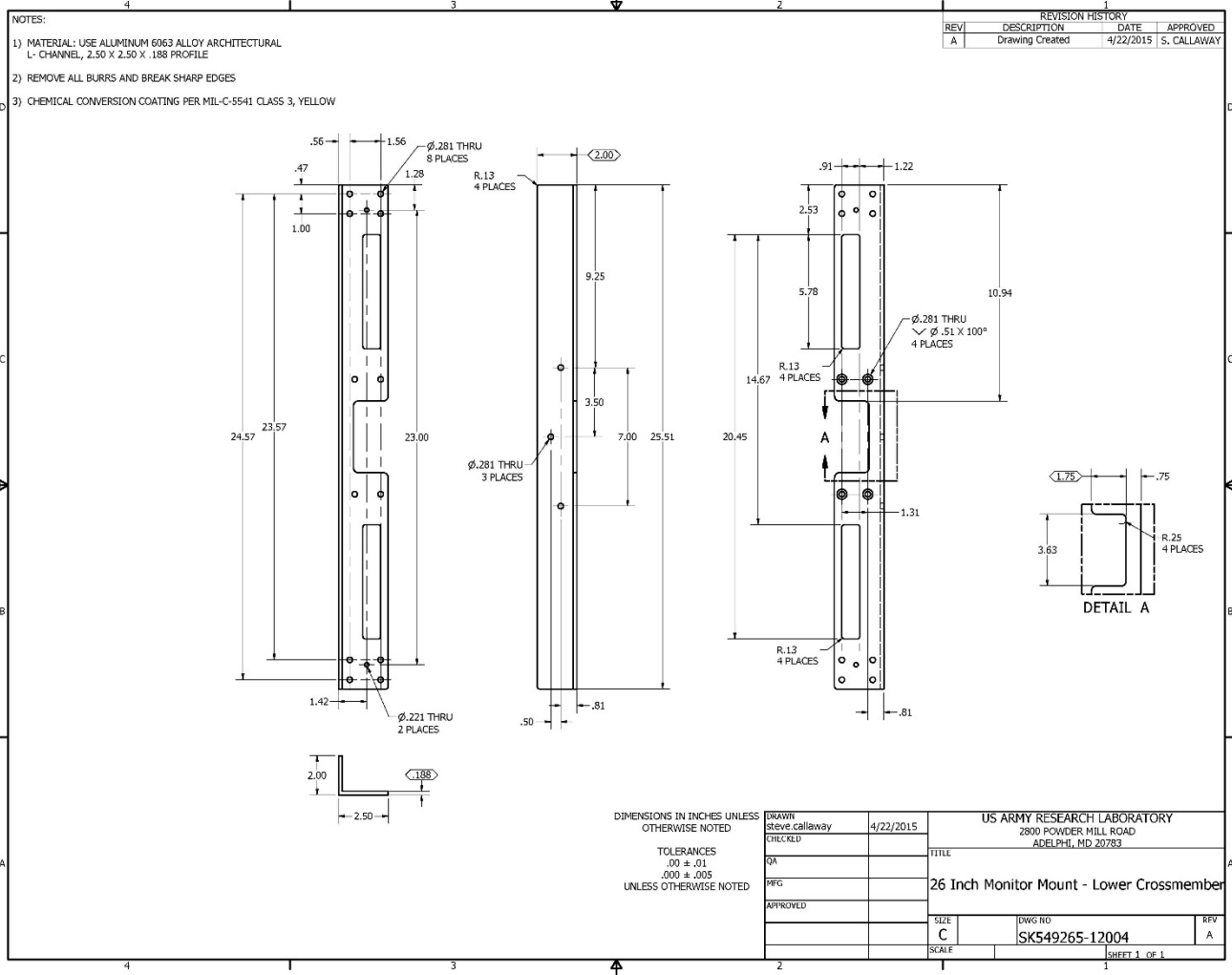

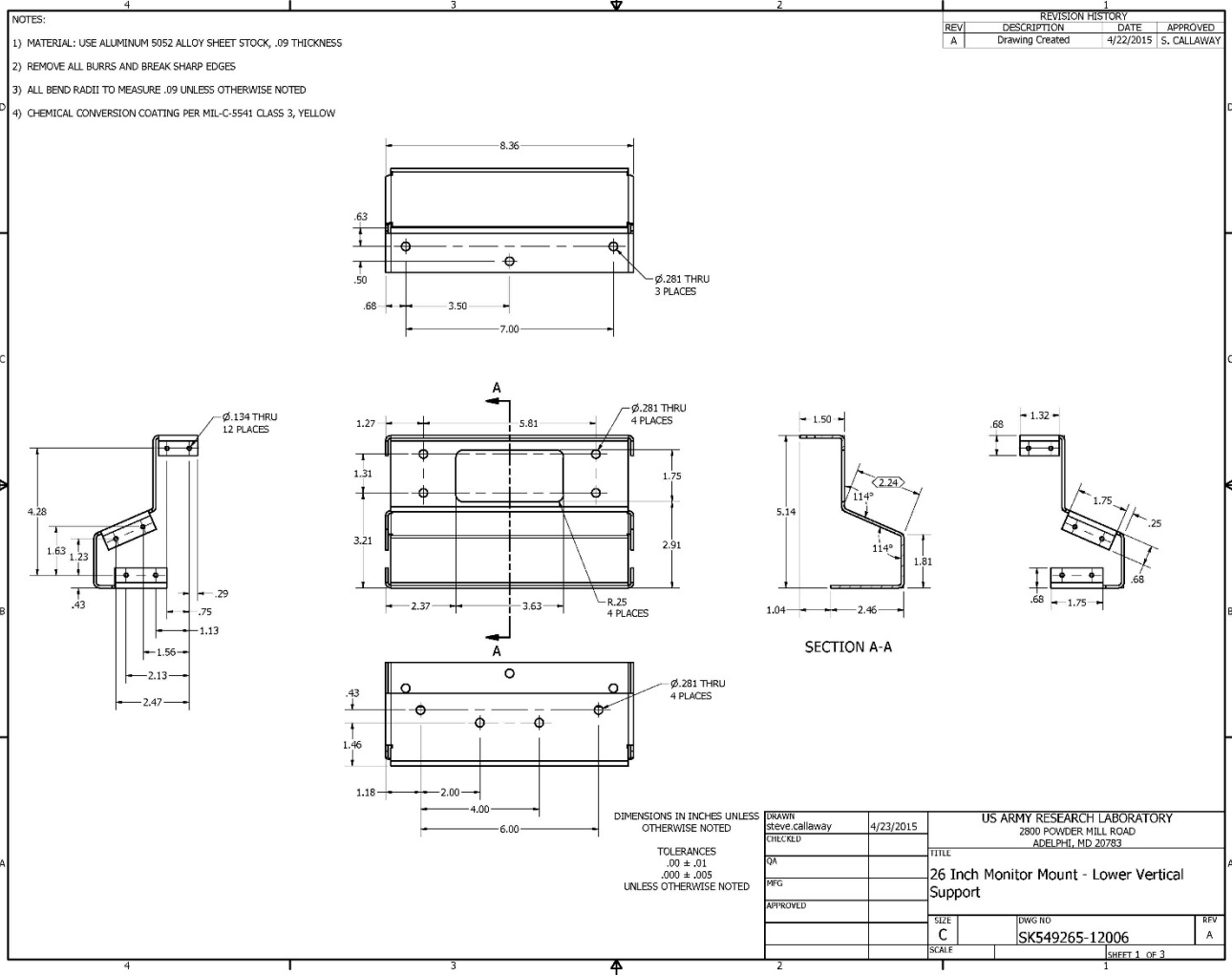

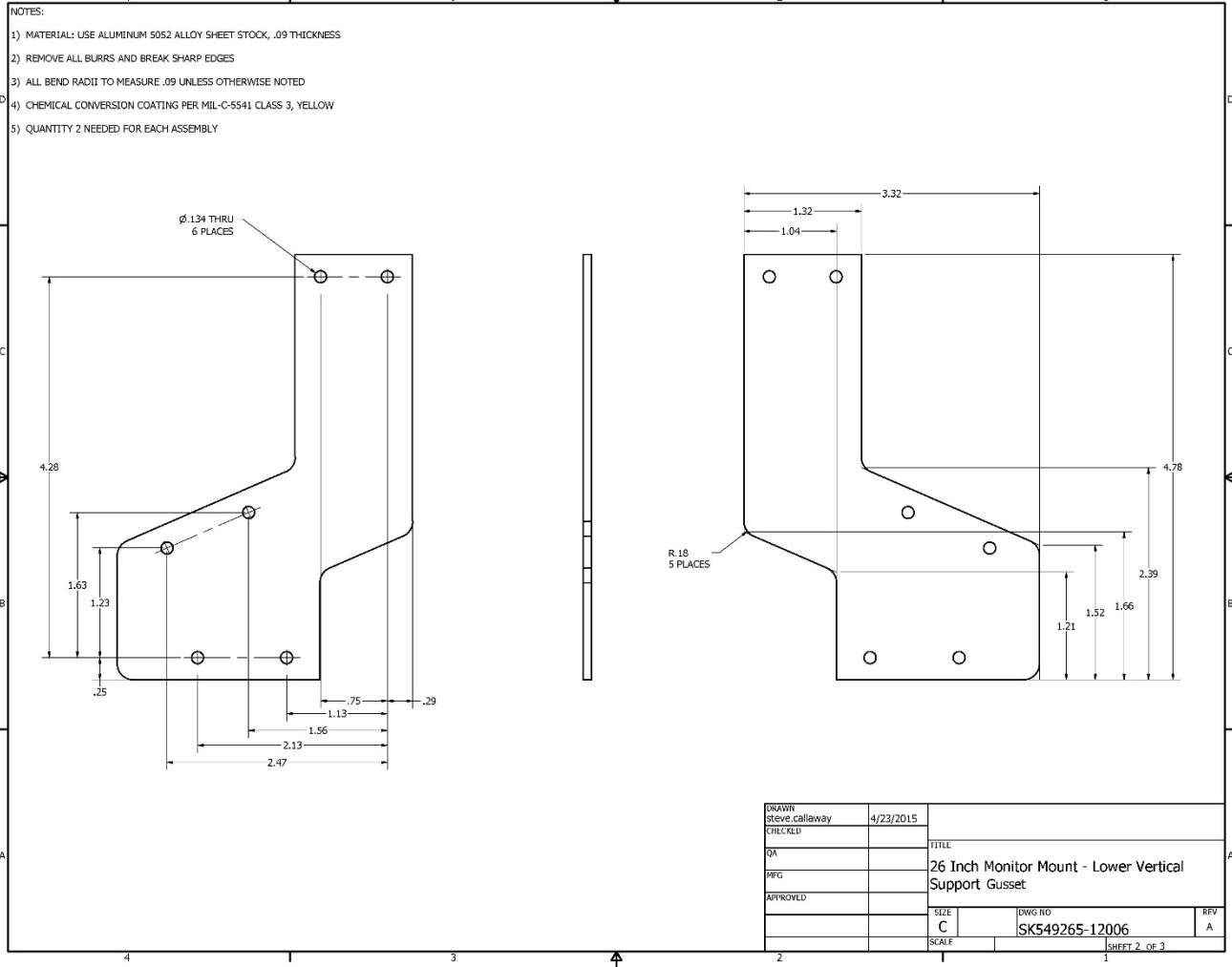

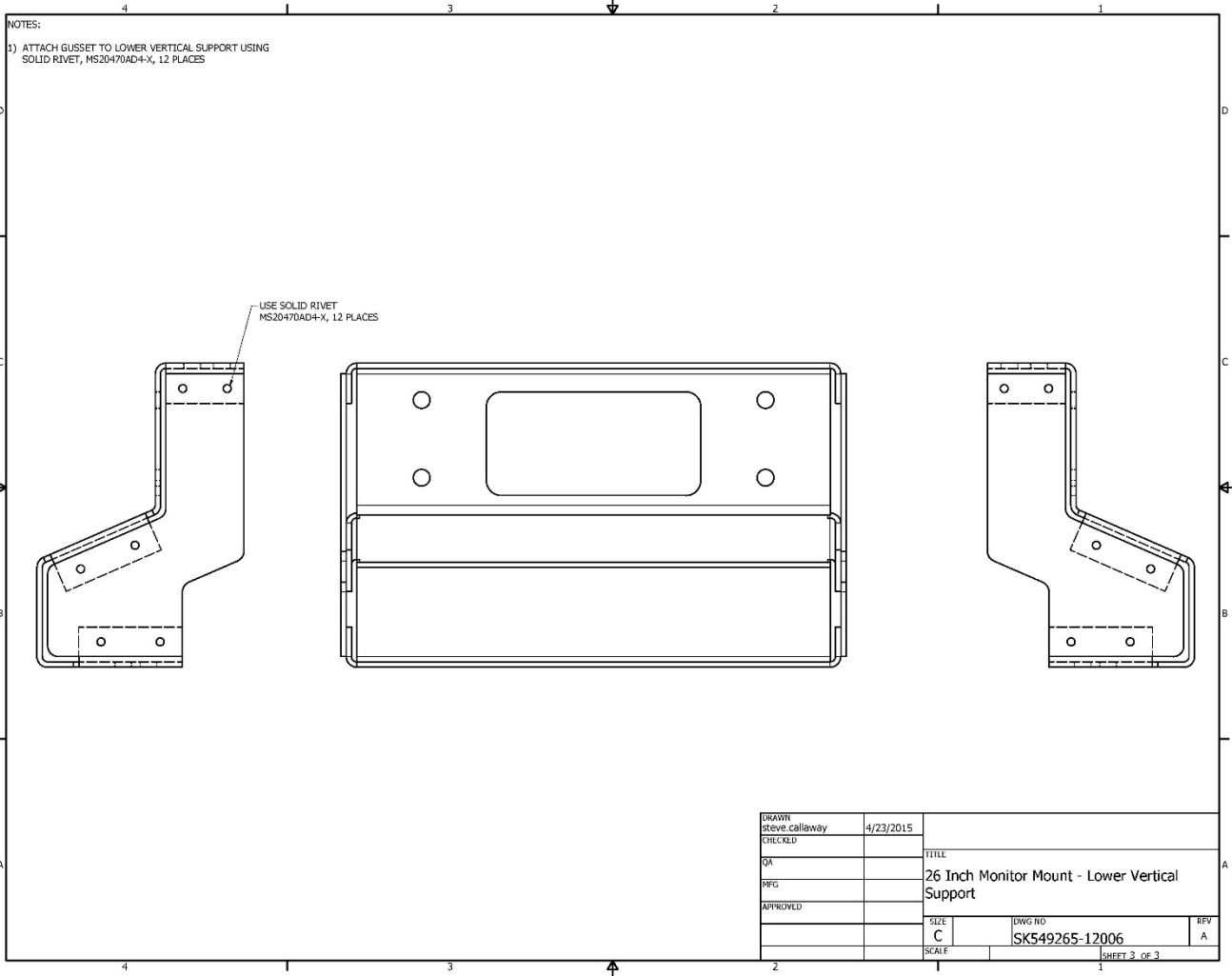

DRAWN	steve.callaway	4/23/2015		
CHECKED				
QA			TITLE	
PFG			26 Inch Monitor Mount - Lower Vertical Support	
APPROVED			SIZE	DWG NO
			C	SK549265-12006
			SCALE	REV
				A
				SHEET 3 OF 3



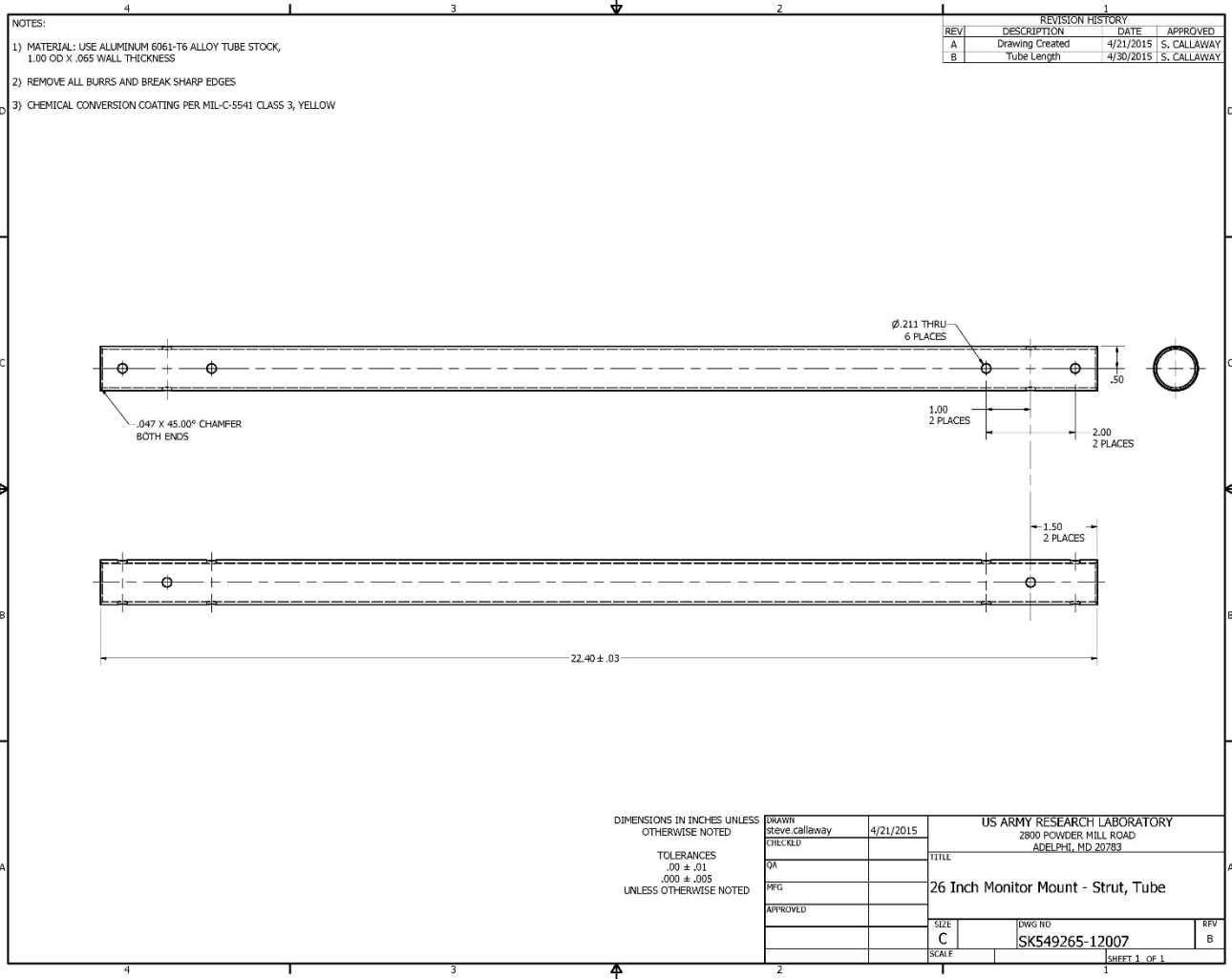

NOTES:  
 1) MATERIAL: USE ALUMINUM 6061-T6 ALLOY TUBE STOCK, 1.00 OD X .065 WALL THICKNESS  
 2) REMOVE ALL BURRS AND BREAK SHARP EDGES  
 3) CHEMICAL CONVERSION COATING PER MIL-C-5541 CLASS 3, YELLOW

REVISION HISTORY			
REV	DESCRIPTION	DATE	APPROVED
A	Drawing Created	4/21/2015	S. CALLAWAY
B	Tube Length	4/30/2015	S. CALLAWAY

DIMENSIONS IN INCHES UNLESS OTHERWISE NOTED  
 TOLERANCES  
 .00 ± .01  
 .000 ± .005  
 UNLESS OTHERWISE NOTED

DRAWN	steve.callaway	4/21/2015	US ARMY RESEARCH LABORATORY	
CHECKED			2800 POWDER MILL ROAD	
QA			ADELPHI, MD 20783	
PWG			TITLE	
APPROVED			26 Inch Monitor Mount - Strut, Tube	
			SIZE	DWG NO
			C	SK549265-12007
			SCALE	REV
				B
				SHEET 1 OF 1

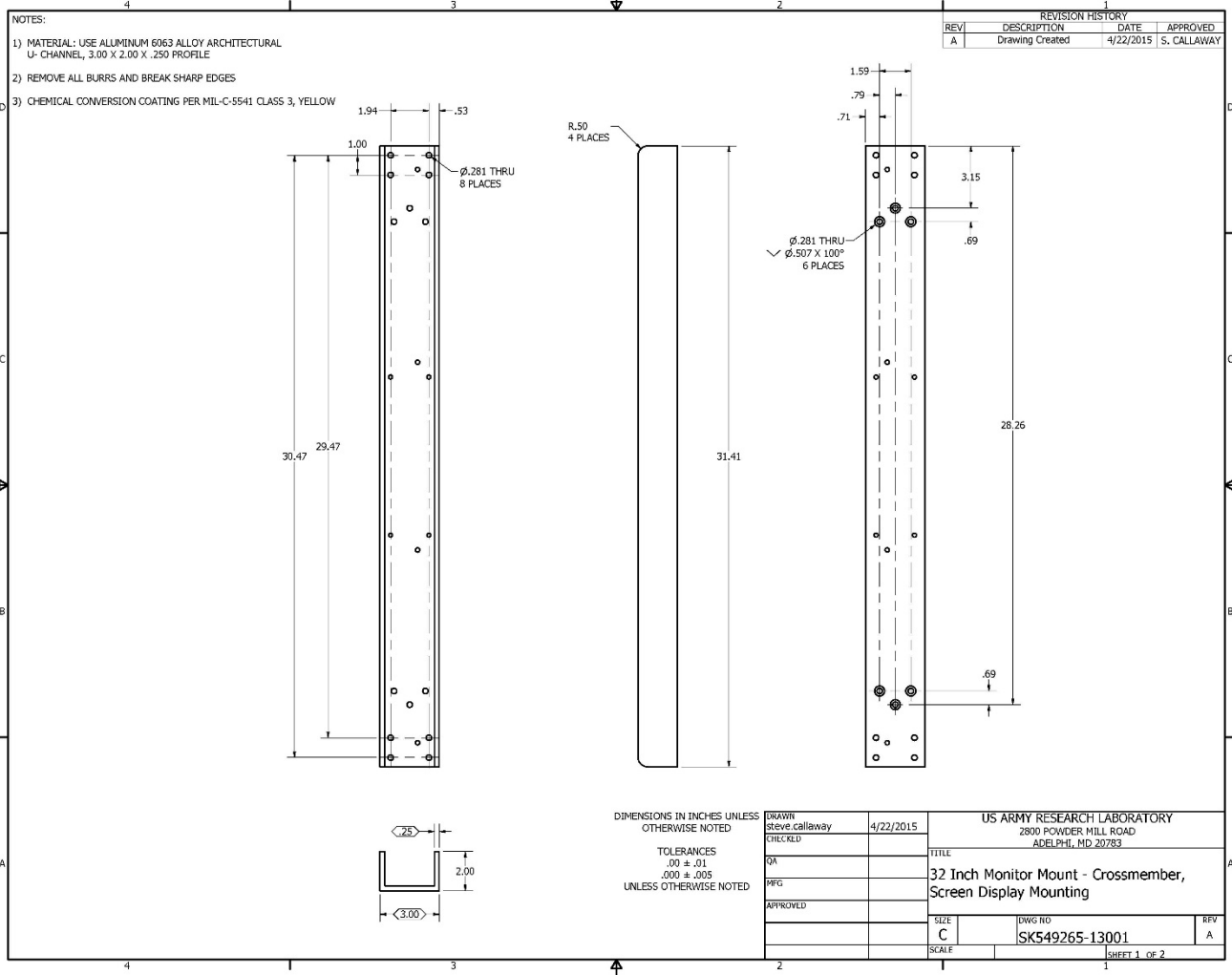

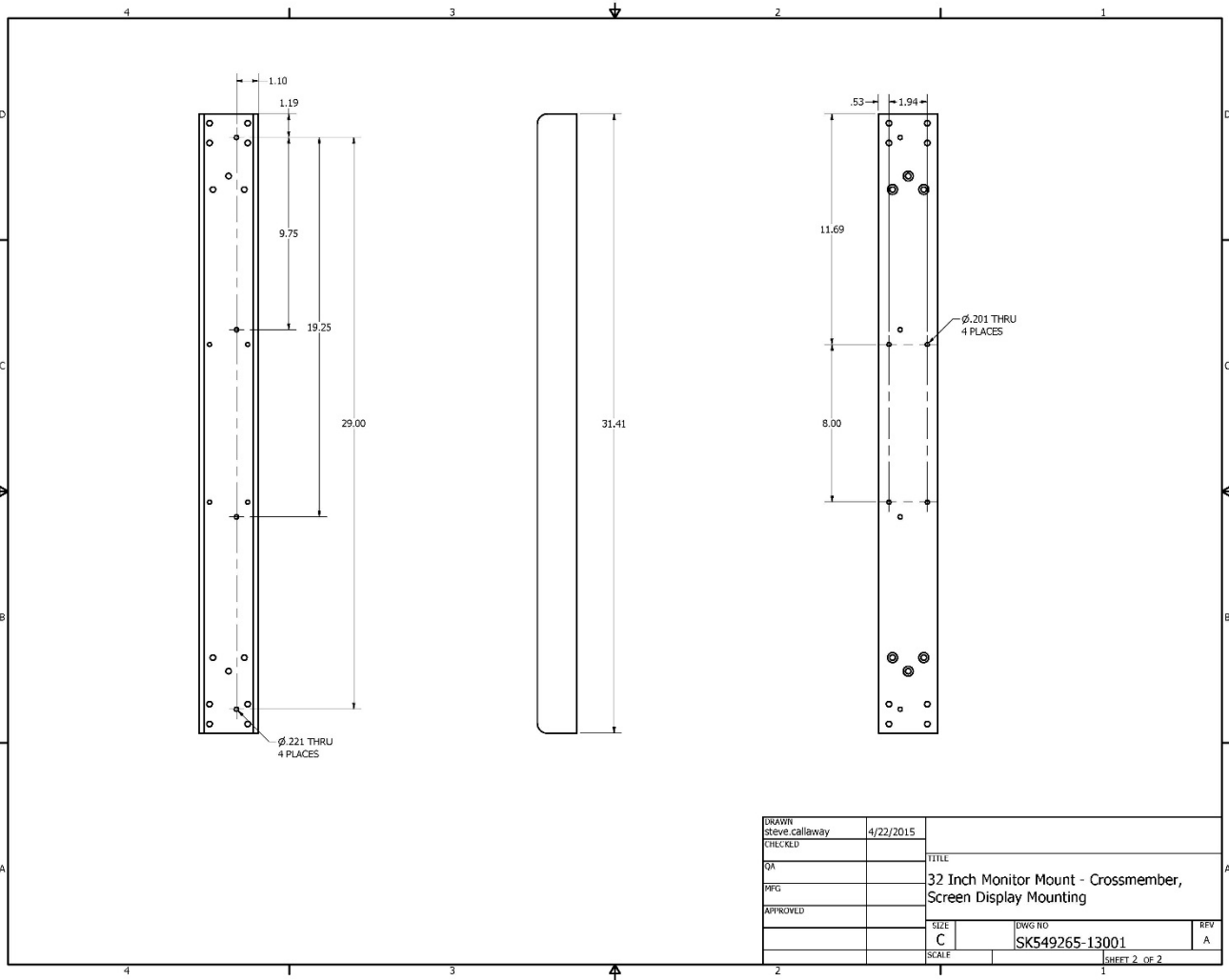

DRAWN	steve.callaway	4/22/2015		
CHECKED			TITLE	
QA			32 Inch Monitor Mount - Crossmember, Screen Display Mounting	
PWG			SIZE	DWG NO
APPROVED			C	SK549265-13001
			SCALE	REV A
				SHEET 2 OF 2

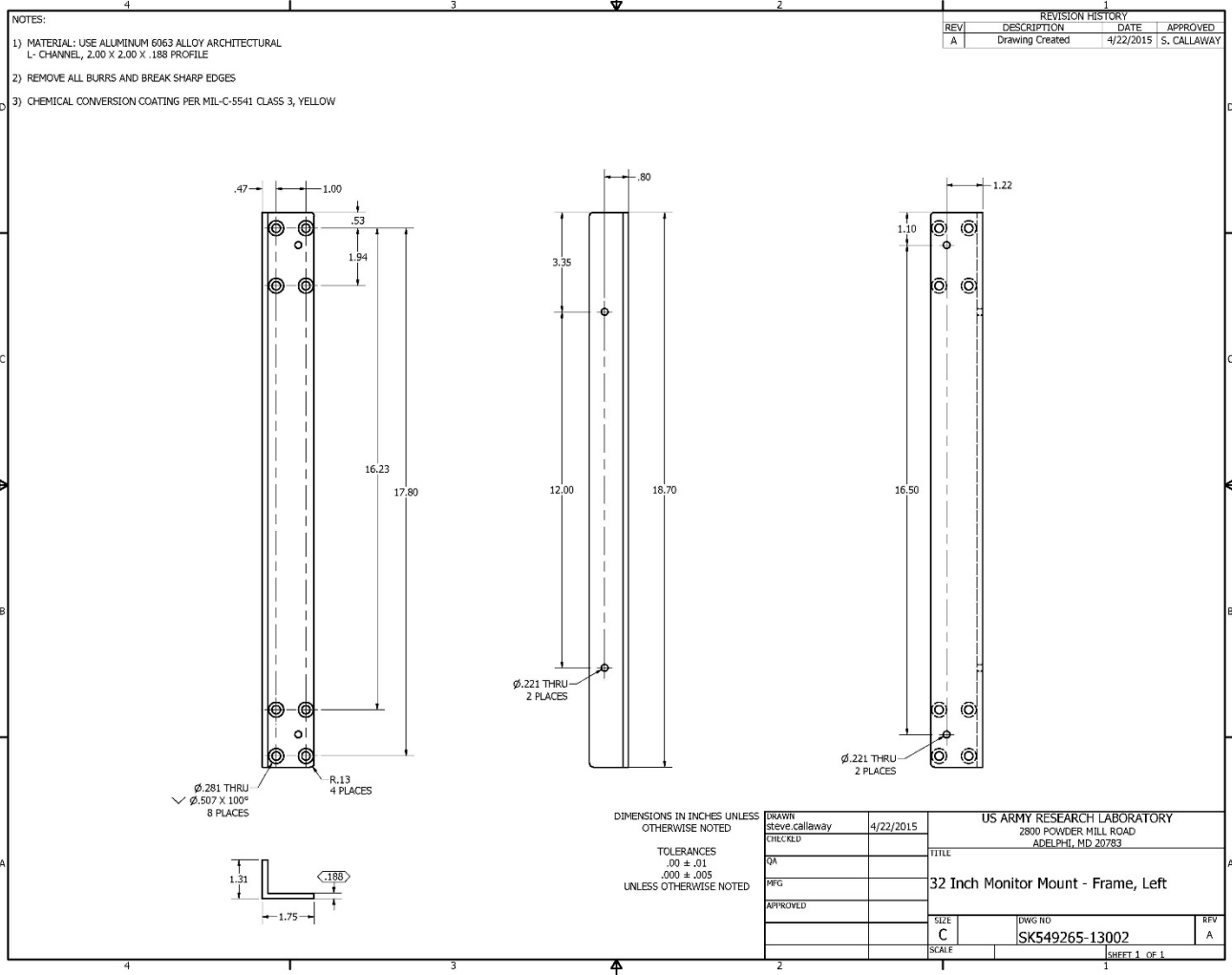

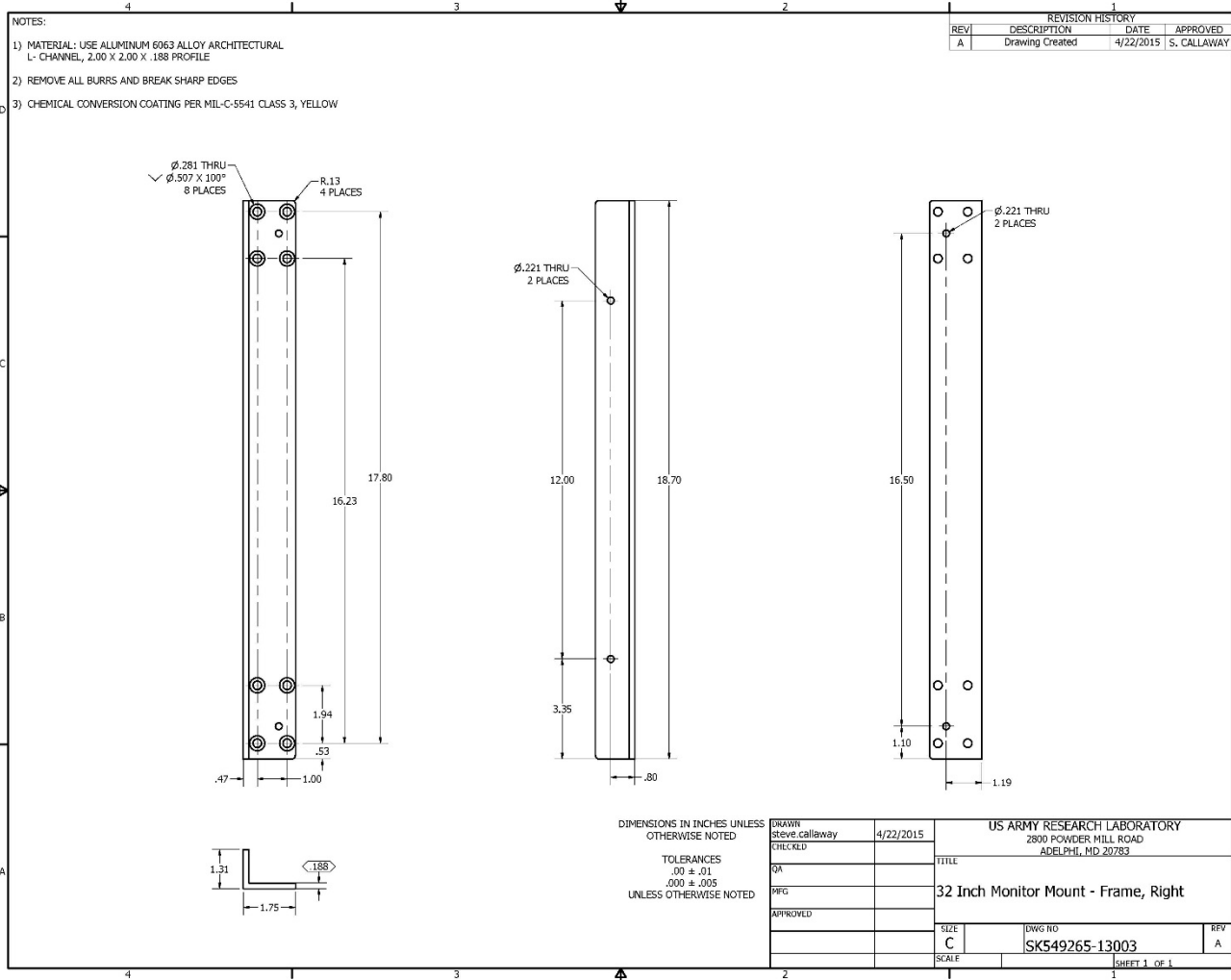

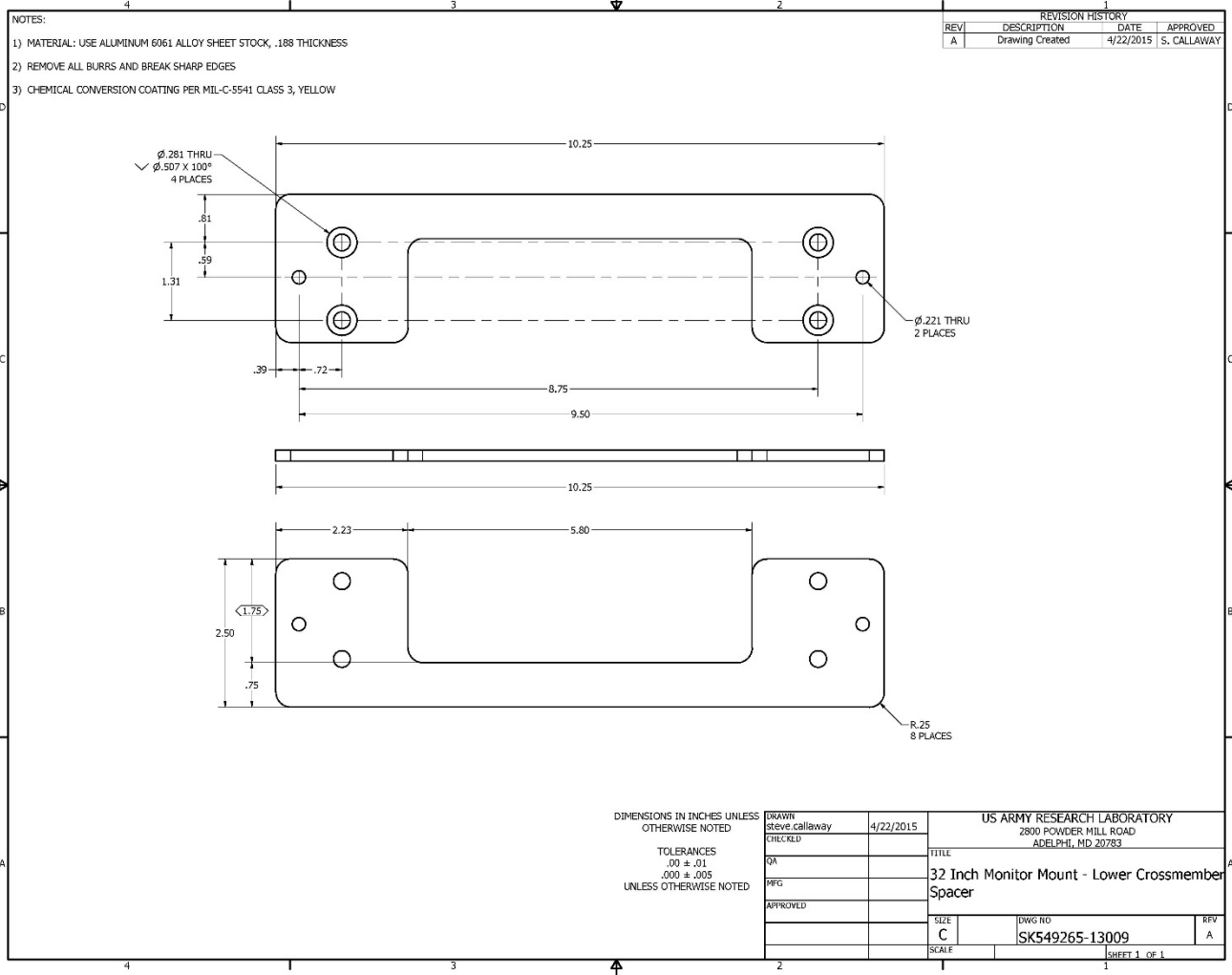

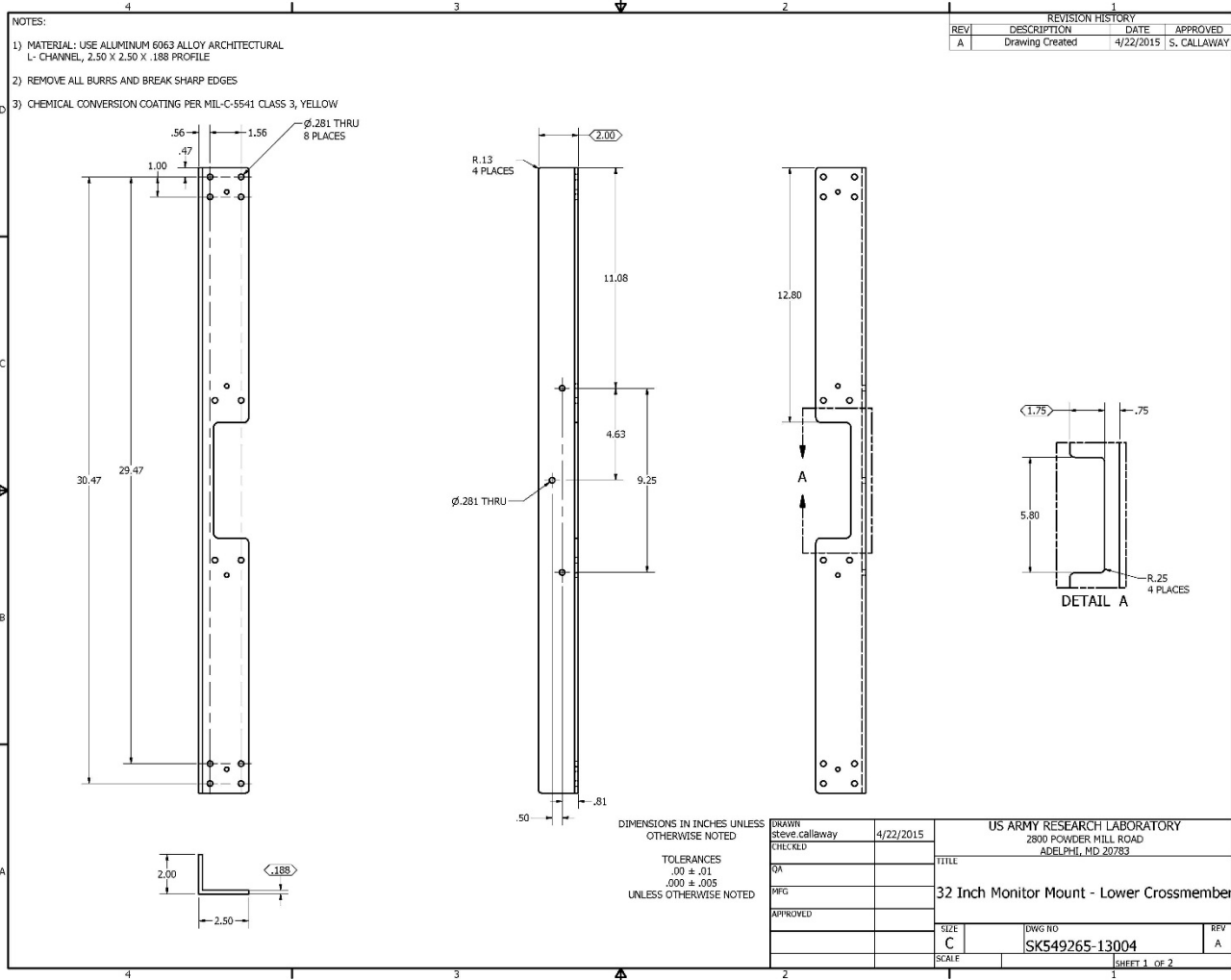

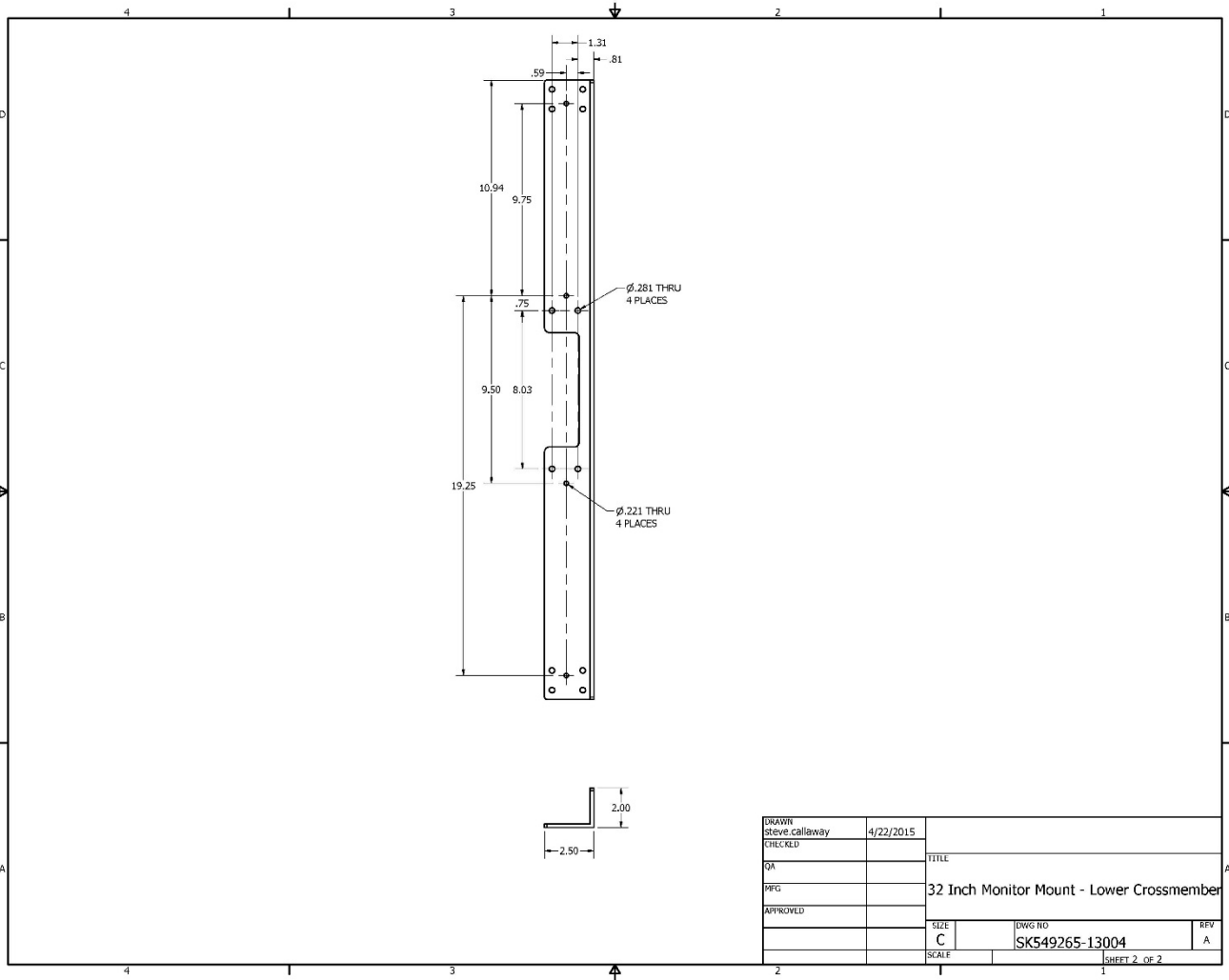

DRAWN	steve.callaway	4/22/2015		
CHECKED			TITLE	
QA			32 Inch Monitor Mount - Lower Crossmember	
PFG			SIZE	DWG NO
APPROVED			C	SK549265-13004
			SCALE	REV
				A
			SHEET 2 OF 2	



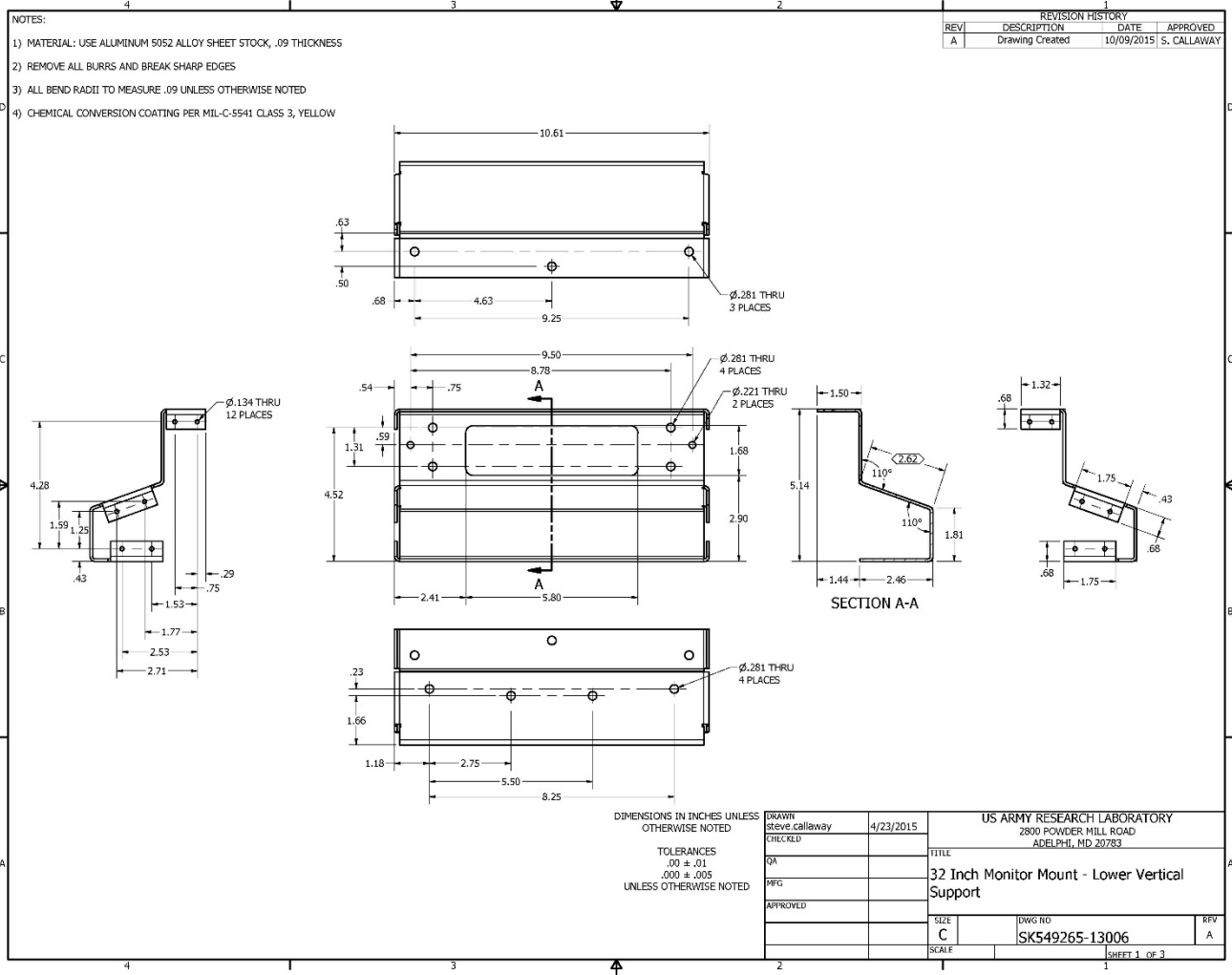

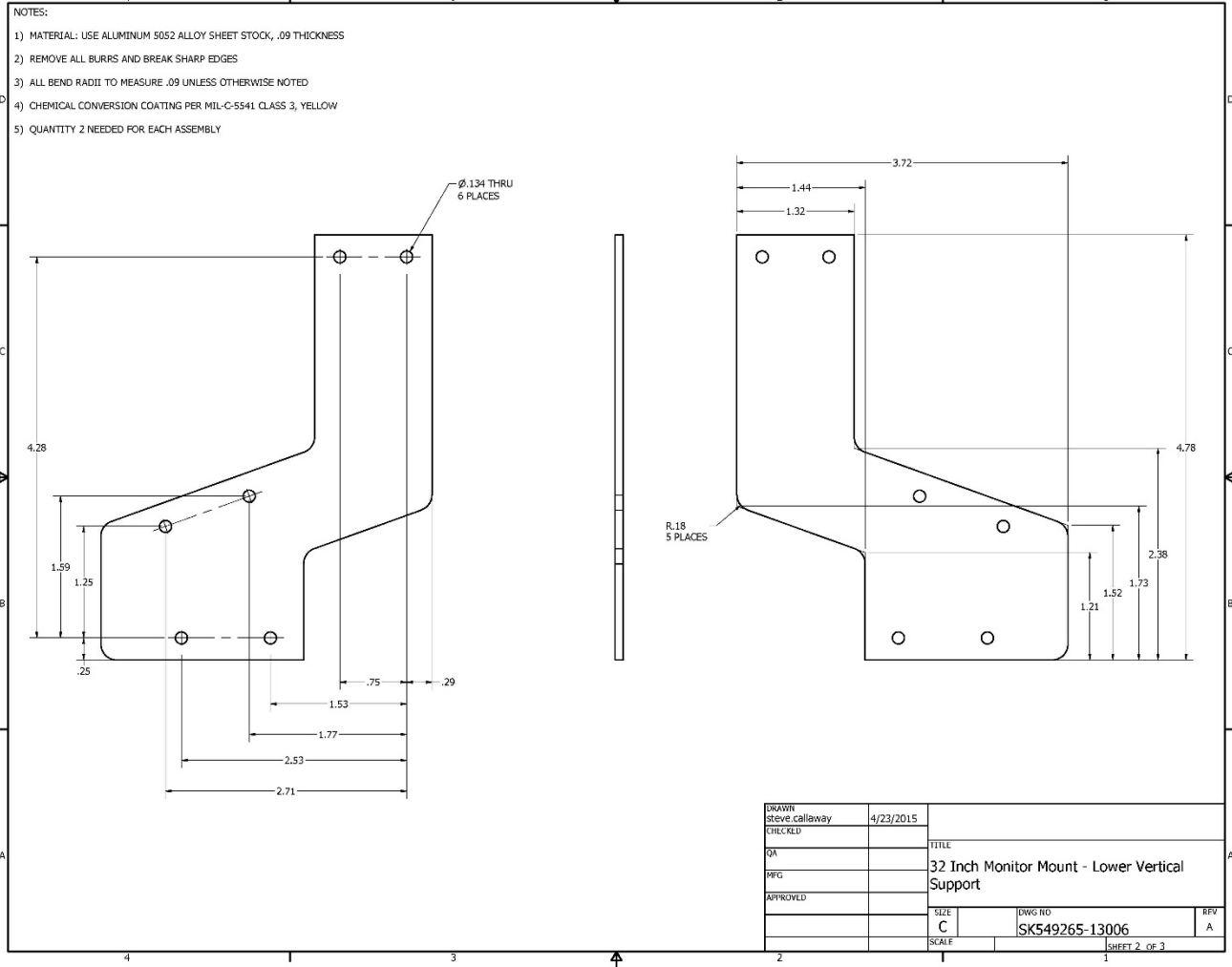

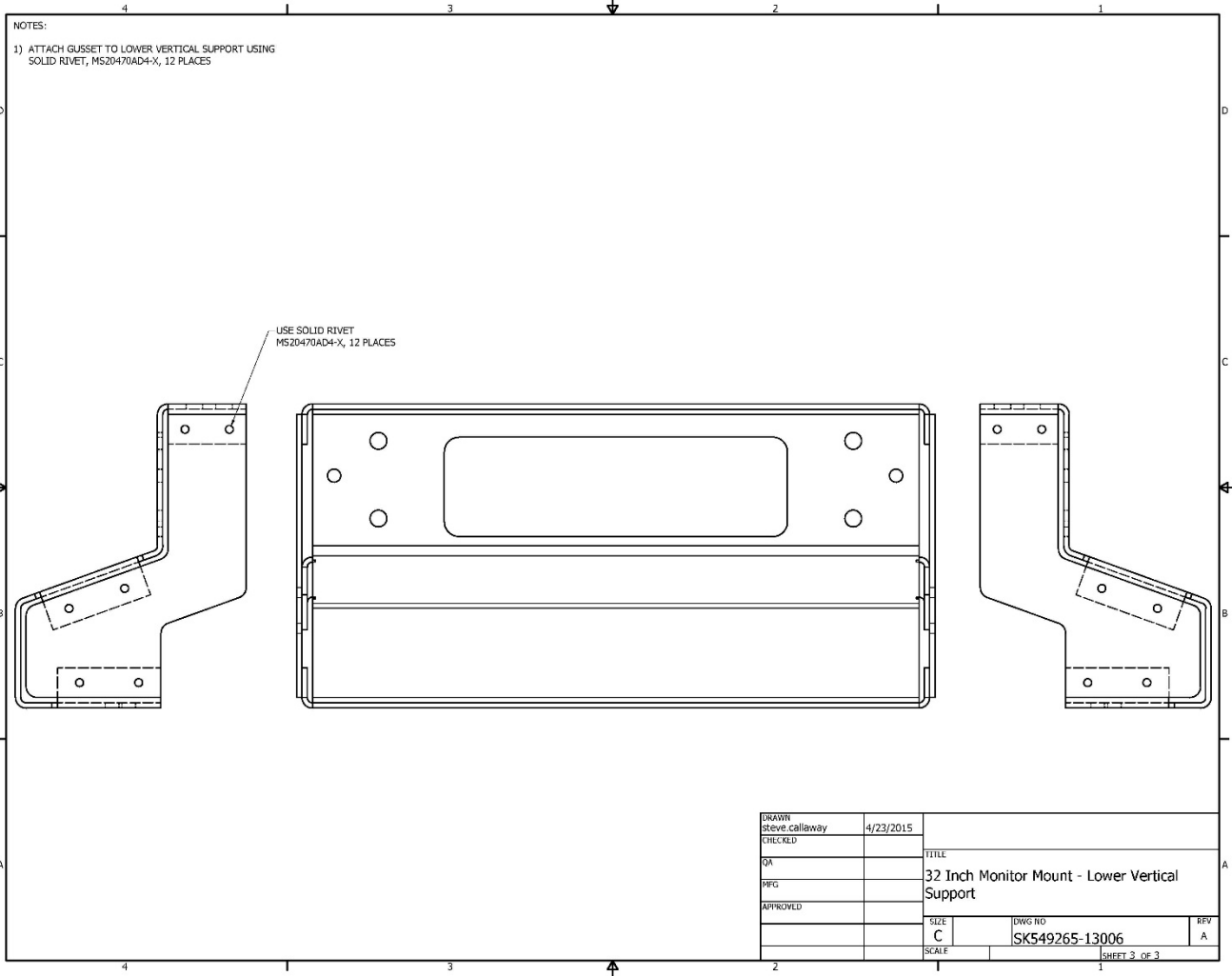

DRAWN	steve.callaway	4/23/2015		
CHECKED				
QA			TITLE	
PFG			32 Inch Monitor Mount - Lower Vertical Support	
APPROVED			SIZE	DWG NO
			C	SK549265-13006
			SCALE	REV
				A
				SHEET 3 OF 3

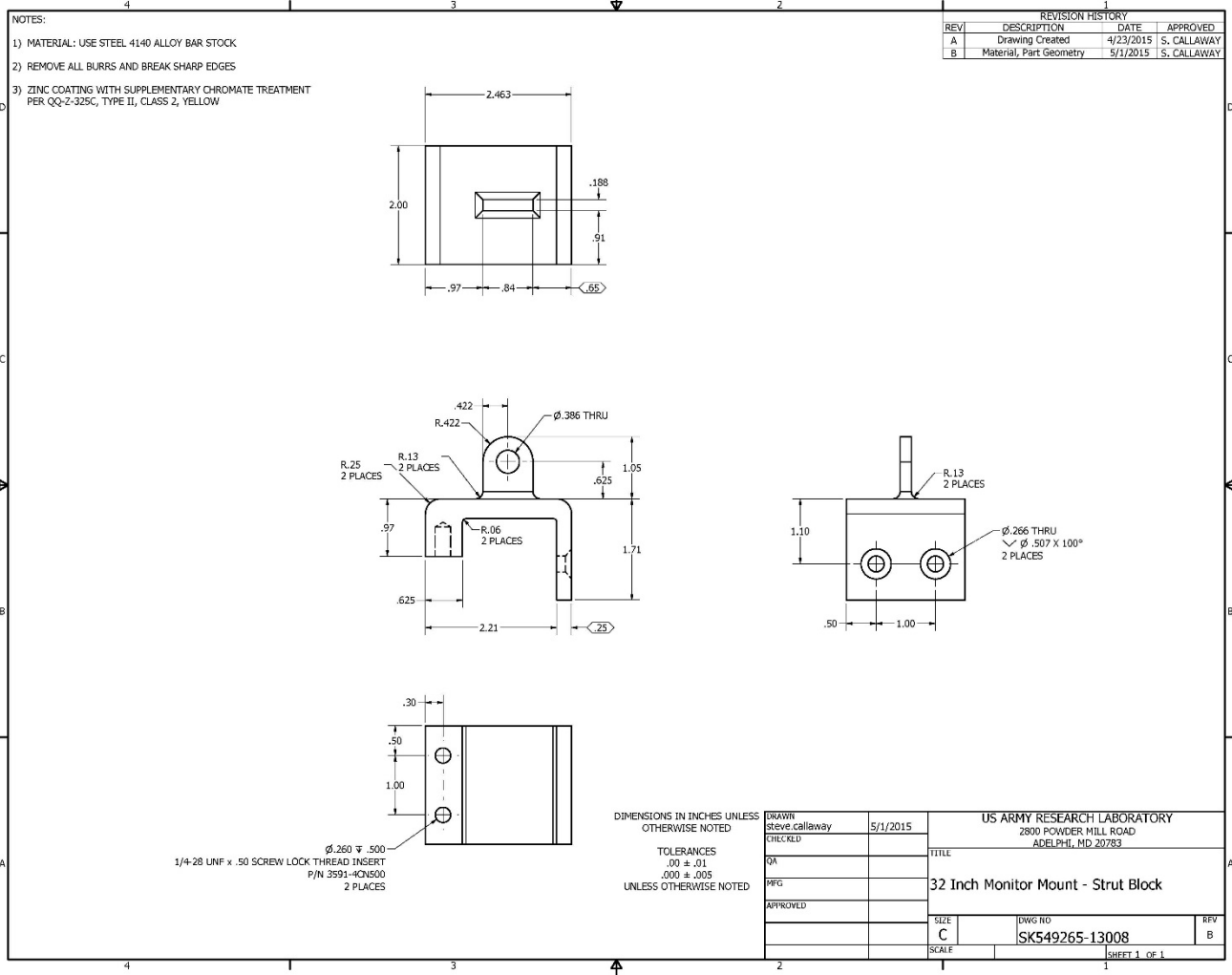

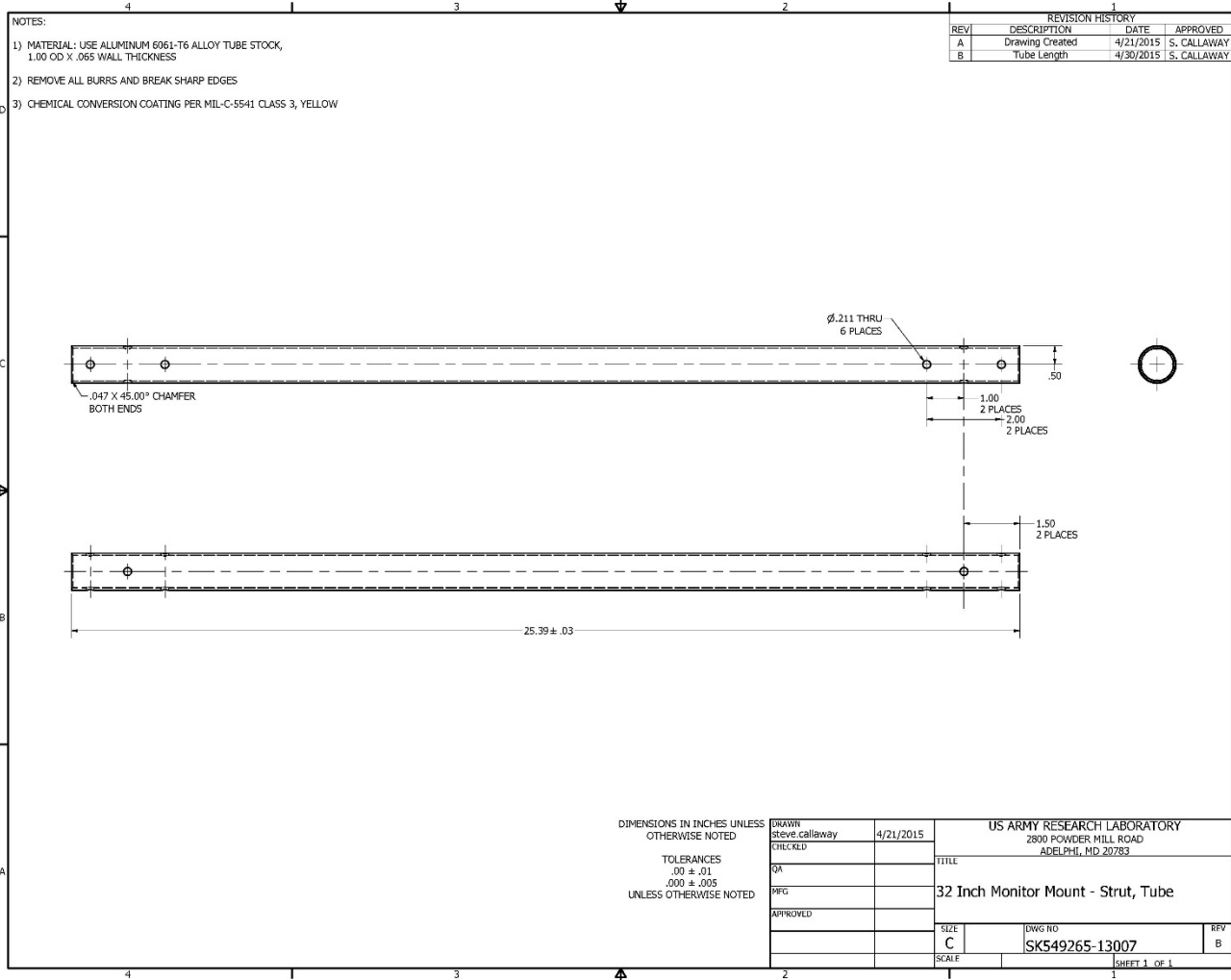

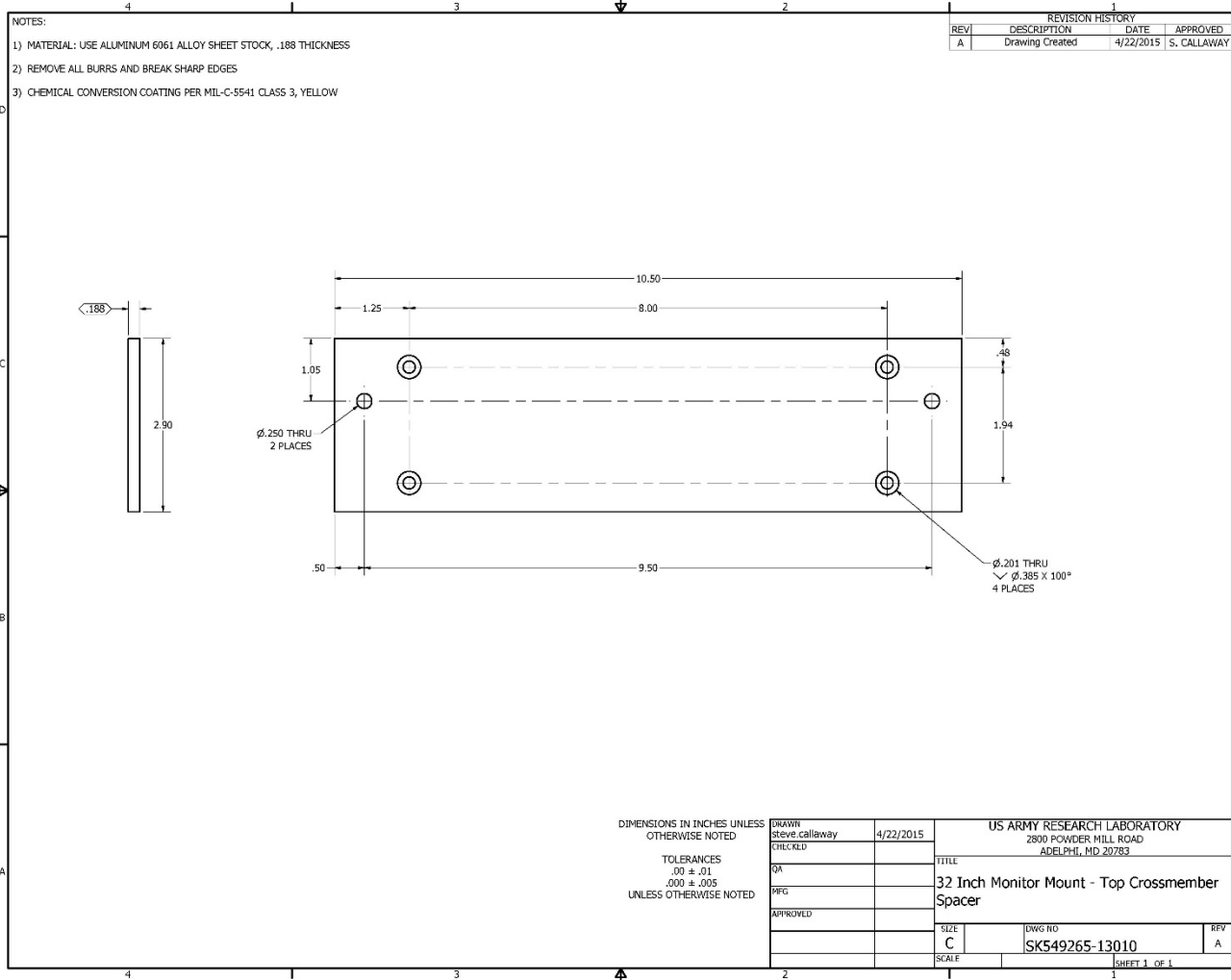

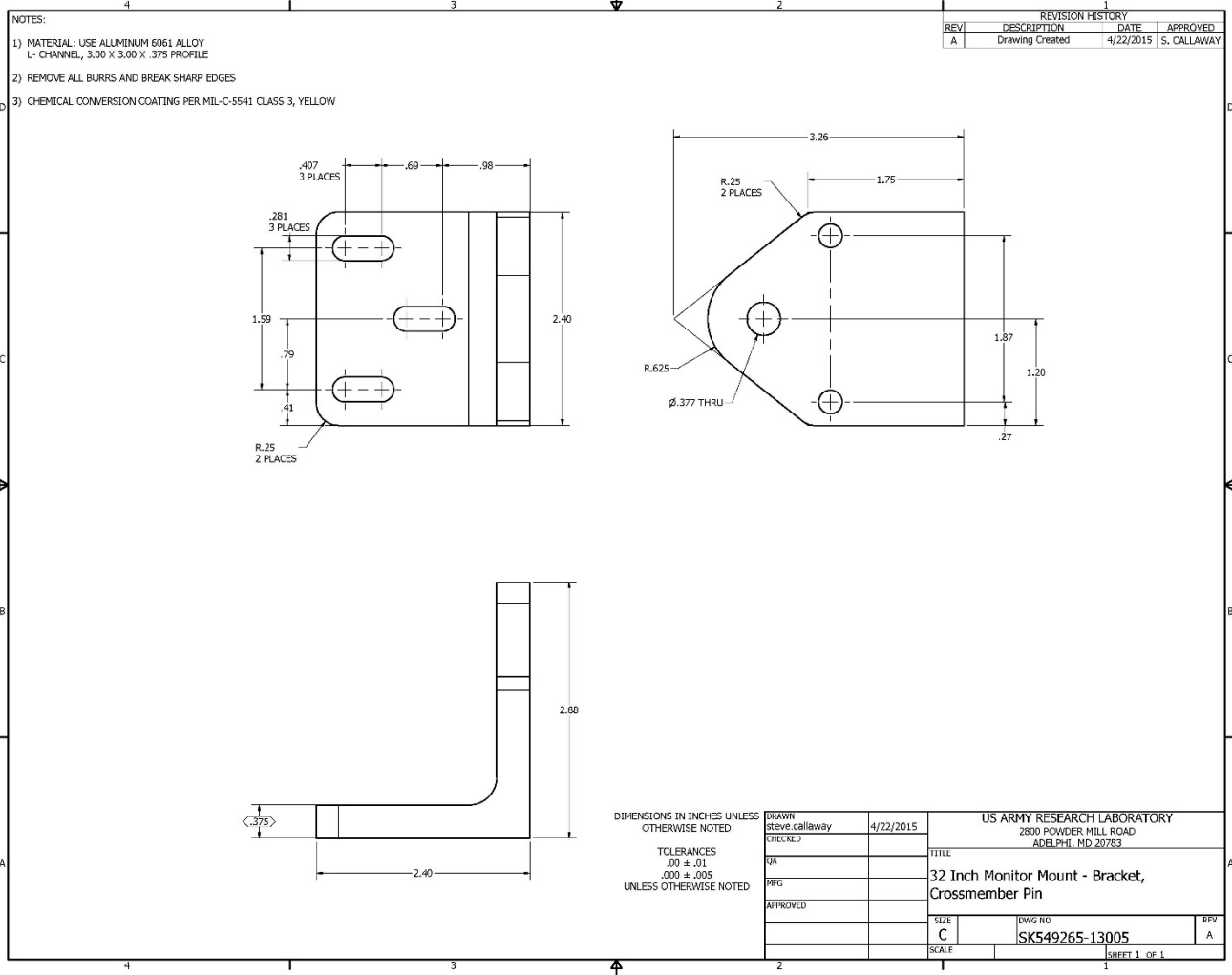

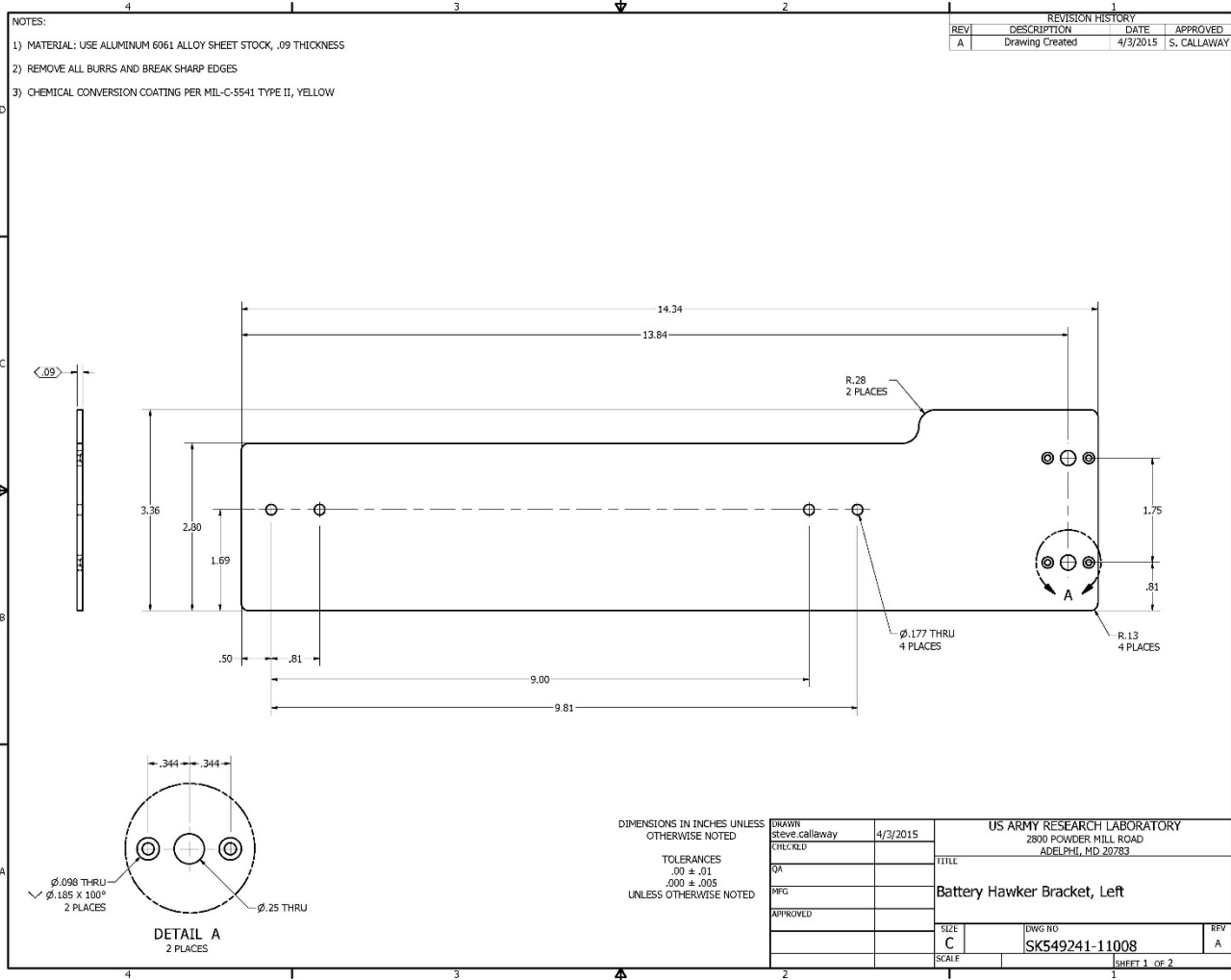



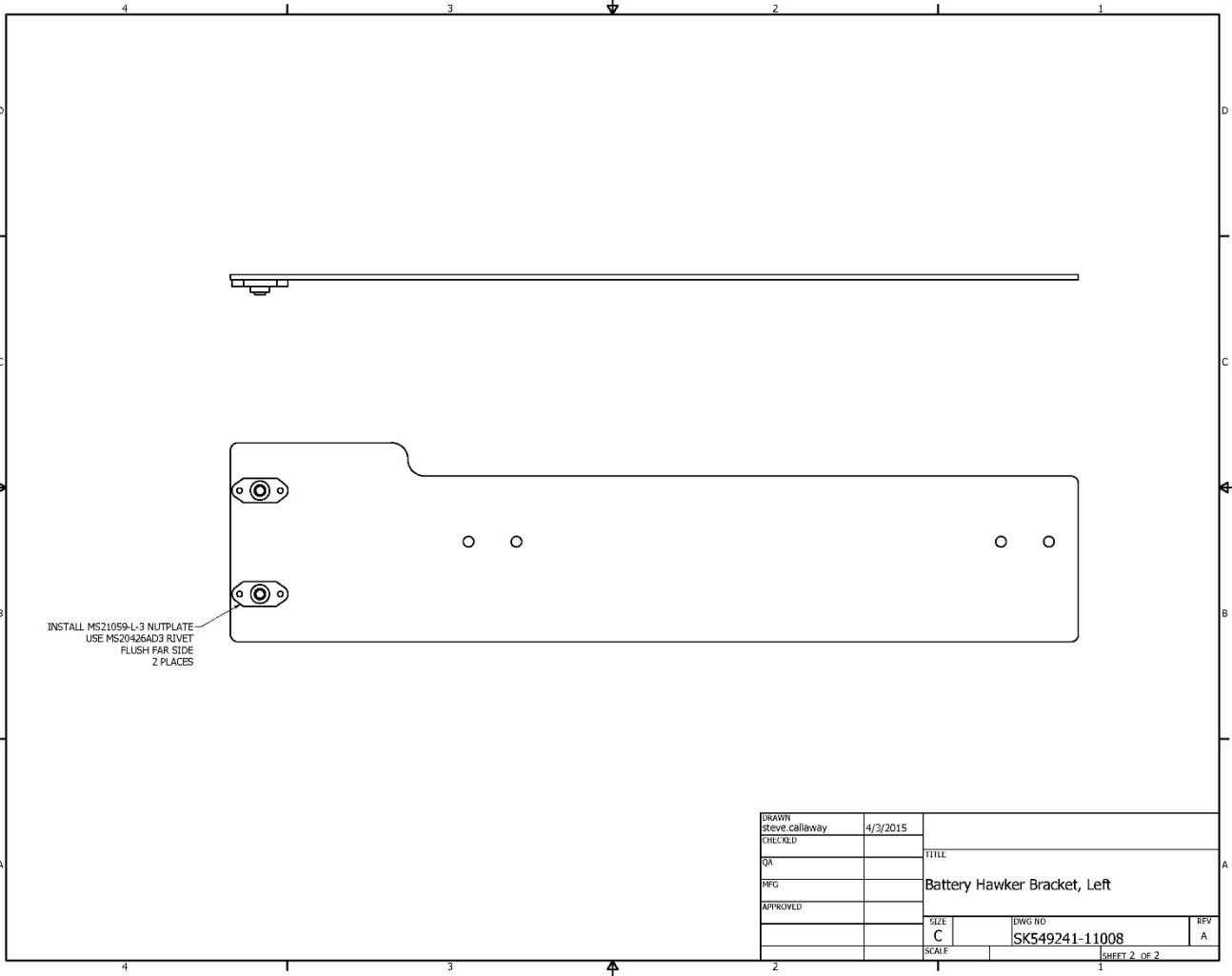

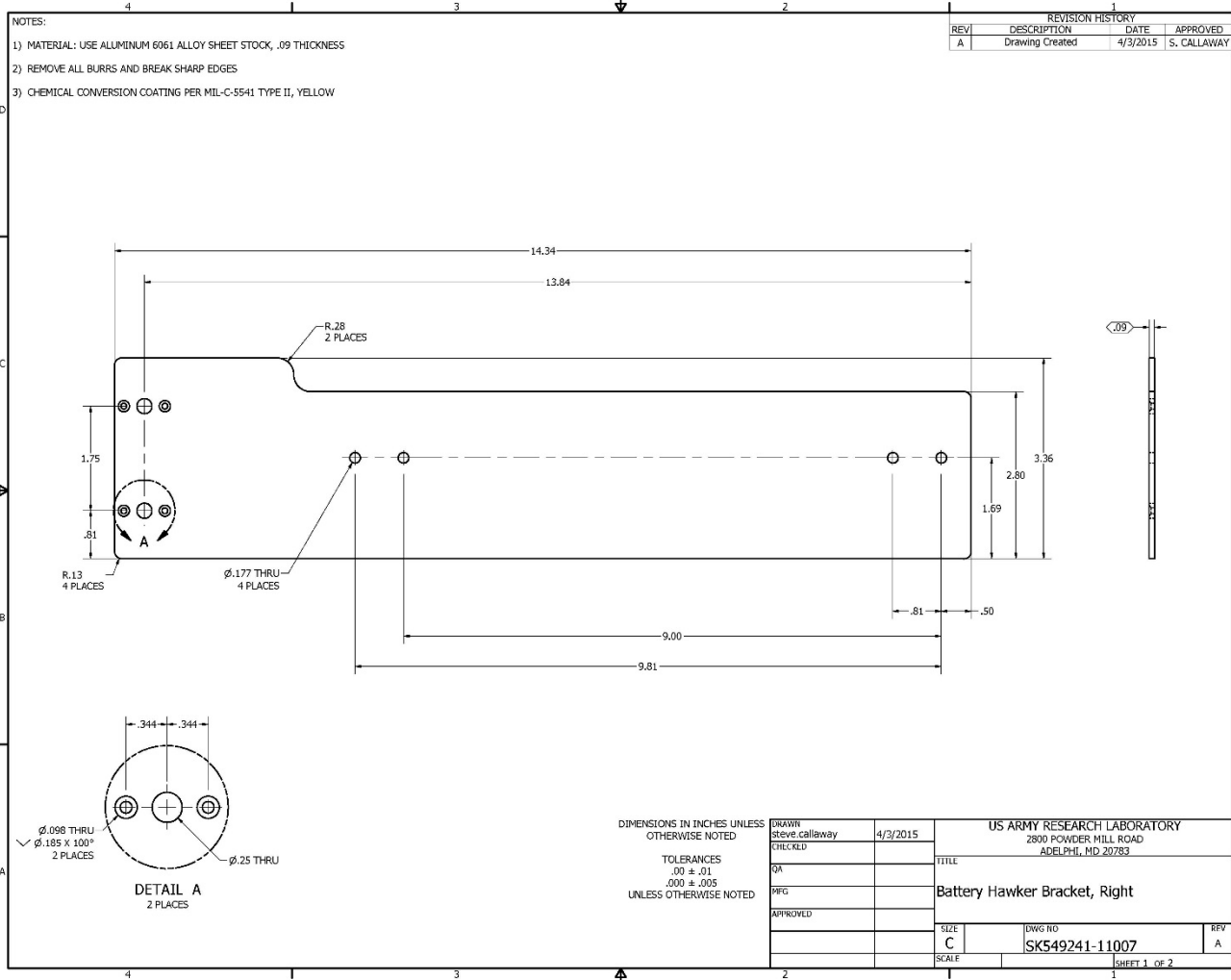

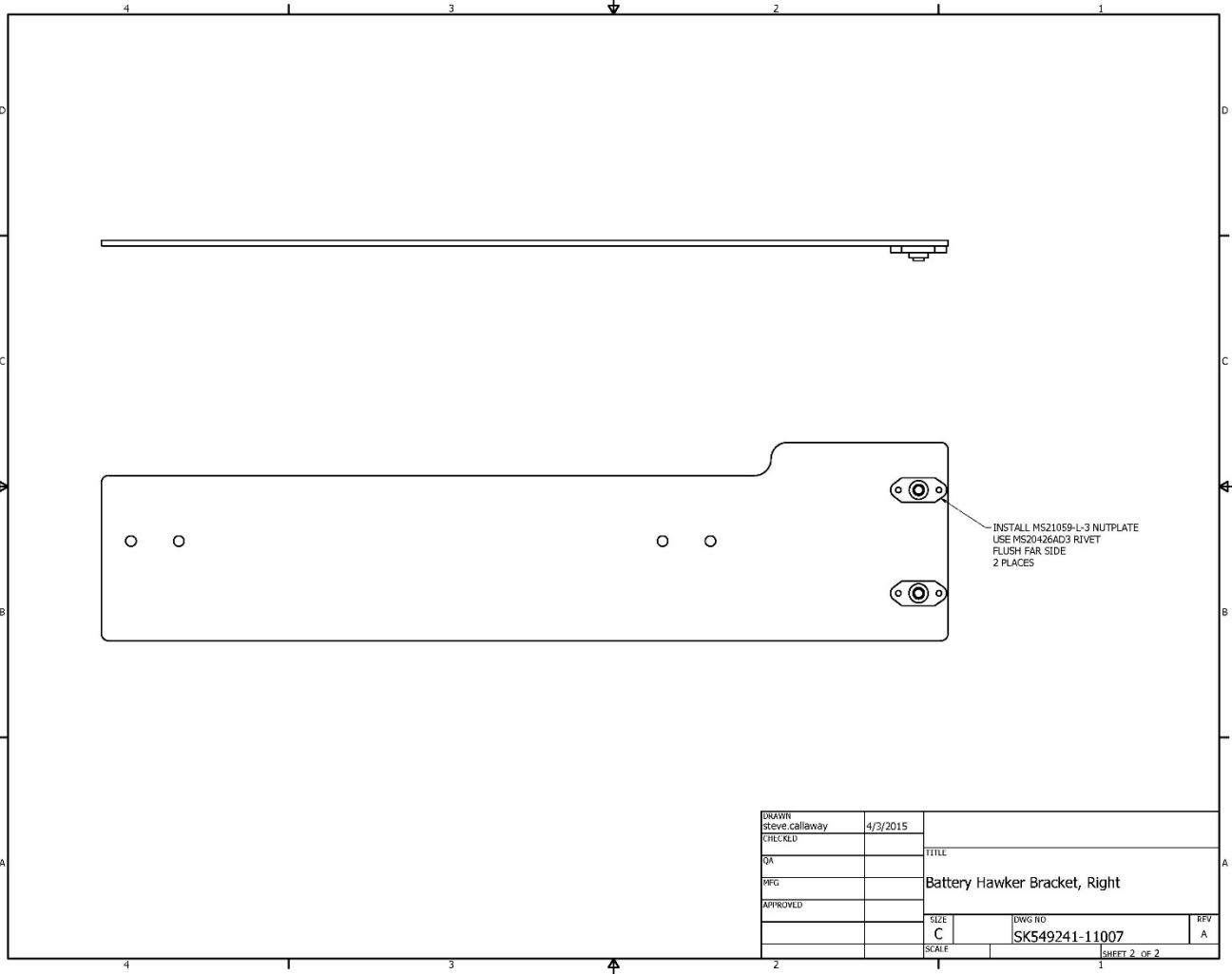

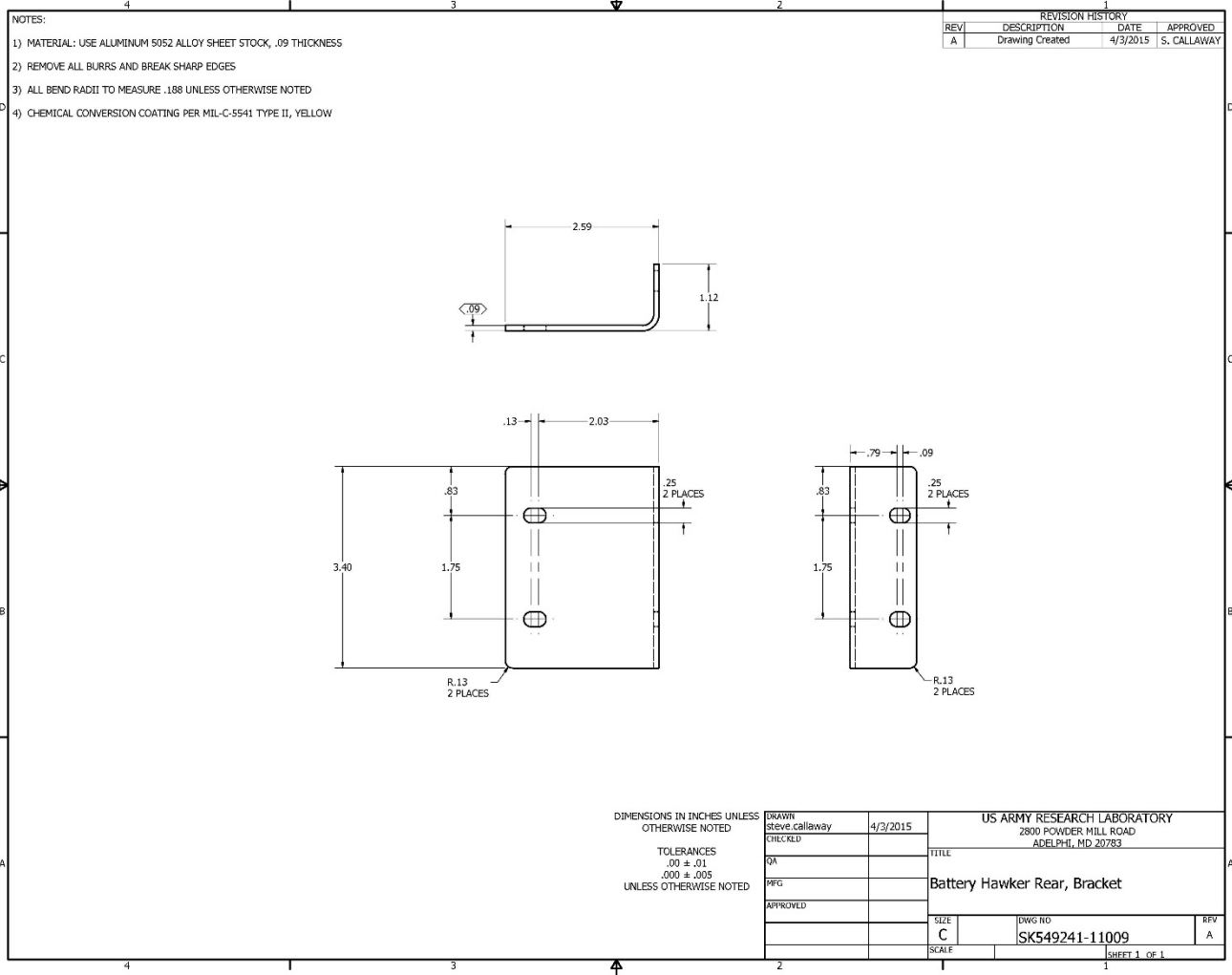

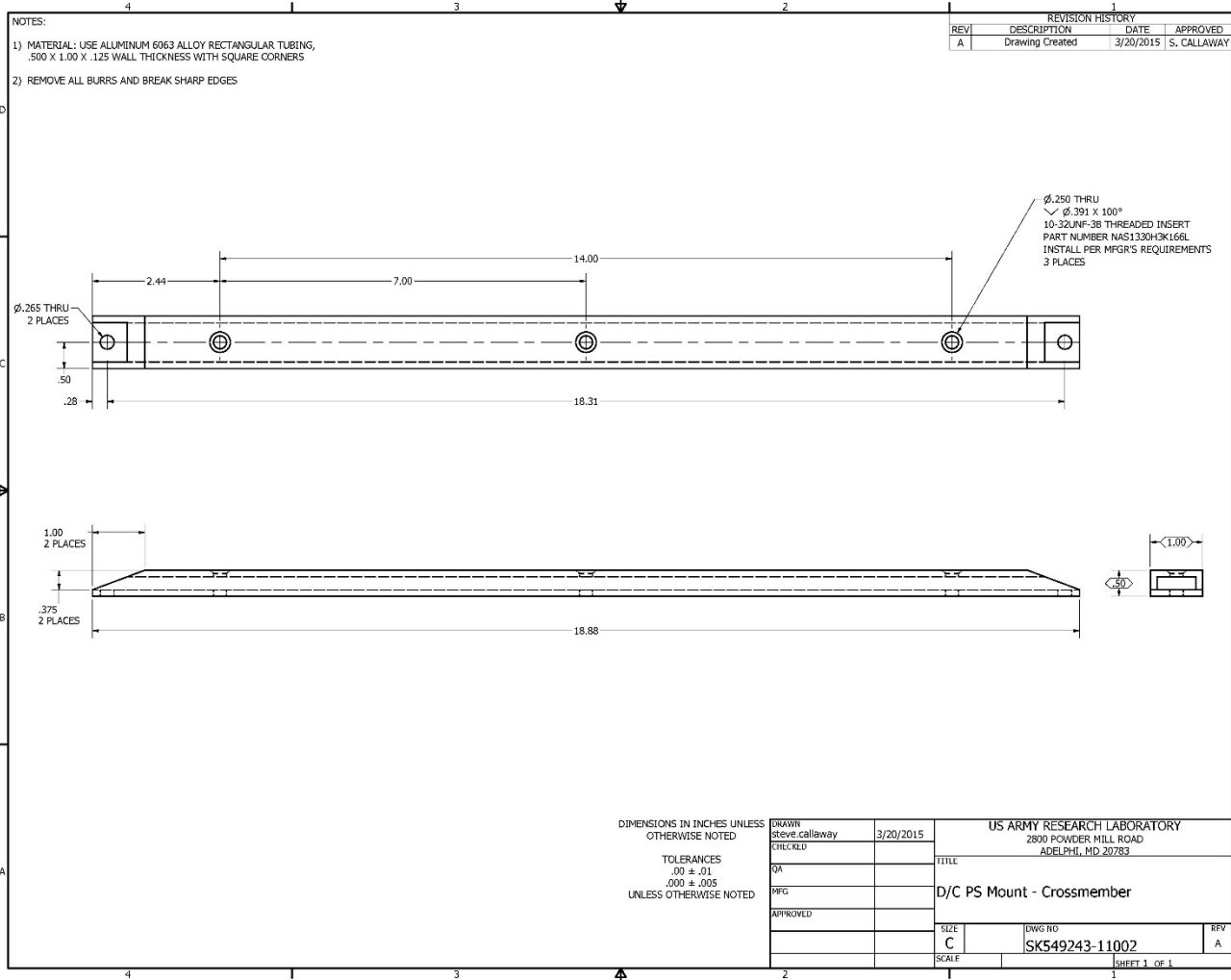

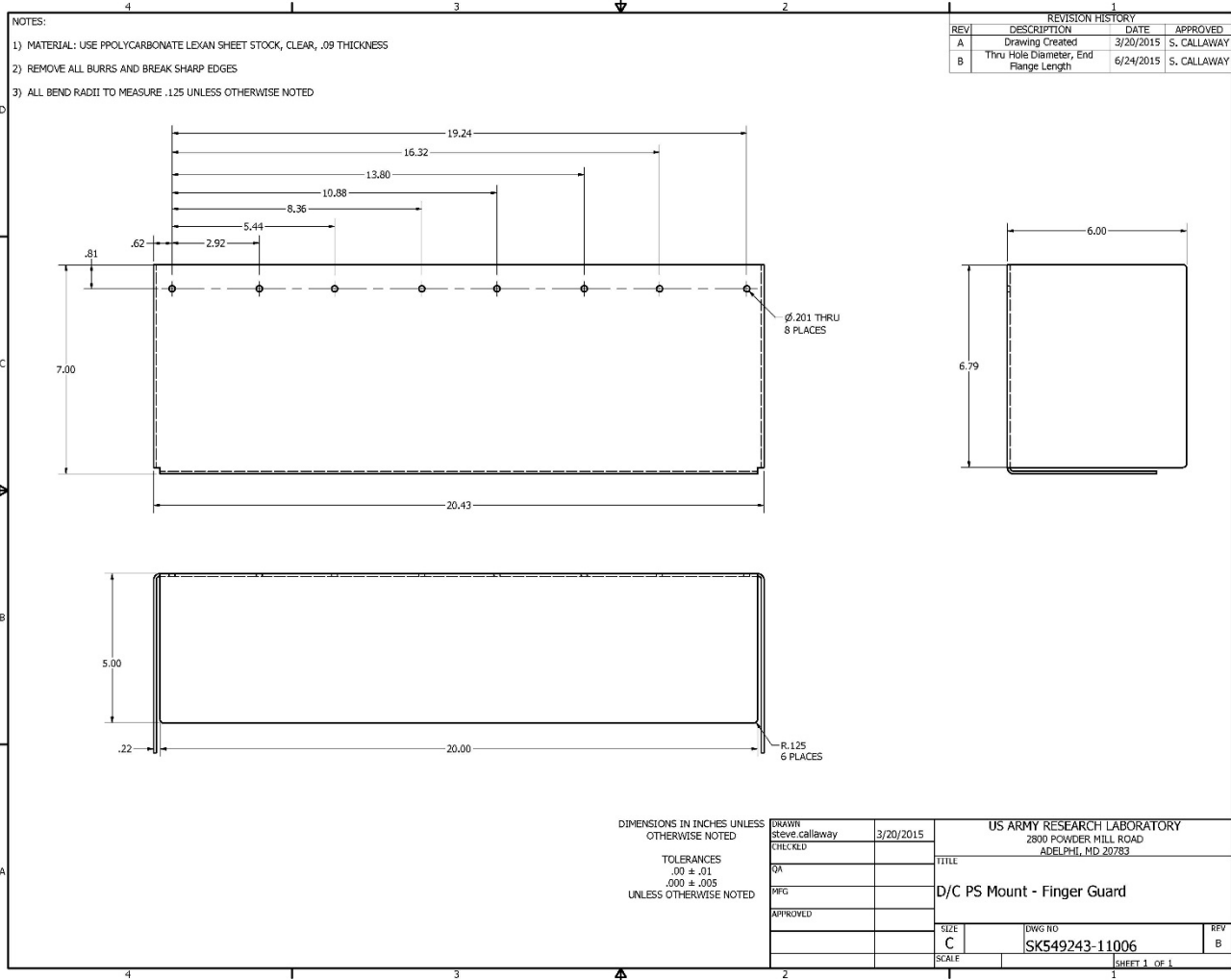

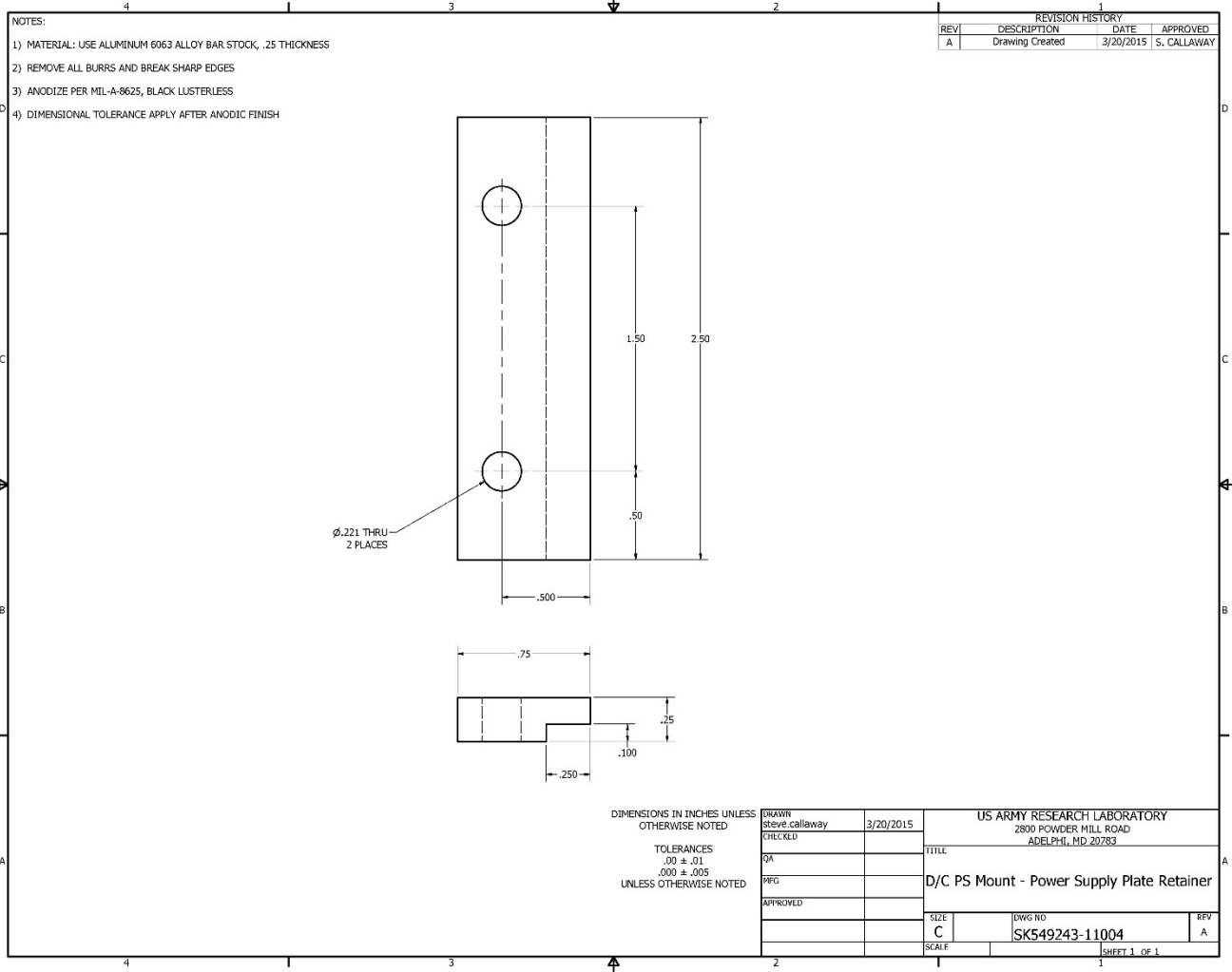

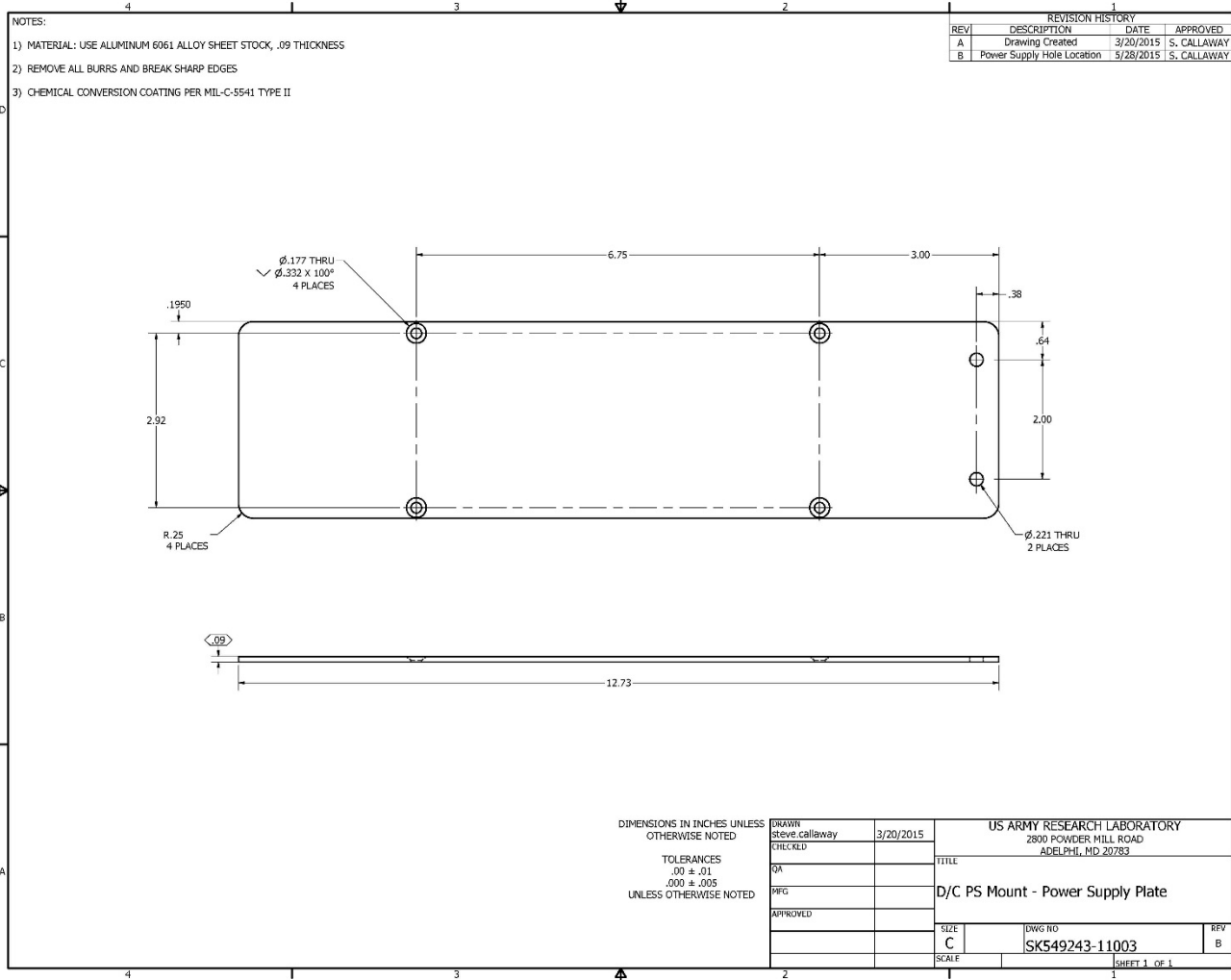



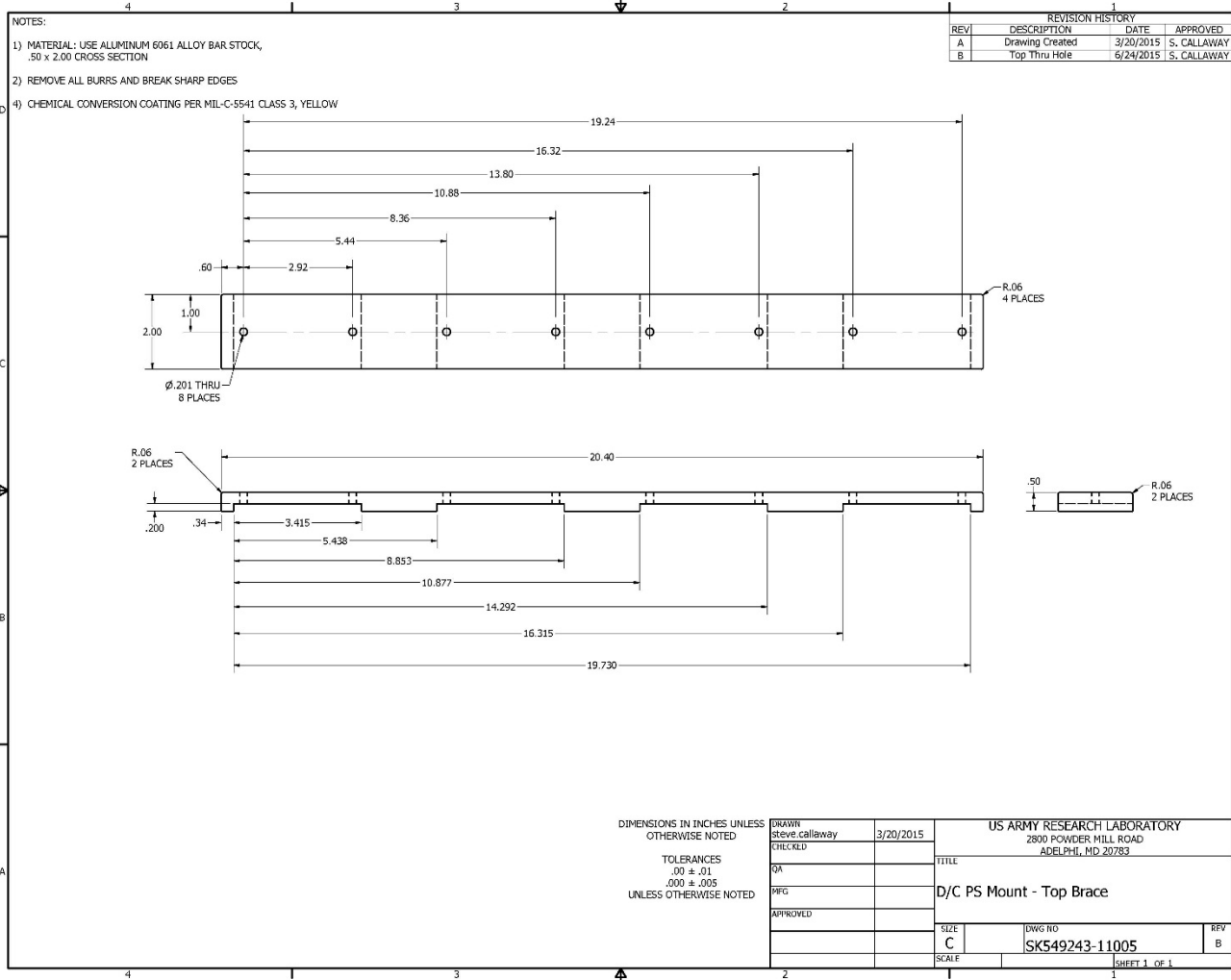

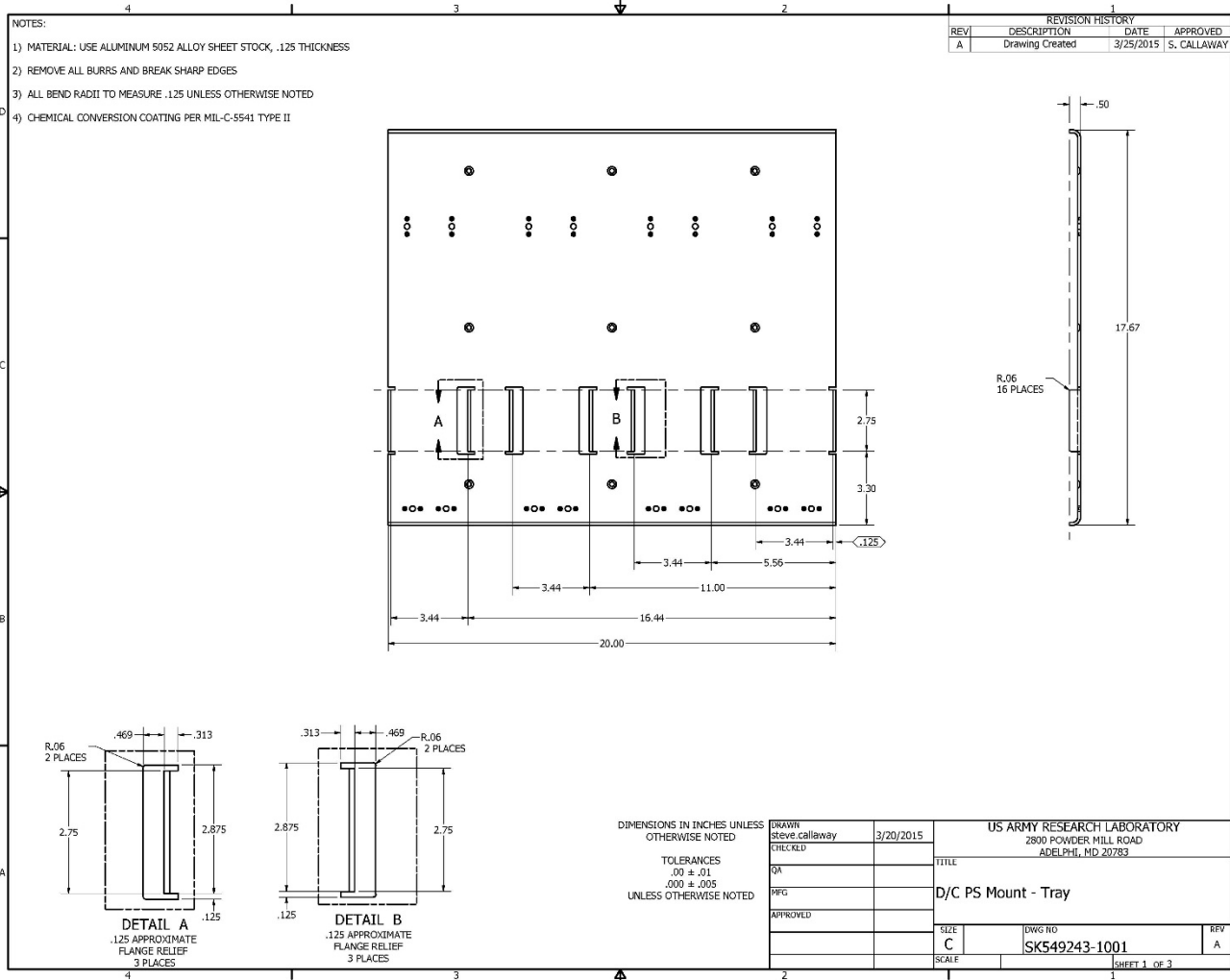

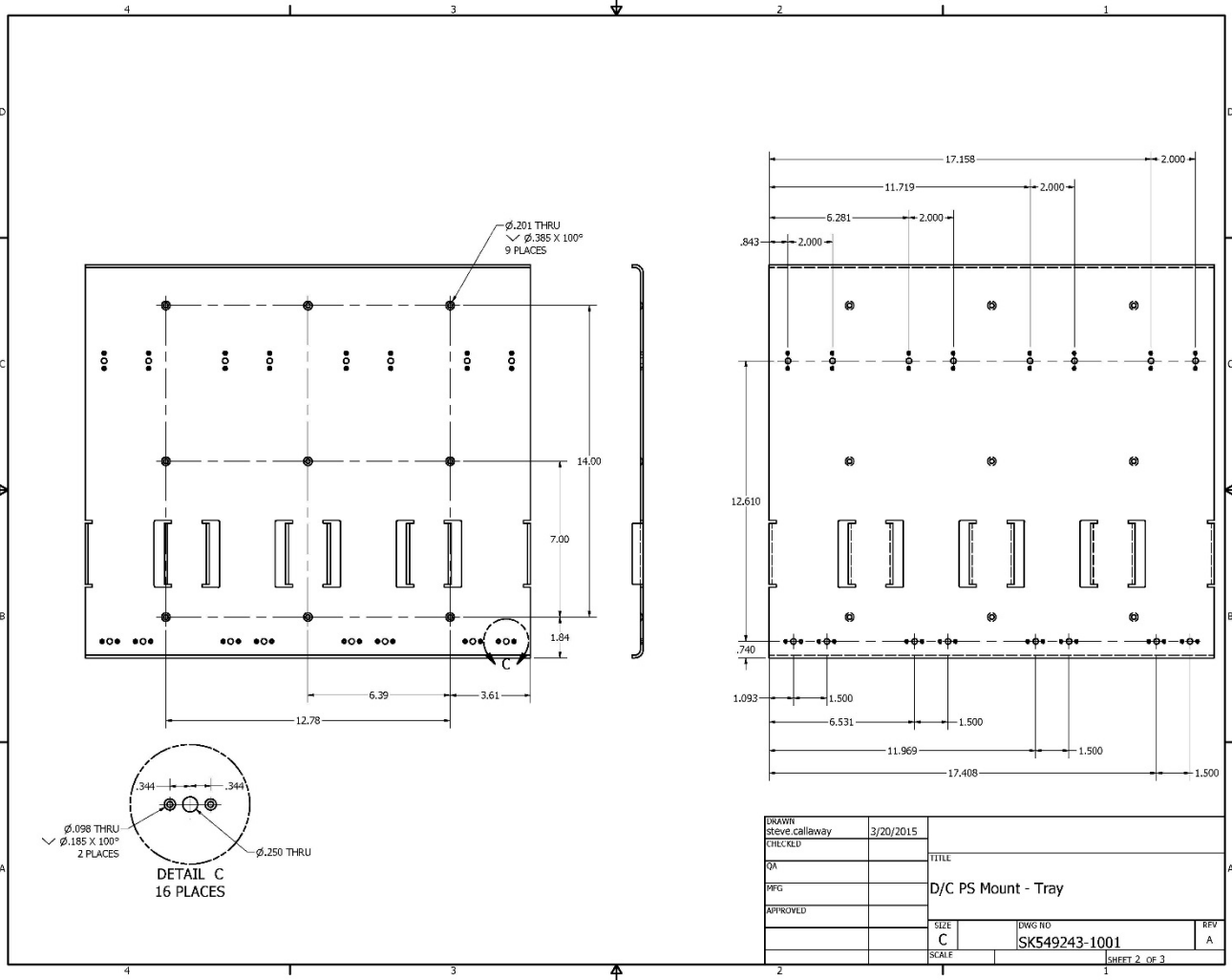

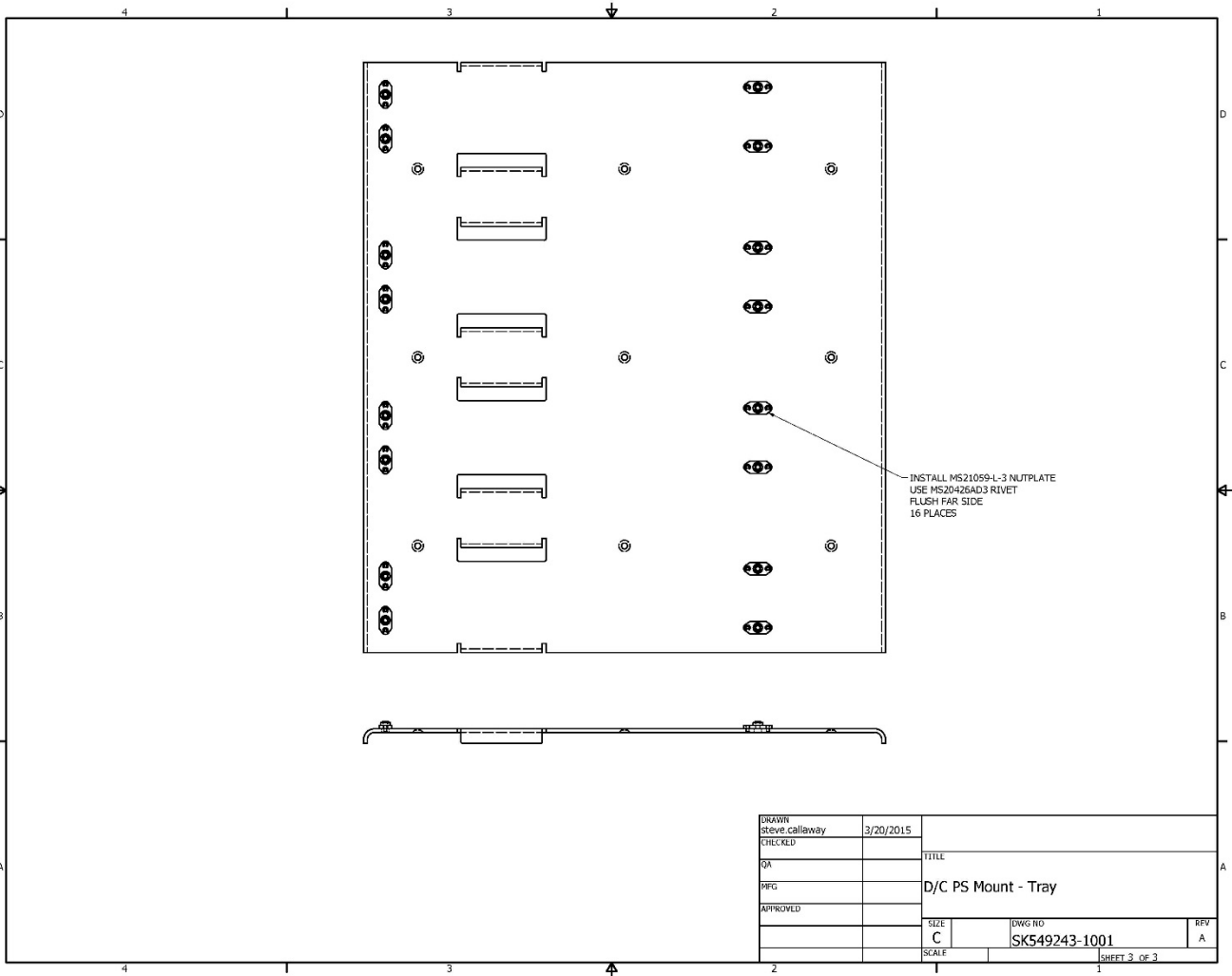

DRAWN	steve.callaway	3/20/2015		
CHECKED			TITLE	
QA			D/C PS Mount - Tray	
PFG			SIZE	DWG NO
APPROVED			C	SK549243-1001
			SCALE	REV A
				SHEET 3 OF 3

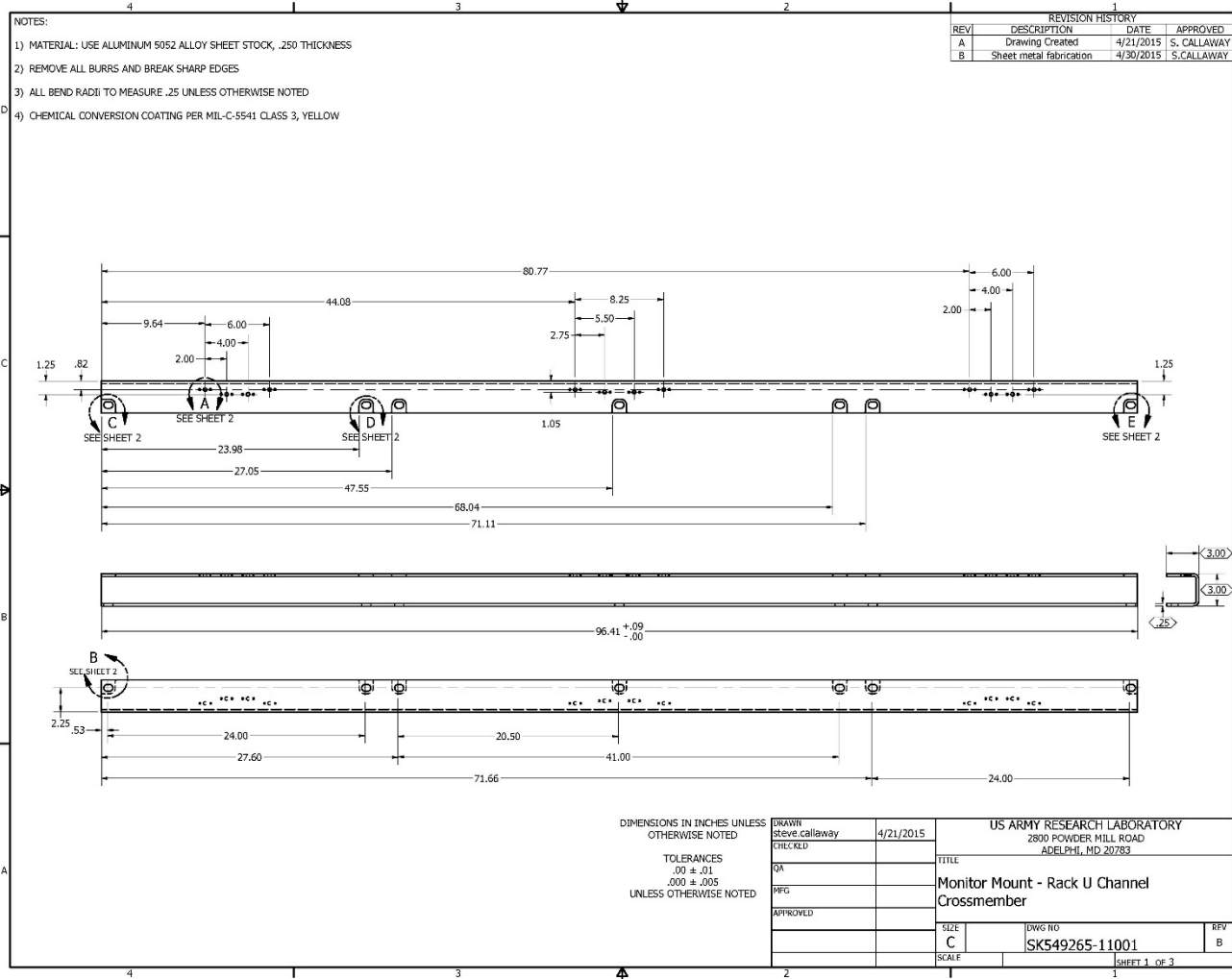

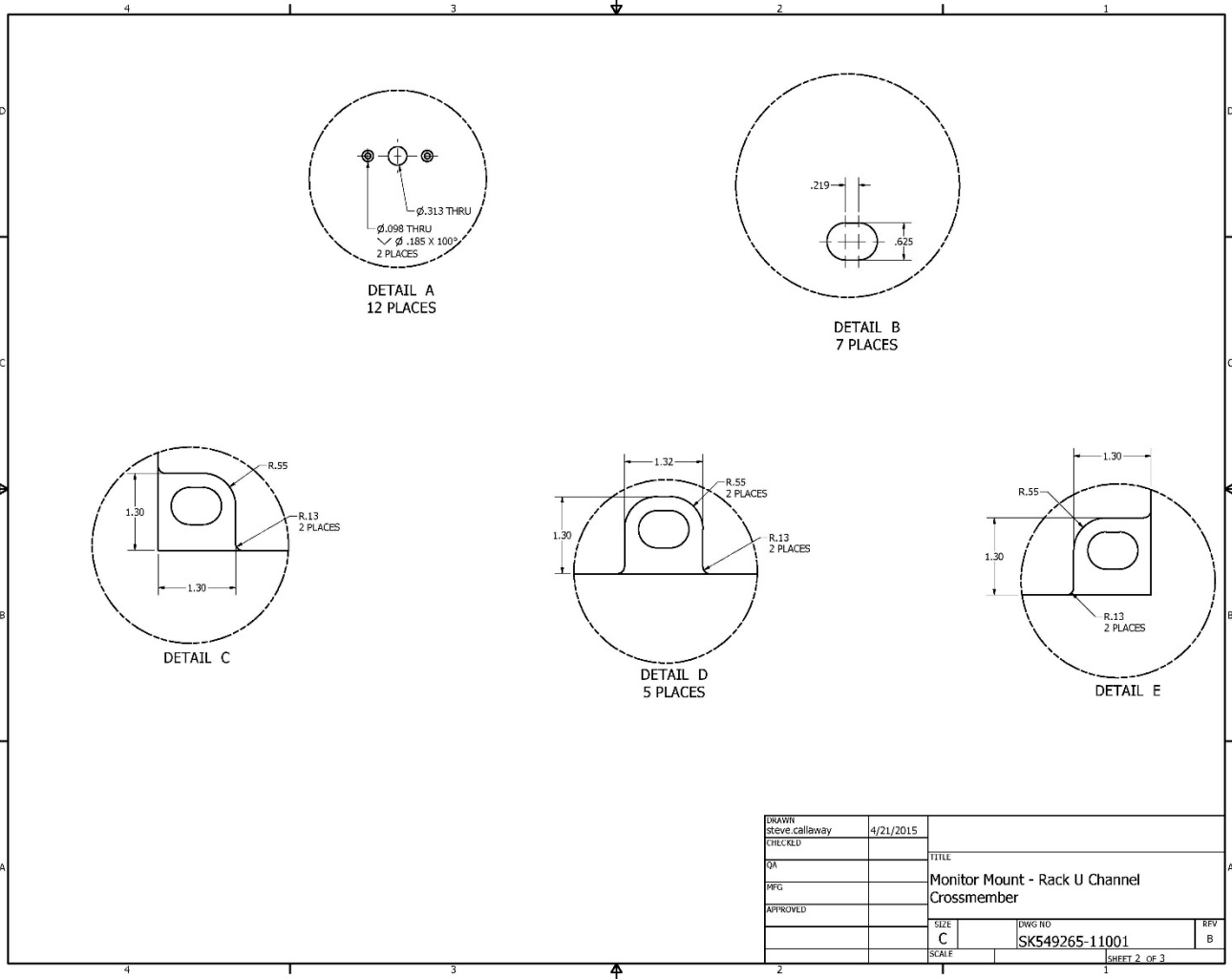

DRAWN	steve.callaway	4/21/2015		
CHECKED				
QA			TITLE	
PWG			Monitor Mount - Rack U Channel Crossmember	
APPROVED			SIZE	DWG NO
			C	SK549265-11001
			SCALE	REV
				B
			SHEET 2 OF 3	

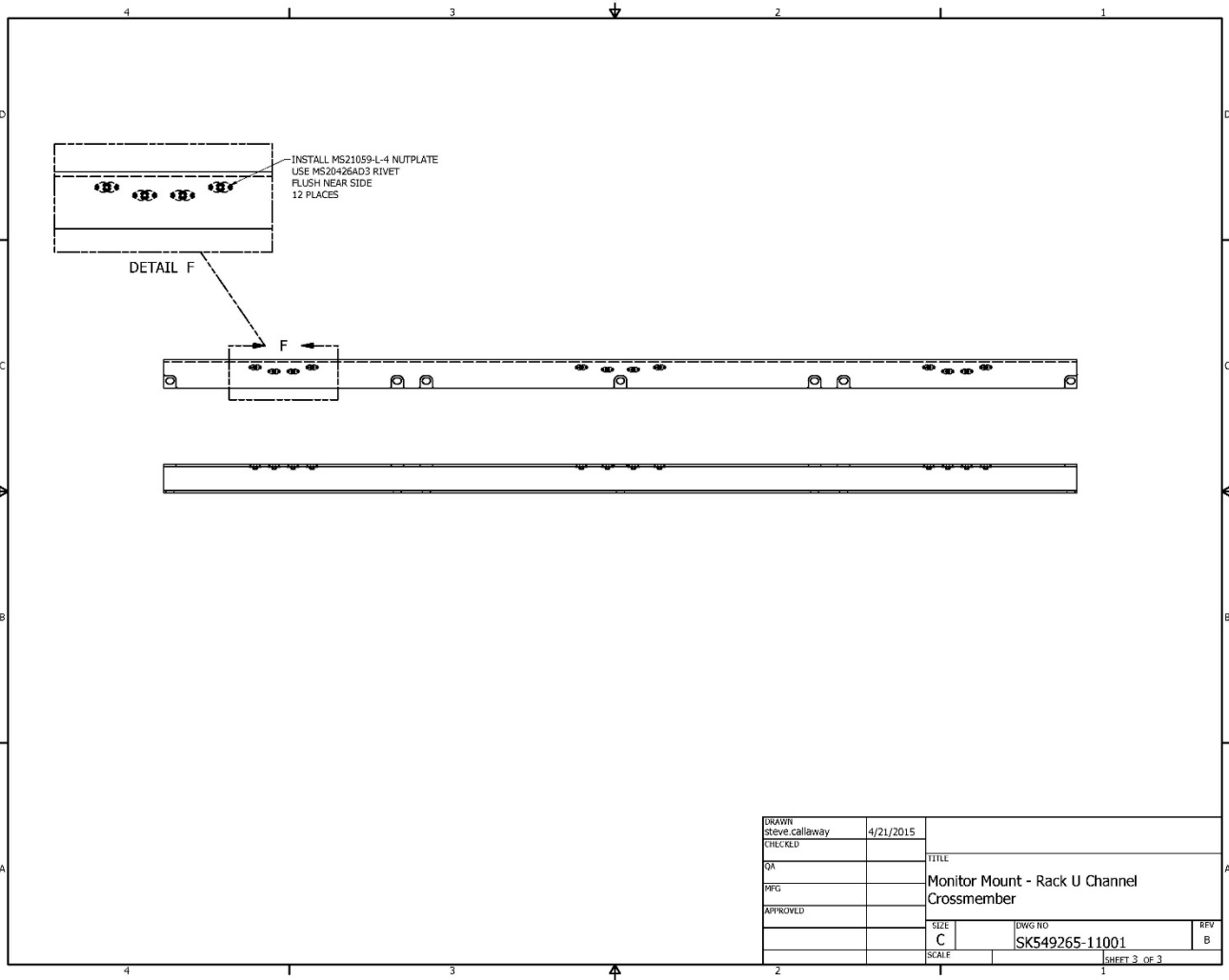

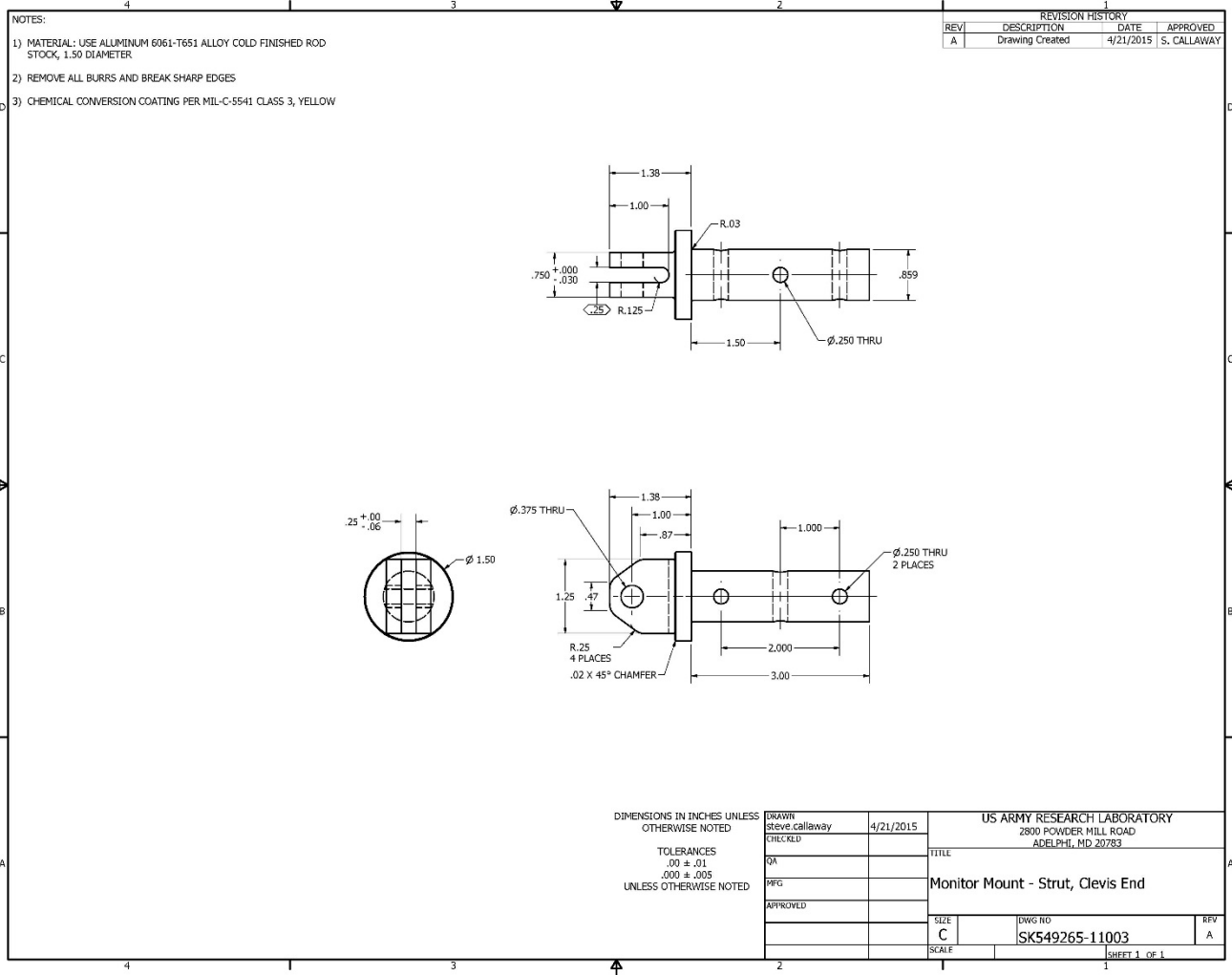



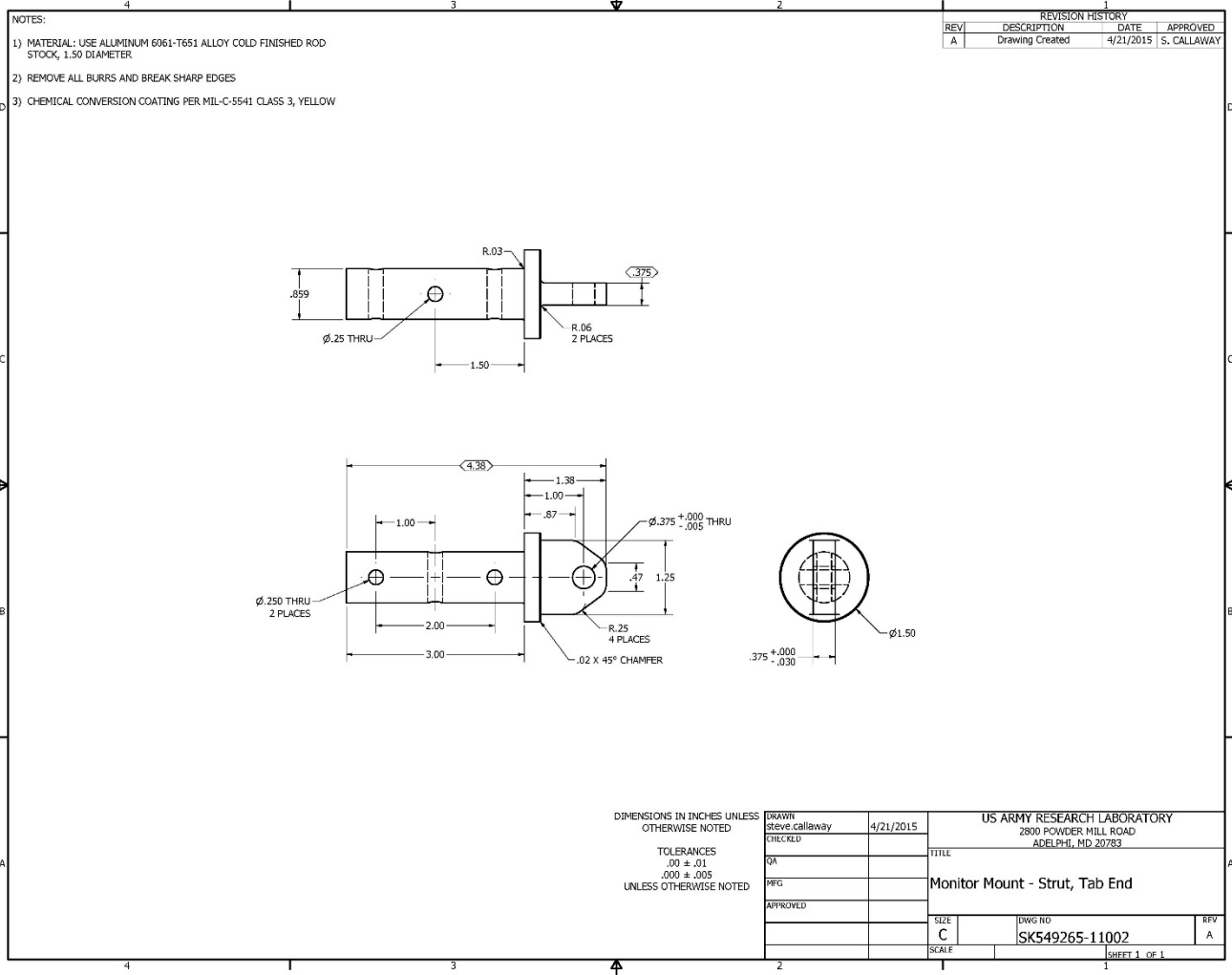

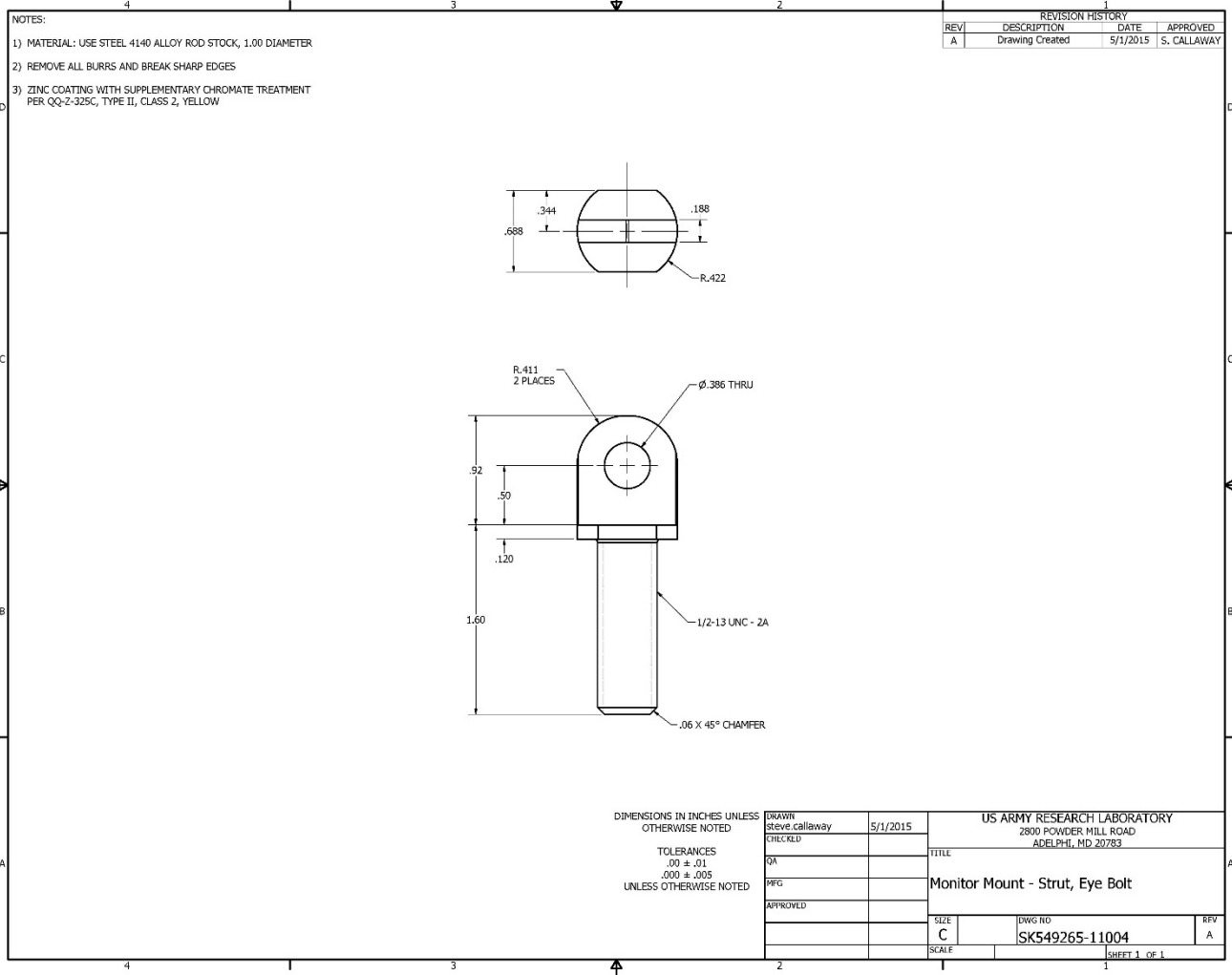

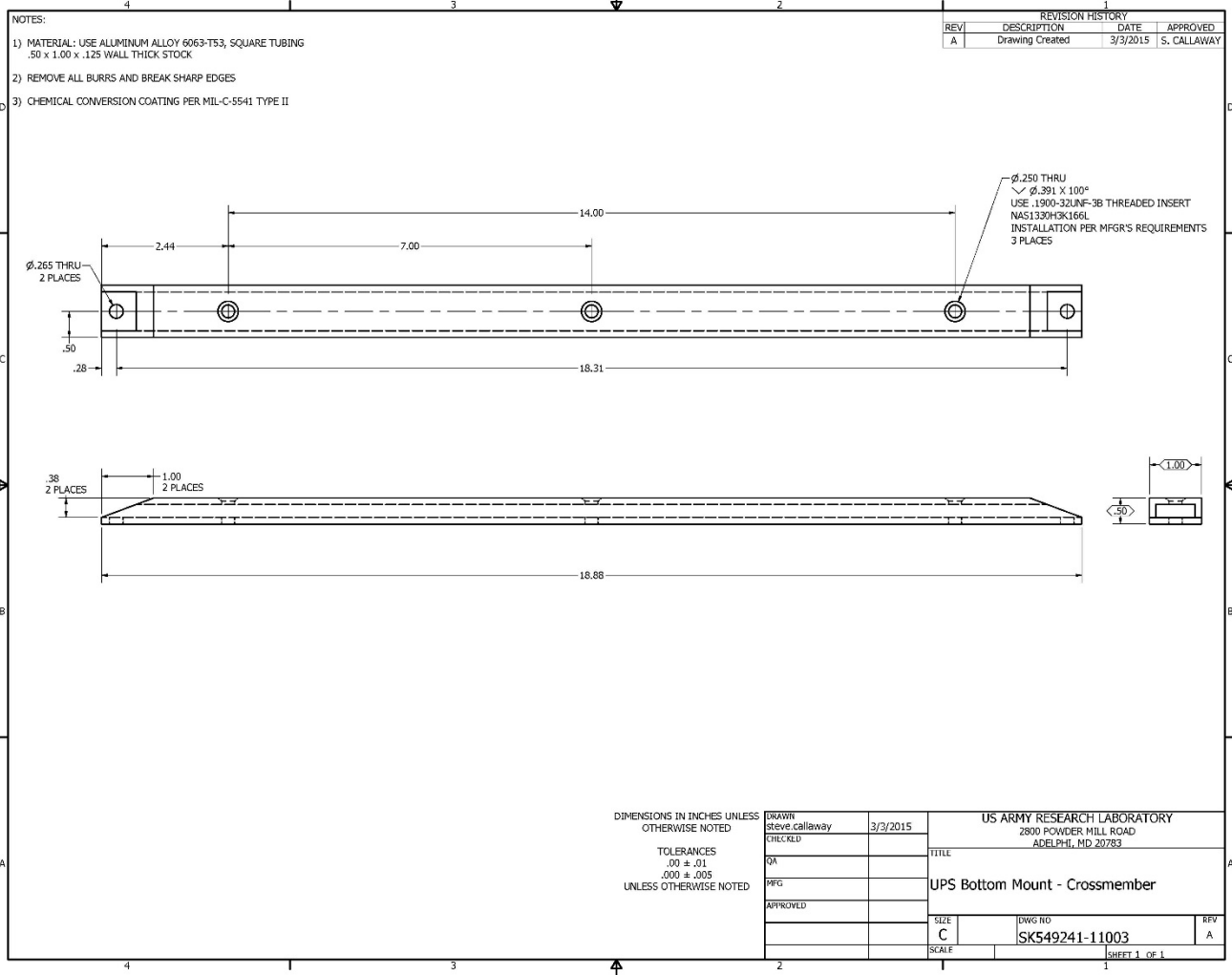

- NOTES:
- 1) MATERIAL: USE ALUMINUM ALLOY 6063-T53, SQUARE TUBING .50 x 1.00 x .125 WALL THICK STOCK
  - 2) REMOVE ALL BURRS AND BREAK SHARP EDGES
  - 3) CHEMICAL CONVERSION COATING PER MIL-C-5541 TYPE II

REVISION HISTORY			
REV	DESCRIPTION	DATE	APPROVED
A	Drawing Created	3/3/2015	S. CALLAWAY

DIMENSIONS IN INCHES UNLESS OTHERWISE NOTED

TOLERANCES  
 .00 ± .01  
 .000 ± .005  
 UNLESS OTHERWISE NOTED

DRAWN	steve.callaway	3/3/2015	US ARMY RESEARCH LABORATORY	
CHECKED			2800 POWDER MILL ROAD	
QA			ADELPHI, MD 20783	
PWG			TITLE	
APPROVED			UPS Bottom Mount - Crossmember	
SIZE	C	DWG NO	SK549241-11003	REV
SCALE				A
			SHEET 1 OF 1	

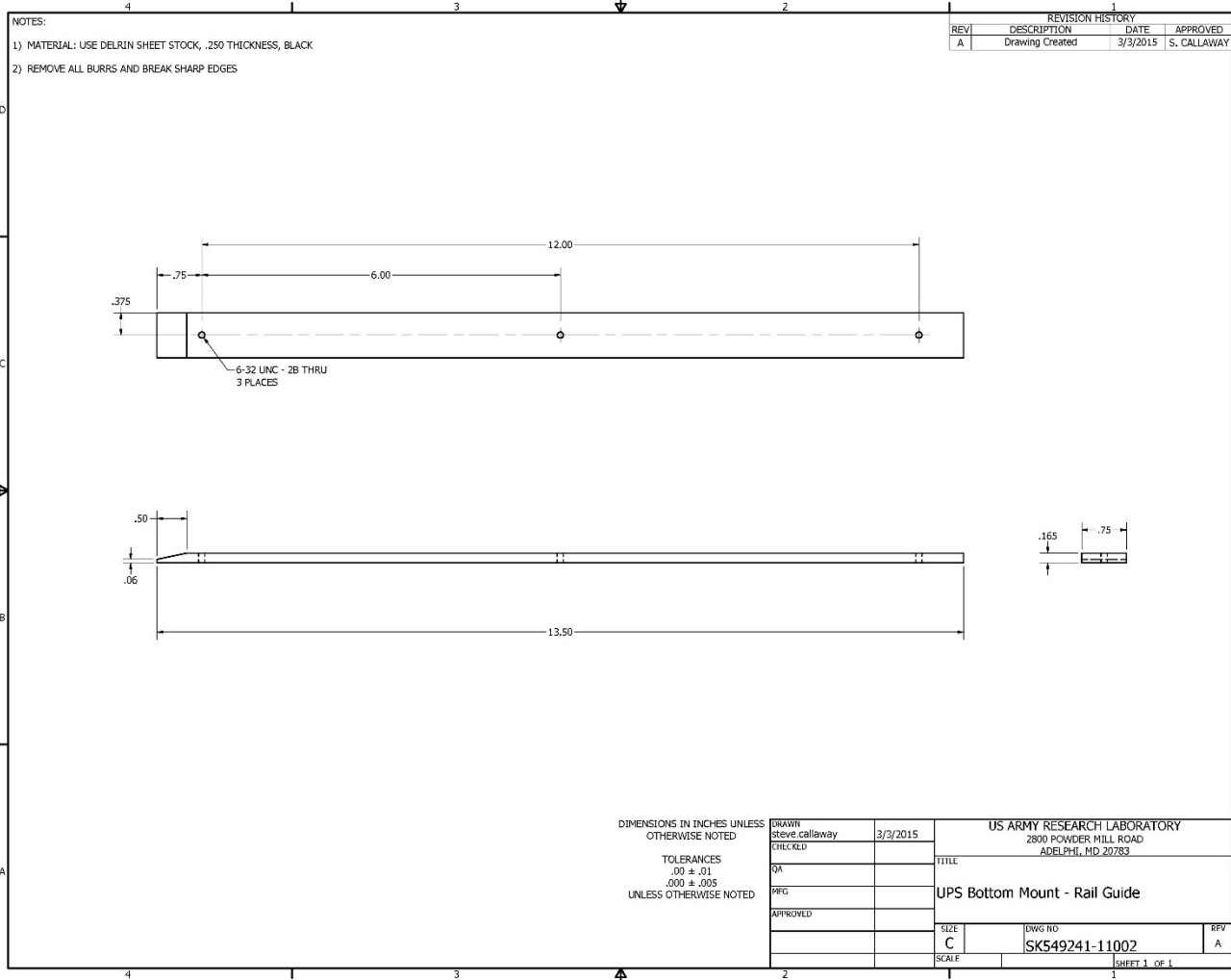

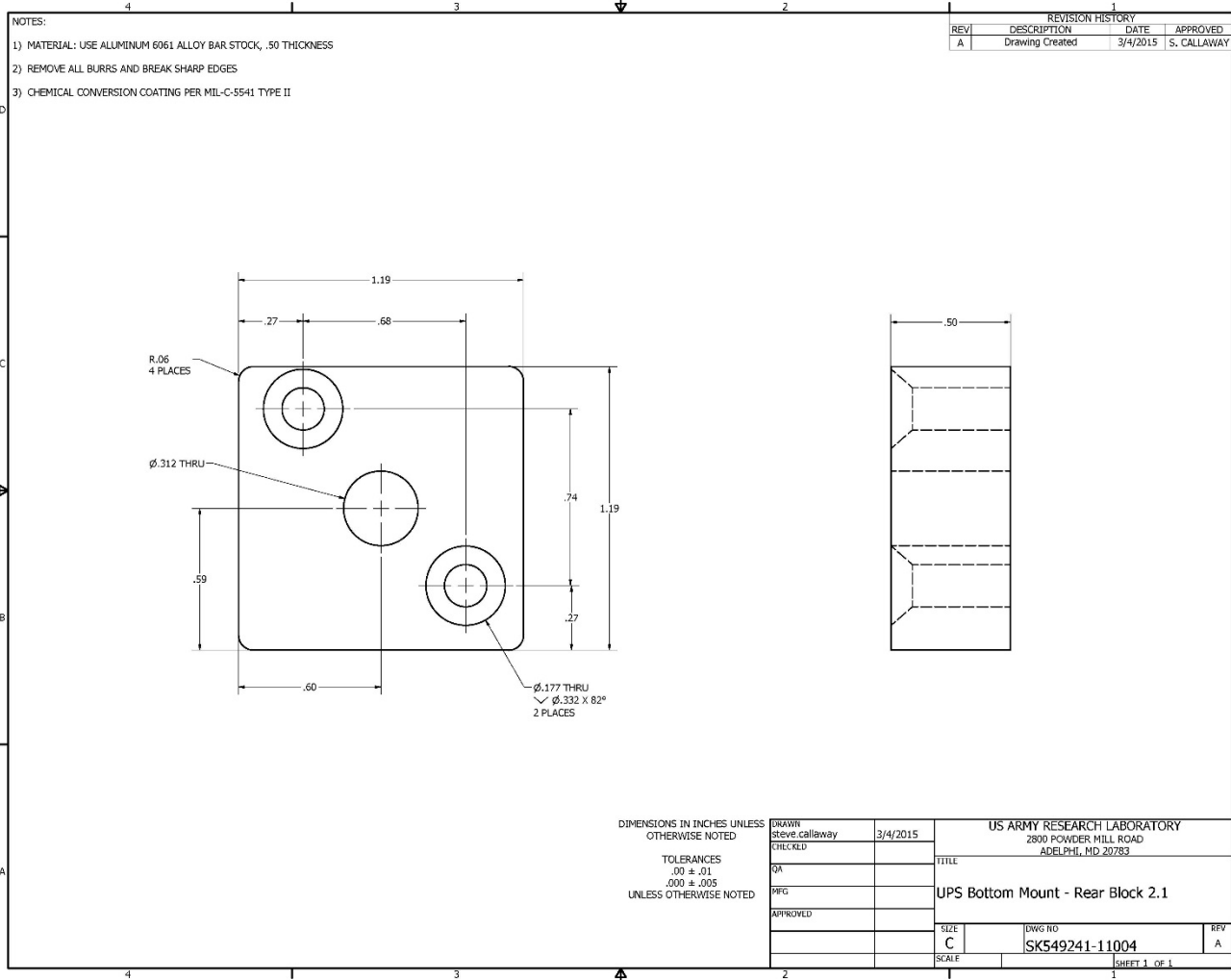

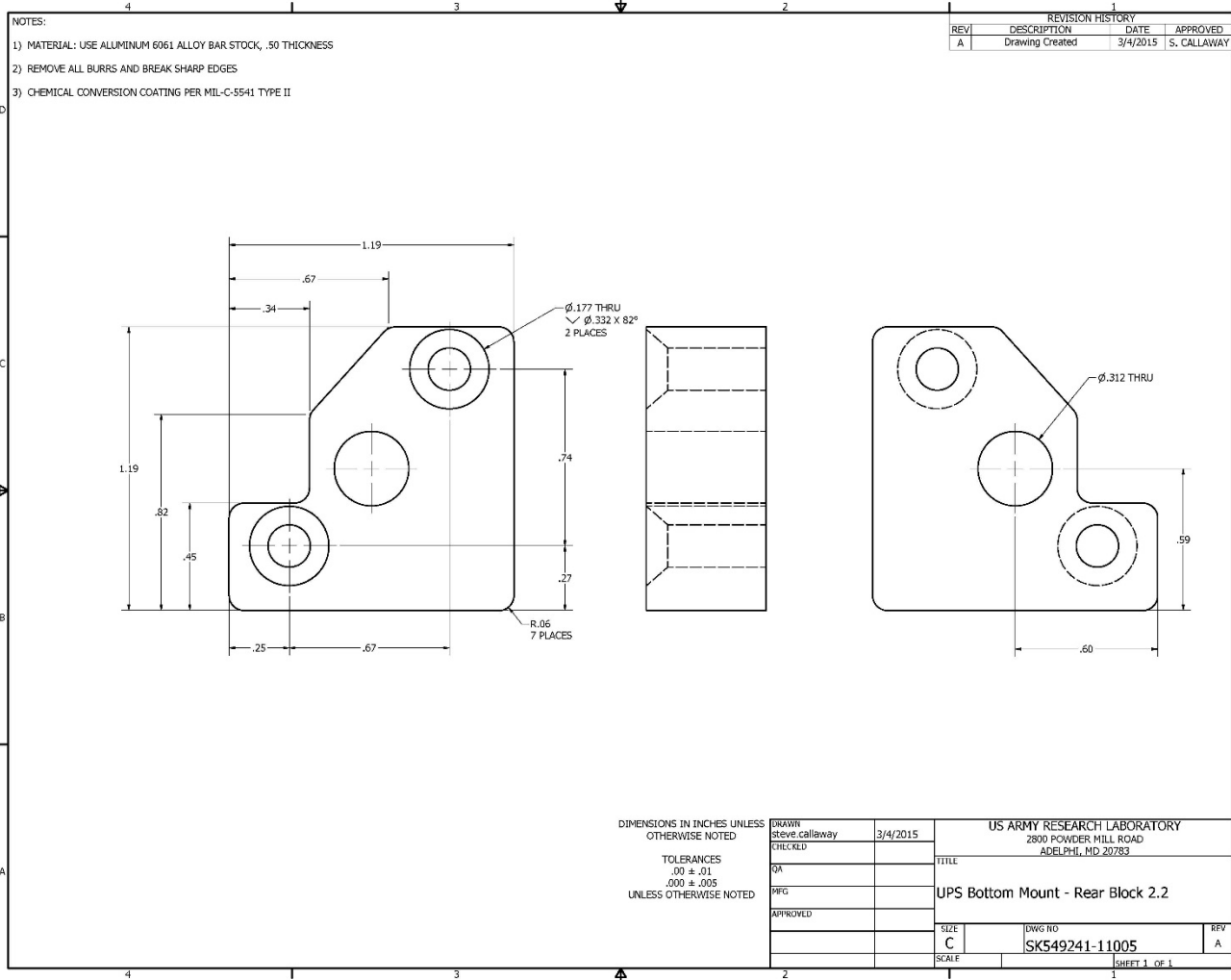

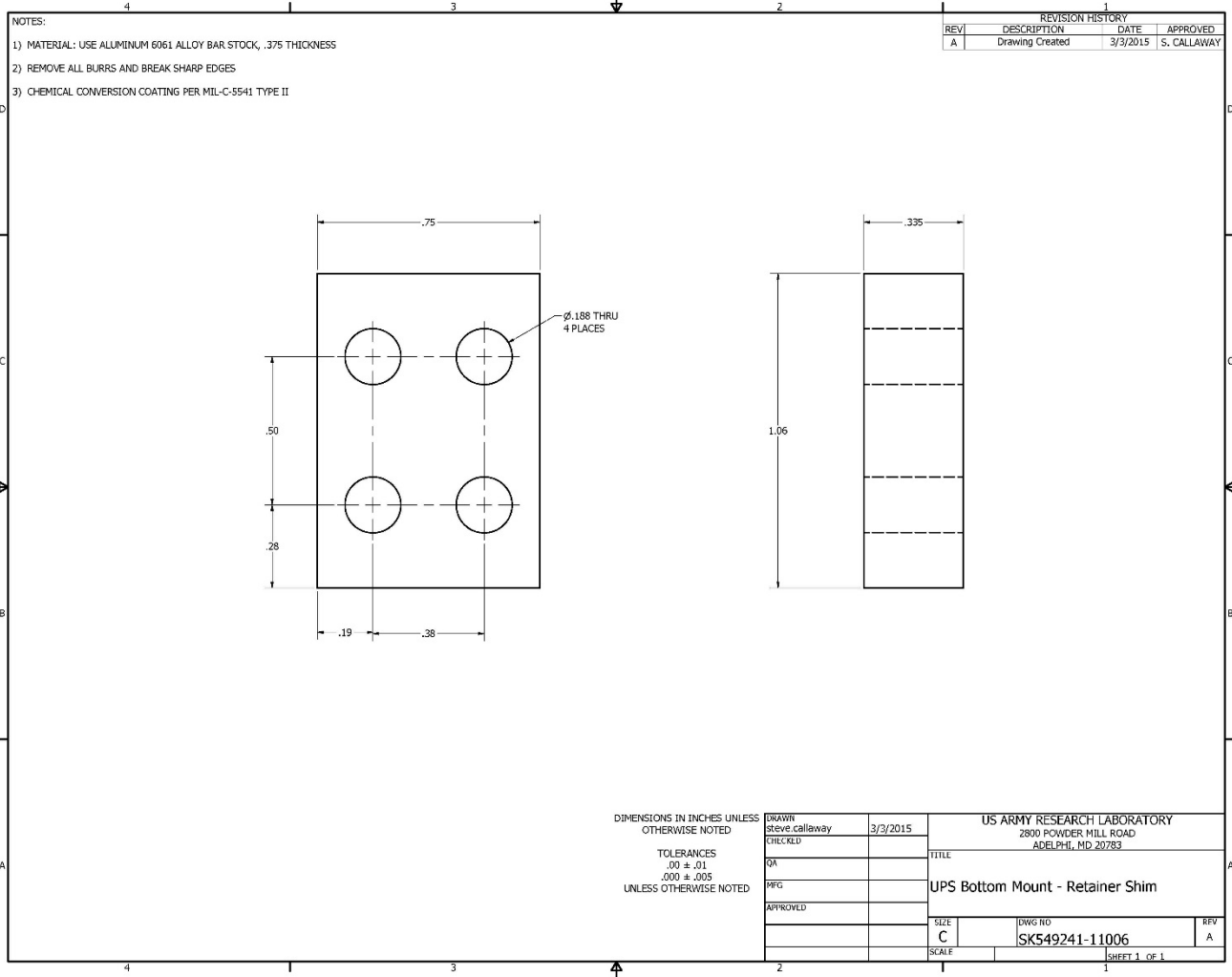

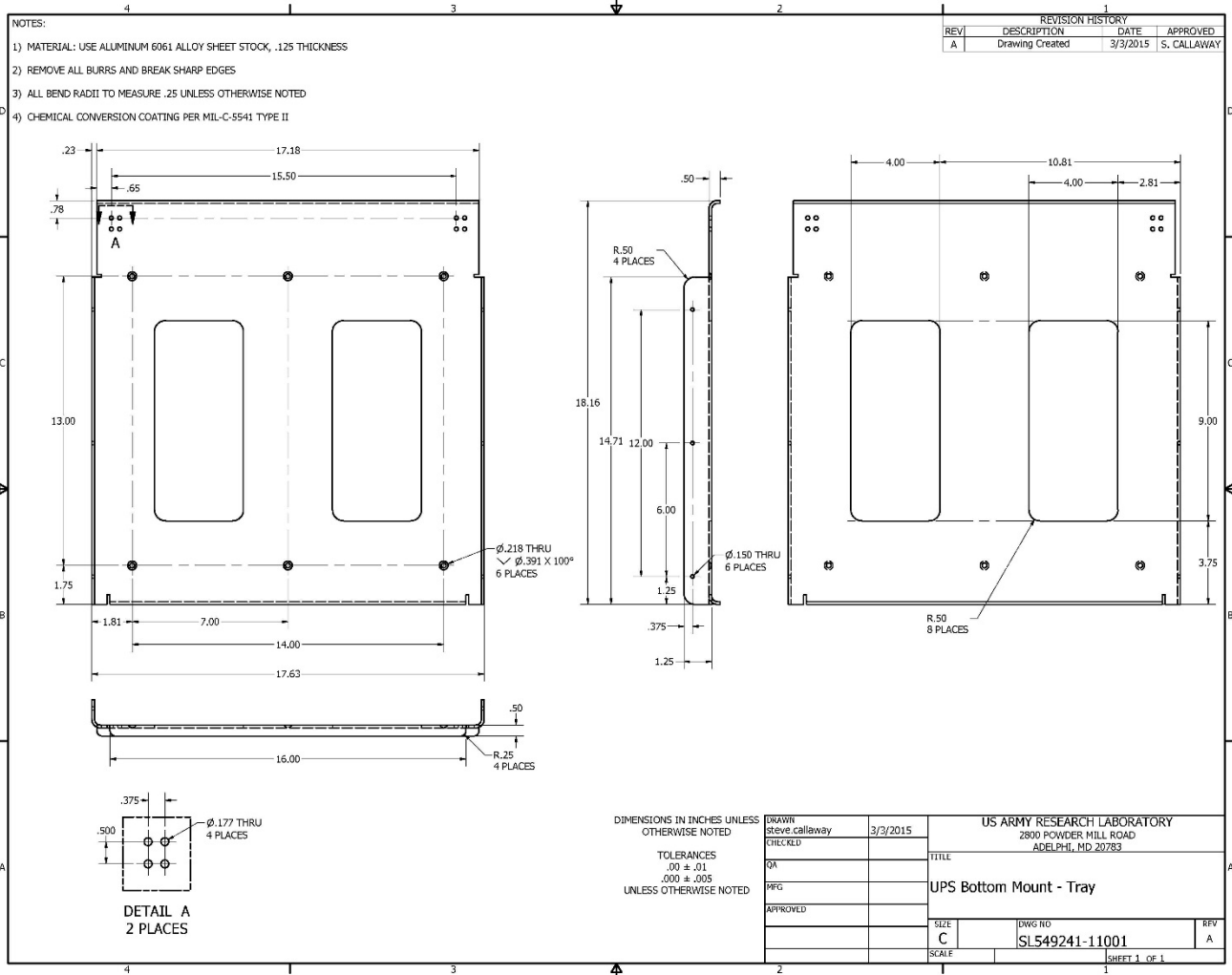



1 DEFENSE TECHNICAL  
(PDF) INFORMATION CTR  
DTIC OCA

2 DIRECTOR  
(PDF) US ARMY RESEARCH LAB  
RDRL CIO LL  
IMAL HRA MAIL & RECORDS  
MGMT

1 GOVT PRINTG OFC  
(PDF) A MALHOTRA

1 DIRECTOR  
(PDF) US ARMY RESEARCH LAB  
RDRL CII B  
S CALLAWAY

INTENTIONALLY LEFT BLANK.