

UNCLASSIFIED

AD NUMBER

AD884151

LIMITATION CHANGES

TO:

Approved for public release; distribution is unlimited. Document partially illegible.

FROM:

Distribution authorized to U.S. Gov't. agencies only; Administrative/Operational Use; APR 1971. Other requests shall be referred to Army Materiel Command, Alexandria, VA. Document partially illegible.

AUTHORITY

USAMC ltr, 14 Jan 1972

THIS PAGE IS UNCLASSIFIED

cy 624-3

ENGINEERING DESIGN HANDBOOK

SYSTEM ANALYSIS

AND

COST-EFFECTIVENESS

LOAN COPY ONLY - DO NOT DESTROY
PROPERTY OF
REDSTONE SCIENTIFIC INFORMATION CENTER
4 JUN 1971

REDSTONE SCIENTIFIC INFORMATION CENTER



5 0510 01030070 2

APPROVED FOR PUBLICATION,
DISTRIBUTION UNLIMITED,
EPC 72-19

FOR REFERENCE ONLY

HEADQUARTERS
UNITED STATES ARMY MATERIEL COMMAND
WASHINGTON, D. C. 20315

AMC PAMPHLET
No. 706-191

9 April 1971

ENGINEERING DESIGN HANDBOOK
SYSTEM ANALYSIS AND COST-EFFECTIVENESS

FOREWORD	viii
CHAPTER 1 - INTRODUCTION	1-1
1.1 Definition of Systems Analysis	1-1
1.2 Definition of Cost-Effectiveness	1-2
1.2.1 Cost-Effectiveness Analysis	1-2
1.2.2 Cost-Effectiveness in Generic Usage	1-2
1.3 Background and History of Systems Analysis/Cost-Effectiveness	1-2
1.3.1 History of Systems Analysis	1-2
1.3.2 History of Cost-Effectiveness	1-5
1.3.3 Systems Analysis/Cost-Effectiveness (SA/CE)	1-7
1.4 Methodology of Systems Analysis/Cost-Effectiveness	1-7
1.5 Application of Systems Analysis/Cost-Effectiveness	1-12
1.5.1 General	1-12
1.5.2 Application of SA/CE to Concept Formulation and Contract Definition	1-14
1.5.3 Conclusion	1-16
1.6 Limitations of Systems Analysis/Cost-Effectiveness	1-17
CHAPTER 2 - GENERAL METHODOLOGICAL APPROACH TO SYSTEMS ANALYSIS/ COST-EFFECTIVENESS STUDIES	2-1
2.1 Input Information	
2.1.1 Army Force Development Plan (AFDP)	2-1
2.1.2 Combat Development Objectives Guide (CDOG)	2-3
2.1.3 Qualitative Materiel Development Objective (QMDO) Approval	2-3
2.1.4 Qualitative Materiel Requirement (QMR)	2-5

AMCP 706-191

CONTENTS (continued)

2.2	Define Requirements and Objectives	2-5
2.3	Develop Mission Profiles	2-7
2.4	Obtain Critical Performance Parameters	2-9
2.5	Synthesize Alternative Systems	2-10
2.5.1	The Total System	2-10
2.5.2	System Configuration Synthesis	2-12
2.5.3	State-of-the-Art Analysis	2-16
2.5.4	Conclusion	2-17
2.6	Develop Hardware Characteristics	2-17
2.7	Establish Basis for Evaluating Effectiveness	2-18
2.7.1	Availability	2-21
2.7.2	Dependability	2-22
2.7.3	Capability	2-23
2.8	Define Measures of Effectiveness	2-24
2.9	Formulate Models	2-25
2.9.1	General	2-25
2.9.2	Assumptions	2-26
2.9.3	Adequacy	2-26
2.9.4	Representativeness	2-26
2.9.5	Uncertainty	2-26
2.9.6	Data	2-27
2.9.7	Validity	2-27
2.9.8	Types of Models	2-27
2.10	Generate Effectiveness Equations	2-29
2.11	Generate Cost Equations	2-43
2.11.1	Cost-Analysis Introduction	2-43
2.11.2	The RAND Method	2-43
2.11.3	Cost-Estimating Relationships	2-48
2.11.4	Problems in Cost-Analysis	2-49
2.11.5	Cost-Analysis Application	2-51

CONTENTS (continued)

2.12	Exercise the Model	2-55
2.12.1	General	2-55
2.12.2	Analysis of Output Data	2-55
2.13	Develop Decision Model	2-62
2.13.1	Optimization Criterion	2-62
2.13.2	Risk and Uncertainty	2-64
2.13.3	Optimization Techniques	2-65
2.13.4	Leverage Effects	2-66
2.13.5	Interpretation	2-67
2.13.6	Conclusion	2-68
CHAPTER 3	- TECHNIQUES	3-1
3.1	Simulation	3-2
3.2	Queueing Theory	3-3
3.3	Sequencing and Markov Processes	3-7
3.4	Inventory and Replacement	3-9
3.5	Linear and Dynamic Programming	3-12
3.5.1	Linear Programming	3-12
3.5.2	Dynamic Programming	3-16
3.6	Game Theory	3-17
3.7	Information Theory	3-22
3.8	Analytic Models	3-28
3.8.1	Lanchester's Equations	3-28
3.8.2	Calculus of Variations	3-30
3.9	Decision Theory	3-30
3.10	Cost-Estimating Relationships and Confidence Intervals	3-31
3.10.1	Cost-Estimating Relationships	3-31
3.10.2	Confidence Intervals	3-32
3.10.3	Example: Simple Linear Regression (Two Variables)	3-35

CONTENTS (continued)

3.11	Experience Curves	3-39
3.12	Cost-Sensitivity Analysis	3-41
3.12.1	General	3-41
3.12.2	Cost-Sensitivity-Analysis Problem	3-41
CHAPTER 4	- BASIC MATHEMATICAL AND STATISTICAL CONCEPTS	4-1
4.1	Introduction	4-1
4.1.1	Preliminary Definitions	4-1
4.1.2	Notation	4-1
4.2	Definitions of Probability	4-2
4.2.1	Classical Definition	4-2
4.2.2	Relative-Frequency Definition	4-2
4.3	Algebraic Principles and Formulas	4-2
4.3.1	Two Basic Counting Principles	4-2
4.3.2	Permutations	4-3
4.3.3	Combinations	4-4
4.3.4	Basic Probability Laws	4-4
4.3.5	Application of Probability Laws to Reliability	4-9
4.4	Probability Distributions	4-9
4.4.1	Definitions	4-9
4.4.2	Properties	4-10
4.4.3	Parameters and Moments	4-12
4.4.4	Discrete Probability Distributions	4-16
4.4.5	Continuous Distributions	4-20
4.5	Statistical Analysis of Test Data -- Estimation	4-28
4.5.1	Nonparametric Estimation	4-29
4.5.2	Parametric Estimates	4-39

CONTENTS (continued)

APPENDIX A:	GLOSSARY	A-1
B:	BIBLIOGRAPHY	B-1
C:	STATISTICAL TABLES	C-1
D:	GUIDE FOR REVIEWERS OF STUDIES CONTAINING COST-EFFECTIVENESS ANALYSIS	D-1
E:	AN EXAMPLE OF A RECENT COMMUNICATIONS COST-EFFECTIVENESS ANALYSIS	E-1

INDEX

TABLES AND FIGURES

TABLES

2-1	Basic Alternatives for the Zenith System	2-14
2-2	Characteristics Pertinent to A State-of-the-Art Analysis (Electronic)	2-16
2-3	Partial List of Techniques for Optimization	2-66
2-4	Array of Cost-Effectiveness Characteristics	2-71
3-1	Systems Analysis/Cost-Effectiveness Techniques	3-2
4-1	Observations of Time to Failure and Censored Time Following A Failure in A Sample of 50 Items	4-56
4-2	Computational Procedure for Estimating the Mean and Standard Deviation of a Normal Distribution, Based on Ordered Observations Involving Censorship	4-57
4-3	Germanium Power Transistors: Accumulative Percent Failure vs. Selected Time Intervals	4-64
4-4	Computations for Maintainability Function	4-70

FIGURES

1-1	Types of Systems Analysis Studies	1-13
1-2	RDT & E Cycle	1-13
2-1	Systems Analysis/Cost-Effectiveness Process	2-2
2-2	Mission-Profile Development	2-8
2-3	The Total System	2-11
2-4	Zenith Missile System - Functional Diagram	2-13
2-5	Hierarchy of Parameters	2-15
2-6	System-Effectiveness Framework	2-20
2-6A	Elements of Effectiveness	2-20
2-7	A Submodel Classification Scheme	2-25
2-8	System Cost Categories	2-45

FIGURES (continued)

2-9	Expressions of Uncertainty	2-57
2-10	Trade-off Curves	2-60
2-11	Interdependencies Between Trade-off Studies and Project Objectives	2-61
2-12	Sensitivity Analysis	2-62
2-13	Examples of Cost-Effectiveness Curves	2-72
4-1	The Exponential Reliability Function	4-21
4-2	Observed Reliability Functions	4-34
4-3	Kolmogorov-Smirnov Test for Exponential Distribution	4-42
4-4	Graphical Estimation of the Parameters of an Assumed Normal Distribution	4-57
4-5	Nonparametric and Theoretical Normal Reliability Functions	4-59
4-6	Weibull Probability Paper	4-62
4-7	Graphic Procedure for Obtaining Estimates of Parameters Associated with the Weibull Distribution	4-65
4-8	Theoretical Weibull Reliability Function	4-66
4-9	Weibull Hazard-Rate Function	4-67
4-10	Plot of Maintenance Data on Log-Normal Probability Paper	4-71

FOREWORD

The purpose of this handbook is to provide a text and reference material in System Analysis and Cost-Effectiveness. It is intended for those technical, scientific, management, and administrative personnel who are responsible for preparing information, making decisions or reviewing decisions made by others regarding life-cycle cost, system effectiveness (availability, dependability, capability), or technical feasibility of a system or equipment at any phase in its life cycle. It is immediately useful to personnel who are familiar with a system or equipment under study but are not familiar with the methodology and techniques of System Analysis and Cost-Effectiveness.

The handbook consists of four chapters: (1) an introduction to the concept of system analysis and cost-effectiveness; (2) a basic framework, or general methodological approach, for conducting and reviewing cost-effectiveness or system analysis studies; (3) a set of techniques (linear programming, queueing theory, simulation, etc.) that can be used for performing cost-effectiveness and system analysis studies; and (4) a review of the basic mathematical and statistical concepts that underlie the scientific approach in the system analysis/cost-effectiveness process.

The handbook was originally written by ARINC Research Corporation, 2551 Riva Road, Annapolis, Maryland 21401, in response to line item 0003 Exhibit A002 of Contract Number DAAB07-68-C-0056 for the Systems/Cost Analysis Office, U. S. Army Electronics Command, Fort Monmouth, New Jersey 07703. Messrs. J. A. Macinko and R. J. Sanford were the USAECOM Project Engineers and Mr. D. P. Salvano, Chief, Systems Evaluation Division, was the Project Advisor. It is now being published as an AMC handbook in this series designated AMCP 706-191.

The handbooks are readily available to all elements of AMC including personnel and contractors who have a need and/or requirement. The U.S. Army Materiel Command policy is to release these Engineering Design Handbooks to other DOD activities and their contractors, and other Government agencies, in accordance with current Army Regulation 70-31, 9 September 1966. Procedures for acquiring these handbooks follow:

a. Activities within AMC and other DOD agencies should direct their requests on an official form to:

Commanding Officer
Letterkenny Army Depot
ATTN: AMXLE-ATD
Chambersburg, Pennsylvania 17201

b. Contractors who have Department of Defense contracts should submit their requests, through their contracting officer with proper justification, to the address indicated in paragraph a.

c. Government agencies other than DOD having need for the handbooks may submit their request directly to the Letterkenny Army Depot, as indicated in paragraph a, or to:

Commanding General
U. S. Army Materiel Command
ATTN: AMCAM-ABS
Washington, D. C. 20315

d. Industries not having a Government contract (this includes Universities) must forward their requests to:

Commanding General
U. S. Army Materiel Command
ATTN: AMCRD-TV
Washington, D. C. 20315

e. All foreign requests must be submitted through the Washington, D. C. Embassy to:

Assistant Chief of Staff for Intelligence
Foreign Liaison Office
Department of the Army
Washington, D. C. 20310

All requests, other than those originating within the DOD, must be accompanied by a *valid justification*.

Comments and suggestions on this handbook are welcome and should be addressed to Army Research Office-Durham, Box CM, Duke Station, Durham, North Carolina 27706.

CHAPTER 1

INTRODUCTION

1.1 DEFINITIONS OF SYSTEMS ANALYSIS

Generally speaking, the nomenclature of Systems Analysis can be applied to any systematic approach that compares alternate means of attaining a specified objective. The specific techniques and methodologies may differ depending on the many factors of each study; those inherent due to the class of problem and those imputed because of problem variation from a "classic case". However, all of the generic classes of Systems Analysis studies have the common feature of systematically examining all classes of problems, whether simple or complex. The application of System Analysis processes are directed towards supplying the decision-makers with maximum information, quantified when possible, in order to help them in selecting preferred alternatives to the attainment of the stated objective. Also, when no alternative means are clearly visible, the process is capable of imparting cogent information which can be utilized in the formulation of new alternatives.

The concept of Systems Analysis has received considerable attention throughout Department of Defense areas of interest; Army, Navy, Marine Corp, and Air Force. However, the subject and applicability are not exclusively military oriented. Extensive use of Systems Analysis has been utilized by non-military activities, both in-house governmental agencies as well as the private sector of the economy.

Materiel Systems Analysis has been defined by the United States Army Materiel Command as follows:¹

1. Materiel Systems Analysis - A generic term which implies both a technique and a function which, for the purposes of this regulation, are defined as follows:
 - a. As a technique -- involves the analytic investigation and quantitative appraisal and comparison of materiel programs or courses of action in terms of the effectiveness, improvement coefficient or cost benefit expected versus the costs either required or anticipated to be incurred. Generally,

¹AMCR 11-1; Research and Development Materiel Systems Analysis; U. S. Army Materiel Command, Headquarters, Washington, D. C., 21 April 1970.

AMCP 706-191

for Systems Analysis for materiel items or programs, the benefits and costs of concern are considered on a "life cycle" basis. Systems Analysis, as a technique, may be applied at any point in the life cycle.

b. As a function -- involves the staff and operation activity necessary and required to discharge the AMC requirement and responsibilities for Systems Analysis in an organized fashion and to fix responsibility. In general, the conduct of the Systems Analysis function takes the form of studies, projects, and investigations involving the technique described above and the application of modern analytics and costing procedures. The studies, projects, and investigations comprising the function of Systems Analysis may variously take the form and title of cost-effectiveness, parametric design/cost-effectiveness (PD/CE), cost-benefit, cost and performance, trade-off, optimum mix, and quantitative inventory mix studies and analyses; product-improvement determinations; and qualitative assessments of approaches in functional activities and programs. The techniques of Systems Analysis are equally applicable to all of the above. As a function, Systems Analysis seeks to aid the decision making process throughout the life cycle of materiel programs.

1.2 DEFINITION OF COST-EFFECTIVENESS

1.2.1 Cost-Effectiveness Analysis (study) has been defined by the United States Army Materiel Command as follows:²

"Cost-effectiveness analysis (study) - The process of comparing alternative solutions to mission requirements in terms of value received (effectiveness) for the resources expended (costs)"

1.2.2 Cost-effectiveness, (C-E) in generic usage, is interpreted as a measure defined implicitly or explicitly by a decision-maker of the benefits to be derived from and the resources expended on a system.'

This can be functionally expressed as:

$$C-E = f (\text{benefits derived; resources expended})$$

1.3 BACKGROUND AND HISTORY OF SYSTEMS ANALYSIS AND COST-EFFECTIVENESS

1.3.1 History of Systems Analysis

Present day use of the word "Systems Analysis" is varied, depending on the user. The chronology of its constituent elements could (at least) regress to:

²Ibid

'Maltese, Jasper; ARINC Research Monograph No. 12., System Cost-Effectiveness; Basic Concepts and Framework for Analysis - ARINC Research Corp., Annapolis, Md., January 1967; p.9.

Aristotelian logic; then to the formulation of methods and procedures of science during the Renaissance (14th-17th centuries); Fredrick W. Taylor's inception of Scientific Management;⁴ sporadic use of statistical decision making in certain World War I studies⁵ and introduction of a scientific method consisting of objectives, constraints, configuration, selection, implementation, evaluation, feedback and conclusion - known by college students for years as a format for problem solving.

The nearest historical milestone (within the generic context of Systems Analysis) that has major import to the ultimate definition is the development and use of operations research in Great Britain during World War II. These operations research studies were devoted to early warning systems, anti-aircraft gunnery, anti-submarine warfare, civilian defense and conduct of bombing raids.

A group consisting of Professor P.M.S. Blockett, three physiologists, two mathematical physicists, one astro physicist, an Army officer, one surveyor, a general physicist, and two mathematicians utilized the mixed-group approach in solving operational problems.⁶ This philosophy is certainly inherent in what we now call Systems Analysis, with the inter-disciplinary group being necessitated by both the complexity of the problem and its means of solution.

The main difficulty in describing what "Systems Analysis" is and is not can be gleaned from the newly developed classifications of analytical activities which have emerged, namely: operations analysis, operations research, systems research, systems engineering, cost-effectiveness and management science.

It is most difficult to determine what the exact definition of each is and which one of the subject titles subsumes the others.

⁴Taylor, F. W., Scientific Management; Harper & Bros., New York, 1947

⁵Trefethen, F. N., Operations Research for Management; The John Hopkins Press, Baltimore, Md., 1954

⁶Flagle, C., et.al., Operations Research & Systems Engineering; The John Hopkins Press, Baltimore, Md., 1960, p.19.

In order to explore areas of difference in understanding about Operations Research and Systems Engineering activities, it would be well for the reader to refer to the following books and periodicals:

Bronowski, J.; Scientific American, Vol. 185, October 1951, pp.75-77.

Machol, R.E.; Mechanical Engineering, Vol. 79, No. 9, September 1957, pp.890-91.

Flagle, C., et.al.; Operations Research & Systems Engineering; The John Hopkins Press, Baltimore, Md., 1960, p.19.

Hall, A. D.; A Methodology for Systems Engineering; D. Van Nostrand Co., Inc., Princeton, New Jersey, 1962.

After World War II, the RAND Corporation interpreted weapons systems analysis as a description of those studies which did not have clearly defined inputs for given objectives and whose future uncertainties were recognized to be less well defined than those of earlier studies.

The post war studies in weapons systems analysis by RAND and other companies is the genesis of the term Systems Analysis. Charles Hitch, formerly of RAND, became Assistant Secretary of Defense, Comptroller in 1961 and introduced the concept of Systems Analysis within the Department of Defense.

Since 1961, the term Systems Analysis has been used by DoD to describe both the philosophy and some of the techniques and methodology applicable to defense programming and budgeting .

In Analysis for Military Decisions, E. S. Quade describes System Analysis,

"While it does make use of much of the same mathematics (as operations research) - it is associated with that class of problems where the difficulty lies in deciding what ought to be done - not simply how to do it.

The total analysis is thus likely to be a more complex and less neat and tidy procedure, one seldom suitable for quantitative optimization. In fact, the process is to a large extent synthesis: the environment will have to be forecast, the alternatives designed and the operational laws invented. Thus with a systems analysis, one associates "broad", "long range", "high level", "choice-of-objectives", problems and "choice of strategy", "qualitative judgment" and "Assistance to logical thinking".⁷

In a later definition, E. S. Quade states:

"System Analysis - a systematic approach to helping a decision-maker choose a course of action by investigating his full problem, searching out objectives and alternatives and comparing them in light of their consequences, using an appropriate framework - insofar as possible, analytic - to bring expert judgment and intuition to bear on the problem."⁸

This latter more explicit view of System Analysis seems to be necessary in view of the increasing sophistication of technical programs and studies which continually cause the decision-maker(s) to need more capacity for understanding and recommending the "best approach". The nature of systems analysis and its objectives are aimed towards this goal.

Most of the material presented above relates to the history and interpretation of systems analysis as viewed by DoD.

⁷Quade, E. S., Analysis for Military Decisions; Defense Documentation Center, Alexandria, Va., AD 453887, November 1964, p.7.

⁸Originally appeared in the book SYSTEMS ANALYSIS AND POLICY PLANNING, Applications in Defense, Edited by E. S. Quade and W. I. Boucher; Published in 1968 by American Elsevier Publishing Company, Inc.

Nonmilitary use of Systems Analysis has, today, culminated in development of management information systems. These MIS are the final output of the efforts of Systems Analysis with the same stipulated objective as DoD programming - that of providing the maximum cogent information to a decision-maker for a given purpose.

Nonmilitary organizations, generally, do not have the inherent complexity of determining the optimum solution to a national defense posture for a given time period, but do have relatively high order of complex problems in such areas as space, management science, planning and forecasting, resources management, product line mixes, transportation, communications and participation in social welfare programs.

As can readily be seen, the problems are somewhat similar in total objective -- The best decision. However, some of the factors aiding utility in civilian Systems Analysis are: costs are more readily determinable; competition aspects are more quantified and the technology is at hand (or can be determined within closer limits than can that of the military).

The stated aim of materiel Systems Analysis is to insure that the Army can accomplish its mission within the level of effectiveness specified and with the minimum expenditure of resources.

This goal encompasses resource management; and although costs have been implied in the foregoing discussion, it now becomes necessary to determine how they were derived and how they interface with Systems Analysis.

1.3.2 History of Cost-Effectiveness

Throughout history, man has reckoned with the cost of the item he acquired. Somehow, through mutual agreement, or other philosophy, man decided what the payment (cost) should be for what he received.

Early Greek philosophy gave us the word Economics - then defined as household management - which, today, is designated as the branch of social science dealing with the description and analysis of the production, distribution and consumption of goods and services.

Economic philosophy started with the "philosophists school", Aristotle and St. Thomas Aquinas (comprehensive codification of "just-price"), then to the modern age economists and the "classical school" (Adam Smith, John Stuart Mill, et.al.), then the "Utopian Socialists" (Robert Owen) and "Scientific Socialists" (Karl Marx).

AMCP 706-191

Today most economic theory is classified as being neo-classical synthesis, i.e., a marriage between micro and macroeconomics.

The essence of neo-classical synthesis is the modern day interpretation of economic analysis. In terms of J. M. Keynes: 9

"The object of our analysis is not to provide a machine or method of blind manipulation which will furnish an infallible answer, but to provide ourselves with an organized and orderly method of thinking out our particular problems; and, after we have reached a provisional conclusion by isolating the complicating factors one by one, we then have to go back on ourselves and allow, as well as we can, for the probable interactions of the factors amongst themselves. This is the nature of economic thinking."

Interpretation of the above-mentioned economic philosophy certainly shows the genesis of modern analytical thought that is now embodied in the definition of Systems Analysis and/or Cost-Effectiveness.

When this philosophy is combined with the theory of Production; Theory of Input-Output Analysis (see also linear programming); Economic Welfare Theory; and such economics-oriented definitions as Cost (Resources); Goods and Services; Value, Price and Utility, (see also marginal utility), it becomes apparent that within the concept of neo-classical synthesis lies the springboard from our definition of Cost-Effectiveness.

More specifically, Economic Welfare Theory constituents of positive theory and welfare theory describe the evolution as such:

Positive theory considers the development of economic principles of operation regardless of desirability or not,

Welfare theory is concerned with the evaluation of the operation of the economy in terms of assumed standards.

The overall objective of Welfare Economics is stated in the term Benefit-Cost Analysis: A means of estimating the prospective economic returns of a project (or projects) in relation to costs.

Comparison of Benefit-Cost Analysis and Cost-Effectiveness leaves little doubt as to the specific genesis of the term Cost-Effectiveness or Cost-Effectiveness Analysis as defined herein.

The evolution of the term "Cost-Effectiveness Analysis" occurred after World War II (see paragraph 1.3.1 under Systems Analysis). Cost-Effectiveness, per se, appears to have been formally introduced during the period from 1961

⁹Keynes, J. M.; General Theory of Employment, Interest and Money; Harcourt, Brace; New York, 1936, p.297.

to 1964. This is evidenced by inclusion of cost-effectiveness requirements formally stipulated in certain type Request for Proposal development/procurements contracting efforts in accordance with DoD Directive, (Series 3900.9; 1964) and The Contract Formulation - Contract Definition Concept Programming of the DoD during this and ensuing periods of time.

1.3.3 Systems Analysis/Cost-Effectiveness

The literal combining of the terms Systems Analysis and Cost-Effectiveness, in view of their previously developed history and subsequent definition could, upon examination, raise much doubt about what each does that the other doesn't.

Immediate questions are:

- Can they be combined as SA/CE?,
- What do they each mean in this form?,
- What methodology combines them?, and
- Aren't they interpretatively redundant?

Previous history and definition of Systems Analysis illustrates that it is more likely to deal with that class of problems directed towards what should be done, not the methodology of how to do it. In this sense, then, it is directed at the suitability of implementing a specific method and the consideration of alternatives directed towards the implementation of this method.

When the effort is directed towards the costs (and/or resources) required between these alternatives, and the effect of changes in either cost or effectiveness, relative to each other and mission objectives, then we use the term cost-effectiveness analysis.

The objective of cost-effectiveness is, usually, to minimize the costs (resources) at which a given level of effectiveness can be attained for a given mission. This also includes the various supporting functions.

In order to further clarify the specific definition of each term and to illustrate their integration, the reader is referred to the immediate following sections, 1.4 (Methodology of SA/CE) and 1.5 (Application of SA/CE). Also, the subsequent chapters of this Guidebook are directed towards defining the role of Systems Analysis and Cost-Effectiveness as they are considered in the ensuing analytical formats.

1.4 METHODOLOGY OF SYSTEMS ANALYSIS/COST-EFFECTIVENESS

There isn't any singular formulation nor is there a standard methodology which is applicable "across-the-board" that allows Systems Analysis/Cost-Effectiveness studies to be performed for all classes or sub-classes of problems explicitly.

AMCP 706-191

The immediate lack of an analytical "cookbook" approach doesn't preclude the implementation of Systems Analysis/Cost-Effectiveness studies however. The main virtue of any stipulated scientific method or programming function is its recognition of change. Comparison of a generalized "x-step" scientific approach with the Systems Analysis/Cost-Effectiveness methodology presented herein reveals both to be dynamic, adaptive processes. The singular discrete difference is in problem formulation and solving activities, due primarily to differences in levels of abstraction.

In order to perform any analysis it is necessary to conceive a disciplined framework, i.e., a systematic approach, with provisions for making comparisons between alternative ways of accomplishing an objective systematically (hopefully quantitatively) in a logical format that can be retraced and verified.

Systems Analysis and Cost-Effectiveness studies utilize the same basic framework for their objectives; therefore, it now becomes necessary to differentiate between them in terms of the definitions given in sections 1.3.1 and 1.3.2. The main difference appears to be in the degree of applied emphasis. When the study is directed towards the determination of "costs" between similar systems that can attain a specific objective, the term Cost-Effectiveness analysis is applied. When the problem is one of broader scope; i.e., consideration of different types of systems that could attain the specific objective, then the term Systems Analysis is used.

Decisions pertaining to choices of alternative weapon systems or force structures and the strategies for their employment are essentially matters of economic choice. Certain elements have evolved which are common to these kinds of decisions and have been contained in Systems Analysis/Cost-Effectiveness studies.¹⁰

1. Objective - Systems Analysis/Cost-Effectiveness studies are initiated in order to aid in determining a particular policy and/or procedure. These analyses are directed toward a description of the objectives - what they should be (or are). This done, the various policies and procedures are evaluated, compared and "scaled" in order to determine what their effectiveness and costs are and to what degree they do "attain" the objective(s).
2. Alternatives - These are the various means that can be used to attain the objective. The alternatives presented should include all known methods (also, within a given time frame, consideration of new means within the "then" known state-of-the-art) that can achieve the desired results. The alternatives can be not quite obvious and consideration of all types and ways of doing things must be included. (As an example, if the objective of any given period of history was peace - one philosophy was to negotiate - another was war. War was a means of attaining peace by unification.)

¹⁰Quade, E. S., Analysis for Military Decisions; AD 453887, p.155.

3. Costs - The costs are, also, not readily obvious. These are the sum total of the resources expended to attain the objective(s) for each of the proposed alternatives. Resources (costs) are those items consumed in the attainment of the stipulated objective which cannot be used for other purposes. Total costs must include consideration of all the factors involved in accomplishing an objective. (As an example, the cost of smoking is determinable at "y" cents per pack. However, if the U. S. Surgeon General's Report is correct, in that smoking reduces life by (on the average) 8.3 years, then the value of reduced life is a cost to be determined and applied to the sum total.)

4. Model - The model is a representation of the reality of the situation or condition being studied. Ideally, it would represent the real situation without error or uncertainty. Usually, in Systems Analysis/Cost Effectiveness studies it can simulate (at best) most, or some portion, of the real world. The model defines its representation of the real world, and through various exercises, simulations, gaming and mathematical representations, supplies numerics or information on the effectiveness of the various alternatives under consideration for use in attainment of objectives.

The structure and capability of the model is a major limiting feature of an analysis.

A basic requirement of any model is that it should provide correct answers to the stated questions in an economical manner. This causes consideration of the following factors: representativeness, uncertainty, data sources and validity; i.e., consistency, sensitivity, plausibility, criticality, workability, and suitability.

5. Criteria - The criteria are the standards or accepted rules which are used to determine the relativeness or desirability of one alternative vs. another and allows for choosing one in preference to others. In a Cost-Effectiveness analysis it provides for weighing and combining cost vs. effectiveness.

At this point in Systems Analysis/Cost-Effectiveness studies we can now interrogate the major operating elements of the scientific methodology within the general framework of the processes of a systematic analysis. Regardless which procedure of scientific inquiry is invoked, the analysis proceeds through the following typical stages:

Hypothesis - At this step, the objective(s) are defined. The constituent elements identified, and the extent of the problem delimited to suit knowledge, time and cost considerations.

Definition - This step explores the alternate configurations, policies or programs that can be directed towards solution of the problem (objective). Inherent in this step are considerations of the resources and other interrelationships.

AMCP 706-191

Analysis - Construction of the model(s) at the necessary level of abstraction; and exercising the model to determine the consequences of alternate programs and considered factors.

Evaluation - This step examines the derived results. It is here that the preferred alternative is identified. The evaluation is based on modification of all factors discovered in the iterative analysis.

Conclusion - This step is concerned with the verification of the resultant analysis by test and/or experimentation.

The above application of the systematic approach is not new and is quite straight forward. The problems encountered in using the approach are not caused by its non-applicability, but because of the vagaries of the environment we are attempting to use it in and for.

In Systems Analysis/Cost-Effectiveness studies the decision-maker and analysts would like to live and operate in a deterministic atmosphere, and, at worst, in a well behaved stochastic environment. In this environment, the decision-makers/analysts can modify hypotheses, which are subjectively probabilistic at worst, with information gleaned from application of a defined scientific methodology, causing revision of the original probabilistic function towards a fully descriptive and validated function which expresses the actual environment exactly.

Unfortunately, the real world precludes such a standardized and ideal approach and solution to problems encountered by present day Systems Analysis/Cost-Effectiveness studies.

Consider the objective of military posture at some time in the future. What should its composition be and what should it be capable of? At once, the objectives are not even known, are certainly multiple and what can be postulated as a figure of merit? Knowing that the Systems Analysis function would be to consider not only pure military posture, but with consideration of the interrelationships between socio-economic and political factors and military affairs, it becomes immediately clear that a "model" would be quite difficult to construct,

The analytical framework postulated above cannot accomplish analyses such as is necessary in view of these objectives in a single pass-through. In order to maximize the amount of information that can be obtained from such an approach, it is necessary to iteratively exercise the framework. Selection of objectives, alternatives, data collection, modelling activities, establishing measures of effectiveness and figures of merit, sensitivity analyses, evaluations, modifications and conclusions should be iterated through the established analytical framework in an attempt to remove the "impurities" of the first

run-through and reduce the overall complex subjective area into a quantifiable real world area as near as can be accomplished.

The iterations produce: delimited, redefined or changed objectives (perhaps even causing suboptimization to be considered in view of total complexity); discovery of new alternatives as by-products of analysis, or modification of type and quantities; redetermination of costs or resources due perhaps to consideration of having to consider non-dollar cost contingencies; necessity of modelling changes in order to more accurately depict the "real world" considering, also, the constraints and configurations in terms of new data or redefinition of objectives and measures of effectiveness and establishment of new criteria in terms of new data, information and/or changes in the inherent elements in the analysis or in more accurate standards or rules so delineated by recursion.

Obviously, the process can continue indefinitely; but normally, it is exercised until the results are deemed satisfactory or the constraints of time and/or money force discontinuance.

At this point in the dissertation it is necessary to digress from the prime purpose of this section - Methodology of Systems Analysis/Cost-Effectiveness - which explains the how it is done, and ask why and for whom. Subsequent sections explain what and when as well as modification of how and why; but, for ~~whom~~ needs a brief explanatory section.

This entire SA/CE studies-analysis is directed towards improving the quantity, quality, and accuracy of information that is necessary (or would be helpful) for a decision-maker, in order that he may make the best possible decision with minimum uncertainty and risk - or, if you will - the decision as to what is more effective, economical and timely. As such, SA/CE is a prime management tool, nothing more - but nothing less.

Granted, the genesis of the reason or need for a study is based on speculation of "decision-makers" and that it does contain subjective value judgments, lack of precise knowledge and/or data, uncertainty of competitive strategy and other uncertainties. However, the studies can aid the decision-makers by assessment of implications gleaned from selection of various alternatives.

Systems Analysis concerns itself with problems of resource allocation, i.e., what mix of "things" should be obtained and how long are they to be considered adequate for their purpose. Cost-Effectiveness reveals the cost versus effectiveness of the "mix" and aids in determination of what is the best way to "spend" the resources.

AMCP 706-191

Without programming this philosophy through a systematic analytical format, there is no better way of determining how many of what can accomplish a mission - i.e., - it is not sensible to intuitively prescribe a posture without considering whatever numerics can be gained from a "study" and what their information content is. It is not the purpose, nor can it be accomplished by SA/CE, to cause a decision-maker to agree beyond all doubt that this information does indeed present the course of action to follow.

The prime purpose is to provide as much quantified information - including limiting conditions whether truly quantified or qualitative - as is possible in order to sharpen the intuition of the decision-makers and help them arrive at the best solution in terms of their observation, intuition, experience and value judgments.

Discussion of limitations of SA/CE will be presented in the final segment of this chapter.

1.5 APPLICATION OF SYSTEMS ANALYSIS/COST-EFFECTIVENESS

1.5.1 General

The concepts and philosophy of Systems Analysis/Cost-Effectiveness can be applied to almost any system at any time during the life cycle.

The Army Materiel Command (AMC) states that a requirement for a Systems Analysis/Cost-Effectiveness study, evaluation, or investigation may exist or be initiated in support of concept formulation (CF), contract definition (CD), program change requests (PCR's), program submissions, technical feasibility studies (FS's), and studies associated with qualitative material development objectives (QMDO's), qualitative material approaches (QMA's), advanced development objectives (ADO's), advanced development plans (ADP's) and technical development plans (TDP's). In addition, other phases in the life cycle where this type of evaluation should be applied are in long range R & D systems planning, maintainability and reliability studies, as well as in major inventory and logistics decisions.

The study may take on any of the forms in Figure 1-1, depending upon where it is in the life cycle as well as what type of decision must be made.

* AMCR 11-1, 21 April 1970.

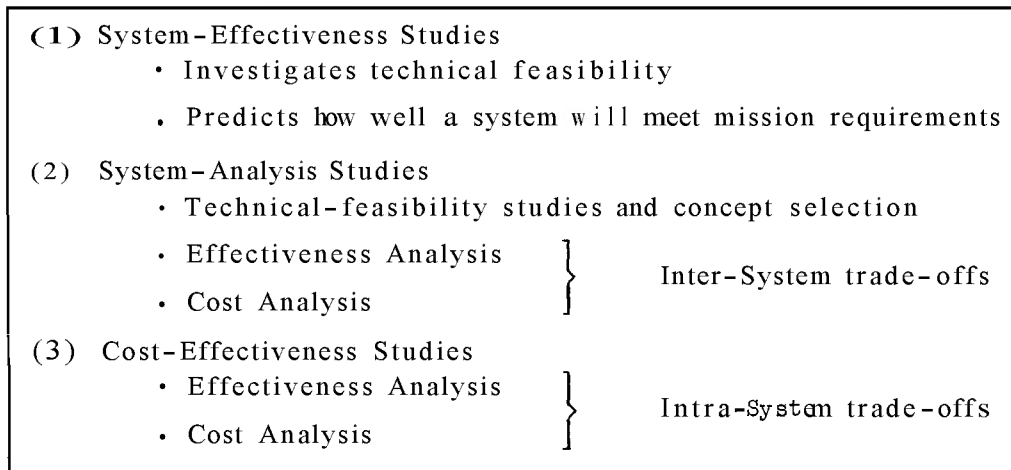

FIGURE 1-1
TYPES OF SYSTEMS-ANALYSIS STUDIES

Category	Orientation	SA/CE Milestones
Research (6.11)	Increase knowledge	
Exploratory Development (6.21)	Technical feasibility	Technical feasibility and concept selection studies
Advanced Development (6.31)	Operational and technical suitability	Inter-system C-E studies
Engineering Development (6.41)	Design Engineering	Intra-system PD/CE studies
Operational Systems Development (6.71)	Production Engineering	

FIGURE 1-2
RDT&E CYCLE

AMCP 706-191

The relationship of the types of studies to the major phases in the RDT & E Cycle is contained in Figure 1-2. During exploratory development (6.21) the type of system analysis studies that are conducted are normally concerned with technical feasibility and concept selection. However, when advanced development (6.31) begins, the primary aim is to conduct inter-system trade-offs in order to choose among several alternative systems capable of performing some given mission, assuming that all contending systems are capable of performance at various levels of effectiveness.

In engineering development (6.41) parametric design/cost effectiveness (PD/CE) studies are conducted. This is a process of formulating and evaluating a complete range of alternative intrasystem trade-offs of components (i.e., designs) to provide the optimum capability for fulfilling a given system mission.

1.5.2 Application of SA/CE to Concept Formulation and Contract Definition

Recent DoD and Army Directives* which establish the concept formulation and contract definition phases of the system life cycle show an increasing awareness of and need for Army program managers to make sound decisions based upon quantitative evaluations which should result in economical and operationally effective system designs capable of meeting the desired performance requirements. In this section, concept formulation and contract definition will be described and the requirements for Systems Analysis/Cost-Effectiveness studies will be discussed.

The objective of concept formulation is to provide the technical, economic, and military basis for a conditional decision to initiate engineering development.

It is accomplished through comprehensive system studies in exploratory and advanced development by means of experimental tests, engineering and analytical studies. This work constitutes the necessary preliminary threat and operational analyses, trade-off and cost effectiveness studies, and development of components and technology - to assure a firm foundation for Engineering Development. The evidence required for a conditional decision to proceed with Engineering Development includes the following prerequisites:

- (a) Primarily engineering rather than experimental effort is required, and the technology needed is sufficiently in hand.
- (b) The mission and performance envelopes are defined.
- (c) The best technical approaches have been selected.
- (d) A thorough trade-off analysis has been made.

*DoD Directive 3200.9, AR 705-5.

- (e) The cost-effectiveness of the proposed item is favorable in relation to that of competing items on a defense-wide basis.
- (f) Cost and schedule estimates are credible and acceptable.

On the basis of this information, the Army requests approval to initiate Engineering Development. The request is made either by memorandum to DDR & E, or if required, by a Program Change Request (PCR). It is accompanied by a Technical Development Plan (TDP), specifically addressed to the six prerequisites cited above, which summarizes pertinent cost-effectiveness studies and developments and provides whatever information may be required to substantiate the achievement of these prerequisites.

If the initiation of Engineering Development receives conditional approval, the Contract Definition phase begins. The objective of Contract Definition is to determine whether the conditional decision to proceed with Engineering Development should be ratified. Its ultimate goal is achievable, firm and realistic performance specifications, backed by a firm fixed price or fully structured incentive proposal for Engineering Development. In addition, it embraces the following subsidiary objectives:

- (a) Precisely define interfaces and responsibilities.
- (b) Identify high risk areas.
- (c) Verify technical approaches.
- (d) Establish firm, realistic schedules and cost estimates for Engineering Development, including production engineering, facilities, construction, and production hardware that will be funded during Engineering Development because of concurrency consideration.
- (e) Establish schedules and cost estimates for planning purposes for the total project, including production, operation, and maintenance.

The Contract Definition procedure is mandatory for all new Engineering Developments or Operational Systems Developments (or major modifications of existing ones) that are estimated to require total cumulative research, development, test, and evaluation financing in excess of \$25 million, or a total production investment in excess of \$100 million. (However, DoD, DA, or AMC may require Contract Definition on other systems which are below the \$25 million and \$100 million thresholds.)

Contract Definition is normally performed by two or more contractors in competition under the technical direction of the cognizant Army activity. It may, however, be performed by a sole source contractor if necessary.

AMCP 706-191

The trade-off studies that are conducted during this phase should be directed toward achieving an optimum balance between total cost, schedule, and operational effectiveness for the system. Total cost (or life cycle cost) includes the cost of development, production, deployment, operation, and maintenance. Operational effectiveness includes all the factors that influence effectiveness in operational use, as well as inherent or pure performance characteristics (as in WSEIAC, the ADC matrices).

The system includes not only the hardware but also all other required items, such as facilities, data, training equipment, and the operational and support personnel who will be required.

The end product of Contract Definition is a complete technical, management, and cost proposal package for Engineering Development. The contractor's package should include such information as a List of the end items required; performance specifications for each item; a work breakdown structure and a PERT network plan; the principal objectives and features of the overall system design, including recommendations for its operational use; a recommended maintenance plan; detailed cost estimates and milestone schedules for five years beyond it; quantitative reliability and maintainability specifications and test plans; time/cost performance trade-off decisions on major alternatives; required new designs and technology; foreseeable technical problems and proposed solutions; technical specifications and performance specifications for support items (facilities, training devices, and so on) for which early Engineering Development is required; delivery schedules and requirements for data and documentation; and a proposed schedule of production engineering and production tooling in relation to Engineering Development, if appropriate.

After a review of the contractors' Contract Definition proposal packages, the Army recommends one of the following actions: to contract for Engineering Development on the basis of the proposals received; to contract with an alternative source; to continue further Contract Definition effort; to defer or abandon the Engineering Development effort; or to undertake further Exploratory or Advanced Development of key components and/or systems studies.

1.5.3 Conclusion

The methodology and application of Systems Analysis/Cost-Effectiveness studies is directed toward supplying the decision-maker with the maximum amount of quantifiable information about alternative approaches to attaining a mission. Also, it stipulates areas of qualified considerations with this, and allows the virtues of a systematic approach - the design and development of proposed objectives and their solutions within a rigorous, logical, adaptive, dynamic framework which can be retraced and verified.

1.6 LIMITATIONS OF SYSTEMS ANALYSIS/COST-EFFECTIVENESS

There are many advantages to Systems Analysis and Cost-Effectiveness. However, they are not panaceas that handle all problems of the system developer, manager, or user, nor are they without limitations. Systems Analysis/Cost-Effectiveness studies must be examined to recognize the limitations built into them, or the premises generated based on given information.

The more prominent limitations inherent in all but extremely simple analytical studies are as follows:

- Inadequate Problem Definition
- Improperly Defined Scope
- Restriction of Alternatives
- Improper Criteria
- Interjection of Bias
- Improper Data Usage
- Incompatible Model
- Misapplication of Model
- Forcing Problem into Improper Framework
- Improper Handling of Relevant Factors
- Poor Assumptions
- Ignoring Uncertainties
- Misinterpreting Model Results
- Insufficient Samples
- Failure to Reappraise
- Failure to Communicate
- Measures of Effectiveness Approximate
- Future Uncertainties
- Analysis Never Truly Complete
- Changing Value Systems
- Neglect of Subjective Elements
- Assignment of Value to "Costs" (Economic Costs)
- Inability to Verify Decision

AMCP 706-191

Consideration of each element described as a limitation is not the purpose of this section. However, in order to show relevancy of limitations and the dangers associated with their non-consideration, a few examples will be given.

First, consider the list of limiting elements described above. If an analysis can never be complete, due to the state of knowledge, time and money, it is fair to assume that this list of elements is not complete.

Consider, also, the statement, "Mustang makes it happen" as an aid to decision making about buying a car. If I am a car buyer, I must make a decision based on what the statement means to me.

- (a) I buy a Mustang and wait for it to happen and, unless I am purely adventurous, I assume it is good.
- (b) I don't buy a Mustang because, if it happens, I am in no position to deal with it; or it is bad (in my opinion) and I don't want it to happen.

Now, either of these decisions can be a misinterpretation depending on the "true" significance of it.

The real difficulty is in the word (information) it; what problem did it answer? The same is true with results of analyses. Do they literally answer the problem or do I still have to interpret meaning within my bias?

As another example; interpretation of a real weather report which states - "Probability of rain - 90% in 25% of the area 10% of the time". I would assume that there is a good chance of rain; that 25% of the area will get rain; and of the duration of time (which this event encompasses) it will rain 10% of that period of time.

Now if the problem is where do I go so that I won't get wet, how do I interpret this? It would appear I would, generally, be wrong in whatever I decide, or have minimum confidence that my decision is correct.

This example, also considers dangers from the elements of limitation of poor assumptions, improperly defined "model" and failure to communicate, at least. Analogous to this problem is the one of forecasting advanced weaponry for use in, say, 1985. What, how many, why and against whom? Basically, the hard information comes from back-feed and is tempered by intuition and judgment to transcend now to the future. However, until the "systems" are operational, in their then environment and we can obtain feedback, we will always have error terms in the analysis - until we pass through the verification/modification stages.

Consider, **also**, data errors and modelling problems in determining how to attach significance to deterrence. Actually, deterrence is, mostly, a matter of philosophy. **What** does an enemy consider it to be - and how do you find out? Also, it will be a changing value with time.

Quantification of numerics is a problem in the area of "costs". How accurately can you predict costs for the future - even in dollars - much less recognize a variable depletion of resources - with a changing value system?

Obviously, it is impossible to consider all the limitations applicable to SA/CE analytical functions, as some apply and some do not, depending on the complexity of the problems.

Yet, the recognition of them and the degree of their accountability is a by-product of an analysis, and does supply information as much as the hard numerics. By the recognition (and measure) of accountability attained, the analytical processes become better by degree and help to sharpen the intuition and judgment functions of the decision-maker.

CHAPTER 2

GENERAL METHODOLOGICAL APPROACH TO SYSTEMS ANALYSIS/COST-EFFECTIVENESS STUDIES

The general methodological approach to the systems analysis/cost-effectiveness process is shown in Figure 2-1.

The approach shown is applicable to both systems analysis and cost-effectiveness. The distinction between systems analysis and cost effectiveness is mainly a difference in the definition of the scope of the study. Systems analysis studies are concerned with problems of large scope and are characterized by the comparison of different types of equipments or systems to determine the best approach for meeting some stated requirement. Technical feasibility, inter-system trade-offs, and the parameterizing of requirements are all associated with systems analysis. Cost-effectiveness studies, on the other hand, deal with narrower problems. Normally, in cost-effectiveness studies, the type of system to be analyzed will be given, and the problem is to conduct intra-system trade-offs to "optimize" the system, i.e., to develop the best system with respect to performance, cost, schedule, manpower, etc.

2.1 INPUT INFORMATION

The initial inputs that lead to the development of requirements and objectives in the systems analysis/cost-effectiveness process are normally attributable to such documents as the Army Force Development Plan, the Combat Development Objective Guide, a Qualitative Materiel Development Objective, or a Qualitative Materiel Requirement.

2.1.1 Army Force Development Plan (AFDP)

The AFDP is a responsibility of the Assistant Chief of Staff for Force Development (ACSFOR) and is constrained by anticipated resource limitations. It provides the planning basis for the Five-Year Force Structure and Financial Program, and its objective is to provide the best possible Army posture within available resources. Specifically, it accomplishes the following:

It plans the development of balanced capabilities within established constraints and strives to achieve the best possible balance between forces, readiness, and modernization.

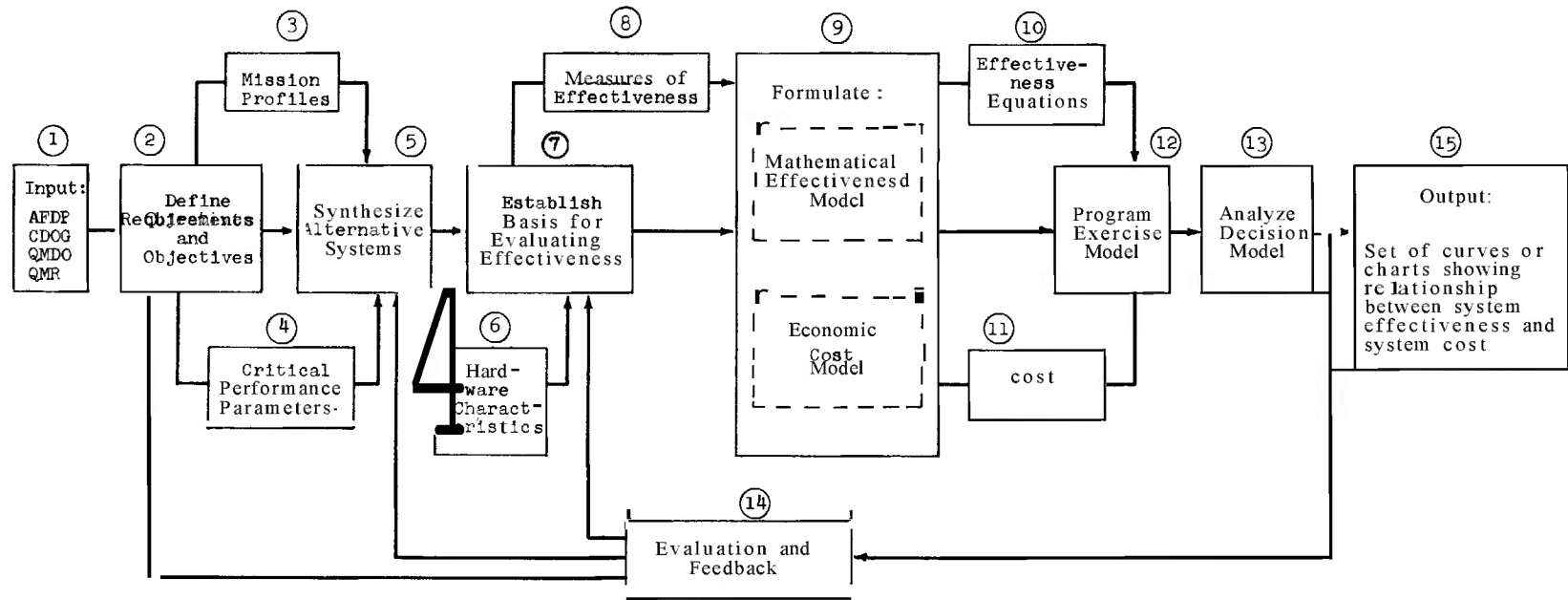

2-2

Block Number	Subject	Guidebook Section	Cognizant Personnel		Block Number	Subject	Guidebook Section	Cognizant Personnel	
			Decision-Maker	Analyst				Decision-Maker	Analyst
1.	Input information	2.1	X		8.	Define measures of effectiveness	2.8		X
2.	Define requirements and objectives	2.2	X	X	9.	Formulate models	2.9	X	X
3.	Develop mission profiles	2.3	X	X	10.	Generate effectiveness equations	2.10		X
4.	Obtain critical performance parameters	2.4		X	11.	Generate cost equations	2.11		X
5.	Synthesize alternative systems	2.5	X	X	12.	Exercise the model	2.12		X
6.	Develop hardware characteristics	2.6		X	13.	Develop decision model	2.13	X	X
7.	Establish basis for evaluating effectiveness	2.7	X	X	14.	Evaluate results and feedback information	2.14		
					15.	Output results	2.15	X	X

FIGURE 2-1
SYSTEMS-ANALYSIS/COST-EFFECTIVENESS PROCESS

- It plans incremental increases in capabilities in order of priority and identifies the associated additional resources necessary to attain them in a reasonable time.
- It plans incremental decreases in capabilities in inverse order of criticality to provide resources to meet unprogrammed requirements.

2.1.2 Combat Development Objectives Guide (CDOG)

The CDOG, prepared by the USACDC, provides guidance for Army combat-development activities and the research and development program. It contains all the DA-approved operational and organizational objectives, Qualitative Materiel Development Objectives, Qualitative Materiel Requirements, and Small Development Requirements and their priorities. It also contains a compilation of studies, field experiments, and tests. These contents are defined as follows:

- Operational objective. An operational objective is an Army-approved need for a new or improved operational capability that pertains to operational concepts, tactics, techniques, and procedures.
- Organizational objective. An organizational objective is an Army-approved need for a new or revised organization to improve Army operational capabilities.
- Qualitative Materiel Development Objective (QMDO). A QMDO is an Army-approved statement of a military need for the development of new materiel, the feasibility of which cannot be determined sufficiently to permit the establishment of a Qualitative Materiel Requirement (QMR).
- Qualitative Materiel Requirement (QMR). A QMR is an Army-approved statement of military need for a new item, system, or assemblage, the development of which is believed feasible.
- Small Development Requirement (SDR). An SDR states an Army need for the development of equipment that can be developed in a relatively short time and does not warrant the major effort required in developing a QMR. An SDR is normally considered the appropriate requirements document if: (1) development of the item is of proven feasibility; (2) the time required for development is 2 years or less; and (3) the RDIE costs will not exceed \$2.5 million, and the projected investment of HEMA funds will not exceed \$10 million.

2.1.3 Qualitative Materiel Development Objective (QMDO) Approval

The first formal requirements document that the Army uses in the research and development cycle is the QMDO. Any individual (military or civilian), unit, or agency may propose a concept or idea that might lead to establishing a QMDO.

AMCP 706-191

However, CDC is delegated the authority and responsibility for preparation and submission of QMDO's to ACSFOR for approval. CDC uses operations-research techniques to relate future tactics to the technical estimates and concepts furnished by AMC as a result of its basic and applied research work. Evaluation of requirements for materiel for the Army dictates continuous liaison between CDC and the developing agencies of CDC at the laboratory and commodity command level. From this point on all research and development must be supported by either an objectives or a requirements document such as a QMDO, QMR, or SDR unless otherwise directed by appropriate DA authority.

The QMDO normally begins with requirements generated by combat-development studies conducted by CDC. These requirements, when reviewed, indicate whether they are within the state-of-the-art or have been sufficiently exploited to permit immediate development. The QMDO is associated with requirements necessitating further research. At this point we are still several years (3-8) away from establishing firm military characteristics. The QMDO states in general terms the objective, the operational and organizational concepts for employment, a description of full justification for the new item, and its priority (I, II, or III). Usually, the QMDO is first circulated in draft form to AMC and other interested commands for comments and suggested revisions. AMC's input generally consists of:

- A "ball park" cost figure for the required research and exploratory development
- A time-frame for completion of the work
- The effect performance might have on already approved programs
- The potential of present knowledge to advance the state-of-the-art sufficiently to make the project feasible

QMDO's may be initiated at any stage in the research-and-development cycle and may result from a combat-development study, operational experience, developmental experience, technological breakthroughs, or feedback of deficiencies in existing equipment.

The Director of Research, Development, and Engineering, Headquarters, AMC, is the AMC focal point for processing all new materiel objectives documents and for ensuring that adequate QMDO plans are prepared. After reviewing all the comments from other agencies on the draft QMDO, CDC revises it and submits it to DA for formal staffing and approval. ACSFOR has DA staff responsibility for all QMDO's. After DA approval, QMDO's are published in CDOG so that all interested commands and agencies can be made aware of the objectives.

2.1.4 Qualitative Materiel Requirement (QMR)

After research and exploratory development have progressed to the point where AMC feels it may be possible to translate technical knowledge acquired by the laboratories into a feasible system, it will prepare a draft QMR or recommend to CDC that a QMR be prepared and issued. The QMR is directed toward attaining new or substantially improved materiel that will significantly advance the Army ability to accomplish its mission. Unlike the QMDO, the QMR is much more specific in describing the requirement. It states major materiel needs in terms of military characteristics and priorities and relates materiel to the operational and organizational context in which it will be used.

2.2 DEFINE REQUIREMENTS AND OBJECTIVES

The basic task of systems analysis is to evaluate systems in terms of achieving objectives and consuming resources. While this evaluation might be made at any point in the life cycle of a system, major interest currently lies in making such evaluations before resources are committed to creating a system. Major emphasis in this section is therefore given to such prior evaluations.

In any systems analysis, it is essential to take the information as stated in the study directive and define an acceptable set of requirements and objectives. Stating the detailed requirements and objectives is a major part of the study effort; they may require updating and redefinition following evaluation and feedback.

In establishing the objective, it is necessary to define the boundaries of the analysis in terms of system objectives, system definition, associated operations, and influencing factors. Initially, the objective should be stated in general terms so that a comprehensive analysis can be made. Extreme care and effort must be made to properly state the system's objectives. It is essential to the entire analysis, since it is the major factor in the selection of the missions, the synthesis of alternative systems, the evaluation criteria as well as dictating the types of models which must be employed in the study. It is not always easy to decide what is to be included in the analysis. Often the decision must be made subjectively, and it may be heavily influenced by such factors as data inadequacies, schedule and manpower limitations, and uncertainties as to the appropriate method for modeling particular aspects of the problem. Nevertheless, proper statement of the objective must be approached as a critical first step in the system analysis/cost-effectiveness process. After obtaining a definitive statement of the system objective and a description of the system boundaries, the specific tasks or mission profiles are generated.

AMCP 706-191

To properly state the system's objectives, the analyst must rely heavily both on past experience gained through conducting and evaluating similar studies as well as his knowledge of the military environment and operation. There are three pitfalls encountered in specifying system objectives:

(1) the analyst may state the objectives too broadly, (2) the objectives may be limited in scope, or (3) the objectives may be stated in such a manner as to describe a particular system rather than a functional need. If the objectives are too broad, this results in an analysis which includes an impractically large number of alternatives. Additionally, broad objectives often lead to a large number of assumptions which must be made in order to evaluate the system(s).

Generally, as the number of assumptions increase, the uncertainty associated with the conclusions reached in the study increases proportionately. If the objectives are limited in scope, good alternative systems or other considerations may be eliminated from the analysis which could result in a less than optimum system selection. Sometimes the objectives are stated in terms of a specific system rather than a functional need. This undoubtedly eliminates worthwhile alternatives from consideration and biases the outcome of the study.

In addition to establishing reasonably complete boundaries for the system, it is necessary to select specific factors to be considered in the analysis. Again, this task cannot be defined for the general systems analysis or cost-effectiveness problem; however, general assumptions can be suggested, and these can be formalized when the requirements of a specific analysis are given. Typical assumptions include the following:

- The system will be in operation for T years.
- All external factors for which the gross cost estimate is less than $X_1\%$ of the estimated cost will not be considered.
- Factors with relative-cost estimates between $X_1\%$ and $X_2\%$ will be included only if sample data and knowledge of the relationship are available to yield an acceptable degree of confidence in results.
- Factors with relative-cost estimates over $X_2\%$ will always be included, except that those with leverage effects will be excluded if their inclusion would entail an additional level of analytical complexity that would threaten the timeliness of the analysis.

All assumptions should be explicitly stated and justified by factual evidence. If none exists, the reason for making the assumption (e.g., mathematical convenience, general consensus) should be stated to indicate how much additional study is required and to pinpoint areas where errors might be introduced.

The constraints placed on the system are essentially a set of boundaries for the various factors within which the solution to the problem must be found. They may include a fixed budget, a period of time, a desired effectiveness, or a method of operating with resources. In other words, the constraints associated with the system serve to designate the amount of freedom allowed in manipulating system variables to obtain a solution to the problem.

Constraints can often be used as the sole basis for distinguishing between the feasible and unfeasible alternatives. However, a constraint can be so stringent that no feasible alternative can be found, and thus there is no solution to the problem. There are problems, however, for which a solution must be obtained. An example is a person who must have a personal automobile: His constraints are that the cost must not exceed \$2,000; that the car must be new; and that it must have an air conditioner, radio, automatic transmission, and a leather interior. There is no solution to this problem within these constraints. If the person must have a car, he must relax one or more of the constraints until at least one feasible alternative can be found.

Thus constraints can be used to reduce the scope of the problem, but they also must be flexible so that they do not preclude solution of the problem.

2.3 DEVELOP MISSION PROFILES

After the requirements and objectives have been formalized, the next step is for the analyst to develop the mission description. These mission descriptions or profiles translate the requirements and objectives of the system into specific statements of performance. They in fact describe the tasks to be performed by the system in order to meet the stated objectives. Also included in the mission profile are such considerations as threat, environment, and tactics.

If the system being studied were a transport helicopter, the set of mission profiles would represent all of the tasks that the transport helicopter was expected to accomplish. Some of the required missions might be of greater importance than others in the set of mission profiles; however, this possibility is taken into account in the presentation of results.

The generation of mission profiles can be characterized by the flow chart shown in Figure 2-2. Initially, the operational requirements and objectives are determined by considering such factors as the number of missions required, the functional concepts to be employed, the enemy threat, the spectrum of environments that may be encountered, and any other requirement as stated in the QMR. These requirements and objectives are then translated into specific statements of performance -- for example, the number and type of communications equipments required for a mission, the information rate and reliability requirements of the communications equipments, and the range and weight constraints.

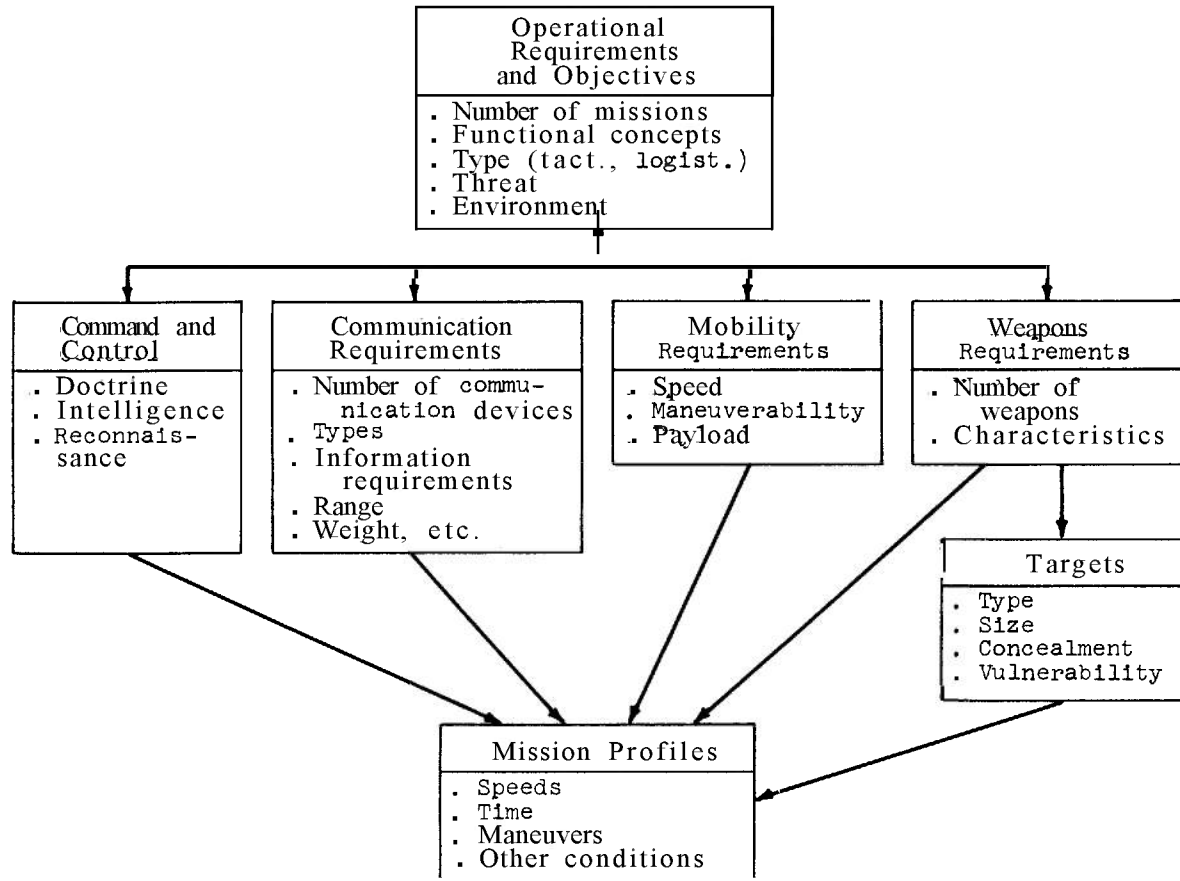

FIGURE 2-2

MISSION-PROFILE DEVELOPMENT

There are several important factors that must be considered in developing the mission profile:

(1) The mission parameters (or set of boundaries of the mission) should be expressed as minimum goals and maximum values. Care must be exercised to avoid undue rigidity in mission parameters and each mission parameter should be assessed as to its criticality in terms of meeting the requirements and objectives.

(2) Postulation of missions is not solely a job for analysts, rather it should be dealt with on a team approach with talent drawn from both the technical and military communities.

(3) As the task progresses it may be necessary to eliminate certain missions because the risks associated with meeting the objectives may be too high.

- (4) The missions must be sufficiently detailed to enable the analyst to test all the significant system parameters.
- (5) The missions must be able to be modeled -- (wargaming/scenarios).

The final step in generating the mission profiles is to combine all the various inputs into a scenario format that represents the combination of system requirements, threat, environment, and tactics. The missions thus serve as transfer functions which relate the system objective to the performance of the alternative systems.

2.4 OBTAIN CRITICAL PERFORMANCE PARAMETERS

There is no precise procedure for defining a system and its boundaries. Consequently, all possible variables within the system, their expected interactions, and their relevance to the problem being addressed must be examined thoroughly.

If many variables are considered in the study, a valid sensitivity analysis can be made. This analysis will show which variables are critical (and may require more detailed study) and which variables can be ignored.

Not all performance parameters of a system will be needed in the evaluation of a system's effectiveness, because some performance requirements interface more closely with the system objectives than do others. The performance requirements of the AN/APN-70A (a navigation receiving set) are a good example. The general description of the AN/APN-70A is that it is a receiving set designed to furnish navigation information to aircraft up to distances of 1500 nautical miles from special ground transmitters.*

Some of the performance requirements listed in the specification for the AN/APN-70A, such as sensitivity, selectivity, accuracy, and stability, are directly associated with the objective of the receiver. Others, such as self-checking function and oscillator radiation, may not be sensitive to the objectives and would, therefore, be of secondary importance in the effectiveness model. However, without knowing the objectives of a system, it would be difficult to distinguish precisely which performance parameters were needed to achieve the objective and which were not. If one of the requirements of the APN-70 is to receive signals without being detected, then an item such as oscillator radiation may be an important parameter. Thus it would appear that that to talk intelligently about the importance of system-performance parameters, it is first necessary to understand which of the many parameters of a system are essential for the objectives of the system. Examples of several performance parameters that may be associated with different types of equipment are as follows:

* From MIL-R-726B

AMCP 706-191

Communications - range, noise characteristics, receiver sensitivities, transmitter power outputs, input power requirements, jamming vulnerability, and number of channels.

Computers - accuracy, computational speed, input-output formats, memory capacity, retrieval speed, language capability, and analogue to digital capability.

Antenna - gain, coverage, transmit and receiver losses, physical limitations.

Another factor that must be considered in defining the critical performance parameters is the concept of controlled and uncontrolled variables.

Some variables can be controlled early in the system's life. For example, the time needed to repair a failed item during the operational phase can be controlled to some extent during the planning and design phases. Later, during system operation, the times to repair are distributed according to some observed function. The expense of changing these repair times is generally higher in the operational phase than in earlier phases. Other variables must be assumed to be distributed according to an assigned or predicted function during the early phases of life. Later, during system operation, these variables can be controlled. Two examples of variables in this category are the mission times and mission frequencies for a new helicopter. Still other variables are never subject to control -- for example, the weather; and there are some variables that can always be controlled -- for example, pay scales.

Some variables that cannot be controlled can be influenced through variables that can be controlled. A common example is the set of variables representing the opposition's reaction to changes in strategy directed at them. Another example is a battlefield war game in which player A's strategy includes influencing player B's moves through the control A has over his own forces.

The cost parameters will depend on how costs have been defined in the cost-effectiveness problem. They may be time, money, lives, distance, or area. The criticality of cost parameters is always subject to change. For example, fuel consumption may be hardly considered until a certain turn of events limits the quantity available. Hence, a military mission can be conceived of in which the cost of fuel exceeds the cost of ammunition even though the dollar costs of the two are the same.

2.5 SYNTHESIZE ALTERNATIVE SYSTEMS

2.5.1 The Total System

The term "System" appears to defy unique definition; i.e., one man's system may be another man's component. For example, a company may have a contract to develop a radar set. Within the company this radar may be thought of as a

system. To the customer, however, this same radar may be visualized as only one element of a larger "system" which he is planning for the control of aircraft over a geographic area. This latter man's system, in turn, might be one part of a much larger system which has a mission of managing a large mass air transportation system. There is really nothing wrong with any one of these persons feeling his own scope of design is a system. However, a definite danger is involved in not recognizing adequately at any given level of consideration the relationship of the given system to all potential supersystems and the implied interfaces.

It will suffice for the purpose of this Guidebook to define the total system as it is shown in Figure 2-3. At the center of the total system is what is termed the Object System. The Object System may be defined fragmentally to coincide with the scope of development responsibility which a prime contractor would normally be charged with. Development of the Object System must be accomplished in consonance with the requirements, constraints, and interface characteristics of the world in which it will ultimately operate. This world is categorized into four blocks, or systems, shown in the figure.

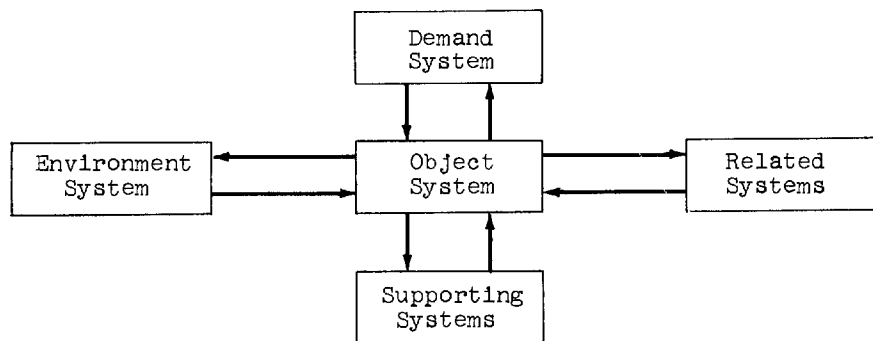

FIGURE 2-3
THE TOTAL SYSTEM

A supporting system is one which is necessary to the performance of the Object System but not in the direct functional line, for example, a maintenance system. The environment which would tend to degrade system performance (such as the physical environment, electromagnetic environment, and others). The demand system characterizes the need for which the Object System is being developed. In a military situation, the demand may take the form of a threat - more specifically, it might be the approach of an enemy aircraft. For an Object System which provides service (such as a communications system) the demand system characterizes the potential users of the communications service and their habits and technical requirements. Related systems are those with which the Object System must cooperate in performing its intended function.

AMCP 706-191

Thus, we see that during the development phase, system analysis should not be confined only to the Object System but should be used to characterize the four surrounding system categories.

2.5.2 System Configuration Synthesis

After the requirements and objectives have been defined, the critical performance parameters obtained, and the mission profile structured, a system or set of alternative systems can be synthesized. System synthesis requires several ingredients, among which the more important are:

- An adequate understanding of the mission profile;
- An appreciation of the ultimate user's capabilities and limitations;
- Intuitive judgment concerning the effect of combinations of equipments operating as a system;
- A working knowledge of the state-of-the-art capabilities and limitations in technical areas from which the potential new system may be drawn; and
- Common sense to seek the advice of experts, in questionable or critical technical areas.

2.5.2.1 Basic Functional Subsystems

The first step past a mission profile definition is the identification of basic functions necessary to any system capable of accomplishing the mission. This identification should be carried down to the lowest mission-oriented level. For example, the functions necessary to support a long-range search radar are (1) power supply, (2) antenna, (3) antenna drive, (4) antenna feeds and matching, (5) signal formation and amplification, (6) single reception and analysis elements, (7) transmit/receive diflexing, (8) signal processing, and (9) signal display. Each of the above functions has a rather direct relationship to the mission of long-range radar search. Figure 2-4 illustrates a similar breakdown for a ground-to-air missile system. This system is more complex than the radar example and in turn the breakdown is not carried to as low a level of detail. The breakdown in Figure 2-4 is shown in block diagram form with the connecting lines indicating only very basic relationships between blocks. One should be careful in taking this first step, not to unintentionally preclude any particular technical approach to configuring a system.

2.5.2.2 Identify Basic Alternatives

Once the basic functional elements supporting a mission have been defined, there is physical realization that each function can be enumerated. Table 2-1 shows such an enumeration for the Zenith missile system. The left-hand column of the Table is an itemization of the basic functions supporting the mission.

These are arranged from top to bottom roughly in a reversed order starting from missile detonation. The first of the basic categories contains the configuration options which could conceivably accomplish the function. Next, is a column for entering design factors which could influence the selection from among the options. An example of a design factor is warhead weight. To accomplish an equivalent effect, a non-nuclear warhead would involve several times the weight of the nuclear warhead. The next column includes factors relating to the use of the system (such things as side effects of the selected options). An example of a related mission factor can again be given regarding the choice of warheads. If the missile is to be detonated over or near friendly forces, a nuclear warhead has certain disadvantages over non-nuclear warheads. Some of the factors entered in these latter two columns will undoubtedly be the basis for eliminating many of the possible configuration options. Others will simply require consideration in making a choice. In studying Table 2-1, certain

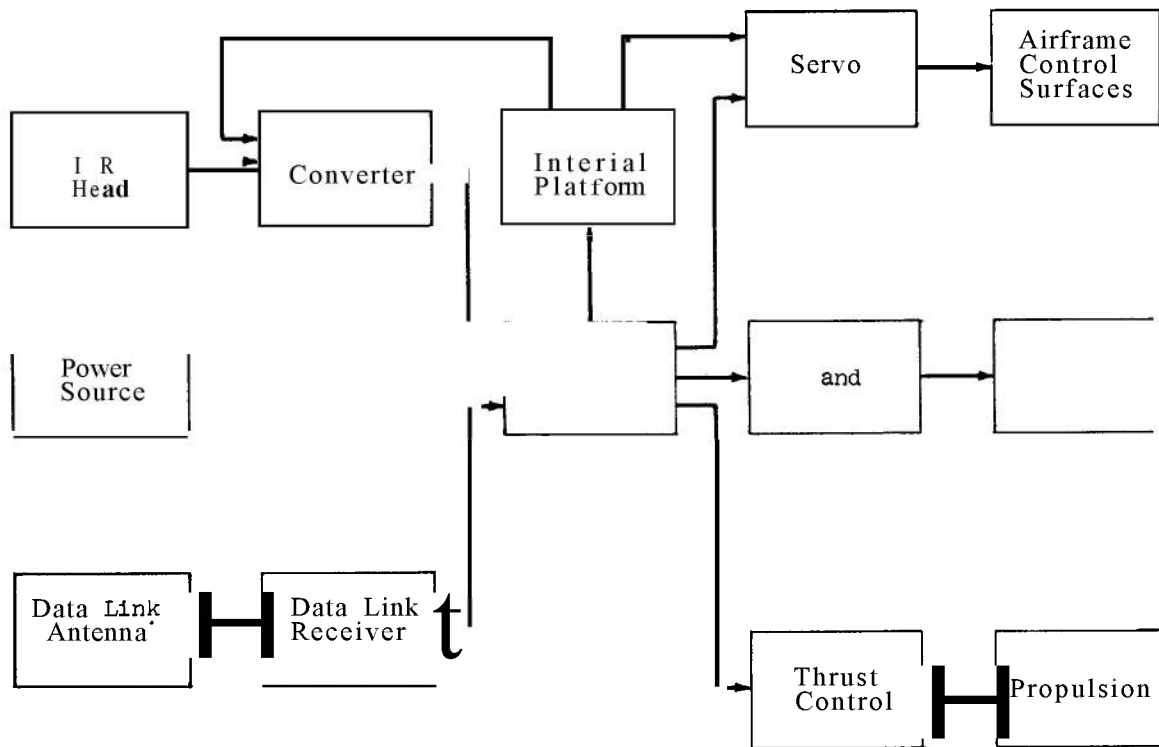

FIGURE 2-4

ZENITH MISSILE SYSTEM - FUNCTIONAL DIAGRAM

TABLE 2-1

BASIC ALTERNATIVES FOR THE ZENITH SYSTEM

Basic Functions	Options				Design Factors	Related Mission Factors
Warhead	Nuclear Miss Distance ≤ 1000 (1σ)	Non-nuclear Miss Distance ≤ 100 (1σ)			Use in all-out or limited war?	
Terminal Guidance Sensor	Optical	Infrared	RF		Background noise, sensor response time	Susceptible to jamming
Mid-Course Guidance Sensor	Radio Link to Ground Radar	Airborne Radar	Doppler Radar	Inertial Position		
Missile Control Technique	Fins	TVC (Vanes)	TVC (liquid)			
Motor	Solid	Jet	Throttleable Solid	Liquid		
Missile Computer	Analog	Digital	Hybrid			
Missile Fuzing	Target Doppler	Intensity				
Missile Arming	Barometric Pressure	Radar and TM Link	Guidance output			
Missile Control Reference	Inertial Platform	Strap-down Components				

combinations of options will turn out to be impractical from the interface standpoint. For example, the use of thrust vector control alone may be ruled out if the terminal flight of the missile is to be unpowered.

2.5.2.3 Identify Useful System Level Performance Parameters

The next step in the process of system synthesis is to define a hierarchy of parameters which bridge the chasms between mission profiles and functional subsystem performance. Figure 2-5 depicts a hierarchy corresponding to the Zenith system. At the top of the figure are two basic mission performance parameters: kill probability (P_K) and time to react and effect a kill. The hierarchy in Figure 2-5 conceivably could be continued down to the level of module and even piece-part output parameters. It is not necessary to do so at this stage of development, however, since the lowest levels in the figure represent parameters which easily relate, in most cases, to statements about state-of-the-art and gross characteristics of design options. The parameters which are underscored with heavy lines represent what, for practical purposes, could be called system-level performance parameters. Avoiding the question of what is system level and what is not, suffice it to say that the underscored parameters are called system level parameters because they are the link between mission profile statements and the basic functional elements as defined in Table 2-1.

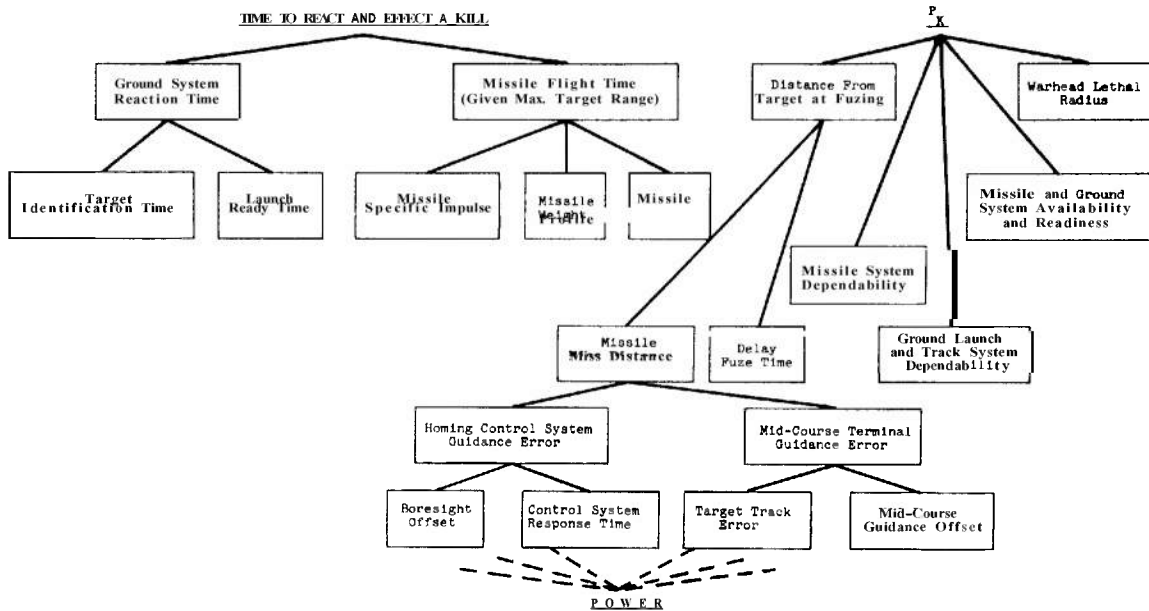

FIGURE 2-5
HIERARCHY OF PARAMETERS

AMCP 706-191

2.5.3 State-of-the-Art Analysis

In a state-of-the-art analysis, each critical design area, or component, should be viewed from three general points of view. They are (1) the technical suitability of a proposed technical approach, (2) time phase consideration describing all of the particular technical approach relating to the mainstream development time frame, and (3) the economic implications of incorporating the technical approach into the system. Table 2-2 is illustrative of the overall items which would be subject of scrutiny in determining the state-of-the-art feasibility or a given critical design area.

TABLE 2-2 CHARACTERISTICS PERTINENT TO A STATE-OF-THE-ART ANALYSIS (ELECTRONIC)		
Continuous Parameter Devices	Dynamic range Noise threshold Saturation limit Linearity Sensitivity Frequency response Gain	Functional Characteristics
Discrete Parameter Devices	Isolation Stability Efficiency Hysteresis Pulse rise time and fall time Overshoot Discrimination Pulse response time Cycle time Jitter	
	Sensitivity to physical environment	Reliability Characteristics
	Schock and vibration Temperature Humidity, water, ice, snow, rain, fungus, dust	
	Radio active bombardment Sensitivity to electromagnetic environment	
	RFI Conducted transients Inductive coupling Capacitive coupling	
	Failure modes	Economic Characteristics
	Development costs Evaluation costs Production costs	
	Special tools, processes, yield, materials	
	Installation costs Maintenance costs Support costs	

2.5.4 Conclusion

The major competing alternatives must be identified or synthesized. The variables to be analyzed for quantification of these alternatives are also identified. Usually, certain alternatives are well defined at the beginning of analysis. One of the major benefits of an analysis is that it can generate new alternatives -- some of which may be combinations or modifications of existing ones -- as the analysis progresses. Initial identification and selection of variables generally require screening, e.g., through preliminary sensitivity analysis. Decisions on alternative and variable selection should be continually re-examined as analysis progresses.

The evolution of a system is a complex process. It begins with an idea and proceeds through various stages, characterized by increases in knowledge about the system until it reaches a stage in which the system is deployed. With each increase in knowledge about the system, some decision is made that furthers the system's definition and reduces the degree of freedom available for subsequent decisions. At each stage there are alternatives that can have a significant effect on the future of the system. Selection of one of these alternatives results in a refocusing of attention to a new set of alternatives.

Different alternatives to a system are applicable at various levels of system detail. At one level, when action is necessary in response to a threat, the alternatives may include the procurement of a new missile, artillery, or aircraft. These are evaluated in terms of defense objectives and resource requirements. Once a decision is made on one of these alternatives, say the missile, attention is focused on alternatives within the missile system. These are evaluated in terms of the objectives and resources applicable to the missile. Selection of this alternative further defines the system's subsystems, and attention is then focused on alternatives within the subsystem, say the communication system. This process continues until the system is completely defined.

2.6 DEVELOP HARDWARE CHARACTERISTICS

The hardware characteristics for each alternative system are determined by the necessity for meeting specific requirements within the mission profiles. These hardware characteristics may be subject to intrasystem trade-offs to optimize each alternative. (Trade-offs will be discussed in section 2.12.) For example, the size of a helicopter airframe can be determined by the requirement to carry a given number of troops. The horsepower for the engines can now be determined by considering the weight of the airframe, troops, etc., and the speed and hover requirements in the mission profiles. In turn, this horsepower requirement may be satisfied with a single engine or multiple engines, and thus a trade-off to determine the optimum engine configuration is desirable.

AMCP 706-191

(Essentially, a single-engine system costs less in maintenance and initial investment, while the multiple-engine is safer and less vulnerable to enemy action.)

The hardware characteristics for a communication system would be determined by the performance requirements (range, channel capacity, system reliability, etc.) and by the constraints on weight, mobility, etc.

2.7 ESTABLISH BASIS FOR EVALUATING EFFECTIVENESS

The ultimate output of any system is the performance of some intended function. This function is frequently called the mission in the case of a weapons system. For other types of systems, it may be described by some system-output characteristic, such as satisfactory message transmission in a communication system or weather identification in an airborne weather radar. The term often used to describe the overall capability of a system to accomplish its mission is system effectiveness. A more precise definition of this expression will be given later, but for the present it is sufficient to observe that system effectiveness is related to that property of system output which was the basic reason for buying the system: the performance of some intended function. If the system is effective, it performs this function well. If it is not effective, attention must be directed to the system attributes that are deficient.

Because of the variety of systems to which it is applied, system effectiveness has been defined in a number of ways. The WSEIAC* effect produced the following general definition:

System Effectiveness is a measure of the extent to which a system may be expected to achieve a set of specific mission requirements. It is a function of the system's availability, dependability and capability.

The basic approach for evaluating the effectiveness of a system can be empirical or analytic.

The empirical approach consists of collecting data and evaluating system effectiveness by observing performance characteristics of systems in the field. However, this approach is applicable only for systems that are in an advanced phase of their life cycles.

The analytic approach, however, does not require that the system be in existence. The approach is based on the construction of a mathematical model that includes predictions of system characteristics within the constraints imposed by the analyst.

The Navy System Performance Manual** says this about the analytic approach:

*WSEIAC -- Weapon System Effectiveness Industry Advisory Committee.

**NAVMAT P3941.

"Purely empirical or purely analytic methodologies are, of course, not very useful. The former yields highly authoritative data too late to be useful, while the latter yields answers unsupported by facts. In practice, a balance is sought. This balance will normally change during the life cycle of a system. As data about the behavior of the system becomes more available, the analytic model gradually merges into an empirical model; as the data becomes more available and as confidence in their value increases, statistical sample data supplant the assumptions."

The need for analytic models to predict system effectiveness is based on the need to evaluate the effectiveness of a system before it has been in the field for many years. Although the empirical methods are required to provide inputs to the systems analysis/cost-effectiveness process, it is the analytic approach that is the most important and useful.

One analytic effectiveness model that has generally been accepted is the WSEIAC model. The WSEIAC model is based on a breakdown of the effectiveness parameter into three major components -- availability, dependability, and capability. Availability is a measure of the system condition at the beginning of a mission; dependability is a measure of the system condition during the mission, given the system condition at the start of the mission; and capability is the ability of the system to perform its mission, given the system condition during the mission.

To apply the model, given a mission definition and system description, it is necessary to delineate possible mission outcomes and significant system states. The availability and dependability measures are then related to the possible system states, and the capability measure relates these possible system states to the possible mission outcomes.

For the very simplest of cases, in which a system must be in either a working or a failed state, the measures of availability, dependability, and capability represent the following fundamental questions:

- Is the system working at the start of the mission?
- If it is working at the start, will it continue working throughout the mission?
- If the system works throughout the mission, will it actually achieve mission success?

As the systems considered become more complex -- e.g., when there are more than two possible systems states, and such factors as in-mission repair, degraded modes of operation, multi-mission requirements, enemy countermeasures, and natural environment are to be quantified elements in the model -- these

AMCP 706-191

questions may be too difficult to answer with simple model construction, but they still represent the fundamental WSEIAC approach towards evaluating effectiveness on a mission-oriented basis.

The general framework for the analysis of system effectiveness is given in Figure 2-6. The elements of system effectiveness are discussed briefly in Sections 2.7.1 through 2.7.3, and are outlined in Figure 2-6A.

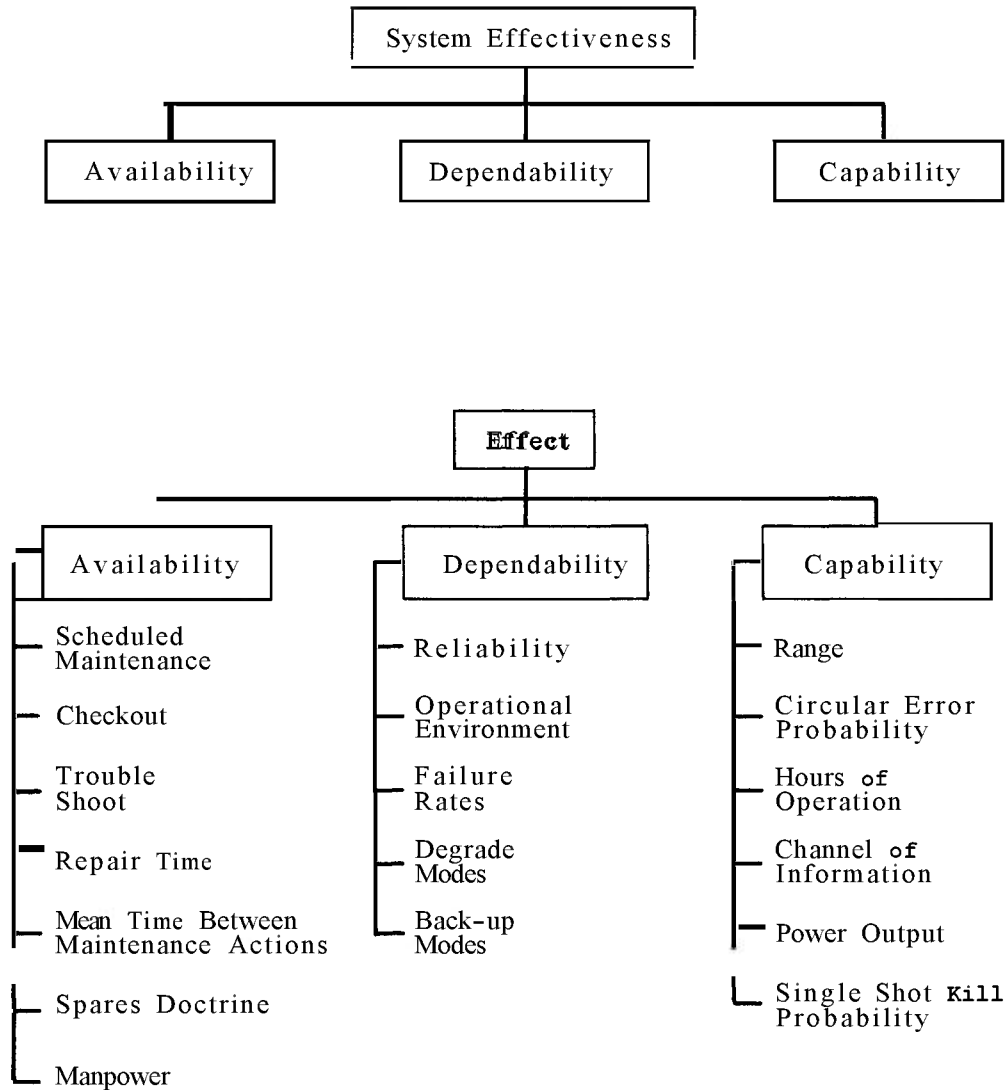

FIGURE 2-6A
ELEMENTS OF EFFECTIVENESS

2.7.1 Availability

The concept of availability concerns the system's condition at the start of a mission. The WSEIAC definition is as follows:

Availability is a measure of the system condition at the start of a mission. It is a function of the relationships among hardware, personnel, and procedures.

Availability has also been expressed as the probability that the system is operating satisfactorily at any time, when used under stated conditions. For this guide book, the more general WSEIAC definition is used.

Application of the availability concept requires clear definition of what is included in the system and of the system's mission. Availability is a specific measure; it is therefore usually necessary to define more than one system and its associated mission and to define availability for each case.

In estimating a system's availability, care must be taken to consider how the "system" has been defined and bounded. For example, with regard to a group of 25 tanks, an analyst may be equally interested in the availability of a single tank, several tanks, and the group of tanks. For the 25 tanks, then, several systems and several corresponding missions can be defined, and the measure of availability will be different in each case.

Assume that the system is defined as a group of four tanks (from the 25) and that the mission is to attack as a group. If at the start of a mission one tank is found to be inoperative, the system will be counted as being in an unavailable state. However, the group mission is not necessarily aborted, since it might be possible to draw a replacement from another group. In this case, then, availability is considered zero, and yet it is not necessary to abort the mission.

On the other hand, if the system consists of all 25 tanks and the system's mission is to provide tanks for specific missions as required, availability might be a measure of the number of tanks available for assignment at any time. It is not a measure of the number of operational tanks, since availability may be zero -- for example, when 80 percent of the tanks are performing specific missions and 20 percent are inoperative. In this case, it is also possible to conceive of an availability of zero when all tanks in the group are operational and performing their assigned missions.

In another situation the measure of interest may be the number of tanks that are operational at any time. The system is the entire group of tanks, and the system mission is to maintain all tanks in operational status. In this case,

AMCP 706-191

it is possible that availability will be 100 percent and yet a specific mission will be aborted because all tanks are already performing specific missions.

2.7.2 Dependability

The second major element in the system-effectiveness framework is dependability. The WSEIAC definition is as follows:

Dependability is a measure of the system condition at one or more points during the mission, given the system condition at the start of the mission.

The nature of this concept is similar to what is commonly referred to as reliability, except that reliability is usually defined as the probability that a system will perform satisfactorily for at least a given period of time when used under stated conditions. The more general WSEIAC definition is used herein since the system's maintainability characteristics also influence its dependability.

As with the concept of availability, application of the dependability concept requires an exact statement of the system's composition and mission.

A single estimate of dependability for the system in question may not convey all that should be known about it and related systems. For instance, when it is said that the probability of hitting a target with a weapon from an attack helicopter is 0.90, it is implied that a favorable result will be obtained, with probability 0.90. This statement also indicates that there is a 0.10 probability that the target will not be hit, but does not give any information about the causes or consequences of such failure. Did the helicopter crash before reaching the target? Did the weapon stray into a friendly area? Did the weapon fail to release from the helicopter? Was the helicopter grounded because of bad weather? To evaluate the system properly, it is necessary to consider the circumstances surrounding a failure.

When the probabilistic definition of reliability first came into general use several years ago, one of the most important prerequisites to applying it was that "failure" be explicitly defined. This is implicit in the definition, since to say what is satisfactory performance under given conditions, it is necessary to state carefully what is not satisfactory performance (i.e., failure) under those same conditions.

The problems become more complex in the case of multiple systems and missions. Interest may be centered on the dependability of a single communications system, an equipment in the system, or a group of systems. Each system may be capable of a number of different missions, some more critical than others. Combining the dependability figures for all systems and missions tends to obscure the favorable or unfavorable characteristics of an individual system or mission. On the other hand, if attention is focused on a single system or mission, the tendency is to ignore the favorable or unfavorable

characteristics of the related systems and mission. Measurement of dependability requires identification not only of each critical system and mission but also of the implications of success or failure in each instance. Then the several estimates of dependability are displayed in the form of a vector. Although this type of display does not facilitate the decision-making process (if anything, it makes the process more difficult), it does lead to more accurate decision-making.

2.7.3 Capability

The third major element in the system-effectiveness concept, capability, is defined in the WSEIAC report as follows:

Capability is a measure of the system's ability to achieve the mission objectives, given the system condition during the mission. Capability specifically accounts for the performance spectrum of the system.

A similar concept that expresses this characteristic of a system in probabilistic terms is Design Adequacy, which has been defined as the probability that a system will successfully accomplish its mission, given that the system is operating within design specifications. In this guide book, the more general WSEIAC definition is used, but in specific instances system capability may be expressed as a probability. It should be noted that capability or design adequacy is not solely an inherent characteristic of system hardware. Capability depends to a significant degree on the mission assigned to the system. A system that was designed to accomplish a specific task may very well have a high capability for that task. (In probabilistic terms, perhaps the Design Adequacy is unity.) However, if it is used for a more difficult or complex mission, its capability for this new mission may be low.

The measurement and prediction of system capability is a rather complex problem in itself. The difficulties introduced by multi-modal systems and multiple missions in the application of availability and dependability concepts are also present in the use of the capability concept. Further, the capability concept has not yet been developed to the extent that it can be quantified by standard techniques.

The system analyst must be particularly careful to distinguish clearly between capability and dependability. It was mentioned earlier that failure and the circumstances surrounding failure must be explicitly defined before the dependability concept can be applied. The same is true of the capability concept. Consider, for example, a 1/4-ton-truck tire blow-out that occurs at 60 mph, on a hot day (110°F), upon impact of the tire with a jagged hole in the pavement. Is the failure attributed to a lack of dependability or capability? If the tire (system) was designed for high-speed and high-temperature environments, and to withstand high impact loads, then the blowout (failure) is attributed to lack of dependability (reliability) since the conditions of

AMCP 706-191

satisfactory operation were defined to include these severe environments. On the other hand, if the blowout occurs on a tire designed to operate in much less severe environments (perhaps 40 mph at 80°F), then the failure is attributed to lack of capability.* In the first case the tire (system) had adequate capability, but its dependability was low. In the second case the system's dependability may have been high, but its capability (for the particular mission) was less than adequate. In either case, it is important to note that the system effectiveness of the tire is below the acceptable level.

2.8 DEFINE MEASURES OF EFFECTIVENESS

The measures of effectiveness** for some systems are easy to obtain and commonly accepted -- such as ton-miles/day for a transportation system, and single-shot kill probability for an anti-tank missile. However, for other systems, including many electronics systems,† no overall measures of effectiveness have been developed. For example, the effectiveness of a communication system may be measured in terms of information rate, information reliability, system reliability, and system availability; however, it is not possible to combine these four factors into one overall measure of effectiveness. This is not necessarily a disadvantage, because the decision-maker can still make a choice even if the effectiveness is presented as four separate numbers; of course, the choice may not be as simple or clear-cut.

The measures of effectiveness are subject to change with time in a battlefield situation. At one time, effectiveness may be measured in terms of the damage inflicted on enemy supply routes. At another time, it may be measured in terms of how long it takes to intercept an intruding tank column.

If the mission profiles have been specifically defined, the problem of defining measures of effectiveness is greatly reduced in that the effectiveness can now be expressed as a probability of accomplishing all or a given part of the system mission. In other cases, where a set of specific mission profiles cannot be obtained, the effectiveness must be related to the physical characteristics of the system -- for example, range, channel capacity, speed, etc.

* In the operational situation, attributing unsatisfactory performance to a lack of either capability or dependability is often based on the frequency of unsatisfactory performance. Frequent failure in normal operation makes capability suspect, while infrequent failure makes dependability suspect.

** Also called criteria for effectiveness.

† Much work is currently under way in this area to define measures of effectiveness.

2.9 FORMULATE MODELS

2.9.1 General

A system model is essentially a mathematical, logical, or physical representation of the interdependencies between the objectives and the resources associated with the system and its use. For dealing with the effectiveness of complex systems, the model is usually in the form of mathematical equations (mathematical model) or computer programs for simulating system operation (simulation model), or both.

On the assumption that a set of system objectives has been translated into an optimization criterion, the model builder is required, minimally, to construct a model that will enable quantification of the critical effectiveness and cost parameters as a function of the resource variables.

The overall cost-effectiveness model is usually one that consists of several sub-models, each of which may be based on models at still lower levels. Figure 2-7 indicates one means for sub-model classification. It should be noted that there are many other schemes for classifying models.

There is, naturally, a great deal of interaction among the sub-models, and model integration is required in the same sense that system integration is required.

Constructing sub-models (and integrating them into an overall model) is, for most "real world" situations, still more of an art than a science, largely because the validity of the model cannot be tested through controlled experimentation; thus the collaboration of people with wide experience in the areas of concern is an important requirement.

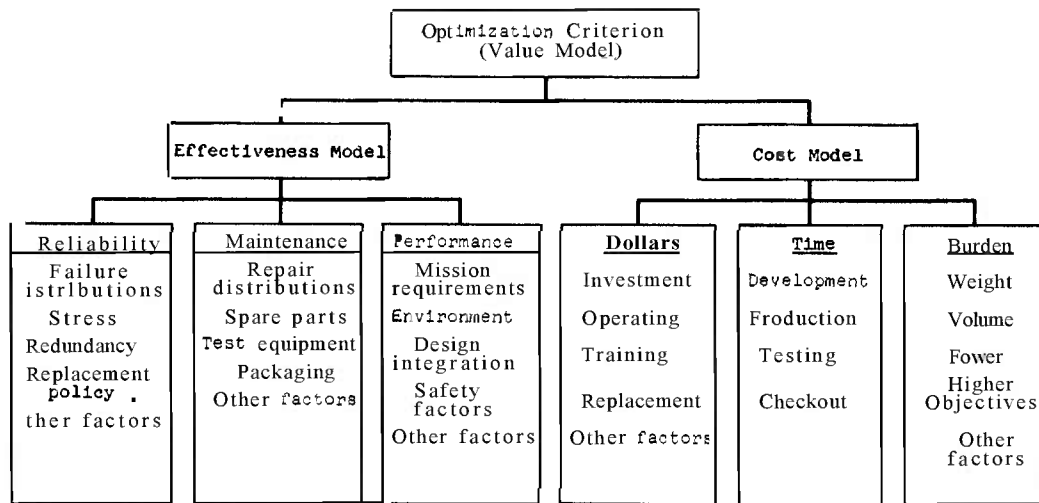

FIGURE 2-7

A SUBMODEL CLASSIFICATION SCHEME

AMCP 706-191

2.9.2 Assumptions

All assumptions required for the model should be explicitly stated and, if possible, supported by factual evidence. If no such evidence exists, it is advisable to state the reason for the assumption, e.g., mathematical simplicity or consensus of opinion, in order to indicate the degree to which the assumptions will require further justification and to pinpoint the areas in which errors might be introduced.

2.9.3 Adequacy

A model must be adequate in the sense that all major variables to which the solution is sensitive are quantitatively considered where possible. Many of these variables will have been preselected. Through manipulation of the model, some of the variables may be excluded or restricted, and others may be introduced. Non-quantifiable variables must be accounted for by modification of the solution rather than by direct incorporation into the model. In this sense they are quantifiable.

2.9.4 Representativeness

Although no model can completely duplicate the "real world", it is required that the model reasonably represent the true situation. For complex problems, this may be possible only for sub-parts of the problem, which must be pieced together through appropriate modeling techniques. As an example, analytic representation may be possible for various phases of a complex maintenance activity. The outputs from these analyses may then be used as inputs to a simulation procedure for modeling the complete maintenance process.

2.9.5 Uncertainty

The various types of uncertainties involved in the problem cannot be ignored, nor can they be "assumed" out; they must be faced squarely. There may be technological uncertainties involved with some of the system alternatives, operational uncertainties involved with planning and carrying out the mission, uncertainties about enemy strategy and action, and statistical uncertainties governed by the laws of chance. The simplest approach is to make "best guesses", but this may lead to disastrous results, since the probability of guessing correctly for every uncertainty is quite small. For cases involving statistical uncertainty, functions-of-random-variables theory or such procedures as Monte Carlo techniques may be used. For the other types of uncertainties, the general approach is to examine all major contingencies and compute resultant cost-effectiveness parameters. The optimization criterion, then, must be adaptable for use in the evaluation of the set of cost effectiveness results. The developments of decision theory and game theory become most applicable in the selection of a decision model in these cases, since different alternatives may be best for different contingencies.

2.9.6 Data

The availability of relevant data plays an important role in the development and application of a model. Data are required to support assumptions, select alternatives, and define constraints, as well as to define the cost and effectiveness constants in the proposed model. Since missing data may prevent valid model application, the model builder should investigate this possibility early in the model development stages and plan to obtain missing data or adjust the model accordingly. If a great expenditure of time and money is required to obtain the necessary data, the analyst may be forced to weigh the risks of using what is available (and making necessary assumptions) against the value received in return for the costs of the data-collection and analysis effort.

2.9.7 Validity

The final test of the model is whether or not it yields the best system. Unfortunately, this determination can be made only after systems are developed and in use, if it can be made at all. However, certain questions will disclose weaknesses that can be corrected:

- (1) Consistency - are results consistent when major parameters are varied?
- (2) Sensitivity - do input-variable changes result in output changes that are consistent with expectations?
- (3) Plausibility - are results plausible for special cases where prior information exists?
- (4) Criticality - do minor changes in assumptions result in major changes in the results?
- (5) Workability - does the model require inputs or computational capabilities that are not available within the research bounds?
- (6) Suitability - is the model consistent with the objectives; i.e., will it answer the right questions?

2.9.8 Types of Models

There are several types of models, including mathematical models, gaming models, simulation models, and operational exercises. These models are described below.

2.9.8.1 Mathematical Models

Mathematical models are characterized by the exclusive use of equations to represent the characteristics of the system and thus are the most abstract of the four categories. The basis for such equations can range from pure hypothesis to the analysis of available and relevant data. Mathematical models generally provide a great deal of flexibility, but often at the expense of simplifying the real-world situation to develop a usable model and thereby decreasing the representativeness of the model.

AMCP 706-191

2.9.8.2 Gaming Models

In the gaming-model technique, operations and resource usage are simulated through scale models, computer programs, or physical analogs. Personnel in operational decision-making capacities are participants as an integral part of the model. Examples of gaming models are military war games and the use of aircraft simulators.

2.9.8.3 Simulation Models

In the simulation-model technique, all aspects of the system, its resource usage, and its operations are simulated in an abstract form, usually through computer programs. The basic operational flow is structured and probabilistic paths are determined through appropriate random-variable generating procedures. Such computer models are popularly called Monte Carlo procedures. An example is the simulation of component failure and repair times to provide estimates of system availability and maintenance and logistic requirements.

2.9.8.4 Operational Exercise

In the operational exercise, actual system resources are used, generally in a simulated operating environment. Examples are a controlled experiment of weapon firings involving military personnel and resources, and a military field maneuver between red and blue forces. The costs of such exercises are generally high, and thus the number and extent of the trials must necessarily be limited.

2.10 GENERATE EFFECTIVENESS EQUATIONS

The basic WSEIAC system-effectiveness equation is the product of an availability vector, a dependability matrix, and a capability vector, which are defined as follows:

$$\underline{A} = [a_1, a_2, \dots, a_n], \text{ the availability vector}$$

a_i = probability system is in state i at the beginning of the mission

$$\underline{D} = \begin{bmatrix} d_{11} & d_{12} & \dots & \dots \\ d_{21} & d_{22} & \dots & d_{2n} \\ \dots & \dots & \dots & \dots \\ d_{n1} & d_{n2} & \dots & d_{nn} \end{bmatrix}, \text{ the dependability matrix}$$

d_{ij} = probability of a system-state transition from state i to stage j over a fixed period of time

$$\underline{C} = \begin{bmatrix} c_1 \\ c_2 \\ \dots \\ \dots \\ c_n \end{bmatrix}, \text{ the capability vector}$$

c_j = the capability of the system for performing the mission, given the system is in state j

A typical term of the product is $\underline{A} \underline{D} \underline{C}$

$$a_i d_{ij} c_j$$

where

a_i is the probability that the system is in state i at the beginning of the mission

d_{ij} is the probability that the system will make the transition from state i to state j over a fixed time period

c_j is the probability (or expected value associated with mission accomplishment) that the system can perform its mission, given state j

It is emphasized that the WSEIAC Model is not a self-contained, directly applicable mathematical equation for effectiveness. As stated many times in several ways in the WSEIAC Task Group II report, the "model" is actually a framework for effectiveness quantification -- a basic routine for constructing an appropriate model. Although the model framework, represented by the

AMCP 706-191

product $\underline{A} \underline{D} \underline{C}$, can in some instances be used directly, this simple product will not work for a particular system-mission combination. It was not intended that this product be always directly applicable -- only that the elements of availability, dependability, and capability be incorporated in such a manner that the model framework could be applied.

As a simple example, the product $\underline{A} \underline{D} \underline{C}$ in actuality is based on the assumption that mission performance is evaluated at a single point in time -- the end of the mission. For many cases, this is not reasonable, If $\underline{D}(t_r, t_s)$ is defined to be the dependability matrix over the time interval (t_r, t_s) , and if the Markov assumption holds, i.e.,

$$\left[\underline{D}(t_r, t_s) \right] = \left[\underline{D}(t_r, t_1) \right] \left[\underline{D}(t_1, t_s) \right]$$

for all t_1 such that $t_r < t_1 < t_s$, then the effectiveness of the system at time t_k is represented by

$$E(t_k) = \underline{A} \left[\underline{D}(0, t_k) \right] \left[\underline{C}(t_k) \right]$$

If the mission is one in which continuous performance is required over the mission length t_m , the effectiveness of the system, assuming well-behaved functions, may possibly be quantified as the time average of $E(t_k)$ -- that is,

$$E = \frac{1}{t_m} \int_0^{t_m} E(t) dt$$

Note that if at each performance time the capability co-efficient c_j equals one, and if state j belongs to the set of satisfactory states and is zero otherwise, the above equation for E reduces to the expected fraction of the mission performance time that the system is in a satisfactory state.

An extension to the WSEIAC methodology is necessary if the Markov assumption does not hold. In this case, the capability matrix must be written as an $N \times N$ Matrix (N = number of system states), with an entry for each state transition.

Exhibit 1 presents a system-effectiveness problem, with its solution, that illustrates the application of this technique.

EXHIBIT 1

EXAMPLE OF SYSTEM-EFFECTIVENESS PROBLEM

Two communications systems, A and B, are used simultaneously to transmit information. Should either of the systems fail, the remaining one is capable of transmitting alone (A and B are statistically independent). Failures in either (or both) systems are not repaired during a transmission period, but are repaired during a period when the equipments are normally shut down.

A transmission will be started whenever at least one of the systems is available (in other words, it is not necessary that both A and B be in operable condition in order to start a transmission).

The respective mean failure times, mean repair times, and bit rates for A and B are given below:

System	Mean Failure Time, \bar{T}	Mean Repair Time, \bar{R}	Transmission Rate, r
A	12 hours (exponential)	8 hours	120,000 bits/hour
B	24 hours (exponential)	6 hours	100,000 bits/hour

A normal transmission period consists of 3 uninterrupted hours.

QUESTIONS

QUESTION 1

What is the effectiveness of A and B combined, if effectiveness is defined as the probability of transmitting at least 300,000 bits during a normal transmission period?

QUESTION 2

What is the effectiveness of A and B combined, if effectiveness is defined as the expected (average) number of bits transmitted during a normal transmission period?

QUESTION 3

What is the answer to Question 1 if both values of \bar{T} are increased 50%?

QUESTION 4

What is the answer to Question 2 if both values of \bar{T} are increased 50%?

QUESTION 5

What is the answer to Question 1 if, instead of changing the values of \bar{T} , the values of \bar{R} are both decreased 50%?

QUESTION 6

What is the answer to Question 2 if, instead of changing the values of \bar{T} , the values of \bar{R} are both decreased 50%?

For all questions, the system state designation will be:

<u>Configuration</u>	<u>State Number</u>
A · B	1
A · \bar{B}	2
\bar{A} · B	3
\bar{A} · \bar{B}	4

DISCUSSIONS AND ANSWERS

NOTE: All calculations rounded off to 2 places as they occur,

QUESTION 1

Availability Calculations: The availability (A) of a system is the probability that a system is operating at any point in time and is given by the equation:

$$A = \frac{\bar{T}}{\bar{T} + \bar{R}}$$

In particular, the availability of subsystems A_A and A_B are as follows:

$$A_A = \frac{12}{12 + 8} = 0.60$$

$$A_B = \frac{24}{24 + 6} = 0.80$$

Definition: $a_1 = p(\text{state 1 exists at start of transmission -- a function of the availabilities of subsystems A and B}):$

$$a_1 = (A_A) (A_B)^* = (0.60) (0.80) = 0.48$$

$$a_2 = (A_A) (1-A_B) = (0.60) (0.20) = 0.12$$

$$a_3 = (1-A_A) (A_B) = (0.40) (0.80) = 0.32$$

$$a_4 = (1-A_A) (1-A_B) = (0.40) (0.20) = 0.08$$

where A_A and A_B are the availabilities of subsystems A and B, respectively.

$$\underline{A} \text{ Matrix: } \underline{A} = [0.48 \quad 0.12 \quad 0.32 \quad 0.08]$$

Dependability Calculations: The measure of dependability that will be used in this example is the reliability measure associated with the operation of subsystems A and B. Reliability, then, is defined as the probability that a system will satisfactorily perform its functions for a given period of time. Because electronic systems are being considered in this example, the reliability function is assumed to be exponential and is given by the equation $R(t) = e^{-\frac{t}{\bar{T}}}$ where t is the mission time. Thus the reliabilities for Subsystems A and B are as follows:

$$\text{Reliability}_A (3 \text{ hours}) = e^{-\frac{t}{\bar{T}_A}} = e^{-\frac{3}{12}} = e^{-0.25} = 0.78$$

$$\text{Reliability}_B (3 \text{ hours}) = e^{-\frac{t}{\bar{T}_B}} = e^{-\frac{3}{24}} = e^{-0.125} = 0.88$$

* Reference Multiplication Law, p. 4-5 of this guidebook.

Elemental Transition Probabilities:

$$\begin{aligned}
 p(A \rightarrow A)_3 &= 0.78 & p(B \rightarrow B)_3 &= 0.88 \\
 p(A \rightarrow \bar{A})_3 &= 0.22 & p(B \rightarrow \bar{B})_3 &= 0.12 \\
 p(\bar{A} \rightarrow A)_3 &= 0 & p(\bar{B} \rightarrow B)_3 &= 0 \\
 p(\bar{A} \rightarrow \bar{A})_3 &= 1 & p(\bar{B} \rightarrow \bar{B})_3 &= 1
 \end{aligned}$$

Definition: $d_{1j} = p(\text{going from state } 1 \text{ to state } j), \text{ hours}$

State Transition Probabilities:

$$\begin{aligned}
 d_{11} &= (0.78) (0.88) = 0.69 & d_{31} &= (0) (0.88) = 0 \\
 d_{12} &= (0.78) (0.12) = 0.09 & d_{32} &= (0) (0.12) = 0 \\
 d_{13} &= (0.22) (0.88) = 0.19 & d_{33} &= (1) (0.88) = 0.88 \\
 d_{14} &= (0.22) (0.12) = 0.03 & d_{34} &= (1) (0.12) = 0.12 \\
 d_{21} &= (0.78) (0) = 0 & d_{41} &= (0) (0) = 0 \\
 d_{22} &= (0.78) (1) = 0.78 & d_{42} &= (0) (1) = 0 \\
 d_{23} &= (0.22) (0) = 0 & d_{43} &= (1) (0) = 0 \\
 d_{24} &= (0.22) (1) = 0.22 & d_{44} &= (1) (1) = 1
 \end{aligned}$$

$$\underline{D} \text{ Matrix: } \underline{D} = \begin{bmatrix} 0.69 & 0.09 & 0.19 & 0.03 \\ 0 & 0.78 & 0 & 0.22 \\ 0 & 0 & 0.88 & 0.12 \\ 0 & 0 & 0 & 1 \end{bmatrix}$$

Capability Calculations

Definition: $c_{1j} = p\{\text{transmitting } \geq 300,000 \text{ bits under the state transition: } (1 \rightarrow j)_3\}$.

$$\begin{aligned}
 c_{11} &= 1 & c_{31} &= 0 \\
 c_{12} &= 1 & c_{32} &= 0 \\
 c_{13} &= 1 & c_{33} &= 1 \\
 c_{14} &= (\text{see below}) & c_{34} &= 0 \\
 c_{21} &= 0 & c_{41} &= 0 \\
 c_{22} &= 1 & c_{42} &= 0 \\
 c_{23} &= 0 & c_{43} &= 0 \\
 c_{24} &= (\text{see below}) & c_{44} &= 0
 \end{aligned}$$

For c_{14} and c_{24} consider notational solution:

- . Transmission rates: r_A, r_B (constant)
- . Failure rates: λ_A, λ_B (exponential)
- . Bits to be transmitted: β
- . Mission time: T
- . Conditions: $r_A T > \beta; r_B T = \beta$

Then

$$c_{24} = \int_{t_A = \frac{\beta}{r_A}}^T \frac{\lambda_A e^{-\lambda_A t_A}}{1 - e^{-\lambda_A T}} dt_A = \frac{1}{1 - e^{-\lambda_A T}} \left[e^{-\frac{\lambda_A}{r_A} \beta} - e^{-\lambda_A T} \right] \quad (1)$$

= 0.15 (for the numbers involved)

$$\text{and } c_{14} = \int_{t_A = \frac{\beta}{r_A}}^T \frac{\lambda_A e^{-\lambda_A t_A}}{1 - e^{-\lambda_A T}} dt_A + \int_{t_A = 0}^{\frac{\beta}{r_A}} \left[\frac{\lambda_A e^{-\lambda_A t_A}}{1 - e^{-\lambda_A T}} dt_A \int_{t_B = \frac{\beta - r_A t_A}{r_B}}^T \frac{\lambda_B e^{-\lambda_B t_B}}{1 - e^{-\lambda_B T}} dt_B \right]$$

$$= 1 - \frac{\left[\frac{\lambda_A}{r_A} e^{-\frac{\lambda_A}{r_A} \beta} - \frac{\lambda_B}{r_B} e^{-\frac{\lambda_A}{r_A} \beta} \right]}{(1 - e^{-\lambda_A T})(1 - e^{-\lambda_B T})} \quad (2)$$

= 0.55 (for the numbers involved)

(NOTE: Equation 2 is very sensitive to round-off errors: 7 place entries are needed to ensure 2 place accuracy of result)

$$\underline{C_{ij}} \text{ Matrix: } \underline{C_{ij}} = \begin{bmatrix} 1 & 1 & 1 & 0.55 \\ 0 & 1 & 0 & 0.15 \\ 0 & 0 & 1 & 0 \\ 0 & 0 & 0 & 0 \end{bmatrix}$$

Effectiveness Calculations

The effectiveness equation is given by:

$$E = \sum_{i=1}^4 \sum_{j=1}^4 a_i d_{ij} c_{ij}, \text{ which may be written:}$$

$$E = \underline{A} \times \begin{bmatrix} \sum_{j=1}^4 d_{1j} c_{1j} \\ \sum_{j=1}^4 d_{2j} c_{2j} \\ \sum_{j=1}^4 d_{3j} c_{3j} \\ \sum_{j=1}^4 d_{4j} c_{4j} \end{bmatrix} \quad (3)$$

$$\sum_{j=1}^4 d_{1j} c_{1j} = (0.69) (1) + (0.09) (1) + (0.19) (1) + (0.03) (0.55) = 0.99$$

$$\sum_{j=1}^4 d_{2j} c_{2j} = (0) (0) + (0.78) (1) + (0) (0) + (0.22) (0.15) = 0.81$$

$$\sum_{j=1}^4 d_{3j} c_{3j} = (0) (0) + (0) (0) + (0.88) (1) + (0.12) (0) = 0.88$$

$$\sum_{j=1}^4 d_{4j} c_{4j} = (0) (0) + (0) (0) + (0) (0) + (1) (0) = 0$$

and

$$E = [0.48 \quad 0.12 \quad 0.32 \quad 0.08] \times \begin{bmatrix} 0.99 \\ 0.81 \\ 0.88 \\ 0 \end{bmatrix}$$

$$= 0.48 + 0.10 + 0.28 + 0 = \underline{0.86} = \text{Answer}$$

QUESTION 2Comment

The only change from Question 1 occurs in the methodology, definitions, and calculations related to the C_{1j} Matrix.

Definition: $\bar{T} | < T$ is the mean failure time of a system subject to the condition that is known to have failed by time T .

For an exponential system with failure rate λ ,

$$\bar{T} | < T = \int_{t=0}^T t \frac{\lambda e^{-\lambda t}}{1 - e^{-\lambda T}} dt = \frac{1}{\lambda} - T \frac{e^{-\lambda T}}{1 - e^{-\lambda T}} \quad (4)$$

Thus, the conditional mean failure times for A and B are:

$$\begin{aligned} \bar{T}_A | < T &= 1.4 \text{ hours} \\ \bar{T}_B | < T &= 1.5 \text{ hours} \end{aligned} \quad (\text{for the numbers involved})$$

Definition: $\bar{B} | < T$ = the expected number of bits transmitted by a system which is known to have failed by time T .

It follows directly that

$$\bar{B} | < T = (\bar{T} | < T) r \quad (5)$$

Thus, for systems A and B,

$$\bar{B}_A | < T = (120,000) (1.4) = 168,000 \text{ bits}$$

$$\bar{B}_B | < T = (100,000) (1.5) = 150,000 \text{ bits}$$

Definition: $\bar{B} | \geq T$ = expected number of bits transmitted by a system which has not failed by time T

It follows directly that

$$\bar{P} \geq T = rT \tag{6}$$

so that

$$\bar{P}_A \geq 3 = (120,000) (3) = 360,000 \text{ bits}$$

$$\bar{P}_B \geq 3 = (100,000) (3) = 300,000 \text{ bits}$$

Definition: c_{ij} = expected number of bits transmitted under the transition: $(i \rightarrow j)_3$

$c_{11} = 360,000 + 300,000 = 660,000$	$c_{31} = 0 + 0 = 0$
$c_{12} = 360,000 + 150,000 = 510,000$	$c_{32} = 0 + 0 = 0$
$c_{13} = 168,000 + 300,000 = 468,000$	$c_{33} = 0 + 300,000 = 300,000$
$c_{14} = 168,000 + 150,000 = 318,000$	$c_{34} = 0 + 150,000 = 150,000$
$c_{21} = 0 + 0 = 0$	$c_{41} = 0 + 0 = 0$
$c_{22} = 360,000 + 0 = 360,000$	$c_{42} = 0 + 0 = 0$
$c_{23} = 0 + 0 = 0$	$c_{43} = 0 + 0 = 0$
$c_{24} = 168,000 + 0 = 168,000$	$c_{44} = 0 + 0 = 0$

$$\underline{c}_{ij} \text{ Matrix: } \underline{c}_{ij} = \begin{bmatrix} 660,000 & 510,000 & 468,000 & 318,000 \\ 0 & 360,000 & 0 & 168,000 \\ 0 & 0 & 300,000 & 150,000 \\ 0 & 0 & 0 & 0 \end{bmatrix}$$

Effectiveness Calculations

Equation 3 still holds, and the \underline{D} Matrix is unchanged:

$$\sum_{j=1}^4 d_{1j} c_{1j} = (0.69)(660,000) + (0.09)(510,000) + (0.19)(468,000) + (0.03)(318,000) = 599,760$$

$$\sum_{j=1}^4 d_{2j} c_{2j} = (0)(0) + (0.78)(360,000) + (0)(0) + (0.22)(168,000) = 317,760$$

$$\sum_{j=1}^4 d_{3j} c_{3j} = (0)(0) + (0)(0) + (0.88)(300,000) + (0.12)(150,000) = 282,000$$

$$\sum_{j=1}^4 d_{4j} c_{4j} = (0)(0) + (0)(0) + (0)(0) + (1)(0) = 0$$

$$\text{and } E = [0.48 \quad 0.12 \quad 0.32 \quad 0.08] \times \begin{bmatrix} 599,760 \\ 382,760 \\ 282,000 \\ 0 \end{bmatrix}$$

$$= 287,885 + 38,131 + 90,240 + 0 = \underline{416,256} \text{ bits} = \text{Answer}$$

QUESTION 3Comments

- 50% increase in T values results in: $T_A = 18$; $T_B = 36$
- The methodology is identical to that of Question 1.

Availability Calculations

$$\text{Availability}_A = \frac{18}{26} = 0.69$$

$$\text{Availability}_B = \frac{36}{42} = 0.86$$

$$\text{A Matrix: } \underline{A} = [0.59 \quad 0.10 \quad 0.27 \quad 0.04]$$

Dependability Calculations

$$\text{Reliability}_A (3 \text{ hours}) = e^{-\frac{3}{18}} = e^{-0.167} = 0.84$$

$$\text{Reliability}_B (3 \text{ hours}) = e^{-\frac{3}{36}} = e^{-0.083} = 0.92$$

$$\underline{D} \text{ Matrix: } \underline{D} = \begin{bmatrix} 0.07 & 0.15 & 0.01 \\ 0.07 & 0.84 & 0 & 0 \\ 0 & 0 & 0.92 & 0.08 \\ 0 & 0 & 0 & 1 \end{bmatrix}$$

Capability Calculations

Comment :

All c_{1j} values, except for c_{14} and c_{24} , are identical to those in Question 1.

From Equation 1, $c_{24} = 0.19$

From Equation 2, $c_{14} = 0.56$

$$c_{1j} \text{ Matrix: } c_{1j} = \begin{bmatrix} 1 & 1 & 1 & 0.56 \\ 0 & 1 & 0 & 0.19 \\ 0 & 0 & 1 & 0 \\ 0 & 0 & 0 & 0 \end{bmatrix}$$

Effectiveness Calculations

From Equation 3,

$$E = [0.59 \quad 0.10 \quad 0.27 \quad 0.04] \times \begin{bmatrix} 1 \\ 0.87 \\ 0.92 \\ 0 \end{bmatrix} \begin{matrix} \text{rounded off} \\ \text{from } 0.996 \end{matrix}$$

$$= 0.59 + 0.09 + 0.25 + 0 = \underline{0.93} = \text{Answer}$$

QUESTION 4

Comments

- 50% increase in T values results in: $T_A = 18$; $T_B = 36$
- A and D Matrices are those of Question 3
- c_{1j} Matrix methodology is identical to that of Question 2

Capability Calculations

From Equation 5,

$$\bar{\beta}_A | < 3 = (120,000) (1.5) = 180,000$$

$$\bar{\beta}_B | < 3 = (100,000) (1.5) = 150,000$$

$$c_{1j} \text{ Matrix: } c_{1j} = \begin{bmatrix} 660,000 & 510,000 & 480,000 & 330,000 \\ 0 & 360,000 & 0 & 180,000 \\ 0 & 0 & 300,000 & 150,000 \\ 0 & 0 & 0 & 0 \end{bmatrix}$$

Effectiveness Calculations

From Equation 3,

$$E = [0.59 \quad 0.10 \quad 0.27 \quad 0.04] \times \begin{bmatrix} 619,200 \\ 331,200 \\ 288,000 \\ 0 \end{bmatrix}$$

$$= 365,328 + 33,120 + 77,760 = \underline{476,208} \text{ bits} = \text{Answer}$$

QUESTION 5

Comments :

- 50% decrease in \bar{R} values results in: $\bar{R}_A = 4$; $\bar{R}_B = 3$
- The only change from Question 1 occurs in the calculation of the A Matrix
- The methodology is identical to that of Question 1

Availability Calculations

$$\text{Availability}_A = \frac{12}{16} = 0.75$$

$$\text{Availability}_g = \frac{24}{27} = 0.89$$

$$\Delta \text{ Matrix: } \underline{A} = (0.67 \quad 0.08 \quad 0.22 \quad 0.03)$$

Effectiveness Calculations

$$E = (0.67 \quad 0.08 \quad 0.22 \quad 0.03) \times \begin{bmatrix} 0.99 \\ 0.81 \\ 0.88 \\ 0 \end{bmatrix} = \underline{0.92} = \text{Answer}$$

QUESTION 6

Comments

- 50% decrease in \bar{R} values results in: $\bar{R}_A = 4$; $\bar{R}_B = 3$
- The only change from Question 2 occurs in the evaluation of the A Matrix.
- The methodology is identical to that of Question 2
- The A Matrix is identical to that calculated in Question 5

Effectiveness Calculations

$$E = [0.67 \quad 0.08 \quad 0.22 \quad 0.03] \times \begin{bmatrix} 599,760 \\ 317,760 \\ 317,760 \\ 0 \end{bmatrix}$$

$$401,839 + 25,421 + 62,040 = \underline{\underline{489,300}} \text{ bits} = \text{Answer}$$

SUMMARY

T_A	T_B	R_A	R_B	E_1 $p(\geq 300,000)$	E_2 Average Bits
12	24	8	6	0.86	416,256
18	36	8	6	0.93	476,208
12	24	4	3	0.92	489,300

2.11 GENERATE COST EQUATIONS

2.11.1 Cost-Analysis Introduction

The method followed in any cost prediction is straightforward enough but is apt to be quite laborious. Furthermore, the data on which any prediction must be based are difficult to collect, and the gross estimates that it is necessary to employ must be treated with a good deal of reserve. To make any cost prediction at all, it is necessary (1) to break the expenditures down into rather small categories, (2) to collect as much past experience on expenditures in each category as possible, and (3) to predict from this information how much is likely to be spent in each category for the project being costed. Thereafter, all the categories must again be combined to obtain the system cost as a function of time.

2.11.2 The RAND Method

Many agencies, both in the DoD and industry, are performing military cost analysis and developing costing methodology. The RAND Corporation has been one of the leaders in the costing field. The major costing concepts proposed by the RAND Corporation are as follows:

- . Categorization of costs into research and development, initial investment, and operating costs
- . Use of individual-system costing and total-force-structure costing
- . Use of incremental costing
- . Concentration on most important cost factors

These concepts are described briefly below, and several of them are discussed in more detail in the following sections.

The categorization of costs into research and development, initial investment, and operating costs is consistent with the DoD programming system. Some advantages of this categorization are that the time phasing of the costs are readily apparent, the total lifetime cost for alternative system lifetimes is easily obtained, and the impact that changes in the research, development, and initial investment costs have on operating costs can be observed and traded off.

Total-force-structure costing is much more involved than individual-system costing. Individual-system costing does not examine the interactions between itself and other systems in the total force. This makes the cost analyst's task simpler, and is particularly useful in costing future systems (where interactions with other systems are not well defined anyway). Total-force-structure costing examines the cost of a system in the framework of the total force. This requires information on interactions among the systems in the total force, and also cost data for the total force.

AMCP 706-191

Incremental costing is an approach that determines the change in cost associated with achieving some change in effectiveness. If a decision is made today to develop a new system, incremental costing is used to determine the cost to develop that system **starting** from today. Costs that have been incurred previously are not counted, and the costs for existing equipment and facilities that can be utilized in the new system are not counted. In most cases, incremental costing is the type of costing that decision-makers are asking for when they say, "What will I be getting for my money?"

A sensitivity analysis consists of changing each of the variables in the study in turn, while the remaining variables are held constant, to determine how small changes in each variable can affect the study result.

A cost-sensitivity analysis is normally used to determine which parameters have the greatest impact on the total cost. The cost analyst can then concentrate his efforts on the most important cost factors.

2.11.2.1 Cost Categorization

System costs have been categorized in a number of ways, depending to a great extent on the type and applicability of available data. The objective in any of these categorizations is to focus attention on the major resources that will be consumed during the life of the system. Information on resources is produced that can be compared with information on available resources; alternative courses of action can be evaluated according to the amount of resource consumption they involve.

The military grouping of costs corresponds to the program phases in which the costs are incurred:

- Research and Development Costs. All the costs necessary to bring a system into readiness for introduction into active inventory.
- Initial Investment Costs. All costs incurred in phasing a system into the operational force. They include the costs of procurement of prime and special equipment, facility construction, personnel training, and procurement of initial spares.
- Operating Costs. All costs necessary to the operation of the system once it has been phased into the operational inventory. While both R&D and investment costs are incurred just once, the operating costs continue throughout the life of the system.

The curves of Figure 2-8 show typical distributions of these **costs** over the life cycle of a system. Further subdivisions of these costs are shown in the following paragraphs.

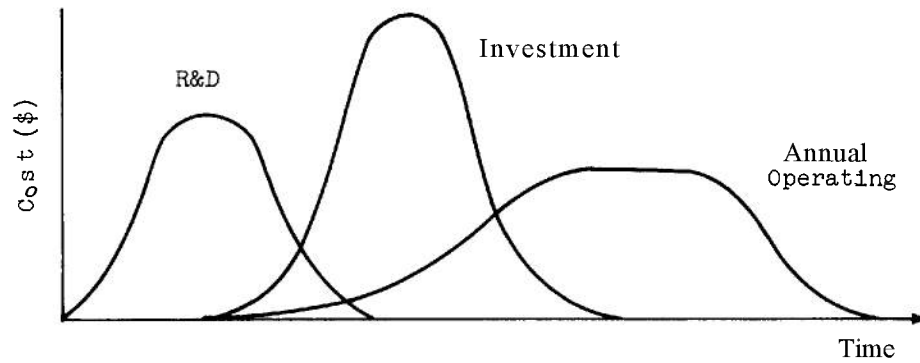

FIGURE 2-8
SYSTEM COST CATEGORIES

Examples of the types of costs in each major category are as follows:

Research and Development Costs

- . Design and development
 - Preliminary research and design studies
 - Development engineering and hardware fabrication
 - Development instrumentation
 - Captive test operations
 - Fuels, propellants, and gases
 - Industrial facilities
- . System test
 - Test-vehicle fabrication
 - Vehicle spares
 - Test operations
 - Test ground support equipment
 - Test facilities
 - Test instrumentation
 - Fuels, propellants, and gases
 - Data reduction and analysis
 - Maintenance, supply, miscellaneous
- . System management and technical direction

Initial Investment Costs

- . Installations
 - Construction of new building, airfields, etc.

AMCP 706-191

- Equipment
 - Primary-mission equipment
 - Specialized equipment
 - Other equipment
- Stocks
 - Initial allowances
 - Maintenance float
 - Equipment spares and spare parts
 - Combat consumption stocks
 - Ammunition
- . Initial training
- . Miscellaneous investment
 - Initial transportation of equipment and spares
 - Initial travel
 - Initial propellants, oils, and lubricants

Operating Costs

- Equipment and installations replacement
 - Primary-mission equipment
 - Specialized equipment
 - Other equipment
 - Installations
- Training
- Pay and allowances
- . Propellants, oils, and lubricants
 - Primary mission equipment
 - Other propellants, oils, and lubricants
- . Services and miscellaneous
 - Transportation
 - Travel
 - Other services and miscellaneous
- Nondirect administrative and support costs

2.11.2.2 Costing Individual Systems and Total Force Structure

A military system can normally be defined by describing three key elements: (1) the mission, with threat and environment; (2) the method of operation; and (3) a description of the physical makeup of the system and its support system.

If these three elements are defined, and there are no interrelationships with other systems that must be considered, then the type of cost analysis that is normally used is the individual system-cost analysis.

Individual system-cost analysis is less involved and requires fewer data than would be necessary if the system were not isolated from the total force.

The difference between individual-system and total-force-structure cost analyses is the level at which the analysis is carried out. The total-force-structure cost analysis is a higher-level analysis and includes many individual systems with the associated interactions among the individual systems.

There are cases in which an individual system cannot be costed realistically without the use of a total-force-structure cost analysis. For example, the development of a new anti-aircraft weapon would require a total-force-structure cost analysis. The entire air-defense capability could be costed (1) with, and (2) without the new individual system. The difference in cost between (1) and (2) would be the cost of the new anti-aircraft weapon.

2.11.2.3 Incremental Costing

Incremental costing accounts for additional costs associated with the additional effectiveness of a new system. The major factors included in the concept of incremental costing are inherited assets, sunk costs, and salvage value.

Inherited assets are those existing equipments, existing facilities, and trained personnel that are available for the new system. Inherited assets are not included in the cost comparison for alternative systems. For example, if a new radar system can utilize existing repair installations, the initial cost of these installations is not included in the cost analysis; i.e., the installations are free.

Sunk costs are those costs that have been expended prior to a given decision point, in time, and these costs are not included in a cost comparison. For example, suppose two alternative communications systems are being considered for development, and one system has already incurred \$2 million of R&D funds, while for the other alternative system (possibly an improved version of an existing system) no R&D fund has been expended. The decision to select either alternative may be based naturally on cost, effectiveness, technical feasibility, time scheduling, etc. However, in costing each alternative, the \$2 million that has already been spent on the first alternative is a sunk cost, and therefore is not included in the cost comparison -- i.e., no matter which alternative is selected, an additional \$1 million of R&D funds will be expended.

AMCP 706-191

Another factor included in the incremental costing concept is salvage value. Salvage value takes into account the cost saving that may be realized from selling or transferring a system to a future organization when the system is phased out, or the cost saving from selling the system as scrap.

2.11.3 Cost-Estimating Relationships

The most important tool available to the cost analyst is the cost-estimating relationship (CER). These provide a method of predicting the cost of a new system. These relationships are developed by collecting accumulated cost data on similar systems and correlating such costs to appropriate characteristics of the new system (weight, size, number of parts, etc.). For some types of systems that have been in existence for many years, such as airframes, enough data have been generated to permit development of CERs for use on new airframes; however, for more advanced systems that incorporate a substantial number of state-of-the-art improvements, currently available cost-prediction techniques do not provide the needed accuracy.

The standard method for developing cost-estimating relationships is through the use of multiple-regression analysis. To use the multiple-regression approach, a general assumption is made that the dependent variable -- in this case, a cost category -- is related to the predictor variables by a linear equation of the following form:

$$f_o(C) = b_o + b_1 f_1(x_{11}, x_{12}, \dots, x_{r_1 1}) + b_2 f_2(x_{12}, x_{12}, \dots, x_{r_2 2}) \\ + \dots + b_n f_n(x_{1n}, x_{2n}, \dots, x_{r_n n})$$

where

$f_o(C)$ is a function of the cost

x_{ij} is the j^{th} prediction parameter in the C^{th} subset

f_1, f_2, \dots, f_n are functions of the x 's

b_o, b_1, \dots, b_n are computed regression coefficients

Although the general function is linear with respect to the regression coefficients, it is not necessarily linear with respect to C or the x 's. Thus, for example, an equation of the form

$$C = a x_1^{b_1} e^{b_2 x_2}$$

transforms to the required linear form

$$\log C = \log a + b_1 \log X_1 + b_2 X_2$$

Although nonlinear equations can be used through various mathematical curve-fitting procedures, the advantages of using a least-squares analysis based on linear equations in the coefficients and the flexibility of such linear forms strongly favors the standard regression approach.

Normally, separate CERs are developed for each of the major cost categories (Research and Development, Initial Investment, and Operating Costs). Factors that influence one cost category may have little effect on another category or may even have an opposite effect. For example, an equipment ultra-high-reliability program, such as that currently being sponsored by DoD through the three services, will increase development costs but, it is hoped, greatly reduce operational costs. Therefore, parameters relating to reliability will have a positive development-cost relationship but a negative operational-cost relationship. It would be unwise to combine the two cost categories into one CER since accuracy will probably be diminished; equally important, trade-off aspects will be lost,

It is desirable to limit the final number of parameters in the CERs to minimize use difficulty as well as to maximize the degrees of freedom in the analysis.

2.11.4 Problems in Cost Analysis

2.11.4.1 Cost Commensurability

There are two main techniques for making costs commensurable: amortization and discounting. Amortization is the spreading of the system research and development and initial investment costs over the lifetime of the system. Discounting is used to reflect the greater value of present money over future money, because of the possibility of investing present money for a gain.

Amortization and discounting are not normally used for military costing, for the following reasons:

- . Government directives call for yearly estimates of actual expenditures; this information aids in the preparation of the annual budget.
- . The discounting rate is difficult to determine; it has been estimated to be from 1 percent to 20 percent.
- . These factors are normally insensitive as compared with other costing considerations.

At present, the discounting rate normally used in Army studies is 15 percent.

2.11.4.2 Cost Uncertainty

Every cost estimate is uncertain, from the initial component-cost estimate up through the aggregation of system costs. Cost analysts have been careful to differentiate between this type of uncertainty in the cost estimates (cost-estimating uncertainty) and uncertainties in what exactly is to be costed (requirements uncertainty). In the latter case, a detailed description of the interrelationships associated with the system may consume as much as 75 percent of the total project time. The most serious errors in the cost analysis can usually be traced to the assumptions and interrelationships on which the cost estimates are based.

AMCP 706-191

Cost-estimating uncertainty Is the statistical uncertainty caused by errors in the cost data, inaccurate cost-estimating relationships, and differences in the cost-analysis approach.

The analyst should develop not only the cost estimates, but also an indication of the confidence level or possible ranges of the costs. Use of the cost-sensitivity analysis is also desirable to show the Impact that uncertainty can have on the final cost estimates.

2.11.4.3 Data Collection

One of the greatest problems in cost analysis is obtaining sufficient data and accurate data. The basic data compiled to support the requirements of the cost analysis should meet the following requirements:

- . They should be collected in sufficient quantity to provide significant sample sizes of the various system characteristics and cost parameters being studied. The confidence in results increases with the quantity of observations. Accordingly, every effort must be made to acquire sufficient data from actual surveillance of systems in an operational environment. If, however, adequate data of this type are not available, it may be necessary to resort to estimating techniques. Several proven techniques are available for various equipments.
- . They should reflect current system conditions. Timely collection of input data is required if the cost analysis is to depict current conditions in the system. Many diverse factors affect the cost of developing, purchasing, operating, and maintaining a modern system. Unfortunately, at least from a cost-development standpoint, almost all of these factors are dynamic.
- . They should be accurate. The Importance of using the most accurate data available cannot be overemphasized. The stringent requirement for accurate data is related to the intrinsic nature of the mathematical approach. Many compound summing operations (or multiplications) will be accomplished during the cost analysis; thus any inaccuracies in the data will also be compounded during these mathematical manipulations..
- . They should be representative of the operational situation of interest. The system-cost characteristics are known to be affected by the operational and maintenance environment. Until such time as the direction and extent of the various Influencing factors upon the system are more explicitly defined, it will be desirable to collect data from the specific operational situation in the cost analysis.

2.11.5 Cost-Analysis Application

2.11.5.1 Problem Formulation *

The specific form that any cost analysis will take depends on the particular system being studied. However, in general, there are three factors that must be considered in every costing problem: (1) the costing methods that will be employed, (2) the type of data that will be required, and (3) the sources of the data. These factors are discussed below.

The costing method employed is normally one of three general types -- a catalogue price, a cost-estimating relationship, or an estimate based on a similar system. The catalogue price is used where the component is an off-the-shelf item. The cost-estimating relationship can be developed on the basis of design and performance characteristics, or previous cost. The estimate of cost based on a similar system is used when the system being analyzed is sufficiently similar to an existing system that a valid cost analogy can be made.

The type of data that is required for a cost analysis may be categorized into the assumptions and constraints, the description of the system, and the cost information. As an example of the types of data required for a cost analysis, assume that the avionics on a group of helicopters is maintained by a dual maintenance organization, consisting of organizational maintenance and direct support maintenance.

If a complaint against an avionic system is received, organizational personnel try to verify the complaint; if they verify it, they (1) perform some maintenance at the helicopter (this may consist of changing a black box) and (2) in a certain percentage of the cases, generate some direct support maintenance.

If they do not verify the complaint, they have, of course, spent some time in the investigation; however, that complaint is disposed of.

The following data are required in the cost analysis of this system:

- . Number of complaints per month
- . Fraction verified
- . Manpower needed to verify
- . Fraction disposed of at the helicopter
- . Manpower needed to dispose of the complaint at the helicopter
- . Cost of the bits and pieces needed at the helicopter
- . Manpower needed to provide the bits and pieces at the helicopter
- . Manpower needed to replace the black box
- . Cost of the replacement black box

*From "Reliability Engineering", copyrighted 1964 by ARINC Research Corporation, Publisher - Prentice-Hall, Inc., Englewood Cliffs, New Jersey.

AMCP 706-191

- . Manpower needed to obtain the black box
- . Time delay before the faulty box is repaired and ready for use
- . Time needed to repair the black box at direct support
- . Cost of the bits and pieces needed at direct support
- . Manpower needed to provide the bits and peices at direct support
- . Cost of loaded manpower for various categories of direct labor
- . Average lifetime of a black box
- . Cost of various categories of loaded manpower

Sources of data include published reports (and unpublished back-up material), equipment catalogues, and financial summaries. Typical sources of data for the example given previously are indicated below.

The number of complaints per month, N

The quantity N is composed of usage rate, reliability, and the number of black boxes in use. If n black boxes are being used, each an average of t hours a month, and if the complaint reliability, i.e., the mean time between complaints (MTBC) on the black box, is λ_c complaints per hour of use, then

$$N = \frac{nt}{\lambda_c}$$

The MTBC can be estimated from field-failure data.

The usage rate, t, must be estimated from deployment plans, as must the number, n, of boxes in use. On a projected system, all these factors will be available. Hence N can be estimated.

The fraction of verified complaints

The fraction of verified complaints, v, is another output of the observation of field failure data. If A_f is the mean time between verified complaints, then,

$$v = \frac{t}{\lambda_f}$$

The fraction of verified complaints that can be disposed of at the helicopter

The fraction of verified complaints that can be disposed of at the helicopter, f, is estimated essentially from two pieces of information:

- (1) A maintenance plan that defines the repairs that will be made at the helicopter. (Adjustments, for instance, will often be made there.)
- (2) A reliability prediction in greater detail than those needed for λ_c and λ_f , namely, a breakdown of A into those cases which will be disposed of at the helicopter and those which will have to go to direct support.

Such predictions can be obtained from a more detailed knowledge of the equipment; or, alternately, statistical values of the fraction f for similar equipments now in service can be used as estimates.

The cost of maintenance manpower

Direct-maintenance manpower is obtainable from maintainability predictions. Suppose the direct-maintenance time required and the corresponding hourly pay required on the average to accomplish the maintenance actions are, respectively,

$$t_i \text{ and } C_i$$

where the subscript i refers to the skill class. Then t_i can be obtained from maintainability predictions; C_i can be obtained from lists of pay classes, together with an estimate of the useful life of maintenance men in grade. Here a suitable definition of useful life might be the percentage of the time in grade during which the man is actually assigned to maintenance duties.

Besides direct labor, there is in any organization a great deal of overhead labor. Much of this is concerned with scheduling and supervision, and some with management; and a good deal goes to leave, training, and nonmaintenance duties of the men themselves.

In general, the loaded time will be a linear function of the direct-labor time. If T_i is the loaded time (direct and overhead) spent in labor class i , then

$$T_i = a_i + b_i t_i$$

The cost of labor is then given by

$$C(T) = \sum T_i C_i = \sum a_i C_i + \sum b_i t_i C_i$$

The constants involved in the equation above are the overhead coefficients, a_i and b_i . Rough estimates of these can be made from tables of organizations and from estimated work-loads.

A good approximation to the equation above can be obtained in the form

$$C(T) = C_a + C_b \cdot t$$

where t is the total active-repair time in all labor classes,

The materials costs at supply

The materials costs at supply are the parameters that connect the different echelons. To estimate them, two kinds of information are needed: (1) the average amount and kinds of materials needed to perform repairs, and (2) the cost of these materials to **supply**. These categories are discussed below.

AMCP 706-191

Estimates of the kinds and quantities of materials can be obtained either from a statistical analysis of the behavior of similar equipments in present use or from a detailed reliability analysis, based on actual schematics.

The cost of these materials at the supply echelon in question will consist of the following:

- Cost at the higher supply echelon, which supplies the one in question
- Cost of the labor needed at the higher echelon and at the echelon in question to move the materials
- Cost of transportation

The materials cost at one echelon then contains implicitly the accrued supply costs at all higher echelons; thus the whole system-support cost will be accounted for.

The cost of supply manpower

The labor cost at supply must be obtained by an analysis similar to that described for the maintenance manpower. If a detailed analysis is not available, probably the best estimate obtainable is to assume that every action, i.e., every requisition and every issue, takes, on the average, about as much labor as every other. Then if the total payroll of the supply organization is divided by the number of pieces of paper generated, an estimate of the labor cost of requisitions and issue is obtained.

The time delay: the average life of a black box

The cost of time delay [involving ΔT , L , and C_c -- the time delay, the average life of a black box in the (partial) system, and the cost of the black box to supply, respectively] has been given as

$$\frac{\Delta T}{L} C_c$$

The estimation of C_c has been discussed above. Time delays must be estimated by observations on similar support organizations. The average life can be estimated from condemnation rates, return rates to higher echelons of maintenance, and the total number in circulation.

If on an average a black boxes a month are condemned, and b are returned to higher echelons of maintenance for repair, then if there are n boxes in circulation,

$$L = \frac{n}{a + b}$$

Again a and b can be estimated from a detailed reliability analysis and a maintenance plan, or from statistical values for similar equipment. The number n is determined by the verified failure rate and by logistic policy,

2.12 EXERCISE THE MODEL

2.12.1 General

The method used in exercising the model is dependent on the type and complexity of model and the time, equipment, personnel, and money available.

For a complex model, the time and cost involved in exercising the model on a computer may be much less than the time and cost for using people with slide rules. However, if this model is only required to be exercised once, the cost of set-up time for the computer may preclude its use.* In general, the computer is much faster for exercising a model than using a slide rule or a desk calculator once the model has been programmed. In actual practice, however, the analyst has an overall time constraint on the study effort, and if a computer is available, the time to exercise the model will not change, because the analyst will use any additional time to conduct sensitivity analyses or expand the original model.

The basic point to be made in exercising the model is that no matter what process is used -- desk calculator, computer, or slide rule -- the final result will be only as good as the model and the information put into the model. The use of a computer does not in itself ensure a more valid result.

2.12.2 Analysis of Output Data

When an analytical model has been developed and sufficient input data gathered, the model can be exercised, either manually or by means of computer. In the simplest of cases, a single dependent variable will result from the process. In most systems analyses, however, a whole family of dependent variables will be generated.

2.12.2.1 Analysis of a Single Dependent Variable

Each model equation will yield one output parameter (the dependent variable) when one set of input parameters (independent variables) is used. The output parameter might represent an average, predicted, or estimated value. The value could represent a measure of cost, effectiveness, reliability or any other parameter of interest upon which the model was based.

The single output parameter could of course be analyzed by comparing it to some previously known standard of acceptability. For example the objective of the analysis may have been to estimate the reliability of a product to determine compliance with a pre-established requirement. In this instance, a judgment of acceptability of the product might be made by simply comparing the estimated value with the required value.

In many cases, however, it is desirable (and often necessary) to analyze the resultant from the standpoint of the associated uncertainties.

* This is one area in which a cost-effectiveness study could be used to determine whether a computer should be employed.

While often difficult to admit, various reasons contribute to uncertainties which affect the nature of estimates, measurements, or expected outcomes. These uncertainties are not necessarily indicative of faulty or careless estimation procedures, but rather are reflective of the difficulty in characterizing the real world. From previous experience ample evidence exists that the process of prediction is a difficult one. History tells us that the estimated cost of building the Suez Canal was off by a factor of twenty. Cost estimates for recently built nuclear power plants have been half of what they eventually wound up costing.

In 9 out of 22 major hardware systems studied recently by the Rand Corporation, the actual procurement cost per article was more than three times an early estimate of cost; and in two cases the actual cost was more than ten times an early estimate.

The problem of uncertainty in estimating cost and effectiveness for new systems can, of course, never be eliminated. However, the analyst can minimize uncertainty and -- more important -- can account for it in providing information to the decision-maker. This, of course, requires knowledge of the types of uncertainty which might be encountered.

Charles Hitch and Roland McKean, in their book, The Economics of Defense in the Nuclear Age, (Harvard University Press, 1963) describe five basic types of uncertainty associated with estimates:

- (a) Uncertainty about planning and cost factors
- (b) Uncertainty about strategic context
- (c) Technological uncertainty
- (d) Uncertainty about the enemy and his reactions
- (e) Statistical uncertainty

The analyst is confronted with the task of deciding how uncertainties are to be treated. The most important advice is of course, "Don't ignore them". Secondly he must be able to recognize the type of uncertainty involved. Third, he must be able to distinguish between the important and unimportant uncertainties in context with the particular analysis. Finally, he must be able to expand on his basic estimate or measurement by additional consideration of the contingencies created by the uncertainty. This may entail:

- (a) Expressing the dependent variable as a range of values, each value having a probability of occurrence.
- (b) Assigning confidence intervals about the estimate.
- (c) Subjectively qualifying the nature of the estimated or measured value.

Figure 2.9 illustrates six different ways of expressing an estimated value. Each successive expression form represents a higher degree of specificity in treating uncertainty.

EXPRESSION FORM	DEGREE OF SPECIFICITY
1. System A is estimated to cost \$15M.	1. No uncertainty expression.
2. System A is estimated to cost \$15M; however, the analyst is not sure (uncertain) about the figure.	2. A vague qualitative expression of uncertainty is given.
3. System A is estimated to cost between \$11M and \$19M.	3. A range is given to express the magnitude of uncertainty. However, no probability information is given; it is not stated whether the analyst believes there is a 1%, a 10% or a 100% chance that the cost will fall between \$11M and \$19M, nor is it indicated whether the cost is likely to be closer to \$11M or \$19M.
4. There is a "strong probability" that System A's cost will be: \$11M - \$15M - \$19M. The \$15M is some measure of central tendency (mean, mode or median). The \$11M and \$19M are the estimated lower and upper cost limits.	4. An adjective descriptor is added to convey a rough indication of probability.
5. With a .95 probability, System A's cost is estimated: \$11M - \$15M - \$19M. The numerical expressions have the same meaning as in 4 above.	5. The adjective descriptor is replaced by the more definitive numeral.
<p>6.</p> 	6. A complete probability distribution is given, and this is depicted by a curve. (Both the problems in getting the Case 6 type information and the amount of additional information provided by Case 6 are of a greater magnitude vs Case 5 than Case 5 is vs Case 4, Case 4 is vs Case 3, etc.)

FIGURE 2-9
EXPRESSIONS OF UNCERTAINTY

2.12.2.2 Analysis of Several Dependent Variables

Most systems analysis problems encountered will involve the treatment of more than one dependent variable. For example, quite often two alternative systems or alternative designs are the subject of the analysis. Further, at least two dependent parameters, -- e.g., cost and effectiveness -- (and probably many more) are of interest in making the comparison. An even more complex situation arises when the study objectives involve "trade-offs" where the dependent variables of interest can assume a broad range of values. In general, the task of analyzing data outputs can be subdivided into:

*Comparative Analyses

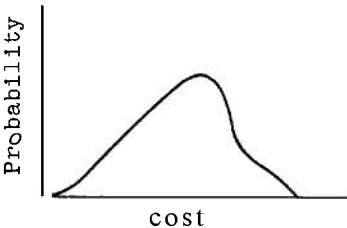
'General Trade-off Studies

AMCP 706-191

Comparative analyses, as defined herein, are studies aimed at determining which of two or more alternatives is better (or best). If a single dependent variable constitutes the basis for comparison, the analysis is a rather simple one. Hence, the problem might be:

- Which of two systems is more effective? or
- Which of two systems is cheaper? or
- Which of two systems is cheaper and better?

In treating the above types of problems, the analyst's responsibility is to recommend a single choice from among the alternatives. Little is left for the decision-maker, except to accept or reject the results of the analysis.

In many cases, however, the analyst's objective is to present more than one alternative to the decision-maker. For example, the terms of the analysis may require that separate values of cost and effectiveness be presented for each system considered, with final choice of the "better one" being the decision-maker's choice. An example of this approach, given below, shows that system B costs more than system A -- but is also more effective. In this example, the judgment of the relative worth of the two systems could, by intent, be that of the decision-maker.

<u>System</u>	<u>cost</u>	<u>Effectiveness</u>
A	\$1.0M	.95
B	\$1.5M	.98

A similar example is one wherein the decision-maker desires to subjectively consider certain factors which, by intent, have not been included in the model. (These factors are called "leverage effects" and will be discussed in greater detail in Section 2.13.) An example of such a case is evident in the analytical process recently employed to select a Chief of Police for the City of Los Angeles. In that situation, there were several candidates for the position. By means of a vigorous analytical approach (actually a model was developed with which to estimate the "effectiveness" of each candidate), the number of choices was reduced to three. The ultimate selection of the best man for the job was made by choice of the decision-maker (in this case, the top City officials). In the example cited, it is to be noted that the analytical model was used to minimize the number of possible alternatives, but was not necessarily used to arrive at the final decision.

Often, the objective of the analyst is to conduct trade-off studies where two or more dependent variables are to be considered over a broad range of possibilities. This form of objective is quite common during the concept formulation phase of a project when requirements are being developed. In this situation, the analyst has been given a minimum level of acceptability and a design

goal for the dependent variables of interest. He then must analyze the many alternatives within the given envelope in order to reduce the number of choices to one -- or to some minimum number. Trade-offs can involve weighing one performance parameter against another or weighing performance against cost. Examples of each situation are given below:

(1) Performance Parameter Trade-offs

One of the major parameters in most effectiveness models is availability. Availability is in turn a function of reliability and maintainability. When reliability is expressed as a frequency of failure (MTBF) and maintainability expressed as the length of time required to restore (MDT) a failed item, availability in some cases can be expressed as

$$A = \frac{MIBF}{MTBF + MDT}$$

If a fixed level of availability is the desired output, it is apparent that MIBF and MDT can be traded off in achieving the desired value.

(2) Performance Versus Cost Trade-offs

Another form of trade-off problem involves performance versus cost. In this type of trade-off problem the principle objective is to weigh varying levels of performance against varying levels of cost. Common trade-offs in this category include:

- Speed versus cost
- Payload versus cost
- Reliability versus cost

Considerable emphasis has been directed recently to the consideration of total life-cycle costs when formulating system level decisions. The reasoning behind the emphasis is that incomplete consideration of the influencing factors often can lead to erroneous decision. A case in point can be illustrated by the following example.

It is assumed that the decision-maker must choose between two systems of differing availability on the basis of cost. It may be generally shown that development cost and initial investment cost increase with increased reliability (see Figure 2.10a). On the other hand annual operating costs (and hence total recurring costs) decrease with increased reliability (see Figure 2.10b). It readily becomes apparent that the cheaper system can only be determined by combined consideration of all costs (Figure 2.10c).

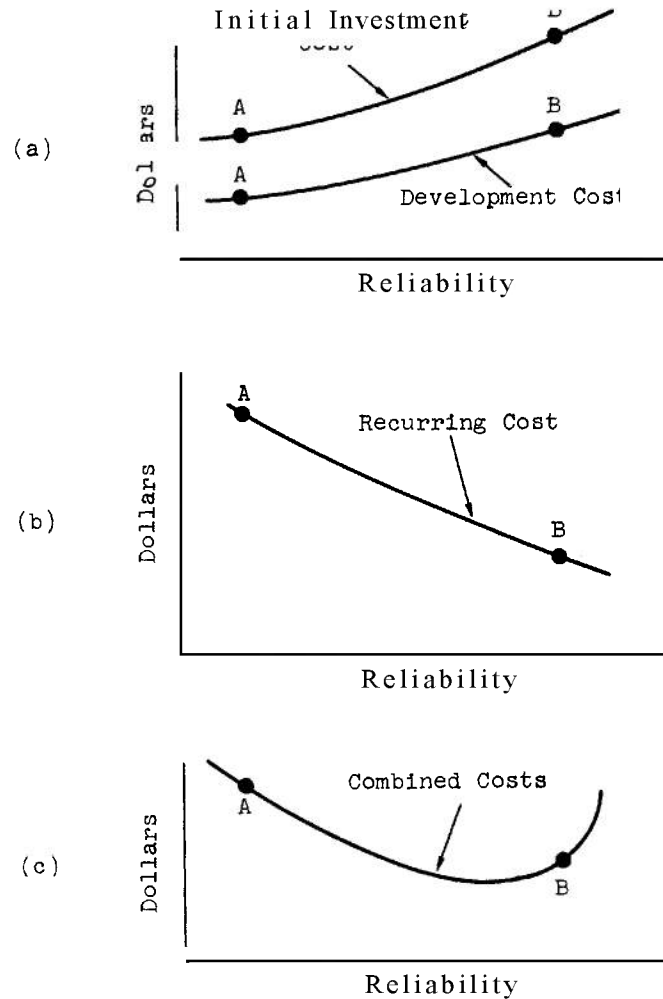

FIGURE 2-10
TRADE-OFF CURVES

(3) Trade-off Analyses Related to Project Objectives

Trade-off analyses are, in general, meaningless unless placed in context with a specific set of objectives. For example, during concept formulation, the following objectives are significant:

- (a) Establish requirements (or envelopes).
- (b) Select a minimum set of design alternatives.
- (c) Prove the technical, economic, and military feasibility of selected design alternatives.

The interdependencies between trade-off studies and the above objectives are shown in Figure 2.11. Any trade-off study must be based on a set of dependent and independent variables. The status of a given project in terms of accomplishment of the objectives would identify the dependent and independent variables for the trade-off study effort. For example, if requirements envelopes have been established, these constitute the set of independent variables for the trade-off study. The objective of the study might then be the selection of a minimum set of design alternatives.

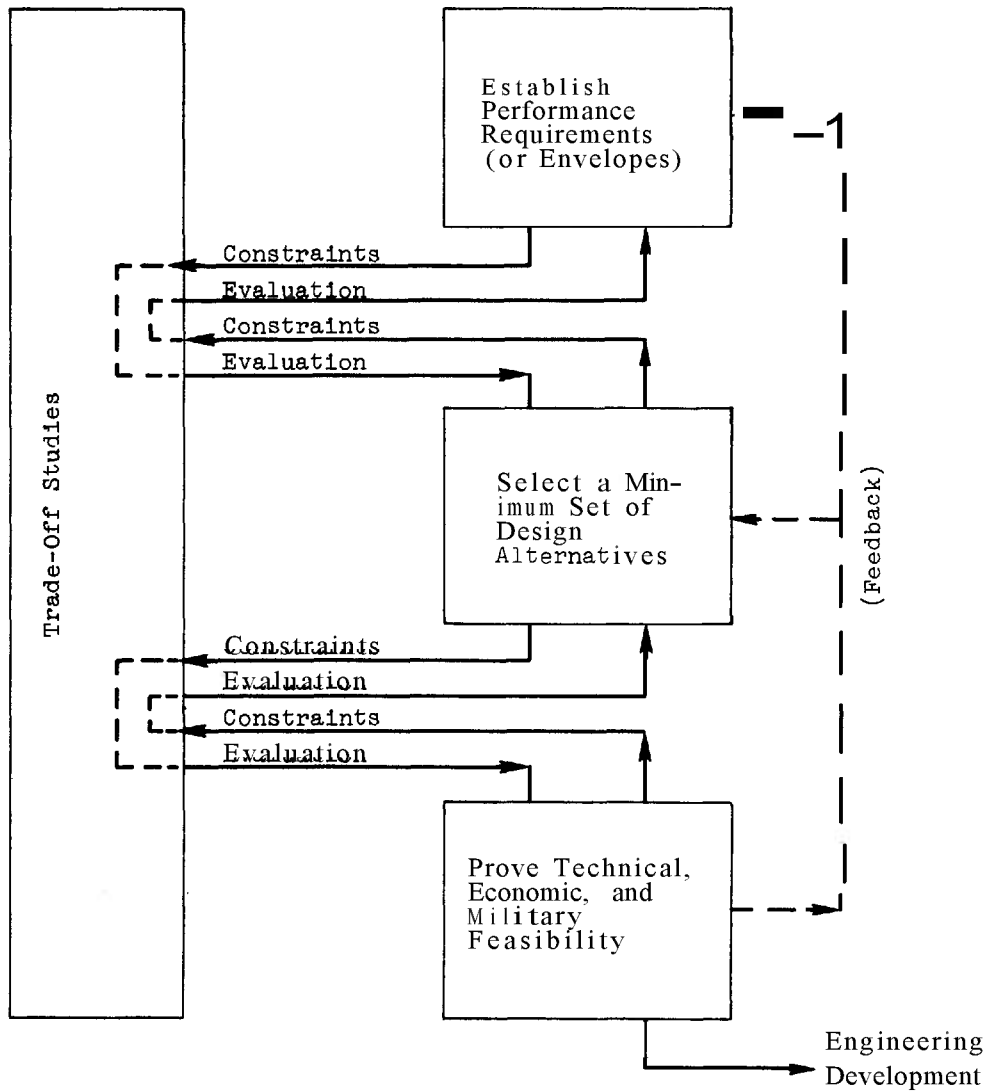

FIGURE 2-11
 INTERDEPENDENCIES BETWEEN TRADEOFF
 STUDIES AND PROJECT OBJECTIVES

AMCP 706-191

(4) Sensitivity Analysis

An important tool in performing trade-off studies is the analysis of sensitivity. In general, sensitivity analysis involves determining the significance of a given variable within some prescribed range of interest. A simple illustration of sensitivity is given in Figure 2-12, which describes the relationship between total system cost and the endurance for a hypothetical manned aircraft. The analyst would conclude from the curve that:

- (a) Cost is highly sensitive to endurance at low levels of endurance.
- (b) Cost is relatively insensitive to endurance of higher values of endurance.

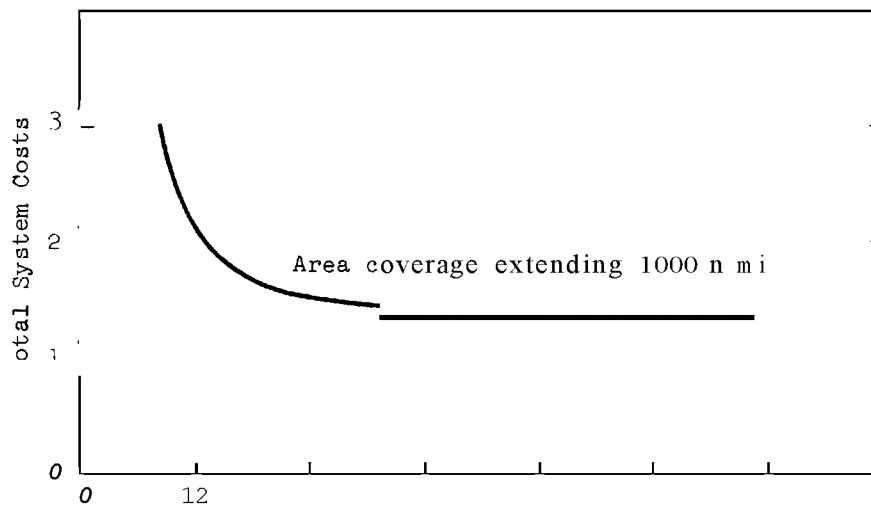

FIGURE 2-12
SENSITIVITY ANALYSIS

2.13 DEVELOP DECISION MODEL

2.13.1 Optimization Criterion

In defining an optimizing criterion, the system analyst is faced with a problem similar to that of putting in precise, quantifiable terms the rules or criteria for choosing the "best" painting or "best" automobile. These examples do have quantifiable characteristics, such as the size of the painting or cost of the automobile; however, artistic judgment and user experience, respectively, are factors in the final choice. In the same sense, the choice of the best system is greatly influenced by the use of good engineering, economic, and operational judgment.

It is most important, however, that the optimizing criterion be defined to the maximum extent possible, for the following reasons:

- (a) The inputs provided to the analyst through use of the criterion can reduce the size of the problem to a point where a judicious choice can be made.
- (b) Defining a criterion forces the analyst to examine all possible alternatives in an objective manner so that the criterion can be adapted to mathematical representation and analysis.
- (c) It is easier to incorporate the ideas and experience of others if a formal basis for optimization is established.
- (d) The (partial) basis for final choice is in precise, quantifiable terms and can therefore be reviewed and revised, and can provide inputs to a learning process for future optimization problems.

When a criterion for optimization is being formulated, the system and the boundaries must be explicitly defined. This definition will influence the choice of parameters in the optimization model. The purchaser of a new automobile, for example, may or may not consider the service policies of the manufacturer and dealer. If he does, the system is both the automobile and service policies; if he does not, the system is only the automobile. In attempting to optimize a weapon system such as a bomber, the analyst has to consider whether the system is to be defined as a single bomber, a squadron of bombers, or the complete bomber fleet. It is possible that optimizing with respect to a single plane (a sub-optimization) may not yield the optimum "squadron" system.

As part of the system-definition process, the analyst also determines the fixed and variable factors pertinent to the system. This task requires a preliminary analysis, since consideration of all possible alternatives will usually lead to problems of unmanageable size. Some factors may be considered fixed if results of previous analyses, perhaps sub-optimizations, indicate the values that have attained the best results in the past. The maintenance troubleshooting routine, for example, might normally be considered as a variable factor, but past research in this area may be used to select a particular routine applicable to the system under study, or perhaps to restrict the range to several alternatives.

Once the mission profile is defined, consideration can be given to the physical and economic limitations that will have to be imposed. These limitations are based on requirements and availabilities, and may involve such factors as minimum system output, maximum reliability, maximum development time, maximum weight and volume, and type and number of support and operational personnel. Through such consideration and envelope of design, development, operational, and support alternatives can be established in such a way that each overall configuration within the envelope will meet physical and economic limitations as well as minimum performance goals.

Now the analyst must select a decision criterion by specifying the types of effectiveness and cost parameters to be investigated and by assigning numerical values where required. The choice of objectives and criteria is perhaps the most difficult task in system effectiveness optimization. It is expected, however, that current research in the optimizing of system effectiveness will develop theory and accumulate experience to help overcome some of the difficulties of this task.

It would be impossible to establish rigid ground rules or procedures for formulating a criterion for optimizing system effectiveness. The answers to the following two basic questions, however, will provide a great deal of insight for such formulation:

- (1) Why is the system being developed?
- (2) What physical and economic limitations exist?

The answer to the first question essentially defines the mission profile of the system. Where possible, the definition should be translated into quantitative parameters -- a difficult task in many cases. A performance measure such as kill-probability for a SAC bomber may be assignable, but the bomber may also have a mission to act as a deterrent -- a measure that is difficult, if not impossible, to quantify. It is for this type of multi-mission case that judgment will become especially important. Even if quantitative requirements can be placed on all mission types, weighting factors would have to be introduced to quantify the relative importance of each mission.

Factors that have relatively little impact on overall effectiveness or cost can be considered to be fixed or, possibly, can be ignored. There is, of course, a risk involved if factors chosen to be fixed or unimportant would have had a significant effect if they had been allowed to vary. Factors that fall in this "gray area" may have constraints imposed upon them in such a manner that the more detailed analysis to be performed in the optimization process will indicate final disposition. For example, if a questionable factor might have a monotonic influence on effectiveness, consideration of only extreme values might be all that is necessary to determine the significance of this influence.

It is important that factor selection, variability, and the final choice of system definition be clearly indicated so that the scope of the optimization process will be known and areas for possible modification of the formal mathematical solution will be made explicit.

2.13.2 Risk and Uncertainty

It is rare for a decision not to include some degree of risk and uncertainty. In many cases, the risks can be identified before the decision is made, and their effects can be included in the analysis. Some degree of control is thus obtained over risks and uncertainties, making it possible, for instance, to specify how much risk can be tolerated.

A distinction should be made between risks and uncertainties. A probability can be assigned to any event that is considered a risk, but no probability can be assigned to an uncertainty. An example of a risk is a gambler making a bet that he will draw a red ball from an urn containing 5 red balls and 10 white balls. The possible outcomes are known, and the probabilities are $1/3$ for a red ball and $2/3$ for a white ball. An example of uncertainty is making the same bet where the number of red balls and the number of white balls are unknown. In this case, all that can be said about the outcome is that a red ball or a white ball will be drawn.

In practice, the distinction is not always clear. It may be known, for example, that the number of red balls is between five and ten and the number of white balls equal ten. Since analyses under conditions of risk are preferred to those under conditions of uncertainty, some effort must be made to learn more about the system and thereby reduce the amount of uncertainty in the decision.

2.13.3 Optimization Techniques

The technique for optimization essentially involves the application of effectiveness and cost models to all feasible designs and selection of the design which, according to the criterion, is optimum.

While this approach is conceptually simple, its implementation is virtually impossible, except for the most simple problems. Consider a problem involving fifteen variables, each of which may take one of only two possible values. More than 32,000 possible system designs would have to be considered, a magnitude that would tax even the largest of the available computers.

Techniques are therefore needed to reduce the amount of mathematics and computation to a size reasonable for computer, geometrical, or even hand solution. In a sense, these techniques are sophisticated trial-and-error routines. Some of the more commonly used techniques, or fields from which such techniques are derived, are listed in Table 2-3. The list is by no means complete. A brief description of several of these techniques is contained in Section 3 of the Guidebook.

TABLE 2-3 PARTIAL LIST OF TECHNIQUES FOR OPTIMIZATION	
I.	<p style="text-align: center;">Mathematical Techniques</p> <p style="text-align: center;">Birth and death processes Calculus of finite differences Calculus of variations Gradient theory Numerical approximation methods Symbolic logic Theory of linear integrals Theory of maximum and minimum</p>
II.	<p style="text-align: center;">Statistical Techniques</p> <p style="text-align: center;">Bayesian analysis Decision theory Experimental design Information theory Method of steepest ascent Stochastic processes</p>
III.	<p style="text-align: center;">Programming Techniques</p> <p style="text-align: center;">Dynamic programming Linear programming Nonlinear programming</p>
IV.	<p style="text-align: center;">Other Operations Research Techniques</p> <p style="text-align: center;">Gaming theory Monte Carlo techniques Queuing theory Renewal theory Search theory Signal flow graphs Simulation Value theory</p>

2.13.4 Leverage Effects

During the analysis of system cost or cost-effectiveness, a great deal of emphasis is necessarily placed on the three basic types of cost: research and development, investment, and operating. However, costs and benefits in another category are often overlooked during these analyses. They are overlooked because they do not increase or diminish the total cost and effectiveness of the system being analyzed. These costs and benefits are called leverage effects in that they come into play when an alternative associated with the system being analyzed influences (acts as a lever on) the cost or some other charac-

teristics of another system. Leverage effects include those allied factors or elements which are external to the system being studied but may have a significant if not overwhelming impact on the final choice among system alternatives.

Leverage effects need not be expressed as a quantity of dollars, time, or other units. They can be simply facts or circumstances that should be considered in the decision. In terms of the definition of cost-effectiveness analysis given earlier, a leverage effect is presented as one component of the array of characteristics mentioned therein.

Leverage effects can be illustrated by a simple example. A military agency is to select for development one of three alternative powerplants, A, B, and C, for use in a new helicopter. It is assumed that the total system cost and effectiveness have been estimated for each alternative as follows:

	<u>Powerplant A</u>	<u>Powerplant B</u>	<u>Powerplant C</u>
Total System Cost	\$60,000,000	\$70,000,000	\$80,000,000
Effectiveness	0.95	0.95	0.95

It is apparent that A is the best choice since it is the least costly and provides the same effectiveness. However, Powerplant C may have certain qualities that would permit its effective use in a new tank that is being developed. It is assumed that the total cost of a new powerplant developed for the tank alone would also be \$80,000,000, but that if Powerplant C were selected and developed for the helicopter, its total cost would be reduced to \$50,000,000 because of shared development costs. This saving of \$30,000,000 in the development of the tank now makes C appear to be the best buy. The \$30,000,000 is a leverage effect, since the powerplant for the helicopter will still cost \$80,000,000, but its development will effect a \$30,000,000 saving in the allied tank program.

It might be argued that leverage effects could be included in either the cost or effectiveness values of the system. However, the analyst is forced to isolate the problem and define a system associated with it in order to perform the analysis at a manageable level. Although the leverage effects are known to influence the decision, many factors must be excluded if the system is to be represented by a model and pertinent information is to be extracted from that model. Then, after the model is applied to the various alternatives, some of the excluded factors, e.g., leverage effects, are reconsidered for the final decision.

2.13.5 Interpretation

As indicated previously, a model of a complex process is usually incomplete because of uncertainties, non-quantitative factors, inadequate data, and inadequate consideration of the effects of the process on systems and operations at

AMCP 706-191

higher echelons. In such cases the results of the optimization process can only indicate the best system within the simplifications, assumptions, restrictions, and omissions required to circumvent the voids.

The effects of these circumventions must then be evaluated through some type of model feedback procedure which, on the basis of the attained results, may reveal some critical deficiencies that can be rectified.

However, even the most modern mathematical techniques and computers will yield only partial analytic solutions, mainly because of the uncertainties. These uncertainties often exist in the overall objective and, when broader contexts are being considered, it may be necessary to examine alternative objectives. We thus have the enlarged problem of first selecting the optimum objective and the associated optimum set of constraints.

The optimization process, therefore, provides the framework for a final decision. If the process is based on a correct formulation of the problem and application of a reasonable model, the decision can be critically evaluated and suitably modified. However, because of our present inability to employ a strictly analytical approach, the experience and judgment of management inherit responsibility for the final choice.

2.13.6 Conclusion

Ideally, the criteria for a decision should be explicitly stated so that there is no doubt concerning the acceptability and accuracy of a decision. In most cases, however, explicitness is impossible because of the uncertainties that prevail and because of limitations of available methods. For instance, a statement about the reliability of a device is meaningless unless a standard of measurement is given. Even if this standard is given, the statement would still be meaningless unless the methods for making the measurement were available. Uncertainties about the validity of the standard of measurement and the accuracy of the method, and about whether the criteria are proper in the first place, further complicate the establishment of decision criteria.

The appropriateness of decision criteria for military systems is a controversial point. The number of offensive weapons for a fixed cost, the number of targets destroyed for a fixed cost, the number of lives saved for a fixed cost -- which should be used? Selecting a particular criterion for lack of a better one can create serious problems if it is the wrong one. However, making decisions in the absence of criteria can also have harmful consequences. An understanding of the complexity of criteria is essential.

The normal criteria are those which result in maximum effectiveness for a given budget or a specified effectiveness at minimum cost. However, the absolute value of gain or cost must not be overlooked, as it would be in simply maximizing

the ratio of effectiveness to cost. The ratio of effectiveness to cost is not generally an adequate criterion for making a choice among competing systems.

The absence of a standard criterion does not preclude the analysis of cost-effectiveness. It means that as much information as possible on the system must be derived for consideration by the decision-makers. Although the information cannot be "wrapped up" into a single valid criterion, it can be displayed in a manner that facilitates its use in conjunction with the decision-maker's expert judgments. This requirement, however, places an additional burden on the analyst, since he must maintain a great deal of flexibility in his modeling to make his analysis adaptable to changing information requirements.

2.14 EVALUATE RESULTS AND FEEDBACK INFORMATION

The major function of the evaluation and feedback information process is to provide constant updating of previous inputs and analysis by using the information gained from the study process as it becomes available.

For example, it may become apparent after exercising the effectiveness model that the alternatives considered in the analysis are all extremely vulnerable to enemy action. At this point in the systems analysis/cost-effectiveness process, the analyst should re-examine the mission profiles, threats, and hardware characteristics to determine which factors are contributing to the high vulnerability. If the mission profiles are causing the high vulnerability to some avoidable tactic, this information should be fed back, to the decision-making level if necessary, so that the mission profiles can be checked for possible changes. If the threat appears to be causing the high vulnerability, the solution may be to go back and consider a new alternative system, or possibly change the performance requirements of the system. Other considerations to be included in the evaluation and feedback process are the following:

- Ensure that all assumptions and subjective judgments used in the analysis are identified. The major assumptions should be explicitly stated at the beginning of the study effort and, if feasible, examined at the decision-making level to determine if the assumptions are valid.
- Ensure that all the uncertainties that occur in the analysis are treated. The uncertainties of future threats, environments, and performance characteristics may have probabilities and confidence levels associated with them, and these should be explicitly stated.
- Examine the output at every stage in the systems analysis/cost-effectiveness process to determine if the result appears to be correct. Results that are intuitively unexpected may lead to a determination that some factor in the analysis was inadvertently omitted.

AMCP 706-191

- Include parametric treatment of assumptions and variables found to be sensitive. If the results of a study are sensitive to the assumption that a system will be in operation for say fifteen years, go back and recalculate for one, two, and five years on either side of fifteen.

2.15 OUTPUT RESULTS

Once the need for, and the absence of any suitable substitute for, the decision-making function is recognized, attention can be directed to the information requirements of the decision-maker. Preparing appropriate information and presenting it to the decision-maker are the functions of the analyst.

Essentially, analysis involves providing the best possible estimate of the effects of selecting various courses of action. The decision-maker must decide which set of effects he is most willing to accept. (He must also, of course, judge the validity of the estimates presented to him,)

One pitfall that must be avoided in the systems analysis/cost effectiveness process concerns the amount of detail the analyst presents to the decision-maker who uses the results of the analysis. The analyst must exercise extreme care to be sure that the decision-maker is aware of any relevant factors that were not considered in the analysis or that may have been obscured by the data-reduction process or by the analysis itself. In short, since data reduction and analysis involve some decisions, the analyst must be careful not to make decisions that more properly belong in the jurisdiction of the decision-maker.

It is emphasized that the systems analysis/cost-effectiveness process does not represent a decision; it is a process that concludes by presenting to the decision-maker, in a useful format, information and data that are essential to his making a proper decision. The array elements shown in Table 2-4 for each of three competing systems represent a set of data considered by the analyst to be important to the decision-maker. However, if the analyst attempts one additional step -- developing a single cost-effectiveness index from some or all of these data -- he may have made some decisions that should have been left to management. If, for example, the analyst decides that the index is, in essence, effectiveness divided by the product of cost and time, but that primary-mission effectiveness is five times as important as the secondary-mission effectiveness (Condition I), system B is apparently the preferred system. This would be indicated through the use of weighting factors; that is, K_1 and K_2 represent the weighted "importance" of the prime and secondary missions. In the example just given (Condition I) $K_1 = 5K_2$.

TABLE 2-4 ARRAY OF COST-EFFECTIVENESS CHARACTERISTICS								
Type	cost (C)			Effectiveness		Time to Deploy Years (T)	C-E (Condition I) (K ₁ = 5K ₂)	C-E (Condition II) (K ₁ = K ₂)
	R&D	Initial Investment	Operating	Prime Mission (E _p)	Secondary Mission (E _s)			
A	\$0.8M	\$10M	\$4M	0.90	0.70	2	0.0292	0.0270
B	0.7M	6M	2M	0.95	0.06	3	0.0306	0.0266
C	0.2M	14M	7M	0.70	0.90	1.5	0.0210	0.0251

Cost-Effectiveness (C-E) is defined for this example by the equation:

$$C-E = \frac{K_1 E_p + K_2 E_s}{(K_1 + K_2) C T}$$

For Condition I, K₁ = 5K₂

For Condition II, K₁ = K₂

Therefore for Condition I, the C-E of system A is calculated as follows:

$$\begin{aligned} C-E &= \frac{K_1 E_p + K_2 E_s}{(K_1 + K_2) C T} \\ &= \frac{5(.90) + 1(.70)}{(5 + 1) (14.8) (2)} \\ &= \frac{5.2}{177.6} \\ &= .0292 \end{aligned}$$

And the C-E of system A for Condition II is calculated as follows:

$$\begin{aligned} C-E &= \frac{K_1 E_p + K_2 E_s}{(K_1 + K_2) C T} \\ &= \frac{1(.90) + 1(.70)}{(1 + 1) (14.8) (2)} \end{aligned}$$

$$= \frac{1.6}{59.2}$$

$$= .0270$$

Therefore, if the analyst decides that primary mission effectiveness is five times as important as the secondary-mission effectiveness (Condition I), B is the preferred system. However, if the analyst decides that the primary and secondary missions are equally important (Condition 11), system A now appears to be the preferred system.

A favorite method for presenting the results of a cost-effectiveness study is a curve that is plotted using cost as the abscissa and effectiveness as the ordinate.

Certain conclusions can be drawn concerning the shape of this type of curve. In general, low slopes (a large gain in effectiveness for a small increase in cost) are the most desirable. Two examples are shown in Figure 2-13. Equipment A costs \$3,500 for an effectiveness of 95 percent. However, by a small increase in the cost, Equipment A can be given an effectiveness of 99 percent. Conversely, for Equipment B, unless there is a need for an effectiveness greater than 98 percent, no more than \$3,000 should be spent on this equipment.

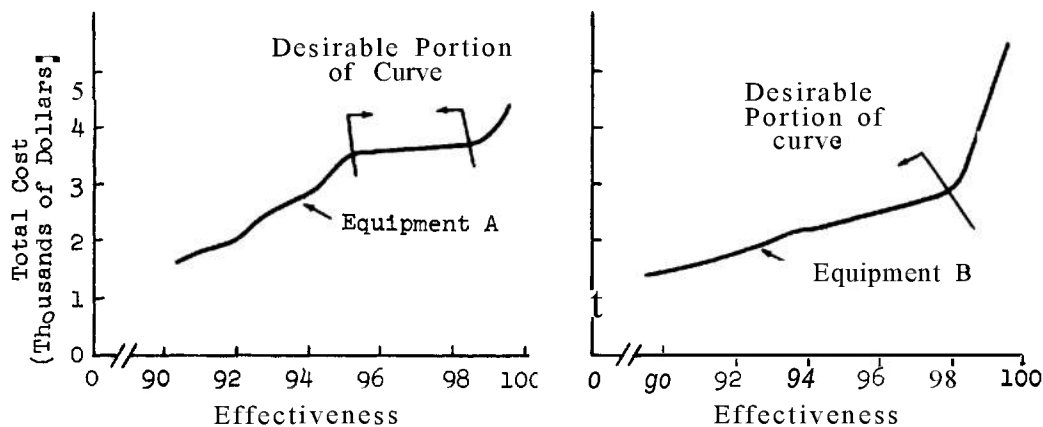

FIGURE 2-13
EXAMPLES OF COST-EFFECTIVENESS CURVES

The prime function of the system analyst is to provide the decision-maker with as much organized, relevant information as possible. However, this information does not automatically identify the preferred alternative, because a common value-measure cannot always be developed. In making such final selection, the decision-maker must also account for the limitations in the quantified analysis, such as data inadequacies, modeling assumptions, and uncertainty. The final selection, therefore, must be based primarily on the decision-maker's judgment, the information in the C-E array providing support for such judgment.

CHAPTER 3

TECHNIQUES

There are three broad classes of techniques that can be applied in systems-analysis and cost-effectiveness studies. The first class consists of techniques that are used to represent a system's behavior as a function of time -- usually in a statistical sense. This description is generally probabilistic in form and thus relies heavily on the theories of probability and statistics. Moreover, since the representations are often complex (both mathematically and physically), a computer is often required to manipulate or solve them.

Within this first class, there are four techniques that are generally applicable in the systems-analysis/cost-effectiveness process.

- Simulation
- Sequencing
- Queuing Theory
- Inventory and Replacement

The second class of techniques applicable to systems analysis/cost-effectiveness is concerned with finding optimal solutions, i.e., the maximization or minimization of some objective function within specified constraints. Within this class are the following techniques:

- Linear and Dynamic Programming
- Analytic Models
- Game Theory
- Decision Theory
- Information Theory

The third class of techniques consists of those statistical and mathematical tools used by the analyst to identify relationships among such system parameters as cost, performance, etc., and determine how critical the parameters are in the decision-making process. This class includes the following techniques:

- Estimating relationships
- Experience Curves
- Confidence Intervals
- Sensitivity Analysis

Table 3-1 lists the various techniques introduced above, indicates the general application of each one, and identifies the section in this guidebook in which the technique is discussed.

TABLE 3-1 SYSTEMS ANALYSIS/COST-EFFECTIVENESS TECHNIQUES						
Technique	Applications					
	Inter- and Intra-System cost-Effectiveness Comparisons	Selection of Optimum Mixes	System Effectiveness Studies	cost Studies	Identification of Critical Parameters and System Problem Areas	Location in Guide Book
Simulation		X		X	X	3.1
Queuing Theory		X			X	3.2
Sequencing and Markov Processes		X			X	3.3
Inventory and Replacement	X	X		X		3.4
Linear and Dynamic Programming	X	X		X		3.5
Game Theory	X	X			X	3.6
Information Theory	X	X				3.7
Analytic Models	X	X		X		3.8
Decision Theory	X	X				3.9
Cost-Estimating Relationships and Confidence Intervals	X			X	X	3.10
Experience Curves	X			X		3.11
Cost-Sensitivity Analysis	X			X	X	3.12

3.1 SIMULATION

A simulation is a model (usually computer) that duplicates a system's behavior without actually employing the system.

A simulation can be employed in many types of systems analysis. Some of the more important areas and circumstances are:

- Environmental problems
- Mathematical formulation
- Lack of analytical solution technique
- Experimental impossibility -- e.g., large-scale conflict
- cost
- Time
- Training

Simulations can be either analog or digital, and both have been applied to a host of problems. Within the set of simulations are several other concepts such as Monte Carlo, Gaming, Training Devices, and Model Sampling.

Analog simulations are most often used as a means of solving sets of differential equations or problems dealing with continuous functions. Generally, the systems analyst is more likely to encounter digital simulations in the exercise of his studies.

The question might properly be asked: how is a digital simulation of a complex system obtained, say, for a forward-area air-defense problem? The following steps are necessary:

- (1) The characteristics of the offense, defense, and environment are determined.
- (2) A general flow diagram for the simulation is developed -- for example, the flow between the threat, detection and tracking radars, and the intercepting missile.
- (3) Detailed flow diagrams and submodels are developed -- for example, the method of computing the lock-on probability for the tracking radar.
- (4) Space and time coordination are developed throughout the simulation for each simulation element.
- (5) Statistical sizes and constraints are determined.
- (6) Inputs are incorporated.
- (7) The simulation model is exercised.

An important aspect of Monte Carlo game simulations is the Design of Experiments for testing numerous variables and reducing output variance while reducing the required sample size. A formal branch of statistics is devoted to this problem.

The applications of simulation techniques are manifold. They range from strategic or tactical operations to management, to simply system operation. They provide a means by which the analyst can handle large numbers of variables, mathematically intractable relationships, and, most important, uncertainties and alternative steps.

3.2 QUEUING THEORY

Queuing problems may develop whenever there are demands for service from a number of more or less independent sources. Queuing theory is a technique, based on probability theory, that supplies a means for mathematical analysis of this class of problems.

AMCP 706-191

Examples of queuing (or waiting line) situations are message flow in a communications center, customer servicing at a repair facility, and flow of traffic through a bottleneck. Many factors must be considered in the analysis of queuing problems. Among these are*:

- The probability distribution underlying arrival times
- The probability distribution underlying servicing times
- The number of waiting lines
- The number of servicing facilities
- The queue discipline

With knowledge of these factors, the analyst can often predict such important results as the average length of the waiting line and the average idle time for a service facility during any specified time interval.

The utility of this method can be demonstrated by an example. Messages arrive at a communications center on the average once every 10 minutes and with Poisson distribution:

$$P_T(n) = \frac{(\lambda T)^n e^{-\lambda T}}{n!}$$

The service times for processing the messages are assumed to be exponentially distributed $[p(t_s) = \mu e^{-\mu t}]$ with means of 3 minutes,

The questions to be answered are:

- (1) What is the average number of messages in the communications center?
- (2) What is the average length of the queue that may form?
- (3) Assuming that another message clerk will be put on when a message would have to wait at least 3 minutes before being processed, what higher rate of arrivals can be tolerated before another man must be assigned?

For this particular type of a queue the following relationships can be derived by means of queuing theory:

- Average number of messages in the communications center = $\frac{A}{\mu - \lambda}$,

where

A = average arrival rate = 0.1 per min.

μ = average service rate = 0.33 per min.

*Reproduced by permission from NAVAL OPERATIONS ANALYSIS; Copyright 1968 by the U. S. Naval Institute, Annapolis, Md., p.238.

- Average length of "non-empty" queues = $\frac{\mu}{\mu-\lambda}$
- Average waiting time = $\frac{A}{\mu(\mu-\lambda)}$

The answers to the three questions posed, then, are:

- (1) Average number of messages in the system = $\frac{0.1}{0.33-0.1} \approx 0.43$ messages
- (2) Average length of non-empty queue = $\frac{0.33}{0.33-0.1} = 1.43$ messages
- (3) Tolerable arrival rate = $\frac{A'}{0.33(0.33-\lambda')} = 3-\lambda' = 0.16$ messages per minute
or
10 messages per hour

To obtain some insight into the underlying theory, consider the simplest case -- that of the single-server queue with Poisson arrivals, just discussed. The number of units in the system is found by developing recursion relationships, which are governed by the previously cited factors.*

Let n = the total number in the system (the number being serviced plus the number in the queue), and P_n = the probability of there being n units in the system. Assume that the queue discipline is such that an arrival moves immediately into the service area if the area is vacant.

The probability of an arrival in a small time increment, Δt , is $\lambda \Delta t$.

The probability of a serviced unit leaving in the interval $t, t + \Delta t$ is:

- 0 if no units are in the system at t
- $\mu \Delta t$ if there are one or more units in the system at t

The probabilities of more than one arrival or service, or both, occurring in the interval are taken to be zero since they are proportional to Δt^2 or higher.

Consider the following two conditions:

- (1) 0 units in system at $t + \Delta t$
- (2) 0 units at time t , no arrivals in $\Delta t + 1$ unit at t and 1 service completed in Δt

These two events are equivalent and thus their probabilities of occurrence must be the same.

Thus $P_0 = P_0 (1 - \lambda \Delta t) + P_1 \mu \Delta t$, or $P_1 = \frac{\lambda}{\mu} P_0$

*M. Sasiени, et. al., Operations Research -- Methods and Problems, John Wiley and Sons, Inc. 1959, p. 128.

AMCP 706-191

To obtain P_2 , apply the same procedure; the result is:

$$P_1 = P_1 \left[1 - (\lambda + \mu) \Delta t \right] + P_0 (\lambda \Delta t) + P_2 (\mu \Delta t)$$

or

$$P_2 = \frac{\lambda + \mu}{\mu} P_1 - \frac{\lambda}{\mu} P_0 = \left(\frac{\lambda}{\mu} \right)^2$$

This can then be generalized to

$$P_n = \frac{\lambda + \mu}{\mu} P_{n-1} - \frac{\lambda}{\mu} P_{n-2}; \quad n \geq 2$$

and, by induction, this can be written as

$$P_n = \left(\frac{\lambda}{\mu} \right)^n P_0; \quad n \geq 0$$

However,

$$\sum_{n=0}^{\infty} P_n = 1$$

so that

$$P_0 = 1 - \sum_{n=1}^{\infty} P_n$$

but

$$\sum_{n=1}^{\infty} P_n = 1 - \frac{\lambda}{\mu}$$

Thus

$$P_n = \left(1 - \frac{\lambda}{\mu} \right) \left(\frac{\lambda}{\mu} \right)^n$$

Once the P_n are determined, relationships such as those used in the previous example can be found. As the arrival and service distributions become more complicated, the number of waiting lines and service facilities increases, or the queue discipline becomes more complex, and the associated mathematics becomes correspondingly more difficult.

When the mathematics becomes too complex for a closed analytical solution or too costly, the approach employed is Monte Carlo. To illustrate, consider the simple case of two sequential service facilities, each performing to some known but not necessarily simple distribution. Similarly, the arrivals have some known but not necessarily simple distribution. For simplicity, again assume the same queue discipline as previously. The desired answer is the expected

time spent in the system. By applying Monte Carlo techniques to the three distributions for each item in the system and keeping track of where the item is throughout the system, the time each item spends in the system can be determined and, by simple averaging, the resulting expected time in the system can be ascertained (subject, of course, to statistical confidence requirements).

In this manner, highly complicated systems with many paths and serving points, varied distributions, and queuing disciplines can be analyzed.

3.3 SEQUENCING AND MARKOV PROCESSES

Sequencing is related to the order in which units requiring servicing are serviced. It applies to a class of problems in which the measure of effectiveness is a function of the sequence or order in which a number of tasks are performed. Sequencing problems fall into two groups*: (1) performing n tasks, each of which requires processing on some or all of m different machines; and (2) processing a list of n tasks with m machines, with the decision of the $n+1$ task being made at the completion of the n^{th} task.

Unfortunately, both types of problems are exceedingly difficult; at present, solutions are known only for some special cases of the first type.

A classical example of the sequencing problem is the "Traveling Salesman" problem in which the salesman must visit a series of locations, stopping at each location only once and returning to his starting point at the conclusion of his travels. An analogous operations problem is the selection of messenger routes within a division.

A further potential application is to use sequencing as a management tool in the development of a complex system requiring numerous tasks with various facilities or resources. The objectives are to determine the optimum use of the facilities through proper sequencing of the tasks performed.

To illustrate the technique, consider a messenger-route problem in which five stops are to be made and the requirement is to find the route involving the minimum total distance to travel**. For this type of problem there are $(n-1)!$ subsets that must be searched for a solution -- in this case, $4!$ or 24.

This problem could also be viewed as an allocation problem, but complicated with the added constraint that the messenger must not pass the same point twice.

* Ibid, p. 250.

**Ibid, p. 264.

AMCP 706-191

From \ To	A	B	C	D	E
A	∞	2	5	7	1
B	2	∞	3	8	2
C	5	3	∞	4	7
D	7	8	4	∞	5
E	1	2	7	5	∞

Assume the distance matrix on the left, where the entries (R's) represent the distances from point to point. (Note: the $R_{1j} = R_{j1}$, though in general cases this need not be so. Also, the R_{kk} 's have been assigned infinite values to remove them from the problem.)

To obtain a solution, first manipulate the matrix as follows:

		Rows				
∞	1	4	6	0		
0	∞	1	6	0		
2	0	∞	1	4		
3	4	0	∞	1		
0	1	6	4	∞		

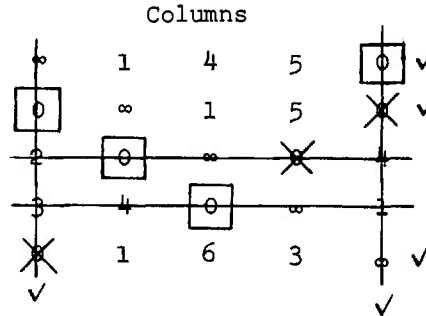

This is accomplished by the following steps:

- (1) Identify zeros and introduce additional zeros.
- (2) Mark unassigned rows.
- (3) Mark columns having zeros in marked rows.
- (4) Mark rows having assignments in marked columns.
- (5) Repeat (3) and (4).
- (6) Draw line through unmarked rows.
- (7) Draw line through marked columns.
- (8) Select smallest unmarked element; add it to intersections; subtract from unmarked.

The smallest value is 1, and the new matrix is as follows:

∞	0	3	4	✓
✓	∞	✓	4	0
3	✓	∞	0	5
4	4	0	∞	2
0	✓	5	2	∞

Identify zeros (the allocation problem has now been solved). Check the sequence: A - B - E - A (No route solution).

Try the next best solution by expanding about the smallest non-zero element, which is 2.

∞	0	3	4	0
4	∞	0	4	0
3	0	∞	0	5
4	4	0	∞	2
0	0	5	2	0

The sequence is now A - B - C - D - E - A, at a cost of 2 miles above the minimum allocation. This is a valid solution. The length of the route is then $2 + 3 + 4 + 5 + 1 = 15$ miles. (Note if the expansion had been performed about the other 2 element, it would have merely reversed the order.) This solution is a minimum route.

The behavior of a system that has discrete states with probabilistic transitions among the states can be represented by what is known as a Markov process -- a conditional process in which the next transition depends on the state the system is in and, for some types of process, on the n preceding states as well. In this sense, it is similar to sequencing. However, the goal here is to describe the system's behavior statistically in terms of its transitions and its ability while in each state.

3.4 INVENTORY AND REPLACEMENT

Inventory can be defined as the physical stock of goods kept on hand by an organization to promote the efficient running of its affairs. The costs associated with maintaining an inventory are normally placed in three categories:

- (1) The cost of ordering goods
- (2) The costs of holding goods in inventory
- (3) The costs of incurring shortages

The problem facing the decision-maker is twofold:

- (1) How often should he replenish?
- (2) How much should he replenish?

Inventory-control theory is a mathematical approach to finding the optimum re-order time and quantity and is usually based on the values that will minimize the overall cost of maintaining the inventory.*

*Reproduced by permission from NAVAL OPERATIONS ANALYSIS; Copyright 1968 by the U. S. Naval Institute, Annapolis, Md., p.240.

AMCP 706-191

The system can thus be thought of as consisting of outputs (demands for the goods) and inputs (replenishment of the goods).

Input and output can be described in terms of their respective rates $a(t)$ and $b(t)$, and the inventory level at any time t is simply

$$I(t) = I_0 + \int_0^t [a(t) - b(t)] dt$$

The input and output rates do not necessarily have to be finite but their time integrals must be finite.

The Inputs and outputs are critical factors in solving inventory problems. Most inventory models include one of the three types of assumptions regarding these:

- (1) Continuous in time
- (2) Discrete and equidistant in time
- (3) Discrete and irregular in time

The inventory problem is also classified in terms of the amount of knowledge regarding these factors; i.e., the factors are either known and hence deterministic, or unknown and hence probabilistic.

Further, if the parameters are constant with time, the problem is said to be static; if they are not, the problem is dynamic, with corresponding increases in mathematical difficulty.

The inventory system itself may be complex, with various stations (series and parallel) and various levels. In addition, the links between stations can vary in form (single, alternative, fusion). Taken as a whole, the system can be considered analogous to a network.

A final consideration to be discussed concerning inventory models is the delay factor between re-order and replenishment. The principal difference that results from including the delay is that further depletion of inventory between the decision and the arrival of replacements must be considered.

To illustrate the technique, consider the simple example* of a single station that has a uniform demand rate $b(t) = B$ units per unit time. Units are re-ordered every T days and the re-order cost is C . There is no appreciable delay in filling orders, so that the practice is to re-order whenever the inventory is zero.

*Sasieni, op. cit., p. 71.

The cost of inventory is assumed to be proportional to the number of units held and the length of time they are held. Thus the Inventory cost here is C_1IT , where C_1 is the unit holding cost per unit time and I is the amount in the inventory. The amount reordered every T must be BT , and the Inventory holding costs are thus

$$C_T = C_1 \int_0^T I dt = C_1 B \int_0^T (rT - bt) dt = \frac{1}{2} C_1 BT^2$$

The average total cost per unit time is

$$C_T = \frac{1}{2} C_1 BT + \frac{C_r}{T}$$

For a minimum cost, differentiate with respect to T and equate to zero:

$$\frac{dC_T}{dT} = \frac{1}{2} C_1 B - \frac{C_r}{T^2} = 0$$

or

$$T = \sqrt{\frac{2C_r}{C_1 B}} \text{ days}$$

The quantity to be re-ordered is then

$$Q = BT = \sqrt{\frac{2BC_r}{C_1}}$$

and the minimum average total cost is

$$\begin{aligned} C_T &= \frac{1}{2} C_1 B \sqrt{\frac{2C_r}{C_1 B}} + \frac{C_r}{\sqrt{\frac{2C_r}{C_1 B}}} \\ &= \sqrt{\frac{C_1 B C_r}{2}} + \sqrt{\frac{C_1 B C_r}{2}} \\ &= \sqrt{2C_1 B C_r} \end{aligned}$$

Replacement theory is concerned with situations in which system performance deteriorates with time and the system can be restored to its initial condition through some kind of action. The problem is to determine when these actions should be taken.

AMCP 706-191

3.5 LINEAR AND DYNAMIC PROGRAMMING

3.5 .1 Linear Programming

Linear programming is used to determine the values of a set of variables in a linear equation that produce an extrema in the objective while the variables are subject to a set of linear constraints.

Linear programming problems generally fall into two categories, assignment and transportation, although the latter is actually a generalization of the former. Assignment problems generally deal with distribution between a number of alternatives in such a manner as to maximize or minimize the total worth or objective. Transportation problems generally deal with routing of units between a number of sources and receivers in such a manner as to maximize or minimize the worth of the operation.

However, the problems need not concern only assignment or transportation for linear-programming techniques to be applied. Any problem that can be formed as optimizing a linear expression subject to linear constraints can be treated.

A mathematical representation of the linear-programming problem is simply

$$M_{\max} = \sum_{n=1}^N a_n x_n$$

subject to

$$x_n \geq 0 \text{ and}$$

$$\sum_{n=1}^N b_{mn} x_n \leq d_m; \quad m=0, 1, \dots, M$$

There are a number of variations in forming these relationships, such as the direction of the inequality and whether the purpose is maximizing or minimizing.

A number of techniques have been developed for solving linear-programming problems. Two of these, one graphical and one analytical, are treated below.

Consider the problem of two types of helicopters, A and B, and the following circumstances:

- Type A carries 30 troops; B carries 20 troops.
- There are fifty pilots available.
- Type A requires two pilots; B requires one pilot.
- There are 40 of the A-type helicopter and 20 of the B type.
- The objective is to move the maximum number of troops.

The above statements can be changed into the following mathematical expression:

Maximize $30X_A + 20X_B$ are the number of the types A and B used, subject to the following constraints:

- (1) $2X_A + X_B \leq 50$
- (2) $X_A \leq 40$
- (3) $X_B \leq 20$

First consider the graphical solution shown below.

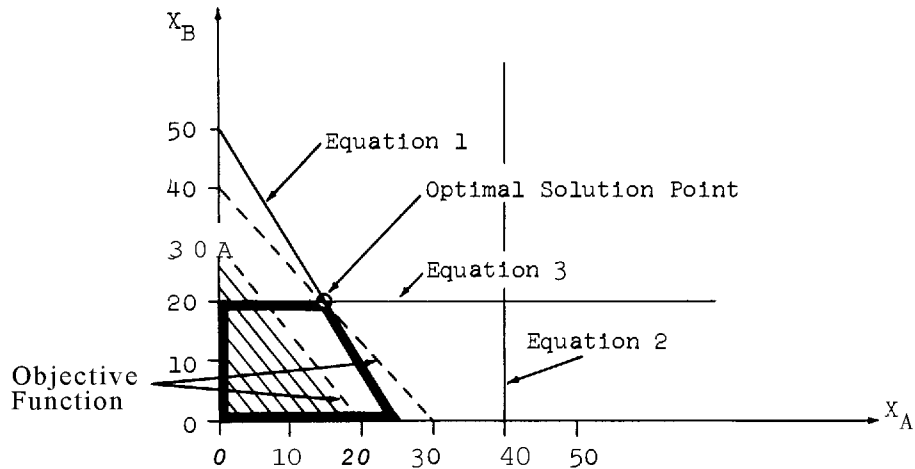

The procedure followed to find the optimal solution is as follows:

- Plot inequalities - Equations 1, 2, and 3.
- Note region allowed by each - inside crosshatched lines.
- Note solution region.
- Plot objective function.
- Move objective function (parallel to itself) away from the origin.
- Note maximum distance point (last point in the solution region that the objective function touches).

The solution here is to use 20 of B, 15 of A.

It should be noted that constraint number 2 could have been neglected without changing the solution in this example.

The graphical method is a quick and easy method for solving linear-programming problems, provided there are only two variables. For three or more variables, analytical techniques are required because the solution space is no longer two-dimensional.

AMCP 706-191

The analytic technique described here is the simplex technique. The theory behind it is complicated, but the application is relatively simple, although tedious. (The technique is readily programmed for solution by computers.)

To solve the sample problem, it is first necessary to write the system of inequalities (constraint equations) as equalities, by introducing a set of slack variables -- S_1 , S_2 , and S_3 :

$$2X_A + X_B + S_1 = 50 \quad (1)$$

$$X_A + S_2 = 40 \quad (2)$$

$$X_B + S_3 = 20 \quad (3)$$

Then, rewrite the objective function as

$$-30X_A - 20X_B + M = 0 \quad (4)$$

where M represents the term to be maximized.

Now construct a matrix of the coefficients of Equations 1 through 4:

<u>X_A</u>	<u>X_B</u>	<u>S_1</u>	<u>S_2</u>	<u>S_3</u>	<u>M</u>	<u>N</u>	
2	1	1	0	0	0	50	
1	0	0	1	0	0	40	
0	1	0	0	1	0	20	
-30	-20	0	0	0	1	0	← Objective Row
					↑		Objective Column

Designate the M column **as** the objective column and the last row (objective function) as the objective **row**. A feasible solution **is** present when at least two of the columns; other than the M and N columns, contain exactly one 1 and **all** the other entries are zeroes and all the 1's are not in the same rows.

For the matrix shown, there is a feasible solution: $S_1 = 50$, $S_2 = 40$, $S_3 = 20$, thus making X_A , X_B , $M = 0$. However, this is not the optimum solution; i.e., no troops are moved.

To check whether the solution is optimum, examine the objective row to **see** if there are any negative entries. If there are no negative entries, the solution is the optimum one. In this case, there is a -30 and a -20; thus the solution is not optimum, and the following procedure is carried out:

- (1) Determine the most negative element in the objective row and identify its column (the X_A column in this problem).

- (2) Divide each positive element in the selected column into its corresponding row value in the N column.
- (3) Circle the element producing the smallest ratio (the element 2 in the X_A column, which has a ratio of 25). This is known as the "pivot" number.
- (4) Next normalize the pivot number and make all other entries in the pivot column zero. This is done by first dividing every element in the pivot row by the pivot number to obtain a new, normalized pivot row. Second, for each other row, multiply the normalized pivot row by the negative of the corresponding pivot-column element, and add the two rows to obtain a new row having a zero in the corresponding position in the pivot column.

For this problem, the normalizing is accomplished by dividing the pivot row by two, then multiplying the new pivot row by -1 and adding element by element, to row 2 to obtain a new row 2. Row 3 is already 0 in the pivot column, therefore, nothing has to be done to it. Finally, multiply the normalized row by 30 and add it to row 4. The resulting matrix is as follows:

X_A	X_B	S_1	S_2	S_3	M	N
1	$\frac{1}{2}$	$\frac{1}{2}$	0	0	0	25
0	$-\frac{1}{2}$	$-\frac{1}{2}$	1	0	0	15
0	1	0	0	1	0	20
0	-5	15	0	0	1	750

This procedure is repeated until there are no longer negative entries in the objective column, and the resulting solution is optimal.

The next pivot element is row 3, X_B column. The resultant matrix is as follows:

X_A	X_B	S_1	S_2	S_3	M	N
1	0	$\frac{1}{2}$	0	$-\frac{1}{2}$	0	15
0	0	$-\frac{1}{2}$	1	$-\frac{1}{2}$	0	25
0	1	0	0	1	0	20
0	0	15	0	5	1	850

Since there is no longer a negative element in the objective row, the solution is optimal and equal to $X_A = 15$, $X_B = 20$, and $M = 850$.

A necessary condition for the formulation of linear programming problems is a linear set of objective functions and constraints. However, there are many situations in systems analysis -- when one or more of the functions are expressed as a product equation in the variables -- in which this technique can be applied

AMCP 706-191

but not all the equations are linear. This often occurs when kill probabilities of targets are being determined. In such a case, the equation is linearized by converting to the logarithm of the function and optimizing on the log (which is monotonic to its antilog).

To illustrate, consider the case in which there are two types of weapons and three types of targets, with P_{ij} being the kill probability of the j^{th} target type by the i^{th} weapon type. The objective is to determine the allocation of weapons to targets to maximize kill probability for at least one target. This is the same as minimizing the probability of not killing any target. Let P denote this probability. Thus

$$P = (1-P_{11})^{N11} (1-P_{12})^{N12} (1-P_{13})^{N13} (1-P_{21})^{N21} (1-P_{22})^{N22} (1-P_{23})^{N23}$$

Taking the logarithm results in

$$\text{Log } P = \sum_{\substack{i=1 \\ j=1}}^{\substack{i=2 \\ j=3}} N_{ij} \text{Log } (1-P_{ij}) = - \sum_{\substack{i=1 \\ j=1}}^{\substack{i=2 \\ j=3}} N_{ij} Q_{ij}$$

This can be minimized by maximizing $\text{Log } \frac{1}{P} = -\text{Log } P$. Thus the objective function is to maximize

$$\text{Log } P = \sum_{\substack{i=1 \\ j=1}}^{\substack{i=2 \\ j=3}} N_{ij} Q_{ij}$$

subject to the constraints cited.

3.5.2 Dynamic Programming

In dynamic programming, there are no restrictions on the set of equations, nor are there any general algorithms for problem solution. Dynamic programming was developed as a means of studying decision processes and determining the sequence of decisions that results in optimizing a predetermined objective function.

In defining this sequence, Bellman* (who is the originator of this method) set forth a principle of optimality stating that an optimal policy was one which insured that each decision, in the sequence of decisions was the optimum decision with respect to the conditions resulting from the prior decisions.

Some recent applications of dynamic-programming techniques include:

- . Determining thrust-control policies and fuel consumption regimes for putting satellites into specified orbit altitudes with maximum horizontal components of velocity

*Bellman, R., Dynamic Programming, Princeton University Press, Princeton, N.J., 1957.

- Determining optimum staging ratio for missiles (how many booster stages of what sizes result in most efficient missiles)
- Establishing optimum inventory control schemes for interacting inventories at different locations

In summary, dynamic programming selects the optimum sequence of decisions to establish a policy that will bring a maximum return.

3.6 GAME THEORY

Game theory is a mathematical theory of decision-making by contestants with various strategies. Originally, it was developed to handle business and economic problems; however, it has found extensive application in military systems and operations analysis.

The theory is defined as a mathematical demonstration that if opposing interests act rationally to achieve desired ends that can be set forth validly in a numerical scale of expected returns, returns that vary according to the success of various plans, the appropriate strategy for each side can be deduced mathematically.*

The following terms are used in discussing game theory:

- Game -- the set of rules that define what can or cannot be done, the size of the bets or penalties, and the payoff methods
- Play of the Game -- one complete run through the game, including payoffs
- Zero-Sum Game -- a game in which the gains of one side equal the losses on the other
- Strategy -- a plan of action that is complete and ready to use before the game commences
- Person - one of the opposing interests
- N-Sided Game -- N opposing persons
- Pure Strategy -- a decision always to follow a particular course of action
- Mixed Strategy -- a decision to choose a course of action for each play in accordance with some probability distribution
- Value -- the expected gain in one play of the game with all players using stable optimum strategies

A competitive game has several characteristics worth noting**:

- There is a finite number of persons.
- Each person has a finite set of strategies.

*Reproduced by permission from NAVAL OPERATIONS ANALYSIS; Copyright 1968 by the U. S. Naval Institute, Annapolis, Md., p.30.

**Sasieni, op.cit., p.156.

AMCP 706-191

- . Strategy choices are made simultaneously.
- . There is an outcome of a play that determines a set of payoffs to each player.

The simplest game is the two-person/zero-sum game. This game is illustrated by a problem in which the commander of a unit is planning to employ a communication system and he has four candidate systems, while the enemy commander has five types of jamming equipment to employ. The payoff for each combination of communication system/jammer is measured in terms of the expected error probability. The problem is to select the strategy to be employed by each commander. Assume that through analysis the following payoff matrix was determined:

Communication System \ Jamming System	Jamming System					Maximum Error
	I	II	III	IV	V	
A	0.1	0.7	0.8	0.6	0.4	0.8(III)
B	0.4	0.5	0.6	0.3	0.3	0.6(III)
C	0.8	0.6	0.7	0.7	0.1	0.8(I)
D	0.4	0.4	0.8	0.8	0.2	0.8(III)
Minimum Error	0.1(A)	0.4(D)	0.6(B)	0.3(B)	0.1(C)	

The commander's objective is to select the strategy that gives him the minimum error probability, while the opposition desires to choose the strategy that maximizes the error probability.

The approach taken is to examine each communications strategy and determine which results in the poorest return, thus reflecting the poorest expected return. This information is shown to the right of the matrix. Similarly, each jamming strategy is examined for its worst case, and the values are shown below the matrix.

Each commander then selects the best of his worst solutions as a strategy (circles appropriate values). Thus, in the rows, look for a Min-Max solution and in the columns, a Max-Min solution.

From the matrix observe that communications system B and Jammer system III would be chosen.

Note that in this case both strategies are defined by the same element. Such a solution is known as a Saddle Point, and the resulting strategies as Pure Strategies. The value of the game is 0.6, and if either side uses a different strategy, his expected return will be reduced (in this case the error probability would increase to the communicator or decrease to the jammer).

If no Saddle Point occurs, the best strategies are mixed strategies, and the game solution is the set that maximizes the expected return. To illustrate

this, consider the same problem as above, but with the (B, III) element changed to say, 0.1. The new matrix is as follows:

Communication System \ Jamming System	I	II	III	IV	V	Maximum Error
A	0.1	0.7	0.8	0.6	0.4	0.8(III)
B	0.4	0.5	0.1	0.3	0.3	0.5(II)
C	0.8	0.6	0.7	0.7	0.1	0.8(I)
D	0.4	0.4	0.8	0.8	0.2	0.8(III, IV)
Minimum Error	0.1(A)	0.4(D)	0.1(B)	0.3(B)	0.1(C)	

From the matrix observe that system B represents the optimum strategy and jammer II represents the best counter-strategy. However, there is no Saddle Point; hence, pure strategies no longer exist.

The first step to the solution of this problem is to try to reduce the dimensionality of the game. It can be seen that no strategy dominates within the rows. However, within the columns, column IV dominates column V in every row. Hence, column V is dropped from further consideration. Of the remaining matrix, row B is now seen to dominate row C. Carrying the elimination procedure to its limit results in the following:

	II	IV
B	0.5	0.3
D	0.4	0.8

Now let $X = (x_B, x_D)$ and $Y = (y_{II}, y_{IV})$ equal the optimum mixed strategies of the two sides.

The gain is now a random variable, g , and the expected value to each side is

$$E(g; x, y) = \sum_{1j} a_{1j} x_1 y_j$$

$$E(-g; x, y) = \sum_{1j} (-a_{1j}) x_1 y_j$$

Let V_1 and V_2 represent the expectation of each side, which is to be optimum.

AMCP 706-191

Thus strategies must be chosen so that:

$$E(g_1; X_0, Y) \leq V_1 \text{ given } X_0 \text{ is optimum communication system strategy}$$

$$E(-g; X, Y_0) \leq V_2 \text{ given } Y_0 \text{ is optimum jammer system strategy}$$

Since the game is zero-sum, $V_1 = -V_2$ and $E(g; X_0, Y_0) = V$, which means that if both sides use their optimal Min-Max strategies, their achieved gains coincide with their Min-Max expected gains (or in this case their maximum) is being minimized.

Thus

$$E(g; X_0, Y) \leq V$$

$$E(g; X, Y_0) \geq V$$

Substituting for the expected payoffs yields

$$Y_{II}(0.5X_B + 0.4X_D) + Y_{IV}(0.3X_B + 0.8X_D) \leq V$$

$$X_B(0.5Y_{II} + 0.3Y_{IV}) + X_D(0.4Y_{II} + 0.8Y_{IV}) \geq V$$

In addition,

$$X_B + X_D = 1$$

$$Y_{II} + Y_{IV} = 1, \text{ and}$$

$$X_i \text{ and } Y_i \geq 0$$

The above inequalities imply the following relationships:

$$0.5X_B + 0.4X_D \leq V$$

$$0.3X_B + 0.8X_D \leq V$$

$$0.5Y_{II} + 0.3Y_{IV} \geq V$$

$$0.4Y_{II} + 0.8Y_{IV} \geq V$$

Thus there are five unknowns and ten relationships. Not all elements can be zero, but it is possible for equalities to hold in the four Inequalities.

Thus

$$0.5X_B + 0.4X_D = V$$

$$0.3X_B + 0.8X_D = V$$

$$0.5Y_{II} + 0.3Y_{IV} = V$$

$$0.4Y_{II} + 0.8Y_{IV} = V$$

$$x_B + x_D = 1$$

$$y_{II} + y_{IV} = 1$$

Solving this system leads to

$$x_B = 2/3$$

$$x_D = 1/3$$

$$y_{II} = 5/6$$

$$y_{IV} = 1/6$$

Thus by using communications set B two-thirds of the time and set D the remainder, the commander will realize a payoff of 0.467, whereas if he were to have stayed with his best pure strategy, he would have been sure of no better than 0.5. Similarly, by jamming with jammer number II five-sixths of the time and jammer IV the remainder, the enemy is assured of a payoff of 0.467, whereas by following his pure strategy, he would not have been sure of doing better than 0.4.

Games with large matrices are often tedious to solve by use of the technique just described. However, it is relatively simple to obtain an approximation of the exact solution*

Consider the reduced matrix of the sample problem:

	II	IV								
B	0.5	0.3	0.3	0.8	1.3	1.8	2.3	2.8	...	→ 2/3
D	0.4	0.8	0.8	1.2	1.6	2.0	2.4	2.8	...	→ 1/3
	0.5	0.3								
	0.9	1.1								
	1.3	1.9								
	1.7	2.7								
	2.1	3.5								
	2.5	4.3								
	.	.								
	.	.								
	↓ ↓									
	3/6	1/6								

*Sasieni, op. cit., p. 170.

AMCP 706-191

Solution rules are as follows:

- (1) Select the row and place under matrix (0.5, 0.3).
- (2) Circle smallest value in the row and write corresponding column to right of the matrix (0.3, 0.8).
- (3) Circle largest value in column and write corresponding row and add to last row*
- (4) Circle smallest value in row and write corresponding column and add to last column*
- (5) Repeat process N times.

The approximate strategies after N iterations are then the number of circled values divided by N for each choice.

Solving this system leads to the following values:

$$\begin{array}{ll} \tilde{x} & = 0.667 & x_B & = 0.667 \\ \tilde{x}_D & = 0.333 & x_D & = 0.333 \\ \tilde{y}_{II} & = 0.723 & y_{II} & = 0.833 \\ \tilde{y}_{IV} & = 0.277 & y_{IV} & = 0.167 \end{array}$$

Note that the values are of the right order, but their convergence is not particularly rapid.

The upper and lower bounds for the game can be determined by dividing the highest number in the last column (8.4 after 18) by the number of iterations, and by dividing the lowest number in the last row (8.3 after 18) by the number of iterations. Thus, for this example, the value is

$$0.45 \leq v \leq 0.468$$

while the predetermined answer was $v = 0.467$.

As the number of sides, the number of moves per play, and the dimensionality increase, the complexity of the game solution increases correspondingly.

3.7 INFORMATION THEORY

Information theory is a relatively new tool to the systems analyst. Its initial and most frequent applications have, of course, been in communication system problems. However, it has received other application in such diverse areas as missile-guidance and maintenance-reporting-system analyses.

*Settle ties by choosing the opposite value from preceding time.

In general, the theory can be applied to any situation in which there is uncertainty to be reduced or, more particularly, where there is a source that has uncertainty connected to an information sink by a channel that may perturb the source outputs.

Thus "information", as used here, does not represent a body of data, but merely the amount of uncertainty that has been reduced.

A possible application of information theory is to measure effectiveness for a communication system, i.e., how much information is conveyed by the system, or how fast it is conveyed.

For a quantitative treatment of this Subject, several concepts must be defined. First, information is defined as being expressed in M-airy units, given by $I = -\text{Log}_M P_i$, where P_i is the probability of having selected message i from a source containing m symbols. The most frequently used case is the binary, in which there are two symbols -- (1, 0). Thus for a message consisting of a single symbol, the information is expressed in binary units and written as

$$I = \text{Log}_2 P_i$$

For example, the information conveyed by flipping a legitimate coin is

$$I = -\text{Log}_2\left(\frac{1}{2}\right) = 1 \text{ bit,}$$

while the information conveyed by a two-headed coin is

$$I = -\text{Log}_2(1) = 0 \text{ bits;}$$

i.e., the outcome is known in advance.

An important concept in the study of information is that of entropy; simply stated, this is the average uncertainty of a source or message. Thus

$$H = \sum_i I_i P_i = - \sum_i P_i \text{Log}_m P_i$$

To illustrate, consider the entropy continued in a two-digit message (binary) having the following message-population distribution:

<u>Message</u>	<u>Probability of Sending</u>
11	1/2
01	1/8
10	1/8
00	1/4

AMCP 706-191

Thus

$$H = \frac{1}{2} \text{Log}_2 2 + \frac{1}{8} \text{Log}_2 8 + \frac{1}{8} \text{Log}_2 8 + \frac{1}{4} \text{Log}_2 4 = 1 \frac{3}{4}$$

bits of information on the average is transmitted by a message from this source.

It can be proved that the maximum entropy is achieved when all of the messages are equally likely. Further, when the symbols are independent with the same distributions, the entropy of a message of length n is n times the entropy of a single symbol.

The next concept to be defined is that of a channel. A channel is described by an input alphabet A and an output alphabet B and a set of conditional probabilities $[P(B_j|A_i)]$, termed the channel matrix, that are the probabilities of receiving message B_j given A_i was sent.

To illustrate, consider a simple binary source having a symmetric channel -- that is, the probability of an error's being introduced on a one is the same as the probability of its being introduced on a zero. Symbolically this is expressed as follows:

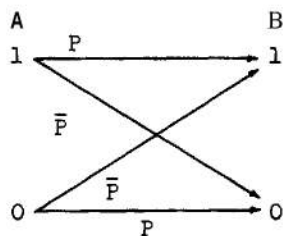

where the channel matrix is:

$$\begin{vmatrix} P & \bar{P} \\ \bar{P} & P \end{vmatrix}$$

Associated with the notion of a channel are several other quantities worth mentioning :

- The a priori entropy of A = $H(A) = - \sum_A P(a) \text{Log} P(a)$.
- The posteriori entropy of A = $H(A|b_j) = - \sum_A P(a|b_j) \text{Log} P(A|b_j)$.
- Conditional entropy $H(A|B) = \sum_B H(A|b_j) P(b_j)$, which is called the equivocation ,
- Mutual Information (the information provided by the observation of an output symbol) = $I (A;B) = H(A) - H(A|B)$

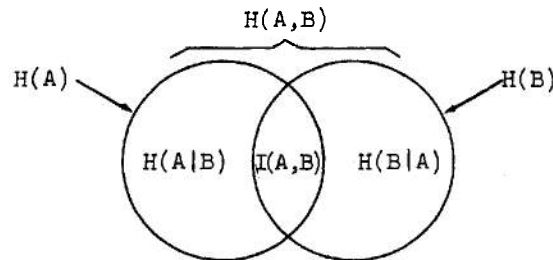

Some interesting properties of mutual information are the following:

- It is always non-negative, i.e., $I(A;B) \geq 0$.
- If channels are cascaded, they will tend to leak information, i.e., $I(A;B) \geq I(A;C)$.
- Mutual information is additive i.e., $I(A;B,C) = I(A;C) + I(A;B|C)$.

Channel capacity is a measure of the ability of the channel to transmit information; it is defined mathematically as $C = \max_{P(a_1)} I(A;B)$.

Channel capacity is commonly expressed in information units per unit of time. The notion of channel capacity leads to one of the fundamental theorems of information theory: "If the average amount of information per message from a source is H and the channel has a capacity of C , then it is possible to encode the messages **so** that they may be transmitted over the channel at a rate R which has a maximum value of C/H ."*

If the concept of a noisy channel is now introduced, the preceding can be modified to "if the rate of transmission is less than the channel capacity, it is possible to encode a message for transmission **so** that an arbitrarily small percentage of errors may be obtained."**

The preceding discussion concerns discrete messages. However, a completely analogous development exists for the continuous case, wherein summations are replaced by integrals and discrete probabilities by density functions, Thus the entropy of a continuous source would be given by***

$$H = - \int_{-\infty}^{\infty} p(x) \log p(x) dx$$

Here entropy will not be unique but will depend on the co-ordinate system used to represent the variable. However, in the noisy-channel situation, it is the mutual information that is of interest:

$$I(x;y) = H(y) - H(y|x)$$

$$= - \int_{-\infty}^{\infty} p(x) \log p(y) dy - \left[- \int_{-\infty}^{\infty} p(x) dx \int_{-\infty}^{\infty} p_x(y) \log p_x(y) dy \right]$$

This equation represents the difference in entropies -- one term representing the received signal and the other term representing the effects of the noise. Then, as long as both terms possess the same units, the solution will be unique and hence not dependent on the co-ordinate system employed.

*C.D. Flagle et. al., Operations Research and Systems Engineering, Johns Hopkins Press, 1960, p.590.

**Ibid., p.597.

***Ibid., p.606.

AMCP 706-191

According to Shannon's Theorem, an amount of information per sample point can be sent over a noisy channel as given by the maximum of the equation above. However, the channel must be evaluated in terms of the specific channel used. The channel is restricted by the bandwidth available and the power available for the signal waveform. For a signal of average power P in the presence of narrow-band Gaussian noise of average power N and bandwidth W , the channel capacity is given by:

$$C = W \text{ Log } \left(1 + \frac{P}{N} \right)$$

Thus the trade-off between power and bandwidth is shown,

When the basic relationships of information theory discussed above are applied to a systems-analysis problem, the components of the system are represented as channels with appropriate characteristics and the inputs and outputs correspond to the information passed by the system.

To demonstrate the application of these techniques, consider a slightly different example -- a maintenance system. A simple system experiences three types of failures and exhibits four types of symptoms. Analysis of symptom/failure frequency data yields the following matrix, where each element is the number of times the corresponding failure/symptom combination was experienced:

Failure \ Symptom	S ₁	S ₂	S ₃	S ₄	Totals
F ₁	5	4	1	0	10
F ₂	2	1	2	5	10
F ₃	1	2	5	2	10
Totals	8	7	8	7	30

The first step in the analysis is to convert the elemental values to probabilities.

Failure \ Symptom	S ₁	S ₂	S ₃	S ₄	Totals
F ₁	1/6	2/15	1/30	0	1/3
F ₂	1/15	1/30	1/15	1/6	1/3
F ₃	1/30	1/15	1/6	1/15	1/3
Totals	4/15	7/30	4/15	7/30	1

The average information contained in a symptom is

$$\begin{aligned}
 H(S) &= -\sum_{i=1}^4 P(S_i) \text{Log}_2 P(S_i) \\
 &= -\frac{8}{15} \text{Log}_2 \frac{4}{15} - \frac{7}{15} \text{Log}_2 \frac{7}{30} \\
 &= \frac{8}{15} (3.907-2.000) + \frac{7}{15} (4.907-2.807) \\
 &= \frac{8}{15} (1.907) + \frac{7}{15} (2.100) \\
 &= 1.997 \text{ bits per symptom}
 \end{aligned}$$

Similarly, the entropy contained in the failures is

$$H(F) = -\sum_{j=1}^3 P(F_j) \text{Log}_2 P(F_j) = -\text{Log}_2 \frac{1}{3} = 1.585 \text{ bits per failure}$$

The joint entropy in a symptom is found directly from the symptom/failure matrix (note that in this case the matrix is not the channel matrix):

$$\begin{aligned}
 H(S,F) &= -\sum_{i=1}^4 \sum_{j=1}^3 P(S_i, F_j) \text{Log}_2 P(S_i, F_j) \\
 &= -\frac{1}{2} \text{Log}_2 \frac{1}{6} - \frac{2}{15} \text{Log}_2 \frac{2}{15} - \frac{1}{10} \text{Log}_2 \frac{1}{30} - \frac{4}{15} \text{Log}_2 \frac{1}{15} \\
 &= \frac{1}{2} (2.585) + \frac{2}{15} (2.907) + \frac{1}{10} (4.907) + \frac{4}{15} \text{Log} 3.907 \\
 &= 3.213 \text{ bits}
 \end{aligned}$$

The information transmitted from symptom to failure (i.e., the mutual information) is given by

$$I(S,F) = H(S) + H(F) - H(S,F)$$

(This can be derived from the earlier expression for I that included equivocation.)

Thus,

$$I(S,F) = 1.997 + 1.585 - 3.213 = 0.369 \text{ bits}$$

One criterion that can be applied is the efficiency of transmission, defined by

$$E = \frac{I(S,F)}{H(F)} = \frac{0.369}{1.585} = 0.233 \text{ or } 23.3\%$$

AMCP 706-191

Other items that can be determined are the equivocation,

$$H(A|B) = H(A,B) - H(B) = 1.628 \text{ bits,}$$

the channel matrix, and the capacity.

The system can now be investigated to determine the value of troubleshooting strategies; the effects of regrouping of components to reduce troubleshooting times; and, in the case of AIDS type systems, the effectiveness of the system.

3.8 ANALYTIC MODELS

Strictly analytic methods are another means of optimizing that the system analyst can employ. One such technique that is common in calculus is equating the derivative to zero. However, two other techniques are worthy of mention: Lanchester's equations, and the calculus of variations.

3.8 .1 Lanchester's Equations

Lanchester's equations deal with the interactions of opposing sides in a dynamic battle. In their simplest form, Lanchester's equations state that in a multiple engagement "the overall effectiveness of a force equals the average effectiveness of the individual units multiplied by the square of the number of units engaged.* In mathematical terms this means that

$$\frac{dB}{dt} = -k_1 R$$

$$\frac{dR}{dt} = -k_2 B$$

where B and R are the numbers of blue and red units, respectively, t is time, and k_1 and k_2 are unit effectiveness factors.

This signifies that on the average each unit will in a given time score a certain number of effective hits, thereby causing the number of units killed to be directly proportional to the numerical strength of the opposing force.

These equations have been subsequently modified to incorporate other factors affecting force strength, such as production rates.

For example, one such modification is to write the two equations as being expressive of national effectiveness in a whole war.** These are written as follows:

$$\frac{dR}{dt} = P_R - O_L N_R - e_B N_B$$

$$\frac{dB}{dt} = P_B - O_L N_B - e_R N_R$$

*G. Merrill, et. al., "Operation Research, Armament, Launching", Principles of Guided Missile Design, D. Van Nostrand Company, Inc., p 113.

**Ibid., p. 114.

where P = production

O_L = operational loss percentage

e = effectiveness = $\frac{\text{Number of enemy destroyed}}{\text{Number of friendlies engaged}}$

N = number of forces engaged

B, R = blue and red, respectively.

The equations may be further complicated by introducing probabilities into the picture and by exercising them through a simulation, using Monte-Carlo techniques to determine engagement outcomes under more realistic conditions and with more variables introduced.

To illustrate the equations simply, consider the following numerical examples. Sides A and B have 10 units each. If all units have equal effectiveness per unit of time, the engagement will be a draw. Let the effectiveness (kills per unit of time) of A be 0.1 and B 0.2.

Thus, $\frac{dA}{dt} = 0.2B$ $A_0 = 10$

$\frac{dB}{dt} = 0.1A_0$ $B_0 = 10$

The resulting time histories for the two sides are approximately as follows:

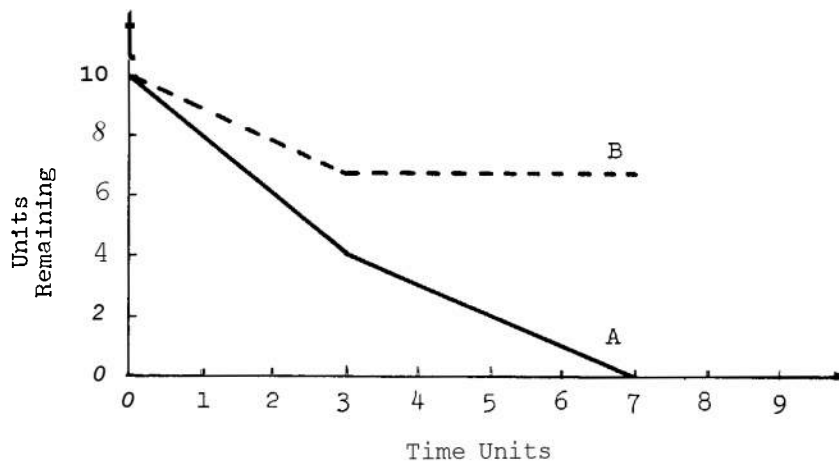

Thus in this simple example B wins, losing but three units while all ten of the opposing A are lost, and yet its unit effectiveness was only twice as good as A's. If B's effectiveness were raised to 0.4 while A's remained the same, A would lose all ten again, but B would lose only 2. Furthermore, the engagement would require three time units whereas before it required seven.

AMCP 706-191

From the example, the trade-offs between numbers and unit effectiveness (and time) are apparent. Thus, by use of these equations, optimal strategies could be devised.

3.8.2 Calculus of Variations

The calculus of variations is an analytic method for dealing with problems of maxima and minima. In particular, it deals with finding the extrema of integrals of one or more unknown functions. Thus, in the calculus of variations, the type of problem that is addressed is as follows: find F such that

$$\int_{t_1}^{t_2} F(x, y, z, x', y', z', t) dt = \text{Maximum or Minimum}$$

The mathematics involved in solving a variational problem is quite complex; however, electrical or mechanical engineers have probably encountered problems that could be solved by the calculus of variations or have applied results that were derived from the application of the calculus of variations. For example, the derivation of the optimum filter is a direct application. In this case, a true signal, $Y(t)$, and a received signal, $\hat{y}(t)$, (at the filter output) are given, and it is desired to find the filter transfer functions such that

$$\int_{t_1}^{t_2} (y - \hat{y})^2 dt = \text{minimum}$$

A second example of the use of this technique is the derivation of the equations of motion of vibrating membranes, plates, etc., from an energy standpoint (e.g., using Hamilton's Principle). In this case the problem is formulated as

$$\int_{t_1}^{t_2} [U(x, y, z, t) - K(x, y, z, t) - A(x, y, z, t)] dt = \text{Minimum}$$

where U , K , A , respectively, represent the potential, kinetic, and applied energies in the system.

The general approach to the solution of these problems is to consider the functions fixed at their end points but free to vary small amounts along the paths of integration.

3.9 DECISION THEORY

Decision theory represents one of the most recent developments in operations research. It has found considerable prior application as part of communications, radar, and pattern-recognition systems. However, its applications to the actual decision process have been relatively recent and few.

In decision theory two factors contribute to a decision:

- (1) The probability of the outcomes if a given decision is made
- (2) The value of the outcomes

The theory, then, attempts to define the decision process in terms of a number of states, values being associated with each. Application of the theory results in identifying a best course of action, generating alternative states, establishing new values, and providing a dynamic framework for the decision process.

3.10 COST-ESTIMATING RELATIONSHIPS AND CONFIDENCE INTERVALS

3.10.1 Cost-Estimating Relationships

When the system is complex, there is usually no simple two-parameter formula that relates system characteristics to system performance or system cost. However, through the use of the statistical technique known as linear regression, the equations or relationships of interest can be approximated by a straight line or by a hyperplane -- that is, a straight line in n dimensions.

The first step in the procedure is to establish a list of system parameters on the basis of engineering judgment; this list includes system characteristics that are expected to contribute significantly to the variability of system performance or system cost at any time during the research and development, initial investment, or operating phases of the system's life cycle. For example, if the system were a radio receiver, the list of system parameters would include such items as weight, volume, sensitivity, selectivity, signal-noise ratio, stress characteristics, and cost.

Great care should be taken in compiling these lists, because the ease of computation and the adequacy of the resulting prediction depend primarily on the discrimination exercised at this point. The following are the usual priorities for parameter selection in the regression analyses:

- (1) Parameters that are considered, on a cost/engineering basis, to have a second-order effect on the applicable cost category are excluded initially.
- (2) Parameters that exhibit little variation among the systems in the study are excluded initially.
- (3) Parameters that might be difficult to quantify during the initial procurement stages have lower priority than others.
- (4) Parameters that are highly correlated with one or more other parameters have lower priority.
- (5) Parameters are selected so that, if possible, at least one from each of the following categories is initially investigated:
 - Mission characteristics
 - State-of-the-art characteristics
 - Complexity or quantity characteristics
 - Effectiveness characteristics

AMCP 706-191

One parameter may represent two of the above characteristics. For example, a complexity characteristic such as number of active elements will often correlate well with reliability.

- (6) Where there is a choice between two or more equally important correlated parameters, the parameter or parameter combination that is most conducive to establishing trade-off relationships is selected initially.

The second step in the procedure is to determine the coefficients of the regression equation. The regression equation in Section 2-12 can be written as

$$X_1 = A + BX_2 + CX_3 + DX_4$$

where A, B, C, and D are coefficients, or constants, that have to be determined and the X's are the system parameters or combination of system parameters. The constants can be determined by solving the following set of equations simultaneously:

$$\Sigma X_1 = NA + B\Sigma X_2 + C\Sigma X_3 + D\Sigma X_4$$

$$\Sigma X_1 X_2 = A\Sigma X_2 + B\Sigma X_2^2 + C\Sigma X_2 X_3 + D\Sigma X_2 X_4$$

$$\Sigma X_1 X_3 = A\Sigma X_3 + B\Sigma X_2 X_3 + C\Sigma X_3^2 + D\Sigma X_3 X_4$$

$$\Sigma X_1 X_4 = A\Sigma X_4 + B\Sigma X_2 X_4 + C\Sigma X_3 X_4 + D\Sigma X_4^2$$

where N is the number of samples.

Once the constants A, B, C, and D have been found, the regression equation is determined, and the value of the multiple correlation coefficient, r , can be calculated from the following formula:

$$r = \frac{B(N \Sigma X_1 X_2 - \Sigma X_1 \Sigma X_2) + C(N \Sigma X_1 X_3 - \Sigma X_1 \Sigma X_3) + D(N \Sigma X_1 X_4 - \Sigma X_1 \Sigma X_4)}{N \Sigma X_1^2 - (\Sigma X_1)^2}$$

The value of the multiple correlation coefficient, r , will always be between 0 and 1, and if the value of r is 1, then all the sample points lie on the plane (or hyperplane). If the value of r is small, say less than 0.7, then the sample points are not approximated by a plane, and thus some other form of a prediction equation should be tried.

3.10.2 Confidence Intervals

The next area of interest in the regression technique is the determination of the standard error of the estimate and the confidence intervals. The vertical

(X) scatter of the sample points about the plane is measured by the standard error of the estimate, S:

$$S = \sigma_X \sqrt{\frac{N-1}{N-K-1} (1-r^2)}$$

where

$$a_X = \sqrt{\frac{N\sum X_1^2 - (\sum X_1)^2}{N(N-1)}}$$

K = Number of variables used in predicting X_1

N = Number of sample points

r = Correlation coefficient

Approximately 68 percent of the sample points lie within $\pm S$ of the plane determined by the regression equation, and 95 percent of the sample points lie within $\pm 2S$ (measured in the X_1 direction).

The standard error of the estimate gives an indication of the spread of the original data points about the regression plane. However, when the regression equation is used to predict the cost of a new piece of equipment, the prediction interval or confidence interval is given by

$$X_1 \pm t_e \sqrt{1 + \frac{1}{N} + N \sum_{j=2}^{K+1} U_{1j} (\hat{X}_1 - \bar{X}_1) (\hat{X}_j - \bar{X}_j)}$$

where

\hat{X}_1 is the predicted value of X_1 obtained from the regression equation

S is the standard estimate of the error

$t_e = t$ at $(\alpha/2, n-2)$ is a value obtained from the t distribution tables

\hat{X} is the value of the parameters for the new equipment

\bar{X} is the mean or average of the x's

K is the number of parameters used in the prediction equation

U_{1j} is as explained below

To obtain the values U_{1j} , the following procedure is used. If the parameters used in predicting X_1 are X_2, X_3, \dots, X_4 , then the first step is to

AMCP 706-191

calculate the quantities V, using the following equations:

$$V_{22} = N\Sigma X_2^2 - (\Sigma X_2)^2$$

$$V_{33} = N\Sigma X_3^2 - (\Sigma X_3)^2$$

$$V_{44} = N\Sigma X_4^2 - (\Sigma X_4)^2$$

$$V_{23} = V_{32} = N\Sigma X_2 X_3 - \Sigma X_2 \Sigma X_3$$

$$V_{24} = V_{42} = N\Sigma X_2 X_4 - \Sigma X_2 \Sigma X_4$$

$$V_{34} = V_{43} = N\Sigma X_3 X_4 - \Sigma X_3 \Sigma X_4$$

Now, to determine the values for U_{22} , U_{23} , and U_{24} , the values of V are substituted in the following equations, which are solved simultaneously:

$$V_{22} U_{22} + V_{23} U_{23} + V_{24} U_{24} = 1$$

$$V_{32} U_{22} + V_{33} U_{23} + V_{34} U_{24} = 0$$

$$V_{42} U_{22} + V_{43} U_{23} + V_{44} U_{24} = 0$$

To determine the values for U_{32} , U_{33} , and U_{34} , the values of V are substituted in the following equations, which again are solved simultaneously:

$$V_{22} U_{32} + V_{23} U_{23} + V_{24} U_{34} = 0$$

$$V_{32} U_{32} + V_{33} U_{33} + V_{34} U_{34} = 1$$

$$V_{42} U_{32} + V_{43} U_{33} + V_{44} U_{34} = 0$$

Finally, to determine the values for U_{42} , U_{43} , and U_{44} , the same values of V are substituted into the following equations, which are solved simultaneously:

$$V_{22} U_{42} + V_{23} U_{43} + V_{24} U_{44} = 0$$

$$V_{32} U_{42} + V_{33} U_{43} + V_{34} U_{44} = 0$$

$$V_{42} U_{42} + V_{43} U_{43} + V_{44} U_{44} = 1$$

The confidence intervals can now be found. For example, if the 95 percent confidence interval is desired, the values of S, N, X, and U are substituted in the confidence interval equation, along with the value of t_e (based on a 95 percent confidence level and the number of samples, N). The relevant statement that

can now be made is that the estimated cost of the new equipment is X_1 , and there is a 95 percent probability that the cost will be somewhere between the upper and lower confidence limits.

3.10.3 Example: Simple Linear Regression (Two Variables)

Given the information in the following table, determine the cost for a new piece of similar-type equipment, the xyz-2, which has a volume of 30 cubic feet.

Existing Equipment	Volume (Cubic Ft.)	cost (Dollars)
URC-32	20	10,392
WRT-2	34	12,278
R-390	2	1,096
URC-35	3	6,628
URC-9	12	3,307
SRC-21	14	4,366
SRC-20	18	7,688
URT-1	36	14,580
XYZ-2	30	X_1

The procedure to be followed consists initially of linear regression, using the method of least squares. If it is found that the data are not essentially linear, then other methods are tried, such as logarithmic, quadratic, etc., until an appropriate prediction equation can be obtained.

The form of the linear equation is

$$X_1 = A + BX_2$$

where X_1 represents the cost and X_2 represents the volume.

The values of the coefficients A and B can be found by simultaneously solving the following equations. Since there are only two variables, the relevant equations (excluding any terms containing X_3 or X_4) are

$$\Sigma X_1 = NA + B\Sigma X_2$$

$$\Sigma X_1 X_2 = A\Sigma X_2 + B\Sigma X_2^2$$

AMCP 706-191

From the information in the preceding table,

$$\Sigma X_1 = 10,392 + 12,278 + \dots = 60,335$$

$$\Sigma X_2 = 20 + 34 + 2 + \dots = 139$$

$$\Sigma X_1 X_2 = 20(10,392) + 34(12,278) + \dots = 1,411,620$$

$$\Sigma X_2^2 = (20)^2 + (34)^2 + \dots = 3529$$

$$N = 8$$

Substituting these values into the above equations gives

$$60,335 = 8A + B(139)$$

$$1,411,620 = A(139) + B(3529)$$

Solving these equations simultaneously for A and B yields

$$A = 1840, B = 326 \text{ and}$$

$$X_1 = 1840 + 326 X_2$$

Thus the cost for an equipment with a volume of 30 is

$$X_1 = 1840 + 326(30) = \$11,600$$

An alternate method of solution, which determines the value of the correlation coefficient r before solving for A and B, does not require the simultaneous solution of two equations.

The correlation coefficient, r , for two variables is given by

$$r = \frac{\Sigma X_1 X_2 - N \bar{X}_1 \bar{X}_2}{N \sigma_{X_1} \sigma_{X_2}}$$

where

the standard deviation, σ_x , of a number of samples, N , is

$$\sigma_x = \sqrt{\frac{N \Sigma x^2 - (\Sigma X)^2}{N(N-1)}}$$

the mean or average of the N sample points, \bar{X} , is

$$\bar{X} = \frac{\Sigma X}{N}$$

Note: the absolute value of the correlation coefficient will be somewhere between 1 and zero. It has been found empirically that an absolute value of r greater than 0.7 will yield an acceptable result; i.e., the data points are essentially linear. If the data points actually do lie on a straight line, the absolute value of r will be 1. A negative value for r indicates a line with a negative slope.

The values of A and B can now be calculated by using the following equations

$$B = \frac{r \sigma_{x_1}}{\sigma_{x_2}}$$

$$A = \bar{X}_1 - B \bar{X}_2$$

For this example, the information from the table is substituted into the above expressions to yield the following:

$$\Sigma X_1 = 10,392 + 12,278 + \dots = 60,335$$

$$\Sigma (X_1)^2 = (10,392)^2 + (12,278)^2 + \dots = 605,554,500$$

$$\bar{X}_1 = \frac{60,335}{8} = 7,542$$

$$\sigma_{X_1} = \sqrt{\frac{8(605,554,500) - (60,335)^2}{8(8-1)}} = 4,637$$

$$\Sigma X_2 = 20 + 34 + 2 + \dots = 139$$

$$\Sigma (X_2)^2 = (20)^2 + (34)^2 + (2)^2 + \dots = 3529$$

$$\bar{X}_2 = \frac{139}{8} = 17.4$$

$$\sigma_{X_2} = \sqrt{\frac{8(3529) - (139)^2}{8(8-1)}} = 12.6$$

$$r = \frac{[(20)(10,392) + (34)(12,278) + \dots] - 8(7,542)(17.4)}{8(4,637)(12.6)} = 0.89$$

$$B = \frac{(0.89)(4637)}{12.6} = 326$$

$$A = 7542 - 326(17.4) = 1840$$

Therefore $X_1 = 1840 + 326 X_2$ and as before, for an equipment with a volume of 30,

$$X_1 = 1840 + 326(30) = \$11,600$$

AMCP 706-191

Determine the standard error of estimate for the above data, and the 95 percent confidence interval for the xyz-2 equipment.

The vertical scatter of the data points about the regression line $X_1 = 1840 + 326 X_2$ is measured in terms of the standard error of estimate, S

where

$$S = \sigma_{X_1} \sqrt{1 - r^2}$$

It has been determined previously that

$$\sigma_{X_1} = 4637, r = 0.89$$

$$\text{therefore } S = 4637 \sqrt{1 - (0.89)^2} = 2130$$

Note: Approximately 68 percent of the data points lie within $\pm S$ of the regression line, and 95 percent lie within $\pm 2S$. Therefore, if a graphical plot of the data points is made, the parallel lines at a vertical distance of 2130 from the regression line $X_1 = 1840 + 326 X_2$ contain approximately 68 percent of the data points and the parallel lines at a vertical distance of 4260 from the regression line contain approximately 95 percent of the data points. As the sample size increases, the number of data points within $\pm S$ and $\pm 2S$ would become closer to 68 percent and 95 percent, respectively.

To calculate the confidence interval for the cost of the xyz-2 equipment, the following equation is used:*

$$X_1 \pm t_e S \sqrt{1 + \frac{1}{N} = \frac{(\hat{X}_2 - \bar{X}_2)^2}{(N-1)(\sigma_{X_2})^2}}$$

where

t_e is a value obtained from the t distribution tables

\hat{X}_2 is the ordinate of the regression line for which the confidence interval is to be found

Other symbols are as in the previous example,

*Note - This is another form of the equation developed previously and is also applicable for simple regression.

For the xyz-2 equipment,

$$X_1 = 11,600$$

$$S = 2130$$

$$t_e = (0.025, 6) = 2.45 \text{ (from "t" table for 95 percent confidence and 8 data points)}$$

$$\hat{X}_2 = 30 \text{ cubic ft}$$

$$\bar{Y}_2 = 17.4$$

$$\sigma_{X_2} = 12.6$$

$$N = 8$$

The 95-percent confidence interval is

$$11,600 \pm 2.447 (2130) \sqrt{1 + \frac{1}{8} + \frac{(30-17.4)^2}{(7)(12.6)^2}}$$

$$= 11,600 \pm 5900$$

Therefore, the estimated cost of the xyz-2 equipment is \$11,600, and there is a 95 percent confidence that the cost will be somewhere between \$17,500 and \$5,700.

This wide range for the confidence interval is quite large. However, the significant fact is that without an indication of the range of probable values, the decision-maker would have no feeling for the accuracy of any predicted parameter. It is better, of course, to have a narrow range for the 95-percent confidence interval, but this can be achieved only if additional supporting data are available.

3.11 EXPERIENCE CURVES

There are several factors that can reduce the unit cost of an equipment as the total number of equipments purchased is increased. Two such factors are the initial tooling cost, which can be spread out over a larger number of equipments; and the cost of materials, which can be reduced for a quantity purchase.

Another factor that can reduce the unit cost of an equipment (unrelated to the two factors above) is the learning curve, or experience curve $Y = aX^b$, where

Y = cost to manufacture equipment X

a = cost to manufacture equipment number 1

X = equipment number

b = exponent of experience-curve slope

AMCP 706-191

Empirical data have shown that the experience curve is appropriate for predicting the costs of aircraft engines and airframes and several types of electronic equipments. Normally, the experience curves are developed by the equipment manufacturer. The experience curve is based on the fact that as the quantity of equipments being manufactured is doubled, the cost to manufacture each successive equipment is reduced by a constant percentage. If one equipment costs \$1000 to manufacture, the second equipment is following a 90-percent learning curve, and the eighth, sixteenth, and thirty-second equipment each cost 90-percent less than the previous quantity.

Normally, the cost reduction described by the experience curve is due entirely to the reduction in man-hours necessary to produce an equipment, through the natural process of man learning his job better by repetition. There are, however, fully automated production lines with experience curves based on the fact that as the production line is operated, supervisors can develop improvements and short-cuts in the process.

The mathematical method for fitting data to the experience curve $Y = aX^b$ is log-log least-squares regression. Once the constants "a" and "b" have been found by using the regression technique, the unit cost of any equipment can now be found. For example, suppose, "a", the cost of the first equipment, is \$20,000, and the value of "b" is -0.322*. The cost for the sixteenth equipment is given by

$$Y_{16} = (20,000) (16)^{-0.322} = \$8,200$$

Tables have been developed by several Army agencies that can be used to reduce the amount of calculation for unit, average, and cumulative costs for any number of equipments with any slope.

Another method that is usually a good approximation for determining the experience curve is the "eyeball" method, i.e., plotting the data points and then drawing a straight line through the spread of points with a straight edge. Graphically, the data points are plotted on log-log paper, and if the relation $Y = aX^b$ exists, then the data points will fall essentially along a straight line. The slope of this experience curve can be found readily from any two points on the straight line whose ordinates are separated by a factor of two (one equipment quantity double the other). For example, if it is found from the curve the ninth equipment costs \$500 and the eighteenth equipment costs \$450, then the slope of the experience curve is 90 percent. To establish the values of "a" and "b" (in the equation $Y = aX^b$) from the graph, note that "a" represents the cost of the

* The value of b will always be negative unless the unit cost for succeeding equipments increases.

first equipment, and that "b" can be determined from the slope. The slope of the experience curve and the exponent b are related by the formula

$$\% \text{ slope} = (2)^b \times 100\%$$

which follows logically from the observation that the cost of the first equipment (for X = 1) is equal to "a" and, by definition, the cost of the second equipment is equal to "a" times the slope; therefore 2^b (for X = 2) must be equal to the slope.

3.12 COST-SENSITIVITY ANALYSIS

3.12.1 General

There are two main areas of usage in which cost-sensitivity analysis is used. First, the individual cost constituents should be checked to determine how changes in them affect the total cost. For example, a 5-percent change in the maintenance cost of an avionic system may change the total lifetime cost of the system by 15 percent, while a 10-percent change in the equipment cost changes the total lifetime cost by less than 1 percent. The implication here is that the cost analyst should concentrate on refining the maintenance-cost prediction, whereas a relatively gross estimate of the equipment cost will be sufficient.

Secondly, any assumptions that were made in the analysis should be checked to determine how changes in the assumptions affect the total cost. For example, if it was assumed that the equipment would be operated for 100 hours per month, the total costs should be calculated for operating times of say 75 and 125 hours per month to determine the effect of this assumption on the overall cost. Of course, if the total cost is sensitive to any assumption, the results of the sensitivity analysis should be shown to the decision-maker with the range of the assumed value indicated.

3.12.2 Cost-Sensitivity-Analysis Problem

The cost information given below for two alternative communications systems

Cost Categories	Total System Cost (10-year lifetime)	
	Communication System A	Communication System B
R&D	\$ 10,000,000	\$ 12,000,000
Equipment Acquisition	300,000, 000	320,000,000
Spares and Spare Parts	14,000,000	8,000,000
Initial Maintenance Facilities	4,500, 000	6,000,000
Publications	500, 000	800,000
Maintenance	160,000,000	120,000,000
Annual Training	1,000,000	900,000
Annual Facilities	2,000,000	2,500,000

AMCP 706-191

The cost figures represent average (or expected) values, with some standard error of estimate. One cost-estimating relationship was developed for each category; therefore, the standard error for each category is the same for system A and B, but the categories will generally have different standard errors. In other words, the standard errors are identical horizontally, but not necessarily vertically.

Question 1: In which cost category does cost uncertainty have the greatest impact on the cost comparison, and how great is this impact?

Question 2: Are the results sensitive to the assumption that the system will be in operation for 10 years?

Answers

Answer to Question 1

The cost totals for each system are:

A: \$492,000,000

B: \$470,200,000

A, then, is ostensibly more expensive than B. However, because of the existence of standard errors, a cost-inversion may be possible, so that B, in fact, is the more expensive system.

Equipment Acquisition and Maintenance are the two biggest categories; between them they account for more than 90 percent of the total system cost.

Assume that if a cost-inversion exists, it is due either to Acquisition or Maintenance cost errors (or both), the other categories being so small relatively (in terms of money) that they are essentially constants.

The difference between system costs is \$21,800,000. Thus if at least one-half of \$21,800,000, or \$10,900,000 were simultaneously added to the total cost of B and subtracted from the total cost of A, an inversion would result.

Now, the total cost for system A can be written as

$$\text{Cost}_A = 32,000,000 + (E_A + M_A)$$

where

E_A = Equipment Acquisition Cost

M_A = Maintenance Cost

The total cost for system B can be written as

$$\text{Cost}_B = 30,200,000 + (E_B + M_B)$$

The probability that system B costs more than system A is given by

$$\begin{aligned}
 p(\text{cost}_B > \text{cost}_A) &= p\left[30,200,000 + (E_B + M_B) > 32,000,000 + (E_A + M_A)\right] \\
 &= p\left[(E_B + M_B) - (E_A + M_A) > 1,800,000\right] = p\left[Z > 1,800,000\right]
 \end{aligned}$$

Since the tabulated values of E_A , E_B , M_A , and M_B were obtained by regression techniques, these values are the expected values.

Thus if Z is the random variable

$$Z = (E_B + M_B) - (E_A + M_A)$$

then the expected value of Z is given by

$$\begin{aligned}
 \bar{Z} = (\bar{E}_B + \bar{M}_B) - (\bar{E}_A + \bar{M}_A) &= (320,000,000 + 120,000,000) - \left[(300,000,000) \right. \\
 &\quad \left. + (160,000,000) \right]
 \end{aligned}$$

$$\text{or } \bar{Z} = -20,000,000$$

Ideally, the standard errors of estimate for E_A , E_B , M_A , and M_B (and the other costs as well) should have been furnished. Since they have not, a "worst" case estimate is obtained as follows:

Assume that the percentage errors in E and M do not exceed some nominal value, say 10 percent; thus 10 percent of $E_A = 30,000,000$, and 10 percent of $E_B = 32,000,000$. If these values are considered to represent three standard errors, which almost guarantees that the error will be less than 10 percent, then

$$S_{E_A} = 10,000,000 \text{ and } S_{E_B} = 10,700,000$$

However, from the assumption that the same regression equation was used, S_{E_A} must equal S_{E_B} , so that if S_{E_A} and S_{E_B} are "averaged",

$$S_{E_A} = S_{E_B} = 10,300,000$$

Similarly,

$$S_{M_A} = S_{M_B} = 4,700,000$$

$$\begin{aligned}
 \text{Then } S_Z &= \sqrt{S_{E_A}^2 + S_{E_B}^2 + S_{M_A}^2 + S_{M_B}^2} = \sqrt{[2(10.3)^2 + 2(4.7)^2] \times 10^{12}} \\
 &= \sqrt{256.36} \times 10^6 \\
 &= 16,000,000
 \end{aligned}$$

AMCP 706-191

The problem is shown graphically below. The curve represents the distribution of equipment acquisition and maintenance costs; i.e., the equipment acquisition and maintenance cost of system B is "expected" to be \$20,000,000 less than the equipment acquisition and maintenance cost of system A, and the standard error of this distribution is \$16,000,000. The zero line represents that point at which the equipment acquisition and maintenance costs for A and B are equal. The \$1,800,000 line represents that point at which the total system costs for A and B will be equal.

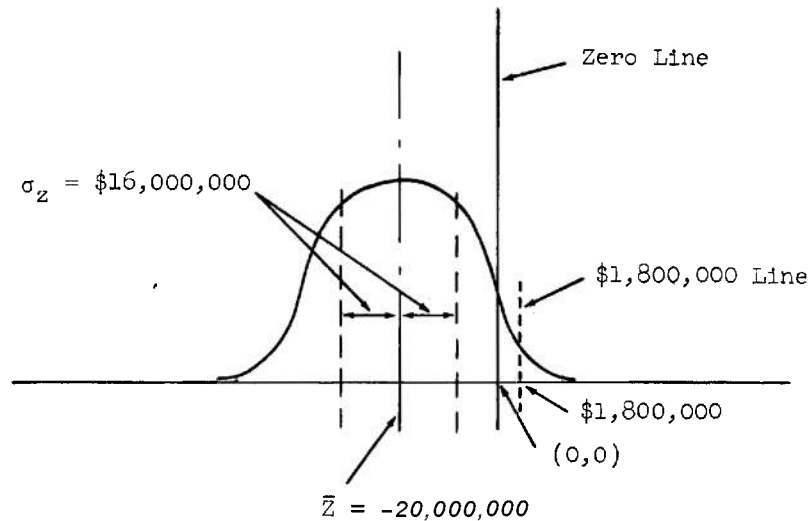

The probability that the cost lies to the right of the \$1,800,000 line (a cost-inversion) is given by

$$\frac{h_1 - \mu}{\sigma}$$

where h_1 is the value of interest on the normal density function

μ is the mean of the function

σ is the standard deviation

Substituting the values from the example problem into the above equations yields

$$\frac{1,800,000 - (-20,000,000)}{16,000,000} = 1.36$$

which, from Table C-1 in Appendix C, corresponds to 0.0869, or approximately 9 percent. Therefore, for an estimated maximum error of 10 percent in the acquisition and maintenance cost, the probability that system B is really more expensive than system A is 9 percent. If this process is repeated for an estimated

maximum error of 100 percent, the calculations lead to the result that the probability that system B is really more expensive than system A is 33 percent.

The answer to question 1, then, is that uncertainty in the predictions of equipment acquisition and maintenance cost have the greatest impact on the cost comparison; and if it is assumed that these predictions may be off by as much as 100 percent, there is still only a 33-percent chance that the cost of system B will be more than the cost of system A.

Answer to Question 2

For this example, assume that Maintenance, Training, and Facilities are time-based costs, and assume further that they are linear with time (although any function other than linear could also be handled easily with, for example, a graphical solution).

Then costs would be categorized as follows:

<u>costs</u>	<u>System A</u>	<u>System B</u>
Fixed Costs	\$329,000,000	\$346,800,000
Annual Costs (per year)	16,300,000	12,340,000

For y years, the cost of system A, therefore, will be

$$\text{Cost}_A = 329,000,000 + 16,300,000 y$$

Similarly,

$$\text{Cost}_B = 346,800,000 + 12,340,000 y$$

Thus $\text{Cost}_A \leq \text{Cost}_B$ when

$$329,000,000 + 16,300,000 y \leq 346,800,000 + 12,340,000 y,$$

$$\text{or when } y \leq \sim 4.5 \text{ years}$$

The answer to Question 2, then, is that the results are not sensitive to the assumption that the system will be operated for 10 years -- that is, the cost of system B will be lower than the cost of system A, unless the system is to be in operation for less than 4.5 years.

(Note very carefully the assumption of linearity, i.e., that the cost is directly proportional to time. This assumption, for specific systems, may very well not be true.)

CHAPTER 4

BASIC MATHEMATICAL AND STATISTICAL CONCEPTS *

4.1 INTRODUCTION

Basic mathematical and statistical concepts are reviewed in this chapter. Topics include algebraic principles and formulas, the various types of probability distributions, and procedures for statistical estimation.

4.1.1 Preliminary Definitions

Some of the principal terms used in this discussion are defined as follows:

Random Outcome. The value of an empirical observation that cannot be predicted (lack of deterministic regularity) but has statistical regularity in that the value has a relative frequency of occurrence in a series of independent observations of the phenomenon (the result of tossing a die, the time-to-failure of a device, etc.).

Trial. An action or experiment that yields a random outcome (tossing a die, life-testing a device).

Independent Trials. Trials of which the outcome of one has no effect on the outcome of others that follow.

Event. A set of outcomes. The event has occurred if one of the outcomes of the set is observed on a trial. (If the event is an even number on the toss of a die, it occurs if the number 2, 4, or 6 is observed.)

Independent Events. Sets of outcomes based on independent trials.

Mutually Exclusive Events. Two or more events that cannot occur simultaneously (odd and even numbers on one toss of a die).

4.1.2 Notation

The following probability notation applies:

$P(E)$ = probability of event E, where $0 \leq P(E) \leq 1$

$P(\bar{E})$ = probability of event "not E" = $1 - P(E)$

*Some of the material used in this chapter was developed by ARINC Research Corporation for the U. S. Weather Bureau under Contract Cwb-11349. Reproduced by permission of the U. S. Weather Bureau.

AMCP 706-191

$P(E_1 + E_2)$ = probability of events E_1 or E_2 (or both if they are not mutually exclusive)

$P(E_1E_2)$ = probability of both events E_1 and E_2

4.2 DEFINITIONS OF PROBABILITY

4.2.1 Classical Definition

The classical definition of probability is as follows:

If an experiment can result in n different, equally likely and mutually exclusive outcomes, and if r of these outcomes correspond to event E , the probability of E , denoted by $P(E)$, is the ratio

$$P(E) = r/n \quad (1)$$

Example: If a card is drawn at random from a full deck, there are $n = 52$ mutually exclusive and equally likely outcomes; $r = 4$ of these are the event of drawing a king. The probability of drawing a king, from Equation 1, is $4/52 = 1/13$.

The classical definition of probability is one that involves an a priori evaluation and is useful only if all the possible outcomes can be enumerated and are equally likely and mutually exclusive. "Equally likely" can be described as the lack of any bias favoring one outcome over another in a trial.

4.2.2 Relative-Frequency Definition

The relative-frequency definition is as follows:

The probability of an event is the limiting ratio of the number of outcomes favorable to an event (r) to the number of trials performed (n) as the number of trials approaches infinity. If n is large, the ratio r/n can be used to estimate the probability.

Example: In the life-testing of 100 devices, it was observed that 15 failures occurred before 20 hours. The estimated probability of failure before 20 hours is therefore $15/100 = 0.15$. The relative-frequency definition of probability requires a statistical estimation involving valid experiments and sufficient data to yield an estimate that is fairly stable.

4.3 ALGEBRAIC PRINCIPLES AND FORMULAS

The following algebraic principles and formulas are useful for applying the classical definition of probability in those cases in which it is valid.

4.3.1 Two Basic Counting Principles

The two basic counting principles are as follows:

- (1) If event A can occur in " a " ways, event B can occur in " b " ways, and both can occur together in " c " ways, then A or B or both can occur in $(a + b - c)$ ways.

Example a: Spade or heart in one draw: A = spade, B = heart. $a = 13, b = 13, c = 0$. A or B in $13 + 13 = 26$ ways.

Example b: Spade or ace in one draw: A = spade, B = ace. $a = 13, b = 4, c = 1$. A or B in $13 + 4 - 1 = 16$ ways.

- (2) If there are "a" ways of performing the first operation and "b" ways of performing the second operation, given that the first operation has occurred, there is a total of $a \times b$ possible ways for both operations.

Example a: Throwing an even number on a die and drawing an ace from a deck: $a = 3, b = 4$. Total number of ways = $3 \times 4 = 12$.

Example b: Drawing two spades from a deck of cards: $a = 13, b = 12$. Total number of possible ways = $13 \times 12 = 156$.

4.3.2 Permutations

A permutation is a particular arrangement of a collection of objects. The total number of permutations of n different objects is

$$P(n, n) = n(n - 1)(n - 2) \dots 3 \times 2 \times 1 \tag{2}$$

$$= n!$$

The total number of permutations of n objects taken k at a time is

$$P(n, k) = \frac{n!}{(n - k)!} \tag{3}$$

The total number of permutations of n objects, k_1 of which are alike, k_2

of which are alike, . . . , k_r of which are alike $\left\{ \sum_{i=1}^r k_i = n \right\}$ is

$$\frac{n!}{k_1! k_2! \dots k_r!} \tag{4}$$

(Note: $0!$ is defined as equal to 1.)

Example a: For the letters ABCDE, there are $5! = 120$ permutations. There are $\frac{5!}{(5-3)!} = 60$ permutations if three of the five letters are to be selected,

AMCP 706-191

Example b: In the word SUCCESS, there is one U ($k_1 = 1$), one E ($k_2 = 1$), two C's ($k_3 = 2$), and three S's ($k_4 = 3$).

From Equation 4, the total number of possible permutations of all seven letters in the word SUCCESS is

$$\frac{7!}{1!1!2!3!} = 420$$

4.3.3 Combinations

A combination is the number of ways in which k out of n different items can be selected without regard to order, symbolized by

$$\binom{n}{k} \text{ or } C_k^n \quad (5)$$

where

$$\binom{n}{k} = \frac{n!}{k!(n-k)!}$$

Example: For a unit composed of five components, at least three must be successful. How many ways can the unit be successful?

From Equation 5,

$$\begin{aligned} \binom{5}{3} + \binom{5}{4} + \binom{5}{5} &= \frac{5!}{3!2!} + \frac{5!}{4!1!} + \frac{5!}{5!0!} \\ &= 10 + 5 + 1 = 16 \end{aligned}$$

4.3.4 Basic Probability Laws

4.3.4.1 Addition Law

If A and B are two mutually exclusive events, the probability that either of them will occur in a single trial is the sum of their respective probabilities, or

$$P(A + B) = P(A) + P(B) \quad (6)$$

In general, if there are k mutually exclusive events,

$$P(A_1 + A_2 + \dots + A_k) = P(A_1) + P(A_2) + \dots + P(A_k) \quad (7)$$

If the two events A and B are not mutually exclusive, the probability that at least one of them will occur is

$$P(A + B) = P(A) + P(B) - P(AB) \quad (8)$$

For three non-mutually exclusive events,

$$P(A + B + C) = P(A) + P(B) + P(C) - P(AB) - P(AC) - P(BC) + P(ABC) \quad (9)$$

The most general form of the addition law states that the probability of an event is the sum of its mutually exclusive forms. It is assumed that A and B are not mutually exclusive but that the three events (A and B), (A and not B), and (B and not A) are mutually exclusive, then

$$P(A + B) = P(AB) + P(A\bar{B}) + P(\bar{A}B) \quad (10)$$

4.3.4.2 Multiplication Law

If events A and B are independent, the probability of the compound event A and B is equal to the product of their respective probabilities, or

$$P(AB) = P(A) P(B) \quad (11)$$

The extension to more than two events follows directly,

4.3.4.3 Conditional Probability

If events A and B are not independent -- i.e., the occurrence of one affects the occurrence of the other -- then conditional probabilities exist. The conditional probability of A given that B has occurred is denoted by $P(A|B)$; similarly, the probability of B given that A has occurred is denoted by $P(B|A)$. If events A and B are not independent,

$$P(AB) = P(A) P(B|A) = P(B) P(A|B), \quad (12)$$

which reduces to $P(A) P(B)$ if A and B are independent.

For three events,

$$P(ABC) = P(A) P(B|A) P(C|AB) \quad (13)$$

Also,

$$P(A|B) = \frac{P(AB)}{P(B)} \quad (14)$$

$$P(B|A) = \frac{P(AB)}{P(A)} \quad (15)$$

AMCP 706-191

Equations 14 and 15 lead to a form of Bayes' Theorem:

$$P(A|B) = \frac{P(A) P(B|A)}{P(B)} = \frac{P(A) P(B|A)}{P(A) P(B|A) + P(\bar{A}) P(B|\bar{A})} \quad (16)$$

In this application, $P(A)$ and $P(\bar{A})$ are usually a priori probabilities of the events A and not A. It is necessary to modify $P(A)$ on the basis that event B has occurred in some experiment whose outcome is known to be influenced by A, as reflected by the terms $P(B|A)$ and $P(B|\bar{A})$.

Example: Assume that a box of 100 outwardly indistinguishable parts is composed as follows:

Quality	Manufacturer			Totals
	A	B	C	
Good, G	40	27	8	75
Bad, \bar{G}	10	3	12	25
Totals	50	30	20	100

The following probabilities are based on the classic definition

$$P(E) = \frac{\text{Total number of outcomes favorable to Event E}}{\text{Total number of possible outcomes}}$$

and on the probability laws discussed above.

Case 1: For a random selection from the box, what is the probability of:

- (a) Drawing a part manufactured by A? From Equation 1,

$$P(A) = \frac{50}{100} = \frac{1}{2}$$

- (b) Drawing a bad part?

$$P(\bar{G}) = \frac{25}{100} = \frac{1}{4}$$

- (c) Drawing a part manufactured by C which is also bad?

$$P(C\bar{G}) = \frac{12}{100} = 0.12$$

- (d) Drawing a bad part manufactured by C, given that a part manufactured by C was selected?

Counting indicates that there are a total of 20 possible ways for selecting a C part, and in 12 cases bad parts will be selected; hence, from Equation 1,

$$P(\bar{G}|C) = \frac{12}{20} = 0.60$$

Similarly, from Equation 14,

$$P(\bar{G}|C) = \frac{P(\bar{G}C)}{P(C)} = \frac{0.12}{0.20} = 0.60$$

Case 2: If one part is drawn randomly, Equation 6 yields

$$P(A + B) = P(A) + P(B) = \frac{50}{100} + \frac{30}{100} = 0.8 = 1 - P(C) = 1 - \frac{20}{100} = 0.8$$

From Equation 8,

$$P(A + E) = P(A) + P(\bar{G}) - P(A\bar{G}) = \frac{1}{2} + \frac{1}{4} - \frac{1}{10} = 0.65$$

Counting indicates that the number (A or \bar{G}) = 50 + 25 - 10 = 65. The number of possible outcomes = 100.

$$P(A + \bar{G}) = \frac{65}{100} = 0.65$$

Case 3: If two draws are made, what is the probability that both items selected are manufactured by A, for the following:

(a) Drawing with replacement, independent events?

$$P(A_1A_2) = \frac{\text{Number of ways of drawing two items manufactured by A}}{\text{Total possible number of two-item draws}}$$

$$= \frac{50 \times 50}{100 \times 100} = 1/4$$

or, from Equation 11,

$$P(A_1A_2) = P(A_1) P(A_2) = 1/2 \times 1/2 = 1/4$$

(b) Drawing without replacement, dependent events?

$$P(A_1A_2) = \frac{50 \times 49}{100 \times 99} = \frac{49}{198}$$

or, from Equation 12,

$$P(A_1A_2) = P(A_1) P(A_2|A_1) = \frac{1}{2} \times \frac{49}{99} = \frac{49}{198}$$

AMCP 706-191

Case 4: What is the probability of selecting a part produced by manufacturer A on the first draw and a bad item (\bar{G}) on the second draw?

(a) With replacement:

$$P(A_1 \bar{G}_2) = P(A_1) P(\bar{G}_2) = 1/2 \times 1/4 = 1/8 = 0.1250$$

(b) Without replacement:

$$P(A_1 \bar{G}_2) = P(A_1) P(\bar{G}_2 | A_1)$$

Since A_1 (A on first draw) consists of the events $A_1 G_1$ (A and G on first draw) or $A_1 \bar{G}_1$ (A and \bar{G} on the first draw), then

$$\begin{aligned} P(A_1 \bar{G}_2) &= P(A_1 G_1) P(\bar{G}_2 | A_1 G_1) + P(A_1 \bar{G}_1) P(\bar{G}_2 | A_1 \bar{G}_1) \\ &= \left(\frac{40}{100}\right) \times \left(\frac{25}{99}\right) + \left(\frac{10}{100}\right) \left(\frac{24}{99}\right) \\ &= 0.1253 \end{aligned}$$

Case 5 (Bayes Theorem Example): Assume that the parts are distributed in two identical boxes as follows:

Manufacturer A	
G	40
\bar{G}	10
Total	50

Not Mfr. A (\bar{A})	
G	35
\bar{G}	15
Total	50

If a box is chosen at random and a part is selected from the box, what is the probability that the part is manufactured by A if it is found to be good?

The a priori probability of choosing a part manufactured by A is $P(A) = 1/2$; that of choosing a part manufactured by not-A is $P(\bar{A}) = 1/2$, since the boxes are identical and one part is randomly chosen. From Bayes Theorem (Equation 16), the probability that box A is chosen, given that a good item is selected, is

$$P(A|G) = \frac{P(A) P(G|A)}{P(A) P(G|A) + P(\bar{A}) P(G|\bar{A})} = \frac{\frac{1}{2} \times \frac{40}{50}}{\frac{1}{2} \times \frac{40}{50} + \frac{1}{2} \times \frac{35}{50}} = \frac{40}{75} = 0.533$$

Hence, by Bayes Theorem, the prior probability that a part manufactured by A was chosen is modified from 0.5 to the posterior probability of 0.533 on the basis of the information that a good part was selected from the chosen box.

4.3.5 Application of Probability Laws to Reliability

In most of the applications of probability theory to reliability work, the events in question are expressed in terms of a time variable; hence, the probabilities themselves are not constants but are functions of time, denoted by t . The above formulas hold equally well when interpreted as functions of time.

As an example, the reliability at time t is equivalent to a probability of no failure before t . If we have two equipments, a and b , the probability that both operate is, by the multiplication law (Equation 11) and under the assumption of independence,

$$R_{ab}(t) = R_a(t) \cdot R_b(t)$$

where $R_1(t)$ is the reliability at time t of equipment 1.

If there are two equipments, a and b , and if the system is successful at time t if either a or b or both are operable, then by the addition law (Equation 8), the system reliability $R_S(t)$ is

$$R_S(t) = R_a(t) + R_b(t) - R_{ab}(t)$$

4.4 PROBABILITY DISTRIBUTIONS

4.4.1 Definitions

The following definitions are pertinent to a discussion of probability distributions or densities:

Random Variable. A quantity, x , for which--for every real number C --there exists a probability that x is less than or equal to C .

Discrete Random Variable. A random variable that can take on only a finite or countable number of distinct values. The random variable "number of failures within the fixed time interval $[0, t]$ " is discrete.

Continuous Random Variable. A random variable that can take on any value within an interval (equivalent to taking on any one of a non-denumerable infinity of values). The random variable "time to failure" is continuous.

Probability Density Function. A mathematical function, say $f(x)$, which, for discrete random variables, gives the probability that the random variable equals x . For continuous random variables, $f(x)$ gives the probability that x lies in an interval, say $[a, b]$, from the equation $P[a < x \leq b] = \int_a^b f(x)dx$.

AMCP 706-191

The probability that a continuous random variable will take on a specific value is defined to be zero (e.g., the probability that a device will fail at exactly 98,000 . . . hours equals zero). Intervals rather than points must be considered for the usual continuous cases.

Cumulative Distribution Function. The mathematical function that expresses the probability that the random variable x is **less** than or equal to some value as determined from the probability density function.

If X represents a given value of x , then for a discrete random variable whose lower limit is L , the cumulative distribution function, $F(X)$, is

$$F(X) = \sum_{x=L}^X f(x) \tag{17}$$

For a continuous random variable,

$$F(X) = \int_{-\infty}^X f(x)dx \tag{18}$$

4.4.2 Properties

If x represents the random variable, and $f(x)$ represents the probability density function of x , then $f(x)$ has the following properties:

(1) $f(x) \geq 0$ for all x

$$\int_L^{\infty} f(x) = 1 \leftarrow \text{if } x \text{ is discrete*} \tag{19a}$$

$$\int_{-\infty}^{\infty} f(x)dx = 1 \leftarrow \text{if } x \text{ is continuous**}$$

The probability that x will take on a value in the interval $[a, b]$ is (19b)

$$P [a < x \leq b] = \begin{cases} \sum_{x=a}^b f(x) & \text{if } x \text{ is discrete} \\ \int_a^b f(x)dx & \text{if } x \text{ is continuous} \end{cases}$$

* \sum represents the **sum** over all possible discrete values of x .
 ** \int

The limits $-\infty$ to ∞ apply if $f(x)$ is defined to be equal to zero for **all** impossible values of x .

All cumulative distribution functions have the following properties:

$F(X) \geq 0$ for all X

$F(X) = 0$ for all $X < L$, the lower limit of the range of x

$F(X) = 1$ for all $X \geq U$, the upper limit of the range of x

$F(X_1) \leq F(X_2)$ if $X_1 \leq X_2$; hence, the cumulative distribution function is monotonically increasing.

4.4.2.1 Example A

The function $f(x)$, shown graphically in Sketch A and stated as

$$f(x) = \begin{cases} 1/2, & x = 1 \\ 1/4, & x = 2 \\ 1/8, & x = 3 \\ 1/8, & x = 4 \\ 0, & \text{otherwise} \end{cases}$$

is a discrete probability density function, since $f(x) \geq 0$ for all x and

$$\sum_{x=1}^4 f(x) = 1.0.$$

The cumulative function is

$$F(X) = \begin{cases} 1/2, & x = 1 \\ 3/4, & x = 2 \\ 7/8, & x = 3 \\ 1, & x = 4 \end{cases}$$

which, when plotted, yields the step-function shown in Sketch B.

The probability that x is greater than 1 and less than or equal to 3 is, from Equation 19a,

$$\sum_{x=2}^3 f(x) = f(2) + f(3) = 1/4 + 1/8 = 3/8,$$

or is equal to the probability that x is less than or equal to 3 minus the probability that it is less than or equal to 1 -- namely,

$$F(3) - F(1) = 7/8 - 1/2 = 3/8.$$

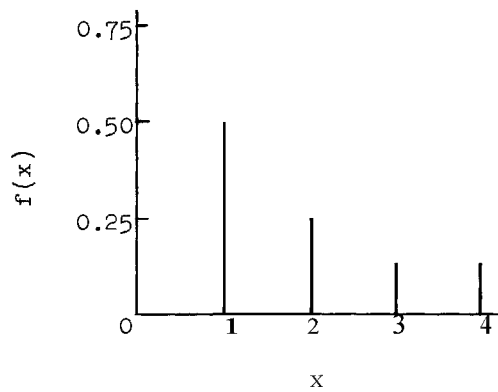

Sketch A

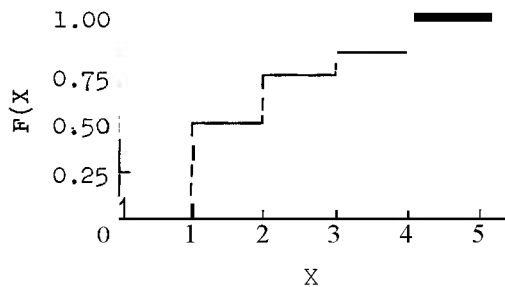

Sketch B

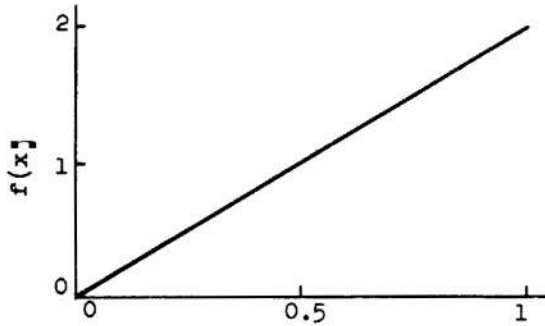

Sketch C

4.4.2.2 Example B

The function $f(x)$, shown graphically in Sketch C and stated as

$$f(x) = \begin{cases} 2x, & 0 \leq x \leq 1 \\ 0, & \text{otherwise} \end{cases}$$

is a continuous probability density function, since x is a continuous variable, and $f(x) \geq 0$ for all x , and

$$\int_0^1 2x dx = x^2 \Big|_0^1 = 1.$$

The cumulative distribution is

$$F(X) = \int_{-\infty}^X f(x) dx = \int_0^X 2x dx = x^2,$$

which is plotted in Sketch D.

The probability that x is between any two values in the range of x , say between a and b , is (from Equation 19b)

$$\int_a^b f(x) dx = F(b) - F(a).$$

Thus the probability that x will be between 0.3 and 0.6 is

$$\begin{aligned} P [0.3 < x \leq 0.6] &= F(0.6) - F(0.3) \\ &= (0.6)^2 - (0.3)^2 \\ &= 0.27 \end{aligned}$$

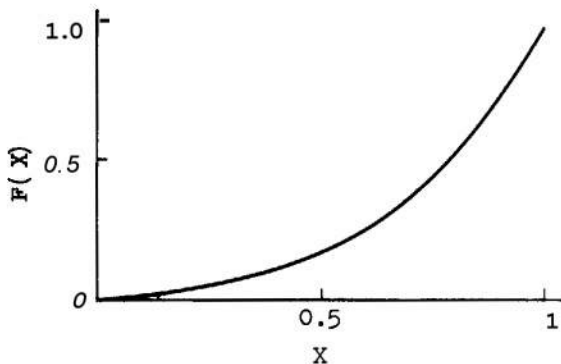

Sketch D

4.4.3 Parameters and Moments

4.4.3.1 Definitions

A parameter is a constant that appears in the probability density function. It is more generally defined as some measurable characteristic of the population, such as the mean or range.

A moment, a descriptive property of a probability density function, is defined as follows:

(1) r^{th} moment about zero:

$$\mu_r = \begin{cases} \sum x^r f(x), & \text{for discrete variables} & (20a) \\ \int_{-\infty}^{\infty} x^r f(x) dx, & \text{for continuous variables} & (20b) \end{cases}$$

(2) r^{th} moment about point "a":

$$\mu'_r = \begin{cases} \sum (x-a)^r f(x), & \text{for discrete variables} & (21a) \\ \int_{-\infty}^{\infty} (x-a)^r f(x) dx, & \text{for continuous variables} & (21b) \end{cases}$$

The first moment about zero (μ_1 or μ) is the mean of the distribution and is a measure of central tendency. Mathematically, the mean is the expected or average value in the population; it is defined by the equation

$$\mu = \begin{cases} \sum x f(x), & \text{for discrete variables} & (22a) \\ \int_{-\infty}^{\infty} x f(x) dx, & \text{for continuous variables} & (22b) \end{cases}$$

The second moment about μ is called the variance, denoted usually by σ^2 (μ'_2 in the previous notation). It is a measure of dispersion about the mean. Mathematically, the variance is the expected or average value of the square of deviations of all possible values from the mean; it is defined by

$$\sigma^2 = \begin{cases} \sum (x-\mu)^2 f(x), & \text{for discrete variables} & (23a) \\ \int_{-\infty}^{\infty} (x-\mu)^2 f(x) dx, & \text{for continuous variables} & (23b) \end{cases}$$

The greater the variance, the more variability there is in the distribution. The square root of the variance is known as the standard deviation.

4.4.3.2 Relationship of Parameters and Moments to Reliability Theory

To relate the above concepts to an important area of reliability -- namely, the time-to-failure density function and the reliability function -- let t denote the random variable time-to-failure and $f(t)$ the time-to-failure probability

AMCP 706-191

density function, ($f(t) = 0$ for $t < 0$). The reliability over a time interval t , denoted by $R(t)$, is, by definition,

$$\begin{aligned} R(t) &= \text{probability that failure occurs after } t \text{ (the reliability function)} \\ &= 1 \text{ minus probability that failure occurs before } t \\ &= 1 \text{ minus } \int_0^t f(t') dt' \text{ (t' is simply a dummy variable of integration)} \\ &= \int_t^\infty f(t') dt' \end{aligned}$$

Since the derivative of the cumulative distribution function is the probability density function for continuous variates,

$$f(x) = \frac{dF(x)}{dx} ,$$

then

$$f(t) = \frac{dF(t)}{dt} = \frac{d [1-R(t)]}{dt} = \frac{-dR(t)}{dt}$$

The probability that an item will fail within the time interval t_1 to t_2 is equal to the probability that it will fail before t_2 minus the probability that it will fail before t_1 ; or, from Equation 19b,

$$\begin{aligned} P [t_1 < t \leq t_2] &= \int_{t_1}^{t_2} f(t) dt \\ &= F(t_2) - F(t_1) \\ &= [1-R(t_2)] - [1-R(t_1)] \\ &= R(t_1) - R(t_2) \end{aligned} \tag{24}$$

The mean time to failure is, from Equation 22b,

$$\mu = \int_0^\infty t f(t) dt,$$

which for most density functions is equivalent to

$$\mu = \int_0^\infty R(t) dt$$

The variance is, from Equation 23b,

$$\sigma^2 = \int_0^\infty (t-\mu)^2 f(t) dt \tag{25}$$

For reliability problems, the following definitions are important:

Mean Life. The first moment of a time-to-failure density function -- i.e., the average (in the sense of arithmetic mean) time that an item will function satisfactorily before failure.

Mean Time to Failure (MTTF). The term often used for the mean life of non-repairable items.

Mean Time Between Failures (MTBF). The term often used for the mean life of repairable items.

(Note: The reliability for a time period equal to the mean life varies with the type of failure distribution; e.g., the reliability at the mean life of a normal failure-time distribution is 0.5, but it is 0.37 for the exponential distribution.)

Median Life. The time interval for which there is a 0.50 reliability (e.g., 50 percent of items that have been life-tested would be expected to fail before the median life and the other 50 percent would be expected to fail after the median life).

Failure Rate. The rate at which failures occur per unit time in the interval t to $t + h$, defined by

$$\lambda(t; h) = \frac{R(t) - R(t + h)}{hR(t)} \quad (26)$$

(Note: The term "failure rate" can be confusing because it is used in various ways. It sometimes represents the expected proportion of failures in an interval, provided all failures are instantly replaced -- especially in connection with the exponential distribution, which is discussed in a subsequent section. Sometimes the term is used to mean the conditional probability of failure during an interval, given survival at the beginning of the interval, in which case the divisor h in the above definition is omitted. In addition, the term is often used to signify the instantaneous failure rate or hazard rate as defined below.)

Hazard Rate. The instantaneous failure rate, defined as follows:

$$\begin{aligned} z(t) &= \lim_{h \rightarrow 0} \lambda(t; h) \\ &= \frac{-d \log R(t)}{dt} \\ &= \frac{f(t)}{R(t)} \end{aligned} \quad (27)$$

Note that $R(t)$ can be shown to be equal to the following expression:

$$R(t) = e^{-\int_0^t z(t)dt} \quad (28)$$

AMCP 706-191

4.4.4 Discrete Probability Distributions

4.4.4.1 Hypergeometric Distribution

The requirements of the hypergeometric distribution are as follows:

- (1) There are only two possible outcomes -- e.g., success or failure, defective or not defective.
- (2) There is a finite population size.
- (3) Sampling is performed without replacement (dependent trials).

Assume that a sample of n items is drawn from a population of size N that contains Np successes (an integer) and $N(1-p) = Nq$ failures (an integer). The hypergeometric probability density function gives the probability of obtaining x failures and $(n-x)$ successes in the sample. It is expressed as follows:

$$f(x) = \frac{\binom{Np}{x} \binom{Nq}{n-x}}{\binom{N}{n}}, \quad x = 0, 1, \dots, n \quad (29)$$

The cumulative distribution is

$$F(x) = \sum_{k=0}^x \frac{\binom{Np}{k} \binom{Nq}{n-k}}{\binom{N}{n}} \quad x = 0, 1, \dots, n \quad (30)$$

The mean is np , and the variance is $npq \left(\frac{N-n}{N-1} \right)$.

If N is large, so that the ratio n/N is small (say $\frac{n}{N} < .05$), hypergeometric probabilities can be closely approximated by the binomial probability distribution, discussed below.

Example: Lots of 30 items each have experienced an average portion defective of 20 percent, or 6 defectives. Thus, $Np = (30)(0.20) = 6$, $Nq = (30)(0.80) = 24$. If 5 items are sampled from a lot, what is the probability of getting (a) exactly 2 defectives?, (b) 2 or fewer defectives?, and (c) more than 2 defectives?

(a) Exactly two defectives:

From Equation 29,

$$f(2) = \frac{\binom{6}{2} \binom{24}{3}}{\binom{30}{5}} = \frac{6!}{2!4!} \frac{24!}{3!21!} = \frac{6 \cdot 5}{2 \cdot 1} \frac{24 \cdot 23 \cdot 22}{3 \cdot 2 \cdot 1} = \frac{30 \cdot 29 \cdot 28 \cdot 27 \cdot 26}{5 \cdot 4 \cdot 3 \cdot 2 \cdot 1} = 0.213$$

(b) Two or fewer defectives:

P [2 or less defectives] = $F(2)$; from Equation 30,

$$\begin{aligned} F(2) &= \sum_{k=0}^2 \frac{\binom{6}{k} \binom{24}{5-k}}{\binom{30}{5}} = \frac{\binom{24}{5}}{\binom{30}{5}} + \frac{\binom{6}{1} \binom{24}{4}}{\binom{30}{5}} + \frac{\binom{6}{2} \binom{24}{3}}{\binom{30}{5}} \\ &= 0.298 + 0.447 + 0.213 \\ &= 0.958 \end{aligned}$$

(c) More than two defectives:

$$\begin{aligned} P \text{ [more than 2 defectives]} &= 1 - P \text{ [2 or less defectives]} \\ &= 1 - F(2) = 1 - 0.958 = 0.042 \end{aligned}$$

4.4.4.2 Binomial Distribution

The requirements of the binomial distribution are as follows:

- (1) There are only two possible outcomes, success or failure.
- (2) The probability of each outcome is constant for all trials.
- (3) The trials are independent (equivalent to sampling with replacement).

For n trials with constant probability p for success and $(1-p)$ for failure, the probability density function for obtaining x successes is

$$f(x) = \binom{n}{x} p^x (1-p)^{n-x}, \quad x = 0, 1, 2, \dots, n \quad (31)$$

and the probability of x or fewer failures is given by the cumulative distribution function

$$F(x) = \sum_{k=0}^x \binom{n}{k} p^k (1-p)^{n-k}, \quad x = 0, 1, 2, \dots, n \quad (32)$$

where

$$\binom{n}{k} = \frac{n!}{k!(n-k)!}$$

$$k! = k(k-1)(k-2) \dots (3)(2)(1)$$

$$0! = 1$$

The mean number of failures is np , and the variance is $np(1-p)$.

Example: Assume that past experience indicates that parts produced from a continuous production process yield 5 percent defective. In a random sample of 30 parts (30 trials), what is the probability that 2 or fewer defectives will be found?

The following information is available:

Categories: "Success" = nondefective part
 "Failure" = defective part

Probabilities: Probability of success = $q = 1-p = 0.95$
 Probability of failure = $p = 0.05$

Sample size, n , is 30

Hence, from Equation 32,

$$P [k \leq 2] = P [k = 0, 1, \text{ or } 2] = F(2)$$

$$\begin{aligned} &= \sum_{k=0}^2 \binom{n}{k} p^k q^{n-k} \\ &= \frac{30!}{0!30!} (0.05)^0 (0.95)^{30} + \frac{30!}{1!29!} (0.05)^1 (0.95)^{29} \\ &\quad + \frac{30!}{2!28!} (0.05)^2 (0.95)^{28} \\ &= 0.812 \end{aligned}$$

4.4.4.3 Poisson Distribution

The Poisson distribution can be used as an approximation of the binomial distribution or as the distribution of number of independent occurrences in a continuum, such as time, length, or volume.

For an approximation of the binomial, the conditions are:

- (1) The binomial law applies.
- (2) The sample size, n , is large; and the probability of failure, p , is small. A practical rule of thumb is $p \leq 0.10$ and $np \geq 10$.

The probability density function is

$$f(x) = \frac{e^{-np} (np)^x}{x!} \quad (x \geq 0, p > 0, n > 0) \quad (33)$$

The parameter np represents the expected or average number of failures in n trials.

Example: Assume that a sample of 25 items is selected from a large lot in which 10 percent of the items are defective. What is the probability of two defectives in the sample?

From the Poisson approximation to the binomial,

$$f(2) = \frac{e^{-(25)(0.10)} [(25)(0.10)]^2}{2!} = 0.2565$$

The binomial probability is

$$f(2) = \binom{25}{2} (0.10)^2 (0.90)^{23} = 0.2659$$

If the Poisson is employed as the distribution of the number of independent occurrences in a continuum, such as time, length, or volume, the conditions are:

- (1) The number of expected occurrences (say successes) per given segment of the continuum (e.g., an interval of time) is a constant.
- (2) The number of occurrences produced in any subsegment is independent of the number of occurrences in any other subsegment.
- (3) No meaning can be ascribed to the number of non-occurrences; e.g., the number of telephone calls not made during a day, or the number of non-defects in a sheet of steel, cannot be evaluated.

If m is the expected number of occurrences per given segment of the continuum, the probability density function is

$$f(x) = \frac{e^{-m} m^x}{x!} \quad (34)$$

Both the mean and the variance are equal to m :

Example: Assume that an item will experience an average of λ failures per hour if each failure is instantly repaired or replaced. It is desired to find the probability that x failures will occur if this item is life-tested for t hours and failures are repaired or replaced with identical items.

If A is the average number of failures for one hour, then $m = \lambda t$ is the average number of failures for t hours. Hence, if x represents the number of failures (occurrences), from Equation 34:

$$f(x) = \frac{e^{-\lambda t} (\lambda t)^x}{x!}, \quad x = 0, 1, 2, \dots$$

AMCP 706-191

If n items are placed on test, the average number of failures is $m = nht$,
or

$$f(x) = \frac{e^{-n\lambda t} (n\lambda t)^x}{x!}, \quad x = 0, 1, 2, \dots$$

If $h = 0.001$ per hour, $t = 50$, and 10 items are put on test, then $m = nht = 10(0.001)(50) = 0.5$. The probability of observing two failures is

$$f(2) = \frac{e^{-0.5} (0.5)^2}{2!} = 0.076$$

4.4.5 Continuous Distributions

4.4.5.1 Exponential Distribution

The probability density of the exponential distribution is given by

$$f(t) \begin{cases} = \frac{1}{\theta} e^{-t/\theta}, & t \geq 0, \theta > 0 \\ = \lambda e^{-\lambda t}, & \lambda = 1/\theta \end{cases} \quad (35a)$$

$$(35b)$$

where

$$\begin{aligned} \text{Mean} &= \theta \\ \text{Variance} &= \theta^2 \end{aligned}$$

The exponential distribution is primarily used as a formula for waiting times, or, in reliability, as a formula for the time-to-failure density function. The latter use is a direct consequence of assuming that the probability of failure in the interval t to $t + h$, given survival to t , is a function only of h , the length of the interval, and is independent of the age of the product, t . This, in turn, implies that if a device has not failed after some period of operation, it is as good as new, which is equivalent to the statement that the hazard rate of the exponential is a constant that equals the reciprocal of the mean life, usually denoted by A .

The reliability function is

$$\begin{aligned} R(t) &= \int_t^{\infty} f(t) dt \\ &= e^{-t/\theta} \\ &= e^{-ht} \end{aligned} \quad (36)$$

At the mean life, θ , the reliability is

$$R(t = \theta) = e^{-\theta/\theta} = e^{-1} = 0.368$$

Given the reliability over a time interval, the mean life can be found from the equation

$$\theta = \frac{-t}{\log_e R(t)} \quad (37)$$

Figure 4-1 shows the exponential reliability function with time given in θ units. A short table of the exponential is given in Appendix C.

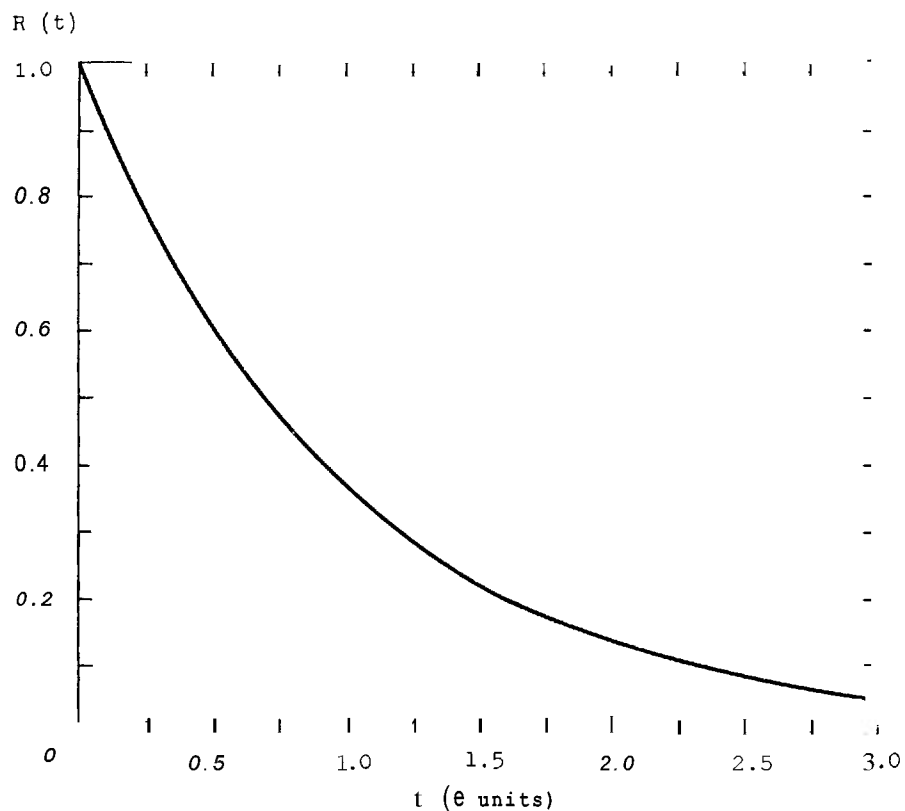

FIGURE 4.1
THE EXPONENTIAL RELIABILITY FUNCTION

The exponential, gamma, and Poisson distributions are related. For the Poisson distribution, the random variable is the number of failures in a given time interval. For the gamma distribution, the random variable is the time to the n th failure. For the exponential distribution, as a special case of the gamma, the random variable is the time to the first failure. "Poisson process" is a term used to encompass these situations.

AMCP 706-191

The mechanism underlying the exponential reliability function is that the hazard rate (or the conditional probability of failure in an interval, given survival at the beginning of the interval) is independent of the accumulated life.

The use of this type of "failure law" for complex systems is usually justified because of the many forces that can act upon the system and produce failure. Different deterioration mechanisms, different part hazard-rate functions, and varying environmental conditions often result in stress-strength combinations that produce failures randomly in time according to the exponential failure law.

Another justification for the exponential in long-life complex systems is the so-called "approach to a steady state," wherein the hazard rate is constant regardless of the failure pattern of individual parts. This state occurs as a result of the mixing of parts of different ages when failed elements in the system are replaced or repaired. As an example, assume that a system contains parts which have increasing hazard rates. When all parts are new, the system hazard rate is low; it increases as the parts age. When a failed part is replaced by a new one, the system hazard rate decreases, and it falls sharply when a number of replacements occur. However, it will again start to rise as these "second generation" parts begin to age. Thus, over a period of time, the system hazard rate decreases, and it falls sharply when a number of replacements occur. However, it will again start to rise as these "second generation" parts begin to age. Thus, over a period of time, the system hazard rate oscillates, but this cyclic movement diminishes in time and approaches a stable state with a constant hazard rate.

A third justification for assuming the exponential distribution is that the exponential is used as an approximation of some other density over a particular interval of time for which the true hazard rate is fairly constant. For example, if the true hazard-rate function is as shown in the curve below (assume that the system is debugged), assumption of an exponential for the period from 0 to 250 hours will give a reasonable approximation.

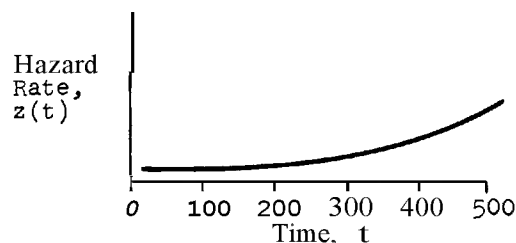

These arguments notwithstanding, indiscriminate use of the exponential (or indiscriminate use of any distribution, for that matter) can lead only to confusion and incorrectness. It is therefore obligatory on the part of the analyst to validate the use of any particular distribution function. Broadly speaking, there are two approaches to validation: (1) Historical -- i.e., examination of the past performance, where available, of the item; (2) Statistical -- i.e., "soundness of fit" (Chi-square and Kolmogorov-Smirnov tests).

4.4.5.2 Weibull Distribution

The probability density of the two-parameter Weibull distribution is given by

$$f(t) = \frac{\beta}{\alpha} t^{\beta-1} e^{-t^{\beta}/\alpha} \quad (38)$$

where

$$\begin{aligned} \text{Mean} &= \alpha^{1/\beta} \Gamma\left(\frac{1}{\beta} + 1\right) \\ \text{Variance} &= \alpha^{(2/\beta+1)} [\Gamma(2/\beta + 1) - \Gamma^2(1/\beta + 1)] \end{aligned}$$

Characteristics

The flexibility of this density is one of its desirable characteristics. a is a scale parameter and β is a shape parameter. When $\beta = 1$, this distribution reduces to the exponential.

Reliability Applications

The Weibull distribution is receiving wide application as the failure pattern of semiconductor devices and mechanical devices, and because of its flexibility, it is also being used to describe failure patterns at the unit and equipment levels. The hazard rate is constant when $\beta = 1$, is an increasing function of time when $\beta > 1$, and is a decreasing function when $\beta < 1$.

4.4.5.3 Gamma Distribution

The probability density* of the gamma distribution is given by

$$f(t) = \frac{e^{-t/b} t^{a-1}}{(a-1)! b^a}, \quad t \geq 0, \quad a \geq 0, \quad b \geq 0 \quad (39)$$

where

$$\begin{aligned} \text{Mean} &= ab \\ \text{Variance} &= a/b^2 \end{aligned}$$

* For "a" not an integer, $(a-1)! = \Gamma(a) = \int_0^{\infty} e^{-y} y^{a-1} dy$

Characteristics

The critical parameter is "a", which controls the shape of the curve; "b" is a scale parameter that determines the abscissa scale (i.e., changing b merely narrows or broadens the curve). When a is equal to 1, the distribution reduces to the exponential.

Reliability Applications

The gamma distribution is important in reliability for two reasons. First, it is an extremely flexible distribution and can therefore be used to fit the failure pattern of items in their various stages of development. When a = 1, the hazard rate is constant. It increases with time when a is greater than one and decreases with time when a is less than one.

The second reason is that the estimated mean life of the commonly used exponential distribution has a gamma density, which can be used to make probability statements for estimates and tests of the mean life.

4.4.5.4 Normal Distribution

The probability density of the normal distribution is given by*

$$f(t) = \frac{1}{\sigma\sqrt{2\pi}} e^{-1/2 \left(\frac{t-\mu}{\sigma}\right)^2}, \quad -\infty < t < \infty \quad (40)$$

where

Mean = μ

Variance = σ^2

Characteristics

The normal is one of the most widely used continuous densities. The density function is a symmetrical bell-shaped curve, as shown on the left.

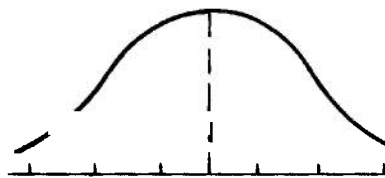

The cumulative function is not directly integrable, but tables of the normal cumulative distribution with a mean of zero and a variance of one (called the standard or normalized form) are widely available. These tables can be used for any normal distribution by transferring the original t variable to a new variable, y, by the equation

$$y = \frac{t-\mu}{\sigma} \quad (41)$$

*The letter t will be generally used to denote the random variable, which is consistent with the use of this letter for failure time.

The variable y is normally distributed with a mean of zero and a variance of one. Thus, to find the probability that t is less than say, c , one can use the tables by first letting $y' = \frac{c - \mu}{\sigma}$ and finding the probability that $y \leq y'$ from the tables. A condensed table of the standard normal is given in Appendix C. Under appropriate conditions the normal distribution can be used to approximate the binomial and Poisson probability laws (see any standard statistical text).

Example: Assume $\mu = 100$ and $\sigma = 5$. It is desired to find the probability of obtaining a value between 95 and 110 on a single trial.

Let

$$y_1 = \frac{95-100}{5} = -1$$

$$y_2 = \frac{110-100}{5} = 2$$

Then

$$\begin{aligned} p [95 < t < 110] &= p [-1 < y < 2] \\ &= F(2) - F(-1) \\ &= 0.977 - 0.159 \\ &= 0.818 \end{aligned}$$

Reliability Applications

Frequently, the normal distribution applies to items in which the failure occurs as a result of some wear-out phenomenon, since the hazard rate of the normal distribution increases with time, in a manner consistent with a wear-out process. Since the normal distribution implies both negative and positive values, it should not be used unless one of the following three conditions is met:

- (1) $\mu/\sigma \geq 3$ (this condition establishes that the probability of a negative failure time is small enough to ignore)
- (2) all negative times observed as zero-hour failures are the result of wear-out during production testing, checkouts, installations, etc.

AMCP 706-191

- (3) A truncated normal distribution is employed that distributes the probability area from $-\infty$ to 0 over the positive range 0 to ∞ . The distribution's density is

$$f(t) = \begin{cases} 0, & \text{for } t < 0 \\ \frac{1}{\alpha \sigma \sqrt{2\pi}} e^{-1/2 \left(\frac{t-\mu}{\sigma}\right)^2}, & \text{for } t > 0 \end{cases} \quad (42)$$

where

$$\alpha = \int_{-\infty}^0 \frac{1}{\sigma \sqrt{2\pi}} e^{-1/2 \left(\frac{t-\mu}{\sigma}\right)^2}$$

A characteristic of the normal distribution is that the mean life and median life are each equal to the time interval for which the reliability is 0.50.

Example: Assume that an item with a normal time-to-failure distribution has a mean life of 300 hours and a standard deviation of 40 hours ($\mu = 300 > 3\sigma = 120$). What is the probability that this item will operate at least 250 hours without failing?

$$\begin{aligned} R(250) &= 1 - F(250) \\ &= 1 - \int_{-\infty}^{250} \frac{1}{40 \sqrt{2\pi}} e^{-1/2 \left(\frac{t-300}{40}\right)^2} dt \end{aligned}$$

If $y = \frac{t-300}{40}$, the limit $t = 250$ transforms to

$$y = \frac{250-300}{40} = -1.25$$

and

$$\begin{aligned} R(t=250) &= R(y=-1.25) = 1 - \int_{-\infty}^{-1.25} \frac{1}{\sqrt{2\pi}} e^{-y^2/2} dy \\ &= 1 - 0.106 \\ &= 0.894 \end{aligned}$$

4.4.5.5 Log-Normal Distribution

The probability density of the log-normal distribution is given by

$$f(t) = \frac{1}{\omega t \sqrt{2\pi}} e^{-1/2 \left(\frac{\log t - \gamma}{\omega} \right)^2} t, \quad \sigma > 0, \quad (43)$$

where

$$\text{Mean} = e^{\gamma + \omega^2/2}$$

$$\text{Median} = e^{\gamma}; \quad \log(\text{median}) = \gamma$$

$$\text{Variance} = e^{2\gamma} + \omega^2 (e^{\omega^2} - 1)$$

Characteristics

If the logarithm of a variable is normally distributed, the variable has a log-normal probability distribution. The probability density function is positively skewed, a large variance being associated with much skewness. Three log-normal distributions with identical means but different variances are plotted at the left.

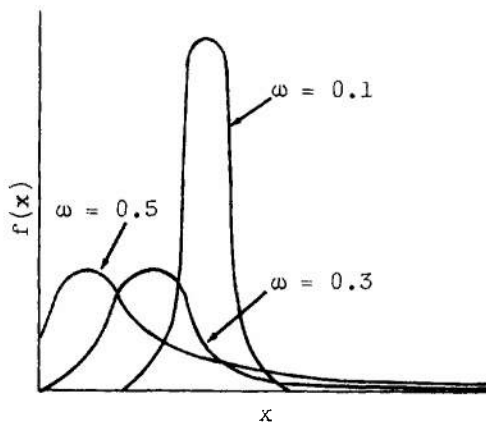
Reliability Applications

The hazard rate of the log-normal increases with time until the mode (most likely failure time) is reached (the time corresponding to the maximum ordinate of the density function), after which it decreases. The median life is the more convenient and usual measure of central tendency since -- unlike the mean -- it is independent of the variance.

The use of the log-normal distribution has been found to reflect adequately the failure pattern of many semiconductor devices and is also often appropriate for system or equipment time-to-repair distributions.

4.4.5.6 Other Distributions

There are many other important probability distributions that have not been discussed. Such distributions as the χ^2 (chi square) and the t are often used

AMCP 706-191

for inferential purposes. Some of the specific uses of these distributions in reliability and maintainability analysis are discussed in the following section.

4.5 STATISTICAL ANALYSIS OF TEST DATA -- ESTIMATION

This section reviews important statistical aspects of the evaluation of tests conducted to make reliability and maintainability inferences about a population of items through estimation procedures. The purpose of estimation is to describe pertinent characteristics about a population through analysis of data on samples. The two major approaches to estimation are as follows:

Nonparametric estimates, those which are made without assumption of any particular form for the probability distribution.

Parametric estimates, those which are based on a known or assumed distribution of the population characteristic of interest. The constants in the equation that describe the probability distribution are called parameters.

As an example of these two approaches, suppose it is desired to estimate the probability that an item will survive for 50 hours. Twenty sample items are tested until they all fail. For the parametric estimate of the 50-hour survival probability, $R(50)$, if an exponential distribution is assumed, $R(50)$ can be obtained from the expression $e^{-50/\hat{\theta}}$, where $\hat{\theta}$ is the estimate of the mean time to failure based on an exponential distribution of failure times. For the nonparametric estimate, the estimate of $R(50)$ is simply the proportion of the sample that survived 50 hours.

Generally, nonparametric estimates are not as efficient as parametric estimates, since the former require greater sample sizes to achieve the same precision as the latter. On the other hand, since no assumption about the population distribution is made for nonparametric tests, errors arising from incorrect assumptions are not encountered.

The three common types of estimates are:

- (1) Point estimate -- a single-value estimate of a parameter or characteristic
- (2) Interval estimate -- an estimate of an interval that is believed to contain the true value of the parameter or Characteristic
- (3) Distribution estimate -- an estimate of the probability distribution of a characteristic

The most common type of point estimate is the maximum-likelihood estimate, i.e., the value that has the maximum probability of producing the observed sample results. A confidence-interval estimate, the most common type of interval estimate, is one for which there is a known degree of confidence (in a probability

sense) that the true value of the unknown parameter or characteristic lies within a computed interval. Whenever possible, a confidence-interval estimate should be given along with the point estimate, for then the degree of precision in the point estimate can be assessed. For example, assume that a 100-hour MTEF is desired. Samples of two different designs are tested and the results are as follows:

<u>Characteristic</u>	<u>Item A</u>	<u>Item E</u>
Point Estimate, $\hat{\theta}$	95 hours	105 hours
90% Confidence Interval ($\hat{\theta}_L, \hat{\theta}_U$)	(90-115)	(40-170)

Although the point estimate for Item B is above the 100-hour requirement, it is seen that the precision of the estimate as determined from the length of the confidence interval is poor in comparison with that of Item A. In this case, since it is more certain that Item A will be close to or exceed the requirement than it is that Item B will, the former may be chosen. If only the point estimates were considered, the reverse decision probably would be made.

Two steps are generally involved in making a distribution estimate: (1) hypothesizing or determining through data analysis the form of the distribution, and (2) making point estimates of appropriate parameters that will completely describe the distribution.

Sections 4.5.1 and 4.5.2 summarize various types of estimation procedures. The general approach for analyzing test data for estimation purposes consists of the following steps:

- State objectives for test data analysis
- Determine appropriate forms of statistical estimates to meet objectives
- Perform any necessary preliminary analyses such as analysis of the distributional form
- Determine if parametric or nonparametric procedures are to be used
- Apply appropriate procedures or equations to obtain estimates
- Note unusual data results and set up test plan for confirming any new hypotheses
- Report on results completely, describing test design, data collection, raw data, and data analysis

4.5.1 Nonparametric Estimation

A summary of various nonparametric estimates is presented in this section.

4.5.1.1 Point and Interval Estimates of Reliability or Maintainability

The simplest estimate of reliability for a time interval (t), denoted by $\hat{R}(t)$, is to calculate the proportion of items that survive over that time interval. Thus if n items are put on test, and f failures occur before time t,

$$\hat{R}(t) = \frac{n-f}{n} \tag{44}$$

Similarly, the probability of completing a specified maintenance action by time t is

$$\hat{M}(t) = \frac{r}{n} \tag{45}$$

where r is the number of such actions completed by time t out of a total of n repair actions.

These equations are for the case of no withdrawal of items (censorship) during the test.

Construction of a confidence interval about $\hat{R}(t)$ or $\hat{M}(t)$ is based on the fact that these estimates correspond to a binomial parameter. The equations for confidence limits are as follows:

Lower (1 - α)% Limit*

$$\hat{R}_{L,\alpha} = \left[\frac{1}{1 + \frac{f}{n-f+1} F_{\alpha} (2f+2, 2n-2f)} \right] \tag{46}$$

where

$F_{\alpha} (2f+2, 2n-2f)$ is the upper α% point of the F distribution with 2f+2, and 2n-2f degrees of freedom. A condensed set of F values is presented in Appendix C.

Upper (1 - α)% Limit

$$\hat{R}_{U, 1-\alpha} = \frac{1}{1 + \frac{f}{n-f+1} \frac{1}{F_{\alpha} (2n-2f+2, 2f+2)}} \tag{47}$$

For a two-sided (1 - α)% limit, the Interval is

$$\left(\hat{R}_{L,\alpha/2}, \hat{R}_{U, 1-\alpha/2} \right) \tag{48}$$

* In this appendix, (1-a)% is to be interpreted as the (1-a) fractile or, equivalently, as 100 (1-a)%, where a is a decimal.

Figure C-1* can be used to obtain the approximate limits directly for $n \geq 30$. The horizontal axis is the point-estimate value, e.g., R or M. Starting at this estimate and proceeding vertically to the appropriate sample-size curve and then horizontally to the Y axis gives the appropriate confidence limit.

Example: Assume $n = 50$ items are put on test and $f = 10$ failures are observed before 60 hours. Find (1) the point estimate of $R(60)$, (2) the lower 90%-confidence limit, and (3) the two-sided 90%-confidence limit.

(1) From Equation 44,

$$\hat{R}(60) = \frac{50-10}{50} = 0.80$$

(2) From Equation 46,

$$\hat{R}_{L, 0.10} = 1 / \left[1 + \frac{11}{40} F_{0.10} (22, 80) \right]$$

From Table C-4,

$$F_{0.10} (22, 80) \approx 1.5$$

and

$$\begin{aligned} \hat{R}_{L, 0.10} &= 1 / \left[1 + \frac{11}{40} (1.5) \right] \\ &\approx 0.71 \end{aligned}$$

In Figure C-1, for $R = 0.8$, the 90%-lower-limit curve yields a value of approximately 0.68.

(3) From Equation 47,

$$\hat{R}_{L, 0.05} = 1 / \left[1 + \frac{11}{40} F_{0.05} (22, 80) \right] = 0.684$$

$$\hat{R}_{U, 0.95} = 1 / \left[1 + \frac{10}{41} F_{0.05} (8, 20) \right] = 0.888$$

From Figure C-1, the approximate 90% interval is (0.69, 0.88)

*Extracted from RADC Reliability Notebook.

AMCP 706-191

The equations are used in the same way for confidence limits if maintenance-time data rather than failure-time data are being analyzed.

4.5.1.2 Reliability Functions

If point estimates of $R(t)$ are made for various values of t , a relationship of R to time, t , which is the reliability function, can be developed. The reliability case is discussed in detail here since essentially the same procedures are used for maintainability.

No Censorship

Two methods are possible when no items are censored -- i.e., no items are withdrawn for reasons other than failure.

- (1) Estimation at fixed points in time, t_1 :

$$\hat{R}(t_1) = \frac{n - \sum_{j=1}^i f_j}{n} = \frac{n - F(t_1)}{n} \quad (49)$$

where

n = number of items originally on test

f_j = number of failures in the interval $t_{j-1} < t \leq t_j$

$F(t_1)$ = number of failures occurring on or before t_1

- (2) Estimation of $R(t)$ at failure times, t_k :

$$R(t_k) = \frac{n - k + 1}{n + 1} \quad (50)$$

where

k is the number of failures occurring on or before the ordered failure time t_k ; i.e., the failure times are ordered so that $t_1 \leq t_2 \leq t_3 \leq \dots$

Thus if the fourth failure out of 10 observations occurs at 20 hours,

$$t_4 = 20 \text{ and } \hat{R}(20) = \frac{10 - 4 + 1}{10 + 1} = 7/11$$

For large samples (say, $n > 30$), Equations 49 and 50 yield nearly identical results.

Example: In a test of 50 items, failures occurred at the following elapsed hours: 7, 18, 25, 27, 35, 41, 47, 50, 54, 60. Obtain the observed reliability function at (1) every 10-hour period up to 60 hours, and (2) each failure time.

- (1) Observed reliability functions at 10-hour intervals, from Equation 49:

t_1	f_j	$F(t_1)$	$n-F(t_1)$	$R(t_1) = \frac{n-F(t_1)}{n}$
0	0	0	50	1.00
10	1	1	49	0.98
20	1	2	48	0.96
30	2	4	46	0.92
40	1	5	45	0.90
50	3	8	42	0.84
60	2	10	40	0.80

- (2) Observed reliability functions at each failure time, from Equation (50):

k	t_k	$n-k+1$	$R(t_k) = \frac{n-k+1}{n+1}$
0	0	51	1.00
1	7	50	0.980
2	18	49	0.961
3	25	48	0.941
4	27	47	0.922
5	35	46	0.902
6	41	45	0.882
7	47	44	0.863
8	50	43	0.843
9	54	42	0.824
10	60	41	0.804

The two functions are plotted in Figure 4-2.

Censorship

If terminated or censored observations occur, and censorship takes place at fixed times, then

$$R(t_1) = \prod_{j=1}^1 \frac{n_j - f_j}{f_j} \tag{51}$$

AMCP 706-191

where n_j is the number of items starting the j^{th} interval; f_j is the number of failures in the interval (t_{j-1}, t_j) . At t_{j-1} , the end of the $(j-1)^{\text{st}}$ interval, some items will be removed; hence $n_j = n_{j-1} - f_{j-1} - w_{j-1}$ (w_{j-1} = number of censored items at t_{j-1}).

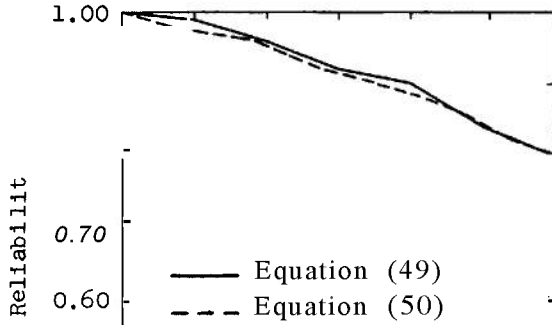

$$\hat{R}(t_1) = \prod_{j=1} \frac{n_j}{n_{j+1}}$$

where n_j is the number of items starting the j^{th} interval. If more than one

OBSERVED RELIABILITY FUNCTIONS

For terminated or censored items occurring randomly within a time interval between failures,

$$\hat{R}(t_1) = \prod_{j=1} \frac{1}{\frac{n_j - w_j/2}{n_j - w_j/2 + 1}} \tag{53}$$

where

w_j is the number of withdrawals during the j^{th} time interval

Example: For the data of the example given above in "No Censorship", assume that one good item was withdrawn every ten hours. Calculate the reliability function at ten-hour intervals.

The following values are derived from Equation 51:

j	Interval (hours)	r_j	w_j	n_j	$\frac{n_j - f_j}{f_j}$	$\frac{1}{\frac{n_j - w_j/2}{n_j - w_j/2 + 1}}$	t_1	$\hat{R}(t_1)$
1	0 ≤ 10	1	1	50	0.980	1	10	0.980
2	10 ≤ 20	1	1	48	0.979	2	20	0.959
3	20 ≤ 30	2	1	46	0.956	3	30	0.917
4	30 ≤ 40	1	1	43	0.977	4	40	0.896
5	40 ≤ 50	3	1	41	0.927	5	50	0.831
6	50 ≤ 60	2	-	37	0.946	6	60	0.786

Example: In addition to the failure times given above in the example of "No Censorship", withdrawals were made at the following times: 2, 5, 20, 22, 25, 47, and 56 hours. Calculate the reliability function at the failure times.

The following values are derived from Equation 53:

j	Interval (hours)	f_j	w_j	n_j	$n_j - w_j / 2$	$\frac{n_j - w_j / 2}{n_j - w_j / 2 + 1}$	t_j	$\hat{R}(t_j)$
1	0 ≤ 7	1	2	50	49	0.980	7	0.980
2	7 ≤ 18	1	0	47	47	0.979	18	0.959
3	18 ≤ 25	1	3	46	44.5	0.978	25	0.938
4	25 ≤ 27	1	0	42	42	0.977	27	0.916
5	27 ≤ 35	1	0	41	41	0.976	35	0.894
6	35 ≤ 41	1	0	40	40	0.976	41	0.873
7	41 ≤ 47	1	1	39	38.5	0.975	47	0.851
8	47 ≤ 50	1	0	37	37	0.974	50	0.829
9	50 ≤ 54	1	0	36	36	0.973	54	0.806
10	54 ≤ 60	1	1	35	34.5	0.972	60	0.784

4.5.1.3 Maintainability-Functions

Where maintainability is concerned, censorship rarely presents a problem since observation can usually be continued until all maintenance actions are complete. The nonparametric estimates of the probability that a maintenance action will be completed by time t are exactly the complement of the reliability formulas if f , the number of failures, is replaced by r , the number of completed repair actions.

Thus, for estimating $M(t)$ at fixed points in time t_j , the following is obtained for the no-censorship case:

$$\hat{M}(t_j) = \frac{1}{n} \sum_{j=1}^j r_j \tag{54}$$

where

n = number of maintenance actions observed

r_j = number of completed repairs in the interval $t_{j-1} < t \leq t_j$

For estimates at repair times, t_k ,

$$\hat{M}(t_k) = \frac{k}{n + 1} \tag{55}$$

when k is the number of repair actions completed on or before the ordered repair time t_k .

Example: Assume that nine repair actions are observed as follows: 0.2, 0.3, 0.4, 0.4, 0.5, 0.6, 0.8, 1.2, 2.0

Then, from Equation 55, the following is obtained:

t	k	$M(t)$
0.2	1	0.10
0.3	2	0.20
0.4	4	0.40
0.5	5	0.50
0.6	6	0.60
0.8	7	0.70
1.2	8	0.80
2.0	9	0.90

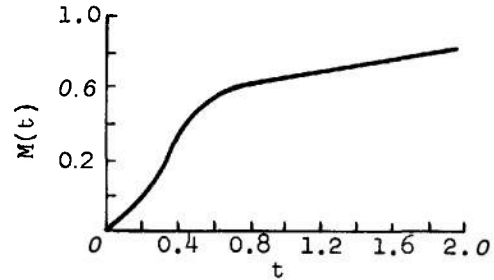

4.5.1.4 Confidence Limits for Reliability and Maintainability Functions

Estimating reliability or maintainability at fixed points in time without censorship corresponds to estimating a binomial parameter. Equations 46, 47, and 48 can be used to obtain limits for the observed functions for cases of no censorship. If censorship takes place, the number of sample items varies. If the total number of censored items, w , is small compared with n (say $w/n < 0.10$), then, as a rough approximation, the sample-size value to be used is $n-w/2$.

4.5.1.5 Measures of Central Tendency and Dispersion

The usual measure of central tendency is the mean or average value; and the measure of dispersion is the variance or its square root, the standard deviation. For the nonparametric case, these measures are valid only if the data are not truncated or censored -- that is, for the reliability case all sample items are tested to failure, and for the maintainability case all started repair actions are completed.

If t_i represents either a failure time or a repair time, the mean or average value is estimated by

$$\bar{t} = \frac{1}{n} \sum_{i=1}^n t_i \tag{56}$$

where n is the number of observed times. The variance is estimated by

$$s^2 = \frac{1}{(n-1)} \sum_{i=1}^n (t_i - \bar{t})^2 \tag{57}$$

For large n (say greater than 30), the central-limit theorem may be used; this states that the quantity

$$y_n = \frac{t - \mu}{\sigma/\sqrt{n}} \quad (58)$$

has approximately a normal distribution with mean 0 and variance 1 where μ and σ are the population mean and variance, respectively.

For large n , s can be used as an estimate for σ , and an approximate $(1 - \alpha)\%$ two-sided confidence interval for μ is obtained from the equation

$$P\left[\bar{t} - t_{\alpha/2, n-1} s/\sqrt{n} \leq \mu \leq \bar{t} + t_{\alpha/2, n-1} s/\sqrt{n}\right] \quad (59)$$

where

$t_{\alpha/2, n-1}$ is the $\alpha/2$ percentage point of the t statistic with $n-1$ degrees of freedom. These values are tabulated in Table C-2. A one-sided limit is obtained by replacing $t_{\alpha/2, n-1}$ by $t_{\alpha, n-1}$ for the limit desired.

Example: Assume that 30 failure times are observed and that $\bar{t} = 150$, $s = 40$. Then the lower 95% confidence limit for the mean failure time, θ , is

$$P\left[\bar{t} - t_{0.05, 29} s/\sqrt{n} \leq \theta\right]$$

or

$$\hat{\theta}_{L, 0.05} = 150 - 1.70 \frac{40}{\sqrt{30}} = 137.4$$

For the nonparametric case, the more usual type of central-tendency measure is the median; for dispersion, it is the difference between two percentage points on the estimated distribution.

Median-Point and Interval Estimates

The median is that value which divides the distribution in half. Thus the median failure time, $t_{0.50}$, is that value of t for which

$$R(t) = 0.50$$

The estimate of $t_{0.50}$ is obtained by constructing the reliability or maintainability function by the methods described and by plotting the distribution to find the value of t for which $R(t)$ or $M(t) = 0.50$. For the reliability case, this procedure requires that testing continue until at least half of the items fail.

AMCP 706-191

Confidence intervals for $t_{0.50}$ are obtained from the equation

$$P \left[t_r < t_{0.50} < t_{n-r+1} \right] = \sum_{i=r}^{n-r} \frac{n!}{i!(n-i)!} \left(\frac{1}{2}\right)^n \quad (60)$$

where t_r and t_{n-r+1} are the r^{th} and $(n-r+1)^{\text{th}}$ observed ordered times in the sample. Note that the confidence levels that can be used are restricted to the values obtainable from the right-hand side of Equation 60.

One-sided limits are given as follows:

$$P \left[t_r < t_{0.50} \right] = \sum_{i=r}^n \binom{n}{i} \left(\frac{1}{2}\right)^n \quad (61)$$

$$P \left[t_{0.50} < t_s \right] = \sum_{i=0}^{s-1} \binom{n}{i} \left(\frac{1}{2}\right)^n \quad (62)$$

where

$$\binom{n}{i} = \frac{n!}{i!(n-i)!} = \frac{n(n-1)(n-2)\dots(n-i-1)}{i(i-1)\dots3\cdot2\cdot1}$$

Example: From the data of the example given in Subsection 4.5.1.3, the median repair time $t_{0.50} = 0.5$. From Equation 60,

$$P \left[t_3 < t_{0.50} < t_7 \right] = \sum_{i=3}^6 \frac{9!}{i!(9-i)!} \left(\frac{1}{2}\right)^9 = 0.8203$$

Tables of the binomial distribution can be used to evaluate the sum on the right to yield a 90.82% two-sided interval of (0.4, 0.8). For a one-sided upper interval, from Equation 62,

$$P \left[t_{0.50} < t_8 \right] = \sum_{i=0}^7 \frac{9!}{i!(9-i)!} \left(\frac{1}{2}\right)^9 = 0.9805$$

or a 98.05% upper limit for $t_{0.50} = 1.2$.

P-Percent Range: A Measure of Dispersion

The 50% or interquartile range defined by

$$\tau_{0.50} = t_{0.75} - t_{0.25} \quad (63)$$

is often used to measure dispersion in nonparametric estimation procedures. For reliability t_p is the value of t for which $\hat{R}(t) = 1-P$, while for maintainability it is the value of t for which $M(t) = P$. $\tau_{0.50}$ is the number of hours over which the middle 50% of the sample observations were recorded. For the data of Example 5, $\tau_{50} = 1.0 - 0.325 = 0.675$.

Values of P other than 50% can be used. For example, the 90-percent range $\tau_{0.90} = t_{0.95} - t_{0.05}$. For the reliability case, with truncated (non-failed) items, the P -percent range can be used if only the minimum value of $\hat{R}(t)$ is less than 0.50 and the maximum value of P is $[1 - 2 \min \hat{R}(t)]$.

4.5.2 Parametric Estimates

Statistical estimation procedures based on a known or assumed form of the probability distribution function are presented in this section. The characteristics of the distributions considered here are discussed in Section 4.4.

4.5.2.1 Determining the Form of the Distribution

The validity of parametric estimates depends greatly on the validity of the assumed distributional form. In some cases, the knowledge of the experiment that produced the data will dictate what the distribution should be. For example, in testing for defects, the number of defective items in a sample of n items is distributed binomially if each sample item is randomly and independently selected from a lot and tested, and if the outcome is either good or defective. In most cases, however, there is no indication of what the true population distribution is. Two fairly simple procedures for analyzing test data to determine the distributional form are presented below. These procedures are called goodness-of-fit tests.

Graphical Procedures

The graphical procedures for goodness of fit involve plotting the sample distribution and comparing it visually with the generic forms of known distribution functions. To aid in such types of analysis, special graph papers have been constructed so that when the observed distribution is plotted, a straight line will result if the distribution conforms.

To test for the exponential distribution, where $R(t) = e^{-t/\theta}$, it is noted that $\ln R(t) = -t/\theta$. Thus if the observed reliability data conform to the exponential failure law, the natural logarithm of the observed reliability function will plot as a straight line against t .

AMCP 706-191

Special types of graph paper for the normal, log-normal, and Weibull distributions can be used for goodness-of-fit tests.

Kolmogorov-Smirnov Test

The Kolmogorov-Smirnov test is an analytical procedure for testing goodness of fit, although the easiest means for performing such a test is graphical. The procedure involves comparing the observed distribution with a completely specified theoretical distribution and finding the maximum deviation. This deviation is then compared with a critical value that is dependent on a preselected level of significance.

The steps are as follows:

- (1) Completely specify the theoretical distribution; that is, if the distribution to be tested has k parameters in the density function, values of each of the k parameters must be specified.*
- (2) Obtain the observed reliability or maintainability function and plot on a graph.
- (3) Find the critical value d from Table C-5, Appendix C, for the selected significance level and observed number of failures. A significance level of α means that $\alpha\%$ of the time the test will reject the hypothesis that the distribution conforms to the one under test when in fact it does. Often this is stated as the $100(1-\alpha)\%$ confidence level.
- (4) Draw curves at a distance of d above and below the specified theoretical distribution. These curves then make up a decision band.
- (5) On the same graph, plot the observed distribution.
- (6) If the observed distribution falls completely within the decision band, the conclusion is that the assumed distribution is correct. If any point of the observed function falls outside the decision band, the assumed distribution is rejected.

In many cases, one is interested only in the form of the distribution and has no basis for parameter specification. In these cases, the parameters can be estimated from the test data to obtain the theoretical cumulative function. However, the critical d values in Table C-5 are too large and will lead to conservative results (lower significance level) since if the observed d value is greater than the critical d value, there is high assurance that the hypothesized population form is incorrect. However, the chances of accepting the hypothesis if it is false is also increased. Results of Monte Carlo investigations have shown that the following adjustments to Table C-5 can be made to yield approximately valued critical values for the normal and exponential distributions.

Normal distribution - estimate μ & σ from the data

Multiply d values in Table C-5 by 0.67

*See following discussion for the case in which parameters are estimated from the data.

Exponential Distribution - estimate θ from the data
 Multiply d values in Table C-5 by 0.80

Example: Assume that the following failure times are observed when a total of 20 items are tested:

18, 25, 28, 39, 40, 48, 60, 66, 80, 81, 83, 96, 105, 108, 130 (5 items survived past 130 hours)

(1) Obtain Theoretical Distribution

Suppose a test is being made for an exponential distribution. Since the reliability function for the exponential is $R(t) = e^{-t/\theta}$, where θ is the mean failure time, the following estimate can be used:

$$\hat{\theta} = \frac{\text{Total Observed Life*}}{\text{Number of Failures}}$$

$$= \frac{\text{Total Time for Failed Items} + \text{Total Time for Non-Failed Items}}{\text{Number of Failures}}$$

or

$$\hat{\theta} = \frac{962 + 650}{15} = 107.5 \text{ hours}$$

Then the estimated theoretical reliability function is

$$\hat{R}(t) = e^{-t/107.5}$$

This function is also plotted in Figure 4-3.

(2) Calculate Observed-Reliability Function

Equation 49 provides the following calculation for the observed reliability function (plotted in Figure 4-3):

t_k	k	$n-k+1$	$R(t_k) = \frac{n-k+1}{n+1}$
8	1	20	0.952
10	2	19	0.905
18	3	18	0.857
19	4	17	0.810
40	5	16	0.762
48	6	15	0.714
60	7	14	0.667
66	8	13	0.619
80	9	12	0.571
81	10	11	0.523
83	11	10	0.476
96	12	9	0.428
105	13	8	0.380
108	14	7	0.333
130	15	6	0.285

*See Subsection 4.5.2.3.

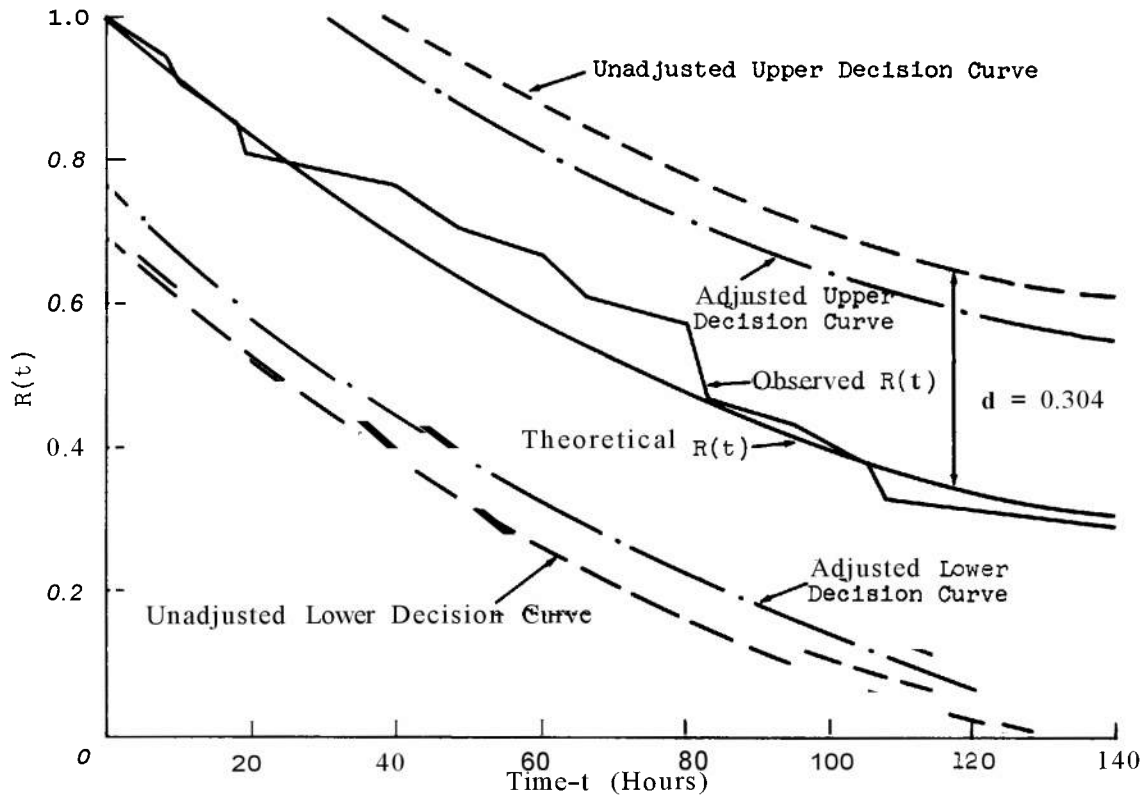

FIGURE 4-3

KOLMOGOROV-SMIRNOV TEST FOR EXPONENTIAL DISTRIBUTION

(3) Obtain Critical d Value

From Table C-5, Appendix C, the unadjusted critical d value for a sample size of 20 is 0.304 when testing is being done at the 10% significance level. By use of the correction factor 0.80 (since θ is estimated from the data) the adjusted critical value becomes 0.243.

(4) Plot Decision Curve

The unadjusted decision curves are constructed by adding and subtracting 0.304 to the theoretical curve, and the adjusted curves are obtained by adding 0.243 to the theoretical curve. These curves are also shown in Figure 4-3.

(5) Decision

Since the observed reliability function falls within the decision curves, the hypothesis of exponentiality cannot be rejected. For small sample sizes, the decision curves are quite wide. For this example, it is likely that other distributions, such as the normal or Weibull, will also not be rejected.

4.5.2.2 Discrete Distributions

The two most common discrete distributions involved in reliability and maintainability testing are the binomial and Poisson distributions.

Binomial

The random variable, x , is the number of occurrences of an attribute in n independent trials when the attribute is classified by either of two mutually exclusive categories. For reliability and maintainability, the attribute of interest is normally a successful outcome, that is, non-failure or satisfactory repair.

The probability density function is expressed as follows:

$$P(x; p, n) = \binom{n}{p} p^x (1-p)^{n-x} \quad (64)$$

where

$P(x; p, n)$ = probability of x occurrences in n trials when the constant occurrence probability on one trial is p .

For the binomial distribution, the mean and variance are:

$$\text{Mean: } \mu = np$$

where

μ is the expected number of occurrences in n trials

$$\text{Variance: } \sigma^2 = np(1-p)$$

Estimates of these values are as follows:

$$\hat{p} = \frac{r}{n} \quad (65)$$

$$\hat{\mu} = r \quad (65A)$$

$$\hat{\sigma}^2 = (n-r) \frac{r}{n} \quad (66)$$

where

r is the number of observed occurrences in n trials

AMCP 706-191

Equations 46, 47, and 48 are used to obtain confidence limits on p . For $n \geq 30$, Figure C-1, Appendix C, can be used.

Example: In a test of 50 items, 46 successes were observed. What is the point estimate of success probability and the associated 90%-confidence limits?

$$\hat{p} = r/n = 46/50 = 0.92$$

From Figure C-1, Appendix C, the 90%-confidence interval is

$$(0.83, 0.97)$$

Poisson Distribution

The random variable, x , is the number of occurrences of an attribute per unit segment (e.g., per unit time). If an item exhibits a constant failure rate, the number of failures in a fixed period of time is Poisson-distributed if failures are replaced as they occur.

The probability density function is expressed as follows:

$$P(x; m, t) = \frac{e^{-mt} (mt)^x}{x!} \quad (67)$$

where

$P(x; m, t)$ = probability of x occurrences in t segments if Poisson parameter is m

m = the mean number of occurrences per unit segment

For the Poisson distribution, the mean and variance are:

Mean: mt

Variance: mt

The estimate of the mean is as follows:

$$\hat{m} = \frac{r}{t} \quad (68)$$

where

r is the number of observed occurrences in t unit segments

To find $(1 - \alpha)\%$ confidence limits on m , given r occurrences in t unit segments, m_L and m_U must be solved for the following equations:

For a lower $(1 - \alpha)\%$ limit, solve for M_L in the equation

$$\sum_{k=0}^{r-1} \frac{e^{-M_L} M_L^k}{k!} = 1 - \alpha \quad (69)$$

Then

$$\hat{m}_L = \frac{M_L}{t}$$

For an upper $(1 - \alpha)\%$ limit, solve for M_U in the equation

$$\sum_{k=0}^r \frac{e^{-M_U} M_U^k}{k!} = \alpha \quad (70)$$

Then

$$\hat{m}_U = \frac{M_U}{t}$$

For two-sided limits, use $1 - \alpha/2$ and $\alpha/2$ in Equations 69 and 70, respectively. Tables of the Poisson function are available for such calculations."

Example: Assume that ten constant-failure-rate items are put on test, each for a period of 100 hours. When they fail, they are replaced by new items. A total of 15 failures occurred. Obtain the estimate of m , the mean number of failures per 100-hour interval, and obtain the 95%-confidence limits.

The estimate of m is r/t . Since 15 failures have been observed in ten 100-hour intervals,

$$\hat{m} = \frac{r}{t} = \frac{15}{10} = 1.5$$

Hence, 1.5 failures per 100 hours can be expected.

From Equations 69 and 70, the 95%-confidence interval for m is

$$(0.84 \leq m \leq 2.47)$$

*R. Ryswick and G. Weiss, Tables of the Incomplete Gamma Function of Integral Order, U.S. Naval Ordnance Laboratory, 1960, ASTIA Number AD251377.

4.5.2.3 Continuous Distributions

Descriptions of and estimation procedures for continuous distributions are presented in this section. Specific distributions considered are the exponential, normal, log normal, and Weibull.

Exponential Distribution

The random variable, t , is the number of unit segments occurring before an event. In reliability, t represents hours or cycles, and the event is item failure. In maintainability, t can be maintenance downtime, and the event is the completion of a maintenance action. It is assumed here that t represents hours and the events represent failures.

The probability distribution function is expressed as follows:

$$f(t; \lambda) = \lambda e^{-\lambda t} \tag{71}$$

where

$t \geq 0$ and λ is the mean number of failures per unit time (per hour), commonly called the failure or hazard rate

Since λ is equal to the reciprocal of the mean number of hours before a failure, the following can be written:

$$f(t, \theta) = \frac{1}{\theta} e^{-t/\theta} \tag{72}$$

where

$$\theta = 1/\lambda = \text{mean failure time}$$

For the exponential distribution, the mean, variance, and hazard rates are:

$$\theta = 1/\lambda \tag{73}$$

$$\sigma^2 = 1/\lambda^2 \tag{74}$$

$$h(t) = \lambda, \text{ a constant} \tag{75}$$

Mean failure time, θ , is estimated by Procedure I or Procedure 11.

Procedure I: Test until r failures occur:

$$\theta = \frac{\text{Total Life Observed}}{\text{Number of Observed Failures}} = \frac{T}{r} \quad (76)$$

To obtain T , the following procedures are used:

Procedure Ia: Replacement Test (failures repaired or replaced)

$$T = nt_r \quad (77)$$

where

n = number of items on test

t_r = time at which the r^{th} failure occurred

Procedure Ib: Nonreplacement Test

$$T = \sum_{i=1}^r t_i + (n-r)t_r \quad (78)$$

where

t_i is the time of i^{th} -ordered failure

Procedure Ic: Censored Items (withdrawal or loss of non-failed items)

$$\text{Failures Replaced: } T = \sum_{j=1}^c t_j + (n-c)t_r \quad (79)$$

where

t_j = time of j^{th} -ordered censorship

c = number of censored items

$$\text{Failures Not Replaced: } T = \sum_{i=1}^r t_i + \sum_{j=1}^c t_j + (n-r-c)t_r \quad (80)$$

AMCP 706-191

Procedure 11: Testing Terminated by Stopping Rule on Test Time:

If the test plan is such that the test terminates after a specified number of test hours, t^* , have accumulated, it is possible that no failures have been observed. Then Equation 76 cannot be used, since it implies that the estimated θ is Infinite.

In general, for Procedure II testing, if the number of failures, r , is small (say $r \leq 5$), a better estimate of θ can be obtained by the equation

$$\tilde{\theta} = \frac{T}{r+1} \tag{81}$$

where

T is calculated as in Procedure I except that t_r is now replaced by t^* , the time at which testing is stopped.

Example 1: Twenty items are placed on test. Testing continues until 10 failures are observed. Calculate the estimated mean life of the items as based on (1) a replacement test, with the 10th failure occurring after 80 hours; (2) a nonreplacement test, with failures occurring at 10, 11, 17, 25, 31, 46, 52, 65, 79, and 100 hours; (3) the same non-replacement test with 4 items censored: 2 at 30 hours, 1 at 50 hours, and 1 at 60 hours.

- (1) From Equations 76 and 77,

$$\theta = \frac{T}{r} = \frac{nt}{r} = \frac{20(80)}{10} = 160 \text{ hours}$$

- (2) From Equations 76 and 78,

$$\begin{aligned} \theta &= \frac{T}{r} = \frac{\sum_{i=1}^r t_i + (n-r)t_r}{r} \\ &= \frac{442 + 10(100)}{10} = 144.2 \text{ hour} \end{aligned}$$

- (3) From Equations 76 and 80,

$$\begin{aligned} \theta &= \frac{\sum_{i=1}^r t_i + \sum_{j=1}^c t_j + (n-r-c)t_r}{r} \\ &= \frac{442 + 170 + 6(100)}{10} \\ &= 121.2 \text{ hours} \end{aligned}$$

Example 2: Twenty Items are placed on test and the test is terminated after 100 hours. Calculate the estimated mean life of the items based on (1) a replacement test, with 8 items failing before 100 hours; (2) a non-replacement test, with failures occurring as in Example 1(2).

(1) From Equations 76 and 77,

$$\theta = \frac{nt^*}{r} = \frac{20(100)}{8} = 250 \text{ hours}$$

(2) Calculations are the same as for Example 1(2).

Confidence-Interval Estimates on θ . Two situations have to be considered for estimating confidence intervals: one in which the test is run until a pre-assigned number of failures (r^*) occur, and one in which the test is stopped after a preassigned number of test hours (t^*) are accumulated. The formula for the confidence interval employs the χ^2 (chi square) distribution. A short table of χ^2 values is given in Appendix C. The general notation used is

$$\chi^2(p, d)$$

where p and d are two constants used to choose the correct value from the table.

The quantity p is a function of the confidence coefficient; d , known as the degrees of freedom, is a function of the number of failures. Equations 82 and 83 are for one-sided and two-sided $100(1 - \alpha)$ percent confidence intervals, respectively. For nonreplacement tests with a fixed truncation time, the limits are only approximate. These confidence limits on mean life are as follows:

<u>Confidence Interval</u>	<u>Fixed Number of Failures, r^*</u>	<u>Fixed Truncation[†] Time t^*</u>	
One-sided (Lower Limit)	$\left(\frac{2T}{\chi^2(\alpha, 2r)}, \infty \right)$	$\left(\frac{2T}{\chi^2(\alpha, 2r + 2)}, \infty \right)$	(82)

Two-Sided Limits	$\left(\frac{2T}{\chi^2(\frac{\alpha}{2}, 2r)}, \frac{2T}{\chi^2(1-\frac{\alpha}{2}, 2r)} \right) \left(\frac{2T}{\chi^2(\frac{\alpha}{2}, 2r + 2)}, \frac{2T}{\chi^2(1-\frac{\alpha}{2}, 2r + 2)} \right)$		(83)
------------------	---	--	------

[†] For non-replacement tests, only one-sided intervals are possible when $r = 0$. Use $2n$ degrees of freedom for the lower limit if all n items on test fail.

Example 1: Twenty items undergo a replacement test. Testing continues until ten failures are observed. The tenth failure occurs at 80 hours. Determine (1) the mean life of the items; and (2) the one-sided and two-sided 95% confidence intervals.

AMCP 706-191

- (1) From Equations 76 and 77,

$$\theta = \frac{nt}{r} = \frac{(20)(80)}{10} = 160 \text{ hours (so that } T = 1600 \text{ hours)}$$

- (2) From Equation 82,

$$\begin{aligned} \left(\frac{2T}{\chi^2(\alpha, 2r)}, \infty \right) &= \left(\frac{2(1600)}{\chi^2(0.05, 20)}, \infty \right) = \left(\frac{3200}{31.41}, \infty \right) \\ &= (101.88, \infty) \end{aligned}$$

- (3) From Equation 83,

$$\begin{aligned} \left(\frac{2T}{\chi^2(\frac{\alpha}{2}, 2r)}, \frac{2T}{\chi^2(1-\frac{\alpha}{2}, 2r)} \right) &= \left(\frac{3200}{34.17}, \frac{3200}{9.591} \right) \\ &= (93.65, 333.65) \end{aligned}$$

Example 2: Twenty items undergo a nonreplacement test, which is terminated at 100 hours. Failure times observed are 10, 16, 17, 25, 31, 46, and 65 hours. Calculate (1) the one-sided approximate 90% confidence interval ($\alpha = 0.10$), and (2) the two-sided approximate 90%-confidence limits:

- (1) From Equation 82,

$$\begin{aligned} \left(\frac{2T}{\chi^2(\alpha, 2r + 2)}, \infty \right) &= \left(\frac{2 \left[\sum_{i=1}^7 t_i + (20-7)(100) \right]}{\chi^2(.10, 16)}, \infty \right) \\ &= \left(\frac{30.20}{23.54}, \infty \right) \\ &= (128.29, \infty) \end{aligned}$$

- (2) From Equation 83,

$$\begin{aligned} \left(\frac{2T}{\chi^2(\frac{\alpha}{2}, 2r + 2)}, \frac{2T}{\chi^2(1-\frac{\alpha}{2}, 2r)} \right) &= \left(\frac{3020}{26.30}, \frac{3020}{6.57} \right) \\ &= (114.83, 459.67). \end{aligned}$$

Table C-7, Appendix C, extracted from the RADC Reliability Notebook, presents the factor $2/\chi^2(p, d)$ for one-sided and two-sided confidence limits, at six confidence levels of each. Multiplying the appropriate factor by the observed total life T gives a confidence limit about $\hat{\theta}$.

Sample-Size Consideration. Since the length of the confidence interval depends on the number of failures, it is possible to calculate the required number of failures to ensure -- with a specified confidence -- that the estimate of θ is within a specified percentage of the true mean time to failure. If a normal approximation to the χ^2 distribution is used in order to be $(1 - \alpha)\%$ confident that $\hat{\theta}$ is within $\delta\%$ of the true mean, θ , that is $P\left(\left|\frac{\hat{\theta} - \theta}{\theta}\right| \leq \delta\right) = 1 - \alpha$, the required number of failures, r^* , is

$$r^* = \frac{Z_{\alpha}^2}{\delta^2} \quad (84)$$

where Z_{α} is the standardized normal deviate corresponding to the $\alpha\%$ point of the normal distribution. Z_{α} is tabulated in Table C-1, Appendix C.

Once r^* is determined, the approximate total test time required can be estimated by the equation $T^* = r^*\theta'$, where θ' is an initial estimate of θ .

Example: How many failures are required to give 90-percent confidence that the estimate $\hat{\theta}$ is within 20-percent of the true value? What will be the total test time if $\theta = 100$ hours?

From Equation 84, for 90-percent confidence, $Z_{\alpha} = Z_{0.10} = 1.645$ and

$$r^* = \frac{(1.645)^2}{(0.20)^2} = 67$$

If $\theta' = 100$ hours, then

$$T^* = r^*\theta' = 67(100) = 6,700 \text{ hours}$$

Table C-8, Appendix C, presents values of r^* for selected confidence and precision levels.

Reliability Estimates, $\hat{R}(t)$. To estimate the probability of survival for a time t , the estimates of θ (Equation 2-76) can be used in the equation

$$\hat{R}(t) = e^{-t/\hat{\theta}} \quad (85)$$

AMCP 706-191

This estimate is biased (pessimistically if $R(t) > 1/e \approx 0.367$), especially if r is small. An unbiased estimate is

$$\hat{R}(t) = (1-t/T)^{r-1}, \quad r > 1, \quad t < T \quad (86)$$

where r is the number of observed failures in T total test hours

Example: If 10 failures are observed in 1600 hours, calculate the reliability estimate for a 30-hour period (note that $\hat{\theta} = 160$ hours)

From Equation 85,

$$\hat{R}(30) = e^{-30/160} = 0.829$$

From Equation 86,

$$\hat{R}(30) = \left(1 - 30/1600\right)^9 = 0.843$$

Confidence Limits on $R(t)$. The confidence limits on θ can be used to obtain confidence limits on $R(t)$ by the equation

$$P \left[e^{-t/\hat{\theta}_{L,\alpha/2}} \leq R(t) \leq e^{-t/\hat{\theta}_{U,1-\alpha/2}} \right] = 1 - \alpha \quad (87)$$

For a one-sided lower limit,

$$P \left[e^{-t/\hat{\theta}_{L,\alpha}} \leq R(t) \right] = 1 - \alpha \quad (88)$$

Example: For a mean life of 160 hours, (1) what is the probability of an item surviving 100 hours? (2) What are the two-sided 95% confidence limits on this probability?

(1) From Equation 85,

$$\hat{R}(100) = e^{-100/\hat{\theta}} = e^{-100/160} = 0.535$$

(2) From Equation 87, the two-sided 95% confidence limits are

$$\left(e^{-\frac{100}{93.65}}, e^{-\frac{100}{333.65}} \right) = (0.344, 0.741).$$

Percentile Estimates. To estimate the time period, \hat{T}_R , for which there is a reliability of R, the estimate \hat{T}_R is

$$\hat{T}_R = \hat{\theta} \ln \frac{1}{R} \quad (89)$$

The confidence limits on T_R define a tolerance Interval, since these limits permit the statement that there is 100 (1 - α) percent confidence that R percent or more of the items in the population will survive T_R or more time units. The 100 (1 - α) percent confidence limits on T_R are given below:

<u>Confidence Interval</u>	<u>Fixed Number of Failures: r*</u>	<u>Fixed Truncation Time: t*</u>	
One-sided (Lower Limit)	$\left(\frac{2T \ln 1/R}{\chi^2(\alpha, 2r)}, \infty \right)$	$\left(\frac{T \ln 1/R}{\chi^2(\alpha, 2r + 2)}, \infty \right)$	(90)

<u>Two-sided Limits</u>	$\left(\frac{2T \ln 1/R}{\chi^2(\frac{\alpha}{2}, 2r)}, \frac{2T \ln 1/R}{\chi^2(1-\frac{\alpha}{2}, 2r)} \right) \left(\frac{2T \ln 1/R}{\chi^2(\frac{\alpha}{2}, 2r + 2)}, \frac{2T \ln 1/R}{\chi^2(1-\frac{\alpha}{2}, 2r)} \right)$		(91)
-------------------------	---	--	------

Example: For a mean life of 160 hours, what is the estimated time period for which the reliability is 0.80? What are the 95-percent one- and two-sided confidence limits on T_R ?

$$\begin{aligned} &\text{Since } \hat{\theta} = 160 \text{ hours, Equation 89 yields } T_{0.80} \\ &= \hat{\theta} \ln \frac{1}{0.8} = 160 (0.22314) = 35.70 \text{ hours} \end{aligned}$$

The 95-percent one-sided and two-sided confidence limits on T_R , from Equations 90 and 91, are

$$\left(\frac{2(1600)(0.22314)}{31.41}, \infty \right) = (22.73, \infty)$$

and

$$\left(\frac{2(1600)(0.22314)}{34.17}, \frac{2(1600)(0.22314)}{9.591} \right) = (20.90, 74.45)$$

Normal Distribution

The normal distribution is one of the most widely used continuous densities because (1) it approximates the distribution of many random variables and (2) the sample estimates tend to be normally distributed with increasing sample size.

AMCP 706-191

If an Item has a normal distribution of failure times, its failure characteristic is consistent with a wearout process.

The normal probability distribution function is expressed as follows:

$$f(t; \mu, \sigma) = \frac{1}{\sigma\sqrt{2\pi}} e^{-\frac{1}{2}\left(\frac{t-\mu}{\sigma}\right)^2} \quad -\infty \leq t \leq \infty \quad (92)$$

Its mean, variance, and hazard rate are expressed as follows:

Mean = μ

Variance = σ^2

Hazard Rate (increases with t) =

$$h(t) \approx \begin{cases} \frac{g(t)}{\sqrt{\pi}\sigma[1+r(t)]} & t \leq \mu \\ \frac{g(t)}{\sqrt{\pi}\sigma[1-r(t)]} & t > \mu \end{cases} \quad (93)$$

where

$$g(t) = \sqrt{2} e^{-1/2 \left(\frac{t-\mu}{\sigma}\right)^2}, \quad r(t) = \left[1 - e^{-\frac{2(t-\mu)^2}{\pi\sigma^2}}\right]^{1/2}$$

The mean is estimated as shown in Cases I and II,

Case I - All tested items fail:

$$\hat{\mu} = \frac{\sum_{i=1}^n t_i}{n} \quad (94)$$

and

$$\hat{\sigma}^2 = \frac{n \sum_{i=1}^n t_i^2 - \left(\sum_{i=1}^n t_i\right)^2}{n(n-1)} \quad (95)$$

where

t_i is time to failure of the i^{th} Item

Case II - Truncated Test (r of n items fail). There are two methods for estimating the mean -- the graphical method and the regression method:

Graphical Method (r/n > 1/2)

- (1) Calculate the nonparametric reliability function, $\hat{R}(t)$, using the most appropriate of the equations (49 to 53).
- (2) Plot $\hat{R}(t)$ on normal probability paper and fit a straight line yielding the estimated normal reliability function $\hat{R}_N(t)$.

Then

$$\hat{\mu} = t_{0.50} \tag{96}$$

where

$t_{0.50}$ = value of t for which $\hat{R}_N(t) = 0.50$

$$\hat{\sigma} = t_{0.50} - t_{0.84} \tag{97}$$

where

$t_{0.84}$ = value of t for which $\hat{R}_N(t) = 0.84$

Regression Method

- (1) Obtain t_i by an experiment where t_i is the failure time.
- (2) For each failure time, t_i , find the normal deviate Z_i corresponding to $\hat{R}(t_i)$, using Table C-1. $\hat{R}(t_i)$ corresponds to $1 - \hat{F}(t_i)$. Thus, for $\hat{R}(t_i) = 0.971$, $Z_i = 1.9$; for $\hat{R}(t_i) = 0.50$, $Z_i = 0$.

Then

$$\hat{\mu} = \frac{bd-ce}{b^2-re} \text{ and} \tag{98}$$

$$\hat{\sigma} = \frac{cb-rd}{b^2-re} \tag{99}$$

where

r = number of failures

$$b = \sum_{i=1}^r Z_i \quad c = \sum_{i=1}^r t_i \quad d = \sum_{i=1}^r Z_i t_i \quad e = \sum_{i=1}^r Z_i^2$$

AMCP 706-191

Example: Assume that failure data are generated as shown in Table 4-1.

	Number of Completed Observations, r_1	Number of Censored Observations at t_1, w_1
	1	4
	1	3
	1	4
	1	3
	1	3
	1	3
	1	4
	1	4
	1	4
	1	4
	1	3
Total	$\Sigma r_1 = 11$	$\Sigma k_1 = 39$

Graphical Method

The graphical method is shown in Figure 4-4:

$$\hat{\mu} = t_{0.50} = 4000$$

$$\sigma = t_{0.50} - t_{0.84} = 4000 - 2740 = 1260$$

Regression Method

The calculations for $\hat{\mu}$ and $\hat{\sigma}$ using Equations 98 and 99 are shown in Table 4-2.

The two-sided 100 (1 - α) percent confidence interval on μ is

$$\left(\hat{\mu} - t_{\alpha/2, r-1} \times \frac{\hat{\sigma}}{\sqrt{r}}, \hat{\mu} + t_{\alpha/2, r-1} \times \frac{\hat{\sigma}}{\sqrt{r}}, \right) \quad (100)$$

where $t_{\alpha/2, r-1}$ is the $\alpha/2$ percentage point of the t distribution with $r-1$ degrees of freedom. This interval is only approximate for truncated tests. Values of t are given in Table C-2, Appendix C. For $t > 30$, Table C-1, Appendix C, of the standardized normal deviate, Z , can be used.

LS-7

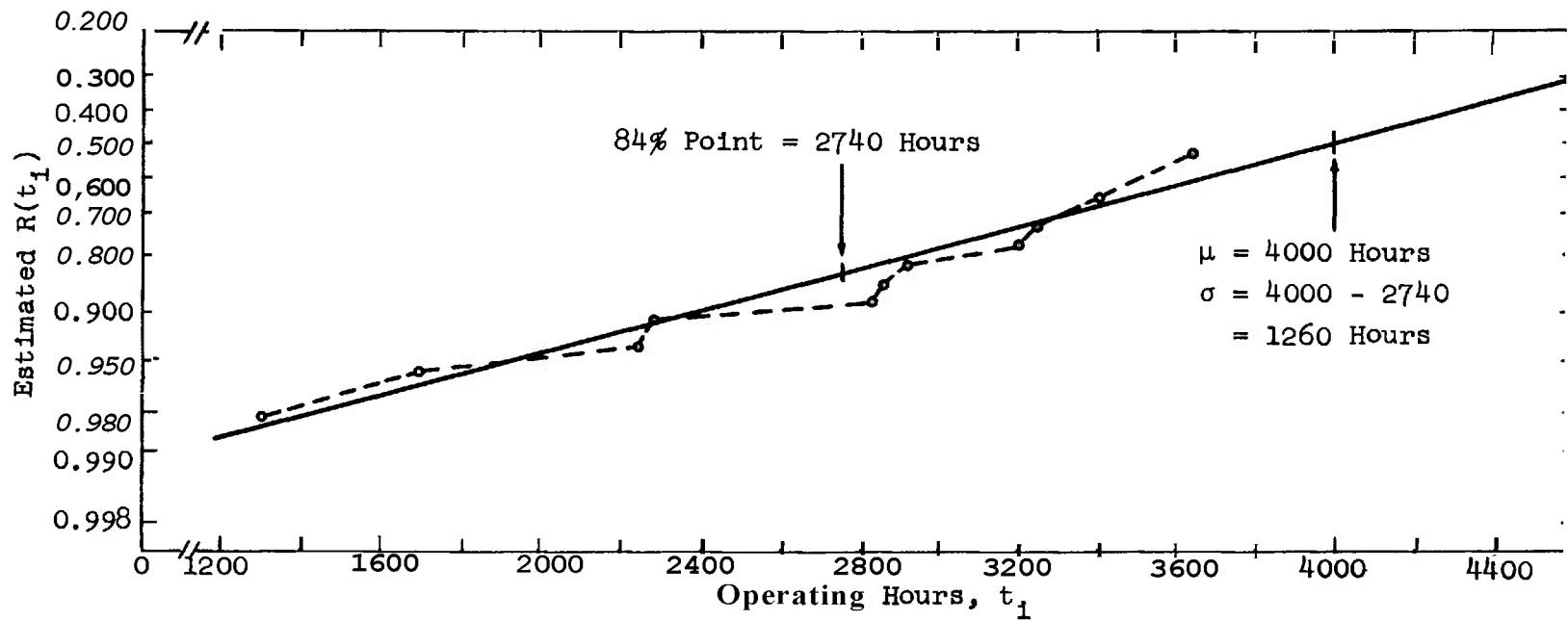

FIGURE 4.4

GRAPHICAL ESTIMATION OF THE PARAMETERS OF AN ASSUMED NORMAL DISTRIBUTION

TABLE 4.2
 COMPUTATIONAL PROCEDURE FOR ESTIMATING THE MEAN AND STANDARD
 DEVIATION OF A NORMAL DISTRIBUTION, BASED ON ORDERED
 OBSERVATIONS INVOLVING CENSORSHIP

Hours to Failure, t_1	Observed Reliability Function, $R(t_1)$	Normal Deviate Corresponding to $R(t_1)$, z_1
1300	0.980	-2.06
1692	0.958	-1.73
2243	0.935	-1.51
2278	0.910	-1.34
2832	0.883	-1.19
2862	0.853	-1.05
2931	0.819	-0.91
3212	0.778	-0.77
3256	0.726	-0.60
3410	0.653	-0.39
3651	0.522	-0.06
$\Sigma t_1 = 29,667$		$\Sigma z_1 = 11.61$
$c = \Sigma t_1 = 29,667$	$b = \Sigma z_1 = -11.61$	$r = 11$
$d = \Sigma t_1 z_1 = -27,062.8$	$e = \Sigma z_1^2 = 15.77$	
$\hat{\mu} = \frac{bd - ce}{b^2 - re} = 3972$		
$\hat{\sigma} = \frac{cb - rd}{b^2 - re} = 1208$		

Example: From the data for the preceding example, calculate the 95-percent confidence interval for θ .

For $r = 11$, and $\alpha = 0.05$, $t_{0.025, 10} = 2.23$

Then, from Equation 100, the 95-percent Interval is

$$\left(3972 - 2.23 \frac{1208}{\sqrt{11}}, 3972 + 2.23 \frac{1208}{\sqrt{11}} \right)$$

$$= (3161, 4783)$$

Given μ and σ , the reliability function is obtained from the equation

$$\hat{R}(t) = \int_Z^\infty \frac{1}{\sqrt{2\pi}} e^{-y^2/2} dy = 1 - F(Z) \tag{101}$$

where

$$Z = \frac{t - \hat{\mu}}{\hat{\sigma}}, F(Z) = \int_{-\infty}^Z \frac{1}{\sqrt{2\pi}} e^{-y^2/2} dy$$

Values for cumulative normal distribution $F(Z)$ are given in Table C-1, Appendix C.

Example: The reliability function for the failure data given in Table 4-1 is presented in Figure 4-5.

For example, to obtain $R(2000)$

$$Z = \frac{2000 - 3972}{1208} = -1.63$$

$$F(-1.63) = 0.072; R(2000) = 1 - F(-1.63) = 0.928$$

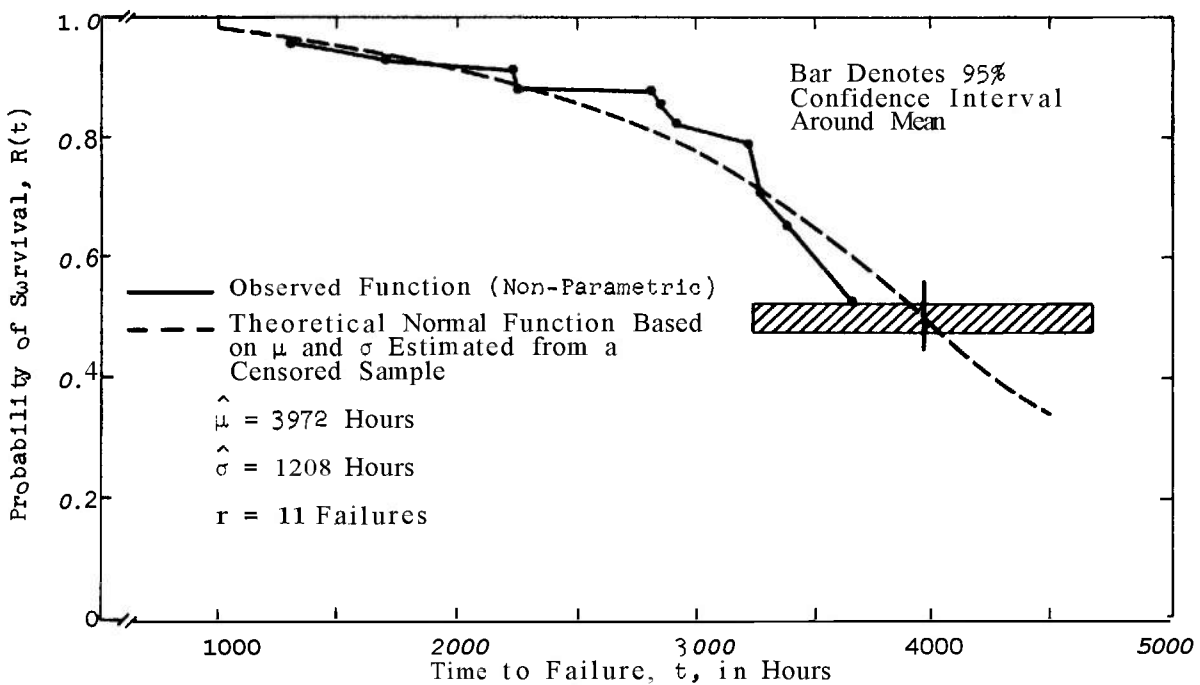

FIGURE 4-5
NONPARAMETRIC AND THEORETICAL NORMAL RELIABILITY FUNCTIONS

AMCP 706-191

Weibull Distribution

Many random variables of failures and repairs can be described by the Weibull distribution, which, because of its three parameters, is quite flexible.

The Weibull probability distribution function is expressed as follows:

$$f(t) = \frac{\beta(t-\gamma)^{\beta-1}}{\alpha} e^{-(t-\gamma)^{\beta}/\alpha} \quad t \geq \gamma, \alpha, \beta, \gamma > 0 \quad (102)$$

where

- α = scale parameter
- β = shape parameter
- γ = location parameter

The location parameter γ represents the minimum failure or repair time. Often it is set equal to zero, and the density is then

$$f(t) = \frac{\beta t^{\beta-1}}{\alpha} e^{-t^{\beta}/\alpha} \quad t \geq 0, \alpha, \beta > 0 \quad (103)$$

If $\beta = 1$, the Weibull reduces to the exponential. If β is known, analysis may proceed exactly as for the exponential except that all times t_1 are replaced by the values t_1^{β} .

The mean, variance, and hazard rate for the Weibull distribution are as follows:

$$\text{Mean} = \mu = \gamma + \alpha^{1/\beta} \Gamma(1/\beta + 1) \quad (104)$$

where

$\Gamma(1/\beta + 1)$ is the gamma function, which for integer values of $(1/\beta + 1)$ is equal to $(1/\beta)!$:

$$\text{Variance} = \sigma^2 = \alpha^{2/\beta} \left[\Gamma(2/\beta + 1) - \Gamma^2(1/\beta + 1) \right] \quad (105)$$

$$\text{Hazard Rate} = h(t) = \frac{\beta}{\alpha} t^{\beta-1} \quad (106)$$

Note:

- $h(t)$ decreases with t if $\beta < 1$
- $h(t)$ is constant if $\beta = 1$
- $h(t)$ increases with t if $\beta > 1$

Estimates of γ , β , and α . Analytical procedures are available for estimating the a , β , and γ parameters of the Weibull distribution from test data*, but they involve fairly complex interactive procedures.

A relatively simple graphical procedure is usually used to obtain estimates from Weibull probability paper. A sample of such paper is shown in Figure 4-6. Two sets of scales are used. The left scale, $F(t)$, and bottom scale, t , are for plotting the raw failure or repair data. The right scale, Y , and the upper scale, X , are called the principal ordinate and principal abscissa scales and are used for obtaining the α and β estimates. The principal abscissa is that horizontal line for which $X = 0$ on the right scale, and the principal ordinate is that vertical line for which $Y = 0$ on the upper scale.

The procedure is described below for the case in which r failures are observed out of a sample of n .

- (1) Compute the failure probability function by the equation

$$F(t_1) = \frac{i}{n+1} \quad (107)$$

where

t_1 is the time of the i^{th} failure

n is the number of items originally on test

- (2) Plot $F(t_1)$ versus t on Weibull probability paper and fit a smooth curve through the points
- (3) Estimate γ . If $F(t_1)$ plots as a straight line, $\hat{\gamma} = 0$. If $F(t_1)$ plots as a curve, a constant value, k , is to be subtracted from t_1 such that the plot of $F(t_1-k)$ versus (t_1-k) is best fitted by a straight line. The initial value of k can be either the first failure time, t_1 , or the t intercept of the curve. Several values of k may have to be tried before a reasonably linear plot of points is obtained. The estimate of γ is then the value of k that produces a linear fit.
- (4) Estimate β . The estimate of β is the slope of the fitted curve. It can be obtained directly from the equation

$$\hat{\beta} = -\frac{Y_0}{X_0} \quad (108)$$

where Y_0 is the intercept with the principal ordinate ($Y_0 < 0$) and X_0 is the intercept with the principal abscissa.

*For example, D. Lloyd and M. Lipow, Reliability: Management Methods and Mathematics, Prentice Hall, 1962, pp. 177-181.

Percent Failure $F(t)$

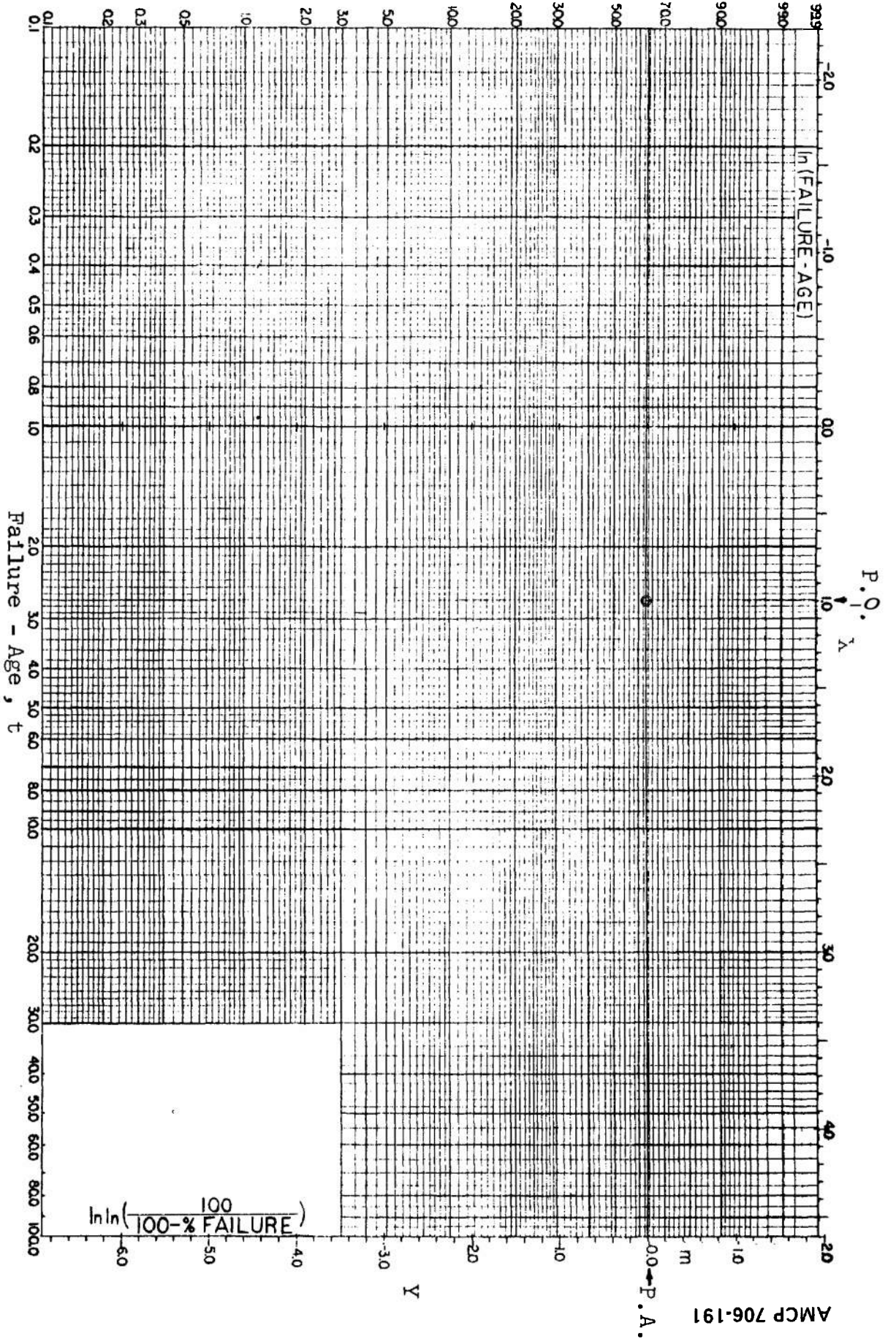

WEIBULL PROBABILITY PAPER

FIGURE 4-6

- (5) Estimate a . The intercept of the fitted line with the principal ordinate is equal to $-\ln \hat{\alpha}$. Hence, if Y_0 is the intercept (which is negative),

$$\hat{\alpha} = e^{-Y_0} \tag{109}$$

$\hat{\alpha}$ can also be obtained from the equation $\ln \hat{\alpha} = \hat{\beta} \ln t^*$, where t^* is the value of t for which $F(t) = 0.628$.

Y_0 or X_0 , or both, may lie outside the graph:

(1) Y_0 outside the graph

β can still be estimated by picking any two points on X , say X_1 and X_2 , and finding the corresponding Y 's, e.g., Y_1 and Y_2 . Then

$$\hat{\beta} = \frac{Y_2 - Y_1}{X_2 - X_1} \tag{110}$$

a is then estimated by the equation

$$\hat{\alpha} = e^{\hat{\beta} X_0} \tag{111}$$

(2) X_0 outside the graph

Since $\hat{\alpha}$ does not depend on X_0 and $\hat{\beta}$ can be obtained by Equation 110, this case presents no difficulties.

(3) X_0 and Y_0 outside the plot

Multiply the t scale by an appropriate power of 10, e.g., 10^1 , 10^{-1} , 10^{-2} , etc. The slope is independent of the scale, and therefore β is estimated as before. The estimate for α is obtained by the equation

$$\hat{\alpha} = 10^{j\hat{\beta}} \hat{\alpha}' \tag{112}$$

where j is the scale factor and $\hat{\alpha}'$ is the graphical estimate of α when the data are plotted on the basis of the $t \times 10^j$ scale.

Another possibility is that the Weibull plot appears as two intersecting lines. For this case, two sets of a , β , and γ estimates are made, one for each

AMCP 706-191

linear portion. The estimated density is then

$$f(t) = \frac{\beta_1(t-\gamma_1)^{\beta_1-1}}{\alpha_1} e^{-(t-\gamma_1)^{\beta_1}/\alpha_1} \quad (113)$$

$i = 1$ for $t \leq t^*$

$i = 2$ for $t > t^*$

and t^* is the time at which the two lines intersect.

Example: Table 4-3 presents failure data (grouped) for germanium power transistors. Seventy-five transistors were put on test for 7000 hours and 44 failures were observed. Failures were noted every 250 hours for the first 1000 hours and every 1000 hours thereafter. Since the sample size is large, the formula for $F(t)$ can be slightly modified by using n in the denominator of Equation 107 rather than $n + 1$.

Step (1)

$F(t_1)$ is calculated as shown in Table 4-3.

TABLE 4-3 GERMANIUM POWER TRANSISTORS: ACCUMULATIVE PERCENT FAILURE VS. SELECTED TIME INTERVALS			
Failure-Age (hours)	Failures	Accumulative Failures/Sample Size of 75	Accumulative Percent Failure
250	17	17/75	22.7
500	8	25/75	33.3
750	1	26/75	34.7
1000	1	27/75	36.0
2000	0	27/75	36.0
3000	5	32/75	42.7
4000	3	35/75	46.7
5000	4	39/75	52.0
6000	3	42/75	56.0
7000	2	44/75	58.7

Step (2)

Figure 4-7 shows the plot of the data on Weibull probability paper. The t axis is multiplied by 10^3 to accommodate the failure times. A straight line fits the data well.

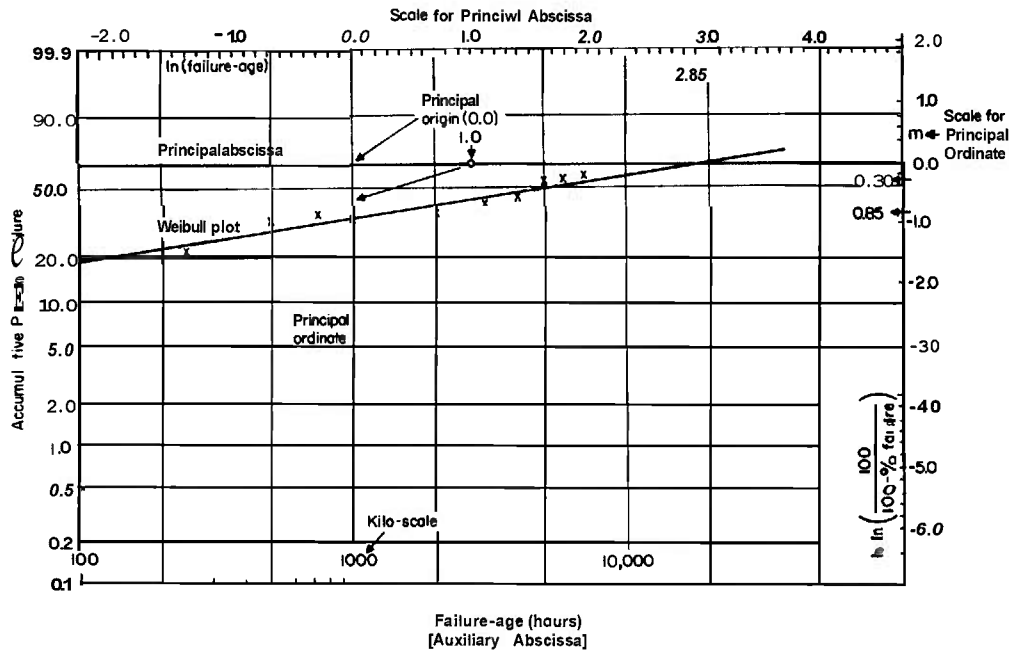

FIGURE 4.7
 GRAPHIC PROCEDURE FOR OBTAINING ESTIMATES OF PARAMETERS
 ASSOCIATED WITH THE WEIBULL DISTRIBUTION

Step (3)

Since the points are fitted by a straight line, $\hat{\gamma} = 0$.

Step (4)

The intercept of the fitted line with the principal abscissa, X_0 , is approximately 2.85; and the principal ordinate intercept, Y_0 , is approximately -0.85. Thus, from Equation 108,

$$\hat{\beta} = - \frac{-0.85}{2.85} = 0.30$$

Step (5)

The intercept of the fitted line with the principal ordinate is approximately -0.85. Hence, from Equation 109,

$$\hat{\alpha}' = e^{-(-0.85)} = e^{0.85} = 2.34$$

and the unscaled estimate is, from Equation 112,

$$\hat{\alpha} = 10^{3(0.30)} (2.34) = 18.6$$

Estimate of the Mean ($\hat{\mu}$). The mean can be estimated by replacing the estimates for α , β , and γ in Equation 104. Then

$$\hat{\mu} = \hat{\gamma} + \hat{\alpha}^{1/\hat{\beta}} \Gamma(1/\hat{\beta} + 1) \tag{114}$$

A short table of $\Gamma(X)$ for $1 \leq X \leq 2$ is presented in Table C-9, Appendix C. The relationship $\Gamma(X + 1) = X\Gamma(X)$ can be used for $X > 2$.

Example: From the data of the preceding example, estimate $\hat{\mu}$.

From Equation 114

$$\begin{aligned} \hat{\mu} &= 18.6^{1/0.30} \Gamma\left(\frac{1}{0.30} + 1\right) \\ &= 16,900 \Gamma(4.33) \end{aligned}$$

Since

$$\Gamma(4.33) = (3.33)(2.33)(1.33)\Gamma(1.33) = 9.216,$$

then

$$\mu = (16,900)(9.216) = 157,000 \text{ hours}$$

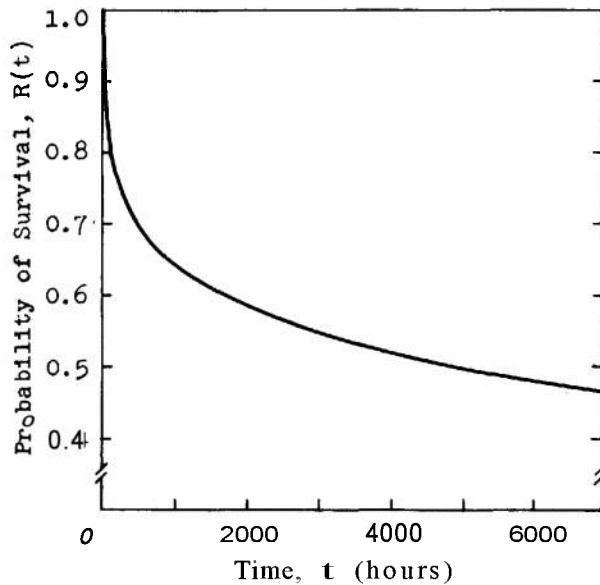

FIGURE 4-8

THEORETICAL WEIBULL RELIABILITY FUNCTION, $\hat{R}(t)$, FOR $\beta=0.30$ AND $\alpha=2.34$ (KILO-SCALE)

Estimate of the Reliability Function. From the estimates of α , β , and γ ,

$$\hat{R}(t) = e^{-(t-\hat{\gamma})^{\hat{\beta}}/\hat{\alpha}} \tag{115}$$

For maintainability, the probability that a repair is completed before t hours is

$$\hat{M}(t) = 1 - e^{-(t-\hat{\gamma})^{\hat{\beta}}/\hat{\alpha}} \tag{116}$$

Example: The reliability function for the data of Table 4-3 is shown in Figure 4-8.

Point and Lower Confidence Limit on R(t)*. The point estimate and lower confidence limit on R(t) for unknown α and β , when r failures out of n are observed, are obtained as follows:

(1) Compute
$$z_a = \sum_{i=1}^r a_i \ln t_i - \ln t \tag{117}$$

$$z_b = \sum_{i=1}^r b_i \ln t_i \tag{118}$$

where

t is the time period of interest

t_i is the i^{th} failure time

a_i and b_i are constants given by Johns and Lieberman,* Table 11.

(2) The estimated reliability is

$$\hat{R}(t) = e^{-z_a/z_b} \tag{119}$$

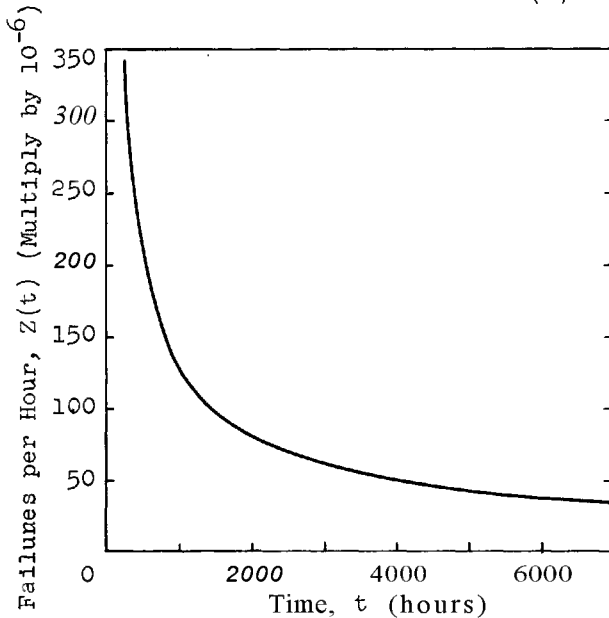

FIGURE 4-9

WEIBULL HAZARD-RATE FUNCTION, Z(t), FOR $\beta=0.30$ AND $\alpha=2.34$ [KILO-SCALE]

(3) Table I of Johns and Lieberman* gives the value of $\hat{R}(t)_{L,1-\alpha}$, the $(1-\alpha)\%$ lower confidence bound on R(t), obtained by entering the table with the calculated (z_a/z_b) value.

Estimate of Hazard-Rate Function.

From Equation 107, the estimated hazard-rate function is

$$\hat{h}(t) = \frac{\hat{\beta}(t-\hat{\gamma})^{\hat{\beta}-1}}{\hat{\alpha}} \tag{120}$$

Example: The hazard-rate function for the data of Table 4-3 is shown in Figure 4-9.

*M.V. Johns and G.J. Lieberman, "An Exact Asymptotically Efficient Confidence Bound for Reliability in the Case of the Weibull Distribution", Technometrics, Volume 8, Number 1, February 1966.

Log-normal Distribution

A random variable whose logarithm is normally distributed is said to have a log-normal distribution. This distribution frequently describes repair-time distributions.

The log-normal probability distribution function is expressed as follows:

$$f(t; v, \omega) = \frac{1}{\omega t} e^{-1/2 (\ln t - v)^2 / \omega^2}, t > 0 \quad (121)$$

The mean, median, variance, and hazard rate of the log-normal distribution are:

Mean: $\mu = e^v + \omega^2/2$ (122)

Median: $m = e^v$ (123)

The median is often used as a central-tendency measure for the log-normal since it is independent of ω .

Variance: $\sigma^2 = e^{2v} + \omega^2 (e^{\omega^2} - 1)$ (124)

Hazard Rate: The hazard rate of the log-normal increases until the mode ($e^{v-\omega^2}$) is reached, and then it decreases.

Estimates. The simplest procedure for estimating the reliability or maintainability function for r data points out of a sample of n is to employ log-normal probability paper. By fitting a straight line through the nonparametric function (Equations 49 through 53), the following estimates are obtained:

$$\hat{v} = \ln t_{0.50} \quad (125)$$

$$\hat{m} = t_{0.50} \quad (126)$$

where

$t_{0.50}$ is the time for which $R(t)$ or $M(t) = 0.50$

For ω ,

$$\hat{\omega} = \ln t_{0.50} - \ln t_{0.84(0.16)} \quad (127)$$

where

$t_{0.84}$ is the time for which $R(t) = 0.84$ or $M(t) = 0.16$

Then

$$\hat{\mu} = m e^{\hat{\omega}^2/2} \quad (128)$$

$$\hat{\sigma}^2 = \hat{m}^2 e^{\hat{\omega}^2} (e^{\hat{\omega}^2} - 1) \quad (129)$$

Confidence Limits on Median. Confidence limits on \hat{v} can be obtained from the equation

$$P\left[\hat{v} - t_{\alpha/2, r-1} \frac{\hat{\omega}}{\sqrt{r}} \leq v \leq \hat{v} + t_{\alpha/2, r-1} \frac{\hat{\omega}}{\sqrt{r}}\right] = 1 - \alpha \quad (130)$$

where $t_{\alpha/2, r-1}$ is the $(\alpha/2)\%$ point of the t statistic with $(r-1)$ degrees of freedom (Table C-2, Appendix C). This represents a confidence interval on the logarithm of the time for which reliability or maintainability is 0.50. Then for the median, $m = t_{0.50}$, for a $(1 - \alpha)\%$ confidence interval

$$\left(e^{\hat{v}_L, \alpha/2}, e^{\hat{v}_U, 1-\alpha/2}\right) \quad (131)$$

where

\hat{v}_L and \hat{v}_U are lower and upper limits on v , respectively.

Example: Forty-six maintenance-action times on an airborne communications receiver are shown in Table 4-4, along with the nonparametric maintainability function. This function is plotted on log-normal probability paper in Figure 4-10.

It is seen that a straight line fits the data points fairly well. The value of $t_{0.50} = 1.95$, and the value of $t_{0.16} = 0.56$.

From Equations 125, 126, and 127,

$$\hat{v} = \ln t_{0.50} = 0.668$$

$$\hat{m} = t_{0.50} = 1.95$$

$$\hat{\omega} = \ln t_{0.50} - Rn t_{0.16} = 0.668 + 0.579 = 1.247$$

AMCP 706-191

Then, from Equations 128 and 129,

$$\hat{\mu} = 1.95 e^{0.78} = 4.25$$

$$\hat{\sigma}^2 = (1.95)^2 e^{1.562} (e^{1.562} - 1) = 68.06$$

From Equation 130,

$$\hat{v}_{L, .025} = 0.668 - 1.95 \frac{1.247}{0.78} = .308$$

$$\hat{v}_{U, .975} = 0.668 + 1.96 \frac{1.27}{0.78} = 1.028$$

and the 95-percent confidence interval on m is, by Equation 131,

$$(1.35, 2.80)$$

TABLE 4-4 COMPUTATIONS FOR MAINTAINABILITY FUNCTION					
Observed Data		Non-parametric Function	Observed Data		Non-parametric Function
t_1	r_1	$\hat{M}(t_1)$	t_1	r_1	$\hat{M}(t_1)$
0.2	1	0.021	3.3	2	0.681
0.3	1	0.043	4.0	2	0.723
0.5	4	0.128	4.5	1	0.745
0.6	2	0.170	4.7	1	0.766
0.7	3	0.234	5.0	1	0.787
0.8	2	0.277	5.4	1	0.808
1.0	4	0.362	5.5	1	0.830
1.1	1	0.383	7.0	1	0.851
1.3	1	0.404	7.5	1	0.872
1.5	4	0.489	8.8	1	0.894
2.0	2	0.532	9.0	1	0.915
2.2	1	0.553	10.3	1	0.936
2.5	1	0.574	22.0	1	0.957
2.7	1	0.596	24.5	1	0.979
3.0	2	0.638			

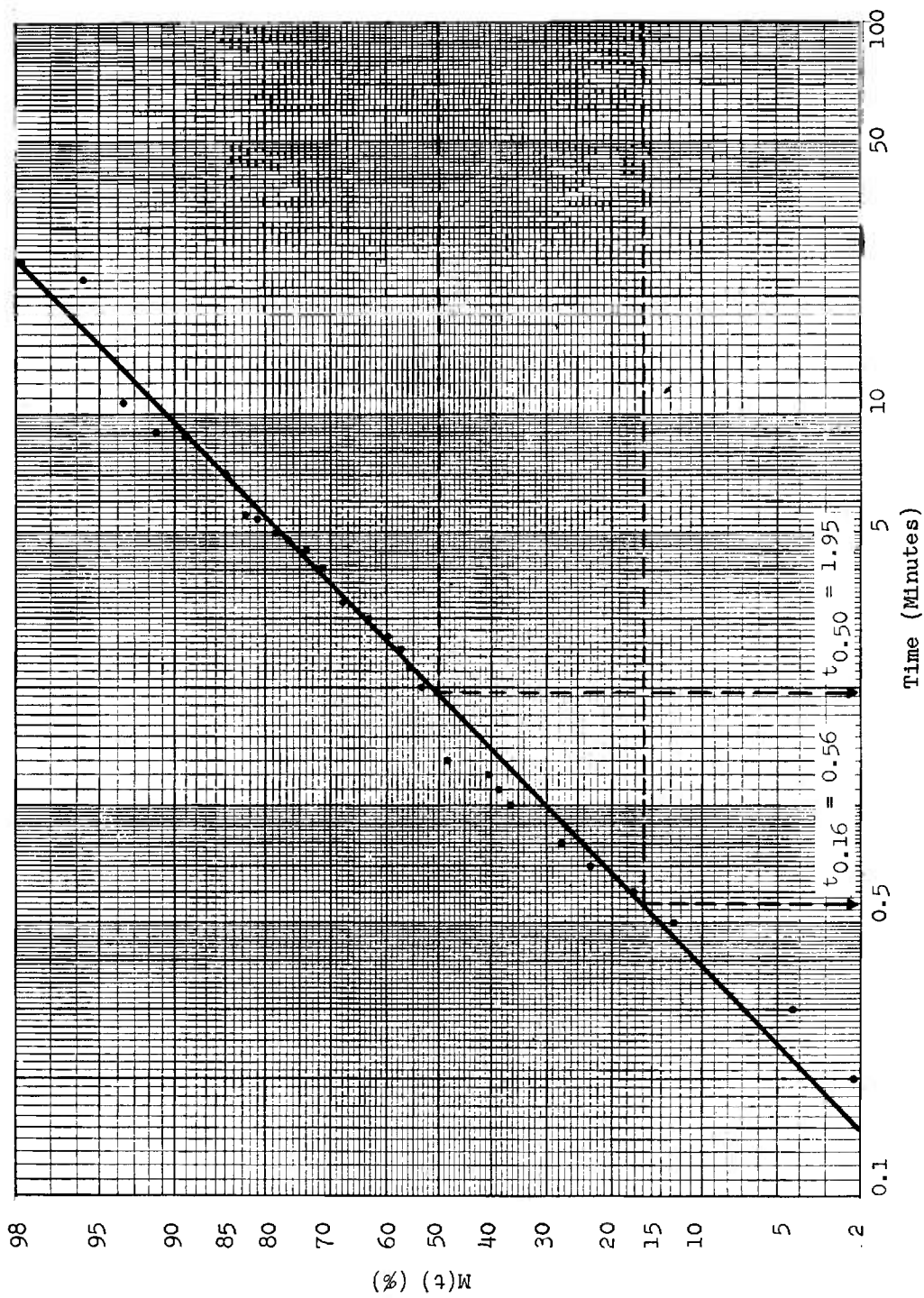

FIG RE 4 10
PLOT OF MAIN EN AN G DATA ON D G-NORMAL PROBABILITY P R R

GLOSSARY *

A FORTIORI ANALYSIS. An analysis deliberately made to favor an alternative system when compared to a judgmental "best" system. If the "best" system receives a favorable comparison under the weighted analysis, its position is strengthened.

ABSCISSA: The horizontal distance from the vertical axis of a graph, usually designated x.

ACCEPTANCE SAMPLING: Inspection of samples of incoming lots to determine acceptance or rejection of the lot. It is characterized by the sample size n and the acceptance number c, or by the average outgoing quality limit.

ACCRUAL ACCOUNTING: The recording and reporting of expenses as the operating transactions occur. This method, in contrast to obligations and disbursements, provides a realistic measurement of resources consumed in doing the work.

ACCUMULATOR: The register and associated equipment in the arithmetic unit of the computer in which arithmetical and logical operations are performed.

ACTIVE REPAIR TIME: The portion of the down time during which one or more technicians are working on the system to effect a repair. This time includes preparation time, fault location time, fault correction time, and final check out time for the system.

ADDRESS: An identification, represented by a name, label or number, for a register or location in storage. Addresses are also a part of an instruction word along with commands, tags, and other symbols.

ADMINISTRATIVE TIME: The portion of the down time not included under active repair time and logistic time.

ALGORITHM: An orderly, step-by-step procedure for performing a mathematical operation in a finite number of steps. The 1040 form is an algorithm for computing personal income tax.

ALLOCATION: (1) The distribution of available resources to the various activities which must be performed in such a way that total effectiveness will be optimized. Allocation is necessary when there are limitations on either the amount of resources available or on the way in which they can be expended such that each separate activity cannot be performed in the most effective way conceivable. (2) An authorization by a designated official of a department making funds available within a prescribed amount to an operating agency for the purpose of making allotments.

*Reproduced by permission of the U. S. Army Management School.

AMCP 706-191

ALLOTMENT: An authorization granted by an operating agency to another office to incur obligations within a specified amount pursuant to an appropriation or other statutory provision and subject to specific procedural, bookkeeping, and reporting requirements.

ALTERNATIVES: The means by which objectives can be attained. They need not be obvious substitutes for one another or perform the same specific function. Thus, to protect civilians against air attack, shelters, "shooting" defenses, and retaliatory striking power are all alternatives.

ANALOG COMPUTER: An electronic device that performs mathematical operations on numbers which are expressed as directly measurable quantities, generally voltages and resistances. Analog computers are less accurate than digital computers, but they are more readily adaptable to changes in the data and structure of a problem. They are especially well suited to problems involving differential equations.

ANALYSIS OF VARIANCE (ANOVA): The basic idea of ANOVA is to express a measure of the total variability of a set of data as a sum of terms, each of which can be attributed to a specific source or cause of variation.

APPORTIONMENT: A distribution made by the Bureau of the Budget of amounts available for obligation or expenditure in an appropriation or fund account into amounts available for specified time periods, activities, functions, projects, objects, or combinations thereof. The amounts so apportioned limit the obligations to be incurred or, when so specified, expenditures to be accrued.

APPRAISAL: Impartial analysis of information conducted at each responsible management and control level to measure the effectiveness and efficiency of the total process and determine preventive/corrective action.

ARGUMENT: (1) An independent variable; e.g., in looking up a quantity in a table, the number or any of the numbers which identifies the location of the desired value; or in a mathematical function, the variable which when a certain value is substituted for it the value of the function is determined. (2) An operand in an operation on one or more variables.

ARTIFICIAL INTELLIGENCE: The study of computer and related techniques to supplement the intellectual capabilities of man. As man has invented and used tools to increase his physical powers, he now is beginning to use artificial intelligence to increase his mental powers. In a more restricted sense, the study of techniques for more effective use of digital computers by improving programming techniques.

ASSEMBLER: A computer program which operates on symbolic input data to produce from such data machine instructions by carrying out such functions as: translation of symbolic operation codes into computer operating instructions; assigning locations in storage for successive instructions; or computation of absolute addresses from symbolic addresses. An assembler generally translates input symbolic codes into machine instructions item for item, and produces as output the same number of instructions or constants which were defined in the input symbolic codes.

AVAILABILITY': The probability that the system is operating satisfactorily at any point in time when used under stated conditions, where the total time considered includes operating time, active repair time, administrative time, and logistic time.

AVERAGE OUTGOING QUALITY LIMIT: The average maximum fraction defective leaving an acceptance sampling plan.

BALANCE OF INTERNATIONAL PAYMENTS: A systematic record of the economic transactions of a country during a given period which involve a transfer of-currency between the country's residents and the residents of the rest of the world.

BAYESIAN STATISTICS: Estimates of (prior) probability distributions, subsequently revised (posterior distribution) to incorporate new data by means of Bayes equation:

$$P(A_1|B) = \frac{P(B|A_1) P(A_1)}{P(B|A_1) P(A_1) + P(B|A_2) P(A_2)}$$

BERNOULLI PROCESS: A random process that yields an either-or outcome on each trial with known probability of occurrence, and results from statistically independent trials.

AMCP 706-191

BIAS: An unbalanced range of error such that the average error is not zero.

BINARY: A characteristic, property, or condition in which there are but two possible alternatives; e.g., the binary number system using **2** as its base and using only the digits zero (0) and one (1).

BINOMIAL DISTRIBUTION: The distribution of many two-valued processes such as heads and tails, or acceptable and unacceptable units.

$$\text{Prob}(x \text{ heads in } n \text{ tosses}) = \frac{n!}{(n-x)!x!} P^x (1-P)^{n-x}$$

BIONICS: The application of knowledge gained from the analysis of living systems to the creation of hardware that will perform functions in a manner analogous to the more sophisticated functions of the living system.

BIT: A unit of information capacity of a storage device.

BLACK BOX: An unknown and often unknowable mechanism or system whose operation is judged solely by observation of its inputs and outputs.

BOOLEAN ALGEBRA: A process of reasoning, or a deductive system of theorems using a symbolic logic, and dealing with classes, propositions, or on-off circuit elements. It employs symbols to represent operators such as AND, OR, NOT, EXCEPT, IF...THEN, etc., to permit mathematical calculation.

BRANCH: The selection of one of two or more possible paths in the flow of control based on some criterion. The instructions which mechanize this concept are sometimes called branch instructions; however, the terms "transfer of control" and "jump" are more widely used.

BREAK-EVEN POINT: In engineering-economic studies, the point at which two alternatives become equally economical by altering the value of one of the variables in a situation,

BUDGET: A proposed plan by an organization for a given period of time reflecting anticipated resources and their estimated expenditure in the pursuit of objectives.

BUILDING BLOCK COST: One kind of a rough estimate of the cost of an alternative for planning purposes. The estimate is not time-phased and does not provide for variations such as in the manning of the unit or cost-quantity relationships,

CENTRAL LIMIT THEOREM: If the sample size is large ($n \geq 30$), the sampling distribution of the means, \bar{x} , can be approximated closely with a normal distribution. Furthermore, this theorem also applies when $n < 30$ provided that the distribution of the population from which the samples are taken can be approximated closely with a normal curve.

CERTAINTY: The state of absolute confidence in which outcomes are sure and predestined,

CETERIBUS PARIBUS: The assumption that **all** conditions other than the ones specifically being analyzed remain constant or unchanged.

CHI SQUARE TEST: A statistical test for relatedness of two discrete variables, say height and weight of officers.

CLEAR: To erase the contents of a storage device by replacing the contents with blanks, or zeros.

COMBINATIONS: Number of possible arrangements of n elements taken c at a time if sequence is ignored.

$$\binom{n}{c} = \frac{n!}{(n-c)!c!}$$

COMMENSURABILITY: The capability of two qualities or values to be measured by a meaningful relevant common index. For example, machine guns and rifles are commensurable either in dollar cost or in effectiveness, e.g., enemy casualties. However, machine guns and friendly casualties are not commensurable in terms of dollars,

COMPILER: A computer program more powerful than an assembler. In addition to its translating function which is generally the same process as that used in an assembler, it is able to replace certain items of input with series of instructions, usually called subroutines. Thus, where an assembler translates item for item, and produces as output the same number of instructions or constants which were put into it, a compiler will do more than this. The program which results from compiling is a translated and expanded version of the original.

COMPUTER: A device capable of accepting information, applying prescribed processes to the information, and supplying the results of these processes.

AMCP 706-191

CONDITIONAL PROBABILITY: The probability-that **A** will occur, given that B has occurred: $P(A|B)$,

CONFIDENCE: The degree of trust or assurance placed in a given result.

CONFIDENCE INTERVALS: A measure of effectiveness in testing, expressed in quantitative terms; e.g., the value of a specific factor (variable) lies within a specified interval 95% of the time.

CONFIDENCE LEVEL: The probability that **the true value of** a parameter lies within **a** stated interval,

CONSOLE: **A** portion of the computer which may be **used** to control **the** machine manually, correct **errors**, determine the status of machine circuits, registers, and counters, determine the contents of **storage**, and manually **revise** the contents of storage.

CONSTANT DOLLARS: **A** statistical series is said to be expressed in "constant dollars" when the effect of changes in **the** purchasing power of the dollar has been **removed**. **Usually** the data are expressed in terms of some **selected year**: or eet of years.

CONSUMER PRICE INDEX. **A** measure of the period-to period fluctuations in the prices of **a** quantitatively constant **market basket of** goods and services selected **as representative of a specific** level of living. **Hence, it can** be thought of **as** the cost of maintaining **a fixed scale** of living.

CONSTRAINT: **A** resource limitation, which **may** be specific (e.g., the supply of skilled manpower or **a** particular metal), or general (e.g., **total available funds**),

CONSUMER RISK: The probability of accepting an item **which** is, in **fact**, unsatisfactory,

CONTINGENCY ANALYSIS: Repetition **of** an analysis with **different** qualitative assumptions such **as** theater, or type of **conflict**, to determine their **effects** on the results of the initial analysis,

CONTRACT DEFINITION PHASE (CDF): The **specification, in** competing contracting studies, of detailed technical **performance characteristics, coats**, and time-and-cost **schedules** for engineering development and production of **a** military end item.

CORRELATION: In a general sense in statistics, correlation denotes the co-relation or covariation between two variables.

CORRELATION COEFFICIENT: A number that attempts to measure the interdependency of variables.

COST. Goods or services used or consumed.

COST ANALYSIS: The systematic examination of cost (total resource implications) of interrelated activities and equipment to determine the relative costs of alternative systems, organizations, and force structures. Cost analysis is not designed to provide the precise measurements required for budgetary purposes.

COST CATEGORIES: Three major program cost categories are:

- (1) Research and Development. Those program costs primarily associated with research and development efforts, including the development of a new or improved capability to the point of operation. These costs include equipment costs funded under the RDT&E appropriations and related Military Construction appropriation costs. They exclude costs that appear in the Military Personnel, Operation and Maintenance, and Procurement appropriations.
- (2) Investment. Those-program-costs required beyond the development phase to introduce into operational use a new capability, to procure initial, additional, or replacement equipment for operational forces or to provide for major modifications of an existing capability. They include Procurement appropriation costs and all Military Construction appropriation costs except those associated with R&D. They exclude RDT&E, Military Personnel, and O&M appropriation costs.
- (3) Operating. Those program costs necessary to operate and maintain the capability. These costs include Military Personnel and O&M appropriation costs, including funds for obtaining replenishment spares from-stock funds. They exclude RDT&E and Military Construction appropriation costs.

COST EFFECTIVENESS ANALYSIS: The quantitative examination of alternative prospective systems for the purpose of identifying a preferred system and its associated equipment, organizations, etc. The examination aims at finding answers to a question and not at justifying a conclusion. The analytical process includes trade-offs among alternatives, design of additional alternatives, and the measurement of the effectiveness and cost of the alternative.

AMCP 706-191

- COST ESTIMATE:** The estimated cost of a component or aggregation of components. The analysis and determination of cost of interrelated activities and equipment is cost analysis.
- COST ESTIMATING RELATION (CER):** A numerical expression of the link between a physical characteristic, resource or activity and a particular cost associated with it; e.g., cost of aircraft maintenance per flying hour.
- COST INFORMATION REPORTING (CIR):** A uniform system for collecting and processing cost and related data on major items of military equipment, Its purpose is to assist both industry and government in planning and managing weapon systems development and production activities.
- COST MODEL:** An ordered arrangement of data and equations that permits translation of physical resources into costs.
- COST SENSITIVITY:** The degree to which costs (e.g., total systems costs) change in response to varying assumptions regarding future weapon system characteristics, operational concepts, logistic concepts, and force mix.
- CRITERION:** Test of preferredness needed to tell how to choose one alternative in preference to another. For each alternative, it compares the extent to which the objectives are attained with the costs or resources used.
- CYBERNETICS:** The field of technology involved in the comparative study of the control and intracommunication of information handling machines and nervous systems of animals and man in order to understand and improve communication.
- DECK:** A collection of punched cards, commonly a complete set of cards which have been punched for a definite service or purpose.
- DEPRECIATION:** Decline in the value of capital assets over time as a result of business operation and/or technological innovation. The Internal Revenue Service defines depreciation as the gradual exhaustion of property employed in the trade or business of a taxpayer—such exhaustion comprising wear and tear, decay or decline from natural causes, and various forms of obsolescence. Accelerated depreciation is any formula for depreciation permitted by the IRS that provides for a more rapid write-off of reproducible assets than would be possible by using rates reflecting true economic depreciation. Accelerated depreciation provides economic incentives for investment in plant and equipment.

DESIGN ADEQUACY: Probability that the system will successfully accomplish its mission, given that the system is operating within design specifications.

DETERMINISTIC MODEL: A model that permits no uncertainty in the magnitudes of either inputs or outputs. An example from gunnery is:

$$W = \frac{RM}{1000}, \text{ where}$$

W is the lateral distance at range R; R is the range, and M is the angular measure in mils of the *arc* subtended by W at range R. For any set of given values for R and M there is one and only one value for W. Many deterministic models use an average as a constant value input.

DIGITAL COMPUTER: An electronic device that performs mathematical operations on numbers which are expressed as digits in some sort of numerical system.

DIMINISHING RETURNS: An increase in some **inputs** relative to other fixed inputs will cause total output to increase; but after a point the extra output resulting from the same additions of extra inputs is likely to become less and **less**. This falling off of extra returns is a consequence of the fact that the new "doses" of the varying resources have less and less of the fixed resources to work with.

DISBURSEMENTS: The amount of expenditure checks issued and cash payments made, net of refunds received.

DOCUMENTATION: **The** group of techniques necessary for the orderly presentation, organization and communication of recorded specialized knowledge, in order to maintain a complete record of reasons for changes in variables. Documentation is necessary not **so** much to give maximum utility as to give an unquestionable historical reference record.

DOWN TIME: Total time during which the system is not in acceptable operating condition. Down time can in turn be subdivided into a number of categories such as active repair time, logistic time, and administrative time.

DYNAMIC PROGRAMMING: In a multistage decision process, a systematic method for **searching** out that sequence of decisions (policy) which maximizes or minimizes some predefined objective function. The method is based on Bellman's **Principle of Optimality** which states that: "An optimal policy **has the** property that whatever the initial state and initial decision are, the remaining decisions must constitute an optimal policy with regard to the state resulting from the first decision."

AMCP 706-191

- ECONOMETRICS:** The branch of economics that uses mathematics and statistics to build and analyze economic models, to explain economic phenomena, and to estimate values for economic variables. The statistical methods used are especially designed to deal with **time-series** data.
- ECONOMIC GROWTH:** The sustained increase in the total and per capita output of a country **as** measured by **its** gross national product (in constant **prices**) or **other output** statistics.
- ECONOMIC LOT SIZE:** The **cost-minimizing size of order** to buy or batch to make.
- ECONOMIES OF SCALE:** **Efficiencies**, usually expressed as reduction in cost per unit of output, that result from increasing the size of the productive unit.
- ECONOMY:** Using the least amount of resources to attain **a** given output or fixed objective.
- EFFECTIVENESS:** The degree or amount of capability to accomplish some **objective(s)**. Various criteria (**e.g.**, targets destroyed, tonnage moved, **etc.**) might be used to provide **a** measure of this amount of capability.
- EFFICIENCY:** Attaining the greatest possible output from a given amount of resources.
- EMPIRICAL PROBABILITY:** The observed relative frequency; **e.g.**, if **d** is a random sample of size **n** drawn from **a** stable universe possessing a given trait, the empirical probability that an element drawn randomly from that universe is estimated to be **d/n**.
- ESSENTIAL ELEMENT OF ANALYSIS:** A question specifically designed to obtain data that will provide an answer in a particular problem area, or information required to conduct an evaluation in a particular functional area.
- EXPECTED VALUE:** The probability of an **event occurring** multiplied by the payoff associated with its occurrence.
- EXTERNAL ECONOMIES:** Those benefits accruing from a grouping of industrial activities or from public **facilities**. One textile plant benefits from the existence of several textile plants in a vicinity.
- EXTRAPOLATE:** Estimate by trend projection the unknown values that lie beyond the range of known values in **a** series.

FAILURE RATE: The number of items replaced per unit time due to failure of that item.

FEASIBILITY STUDY: (1) A study of the applicability or desirability of any management or procedural system from the standpoint of advantages versus disadvantages in any given case; (2) also a study to determine the time at which it would be practicable or desirable to install such a system when determined to be advantageous; (3) a study to determine whether a plan is capable of being accomplished successfully.

FIELD EXPERIMENT: A mode of research involving the response of personnel in a field situation or environment to a test situation. A field experiment is conducted under statistically controlled conditions to discover the capabilities and limitations of some military plan, organization, or material.

FIXED COSTS: Those elements of cost that do not vary with volume of production.

FIXED POINT ARITHMETIC: (1) A method of calculation in which operations take place in an invariant-manner, and in which the computer does not consider the location of the decimal point. (2) A type of arithmetic in which the operands and results of all arithmetic operations must be properly scaled so as to have a magnitude between certain fixed values.

FLOATING POINT ARITHMETIC: A method of calculation which automatically accounts for the location of the decimal point. This is accomplished by handling the number as a signed mantissa times the radix raised to an integral exponent; e.g., the decimal number +88.3 might be written as $+0.88300000 \times 10^2$.

FLOW CHART: A graphic representation of the major steps of work in a process. The illustrative symbols may represent documents, machines, or actions taken during the process. The area of concentration is on where or who does what rather than on how it is to be done.

FORCE STRUCTURE ANALYSIS: The analysis of proposed forces to obtain a picture of resource implications for planning.

FORCE STRUCTURE COSTING: The determination of the resource implications (manpower, materiel, support, training, etc.) in dollar terms of a given force structure or change to it.

FORCASTING: Attempting to define possible courses of future events. May include estimating **probabilities** associated with each course of events.

FORTTRAN: A programming **language** designed for problems which can be expressed in algebraic notation, allowing for exponentiation and up to three subscripts. The **FORTTRAN compiler** is a routine for a given machine which accepts a program written in **FORTTRAN** source language and produces a machine language **routine** object program. **FORTTRAN II** added considerably to the power of the **original** language by giving it the ability to define and use almost unlimited hierarchies of subroutines, all sharing a common storage region if desired. Later improvements have added the ability to use Boolean expressions, and some capabilities for inserting symbolic machine language sequences within a source program.

FREE TIME: Time during which operational use of the system **is** not required. This may or may not be down time, depending on whether the system is in operable condition.

FREQUENCY DISTRIBUTION: An arrangement of statistical data that divides a series of **items** into classes and indicates the number of items falling into each class. An example is the income distribution in which the number of persons falling within each income class is stated.

FULL EMPLOYMENT: According to the President's Council of Economic Advisers, the full employment level **is** reached when no more than four percent of the civilian labor force is unemployed.

GAMING: A method of examining **policies** and strategies under the conditions of a particular scenario, **allowing** factors (human and chance) to **vary** in the scenario.

GANTT CHART: A chart of **activity** plotted **against** time usually used to schedule or reserve resources for specific activities.

GROSS NATIONAL PRODUCT (GNP): Total value at market prices of **all** goods and services produced by the nation's economy during a period of one calendar year. As calculated quarterly by the Department of Commerce, **gross** national product is the broadest available measure of the rate of economic activity.

GROSS PRIVATE DOMESTIC INVESTMENT: One of the major components of GNP, gross private domestic investment includes annual outlays for producers' durable goods (machinery and equipment), private new construction of both residential and **non-residential** buildings (including those acquired by **owner/occupants**), and the net change of business investment in inventories.

- HEURISTIC: Pertaining to systematic trial and error methods of obtaining solutions to problems.
- HISTOGRAM: A graphical representation of a frequency distribution by means of rectangles whose widths represent the class intervals and whose heights represent the corresponding frequencies.
- HOLLERITH: A widely used system of encoding alphanumeric information onto cards, hence "Hollerith" cards is synonymous with punch cards.
- HOMOSTASIS: The dynamic condition of a system wherein the input and output are balanced precisely, thus presenting an appearance of no change, hence a steady state.
- HUMAN FACTORS ANALYSIS: Individual, behavioral, cultural, or social systems and their relation to organizations, procedures, and material.
- HUMAN FACTORS ENGINEERING: The development and application of scientific methods and knowledge about human capabilities and limitations to the selection, design, and control of operations, environment, and material, and to the selection and training of personnel.
- HYSTERESIS: The lagging in the response of a unit of a system behind an increase or a decrease in the strength of a signal. It is a phenomenon demonstrated by materials which make their behavior a function of the history of the environment to which they have been subjected.
- IMPLIED AND INDUCED OUTPUT: Implied output is that which can be estimated directly from the nature of the project including all activities without which the project could not function. Induced output covers the interindustry, or intermediate, requirements of those activities that supply the project and those which purchase or use its output; usually measured by using an input-output table.
- INCOMMENSURABILITY: The inability of two qualities or values to be measured by a meaningful relevant common index.
- INCREMENTAL COST: The added costs of a change in the level or nature of activity. They can refer to any kind of change: adding a new product, changing distribution channels, adding new machinery. Although they are sometimes interpreted to be the same as marginal cost, the latter has a much more limited meaning, referring to cost of an added unit of output.

AMCP 706-191

- INDIVIDUAL SYSTEM COSTING:** The determination of the total resource implications of a system (organization) without consideration of the interaction of the system (organization) as part of a force structure.
- INDEX NUMBER:** A magnitude expressed as a percentage of the corresponding magnitude in some "base" period. The base is usually designated **as** equal to 100.
- INDIFFERENCE MAP:** A two-dimensional graph denoting an individual's preference system with respect to two economic quantities. The body of the graph consists of a family of nonintersecting lines convex to the origin. Each line of the family represents an equally desirable mixture of the quantities in question.
- INDUSTRIAL DYNAMICS:** A philosophy relating to **simulation** of a **system** conceived as a **network** of **flows** and **feedback** loops **interconnecting** a **number** of inventories or levels and **responding** to **changes** in its **environment**.
- INFLATION:** A rise in the general level of prices.
(Pure inflation is defined as a rise in the general level of prices unaccompanied by a rise in output.)
- INFORMATION SYSTEM:** A combination of personnel, efforts, forms, formats, instructions, procedures, data, communication facilities and equipment that provides an organized and interconnected means--automated, manual, or a combination of these--for recording, collecting, processing, transmitting and displaying information in support of specific functions.
- INFRASTRUCTURE (SOCIAL OVERHEAD CAPITAL):** The foundation underlying a nation's, region's, or community's economy (transportation and communications systems, power facilities, schools, hospitals, etc.).
- INPUT-OUTPUT ANALYSIS:** A quantitative study of the interdependence of a group of activities based on the relationship between inputs and outputs of the activities. The basic tool of analysis is a square input-output table, interaction model, for a given period that shows simultaneously for each activity the value of inputs and outputs, as well as the value of transactions within each activity itself. It has been applied to the economy and the "industries" into which the economy can be divided.
- INSTRUCTION:** A set of characters which defines an operation together with one or more addresses, or no address, and which, as a unit, causes the computer to perform the operation on the indicated quantities.

- INTERACTION: The difference between a whole and the simple sum of its parts.
- INTERCEPT: Intersection of a line and an axis.
- INTERPOLATE: Estimate the intermediate value in a series of numbers by using a formula that relates the unknown value to the pattern of known values in the series.
- INTRINSIC PROBABILITY: The probability that the system is operating satisfactorily at any point in time when used under the stated conditions, where the time considered is operating time and active repair time.
- INVESTMENT COST: The cost beyond the Research and Development phase to introduce a new capability into operational use.
- ISOCONTOURS: Graphical representation showing all combinations of inputs that produce equal outputs.
- ITERATIVE: Describing a procedure or process which repeatedly executes a series of operations until some condition is satisfied. An iterative procedure can be implemented by a loop in a routine. Each iteration or cycle used data from the preceding cycle and supplies data to the following.
- ISOMORPHIC: Similar in pattern.
- JOINT COSTS: Costs that are shared by several departments or activities, such as an airbase serving fighter squadrons and transport planes; or a dam providing power, irrigation, flood control, and recreation.
- JOINT PROBABILITY: The probability that both event A and event B will occur. If A and B are independent, it is the product of their separate probabilities.
- KNOWN UNIVERSE: An idealized abstraction from the real world, in which the probabilities of every element in the population are known.
- LANGUAGE: A system for representing and communicating information which is intelligible to a specific machine. Such a language may include instructions which define and direct machine operations, and information to be recorded by or acted upon by these machine operations.
- LATIN SQUARES: Experimental designs to avoid compounding the effects of inputs while reducing the number of observations (and the cost) required to achieve a satisfactory confidence level.

AMCP 706-191

LEARNING CURVE: The cost-quantity relationships for estimating costs of equipment. Generally used to predict or describe the decrease in the cost of a unit as the number of units produced increases.

LEAST-SQUARES METHOD: A method of fitting a calculated trend to statistical data, so called because the sum of the squared deviations of the calculated from the observed variables is a minimum. "Least squares" also refers to the criterion that, when followed, yields this result.

LIABILITIES: The amounts owed for goods and services received, other assets acquired, and performance accepted. This includes amounts administratively approved for payments of grants, pensions, awards, and other indebtedness not involving the furnishing of goods and services.

LINEAR PROGRAMMING: A mathematical method used to determine the most effective allocation of limited resources between competing demands. Mathematical requirements for applicability of linear programming are: (1) both resources and activities that use them are non-negative quantities; and (2) both the objective (e.g., profit or cost) and the restrictions on its attainment are expressible as a system of linear equalities or inequalities ($y = a+bx$). Linear programming has been employed in areas such as the determination of the best product mix and the selection of least-cost transportation routes.

LOGARITHM: The logarithm of a number is the exponent or power to which the logarithmic base must be raised to equal that number.

LOGARITHMIC SCALE. When the vertical axis of a chart is laid off in terms of the logarithms of natural numbers the arrangement is known as a semilog chart and the vertical scale is called a log scale. A curve plotted on such a chart represents not the numbers in the series but the logarithms of these numbers. Changes in the slope of such a curve show changes in the percentage increase or decrease of the original series. As long as there is no change in direction, equal distances on the vertical scale correspond to the same percentage change in the original series.

LOGISTIC TIME: That portion of down time-during which repair is delayed solely because of the necessity of mailing for a replacement part or other subdivision of the system.

LOOP: A self-contained series of instructions in which the last instruction can modify and repeat itself until a terminal condition is reached.

MACHINE LANGUAGE: A system for expressing information which is intelligible to a specific machine. Such a language may include instructions which define and direct machine operations, and information to be recorded by or acted upon by these machine operations,

MAINTAINABILITY: Probability that, when maintenance action is initiated under stated conditions, a failed system will be restored to operable condition within a specified total down time.

MARGINAL COST; REVENUE: Costs incurred or expected to be incurred in the production of an additional unit of output. Marginal revenue is revenue received or expected to be received from the sale of an additional unit of output. To maximize its profits, a firm has to extend production to the point where marginal revenue equals marginal cost.

MARGINAL OUTPUT OR PRODUCT: The output to be derived from the use of an additional unit of a productive resource (land, labor, capital, or materials).

MARGINAL UTILITY: Satisfaction derived from the last or additional expenditure. Additional increments of expenditure for a given product tend to result in declining additions of utility. If utility is to be maximized, the satisfaction derived from the last dollar spent on each product or service should be the same,

MASTER PLANNING BUDGET: The estimated cash receipts and disbursements classified as to causes (contra accounts) and spread over the future periods in which they are predicted to occur. For comparability with other plans, each estimated cash flow is converted into an expected value, adjusted for risk and diminishing utility, and discounted to its present value.

MATHEMATICAL MODEL: The general characterization of a process, object, or concept, in terms of mathematical symbols, which enables the relatively simple manipulation of variables to be accomplished in order to determine how the process, object, or concept would behave in different situations.

MATRIX: A rectangular array of terms called elements. It is used to facilitate the study of problems in which the relation between these elements is fundamental. A matrix is usually capable of being subject to a mathematical operation by means of an operator or another matrix according to prescribed rules.

AMCP 706-191

MEAN: The most common measure of central tendency equal to the sum of the observed quantities divided by the number of observed quantities divided by the number of observations.

MEDIAN: Halfway point between the two end points of **an array**.

MISSION: The specific task or responsibility that a person or a body of persons is assigned to do or fulfill.

MISSION RELIABILITY: Probability that under stated conditions, the system will operate in the mode for which **it** was **d** designed for the duration of a mission, given that **it** was operating in this at the beginning of the mission.

MODE: A computer system of data representation. The value in a set of values that occurs with the greatest frequency.

MODEL: A simplified representation of an operation, containing only those aspects of primary importance to the problem under study. The means of representation may vary from a set of mathematical equations or a computer program to a purely verbal description of the situation. In cost/effectiveness analysis (or any analysis of choice), the role of the model is to predict the costs that each alternative would incur and the extent to which each would attain the objective.

MONTE CARLO METHOD: Any procedure that involves statistical sampling techniques from a distribution of possible outcomes for obtaining a probabilistic approximation to the solution of a mathematical or physical problem. Monte Carlo Methods are often used when a great number of variables are present, with inter-relationships so extremely complex as to forestall straightforward analytical handling. This method generally involves the use of simulated data acquired by putting random numbers through transformations such that the data imitates significant aspects of a situation.

MONOTONICITY: In the mathematical sense, monotonicity refers to the constancy of a type of change. For example, if a curve is rising (falling) throughout the range of interest we say **it is** a monotonically increasing (decreasing) **curve**

MOVING AVERAGE: A series of averages frequently used to reduce irregularities in a time series by selecting a set number of successive items in the series, computing the average, then dropping the first item and adding the next succeeding one, etc. The process is intended to average out random movements and, thereby, reveal underlying trends.

MUTUALLY EXCLUSIVE: Describing any event the occurrence of which precludes the occurrence of all other events under consideration.

NATIONAL INCOME: The money measure of the overall annual flow of goods and services in a community equal to the sum of compensation of employees, profits of corporate and unincorporated enterprises, net interest, and rental income of persons. Is also equal essentially to GNP minus (1) allowance for depreciation and other capital consumption, and (2) indirect business tax and non-tax liability to government.

NUMERICAL ANALYSIS: The study of methods of obtaining useful quantitative solutions to mathematical problems, regardless of whether an analytic solution exists or not, and the study of the errors and bounds on errors in obtaining such solutions.

OBJECTIVE: The purpose to be achieved or the position to be obtained. Objectives vary with the level of suboptimization of the study.

OBJECTIVE FUNCTION: A mathematical statement of goals, usually profit maximization.

OPERAND: A quantity entering or arising in an instruction. An operand may be an argument, a result, a parameter, or an indication of the location of the next instruction, as opposed to the operation code or symbol itself.

OPERATING COST: The recurring cost required to operate and maintain an operational capability.

OPERATING TIME: Time during which the system is operating in a manner acceptable to the operator, although unsatisfactory operation is sometimes the result of judgment of the maintenance man.

OPERATIONAL READINESS: The probability that, at any point in time, the system is either operating satisfactorily or ready to be placed in operation on demand when used under stated conditions, including stated allowable warning time.

OPERATIONS RESEARCH: The use of analytic methods adopted from mathematics for solving operational problems. The objective is to provide management with a more logical basis for making sound predictions and decisions. Among the common scientific techniques used in operations research are mathematical programming, statistical theory, information theory, game theory, monte carlo methods, and **queueing** theory.

AMCP 706-191

OPERATOR: A mathematical symbol which represents a mathematical process to be performed on an associated operand.

OPPORTUNITY COST: The cost of foregone opportunities; the sacrificed amount of money, equipment, or units of production that could have been realized by a separate course of action (alternative) with the same time and effort expended.

OPTIMIZATION: The attainment of the best possible result, i.e., the maximization (minimization) of some desirable (undesirable) criterion measure, subject to the constraints imposed on the choice of solutions.

ORDINATE: The vertical distance on a graph; i.e., the distance from the horizontal axis.

PARAMETER: A constant or a variable in mathematics which remains constant during some calculation. It is generally a definable characteristic of an item, device, or system.

PARAMETRIC ANALYSIS: Parametric analysis assumes a range of values for each parameter which will bracket the expected values of that parameter, and a solution to the problem is obtained for each set of assumed parameter values.

PAYOFF: The gain to be derived if a particular course of events develops.

PERIPHERAL EQUIPMENT: The auxiliary machines which may be placed under the control of the central computer. Examples of this are card readers, card punches, magnetic tape feeds, and high-Speed printers.

PERMUTATIONS: The number of possible sequences of n items taken c at a time.

$$P\left(\frac{n}{n}\right) = n! \quad P\left(\frac{n}{c}\right) = \frac{n!}{(n-c)!} = c\left(\frac{n}{c}\right)c!$$

- PLANNING:** The selection of courses of **action** through a systematic consideration of **alternatives in** order to attain organizational objectives.
- PLOTTER:** A visual display or board controlled by a computer in which a dependent variable is graphed by an automatically controlled pen or pencil as a function of one or more variables.
- PRESENT VALUE:** The estimated present worth of a stream of future benefits or costs arrived at by discounting the future values, using an appropriate interest rate.
- PROBABILISTIC MODEL:** A model that makes allowances for randomness in one or more of the factors that determine the outputs of the model. For example, an inventory model that optimizes an inventory policy to avoid inventory **shortages is** probabilistic if it takes explicit account of uncertainty over time, in the distribution of demands on the inventory. On the other hand, the model would be deterministic if it assumed that the rate of demand against the inventory is always the same (usually the estimated average demand). In this example, a deterministic model would most probably give answers that would lead to bad inventory policies. However, there are times when the use of a deterministic model in a **probabilistic** situation does no harm.
- PROBABILITY:** A number between 0 and 1 that, when assigned to an event or occurrence, expresses the likelihood that the event will occur.
- PROBABILITY DISTRIBUTION:** Tables showing relative frequencies of each subset into which the total population is divided: a table showing the probability of occurrence of each possible value.
- PRODUCER'S RISK:** The probability of rejecting an item which is, **in fact**, satisfactory.
- PROGRAM:** (1) A plan or scheme of action designed for the accomplishment of a definite objective that is specific as to the time-phasing of the work to be done and the means proposed for its accomplishment, particularly in quantitative terms, with respect to manpower, material, and facilities requirements: thus a program provides a basis for budgeting: (2) a segment or element of a complete plan: (3) a budget account classification.

AMCP 706-191

- PROGRAMMING:** The process of translating planned-military force requirements into specific **time-phased, scheduled** actions, and of identifying in relatively precise terms the resources required. It is the bridge between planning and budgeting.
- QUANTIFY:** To qualify with respect to quantity. In analysis, to translate observed physical relationships into analogous mathematical relationships.
- QUEUING THEORY:** A theory that deals with the analysis of costs and effectiveness when items appear with some randomness for processing at a facility with a capacity for processing simultaneously fewer items that may be waiting at **a** given time. The costs are costs of waiting and of providing the capacity to reduce the amount of waiting. Examples of queuing problems are: (1) determination of a number of checkout counters at a supermarket that minimizes the sum of costs of customer dissatisfaction if they must wait in line and costs of providing additional **checkers**; **(2)** determination of the capacity of communications capacity and of delays in the processing of messages.
- RANDOM ACCESS:** Pertaining to the process **of** obtaining information from or placing information into computer storage where the time required **for** such access is independent of the location of the information most recently obtained or **placed** in storage.
- RANDOM NUMBERS:** A sequence of digits in which **each** digit has an equal probability of occurring in each position, wholly independent of which digits appear elsewhere in the sequence.
- RANDOM NUMBER GENERATOR:** A special computer routine designed to produce a random number or **series of** random numbers according to specified limitations.
- RANDOM SAMPLE:** A **sample selected**, from a population to be tested, in such a manner that **every** element in the population has an equal chance of being chosen for the sample.
- RANDOM VARIABLE:** A function defined on a sample space. It is called discrete if it assumes **only** a finite or denumerable **number** of ~~values~~ and continuous if it assumes a continuum of values.
- R CHARTS:** Charts of the range of small samples, **useful** in monitoring change in dispersion in the product of a system.

REAL TIME OPERATION: The use of the computer as an element of a processing system in which the times of occurrence of data transmission are controlled by other portions of the system, or by physical events outside the system, and cannot be modified for convenience in computer programming.

REDUNDANCY: The existence of more than one means for accomplishing a given task, where all means must fail before there is an overall failure of the system.

RELATIVE FREQUENCY: The ratio of the number of observations (elements) in a class (subset) to the total number of observations constituting a population (universe or set).

RELIABILITY: The probability that the system will perform satisfactorily for at least a given period of time when used under stated conditions.

REORDER LEVEL: The inventory balance at which a replacement order is placed.

REPAIRABILITY: The probability that a failed system will be restored to operable condition within a specified active repair time.

REPROGRAMMING: The reapplication of funds between budget activities or line items within a single appropriation account.

REQUIREMENT: The need or demand for personnel, equipment, facilities, other resources or services, expressed in specific quantities for specific time periods.

RESEARCH AND DEVELOPMENT (R&D): Basic and applied research in the sciences and engineering, and the design and development of prototypes and processes. Excludes routine product testing, market research, sales promotion, sales service, and other non-technological activities or technical services.

Basic research includes original investigations for the advancement of scientific knowledge that do not have specific practical objectives.

Applied research is the practical application of knowledge, material and/or techniques toward a solution to an existent or anticipated military or technological requirement.

Development includes technical activities of a nonroutine nature concerned with translating research findings or other scientific knowledge into products or processes. Development does not include routine technical services or other activities excluded from the above definition of research and development.

- RESEARCH AND DEVELOPMENT (R&D) COSTS: The cost of developing a new capability to the point where it is ready for procurement for operational units.
- RESOURCE IMPACT: The cost of adopting a course of action stated in measurable terms. Resource impacts cannot always be reduced to dollar terms.
- REVOLVING FUND: A fund established to finance a cycle of operations to which reimbursements and collections are returned for reuse in a manner such as to maintain the principle of the fund; e.g., working-capital fund, stock fund.
- RISK: As used in cost-effectiveness analysis and operations research, a situation is characterized as risk if it is possible to describe all possible outcomes and to assign meaningful, objective numerical probability weights to each one. For example, an action might lead to this risky outcome: a reward of \$10 if a "fair" coin comes up heads, and a loss of \$5 if it comes up tails. Another example, 50% of all missiles fired can be expected to land within one CEP of the target.
- ROUTINE: A set of coded instructions arranged in proper sequence to direct the computer to perform a desired operation or sequence of operations.
- SAMPLE SPACE: The range of feasible solutions.
- SAMPLING: The process of determining characteristics of a population by collecting and analyzing data from a representative segment of the population.
- SAMPLING ERROR: That part of the variation in the data resulting from an experiment that is not explained by the variation in the factors controlled during the experimentation.
- SCENARIO: A word picture of a fixed sequence of events in a defined environment.

SENSITIVITY ANALYSIS: Repetition of an analysis with different quantitative values for cost or operational assumptions or estimates such as hit-kill probabilities, activity rates, or R&D costs, in order to determine their effects for the purposes of comparison with the results of the basic analysis. If a small change in an assumption results in a proportionately or greater change in the the results, then the results are said to be sensitive to that assumption or parameter.

SETS: A collection of items (elements) chosen as pertinent.

SHADOW PRICE: The shadow price of a factor is a measure of its opportunity cost or its marginal product. For example, when unemployment is widespread, the opportunity cost of labor may be near zero, so that the shadow price of labor may be well below the prevailing wages of those workers who are actually employed.

SIMULATION: The representation of physical systems and phenomena by computers, models, or other equipment. The model or computer representation is manipulated to imitate significant aspects of a situation.

SPURIOUS CORRELATION: Accidental correlation having no causative basis and without expectation of continuance.

STANDARD DEVIATION: A measure of the dispersion of observed data. Mathematically, it is the positive square root of the variance.

STANDARD ERROR: The standard deviation of a group of measures of the same characteristics (often termed a "statistic" or a "parameter"), each obtained from a distinct sample drawn from a larger "universe" or "population".

STATISTICAL BIAS: If some samples or observation data are more likely to be chosen than others, or if subjective methods are used in selecting sample data, the results are considered biased.

STATISTICAL DECISION THEORY: Theory dealing with logical analysis of choice among courses of action when (1) the consequence of any course of action will depend upon the "state of the world", (2) the true state is as yet unknown, but (3) it is possible at a cost to obtain additional information about the state.

AMCP 706-191

STOCHASTIC PROCESS: The statistical concept underlying the prediction of the condition of an element of a larger group when the probable average condition of the larger group is known. For example, assume that an armored division, under certain circumstances, has on the average a certain number of tanks deadlined for unscheduled maintenance. The probability that any given tank under the same circumstances will be deadlined for unscheduled maintenance on a specific day is described by a stochastic process.

STOCKOUT COST: The cost due to disrupted schedules or to inability to satisfy customers because items ordinarily stocked are not available,

STORAGE TIME: The time during which the system is presumed to be inoperable condition, but is being held for emergency; e.g., as a spare.

SUBOPTIMIZATION: Optimization refers to a selection of a set of actions that maximize the achievement of some objective subject to all of the real constraints that exist. For example, one may optimize a choice of weapons for achieving certain objectives of a decision but within the given constraint of a certain maximum cost of a division. But one suboptimizes on achievement of the division objective if he is given discretion only over the amount and kind of armor and is given a maximum amount of money to spend on armor. The objective he maximizes directly may be only the mission of armor in the division's objective. Such a suboptimization will yield something inferior to an optimized expenditure on different kinds of armor if the total budget for armor given to the suboptimizer is really not optimal, or if there are interdependencies between decisions on armor and decisions on other things that are outside the discretion of the person suboptimizing on armor.

SUBROUTINE: The set of instructions necessary to direct the computer to carry out a well defined mathematical or logical operation.

SUBSET: A collection wholly contained within a larger collection; a group of elements constituting part of a universe.

SYMBOLIC LOGIC: The study of formal logic and mathematics by means of a special written language which seeks to avoid the ambiguity and inadequacy of ordinary language.

SYSTEM: Weapon system is composed of equipment, skills and techniques, the composite of which forms an instrument of combat, The complete weapon system includes all related facilities, equipment, materials, services, and personnel required solely for its operation, so that the instrument of combat becomes a self-sufficient unit

of striking power in its intended operational environment. Support system is a composite of equipment, skills, and techniques that, while not an instrument of combat, is capable of performing a clearly defined function in support of a mission. A complete support system includes all related facilities, equipment, materials, services, and personnel required for operation of the system, so that it can be considered a self-sufficient unit in its intended operational environment.

SYSTEMS ANALYSIS (SA): A **formal** inquiry intended to advise a decision maker on the policy choices involved in a major decisions. In DoD a systems analysis may be concerned with such matters as weapon development, force posture design, or the determination of strategic objectives. To qualify as a system analysis a study must look at an entire problem as a whole. Characteristically, it will involve a systematic investigation of the decision-maker's objectives and of the relevant criteria; a comparison--quantitative when possible--of the costs, effectiveness, and risks associated with the alternative policies or strategies for achieving each objective; and an attempt to formulate additional alternatives if those examined are deficient.

SYSTEMS EFFECTIVENESS: The probability that the system can successfully meet an operational demand within a given time when operated under specified conditions.

SYSTEMS APPROACH: The art of examining the entire context within which the item of interest will function.

TCHEBYCHEFF'S THEOREM: The proportion of the observations falling between $-k\sigma$ and $+k\sigma$ is at least as large as $1 - (1/k^2)$ regardless of the distribution.

TIME-PHASED COSTS: A presentation of the cost results broken down by the time period in which the costs occur rather than a single total cost figure.

TOTAL OBLIGATION AUTHORITY (TOA): The cost allocated to a given system or organization. This cost when related to a specific time period, for example a year, represents obligations that can be incurred during that year and not necessarily expenditures. The total obligation authority for a specific year to furnish a house is the cost of what can be ordered during that year even if deliveries and payments are made in later years.

TOTAL SYSTEM COST: The total R&D, Investment, and Operating Costs (for a specified number of years of operation) required to develop, procure, and operate the particular weapon system.

AMCP 706-191

TRANSFORM: The derivation of a new body of data from a given one according to specific procedures, often leaving some feature invariant.

TROOP TEST: A troop test is a test conducted in the field, using TOE units or units organized under proposed TOE, to evaluate current or proposed doctrine and organizations. Material is considered in the conduct of troop tests only insofar as material affects the doctrine or organization being evaluated.

TYPE I ERROR: The belief that something true is false.

TYPE II ERROR: The belief that something false is true.

UNCERTAINTY: A situation is uncertain if there is no objective basis for assigning numerical probability weights to the different possible outcomes or there is no way to describe the possible outcomes. For example, the probability of a foreign nation continuing to furnish the U.S. with base rights is an **uncertainty**

UTILITY: A personal subjective value of a tangible or intangible commodity.

VALUE ADDED BY MANUFACTURE: That **part** of value given products shipped actually created within a given industry. The unadjusted series is calculated by **subtracting** the cost of materials, supplies, containers, fuel, purchased electric energy, and contract work from the value **of** shipments. The adjusted series, which is more inclusive, is equal to the unadjusted series plus: (1) value added by merchandising operations, and (2) the net change in inventories (both finished goods and work-in-progress) between the beginning and end of the year. (Value added is almost free statistically from the duplication of values existing in the value of shipments and approximates the net value of manufacturers).

VARIABLE COSTS: Those costs that vary with the volume of output as contrasted with fixed costs, which do not vary with output.

VARIABLES: General numbers, such as x or y which may take on many values or which may have conditional fixed values as in $x^2 + 2x = 19$.

VARIANCE: A measure of dispersion of a frequency distribution computed by summing the squares of the difference between each observation and the arithmetic mean of the distribution and then dividing by the number **of** observations.

WAR GAME: A simulation, by whatever means, of a military operation involving two or more opposing forces, conducted using rules, data, and procedures designated to depict an actual or assumed real life situation.

APPENDIX B

BIBLIOGRAPHY

- I. SYSTEMS ANALYSIS
- II. SYSTEMS EFFECTIVENESS
- III. COST ANALYSIS
- IV. COST EFFECTIVENESS
- V. RELIABILITY AND MAINTAINABILITY
- VI. SIMULATION
- VII. QUEUEING
- VIII. SEQUENCING
- IX. INVENTORY
- X. LINEAR PROGRAMMING
- XI. DYNAMIC PROGRAMMING
- XII. GAME THEORY
- XIV. INFORMATION THEORY
- XIV. DECISION THEORY
- XV. OFFICIAL REGULATIONS

SYSTEMS ANALYSIS

1. Enthoven, A. C., "Systems Analysis and Decision Making", Military Review (January 1963)
2. Feeney, G. J. and Sherbrooke, C. C., "Systems Analysis and Supply Management", The RAND Corporation, RM-4054-PR (April 1964)
3. Hayes, James H., "Systems Analysis", Military Review (April 1965)
4. Hitch, C., "An Appreciation of Systems Analysis", Journal of the Operations Research Society of America (November 1955)
5. Hitch, Charles J., "Decision Making for Defense", University of California Press, Los Angeles (1965)
6. Hitch, C. J. and McKean, R. N., "The Economics of Defense in the Nuclear Age", The RAND Corporation, Report R-346 (March 1960) Harvard University Press, Cambridge, Mass. (1960) 420 pp. (AD 243098)
7. Kahn, Herman and Mann, Irwin, "Techniques of Systems Analysis", The RAND Corporation, Research Memorandum RM-1222 (1957)
8. Kahn, Herman and Mann, Irwin, "Ten Common Pitfalls", The RAND Corporation, RM-1937 (AD 133035) (July 1957)
9. Linstone, H. A., "The Weapons Planning Program for General Purpose Forces: A Suggested Approach", RM-3202-ISA (April 1962) The RAND Corporation (AD 414817)
10. McKean, R. N., "Efficiency in Government Through Systems Analysis", John Wiley & Sons, Inc., New York (1958)
11. Morgenstern, O., "The Question of National Defense", New York Random House (1959)
12. Murray, R., 2nd, "Some Facets of Systems Analysis", Management Views (1963-1964) Vol. IX, Part 2, Selected Speeches, U. S. Army Management School
13. Peck, M. J. and Scherer, F. M., "The Weapons Acquisition Process: An Economic Analysis", Division of Research, Graduate School of Business Administration, Harvard University, Boston (1962)

14. Quade, E, S., Ed. "Analysis for Military Decisions",
Rand-McNally
15. Quade, E, S., "Military Systems Analysis", The RAND Cor-
poration, RM-3452-PR (January 1963)
16. Quade, E, S., "Systems Analysis Techniques for Planning -
Programming - Budgeting", The RAND Corporation, AD 629 564
(March 1966)
17. Schlesinger, J. R., "Quantitative Analysis and National
Security", World Politics, Vol. XV, No. 2, pp. 295-315
(January 1963)

SYSTEM EFFECTIVENESS

1. Balaban, H. S. and Costello, D. L., "Study Effectiveness Concepts and Analytical Techniques", ARINC Research Publication No. 267-01-7-419, ASD/AFSC Contract No. AF(33-657)-10594, ARINC Research Corporation, Annapolis, Md. (January 1964)
2. Giordano, P., Seltzer, S., and Sontz, C., "General Effectiveness Methodology", ORSA 30 National Meeting (October 1966)
3. U. S. Department of Defense, "Survey of Studies and Computer Programming Efforts for Reliability, Maintainability, and System Effectiveness" (September 1965)
4. Welker, E. L., Ph.D., and Horne, Riley C., Jr., "Concepts Associated with System Effectiveness", ARINC Research Corporation, Annapolis, Maryland, Monograph No. 9 (July 1960)
5. AFSC-TR-65-1 "Requirements Methodology", Final Report of the WSEIAC Task Group I (January 1965)
6. AFSC-TR-65-2, Volume I, "Prediction - Measurement (Summary Conclusions, and Recommendations)", Final Report of the WSEIAC Task Group II (January 1965)
7. AFSC-TR-65-2, Volume 11, "Prediction - Measurement (Concepts, Task Analysis, Principles of Model Construction)", Final Report of the WSEIAC Task Group II (January 1965)
8. AFSC-TR-65-3, "Data Collection and Management Reports", Final Report of the WSEIAC Task Group III (January 1965)
9. AFSC-TR-65-4, Volume I, "Cost-Effectiveness Optimization (Summary, Conclusions, and Recommendations)", Final Report of the WSEIAC Task Group IV (January 1965)
10. AFSC-TR-65-4, Volume II, "Cost-Effectiveness Optimization and Analysis Methodology", Final Report of the WSEIAC Task Group IV (January 1965)
11. AFSC-TR-65-4, Volume III, "Cost-Effectiveness Optimization (Technical Supplement)", Final Report of the WSEIAC Task Group IV (January 1965)

12. AFSC-TR-65-5, Volume I, "Management System (System Effectiveness Assurance - Summary, Policy Issues, Recommendations)", Final Report of WSEIAC Task Group V (January 1965)
13. AFSC-TR-65-5, Volume II, "Management Systems (Elements of Effectiveness Assurance Management)", Final Report of the WSEIAC Task Group V (January 1965)
14. AFSC-TR-65-5, "Chairmans Final Report", WSEIAC Final Summary Report
15. "bureau of Naval Weapons System Effectiveness Management Course", Publication 357-01-1-579

COST ANALYSIS

1. Abert, J. G., "Some Problems in Cost Analysis", Institute for Defense Analyses (June 1965)
2. Baker, C. L., McCullough, J. D., Meltsner, A. J., and Proschan, A., Army Cost Model Preliminary Report, FOUO, RM-3250-ASDO, The RAND Corporation
3. "Basic Techniques for the Development of Life Cycle Equipment Costs", U. S. Army Electronics Command, Logistics Research Agency, Philadelphia, Annex to USAECOM Logistics Research Agency, Study No. 64-201 (November 1966)
4. Dienemann, Paul F., "Estimating Cost Uncertainty Using Monte Carlo Techniques", Rand Report RM-4854-PR, The RAND Corporation (January 1966)
5. Dienemann, P., "Use of Cost Estimating Relationships in System and Force Planning", The RAND Corporation (October 1966)
6. Early, L. B., Barro, S. M., and Margolis, M. A., "Procedures for Estimating Electronic Equipment Costs", RM-3072-PR, The RAND Corporation (May 1963)
7. "Estimating Methods and Data Sources Used in Costing Military Systems", ESD-TR-65-396 (December 1965)
8. Farr, L., et.al., "Quantitative Analysis of Computer Programming Cost Factors: A Progress Report", System Development Corporation, AD-612 723, Santa Monica, Calif. (August 1965)
9. Fisher, G. H., "A Discussion of Uncertainty in Cost Analysis", RM-3071, The RAND Corporation (April 1962)
10. Fisher, G. H., "Allocation of Indirect Costs", P-511, The RAND Corporation (September 1956)
11. Fisher, G. H., "Derivation of Estimating Relationships - An Illustrative Example", RM-3366-PR, The RAND Corporation (November 1962)
12. Fisher, G. H., "Military Systems Cost Analysis", RM-2975-PR, The RAND Corporation
13. Fisher, G. H., "Weapon System Cost Analysis", P-823, The RAND Corporation

14. Fisher, G. H., "What is Resource Analysis?", P-2688, The RAND Corporation (January 1963)
15. Graziano, Eugene E., "Cost Estimating for Research, Development, and Information Processing Programs: An Annotated Bibliography", Lockheed Missiles & Space Company, Sunnyvale, Calif. (AD-422 397) (October 1963)
16. Grosse, R.N., "Army Cost Model", FOUO, RM-344-ASDC, The RAND Corporation
17. Grosse, R. N., and Prochan, A., "Military Cost Analysis" RAC Paper, RAC-P-6, Research Analysis Corp. (August 1965)
18. Grosse, R. N., and Prochan, A., "Uses of Automated Force Cost Models", RM-3608-ASDC, FOUO, The RAND Corporation
19. Hawkins, et.al., "DOD Programming System, An Explanation and Evaluation", AD 628-101, Air Force Institute of Technology, Wright-Patterson AFB, Ohio (August 1965)
20. Hoag, M. W., "The Relevance of Costs in Operations Research", P-820, The RAND Corporation (April 1956)
21. Jones, V., "System Cost Analysis: A Management Tool for Decision Making", The Mitre Corporation, Bedford, Mass., AD-624-893 (November 1965)
22. Keeling, J. A., "An Outline of a Method for Weapon System Cost Analysis", Working Paper #49, OR Dept., Martin-Marietta Corp., Aerospace Division, Denver (July 1961)
23. Kriebel, Charles H., "On Statistical Cost Analysis and Operations Research", AD 623 394, Carnegie Institute of Technology, Pittsburgh, Pa. (August 1965)
24. Large, J. P., "Concepts and Procedures of Cost Analysis", RM-3589-PR, The RAND Corporation (June 1963)
25. Margolis, M. A., "Cost Analysis: Concepts and Methods Outline", Rand Report, The RAND Corporation (April 1966)
26. McCullough, J. D., "Cost Analysis for Planning - Programming - Budgeting Cost - Benefit Studies", Rand Report, The RAND Corporation (November 1966)
27. McCullough, J. D., "Cost Effectiveness: Estimating Systems Costs", The RAND Corporation, AD 622 023 (September 1965)

AMCP 706-191

28. Meltsner, A. J., Martyn, R. A., and Pringle, J. J., "Army Cost Model Data", FOUO, RM-3639-ASDO, The RAND Corporation
29. Meltsner, A. J., and Swaine, H. R., "Navy Cost Model", RM-3660-ASDC, The RAND Corporation
30. Milton, H. S., "Cost of Research Index, 1920-1965", AD 629 700, The RAND Corporation (March 1966)
31. Noah, J. W., "Identifying and Estimating R & D Costs", RM-3067-PR, The RAND Corporation (May 1962)
32. Noah, J. W., and Smith, R. W., "Cost - Quantity Calculator", RM-2786-PR, The RAND Corporation (January 1962)
33. Novick, D., "Costing Tomorrow's Weapon Systems", RM-3170-PR, The RAND Corporation (June 1962)
34. Novick, D., "Resource Analysis and Long-Range Planning", RM-3658, The RAND Corporation (June 1963)
35. Novick, D., "The Cost of Advanced Weapons", AD 291 605, The RAND Corporation (February 1962)
36. Novick, D., "Use of the Learning Curve", P-267, The RAND Corporation (November 1951)
37. Novick, D., "Weapon Systems Cost Analysis", P-794, The RAND Corporation (January 1956)
38. Novick, D., "System and Total Force Cost Analysis", RM-2695, AD 408 623, The RAND Corporation
39. Petruschell, R. L., and Chester, J. M., "Total System Cost Analysis", RM-3069-PR, The RAND Corporation (January 1963)
40. Rattner, E., "Cost Variance: A Proposed New Cost Prediction Method", Working Paper \$67, OR Dept., Martin-Marietta Corp., Aerospace Division, Denver, (July 1961)
41. Rich, Arthur, and Henry, R. T., "A Method of Cost Analysis and Control Through Simulation", Linde Co. (May 1960)
42. Springstead, E. T., and Caulkins, D. R., "Determination of Obsolescence Costs", Vickers, Inc. (November 1961)

43. Summers, Robert, "Cost Estimates as Predictors of Actual Weapon Costs: A Study of Major Hardware Articles", AD 612 723, The RAND Corporation (March 1965)
44. Tenzer, A. J., "Cost Sensitivity Analysis", The RAND Corporation
45. "The Use of Classical Statistics in Deriving and Evaluating CER's", Office of Assistant Secretary of Defense - Systems Analysis (October 1966)
46. Westerman, Dean P., and Mathias, Ronald F., "A Cost Model for Use in Cost-Effectiveness of Dissimilar Weapon Systems", BRL #1602, Ballistics Research Laboratories

COST EFFECTIVENESS

1. Albert, Bernard S., "Cost Effectiveness Evaluation for Mixes of Naval Air Weapon Systems", Journal of the Operations Research Society of America (March-April, 1963)
2. Bell, Chauncey F. "Cost Effectiveness Analysis as A Management Tool', The RAND Corporation
3. Blumstein, A. , "The Choice of Analytical Techniques in Cost-Effectiveness Analysis", AD 625 947, Institute for Defense Analyses, Arlington, Virginia (October 1965)
4. Bryk, Oliver, "Models in Cost-Effectiveness Analysis: An Example", AD 622, Research Analysis Corporation, McLean, Virginia (June 1965)
5. Dishong, W. R., Jr., et.al., "Cost Effectiveness Analysis Applied to AF Communications Link", U. S. Navy Electronics Laboratory Report 144204 (January 1967)
6. Dishong, W. R., Jr., et.al., U. S. Navy Electronics Laboratory Report 1323 (October 1965)
7. Goldman, A. S., "Risk and Uncertainty in Cost Effectiveness Analysis and Budgeting", TEMPO, General Electric Co. (January 1964)
8. Grosse, R. N., "An Introduction to Cost-Effectiveness Analysis", AD 622 112, Research Analysis Corporation (November 1964)
9. Hadley, W. L., and Brill, M. A., "Reliability -Cost Schedule Tradeoffs", NTN-58, RL 43,926, Martin Company (September 1963)
10. Knorr, Klaus, "On the Cost Effectiveness Approach to Military R & D: A Critique", AD 635 117, Princeton University, Princeton, New Jersey (June 1966)
11. Kornfeld, J. P., "Cost Effectiveness as a Method of Evaluating Design Changes", Boeing Airplane Co. (October 1960)

12. Maltese, Jasper G., "System Effectiveness: Basic Concepts and Framework for Analysis", Monograph 12, ARINC Research Corporation, Annapolis, Md. (January 1967)
13. Novick, D., "Concepts of Costs for Use in Studies of Effectiveness", P-1182, The RAND Corporation (October 1965)
14. O'Neill, D. et.al., "Cost-Effectiveness Analysis", BRL Report R 1315 (March 1966)
15. Quade, E, S., "Cost Effectiveness Analysis: **An** Appreciation", AD 623 105, The RAND Corporation (October 1965)
16. Quade, E, S., "Cost Effectiveness: **An** Introduction and Overview", AD 616 339, The RAND Corporation (May 1965)
17. Quade, E, S., "Some Comments on Cost-Effectiveness", AD 615 394 The RAND Corporation (March 1965)
18. Quade, E, S., "The Limitations of a Cost-Effectiveness Approach to Military Decision-Making", P-2798, The RAND Corporation
19. Visco, Eugene P., "A Beginning to Cost-Effectiveness Analysis", AD-422 374, Research Analysis Corp.

RELIABILITY AND MAINTAINABILITY

1. Advisory Group on Reliability of Electronic Equipment, Office of the Assistant Secretary of Defense (Research and Engineering, "Reliability of Military Electronic Equipment" (June 1957)
2. ARINC Research Corporation, Annapolis, Md., "Electronic Reliability in Military Applications", General Report No. 2, Publication No. 102 (July 1957)
3. Bayovsky, Igor, "Reliability Theory and Practice", Prentice-Hall, Inc. (1961)
4. Bishop, Walton B., "Reliability and Maintainability Assurance", Electronic Material Sciences Laboratory, Bedford, Mass. AFRCR-TN-58-569, AD 160 882, (November 1958)
5. Bosinoff, et.al., "Transfer Functions in Mathematical Simulation for Reliability Prediction", Sylvania Document No. F 491-2, Contract No. AF 30(602)-2376, Sylvania Electronic Systems Div. (January 1963)
6. Carhart, R. R., "A Survey of the Current Status of the Electronic Reliability Problem", Rand Research Memo. RM-1131, AD 80 637, The RAND Corporation (August 1953)
7. Drummer, G.W.A., and Griffin, N., "Electronic Equipment Reliability", John Wiley and Sons, Inc. (1960)
8. Friddell, H. G., and Jacks, H. G., "System Operational Effectiveness", Proceedings of the Fifth National Symposium on Reliability and Quality Control (January 1949)
9. Gaveretal, D. P., "Statistical Estimation in a Problem of System Reliability" (February 1967)
10. Horne, Riley C., Jr., "Analysis of Operator Equipment Relationships", ARINC Research Corporation, Annapolis, Md., Publication No. 101-7-131 (December 1958)
11. Hosford, J. D., "Measure of Dependability", Journal of Operations Research Society of America, Vol. 8, No. 1 (January - February 1960)

12. Howard, W. J., "Some Physical Qualifications for Reliability Formulas", Rand Research Memo. RM-1724, AD 109 936, The RAND Corporation (June 1956)
13. Kaufman, N. , "Weapon System Availability Models and the Estimation of Their Parameters", Long Island Quality Control and Reliability Conference (April 1963)
14. Knight, C. R., and Jervis, E. R., "Electronic Reliability - A Discussion of Some Basic Theoretical Concepts and A Review of Progress Since World War II", Monograph No. 1, ARINC Research Corporation, Annapolis, Md. (May 1955)
15. Leake, C. E. , "Understanding Reliability", Pasadena Lithographer (1960)
16. Lloyd, D. K., and Lipow, M., "Reliability: Management, Methods and Mathematics", Prentice-Hall, Inc. (December 1961)
17. "Maintainability Engineering", Phase V, Vol. 11, RADC Document No. RADC-TDR-63-85, DDC No. AD 404898, RADC Contract No. AF 30(602)-2057 (February 1963)
18. "Maintainability Measurement and Prediction Methods for AF Ground Electronic Equipment", Field Data Collection, Phase II, DDC No. AD 247155, Contract No. AF 30(602)-2057 (September 1960)
19. "Maintainability Prediction Techniques", RADC Document No. RADC-TDR-62-156 (Phase IV) RADC Contract No. AF 30(602)-2057, DDC No. AD 277199 (March 1962)
20. "Maintainability Technique Study", Final Tech. Report, Phase V., Vol. I., RADC Document No. RADC-TDR-63-85, DDC No. AD 404899, Contract No. AF 30(602)-2057 (February 1963)
21. "Mathematical Models for System Reliability", Sylvania Electronic Defense Laboratories, SEDL Publication No. EDL-E35, DDC No. AD 228131 (August 1959)
22. Moskowitz, Fred, and McLean, John B., "Some Reliability Aspects of System Design", Rome Air Development Center, Griffiss Air Force Base, Rome, New York, RADC TN-55-4, AD 66 802, also, IRE Transactions on Reliability and Quality Control, PGRQC-8 (September 1956)

AMCP 706-191

23. "Production and Field Reliability", Electronics Division, American Society for Quality Control (February 1959)
24. RADC Reliability Notebook, RADC No. Tr-58-111, OTS Nos. PB-161894, Basic, October 1959; PB-161894-2, Rev. 2, December 1961; PB-161894-3, Rev. 3, January 1963
25. "Reliability Notebook," RADC TR-58-111, AD 148 868, (October 1959)
26. "Reliability of Radio-Electronic Equipment", Office of Technical Services, U. S. Department of Commerce, Washington, D. C. (1958)
27. "Reliability Stress and Failure Rate Data for Electronic Equipment", Military Handbook No. 217A
28. "Reliability Training Text", 2nd Edition, Institute of Radio Engineers (March 1960)
29. "Research and Development Reliability", American Society for quality Control, Electronics Division (February 1961)
30. Reza, F. M., and Jutila, S., "System Reliability Studies", Rome Air Development Center, Griffiss Air Force Base, Rome, New York, RADC TR-59-24, AD 210 729 (December 1958)
31. Rosenblatt, J. R., "Confidence Limits for the Reliability of Complex Systems", Statistical Theory of Reliability, edited by M. Zelen, University of Wisconsin Press, Madison (1963)
32. Sandler, G. H., "System Reliability Engineering", Prentice-Hall, Inc. (1963)
33. Shellard, Gordon D., "Failure of Complex Equipment", Operations Research for Management, Vol. 11, McCloskey and Coppinger, Johns Hopkins Press, 1956; Also, Journal Operations Research Society of America, Vol. I, No. 3, May 1953
34. Shwap, J. E., and Sullivan, H. J. (Editors), "Semiconductor Reliability", Engineering Publishers, Elizabeth, New Jersey (1961)
35. "System Reliability Prediction by Function", RADC Document No. RADC TDR-63-146, DDC No. AD 406191, RADC Contract No. AF 30(602)-2687, Federal Electric Corp., May 1963

36. Tangerman, E, J. (Editor), "A Manual of Reliability",
Product Engineering (May 1960)
37. Von Alven, W. H. (Editor), "Semiconductor Reliability",
Vol. II, Engineering Publishers, Elizabeth, New Jersey,
(1962)
38. Von Alven, W, H, (Editor), "Reliability Engineering",
ARINC Research Corporation, Prentice-Hall, Inc., Englewood
Cliffs, New Jersey (1964)

SIMULATION

1. Adams, E. A., and Forrester, R. D., Carmonette: A Computer Combat Simulation, Operations Research Office, Johns Hopkins University, Washington, D. C., 1959.
2. Bellman, R., et al. "On the Construction of Multi-Stage Multi-Person Business Game," Operations Research, Vol. 5, No. 4 (August, 1957).
3. Biel, W. C., Operations Research Based on Simulations for Training, SP-16, System Development Corporation, National Conf. of Aeronautical Electronics (1958).
4. Blumstein, A., "A Monte Carlo Analysis of the Ground Controlled Approach System," Opns. Res., 5, 397-408 (1957).
5. Bond, G. W., Gale, K. S., and Moore, C. J., Digital Simulation of Air Traffic Control Systems, presented at Natl. Conf. on Aeronautical Electronics, Dayton, Ohio, 1958.
6. Bradford, J. C., and Fain, W. W., Operations Research for Weapon System Analysis, Chance Vought Aircraft, Inc., Dallas, Texas, 1959.
7. Brotman, L., and Seid, B., Digital Simulation of a Massed Bomber-Manned Interceptor Encounter, Hughes Research and Development Labs. (no date).
8. Carlisle, R., Model Techniques for Communication Systems, Broadview Research Corp., Burlingame, Calif. (1957).
9. Clapham, J. C. R. "A Monte Carlo Problem in Underground Communications," Operations Research Quarterly, Vol. 9, No. 1 (March, 1958).
10. Drescher, Melvin, "Theory and Applications of Games of Strategy," R-216, The RAND Corporation, December 1, 1951.
11. Driggs, I., "A Monte Carlo Model of Lanchester's Square Law," Opns. Res., 4, 148-151 (1956).
12. Dunne, J. J., and Sebastian, R. A., Computer Played War Games, Office of Ordnance Research, Report No. 59-3, Ordnance Corps, Durham, North Carolina (1959).
13. Enke, S., Use of a Simulation Laboratory to Study the Organization and Effectiveness of Air Force Logistics, P-1343, The RAND Corp., Santa Monica, Calif. (1958).

14. Flannagan, J. C., A Monte Carlo Computer Simulation for the Evaluation of Anti-Armor Weapons Systems, presented at 15th Annual Meeting of ORSA, 1959.
15. Ford, L. R., Jr., Isaacson, H. S., and Pethel, F. C., "Computer Terrain Simulation for Line-of-Sight Calculations," Opns. Res., 7, 478-482 (1959).
16. Forsythe, G. E., Germand, H. H., and Householder, A. S. (eds.). Monte Carlo Method. NBS Applied Mathematics Series. Washington, D. C.: U. S. Government Printing Office, 1951.
17. Fulkerson, D. R., and Johnson, S. M., "A Tactical Air Game," Opns. Res., 5, 704-712 (1957).
18. Geisler, M. A., The Use of Man-Machine Simulation in the Design of Control Systems, P-1780, The RAND Corp., Santa Monica, Calif. (1959).
19. Geisler, M. A., "The Use of Monte Carlo Models, Man-Machine Simulation, and Analytical Methods for Studying Large Human Organizations," P-1634, The RAND Corporation, March 11, 1959.
20. Goen, R. L., Monte Carlo Simulation of Missile Maintenance Cycling, No. Am. Aviation, Inc., Downey, Calif., 1959.
21. Goode, H. H., and Machol, R. E. System Engineering. New York: McGraw-Hill, 1957.
22. Harling, J., "Simulation Techniques in Operations Research -- A Review," Operations Research, Vol. 6, No. 3 (May-June, 1958).
23. Helmer, O., and Shapley, L. S., "Brief Description of the SWAP Game" (confidential), RM-2058, The RAND Corporation, December 12, 1957.
24. Isaacs, Rufus, "Differential Games -- I. Introduction, II. The Definition and Formulation, III. The Basic Principles of the Solution Process, IV. Mainly Examples," RM-1391, RM-1399, RM-1411, RM-1486, The RAND Corporation, March 25, 1955.
25. Kahn, Herman, and Mann, Irwin, "War Gaming," P-1167, The RAND Corp., July 30, 1957.
26. Kahn, H., and Marshall, A. W., "Methods of Reducing Sample Size in Monte Carlo Computations," Opns. Res., 1, 263-278 (1953).
27. King, G., "The Monte Carlo Method as a Natural Mode of Expression in Operations Research," Operations Research Society of America, Vol. 1, No. 2 (February, 1953).

AMCP 706-191

28. Law, C. E., War Gaming in the Canadian Army, Department of National Defense, CAORE Memo No. 49/5, Ottawa, Canada (1959).
29. Luce, R. Duncan, and Raiffa, Howard, Games and Decisions, John Wiley and Sons, New York, 1957.
30. Marshall, A. W., Experimentation by Simulation and Monte Carlo, P-1174, The RAND Corp., Santa Monica., Calif. (1958).
31. McCracken, D. D., "The Monte Carlo Method," Sci. Amer., 192, 90-96 (1955).
32. McKown, D. C., Survey of Methods for Finding Maximum Values Experimentally, Chance Vought Aircraft, Inc., Dallas, Texas, 1958.
33. McKown, D. C., Reedy, D. M., and Poe, P. H., Air Battle Simulation Experiences with the IBM 704, Chance Vought Aircraft, Inc., Dallas, Texas (no date).
34. Meyer, H. A. (ed.). Symposium on Monte Carlo Methods. New York: John Wiley and Sons, 1956.
35. Mood, A. M., "War Gaming as a Technique of Analysis," P-899, The RAND Corporation, September 3, 1954.
36. Mood, A. M., and Specht, R. D., "Gaming as a Technique of Analysis," P-579, The RAND Corporation, October 19, 1954.
37. Morgenthaler, G. W., and Hesse, H., A Conceptual Model for Studying Strategic Aerial Penetration, Institute for Air Weapons Research, Report 57-3, University of Chicago, Chicago, Ill. (1957).
38. Morgenthaler, G. W., Some Target Coverage Problems, The Martin Co., Denver, Colo., 1959.
39. OMEGA, "A Guide to the Air Battle Model" (Vol. I on Flow Charts, Vol. II on Notations), SM58-5, Technical Operations, Inc., Washington, D. C., April 10, 1958.
40. Orcutt, G. H., Greenberger, M., and Rivlin, A., Decision-Unit Models and Simulation of the United States Economy, preliminary draft, 1958.
41. Rich, R. P., "Simulation As an Aid in Model Building," Opns. Res., 3, 15-19 (1955).
42. Robinson, P. J., Cases in Simulation -- A Research Aid as a Management "Demonstration Piece," Presentation at Seminar on Techniques of Industrial Operations Research, Ill. Inst. of Technology, Chicago, Ill., 1957.

43. Schiller, D. H., and Lavin, M. M., "The Determination of Requirements for Warehouse Dock Facilities," Opns. Res., 4, 231-242 (1956).
44. Smith, N. M., Jr., "A Rationale for Operational Gaming," paper presented to 8th National Meeting of ORSA, Ottawa, Canada, January 10, 1956.
45. Spanier, J., Kuehn, H., and Guilinger, W., A Two-Dimensional Monte Carlo Calculation of Capture Fractions on the IBM-704, WAPD-TM-125, Office of Tech. Services, Dept. of Commerce, Washington, D. C. (1959).
46. Spanier, J., Monte Carlo Methods and Their Application to Neutron Transport Problems, WAPD-195, Office of Technical Services, Dept. of Commerce, Washington, D. C. (1959).
47. Spanier, J., The Physics and Mathematical Analysis for the Monte Carlo Code TUT-T5, WAPD-TM-186, Office of Technical Services, Dept. of Commerce, Washington, D. C. (1959).
48. Strauss, W., and Feurzeig, N., IAWR-SAC Penetration Campaign Model as Applied in March, 1957, Institute for Air Weapons Research, Report 57-4, University of Chicago, Chicago (1957).
49. Taylor, J. L., "Development and Application of a Terminal Air Battle Model," Opns. Res., 7, 783-796 (1959).
50. Thomas, C. J., "The Genesis and Practice of Operational Gaming," Proc. of the First Inter. Conf. on OR, 64-81, ORSA, Baltimore, 1957.
51. Thomas, C. J., and Deemer, W. L., Jr., "The Role of Operational Gaming in Operations Research," Operations Research, Vol. 5, No. 1 (1957).
52. Thomas, L. H., "A Comparison of Stochastic and Direct Methods for the Solution of Some Special Problems," Opns. Res., 1, 181-186 (1953).
53. U. S. Dept of Commerce, National Bureau of Standards, Monte Carlo Method, Applied Math. Series 12, 1951.
54. Vazsonyi, A., Electronic Simulation of Business Operations (The Monte Carlo Method), presented to 2nd Annual West Coast Engineering Management Conf., 1957.

AMCP 706-191

55. Webb, K. W., and Moshman, J., **A Simulation for Optimal Scheduling of Maintenance of Aircraft**, C.E.I.R., Inc., Arlington, Va., 1959.
56. Weiner, M. G., "An Introduction to War Games," P-1773, The RAND Corporation, August 17, 1959.
57. Weiss, Herbert K., "Lanchester-Type Models of Warfare," Proc. of the First Inter. Conf. on OR, Oxford, September 1957.
58. Weiss, Herbert K., "Some Differential Games of Tactical Interest and the Value of a Supporting Weapon System," Opns. Res., 7, 180-196 (1959).
59. Woodall, H. McG., A Simulation Model for Determining Optimum Machine Assignment, M.S. Thesis, North Carolina State College, Raleigh, N. C., 1959.
60. Zimmerman, Richard E. "A Monte Carlo Model for Military Analysis," Operations Research for Management, Vol. II. Edited by Joseph F. McCloskey and John F. Copping. Baltimore: The Johns Hopkins Press, 1956.

QUEUEING

1. Barry, J. Y., "A Priority Queueing Problem," *Opns. Res.* 4, 385 (June 1956).
2. Brigham, G., "On a Congestion Problem in an Aircraft Factory," *Opns. Res.*, Vol 3, No. 4 (1955).
3. Churchman, C. W., Ackoff, R. G., and Arnoff, E. L., *Introduction to Operations Research*. New York: John Wiley and Sons, 1957.
4. Clarke, A. B., "A Waiting Line Process of Markov Type," *Ann. Math. Stat.* 27, No. 2 (June 1956).
5. Clarke, A. B., "The Time-Dependent Waiting Line Problem," *University of Michigan Engineering Research Inst. Report No. M720-1 R 39*, 1953.
6. Edie, Leslie C., "Optimization of Traffic Delays at Toll Booths," *Opns. Res.*, Vol. 2, No. 2 (1954).
7. Goode, H. H., and Machol, R. E. *System Engineering*. New York: McGraw-Hill, 1957.
8. Kendall, W. G., "Some Problems in the Theory of Queues," *Journal of the Royal Statistical Society, Series B*, Vol. XIII, No. 2.
9. Kendall, W. G., "Stochastic Processes Occurring in the Theory of Queues," *J. Roy. Stat. Soc. B* 13, No. 2 (1951).
10. Luchak, George, "The Solution of the Single-Channel Queueing Equations Characterized by a Time-Dependent Poisson-Distributed Arrival Rate and a General Class of Holding Times," *Operations Research*, Vol. 4, No. 6 (1956).
11. Morse, P. M., "Stochastic Properties of Waiting Lines," *J. Opns. Res. Soc. Am.* 3, 255 (1955).
12. Morse, Philip M., *Queues, Inventories, and Maintenance*, John Wiley & Sons, New York, 1958.
13. Saaty, Thomas L., "Resume of Useful Formulas in Queueing Theory," *Opns. Res.*, Vol. 5, No. 2 (April 1957).

SEQUENCING

1. Bellman, R., "Some Mathematical Aspects of Scheduling Theory," J. Soc. Indust. and Appl. Math., 4, 168-205 (1956).
2. Blake, K. R., and Stopakis, W. S., Some Theoretical Results on the Job Shop Scheduling Problem, Report M-1433-1, United Aircraft Corp., Research Dept., East Hartford, Conn. (July 1, 1959).
3. Bowman, E. H., "The Schedule-Sequencing Problem," Opns. Res., 7, 621-624 (1959).
4. Conway, R. W., Johnson, B. M., and Maxwell, W. L., "Some Problems of Digital Systems Simulation," Mgmt. Sci., 6, 92-110 (1959).
5. Churchman, C. W., Ackoff, R. L., and Arnoff, E. L., Introduction to Operations Research, John Wiley and Sons, New York, 1957, Chapter 16.
6. Dantzig, G. B., Fulkerson, D. R., and Johnson, S. M., "Solution of a Large-Scale Traveling Salesman Problem," Opns. Res., 2, 393-410 (1954); also see these authors' later paper on "Linear Programming, Combinatorial Approach to the Traveling Salesman Problem," Opns. Res., 7, 58-66 (1959).
7. Heller, J., Combinatorial, Probabilistic and Statistical Aspects of an M×J Scheduling Problem, Report NYO-2540, AEC Computing and Applied Mathematics Center, Institute of Mathematical Science, New York University, New York (Feb. 1, 1959).
8. Johnson, S. M., "Optimal Two and Three Stage Production Schedules with Setup Times Included," Nav. Res. Log. Quart., 1, 61-68 (1954).
9. Manne, Alan S., On the Job-Shop Scheduling Problem, Cowles Foundation Discussion Paper No. 73 (May 8, 1959).
10. Mitten, L. G., "A Scheduling Problem," J. of Ind. Engr., 10, 131-134 (1959). This includes results of Mitten's "Sequencing in Jobs on Two Machines with Arbitrary Time Lags," Mgmt, Sci., 5, 293-298 (1959).
11. Rowe, A. J., Toward a Theory of Scheduling, Report SP-61, System Development Corp., Santa Monica., Calif. (April 1, 1959).
12. Sasieni, M. W., Yaspan, A., and Friedman, L., Operations Research: Methods and Problems, John Wiley and Sons, New York, 1959, Chapter 9.
13. Sisson, R. L., "Sequencing in Job Shops -- A Review," Opns. Res., 7, 10-29 (1959).

INVENTORY

1. Arrow, Kenneth J., Harris, Theodore, and Marschak, Jacob. "Optimal Inventory Policy," *Econometrica*, Vol. 19, No. 3 (July, 1951), 250-72.
2. Arrow, Kenneth J., Karlin, Samuel, and Scarf, Herbert. *Studies in the Mathematical Theory of Inventory and Production*. Stanford: Stanford University Press, 1958.
3. Dvoretzky, A., Kiefer, J., and Wolfowitz, J. "The Inventory Problem," *Econometrica*, Vol. 20, No. 2 (April, 1952), 187-222.
4. Laderman, J., Littauer, S. B., and Weiss, Lionel. "The Inventory Problem." *Journal of the American Statistical Association*, Vol. 48, No. 264 (December, 1953), 717-23.
5. Magee, J. F., *Production Planning and Inventory Control*, McGraw-Hill, New York, 1958.
6. Magee, John P. "Guides to Inventory Policy," *Harvard Business Review*. Vol. 34, Nos. 1, 2, and 3 (January, March, and May, 1956).
7. Naddor, E., "Some Models of Inventory and an Application," *Mgmt. Sci.*, 2, 299-312 (1956).
8. Naddor, Eliezer. "Elementary Inventory Models," *Introduction to Operations Research*. Edited by C. West Churchman, Russell L. Ackoff and E; Leonard Arnoff. New York: John Wiley and Sons, 1957.
9. Simon, Herbert A., and Holt, Charles C. "The Control of Inventories and Production Rates -- A Survey," *Operations Research*, Vol. 2, No. 3 (August, 1954), 289-301.
10. Solomon, M. J., "A Scientific Method for Establishing Reorder Points," *Nav. Res. Log. Quart.*, 1, 289-294 (1954).
11. Welch, W. Evert. *Scientific Inventory Control*. Greenwich, Conn.: Management Publishing Corp., 1956.
12. Whitin, Thomson M. "Inventory Control Research: A Survey," *Management Science*, Vol. 1, No. 1 (October, 1954), 32-40.
13. Whitin, Thomson M. *The Theory of Inventory Management*, Princeton University Press, Princeton, N. J., 1953.
14. Whitin, Thomson M. "Inventory Control and Price Theory," *Mgmt. Sci.*, 2, 61-68 (1955).
15. Whitin, Thomson M, and Youngs, J. W. T., "A Method for Calculating Optimal Inventory Levels and Delivery Time," *Nav. Res. Log. Quart.*, 2, 157-174 (1955).

LINEAR PROGRAMMING

1. Antosiewicz, H. A. (ed.). Second Symposium, Linear Programming. Washington, D. C.: National Bureau of Standards, 1955.
2. Arnoff, E. Leonard. "An Application of Linear Programming," Proceedings of the Conference on Operations Research in Production and Inventory Control. Cleveland: Case Institute of Technology, 1954.
3. Charnes, A. "Optimality and Degeneracy in in Linear Programming," *Econometrica*, Vol. 20 (1952), 160-70.
4. Charnes, A., Cooper, W. W. and A. Henderson, An Introduction to Linear Programming, John Wiley & Sons, New York, 1953.
5. Churchman, C. W., R. L. Ackoff, and E. L. Arnoff, Introduction to Operations Research, John Wiley & Sons, New York, 1957.
6. Dantzig, G. B., "Computational Algorithm of the Revised Simplex Method," RAND Memorandum RM-1266, 1953.
7. Dantzig, G. B., "Maximization of a Linear Function of Variables Subject to Linear Inequalities," Activity Analysis of Production and Allocation, Cowles Commission Monograph No, 13. Edited by T. C. Koopmans. New York: John Wiley and Sons, 1951.
8. Dantzig, G. B., and Orchard-Hays, W., "Alternate Algorithm for the Revised Simplex Method," RAND Memorandum RM-1268, 1953.
9. Dantzig, G. B., Orden, A., and Wolfe, P., "The Generalized Simplex Method for Minimizing a Linear Form under Linear Inequality Restraints," RAND Memorandum RM-1264, 1954.
10. Dantzig, G. B., "The Simplex Method," RAND Report P-891, July 9, 1956a.
11. Dorfman, R., Samuelson, P. A., and Solow, R. M., Linear Programming and Economic Analysis, McGraw-Hill Book Co., New York, 1958.
12. Ferguson, A. R., and Dantzig, G. B., "The Problem of Routing Aircraft -- A Mathematical Solution," *Aero. Eng. Review*, 14, 51-55 (1955).
13. Ferguson, A. R., and Dantzig, G. B., " Allocation of Aircraft to Routes -- An Example of Linear Programming under Uncertain Demand," *Mgmt. Sci.*, 3, 45-73 (1956). Also published as RAND Memo RM-1833, Dec. 7, 1956.

14. Flood, M. M., "The Traveling-Salesman Problem," Operations Research for Management. Vol. II. Edited by Joseph F. McCloskey and John F. Copinger. Baltimore: The Johns Hopkins Press, 1956.
15. Goldman, A. J., and Tucker, A. W., "Theory of Linear Programming" in Kuhn and Tucker (1956), pp. 53-98.
16. Harrison, Joseph O., Jr., "Linear Programming and Operations Research," Seminar Paper No. 2 in Informal Seminar in Operations Research. Baltimore: The Johns Hopkins Press, 1953.
17. Henderson, A., and Schlaifer, R., "Mathematical Programming," Harvard Business Review, May-June, 1954.
18. Hitchcock, F. L., "The Distribution of a Product from Several Sources to Numerous Localities," J. Math. and Phys., 20, 224-230 (1941).
19. Hoffman, Alan J., "How to Solve a Linear Programming Problem," in Antosiewicz (1955), pp. 397-424.
20. Lemke, C. E., "The Dual Method of Solving the Linear Programming Problem," Nav. Res. Log. Quart., 1, 36-47 (1954).
21. Orchard-Hays, W., "A Composite Simplex Algorithm -- II," Notes on Linear Programming -- Part XII, RAND Memo RM-1275, May 7, 1954a.
22. Orchard-Hays, W., "Background, Development and Extension of the Revised Simplex Method," RAND Memo RM-1433, April, 1954b.
23. Orden, A., "Survey of Research on Mathematical Solutions of Programming Problems," Management Science, Vol. 1 (1955) 170-72.
24. Project SCOOP. Symposium of Linear Inequalities and Programming. Washington, D. C.: U. S. Air Force, 1952.
25. Riley, Vera, and Gass, S. I., Linear Programming and Associated Techniques: A Comprehensive Bibliography on Linear, Nonlinear and Dynamic Programming, The Johns Hopkins Press, Baltimore, 1958.
26. Rohde, F. Virginia, "Bibliography on Linear Programming," Operations Research, Vol. 5, No. 1 (Feb. 1957).
27. Sasieni, M. W., Yaspan, A., and Friedman, L., Operations Research: Methods and Problems, Wiley, New York, 1959.
28. Satty, Thomas L., Mathematical Methods of Operations Research, McGraw-Hill, New York, 1959a.

AMCP 706-191

29. Vajda, S., *The Theory of Games and Linear Programming*, Wiley, New York, 1956.
30. Votaw, D. F., and Orden, A., "The Personnel Assignment Problem," *Symposium on Linear Inequalities and Programming*. Washington, D. C.: Project SCOOP, U. S. Air Force, 1952.
31. Wagner, Harvey M., "The Simplex Method for Beginners, : *Journal of the Operations Research Society of America*, March-April, 1958, pp. 190-99.
32. Wagner, Harvey M., "A Supplementary Bibliography on Linear Programming," *Opns. Res.*, 5, 555-562 (1957c).

DYNAMIC PROGRAMMING

1. Bellman, R., "On the Theory of Dynamic Programming -- A Warehousing Problem," *Mgmt. Sci.*, 2, 272-275 (1956).
2. Bellman, R., "Dynamic Programming and the Smoothing Problem," *Mgmt. Sci.*, 3, 111-113 (1956).
3. Bellman, R., "On a Dynamic Programming Approach to the Caterer Problem -- I," *Mgmt. Sci.*, 3, 270-278 (1957).
4. Bellman, R., *Dynamic Programming*, Princeton University Press, Princeton, N. J., 1957.
5. Cartaino, T., and Dreyfus, S., "Application of Dynamic Programming to the Airplane Minimum Time-to-Climb Problem," *Aero. Engr., Rev.*, 16, 74-77 (1957).
6. Dreyfus, S., "A Generalized Equipment Replacement Study," *J. of SIAM*, 8, 425-435 (1960).
7. *Econometric Analysis of the United States Manganese Problem*, *Econometric Research Program*, RM 3, Princeton University, Princeton, N. J., Oct. 1958.
8. Howard, R., *Dynamic Programming and Markov Processes*, Technology Press and Wiley, 1960.
9. Schlager, K. J., Optimization of a Von Thuenen Model of the Firm by Dynamic Programming, Fifteenth National Meeting of the Operations Research Society, May 1959.
10. Ten Dyke, R. P., "Computation of Rocket Step Weights to Minimize Initial Gross Weight," *Jet Propulsion*, 28, 338-340 (1958).
11. Vazsonyi, Andrew, *Scientific Programming in Business and Industry*, John Wiley and Sons, New York, 1958.

GAME THEORY

1. Blackwell, David, "Game Theory," Operations Research for Management. Vol. I. Edited by Joseph F. McCloskey and Florence N. Trefethen. Baltimore: The Johns Hopkins Press, 1954.
2. Blackwell, David, and Girshick, M. A., Theory of Games and Statistical Decisions. New York: John Wiley and Sons, 1954.
3. Brown, George W., "Iterative Solution of Games by Fictitious Play," Activity Analysis of Production and Allocation, Cowles Commission Monograph No. 13. Edited by T. C. Koopmans. New York: John Wiley and Sons, 1951.
4. Luce, R. Duncan, and Raiffa, Howard. Games and Decisions. New York: John Wiley and Sons, 1957.
5. McKinsey, J. C. C., Introduction to the Theory of Games. New York: McGraw-Hill, 1952.
6. Naddor, Eliezer, "The Theory of Games," Introduction to Operations Research. Edited by C. W. Churchman, R. L. Ackoff, and E. L. Arnoff. New York: John Wiley and Sons, 1957.
7. Vajda, S., The Theory of Games and Linear Programming. London: Methuen, Ltd., and New York: John Wiley and Sons, 1956.
8. von Neumann, J., and Morgenstern, O., Theory of Games and Economic Behavior. Princeton: Princeton University Press, 1947.
9. Williams, J. D., The Compleat Strategyst. New York: McGraw-Hill, 1954.

INFORMATION THEORY

1. Abramson, N., Information Theory and Coding, McGraw-Hill, New York, 1963.
2. Bell, D. A. (1953): "Information Theory and Its Engineering Applications," Sir Isaac Pitman & Sons, Ltd., London.
3. Brillouin, L. (1956): "Science and Information Theory," Academic Press Inc., New York.
4. Cherry, C. (1957): "On Human Communication," John Wiley & Sons, Inc., New York.
5. Fano, R. (1949): The Transmission of Information, I, MIT Res. Lab. Electron. Tech. Rept. 65.
6. Fano, R. (1950): The Transmission of Information, 11, MIT Res. Lab. Electron. Tech. Rept. 149.
7. Fano, R. (1961): "Transmission of Information," John Wiley & Sons, Inc., New York.
8. Feinstein, A. (1958): "Foundations of Information Theory," McGraw-Hill Book Company, Inc., New York.
9. Harman, W. W. (1963): "Principles of the Statistical Theory of Communication," McGraw Hill Book Company, Inc., New York.
10. Hartley, R. V. L. (1928): Transmission of Information, Bell System Tech. J., vol. 7, pp. 535-563.
11. Khinchin, A. I. (1957): "Mathematical Foundations of Information Theory," Dover Publications, Inc., New York.
12. Kullback, S. (1959): "Information Theory and Statistics," John Wiley & Sons, Inc., New York.
13. McMillan, B. (1953): The Basic Theorems of Information Theory, Ann. Math. Statist., vol. 24, pp. 196-219.
14. Powers, K. H. (1956): "A Unified Theory of Information," MIT Res. Lab. Electron. Tech. Rept. 311, February.
15. Quastler, H. (1956): "Information Theory in Psychology," The Free Press of Glencoe, New York.
16. Reza, F. M. (1961): "An Introduction to Information Theory," McGraw-Hill Book Company, Inc., New York.
17. Shannon, C. E. (1956): The Zero Error Capacity of a **Noisy** Channel, IRE Trans.
18. Shannon, C. E. and W. Weaver (1949): "The Mathematical Theory of Communication," The University of Illinois Press, Urbana, Ill.

1. Ackoff, R. L., "Operations Research and National Planning," *Opns. Res.*, 5, 457-468 (1957).
2. Adams, E., and Fagot, R., "A Model of Riskless Choice," *Behavioral Science*, 4, 1-10 (1959).
3. Anderson, N. H., and Grant, D. A., "A Test of Statistical Learning Theory Model for Two-Choice Behavior with Double Stimulus Events," *Journal of Experimental Psychology*, 54, 305-317 (1957).
4. Arrow, K. J., "Alternative Approaches to the Theory of Choice in the Risk-Taking Situations," *Econometrica*, 19, 404-437 (1951).
5. Arrow, K. J., "Rational Choice Functions and Orderings," *Economica*, 24, 121-127 (1959).
6. Chernoff, H., and Moses, L. E., *Elementary Decision Theory*, John Wiley and Sons, New York, 1959.
7. Churchman, C. W., "Problems of Value Measurement for a Theory of Induction and Decisions," *Proceedings of the Third Berkeley Symposium on Mathematical Statistics and Probability*, University of California Press, Berkeley, 1955.
8. Churchman, C. W., and Ackoff, R. L., "An Approximate Measure of Value," *J. of Opns. Res.*, 2, 172-187 (1954).
9. Churchman, C. W., and Ackoff, R. L., and Arnoff, L. E., *Introduction to Operations Research*, John Wiley and Sons, New York, 1947, Ch. 5, 105-135.
10. Churchman, C. W. and Ratoosh, P. (eds.), *Measurement: Definitions and Theories*, John Wiley and Sons, New York, 1959.
11. Cyert, R. M., Dill, W. R., and March, J. G., "The Role of Expectations in Business Decision Making," *Administrative Sci., Quart.*, 3, 307-340 (1958).
12. Livingston, S. J., "Decision Making in Weapons Development," *Harvard Business Review*, 36, 127-136 (1958).
13. Luce, D. R., and Raiffa, H., *Games and Decisions: Introduction and Critical Survey*, John Wiley and Sons, New York, 1957.

14. Marschak, J., "Elements for a Theory of Teams," *Mgmt. Sci.*, 1, 127-137 (1955).
15. McGlothlin, William H., "Stability of Choices Among Uncertain Alternatives," *Amer. J. of Psychology*, 69, 604-615 (1956).
16. Nelson, Arthur W., "Present Accomplishments and Future Trends in Problem-Solving and Learning Theory," *Amer. Psychology*, 11, 278-281 (1950).
17. Pepper, C. S., *The Sources of Value*, University of California Press, Berkeley, 1958.
18. Siegel, S., and Goldstein, A. D., "Decision Making Behavior in a Free Choice Uncertain Outcome Situation," *J. of Experimental Psychology*, 57, 37-42 (1959).
19. Simon, H. A., *Models of Man*, John Wiley and Sons, New York, 1957.
20. Simon, H. A., "Theories of Decision Making in Economics and Behavioral Science," *American Economic Review*, 49, 253-283 (1959).
21. Thrall, R. W., Coombs, C. H., and Davis, R. L. (eds.), *Decision Processes*, John Wiley and Sons, New York, 1954.
22. Salvesson, M. E., "An Analysis of Decisions," *Mgmt. Sci.*, 4, 203-217 (1958).

1. "Army Programs, Guide to Life Cycle of U. S. Army Material", AMCP 11-2 (June 1965)
2. "Concept Formulation - Prerequisites to Initiating Engineering or Operational Systems Development Effort", AMC 70-30 (May 1966)
3. "Cost Analysis Handbook", Army Materiel Command (January 1968)
4. "Cost Analysis Program", AR 11-18 (March 1968)
5. DOD "Programming System", Department of Defense Directive, 7045.1
6. "Processing Qualitative Materiel Requirements, Small Development Requirements and Qualitative Materiel Development Objectives", AMC 70-14 (July 1966)
7. "Project Definition", Phase I, Department of Defense Directive 3200.9
8. "Research and Development of Materiel, Planning, Volume I, Principles and Philosophy", AMCP 705-1, Volume I (January 1966)
9. "Research and Development of Materiel, Army Research and Development", AR 705-5 (October 1964)
10. "Research and Development, Materiel Systems Analysis", AMC 70-28 (January 1968)
11. "U. S. Army Materiel Command Materiel Studies Review Committee", AMC 15-8 (August 1966)
12. "Weapon/Support Systems Cost Categories and Elements", AR 37-18 (July 1968)

APPENDIX C
STATISTICAL TABLES

<u>Table</u>	<u>Title</u>
C-1	Standard Normal Table
c-2	Table of t Statistic
C-3	Chi Squared Table
c-4	Table of F Values
C-5	Table of Critical I Values
C-6	Exponential Table
C-7	Table of $z/\chi^2(p, d)$
C-8	Table of Values of r^* (required number of failures)
C-9	Table of $F(x)$
Figure C-1	Confidence Belts for Proportions

TABLE C-1
AREAS OF THE NORMAL CURVE

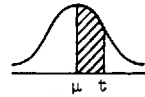

Z	0.00	0.01	0.02	0.03	0.04	0.05	0.06	0.07	0.08	0.09
0.0	0.0000	1.0040	0.0080	0.0120	3.0159	3.0199	0.0239	0.0279	0.0319	0.0359
0.1	0.0398	1.0438	0.0478	0.0517	3.0557	3.0596	0.0636	0.0675	0.0714	0.0753
0.2	0.0793	1.0832	0.0871	0.0910	3.0948	3.0987	0.1026	0.1064	0.1103	0.1141
0.3	0.1179	1.1217	0.1255	0.1293	3.1331	3.1368	0.1406	0.1443	0.1480	0.1517
0.4	0.1554	1.1591	0.1628	0.1664	3.1700	3.1736	0.1772	0.1808	0.1844	0.1879
0.5	0.1915	1.1950	0.1985	0.2019	3.2054	3.2088	0.2123	0.2157	0.2190	0.2224
0.6	0.2257	1.2291	0.2324	0.2357	3.2389	3.2422	0.2454	0.2486	0.2518	0.2549
0.7	0.2580	1.2612	0.2642	0.2673	3.2704	0.2734	0.2764	0.2794	0.2823	0.2852
0.8	0.2881	0.2910	0.2939	0.2967	0.2995	3.3023	0.3051	0.3078	0.3106	0.3233
0.9	0.3159	1.3186	0.3212	0.3238	3.3264	3.3289	0.3315	0.3340	0.3365	0.3389
1.0	0.3413	1.3438	0.3461	0.3485	3.3508	0.3531	0.3554	0.3577	0.3599	0.3621
1.1	0.3643	0.3665	0.3686	0.3718	3.3729	0.3749	0.3770	0.3790	0.3810	0.3830
1.2	0.3849	1.3869	0.3888	0.3907	3.3925	0.3944	0.3962	0.3980	0.3997	0.4015
1.3	0.4032	1.4049	0.4066	0.4083	0.4099	0.4115	0.4131	0.4147	0.4162	0.4177
1.4	0.4192	0.4207	0.4222	0.4236	3.4251	0.4265	0.4279	0.4292	0.4306	0.4319
1.5	0.4332	1.4345	0.4357	0.4370	3.4382	0.4394	0.4406	0.4418	0.4430	0.4441
1.6	0.4452	0.4463	0.4474	0.4485	3.4495	0.4505	0.4515	0.4525	0.4535	0.4545
1.7	0.4554	1.4564	0.4573	0.4582	3.4591	0.4599	0.4608	0.4616	0.4625	0.4633
1.8	0.4641	1.4649	0.4656	0.4664	3.4671	0.4678	0.4686	0.4693	0.4699	0.4706
1.9	0.4713	1.4719	0.4726	0.4732	3.4738	0.4744	0.4750	0.4758	0.4762	0.4767
2.0	0.4773	1.4778	0.4783	0.4788	3.4793	0.4798	0.4803	0.4808	0.4812	0.4817
2.1	0.4821	1.4826	0.4830	0.4834	3.4838	0.4842	0.4846	0.4850	0.4854	0.4857
2.2	0.4861	0.4865	0.4868	0.4871	3.4875	0.4878	0.4881	0.4884	0.4887	0.4890
2.3	0.4893	0.4896	0.4898	0.4901	3.4904	0.4906	0.4909	0.4911	0.4913	0.4916
2.4	0.4918	1.4920	0.4922	0.4925	3.4927	0.4929	0.4931	0.4932	0.4934	0.4936
2.5	0.4938	1.4940	0.4941	0.4943	3.4945	0.4946	0.4948	0.4949	0.4951	0.4952
2.6	0.4953	1.4955	0.4956	0.4957	3.4959	0.4960	0.4961	0.4962	0.4963	0.4964
2.7	0.4965	0.4966	0.4967	0.4968	3.4969	0.4970	0.4971	0.4972	0.4973	0.4974
2.8	0.4974	1.4975	0.4976	0.4977	3.4977	0.4978	0.4979	0.4980	0.4980	0.4981
2.9	0.4981	1.4982	0.4983	0.4984	3.4984	0.4984	0.4985	0.4985	0.4986	0.4986
3.0	0.4986	1.4987	0.4987	0.4988	3.4988	0.4988	0.4989	0.4989	0.4989	0.4990
3.1	0.4990	1.4991	0.4991	0.4991	3.4992	0.4992	0.4992	0.4992	0.4993	0.4993
3.2	0.4993									
3.3	0.4995									
3.4	0.4996									
3.5	0.4997									
3.6	0.4998									
3.7	0.4998									
3.8	0.4999									
3.9	0.4999									
4.0	0.4999									

$$z = \frac{t - \mu}{\sigma}$$

$$\text{Area} = \int_0^z f(z') dz' = \int_z^0 f(z') dz'$$

TABLE C-2					
TABLE OF t					
Degrees of Freedom	Probabilit				
	0.50	0.10	0.05	0.02	0.01
1	1.000	6.34	12.71	31.82	63.66
2	0.816	2.92	4.30	6.96	9.92
3	0.765	2.35	3.18	4.54	5.84
4	0.741	2.13	2.78	3.75	4.60
5	0.727	2.02	2.57	3.36	4.03
6	0.718	1.94	2.45	3.14	3.71
7	0.711	1.90	2.36	3.00	3.50
8	0.706	1.86	2.31	2.90	3.36
9	0.703	1.83	2.26	2.82	3.25
10	0.700	1.81	2.23	2.76	3.17
11	0.697	1.80	2.20	2.72	3.11
12	0.695	1.78	2.18	2.68	3.06
13	0.694	1.77	2.16	2.65	3.01
14	0.692	1.76	2.14	2.62	2.98
15	0.691	1.75	2.13	2.60	2.95
16	0.690	1.75	2.12	2.58	2.92
17	0.689	1.74	2.11	2.57	2.90
18	0.688	1.73	2.10	2.55	2.88
19	0.688	1.73	2.09	2.54	2.86
20	0.687	1.72	2.09	2.53	2.84
21	0.686	1.72	2.08	2.52	2.83
22	0.686	1.72	2.07	2.51	2.82
23	0.685	1.71	2.07	2.50	2.81
24	0.685	1.71	2.06	2.49	2.80
25	0.684	1.71	2.06	2.48	2.79
26	0.684	1.71	2.06	2.48	2.78
27	0.684	1.70	2.05	2.47	2.77
28	0.683	1.70	2.05	2.47	2.76
29	0.683	1.70	2.04	2.46	2.76
30	0.683	1.70	2.04	2.46	2.75
35	0.682	1.69	2.03	2.44	2.72
40	0.681	1.68	2.02	2.42	2.71
45	0.680	1.68	2.02	2.41	2.69
50	0.679	1.68	2.01	2.40	2.68
60	0.678	1.67	2.00	2.39	2.66
70	0.678	1.67	2.00	2.38	2.65
80	0.677	1.66	1.99	2.38	2.64
90	0.677	1.66	1.99	2.37	2.63
100	0.677	1.66	1.98	2.36	2.63
125	0.676	1.66	1.98	2.36	2.62
150	0.676	1.66	1.98	2.35	2.61
200	0.675	1.65	1.97	2.35	2.60
300	0.675	1.65	1.97	2.34	2.59
400	0.675	1.65	1.97	2.34	2.59
500	0.674	1.65	1.96	2.33	2.59
1000	0.674	1.65	1.96	2.33	2.58
∞	0.674	1.64	1.96	2.33	2.58

TABLE C-3
DISTRIBUTION OF χ^2

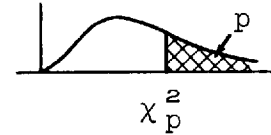

DF	Probability, p													
	0.99	0.975	0.95	0.90	0.80	0.75	0.50	0.25	0.20	0.10	0.05	0.025	0.01	0.001
1	0.00157	0.00982	0.00393	0.0158	0.0642	0.10153	0.455	1.323	1.642	2.706	3.841	5.024	6.635	10.827
2	0.0201	0.0506	0.103	0.211	0.446	0.5753	1.386	2.772	3.219	4.605	5.991	7.377	9.210	13.815
3	0.115	0.216	0.352	0.584	1.005	1.2125	2.366	4.108	4.642	6.251	7.815	9.348	11.345	16.268
4	0.297	0.484	0.711	1.064	1.649	1.9225	3.357	5.385	5.989	7.779	9.488	11.143	13.277	18.465
5	0.554	0.831	1.145	1.610	2.343	2.674	4.351	6.625	7.289	9.236	11.070	12.832	15.08%	20.517
6	0.872	1.237	1.635	2.204	3.070	3.454	5.348	7.840	8.558	10.645	12.592	14.449	16.812	22.457
7	1.239	1.689	2.167	2.833	3.822	4.254	6.346	9.037	9.803	12.017	14.067	16.013	18.475	24.322
8	1.646	2.179	2.733	3.490	4.594	5.070	7.344	10.218	11.030	13.362	15.507	17.534	20.090	26.125
9	2.088	2.700	3.325	4.168	5.380	5.898	8.343	11.388	12.242	14.684	16.919	19.023	21.666	27.877
10	2.558	3.247	3.940	4.865	6.179	6.737	9.342	12.548	13.442	15.987	18.307	20.483	23.209	29.588
11	3.053	3.816	4.575	5.578	6.989	7.584	10.341	13.701	14.631	17.275	19.675	21.920	24.725	31.264
12	3.571	4.404	5.226	6.304	7.807	8.438	11.340	14.845	15.812	18.549	21.026	23.336	26.217	32.909
13	4.107	5.008	5.892	7.042	8.634	9.299	12.340	15.984	16.985	19.812	22.362	24.735	27.688	34.528
14	4.660	5.628	6.571	7.790	9.467	10.165	13.339	17.117	18.151	21.064	23.685	26.119	29.141	36.123
15	5.229	6.262	7.261	8.547	10.307	11.036	14.339	18.245	19.311	22.307	24.996	27.488	30.578	37.697
16	5.812	6.907	7.962	9.312	11.152	11.912	15.338	19.368	20.465	23.542	26.296	28.845	32.000	39.252
17	6.408	7.564	8.672	10.085	12.002	12.791	16.338	20.488	21.615	24.769	27.587	30.191	33.409	40.790
18	7.015	8.231	9.390	10.865	12.857	13.675	17.338	21.605	22.760	25.989	28.869	31.526	34.805	42.312
19	7.633	8.906	10.117	11.651	~3.716	14.562	18.338	22.717	23.900	27.204	30.144	32.852	36.191	43.820
20	8.260	9.591	10.851	12.443	~4.578	15.452	19.337	23.827	25.038	28.412	31.410	34.169	37.566	45.315
21	8.857	10.283	11.591	13.240	15.445	16.344	20.337	24.935	26.171	29.615	32.671	35.479	38.932	46.797
22	9.52	10.982	12.338	14.041	16.314	17.239	21.337	26.039	27.301	30.813	33.924	36.780	40.289	48.268
23	10.196	11.688	13.091	14.848	~7.187	18.137	22.337	27.141	28.429	32.007	35.172	38.075	41.638	49.728
24	10.856	12.400	13.848	15.659	~8.062	19.037	23.337	28.241	29.553	33.196	36.415	39.364	42.980	51.179
25	11.524	13.119	14.611	16.473	18.940	19.939	24.337	29.339	30.675	34.382	37.652	40.646	44.314	52.620
26	12.198	13.844	15.379	17.292	19.820	20.843	25.336	30.434	31.795	35.563	38.885	41.923	45.642	54.052
27	12.879	14.573	16.151	18.114	20.703	21.749	26.336	31.528	32.912	36.741	40.113	43.194	46.963	55.476
28	13.565	15.308	16.928	18.933	21.588	22.657	27.336	32.620	34.027	37.916	41.337	44.460	48.278	56.893
29	14.256	16.047	17.708	19.768	22.475	23.566	28.336	33.711	35.139	39.087	42.557	45.722	49.588	58.302
30	14.953	16.791	18.493	20.599	23.364	24.476	29.336	34.799	36.250	40.256	43.773	46.980	50.892	59.703

For degrees of freedom greater than 30, the quantity $\sqrt{2\chi^2}$ is approximately normally distributed with mean $\sqrt{2(DF)-1}$ and variance 1.

C-4

TABLE C-4

F Distribution: Upper 1 Percent Points										
Degrees of Freedom in Numerator ν_1										
		1	2	3	4	5	6	7	8	9
Degrees of Freedom in Denominator ν_2	1	4052.2	4999.5	5403.3	5624.6	5763.7	5859.0	5928.3	5981.6	6022.5
	2	98.503	99.000	99.166	99.249	99.299	99.332	99.356	99.374	99.388
	3	34.116	30.817	29.457	28.710	28.237	27.911	27.672	27.489	27.345
	4	21.198	18.000	16.694	15.977	15.522	15.207	14.976	14.799	14.659
	5	16.258	13.274	12.060	11.392	10.967	10.672	10.456	10.289	10.158
	6	13.745	10.925	9.7795	9.1483	8.7459	8.4661	8.2600	8.1016	7.9761
	7	12.246	9.5466	8.4513	7.8467	7.4604	7.1914	6.9928	6.8401	6.7188
	8	11.259	8.6491	7.5910	7.0060	6.6318	6.3707	6.1776	6.0289	5.9106
	9	10.561	8.0215	6.9919	6.4221	6.0569	5.8018	5.6129	5.4671	5.3511
	10	10.044	7.5594	6.5523	5.9943	5.6363	5.3858	5.2001	5.0567	4.9424
	11	9.6460	7.2057	6.2167	5.6683	5.3160	5.0692	4.8861	4.7445	4.6315
	12	9.3302	6.9266	5.9526	5.4119	5.0643	4.8206	4.6395	4.4994	4.3875
	13	9.0738	6.7010	5.7394	5.2053	4.8616	4.6204	4.4410	4.3021	4.1911
	14	8.8616	6.5149	5.5639	5.0354	4.6950	4.4558	4.2779	4.1399	4.0297
	15	8.6831	6.3589	5.4170	4.8932	4.5556	4.3183	4.1415	4.0045	3.8948
	16	8.5310	6.2262	5.2922	4.7726	4.4374	4.2016	4.0259	3.8896	3.7804
	17	8.3997	6.1121	5.1850	4.6690	4.3359	4.1015	3.9267	3.7910	3.6822
	18	8.2854	6.0129	5.0919	4.5790	4.2479	4.0146	3.8406	3.7054	3.5971
	19	8.1850	5.9259	5.0103	4.5003	4.1708	3.9386	3.7653	3.6305	3.5225
	20	8.0960	5.8489	4.9382	4.4307	4.1027	3.8714	3.6987	3.5644	3.4567
	21	8.0166	5.7804	4.8740	4.3688	4.0421	3.8117	3.6396	3.5056	3.3961
	22	7.9454	5.7190	4.8166	4.3134	3.9880	3.7583	3.5867	3.4530	3.3458
	23	7.8811	5.6637	4.7649	4.2635	3.9392	3.7102	3.5290	3.4057	3.2986
	24	7.8229	5.6136	4.7181	4.2184	3.8951	3.6667	3.4959	3.3629	3.2560
	25	7.7698	5.5680	4.6755	4.1774	3.8550	3.6272	3.4568	3.3239	3.2172
	26	7.7213	5.5263	4.6366	4.1400	3.8183	3.5911	3.4210	3.2884	3.1818
	27	7.6767	5.4881	4.6009	4.1056	3.7848	3.5580	3.3882	3.2558	3.1494
	28	7.6356	5.4529	4.5681	4.0740	3.7539	3.5276	3.3581	3.2259	3.1195
	29	7.5976	5.4205	4.5378	4.0449	3.7254	3.4995	3.3302	3.1982	3.0920
	30	7.5625	5.3904	4.5097	4.0179	3.6990	3.4735	3.3045	3.1726	3.0665
	40	7.3141	5.1785	4.3126	3.8283	3.5138	3.2910	3.1238	2.9930	2.8876
60	7.0771	4.9774	4.1259	3.6491	3.3389	3.1187	2.9530	2.8233	2.7185	
120	6.8510	4.7865	3.9493	3.4796	3.1735	2.9559	2.7918	2.6629	2.5586	
∞	6.6349	4.6052	3.7816	3.3192	3.0173	2.8020	2.6393	2.5113	2.4073	

TABLE C-4 (continued)

F Distribution: Upper 1 Percent Points											
Degrees of Freedom in Numerator ν_1											
		10	12	15	20	24	30	40	60	120	∞
Degrees of Freedom in Denominator ν_2	1	6055.8	6106.3	6157.3	6208.7	6234.6	6260.7	6286.8	6313.0	6339.4	6366.0
	2	99.399	99.416	99.432	99.449	99.458	99.466	99.474	99.483	99.491	99.501
	3	27.229	27.052	26.872	26.690	26.598	26.505	26.411	26.316	26.221	26.125
	4	14.546	14.374	14.198	14.020	13.929	13.838	13.745	13.652	13.558	13.463
	5	10.051	9.8883	9.7222	9.5527	9.4665	9.3793	9.2912	9.2020	9.1118	9.0204
	6	7.8741	7.7183	7.5590	7.3958	7.3127	7.2285	7.1432	7.0568	6.9690	6.8801
	7	6.6201	6.4691	6.3143	6.1554	6.0743	5.9921	5.9084	5.8326	5.7572	5.6495
	8	5.8143	5.6668	5.5151	5.3591	5.2793	5.1981	5.1156	5.0316	4.9460	4.8588
	9	5.2565	5.1114	4.9621	4.8080	4.7290	4.6486	4.5667	4.4831	4.3978	4.3105
	10	4.8492	4.7059	4.5582	4.4054	4.3269	4.2469	4.1653	4.0819	3.9965	3.9090
	11	4.5393	4.3974	4.2509	4.0990	4.0209	3.9411	3.8596	3.7761	3.6904	3.6025
	12	4.2961	4.1553	4.0096	3.8584	3.7805	3.7008	3.6192	3.5355	3.4494	3.3608
	13	4.1003	3.9603	3.8154	3.6646	3.5868	3.5070	3.4253	3.3413	3.2548	3.1654
	14	3.9394	3.8001	3.6557	3.5052	3.4274	3.3476	3.2656	3.1813	3.0942	3.0040
	15	3.8049	3.6662	3.5222	3.3719	3.2940	3.2141	3.1319	3.0471	2.9595	2.8684
	16	3.6909	3.5527	3.4089	3.2588	3.1808	3.1007	3.0182	2.9330	2.8447	2.7528
	17	3.5931	3.4552	3.3117	3.1615	3.0835	3.0032	2.9205	2.8348	2.7459	2.6530
	18	3.5082	3.3706	3.2273	3.0771	2.9990	2.9185	2.8354	2.7493	2.6597	2.5660
	19	3.4338	3.2965	3.1533	3.0031	2.9249	2.8442	2.7608	2.6742	2.5839	2.4893
	20	3.3682	3.2311	3.0880	2.9377	2.8594	2.7785	2.6947	2.6077	2.5168	2.4212
	21	3.3098	3.1729	3.0299	2.8796	2.8011	2.7200	2.6359	2.5484	2.4568	2.3603
	22	3.2576	3.1209	2.9780	2.8274	2.7488	2.6675	2.5831	2.4951	2.4029	2.3055
	23	3.2106	3.0740	2.9311	2.7805	2.7017	2.6202	2.5355	2.4471	2.3542	2.2559
	24	3.1681	3.0316	2.8887	2.7380	2.6591	2.5773	2.4923	2.4035	2.3099	2.2107
	25	3.1294	2.9931	2.8502	2.6993	2.6203	2.5383	2.4530	2.3637	2.2695	2.1694
	26	3.0941	2.9579	2.8150	2.6640	2.5848	2.5026	2.4170	2.3273	2.2325	2.1315
	27	3.0618	2.9256	2.7827	2.6316	2.5522	2.4699	2.3840	2.2938	2.1984	2.0965
	28	3.0320	2.8959	2.7530	2.6017	2.5223	2.4397	2.3535	2.2629	2.1670	2.0642
	29	3.0045	2.8685	2.7256	2.5742	2.4946	2.4118	2.3253	2.2344	2.1378	2.0342
	30	2.9791	2.8431	2.7002	2.5487	2.4689	2.3860	2.2992	2.2079	2.1107	2.0062
	40	2.8005	2.6648	2.5216	2.3689	2.2880	2.2034	2.1142	2.0194	1.9172	1.8047
	60	2.6318	2.4961	2.3523	2.1978	2.1154	2.0285	1.9360	1.8363	1.7263	1.6006
120	2.4721	2.3363	2.1915	2.0346	1.9500	1.8600	1.7628	1.6557	1.5330	1.3805	
∞	2.3209	2.1848	2.0385	1.8783	1.7908	1.6964	1.5923	1.4730	1.3246	1.000	

TABLE C-4 (continued)

F Distribution: Upper 2.5 Percent Points										
Degrees of Freedom in Numerator ν_1										
		1	2	3	4	5	6	7	8	9
Degrees of Freedom in Denominator ν_2	1	647.79	799.50	864.16	899.58	921.85	937.11	948.22	956.66	963.28
	2	38.506	39.000	39.165	39.248	39.298	39.331	39.355	39.373	39.387
	3	17.443	16.044	15.439	15.101	14.885	14.735	14.624	14.540	14.473
	4	12.218	10.649	9.9792	9.6045	9.3645	9.1973	9.0741	8.9796	8.9047
	5	10.007	8.4336	7.7636	7.3879	7.1464	6.9777	6.8531	6.7572	6.6810
	6	8.8131	7.2598	6.5988	6.2272	5.9876	5.8197	5.6955	5.5996	5.5234
	7	8.0727	6.5415	5.8898	5.5226	5.2852	5.1186	4.9949	4.8994	4.8232
	8	7.5709	6.0595	5.4160	5.0526	4.8173	4.6517	4.5286	4.4332	4.3572
	9	7.2093	5.7147	5.0781	4.7181	4.4844	4.3197	4.1971	4.1020	4.0260
	10	6.9367	5.4564	4.8256	4.4683	4.2361	4.0721	3.9498	3.8549	3.7790
	11	6.7241	5.2559	4.6300	4.2751	4.0440	3.8807	3.7586	3.6638	3.5879
	12	6.5538	5.0959	4.4742	4.1212	3.8911	3.7283	3.6065	3.5118	3.4358
	13	6.4143	4.9653	4.3472	3.9959	3.7567	3.6043	3.4827	3.3880	3.3120
	14	6.2979	4.8567	4.2417	3.8919	3.6634	3.5014	3.3799	3.2853	3.2093
	15	6.1995	4.7650	4.1528	3.8043	3.5764	3.4147	3.2934	3.1987	3.1227
	16	6.1151	4.6867	4.0768	3.7294	3.5021	3.3406	3.2194	3.1248	3.0488
	17	6.0420	4.6189	4.0112	3.6648	3.4379	3.2767	3.1556	3.0610	2.9849
	18	5.9781	4.5597	3.9539	3.6083	3.3820	3.2209	3.0999	3.0053	2.9291
	19	5.9216	4.5075	3.9034	3.5587	3.3327	3.1718	3.0509	2.9563	2.8800
	20	5.8715	4.4613	3.8587	3.5147	3.2891	3.1283	3.0074	2.9128	2.8365
	21	5.8266	4.4199	3.8188	3.4754	3.2501	3.0895	2.9686	2.8740	2.7977
	22	5.7863	4.3828	3.7829	3.4401	3.2151	3.0546	2.9338	2.8392	2.7628
	23	5.7498	4.3492	3.7505	3.4083	3.1835	3.0232	2.9024	2.8077	2.7313
	24	5.7167	4.3187	3.7211	3.3794	3.1548	2.9946	2.8738	2.7791	2.7027
	25	5.6864	4.2909	3.6943	3.3530	3.1287	2.9685	2.8478	2.7531	2.6766
	26	5.6586	4.2655	3.6697	3.3289	3.1048	2.9447	2.8240	2.7293	2.6528
	27	5.6331	4.2421	3.6472	3.3067	3.0828	2.9228	2.8021	2.7074	2.6309
	28	5.6096	4.2205	3.6264	3.2863	3.0625	2.9027	2.7820	2.6872	2.6106
	29	5.5878	4.2006	3.6072	3.2674	3.0438	2.8840	2.7633	2.6686	2.5919
	30	5.5675	4.1821	3.5894	3.2499	3.0265	2.8667	2.7460	2.6513	2.5746
40	5.4239	4.0510	3.4633	3.1261	2.9037	2.7444	2.6238	2.5289	2.4519	
60	5.2857	3.9253	3.3425	3.0077	2.7863	2.6274	2.5068	2.4117	2.3344	
120	5.1524	3.8046	3.2270	2.8943	2.6740	2.5154	2.3948	2.2994	2.2217	
∞	5.0239	3.6889	3.1161	2.7858	2.5665	2.4082	2.2875	2.1918	2.1136	

TABLE C-4 (continued)

F Distribution: Upper 2.5 Percent Points											
Degrees of Freedom in Numerator v_1											
		10	12	15	20	24	30	40	60	120	∞
Degrees of Freedom in Denominator v_2	1	968.63	976.71	984.87	993.10	997.25	1001.4	1005.6	1009.8	1014.0	1018.3
	2	39.398	39.415	39.431	39.440	39.456	39.465	39.473	39.481	39.490	39.498
	3	14.419	14.337	14.253	14.167	14.124	14.081	14.037	13.992	13.947	13.902
	4	8.8439	8.7512	8.6565	8.5599	8.5109	8.4613	8.4111	8.3604	8.3092	8.2573
	5	6.6192	6.5246	6.4277	6.3285	6.2780	6.2269	6.1751	6.1225	6.0693	6.0153
	6	5.4613	5.3662	5.2687	5.1684	5.1172	5.0652	5.0125	4.9589	4.9045	4.8491
	7	4.7611	4.6658	4.5678	4.4667	4.4150	4.3624	4.3089	4.2544	4.1989	4.1423
	8	4.2951	4.1997	4.1012	3.9995	3.9472	3.8940	3.8398	3.7844	3.7279	3.6702
	9	3.9639	3.8682	3.7694	3.6669	3.6142	3.5604	3.5055	3.4493	3.3918	3.3329
	10	3.7168	3.6209	3.5217	3.4186	3.3654	3.3110	3.2554	3.1984	3.1399	3.0798
	11	3.5257	3.4296	3.3299	3.2261	3.1725	3.1176	3.0613	3.0035	2.9441	2.8828
	12	3.3736	3.2773	3.1772	3.0728	3.0187	2.9633	2.9063	2.8478	2.7874	2.7249
	13	3.2497	3.1532	3.0527	2.9477	2.8932	2.8373	2.7797	2.7204	2.6590	2.5955
	14	3.1469	3.0501	2.9493	2.8437	2.7888	2.7324	2.6742	2.6142	2.5519	2.4872
	15	3.0602	2.9633	2.8621	2.7559	2.7006	2.6437	2.5850	2.5242	2.4611	2.3953
	16	2.9862	2.8890	2.7875	2.6808	2.6252	2.5678	2.5085	2.4471	2.3831	2.3167
	17	2.9222	2.8249	2.7230	2.6158	2.5598	2.5021	2.4422	2.3801	2.3153	2.2474
	18	2.8664	2.7689	2.6667	2.5590	2.5027	2.4445	2.3842	2.3214	2.2558	2.1869
	19	2.8173	2.7196	2.6171	2.5089	2.4523	2.3937	2.3329	2.2695	2.2032	2.1333
	20	2.7737	2.6758	2.5731	2.4645	2.4076	2.3486	2.2873	2.2234	2.1562	2.0853
	21	2.7348	2.6368	2.5338	2.4247	2.3675	2.3082	2.2465	2.1819	2.1141	2.0422
	22	2.6998	2.6017	2.4984	2.3890	2.3315	2.2718	2.2097	2.1446	2.0760	2.0032
	23	2.6682	2.5699	2.4665	2.3567	2.2989	2.2389	2.1763	2.1107	2.0415	1.9677
	24	2.6396	2.5412	2.4374	2.3273	2.2693	2.2090	2.1460	2.0799	2.0099	1.9353
	25	2.6135	2.5149	2.4110	2.3005	2.2422	2.1816	2.1183	2.0517	1.9811	1.9055
	26	2.5895	2.4909	2.3867	2.2759	2.2174	2.1565	2.0928	2.0257	1.9545	1.8781
	27	2.5676	2.4688	2.3644	2.2533	2.1946	2.1334	2.0693	2.0018	1.9299	1.8527
	28	2.5473	2.4484	2.3438	2.2324	2.1735	2.1121	2.0477	1.9796	1.9072	1.8291
	29	2.5286	2.4295	2.3248	2.2131	2.1540	2.0923	2.0276	1.9591	1.8861	1.8072
	30	2.5112	2.4120	2.3072	2.1952	2.1359	2.0739	2.0089	1.9400	1.8664	1.7867
40	2.3882	2.2882	2.1819	2.0677	2.0069	1.9429	1.8752	1.8028	1.7242	1.6371	
60	2.2702	2.1692	2.0613	1.9445	1.8817	1.8152	1.7440	1.6668	1.5810	1.4822	
120	2.1570	2.0548	1.9450	1.8249	1.7597	1.6899	1.6141	1.5299	1.4327	1.3104	
∞	2.0483	1.9447	1.8326	1.7085	1.6402	1.5660	1.4835	1.3883	1.2684	1.0000	

TABLE C-4 (continued)

F Distribution: Upper 5 Percent Points										
Degrees of Freedom in Numerator, ν										
	1	2	3	4	5	6	7	8	9	
Degrees of Freedom in Denominator, ν_2	1	161.45	199.50	215.71	224.58	230.16	233.99	236.77	238.88	240.54
	2	18.513	19.000	19.164	19.247	19.296	19.330	19.353	19.371	19.385
	3	10.128	9.5521	9.2766	9.1172	9.0135	8.9406	8.8868	8.8452	8.8123
	4	7.7086	6.9443	6.5914	6.3883	6.2560	6.1631	6.0942	6.0410	5.9988
	5	6.6079	5.7861	5.4095	5.1922	5.0503	4.9503	4.8759	4.8183	4.7725
	6	5.9874	5.1433	4.7571	4.5337	4.3874	4.2839	4.2066	4.1463	4.0990
	7	5.5914	4.7374	4.3468	4.1203	3.9715	3.8660	3.7870	3.7257	3.6767
	8	5.3177	4.4590	4.0662	3.8378	3.6875	3.5806	3.5005	3.4381	3.3881
	9	5.1174	4.2565	3.8626	3.6331	3.4817	3.3738	3.2927	3.2296	3.1789
	10	4.9646	4.1028	3.7083	3.4780	3.3258	3.2172	3.1355	3.0717	3.0204
	11	4.8443	3.9823	3.5874	3.3507	3.2039	3.0946	3.0123	2.9480	2.8962
	12	4.7472	3.8853	3.4903	3.2592	3.1059	2.9961	2.9134	2.8486	2.7964
	13	4.6672	3.8056	3.4105	3.1791	3.0254	2.9153	2.8321	2.7669	2.7144
	14	4.6001	3.7389	3.3439	3.1122	2.9582	2.8477	2.7642	2.6987	2.6458
	15	4.5431	3.6823	3.2874	3.0556	2.9013	2.7905	2.7066	2.6408	2.5876
	16	4.4940	3.6337	3.2389	3.0069	2.8524	2.7413	2.6572	2.5911	2.5377
	17	4.4513	3.5915	3.1968	2.9647	2.8100	2.6987	2.6143	2.5480	2.4943
	18	4.4139	3.5546	3.1599	2.9277	2.7729	2.6613	2.5767	2.5102	2.4563
	19	4.3803	3.5219	3.1274	2.8951	2.7401	2.6283	2.5435	2.4768	2.4227
	20	4.3513	3.4928	3.0984	2.8661	2.7109	2.5990	2.5140	2.4471	2.3928
	21	4.3248	3.4668	3.0725	2.8401	2.6848	2.5727	2.4876	2.4205	2.3661
	22	4.3009	3.4434	3.0491	2.8187	2.6613	2.5491	2.4638	2.3965	2.3419
	23	4.2793	3.4221	3.0280	2.7955	2.6400	2.5277	2.4422	2.3748	2.3201
	24	4.2597	3.4028	3.0088	2.7763	2.6207	2.5082	2.4226	2.3551	2.3002
	25	4.2417	3.3852	2.9912	2.7587	2.6030	2.4904	2.4047	2.3371	2.2821
	26	4.2252	3.3690	2.9751	2.7426	2.5868	2.4741	2.3883	2.3205	2.2655
	27	4.2100	3.3541	2.9604	2.7278	2.5719	2.4591	2.3732	2.3053	2.2501
	28	4.1960	3.3404	2.9467	2.7141	2.5581	2.4453	2.3593	2.2913	2.2360
	29	4.1830	3.3277	2.9340	2.7014	2.5454	2.4324	2.3463	2.2782	2.2229
	30	4.1709	3.3158	2.9223	2.6896	2.5336	2.4205	2.3343	2.2662	2.2107
40	4.0848	3.2317	2.8387	2.6060	2.4495	2.3359	2.2490	2.1802	2.1240	
60	4.0012	3.1504	2.7581	2.5252	2.3683	2.2540	2.1665	2.0970	2.0401	
120	3.9201	3.0718	2.6802	2.4472	2.2900	2.1750	2.0867	2.0164	1.9588	
∞	3.8415	2.9957	2.6049	2.3719	2.2141	2.0986	2.0096	1.9384	1.8799	

TABLE C-4 (continued)

F Distribution: Upper 5 Percent Points											
Degrees of Freedom in Numerator, v_1											
	10	12	15	20	24	30	40	60	120	∞	
Degrees of Freedom in Denominator, v_2	1	241.88	243.91	245.95	248.01	249.05	250.09	251.14	252.20	253.25	254.32
	2	19.396	19.413	19.429	19.446	19.454	19.462	19.471	19.479	19.487	19.496
	3	8.7855	8.7446	8.7029	8.6602	8.6385	8.6166	8.5944	8.5720	8.5494	8.5265
	4	5.9644	5.9117	5.8578	5.8025	5.7744	5.7459	5.7170	5.6878	5.6581	5.6281
	5	4.7351	4.6777	4.6188	4.5581	4.5272	4.4957	4.4638	4.4314	4.3984	4.3650
	6	4.0600	3.9999	3.9381	3.8742	3.8415	3.8082	3.7743	3.7398	3.7047	3.6688
	7	3.6365	3.5747	3.5108	3.4445	3.4105	3.3758	3.3404	3.3043	3.2674	3.2298
	8	3.3472	3.2840	3.2184	3.1503	3.1152	3.0794	3.0428	3.0053	2.9669	2.9276
	9	3.1373	3.0729	3.0061	2.9365	2.9005	2.8637	2.8259	2.7872	2.7473	2.7067
	10	2.9782	2.9130	2.8450	2.7740	2.7372	2.6996	2.6609	2.6211	2.5801	2.5379
	11	2.8536	2.7876	2.7186	2.6464	2.6090	2.5705	2.5309	2.4901	2.4480	2.4045
	12	2.7534	2.6866	2.6169	2.5436	2.5055	2.4663	2.4259	2.3842	2.3410	2.2962
	13	2.6710	2.6037	2.5331	2.4589	2.4202	2.3803	2.3392	2.2966	2.2524	2.2064
	14	2.6021	2.5342	2.4630	2.3879	2.3487	2.3082	2.2664	2.2230	2.1778	2.1307
	15	2.5437	2.4753	2.4035	2.3275	2.2878	2.2468	2.2043	2.1601	2.1141	2.0658
	16	2.4935	2.4247	2.3522	2.2756	2.2354	2.1938	2.1507	2.1058	2.0589	2.0096
	17	2.4499	2.3807	2.3077	2.2304	2.1898	2.1477	2.1040	2.0584	2.0107	1.9604
	18	2.4117	2.3421	2.2686	2.1906	2.1497	2.1071	2.0629	2.0166	1.9681	1.9168
	19	2.3779	2.3080	2.2341	2.1555	2.1141	2.0712	2.0264	1.9796	1.9302	1.8780
	20	2.3479	2.2776	2.2033	2.1242	2.0825	2.0391	1.9938	1.9464	1.8963	1.8432
	21	2.3210	2.2504	2.1757	2.0960	2.0540	2.0102	1.9645	1.9165	1.8657	1.8117
	22	2.2967	2.2258	2.1508	2.0707	2.0283	1.9842	1.9380	1.8895	1.8380	1.7831
	23	2.2747	2.2036	2.1282	2.0476	2.0050	1.9605	1.9190	1.8649	1.8128	1.7570
	24	2.2547	2.1834	2.1077	2.0267	1.9838	1.9390	1.8920	1.8424	1.7897	1.7331
	25	2.2365	2.1649	2.0889	2.0075	1.9643	1.9192	1.8718	1.8217	1.7684	1.7110
	26	2.2197	2.1479	2.0716	1.9898	1.9464	1.9010	1.8533	1.8027	1.7488	1.6906
	27	2.2043	2.1323	2.0558	1.9736	1.9299	1.8842	1.8361	1.7851	1.7307	1.6717
	28	2.1900	2.1179	2.0411	1.9586	1.9147	1.8687	1.8203	1.7689	1.7138	1.6541
	29	2.1768	2.1045	2.0275	1.9446	1.9005	1.8543	1.8055	1.7537	1.6981	1.6377
	30	2.1646	2.0921	2.0148	1.9317	1.8874	1.8409	1.7918	1.7396	1.6835	1.6223
40	2.0772	2.0035	1.9245	1.8389	1.7929	1.7444	1.6928	1.6373	1.5766	1.5089	
60	1.9926	1.9174	1.8364	1.7480	1.7001	1.6491	1.5943	1.5343	1.4673	1.3893	
120	1.9105	1.8337	1.7505	1.6587	1.6084	1.5543	1.4952	1.4290	1.3519	1.2539	
∞	1.8307	1.7522	1.6664	1.5705	1.5173	1.4591	1.3940	1.3180	1.2214	1.0000	

TABLE C-4 (continued)

F Distribution: Upper 10 Percent Points										
Degrees of Freedom in Numerator v_1										
		1	2	3	4	5	6	7	8	9
Degrees of Freedom in Denominator v_2	1	39.864	49.500	53.593	55.833	57.241	58.204	58.906	59.439	59.858
	2	8.5263	9.0000	9.1618	9.2434	9.2926	9.3255	9.3491	9.3668	9.3805
	3	5.5383	5.4624	5.3908	5.3427	5.3092	5.2847	5.2662	5.2517	5.2400
	4	4.5448	4.3246	4.1908	4.1073	4.0506	4.0098	3.9790	3.9549	3.9357
	5	4.0604	3.7797	3.6195	3.5202	3.4530	3.4045	3.3679	3.3393	3.3163
	6	3.7760	3.4633	3.2888	3.1808	3.1075	3.0546	3.0145	2.9830	2.9577
	7	3.5894	3.2574	3.0741	2.9605	2.8833	2.8274	2.7849	2.7516	2.7247
	8	3.4579	3.1131	2.9238	2.8064	2.7265	2.6683	2.6241	2.5893	2.5612
	9	3.3603	3.0065	2.8129	2.6927	2.6106	2.5509	2.5053	2.4694	2.4403
	10	3.2850	2.9245	2.7277	2.6053	2.5216	2.4606	2.4140	2.3772	2.3473
	11	3.2252	2.8595	2.6602	2.5362	2.4512	2.3891	2.3416	2.3040	2.2735
	12	3.1765	2.8068	2.6055	2.4801	2.3940	2.3310	2.2828	2.2446	2.2135
	13	3.1362	2.7632	2.5603	2.4337	2.3467	2.2830	2.2341	2.1953	2.1638
	14	3.1022	2.7265	2.5222	2.3947	2.3069	2.2426	2.1931	2.1539	2.1220
	15	3.0732	2.6952	2.4898	2.3614	2.2730	2.2081	2.1582	2.1185	2.0862
	16	3.0481	2.6682	2.4618	2.3327	2.2438	2.1783	2.1280	2.0880	2.0553
	17	3.0262	2.6446	2.4374	2.3077	2.2183	2.1524	2.1017	2.0613	2.0284
	18	3.0070	2.6239	2.4160	2.2858	2.1958	2.1296	2.0785	2.0379	2.0047
	19	2.9899	2.6056	2.3970	2.2663	2.1760	2.1094	2.0580	2.0171	1.9836
	20	2.9747	2.5893	2.3801	2.2489	2.1582	2.0913	2.0397	1.9985	1.9649
	21	2.9609	2.5746	2.3649	2.2333	2.1423	2.0751	2.0232	1.9819	1.9480
	22	2.9486	2.5613	2.3512	2.2193	2.1279	2.0605	2.0084	1.9668	1.9327
	23	2.9374	2.5493	2.3387	2.2065	2.1149	2.0472	1.9949	1.9531	1.9189
	24	2.9271	2.5383	2.3274	2.1949	2.1030	2.0351	1.9826	1.9407	1.9063
	25	2.9177	2.5283	2.3170	2.1843	2.0922	2.0241	1.9714	1.9292	1.8947
	26	2.9091	2.5191	2.3075	2.1745	2.0822	2.0139	1.9610	1.9188	1.8841
	27	2.9012	2.5106	2.2987	2.1655	2.0730	2.0045	1.9515	1.9091	1.8743
	28	2.8939	2.5028	2.2906	2.1571	2.0045	1.9959	1.9427	1.9001	1.8652
	29	2.8871	2.4955	2.2831	2.1494	2.0566	1.9878	1.9345	1.8918	1.8568
	30	2.8807	2.4887	2.2761	2.1422	2.0492	1.9803	1.9269	1.8841	1.8490
40	2.8354	2.4404	2.2261	2.0909	1.9968	1.9269	1.8725	1.8289	1.7929	
60	2.7914	2.3932	2.1774	2.0410	1.9457	1.8747	1.8194	1.7748	1.7380	
120	2.7478	2.3473	2.1300	1.9923	1.8959	1.8238	1.7675	1.7220	1.6843	
∞	2.7055	2.3026	2.0838	1.9449	1.8473	1.7741	1.7167	1.6702	1.6315	

TABLE C-4 (continued)

F Distribution: Upper 10 Percent Points											
Degrees of Freedom in Numerator v_1											
		10	12	15	20	24	30	40	60	120	∞
Degrees of Freedom in Denominator v_2	1	60.195	60.705	61.220	61.740	62.002	62.265	62.529	62.794	63.061	63.328
	2	9.3916	9.4081	9.4247	9.4413	9.4496	9.4579	9.4663	9.4746	9.4829	9.4913
	3	5.2304	5.2156	5.2003	5.1845	5.1764	5.1681	5.1597	5.1512	5.1425	5.1337
	4	3.9199	3.8955	3.8689	3.8443	3.8310	3.8174	3.8036	3.7896	3.7753	3.7607
	5	3.2974	3.2682	3.2380	3.2067	3.1905	3.1741	3.1573	3.1402	3.1228	3.1050
	6	2.9369	2.9047	2.8712	2.8363	2.8183	2.8000	2.7812	2.7620	2.7423	2.7222
	7	2.7025	2.6681	2.6322	2.5947	2.5753	2.5555	2.5351	2.5142	2.4928	2.4708
	8	2.5380	2.5020	2.4642	2.4246	2.4041	2.3830	2.3614	2.3391	2.3162	2.2926
	9	2.4163	2.3789	2.3396	2.2983	2.2768	2.2547	2.2320	2.2085	2.1843	2.1592
	10	2.3226	2.2841	2.2435	2.2007	2.1784	2.1554	2.1317	2.1072	2.0818	2.0554
	11	2.2482	2.2087	2.1671	2.1230	2.1000	2.0762	2.0516	2.0261	1.9997	1.9721
	12	2.1878	2.1474	2.1049	2.0597	2.0360	2.0115	1.9861	1.9597	1.9323	1.9036
	13	2.1376	2.0966	2.0532	2.0070	1.9827	1.9576	1.9315	1.9043	1.8759	1.8462
	14	2.0954	2.0537	2.0095	1.9625	1.9377	1.9119	1.8852	1.8572	1.8280	1.7973
	15	2.0593	2.0171	1.9722	1.9243	1.8990	1.8728	1.8454	1.8168	1.7867	1.7551
	16	2.0281	1.9854	1.9399	1.8913	1.8656	1.8388	1.8108	1.7816	1.7507	1.7177
	17	2.0009	1.9577	1.9117	1.8624	1.8362	1.8090	1.7805	1.7506	1.7191	1.6856
	18	1.9770	1.9333	1.8868	1.8368	1.8103	1.7827	1.7537	1.7232	1.6910	1.6567
	19	1.9557	1.9117	1.8647	1.8142	1.7873	1.7592	1.7298	1.6988	1.6659	1.6308
	20	1.9367	1.8924	1.8449	1.7938	1.7667	1.7382	1.7083	1.6768	1.6433	1.6074
	21	1.9197	1.8750	1.8272	1.7756	1.7481	1.7193	1.6890	1.6569	1.6228	1.5862
	22	1.9043	1.8593	1.8111	1.7590	1.7312	1.7021	1.6714	1.6389	1.6042	1.5668
	23	1.8903	1.8450	1.7964	1.7439	1.7159	1.6864	1.6554	1.6224	1.5871	1.5490
	24	1.8775	1.8319	1.7831	1.7302	1.7019	1.6721	1.6407	1.6073	1.5715	1.5327
	25	1.8658	1.8200	1.7708	1.7175	1.6890	1.6589	1.6272	1.5934	1.5570	1.5176
	26	1.8550	1.8090	1.7596	1.7059	1.6771	1.6468	1.6147	1.5805	1.5437	1.5036
	27	1.8451	1.7989	1.7492	1.6951	1.6662	1.6356	1.6032	1.5686	1.5313	1.4906
	28	1.8359	1.7895	1.7395	1.6852	1.6560	1.6252	1.5925	1.5575	1.5198	1.4784
	29	1.8274	1.7808	1.7306	1.6759	1.6465	1.6155	1.5825	1.5472	1.5090	1.4670
	30	1.8195	1.7727	1.7223	1.6673	1.6377	1.6065	1.5732	1.5376	1.4989	1.4564
40	1.7627	1.7146	1.6624	1.6052	1.5741	1.5411	1.5056	1.4672	1.4248	1.3769	
60	1.7070	1.6574	1.6034	1.5435	1.5107	1.4755	1.4373	1.3952	1.3476	1.2915	
120	1.6524	1.6012	1.5450	1.4821	1.4472	1.4094	1.3676	1.3203	1.2646	1.1926	
∞	1.5987	1.5458	1.4871	1.4206	1.3832	1.3419	1.2951	1.2400	1.1686	1.0000	

TABLE C-5					
CRITICAL VALUES $d\alpha(n)$ OF THE MAXIMUM ABSOLUTE DIFFERENCE BETWEEN SAMPLE AND POPULATION RELIABILITY FUNCTIONS					
Sample Size (N)	Level of Significance (α)				
	0.20	0.15	0.10	0.05	0.01
3	0.565	0.597	0.642	0.708	0.828
4	0.494	0.525	0.564	0.624	0.733
5	0.446	0.474	0.474	0.565	0.669
10	0.322	0.342	0.368	0.410	0.490
15	0.266	0.283	0.304	0.338	0.404
20	0.231	0.246	0.264	0.294	0.356
25	0.21	0.22	0.24	0.27	0.32
30	0.19	0.20	0.22	0.24	0.29
35	0.18	0.19	0.21	0.23	0.27
40	0.17	0.18	0.19	0.21	0.25
45	0.16	0.17	0.18	0.20	0.24
50	0.15	0.16	0.17	0.19	0.23
Over } 50 }	$\frac{1.07}{\sqrt{n}}$	$\frac{1.14}{\sqrt{n}}$	$\frac{1.22}{\sqrt{n}}$	$\frac{1.36}{\sqrt{n}}$	$\frac{1.63}{\sqrt{n}}$

TABLE C-6

Reliability Exponential Function ($R = e^{-\lambda t}$)

At	R	At	R
0.001	0.999999	0.051	0.950279
0.002	0.998002	0.052	0.949329
0.003	0.997004	0.053	0.948380
0.004	0.996008	0.054	0.947432
0.005	0.995012	0.055	0.946485
0.006	0.994018	0.056	0.945539
0.007	0.993024	0.057	0.944594
0.008	0.992032	0.058	0.943650
0.009	0.991040	0.059	0.942709
0.010	0.990050	0.060	0.941765
0.011	0.989060	0.061	0.940823
0.012	0.988072	0.062	0.939883
0.013	0.987084	0.063	0.938943
0.014	0.986098	0.064	0.938005
0.015	0.985112	0.065	0.937067
0.016	0.984127	0.066	0.936131
0.017	0.983144	0.067	0.935195
0.018	0.982161	0.068	0.934260
0.019	0.981179	0.069	0.933329
0.020	0.980199	0.070	0.932394
0.021	0.979219	0.071	0.931462
0.022	0.978240	0.072	0.930531
0.023	0.977262	0.073	0.929601
0.024	0.976286	0.074	0.928677
0.025	0.975310	0.075	0.927743
0.026	0.974335	0.076	0.926816
0.027	0.973361	0.077	0.925890
0.028	0.972388	0.078	0.924964
0.029	0.971416	0.079	0.924040
0.030	0.970446	0.080	0.923116
0.031	0.969476	0.081	0.922194
0.032	0.968507	0.082	0.921272
0.033	0.967539	0.083	0.920351
0.034	0.966572	0.084	0.919431
0.035	0.965605	0.085	0.918512
0.036	0.964640	0.086	0.917594
0.037	0.963676	0.087	0.916677
0.038	0.962713	0.088	0.915761
0.039	0.961751	0.089	0.914846
0.040	0.960789	0.090	0.913931
0.041	0.959829	0.091	0.913018
0.042	0.958870	0.092	0.912105
0.043	0.957911	0.093	0.911194
0.044	0.956954	0.094	0.910283
0.045	0.955997	0.095	0.909373
0.046	0.955042	0.096	0.908464
0.047	0.954087	0.097	0.907556
0.048	0.953134	0.098	0.906649
0.049	0.952181	0.099	0.905743
0.050	0.951229	0.100	0.904837

TABLE C-6 (continued)

Reliability Exponential Function ($R = e^{-\lambda t}$) (Cont.)

λt	R	λt	R
0.110	0.895834	0.65	0.522046
0.120	0.886920	0.70	0.496585
0.130	0.878095	0.75	0.472367
0.140	0.869358	0.80	0.449329
0.150	0.860708	0.85	0.427415
0.160	0.852144	0.90	0.406570
0.170	0.843665	0.95	0.386741
0.180	0.835270	1.00	0.367878
0.190	0.826959	1.05	0.34993
0.200	0.818731	1.10	0.332871
0.210	0.810584	1.15	0.316637
0.220	0.802519	1.20	0.301194
0.230	0.794534	1.25	0.286505
0.240	0.786628	1.30	0.272532
0.250	0.778801	1.35	0.259240
0.260	0.771052	1.40	0.246597
0.270	0.763379	1.45	0.234570
0.280	0.755784	1.50	0.223130
0.290	0.748264	1.55	0.212248
0.300	0.740818	1.60	0.201897
0.310	0.733447	1.70	0.182684
0.320	0.726149	1.80	0.165299
0.330	0.718924	1.90	0.149569
0.340	0.711770	2.00	0.135335
0.350	0.704688	2.10	0.122456
0.360	0.697676	2.20	0.110803
0.370	0.690734	2.30	0.100259
0.380	0.683861	2.40	0.090718
0.390	0.677057	2.50	0.082085
0.400	0.670320	2.60	0.074274
0.410	0.663650	2.70	0.067206
0.420	0.657047	2.80	0.060810
0.430	0.650509	2.90	0.055023
0.440	0.644036	3.00	0.049787
0.450	0.637628	3.25	0.038774
0.460	0.631284	3.50	0.030197
0.470	0.625002	3.75	0.023518
0.480	0.618783	4.00	0.018316
0.490	0.612626	4.25	0.014264
0.500	0.606531	4.50	0.011109
0.510	0.600496	4.75	0.008652
0.520	0.594521	5.00	0.006738
0.530	0.588605	5.50	0.004087
0.540	0.582748	6.00	0.002479
0.550	0.576950	6.50	0.001503
0.560	0.571209	7.00	0.000912
0.570	0.565525	7.50	0.000553
0.580	0.559898	8.00	0.000335
0.590	0.554327	9.00	0.000123
0.600	0.548812	10.0	0.000045

TABLE C-7
 FACTORS FOR CALCULATION OF MEAN LIFE
 CONFIDENCE INTERVALS FROM TEST DATA [Factors = $2/\chi^2(p, d)$]
 (Exponential Distribution Assumed)

Degrees of Freedom, ν	95% Two-sided						97-1/2% One-sided					
	90% Two-Sided			95% One-sided			90% Two-Sided			95% One-sided		
	80% Two-sided			90% One-sided			60% Two-sided			80% One-sided		
	Lower Limit						Upper Limit					
2	.185	.217	.272	.333	.433	.619	4.47	9.462	19.388	59.58	100.0	200.0
4	.135	.151	.180	.210	.257	.334	1.21	1.882	2.826	4.102	6.667	10.00
6	.108	.119	.139	.159	.188	.234	.652	.909	1.221	1.613	2.3077	3.007
8	.0909	.100	.114	.129	.150	.181	.437	.573	0.733	.921	1.212	1.481
10	.0800	.0857	.0976	.109	.125	.149	.324	.411	.508	.600	.789	.909
12	.0702	.0759	.0856	.0952	.107	.126	.256	.317	.383	.454	.555	.645
14	.0635	.0690	.0765	.0843	.0948	.109	.211	.257	.305	.355	.431	.500
16	.0588	.0625	.0693	.0760	.0848	.0976	.179	.215	.251	.290	.345	.385
18	.0536	.0571	.0633	.0693	.0769	.0878	.156	.184	.213	.243	.286	.322
20	.0500	.0531	.0585	.0635	.0703	.0799	.137	.158	.184	.208	.242	.270
22	.0465	.0495	.0543	.0589	.0648	.0732	.123	.142	.162	.182	.208	.232
24	.0439	.0463	.0507	.0548	.0601	.0676	.111	.128	.144	.161	.185	.200
26	.0417	.0438	.0476	.0513	.0561	.0629	.101	.116	.130	.144	.164	.178
28	.0392	.0413	.0449	.0483	.0527	.0588	.0927	.106	.118	.131	.147	.161
30	.0373	.0393	.0425	.0456	.0496	.0551	.0856	.0971	.108	.119	.133	.145
32	.0355	.0374	.0404	.0433	.0469	.0519	.0795	.0899	.0997	.109	.122	.131
34	.0339	.0357	.0385	.0411	.0445	.0491	.0742	.0834	.0925	.101	.113	.122
36	.0325	.0342	.0367	.0392	.0423	.0466	.0696	.0781	.0899	.0939	.104	.111
38	.0311	.0327	.0351	.0375	.0404	.0443	.0656	.0732	.0804	.0874	.0971	.103
40	.0299	.0314	.0337	.0359	.0386	.0423	.0619	.0689	.0756	.0820	.0901	.0966

To Use: Multiply value shown by total part hours to get MIBF figures in hours

Note: $d=2r$, except for the lower limit on tests truncated at a fixed time and where $r < n$. In such cases, use $d=2(r+1)$.

TABLE C-8				
REQUIRED NUMBER OF FAILURES FOR VARIOUS VALUES OF CONFIDENCE AND PRECISION (Exponential Distribution)				
Precision- 6	Confidence			
	85%	90%	95%	99%
5%	830	1082	1537	2655
10%	207	271	384	664
15%	92	120	171	295
20%	52	67	96	166
25%	33	43	61	106
30%	23	30	43	74
35%	17	22	31	54

Example: 43 failures are required to be 90% confident that the estimated MIBF is within 25% of the true value.

TABLE C-9 GAMMA FUNCTION Values of $\Gamma(n) = \int_0^{\infty} e^{-x} x^{n-1} dx; \Gamma(n + 1) = n\Gamma(n)$							
n	$\Gamma(n)$	n	$\Gamma(n)$	n	$\Gamma(n)$	n	$\Gamma(n)$
1.00	1.00000	1.25	0.90640	1.50	0.88623	1.75	0.91906
1.01	0.99433	1.26	0.90440	1.51	0.88659	1.76	0.92137
1.02	0.98884	1.27	0.90250	1.52	0.88704	1.77	0.92376
1.03	0.98355	1.28	0.90072	1.53	0.88757	1.78	0.92623
1.04	0.97844	1.29	0.89904	1.54	0.88818	1.79	0.92877
1.05	0.97350	1.30	0.89747	1.55	0.88887	1.80	0.93138
1.06	0.96874	1.31	0.89600	1.56	0.88964	1.81	0.93408
1.07	0.96516	1.32	0.89464	1.57	0.89049	1.82	0.93685
1.08	0.95973	1.33	0.89338	1.58	0.89142	1.83	0.93969
1.09	0.95546	1.34	0.89222	1.59	0.89243	1.84	0.94261
1.10	0.95135	1.35	0.89115	1.60	0.89352	1.85	0.94561
1.11	0.94739	1.36	0.89018	1.61	0.89468	1.86	0.94869
1.12	0.94359	1.37	0.88931	1.62	0.89592	1.87	0.95184
1.13	0.93993	1.38	0.88854	1.63	0.89724	1.88	0.95507
1.14	0.93642	1.39	0.88785	1.64	0.89864	1.89	0.95838
1.15	0.93304	1.40	0.88726	1.65	0.90012	1.90	0.96177
1.16	0.92980	1.41	0.88676	1.66	0.90167	1.91	0.96523
1.17	0.92670	1.42	0.88636	1.67	0.90330	1.92	0.96878
1.18	0.92373	1.43	0.88604	1.68	0.90500	1.93	0.97240
1.19	0.92088	1.44	0.88580	1.69	0.90678	1.94	0.97610
1.20	0.91817	1.45	0.88565	1.70	0.90864	1.95	0.97988
1.21	0.91558	1.46	0.88560	1.71	0.91057	1.96	0.98374
1.22	0.91311	1.47	0.88563	1.72	0.91258	1.97	0.98768
1.23	0.91075	1.48	0.88575	1.73	0.91466	1.98	0.99171
1.24	0.90852	1.49	0.88595	1.74	0.91683	1.99	0.99581
						2.00	1.00000

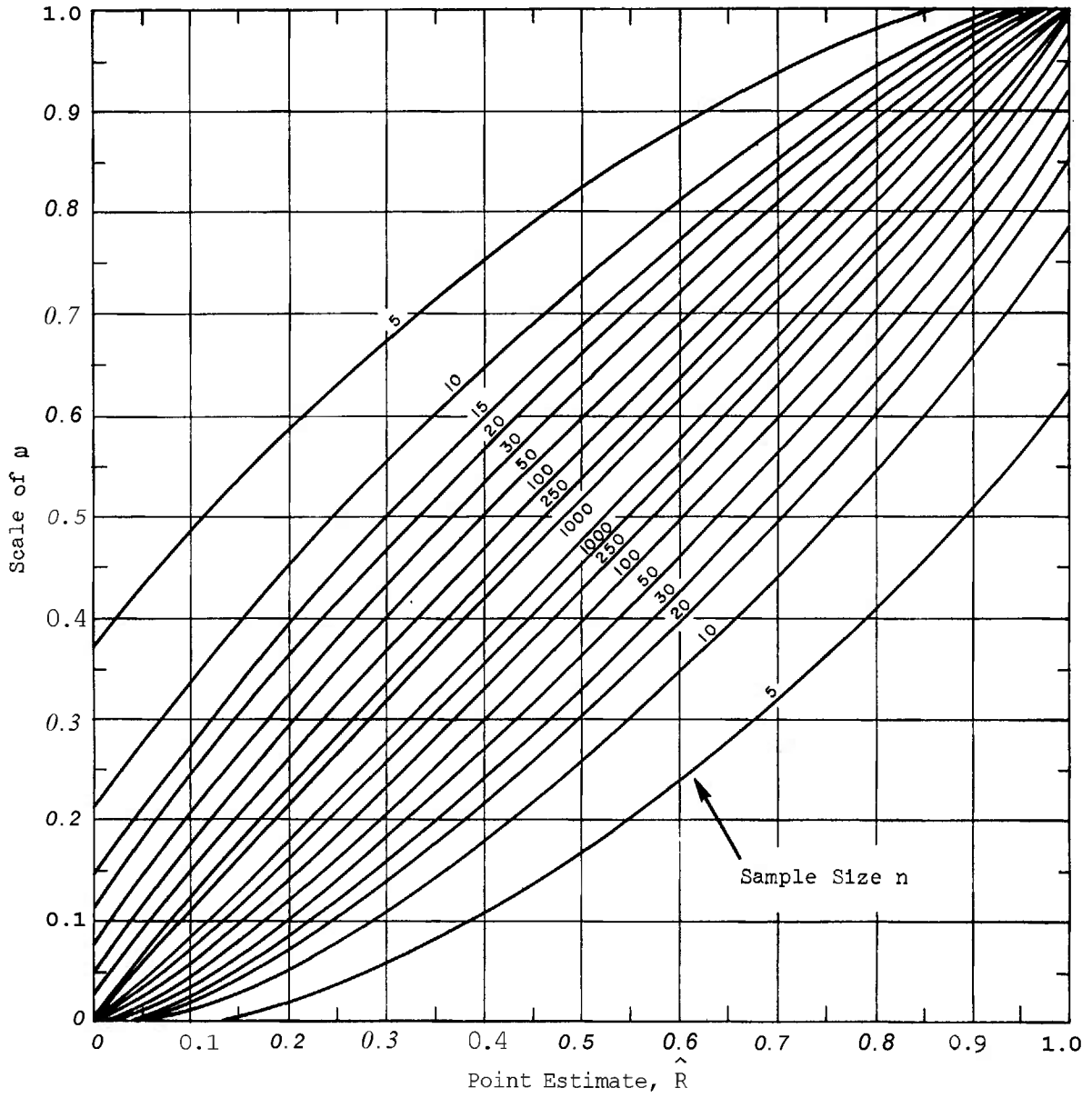

FIGURE C-1A
 CONFIDENCE BELTS FOR PROPORTIONS
 Confidence Coefficients: 0.80
 for Two-sided Estimation, 0.90
 for One-Sided Estimation

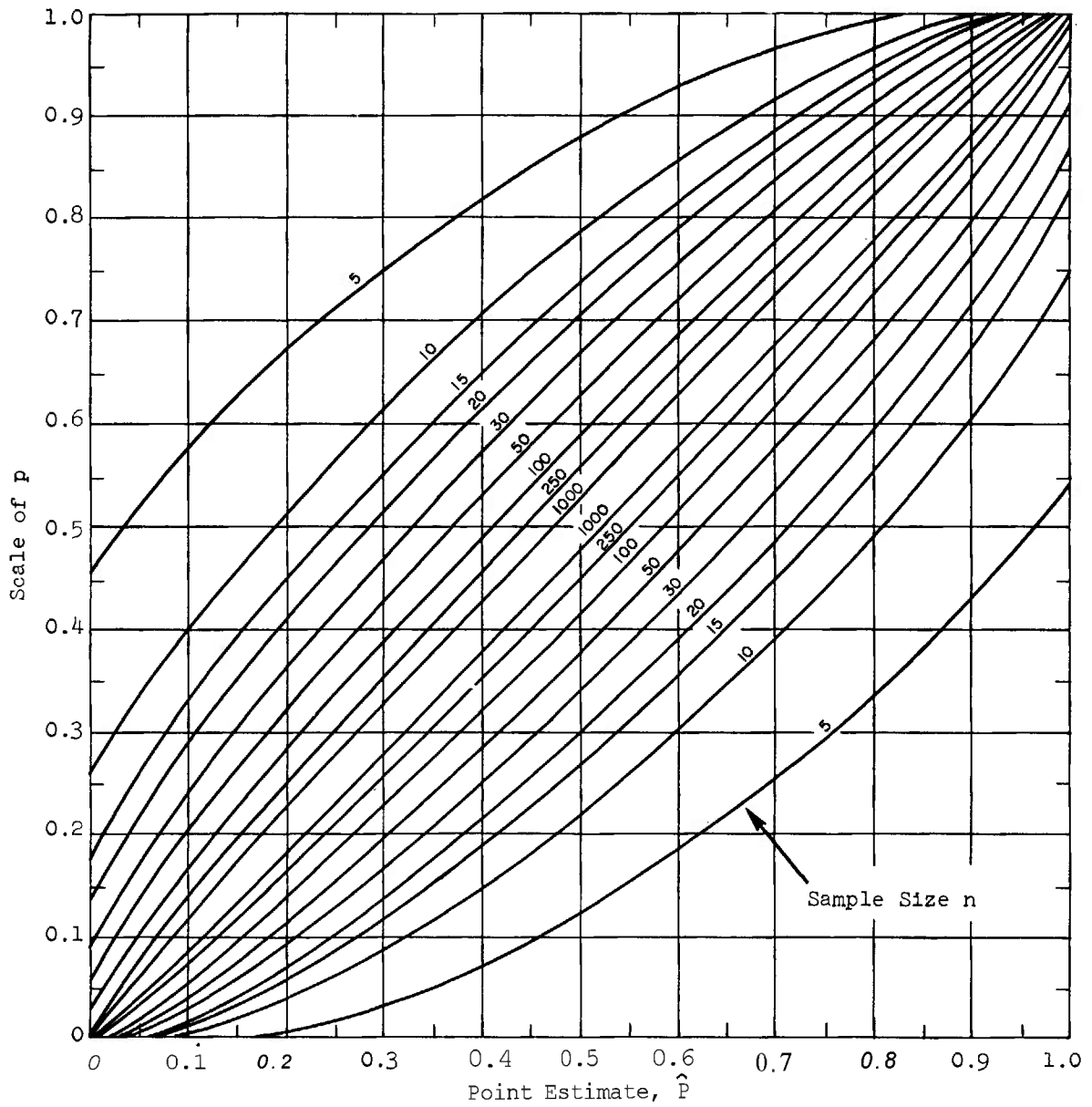

FIGURE C-1B

CONFIDENCE BELTS FOR PROPORTIONS
 Confidence Coefficients: 0.90
 for Two-sided Estimation, 0.95
 for One-sided Estimation

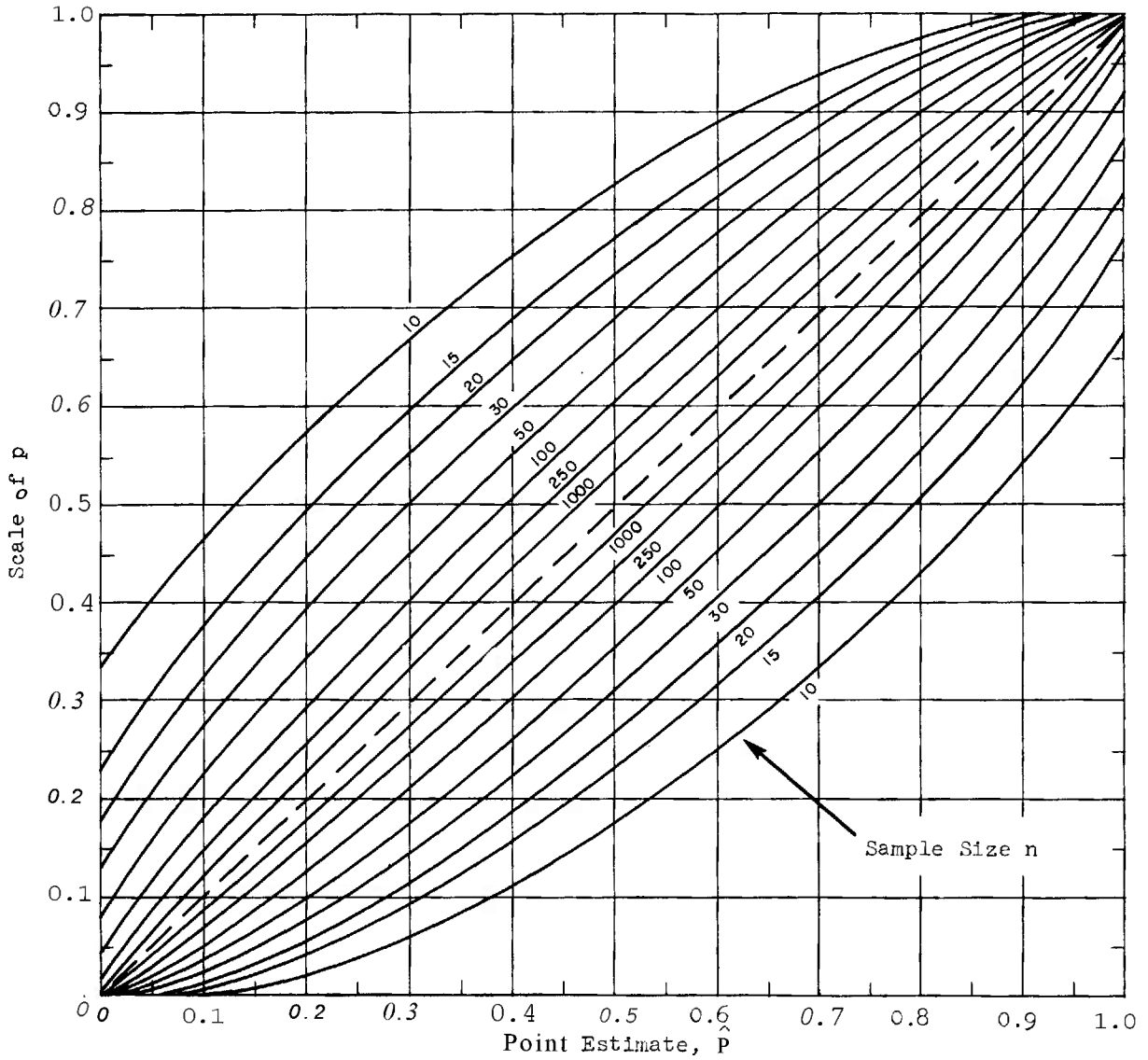

FIGURE C-1C

CONFIDENCE BELTS FOR PROPORTIONS
 Confidence Coefficients: 0.95
 for Two-sided Estimation, 0.975
 for One-Sided Estimation

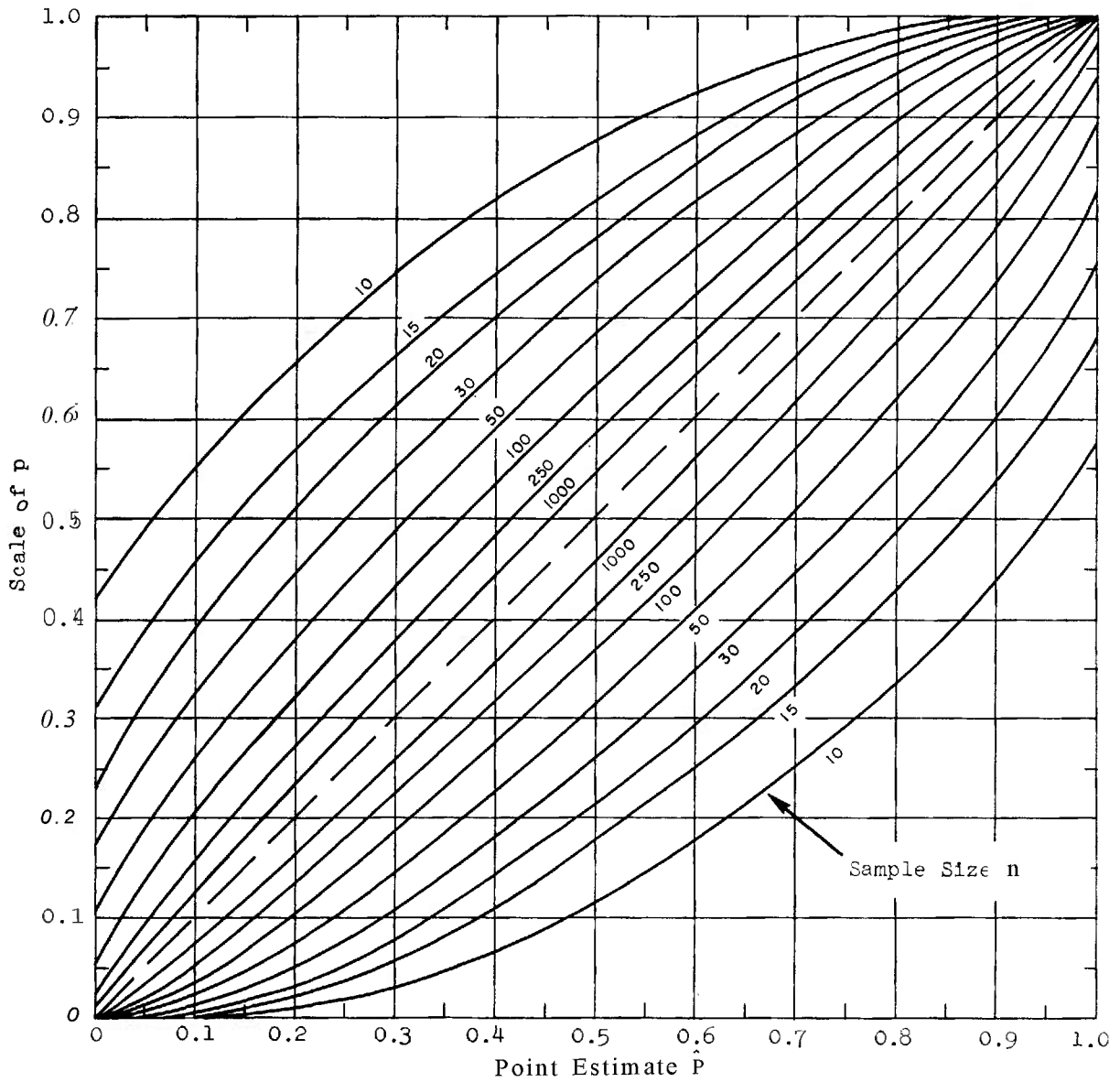

FIGURE C-10

CONFIDENCE BELTS FOR PROPORTIONS
Confidence Coefficients: 0.99
for Two-sided Estimation, 0.995
for One-Sided Estimation

GUIDE FOR REVIEWERS OF STUDIES CONTAINING COST-EFFECTIVENESS ANALYSIS *

CHAPTER I

GENERAL BACKGROUND

Introduction

To assist in the review of studies containing cost-effectiveness analyses, a series of key questions with explanatory notes have been prepared and are contained in the next chapter. These questions, taken together, will not necessarily cover all aspects of all cost-effectiveness analyses. No one general list of questions can do that. Rather, the questions are designed to focus the attention of the reviewer on selected aspects to assist him in evaluating the analysis. All the questions are not applicable to all studies and they are not necessarily of equal importance to those studies where they do apply. The reviewer must exercise his judgment on whether the questions are applicable and the degree of applicability to the study being reviewed. Those questions that are considered particularly important and of widest application have been underlined, and are also listed separately for convenience in the back as "SELECTED QUESTIONS."** This document is intended only as a guide and not as a full and comprehensive treatment of all aspects of cost-effectiveness analysis.

Questions that do not bear on military cost-effectiveness analyses are not included in the next chapter. Furthermore, no questions are addressed to the subject of the intuitive judgment and other factors used in making decisions to which cost-effectiveness analyses contribute.

Cost-Effectiveness Analysis and the Estimate of the Situation

Cost-effectiveness analysis is a method for studying how to make the best of several choices. By cost-effectiveness is meant the relation of the resources required (cost) to achieve a certain ability to accomplish an objective (effectiveness). The term cost-effectiveness is always used in relation to the effectiveness of alternative systems; organizations, or activities.

Cost-effectiveness analysis is based on the economic concept that all military decisions involve the allocation (best use) of limited resources among competing requirements. The allocation is determined by studying how to get the best use of the available resources. This same concept is embodied in Army decision processes. It is used by a combat commander when he determines (estimate of the situation) the allocation of his resources

** Questions 1, 4, 12, 13, 14, 22, 23, 31, 37, 44, 46, 57, 60, 66, and 73.

*Reproduced by permission of the Research Analysis Corporation, McLean, va.,
Authored by I. Heymont, O. Bryk, H. Linstone, and J. Surmeier.

AMCP 706-191

(forces) among the main and secondary efforts and reserves in the offense or between the forward and reserve forces in the defense. A *G3* uses the same concept in preparing his recommendations for reallocating among the elements of the command the ammunition available supply rate announced by the higher headquarters. The company commander goes through the **same** process in deciding how to spend his company funds.

Although cost-effectiveness analysis and the estimate of the situation are similar in concept, they differ in several aspects. The purpose of an estimate of the situation is to arrive at a recommended course of action. It is usually a process to arrive at decisions to solve "today's problems today." It does not concern itself, in a realistic sense, with problems, operations, or systems of the future, even though it is sometimes not clear where the problem of today ends and the problem of tomorrow starts. Because it deals with relatively immediate problems, the formulation of possible courses of action in an estimate of the situation is severely limited. The resources (forces and weapons) available to the commander are fixed by what has been made available and there is no real flexibility in changing their composition or basic organization. In practice, it is also usually difficult to obtain additional resources from the next higher commander.

Another severe constraint on the estimate of the situation is the time factor. Information is usually incomplete and the time available before a decision is required often does not permit filling in gaps--even if it were possible. Often there is only sufficient time to analyze the mission, gather staff estimates, formulate a few possible courses of action and quickly weigh these courses of action against the enemy capabilities (or difficulties to be overcome) and with each other, and select a course of action based on some criteria--often called the governing factors. Time usually does not permit testing the range of the dependence of the proposed course of action on the staff estimates and planning assumptions.

Military cost-effectiveness analysis is not a decision process but **an aid** in facilitating decisions that must be made now in regard to development, force composition, and logistical and manpower policy problems in order to be prepared for wars in the future. The analytical techniques employed in cost-effectiveness analysis are required to supplement those employed in the estimate of the situation because, as we look into the future, the number of uncertainties multiply. These uncertainties include such things as planning factors, the enemy and his reactions, the strategic concept, technology, change, and even the national objectives which can be expected to change in the future as alliances shift and new forces in the world develop. Advances in technology create new opportunities that may require changes in organization **and** doctrine as well as hardware. All these uncertainties lead to a large number of variables that must be considered. Some of these variables are subject to our control, some to the enemy's and others to nobody's control. But all are variables, and all are interdependent.

The increase in numbers and kinds of variables associated with problems of the future can be illustrated, on a small scale, in a hypothetical study of a future weapons system for an infantry platoon--assuming that the infantry platoon will be present in the time frame under consideration. The variables that would require study would include such parameters as alternative weapons systems that can be available in the time frame under study, composition (mix) of kinds of weapons within the total system, the number of individual weapons within each mix of weapons, levels of warfare, expected locales of war, and effects of supporting weapons of higher echelons. If each of these parameters takes only three alternative values, for example, levels of warfare to be considered are nuclear warfare, conventional war, and one type of stability of operations, over 700 cases result--and all significant parameters have not been listed. If the number of candidate weapons systems is increased from three to six there are over 1400 cases to be considered.

It is in this environment of uncertainties and flexibility in use and interchangeability of resources (people, dollars, and hardware) that cost-effectiveness analysis is a useful aid. It assists in providing increased insight into the problem and as much relevant information as possible in order that the decision maker can concentrate on those areas where judgment must be applied, particularly in consideration of qualitative aspects and consistency with higher echelon considerations. For example, in a hypothetical force composition problem where flexibility in force composition is possible, it has been determined that the force must have a capability to destroy certain kinds of targets at certain expected ranges. Two possible alternatives are artillery and tactical air. The time required and the cost to destroy these targets by use of each alternative can be calculated. However, the importance of having a capability to attack these targets at any time of the day or night, regardless of weather conditions, is a matter of judgment. This judgment can be better made when the cost-effectiveness of each alternative is known, in other words, the price to be paid for an all-weather capability stated in sufficient detail and accuracy to be useful for planning.

The effort to provide information so the commander can better exercise his judgment is also found in the estimate of the situation process. For example, a combat commander can better apply his judgment to selection among possible courses of actions when he has staff estimates--even if **only** rough--of the number of casualties he will suffer and the time required to accomplish the mission for each of the proposed courses of action. However, the variables that a **staff** estimate must contend with are relatively limited. The friendly organization **is** fixed, there is only one enemy in only one area and the options open to the enemy are relatively few. For example, the enemy can attack, defend, or execute some variation of a withdrawal. For practical purposes, neither the enemy nor the friendly force can introduce new weapons systems or change their fundamental organization or doctrines in the time period covered by the estimate of the situation.

The basis of cost-effectiveness analysis is that there are alternate ways of reaching an objective and each alternative requires certain resources and produces certain results. This is the same basis of the estimate of the situation which studies proposed courses of actions, each of which requires certain resources (forces and supplies) and produces certain expected results (time to take the objective, casualties incurred). A cost-effectiveness analysis is designed to examine systematically and relate costs, effectiveness, and risks of alternative ways of accomplishing an objective and designing additional alternatives (proposed courses of action) if those examined are found wanting. It is an analysis of the cost and effectiveness of a system, such as a forward area air defense or an air mobile division, and all of the system implications. It can be considered as a kind of Consumers Research to assist in getting the most for the resources to be expended and not as a search for the cheapest regardless of effectiveness.

A major methodological difference between cost-effectiveness analyses and other military studies is the manner in which the results are presented. A staff study or a staff estimate, like a cost-effectiveness analysis, considers sources of action (alternatives). However, the staff estimate and staff study usually embody a single recommendation with the other alternatives either rarely mentioned or not as fully discussed as the recommended course of action. The commander (decision maker) is given the full reasoning behind the recommended course of action which is frequently presented so that the only option open is a "yes" or "no" decision.

In a cost-effectiveness analysis, the significant alternatives, the available facts, the reasoning process and the pertinent considerations pertaining to each significant alternative are presented. All identifiable assumptions and data are presented so that their validity can be questioned. In addition, and this is a major goal of a cost-effectiveness analysis, the dependence of the results of the analyses on these assumptions and data are tested.

The staff estimate and staff study do identify major assumptions. However, an implied assumption is often introduced when several different courses of action are open and a decision is made to proceed in one direction. Such a decision is then accepted as a known quantity when, in reality, it really is an assumption. There are many reasons for such assumptions, but frequently the result of the study or estimate is not tested for sensitivity to such hidden assumptions.

Cost-effectiveness analysis places great emphasis on use of numbers and calculations in any effort to determine quantitative factors where possible. Of course, there are many aspects of military activities that cannot be reduced to a quantitative factor. There is now no valid way of assigning a number to morale, the psychological effects of a certain military operations, or a host of other factors. However, it is possible to calculate the number of 155-mm howitzer rounds and total cost required to destroy a certain type of target. The impact of factors such as morale, training, reliability of

allies cannot yet be calculated and are now matters of intuitive judgment. A cost-effectiveness analysis seeks to quantify what can be logically calculated so that the decision maker knows the extent to which intuitive judgment must be used in making a decision.

Essential Elements

The essential elements of a cost-effectiveness analysis are:

1. Objective(s) (functions to be accomplished).
2. Alternatives (feasible ways of achieving the desired military capability or accomplishing the function).
3. Cost of resources required by each alternative.
4. A set of mathematical or logical relationships among the objectives, alternatives, environment and resources (models).
5. A criterion for choosing the preferred alternative.

The Objective

The determination of the objective is often complex. In order to design alternatives properly, the problem must be analyzed to determine the real functional need underlying the requirements for certain organizations and hardware systems. Thorough examination of the functional need usually brings insight into the problem and leads to generating alternatives that may accomplish the desired goal. Close examination of objectives stated only in terms of specific organizations or systems often discloses that the net result is not a significantly new or improved capability but a relatively minor product improvement. This does not imply that product improvements are not needed but rather that a full understanding of the true significance of what is being proposed for purchase is necessary. For example, in stating a requirement for an artillery system with a specified minimum range capability, the real objective may be a capability to destroy certain kinds of targets under certain conditions. By examining the problem from the functional basis, the planner is better able to understand the problem. This insight may lead to other alternatives that should be studied. The examination may show that the proposed new artillery system is only one alternative to accomplishing the objective and that another alternative may be preferable.

There are practical limits on the definition of the objective. Every military activity is part of a larger activity and it is necessary to draw the line at some point. However, the objective should not be unduly restricted by confusion with performance characteristics such as speeds, weights, muzzle velocities, hit-kill probabilities, and so forth.

Alternatives

In military planning there is rarely **only** one exclusive **way** of achieving a given objective. Each way has its own price **tag** of time, men, facilities, materiel, and money. **Assume**, for example, that the planning problem -- admittedly over-simplified -- is to design a new type of division with certain capabilities. In satisfying these capabilities, the TOE designer has many alternatives. For the same capability, is it better to have more mobility (trucks, aircraft, and other vehicles) and less manpower, or perhaps more mortars and fewer riflemen? The alternatives are limited only by creative imagination and good military judgment. By exploring alternative ways of using resources it is often possible to discover ways of achieving an objective with fewer resources, or accomplishing more with the same resources. All feasible and significant capabilities to accomplish the objective should be considered, including the capabilities of the Navy, Air Force, and Marines. Prejudices, "**party-line**" and other forms of preconceived notions should be avoided in the design of alternatives.

cost

Determining the cost of each alternative is based on incremental costs. These are the net costs of adopting the alternative. Such costs are determined after due allowances for those resources already paid for regardless of whether the alternative is adopted, and would be available for use under the alternative if it were adopted. In determining the cost of an alternative all the resource implications are considered. The alternative is treated in a system context. For example, the cost, admittedly oversimplified, of adopting a new radio would include not only the cost of the radio and its development, but also the costs of training people to operate it, the total cost of maintaining the radios, and the cost of the additional radios required for maintenance float, replacement, combat consumption, and so forth.

Costs need not be stated in precise terms down to the last dollar or man. However, the costs must be accurate enough to permit evaluating the military worth (effectiveness) together with the costs. Like everything else, this rule must be applied with discretion. In dealing with systems way out in the future **the** accuracy of the cost estimate, whether it is an absolute figure or a range, probably is inverse to the distance out in the future. Usually cost estimates are tested by sensitivity analysis. These are repetitive analyses using different quantitative values to determine if the results are sensitive to the values assigned. Such analyses give the decision maker a better understanding of how much uncertainty is involved if there are significant errors in the cost estimates. He can then better judge if the investment is worth the payoff considering the uncertainties involved.

Models

Models are used in cost-effectiveness analysis to cope with the host of

variables that are inherent in problems of the future. A model is simply certain relationships expressed in some way to simulate real or expected conditions in order to foresee, even to a limited extent, the expected outcome of a course of action. Models assist in simplifying the problem, in identifying the significant components and interrelations, in determining which variables are especially important for the decision at issue, and which variables can be suppressed. In this manner, the decision process can be more precisely focussed on those areas which require a judgment decision.

Models range from simple graphs to complex equations and can also take the form of a wargame or field maneuver. The estimate of the situation and staff estimates also use models. The comparison of proposed courses of action against enemy capabilities or expected difficulties and the comparison among the proposed courses of action represent uses of models to foresee the future outcome of an action.

All models, simple or complex, are abstractions of the real world and their validity depends on the proper selection of assumptions and the correctness of the relations portrayed, and the pertinence of the factors included in the model. Two aspects of model building are particularly troublesome, quantification and the treatment of uncertainty. Some variables are difficult to quantify, such as the continued availability of certain support from an ally. This difficulty leads either to the neglect of such variables by ignoring them or by a qualitative modification of a solution derived from the treatment of other variables that have been properly quantified. Such treatment often results in the difficult-to-quantify variables being lost within all the other qualitative considerations that must be weighed when the time comes to recommend action on the basis of the solution from the model.

The influence of the variable that cannot be quantified and all uncertainties must be specifically addressed in the model unless it can be demonstrated by logic or analysis that they are trivial, affect all alternatives roughly the same, or the results are insensitive to them. Guessing may lead to disaster. For example, if there is uncertainty about 8 factors, a best guess might be made on each of them. If there is a 60% probability that each best guess is right, then the probability that all guesses are right is less than 2%. Relying on best guesses, in this case, would be ignoring all the outcomes with more than 98% probability of occurring. Uncertainties and the problem of the factors that cannot be quantified can be handled through various techniques such as Monte Carlo sampling, contingency analysis, (see Glossary) and even wargaming for certain purposes.

Models that portray relations incorrectly also lead to false results. For example, some models are based on the persistence principle which states that what is happening or has happened will persist. This type of model is dangerous except for very short-term uses. For example, it is wrong to assume that the enemy tactics used during the Korean war will continue to be used in the future against new types of equipment and tactics that may be introduced. Some models depend on extrapolation which assumes

that trends will continue uninterrupted. Such models lend themselves readily to mathematical treatment but are often erroneous because of failure to consider what is called the Law of Diminishing Returns. For example, a machine gun can fire at a certain high rate. However, this high rate cannot be maintained for very long (extrapolation) because the barrel would soon be burned out.

Models can be classified into two general types--exact (deterministic) or probabilistic. An exact model of warfare, of course, is impossible in peacetime. However, it is possible to create an almost exact model of some specific piece of hardware or activity and subject it to test. The final product of the model will then closely approximate the results from the actual hardware or activity. March graphs used for planning administrative movements are examples of deterministic models. Most military problems are, by nature, made up of uncertainties. Consequently, they are considered as probabilistic when the uncertainty is identified by a probability factor. For example, a wargame using a certain kill probability for an air defense system is a probabilistic model.

The construction of models to evaluate effectiveness is often difficult. The difficulties arise in selection of criteria of effectiveness. It is relatively easy to measure the comparative effectiveness of two similar pieces of equipment designed to accomplish the same general objective as, for example, in comparison of a towed 105-mm and a self-propelled 105-mm howitzer. However, it is more difficult to compare the effectiveness of general purpose force organizations such as two different kinds of divisions or even two equal-strength infantry battalions having the same general kinds of weapons but one having three rifle companies and the other having four. The impact on effectiveness of intangibles such as morale and leadership can hardly be calculated and requires the application of judgment. Each study virtually requires a consideration of its own criteria of effectiveness.

Models used in cost-effectiveness analysis sometimes tend to become mathematical and abstract. Consequently, they may be difficult to understand. A good cost-effectiveness analysis strikes a balance in the use of models between simplicity and retention of enough detail to ensure that the expected outcome of an expected action will be adequately portrayed. In any case all models have certain common elements. These are broadly stated as a definition of the problem, principal factors or constraints, verification and the decision process—or application of criteria. The validity of conceptual or mathematical models cannot be verified in a cost-effectiveness analysis by controlled experiments. At the best, they can be tested by their workability. Questions 37 to 44 in the next chapter are designed to assist a review to test the workability of models used in cost-effectiveness analyses.

Criteria

The most widely used criteria in Army studies for selecting the pre-

ferred alternative are usually based on either equal cost or equal effectiveness of the alternatives. Another method, known as incremental effectiveness at incremental cost, is used in special cases. In the equal cost form it is assumed that there is an arbitrary fixed budget or series of fixed budgets, and the analysis determines which alternative gives the greatest effectiveness for the same expenditures or resources. In the equal effectiveness form, a specified and measurable military effectiveness (capability) is stated and the analysis is to determine which alternative achieves this effectiveness at least cost. The incremental effectiveness at incremental cost method relates the increase in effectiveness achieved to the associated increase in resources involved. This method is normally used only as a last resort when neither costs nor effectiveness of alternatives can be made equal, e. g., when a capability based on a new technology is to be added to the force and this new capability cannot be approximated by any practicable combination of existing materiel and men.

Role of Judgment

Judgment is used throughout a cost-effectiveness analysis in the same manner as in the making of an estimate of the situation or a staff estimate. Judgment is used in analyzing the objective, deciding which alternatives (courses of action) to consider, which factors are relevant and the interrelations among these factors, which numerical values are to be used, and in analyzing and interpreting the results of the analysis. The goal of a cost-effectiveness analysis is to keep all judgments in plain view and to make clear the logic used. It also shows the sensitivity of the results to the significant judgments made. The depth of a cost-effectiveness analysis is tempered by the time and manpower available and the importance of the subject matter. A cost-effectiveness analysis requires resources and it must serve as an aid to the making of decisions and not be a mere intellectual exercise,

Review of Studies

There are probably almost as many different ways of reviewing a study containing cost-effectiveness analysis as there are reviewers. Furthermore, the time available for review is variable and studies lack a common format. It is suggested that the points listed below be checked specifically in the early stages of a review.

- a. Statement of criteria used to judge effectiveness.
- b. Statement of criterion used to select preferred alternative,
- c. Use of incremental costs.
- d. Explanation of logic of models.

- e. Presence or lack of analysis of sensitivity of the results to significant data and assumptions.

Without these elements being present, the study will probably be of poor quality.

Army--conducted studies containing cost-effectiveness analysis usually do not have a uniform organizational pattern but many generally follow the Staff Study format. On that basis, the key questions in the next chapter have been grouped under these headings:

- Statement of the Problem
- Assumptions
- Alternatives
- Documentation
- cost
- Relationships (Models)
- Effectiveness
- Criteria
- Conclusions and Recommendations

The grouping under the above headings inevitably leads to some duplication of material, particularly on the use of analytical tools such as sensitivity and contingency analysis. This duplication has been kept to a minimum but full coverage has been retained under each heading as a convenience to the reviewer who wishes to refer to a specific heading.

The Glossary is designed to give a non-technical definition of terms frequently used in cost-effectiveness analyses.

The annotated Bibliography has been designed for the reviewer who desires to read further into the methodology of cost-effectiveness analysis.

Chapter 11

KEY QUESTIONS*

STATEMENT OF THE PROBLEM

1. IS THE PROBLEM STATED THE REAL PROBLEM?

An improper statement of the problem often results in either studying the wrong problem or precluding consideration of worthy alternatives. These defects are usually avoided by a statement of the problem in terms of a functional need--the job(s) to be done--without implying how it is to be done. A statement of the problem in terms of requirements for kinds of forces, systems, or performance characteristics, except if it is a follow-on to a previously approved study of a functional need, should be critically examined to ensure that the wrong problem is not being studied and that worthy alternatives are not automatically excluded from consideration. For example, although the stated problem (no previous study of functional need) may be to select a rifle to meet certain capabilities (requirement statement), the real problem might be providing the rifle squad with adequate firepower to accomplish certain functions (functional need). In such a case, a rifle is only one possible alternative.

A word of caution is in order. There often is a practical limit on the depth of the statement of the functional need or the study may become unmanageable. For example, in the case cited the functional need could be conceivably so stated that the rifle squad itself becomes only one alternative to solving a larger problem. To avoid this difficulty, either certain broader decisions must be considered as made, thereby narrowing the scope of the study, or the broader study undertaken. When the former approach is taken, the study is known as a suboptimization. The reviewer, based on his knowledge and judgment, must determine if the suboptimization has so narrowed the scope of the problem that the real problem has been missed or worthwhile alternatives excluded.

2. DOES THE STUDY IDENTIFY IMPLIED SIGNIFICANT COMPONENTS OF THE PROBLEM THAT MUST BE FULLY TREATED IN THE STUDY?

Like the mission statement in an estimate of the situation, the problem to be treated in a cost-effectiveness analysis must be analyzed to identify all functions that must be performed. Some of these implied functions are

*Those questions that are considered particularly important and of widest application have been underlined.

AMCP 706-191

often not apparent at first. The reviewer should watch for implied significant component parts of the problem that are neither identified nor treated fully in the study. The reviewer should also watch for other problems that are opened up or revealed by the study that should be further investigated.

ASSUMPTIONS

3. ARE ALL ASSUMPTIONS IDENTIFIED?

The reviewer should watch for assumptions that are not identified as such because **assumptions** imply a limitation or a judgment. In order to evaluate the study properly, it is necessary to assess the impact of the limitations and the validity of the judgments contained in **all** the assumptions. An example of a common assumption **that** is often not identified is **that a given unit operates by itself**. As a result, in measuring the effectiveness of a division, for example, inadequate consideration is sometimes given to the support the division receives from non-divisional units such as corps artillery or tactical air units. This failure to consider non-divisional support may lead to erroneous conclusions and recommendations. Another frequently hidden assumption is **that the enemy's doctrine and tactics are rigid although ours are flexible**.

4. ARE THE ASSUMPTIONS **UNDULY** RESTRICTIVE?

Assumptions are properly used to narrow the scope of the study to manageable proportions. However, the assumptions should be examined to determine whether they unduly restrict the study by eliminating possible significant alternatives or by narrowing the scope of consideration to the point **that** the conclusions and recommendations may be in error. **This** examination may be required throughout the review of the study and not only during the review of the stated assumptions.

Assumptions covering the subjects listed below often unduly restrict the scope of the study and lead to questionable conclusions and recommendations.

- a. Non-availability or limited availability of support from other services (e. g., tactical air support or MATS effort).
- b. Locale of operations.
- c. Duration and intensity of operations.
- d. Enemy organization, operations, and reactions to our decisions.
- e. Time period covered.

5. DO ANY OF THE MAJOR ASSUMPTIONS UNJUSTIFIABLY TREAT QUANTITATIVE UNCERTAINTIES AS FACTS?

An uncertainty can be defined as the lack of definitive knowledge for assigning values or probabilities to factors that influence decisions. Uncertainties can be either quantitative (risks) or qualitative. (See UNCERTAINTY and RISK in Glossary.) Examples of quantitative uncertainties are hit-kill probabilities, equipment availability rates, ammunition expenditure rates, and reliability statements. The availability of base rights in a foreign country at some future time, or the start of aggression by the potential enemy in a given year are examples of a qualitative uncertainty. (See next question.)

The reviewer should be alert for stated and implied major assumptions that assign fixed values to quantitative uncertainties and then treat these estimates as facts. A common example is the assumption that a proposed weapon system will have a certain hit-kill probability. It is often better to handle significant uncertainties by sensitivity analysis. This is a repetitive analysis using different quantitative values to determine if the results are sensitive to the values assigned. When significant uncertainties are treated as facts by assumption, the conclusions and recommendations of the study may be no more valid than the assumption unless it can be demonstrated that the conclusions and recommendations are not sensitive to plausible errors in the " facts. "

The number of sensitivity analyses required, and feasible, is a matter of judgment. There are limits to the time and manpower available for a given study. Sometimes an educated guess, considering all the circumstances, will suffice. In effect, the reviewer must judge whether the study agency has performed adequate sensitivity analyses considering all the circumstances, the importance of the subject, and whether further sensitivity analysis may significantly affect the conclusions and recommendations.

6. DO ANY OF THE MAJOR ASSUMPTIONS TREAT QUALITATIVE UNCERTAINTIES AS FACTS?

Major qualitative uncertainties treated as assumptions also tend to dictate conclusions. A common qualitative uncertainty that may dictate the conclusions concerns the estimate of the enemy. Many studies are based on intelligence estimates, or target arrays prepared or approved by the Defense Intelligence Agency. However, these estimates are sometimes assumed to be facts. In such cases, this often results in the enemy being considered to be inflexible and no allowances are made for him to react in different ways to our operations or to our introduction of new capabilities. When it is not definitely known how we will operate or be equipped 10 years hence, it is questionable to assume that the enemy operations and equipment in the future can be predicted with certainty.

Other qualitative uncertainties, stated or implied, that should be treated with caution are those associated with political considerations. Examples are availability of base rights, assurance of overflight permission, and composition of political and military alliances on either side.

Treatment of the kinds of uncertainties discussed above in an analysis is not simple, but the effects of such uncertainties on the conclusions should not be neglected in a study. One method to cope with significant uncertainties of this kind is to use contingency analysis. This involves repetitive analysis with different qualitative assumptions, such as type of conflict or enemy capabilities, to determine their effects for comparison with the results of the initial analysis. The amount of contingency analysis required has to be a matter of judgment, as discussed in the previous question.

7. ARE THE MAJOR ASSUMPTIONS REASONABLE?

Major assumptions should also be tested to determine if they are reasonable. This test can be facilitated if the study documents or provides some explanation of why each assumption was made **so that** the reasons can be evaluated by the reviewer. **A** useful technique for reviewers **is** to try to think of other major assumptions that are plausible. **If** these invalidate the conclusions and recommendations, then the study is questionable.

ALTERNATIVES

8. ARE CURRENT CAPABILITIES ADEQUATELY CONSIDERED AMONG **THE** ALTERNATIVES?

Current capabilities should not be omitted from consideration in construction of alternatives except for valid reasons that are clearly stated. Valid reasons may include failure of the current system to accomplish the current mission, or a significant degradation of capability relative to that of the potential enemy. Consideration of current capabilities is an improvement that is worth the expenditure of new resources. By considering current capabilities, much of whose costs are already paid for, as an alternative, the study can show the difference in effectiveness and costs that result from the adoption of the proposed new system or organization. (See question 23.) Current capabilities should also be considered, where appropriate, **as** a component of an alternative.

9. ARE "TRADE-OFFS" **WITH** EXISTING SYSTEMS OR ORGANIZATIONS ADEQUATELY CONSIDERED WITHIN THE ALTERNATIVES?

Where appropriate, the design of alternatives should consider "trade-offs" with existing systems or organizations. Possible examples are: (1) in studying the increased use of Army transport aircraft an alternative might include reduction in other **means** of transport; (2) in a study on an improved fire control system an alternative might include a reduction in ammunition stockage.

10. ARE THE APPROPRIATE CAPABILITIES OF THE AIR FORCE, NAVY, OR MARINE CORPS CONSIDERED AMONG THE ALTERNATIVES?

The alternatives should consider the capabilities of Air Force, Navy, or Marine Corps as appropriate. The Army usually conducts combat operations with the support of one or more of the other Services and the other Services are charged by law with furnishing certain support to the Army. These types of supports are listed in JCS Publication 2 (UNAAF). For example, CONUS air defense is not the exclusive responsibility of either the Air Force or the Army. A **CONUS** air defense problem must consider Army surface-to-air missiles, Air Force manned interceptors, and Air Force surface-to-air missiles.

Current and projected capabilities of the other Services can be obtained from a number of different sources including the Five-Year Force Structure and Financial Plan maintained by each Service. The reviewer should bear in mind that functions such as air defense, the attack of surface targets, reconnaissance in the vicinity of the FEBA, and transportation within a theater are not the exclusive responsibilities of the Army.

11. ARE MIXTURES OF SYSTEMS (ORGANIZATIONS) CONSIDERED AMONG THE ALTERNATIVES?

The reviewer should watch for failure to consider appropriate alternatives that are based on mixtures of two or more systems (organizations) to combine the best features of each. For example, in comparing certain transportation systems one alternative for surface transportation might be a combination of truck, rail and water systems rather than only a truck system. In the same manner, the study of a proposed new missile system might consider as an alternative a suitable combination of existing missile and gun systems and aerial fire support rather than only an existing missile system.

12. ARE ANY FEASIBLE AND SIGNIFICANT ALTERNATIVES OMITTED?

A major contribution that a reviewer can make is to point out significant and feasible alternatives that the study may have failed to consider. If any of the answers to the previous questions on " Alternatives" are in the negative then it is possible that some feasible and significant alternatives were not considered. However, the reviewer must exercise judgment before criticizing a study for failure to consider all possible alternatives. There are practical limits on the time and manpower available for a given study. The relative importance of the decision on the subject under study will also influence the number of alternatives examined. The reviewer should consider these aspects in determining whether feasible and significant alternatives have been omitted to the detriment of arriving at sound recommendations .

On the other hand, a large number of alternatives may only indicate that minor variations have been considered as new alternatives. Excessive use of such minor variations as alternatives often beclouds significant choices.

DOCUMENTATION AND DATA

13. IS THE STUDY ADEQUATELY DOCUMENTED?

A key element of systematic analysis is sufficient documentation of methods and sources so that with the same material, other study groups can arrive at substantially the same results. Without such documentation, a study appeals for acceptance solely on faith in the authority and expertise of the study group and without critical examination of the sources and methods used to arrive at the recommendations.

The test of adequacy can be applied by examining the models, data, assumptions, etc., to determine if they are stated in such a way that another study agency could trace through the steps of the study and arrive at substantially the same results and conclusions. A study that is not adequately documented will usually fare poorly when reviewed by agencies lacking the detailed knowledge of the problem that can sometimes compensate for poor documentation. Inadequately documented studies may require only slight additions to be properly documented.

14. ARE THE FACTS STATED CORRECT?

It is usually neither possible nor necessary for a reviewer to verify all the factual material presented in a study, but it is advisable to spot check. Particular attention should be paid, where possible, to the factual material on which conclusions and recommendations depend. If many errors are involved then a thorough verification of the facts presented may be in order.

In reviewing factual material, its source should be examined critically. For example, frequent use is made of data contained in FM 101-10, "Organization, Technical, and Logistical Data" and similar publications. The data contained in these manuals are usually averages of historical data obtained from certain kinds of operations in specific theaters. The unquestioning use of these average figures may lead to erroneous conclusions because the use of an average hides significant variations that exist in the real world. A tank battalion does not always cover the same number of miles each day even over the same terrain. Further, the data contained in the reference manuals may not have been computed for the purpose required in the study and considerations important to the study may not be included in the calculations. For example, ammunition expenditure rates contained in FM 101-10 are based on World War II and Korean experience and organizations. The use of these rates for projected operations in the 1965-70 time frame would be questionable.

Projection of current operational experiences into future time frames should also be examined critically. For example, a study used as data

that an armed helicopter's missions are A% escort, B% casualty production, and the remaining missions for suppressive fire. These data were obtained from experience in Viet Nam operations. **This** unquestioning projection of such data into future operations in other areas fails to allow for possible introduction of significantly new US and enemy tactics and may result in conclusions and recommendations on how better to cope with the last war.

15. ARE THE FACTS STATED WITH PROPER QUALIFICATION?

In addition to checking the validity of the factual material, it is **good** practice to check the factual material for completeness. Some material may be factually correct in isolation but may take on a different significance when other facts are added. For example, it is true that infantry units can march at an average rate of 2.5 miles per hour. However, this rate is valid only on relatively level roads.

16. ARE FINDINGS AND DATA FROM FIELD EXERCISES AND FIELD TESTS USED?

Field exercises and field tests can be excellent sources for effectiveness data. When used in a study, such data should be carefully examined. The reviewer should determine whether the data were obtained by measurements or by judgment of individuals and if similar data would likely be obtained if the field test or field exercise were conducted again by another agency or unit. The circumstances surrounding the field exercise or field test should be reviewed, where possible, to determine if any artificialities (there are always some in any peacetime operation) were of sufficient influence to affect the results of the study based on field data. Field exercises usually have many parameters and very few runs, therefore making it very difficult to single out cause and effect.

Common artificialities that may significantly affect data from field exercises and field tests include:

- a. Inability to assess effectiveness of air defense fires, air-to-surface fires, and ground-to-ground fires.
- b. Lack of realistic levels of support from the other Services or other supporting units. Often this support is either not available or available in abnormally large amounts.
- c. Use of administrative breaks for rests, intensive resupply, and maintenance operations.

- d. Unrealistic maneuver and deployment because of restricted maneuver areas.
- e. The units or quantities of materiel tested are not a valid sample either because of inadequate size or of bias in composition.
- f. Poor or inadequate reporting of events of the exercise.
- g. Effect on actions of participants caused by use of only blank ammunition.

17. ARE THE DATA FROM SUPPORTING WARGAMES VALID?

Studies sometimes use the findings of wargames as facts. In evaluating such facts, the reviewer should bear in mind the nature of wargames. Basically, a wargame involves a hypothetical situation in which two opposing sides interact in accordance with a set of more or less definite rules. In all forms of wargames, the play is determined either by mechanistic rules or judgments made by individuals or both. These rules and judgments are based on assumed situations and known or assumed facts and system characteristics. Well planned and executed wargames are excellent teaching devices and provide the participants with good insights into the problem gamed. Such games, if well documented, usually provide a body of synthetic data which, when analyzed, provides clues to problem areas that need further investigation.

In determining the validity of the findings of wargames, the reviewer should judge how well the game portrayed reality and should satisfy himself on the validity of the judgments and assumptions used in the conduct of the game. The study should lay out for scrutiny the major judgments and assumptions used in the wargame. It is recognized that it is usually not possible to lay out all judgments and assumptions used in the wargame. In any case, the reviewer should weigh the dependence of the conclusions and recommendations on the findings of the wargame and consider whether other competent players playing the same game would have arrived at similar results.

18. ARE THE PERFORMANCE CHARACTERISTICS VALID?

Performance characteristics data are often the key elements in the determination of the effectiveness of a system. In evaluating the validity of performance characteristics, the source of the data should be examined. When the claimed performance characteristics are essential to the conclusions and recommendations and the source of the data is not clearly

stated, additional information may be required from the agency that prepared the study. This may not be necessary if the study contains a sensitivity analysis of a reasonable range of values for the performance characteristics.

Performance characteristics based on a manufacturer's claims **are** often too optimistic. Performance characteristics derived from tests at research installations also require examination. Sometimes, such performance characteristics are derived under controlled conditions that neglect the man-machine relation that exists under field condition. Even performance characteristics derived from field tests should be examined. Such tests can, at times, produce misleading results due to artificialities caused **by** various peacetime restrictions such as safety regulations and choice of test areas.

If faced with questionable performance characteristics that are key to the conclusions, the reviewer should consider: **(1)** performing a sensitivity analysis himself if his time and the data in the study permit; **(2)** requesting validation of the performance characteristics and sensitivity analysis.

19. ARE ANY OF THE DATA DERIVED FROM QUESTIONNAIRES?

The data obtained from questionnaires should be examined to determine the validity of the questions, the adequacy of the sample and statistical procedures, and the expertness of the personnel questioned. For example, one study cited data on the frequency of kinds of missions expected to be flown by Army aircraft in a conventional war. The data were based on **a** questionnaire completed by Army aviators at one Army post. There was no operational experience applicable to the study and an educated guess or subjective judgment was in order. However, in this case, the judgment of those who order Army aviation missions flown (commanders, operations and intelligence officers) should have been elicited rather than the judgment only of those who execute the missions.

20. ARE GUESSES AND INTUITIVE JUDGMENTS IDENTIFIED?

At times it is necessary to fill in data gaps with educated guesses and intuitive judgment. These educated guesses and judgments should be identified in the study and not "swept under the rug." The reviewer should evaluate these judgments and weigh their impact on the conclusions and recommendations.

COST

21. IS THE COST MODEL IDENTIFIED?

Every cost-effectiveness analysis contains a cost model. A cost model generates cost estimates by application of cost estimating relations and cost factors to specified physical resources. (For a further discussion on models in general see question 37.) This model can be very complex and computer assisted or it may consist of a few relatively simple equations readily computed by hand. The study should sufficiently identify the cost model so that the reviewer can determine how the total system cost estimates were derived from the material in the study. If the material in the study does not permit the reviewer to do this, then additional information is required from the agency that prepared the study.

The cost models are utilized to estimate the probable economic impact on the Service (or Nation) of introducing a new capability. For planning, these costs are normally stated in terms of research and development costs, investment costs, and operating costs. Research and development costs include those costs primarily associated with the development of a new capability to the point where it is ready for operational use. Investment costs are those costs beyond the development phase to introduce a new capability into operational use. Operating costs are recurring costs required to operate and maintain the capability.

22. ARE THE COST ESTIMATES RELEVANT?

Cost estimates depend on the problem under study and can rarely be obtained from books containing cost data although cost factors and cost estimating relations (CERs) can sometimes be found in such books. For example, a hypothetical study considers as an alternative a new kind of light infantry division which has been designed to the extent of an outline TOE. The answer to the seemingly simple question, "What is the cost of this new division?" depends on many factors including:

Will it be an additional division to those already in the force structure?

Will it replace an existing division? If so, what kind?

Where will it be stationed? e.g., in the CONUS, Pacific, Europe, etc.

Will it have new Standard A equipment, or will existing assets of Standard B type equipment be used?

Are there any existing Army units whose personnel, equipment, and facilities can be used by the new division?

The determination of which costs are relevant requires considerable analysis and judgment. It is not possible to prepare a universal list of costs that are always relevant. Ideally, a study should indicate why certain costs were considered relevant and others not. The questions that follow are designed to help the reviewer determine whether the cost estimates used in a study are relevant.

23. ARE INCREMENTAL COSTS CONSIDERED?

Inherited assets are those resources such as installations, equipment, and trained personnel inherited from earlier systems which are phasing out of the force structure and are usable in one or more of the alternatives under study. The costs which are usually pertinent for planning purposes are those costs yet to be incurred. For example, a study considers as an alternative the conversion of certain artillery units from tube to missile weapons. In determining the incremental costs consideration should be given to the inherited assets of trained personnel, equipment, and facilities that are or can readily be made common to both units.

Sunk costs are those costs already expended. These previously incurred costs are normally excluded from costs presented in cost-effectiveness analysis. For example, a study considers as possible alternatives weapons systems A, B, and C, each with an associated research and development cost. Only alternative A is already under development. The cost already expended on Alternative A is a sunk cost and the research and development cost of Alternative A in the study should be only what must **yet** be spent (to complete the research and development of Alternative A).

An occasional error is the failure to consider the research, development and investment costs of existing systems as sunk costs. For example, in a hypothetical study of the conversion of certain artillery units from tube to missile weapons, one of the alternatives is retention of all of the tube weapons units. The cost of that alternative would not include the sunk costs represented by the research and development and investment costs already expended in bringing those units into the force structure.

Including the costs of inherited assets and other sunk costs leads to distorted cost estimates with consequent effect on the conclusions and recommendations.

AMCP 706-191

24. ARE DIRECTLY RELATED SUPPORT COSTS INCLUDED?

Cost estimates of systems or organizations should include the proportionate cost of those other units or elements required in direct support. For example, the cost estimate of HAWK battalions should include the costs of the associated HAWK direct and general support detachments. In the same manner, the cost of aviation units should include a direct share of the cost of aviation maintenance units. Failure to include directly related support costs may result in misleading cost estimates of alternatives.

25. ARE COMBAT CONSUMPTION, REPLACEMENT/ CONSUMPTION, AND MAINTENANCE FLOAT COSTS INCLUDED?

Cost estimates for the major equipment items should include not only the operational equipment assigned to organizations, but also the costs for those additional items required for initial stockage as well as replacement items over the period in which the system is to be in use. (See question 32.) If the resource implications for procuring and maintaining authorized maintenance float, replacement/ consumption, and combat consumption stockage are excluded, the total costs of the system alternatives may be significantly misleading. (These levels of stockage are, of course, subject to logistics guidance.) For example, a common error is to include only the cost of the basic load of ammunition and to neglect the cost of the additional ammunition requirements for support of the weapon system or organization. The total ammunition required, to include peacetime training requirements and expenditures in the first part of a war until wartime production becomes available, must be purchased and stocked in peacetime.

26. ARE ALL TRAINING COSTS INCLUDED?

The resource implications of training military personnel can be significant. Initial training costs represent the resources required for the training of personnel necessary for introduction of the alternative into the force structure. The availability of fully-trained personnel, as well as the number of personnel requiring complete or transitional training, are taken into consideration in determining the resources required. Annual training costs represent the resource implications for training replacements. These replacements are required because of normal attrition.

Training costs usually include such items as: (1) procurement of equipment utilized for training purposes; (2) construction of any necessary additional facilities; (3) operation and maintenance costs of the facilities; (4) the pay and allowances of the trainees. For example, the cost implications of communications-electronic equipment utilized for training purposes could be highly significant.

27. ARE CONSTRUCTION COSTS INCLUDED?

The costs for additional installations or facilities are often overlooked yet these costs can be important. If the study does not include any construction costs and does not state how the facilities were obtained, then the reviewer must either satisfy himself that no construction is required or take necessary steps to have the study corrected.

28. ARE THE COST DATA REASONABLY ACCURATE?

Although it is not usually possible for a reviewer to check all cost data for accuracy, he should spot-check and examine the sources of the data.

Cost data furnished by manufacturers should be viewed critically. Experience has shown that such data are usually understated, particularly for advanced systems. Advanced system costs stated as an exact figure rather than as estimated lower and upper values are particularly suspect.

The basis of the cost data for advanced systems should be included in the study. There are a number of ways for arriving at such estimates. One commonly accepted method relates the cost data for the components of existing analogous systems to the cost of the advanced system. Unsupported cost data are suspect.

Great accuracy in cost estimates is not required and often is not feasible. In fact, in dealing with costs of advanced systems it is usually more realistic to have a range of possible costs (upper and lower values) rather than the pseudo-accuracy of one cost figure which assumes no uncertainties in arriving at that figure.

29. ARE COST ASPECTS OF ALL ALTERNATIVES TREATED IN A COMPARABLE MANNER?

Inconsistency in handling the cost aspects of competing alternatives prevents an objective evaluation of their comparative or relative costs and usually leads to erroneous conclusions. It is not always possible to use the same cost estimating technique for calculating a cost element such as attrition replacements. This is often the case in studies involving alternative systems of other military services. For example, one service may calculate aircraft attrition replacement as a function of an activity rate (e.g., per 100,000 flying hours) while another service may calculate it as a function of the activity inventory (3 percent of the active inventory per year). The reviewer should determine that the final dollar estimate is related to the actual resource requirements for the alternative and that computational peculiarities do not distort the cost results.

Treating alternatives in a comparable manner must not be carried to the point that costs which may be insignificant in one alternative are therefore not considered at all in other alternatives. For example, civilian personnel might not be used in one alternative but may be required by another alternative in significant numbers. To exclude this cost could distort the results.

30. ARE THE COST ESTIMATING RELATIONS VALID?

Cost estimating relations may be crude factors, simple extrapolation of recent experience, or complex equations with many variables. In all cases, the purpose of a cost estimating relation is to translate a specification of a physical resource into a cost. The design of valid cost estimating relations is a complex subject beyond the scope of this publication. However, several common errors made in establishing cost relations are discussed below.

Cost estimating relations should be based on current data or distorted estimates may result. For example, the maintenance cost per flying hour for an Army helicopter has decreased significantly over the past several years as new helicopters have been introduced into the force structure. If the cost estimating relations used in a study were based on information for early Army helicopters (e.g., 1946 through 1954 data) the maintenance cost per flying hour for a present system as well as for future systems alternatives could be distorted.

At times a properly constructed cost estimating relation may be inapplicable. If the system alternatives are very advanced developments, the cost estimating relations based on the current technology may lead to false results. For example, the V/STOL aircraft concept represents a departure from aircraft currently in production. While many design characteristics may be similar to present aircraft, there may be a number of factors which could increase the complexity and hence, the cost of the aircraft; a cost estimating relation based on the present state-of-the-art may not be appropriate.

31. IS AN AMORTIZED COST USED?

Amortized costs reduce the total program cost of the system to an annual cost by taking the total operating cost of the program, adding to it the research and development and investment costs, and reducing the total to an annual basis by dividing by the number of years of expected service life of the system. The same general procedure may be utilized to amortize the costs per month, per day, per sortie, etc. This approach disguises the differences between annual operating costs resulting from shifting deployment patterns over the life of the system and from a varying set of inherited assets over time. This approach makes an arbitrary

allocation of the fixed costs of a system over time. There is no basis for the assumption that the last year of system life must be charged with the same amount of R&D cost as the first year. The first year gets the newest technology; the last year, obsolete technology. Further, an amortized cost does not present a true picture of the total resource implications. If the system is to be in the force structure for say 10 years, the amortized annual costs may look relatively small, yet in reality there may be relatively large dollar costs. It is the total cost of the alternatives which is of primary concern.

The reviewer should attempt to convert amortized costs into total program costs and use such costs for comparative purposes. If this cannot be done readily from the material contained in the study, then additional information is required from the study agency.

32. WERE PEACETIME OR WARTIME COSTS INCLUDED?

The results of a cost-effectiveness study may be very sensitive to the use made of peacetime and wartime costs. The use of peacetime costs only may indicate that System A is preferred while the same study, if wartime costs were used, may have concluded that System B is preferable.

Peacetime costs may be defined as the costs associated with developing, buying, and maintaining a capability for potential war during peacetime. Such costs also include combat consumption stocks (war reserves) to cover the period from the beginning of a war until wartime production is able to replace battle losses. Wartime costs are the costs of procurement after the war has begun, as is the cost of replacing the combat consumption stocks if the war terminated during the useful life of the system.

In the case of general purpose forces there may be significant production of weapons and expenditure of resources after a limited conflict begins (as in the Korean Conflict and the military assistance rendered to South Vietnam). In this case, wartime costs could be significant. However, wartime costs are difficult to determine because of uncertainty regarding the duration of the war, loss rates; and missions undertaken.

The reviewer should be guided in considering the proper cost approach (peacetime or wartime) by existing policy or directive from the agency directing that the study be made.

33. WAS A WARTIME ORDNANCE COST PER MISSION USED?

The use of a wartime ordnance cost per mission should be reviewed carefully. Variations on this approach include ordnance cost per target killed, per casualty and per sortie. This approach is usually deficient because of failure to consider all the costs of putting into place and

AMCP 706-191

maintaining a capability for potential war throughout the projected life of the system in the active force structure. Often, this approach includes only the ammunition costs expended during a brief battle, and neglects the bulk of the significant costs associated with developing, buying and operating the system in peacetime.

34. WAS AN AMORTIZED WARTIME-PEACETIME COST USED?

In this approach the total peacetime cost of the system is reduced to an annual basis as explained in question 31. To this amortized peacetime cost is added the estimated annual wartime replacement/ consumption costs. No distinction is made between wartime and peacetime costs. This approach is deficient because: (1) it assumes the war will continue over the entire projected service life of the system; (2) the cost results use weighted wartime costs; (3) wartime and peacetime costs may not be commensurable; and (4) it does not present a true picture of the total resource implications as discussed in question 31.

Adding amortized costs in one stream to another annual cost stream infers that both cost streams represent the same total time duration. If this is not the case, then the two cost streams should not be added together because they are incommensurables. Adding the amortized peacetime costs to the annual wartime cost implicitly assumes that the war will continue over the entire "service life" of the system. If the peacetime costs had been amortized to a per day or per mission cost instead of a per year basis, the same result would hold, the inference being that the war would continue over the entire "service life" of the system. The implied assumption that the war would last for the "service life" of the weapon system is questionable.

Costs computed by this method are weighted because wartime costs do not cover the same length of time as peacetime costs. Such weighted results favor the shorter time period--the wartime costs. It is only when the two cost streams are of equal length that the costs results are not distorted.

To assume that wartime and peacetime costs are commensurable may be erroneous. This assumes a common measure between the values of resources procured in wartime and those procured in peacetime. During wartime, the cost of a resource may be quite different from that in peacetime. Military budget constraints during peacetime and physical resource constraints during wartime may produce entirely different sets of costs for the same military resources. As a greater proportion of the national budget is shifted to military purposes during wartime, the scarcity of dollars for military resources may become relatively less or more than during peacetime. Commensurability between wartime and peacetime costs will depend upon such uncertainties as the type and duration of war and whether a war will actually occur.

35. WAS A DOLLAR COST ASSIGNED TO THE LOSS OF HUMAN LIFE?

Frequently, a study will assign a dollar cost to a human casualty. The loss of human life is certainly important in selection among alternatives. However, the value of a human life is incommensurable with the dollar costs associated with an alternative. It is better to treat human losses as a separate measure without assigning dollar values. Manpower availability in both peace and war is very important but this problem cannot be properly treated only in terms of dollar costs. Men and dollars may not be interchanged.

36. IS THE SENSITIVITY OF COST ASSUMPTIONS EXAMINED?

In comparing costs of alternative systems, it is important to determine whether the results are independent of the cost assumptions. For example, would ten years of peacetime operations as opposed to five make a significant difference in the relative costs of the alternatives? Would it make **any** difference if the procurement levels or number of units to be organized changed? The study should make clear the sensitivity of the cost estimates to the major cost assumptions. If the study fails to do this, the reviewer should attempt to determine if there is any such significant sensitivity by rough calculation.

RELATIONSHIPS (MODELS)

37. ARE THE MODELS ADEQUATELY IDENTIFIED AND EXPLAINED?

The conclusions and recommendations of a cost-effectiveness analysis cannot be evaluated properly unless the models are adequately identified and explained. Every model portrays the real or expected world by abstraction and simplification in order to predict the outcome of a possible action (see Glossary). Therefore, the explanation of the model should be sufficient to provide ready understanding of which aspects of the real world are included in the model, which aspects have been omitted, and the underlying assumptions for the abstraction. Basically, a good model emphasizes the specific areas in which decisions are to be made by removing those relatively constant elements of the real or expected world that can be described with a great degree of certainty.

The study should contain sufficient explanation to permit tracing the operation of the model from input to output. The detail should be sufficient to permit calculation of new results from different input values (sensitivity analysis). In cases where a model is machine-programmed, sufficient explanation should be provided for following the general logic of the program.

38. ARE COST AND EFFECTIVENESS LINKED LOGICALLY?

A properly structured cost-effectiveness analysis contains a number of models that link effectiveness and cost through logical interrelations. Usually there are some kinds of an effectiveness model, a system and organization model, a cost model, and a cost-effectiveness model. The exact nature and number of these models will vary with the problem. The study should provide sufficient information and explanation for the reviewer to follow the logic by which the models relate cost and effectiveness.

An effectiveness model relates measures of effectiveness to measures of performance in an operational context. For example, a study on combat vehicle weapons systems used as a measure of effectiveness the probability of 1, 2, 3, . . . friendly tanks winning an engagement with 1, 2, 3, . . . enemy tanks under different tactical situations. This was related to performance measures such as muzzle velocity, warhead specifics, turret slewrates, turret stability, hull characteristics, rate of fire, target acquisition accuracy, and others, under various tactical situations and rules for conduct of fire.

A system and organization model describes the physical resources required to provide the performance used in the effectiveness model. For example, in the combat vehicle weapons system study referred to,

this included the physical description of each alternative, the complete vehicle, ammunition, armament, fire control, communications, TOE unit description, the support and maintenance requirements, and so forth, consistent with the planned operational concept.

A cost model relates dollar costs to the physical resources (and their peacetime activity rates) described in the system/organization model. The cost model applies cost estimating relations and factors. For example, the same study used the total future cost of acquisition and ownership (R&D, initial investment, annual operating) for various quantities of systems. Included in these total costs were not only the development and procurement of the preferred item but also such additional costs caused by training of personnel, peacetime ammunition use, equipment maintenance, etc. (See question 22).

The cost-effectiveness model finally relates the costs of each alternative to its effectiveness under varying assumptions. Depending on the criterion, the model may compare effectiveness and costs of alternatives at equal cost, at equal effectiveness, or at different cost and different effectiveness (see page 9). The method and the techniques used to achieve this cost and effectiveness relation should be logical and explained. For example, in one anti-tank weapons study the equal effectiveness method (winning the duel - all pertinent factors considered) was employed. Effectiveness was related to cost by a numerical formula for calculation of cost of achieving duel success at a given range under specified conditions. This permitted plotting the following graph:

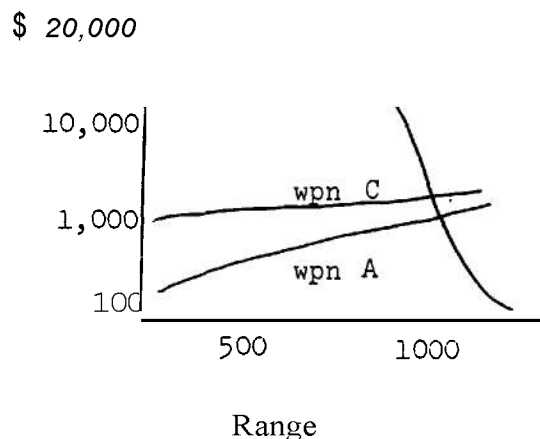

Figure 1. Equal Effectiveness Method

AMCP 706-191

The graph shows the cost of winning a "duel", i. e. , killing the target at various ranges. (The graph portrayed above is highly simplified. In the actual study rather than a simple line, a band was used to portray the variance in costs for winning a duel at a given range. See Bibliography Item No. 1, pages 13-17 for more complete description).

39. DOES THE MODEL TREAT THE PROBLEM IN A SYSTEM CONTEXT?

Most military systems have many subsystems, sub-subsystems and so forth. Models should provide for the proper relations among subsystems so that the full implications of a change in one part of the system will be reflected in the rest of the system. For example, a model in a study of an airborne surveillance system must not only show the interrelations among the aircraft (or drones), the sensors and their maintenance, but also the interrelations with the information processing functions to be performed on the ground.

40. DOES THE MODEL ALLOW FOR ENEMY REACTION?

It normally takes several years to implement fully a decision to deploy a new system. Therefore, the enemy should be considered to have time to adjust to our system decisions. A major aspect of the effectiveness of our system is the degree to which it makes such adaptation for the enemy either technologically difficult or economically unattractive.

For example, a study of a proposed system was based on its incorporation into the current force structure. The model for judging the effectiveness of the proposed system was dominated by current or recent conflict situations (e. g. , Vietnam, Korea, Europe). In using the model to evaluate the effectiveness of the future system only in the light of these current or recent conflict scenarios, the study failed to consider the steps that the enemy could take to counter the proposed system. (See question 6).

41. ARE STRAIGHT EXTRAPOLATIONS USED WITHOUT PROOF?

While straight extrapolations (linear relation) often do apply over limited ranges of performance, consumption, or similar planning figures based on averages of large numbers, they rarely apply to effectiveness or cost data.

For example, the relation between the total weight of rations for one infantry division-month and the weight for 10 division-months is a straight extrapolation. The relation between the total cost of the first 100 and that of the first 1,000 units of a new main battle tank is not linear or a straight extrapolation. If a missile system has 10 missiles, costs \$1,000,000, and is 50% effective (on some valid measure), then

a missile system with 20 missiles, costing \$2,000,000, will not be 100% effective but (at best) 75%.

42. ARE DETERMINISTIC AND PROBABILISTIC MODELS USED PROPERLY?

A deterministic model (see Glossary) uses relations of the type, "If A is 5, then B is always 8". A probabilistic model (see Glossary) uses relations of the type, "If A is 5, then B will be 6-10 in 50% of the cases, 4 or 5 in 25% of the cases, and 11 or 12 in 25% of the cases".

Cost-effectiveness analyses frequently require many intermediate calculations involving data. The indiscriminate use of specific values often creates what is in effect a deterministic model. In reality, the majority of the coefficients and planning factors used in models are only averages with variances and different degrees of confidence. The reviewer should try to identify the probable range of variance about the averages that are used as inputs and have at least an intuitive feeling about the confidence of the numerical results.

Additionally, the reviewer should distinguish those cases in which a probabilistic model is needed to reflect the real world situation. Deterministic models are usually appropriate (1) when the planning factor has an insignificant variance, such as weight of rations **per** day per man for large forces, (2) if the uncertain factor is multiplied by a point value, such as cost of \$8,000 to \$12,000 per man for a force of 20,000 men, (3) a varying factor is multiplied by a linear function, such as an uncertain flying hour rate (e. g. , 2 to 6 hours per day) multiplied by a flying hour cost function of \$20 a day plus \$40 per flying hour. The deterministic technique is correct in these three cases because it will give the same most probable result as if probabilistic techniques had been applied. Of course, there may still be a problem if the most probable result is not the only one of interest.

Probabilistic models are used where the variables in the problem may assume, at any given time, any one value of a known range and frequency of values, as opposed to deterministic models which use fixed or average values all the time. There are two principal types of probabilistic models: static models using probability statements instead of other values, and dynamic (stochastic) models involving change.

Some stochastic models use random numbers, representing change, to select values from frequency distributions for a given problem. For example, an analysis of a maintenance support organization may include a model which represents the demands for maintenance effort placed on the support organization. Of any 100 jobs (demands), 20 will require 1 man-hour, 30 will require 2 manhours, 10 will require 3 manhours, 15 will require 4 manhours, 5 will require 5 manhours, 10 will require 10 manhours, 5 will require 20 manhours, 2 will require 30 manhours,

AMCP 706-191

2 will require 40 manhours, and 1 will require 80 manhours. This information is arranged into a cumulative distribution as shown below:

0-19	:	1 manhours	80-89	:	10 manhours
20-49	:	2 "	90-94	:	20 "
50-59	:	3 "	95-96	:	30 "
60-74	:	4 "	97-98	:	40 "
75-79	:	5 "	99	:	80 "

To represent requests for work, a two-digit random number, say, 37, is drawn (from a table of random numbers or a random number generator); the corresponding value is 2 manhours. The next random number is, say 84, and the value is 10 manhours. This process continues at some rate (which is probabilistic) and the requests for maintenance are arranged (queued) in the order of simulated requests: 2 manhours, 10 manhours, 4 manhours, and so forth. Available maintenance men would be assigned to requests under various rules, e. g. , 1 man to jobs less than 4 hours, 2 men to jobs of 4 to 8 hours, etc. The model would keep track of the time elapsed between generating and completing a request for maintenance. In this manner, the relation of number of maintenance personnel and delay can be determined for various assumptions about demand for maintenance effort.

The so-called Monte-Carlo model described above requires, however, a sufficient number of repetitions to obtain adequate information about the range of values of the solution.

A static model using probability statements may, for example, apply in a study on aircraft vulnerability. The probability of survival for a specified time is given by the product resulting from the multiplication of the following probabilities:

- Probability of aircraft being detected
- Probability of aircraft being acquired by a weapon, if detected
- Probability of being hit, if acquired by a weapon
- Probability of kill, if hit.

Probability data for each of the probabilities listed above are derived from tests and experiments.

43. IS A ZERO-SUM GAME MODEL USED WHERE IT IS NOT APPLICABLE ?

A zero-sum two-person game is a conflict in which there are two sides and the gains of one side equal the losses of the other. Most conflict situations do not justify the use of this type of model. For example, in a hypothetical study, the effectiveness of alternative US tank systems was based on a study of duels between US tanks and enemy tanks. Duel

results were based on the losses incurred by each side. An enemy loss of one tank was equated to a US gain of one tank. The net US gain was used to determine the effectiveness for each alternative.

Our gain is not the enemy's loss. The situation is not always symmetrical. The attacker must move, the defender must inhibit movement. Hence, the objective of a US tank may differ from the objective of the enemy tank. In fact, other alternative concepts might inhibit enemy tank movement more effectively than would a US tank similar to an enemy tank.

44. ARE THE MODELS INTUITIVELY ACCEPTABLE?

Models tend to become mathematical and many are difficult to understand even in their broad aspects. Yet, overly-simplified models tend to become superficial by limitation in choice of detail and omission of important variables. The objective of a good model is to be near enough to reality so that the model outputs can be used to predict some portions of the future with an acceptable degree of confidence.

Models can be tested by determining if they represent correctly known facts and situations not considered in the study. Conversely, if absurd facts and situations are introduced into the model, comparable absurd answers should be produced by the model. If the reviewer is aware of special cases in which there is some indication of the outcome, the model can be tested to determine if the results are in general agreement with the indicated outcome. Another test that can be applied, at times, is to vary some of the principal parameters and determine if the model produces results that are consistent and plausible.

EFFECTIVENESS

45. ARE THE MEASURES OF EFFECTIVENESS IDENTIFIED?

The study should clearly identify the standards or measures used for evaluating the effectiveness of the system or organization under study. If not explicitly stated, the reviewer should attempt to identify these measures from **the** material contained in **the** study. The conclusions and recommendations cannot be properly evaluated, particularly when the study is based on equal cost alternatives, without prior evaluation of the measures of effectiveness.

46. IS THE EFFECTIVENESS MEASURE APPROPRIATE TO THE FUNCTION OR MISSION?

The reviewer should satisfy himself that the measures used to evaluate effectiveness are appropriate to the function or mission of the system or organization under study. Failure to use meaningful measures of effectiveness is a major contributing factor to unacceptable studies. Examination of the effectiveness measures requires analysis and sound military judgment. The example below illustrates one use of an effectiveness measure that was not appropriate.

In a study of selected infantry and artillery weapons systems, the measure of effectiveness was a division firepower score. This score was the sum of the firepower scores of the units within the division. The firepower score of a unit was based on sustained rates of fire, effective width of burst, and the fragmentation area of the weapon in comparison with other weapons. Specifically, direct-fire weapons such as rifles were assessed in terms of probable hits per minute against personnel in the open. Mortars and artillery were assessed in terms of maximum effective range and lethal area coverage per minute.

This use of a firepower score was wrong for a number of reasons. Primarily, it failed to differentiate between the effectiveness of weapons when used for neutralization and when used to produce casualties. For neutralization, the effectiveness is strongly dependent on burst rate of fire, incipient damage area produced by the burst, and ability to maintain fire over the required time (the latter a function of weapon characteristics and ammunition requirements). On the other hand, casualty production depends strongly on the probability of hit, which in turn depends on target acquisition and weapon guidance or accuracy. Thus, in this case, several measures must be used to have a valid analysis.

The total division firepower score used in the study also assumed an inexhaustible and uniform supply of ammunition regardless of whether the weapon was a rifle company machine gun or a division general support artillery cannon.

47. DO THE EFFECTIVENESS MEASURES IGNORE SOME OBJECTIVES AND CONCENTRATE ATTENTION ON A SINGLE ONE?

In the measurement of effectiveness, the reviewer should watch for any tendencies to concentrate on only one or two objectives. Such a situation indicates an unstated assumption that other objectives are unimportant. The resulting conclusions and recommendations, if implemented, may cause an imbalance and reduce the capability to achieve other objectives.

For example, a study indicates that the most vulnerable element in a line of communications system are the bridges in a rail network and measures effectiveness of deployment of given air defense units by degree of protection afforded railway bridges. In evaluating the overall effectiveness of the air defense deployment, the study fails to consider that the vulnerability of other elements in the line of communications system may be greatly increased by the redeployment of the air defense.

A possible test for effectiveness measures suspected of concentrating on a single objective is to evaluate them against a hypothetical obviously absurd weapon or device that does only one job. Valid measures of effectiveness should show an absurd hypothetical weapon or device in its true light.

48. ARE PERFORMANCE MEASURES MISTAKEN FOR EFFECTIVENESS MEASURES?

Measures of performance characteristics are sometimes **miscon-**
shed as measures of the ability of the system or organization to accomplish its function. Performance characteristics may contribute one of the many inputs required to achieve the effectiveness of the system or organization as a whole. For example, the speed of movement or mobility of a unit is only one aspect of the unit's capability to accomplish its function. The speed at which a unit can attack the enemy is not in itself a measure of the ability of the unit to defeat the enemy. The weapon **with** the smaller CEP is not necessarily the more effective weapon; the relation of lethal radius to CEP may be more significant. Other factors that must be also considered in weapon effectiveness include target acquisition, weapon guidance, and target size.

49. IS THE EFFECTIVENESS CALCULATED ON THE BASIS OF EITHER A COOPERATIVE ENEMY OR AN OMNIPOTENT ENEMY?

Neither basis is valid. The enemy should be expected to adjust his decisions to our **own** planning as much as his resources permit. **An** unstated assumption that the enemy is inflexible in the face of our changes is a common error in cost-effectiveness studies.

For example, a counter-guerrilla study used a scenario in which **the** hostile guerrilla forces retreat to a mountain redoubt to be surrounded

by US troops air-landed by helicopters. This scenario makes conventional tactics palatable in counter-guerrilla warfare, but is hardly realistic. A capable guerrilla leader should not be expected to use such disastrous tactics. Adaptation of enemy tactics (e.g., rapid dispersal) in face of the new US capability for air landing is certainly feasible. A comparable adaptation to the enemy capabilities was illustrated during World War II. German air defense analyses prior to that war were based on the attacking aircraft using certain altitudes that were optimum for the air defense batteries. Allied bomber aircraft did not oblige and avoided the "optimum" altitude range.

Some studies assume maximum future enemy capability in all weapon areas. The enemy cannot simultaneously maximize all of these capabilities if constraints in physical resources and budgets are present, particularly in the case of peacetime budgets. If he maximizes his strategic forces, he will have to limit his tactical capabilities, and vice versa. Alternatives, where appropriate, should be pitted against a variety of enemy postures and the choice should make none of these postures particularly attractive to the enemy.

In theory, the enemy can counter every system we design and our effectiveness will not be sufficiently high to warrant a positive decision. The real question is: how much does it cost the enemy in time and resources to effect a direct counter? If the price is very high he will probably seek other lesser alternatives. (See question 6).

50. IS THE EFFECTIVENESS MEASURED BY ANALYSIS OF WARGAMES?

When effectiveness is measured by analysis of wargames the reviewer should look to sensitivity analysis of the results. As a rule, wargames are a questionable means for measuring effectiveness because of the difficulty of testing the sensitivity of the results. To do so means challenging the effect of changes in players, referees, communications, as well as payoff functions. (See question 18.)

51. IS THE EVALUATION OF EFFECTIVENESS BASED ON STRAIGHT EXTRAPOLATION?

Occasionally a study may evaluate effectiveness by straight (linear) extrapolation from the measurement of effectiveness of a small unit. For example, a hypothetical study may show that 6 riflemen can destroy 10 targets. An extrapolation that states 100 targets can be destroyed by 60 riflemen is not justified without supporting evidence. The variables in target and fire distribution are not necessarily the same in both cases. Further, in a force of 60 riflemen the percentage who will actually fire at targets may not be the same as for a force of 6 riflemen.

Another error in straight or linear extrapolation is disregard of the element of diminishing returns or marginal utility. For example, 200

missiles do not signify twice as much effectiveness as 100 missiles if there are only 50 targets. Furthermore, all targets are not of equal value or importance.

52. ARE THE OPERATIONS OF OTHER SERVICES IGNORED?

In measuring the effectiveness of a system or organization, consideration must be given to the operations of other Services, where appropriate. Failure to do so is the equivalent of making the erroneous unstated assumption that only the Army will participate in the operation. For example, the measurement of effectiveness of Army air defense operations must consider the communications, command and control, and IFF aspects of operations with the U.S. Air Force and allied air forces. Further, the effectiveness of certain Army operations is dependent upon the degree of air superiority achieved by the Air Force. The ability to achieve this air superiority and the degree of dependence upon it should be examined. (See question 10.)

53. IS THE IMPACT ON OTHER ARMY OPERATIONS IGNORED?

In measuring the effectiveness of a system or organization, the effects on other Army operations should be considered. For example, the use of tactical nuclear weapons in a certain manner may accomplish its function by stopping enemy ground movement. However, the judgment of the effectiveness of the system should also examine the effect on the ground movement of U. S. units. In the same manner certain protective clothing may be effective against enemy chemical agents. However, the clothing may cause such body heating that it can only be worn for very short periods.

54. ARE SOME ASPECTS OF EFFECTIVENESS INCOMMENSURABLE OR UNMEASURABLE?

The reviewer should examine carefully the treatment of incommensurables and unmeasurable aspects of performance in the total measurement of effectiveness. Misleading measures of effectiveness are now often obtained by quantifying such aspects as morale, or leadership. At times, the only practicable solution may be a qualitative discussion of these factors.

55. DOES THE EFFECTIVENESS OF A FUTURE SYSTEM TAKE INTO ACCOUNT THE TIME DIMENSION?

The effectiveness of proposed future systems is often dependent upon when they can be available for operational use and the total operational life span of the systems. In examining the effect of the time dimension upon effectiveness, particular attention should be given to (1) the time between the present and the initial operational availability of the complete system, and (2) the latter part of the system operational life span.

AMCP 706-191

For example, the effectiveness of Weapon Y, deployable in 1972, is compared with that of the current Weapon X. Weapon Y is judged to be more effective and requires entirely new support equipment not compatible with that of Weapon X. This equipment cannot be operationally available until 1974. It is very possible that the changeover from X to Y implies a dip in effectiveness during the 1970-74 interval. The old weapon is becoming obsolete and the new one is not fully effective. A quick fix means may be needed to bridge this gap and must be charged to the cost of X and Y.

In another case involving the time dimension, Weapon B, deployable in 1972, replaces Weapon A and is designed to perform the same mission more effectively. It is stated to have an operational life of 15 years. Effectiveness is calculated on the basis of the 1972 environment. In the 1972 to 1987 period (the operational life of B) the international environment, and hence the missions may undergo major changes. In fact, the mission for which A is designed may already be on the decline. Effectiveness is not always constant but often must be related to time.

It is necessary to recognize that missions do not remain fixed. Effectiveness should not be evaluated on the basis of either a specific probability of the continuity of the mission or of a specified new mission. Rather, the system should be judged on its ability to adjust to such changes.

Similar comments apply with respect to changes in technology. Breakthroughs cannot be predicted very successfully. Nevertheless, certain trends are noticeable. For example, anti-tank weapons have improved more rapidly than tanks since World War II. The sensitivity of the system to jumps in technology is a vital input to effectiveness evaluation of massive long lifetime systems.

56. ARE EXPECTED AND AVERAGE VALUES USED INCORRECTLY TO MEASURE EFFECTIVENESS?

It is an error to employ an expected value or average as part of a measure of effectiveness if the objective really requires a specified minimum. In such a case, the possible variances, or dispersions about the average, constitute an unacceptable risk for any single event. This risk is unacceptable even though over many events the results will average out to the expected value.

For example, assume that at the same cost, air defense System A destroys from 0 to 99 of 100 approaching enemy aircraft but on the average destroys 50. System B, on the other hand, destroys from 25 to 35 of 100 approaching aircraft with an average destruction of 30. The risk associated with the possibility that, in any given individual attack by 100 aircraft, System A may not destroy any aircraft at all, whereas System B can be counted on to destroy at least 25 aircraft, makes A an unacceptable system, if the objective is air defense. If the objective

were destruction of as many enemy aircraft as possible over some period of time but without regard to their damage to us, (an unlikely objective) System A would be preferred.

57. IF QUANTITATIVE MEASURES OF EFFECTIVENESS ARE UN-ATTAINABLE, IS A QUALITATIVE COMPARISON FEASIBLE?

There are times when the effectiveness of a system or organization cannot be presented adequately in quantitative terms. This situation is common in comparison of general purpose forces such as in studies of alternative divisions. A study that assigns numerical values to effectiveness of general purpose forces should be examined carefully.

One study compared alternative divisions in terms of numerical scores. Each of the six basic factors (firepower, intelligence, mobility, command/control/communications, logistics, survivability) was given a numerical value and these values were summed for each alternative. The resulting sums were compared as effectiveness measures. These numerical values are likely to be meaningless because the six basic factors are inputs and not objectives. They combine in undetermined ways to make up the effectiveness of tactics. The tactics, in turn, combine to evolve strategies. For example, deception tactics strongly involve the basic building blocks of intelligence, command/control/communications, and mobility. However, this does not mean **that** we can simply add up so-called scores of these three basic factors and thereupon compare the deception capability of various alternatives.

A qualitative comparison is possible, however. Various pertinent aspects can be described and characterized by "yes-no" or "good-fair-poor." A tabular comparison can be useful in weeding out some alternatives. It may be justifiable to say that Alternative A is more effective than B (denoted $\frac{A}{B}$) in a certain characteristic, even if it is not known whether A is $1\frac{1}{2}$ times or twice as effective as B. If it can be determined that $\frac{A}{B}$ and $\frac{A}{C}$ we have a partial ordering $\frac{A}{B, C}$, i. e., we cannot distinguish between B and C but either is inferior to A, we may obtain a grouping as follows:

$$\frac{A}{\frac{B, C, D}{E}}$$

Let us reconsider the example of the deception tactic. Its key ingredients are mobility, command/control/communications, and intelligence. Suppose we know that Division A is more mobile than B, therefore, $\frac{A}{B}$. If we should arrive at the same ranking for the other two basic factors, then we conclude that $\frac{A}{B}$ is also true for the deception tactic. On the other hand, it may be that $\frac{A}{B}$ for mobility and $\frac{B}{A}$ for intelligence. Then no statement can be made for the relative ranking of A and B for the deception tactic.

AMCP 706-191

In this manner, tactics of interest can be investigated and valid partial orderings of alternatives obtained. We may find dominant alternatives. Suppose we obtain

<u>Mobility</u>	<u>Intelligence</u>	<u>Command, Control, Communications</u>
$\frac{A, B}{C}$	$\frac{E, A}{B, C, D}$	$\frac{E}{A, B, C}$
$\frac{D, E}{D, E}$		$\frac{D}{D}$

We have now learned that D is dominated by A for all three basic factors, and hence for the deception function. So D can be eliminated if all alternatives have equal cost. It should not be assumed that rankings of alternatives with respect to the tactical level can only be derived by buildup and integration from the basic level. There may be direct qualitative comparisons with respect to, say, deception effectiveness as a result of wargames or field exercises. A combination of both buildup and direct approaches would probably prove most fruitful.

The reviewer should recognize that while cost-effectiveness analysis is performed preferably by quantitative analysis, there are limits to suboptimizing or idealizing the problem to make it amenable to quantitative analysis. When carried too far, the quantitative results are often only of academic interest and offer little or no help to the decision maker.

58. IS THE EFFECTIVENESS SENSITIVE TO CHANGES IN ASSUMPTIONS?

The effectiveness derived in most studies is usually dependent to a degree on the assumptions. The reviewer should isolate the degree of dependence and determine if it is acceptable. Generally, a good study will isolate this dependence, where it exists, and lay out the degree of dependence by various kinds of sensitivity or contingency analysis. The assumptions that most commonly influence effectiveness and are often not subjected to contingency analysis concern the locale, the time and level of warfare, and enemy forces and tactics.

A slight change in any of these assumptions may produce significant changes in the effectiveness measured. For example, additions of a new ECM band width to the enemy's capability may drastically degrade an otherwise outstanding U. S. system. (See questions 5 and 6.)

CRITERIA

59. ARE THE CRITERIA IDENTIFIED?

The criteria, or tests of preferredness, are the basis for the conclusions and recommendations. The criteria should be stated specifically and clearly. If this is not the case, the reviewer should attempt to identify the criteria from the material contained in the study. When **this** does not prove possible, consideration should be given to having the study returned for further clarification. This is particularly important if the study is also to be reviewed by agencies outside the Army.

60. ARE THE CRITERIA CONSISTENT WITH HIGHER ECHELON OBJECTIVES?

No matter what the concern of a study, the subject falls into a larger framework. For example, problems of air defense of the CONUS **are** aspects of the larger problem of restricting possible damage to the CONUS to certain levels. The design of artillery systems is part of the larger problem of design of land battle forces. Therefore, the reviewer must determine if the criteria used in a study are consistent with higher level objectives. This requires good military judgment and the necessity to examine the larger context of the problem. If the study criteria are not consistent with the objectives at the higher level then the wrong problem may be solved. Overall Army objectives are contained in documents such as the Basic Army Strategic Estimate (BASE), Army Force Development Plan (AFDP), Army Strategic Plan (ASP), and the Combat Developments Objective Guide (CDOG).

An example of incorrectly chosen criteria is illustrated in the use of mobility as the sole criterion in the selection among different organizations. A study could conceivably demonstrate that organization A can **be** made more mobile **than** organizations B and C with a lesser expenditure of resources. Yet A may not be the preferred organization because **the** mobility was achieved by degrading other factors that contribute to the higher objective of efficient control of conflict situations (e. g. , fire-power , sustainability , etc.).

61. ARE THE CRITERIA TOO GENERAL?

Generalized criteria are suspect. For example, a study may state that the criterion is "**the** system with maximum military worth" or the "best system". Such generalizations are meaningless and cannot be related to the analysis as can a good criterion such as "the minimum cost of maintaining a [specified] level of transport capability over a [specified] time span."

62. ARE THE CRITERIA OVERDETERMINED?

Overdetermined criteria lead to erroneous conclusions. A criterion that states "to maximize the damage to the enemy while at the same time minimizing the cost to the U. S." or "causing the maximum amount of casualties with the least expenditure of ammunition" suggests that something can be obtained for nothing. It is impossible to maximize gain and simultaneously minimize cost. It is not possible to increase effectiveness without some increase in resources (cost). The minimum cost is to do nothing--and achieve no effectiveness. Occasionally it may turn out that system A is both more effective than system B and costs less. However, system A will not be both more effective and cost less when compared with additional alternatives. The danger of using an overdetermined criterion, such as the one described, is that it leads to invalid compromise criteria by using some erroneous constraint on effectiveness or cost in an effort to make an impossible test seem feasible.

63. ARE GOOD CRITERIA APPLIED TO THE WRONG PROBLEMS?

At times a valid criterion for one element of the problem is incorrectly applied to the total problem. For example, a hypothetical study involving proposed surveillance aircraft shows that aircraft A offers greater mission flexibility than aircraft B at the same cost and is therefore preferred. In this case, the choice of aircraft is not the real problem. The subsystems carried by the aircraft are really more crucial. The all-weather sensor effectiveness and avionics cost may even determine whether there should even be an aircraft A or B.

64. IS THE ABSOLUTE SIZE OF GAIN OR COST INGNORED?

If the absolute size of the cost of a system alternative, or the effectiveness to be achieved by it, is not given or is incorrect, the analysis often leads to wrong conclusions and recommendations. For example, cost-effectiveness curves for two hypothetical system alternatives are given below:

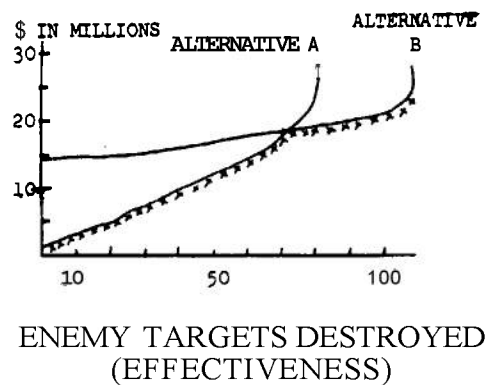

Figure 2. Cost-Effectiveness Curves

In this situation, at low levels of effectiveness, alternative A is preferred (up to about 70 enemy targets destroyed); at larger levels of effectiveness alternative B is preferred (from about 70 to 110). If the capability to destroy more than 110 enemy targets is to be achieved, then neither alternatives A or B is preferred or even acceptable. The crucial question is how many enemy targets are required to be destroyed. If the number of enemy targets to be destroyed or cost limits are not indicated, there is no real basis to recommend either alternative A or B, or some other alternative.

Either the study should be based on an absolute size of gain or cost required or the study should present a cost-effectiveness curve (or points) from which decisions can be made. If the study presents a cost-effectiveness curve as shown above, the envelope (indicated by line of X's in the graph) *along* the bottom says, "This is a curve which gives the most for the resources expended, and other things have to be taken into consideration at higher levels to determine what the absolute gain (number of targets destroyed) should be or the maximum resources (cost) that can be made available."

At times, studies ignore absolute size of gain or cost and use effectiveness-to-cost ratios. The flaw in the use of such ratios is the absence of any specified level of effectiveness required or resources available as discussed above. If the level of activity is fixed, a ratio may be useful in ranking among alternative systems. However, the effectiveness-to-cost ratio criterion is often applied when the level of activity is not fixed. For example, in the graph above alternative A destroys 10 enemy targets for \$1 million, and alternative B destroys 100 enemy targets for \$25 million. If only this information were converted to effectiveness-to-cost ratios, alternative A would have a ratio of 10:1 and alternative B, 4:1. Which is the preferred? If one did not look at the absolute level of effectiveness required to achieve the military task but only at the effectiveness-to-cost ratio, then alternative A would be preferred. The selection of alternative A on this basis may be correct, but only by coincidence and is obviously wrong when the system must be capable of destroying more than 70 targets.

Until the absolute level (magnitude) of effectiveness or the absolute level (magnitude) of the cost is specified the preferred alternative cannot be determined. The effectiveness-to-cost ratio can be misleading and, at times, a dangerous criterion.

CONCLUSIONS AND RECOMMENDATIONS

65. ARE THE CONCLUSIONS AND RECOMMENDATIONS LOGICALLY DERIVED FROM THE MATERIAL CONTAINED IN THE STUDY?

The conclusions and recommendations should be derived logically from the material contained in the study. Some studies, unfortunately, draw conclusions based on previous studies and materials that are not fully documented within the study (mention in a bibliography is hardly sufficient). If input from another study is essential, it should be documented and explained in detail. This requires, at least, a statement as to validity, scope of application and uncertainty which is associated with the particular input.

The determination of whether the conclusions and recommendations follow logically from the material in the study is a matter of judgment by the reviewer. In making this judgment, the reviewer should consider whether other prudent study agencies would probably arrive at substantially the same conclusions and recommendations given only the material contained in the study.

66. HAVE ALL THE SIGNIFICANT RAMIFICATIONS BEEN CONSIDERED IN ARRIVING AT THE CONCLUSIONS AND RECOMMENDATIONS CONSIDERED?

Sometimes a study fails to consider all the pertinent ramifications in arriving at the conclusions and recommendations. These unconsidered ramifications may either influence the validity of the conclusions and recommendations of the study or the decisions to be made as a result of the study. These ramifications are often referred to as "spillovers." For example, if a hypothetical study recommended adoption of an engine requiring a new type of fuel, the Army supply system to include supply, storage and transportation operations would be affected. Spillover effects are not always negative. For example, the adoption of dehydrated rations to achieve greater shelf-life may also reduce construction and transportation costs because of the smaller unit volume of dehydrated food.

Other ramifications that are sometimes neglected are factors that should be considered jointly with the problem under study. At times, consideration of such joint decisions could affect the conclusions and recommendations of the study. For example, a study may recommend adoption of a new weapon system to fulfill a certain function. However, the study may neglect to examine the maintenance support and the maintenance units that would have to be in existence concurrently with the proposed weapon system. The resources required to organize and maintain the maintenance system will influence decisions on the proposed weapon system.

If significant ramifications are uncovered that are not adequately considered, the reviewer should, if possible, determine the effects of these ramifications on the conclusions and recommendations. (See question 2.)

67. ARE THE CONCLUSIONS AND RECOMMENDATIONS REALLY FEASIBLE IN THE LIGHT OF POLITICAL, CULTURAL, POLICY OR OTHER CONSIDERATIONS?

In reviewing the conclusions and recommendations of a study, it is necessary to be cognizant of the real world in which the Army must operate. At times some recommendations of a study may appear to be eminently feasible from a strictly economic or military view, but really are not so in the light of other considerations that influence military operations. For example, a particular toxic chemical munitions system may be demonstrated to be superior, considering cost and effectiveness, to a high explosive munitions system for accomplishing a certain function. However, because of national policies on employment of toxic chemicals, the adoption of the high explosive munitions system may be the only feasible solution.

The reviewer should also consider the impact of policies that may not have been known to the agency that prepared the study or were promulgated too late to influence the study.

68. ARE THE CONCLUSIONS AND RECOMMENDATIONS RELATED TO THE LIMITATIONS OF THE STUDY?

In evaluating conclusions and recommendations, the reviewer should bear in mind the limitations of the study. Studies, as a rule, have varying degrees of limitations. The more common types of limitations include inadequate data base, criticality of assumptions, criticality of uncertainties and validity of cost and effectiveness models. While the limitations may be treated within the study, the dependence of the conclusions and recommendations on the limitations is sometimes neglected. For example, the study conclusions and recommendations may depend upon the validity of particular assumptions but this relation may not be pointed out.

It may be advisable for the reviewer to refresh his memory on the study limitations, particularly when the study is voluminous, before evaluating the conclusions and recommendations.

69. DO THE CONCLUSIONS AND RECOMMENDATIONS INDICATE BIAS?

Studies sometimes unwittingly reflect bias because of parochial or institutional interests. To assist in detecting bias, the reviewer should consider the relation of the agency that prepared the study and the effects of the implementation of the study recommendations. If such implementation does not appear to further what are generally considered to be the

AMCP 706-191

particular interests of the preparing agency, then one occasional form of bias is probably not present. Another test for bias is to judge whether substantially the same conclusions and recommendations would be reached, based on the material in the study, by another study agency. Bias is often displayed by arbitrarily excluding certain reasonable alternatives, maximizing selected enemy capabilities, treating significant uncertainties as assumptions, and in selection of effectiveness criteria-

A relatively minor form of bias is sometimes found in the use of prejudicial adjectives. Unnecessarily referring to all Air Force fixed wing aircraft as "long **take** off and landing" aircraft is an example. This type **of** bias may be prejudicial to the interests **of** the Army when the study is reviewed by non-Army agencies.

70. ARE THE CONCLUSIONS AND RECOMMENDATIONS BASED ON EXTERNAL CONSIDERATIONS?

At times, recommended selections **among** alternatives must be made in the face of **great** uncertainty. A study may find that several **alternatives** exhibit similar cost-effectiveness, but the **results** are very sensitive to the values assigned to the inputs. In this situation some studies arrive at conclusions and recommendations based on considerations other than those studies. In other words, the study agency is stating that after having made the analysis, the application of the criteria does not lead to preference, but indifference, among the alternatives and therefore the issue was decided on the basis of other unstudied **criteria**. In situations **of** this kind, when recommendation of an alternative is necessary, sensitivity to new **criteria** must be fully studied.

71. ARE THE CONCLUSIONS AND RECOMMENDATIONS BASED ON INSIGNIFICANT DIFFERENCES?

At times a study will present one alternative **as** having the highest value of effectiveness **of** the measures applied to all alternatives. The difference in effectiveness among the "optimum" alternative and the other alternatives should be examined. **If** the differences are relatively slight and probably no greater than the uncertainties in the data, then other grounds should also be demonstrated for selecting among the alternatives that are close in effectiveness.

72. IF PRIORITIES ARE LISTED, ARE THEY STATED MEANINGFULLY?

Conclusions and recommendations often list items of equipment in order of priority of recommended procurement or adoption. The use of this technique without explanation, particularly **for** materiel, is often poor because it provides no basis for a decision. For example, a study

may conclude that in order to accomplish certain functions, infantry units should be equipped with specified items of equipment that are listed in order of priority. Assume that the items found necessary by the study for infantry units to accomplish the required functions are, in order of priority:

- (1) Seven League Boots
- (2) Disintegrator Ray Pistol
- (3) Universal Viewing Device
- (4) Camouflage Suit (makes the wearer invisible)

Although the study concluded that all of these items are required, the listing of priorities without any quantitative considerations could have any of these meanings:

a. Buy all of the Seven League Boots required. Then, as resources are available, buy all of the Disintegrator Ray Pistols required. Continue down the list of priorities in this manner until the available resources are exhausted. This meaning also infers that even though all 4 items are required, the Army can do without the lower priority items if sufficient resources are not available to procure them all. For example, with limited resources it is better to have all Seven League Boots and none of the other items rather than some of each item.

b. Buy all 4 items at once but spend more money on Seven League Boots than on Disintegrator Ray Pistols and even less amounts on Universal Viewing Devices and Camouflage Suits.

When faced with this kind of situation, consideration should be given to returning the study to the preparing agency for further recommendations on how much should be allocated to each item for various budget levels, either given or assumed.

73. ARE THE CONCLUSIONS AND RECOMMENDATIONS INTUITIVELY SATISFYING?

When the conclusions and recommendations of the study are not intuitively satisfying, the reviewer should attempt to isolate the cause. If the study fails to demonstrate by data, models and other means that the reviewer's intuition was wrong, then further examination is required to determine if some subtle considerations have not been considered because of oversimplification or other reasons which the reviewer intuitively knows are pertinent.

AN EXAMPLE OF A RECENT COMMUNICATIONS COST-EFFECTIVENESS ANALYSIS *

THE PROBLEM

Demonstrate the feasibility of the communication-system cost-effectiveness method developed and reported previously in NEL report 1323.¹

RESULT

1. The communication-system cost-effectiveness method has been computerized and applied to the analysis of a shore-to-ship hf link.
 - a. Sensitivity-analysis curves are developed for the variable parameters used in the analysis.
 - b. Cost-estimating equations have been developed for the basic equipments comprising an hf communication link.
 - c. Trade-off curves illustrating system cost versus system parameters, such as propagation loss, effective antenna noise figure, and error rates, are provided.

RECOMMENDATIONS

1. Establish a central Navy-wide data storage and retrieval system to standardize and maintain historical and current data to support future resource-effectiveness analysis.
2. Extend the method to include the communication system in the operational environment.
3. Develop a local data storage and retrieval program to support further resource-effectiveness analysis.

ADMINISTRATIVE INFORMATION

Work was performed under XF 006 01 07, Task 7592 (NEL B20871), by members of the Communication Techniques Division. The report covers work from June 1965 to September 1966 and was approved for publication 4 January 1967.

1. See references in appendix

*Cost-Effectiveness Analysis Applied to H F Communications Link by W. R. Dishong, Jr., and R. T. Marloth., 4 January 1967; NEL Report 1422; Reproduced by permission of U. S. Navy Electronics Laboratory, San Diego, Calif.

CONTENTS

INTRODUCTION . . . page E-4
 Historical background . . . E-4
 Statement of problem . . . E-4

METHODS.. . E-5
 Problems in cost-effectiveness analysis . . . E-5
 System effectiveness model . . . E-7
 Performance . . . E-9
 Data base . . . E-13
 Cost analysis . . . E-14
 Optimization technique . . . E-15
 Confidence level of predicted performance . . . E-16

RESULTS.. . E-17
 Submodel cost prediction . . . E-20
 The effect of primary-power requirements upon system design . . . E-22
 System cost versus range for various values of F_a . . . E-24
 System cost versus BER as a function of F_a . . . E-25
 Sensitivity analysis . . . E-30
 System comparison . . . E-35

CONCLUSIONS. . . E-36

RECOMMENDATIONS . . . E-37

APPENDIX A: A SINGLE MEASURE OF EFFECTIVENESS . . . E-38

APPENDIX B: SURVEY OF PROPAGATION-PREDICTION PROGRAMS . . . E-43

APPENDIX C: DATA TYPE AND SOURCE . . . E-51

APPENDIX D: MULTIPLE-REGRESSION ANALYSIS. . . E-53

APPENDIX E: METHOD OF STEEPEST DESCENT. . . E-56

APPENDIX F: LIST OF SYMBOLS. . . E-58

APPENDIX G: REFERENCES. . . E-59

ILLUSTRATIONS

1. Procedure used in resource-effectiveness analysis . . . page E-8
2. Typical printout for optimization program . . . E-18
3. System cost versus range for various values of F_a . . .E-24
4. System cost versus BER as a function of F_a . . .E-26
5. System cost versus P_e for various path losses . . .E-27
6. Receiver cost versus center frequency for various values of receiver sensitivity . . E-28
Hf shore transmitter cost versus power for various values of transmitter stability . . .E-29
8. System cost versus transmitter antenna coupler VSWR . . . E-30
9. System cost versus transmitter stability . . . E-31
10. System cost versus receiver stability . . . E-32
11. System cost versus receiver sensitivity . . .E-33
12. System cost versus transmitter power . . . E-34
13. System cost versus receiver antenna coupler noise figure. . .E-35
- A1. Cumulative density of products (single measure of effectiveness) . . .E-39

TABLES

1. Submodel cost and performance factors . . . page E-10
2. System cost and power requirements . . . E-23
3. System comparison . . .E-36
- A1. Four-number ordered combinations and their products (single measure of effectiveness) . . . E-40

INTRODUCTION

Historical Background

This report summarizes the continuation of the work in analysis of communication-system effectiveness reported in NEL report 1323.¹

Many reports such as the foregoing are available to guide analysts in evaluating and analyzing various system configurations. Some of the reported methods call for many judgment decisions on the part of the analyst, and in some cases require cost data that are impossible to obtain. Also, some methods permit grouping all the system characteristics into a single "figure of merit," or measure of effectiveness. The latter method is often misleading and meaningless to the system analyst and decision maker. Other methods allow system effectiveness to be specified in terms of multiple measures of effectiveness. Several reasons for using multiple measures of effectiveness are contained in reference 1, as well as in appendix A.

Single methods are not used in this report, as they are considered unrealistic in the evaluation of complex systems that have multiple objectives.

Another method for analysis of cost effectiveness is one that realistically represents the pertinent system characteristics and costs, is capable of being implemented, and can be used in a meaningful manner by the system analyst and decision maker. (Unfortunately, the more realistic and representative a model is, the more difficult it is to implement, and often compromises have to be made because of the time required for analysis.) It is this method that is being developed.

Statement of Problem

The ultimate objective of the work in communication effectiveness is twofold - to develop a communication-system resource-effectiveness method, and to perform resource-effectiveness analysis of communication systems.

The method is intended for use as a management tool and as a design tool. As a management tool, the method can be used in the preparation of Proposed Technical Approaches (PTA), Technical Development Plans (TDP), and Detailed Action Plans (DAP) to:

1. Determine resource effectiveness of a set of technical approaches,
2. Establish performance estimates, and
3. Conduct resource-effectiveness trade-off studies.

As a design tool, the method can be used to:

1. Specify system characteristics,
2. Specify system effectiveness, and
3. Specify system resource requirements.

This report summarizes the work accomplished to date in implementing the cost-effectiveness method developed and documented in NEL report 1323. The method as developed to date was applied to a real communication situation to

determine its validity. An hf Fleet broadcast link was selected because of the availability of data pertaining to hf equipments and other studies concerning this type of link. The performance model was used to evaluate and analyze an hf Fleet broadcast link with respect to performance and cost. The analysis illustrates the contribution of various system parameters to overall system performance. A particular geographical hf link was selected for the analysis to provide propagation losses, noise levels, operating frequency, and antenna gain as functions of radiation path.

Primary effort to date has been directed to the system performance model and its cost analysis. During the course of this work, it became obvious that the parameter "cost" as used in cost effectiveness should be more general and should include, in addition to dollar cost, such items as material, time, and personnel. The more general descriptor "resource" will be used in place of "cost" in order to consider these items in proper perspective. In most cases, dollars will still be involved in the analysis. However, the limitation of associating everything with dollars is removed.

METHODS

Problems in Cost-Effectiveness Analysis

The following comments on techniques for the analysis of cost effectiveness draw from the content of related references 2 through 5 as well as from experience gained during the course of this investigation. The uninitiated are likely to think of cost effectiveness as a method that maximizes effectiveness while minimizing cost. This conception is overly optimistic. What cost-effectiveness methods can do is to minimize cost of a system while holding effectiveness to some minimum acceptable level or to maximize effectiveness while holding cost to some maximum acceptable level. The possibility arises that the analysis will be misleading if the wrong fixed levels are chosen for cost or effectiveness. A way around this difficulty is to compare the results of analysis at several levels of cost and/or effectiveness.

The optimization should be executed for the system as a whole. If the subsystems are optimized individually ("suboptimization"), the result will most likely not be true optimization. For instance, the best receiver for some given cost might have high sensitivity and low stability, but the best system might call for a receiver with moderately good values of each.

PROBABILITY LIMITATIONS

The single-link problem can be expressed in terms of physical parameters rather than probabilistic terms. This method avoids the problems associated

AMCP 706-191

with the use of unverified probabilities. Solutions to the problems associated with unverified probabilities will be sought during subsequent investigations. **An** example of an unverified probability is in the answer to this question: What is the probability that two ships will be transmitting on the same frequency simultaneously? Sometimes questions like this one cannot be avoided. If they cannot, the sensitivity of the analysis to the assumed probability should be tested by analyzing the system for various values of the probability under consideration. If the analysis turns out to be sensitive to the probability, the results should be considered skeptically. One tempting way out of the unverified-probability impasse is to accept the word of some outside authority on the matter; but this is merely a way of avoiding the chore of reconciling the analysis to this problem, since it is obvious that if the probability is unverifiable, the expert has no more assurance of its correctness than the analyst does.

Again, in treating matters of probability, the analyst must realize that the most likely event does not always happen. Low-probability eventualities should be inspected, too, for disastrous outcomes. When the real situation becomes so complex that it cannot be analyzed directly, a simplified model is used, with the danger that the analyst will become more interested in the model than in the real situation. Game theory is deplored by many because it is so often invoked for simple models, but is so difficult to apply to complex real-life situations.

DATA LIMITATIONS

A problem which this study encountered was the limited cost data available. This is a warning that the cost equations obtained by the regression analysis will not be as accurate as desirable. Under these circumstances it is especially dangerous to extrapolate the results to ranges of the variables for which there are no data.

In the same vein, it is a mistake to ignore a variable which cannot be quantized; for example, ease of operation of equipment. It is always easier for the analyst to insert the effect of a quantifiable variable into a performance equation than to philosophize upon the effect of an unquantifiable one, but the tendency to ignore unquantifiable factors should be controlled.

When the present study is expanded to include more complex problems of evaluating large communication systems to be built in the future, the costing methods will have to be modified and extended. Some of the considerations which will become important are the period over which the cost of new equipment is amortized, the difference between sunk costs (money already spent) and future costs, the significance of cost differences, and ways to attach dollar costs to training of personnel and other expenses not directly for equipment.

LIMITATIONS OF SINGLE-PARAMETER ANALYSIS

Most systems are not so simple that their effectiveness can be expressed as a single parameter. If they were, cost-effectiveness analyses would be much

more straightforward than they are. For example, if the effectiveness of a communication system were equated with information rate, all considerations of reliability and maintainability would be sacrificed.

Combining the effectiveness measures of a system into a single "quality factor" is also specious. For a time, this was a popular practice, but now it is discouraged by many practiced analysts. Appendix A illustrates one problem associated with defining effectiveness as a single measure. A particularly strong statement on the subject was made by E. S. Quade:³ "One thing we cannot do is construct from all the individual objectives some group objective by appropriately weighing all separate ones; this is a practical absurdity and it has been theoretically demonstrated that there is no unique and satisfying way to do it." For example, consider two systems with performance factors, A, B, and C of equal importance (weight) evaluated on a scale from 1 to 5:

Factor	A	B	C	Sum	Product
System I	4	1	5	10	20 Q_I
System II	3	4	2	9	24 Q_{II}

If the quality factor $Q = A + B + C$, system I has the higher Q; if $Q = A \times B \times C$, system II does. And there is no way of deciding which formula for Q (if either) is legitimate. Furthermore, deciding upon the relative importance of the performance factors is an arbitrary process with serious consequences. If the product form of Q is used, weighting does not affect the ratio Q_I/Q_{II} . However, when the sum form of Q is used, giving factor B a relative weight of 2 gives system II the advantage of 13 to 11. Likewise, system I has a 15 to 11 advantage if factor C is given a relative weight of 2. Finally, the evaluations are sensitive to small changes in the values of the performance factors. If these are not specifically quantifiable, the danger of upsetting the results is great; for example, if factor B of system I is changed from 1 to 2, the product Q is doubled and far outstrips the comparable Q of system II.

After all the arbitrary manipulations are made, the probability is surprisingly high that the (product) Q factors of the two systems will be equal, as shown in Appendix A.

System Effectiveness Model

If the description of a hypothetical communication situation is given, system requirements can be specified. The requirements determine the objectives of the system. Communication-system objectives may be many and varied. Some typical communication-system objectives are:

1. Information reliability
2. Information rate
3. System reliability
4. System availability
5. Anti-DF
6. Anti-jam

This report considers only the first two objectives. Subsequent work will integrate other objectives into the overall model. System objectives may in many cases be considered as measures of system effectiveness. Cost as a resource element is not considered a measure of effectiveness. Cost is a criterion for choosing between alternative systems at some specified effectiveness level. The RESULTS section illustrates how cost can also be used to select between alternative systems that exceed the minimum requirements to different degrees.

Figure 1 illustrates the procedure followed in evaluating system resource requirements and effectiveness.

The resource-effectiveness analysis begins with a given set of system requirements as shown in figure 1. From the requirements, mission objectives are specified. The mission objectives indicate the type of optimization to be sought; that is, the most effective system for a given level of funding or the least expensive system for a specified level of effectiveness. The type of objective is also reflected in the constraints imposed on the optimization procedure. The system model is an analytical model of the system intended to fulfill the stated objectives. The system model interrelates system characteristics

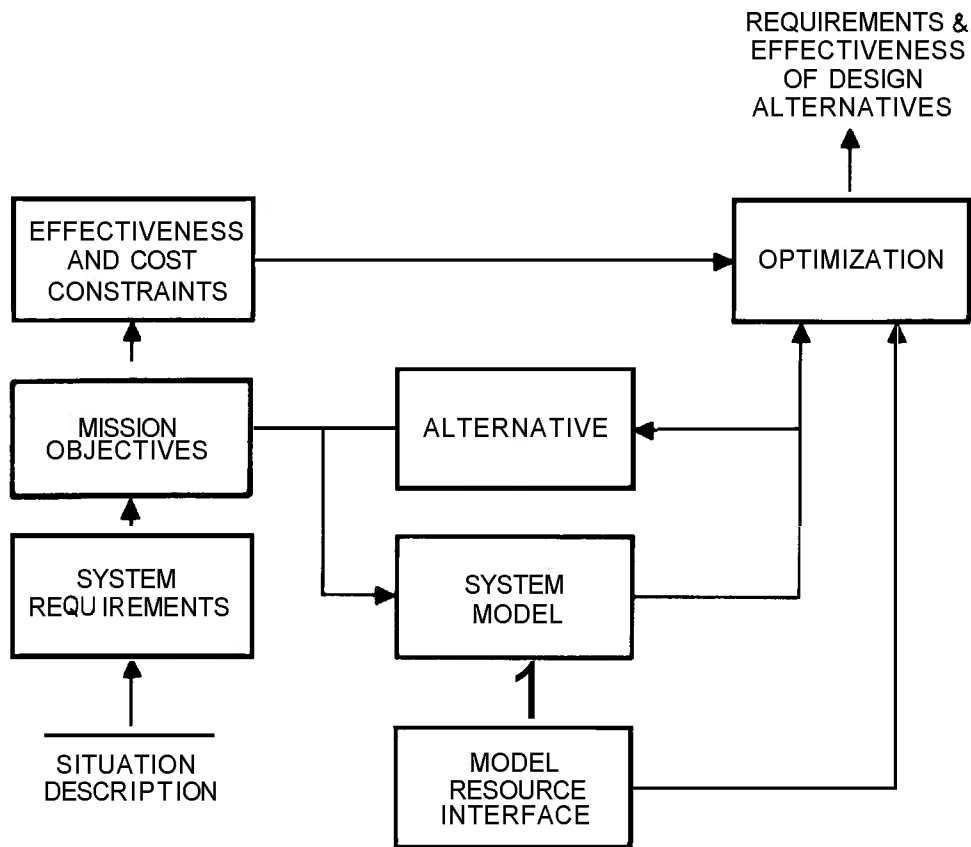

Figure 1. Procedure used in resource-effectiveness analysis.

and mission objectives. In some instances the system model may be modified to evaluate an alternative solution to the mission objectives. This alternative could require an entirely new system model. System characteristics are categorized by submodels; each submodel symbolizes a particular type of communication equipment. The resource interface model (cost analysis) assigns cost factors to system characteristics within each submodel. The submodel cost expressions are then used in the optimization program as either criterion or constraint expressions, the use depending upon the type of optimization being performed.

The optimization procedure provides the analysis outputs, an analysis of sensitivity of cost or effectiveness to changes in system characteristics in addition to the optimized system cost or effectiveness configuration.

In RESULTS system characteristics are shown against cost to indicate the type of trade-off analysis possible from the method.

In the previously developed method,¹ the cost (resource) effectiveness of a communication system included system availability and system reliability in addition to system performance as measures of system effectiveness. Available time has precluded the inclusion of system availability and system reliability in this report. Refer to appendix F for explanations of the symbols used throughout the report.

Performance

The effectiveness model which evaluates the performance of an hf shore-to-ship communication link consists of several submodels. Each submodel serves as an interface between subsystem characteristics and subsystem cost. The submodels are:

1. Transmitting terminal
2. Transmitting
3. Transmitting antenna coupler
4. Transmitting antenna
5. Receiving antenna
6. Receiving antenna coupler
7. Receiver
8. Receiving terminal

Execution of the method depends upon the ability to associate a cost factor with a system performance factor. The procedure for determining cost factors is described in Cost Analysis. The procedure was used to determine the cost factors listed in table 1. These items were shown to be critical in the establishment of cost and performance factors.

Subsystem performance factors are those major subsystem characteristics that directly influence the attainment of the systems objectives. The system performance factors are combined by analytical expressions according to communication theory to yield the measures of system performance. The performance as defined here consists of information reliability and information rate. System cost factors modified by system performance factors are combined to give system cost for the predicted level of performance.

AMCP 706-191

TABLE 1. SUBMODEL COST AND PERFORMANCE FACTORS.

Performance Factor	Submodel	cost Factor
Number of channels Bit duration Type modulation	Transmitting terminal	Number of channels Quantity of units
Average power Stability	Transmitter	Average power Frequency Stability
VSWR	Transmitting antenna coupler	VSWR Frequency Number of inputs
Gain Antenna pattern Antenna orientation	Transmitting antenna	Cost per antenna
Gain Antenna pattern Antenna orientation	Receiving antenna	Cost per antenna
Noise figure	Receiving antenna coupler	Noise figure
Sensitivity Stability	Receiver	Sensitivity Stability Frequency Quantity of units
Number of channels Bit duration Type modulation	Receiving terminal	Number of channels Quantity of units

The minimum-cost system may be defined for a specific level of performance by utilizing optimization procedures. Also, the maximum-performance system may be defined for a fixed investment.

PROPAGATION MEDIUM

Propagation-prediction programs provide a method of simulating analytically those geographical and environmental factors which affect a system's

effectiveness. There are several computerized propagation-prediction programs available to the analyst. The capabilities and limitations of the programs vary. A survey of propagation-prediction programs known and available at NEL is contained in appendix B. It is this type of computer program that will be used in propagation modeling.

For this analysis, the NEL High-Frequency Radio Propagation Computer Program' was used for modeling the propagation medium. The program calculates the following characteristics of the propagation path(s) as a function of the time of day, month, sunspot number, transmitter location, and receiver location.

1. Noise voltage (receiver)
2. Propagation losses
3. Skywave mode (number of hops, reflecting layer)
4. Antenna gain as determined by take-off angle and angle of arrival

The program also permits various antenna types and patterns to be considered in the calculations.

All calculations in this report were based on a shore transmitter located in Honolulu, and a shipboard receiver located at various distances along a 00 azimuth from Honolulu.

The other characteristics of the communications link are:

Sunspot number	20
Month	December
Hour	0600

INFORMATION RELIABILITY

A major objective in any communications system is the reliable transfer of information. Information reliability may be measured in several ways; however, each method is dependent upon the received energy per bit and the noise power density at the receiver. The more common measures of information reliability are bit error rate (BER), character error rate, and word error rate. Each measure of information reliability is a function of the BER, which is dependent upon the normalized S/N ratio (R).

The current computerized model for information reliability does not convert the probability of bit error (P_e) to the corresponding normalized S/N ratio. This conversion is made outside the program and is selected from the appropriate equation listed in reference (1). Equation (1) relates the S/N ratio improvement possible in the detection model, from the predetection S/N ratio (RPRE) to the postdetection S/N ratio S_0/N_0 . The analysis of FSK detection which follows is for a nonlinear receiver with a single filter and linear discriminator.

$$RPRE \approx c 1.5 \times \frac{f_m}{0.84(B_{if})_L} \times \frac{S_0}{N_0}$$

AMCP 706-191

where

$$\begin{aligned}S_0/N_0 &= RT_0 B_1 \\f_m &= B_1/2 = 3/(4T_0) \\B_1 &= 3/(2T_0) \\(B_{if})_L &\approx B_{if} = 2D + B_1\end{aligned}$$

then

$$RPRE = c^{1.5} \times \frac{3/(4T_0)}{0.84 (2D + 3/(2T_0))} \times \frac{3RT_0}{2(T_0 - \delta)} \quad (1)$$

RPRE is a function of modulation type, receiver filtering, pulse length, guard time, and number of channels.

Equation (2) equates RPRE to the propagation medium characteristics and performance parameters of the system submodels.

$$\begin{aligned}10 \log_{10} (RPRE) &= 10 \log_{10} P_t + 30 + G_t + G_r + 10 \log_{10} \left[\frac{4r_{ct}}{(1+r_{ct})^2} \right] \\&\quad - L_p - F - C_f - 10 \log_{10} \left[1 + f_{Mc/s} (S_r + S_t) \right] + KTB\end{aligned} \quad (2)$$

where

$$\begin{aligned}F_a &= E_n - 20 \log_{10} f_{Mc/s} + 65.5 + 10 \log_{10} b \\F &= 10 \log_{10} \left[f_a - 1 + f_c f_t f_r \right] \\KTB &= 134 - 10 \log_{10} b\end{aligned}$$

The following propagation factors are obtained as output data from the NEL propagation-prediction program.⁶

Propagation loss	(L_p)
Transmit antenna gain	(G_t)
Receive antenna gain	(G_r)
Effective antenna noise	(E_n)
Frequency of operation	($f_{Mc/s}$)

The foregoing propagation factors permit a system's performance to be analyzed for a specific geographical location, time, and range.

INFORMATION RATE

In the design of communication systems, there are certain trade-offs that can be made between information reliability and information rate. A computer

subroutine has been written that enables these trade-offs to be taken into account. Examples of the trade-offs possible are as follows:

The greater the duration (slow rate) of the pulse element, the greater the probability (high reliability) of receiving the element correctly. The converse is also true. Also, the more errors there are in a message, the less information can be transferred from source to user.

When two systems that use different coding techniques are compared, a detailed analysis is required to determine the rate at which information is transferred. In teletype systems, the start and stop bits, as well as error detection and correction bits, must be considered in the determination of information rate. When two systems that use the same coding technique are compared, it is not difficult to determine their relative information rates. However, coding techniques and information rate must be related to some common factor for incorporation within the method. This common factor is given by equation (3). Equation (3) states that the channel information rate is equal to the source rate reduced by the channel equivocation.

$$I_{RC} = H(x) - H_y(x) \quad (3)$$

I_{RC} = Rate at which information is transferred

$H(x)$ = Source transmission rate

$H_y(x)$ = Equivocation

The source information rate (H_x) is modified to consider both start and stop bits as well as error-detection bits to facilitate calculations. That is, the source data rate is reduced by the effect of start and stop bits and error-detection bits. In the final measure of information transferred by the source, information rate is further reduced by the channel equivocation. For the binary system the channel information rate is

$$I_{RC} = \frac{1}{T_0} + \frac{1}{T_0} \left[(1 - P_e) \log_2(1 - P_e) + P_e \log_2 P_e \right] \quad (4)$$

The overall system information rate is directly proportional to the number of channels c and inversely proportional to the order of diversity m as given in equation (5)

$$I_{RT} = c/m \times I_{RC} \quad (5)$$

Data Base

One of the problems associated with cost-effectiveness analysis is the collection of reliable data. Standardized sources of system characteristics and cost are definitely lacking. Steps have been taken to establish a data storage and retrieval system at NEL to support the resource-effectiveness program. This

AMCP 706-191

data base will be continually updated to provide a sliding historical data base. The storage and retrieval program will provide data from which cost factors can be determined. In order for cost effectiveness to become a continuing part of the Navy procurement process, a complete data base of Navy equipment is required. The best time to acquire equipment data is in the initial stages of a system's life cycle. The types of data that are required to support resource-effectiveness analysis are as follows:

1. Standardized listing of equipment characteristics by type of equipment
2. MTBF
 - a. Specification value
 - b. Predicted value
 - c. Actual value
3. MTTR
 - a. Specification value
 - b. Predicted value
 - c. Actual value
4. Unit cost
 - a. Quantity procured
 - b. Date procured
 - c. Spares
5. Training cost
6. Installation cost
7. Personnel requirements
8. Development costs

The data sources used to support the resource-effectiveness analysis of the hf link contained in this report are listed in appendix C with type of data.

Cost Analysis

The cost analysis applied here assigns a cost factor to each specific equipment characteristic so that equipment costs can be predicted as a function of equipment characteristics. A computerized statistical multiple-regression program is used to determine each cost function from historical cost data and equipment characteristics. A brief explanation of the theory and analytical process involved in curve fitting via multiple regression is contained in appendix D.

Total equipment costs can be considered to consist of fixed costs and variable costs. Fixed costs are independent of the performance expressions (METHODS, equations 2 and 5). Variable costs vary with level of performance. Fixed costs here also include performance factors that fail to correlate with cost.

Total cost = fixed cost + variable cost.

On the first try at determining a cost expression for a particular type of equipment – for example, a receiver – all equipment characteristics (all on which there are sufficient data) are submitted to the regression program at once. If the equipment cost fails to correlate with the pertinent equipment characteristics, the equipments are further categorized by frequency range, type installation, or other differences. Graph plotting of equipment characteristics versus cost may be employed to help determine the analytical form of the cost expression.

In some instances the equipment characteristics required to evaluate a system's effectiveness may not correlate with equipment cost. Such pertinent equipment characteristics as modulation types, number of types of modulation, transistorized equipment, number of channels and isolation did not correlate at a significant level with equipment cost. It is not implied that they will not correlate, but only that information in extreme depth was not available. Also, equipment characteristics may correlate negatively with cost (that is, receiver cost decreases with a decrease in sensitivity). In lower-cost equipments (\$3000 or less) the quantity of units procured affects the unit cost significantly. In this price area, as well as with the more expensive equipments, the quantity of units procured is considered when this type of information is available.

If the data on a particular type of equipment are insufficient to permit curve fitting, the equipment should be treated as a discrete entry in the performance and cost equations. This approach was taken in the following analysis with respect to shipboard and shore antennas.

The computer program used in the curve-fitting process provides several statistical tests to evaluate the "goodness" of the fitted curve. These tests are the *t* test and *F* ratio test that are described in appendix D. The multiple-correlation coefficient and standard error of estimate are also calculated.

Optimization Technique

One of the main tools of the resource-effectiveness method is the Systems Optimization Program (SOP).⁷ Several minor modifications have been made to the SOP, some as adaptations to the current problem, and some for compatibility with NEL computing equipment. The SOP minimizes a given function, called the criterion, while satisfying two types of constraints. The constraints can be in the form of equations or bounds on the individual variables. These constraints are always satisfied during the optimization procedure.

In connection with the present evaluations of communication systems, the cost is written as a function of system parameters, and this expression becomes the criterion equation in the SOP. Only one constraint equation is used; in it the gains (power, antenna gain) are balanced against the losses (path loss, noise, *S/N* ratio). Some of the variables are also constrained within preset limits.

The roles of the cost and gain-loss equations can be interchanged; that is, the cost can be held less than or equal to a certain amount. The gain-loss equation can be used as the criterion by writing *S/N* ratio in terms of the gains and losses. Then the SOP will maximize *S/N* ratio by minimizing its negative.

The SOP has four major subroutines, called Mode 1, Mode 2, Mode 3, and Mode 5. Mode 1 is the most important, as it executes the optimization. The technique used is the method of steepest descent, modified to work with constraints (see appendix E). The cost and criterion equations are written as functions of the system parameters. Some of the parameters are variables and may be perturbed in the process of minimizing the criterion. These parameters currently are transmitter coupler VSWR, transmitter and receiver stability, receiver sensitivity, transmitter power, and receiver coupler VSWR. A greater number of the system parameters are held fixed, but may be changed for each

AMCP 706-191

run of the program. They include transmitter operation time, number of transmitters purchased, path loss, and environmental noise.

Mode 2 evaluates chosen functions and their derivatives while varying one parameter. It can also plot these results, a capability which allows the analyst a convenient way to judge the effects of individual parameters upon the complete system.

Mode 3 evaluates chosen functions while varying several parameters simultaneously.

Mode 5 is a sophisticated output routine that lists the results of Mode 1 in a complete and readable form. It can also convert units from those convenient for calculation in Mode 1 to those appealing to persons using the results.

Confidence level of Predicted Performance

The performance equation contains, or is dependent upon, several parameters for which one cannot specify a "true" value but only the most likely value. Hence, these parameters are represented in the performance equations by their most likely, or mean, values. A statistical confidence factor is used to compensate for the effect of parameter uncertainty upon system performance, thereby assuring a specified level of performance with a given degree of confidence. The confidence factor is included in the performance expression (METHODS, equation 2) as additional system loss. The confidence factor is determined from system parameter uncertainties⁸ and the desired level of confidence.

The uncertainties are:

σ_{SIG} = uncertainty in predicting signal strength over ionospheric path.

σ_{TA} = noise variation about the mean.

σ_{ANT} = uncertainty in receiver antenna gain due to receiver antenna characteristics.

σ_{Fa} = uncertainty in mean value of noise.

σ_{NF} = uncertainty in receiver noise figure value.

The total uncertainty σ_T is

$$\sigma_T = \left[\sigma_{ANT}^2 + \sigma_{SIG}^2 + \sigma_{TA}^2 + \sigma_{Fa}^2 + \sigma_{NF}^2 \right]^{1/2}$$

Confidence factor (C) = $K\sigma_T$

<u>Confidence Interval, Percent</u>	<u>K</u>
50	0
90	1.282
95	1.645
99.9	3.09

The confidence factor used in these calculations were obtained from the following system uncertainties.

$\sigma_{SIG} = 8 \text{ dB}$

$\sigma_{ANT} = 8 \text{ dB}$

$$\begin{aligned}\sigma_{TA} &= 5 \text{ dB} \\ \sigma_{Fa} &= 5 \text{ dB} \\ \sigma_{NF} &= 3 \text{ dB}\end{aligned}$$

The total system uncertainty (σ_T) is found to be 13.675 dB. The confidence factor for a 95-percent confidence is then:

$$C_f = K\sigma_T = 1.645 \times 13.675 \text{ dB} = 22.495 \text{ dB}$$

RESULTS

The results of analysis of hf-link effectiveness are presented in various forms to illustrate the capability and versatility of the method so far developed under this program. Performance and cost equations utilized in the optimization program are discussed with respect to contributing factors and their interrelationships. Depending upon the form of the optimization process, the performance equation may be either the criterion or the constraint equation. Correspondingly, the cost equation will then be the constraint or the criterion equation.

In the optimization program a local minimum is sometimes found rather than the global minimum. In this case the starting values for the variable parameters are changed to determine if the optimization process can locate a new minimum for the criterion expression.

The optimization program uses 26 parameters (fig. 2), of which only six are allowed to vary (variable parameters). Other parameters could be selected as variable parameters; however, the six selected (fig. 2B) are believed to be the most significant with respect to system cost-performance trade-offs. Figure 2 is a typical SOP output page. It was taken from a computer run in which system cost, parameter 12, was used as a constraint on system effectiveness.

FIXED PARAMETERS

PARAM NUMBER	PARAMETER DESCRIPTION	FIXED VALUE	UNITS
1	TRANSMITTING ANTENNA GAIN	-5.90000E 00	DECIBELS
2	RECEIVING ANTENNA GAIN	-2.00000E-01	DECIBELS
3	RF BANDWIDTH	2.80000E 01	MEGACYCLES
4	CENTER FREQUENCY	1.60000E 01	MEGACYCLES
5	PATH LOSS	8.00000E 01	DECIBELS
6	NUMBER OF RECEIVERS PURCHASED	1.00000E 01	DECIBELS
12	SYSTEM COST	7.50000E 04	DOLLARS
13	NUMBER OF TRANSMITTER COUPLER INPUTS	1.00000E 00	NONE
15	NUMBER OF CHANNELS	8.00000E 00	NONE
16	GUARD TIME	0	SECONDS
17	BIT DURATION	1.30000E-02	SECONDS
18	FREQUENCY SHIFT	4.25000E 01	CYCLES PER SECOND
19	NUMBER OF TRANSMITTERS PURCHASED	1.00000E 00	NONE
20	ATM., MANMD., OR GAL. NOISE	1.30000E 01	DB OVER 1 UV/M
21	OPERATING FREQUENCY	2.40000E 01	MEGACYCLES
22	IF BANDWIDTH	1.50000E 00	RATIO TO 1KC
23	TRANSMITTER OPERATING TIME	7.20000E 02	HOURS PER MONTH
24	CONFIDENCE FACTOR	2.24950E 01	DECIBELS
25	ERROR RATE	1.00000E-03	PER SECOND
26	DIVERSITY	1.00000E 00	DIVERSITY

A

Figure 2. Typical printout for optimization program.

VARIABLE PARAMETERS

PARAM NUMBER	PARAMETER DESCRIPTION	STARTING VALUE	FINAL VALUE	UNITS
7	TRANSMITTER COUPLER VSWR	2.50000E 00	2.29235E 00	ONES PER MILLION
8	TRANSMITTER STABILITY	1.00000E-01	1.84630E-02	SAME
9	RECEIVER STABILITY	1.00000E-01	1.00000E-02 MINIMUM VALUE	
10	RECEIVER SENSITIVITY	5.00000E 00	3.46897E 00	MICROVOLTS
11	TRANSMITTER POWER	1.22234E 04	7,725806 03	WATTS
14	RECEIVER COUPLER NOISE FIGURE	1.00000E 01	9.966776 00	DECIBELS

B

Figure 2. Continued.

E-19

AMCP 706-191

Submodel Cost Prediction

The method of analysis required that cost expressions be generated for each submodel of the communications system. The expressions were developed for all but the two antenna systems, shipboard receiving and shore transmitting. The data available on these types of antennas were insufficient to permit cost expressions to be developed by regression analysis. The costs and characteristics used for the antennas were taken from vendor literature.

The cost expression for each submodel along with the multiple-correlation coefficient and standard error of cost estimate (σ) are included in the summary that follows. The range for each parameter used in the regression analysis is also indicated.

The symbol Q is used to denote where applicable the quantity of units to be considered in predicting the cost of a submodel. Each of the submodel cost-prediction expressions was generated by means of the techniques described in the Cost Analysis section of METHODS. For an explanation of the symbols used in the cost expression, see appendix F.

Consider a typical example of unit-cost prediction using the following receiver characteristics and the receiver cost-prediction expression (METHODS, equation 3).

Receiver Characteristics

- Q = 30 = Quantity of units to be procured
- $F_0 = 16.250 \text{ Mc/s} =$ Receiver center frequency
- $S_n = 1.5\mu v =$ Receiver sensitivity
- $S_r = 1 \text{ PPM} =$ Receiver stability

$$\begin{aligned} \text{Receiver cost (\$)} = & \text{\$5,382.916} - \text{\$2,48269 (30)} - \text{\$659,2069} \log_{10}(16.25 \times 10^6) \\ & \text{fixed cost} \quad \text{variable cost} \quad \text{variable cost} \\ & \text{due to quantity} \quad \text{due to frequency} \\ & - \text{\$1,786.0931} \left[\log_{10} (10 \times 1.5) \right] + \text{\$2,016.81387} \log_{10} (100/1) \\ & \text{variable cost} \quad \text{variable cost} \\ & \text{due to sensitivity} \quad \text{due to stability} \end{aligned}$$

Receiver Cost (\$) = \$2,481 when bought in quantities of 30.

The range for each variable used in the receiver cost analysis is as follows:

$34 \leq Q \leq 2,217$	Quantity
$22 \leq f_0 \leq 323,375 \text{kc/s}$	Frequency
$1 \leq S_n \leq 10\mu v$	Sensitivity
$.01 \leq S_r \leq 1 \text{ PPM}$	Stability

Predicted costs can be obtained for the other equipments comprising the system from the appropriate submodel equation in the summary which follows. The coefficients assigned each cost factor are the performance factors and are determined by the optimization program. The total hf system cost is the sum of the individual submodel costs.

Summary of submodel cost prediction equations.

1. Terminal Equipment
 - a. Receive or Transmit Terminal Cost (\$)

$$= -843.239356 + 1091.535361 (c) - 69.089276 (Q)$$

$$1 \leq Q \leq 25$$

$$1 \leq c \leq 16$$
 Multiple Correlation 0.99909
 $a = \$635.46589$
 - b. Receive and Transmit Terminal Cost (\$)

$$= -843.239356 + 2183.070722 (c) - 138.17552 (Q)$$

$$1 \leq Q \leq 5$$

$$1 \leq c \leq 16$$
 Multiple Correlation 0.99909
 $\sigma = \$635.46589$
2. Receiver Coupler Cost (\$) =

$$3014.239578 - 746.668745 (F_c) + 85.11956 (F_c)^2 - 3.181748 (F_c)^3$$

$$6 \leq F_c \leq 15$$
 Multiple Correlation 0.99005
 $a = \$40.799290$
3. Receiver Cost (\$) = 5,382.916

$$-2,486,269 (Q)$$

$$-659.2069 \log_{10} f_0$$

$$-1786.0931 [\log_{10}(10S_n)]$$

$$+ 2016.81387 \log_{10}(100/S_r)$$

$$34 \leq Q \leq 2,217$$

$$22 \leq f_0 \leq 323,375 \text{kc}$$

$$1 \leq S_n \leq 10$$

$$0.01 \leq S_r \leq 1 \text{ PPM}$$
 Multiple Correlation 0.980429
 $\sigma = \$568.483091$
4. Transmitter Cost (\$) = -154,942.190818

$$+ 7216.0810 \log_{10} P_t$$

$$+ 1.7039107 p_t$$

$$+ 71683.2036 (S_{bw}/f_0)$$

$$+ 9205.5072 \log_{10}(100/S_t)$$

$$0.01 \leq S_t \leq 1.0 \text{ PPM}$$

$$22 \leq f_{bw} \leq 28 \text{ Mc/s}$$

$$15 \leq f_0 \leq 16 \text{ Mc/s}$$

$$500 \leq p_t \leq 20,000 \text{ watts}$$
 Multiple Correlation 0.997445
 $a = \$1052.209776$
5. Transmit Coupler Cost \$ =

$$14,957.591461$$

$$- 2057.4931 \log_{10} f_0 - 349.1224 r_{ct}$$

$$+ 1188.842182 c_t$$

$$1.1 \leq r_{ct} \leq 2.0:1$$

$$13.15 \leq f_0 \leq 312.5 \text{ Mc/s}$$

$$1 \leq c_t \leq 4$$

Multiple Correlation **0.913099**

$$\sigma = \text{\$}249.653032$$

6. Antennas

a. Transmit Antenna - Conical Monopole Cost (\$) = **\\$6,275**

b. Receive Antenna - Vertical Whip Cost (\$) = **\\$300**

The Effect of Primary-Power Requirements Upon System Design

Table 2 illustrates the cost of an hf communication link as a function of a receiver removed from the transmitter in a fixed direction with range as a variable parameter. The variables that affect the system cost are frequency of operation $f_{Mc/s}$, external noise power (E_e) available at the antenna, and propagation loss (L_p). The values for these variables are determined by the propagation-prediction program for each specific range. Also, the frequency of operation selected is the optimum frequency for that range and receiver location. The S/N ratio at a specific receiving location is a function of the effective antenna noise figure and transmission path loss. The received noise field strength and operating frequency cause the effective antenna noise figure to vary irregularly with range. The variation causes system price to fluctuate along the selected path rather than being monotonic with distance. The first three line entries in table 2 illustrate this situation. The path loss (L_e) is monotonic with range, increasing from **64.7 dB** at **240 n.m.** to **74.7 dB** at **960 n.m.** However, the effective noise at the receiver antenna (E_e) decreases from **14.3 μv** at **240 n.m.** to **3.4 μv** at **960 n.m.** This decrease in E_e combined with an increase in operating frequency more than compensates for the 10-dB increase in path loss, resulting in a less expensive system for **960 n.m.** than for **240 n.m.**

In the last two columns the effect of primary power (or commercial power) is shown. The primary-power cost for a 5-year period was included in the cost (criterion) equation. The equipment was considered to be in operation **720** hours per month. In most cases, the effect of considering primary power and its associated cost was to reduce the amount of the transmitter power output required, causing the system to seek additional gain from other system parameters at less cost to the system.

The expression for primary-power cost uses the rate structure of the San Diego Gas & Electric Co., as this information was readily available. The amount of primary power required is dependent upon the efficiency of the transmitter, plus other items. The efficiency of shore transmitters was found to decrease as transmitter power is increased, and this relationship was included in the expression for primary-power cost. The effect of transmitter efficiency on system cost becomes significant as the communication-link range is increased from **1,980 n.m.** to **5,040 n.m.** The communication link analyzed consisted of eight digital channels, each operating with a bit error rate (BER) of 10^{-3} errors per bit. The link was optimized for each range considered. The confidence

TABLE 2. SYSTEM COST AND POWER REQUIREMENTS.

Range, n.m.	L_p , dB	E_n μV	$f_{Mc/s}$	Without Primary- Power Costs		With Primary- Power Costs	
				Cost, Dollars	Power, Watts	cost, Dollars	Power, Watts
240	64.7	14.3	4	46,338	2,283	56,830	1,193
480	68.6	14.8	4	49,298	2,767	63,599	1,589
960	74.7	3.4	20	35,756	1,000	37,663	250
1,980	80.2	-5.5	24	33,321	500	36,081	500
3,000	84.1	-3.4	20	37,117	1,000	42,114	500
4,980	90.8	-1.0	16	47,292	1,952	56,605	3,139
5,040	96.0	8.2	8	166,088	56,515	1,400,775	56,293

level associated with the error rate is 95 percent. The BER was determined for noncoherent FSK modulation subjected to Rayleigh fading and Gaussian noise. In addition to transmitter power, the optimization program varied other system characteristics. The other system variables that were permitted to vary are:

- 1 Transmitter stability
- 2 Receiver stability
- 3 Receiver sensitivity
- 4 Receiver coupler noise figure
- 5 Transmitter coupler VSWR

Because of the interaction of variables L_p , E_n , and $f_{Mc/s}$, the worst-case configuration may not occur at the maximum range over which communications are desired. Intermediate ranges, geographical locations, and time should all be considered in determining the design requirements or the adequacy of a communications system. Also of importance in the design of a system is the transmitter efficiency with its associated primary-power cost.

System Cost Versus Range for Various Values of F_a

Figure 3 illustrates the effect of communication-link range on system cost. The curves are for effective antenna noise figures (F_a) of 40, 50, and 60 dB. The link performance for these calculations is constrained to an eight-channel system operating with a BER of 10^{-3} errors per bit with a 95-percent confidence factor. Each point plotted in figure 3 represents an optimized (minimum cost) system.

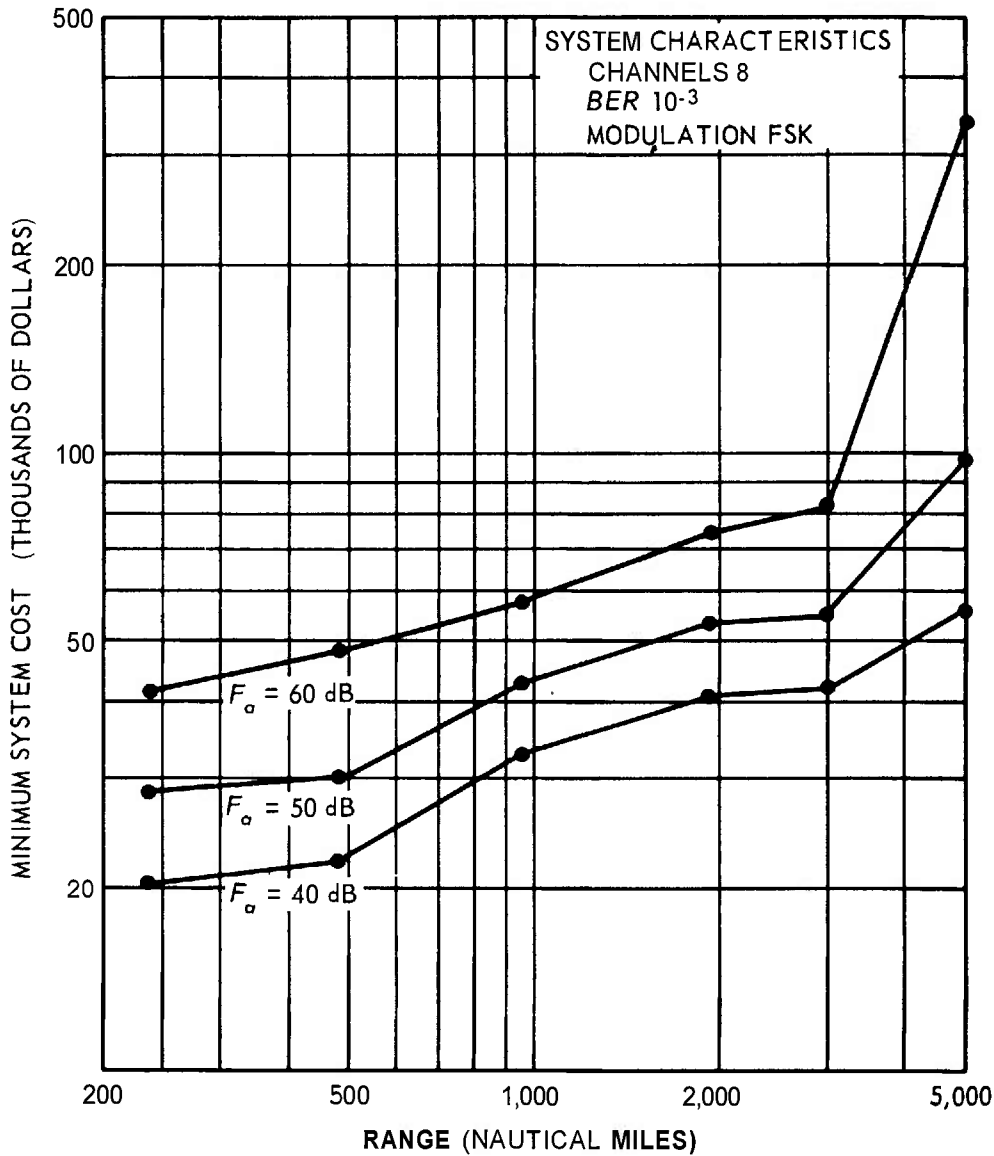

Figure 3. System cost versus range for various values of F_a .

Specific communication-link characteristics are:

Link location	0° azimuth from Honolulu, Hawaii
Modulation	Noncoherent FSK
Sunspot number	20
Month	December
Hour	0600
Transmit Antenna	Conical Monopole
Receive Antenna	Vertical Whip

The curves illustrate the cost increase associated with a 10-dB increase in the effective antenna noise figure. For a 2,000-n.m. link, an increase in the effective antenna noise figure from 50 dB to 60 dB would require an additional \$21,000 investment (39 percent increase) in the system.

System Cost Versus **BER** as a Function of F_a

Figure 4 is a graph of System Cost versus BER as a function of F_a (effective antenna noise figure) for values of 40, 50, and 60 dB. Each point plotted represents an optimized system (that is, minimum cost) evaluated to provide a specified level of performance. All calculations are for a fixed range to eliminate variations in S/N ratio due to path loss and receiver location.

The characteristics of the link are as follows:

Range	3,000 n.m.
Confidence	95 percent
Channels	8
Modulation	Noncoherent FSK
Location	0° azimuth (Hawaii)
Sunspot number	20
Month	December
Hour	0600

The graph illustrates the cost associated with designing a system for different effective antenna noise figures. The curves indicate that for a very slight increase in system cost the BER can be improved from 8×10^{-4} to 5×10^{-4} errors per bit.

This type of curve can be used to compare the BER improvement with coding with that obtained from a different system design.

Figure 5 illustrates the improvement in information reliability obtainable with an increase in system cost. The calculations have been made for path losses of 70, 80, and 90 dB. The effective antenna noise figure used in the optimization calculations was constrained at 50 dB. The optimum frequency of operation was determined by the hf propagation - prediction program, and was used in each calculation for the range involved. In this type of optimization, cost is a constraint and information reliability is the criterion.

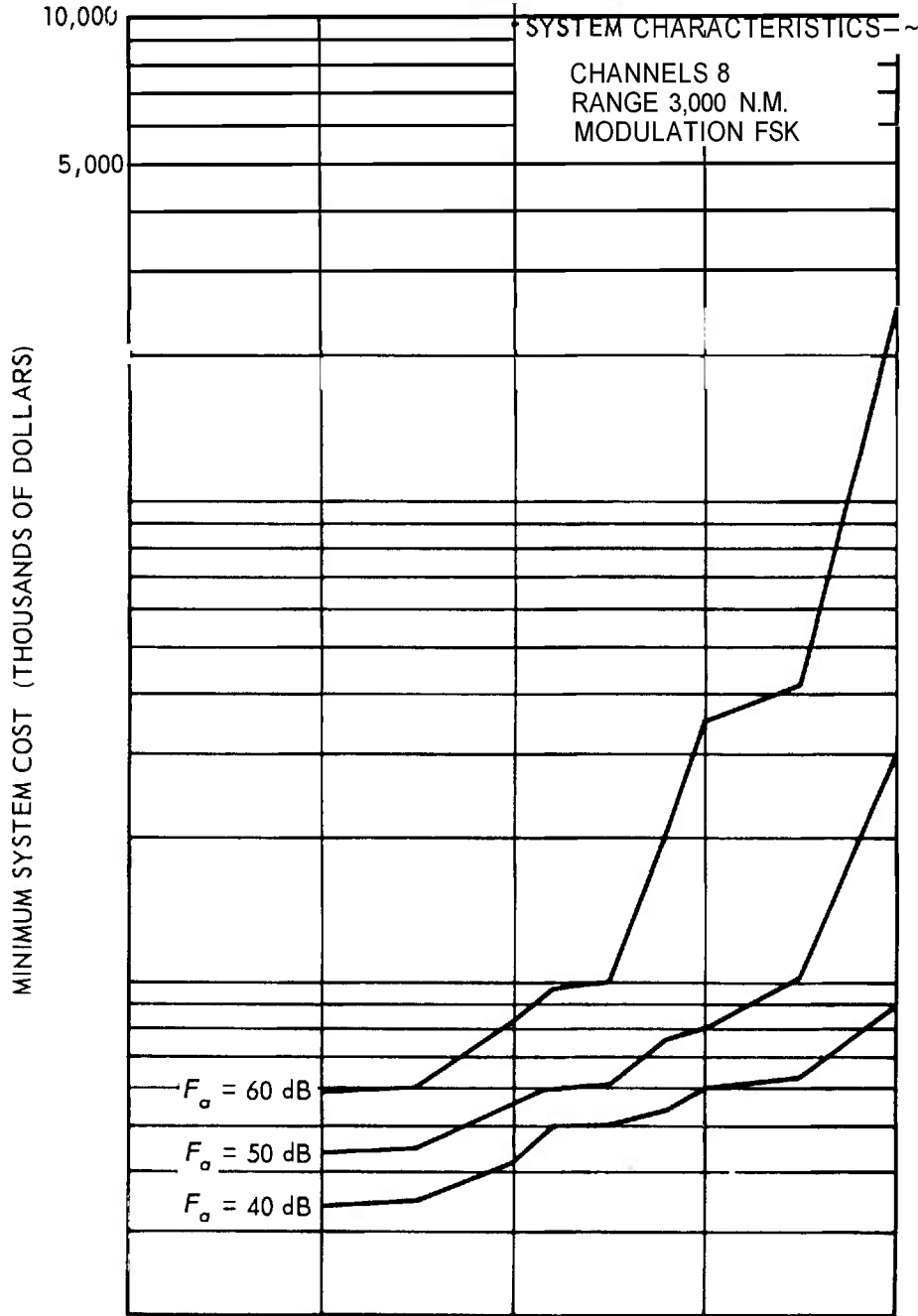

Figure 4. System cost versus BER as a function of F_{σ} .

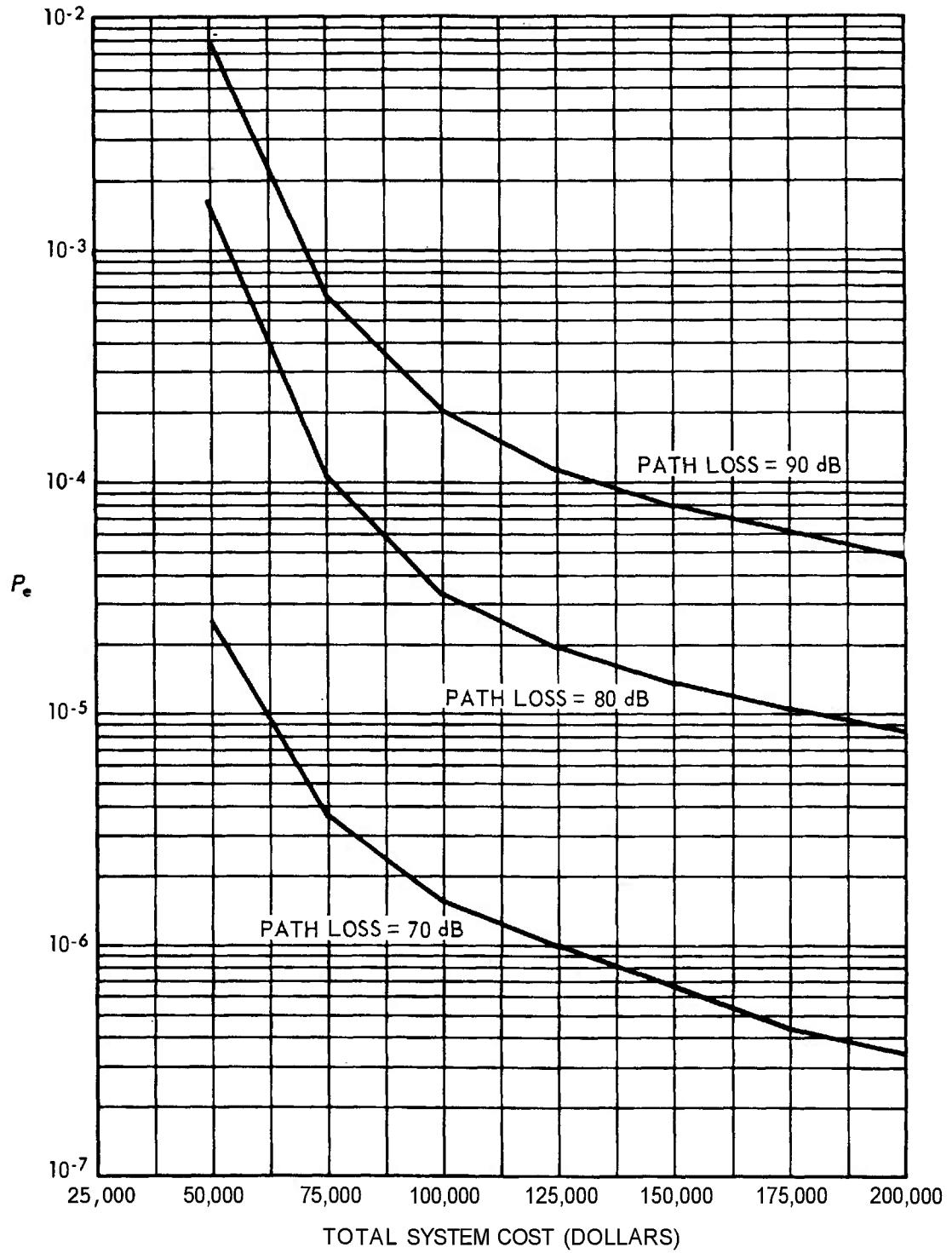

Figure 5. System cost versus P_e for various path losses.

AMCP 706-191

Figure 6 shows receiver cost versus receiver center frequency for three values of sensitivity. The average ratio of receiver range to center frequency was 1.58. The ratio seems to hold in most cases regardless of receiver center frequency.

Figure 7 illustrates the relationship of hf transmitter cost and average transmitter power output. The curves have been plotted for three levels of transmitter stability.

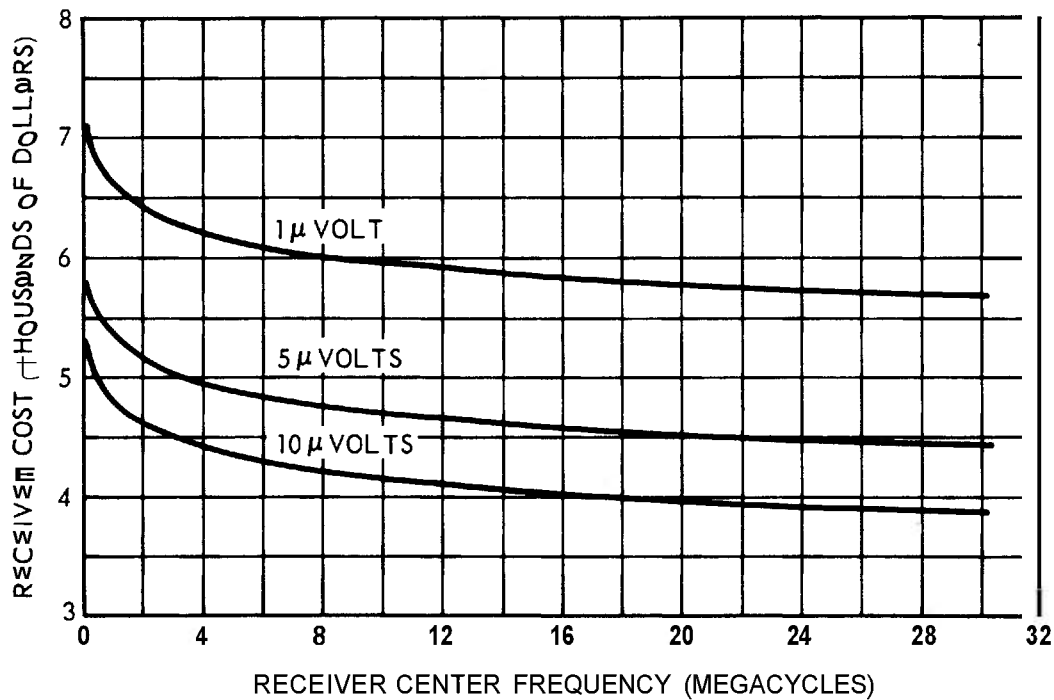

Figure 6. Receiver cost versus center frequency for various values of receiver sensitivity.

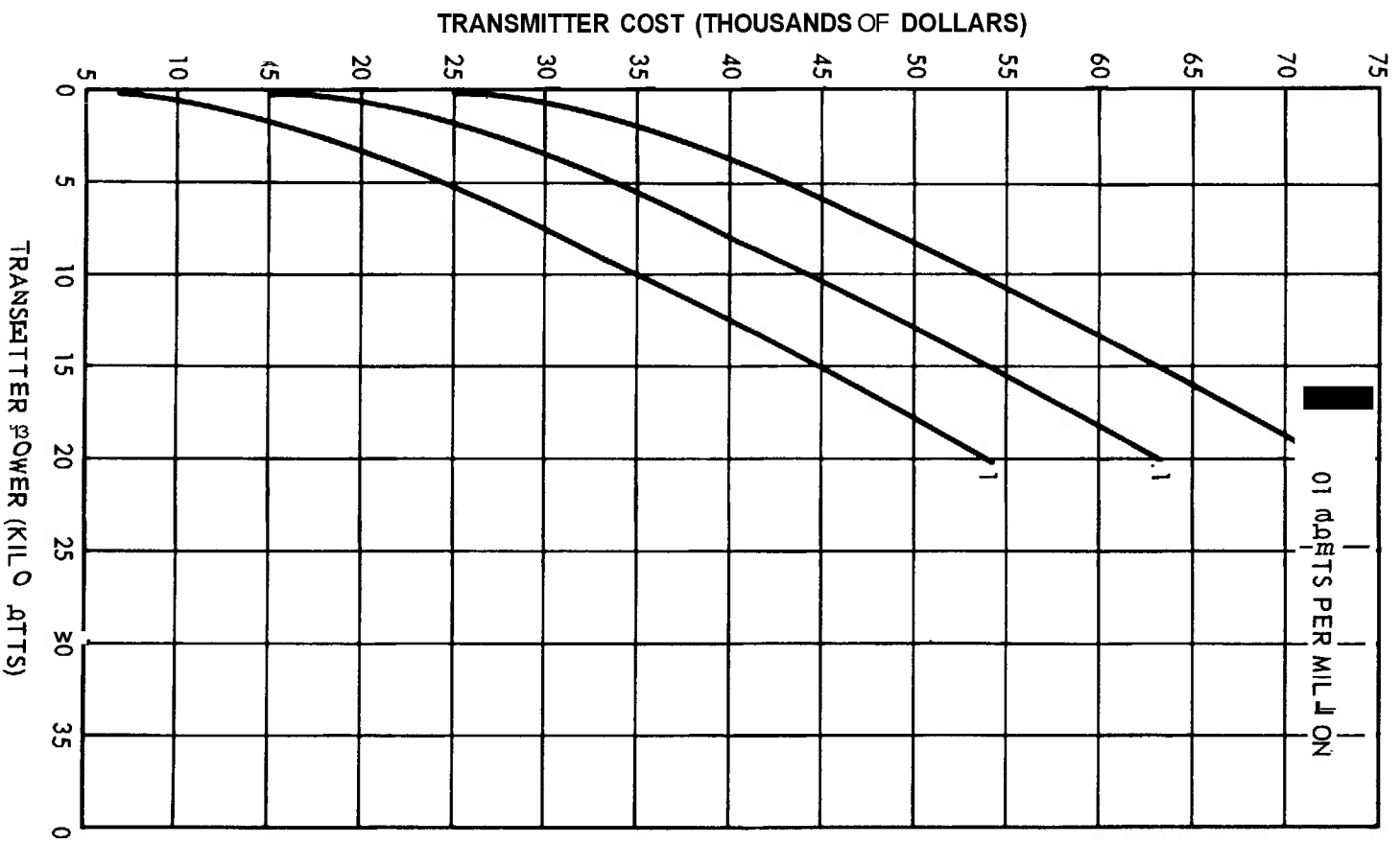

Figure 7. H_f shore transmitter cost versus power for various values of transmitter stability.

Sensitivity Analysis

The hf link configuration was evaluated to determine the sensitivity of system cost to each of the six variable parameters. The system was first optimized in terms of cost (minimum cost) to provide an eight-channel link with each channel operating at a bit error rate of 10^{-3} errors per bit. The confidence level over the 3,000-n.m. link is 95 percent. Figures 8 through 13 illustrate the effects of the variable parameters on system cost.

The optimum system cost was determined to be 55,530 and is indicated on each parameter curve. Figure 9 and 12 indicate that system cost is most sensitive to the characteristics of the transmitter, specifically, transmitter stability and power. The transmitter cost analysis should be reviewed to verify the cost-prediction expressions before finalizing the analysis.

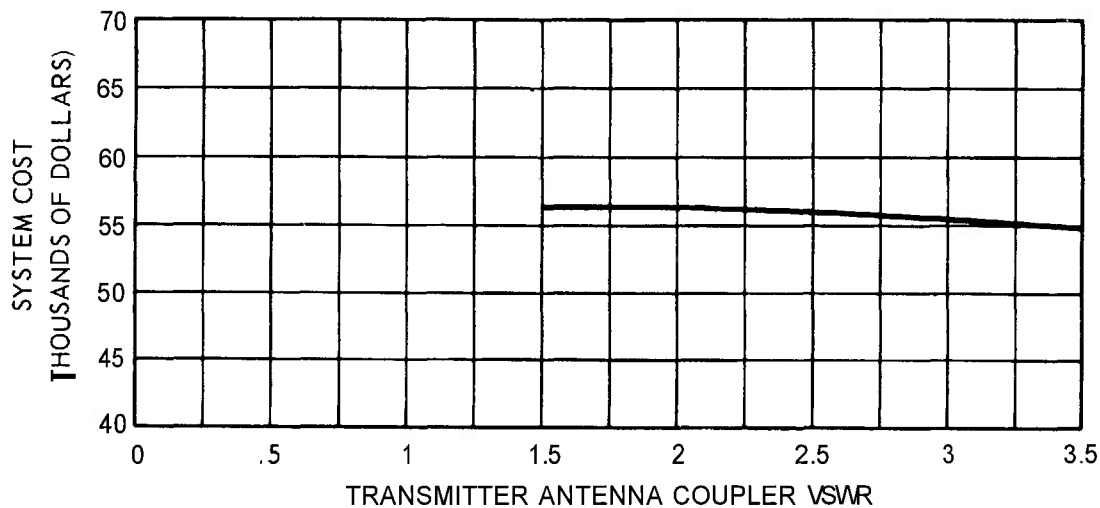

Figure 8. System cost versus transmitter antenna coupler VSWR.

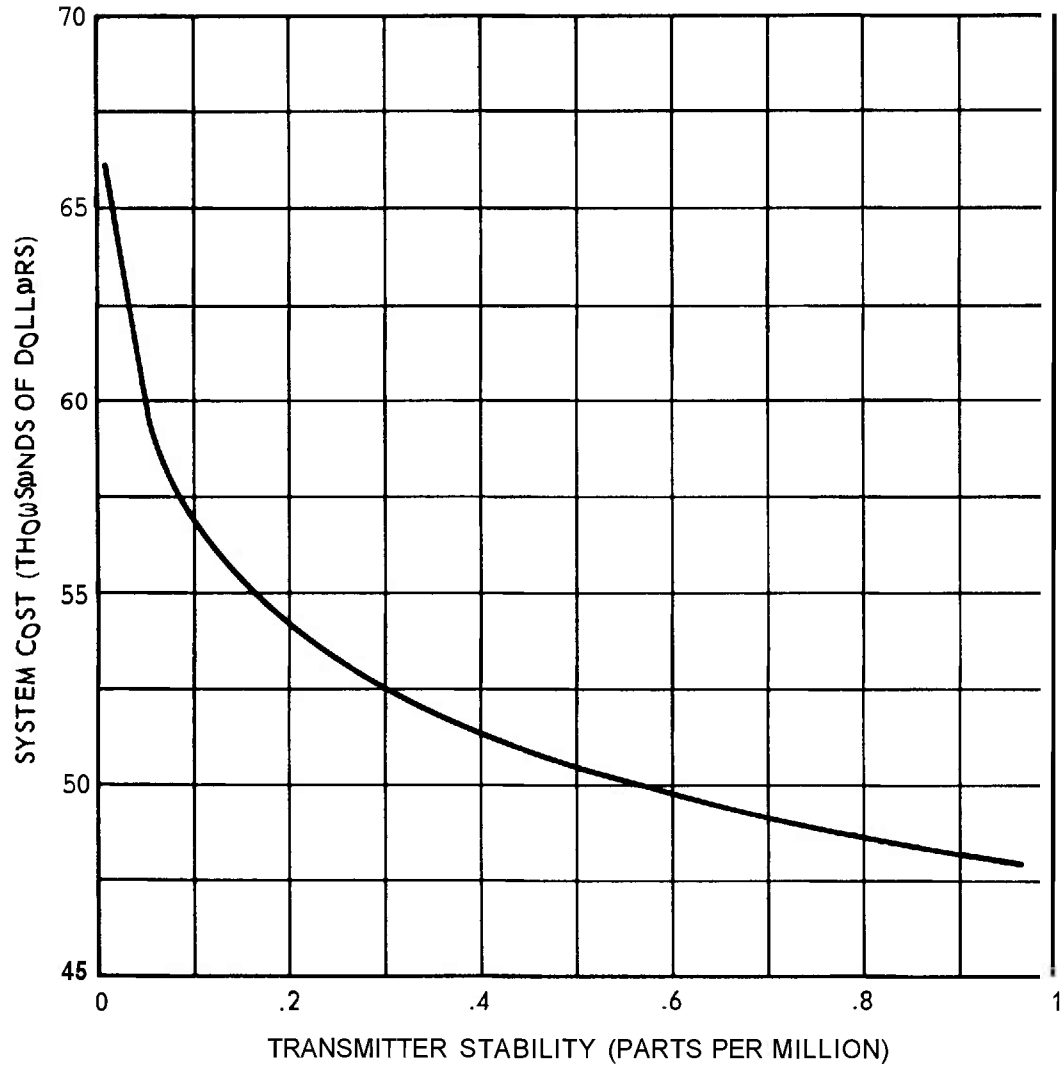

Figure 9. System cost versus transmitter stability.

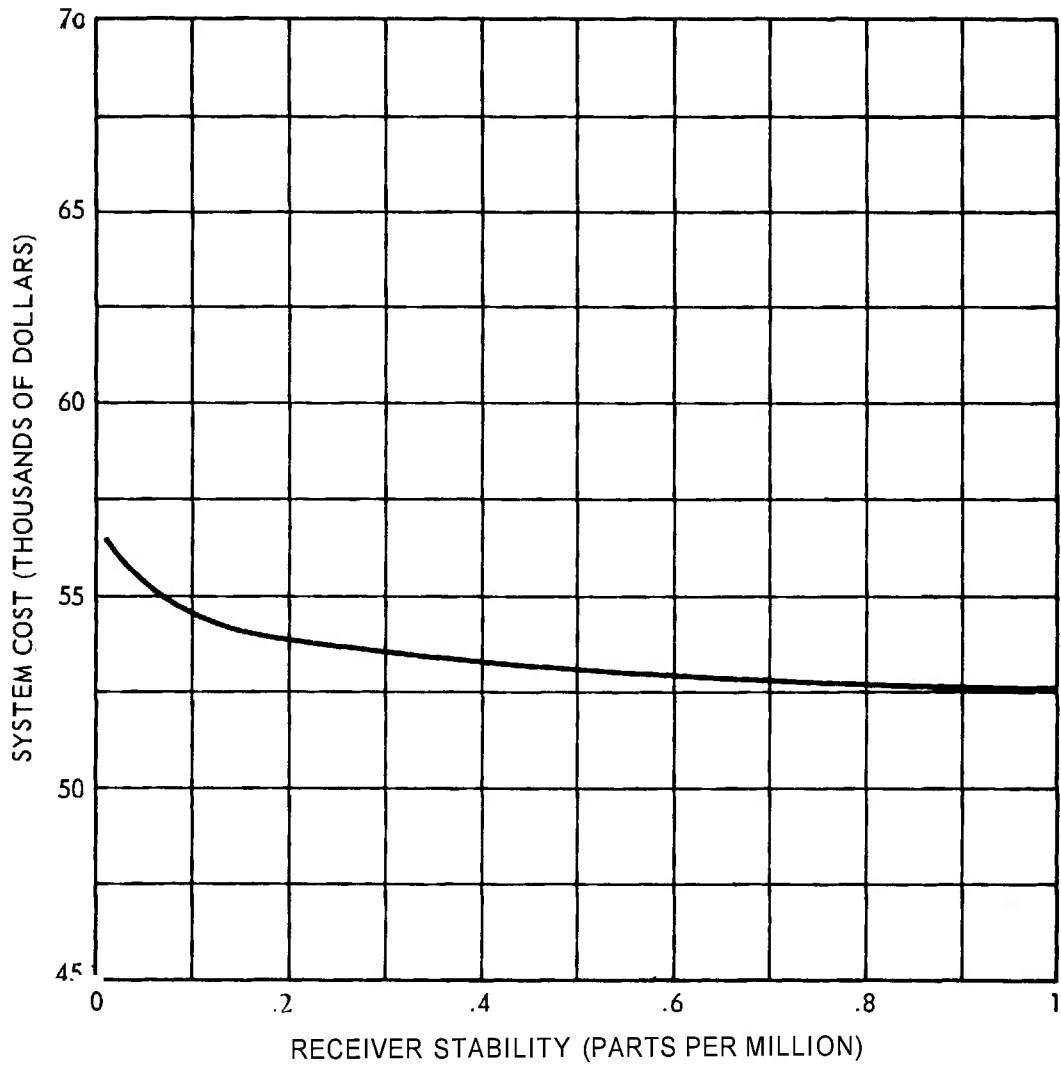

Figure 10. System cost versus receiver stability.

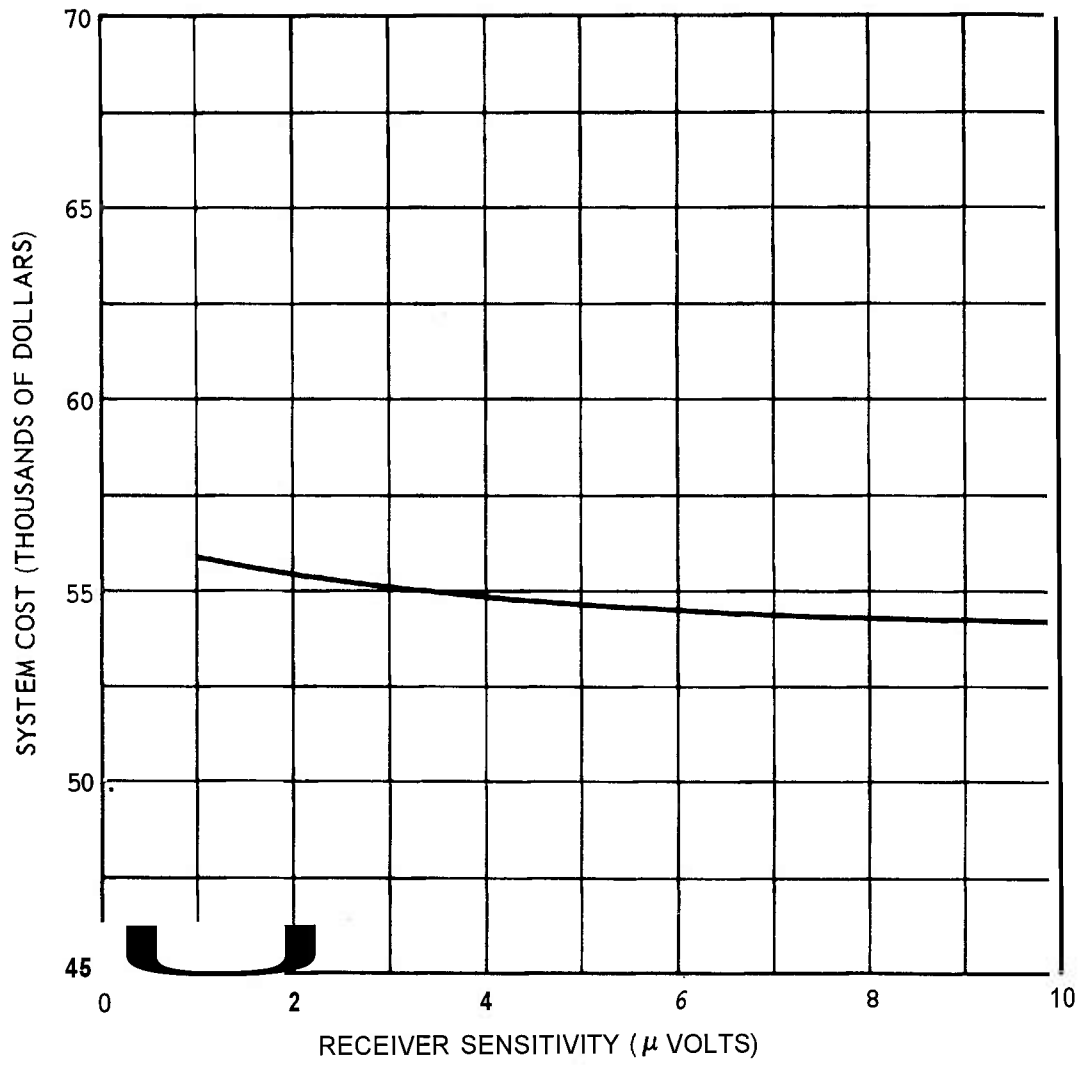

Figure 11. System cost versus receiver sensitivity.

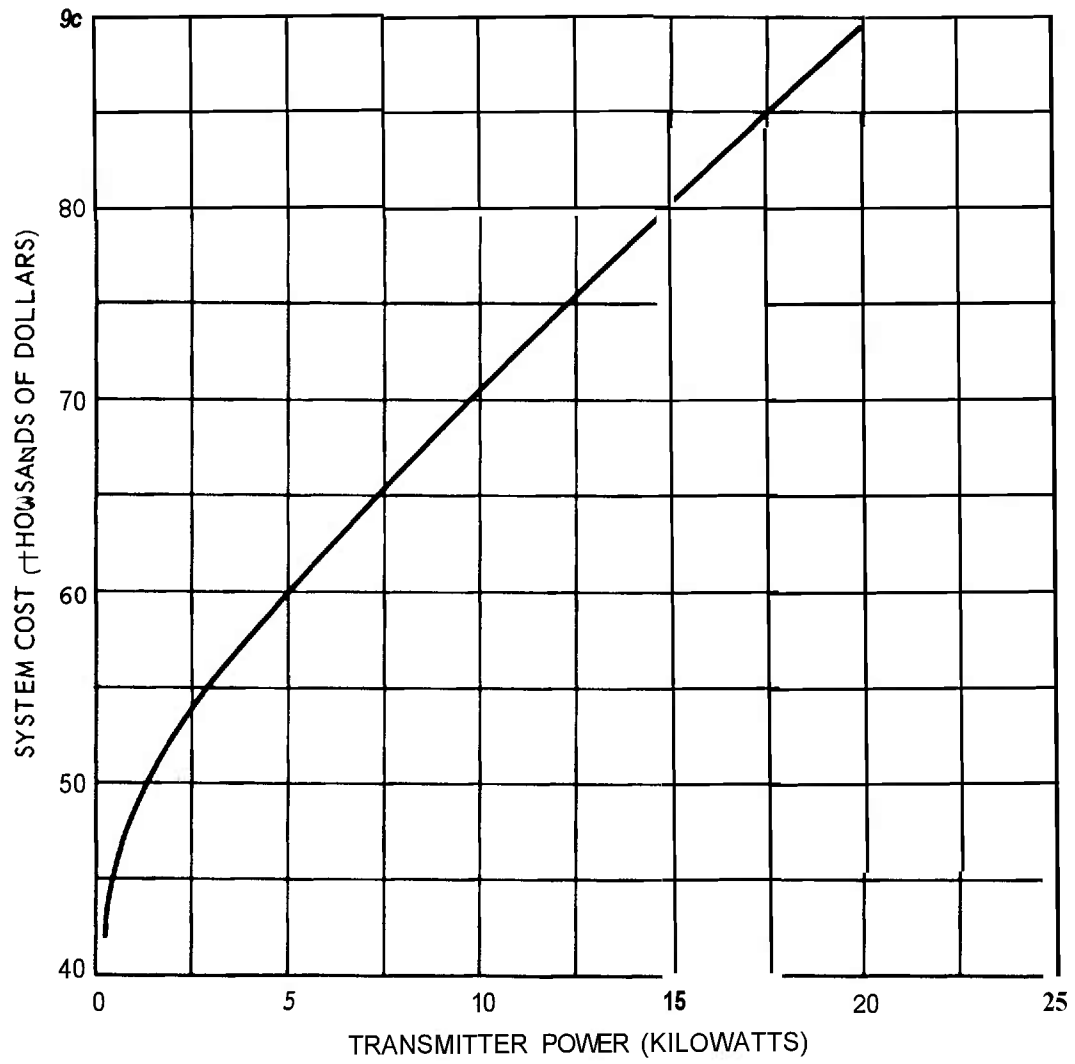

Figure 12. System cost versus transmitter power.

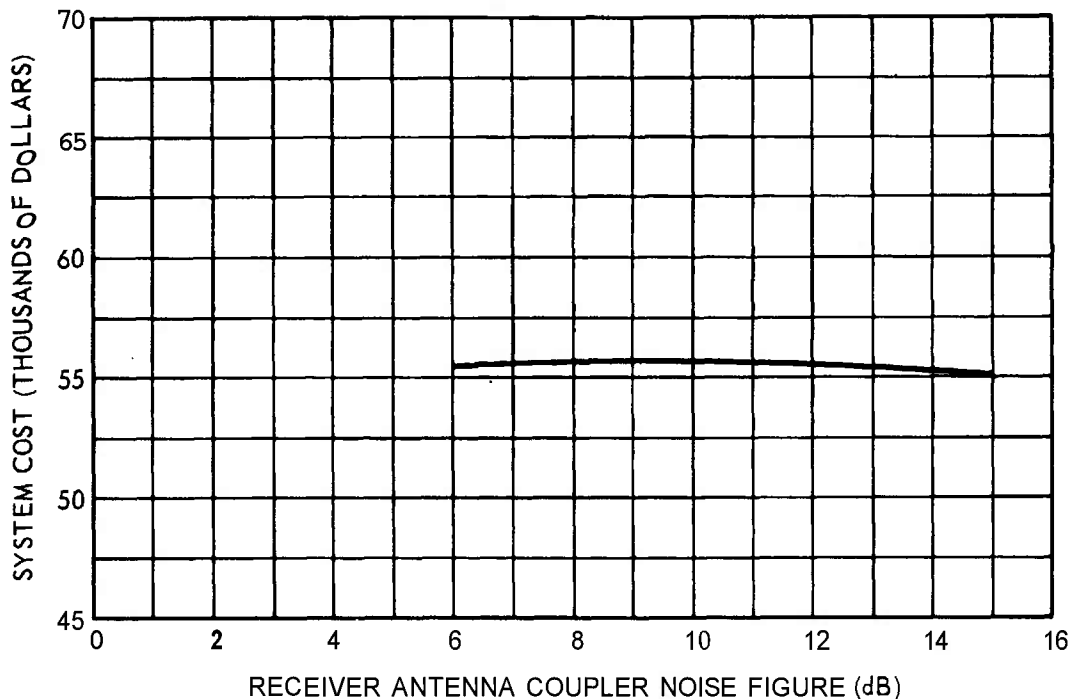

Figure 13. System cost versus receiver antenna coupler noise figure.

System Comparison

The following technique provides one method of comparing two or more systems with multiple measures of effectiveness. The effectiveness of each system is determined for a specific communications link. The particular environmental conditions used for the comparison are a 3,000-n.m. link with an effective antenna noise figure of 50 dB. In the example selected each measure of effectiveness exceeds the system requirements. The technique is to cost out the increased effectiveness of each measure and subtract the increased effectiveness cost from the total system cost. The lowest measure of effectiveness in each area is used as the basis for the cost comparison.

In this example, the cost of system 1 with information reliability of 2×10^{-4} was reduced to the cost of system 2 with information reliability of 8×10^{-4} . The difference in system cost is \$15,891, or the excess performance cost of system 1 over system 2 is \$15,891.

A similar comparison can be made for system reliability. The result of determining the excess effectiveness cost is to normalize the performance of each system for comparison. The chart of table 3 indicates that system 2 is the better buy of the two systems.

TABLE 3. SYSTEM COMPARISON.

	System 1	System 2	System Requirements
Performance Info Reliability	2×10^{-4}	8×10^{-4}	1×10^{-3}
Info Rate Required	75 baud	75 baud	75 baud
Actual	76.712	76.201	76.05
System Reliability (MTBF)	1900 hrs	2300 hrs	1700 hrs
System Availability	*0.997375	*0.9978	0.99
System cost	480,427	\$65,000	—
Excess Performance cost	\$15,891**	—	—

Excess Reliability Cost	—	\$4,000
----------------------------	---	---------

cost of *** Normalized System	564,536	\$61,000
----------------------------------	---------	----------

* MTTR = 1 hour

** Results from \$76,427 – \$60,536. See figure 4.

*** Normalized to the same level of effectiveness.

CONCLUSIONS

1. The feasibility of implementing the method developed in NEL report 1323 has been demonstrated.
2. There is a definite need for a standardized Navy-wide data bank if cost-effectiveness analysis is to continue as a Navy design and management tool.
3. Detailed costing of equipment characteristics such as kind of detection, type of modulation, and use of transistors by statistical multiple regression may not be possible, because of other equipment characteristics which mask these

fine-grain characteristics in the regression analysis. This costing may require the acquisition of more detailed cost data or the development of new cost-prediction techniques.

4. The models developed provide a base for more detailed and comprehensive link analysis.

5. The method and techniques developed can be used in the analysis and evaluation of hf equipments and systems. They can also be useful in the preparation of PTA, TDP, and DAP.

RECOMMENDATIONS

1. Integrate equipment reliability and maintainability into the existing method.
2. Incorporate the effects of jamming and interference in future refinements of resource-effectiveness analysis.
3. Extend the method to include the communications system in the operational environments.
4. Establish a centralized collection and distribution service concerning data on Navy equipments.
5. Extend resource-effectiveness models to encompass other frequency ranges.

APPENDIX A: A SINGLE MEASURE OF EFFECTIVENESS

Several recent publications have recommended a single measure of effectiveness, or figure of merit, as a means of rating and comparing systems. The single measure of effectiveness is generally the product of several probabilities or rank designators that represent some of the characteristics of the systems being evaluated. The probabilities can represent system factors, such as reliability, system availability, or probability of mission success. The ranking scheme involves rating these system characteristics on a scale of a to b ($b > a$). The purpose of this appendix is to demonstrate some of the more basic limitations associated with single measures of effectiveness.

To determine whether a single measure of effectiveness is appropriate, we must first look to the purpose of a resource-effectiveness analysis. An analysis of system effectiveness is designed to present all significant alternatives in system configuration with their inherent ramifications of resource requirements and mission fulfillment in perspective. Where a single measure of system effectiveness is used, it is difficult, if not impossible, to relate trade-offs to the overall system objective(s), particularly in those cases in which the system factors are weighted on some arbitrary basis. Large systems with multiple objectives are definitely more suited to the use of multiple measures of effectiveness than to the use of a single measure. Decision makers quite frequently request a single measure of effectiveness, as it facilitates decision making and decreases the administrative problems associated with it. A resource-effectiveness analysis should present an unbiased array of possible trade-offs. It should not force a specific decision through previous decisions in the course of analysis as a single measure of effectiveness would.

The case in which a system's major characteristics are ranked from 1 to 9 and then combined as a product into a single measure of effectiveness is examined in detail in the following paragraphs.

Assume the situation in which system effectiveness is the product of four system characteristics α , β , γ , and δ
 or effectiveness = $\alpha\beta\gamma\delta$
 where

$$1 \leq \alpha \leq 9$$

$$1 \leq \beta \leq 9$$

$$1 \leq \gamma \leq 9$$

$$1 \leq \delta \leq 9$$

$\alpha, \beta, \gamma, \delta$ are integers.

Figure A1 graphically illustrates the cumulative density of available products. There are 6,561 possible different ordered combinations of α , β , γ , and δ yielding 225 different products. Consider the situation in which a system rating is 3024. There are 24 different system configurations defined by the rating system that will provide the product of 3024. A system with effectiveness parameters 9•8•6•7 is different from a system with parameters 6•7•9•8. However, whatever difference the systems have is masked by the single measure of effectiveness. If the effectiveness rating is 144, there are 132 possible different system configurations.

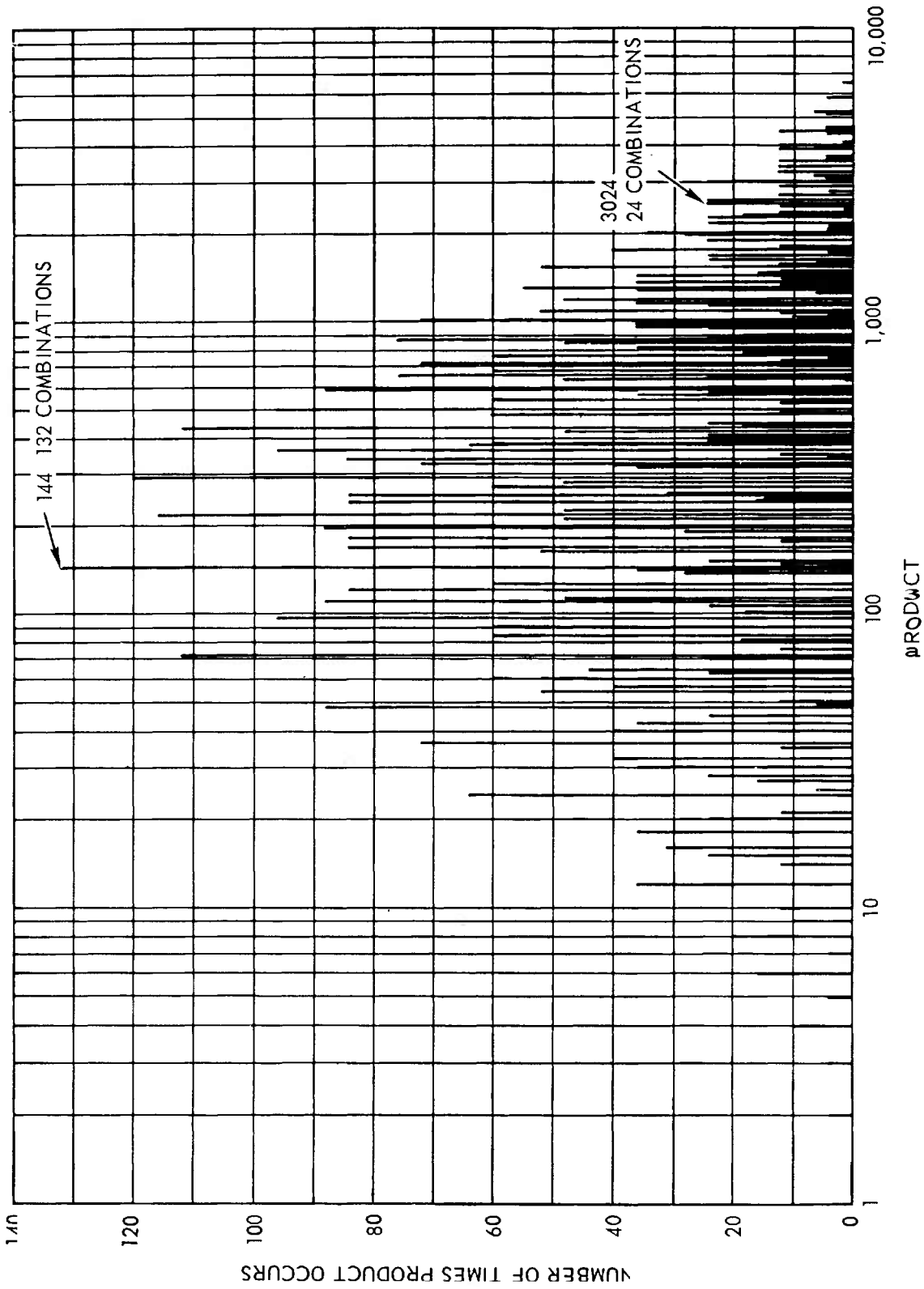

Figure A1. Cumulative density of products (single measure of effectiveness).

AMCP 706-191

Table A1 indicates the number of ordered combinations that give a particular product. An ordered combination would consider the permutations possible with a specific combination of numbers.

TABLE A1. 4-NUMBER ORDERED COMBINATIONS AND THEIR PRODUCTS
($1 \leq$ each number ≤ 9) (Continued through page E-42)

Product	Number Ordered Combinations Giving Product	Product	Number Ordered Combinations Giving Product	Product	Number Ordered Combinations Giving Product
1	1	50	12	168	84
2	4	54	52	175	12
3	4	56	40	180	84
4	10	60	60	189	28
5	4	63	24	192	88
6	16	64	44	196	18
7	7	70	24	200	24
8	20	72	112	210	48
9	10	75	12	216	116
10	12	80	48	224	48
12	36	81	19	225	18
14	12	84	60	240	84
15	12	90	60	243	16
16	31	96	96	245	12
18	36	98	12	250	4
20	24	100	18	252	84
21	12	105	24	256	31
24	64	108	88	270	60
25	6	112	48	280	48
27	16	120	84	288	120
28	24	125	4	294	24
30	36	126	60	300	24
32	40	128	40	315	36
35	12	135	28	320	40
36	72	140	36	324	72
40	40	144	132	336	84
42	36	147	12	343	4
45	24	150	24	350	12
48	88	160	48	360	96
49	6	162	52	375	4

TABLE A1. (Continued).

Product	Number Ordered Combinations Giving Product	Product	Number Ordered Combinations Giving Product	Product	Number Ordered Combinations Giving Product
378	60	756	60	1372	4
384	64	768	36	1400	12
392	24	784	18	1440	36
400	18	800	12	1456	16
405	24	810	36	1470	12
420	48	840	48	1512	52
432	112	864	76	1536	16
441	18	875	4	1568	12
448	40	882	24	1575	12
450	24	896	24	1600	6
480	60	900	18	1620	24
486	36	945	24	1680	24
490	12	960	36	1701	12
500	4	972	36	1715	4
504	96	980	12	1728	40
512	20	1000	4	1764	18
525	12	1008	72	1792	12
540	60	1024	10	1800	12
560	36	1029	4	1890	24
567	24	1050	12	1920	12
576	88	1080	52	1944	28
588	24	1020	24	1960	12
600	24	1025	4	2016	36
625	1	1134	36	2025	6
630	48	1152	48	2048	4
640	24	1176	24	2058	4
648	76	1200	12	2106	24
672	60	1215	12	2187	4
675	12	1225	6	2205	12
686	4	1260	36	2240	12
700	12	1280	12	2268	24
720	72	1296	55	2304	18
729	10	1323	12	2352	12
735	12	1344	36	2401	1
750	4	1350	12	2430	12

TABLE A1. (Continued).

Product	Number Ordered Combinations Giving Product	Product	Number Ordered Combinations Giving Product	Product	Number Ordered Combinations Giving Product
2520	24	3072	4	3969	6
2560	4	3087	4	4032	12
2592	24	3136	6	4096	1
2646	12	3240	12	4374	4
2688	12	3402	12	4536	12
2744	4	3456	12	4608	4
2835	12	3528	12	5103	4
2880	12	3584	4	5184	6
2916	10	3645	4	5832	4
3024	24	3888	12	6561	1

APPENDIX B': SURVEY OF PROPAGATION- PREDICTION PROGRAMS*

Introduction

Use of digital computers for propagation calculations has grown with the computer development. Thus a step-at-a-time advance in this use has occurred with initial applications in the hf spectral region. No comprehensive programs adapted to the entire spectrum exist. Various groups have produced programs restricted to use in appropriate spectral regions.

In the spectral range from vlf to microwaves the most intense effort toward computer solutions has been made in the hf and vlf regions. Nearly every hf solution in existence can trace its origin to the procedures developed at Central Radio Propagation Laboratory (CRPL). The programs provide estimates of maximum usable frequencies (MUF), field strength, signal-to-noise ratio, and hop structure. The vlf programs depend generally upon solutions of the modal equations for the earth-ionosphere wave guide.

Less effort has been devoted to generating programs for frequencies above hf, mostly because adequate solutions for system design are available rather directly by non-machine procedures. A general exception to this statement are the ray-trace programs, which have been adapted to machine programs extensively. These programs provide a picture of the energy distribution on the space illuminated by the antenna. Programs of this kind exist for hf ionospheric scatter from 30 to 100 megacycles, and for tropospheric ducting in the microwave region. Most provide some kind of estimate of signal loss as well as the primary ray-trajectory output.

Propagation-prediction programs have been generated at the following facilities:

1. ITSA, ESSA, U.S. D.O.C. (CRPL)
2. NRL
3. Stanford University
4. Stanford Research Institute
5. DECO Electronics, Inc.
6. Collins Radio Corporation
7. Raytheon Corporation
8. NEL
9. AVCO Corporation
10. RCA
11. USRPA, Ft. Monmouth
12. DRTE, Canada
13. Radio Research Laboratories, Tokyo, Japan

*The survey of propagation-prediction programs was generated specifically for this problem by personnel of the NEL Radio Physics Division under the direction of C. H. Freres.

14. Radio Research Station, Slough, England

15. Ion Prediction Service, Sydney, Australia

In addition both DCA and NAVCOSSACT employ a wide range of computer prediction programs.

Brief summaries of programs about which NEL's Radio Physics Division has more than superficial knowledge follow. They are intended to do no more than indicate the scope and intended use of the programs. A program-characteristic matrix that provides some comparison detail is appended.

NEL High-Frequency Propagation-Prediction Computer Program

Radio system parameters are combined with geophysical and ionospheric characteristics to predict the performance of high-frequency sky-wave communication circuits. The program computes Maximum Usable Frequencies (MUF), probable modes of propagation, E layer MUF and cutoff frequencies, angles of arrival, ground losses, total losses, field strength, antenna gains, absorption losses, signal strength, noise strength, and signal-to-noise ratios. In contrast to the CRPL program, the program utilizes hf characteristic charts for critical frequencies and atmospheric noise (CCIR report 65). The solution is divided into two parts – an estimation of the field strength independent of equipment parameters, and an estimation of signal-to-noise ratio using antenna gains. The program was written for the CDC 1604 computer and is in NELIAC 5m. There is an output for every operational mode, whereas the CRPL outputs only for the optimum mode. Computer time is less than for the CRPL program.

AVCO Polar HF Prediction Program

This program determines the highest and lowest frequencies available between two particular stations as a function of time, and the geophysical and ionospheric parameters. Propagation losses are determined for specific frequencies within this calculated range. The calculation is extended to ionospherically disturbed conditions, but all calculations are valid only for high sunspot number. The computer program is written in standard Fortran and includes 19 modes of propagation. Frequencies from 3 to 30 Mc/s in intervals of 3 Mc/s are considered. The program prints mode, transmission angle, and available frequency range. In addition, it prints space, absorption, sporadic E, and total losses for each test frequency within the available frequency range.

CRPL Propagation - Prediction Program

Radio system parameters are combined with geophysical and ionospheric characteristics to predict the performance of high-frequency sky-wave communication circuits. The program computes maximum usable frequencies, optimum traffic frequencies, lowest useful frequencies, probable modes of propagation, angles of arrival, circuit reliability, system loss, available signal-to-noise ratios, and field strength. Numerical representation is used for all parameters not expressed in closed mathematical form, such as world maps of critical frequency and atmospheric noise. The solution of the problem is divided into two parts – an estimation of the available signal, and an estimation of the required signal. The program was initially written for IBM 7090-class computers and was translated at NEL to Fortran **63** for the CDC **1604**. At a later date, NEL added CCIR report 322 noise data to the program. In the 322 version the calculations of circuit reliability cannot be made.

Collins Radio HF Program

The program is similar to that used by NBS and yields comparable data. The differences are in the calculation of Lowest Usable Frequency (LUF) and auroral absorption. At present, the median noise levels are used to calculate the frequency that satisfies the loss equation; this frequency is called the LUF. In the NBS program for LUF, the loss equation is solved by trial and error for a reliability of 90 percent, taking into account changes of mode with a two-dimensional antenna gain function. In the NBS program, the additional loss is determined by the F2-layer control point location. In the Collins method, the average of two absorption indices is calculated from geomagnetic coordinates of the rays.

Input insertion of links is unique. As many as **150** stations are permitted with as many as 200 combinations of stations as links.

Canada DRTE HF Program

This program computes the maximum usable frequency (MUF) and lowest usable frequency due to E layer cut-off of the F layer for a given mode or modes. The basic ionospheric data used for the prediction of the F2 and E layer MUF are obtained from DRTE's manual prediction system.

VLF Program (Pappert) - NELIAC MOD 7 (1604)

The program solves the earth-ionosphere wave-guide mode equation. In general, Budden's formalism is employed. Solutions to Stokes' equation in

AMCP 706-191

terms of third-order modified Hankel functions are employed to determine the reflection matrix solution to the problem of the three-layer boundary value. Gossard's solution for the upgoing wave is incorporated in the Pappert solution.

Required program inputs are the initial admittance matrix (Gossard-Smith program), profile increment, integration limits, path data, geophysical data, and control parameters.

The program output lists the characteristic mode angles, phase velocity, attenuation, excitation factor, and modulus of the polarization vector.

VLF Program (Smith/Gossard)

A full-wave solution is made for electromagnetic propagation in a continuous ionosphere with arbitrary parameters (electron density and collision frequency). Budden's solution is the basis.

Inputs are initial conditions at high altitude, height, complex angle of incidence, propagation angle, dip angle and magnetic field strength, frequency, collision frequency, and vertical profile of electron density.

The basic program output is the reflection coefficient matrix expressed in polar coordinates as a function of height.

The program employs a procedure for finding an appropriate initial value for the reflection coefficient prior to performing the real ionosphere integration.

DECO Program

This program predicts the mean intensity of atmospheric noise for any frequency for which a wave-guide model of earth-ionosphere is acceptable. The wave-guide mode equation is used. The program assumes that the mean noise intensity at a receiver may be simulated by properly combining fields produced by a number of transmitters that replace the actual thunderstorm sources.

The program output is the summed field intensities for given locations and times. With an appropriate plotter worldwide contour maps of noise intensities can be produced.

DECO Program (NEL Variation)

The basic DECO program will be modified to provide predictions for the phase and amplitude of given transmitters for any location on the earth.

Kift-fooks Ray Trace (Stanford/NEL Version)

This program employs a simplified approximate procedure for tracing rays between a terminal pair. It provides an assessment of possible hop structures, using a zeroing-in procedure to reject all rays not within ± 100 km of the receiving point. The ionospheric model is keyed to the CRPL predictions, but represents the layers as parabolic and concentric. The magnetic field effects are not included.

The output includes the path modes, frequency, take-off angles, great-circle path length, travel time along the ray path, ionospheric absorption loss (only) along route, and the maximum usable frequency.

The inputs required are the terminal coordinates, the appropriate CRPL predicted ionosphere or a measured set of vertical soundings, declination of sun, frequencies, range take-off angle aperture, and time. E_s layers may be included "after the fact."

Separate auxiliary programs provide for tape-loading the CRPL ionosphere, and for plotting the outputs on the **160-A** printer.

Ray Trace Program (Sheddy)

The Haselgrove equations are used to trace ray paths in three dimensions in a model ionosphere. The ionospheric model is a three-dimensional combination of parabolic layers and CRPL (Gallet-Jones) world maps. It traces both ordinary and extraordinary rays. No special provision has been made to use values of frequency below the gyro frequency.

Input parameters are terminal coordinates or azimuth and maximum distance, elevation angle, frequency, year, month, and hour.

Outputs include great-circle path length, ray angle, ray height, and geographic coordinates at each computed point.

The program permits ready substitution of alternate ionospheric models.

Characteristics/Source	NEL/hf	AVCO/hf	CRPL/hf	Collins/hf	Canada DRTE/hf	Ionosscatter SRI	SRI Trop Scatter	NEL/vlf (Pappert)	NEL/vlf (Smith-Gossard)	DECO/vlf	NEL/Standard Kift/ Fooks Raytrace	NEL Stredy ^{dyce}
<u>General</u>												
Computer	CDC 1604	IBM 7094	IBM 7090 CDC 1604	Unknown	IBM 650	IBM 7090	IBM 7090	CDC 1604	CDC 1604	CDC 3600	CDC 1604	CDC 1604
Language	NELIAC 5M	FORTRAN	FORTRAN	Unknown	Unknown	FORTRAN	FORTRAN	NELIAC 7*	NELIAC	FORTRAN	FORTRAN	FORTRAN
Geographic Limitations	None	None	None	None	Northern Latitudes	None		None	None	None	None	None
Ionospheric Model	Graphical Representation of ionospheric data	Numeric map	Numeric map	Same as CRPL	DRTE/RPL ion para. and mono-	Same as NEL/hf					Numeric map	Numeric map
Availability	In-house	Unknown	In-house	Unknown	Unknown			In-house	In-house	In-house	In-house	In-house
Speed	480 modes minute	400 modes minute		Unknown	3 min/mo. of MUF, LUF data							
Special features	Detailed output and 14 types of antennas	Consider disturbed ionosphere	3 antenna types	Auroral zone absorption and 6 antenna types	Include IF layer	Includes jamming	Considers jamming					
Frequencies	3-30 Mc/s	3-30 Mc/s	3-30 Mc/s	3-30 Mc/s	3-30 Mc/s			10-30 kc/s	10-30 kc/s	10-30 kc/s	3-30 Mc/s	3-30 Mc/s
<u>Inputs</u>												
Year	No	Yes	No	No		No					Yes	
Month	Yes	Yes	Yes	Yes	Yes	Yes					Yes	
Sunspot number	Yes	Yes	Yes	Yes	Yes	Yes					Yes	
Jammer coordinates							Yes					
Transmitter coordinates	Yes	Yes	Yes	Yes	Yes	Yes	Yes				Yes	Yes
Transmitter altitude							Yes					
Receiver coordinates	Yes	Yes	Yes	Yes	Yes	Yes	Yes				Yes	Yes
Effective receiver temperature							Yes					
Path length	No	No	No	No								Opt
Receiver altitude							Yes					Opt
Azimuth	No	No	No	No								
Surface refractivity at R&T							Yes					
Power	Yes	No	Yes	Yes		Yes	Yes					
Frequencies	Yes	No	Yes	No		Yes					Yes	
Antenna pattern	No	No	opt.	Yes		Yes	Yes				No	

Characteristics/Source	NEL/hf	AVCO/hf	CRPL/hf	Collins/hf	Canada DRTE/hf	Ionoscat SRI	SRI Trop Scatter	NEL/vlf (Pappert)	NEL/vlf (Smith- Gossard)	DECO/vlf	NEL/Standard Kift/Fooks Raytrace	NEL Sheddy Raytrace
Inputs (Continued)												
Antenna bearing	Opt.	No	Opt.	No		Yes					No	
Launch elevation angle												Yes
Man made noise	Opt.	No	Opt.	No								
Universal time	Yes	Yes	No	Yes		Yes	Yes				Yes	
Day of month	No	Yes	No	No								
Day of year	No	Yes	No	No								
Magnetic index, Kp	No	Yes	No	No								
Ionospheric storm parameters	No	Yes	No	No								
Required S/N	No	No	Yes	Yes								
BOW	Yes	No	No	Yes		Yes	Yes					
Outputs												
Absorption losses	Yes	Yes	No								Yes	
Space losses	Yes	Yes	No									
Sporadic E losses	No	Yes	No									
Ground losses	Yes	No	No									
Field strength	Yes	No	Yes									
Reflection coeffi- cients									Yes			
Signal strength	Yes	No	No				Yes			Yes		
Antenna gains	Yes	No	Yes	Yes								
Noise	Yes	No	No				Yes					
Delay time	No	No	No								Yes	Yes
Effective height	Yes	No	No									
Transmission angle	Yes	Yes	Yes								Yes	
M ₃₀₀₀ transmission angle	Yes	No	No									
Modes	Yes	No	Yes								Yes	
MUF-HAF	Yes	Yes	Yes	Yes							Yes	
Service Probability, reliability	No	No	Opt									
LUF	No	Yes	Opt	Yes	Yes							
FOT	No	No	Opt	Yes								
Signal-to-noise ratio	Yes	No	Yes				Yes					
Auroral Zone Absorption	No	Yes	No									

Characteristics/Source	NEL/hf	AVCO/hf	CRPL/hf	Collins/hf	Canada DRTE/hf	Ionoscatte SRI	SRI Trop Scatter	NEL/vlf (Pappert)	NEL/vlf (Smith- Gossard)	DECO/vlf	NEL/Standard Kift/Fooks Raytrace	NEL Sheddy Raytrace
<u>Outputs (Continued)</u>												
Equatorial Zone Absorption	No	No	No									
E MUF	Yes	No	No	Yes								
Path identification	Yes	Yes	Yes	Yes	Yes	Yes	Yes				Yes	
Path length											Yes	Yes
Time, month	Yes	Yes	Yes	Yes	Yes	Yes	Yes				Yes	
Year or sunspot number	Yes	Yes	Yes	Yes	Yes	Yes					Yes	
Power	Yes	No	Yes	Yes								
Frequencies opera- ting	Yes	Yes	Yes				Yes				Yes	
Reflection Point Coord.												Yes
Layer height	Yes	Yes	No									
Ray height												Yes
Total losses	Yes	Yes	opt.									
BDW	No	No	No	Yes								
Required S/N	No	No	Yes	Yes		Yes						
Turbulent signal component						Yes						
Meteor signal component						Yes						

MC 706-191

E-50

APPENDIX C⁰: DATA TYPE AND SOURCE

<u>Data Type</u>	<u>Data Source</u>
Average Prices of Navy Electronic Equipment	Bureau of Ships NavShips 92,563(B), <u>Index to Bureau of Ships Controlled Electronics Equipment (F Cognizance)</u> , 15 March 1963
General Characteristics of AN type Electronic Equipment by AN designation	Bureau of Ships NavShips 900,123(D), <u>Nomenclature Assigned to Naval Electronic Equipment</u> , CONFIDENTIAL, August 1963
Equipment Characteristics and some price information	Bureau of Ships NavShips 94,200.01, <u>Directory of Communication Equipment</u> , SECRET, April 1964
	Bureau of Ships NavShips 94,200.0100, <u>Directory of Classified Electronics Major Units</u> , CONFIDENTIAL, January 1964
	Bureau of Ships NavShips 94,200.1, Section 1, <u>Directory of Communication Equipment</u> , n.d.
	Bureau of Ships NavShips 94,200.1, Section 2, <u>Directory of Communication Equipment</u> , n.d.
	Bureau of Ships NavShips 94,200.1, Section 3, <u>Directory of Communication Equipment</u> , n.d.
	Bureau of Ships NavShips 94,200.1, Section 4, <u>Directory of Communication Equipment</u> , n.d.
	Bureau of Ships NavShips 94,200.1, Section 5, <u>Directory of Communication Equipment</u> , n.d.
	Bureau of Ships NavShips 94,200.1, Section 6, <u>Directory of Communication Equipment</u> , n.d.
	Bureau of Ships NavShips 94,200.1, Section 7, <u>Directory of Communication Equipment</u> , n.d.

**Bureau of Ships NavShips 94,200.1,
Section 8, Directory of Communication
Equipment, n.d.**

**Bureau of Ships NavShips 94,200.1,
Section 9, Directory of Communication
Equipment, n.d.**

**Equipment Characteristics
and specification MTBF value**

Ships Specifications

**Equipment Cost,
Quantity and Date of procurement**

**F Cognizance
Material Control Branch
(Code 6627)**

**Electronic Equipment
MTBF and MTTR values**

**Fleet Electronic Effectiveness Branch
(Code 6678)**

APPENDIX D: MULTIPLE-REGRESSION ANALYSIS 9

Regression analysis presupposes that some relationship exists between a dependent variable Y and one or more independent variables $X_1, X_2, X_3, \dots, X_n$. The simplest case is approximated by the linear equation of the form

$$Y = \beta_0 + \sum_{i=1}^n \beta_i X_i + e'$$

β_i are the parameters in a one-dimensional space generated by the regression plane. The quantity e' represents the random or simple error in the variation of Y not accounted for in the regression plane. General transformations such as $X_1' = 1/X_1$ or $X_2' = X_2^2$ will yield an equivalent form of the foregoing equation.

The true values of constants $\beta_0, \beta_1, \beta_2, \dots, \beta_n$ can never be determined. However, estimates of these constants can be obtained from m observations of Y and corresponding X_i values. A simple way of writing the m observations is in the form of a table as shown below:

	X_1	X_2	X_n
Y_1	a_{11}	a_{12}	a_{1n}
Y_2	a_{21}	a_{22}	a_{2n}
				..
Y_m	a_{m1}	a_{m2}	a_{mn}

The linear estimating equation then has the form

$$Y = a_0 + \sum_{i=1}^n a_i X_i + e$$

where

a_i is the regression coefficient and is an estimate of the true but unknown coefficient β_i

e is the residual of the true Y about the regression plane

X_i is the independent variable

Several assumptions are made about the independent and dependent variables that permit significance tests and confidence interval estimates to be made.

These assumptions also lend themselves to the least-squares method of estimating the value of a_i .

These assumptions are

1. All X_i 's are fixed variables (that is, there are no probability distributions).

2. The Y's are all normally and independently distributed about the mean $(a_0 + \sum_{i=1}^n a_i X_i)$ with variance σ^2 .

The least-squares method minimizes the sum of squares of deviation (G) from the estimated regression plane.

$$G = \sum_{j=1}^m e_j^2$$

$$G = \sum_{j=1}^m \left[Y_j - \left(a_0 + \sum_{i=1}^n a_i X_{ij} \right) \right]^2 \tag{D1}$$

Graphical procedures are used to determine the form and transformations required in the linear regression equation.

Multiple-regression analysis makes use of several statistical tests to determine the significance of coefficients and equations. The F-test determines whether the form of the equation is statistically significant. The t-test checks the significance of the partial-regression coefficients. The multiple-correlation coefficient R gives the degree of correlation between the dependent variable Y and the independent variables $X_1, X_2, X_3 \dots X_n$. A more detailed discussion of these tests follows.

Multiple-Correlation Coefficient R

The square of the multiple-correlation coefficient is defined as the fraction of the total variance of Y which is contributed by its regression upon the variables $X_1, X_2, \dots X_n$.

$$R^2 = \frac{\sum_{i=1}^n a_i \sum_{j=1}^m X_{ij} Y_j}{\sum_{j=1}^m Y_j^2}$$

The foregoing is obtained by expanding equation D1 and grouping into total sum of squares (denominator) and the sum of squares due to regression (numerator).

A value of zero gives no correlation between Y and $X_1, X_2, \dots X_n$, whereas a value of 1 means all sample points lie on the regression plane.

F Ratio Test

The F-test determines whether the form of the regression equation is statistically significant by comparing a calculated F value with a critical F for

(n) and (m-n-1) degrees of freedom at a preselected significance level of alpha

$$F = \frac{R^2(m-n-1)}{(1-R^2)(n)}$$

If the calculated value of F is greater than the critical value of F, then the null hypothesis that all $a_i = 0$ is rejected and the overall regression is judged to be significant for the alpha significance level.

The F-test compares the sum of the squares due to regression with the sum of squares due to error.

Student t Distribution

The variable t has the Student t distribution.

$$t = \frac{\bar{X} - \mu}{s} \sqrt{n} \quad \text{or} \quad t = \frac{\bar{X} - \mu}{s/\sqrt{n}} = \frac{\bar{X} - \mu}{s'}$$

where

\bar{X} = is the arithmetic mean of the data selected for a random sample of size n
 s = is the standard deviation of this random sample, and s/\sqrt{n} is the standard error, s' of \bar{X}

μ = is the arithmetic mean of all the values composing a normal population that has a standard deviation σ .

If the calculated value of t exceeds the critical value of t for the significance level selected and m-n-1 degrees of freedom, it can be said there is probability α that the actual divergence of the sample mean occurred simply by chance.

For n greater than 30, the normal distribution gives a sufficiently precise approximation; for $n \leq 30$ the t distribution should be used.

The level of significance indicates the probability of obtaining a value of t outside the range of $\pm t$ (critical), for the degrees of freedom from 1 to 30, purely as a result of random sampling variation.

APPENDIX E: METHOD OF STEEPEST DESCENT

The method of steepest descent is an optimization procedure that will locate an extreme value (in this case a minimum) of a criterion function. The method can be extended to functions with constraints. Changing the sign of the criterion function interchanges the roles of the extreme values. For example, the minimum of $F(x, y, z)$ is the maximum of $-F(x, y, z)$.

The method of steepest descent uses successive approximations to find an extreme value of the criterion function. Each new point P_{i+1} is determined from the expression

$$P_{i+1} = (x_{i+1}, y_{i+1}, z_{i+1}) = (x_i, y_i, z_i) - \lambda \left(\frac{\partial F}{\partial x}, \frac{\partial F}{\partial y}, \frac{\partial F}{\partial z} \right) \Big|_{(x_i, y_i, z_i)}$$

In this expression $\left(\frac{\partial F}{\partial x}, \frac{\partial F}{\partial y}, \frac{\partial F}{\partial z} \right)$ is the gradient of F (denoted ∇F) and is a vector in the direction of greatest increase of F .

That the gradient is in the direction of greatest increase can be seen from the following argument:

$$\begin{aligned} dF &= \frac{\partial F}{\partial x} dx + \frac{\partial F}{\partial y} dy + \frac{\partial F}{\partial z} dz \\ &= \nabla F \cdot d\vec{P} \\ &= |\nabla F| |d\vec{P}| \cos \theta \end{aligned}$$

This expression for the differential or increment in F is greatest when θ is 0; that is, when the gradient and the increment in the parameter vector are co-directional.

The constant λ ($\lambda > 0$) is a scalar indicating the step size for the next set of coordinates in the direction of the gradient. The use of $-\lambda \nabla F$ indicates that the path P_1, P_2, \dots, P_n leads in the steepest direction to a maximum of $-F$; that is, to a minimum of F . Thus, the name "method of steepest descent."

Following the selection of a new point, the criterion function is evaluated. If $F(x_{i+1}, y_{i+1}, z_{i+1}) < F(x_i, y_i, z_i)$ and the variables remain within present bounds, the point \vec{P}_{i+1} becomes the new point of departure for finding \vec{P}_{i+2} . If not, a new λ is chosen. There are several ways of choosing λ , giving rise to variations of the method.

When the magnitude of the gradient becomes zero, it is concluded that F has reached a minimum. However, three things can happen to contravene a valid solution:

1. the minimum may be a local minimum,
2. the point may be on a ledge, or
3. the point may be a saddle point.

In either of cases 2 or 3, further variation of the variables would produce a further decrease in F .

The method of steepest descent is adaptable to problems with constraints of two types:

$$f(x,y,z) = a \quad (i)$$

$$g(x,y,z) \leq b \quad (ii)$$

A constraint of type (i) can be written $f(x, y, z) - a = 0$ so that z is defined as an implicit function of x and y ,

$$z = \phi(x,y).$$

Then $F(x, y, \phi(x,y)) = G(x,y)$, and

$$\nabla F = \left(\frac{\partial G}{\partial x}, \frac{\partial G}{\partial y} \right)$$

where

$$\frac{\partial G}{\partial x} = \frac{\partial F}{\partial x} + \frac{\partial F}{\partial z} \frac{\partial z}{\partial x} \quad \text{and} \quad \frac{\partial G}{\partial y} = \frac{\partial F}{\partial y} + \frac{\partial F}{\partial z} \frac{\partial z}{\partial y}$$

The partial derivatives $\frac{\partial z}{\partial x}$ and $\frac{\partial z}{\partial y}$ are evaluated with the aid of a theorem on the differentiation of an implicit function that states that

$$\frac{\partial z}{\partial x} = - \frac{\frac{\partial f}{\partial x}}{\frac{\partial f}{\partial z}} \quad \text{if} \quad \frac{\partial f}{\partial z} \neq 0, \text{ and similarly for } \frac{\partial z}{\partial y}$$

Each constraint equation has the effect of eliminating one variable from the problem. In the case discussed, the variable eliminated is z , since the function f specifies it as dependent upon x and y . This is the key to the problem with constraints of type (ii). As long as the constraint is satisfied, the problem is treated as one with no constraints. As soon as the constraint is violated by some point (x_i, y_i, z_i) , the equality sign is assumed to hold, and the problem is treated as one with a type (i) constraint.

The method of steepest descent has one major liability; namely, the local minimum nearest the initial point (x_1, y_1, z_1) will be found. If the function has more than one local minimum, the true (global) minimum may be missed. The programmer should have some idea of what answer to expect in order to eliminate possible spurious answers by a wise choice of the initial values of x , y , and z .

APPENDIX F: LIST OF SYMBOLS

In most cases in this report the relationship between capital and lower-case symbols is: $F = 10 \log_{10} f$

B	= Bandwidth relative to 1 kc/s
c	= Number of channels
C_f	= Confidence factor
D	= Frequency shift ≈ 42.5 c/s
E_n	= Equivalent vertically polarized ground-wave root-mean-square noise field strength in dB above $1\mu\text{V/m}$ for 1-kc/s bandwidth
F	= Effective receiver noise figure
F_a	= Effective antenna noise figure
F_c	= Effective receiver antenna coupler noise figure
f_0	= Center frequency of frequency range f_{bw}
f_m	= Band width of low-pass filter
f_r	= Receiver noise figure
f_t	= Transmission line noise figure
f_x	= Operating frequency in x units of c/s
f_{bw}	= Frequency range
G_r	= Receive antenna gain
G_t	= Transmit antenna gain
hf	= High frequency
K	= Boltzmann constant 1.38 $\times 10^{-23}$ W/°K c/s
L_p	= Propagation path loss
m	= Order of frequency diversity
N_0	= Noise power per 1-c/s bandwidth
P_e	= Bit error rate
P_t	= Average transmitter power
Q	= Quantity of units
R	= ST_0/N_0 = normalized post-detection S/N ratio
r_{ct}	= Transmit antenna coupler VSWH
RPRE	= Predetection S/N ratio
S_r	= Receiver stability, PPM
S_t	= Transmitter stability, PPM
T	= Temperature (°K)
T_0	= Baud length (pulse length)
vlf	= Very low frequency
a	= Standard error

Appendix G: REFERENCES

1. Navy Electronics Laboratory Report 1323, Cost Effectiveness in Communication Systems, by W. R. Dishong and R. O. Eastman, 1 October 1965
2. Quade, E.S., Analysis for Military Decisions, p. 160, Rand McNally, 1964
- 3A. Koopman, B.O., "Fallacies in Operations Research," Operations Research, v.4, p.422-426, August 1956
- 3B. Hitch, C., "Comments on 'Fallacies in Operations Research,' " Operations Research, v.4, p.426-430, August 1956
4. Kazanowski, A. D., "Cost Effectiveness Fallacies and Misconceptions Revisited(Abstract)," Operations Research, v. 14, Suppl. 1, p. B-80, Spring 1966
5. Rand Corporation Memorandum RM-1937, Ten Common Pitfalls, by H. Kahn and I. Mann, 17 July 1957
6. Navy Electronics Laboratory Report 1358, High-Frequency Propagation Prediction Program For the CDC 1604 Computer, by D.B. Sailors, 28 February 1966
7. Radio Corporation of America Laboratories Technical Report PTR-1281, SOP, A Computer Program to Optimize System Design, by J. A. Goodman, 9 August 1962
8. Smyth Research Associates SRA-452, Design Study of a Fleet Broadcast System Covering HF Bands, Final Report, July 1965
9. Neville, A.M. and Kennedy, J.B., Basic Statistical Methods For Engineers and Scientists, International Textbook Company, 1964

INDEX

- Alternative Systems
 - Identify Basic Alternatives, 2-12 to 2-15
 - Synthesize Alternative Systems, 2-10 to 2-17
- Alternatives, 1-8
- Application of SA/CE, 1-12 to 1-16
- Analytic Models, 3-2, 3-28 to 3-30
- Army Force Development Plan (AFDP), 2-1
- Assumptions, 2-6, 2-26, 2-69
- Availability, 2-21
 - Calculation of, 2-33, 2-40, 2-41
- Calculus of Variations, 3-30
- Capability, 2-23
 - Calculation of, 2-34, 2-39
- Characteristics
 - Develop Hardware Characteristics, 2-17 to 2-18
- Combat Development Objective Guide (CDOG), 2-3
- Concept Formulation
 - Application of SA/CE during, 1-14 to 1-16
- Contract Definition
 - Application of SA/CE during, 1-14 to 1-16
 - Prerequisites to, 1-14 to 1-15
 - Requirements for, 1-15
- Cost Analysis, 1-9, 2-43 to 2-54
 - Cost Analysis Problem, 2-51 to 2-54
 - Cost Categorization, 2-44
 - Cost Commensurability, 2-49
 - Cost Estimating Relationship, 2-48, 3-31 to 3-39
 - Cost of Maintenance Manpower, 2-53
 - Cost of Supply Manpower, 2-54
 - Cost Model, 2-25
 - Cost Uncertainty, 2-49
 - Experience Curves, 3-39
 - Incremental Costing, 2-43, 2-47
 - Investment Costs, 2-44, 2-45, 2-46
 - Material Costs at Supply, 2-53
 - Operating Costs, 2-44, 2-46
 - R & D Costs, 2-44, 2-45
 - Sensitivity Analysis, 2-44, 3-41 to 3-45
 - The RAND Method, 2-43

INDEX (continued)

- Cost-Effectiveness
 - Array of CE Characteristics, 2-71
 - Application of, 1-12 to 1-16
 - Application of, to Concept Formulation and Contract Definition, 1-14 to 1-16
 - Background and History of, 1-5 to 1-7
 - Combination with Systems Analysis, 1-7
 - Definition of, 1-2
 - Examples of CE Curves, 2-72
 - Limitations of, 1-17 to 1-19
 - Methodology of (Detailed), Chapter 2
 - Methodology of (General), 1-7 to 1-12
 - Requirement for During Life Cycle, 1-12 to 1-13
 - See also, Cost
 - See also, Effectiveness
- Cost Sensitivity Analysis, 3-41 to 3-45
- Criteria, 1-9
- Data
 - Collection of, 2-50
 - Statistical Analysis of Test Data, 4-28 to 4-71
- Decision Theory, 3-2, 3-30, 3-31
- Definitions of Cost-Effectiveness, 1-2
- Definitions of Systems Analysis, 1-1, 1-4
- Dependability, 2-22
 - Calculation of, 2-33, 2-40
- Dynamic Programming, 3-2, 3-16 to 3-17
- Economic Welfare Theory
 - As it Relates to Cost-Effectiveness, 1-6
- Effectiveness
 - Availability, 2-21
 - Basis for Evaluating, 2-18 to 2-24
 - Capability, 2-23
 - Define Measures of, 2-24
 - Dependability, 2-22
 - Effectiveness Equations, 2-29 to 2-30
 - Effectiveness Model, 2-25
 - Elements of Effectiveness, 2-20
 - System Effectiveness, 2-20
 - System Effectiveness Problem, 2-31 to 2-42
- Experience Curves, 3-39 to 3-41
- Game Theory, 3-2, 3-17 to 3-22

INDEX (continued)

- History of Cost-Effectiveness, 1-5 to 1-7
- History of Systems Analysis, 1-2 to 1-5
- Incremental Costing, 2-43, 2-47
- Information Theory, 3-2, 3-22 to 3-28
- Inventory and Replacement, 3-2, 3-9 to 3-11
- Investment Cost, 2-44
- Kolmogorov-Smirnov Test, 4-40
- Lanchester's Equations, 3-28 to 3-30
- Leverage Effects, 2-66 to 2-67
- Limitations of SA/CE, 1-17 to 1-19
- Linear Programming, 3-2, 3-12 to 3-16
- Maintainability
 - Confidence Limits for Maintainability Functions, 4-36
 - Maintainability Functions, 4-35
 - Point and Internal Estimates of, 4-30
- Methodology of SA/CE
 - General, 1-7 to 1-12
 - Detailed, Chapter 2
- Mission Profiles, 2-7 to 2-9
- Models, 1-9
 - Analytic Models, 3-2, 3-28 to 3-30
 - Cost Model, 2-25
 - Decision Model, 2-62 to 2-69
 - Effectiveness Model, 2-25
 - Exercise of, 2-55 to 2-62
 - Formulate, 2-25 to 2-28
 - Gaming Models, 2-28
 - Mathematical, 2-27
 - Operational Exercise, 2-28
 - Simulation Models, 2-28
 - Types of, 2-27
- Objectives, 1-8
- Operating Costs, 2-44

INDEX (continued)

- Optimization
 - Criterion, 2-62
 - List of Techniques, 2-66
- Output Results, 2-70 to 2-73
- Performance Parameters, 2-9 to 2-10
- Prerequisites to Contract Definition, 1-14 to 1-15
- Probability
 - Basic Laws, 4-4 to 4-9
 - Definition, 4-2
 - Distributions, 4-9 to 4-27
- Qualitative Material Development Objective (QMDO), 1-12, 2-3
- Qualitative Material Requirements (QMR), 1-12, 2-3, 2-5
- Queueing Theory, 3-2, 3-3 to 3-7
- Reliability
 - Applications of, 4-25 to 4-28
 - Confidence Limits for Reliability Functions, 4-36
 - Point and Internal Estimates of, 4-30
- Requirements
 - Defining, 2-5 to 2-7
- Research and Development Costs, 2-44, 2-45
- Sensitivity Analysis, 2-43, 2-62, 3-41 to 3-45
- Sequencing and Markov Processes, 3-2, 3-7 to 3-9
- Simulation, 3-2, 3-3
 - Models, 2-28
- Small Development Requirements (SDR), 2-3
- State-of-the-Art Analysis, 2-16
- System
 - Total System, 2-10 to 2-11
 - See also, Alternative Systems
- Systems Analysis
 - Application of, 1-12 to 1-16
 - Application of, to Concept Formulation and Contract Definition, 1-14 to 1-16
 - Background and History of, 1-2 to 1-5
 - Combination with Cost Effectiveness, 1-7
 - Definition of, 1-1, 1-4
 - Limitations of 1-17 to 1-19

INDEX (continued)

- Systems Analysis (~~continued~~)
 - Methodology of ~~Continued~~ Detailed), Chapter 2
 - Methodology of [General], 1-7 to 1-12
 - Nonmilitary use of, 1-5
 - Requirement for during Life Cycle, 1-12 to 1-13
- Trade-off Analyses, 2-57 to 2-62
 - Interdependence Between Trade-off Studies and Project Objectives, 2-61
 - Performance Parameter Trade-offs, 2-59
 - Performance vs. Cost Trade-offs, 2-59
- Uncertainty, 2-26, 2-69
 - Confidence Intervals 3-32 to 3-35
 - Cost Uncertainty, 2-49 to 2-50
 - Expressions of, 2-57
 - Risk and Uncertainty, 2-64, 2-65
- Weibull Distribution, 4-60
- WSEIAC, 2-19
 - Availability, 2-21
 - Capability, 2-23
 - Dependability, 2-22
 - Effectiveness Equations, 2-29 to 2-30

(AMCRD-TV)

FOR THE COMMANDER:

OFFICIAL:

R. D. Lewis
W. J. PHILLIPS *Major, GS*
Colonel, GS
Chief, HQ Admin Mgt Ofc

CHARLES T. HORNER, JR.,
Major General, USA
Chief of Staff

DISTRIBUTION :
Special

ENGINEERING DESIGN HANDBOOKS

Listed below are the Handbooks which have been published or are currently under preparation. Handbooks with publication dates prior to 1 August 1962 were published as 20-series Ordnance Corps Pamphlets. AMC Circular 310-38, 19 July 1963, redesignated those publications as 706-series AMC Pamphlets [e.g., CRDP 20-138 was redesignated AMCP 706-138]. All new, reprinted, or revised Handbooks are being published as 706-series AMC Pamphlets.

No. AMCP 706-	Title	No. AMCP 706-	Title
100	*Design Guidance for Producibility	201	*Rotorcraft Engineering, Part One, Preliminary Design
104	*Value Engineering	202	*Rotorcraft Engineering, Part Two, Detail Design
106	Elements of Armament Engineering, Part One, Sources of Energy	203	*Rotorcraft Engineering, Part Three, Qualification Assurance
107	Elements of Armament Engineering, Part Two, Ballistics	205	*Timing Systems and Components
108	Elements of Armament Engineering, Part Three, Weapon Systems and Components	210	Fuzes
109	Tables of the Cumulative Binomial Probabilities	211(C)	Fuzes, Proximity, Electrical, Part One (U)
110	Experimental Statistics, Section 1, Basic Concepts and Analysis of Measurement Data	212(S)	Fuzes, Proximity, Electrical, Part Two (U)
111	Experimental Statistics, Section 2, Analysis of Enumerative and Classificatory Data	213(S)	Fuzes, Proximity, Electrical, Part Three (U)
112	Experimental Statistics, Section 3, Planning and Analysis of Comparative Experiments	214(S)	Fuzes, Proximity, Electrical, Part Four (U)
113	Experimental Statistics, Section 4, Special Topics	215(C)	Fuzes, Proximity, Electrical, Part Five (U)
114	Experimental Statistics, Section 5, Tables	235	*Hardening Weapon Systems Against RF Energy
115	Environmental Series, Part One, Basic Environmental Concepts	239(S)	*Small Arms Ammunition (U)
116	*Environmental Series, Part Two, Basic Environmental Factors	240(S)	Grenades (U)
120	*Criteria for Environmental Control of Mobile Systems	241(S)	*Land Mines (U)
121	**Packaging and Pack Engineering	242	Design for Control of Projectile Flight Characteristics (REPLACES -246)
123	Hydraulic Fluids	244	Ammunition, Section 1, Artillery Ammunition--General, with Table of Contents, Glossary, and Index for Series
125	Electrical Wire and Cable	245(C)	Ammunition, Section 2, Design for Terminal Effects (U)
127	Infrared Military Systems, Part One	246	+Ammunition, Section 3, Design for Control of Flight Characteristics (REPLACED BY -242)
128(S)	*Infrared Military Systems, Part Two (U)	247	Ammunition, Section 4, Design for Projection
130	Oesign for Air Transport and Airdrop of Materiel	248	+Ammunition, Section 5, Inspection Aspects of Artillery Ammunition Design
133	*Maintainability Engineering Theory and Practice	249	Ammunition, Section 6, Manufacture of Metallic Components of Artillery Ammunition
134	Maintainability Guide for Design	250	Guns--General
135	Inventions, Patents, and Related Matters	251	Muzzle Devices
136	Servomechanisms, Section 1, Theory	252	Gun Tubes
137	Servomechanisms, Section 2, Measurement and Signal Converters	255	Spectral Characteristics of Muzzle Flash
138	Servomechanisms, Section 3, Amplification	260	Automatic Weapons
139	Servomechanisms, Section 4, Power Elements and System Design	270	Propellant Actuated Devices
140	Trajectories, Differential Effects, and Data for Projectiles	260	Design of Aerodynamically Stabilized Free Rockets
145	*Dynamics of a Tracking Gimbal System	281(SRD)	Weapon System Effectiveness (U)
150	Interior Ballistics of Guns	282	+Propulsion and Propellants (REPLACED BY -285)
160(S)	Elements of Terminal Ballistics, Part One, Kill Mechanisms and Vulnerability (U)	283	Aerodynamics
161(S)	Elements of Terminal Ballistics, Part Two, Collection and Analysis of Data Concerning Targets (U)	284(C)	Trajectories (U)
162(SRD)	Elements of Terminal Ballistics, Part Three, Application to Missile and Space Targets (U)	285	Elements of Aircraft and Missile Propulsion (REPLACES -282)
165	Liquid-Filled Projectile Design	286	Structures
170(C)	**Armor and Its Application (U)	290(C)	Warheads--General (U)
175	Solid Propellants, Part One	291	Surface-to-Air Missiles, Part One, System Integration
176(C)	Solid Propellants, Part Two (U)	292	Surface-to-Air Missiles, Part Two, Weapon Control
177	Properties of Explosives of Military Interest	293	Surface-to-Air Missiles, Part Three, Computers
178(C)	+Properties of Explosives of Military Interest, Section 2 (U) (REPLACED BY -177)	294(S)	Surface-to-Air Missiles, Part Four, Missile Armament (U)
179	Explosive Trains	295(S)	Surface-to-Air Missiles, Part Five, Countermeasures (U)
180	*Principles of Explosive Behavior	296	Surface-to-Air Missiles, Part Six, Structures and Power Sources
185	Military Pyrotechnics, Part One, Theory and Application	297(S)	Surface-to-Air Missiles, Part Seven, Sample Problem (U)
186	Military Pyrotechnics, Part Two, Safety, Procedures and Glossary	327	Fire Control Systems--General
187	Military Pyrotechnics, Part Three, Properties of Materials Used in Pyrotechnic Compositions	329	Fire Control Computing Systems
188	*Military Pyrotechnics, Part Four, Design of Ammunition for Pyrotechnic Effects	331	Compensating Elements
189	Military Pyrotechnics, Part Five, Bibliography	335(SRD)	*Design Engineers' Nuclear Effects Manual, Volume I, Munitions and Weapon Systems (U)
190	*Army Weapon System Analysis	336(SRD)	*Design Engineers' Nuclear Effects Manual, Volume II, Electronic Systems and Logistical Systems (U)
191	*System Analysis and Cost-Effectiveness	337(SRD)	*Design Engineers' Nuclear Effects Manual, Volume III, Nuclear Environment (U)
195	*Development Guide for Reliability, Part One, Introduction, Background, and Planning for Army Materiel Requirements	338(SRD)	*Design Engineers' Nuclear Effects Manual, Volume IV, Nuclear Effects (U)
196	*Development Guide for Reliability, Part Two, Design for Reliability	340	Carriages and Mounts--General
197	*Development Guide for Reliability, Part Three, Reliability Prediction	341	Cradles
198	*Development Guide for Reliability, Part Four, Reliability Measurement	342	Recoil Systems
199	*Development Guide for Reliability, Part Five, Contracting for Reliability	343	Top Carriages
200	*Development Guide for Reliability, Part Six, Mathematical Appendix and Glossary	344	Bottom Carriages
		345	Equilibrators
		346	Elevating Mechanisms
		347	Traversing Mechanisms
		350	Wheeled Amphibians
		355	The Automotive Assembly
		356	Automotive Suspensions
		357	Automotive Bodies and Hulls

*UNDER PREPARATION--not available
+OBSOLETE--out of stock

**REVISION UNDER PREPARATION