

UNCLASSIFIED

AD NUMBER
AD883868
NEW LIMITATION CHANGE
TO Approved for public release, distribution unlimited
FROM Distribution authorized to U.S. Gov't. agencies only; Administrative/Operational Use; MAR 1971. Other requests shall be referred to Air Force Weapons Lab., Kirtland AFB, NM.
AUTHORITY
AFWL ltr, 23 Aug 1979

THIS PAGE IS UNCLASSIFIED

THIS REPORT HAS BEEN DELIMITED
AND CLEARED FOR PUBLIC RELEASE
UNDER DOD DIRECTIVE 5200.20 AND
NO RESTRICTIONS ARE IMPOSED UPON
ITS USE AND DISCLOSURE.

DISTRIBUTION STATEMENT A

APPROVED FOR PUBLIC RELEASE;
DISTRIBUTION UNLIMITED.

L

922
2

AFWL-TR-69-68

AFWL-TR
69-68

AD883868

MODIFIED ELEMENTAL VOLUME DOSE PROGRAM (MEVDP)

B. Liley

S. C. Hamilton

North American Rockwell Corporation

TECHNICAL REPORT NO. AFWL-TR-69-68

March 1971

AIR FORCE WEAPONS LABORATORY

Air Force Systems Command

Kirtland Air Force Base

New Mexico

DDC
RECORDED
MAY 25 1971
REGULATED
C

AD No. FILE COPY



Each transmittal of this document outside the agencies of the U. S. Government must have prior approval of AFWL (SAH), Kirtland AFB, NM, 87117.

278

UNCLASSIFIED

Security Classification

DOCUMENT CONTROL DATA - R & D		
<i>(Security classification of title, body of abstract and indexing annotation must be entered when the overall report is classified)</i>		
1. ORIGINATING ACTIVITY (Corporate author) North American Rockwell Corporation, Space Division 12214 Lakewood Blvd. Downey, California 90241		2a. REPORT SECURITY CLASSIFICATION UNCLASSIFIED
		2b. GROUP
3. REPORT TITLE MODIFIED ELEMENTAL VOLUME DOSE PROGRAM (MEVDP)		
4. DESCRIPTIVE NOTES (Type of report and inclusive dates) 7 February 1969 to 7 August 1969		
5. AUTHOR(S) (First name, middle initial, last name) B. Liley and S. C. Hamilton		
6. REPORT DATE March 1971	7a. TOTAL NO. OF PAGES 224	7b. NO. OF REFS 2
8a. CONTRACT OR GRANT NO. F 29(601)-69-C-0051 <i>new</i>	8b. ORIGINATOR'S REPORT NUMBER(S) AFWL-TR-69-68	
a. PROJECT NO. 8803	8c. OTHER REPORT NO(S) (Any other numbers that may be assigned this report)	
c.		
d.		
10. DISTRIBUTION STATEMENT Each transmittal of this document outside the agencies of the US Government must have prior approval of AFWL (SAH), Kirtland AFB, NM. Distribution is limited because of the technology discussed in the report.		
11. SUPPLEMENTARY NOTES	12. SPONSORING MILITARY ACTIVITY AFWL (SAH) Kirtland AFB, NM 87117	
13. ABSTRACT (Distribution Limitation Statement No. 3) The Modified Elemental Volume Dose Program (MEVDP) generates ordered path-length areal densities for primary electron, electron-bremsstrahlung, and secondary particle radiation transport calculations. The code also generates standard-material areal-density distribution functions for proton and heavy ionizing nuclear radiation. The primary and secondary areal-density functions can be used for particle transport calculations to compute emergent fluxes and energy deposition. The code has been successfully run with the complex Apollo command and service modules and the lunar module, which are represented by 1000 elemental volume shield configurations. The MEVDP has evolved as a versatile, accurate, and fast executing program.		

DD FORM 1473

NOV 68

REPLACES DD FORM 1473, 1 JAN 64, WHICH IS OBSOLETE FOR ARMY USE.

UNCLASSIFIED

Security Classification

UNCLASSIFIED

Security Classification

14 KEY WORDS	LINK A		LINK B		LINK C	
	ROLE	WT	ROLE	WT	ROLE	WT
Shielding Multi-layered shielding Material distribution Path-length computations Radiation transport Areal-density distribution functions Sectoring Computer sectoring Geometrical sectoring Elemental volume descriptions Dose Conversion factors Radiation calculation Calculated dose rates Radiation hazard Radiation vulnerability						

UNCLASSIFIED

TAC - HAFB, NM

Security Classification

AFWL-TR-69-68

MODIFIED ELEMENTAL VOLUME DOSE PROGRAM
(MEVDP)

B. Liley
S. C. Hamilton

North American Rockwell Corporation

TECHNICAL REPORT NO. AFWL-TR-69-68

Each transmittal of this document outside the agencies of the U. S. Government must have prior approval of AFWL (SAH), Kirtland AFB, NM 87117. Distribution is limited because of the technology discussed in the report.

FOREWORD

This report was prepared by the North American Rockwell Corporation, Downey, California, under Contract #F 29(601)-69-C-0051. The research was performed under Program Element 6.11.02.F, Project 8803, and was funded by the Office of Aerospace Research (OAR).

Inclusive dates of research were 7 February 1969 to 7 August 1969. The report was submitted 22 January 1971 by the Air Force Weapons Laboratory Project Officer, Captain Christopher R. Kopf (SAH).

This technical report has been reviewed and is approved.

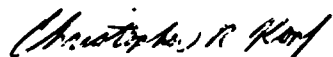

CHRISTOPHER R. KOPF
Captain, USAF
Project Officer

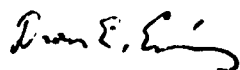

DEAN E. EWING
Major, USAF, VC
Chief, Biomedical Branch



MARVIN B. SULLIVAN
Lt Colonel, USAF
Chief, Analysis Division

ABSTRACT

(Distribution Limitation Statement No. 3)

The Modified Elemental Volume Dose Program (MEVDP) generates ordered path-length areal densities for primary electron, electron-bremsstrahlung, and secondary particle radiation transport calculations. The code also generates standard-material areal-density distribution functions for proton and heavy ionizing nuclear radiation. The primary and secondary areal-density functions can be used for particle transport calculations to compute emergent fluxes and energy deposition. The code has been successfully run with the complex Apollo command and service modules and the lunar module, which are represented by 1000 elemental volume shield configurations. The MEVDP has evolved as a versatile, accurate, and fast executing program.

A user's manual, which is an integral part of this report, illustrates the procedure for input data preparation and execution of the MEVDP.

This page intentionally left blank.

CONTENTS

<u>Section</u>	<u>Page</u>
I	INTRODUCTION 1
II	GEOMETRICAL SECTORING TECHNIQUE 2 1. Selection of the Incident Source Direction Cosines 2 2. Coordinate Systems 7 3. Surface Path-Length Computations for Planes and Conic Surfaces 12 4. Coordinate Systems for Path-Length Computations 22 5. Coordinate System: Rotation Transformations 23 6. Volume Path-Length Computations 27 7. Areal-Density Functions 41
III	MODIFIED ELEMENTAL VOLUME DOSE PROGRAM 46 1. Main Program 51 2. Subroutine GENTAP 51 3. Subroutine FILE 51 4. Subroutine TRSHLD 52 5. Subroutine FANTOM 68 6. Subroutine LIMROT (NCOMP, XCMAN, XRMAN, EPSLN) 70 7. Subroutine ESDOSE 70 8. Subroutine TRACK 75 9. Subroutine OCTCOS 77 10. Subroutine ELIMS 77 11. Subroutine COMPSP 78 12. Subroutine TKHEX (HXPTH, NP, DP) 78 13. Subroutine TKCYL 82 14. Subroutine TKSPH 83 15. Subroutine TKHM 83 16. Subroutine TKCON 85 17. Subroutine TKELL 86 18. Subroutine GEOMDS 87 19. Subroutine ORDER 88

<u>Section</u>	<u>Page</u>
IV	PROGRAM UTILIZATION (USER'S MANUAL) 90
	1. Numerical Geometrical Data Preparation 90
	2. MEVDP Input Data Format 93
	3. Tape Unit Utilization 99
V	SAMPLE PROBLEM SOLUTION 103
	APPENDIXES
	I. MEVDP AFWL Sample Problem Solution
	Output Data 121
	II. Modified Elemental Volume Dose Program
	Listings 148
	REFERENCES 214

ILLUSTRATIONS

<u>Figure</u>		<u>Page</u>
1	Solid-Angle Element	4
2	Absolute Coordinate System (ABCS)	7
3	Elemental Volumes	9
4	Dosimeter (DSCS) and Absolute (ABCS) Coordinate Systems	10
5	Rotated Detector Coordinate System (RDCS)	11
6	Truncated Ellipsoid (RDCS)	13
7	Sphere Coordinate System (DSCS)	17
8	Cylinder, Hemisphere and Truncated Cone (RDCS)	18
9	Plane and Line Vectors	19
10	Hexahedron Face Vectors in the DSCS	20
11	Projection of Hexahedron Face (RDCS)	21
12	Coordinate Systems, Ellipsoid (DSCS and RDCS)	25
13	Location of Dosimeter Relative to the Hexahedron	30
14	Illustrated Positive and Negative Path Lengths	31
15	Composite Shield Tracking Sequence	34
16	Projection of Hexahedron Face	37
17	Thickness Weighting Function	45
18	Functional Diagram of the MEVDP	50
19	NASA-MSD Standard Man Model	58
20	SMCS and ABCS Coordinate Systems	62
21	Projection of Cylinder Base Plane	84
22	Sectoring Code Work Sheet	91
23	Sectoring Code Work Sheet Instructions	92
24	MEVDP Input Data Schematic	98
25	Elemental Volume Components of the AFWL Sample Problem	104
26	AFWL Sample Problem Shield Configuration	105
27	AFWL Sample Problem (x, y) Plane, Center (0, 0, 0)	114
28	AFWL Sample Problem (y, z) Plane, Center (0, 0, 0)	115
29	AFWL Sample Problem (y, z) Plane, Center (-20.1, 0, 0)	116
30	AFWL Sample Problem (y, z) Plane, Center (50, 0, 0)	117

TABLES

<u>Table</u>		<u>Page</u>
I	Coordinate Systems	23
II	Octant Definition	36
III	Octant Logic	38
IV	Functional Description of the MEVDP Subroutines	47
V	Fixed and Rotated Points and Angles for Astronaut Limb Rotations	61
VI	MEVDP Input Data Format	94
VII	Tape Unit Use and Requirements	99
VIII	Use of Output Tape Units Versus IPUNCH	101
IX	AFWL Sample Problem Component Shield Properties	106
X	AFWL Sample Problem Dimensions and Dosimeter Locations	107
XI	Shield Coordinates and Parameters	108
XII	AFWL Sample Problem Input Data	110

SECTION I

INTRODUCTION

To facilitate the calculation of primary radiation transport through the complex geometry of the Apollo vehicle, the North American Rockwell Corporation Space Division (NR/SD) developed the Elemental Volume Dose Program (EVDP). The EVDP was developed to calculate primary radiation doses from protons and alpha particles associated with solar-flare particle events and the earth's trapped radiation for deep space and earth orbital missions. The EVDP converts the material paths traversed to an equivalent standard-material path length. Because of the general versatility and computational efficiency of the EVDP, a modified version of the EVDP has been developed for electron, electron-bremsstrahlung, and secondary particle transport calculations.

The modified EVDP (MEVDP) generates spatially oriented arrays of material type and associated thicknesses which are encountered by radiation traveling toward a dosimeter point within any complex geometrical shielding configuration. These thickness arrays are available in the order in which the incident rays encounter the different materials. The modified program also retains the EVDP capability for computing the standard-material areal-density distribution function versus fractional solid angle for heavy charged particle dose computations. The new version of the EVDP contains the source ray selection and geometrical options of the original EVDP, including the composite shield routine. These features have been modified and augmented by a subroutine to order the computed nuclear transport parameters. The ordered arrays can be used for electron and secondary transport calculations with the straight-ahead approximation.

This report documents the following aspects of the modified EVDP: (1) geometrical sectoring technique, (2) analytical techniques incorporated in the code, (3) user's manual, (4) modified program listing, and (5) an AFWL sample problem and its computer solution. The analytical techniques and logical operations used in the code are discussed in detail. Analytical equations are derived and correlated with the source program FORTRAN listing. The user's manual, an integral part of the report, concisely and systematically illustrates the procedure for data preparation and its execution to obtain computer solutions. The solution for a sample problem illustrates the format of the MEVDP input data and demonstrates that the program is operational.

SECTION II

GEOMETRICAL SECTORING TECHNIQUE

The dosimeter position can be imbedded inside any of the system structural components or the spacecraft crew. The source flux is assumed to be isotropic and that each selected particle ray maintains its original direction when penetrating the material between the incident particle and the dosimeter. Both random and systematic methods can be used to select the ray directions of the source nucleons or photons.

Versatile elemental volumes will be utilized to permit a relatively complete description of the spacecraft and crew structural configurations and compositions. This versatility will eliminate the necessity for excessive use of homogenization in the geometrical representation of subsystem components. This section presents the technical analysis and Section III directly correlates the analysis to the computer program. The analysis begins by presenting the method for selecting the directions of the source nucleons or photons.

1. SELECTION OF THE INCIDENT SOURCE DIRECTION COSINES

If the random method is used for dose or flux computations, the direction cosines will be selected by random sampling uniformly over the unit sphere. The systematic method will select directions at the center of a preselected number of equivalent solid angles. Also different solid-angle increments can be used for ray tracing in different portions of the unit sphere centered at the dosimeter position. The differential selection of the solid-angle increment can result in a more accurate dose computation by selecting larger ray densities for the higher dose regions.

a. Random Direction Cosines

For random selection of unnormalized ray direction cosines (α_0 , β_0 , γ_0) over the unit sphere

$$\alpha_0 = 1 - 2\eta_1$$

$$\beta_0 = 1 - 2\eta_2$$

$$\gamma_0 = 1 - 2\eta_3$$

where

$$\alpha_0^2 + \beta_0^2 + \gamma_0^2 \leq 1$$

and η_1 , η_2 , and η_3 are random numbers from a uniform distribution in the interval

$$0 \leq \eta_i \leq 1; \quad i=1, 2, 3$$

The normalized direction cosines are α , β , and γ where

$$\alpha = \alpha_0 / \epsilon$$

$$\beta = \beta_0 / \epsilon$$

$$\gamma = \gamma_0 / \epsilon$$

$$\epsilon = (\alpha_0^2 + \beta_0^2 + \gamma_0^2)^{1/2} \quad (1)$$

b. Systematic Selection of Direction Cosines

The ray direction cosines are selected at the center of equal solid-angle increments as depicted in Figure 1. A right-handed spherical coordinate system is used with θ and ϕ as colatitude and azimuthal angles, respectively.

A microscopic solid-angle portion of the unit sphere is considered, which is defined by the colatitude interval (θ_I, θ_F) and the azimuthal interval (ϕ_I, ϕ_F) and divided into NSA microscopic solid-angle increments. The following definitions are used:

NTS = total number of solid-angle increments in the unit sphere

FSA = fraction of the total unit sphere solid angle in the angular region $(\theta_I, \theta_F; \phi_I, \phi_F)$

NSA = number of solid-angle increments in the FSA portion of the unit sphere

N_θ = number of θ increments in NSA

N_ϕ = number of ϕ increments in NSA

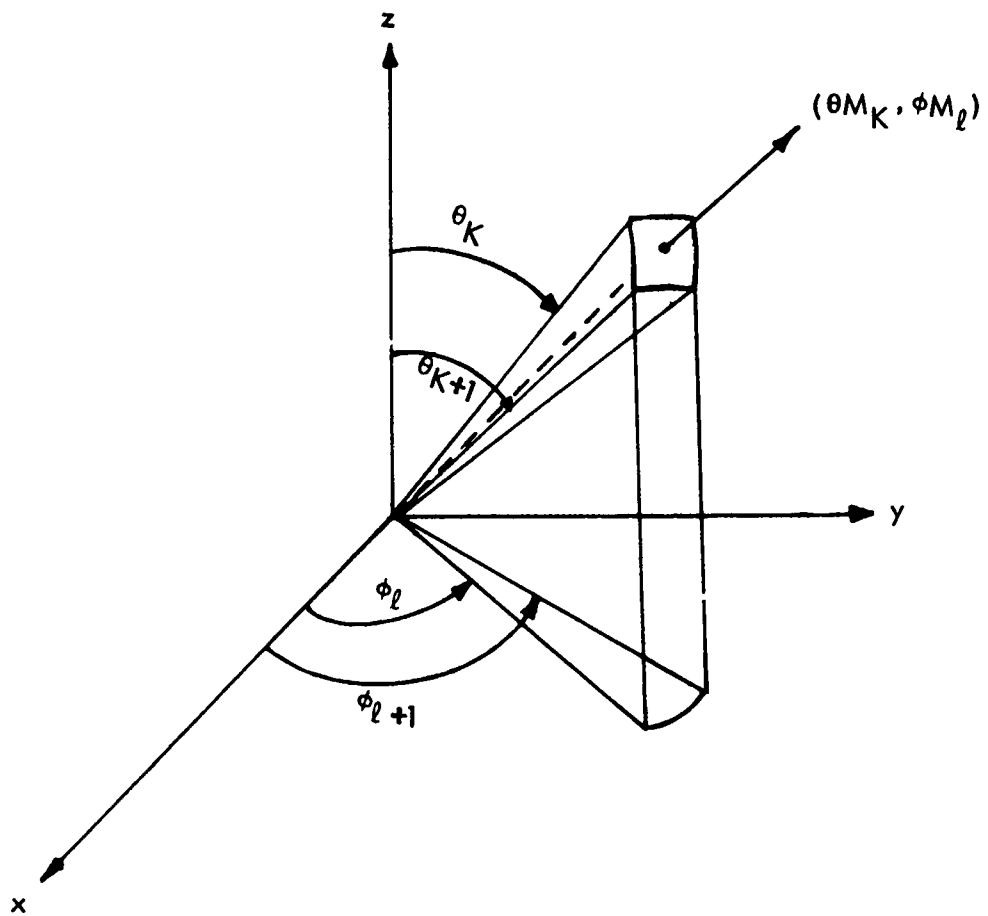

Figure 1. Solid-Angle Element

For symmetry, the θ and ϕ angular magnitudes of all incremental solid angles are considered to be equivalent, or

$$\frac{\phi_F - \phi_I}{N_\phi} = \frac{\theta_F - \theta_I}{N_\theta} \quad (2)$$

The fraction solid angle (FSA) can be derived as

$$\begin{aligned} \text{FSA} &= \frac{1}{4\pi} \int_{\phi_I}^{\phi_F} \int_{\theta_I}^{\theta_F} \sin \theta d\theta d\phi \\ &= \left(\frac{\phi_F - \phi_I}{4\pi} \right) (\cos \theta_I - \cos \theta_F) \end{aligned} \quad (3)$$

and

$$\text{NSA} = \text{FSA} \cdot \text{NTS} = N_\theta N_\phi \quad (4)$$

From Equations 2 and 4

$$\text{NSA} = N_\theta^2 \left(\frac{\phi_F - \phi_I}{\theta_F - \theta_I} \right)$$

and

$$N'_\theta = \text{IPO} \left\{ \left(\frac{\theta_F - \theta_I}{\phi_F - \phi_I} \right) \text{NSA} \right\}^{1/2} + 1 \quad (5)$$

where IPO(X) is defined as the integral part of (X). The modification of N_θ (Equation 5) is necessary, because N_θ must be a nonzero integer.

Since the incremental solid angles are equivalent

$$\left(\frac{\phi_I - \phi_F}{N_\phi} \right) \left(\frac{\cos \theta_I - \cos \theta_K}{K} \right) = \left(\frac{\cos \theta_I - \cos \theta_F}{N_\theta} \right) \left(\frac{\phi_I - \phi_F}{N_\phi} \right) \quad (6)$$

where $K = 1, 2, \dots, N_\theta$.

It follows that

$$\begin{aligned}\cos \theta_K &= \cos \theta_I - \frac{K}{N'_\theta} (\cos \theta_I - \cos \theta_F) \\ \theta_K &= \cos^{-1} (\cos \theta_K)\end{aligned}\quad (7)$$

The θ_K are the θ boundaries of the incremental solid angles.

From Equation 2

$$N'_\phi = \text{IPO} \left[\left(\frac{\phi_F - \phi_I}{\theta_F - \theta_I} \right) (N'_\theta - 1) \right] + 1$$

The ϕ boundaries are defined by

$$\phi_\ell = \phi_I + \frac{\ell}{N'_\phi} (\phi_F - \phi_I); \ell=0, N'_\phi \quad (8)$$

The solid-angle midpoints ($\theta \equiv \theta_M$) and ($\phi \equiv \phi_M$) are

$$\begin{aligned}\theta_{M_K} &= 0.5 (\theta_K + \theta_{K+1}) \\ \phi_{M_\ell} &= 0.5 (\phi_\ell + \phi_{\ell+1})\end{aligned}\quad (9)$$

The total number of computed incremental solid angles is the product of N'_θ and N'_ϕ .

Finally, the systematic direction cosines are

$$\begin{aligned}\alpha &= \sin \theta \cos \phi \\ \beta &= \sin \theta \sin \phi \\ \gamma &= \cos \theta\end{aligned}\quad (10)$$

The next logical step is utilization of the ray direction cosines to compute the traversal path lengths through the geometrical structure. Several different coordinate systems will be used to simplify the path-length computations.

2. COORDINATE SYSTEMS

The geometrical structural configurations are originally defined by elemental volume coordinates and parameters in a coordinate system (Figure 2) designated as the Absolute Coordinate System (ABCS). In order to substantially decrease the amount of ray tracing or tracking required, the elemental volumes are classified according to their octant location in a coordinate system centered at the detector.

With this choice of the coordinate origin, the incident particle track must traverse only one octant.

However, if the volume octants are selected relative to the ABCS, there will be unnecessary tracking because the source rays are directed toward the dosimeter, which is generally displaced from the origin of the ABCS. Therefore, the proton track could traverse four octants. Tracks along the coordinate axes are considered as special cases.

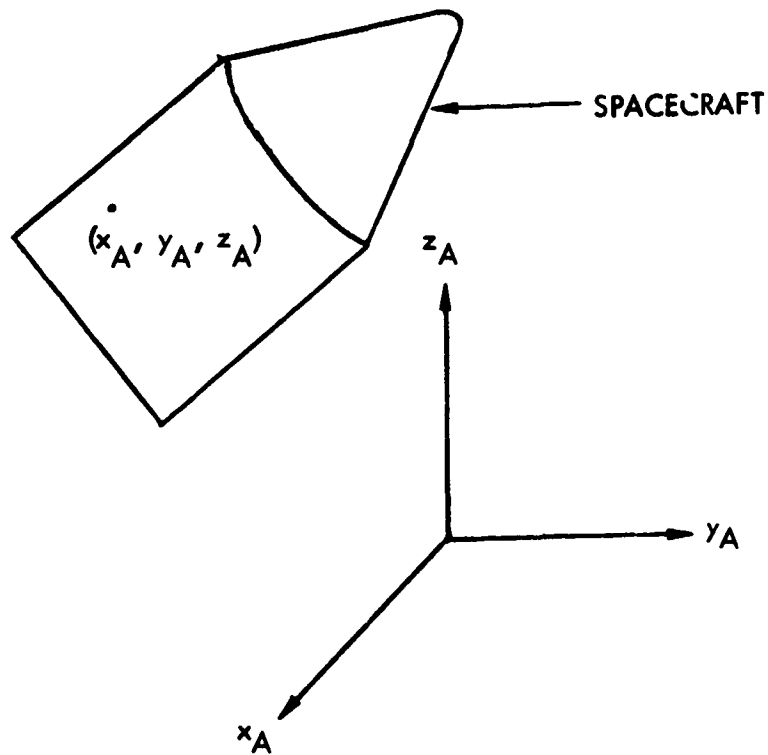

Figure 2. Absolute Coordinate System (ABCS)

The pertinent parameters and coordinates used to define the elemental shield volumes are depicted in Figure 3 for the ABCS.

Figure 4 depicts the Dosimeter Coordinate System (DSCS) and the ABCS. To transform a coordinate point $\vec{R}_A \equiv (x_A, y_A, z_A)$ of the spacecraft to the DSCS, the following displacement is required:

$$\begin{aligned}\vec{R}_D &= \vec{R}_A - \vec{R}_{AD} \\ x_D &= x_A - x_{AD} \\ y_D &= y_A - y_{AD} \\ z_D &= z_A - z_{AD}\end{aligned}\tag{11}$$

where

$\vec{R}_A = (x_A, y_A, z_A)$ = position of the spacecraft point relative to the ABCS

$\vec{R}_D = (x_D, y_D, z_D)$ = position of the spacecraft point relative to the DSCS

$\vec{R}_{AD} = (x_{AD}, y_{AD}, z_{AD})$ = position of the DSCS origin relative to the ABCS

For several elemental volumes, it is most convenient to have a detector coordinate system with one or more of its axes directed along the reference axes of the elemental volumes. Since the new detector system has the same origin as the DSCS, the direction cosines can be converted to the new system by matrix rotations. The new system will be designated as the Rotated Detector Coordinate System (RDSCS). The RDSCS is illustrated in Figure 5 for a cylinder. θ and ϕ are the component rotation angles. The ϕ rotation about the DSCS z axis is followed by a θ rotation about intermediate coordinate system (x_I, y_I, z_I) negative x_I axis.

In order to select the rotation matrix transformations for the elemental volumes, it is necessary to determine convenient coordinate systems relative to the elemental volume reference axes. The most convenient axes were selected as those which facilitate calculations of path lengths to the elemental surfaces.

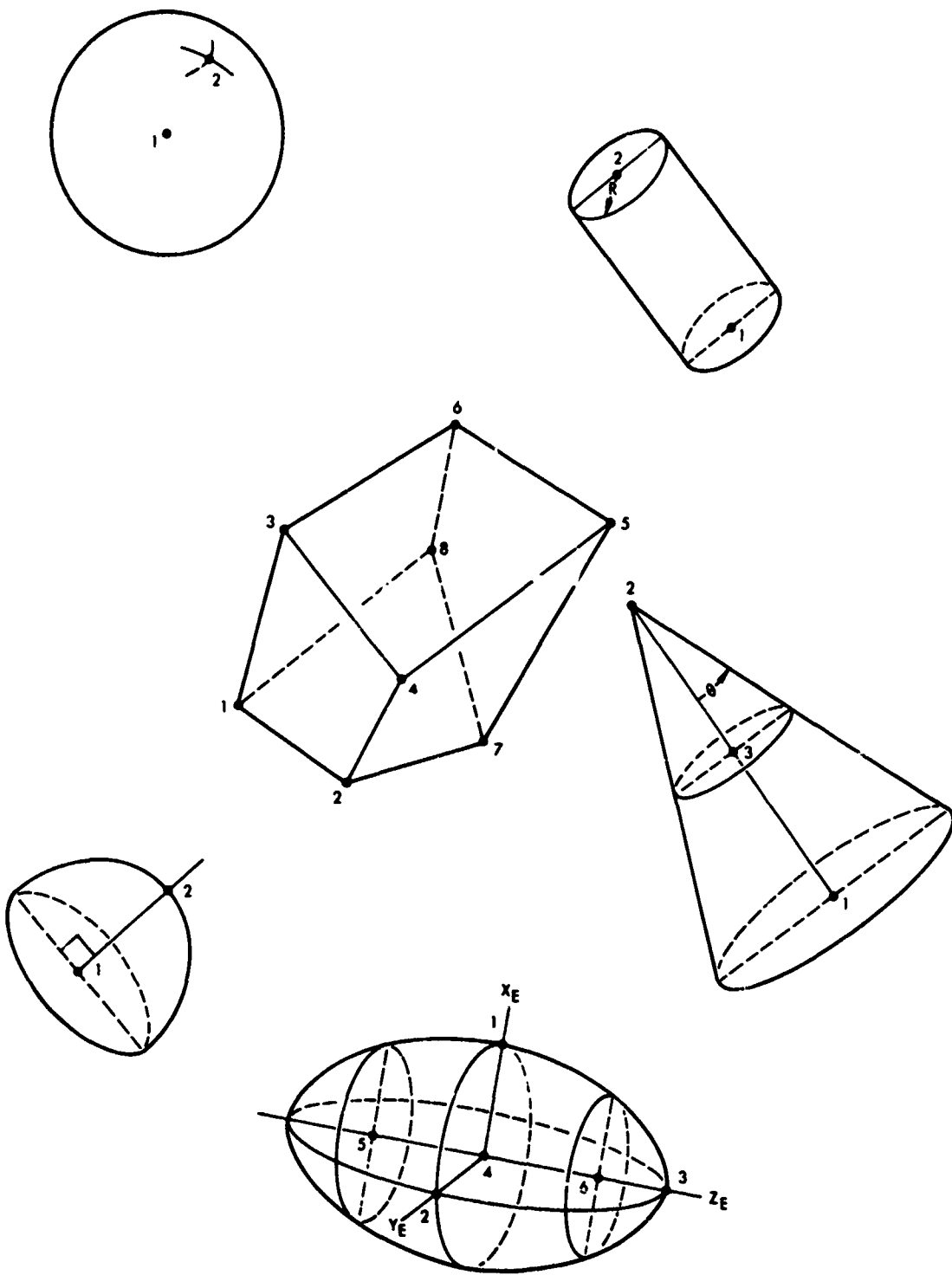

Figure 3. Elemental Volumes

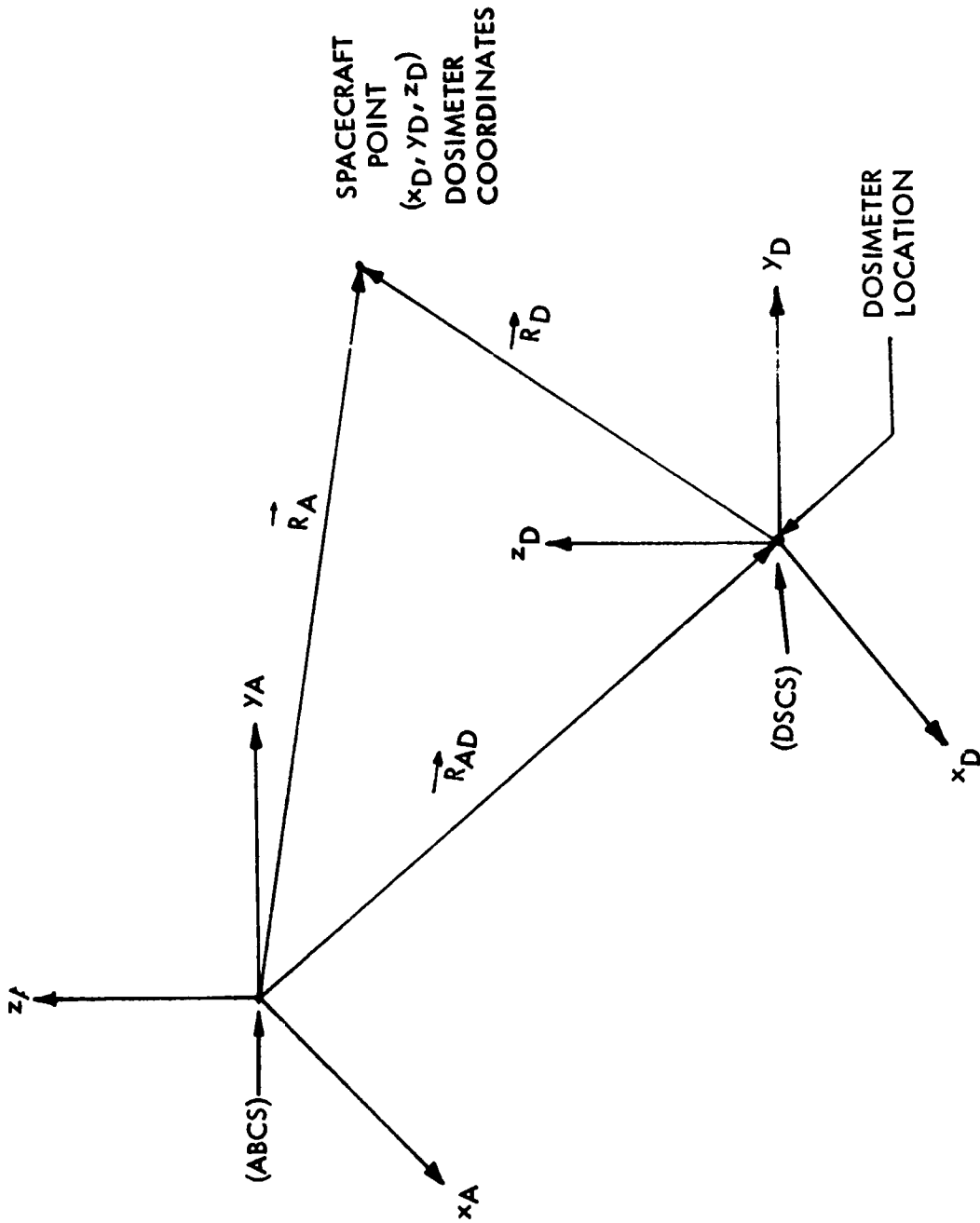

Figure 4. Dosimeter (DSCS) and Absolute (ABCS) Coordinate Systems

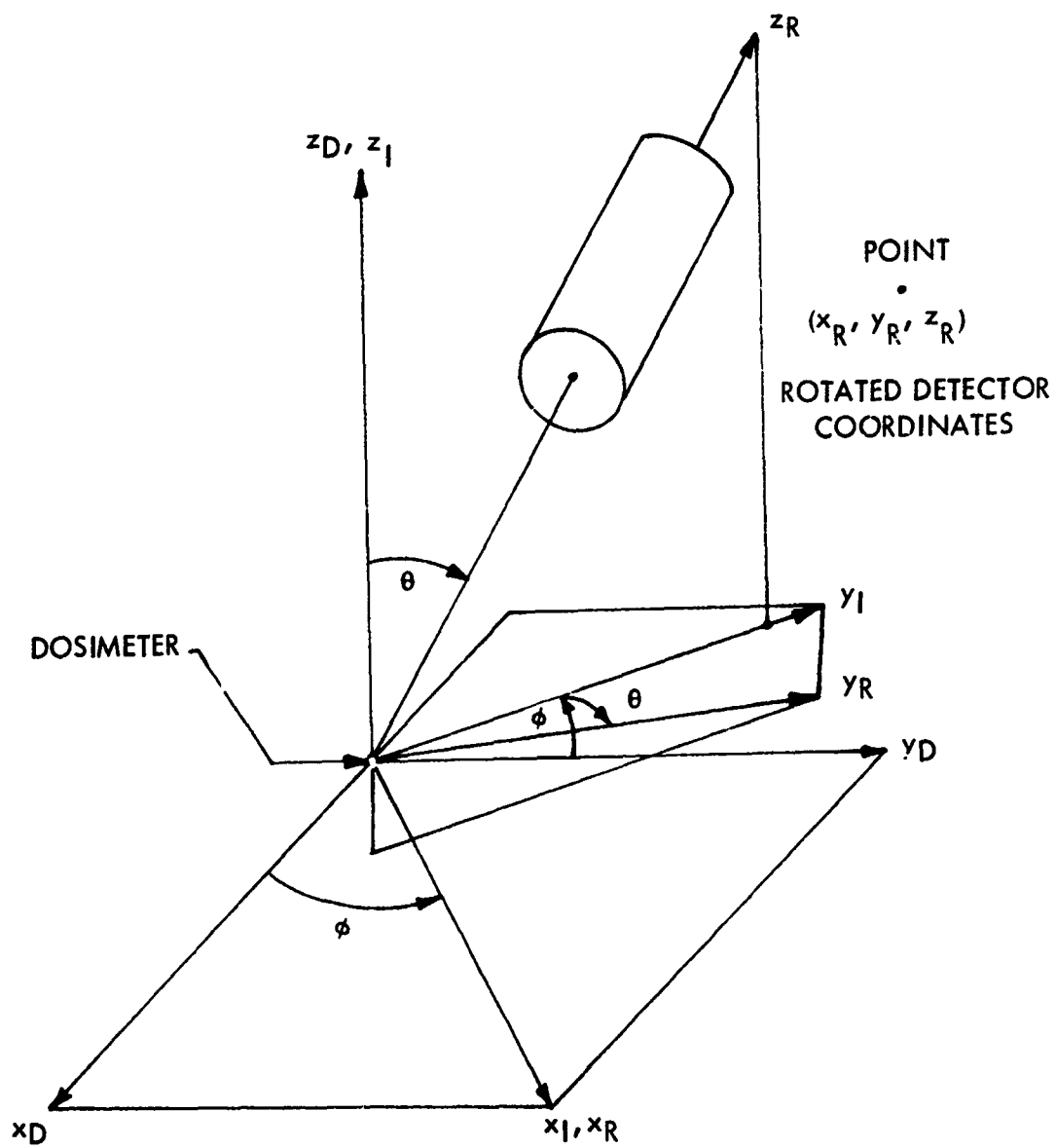

Figure 5. Rotated Detector Coordinate System (RDCS)

3. SURFACE PATH-LENGTH COMPUTATIONS FOR PLANES AND CONIC SURFACES

Path length computations are described for the following elemental surfaces: sphere, ellipsoid, cone, cylinder, and plane.

The path length is generally computed as the difference between the two path lengths to the surfaces of the volumes. If the dosimeter is inside the volume, the volume path length is determined by a single path length. However, additional tests are required for truncated volumes and for the hexahedron; these are discussed in the latter portion of this section.

The equation of the surfaces which encompass the elemental volumes are quadratic forms. The hexahedron and truncated surfaces are combinations of planes. Figure 6 shows the points and reference axes used to define the ellipsoid. This volume is used to illustrate the method of computing path lengths for all volumes except the hexahedron.

The following definitions are used in Equations 12 through 17 (see Figure 6):

$(x_R, y_R, z_R) \equiv$ coordinates (RDCS) of the point where the particle path traverses the ellipsoid surface

$(x_{R4}, y_{R4}, z_{R4}) \equiv$ center of the ellipsoid

$(a, b, c) \equiv$ ellipsoid major axes

$(x_o, y_o, z_o) \equiv$ a point on the particle path

$(\alpha_R, \beta_R, \gamma_R) \equiv$ direction cosines of the particle path in the RDCS

In the rotated coordinate system, the equation of the ellipsoid surface is

$$\left(\frac{x_R - x_{R4}}{a}\right)^2 + \left(\frac{y_R - y_{R4}}{b}\right)^2 + \left(\frac{z_R - z_{R4}}{c}\right)^2 = 1 \quad (12)$$

The equation of a line through the point (x_o, y_o, z_o) in the RDCS is

$$\left(\frac{x_R - x_o}{\alpha_R}\right) = \left(\frac{y_R - y_o}{\beta_R}\right) = \left(\frac{z_R - z_o}{\gamma_R}\right) \quad (13)$$

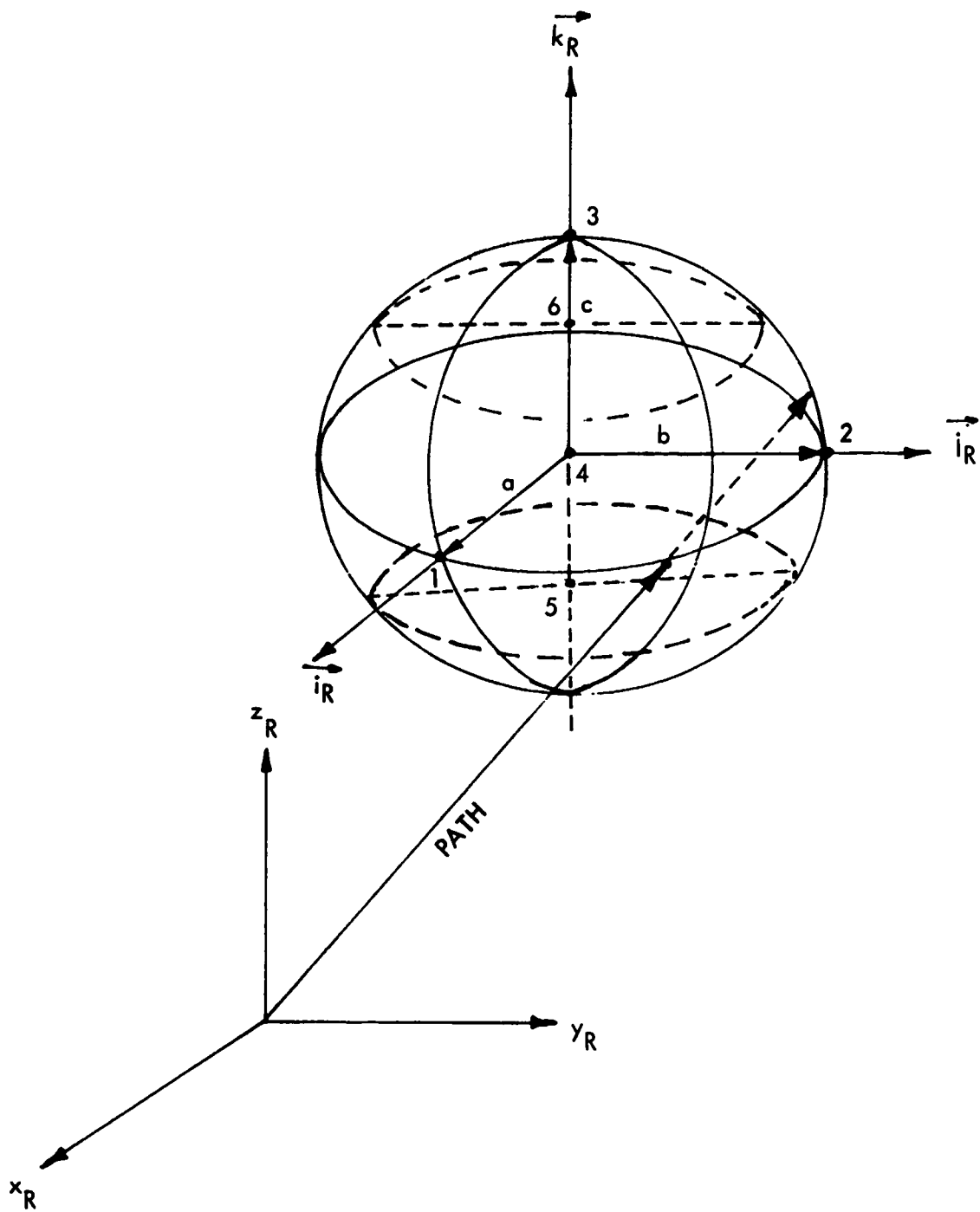

Figure 6. Truncated Ellipsoid (RDCS)

Since the path length to the ellipsoid from the point (x_o, y_o, z_o) is P , where

$$P = \left(\frac{z_R - z_o}{\gamma_R} \right) \quad (14)$$

Equation 13 can be used to derive

$$\begin{aligned} x_R &= x_o + \alpha_R \frac{(z_R - z_o)}{\gamma_R} \\ y_R &= y_o + \beta_R \frac{(z_R - z_o)}{\gamma_R} \\ z_R &= z_o + \gamma_R \frac{(z_R - z_o)}{\gamma_R} \end{aligned} \quad (15)$$

When Equation 14 is substituted into Equation 15

$$\begin{aligned} x_R &= x_o + \alpha_R P \\ y_R &= y_o + \beta_R P \\ z_R &= z_o + \gamma_R P \end{aligned} \quad (16)$$

and, subsequently, when Equation 16 is substituted into Equation 12, it follows that

$$AP^2 + BP + C = 0$$

where

$$\begin{aligned} A &= \left(\frac{\alpha_R}{a} \right)^2 + \left(\frac{\beta_R}{b} \right)^2 + \left(\frac{\gamma_R}{c} \right)^2 \\ B &= 2 \left\{ \frac{\alpha_R (x_o - x_{R4})}{a^2} + \frac{\beta_R (y_o - y_{R4})}{b^2} + \frac{\gamma_R (z_o - z_{R4})}{c^2} \right\} \\ C &= \left(\frac{x_o - x_{R4}}{a} \right)^2 + \left(\frac{y_o - y_{R4}}{b} \right)^2 + \left(\frac{z_o - z_{R4}}{c} \right)^2 - 1 \end{aligned} \quad (17)$$

and the two path lengths are

$$P_{\pm} = \frac{-B \pm \sqrt{B^2 - 4AC}}{2A} \quad (18)$$

The solutions for the cone, cylinder, and sphere are also quadratic in form. In some cases, it is possible that $A = 0$ or one path length is an indeterminate form. For example

$$P_{+} = \frac{0}{0}$$

Using L'Hôpital's rule, this indeterminate form can be evaluated as

$$P_{+} = \frac{\lim_{A \rightarrow 0} \frac{\partial}{\partial A} (-B + \sqrt{B^2 - 4AC})}{\lim_{A \rightarrow 0} \frac{\partial}{\partial A} (2A)} = -\frac{C}{B} \quad (19)$$

For the other volumes, A , B , and C are as follows:

a. Sphere

$$A = 1.0$$

$$B = -2 (\alpha_D x_{D1} + \beta_D y_{D1} + \gamma_D z_{D1})$$

$$C = x_{D1}^2 + y_{D1}^2 + z_{D1}^2 - R^2$$

$$R^2 = (x_{D2} - x_{D1})^2 + (y_{D2} - y_{D1})^2 + (z_{D2} - z_{D1})^2 \quad (20)$$

b. Cylinder

$$A = \alpha_R^2 + \beta_R^2$$

$$B = 2 \left[\alpha_R (x_o - x_{R1}) + \beta_R (y_o - y_{R1}) \right]$$

$$C = (x_o - x_{R1})^2 + (y_o - y_{R1})^2 - R^2 \quad (21)$$

c. Cone

$$\begin{aligned}
 A & \alpha_R^2 + \beta_R^2 - \gamma_R^2 \tan^2 \theta \\
 B & - 2 \left[\alpha_R (x_o - x_{R2}) + \beta_R (y_o - y_{R2}) - \gamma_R (z_o - z_{R2}) \times \tan^2 \theta \right] \\
 C & = (x_o - x_{R2})^2 + (y_o - y_{R2})^2 - (z_o - z_{R2})^2 \tan^2 \theta \quad (22)
 \end{aligned}$$

where subscripts R and D refer to the RDCS and DSCS, respectively, and the numbers used in the subscripts are defined in Figures 7 and 8. If the ray tracing direction passes through the origin of the coordinate system

$$x_o = y_o = z_o = 0$$

d. Plane

The plane path-length equation is not a quadratic function. In Figure 9, a plane defined by a point P and a unit vector \vec{e}_{PL} is intersected by a line which is defined by the point O and the unit vector \vec{e}_L . The path length, which is $|\vec{P}_{TH}| \equiv P_{TH}$ can be computed from the equivalents of two scalars

$$(\vec{R}_P - \vec{R}_O) \cdot \vec{e}_{PL} = P_{TH} \vec{e}_L \cdot \vec{e}_{PL}$$

$$P_{TH} = \left[\frac{\vec{e}_{PL} \cdot (\vec{R}_P - \vec{R}_O)}{\vec{e}_L \cdot \vec{e}_{PL}} \right] \quad (23)$$

$$\text{where } P_{TH} = 0 \text{ if } \vec{e}_L \cdot \vec{e}_{PL} \cong 0 \quad (24)$$

e. Hexahedron

The hexahedron is a combination of planes, so the plane path-length formula can be used to determine the hexahedron path lengths. The hexahedron plane in Figure 10 is defined by vectors $\vec{V}(1)$ through $\vec{V}(4)$. Figure 11 shows a projection of a hexahedron surface in the (x_R, y_R) plane of the RDCS. The RDCS is defined with the tracking ray directed along the z_R axis. Points B and A represent hits or misses of the projected hexahedron

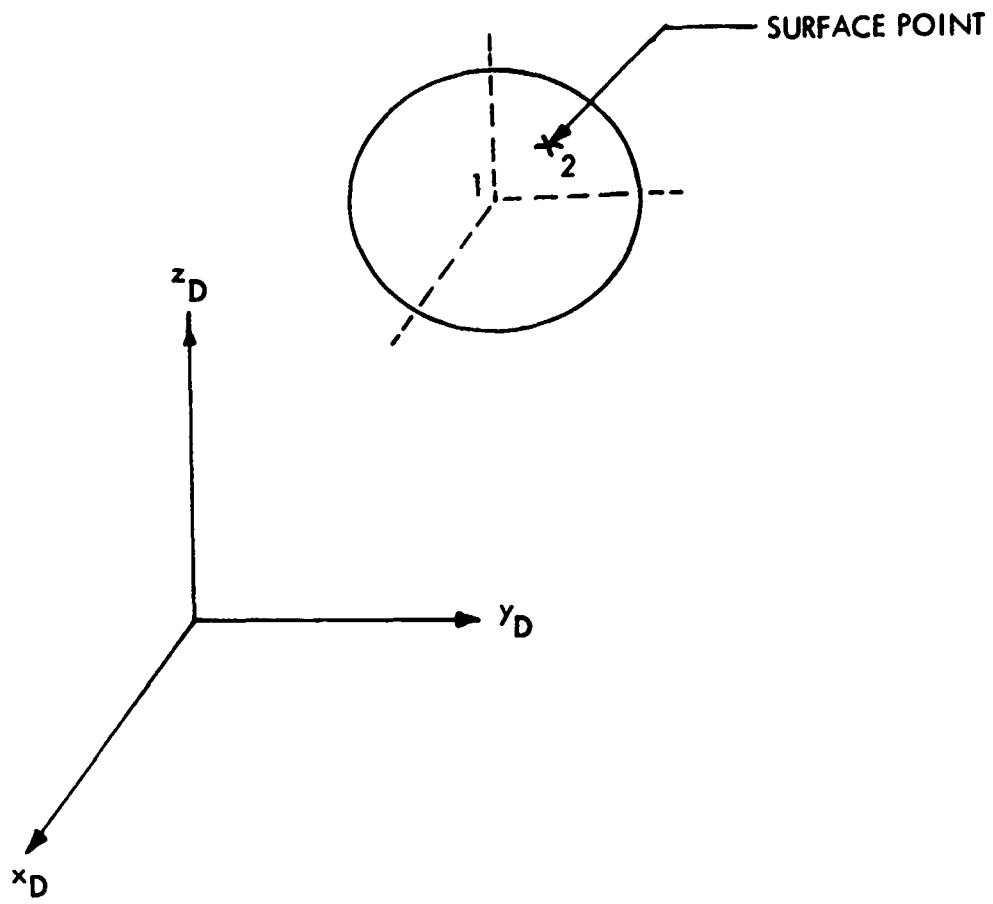

Figure 7. Sphere Coordinate System (DSCS)

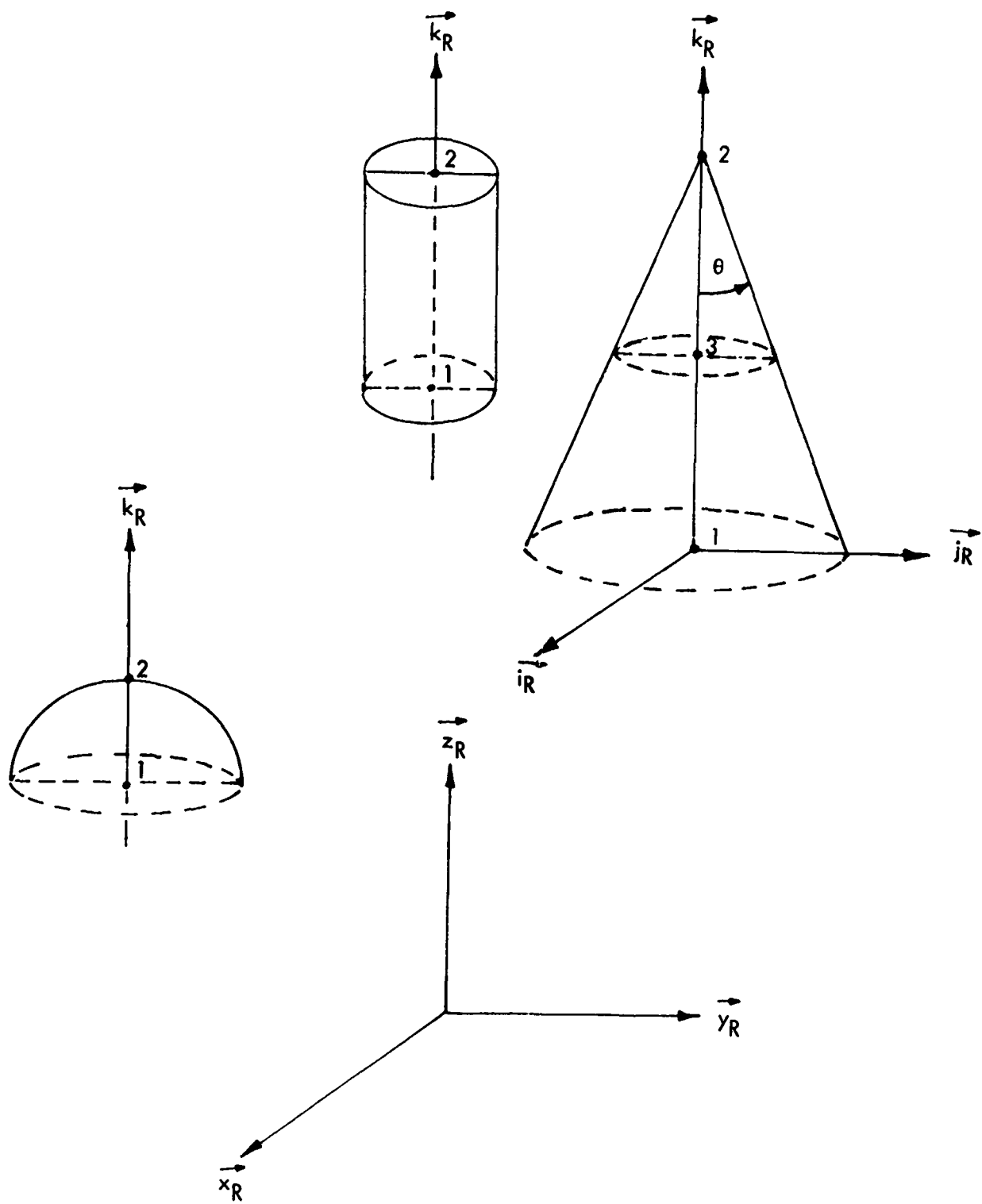

Figure 8. Cylinder, Hemisphere and Truncated Cone (RDCS)

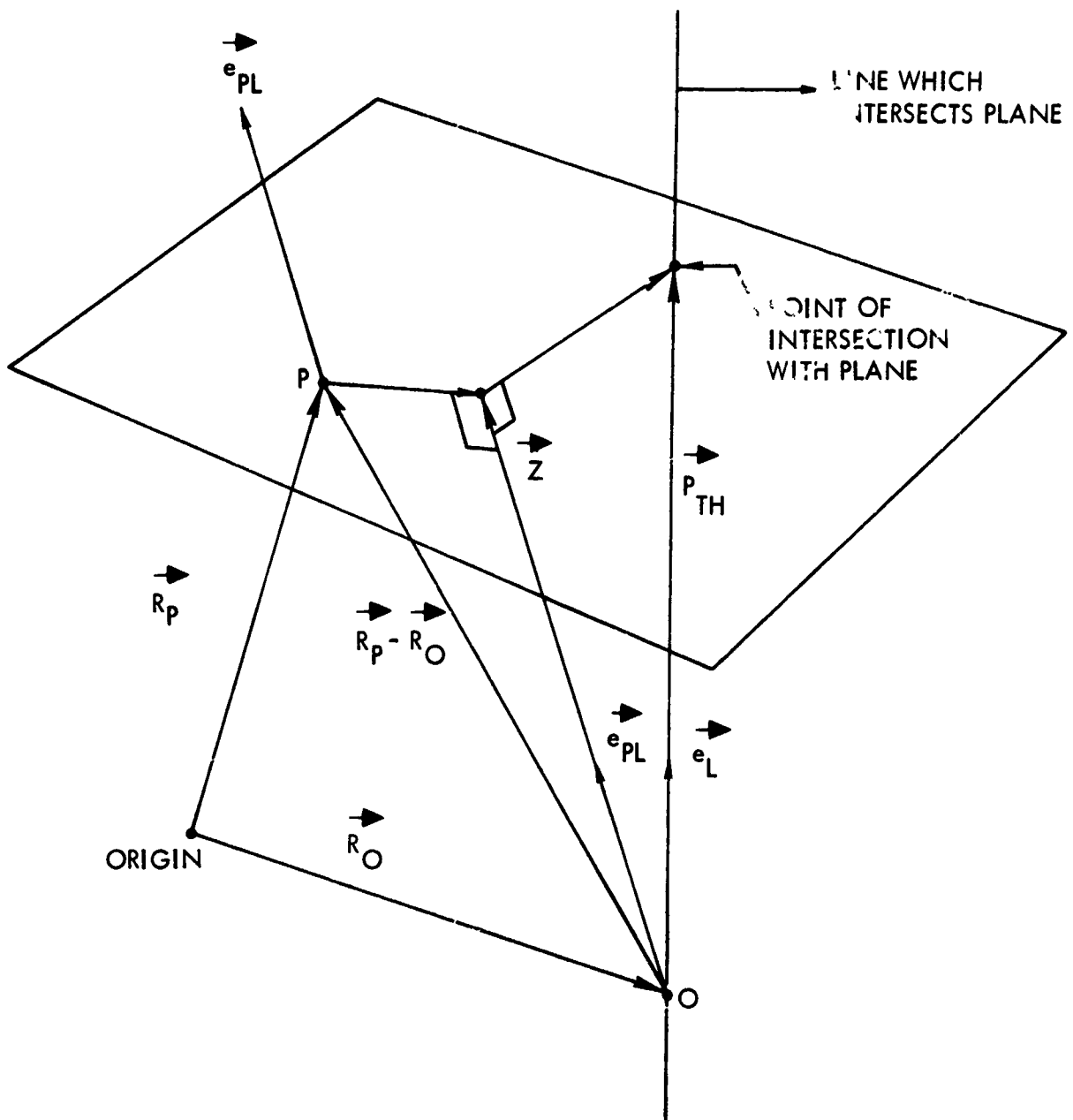

Figure 9 . Plane and Line Vectors

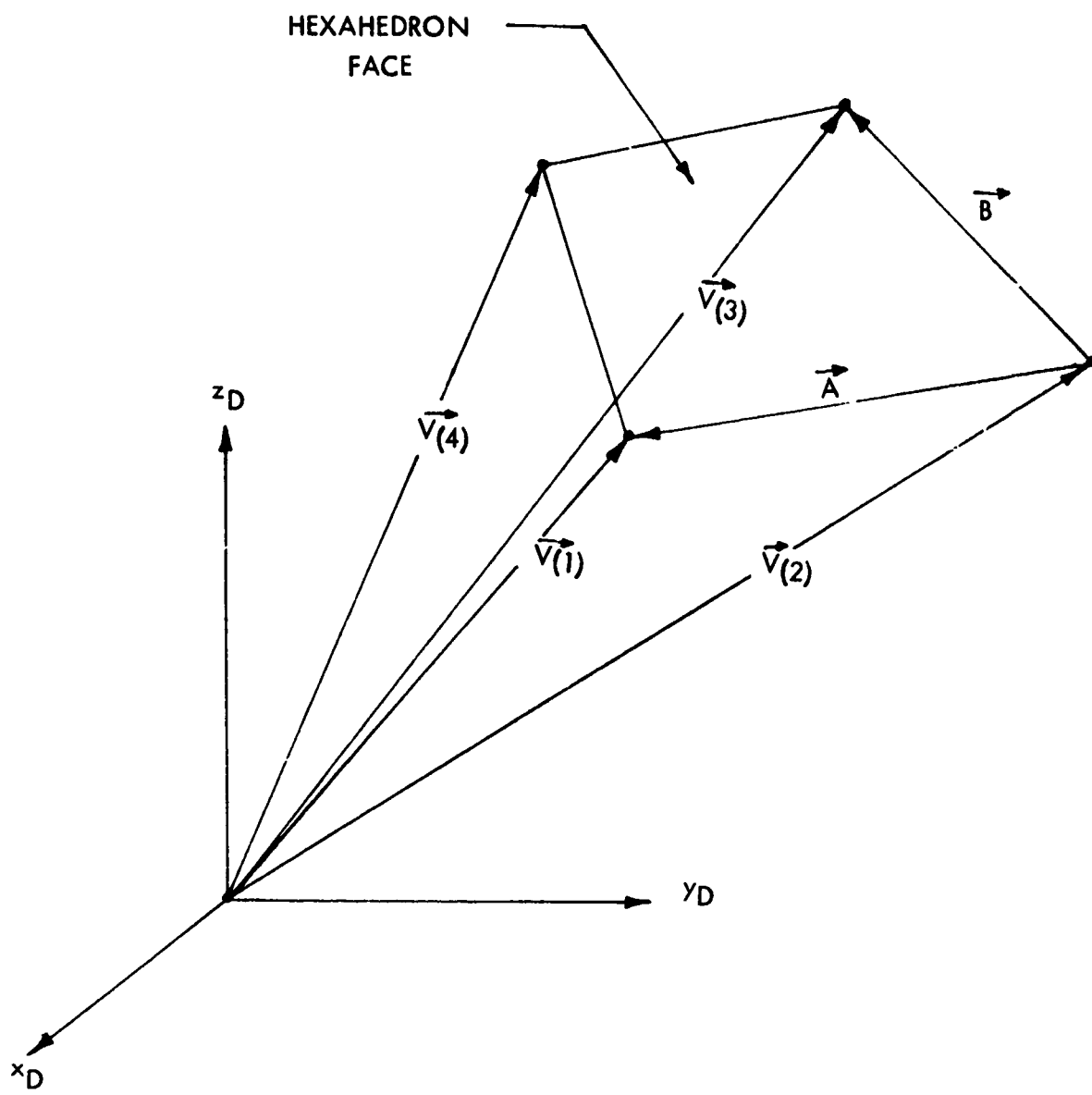

Figure 10. Hexahedron Face Vectors in the DSCS

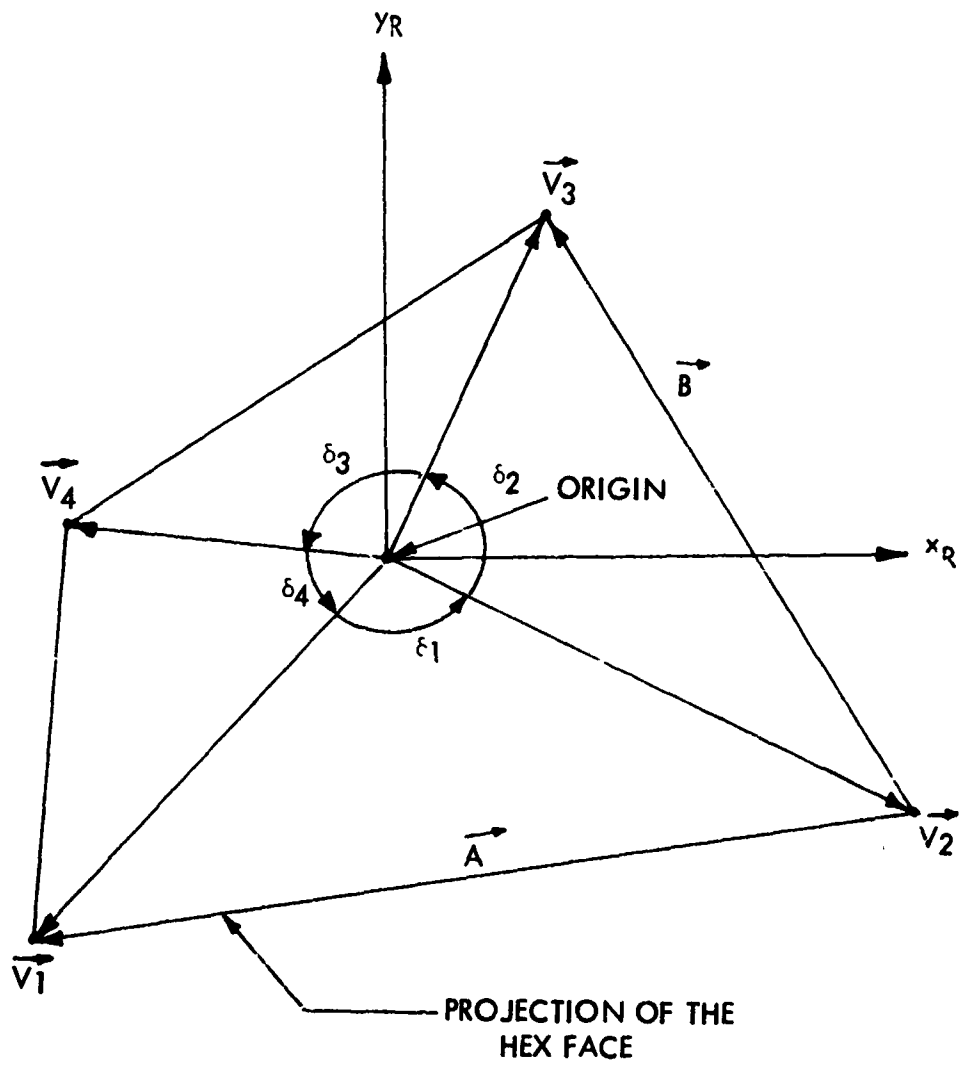

Figure 11. Projection of Hexahedron Face (RDCS)

face for the origin of the RDCS. If the origin is inside the projected-plane perimeter, the ray hits the face. Figure 11 illustrates a set of angles (δ) which will be used as a test to determine if the ray hits the hexahedron face. A hit-or-miss criterion can be derived from the sum of the angles subtended by the sides of the projected plane as follows:

$$\sum_{i=1}^4 \delta_i = 0 ; \text{ Miss}$$

$$= 2\pi \text{ radians ; Hit} \quad (25)$$

However, a simpler criterion is possible because $\delta_i < 180$ degrees. The simpler hit-or-miss criteria is

$$\left| \sum_{i=1}^4 \text{sign} \left(\vec{K} \cdot \left[\vec{V}_R(i) \times \vec{V}_R(i+1) \right] \right) \right| \neq 4 ; \text{ Miss}$$

$$= 4 ; \text{ Hit} \quad (26)$$

where

$$\vec{V}_R(5) = \vec{V}_R(1)$$

$$\text{sign}(\mathbf{x}) \equiv \frac{\mathbf{x}}{|\mathbf{x}|}$$

This criterion is used to determine which faces of the hexahedron are intersected and Equation 23 is used to compute the associated path lengths.

4. COORDINATE SYSTEMS FOR PATH-LENGTH COMPUTATIONS

The convenient coordinate systems, and directions of the RDCS z-axis orientations are defined in Table I.

Several of the elemental volume types require transformations from the Absolute Coordinate System (ABCS) to the Rotated Detector Coordinate System (RDCS).

Table I
Coordinate Systems

Elemental Volume	Coordinate System	Direction of the Axes Relative to Elemental Volume
Sphere	DSCS	-
Cylinder	RDCS	Axis of cylinder along z_R
Cone and truncated cone	RDCS	Axis of cone along z_R
Ellipsoid and truncated ellipsoid	RDCS	Axis of z_R along truncation and all RDCS axes along major axes
Hexahedron	RDCS	z_R along direction of tracking ray
Hemisphere	RDCS	z_R along direction of truncation

5. COORDINATE SYSTEMS ROTATION TRANSFORMATIONS

Several elemental volumes have surfaces for which path lengths can be more conveniently computed in the RDCS by transformations which require equivalent matrix rotations of the DSCS to the RDCS. This subsection derives the required transformations.

a. Ellipsoid

Since the path lengths are computed in the Rotated Detector Coordinate System (RDCS), the ellipsoid detector system coordinates must be transformed to the RDCS as follows:

Let \vec{R}_k be a vector equivalent of the k th point of the ellipsoid (Figure 6) and

$$\vec{R}_k \equiv R(k) \equiv [x(k)_1, x(k)_2, x(k)_3] \quad (27)$$

Using the summation convention definition

$$A_\alpha B_\alpha \equiv \sum_{i=1}^3 A_i B_i$$

it follows that since an actual vector or tensor of rank 1 is invariant in any coordinate system, for the DSCS and RDCS

$$\vec{R}(k) = \vec{i}_{R\alpha} x(k)_{R\alpha} = \vec{i}_{D\alpha} x(k)_{D\alpha} \quad (28)$$

where subscripts R and D refer to the RDCS and DSCS, respectively, and the subscript α refers to the α th coordinate component.

The i th component of the k th point in the RDCS is

$$x(k)_{Ri} = (\vec{i}_{Ri} \cdot \vec{i}_{D\alpha}) x(k)_{D\alpha} \quad (29)$$

Since the ellipsoid points numbered $k = 1$ to 4 in Figure 6 can be transformed to the DSCS by Equation 11, the unit vector in the RDCS can be resolved in the DSCS as follows (Figure 12):

$$\vec{i}_{Rk} = \frac{\vec{i}_D [x(k)_D - x(4)_D]}{\left[\sum_{j=1}^3 [x(k)_{Dj} - x(4)_{Dj}]^2 \right]^{1/2}}; k = 1, 2, 3$$

$$\vec{i}_{Rk} = \vec{i}_{D\alpha} \ell(k)_{D\alpha} \quad (30)$$

where \vec{i}_{Rk} is a unit vector directed from point 4 to point k .

From Equations 29 and 30

$$x(k)_{Rj} = \left[\vec{i}_{D\beta} \ell(j)_{D\beta} \cdot \vec{i}_{D\alpha} \right] x(k)_{D\alpha}$$

$$= \delta_{\beta\alpha} \ell(j)_{D\beta} x(k)_{D\alpha} = \ell(j)_{D\alpha} x(k)_{D\alpha}$$

$$a = \left| x(1)_{D1} - x(4)_{D1} \right| \text{ etc.} \quad (31)$$

b. Hemisphere, Cylinder, and Cone

From Figure 5 the cone coordinate transformation can be effected by rotations about the z_D and x_I axes of angles ϕ and $-\theta$, respectively. If a

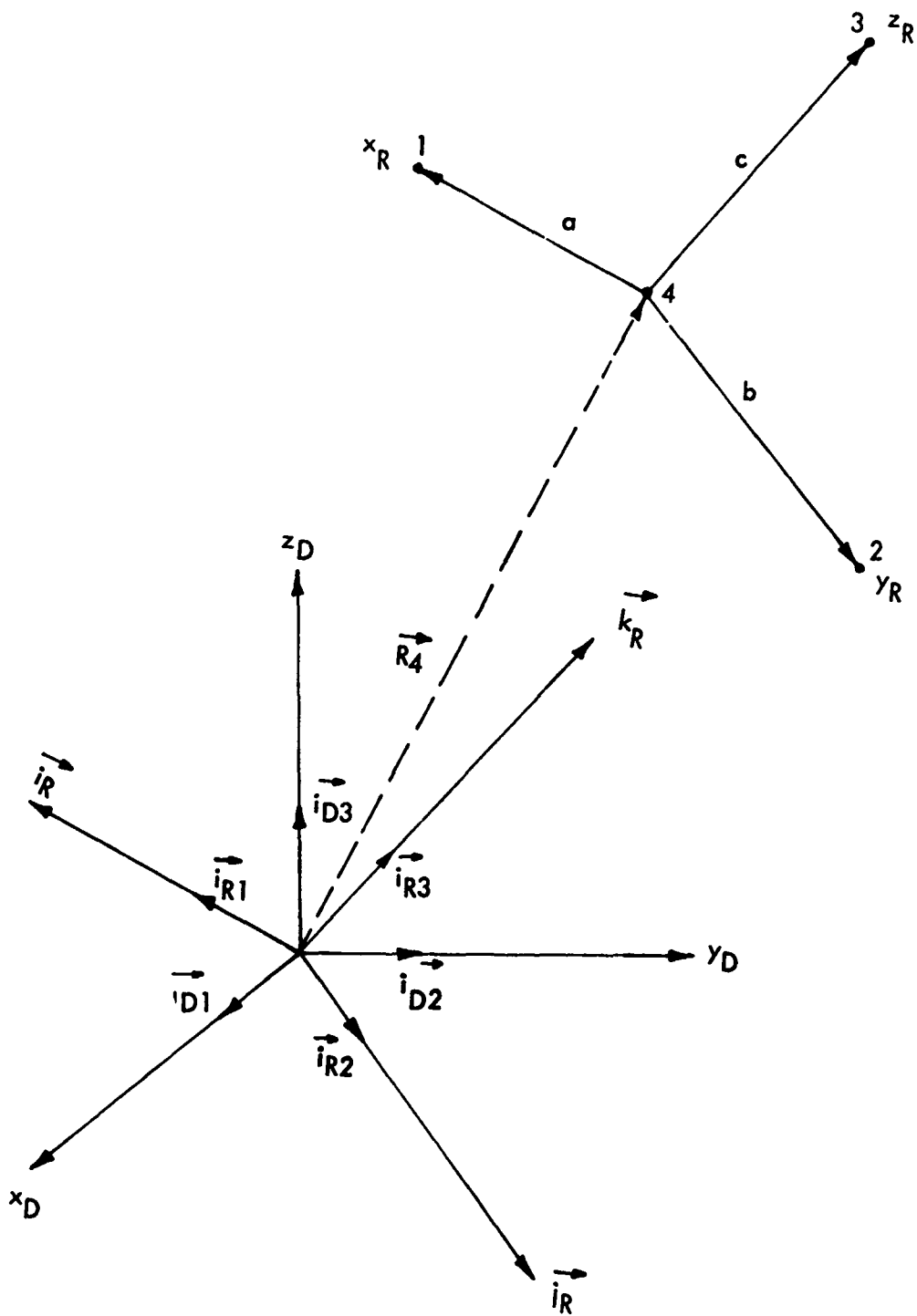

Figure 12. Coordinate Systems, Ellipsoid (DSCS and RDCS)

matrix rotation is defined by $\underline{M}_k(\epsilon)$ where k refers to the axis system and ϵ to the angle of rotation, then a vector position \underline{x} is transformed by

$$\underline{x}(\text{RDCS}) = \underline{M}_{xI}(-\theta) \underline{M}'_{zA}(\phi-90^\circ) \underline{x}(\text{DSCS}) \quad (32)$$

$$\underline{M}'_{zA}(\phi) = \begin{pmatrix} \cos \phi & \sin \phi & 0 \\ -\sin \phi & \cos \phi & 0 \\ 0 & 0 & 1 \end{pmatrix} \quad (33)$$

and

$$\underline{M}_{xI}(\theta) = \begin{pmatrix} 1 & 0 & 0 \\ 0 & \cos \theta & \sin \theta \\ 0 & -\sin \theta & \cos \theta \end{pmatrix}$$

The \underline{x} matrix is a column matrix.

Since

$$\cos(\phi-90^\circ) = \sin \phi$$

$$\sin(\phi-90^\circ) = -\cos \phi,$$

$$\underline{M}_{xI}(-\theta) \underline{M}'_{zA}(\phi-90^\circ) = \begin{pmatrix} \sin \phi & -\cos \phi & 0 \\ \cos \theta \cos \phi & \cos \theta \sin \phi & -\sin \theta \\ \sin \theta \cos \phi & \sin \theta \sin \phi & \cos \theta \end{pmatrix} \equiv \underline{M} \quad (34)$$

The trigonometric functions of θ and ϕ are determined as follows: If the direction cosines of the centerline of the cone, cylinder, etc. are defined by (α, β, γ) , then

$$\cos \theta = \gamma$$

$$\sin \theta = (1 - \gamma^2)^{1/2} \quad (35)$$

since $\theta \leq 180$ degrees.

If $\alpha=0$, $\sin \phi = 1.0 \times \text{sign of } \beta$ and $\cos \phi = 0.0$.

If $\alpha=0$, and $\gamma = 1$, $\sin \phi = \cos \theta$ and $\cos \phi = 0.0$.

Otherwise

$$\begin{aligned}\tan \phi &= \beta / \alpha \\ \cos \phi &= \pm(1 + \tan^2 \phi)^{-1/2}\end{aligned}$$

where

$$\begin{aligned}\cos \phi &> 0 \quad \text{if } \alpha \geq 0 \\ \cos \phi &< 0 \quad \text{if } \alpha < 0 \\ \sin \phi &= \pm(1 - \cos^2 \phi)^{1/2}\end{aligned}\tag{36}$$

where

$$\begin{aligned}\sin \phi &< 0 \quad \text{if } \beta < 0 \\ \sin \phi &> 0 \quad \text{if } \beta \geq 0\end{aligned}$$

The matrix equivalent of Equation 34 is used to transform the direction cosines as follows:

$$\underline{\alpha}_R = \begin{bmatrix} \alpha_R \\ \beta_R \\ \gamma_R \end{bmatrix} = \underline{M}\underline{\alpha}_D\tag{37}$$

where $(\underline{M})_{ij} = \ell(i)_{Dj}$ for the ellipsoid. The discussion of the analysis required to compute the path lengths to the elemental volume surfaces is now complete. However, these surface path lengths must be transformed to volume path lengths; i. e., path lengths through volumes.

6. VOLUME PATH-LENGTH COMPUTATIONS

The elemental volumes are in general composite surfaces, including conical and plane surfaces. It is necessary to know whether the dosimeter is inside the elemental volume, because in some cases the path through the volume is the difference between two allowed path lengths, while if the elemental volume contains the dosimeter, the path through the volume is equivalent to one of the allowed surface path lengths.

a. Test for Dosimeter Inside Elemental Volume

Sphere

The dosimeter is inside when the distance from the dosimeter to the sphere center is less than the sphere radius, or (Figure 7)

$$x_D^2(1) + y_D^2(1) + z_D^2(1) < R^2 \quad (38)$$

This condition for the conic surfaces corresponds to C less than zero (Equations 17 and 20 through 22).

Hemisphere

A sphere with the same radius as the hemisphere and centered at the hemisphere center must contain the dosimeter, and the origin components in the RDCS must be bounded by the z components of points 1 and 2 (Figure 8). This is true if

$$z_R(1) z_R(2) < 0$$

and

$$x_R^2(1) + y_R^2(1) + z_R^2(1) < R^2 \quad (39)$$

Cone

The origin must be bounded by the z components of the base and apex of the cone, and the circular intersection of the (x_R , y_R) plane and the cone must contain the dosimeter (Figure 8). These conditions are satisfied if

$$z_R(1) z_R(2) < 0$$

and

$$x_R^2(2) + y_R^2(2) < \left[z_R(2) \tan \theta \right]^2 \quad (40)$$

Similar logic can also be used to determine the following inequalities for the cylinder and ellipsoid.

Cylinder (Figure 8)

$$z_R(1) z_R(2) < 0$$

and

$$x_R^2(1) + y_R^2(1) < R \quad (41)$$

Ellipsoid (Figure 6)

$$\frac{x_R^2(4)}{a^2} + \frac{y_R^2(4)}{b^2} + \frac{z_R^2(4)}{c^2} < 1 \quad (42)$$

and for double truncation also

$$z_R(5) z_R(6) < 0$$

Hexahedron

If M is the midpoint of a vector from points 1 to 5, then the dose point D is inside if MD is less than MP (Figure 13). P is the point of intersection of a vector from M in the direction of D.

After it is determined that the dosimeter is outside, additional logic is necessary to accommodate unique cases such as glancing incidence, etc.

b. Volume Path-Length Logic

There are three basic types of computed path lengths, i. e., positive, negative, and path lengths to unacceptable regions of a surface. Figure 14 illustrates these path lengths. The particle ray direction is defined from the dosimeter position inside the cone to point A on the cone surface. This ray also intersects the cone base plane. The distance from the dosimeter to point A (P_1) is defined as a positive path length. The path length from the dosimeter to the base plane is an unacceptable path length because only the base plane path lengths to the circular region of the base plane are allowed. The path lengths computed, for this case, with Equation 18 will have positive and negative values. The negative path-length value will be P_2 in Figure 14. This is another case of an unacceptable path length. The unacceptable path lengths are used in the path-length logic and are assigned arbitrary large values of 10^{20} .

If the dosimeter is outside a composite surface volume, in general, the difference between two path lengths is the path length through the volume.

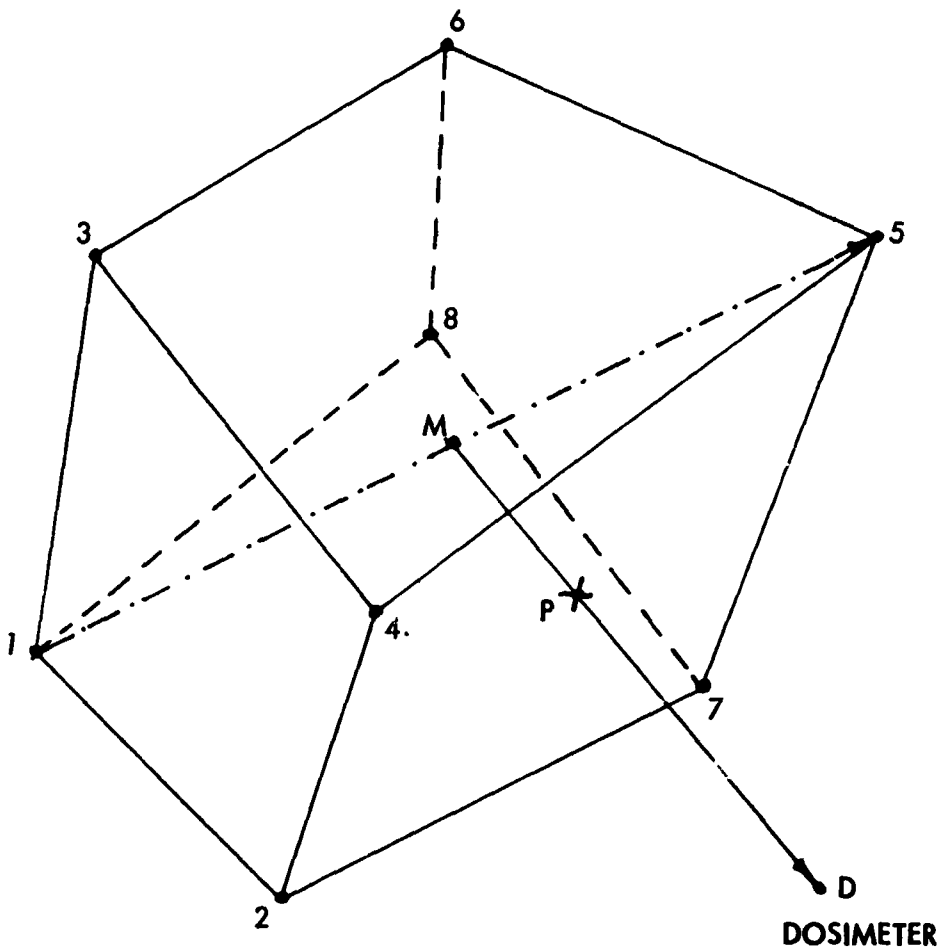

Figure 13. Location of Dosimeter Relative to the Hexahedron

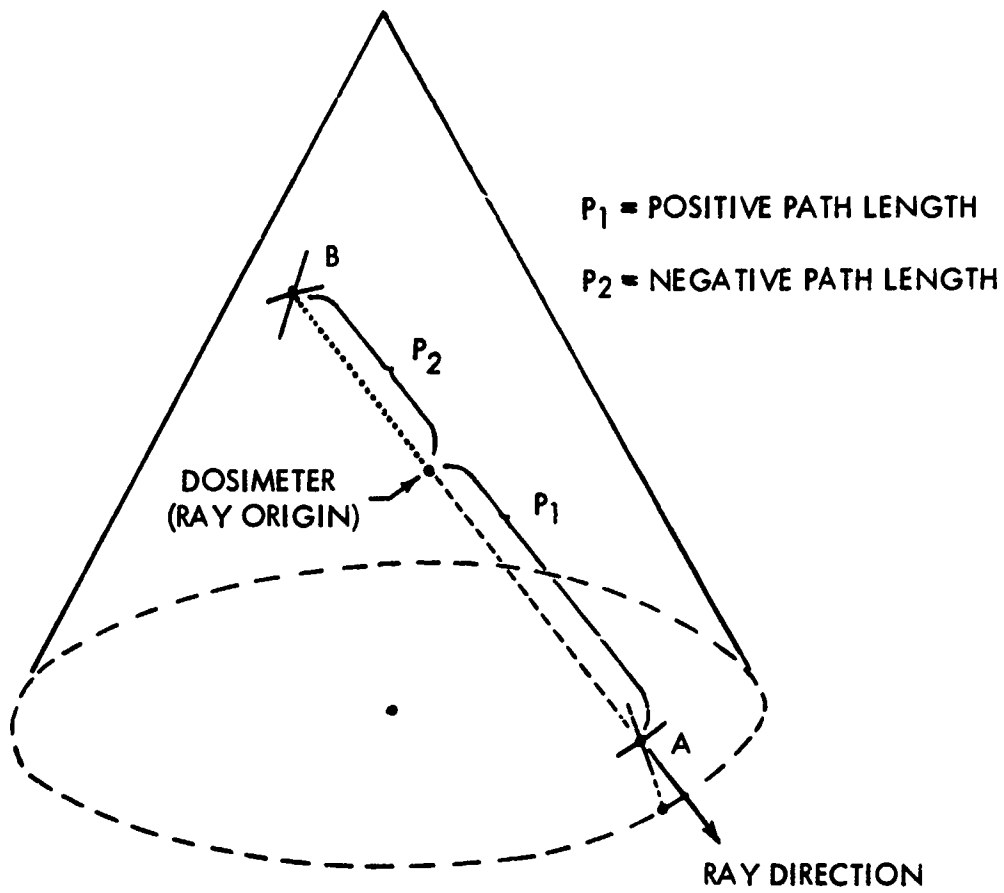

Figure 14. Illustrated Positive and Negative Path Lengths

This is also true when the tracking ray is tangent to one of the volume surfaces and the path lengths are equal. However, if the ray passes through a single surface and the intersection of two of the composite surfaces, there will be three path lengths with two being equal. Therefore, for all volumes except the hexahedron, if there are three or more paths, the minimum path is determined; then it and all equivalent paths are set equal to 10^{20} . This is repeated for the second minimum, and the volume path length is the difference between the two minimum paths.

For the hexahedron, if there are only two allowed path lengths, the volume path-length computation is the same as for the other elemental volumes. If there are three or more allowed path lengths, the minimum of the path lengths is picked, and it and all equivalent values are set to 10^{20} . Next, the second minimum is picked and tested for equivalences to 10^{20} . If the second minimum is equivalent to 10^{20} , there is glancing incidence, and the volume path length is zero. Otherwise, the volume path is the difference between the first and second minima.

c. Composite Shield

The elemental volumes are defined as positive and negative or solid and void, respectively. A negative or void volume is defined as voiding all the portions of the solid volumes which intersect its spatial region. The negative volume only voids solid shields in its particular composite shield. The composite shield is a combination of up to 10 elemental volumes.

The composite shield permits imbedding in which the positive shield may contain a portion or all of the negative or void shield. Also, the composite shield positive shield components may have different material types and densities. Portions of several of the positive shield components may contain portions of a single negative or void shield. These additions result in a very significant improvement in the geometrical representation capability of the program.

The negative or void shields are defined such that the portions of positive shields which are contained in the negative shield volumes are considered as void regions. The positive shields are considered separately and their portions contained in the negative shields voided. Since the individual negative shields may intersect some or all of the positive shields, all the negative shields must be tested for intersections with each positive shield. The tracking ray will sequentially traverse the negative shields according to their increasing distance from the dosimeter location. So the negative shields are ordered in a path-length array [PN (I, J)] where

I refers to a set of path lengths for a negative shield

J refers to the two path lengths at the tracking ray's entrance and exit from the elemental negative shield, i. e. , $[PN(I, 1) < PN(I, 2)]$

and

$PN(I + 1, 1) > PN(I, 1)$, $I=1$, No. negative shields traversed in the composite shield

The positive shield's path lengths are redefined in an array $PP(I, J)$ where I, J refer to the positive shields and their two path lengths, respectively. The array of positive path lengths is not ordered. Therefore, they are redefined in the same sequence that the respective positive shields are tracked. Another array $IMAT(I)$ contains the material type corresponding to the positive shield. $IMAT$ refers to the material type for the areal-density computations. In Figure 15, the logic for the traversal path lengths and plotting points is illustrated for the positive shield (+1) and the void shields (-2 and -3). For convenience the positive and negative shield path lengths are defined as $[P(1), P(4)]$ and $[P(2), P(3)]$, respectively for the first negative shield intersected. If the negative (-3) shield does not intersect the positive shield (+1), the following test must be satisfied:

$$P(3) \leq P(1) \text{ or } P(2) \geq P(4)$$

Otherwise, the negative voids a portion of the positive shield.

If $P(2) > P(1)$, the portion of the positive shield between $P(1)$ and $P(2)$ is plotted or the path-length equivalent areal density is computed and added to the other equivalent path lengths of the particular tracking ray. However, if $P(2) < P(1)$ the negative shield can completely void the positive. In this case, if $P(3) \geq P(4)$, the positive shield track is completely voided and another positive shield is selected. However, if $P(4) > P(3)$, the portion of the positive shield between $P(1)$ and $P(3)$ is voided by redefining the positive shield path lengths as $Q(1), Q(4)$, where

$$Q(1) = P(3)$$

$$Q(4) = P(4)$$

If $P(2) > P(1)$, the test must also be made with $P(3)$ and $P(4)$ to determine if the remainder of positive shield is voided. If all the negative shields are processed without satisfying the condition $P(3) \geq P(4)$, $Q(3) \geq Q(4)$ etc. the path length between $P(3)$ and $P(4)$ is used and another positive shield is selected.

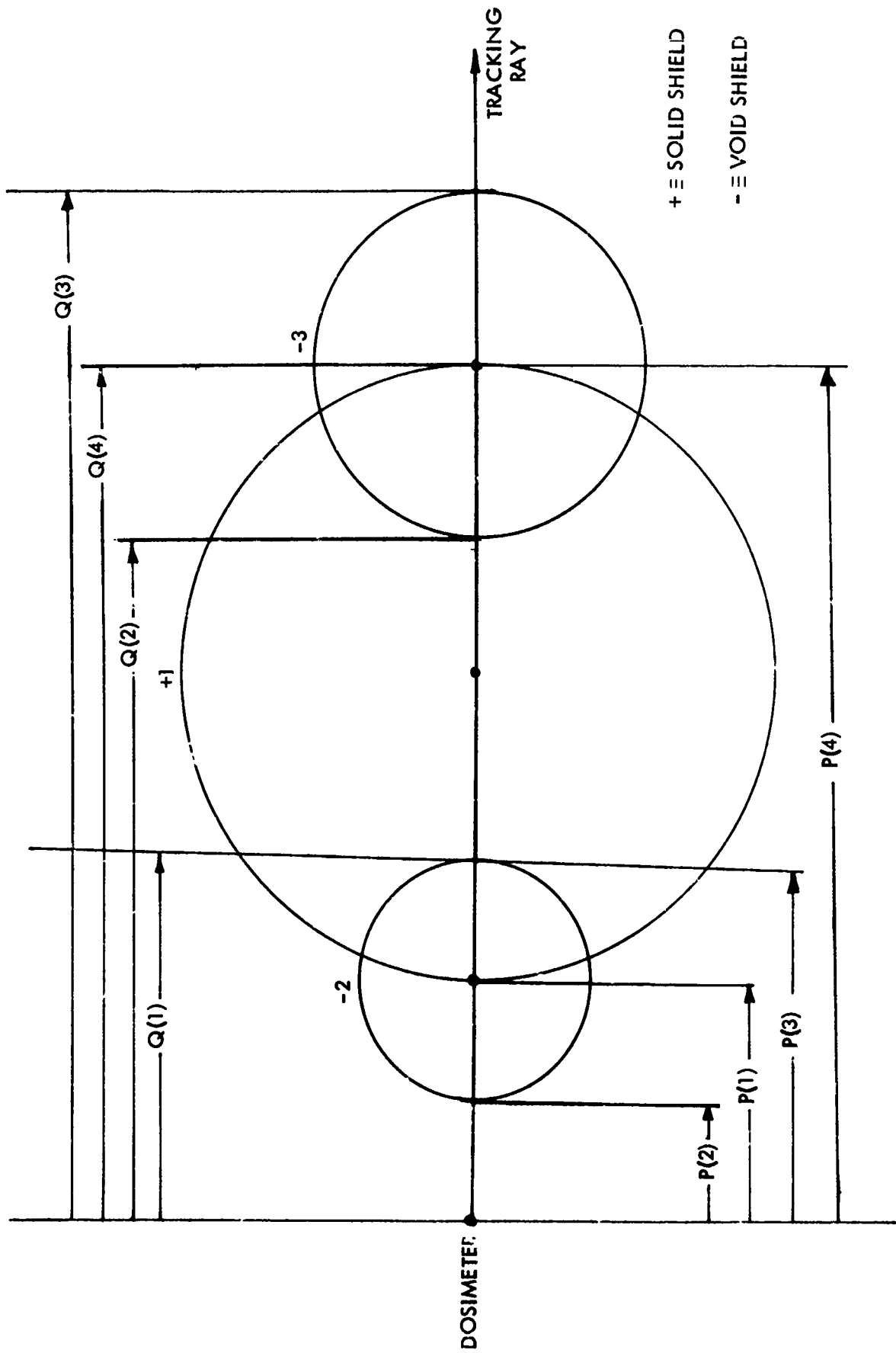

Figure 15. Composite Shield Tracking Sequence

d. Hit-or-Miss Criteria

To eliminate unnecessary path-length computations, the first portion of the volume path-length calculations will determine if the tracking ray misses a simple boundary which contains the elemental volume. For example, the sphere contains the hemisphere elemental volume. However, if the ray hits the spherical volume it may hit or miss the hemisphere.

Sphere

The sphere is missed if the discriminant of Equation 18 is negative

$$B^2 - 4AC \leq 0$$

which means the path length through the sphere is imaginary or zero.

Cylinder and Cone

This criterion is based on intersection of the tracking ray with the projection of the cylinder and the larger radius of the cone on the (x, y) plane in the RDCS. This is done by using the center point of the circular projection as the center of a sphere with the radius of the projection. The tracking ray misses the volume if the component of the tracking ray in the (x, y) plane does not intersect the aforementioned sphere. The discriminant of Equation 18 becomes

$$\begin{aligned} A_1 &= 1.0 \\ B_1 &= -2 \left[\alpha_R x_{R1} + \beta_R y_{R1} \right] / \left(\alpha_R^2 + \beta_R^2 \right)^{1/2} \\ C_1 &= x_{R1}^2 + y_{R1}^2 - R^2 \end{aligned} \tag{43}$$

and there is a miss if

$$B_1^2 - 4A_1C_1 < 0$$

Ellipsoid

The ellipsoid miss criterion is the same as that for the sphere, except that the ellipsoid is in the RDCS and the radius is the largest ellipsoid major axis.

Hexahedron

The hexahedron and each plane face of the hexahedron is projected on a plane perpendicular to the ray direction. Then, in the RDCS, a rectangle is defined by the minimum and maximum x and y values (Figure 16). If the rectangle does not contain the origin, the tracking ray misses the face.

Another form of hit-or-miss check is tracking by octant, and considering only shields in the octant of the tracking ray.

The octants are defined by the DSCS coordinate sign convention in Table II. By using the DSCS, the matrix rotation calculations required for the RDCS can be eliminated if the ray and shield octants are not identical.

Table II
Octant Definition

Coordinate Component Signs			Octant No.
x	y	z	
-	-	-	1
-	-	+	2
-	+	-	3
-	+	+	4
+	-	-	5
+	-	+	6
+	+	-	7
+	+	+	8
Volumes intersecting planes			9

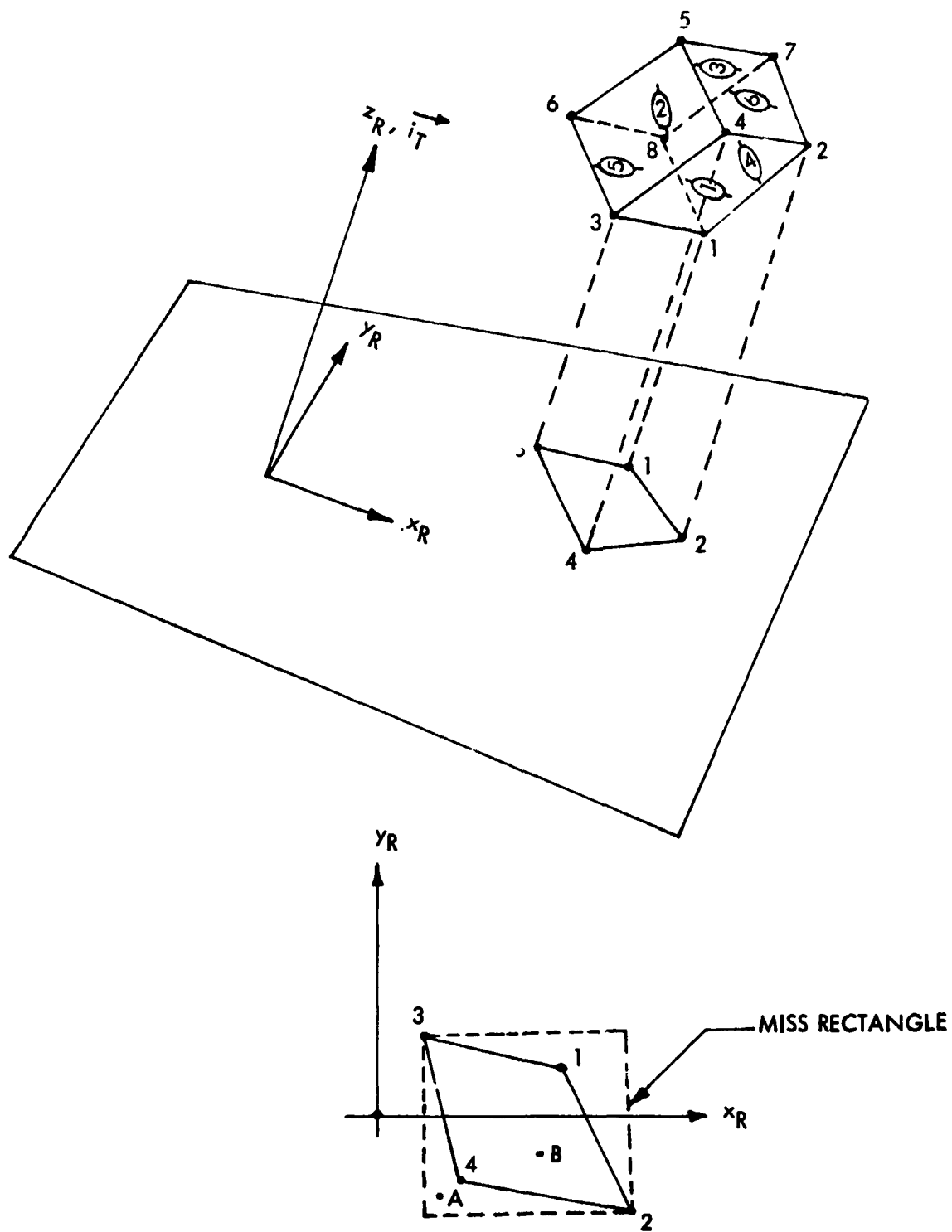

Figure 16. Projection of Hexahedron Face

Table III and the following definitions of the parameters IN, JN and KN

$$\begin{aligned}
 IN &= 0, \quad x < 0 \\
 &= 4, \quad x > 0 \\
 JN &= 0, \quad y < 0 \\
 &= 2, \quad y > 0 \\
 KN &= 0, \quad z < 0 \\
 &= 1, \quad z > 0
 \end{aligned}
 \tag{44}$$

are used as an algorithm for computation of octants with coordinate components. The octant of a point is defined as 9 if either x , y , or $z = 0$.

The following outline delineates the steps necessary to determine the octant numbers of the elemental volumes.

Table III
Octant Logic

Octant No.	IN	JN	KN	Sum = IN+JN+KN+1
1	0	0	0	1
2	0	0	1	2
3	0	2	0	3
4	0	2	1	4
5	4	0	0	5
6	4	0	1	6
7	4	2	0	7
8	4	2	1	8

Sphere

The octant of the center of the sphere is determined; then, the following differences are checked for negative values:

$$\begin{aligned} |x_D(1)| - R \\ |y_D(1)| - R \\ |z_D(1)| - R \end{aligned} \tag{45}$$

If there are no negative numbers, the octant number of the center point is used. If there are negative numbers octant 9 is used.

Hemisphere

The octant numbers of the two points which define the hemisphere are determined. If the two octant numbers are identical, differences in Equation 45 are checked for negative values. If there are no negative numbers, the octant number of the two points is used. Otherwise, octant 9 is used.

Cylinder

The octant numbers of the two points on the center line of the cylinder are determined. If the two points have the same octant numbers, the differences in Equation 45 are checked for negative values for points 1 and 2 (Figure 4). If there are no negative numbers, the octant numbers of the two points are used. Otherwise, octant 9 is used.

Cone

The octant numbers of the points (1, 2) for the cone and (1, 3) for the truncated cone are determined. If the two points have the same octant, the following differences are checked:

$$\begin{aligned} |x_D(I)| - R(I) \\ |y_D(I)| - R(I) \\ |z_D(I)| - R(I) \end{aligned} \tag{46}$$

where, for the regular cone

$I = 1$ and $R(1) =$ radius of the base and for the truncated cone

and for the truncated cone

$I = 1, 2$ with $R(1) =$ radius of the base
 $R(2) =$ truncation radius

If there are no negative differences, the octant number of point 1 is used. Otherwise, octant 9 is used.

Ellipsoid

The octant of point 4 of center of the ellipsoid is determined. The following differences are checked for negative values:

$$\begin{aligned} |x_D(4)| - R_m \\ |y_D(4)| - R_m \\ |z_D(4)| - R_m \end{aligned} \tag{47}$$

where

$R_m =$ maximum major axis

If all differences are positive, the octant of point 4 is used. Otherwise, octant 9 is used.

Hexahedron

The octants of the eight points defining the hexahedron are determined. If they are identical, the computed octant is used; otherwise, octant 9 is used.

This concludes the analysis required to determine the individual shield volume path-length computations. The computed path lengths are now converted from inch units to areal-density units.

7. AREAL-DENSITY FUNCTIONS

The previous subsections discussed the procedure for selecting the source particle directions and penetration path lengths through the structural materials. Now the incident source particles must be traced from the shield external surface to the dosimeter. Also, the path lengths are converted from length to areal-density units.

Two forms of areal density are computed for: (1) electron primary and (2) heavy charged primary dose computations.

a. Electron Areal-Density Function

For the electron computations, the volume path lengths (P_{ij}) are ordered according to decreasing distances to the volumes (Q_{ij}) and transformed to an areal-density array ($A_{i\ell}$). Therefore

$$\begin{aligned} A_{i1} &= \rho_j P_{ij} \\ A_{i2} &= \rho_r P_{ir} \\ &\vdots \\ A_{in} &= \rho_m P_{im} \end{aligned} \tag{48}$$

where

$$Q_{ij} > Q_{ir} > \dots > Q_{im}$$

and

P_{ij} = path length for the i th ray and the j th material

Q_{ij} = distance to the j th path length of the i th ray

ρ_j = material density of the j th path length for the i th ray

$A_{i\ell}$ = path-length areal density in (grams/cm²) units for the i th ray and the ℓ th path length

n = number of path lengths for the i th ray

b. Heavy Charged Particle Areal-Density Function

It is desirable to convert the path lengths for the various materials to equivalent path lengths in a standard material, which will have the same

effective heavy charged particle ionization transport properties. The equivalent path lengths can be computed without ordering the path length according to distance.

The conversion to a standard material permits propagation of the total spectrum from incidence to emergence. This eliminates the necessity of considering individual spectral energies and their propagation through each material encountered.

If the range (R) versus energy (E) is approximated by the empirical equation

$$R = \delta E^\eta \quad (49)$$

the energy transport equation is

$$R(E_0) = R(E_1) + x \quad (50)$$

where

E_0 \equiv charged particle incident energy

E_1 \equiv charged particle emergent energy

x \equiv shield areal density (grams/cm²)

From Equations 49 and 50

$$\delta_s E_0^{\eta_s} = \delta_s E_1^{\eta_s} + x_s \quad (51)$$

where subscript s refers to a standard material. Also

$$\delta_A E_0^{\eta_A} = \delta_A E_1^{\eta_A} + x_A \quad (52)$$

and A refers to an actual material. Therefore

$$\begin{aligned} x_s &= x_s(E_0, E_1) \\ x_A &= x_A(E_0, E_1) \end{aligned} \quad (53)$$

E_1 is eliminated; then

$$x_s = x_s(x_A, E_0) \quad (54)$$

However, to the first order, x_s can be determined as a function of x_A as follows:

For $E_1 = 0$

$$x_s = \delta_s E_0^{\eta_s} \quad (55)$$

$$x_A = \delta_A E_0^{\eta_A} \quad (56)$$

$$E_0 = \left(\frac{x_s}{\delta_s} \right)^{\frac{1}{\eta_s}} = \left(\frac{x_A}{\delta_A} \right)^{\frac{1}{\eta_A}} \quad (57)$$

So, to the first order

$$x_s = \delta_s \left(\frac{x_A}{\delta_A} \right)^{\frac{\eta_s}{\eta_A}} \quad (58)$$

The error in this approximation increases as a function of increasing emergent energy and with smaller atomic weights. However, it is a good approximation for most practical applications.

With systematic or random selection of the proton incident direction, an accumulative distribution function of the solid (S_a) as a function of a real density (T) is computed, where

$S_a(T) \equiv$ fraction of the total unit sphere with areal densities less than T

If $S_a(T)$ is determined as a polynomial least-square fit, then

$$S_a = \sum_{i=0}^N C_i T^i \quad (59)$$

The fraction of solid angle (S_a) less than an arbitrary thickness (T) can be utilized for future dose calculations with the same material and structural configuration and dosimeter location. The areal-density range of values may, for example, be 0.1 to 40 grams per centimeter square. However, the smaller thickness range would contribute the larger portion of the dose or emergent flux. Therefore it is necessary to place larger weight or significance on the smaller thicknesses. This is done by using more joints for the least-square fit of $S_a(T)$ at smaller values of T .

For discrete selection of T values (see Figure 17) let the value of the weight function for n th thickness be

$$R_n = n\delta R$$

$$= R_{\min} + (1 - R_{\min}) \left\{ \frac{\left[1 - \cos \pi \left(\frac{T_n - T_{\min}}{T_{\max} - T_{\min}} \right) \right]}{2} \right\}^{\frac{1}{\tau}} \quad (60)$$

then

$$T_n = T_{\min} + \left\{ \frac{T_{\max} - T_{\min}}{\pi} \right\} \cos^{-1} (1 - u_n) \quad (61)$$

where

$$u_n = 2 \left(\frac{n\delta R - R_{\min}}{1 - R_{\min}} \right)^{\tau}$$

The range of n values is

$$\left[\text{IPO} \left(\frac{R_{\min}}{\delta R} \right) + 1 \right] \text{ to } \left[\text{IPO} \left(\frac{1.0}{\delta R} \right) \right] \quad (62)$$

where

$\text{IPO}(X) \equiv$ Integral part of (X)

In general, the weight function shape parameter (τ) should be selected inversely proportional to the minimum areal density of the distribution function. Section III describes the computer program and correlates its computational operations with the analysis.

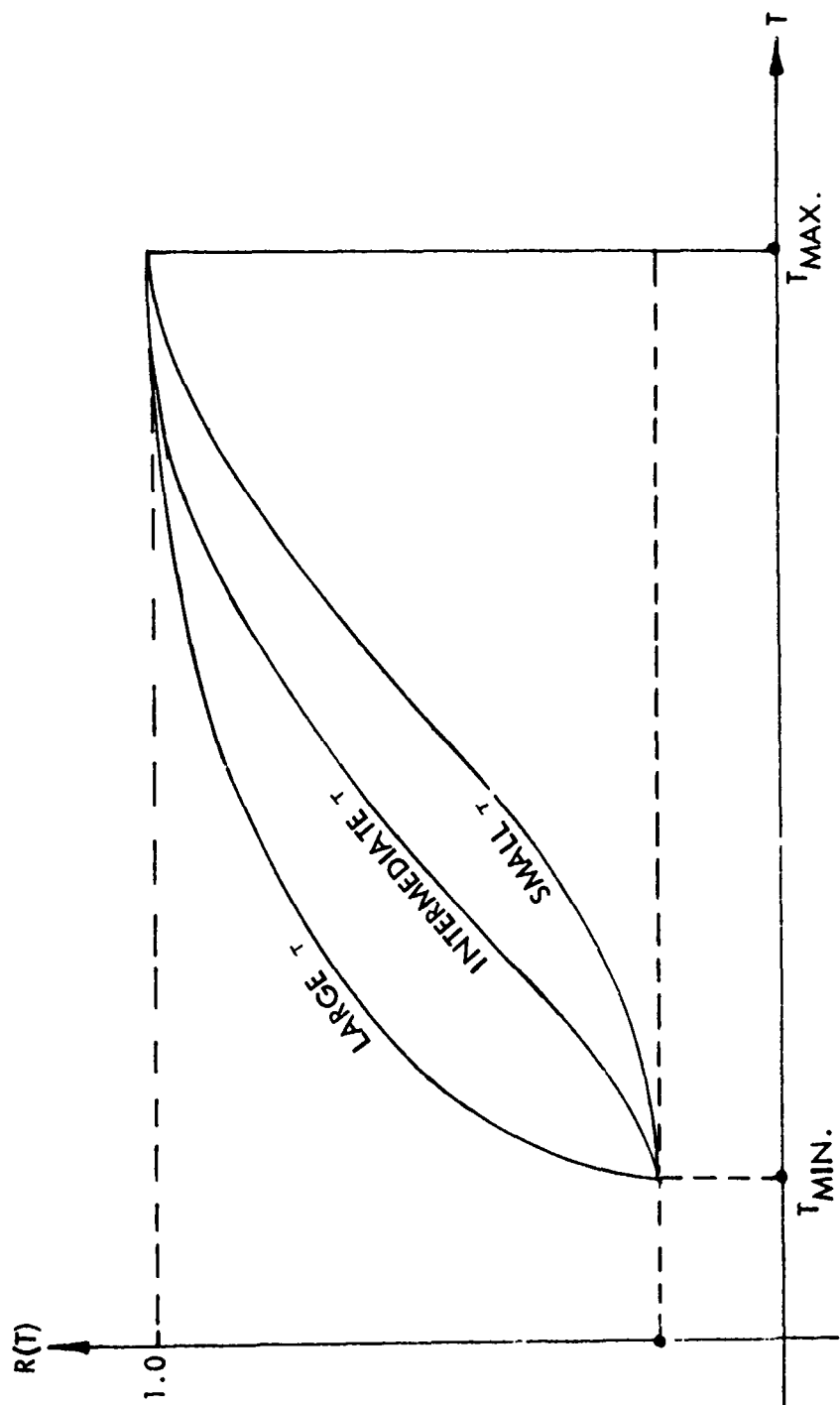

Figure 17. Thickness Weighting Function

SECTION III

MODIFIED ELEMENTAL VOLUME DOSE PROGRAM

A functional block diagram (Figure 18) depicts the operational functions of the ray tracing subroutines of the modified EVDP (MEVDP). These operations are correlated with the subroutines in Table IV. This table illustrates the functional parts of the MEVDP. The program is organized into three major functional parts: (1) data input and transformation, (2) ray tracing, and (3) areal-density computations. The data input and transformation section of the program reads the astronaut and spacecraft input data in their respective coordinate systems. Then the astronaut data are modified to account for limb rotation. Subsequently, both sets of data are transformed to a coordinate system positioned at the dosimeter location. The transformed elemental volume data are modified by matrix or coordinate axes rotations. The ray tracing section of the program computes the ray direction cosines with two options: (1) random and (2) systematic selection. The random option is desirable for shielding configurations with a relatively large degree of spatial inhomogeneity. However, the systematic selection option is suitable for most applications. A North American Rockwell comparison of these options is published in Reference 1. The third part of the program uses the data, which will derive from the other two parts to calculate the desired areal-density data to be used in AFWL secondary and primary nuclear radiation programs.

Further explanation is required to amplify and reiterate the purpose of the coordinate systems introduced in Figure 18.

The spacecraft geometrical structural configuration is originally defined by elemental volume coordinates plus parameters in the ABCS (Figure 18). In order to substantially decrease the amount of ray tracing or tracking required, the elemental volumes are classified according to their octant location in a coordinate system. However, if the volume octants are selected relative to the ABCS, there will be unnecessary tracking. This results from the fact that, for isotropic source ray tracing calculations, the rays are directed toward the dosimeter which is generally displaced from the origin of the ABCS. Therefore, the ray could traverse four octants. However, if the geometry is transformed to a coordinate system centered at the detector (DSCS), the rays traverse only one octant. Tracks along the axes are considered as special cases. The axes of the ABCS and the DSCS have the same vectorial direction and therefore differ only by a vectorial displacement.

For several elemental volumes it is convenient to have a detector coordinate system with one or more of its axes directed along the reference

**Table IV
Functional Description of the MEVDP Subroutines**

Functional Block No.	Operation Description	Subroutines
1	Read spacecraft and astronaut input data in the Absolute Coordinate System (ABCS) and the Standard Man Coordinate System (SMCS), respectively	GENTAP
2	Store the spacecraft and astronaut data in separate files on tape or disk	GENTAP
3	Rotate the astronaut's limbs in the Standard Man Coordinate System (SMCS)	LIMROT
4	Translation and rotation of the rotated limb astronaut in the (SMCS) to the (ABCS)	FANTOM
5	Translate the data to the DSCS	TRSHLD HEX (hexahedron) SPHERE (sphere) CYLNDR (cylinder) HEMIS (hemisphere) CONE (cone) TRCON (truncated cone) ELIPSD (ellipsoid)
6	Rotate the shield data to the Rotated Detector Coordinate System (RDSCS)	The same routines in (5) except for the HEX and ELIPSD routines
7	Control computation of ray direction cosines and Ray Tracing	ESDOSE

Table IV (Continued)
Functional Description of the MEDVP Subroutines

Functional Block No.	Operation Description	Subroutines
8	Random selection	RNDSEL
9	Systematic selection at the center of group of equal solid angles	SYSSEL
10	Octant determination for each shield	OCTCOS
11	Change original shield densities as required	TRACK
12	Select each ray's direction cosines	TRACK
13	Select each shield's data	TRACK
14, 15, 16	Transform ray to the shield's RDCS; Perform single shield "hit-or-miss" test; Path-length computations	TRACK
17	Composite shield "hit-or-miss" test	TKHEX (hexahedron) TKCYL (cylinder) TKSPH (sphere) TKHM (hemisphere) TKCON (conc) TKELL (ellipsoid)
18, 20	Compute the composite shield's traversal path areal-density entrance path length and material type	ELMIS COMPSP

**Table IV (Concluded)
Functional Description of the MEDVP Subroutines**

Functional Block No.	Operation Description	Subroutines
19, 23, 24	Compute the accumulative areal density and store on disk or tape	TRACK
21, 22	Sort areal densities as a function of entrance path length for each ray and store traversal path areal density and material type on disk or tape	ORDER
25, 26	AFWL Secondary and Primary Dose and/or Flux computation programs	

Figure 18 is located on page 215.

Figure 18. Functional Diagram of the MEVDP

axes of the elemental volumes. Since the new detector system has the same origin as the DSCS, the ray direction cosines can be converted to the new system by matrix rotations. The new system is designated the Rotated Detector Coordinate System (RDCS). In order to select the rotation matrix transformations for the elemental volumes, it is necessary to determine convenient coordinate systems relative to the elemental volumes reference axes. The most convenient axes are selected as those which facilitate calculations of path lengths to the elemental surfaces.

1. MAIN PROGRAM

The main program controls the calling sequence of the major routines for data input and transformation, ray tracing, and areal-density computations. For the reader's convenience, the discussion coordinates the FORTRAN IV program listing (Appendix II) with the first section of this document. R I is used to define the reference statement I which is nearest to the operation being discussed. These references are comment cards, in the program listing, entitled "Program Operation Reference No. I," where I is the number in R I. Reference comment cards before DO loops refer to the operations performed in the indicated loop. Scratch disk storage devices are designated as SYSDA. The main program rewinds tape units 8 and 9 and reads the parameters N10GEN and CONTEN. CONTEN is a descriptive title and N10GEN specifies that the input geometry is read as cards or from tape unit 10. At R1, subroutine GENTAP is called to generate a card image of the geometry data on tape unit 10 if N10GEN > 0. At R2, the input parameter OPTN transfers to R3 to input a new set of geometry or continues and calls subroutines CLOCK and TRSHLD. CLOCK is used to compute the elapse time in TRSHLD, which transforms the geometry data. Then routines ESDOSE and ORDER are called to (1) perform ray tracing and areal-density computations, and (2) order the areal-density data according to ray numbers and decreasing distance from the dosimeter location. Subroutine CLOCK uses the library function SECOND to compute current time in seconds, and converts the time to minutes.

2. SUBROUTINE GENTAP

The function of this subroutine is to read geometry card input data and generate two files containing (1) the basic spacecraft geometry and (2) the simulated astronaut geometry on tape unit 10 in card image. The end of the input data is determined by testing after R4 for a blank card.

3. SUBROUTINE FILE

Subroutine FILE moves tape unit number NTAPE to the beginning of the file numbered (NEWF+1). If tape number NTAPE has been used, the old file number, NOLDF, of NTAPE is used with NEWF to avoid rewinding when tape NAPE can be advanced to the proper file (i. e. , NSKIP > 0 at R5).

4. SUBROUTINE TRSHLD

a. Geometry Data Transformation

This subroutine uses input geometry data, which define the elemental volumes (Figure 4) and the dosimeter location. The original coordinates, in the ABCS, are transformed to the DSCS by a translation (Equation 11); then the DSCS and tracking ray direction cosines are transformed to the RDCS by an equivalent matrix rotation of the DSCS, and the octants computed in the DSCS for each shield. Auxiliary computations include the ellipsoid major axes, radius of the base of the cone, etc.

The composite transformed and auxiliary data for each shield is written on a SYSDA unit. This tape will be input data for the areal-density computations. The following discussion presents the definitions, analysis, and logic used to implement the functions of TRSHLD.

The variables N and NSO are set to zero, where

N = a counter which is equal to the number of the elemental volume being transformed

NSO = number of shields in the Ith octant in the DSCS

Then the following input data are read:

XDET(I) = detector coordinates in the ABCS and I = 1, 2, 3 refer to the x_A , y_A , z_A components

NS = number of input elemental volumes or a positive integer for one or more volumes, and zero for no spacecraft volumes

PRNT = printout control parameter (=0, no detail tracking printout desired; $\neq 0$, all printout required)

NOMAN = total number of elemental volumes comprising one astronaut

NMEN = number of astronauts (≤ 10)

NLIMB(I) = number of composite shields which will be rotated for the Ith astronaut and is defined as unity for the NASA-MSM model astronaut

NOMAN is redefined as the total number of elemental volumes comprising the crew

Tape unit 12 (SYSDA), which will contain the transformed data, is rewound. Then the elemental volumes counter, N, is increased by one and tested to determine if all shields have been transformed. The following parameters are read as input data for the Nth shield from tape 10:

SSN = shield serial number

ST = shield type

MATCD = material code number which defines the shield material composition

RPHI = radius of cylinder or radian half-angle of a cone

RHO = shield density (grams/cm³)

JMAX = type of ellipsoid (degree of truncation)

NCOMP = the number of elemental volumes comprising a composite shield (≤ 10)

As many as ten of the elemental volumes may be combined to form more complex shields, which are designated as composite shields. The void (negative) elemental volume components are used to void the spatial region they occupy. The composite shield permits imbedding, in which the positive (solid) shield may contain all or a portion of a void shield. Also, the solid shield components may have different material types and densities. Portions of several of the positive shield components may contain portions of a single void shield. This versatility results in a very significant improvement in the geometrical representation capability and reduces the magnitude of the shield synthesis effort.

The variable TG is used to define tape unit 10. The shield types (ST) are defined as follows:

Type of Shield	Hollow Shield	Solid Shield
Hexahedron	0	1
Cylinder	2	3
Sphere	4	5
Hemisphere	6	7
Cone	8	9
Truncated Cone	10	11
Ellipsoid	12	13

JMAX is defined as follows, and is applicable only to elliptical volumes:

JMAX	Type of Ellipsoid Truncation
4	Non-truncated
+5	Single truncation with lower portion Eliminated with respect to z_R axis
-5	Single truncation with upper portion Eliminated with respect to $+z_R$ axis
6	Double truncation

The next portion of the program through R6 uses ST to determine the number of coordinate points used to define the shield. From Figure 4, the number of coordinates as a function of shield types is as follows:

ST	Number of Shield Coordinates
0, 1	8
2 through 9	2
10, 11	3
12, 13; JMAX = 4	4
= ±4	5
= 6	6

After the program logic is used to compute the number of coordinates, the coordinates $[X(I, J)]$ are read as input data from tape unit TG. I and J refer respectively to the point number and coordinate components (x_A , y_A , z_A). NP is equivalent to the maximum number of coordinates for a given shield type.

Between R7 and R8, the shield coordinates are converted from the two-dimensional array $X(I, J)$ to a one-dimensional array, $XTRAN(IJ)$, with the following equivalence:

I	J	IJ
1 → NP	1	1 → NP
1 → NP	2	NP+1 → 2NP
1 → NP	3	2NP+1 → 3NP

Since $ST = 0$ is not permitted in the subsequent GO TO logical statement, it will be incremented by 1 and defined as IST . The logical statement after R9 transfers control to subroutines which perform the transformations for the required shield type (see Functional Block 8 of Table IV).

The translation and rotation transformations are performed for the Nth shield as follows:

Translation

Since the translation to the DSCS is performed in a similar manner for each shield, it will be shown only for the hexahedron. Through equivalence $XTRAN$ is redefined as $XHEX$. From Equation 11, the translation from the ABCS to the DSCS is

$$XHEX(I, J) = XHEX(I, J) - XDET(J)$$

Another example of this translation is R10 of subroutine CYLNDR.

Rotation

For the hexahedron, the rotation matrix is based on the vectorial direction of the tracking ray, which is not yet defined. Therefore, no rotation is done for this shield in the geometry data transformation subroutine.

For the other elemental volumes, the generalized matrix of rotation (Equation 34) is redefined by $M_{XI}(\theta') \cdot M_{ZA}(\phi') = A(K, J)$, $K = 1, 3$ and $J = 1, 3$.

The trigonometric functions of the angles of the rotation matrix are computed as follows: a vector distance between points 2 and 1 is defined by the components

$$DX(K) = X(2, K) - X(1, K); K = 1, 3$$

From Eqs. 35 and 36

$$\text{TANPHI} = \tan \phi$$

$$\text{COSPFI} = \cos \phi$$

$$\text{SINPHI} = \sin \phi$$

The magnitude of the vector is CL and

$$\text{COSTH} = \cos \theta$$

$$\text{SINTH} = \sin \theta$$

To account for the signs of the trigonometric functions as function of quadrant, the logical equivalents to Equations 35 and 36 are executed between R11 and R12 for the cylinder subroutine (CYLNDR). The same logic is also used for the hemisphere and cones.

Now the rotation matrix is defined and computed from Equation 34

where $\underline{XR} = \underline{X}$ (RDCS), $\underline{XD} = \underline{X}$ (DSCS)

with the equivalent $\underline{XR} = \underline{A} \cdot \underline{XD}$, or

$$XR(I, K) = \sum_{J=1}^3 A(K, J)XD(I, J)$$

where $I = 1, NP$ points and K refers to the 3 components

Rotation of the ellipsoid from the DSCS to the RDCS requires a special matrix (see Subroutine ELIPSD). The R_K vectors defining the major axes are computed as follows:

The magnitudes and direction cosines of the vectors are $DIST(K)$, where K refers to the three axial vectors in the DSCS and R13 of ELIPSD, and

$$DIR(K, J) = \left[\frac{XD(K, J) - XD(4, J)}{DIST(K)} \right], \quad J = 1, 2, 3 \text{ and } K = 1, 2, 3$$

From Equation 31, the FORTRAN equivalent for the rotation matrix is DIR(I, J), and the coordinates in the RDCS are

$$XR(I, K) = \sum_{J=1}^3 DIR(K, J) \cdot XD(I, J) \text{ where } \ell(I)_{DJ} = DIR(I, J)$$

The lengths of the ellipsoid axes (a, b, c), which are defined as SMMA(K), are computed in the rotated system as

$$SMMA(K) = XR(K, K) - XR(4 K), \quad K = 1, 3 \text{ axes}$$

Since the standard astronaut is defined in a unique coordinate system, special transformations are required.

The standard man is a NASA-MSD model which is used for shielding calculations (Reference 2). Figure 19 shows a diagram of the man with his cylindrical limbs designated C1 through C6. The Standard Man Coordinate System (SMCS) is a right-handed orthogonal set with the x axis directed from the back toward the front of the standard man. The man's feet are represented by the hexahedrons H6 and H8. The correspondence between the NASA-MSD man's limbs and the North American Rockwell Space Division (NR-SD) shield serial numbers (SSN) is as follows:

NASA-MSD Man's Limb	NR-SD Shield Serial Number
C1	9010
C2	9011
C3	9012
C4	9013
C5	9014
C6	9015
C7	9016
C8	9017
H6	9018
H8	9019

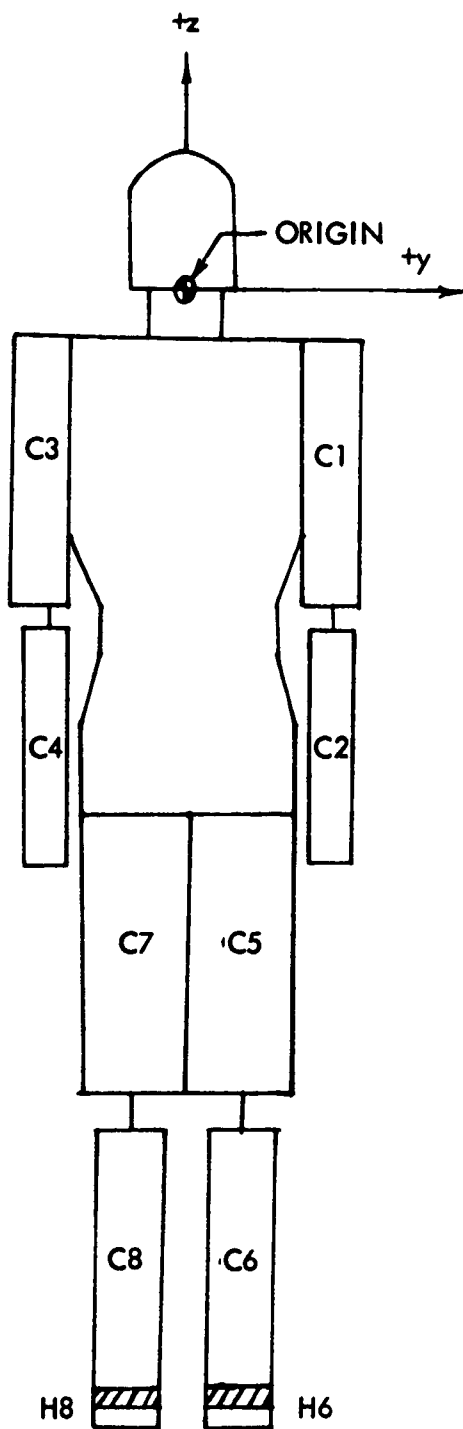

Figure 19. NASA-MSC
Standard Man Model

In Figure 19 the standard man is in the standing position. Therefore, the limbs and feet must be rotated in order to place him in reclining or sitting positions relative to the SMCS. Additional rotations and translations will be required to transform the man's numerical shield coordinates to the ABCS. The man's limbs are rotated with a vector matrix. Let \vec{V}_R and \vec{V}_F be the vector position of a point (R) to be rotated relative to a fixed point (F). Then $(\vec{V}_R - \vec{V}_F)$ is the vector, representing the limb, which is to be rotated. The new vectorial position of point R is \vec{V}_{R1} where

$$\vec{V}_{R1} = (\vec{V}_R - \vec{V}_F)_1 + \vec{V}_F \quad (64)$$

If $(\vec{V}_R - \vec{V}_F)$ is rotated through an angle ϵ about the y axis, using an equation developed by Rodriguez, where

$$\begin{aligned} \vec{E}_1 &= \vec{V}_R - \vec{V}_F \equiv \vec{i}x + \vec{j}y + \vec{k}z \\ \vec{E} &= \vec{j} \\ \mu &= \epsilon \\ \vec{E}_2 &= (\vec{V}_{R1} - \vec{V}_F)_1 \end{aligned}$$

then

$$\vec{E}_2 = \vec{E}_1 + (\cos \mu - 1) \left[\vec{E}_1 - (\vec{E} \cdot \vec{E}_1) \vec{E} \right] + \sin \mu \vec{E} \times \vec{E}_1 \quad (65)$$

In general the vector \vec{E}_1 is rotated about \vec{E} through an angle μ in the direction of a right-hand screw directed along \vec{E} . If the original angle between \vec{E} and \vec{E}_1 is constant during the rotation, the vector \vec{E}_1 is transformed to \vec{E}_2 .

Since

$$\begin{aligned} \vec{E} \cdot \vec{E}_1 &= y \\ \vec{E} \times \vec{E}_1 &= \vec{i}z - \vec{k}x, \end{aligned}$$

in matrix notation

$$\begin{aligned} \underline{(\vec{V}_R - \vec{V}_F)_1} &= \begin{pmatrix} \cos \epsilon & 0 & \sin \epsilon \\ 0 & 1 & 0 \\ -\sin \epsilon & 0 & \cos \epsilon \end{pmatrix} \underline{(\vec{V}_R - \vec{V}_F)} \\ &= \underline{\alpha} \underline{(V_R - V_F)} \end{aligned} \quad (66)$$

Equations 65 and 66 are used to compute the shield coordinates \vec{V}_{R1} after the limb and feet rotations. For the cylinders (Figure 19), point 1 is defined as the point with the larger z value. The fixed points for limb rotations will always be point one of a cylinder. The sequence of rotations is defined in Table V in terms of the fixed point, rotated point and angle of rotation. The limb rotated man is transformed to the ABCS by a combination of translation and rotation. In Figure 20, points 1 through 4 are used to define the desired position and orientation of an astronaut relative to the ABCS.

If point P of one of the man's elemental volume components is defined as \vec{R}_M relative to the SMCS, then its coordinates can be defined relative to the ABCS as \vec{R}_A where

$$\vec{R}_A = \vec{R}_M + \vec{R}_4 \quad (67)$$

Equation 67 represents the required translation. However, to effect the translation \vec{R}_M must be transformed to the ABCS. Let

$$\vec{R}_M = \vec{i}_{M_\alpha} x_\alpha = \vec{i}_{A_\alpha} y_\alpha \quad (68)$$

where α refers to summation notation, defined after Equation 27, and x and y are coordinate components in the SMCS and ABCS respectively. From Figure 20

$$\vec{i}_{M_j} = l_{j\alpha} \vec{i}_{A_\alpha}; \alpha = 1, 3; j = 1, 3 \quad (69)$$

where

$$l_{jm} = \frac{|x^{(j)}_m - x^{(4)}_m|}{\left\{ \sum_{m=1}^3 |x^{(j)}_m - x^{(4)}_m|^2 \right\}^{1/2}} \quad (70)$$

and

j \equiv coordinate axes points (see Figure 20) where (1, 2, 3, 4) correspond to the (x, y, z axes and the origin)

m refers to a point's coordinate components

For the next derivation the summation convention is further defined as follows; if in some expression a certain index occurs twice, it shall mean that this expression is summed with respect to that index for all admissible values of that index.

Table V
Fixed and Rotated Points and Angles for Astronaut Limb Rotations

Fixed Point			Rotated Point		
Rotation Number	CCN	CPN	CCN	CPN	Angle of Rotation
1	1	1	1	2	1
2	1	1	2	1	1
3	1	1	2	2	1
4	2	1	2	2	2
5	3	1	3	2	3
6	3	1	4	1	3
7	3	1	4	2	3
8	4	1	4	2	4
9	5	1	5	2	5
10	5	1	6	1	5
11	5	1	6	2	5
12-19	5	1	9	1-8	5
20	6	1	6	2	6
21-28	6	1	9	1-8	6
29	7	1	7	2	7
30	7	1	8	1	7
31	7	1	8	2	7
32-39	7	1	10	1-8	7
40	8	1	8	2	8
41-48	8	1	10	1-8	8

*CCN ≡ Composite shield component number (SSN 9010 ~ CCN=1 etc.)
 CPN ≡ Component shield point number
 Angle I ≡ ϵ_1

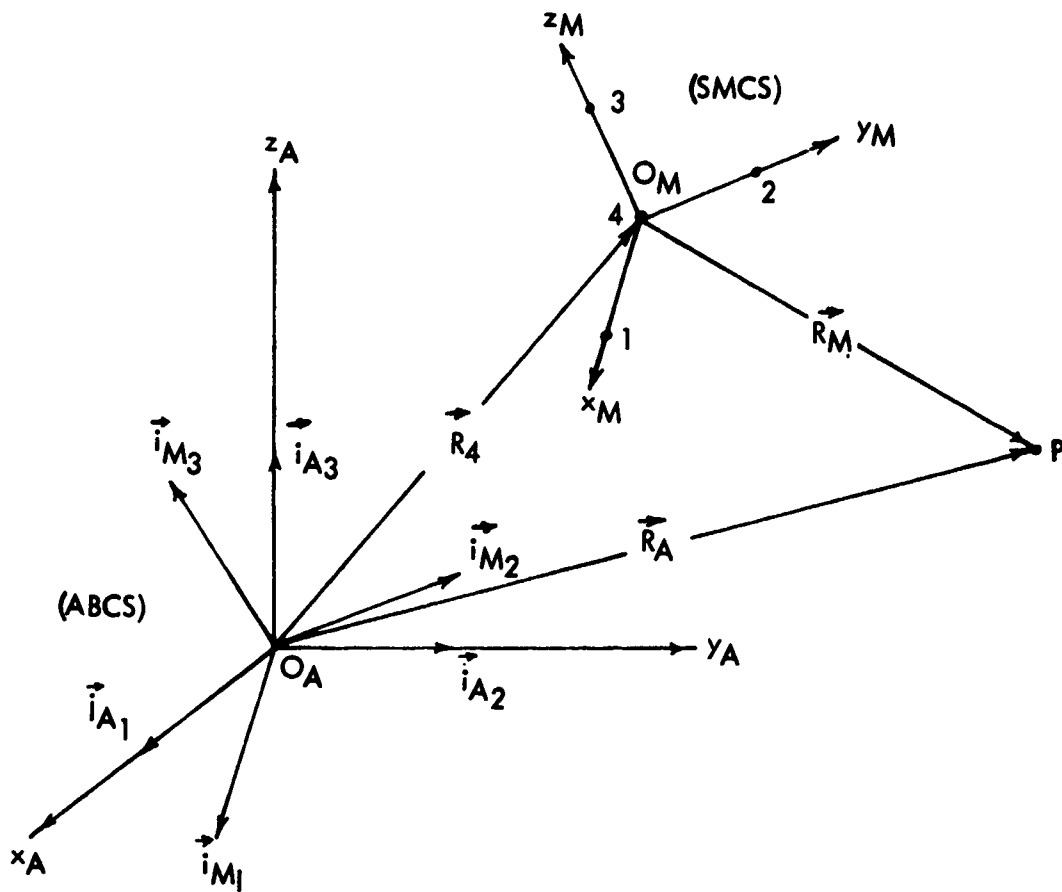

Figure 20. SMCS and ABCS Coordinate Systems

From Equations (68) and (69)

$$\vec{i}_{A\alpha} y_\alpha = l_{\alpha\beta} \vec{i}_{A\beta} x_{\alpha\beta} \quad (71)$$

so

$$y_j = l_{\alpha\beta} \vec{i}_{Aj} \cdot \vec{i}_{A\beta} x_\alpha = l_{\alpha\beta} \delta_{j\beta} x_\alpha$$

$$y_j = l_{\alpha j} x_\alpha \quad (72)$$

Summarizing, Equations 67, 70, and 72 will transform the man's elemental volume coordinates to the ABCS. The transformation of the crew shields to the ABCS are executed in subroutines FANTOM R14 and LIMROT (limb rotations), after which (R15 of TRSHLD) the astronaut elemental volumes are transformed to the RDCS.

b. Octant Determination

Hexahedron

The octant of the position of the 8 apexes is computed in the DSCS. If any component of the coordinates of any point is zero, the octant is defined as 9. That is, the figure may be in more than one octant.

Equation 44 and Tables 2 and 3 are implemented with the following equivalent variables:

$$\begin{aligned} \text{XHEX}(I, J) &= (X_I, Y_I, Z_I); & J &= 1, 2, 3 \\ & & I &= 1, 2, \dots, 8 \\ \text{IN}(J, K) &= (\text{IN}_J, \text{JN}_J, \text{KN}_J); & K &= 1, 3 \\ & & J &= 1, 2, \dots, 8 \end{aligned}$$

Then the octant of the Jth point is $\text{IN}(J, 1) = \text{IN}(J, 1) + \text{IN}(J, 2) + \text{IN}(J, 3) + 1$. If any $\text{IN}(J, 1)$, $J = 1, 8$ are different, then the octant number is 9. Otherwise the octant is $\text{IN}(J, 1)$.

The other elemental volumes, or volumes which contain them, are checked for intersections with the coordinate planes in the DSCS.

A slight variation of Equations 45 to 47 is used to determine if each volume intersects any coordinate planes. The method is as follows:

Equation 45 is replaced by

$$X_D(1) \pm R$$

$$Y_D(1) \pm R$$

$$Z_D(1) \pm R$$

If signs of $[X_D(1) + R]$ and $[X_D(1) - R]$ and the similar terms of the other components are the same, there is no intersection with the coordinate planes.

This method is incorporated in the program as follows:

The signs of $\left| X_D(1) + R \right|$, $\left| X_D(1) - R \right|$ are determined with the aid of FORTRAN IV library function SIGN. SIGN is used to define S_1 and S_2 as follows:

$$\begin{aligned} S_1 &= \text{SIGN} \left\{ X_D(I, K), \left| X_D(I, K) + R \right| \right\} \\ &= \left[\text{sign of } X_D(I, K) + R \right] \cdot \left| X_D(I, K) \right|, \text{ and} \\ S_2 &= \text{SIGN} \left\{ X_D(I, K), \left| X_D(I, K) - R \right| \right\} \end{aligned}$$

If $S_1 + S_2 = 0$ for either coordinate component, the elemental volume intersects a coordinate plane. Otherwise the octant of the coordinate of the center of volume is used. For the ellipsoid R is replaced by the largest major axis.

Auxiliary Computations

The radius of the sphere and hemisphere is computed as the magnitude of the vector between points 2 and 1 of the volume.

The radius (RCON) of the base of the cone is computed as follows:

PHICON = RPHI is defined as the radian half-angle of the cone

The magnitude (CL) of the vector between points 2 and 1 is used to compute the radius by

$$RCON = CL \tan(\text{PHICON}) = CL * \text{TANCON}$$

The radii of the two bases of the truncated cone are computed as follows (Figure 8):

The distance (DZ) from point 2 to 3 is determined with the RDCS points by

$$DZ = XR(2, 3) - XR(3, 3)$$

then the radii of the bases at points 3 and 1 (RT, RB) are

$$RT = DZ * \text{TANCON}$$

$$RB = RCON$$

This concludes the algebraic and logical operations necessary to perform the data transformations, octant computations, and auxiliary computations. All information for each shield is stored in a single subscripted array called SHLDD at R16 in TRSHLD. The maximum number of locations used for a shield is 38, i. e., for the ellipsoid. Although, for convenience, all of the SHLDD arrays contain 38 words, some words are undefined. NSO(I) is used as a counter to determine the number of shields in the Ith octant. The components of the SHLDD array are as follows:

In general the array contains:

SHLDD(1) = OCT \equiv octant in which shield lies

SHLDD(2) = ST \equiv shield type

SHLDD(3) = SSN \equiv shield serial number

SHLDD(4) = MATCD \equiv material code

SHLDD(5) = RHO \equiv density of materials (gm/cm.³)

SHLDD(6) = NP \equiv no. sets of coordinates

SHLDD(7) = RPHI \equiv radius (inches) or [half-angle of cone (radians)],
whichever applicable

SHLDD(8 - 37) = XR(I, J), I = 1, 2, ..., NP and J = 1, 2, 3, \equiv
coordinates (inches) in rotated detector system
and other information

SHLDD(38) = NCOMP = number of composite shield components

FOR SPECIFIC SHIELD TYPES:

1. SHLDD(2) = 0 or 1 for hollow or solid hexahedron, respectively

SHLDD(6) = 8 = no. corners of hexahedron

SHLDD(8 - 15) = XHEX(I, 1); SHLDD(16-23) = XHEX(I, 2):
I = 1, 2, ..., 8

SHLDD(24-31) = XHEX(I, 3); I = 1, 2, ..., 8

SHLDD(32-37) contain zeros, not needed for the hexahedron

NOTE: Locations not mentioned contain information described
in general for all shields.

2. SHLDD(2) = 2 or 3 for cylinder (hollow or solid)
 - SHLDD(6) = 2 sets of coordinates for the centers of the bases
 - SHLDD(7) = RPHI = radius
 - SHLDD(8-9) = XR(I, 1); SHLDD(10-11) = X(I, 2); SHLDD(12-13) = X(I, 3); I = 1, 2
 - SHLDD(14-22) = Rotation matrix A(3, 3) where the order is:
A(1, 1), A(2, 1), A(3, 1), A(1, 2), A(2, 2), A(3, 2), A(1, 3),
A(2, 3), A(3, 3)

3. SHLDD(2) = 4 or 5 for sphere (hollow or solid)
 - SHLDD(6) = 2 sets of coordinates where the first is the center of the sphere and the second is a point on the surface
 - SHLDD(7) = Radius
 - SHLDD(8-9) = XD(I, 1); SHLDD(10-11) = XD(I, 2);
SHLDD(12-13) = XD(I, 3), I=1, 2
 - SHLDD(14-37) contain zeros

4. SHLDD(2) = 6 or 7 for hemisphere (hollow or solid)
 - SHLDD(6) = 2 sets of coordinates where the first is the center of the base and the second is on the z axis of the hemisphere and on the surface
 - SHLDD(7) = Radius
 - SHLDD(8-9) = XR(I, 1); SHLDD(10-11) = XR(I, 2);
SHLDD(12-13) = XR(I, 3), I=1, 2
 - SHLDD(14-22) = Rotation matrix A; for order of storage see cylinder
 - SHLDD(23-37) contain zeros

5. SHLDD(2) = 8 or 9 for cone (hollow or solid)
- SHLDD(6) = 2 sets of coordinates where the first is at the center of the base and the second is at the apex
- SHLDD(7) = PHI = half-angle at apex in radians
- SHLDD(8-9) = XR(I, 1); SHLDD(10-11) = XR(I, 2);
SHLDD(12-13) = XR(I, 3), I=1, 2
- SHLDD(14-22) = Rotation matrix A - order: same as cylinder
- SHLDD(23) = Radius of base
- SHLDD(24-37) contain zeros
6. SHLDD(2) = 10 or 11 for truncated cone (hollow or solid)
- SHLDD(6) = 3 sets of coordinates where the first is at the center of the base, the second is at the imaginary apex and the third is on the axis of the cone at the plane of truncation
- SHLDD(7) = PHI = half-angle of cone at imaginary apex in radians
- SHLDD(8-10) = XR(I, 1); SHLDD(11-13) = XR(I, 2);
SHLDD(14-16) = XR(I, 3), I=1, 2, 3
- SHLDD(17-25) = rotation matrix A - order of storage same as for cylinder
- SHLDD(26) = Radius of base
- SHLDD(27) = Radius of cone at plane of truncation.
- SHLDD(28-37) contain zeros
7. SHLDD(2) = 12 or 13 for ellipsoid (hollow or solid) of 0, 1, or 2 truncations
- SHLDD(6) = JMAX

SHLDD(8-13) = XR(I, 1); SHLDD(14-19) = XR(I, 2);
SHLDD(20-25) = XR(I, 3), I = 1, 2, ..., 6

(If |JMAX| < 6, zeros are stored in the unused locations.)

SHLDD(26-34) = direction cosines of ellipsoid axes, and the order of storage is the same as that of the rotation matrix of the cylinder

SHLDD(35-37) = SMMA(K), K = 1, 3 = length of the ellipsoid axes (a, b, c)

At R17 in TRSHLD after the hexahedron shield data have been transformed, the parameter NX is defined. NX is the number of numerical coordinates and dimension parameters as a function of shield type. At R18, the transformed dimension data, i. e., XYZ(I), are transferred to the SHLDD array. At R19, the data for a composite shield component are stored in the two-dimensional array SPN(I, J), where J refers to the shield component number. Then, the complete composite shield data are written on SYSDA unit 12. If all the spacecraft shields (NOS) have been transformed, the end of file test after R20 transfers to R14 for transformation of the crew shields. However, before continuing with the program description, the standard man and the transformations required to define the astronaut in the ABCS will be delineated.

5. SUBROUTINE FANTOM

This subroutine simulates up to ten astronauts in the vicinity of the spacecraft. The process is accomplished by describing one standard man in the basic Standard Man Coordinate System (SMCS) on the input shield geometry tape (unit 10). All limbs are defined as one composite shield of 10 components and each limb may be rotated through a physically reasonable angle about the standard man's y axis.

Input arguments to this subroutine are as follows:

NOMAN, NMEN, NLB(I)=NLIMB(I) for I = 1, NMEN, and NGT, where

NGT is equivalent to TG or tape number 10

The SYSDA unit 13, which will contain the astronaut geometry in the ABCS, is rewound. Tape NGT is positioned at the beginning of the second file by use of the FILE subroutine for each astronaut. The major loop transforms the M = 1, NMEN astronauts to the ABCS. The number of composite shield volumes, which will be rotated in the Mth man is redefined as

NLIMB = NLB(M)

The direction cosines and coordinate components of Equation 70 are defined in the program as follows:

$$x(j)_m = W(J, M)$$

$$x(j)_4 = R_{4A}(J)$$

$$l_{ij} = L(J, M)$$

After W and R_{4A} are input, the L matrix is computed. Then all required rotations for the M th man are performed. The title record is read from tape NGT and reread because of input requirements for TRSHLD and this subroutine.

The first eight volumes on the second file of tape NGT are cylinders defining the man's arms and legs; the ninth and tenth volumes are hexahedrons defining the feet. The first cylinder is read and stored in the array XCMAN(I, J, 1), where $j=1, 3$ coordinate components and $I=1, 2$ points for the cylinder.

The number of components (elemental volumes) for rotation is defined as NCOMP. The 10 component angles for rotation are read as the array EPSLN. However, only eight of the angles will be used for the limb rotations. Then the header records and coordinates of the remaining shields for rotation are read as TITLE(I, ICP) and XCMAN(I, J, ICP) where ICP denotes the component number.

The subroutine LIMROT is then called for the limb rotations. The table defining the fixed point, the point to be rotated, the angles through which the components are to be rotated, and the rotation number is used with Equation 65 to perform the limb rotations. All component coordinates are returned in the array XRMAN relative to the SMCS. Then XRMAN is transformed by a coordinate rotation with Equation 72 and defined as the variable Y . Finally a translation of Y converts XRMAN to the ABCS. Now the NCOMP header records and transformed coordinates in the ABCS are written on SYSDA unit 13. This completes the limb rotations and transformation of the coordinates (XRMAN) to the vehicle or Absolute Coordinate System.

The other volumes of the M th man, which are not rotated, are transformed to the ABCS. The final coordinates are stored in the array XMT and the title records along with XMT are written on unit 13 sequentially.

The above process is continued until $M = NMEN$. Then unit 13 is rewound, NGT is redefined as 13 for use by TRSHLD, and the astronaut geometry is added to the spacecraft geometry on SYSDA unit 12.

6. SUBROUTINE LIMROT (NCOMP, XCMAN, XRMAN, EPSLN)

This subroutine performs the rotations of the limbs of an astronaut in the man coordinate system through the required angles (EPSLN). Rotations are made about the y axis of the standard man in the SMCS.

The subroutine input arguments are defined as follows:

NCOMP = number of components (≤ 10)

XCMAN = unrotated coordinates of all components

EPSLN = angles of rotation

The subscripts of the components, point numbers, etc., are stored by use of the data statement (see Table V)

where

NCF(I), I = 1, 48 = number of the component of the fixed point of the rotated limb

NCROT(J), J = 1, 48 = number of the component of the point which is is moved by limb rotation

NCPT(K), K = 1, 48 = number of point which will be moved by limb rotation

The particular fixed point component, rotation point component and point number within the rotation component are respectively defined as

$$NF = NCF(IR)$$

$$NR = NCROT(IR)$$

$$NC = NCPT(IR)$$

The IRth rotation matrix $\underline{\alpha}$ is computed from Equation 66 and defined as ALPHA. Then ALPHA is used to transform the vector components XYZ(K) and the rotated coordinates are defined as XRMAN(NC, J, NR). This computation is performed for the 48 limb rotations.

7. SUBROUTINE ESDOSE

This major section of the program computes the areal-density functions. One of two methods will be used for obtaining the direction cosines of a

specified number of rays. One method randomly selects the directions by random sampling from an equally probable distribution between zero and one. The second method systematically selects the ray direction to pass through the centers of equal solid angles which comprise the unit sphere or a portion thereof.

After all ray directions are generated, tracking through the geometry is commenced for the dose point defined. The geometry input on SYSDA unit has been transformed to the dose point as described in the previous section.

For each ray direction, the individual accumulation of thickness of material penetrated is generated. Prior to the accumulation, each path length is converted to a standard-material equivalent path length. The accumulation is made for each direction. Some unnecessary tracking is eliminated by comparing the octant of the shield with the octant of the ray. Other unnecessary tracking is eliminated by hit-or-miss criteria.

When tracking has been completed, the normalized geometry distribution is computed and curve fit by the least-squares method. Doses can be computed with dose vs. thickness curves for arbitrary solar-flare spectra by integration of the product of dose and the derivative of solid angle as a function of thickness (areal density). Also, the emergent fluxes may be computed from incident energy spectra by integrating the product of the emergent integral spectrum and the derivative of the thickness solid-angle distribution function.

ESDOSE is the major subroutine which controls the elemental volume path-length computations.

In ESDOSE, the following input data are read for each run of this routine:

ORD (I,J) for $J = 1, 4$ and $I = 1, 6$, where $J = 1, 4$ refers to the point within the I th plane of the hexahedron

In Figure 13, the hexahedron is defined by six planes and eight points. The points are ordered counterclockwise or in the direction of a right-hand screw, directed outward from the hex volume. This direction is the same as the surface normal.

The following sequence of points is recommended for input of the point order:

ORD (I, J)				
I	J			
	1	2	3	4
1	1	2	4	3
2	3	4	5	6
3	7	8	6	5
4	2	1	8	7
5	1	3	6	8
6	2	7	5	4

Next, the parameter IRS is read as a dummy variable. For each areal-density computation, the following input data are read:

RANDOM = indicator for ray selection method (>0 for random, = 0 for equal solid angles, < 0 return to the main program)

N = number of rays to be selected

NMAT = number of different materials

NRHO = number of solid elemental volumes whose density will be changed

NRPT1 = printout indicator for ray direction cosines ($\neq 0$, direction cosines are to be printed; = 0, direction cosines will not be printed)

NPRT2 = printout indicator for tracking information ($\neq 0$, shield identification, tracking direction, equivalent thickness and accumulative thickness will be printed; = 0, the previous quantities will not be printed)

NDIV = number of microscopic solid-angle increments

IPUNCH = indicator for medium of sorted output (= 0 printed only;
= 7 printed and punched; = 8 printed and on binary tape; > 0 and < 7,
printed, punched, and on binary tape)

If NRHO > 0, the information for altering the original material
densities is read as follows:

[NSS(I) for I = 1, NRHO] where NSS is the shield serial numbers
for which the densities are changed, and [DENS(I) for I = 1, NRHO]
where DENS is new densities (gm/cm^3) corresponding to the NSS
serial numbers

CASE = alphanumeric description of the particular problem being
solved

NEWF9 = number of end of file marks preceding the file for writing
the areal-density distribution function and associated variables on
tape 9 (reserve tape) (If NEWF9 = 0, the distribution function is not
saved. In order to create the tape on unit 9, NEWF9 should be
input as -1.)

TMX = maximum areal density (gm/cm^2) for which tracking is
allowed

EPSLN \equiv parameter used to compensate for tracking and hit-or-miss
test round-off errors

Next, the range-energy constants for the standard material and the NMAT
materials are input.

DSTD = δ_s

ESTD = η_s

[DELTA(I), ETA(I), I = 1, NMAT] = [δ_A and η_A for NMAT
materials]

Titles for the standard and actual materials are read as [TTLSTD(I),
I = 1, 3] and [TTLMAT(I, J), I = 1, 3 and J = 1, NMAT].

The variable RANDOM is tested to determine whether random or
systematic selection of the rays will be used.

a. Systematic Selection

For the systematic selection process, the ray direction cosines are selected at the center of equal solid angles with Equations 4 through 9. The input angular boundaries for the azimuthal (ϕ) and colatitude (θ) angles are input and defined as follows:

$$\begin{aligned}\text{PHII} &= \phi_I \text{ (angles in degrees)} \\ \text{PHIF} &= \phi_F \\ \text{THETI} &= \theta_I \\ \text{THETF} &= \theta_F\end{aligned}$$

The computed variables are as follows:

$$\begin{aligned}\text{NTSA} &= \text{NTS} \\ \text{NTH} &= N_\theta \\ \text{NPH} &= N_\phi \\ \text{THK (K)} &= \theta_K \\ \text{PHL (L)} &= \phi_L\end{aligned}$$

The systematically selected direction cosines are computed and defined as follows:

$$\begin{aligned}\text{DIRCOS (1,J)} &= \alpha_J \\ \text{DIRCOS (2,J)} &= \beta_J \\ \text{DIRCOS (3,J)} &= \gamma_J\end{aligned}$$

where J refers to the Jth ray.

The direction cosines are computed for NDIV macroscopic solid-angle increments. The NRAYS direction cosines are printed (when NPRT1 = 1) before returning to ESDOSE.

b. Random Selection of N Ray Direction Cosines

Subroutine RNDSEL is called if $\text{RANDOM} > 0$. The statement $\text{DUMY} = \text{RANF}(1)$ initializes the random number generation process.

The statement $x(J) = \text{RANF}(0)$ generates the random numbers where $0 < X(J) < 1$ and J refers to the three component direction cosines of a randomly oriented vector. From Equation 1, the unnormalized direction cosines ($\alpha_0, \beta_0, \gamma_0$) are computed as follows:

$$\text{UNDCS}(J) = 1.0 - 2.0 * x(J)$$

for $J = 1, 3$.

The normalized ray direction cosines are defined as $\text{DIRCOS}(J, I)$ where J and I refer to the Jth component of the Ith direction. After the direction cosines are computed, they are printed if $\text{NPRT1} = 1$. The last computation is $\text{DUMY} = \text{RANF}(1)$, which is used to generate a new sequence of random numbers.

After R21, ESDOSE calls the subroutine TRACK to ray trace the transformed geometry with the selected ray directions.

8. SUBROUTINE TRACK

The octants of all rays are computed by the subroutine OCTCOS and stored in the array OCTR for NRAYS rays.

The variable IS is used to count up to the total number of elemental volumes (NOS) to be tracked. Then the first elemental volume parameters of a shield are read and stored in the array SHIELD (I, 1), where the number of components of the composite shield is defined as NCOMP. Afterwards, the data for the remaining NCOMP - 1 volumes are read and stored in the array SHIELD (I, ICP). The shield serial numbers are compared with $\text{NSS}(I)$ if $\text{NRHO} > 0$ and densities are changed as required.

The tracking process begins by selecting ray number IR. The array PATH for NRAYS will contain the accumulative areal density. If $\text{PATH}(\text{IR}) \geq$ the prespecified maximum areal density, tracking is discontinued for the IRth ray.

Then variables IPLS, ING, and INTS are initialized as zero, and used respectively to count the number of positive, negative, and total number of elemental volumes intersected for the IRth ray.

The ray direction cosines are stored in SHLDD (38-40) for all volume path-length computation subroutines.

Then, R22 tracks through each composite shield component for the IRth ray. The elemental volume data SHIELD (I, ICP) is then transferred to SHLDD (I). Density (RHO), material type = [SHLDD (2) + 1], and shield octant (SOCT) are then defined. If SOCT = 9, the ray tracing procedure will continue. Otherwise SOCT is compared to the ray octant [OCTR (IR)]. If they are not equivalent, the tracking procedure is discontinued and another volume is selected for ray tracing.

When the tracking process continues, the volume path length (SHLP) is set to zero before the volume path-length computation begins. Then CS is defined as ± 1.0 to designate a solid and a void region, respectively. After R23, a logical test is used to eliminate unnecessary tracking. If IPLS = 0 and CS = -1, there are no positive composite shield components. The volume path length is now computed by one of the following subroutines:

Volume	Subroutine
Hexahedron	TKHEX
Cylinder	TKCYL
Sphere	TKSPH
Hemisphere	TKHM
Cone	TKCON
Truncated cone	TKCON
Ellipsoid	TKELL

The arguments of the subroutines are defined as follows:

SHLP = path length computed through the volume

DP(1), DP(2) = minimum and maximum distances through the volume for the IRth ray

Hit-or-miss logical tests are also made in each subroutine to avoid unnecessary tracking. If SHLP is zero after R24, etc., control is transferred to R25 because there is no volume intersection, and the next volume is selected. If not zero, the distances through the volume surfaces are converted from inches to centimeters, designated as plus or minus, and stored in the array ELEMP. The plus and minus signs refer to solid and void shields respectively. RHO and MAT are stored as RHOS and MATS. Then INTS and ING or IPLS are incremented. Next, the subroutine ELIMS is called to determine if any or all negative volumes completely void all the

solid regions. If the solid regions of a composite are voided, the next ray is selected and ray tracing is continued. Otherwise, the areal density (XS) is computed for the composite shield components by subroutine COMPSP. The areal density is then accumulated in the array designated as PATH.

The above process continues until computations for all NRAYS have been completed.

Then IS, which is now the total number of elemental volumes processed, is increased by (NCOMP-1). If IS is less than NSO (the total number of volumes), another composite shield volume set is selected for tracking. Otherwise control is returned to subroutine ESDOSE.

The subroutines used by TRACK will now be explained in more detail.

9. SUBROUTINE OCTCOS

This subroutine uses the same method described in Section III-4. b. to compute octant numbers. However, the previous computations were for volume rather than for ray octants. For zero radii the two methods are the same.

10. SUBROUTINE ELIMS

After the solid shields of a composite shield have been tracked, the routine ELIMS is used after tracking each void component to determine if the solid shield traversal paths have been voided. This eliminates unnecessary ray tracing and areal-density computations for some of the composite shield's void components. The array ELEMP(I, ICP) contains the entrance (I=1) and exit (I=2) distances to ICP composite shield components. The array elements are positive and negative for solid and void regions respectively. Logic used in ELIMS is discussed in detail in Section II-6. c. The variable ISIT is initially zero and changed to unity if the solid shield components are voided (R26).

In the loop R27 the distance for the solid (positive) shields are transferred from ELEMP to DPPOS. ING, the number of void components that have been tracked, is tested for a nonzero value. If solid and void components have been tracked, R28 orders the void region distances by entrance path lengths in array DPNEG. Then R29 independently determines the remaining portions of each solid shield component.

11. SUBROUTINE COMPSP

If the solid portions of a composite shield are not voided, subroutine TRACK (R30) calls COMPSP to compute the solid path areal density. COMPSP is also called for single-element solid shields. This routine computes the following: the distance from the dosimeter to the exit surface of each solid region [X(1) or X(3)]; the accumulative standard-material areal density [XS], and the solid region's areal densities [DM] for each solid shield component. These data are stored on SYSDA 20.

12. SUBROUTINE TKHEX (HXPTH, NP, DP)

NP and DP have been defined as the order of the hexahedron coordinate points and the path lengths to the hexahedron surfaces. HXPTH, the path length through the hexahedron volume, is

$$\text{HXPTH} = |\text{DP}(2) - \text{DP}(1)|$$

If the dosimeter is inside the hexahedron, DP(1) is defined as zero and DP(2) is the distance from the dosimeter to surface.

NT specifies whether the subroutine logic is used to determine if the dosimeter is inside (NT=2) or to compute DP (NT=1).

NT is set equal to unity, and the number of non-zero positive intersections with the hexahedron faces is calculated. If the number of intersections is unity, the dosimeter is inside and HXPTH=DP(2). The hit-or-miss criteria eliminate cases with no intersections. If there are two or more intersections, there are possible path-length equivalent combinations with different volume path lengths. For example, there may be glancing incidence at a point on the surface or a ray from a dosimeter inside the hexahedron volume passing through an apex or corner which has the same surface path lengths. These ambiguities will be eliminated by determining if the dosimeter is inside or outside the hex volumes, and using the following logic:

Type of Intersection	Volume Path Length
Dosimeter inside and passing through a corner or apex point	$\text{HXPTH} = \text{DP}(2)$
Dosimeter outside with glancing incidence	$\text{HXPTH} = \text{DP}(2) - \text{DP}(1) = 0$
Dosimeter outside with ray in the plane of a hexahedron face	$\text{HXPTH} = \text{DP}(2) - \text{DP}(1) \neq 0$ (see the second paragraph of subsection II-6. b.)

The subroutine TKHEX starts by initializing XO and defining
DIR = DIRCSA.

XO(K), K=1, 3 are the coordinate components of point M of Figure 13.

DIRCSA(K) are the direction cosines of the tracking ray.

NT is set equal to unity to indicate that the surface path lengths will be computed for the tracking ray. Equations 35, 36 are then used to compute the trigonometric functions for the rotation matrix M (Equation 34). In the program

$$A(I, J) = M(I, J)$$

At R31 the DSCS coordinates X (I, J) are transformed to the RDCS as XR(I, J). I and J refer to the coordinate point and component respectively. Next NT is tested, because if the calculation mode is determining whether the dosimeter is inside or outside the hexahedron volume, hit-or-miss criteria are not necessary. If NT = 2 it has been determined that the ray intersects the volume. If it had not intersected the volume there would have been an exit near R32. Between R33 and R34 the hexahedron miss-rectangle criteria (Figure 16) are used in the form of the following logic and definitions:

Let $x(J, K)$ be defined as the Kth component of the Jth point of a projected hexahedron face in the RDCS (x,y) plane

If $x(J, K)$ is bounded by $\pm \epsilon$, the coordinate x of point J is at a neutral position and is considered both negative and positive

The variables NEG and IMPOS are incremented for negative and positive coordinate components, respectively. If all XR(J,K), for a given K, have the same value, the miss rectangle will not contain the origin, i. e., the ray misses the rectangle. The two tests between R33 and R34 check for this condition. If

$$\text{IMPOS or NEG} = 8$$

for either the XR or YR component, the ray misses the rectangle and control is transferred back to TRACK. Otherwise, the calculation is continued.

INTSCT \equiv the number of intersections with hexahedron planes

NPL \equiv number of one of 6 hexahedron faces

Now the hexahedron miss rectangle will be applied to each face of the hexahedron. If there is a miss for the NPL plane, i. e., IMPOS or NEG = 4,

there is a transfer to R35 and the next face is tested for intersection. If there is a possible hit, i. e. , IMPOS and $NEG < 4$, transfer is made to R36 , which makes the final miss test. This test (Equation 51) performs an exact test for determining whether there is a hit or miss. The following definitions are used to implement this test:

$$J1, J2 = \text{points defining the vectors } \vec{VR}(J1) \text{ and } \vec{VR}(J2)$$

$$VECTPR = \vec{k} \cdot \left[\vec{VR}(J1) \times \vec{VR}(J2) \right] \text{ (Figure 11)}$$

After R37, IMPOS and NEG are tested for an intersections and INTSCT is incremented if the test is satisfied. Also the array NFACE is defined such that NFACE(I) is equal to the set of planes intersected, with I=1, INTSCT.

If NT=1 , this is the first cycle through the subroutine and INTSCT is checked for plane intersections. If INTSCT=0 , there are no intersections and there is a return to TRACK. Otherwise, R38 computes the path lengths to the intersected planes. R39 redefines the hexahedron points in the DSCS as XC(J,M). Then R40 computes the components of vectors (Figure 10)

\vec{A} and \vec{B} , where

$$\vec{A} = \vec{V}(1) - \vec{V}(2)$$

$$\vec{B} = \vec{V}(3) - \vec{V}(2)$$

and

$$\text{the } J\text{th component of } \vec{V}(I) = XC(I, J)$$

The vector $\vec{A} \times \vec{B}$ is in the direction of the plane defined by \vec{A} and \vec{B} , so e_{PL} of Equation 23 is computed from

$$\vec{e}_{PL} = \frac{\vec{A} \times \vec{B}}{|\vec{A} \times \vec{B}|}$$

where

$$AKB(I) \equiv \text{Ith component of } \vec{A} \times \vec{B}$$

$$VAKB \equiv |\vec{A} \times \vec{B}|$$

The components of \vec{e}_{PL} (R41), i.e., the direction cosines of the hexahedron planes, are defined as ALPHA(M), so

$$\alpha_p \equiv \text{ALPHA}(1), \text{ etc.}$$

From Equation 23

$$\vec{e}_L \cdot \vec{e}_{PL} = \alpha_L \alpha_{PL} + \beta_L \beta_{PL} + \gamma_L \gamma_{PL} \equiv \text{DEN}$$

and

$$\text{ALPHA}(I) \equiv \text{Ith component of } \vec{e}_L$$

If $|\text{DEN}| < \epsilon$ where ϵ is $\equiv 10^{-4}$, i.e., $\text{DEN} \approx 0$, the line \vec{e}_L is parallel to the hexahedron plane and there is no intersection. In this case the path length ($P_{TH} = PR$) is set equal to a large number, namely 10^{20} . Later, such large path lengths will indicate plane misses or non-intersections. This large value will also be substituted for negative path lengths or $PR(I) < 0$. The path length (PR) was computed (R43) from the following form of Equation 49:

$$P_{TH} = \frac{-\vec{e}_{PL} \cdot \vec{V}(1)}{\vec{e}_L \cdot \vec{e}_{PL}} \quad \text{since } \vec{R}_o = 0$$

After R42 if $NT = 1$, INTSCT is checked for more than one intersection. If there is only one intersection it is equivalent to the volume path length because the dosimeter must be inside the hexahedron. For several intersections, R44 uses $PMIN = 10^{20}$ and the library routine AMIN1 is used with $PR(I)$ to determine the minimum path length $PMIN = DP(1)$. It also stores the array $PR(I)$ into $PRHEX(I)$.

R45 replaces the minimum $PR(I)$ by 10^{20} . R46 computes the coordinates of the point M (Figure 13). DIST is the distance from the dosimeter to M. The R47 statements compute the direction cosines of a vector from M to D and translate the origin to point M. NT has been set equal to two and control is now transferred to R48. This recycle will compute the allowed path lengths to the hexahedron surfaces for a ray directed from M to D. The minimum path length can be compared with DIST (the distance from M to D) to determine whether the dosimeter is inside or outside the hexahedron volume. The calculations will proceed as before up to R43. Then NT will be tested and control transferred to R49, which will compute the minimum

path for the vector directed from M to D. If $MP > MD$, the dosimeter is inside and the volume path length HXP_{TH} is P_{MIN} . In this case the ray passes through a corner or edge of the hexahedron. Otherwise, R50 computes the second minimum and the volume path length is the difference between the first and second minima. If there is glancing incidence, the two path-length minima will be identical and the volume path equals zero.

13. SUBROUTINE TKCYL

Since tracking through all shields, except hexahedrons and spheres, is done in the RDCS, the ray direction cosines DIRSCA are rotated by the rotation matrix $A(K, J)$ for cylinders, cones, and ellipsoids, etc., as follows:

$$DIRRAY(K) = \sum_{L=1}^3 A(K, L) DIRCSA(L)$$

In the rotated system, the z axis of the cylinder is parallel to the coordinate z axis. Starting at R51 the calculations will determine whether the dosimeter is inside or outside the cylinder. If it is inside (Figure 8), the origin (dosimeter location) is bounded by the z component of points 1 and 2. In the RDCS the cylinder coordinates are defined by $XCY(I, J)$, where I and J refer respectively to the point and component. If the dosimeter is inside, C of Equation 21 is negative or zero (R52). If the detector is inside the cylinder, the path-length computation is as follows:

If $DIRRAY(3) = 0$, the ray is in the (x, y) plane and therefore will not intersect either of the plane bases. In this case control is transferred to R53 and Equation 47 is implemented. The components for the quadratic solution for intersection with the cylinder are evaluated with subroutine ROOT. The subroutine ROOT solves the conic surface quadratic for the path lengths $\equiv PR(3), PR(4)$. If a path length is negative, it is defined as 10^{20} , since it is not allowed. The minimum of the roots $PR(3), PR(4)$ is the path length. If $DIRRAY(3) \neq 0$, the ray intersects the cylindrical surface or a base plane. The computation is as follows: for each base $I=1, 2$ the distance from the detector to the bases are computed from Equation 40, whose computer equivalent is

$$DP(I) = \frac{ZBOUND(I)}{DIRRAY(3)}$$

if $DP(I) < 0$, the ray does not intersect the I th base. Otherwise, since the dosimeter is inside, the projection of the ray on the (x, y) plane must be less than or equal to the cylinder radius for intersection. The end point coordinates (R54) of the projected line are defined as $CXY(J)$, and C of Equation 21 is defined as $C2$. If $C2$ is positive, the ray intersects the cylindrical surface and control is transferred to R53. The subsequent operations have been explained. If the detector is outside, all possible types of intersection must be examined. If $DIRRAY(3) = 0$, intersection possibilities exist only with the cylindrical surface. Therefore, path lengths $PR(I)$, $I=1, 2$ are defined as 10^{20} . If $DIRRAY(3) \neq 0$, intersection possibilities with the cylinder bases are considered. The distances to the bases are computed as before. From Figure 21 the projected center and point of intersection of the ray with the base must be separated by a distance less than the cylinder radius, or the associated path length is not allowed, i. e., R_{DC} , which is defined as $C2$, is less than R . The next section (R55) computes the path lengths for intersection with the cylindrical surface. If γ_R of the tracking ray is 1.0 or A of Equation 21 is zero, there is no intersection. Otherwise the quadratic solution must be used to determine the cylinder path lengths $PR(3)$ and $PR(4)$. The coordinates of the points of intersection of the tracking ray with the cylinder (R56) are computed and checked to determine if they are bounded by the coordinates of the cylinder end surfaces. If the z coordinates are not bounded, the corresponding path lengths are not allowed. The two minima of the $PR(I)$, $I=1, 4$ are computed (R57) and the path ($CYPATH$) through the cylinder is the positive difference between them.

14. SUBROUTINE TKSPH

The quadratic form of solution is evaluated in the DSCS and invalid roots are set to the arbitrarily large value. The distance to the center of the sphere is compared to the sphere radius to determine the detector location. If inside, the path length is equivalent to the minimum value computed by the root evaluation (Equation 18). If outside, the volume path length is the positive difference between the two spherical surface path lengths.

15. SUBROUTINE TKHM

The ray direction cosines are transformed to the $RDCS(R58)$ and path lengths to the spherical surface are computed by $ROOT$. $ISC = 0, 1$, respectively, indicates that the ray hits or misses the spherical surface. If $ISC = 1$, the ray must miss the hemisphere which is contained by the sphere. If the spherical surface paths are valid ($ISC = 0$), R59 computes the coordinates of the points of intersection with the spherical surface. Between R59 and R60 tests are made to determine if the intersection coordinates are bounded by points 1 and 2 (Figure 8). Next the hemisphere base is examined

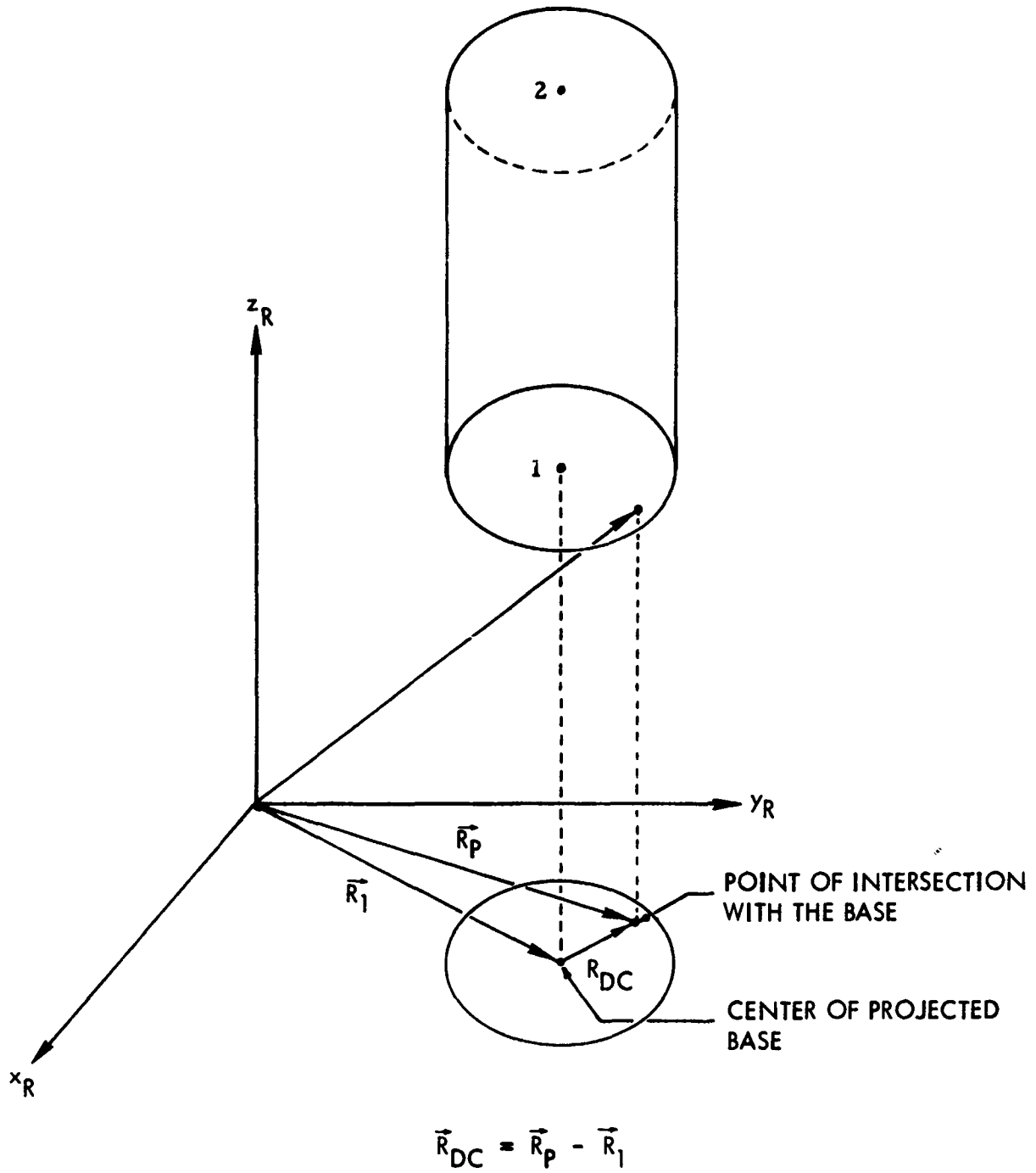

Figure 21. Projection of Cylinder Base Plane

for possible intersection as follows: if DIRRAY(3) = 0, there is no intersection with the base and PR(2) is set equal to 10²⁰.

If DIRRAY(3) ≠ 0, the distance R61 to the plane DFL is evaluated. If DPL is within the radial bounds and positive, it is a valid path (R62), and the two minima (not equal) of PR(2), PR(3), and PR(4) are selected as DP(1) and DP(2). From Figure 8, if the origin is bounded by the z (R63) components of points one and two, the dosimeter is inside and the hemisphere volume path length is DP(1). If the detector is outside and DP(1) is 10²⁰, there is no intersection. Otherwise the path length is the difference between the two minima.

16. SUBROUTINE TKCON

NP is used to designate the type of cone. Values of 2 and 3 refer respectively to non-truncated and truncated cones. R64 defines the cone's RDCS coordinates X (I, J). R65 defines the rotation matrix AR (I,J) which is used in R66 to transform the ray direction cosines from the DSCS to the RDCS. Also the cone radii at the base and truncation plane are respectively defined as RB and RT. After R67, logical tests are used to determine whether the dosimeter is inside or outside the cone volume. If the dosimeter is inside (Equation 40) the volume, the origin is bounded by the z components of Z_R(1) and Z_R(NP) and the distance from the center line of the cone to the dosimeter or origin must be less than the radius of the cone cross section in the (x_R, y_R) plane.

RCD = radius of the cone cross section in the (x, y) plane

$\sqrt{\text{RDET}}$ = distance from the cone centerline to the dosimeter

If the detector is inside, special cases of γ_R are considered as follows:

$\gamma_R = 0$, the ray is in the (x_R, y_R) plane and only intersects the conical surface (R68)

$\gamma_R = -1$, the ray intersects the base plane (R69)

and for the more general case the path lengths to the bases (Z1) are computed first (R70). Then they are tested for positive values.

At R71 the conical surface path lengths [PR(3), PR(4)] are computed and the minimum (R72) of the three path lengths is selected as the volume path length. If the dosimeter is outside the cone volume, control is transferred to R73. Then γ_R is tested for a zero value. If zero, the ray is in the (x_R, y_R) plane and does not intersect either of the cone bases. Otherwise, the distance to the base plane PR(1) is computed and tested for a

negative value. Then PROJ R must be less than RB^2 . PROJ R is the square of the (x_R, y_R) plane-projected distance of a vector from the plane point of intersection to the cone centerline. A similar method is used to compute the path length PR(2) to the truncation plane. Subsequently at R74 the path lengths to the conical surface PR(3), PR(4) are calculated. Starting at R75, the two minimum path lengths are computed and the volume path length defined as their difference.

17. SUBROUTINE TKELL

At R76, the ray direction cosines of the ellipsoid coordinate axes are transformed by DIR (I, J) to the RDCS as DIRRAY(I). The transformation matrix is defined by Equation 31. JMAX is used to indicate the type of ellipsoid and after R77 the z bounds of the ellipsoid are established in the RDCS. JMAX and the bounds are defined as follows (Figure 6):

JMAX = 4, the ellipsoid is nontruncated

= 5, the ellipsoid is truncated and bounded by the coordinates of points 3 and 5

= -5, truncated and bounded by point 5 and $ZB(1) \equiv X(4) - C$

= 6, truncated and bounded by points 5 and 6

After the z coordinate bounds are specified, R78 computes the path lengths to intersections with the coordinate planes.

If IEL = 1, 2, 3, which is equivalent to $|JMAX| = 4, 5, 6$, (R79) there are 0, 1, and 2 intersections with the truncation planes. If there are two plane intersections, and $[PR(1) + PR(2)] > 10^{20}$ there is at most one intersection with the truncation planes. In this case, a transfer is made to R80 to find a possible intersection with the ellipsoid surface. This subroutine allows for cases where the dosimeter is located inside the ellipsoid.

At R81, the z coordinate of the ellipsoid intersections are checked to see if they are bounded by the z coordinates of the truncation planes. R82 selects two nonequal minimum path lengths, i. e., if such exist. At R83, C of Equation 17 is checked for a negative value. If C is negative, the dosimeter is inside the ellipse and the volume path length is the first minimum of the path lengths. If the dosimeter is outside the ellipsoid and either of the two minimum path lengths is 10^{20} , the ray misses the ellipsoid. Otherwise, the volume path length is the difference between two minima.

At R84 of subroutine TRACK a transfer is made to subroutine GEOMDS to compute the normalized geometry distribution and curve fit coefficients.

18. SUBROUTINE GEOMDS

In order to represent the areal-density distribution function more accurately, least-square curve fits are made by fitting the function in sections for particular thickness intervals. This is necessary because a large portion of the primary dose comes from the region of smaller thicknesses and normally there is a large variation in the distribution from minimum to maximum thickness.

The input data variables are defined as follows:

NSECT = number of curve fit sections

NSDEG(N) = the degree of polynomial used for each section

XMAX = TMX (gm/cm²)

TAU = τ

DELR = δR

TMAX = XMAX = maximum areal density for least-squares curve fits

The minimum value of THK, TMIN is selected from the computed equivalent thicknesses previously generated. TMIN is used with TMAX, τ , and δR to compute the weighted THK values with Equation 61.

The maximum thicknesses (XFIT) are required for each section to be curve fit and are computed using the logarithmic relationship

$$XFIT(L) = TMIN \left(\frac{TMAX}{TMIN} \right)^{L/NSECT}$$

R85 computes the fraction of the solid angles (GM) with thickness less than THK.

The normalized distribution is computed by dividing the GM array by the number of rays (NSA) in R86 . .

The loop R87 computes the least-square polynomial curve fit coefficients (CSEC'I) for each areal-density section. A classical least-squares subroutine, designated LEAST, is used.

19. SUBROUTINE ORDER

Subroutine ORDER sorts the path-length data, which have been stored on SYSDA unit 20 by subroutine COMPSP, according to ray number and decreasing distance relative to dosimeter location. The following variable definitions are used:

NMAX = the maximum number of core storage locations available for the sorted data

BPL = the array which contains the sorted distances, path lengths and material numbers data; the data are packed to use all available storage locations and are dimensioned by NMAX (21000)

IPATH = total number of path lengths computed for each ray (dimensioned 1000)

IR1 and IR2 = the minimum and maximum ray numbers for which core is available for storing path length data into BPL; these parameters may not necessarily be 1 and NRAYS, respectively, since the number of locations needed for the complete set of data can exceed NMAX

The first section ORDER performs initialization of IR1 as 1, zeros out arrays BPL, PLDATA and MATNO (final sorted data per ray) and computes the number of unsorted data records (NEND) on the temporary storage SYSDA unit 20. The number of records (R88) is computed as

$$NEND = \sum_{i=1}^{NRAYS} IPATH(I)$$

The next sequence of operations (R89-R90) determines the number of storage locations (NSMAX) used in BPL for the data for rays numbered IR1 to IR2. The NSMAX summation is continued until NSMAX exceeds NMAX or IR2 becomes equal to NRAYS. Then the locations (IPOSN) for storing the path-length data into the BPL array are computed.

The loop R91 reads, prints, and stores the path-length data corresponding to all rays and paths contained in the ray number interval (IR1, IR2). These variables are defined as:

IR = particular ray number

IPT = path number

X = distance to the volume exit surface

DX = path length (gm/cm²) through the shield

MAT = material number

The next section (R92) performs the sorting according to the variable X for each ray and produces the desired output on the required output data medium. The sorting is executed as follows:

The number of solid parts encountered for IRth ray is NHIT, which is picked up as IPATH (IR). The set of data for each ray is selected sequentially from BPL. At R93, the sorted data results are printed and stored on the designated medium. The variable IPUNCH determines the output data as follows:

I Punch	Output Data Form
Positive and less than 7	Punched cards on binary tape on unit 8
7	Punched cards
8	Binary tape on unit 8

SECTION IV

PROGRAM UTILIZATION (USER'S MANUAL)

This section defines the procedure for data preparation, the MEVDP input data format, and tape unit use; it is not intended to be used entirely independently of other sections of this document.

1. NUMERICAL GEOMETRICAL DATA PREPARATION

A numerical geometrical model contains two types of data: (1) analytical geometrical coordinates, and (2) material parameter data. The material data are the shield's material type or code (MATCD) and its density (RHO) in units of grams/centimeter³. The material code is a number referring to a particular material type. The analytical coordinate and parameter data include the type of geometrical volume (ST), point coordinates in inches, and volume radius (RPHI) or cone half-angle in inches and radians, respectively. If the volume is an ellipsoid, an additional parameter (JMAX) defines its degree of truncation. The elemental volumes and their defining points are depicted in Figure 4. AFWL has found it efficient to use a standard form to record the data for each shield. Figure 22 is a reproduction of the form used for this purpose, the Sectoring Code Work Sheet. Figure 23 is the instructions printed on each work sheet to assist in its preparation. The data on each work sheet are sufficient to define the location, nature, material, and type of shield. The relationships between the data blocks in Figure 22 and the computer code variables are summarized as follows:

SSN = shield serial number

ST = shield type

MATCD = material code number which defines the shield material composition

RPHI = radius of cylinder or radian half-angle of a cone

RHO = shield density (grams/centimeter³)

JMAX = type of ellipsoid (degree of truncation)

SECTORING CODE WORK SHEET

SHIELD SERIAL NO.				SHIELD TYPE	+	
					-	
MATERIAL CODE	NO.			CHEMICAL COMPOSITION		
OCTANT NO.				DENSITY (GM/CM³)		
CYL RAD (in.) OR CONE HALF-ANG (RAD)						
	SPHERE (2)	1	X	Y	Z	
	HEMISPHERE (2)					
	CYLINDER (2)	2				
	CONE (2)					
	TRUNCATED CONE (3) (TRUNCATION PT)	3				
	SIMPLE ELLIPSOID (4)	4				
	TRUNCATED ELLIPSOID (5 OR 6) (TRUNCATION PT)	5				
		6				
	HEXAHEDRON (8)	7				
		8				
REMARKS						

Figure 22. Sectoring Code Work Sheet

INSTRUCTIONS FOR FILLING OUT SECTORING CODE WORK SHEETS

A right-handed coordinate system is used, about whose origin all shields are described. All shields must be one of the geometrical shapes listed below. Coordinates must be in inches, angles in radians, and densities in g/cm^3 .

1. Shield Serial Number: use a unique 4-digit number for each shield. Numbering shall reflect a logical breakdown of the geometry being sectorized, i.e. digits 1 and 2 denote the major segment, digit 3 the order of shields within the segment, and digit 4 the number of a shield within a composite shield.
2. Shield Type: a 2-digit integer (see list below) denoting the shield type.
3. Octant Number: a 1-digit integer denoting the octant in which the shield appears; if a shield overlaps more than 1 octant, use octant number 9.
4. Material Code: a 2-digit number assigned to denote the material type. The chemical composition shall be placed in the space provided, if space permits, otherwise use the remarks block (at bottom of form).
5. Cylinder Radius, Cone Half-Angle, Density: see above for units to be used.
6. Shield Input Requirements:
 - a. Sphere (2 points)
 1. center of sphere
 2. any point on surface
 - b. Hemisphere (2 points)
 1. center of hemisphere
 2. polar point
 - c. Cylinder (2 points, radius)
 1. centers of bases (2)
 2. radius of cylinder
 - d. Cone (2 points, half-angle)
 1. apex point
 2. center of base
 3. half-angle (radians)
 - e. Truncated Cone (2 points, half-angle, truncation point)
 1. same as in d.
 2. axis truncation point
 - f. Hexahedron (8 points)
 1. all apex points in order specified on diagram
 - g. Ellipsoid (4 points)
 1. center of ellipsoid
 2. surface points on 3 semi-major axes.
 - h. Truncated Ellipsoid (5 or 6 points)
 1. same as in g.
 2. axis truncation point(s) (see diagram)
7. Shield Type Code:

0,1 Hexahedron	2,3 Cylinder
4,5 Sphere	6,7 Hemisphere
8,9 Cone	10,11 Truncated
12,13 Ellipsoid	Cone

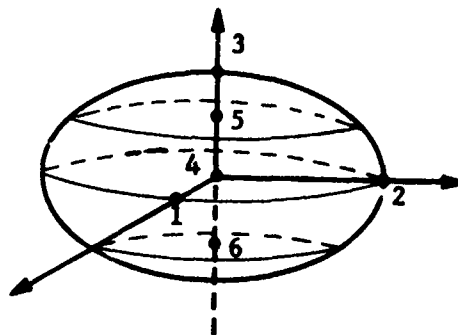

Ellipsoid: Point Order and Location

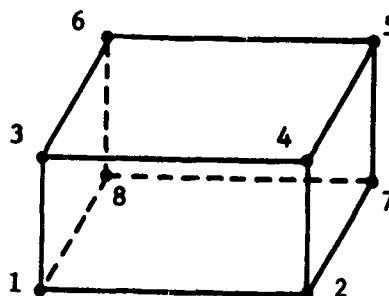

Hexahedron: Point Order and Location

note: Even integers refer to void shields.

Figure 23. Sectoring Code Work Sheet Instructions

JMAX is further defined as follows:

JMAX	Type of Ellipsoid Truncation
4	Nontruncated
+5	Single truncation with lower portion eliminated with respect to z_R axis.
-5	Single truncation with upper portion eliminated with respect to $+z_R$ axis
6	Double truncation

The shield types (ST) and number of points required for each shield type are shown in Figure 23.

The final geometric parameter is the number of components (NCOMP) which comprise a composite shield. A composite shield represents a complex shield which is defined by a combination of as many as ten solid and void shields. Each void shield is defined as voiding all the portions of solid shields that it intersects. In a composite shield, the all-solid components must be followed by all the void components because of a computer program constraint.

Numerical coordinates are defined in a reference Cartesian coordinate system (ABCS) which is fixed relative to the numerical model. The coordinates which define the position and size of the geometrical volumes are illustrated in Figure 4. The ellipsoid (x, y, z) axes must be a right-handed orthogonal set and are not necessarily spatially coincident with the right-hand reference coordinate system. Also, the z axis of the ellipsoid in the ABCS must be the axis of truncation.

2. MEVDP INPUT DATA FORMAT

The format for the input data is listed in Table VI. This table includes the card sequence, subroutines in which the variables are read, input variables, FORTRAN nomenclature, and the input data format. Table VI also includes the analysis and program sections where the variables are defined and explained in greater detail. Also, where there is a correlation, reference is made to other input data cards. A column designated as "Conditions for Data Inclusion or Specific Parameter Values" is used to define the conditions for which the particular card is included in the data and the particular values of variables required for different MEVDP program computational options. Figure 24 is a schematic showing the MEVDP input data. Table VI has a reference column to be used to obtain a full explanation of the meaning of a specific input variable.

Table VI
MEVDP Input Data Format

Card Sequence	Variable Description	FORTRAN Nomenclature	Format	Routine Which Reads Data	Condition for Data Inclusion or Specific Parameter Value	References
1.1	Form of shield geometrical configuration input data indicator	NIOGEN	I12	MAIN		Figure 24
	a Card data read and stored on physical tape unit - 10 in two files				NIOGEN = 1	Section IV-3., Cards 1.2, 1.3, 1.5
	b Data read from reserve physical tape Unit 10				NIOGEN = 0	
	c Card data read and stored on physical tape Unit 10 in two files - program execution terminated				NIOGEN > 1	
	d Program execution terminated				NIOGEN < 0	
	e Descriptive title for the geometry data	CONTEN	15A4		NIOGEN = 1	
1.2	Shield description			GENTAP	NIOGEN ≥ 1	File 1 of Unit 10, Section IV-1, Figure 23, Subsection III-4. a.
	a Shield type number	SSN	I1, I4			
	b Shield type (0 - 13, odd numbers indicate solid region, even numbers correspond to void region)	ST	I2			
	c Material number (1 - 50)	MATCD	I3			
	d Radius (inches) of volume or radian half-angle of cone (regular or truncated), whichever is applicable	RPHI	F10.0			
	e Material density (gm/cm ³)	RHO	F10.0			
	f Number of sets of coordinates (if ST = 12 or 13, for ellipsoid = 4 regular ellipsoid = 6 two truncations, = +5 upper portion with respect to its semimajor, = -5 bottom portion)	JMAX	I5			
	g Number of elemental volumes defining the solid all solid elemental volumes must be listed for the particular shield before void regions are encountered	NCOMP*	I5			
1.3	Coordinates of volume in ABCS	X (I, J), J = 1, 3, I = 1, number points	6F10.0	GENTAP	NIOGEN ≥ 1	Figure 4 and 23
	a Hexahedron (ST = 0 or 1) 4 cards Apex coordinate components	X (I, J), J = 1, 3, I = 1, 8	6F10.0	GENTAP	NIOGEN ≥ 1	For order of points see Figure 13 and Section III-7, Card 3.1
	b Cylinder 1 card Centerline coordinate components	X (I, J), J = 1, 3 I = 1, 2	6F10.0			
	c Sphere (ST = 4 or 5) 1 card Center and one point on sphere	X (I, J), J = 1, 3, I = 1, 2	6F10.0			
	d Hemisphere (ST = 6 or 7) 1 card Center and one point on surface	X (I, J), J = 1, 3, I = 1, 2	6F10.0			
	e Cone (ST = 8 or 9) 1 card Base center and apex point	X (I, J), J = 1, 3, I = 1, 2	6F10.0			
	f Truncated cone (ST = 10 or 11) 2 cards Base center and apex, and truncation point	X (I, J), I = 1, 3, J = 1, 3	6F10.0			
	g Ellipsoid (ST = 12 or 13) 2 or 3 cards Center, semimajor axes, and truncation points	X (I, J), J = 1, 3, I = 1, JMAX	6F10.0			
1.4	Control card which signals end of spacecraft geometrical data	BLANK	Blank card	GENTAP		
1.5	Astronaut geometrical configuration (NASA-MSC model Reference 2)	TAPE		GENTAP		File 2 of tape Unit 10, Figure 19, Subsection III-4. a.
	a Repeat 1.2 and 1.3 for astronaut geometry data				NMEN > 0	Card 2.3. b
	b Descriptive cards which will be printed (must not include any blank cards)				NMEN = 0	

Comments: Card sequences 1.2 and 1.3 are repeated for the remaining elemental volumes.
As many as ten of these elemental geometrical volumes are combined to form more complex shields, which are designated as composite shields. The void elemental volume components are used to void the spatial region they occupy. The composite shield permits imbedding, in which the positive shield may contain all or a portion of a void shield. Also, the solid shield components may have different material types and densities. Portions of several of the positive shield components may contain portions of a single void shield. This versatility results in a very significant improvement in the geometrical representation capability and reduces the magnitude of the shield synthesis effort.

Table VI (Continued)
MEVDP Input Data Format

Card Sequence	Variable Description	FORTTRAN Nomenclature	Fcrmat	Routine Which Reads Data	Condition for Data Inclusion or Specific Parameter Value	References
1.6	Control card which signals end of astronaut geometry	BLANK	Blank card	GENTAF		
2.1	Geometrical configuration selection parameter a. Use data on physical tape Unit 10 b. Use new geometry data-go to Card Sequence 1.1	OPTN	112	MAIN	OPTN ≥ 1 OPTN < 1	Figure 24
2.2	Detector position and transformed geometry parameters a. Detector coordinates in ABCS b. Spacecraft geometrical data usage indicator 1. Spacecraft data on first file of physical Tape 10 (card image) will be used. 2. Spacecraft data will not be used. c. Transformed geometry output print indicator 1. Transformed geometry data printed 2. Transformed geometry data not printed	XDET (I), I = 1, 3 NS PRNT	3E12.8 110 110	TRSHLD	NS > 0 NS < 0 PRNT = 1 PRNT = 0	Figure 24
2.3	Crew configuration parameters a. Number of elemental volumes per astronaut (NOMAN = 34 for NASA- MSC model astronaut) b. Number of astronauts in crew c. Number of astronaut limb composite shields rotated per astronaut (NLIMB(I) = 1, for NASA- MSC model astronaut) (1) NLIMB (I) = 0 (2) NLIMB (I) = 1	NOMAN NMEN NLIMB(I), I = 1, NMEN	1415	TRSHLD	NMEN = 0 NMEN ≥ 1 NMEN > 0	Subsection III-4. a., Figure 20
2.4	Crew coordinates and orientation a. Astronaut position and orientation b. Astronaut SMCS origin position in ABCS = W (4, K)	W(I, J), J = 1, 3; I = 1, 4 R4A(K), K = 1, 3				
2.5	Angles of rotations for crew limb components (NCOMP = 8 for NASA- MSC model astronaut)	EPSLN(I), I = 1, NCOMP			NMEN > 0 NMEN > 1	Figure 19, Table V
Comment	2.4 and 2.5 repeated for each astronaut					
3.1	Hexahedron point order	ORD(I, J), J = 1, 4; I = 1, 6	2413	ESDOSE		Figure 13 and Section III-7.
3.2	Initiator for random number generation (this parameter read but not used)	IR	112			
3.3	Special geometrical, material, and ray selection parameters a. Ray selection method indicator 1. Systematic ray selection 2. Random ray selection b. Number of rays selected (≤1000) c. Number of material types (≤50) d. Number of shield elemental volumes requiring new densities relative to data or physical tape Unit 10. e. Direction cosines print indicator 1. Direction cosine data printed 2. Direction cosine data not printed	RANDOM N NMAT NRHO NPRT1	1216		RANDOM = 0 RANDOM > 0 NPRT1 = 1 NPRT1 = 0	Section II-1

Table VI (Continued)
MEVDP Input Data Format

Card Sequence	Variable Description	FORTTRAN Nomenclature	Format	Routine Which Reads Data	Condition for Data Inclusion or Specific Parameter Value	References
	f. Detail ray tracing print indicator 1. Tracking data printed 2. Tracking data not printed	NPR I2			NPRT2 = 1 NPRT2 = 0	Section 1'-1
	g. Number of macroscopic solid-angle increments for systematic ray selection (≤ 10)	NDIV				
	h. Sorted material and path-length output storage medium indicator 1. Sorted data printed only 2. Sorted data stored on tape Unit 7 with format for punched card output and printed 3. Sorted data on tape Unit 8 in binary form 4. Sorted data stored on Units 7 (punched card format) and 8 (binary form) and printed	IPUNCH			IPUNCH = 0 IPUNCH = 7 IPUNCH = 8 0 < IPUNCH < 7	Section II-19 and IV-3.
3 4	Shield serial numbers for shields with specified density changes	NSS(I), I = 1, NRHO	12I6		NRHO > 0	Card 3.3d
3 5	New shield densities corresponding to shield serial numbers	DENS(I), I = 1, NRHO	6E12.8		NRHO > 0	Card 3.4
3.6	Title card for problem description	CASE	18A4	ESDOSE		
3.7	Curve fit data for standard-material areal-density curve fit parameter a. Tape 9 usage parameter 1. Store curve fit data on new reserve tape on tape Unit 9 for one or several dosimeter positions 2. Curve fit data will not be saved on tape 3. Curve fit data added to a previously generated tape which is mounted on tape Unit 9. If the data are to be added after File I for several dosimeter positions, then NEWF9 = 1, 1 + 1, 1 + 2, etc., for the 1, 2, 3, etc., dosimeter locations. b. Cut off equivalent areal density for ray tracing, including sorted data c. Parameter used to compensate for tracking roundoff error (suggested value = 0.001)	NEWF9	I12		NEWF9 = -1 NEWF9 = 0 NEWF9 > 0	Section IV-3.
3.8	Range-energy curve fit parameters a. Standard-material parameters (δ_{STD} , η_{STD}) b. Actual material parameters (δ_i , η_i , $i = 1, NMAT$)	TMX EPSLN	E12.8 E12.8			Subsection II-7. a.
3.9	Standard-material name for print output	DSTD, ESTD				
3.10	Actual material names for print output (two per card with 30 columns each)	DELTA(I), ETA (I), I = 1, NMAT				
3.11	Systematic ray selection parameters a. Number of microscopic solid-angle discrete divisions b. Azimuthal angles ϕ_i , ϕ_f (degrees) c. Colatitude angles θ_i , θ_f (degrees)	TTLSTD(I), I = 1, 3)	3A10			
3.12	Areal-density curve fit sections parameters a. Number of sections (≤ 5)	TTLMAT (I, J), I = 1, 3, J = 1, NMAT	6A10			
3.11		N	I12	ESDOSE	RANDOM = 0	Subsection II-1. b.
3.11		PHI1, PHIF	4E12.8			
3.11		THET1, THETF				
Comment	Repeat 3.11 for NDIV macroscopic solid angles with $\sum N_c \leq 1000$ where N_c = number of solid angles computed by the program corresponding to N					
3.12		NSECT		GEOMDS		Section III-18.

Table VI (Concluded)
MEVDP Input Data Format

Card Sequence	Variable Descriptions	FORTTRAN Nomenclature	Format	Routine Which Reads Data	Condition for Data Inclusion or Specific Parameter Value	References
3. 13	<p>b. Degree of polynomial used for each section (≤19 per section)</p> <p>Areal-density curve fit point density parameters</p> <p>a. Maximum areal density</p> <p>b. τ (suggested value = 8.0)</p> <p>c. δR (suggested value = 0.105)</p> <p>d. Maximum areal density</p>	<p>NSDEG(I), I = 1, NSECT</p> <p>XMAX TMX (3. 7b)</p> <p>TAU</p> <p>DELR</p> <p>TMAX = XMAX</p>	<p>6112</p> <p>4E12.8</p>	GEOMDS		Section III-18
3. 14	<p>End of data case for a dosimeter position (IDUMMY must be less than zero)</p>	IDUMMY	112			
Comment	GO to Card 2. 1					

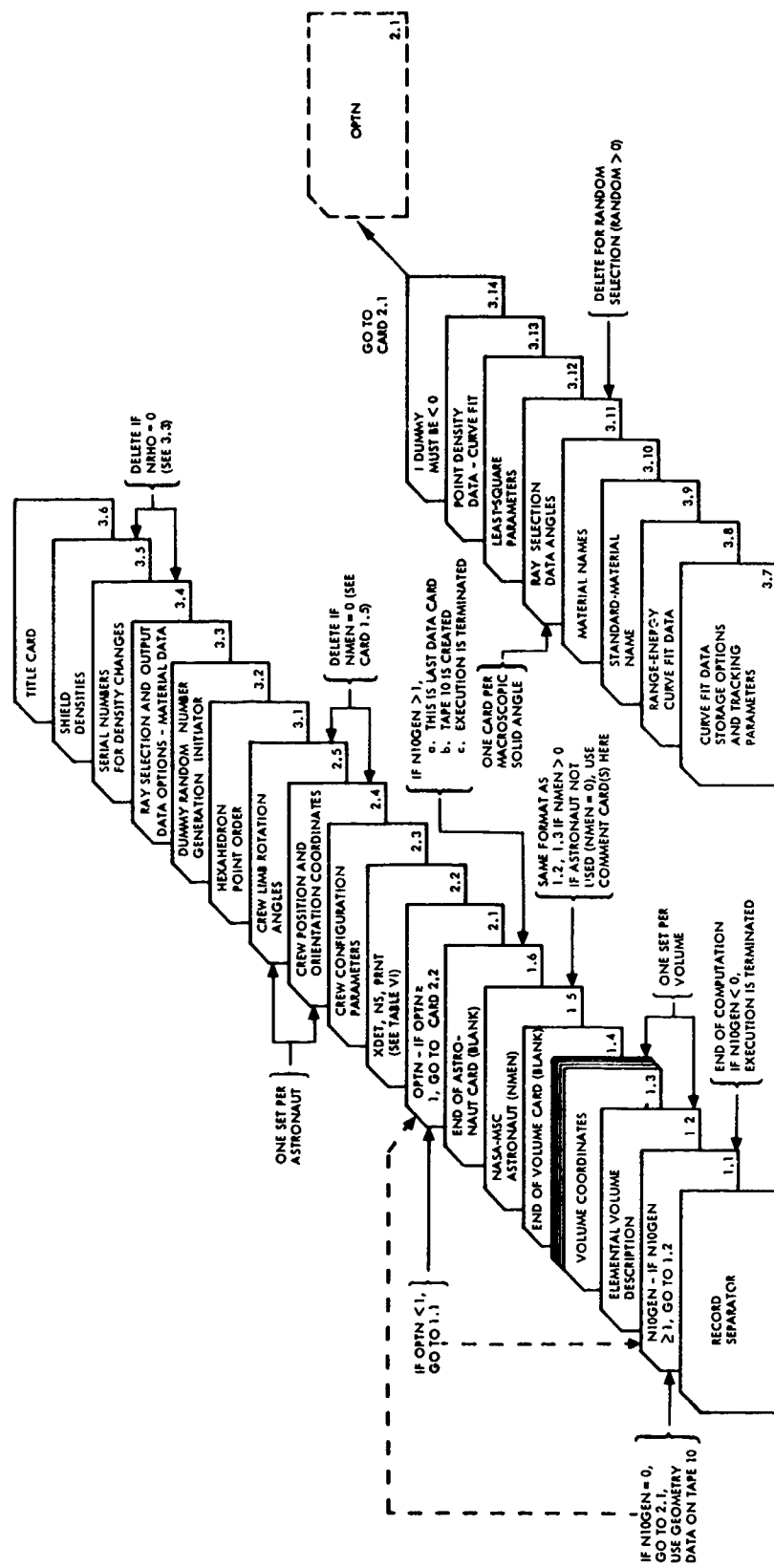

Figure 24. MEVDP Input Data Schematic

3. TAPE UNIT UTILIZATION

Table VII is a summary of the tapes required in the MEVDP; individual and more detailed explanation of the data on each tape follows.

Table VII
Tape Unit Use and Requirements

Tape Unit	Use
5	Input
6	Output
7	Storage - punch card output of sorted data
8	Storage - binary form of data on Tape 7
9*	Multiple file storage tape - optional physical tape
10	Input data - optional physical tape - (See cards 1.2 and 1.3, Table VI)
12	Scratch disk file
13	Scratch disk file
<p>*Note: Tape 9, a physical tape, is only required for permanent storage of the standard- material areal-density distribution data.</p>	

The computer system tape units 5 and 6 are used as standard input and output devices. For the other required tape units, the following definitions will be used:

SYSDA = system direct access device (disk scratch unit)

Temporary storage unit = disk unit

Physical tape unit = actual mounted reserve or scratch physical
tape unit, a physical unit tape

Unit 10 contains two card-image files: (1) spacecraft geometry and material model, and (2) the astronaut geometry and material model. The numerical geometrical model can be input as cards and written on disk unit 10, or unit 10 can be a mounted reserve tape containing the required two numerical model files. For additional discussion, refer to cards 1.1 through 2.2 of Table VI, and Subroutine GFNTAP (Section III-2.).

Unit 12, a scratch disk file, is used for temporary storage of numerical model data after they have been transformed to the RDCS for an input dosimeter position.

Unit 13, a scratch disk file, is used for temporary storage of the astronaut numerical model data (NASA - MSC Astronaut Model) after they have been transformed to the ABCS. Subroutine TRSHLD uses unit 13 to generate the transformed data for the crew in the RDCS, and adds the data to the transformed spacecraft data on unit 12. Other references to unit 13 are in Subroutine TRSHLD (Section III-4.).

Unit 9, a physical unit file, is used for storage of the standard-material real density distribution curve fit data. If the curve fit data are not requested, unit 9 can be specified as a scratch disk file. In general, unit 9 will be a multifile reserve tape with following data records for each dosimeter position:

Record 1.

- a. NRAYS = number of rays for tracking
- b. NPTS = number of points used for the curve fits
- c. NSECT = number of curve fit sections
- d. [NDEG (I), I = 1, NSECT] = degree of least-square polynomial used for each section

Record 2.

- a. TMIN = minimum equivalent thickness (grams/cm²) computed for a particular ray
- b. TMAX = specified maximum equivalent thickness for ray tracing
- c. [XFIT(I), I = 1, NSECT] = maximum equivalent thickness for each sectional curve fit
- d. [THK(J), J = 1, NPTS] = computed weighted equivalent thickness values for the areal-density distribution function

Record 3.

[PATH(I), I = 1, NRAYS] = total equivalent thickness for each ray

Next NSECT Records

The generalized nth record contains the following polynomial curve fit coefficients:

[CSECT(J, N), J = 1, NDEG(N) + 1] = polynomial curve fit coefficients

For further discussion refer to card 3.7 of Table VI and subroutine GEOMDS (Section 3.18).

The areal-density function fractional solid angle (Y_i) corresponding to the ith areal-density point value T_i is computed from the curve fit coefficients with

$$Y_i = \sum_{R=1}^{NDEG(N)+1} CSECT(R, N) T_i^{R-1}$$

where

$$XFIT(N-1) \leq T_i \leq SFIT(N)$$

Unit 7, system punch card output tape, and unit 8, a scratch disk file or a physical reserve tape, are used for storage of the sorted computed path-length and material data. These output units are used according to the value of the variable IPUNCH as given in Table III.

Table VIII
Use of Output Tape Units Versus IPUNCH

IPUNCH	Sorted Data Output Form		
	Print Data On Unit 6	Punch Data On Unit 7	Binary Data On Unit 8
0	Yes	No	No
7	Yes	Yes	No
8	Yes	No	Yes
0 < IPUNCH < 7	Yes	Yes	Yes

For tape unit 7, the IRth record of the first NRAYs records contain the macroscopic solid-angle parameters.

IR, [DIRCOS(J,IR), J = 1, 3], NRSA, FSA

with the format

I5, 3E15.8, I5, E15.8

where

IR = ray number

DIRCOS = ray direction cosine components

NRSA = number of rays for the macroscopic solid angle containing the IRth ray

FSA = solid angle subtended by the IRth ray

These records are followed by the sorted material and path-length data. Each record contains the variables

IR, I, MAT(I), X(I), DX(I)

with the format

3I5, 2E15.8

where

IR = ray number

I = path-length number

MAT(I) = material number

X(I) = sorted ordered distance for the Ith path of the IRth ray

DX(I) = traversal areal density for the Ith path length of the IRth ray

The macroscopic solid-angle parameters and sorted path-length and material data, which can be written on unit 7, can also be written on unit 8 in binary form, i. e., without format. Arrangement of the data, by record, is the same for units 7 and 8. Additional discourse on the use of units 7 and 8 is in card 3.3h of Table VI, and subroutine ORDER (Section III-19).

SECTION V

SAMPLE PROBLEM SOLUTION

A sample problem, supplied by AFWL, is defined in Figures 25 and 26. The elemental volume components of the sample problem are depicted in Figure 25 and the composite configuration is illustrated in Figure 26 with associated dimensional parameters. Tables XI and XII tabulate (1) the material properties, (2) geometrical dimensional data, and (3) the derived coordinates and parameters required as input data for the MEVDP. The dimensional parameters in Table X are illustrated in Figure 26.

Input data for the sample problem are listed in Table XII for three dosimeter locations. The cards are referenced to the input data format in Table VI and the input data schematic in Figure 24 through the identification field, i. e., columns 73 to 80. The numbers in columns 73 through 76 refer to the card numbers, for example 31 and 314 are interpreted as cards 3.1 and 3.14, respectively. Lines 1 through 53 also indicate the corresponding shield serial numbers for the sample problem geometrical configuration. Table IX shows the correlation between the shield serial numbers and the shield elemental volume number in Figure 25.

In order to assure the accuracy of the transformation of the AFWL sample problem data into proper format for the MEVDP, cathode ray tube (CRT) pictures were generated for several cross sections. These cross sections are depicted in Figures 27 through 30. The titles denote the planes of the cross sections and their center-point coordinates in inches relative to the coordinate system in Figure 25. The sample problem data have been executed with similar results on the North American Rockwell Space Division (NR SD) IBM System 360 and the AFWL CDC System 6600. The insignificant numerical differences were due to inherent differences in the number of significant figures for the two computer systems.

This section is concluded with a brief explanation of the output data format. Appendix I is a listing of excerpts from the NR SD IBM System 360 computer solution for the AFWL sample problem with the dosimeter at ($x = 0$, $y = 0$, $z = 0$ inches).

There were two changes in the program listing (Appendix II) in subroutine ORDER. The dimension of BPL (card F2) and the variable NMAX (card F12) were reduced to 3000. This change was made to demonstrate the capability of the program to perform an internal sort of the path-length data

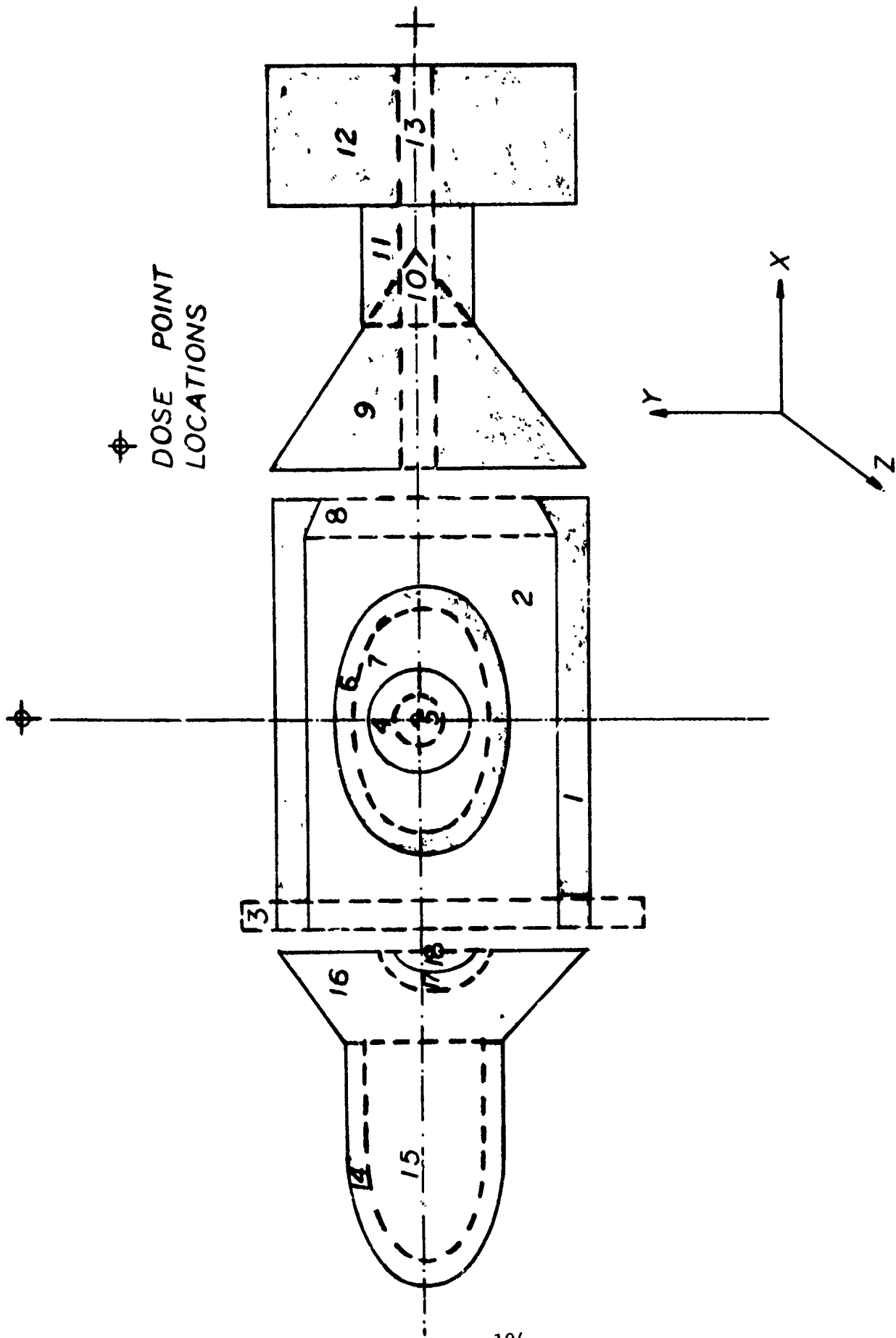

Figure 25. Elemental Volume Components of the AFWL Sample Problem

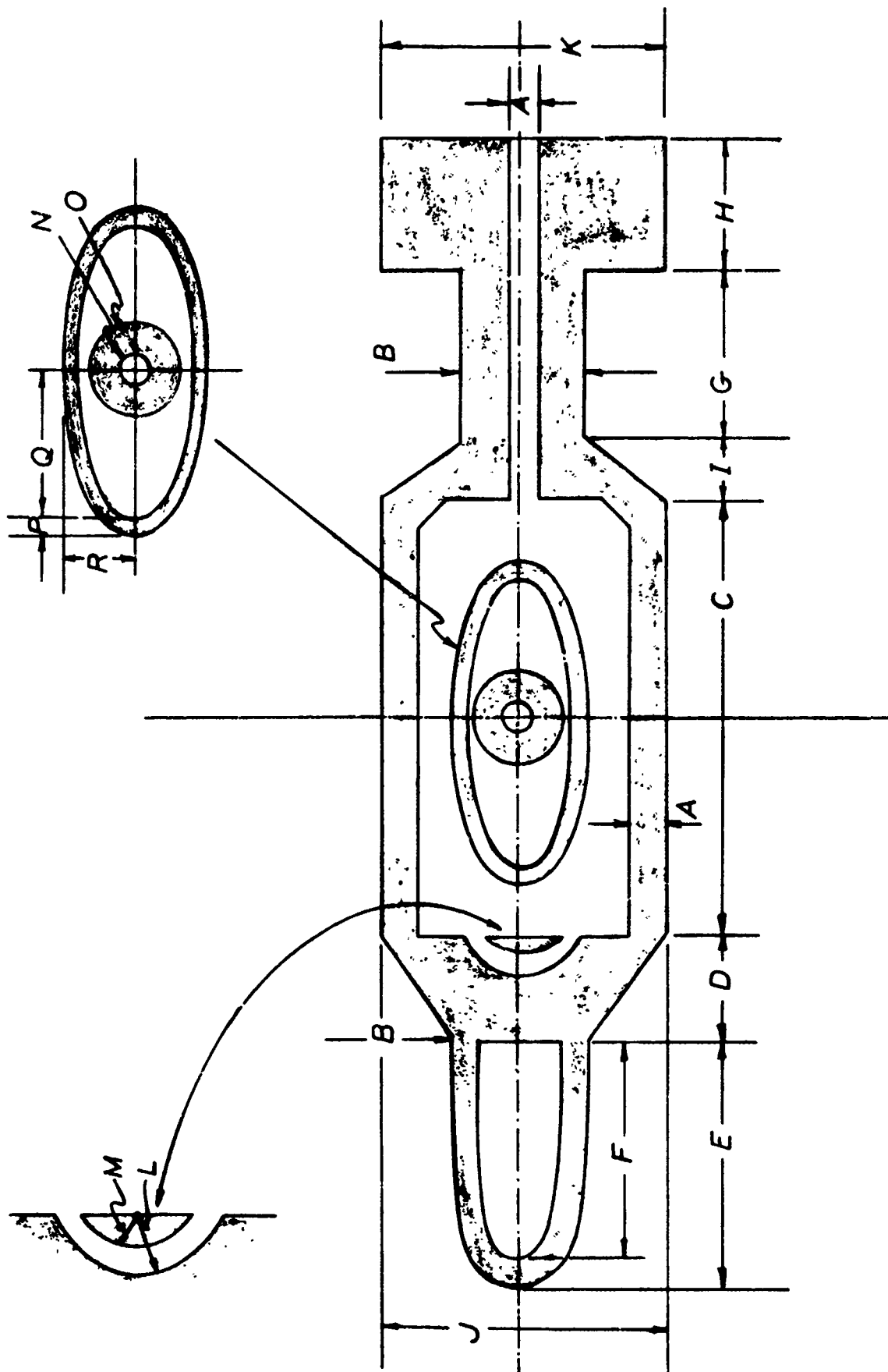

Figure 26. AFWL Sample Problem Shield Configuration

Table IX
AFWL Sample Problem Component Shield Properties

Shield Properties							
Number	Volume Type	Mass Type	Material	Serial No.	Composite No.	Density (gm/cm ³)	Material Symbol
1	Cylinder	Solid	Aluminum	1010	1	2.699	x
2	Cylinder	Void		1011	1		
3	Hexahedron	Void		1012	1		
4	Sphere	Solid	Copper	1020	2	8.94	.
5	Sphere	Void		1021	2		
6	Ellipsoid	Solid	Beryllium	1030	3	1.84	*
7	Ellipsoid	Void		1031	3		
8	Truncated cone	Void		1013	1		
9	Cone	Solid	Iron	1040	4	7.87	□
10	Cone	Void		1041	4		
11	Cylinder	Solid	Iron	1050	5	7.87	
12	Hexahedron	Solid	Iron	1051	5	7.87	
13	Cylinder	Void		1042,	4, 5		
				1052			
14	Truncated ellipsoid	Solid	Lead	1060	6	11.35	0
15	Truncated ellipsoid	Void		1061	6		
16	Truncated cone	Solid	Silicon	1070	7	2.42	c
17	Hemisphere	Void		1071	7		
18	Hemisphere	Solid	Magnesium	1080	8	1.741	+

Table X
 AFWL Sample Problem Dimensions and Dosimeter Locations

Parameter	Dimension (in.)	Dosimeter Location		
		Coordinates (in.)		
		X	Y	Z
A	2.0			
B	16.0			
C	40.0			
D	8.0			
E	30.0			
F	28.0			
G	16.0	0.0	0.0	0.0
H	12.0	56.0	0.0	0.0
I	8.0	0.0	30.0	0.0
J	24.0			
K	30.0			
L	7.0			
M	4.0			
N	2.0			
O	4.0			
P	2.0			
Q	30.0			
R	8.0			

Table XI
Shield Coordinates and Parameters

Shield No.	Radius (in.)	Half-Angle (radians)	Point No.	Point Coordinates (in.)			Ellipsoid Axes (in.)			Ellipsoid Truncation Parameter	
				X	Y	Z	a	b	c		
1	12.0		1	-21.0	0.0	0.0					
2	10.0		2	20.0	0.0	0.0					
3			1	19.0	0.0	0.0					
			2	-21.0	13.0	13.0					
			3	-21.0	-13.0	13.0					
			4	-20.0	13.0	13.0					
			5	-20.0	-13.0	13.0					
			6	-20.0	13.0	-13.0					
			7	-21.0	-13.0	-13.0					
			8	-21.0	13.0	-13.0					
4	4.0		1	0.0	0.0	0.0					
2			2	4.0	0.0	0.0					
5	2.0		1	0.0	0.0	0.0					
2			2	2.0	0.0	0.0					
6			1	16.0	0.0	0.0	16.0	8.0	8.0	4	
			2	0.0	8.0	0.0					
			3	0.0	0.0	8.0					
			4	0.0	0.0	0.0					
7			1	15.0	0.0	0.0	15.0	7.0	7.0	4	
			2	0.0	7.0	0.0					
			3	0.0	0.0	7.0					
			4	0.0	0.0	0.0					
8		$\tan^{-1} (1/2)$	1	19.0	0.0	0.0					
			2	29.0	0.0	0.0					
			3	20.0	0.0	0.0					
9		$\tan^{-1} (1/2)$	1	20.0	0.0	0.0					
			2	44.0	0.0	0.0					
			3	28.0	0.0	0.0					
10		$\tan^{-1} (1/2)$	1	44.0	0.0	0.0					
			2	28.0	0.0	0.0					
11	8.0		1	28.0	0.0	0.0					
			2	44.0	0.0	0.0					
12			1	44.0	15.0	15.0					
			2	44.0	-15.0	15.0					

Table XI (Concluded)
Shield Coordinates and Parameters

Shield No.	Radius (in.)	Half Angle (radians)	Point No.	Point Coordinates (in.)			Ellipsoid Axes (in.)			Ellipsoid Truncation Parameter
				X	Y	Z	a	b	c	
13			3	56.0	15.0	15.0				
			4	56.0	-15.0	15.0				
			5	56.0	-15.0	-15.0				
			6	56.0	15.0	-15.0				
			7	44.0	-15.0	-15.0				
			8	44.0	15.0	-15.0				
			1	20.0	0.0	0.0				
			2	56.0	0.0	0.0				
14			1	-28.0	0.0	8.0	30.0	8.0	8.0	-5
			2	-28.0	8.0	0.0				
			3	2.0	0.0	0.0				
			4	-28.0	0.0	0.0				
			5	-28.0	0.0	0.0				
15			1	-28.0	0.0	6.0	28.0	6.0	6.0	-5
			2	-28.0	6.0	0.0				
			3	0.0	0.0	0.0				
			4	-28.0	0.0	0.0				
			5	-28.0	0.0	0.0				
16		$\tan^{-1} (1/2)$	1	-20.0	0.0	0.0				
			2	-44.0	0.0	0.0				
			3	-28.0	0.0	0.0				
17	7.0		1	-20.0	0.0	0.0				
			2	-27.0	0.0	0.0				
18	4.0		1	-20.0	0.0	0.0				
			2	-24.0	0.0	0.0				

Table XII
 AFWL Sample Problem Input Data

Problem ID	Sample	AFWL	1	AFWL	2	AFWL	3	AFWL	4	AFWL	5	AFWL	6	AFWL	7	AFWL	8
L.0001	1010	3	1	12.0	2.599	0.0	20.0	0.0	0.0	0.0						11	
L.0002	-21.0	0.0														12-1010A	
L.0003	1011	2	1	10.0	0.0	19.0	0.0	0.0	0.0							13-1010B	
L.0004	-20.0	0.0														12-1011A	
L.0005	1012	0	1	13.0	13.0	-21.0	-13.0	-13.0	13.0							13-1011B	
L.0006	-21.0	0.0														12-1012A	
L.0007	-20.0	0.0														13-1012B	
L.0008	-20.0	0.0														13-1012C	
L.0009	-20.0	0.0														13-1012D	
L.0010	-21.0	0.0														13-1012E	
L.0011	1013	10	1	0.78540	0.0	29.0	0.0	0.0	0.0							12-1013A	
L.0012	13.0	0.0														13-1013B	
L.0013	20.0	0.0			0.0											13-1013C	
L.0014	1020	5	2	4.0	8.94	4.0	0.0	0.0	0.0							12-1020A	
L.0015	0.0	0.0														13-1020B	
L.0016	1021	4	2	2.0	0.0	2.0	0.0	0.0	0.0							12-1021A	
L.0017	0.0	0.0														13-1021B	
L.0018	1030	13	3	1.84	1.84	0.0	0.0	8.0	8.0							12-1030A	
L.0019	16.0	0.0														13-1030B	
L.0020	0.0	0.0														13-1030C	
L.0021	1031	12	3	0.0	0.0	0.0	0.0	7.0	0.0							12-1031A	
L.0022	15.0	0.0														13-1031B	
L.0023	0.0	0.0														13-1031C	
L.0024	1040	9	4	0.45368	7.87	44.0	0.0	0.0	0.0							12-1040A	
L.0025	20.0	0.0														13-1040B	
L.0026	1041	8	4	0.45368	0.0	44.0	0.0	0.0	0.0							12-1041A	
L.0027	28.0	0.0														13-1041B	
L.0028	1042	2	1	1.0	0.0	56.0	0.0	0.0	0.0							12-1042A	
L.0029	20.0	0.0														13-1042B	
L.0030	1050	3	4	8.0	7.87	44.0	0.0	0.0	0.0							12-1050A	
L.0031	28.0	0.0														13-1050B	
L.0032	1051	1	4	15.0	7.87	44.0	-15.0	-15.0	15.0							12-1051A	
L.0033	44.0	0.0														13-1051B	
L.0034	56.0	0.0														13-1051C	
L.0035	56.0	0.0														13-1051D	
L.0036	44.0	0.0														13-1051E	

COLUMN NUMBERS

0 0 0 1 1 2 2 2 3 3 4 4 5 5 6 6 7 7 8 8

Table XII (Continued)
AFWL Sample Problem Input Data

L.0073	500	0.0						360.0	0.0		180.0						311					
L.0074		3						10			8						312					
L.0075	1000.0		8.0					0.0105	10		1000.0						313					
L.0076	-1																314					
L.0077		1									1						21					
L.0078	56.0		0.0					0.0				1					22					
L.0079	34	0	0														23					
L.0080	1	2	3	4	5	6	7	8	6	5	2	1	8	7	1	3	6	8	2	7	5	
L.0081																						431
L.0082		0	500	7	0				1			1		0								32
L.0083			AFWL SAMPLE PROBLEM FOR THE MEVDP - DOSIMETER COORDINATES (56,0,0)													33						
L.0084		0	1						+07	0.001												36
L.0085	303		-02	1.751					303						4133				-02	1.726		37
L.0086	2546		-02	1.775					3683						7328				-02	1.680		38
L.0087	2927		-02	1.751					293										-02	1.680		38
L.0088	ALUMINUM	20-300MEV-PROTONS													39							
L.0089	ALUMINUM														310							
L.0090	BERYLLIUM														310							
L.0091	LEAD														310							
L.0092	MAGNESIUM														310							
L.0093		500	0.0					360.0	0.0		180.0											311
L.0094		3						10			8											312
L.0095	1000.0		8.0					0.0105	1000.0													313
L.0096	-1																					314
L.0097		1									1			1								21
L.0098	0.0		0.0					30.0														22
L.0099	34	0	0																			23
L.0100	1	2	3	4	5	6	7	8	6	5	2	1	8	7	1	3	6	8	2	7	5	431
L.0101																						32
L.0102		0	500	7	0				1			1		0								33
L.0103			AFWL SAMPLE PROBLEM FOR THE MEVDP - DOSIMETER COORDINATES (0,0,30)													36						
L.0104		0	1						+07	0.001												37
L.0105	303		-02	1.751					303						4133				-02	1.726		38
L.0106	2546		-02	1.775					3683						7328				-02	1.680		38
L.0107	2927		-02	1.751					293										-02	1.680		38
L.0108	ALUMINUM	20-300MEV-PROTONS													33							
	0	0	1	1	2	2	3	3	3	4	4	4	5	5	5	6	6	7	7	8	8	
	1	5	0	1	5	0	2	5	0	3	5	0	4	5	0	5	0	6	5	0	7	8

COLUMN NUMBERS

Table XII (Concluded)
 AFWL Sample Problem Input Data

ALUMINIUM	BERYLLIUM	LEAD	MAGNESIUM	COPPER	IRON	SILICON
L.0109	500	0.0	10	360.0	0.0	180.0
L.0110	3		8			
L.0111						
L.0112						
L.0113						
L.0114	1000.0	8.0	1000.0			
L.0115	-1					
L.0116	-1					
L.0117						
L.0118						

0	0	1	1	2	2	3	3	4	4	5	5	6	6	7	7	8
1	5	0	5	0	5	0	5	0	5	0	5	0	5	0	5	0

COLUMN NUMBERS

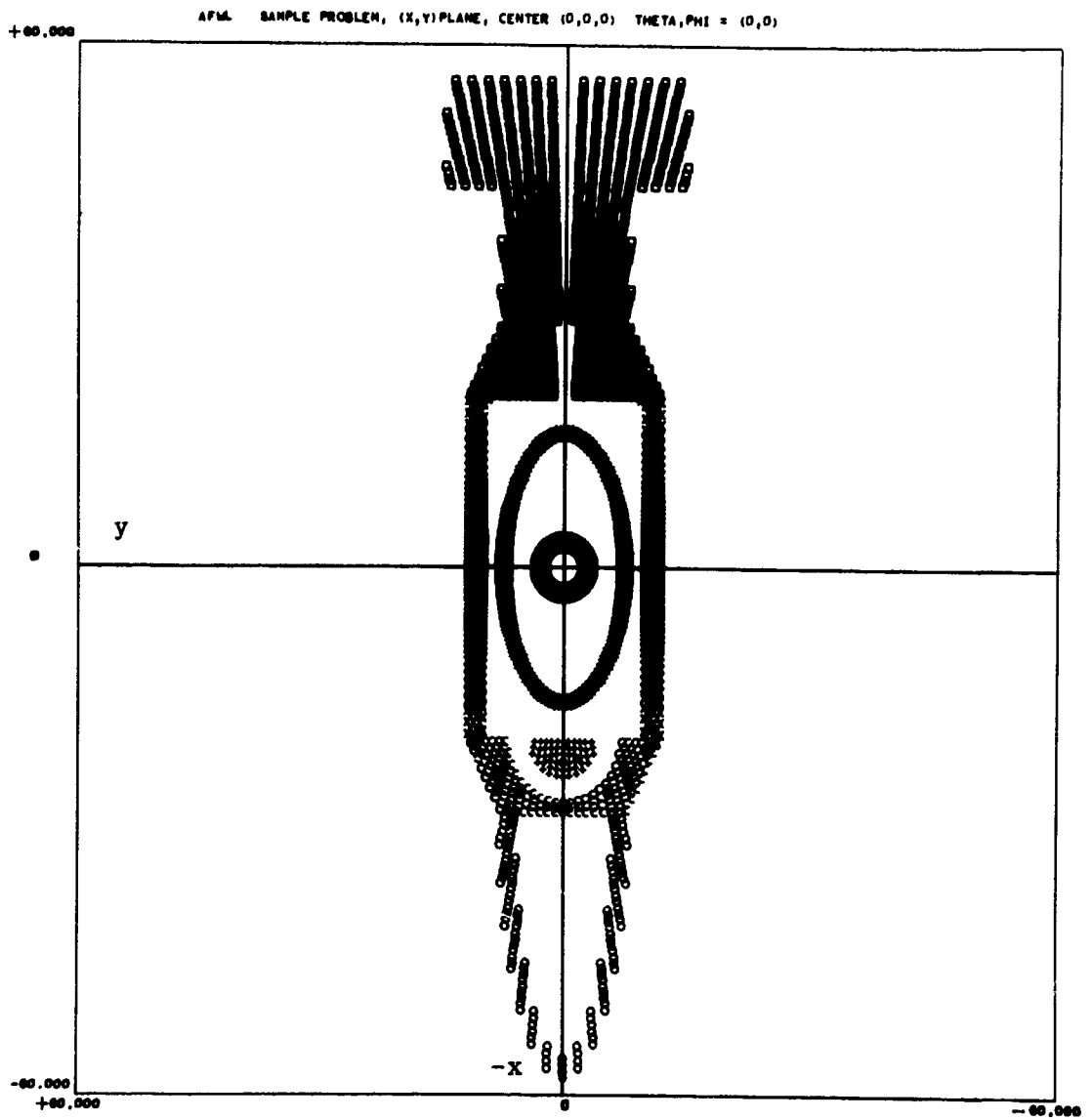

Figure 27. AFWL Sample Problem (x, y) Plane, Center (0, 0, 0)

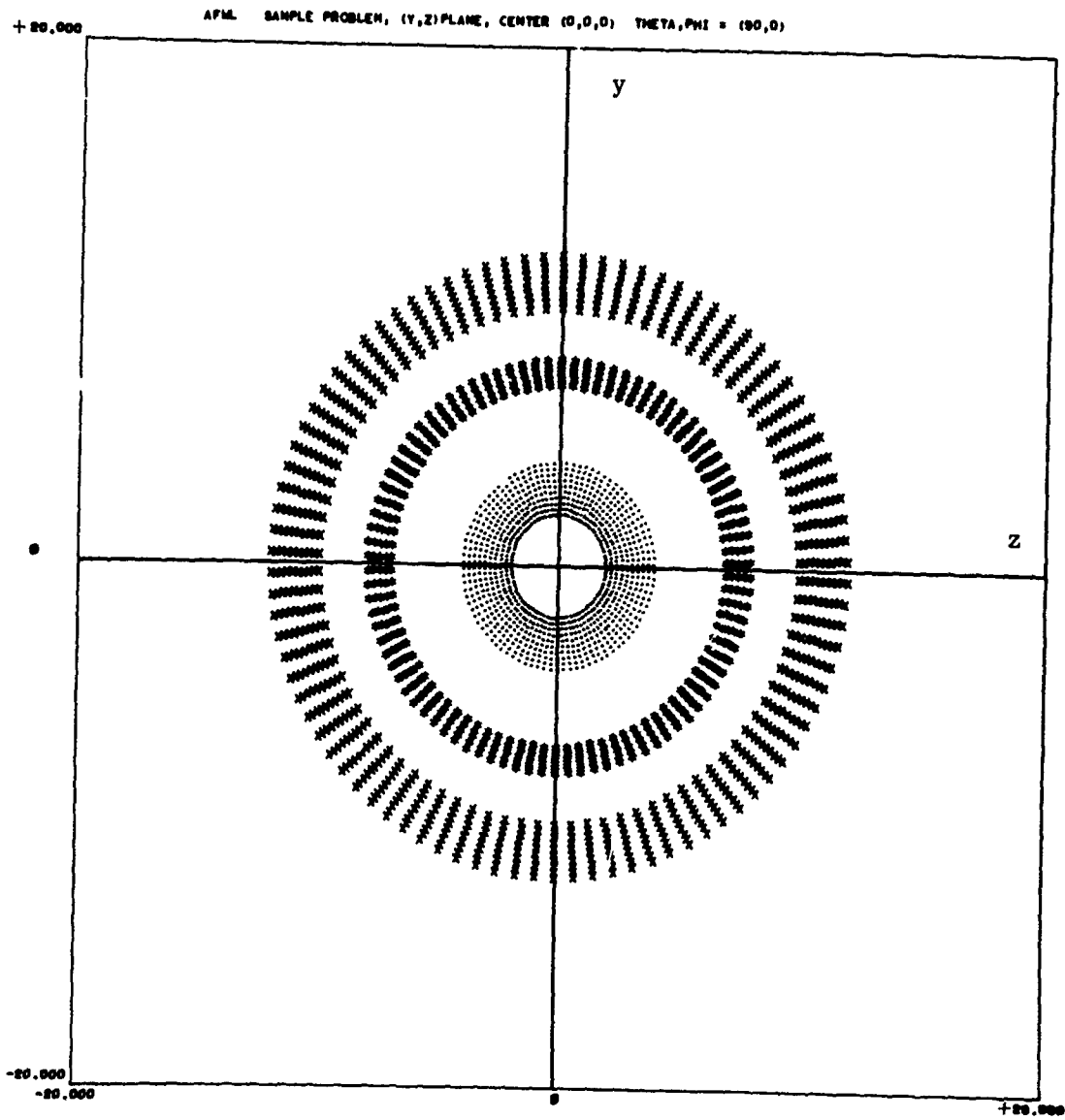

Figure 28. AFWL Sample Problem (y, z) Plane, Center (0, 0, 0)

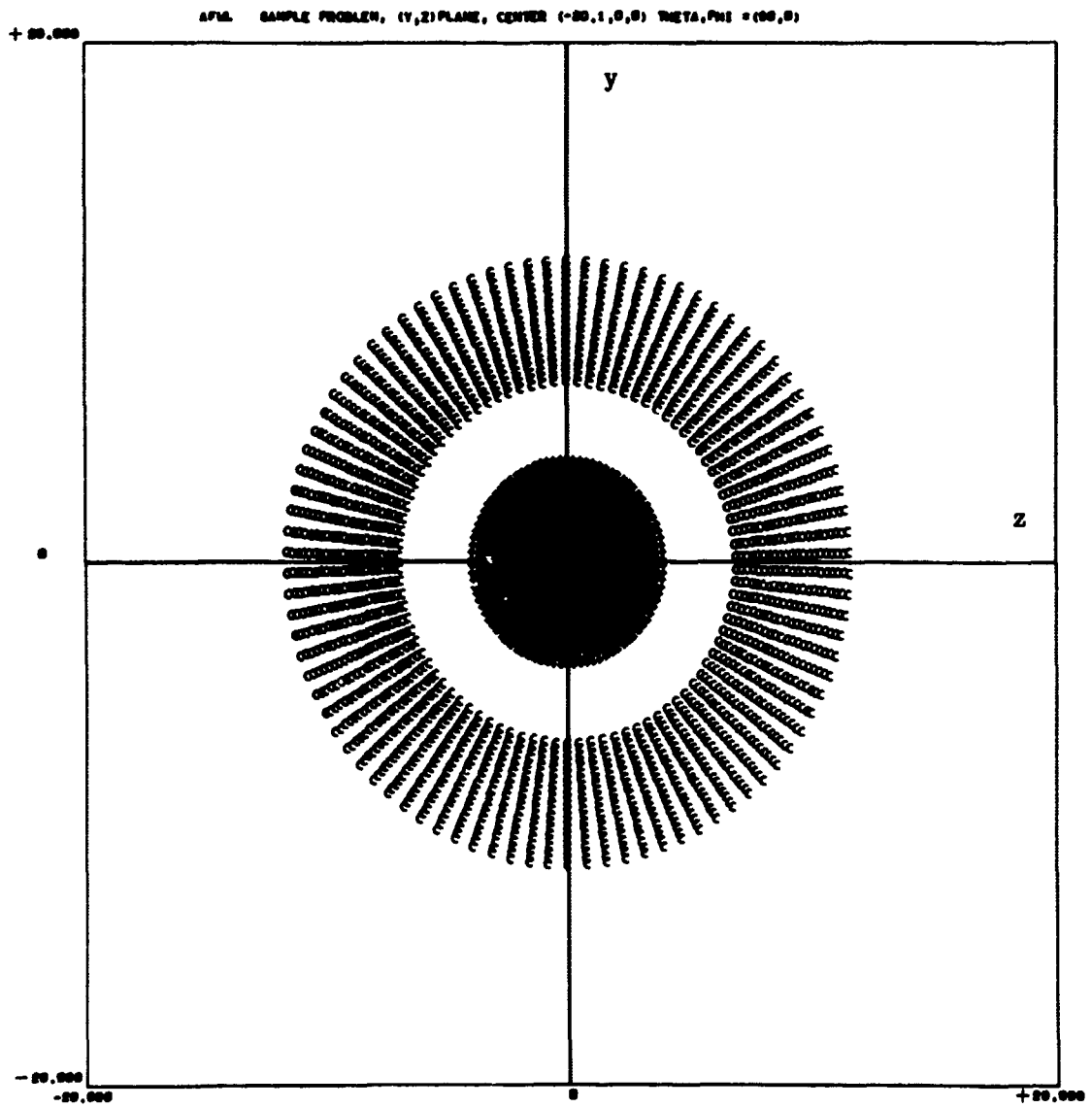

Figure 29. AFWL Sample Problem (y, z) Plane, Center (-20.1, 0, 0)

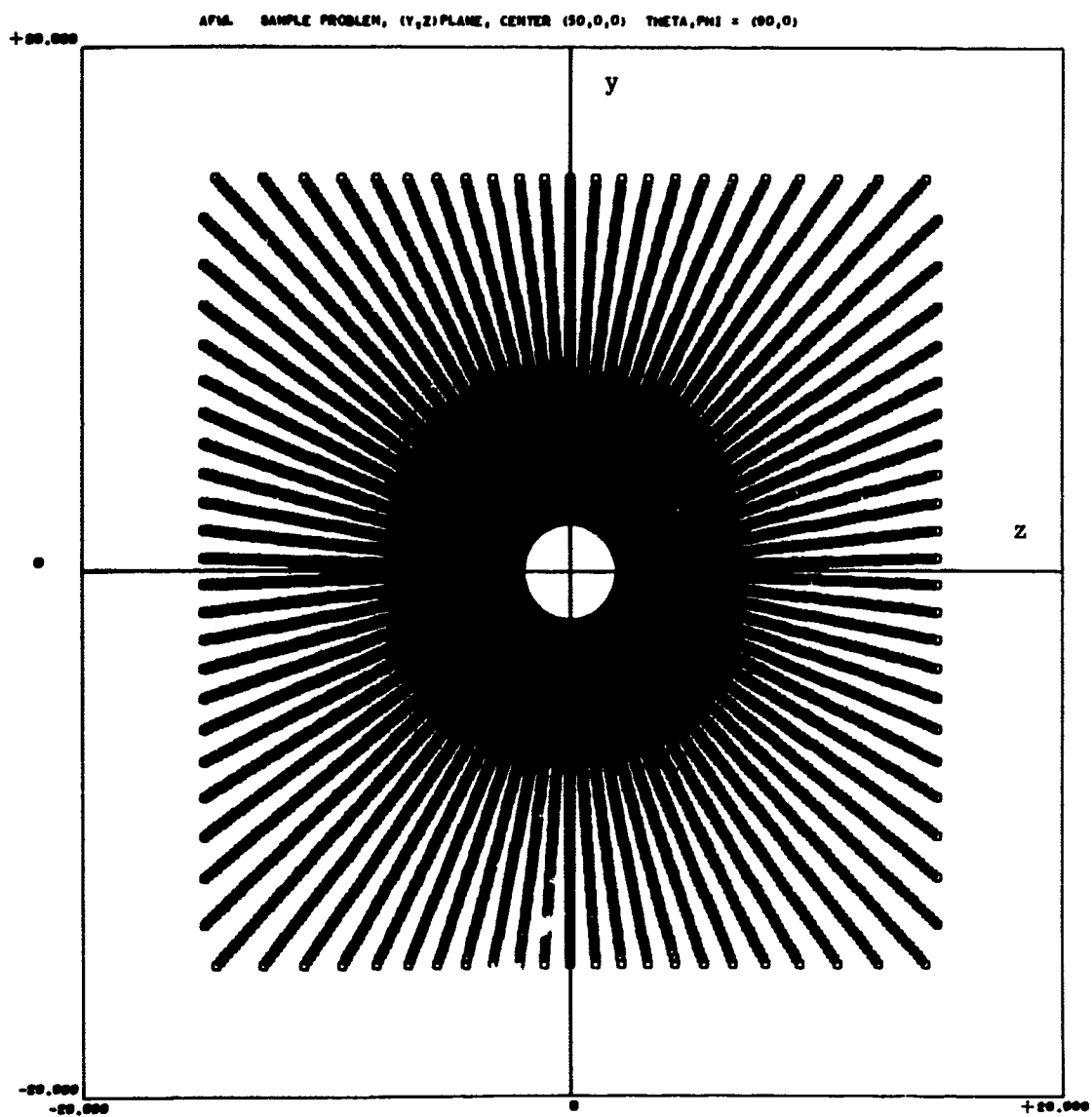

Figure 30. AFWL Sample Problem (y, z) Plane, Center (50, 0, 0)

when the amount of data exceeds the available core space. The variable NMAX is three times the number of path lengths for which the associated data can be sorted in the available core space.

The output data commence with a descriptive title for the input geometrical configuration data which follow. The geometrical data include the record number and associated card image of the input geometry data which are stored on physical tape unit 10. These data correspond to the data format of cards 1.2 and 1.3 in Table VI.

The geometrical configuration data are followed by the card images for the astronaut geometry data. Since NMEN = 0 (see card 1.5b in Table VI), there are no astronauts, and the astronaut geometrical records only include a descriptive output message.

The next output data are the dosimeter coordinates in the ABCS. Because the variable PRNT is unity, the transformed geometry data are printed next (see card 2.2 of Tables VI and IX). These data include (1) the shield serial number, (2) shield geometrical form or type, (3) shield octant location in the RDCS, (4) material type, and (5) the material density in grams per cubic centimeter. The transformed data also include the coordinates (inches) of the defining points of each shield in the RDCS and the rotation matrix which transformed the point coordinates from the DSCS to the RDCS. Other miscellaneous data include the sphere and cone radii, ellipsoid major axes, the cone half-angle in radians and the cone base (RB) and truncation radius (RT). These coordinates and length dimensions have inch units.

The transformed data are followed by a listing of the number of shields in each octant in the RDCS, and the CPU time expended for data transformation in minutes.

A descriptive problem title is printed next, followed by the macroscopic solid angle ϕ (PHI) and θ (THETA) boundaries in degree units in the DSCS. The next section is a listing of the ray number, colatitude and azimuthal angles of each ray direction in the DSCS, and the direction cosines. These data are not printed if NPRT1 = 0 (see card 3.3 of Table VI).

The ray directional data are followed by the number of rays in the particular macroscopic solid-angle increment and the subtended solid angle per ray in steradians.

The next output, comprising three columns, denotes the material range-energy curve fit parameters (see Equation 49) δ (DELTA) and η (ETA),

and the material names. The abbreviation "STD" refers to the standard material, and the subscripted variables refer to the actual materials which are used in the geometrical configuration data cards for the material types. The subscript I refers to the Ith material type.

The material data are followed by detail path-length data for each composite shield if NPRT2 = 1 (see card 3.3 of Table VI). These data include the number of composite shield components, and the serial number, geometrical type, and density (grams per cubic centimeter) for each component; the ray numbers, direction cosines in the DSCS, path-length areal density (XS in grams per square centimeter), and the accumulative areal density for the ray directions. These output data occur only for rays which intercept the composite shield.

The "Track Time" is the CPU time in minutes used to ray trace the elemental volumes.

Next, the total areal density is printed for the standard material for each ray direction. Each row starts with the areal density for the ray number in the left column and corresponds to increasing ray numbers moving from left to right.

The ray areal density is followed by the areal-density curve fit parameters, in Equation 60, i. e.

$$XMAX = T_{MAX}$$

$$TAU = \tau$$

$$DELR = \delta R$$

These are in turn followed by the weighted values of thickness (areal density in grams per square centimeter) computed with Equation 61.

The next set of output data is the computed fraction of solid angle ("Distribution" column) with areal densities less than the corresponding areal densities ("Thickness" column). The fractions of solid-angle values are computed from the standard-material areal densities for each ray and the weighted values of areal density. The column entitled, "Curve Fit Points", is the curve fit of fraction of solid angle i. e., the "Distribution" column. The least-square curve fit is computed with Equation 59. The subsequent three columns of data entitled, "Coefficients" are the values of the C_i constants in Equation 59 where the values of i increase row-wise from left to right. This type of data is repeated for each of the specified number of curve fit sections (see card 3.12 in Table VI), i. e., three for this case.

The CPU times used in subroutines GEOMDS and ESDOSE are printed next.

The output data are concluded with listings of the unsorted and sorted data for each path length of material encountered for each ray. The next line of output data denotes the total number (1604) of path lengths encountered for all the rays and the number (998) of path lengths which can be sorted with the available core space, which normally corresponds to 7,000 path lengths and was changed to 1,000 for this problem.

The next set of data is a listing of the unsorted data, denoting the (1) ray number, (2) path number for the ray, (3) distance to the path length, (4) path length or distance through, and (5) the path-length material number. The unsorted data are followed by a listing of the areal densities sorted according to ray number and distance to the path lengths traversed. The sorted data include the (1) ray number, (2) path-length number for the ray, (3) distance to the path length, (4) path-length areal density, (5) path-length material number, and (6) the material name. The line in the middle of the sorted data, denoting 606 of 1604 path lengths, indicates that the unsorted data tape had to be read a second time because of insufficient core space allocation for sorting all the path lengths. The sorted data follow for the remaining 606 path lengths.

APPENDIX I

MEVDP AFWL SAMPLE PROBLEM
SOLUTION OUTPUT DATA

AFWL SAMPLE PROBLEM FOR THE MEVDP

RECORD NO.	CONTENTS	
1	1010 3 1 12.0	2.699
2	-21.0 0.0	0.0
3	1011 2 1 10.0	20.0
4	-20.0 0.0	19.0
5	1012 0 1	0.0
6	-21.0 13.0	13.0
7	-20.0 13.0	13.0
8	-20.0 -13.0	-13.0
9	-21.0 -13.0	-13.0
10	101310 1 0.78540	
11	19.0 0.0	0.0
12	20.0 0.0	0.0
13	1020 5 2 4.0	8.94
14	0.0 0.0	0.0
15	1021 4 2 2.0	4.0
16	0.0 0.0	2.0
17	103013 3	1.84
18	16.0 0.0	0.0
19	0.0 0.0	8.0
20	103112 3	8.0
21	15.0 0.0	0.0
22	0.0 0.0	7.0
23	1040 9 4 0.45368	7.87
24	20.0 0.0	0.0
25	1041 8 4 0.45368	0.0
26	28.0 0.0	0.0
27	1042 2 1 1.0	0.0
28	20.0 0.0	0.0
29	1050 3 4 8.0	7.87
30	28.0 0.0	0.0
31	1051 1 4	7.87
32	44.0 15.0	15.0
33	56.0 15.0	15.0
34	56.0 -15.0	-15.0
35	44.0 -15.0	-15.0
36	1052 2 1 1.0	0.0
37	20.0 0.0	0.0
38	106013 5	11.35

4 0.0 0.0
 0.0 0.0
 0.0 0.0
 -13.0 13.0
 -13.0 13.0
 -13.0 13.0
 0.0 0.0
 0.0 0.0
 8.94 0.0
 4.0 0.0
 2.0 0.0
 1.84 2
 0.0 0.0
 8.0 0.0
 8.0 0.0
 0.0 7.0
 7.0 0.0
 7.87 3
 0.0 0.0
 0.0 0.0
 0.0 0.0
 0.0 0.0
 7.87 3
 0.0 0.0
 7.87 3
 15.0 -15.0
 15.0 -15.0
 -15.0 15.0
 -15.0 15.0
 0.0 0.0
 7.87 3
 15.0 -15.0
 15.0 -15.0
 -15.0 15.0
 -15.0 15.0
 0.0 0.0
 11.35 2

39	-28.0	0.0	0.0	0.0	8.0	-28.0	8.0	0.0
40	2.0	0.0	0.0	0.0	0.0	-28.0	0.0	0.0
41	-28.0	0.0	0.0	0.0	0.0			
42	106112	5				-5		
43	-28.0	0.0	0.0	6.0	6.0	-28.0	6.0	0.0
44	0.0	0.0	0.0	0.0	0.0	-29.0	0.0	0.0
45	-28.0	0.0	0.0	0.0	0.0			
46	107011	6	0.45368	2.42	2.42		2	0.0
47	-20.0	0.0	0.0	0.0	0.0	-44.0	0.0	0.0
48	-28.0	0.0	0.0	0.0	0.0			
49	1071	6	7.0	0.0	0.0	-27.0	0.0	0.0
50	-20.0	0.0	0.0	0.0	0.0			
51	1080	7	4.0	1.741	1.741		1	
52	-20.0	0.0	0.0	0.0	0.0	-24.0	0.0	0.0

SIMULATED ASTRONAUT GEOMETRY

RECORD NO. CONTENTS

1 ASTRONAUT DESCRIPTION IS NOT USED FOR THIS CASE

DETECTOR POINT COORDINATES

X
 0.0
 Y
 C.0
 Z
 C.0
 SER. NO. 1010 TYPE 3 OCTANT 9 MATERIAL 1 DENSITY C.26989994E 01
 X
 0.0
 0.0
 0.0
 Y
 0.0
 0.0
 Z
 -0.21000000E 02
 0.20000000E 02
 RADIUS = 0.12000000E 02

ROTATION MATRIX - A
 0.0
 0.0
 0.0
 Y
 -0.10000000E 01
 0.0
 0.0
 Z
 0.0
 -0.10000000E 01
 0.0

SER. NO. 1011 TYPE 2 OCTANT 9 MATERIAL 1 DENSITY 0.0
 X
 0.0
 0.0
 Y
 0.0
 0.0
 Z
 -0.20000000E 02
 0.19000000E 02
 RADIUS = 0.10000000E 02

ROTATION MATRIX - A
 0.0
 0.0
 0.0
 Y
 -0.10000000E 01
 0.0
 0.0
 Z
 0.0
 -0.10000000E 01
 0.0

SER. NO. 1012 TYPE 0 OCTANT 9 MATERIAL 1 DENSITY 0.0
 X
 -0.21000000E 02
 -0.21000000E 02
 -0.20000000E 02
 -0.20000000E 02
 -0.20000000E 02
 -0.20000000E 02
 -0.21000000E 02
 -0.21000000E 02
 Y
 0.13000000E 02
 -0.13000000E 02
 0.13000000E 02
 -0.13000000E 02
 0.13000000E 02
 -0.13000000E 02
 0.13000000E 02
 -0.13000000E 02
 Z
 0.13000000E 02
 0.13000000E 02
 0.13000000E 02
 -0.13000000E 02
 -0.13000000E 02
 -0.13000000E 02
 -0.13000000E 02
 -0.13000000E 02
 RADIUS = 0.13000000E 02

SER. NO. 1013 TYPE 10 OCTANT 9 MATERIAL 1 DENSITY 0.0

X Y Z
 0.0 0.0 0.19000000E 02
 0.0 0.0 0.29000000E 02
 0.0 0.0 0.20000000E 02
 PHI = 0.7853997E 00 RB = 0.10000029E 02 RT = 0.90000257E 01

ROTATION MATRIX - A
 0.0 -0.10000000E 01 0.0
 0.0 0.0 -0.10000000E 01
 0.10000000E 01 0.0 0.0

SER. NO. 1020 TYPE 5 OCTANT 9 MATERIAL 2 DENSITY C.893999992E 01

X Y Z
 0.0 0.0 0.0
 0.40000000E 01 0.0 0.0
 RADIUS = 0.40000000E 01

SER. NO. 1021 TYPE 4 OCTANT 9 MATERIAL 2 DENSITY C.0

X Y Z
 0.0 0.0 0.0
 0.20000000E 01 0.0 0.0
 RADIUS = 0.20000000E 01

SER. NO. 1030 TYPE 13 OCTANT 9 MATERIAL 3 DENSITY C.183999992E 01

X Y Z
 0.16000000E 02 0.0 0.0
 0.0 0.80000000E 01 0.0
 0.0 0.0 0.80000000E 01
 0.0 0.0 0.0

ROTATION MATRIX - A
 0.10000000E 01 0.0 0.0
 0.0 0.10000000E 01 0.0
 0.0 0.0 0.10000000E 01

LENGTH OF ELLIPSOID AXES
 0.16000000E 02 0.80000000E 01 0.80000000E 01

SER. NO. 1031 TYPE 12 OCTANT 9 MATERIAL 3 DENSITY C.0

	X	Y	Z
0.15000000E 02	0.0	0.0	0.0
0.0	0.70000000E 01	0.0	0.0
0.0	0.0	0.70000000E 01	0.0
0.0	0.0	0.0	0.0

ROTATION MATRIX - A

0.10000000E 01	0.0	0.0
0.0	0.10000000E 01	0.0
0.0	0.0	0.10000000E 01

LENGTH OF ELLIPSOID AXES

0.15000000E 02 0.70000000E 01 0.70000000E 01

SER. NO. 1040 TYPE 9 OCTANT 9 MATERIAL 4 DENSITY 0.78699999E 01

	X	Y	Z
0.0	0.0	0.0	0.20000000E 02
0.0	0.0	0.0	0.44000000E 02

PHI = 0.45367998E 00 RADIUS = 0.11702441E 02

ROTATION MATRIX - A

0.0	-0.10000000E 01	0.0
0.0	0.0	-0.10000000E 01
0.10000000E 01	0.0	0.0

SER. NO. 1041 TYPE 8 OCTANT 9 MATERIAL 4 DENSITY 0.0

	X	Y	Z
0.0	0.0	0.0	0.28000000E 02
0.0	0.0	0.0	0.44000000E 02

PHI = 0.45367998E 00 RADIUS = 0.78016272E 01

ROTATION MATRIX - A

0.0	-0.10000000E 01	0.0
0.0	0.0	-0.10000000E 01
0.10000000E 01	0.0	0.0

SER. NO. 1042 TYPE 2 OCTANT 9 MATERIAL 1 DENSITY 0.0

	X	Y	Z
0.0	0.0	0.0	0.20000000E 02
0.0	0.0	0.0	0.56000000E 02

RADIUS = 0.1000000E 01

ROTATION MATRIX - A

0.0
0.0
0.1000000E 01 0.0 0.0
-0.1000000E 01 0.0
0.0

SER. NO. 1050 TYPE 3 OCTANT 9 MATERIAL 4 DENSITY 0.78699999E C1

X Y Z

0.0 0.0 0.2800000E 02
0.0 0.0 0.4400000E 02

RADIUS = 0.8000000E 01

ROTATION MATRIX - A

0.0
0.0
0.1000000E 01 0.0 0.0
-0.1000000E 01 0.0

SER. NO. 1051 TYPE 1 OCTANT 9 MATERIAL 4 DENSITY C.78699999E C1

X Y Z

0.4400000E 02 0.1500000E 02 0.1500000E 02
0.4400000E 02 -0.1500000E 02 0.1500000E 02
0.5600000E 02 0.1500000E 02 0.1500000E 02
0.5600000E 02 -0.1500000E 02 0.1500000E 02
0.5600000E 02 -0.1500000E 02 -0.1500000E 02
0.4400000E 02 -0.1500000E 02 -0.1500000E 02
0.4400000E 02 0.1500000E 02 -0.1500000E 02

SER. NO. 1052 TYPE 2 OCTANT 9 MATERIAL 1 DENSITY 0.0

X Y Z

0.0 0.0 0.2000000E 02
0.0 0.0 0.5600000E 02

RADIUS = 0.1000000E 01

ROTATION MATRIX - A

0.0
0.0
0.1000000E 01 0.0 0.0
-0.1000000E 01 0.0

SER. NO. 1060 TYPE 13 OCTANT 9 MATERIAL 5 DENSITY C.11349999E C2

	X	Y	Z
0.8000000E 01	0.0	0.8000000E 01	-0.2800000E 02
0.0	0.8000000E 01	0.0	-0.2800000E 02
0.0	0.0	0.2000000E 01	0.2000000E 01
0.0	0.0	-0.2800000E 02	-0.2800000E 02
0.0	0.0	0.0	-0.2800000E 02

ROTATION MATRIX - A

0.0	0.0	0.1000000E 01
0.0	0.1000000E 01	0.0
0.1000000E 01	0.0	0.0

LENGTH OF ELLIPSOID AXES

0.8000000E 01 0.8000000E 01 0.3000000E 02

SER. NO. 1061 TYPE 12 OCTANT 9 MATERIAL 5 DENSITY C.0

	X	Y	Z
0.6000000E 01	0.0	0.6000000E 01	-0.2800000E 02
0.0	0.6000000E 01	0.0	-0.2800000E 02
0.0	0.0	0.0	0.0
0.0	0.0	0.0	-0.2800000E 02
0.0	0.0	0.0	-0.2800000E 02

ROTATION MATRIX - A

0.0	0.0	0.1000000E 01
0.0	0.1000000E 01	0.0
0.1000000E 01	0.0	0.0

LENGTH OF ELLIPSOID AXES

0.6000000E 01 0.6000000E 01 0.2800000E 02

SER. NO. 1070 TYPE 11 OCTANT 9 MATERIAL 6 DENSITY 0.2419999E C1

	X	Y	Z
0.0	0.0	0.0	0.2000000E 02
0.0	0.0	0.0	0.4400000E 02
0.0	0.0	0.0	0.2800000E 02

PHI = 0.45367998E 00 RB = 0.11702440E 02 RT = 0.78016272E C1

ROTATION MATRIX - A

0.0 0.1000000E 01 0.0
 0.0 -0.1000000E 01
 -0.1000000E 01 0.0 0.0

SER. NO. 1071 TYPE 6 OCTANT 9 MATERIAL 6 DENSITY C.0

X Y Z
 0.0 0.0 0.2000000E 02
 0.0 0.0 0.2700000E 02
 RADIUS = 0.7000000E 01

ROTATION MATRIX - A
 0.0 0.1000000E 01 0.0
 0.0 0.0 -0.1000000E 01
 -0.1000000E 01 0.0 0.0

SER. NO. 1080 TYPE 7 OCTANT 9 MATERIAL 7 DENSITY 0.174C9992E C1

X Y Z
 0.0 0.0 0.2000000E 02
 0.0 0.0 0.2400000E 02
 RADIUS = 0.4000000E 01

ROTATION MATRIX - A
 0.0 0.1000000E 01 0.0
 0.0 0.0 -0.1000000E 01
 -0.1000000E 01 0.0 0.0

NO. VOLUMES OF SPACECRAFT = 19 DESCRIBING ASTRONAUTS = 0

NO. SHIELDS IN OCTANT

0	1
0	2
0	3
0	4
0	5
0	6
0	7
0	8
19	9

TRANSFORMATION TIME= 0.06 MIN

AFWL SAMPLE PROBLEM FOR THE MEVDP - DOSIMETER COORDINATES (C,C,O)

MACROSCOPIC SOLID ANGLE 1
 PHI 0.0 C.36000000E 03 AND THETA 9.0 0.18000000E 03

RAY DIRECTION COSINES
 SYSTEMATIC SELECTION FROM CENTER OF EQUAL SOLID ANGLES

	THETA (DEG)	PHI (DEG)	COS (ALPHA)	COS (BETA)	COS (GAMMA)
1	0.14477510E 02	0.56249981E 01	0.24879611E 00	0.24504252E-01	0.96824592E 00
2	0.14477510E 02	0.16874985E 02	0.23923504E 00	0.72571099E-01	0.96824592E 00
3	0.14477510E 02	0.28124985E 02	0.22048026E 00	0.11784911E 00	0.96824592E 00
4	0.14477510E 02	0.39374969E 02	0.19325262E 00	0.15859818E 00	0.96824592E 00
5	0.14477510E 02	0.50624969E 02	0.15859830E 00	0.19325250E 00	0.96824592E 00
6	0.14477510E 02	0.61874939E 02	0.11784929E 00	0.22048014E 00	0.96824592E 00
7	0.14477510E 02	0.73124924E 02	0.72571397E-01	0.23923492E 00	0.96824592E 00
8	0.14477510E 02	0.84374954E 02	0.24504416E-01	0.24879611E 00	0.96824592E 00
9	0.14477510E 02	0.95624924E 02	-0.24504013E-01	0.24879616E 00	0.96824592E 00
10	0.14477510E 02	0.10687495E 03	-0.72570980E-01	0.23923504E 00	0.96824592E 00
11	0.14477510E 02	0.11812494E 03	-0.11784893E 00	0.22048032E 00	0.96824592E 00
12	0.14477510E 02	0.12937491E 03	-0.15859801E 00	0.19325274E 00	0.96824592E 00
13	0.14477510E 02	0.14062494E 03	-0.19325244E 00	0.15859836E 00	0.96824592E 00
14	0.14477510E 02	0.15187492E 03	-0.22048014E 00	0.11784935E 00	0.96824592E 00
15	0.14477510E 02	0.16312495E 03	-0.23923498E 00	0.72571218E-01	0.96824592E 00
16	0.14477510E 02	0.17437492E 03	-0.24879611E 00	0.24504505E-01	0.96824592E 00
17	0.14477510E 02	0.18562491E 03	-0.24879616E 00	-0.24503939E-01	0.96824592E 00
18	0.14477510E 02	0.19687494E 03	-0.23923510E 00	-0.72570920E-01	0.96824592E 00
19	0.14477510E 02	0.20812491E 03	-0.22048038E 00	-0.11784887E 00	0.96824592E 00
20	0.14477510E 02	0.21937495E 03	-0.19325262E 00	-0.15859812E 00	0.96824592E 00
21	0.14477510E 02	0.23062492E 03	-0.15859842E 00	-0.19325238E 00	0.96824592E 00
22	0.14477510E 02	0.24187489E 03	-0.11784941E 00	-0.22048008E 00	0.96824592E 00
23	0.14477510E 02	0.25312492E 03	-0.72571337E-01	-0.23923498E 00	0.96824592E 00
24	0.14477510E 02	0.26437476E 03	-0.24504580E-01	-0.24879611E 00	0.96824592E 00
25	0.14477510E 02	0.27562476E 03	0.24504088E-01	-0.24879611E 00	0.96824592E 00
26	0.14477510E 02	0.28687476E 03	0.72570860E-01	-0.23923510E 00	0.96824592E 00
27	0.14477510E 02	0.29812476E 03	0.11784881E 00	-0.22048044E 00	0.96824592E 00
28	0.14477510E 02	0.30937476E 03	0.15859807E 00	-0.19325268E 00	0.96824592E 00
29	0.14477510E 02	0.32062476E 03	0.19325233E 00	-0.15859848E 00	0.96824592E 00
30	0.14477510E 02	0.33187476E 03	0.22048014E 00	-0.11784929E 00	0.96824592E 00
31	0.14477510E 02	0.34312476E 03	0.23923492E 00	-0.72571397E-01	0.96824592E 00
32	0.14477510E 02	0.35437476E 03	0.24879611E 00	-0.24504416E-01	0.96824592E 00

(PART OF THESE DATA ARE OMITTED)

506	0.16552246E 03	0.28687476E 03	0.72570920E-01	-0.23923534E 00	-0.96824586E 00
507	0.16552246E 03	0.29812476E 03	0.11784887E 00	-0.22048062E 00	-0.96824586E 00
508	0.16552246E 03	0.30937476E 03	0.15859824E 00	-0.19325286E 00	-0.96824586E 00
509	0.16552246E 03	0.32062476E 03	0.19325250E 00	-0.15859866E 00	-0.96824586E 00
510	0.16552246E 03	0.33187476E 03	0.22048038E 00	-0.11784941E 00	-0.96824586E 00
511	0.16552246E 03	0.34312476E 03	0.23923516E 00	-0.72571456E-01	-0.96824586E 00
512	0.16552246E 03	0.35437476E 03	0.24879634E 00	-0.24504438E-01	-0.96824586E 00

NO. SOLID ANGLES IN ELEMENT SUBTENDED SOLID ANGLE PER RAY
512 0.24543688E-01

DELTA STD = 0.30299998E-02	ETA STD = 0.17509995E 01	ALUMINUM	20-300MEV-PROTONS
DELTA(1)= 0.30299998E-02	ETA(1)= 0.17509995E 01	ALUMINUM	
DELTA(2)= 0.41329972E-02	ETA(2)= 0.17259998E 01	COPPER	
DELTA(3)= 0.25459998E-02	ETA(3)= 0.17749996E 01	BERYLLIUM	
DELTA(4)= 0.36829999E-02	ETA(4)= 0.17349997E 01	IRON	
DELTA(5)= 0.73279999E-02	ETA(5)= 0.16799994E 01	LEAD	
DELTA(6)= 0.29269999E-02	ETA(6)= 0.17509995E 01	SILICON	
DELTA(7)= 0.29300000E-02	ETA(7)= 0.17509995E 01	MAGNESIUM	

NO. COMPONENTS = 4
SHIELD SERIAL NO.

NO.	TYPE	DENSITY
1010	3	0.26989994E 01
1011	2	0.0
1012	0	0.0
1013	10	0.0

RAY NO.	COS (ALPHA)	COS (BETA)	COS (GAMMA)	XS	ACCUM THICKNESS
1	0.24979611E 00	0.24504252E-01	0.96824592E 00	0.14156064E 02	0.14156064E 02
2	0.23923504E 00	0.72571099E-01	0.96824592E 00	0.14120982E 02	0.14120982E 02
3	0.22048026E 00	0.11784911E 00	0.96824592E 00	0.14056867E 02	0.14056867E 02
4	0.19325262E 00	0.15859818E 00	0.96824592E 00	0.13974370E 02	0.13974370E 02
5	0.15859830E 00	0.19325250E 00	0.96824592E 00	0.13886702E 02	0.13886702E 02
6	0.11784929E 00	0.22048014E 00	0.96824592E 00	0.13807199E 02	0.13807199E 02
7	0.72571397E-01	0.23923492E 00	0.96824592E 00	0.13747215E 02	0.13747215E 02
8	0.24504416E-01	0.24879611E 00	0.96824592E 00	0.13715093E 02	0.13715093E 02
9	-0.24504013E-01	0.24879616E 00	0.96824592E 00	0.13715093E 02	0.13715093E 02
10	-0.72570980E-01	0.23923504E 00	0.96824592E 00	0.13747215E 02	0.13747215E 02
11	-0.11784893E 00	0.22048032E 00	0.96824592E 00	0.13807129E 02	0.13807129E 02

(PART OF THESE DATA ARE OMITTED)

NO. COMPONENTS = 2
 SHIELD SERIAL NO.
 1070
 1071

TYPE DENSITY
 11 0.24199991E 01
 6 0.0

RAY NO.	COS (ALPHA)	COS (BETA)	COS (GAMMA)	XS	ACCUM THICKNES
144	-0.89437342E 00	0.8808870E-01	C.43856198E 00	0.12236762E 02	0.56426910E 02
145	-0.89437366E 00	-0.88085843E-01	0.43856198E 00	0.12234324E 02	0.56424377E 02
175	-0.90880054E 00	0.27568209E 00	0.31317937E 00	0.18643677E 02	C.62767395E 02
176	-0.94512099E 00	0.93087137E-01	0.31317937E 00	0.37090958E 02	C.81064880E 02
177	-0.94512117E 00	-0.93084991E-01	0.31317937E 00	0.37090179E 02	C.81064133E 02
178	-0.90880084E 00	-0.27568090E 00	0.31317937E 00	0.18642532E 02	0.62766251E 02
206	-0.86621523E 00	0.46300286E 00	0.18788189E 00	0.11419144E 01	0.66374924E 02
207	-0.93989879E 00	0.28511566E 00	C.18788189E 00	C.35300049E 02	C.79307312E 02
208	-0.97746205E 00	0.96272469E-01	0.18788189E 00	0.22354279E 02	C.21282291E 03
209	-0.97746229E 00	-0.96270263E-01	0.18788189E 00	0.22354279E 02	0.21282585E 03
210	-0.93989915E 00	-0.28511441E 00	C.18788189E 00	0.35300446E 02	0.79307709E 02
211	-0.86621630E 00	-0.46300089E 00	C.18788189E 00	0.11427174E 01	0.66375046E 02
238	-0.88018984E 00	0.47047246E 00	0.62623382E-01	0.64612846E 01	0.61943726E 02
239	-0.95506203E 00	0.28971541E 00	0.62623382E-01	0.33904205E 02	0.77799469E 02
240	-0.99323136E 00	0.97825646E-01	0.62623382E-01	0.10963085E 02	0.16078584E 03
241	-0.99323159E 00	-0.97823381E-01	0.62623382E-01	0.10963012E 02	0.16078455E 03
242	-0.95506239E 00	-0.28971416E 00	0.62623382E-01	0.33903915E 02	0.77799210E 02
243	-0.88019091E 00	-0.47047043E 00	0.62623382E-01	0.64617777E 01	0.61943558E 02
270	-0.88018978E 00	0.47047240E 00	-0.62623620E-01	0.64612846E 01	C.61943756E 02
271	-0.95506197E 00	0.28971535E 00	-0.62623620E-01	0.33904205E 02	C.77799469E 02
272	-0.99323130E 00	0.97825646E-01	-0.62623620E-01	0.10963085E 02	0.16078609E 03
273	-0.99323153E 00	-0.97823381E-01	-0.62623620E-01	0.10963012E 02	C.16078455E 03
274	-0.95506233E 00	-0.28971410E 00	-0.62623620E-01	0.33903915E 02	C.77799179E 02
275	-0.88019085E 00	-0.47047037E 00	-0.62623620E-01	0.64619751E 01	0.61943680E 02
302	-0.86621535E 00	0.46300292E 00	-0.18788123E 00	0.11418381E 01	C.66374725E 02
303	-0.93989891E 00	0.28511566E 00	-0.18788123E 00	0.35300247E 02	0.79307480E 02
304	-0.97746217E 00	0.96272469E-01	-0.18788123E 00	0.22354279E 02	C.21282439E 03
305	-0.97746241E 00	-0.96270263E-01	-0.18788123E 00	0.22354279E 02	C.21282736E 03
306	-0.93989921E 00	-0.28511447E 00	-0.18788123E 00	0.35300446E 02	C.79307678E 02
307	-0.86621642E 00	-0.46300095E 00	-0.18788123E 00	0.11427174E 01	0.66374939E 02
335	-0.90880042E 00	0.27568203E 00	-0.31317967E 00	0.18643173E 02	0.62766891E 02
336	-0.94512087E 00	0.93087137E-01	-0.31317967E 00	0.37090866E 02	0.81064758E 02
337	-0.94512105E 00	-0.93084991E-01	-0.31317967E 00	0.37090073E 02	0.81064026E 02
338	-0.90880072E 00	-0.27568084E 00	-0.31317967E 00	0.18641541E 02	C.62765259E 02
368	-0.89437330E 00	0.88088970E-01	-0.43856221E 00	C.1223696CE 02	C.56427231E 02

369 -0.89437354E 00 -0.88086843E-01 -0.43856221E 00 0.12234627E 02 C.56424774E 02

ND. COMPONENTS = 1
SHIELD SERIAL NO. 1080

TYPE 7 DENSITY 0.1740992E 01

RAY NO.	COS (ALPHA)	COS (BETA)	COS (GAMMA)	XS	ACCUM THICKNESS
240	-0.99323136E 00	0.97825646E-01	0.62623382E-01	0.13648740E 02	C.17443457E 03
241	-0.99323159E 00	-0.97823381E-01	0.62623382E-01	0.13648835E 02	0.17443338E 03
272	-0.99323130E 00	0.97825646E-01	-0.62623620E-01	0.13648740E 02	0.17443481E 03
273	-0.99323153E 00	-0.97823381E-01	-0.62623620E-01	0.13648740E 02	0.17443327E 03

TRACK TIME = 0.42 MIN

512 AREAL DENSITY FUNCTIONS (GM/SQ.CM.)

1	0.57360992E 02	0.57319626E 02	0.57243927E 02	0.57146408E 02	0.57042587E 02	0.56948273E 02
7	0.56877029E 02	0.56838806E 02	0.56838806E 02	0.56877029E 02	0.56948212E 02	0.57042587E 02
13	0.57146408E 02	0.57243927E 02	0.57319626E 02	0.57360992E 02	0.57360992E 02	0.57319626E 02
19	0.57243927E 02	0.57146408E 02	0.57042587E 02	0.56948273E 02	0.56877029E 02	0.56838806E 02
25	0.56838806E 02	0.56877029E 02	0.56948212E 02	0.57042587E 02	0.57146408E 02	0.57243927E 02
31	0.57319626E 02	0.57360992E 02	0.57243927E 02	0.57360992E 02	0.57360992E 02	0.57319626E 02
37	0.58034042E 02	0.57467468E 02	0.57066513E 02	0.56859970E 02	0.56859970E 02	0.57066513E 02
43	0.57467468E 02	0.58034042E 02	0.58710312E 02	0.59404480E 02	0.59989288E 02	0.50327942E 02
49	0.60327942E 02	0.59989288E 02	0.59404480E 02	0.58710312E 02	0.58034042E 02	0.57467468E 02
55	0.57066513E 02	0.56860016E 02	0.56859970E 02	0.57066513E 02	0.57467468E 02	0.58034042E 02
61	0.58710342E 02	0.59404480E 02	0.59989288E 02	0.60327942E 02	0.62834396E 02	0.62834396E 02
67	0.61525497E 02	0.60110062E 02	0.58848587E 02	0.57865738E 02	0.57205002E 02	0.56875046E 02
73	0.56875046E 02	0.57204956E 02	0.57865814E 02	0.58848648E 02	0.60110062E 02	0.61525452E 02
79	0.62834427E 02	0.63651428E 02	0.63651382E 02	0.62834457E 02	0.61525452E 02	0.60110031E 02
85	0.58848648E 02	0.57865738E 02	0.57205002E 02	0.56875046E 02	0.56875046E 02	0.57205032E 02
91	0.57865814E 02	0.58848587E 02	0.60110062E 02	0.61525528E 02	0.62834396E 02	0.63651428E 02
97	0.68153168E 02	0.66405685E 02	0.63909378E 02	0.61525192E 02	0.59605240E 02	0.58213776E 02
103	0.57321579E 02	0.56887589E 02	0.56887543E 02	0.521503E 02	0.58213837E 02	0.59605209E 02
109	0.61525192E 02	0.63909378E 02	0.66405685E 02	0.68153198E 02	0.68153198E 02	0.66405655E 02
115	0.63909470E 02	0.61525223E 02	0.59605301E 02	0.58213776E 02	0.57321609E 02	0.56887558E 02
121	0.56887589E 02	0.57321533E 02	0.58213806E 02	0.59605209E 02	0.61525238E 02	0.63909332E 02
127	0.66405655E 02	0.68153168E 02	0.83711075E 02	0.69227066E 02	0.66526535E 02	0.62893219E 02
133	0.60275757E 02	0.58505600E 02	0.57416031E 02	0.56897476E 02	0.56897476E 02	0.57416077E 02
139	0.58505524E 02	0.60275711E 02	0.62893188E 02	0.66526489E 02	0.69227066E 02	0.56426910E 02

145	0.56424377E 02	0.69226807E 02	0.66526611F 02	0.62893219E 02	0.60275772E 02	0.58505524E 02
151	0.57416031E 02	0.56897476F 02	0.56897476E 02	0.57416077E 02	0.59505478E 02	0.50275589E 02
157	0.62893265E 02	0.66526581F 02	0.69227112E 02	0.83703125E 02	0.17797511F 03	0.97742844E 02
163	0.69213943E 02	0.64109558E 02	0.60824051E 02	0.58732895E 02	0.57487732E 02	0.56904999E 02
169	0.56904999E 02	0.57487732E 02	0.58732895E 02	0.60823959E 02	0.64109467E 02	0.69213974E 02
175	0.62767395E 02	0.81064880E 02	0.81064133E 02	0.62766251E 02	0.69213913E 02	0.64109451E 02
181	0.60824020E 02	0.58732925E 02	0.57487732E 02	0.56904999E 02	0.56904999E 02	0.57487762E 02
187	0.58732864E 02	0.60824020E 02	0.64109497E 02	0.69213989E 02	0.97738846E 02	0.17797514E 03
193	0.58392212E 03	0.24922832E 03	0.68377274E 02	0.65039322E 02	0.61214508E 02	0.58888870E 02
199	0.57535995E 02	0.56909988E 02	0.56909988E 02	0.57535873E 02	0.58888824E 02	0.61214508E 02
205	0.65039215E 02	0.66374924E 02	0.79307312E 02	0.21282291E 03	0.21282291E 03	0.79307709E 02
211	0.66375046E 02	0.65039276E 02	0.61214584E 02	0.5888916E 02	0.57535995E 02	0.56909927E 02
217	0.56909988E 02	0.57535873E 02	0.5888885E 02	0.61214554E 02	0.65039215E 02	0.68378418E 02
223	0.24922282E 03	0.58392139E 03	0.70379834E 03	0.27783325E 03	0.73561172E 02	0.65547729E 02
229	0.61418015E 02	0.58968246E 02	0.57560165E 02	0.56912399E 02	0.56912399E 02	0.57560165E 02
235	0.58968246E 02	0.61417984E 02	0.65547699E 02	0.61943726E 02	0.77799469E 02	0.17443457E 03
241	0.17443338E 03	0.77799210E 02	0.61943558E 02	0.65547729E 02	0.61418045E 02	0.58968246E 02
247	0.57560135E 02	0.56912476F 02	0.56912369E 02	0.57560165E 02	0.58968201E 02	0.61417984E 02
253	0.65547699F 02	0.73562653E 02	0.27782886E 03	0.70379834E 03	0.70379834E 03	0.27783350E 03
259	0.73561707E 02	0.65547729E 02	0.61418015E 02	0.58968170E 02	0.57560165E 02	0.56912476E 02
265	0.56912369E 02	0.57560181E 02	0.58968246E 02	0.61417984E 02	0.65547699E 02	0.61943756E 02
271	0.77799469E 02	0.17443481E 03	0.17443327E 03	0.77799179E 02	0.61943680E 02	0.65547729E 02
277	0.61418076E 02	0.58968246E 02	0.57560165E 02	0.56912476E 02	0.56912369E 02	0.57560165E 02
283	0.58968246E 02	0.61418045E 02	0.65547668E 02	0.73563202E 02	0.27782910E 03	0.70379834E 03
289	0.58392383E 03	0.24922801E 03	0.68378632E 02	0.65039246E 02	0.61214523E 02	0.58888870E 02
295	0.57535995E 02	0.56909988E 02	0.56909988E 02	0.57535873E 02	0.58888794E 02	0.61214554E 02
301	0.65039215E 02	0.66374725E 02	0.79307480E 02	0.21282439E 03	0.21282736E 03	0.79307678E 02
307	0.66374939E 02	0.65039276E 02	0.61214584E 02	0.5888947E 02	0.57535995E 02	0.56909927E 02
313	0.56909988E 02	0.57535934E 02	0.5888916E 02	0.61214554E 02	0.65039276E 02	0.68377762E 02
319	0.24922305E 03	0.58392310E 03	0.17797401E 03	0.97741394E 02	0.69213898E 02	0.64109558E 02
325	0.60824051E 02	0.58732864E 02	0.57487732E 02	0.56904999E 02	0.56904999E 02	0.57487686E 02
331	0.58732971E 02	0.60823975E 02	0.64109467E 02	0.69213974E 02	0.62766891E 02	0.81064753E 02
337	0.81064026E 02	0.62765259E 02	0.69213959E 02	0.64109558E 02	0.60824020E 02	0.58732925E 02
343	0.57487732E 02	0.56904999E 02	0.56904999E 02	0.57487732E 02	0.58732895E 02	0.60824051E 02
349	0.64109497E 02	0.69213867E 02	0.97743469E 02	0.17797377E 03	0.83711838E 02	0.69227066E 02
355	0.66526505E 02	0.62893219E 02	0.60275696E 02	0.58505554E 02	0.56897507E 02	0.56897507E 02
361	0.56897476E 02	0.57416077E 02	0.58505524E 02	0.60275681E 02	0.62893219E 02	0.66526611F 02
367	0.69227112E 02	0.56427231E 02	0.5642474E 02	0.69226913E 02	0.66526581E 02	0.62893250E 02
373	0.60275772E 02	0.58505524E 02	0.57416000E 02	0.56897476E 02	0.55897476E 02	0.57416077E 02
379	0.58505463E 02	0.60275589E 02	0.52893219E 02	0.66526459E 02	0.69227264E 02	0.83706284E 02
385	0.68153244E 02	0.66405746E 02	0.63909363E 02	0.61525299E 02	0.59605270E 02	0.58213776E 02
391	0.57321503E 02	0.56887558F 02	0.56887543E 02	0.57321533E 02	0.58213806E 02	0.59605209E 02
397	0.61525238E 02	0.63909378E 02	0.66405685E 02	0.68153244E 02	0.68153244E 02	0.66405585E 02

403	0.63909378E 02	0.61525299E 02	C.59605301E 02	0.58213898E 02	0.57321503E 02	0.56897553E 02
409	0.56887589E 02	0.57321533F 02	C.58213806E 02	0.59805770E 02	0.61525192E 02	0.63909500E 02
415	0.66405685E 02	0.68153244E 02	C.63651550E 02	C.62834427E 02	C.61525391E 02	0.60110062E 02
421	0.59848648E 02	0.57865738E 02	0.57205002E 02	0.56875046E 02	C.56875046E 02	0.57204956E 02
427	0.57865723E 02	0.58848587E 02	0.60110062E 02	0.61525482E 02	C.62834488E 02	0.63651459E 02
433	0.63651382E 02	0.62834427E 02	0.61525452E 02	0.60110107E 02	C.58848649E 02	0.57865738E 02
439	0.57205002E 02	0.56875046E 02	0.56875046E 02	0.57204956E 02	C.57865814E 02	0.58848587E 02
445	0.60110062E 02	0.61525452E 02	0.62834457E 02	0.63651459E 02	C.60327942E 02	0.59989197E 02
451	0.59404465E 02	0.58710251E 02	0.58034042E 02	0.57467499E 02	C.57066513E 02	0.56859970E 02
457	0.56859970E 02	0.57066452E 02	0.57467514E 02	0.58034042E 02	C.58710281E 02	0.59404495E 02
463	0.59989197E 02	0.60327942E 02	0.60327942E 02	0.59989197E 02	C.59404495E 02	0.58710251E 02
469	0.58034042E 02	0.57467499E 02	0.57066513E 02	0.56859970E 02	C.56859970E 02	0.57066452E 02
475	0.57467514E 02	0.58034042E 02	0.58710281E 02	0.59404495E 02	C.59989197E 02	0.60327942E 02
481	0.57360992E 02	0.57319626E 02	C.57243927E 02	0.57146408E 02	C.57042587E 02	0.56348273E 02
487	0.56877029E 02	0.56838837E 02	0.56838837E 02	0.56876999E 02	C.56948212E 02	0.57042587E 02
493	0.57146408E 02	0.57243927E 02	0.57319626E 02	0.57360992E 02	C.57360992E 02	0.57319626E 02
499	0.57243927E 02	0.57146408E 02	0.57042587E 02	0.56948273E 02	C.56877029E 02	0.56838837E 02
505	0.56838837E 02	0.56876999E 02	0.56948212E 02	0.57042587E 02	C.57146408E 02	0.57243927E 02
511	0.57319626E 02	0.57360992E 02				

XMAX = 0.1000000E 04 TAU = 0.8000000E 01 DELR = 0.1050000E-01

86 WEIGHTED VALUES OF THICKNESS (GM/SQ.CM.)

0.56424377E 02	0.56528076E 02	0.56571030E 02	0.56656250E 02	0.56735474E 02
0.56826004E 02	0.56942871E 02	0.57088379E 02	0.57260437E 02	0.57456177E 02
0.57690201E 02	0.57959000E 02	0.58270706E 02	0.58626648E 02	0.59031372E 02
0.59488388E 02	0.60004700E 02	0.60581497E 02	0.61226105E 02	0.61943039E 02
0.62737457E 02	0.63615112E 02	0.64580139E 02	0.65640106E 02	0.66799622E 02
0.68065475E 02	0.69443436E 02	0.70940552E 02	0.72563690E 02	0.74318924E 02
0.76213852E 02	0.78255646F 02	0.80451523E 02	0.82809555E 02	0.85337173E 02
0.88042847E 02	0.90934540E 02	0.94020889E 02	0.97310562E 02	0.10081264E 03
0.10453622E 03	0.10849097E 03	0.11268652E 03	0.11713293E 03	0.12184082E 03
0.12682054E 03	0.13208344E 03	0.13764096E 03	0.14350508E 03	0.14968797E 03
0.15620288E 03	0.16306311E 03	0.17028290E 03	0.17787695E 03	0.18586113E 03
0.19425200E 03	0.20306705E 03	0.21232494E 03	0.22204602E 03	0.23225165E 03
0.24296515E 03	0.254021193E 03	0.26360193E 03	0.27841846E 03	0.29144189E 03
0.30512744E 03	0.31951660E 03	0.33465674E 03	0.35060107E 03	0.36741138E 03
0.38515894E 03	0.40392749E 03	0.42381616E 03	0.44494385E 03	0.46745679E 03
0.49153687E 03	0.51741626E 03	0.54539941E 03	0.57589722E 03	0.60949438E 03
0.64706909E 03	0.69005737E 03	0.74113232E 03	0.80658691E 03	0.91480103E 03
0.10000000E 04				

CURVE FIT OF SECTION 1

THICKNESS	DISTRIBUTION	CURVE FIT PT.
0.56424377E 02	0.19531250E-02	-0.69495797E-01
0.56528076E 02	0.78125000E-02	-0.48584733E-01
0.56571030E 02	0.78125000E-02	-0.39971590E-01
0.56656250E 02	0.78125000E-02	-0.23027621E-01
0.56732474E 02	0.78125000E-02	-0.74048825E-02
0.56826004E 02	0.78125000E-02	0.10313112E-01
0.56942871E 02	0.14843750E 00	0.32935519E-01
0.57088379E 02	0.19531250E 00	0.60712613E-01
0.57250437E 02	0.24218750E 00	0.93017757E-01
0.57456177E 02	0.30468750E 00	0.12908173E 00
0.57690201E 02	0.36718750E 00	0.17123663E 00
0.57959000E 02	0.38281250E 00	0.21835619E 00
0.58270706E 02	0.41406250E 00	0.27129549E 00
0.58626648E 02	0.42968750E 00	0.32952464E 00
0.59031372E 02	0.50781250E 00	0.39288163E 00
0.59488388E 02	0.52343750E 00	0.46092391E 00
0.60004700E 02	0.55468750E 00	0.53334951E 00
0.60581497E 02	0.60156250E 00	0.60883904E 00
0.61226105E 02	0.63281250E 00	0.68662536E 00
0.61943039E 02	0.67968750E 00	0.76522154E 00
0.62737457E 02	0.68750000E 00	0.84300280E 00
0.63615112E 02	0.72656250E 00	0.91800940E 00
0.64580139E 02	0.77343750E 00	0.98790220E 00
0.65640106E 02	0.80468750E 00	0.10504999E 01
0.66799622E 02	0.84375000E 00	0.11029558E 01
0.68065475E 02	0.84375000E 00	0.11428061E 01
0.69443436E 02	0.89843750E 00	0.11674185E 01
0.70940552E 02	0.89843750E 00	0.11747456E 01
0.72563690E 02	0.89843750E 00	0.11627378E 01
0.74318924E 02	0.90625000E 00	0.11306725E 01
0.76213852E 02	0.90625000E 00	0.10786572E 01
0.78255646E 02	0.91406250E 00	0.10084248E 01
0.80451523E 02	0.92187500E 00	0.92346954E 00
0.82809555E 02	0.92968750E 00	0.82950401E 00
0.85337173E 02	0.93750000E 00	0.73486519E 00
0.88042847E 02	0.93750000E 00	0.64997292E 00
0.90934540E 02	0.93750000E 00	0.58746815E 00
0.94020889E 02	0.93750000E 00	0.56119061E 00

THICKNESS \equiv AREAL DENSITY IN
GRAMS/CM² \equiv T

DISTRIBUTION \equiv FRACTION OF SOLID
ANGLE LESS THAN T

CURVE FIT PT. \equiv LEAST-SQUARE CURVE
FIT OF THE FRACTION
OF SOLID ANGLE $<$ T

0.97310562E 02	0.93750000E 00	0.58393288E 00
0.10081264E 03	0.94531250E 00	0.66483784E 00
0.10453622E 03	0.94531250E 00	0.80513000E 00
0.10849097E 03	0.94531250E 00	0.99243164E 00
0.11268652E 03	0.94531250E 00	0.11946106E 01
0.11713293E 03	0.94531250E 00	0.13556519E 01
0.12184082E 03	0.94531250E 00	0.13971405E 01
0.12682054E 03	0.94531250E 00	0.12388763E 01
0.13208344E 03	0.94531250E 00	0.85408020E 00
0.13764096E 03	0.94531250E 00	0.40185547E 00
0.14350508E 03	0.94531250E 00	0.50756836E 00
0.14711073E 03	0.94531250E 00	0.14219785E 01

11 COEFFICIENTS

	I	I + 1	I + 2
-0.59121475E 02	0.19950714E 01		-0.15375897E-01
-0.89934474E-04	0.13520212E-05		-0.65145045E-08
0.67617426E-10	-0.33896703E-12		0.17392329E-14
-0.30115873E-16	0.12896888E-18		

CURVE FIT OF SECTION 2

THICKNESS	DISTRIBUTION	CURVE FIT PT.
0.14711073E 03	0.94531250E 00	0.94389057E 00
0.14968797E 03	0.94531250E 00	0.94455910E 00
0.15620288E 03	0.94531250E 00	0.94628519E 00
0.16306311E 03	0.94531250E 00	0.94816697E 00
0.17028290E 03	0.94531250E 00	0.95022172E 00
0.17787695E 03	0.95312500E 00	0.95246583E 00
0.18586113E 03	0.96093750E 00	0.95491040E 00
0.19425200E 03	0.96093750E 00	0.95756215E 00
0.20306705E 03	0.96093750E 00	0.96041262E 00
0.21232494E 03	0.96093750E 00	0.96344507E 00
0.22204602E 03	0.96875000E 00	0.96661699E 00
0.23225165E 03	0.96875000E 00	0.96986234E 00
0.24296515E 03	0.96875000E 00	0.97308546E 00
0.25421193E 03	0.97656250E 00	0.97616780E 00
0.26601953E 03	0.97656250E 00	0.97895926E 00
0.27841846E 03	0.98437500E 00	0.98130691E 00
0.29144189E 03	0.98437500E 00	0.98306978E 00

0.30512744E 03	0.98437500E 00	0.98416770E 00
0.31951660E 03	0.98437500E 00	0.98463583E 00
0.33465674E 03	0.98437500E 00	0.98466498E 00
0.35060107E 03	0.98437500E 00	0.98458004E 00
0.36741138E 03	0.98437500E 00	0.98459530E 00
0.38354956E 03	0.98437500E 00	0.98415852E 00

11 COEFFICIENTS

	<u>1</u>	<u>1+1</u>	<u>1+2</u>
0.88055998E 00	0.10166937E-02	-0.81648359E-05	
0.41367642E-07	-0.11512664E-09	0.12791948E-12	
0.94218185E-15	-0.36386972E-17	-0.66473785E-20	
0.44664509E-22	-0.50161508E-25		

CURVE FIT OF SECTION 3

THICKNESS	DISTRIBUTION	CURVE FIT PT.
0.38354956E 03	0.98437500E 00	0.98481250E 00
0.38515894E 03	0.98437500E 00	0.98476923E 00
0.40392749E 03	0.98437500E 00	0.9843232E 00
0.42381616E 03	0.98437500E 00	0.98397958E 00
0.44494385E 03	0.98437500E 00	0.98377562E 00
0.46745679E 03	0.98437500E 00	0.98375952E 00
0.49153687E 03	0.98437500E 00	0.98399073E 00
0.51741626E 03	0.98437500E 00	0.98453873E 00
0.54539941E 03	0.98437500E 00	0.98548323E 00
0.57589722E 03	0.98437500E 00	0.98691005E 00
0.60949438E 03	0.99218750E 00	0.98890150E 00
0.64706909E 03	0.99218750E 00	0.99151140E 00
0.69005737E 03	0.99218750E 00	0.99469531E 00
0.74113232E 03	C.10000000E 01	0.99816912E 00
0.80658691E 03	0.10000000E 01	0.10009451E 01
0.91480103E 03	0.10000000E 01	0.99961197E 00
0.99999927E 03	0.10000000E 01	0.10001059E 01

9 COEFFICIENTS

	<u>1</u>	<u>1+1</u>	<u>1+2</u>
0.10158415E 01	-0.21126155E-03	0.77824910E-06	
-0.17263750E-08	0.10944639E-11	0.18677081E-14	

-0.15165389E-17 -0.17239244E-20 0.14219431E-23

GEOMDS TIME = 0.03 MIN

EXECUTION TIME FOR ESDOSE IS 0.53 MIN

NO. PATHS IS 998 OF TOTAL 1604

RAY NO. PATH NO. DISTANCE TO (CM.) PATH THROUGH (GM./SQ.CM.) MATERIAL NO.

1	1	0.31469574E 02	0.14156074E 02	1
2	1	0.31391586E 02	0.14120985E 02	1
3	1	0.31249023E 02	0.14056863E 02	1
4	1	0.31065659E 02	0.13974372E 02	1
5	1	0.30870773E 02	0.13886692E 02	1
6	1	0.30693939E 02	0.13807208E 02	1
7	1	0.30560623E 02	0.13747204E 02	1
8	1	0.30489197E 02	0.13715081E 02	1
9	1	0.30489197E 02	0.13715081E 02	1
10	1	0.30500623E 02	0.13747204E 02	1
11	1	0.30693924E 02	0.13807126E 02	1
12	1	0.30870773E 02	0.13886692E 02	1
13	1	0.31065659E 02	0.13974372E 02	1
14	1	0.31249023E 02	0.14056863E 02	1
15	1	0.31391586E 02	0.14120985E 02	1
16	1	0.31469574E 02	0.14156074E 02	1
17	1	0.31469574E 02	0.14156074E 02	1
18	1	0.31391602E 02	0.14120985E 02	1
19	1	0.31249023E 02	0.14056863E 02	1
20	1	0.31065659E 02	0.13974372E 02	1
21	1	0.30870773E 02	0.13886692E 02	1
22	1	0.30693939E 02	0.13807208E 02	1
23	1	0.30560623E 02	0.13747204E 02	1
24	1	0.30489197E 02	0.13715081E 02	1
25	1	0.30489197E 02	0.13715081E 02	1
26	1	0.30560623E 02	0.13747204E 02	1
27	1	0.30693924E 02	0.13807126E 02	1
28	1	0.30870773E 02	0.13886692E 02	1
29	1	0.31065659E 02	0.13974372E 02	1
30	1	0.31249023E 02	0.14056863E 02	1
31	1	0.31391586E 02	0.14120985E 02	1
32	1	0.31469574E 02	0.14156074E 02	1
33	1	0.37203812E 02	0.16735504E 02	1
34	1	0.36535370E 02	0.16434875E 02	1
35	1	0.35339603E 02	0.15919426E 02	1
36	1	0.34043167E 02	0.15313741E 02	1
37	1	0.32746002E 02	0.14730253E 02	1
38	1	0.31670609E 02	0.14246471E 02	1

39	1	0.30915543E 02	0.13906914E 02	1
40	1	0.30528763E 02	0.13732872E 02	1
41	1	0.30528763E 02	0.13732872E 02	1
42	1	0.30915527E 02	0.13906831E 02	1
43	1	0.31670609E 02	0.14246512E 02	1
44	1	0.32746017E 02	0.14730253E 02	1
45	1	0.34043167E 02	0.15313741E 02	1
46	1	0.35389572E 02	0.15919385E 02	1
47	1	0.36535370E 02	0.16434875E 02	1
48	1	0.37203812E 02	0.16735504E 02	1
49	1	0.37203812E 02	0.16735504E 02	1
50	1	0.36535370E 02	0.16434875E 02	1
51	1	0.35389603E 02	0.15919426E 02	1
52	1	0.34043167E 02	0.15313741E 02	1
53	1	0.32746002E 02	0.14730253E 02	1
54	1	0.31670624E 02	0.14246471E 02	1
55	1	0.30915543E 02	0.13906914E 02	1
56	1	0.30528778E 02	0.13732913E 02	1
57	1	0.30528763E 02	0.13732872E 02	1
58	1	0.30915527E 02	0.13906831E 02	1
59	1	0.31670609E 02	0.14246512E 02	1
60	1	0.32746017E 02	0.14730253E 02	1
61	1	0.34043152E 02	0.15313782E 02	1
62	1	0.35389572E 02	0.15919385E 02	1
63	1	0.36535385E 02	0.16434875E 02	1
64	1	0.37203812E 02	0.16735504E 02	1
65	1	0.43937393E 02	0.19764389E 02	1
66	1	0.42254166E 02	0.19007233E 02	1
67	1	0.39594421E 02	0.17810898E 02	1
68	1	0.36773407E 02	0.16541901E 02	1
69	1	0.34310165E 02	0.15433831E 02	1
70	1	0.32425491E 02	0.14586070E 02	1
71	1	0.31175812E 02	0.14023915E 02	1
72	1	0.30557022E 02	0.13745557E 02	1
73	1	0.30557007E 02	0.13745557E 02	1
74	1	0.31175797E 02	0.14023874E 02	1
75	1	0.32425476E 02	0.14586111E 02	1
76	1	0.34310150E 02	0.15433873E 02	1
77	1	0.36773392E 02	0.16541901E 02	1
78	1	0.39594391E 02	0.17810852E 02	1
79	1	0.42254166E 02	0.19007233E 02	1
80	1	0.43937393E 02	0.19764435E 02	1
81	1	0.43937393E 02	0.19764389E 02	1

272	4	0.716C4782E 02	0.10590413E 02	6
273	4	0.716C4752E 02	0.10590339E 02	6
274	3	0.7150618CE 02	0.32751404E 02	6
275	4	0.60294296E C2	0.62423C96E 01	6
302	4	0.531018C7E 02	0.11030235E 01	6
303	3	0.68139450E 02	0.341C0281E 02	6
304	4	0.72759949E C2	0.21594391E 02	6
305	4	0.72759949E C2	0.21594391E 02	6
306	3	0.68139526E C2	0.34100464E 02	6
307	4	0.59102081E 02	0.11038733E 01	6
335	3	0.63339844E 02	0.18009445E 02	6
336	3	0.69193771E 02	0.35830017E 02	6
337	3	0.69193802E 02	0.35829239E 02	6
338	3	0.63339188E 02	0.18007858E 02	6
368	4	0.61684326E 02	0.11820980E 02	6
369	4	0.61683395E 02	0.11818727E 02	6
240	5	0.58727142E 02	0.13198291E 02	7
241	5	0.58727142F 02	0.13198371E 02	7
272	5	0.58727142E 02	0.13198291E 02	7
273	5	0.58727142E 02	0.13198291E 02	7

AREAL DENSITIES, SORTED ACCORDING TO RAY NO., AND DISTANCE

RAY NO.	PATH NO.	DISTANCE TO (CM.)	PATH THROUGH (GM./SQ.CM.)	MAT. NO.	MAT. NAME
1	1	0.31469574E 02	0.14156074E 02	1	ALUMINUM
	2	0.20808792E 02	0.47509346E 01	3	BERYLLIUM
	3	0.10160019E 02	0.45415268E 02	2	COPPER
2	1	0.31391586E 02	0.14120985E 02	1	ALUMINUM
	2	0.20770721E 02	0.47450113E 01	3	BERYLLIUM
	3	0.10160019E 02	0.45415268E 02	2	COPPER
3	1	0.31249023E 02	0.14056863E 02	1	ALUMINUM
	2	0.20700897E 02	0.47340889E 01	3	BERYLLIUM
	3	0.10160019E 02	0.45415268E 02	2	COPPER
4	1	0.31065659E 02	0.13974372E 02	1	ALUMINUM
	2	0.20610733E 02	0.47199106E 01	3	BERYLLIUM
	3	0.10160019E 02	0.45415268E 02	2	COPPER
5	1	0.30870773E 02	0.13886692E 02	1	ALUMINUM
	2	0.20514465E 02	0.47046938E 01	3	BERYLLIUM

6	3	0.10160019E 02	0.45415268E 02	2	COPPER
	1	0.30693939E 02	0.13807208E 02	1	ALUMINUM
	2	0.20426697E 02	0.46907120E 01	3	BERYLLIUM
	3	0.10160019E 02	0.45415268E 02	2	COPPER
7	1	0.30560623E 02	0.13747204E 02	1	ALUMINUM
	2	0.20360291E 02	0.46800985E 01	3	BERYLLIUM
	3	0.10160019E 02	0.45415268E 02	2	COPPER
8	1	0.30489197E 02	0.13715081E 02	1	ALUMINUM
	2	0.20324615E 02	0.46743431E 01	3	BERYLLIUM
	3	0.10160019E 02	0.45415268E 02	2	COPPER
9	1	0.30489197E 02	0.13715081E 02	1	ALUMINUM
	2	0.20324615E 02	0.46743431E 01	3	BERYLLIUM
	3	0.10160019E 02	0.45415268E 02	2	COPPER
10	1	0.30560623E 02	0.13747204E 02	1	ALUMINUM
	2	0.20360291E 02	0.46800985E 01	3	BERYLLIUM
	3	0.10160019E 02	0.45415268E 02	2	COPPER
11	1	0.30693924E 02	0.13807126E 02	1	ALUMINUM
	2	0.20426697E 02	0.46907120E 01	3	BERYLLIUM
	3	0.10160019E 02	0.45415268E 02	2	COPPER
12	1	0.30870773E 02	0.13886692E 02	1	ALUMINUM
	2	0.20514465E 02	0.47046938E 01	3	BERYLLIUM
	3	0.10160019E 02	0.45415268E 02	2	COPPER
13	1	0.31065659E 02	0.13974372E 02	1	ALUMINUM
	2	0.20610733E 02	0.47199106E 01	3	BERYLLIUM
	3	0.10160019E 02	0.45415268E 02	2	COPPER
14	1	0.31249023E 02	0.14056863E 02	1	ALUMINUM
	2	0.20700897E 02	0.47340889E 01	3	BERYLLIUM
	3	0.10160019E 02	0.45415268E 02	2	COPPER
15	1	0.31391586E 02	0.14120985E 02	1	ALUMINUM
	2	0.20770721E 02	0.47450113E 01	3	BERYLLIUM
	3	0.10160019E 02	0.45415268E 02	2	COPPER
16	1	0.31469574E 02	0.14156074E 02	1	ALUMINUM

(PART OF THESE DATA ARE OMITTED)

308	3	0.30729721E 02	0.56405277E 01	3	BERYLLIUM
	4	0.10160019E 02	0.45415268E 02	2	COPPER
309	1	0.46834351E 02	0.21067596E 02	1	ALUMINUM
	2	0.26969955E 02	0.54747657E 01	3	BERYLLIUM
	3	0.10160019E 02	0.45415268E 02	2	COPPER
310	1	0.38969818E 02	0.17529892E 02	1	ALUMINUM
	2	0.24135635E 02	0.52036915E 01	3	BERYLLIUM
	3	0.10160019E 02	0.45415268E 02	2	COPPER
311	1	0.34388016E 02	0.15468920E 02	1	ALUMINUM
	2	0.22181274E 02	0.49538412E 01	3	BERYLLIUM
	3	0.10160019E 02	0.45415268E 02	2	COPPER
312	1	0.31799973E 02	0.14304746E 02	1	ALUMINUM
	2	0.20969315E 02	0.47757540E 01	3	BERYLLIUM
	3	0.10160019E 02	0.45415268E 02	2	COPPER
313	1	0.30622284E 02	0.13774920E 02	1	ALUMINUM
	2	0.20391037E 02	0.46850119E 01	3	BERYLLIUM
	3	0.10160019E 02	0.45415268E 02	2	COPPER
314	1	0.31799942E 02	0.13774961E 02	1	ALUMINUM
	2	0.20391022E 02	0.46850119E 01	3	BERYLLIUM
	3	0.10160019E 02	0.45415268E 02	2	COPPER

NO. PATHS IS 606 OF TOTAL 1604

315	1	0.34387970E 02	0.15468920E 02	1	ALUMINUM
	2	0.22181244E 02	0.49538135E 01	3	BERYLLIUM
	3	0.10160019E 02	0.45415268E 02	2	COPPER
316	1	0.38969757E 02	0.17529861E 02	1	ALUMINUM
	2	0.24135605E 02	0.52036629E 01	3	BERYLLIUM
	3	0.10160019E 02	0.45415268E 02	2	COPPER
317	1	0.46834274E 02	0.21067596E 02	1	ALUMINUM
	2	0.26969925E 02	0.54747667E 01	3	BERYLLIUM
	3	0.10160019E 02	0.45415268E 02	2	COPPER
318	1	0.59101883E 02	0.35877085E 01	4	IRON
	2	0.58646011E 02	0.21085754E 02	1	ALUMINUM
	3	0.30729675E 02	0.56405001E 01	3	BERYLLIUM
	4	0.10160019E 02	0.45415268E 02	2	COPPER
319	1	0.13362991E 03	0.11587222E 03	4	IRON
	2	0.68139404E 02	0.11089571E 03	4	IRON
	3	0.34980362E 02	0.55083456E 01	3	BERYLLIUM
	4	0.10160019E 02	0.45415268E 02	2	COPPER
320	1	0.14551994E 03	0.24540898E 03	4	IRON
	2	0.96253021E 02	0.18489047E 03	4	IRON
	3	0.72759949E 02	0.16360606E 03	4	IRON
	4	0.38168472E 02	0.51421766E 01	3	BERYLLIUM
	5	0.10160019E 02	0.45415268E 02	2	COPPER
321	1	0.12165562E 03	0.26805252E 02	4	IRON
	2	0.69193802E 02	0.12154427E 03	4	IRON
	3	0.35369431E 02	0.54768724E 01	3	BERYLLIUM
	4	0.10160019E 02	0.45415268E 02	2	COPPER
322	1	0.63339493E 02	0.58565186E 02	4	IRON
	2	0.55897919E 02	0.94058907E 00	1	ALUMINUM
	3	0.32939117E 02	0.56184044E 01	3	BERYLLIUM
	4	0.10160019E 02	0.45415268E 02	2	COPPER
323	1	0.55788208E 02	0.25095337E 02	1	ALUMINUM
	2	0.29518356E 02	0.56135473E 01	3	BERYLLIUM
	3	0.10160019E 02	0.45415268E 02	2	COPPER

(PART OF THESE DATA ARE OMITTED)

498	1	C.31391602E 02	C.14120985E 02	1	ALUMINUM
	2	0.20770721E 02	0.47450113E 01	3	BERYLLIUM
	3	0.10160019E 02	0.45415268E 02	2	COPPER
499	1	C.31249023E 02	U.14056863F 02	1	ALUMINUM
	2	0.20700897E 02	C.47340889F 01	3	BERYLLIUM
	3	0.10160019E 02	0.45415268F 02	2	COPPER
500	1	0.31065659E 02	C.13974372E 02	1	ALUMINUM
	2	0.20610733E 02	C.47199106E 01	3	BERYLLIUM
	3	0.10160019E 02	0.45415268E 02	2	COPPER
501	1	0.30870773E 02	0.13886692E 02	1	ALUMINUM
	2	0.20514465E 02	0.47046938E 01	3	BERYLLIUM
	3	0.10160019E 02	0.45415268E 02	2	COPPER
502	1	C.30693939E 02	C.13807208E 02	1	ALUMINUM
	2	0.20426697E 02	C.46907120E 01	3	BERYLLIUM
	3	0.10160019E 02	0.45415268E 02	2	COPPER
503	1	0.30560623E 02	0.13747204E 02	1	ALUMINUM
	2	0.20360291E 02	C.46800985E 01	3	BERYLLIUM
	3	0.10160019E 02	0.45415268E 02	2	COPPER
504	1	0.30489197E 02	0.13715081E 02	1	ALUMINUM
	2	0.20324615E 02	C.46743717E 01	3	BERYLLIUM
	3	0.10160019E 02	0.45415268E 02	2	COPPER
505	1	0.30489197E 02	0.13715081E 02	1	ALUMINUM
	2	0.20324615E 02	0.46743717E 01	3	BERYLLIUM
	3	0.10160019E 02	0.45415268E 02	2	COPPER
506	1	0.30560623E 02	0.13747204E 02	1	ALUMINUM
	2	0.20360275E 02	0.46800709E 01	3	BERYLLIUM
	3	0.10160019E 02	0.45415268E 02	2	COPPER
507	1	0.30693924E 02	0.13807126E 02	1	ALUMINUM
	2	0.20426697E 02	0.46907120E 01	3	BERYLLIUM
	3	0.10160019E 02	0.45415268E 02	2	COPPER
508	1	0.30870773E 02	0.13886692E 02	1	ALUMINUM
	2	0.20514465E 02	C.47046938E 01	3	BERYLLIUM
	3	0.10160019E 02	0.45415268E 02	2	COPPER

509	1	0.1065659E 02	0.13974372E 02	1	ALUMINUM
	2	0.20610733E 02	0.47199106E 01	3	BERYLLIUM
	3	0.10160019E 02	0.45415268E 02	2	COPPER
510	1	0.31249023E 02	0.14056863E 02	1	ALUMINUM
	2	0.20700897E 02	0.47340889E 01	3	BERYLLIUM
	3	0.10160019E 02	0.45415268E 02	2	COPPER
511	1	0.31391602E 02	0.14120985E 02	1	ALUMINUM
	2	0.20770721E 02	0.47450113E 01	3	BERYLLIUM
	3	0.10160019E 02	0.45415268E 02	2	COPPER
512	1	0.31469574E 02	0.14156074E 02	1	ALUMINUM
	2	0.20808792E 02	0.47509346E 01	3	BERYLLIUM
	3	0.10160019E 02	0.45415268E 02	2	COPPER

APPENDIX II
MODIFIED ELEMENTAL VOLUME DOSE PROGRAM
LISTINGS

Subroutine Card Listing Identification Field Reference

Subroutine	Identification* Field Reference	Subroutine	Identification* Field Reference
MAIN PROGRAM (MEVDP)	A	SPHERE	P
ESDOSE	B	HEMIS	Q
COMPSP	C	CONE	R
TKHM	D	TRCONE	S
GEOMDS	E	ELIPSD	T
ORDER	F	TRACK	U
CLOCK	G	SYSEL	V
GENTAP	H	RNDSEL	W
TRSHLD	I	ELMIS	X
FILE	J	OCTOS	Y
FANTOM	K	TKHEX	Z
LIMROT	L	TKCYL	AA
ROOT	M	TKSPH	AB
HEX	N	TKCON	AC
CYLNDR	O	TKELL	AD
		LEAST	AE

*IBM Card Columns 74 and 75.

==C1

PROGR. MEVDP(INPUT,OUTPUT,TAPES=INPUT,TAPE6=OUTPUT,TAPE7,TAPE8,TA	A	1
PE9,TAPE10,TAPE11,TAPE12,TAPE13,TAPE20)	A	2
PRIMARY IONIZATION DOSE PROGRAM (ELEMENTAL VOLUMES)	A	3
CONTROL PROGRAM TO - - -	A	4
(1.) TRANSFORMATION OF VEHICLE GEOMETRY - TRSHLD	A	5
(3.) TRACKING FOR AREAL DENSITY FUNCTION, GEOMETRY DISTRIBUTION,	A	6
DOSE EVALUATION, AND EMERGENT SPECTRA - ESDOSE	A	7
	A	8
	A	9
DIMENSION NOPT(4), CONTEN(15)	A	10
INTEGER OPTN	A	11
COMMON /DATA/ SHLDD(4C)/VARID/EPSLN	A	12
COMMON /ITSTOP/ IPATH(1000),IREC,NRTOT,NPARTS,IPUNCH,ISORT	A	13
COMMON /MATYPE/ NMAT,ITLSTD(3),ITLMAT(3,50)	A	14
	A	15
	A	16
	A	17
	A	18
	A	19
	A	20
REWIND 7	A	21
REWIND 8	A	22
REWIND 9	A	23
IREC=0	A	24
NOLOF=0	A	25
***** * PROGRAM OPERATION REFERENCE NO. 3 *****	A	26
READ (5,5) NIOGEN,CONTEN	A	27
***** * PROGRAM OPERATION REFERENCE NO. 1 *****	A	28
IF (NIOGEN) 4,3,2	A	29
CALL GENTAP (CONTEN)	A	30
IF (NIOGEN.EQ.1) GO TO 3	A	31
WRITE (5,6)	A	32
GO TO 4	A	33
***** * PROGRAM OPERATION REFERENCE NO. 2 *****	A	34
READ (5,7) OPTN,NFIL	A	35
IF (OPTN.LT.1) GO TO 1	A	36
CALL CLOCK (T1)	A	37
GEOMETRY DATA TRANSFORMATION PROGRAM	A	38
CALL TRSHLD (NDS)	A	39
CALL CLOCK (T2)		
TIME=T2-T1		
WRITE (6,8) TIME		
T1=T2		

==C2

```

C C PRIMARY IONIZATION DOSE AND FLUX
C CALL ESDOSE (NDS,NOPT,NFIL,NOLDF)
C CALL CLOCK (T2)
C TIME=T2-T1
C WRITE (6,9) TIME
C T1=T2
C CALL ORDER
C GO TO 3
C
C STOP
C
C FORMAT (I12,15A4)
6 FORMAT (I10,10X,43HRE-CHECK GEOMETRY BEFORE CONTINUING PROBLEM)
7 FORMAT (6I12)
8 FORMAT (I10,5X,20HTRANSFORMATION TIME=F6.2,4H MIN)
9 FORMAT (I10,5X,28HEXECUTION TIME FOR ESDOSE IS,F6.2,4H MIN)
END
SUBROUTINE ESDOSE (NSO,NOPT,NFIL,NEWF9)
C
C PRIMARY IONIZATION DOSE PROGRAM (ELEMENTAL VOLUMES)
C SHIELD GEOMETRY AND ASSOCIATED INFORMATION FOR ALL
C UNTRACKED GEOMETRY AT XDET HAS BEEN PREPARED ON TAPE 12
C
C DIMENSION NRSA(10), FSA(10)
C DIMENSION NOPT(4), CASE(18), NSS(50), DENS(50), TPEQVT(1000)
C INTEGER RANDOM,ORD(6,4)
C COMMON /DIRAY/ DIRCOS(3,1000)/VARIB/EPSLV/DATA/SHLDD(40)/GMDST/PAT
C 1H(1000)/COEF/DSTD,ESTD,DELTA(50),ETA(50)/SECTN/XFIT(5),TMIN,TMAX,C
C 2SECT(20,5),NSECT,NDEG(5)/GEOMT/THK(1000),NPTS
C COMMON /ITSTOR/ IPATH(1000),IREC,NRTOT,NPARTS,IPUNCH,ISORT
C COMMON /MATYPE/ NMAT,ITLSTD(3),ITLMAT(3,50)
C
C ORDER OF POINTS WITHIN PLANES FOR HEXAHEDRON
C READ (5,18) ((ORD(I,J),J=1,4),I=1,6)
C READ (5,20) IRS
C
C READ (5,19) RANDOM,N,MAT,NRHO,NPRT1,NPRT2,NDIV,IPUNCH,ISORT
C IF (RANDOM.LT.3) RETURN
C IF (NRHO.LE.0) GO TO 2
C READ (5,19) (NSS(I),I=1,NRHO)
C READ (5,24) (DENS(I),I=1,NRHO)

```

```

A 40
A 41
A 42
A 43
A 44
A 45
A 46
A 47
A 48
A 49
A 50
A 51
A 52
A 53
A 54
A 55
A 56
A 57-
B 1
B 2
B 3
B 4
B 5
B 6
B 7
B 8
B 9
B 10
B 11
B 12
B 13
B 14
B 15
B 16
B 17
B 18
B 19
B 20
B 21
B 22
B 23
B 24

```

=C3

```
2      READ (5,21) CASF
      READ (5,22) NEWF9,TM $\chi$ ,FPSLN
      WRITE (6,23) CASE
C
C      COEFFICIENTS FROM CURVE-FIT OF RANGE-ENERGY RELATIONS
      READ (5,24) DSTD,ESTD,(DELTA(I),ETA(I),I=1,NMAT)
      READ (5,25) TTLSTD
      READ (5,25) ((TTLMAT(J,M),J=1,3),M=1,NMAT)
      REWIND 12
      IF (RANDOM) 17,3,7
      NRAYS=0
      DO 6 ND=1,NDIV
      READ (5,26) N,PHI1,PHIF,THET1,THETF
      WRITE (6,27) ND,PHIT,PHIF,THETI,THETF
      NSTRT=NRAYS+1
C
C      FIND ALL DIRECTION COSINES BY SYSTEMATIC SELECTION IN
      INTERVAL DEFINED ON UNIT SPHERE.
      CALL SYssel (N,PHI1,PHIF,THET1,THETF,NSA,NPRT1,NSTRT,FSAE)
      FSA(ND)=FSAE#12.56637/FLOAT(NSA)
      NRSA(ND)=NSA
      NRAYS=NRAYS+NSA
      WRITE (6,28) NRSA(ND),FSA(ND)
      IF (IPUNCH.LE.0) GO TO 6
      I1=NRAYS-NSA+1
      DO 5 I=I1,NRAYS
      IF (IPUNCH.GT.7) GO TO 4
      WRITE (7,29) I,(DIRCOS(J,I),J=1,3),NRSA(ND),FSA(ND)
      IF (IPUNCH.EQ.7) GO TO 5
      WRITE (8) I,(DIRCOS(J,I),J=1,3),NRSA(ND),FSA(ND)
      CONTINUE
      CONTINUE
      GO TO 8
C
C      DIRECTION COSINES OF ALL RAYS BY RANDOM SELECTION OF
      AN EQUALLY PROBABLE DISTRIBUTION BETWEEN ZERO AND ONE
      CALL RNDSEL (N,IRS,NPRT1)
      NRAYS=N
      WRITE (6,30) DSTD,ESTD,(TTLSTD(I),I=1,3)
      DO 9 I=1,NMAT
      NM=I
      WRITE (6,31) NM,DELTA(I),NM,ETA(I),(TTLMAT(J,I),J=1,3)
R 25
R 26
R 27
R 28
R 29
R 30
R 31
R 32
R 33
R 34
R 35
R 36
R 37
R 38
R 39
R 40
R 41
R 42
R 43
R 44
R 45
R 46
R 47
R 48
R 49
R 50
R 51
R 52
R 53
R 54
R 55
R 56
R 57
R 58
R 59
R 60
R 61
R 62
R 63
R 64
R 65
R 66
```

==C4

```

9 CONTINUE
C
C SET UP NON-SEQUENTIAL DATA SET (UNIT 20)
  NPARTS=100
  NRTOT=NPARTS*NRAYS
  REWIND 20
  DO 10 IR=1,1000
    IPATH(IR)=0
  10 PATH(IR)=0.0
    IF (RANDOM.LE.0) GO TO 14
  C
    IF (IPUNCH.GT.7) GO TO 12
    IF (IPUNCH.LE.0) GO TO 14
  C
  C PUNCHED CARD OUTPUT FOR AFWL
  DO 11 I=1,NRAYS
    WRITE (7,32) I,(DIRCOS(J,I),J=1,3)
  11 CONTINUE
    IF (IPUNCH.EQ.7) GO TO 14
  C
  C BINARY OUTPUT FOR AFWL
  DO 13 I=1,NRAYS
    WRITE (8) I,(DIRCOS(J,I),J=1,3)
  13 CONTINUE
  C ***** * PROGRAM OPERATION REFERENCE NO. 21 *****
  14 CALL CLOCK (T1)
    CALL TRACK (NRAYS,NSO,ORD,NRHO,DENS,NSS,IMX,NPRT2)
    CALL CLOCK (T2)
    END FILE 20
    TIME=T2-T1
    WRITE (6,33) TIME
    REWIND 12
    WRITE (6,34) NRAYS
    DO 15 IR=1,NRAYS,6
      NPL=IR+5
      IF (NPL.GT.NRAYS) NPL=NRAYS
      WRITE (6,35) IR,(PATH(I),I=IR,NPL)
    15 CONTINUE
  C
  C GEOMETRY DISTRIBUTION
  C
  C CALL CLOCK (T1)

```

```

B 67
B 68
B 69
B 70
B 71
B 72
B 73
B 74
B 75
B 76
B 77
B 78
B 79
B 80
B 81
B 82
B 83
B 84
B 85
B 86
B 87
B 88
B 89
B 90
B 91
B 92
B 93
B 94
B 95
B 96
B 97
B 98
B 99
B 100
B 101
B 102
B 103
B 104
B 105
B 106
B 107

```

```

CALL GEOMOS (NRAYS)
CALL CLOCK (T2)
TIME=T2-T1
WRITE (6,36) TIME
IF (NPTS.EQ.1) GO TO 1
IF (NEWF9.EQ.0) GO TO 1
IF (NEWF9.GT.0) CALL FILE (9,NEWF9,NFIL)
WRITE (9) NRAYS,NPTS,NSECT,(NDEG(I),I=1,NSECT)
WRITE (9) TMIN,TMAX,(XFIT(I),I=1,NSECT),(THK(J),J=1,NPTS)
WRITE (9) (PATH(I),I=1,NRAYS)
DO 16 I=1,NSECT
NCF=NDEG(I)+1
WRITE (9) (CSECT(J,I),J=1,NCF)
END FILE 9
GO TO 1

16
C
17 RETURN
C
18 FORMAT (24I3)
19 FORMAT (12I6)
20 FORMAT (112)
21 FORMAT (18A4)
22 FORMAT (112,2E12.8)
23 FORMAT (1H1,4X,18A4)
24 FORMAT (6E12.8)
25 FORMAT (6A10)
26 FORMAT (112,4E12.8)
27 FORMAT (1H0,4X,23HMACROSCOPIC SOLID ANGLE,I3/5X,3HPHI,2E16.8,2X,9H
1AND THETA,2E16.8)
28 FORMAT (1H0,4X,27HNO. SOLID ANGLES IN ELEMENT,4X,29HSUBTENDED SOLI
ID ANGLE PER RAY/I4X,I5,29X,E16.8//)
29 FORMAT (15,3E15.8,I5,E15.8)
30 FORMAT (1H0,10X,11HDELTA STD =,E15.8,3X,9HETA STD =,E15.8,3X,3A1G)
31 FORMAT (11X,6HDELTA(I3,2H)=,E15.8,3X,4HETA(I3,2H)=,E15.8,3X,3A1G
1)
32 FORMAT (15,3E15.8)
33 FORMAT (1H0,5X,12HTRACK TIME =,F6.2,4H MIN)
34 FORMAT (1H0,10X,I5,2X,35HAREAL DENSITY FUNCTIONS (GM/SQ.CM.))//)
35 FORMAT (2X,I4,6E17.8)
36 FORMAT (1H0,5X,13HGFOMDS TIME =,F6.2,4H MIN)
END
SUBROUTINE COMPSP (XS,IR)
C
1

```

==06

```

DIMENSION X(4)
COMMON /VARIR/ FPSLN/COFF/DSTD,ESTD,DELTA(50),ETA(50)/DPCOMP/DPPOS
1(2,10),DPNEG(2,10),RHO(10),MPOS,NNEG,MAT(12)
COMMON /ITSTOR/ IPATH(1000),IREC,NRTOT,NPARTS,IPUNCH,ISORT
C
C COMPUTATION OF THE TOTAL EQUIVALENT THICKNESS THROUGH A
C COMPOSITE SHIELD IN THE DIRECTION SPECIFIED
C
XS=0.0
DO 4 NP=1,NPNS
X(1)=DPPOS(1,NP)
X(3)=X(1)
X(4)=DPPOS(2,NP)
M=MAT(NP)
IF (NNEG.EQ.0) GO TO 3
DO 2 NN=1,NNEG
IF (ABS(DPNEG(2,NN)).LE.X(1)) GO TO 2
IF (ABS(DPNEG(1,NN)).GE.X(4)) GO TO 3
X(2)=ABS(DPNEG(1,NN))
X(3)=ABS(DPNEG(2,NN))
IF ((X(2)-X(1)).LE.EPSLN) GO TO 1
IPATH(IR)=IPATH(IR)+1
DX=DSTD*(RHO(NP)*(X(2)-X(1))/DELTA(M))**(ESTD/ETA(M))
XS=DX+XS
DM=RHO(NP)*(X(2)-X(1))
WRITE (20) IR,IPATH(IR),X(2),DM,MAT(NP)
X(1)=X(3)
IF (X(3).GE.X(4)) GO TO 4
CONTINUE
IF ((X(4)-X(3)).LE.EPSLN) GO TO 4
IPATH(IR)=IPATH(IR)+1
DX=DSTD*(RHO(NP)*(X(4)-X(3))/DELTA(M))**(ESTD/ETA(M))
XS=DX+XS
DM=RHO(NP)*(X(4)-X(3))
WRITE (20) IR,IPATH(IR),X(4),DM,MAT(NP)
CONTINUE
RETURN
END
SUBROUTINE TKHM (HSPTH,NP)
C
C TRACKING OF PROTONS THROUGH A HEMISPHERE
C

```

==0.7

```

C
D DIMENSION X(2,3), AR(3,3), DIRRAY(3), DIRCSA(3), PR(4), ZBH(4), DP
D I(2)
D D
D D
D COMMON /DIRAY/ DIRCOS(3,1000)/VARIB/EPSLN/DATA/SHLDD(40)/GMDST/PAT
D IH(1000)
D D
D D
D EQUIVALENCE (SHLDD(7),RHMS), (SHLDD(8),X), (SHLDD(14),AR), (SHLDD(
D 138),DIRCSA)
D D
D DO 1 I=1,4
D PR(I)=0.0
D DUMY=1.0E+21
D D
C ***** * PROGRAM OPERATION REFERENCE NO. 58 *****
C DIRECTION COSINES OF TRACKING RAY IN ROTATED SYSTEM *****
C DO 2 K=1,3
C DIRRAY(K)=AR(K,1)*DIRCSA(1)+AR(K,2)*DIRCSA(2)+AR(K,3)*DIRCSA(3)
C CONTINUE
C
C COMPONENTS OF QUADRATIC SOLUTION FOR INTERSECTION
C ISC=0
C A=1.0
C B=-2.*(DIRRAY(1)*X(1,1)+DIRRAY(2)*X(1,2)+DIRRAY(3)*X(1,3))
C C=X(1,1)**2+X(1,2)**2+X(1,3)**2-.4MS**2
C CALL ROOT (A,B,C,PR(3),PR(4),ISC)
C IF (ISC) 3,6,3
C
C NO INTERSECTION
C DO 4 I=1,4
C PR(I)=1.0E+20
C DO 5 I=1,2
C DP(I)=PR(I)
C RETURN
C
C ***** * PROGRAM OPERATION REFERENCE NO. 59 *****
C SET UP Z-BOUNDS + ELIMINATE NON-HEMISPHERE PATH LENGTHS *****
C DO 7 I=3,4
C ZBH(I)=DIRRAY(3)*PR(I)
C IF (X(1,3)-X(2,3)) 9,9,8
C ZBH(1)=X(2,3)
C ZBH(2)=X(1,3)
C GO TO 10
C ZBH(1)=X(1,3)

```

==08

```

10 ZBH(2)=X(2,3)
DO 13 I=3,4
IF (ZBH(1)-7BH(1)+EPSLN) 12,13,11
IF (ZBH(1)-7BH(2)-EPSLN) 13,13,12
12 PR(1)=1.GE+20
C ***** * PROGRAM OPERATION REFERENCE NO. 60
13 CONTINUE
C
C EXAMINE PLANAR SURFACE FOR INTERSECTION
IF (DIRRAY(3)) 15,14,15
14 PR(2)=1.OE+20
GO TO 18
C ***** * PROGRAM OPERATION REFERENCE NO. 61
15 DPL=X(1,3)/DIRRAY(3)
RZ2=(DPL*DIRRAY(1)-X(1,1))*2+(DPL*DIRRAY(2)-X(1,2))*2
IF (RZ2-EPSLN-RHMS*2) 16,16,14
16 IF (DPL) 14,17,17
17 PR(2)=DPL
C
C FIND MINIMUM PATH
18 IF (C.GE.0.0) GO TO 19
C ***** * PROGRAM OPERATION REFERENCE NO. 62
IF ((ZBH(1)).LT.0.0).AND.(ZBH(2).GT.0.0) GO TO 24
19 DP(1)=AMIN1(DUMY,PR(2),PR(3),PR(4))
DO 21 I=2,4
IF (PR(I)-DP(1)) 21,20,21
20 PR(1)=1.GE+20
GO TO 22
21 CONTINUE
22 DP(2)=AMIN1(DUMY,PR(2),PR(3),PR(4))
C
IF ((DP(1).GE.1.OE+20).OR.(DP(2).GE.1.OE+20)) GO TO 23
HSPH=ABS(DP(1)-DP(2))
23 RETURN
C
C ***** * PROGRAM OPERATION REFERENCE NO. 63
24 HSPH=AMIN1(DUMY,PR(2),PR(3),PR(4))
IF (HSPH.GE.1.OE+20) HSPH=0.C
DP(2)=HSPH
DP(1)=0.0
RETURN
END

```

D 45
D 46
D 47
D 48
D 49
D 50
D 51
D 52
D 53
D 54
D 55
D 56
D 57
D 58
D 59
D 60
D 61
D 62
D 63
D 64
D 65
D 66
D 67
D 68
D 69
D 70
D 71
D 72
D 73
D 74
D 75
D 76
D 77
D 78
D 79
D 80
D 81
D 82-

==09

```

1  F
2  E
3  C
4  E
5  E
6  E
7  E
8  E
9  E
10 E
11 E
12 E
13 E
14 E
15 E
16 E
17 E
18 E
19 E
20 E
21 E
22 E
23 E
24 E
25 E
26 E
27 E
28 E
29 E
30 E
31 E
32 E
33 E
34 E
35 E
36 E
37 E
38 E
39 E
40 E
41 E
42 E

SUBROUTINE GFEMDS (NSA)
DIMENSION Y(100), GM(1000), NMIN(5), NSTOP(5), YFIT(5), ALNK(10)
REAL MU

C
C      COMPUTATION OF THE AREAL DENSITY DISTRIBUTION FUNCTION
C      METHOD - LEAST SQUARES CURVE FITS IN SECTIONS
C
COMMON /GMDST/ EQVT(1000)/GEOMT/THK(1000),NPTS/COEF/DSTD,ESTD,DELT
1A(50),ETA(50)/SECTN/XFIT(5),TMIN,TMAX,CSECT(20,5),NSECT,NSDEG(5)/L
2STSQ/T(100),GTHDS(100),C(20),KEEP,NDEG
DATA EPS,PI/1.0E-2,3.1415927/

C      DO 1 I=1,5
XFIT(I)=0.0
NSDEG(I)=0
DO 1 J=1,20
CSECT(J,I)=0.0
DO 2 I=1,100
T(I)=0.0
2  GTHDS(I)=0.0
DO 3 I=1,20
C(I)=0.0
3  READ (5,22) NSECT,(NSDEG(N),N=1,NSECT)
READ (5,23) XMAX,TAU,DELR,TMAX
DO 4 I=1,100
GM(I)=0.0
4  WRITE (6,24) XMAX,TAU,DELR

C      COMPUTATION OF WEIGHTED FUNCTION OF T
C
C      XM=0.0
XM=XMAX+1.0
DO 5 I=1,NSA
IF (EQVT(I).LE.1.0E-6) EQVT(I)=1.0E-6
5  XMIN=AMINI(XMIN,EQVT(I))
XM2=XMIN+EPS
DO 6 I=1,NSA
6  IF (XMIN.LE.EQVT(I).AND.EQVT(I).LE.XM2) XM=XM+1.0
CONTINUE
N=1
THK(1)=XMIN
DXOPI=(XMAX-XMIN)/PI

```

==1C

```

XTF=XM/FLOAT(NSA)
ZMX=AINT(1.0/DELR)
ZM=AINT(XTF/DELR)
IF (ABS(XTF-1.0).GT.1.0E-6) GO TO 7
NPTS=1
WRITE(6,31) THK(1)
RETURN
7 N=N+1
  ZM=ZM+1.0
  MU=2.0*((ZM*DELR-XTF)/(1.0-XTF))**TAU
  IF (MU.GE.2.0) MU=2.0-1.0E-7
  THK(N)=XMIN+ACOS(1.0-MU)*DXUP
  IF (THK(N).EQ.THK(N-1)) N=N-1
  IF (ZM.LT.ZMX) GO TO 7
TMIN=XMIN
IF (THK(N).GE.TMAX) GO TO 8
N=N+1
THK(N)=TMAX
8 COMPUTATION OF CUT OFF T FOR SECTIONED CURVE FIT
  TRATIO=TMAX/TMIN
  SECT=NSECT
  DO 9 I=1,NSECT
    EXNS=FLOAT(I)/SECT
    XFIT(I)=TMIN*TRATIO**EXNS
  WRITE (6,25) N
  WRITE (6,26) (THK(I),I=1,N)
9 COMPUTATION OF GEOMETRY DISTRIBUTION AND
  NORMALIZED DISTRIBUTION FUNCTION
C ***** * PROGRAM OPERATION REFERENCE NO. 85 *****
C
  IMIN=N
  DO 13 IR=1,NSA
    DO 10 I=1,N
      IBIN=I
      IF (EQVT(IR).LE.THK(I)) GO TO 11
10 CONTINUE
    GO TO 13
11 IMIN=MIN0(IBIN,IMIN)
    DO 12 IB=IBIN,N
      GM(IB)=GM(IB)+1.0
12

```

E 43
E 44
E 45
E 45A
E 45M
E 45C
E 45U
E 46
E 47
E 48
E 49
E 50
E 51
E 52
E 53
E 54
E 55
E 56
E 57
E 58
E 59
E 60
E 61
E 62
E 63
E 64
E 65
E 66
E 67
E 68
E 69
E 70
E 71
E 72
E 73
E 74
E 75
E 76
E 77
E 78
E 79

==11

```

13 CONTINUE
   NPTS=N-IMIN+1
   I=IMIN-1
   C ***** * PROGRAM OPERATION REFERENCE NO. 86 *****
     TNSA=NSA
     DO 14 K=1,NPTS
       I=I+1
       THK(K)=THK(I)
       GM(K)=GM(I)/TNSA
       NMIN(I)=1
       NSTOP(I)=0
   C
   C      SPLIT DISTRIBUTION FUNCTION INTO NSECT PARTS AND
   C      CURVE FIT EACH BY LEAST SQUARES
   C ***** * PROGRAM OPERATION REFERENCE NO. 87 *****
     DO 21 NSC=1,NSECT
       KEEP=0
       IF (NSC.GT.1) KFEF=1
       NM=NMIN(NSC)
       DO 15 NI=NM,NPTS
         IF (THK(NI).GT.XFIT(NSC)) GO TO 16
         KEEP=KEEP+1
         T(KEEP)=THK(NI)
         GTHDS(KEEP)=GM(NI)
       CONTINUE
       NI=NPTS
       IF (KEEP.GT.1) GO TO 17
       NSDEG(NSC)=0
       WRITE (6,27) NSC
       NS1=NSC+1
       IF (NSC.LT.NSECT) NMIN(NS1)=NMIN(NSC)
       GO TO 21
   C
   C 17 NSTOP(NSC)=NI-1
       NDEG=NSDEG(NSC)
       IF (T(KEEP).EQ.XFIT(NSC)) GO TO 18
       KEEP=KEEP+1
       T(KEEP)=XFIT(NSC)
       GTHDS(KEEP)=((GM(NI)-GM(NI-1))/(THK(NI)-THK(NI-1)))*(XFIT(NSC)-THK
       1(NI-1))+GM(NI-1)
       CALL LEAST
   C 18

```

E 80
E 81
E 82

E 83
E 84
E 85
E 86
E 87
E 88
E 89
E 90
E 91
E 92

E 93
E 94
E 95
E 96
E 97
E 98
E 99
E 100
E 101
E 102
E 103
E 104
E 105
E 106
E 107
E 108
E 109
E 110
E 111
E 112
E 113
E 114
E 115
E 116
E 117
E 118
E 119

==12

```

YFIT(NSC)=GTHDS(KEEP)
WRITE (6,28) NSC
NCF=NDEG+1
DO 19 K=1,KEEP
Y(K)=C(I)
XP=1.0
DO 19 J=2,NCF
XP=XP*T(K)
19 Y(K)=C(J)*XP+Y(K)
WRITE (6,29) (T(K),GTHDS(K),Y(K),K=1,KEEP)
WRITE (6,30) NCF
WRITE (6,29) (C(J),J=1,NCF)
DO 20 J=1,NCF
CSECT(J,NSC)=C(J)
20 C
IF (NSC.GE.NSECT) GO TO 21
T(1)=XFIT(NSC)
GTHDS(1)=GTHDS(KEEP)
NSI=NSC+1
NMIN(NSI)=NSTOP(NSC)+1
21 CONTINUE
C
RETURN
C
22 FORMAT (6I12)
23 FORMAT (6E12.8)
24 FORMAT (1H0,10X,6HXMAX =,E14.7,2X,5HTAU =,E14.7,2X,6HDELR =,E14.7)
25 FORMAT (1H0,5X,15,2X,28HWEIGHTED VALUES OF THICKNESS//)
26 FORMAT (5X,5E20.8)
27 FORMAT (1H0,5X,26HZERO POINTS WITHIN SECTION,I4)
28 FORMAT (1H0,15X,20HCURVE FIT OF SECTION,I5/1H0,20X,9HTHICKNESS,11X
1,12HDISTRIBUTION,8X,13HCURVE FIT PT.//)
29 FORMAT (14X,3E20.8)
30 FORMAT (1H0,20X,I3,3X,12HCOEFFICIENTS//)
31 FCRMAT(1H0,5X,43HTHE SOLID ANGLE AREAL DENSITY DISTRIBUTION ,22HIS
1 A STEP FUNCTION AND/6X,14HITS CURVE FIT ,50HCOEFFICIENTS ARE NOT
2COMPUTED OR STORED ON TAPE 9./1H0,5X,44HALL SOLID ANGLE AREAL DENS
3ITIES ARE EQUAL TO,E17.8,13H GRAMS/SQ.CM.)
END
SUBROUTINE ORDER
DIMENSION BPL(21000), PLDATA(2,1000), MATND(1000)
DIMENSION IPOSN(1000)

```

E 120
E 121
F 122
E 123
E 124
E 125
E 126
E 127
E 128
E 129
E 130
E 131
E 132
E 133
E 134
E 135
E 136
E 137
E 138
E 139
E 140
E 141
E 142
E 143
E 144
E 145
E 146
E 147
E 148
E 149
E 150
E 151
E 152
E 153
E 153A
E 153R
E 153C
E 153D
E 154-
F 1
F 2
F 3

==13

```

C      COMMON /ITSTOR/ IPATH(1000), IREC, NRTOT, NPARTS, (PUNCH, ISORT
C      COMMON /MAT, TTLSTD(3), TTLMAT(3,50)
C
C      THIS ROUTINE CONTROLS THE MEANS OF SORTING ACCORDING
C      TO RAY NUMBER AND ORDER OF SOLIDS ENCOUNTERED FOR EACH RAY.
C
C      ISORT=0
C      REWIND 20
C      NMAX=21000
C      IRI=1
C      NRAYS=NRTOT/NPARTS
C      ***** * PROGRAM OPERATION REFERENCE NO. 88 *****
C      NEND=0
C      DO 1 IR=1, NRAYS
C      NEND=IPATH(IR)+NEND
C
C      DO 3 I=1, 1000
C      MA1NO(I)=C
C      DO 3 J=1, 2
C      PLDATA(J, I)=0.0
C      DO 4 I=1, NMAX
C      BPL(I)=0.0
C
C      COMPUTE NO. LOCATIONS NEEDED FOR ALL OR PORTION
C      ***** * PROGRAM OPERATION REFERENCE NO. 89 *****
C      OF PATH LENGTH DATA
C      NSMAX=0
C      DO 6 IR=IR1, NRAYS
C      IR2=IR
C      NSMAX=3*IPATH(IR)+NSMAX
C      IF (NSMAX-NMAX) 6, 7, 5
C      NSMAX=NSMAX-3*IPATH(IR)
C      IR2=IR2-1
C      GO TO 7
C      ***** * PROGRAM OPERATION REFERENCE NO. 90 *****
C      CONTINUE
C      NPC=NSMAX/3
C      WRITE (6,23) NPC, NEND
C
C      INTERNAL SORT BY PACKING PATH LENGTH DATA IN AVAILABLE CORE
C      ACCORDING TO RAY NO. TO BE SORTED ON X IN CM.
C

```

F 4
 F 5
 F 6
 F 7
 F 8
 F 9
 F 10
 F 11
 F 12
 F 13
 F 14
 F 15
 F 16
 F 17
 F 18
 F 19
 F 20
 F 21
 F 22
 F 23
 F 24
 F 25
 F 26
 F 27
 F 28
 F 29
 F 30
 F 31
 F 32
 F 33
 F 34
 F 35
 F 36
 F 37
 F 38
 F 39
 F 40
 F 41
 F 42

=14

```

IF (ISORT.EQ.0) WRITE (6,19)
INDEX=1
IPOSN(1)=1
IR3=IR1+1
IF (IR3.GT.NRAYS) IR3=NRAYS
IF (IR3.EQ.IR2) GO TO 9
DO 8 IR=IR3,IR2
INDEX=INDEX+1
8 IPOSN(INDEX)=3*IPATH(IR-1)+IPOSN(INDEX-1)
C ***** * PROGRAM OPERATION REFERENCE NO. 91
9 DO 10 N=1,NEND
READ (20) IR,IPT,X,DX,MAT
IF (ISORT.EQ.0) WRITE (6,20) IR,IPT,X,DX,MAT
IF (IR1.GT.IR.OR.IR2.LT.IR) GO TO 10
C
C STORAGE BLOCK
INDEX=IR-IR1+1
NBLOC=3*(IPT-1)+IPOSN(INDEX)
BPL(NBLOC)=X
BPL(NBLOC+1)=DX
BPL(NBLOC+2)=MAT
10 CONTINUE
C
C STORAGE COMPLETED, NOW SORT ON X FOR EACH IR
IF (ISORT.EQ.0) WRITE (6,24)
IF (ISORT.EQ.0) WRITE (6,25)
ISORT=1
C ***** * PROGRAM OPERATION REFERENCE NO. 92
NSTRT=1
DO 17 IR=IR1,IR2
NHIT=IPATH(IR)
IF (NHIT.LE.0) GO TO 17
DO 12 I=1,NHIT
N1=NSTRT
PLDATA(I,I)=-1.0
INDX=N1
C GET MAXIMUM, THEN THROW OUT
DO 11 J=1,NHIT
IF (BPL(N1).LE.PLDATA(I,I)) GO TO 11
INDX=N1
IF (BPL(N1).LE.PLDATA(I,I)) GO TO 11
INDX=N1

```

```

F 43
F 44
F 45
F 46
F 47
F 48
F 49
F 50
F 51
*****
F 52
F 53
F 54
F 55
F 56
F 57
F 58
F 59
F 60
F 61
F 62
F 63
F 64
F 65
F 66
F 67
F 68
F 69
F 70
F 71
F 72
F 73
F 74
F 75
F 76
F 77
F 78
F 79
F 80
F 79
F 80

```

=15

```
PLDATA(1,1)=BPL(N1)
PLDATA(2,1)=8PL(N1+1)
MATNO(I)=8PL(N1+2)
N1=N1+3
BPL(INDX)=-1.0
CONTINUE
NSTRT=3*NHIT+NSTRT

      PUNCH AND/OR BINARY TAPE ACCORDING TO VALUE OF IPUNCH *****
      ***** * PROGRAM OPERATION REFERENCE NO. 93 *****
C
C
C
C
C
C
DO 16 I=1,NHIT
MN=MATNO(I)
IF (I.GT.1) GO TO 13
WRITE (6,21) IR,I,(PLDATA(J,I),J=1,2),MN,(TTLMAT(K,MN),K=1,3)
GO TO 14
13 WRITE (6,22) I,(PLDATA(J,I),J=1,2),MN,(TTLMAT(K,MN),K=1,3)
14 IF (IPUNCH.LE.0) GO TO 16
IF (IPUNCH.GT.7) GO TO 15
WRITE (7,26) IR,I,MATNO(I),(PLDATA(J,I),J=1,2)
IF (IPUNCH.EQ.7) GO TO 15
15 WRITE (8) IR,I,MATNO(I),(PLDATA(J,I),J=1,2)
16 CONTINUE
17 CONTINUE
IF (IR2.GE.NRAYS) GO TO 18
IR1=IR2+1
REWIND 20
GO TO 2
C
18 IF (IPUNCH.LE.0.OR.IPUNCH.EQ.7) RETURN
END FILE 8
RETURN
C
19 FORMAT (8HORAY NO.,2X,8HPATH NO.,1X,17HDISTANCE TO (CM.),4X,25HPAT
1H THROUGH (GM./SQ.CM.),4X,12HMATERIAL NO.//)
20 FORMAT (3X,I5,6X,I4,3X,E15.8,10X,E15.8,16X,I4)
21 FORMAT (1H0,3X,I5,6X,I4,3X,E15.8,10X,E15.8,7X,I4,2X,3A1C)
22 FORMAT (15X,I4,3X,E15.8,10X,E15.8,7X,I4,2X,3A10)
23 FORMAT (1H1,10X,12HNO. PATHS IS,16,9H OF TOTAL,17)
24 FORMAT (1H0,4X,37HAREAL DENSITIES, SORTED ACCORDING TO ,2CHRAY NO.
1 AND DISTANCE)
```

==16

```

25  FORMAT (8HORAY NO.,2X,8HPATH NO.,1X,17HDISTANCE TO (CM.),4X,25HPAT F 122
    1H THROUGH (GM./SQ.CM.),4X,8HMAT. NO.,2X,9HMAT. NAME//) F 123
26  FORMAT (3I5,2E15.8) F 124
    END F 125-
    SUBROUTINE CLOCK (TIME) G 1
    CALL SECOND (X) G 2
    TIME=X/60 G 3
    RETURN G 4
    END G 5-
    SUBROUTINE GENTAP (CONTEN) H 1
    DIMENSION CONTEN(15), GEOMTY(7) H 2
    C THIS SUBROUTINE CREATES THE MULTIFILE TAPE CONTAINING -- H 3
    C 1.) SPACECRAFT GEOMETRY H 4
    C 2.) SIMULATED ASTRONAUT GEOMETRY H 5
    DATA BLANK/1CH H 6
    WRITE (6,6) CONTEN H 7
    WRITE (6,7) H 8
    NT=10 H 9
    REWIND NT H 10
    NF=1 H 11
    C ***** * PROGRAM OPERATION REFERENCE NO. 4 ***** H 12
    NCD=0 H 13
    1 READ (5,8) GEOMTY H 14
    NCD=NCD+1 H 15
    DO 2 I=1,7 H 16
    IF (GEOMTY(I).NE.BLANK) GO TO 3 H 17
    CONTINUE H 18
    GO TO 4 H 19
    C H 20
    3 WRITE (6,9) NCD,GEOMTY H 21
    WRITE (NT,8) GEOMTY H 22
    GO TO 1 H 23
    C H 24
    4 NCD=NCD-1 H 25
    END FILE NT H 26
    IF (NF.EQ.2) GO TO 5 H 27
    NF=2 H 28
    WRITE (6,10) H 29
    WRITE (6,7) H 30
    NCD=0 H 31
    H 32

```

=17

```

C      GO TO 1
5      REWIND NT
      RETURN
C
6      FORMAT (1H1,10X,15A4)
7      FORMAT (12H0 RECORD NO.,10X,8HCONTENTS//)
8      FORMAT (7A10)
9      FORMAT (112,3X,7A10)
10     FORMAT (1H1,10X,28HSIMULATED ASTRONAUT GEOMETRY)
      END
      SUBROUTINE TRSHLD (NOS)
      DIMENSION SHLDD(38), XDET(3), X(8,3), XTRAN(30), NSO(9), SPN(38,10)
      1), NLIMB(10)
      INTEGER SSN,ST,OCT,TG,PRNT
      COMMON /COORD/ XYZ(40)
      EQUIVALENCE (XY7(1),XDET), (XYZ(4),RPHI), (XYZ(5),XTRAN)
C
C      PREPARATION OF GEOMETRY TRANSFORMATION DATA TAPE FOR THE
C      PRIMARY IONIZATION DOSE AND FLUX ANALYSIS AND/OR CHECK OF
C      GEOMETRY BY RADIAL SCANS OF ANY CROSS SECTION ON THE CRT
C
      REWIND 10
      REWIND 12
      N=0
      NOS=0
      DO 1 J=1,9
      NSO(J)=0
      READ (5,42) (XDET(I),I=1,3),NS,PRNT
      READ (5,43) NOMAN,NMEN,(NLIMB(I),I=1,NMEN)
      NOMAN=NMEN*NOMAN
      WRITE (6,44) (XDET(I),I=1,3)
      INN=0
      TG=10
C
      IF (NOMAN.GT.0.OR.NS.GT.0) GO TO 2
C      INPUT DATA ERROR
      WRITE (6,45) NOS,NOMAN
      STOP
2      IF (NS.LE.0) GO TO 39
C      ***** * PROGRAM OPERATION REFERENCE NO. 20 *****

```

```

H 33
H 34
H 35
H 36
H 37
H 38
H 39
H 40
H 41
H 42
H 43-
I 1
I 2
I 3
I 4
I 5
I 6
I 7
I 8
I 9
I 10
I 11
I 12
I 13
I 14
I 15
I 16
I 17
I 18
I 19
I 20
I 21
I 22
I 23
I 24
I 25
I 26
I 27
I 28
I 29
I 30

```

==18

```
C 3 READ (TG,46) SSN,ST,MATCD,RPHI,RHG,JMAX,VCOMP
C ***** * PROGRAM OPERATION REFERENCE NO. 15
C IF (ENDFILE TG) 39,4
4 NOS=NUS+1
C IF (NCOMP.GT.0.AND.NCOMP.LE.10) GO TO 5
5 IF (ST.GT.1) GO TO 6
  NP=8
  GO TO 10
6 IF (ST.GT.9) GO TO 7
  NP=2
  GO TO 10
C ***** * PROGRAM OPERATION REFERENCE NO. 6
7 IF (ST.LT.12) GO TO 9
  NP=6
  JM=IABS(JMAX)
  READ (TG,47) ((X(I,J),J=1,3),I=1,JM)
  IF (JM.GE.6) GO TO 11
  JJ=JM+1
  DO 8 I=JJ,6
  DO 8 K=1,3
  X(I,K)=0.0
  GO TO 11
9 NP=3
10 READ (TG,47) ((X(I,J),J=1,3),I=1,NP)
C ***** * PROGRAM OPERATION REFERENCE NO. 7
C *****
11 IJ=0
  DO 12 I=1,3
  DO 12 J=1,NP
  IJ=IJ+1
C ***** * PROGRAM OPERATION REFERENCE NO. 8
12 XTRAN(IJ)=X(J,I)
C ***** * PROGRAM OPERATION REFERENCE NO. 9
C *****
C ELEMENTAL VOLUME TRANSFORMATIONS
  IST=ST+1
C
C HEX. CYL. SPH. HFM.
C GO TO (13,13,15,15,19,19,21,21,22,22,25,25,28,28), IST
C CON TR. CONE ELL.
I 31
I 32
*****
I 33
I 34
I 35
I 36
I 37
I 38
I 39
I 40
I 41
I 42
*****
I 43
I 44
I 45
I 46
I 47
I 48
I 49
I 50
I 51
I 52
I 53
I 54
*****
I 55
I 56
I 57
I 58
I 59
*****
I 60
*****
I 61
I 62
I 63
I 64
I 65
I 66
I 67
```

==19

```

C      SHIELD TYPE ERROR
C      WRITE (6,48) SSN,ST
C      STOP
C      ***** * PROGRAM OPERATION REFERENCE NO. 17 *****
C      CALL HEX (OCT)
13     NX=28
        IF (PRNT.EQ.0) GO TO 31
        WRITE (6,49) SSN,ST,OCT,MATCD,RHO
        DO 14 I=1,8
14     WRITE (6,50) (XTRAN(J),J=1,24,8)
        GO TO 31
C
15     CALL CYLNR (OCT)
        NX=19
        IF (PRNT.EQ.0) GO TO 31
        WRITE (6,49) SSN,ST,OCT,MATCD,RHO
        DO 17 I=1,2
17     WRITE (6,50) (XTRAN(J),J=1,6,2)
        WRITE (6,51) RPHI
        WRITE (6,52)
        DO 18 I=7,9
18     WRITE (6,50) (XTRAN(J),J=1,15,3)
        GO TO 31
C
19     CALL SPHERE (OCT)
        NX=10
        IF (PRNT.EQ.0) GO TO 31
        WRITE (6,49) SSN,ST,OCT,MATCD,RHO
        DO 20 I=1,2
20     WRITE (6,50) (XTRAN(J),J=1,6,2)
        WRITE (6,51) RPHI
        GO TO 31
C
21     CALL HEMIS (OCT)
        NX=19
        GO TO 16
C
22     CALL CONE (OCT)
        NX=20
        IF (PRNT.EQ.0) GO TO 31

```

```

I 68
I 69
I 70
I 71
I 72
I 73
I 74
I 75
I 76
I 77
I 78
I 79
I 80
I 81
I 82
I 83
I 84
I 85
I 86
I 87
I 88
I 89
I 90
I 91
I 92
I 93
I 94
I 95
I 96
I 97
I 98
I 99
I 100
I 101
I 102
I 103
I 104
I 105
I 106
I 107
I 108

```

==20

```

WRITE (6,49) SSN,ST,OCT,MATCD,RHO
DO 23 I=1,2
WRITE (6,50) (XTRAN(J),J=I,6,2)
WRITE (6,53) RPHI,XYZ(27)
WRITE (6,52)
DO 24 I=7,9
WRITE (6,50) (XTRAN(J),J=I,15,3)
GO TO 31
C
25 CALL TRCON (OCT)
   NX=24
   IF (PRNT.EQ.0) GO TO 31
   WRITE (6,49) SSN,ST,OCT,MATCD,RHO
   DO 26 I=1,3
   WRITE (6,50) (XTRAN(J),J=I,9,3)
   WRITE (6,54) RPHI,XYZ(23),XYZ(24)
   WRITE (6,52)
   DO 27 I=10,12
   WRITE (6,50) (XTRAN(J),J=I,18,3)
   GO TO 31
C
28 CALL ELIPSD (OCT,JM)
   NP=JMAX
   NX=34
   IF (PRNT.EQ.0) GO TO 31
   WRITE (6,49) SSN,ST,OCT,MATCD,RHO
   DO 29 I=1,JM
   WRITE (6,50) (XTRAN(J),J=I,18,6)
   WRITE (6,52)
   DO 30 I=19,21
   WRITE (6,50) (XTRAN(J),J=I,27,3)
   WRITE (6,55) (XTRAN(I),I=28,30)
C
C ***** * PROGRAM OPERATION REFERENCE NO. 16 *****
C TRANSFORMATION COMPLETE
31 SHLDD(1)=OCT
   SHLDD(2)=ST
   SHLDD(3)=SSN
   SHLDD(4)=MATCD
   SHLDD(5)=RHO
   SHLDD(6)=NP
   SHLDD(7)=RPHI

```

```

I 109
I 110
I 111
I 112
I 113
I 114
I 115
I 116
I 117
I 118
I 119
I 120
I 121
I 122
I 123
I 124
I 125
I 126
I 127
I 128
I 129
I 130
I 131
I 132
I 133
I 134
I 135
I 136
I 137
I 138
I 139
I 140
I 141
I 142
I 143
I 144
I 145
I 146
I 147
I 148
I 149

```

=21

```
I 150
I 151
I 152
I 153
I 154
I 155
I 156
I 157
I 158
I 159
I 160
I 161
I 162
I 163
I 164
I 165
I 166
I 167
I 168
I 169
I 170
I 171
I 172
I 173
I 174
I 175
I 176
I 177
I 178
I 179
I 180
I 181
I 182
I 183
I 184
I 185
I 186
I 187
I 188

SHLDD(3R)=NCOMP
NSO(OCT)=NSO(OCT)+1
NSD=NX+3
DO 32 I=8,NSD
C ***** * PROGRAM OPERATION REFERENCE NO. 18 *****
32 SHLDD(I)=XYZ(I-3)
K=NSD+1
IF (NSD.GE.37) GO TO 34
DO 33 I=K,37
33 SHLDD(I)=0.0
C
34 IF (NCOMP.EQ.1) GO TO 38
IF (INN+1.GF.NCOMP) GO TO 36
C ***** * PROGRAM OPERATION REFERENCE NO. 19 *****
INN=INN+1
DO 35 J=1,38
35 SPN(J,INN)=SHLDD(J)
NDS=NDS+1
READ (TG,46) SSN,ST,MATCD,RPHI,RHD,JMAX
GO TO 5
C
C COMPOSITE SHIELD COMPLETED - PLACE ON DIRECT ACCESS
36 INN=0
NC1=NCOMP-1
DO 37 ICP=1,NC1
37 WRITE (I2) (SPN(J,ICP),J=1,38)
C
38 WRITE (I2) (SHLDD(J),J=1,38)
GO TO 3
C
39 IF (NMEN.LE.0) GO TO 40
C
C SIMULATE ASTRONAUTS IN SURSEQUENT SUBROUTINE.
C ***** * PROGRAM OPERATION REFERENCE NO. 14 *****
C TRANSFORMATION TO SPACECRAFT COORDINATE SYSTEM
CALL FANTOM (NOMAN,NMEN,NLIMB,TG)
NMEN=0
GO TO 3
C
40 NSPCR=NDS-NOMAN
WRITE (6,56) NSPCR,NOMAN
END FILE 12
```

==22

```

WRITE (6,57)
DO 41 J=1,9
WRITE (6,58) NSO(J),J
RETURN
C
42 FORMAT (3E12.8,2I10)
43 FORMAT (14I5)
44 FORMAT (1H1,19X,26HDETECTOR POINT COORDINATES/1HC,16X,1HX,16X,1HY,
116X,1HZ/(13X,3E17.8))
45 FORMAT (1HC,5X,16HINPUT DATA ERROR/6X,22HNO. SPACECRAFT VOLUMES,I6
1,3X,21HNO. ASTRONAUT VOLUMES,I6)
46 FORMAT (1X,I4,I2,I3,2F10.0,2I5)
47 FORMAT (6F10.0)
48 FORMAT (1H0,5X,15HSHIELD SER. NO.,I6,3X,4HTYPE,I4)
49 FORMAT (1H0,16X,8HSER. NO.,I5,3X,4HTYPE,I3,3X,6HOCTANT,I2,3X,8HMAT
SERIAL,I4,3X,7HDFENSITY,E15.8/1H0,26X,1HX,16X,1HY,16X,1HZ)
50 FORMAT (20X,3E17.8)
51 FORMAT (22X,8HRADIUS =,E15.8)
52 FORMAT (1H0,26X,19HROTATION MATRIX - A1
FORMAT (22X,5HPHI =,E15.8,3X,8HRADIUS =,E15.8)
53
54 FORMAT (22X,5HPHI =,E15.8,3X,4HRB =,E15.8,3X,4HRT =,F15.8)
55 FORMAT (1H0,21X,24HLENGTH OF ELLIPSOID AXES/(20X,3E17.8))
56 FORMAT (1H0,19X,27HNO. VOLUMES OF SPACECRAFT =,I6,3X,27HNO. DESCRI
BING ASTRONAUTS =,I6)
57 FORMAT (1H0,19X,21HNO. SHIELDS IN OCTANT)
58 FORMAT (23X,I5,9X,I2)
END
SUBROUTINE FILE (NTAPE,NEWF,NOLDF)
C
C THIS SUBROUTINE WILL MOVE TAPE NO. NTAPE TO BEGINNING OF
C FILE NO. NEWF + 1.
C THIS ROUTINE IS TO BE USED WITH XK0009 (APDL17) ON OS/360.
C
C CONDITIONS - - -
C 1.) TAPE UNIT MUST NOT CHANGE WITHIN ANY COMPUTER RUN.
C 2.) NEWF = NO. OF END OF FILE MARKS (DATA SETS) PRECEDING
C THE FILE TO READ OR WRITE.
C 3.) NOLDF = NO. OF THE LAST FILE PROCESSED.
C
IF (NEWF.EQ.0.AND.NOLDF.EQ.0) RETURN
IF (NOLDF.EQ.J.OR.NEWF.LT.NOLDF) GO TO 6
IF (NEWF.GT.NOLDF) GO TO 2
BACKSPACE NTAPE

```

I 189
I 190
I 191
I 192
I 193
I 194
I 195
I 196
I 197
I 198
I 199
I 200
I 201
I 202
I 203
I 204
I 205
I 206
I 207
I 208
I 209
I 210
I 211
I 212
I 213
I 214
I 215-
J 1
J 2
J 3
J 4
J 5
J 6
J 7
J 8
J 9
J 10
J 11
J 12
J 13
J 14
J 15

==23

```

1 READ (NTAPE)
C IF (ENDFILE NTAPE) 5,1
C ***** * PROGRAM OPERATION REFERENCE NO. 5 *****
C READ TO AHEAD TO BEGIN AT NEWF+1
2 NSKIP=NEWF-NOLDF
C DO 4 N=1,NSKIP
3 READ (NTAPE)
C IF (ENDFILE NTAPE) 4,3
4 CONTINUE
5 NOLDF=NEWF+1
C RETURN
C NEW FILE .LE. OLD FILE NUMBER
C REWIND NTAPE
6 IF (NEWF.LT.1) RETURN
C DO 8 N=1,NEWF
7 READ (NTAPE)
C IF (ENDFILE NTAPE) 8,7
8 CONTINUE
C NOLDF=NEWF+1
C RETURN
C END
C SUBROUTINE FANTOM (NOMAN,NMEN,NLB,NGT)
C DIMENSION EPSLN(10), XCMAN(8,3,10), Y(8,3,10), XRMAN(8,3,10), TITL
C 1E(7,10), W(4,3), R4A(3), NLB(10), SHIELD(7), XMAN(8,3), XMA(8,3),
C 2XMT(8,3)
C INTEGER SSN,ST
C REAL L(3,3)
C DATA NZ,PI/O,3.1415927/
C
C NOMAN = TOTAL NO. ELEMENTAL VOLUMES OF ALL MEN.
C NLIMB = NO. COMPOSITE SHIELDS TO ROTATE IN EACH MAN.
C BASIC MAN DATA ON TAPE UNIT NGT.
C ALL VOLUMES TO ROTATE ARE C/LINDERS.
C
C ADCV=PI/180.0
C N11MAN=NOMAN/NMEN
C REWIND 13
C DO 24 M=1,NMEN
C CALL FILE (NGT,1,NZ)
C NLIMB=NLB(M)

```

J 16
J 17
J 18
J 19
J 20
J 21
J 22
J 23
J 24
J 25
J 26
J 27
J 28
J 29
J 30
J 31
J 32
J 33
J 34
J 35
J 36
J 37-
K 1
K 2
K 3
K 4
K 5
K 6
K 7
K 8
K 9
K 10
K 11
K 12
K 13
K 14
K 15
K 16
K 17
K 18
K 19

==24

```

      READ (5,27) ((W(I,J),J=1,3),I=1,4),(R4A(K),K=1,3)
      DO 1 I=1,3
        DIST=SQRT((W(I,1)-W(4,1))**2+(W(I,2)-W(4,2))**2+(W(I,3)-W(4,3))**2
        1)
      DO 1 J=1,3
        L(I,J)=(W(I,J)-W(4,J))/DIST
        IF (NLIMB.LE.C) GO TO 14
C-----
      DO 13 N=1,NLIMB
        READ (NGT,25) (TITLE(I,1),I=1,7)
        BACKSPACE NGT
        READ (NGT,26) SSN,ST,MATCD,RPHI,RHO,JMAX,NCOMP
        READ (NGT,27) (XCMAN(I,J,1),J=1,3),I=1,2)
      DO 2 J=1,3
      DO 2 I=1,3,8
        XCMAN(I,J,1)=0.0
        READ (5,27) (EPSLN(I),I=1,NCOMP)
        IF (NCOMP.LF.1) GO TO 7
        NCM2=NCOMP-?
        NCHX=NCM2+1
      DO 4 ICP=2,NCM2
        READ (NGT,25) (TITLE(I,ICP),I=1,7)
        READ (NGT,27) (XCMAN(I,J,ICP),J=1,3),I=1,2)
      DO 3 J=1,3
      DO 3 I=1,3,8
        XCMAN(I,J,ICP)=0.0
      CONTINUE
      DO 5 ICP=NCHX,NCOMP
        READ (NGT,25) (TITLE(I,ICP),I=1,7)
        READ (NGT,27) (XCMAN(I,J,ICP),J=1,3),I=1,8)
      DO 6 ICP=1,NCOMP
        EPSLN(ICP)=RADCV*EPSLN(ICP)
C-----
      ROTATION OF LIMBS
      CALL LIMROT (NCOMP,XCMAN,XRMAN,EPSSLN)
C-----
      ROTATION AND TRANSLATION TO ABCS
      DO 9 ICP=1,NCOMP
      DO 9 I=1,8
      DO 8 K=1,3
        Y(I,K,ICP)=L(1,K)*XRMAN(I,1,ICP)+L(2,K)*XRMAN(I,2,ICP)+L(3,K)*XRMA
        1N(I,3,ICP)

```

X 62
 K 63
 K 64
 K 65
 K 66
 K 67
 K 68
 K 69
 K 70
 K 71
 K 72
 K 73
 K 74
 K 75
 K 76
 K 77
 K 78
 K 79
 K 80
 K 81
 K 82
 K 83
 K 84
 K 85
 K 86
 K 87
 K 88
 K 89
 K 90
 K 91
 K 92
 K 93
 K 94
 K 95
 K 96
 K 97
 K 98
 K 99
 K 100
 K 101
 K 102
 K 103

```

8 CONTINUE
9 DO 9 K=1,3
  XRMAN(I,K,ICP)=R4A(K)+Y(I,K,ICP)
  DO 10 ICP=1,NCM2
  WRITE (13,25) (TITLE(I,ICP),I=1,7)
  WRITE (13,27) ((XRMAN(I,J,ICP),J=1,3),I=1,2)
  DO 11 ICP=NCHX,NCOMP
  DO 11 I=5,7,2
  II=I+1
  DO 11 J=1,3
  Y(I,J,ICP)=XRMAN(II,J,ICP)
  Y(II,J,ICP)=XRMAN(I,J,ICP)
  XRMAN(I,J,ICP)=Y(I,J,ICP)
  XRMAN(II,J,ICP)=Y(II,J,ICP)
  DO 12 ICP=NCHX,NCOMP
  WRITE (13,25) (TITLE(I,ICP),I=1,7)
  WRITE (13,27) ((XRMAN(I,J,ICP),J=1,3),I=1,8)
  CONTINUE
  NLEFT=NIIMAN-NCOMP
  IF (NLEFT.LE.0) GO TO 24
  C
  C TRANSFORMATION OF REMAINING MAN COORDINATES TO ABCS
  DO 23 N=1,NLEFT
  READ (NGT,25) SHIELD
  BACKSPACE NGT
  READ (NGT,26) SSN,ST,MATCD,RPHI,PHO,JMAX,NCOMP
  WRITE (13,25) SHIELD
  NST=ST+1
  C
  C GO TO (15,15,16,16,16,16,16,16,16,16,17,17,18,18), NST
  C
  NP=8
  GO TO 19
  NP=2
  GO TO 19
  NP=3
  GO TO 19
  NP=IABS(JMAX)
  C
  READ (NGT,27) ((XMAN(I,J),J=1,3),I=1,NP)
  IF (NST.GT.2) GO TO 21
  DO 20 I=5,7,2
  
```

```

I1=I+1
DO 20 J=1,3
XMT(I,J)=XMAN(I1,J)
XMT(I1,J)=XMAN(I,J)
XMAN(I,J)=XMT(I,J)
XMAN(I1,J)=XMT(I1,J)
20 C
DO 22 I=1,NP
DO 22 J=1,3
XMA(I,J)=L(1,J)*XMAN(I,1)+L(2,J)*XMAN(I,2)+L(3,J)*XMAN(I,3)
XMT(I,J)=XMA(I,J)+R4A(J)
22 C
WRITE (13,27) ((XMT(I,J),J=1,3),I=1,NP)
24 CONTINUE
NGT=13
REWIND 13
RETURN
C
FORMAT (7A10)
25 FORMAT (15,I2,I3,2F10.0,2I5)
26 FORMAT (6F10.5)
27 END
SUBROUTINE LIMROT (NCOMP,XCMAN,XRMAN,EPSSLN)
DIMENSION XCMAN(8,3,10),XRMAN(8,3,10),EPSSLN(10),ALPHA(3,3),NCF
1(48),NCROT(48),NCPT(48),XFR(8,3,10),XYZ(3)
C
DATA NCF/3*1,2,3*3,4,11*5,9*6,11*7,9*8/,NCRPT/1,3*2,3,3*4,5,2*6,8*
19,6,8*9,7,2*8,8*10,8,8*10/,NCPT/2,1,3*2,1,3*2,1,2,1,2,3,4,5,6,7,8,
22,1,2,3,4,5,6,7,8,2,1,2,1,2,3,4,5,6,7,8,2,1,2,3,4,5,6,7,8/
C
ROTATION OF THE LIMBS OF THE ASTRONAUT IN THE
MAN COORDINATE SYSTEM
C
DO 1 I=1,NCOMP
DO 1 J=1,8
DO 1 K=1,3
XRMAN(J,K,I)=XCMAN(J,K,I)
XFR(J,K,I)=XCMAN(J,K,I)
1 C
ROTATION OF POINTS
DO 7 IR=1,48
NF=NCF(IR)
NR=NCROT(IR)
C

```

K 104
K 105
K 106
K 107
K 108
K 109
K 110
K 111
K 112
K 113
K 114
K 115
K 116
K 117
K 118
K 119
K 120
K 121
K 122
K 123
K 124-
L 1
L 2
L 3
L 4
L 5
L 6
L 7
L 8
L 9
L 10
L 11
L 12
L 13
L 14
L 15
L 16
L 17
L 18
L 19
L 20
L 21

==27

L	22
L	23
L	24
L	25
L	26
L	27
L	28
L	29
L	30
L	31
L	32
L	33
L	34
L	35
L	36
L	37
L	38
L	39
L	40
L	41
L	42
L	43-
M	1
M	2
M	3
M	4
M	5
M	6
M	7
M	8
M	9
M	10
M	11
M	12
M	13
M	14
M	15
M	16
M	17
M	18
M	19
M	20

```

NC=NCPT(IR)
SINEPS=SIN(EPSLN(NF))
COSEPS=COS(EPSLN(NF))
DO 2 I=1,3,2
  ALPHA(I,2)=0.0
  ALPHA(I,1)=COSEPS
  ALPHA(2,2)=1.0
  ALPHA(1,3)=SINEPS
  ALPHA(3,1)=-SINEPS
DO 3 K=1,3
  XYZ(K)=XRMAN(NC,K,NR)-XFR(1,K,NF)
DO 5 K=1,3
  SUM=C.0
DO 4 J=1,3
  SUM=ALPHA(K,J)*XYZ(J)+SUM
XRMAN(NC,K,NR)=SUM+XFR(1,K,NF)
DO 6 K=1,3
  XFR(NC,K,NR)=XRMAN(NC,K,NR)
CONTINUE
RETURN
END
SUBROUTINE ROOT (A,B,C,R1,R2,ISC)
C
C   TO OBTAIN THE ROOTS OF THE QUADRATIC EQUATION OF
C   VARIOUS SHIELD TYPES
C   SOLUTION FOR SURFACE INTERSECTION
C
COMMON /VARI8/ EPSLN
TWA=2.0*A
DISC=B**2-2.0*TWA*C
IF (ABS(DISC)-1.0E-6*H**2) 2,2,1
IF (DISC) 5,2,3
DISC=C.0
R1=-B/TWA
R2=R1
RETURN
C
C   THERE EXISTS AN INTERSECTION
C   IF (ABS(A).LT.1.E-5) GO TO 6
R1=(-B+SQR(DISC))/TWA
R2=(-B-SQR(DISC))/TWA

```

==28

M	21
M	22
M	23
M	24
M	25
M	26
M	27
M	28
M	29
M	30
M	31
M	32
M	33
M	34
M	35
M	36-
N	1
N	2
N	3
N	4
N	5
N	6
N	7
N	8
N	9
N	10
N	11
N	12
N	13
N	14
N	15
N	16
N	17
N	18
N	19
N	20
N	21
N	22
N	23
N	24
N	25
N	26

```

IF (ABS(K1).LE.EPSLN) R1=0.0
IF (ABS(R2).LE.EPSLN) R2=0.0
IF (R1.LT.0.0.AND.R2.LT.0.0) GO TO 5
IF (R1.LT.0.0) R1=1.0E+20
IF (R2.LT.0.0) R2=1.0E+20
RETURN
C INTERSECTION IMPOSSIBLE
C R1=1.0E+20
C ISC=1
C R2=1.0E+20
C RETURN
C R1=-C/B
C R2=1.0E+20
C GO TO 4
C END
C SUBROUTINE HEX (OCT)
C DIMENSION XHEX(8,3), IN(8,3), DET(3)
C INTEGER OCT
C COMMON /COORD/ XYZ(40)
C EQUIVALENCE (XYZ(1),DET), (XYZ(5),XHEX)
C TO PERFORM A TRANSLATION OF AXES OF HOLLOW AND SOLID HEXAHEDRONS
C TO THE DETECTOR COORDINATE SYSTEM. NO ROTATION OF AXES SINCE IT
C IS DEPENDENT UPON THE DIRECTION OF THE TRACKING RAY.
C SHIELDS IDENTIFIED BY TYPE 0 OR 1
C TRANSLATION OF AXES
C DO 1 J=1,8
C DO 1 K=1,3
C XHEX(J,K)=XHEX(J,K)-DET(K)
C DECIDE OCTANT(S) IN WHICH FIGURE LIES
C DO 8 J=1,8
C DO 7 K=1,3
C IF (XHEX(J,K)) 2,10,3
C IN(J,K)=0
C GO TO 7
C K=K
C GO TO (4,5,6), K
C STOP
C IN(J,1)=4

```

==29

```

5      GO TO 7
      IN(J,2)=2
6      GO TO 7
      IN(J,3)=1
7      CONTINUE
8      IN(J,1)=IN(J,1)+IN(J,2)+IN(J,3)
      DO 9 J=2,8
9      IF (IN(J,1)-IN(J-1,1)) 10,9,10
      CONTINUE
      OCT=IN(1,1)+1
      GO TO 11
      OCT=9
10     RETURN
11     END
      SUBROUTINE CYLNDR (OCT)
      DIMENSION XCL(2,3), X(2,3), A(3,3), IN(2,3), DX(3), DET(3)
      INTEGER OCT
      COMMON /COORD/ XYZ(40)
      EQUIVALENCE (XYZ(1),DET), (XYZ(4),RCL), (XYZ(5),XCL), (XYZ(11),A)
      TO PERFORM TRANSLATION AND ROTATION OF AXES OF HOLLOW AND SOLID
      CYLINDERS SO THAT THE Z-AXIS IS PARALLEL TO AXIS OF CYLINDER.
      SHIELDS ARE IDENTIFIED BY TYPE 2 OR 3.
      ***** * PROGRAM OPERATION REFERENCE NO. 10 *****
      TRANSLATION OF AXES TO DETECTOR SYSTEM
      DO 2 K=1,3
      DO 1 J=1,2
1      X(J,K)=XCL(J,K)-DET(K)
2      DX(K)=X(2,K)-X(1,K)
      ***** * PROGRAM OPERATION REFERENCE NO. 11 *****
      FUNCTIONS OF ANGLES FOR ROTATION OF AXES
      IF (DX(1)) 4,3,5
3      COSPHI=0.0
      SINPHI=1.0
      GO TO 7
4      C=-1.0
      GO TO 6
5      C=1.0
      TANPHI=DX(2)/DX(1)
6      COSPHI=C/SQRT(1.0+TANPHI**2)

```

```

N 27
N 28
N 29
N 30
N 31
N 32
N 33
N 34
N 35
N 36
N 37
N 38
N 39
N 40-
O 1
O 2
O 3
O 4
O 5
O 6
O 7
O 8
O 9
O 10
O 11
O 12
O 13
O 14
O 15
O 16
O 17
O 18
O 19
O 20
O 21
O 22
O 23
O 24
O 25
O 26

```

==3C

```

7      SINPHI=SQRT(1.0-COSPHI**2)
8      IF (DX(2)) 9,9,9
9      SINPHI=-SINPHI
      CL=SQRT(DX(1)**2+DX(2)**2+DX(3)**2)
      COSTH=DX(3)/CL
      SINTH=SQRT(1.0-COSTH**2)
      IF (ABS(COSTH).NE.1.0) GO TO 10
      COSPHI=0.0
      ***** * PROGRAM OPERATION REFERENCE NO. 12 *****
      SINPHI=COSTH
      C
      C      SET UP MATRIX FOR ROTATION
10     A(1,1)=SINPHI
      A(1,2)=-COSPHI
      A(1,3)=0.0
      A(2,1)=COSTH*COSPHI
      A(2,2)=COSTH*SINPHI
      A(2,3)=-SINTH
      A(3,1)=SINTH*COSPHI
      A(3,2)=SINTH*SINPHI
      A(3,3)=COSTH
      C
      C      COORDINATES IN ROTATED DETECTOR SYSTEM
      DO 11 I=1,2
      DO 11 K=1,3
      XCL(I,K)=A(K,1)*X(I,1)+A(K,2)*X(I,2)+A(K,3)*X(I,3)
      C
      C      DECIDE THE OCTANT IN WHICH THE FIGURE LIES
      DO 19 I=1,2
      DO 18 K=1,3
      XIK=X(I,K)
      S1=SIGN(XIK,XIK+RCL)
      S2=SIGN(XIK,XIK-RCL)
      IF (S2-S1) 21,12,21
      IF (X(I,K)) 13,21,14
      IN(I,K)=C
      GO TO 18
      GO TO (15,16,17), K
      STOP
      IN(I,K)=4
      GO TO 18
      IN(I,K)=2

```

```

0 27
0 28
0 29
0 30
0 31
0 32
0 33
0 34
0 35
0 36
0 37
0 38
0 39
0 40
0 41
0 42
0 43
0 44
0 45
0 46
0 47
0 48
0 49
0 50
0 51
0 52
0 53
0 54
0 55
0 56
0 57
0 58
0 59
0 60
0 61
0 62
0 63
0 64
0 65
0 66
0 67

```

```

17 GO TO 18
18 IN(I,K)=1
19 CONTINUE
20 IN(I,1)=IN(I,1)+IN(I,2)+IN(I,3)
   IF (IN(1,1)-IN(2,1)) 21,20,21
21 OCT=IN(1,1)+1
22 GO TO 22
   OCT=9
   RETURN
   END
   SUBROUTINE SPHERE (OCT)
   DIMENSION XSP(2,3), IN(2,3), DET(3), DX(3)
   INTEGER OCT
   COMMON /COORD/ XYZ(40)
   EQUIVALENCE (XYZ(1),DET), (XYZ(4),RSP), (XYZ(5),XSP)

C   TO PERFORM A TRANSLATION OF AXES OF HOLLOW AND SOLID SPHERES TO
C   THE DETECTOR COORDINATE SYSTEM. NO ROTATION OF AXES REQUIRED.
C   SHIELDS IDENTIFIED BY TYPE 4 OR 5
C
   DO 2 K=1,3
   DO 1 I=1,2
   XSP(I,K)=XSP(I,K)-DET(K)
   DX(K)=XSP(2,K)-XSP(1,K)
   RSP=SQRT(DX(1)**2+DX(2)**2+DX(3)**2)

C   DECIDE THE OCTANT IN WHICH THE FIGURE LIES
   DO 3 K=1,3
   XIK=XSP(1,K)
   S1=SIGN(XIK,XIK+RSP)
   S2=SIGN(XIK,XIK-RSP)
   IF (S2-S1) 10,3,10
   CONTINUE
   J=1
   DO 9 K=1,3
   IF (XSP(J,K)) 4,10,5
   IN(J,K)=0
   GO TO 9
   K=K
   GO TO (6,7,8), K
   STOP
   IN(J,K)=4

```

```

P 68
U 69
O 70
O 71
O 72
O 73
O 74
O 75
U 76
O 77-
P 1
P 2
P 3
P 4
P 5
P 6
P 7
P 8
P 9
P 10
P 11
P 12
P 13
P 14
P 15
P 16
P 17
P 18
P 19
P 20
P 21
P 22
P 23
P 24
P 25
P 26
P 27
P 28
P 29
P 30
P 31
P 32

```

==32

```

7      GO TO 9
      IN(J,K)=2
      GO TO 9
8      IN(J,K)=1
9      CONTINUE
      IN(J,1)=IN(J,1)+IN(J,2)+IN(J,3)
      OCT=IN(1,1)+1
      GO TO 11
10     OCT=9
11     RETURN
      END
      SUBROUTINE HEMIS (OCT)
      DIMENSION XHS(2,3), X(2,3), A(3,3), IN(2,3), DX(3), DET(3)
      INTEGER OCT
      COMMON /COORD/ XYZ(40)
      EQUIVALENCE (XYZ(1),DET), (XYZ(4),RHS), (XYZ(5),XHS), (XYZ(11),A)
C      TO PERFORM A TRANSLATION AND ROTATION OF AXES OF HOLLOW AND SOLID
C      HEMISPHERES TO THE ROTATED DETECTOR SYSTEM.
C      SHIELDS IDENTIFIED BY TYPES 6 AND 7
C      TRANSLATION OF AXES
      DO 2 K=1,3
      DO 1 J=1,2
1      X(J,K)=XHS(J,K)-DET(K)
2      DX(K)=X(2,K)-X(1,K)
      RHS=SQRT(DX(1)**2+DX(2)**2+DX(3)**2)
C      SET UP FUNCTIONS OF ANGLES FOR ROTATION OF AXES
      COSTH=DX(3)/RHS
      SINTH=SQRT(1.0-COSTH**2)
      IF (SINTH.LT.1.0E-3) SINTH=0.0
      IF (DX(1)) 4,3,5
3      COSPHI=0.0
      SINPHI=1.0
      GO TO 7
4      C=-1.0
      GO TO 6
5      C=1.0
      TANPHI=DX(2)/DX(1)
6      COSPHI=C/SQRT(1.0+TANPHI**2)
      SINPHI=SQRT(1.0-COSPHI**2)

```

P	33
P	34
P	35
P	36
P	37
P	38
P	39
P	40
P	41
P	42
P	43-
Q	1
Q	2
Q	3
Q	4
Q	5
Q	6
Q	7
Q	8
Q	9
Q	10
Q	11
Q	12
Q	13
Q	14
Q	15
Q	16
Q	17
Q	18
Q	19
Q	20
Q	21
Q	22
Q	23
Q	24
Q	25
Q	26
Q	27
Q	28
Q	29
Q	30
Q	31

==33

```

7 IF (DX(2)) 8,9,9
8 SINPHI=-SINPHI
9 IF (ABS(COSTH).NE.1.0) GO TO 10
   COSPHI=0.0
   SINPHI=COSTH
C
C   SET UP A-MATRIX FOR ROTATION
10 A(1,1)=SINPHI
   A(1,2)=-COSPHI
   A(1,3)=0.0
   A(2,1)=COSTH*COSPHI
   A(2,2)=COSTH*SINPHI
   A(2,3)=-SINTH
   A(3,1)=SINTH*COSPHI
   A(3,2)=SINTH*SINPHI
   A(3,3)=COSTH
C
C   COORDINATES IN ROTATED DETECTOR SYSTEM
11 DO 11 J=1,2
   DO 11 K=1,3
   XHS(J,K)=A(K,1)*X(J,1)+A(K,2)*X(J,2)+A(K,3)*X(J,3)
C
C   DECIDE OCTANT(S) IN WHICH FIGURE LIES
   I=1
   DO 19 K=1,3
   I=I
   K=K
   IF (I-2) 12,13,13
   XIK=X(I,K)
   S1=SIGN(XIK,XIK+RHS)
   S2=SIGN(XIK,XIK-RHS)
   IF (S1-S2) 20,13,20
   IF (X(I,K)) 14,20,15
   IN(I,K)=0
   GO TO 19
   GO TO (16,17,18), K
   STOP
16 IN(I,K)=4
   GO TO 19
17 IN(I,K)=2
   GO TO 19
18 IN(I,K)=1

```

```

0 32
0 33
0 34
0 35
0 36
0 37
0 38
0 39
0 40
0 41
0 42
0 43
0 44
0 45
0 46
0 47
0 48
0 49
0 50
0 51
0 52
0 53
0 54
0 55
0 56
0 57
0 58
0 59
0 60
0 61
0 62
0 63
0 64
0 65
0 66
0 67
0 68
0 69
0 70
0 71
0 72
0 73

```

==34

```

19 CONTINUE
   IN(I,1)=IN(I,1)+IN(I,2)+IN(I,3)
   OCT=IN(1,1)+1
   GO TO 21
20 OCT=9
21 RETURN
   END
   SUBROUTINE CONE (OCT)
   DIMENSION XCO(2,3), X(2,3), IN(2,3), A(3,3), DET(3), DX(3)
   COMMON /COORD/ XYZ(40)
   EQUIVALENCE (XYZ(1),DET), (XYZ(4),PHICON), (XYZ(5),XCO), (XYZ(11),
1A), (XYZ(20),RCON)
   INTEGER OCT
C
C TO PERFORM A TRANSLATION AND ROTATION OF AXES OF HOLLOW
C AND SOLID CONES TO THE ROTATED DETECTOR COORDINATE SYSTEM.
C SHIELDS IDENTIFIED BY TYPE R OR 9
C
C TRANSLATION OF AXES
DO 2 K=1,3
DO 1 J=1,2
X(J,K)=XCO(J,K)-DET(K)
DX(K)=X(2,K)-X(1,K)
CL=SQRT(DX(1)**2+DX(2)**2+DX(3)**2)
RCON=CL*SIN(PHICON)/COS(PHICON)
C
C FUNCTIONS OF ANGLES FOR ROTATION
COSTH=DX(3)/CL
SINTH=SQRT(1.0-COSTH**2)
IF (DX(1)) 4,3,5
3 COSPHI=0.0
SINPHI=1.0
GO TO 7
4 C=-1.0
GO TO 6
5 C=1.0
6 TANPHI=DX(2)/DX(1)
COSPHI=C/SQRT(1.0+TANPHI**2)
SINPHI=SQRT(1.0-COSPHI**2)
IF (DX(2)) 8,9,9
8 SINPHI=-SINPHI
9 IF (ABS(COSTH).NE.1.0) GO TO 10

```

Q 74
Q 75
Q 76
Q 77
Q 78
Q 79
Q 80-
R 1
R 2
R 3
R 4
R 5
R 6
R 7
R 8
R 9
R 10
R 11
R 12
R 13
R 14
R 15
R 16
R 17
R 18
R 19
R 20
R 21
R 22
R 23
R 24
R 25
R 26
R 27
R 28
R 29
R 30
R 31
R 32
R 33
R 34
R 35

=35

```

C      COSPHI=C*0
C      SINPHI=COSTH
C      10      SET UP A-MATRIX FOR ROTATION
C      A(1,1)=SINPHI
C      A(1,2)=-COSPHI
C      A(1,3)=0.0
C      A(2,1)=COSTH*COSPHI
C      A(2,2)=COSTH*SINPHI
C      A(2,3)=-SINTH
C      A(3,1)=SINTH*COSPHI
C      A(3,2)=SINTH*SINPHI
C      A(3,3)=COSTH
C      C      COORDINATES IN ROTATED DETECTOR SYSTEM
C      DO 11 J=1,2
C      DO 11 K=1,3
C      XCO(J,K)=A(K,1)*X(J,1)+A(K,2)*X(J,2)+A(K,3)*X(J,3)
C      C      DECIDE OCTANT(S). IN WHICH FIGURE LIES
C      DO 12 K=1,3
C      XIK=X(I,K)
C      S1=SIGN(XIK,XIK+RCON)
C      S2=SIGN(XIK,XIK-RCON)
C      IF (S1-S2) 21,12,21
C      CONTINUE
C      DO 19 J=1,2
C      DO 18 K=1,3
C      IF (X(J,K)) 13,21,14
C      IN(J,K)=0
C      GO TO 18
C      K=K
C      GO TO (15,16,17), K
C      STOP
C      IN(J,K)=4
C      GO TO 18
C      IN(J,K)=2
C      GO TO 18
C      IN(J,K)=1
C      CONTINUE
C      IN(J,1)=IN(J,1)+IN(J,2)+IN(J,3)
C      IF (IN(1,1)-IN(2,1)) 21,20,21
C      12
C      13
C      14
C      15
C      16
C      17
C      18
C      19

```

```

R 36
R 37
R 38
R 39
R 40
R 41
R 42
R 43
R 44
R 45
R 46
R 47
R 48
R 49
R 50
R 51
R 52
R 53
R 54
R 55
R 56
R 57
R 58
R 59
R 60
R 61
R 62
R 63
R 64
R 65
R 66
R 67
R 68
R 69
R 70
R 71
R 72
R 73
R 74
R 75
R 76
R 77

```

==36

```

20 OCT=IN(1,1)+1
GO TO 22
21 OCT=9
22 RETURN
END
SUBROUTINE TRCON (OCT)
DIMENSION XTRC(3,3), X(3,3), IN(3,3), A(3,3), DET(3), DX(2,3)
INTEGER OCT
COMMON /COORD/ XYZ(40)
EQUIVALENCE (XYZ(1),DET), (XYZ(4),PHICON), (XYZ(5),XTRC), (XYZ(14)
1,A), (XYZ(23),RB), (XYZ(24),RT)
C
C TO PERFORM A TRANSLATION AND ROTATION OF COORDINATES OF
C HOLLOW AND SOLID TRUNCATED CONES TO THE ROTATED DETECTOR SYSTEM
C CONES ARE DESCRIBED BY COORDINATES OF BASE, IMAGINARY APEX AND
C CENTER OF TRUNCATING PLANE, AND HALF-ANGLE AT APEX
C SHIELDS IDENTIFIED BY TYPE 10 OR 11
C
C TRANSLATION OF AXES
DO 1 K=1,3
DO 1 I=1,3
X(I,K)=XTRC(I,K)-DET(K)
DO 2 K=1,3
DX(1,K)=X(3,K)-X(1,K)
DX(2,K)=X(2,K)-X(3,K)
TANCON=SIN(PHICON)/COS(PHICON)
CL=SQRT( (1,1)+DX(2,1))**2+(DX(1,2)+DX(2,2))**2+(DX(1,3)+DX(2,3)
1)**2)
C
C FUNCTIONS OF ANGLES FOR ROTATION OF AXES
IF (DX(1,1)) 4,3,5
COSPFI=0.0
SINPHI=1.0
GO TO 7
C=-1.0
GO TO 6
C=1.0
TANPHI=(DX(1,2)+DX(2,2))/(DX(1,1)+DX(2,1))
COSPFI=C/SQRT(1.0+TANPHI**2)
SINPHI=SQRT(1.0-COSPFI**2)
IF (DX(1,2)) 8,9,9
SINPHI=-SINPHI

```

K 78
R 79
R RC
R 81
R 82-
S 1
S 2
S 3
S 4
S 5
S 6
S 7
S 8
S 9
S 10
S 11
S 12
S 13
S 14
S 15
S 16
S 17
S 18
S 19
S 20
S 21
S 22
S 23
S 24
S 25
S 26
S 27
S 28
S 29
S 30
S 31
S 32
S 33
S 34
S 35
S 36
S 37

==37

```

9      COSTH=(DX(1,3)+DX(2,3))/CL
      SIN7H=SQRT(1.0-COSTH**2)
      IF (ABS(COSTH).NE.1.0) GO TO 10
      COSPHI=0.0
      SINPHI=COSTH

C
C      SET UP A-MATRIX FOR ROTATION
10     A(1,1)=SINPHI
      A(1,2)=-COSPHI
      A(1,3)=0.0
      A(2,1)=COSTH*COSPHI
      A(2,2)=COSTH*SINPHI
      A(2,3)=-SINTH
      A(3,1)=SINTH*COSPHI
      A(3,2)=SINTH*SINPHI
      A(3,3)=COSTH

C
C      COORDINATES IN ROTATED DETECTOR SYSTEM
11     DO 11 J=1,3
      DO 11 K=1,3
      XTRC(J,K)=A(K,1)*X(J,1)+A(K,2)*X(J,2)+A(K,3)*X(J,3)
      DZ=ABS(XTRC(2,3)-XTRC(3,3))
      RB=CL*TANCON
      RT=DZ*TANCON

C
C      DECIDE OCTANT(S) IN WHICH FIGURE LIES
12     RAD=RR
13     DO 13 J=1,3,2
      DO 13 K=1,3
      XJK=X(J,K)
      S1=SIGN(XJK,XJK+RAD)
      S2=SIGN(XJK,XJK-RAD)
      IF (S1-S2) 22,12,22
      CONTINUE
      RAD=RT
      DO 20 J=1,3,2
      DO 19 K=1,3
      IF (X(J,K)) 14,22,15
      GO TO 19
      K=K

14     IN(J,K)=0
15     K=K

```

S 38
S 39
S 40
S 41
S 42
S 43
S 44
S 45
S 46
S 47
S 48
S 49
S 50
S 51
S 52
S 53
S 54
S 55
S 56
S 57
S 58
S 59
S 60
S 61
S 62
S 63
S 64
S 65
S 66
S 67
S 68
S 69
S 70
S 71
S 72
S 73
S 74
S 75
S 76
S 77
S 78
S 79

==38

```

16 GO TO (16,17,18), K
STOP
IN(J,K)=4
GO TO 19
17 IN(J,K)=2
GO TO 19
18 IN(J,K)=1
19 CONTINUE
20 IN(J,1)=IN(J,1)+IN(J,2)+IN(J,3)
IF (IN(3,1)-IN(1,1)) 22,21,22
21 OCT=IN(1,1)+1
GO TO 23
22 OCT=9
23 RETURN
END
SUBROUTINE ELIPSD (OCT,JMAX)
DIMENSION XEL(6,3), X(6,3), IN(6,3), DIR(3,3), DET(3), SMMA(3)
INTEGER OCT
COMMON /COORD/ XYZ(40)
EQUIVALENCE (XYZ(1),DET), (XYZ(5),XEL), (XYZ(23),DIR), (XYZ(32),SM
1MA)
C
C TO PERFORM A TRANSLATION AND ROTATION OF COORDINATES OF AN
C ELLIPSOID. THE FIGURE IS DESCRIBED BY COORDINATES OF ENDS OF
C SEMI-MAJOR AND MINOR AXES AND CENTER, AND COORDINATES OF
C SHIELDS IDENTIFIED BY TYPE 12 OR 13
C
C TRANSLATION OF AXES
DO 1 K=1,3
DO 1 J=1,JMAX
1 X(J,K)=XEL(J,K)-DET(K)
C
C ***** * PROGRAM OPERATION REFERENCE NO. 13 *****
C DIRECTION COSINES OF ELLIPSOID AXES
DO 2 K1=1,3
DIST=SQRT((X(K1,1)-X(4,1))**2+(X(K1,2)-X(4,2))**2+(X(K1,3)-X(4,3))
1**2)
DO 2 K=1,3
DIR(K1,K)=(X(K1,K)-X(4,K))/DIST
C
C COORDINATES IN ROTATED DETECTOR SYSTEM
DO 3 J=1,JMAX

```

```

S 80
S 81
S 82
S 83
S 84
S 85
S 86
S 87
S 88
S 89
S 90
S 91
S 92
S 93
S 94-
T 1
T 2
T 3
T 4
T 5
T 6
T 7
T 8
T 9
T 10
T 11
T 12
T 13
T 14
T 15
T 16
T 17
T 18
T 19
T 20
T 21
T 22
T 23
T 24
T 25
T 26

```

==39

```

3      DO 3 K=1,3
C      XEL(J,K)=D(R(K,1)*X(J,1)+DIR(K,2)*X(J,2)+DIR(K,3)*X(J,3))
4      DO 4 K=1,3
C      SMMA(K)=ABS(XEL(K,K)-XEL(4,K))
C      DECIDE OCTANT(S) IN WHICH FIGURE LIES
      AA XIS=SMMA(1)
      SMMAX=AMAX1(AAXIS,SMMA(2),SMMA(3))
      DO 5 K=1,3
      XCTR=X(4,K)
      S1=SIGN(XCTR,XCTR+SMMAX)
      S2=SIGN(XCTR,XCTR-SMMAX)
      IF (S1-S2) 14,5,14
5      CONTINUE
      DO 12 J=1,JMAX
      DO 11 K=1,3
      IF (X(J,K)) 6,14,7
6      IN(J,K)=0
      GO TO 11
7      K=K
      GO TO (8,9,10), K
      STOP
8      IN(J,1)=4
      GO TO 11
9      IN(J,2)=2
      GO TO 11
10     IN(J,3)=1
11     CONTINUE
12     IN(J,1)=IN(J,1)+IN(J,2)+IN(J,3)
      DO 13 J=2,JMAX
      IF (IN(J,1)-IN(J-1,1)) 14,13,14
13     CONTINUE
      OCT=IN(1,1)+1
14     GO TO 15
15     OCT=9
      RETURN
      END
      SUBROUTINE TRACK (NRAYS,NSO,ORD,NRHO,DENS,NSS,TMX,NPRT)
      DIMENSION DPS(2), SHIELD(37,10), ELEMP(2,10), DENS(50), NSS(50), R
      IHOS(10), MATS(10)
      INTEGER OCTR(1000),TYPE,ORD(6,4),SSN,SOCT

```

```

T 27
T 28
T 29
T 30
T 31
T 32
T 33
T 34
T 35
T 36
T 37
T 38
T 39
T 40
T 41
T 42
T 43
T 44
T 45
T 46
T 47
T 48
T 49
T 50
T 51
T 52
T 53
T 54
T 55
T 56
T 57
T 58
T 59
T 60
T 61
T 62
T 63
T 64-
U 1
U 2
U 3
U 4

```

==40

```

C      COMMON /DIRAY/ DIRCOS(3,1000)/VARIB/EPSSLN/DATA/SHLDD(40)/GMDST/PAT
      1H(1000)/COEF/DSTD,ESTD,DELTA(50),ETA(50)/DPCOMP/PDS(2,10),PNG(2,10
      2),RC(10),IPLS,ING,MC(10)
C
C      TRACKING PROCESS
C
      DATA CM/2.540005/
      DO 1 IR=1,1000
      PAT(IR)=0.0
      CALL OCTCOS (OCTR,NRAYS)
C
      IS=0
C
      IS=IS+1
      READ (12) (SHIELD(I,1),I=1,37),DUM
      IDID=0
      NCOMP=DUM
      IF (NCOMP.EQ.1) GO TO 4
      DO 3 ICP=2,NCOMP
      READ (12) (SHIELD(I,ICP),I=1,37)
      IF (NPRT.NE.0) WRITE (6,27) NCOMP
C
C      CHECK FOR SHIELDS WITH VARIABLE DENSITIES
      IF (NRHO.LE.0) GO TO 8
      DO 7 ICP=1,NCOMP
      SSN=SHIELD(3,ICP)
      DO 5 ND=1,NRHO
      IF (SSN.EQ.NSS(ND)) GO TO 6
      CONTINUE
      GO TO 7
      SHIELD(5,ICP)=DENS(ND)
      CONTINUE
      DO 9 ICP=1,NCOMP
      NTP=SHIELD(2,ICP)
      SSN=SHIELD(3,ICP)
      RHO=SHIELD(5,ICP)
      IF (NPRT.EQ.0) GO TO 9
      WRITE (6,28) SSN,NTP,RHO
      CONTINUE
C
C      SELECT RAYS FOR TRACKING
      U 5
      U 6
      U 7
      U 8
      U 9
      U 10
      U 11
      U 12
      U 13
      U 14
      U 15
      U 16
      U 17
      U 18
      U 19
      U 20
      U 21
      U 22
      U 23
      U 24
      U 25
      U 26
      U 27
      U 28
      U 29
      U 30
      U 31
      U 32
      U 33
      U 34
      U 35
      U 36
      U 37
      U 38
      U 39
      U 40
      U 41
      U 42
      U 43
      U 44
      U 45
      U 46

```

==41

```

DO 26 IR=1,NRAYS
IF (PATH(IR).GE.TMX) GO TO 26
IPLS=0
ING=C
INTS=C
C
K=0
DO 10 IDIR=38,40
K=K+1
SHLDD(IDIR)=DIRCOS(K,IR)
DO 11 ICP=1,NCOMP
DO 11 I=1,2
ELEMP(I,ICP)=0.0
C
C ***** * PROGRAM OPERATION REFERENCE NO. 22 *****
C TRACK THROUGH SHIELD COMPONENT(S)
C
DO 24 ICP=1,NCOMP
RHOS(ICP)=0.0
DO 12 I=1,37
SHLDD(I)=SHIELD(I,ICP)
RHO=SHLDD(5)
SHLP=0.0
SOCT=SHLDD(1)
IF (SOCT.EQ.9) GO TO 13
IF (OCTR(IR).NE.SOCT) GO TO 24
13 MAT=SHLDD(4)
CS=1.0
TYPE=SHLDD(2)+1.0
IF (TYPE.EQ.1.OR.TYPE.EQ.3.OR.TYPE.EQ.5.OR.TYPE.EQ.7.OR.TYPE.EQ.9.
***** * PROGRAM OPERATION REFERENCE NO. 23 *****
IOR.TYPE.EQ.11.OR.TYPE.EQ.13) CS=-1.0
IF (IPLS.EQ.0.AND.CS.EQ.-1.0) GO TO 26
C
C HEX. CYL. SPH. HEM.
GO TO (14,14,15,15,16,16,17,17,18,18,18,19,19), TYPE
STOP
C
C CONE TR.CONE ELL.
C
***** * PROGRAM OPERATION REFERENCE NO. 24 *****
14 CALL TKHEX (SHLP,ORD,DPS)
IF (SHLP) 24,24,20
C

```

```

U 47
U 48
U 49
U 50
U 51
U 52
U 53
U 54
U 55
U 56
U 57
U 58
U 59
U 60
U 61
U 62
U 63
U 64
U 65
U 66
U 67
U 68
U 69
U 70
U 71
U 72
U 73
U 74
U 75
U 76
U 77
U 78
U 79
U 80
U 81
U 82
U 83
U 84
U 85

```

==42

```
15 CALL TKCYL (SHLP,DPS)
   IF (SHLP) 24,24,20
C
16 CALL TKSPH (SHLP,DPS)
   IF (SHLP) 24,24,20
C
17 CALL TKHM (SHLP,DPS)
   IF (SHLP) 24,24,20
C
18 CALL TKCON (SHLP,DPS)
   IF (SHLP) 24,24,20
C
19 CALL TKELL (SHLP,DPS)
   IF (SHLP.EQ.0.0) GO TO 24
C
20 DO 21 I=1,2
21 ELEM(I,ICP)=CM*CS*DPS(I)
   RHOS(ICP)=RHO
   MATS(ICP)=MAT
   INTS=INTS+1
   IF (CS.GT.0.0) GO TO 22
   ING=ING+1
   GO TO 23
22 IPLS=IPLS+1
23 CALL ELIMS (ELEM,ICP,ISIT,RHOS,MATS)
   IF (ISIT.EQ.1) GO TO 26
   IF (IDIO.EQ.0.AND.NPRT.NE.0) WRITE (6,29)
C ***** * PROGRAM OPERATION REFERENCE NO. 25
   IDIO=1
24 CONTINUE
C
   IF (INTS.LE.0) GO TO 26
   IF (INCOMP.EQ.1.AND.SHLP.EQ.0.0) GO TO 26
   CALL COMPSP (XS,IR)
C ***** * PROGRAM OPERATION REFERENCE NO. 30
   IF (XS) 26,26,25
25 PATH(IR)=PATH(IR)+XS
   IF (NPRT.EQ.0) GO TO 26
   WRITE (6,30) IR,(SHLDD(ID),ID=38,40),XS,PATH(IR)
   CONTINUE
26 IS=IS+NCOMP-1
   IF (IS.LT.NSO) GO TO 2
```

```

C ***** * PROGRAM OPERATION REFERENCE NO. 84 *****
C RETURN
C
27 FORMAT (IHO,LOX,LOX,16HNO. COMPONENTS =,13/11X,17HSHIELD SERIAL NO.,6X
1,4HTYPE,6X,7HDENSITY)
28 FORMAT (19X,I5,10X,I3,4X,E15.8)
29 FORMAT (IHO,2X,7HRAY NO.,5X,11HCOS (ALPHA),6X,10HCOS (BETA),7X,11H
1COS (GAMMA),6X,2HXS,13X,15HACCUM THICKNESS//)
30 FORMAT (5X,I5,1X,5E17.8)
END
SUBROUTINE SYSSEL (NTSA,PHII,PHIF,THETA1,THETA2,NSA,NPRT,NSTRT,FSA
1)
DIMENSION PHL(600), THK(600), PHIMID(600), THMID(600)
COMMON /DIRAY/ DIRCOS(3,1000)/VARIB/EPULN/DATA/SHLDD(40)/GMOST/PAT
IH(1000)
DATA PI/3.1415926/
C
C TO SELECT THE DIRECTION COSINES BY THE SYSTEMATIC DEFINITION
C OF THE VEHICLE BY A SPECIFIED NUMBER OF EQUAL SOLID
C ANGLES ABOUT THE ORIGIN
C
CDEG=180.0/PI
PHII=PHII/CDEG
PHIF=PHIF/CDEG
THETA1=THETA1/CDEG
THETA2=THETA2/CDEG
PHIDF=PHIF-PHII
COSTH=COS(THETA1)
DCOSTH=COSTH-COS(THETA2)
TSA=NTSA
C
C FRACTION OF SOLID ANGLE IN INTERVAL DESCRIBED
C BY PHI AND THETA
C
FSA=PHIDF/4.0*DCOSTH/PI
NSA=TSA*FSA
DTHETA=THETA2-THETA1
RATIO=DTHETA/PHIDF
AXNTH=SQRT(RATIO*FLOAT(NSA))
NTH=AINT(AXNTH)+1.0
NPH=AINT(AXNTH/RATIO)+1.0
NSA=NTH*NPH
NPL=NPH+1

```

```

U 126
U 127
U 128
U 129
U 130
U 131
U 132
U 133
U 134-
V 1
V 2
V 3
V 4
V 5
V 6
V 7
V 8
V 9
V 10
V 11
V 12
V 13
V 14
V 15
V 16
V 17
V 18
V 19
V 20
V 21
V 22
V 23
V 24
V 25
V 26
V 27
V 28
V 29
V 30
V 31
V 32

```

==44

```
CP=NPH
DO 1 L=1,NPL
C1=FLOAT(L-1)/CP
PHL(L)=PHI1+C1*PHIDF
NTK=NTH+1
CT=NTH
DO 2 K=1,NTK
C2=FLOAT(K-1)/CT
THK(K)=ACOS(COSTH-C2*DCOSTH)
C
C   ASSUME RAY ORIGINATES AT MIDPOINT OF SOLID ANGLE
DO 3 K=1,NTH
THTMID(K)=0.5*(THK(K)+THK(K+1))
DO 4 L=1,NPH
PHIMID(L)=C.5*(PHL(L)+PHL(L+1))
C
C   DIRECTION LOSINES MAY NOW BE DEFINED
I=NSTRT-1
IF (NPRT.NE.0) WRITE (6,6)
DO 5 K=1,NTH
THETA=CDEG*THTMID(K)
SINTH=+SIN(THTMID(K))
COSMID=+COS(THTMID(K))
DO 5 L=1,NPH
I=I+1
PHI=CDEG*PHIMID(L)
DIRCOS(1,I)=SINTH*COS(PHIMID(L))
DIRCOS(2,I)=SINTH*SIN(PHIMID(L))
DIRCOS(3,I)=COSMID
IF (NPRT.EQ.0) GO TO 5
WRITE (6,7) I,THETA,PHI,(DIRCOS(J,I),J=1,3)
CONTINUE
5
C
RETURN
C
6   FORMAT (1H0,10X,21HRAY DIRECTION COSINES/11X,54HSYSTEMATIC SELECTI
10N FROM CENTER OF EQUAL SOLID ANGLES/1H0,10X,11HTHETA (DEG),6X,9HP
2HI (DEG),8X,11HCOS (ALPHA),6X,10HCOS (BETA),7X,11HCOS (GAMMA)//)
7   FORMAT (2X,14,1X,5E17.8)
END
SUBROUTINE RNDSEL (NRAYS,IRS,NPRT)
DIMENSION X(3), UNDCS(3)
```

V 33
V 34
V 35
V 36
V 37
V 38
V 39
V 40
V 41
V 42
V 43
V 44
V 45
V 46
V 47
V 48
V 49
V 50
V 51
V 52
V 53
V 54
V 55
V 56
V 57
V 58
V 59
V 60
V 61
V 62
V 63
V 64
V 65
V 66
V 67
V 68
V 69
V 70
V 71
V 72-
H 1
H 2

```

C      COMMON /DIRAY/ DIRCOS(3,1000)/VARIR/EPSSLN/DATA/SHLDD(4C)/GMDST/PAT
      1H(100C)
C
C      TO GENERATE THE DIRECTION COSINES OF THE TRACKING RAYS
C      IN THE ABSOLUTE SYSTEM BY RANDOM SELECTION FROM AN
C      EQUALLY PROBABLE DISTRIBUTION BETWEEN ZERO AND ONE.
C
      DUMY=RANF(1)
C
      DO 3 I=1,NRAYS
      DO 1 J=1,3
      X(J)=RANF(0)
      UNDCS(J)=1.0-2.0*X(J)
      SUM=UNDCS(1)**2+UNDCS(2)**2+UNDCS(3)**2
      IF (SUM.GT.1.0) GO TO 10
      SUM=SQRT (SUM)
      DO 2 J=1,3
      DIRCOS(J,I)=UNDCS(J)/SUM
      CONTINUE
      IF (NPRT.EQ.0) GO TO 5
      WRITE (6,6)
      DO 4 I=1,NRAYS
      WRITE (6,7) I,(DIRCOS(J,I),J=1,3)
      CONTINUE
      DUMY=RANF(1)
      WRITE (6,8) DUMY
      RETURN
C
      FORMAT (1H0,20X,37HDIRECTION COSINES BY RANDOM SELECTION/1H0,14X,1
      1H,5X,11HCOS (ALPHA),6X,10HCOS (BETA),7X,11HCOS (GAMMA)//)
      FORMAT (12X,14,3X,3E17.8)
      FORMAT (1H0,10X,2RHFOR NEXT CASE OR RESTART USE,E15.8)
      END
      SUBROUTINE ELIMS (ELEMP,ICP,ISIT,RHOS,MATS)
      DIMENSION ELEMP(2,10), RHOS(10), MATS(10), X(4)
      COMMON /VARIB/ EPSSLN/DPCOMP/DPOS(2,10),DPNEG(2,10),RHO(10),IPLS,I
      1NG,MAT(10)
      TO DETERMINE IF THE VOID PARTS OF A COMPOSITE SHIELD
      COMPLETELY VOID REGION IN SPECIFIED DIRFCTION
      ISIT=0
  
```

W 3
 W 4
 W 5
 W 6
 W 7
 W 8
 W 9
 W 10
 W 11
 W 12
 W 13
 W 14
 W 15
 W 16
 W 17
 W 18
 W 18A
 W 19
 W 20
 W 21
 W 22
 W 23
 W 24
 W 25
 W 26
 W 27
 W 28
 W 29
 W 30
 W 31
 W 32
 W 33
 W 34
 W 35-
 W 1
 X 2
 X 3
 X 4
 X 5
 X 6
 X 7
 X 8

```

C ***** * PROGRAM OPERATION REFERENCE NO. 27 *****
J=0
DO 1 I=1,ICP
IF (ELEM(2,I).LE.0.0) GO TO 1
J=J+1
DPPOS(1,J)=ELEM(1,I)
DPPOS(2,J)=ELEM(2,I)
RHO(J)=RHOS(I)
MAT(J)=MATS(I)
1 CONTINUE
IF (ING.EQ.0) RETURN
XPOS=0.0
C
C ORDER NEGATIVE COMPONENTS OF COMPOSITE SHIELD
C ***** * PROGRAM OPERATION REFERENCE NO. 28 *****
J1=J+1
DO 5 N=1,ING
DPNEG(1,N)=1.0E+20
DPNEG(2,N)=1.0E+20
DO 2 I=J1,ICP
IF (ELEM(2,I).GE.0.0) GO TO 2
IF (ABS(ELEM(1,I)).GT.ABS(DPNEG(1,N))) GO TO 2
DPNEG(1,N)=ELEM(1,I)
DPNEG(2,N)=ELEM(2,I)
2 CONTINUE
DO 3 I=J1,ICP
IF (DPNEG(1,N).EQ.ELEM(1,I).AND.DPNEG(2,N).EQ.ELEM(2,I)) GO TO 4
3 CONTINUE
GO TO 5
4 ELEM(1,I)=1.0E+21
ELEM(2,I)=1.0E+21
5 CONTINUE
J=J1-1
J2=ING+1PLS
DO 6 N=1,ING
J=J+1
ELEM(1,J)=DPNEG(1,N)
ELEM(2,J)=DPNEG(2,N)
IF (J2.GE.ICP) GO TO 8
NL=J2+1
DO 7 N=NL,ICP
X 9
X 10
X 11
X 12
X 13
X 14
X 15
X 16
X 17
X 18
X 19
X 20
X 21
X 22
X 23
X 24
X 25
X 26
X 27
X 28
X 29
X 30
X 31
X 32
X 33
X 34
X 35
X 36
X 37
X 38
X 39
X 40
X 41
X 42
X 43
X 44
X 45
X 46
X 47
X 48

```

==47

```

7      ELEMP(1,N)=0.0
C      ELEMP(2,N)=0.0
C      INVESTIGATE POSSIBILITY OF SHIELDS ELIMINATED
C      ***** * PROGRAM OPERATION REFERENCE NO. 79
C
8      DO 12 NP=1,IPLS
          X(1)=DPPOS(1,NP)
          X(3)=X(1)
          X(4)=DPPOS(2,NP)
          DO 10 NN=1,ING
              IF (ABS(DPNEG(2,NN)).LE.X(1)) GO TO 10
              IF (ABS(DPNEG(1,NN)).GE.X(4)) GO TO 11
              X(2)=ABS(DPNEG(1,NN))
              X(3)=ABS(DPNEG(2,NN))
              IF ((X(2)-X(1)).LE.EPSLN) GO TO 9
              XPOS=X(2)-X(1)+XPOS
              X(1)=X(3)
              IF (X(3).GE.X(4)) GO TO 12
          CONTINUE
10     CONTINUE
11     IF ((X(4)-X(3)).LE.EPSLN) GO TO 12
          XPOS=X(4)-X(3)+XPOS
12     CONTINUE
C      ***** * PROGRAM OPERATION REFERENCE NO. 26
C      IF (XPOS.LE.0.0) ISIT=1
          RETURN
          END
          SUBROUTINE OCTCOS (OCT,NRAYS)
          DIMENSION IN(3)
          INTEGER OCT(1000)
          COMMON /DIRAY/ DIRCOS(3,1000)/VARIB/EPSSLN
          TO FIND THE OCTANT IN WHICH TO START THE TRACKING PROCESS
          BY CHECKING THE SIGNS OF THE DIRECTION COSINES OF THE
          TRACKING RAY FROM THE ORIGIN
          DO 10 I=1,NRAYS
              DO 1 K=1,3
                  IF (DIRCOS(K,I)) 1,2,1
          CONTINUE
          GO TO 3
          OCT(I)=9
1      1
2      2

```

```

X 49
X 50
X 51
X 52
*****
X 53
X 54
X 55
X 56
X 57
X 58
X 59
X 60
X 61
X 62
X 63
X 64
X 65
X 66
X 67
X 68
X 69
X 70
*****
X 71
X 72
X 73-
Y 1
Y 2
Y 3
Y 4
Y 5
Y 6
Y 7
Y 8
Y 9
Y 10
Y 11
Y 12
Y 13
Y 14
Y 15

```

==48

```

C          GO TO 10
C 3        DO 9 K=1,3
C          IF (DIRCOS(K,I)) 4,4,5
C 4        IN(K)=0
C          GO TO 9
C 5        K=K
C          GO TO (6,7,8), K
C          STOP
C 6        IN(1)=4
C          GO TO 9
C 7        IN(2)=2
C          GO TO 9
C 8        IN(3)=1
C 9        CONTINUE
C 10       OCT(I)=IN(1)+IN(2)+IN(3)+1
C          CONTINUE
C          RETURN
C          END
C          SUBROUTINE TKHEX (HXPTH, NP, DP)
C          TRACKING OF PROTONS THROUGH A HEXAHEDRON
C          DIMENSION X(8,3), A(3,3), XR(8,3), NP(6,4), NFACE(6), PR(6), VECTP
C          IR(6,4), ALPHA(3), AV(3), BV(3), AKB(3), XC(3,3), DIRCSA(3), XO(3),
C          2 DIR(3), PRHEX(6), DP(2), XNP(8,3)
C          COMMON /DIRAY/ DIRCOS(3,1000)/VARIB/EP SLN/DATA/SHLDD(40)/GMDST/PAT
C          1H(1000)
C          EQUIVALENCE (SHLDD(8),XNP), (SHLDD(38),DIRCSA)
C          ROTATION MATRIX TO ORIENT THE HEXAHEDRON SUCH THAT
C          THE Z-AXIS IS COLLINER WITH THE TRACKING RAY
C          NT=1
C          DO 1 K=1,3
C          DO 1 J=1,8
C          X(J,K)=XNP(J,K)
C          DO 2 K=1,3
C          XO(K)=0.0
C          DIR(K)=DIRCSA(K)
C          DO 3 I=1,2
C          DP(I)=1.0E+20

```

Y 16
Y 17
Y 18
Y 19
Y 20
Y 21
Y 22
Y 23
Y 24
Y 25
Y 26
Y 27
Y 28
Y 29
Y 30
Y 31
Y 32
Y 33
Y 34
Z 1
Z 2
Z 3
Z 4
Z 5
Z 6
Z 7
Z 8
Z 9
Z 10
Z 11
Z 12
Z 13
Z 14
Z 15
Z 16
Z 17
Z 18
Z 19
Z 20
Z 21
Z 22
Z 23

=49

```
C
C      SET UP ROTATION MATRIX
C      DO 5 K=1,3
C      A(3,K)=DIR(K)
C      IF ((ABS(DIR(3))+EPSLN).GE.1.0) GO TO 6
C      COSTH=DIR(3)
C      SINTH=SQRT(1.0-COSTH**2)
C      COSPHI=DIR(1)/SINTH
C      SINPHI=DIR(2)/SINTH
C      A(1,1)=SINPHI
C      A(1,2)=-COSPHI
C      A(1,3)=0.0
C      A(2,1)=COSTH*COSPHI
C      A(2,2)=COSTH*SINPHI
C      A(2,3)=-SINTH
C      GO TO 8
C
C      DO 7 J=1,3
C      DO 7 I=1,2
C      A(I,J)=0.0
C      A(1,1)=DIR(3)
C      A(2,2)=1.0
C
C      ***** * PROGRAM OPERATION REFERENCE NO. 31
C      *****
C      ROTATION OF COORDINATES
C      DO 9 J=1,8
C      DO 9 K=1,3
C      XR(J,K)=A(K,1)*X(J,1)+A(K,2)*X(J,2)+A(K,3)*X(J,3)
C      IF (NT.GT.1) GO TO 15
C
C      ***** * PROGRAM OPERATION REFERENCE NO. 33
C      *****
C      EXAMINE COORDINATES (X,Y) FOR POSSIBLE INTERSECTION
C      DO 14 K=1,2
C      IMPOS=0
C      NEG=0
C      DO 13 J=1,8
C      IF (ABS(XR(J,K)).LT.EPSLN) GO TO 10
C      IF (XR(J,K)) 12,11,11
C      NEG=NEG+1
C      IMPOS=IMPOS+1
C      GO TO 13
C      NEG=NEG+1
C
C      *****
C      *****
```

==50

```

13  C ***** * PROGRAM OPERATION REFERENCE NO. 32
C CONTINUE
IF (IMPOS.EQ.8.AND.NEG.EQ.0) RETURN
IF (NEG.EQ.8.AND.IMPOS.EQ.0) RETURN
14  C CONTINUE
C ***** * PROGRAM OPERATION REFERENCE NO. 34
C *****
C
C
C SOME MISSES OF RAY HAVE BEEN ELIMINATED
C EXAMINE THE SIX PLANES FOR INTERSECTION
15  INTSCT=0
DO 28 NPL=1,6
DO 19 K=1,2
IMPOS=0
NEG=0
C EXAMINATION OF POINTS IN ORDER IN PLANE NPL
DO 18 I=1,4
JJ=NP(NPL,I)
IF (ABS(XR(JJ,K)).LT.EPSLN) GO TO 20
IF (XR(JJ,K)) 17,16,16
16  IMPOS=IMPOS+1
GO TO 18
17  NEG=NEG+1
18  CONTINUE
IF (IMPOS.EQ.4.AND.NEG.EQ.0) GO TO 28
IF (NEG.EQ.4.AND.IMPOS.EQ.0) GO TO 28
19  CONTINUE
C ***** * PROGRAM OPERATION REFERENCE NO. 37
C *****
C ORDERING OF POINTS INDICATES MAY BE INTERSECTED WITH PLANE
20  NEG=0
IMPOS=0
DO 26 I=1,4
J1=NP(NPL,I)
J2=NP(NPL,I+1)
IF (I-4) 22,21,22
J2=NP(NPL,1)
21  VECTORS BETWEEN SUCCESSIVE PAIRS OF POINTS
C VECTPR(NPL,I)=XR(J1,1)*XR(J2,2)-XR(J1,2)*XR(J2,1)
22  IF (ABS(VECTPR(NPL,I)).LT.2.0E-2) GO TO 23
IF (VECTPR(NPL,I)) 25,23,24
Z 64 *****
Z 65 *****
Z 66 *****
Z 67 *****
Z 68 *****
Z 69 *****
Z 70 *****
Z 71 *****
Z 72 *****
Z 73 *****
Z 74 *****
Z 75 *****
Z 76 *****
Z 77 *****
Z 78 *****
Z 79 *****
Z 80 *****
Z 81 *****
Z 82 *****
Z 83 *****
Z 84 *****
Z 85 *****
Z 86 *****
Z 87 *****
Z 88 *****
Z 89 *****
Z 90 *****
Z 91 *****
Z 92 *****
Z 93 *****
Z 94 *****
Z 95 *****
Z 96 *****
Z 97 *****
Z 98 *****
Z 99 *****
Z 100 *****
Z 101 *****
Z 102 *****

```

```

23 NEG=NEG+1
24 IMPOS=IMPOS+1
   GO TO 26
25 NEG=NFG+1
   ***** * PROGRAM OPERATION REFERENCE NO. 37 *****
26 CONTINUE
   IF (IMPOS.GE.4) GO TO 27
   IF (NEG.LT.4) GO TO 28
27 INTSCT=INTSCT+1
   NFACE(INTSCT)=NPL
   ***** * PROGRAM OPERATION REFERENCE NO. 35 *****
28 CONTINUE
   IF (INT.GT.1) GO TO 29
   IF (INTSCT-1) 47,29,29
C
C
C
C ***** * PROGRAM OPERATION REFERENCE NO. 38 *****
C ***** * PROGRAM OPERATION REFERENCE NO. 39 *****
29 DO 34 I=1,INTSCT
   ***** * PROGRAM OPERATION REFERENCE NO. 39 *****
   I1=NFACE(I)
   DO 30 J=1,3
   NP1=NP(I1,J)
C
C
C
C ***** * PROGRAM OPERATION REFERENCE NO. 40 *****
C ***** * PROGRAM OPERATION REFERENCE NO. 41 *****
C ***** * PROGRAM OPERATION REFERENCE NO. 41 *****
30 COORD. OF PTS. OF PLANE OF INTERSECTION
   DO 30 M=1,3
   XC(J,M)=X(NP1,M)
C
C ***** * PROGRAM OPERATION REFERENCE NO. 40 *****
C ***** * PROGRAM OPERATION REFERENCE NO. 40 *****
31 COMPONENTS OF VECTORS BETWEEN PTS.
   DO 31 M=1,3
   AV(M)=XC(I,M)-XC(2,M)
   BV(M)=XC(3,M)-XC(2,M)
   AKR(1)=AV(2)*BV(3)-AV(3)*BV(2)
   AKR(2)=AV(3)*BV(1)-AV(1)*BV(3)
   AKR(3)=AV(1)*BV(2)-AV(2)*BV(1)
   VAKB=SQRT(AKR(1)**2+AKR(2)**2+AKR(3)**2)
C ***** * PROGRAM OPERATION REFERENCE NO. 41 *****
32 DO 32 M=1,3
   ALPHA(M)=AKR(M)/VAKB
   DEN=ALPHA(1)*A(3,1)+ALPHA(2)*A(3,2)+ALPHA(3)*A(3,3)

```

Z 103
Z 104
Z 105
Z 106

Z 107
Z 108
Z 109
Z 110
Z 111

Z 112
Z 113
Z 114
Z 115
Z 116
Z 117

Z 118
Z 119

Z 120
Z 121
Z 122
Z 123
Z 124
Z 125
Z 126
Z 127

Z 128
Z 129
Z 130
Z 131
Z 132
Z 133
Z 134
Z 135

Z 136
Z 137
Z 138

=52

```
IF (ABS(DEN).GE.FPSLN) GO TO 33
PR(I)=1.0E+20
GO TO 34
C ***** * PROGRAM OPERATION REFERENCE NO. 42 *****
C ***** * PROGRAM OPERATION REFERENCE NO. 43 *****
33 PR(I)=(ALPHA(1)*(XC(1,1)-XO(1))+ALPHA(2)*(XC(1,2)-XO(2))+ALPHA(3)*
1(XC(1,3)-XO(3)))/DEN
IF (PR(I).LT.0.0) PR(I)=1.0E+20
34 CONTINUE
C ***** * PROGRAM OPERATION REFERENCE NO. 43 *****
IF (NT.GT.1) GO TO 42
IF (INTSCT.GT.1) GO TO 35
HXPTH=PR(I)
DP(1)=0.0
DP(2)=HXPTH
IF (HXPTH.GE.0.9E+20) HXPTH=0.0
RETURN
C
35 NT=2
ISCT1=INTSCT
C ***** * PROGRAM OPERATION REFERENCE NO. 44 *****
C ***** * PROGRAM OPERATION REFERENCE NO. 44 *****
C ***** * PROGRAM OPERATION REFERENCE NO. 44 *****
SELECT MINIMUM OF ACTUAL PATHS
PMIN=1.0E+20
DO 36 I=1,ISCT1
PMIN=AMINI(PMIN,PR(I))
36 PRHEX(I)=PR(I)
IF (PMIN.GE.0.9E+20) RETURN
C ***** * PROGRAM OPERATION REFERENCE NO. 45 *****
DP(1)=PMIN
DO 37 I=1,ISCT1
IF (ABS(PMIN-PRHEX(I)).LE.EPSLN) PRHEX(I)=1.0E+20
37 CONTINUE
PM2=1.0E+20
DO 38 I=1,ISCT1
C ***** * PROGRAM OPERATION REFERENCE NO. 46 *****
38 PM2=AMINI(PM2,PRHEX(I))
DO 39 K=1,3
XO(K)=0.5*(X(5,K)+X(1,K))
DIST=SQRT(XO(1)**2+XO(2)**2+XO(3)**2)
IF (DIST.LT.1.0E-6) GO TO 44
C
```

```

C ***** * PROGRAM OPERATION REFERENCE NO. 47 *****
C DIRECTION COSINES OF LINE FROM DETECTOR TO MIDPOINT OF
C DIAGONAL 1-5. TRACK IN THIS DIRECTION.
      DN 40 K=1,3
      DIR(K)=-XO(K)/DIST
      DO 40 J=1,8
      X(J,K)=X(J,K)-XO(K)
      DO 41 K=1,3
      XO(K)=0.0
C ***** * PROGRAM OPERATION REFERENCE NO. 48 *****
      GO TO 4
C
C ***** * PROGRAM OPERATION REFERENCE NO. 49 *****
C DETECTOR MAY BE OUTSIDE
      PMIND=1.0E+20
      DO 43 I=1,INTSCT
      PMIND=AMINI(PMIND,PR(I))
      IF (PMIND-DIST+EPSLN) 45,44,44
C
C DETECTOR INSIDE AND RAY GOES THROUGH CORNER OR EDGE
      HXPTH=PMIN
      IF (PMIN.LE.EPSLN.AND.PM2.LT.0.9E+20) HXPTH=PM2
      DP(1)=0.0
      DP(2)=HXPTH
      RETURN
C
C DETECTOR OUTSIDE AND RAY GOES THROUGH ISCT1 PLANES
C ***** * PROGRAM OPERATION REFERENCE NO. 50 *****
      SELECT SECOND MINIMUM PATH
      PMIN2=1.0E+20
      DO 46 I=1,ISCT1
      PMIN2=AMINI(PMIN2,PRHEX(I))
      DP(2)=PMIN2
      IF (PMIN2.GE.1.0E+20) GO TO 48
      HXPTH=ABS(PMIN2-PMIN)
      RETURN
      DP(1)=1.0E+20
      RETURN
      END
C SUBROUTINE TKCYL (CYPATH,DP)
C TRACKING OF PROTON RAY THROUGH A CYLINDER

```

```

Z 176
Z 177
Z 178
Z 179
Z 180
Z 181
Z 182
Z 183
Z 184
Z 185
Z 186
Z 187
Z 188
Z 189
Z 190
Z 191
Z 192
Z 193
Z 194
Z 195
Z 196
Z 197
Z 198
Z 199
Z 200
Z 201
Z 202
Z 203
Z 204
Z 205
Z 206
Z 207
Z 208
Z 209
Z 210-
AA 01
AA 02
AA 03

```

=54

```

C      DIMENSION XCY(2,3), AR(3,3), DIRCSA(3), DIRRAY(3), PR(4), ZBOUND(4
AA C4
1), DP(2), CXY(2) AA C5
COMMON /DIRAY/ DIRCOS(3,IC00)/VARIB/EPSLN/DATA/SHLDD(40)/GMJST/PAT AA C6
IH(1000) AA C7
C      EQUIVALENCE (SHLDD(7),RADI), (SHLDD(8),XCY), (SHLDD(14),AR), (SHL
AA C9
1D(38),DIRCSA) AA C10
C      DIRECTION COSINES OF RAY AA C11
DO I K=1,3 AA C12
DIRRAY(K)=AR(K,1)*DIRCSA(1)+AR(K,2)*DIRCSA(2)+AR(K,3)*DIRCSA(3) AA C13
CONTINUE AA C14
DUMV=1.0E+21 AA C15
C ***** * PROGRAM OPERATION REFERENCE NO. 51 ***** AA C16
C EXAMINE Z AND RADIAL BOUNDS TO LOCATE DETECTOR AA C17
IF (XCY(1,3)-XCY(2,3)) 3,3,2 AA C18
ZBOUND(1)=XCY(2,3) AA C19
ZBOUND(2)=XCY(1,3) AA C20
GO TO 4 AA C21
ZBOUND(1)=XCY(1,3) AA C22
ZBOUND(2)=XCY(2,3) AA C23
IF (ZBOUND(2)) 14,5,5 AA C24
IF (ZBOUND(1)) 6,6,14 AA C25
C1=XCY(1,1)**2+XCY(1,2)**2-RADI**2 AA C26
***** * PROGRAM OPERATION REFERENCE NO. 52 ***** AA C27
IF (C1) 7,14,14 AA C28
C      DETECTOR LOCATED INSIDE CYLINDER AA C29
C      IF (DIRRAY(3)) 8,13,8 AA C30
C      IF (ZBOUND(1).EQ.0.0) 7HOUND(1)=-EPSLN AA C31
C      IF (ZBOUND(2).EQ.C.0) ZBOUND(2)=EPSLN AA C32
DO I2 I=1,2 AA C33
DP(I)=ZBOUND(I)/DIRRAY(3) AA C33A
IF (DP(I)) 12,9,9 AA C33B
***** * PROGRAM OPERATION REFERENCE NO. 54 ***** AA C34
DO I0 J=1,2 AA C35
CXY(J)=DIRRAY(J)*DP(I)-XCY(1,J) AA C36
C2=CXY(1)**2+CXY(2)**2-RADI**2 AA C37
IF (C2) 11,11,12 AA C38
C AA C39
AA C40

```

==55

```

C 11 INTERSECTION IS WITH ENDS OF CYLINDER
    CYPATH=DP(I)
    DP(2)=CYPATH
    DP(1)=0.0
    RETURN
C 12 CONTINUE
C ***** * PROGRAM OPERATION REFERENCE NO. 53
C INTERSECTION IS NOT WITH ENDS, MUST TRY SURFACE
C 13 C=XCY(1,1)**2+XCY(1,2)**2-RADI**2
    B=-2.*(DIRRAY(1)*XCY(1,1)+DIRRAY(2)*XCY(1,2))
    A=DIRRAY(1)**2+DIRRAY(2)**2
    CALL ROOT (A,B,C,PR(3),PR(4),ISC)
    CYPATH=AMIN1(DUMY,PR(3),PR(4))
    DP(2)=CYPATH
    DP(1)=0.0
    RETURN
C DOSIMETER LOCATED OUTSIDE CYLINDER
C 14 IF (DIRRAY(3)) 16,15,16
C 15 PR(1)=1.0E+20
    PR(2)=1.0E+20
    GO TO 22
C BOTH TYPES OF INTERSECTION POSSIBLE
C 16 RDET2=XCY(1,1)**2+XCY(1,2)**2
    DO 21 I=1,2
    DP(I)=ZROUND(I)/DIRRAY(3)
    IF (DP(I)) 19,17,17
    DO 18 J=1,2
    CXY(J)=DIRRAY(J)*DP(I)-XCY(1,J)
    C2=CXY(1)**2+CXY(2)**2
    IF (C2-RADI**2) 20,20,19
    PR(I)=1.0E+20
    GO TO 21
    PR(I)=DP(I)
    CONTINUE
C ***** * PROGRAM OPERATION REFERENCE NO. 55
C POSSIBILITY OF CYLINDRICAL SURFACE INTERSECTION
C 22 A=DIRRAY(1)**2+DIRRAY(2)**2

```

```

AA 41
AA 42
AA 43
AA 44
AA 45
AA 46
AA 47
AA 48
AA 49
AA 50
AA 51
AA 52
AA 53
AA 54
AA 55
AA 56
AA 57
AA 58
AA 59
AA 60
AA 61
AA 62
AA 63
AA 64
AA 65
AA 66
AA 67
AA 68
AA 69
AA 70
AA 71
AA 72
AA 73
AA 74
AA 75
AA 76
AA 77
AA 78
AA 79
AA 80

```

==56

```

23 IF (A) 24,23,24
   PR(3)=1.0E+20
   PR(4)=1.0E+20
   GO TO 29
C
24 C=XCY(1,1)**2+XCY(1,2)**2-RADI**2
   B=-2.*(DIRRAY(1)*XCY(1,1)+DIRRAY(2)*XCY(1,2))
C ***** * PROGRAM OPERATION REFERENCE NO. 56 *****
CALL ROOT (A,B,C,PR(3),PR(4),ISC)
DO 25 I=3,4
ZBOUND(I)=PR(I)*DIRRAY(3)
DO 28 I=3,4
IF (ZBOUND(I)-ZBOUND(1)+EPSLN) 27,28,26
IF (ZBOUND(I)-ZBOUND(2)-EPSLN) 28,28,27
26 PR(I)=1.0E+20
27 CONTINUE
28 CONTINUE
C
C ***** * PROGRAM OPERATION REFERENCE NO. 57 *****
C FIND ACTUAL PATH LENGTH
29 DP(1)=AMINI(DUMY,PR(1),PR(2),PR(3),PR(4))
DO 31 I=1,4
IF (PR(I)-DP(1)) 31,30,31
30 PR(I)=1.0E+20
GO TO 32
31 CONTINUE
32 DP(2)=AMINI(DUMY,PR(1),PR(2),PR(3),PR(4))
IF ((DP(1).GE.1.0E+20).OR.(DP(2).GE.1.0E+20)) GO TO 33
CYPATH=ABS(DP(1)-DP(2))
33 RETURN
END
SUBROUTINE TKSPH (SPTH,DP)
C
C TO FIND THE PARTICLE PATH LENGTH THROUGH A SPHERE
C IF AN INTERSECTION IS MADE
C
DIMENSION X(2,3), DIRCSA(3), PR(4), DP(2)
COMMON /DIRAY/ DIRCOS(3,1000)/VARIB/EPSSLN/DATA/SHLDD(40)/GMDST/PAT
IH(1000)
C
C EQUIVALENCE (SHLDD(7),RSP), (SHLDD(8),X), (SHLDD(38),DIRCSA)
C
A=1.0

```

AA 81
AA 82
AA 83
AA 84
AA 85
AA 86
AA 87
AA 88
AA 89
AA 90
AA 91
AA 92
AA 93
AA 94
AA 95
AA 96
AA 97
AA 98
AA 99
AA 100
AA 101
AA 102
AA 103
AA 104
AA 105
AA 106
AA 107
AA 108
AB 1
AB 2
AB 3
AB 4
AB 5
AB 6
AB 7
AB 8
AB 9
AB 10
AB 11
AB 12

```

1      B=-2.*(DIRCSA(1)*X(1,1)+DIRCSA(2)*X(1,2)+DIRCSA(3)*X(1,3))
      C=X(1,1)*2+X(1,2)*2+X(1,3)*2-RSP**2
      CALL KONT (A,B,C,PR(3),PR(4),ISC)
      IF (C-EPSLN) 1,1,2
      SPTH=PR(3)
      IF (SPTH.GE.1.0E+20) SPTH=0.0
      DP(1)=0.0
      DP(2)=SPTH
      RETURN
C
2      SPTH=ABS(PR(3)-PR(4))
      IF (PR(3).GE.1.0E+20.OR.PD(4).GE.1.0E+20) SPTH=0.0
      DUMY=1.0E+21
      DP(1)=AMINI(DUMY,PR(3),PR(4))
      DUMY=0.0
      DP(2)=AMAX1(DUMY,PR(3),PR(4))
      RETURN
      END
SUBROUTINE TKCON (CNPTH,DP)
C
C      TRACKING OF PROTON RAY THROUGH A CONE
C      WITH OR WITHOUT TRUNCATIONS
C
      DIMENSION X(3,3), AR(3,3), DIRCSA(3), ZB(2), PR(4), DIRR(3), DP(2)
      COMMON /DIRAY/ DIRCOS(3,1000)/VARIB/EPSLN/DATA/SHLDD(40)/GMDST/PAT
      IH(1000)
C
      EQUIVALENCE (SHLDD(6),PTS), (SHLDD(7),PHI), (SHLDD(38),DIRCSA)
C
C      SET UP COORDINATES AND ROTATION MATRIX IN ARRAYS FROM
      COMMON DATA DEPENDING ON TYPE OF CONE
      DUMY=1.0E+21
      NP=PTS
      IJ=7
      DO 1 J=1,3
      DO 1 I=1,NP
      IJ=IJ+1
1      X(I,J)=SHLDD(IJ)
C      ***** * PROGRAM OPERATION REFERENCE NO. 65 *****
      DO 2 I=1,3
      DO 2 J=1,3

```

```

AH 13
AB 14
AB 15
AB 16
AB 17
AR 18
AB 19
AB 20
AB 21
AB 22
AB 23
AB 24
AB 25
AB 26
AB 27
AB 28
AB 29
AR 30-
AC 1
AC 2
AC 3
AC 4
AC 5
AC 6
AC 7
AC 8
AC 9
AC 10
AC 11
AC 12
AC 13
AC 14
AC 15
AC 16
AC 17
AC 18
AC 19
AC 20
AC 21
AC 22

```

=58

```

2  IJ=IJ+1
   AR(J,I)=SHLDD(IJ)
   RR=SHLDD(IJ+1)
   IF (NP-2) 4,4,3
   RT=SHLDD(IJ+2)
   AC 23
AC 24
AC 25
AC 26
AC 27
AC 28

C ***** * PROGRAM OPERATION REFERENCE NO. 66
C ROTATION OF DIRECTION COSINES OF PROTON RAY
C DO 5 K=1,3
C DIRR(K)=AR(K,1)*DIRCSA(1)+AR(K,2)*DIRCSA(2)+AR(K,3)*DIRCSA(3)
C ***** * PROGRAM OPERATION REFERENCE NO. 67
C *****
C IF (X(1,3)-X(NP,3)) 6,6,7
C ZB(1)=X(1,3)
C ZB(2)=X(NP,3)
C GO TO 8
C ZB(1)=X(NP,3)
C ZB(2)=X(1,3)
C DZ=X(2,3)-X(1,3)
C RCD=RB+X(2,3)/DZ
C RDET=X(1,1)**2+X(1,2)**2
C TANCN2=(RB/DZ)**2
C RZ=X(2,3)**2*TANCN2
C C=RDET-RZ
C IF (ZB(2)) 21,9,9
C IF (ZB(1)) 10,10,21
C IF (RDET-RCD**2+EPSLN) 11,11,21
C DOSIMETER LOCATED WITHIN CONE
C IF (DIRR(3)) 13,12,15
C ***** * PROGRAM OPERATION REFERENCE NO. 68
C INTERSECTION WITH CONICAL SURFACE
C A=DIRR(1)**2+DIRR(2)**2
C B=-2.0*(X(2,1)*DIRR(1)+X(2,2)*DIRR(2))
C CALL ROOT (A,B,C,PR(3),PR(4),ISC)
C CNPTH=AMIN1(DUMY,PR(3),PR(4))
C GO TO 20
C IF (DIRR(3)+1.0) 15,14,15
C
C
C

```

```

C ***** * PROGRAM OPERATION REFERENCE NO. 69
C INTERSECTION WITH BASE BEFORE DOSIMETER
14 CNPTH=X(1,3)/DIRR(3)
   GO TO 20
C *****
C ***** * PROGRAM OPERATION REFERENCE NO. 70
C ALL TYPES OF INTERSECTION MUST BE CONSIDERED
15 PR(2)=1.0E+20
   Z1=X(1,3)/DIRR(3)
   IF (Z1) 17,16,16
16 PR(2)=Z1
   GO TO 19
C
17 IF (NP-2) 19,19,18
18 Z1=X(3,3)/DIRR(3)
   IF (Z1.GT.0.0) GO TO 16
   IF (Z1+EPSLN.GE.0.0) PR(2)=0.0
C
C ***** * PROGRAM OPERATION REFERENCE NO. 71
C CONICAL INTERSECTION
19 A=DIRR(1)**2+DIRR(2)**2-TANCN2*DIRR(3)**2
   B=-2.0*(X(2,1)*DIRR(1)+X(2,2)*DIRR(2)-TANCN2*X(2,3)*DIRR(3))
   CALL ROOT (A,B,C,PR(3),PR(4),ISC)
C ***** * PROGRAM OPERATION REFERENCE NO. 72
20 CNPTH=AMINI(DUMY,PR(2),PR(3),PR(4))
   DP(2)=CNPTH
   DP(1)=0.0
   RETURN
C
C DOSIMETER LOCATED OUTSIDE CONE
C ***** * PROGRAM OPERATION REFERENCE NO. 73
21 IF (DIRR(3)) 27,22,27
22 IF (ZR(2)) 23,26,25
23 DO 24 I=1,2
24 DP(I)=1.0E+20
   RETURN
25 IF (ZB(I)) 26,26,23
C
C RAY PASSES ALONG X OR Y AXIS OF SYSTEM
26 PR(1)=1.0E+20
   PR(2)=1.0E+20

```

=6C

```

C          GO TO 31
C          INVESTIGATION OF ALL TYPES OF POSSIBLE INTERSECTIONS
27         PR(1)=X(1,3)/DIRR(3)
           IF (PR(1).LT.0.0) GO TO 28
           PROJ=(PR(1)*DIRR(1)-X(2,1))**2+(PR(1)*DIRR(2)-X(2,2))**2
           IF ((PROJ-RB**2).LE.0.0) GO TO 29
28         PR(1)=1.0E+20
29         IF (NP.LE.2) GO TO 30
           PR(2)=X(3,3)/DIRR(3)
           IF (PR(2).LT.0.0) GO TO 30
           PROJ=(PR(2)*DIRR(1)-X(2,1))**2+(PR(2)*DIRR(2)-X(2,2))**2
           IF ((PROJ-RT**2).LE.0.0) GO TO 31
C          ***** * PROGRAM OPERATION REFERENCE NO. 74 *****
30         PR(2)=1.0E+20
31         A=DIRR(1)**2+DIRR(2)**2-TANCN2*DIRR(3)**2
           B=-2.0*(X(2,1)*DIRR(1)+X(2,2)*DIRR(2)-TANCN2*X(2,3)*DIRR(3))
           CALL ROOT (A,B,C,PR(3),PR(4),ISC)
C          ***** * PROGRAM OPERATION REFERENCE NO. 75 *****
           DO 32 I=3,4
           CSOLN=PR(I)*DIRR(3)
           IF ((CSOLN-EPSSLN).GT.ZB(2)) PR(1)=1.0E+20
           IF ((CSOLN+EPSSLN).LT.ZB(1)) PR(1)=1.0E+20
32         CONTINUE
           DO 33 I=1,2
           DP(I)=AMINI(DUMY,PR(1),PR(2),PR(3),PR(4))
           DO 33 J=1,4
           IF (ABS(PR(J)-DP(I)).LE.EPSSLN) PR(J)=1.0E+20
33         CONTINUE
           IF ((DP(1).GE.1.0E+20).OR.(DP(2).GE.1.0E+20)) GO TO 34
           CNPTH=ABS(OP(2)-DP(1))
           IF (DP(1).GT.DP(2)) GO TO 35
34         RETURN
C
35         CP=DP(1)
           DP(1)=DP(2)
           DP(2)=CP
           RETURN
           END
C          SUBROUTINE TKELL (ELIPTH,DP)
C          TRACKING OF PROTONS THROUGH AN ELLIPSOID

```

AC 99
AC 100
AC 101
AC 102
AC 103
AC 104
AC 105
AC 106
AC 107
AC 108
AC 109
AC 110
AC 111

AC 112
AC 113
AC 114
AC 115

AC 116
AC 117
AC 118
AC 119
AC 120
AC 121
AC 122
AC 123
AC 124
AC 125
AC 126
AC 127
AC 128
AC 129
AC 130
AC 131
AC 132
AC 133
AC 134
AC 135-
AD 1
AD 2
AD 3

==61

```

C          4
          5
          6
          7
          8
          9
          10
          11
          12
          13
          14
          15
          16
          17
          18
          19
          20
          21
          22
          23
          24
          25
          26
          27
          28
          29
          30
          31
          32
          33
          34
          35
          36
          37
          38
          39
          40
          41
          42
          43

DIMENSION X(6,3), DIR(3,3), DIRCSA(3), DIRRAY(3), CXYZ(3), SMMA(3)
1, PR(4), DP(2), ZB(4)
COMMON /DIRAY/ DIRCONS(3,1000)/VARIB/EPSLN/DATA/SHLDD(40)/GMDST/PAT
IH(1000)
EQUIVALENCE (SHLDD(6),PTS), (SHLDD(8),X), (SHLDD(26),DIR), (SHLDD(
135),SMMA), (SHLDD(38),DIRCSA)
ELIPHTH=0.0
JMAX=ABS(PTS)
DUM1=1.0E+21
DUM2=0.0
C          ROTATION OF DIRECTION COSINES OF PROTON RAY
C          ***** * PROGRAM OPERATION REFERENCE NO. 76 *****
C          DO I K=1,3
DIRRAY(K)=DIR(K,1)*DIRCSA(1)+DIR(K,2)*DIRCSA(2)+DIR(K,3)*DIRCSA(3)
CONTINUE
C          ELIMINATION OF IMPOSSIBLE INTERSECTIONS
C          ***** * PROGRAM OPERATION REFERENCE NO. 77 *****
C          IEL=JMAX-3
GO TO (2,3,6), IEL
STOP
C          ZERO TRUNCATIONS, INTERSECTION POSSIBLE WITH SURFACE ONLY
C          PR(1)=1.0E+20
C          PR(2)=1.0E+20
C          ZB(1)=X(4,3)-SMMA(3)
C          ZB(2)=X(3,3)
GO TO 17
C          IF (PTS) 5,4,4
C          ZB(2)=X(3,3)
C          ZB(1)=X(5,3)
GO TO 9
C          ZB(2)=X(5,3)
C          ZB(1)=X(4,3)-SMMA(3)
GO TO 9
C          IF (X(6,3)-X(5,3)) 7,7,8
C          ZB(1)=X(6,3)
C          ZB(2)=X(5,3)
GO TO 9

```

==62

```

8      ZB(2)=X(6,3)
      ZB(1)=X(5,3)
C
C ***** * PROGRAM OPERATION REFERENCE NO. 78 *****
C   INVESTIGATE POSSIBLE INTERSECTION WITH TRUNCATING PLANE(S)
9      IELP=IEL-1
      DO 14 I=1,IELP
      IF (DIRRAY(3).EQ.0.0) GO TO 13
      DP(I)=X(I+4,3)/DIRRAY(3)
      IF (DP(I)) 13,10,10
10     DO 11 J=1,2
11     CXYZ(J)=(DIRRAY(J)*DP(I)-X(4,J))/SMMA(J)
      CXYZ(3)=(X(I+4,3)-X(4,3))/SMMA(3)
      C2=CXYZ(1)**2+CXYZ(2)**2+CXYZ(3)**2-1.0
      IF (C2) 12,12,13
12     PR(I)=DP(I)
      GO TO 14
13     PR(I)=1.0E+20
C ***** * PROGRAM OPERATION REFERENCE NO. 79 *****
14     CONTINUE
      IF (IEL-2) 17,15,16
15     PR(2)=1.0E+20
16     IF (PR(1)+PR(2)-1.E+20) 26,17,17
C
C   ONE OR NFITHER OF 1ST 2 PATHS HAS BEEN EVALUATED
C ***** * PROGRAM OPERATION REFERENCE NO. 80 *****
C   TRY FOR SOLUTION OF SURFACE INTERSECTION
17     A=(DIRRAY(1)/SMMA(1))**2+(DIRRAY(2)/SMMA(2))**2+(DIRRAY(3)/SMMA(3)
      1)**2
      B=-2.*(DIRRAY(1)*X(4,1)/(SMMA(1)**2)+DIRRAY(2)*X(4,2)/(SMMA(2)**2)
      1+DIRRAY(3)*X(4,3)/(SMMA(3)**2))
      C=(X(4,1)/SMMA(1))**2+(X(4,2)/SMMA(2))**2+(X(4,3)/SMMA(3))**2-1.0
      CALL ROOT (A,B,C,PR(3),PR(4),ISC)
C ***** * PROGRAM OPERATION REFERENCE NO. 81 *****
      DO 20 I=3,4
      ZB(I)=PR(I)*DIRRAY(3)
      IF (ZB(I)-ZB(2)-EPSLN) 18,20,19
18     IF (ZB(I)-ZB(1)+EPSLN) 19,20,20
19     PR(I)=1.0E+20
20     CONTINUE
C ***** * PROGRAM OPERATION REFERENCE NO. 82 *****
      DO 23 I=1,2

```

```

AD 44
AD 45
AD 46
AD 47
AD 48
AD 49
AD 50
AD 51
AD 52
AD 53
AD 54
AD 55
AD 56
AD 57
AD 58
AD 59
AD 60
AD 61
AD 62
AD 63
AD 64
AD 65
AD 66
AD 67
AD 68
AD 69
AD 70
AD 71
AD 72
AD 73
AD 74
AD 75
AD 76
AD 77
AD 78
AD 79
AD 80

```

```

DP(I)=AMINI(DUM1,PR(1),PR(2),PR(3),PR(4))
DO 21 J=1,4
J=J
IF (PR(J)-DP(I)) 21,22,21
CONTINUE
PR(J)=1.0E+20
CONTINUE
IF ((ZB(2).GT.0.C).AND.(ZB(1).LT.0.C)) GO TO 25
IF ((DP(1).GE.1.0E+20).OR.(DP(2).GE.1.0E+20)) GO TO 27
ELIPTH=ABS(DP(2)-DP(1))
RETURN
C ***** * PROGRAM OPERATION REFERENCE NO. 83 *****
C IF (C.GE.0.0) GO TO 24
ELIPTH=AMINI(DUM1,DP(1),DP(2))
DP(2)=ELIPTH
DP(1)=0.0
RETURN
C
C 26 IF (PR(1).LT.0.0) PR(1)=0.0
IF (PR(2).LT.0.0) PR(2)=0.0
ELIPTH=ABS(PR(1)-PR(2))
DP(1)=AMINI(DUM1,PR(1),PR(2))
DP(2)=AMAX1(DUM2,PR(1),PR(2))
RETURN
END
SUBROUTINE LEAST
DIMENSION SUM(39), V(20), B(20,21)
COMMON /LSTSQ/ X(100),Y(100),A(20),N,M
C
C COMPUTES THE BEST-FIT POLYNOMIAL OF DEGREE M (I20)
C THROUGH A SET OF N POINTS OF (X,Y) DATA
C THE COEFFICIENTS OF THE RESULTING POLYNOMIAL ARE THE A(I) VALUES
C
LS=2*M+1
LB=M+2
LV=M+1
DO 1 J=2,LS
SUM(J)=0.0
SUM(1)=N
DO 2 J=1,LV
V(J)=0.0

```

AD 81
AD 82
AD 83
AD 84
AD 85
AD 86
AD 87
AD 88
AD 89
AD 90
AD 91
AD 92
AD 93
AD 94
AD 95
AD 96
AD 97
AD 98
AD 99
AD 100
AD 101
AD 102
AD 103
AD 104
AD 105-
AE 1
AE 2
AE 3
AE 4
AE 5
AE 6
AE 7
AE 8
AE 9
AE 10
AE 11
AE 12
AE 13
AE 14
AE 15
AE 16

==64

```

DO 4 I=1,N
P=1.0
V(I)=V(I)+Y(I)
DO 3 J=2,LV
P=X(I)*P
SUM(J)=SUM(J)+P
V(J)=V(J)+Y(I)*P
3 DO 4 J=LB,LS
P=X(I)*P
SUM(J)=SUM(J)+P
4 DO 5 I=1,LV
DO 5 K=1,LV
J=K+I
5 B(K,I)=SUM(J-I)
DO 6 K=1,LV
B(K,LB)=V(K)
6 DO 9 L=1,LV
DIV8=B(L,L)
DO 7 J=L,LB
7 B(L,J)=B(L,J)/DIV8
I1=L+1
IF (I1-LB) 8,10,10
8 DO 9 I=1,LV
FMULT8=B(I,L)
DO 9 J=L,LB
9 B(I,J)=B(I,J)-B(L,J)*FMULT8
10 A(LV)=B(LV,LB)
I=LV
11 SIGMA=0.0
DO 12 J=1,LV
12 SIGMA=SIGMA+R(I-1,J)*A(J)
I=I-1
A(I)=B(I,LB)-SIGMA
IF (I-1) 13,13,11
13 RETURN
END
```

AE 17
AE 18
AE 19
AE 20
AE 21
AE 22
AE 23
AE 24
AE 25
AE 26
AE 27
AE 28
AE 29
AE 30
AE 31
AE 32
AE 33
AE 34
AE 35
AE 36
AE 37
AE 38
AE 39
AE 40
AE 41
AE 42
AE 43
AE 44
AE 45
AE 46
AE 47
AE 48
AE 49
AE 50
AE 51
AE 52-

REFERENCES

1. Liley, B, and G. Schaedle, "An Examination of the Relative Merits of Stochastic and Nonstatistical Methods of Computing Primary Ionization Doses" Second Symposium on Protection Against Radiations In Space, Gatlinburg, Tenn. (12-14 Oct. 1964), (NAA S&ID).
2. Malone, C.F. Shield Thickness Calculation Program, Vol. 1 NASA-MSC (May 1965), p. 90.

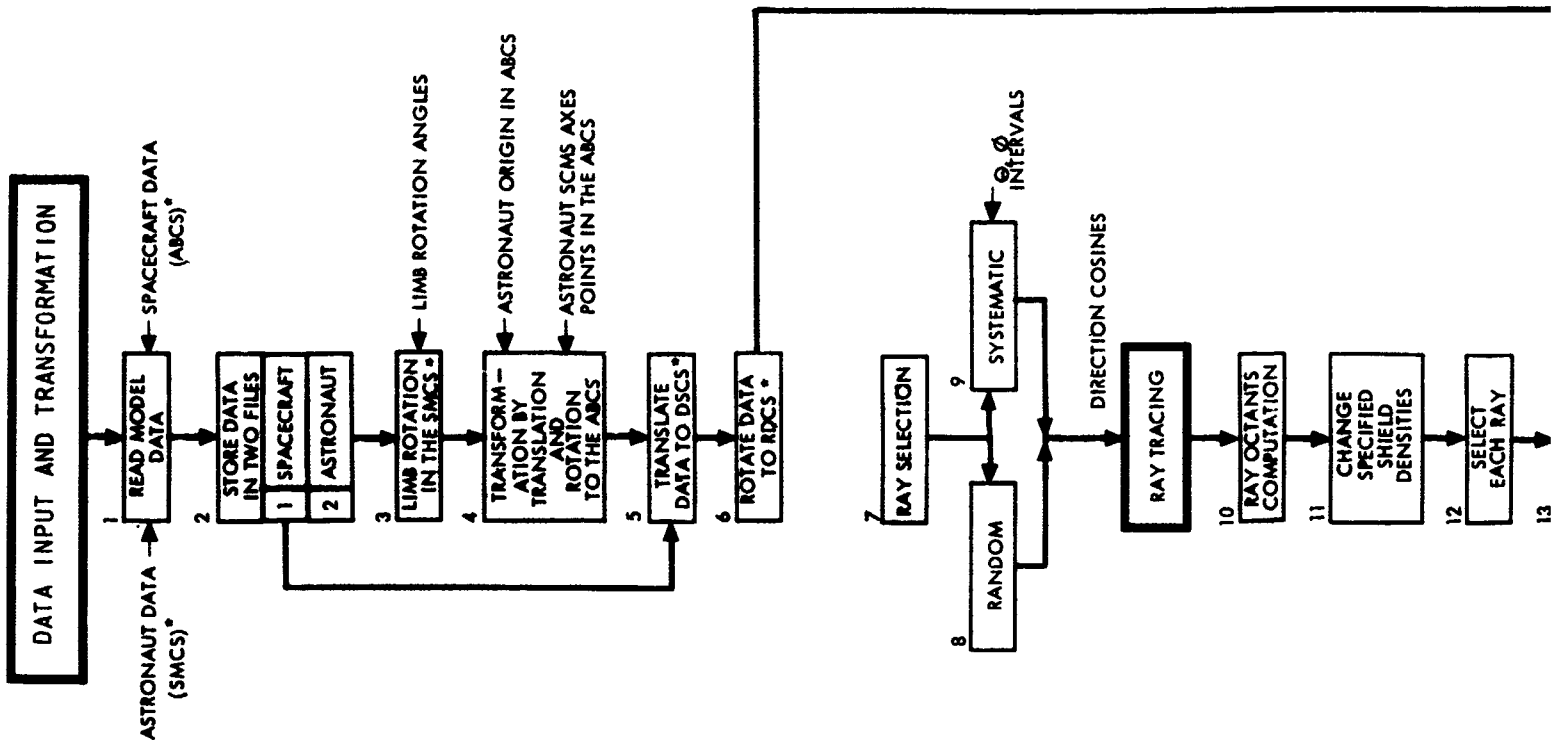

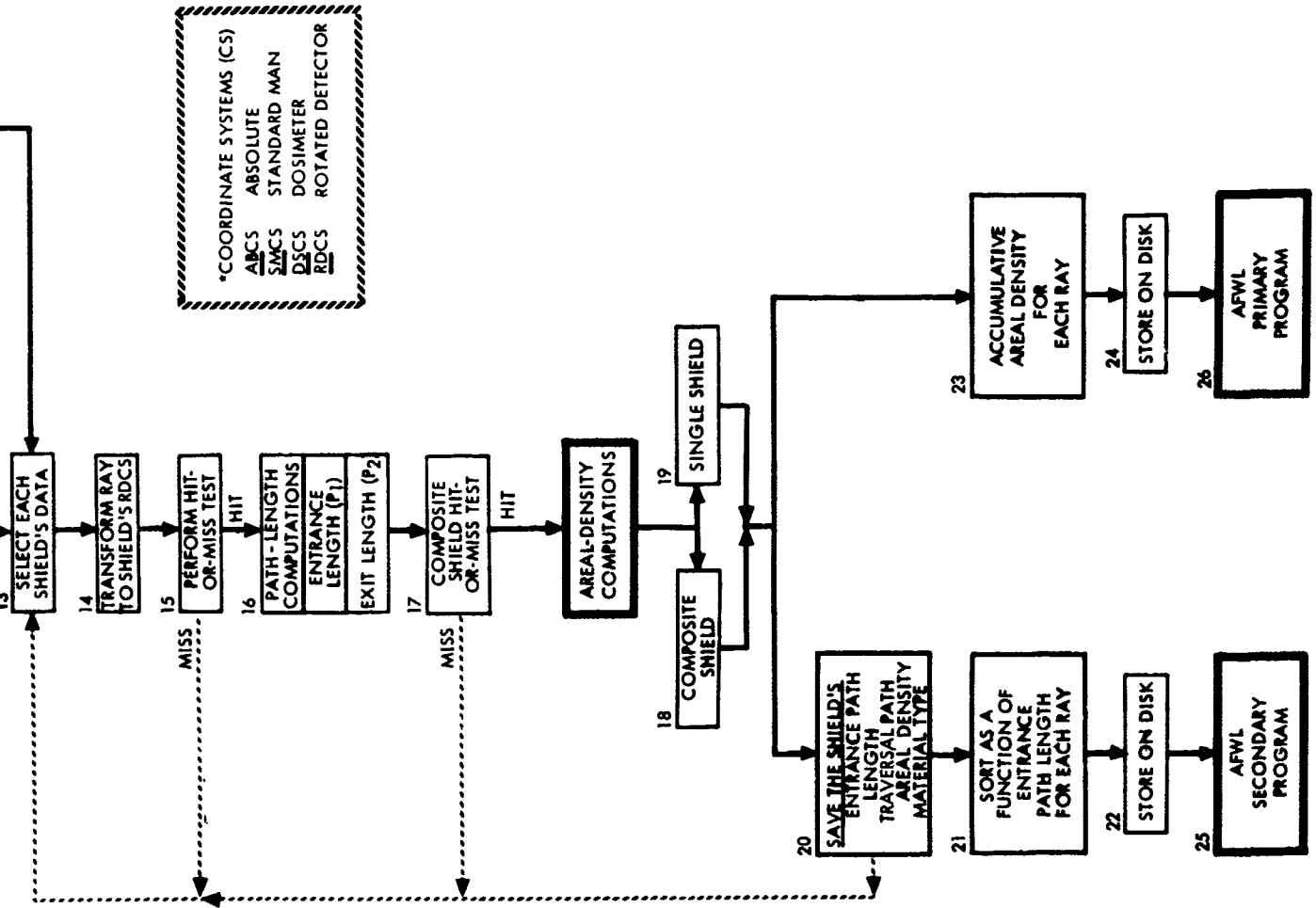

Figure 18. Functional Diagram of the MEVDP