

UNCLASSIFIED

AD NUMBER

AD874672

LIMITATION CHANGES

TO:

Approved for public release; distribution is unlimited.

FROM:

Distribution authorized to U.S. Gov't. agencies and their contractors;
Administrative/Operational Use; 08 MAY 1970.
Other requests shall be referred to Office of the Adjutant General (Army), Washington, DC 20310.

AUTHORITY

AGO ltr 29 Apr 1980

THIS PAGE IS UNCLASSIFIED

**THIS REPORT HAS BEEN DELIMITED
AND CLEARED FOR PUBLIC RELEASE
UNDER DOD DIRECTIVE 5200.20 AND
NO RESTRICTIONS ARE IMPOSED UPON
ITS USE AND DISCLOSURE.**

DISTRIBUTION STATEMENT A

**APPROVED FOR PUBLIC RELEASE,
DISTRIBUTION UNLIMITED.**



DEPARTMENT OF THE ARMY
OFFICE OF THE ADJUTANT GENERAL
WASHINGTON, D.C. 20310

(Handwritten initials)

IN REPLY REFER TO

AGDA (M) (4 Sep 70)

FOR OT UT 702196

8 September 1970

SUBJECT: Operational Report - Lessons Learned, Headquarters, 48th
Transportation Group, Period Ending 30 April 1970

DDC
RECEIVED
SEP 25 1970
(Handwritten signature)

SEE DISTRIBUTION

1. Subject report is forwarded for review and evaluation in accordance with paragraph 4b, AR 525-15. Information of actions initiated as a result of subject report should be forwarded to ACSFOR OT UT within 90 days of receipt of covering letter.

2. Information contained in this report is provided to insure appropriate benefits in the future from lessons learned during current operations and may be adapted for use in developing training material.

BY ORDER OF THE SECRETARY OF THE ARMY:

(Handwritten signature: Kenneth G. Wickham)

KENNETH G. WICKHAM
Major General, USA
The Adjutant General

1 Incl
as

DISTRIBUTION:

- Commanding Generals
 - US Continental Army Command
 - US Army Combat Developments Command
 - US Army Materiel Command

Commandants

- US Army War College
- US Army Command and General Staff College
- US Army Armor School
- US Army Engineer School
- US Army Field Artillery School
- US Army Infantry School
- US Army Ordnance School
- US Army Quartermaster School
- US Army Transportation School

UNCLASSIFIED REPORT
DISTRIBUTION NO FOREIGN WITHOUT APPROVAL OF
ASSISTANT CHIEF OF STAFF FOR FORCE DEVELOPMENT
(ARMY) ATTN: FOR OT UT, WASHINGTON, D.C. 20310

Protective marking cancelled when
separated from inclosure.

FOR OFFICIAL USE ONLY

18

AD NO. _____

DDG FILE COPY

874672

(Diagonal stamp: This document is subject to special export controls and each transmittal to foreign governments or foreign nationals may be made only with prior approval of STATEMENT #2 UNCLASSIFIED)

DEPARTMENT OF THE ARMY
HEADQUARTERS, 48TH TRANSPORTATION GROUP (MOTOR TRANSPORT)
APO 96491

AVCA SGN AB CO

8 May 1970

SUBJECT: Operational Report - Lessons Learned 48th Transportation Group
(MT), Period Ending 30 April 1970, RCS CSFOR - 65 (R-2)

THRU: Commanding Officer
US Army Support Command, Saigon
APO 96491

TO: Assistant Chief of Staff for Force Development
Department of the Army
Washington, D. C., 20310

1. Operations: Significant Activities

a. Under the command of Colonel Robert H. Schwarz, the 48th Transportation Group has the mission of providing general support motor transport service in III and IV Corps. In addition the Group is responsible for providing perimeter security for its assigned sector of Long Binh Post.

b. Headquarters, 48th Group, exercises command and control over the 6th and 7th Transportation Battalions (Truck) and the Consolidated Trailer Activity. (Organizational Chart - Inclosure 1). There has been a substantial change in the Group's organizational structure since the last reporting period. On 20 March 1970, the Group gained the 47th Transportation Company (POL) and the 538th Transportation Company (POL) from the 64th Quartermaster Battalion. These companies were assigned to the 7th Transportation Battalion and provide both line and local haul transportation of bulk POL products; The 48th Group lost a company on 28 February 1970. The 120th Transportation Company (Light Truck) with its headquarters in Can Tho was reassigned to the 29th General Support Group. Internal adjustment within the Group was reflected in the transfer of the 261st Transportation Company from Headquarters, 48th Group to the 6th Transportation Battalion. The 6th Battalion also gained the 563rd Transportation Company (Medium Truck) from the 7th Battalion. During this same period, the 233rd Transportation Company (Heavy Lift) was transferred from the 6th Transportation Battalion to the 7th Transportation Battalion. This Company presently has attached to it a provisional heavy lift platoon.

FDR OT UT
702196
Inclosure

FOR OFFICIAL USE ONLY

8 May 1970

SUBJECT: Operational Report - Lessons Learned 48th Transportation Group (MT), Period Ending 30 April 1970, NCS CSFOR - 65 (A-2)

c. In performing its motor transport mission, the Group engages in several specific types of operations, the most prominent of which are listed below:

(1) Line Haul Operations: The Group continued to provide line haul support to tactical forces in the Republic of Vietnam. Primary destinations for convoy operations included Tay Ninh, Dau Tieng, Cu Chi, Quan Loi, Phuoc Vinh, Lai Khe, Vung Tau, Tan An, Dong Tam. (See Time-Distance Chart at Inclosure 2).

(2) Local Haul Motor Transport Service is provided within a 25 mile radius of the Long Binh Post area. This mission involves multi-service support on a 24 hour per day basis.

(3) Port and Beach Operations were conducted as directed by the 3rd Transportation Center (MCC), Saigon Support Command. A commercial truck contractor (Pope, Evans, Robbins, International Limited) (PERIL), has the primary mission of augmenting port clearance in the III Corps area.

(4) Retrograde Transportation Operations are conducted incident to both line and local haul operations. Retrograde equipment is picked up in convoy areas (See Inclosure 2) and returned through Long Binh for salvage, re-issue or retrograde out of country.

(5) Driveaway Operations are conducted by the Group as directed by 3rd Transportation Center (MCC), Saigon Support Command. Driveaway operations include both wheeled and track vehicles, and involve the movement of equipment from Newport to first destination.

d. The following major developments have occurred during the reporting period:

(1) The Trailer Control Agency (TCA) is charged with accounting for the 1,080 12 ton S&P trailers that comprise the 48th Group fleet. Within the Group there are two line haul Trailer Transfer Points (TTP) at Long Binh and Tay Ninh and three local haul TTP's in support of port and beach operations. As of the last day of the reporting period, three additional TTP's were under construction in the line haul areas of Quan Loi, Phuoc Vinh and Vung Tau. In an effort to further upgrade the trailer fleet the following actions are being carried out under the supervision of the TCA:

FOR OFFICIAL USE ONLY

8 May 1970

SUBJECT: Operational Report - Lessons Learned 48th Transportation Group (MT), Period Ending 30 April 1970, RCS CSFOR - 65 (R-2)

(a) Two drop pads are being constructed at local consignee yards (3rd Ordnance Battalion and PDO) where daily operations require regular dropping of trailers.

(b) A training program is being instituted to train drivers in the operation of the tractor trailer. A further objective of the training program will be to instruct Battalion personnel regarding the "no-drop" policy adopted by 48th Group in the local and intermediate areas.

(2) Line haul operations continued to require the bulk of the Group's transportation capability. Overall operations to line haul destinations showed 187,072 short tons of cargo moved; compiling 11,217,038 ton miles. This cargo was transported to various destinations. The locations listed in paragraph 1c (1) above are convoyed to on a recurring basis. Several special convoys were ordered during this reporting period and they are noted below:

(a) A convoy of 5 S&P's was dispatched to Vinh Long on a special resupply mission of Class V. This convoy was forced to RON because of distance and travel time from Long Binh.

(b) On two separate occasions during the quarter, five tankers traveled north of Tay Ninh to FSB Barbara (III Corps). In both cases the tankers were required to RON in Tay Ninh on the return trip; they returned to Long Binh the next day.

(c) The 48th Group convoyed to Go Cong (IV Corps) for the first time in early April with five 5 ton trucks. The mission was to resupply that location with 55 gallon drums containing JP-4.

(d) A convoy was dispatched to Ben Tre (IV Corps) in early April on a POL resupply mission. The convoy RON'd due to extensive delays at a ferry crossing enroute. This was the first convoy that has been sent to that location by the 48th Group.

(e) In mid-April, 48th Group heavy lift vehicles convoyed to FSB Ellingsworth (III Corps) located north of Tay Ninh with asphalt. The convoy returned to Long Binh the next day with retrograde track vehicles.

(f) Song Be was a frequent convoy this quarter but has not been classified a recurring convoy. On twelve occasions during this quarter the 48th Group has convoyed to Song Be in support of the 1st Cavalry Division. On two of these convoys hostile enemy action was

8 May 1970

SUBJECT: Operational Report -- Lessons Learned 48th Transportation Group (MT), Period Ending 30 April 1970, RCS CSFOR - 65 (R-2)

encountered. Details of these encounters are covered in paragraphs 1 f (1) and 1 f (2).

(3) During this reporting period, Group supported several unit moves. The most prominent was Keystone Bluejay. This move started last quarter and was completed on 20 April 1970 when the last trailers of retrograde were loaded and pulled from Di An. At the peak of activity, the move was supported with as many as fifty USATSA trailers. The average support was approximately 35 trailers daily.

(4) The Group has been continuously engaged in a variety of port and beach clearance operations. These operations are supported with an average of 70 vehicles and 146 S&P trailers on a 24 hour basis. As the quarter came to a close, the 146 12 ton S&P's were being phased out of the port and beach systems and were being replaced by commercial "Fontaine" trailers. The "Fontaine" trailers were obtained 27 April 1970. The equipment was purchased from the former operator, Philco-Ford. These trailers are 35 feet long with a 25 ton capacity which exceeds the capacity of the S&P by 50%. A total of 120 of these trailers will be used to support port and beach operations as follows:

(a) Eighty of the trailers will be used to support the mission of port clearance at the Newport and Saigon docks. The tractor assets to support this operation has averaged forty-five 5 ton tractors during the day and 30 tractors at night throughout this quarter. During this period, 48th Group continued to use USATSA non-refrigerated vans for the movement of freeze cargo. Extensive use of these vans over a long period of time has clearly established that they expedite off-loading due to forklift access through the rear double-doors and that they maintain a desirable temperature for Class I freeze cargo.

(b) Thirty-four trailers will be used in support of the Cogido Ammunition Barge Site. These trailers will be partially boxed with side boards to reduce Class V spillage. Seventeen 5 ton tractors and sixteen 5 ton cargo trucks support that 24 hour operation. The 25 ton "Fontaine" trailers are expected to enhance the efficiency of the operation. The volume of tonnage moved from Cogido this quarter was 95,048 short tons.

(c) The remaining 6 of the 120 trailers will be tasked to support the Bien Hoa Class V barge site. This barge site operates from one pier and is supported by six tractors. The site is oriented toward the movement of USAF and VNAF Class V cargo.

FOR OFFICIAL USE ONLY

8 May 1970

SUBJECT: Operational Report -- Lessons Learned 48th Transportation Group (MT), Period Ending 30 April 1970, RCS CSFOR - 65 (R-2)

e. The continued performance of the 48th Group's mission has resulted in combat service support to the 1st, 9th and 25th Infantry Divisions, 1st Cavalary Division, 11th Armored Cavalry Regiment, 199th Light Infantry Brigade, Royal Thai Army Volunteer Force and the Royal Australian Task Force. In providing this support, the Group moved 577,999 short tons during this period and compiled a total of 16,877,239 ton miles. (Statistical Summary - Inclosure 3).

f. Enemy action remained light during the period.

(1) Ambush Incidents: On 1 March 1970, at 0125 hours, two tractors were returning from Bien Hoa Army Base to Long Binh Post when they were ambushed by an unknown size enemy force. The enemy used a land mine and small arms fire to damage both trucks. Neither driver received injuries. On 7 April 1970, at 1635 hours, a downed vehicle and several other vehicles moving in convoy to Song Be received rocket, mortar and small arms fire. There were no casualties. One vehicle received light damage. Security personnel returned fire immediately.

(2) Mine Incidents: On 22 March 1970 at 1:00 hours, a 5 ton tractor hit a mine just north of FSB Thunder III on QL 13. The driver was not injured and the truck sustained only minor damage. In another incident on 22 March at 1117 hours, a vehicle in convoy from Song Be hit a mine 7 miles north of Bunard Special Forces Camp. The driver was slightly injured and the vehicle was a combat loss. On 6 April at 1410 hours a tanker struck a mine while on a Class III resupply mission to FSB Mace. The driver received minor injuries, however the shotgunner riding in the vehicle was seriously injured. The vehicle was a combat loss. On 9 April at 1100 hours, a 5 ton tractor and tanker detonated a mine on QL 13 enroute to Quan Loi. The driver was not injured. The vehicle was moderately damaged.

g. Perimeter Security: The 48th Transportation Group operates and maintains one of the four defense sectors on the perimeter of Long Binh Post. This is approximately a 3 mile sector and consists of 29 tower/ground bunkers, and three 60 foot towers; "Hotel", "India", and "Juliet". During this reporting period, there has been approximately a 30% increase in the area of responsibility assigned to 48th Group. The 64th Quartermaster Battalion's area of responsibility, which consisted of 9 defensive positions, was assigned to the 48th Group upon deactivation of that Battalion on 1 April 1970. In addition to the sector defense mission the 48th Group has responsibility to insure that the subsector of USARV Special Troops maintains adequate security of the 1st Logistical Command/USARV Headquarters Complex to include the General Officers Quarters. To perform the above mission the 48th Group maintains command and operational control over four subsectors through the 48th Group Sector Operations Center

FOR OFFICIAL USE ONLY

8 May 1970

SUBJECT: Operational Report - Lessons Learned 48th Transportation Group (MT), Period Ending 30 April 1970, RCS CSFOR - 65 (R-2)

(SOC). All defense matters are reported to the SOC by the Sub-Sector Operations Centers (SSOC) for evaluation and determination of actions to be effected. The SOC coordinates all defense action with the Headquarters, Long Binh Post Tactical Operations Center (TOC), which effects coordination between the four primary Sectors.

h. Logistics:

(1) During the period covered by this report, this headquarters received a total of 107 military vehicles. Included were: Twenty-four 12 ton S&P trailers, one 5,000 gallon tanker, two 5 ton wreckers, one 40 ton lowbed semi-trailer, three 400 gallon water trailers, fifty-five 5 ton tractors, and twenty-one $\frac{1}{2}$ ton vehicles. Additionally, 157 commercial vehicles were obtained from Philco-Ford company assets. These are as follows: Eight 10 ton Ford tractors, two 5 ton Ford tractors, one 40 ton Ford wrecker, twenty-one 40 ton lowbed Fontaine trailers, and one hundred and twenty 25 ton stake and platform trailers.

(2) This headquarters submitted a cost reduction item during the quarter that totaled \$288,414.00. This savings was made possible by utilizing chains and chain binders instead of expensive side boards on the 12 ton S&P trailers. Since almost 90% of our cargo can be secured by chain binders, it is far more economical to use chains and binders instead of side boards in hauling this type cargo. Savings in manpower and MHE has also been realized. It takes two men and one forklift approximately thirty minutes to box a trailer. One man can secure cargo with a binder in fifteen minutes and obtain a more secure load.

(3) The 48th Transportation Group has undergone a direct support realignment of maintenance and repair parts support. The radical change was in the area of repair parts when the Group switched from the 59th Signal, AT8575, to the 549th Light Maintenance Company, AT87RW. It is significant to note that since the realignment on 1 April, the 48th Group average deadline rate has dropped from 7% in March to a low average of 5.2% during the month of April. The initiation of maintenance float procedures by the 549th has assisted in this achievement.

(4) Although 11.00 x 20 tires have been received in larger quantities than in the previous period, implementation of the direct exchange program has deprived the Group of practically all tires due out from the 59th Signal Company under the old procedure. As a result, 48th Group units are short approximately 1,900 spare tires and tubes

FOR OFFICIAL USE ONLY

AVCA SGN AB CO

8 May 1970

SUBJECT: Operational Report - Lessons Learned 48th Transportation Group (MT), Period Ending 30 April 1970, RCS CSFOR - 65 (R-2)

in addition to those authorized as PLL stock. A one time issue of these shortages would permit exchange of tires before they are worn past the repair point.

(5) The following 48th Transportation Group units have received 1st Logistical Command CMMI inspections during the quarter:

<u>DATE</u>	<u>UNIT</u>	<u>MATERIAL SCORE</u>	<u>MANAGEMENT SCORE</u>
13 Feb	86th Trans Co	79%	76%
23 Feb	321st Trans Co	93%	91%
12 Mar	543rd Trans Co	90%	89%
10 Apr	563rd Trans Co	90%	87%
16 Mar	62nd Trans Co	92%	79%
9 Feb	261st Trans Co	85%	85%
9 Feb	506th Trans Det	85%	85%
9 Mar	538th Trans Co	83%	76%

(6) The following units of the 48th Transportation Group underwent Annual General Inspections during the last quarter. All were rated satisfactory.

<u>DATE</u>	<u>UNIT</u>
19 Feb	572nd Trans Co
14 Mar	HHD, 7th Trans Bn
16 Apr	47th Trans Co
21 Apr	538th Trans Co

(7) Seventy-three M127 series trailers have been shipped to Okinawa for overhaul under the 2nd Logistical Command Repair and Return Program. Thirty-six are presently waiting shipment. Sixty have been returned. Turn-around time for the first thirty-four averaged 113 days.

2. Lessons Learned: Commanders Observation, Evaluation, and Recommendations.

- a. Personnel. None.
- b. Intelligence. None.
- c. Operations.

(1) Line haul support to tactical forces below Brigade Base Camp Level results in wasted transportation capability.

FOR OFFICIAL USE ONLY

AVCA SGN AB CO

8 May 1970

SUBJECT: Operational Report - Lessons Learned 48th Transportation Group (MT), Period Ending 30 April 1970, RCS CSFOR - 65 (R-2)

(a) OBSERVATION: Attempts to extend line haul transportation support forward of Brigade Base Camps results in costly unloading delays.

(b) EVALUATION: Improved support of tactical forces is erroneously defined in terms of how far forward supplies are transported by the line haul transportation service. Recent experience during the reporting period reveals that attempts to support Battalion or Battery Level fire bases cause excessive delay in off-loading. Delays are a function of three factors, i.e., limited materials handling equipment, lack of supervision and concern for the equipment after delivery and an inability to see the effects and cost of off-loading delays. In the current Cambodian operation, the Group lost a total of 124 vehicle days in attempting to deliver 31 truck loads of cargo only 42 KM north of its normal destination at Tay Ninh. All three factors mentioned above coupled with a poor road net and the threat of enemy activity contributed to the three day delay in off-loading. The loss of the 124 vehicle days of capability was absorbed by the same division which requested the support forward. Total tonnage delivered to the division to support its operations was thus reduced.

(c) RECOMMENDATION: That support forward of Brigade Base Camps not be undertaken in the name of improved support without an analysis of the total cost in transportation terms of such operations.

d. Organization.

(1) Consolidated Trailer Activity.

(a) OBSERVATION: Operation of a line haul transportation service in Vietnam requires the centralization of the trailer fleet.

(b) EVALUATION: The demands of a line haul transportation service for centralized direction, accountability and maintenance of trailers requires the development of a specially designed unit to perform the task. The 48th Group has submitted a study describing the specific functions performed by such an organization. Generally the Activity is composed of a Trailer Control Agency (accountability and control), a Trailer Maintenance Activity (centralized organizational maintenance) and a Trailer Transfer Point Augmentation (Trailer Interchange). This study has been forwarded to Combat Developments Command (CDC).

(c) RECOMMENDATION: That cellular units be designed by CDC to perform the centralized trailer activity functions for future line haul operations.

FOR OFFICIAL USE ONLY

AVCA SGN AB CO

8 May 1970

SUBJECT: Operational Report - Lessons Learned 48th Transportation Group
(MT), Period Ending 30 April 1970, RCS CSFOR - 65 (R-2)

- e. Training. None.
- f. Logistics. None.
- g. Communications. None.
- h. Material. None.
- i. Other. None.

3 Incl
as

ROBERT H. SCHWARZ
Colonel, TC
Commanding

Cy Furn:
2 - CINCUSARPAC, ATTN: GPOP-DT
3 - USARV, ATTN: AVHGC-DST

FOR OFFICIAL USE ONLY

AVCA SGN GO MH (8 May 70) 1st Ind
SUBJECT: Operational Report - Lessons Learned, 48th Transportation
Group, Period Ending 30 April 1970, RCS CSFOR-65 (R2)

HQ, US Army Support Command, Saigon, APO 96491 22 MAY 1970

TO: Assistant Chief of Staff for Force Development, Department of the
Army, Washington, D.C. 20310

Commanding General, 1st Logistical Command, ATTN: AVCA GO-MH,
APO 96384

1. Reference paragraph 1 h(4), page 6. NONCONCUR. It would appear that when tires became a DX item, the 48th Group lost dues-out. However, it is well known that hand carries straight to USADLB on several occasions resulted in hundreds of tires being issued to 48th Group units without cancellation of the dues-out. Proper cancellation each time a request was hand carried to the Depot would have corrected the erroneous conclusion that tires have not been received. There are currently 1100X20 tires available for DX in limited quantities at the DSU. The new recap facility will make a larger quantity available to enable ease of operation of the DX program.
2. Reference paragraph 2 c(1), page 7. CONCUR. Support forward of Brigade-level Base Camps should not be undertaken in the name of improved support without an analysis of the total cost in transportation terms of such operations. When support is provided to areas forward of Brigade Level Base Camps, past experience indicates that excessive delays in off-loading occur. Even though this method results in the more expedient delivery of cargo to the consignees, transportation assets are removed from the system for a longer period of time than is normally acceptable. It is recommended that such deliveries be undertaken only when the priority of the cargo to be delivered exceeds the value of the transportation assets lost.
3. Reference paragraph 2 d(1), page 8. CONCUR. Cellular units should be designed by CDC to perform the centralized trailer activity functions for future line haul operations. Based upon the comprehensive study prepared by the 48th Transportation Group on the consolidated trailer activity a definite requirement exists for such an organization in the TO&E of a transportation group (MT).

FOR OFFICIAL USE ONLY

AVCA SGN GO MH (8 May 70) 1st Ind

22 MAY 1970

SUBJECT: Operational Report - Lessons Learned, 48th Transportation Group, Period Ending 30 April 1970, RCS CSFOR-65 (R2)

4. Lessons Learned, observations, and recommendations are concurred in by this command with the above exception.

FOR THE COMMANDER:

TEL: LBN 2604

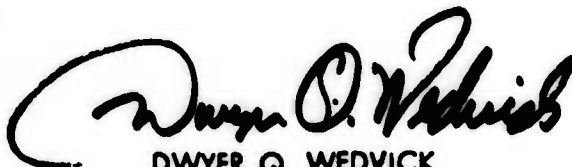

DWYER Q. WEDVICK
Captain, AGC
Asst AG

CF:
48th Trans Gp

11
FOR OFFICIAL USE ONLY

AVCA GO-MH (25 May 70) 2nd Ind

SUBJECT: Operational Report - Lessons Learned, 48th Transportation Group
for period ending 30 April 1970 RCS CSFOR-65 (R2)

DA, Headquarters, 1st Logistical Command, APO 96384

TO: Commanding General, United States Army, Vietnam, ATTN: AVHGC-DST,
APO 96375

1. The Operational Report - Lessons Learned submitted by Headquarters, 48th
Transportation Group for the quarterly period ending 30 April 1970 is forwarded.

2. Due to closing of this headquarters, staffing cannot be completed. Normal
staffing will be done by Headquarters, USARV.

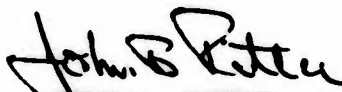

JOHN B. RITTER

CPT, OrdC

CO, 15th MID

AVHGC-DST (8 May 70) 3d Ind
SUBJECT: Operational Report - Lessons Learned 48th Transportation Group
(MT), Period Ending 30 April 1970, RCS CSFOR - 65 (R-2)

Headquarters, United States Army, Vietnam, APO San Francisco 96375 4 JUL 1970

TO: Commander in Chief, United States Army, Pacific, ATTN: GPOC-DT,
APO 96558

1. This headquarters has reviewed the Operational Report-Lessons Learned for the quarterly period ending 30 April 1970 from Headquarters, 48th Transportation Group (MT) and concurs with the comments of indorsing headquarters.

2. Comments follow:

a. Reference item concerning "Line Haul Support to Tactical Forces below Brigade Base Camp Level Results in Wasted Transportation Capability", page 7, paragraph c(1): Concur. Although flexibility of operation is desirable to meet the needs of users of the common user land transportation system, overall requirements must be considered. Increasing the length of the supply line and providing delivery to the unit must be considered in relation to the entire system's ability to sustain optimum performance. Degrading the operating efficiency of the line haul mission should only be done in emergency situations. No action by USARPAC or DA is recommended.

b. Reference item concerning "Consolidated Trailer Activity", page 8, paragraph d(1): Concur. Concur with recommendation to locate the Trailer Control Agency (TCA) under operational control of S2/3 and the Trailer Maintenance Activity under operational control of the S4 to provide improved accountability and maintenance of pooled group trailer assets. Recommend that CDC develop cellular units to eliminate duplication of trailer control activities and functions. Action by USARPAC or DA is recommended.

FOR THE COMMANDER:

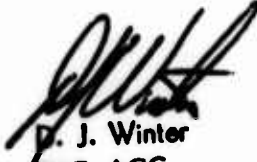
D. J. Winter
CPT, AGC
Assistant Adjutant General

CF:
HQ, 48th Trans Gp (MT)
HQ, USA Spt Comd, Sgn

GPOP-DT (8 May 70) 4th Ind

SUBJECT: Operational Report of HQ, 48th Transportation Group (Motor
Transport) for Period Ending 30 April 1970, RCS CSFOR-65 (R2)

HQ, US Army, Pacific, APO San Francisco 96558

23 JUL 70

TO: Assistant Chief of Staff for Force Development, Department of the
Army, Washington, D. C. 20310

This headquarters concurs in subject report as indorsed.

FOR THE COMMANDER IN CHIEF:



L.M. OZARK
CPT, AGC
Asst AG

ORGANIZATIONAL CHART
20 March 1970

LONG BINH - LB
TAY NINH - TN

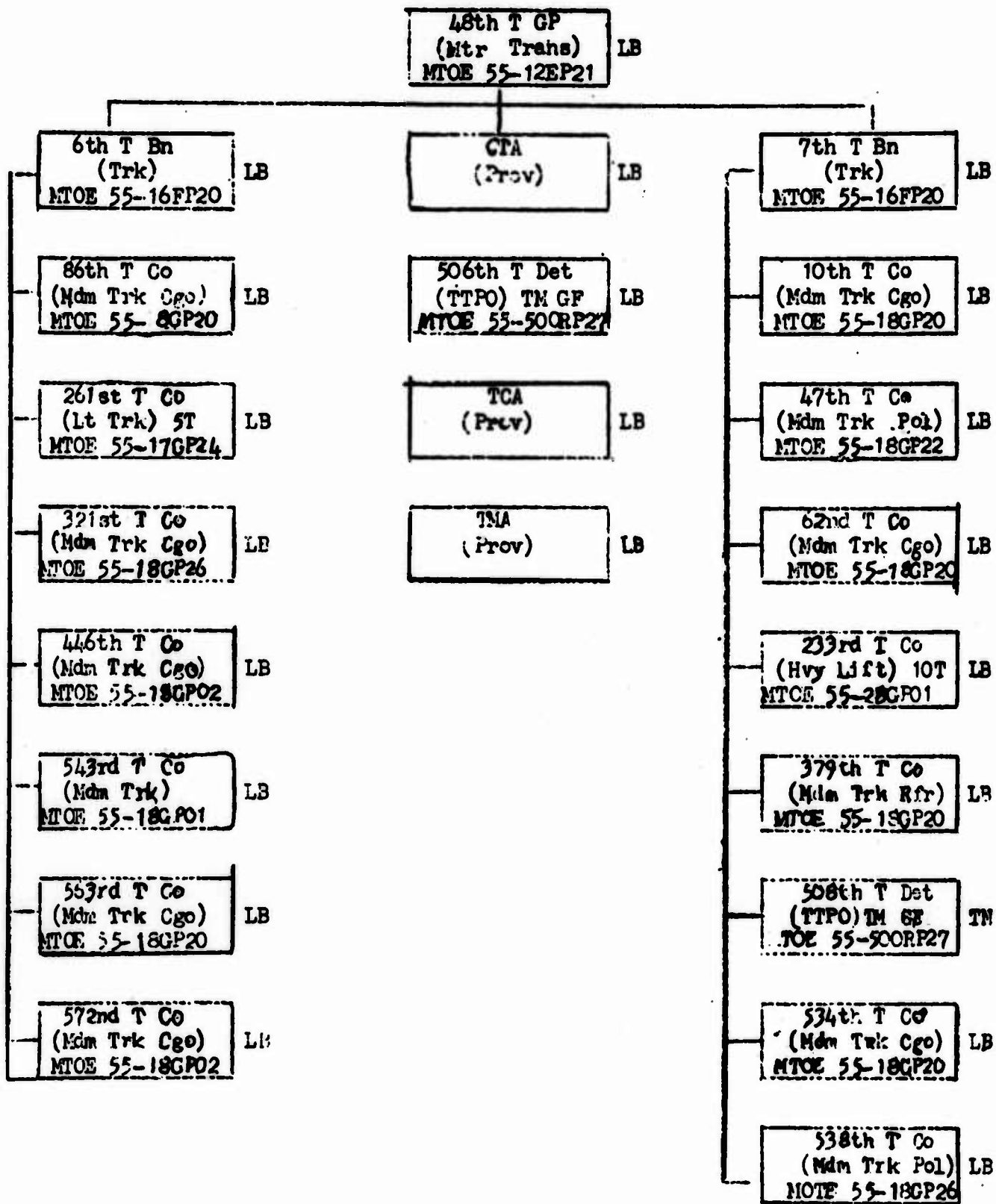

Incl 1

DEPARTMENT OF THE ARMY
 HEADQUARTERS, 48TH TRANSPORTATION GROUP (MOTOR TRANSPORT)
 APO 96491

3 May 1970

Distances and Times to Convoy Destinations

(This schematic supersedes undated schematic based on data to 15 Mar 69.)

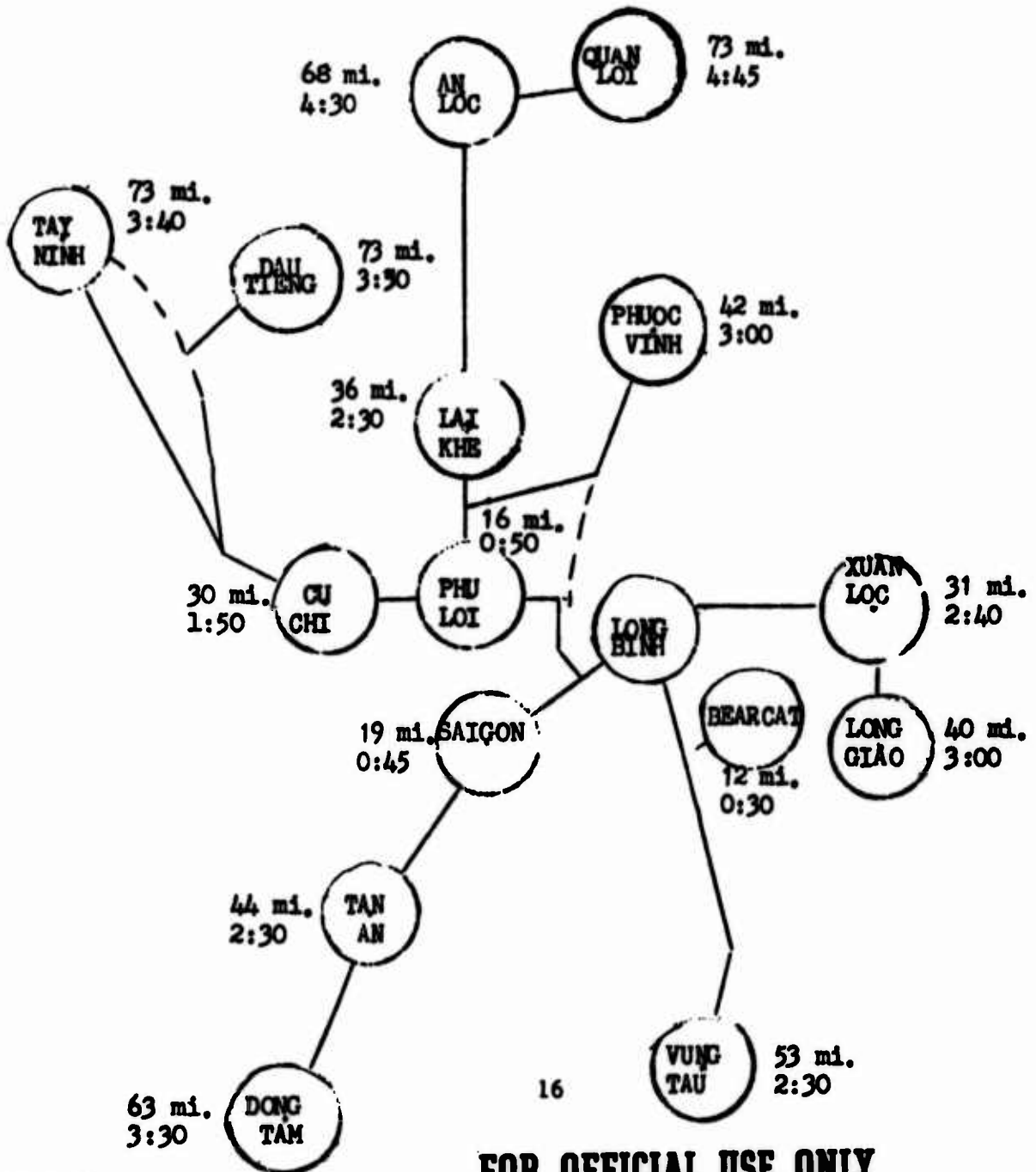

FOR OFFICIAL USE ONLY

Incl 2

TONNAGE HAULED FOR THE QUARTER ENDING 30 APRIL 1970

	LINE HAUL	LOCAL HAUL	PORT AND BEACH LINE	PORT AND BEACH LOCAL	RETRO	TOTAL
FEBRUARY	44,608	50,817	68,760	5,825	10,586	180,596
MARCH	47,115	56,301	67,181	4,356	8,990	183,943
APRIL	60,333	79,954	59,091	5,848	8,234	213,460
TOTAL	152,056	187,072	195,032	16,029	27,810	577,999

TOTAL FOR ALL TYPES OF OPERATIONS 577,999

TON MILES FOR THE QUARTER ENDING 30 APRIL 1970

	LINE HAUL	LOCAL HAUL	PORT AND BEACH LINE	PORT AND BEACH LOCAL	RETRO	TOTAL
FEBRUARY	571,354	3,088,734	853,902	175,160	262,675	4,951,825
MARCH	689,735	3,422,884	731,634	138,751	247,658	5,230,662
APRIL	801,672	4,705,420	730,238	264,367	193,055	6,694,752
TOTAL	2,062,761	11,217,038	2,315,774	578,278	703,388	16,877,239

TOTAL FOR ALL TYPES OF OPERATIONS 16,877,239

UNCLASSIFIED

Security Classification

DOCUMENT CONTROL DATA - R & D

(Security classification of title, body of abstract and indexing annotation must be entered when the overall report is classified.)

1. ORIGINATING ACTIVITY (Corporate author) HQ, OACSFOR, DA, Washington, D.C. 20310		2a. REPORT SECURITY CLASSIFICATION FOR OFFICIAL USE ONLY	
		2b. GROUP	
3. REPORT TITLE Operational Report - Lessons Learned, HQ, 48th Transportation Group			
4. DESCRIPTIVE NOTES (Type of report and inclusive dates) Experiences of unit engaged in counterinsurgency operations, 1 Feb to 30 Apr 70.			
5. AUTHOR(S) (First name, middle initial, last name) CO, 48th Transportation Group			
6. REPORT DATE 8 May 1970		7a. TOTAL NO. OF PAGES 20	7b. NO. OF REFS
8a. CONTRACT OR GRANT NO.		8b. ORIGINATOR'S REPORT NUMBER(S) 702196	
a. PROJECT NO. N/A		8c. OTHER REPORT NO(S) (Any other numbers that may be assigned this report)	
c.			
d.			
10. DISTRIBUTION STATEMENT			
11. SUPPLEMENTARY NOTES N/A		12. SPONSORING MILITARY ACTIVITY OACSFOR, DA, Washington, D.C. 20310	
13. ABSTRACT			