

UNCLASSIFIED

AD NUMBER

AD871981

LIMITATION CHANGES

TO:

Approved for public release; distribution is unlimited.

FROM:

Distribution authorized to U.S. Gov't. agencies and their contractors;  
Administrative/Operational Use; OCT 1969. Other requests shall be referred to Air Force Materials Lab., Wright-Patterson AFB, OH 45433.

AUTHORITY

AFML ltr 29 Mar 1972

THIS PAGE IS UNCLASSIFIED

20

AFML-TR-69-263

INVESTIGATION OF LIGHT WEIGHT, IMPACT RESISTANT,  
LAMELLAR COMPOSITES OF TITANIUM-CLAD BERYLLIUM  
FOR AIR BREATHING ENGINE COMPRESSOR BLADES

F. A. Zorko  
R. G. O'Rourke  
W. W. Beaver

The Brush Beryllium Company

Technical Report AFML-TR-69-263  
October, 1969

"This document is subject to special export controls and each transmittal to foreign governments or foreign nationals may be made only with prior approval of the Air Force Materials Laboratory (MAM), Wright-Patterson Air Force Base, Ohio 45433".

Air Force Materials Laboratory  
Air Force Systems Command  
Wright-Patterson Air Force Base, Ohio 45433

AD No. \_\_\_\_\_  
PREP FILE COPY

AD871981

CD  
D D C  
RECEIVED  
JUL 27 1970  
RECEIVED

72

## NOTICES

When Government drawings, specifications, or other data are used for any purpose other than in connection with a definitely related Government procurement operation, the United States Government thereby incurs no responsibility nor any obligation whatsoever; and the fact that the Government may have formulated, furnished, or in any way supplied the said drawings, specifications, or other data, is not to be regarded by implication or otherwise as in any manner licensing the holder or any other person or corporation, or conveying any rights or permission to manufacture, use, or sell any patented invention that may in any way be related thereto.

This document is subject to special export controls and each transmittal to foreign governments or foreign nationals may be made only with prior approval of the Metals and Ceramics Division (MAM), Air Force Materials Laboratory, Wright-Patterson AFB, Ohio 45433.

Distribution of this report is limited because the report contains technology identifiable with items on the strategic embargo lists excluded from export under the U.S. Export Control Act, as implemented by AFR 310-2 and AFSC 80-20.

ACCESSION for		
CPSTI	WHITE SECTION	<input type="checkbox"/>
ODC	DUFF SECTION	<input checked="" type="checkbox"/>
UNANNOUNCED		<input type="checkbox"/>
JUSTIFICATION		
BY		
DISTRIBUTION/AVAILABILITY CODES		
DIST.	AVAIL.	SPECIAL
2		

Copies of this report should not be returned unless return is required by security considerations, contractual obligations, or notice on a specific document.

**INVESTIGATION OF LIGHT WEIGHT, IMPACT RESISTANT,  
LAMELLAR COMPOSITES OF TITANIUM-CLAD BERYLLIUM  
FOR AIR BREATHING ENGINE COMPRESSOR BLADES**

**F. A. Zorko  
R. G. O'Rourke  
W. W. Beaver**

**October 1969**

**"This document is subject to special export controls and each transmittal to foreign governments or foreign nationals may be made only with prior approval of the Air Force Materials Laboratory (MAM), Wright-Patterson Air Force Base, Ohio 45433".**

## FOREWORD

This report was prepared by The Brush Beryllium Company, Cleveland, Ohio under USAF Contract AF33(615)-2223. This contract was part of the cooperative research and development program established under the Thorneycroft-McNamara Agreement of May 1963 to jointly develop beryllium metal for use in turbine engine components. The financial support and technical direction were provided by the Ministry of Technology (formerly Ministry of Aviation), London, United Kingdom of Great Britain and Northern Ireland and the United States Air Force Systems Command's Materials and Aero Propulsion Laboratories at Wright-Patterson Air Force Base, Ohio

This report covers work conducted from May 1968 through August 1969.

The work under this contract was administered under the direction of Mr. George M. Glenn, Manufacturing Technology Division and Mr. Kenneth L. Kojola, Metals and Ceramics Division, Air Force Materials Laboratory, Air Force Systems Command, Wright-Patterson Air Force Base, Ohio.

The work was carried out under the direction of W. W. Beaver, Vice-President, Research and Development. R. G. O'Rourke was the Project Manager with F. Zorko as Project Engineer.

Manuscript released by authors 1 August 1969 for publication as a Technical Report

This technical report has been reviewed and is approved.



THOMAS D. COOPER, Chief  
Processing and Nondestructive  
Testing Branch  
Metals and Ceramic Division

**BLANK PAGE**

## ABSTRACT

Lamellar composites of beryllium and titanium have been tested by ballistic impact, tensile testing after impact, and impacting while under tensile stress.

The titanium cover plates minimize and localize the impact damage to the beryllium core. Use of high strength beryllium sheet to maximize the strength-to-weight ratio of the composite resulted in increased ballistic impact damage. For all types of beryllium utilized, the damage induced by ballistic impact energy levels of 1 ft-lb and greater in specimens while under tensile load, lead to crack propagation throughout the cross-section of the beryllium substrate with a resultant loss in load carrying ability. Therefore future efforts on this composite approach for turbine engine blading is not warranted.

The program was aimed at rapid evaluation of composite potential in the one application and materials and techniques were not optimized. Potential in other less demanding areas or armoring was not evaluated.

"This document is subject to special export controls and each transmittal to foreign governments or foreign nationals may be made only with prior approval of the Air Force Materials Laboratory (MAM), Wright-Patterson Air Force Base, Ohio 45433".

## TABLE OF CONTENTS

<u>SECTION</u>	<u>PAGE NO.</u>
I. Introduction . . . . .	1
A. Contractual Specifications . . . . .	13
II. Summary . . . . .	15
III. Experimental . . . . .	16
A. Contractual Specifications . . . . .	16
B. Materials . . . . .	16
C. Composite Fabrication . . . . .	17
D. Specimen Geometries and Tolerances . . . . .	18
E. Testing . . . . .	20
F. Evaluation . . . . .	20
IV. Experimental Results . . . . .	22
A. General . . . . .	22
B. Wrought S-200 . . . . .	23
C. Hot Pressed S-200 . . . . .	33
D. Wrought I-400 . . . . .	46
E. Hot Pressed I-400 . . . . .	46
V. Discussion of Results . . . . .	56
VI. Conclusions . . . . .	59
VII. Recommendations . . . . .	60



## LIST OF TABLES

TABLE NO.	PAGE NO.
I. Mechanical Properties of Materials of Construction and Their Composite Assemblies . . . . .	9
II. Heat Treated Wrought S-200 Base Composites Ballistic Test Results . . . . .	25
III. Unheat Treated Wrought S-200 Base Composites Ballistic Test Results . . . . .	29
IV. Heat Treated Wrought S-200 Base Composites Tensile Ballistic Test Results . . . . .	34
V. Unheat Treated Wrought S-200 Base Composites Tensile Ballistic Test Results . . . . .	35
VI. Unheat Treated Wrought S-200 Base Composites Ballistic Tensile Test Results . . . . .	38
VII. Hot Pressed S-200 Base Composites Ballistic Test Results . . . . .	41
VIII. Hot Pressed S-200 Base Composites Tensile Ballistic Test Results . . . . .	44
IX. Hot Pressed S-200 Base Composites Ballistic Tensile Test Results . . . . .	48
X. Wrought I-400 Base Composites Ballistic Tensile Test Results . . . . .	49
XI. Hot Pressed I-400 Base Composites Tensile Ballistic Test Results . . . . .	51
XII. Hot Pressed I-400 Base Composites Ballistic Tensile Test Results . . . . .	54
XIII. Summary of the Observed and Theoretical Mechanical Properties as a Function of Beryllium Substrate Grade . . . . .	58

## LIST OF ILLUSTRATIONS

<u>FIG. NO.</u>	<u>PAGE NO.</u>
1. Beryllium-Titanium Composite Density Ratio as a Function of Pair Thickness Ratio . . . . .	4
2. Typical Coefficient of Linear Thermal Expansion Curves for Beryllium and Ti-6Al-4V as a Function of Temperature (°F) . . . . .	5
3. Typical Moduli of Elasticity of Beryllium and Ti-6Al-4V as a Function of Temperature (°F) . . . . .	7
4. Typical Mechanical Properties of Beryllium and Solution Treated and Aged Ti-6Al-4V as a Function of Temperature (°F) . . . . .	8
5. Comparison of Typical Stress-Strain Curves for Various Beryllium Grades and Solution Treated and Aged Ti-6Al-4V . . . . .	12
6. Composite Geometry for Ballistic Test Specimen . . . . .	19
7. Composite Tensile Bar Geometry for Tensile Ballistic and Ballistic Tensile Testing . . . . .	19
8. Ballistic Test Results on Heat Treated Wrought S-200 Base Composites as a Function of Impact Level, Impact Side of Stripped Assembly . . . . .	26
9. Ballistic Test Results on Heat Treated Wrought S-200 Base Composites as a Function of Impact Level, Reverse Side of Stripped Assembly . . . . .	27
10. Ballistic Test Results on Heat Treated Wrought S-200 Base Composites as a Function of Impact Level, Photoelastic Stress Pattern Generated by Impact . . . . .	28
11. Ballistic Test Results on Unheat Treated Wrought S-200 Base Composites as a Function of Impact Level, Impact Side of Stripped Assembly . . . . .	30

LIST OF ILLUSTRATIONS (Continued)

<u>FIG. NO.</u>	<u>PAGE NO.</u>
12. Ballistic Test Results of Unheat Treated Wrought S-200 Base Composites as a Function of Impact Level, Reserve Side of Stripped Assembly . . . . .	31
13. Ballistic Test Results on Unheat Treated Wrought S-200 Base Composites as a Function of Impact Level, Photoelastic Stress Pattern Generated by Impact . . . . .	32
14. Tensile Ballistic Test Results as a Function of Increasing Static Tensile Load and Ballistic Impact Levels on Heat Treated Wrought S-200 Base Composites Stripped Assembly . . . . .	36
15. Tensile Ballistic Test Results as a Function of Increasing Static Tensile Load and Ballistic Impact Levels on Unheat Treated Wrought S-200 Base Composites Stripped Assembly . . . . .	37
16. Ballistic Tensile Test Results as a Function of Increasing Ballistic Level on Unheat Treated Wrought S-200 Base Composites, Stripped Assemblies . . . . .	39
17. Ballistic Test Results on Hot Pressed S-200 Base Composites as a Function of Increasing Impact Level, Impact Side of Stripped Assembly . . . . .	42
18. Ballistic Test Results on Hot Pressed S-200 Base Composites as a Function of Increasing Impact Level, Reverse Side of Stripped Assembly . . . . .	43
19. Tensile Ballistic Test Results as a Function of Increasing Static Tensile Load and Ballistic Level on Hot Pressed S-200 Base Composites, Stripped Assembly . . . . .	45

LIST OF ILLUSTRATIONS (Continued)

<u>FIG. NO.</u>	<u>PAGE NO.</u>
20. Ballistic Tensile Test Results as a Function of Increasing Ballistic Level on Hot Pressed S-200 Base Composites, Stripped Assembly . . . . .	47
21. Tensile Ballistic Test Results as a Function of Increasing Static Tensile Load and Ballistic Level on Wrought I-400 Base Composites, Stripped Assembly . . . . .	50
22. Tensile Ballistic Test Results as a Function of Increasing Static Tensile Load and Impact Level on Hot Pressed I-400 Base Composites, Stripped Assembly . . . . .	52
23. Ballistic Tensile Test Results as a Function of Increasing Impact Level on Hot Pressed I-400 Base Composites, Stripped Assembly . . . . .	55

## I. INTRODUCTION

Summary of past studies has indicated that beryllium, in spite of its high moduli of elasticity and rigidity, has been an extremely poor material in applications requiring ballistic impact resistance.

The prime factor contributing to its poor ballistic quality is that which is responsible for its limited tensile ductility, the lack of sufficient slip systems operating at room temperature. In wrought material, this lack is further emphasized by preferential orientation, which may reduce the availability of desirable slip systems in the path of impact energies. Extensive studies have shown that the prime mode of plastic deformation is by slip on the basal plane (0001). It has been further demonstrated that the basal plane during rolling becomes oriented such that it is parallel with the rolled surface. In contrast to this condition, the low ductility ( $11\bar{2}0$ ) prismatic plane becomes oriented normal to the rolled surface.

The mere fact that beryllium is anisotropic such that the slip capabilities are greatest on the basal plane (0001), to a lesser degree on the type I prismatic plane ( $10\bar{1}0$ ) and least on the type II prismatic ( $11\bar{2}0$ ) plane has been demonstrated. Introduction of mechanical deformation, such as rolling, results in the development of preferred crystallographic orientation in which the basal plane is oriented in rolled plane and the types I and II prismatic planes become respectively normal and parallel with the rolling direction.

Considering the resultant crystallographic orientations and relating these to the geometry of the applied impact force on either armored or unarmored wrought sheet beryllium, one observes that the potential of either elastic and/or plastic absorption of the resultant kinetic energy without mechanical failure is very low. Since the prismatic planes are normal to the plane of the sheet and parallel with the direction of impact, the strain resulting from the tensile and shear stresses caused by the interaction of the compressive and reflective wave fronts, particularly on the low ductility type II prismatic planes gives rise to potential failure because of its poor elastic and plastic capabilities.

A study to improve impact resistance<sup>(1)</sup> suggested that though only a marginal increase in impact levels required to initiate fracture in

(1) Woodard, D. H., Stonehouse, A. J., and Beaver, W. W., "Development of Beryllium With Improved Impact Resistance" - February 15, 1968. AFML-TR-67-250.

beryllium itself could be obtained, the degree of propagation could be markedly affected by a few schemes. One of the more practical methods involved preparation of laminates and later developments indicated impressive results when beryllium was armored with titanium sheet.

Ballistic impacts at high levels (6 to 12 foot pounds) would dent and bulge the cover plates, but not show cracking at the exposed beryllium periphery. When the components were separated, the failure in the beryllium was localized and though cracks were evident around the penetration, they did not extend very far.

When this concept was considered as a potential method for preparation of impact resistant turbine blading, its load carrying ability was of immediate concern. The tests which generated interest in the armored composite had been made on material containing isotropic hot pressed beryllium as a core material. Calculations indicated that the tensile strength of this combination would result in a strength-to-weight ratio at a level which was too low to warrant studying as a replacement for conventional materials. High strength wrought beryllium would be required in the composite to increase the ratio level to a point where further development could be justified. Thus, the program laid out for the first effort was essentially a screening probe to determine feasibility of the approach, and success in this endeavor would lead to a study to optimize individual materials.

Addition of titanium armor, for all practical purposes, does not alleviate the internal condition of the beryllium, but merely acts as an impact cushion and a retainer for secondary ballistic particles that may be generated as the result of the initial impact. Application of the titanium armor obviously compromised the density, moduli and strength-weight ratios; however, the proposed system offered compromises which were still attractive. Initially, considering the effectiveness of the armor as well as the combined density, moduli and strength-weight ratios, it was concluded that a geometric cross-sectional ratio of beryllium to titanium to bond material of 68:30:2 offered the best potential. The latter, in this ratio, was the aluminum braze contribution. Estimated properties applying the rule of mixtures to this ratio were density, 2.60 grams per cubic centimeter and modulus of elasticity of  $35 \times 10^6$  pounds per square inch.

Qualitative observations of deviations from this optimized ratio appear to result in either reduced ballistic effectiveness with a reduction of armor cross-section or stressing the beryllium substrate with the forces

generated by the differences in the respective thermal expansions to failure with increased armor thickness. Increasing the armor cross-section at the expense of the beryllium substrate would, in addition to the above observation, result in an increase of the composite density. Graphical variations of the composite density as a function of the armor-substrate geometric ratio may be seen in Fig. 1.

Collectively, the mechanical properties would appear to offer significant improvement in ballistic and crack propagation characteristics in comparison with materials of comparable density. Further analysis of the related physical properties revealed that the method of joining has a potential of producing deleterious effects. Since joining the components involves thermal processing, the resultant effect of the differential thermal expansions of the principal materials was such that the beryllium would be stressed in tension at room temperature.

Tabulated properties, such as the coefficient of linear thermal expansion, are usually reported as average values over a given temperature range neglecting incremental changes which are either linear or non-linear. Referring to Fig. 2, it may be observed that the relative differences of the linear expansion curves for beryllium and Ti-6Al-4V in the temperature range from room temperature to 800°F are for all intents and purposes linear. The differences shown which would result in the potential development of residual stresses are dependent on the magnitude and rate of change of linear expansion as a function of temperature.

Upon further consideration of the effect of temperature on the volume coefficient of expansion one finds, particularly in wrought beryllium, the orientation had a decided influence. Gordon<sup>(2)</sup> demonstrated that expansion in the transverse and longitudinal directions of extruded beryllium varied with the development of the degree of preferred crystallographic orientation. He reported that thermal expansion in the transverse (c-axis or prismatic) was 15 to 18 percent greater than that observed for the longitudinal (a-axis, basal plane) direction. A parallel analogy would apply to the rolled beryllium sheet used for this study.

(2) Gordon, P., "A High Temperature Precision X-Ray Camera. Some Measurement of the Thermal Coefficient of Expansion of Beryllium" J. Appl. Phys. 20 (1949), 908.

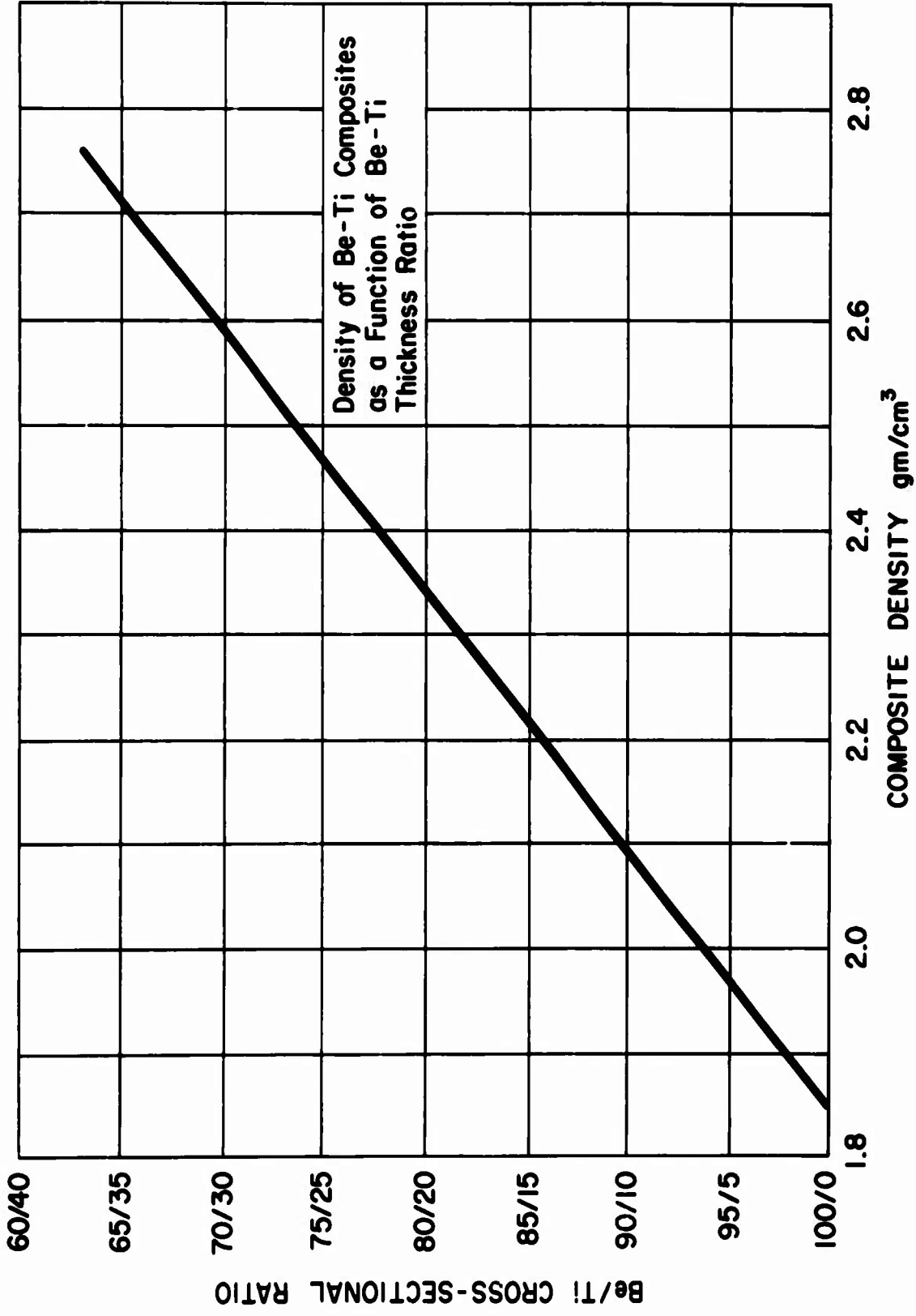

Fig. 1 - Beryllium-Titanium Composite Density Ratio as a Function of Pair Thickness Ratio



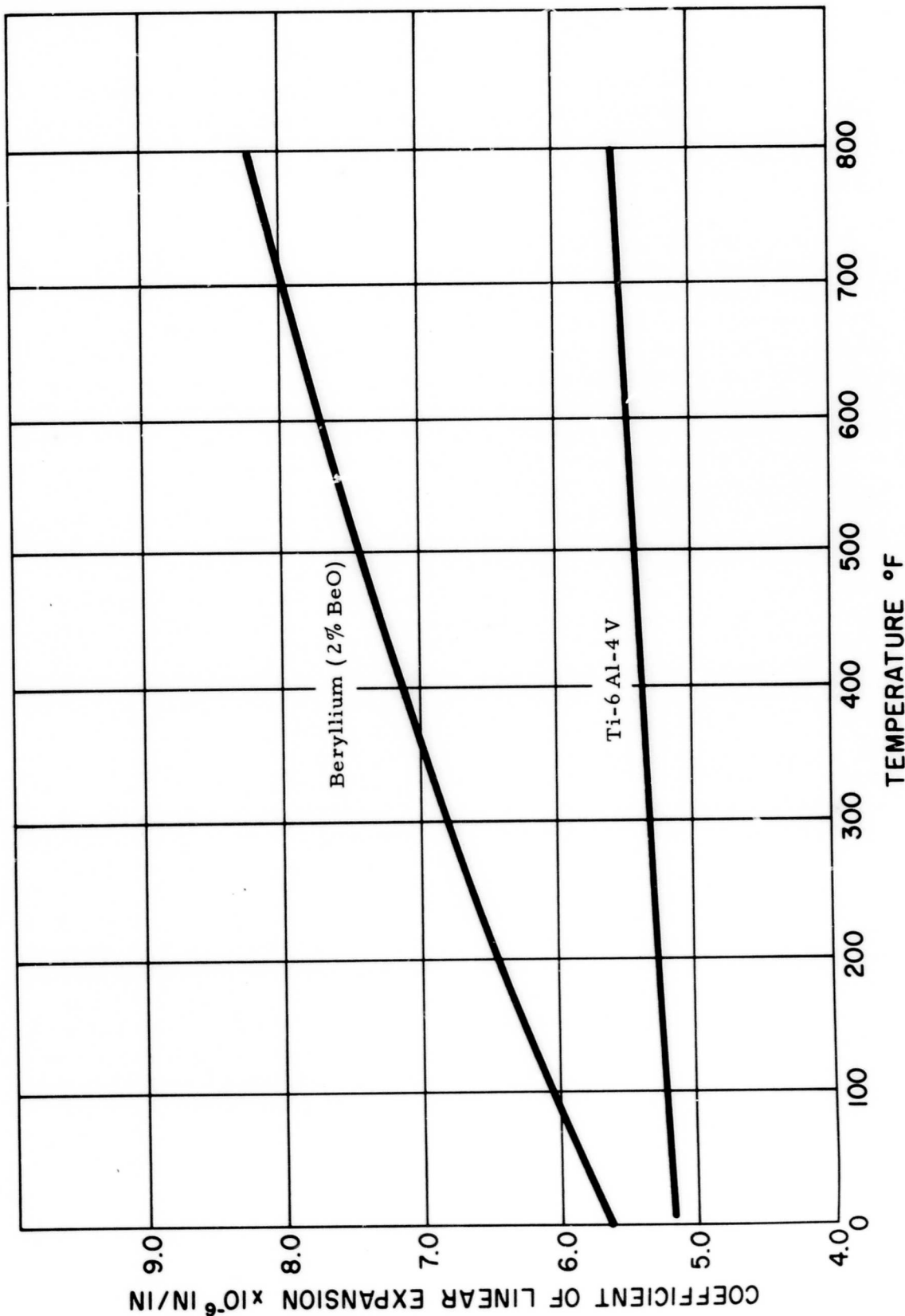

Fig. 2 - Typical Coefficient of Linear Thermal Expansion Curves for Beryllium and Ti-6Al-4V as a Function of Temperature ( $^{\circ}$ F)

The effect of temperature on the volume thermal expansion rate of solution treated and aged Ti-6Al-4V and hot pressed beryllium would follow their respective linear rates since the orientation of the principal crystallographic planes are, within the realm of experimental error, random.

Extending the effect of temperature to the mechanical properties one finds that the elastic moduli and the tensile yield strength of wrought and hot pressed beryllium as well as solution treated and aged Ti-6Al-4V decrease with increase in temperature where as the elongation exhibits an overall increase to a maximum. In spite of the fact that the losses in yield strength and elastic moduli are significant, the values within the temperature range chosen are of the same order of magnitude as the room temperature values. See Figs. 3 and 4. Since beryllium and Ti-6Al-4V were joined with aluminum, the effective maximum temperature at which the bonding media offers resistance to relaxation of stresses caused by the difference in thermal expansion is of the order of 600° F. Delineating the effect of temperature on the physical and mechanical properties within this range, observing average values of expansion coefficient as well as for moduli, yield strength and elongation, the resultant residual stress in the beryllium substrate is 10 ksi axially and 15 ksi vectorially in tension.

In a laminated system, which in this case is identified as beryllium braze bonded to and constrained by two Ti-6Al-4V cover plates, prediction of the mechanical properties is based on the premise that the composite components are continuous and firmly bonded such that no slippage can occur between the bonded interfaces. For all intents and purposes, the contribution of the aluminum braze to the mechanical properties of the composite has been neglected since its volume fraction-modulus product is relatively small in comparison with the major constituents.

Neglecting for the moment the residual stress resulting from the differential thermal expansion, the estimate of the theoretical properties of the beryllium - Ti-6Al-4V constrained composite is dependent on the condition and type of components as well as the effects of the thermal bonding cycle. Using published data and verified by dummy experimentation on the individual components, using the tooling and cycle described in section II-C, estimates of the mechanical properties of beryllium constrained by Ti-6Al-4V were made using the rule of mixtures tabulated in Table I. It follows that since the beryllium substrate and the Ti-6Al-4V are continuously bonded along the axis parallel with the applied tensile load that

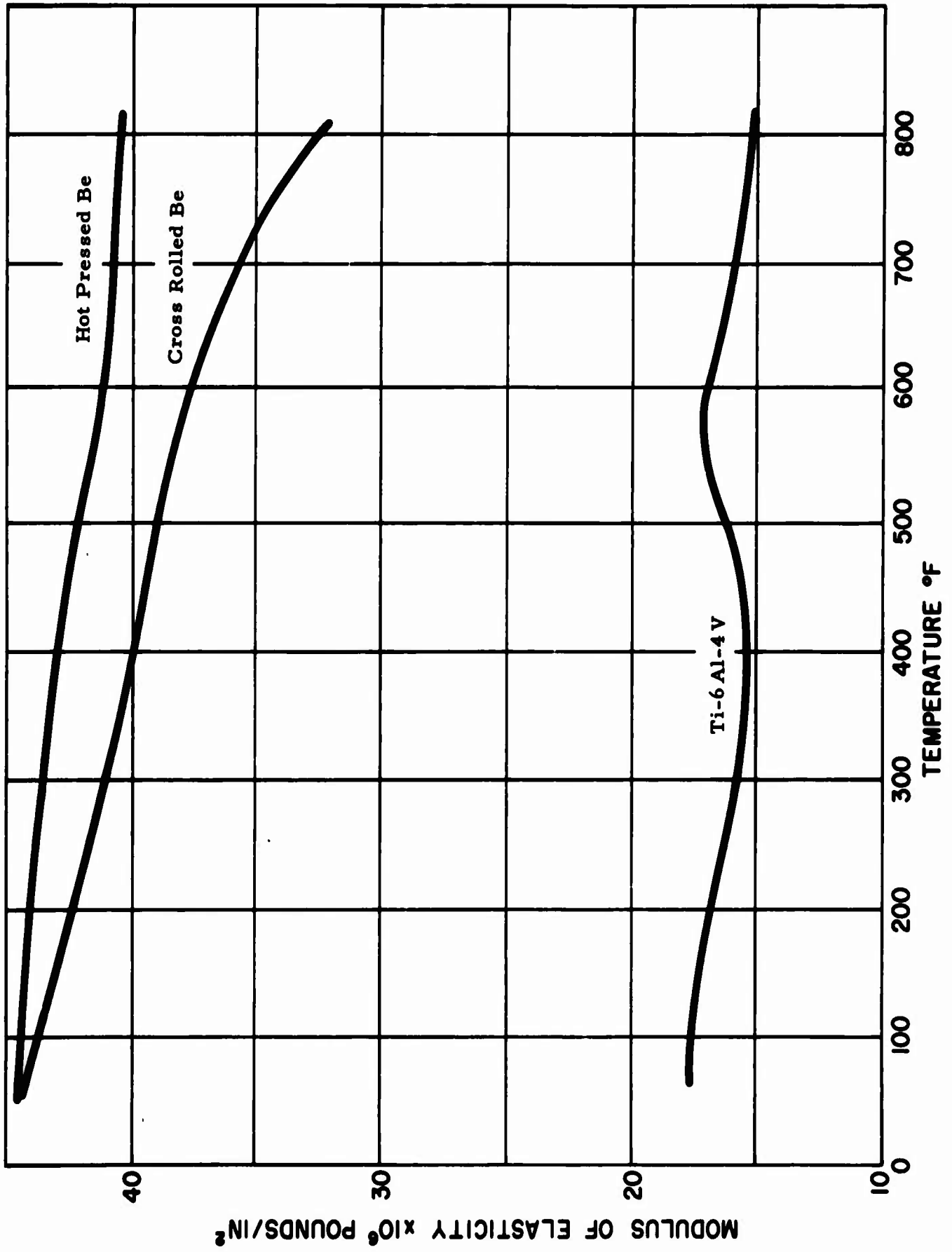

Fig. 3 - Typical Moduli of Elasticity of Beryllium and Ti-6 Al-4 V as a Function of Temperature (°F)

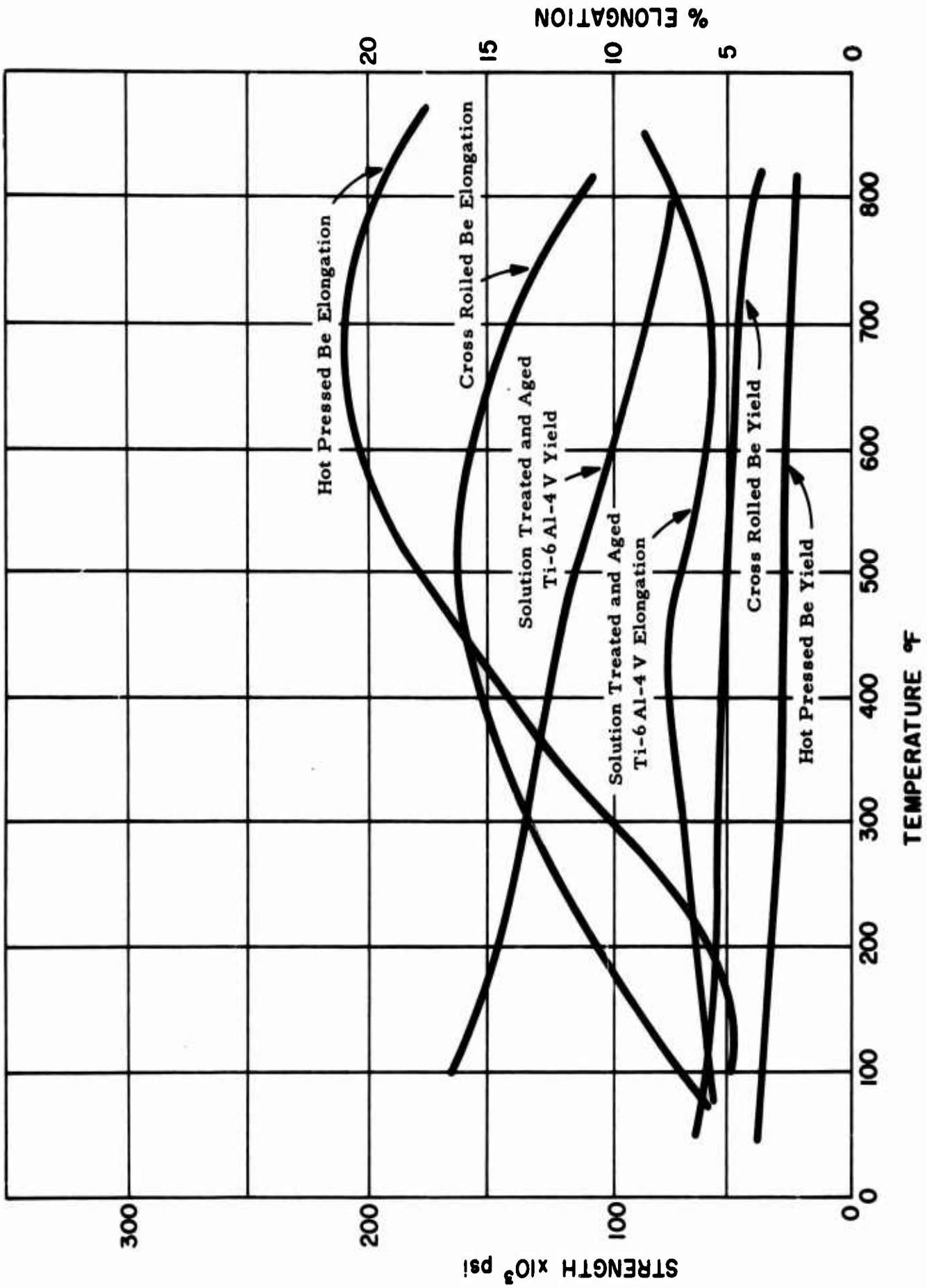

Fig. 4 - Typical Mechanical Properties of Beryllium and Solution Treated and Aged Ti-6Al-4V as a Function of Temperature (°F)

TABLE I  
MECHANICAL PROPERTIES OF MATERIALS OF CONSTRUCTION  
AND THEIR COMPOSITE ASSEMBLIES

Type of Beryllium Substrate	Yield (ksi)		Beryllium Mechanical Properties Ultimate (ksi)		Elong. (%)		Titanium* (ksi)		Composite (ksi)**		Composite Modulus $\times 10^3$ ksi $E_c$
	Long.	Trans.	Long.	Trans.	Long.	Trans.	$\sigma'_{Ti_y}$	$\sigma'_{Ti_u}$	$\sigma_{c_y}$	$\sigma_{c_u}$	
Hot Pressed											
S-200, lot 204-2-2200	36.6	37.8	40.5	40.6	1.0	1.0	60	135	43.6	68.8	35.0
Wrought											
S-200, lot 752B2	51.3	50.6	75.9	74.7	14.0	11.5	67	167	56.0	103.0	35.0
Hot Pressed											
I-400, lot 5442		69.3		80.7		2.4	75	153	67.3	102.1	35.0
Wrought											
I-400, lot 1136B	71.2		92.5		30	21	81	167	73.8	114.9	35.0

\* Estimated stress in titanium cover plates at the respective yield and ultimate strength of beryllium substrate. Mechanical properties obtained for solution treated and aged Ti-6Al-4V-178, 500 psi ultimate, 164,000 psi yield and 5% elongation.

Above data based on solution treated, aged, then given a standard braze cycle as outlined in II-C-1. Post braze cycle properties 167,000 psi ultimate, 141,000 psi yield and 5% elongation.

\*\* Estimation of theoretical properties using longitudinal properties of beryllium.

$$P_c = P_{Be} + P_{Ti} \quad (1)$$

The strain and tensile stress distribution then can be represented by the relationships

$$\sigma_c = \sigma_{Be} A_{Be} + \sigma_{Ti} A_{Ti} \quad (2)$$

$$\sigma_c = \sigma_{Be} V_{Be} + \sigma_{Ti} V_{Ti} \quad (3)$$

and  $e_c = e_{Be} = e_{Ti} \quad (4)$

Equating  $\sigma = E \cdot e$  and taking (3) and (4) the relationship reduces to

$$\sigma_{cy} = E_{Be} e_{Be} V_{Be} + E_{Ti} e_{Ti} V_{Ti} \quad (5)$$

Since  $V_{Be} + V_{Ti} = 1$  and  $e_c = e_{Be} = e_{Ti}$

the relationship is further reduced to

$$\sigma_{cy} = [E_{Be} V_{Be} + E_{Ti} (1 - V_{Be})] e_c \quad (6)$$

where:  $P_c, P_{Be}$  and  $P_{Ti}$  = Total and component applied tensile loads, respectively.

$\sigma_{cy}$  = Yield strength of composite applied.

$\sigma_c, \sigma_{Be}, \sigma_{Ti}$  = Total and component tensile stress, respectively.

$A_{Be}, A_{Ti}$  = Cross-sectional area fraction.

$V_{Be}, V_{Ti}$  = Volume fraction.

$e_c, e_{Be}, e_{Ti}$  = Strain (0.2% = 0.002 at Y.P.)

$E_{Be}, E_{Ti}$  = Respective elastic moduli.

Extension of the rule of mixtures to the estimation of the theoretical ultimate tensile strengths follows the same relationship as identified in (3) above and qualified with the following notations, these are:

$$\sigma_{c_u} = V_{Be} \sigma_{Be_u} + (1 - V_{Be}) \sigma'_{Ti_T} \quad (7)$$

where:  $\sigma_{c_u}$  = Ultimate tensile strength of the Ti-6Al-4V constrained beryllium composite

$V_{Be}$  = Volume fraction of the beryllium substrate

$\sigma_{Be_u}$  = Ultimate tensile strength of beryllium

$\sigma'_{Ti_T}$  = Stress in the Ti-6Al-4V cover plates at  $\sigma_{Be_u}$ ,  
from graph (Fig. 5).

Using the relationships (6) and (7) with the graphical relationship shown in Fig. 5, estimates of the theoretical yield and tensile strengths of beryllium constrained by Ti-6Al-4V cover plates are as indicated in Table I.

Collectively, assuming that no residual stresses were evident in beryllium constrained by Ti-6Al-4V cover plates, the range of yields and ultimate tensile strength estimates are 43 to 74 ksi and 69 to 115 ksi, respectively, with the ranges cited being dependent on the type and condition of the beryllium substrate. The mere fact that the beryllium substrate has a higher thermal coefficient of linear (and volume) expansion than the Ti-6Al-4V cover plates, demonstrates the potential of the development of tensile residual stresses in the former because of the mode of joining. Further, the relative orientation of the basal and types I and II prismatic planes, particularly in wrought beryllium, such that these planes are respectively normal and parallel to the direction of applied impact would appear to reduce the ballistic effectiveness of the composite.

Although the original proposal concerned itself with titanium armored wrought S-200 grade beryllium, the study was extended to include hot pressed S-200 and I-400 as well as wrought I-400. Incorporation of these additional substrate materials was to insure as broad a study as possible of the immediately available materials to complete scoping of the concept even though this was beyond contract requirements.

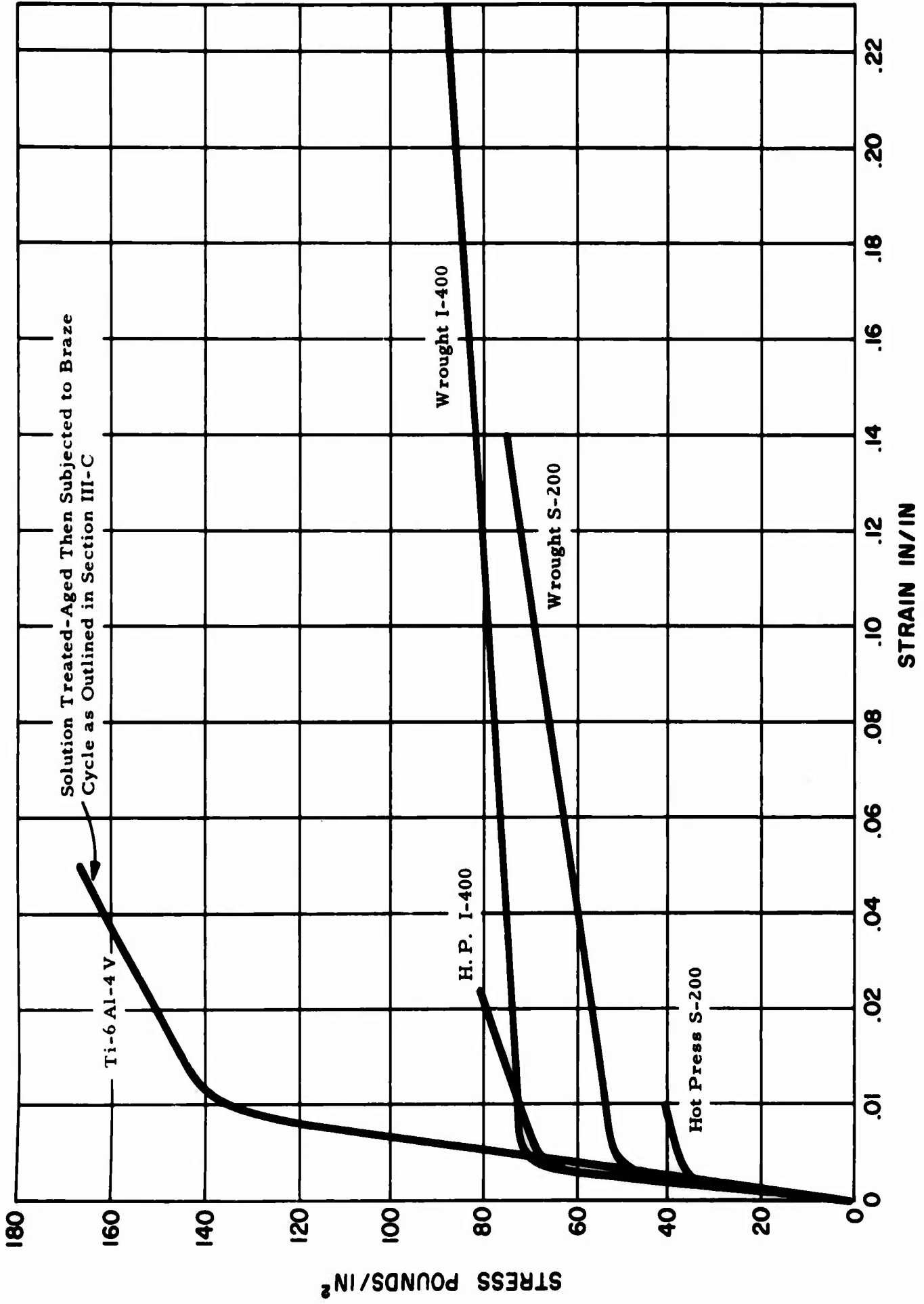

Fig. 5 - Comparison of Typical Stress-Strain Curves for Various Beryllium Grades and Solution Treated and Aged Ti-6Al-4 V



## **A. Contractual Specifications**

The contract was for a two phase effort with initial approval to proceed only with Phase I. Initiation of Phase II was dependent on results deemed encouraging to the US/UK program managers.

### **Phase I - Initial Testing and Evaluation of Brush-Developed Composites**

1. **Approach.** The effort in this phase is to test the composite concept in relation to suggested utilization and manufacturing methods for production. It is not necessary for optimization of material or fabrication methods in this phase. The structure for evaluation will be an assembly of beryllium and Ti-6Al-4V with about 35% titanium by volume having the target property of 100,000 psi ultimate strength.

2. Initial testing and evaluation shall be conducted as follows:

#### **(a) Part A: Determination of Impact Level at Which Cracking Begins**

Prepare a series of ballistic impact specimens nominally 2 inches by 1 inch by 0.100 inch thick from titanium and beryllium. Initially, impact at low level and increase impact energy until cracks appear. Disassemble the impacted specimens and determine level at which first crack in beryllium appeared.

#### **(b) Part B: Determination of Effect of Crack on Tensile Properties of Composites**

Prepare twelve tensile specimens of composite assembly. Test two specimens as assembled at room temperature. Select five impact energy levels to provide varying amounts of damage, based on results of Part A. Impact two tensile specimens at each energy level. Tensile test specimens at room temperature.

#### **(c) Part C: Determination of Effect of Combined Tensile and Impact Loading**

Prepare eight tensile specimens of composite assembly. Make two tests under each of the following conditions:

(1) Tensile load specimen to 60% of its nominal yield strength (at 0.2% offset), impact in the gage section at a level which on previous tests was sufficient to initiate first crack. Record effects.

(2) Tensile load specimen in same manner as (a), but impact at higher level. Record effects.

(3) Tensile load specimen to 80% of its nominal yield strength (at 0.2% offset), impact in the gage section at level as in (a). Record effects.

(4) Tensile load specimen in same manner as (c), but impact at level as in (b). Record effects.

## II. SUMMARY

As in the result of previous experimental effort, it was determined that lamellar composites of beryllium and titanium had the ability to absorb relatively high levels of ballistic impact and externally appear sound and crack free. Though subsequently it was determined that internal damage did occur, this damage was limited and highly localized.

The experimental effort reported was an attempt to rapidly evaluate the effect of such damage on mechanical properties of these composites. The work was restricted to the study of a minimum number of variables, and no attempt was made to optimize input materials.

Specific strength-to-weight ratios were desired to qualify the composites as distinctly superior to current materials, further limiting the scope of the selection of components.

Greater impact damage occurred when high strength beryllium was used to achieve these high strength-to-weight ratios. Tensile data showed that the beryllium core did not contribute to the load carrying characteristics of the composite after impact. On this basis, it appeared that the system would not have utility for blading in turbine engines, and continued effort to optimize the components was not recommended.

### III. EXPERIMENTAL

#### A. Contractual Specifications

Geometric limitations for the ballistic studies of beryllium armored with titanium required a nominal cross-sectional thickness of 0.100 inch. Since joining was with an aluminum braze, this permitted the use of 0.015 inch thick titanium alloy armor on each face of 0.068 inch thick beryllium. The maximum thickness allowed for the aluminum braze at each joint was 0.001 with a total of 0.002 inch. Nominal density established for a titanium armored beryllium composite whose cross-section was controlled at 0.100 inch  $\pm$  0.001 inch was of the order of 2.55 to 2.60 g/cm<sup>3</sup>. The method employed in joining allowed sufficient control of both thickness and density within the limits chosen.

#### B. Materials

##### 1. Armor

Armor material chosen for this investigation was solution treated and aged Ti-6Al-4V. In order to establish maximums in the mechanical properties, heat treatment was done in-house on segments of comparable geometry used in the assembly. Properties obtained after solution treating at 1700° F for 40 minutes followed by a brine quench and aging at 925° F for 18 hours were 178,500 psi ultimate, 164,000 psi yield and 5% elongation.

Since the solution treated and aged Ti-6Al-4V alloy was in part effected by the dip brazing cycle, blanks enclosed in the graphite punch and die set were subjected to this treatment to determine the amount of change in the mechanical properties. Although the melt temperature was stabilized at 1550° F prior to immersion of the punch and die set, the mass and associated heat sink of the latter was such that the bath temperature dropped to 1300-1325° F at the end of the 2 minute cycle.

The mechanical properties of the solution treated and aged Ti-6Al-4V which was subjected to the dip braze cycle were 167,000 psi ultimate, 141,000 yield and 5% elongation

## 2. Pretesting Preparation and Inspection

Finished machined ballistic and tensile specimens were etched in a dilute nitric-hydrofluoric acid mixture to remove machine damage and followed by a DyChek penetrant inspection for bond discontinuities and/or cracks in the beryllium substrate. All visual inspection was done at 10X magnification. Random selection of the wrought S-200 base composites was made for the purpose of evaluating the effect of a stress-relieving treatment. Specimens chosen for the stress relieving heat treatment were heated to 840°F for four hours and followed by a slow cooling cycle. The heat treated specimens were etched again and subjected to DyChek penetrant testing and inspection.

Samples of all categories and grades which survived the above screening were then further randomly selected for various levels of impact and/or tensile preload.

## 3. Photoelastic Film Preparation

Wrought S-200 base composites were coated with a photoelastic film on the side opposite to the impact in order to discern and correlate the nature and magnitude of failure of the beryllium substrate.

## D. Specimen Geometries and Tolerances

### 1. Ballistic Test Samples

The geometry of the ballistic test sample was 1 x 2 x 0.100 inch thick such as pictured in Fig. 6. Variations in the lateral dimensions were kept at  $\pm 0.005$  inch whereas, the thickness variations were at + 0.003 - 0.000 inch.

### 2. Tensile Specimens

In order to draw a comparison of the effect of ballistic impact on the composite under tension with that of the standard ballistic specimen, as demonstrated in Fig. 6, the geometry of the tensile-ballistic test bar gauge section was made equivalent (i. e., 1 inch x 2 inch x 0.100 inch thick). Although the gauge section was symmetrical, the clamp tabs had to be altered to accommodate the maximum available tensile jaw width so as to eliminate the potential of axial bending in the plane of the 2 inch x 0.100 inch dimensions (see Fig. 7). This alteration of tab geometry was made as the result of initial tests made on symmetrical tensile-ballistic test bars which appeared to fail, in part, due to axial bending.

## 2. Substrate Material

In all four classifications of beryllium were used for this study, the grades, lot numbers and mechanical properties are as outlined in Table I.

## 3. Bonding Material

Commercially pure aluminum ingot was used for bonding with fluoride base fluxes for inhibition of dross formation and assuring adequate wettability of the beryllium and Ti-6Al-4V by the aluminum.

Each of the materials indicated in Table I both as components and as composite assemblies, were given, within limits identical preparatory treatments such that the resultant results were a direct comparison of materials, conditions and/or heat treatment.

## C. Composite Fabrication

Titanium armored beryllium for the tensile-ballistic, ballistic-tensile and ballistic testing were made from a standard bonded blank whose geometry was 1.5 x 6.5 x 0.100 inch thick. This blank configuration permitted conversion into either three 1 x 2 x 0.100 inch-ballistic samples or one 1.25 x 4 x 0.100 inch-tensile blank and one 1 x 2 x 0.100 inch-ballistic sample.

### 1. Assembly

Ti-6Al-4V and beryllium components, which were given conventional surface treatments to insure wetting by the braze material, were assembled in a graphite punch and die set, then dipped into superheated, commercially pure aluminum bath. Although the aluminum melt was superheated to 1550 F the chilling effect of the cold punch and die assembly was such that the overall temperature after a fixed 2 minute cycle was still above the liquidus and of the order of 1275° to 1300°F. On thermal stabilization of the melt and die assembly, the latter was removed to a hydraulic press and pressure of approximately 1000 psi was applied and held until the entire mass was cooled to room temperature. Application of the static load before and during solidification of the braze removed excess aluminum insured bond continuity in addition to maintenance of flatness and gauge.

Bonded blanks which did not exhibit defects such as interfacial blisters, substrate cracks and/or bond discontinuities were then segmented into ballistic or tensile blanks.

TR-450-248X

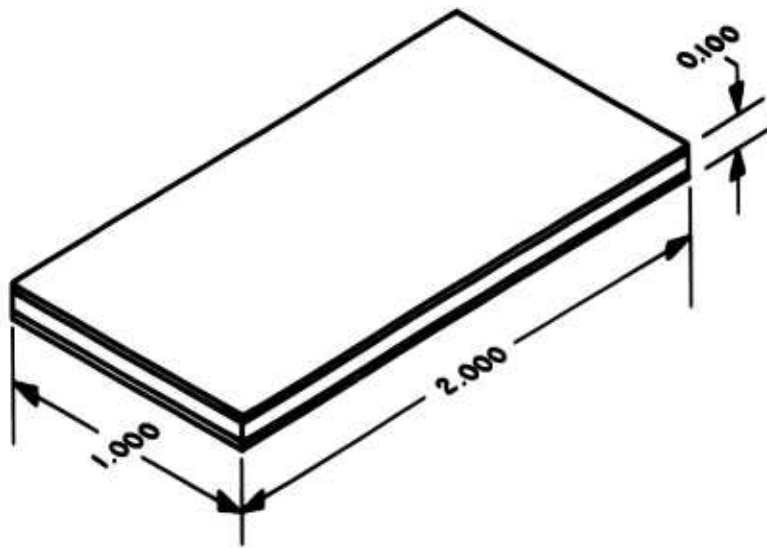

Fig. 6 - Composite Geometry for Ballistic Test Specimen

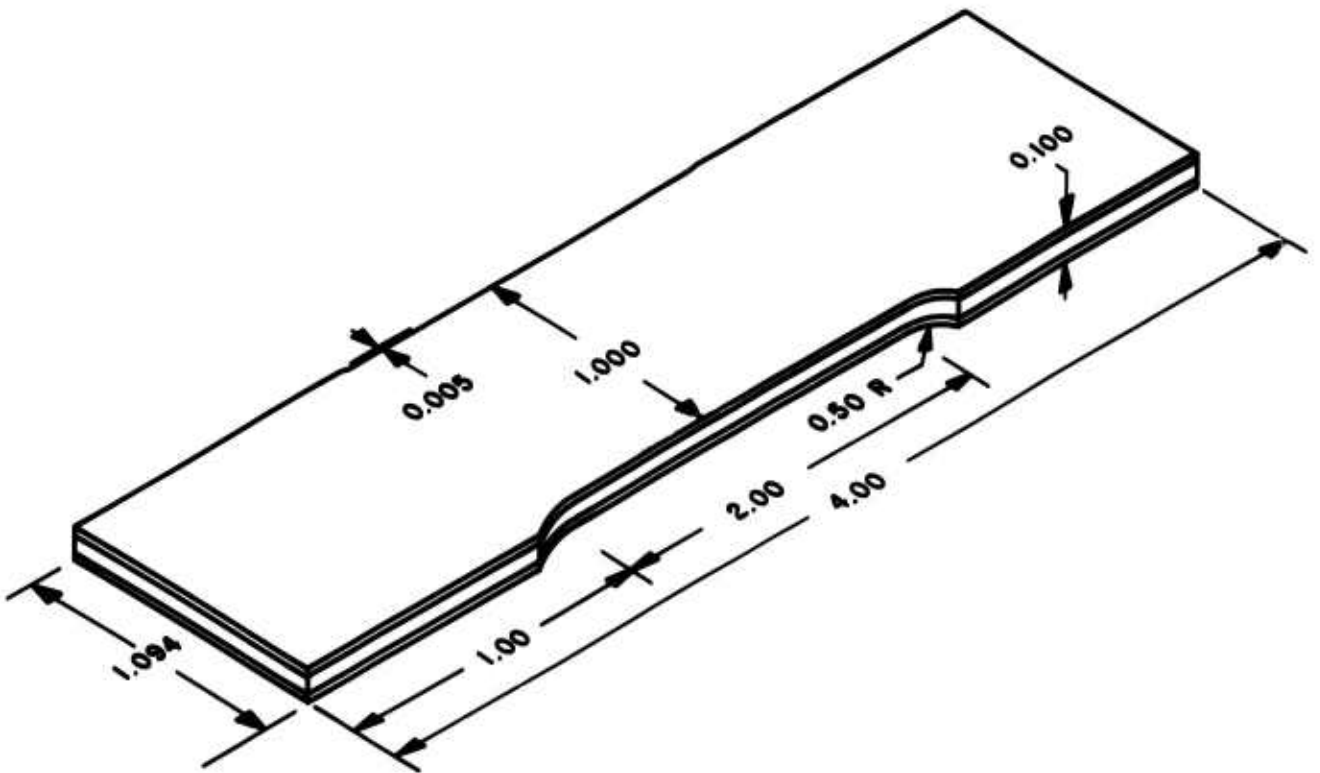

Fig. 7 - Composite Tensile Bar Geometry for Tensile Ballistic and Ballistic Tensile Testing

## E. Testing

### 1. Ballistic Impact

Ballistic impact testing at levels up to 4 ft-lbs was with a 0.177 caliber pistol using a 0.174-inch diameter ball. For impact loads in excess of 4 ft-lbs up to and including 12 ft-lbs, a modified 22 caliber rifle was used. The bore and ball sizes were 0.220 and 0.2185 inch, respectively.

The ballistic specimens were held on one end in a foam rubber lined vise. This method of specimen retention reduced the effect of failure due to bending along the vise edge.

In order to eliminate impact interaction effects, each specimen was subjected to only one impact. Within limits the ballistic impact was centered and positioned such that the effective bending moment on the specimens was the same.

### 2. Tensile Ballistic

Specimens to be ballistically impacted under a static tensile load were mounted in the normal manner required for tensile testing. Once these specimens became statically loaded at the level programmed, the chart drive was activated so that the immediate and delayed effects of the impact might be observed.

### 3. Ballistic Tensile

Tensile bars, which were ballistically impacted using the same method and positioning as for the 1 x 2 inch specimens, were pulled to failure. All tensile testing was done on a 10,000-pound-capacity Instron Universal Testing Machine.

## F. Evaluation

Determination of the effect of ballistic impact was principally concerned with fact of survival. Extension of the immediate conclusion of either success or failure of the specimen was based on a qualitative interpretation of the degree of failure. All specimens were examined immediately after impact under 10X magnification for edge substrate cracking and bond failures. It has been observed that delays in examination result in changes of the size and number of cracks in the substrate



due to internal stress relaxations. Where photoelastic film was used to record the effect of the impact, the developed stress pattern was photographed and it was used for comparison with the stripped beryllium substrate. In order to determine the degree of damage to the substrate material, these test specimens were thermally stripped and etched to remove the residual aluminum bonding material. Failure analysis of the substrate material was compared with the photoelastic stress pattern, where possible.

In general, differentiating the magnitude of failure in this study is simply an academic exercise. The prime conclusion that must be made is whether or not the composite survived the impact.

## IV. EXPERIMENTAL RESULTS

### A. General

Although there was a marked degree of superiority of the titanium alloy armored over the unarmored beryllium in its resistance to complete failure by ballistic impact, it still did not have the degree of reliability for service application. Crack initiation and/or failure were evident to some degree in all combinations tested in the range of 1.00 to 12.00 ft lbs. The single advantage that one could offer in support of armored beryllium was that the composite structure did inhibit the release of secondary ballistic particles.

In spite of the fact that every attempt was made to screen out composite specimens which exhibited crack defects in the substrate and bond, the mechanical properties obtained appear to indicate that the beryllium was not only residually stressed in tension but was also internally damaged. The extent of the substrate damage, which was not evident with either dye penetrant or visual examination, apparently had continuity such that the majority of the applied tensile was transmitted through the titanium armor.

With the exception of the wrought S-200 grade beryllium base composites, all experimental tensile results on control specimens appeared to reflect the mechanical properties of the titanium armor.

The differences in the thermal coefficient of linear expansion between beryllium and its Ti-6Al-4V constraining cover plates resulting in tensile stresses must be accompanied within the composite by plastic flow and/or elastic strain. Further, these residual elastic tensile strains in the beryllium substrate at room ambient represent a significant portion of the yield strain.

In order to demonstrate, at least qualitatively, the effect of the differential thermal coefficient of linear expansion between beryllium and Ti-6Al-4V, several preliminary exploratory composite models were made using various volume fraction combinations. Composites of equal volume fractions of beryllium and Ti-6Al-4V that were dip brazed and cooled under pressure exhibited tensile failure of the former during the cooling cycle and while still above the room ambient. Qualitative indications that tensile failure had occurred was associated with an audible crack and verified by

thermally stripping the Ti-6Al-4V from the substrate revealing randomly oriented crack separations normal to the plane of the beryllium sheet. The mere presence of these crack failures indicated that the stress level developed as the result of the differences in their coefficient of linear thermal expansion resulted in a progression of elastic strain followed by plastic deformation and ultimately tensile failure.

Examination of the observed mechanical properties of the composites whose beryllium volume fraction was 0.68, revealed some rather interesting results. Comparison of the observed yield strengths with that of the theoretical values obtained by the rule of mixtures demonstrates that both hot pressed and wrought S-200 beryllium constrained by Ti-6Al-4V cover plates were significantly higher than that predicted. Hot pressed and wrought I-400, on the other hand, had yield strengths significantly lower than that predicted. All varieties of beryllium constrained by Ti-6Al-4V cover plates exhibited ultimate tensile strengths that were significantly lower than that predicted by the rule of mixtures.

In light of the difficulty observed in obtaining sound Ti-6Al-4V constrained substrates of either hot pressed or wrought I-400 beryllium, it was felt that those specimens which did not indicate penetrant defects were marginal and in all probability had internal damage.

Specific analysis of the individual grades investigated along with the test variations cited are as indicated in the text that follows.

#### B. Wrought S-200

Qualitative evidence, supported by the theoretical considerations, has demonstrated that residual tensile strain and/or plastic flow occur in beryllium constrained by Ti-6Al-4V cover plates. In order to alleviate the residual tensile strain in the beryllium substrate, an 800°F thermal treatment was investigated to determine what, if any, improvement could be made in ballistic and/or tensile properties. Resultant effect of the heat treatment was somewhat nebulous in that there was no clean cut differentiation in any of time variations at 800°F.

##### 1. Ballistic

Impact levels of from 0.5 to 12.00 ft-lbs on both the heat treated and un-heat treated wrought S-200 ballistic specimens demonstrated a progressive degree of failure with the increase in impact level. Results of the

ballistic impact tests on the heat treated specimens may be seen in Table II and Figs. 8 through 10. Comparable qualitative appraisals of the un-heat treated wrought S-200 base composites may be seen in Table III and Figs. 11 through 13.

For both the heat treated and un-heat treated wrought S-200 base composites, impact levels in excess of 7 ft-lbs experienced substantial delamination of the rear titanium armor with failure occurring in the aluminum bond.

Attempts to reduce and/or eliminate the residual stress effects with heat treatment did not offer any apparent improvement in the ballistic qualities.

In addition to the visual examination of the impacted specimens for surface deformation and crack propagation from the point of impact to the edges, specimens which were coated with a photoelastic film had shown corrolary results of substrate failure pattern.

## 2. Tensile Ballistic

Heat treated and un-heat treated tensile specimens, containing wrought S-200 beryllium in the substrate, that were ballistically impacted while under a static tensile load, all experienced an immediate drop-off in load from the programmed level as the result of failure of the substrate and plastic relaxation of the armor. Impact failure of the substrate caused the entire load to be assumed by the armor.

Visual analyses of the heat treated tensile-ballistic specimens appear to have a single crack failure normal to the applied tensile load at or adjacent to the impact site. With the exception of the low level impact of 1 ft-lb on 40 ksi statically loaded tensile specimens containing un-heat treated wrought S-200 beryllium, all crack failures were radially oriented from the impact site. The tensile specimen which was impacted at the 1 ft-lb level under a static load of 40 ksi did not exhibit any evidence of damage other than a slight dimple. It would appear that the stress relieving heat treatment on the tensile specimens did benefit and/or alter the nature of the crack failures in the substrate. Since the crack failures in the heat treated specimens became singular, unidirectional and normal to the direction of applied tensile load, as opposed to the radial and randomly oriented character of the un-heat treated tensile ballistic results, one could presume that a change in the residual stress concentrations and

TABLE II  
HEAT TREATED WROUGHT S-200 BASE COMPOSITES BALLISTIC TEST RESULTS

Specimen No.	Impact Level, ft-lb	Qualitative Analysis of the Effect of Impact	
		Composite	Stripped Beryllium Substrate
7668-44	3.5	No visible crack propagation to the edges from impact site. Photoelastic stress pattern appeared to be uniform around impact site with no apparent discontinuities which may have resulted from crack formation. See Fig. 10.	The substrate appears to exhibit some evidence of conical "punch out". Some cracking was noted radiating from central point of impact but did not extend beyond the immediate impact zone. See Figs. 8 and 9.
7668-12	4.0	Several fine cracks noted on two of the three edges adjacent to impact site. Slight evidence of delamination of the rear titanium armor. Photo elastic stress pattern indicated some relaxation of the stress as the result of crack formation and propagation. The magnitude of the crack formation was apparently reduced because of the delamination of rear titanium armor. See Fig. 10.	Evidence of double ringed "punch out". Radial cracks extend from inner punch out, but do not progress to outer punch out. Fine cracks appear to extend from outer punch out ring to the edges. See Figs. 8 and 9.
6668-11	5.0	Well defined stress pattern around the impact site. Slight bend separation noted on the rear titanium armor. Stress pattern appeared to indicate some fine crack formation. Slight evidence of a crack on one edge of specimen. See Fig. 10	Fine crack pattern randomly oriented from point of impact (not radial). One crack extended from impact site to edge. Slight evidence of punch out formation. See Figs. 8 and 9.
7668-21	5.0	Although the photoelastic stress pattern did not appear to be as broad as 6668-11 above, crack damage observed on the edges was similar. The bonds between the components appeared to contain the impact. Since the stress pattern appeared to be bimodal, crack formation would be suspected.	The beryllium substrate had randomly oriented crack distribution not necessarily originating from the impact site. Type of crack distribution would indicate that failure was due to the bending moment caused by the impact.
29568-11	6.0	Photoelastic stress pattern outside the impact site appeared indicating crack formation in the beryllium substrate. Examination of edges revealed a small crack at one edge. See Fig. 10.	Impacted site had shown evidence of "punch out". One crack propagated from impact site to one edge. See Figs. 8 and 9.
17568-31	7.5	Photoelastic stress pattern outside of the impact site was diffuse and indicated relaxation as the result of cracking and delamination of the rear titanium armor.	Evidence of "punch out" randomly oriented cracks initiated from impact site.
7668-11	8.0	Stress pattern did not appear to indicate crack formation. Delamination of the rear titanium armor probably resulted in the bimodal stress pattern.	Well defined conical "punch out" at impact site. No visible evidence of crack formation and/or propagation.
29568-11	8.0	Similar stress pattern as that observed in 7668-11 above. Cracks visible on all edges adjacent to impact site.	Although there was some evidence of "punch out", failure was attributed to bending since the crack formation appeared to be concentrated out of the impact zone.
7668-41	9.0	Diffuse photoelastic stress pattern outside the impact site indicating crack formation in the beryllium substrate. Slight evidence of bond separation of the rear titanium armor. Cracks visible on two of the three edges adjacent to impact site.	Definite conical "punch out" with well defined crack formation at impact site and propagation to the edges.
7668-43	10.0	Diffuse stress pattern outside the impact site indicating crack formation in the beryllium substrate. Edge cracking in the beryllium normal to the impact direction. Some tearing was observed on the impact side of the titanium armor.	Well defined conical "punch out" cracks propagated radially from impact site to all three adjacent edges.
17568-12	10.0	Photoelastic stress pattern indicated potential crack formation outside the impact zone. Edge cracking noted on all three sides adjacent to impact site. Rear titanium armor bond was broken.	Some evidence of "punch out" formation. Crack formation appeared to be the result of bending due to the impact since it did not appear to originate from impact site.
7668-22	11.0	Totally diffuse photoelastic stress pattern appeared to indicate complete crack failure of the beryllium substrate. Several pieces of the beryllium were broken free from the composite. Bond separation of the rear titanium armor with edge cracks on all edges adjacent to the impact site.	Complete failure of the beryllium substrate. Evidence of the formation of a conical "punch out".

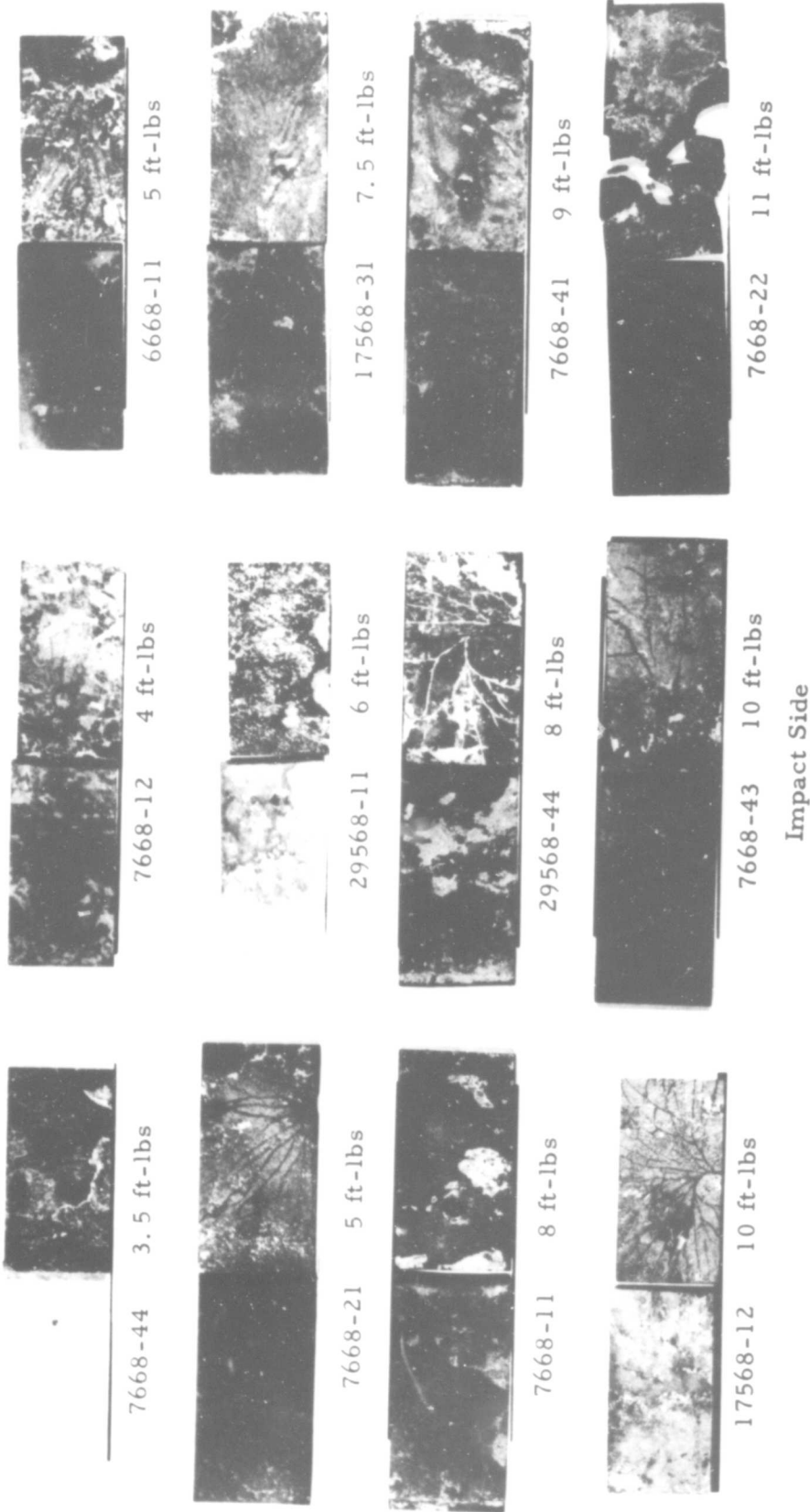
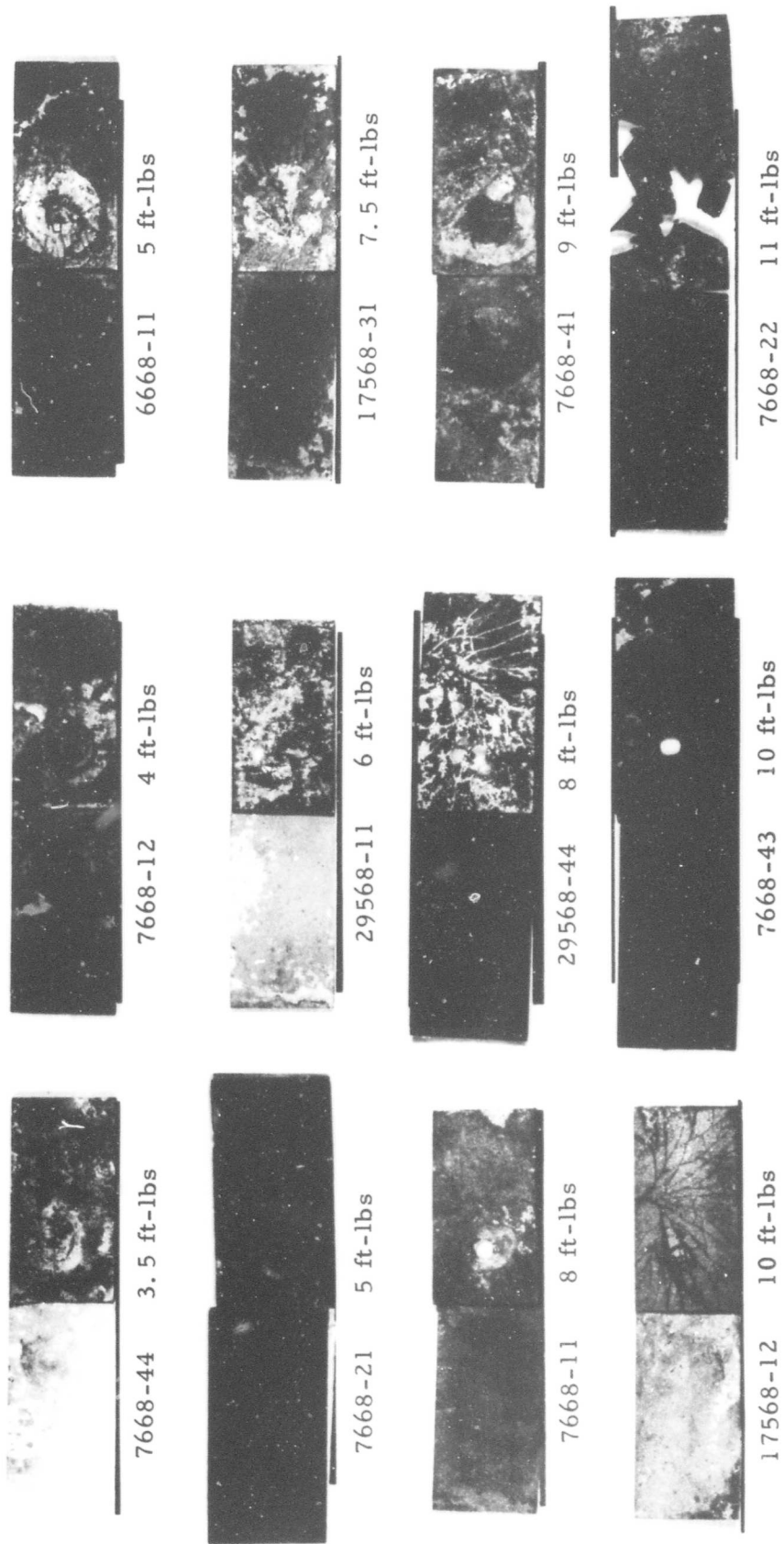

Fig. 8 - Ballistic Test Results on Heat Treated Wrought S-200 Base Composites as a Function of Impact Level, Impact Side of Stripped Assembly



Reverse Side

Fig. 9 - Ballistic Test Results on Heat Treated Wrought S-200 Base Composites as a Function of Impact Level, Reverse Side of Stripped Assembly

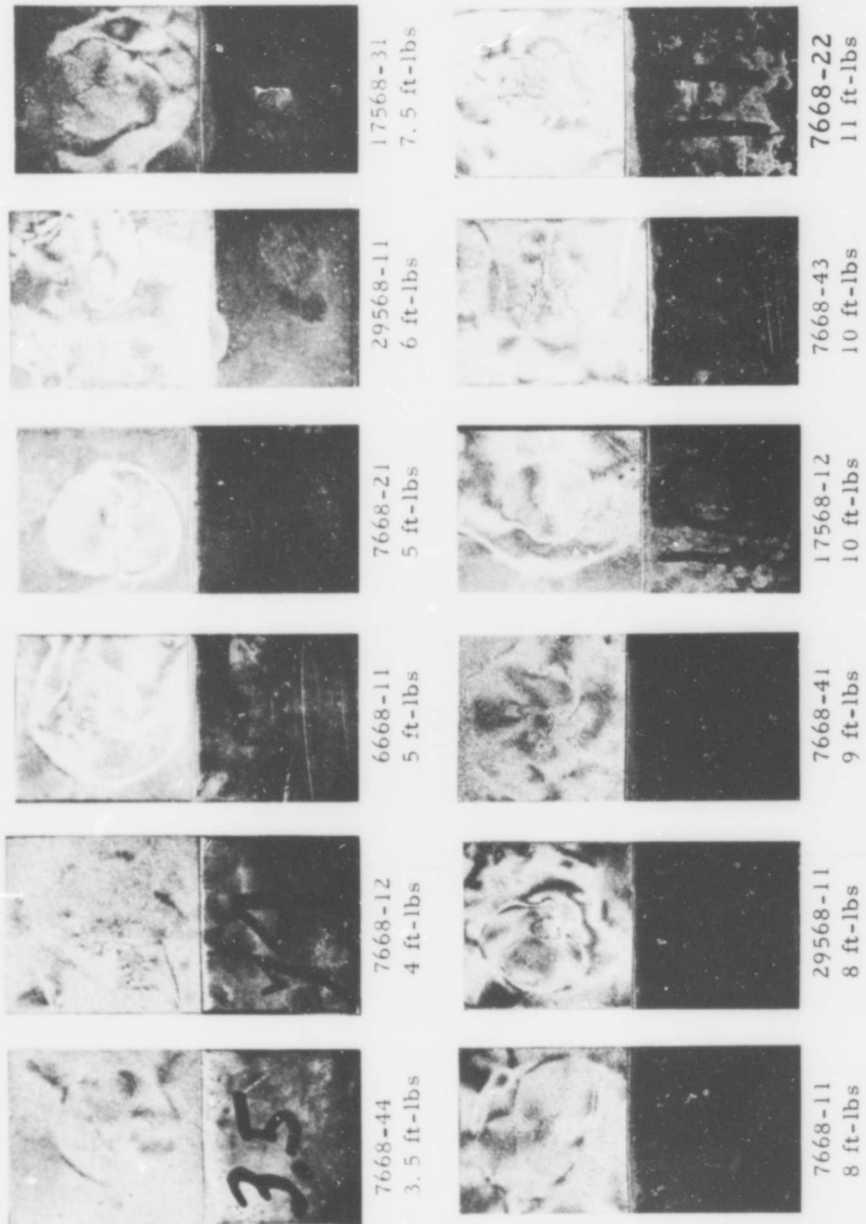

Fig. 10 - Ballistic Test Results on Heat Treated Wrought S-200 Base Composites as a Function of Impact Level, Photoelastic Stress Pattern Generated by Impact



TABLE III

## UNHEAT TREATED WROUGHT S-200 BASE COMPOSITES BALLISTIC TEST RESULTS

Specimen No.	Impact Level, ft-lb	Qualitative Analysis of the Effect of Impact	
		Composite	Stripped Beryllium Substrate
5668-12	5.0	No apparent propagation from impact site to edges. Photoelastic stress pattern exhibits uniform deformation around impact site. See Fig. 13.	Failure confined to impact site, evidence of conical "punch out" in the beryllium. See Figs. 11 and 12.
29568-13	6.0	Crack propagation to three edges from impact site. Photoelastic stress pattern indicated crack formation as the result of the diffuse stress pattern. See Fig. 13.	Failure as the result of crack propagation from impact site. Some evidence of "punch out". See Figs. 11 and 12.
5668-11	7.0	Slight delamination of the rear titanium armour. Bimodal stress pattern on photoelastic membrane. No apparent crack propagation from impact site. See Fig. 13.	Impacted specimen indicated "punch out" failure with no apparent crack propagation from impact site. Attenuation of the crack propagation presumably the result of the delamination of the rear titanium armour. See Figs. 11 and 12.

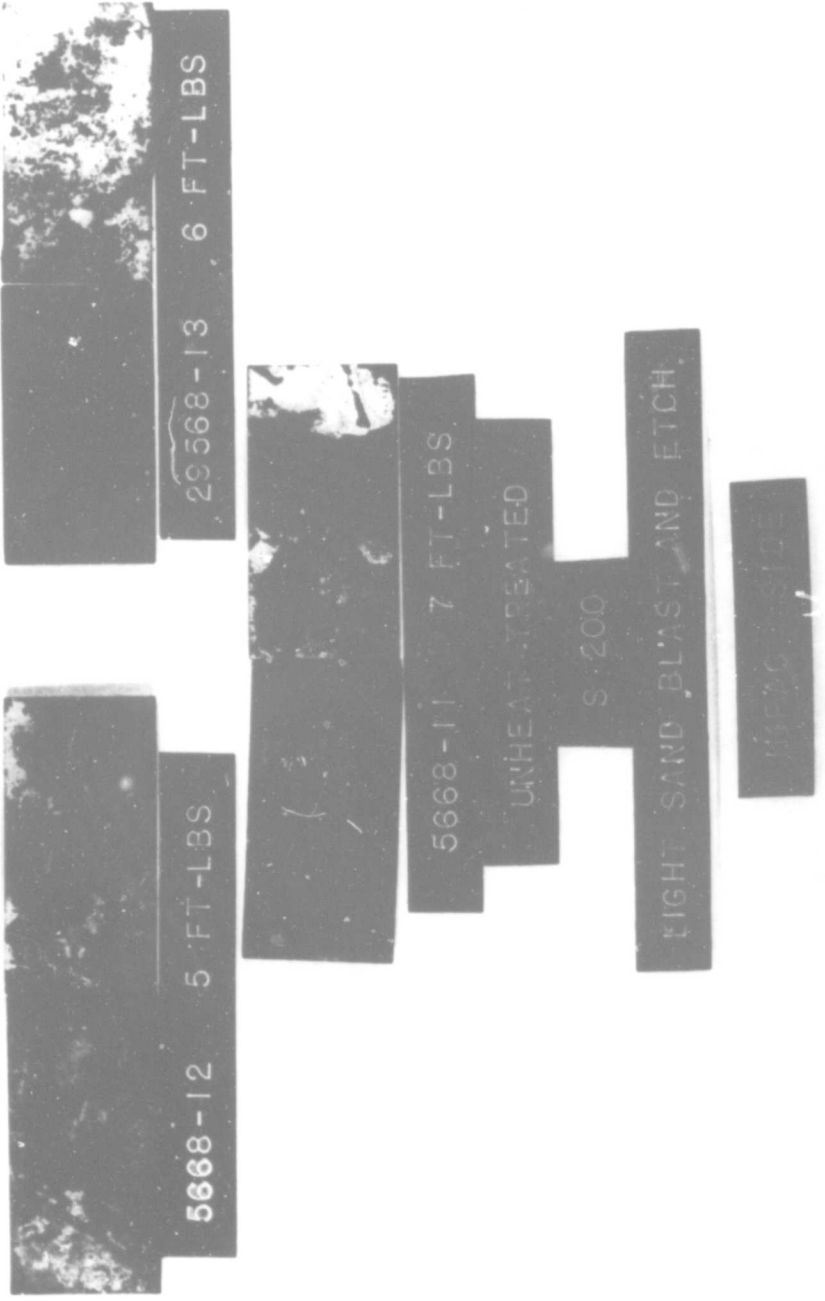

Impact Side

Fig. 11 - Ballistic Test Results on Unheat Treated Wrought S-200 Base Composites as a Function of Impact Level, Impact Side of Stripped Assembly

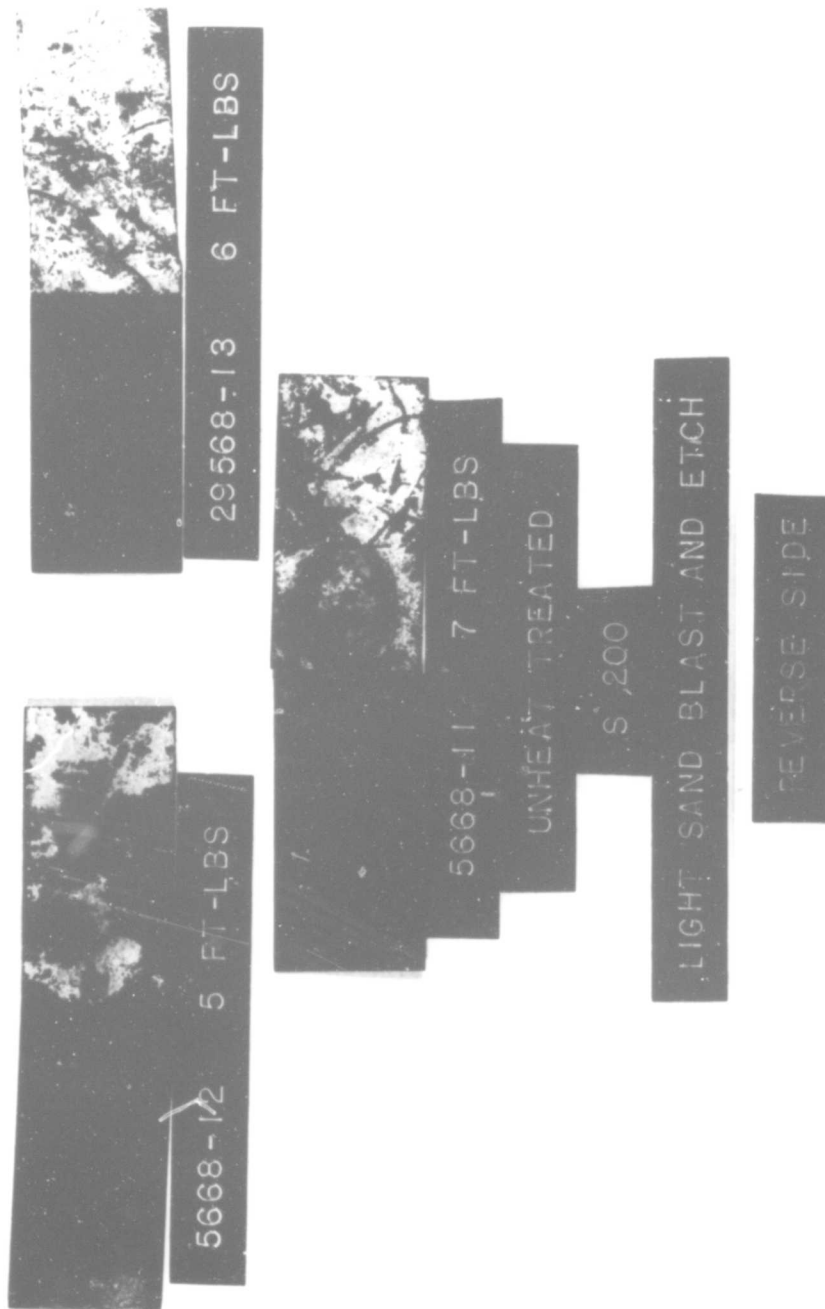

Reverse Side

Fig. 12 - Ballistic Test Results of Unheat Treated Wrought S-200 Base Composites as a Function of Impact Level, Reverse Side of Stripped Assembly

TR-450-248X

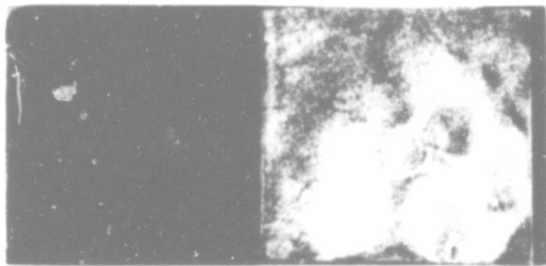

5668-12 5 ft. -lbs.

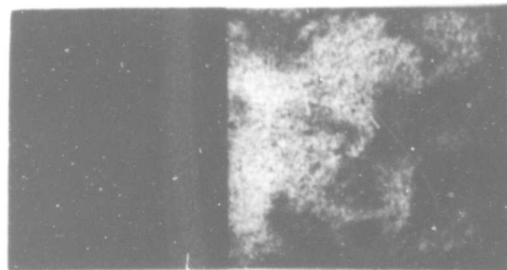

29568-13 6 ft. -lbs.

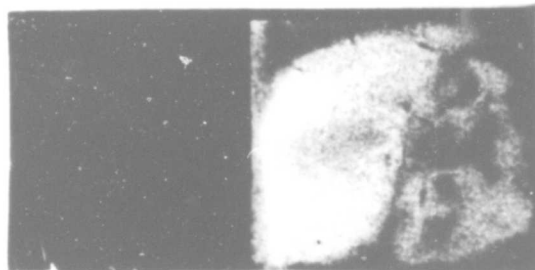

5668-11 7 ft. -lbs.

**Fig. 13 - Ballistic Test Results on Unheat Treated Wrought S-200 Base Composites as a Function of Impact Level, Photoelastic Stress Pattern Generated by Impact**

and orientations was effected. Whether or not these changes could be considered to be beneficial in light of the fact that both failed under impact is subject to question.

Qualitative observations of the test results for the heat treated and un-heat treated wrought S-200 base substrate may be observed in Tables IV and V, respectively. Photographic comparison of these tests may be seen in Figs. 14 and 15.

### 3. Ballistic Tensile

In light of the marginal effects of heat treatment on wrought S-200 base composites on ballistic properties, it was decided that ballistic-tensile tests be confined to the un-heat treated condition. Un-heat treated S-200 base composites which were first impacted at the levels indicated, then pulled to failure demonstrated a significant drop-off in both yield and ultimate tensile strengths. Examination of the nature of the substrate failure indicated a single crack through the impact zone and normal to the tensile axis. In all cases when the specimen was pulled to failure, the bond failed in shear before the armor was ruptured. Qualitatively, the wrought S-200 substrate appeared to contribute significantly to the tensile strength of the undamaged composite. Qualitative analysis of the ballistic tensile tests made may be seen in Table VI with photographic comparison in Fig. 16.

### C. Hot Pressed S-200

Although the theoretical ultimate tensile strength of 70,000 psi for hot pressed S-200 beryllium constrained by Ti-6Al-4V cover plates is well below the target of 100,000 psi indicated in the contractual proposal, it does have an attribute which would be advantageous in ballistic applications. Since the crystallographic and associated slip planes of hot pressed S-200 beryllium are randomly oriented within the limits of the manufacturing process, it would appear to have a greater tendency to absorb the shock of ballistic impact without failure than would wrought S-200 beryllium. In light of this potential attribute, the mechanical properties of hot pressed S-200 beryllium constrained by Ti-6Al-4V cover plates could be compromised.

#### 1. Ballistic

Ballistic damage on composites which had hot pressed S-200 in the substrate appeared to have less internal damage than did the wrought S-200. Not only was there less damage but the pattern of damage was

TABLE IV

## HEAT TREATED WROUGHT 5-200 BASE COMPOSITES TENSILE-BALLISTIC TEST RESULTS

Specimen No.	Tensile Static Load (ksi)	Impact Level ft-lb	Qualitative Analysis of Tensile Impact	
			Composite	Stripped Beryllium Substrate
81068-2	50.0	2.00	Programmed load was 60.0 ksi, initiation of failure occurred during loading at 52.5 ksi with impact being made at 50.0 ksi. Post impact load fell to 44.0 ksi. No further unloading was apparent. Two very slight cracks were noted on the two edges of the beryllium substrate.	Examination of the stripped beryllium substrate revealed radial cracking from the point of impact. Two very fine cracks between the impact zone and the edge. The beryllium, even with the cracks, remained in one piece. See Fig. 14.
41068-4	40.0	3.00	The static load after impact dropped to 35.0 ksi. No further unloading was observed. Two cracks were noted in the beryllium substrate edges.	Crack failure normal to the applied load occurred outside the point of impact. The impact zone had some radial cracks but were not related to the failure. Some evidence of "punch out" at point of impact. See Fig. 14.
81064-4	50.0	3.00	Static load dropped to 39.7 ksi after impact. No further unloading was observed as the result of plastic flow. One crack was noted on the edge of the beryllium substrate.	The stripped beryllium substrate had one well defined crack from the point of impact to the edge normal to direction of the applied tensile load. A very fine crack was observed between the impact site and the opposite edge. Impacted area appeared to exhibit some evidence of "punch out". Cracking on the impact side appeared to be somewhat circumferential whereas the reverse side cracking was radial. See Fig. 14.
101068-3	20.0	4.00	Programmed load for this specimen was 50 ksi; however, failure occurred on loading in the jaw at 44 ksi. Specimen was impacted at 20 ksi with the resulting post impact load falling to 18 ksi. One crack normal to the direction of applied tensile load was noted in the clamping area. No cracks were observed in the beryllium substrate edge adjacent to the impact site.	Stripped beryllium substrate had crack normal to the applied tensile load in the clamp zone. Evidence of "punch out" with circumferential and radial cracks on the impact side and radial cracks on the reverse side. No evidence of cracking between the impact site and edges. Some of the impact energy appeared to be absorbed in bending since beryllium substrate retained approximately 10° displacement from the original specimen axis. See Fig. 14.

TABLE V  
UNHEAT TREATED WROUGHT S-200 BASE COMPOSITES TENSILE BALLISTIC TEST RESULTS

Specimen No.	Tensile Static Load (ksi)	Impact Level ft-lb	Qualitative Analysis of Tensile Impact	
			Composite	Stripped Beryllium Substrate
9868-3	40.0	1.00	Static stress level dropped to 33.4 ksi on impact. $\Delta\sigma$ 6.6 ksi	No visible cracking in substrate. Material did not appear to have any damage other than a slight dimple. See Fig. 15.
13868-1	40.0	2.00	Static tensile level dropped to 29.5 ksi on impact. $\Delta\sigma$ 10.5 ksi	Cracks initiated from impact site randomly oriented. See Fig. 15.
9868-1	50.0	2.00	Static tensile stress level dropped to 36.6 ksi on impact. $\Delta\sigma$ 13.4 ksi	Randomly oriented crack initiated from impact site. See Fig. 15.
13868-2	60.0	2.00	Static tensile stress level dropped to 41.3 ksi on impact. $\Delta\sigma$ 18.7 ksi	One crack normal to direction of applied tensile load and through point of impact. See Fig. 15.
14868-1	85.8	0	Control typical compact failure. Be brittle, Ti ductile. Bond failed in shear.	



81068-2



41068-4

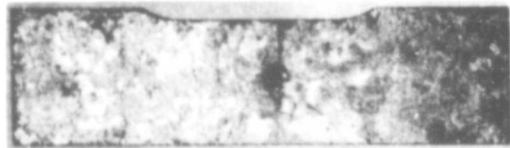

81068-4

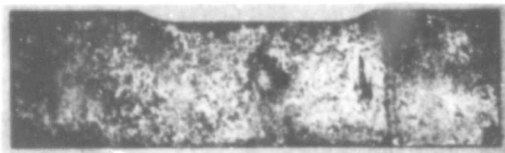

101068-3

Fig. 14 - Tensile Ballistic Test Results as a Function of Increasing Static Tensile Load and Ballistic Impact Levels on Heat Treated Wrought S-200 Base Composites Stripped Assembly



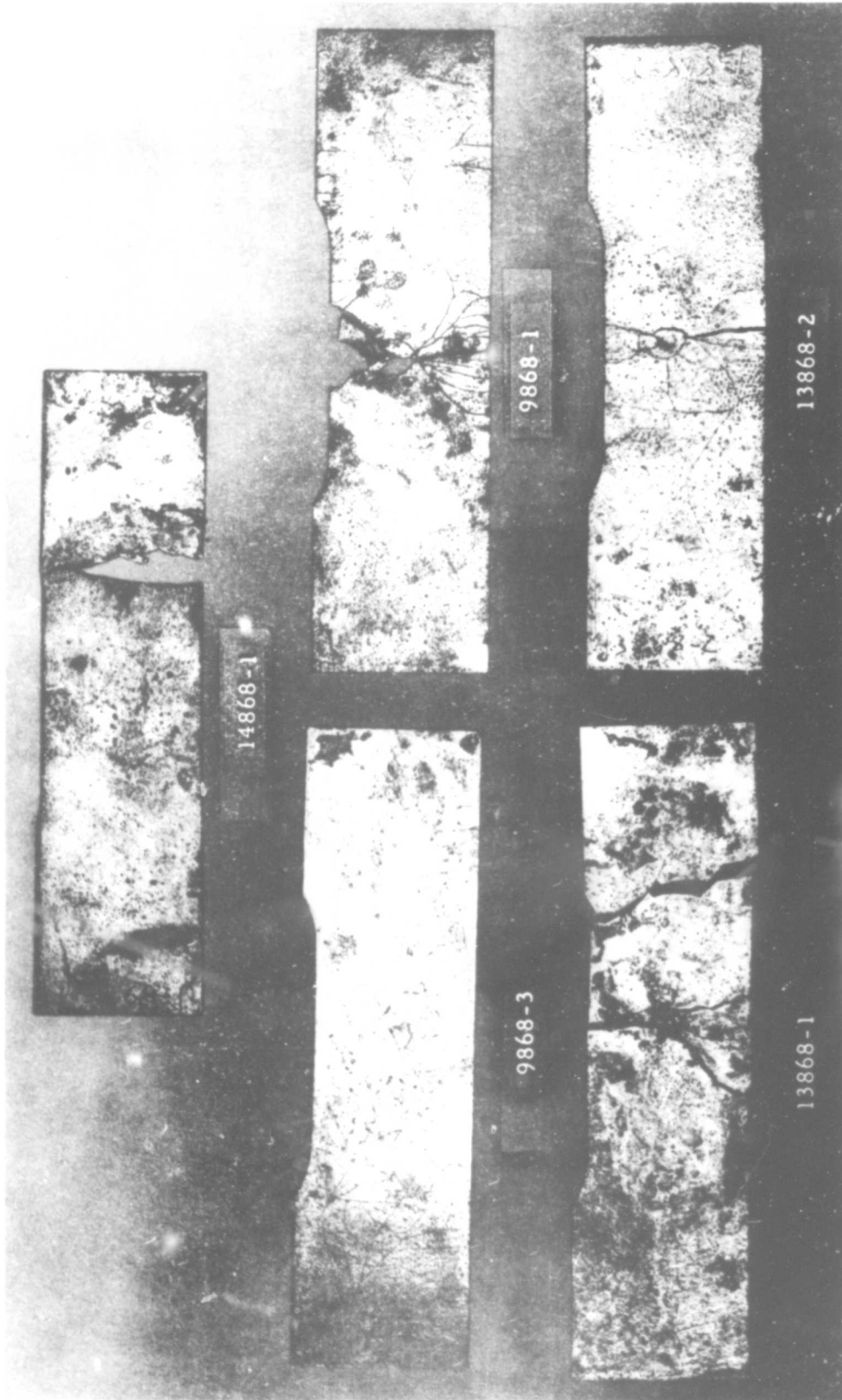
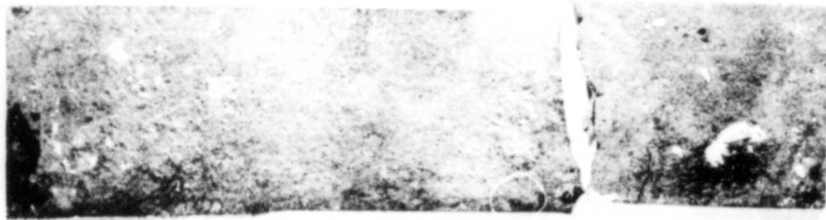

Fig. 15 - Tensile Ballistic Test Results as a Function of Increasing Static Tensile Load and Ballistic Impact Levels on Unheat Treated Wrought S-200 Base Composites Stripped Assembly

TABLE VI

UNHEAT TREATED WROUGHT S-200 BASE COMPOSITES BALLISTIC-TENSILE TEST RESULTS

Specimen No	Impact Level ft-lb	Tensile Data		Qualitative Analysis of Impact Tensile	
		Yield	U. T. S.	Composites	Stripped Beryllium Substrate
14868-1	0	65.9	85.8	Control i. e. , beryllium brittle failure, titanium ductile and bond failed in shear	
27568-3	1.0	42.6	47.6	Several cracks observed on substrate of beryllium after impact and prior to tensile test. Substrate failed at two sites Normal to direction of applied load. Bond failed in shear	Beryllium substrate failed through the point of impact as well as adjacent to clamp site. Other than the process of ballistic indent no other impact effects ( cracks ) noted.
27568-4	3.00	39.6	41.6	Several cracks observed on edges of Be substrate before impact. Bond failed in shear.	Beryllium substrate failed completely, crack formation oriented to site of ballistic impact. Evidence of conical "punch out" formation.



11868-1

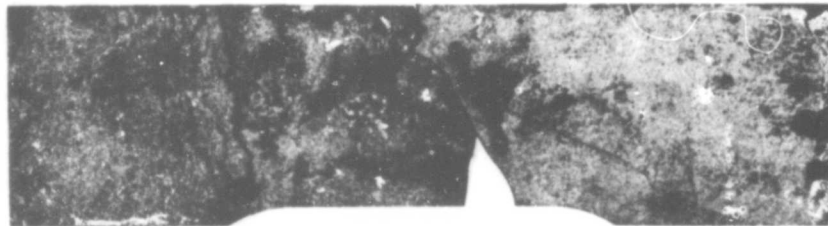

27568-3

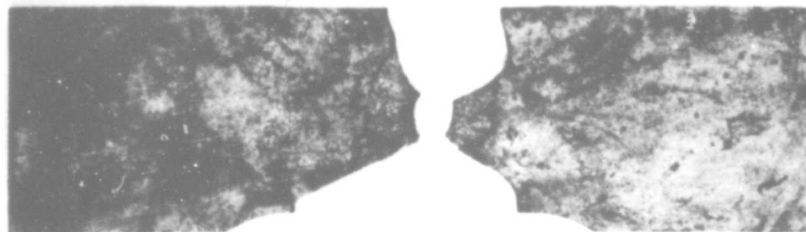

27568-1

**Fig. 16 - Ballistic Tensile Test Results as a Function of Increasing Ballistic Level on Unheat Treated Wrought S-200 Base Composites, Stripped Assemblies**

completely different from that of the wrought base composite. Although no tests were performed between 2 and 10 ft-lbs, the results appear to indicate that crack formation and propagation from the impact zone was non-existent. Impact levels of 10 and 12 ft-lbs resulted in localized damage to both the armor and substrate. Failure was caused by "punch out" of a conical plug. Substrate material adjacent to the "punch out" zone was void of visible radial and circumferential cracking.

Table VII and Figs. 17 and 18 present qualitatively the results of these tests.

## 2. Tensile-Ballistic

Hot pressed S-200 based composites, impacted while under a static tensile load, all exhibited the same stress relaxation as observed in the wrought material. As in the other materials tested the stress relaxation attenuated instantaneously to a constant level which held for the duration of the test cycle.

Examination of the substrate damage appeared to demonstrate that the beryllium still had load carrying capacity since the damage was confined to the impact area. However, for static tensile levels in excess of the contribution of the titanium armor (i. e. , 50 ksi), the beryllium failed normal to the applied load before impact indicating that the substrate material did not contribute substantially to the mechanical properties of the composite.

Table VIII and Fig. 19 present qualitative results of the tensile ballistic tests performed on hot pressed S-200 based composites.

## 3. Ballistic Tensile

Observed yield strength of undamaged hot pressed S-200 beryllium constrained with Ti-6Al-4V cover plates were significantly higher than that predicted using the rule of mixtures relationship. Conversely, the observed ultimate tensile strengths were considerably lower than the predicted values.

The effect of 2 ft-lbs ballistic impact on the tensile test bar prior to testing did not appear to cause any loss in either yield or ultimate tensile strengths. Increasing the ballistic impact level to 4 ft-lbs resulted in a significant loss in both yield and ultimate tensile strengths indicating

TABLE VII

## HOT PRESSED S-200 BASE COMPOSITES BALLISTIC TEST RESULTS

Specimen No.	Impact Level ft-lb	Qualitative Analysis of the Effect of Impact	
		Composite	Stripped Beryllium Substrate
6968-11	0.5	Slight dent on impact side, no visible cracks on edges adjacent to impact site. No apparent bond separation.	Slight dimple on the beryllium substrate. No visible crack formation anywhere on substrate material.
6968-12	1.0	Slight dent on impact side, no visible cracks on edges adjacent to impact site. No apparent bond separation.	Magnitude of dimple slightly larger than that observed in 6968-11 at 0.5 ft-lb. No crack formation in the beryllium substrate at the impact site or anywhere else on the material.
6968-13	2.0	Slight indent on impact side of titanium armor. No discernible bulge on rear armor. No visible cracks on edges adjacent to the impact site. No apparent bond separation.	Magnitude of dimple larger than cited above in 6968-12 at 1 ft-lb. No crack formation at either impact site or anywhere on the beryllium substrate material.
6968-31	10.0	Front titanium armor cupped and broke. No visible cracks on the edges adjacent to the impact site. No apparent bond separation.	Beryllium substrate developed a conical "punch out" which was a clean break with absence of any crack formation or propagation.
6968-22	12.0	"Punch out" on front titanium armor through to the beryllium substrate. Some of the beryllium remained bonded to the rear titanium armor which pulled away on impact. No edge cracks apparent on beryllium substrate adjacent to the impact site.	"Punch out" was clean in both the front titanium armor as well as the beryllium substrate. No cracks were visible at either the impact site or anywhere on the substrate material.

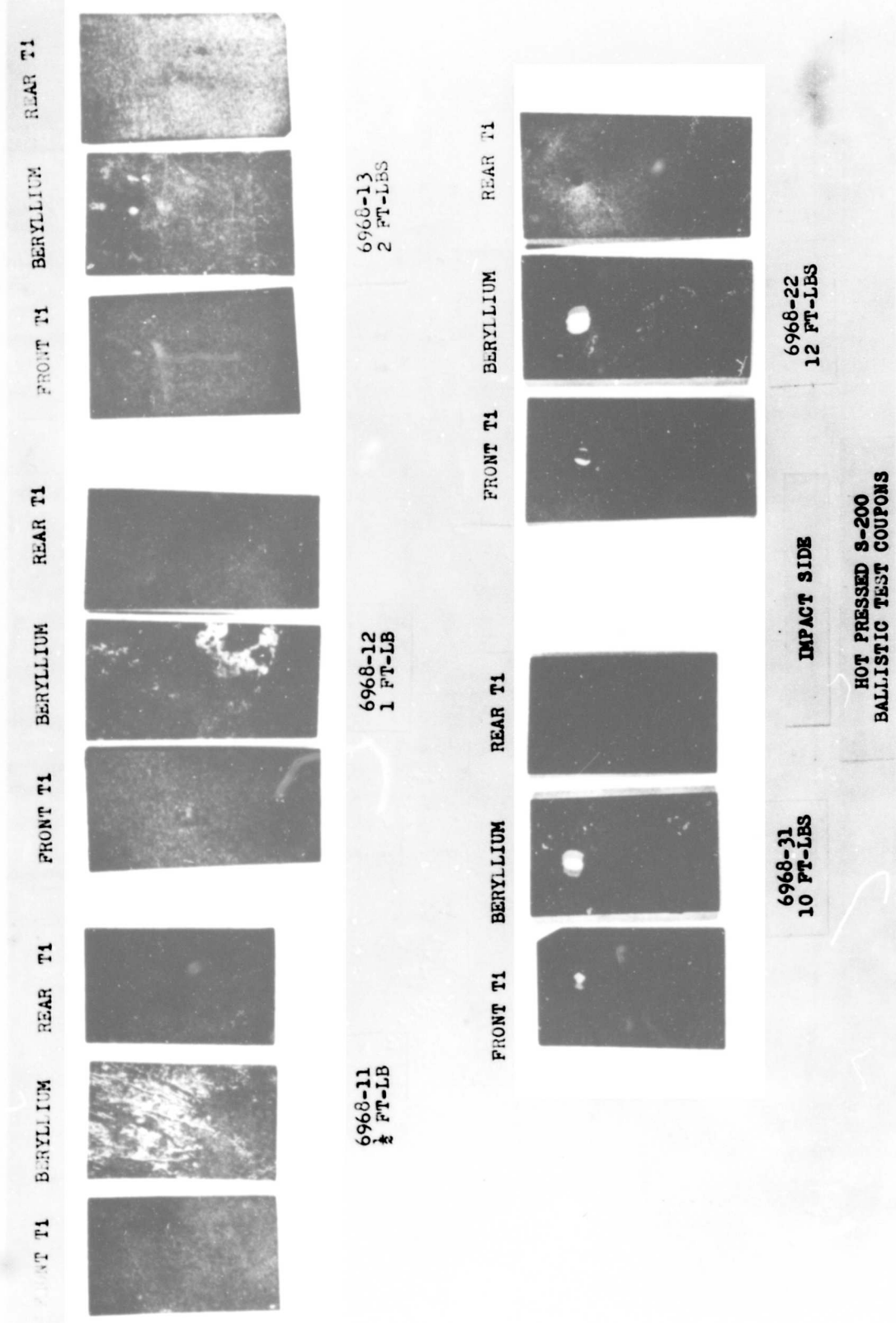

Fig. 17 - Ballistic Test Results on Hot Pressed S-200 Base Composites as a Function of Increasing Impact Level, Impact Side of Stripped Assembly

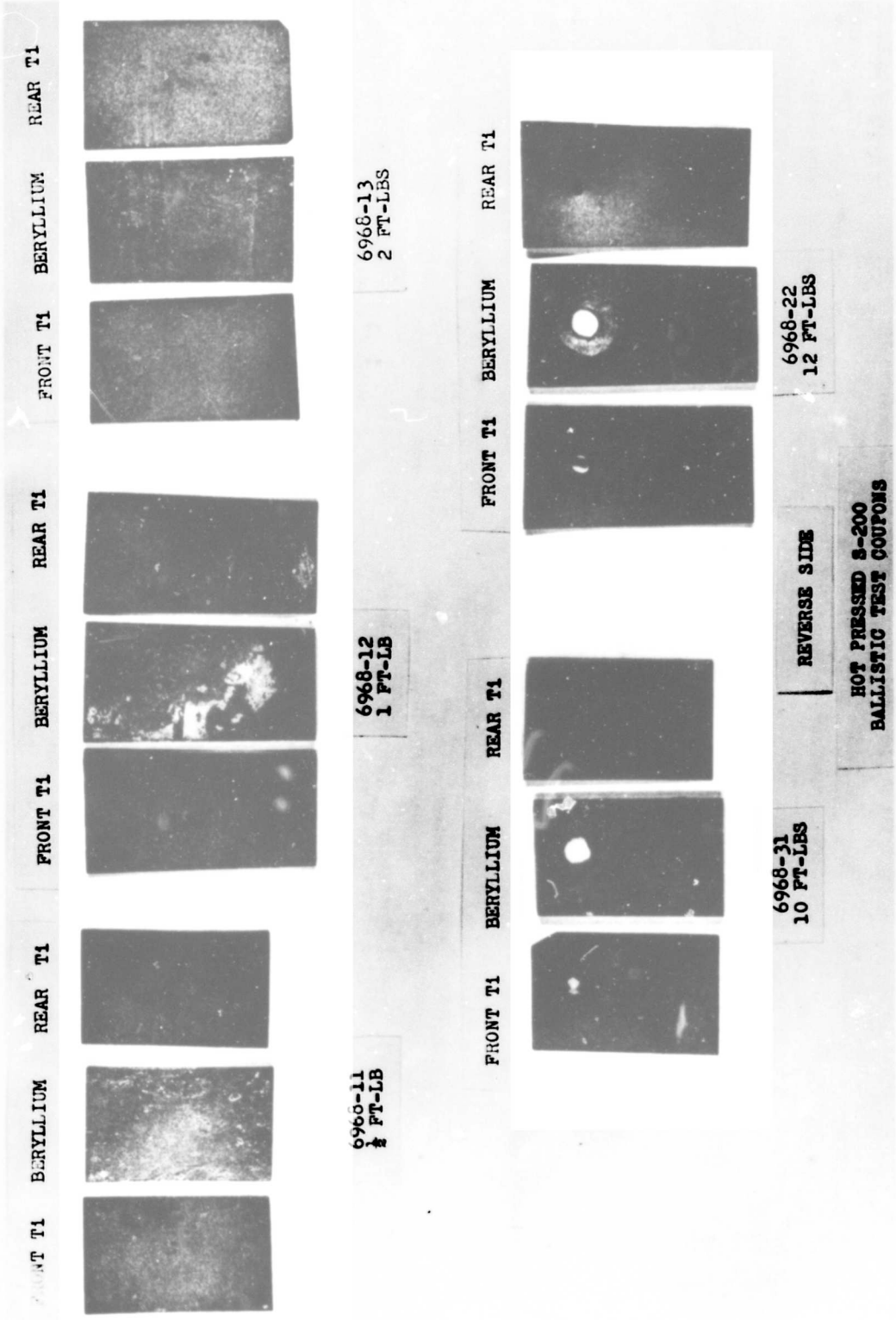

Fig. 18 - Ballistic Test Results on Hot Pressed S-200 Base Composites as a Function of Increasing Impact Level, Reverse Side of Stripped Assembly

TABLE VIII

## HOT PRESSED S-200 BASE COMPOSITES TENSILE BALLISTIC TEST RESULTS

Specimen No.	Tensile Static Load (ksi)	Impact Level ft-lb	Qualitative Analysis of Tensile Impact	
			Composite	Stripped Beryllium Substrate
41068-2	35.0	1.00	Static load dropped after impact to 31.6 ksi, a drop off of 3.4 ksi. The post impact static load remained at this level without any apparent further relaxation. No cracks were noted on the edges of the beryllium substrate.	The beryllium substrate did not show any catastrophic crack failures. The area immediately around the impact zone did exhibit slight radial cracks.
111068-2	43.0	1.00	Static load programmed was 52.0 ksi, failure occurred on loading at 46.5 ksi with impact being made at 43.0 ksi. Post impact static load dropped to 36.5 ksi a drop off of 6.5 ksi. Post impact static load remained at 36.5 with no further apparent load relaxation. Cracks were noted on 2 edges of the beryllium substrate.	The beryllium substrate failed approximately normal to the direction of applied load. The focal point of the crack failure was at the point of impact.
41068-1	44.0	1.00	Static load dropped after impact to 39.5 ksi. Post impact static load remained at this level with no apparent further unloading. No cracks were visible on the edges of the beryllium substrate.	The beryllium substrate material did not exhibit any catastrophic cracking. Slight radial cracks were visible in the immediate impact zone.
71068-1	44.0	2.00	Post impact static load dropped to 37.0 ksi. Post impact static load remained at this level until specimen was purposely unloaded. No visible cracks noted on beryllium substrate edge.	The beryllium did not exhibit any evidence of crack failure from point of impact to edge. Impact area did show some radial cracking with the start of "punch out" failure.
101068-4	40.0	3.0	No crack observed in edge of substrate. Load dropped to 35 ksi on impact.	Stripped beryllium had one single dimple at impact site, no cracking observed.
41068-3	20.0	4.00	Specimen programmed for static tensile load at 50 ksi, failed in jaw at 44 ksi, impacted at 20 ksi, stress relaxation to 18 ksi. One crack was observed in jaw zone.	Stripped composite had one crack normal to applied tensile load in jaw area. Impact produced conical "punch out", circumferential cracks around impact. No other crack propagation.
111068-1	40.0	4.00	Static load dropped to 34 ksi after impact. One crack observed on the edge of the beryllium substrate after impact.	Stripped beryllium substrate exhibited one crack between the impact zone and one edge normal to the applied tensile load. Impact side exhibited circumferential and radial cracks whereas the reverse side was cracked radially in the immediate impact zone. "Punch out" condition evident.
101068-1	50.0	4.00	Static load dropped to 40.5 ksi after impact. Cracks noted on two adjacent edges of the beryllium substrate after impact.	Stripped beryllium substrate was cracked normal to the direction of applied tensile stress and through the impact zone. Impact side had radial and circumferential cracks whereas the reverse side was all radial. Slight evidence of "punch out."



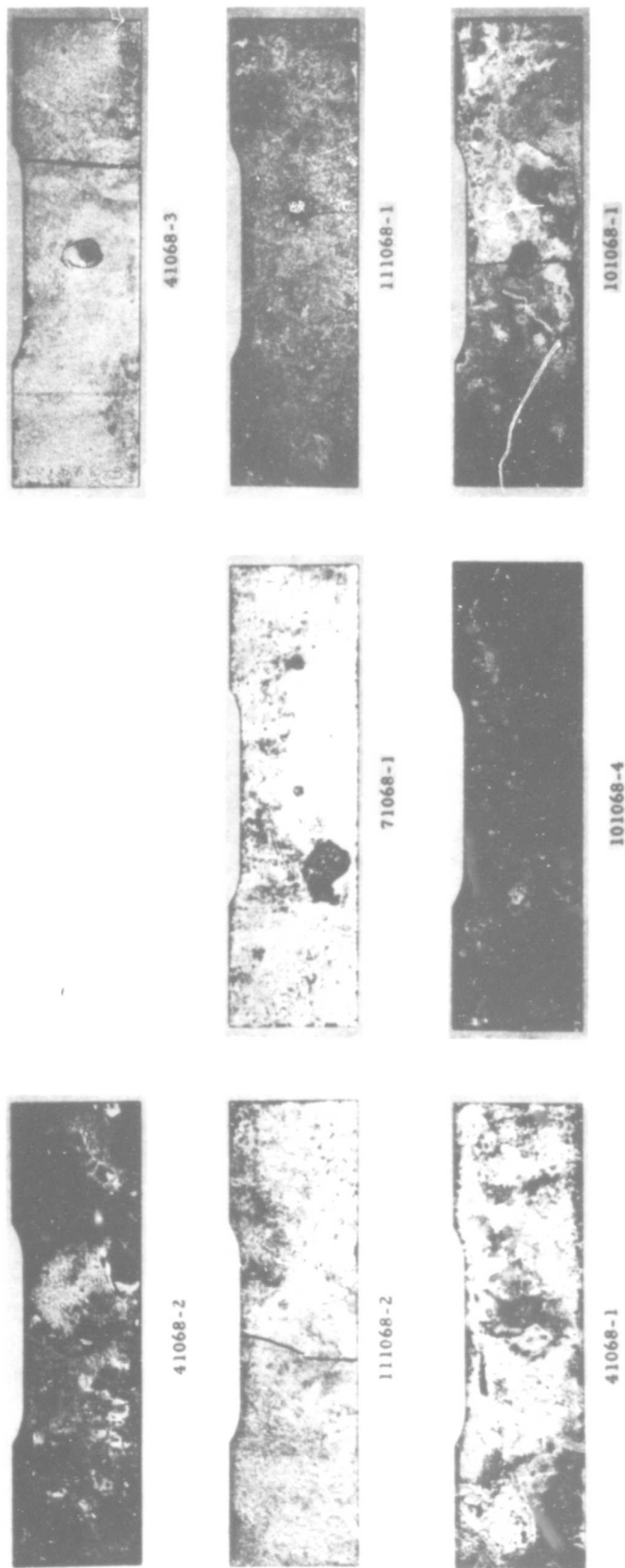

Fig. 19 - Tensile Ballistic Test Results as a Function of Increasing Static Tensile Load and Ballistic Level on Hot Pressed S-200 Base Composites, Stripped Assembly

that the beryllium substrate was damaged by the impact. Examination of substrates in Fig. 20 and comparing these with the tabulated data on Table IX appear to substantiate that the beryllium was damaged by the impact.

#### D. Wrought I-400

Considerable difficulty was encountered in obtaining crack free composite blanks suitable for either ballistic or tensile specimens using wrought I-400 beryllium. In spite of the fact that the wrought I-400 material had relatively high elongation, successes in obtaining crack free substrates were somewhat limited. Since the samples were limited, tests on the wrought I-400 composites were confined to ballistic tensile evaluation.

##### 1. Ballistic Tensile

Since both yield and ultimate tensile strengths of un-impacted Ti-6Al-4V constrained wrought I-400 beryllium tensile bars were considerably below the rule of mixtures prediction, it would appear that the beryllium substrate was damaged and discontinuous before testing. Ballistic impact at the 1 ft-lb level did not affect any further reduction in either yield or ultimate tensile strengths. Table X and Fig. 21 exhibit the limited test results obtained.

#### E. Hot Pressed I-400

Hot pressed I-400 also presented difficulties in obtaining blanks for ballistic and tensile composites suitable for testing. Specimen rejection as the result of substrate cracks normal to the long axis re-emphasized the effect of the differential thermal expansion coefficients of the two base materials. Those specimens that appeared to be free from visible cracks in the substrate were converted into tensile bars for tensile ballistic and ballistic tensile appraisal.

##### 1. Tensile Ballistic

Composite tensile specimens with hot pressed I-400 beryllium in the substrate, statically loaded in tension and impacted, all cracked normal to the direction of applied load. Damage to the substrate was complete such that the entire static tensile load after impact was transmitted through the armor. Qualitative results of these tests may be seen in Table XI and Fig. 22.

TR-450-248X

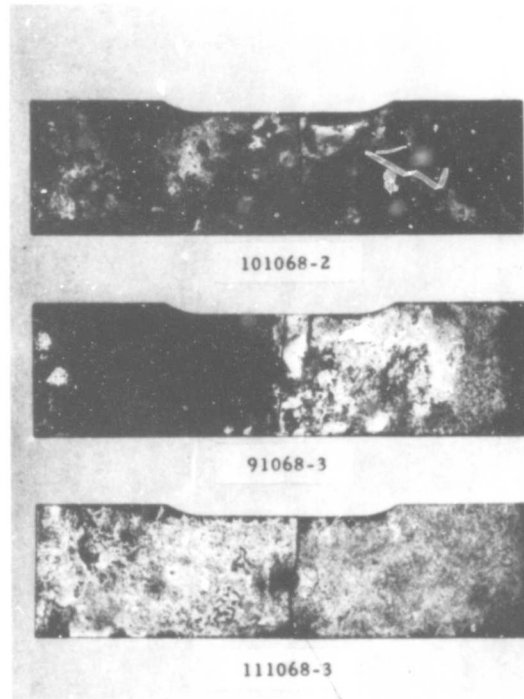

**Fig. 20 - Ballistic Tensile Test Results as a Function of Increasing Ballistic Level on Hot Pressed S-200 Base Composites, Stripped Assembly**

TABLE IX

## HOT PRESSED S-200 BASE COMPOSITES BALLISTIC TENSILE TEST RESULTS

Specimen No	Impact Level ft-lb	Tensile Data		Qualitative Analysis of Impact Tensile	
		Yield	U T. S.	Composites	Stripped Beryllium Substrate
101068-2	0	46.0	46.0	The beryllium substrate broke normal to the direction of applied load in what may be considered to be brittle fracture, whereas the titanium armor exhibited ductile failure. Bond separation was noted as the result of shear failure.	Beryllium substrate exhibited a clamp failure normal to the direction of applied tensile load.
91068-1	0	49.0	50.2	Failure occurred in the clamp area. Beryllium failure was normal to the direction of applied tensile load. Bond separation was noted with failure being the result of shear. Titanium armor failed in the usual ductile manner.	In addition to the failure of the beryllium substrate in the clamp area several other cracks were noted within the gage length normal to the direction of applied tensile load
91068-3	2.0	48.4	48.7	Beryllium exhibited brittle failure, titanium armor exhibited ductile failure. Shear failure was noted in the bond.	Beryllium substrate failed normal to the direction of applied load and coincident with the point of ballistic impact. Very fine cracks were observed around the point of impact.
111068-3	4.0	39.3	39.8	Beryllium substrate broke in brittle failure, titanium armor in ductile and the bond failure was in shear.	Beryllium substrate failed normal to the direction of applied tensile load through the site of ballistic impact. Impact face had typical radial and circumferential cracks.

TABLE X  
WROUGHT I-400 BASE COMPOSITES BALLISTIC TENSILE TEST RESULTS

Specimen No.	Impact Level ft-lb	Tensile Data		Qualitative Analysis of Impact Tensile	
		Yield	U. T. S.	Composites	Stripped Beryllium Substrate
13668-2	1.00	32.4	40.1	Impact specimen had a slight indent, visible cracks on one edge. Bond failure in shear.	Substrate material failed completely. Crack formation random and not necessarily oriented to impact site.
27568-3	1.00	34.6	38.6	Cracks throughout the beryllium substrate on impact prior to tensile testing.	Substrate material failed completely. Crack formation random and not necessarily oriented to point of impact.

TR-450-248X

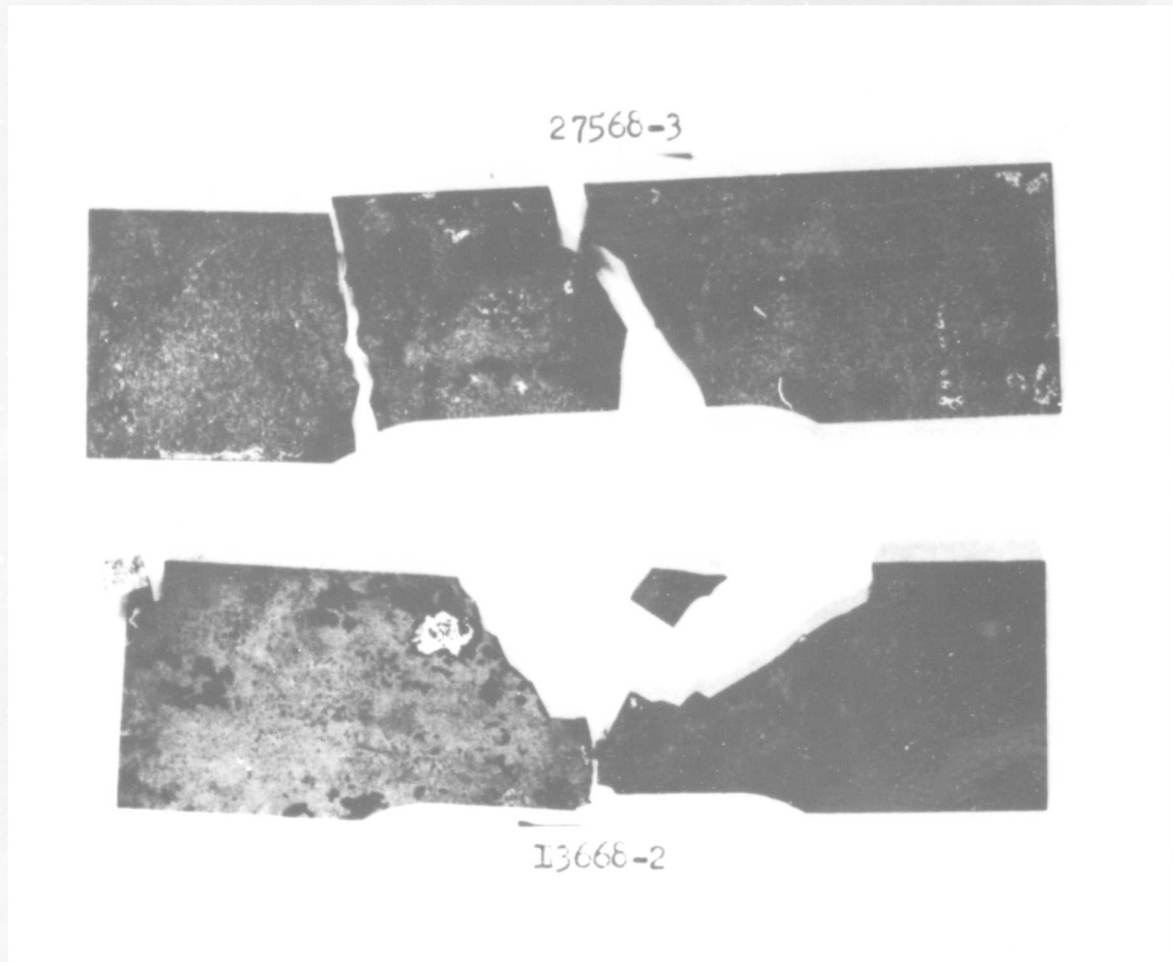

**Fig. 21 - Tensile Ballistic Test Results as a Function of Increasing Static Tensile Load and Ballistic Level on Wrought I-400 Base Composites, Stripped Assembly**

TABLE XI  
HOT PRESSED I-400 BASE COMPOSITES TENSILE BALLISTIC TEST RESULTS

Specimen No.	Tensile Static Load (ksi)	Impact Level ft-lb	Qualitative Analysis of Tensile Impact	
			Composite	Stripped Beryllium Substrate
141068-2	29.0	2.00	Programmed load was 40 ksi, specimen apparently cracked at 39.5 ksi and impacted at 29 ksi. Post impact static load remained at 27 ksi. A series of cracks were observed on both edges of the beryllium substrate.	Stripped beryllium substrate revealed randomly oriented cracks at the impact site as well as the site adjacent to the portion of clamping. It appeared that the cracks in both cases initiated at the edge, then feathered out in a random pattern. Characteristic cracks around the impact site were not present.
101068-4	40.0	3.00	Post impact static load dropped to 31 ksi. No cracks were observed in the substrate immediately after impact.	Single crack failure approximately normal to the direction of applied tensile load.
181068-1	40.0	3.00	Post impact static load dropped to 27.5 ksi. Series of cracks were noted on both edges of the beryllium substrate.	The beryllium substrate indicated complete failure. Although the bulk of the cracks was normal to the applied load, one was parallel. The impact zone showed some evidence of "punch out" in spite of the lack of radial cracking and plastic deformation.
181068-4	23.5	3.00	Programmed load was 50 ksi, specimen apparently cracked at 25 ksi with impact occurring at 23.5 ksi. Cracks were observed on both edges of the beryllium substrate.	Crack failure on the beryllium substrate was principally normal to the applied tensile load. Primary failure occurred in line with the impact site. Characteristic radial cracking in the immediate impact zone was not observed.
141068-4	36.5	4.00	Programmed static load was 50 ksi. Specimen apparently cracked at 45.5 ksi and impacted at 36.5 ksi. Post impact static load was 29 ksi. Whole series of cracks were noted on both edges of the beryllium substrate.	The beryllium substrate failed completely. Crack failure random, with some evidence of conical "punch out".
141068-3	40.0	4.00	Post impact static load dropped to 28 ksi. Cracks were noted on both edges of the beryllium substrate adjacent to the point of impact.	Beryllium substrate failed completely normal to the direction of applied tensile load. Conical "punch out" was evident without the characteristic radial cracks on the reverse side.

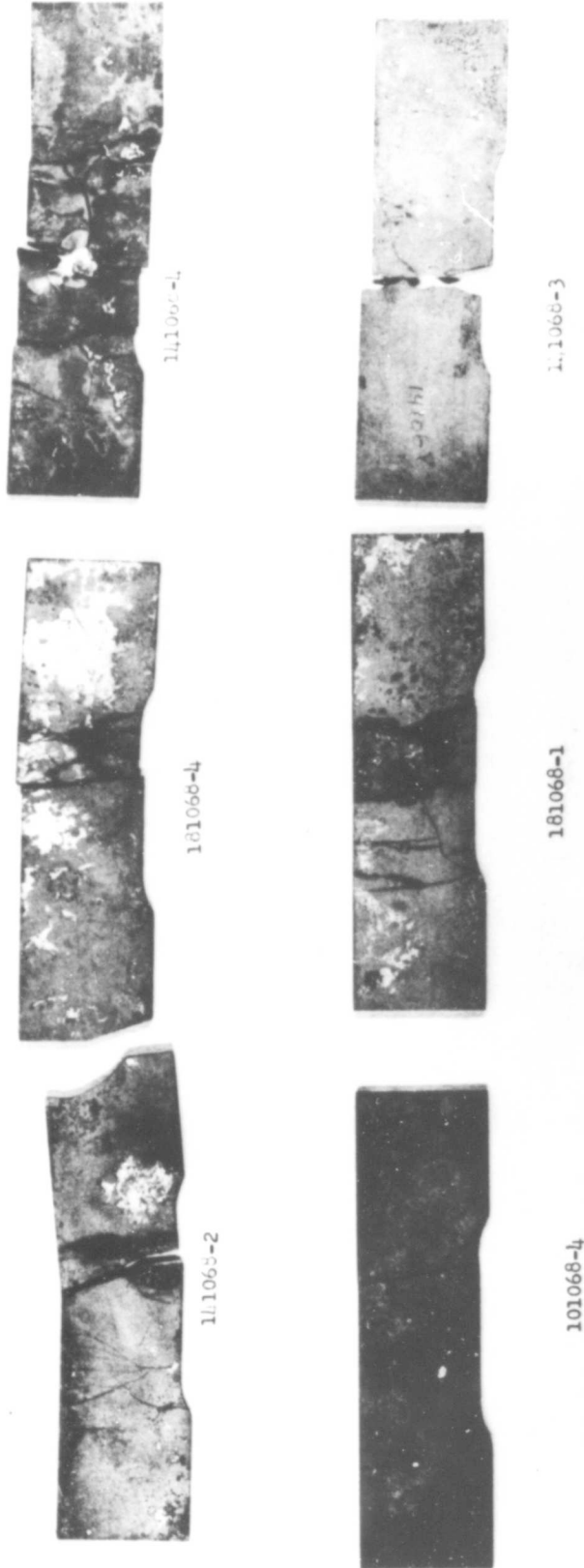

Fig. 22 - Tensile Ballistic Test Results as a Function of Increasing Static Tensile Load and Impact Level on Hot Pressed I-400 Base Composites, Stripped Assembly



## 2. Ballistic Tensile

The yield and ultimate tensile strengths of hot pressed I-400 beryllium constrained by Ti-6Al-4V cover plates, which have not been subjected to ballistic impact, were considerably below the level predicted by the rule of mixtures. Specimens which were ballistically impacted at 2 and 4 ft-lb levels, then pulled to failure, showed equivalent reductions in both yield and ultimate tensile strength below that of the supposedly undamaged test bar. Although the 2 and 4 ft-lb impact levels on the respective specimens resulted in equivalent yield and ultimate tensile strengths, the type and degree of failure of the beryllium substrate was not congruent. The hot pressed I-400 beryllium constrained with Ti-6Al-4V that was impacted at the 2 ft-lb level, then pulled to failure exhibited randomly oriented brittle crack failures, not only around the impact site, but also throughout the entire gage section. The equivalent tensile specimen impacted at the 4 ft-lb level and pulled to failure, on the other hand, exhibited damage that was localized around the impact site.

In light of the observation that the substrate in the ballistic-tensile test specimen subjected a 2 ft-lb impact suffered complete failure, it would appear that there was some question as to the structural integrity of beryllium prior to testing. Further, since the majority of the crack failures of the beryllium were not necessarily oriented to the impact site, it would increase doubts as to its structural integrity in spite of the fact that Dy-Chek penetrant tests did not appear to reveal any discontinuities in either the bond or substrate. Table XII and Fig. 23 exhibit the qualitative result of these tests.

TABLE XII

## HOT PRESSED I-400 BASE COMPOSITES BALLISTIC TENSILE TEST RESULTS

Specimen No	Impact Level ft-lb	Tensile Data		Qualitative Analysis of Impact Tensile	
		Yield	U. T S	Composite	Stripped Beryllium Substrate
171068-2	0	50.6	50.6	Crack failure occurred in the beryllium along two parallel lines normal to the tensile direction. Titanium armor broke in a ductile fracture whereas the beryllium appeared to break in brittle fracture. Bond failed in shear.	Beryllium fractures were somewhat normal to the tensile direction. Overall failure of beryllium substrate.
151068-1	2.0	39.5	40.6	Cracks were observed on the edges of the beryllium substrate after impact and before tensile test. Bond failed in shear.	Crack failure of the beryllium substrate was randomly oriented around the impact site. Other crack failures were observed to be displaced from the impact site.
141068-1	4.00	38.0	39.1	A crack was noted on edges of beryllium substrate after impact and before tensile testing. Bond failed in shear.	Conical "punch out" was observed in the impact site with the characteristic circumferential cracks on the impact site. Crack failure which coincided with the point of impact was somewhat normal to the tensile direction.

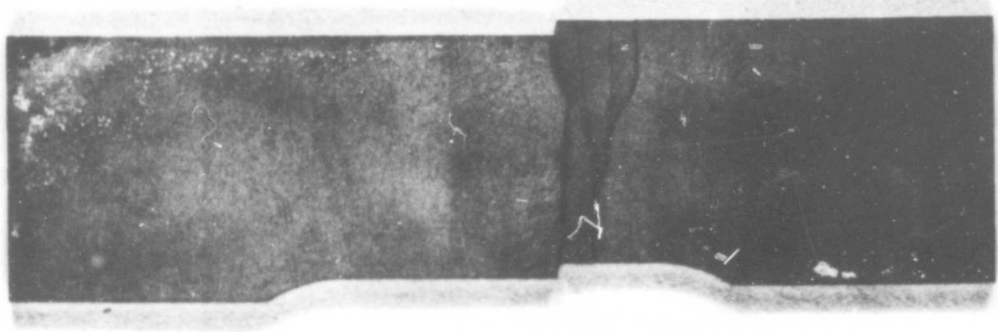

171068-2

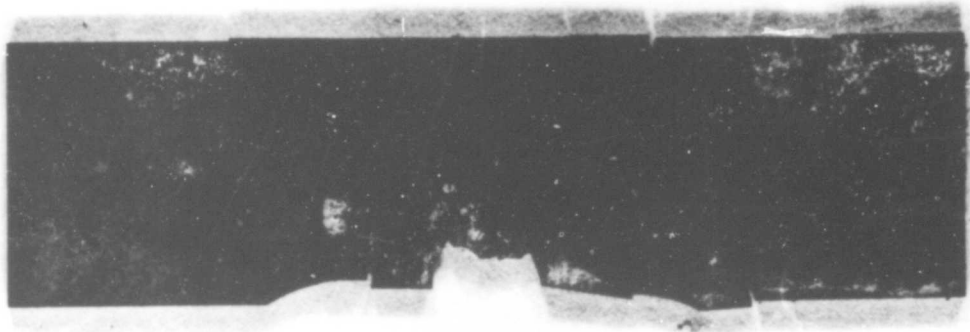

151068-1

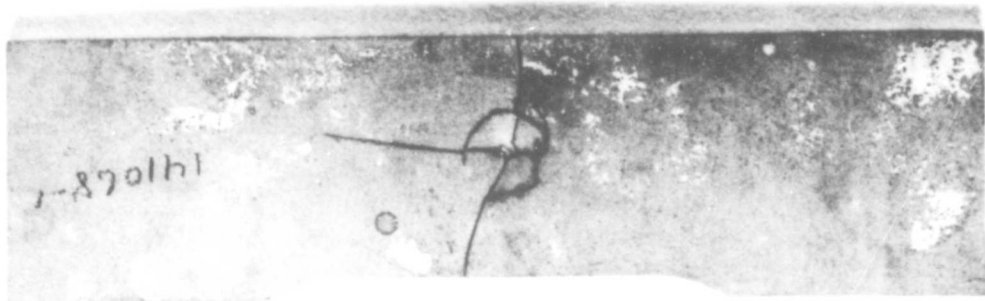

141068-1

Fig. 23 - Ballistic Tensile Test Results as a Function of Increasing Impact Level on Hot Pressed I-400 Base Composites, Stripped Assembly

## V. DISCUSSION OF RESULTS

Qualitative comparison of the respective resistances to ballistic impact of equivalent cross-sections of beryllium and beryllium constrained with Ti-6Al-4V cover plates has shown that the latter can sustain impacts without failure which may be as much as an order of magnitude greater than the former. Conditions governing this general observation were that the experimental parameters, such as the overall geometric and testing procedures, were equivalent.

Using these qualifications, the typical ballistic results reported by Woodard, et al<sup>(1)</sup> on standard 2 inch x 1 inch x 0.100 inch thick polycrystalline hot pressed or wrought beryllium shapes failed by cracking under ballistic impact levels of less than 1 ft-lb. Actually, ballistic impact levels which resulted in crack failure of both hot pressed and wrought beryllium were between 0.2 and 0.7 ft-lb.

Qualitative examination of both hot pressed and wrought S-200 beryllium which was constrained by Ti-6Al-4V cover plates revealed several interesting characteristics. These are:

1. Principle failure of the beryllium was usually confined to the immediate impact zone for all levels up to and including 12 ft-lbs depending on the degree of work put into the material prior to assembly.
2. Other than the radial and circumferential cracking around the immediate impact zone, there were random failures that were not necessarily oriented to the impact site. It would appear that the non-impact zone oriented crack failures were the result of axial bending during impact. These randomly oriented crack failures were particularly characteristic of the wrought S-200 grade.
3. Impact failures identified as a shear-tensile cup and cone "punch-out" at levels up to and including 12 ft-lbs appeared to be accompanied by a significant degree of plastic deformation as well as tensile failure of the aluminum bond.
4. Ballistically impacted hot pressed S-200 beryllium constrained by Ti-6Al-4V did not exhibit any evidence of cracking beyond

the immediate impact zone. It appears that all of the impact energy in levels up to and including 12 ft-lbs was cumulatively absorbed by plastic deformation, shear-tensile cup and cone "punch-out" and tensile failure of the aluminum bond.

Although significant improvement was observed in the ballistic impact behavior of beryllium constrained by Ti-6Al-4V, the incorporation of such a composite system also causes conditions which are unfavorable. Differences in the coefficient of thermal expansion of the armor and the substrate have shown that the beryllium, when braze bonded to the titanium, has a residual tensile stress of sufficient magnitude to cause failure even before impact. The net effect of a ballistic impact normal to the residual tensile stress direction and parallel to the brittle prismatic planes can only be failure by cracking. Although the mechanical properties of the hot pressed S-200 grade beryllium did not completely lend themselves to the strength required of the composites, they did exhibit a reasonable degree of elasto-plasticity which permitted impact without catastrophic failure. This behavior, perhaps, is attributed to random orientation of the crystallographic planes. Of the materials that were investigated, ignoring the mechanical properties, the hot pressed S-200 was felt to have the greatest ballistic armor potential.

Classification of the four basic substrate variations and considering both the mechanical properties as well as the ballistic quality, the order of their performance was wrought S-200, hot pressed S-200, hot pressed I-400 and wrought I-400. Considering the ballistic qualities alone, the order of performance would be hot pressed S-200, wrought S-200, with both wrought and hot pressed I-400 failing completely.

Tabulation of the theoretical and observed mechanical properties of the various grades of beryllium constrained by Ti-6Al-4V cover plates are shown in Table XIII.

**TABLE XIII**  
**SUMMARY OF THE OBSERVED AND THEORETICAL MECHANICAL**  
**PROPERTIES AS A FUNCTION OF BERYLLIUM SUBSTRATE GRADE**

<u>Composite Substrate</u>	<u>Theoretical Strengths<sup>(1)</sup></u>		<u>Observed Strengths</u>		<u>Differences</u>	
	<u>Yield (psi)</u>	<u>Ultimate (psi)</u>	<u>Yield (psi)</u>	<u>Ultimate (psi)</u>	<u>Yield (psi)</u>	<u>Ultimate (psi)</u>
Hot Pressed S-200	43,600	68,800	47,500	48,100	+ 3,900	-20,700
Wrought S-200	56,000	103,000	65,900	85,800	+ 9,900	-17,200
Hot Pressed I-400	67,300	102,100	50,600	50,600	- 16,700	-51,500
Wrought I-400	73,800	114,200	34,600	38,600	- 39,200	-79,300

<sup>(1)</sup> Using Rule of Mixtures

## VI. CONCLUSIONS

1. Beryllium constrained by Ti-6Al-4V cover plates offers interesting ballistic energy absorption characteristics in addition to its low density. Damage is localized and the fragments are held in place.
2. Based on the limited data, wrought S-200 grade beryllium showed less resistance to ballistic crack failure than did hot pressed S-200 grade beryllium when constrained by Ti-6Al-4V cover plates. Failures of hot pressed S-200 grade beryllium constrained by Ti-6Al-4V cover plates were localized at the point of impact and accompanied by a substantial degree of plastic deformation.
3. Ballistic impact at levels up to 4 ft-lbs on specimens which were under tensile load showed an immediate loss in load carrying ability of the beryllium substrates with transfer of all of the load to the Ti-6Al-4V cover plates. Actual impact levels at which the load transfer occurs varies with the type of beryllium used.
4. Ballistic levels at 1 ft-lb on specimens before tensile testing resulted in sufficient damage to the beryllium substrate to cause failures of the composite at loads equivalent to that required to rupture the Ti-6Al-4V armor alone. Again, the levels at which these occurred was dependent on the type of beryllium used.
5. The method of joining coupled with the differences in the coefficient of linear thermal expansions of beryllium and the Ti-6Al-4V cover plates leads to the potential development of residual tensile strains in the former. Although both hot pressed and wrought S-200 grades of beryllium constrained by Ti-6Al-4V exhibited ultimate tensile strengths lower than predicted by rule of mixtures, their yield strengths were significantly higher. This synergistic effect could be attributed to the plastic strain hardening associated with the stresses developed by the differences in thermal expansion of the substrate and the cover plates.
6. Considering the level of the tensile strength required in the composite to warrant further study as a potential replacement of conventional compressor blading in turbine engines, there is no evidence to indicate that even an optimized system will be adequately impact resistant. However, in applications where lower stress levels are encountered, these composites with their improved impact behavior may be extremely attractive.

## VII. RECOMMENDATIONS

Though the application of Ti-6Al-4V cover plates to a beryllium substrate does result in a composite that absorbs relatively high levels of ballistic impact, the load carrying ability of that composite is reduced below the levels required for specific engine blading applications. On this basis, further work on this scheme cannot be recommended for that ultimate usage.



UNCLASSIFIED

DOCUMENT CONTROL DATA - R&D		
1. REPORT ORIGINATOR The Brush Beryllium Company 17876 St. Clair Avenue Cleveland, Ohio 44110		2A. REPORT SECURITY CLASSIFICATION <b>UNCLASSIFIED</b> 2B. GROUP
3. REPORT TITLE <b>Investigation of Light Weight, Impact Resistant, Lamellar Composites of Titanium-Clad Beryllium for Air Breathing Engine Compressor Blades</b>		
4. REPORTABLE NOTES (Type of report and inclusive dates) <b>Final Technical Report - May 15, 1968 to August 1, 1969</b>		
5. AUTHOR(S) (Last name, first name, initial) <b>Zorko, F., O'Rourke, R.G., Beaver, W.W.</b>		
6. REPORT DATE <b>October, 1969</b>	7A. TOTAL NO. OF PAGES <b>72</b>	7B. NO. OF PAGES <b>2</b>
8A. CONTRACT OR GRANT NO. <b>AF 33(615)-2223</b>	9A. ORIGINATOR'S REPORT NUMBER(S) <b>BBC-450-248X</b>	
8. PROJECT NO. <b>668A and 190-8</b>	9B. OTHER REPORT NO(S) (Any other numbers that may be assigned this report) <b>AFML-TR-69-263</b>	
10. SECURITY LIMITATION NOTICES <b>"This document is subject to special export controls and each transmittal to foreign governments or foreign nationals may be made only with prior approval of the Air Force Materials Laboratory (MAM), Wright-Patterson Air Force Base, Ohio 45433".</b>		
11. SUPPLEMENTARY NOTES	12. SPONSORING MILITARY ACTIVITY <b>Air Force Materials Laboratory Air Force Systems Command Wright-Patterson AFB, Ohio 45433</b>	
13. ABSTRACT <p>Lamellar composites of beryllium and titanium have been tested by ballistic impact, tensile testing after impact, and impacting while under tensile stress.</p> <p>The titanium cover plates minimize and localize the impact damage to the beryllium core. Use of high strength beryllium sheet to maximize the strength-to-weight ratio of the composite resulted in increased ballistic impact damage. For all types of beryllium utilized, the damage induced by ballistic impact energy levels of 1 ft-lb and greater in specimens while under tensile load, lead to crack propagation throughout the cross-section of the beryllium substrate with a resultant loss in load carrying ability. Therefore future efforts on this composite approach for turbine engine blading is not warranted.</p> <p>The program was aimed at rapid evaluation of composite potential in the one application and materials and techniques were not optimized. Potential in other less demanding areas or armoring was not evaluated.</p> <p>"This document is subject to special export controls and each transmittal to foreign governments or foreign nationals may be made only with prior approval of the Air Force Materials Laboratory (MAM), Wright-Patterson Air Force Base, Ohio 45433".</p>		

DD FORM 1473

UNCLASSIFIED

Security Classification

UNCLASSIFIED

Security Classification

14 KEY WORDS	LINK A		LINK B		LINK C	
	ROLE	WT	ROLE	WT	ROLE	WT
Ballistic Beryllium Lamellar Composites Ti-6 Al-4 V						

INSTRUCTIONS

1. **ORIGINATING ACTIVITY:** Enter the name and address of the contractor, subcontractor, grantee, Department of Defense activity or other organization (corporate author) issuing the report.

2a. **REPORT SECURITY CLASSIFICATION:** Enter the overall security classification of the report. Indicate whether "Restricted Data" is included. Marking is to be in accordance with appropriate security regulations.

2b. **GROUP:** Automatic downgrading is specified in DoD Directive 5200.10 and Armed Forces Industrial Manual. Enter the group number. Also, when applicable, show that optional markings have been used for Group 1 and Group 4 as authorized.

3. **REPORT TITLE:** Enter the complete report title in all capital letters. Titles in all cases should be unclassified. If a meaningful title cannot be selected without classification, show title classification in all capitals in parenthesis immediately following the title.

4. **DESCRIPTIVE NOTES:** If appropriate, enter the type of report, e.g., interim, progress, summary, annual, or final. Give the inclusive dates when a specific reporting period is covered.

5. **AUTHOR(S):** Enter the name(s) of author(s) as shown on or in the report. Enter last name, first name, middle initial. If military, show rank and branch of service. The name of the principal author is an absolute minimum requirement.

6. **REPORT DATE:** Enter the date of the report as day, month, year, or month, year. If more than one date appears on the report, use date of publication.

7a. **TOTAL NUMBER OF PAGES:** The total page count should follow normal pagination procedures, i.e., enter the number of pages containing information.

7b. **NUMBER OF REFERENCES:** Enter the total number of references cited in the report.

8a. **CONTRACT OR GRANT NUMBER:** If appropriate, enter the applicable number of the contract or grant under which the report was written.

8b, c, & 8d. **PROJECT NUMBER:** Enter the appropriate military department identification, such as project number, subproject number, system numbers, task number, etc.

9a. **ORIGINATOR'S REPORT NUMBER(S):** Enter the official report number by which the document will be identified and controlled by the originating activity. This number must be unique to this report.

9b. **OTHER REPORT NUMBER(S):** If the report has been assigned any other report numbers (either by the originator or by the sponsor), also enter this number(s).

10. **AVAILABILITY/LIMITATION NOTICES:** Enter any limitations on further dissemination of the report, other than those

imposed by security classification, using standard statements such as:

- (1) "Qualified requesters may obtain copies of this report from DDC."
- (2) "Foreign announcement and dissemination of this report by DDC is not authorized."
- (3) "U. S. Government agencies may obtain copies of this report directly from DDC. Other qualified DDC users shall request through \_\_\_\_\_."
- (4) "U. S. military agencies may obtain copies of this report directly from DDC. Other qualified users shall request through \_\_\_\_\_."
- (5) "All distribution of this report is controlled. Qualified DDC users shall request through \_\_\_\_\_."

If the report has been furnished to the Office of Technical Services, Department of Commerce, for sale to the public, indicate this fact and enter the price, if known.

11. **SUPPLEMENTARY NOTES:** Use for additional explanatory notes.

12. **SPONSORING MILITARY ACTIVITY:** Enter the name of the departmental project office or laboratory sponsoring (paying for) the research and development. Include address.

13. **ABSTRACT:** Enter an abstract giving a brief and factual summary of the document indicative of the report, even though it may also appear elsewhere in the body of the technical report. If additional space is required, a continuation sheet shall be attached.

It is highly desirable that the abstract of classified reports be unclassified. Each paragraph of the abstract shall end with an indication of the military security classification of the information in the paragraph, represented as (TS), (S), (C), or (U).

There is no limitation on the length of the abstract. However, the suggested length is from 150 to 225 words.

14. **KEY WORDS:** Key words are technically meaningful terms or short phrases that characterize a report and may be used as index entries for cataloging the report. Key words must be selected so that no security classification is required. Identifiers, such as equipment model designation, trade name, military project code name, geographic location, may be used as key words but will be followed by an indication of technical content. The assignment of links, rules, and weights is optional.

UNCLASSIFIED

Security Classification