

UNCLASSIFIED

AD NUMBER
AD871756
NEW LIMITATION CHANGE
TO Approved for public release, distribution unlimited
FROM Distribution: Further dissemination only as directed by Army Missile Research Development and Engineering Lab, Redstone Arsenal, AL; May 1970 or higher DoD authority.
AUTHORITY
USAMC ltr 15 Nov 1972.

THIS PAGE IS UNCLASSIFIED

AD

20

REPORT NO. RD-TR-65-7

# LONGITUDINAL STABILITY CHARACTERISTICS OF A SERIES OF RINGTAIL-BODY COMBINATIONS AT MACH NUMBERS OF 0.8-4.5

by

Charles E. Brazzel  
James H. Henderson  
Joseph C. Craft

May 1970

AD No. — AD871756

DDC FILE COPY

*This document is subject to special export controls  
and each transmittal to foreign governments or foreign  
nationals may be made only with prior approval of this  
Command, ATTN: AMSMI-RD.*



## U.S. ARMY MISSILE COMMAND

Redstone Arsenal, Alabama 35809

DDC  
RECEIVED  
JUL 21 1970  
JWC

82

12 May 1970

Report No. RD-TR-65-7

**LONGITUDINAL STABILITY CHARACTERISTICS  
OF A SERIES OF RINGTAIL-BODY COMBINATIONS  
AT MACH NUMBERS OF 0.8-4.5**

by

**Charles E. Brazzel  
James H. Henderson  
Joseph C. Craft**

**DA Project No. 1S222901A206  
AMC Management Structure Code No. 5221.11.148**

*This document is subject to special export controls  
and each transmittal to foreign governments or foreign  
nationals may be made only with prior approval of this  
Command, ATTN: AMSMI-RD.*

**Aerodynamics Branch  
Advanced Systems Laboratory  
Research and Engineering Directorate  
U. S. Army Missile Command  
Redstone Arsenal, Alabama 35809**

### **Abstract**

An analysis is made of experimentally determined stability characteristics of a series of ringtails in combination with bodies of revolution. Results of the analysis show ringtails to be efficient stabilizing devices, when missile overall diameter is limited.

## Contents

	Page
1. Introduction . . . . .	i
2. Apparatus and Tests . . . . .	1
3. Presentation of Results . . . . .	2
4. Discussion . . . . .	3
5. Conclusions. . . . .	9
 Appendix. Parameters Used in Correlation of Ringtail Supersonic Normal Force . . . . .	 53
 References . . . . .	 71

## Illustrations

Table	Page
I Total Configuration Coefficients . . . . .	11
II Ringtail Coefficients . . . . .	20
A-I Ringtail Correlation Parameters, Definition of Terms . . . . .	54
A-II Critical Mach Numbers for Each Flow Condition, $\delta = 4$ deg . . . . .	55
A-III Critical Betas for Each Flow Condition, $\delta = 4$ deg . . . . .	56
A-IV Ringtail Correlating Parameters. . . . .	57

Figure	Page
1 Body Configurations . . . . .	29
2 Ringtail Geometry, 4-Degree Internal Expansion Angle. . . . .	30
3 Ringtail Geometry, Various Internal Angles . . . . .	31
4 Geometry of Noncircular Support Struts . . . . .	32
5 Model Installation, Transonic Tunnel. . . . .	33
6 Model Installation, Supersonic Tunnel . . . . .	33
7 Variation of Center of Pressure with Mach Number for Some Typical Configurations, $\delta = 4$ deg, $\phi = 4$ deg. . . . .	 34
8 Variation of Mean Value of Ringtail Center of Pressure with Mach Number . . . . .	 35
9 Effect of Ringtail Geometry and Longitudinal Position on the Variation of $\Delta C_{N\alpha}$ with Mach Number, $\delta = 4$ deg, $\phi = 4$ deg . . . . .	 36

### Illustrations (Concluded)

Figure	Page	
10	Effect of Ringtail Internal Angle on $\Delta C_{N_\alpha}$ (Constant Leading Diameter, $A = 2$ ) . . . . .	39
11	Effect of Ringtail Internal Angle on $\Delta C_{N_\alpha}$ (Constant Diameter at Ringtail Midchord) . . . . .	41
12	Effect of Planar Type Support Struts on $\Delta C_{N_\alpha}$ . . . . .	42
13	Afterbody Geometry Effect on Ringtail Contribution to Normal Force, $A = 2$ , $C = 1$ , $\delta = 4$ deg. . . . .	43
14	Effects of Chord, Diameter, and Longitudinal Position on $\Delta C_{N_\alpha}$ of Ringtails, $\delta = 4$ deg. . . . .	44
15	Comparison of Ringtail with Equivalent Planar Fin $\Delta C_{N_\alpha}$ . . . . .	49
16	Correlation of Ringtail $\Delta C_{N_\alpha}$ (Ringtail Leading Edge Mach Line Does Not Impinge Upon Body). . . . .	50
17	Correlation of Ringtail $\Delta C_{N_\alpha}$ (Ringtail Leading Edge Mach Line Impinges Upon Body; Reflected Mach Line Misses Ringtail Surface). . . . .	51
A-1	Ringtail Geometry Nomenclature. . . . .	68
A-2	Flow Conditions. . . . .	69

## Symbols

Text	Tables		
A	A	ringtail diameter in the plane of the leading edge (Figure 2)	calibers
$a_t$		for equivalent planar fins, the slope of the line connecting tip leading edge to root trailing edge divided by the slope of the Mach line	
B		ringtail diameter in the plane of the trailing edge (Figure 2)	calibers
C	C	longitudinal distance between ringtail leading edge and trailing edge (Figure 2)	calibers
$C_N$		normal force/ (qS)	
$C_m$		pitching moment about body nose/ (q SD)	
$C_{N\alpha}$	A1	initial slope of normal force coefficient curve (Table I)	deg <sup>-1</sup>
	A3	nonlinear coefficient of $C_N$ as a function of $\alpha$ (Table I, Equation 1)	deg <sup>-3</sup>
$C_{m\alpha}$	B1	initial slope of pitching moment curve (Table I)	deg <sup>-1</sup>
	B3	nonlinear coefficient for $C_m$ as a function of $\alpha$ (Table I, Equation 2)	deg <sup>-3</sup>
D		body diameter = 1 cal = 1.15 in.	
E	E	longitudinal distance between ringtail trailing edge and the plane of the body base (positive ahead of base) (Figure A-1, Tables A-II and A-III)	calibers

Symbols (Continued)

Text	Tables		
E	E	ratio of value of center of pressure determined from the variation of normal force and pitching moment with angle of attack to the value of center of pressure determined from the variation of pitching moment with normal force (Equation 4, Table I)	
F		diameter of circular cross section strut	calibers
G		longitudinal distance from ringtail leading edge to projection of circular strut centerline on ringtail external surface	calibers
M		Mach number	
q		dynamic pressure	psi
S		reference area, $\pi D^2/4$	cal <sup>2</sup>
$X_{cp}/D$	C1	center of pressure location of total configuration aft of nos. (Table I)	calibers
$X_{cp}/C$	XCP/C	center of pressure location of ringtail fraction of chord from leading edge (Table II, Equation 5)	
$\alpha$		angle of attack in pitch plane	deg
$\beta$		$\sqrt{M^2 - 1}$	
$\Delta C_{N_\alpha}$	A1	$C_{N_\alpha}$ (body with ringtail) — $C_{N_\alpha}$ (body alone) (Table II)	deg <sup>-1</sup>



### Symbols (Concluded)

Text	Tables														
$\Delta C_{m\alpha}$		$C_{m\alpha}^{in}$ (body with ringtail) $C_{m\alpha}^m$ (body alone)	— (Table II) deg <sup>-1</sup>												
$\delta$		angle between the chordline of the ringtail section and model longitudinal axis (centerline)	deg												
$\phi$		angle between outer surface of ringtail at leading edge and model longitudinal axis (centerline)	deg												
<u>Model Nomenclature</u>															
B		body (Figure 1)													
T		ringtail configuration (Figures 2, 3, and 4)													
X		ringtail longitudinal position relative to the body base													
		<table border="0" style="margin: auto;"> <thead> <tr> <th style="border-right: 1px solid black; padding: 5px;"></th> <th style="padding: 5px;">Longitudinal distance, E</th> </tr> </thead> <tbody> <tr> <td style="border-right: 1px solid black; padding: 5px;">X1</td> <td style="padding: 5px;">0.5</td> </tr> <tr> <td style="border-right: 1px solid black; padding: 5px;">X2</td> <td style="padding: 5px;">0.0</td> </tr> <tr> <td style="border-right: 1px solid black; padding: 5px;">X3</td> <td style="padding: 5px;">-0.5</td> </tr> <tr> <td style="border-right: 1px solid black; padding: 5px;">X4</td> <td style="padding: 5px;">-0.9</td> </tr> <tr> <td style="border-right: 1px solid black; padding: 5px;">X5</td> <td style="padding: 5px;">-0.25</td> </tr> </tbody> </table>		Longitudinal distance, E	X1	0.5	X2	0.0	X3	-0.5	X4	-0.9	X5	-0.25	
	Longitudinal distance, E														
X1	0.5														
X2	0.0														
X3	-0.5														
X4	-0.9														
X5	-0.25														
R		ringtail configuration tested aft end forward (for example, T13R)													
S		ringtail configuration with faired support strut (for example, T13S)													

## 1. Introduction

A considerable amount of interest has been shown recently in the use of ringtails as stabilizing surfaces. A part of this interest can be attributed to the need for stabilizer configurations which have the required stability characteristics and which fit within the geometric restraints imposed by stowage or launcher considerations.

Presented is the analysis of stability characteristics on a series of ringtail configurations. The test data used for this analysis was obtained as part of an investigation of base drag reduction by means of favorable interference (such as that induced by ringtails). Before exploring base drag reduction by favorable interference, it appeared reasonable to first insure that ringtails had no undesirable stability characteristics. Tabulated data from these tests have been published previously [1] and an analysis of drag characteristics was presented [2]. Subsequent to completion of the ringtail stability tests an exploratory investigation of the effects of favorable interference on base pressure at supersonic speeds has been made [3].

## 2. Apparatus and Tests

The tests were conducted in the Aerodynamic Wind Tunnel, 1-foot transonic tunnel, Propulsion Wind Tunnel Facility, Arnold Engineering Development Center, Tennessee, and in Supersonic Tunnel No. 1, Ballistic Research Laboratories, Aberdeen Proving Grounds, Maryland. The transonic facility is a continuous flow, nonreturn type with a perforated wall test section 1 foot square in cross section capable of operating at Mach numbers from 0.55 to 1.5 [4]. The supersonic tunnel [5] is a closed-circuit, continuous flow, variable pressure facility with a flexible nozzle for obtaining a range of Mach numbers from 1.5 to 5.0. The test section is 13 inches wide by 15 inches high.

The test bodies of revolution (Figure 1) had a diameter (1 caliber) of 1.15 inch, a 4-caliber ogival nose, and a total length of 10 calibers. The basic body used in the test had a cylindrical afterbody. One configuration was tested with a boattailed afterbody.

The ringtails had a half-diamond profile and were attached to the body either by four posts of circular cross section or four faired support struts. The wind-tunnel model was designed to allow testing each ringtail at several longitudinal positions relative to the body. The configurations tested had an internal expansion angle of 4 degrees and were supported by four circular cross section posts. Chord length, ringtail diameter, and longitudinal position were varied for this group of tests to determine their effect on longitudinal static

stability. The diverging annulus configuration was selected to avoid choking in the ringtail-body annulus and to minimize the effect of support posts on normal force. The geometry of this series of ringtails is presented in Figure 2. Additional ringtail-body configurations were tested to determine the effects of ringtail internal expansion angle (Figure 3), non-circular support struts (Figure 4), and a boattailed afterbody.

The models were sting mounted in the test sections on a six-component internal strain-gage balance. Photographs of the model installed in the transonic and supersonic test sections are shown in Figures 5 and 6, respectively. The investigation was conducted at Reynolds numbers of  $3 \times 10^6$  to  $5 \times 10^6$ , based on model length. The Mach number range was from 0.8 to 4.5 and the angle-of-attack range was from  $-4$  to  $+10$  degrees. A transition strip 0.25 inch wide, located 0.5 inch from the body nose, was used during the tests.

During preliminary analysis difficulties were encountered in reading slopes to an acceptable accuracy. The errors were of the same order of magnitude as the effects of some of the variables being studied. To minimize scatter and uncertainties in the analysis, a least-squares routine was developed to fit a third-order curve through the data points, assuming skew-symmetry through a displaced origin. The routine was mechanized for machine computation to yield initial slopes, third-order effects, displacement from the origin, and an indication of the quality of the curve fit. A discussion of the curve-fitting routine is presented by Adams [6].

### 3. Presentation of Results

Stability coefficients and higher-order effects of angle of attack were generated by the curve fitting routine [6]. Presented in Table I are coefficients representing data for body-ringtail configurations. These coefficients are defined in the following equations:

$$C_N = (A1) \alpha + (A3) \alpha^3 \text{ where } (A1) = C_{N_\alpha} \text{ at } \alpha = 0 \quad (1)$$

$$C_m = (B1) \alpha + (B3) \alpha^3 \text{ where } (B1) = C_{m_\alpha} \text{ at } \alpha = 0 \quad (2)$$

$$C_m = (C1) C_N + (C3) C_N^3 \text{ where } (C1) = X_{cp}/D \text{ at } C_N = 0 \quad (3)$$

Equation (4) is a ratio of center of pressure as determined by equations (1) and (2) divided by center of pressure as determined from equation (3).

$$E = [(B1)/(A1)]/(C1) \approx \left[ \frac{dC_m/d\alpha}{dC_N/d\alpha} \right] / \left( \frac{dC_m}{dC_N} \right) . \quad (4)$$

The experimental data were curve fit to the above equations using the method of least squares. Table II shows the constants determined from these curve fits and represents total configuration minus body alone normal force and pitching moment. Therefore, all interference factors are included. Center of pressure is determined from the resulting force contributions of ringtails. Ringtail normal force,  $\Delta C_{N_\alpha}$ , was determined by subtracting A1 for body alone

from A1 for total configuration. Pitching moment was determined in the same way using B1. Then center of pressure is given by equation (5):

$$X_{cp}/C = \left( -\Delta C_{m_\alpha} / \Delta C_{N_\alpha} \right) (D/C) . \quad (5)$$

The variation of total configuration center of pressure location with Mach number is presented in Figure 7 for several typical body-ringtail combinations. Because of the large amount of scatter noted in center of pressure location,  $X_{cp}/C$ , data in Table II, a mean value at each Mach number was determined by using all data shown. This mean value is presented in Figure 8 as a function of Mach number.

The variation of the ringtail contribution to initial normal coefficient curve slope with Mach number is shown in Figure 9 for the ringtail configurations with circular support struts and an internal expansion angle of 4 degrees (Figure 2). The effect of ringtail internal angle on ringtail normal force,  $\Delta C_{N_\alpha}$ , is shown in Figures 10 and 11. The effect of planar-type supports on  $\Delta C_{N_\alpha}$  is presented in Figure 12. Figure 13 shows the effects of body boattail on ringtail  $\Delta C_{N_\alpha}$  compared to the effects with a cylindrical afterbody.

#### 4. Discussion

##### a. Center of Pressure

The center of pressure on ringtails is expressed in percent chord in equation (5) and tabulated in Table II. As expected, there is a wide variation in the values for a given Mach number. Much of this can be explained from an error analysis of the numerical steps involved in determining center of pressure location,  $X_{cp}/C$ . A small error in A1 or B1 in equations (1) and (2) could be magnified several times in  $X_{cp}/C$ . Some of the scatter no doubt is

due to changing flow conditions with geometry variations; for example, longitudinal position. In order to eliminate the scatter, a mean value for  $X_{cp}/C$  was determined at each Mach number. These mean values, which represent all ringtail configurations, are presented in Figure 8. These values are adequate for engineering estimates of total configuration static stability of ringtail missile configurations. The error resulting from the use of these mean values will be small compared to the moment arm of the ringtail  $\Delta C_{N_\alpha}$ . Ringtail effects on configuration geometry are illustrated then by variations in  $\Delta C_{N_\alpha}$ .

The stabilizing efficiency of ringtails, especially at the higher Mach numbers, compares favorably with that of planar fins. To illustrate this, a line is shown at high Mach numbers on Figure 7 representing  $X_{cp}/D$  for a planar fin. These values show the most stable position possible for a rectangular planar fin with a total span equal to the ringtail maximum diameter. Planar fins are flush with the missile base corresponding to position X2 for ringtails.

#### b. Normal Force Characteristics

As indicated in the previous section, the ringtail contribution to total stability is characterized by variation of  $\Delta C_{N_\alpha}$  with geometric variations. Discussed in the following paragraphs are the variations of  $\Delta C_{N_\alpha}$  with planform geometry and longitudinal position, internal angle of ringtail, support strut profile, and body boattail.

(1) Planform Geometry and Longitudinal Position. Values of  $\Delta C_{N_\alpha}$  for the series of ringtails having a 4-degree internal expansion angle,  $\delta$ , and support struts of circular cross section have been cross-plotted to yield the carpet plots presented in Figure 14. These plots are convenient for design purposes since they show the effects of chord, leading edge diameter, and longitudinal position on  $\Delta C_{N_\alpha}$ . It is obvious that additional lift is obtainable with ringtails by increasing either the chord or the diameter. This is analogous to the results of planar fins. Where boundary layer thickness is large compared to the distance between the ringtail and body, an increase in chord length will not necessarily produce additional normal force. This is comparable to low-aspect ratio planar fins.

Evaluation of the supersonic lifting efficiency of ringtails was made by comparing planar fins having equal chords and having total spans equal to ring

maximum diameter. Ringtail configurations have a 4-degree internal expansion and at longitudinal positions with the trailing edge flush with the base (position X2) were used in the comparison. Planar fin normal force and fin-body interference were determined by the method of Gafarian [7].

A convenient way of presenting the comparison between ringtails and planar fins is by the use of the parameter  $a_t$ , which is the ratio of the slope of the line connecting the equivalent planar fin leading edge tip and root trailing edge to the Mach line slope. The variation with  $a_t$  of ringtail  $\Delta C_{N_\alpha}$  to planar fin  $C_{N_\alpha}$  ratio (which includes fin-body interference) is shown in Figure 15.

This ratio varies from about 1.3 to 2.0. The minimum values of the normal force ratio occurs at approximately the same value of  $a_t$  for the various configurations.

The ringtail leading edge Mach line (Figure 15) would intersect with the body base at an  $a_t$  of 1.0 for a hypothetical ringtail having a 0-degree internal expansion angle. For the actual configurations compared, Mach line impingement occurs at values of  $a_t$  slightly above 1 and the reflected Mach line impinges the ringtail trailing edge at values of  $a_t$  slightly above 0.5. With decreasing values of  $a_t$ , it appears that the minimum value of normal force ratio occurs at an  $a_t$  between the leading edge Mach line impingement on the body and the impingement of the reflected Mach line at ring trailing edge.

The strong similarity in the variation of normal force ratio with  $a_t$  for such a wide variation in geometry and Mach number suggests that supersonic linearized planar wing theory may be useful in the analysis of ringtail aerodynamics.

Examination of Figure 9 indicates that ringtail longitudinal position has a major effect on the variation of  $\Delta C_{N_\alpha}$  with Mach number for the various configurations. There is a relationship between  $\Delta C_{N_\alpha}$  and the Mach number of ringtail Mach line impingement upon the body. For example, in Figure 9 (configuration T4) the values of  $\Delta C_{N_\alpha}$  for ringtail positions X1 and X2 depart from the data for position X3 as Mach number is decreased. The points of departure appear to be at a slightly higher Mach number than where Mach line impingement occurs. If boundary layer and strut effects were accounted for,

it is possible that the point of departure relative to the Mach line location could be predicted. These effects are also noticeable in Figure 14 for Mach numbers of 2.5 and 3.0 where on the left side of the plot no effect of longitudinal position on  $\Delta C_{N_\alpha}$  is apparent.

It is also apparent from Figure 9f that  $\Delta C_{N_\alpha}$  is affected by the body base expansion wave. The data for position X4 (most rearward position) depart from the X3 data as Mach number is decreased.

As Mach number is further decreased, the reflected Mach line impinges upon the ringtail trailing edge resulting in a recovery of  $\Delta C_{N_\alpha}$ . This recovery is indicated in Figure 9d for configuration T2X1 and T2X2. For the rearward longitudinal position (X3) no recovery in  $\Delta C_{N_\alpha}$  is apparent. This is likely to the effect of the body expansion wave.

In general, the position of Mach lines emanating from the ringtail leading edge and their reflections from the body in relation to the body base and ringtail trailing edge results in an oscillatory variation of  $\Delta C_{N_\alpha}$  with Mach number as indicated by Ehlers [8,9].

The appendix has been prepared to define various flow conditions and to indicate the Mach numbers corresponding to these for the various ringtail configurations. The flow conditions considered are:

- 1) Ringtail leading edge Mach line impingement on body base

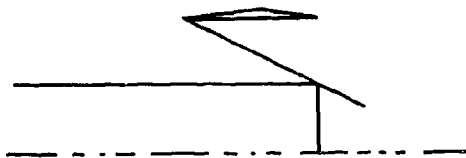

- 2) Ringtail leading edge Mach line impingement on ringtail trailing edge after reflection on body

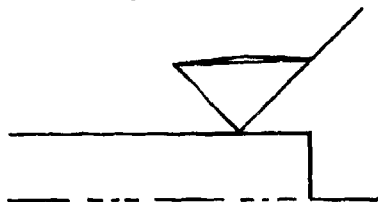

- 3) Body base Mach line impingement on ringtail trailing edge

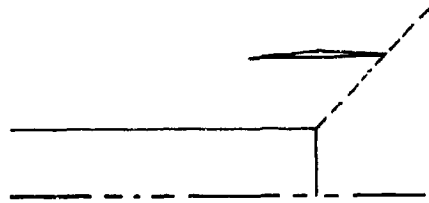

- 4) Ringtail leading edge Mach line reflection from body surface and impingement on the ringtail inner surface concurrently with impingement on body base.

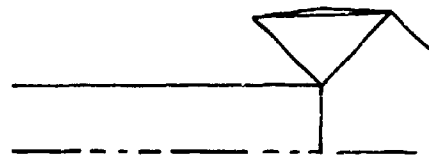

- 5) Ringtail leading edge Mach line impingement on body base after reflection from body and ringtail inner surface

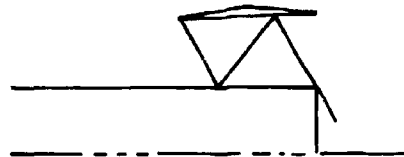

The effects of conditions 4 and 5 on ringtail normal force characteristics are not apparent in Figure 9. The small Mach number increment between conditions for particular configurations, the occurrence of more than one condition at the same Mach number, and the fact that these conditions occur in the transonic region complicates any analysis of normal force characteristics where multiple Mach line reflections occur. The oscillations are to be expected because of the many interactions.

An attempt was made to correlate ringtail normal force for the various ringtail configurations having an internal expansion angle of 4 degrees. It was found that a reasonable correlation could be found for Mach numbers higher than the value for Mach line impingement on the body (condition 1). A second correlation was obtained at Mach numbers between the impingement of the leading edge Mach line on the body base and the reflection of this Mach line on the ringtail trailing edge (between conditions 1 and 2). No data were included in either correlation for the condition where the body base Mach line (expansion of flow



around base) impinged on the ringtail inner surface. The coefficients used in the two correlations and a summary of Mach numbers corresponding to each condition are tabulated in the appendix.

The correlation of Mach numbers higher than condition 1 is presented in

Figure 16. The correlating terms are  $\frac{\Delta C_{N\alpha}}{B^2-1}$  which represent normal force based on ringtail trailing edge body base annulus area [8, 10] and  $\beta \frac{A}{C}$  which is the geometric relationship of the leading edge Mach line to the body base. Data that do not correlate well are generally for the smallest ringtail diameter configurations where boundary layer effects are more pronounced. For this correlation, it appears that the position of the ringtail trailing edge with respect to the body base has little effect as long as the body base expansion wave is avoided.

Normal force also correlates well using the parameter  $\frac{\Delta C_{N\alpha}}{A^2-1}$  which bases normal force on the annulus area at ringtail leading edge. This parameter is also tabulated in the appendix.

The second correlation of  $\Delta C_{N\alpha}$  is presented in Figure 17. This correlation represents Mach numbers below where the leading edge Mach line impinges on the body base and Mach numbers above the impingement of the reflected Mach line of the ringtail trailing edge (between condition 1 and condition 2). As in the case of the first correlation, conditions were avoided where the base expansion interferes with the ringtail. The ordinate in Figure 17 is the same as for the first correlation except that it has been multiplied by ringtail leading edge diameter to chord ratio  $\frac{A}{C}$ .

The abscissa in Figure 17 is the product of the slope of the leading edge Mach lines at critical conditions 1 and 2 each normalized by the Mach line slope (appendix, Figure A-2).

Correlation of flow regimes having multiple reflections of the leading edge Mach line may be possible. However, for the present investigation, the large increments in Mach number and longitudinal position did not provide sufficient data points. Using critical Mach numbers in Table A-2 enables one to trace the oscillations due to multiple reflections, but no general expression was found to describe this region.

(2) Ringtail Internal Angle. Shown in Figure 1 are the effects of internal angle on  $\Delta C_{N\alpha}$  for various ringtail longitudinal positions. (It should

be noted that configuration T7 has the same ringtail cross section as configuration T4 but has been rotated to give a zero internal angle). In general, increasing internal angle increases the supersonic  $\Delta C_{N\alpha}$  for the most forward ringtail

location (X1). This effect is less pronounced as the ringtail moves aft. The effect of internal angle on  $\Delta C_{N\alpha}$  for configurations T13, T13R, and T14 are

shown in Figure 11 for several longitudinal positions. T14 is configuration T13 rotated to zero internal angle and T13R is T13 mounted onto the body backward. The configurations with the converging ringtail-body annulus (T13R) have choked flow resulting in a negative slope of  $\Delta C_{N\alpha}$ .

(3) Support Strut Profile. Circular support struts were used in the investigation of ringtail geometry effects to minimize the strut normal force contribution. Two configurations T8S and T13S were investigated with noncircular supports. Support strut geometry is shown in Figure 4. The incremental strut effects on  $\Delta C_{N\alpha}$  for these configurations are shown in Figures 12a and 12b. Strut effects on  $\Delta C_{N\alpha}$  for the smaller diameter ringtail configuration (T13, T13S) are negligible.

One configuration geometrically similar to ringtail T1 with a noncircular strut was tested on a cylindrical afterbody in the Langley Unitary tunnel and Cornell 8-foot Transonic Tunnel as a part of another investigation. This configuration (T1F) is compared to ringtail T1X3 of the present investigation in Figure 12c. Geometry of ringtail, T1F, is presented in the same figure. The variation of  $\Delta C_{N\alpha}$  with Mach number shows similar trends for both configurations.

(4) Boattail Effects. The effect of boattailing the afterbody on  $\Delta C_{N\alpha}$  is shown in Figure 13 for configuration T4 for the various longitudinal positions. The boattail effect on  $\Delta C_{N\alpha}$  is small and dependent upon ringtail longitudinal position.

## 5. Conclusions

The results of an investigation of a parametric series of ringtails in combination with bodies of revolution lead to the following conclusions:

- 1) The ringtail is an efficient stabilizing device especially where a total span limitation is imposed by launchers and stowage considerations.

- 2) No undesirable stability characteristics are apparent in the present results except for configurations where the annulus between the ringtail and body is smaller at the trailing edge than at the leading edge. However, these results are applicable only to coasting stages or low acceleration regimes. Missiles with moderate to high acceleration rates may show detrimental effects on stability induced by the jet plume to be larger on ringtails than on comparable planar fins.
- 3) It appears that ringtail supersonic normal force can be correlated by simple parameters suggested by linear theory.

TABLE I. TOTAL CONFIGURATION COEFFICIENTS

CONFIG	HN	A1	B1	C1	A3	B3	C3	E
BIT1X1	.80	.07859	-.7214	-3.828	.000177	-.00188	-.60345	.997
BIT1X1	.90	.07859	-.7214	-3.828	.000401	-.00359	-1.16310	.984
BIT1X1	.95	.09074	-.6504	-6.185	.000221	-.00172	-.29530	.998
BIT1X1	1.00	.09872	-.6107	-6.285	.000055	-.00039	-.04174	1.022
BIT1X1	1.05	.08464	-.6007	-5.930	.000231	-.00180	-.48678	.997
BIT1X1	1.10	.07879	-.4385	-5.600	.000263	-.00216	-.84063	.993
BIT1X1	1.20	.04861	-.7233	-6.087	.000020	-.00028	1.48930	2.444
BIT1X1	1.30	.09303	-.5491	-5.986	.000070	-.00031	-.10837	.986
BIT1X1	1.40	.08670	-.4847	-5.594	.000201	-.00138	-.28581	.999
BIT1X1	1.75	.08056	-.4109	-5.114	.000226	-.00162	-.63191	.997
BIT1X1	2.00	.07658	-.4903	-4.903	.000139	-.00088	-.36788	.999
BIT1X1	2.50	.07650	-.3682	-4.779	.000167	-.00085	-.10426	1.001
BIT1X1	3.00	.07618	-.3427	-4.322	.000289	-.00201	-1.04425	.994
BIT1X1	4.00	.07894	-.3694	-4.701	.000351	-.00230	-.80949	.995
BIT1X1	4.50	.08039	-.3864	-4.820	.000333	-.00218	-.73564	.997
BIT1X2	.80	.08849	-.5534	-6.235	.000134	-.00090	-.02945	1.002
BIT1X2	.90	.09298	-.6033	-6.522	.000330	-.00303	-.66567	.994
BIT1X2	.95	.08245	-.5037	-6.057	.000175	-.00151	-.26192	1.008
BIT1X2	1.00	.09032	-.5823	-6.450	.000159	-.00119	-.17805	.999
BIT1X2	1.05	.09238	-.6030	-6.516	.000175	-.00127	-.12740	1.001
BIT1X2	1.10	.10278	-.6719	-6.498	-.000129	.00080	-.05052	1.005
BIT1X2	1.20	.09849	-.6487	-6.590	.000113	-.00064	.09412	.998
BIT1X2	1.30	.08971	-.4808	-6.705	.000233	-.00073	.36981	1.026
BIT1X2	1.40	.08984	-.4708	-6.400	.000118	-.00060	-.10554	.958
BIT1X2	1.75	.08849	-.4266	-5.870	.000242	-.00176	-.34231	.998
BIT1X2	2.00	.08742	-.4239	-5.671	.000111	-.00049	.18229	.998
BIT1X2	2.50	.08742	-.4239	-5.671	.000188	-.00096	-.06954	1.000
BIT1X2	3.00	.08742	-.4239	-5.671	.000232	-.00161	-.48203	.998
BIT1X2	4.00	.08932	-.4093	-5.019	.000363	-.00237	-.62239	.996
BIT1X2	4.50	.08922	-.4013	-5.026	.000424	-.00278	-.72980	.995
BIT1X3	.80	.07718	-.6184	-6.672	.000062	-.00046	-.06020	1.000
BIT1X3	.90	.07718	-.6400	-6.400	.000412	-.00399	-1.05732	.985
BIT1X3	.95	.07718	-.4440	-6.198	.000217	-.00282	-.103696	.992
BIT1X3	1.00	.07718	-.4414	-6.002	.000291	-.00262	-.123388	.994
BIT1X3	1.05	.07718	-.4570	-6.029	.000171	-.00136	-.51785	.997
BIT1X3	1.10	.07718	-.4570	-6.029	.000217	-.00181	-.88806	.998
BIT1X3	1.20	.07718	-.4570	-6.029	.000518	-.00160	-.37334	.998
BIT1X3	1.30	.07718	-.4570	-6.029	.000184	-.00140	-.21787	.997
BIT1X3	1.40	.07718	-.4570	-6.029	.000145	-.00080	.13608	.989
BIT1X3	1.75	.07718	-.4570	-6.029	.000138	-.00078	.10616	.999
BIT1X3	2.00	.07718	-.4570	-6.029	.000119	-.00062	.12850	1.000
BIT1X3	2.50	.07718	-.4570	-6.029	.000208	-.00117	-.02380	.998
BIT1X3	3.00	.07718	-.4570	-6.029	.000384	-.00168	-.24554	.999
BIT1X3	4.00	.07718	-.4570	-6.029	.000384	-.00225	-.45483	.998
BIT1X3	4.50	.07718	-.4570	-6.029	.000380	-.00232	-.35504	1.001
BIT1X3	.80	.07718	-.4570	-6.029	.000413	-.00365	-1.12695	.990
BIT1X3	.90	.07718	-.4570	-6.029	.000273	-.00325	-.35686	.994
BIT1X3	.95	.07718	-.4570	-6.029	.000273	-.00240	-.14145	.991
BIT1X3	1.00	.07718	-.4570	-6.029	.000213	-.00186	-.32457	.998
BIT1X3	1.05	.07718	-.4570	-6.029	.000018	-.00007	-.10980	1.002
BIT1X3	1.10	.07718	-1.0180	-6.747	.000024	.00004	.12990	1.293
BIT1X3	1.20	.07718	-.6222	-6.222	.000256	-.00206	-.25021	.997
BIT1X3	1.30	.07718	-.7125	-6.245	.000114	-.00085	-.06867	.999
BIT1X3	1.40	.07718	-.6222	-6.222	.000130	-.00081	-.01123	1.001
BIT1X3	2.00	.07718	-.6222	-6.222	-.000039	.00092	.65299	.994
BIT1X3	2.50	.08867	-.4618	-5.214	.000239	-.00160	-.37423	.998
BIT1X3	3.00	.08902	-.4486	-5.043	.000210	-.00138	-.35676	.999
BIT1X3	4.00	.08445	-.4305	-4.989	.000362	-.00256	-.75910	.995
BIT1X3	4.50	.08473	-.4417	-5.108	.000388	-.00254	-.55307	.996
BIT2X2	.80	.09283	-.5777	-6.275	.000330	-.00317	-.75505	.994
BIT2X2	.90	.09283	-.5777	-6.275	.000719	-.00679	-.62134	.988
BIT2X2	.95	.09283	-.5777	-6.275	.000416	-.00371	-.64408	.980
BIT2X2	1.00	.10321	-.5084	-6.147	.000466	-.00420	-.74273	.981
BIT2X2	1.05	.10321	-.7047	-6.695	.000137	-.00117	-.07894	1.000
BIT2X2	1.10	.12432	-.8814	-7.041	.000050	.00008	.21537	1.005
BIT2X2	1.20	.13165	-.9389	-7.160	-.000065	.00166	.59775	.996
BIT2X2	1.30	.12252	-.8442	-6.900	-.000049	.00115	.45638	.999
BIT2X2	2.00	.11224	-.7305	-6.241	-.000011	.00090	.58363	.983
BIT2X2	2.50	.09459	-.5447	-5.773	.000304	-.00217	-.33129	.998
BIT2X2	3.00	.09319	-.5107	-5.483	.000226	-.00150	-.24849	.999
BIT2X2	4.00	.09073	-.4871	-5.386	.000366	-.00259	-.55381	.997
BIT2X2	4.50	.08930	-.4818	-5.407	.000413	-.00275	-.45172	.997

TABLE I. TOTAL CONFIGURATION COEFFICIENTS (Continued)

CONFIG	MN	A1	B1	C1	A2	B2	C2	Z
B1T2X3	.80	.09407	-.6181	-6.602	.000332	-.00297	-.56411	.995
B1T2X3	.90	.09789	-.6642	-6.880	.006778	-.00765	-1.08788	.986
B1T2X3	.95	.08335	-.5417	-6.417	.000360	-.00348	-.97014	.986
B1T2X3	1.00	.10209	-.7024	-7.011	.000089	-.00037	.5046	.982
B1T2X3	1.05	.10465	-.7404	-7.076	.000105	-.00054	.5883	.999
B1T2X3	1.10	.10043	-.6934	-6.910	.000221	-.00177	-.16718	.999
B1T2X3	1.30	.12008	-.9622	-7.319	.000637	-.00622	-.68838	1.034
B1T2X3	1.50	.12438	-.9152	-7.290	.000087	-.00044	-.08028	.993
B1T2X3	1.75	.12256	-.8901	-7.228	.000016	-.00070	-.43376	1.004
B1T2X3	2.00	.11286	-.7768	-6.879	.000142	-.00043	.32754	1.000
B1T2X3	2.50	.10497	-.6770	-6.445	.000208	-.00101	.23193	1.000
B1T2X3	3.00	.04534	-.8466	-6.191	.000170	-.00073	-.22873	1.000
B1T2X3	4.00	.02340	-.5312	-5.101	.000372	-.00268	-.42862	.997
B1T2X3	4.50	.09035	-.5093	-5.650	.000434	-.00290	-.35419	.997
B1T3X1	.80	.24112	-1.7891	-7.444	-.000728	.00691	.16362	.996
B1T3X1	.90	.30615	-2.4253	-7.966	-.000919	.00908	-.11111	.994
B1T3X1	.95	.19095	-1.3598	-7.139	-.000544	-.00481	-.04967	.997
B1T3X1	1.00	.26940	-2.0792	-7.727	-.000381	.00378	-.05443	.998
B1T3X1	1.05	.31286	-2.5047	-8.037	-.000638	.00633	.06503	.996
B1T3X1	1.10	.29527	-2.3383	-7.934	-.000366	.00383	.04823	.998
B1T3X1	1.30	.30753	-2.3026	-7.540	-.002238	.01461	-.00562	.992
B1T3X1	1.50	.23319	-1.7632	-7.565	.000329	-.00190	.03708	.999
B1T3X1	1.75	.20825	-1.5216	-7.312	.000317	-.00211	.02080	.999
B1T3X1	2.00	.18684	-1.3197	-7.065	.000165	-.00077	.05412	.999
B1T3X1	2.50	.16141	-1.0767	-6.680	.000189	-.00111	.03071	.998
B1T3X1	3.00	.15285	-.9922	-6.499	.000245	-.00138	.05126	.998
B1T3X1	4.00	.14002	-.8418	-6.374	.000324	-.00189	.05102	.999
B1T3X1	4.50	.13760	-.8845	-6.421	.000302	-.00159	.10015	1.000
B1T3X2	.80	.23210	-1.8008	-7.769	-.000558	.00532	.10638	.998
B1T3X2	.90	.30369	-2.5380	-8.299	-.000748	.00785	-.08988	.998
B1T3X2	.95	.18760	-1.4114	-7.860	.000076	-.00798	-.10829	.995
B1T3X2	1.00	.22330	-1.7984	-7.897	-.000130	-.00079	.01724	.997
B1T3X2	1.05	.27218	-2.2138	-8.172	-.000687	.00632	-.04796	.995
B1T3X2	1.10	.26566	-2.1642	-8.150	-.000082	.00125	.03379	.999
B1T3X2	1.30	.32747	-2.5681	-8.373	-.002593	.01736	.04247	.951
B1T3X2	1.50	.24900	-2.0349	-8.041	.000038	-.00028	.03566	1.016
B1T3X2	1.75	.21466	-1.6897	-7.780	.000350	-.00235	.01290	.999
B1T3X2	2.00	.19283	-1.4527	-7.543	.000208	-.00110	.05751	.998
B1T3X2	2.50	.17241	-1.2455	-7.227	.000187	-.00085	.08578	.999
B1T3X2	3.00	.16937	-1.0988	-7.148	.000107	-.00001	.14039	.907
B1T3X2	4.00	.15062	-1.0431	-6.921	.000284	-.00143	.12393	1.000
B1T3X2	4.50	.14317	-.9803	-6.052	.000342	-.00160	.19616	.999
B1T3X3	.80	.21715	-1.6702	-8.000	-.000025	.00060	.04346	.961
B1T3X3	.90	.28827	-2.5103	-8.729	-.000598	.00672	.09003	.997
B1T3X3	.95	.23060	-1.9350	-8.390	.000257	-.00185	.02148	1.000
B1T3X3	1.00	.22849	-1.9168	-8.396	.000193	-.00110	.03876	.999
B1T3X3	1.05	.23105	-2.0860	-8.427	.000054	.00012	.04043	1.071
B1T3X3	1.10	.24644	-2.2861	-8.478	.000054	.00003	.03309	1.094
B1T3X3	1.30	.28689	-2.4992	-8.826	-.000094	.00173	.04627	.993
B1T3X3	1.50	.23244	-2.2181	-8.303	.000124	-.00049	.03892	1.030
B1T3X3	1.75	.23280	-1.9399	-8.340	.000319	-.00224	.02918	.999
B1T3X3	2.00	.22397	-1.8419	-8.235	-.000040	.00145	.10096	.998
B1T3X3	2.50	.19495	-1.5488	-7.918	.000060	-.00054	.13194	1.003
B1T3X3	3.00	.17721	-1.3481	-7.635	.000179	-.00046	.14292	.996
B1T3X3	4.00	.15165	-1.1024	-7.268	.000291	-.00120	.21223	1.000
B1T3X3	4.50	.14497	-1.0362	-7.156	.000264	-.00108	.21668	.998
B1T4X1	.80	.18059	-1.3246	-7.338	.000057	-.00034	-.01227	.999
B1T4X1	.90	.18905	-1.4170	-7.526	.000767	-.00683	-.08219	.995
B1T4X1	.95	.20467	-1.5683	-7.670	-.000331	.00325	.10153	.999
B1T4X1	1.00	.24346	-1.9415	-7.980	-.000205	.00204	.03893	.999
B1T4X1	1.05	.23625	-1.8841	-7.987	-.000335	.00357	.08827	.998
B1T4X1	1.10	.22500	-1.7733	-7.897	-.000333	.00367	.12311	.997
B1T4X1	1.30	.20982	-1.5914	-7.596	-.000125	.00159	.06479	.998
B1T4X1	1.50	.17977	-1.3151	-7.337	.000096	-.00041	.04545	.997
B1T4X1	1.75	.15275	-1.0660	-6.992	.000260	-.00175	.18848	.998
B1T4X1	2.00	.13783	-.9209	-6.680	.000198	-.00103	.09576	1.000
B1T4X1	2.50	.12951	-.8318	-6.425	.000225	-.00126	.07115	.999
B1T4X1	3.00	.12762	-.8005	-6.272	.000196	-.00114	.03446	1.000
B1T4X1	4.00	.11950	-.7368	-6.171	.000316	-.00190	.01790	.999
B1T4X1	4.50	.11552	-.7126	-6.164	.000369	-.00207	.08956	1.000
B1T4X2	.80	.20654	-1.5978	-7.613	-.000197	.00152	-.00130	1.016
B1T4X2	.90	.21258	-1.7228	-8.108	.000408	-.00353	-.01586	.999
B1T4X2	.95	.16140	-1.2168	-7.602	.000799	-.00764	-.16561	.991
B1T4X2	1.00	.28228	-2.4349	-8.269	-.000006	.00007	.00923	1.043
B1T4X2	1.05	.22398	-1.8139	-8.183	-.0001025	.00901	.07676	.989

TABLE I. TOTAL CONFIGURATION COEFFICIENTS (Continued)

CONFIG	HN	A1	B1	C1	A3	B3	C3	E
B1T4X2	1.10	.21407	-2.2573	-10.656	-.000175	.03620	3.85507	.989
B1T4X2	1.20	.22304	-2.3276	-10.702	-.000322	.03710	3.71409	.975
B1T4X2	1.30	.22395	-1.8206	-8.163	-.000154	-.00210	-.08921	.998
B1T4X2	1.50	.18478	-1.4385	-7.769	.000331	-.00271	-.01521	1.000
B1T4X2	1.75	.16261	-1.2222	-7.527	.000313	-.00229	.01444	.997
B1T4X2	2.00	.15650	-1.1620	-7.390	.000077	.00012	.17162	1.004
B1T4X2	2.50	.14784	-1.0599	-7.184	.000161	-.00046	.18678	.997
B1T4X2	3.00	.13891	-.9543	-6.874	.000150	-.00053	.16297	.999
B1T4X2	4.00	.12254	-.7991	-6.522	.000272	-.00143	.13998	.999
B1T4X2	4.50	.11719	-.7573	-6.454	.000397	-.00217	.16672	1.001
B1T4X3	.80	.18677	-1.5196	-8.135	.000267	-.00245	-.03640	1.000
B1T4X3	.90	.22957	-1.9633	-8.365	.000230	-.00207	-.00387	1.022
B1T4X3	.95	.16628	-1.3248	-7.988	.000579	-.00557	-.12724	.997
B1T4X3	1.00	.17614	-1.4226	-8.084	.000328	-.00314	-.06453	.999
B1T4X3	1.05	.18506	-1.5225	-8.229	.000404	-.00349	-.01921	.999
B1T4X3	1.10	.18941	-1.5871	-8.384	.000623	-.00499	-.02605	.999
B1T4X3	1.20	.23062	-1.9444	-8.293	-.001008	-.00918	.02663	.992
B1T4X3	1.30	.23080	-1.9783	-8.589	-.000051	.00110	.05973	.997
B1T4X3	1.50	.20741	-1.8230	-8.442	.000028	.00032	.05378	1.041
B1T4X3	1.75	.18479	-1.5118	-8.180	.000173	-.00080	.08781	1.000
B1T4X3	2.00	.16926	-1.3416	-7.955	.000129	-.00025	.14640	.996
B1T4X3	2.50	.15187	-1.1507	-7.585	.000181	-.00065	.18042	.998
B1T4X3	3.00	.13841	-.9967	-7.202	.000213	-.00091	.19666	.998
B1T4X3	4.00	.12372	-.8423	-6.805	.000232	-.00097	.25054	1.000
B1T4X3	4.50	.11895	-.8006	-6.745	.000235	-.00081	.36392	.997
B1T4X4	.80	.16928	-1.3933	-8.237	.000401	-.00390	-.08879	.999
B1T4X4	.90	.20849	-1.8162	-8.707	.000645	-.00842	-.06319	1.000
B1T4X4	.95	.14975	-1.1883	-8.016	.000829	-.00847	-.27096	.992
B1T4X4	1.00	.15532	-1.2574	-8.133	.000696	-.00702	-.19962	.995
B1T4X4	1.05	.19060	-1.6354	-8.603	-.000074	.00140	.12588	.997
B1T4X4	1.10	.18361	-1.5583	-8.515	.000208	-.00176	.00059	.996
B1T4X4	1.20	.18990	-1.5896	-8.493	.000053	-.00026	.02511	.990
B1T4X4	1.30	.19735	-1.7012	-8.623	.000118	-.00063	.04567	.999
B1T4X4	1.50	.18757	-1.5892	-8.473	.000141	-.00091	.03710	.999
B1T4X4	1.75	.16134	-1.3373	-8.278	.000206	-.00121	.08941	1.001
B1T4X4	2.50	.13928	-1.0797	-7.729	.000228	-.00106	.16957	1.003
B1T4X4	3.00	.13042	-.9667	-7.387	.000267	-.00135	.16485	1.003
B1T5X1	.80	.14674	-1.0692	-7.288	.000196	-.00166	-.05768	.999
B1T5X1	.90	.13613	-.9681	-7.122	.000332	-.00293	-.15700	.998
B1T5X1	.95	.16260	-1.2173	-7.628	.000175	-.00338	-.03655	.981
B1T5X1	1.00	.14784	-1.0920	-7.490	.000274	-.00233	-.08857	.993
B1T5X1	1.05	.12874	-.9056	-7.053	.000339	-.00300	-.18171	.997
B1T5X1	1.10	.12475	-.8612	-6.919	.000326	-.00287	-.20799	.997
B1T5X1	1.30	.13712	-.9665	-7.047	.000072	-.00028	-.07963	1.000
B1T5X1	1.50	.11996	-.7956	-6.637	.000256	-.00184	-.05243	.999
B1T5X1	1.75	.10899	-.6843	-6.314	.000185	-.00107	-.06340	1.000
B1T5X1	2.00	.10375	-.6309	-6.078	.000206	-.00126	-.00240	1.000
B1T5X1	2.50	.10754	-.6550	-6.086	.000133	-.00048	.22187	.999
B1T5X1	3.00	.10327	-.5989	-5.799	.000238	-.00143	-.03180	.999
B1T5X1	4.00	.09856	-.5538	-5.623	.000294	-.00191	-.18888	.999
B1T5X1	4.50	.09696	-.5464	-5.790	.000295	-.00164	.02474	.973
B1T5X2	.80	.15498	-1.2011	-7.751	.000268	-.00226	-.04005	.999
B1T5X2	.90	.13742	-1.0532	-7.663	.000647	-.00534	-.09253	1.000
B1T5X2	.95	.15946	-1.2495	-7.837	.000114	-.00084	-.01279	.999
B1T5X2	1.00	.15198	-1.1804	-7.766	.000248	-.00200	-.01359	1.000
B1T5X2	1.05	.14392	-1.0989	-7.641	.000248	-.00216	-.06457	.999
B1T5X2	1.10	.14192	-1.0767	-7.592	.000292	-.00245	-.05837	.999
B1T5X2	1.20	.14782	-1.1266	-7.641	.000217	-.00164	.08517	.997
B1T5X2	1.30	.15731	-1.1582	-7.766	.000049	-.00003	.08872	.948
B1T5X2	1.50	.13243	-.9666	-7.267	.000251	-.00197	-.02203	1.004
B1T5X2	1.75	.12702	-.9069	-7.140	.000174	-.00092	.13650	.999
B1T5X2	2.00	.12144	-.8446	-6.957	.000216	-.00117	.15593	.999
B1T5X2	2.50	.11365	-.7500	-6.603	.000169	-.00058	.31037	.999
B1T5X2	3.00	.10562	-.6509	-6.163	.000251	-.00139	.10603	.999
B1T5X2	4.00	.09880	-.5797	-5.934	.000301	-.00175	.00880	.988
B1T5X2	4.50	.09758	-.5680	-5.992	.000282	-.00161	.01583	.971
B1T5X3	.80	.16523	-1.9127	-11.301	.000139	.04054	8.19931	1.024
B1T5X3	.90	.14066	-1.1103	-7.915	.000418	-.00408	-.16807	.997
B1T5X3	.95	.14649	-1.1829	-8.062	.000520	-.00446	-.06026	1.001
B1T5X3	1.00	.15321	-1.2468	-8.121	.000173	-.00145	-.00953	1.002
B1T5X3	1.05	.14388	-1.1519	-8.006	.000200	-.00167	-.01795	1.000

TABLE I. TOTAL CONFIGURATION COEFFICIENTS (Continued)

CONFIG	M1	A1	B1	L1	A3	B3	C3	F
B1T5X3	1.10	.14229	-1.1322	-7.957	.000225	-.00168	.03240	1.000
B1T5X3	1.20	.14915	-1.1626	-8.000	.000046	-.00004	.09145	.974
B1T5X3	1.30	.14912	-1.1938	-8.024	.000085	-.00034	.04509	.997
B1T5X3	1.50	.14379	-1.1182	-7.820	.000073	-.00015	.12358	.994
B1T5X3	1.75	.13138	-.9939	-7.566	.000214	-.00125	.13880	.999
B1T5X3	2.00	.12668	-.8957	-7.300	.000229	-.00132	.15588	1.000
B1T5X3	2.50	.11322	-.7760	-6.855	.000185	-.00073	.30761	.999
B1T5X3	3.00	.10650	-.6629	-6.413	.000206	-.00101	.20469	.999
B1T5X3	4.00	.09887	-.6043	-6.116	.000308	-.00171	.09960	.999
B1T5X3	4.50	.09783	-.5919	-6.044	.000326	-.00181	.10589	1.001
B2T6X1	.80	.17615	-1.2857	-7.653	.000137	-.00099	.00011	.953
B2T6X1	.90	.18058	-1.3387	-7.450	.000532	-.00459	-.06470	.997
B2T6X1	.95	.18058	-1.3289	-7.316	.000370	-.00323	-.04088	1.005
B2T6X1	1.00	.20503	-1.3812	-7.128	.000800	-.00727	-.07731	.997
B2T6X1	1.05	.21066	-1.6347	-7.775	.000395	-.00305	-.01879	1.001
B2T6X1	1.10	.20450	-1.5707	-7.812	.000160	-.00112	.01431	.983
B2T6X1	1.30	.20263	-2.1027	-7.588	.000042	-.00003	.04290	1.367
B2T6X1	1.50	.17909	-1.3034	-7.318	.000188	-.00134	.00124	.994
B2T6X1	1.75	.13110	-1.0477	-6.939	.000181	-.00107	.04917	.999
B2T6X1	2.00	.13914	-.9314	-6.693	.000224	-.00132	.05519	.999
B2T6X1	2.50	.13178	-.8455	-6.419	.000223	-.00138	.01680	.999
B2T6X1	3.00	.12897	-.8183	-6.343	.000172	-.00085	.09379	1.000
B2T6X1	4.00	.11844	-.7250	-6.127	.000280	-.00159	.05615	.999
B2T6X1	4.50	.11430	-.6935	-5.076	.000304	-.00171	.06701	.998
B2T6X2	.80	.17347	-1.2999	-7.756	.000041	-.00009	.03914	.966
B2T6X2	.90	.16517	-1.2709	-7.775	.001036	-.00979	-.11508	.989
B2T6X2	.95	.15514	-1.1758	-6.987	.000223	-.00191	-.00721	1.084
B2T6X2	1.00	.18128	-1.4220	-8.052	.000162	-.00121	.01841	.974
B2T6X2	1.05	.18301	-1.4565	-7.961	.000276	-.00220	.00054	.999
B2T6X2	1.10	.18510	-1.4713	-7.950	.000194	-.00146	.01336	.999
B2T6X2	1.30	.19589	-1.5545	-7.938	.000272	-.00205	.01240	.999
B2T6X2	1.50	.16941	-1.2805	-7.561	.000337	-.00284	-.04263	.999
B2T6X2	1.75	.15564	-1.1545	-7.419	.000200	-.00111	.08698	.999
B2T6X2	2.00	.15234	-1.1153	-7.337	.000165	-.00065	.14131	.997
B2T6X2	2.50	.14688	-1.0472	-7.142	.000153	-.00039	.19414	.998
B2T6X2	3.00	.13550	-.9247	-6.825	.000203	-.00092	.15975	.995
B2T6X2	4.00	.11966	-.7735	-6.464	.000308	-.00163	.15925	.995
B2T6X2	4.50	.11407	-.7346	-6.383	.000364	-.00202	.14362	1.000
B2T6X3	.80	.18216	-1.5013	-8.244	.000380	-.00333	-.02380	.999
B2T6X3	.90	.17647	-1.4557	-8.292	.000958	-.00924	-.10342	.994
B2T6X3	.95	.14880	-1.1669	-7.871	.000770	-.00748	-.23665	.984
B2T6X3	1.00	.16231	-1.3070	-8.067	.000777	-.00743	-.14479	.998
B2T6X3	1.05	.18864	-1.5817	-8.378	.000355	-.00309	-.01266	1.000
B2T6X3	1.10	.19847	-1.6740	-8.449	.000135	-.00097	.01939	.999
B2T6X3	1.30	.22577	-1.9012	-8.541	.000053	-.00006	.03339	.985
B2T6X3	1.50	.19680	-.8225	-8.343	.000069	-.00000	.06861	.980
B2T6X3	1.75	.16908	-1.3614	-8.027	.000186	-.00065	.10948	.987
B2T6X3	2.00	.15544	-1.2053	-7.752	.000222	-.00133	.09068	.999
B2T6X3	2.50	.14145	-1.0430	-7.373	.000238	-.00128	.14070	.999
B2T6X3	3.00	.12972	-.9076	-6.993	.000251	-.00132	.15644	1.000
B2T6X3	4.00	.12061	-.8099	-6.718	.000271	-.00091	.26514	.999
B2T6X3	4.50	.11576	-.7688	-6.639	.000302	-.00143	.27588	1.030
B1T7X1	.80	.20511	-1.6136	-7.959	-.000008	-.00043	-.04577	.988
B1T7X1	.90	.19640	-1.5485	-7.883	.000420	-.00373	-.04371	1.000
B1T7X1	.95	.23274	-1.8980	-8.190	.000096	-.00056	-.01608	.997
B1T7X1	1.00	.23632	-1.9368	-8.196	-.000113	.00106	.01131	.998
B1T7X1	1.05	.22701	-1.8547	-8.175	-.000138	.00145	.03115	.999
B1T7X1	1.10	.22761	-1.8603	-8.180	-.000290	.00304	.07133	.999
B1T7X1	1.30	.17212	-1.3303	-7.726	-.000134	-.00073	.04984	1.000
B1T7X1	1.50	.18818	-1.4261	-7.593	-.000375	.00339	.11648	.998
B1T7X1	1.75	.18729	-1.3447	-7.186	-.000282	.00338	.23860	.998
B1T7X1	2.00	.13831	-.9241	-6.726	-.000849	-.00668	-.18898	.995
B1T7X1	2.50	.11834	-.7149	-6.075	.000282	-.00193	-.10226	.999
B1T7X1	3.00	.11392	-.6679	-5.865	.000264	-.00178	-.11927	.997
B1T7X1	4.00	.10604	-.5984	-5.635	.000304	-.00219	-.29192	.998
B1T7X1	4.50	.10275	-.5813	-5.659	.000307	-.00189	-.11192	.999
B1T7X2	.80	.17773	-1.6033	-7.932	.000001	-.00036	-.04779	1.137
B1T7X2	.90	.19772	-1.5507	-7.845	.000350	-.00307	-.03344	.999
B1T7X2	.95	.23856	-1.9239	-8.140	-.000009	.00026	.01277	.990
B1T7X2	1.00	.23796	-1.9400	-8.166	-.000058	.00075	.02296	.998
B1T7X2	1.05	.22954	-1.8694	-8.146	-.000203	.00216	.04778	.999

TABLE I. TOTAL CONFIGURATION COEFFICIENTS (Continued)

CONFIG	MN	A1	B1	C1	A3	B3	C3	E
8117X2	1.10	.22829	-1.8594	-8.153	-.000345	.00355	.08018	.998
8117X2	1.20	.20234	-1.6196	-8.010	-.000208	-.00242	.10751	.999
8117X2	.80	.19565	-1.4695	-7.520	.000047	-.00014	.02723	.998
8117X2	.90	.18593	-1.3749	-7.401	.000451	-.00388	-.06088	.999
8117X2	.95	.23505	-1.8311	-7.810	.000118	-.00682	.00676	.997
8117X2	1.00	.22998	-1.7844	-7.757	.000097	-.00085	-.00716	1.000
8117X2	1.05	.21986	-1.6938	-7.744	.000008	-.00002	.00341	.994
8117X2	1.10	.22068	-1.7088	-7.748	-.000210	-.00208	.04945	.999
8117X2	1.30	.16670	-1.2156	-7.511	.000247	-.00177	.00169	.970
8117X2	1.50	.19718	-1.4395	-7.333	-.000348	.00323	.16487	.995
8117X2	1.75	.23940	-1.9679	-8.377	-.001623	.01739	.71620	.981
8117X2	2.00	.15640	-1.1603	-7.441	.000941	-.00784	-.11616	.996
8117X2	2.50	.13190	-.8935	-6.774	.000296	-.00195	.02058	.999
8117X2	3.00	.12918	-.8548	-6.615	.000171	-.00074	.15460	1.000
8117X2	4.00	.11958	-.7663	-6.416	.000184	-.00052	.32284	.995
8117X2	4.50	.11381	-.7163	-6.290	.000195	-.00066	.31392	1.000
8117X3	.80	.19591	-1.6195	-8.266	-.000026	.00065	.05816	.999
8117X3	.90	.19254	-1.5789	-8.202	.000341	-.00304	-.02675	.999
8117X3	.95	.21434	-1.7989	-8.393	.000236	-.00233	-.02849	.999
8117X3	1.00	.20964	-1.7581	-8.385	.000234	-.00218	-.02035	1.000
8117X3	1.05	.20244	-1.6858	-8.325	.000186	-.00167	-.01315	1.000
8117X3	1.10	.20550	-1.7143	-8.347	-.000113	.00128	.04081	.999
8117X3	1.20	.18372	-1.5102	-8.205	.000028	.00019	.06575	1.001
8117X3	1.30	.16343	-1.3041	-7.980	.000328	-.00265	-.00629	.999
8117X3	1.50	.22340	-1.8516	-8.340	-.000731	-.00725	.21645	.993
8117X3	1.75	.19265	-1.5837	-8.234	.000229	-.00122	.08281	.998
8117X3	2.00	.16879	-1.3317	-7.899	.000187	-.00085	.11320	.998
8117X3	2.50	.15175	-1.1366	-7.508	.000158	-.00045	.18593	.999
8117X3	3.00	.13774	-.9808	-7.121	.000196	-.00090	.16163	.999
8117X3	4.00	.12118	-.8106	-6.713	.000168	-.00027	.40758	.996
8117X3	4.50	.11425	-.7510	-6.575	.000211	-.00050	.47958	.999
8117X4	.80	.16937	-1.4756	-8.418	.000440	-.00354	-.02505	.999
8117X4	.90	.18201	-1.5507	-8.413	.000409	-.00379	-.04491	.999
8117X4	.95	.21868	-1.8937	-8.804	.000072	-.00024	.03463	.983
8117X4	1.00	.21528	-1.8698	-8.740	-.000029	.00069	.04678	.993
8117X4	1.05	.18619	-1.5778	-8.477	.000236	-.00216	-.01874	.999
8117X4	1.10	.19220	-1.6356	-8.511	.000212	-.00197	-.02057	.999
8117X4	1.20	.19226	-1.6373	-8.529	.000034	.00000	.04052	1.023
8117X4	1.30	.19566	-1.6859	-8.611	.000038	.00001	.04462	1.012
8117X4	1.50	.19751	-1.6905	-8.553	.000062	.00014	.08335	1.000
8117X4	1.75	.16599	-1.3814	-8.320	.000175	-.00084	.10333	1.000
8117X4	2.00	.14106	-1.0867	-7.682	.000179	-.00057	.20279	1.002
8117X4	3.00	.13065	-.9658	-7.383	.000181	-.00045	.26687	1.001
8118X1	1.75	.15632	-1.0976	-7.030	.000090	-.00014	.11950	.998
8118X1	2.00	.14482	-.9836	-6.751	.000185	-.00099	.07655	1.000
8118X1	2.50	.13943	-.9221	-6.616	.000173	-.00079	.11479	.999
8118X1	3.00	.13811	-.9044	-6.546	.000153	-.00060	.13021	1.000
8118X1	4.00	.12701	-.8101	-6.376	.000294	-.00156	.11540	1.000
8118X1	4.50	.12260	-.7767	-6.334	.000356	-.00202	.09075	1.000
8118X2	1.75	.17068	-1.3037	-7.637	.000068	.00017	.13436	1.000
8118X2	2.00	.16627	-1.2605	-7.547	.000054	.00042	.17455	1.004
8118X2	2.50	.15320	-1.1108	-7.255	.000173	-.00060	.15837	.999
8118X2	3.00	.14217	-.9900	-6.952	.000210	-.00098	.14086	1.000
8118X2	4.00	.12761	-.8497	-6.659	.000286	-.00141	.18320	.999
8118X2	4.50	.12400	-.8195	-6.607	.000319	-.00172	.15069	1.000
8118X3	1.75	.19146	-1.5201	-8.207	.000109	-.00010	.11287	.993
8118X3	2.00	.18217	-1.3623	-7.989	.000101	-.00008	.13271	.990
8118X3	2.50	.15249	-1.1257	-7.584	.000188	-.00076	.16582	.999
8118X3	3.00	.14196	-1.0254	-7.253	.000195	-.00088	.16058	.999
8118X3	4.00	.12014	-.8891	-6.934	.000252	-.00112	.23246	1.000
8118X3	4.50	.12350	-.8511	-6.887	.000354	-.00173	.27368	1.000
81185X1	1.75	.19411	-1.4263	-7.345	.000032	.00036	.08040	1.000
81185X1	2.00	.18259	-1.3191	-7.224	.000145	-.00054	.07744	.999
81185X1	2.50	.16803	-1.1820	-7.043	.000190	-.00070	.11792	.998
81185X1	3.00	.15584	-1.0600	-6.802	.000208	-.00101	.09206	.999
81185X1	4.00	.13788	-.9048	-6.560	.000367	-.00219	.06120	1.000
81185X1	4.50	.13239	-.8591	-6.489	.000383	-.00245	.00926	.999



TABLE I. TOTAL CONFIGURATION COEFFICIENTS (Continued)

CONFIG	MN	A1	B1	C1	A3	B3	C3	E
BITASX2	1.75	.20992	-1.8623	-7.925	-.000004	.00097	.10259	.999
BITASX2	2.00	.19382	-1.5060	-7.770	.000127	-.00031	.08680	.999
BITASX2	2.50	.17125	-1.2749	-7.450	.000202	-.00083	.11790	.999
BITASX2	3.00	.15543	-1.1076	-7.127	.000207	-.00103	.10303	.999
BITASX2	4.00	.13646	-.9347	-6.823	.000310	-.00162	.14981	1.000
BITASX2	4.50	.13187	-.8946	-6.779	.000402	-.00231	.13295	1.000
BITASX3	1.75	.20991	-1.7512	-8.320	.000071	.00020	.08308	1.002
BITASX3	2.00	.19091	-1.5500	-8.127	.000177	-.00064	.10370	.998
BITASX3	2.50	.16649	-1.2870	-7.737	.000294	-.00172	.09873	.999
BITASX3	3.00	.15253	-1.1306	-7.414	.000235	-.00109	.15681	.999
BITASX3	4.00	.13595	-.9642	-7.097	.000315	-.00145	.24285	.999
BITASX3	4.50	.13155	-.9231	-7.014	.000334	-.00186	.16002	1.000
BITIOX1	1.75	.23923	-1.8062	-7.558	.000301	-.00200	.01754	.998
BITIOX1	2.00	.21926	-1.6169	-7.378	.000278	-.00188	.01441	.999
BITIOX1	2.50	.21233	-1.4587	-7.353	.000167	-.00052	.06806	.998
BITIOX1	3.00	.20060	-1.4519	-7.240	.000117	-.00019	.07620	.999
BITIOX1	4.00	.16643	-1.1570	-6.629	.000306	-.00160	.09043	1.000
BITIOX1	4.50	.15864	-1.0873	-6.853	.000310	-.00162	.10216	1.000
BITIOX2	1.75	.25531	-2.0719	-8.116	.000291	-.00189	.02536	.999
BITIOX2	2.00	.25085	-1.8936	-8.099	.000049	.00060	.06196	1.002
BITIOX2	2.50	.22865	-1.8392	-7.919	.000085	.00027	.07571	1.015
BITIOX2	3.00	.20282	-1.5467	-7.641	.000129	-.00014	.09400	.997
BITIOX2	4.00	.16892	-1.2310	-7.289	.000271	-.00115	.14346	.999
BITIOX2	4.50	.15957	-1.1475	-7.188	.000305	-.00150	.13922	1.000
BITIOX3	1.75	.28300	-2.4602	-8.716	.000142	-.00025	.04126	.997
BITIOX3	2.00	.25941	-2.2087	-8.569	.000143	-.00022	.05384	.993
BITIOX3	2.50	.22561	-1.8516	-8.286	.000146	-.00036	.08054	.990
BITIOX3	3.00	.20371	-1.6253	-8.005	.000143	-.00019	.10343	.996
BITIOX3	4.00	.17147	-1.3064	-7.627	.000210	-.00065	.16526	.998
BITIOX3	4.50	.16132	-1.2139	-7.528	.000278	-.00108	.20143	.999
BITI1X1	1.75	.16953	-1.2350	-7.288	.000250	-.00161	.03893	.999
BITI1X1	2.00	.17336	-1.2469	-7.309	.000150	-.00053	.09824	1.000
BITI1X1	2.50	.16170	-1.1520	-7.127	.000176	-.00060	.13454	.999
BITI1X1	3.00	.14724	-.9994	-6.800	.000181	-.00040	.13627	.998
BITI1X1	4.00	.12790	-.8223	-6.426	.000278	-.00162	.05940	1.000
BITI1X1	4.50	.12286	-.7852	-6.387	.000337	-.00195	.07574	1.000
BITI1X2	1.75	.19631	-1.5691	-8.018	.000135	-.00037	.08652	.996
BITI1X2	2.00	.17969	-1.4012	-7.808	.000211	-.00111	.08051	.998
BITI1X2	2.50	.16083	-1.1984	-7.464	.000150	-.00068	.15480	.998
BITI1X2	3.00	.14690	-1.0440	-7.126	.000149	-.00031	.20740	.997
BITI1X2	4.00	.12835	-.8653	-6.735	.000281	-.00137	.19253	1.000
BITI1X2	4.50	.12329	-.8238	-6.674	.000328	-.00173	.17883	1.001
BITI1X3	1.75	.19627	-1.6453	-8.388	.000169	-.00081	.07268	.999
BITI1X3	2.00	.17274	-1.3998	-8.118	.000303	-.00194	.08220	.998
BITI1X3	2.50	.16118	-1.2561	-7.801	.000168	-.00049	.17140	.998
BITI1X3	3.00	.14660	-1.0882	-7.429	.000181	-.00058	.21065	.995
BITI1X3	4.00	.12906	-.9060	-7.012	.000288	-.00130	.24972	1.001
BITI1X3	4.50	.12400	-.8637	-6.956	.000336	-.00151	.32519	1.001
BITI2X1	.80	.07888	-.4353	-5.493	-.000172	.00186	1.86333	1.004
BITI2X1	.90	.05741	-.2370	-4.372	.000442	-.00388	1.96612	.944
BITI2X1	.95	.06000	-.2613	-4.650	.000509	-.00453	1.13659	.936
BITI2X1	1.00	.05856	-.2490	-4.460	.000434	-.00386	1.73544	.953
BITI2X1	1.05	.06363	-.2956	-4.691	.000217	-.00184	1.95989	.990
BITI2X1	1.10	.06589	-.3145	-4.779	.000159	-.00116	1.03771	.998
BITI2X1	1.30	.06449	-.2890	-4.539	.000257	-.00190	1.44333	.987
BITI2X1	1.50	.07280	-.3468	-4.805	.000261	-.00187	.89246	.991
BITI2X1	1.75	.07213	-.3470	-4.838	.000191	-.00110	1.35112	.994
BITI2X1	2.00	.07022	-.3276	-4.695	.000196	-.00116	1.30818	.993
BITI2X1	2.50	.06976	-.3054	-4.435	.000269	-.00165	.54527	.987
BITI2X1	3.00	.06958	-.2984	-4.376	.000323	-.00208	.73079	.980
BITI2X2	.80	.07960	-.4728	-6.104	.000111	-.00046	1.34531	.973
BITI2X2	.90	.07197	-.3982	-5.586	.000291	-.00256	1.46227	.990
BITI2X2	.95	.06855	-.3707	-5.497	.000397	-.00344	1.88397	.983
BITI2X2	1.00	.06270	-.3103	-5.013	.000270	-.00225	1.74635	.986
BITI2X2	1.05	.05637	-.2483	-4.663	.000481	-.00422	1.50659	.944

TABLE I. TOTAL CONFIGURATION COEFFICIENTS (Continued)

CONFIG	MN	A1	B1	C1	A3	B3	C3	E
B1T12X2	1.10	.05494	-.2485	-4.870	.000426	-.00370	-2.42070	-.977
B1T12X2	1.30	.07357	-.2968	-5.611	.000051	-.00001	-.56490	-.965
B1T12X2	1.50	.07916	-.4300	-5.433	.000145	-.00094	-.18711	-.999
B1T12X2	1.75	.07986	-.4456	-5.422	.000129	-.00057	-.18982	1.001
B1T12X2	2.00	.06777	-.4120	-5.581	.000172	-.00085	.06200	.997
B1T12X2	2.50	.07553	-.3800	-5.024	.000241	-.00136	-.21649	1.001
B1T12X2	3.00	.01439	-.0396	-4.137	.001910	-.01247	-.02235	-.666
B1T12X5	.80	.08794	-.5649	-6.462	-.000270	.00296	2.55997	.993
B1T12X5	.90	.07356	-.4259	-5.840	.000132	-.00080	.05285	.991
B1T12X5	.95	.07102	-.3504	-6.202	.000072	-.00027	.42000	.795
B1T12X5	1.00	.06143	-.3056	-5.116	.000370	-.00326	-2.47270	.972
B1T12X5	1.05	.06007	-.2916	-4.972	.000372	-.00325	-2.98823	.976
B1T12X5	1.10	.06026	-.2868	-4.865	.000370	-.00323	-3.16818	.978
B1T12X5	1.30	.07297	-.3959	-5.468	.000265	-.00217	-1.06908	.992
B1T12X5	1.50	.07750	-.4237	-5.480	.000195	-.00142	-.49780	.997
B1T12X5	1.75	.07865	-.4604	-5.243	.000176	-.00105	-.14884	1.010
B1T12X5	2.00	.07710	-.4258	-5.426	.000195	-.00106	-.01044	1.017
B1T12X5	2.50	.07648	-.3977	-5.196	.000248	-.00140	-.15261	1.000
B1T12X5	3.00	.07516	-.3730	-5.001	.000335	-.00212	-.44793	.992
B1T13X1	.80	.06774	-.3423	-5.062	.000072	-.00063	-.68456	.998
B1T13X1	.90	.06011	-.2770	-4.674	.000214	-.00173	-1.80566	.985
B1T13X1	.95	.04971	-.1777	-3.797	.000329	-.00281	-5.04970	.941
B1T13X1	1.00	.05893	-.2677	-4.582	.000181	-.00136	-1.51471	.991
B1T13X1	1.05	.05978	-.2774	-4.663	.000165	-.00115	-1.08310	.995
B1T13X1	1.10	.05922	-.2722	-4.542	.000065	-.00042	-.35615	1.000
B1T13X1	1.30	.05646	-.2352	-4.078	.000295	-.00217	-1.32220	.970
B1T13X1	1.50	.06292	-.2645	-4.270	.000218	-.00147	-1.36300	.984
B1T13X1	1.75	.06300	-.2661	-4.292	.000204	-.00147	-.80599	.983
B1T13X1	2.00	.06193	-.2570	-4.209	.000216	-.00132	-.71423	.985
B1T13X1	2.50	.06252	-.2457	-4.022	.000269	-.00168	-.79331	.976
B1T13X1	3.00	.06361	-.2440	-4.005	.000354	-.00242	-1.02569	.957
B1T13X2	.80	.07779	-.4670	-6.048	-.000107	.00152	2.49280	.992
B1T13X2	.90	.07151	-.4017	-5.685	.000224	-.00209	-1.25588	.988
B1T13X2	.95	.06624	-.3561	-5.404	.000221	-.00174	-1.21062	.994
B1T13X2	1.00	.05822	-.2760	-4.856	.000344	-.00285	-2.65081	.976
B1T13X2	1.05	.05894	-.2802	-4.813	.000273	-.00220	-2.43099	.987
B1T13X2	1.10	.06125	-.3004	-4.923	.000218	-.00157	-1.44440	.990
B1T13X2	1.30	.06551	-.3282	-4.978	.000182	-.00139	-1.03375	.994
B1T13X2	1.50	.07191	-.3627	-6.444	.000095	-.00055	-.02464	.982
B1T13X2	1.75	.06983	-.3490	-5.007	.000173	-.00100	-.22926	.998
B1T13X2	2.00	.06838	-.3346	-4.897	.000179	-.00096	-.16326	.998
B1T13X2	2.50	.06761	-.3061	-4.567	.000265	-.00154	-.46426	.991
B1T13X2	3.00	.06746	-.2908	-4.431	.000367	-.00244	-.80802	.972
B1T13X5	.80	.07127	-.3982	-5.611	-.000023	.00048	.98812	.995
B1T13X5	.90	.07553	-.4559	-6.050	.000145	-.00108	-.31531	.997
B1T13X5	.95	.06854	-.3903	-5.669	.000150	-.00115	-.62610	.997
B1T13X5	1.00	.06407	-.3412	-5.306	.000181	-.00131	-.59732	1.003
B1T13X5	1.05	.05957	-.2901	-4.911	.000203	-.00162	-1.40395	.991
B1T13X5	1.10	.05865	-.2760	-4.764	.000207	-.00172	-1.73348	.987
B1T13X5	1.30	.07053	-.3824	-5.429	.000181	-.00114	-.31720	.998
B1T13X5	1.50	.07426	-.4006	-5.394	.000097	-.00053	-.03561	1.000
B1T13X5	1.75	.06957	-.3555	-5.124	.000195	-.00118	-.21744	.997
B1T13X5	2.00	.06834	-.3405	-5.009	.000215	-.00130	-.30809	.994
B1T13X5	2.50	.06768	-.3117	-4.669	.000290	-.00181	-.54098	.986
B1T13X5	3.00	.06753	-.2998	-4.556	.000355	-.00238	-.74061	.974
B1T13RX1	.80	.04041	-.1445	-3.682	.000275	-.00191	-6.13485	.971
B1T13RX1	.90	.03511	-.0964	-3.116	.000416	-.00323	12.57245	.881
B1T13RX1	.95	.02924	-.0894	-3.112	.000514	-.00405	10.27203	.808
B1T13RX1	1.00	.04747	-.1978	-4.214	.000453	-.00359	-4.53453	.944
B1T13RX1	1.05	.04435	-.1741	-4.209	.000500	-.00387	-5.40850	.928
B1T13RX1	1.10	.03695	-.1223	-3.615	.000533	-.00413	-7.73023	.868
B1T13RX1	1.30	.00988	.1627	4.545	.000878	-.00718	14.17061	3.624
B1T13RX1	1.75	.01063	.1515	5.979	.000621	-.00474	15.33287	2.383
B1T13RX1	2.00	.00537	.1963	-5.831	.000746	-.00561	9.55541	6.262
B1T13RX2	.80	.04489	-.1698	-3.783	.000080	-.00063	-2.87304	.999
B1T13RX2	.90	.02639	-.0032	-.892	.000367	-.00291	37.19969	1.136
B1T13RX2	.95	.05462	-.2722	-5.053	.000321	-.00244	-2.42096	.986
B1T13RX2	1.00	.05948	-.3202	-5.526	.000489	-.00401	-2.22427	.973
B1T13RX2	1.05	.05519	-.2784	-5.252	.000518	-.00432	-2.90273	.960

TABLE I. TOTAL CONFIGURATION COEFFICIENTS (Continued)

CONFIG	MN	A1	B1	C1	A3	B3	C3	E
BIT13RX2	1.10	.04723	-.2040	-4.685	.000599	-.00492	-4.76953	.921
BIT13RX2	1.30	.02331	-.0354	-1.363	.000744	-.00428	13.47291	1.113
BIT13RX2	1.50	.01290	.1443	-1.785	.000858	-.00712	20.36411	6.263
BIT13RX2	1.75	.00571	.2158	-6.236	.000620	-.00491	29.41389	6.054
BIT13RX5	.80	.04920	-.1312	-2.497	.000031	-.00012	-.07994	1.556
BIT13RX5	.90	.04741	-.1974	-4.418	.000147	-.00202	26.19680	.942
BIT13RX5	.95	.06270	-.5091	-5.984	.000047	-.00021	1.84295	1.356
BIT13RX5	1.00	.06983	-.4167	-5.987	.000326	-.00266	-1.22694	.995
BIT13RX5	1.05	.06745	-.3954	-5.890	.000311	-.00243	-1.13936	.995
BIT13RX5	1.10	.05995	-.3188	-5.395	.000324	-.00265	-1.91533	.985
BIT13RX5	1.30	.02179	.0702	-.424	.000759	-.00679	25.16602	7.594
BIT13RX5	1.50	.00624	.2410	7.474	.000911	-.00818	31.08602	5.162
BIT13RX5	2.00	-.02043	.5108	4.546	.000961	-.00822		5.498
BIT13SX1	.80	.08039	-.3491	-5.125	-.000002	.00017	.57508	.847
BIT13SX1	.90	.06863	-.3586	-5.225	.000132	-.00102	-.74859	.999
BIT13SX1	.95	.06496	-.3169	-4.892	.000243	-.00205	-2.12009	.997
BIT13SX1	1.00	.06505	-.3229	-4.980	-.000235	-.00180	-1.53603	.996
BIT13SX1	1.05	.09309	-.3988	-5.368	-.000020	.00082	2.40246	.798
BIT13SX1	1.10	.06537	-.3238	-4.967	.000155	-.00105	-.82556	.997
BIT13SX1	1.30	.06444	-.2980	-4.668	.000211	-.00172	-.13345	.990
BIT13SX1	1.50	.06167	-.2599	-4.362	.000373	-.00286	-1.89325	.966
BIT13SX1	1.75	.06428	-.2835	-4.454	.000200	-.00128	-.52196	.990
BIT13SX1	2.00	.06596	-.2945	-4.496	.000195	-.00116	-.46960	.992
BIT13SX1	2.50	.06671	-.2818	-4.294	.000268	-.00167	-.67123	.983
BIT13SX1	3.00	.06716	-.2795	-4.277	.000336	-.00223	-.83035	.972
BIT13SX2	.80	.08380	-.5211	-6.254	-.000182	.00206	2.18256	.994
BIT13SX2	.90	.07690	-.4562	-5.946	.000113	-.00080	-1.52200	.997
BIT13SX2	.95	.07212	-.4088	-5.688	.000335	-.00296	-1.80970	.996
BIT13SX2	1.00	.07194	-.4080	-5.814	.000081	-.00032	.20593	.975
BIT13SX2	1.05	.06257	.4931	-5.724	.000054	-.00003	.87978	1.376
BIT13SX2	1.10	.06194	-.1291	-5.793	.000066	-.00016	.73387	.359
BIT13SX2	1.30	.06709	-.3483	-5.160	.000228	-.00175	-.91621	.994
BIT13SX2	1.50	.06656	-.3134	-4.830	.000347	-.00298	-1.69477	.974
BIT13SX2	1.75	.06689	-.3226	-4.830	.000210	-.00135	-.31126	.998
BIT13SX2	2.00	.06873	-.3354	-4.899	.000192	-.00112	-.24225	.996
BIT13SX2	2.50	.07008	-.3280	4.703	.000264	-.00157	-.47966	.995
BIT13SX2	3.00	.06896	-.3073	-4.554	.000354	-.00235	-.78495	.978
BIT13SX5	.80	.08569	-.5468	-6.415	-.000106	.00172	1.33804	.794
BIT13SX5	.90	.08824	-.5799	-6.585	-.000038	.00073	.80833	.997
BIT13SX5	.95	.07777	-.4753	-6.023	.000128	-.00082	-.10281	1.014
BIT13SX5	1.00	.06613	-.3571	-5.422	.000277	-.00246	-2.18857	.995
BIT13SX5	1.05	.06383	-.3310	-5.222	.000212	-.00185	-1.93776	.992
BIT13SX5	1.10	.06257	-.3193	-5.145	.000273	-.00216	-1.85162	.991
BIT13SX5	1.30	.07137	-.3879	-5.467	.000225	-.00173	-.73452	.994
BIT13SX5	1.50	.07319	-.3878	-5.315	.000189	-.00130	-.47359	.996
BIT13SX5	1.75	.06665	-.3258	-4.916	.000236	-.00160	-.40501	.994
BIT13SX5	2.00	.06894	-.3445	-5.014	.000205	-.00125	-.24763	.996
BIT13SX5	2.50	.06987	-.3328	-4.799	.000279	-.00173	-.53160	.992
BIT13SX5	3.00	.06921	-.3175	-4.691	.000368	-.00246	-.70398	.977
BIT14X1	.80	.07272	-.3986	-5.511	.000038	-.00006	.33101	.994
BIT14X1	.90	.07258	-.3992	-5.481	.000009	.00016	.53730	1.003
BIT14X1	.95	.08761	-.5349	-6.115	-.000042	.00073	.74690	.998
BIT14X1	1.00	.07773	-.4442	-5.711	.000100	-.00059	-.04702	1.000
BIT14X1	1.05	.07611	-.4295	-5.626	.000115	-.00068	-.08993	1.003
BIT14X1	1.10	.07289	-.3981	-5.467	.000188	-.00120	-.32178	.998
BIT14X1	1.30	.05869	-.2608	-4.515	.000285	-.00206	-1.84448	.934
BIT14X1	1.50	.05637	-.2216	-4.129	.000388	-.00294	-2.30037	.951
BIT14X1	1.75	.06283	-.2784	-4.540	.000246	-.00161	-.71836	.976
BIT14X1	2.00	.07263	-.3518	-5.992	.000132	-.00055	-.08449	1.213
BIT14X1	2.50	.07268	-.3364	-4.517	.000213	-.00111	-.41430	1.024
BIT14X1	3.00	.06623	-.2771	-4.275	.000290	-.00182	-.64719	.978
BIT14X2	.80	.07312	-.4187	-5.779	.000034	-.00011	.19220	.990
BIT14X2	.90	.06439	-.3295	-5.149	.000262	-.00224	-2.15544	.993
BIT14X2	.95	.09379	-.5917	-6.519	-.000010	.00068	.82322	.967
BIT14X2	1.00	.07745	-.4612	-6.071	.000072	-.00039	.05448	.980
BIT14X2	1.05	.07489	-.4282	-5.722	.000224	-.00163	-.02655	.999
BIT14X2	1.10	.07516	-.4287	-5.715	.000111	-.00076	-.29261	.997
BIT14X2	1.30	.06467	-.3231	-5.010	.000241	-.00204	-2.02783	.997

TABLE I. TOTAL CONFIGURATION COEFFICIENTS (Concluded)

CONFIG	MN	A1	B1	C1	A3	B3	C3	E
BIT14X2	1.50	.05791	-.2411	-4.244	.000307	-.00238	-1.37120	.981
BIT14X2	1.75	.05651	-.2284	-4.243	.000303	-.00215	-1.10028	.952
BIT14X2	2.00	.06807	-.3244	-4.687	.000188	-.00106	-.59533	1.017
BIT14X2	2.50	.07071	-.3311	-4.578	.000269	-.00162	-.94725	1.024
BIT14X2	3.00	.06694	-.3221	-4.641	.000342	-.00219	-.73475	.992
BIT14X5	.80	.07050	-.4033	-5.754	.000080	-.00039	.17859	.994
BIT14X5	.90	.07431	-.4273	-5.819	.000086	-.00134	2.51080	.988
BIT14X5	.95	.07516	-.4519	-6.036	.000287	-.00234	-.88331	.996
BIT14X5	1.00	.07002	-.3973	-5.722	.000307	-.00248	-1.09025	.991
BIT14X5	1.05	.06679	-.3619	-5.488	.000311	-.00272	-1.73203	.987
BIT14X5	1.10	.06772	-.3700	-5.530	.000321	-.00268	-1.40181	.987
BIT14X5	1.30	.05146	-.2077	-4.231	.000475	-.00397	-3.19824	.930
BIT14X5	1.50	.04231	-.0870	-3.031	.000647	-.00580	-7.27127	.678
BIT14X5	1.75	.04431	-.0987	-2.390	.000450	-.00378	-1.26848	.932
BIT14X5	2.00	.05742	-.2231	-4.090	.000315	-.00236	-1.60953	.949
BIT14X5	2.50	.06958	-.3262	-4.622	.000308	-.00199	-1.22909	1.014
BIT14X5	3.00	.07331	-.3579	-4.882	.000320	-.00197	-.57056	1.000

TABLE II. RINGTAIL COEFFICIENTS

CONFIG	MN	A1	A3	B1	B3	XCP/C
T1X1	.80	.04293	.000142	.0577	.00013	-.125
T1X1	.90	.03701	.000325	.0490	.00018	-.098
T1X1	.95	.04700	.000143	.0482	.00024	.301
T1X1	1.00	.05387	-.000010	.0524	-.00019	.196
T1X1	1.05	.03990	.000137	.0453	-.00009	.152
T1X1	1.10	.03374	.000195	.0409	.00011	.050
T1X1	1.20	.00510	-.000071	-.5502	.00002	----
T1X1	1.30	.05038	-.000061	.0510	-.00015	.052
T1X1	1.50	.04398	.000015	.0472	-.00004	-.232
T1X1	1.75	.03549	.000062	.0483	.00013	-.147
T1X1	2.00	.03111	-.000066	.0367	-.00019	.093
T1X1	2.50	.02659	-.000091	.0214	.00002	.593
T1X1	3.00	.02182	-.000026	.0194	.00010	.481
T1X1	4.00	.02118	-.000086	.0198	.00004	.420
T1X1	4.50	.02059	-.000092	.0226	-.00004	.203
T1X2	.80	.04605	.000077	.0326	.00026	.056
T1X2	.90	.05000	.000255	.0391	.00003	.274
T1X2	.95	.03877	.000593	.0320	-.00005	.543
T1X2	1.00	.04547	.000094	.0238	.00005	.302
T1X2	1.05	.04764	.000081	.0204	-.00012	.429
T1X2	1.10	.05773	-.000197	.0474	-.00085	-.094
T1X2	1.20	.05498	.000022	.0237	.00003	.425
T1X2	1.30	.06352	-.000098	.0307	-.00002	.985
T1X2	1.50	.05647	-.000077	.0266	-.00015	.466
T1X2	1.75	.04472	.000078	.0254	.00015	.243
T1X2	2.00	.03985	-.000094	.0162	-.00008	.457
T1X2	2.50	.03434	-.000070	.0056	-.00012	.782
T1X2	3.00	.03014	-.000083	.0091	-.00007	.597
T1X2	4.00	.02407	-.000074	.0086	.00009	.923
T1X2	4.50	.02042	-.000001	.0060	.00027	.608
T1X3	.80	.04994	.000005	.0085	-.00002	.106
T1X3	.90	.03883	.000337	.0049	-.00011	.165
T1X3	.95	.03497	.000230	.0037	.00001	.192
T1X3	1.00	.03077	.000226	.0077	-.00006	0.000
T1X3	1.05	.03122	.000077	.0022	-.00023	.239
T1X3	1.10	.03041	.000149	.0023	0.00000	.232
T1X3	1.20	.03659	.000127	.0052	-.00012	.326
T1X3	1.30	.04397	-.000053	.0029	-.00010	.245
T1X3	1.50	.05008	-.000041	-.0017	-.00002	.378
T1X3	1.75	.04672	-.000026	-.0085	-.00009	.575
T1X3	2.00	.04406	-.000086	-.0032	-.00013	.430
T1X3	2.50	.03531	-.000050	-.0113	.00011	.760
T1X3	3.00	.03176	-.000082	-.0079	.00006	.683
T1X3	4.00	.02442	-.000084	-.0067	.00011	.684
T1X3	4.50	.02238	-.000045	-.0054	.00029	.655
T2X1	.80	.04590	.000283	.0859	.00007	-.219
T2X1	.90	.06808	.000240	.0968	0.00000	-.180
T2X1	.95	.02792	.000191	.0612	.00004	-.503
T2X1	1.00	.06193	.000139	.0886	-.00006	.172
T2X1	1.05	.07477	-.000078	.0846	-.00037	.438
T2X1	1.10	.07276	-.000083	-.1574	-.00005	----
T2X1	1.30	.06616	.000094	.0926	-.00010	.200
T2X1	1.50	.07081	-.000036	.0915	-.00020	.295
T2X1	1.75	.06134	-.000034	.0717	-.00002	.405
T2X1	2.00	.05757	-.000244	.0751	-.00017	.264
T2X1	2.50	.03836	-.000019	.0455	-.00001	.390
T2X1	3.00	.04486	-.000105	.0419	-.00006	.349
T2X1	4.00	.02889	-.000075	.0358	-.00011	.342
T2X1	4.50	.02693	-.000037	.0307	.00015	.431
T2X2	.80	.05231	.000220	.0596	-.00008	-.012
T2X2	.90	.06805	.000587	.0595	-.00007	.232
T2X2	.95	.04791	.000334	.0392	.00016	.272
T2X2	1.00	.02983	.000093	.0377	.00014	.156
T2X2	1.05	-.05153	.006561	1.2068	.07257	----
T2X2	1.10	.06161	.000050	.0424	.00007	.388
T2X2	1.30	.08340	-.000112	.0493	-.00002	.474
T2X2	1.50	.08836	-.000215	.0406	.00052	.591
T2X2	1.75	.07738	-.000213	.0339	.00015	.610
T2X2	2.00	.06795	-.000216	.0906	.00009	.538
T2X2	2.50	.04422	.000046	.0212	.00007	.573
T2X2	3.00	.03883	-.000089	.0215	-.00002	.507
T2X2	4.00	.03297	-.000071	.0200	-.00010	.460
T2X2	4.50	.02950	-.000012	.0163	.00019	.508

TABLE II. RINGTAIL COEFFICIENTS (Continued)

CONFIG	MN	A1	A3	B1	B3	XCP/C
T2X3	.80	.05376	.000202	.0337	-.00006	-.001
T2X3	.90	.05591	.000546	.0241	-.00034	.172
T2X3	.95	.04187	.000298	.0136	-.00017	.178
T2X3	1.00	.05768	.000097	.0214	.00011	.225
T2X4	1.05	.05991	.000011	.0657	-.00006	.470
T2X3	1.10	.05683	.000114	.0059	.00011	.463
T2X3	1.30	.07896	-.000125	-.0759	-.00001	1.409
T2X3	1.50	.08309	-.000063	.0116	-.00006	.431
T2X3	1.75	.07749	-.000148	-.0109	.00035	.680
T2X3	2.00	.06729	-.000063	-.0023	.00029	.585
T2X3	2.50	.05466	-.000050	-.0067	.00027	.664
T2X3	3.00	.04998	-.000145	-.0039	.00020	.607
T2X3	4.00	.03544	-.000065	.0026	-.00003	.490
T2X3	4.50	.03055	.000009	-.0007	.00025	.575
T3X1	.80	.19991	-.000809	.3339	-.00081	.219
T3X1	.90	.26448	-.001017	.3450	-.00045	.463
T3X1	.95	.14727	.000462	.2509	.00054	.197
T3X1	1.00	.22378	-.000474	.3218	-.00052	.283
T3X1	1.05	.26812	-.000732	.3235	-.00065	.528
T3X1	1.10	.25076	-.000444	.3106	-.00025	.507
T3X1	1.30	.26640	-.002364	.4569	-.00822	.189
T3X1	1.50	.19020	.000145	.2329	.00078	.516
T3X1	1.75	.16318	.000153	.2145	.00055	.457
T3X1	2.00	.14127	-.000040	.1946	.00018	.414
T3X1	2.50	.11110	-.000069	.1580	-.00002	.385
T3X1	3.00	.09849	-.000070	.1366	.00029	.408
T3X1	4.00	.08426	-.000113	.1082	.00018	.456
T3X1	4.50	.07789	-.000123	.0975	.00024	.498
T3X2	.80	.19089	-.000639	.2320	-.00070	.189
T3X2	.90	.26202	-.000846	.2077	.00003	.471
T3X2	.95	.14392	.000794	.1658	.00049	.231
T3X2	1.00	.18468	.000037	.1917	-.00002	.307
T3X2	1.05	.22744	-.000781	.2076	-.00115	.391
T3X2	1.10	.22115	-.000160	.1886	.00001	.431
T3X2	1.30	.28124	-.002719	.3408	-.00902	.192
T3X2	1.50	.20601	.000144	.1783	.00005	.413
T3X2	1.75	.16956	.000186	.1405	.00044	.484
T3X2	2.00	.14728	.000003	.1217	.00028	.449
T3X2	2.50	.12210	-.000071	.0992	.00022	.458
T3X2	3.00	.11501	-.000208	.1952	.00028	-.131
T3X2	4.00	.09286	-.000153	.0629	.00024	.548
T3X2	4.50	.08337	-.000083	.0565	.00063	.548
T3X3	.80	.17594	-.000106	.2131	-.00009	-.140
T3X3	.90	.24660	-.000696	.0812	.00040	.447
T3X3	.95	.18692	.000175	.0722	.00043	.409
T3X3	1.00	.18487	.000100	.0752	.00034	.395
T3X3	1.05	.18631	-.000040	-.0759	.00006	.938
T3X3	1.10	.20193	-.000024	-.1255	.00015	1.081
T3X3	1.30	.24576	-.000220	.0939	.00034	.411
T3X3	1.50	.21025	-.000160	-.0215	.00012	.734
T3X3	1.75	.18773	.000155	.0417	.00044	.518
T3X3	2.00	.17840	-.000245	.0437	.00035	.503
T3X3	2.50	.14464	-.000198	.0213	.00034	.568
T3X3	3.00	.12284	-.000136	.0242	.00055	.535
T3X3	4.00	.09389	-.000146	.0139	.00054	.567
T3X3	4.50	.08517	-.000161	.0186	.00037	.521
T4X1	.80	.13938	-.000024	.1931	-.00021	.114
T4X1	.90	.14738	.000669	.1823	.00050	.263
T4X1	.95	.16099	-.000413	.1796	-.00035	.384
T4X1	1.00	.19984	-.000298	.2002	-.00050	.428
T4X1	1.05	.19151	-.000429	.1780	-.00038	.570
T4X1	1.10	.18049	-.000411	.1729	-.00008	.542
T4X1	1.30	.16869	-.000251	.1910	-.00011	.367
T4X1	1.50	.13678	-.000088	.1468	-.00006	.426
T4X1	1.75	.10768	.000096	.1151	.00034	.431
T4X1	2.00	.09226	-.000007	.1033	.00025	.380
T4X1	2.50	.07920	-.000033	.0839	.00019	.440
T4X1	3.00	.07346	-.000113	.0760	.00004	.462
T4X1	4.00	.06174	-.000171	.0580	.00009	.560
T4X1	4.50	.05472	-.000056	.0477	.00043	.643

TABLE II. RINGTAIL COEFFICIENTS (Continued)

CONFIG	MN	A1	A3	R1	R2	COEFF
T4X2	.80	.16410	-.000254	.1687	-.00063	-.028
T4X2	.90	.16960	.000333	.1056	.00031	.377
T4X2	.95	.11772	.000713	.0984	.00006	.164
T4X2	1.00	.17743	-.000011	.0908	-.00034	.617
T4X2	1.05	.17924	-.001119	.1255	-.00184	.299
T4X2	1.10	.16902	-.000243	-.4251	.03409	---
T4X2	1.20	.17953	-.000413	-.4102	.03342	---
T4X2	1.30	.18286	-.000280	.0975	.00011	.466
T4X2	1.40	.14179	.000147	.0752	-.00001	.467
T4X2	1.75	.11754	.000149	.0575	.00033	.510
T4X2	2.00	.11093	-.000128	.0489	.00019	.559
T4X2	2.50	.09753	-.000097	.0391	.00035	.599
T4X2	3.00	.08453	-.000165	.0351	.00019	.584
T4X2	4.00	.06478	-.000165	.0261	.00012	.597
T4X2	4.50	.05739	-.000028	.0197	.00061	.656
T4X3	.80	.14433	.000210	.0492	-.00004	.159
T4X3	.90	.18659	.000155	.0350	-.00001	.312
T4X3	.95	.12760	.000497	.0392	-.00007	.180
T4X3	1.00	.13129	.000263	.0417	-.00021	.582
T4X3	1.05	.14032	.000310	.0277	-.00005	.302
T4X3	1.10	.14436	-.000555	-.0015	.00008	.510
T4X3	1.20	.18711	-.001099	.0483	-.00136	.241
T4X3	1.30	.18967	-.000177	-.0139	-.00014	.426
T4X3	1.40	.16442	-.000156	-.0847	-.00001	1.015
T4X3	1.75	.13972	.000009	-.0103	.00042	.573
T4X3	2.00	.12369	-.000076	-.0031	.00034	.525
T4X3	2.50	.10156	-.000077	-.0114	.00036	.612
T4X3	3.00	.08408	-.000102	-.0123	.00044	.646
T4X3	4.00	.06596	-.000206	-.0053	.00018	.580
T4X3	4.50	.05915	-.000190	-.0060	.00039	.601
T4X4	.80	.12684	.000344	.00006	-.00007	.095
T4X4	.90	.16221	.000570	-.0287	-.00021	.273
T4X4	.95	.10271	.000747	.0064	-.00047	.039
T4X4	1.00	.11047	.000631	-.0013	-.00041	.111
T4X4	1.05	.14586	-.000168	-.0298	.00006	.304
T4X4	1.10	.13856	-.000140	-.0307	-.00004	.321
T4X4	1.20	.14539	-.000038	-.0136	-.00019	.195
T4X4	1.30	.15622	-.000008	-.0435	.00010	.378
T4X4	1.40	.14498	-.000043	-.0493	-.00011	.440
T4X4	1.75	.11878	-.000013	-.0535	.00001	.550
T4X4	2.50	.09236	-.000088	-.0475	.00013	.614
T4X4	3.00	.08033	-.000155	-.0400	.00003	.597
T5X1	.80	.10553	.000115	.1100	-.00014	.096
T5X1	.90	.09446	.000234	.1020	.00005	.033
T5X1	.95	.11892	-.000007	.1099	.00008	.293
T5X1	1.00	.10422	.000181	.0935	-.00008	.338
T5X1	1.05	.08400	.000245	.0814	-.00021	.218
T5X1	1.10	.08024	.000248	.0825	-.00003	.119
T5X1	1.20	.09592	-.000054	.0869	-.00001	.266
T5X1	1.30	.07697	.000072	.0682	.00011	.356
T5X1	1.40	.06332	.000021	.0530	.00027	.438
T5X1	2.00	.05818	.000001	.0525	.00010	.329
T5X1	2.50	.05733	-.000125	.0420	.00005	.612
T5X1	3.00	.04891	-.000077	.0341	.00017	.671
T5X1	4.00	.04080	-.000143	.0316	-.00014	.542
T5X1	4.50	.03716	-.000130	.0283	.00012	.564
T5X2	.80	.11254	.000211	.0498	.00024	.262
T5X2	.90	.09444	.000572	.0236	.00089	.593
T5X2	.95	.11578	.000032	.0463	.00001	.333
T5X2	1.00	.10713	.000183	.0423	.00013	.341
T5X2	1.05	.09918	.000154	.0399	-.00028	.329
T5X2	1.10	.09687	.000224	.0340	.00011	.415
T5X2	1.20	.10431	.000126	.0386	.00007	.455
T5X2	1.30	.11618	-.000077	.0991	.00001	.353
T5X2	1.40	.08944	.000067	.0219	-.00007	.521
T5X2	1.75	.08145	.000010	.0169	.00031	.656
T5X2	2.00	.07587	.000011	.0157	.00029	.655
T5X2	2.50	.06334	-.000089	.0071	.00031	.813
T5X2	3.00	.05126	-.000064	.0056	.00034	.817
T5X2	4.00	.04104	-.000136	.0081	.00009	.671
T5X2	4.50	.03778	-.000143	.0129	.00002	.430

TABLE II. RINGTAIL COEFFICIENTS (Continued)

CONFIG	MN	A1	A3	B1	B3	XCP/C
T6X3	.80	.12279	.000082	-.5593	-.04175	----
T6X3	.90	.06968	.000324	-.0011	-.00014	.185
T6X3	.95	.10281	.000438	-.0168	.00045	.439
T6X3	1.00	.10836	.000108	-.0118	-.00007	.348
T6X3	1.05	.09914	.000106	-.0135	-.00027	.393
T6X3	1.10	.09724	.000157	-.0178	-.00021	.471
T6X3	1.20	.10524	-.000045	-.0159	-.00004	-.084
T6X3	1.30	.10799	-.000041	-.0184	.00007	.450
T6X3	1.40	.10080	-.000111	-.0161	-.00003	.432
T6X3	1.75	.08631	.000050	-.0265	.00038	.678
T6X3	2.00	.07711	.000024	-.0230	.00027	.663
T6X3	2.50	.06291	-.000073	-.0232	.00032	.781
T6X3	3.00	.05214	-.000109	-.0176	.00027	.729
T6X3	4.00	.04111	.000129	-.0160	.00020	.815
T6X3	4.50	.03803	-.000099	-.0085	.00026	.539
T6X1	.80	.14527	.000010	.1868	.00008	.214
T6X1	.90	.14995	.000377	.1764	.00034	.323
T6X1	.95	.12069	.000207	.1896	.00008	.249
T6X1	1.00	.17571	.000604	.1758	.00033	.489
T6X1	1.05	.17631	.000169	.1707	0.00000	.342
T6X1	1.10	.17067	-.000011	.1732	.00001	.485
T6X1	1.20	.16727	-.000121	-.3934	-.00006	----
T6X1	1.30	.14094	-.000016	.1531	-.00010	.413
T6X1	1.75	.11012	0.000000	.1171	.00031	.436
T6X1	2.00	.09703	.000011	.1052	.00036	.415
T6X1	2.50	.08510	-.000061	.0955	.00003	.377
T6X1	3.00	.07825	-.000182	.0750	.00001	.541
T6X1	4.00	.06312	-.000149	.0578	.00017	.584
T6X1	4.50	.05699	-.000107	.0550	.00013	.534
T6X2	.80	.14259	-.000086	.1458	.00002	-.022
T6X2	.90	.14507	.000081	.1954	.00018	.265
T6X2	.95	.12530	.000060	.0888	-.00011	.291
T6X2	1.00	.15196	-.000032	.0975	.00003	.358
T6X2	1.05	.15066	.000090	.0774	.00006	.486
T6X2	1.10	.15127	.000023	.0786	.00001	.480
T6X2	1.20	.16053	.000109	.0874	.00016	.455
T6X2	1.30	.13126	.000133	.0792	-.00011	.396
T6X2	1.75	.11466	.000109	.0552	.00046	.514
T6X2	2.00	.11018	-.000048	.0528	.00044	.520
T6X2	2.50	.10020	-.000131	.0448	.00032	.552
T6X2	3.00	.08478	-.000151	.0339	.00025	.600
T6X2	4.00	.06434	-.000121	.0215	.00041	.665
T6X2	4.50	.05766	-.000047	.0206	.00042	.642
T6X3	.80	.15128	.000253	.0313	.00017	.293
T6X3	.90	.14657	.000803	.0236	-.00005	.338
T6X3	.95	.11891	.000607	.0338	-.00021	.215
T6X3	1.00	.13299	.000581	.0228	-.00006	.328
T6X3	1.05	.15629	.000169	.0085	-.00004	.445
T6X3	1.10	.16464	-.000036	.0067	-.00009	.459
T6X3	1.20	.19081	-.000110	.0395	-.00004	.292
T6X3	1.30	.15824	-.000135	.0114	.00005	----
T6X3	1.75	.12900	-.000025	-.0078	.00048	.560
T6X3	2.00	.11333	.000009	-.0057	.00033	.550
T6X3	2.50	.09477	-.000046	-.0053	.00028	.555
T6X3	3.00	.07900	-.000103	-.0068	.00033	.586
T6X3	4.00	.06529	-.000208	-.0054	.00026	.582
T6X3	4.50	.05845	-.000109	-.0057	.00039	.597
T7X1	.80	.16390	-.000089	.1493	-.00009	.589
T7X1	.90	.15473	.000322	.1243	.00013	.696
T7X1	.95	.18856	.000014	.1256	.00011	.833
T7X1	1.00	.19270	-.000206	.1355	-.00055	.796
T7X1	1.05	.18227	-.000232	.1150	-.00053	.869
T7X1	1.10	.18510	-.000368	.1120	-.00028	.888
T7X1	1.20	.13099	.000008	.0751	.00016	.926
T7X1	1.30	.14519	-.000559	.1199	-.00097	.674
T7X1	1.75	.14222	-.000446	.1618	.00005	.221
T7X1	2.00	.09274	.000644	.1029	.00111	.390
T7X1	2.50	.06803	.000024	.0851	.00009	.249
T7X1	3.00	.05956	-.000021	.0716	.00008	.297
T7X1	4.00	.04833	-.000133	.0638	-.00032	.179
T7X1	4.50	.04295	-.000118	.0513	-.00001	.305



TABLE II. RINGTAIL COEFFICIENTS (Continued)

CONFIC	MN	A1	A2	B1	B2	YCP/C
T7X2	.80	.13529	-.000049	-.1249	.00066	1.923
T7X2	.90	.15474	-.000275	.1291	.00019	.165
T7X2	.95	.19444	-.000091	.1629	-.00017	.164
T7X2	1.00	.19311	-.000123	.1425	-.00018	.262
T7X2	1.05	.18485	-.000297	.1261	-.00047	.317
T7X2	1.10	.18324	-.000413	.1150	-.00026	.372
T7X2	1.20	.15883	-.000299	.0908	-.00012	.428
T7X2	.80	.15444	-.000034	.1988	-.00011	-.287
T7X2	.90	.14426	-.000353	.1932	.00029	-.339
T7X2	.95	.19137	.000036	.2206	.00007	-.152
T7X2	1.00	.18636	.000004	.2225	-.00027	-.193
T7X2	1.05	.17514	-.000086	.2044	-.00021	-.167
T7X2	1.10	.17257	-.000288	.1942	-.00044	-.102
T7X2	1.20	.15419	-.000123	.1356	.00025	-.079
T7X2	1.50	.15419	-.000532	.1965	-.00086	-.274
T7X2	1.75	.19433	-.001787	.0797	.00065	.589
T7X2	2.00	.11083	.000736	.0496	.00087	.552
T7X2	2.50	.08159	.000038	.0461	.00021	.434
T7X2	3.00	.07482	-.000144	.0373	.00015	.501
T7X2	4.00	.06182	-.000253	.0293	.00015	.526
T7X2	4.50	.05401	-.000230	.0269	.00010	.501
T7X3	.80	.15347	-.000083	.0407	.00021	.234
T7X3	.90	.14956	.000266	.0491	.00013	.171
T7X3	.95	.17046	.000154	.0451	-.00026	.276
T7X3	1.00	.18479	.000169	.0412	-.00019	.246
T7X3	1.05	.15770	.000092	.0382	-.00041	.257
T7X3	1.10	.16045	-.000181	.0322	-.00021	.299
T7X3	1.20	.14021	-.000063	.0140	.00001	.400
T7X3	1.30	.12230	.000202	.0144	.00018	.382
T7X3	1.50	.18041	-.000915	.0466	-.00067	.241
T7X3	1.75	.14758	.000065	-.0036	.00056	.524
T7X3	2.00	.12322	-.000018	.0021	.00032	.482
T7X3	2.50	.10144	-.000100	-.0005	.00033	.504
T7X3	3.00	.08338	-.000119	-.0031	.00028	.537
T7X3	4.00	.06342	-.000269	-.0010	.00024	.484
T7X3	4.50	.05445	-.000214	-.0034	.00042	.562
T7X4	.80	.12693	.000383	-.0308	.00068	.342
T7X4	.90	.15903	.000334	-.0080	.00006	.157
T7X4	.95	.17500	-.000010	-.0057	.00019	.132
T7X4	1.00	.17043	-.000094	-.0141	.00005	.182
T7X4	1.05	.14145	.000142	-.0163	-.00040	.215
T7X4	1.10	.14715	.000144	-.0221	-.00021	.250
T7X4	1.20	.14875	-.000057	-.0687	-.00012	.561
T7X4	1.30	.15423	-.000088	-.0451	-.00006	.391
T7X4	1.50	.15452	-.000122	-.0512	.00015	.451
T7X4	1.75	.12345	-.000044	-.0511	.00007	.513
T7X4	2.00	.09666	-.000051	-.0218	.00039	.325
T7X4	3.00	.08056	-.000241	-.0368	.00007	.556
T8X1	1.75	.11125	-.000074	.1192	.00025	.428
T8X1	2.00	.09955	-.000020	.1105	.00016	.386
T8X1	2.50	.08912	-.000085	.0928	.00014	.458
T8X1	3.00	.08375	-.000162	.0770	.00015	.580
T8X1	4.00	.06925	-.000143	.0598	.00021	.636
T8X1	4.50	.06280	-.000069	.0544	.00035	.633
T8X2	1.75	.12561	-.000096	.0567	.00034	.548
T8X2	2.00	.12070	-.000151	.0481	.00026	.601
T8X2	2.50	.10289	-.000085	.0418	.00033	.593
T8X2	3.00	.08781	-.000105	.0320	.00034	.635
T8X2	4.00	.06985	-.000151	.0262	.00028	.624
T8X2	4.50	.07420	-.000106	.0256	.00028	.601
T8X3	1.75	.14139	-.000055	-.0019	.00048	.513
T8X3	2.00	.12660	-.000102	.0053	.00023	.458
T8X3	2.50	.10218	-.000069	-.0102	.00033	.599
T8X3	3.00	.08760	-.000120	-.0095	.00029	.608
T8X3	4.00	.07038	-.000185	-.0079	.00023	.612
T8X3	4.50	.06370	-.000071	-.0110	.00062	.672

TABLE II. RINGTAIL COEFFICIENTS (Continued)

CONFIG	MN	A1	A3	B1	B3	XCP/C
T8SX1	1.75	.14904	-.000132	.1684	.00017	.370
T8SX1	2.00	.13702	-.000060	.1527	.00021	.395
T8SX1	2.50	.11772	-.000068	.1189	.00040	.489
T8SX1	3.00	.10148	-.000107	.0987	.00029	.527
T8SX1	4.00	.08012	-.000070	.0738	.00031	.578
T8SX1	4.50	.07259	-.000042	.0699	.00019	.537
T8SX2	1.75	.16485	-.000168	.0905	.00042	.451
T8SX2	2.00	.14825	-.000078	.0781	.00026	.473
T8SX2	2.50	.12054	-.000056	.0582	.00039	.518
T8SX2	3.00	.10107	-.000108	.0470	.00026	.534
T8SX2	4.00	.07920	-.000127	.0247	.00031	.561
T8SX2	4.50	.07207	-.000023	.0292	.00052	.594
T8SX3	1.75	.16484	-.000093	.0015	.00040	.490
T8SX3	2.00	.14534	-.000028	.0050	.00043	.465
T8SX3	2.50	.12118	-.000036	-.0015	.00042	.512
T8SX3	3.00	.09817	-.000080	-.0050	.00048	.550
T8SX3	4.00	.07819	-.000122	-.0049	.00053	.562
T8SX3	4.50	.07175	-.000091	-.0025	.00029	.534
T10X1	1.75	.19416	.000137	.2397	.00050	.412
T10X1	2.00	.17849	-.000073	.2216	.00020	.395
T10X1	2.50	.16202	-.000091	.1852	.00035	.485
T10X1	3.00	.14624	-.000198	.1544	.00020	.555
T10X1	4.00	.10917	-.000131	.1121	.00029	.578
T10X1	4.50	.09884	-.000115	.1042	.00029	.556
T10X2	1.75	.21024	.000127	.1348	.00051	.487
T10X2	2.00	.19523	-.000146	.1168	.00039	.544
T10X2	2.50	.17835	-.000173	.0680	.00032	.604
T10X2	3.00	.14846	-.000186	.0818	.00037	.559
T10X2	4.00	.11116	-.000166	.0580	.00039	.582
T10X2	4.50	.09977	-.000120	.0533	.00036	.572
T10X3	1.75	.23793	-.000022	.0234	.00066	.521
T10X3	2.00	.21834	-.000052	.0211	.00051	.485
T10X3	2.50	.19330	-.000092	.0241	.00050	.488
T10X3	3.00	.14935	-.000172	.0121	.00046	.535
T10X3	4.00	.11371	-.000227	.0081	.00028	.543
T10X3	4.50	.10152	-.000147	.0044	.00051	.565
T11X1	1.75	.12446	.000086	.1139	.00038	.446
T11X1	2.00	.12139	-.000088	.1139	.00027	.471
T11X1	2.50	.10524	-.000082	.0856	.00036	.642
T11X1	3.00	.09288	-.000184	.0733	.00013	.614
T11X1	4.00	.07014	-.000159	.0565	-.00001	.592
T11X1	4.50	.06306	-.000088	.0485	.00023	.641
T11X2	1.75	.15124	-.000029	.0476	.00047	.580
T11X2	2.00	.13412	-.000066	.0416	.00030	.586
T11X2	2.50	.11052	-.000088	.0305	.00042	.632
T11X2	3.00	.09254	-.000166	.0253	.00046	.635
T11X2	4.00	.07059	-.000156	.0180	.00027	.660
T11X2	4.50	.06349	-.000097	.0142	.00036	.701
T11X3	1.75	.15120	.000005	-.0290	.00037	.589
T11X3	2.00	.12717	-.000098	-.0262	.00039	.611
T11X3	2.50	.11087	-.000090	-.0277	.00039	.618
T11X3	3.00	.09224	-.000134	-.0219	.00045	.649
T11X3	4.00	.07150	-.000149	-.0186	.00041	.625
T11X3	4.50	.06420	-.000089	-.0186	.00066	.719
T12X1	.80	.03767	-.000253	.0653	-.00030	.013
T12X1	.90	.01574	.000344	.0459	.00020	-.932
T12X1	1.00	.01632	.000427	.0399	.00027	-.955
T12X1	1.05	.01869	.000341	.0477	-.00001	-.940
T12X1	1.05	.01869	.000123	.0403	-.00027	-.306
T12X1	1.10	.02138	.000081	.0406	.00001	-.119
T12X1	1.30	.02336	.000131	.0401	.00022	.026
T12X1	1.50	.02981	-.000077	.0454	.00013	.181
T12X1	1.75	.02957	-.000048	.0447	-.00023	.190
T12X1	2.00	.02582	-.000034	.0289	-.00005	.504
T12X1	2.50	.02284	-.000047	.0316	-.00005	.293
T12X1	3.00	.01949	-.000099	.0199	-.00014	.583

TABLE II. RINGTAIL COEFFICIENTS (Continued)

CONF IG	MN	A1	A3	B1	B3	XCP/C
T12X2	.80	.03929	-.000019	.0343	-.00024	.301
T12X2	.90	.02999	.000159	.0309	-.00012	.175
T12X2	.95	.02487	.000319	.0160	.00024	.485
T12X2	1.00	.01829	.000197	.0204	.00013	.107
T12X2	1.05	.01163	.000347	.0150	-.00001	-.031
T12X2	1.10	.01336	-.000328	.0161	-.00023	.035
T12X2	1.30	.03245	-.000111	.8180	-.00010	----
T12X2	1.50	.03587	-.000005	.0246	-.00002	.451
T12X2	1.75	.03730	-.000090	.0234	-.00012	.498
T12X2	2.00	.03237	-.000058	.0100	-.00004	.752
T12X2	2.50	-.02861	-.000075	.0147	-.00004	.588
T12X2	3.00	-.03570	-.001488	-.1940	-.00534	----
T12X5	.80	.04673	-.000351	.0263	-.00018	.349
T12X5	.90	.03189	.000034	.0185	.00018	.335
T12X5	.95	.02734	-.000010	.0610	-.00016	-.984
T12X5	1.00	.01781	.000277	.0158	-.00005	.090
T12X5	1.05	.01533	.000278	.0087	-.00013	.345
T12X5	1.10	.01575	.000292	.0120	.00005	.190
T12X5	1.30	.03184	.000139	.0189	.00003	.247
T12X5	1.50	.03451	.000011	.0155	-.00008	.440
T12X5	1.75	.03609	-.000043	.0165	-.00013	.434
T12X5	2.00	.03270	-.000035	-.0005	.00006	.812
T12X5	2.50	.02956	-.000068	.0065	-.00001	.624
T12X5	3.00	.02507	-.000087	.0011	-.00006	.764
T13X1	.80	.02743	-.000058	.0462	-.00032	-.263
T13X1	.90	.01813	.000082	.0335	-.00006	-.238
T13X1	.95	.00603	.000247	.0206	.00019	----
T13X1	1.00	.01452	.000108	.0253	.00013	-.325
T13X1	1.05	.01504	.000071	.0200	-.00010	.114
T13X1	1.10	.01632	-.000042	.0220	-.00010	-.094
T13X1	1.30	.01534	.000113	.0267	-.00002	-.323
T13X1	1.50	.01963	.000068	.0277	.00002	-.027
T13X1	1.75	.02044	-.000015	.0343	-.00017	-.657
T13X1	2.00	.01753	-.000014	.0166	.00001	.523
T13X1	2.50	.01560	-.000047	.0189	-.00008	.240
T13X1	3.00	.01352	-.000068	.0146	-.00017	.381
T13X2	.80	.03748	-.000237	.0220	-.00004	.373
T13X2	.90	.02953	.000082	.0278	-.00032	.175
T13X2	.95	.02256	.000139	.0015	.00018	.645
T13X2	1.00	.01381	.000271	.0099	.00027	.534
T13X2	1.05	.01420	.000179	.0088	-.00007	.338
T13X2	1.10	.01765	.000111	.0071	-.00028	.570
T13X2	1.30	.02519	.000020	.0204	-.00017	.135
T13X2	1.50	.02862	-.000051	.0194	-.00005	.276
T13X2	1.75	.02724	-.000045	.0197	-.00011	.229
T13X2	2.00	.02398	-.000051	.0035	0.00000	.844
T13X2	2.50	.02069	-.000051	.0094	-.00002	.515
T13X2	3.00	.01737	-.000055	.0003	-.00006	.612
T13X5	.80	.03096	-.000153	.0256	-.00016	-.149
T13X5	.90	.03355	.000013	.0088	-.00010	.453
T13X5	.95	.02531	.000068	.0008	.00006	.699
T13X5	1.00	.01568	.000108	.0034	.00018	.348
T13X5	1.05	.01483	.000109	.0052	-.00019	.358
T13X5	1.10	.01505	.000100	.0055	.00002	.343
T13X5	1.30	.02941	.000019	.0084	.00007	.428
T13X5	1.50	.03097	-.000053	.0050	-.00005	.560
T13X5	1.75	.02701	-.000024	.0106	-.00007	.314
T13X5	2.00	.02394	-.000015	-.0028	.00002	.858
T13X5	2.50	.02076	-.000026	.0045	0.00000	.501
T13X5	3.00	.01744	-.000057	-.0020	-.00012	.855
T13RX1	.80	.00010	.000145	-.0293	.00043	----
T13RX1	.90	-.00687	.000284	-.0359	.00046	----
T13RX1	.95	-.00816	.000432	-.0330	.00080	----
T13RX1	1.00	.00306	.000350	-.0194	.00042	----
T13RX1	1.05	-.00019	.000406	-.0290	.00053	----
T13RX1	1.10	-.00465	.000426	-.0378	.00087	----
T13RX1	1.30	-.02274	.000598	-.0578	.00078	-1.179
T13RX1	1.50	-.03341	.000728	-.0755	.00111	-.878
T13RX1	1.75	-.03193	.000462	-.0718	.00063	-.866
T13RX1	2.00	-.03903	.000516	-.0957	.00102	-1.083

TABLE II. RINGTAIL COEFFICIENTS (Continued)

CONFIG	MN	A1	A3	B1	R3	YCP/C
T13RX2	.80	.00458	-.000050	-.0098	-.00024	----
T13RX2	.90	-.01559	.000235	-.0299	.00029	-1.046
T13RX2	1.05	.01094	.000239	-.0248	.00048	----
T13RX2	1.30	-.01207	.000416	-.0217	.00056	----
T13RX2	1.50	.01045	.000424	-.0269	.00026	----
T13RX2	1.10	.00363	.000492	-.0367	.00074	----
T13RX2	1.30	-.01781	.000582	-.0460	.00056	-1.756
T13RX2	1.50	-.03039	.000708	-.0637	.00097	-1.237
T13RX2	1.75	-.03685	.000401	-.0567	.00045	-.642
T13RX2	2.00	-.05052	.000594	-.0749	.00082	-.582
T13RX5	.80	.00889	-.000099	.0119	-.00022	-.695
T13RX5	.90	.00543	-.000279	-.0139	.00008	3.465
T13RX5	1.05	.01902	-.000035	-.1809	.00039	----
T13RX5	1.30	.02542	.000253	-.0147	.00028	1.350
T13RX5	1.50	.02271	.000217	-.0213	.00008	1.734
T13RX5	1.10	.01635	.000217	-.0243	.00026	----
T13RX5	1.30	-.01933	.000597	-.0264	.00020	-.724
T13RX5	1.50	-.03705	.000741	-.0336	.00044	-.234
T13RX5	1.75	-.05107	.000530	-.0288	.00027	.131
T13RX5	2.00	-.06483	.000731	-.0392	.00056	.087
T13RX5	2.50	-.06086	.000776	-.0256	.00046	.284
T13RX5	3.00	-.04525	.000644	-.0191	.00026	.282
T135X1	.80	.04008	-.000132	.1659	-.00026	----
T135X1	.90	.02665	0.000000	.0371	-.00017	.047
T135X1	1.05	.02128	.000161	.0339	.00009	-.166
T135X1	1.30	.02064	.000162	.0313	.00023	-.084
T135X1	1.50	.04835	-.000114	.2317	.00002	----
T135X1	1.10	.02177	.000048	.0249	-.00017	.312
T135X1	1.30	.02332	.000049	.0319	-.00021	.073
T135X1	1.50	.01938	.000223	.0198	.00038	.383
T135X1	1.75	.02172	-.000019	.0298	-.00012	.074
T135X1	2.00	.02156	-.000035	.0194	-.00004	.573
T135X1	2.50	.01979	-.000048	.0247	-.00008	.201
T135X1	3.00	.01707	-.000086	.0146	-.00016	.620
T135X2	.80	.04349	-.000312	.0280	-.00017	.312
T135X2	.90	.04922	-.000016	.0222	-.00014	.321
T135X2	1.05	.02844	.000253	.0136	.00010	.489
T135X2	1.30	.02753	-.000008	.0151	.00017	.414
T135X2	1.50	.01783	-.000040	.8184	-.00009	----
T135X2	1.10	.01834	-.000041	.1853	-.00017	----
T135X2	1.30	.02677	.000066	.0161	-.00007	.358
T135X2	1.50	.02327	.000197	.0152	0.00000	.302
T135X2	1.75	.02433	-.000009	.0167	-.00009	.267
T135X2	2.00	.02433	-.000038	.0062	-.00003	.728
T135X2	2.50	.02316	-.000052	.0122	-.00002	.437
T135X2	3.00	.01887	-.000068	.0048	-.00010	.728
T135X5	.80	.04538	-.000236	.0212	-.00025	.234
T135X5	.90	.04631	-.000170	.0124	-.00012	.447
T135X5	1.05	.03409	.000046	.0036	.00017	.620
T135X5	1.30	.02172	.000204	.0079	-.00001	.345
T135X5	1.50	.01909	.000118	.0069	-.00033	.347
T135X5	1.10	.01897	.000166	.0014	.00024	.654
T135X5	1.30	.01025	.000063	.0113	-.00008	.334
T135X5	1.50	.0190	.000039	.0071	.00010	.479
T135X5	1.75	.0209	-.000017	.0111	-.00008	.241
T135X5	2.00	.0234	-.000025	-.0008	-.00003	.767
T135X5	2.50	.02290	-.000037	-.0053	-.00003	.486
T135X5	3.00	.01912	-.000054	-.0029	-.00007	.895
T14X1	.80	.03241	-.000092	.0397	-.00009	.226
T14X1	.90	.03060	-.000123	.0360	-.00022	.278
T14X1	1.05	.04393	-.000124	.0424	.00002	.503
T14X1	1.30	.03332	.000027	.0368	.00009	.354
T14X1	1.50	.03137	.000021	.0312	-.00013	.472
T14X1	1.10	.02929	.000081	.0258	.00035	.593
T14X1	1.30	.01957	.000123	.0116	.00019	.829
T14X1	1.50	.01738	.000238	.0051	.00045	1.117
T14X1	1.75	.02227	.000027	.0203	.00001	.464
T14X1	2.00	.0247	-.000098	.0288	-.00006	.444
T14X1	2.50	.02576	-.000103	.0298	-.00007	.799
T14X1	3.00	.01614	-.000132	.0077	-.00021	1.024

TABLE II. RINGTAIL COEFFICIENTS (Concluded)

CONFIG	MN	A1	A3	B1	B3	XCP/C
T14X2	.80	-.03281	-.000096	.0236	-.00018	.232
T14X2	.90	.02241	-.000130	.0238	-.00009	-.133
T14X2	.95	.05011	-.000092	.0474	.00029	-.450
T14X2	1.00	.03304	-.000001	.0170	.00001	.450
T14X2	1.05	.03015	.000130	.0203	.00001	.281
T14X2	1.10	.03156	-.000004	.0179	.00002	.394
T14X2	1.30	.02355	.000079	.0091	-.00023	.587
T14X2	1.50	.01462	.000157	.0010	.00020	.927
T14X2	1.75	.01395	.000084	.0071	.00004	.456
T14X2	2.00	.02367	-.000042	.0104	-.00001	.531
T14X2	2.50	.02379	-.000047	.0149	-.00002	1.331
T14X2	3.00	.01985	-.000080	-.0002	-.00002	1.010
T14X5	.80	.03019	-.000050	.0128	0.00000	.280
T14X5	.90	.03233	-.000218	.0252	.00001	-.098
T14X5	.95	.03148	.000205	.0009	.00024	.702
T14X5	1.00	.02561	.000234	.0066	.00027	.428
T14X5	1.05	.02205	.000217	.0056	-.00021	.462
T14X5	1.10	.02412	.000214	.0022	.00020	.635
T14X5	1.30	.01034	.000313	-.0026	.00018	1.001
T14X5	1.50	-.00098	.000497	-.0009	.00018	-.246
T14X5	1.75	.00175	.000231	.0148	-.00012	-.222
T14X5	2.00	.01302	.000085	.0054	-.00004	.290
T14X5	2.50	.02266	-.000008	.0090	0.00000	.309
T14X5	3.00	.02322	-.000102	-.0023	-.00006	.838

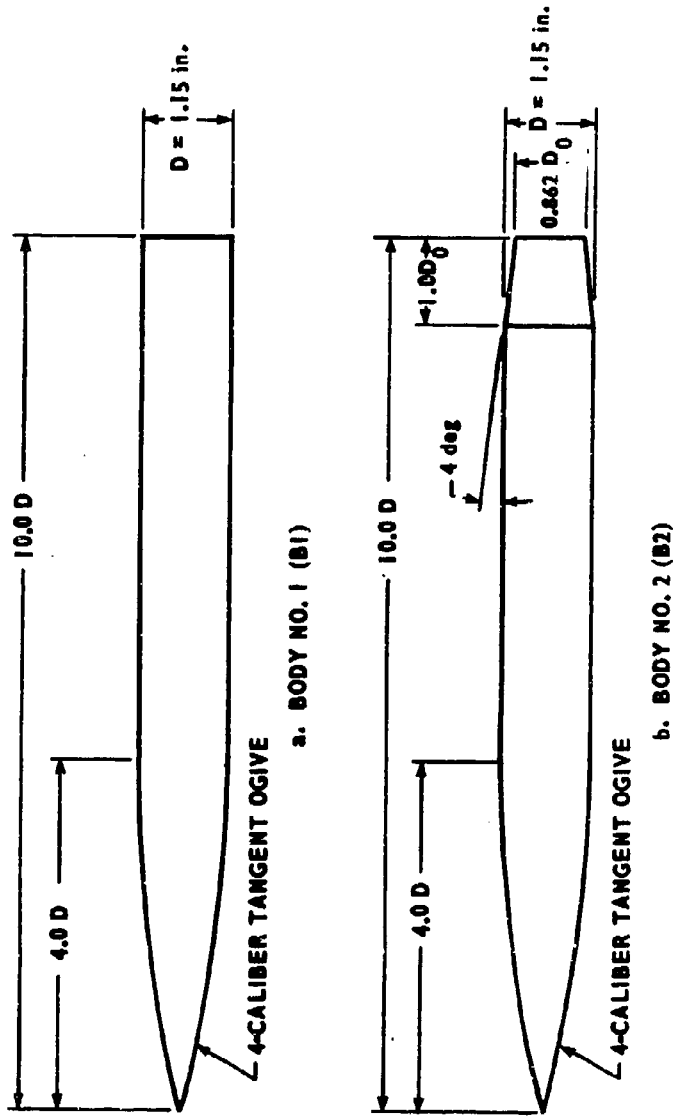
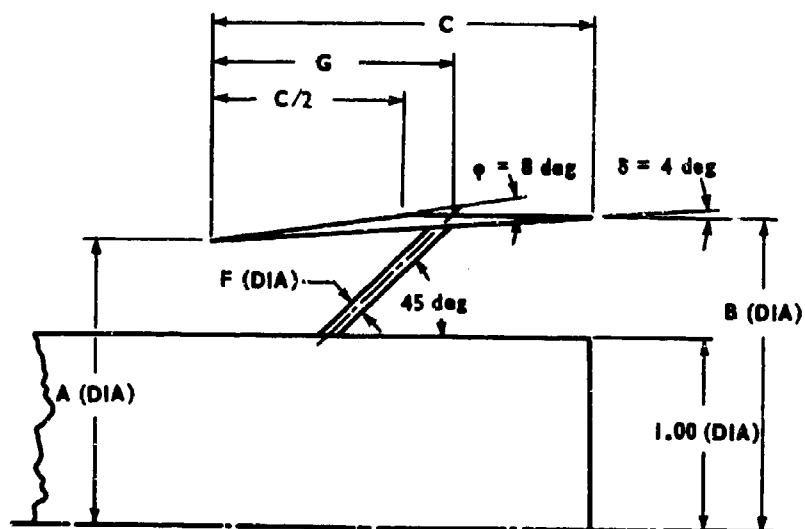
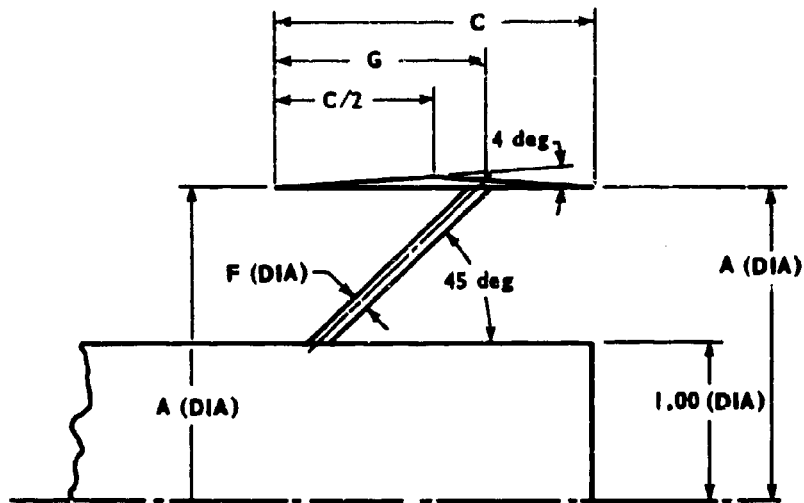

FIGURE 1. BODY CONFIGURATIONS



<u>RINGTAIL</u>	<u>A</u>	<u>B</u>	<u>C</u>	<u>F</u>	<u>G</u>
T1	1.500	1.605	0.750	0.046	0.375
T2	1.500	1.657	1.125	0.052	0.563
T3	2.000	2.210	1.500	0.080	0.750
T4	2.000	2.140	1.000	0.070	0.500
T5	2.000	2.080	0.600	0.060	0.300
T10	2.500	2.675	1.250	0.092	0.625
T11	2.500	2.605	0.750	0.080	0.375
T12	1.250	1.425	1.250	0.048	0.782
T13	1.250	1.381	0.937	0.048	0.623

FIGURE 2. RINGTAIL GEOMETRY, 4-DEGREE INTERNAL EXPANSION ANGLE



RINGTAIL	A	C	F	G
T7	2.000	1.000	0.070	0.500
T14	1.316	0.937	0.048	0.612

a. 0-DEGREE INTERNAL EXPANSION

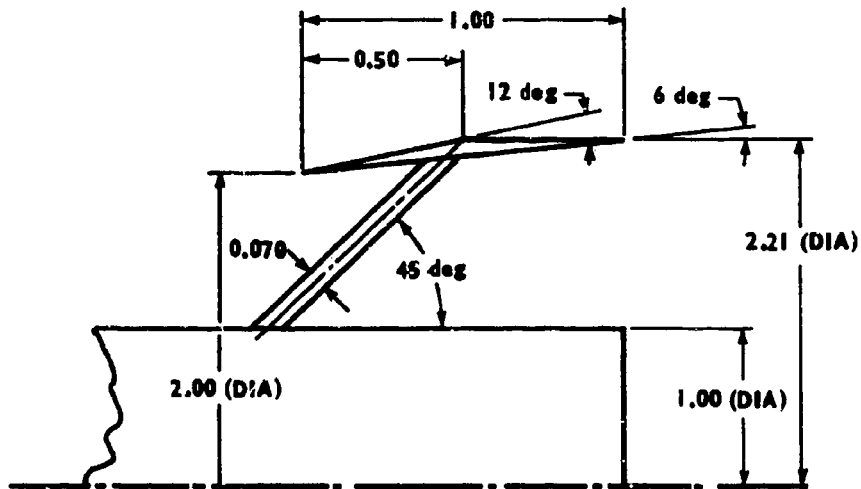

RINGTAIL T8

b. 6-DEGREE INTERNAL EXPANSION

c. T13R - 4-DEGREE INTERNAL COMPRESSION  
OBTAINED BY REVERSING CONFIGURATION  
T13 (FIGURE 2)

FIGURE 3. RINGTAIL GEOMETRY, VARIOUS INTERNAL ANGLES



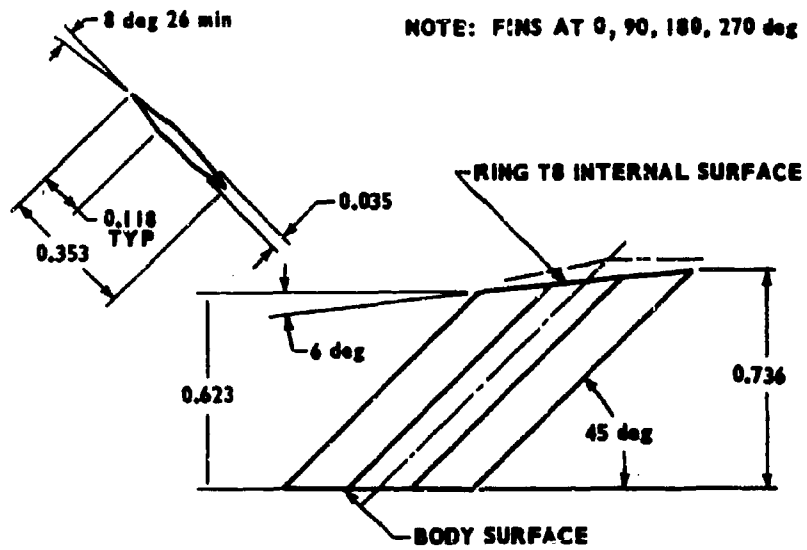

a. T85 SUPPORT STRUT

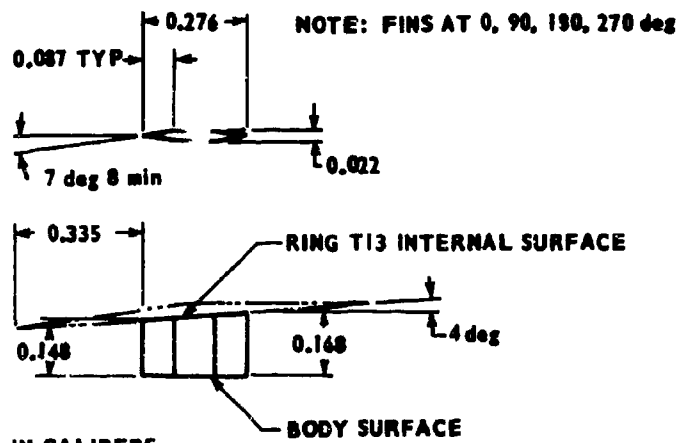

ALL DIMENSIONS IN CALIBERS

b. T135 SUPPORT STRUT

FIGURE 4. GEOMETRY OF NONCIRCULAR SUPPORT STRUTS

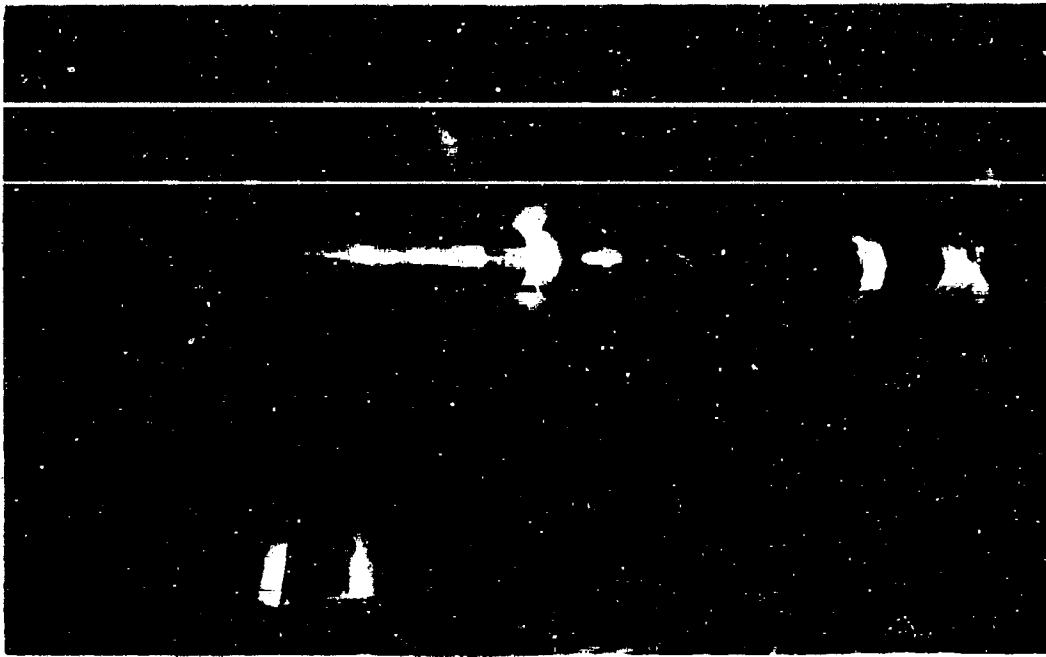

FIGURE 5. MODEL INSTALLATION, TRANSONIC TUNNEL

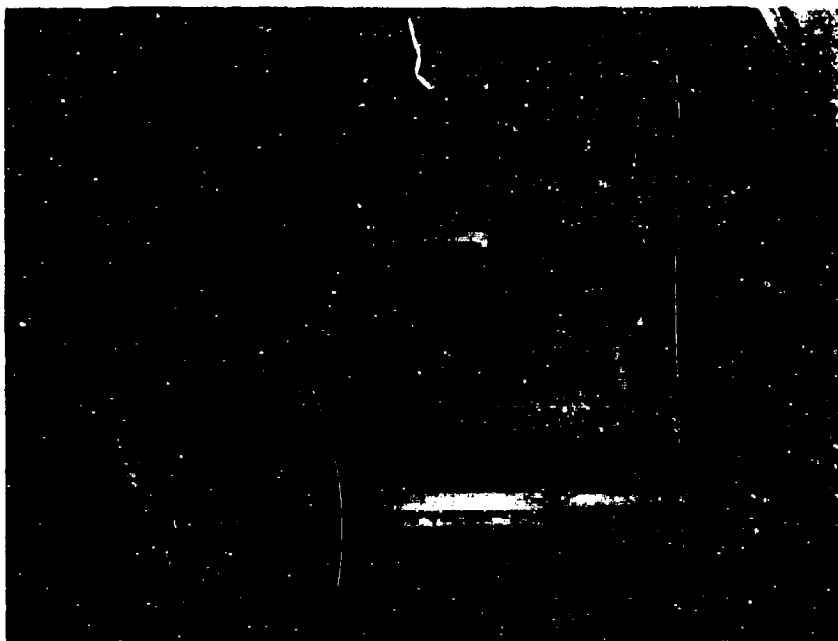

FIGURE 6. MODEL INSTALLATION, SUPERSONIC TUNNEL

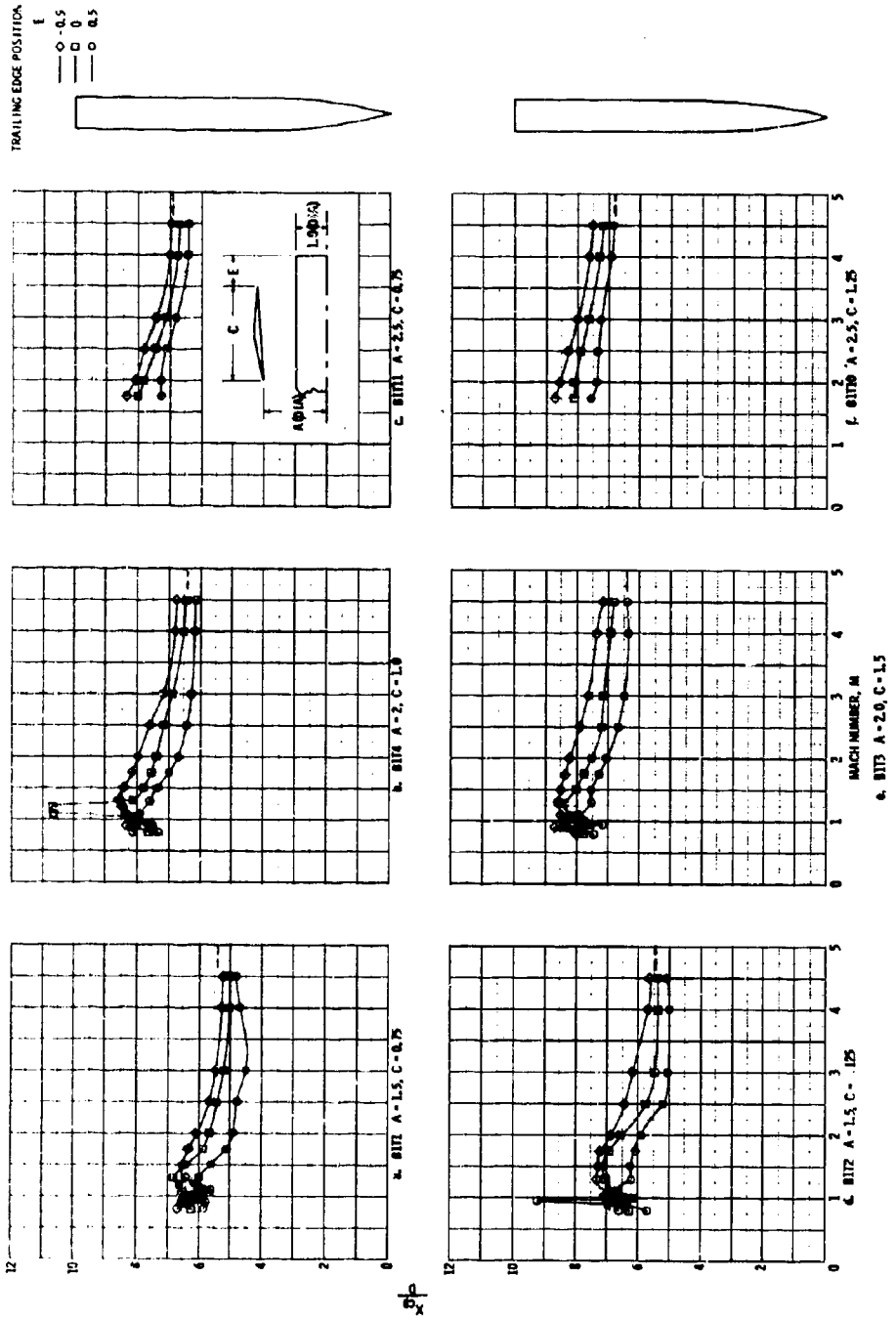

FIGURE 7. VARIATION OF CENTER OF PRESSURE WITH MACH NUMBER FOR SOME TYPICAL CONFIGURATIONS,  $\delta = 4$  deg,  $\phi = 4$  deg

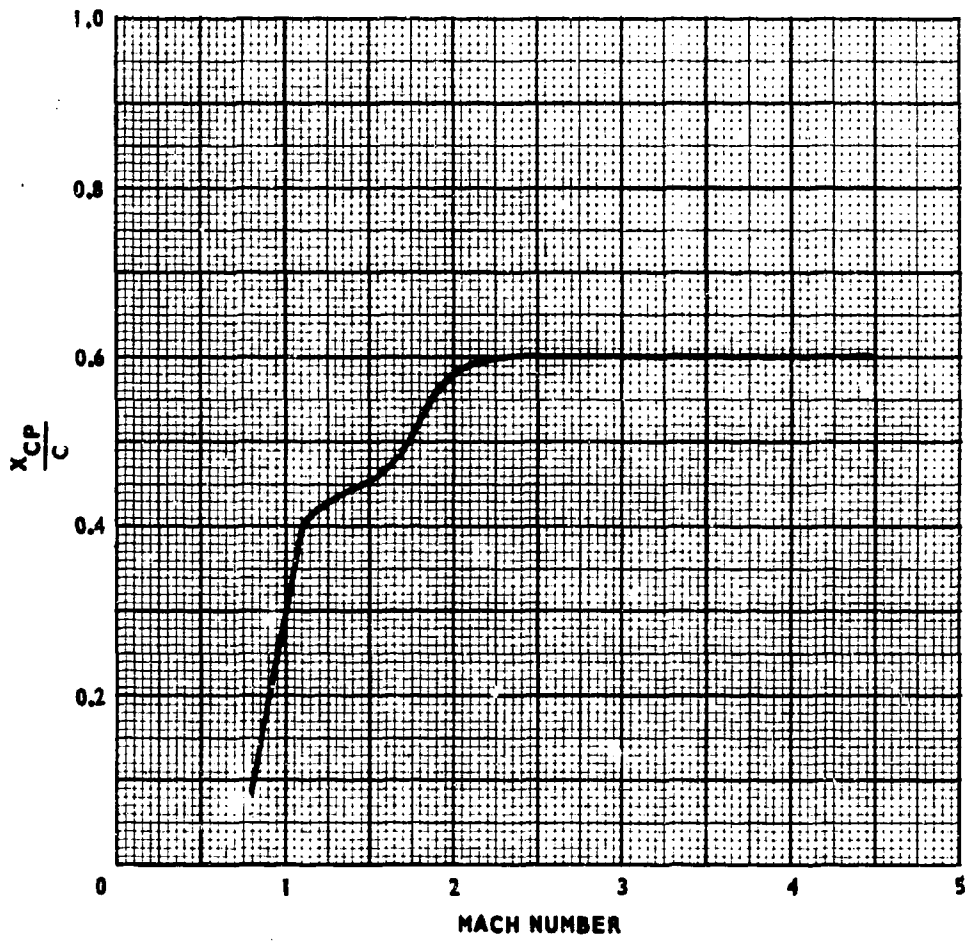

FIGURE 8. VARIATION OF MEAN VALUE OF RINGTAIL CENTER OF PRESSURE WITH MACH NUMBER

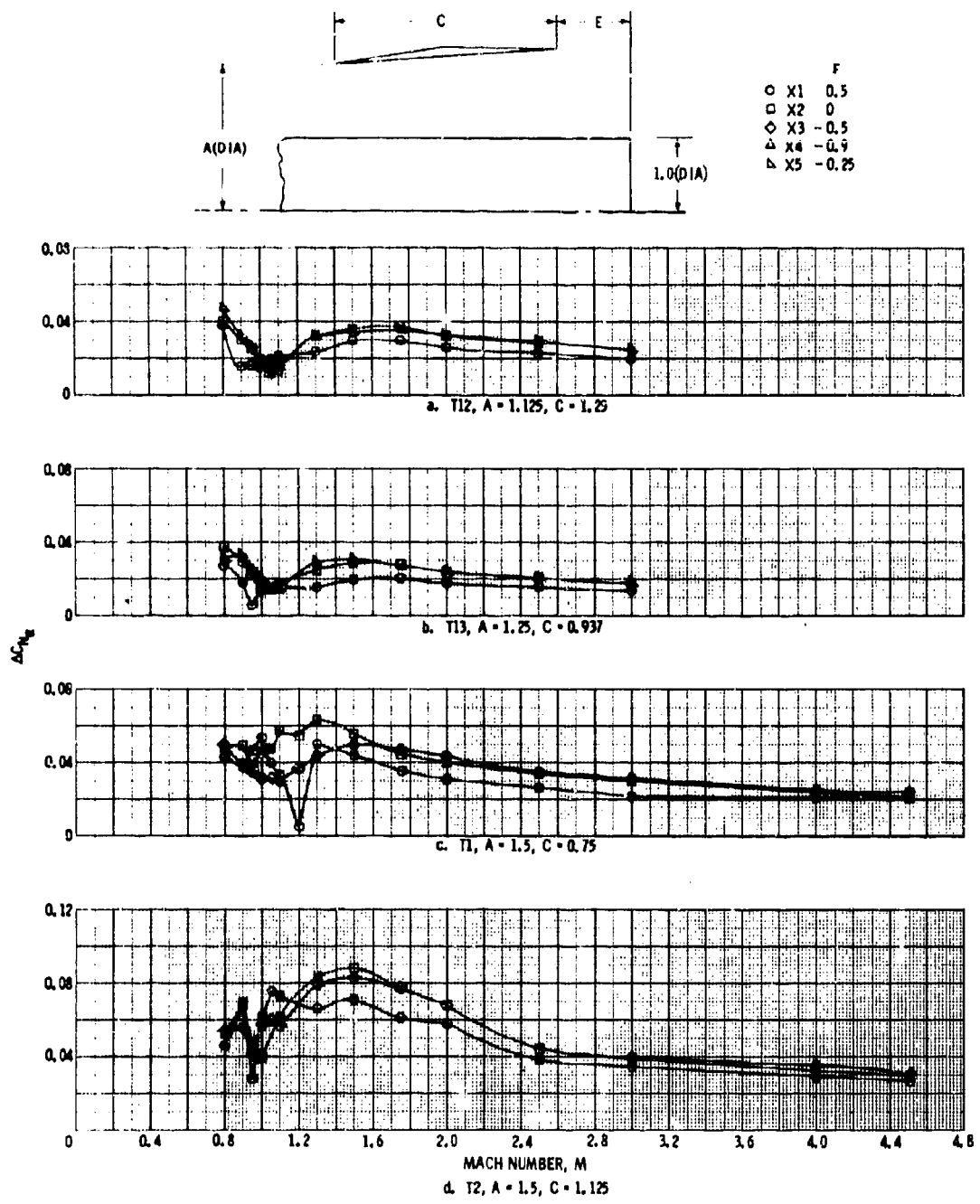

FIGURE 9. EFFECT OF RINGTAIL GEOMETRY AND LONGITUDINAL POSITION ON THE VARIATION OF  $\Delta C_{N\alpha}$  WITH MACH NUMBER,  $\delta = 4$  deg,  $\phi = 4$  deg

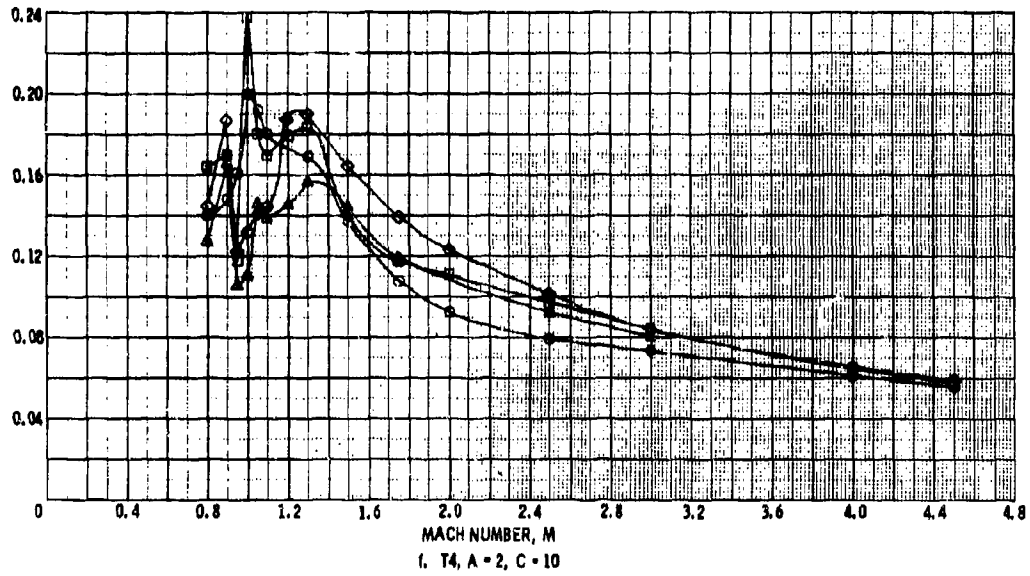
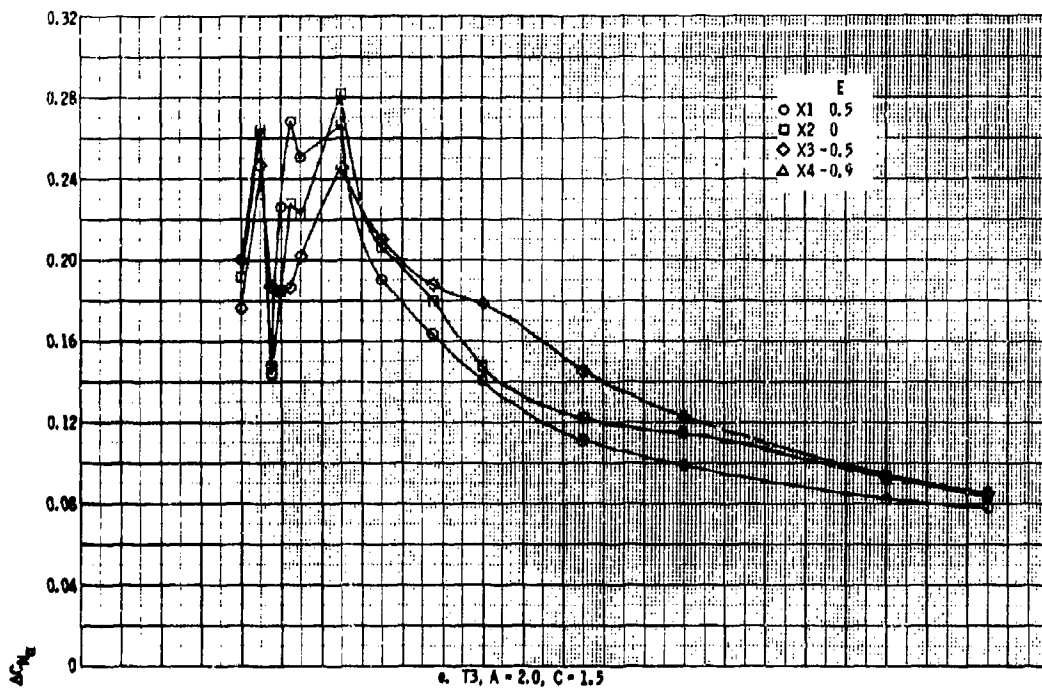

FIGURE 9. EFFECT OF RINGTAIL GEOMETRY AND LONGITUDINAL POSITION ON THE VARIATION OF  $\Delta C_{N\alpha}$  WITH MACH NUMBER,  $\delta = 4$  deg,  $\phi = 4$  deg (Continued).

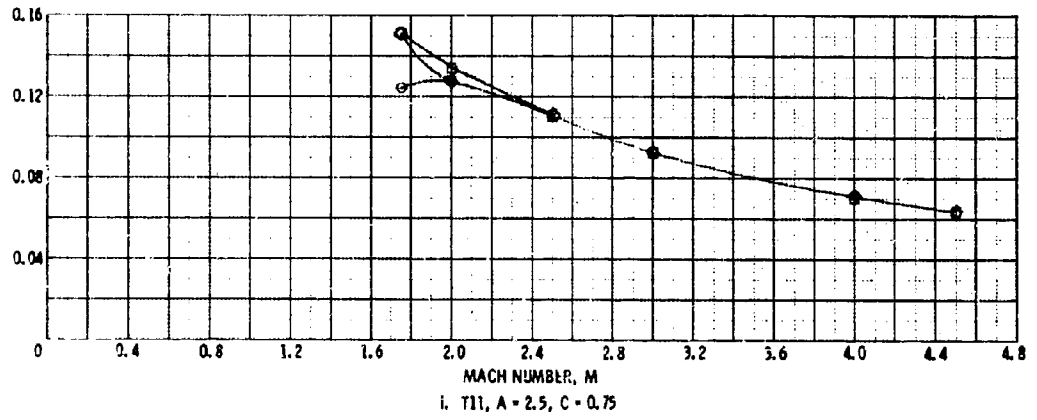
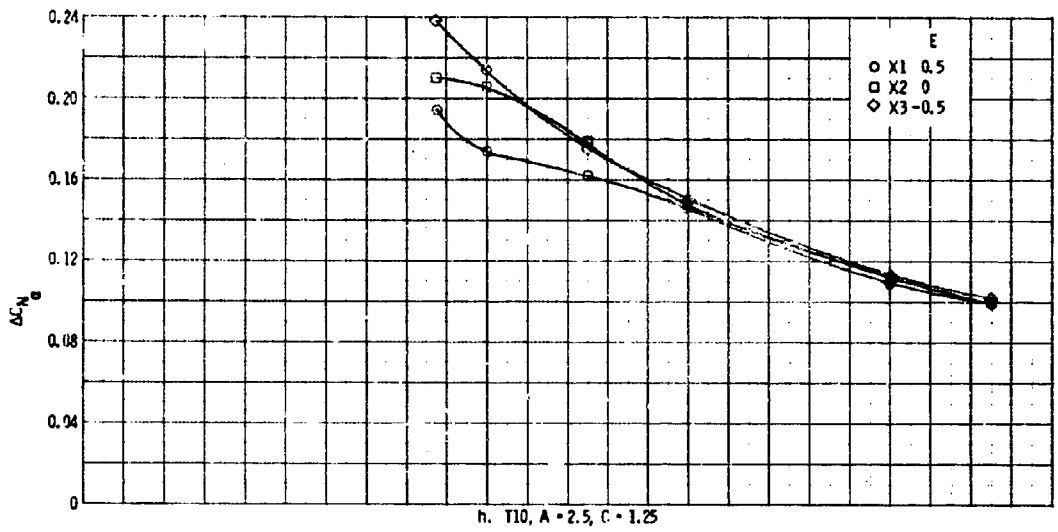
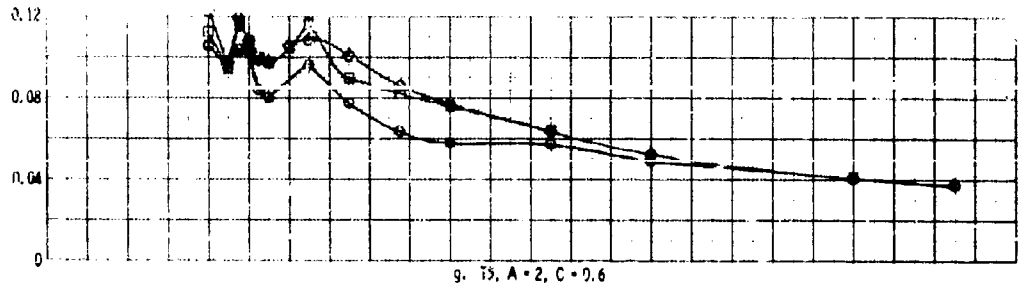

FIGURE 9. EFFECT OF RINGTAIL GEOMETRY AND LONGITUDINAL POSITION ON THE VARIATION OF  $\Delta C_N$  WITH MACH NUMBER,  $\delta = 4$  deg,  $\psi = 4$  deg (Concluded)

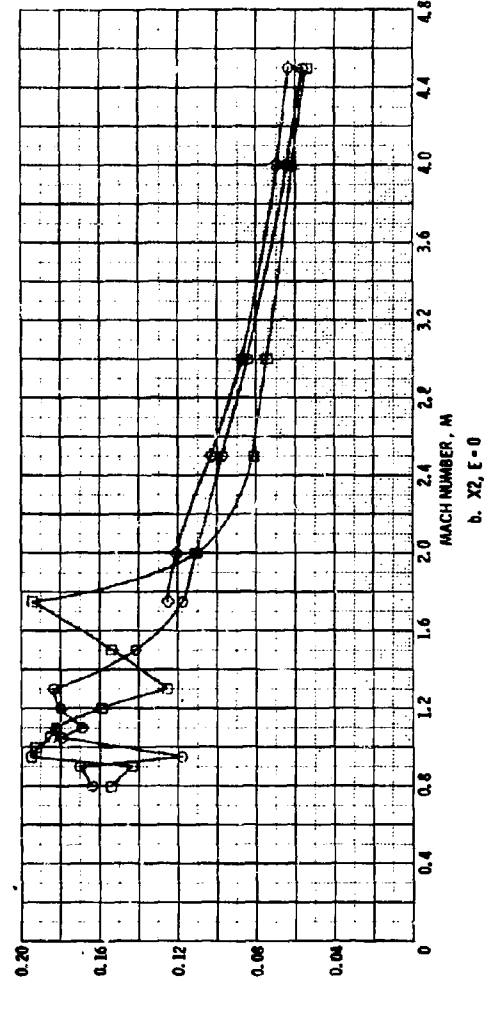
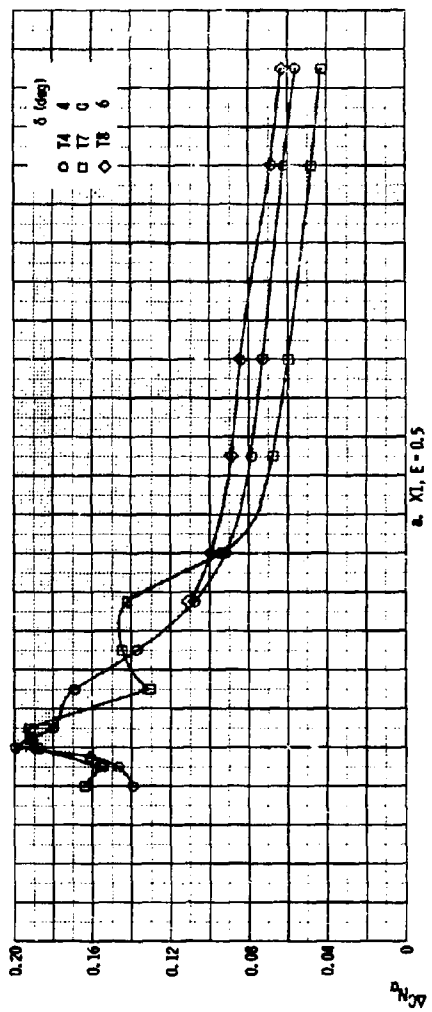

FIGURE 10. EFFECT OF RINGTAIL INTERNAL ANGLE ON  $\Delta C_{N\alpha}$  (CONSTANT LEADING DIAMETER,  $A = 2$ )



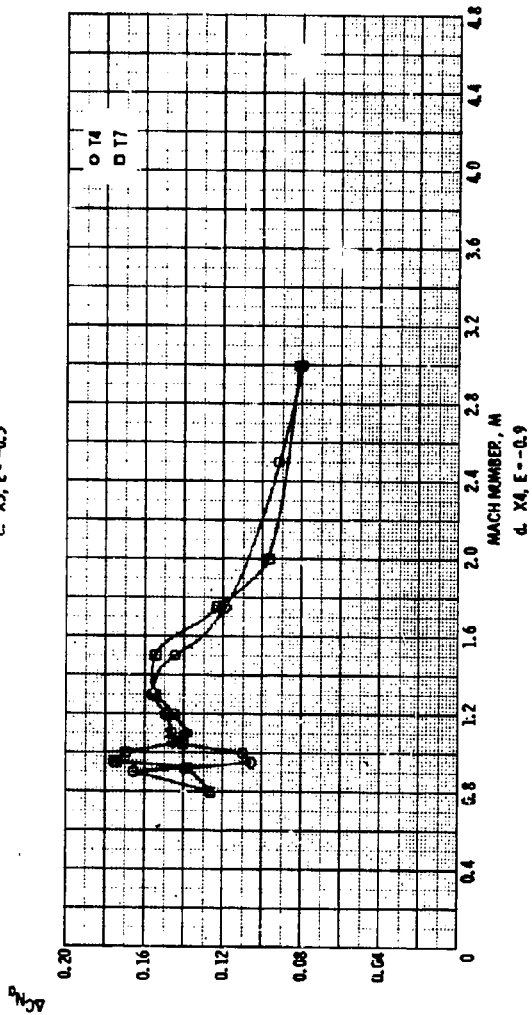
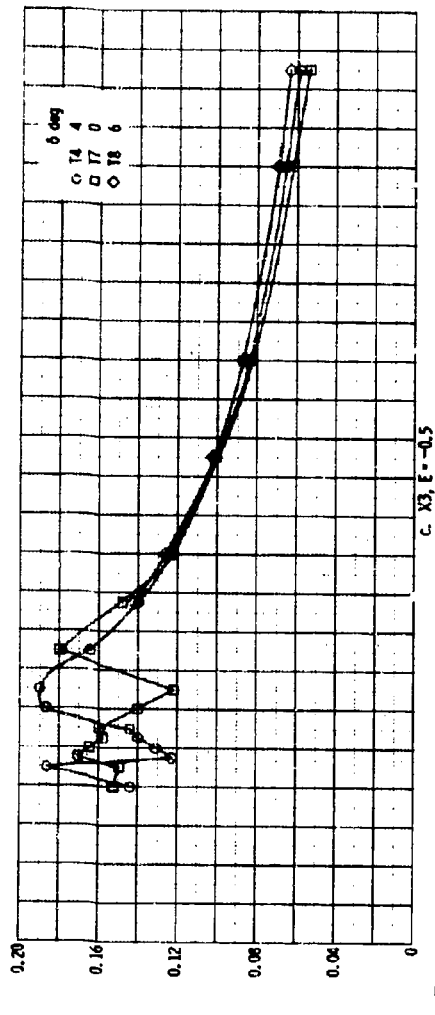

FIGURE 10. EFFECT OF RINGTAIL INTERNAL ANGLE ON  $AC_N$  (CONSTANT LEADING DIAMETER,  $A = 2$ ) (Continued)

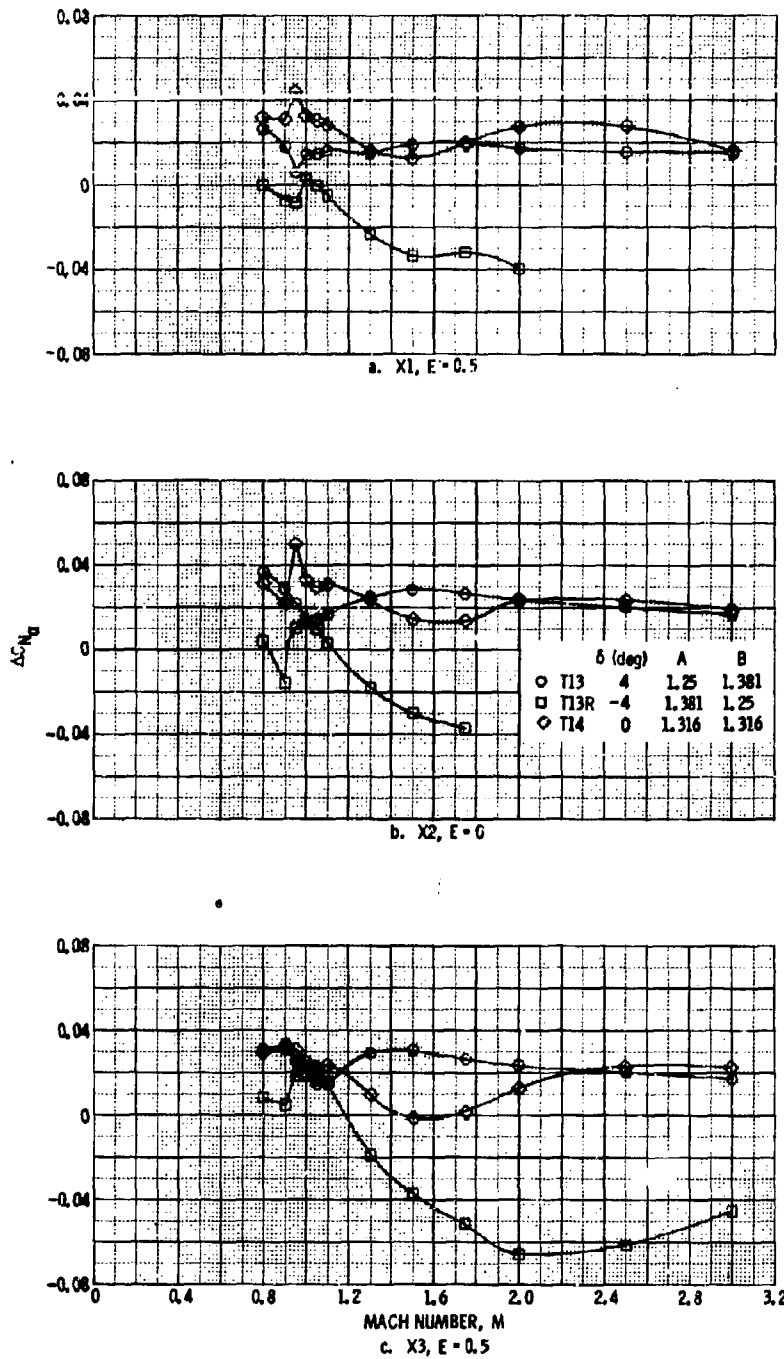

FIGURE 11. EFFECT OF RINGTAIL INTERNAL ANGLE ON  $\Delta C_{N\alpha}$   
 (CONSTANT DIAMETER AT RINGTAIL, MIDCHORD)

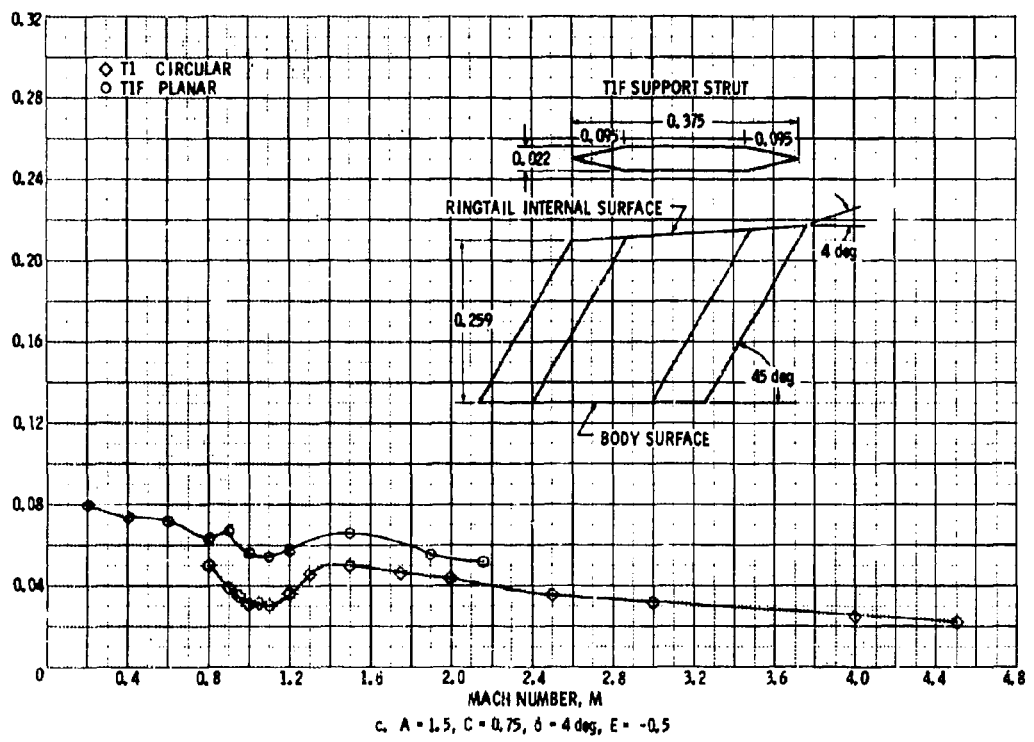
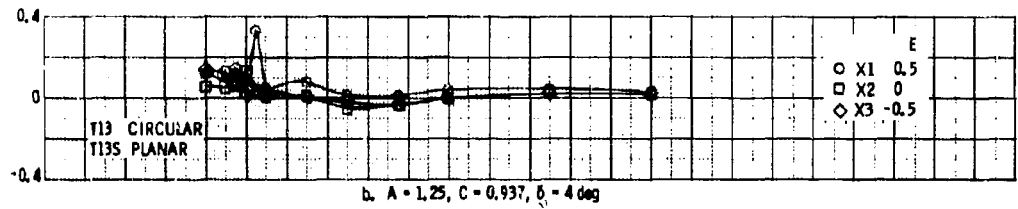
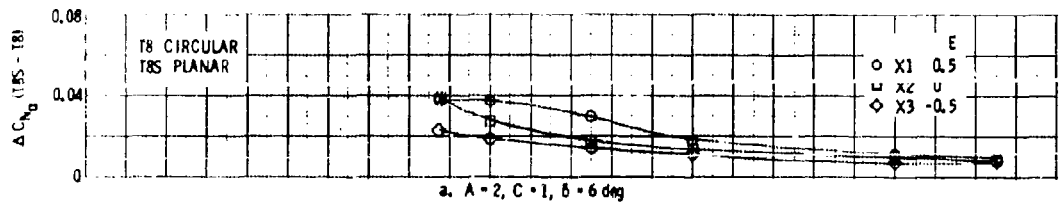

FIGURE 12. EFFECT OF PLANAR TYPE SUPPORT STRUTS ON  $\Delta C_{N\alpha}$

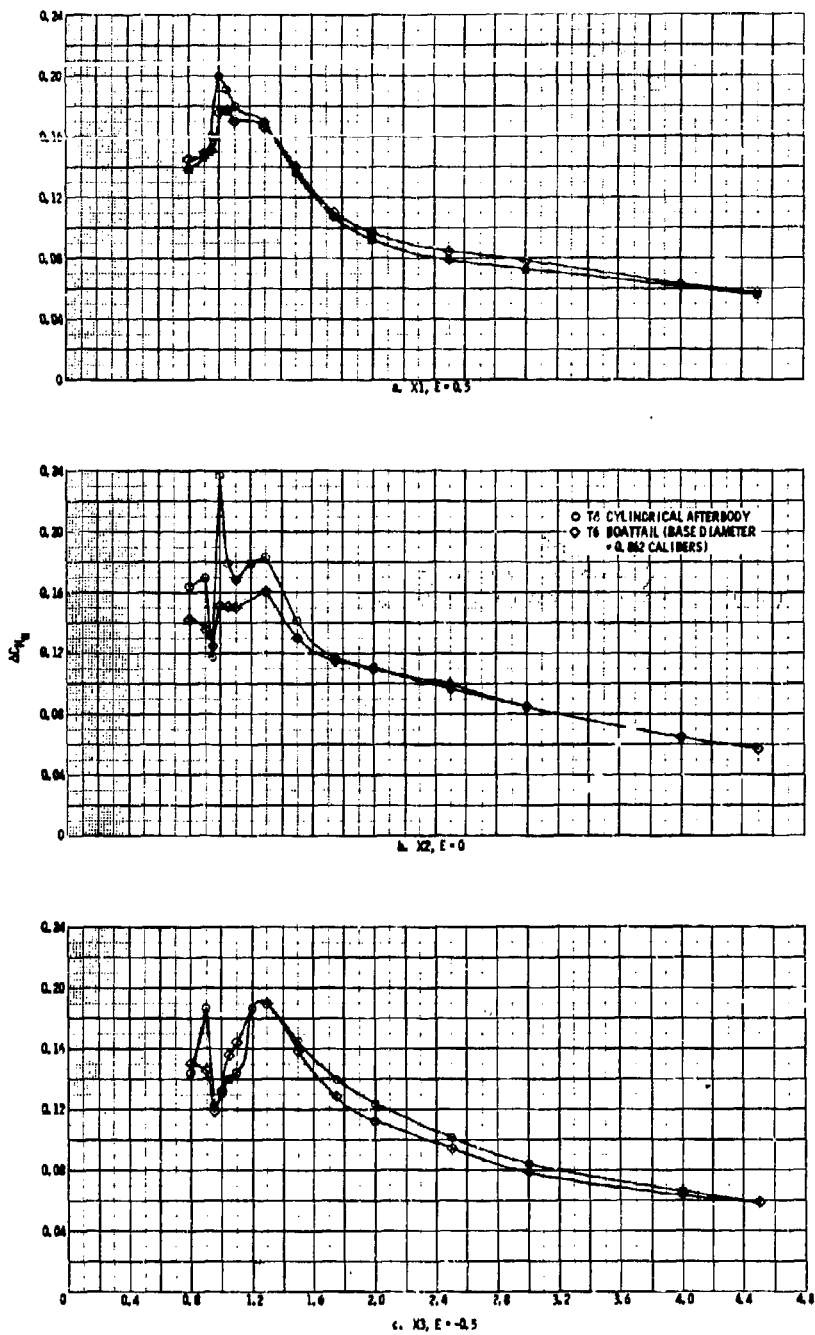

FIGURE 13. AFTERBODY GEOMETRY EFFECT ON RINGTAIL CONTRIBUTION TO NORMAL FORCE,  $A = 2$ ,  $C = 1$ ,  $\delta = 4$  deg

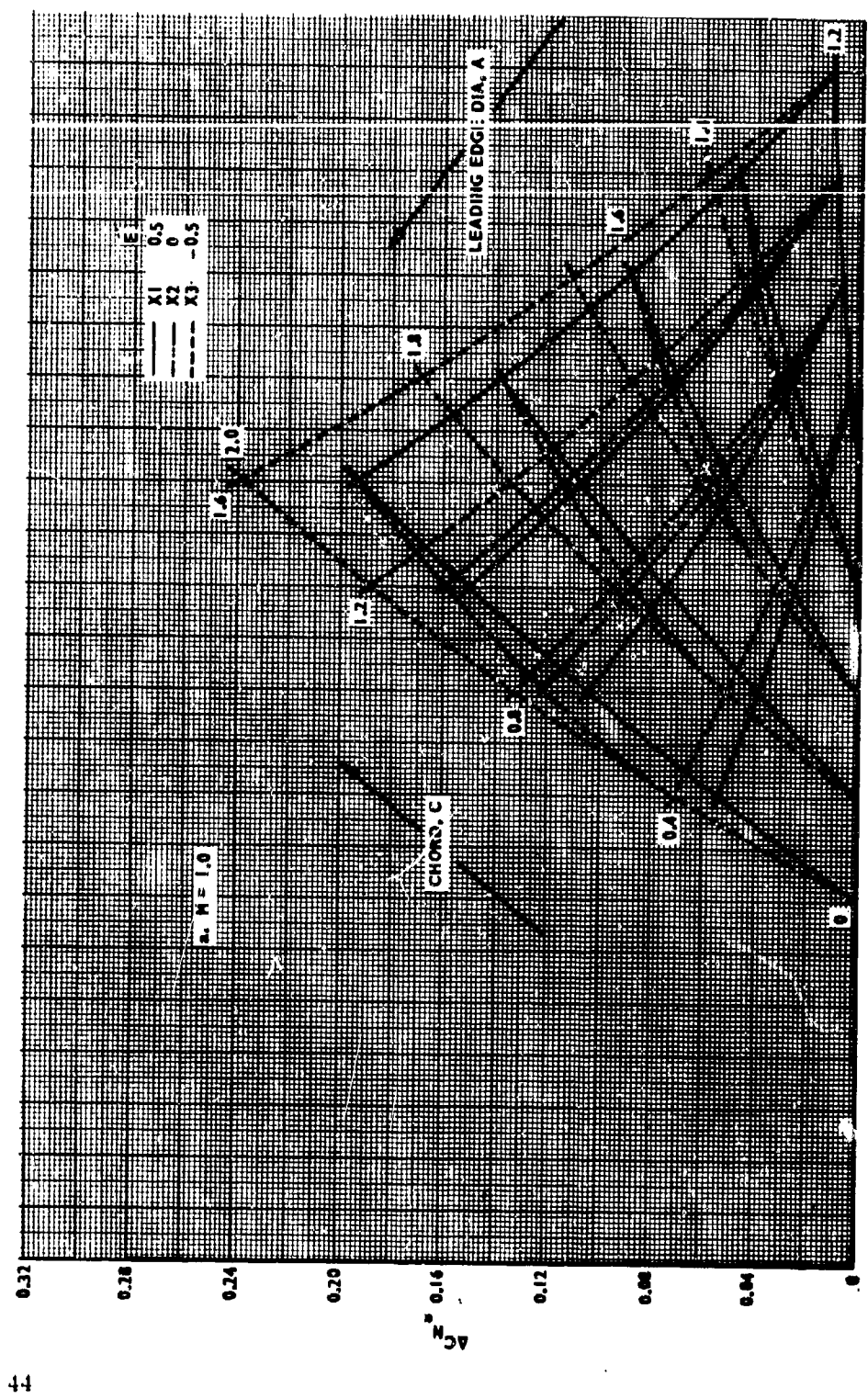

FIGURE 14. EFFECTS OF CHORD, DIAMETER, AND LONGITUDINAL POSITION ON  $AC_N$  OF RINGTAILS,  $\delta = 4$  deg

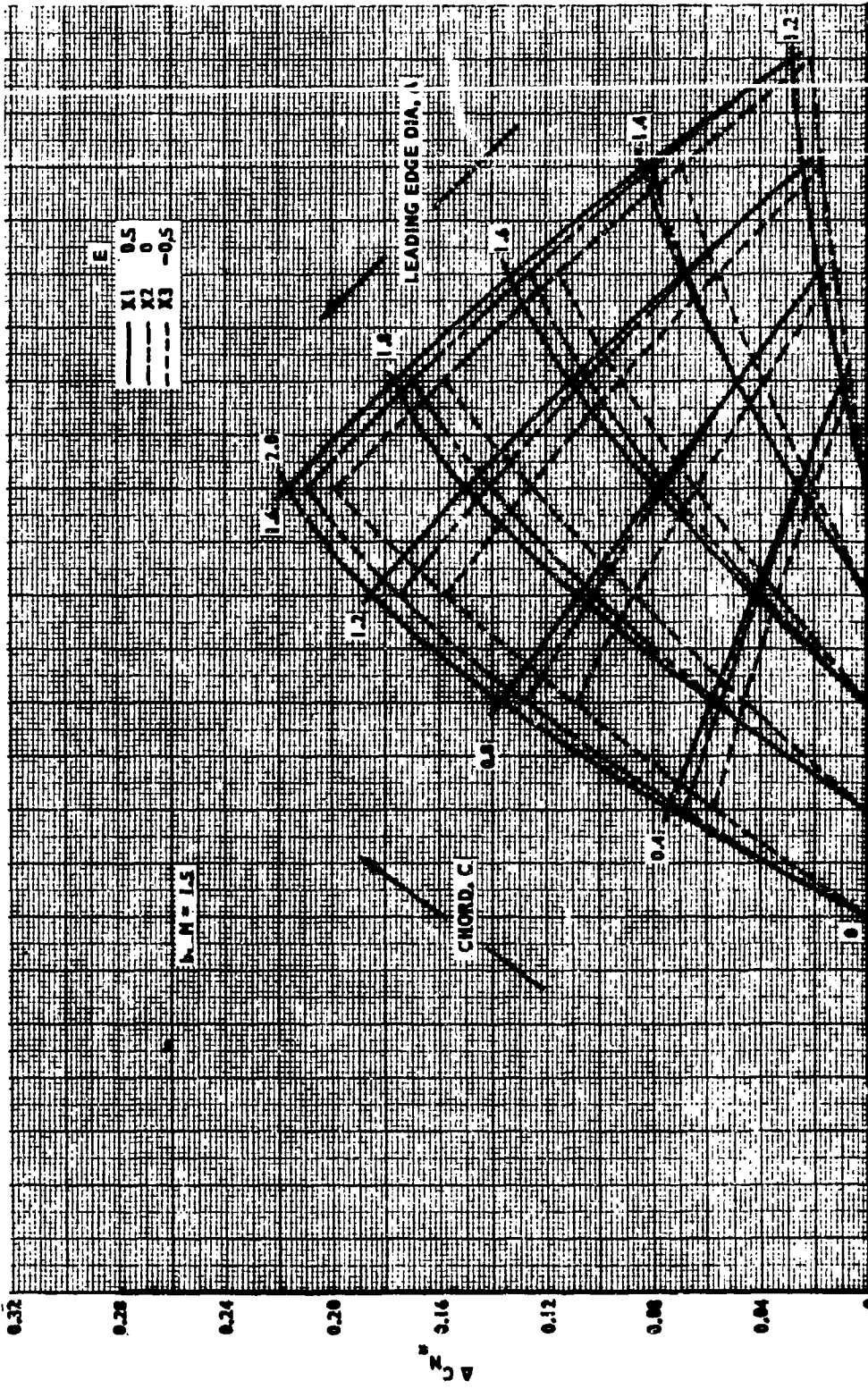

FIGURE 14. EFFECTS OF CHORD, DIAMETER, AND LONGITUDINAL POSIT ON ON  $\Delta C_N$   
 OF RINGTAILS,  $\delta = 4$  deg (Continued)

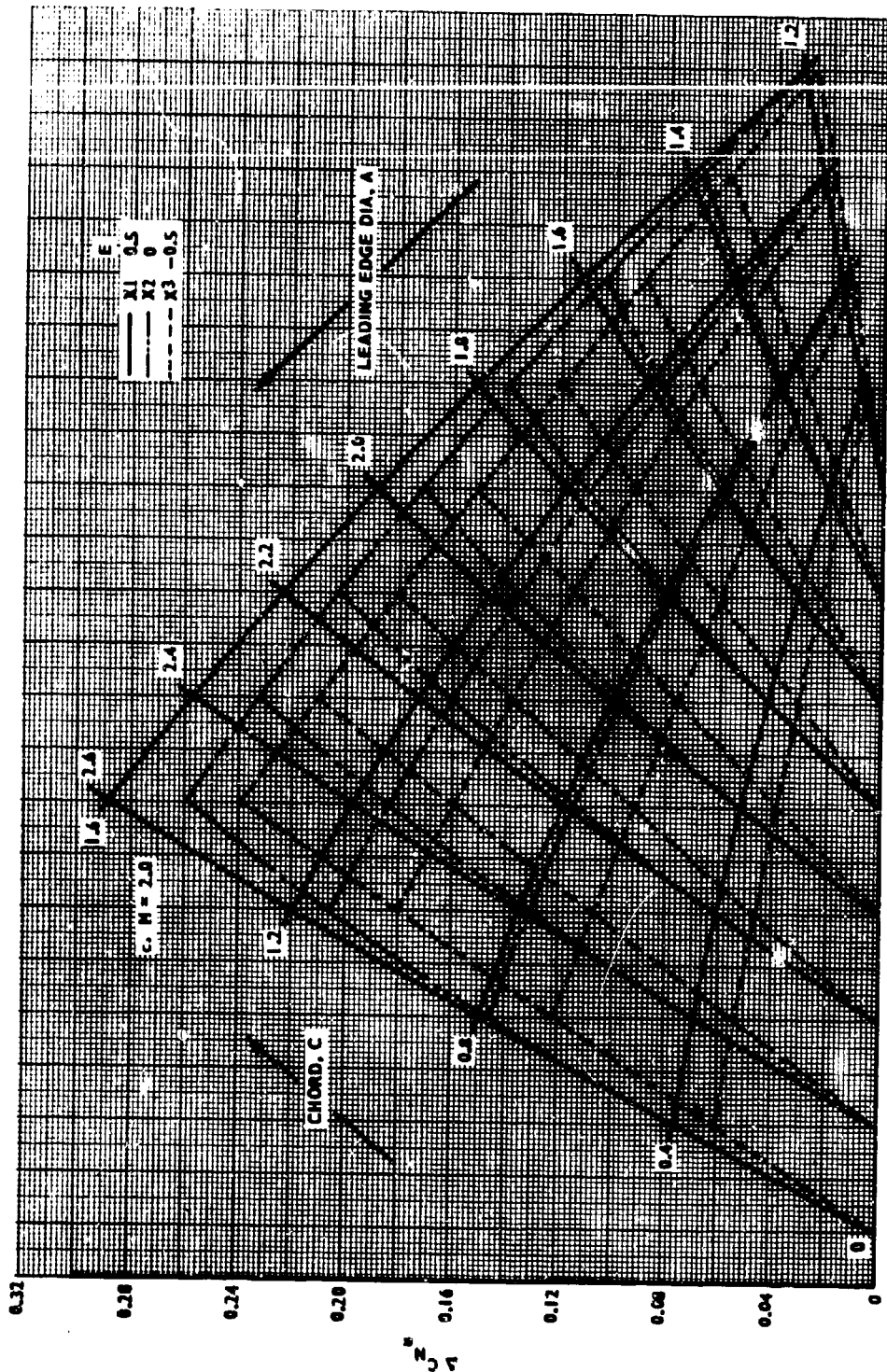

FIGURE 14. EFFECTS OF CHORD, DIAMETER, AND LONGITUDINAL POSITION ON  $\Delta C_{N_{\alpha}}$  OF RINGTAILS,  $\delta = 4$  deg (Continued)

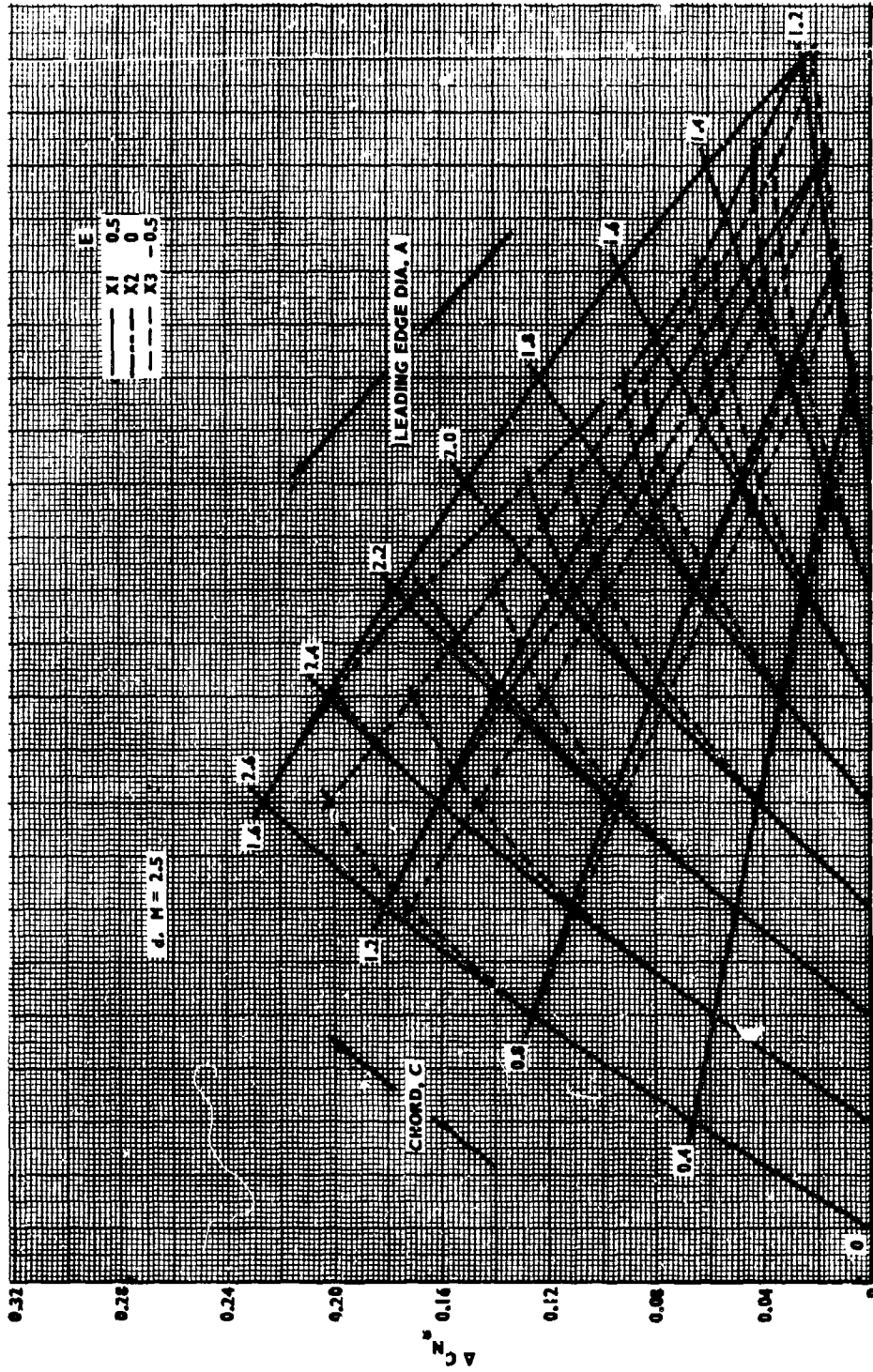

FIGURE 14. EFFECTS OF CHORD, DIAMETER, AND LONGITUDINAL POSITION ON  $ACN^\alpha$  OF RINGTAILS,  $\delta = 4$  deg (Continued)



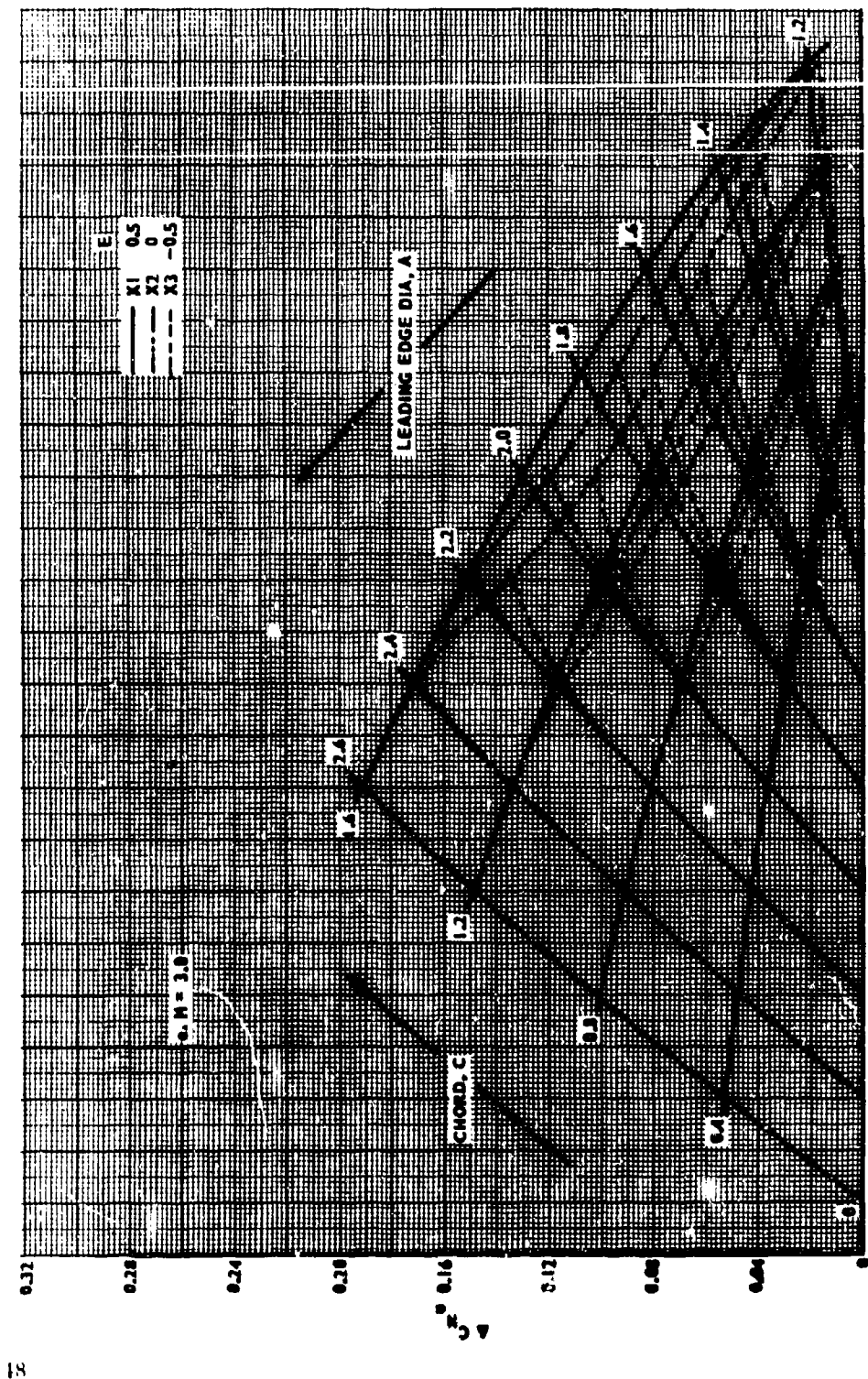

FIGURE 14. EFFECTS OF CHORD, DIAMETER, AND LONGITUDINAL POSITION ON  $\Delta C_N^\alpha$  OF RINGTAILS,  $\delta = 4$  deg (Concluded)

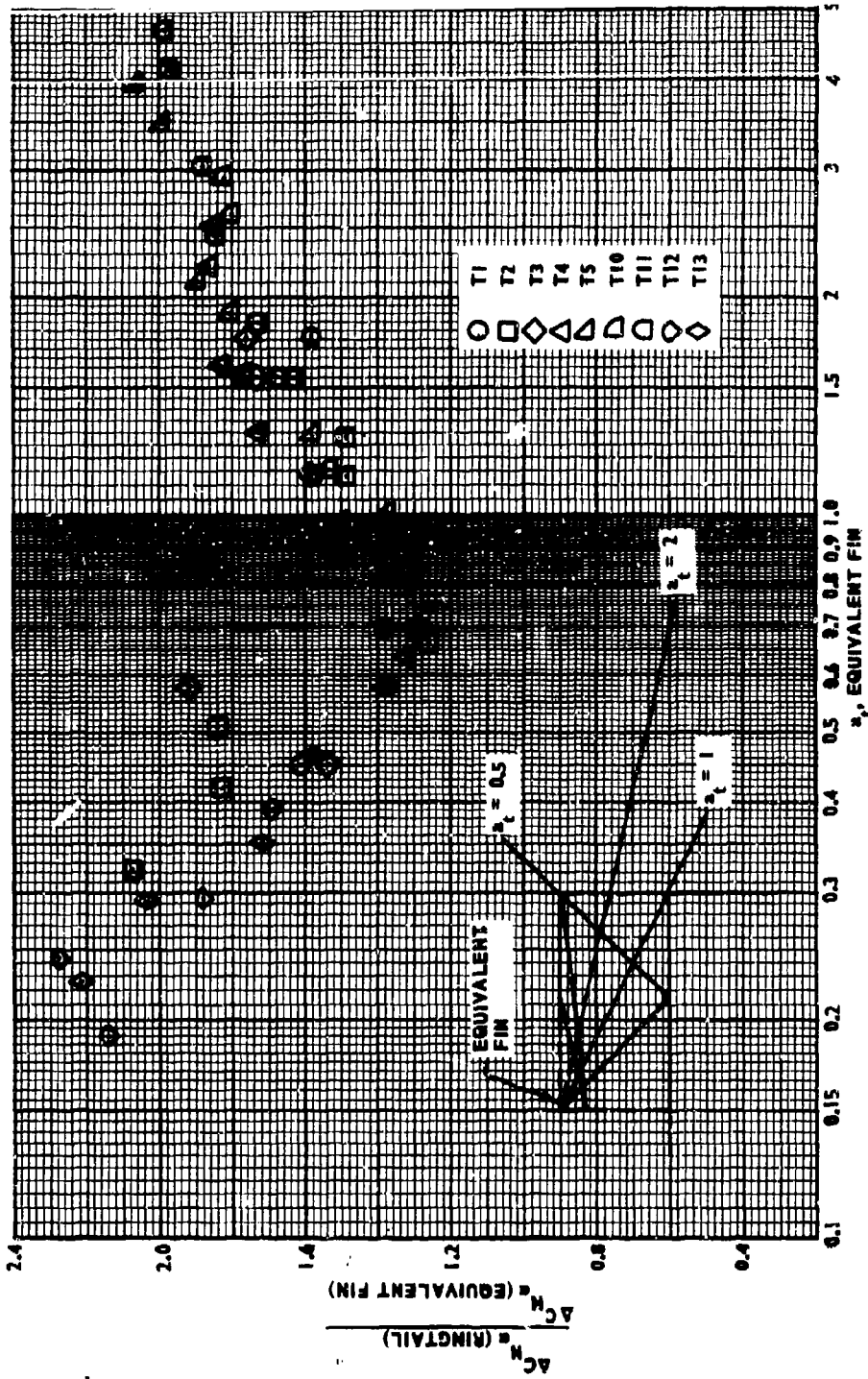

FIGURE 15. COMPARISON OF RINGTAIL WITH EQUIVALENT PLANAR FIN  $\Delta C_{N_\alpha}$

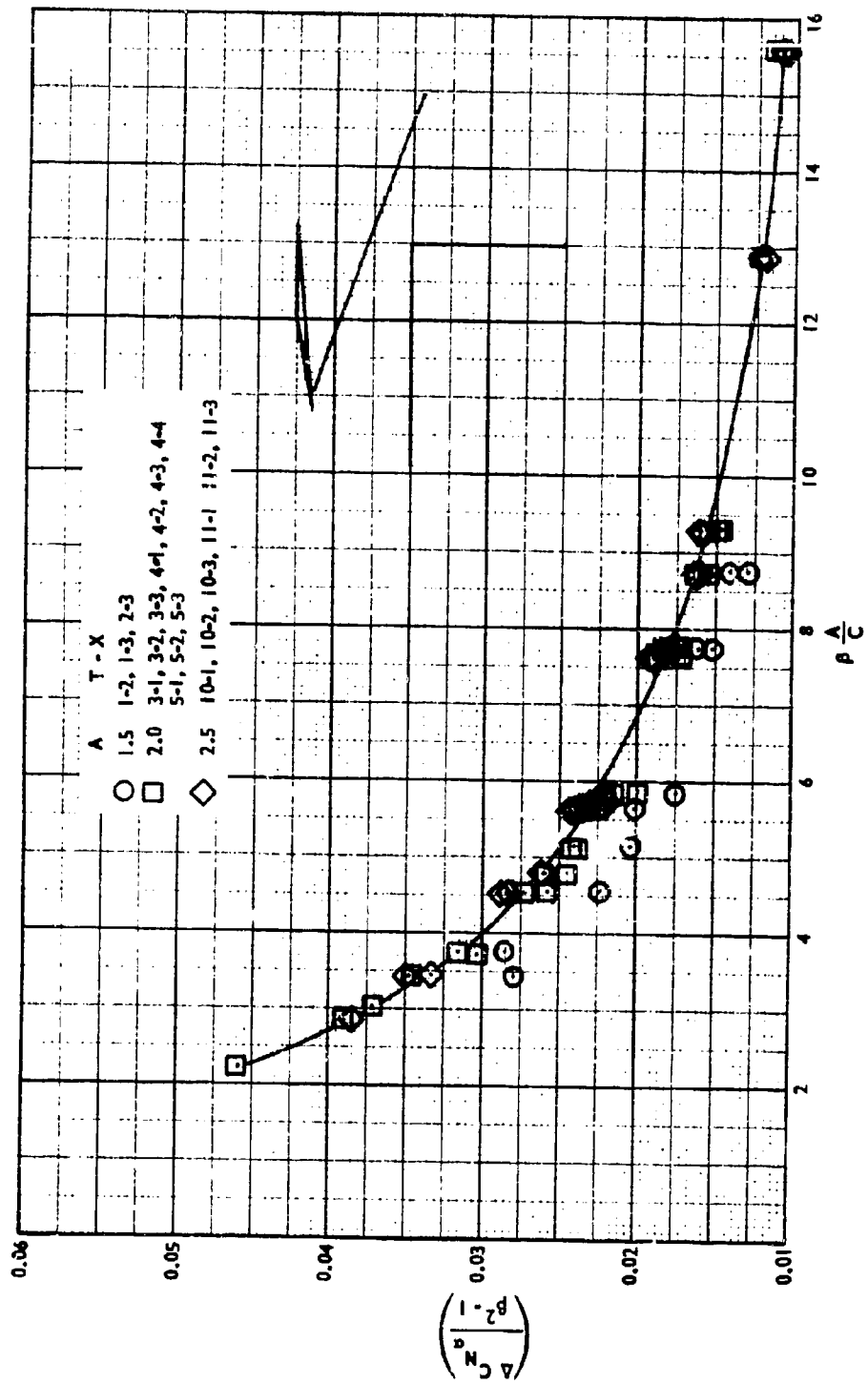

FIGURE 16. CORRELATION OF RINGTAIL  $\Delta C_{N\alpha}$  (RINGTAIL LEADING EDGE MACH LINE DOES NOT IMPINGE UPON BODY)

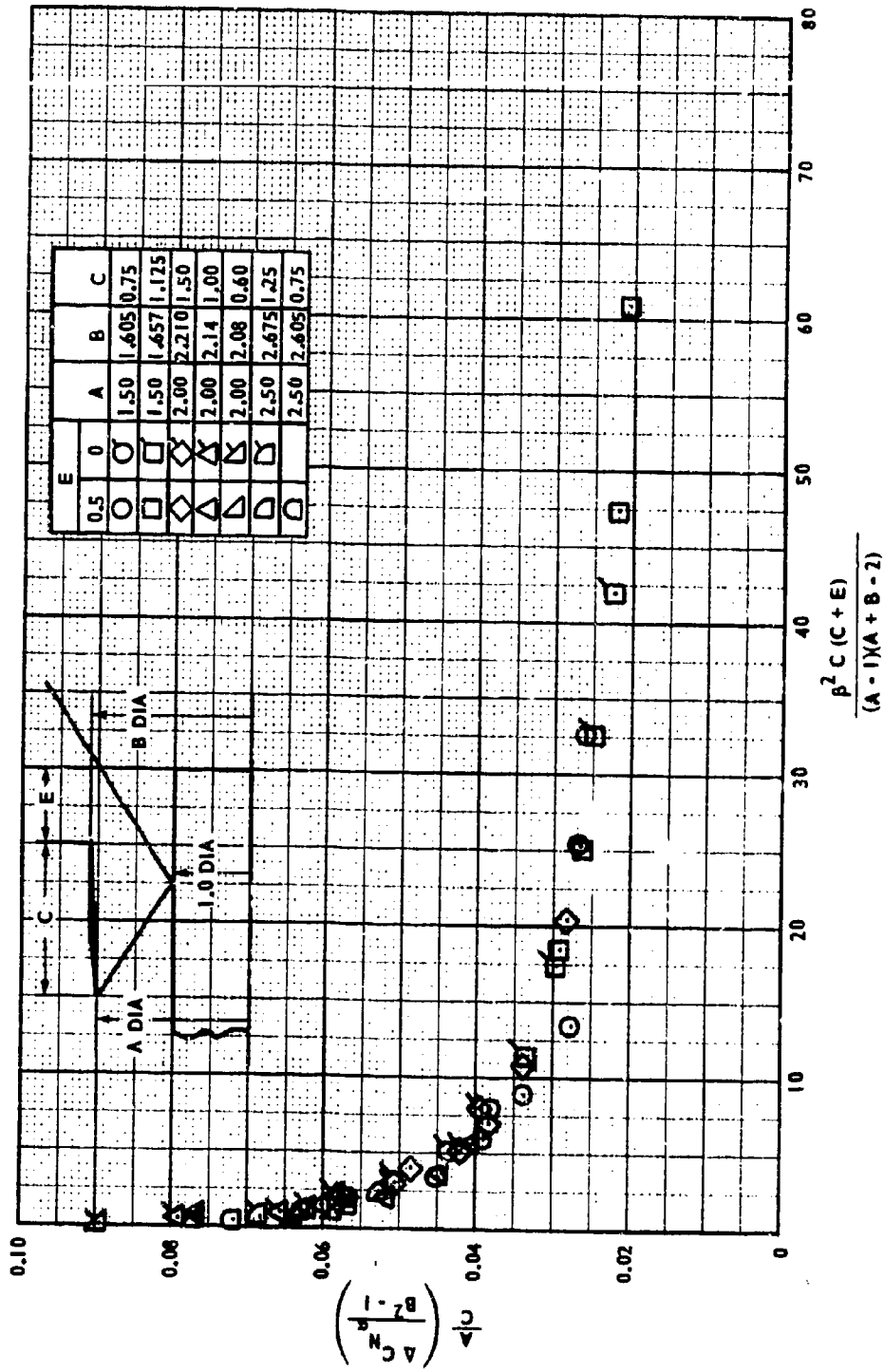

FIGURE 17. CORRELATION OF RINGTAIL  $\Delta C_N \alpha$  (RINGTAIL LEADING EDGE MACH LINE IMPINGES UPON BODY; REFLECTED MACH LINE MISSES RINGTAIL SURFACE)

**Appendix  
Parameters Used in Correlation  
of Ringtail Supersonic Normal Force**

Definitions of the ringtail correlating parameters are shown in Table A-I. Plots using these parameters were seen in Figures 16 and 17. A summary of the Mach numbers and  $\beta$ 's corresponding to the critical conditions is shown in Tables A-II and A-III. The COND column in Table A-IV may be used to help in identifying the data points used in Figures 16 and 17. This column has been left blank for the reader's use. The first regime for correlation includes Mach numbers greater than critical condition 1 (where the ringtail leading edge Mach line impinges on the body base). The second regime includes Mach numbers less than condition 1 and above condition 2 (where the Mach line impinges on the ring surface after reflection from the body surface). An additional condition is imposed on both regimes; that is, the expansion wave from the body base does not impinge on the ringtail surface. Tables of correlating parameters are presented for all Mach numbers tested, but only the points within the regimes and above a Mach number of 1.5 were included in Figures 16 and 17.

Flow conditions 3 and 4 occur only on longitudinal position which extend aft of the base. Flow condition 5 is used as a limiting condition which overrides conditions 1 and 2 if condition 5 is greater than condition 1 or condition 2.

Figure A-1 shows the geometry rotation used for the ringtail configurations. Sketches illustrating the five flow conditions are shown in Figure A-2.

Data points outside the limits imposed for Figures 16 and 17 are not as easily correlated. The effects of the reflections and impingements are easily traced in Figure 9 and Figure 14.

TABLE A-1. RINGTAIL CORRELATION PARAMETERS, DEFINITION OF TERMS

M	Mach number
$\beta$	$\beta = \sqrt{ (M^2 - 1) }$
FCT1	$\Delta C_{N\alpha}$
FCT2	$(A/C)\beta$
FCT3	$\Delta C_{N\alpha} / (A^2 - 1)$
FCT4	$\Delta C_{N\alpha} / (B^2 - 1)$
FCT5	$\beta^2 C (C + E) / [(A - 1)(A + B - 2)]$
FCT6	$(A/C) \Delta C_{N\alpha} / (A^2 - 1)$
FCT7	$(A/C) \Delta C_{N\alpha} / (B^2 - 1)$
COND	critical condition

TABLE A-II. CRITICAL MACH NUMBERS FOR EACH FLOW CONDITION,  
 $\delta = 4$  deg

CONF	A	C	E	COND1	COND2	COND3	COND4	COND5
T1X1	1.5	0.750	0.5	5.099	1.686	-	-	1.644
T1X2	1.5	0.750	0.0	3.162	1.686	-	-	1.300
T1X3	1.5	0.750	-0.5	1.414	1.686	1.931	1.414	1.036
T2X1	1.5	1.125	0.5	6.576	2.186	-	-	1.901
T2X2	1.5	1.125	0.0	4.609	2.186	-	-	1.557
T2X3	1.5	1.125	-0.5	2.692	2.186	1.821	2.692	1.220
T3X1	2.0	1.500	0.5	4.123	1.686	-	-	1.469
T3X2	2.0	1.500	0.0	3.162	1.686	-	-	1.300
T3X3	2.0	1.500	-0.5	2.236	1.686	1.297	2.236	1.147
T4X1	2.0	1.000	0.5	3.162	1.368	-	-	1.300
T4X2	2.0	1.000	0.0	2.236	1.368	-	-	1.147
T4X3	2.0	1.000	-0.5	1.414	1.368	1.330	1.414	1.036
T4X4	2.0	1.000	-0.9	1.019	1.368	1.868	1.019	1.000
T5X1	2.0	0.600	0.5	2.416	1.154	-	-	1.178
T5X2	2.0	0.600	0.0	1.562	1.154	-	-	1.054
T5X3	2.0	0.600	-0.5	1.019	1.154	1.362	1.019	1.000
T10X1	2.5	1.250	0.5	2.538	1.272	-	-	1.195
T10X2	2.5	1.250	0.0	1.943	1.272	-	-	1.104
T10X3	2.5	1.250	-0.5	1.414	1.272	1.164	-	1.036
T11X1	2.5	0.750	0.5	1.943	1.110	-	-	1.104
T11X2	2.5	0.750	0.0	1.414	1.110	-	-	1.036
T11X3	2.5	0.750	-0.5	1.054	1.110	1.178	1.054	1.001
T12X1	1.25	1.250	0.5	14.035	3.836	-	-	2.952
T12X2	1.25	1.250	0.0	10.049	3.836	-	-	2.441
T12X5	1.25	1.250	-0.25	8.062	3.836	1.544	8.062	2.143
T13X1	1.25	0.937	0.5	11.539	3.133	-	-	2.646
T13X2	1.25	0.937	0.0	7.562	3.133	-	-	2.064
T13X5	1.25	0.937	-0.25	5.586	3.133	1.649	-	1.730

TABLE A-III. CRITICAL BETAS FOR EACH FLOW CONDITION,  $\delta = 4$  deg

CONF	A	C	E	COND1	COND2	COND3	COND4	COND5
T1X1	1.5	0.750	0.5	5.000	1.357	-	-	1.305
T1X2	1.5	0.750	0.0	3.000	1.357	-	-	0.830
T1X3	1.5	0.750	-0.5	1.000	1.357	1.652	1.000	0.271
T2X1	1.5	1.125	0.5	6.500	1.944	-	-	1.617
T2X2	1.5	1.125	0.0	4.500	1.944	-	-	1.194
T2X3	1.5	1.125	-0.5	2.500	1.944	1.522	2.500	0.700
T3X1	2.0	1.500	0.5	4.000	1.357	-	-	1.077
T3X2	2.0	1.500	0.0	3.000	1.357	-	-	0.830
T3X3	2.0	1.500	-0.5	2.000	1.357	0.826	2.000	0.563
T4X1	2.0	1.000	0.5	3.000	0.934	-	-	0.830
T4X2	2.0	1.000	0.0	2.000	0.934	-	-	0.563
T4X3	2.0	1.000	-0.5	1.000	0.934	0.877	1.000	0.271
T4X4	2.0	1.000	-0.9	0.200	0.934	1.578	0.200	0.019
T5X1	2.0	0.600	0.5	2.200	0.576	-	-	0.623
T5X2	2.0	0.600	0.0	1.200	0.576	-	-	0.335
T5X3	2.0	0.600	-0.5	0.200	0.576	0.925	0.200	0.021
T10X1	2.5	1.250	0.5	2.333	0.787	-	-	0.654
T10X2	2.5	1.250	0.0	1.666	0.787	-	-	0.468
T10X3	2.5	1.250	-0.5	1.000	0.787	0.597	-	0.271
T11X1	2.5	0.750	0.5	1.666	0.483	-	-	0.468
T11X2	2.5	0.750	0.0	1.000	0.483	-	-	0.271
T11X3	2.5	0.750	-0.5	0.333	0.483	0.623	0.333	0.062
T12X1	1.25	1.250	0.5	14.000	3.703	-	-	2.777
T12X2	1.25	1.250	0.0	10.000	3.703	-	-	2.227
T12X5	1.25	1.250	-0.25	8.000	3.703	1.176	8.000	1.895
T13X1	1.25	0.937	0.5	11.496	2.969	-	-	2.450
T13X2	1.25	0.937	0.0	7.496	2.969	-	-	1.806
T13X5	1.25	0.937	-0.25	5.496	2.969	1.312	-	1.412



TABLE A-IV. RINGTAIL CORRELATING PARAMFTERS

CONF	MACH	BETA	FCT1	FCT2	FCT3	FCT4	FCT5	FCT6	FCT7	CFAC
T1X1	.80	.500	.0429	1.20	.0343	.0272	.61	.0686	.0544	
T1X1	.90	.435	.0370	.87	.0296	.0234	.32	.0572	.0469	
T1X1	.95	.512	.0470	.62	.0376	.0298	.16	.0752	.0596	
T1X1	1.00	0.000	.0538	0.00	.0430	.0341	0.00	.0860	.0682	
T1X1	1.05	.320	.0399	.64	.0319	.0253	.17	.0638	.0506	
T1X1	1.10	.458	.0337	.91	.0269	.0213	.35	.0539	.0427	
T1X1	1.20	.563	.0051	1.32	.0040	.0032	.74	.0081	.0064	
T1X1	1.30	.630	.0503	1.66	.0402	.0319	1.17	.0804	.0638	
T1X1	1.50	1.118	.0439	2.23	.0351	.0278	2.12	.0702	.0557	
T1X1	1.75	1.436	.0354	2.87	.0283	.0224	3.49	.0566	.0449	
T1X1	2.00	1.732	.0311	3.46	.0248	.0197	5.09	.0447	.0354	
T1X1	2.50	2.491	.0265	4.58	.0212	.0168	8.90	.0424	.0336	
T1X1	3.00	2.828	.0218	5.65	.0174	.0138	13.57	.0348	.0276	
T1X1	4.00	3.872	.0211	7.74	.0168	.0133	25.45	.0237	.0267	
T1X1	4.50	4.387	.0205	8.77	.0164	.0130	32.66	.0228	.0260	
T1X2	.80	.600	.0460	1.20	.0369	.0291	.36	.0736	.0583	
T1X2	.90	.435	.0500	.87	.0400	.0317	.19	.0500	.0634	
T1X2	.95	.512	.0387	.62	.0309	.0245	.09	.0619	.0491	
T1X2	1.00	0.000	.0454	0.00	.0363	.0288	0.00	.0726	.0576	
T1X2	1.05	.320	.0476	.64	.0380	.0302	.10	.0761	.0604	
T1X2	1.10	.458	.0577	.91	.0461	.0366	.21	.0923	.0732	
T1X2	1.20	.563	.0549	1.32	.0439	.0348	.44	.0878	.0696	
T1X2	1.30	.630	.0635	1.66	.0508	.0402	.70	.1016	.0805	
T1X2	1.50	1.118	.0564	2.23	.0451	.0357	1.27	.0902	.0715	
T1X2	1.75	1.436	.0447	2.87	.0357	.0283	2.09	.0715	.0567	
T1X2	2.00	1.732	.0398	3.46	.0318	.0252	3.05	.0636	.0505	
T1X2	2.50	2.491	.0343	4.58	.0274	.0217	5.34	.0549	.0435	
T1X2	3.00	2.828	.0301	5.65	.0240	.0190	8.14	.0481	.0381	
T1X2	4.00	3.872	.0240	7.74	.0152	.0152	15.27	.0384	.0304	
T1X2	4.50	4.387	.0204	8.77	.0163	.0129	19.59	.0326	.0258	
T1X3	.80	.600	.0499	1.20	.0399	.0316	.12	.0798	.0633	
T1X3	.90	.435	.0388	.87	.0310	.0246	.06	.0620	.0492	
T1X3	.95	.512	.0349	.62	.0279	.0221	.03	.0538	.0442	
T1X3	1.00	0.000	.0307	0.00	.0245	.0194	0.00	.0491	.0389	
T1X3	1.05	.320	.0312	.64	.0249	.0197	.03	.0499	.0395	
T1X3	1.10	.458	.0304	.91	.0243	.0192	.07	.0486	.0385	
T1X3	1.20	.563	.0365	1.32	.0292	.0231	.14	.0584	.0463	
T1X3	1.30	.630	.0435	1.66	.0351	.0278	.23	.0702	.0557	
T1X3	1.50	1.118	.0500	2.23	.0400	.0317	.42	.0800	.0634	
T1X3	1.75	1.436	.0467	2.87	.0373	.0296	.69	.0747	.0592	
T1X3	2.00	1.732	.0440	3.46	.0352	.0279	1.01	.0704	.0558	
T1X3	2.50	2.491	.0353	4.58	.0282	.0223	1.78	.0564	.0447	
T1X3	3.00	2.828	.0319	5.65	.0255	.0202	2.71	.0510	.0404	
T1X3	4.00	3.872	.0254	7.74	.0203	.0161	5.09	.0406	.0322	
T1X3	4.50	4.387	.0223	8.77	.0178	.0141	6.93	.0356	.0282	

TABLE A-IV. RINGTAIL CORRELATING PARAMETERS (Continued)

CONF	YACH	FCTA	FCT1	FCT2	FCT3	FCT4	FCT5	FCT6	FCT7	CCAL
T2X1	.80	.000	.0459	.80	.0367	.0262	1.13	.0489	.0350	
T2X1	.90	.433	.0680	.58	.0544	.0389	.60	.0725	.0519	
T2X1	.95	.312	.0279	.41	.0223	.0159	.30	.0297	.0213	
T2X1	1.00	0.000	.0619	0.00	.0495	.0354	0.00	.0660	.0472	
T2X1	1.05	.320	.0747	.42	.0597	.0427	.32	.0796	.0570	
T2X1	1.10	.453	.0727	.61	.0581	.0416	.66	.0775	.0555	
T2X1	1.30	.330	.0661	1.10	.0528	.0378	2.18	.0705	.0504	
T2X1	1.50	1.113	.0708	1.49	.0566	.0405	3.94	.0755	.0540	
T2X1	1.75	1.436	.0613	1.91	.0490	.0351	6.51	.0653	.0468	
T2X1	2.00	1.732	.0575	2.30	.0460	.0329	9.47	.0613	.0439	
T2X1	2.50	2.291	.0383	3.05	.0306	.0219	16.38	.0408	.0292	
T2X1	3.00	2.328	.0346	3.77	.0276	.0198	25.28	.0369	.0264	
T2X1	4.00	3.372	.0288	5.16	.0230	.0164	47.39	.0307	.0219	
T2X1	4.50	4.387	.0269	5.84	.0215	.0154	60.32	.0286	.0205	
T2X2	.80	.000	.0523	.80	.0419	.0299	.78	.0557	.0399	
T2X2	.90	.433	.0689	.58	.0551	.0354	.41	.0734	.0526	
T2X2	.95	.312	.0479	.41	.0333	.0274	.21	.0510	.0365	
T2X2	1.00	0.000	.0398	0.00	.0318	.0227	0.00	.0424	.0303	
T2X2	1.05	.320	.0315	.42	.0412	.0295	.22	.0549	.0393	
T2X2	1.10	.453	.0616	.61	.0492	.0352	.45	.0657	.0470	
T2X2	1.30	.330	.0834	1.10	.0567	.0477	1.50	.0889	.0637	
T2X2	1.50	1.118	.0883	1.49	.0706	.0505	2.73	.0941	.0674	
T2X2	1.75	1.436	.0773	1.91	.0618	.0442	4.51	.0824	.0590	
T2X2	2.00	1.732	.0679	2.30	.0543	.0388	6.56	.0724	.0518	
T2X2	2.50	2.291	.0442	3.05	.0353	.0253	11.48	.0471	.0337	
T2X2	3.00	2.328	.0388	3.77	.0310	.0222	17.50	.0413	.0296	
T2X2	4.00	3.372	.0329	5.16	.0263	.0188	32.81	.0350	.0251	
T2X2	4.50	4.387	.0295	5.84	.0236	.0158	42.11	.0314	.0225	
T2X3	.80	.000	.0537	.80	.0429	.0307	.43	.0572	.0410	
T2X3	.90	.433	.0559	.58	.0447	.0320	.23	.0596	.0426	
T2X3	.95	.312	.0416	.41	.0332	.0238	.11	.0443	.0317	
T2X3	1.00	0.000	.0576	0.00	.0460	.0329	0.00	.0614	.0439	
T2X3	1.05	.320	.0599	.42	.0479	.0343	.12	.0638	.0457	
T2X3	1.10	.453	.0568	.61	.0454	.0325	.25	.0605	.0433	
T2X3	1.30	.330	.0789	1.10	.0631	.0451	.83	.0841	.0602	
T2X3	1.50	1.118	.0830	1.49	.0564	.0475	1.51	.0885	.0633	
T2X3	1.75	1.436	.0774	1.91	.0619	.0443	2.50	.0825	.0591	
T2X3	2.00	1.732	.0672	2.30	.0537	.0384	3.64	.0716	.0513	
T2X3	2.50	2.291	.0546	3.05	.0436	.0312	6.38	.0582	.0417	
T2X3	3.00	2.328	.0499	3.77	.0399	.0285	9.72	.0532	.0381	
T2X3	4.00	3.372	.0356	5.16	.0284	.0203	18.23	.0379	.0271	
T2X3	4.50	4.387	.0305	5.84	.0244	.0174	23.39	.0325	.0232	

TABLE A-IV. RINGTAIL CORRELATING PARAMETERS (Continued)

CONF	MACH	BETA	FCT1	FCT2	FCT3	FCT4	FCT5	FCT6	FCT7	CONF
T3X1	.80	.600	.1999	.80	.0566	.0514	.48	.0888	.0686	
T3X1	.90	.435	.2644	.58	.0881	.0680	.25	.1175	.0907	
T3X1	.95	.312	.1472	.41	.0490	.0378	.13	.0654	.0505	
T3X1	1.00	0.000	.2257	0.00	.0752	.0581	0.00	.1003	.0774	
T3X1	1.05	.520	.2681	.42	.0893	.0590	.13	.1191	.0920	
T3X1	1.10	.458	.2507	.61	.0835	.0645	.28	.1114	.0860	
T3X1	1.30	.830	.2664	1.10	.0883	.0635	.73	.1183	.0914	
T3X1	1.50	1.118	.1902	1.49	.0634	.0489	1.69	.0845	.0652	
T3X1	1.75	1.436	.1631	1.91	.0543	.0419	2.79	.0724	.0529	
T3X1	2.00	1.732	.1412	2.30	.0470	.0363	4.07	.0627	.0484	
T3X1	2.50	2.291	.1111	3.05	.0370	.0286	7.12	.0493	.0381	
T3X1	3.00	2.828	.0984	3.77	.0328	.0253	10.85	.0437	.0337	
T3X1	4.00	3.872	.0822	5.16	.0274	.0211	20.36	.0365	.0282	
T3X1	4.50	4.387	.0778	5.84	.0259	.0200	26.13	.0345	.0267	
T3X2	.80	.600	.1908	.80	.0636	.0491	.36	.0847	.0654	
T3X2	.90	.435	.2620	.55	.0873	.0674	.19	.1164	.0899	
T3X2	.95	.512	.1439	.41	.0479	.0370	.09	.0639	.0493	
T3X2	1.00	0.000	.1846	0.00	.0617	.0475	0.00	.0820	.0623	
T3X2	1.05	.320	.2274	.42	.0758	.0585	.10	.1010	.0780	
T3X2	1.10	.458	.2211	.61	.0737	.0569	.21	.0982	.0758	
T3X2	1.30	.830	.2813	1.10	.0537	.0424	.70	.1250	.0965	
T3X2	1.50	1.118	.2060	1.49	.0686	.0530	1.27	.0915	.0707	
T3X2	1.75	1.436	.1695	1.91	.0565	.0436	2.09	.0753	.0581	
T3X2	2.00	1.732	.1472	2.30	.0490	.0378	3.05	.0654	.0505	
T3X2	2.50	2.291	.1221	3.05	.0407	.0314	5.34	.0542	.0419	
T3X2	3.00	2.828	.1150	3.77	.0383	.0296	8.14	.0511	.0394	
T3X2	4.00	3.872	.0928	5.16	.0309	.0238	15.27	.0412	.0318	
T3X2	4.50	4.387	.0833	5.84	.0277	.0214	19.39	.0370	.0285	
T3X3	.80	.600	.1759	.80	.0586	.0452	.24	.0781	.0603	
T3X3	.90	.435	.2466	.58	.0822	.0634	.12	.1095	.0846	
T3X3	.95	.512	.1869	.41	.0623	.0481	.06	.0830	.0641	
T3X3	1.00	0.000	.1948	0.00	.0616	.0475	0.00	.0821	.0634	
T3X3	1.05	.520	.1863	.42	.0621	.0479	.06	.0827	.0639	
T3X3	1.10	.458	.2019	.61	.0673	.0519	.14	.0897	.0693	
T3X3	1.30	.830	.2457	1.10	.0819	.0632	.46	.1091	.0843	
T3X3	1.50	1.118	.2102	1.49	.0700	.0541	.84	.0934	.0721	
T3X3	1.75	1.436	.1877	1.91	.0625	.0483	1.39	.0834	.0644	
T3X3	2.00	1.732	.1784	2.30	.0594	.0459	2.03	.0792	.0612	
T3X3	2.50	2.291	.1446	3.05	.0482	.0372	3.56	.0642	.0496	
T3X3	3.00	2.828	.1228	3.77	.0409	.0316	5.42	.0545	.0421	
T3X3	4.00	3.872	.0938	5.16	.0312	.0241	10.18	.0416	.0321	
T3X3	4.50	4.387	.0851	5.84	.0283	.0219	13.06	.0378	.0292	

TABLE A-IV. RINGTAIL CORRELATING PARAMETERS (Continued)

CONF	MACH	BETA	FCT1	FCT2	FCT3	FCT4	FCT5	FCT6	FCT7	CCND
T4X1	.80	.600	.1393	1.20	.0464	.0389	.25	.0928	.0778	
T4X1	.90	.435	.1473	.87	.0491	.0411	.13	.0982	.0822	
T4X1	.95	.312	.1609	.62	.0536	.0449	.06	.1072	.0896	
T4X1	1.00	0.000	.1998	0.00	.0666	.0558	0.00	.1332	.1116	
T4X1	1.05	.350	.1915	.64	.0638	.0534	.07	.1276	.1069	
T4X1	1.10	.458	.1604	.91	.0601	.0503	.14	.1202	.1007	
T4X1	1.30	.330	.1686	1.65	.0562	.0471	.48	.1124	.0942	
T4X1	1.50	1.119	.1367	2.23	.0450	.0381	.87	.0911	.0763	
T4X1	1.75	1.436	.1076	2.87	.0358	.0300	1.44	.0717	.0601	
T4X1	2.00	1.732	.0922	3.46	.0307	.0257	2.10	.0614	.0515	
T4X1	2.50	2.291	.0792	4.56	.0264	.0221	2.87	.0528	.0442	
T4X1	3.00	2.828	.0732	5.65	.0244	.0204	5.60	.0488	.0408	
T4X1	4.00	3.872	.0617	7.74	.0205	.0172	10.51	.0411	.0344	
T4X1	4.50	4.587	.0557	8.77	.0185	.0155	13.49	.0371	.0311	
T4X2	.80	.600	.1641	1.20	.0547	.0458	.16	.1094	.0916	
T4X2	.90	.435	.1696	.87	.0565	.0473	.08	.1130	.0947	
T4X2	.95	.312	.1177	.62	.0392	.0328	.04	.0794	.0657	
T4X2	1.00	0.000	.2374	0.00	.0791	.0563	0.00	.1582	.1326	
T4X2	1.05	.320	.1792	.64	.0557	.0500	.04	.1194	.1001	
T4X2	1.10	.458	.1690	.91	.0563	.0472	.09	.1126	.0944	
T4X2	1.20	.603	.1795	1.32	.0598	.0501	.20	.1196	.1002	
T4X2	1.30	.630	.1828	1.66	.0609	.0510	.32	.1218	.1021	
T4X2	1.50	1.119	.1417	2.23	.0472	.0395	.58	.0944	.0791	
T4X2	1.75	1.436	.1175	2.87	.0391	.0328	.96	.0783	.0656	
T4X2	2.00	1.732	.1109	3.46	.0369	.0309	1.40	.0739	.0619	
T4X2	2.50	2.291	.0975	4.56	.0325	.0272	2.45	.0650	.0544	
T4X2	3.00	2.828	.0845	5.65	.0281	.0236	3.73	.0563	.0472	
T4X2	4.00	3.872	.0647	7.74	.0215	.0180	7.00	.0431	.0361	
T4X2	4.50	4.587	.0573	8.77	.0191	.0160	8.99	.0382	.0320	
T4X3	.80	.600	.1442	1.20	.0481	.0403	.08	.0962	.0806	
T4X3	.90	.435	.1865	.87	.0521	.0521	.04	.1243	.1042	
T4X3	.95	.312	.1226	.62	.0402	.0342	.02	.0817	.0684	
T4X3	1.00	0.000	.1312	0.00	.0437	.0366	0.00	.0874	.0733	
T4X3	1.05	.320	.1403	.64	.0467	.0391	.02	.0935	.0783	
T4X3	1.10	.458	.1443	.91	.0481	.0403	.04	.0962	.0806	
T4X3	1.20	.603	.1871	1.32	.0623	.0522	.10	.1247	.1045	
T4X3	1.30	.630	.1896	1.66	.0632	.0529	.16	.1264	.1059	
T4X3	1.50	1.113	.1644	2.23	.0548	.0459	.29	.1096	.0918	
T4X3	1.75	1.435	.1397	2.87	.0465	.0390	.48	.0931	.0780	
T4X3	2.00	1.732	.1236	3.46	.0412	.0345	.70	.0824	.0690	
T4X3	2.50	2.291	.1015	4.56	.0334	.0283	1.22	.0676	.0567	
T4X3	3.00	2.828	.0840	5.65	.0280	.0234	1.86	.0560	.0469	
T4X3	4.00	3.872	.0659	7.74	.0219	.0184	3.50	.0439	.0368	
T4X3	4.50	4.587	.0591	8.77	.0197	.0165	4.49	.0394	.0330	
T4X4	.80	.600	.1268	1.20	.0422	.0334	.01	.0645	.0508	
T4X4	.90	.435	.1655	.87	.0551	.0462	0.00	.1103	.0924	
T4X4	.95	.312	.1056	.62	.0352	.0295	0.00	.0704	.0590	
T4X4	1.00	0.000	.1104	0.00	.0368	.0308	0.00	.0736	.0616	
T4X4	1.05	.320	.1458	.64	.0426	.0407	0.00	.0972	.0814	
T4X4	1.10	.458	.1385	.91	.0461	.0386	0.00	.0923	.0773	
T4X4	1.20	.603	.1453	1.32	.0484	.0405	.02	.0968	.0811	
T4X4	1.30	.630	.1562	1.66	.0520	.0436	.03	.1041	.0872	
T4X4	1.50	1.113	.1445	2.23	.0461	.0403	.05	.0963	.0807	
T4X4	1.75	1.436	.1187	2.87	.0395	.0331	.09	.0791	.0663	
T4X4	2.00	2.291	.0923	4.56	.0307	.0257	.24	.0615	.0515	
T4X4	3.00	2.828	.0803	5.65	.0267	.0224	.37	.0535	.0448	

TABLE A-IV. RINGTAIL CORRELATING PARAMETERS (Continued)

CCNF	MACH	BETA	FCT1	FCT2	FCT3	FCT4	FCT5	FCT6	FCT7	CCNF
T5X1	.80	.400	.1055	2.00	.0351	.0317	.11	.1172	.1057	
T5X1	.90	.435	.0944	1.45	.0314	.0283	.06	.1048	.0945	
T5X1	.95	.312	.1189	1.04	.0396	.0357	.03	.1321	.1191	
T5X1	1.00	0.000	.1042	0.00	.0347	.0313	0.00	.1157	.1044	
T5X1	1.05	.320	.0840	1.06	.0280	.0252	.03	.0933	.0841	
T5X1	1.10	.458	.0602	1.52	.0267	.0241	.06	.0891	.0803	
T5X1	1.30	.830	.0959	2.76	.0319	.0288	.21	.1065	.0960	
T5X1	1.50	1.118	.0769	3.72	.0256	.0231	.39	.0854	.0770	
T5X1	1.75	1.436	.0633	4.78	.0211	.0190	.65	.0703	.0624	
T5X1	2.00	1.732	.0581	5.77	.0193	.0174	.95	.0645	.0582	
T5X1	2.50	2.291	.0573	7.63	.0191	.0172	1.66	.0636	.0574	
T5X1	3.00	2.628	.0489	9.42	.0163	.0147	2.53	.0543	.0490	
T5X1	4.00	3.672	.0408	12.90	.0136	.0122	4.75	.0453	.0408	
T5X1	4.50	4.387	.0371	14.62	.0123	.0111	6.10	.0412	.0371	
T5X2	.80	.600	.1125	2.00	.0375	.0338	.06	.1249	.1127	
T5X2	.90	.435	.0944	1.45	.0314	.0283	.03	.1048	.0945	
T5X2	.95	.312	.1157	1.04	.0385	.0347	.01	.1285	.1159	
T5X2	1.00	0.000	.1071	0.00	.0357	.0321	0.00	.1189	.1073	
T5X2	1.05	.320	.0991	1.06	.0330	.0297	.01	.1101	.0993	
T5X2	1.10	.458	.0968	1.52	.0322	.0291	.03	.1075	.0970	
T5X2	1.20	.663	.1043	2.21	.0347	.0313	.07	.1158	.1045	
T5X2	1.30	.830	.1161	2.76	.0387	.0349	.11	.1289	.1163	
T5X2	1.50	1.118	.0894	3.72	.0298	.0268	.21	.0993	.0895	
T5X2	1.75	1.436	.0819	4.78	.0273	.0246	.35	.0909	.0820	
T5X2	2.00	1.732	.0758	5.77	.0252	.0227	.51	.0842	.0759	
T5X2	2.50	2.291	.0633	7.63	.0211	.0190	.90	.0703	.0634	
T5X2	3.00	2.628	.0512	9.42	.0170	.0153	1.38	.0568	.0513	
T5X2	4.00	3.672	.0410	12.90	.0136	.0123	2.59	.0455	.0410	
T5X2	4.50	4.387	.0377	14.62	.0125	.0111	3.33	.0410	.0377	
T5X3	.80	.600	.1227	2.00	.0409	.0368	.01	.1363	.1229	
T5X3	.90	.435	.0976	1.45	.0325	.0293	0.00	.1084	.0978	
T5X3	.95	.312	.1028	1.04	.0342	.0309	0.00	.1142	.1030	
T5X3	1.00	0.000	.1083	0.00	.0361	.0325	0.00	.1203	.1085	
T5X3	1.05	.320	.0991	1.06	.0330	.0297	0.00	.1101	.0993	
T5X3	1.10	.458	.0972	1.52	.0324	.0292	0.00	.1079	.0974	
T5X3	1.20	.663	.1056	2.21	.0352	.0317	.01	.1173	.1058	
T5X3	1.30	.830	.1079	2.76	.0359	.0324	.01	.1198	.1081	
T5X3	1.50	1.118	.1008	3.72	.0336	.0303	.03	.1119	.1010	
T5X3	1.75	1.436	.0863	4.78	.0287	.0259	.05	.0958	.0864	
T5X3	2.00	1.732	.0771	5.77	.0257	.0231	.08	.0856	.0772	
T5X3	2.50	2.291	.0629	7.63	.0209	.0189	.15	.0693	.0630	
T5X3	3.00	2.628	.0521	9.42	.0173	.0156	.23	.0578	.0522	
T5X3	4.00	3.672	.0411	12.90	.0137	.0123	.43	.0456	.0411	
T5X3	4.50	4.387	.0380	14.62	.0126	.0114	.55	.0422	.0380	

TABLE A-IV. RINGTAIL CORRELATING PARAMETERS (Continued)

CLNF	MACH	BETA	FCT1	FCT2	FCT3	FCT4	FCT5	FCT6	FCT7	CCND
T6X1	.80	.600	.1452	1.20	.0464	.0405	.25	.0968	.0811	
T6X1	.90	.435	.1499	.87	.0499	.0418	.13	.0999	.0837	
T6X1	.95	.312	.1506	.62	.0502	.0420	.06	.1004	.0841	
T6X1	1.00	0.000	.1757	0.00	.0585	.0490	0.00	.1171	.0981	
T6X1	1.05	.320	.1783	.64	.0594	.0498	.07	.1188	.0996	
T6X1	1.10	.458	.1706	.91	.0568	.0476	.14	.1137	.0953	
T6X1	1.30	.630	.1672	1.66	.0557	.0467	.48	.1114	.0934	
T6X1	1.50	1.118	.1409	2.23	.0465	.0393	.87	.0939	.0787	
T6X1	1.75	1.436	.1101	2.87	.0367	.0307	1.44	.0734	.0615	
T6X1	2.00	1.732	.0970	3.46	.0323	.0270	2.10	.0646	.0541	
T6X1	2.50	2.291	.0851	4.58	.0283	.0237	3.67	.0567	.0475	
T6X1	3.00	2.628	.0782	5.65	.0260	.0218	5.60	.0521	.0436	
T6X1	4.00	3.872	.0631	7.74	.0210	.0176	10.51	.0420	.0352	
T6X1	4.50	4.387	.0569	8.77	.0189	.0158	13.49	.0379	.0317	
T6X2	.80	.600	.1425	1.20	.0475	.0398	.16	.0950	.0796	
T6X2	.90	.435	.1350	.87	.0450	.0377	.08	.0900	.0754	
T6X2	.95	.312	.1253	.62	.0417	.0350	.04	.0835	.0700	
T6X2	1.00	0.000	.1519	0.00	.0506	.0424	0.00	.1012	.0848	
T6X2	1.05	.320	.1506	.64	.0502	.0420	.04	.1004	.0841	
T6X2	1.10	.458	.1512	.91	.0504	.0422	.09	.1008	.0844	
T6X2	1.30	.630	.1605	1.66	.0535	.0448	.32	.1070	.0896	
T6X2	1.50	1.118	.1312	2.23	.0437	.0366	.58	.0874	.0733	
T6X2	1.75	1.436	.1146	2.87	.0382	.0320	.96	.0764	.0640	
T6X2	2.00	1.732	.1101	3.46	.0367	.0307	1.40	.0734	.0615	
T6X2	2.50	2.291	.1002	4.58	.0334	.0279	2.45	.0668	.0559	
T6X2	3.00	2.628	.0847	5.65	.0282	.0236	3.73	.0564	.0473	
T6X2	4.00	3.872	.0643	7.74	.0214	.0179	7.00	.0428	.0359	
T6X2	4.50	4.387	.0576	8.77	.0192	.0160	8.99	.0384	.0321	
T6X3	.80	.600	.1512	1.20	.0504	.0422	.08	.1008	.0844	
T6X3	.90	.435	.1463	.87	.0487	.0408	.04	.0975	.0817	
T6X3	.95	.312	.1189	.62	.0396	.0332	.02	.0792	.0664	
T6X3	1.00	0.000	.1329	0.00	.0443	.0371	0.00	.0886	.0742	
T6X3	1.05	.320	.1562	.64	.0520	.0436	.02	.1041	.0872	
T6X3	1.10	.458	.1646	.91	.0548	.0459	.04	.1097	.0919	
T6X3	1.30	.630	.1904	1.66	.0634	.0531	.16	.1269	.1063	
T6X3	1.50	1.118	.1586	2.23	.0528	.0443	.29	.1057	.0886	
T6X3	1.75	1.436	.1290	2.87	.0430	.0360	.48	.0860	.0720	
T6X3	2.00	1.732	.1133	3.46	.0377	.0316	.70	.0755	.0633	
T6X3	2.50	2.291	.0947	4.58	.0315	.0264	1.22	.0631	.0529	
T6X3	3.00	2.628	.0790	5.65	.0263	.0220	1.86	.0526	.0441	
T6X3	4.00	3.872	.0652	7.74	.0217	.0182	3.50	.0434	.0364	
T6X3	4.50	4.387	.0584	8.77	.0194	.0163	4.49	.0389	.0326	

TABLE A-IV. RINGTAIL CORRELATING PARAMETERS (Continued)

CCAF	MACH	BEIA	FCT1	FCT2	FCT3	FCT4	FCT5	FCT6	FCT7	CCAC
T7X1	.80	.600	.1639	1.20	.0546	.0546	.27	.1092	.1092	
T7X1	.90	.435	.1547	.87	.0515	.0515	.14	.1031	.1021	
T7X1	.95	.312	.1885	.62	.0628	.0628	.07	.1256	.1256	
T7X1	1.00	0.000	.1927	0.00	.0642	.0642	0.00	.1284	.1284	
T7X1	1.05	.520	.1822	.64	.0507	.0607	.07	.1214	.1214	
T7X1	1.10	.458	.1831	.91	.0610	.0610	.15	.1220	.1220	
T7X1	1.30	.630	.1309	1.66	.0436	.0436	.51	.0872	.0872	
T7X1	1.50	1.118	.1451	2.23	.0483	.0483	.93	.0967	.0967	
T7X1	1.75	1.436	.1422	2.87	.0474	.0474	1.54	.0948	.0948	
T7X1	2.00	1.732	.0927	3.46	.0309	.0309	2.24	.0618	.0618	
T7X1	2.50	2.291	.0680	4.58	.0226	.0226	3.93	.0453	.0453	
T7X1	3.00	2.828	.0595	5.65	.0199	.0199	5.99	.0376	.0396	
T7X1	4.00	3.872	.0483	7.74	.0161	.0161	11.24	.0322	.0322	
T7X1	4.50	4.387	.0429	8.77	.0143	.0143	14.43	.0286	.0286	
T7X2	.80	.600	.1352	1.20	.0450	.0450	.18	.0901	.0901	
T7X2	.90	.435	.1547	.87	.0515	.0515	.09	.1031	.1031	
T7X2	.95	.312	.1948	.62	.0649	.0649	.04	.1298	.1298	
T7X2	1.00	0.000	.1931	0.00	.0643	.0643	0.00	.1287	.1287	
T7X2	1.05	.520	.1848	.64	.0616	.0616	.05	.1232	.1232	
T7X2	1.10	.458	.1832	.91	.0610	.0610	.10	.1221	.1221	
T7X2	1.20	.663	.1588	1.32	.0529	.0529	.21	.1058	.1058	
T7X2	.80	.600	.1544	1.20	.0514	.0514	.18	.1029	.1029	
T7X2	.90	.435	.1442	.87	.0480	.0480	.09	.0961	.0961	
T7X2	.95	.312	.1913	.62	.0637	.0637	.04	.1275	.1275	
T7X2	1.00	0.000	.1867	0.00	.0621	.0621	0.00	.1242	.1242	
T7X2	1.05	.320	.1751	.64	.0583	.0583	.05	.1167	.1167	
T7X2	1.10	.458	.1761	.91	.0587	.0587	.10	.1174	.1174	
T7X2	1.30	.830	.1255	1.66	.0418	.0418	.34	.0836	.0836	
T7X2	1.50	1.118	.1541	2.23	.0513	.0513	.62	.1027	.1027	
T7X2	1.75	1.436	.1943	2.87	.0647	.0647	1.03	.1295	.1295	
T7X2	2.00	1.732	.1108	3.46	.0369	.0369	1.49	.0738	.0738	
T7X2	2.50	2.291	.0815	4.58	.0271	.0271	2.62	.0543	.0543	
T7X2	3.00	2.828	.0748	5.65	.0249	.0249	3.99	.0498	.0498	
T7X2	4.00	3.872	.0618	7.74	.0206	.0206	7.49	.0412	.0412	
T7X2	4.50	4.387	.0540	8.77	.0180	.0180	9.62	.0360	.0360	
T7X3	.80	.600	.1534	1.20	.0511	.0511	.09	.1022	.1022	
T7X3	.90	.435	.1495	.87	.0498	.0498	.04	.0996	.0996	

TABLE A-IV. RINGTAIL CORRELATING PARAMETERS (Continued)

T7X3	.95	.312	.1706	.62	.0568	.0568	.02	.1137	.1137
T7X3	1.00	0.000	.1647	0.00	.0549	.0549	0.00	.1098	.1098
T7X3	1.05	.320	.1577	.64	.0525	.0525	.02	.1051	.1051
T7X3	1.10	.458	.1604	.91	.0534	.0534	.05	.1069	.1069
T7X3	1.20	.563	.1402	1.32	.0467	.0467	.10	.0934	.0934
T7X3	1.30	.630	.1223	1.66	.0407	.0407	.17	.0815	.0815
T7X3	1.50	1.118	.1804	2.23	.0601	.0601	.31	.1202	.1202
T7X3	1.75	1.436	.1475	2.87	.0491	.0491	.51	.0983	.0983
T7X3	2.00	1.732	.1232	3.46	.0410	.0410	.74	.0821	.0821
T7X3	2.50	2.491	.1014	4.58	.0338	.0338	1.31	.0676	.0676
T7X3	3.00	2.828	.0833	5.65	.0277	.0277	1.99	.0555	.0555
T7X3	4.00	3.672	.0634	7.74	.0211	.0211	3.74	.0422	.0422
T7X3	4.50	4.387	.0544	8.77	.0181	.0181	4.31	.0362	.0362
T7X4	.80	.200	.1269	1.20	.0423	.0423	.01	.0846	.0846
T7X4	.90	.435	.1390	.87	.0463	.0463	0.00	.0926	.0926
T7X4	.95	.312	.1750	.62	.0583	.0583	0.00	.1166	.1166
T7X4	1.00	0.000	.1704	0.00	.0568	.0568	0.00	.1136	.1136
T7X4	1.05	.320	.1414	.64	.0471	.0471	0.00	.0942	.0942
T7X4	1.10	.458	.1471	.91	.0490	.0490	.01	.0980	.0980
T7X4	1.20	.563	.1487	1.32	.0495	.0495	.02	.0991	.0991
T7X4	1.30	.630	.1545	1.66	.0515	.0515	.03	.1030	.1030
T7X4	1.50	1.118	.1545	2.23	.0515	.0515	.06	.1030	.1030
T7X4	1.75	1.436	.1234	2.87	.0411	.0411	.10	.0822	.0822
T7X4	2.00	1.732	.0966	3.46	.0322	.0322	.14	.0644	.0644
T7X4	3.00	2.828	.0805	5.65	.0268	.0268	.39	.0536	.0536
T7X4	.80	.200	.1269	1.20	.0423	.0423	.01	.0846	.0846
T7X4	.90	.435	.1390	.87	.0463	.0463	0.00	.0926	.0926
T7X4	.95	.312	.1750	.62	.0583	.0583	0.00	.1166	.1166
T7X4	1.00	0.000	.1704	0.00	.0568	.0568	0.00	.1136	.1136
T7X4	1.05	.320	.1414	.64	.0471	.0471	0.00	.0942	.0942
T7X4	1.10	.458	.1471	.91	.0490	.0490	.01	.0980	.0980
T7X4	1.20	.563	.1487	1.32	.0495	.0495	.02	.0991	.0991
T7X4	1.30	.630	.1545	1.66	.0515	.0515	.03	.1030	.1030
T7X4	1.50	1.118	.1545	2.23	.0515	.0515	.06	.1030	.1030
T7X4	1.75	1.436	.1234	2.87	.0411	.0411	.10	.0822	.0822
T7X4	2.00	1.732	.0966	3.46	.0322	.0322	.14	.0644	.0644
T7X4	3.00	2.828	.0805	5.65	.0268	.0268	.39	.0536	.0536



TABLE A-IV. RINGTAIL CORRELATING PARAMETERS (Continued)

CONF	MACH	BETA	FCT1	FCT2	FCT3	FCT4	FCT5	FCT6	FCT7	CCNC
T8X1	1.75	1.436	.1112	2.87	.0370	.0286	1.39	.0741	.0572	
T8X1	2.00	1.732	.0992	3.46	.0330	.0255	2.03	.0661	.0510	
T8X1	2.50	2.291	.0891	4.58	.0297	.0229	3.56	.0594	.0458	
T8X1	3.00	2.828	.0837	5.65	.0279	.0215	5.42	.0558	.0430	
T8X1	4.00	3.872	.0692	7.74	.0230	.0178	10.18	.0461	.0356	
T8X1	4.50	4.387	.0628	8.77	.0209	.0161	13.06	.0418	.0323	
T8X2	1.75	1.436	.1256	2.87	.0418	.0323	.93	.0837	.0646	
T8X2	2.00	1.732	.1207	3.46	.0402	.0310	1.35	.0804	.0621	
T8X2	2.50	2.291	.1028	4.58	.0342	.0264	2.37	.0685	.0529	
T8X2	3.00	2.828	.0878	5.65	.0292	.0226	3.61	.0585	.0452	
T8X2	4.00	3.872	.0698	7.74	.0232	.0179	6.78	.0465	.0359	
T8X2	4.50	4.387	.0642	8.77	.0214	.0165	8.71	.0428	.0330	
T8X3	1.75	1.436	.1413	2.87	.0471	.0363	.46	.0942	.0727	
T8X3	2.00	1.732	.1266	3.46	.0422	.0325	.67	.0844	.0651	
T8X3	2.50	2.291	.1021	4.58	.0340	.0262	1.18	.0680	.0525	
T8X3	3.00	2.828	.0876	5.65	.0292	.0225	1.80	.0584	.0451	
T8X3	4.00	3.872	.0703	7.74	.0234	.0180	3.39	.0468	.0361	
T8X3	4.50	4.387	.0637	8.77	.0212	.0164	4.35	.0424	.0328	
T10X1	1.75	1.436	.1941	2.87	.0369	.0315	.94	.0739	.0630	
T10X1	2.00	1.732	.1736	3.46	.0330	.0282	1.37	.0661	.0564	
T10X1	2.50	2.291	.1620	4.58	.0308	.0263	2.41	.0617	.0526	
T10X1	3.00	2.828	.1462	5.65	.0278	.0237	3.67	.0556	.0475	
T10X1	4.00	3.872	.1091	7.74	.0207	.0177	6.88	.0415	.0354	
T10X1	4.50	4.387	.0988	8.77	.0188	.0160	8.84	.0376	.0321	
T10X2	1.75	1.436	.2102	2.87	.0400	.0341	.67	.0800	.0682	
T10X2	2.00	1.732	.2052	3.46	.0390	.0333	.98	.0781	.0666	
T10X2	2.50	2.291	.1783	4.58	.0339	.0289	1.72	.0679	.0579	
T10X2	3.00	2.828	.1484	5.65	.0282	.0241	2.62	.0565	.0482	
T10X2	4.00	3.872	.1111	7.74	.0211	.0180	4.92	.0423	.0360	
T10X2	4.50	4.387	.0997	8.77	.0189	.0161	6.31	.0379	.0323	
T10X3	1.75	1.436	.2379	2.87	.0453	.0386	.40	.0906	.0772	
T10X3	2.00	1.732	.2138	3.46	.0407	.0347	.59	.0814	.0694	
T10X3	2.50	2.291	.1753	4.58	.0333	.0284	1.03	.0667	.0569	
T10X3	3.00	2.828	.1493	5.65	.0284	.0242	1.57	.0568	.0485	
T10X3	4.00	3.872	.1137	7.74	.0216	.0184	2.95	.0433	.0369	
T10X3	4.50	4.387	.1015	8.77	.0193	.0164	3.78	.0386	.0329	
T11X1	1.75	1.436	.1244	4.78	.0236	.0215	.41	.0789	.0716	
T11X1	2.00	1.732	.1277	5.77	.0243	.0220	.60	.0810	.0735	
T11X1	2.50	2.291	.1113	7.63	.0212	.0192	1.05	.0706	.0641	
T11X1	3.00	2.828	.0928	9.42	.0176	.0160	1.61	.0589	.0524	
T11X1	4.00	3.872	.0701	12.90	.0133	.0121	3.01	.0445	.0403	
T11X1	4.50	4.387	.0630	14.62	.0120	.0108	3.67	.0399	.0362	
T11X2	1.75	1.436	.1512	4.78	.0288	.0261	.24	.0959	.0871	
T11X2	2.00	1.732	.1341	5.77	.0255	.0231	.36	.0851	.0772	
T11X2	2.50	2.291	.1105	7.63	.0210	.0190	.63	.0701	.0636	
T11X2	3.00	2.828	.0925	9.42	.0176	.0159	.96	.0587	.0532	
T11X2	4.00	3.872	.0705	12.90	.0134	.0121	1.81	.0447	.0406	
T11X2	4.50	4.387	.0634	14.62	.0120	.0109	2.32	.0402	.0365	
T11X3	1.75	1.436	.1512	4.78	.0288	.0261	.08	.0959	.0871	
T11X3	2.00	1.732	.1271	5.77	.0242	.0219	.12	.0806	.0732	
T11X3	2.50	2.291	.1108	7.63	.0211	.0191	.21	.0703	.0638	
T11X3	3.00	2.828	.0922	9.42	.0175	.0159	.32	.0585	.0531	
T11X3	4.00	3.872	.0713	12.90	.0135	.0123	.60	.0452	.0410	
T11X3	4.50	4.387	.0642	14.62	.0122	.0110	.77	.0407	.0369	

TABLE A-IV. RINGTAIL CORRELATING PARAMETERS (Continued)

CONF	MACH	BETA	FCT1	FCT2	FCT3	FCT4	FCT5	FCT6	FCT7	CCND
T12X1	.80	.600	.0376	.60	.0668	.0364	4.66	.0668	.0364	
T12X1	.90	.435	.0157	.43	.0279	.0157	2.46	.0279	.0157	
T12X1	.95	.312	.0163	.31	.0289	.0158	1.26	.0289	.0158	
T12X1	1.00	0.000	.0149	0.00	.0264	.0144	0.00	.0264	.0144	
T12X1	1.05	.320	.0188	.32	.0334	.0182	1.32	.0334	.0182	
T12X1	1.10	.458	.0213	.45	.0378	.0206	2.72	.0378	.0206	
T12X1	1.30	.630	.0233	.83	.0414	.0226	8.94	.0414	.0226	
T12X1	1.50	1.118	.0298	1.11	.0529	.0289	16.20	.0529	.0289	
T12X1	1.75	1.436	.0295	1.43	.0524	.0286	26.73	.0524	.0286	
T12X1	2.00	1.732	.0258	1.73	.0458	.0250	38.88	.0458	.0250	
T12X1	2.50	2.291	.0223	2.27	.0405	.0221	68.05	.0405	.0221	
T12X1	3.00	2.828	.0194	2.82	.0344	.0188	103.70	.0344	.0188	
T12X2	.80	.600	.0392	.60	.0696	.0380	3.33	.0696	.0380	
T12X2	.90	.435	.0299	.43	.0531	.0290	1.75	.0531	.0290	
T12X2	.95	.312	.0248	.31	.0440	.0240	.90	.0440	.0240	
T12X2	1.00	0.000	.0192	0.00	.0323	.0176	0.00	.0323	.0176	
T12X2	1.05	.320	.0116	.32	.0206	.0112	.94	.0206	.0112	
T12X2	1.10	.458	.0133	.45	.0236	.0129	1.94	.0236	.0129	
T12X2	1.30	.630	.0324	.83	.0576	.0314	6.38	.0576	.0314	
T12X2	1.50	1.118	.0358	1.11	.0636	.0347	11.57	.0636	.0347	
T12X2	1.75	1.436	.0373	1.43	.0663	.0361	19.09	.0663	.0361	
T12X2	2.00	1.732	.0323	1.73	.0574	.0313	27.77	.0574	.0313	
T12X2	2.50	2.291	.0286	2.29	.0508	.0277	48.60	.0508	.0277	
T12X2	3.00	2.828	.0357	2.82	.0634	.0346	74.07	.0634	.0346	
T12X5	.80	.600	.0467	.60	.0830	.0453	2.66	.0830	.0453	
T12X5	.90	.435	.0318	.43	.0565	.0308	1.40	.0565	.0308	
T12X5	.95	.312	.0273	.31	.0485	.0264	.72	.0485	.0264	
T12X5	1.00	0.000	.0178	0.00	.0316	.0172	0.00	.0316	.0172	
T12X5	1.05	.320	.0153	.32	.0272	.0148	.75	.0272	.0148	
T12X5	1.10	.458	.0157	.45	.0279	.0152	1.55	.0279	.0152	
T12X5	1.30	.630	.0318	.83	.0565	.0308	5.11	.0565	.0308	
T12X5	1.50	1.118	.0345	1.11	.0612	.0334	9.25	.0612	.0334	
T12X5	1.75	1.436	.0360	1.43	.0640	.0349	15.27	.0640	.0349	
T12X5	2.00	1.732	.0327	1.73	.0581	.0317	22.22	.0581	.0317	
T12X5	2.50	2.291	.0295	2.29	.0524	.0286	38.88	.0524	.0286	
T12X5	3.00	2.828	.0250	2.82	.0444	.0242	59.25	.0444	.0242	

TABLE A-IV. RINGTAIL CORRELATING PARAMETERS (Concluded)

CLNF	MACH	BETA	FCT1	FCT2	FCT3	FCT4	FCT5	FCT6	FCT7	CCNC
T13X1	.80	.600	.0274	.80	.0487	.0302	3.07	.0649	.0402	
T13X1	.90	.435	.0181	.58	.0321	.0199	1.62	.0429	.0266	
T13X1	.95	.312	.0060	.41	.0106	.0066	.83	.0142	.0088	
T13X1	1.00	0.000	.0145	0.00	.0257	.0159	0.00	.0343	.0213	
T13X1	1.05	.320	.0150	.42	.0266	.0165	.87	.0355	.0220	
T13X1	1.10	.458	.0163	.61	.0289	.0179	1.79	.0386	.0239	
T13X1	1.30	.830	.0153	1.10	.0272	.0168	5.88	.0362	.0224	
T13X1	1.50	1.118	.0196	1.49	.0348	.0216	10.66	.0414	.0288	
T13X1	1.75	1.436	.0204	1.91	.0362	.0224	17.60	.0414	.0299	
T13X1	2.00	1.732	.0175	2.31	.0311	.0192	25.60	.0415	.0257	
T13X1	2.50	2.291	.0156	3.05	.0277	.0171	44.80	.0369	.0229	
T13X1	3.00	2.828	.0135	3.77	.0240	.0148	68.28	.0320	.0198	
T13X2	.80	.600	.0374	.90	.0664	.0412	2.00	.0886	.0549	
T13X2	.90	.435	.0295	.58	.0524	.0325	1.05	.0699	.0433	
T13X2	.95	.312	.0225	.41	.0400	.0248	.54	.0533	.0330	
T13X2	1.00	0.000	.0138	0.00	.0245	.0152	0.00	.0327	.0202	
T13X2	1.05	.320	.0142	.42	.0252	.0156	.57	.0336	.0208	
T13X2	1.10	.458	.0176	.61	.0312	.0194	1.16	.0417	.0258	
T13X2	1.30	.830	.0251	1.10	.0446	.0276	3.83	.0595	.0369	
T13X2	1.50	1.118	.0286	1.49	.0508	.0315	6.95	.0678	.0420	
T13X2	1.75	1.436	.0272	1.91	.0483	.0299	11.47	.0645	.0399	
T13X2	2.00	1.732	.0239	2.31	.0424	.0263	16.69	.0566	.0351	
T13X2	2.50	2.291	.0206	3.05	.0366	.0227	29.21	.0488	.0302	
T13X2	3.00	2.828	.0173	3.77	.0307	.0190	44.52	.0410	.0254	
T13X5	.80	.600	.0309	.80	.0549	.0340	1.46	.0732	.0454	
T13X5	.90	.435	.0335	.58	.0565	.0369	.77	.0794	.0492	
T13X5	.95	.312	.0253	.41	.0419	.0278	.39	.0600	.0372	
T13X5	1.00	0.000	.0196	0.00	.0348	.0216	0.00	.0464	.0288	
T13X5	1.05	.320	.0148	.42	.0263	.0163	.41	.0351	.0217	
T13X5	1.10	.458	.0150	.61	.0266	.0165	.85	.0355	.0220	
T13X5	1.30	.830	.0294	1.10	.0522	.0324	2.81	.0697	.0432	
T13X5	1.50	1.118	.0309	1.49	.0549	.0340	5.10	.0732	.0454	
T13X5	1.75	1.436	.0270	1.91	.0480	.0297	8.41	.0640	.0397	
T13X5	2.00	1.732	.0239	2.31	.0424	.0263	12.24	.0566	.0351	
T13X5	2.50	2.291	.0207	3.05	.0368	.0228	21.42	.0490	.0304	
T13X5	3.00	2.828	.0174	3.77	.0309	.0191	32.64	.0412	.0255	

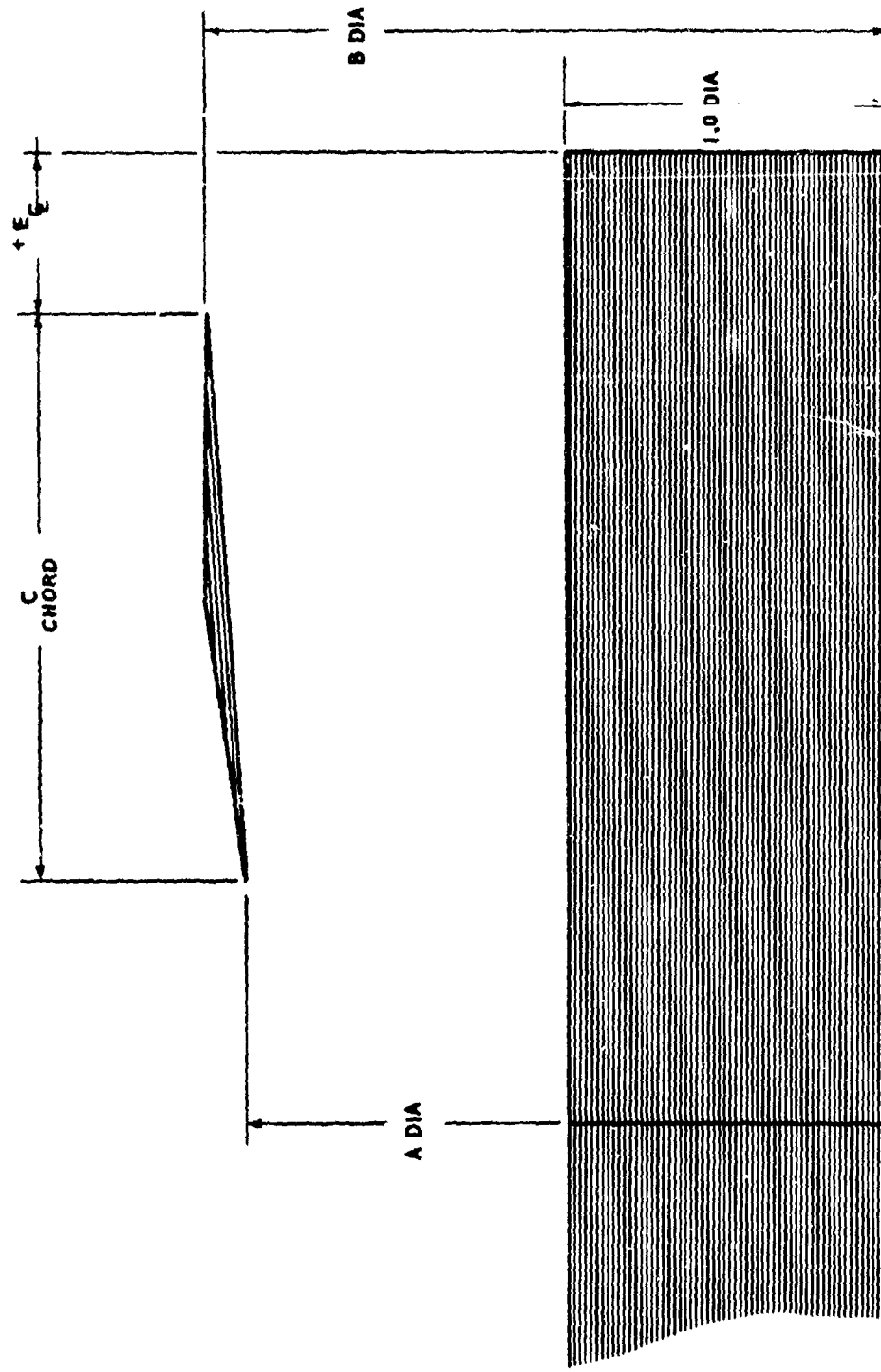
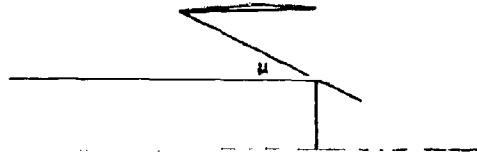

FIGURE A-1. RINGTAIL GEOMETRY NOMENCLATURE

CONDITION 1 RINGTAIL LEADING EDGE MACH LINE IMPINGEMENT ON BODY BASE

$$\cot \mu = \beta = \frac{2(C + E)}{A - 1}$$



CONDITION 2 RINGTAIL LEADING EDGE MACH LINE IMPINGEMENT ON RINGTAIL TRAILING EDGE AFTER REFLECTION ON BODY

$$\cot \mu = \beta = \frac{2C}{A + B - 2}$$

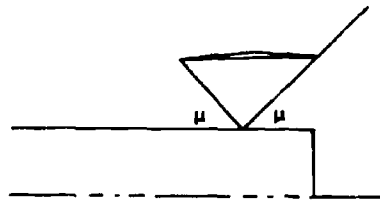

CONDITION 3 BODY BASE MACH LINE IMPINGEMENT ON RINGTAIL TRAILING EDGE

$$\cot \mu = \beta = \frac{2E}{B - 1}$$

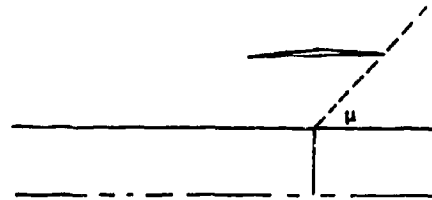

CONDITION 4 RINGTAIL LEADING EDGE MACH LINE REFLECTION FROM BODY SURFACE AND IMPINGEMENT ON THE RINGTAIL INNER SURFACE CONCURRENTLY WITH IMPINGEMENT ON BODY BASE.

$$\cot(\mu) = \beta$$

IF

$$\frac{(A - B)(C + E)^2 + (A - 1)(C + E)}{C(A - 1) - (A - B)(C + E)} > E$$

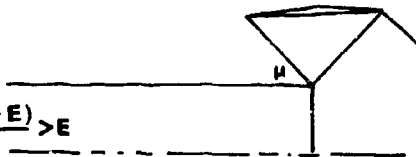

CONDITION 5 RINGTAIL LEADING EDGE MACH LINE IMPINGEMENT ON BODY BASE AFTER REFLECTION FROM BODY AND RINGTAIL INNER SURFACE

$$\cot \mu = \beta = \frac{X \cos 2\delta - \sin 2\delta}{\cos 2\delta + X \sin 2\delta + 2}$$

WHERE

$$X = \frac{2(C + E)}{(A - 1)}$$

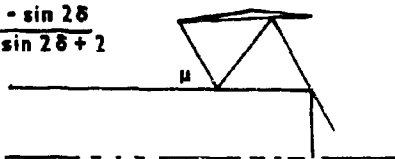

FIGURE A-2. FLOW CONDITIONS

## References

1. Rubin, Donald V. , Exploratory Investigation of the Effect of Ringtail on the Jet On Base Pressure of a Body of Revolution at Free Stream Mach Numbers of 2.5 and 3.0, U. S. Army Missile Command, Redstone Arsenal, Alabama. 5 July 1966, Report No. RD-TR-66-16 (Unclassified).
2. Rubin, Donald V. , Tabulated Stability Data for a Series of Ring-tail-Body Configurations at Mach Numbers from 0.8 to 4.5, U. S. Army Missile Command, Redstone Arsenal, Alabama, 1 April 1965, Report No. RD-TR-65-6 (Unclassified).
3. Connolly, Paul R. , The Zero-Lift Foredrag and Body Base Drag Coefficients of a Series of Ringtail-Strut Body Configurations at Mach Numbers from 0.8 to 4.50, U. S. Army Missile Command, Redstone Arsenal, Alabama, May 1965, Report No. RE-TR-65-8 (Unclassified).
4. Propulsion Wind Tunnel Facility, Test Facilities Handbook, 3, 5th ed. , Arnold Engineering Development Center, Tullahoma, Tennessee, July 1963.
5. BRL Memo 1292, Ballistic Research Laboratories, Aberdeen Proving Grounds, Maryland, July 1960.
6. Adams, Carl L. , Computer Method for Wind Tunnel Analysis, U. S. Army Missile Command, Redstone Arsenal, Alabama, 14 April 1966, Report No. RE-TM-66-5.
7. Gafarian, A. V. , and Phillips, W. L. , The Supersonic Lift and Centers of Pressure of Rectangular and Clipped-Delta Fins in Combination with Long Cylindrical Bodies-Comparison Between Theory and Experiment, Naval Ordnance Test Station, China Lake, California, 1953, NOTSTM-966.
8. Ehlers, F. E. , "On the Lift, Drag and Moment on a Ring Concentric to a Cylindrical Body in Supersonic Flow," Journal of Aeronautical Sciences, 28, No. 2, February 1961, pp. 170-171.
9. Ehlers, F. E. , "The Lift and Moment on a Ring Concentric to a Cylindrical Body in Supersonic Flow," Journal of Aeronautical Sciences, 22, No. 4, April 1955, pp. 239-248.
10. Ribner, H. , "The Ring Airfoil in Non-Axial Flow," Journal of the Aeronautical Sciences, 14, No. 9, September 1947, pp. 529-530.

UNCLASSIFIED

Security Classification

DOCUMENT CONTROL DATA - R & D		
<i>(Security classification of title, body of abstract and indexing annotation must be entered when the overall report is classified)</i>		
1. ORIGINATING ACTIVITY (Corporate author) Advanced Systems Laboratory Research and Engineering Directorate U. S. Army Missile Command Redstone Arsenal, Alabama 35809		2a. REPORT SECURITY CLASSIFICATION Unclassified
		2b. GROUP NA
3. REPORT TITLE LONGITUDINAL STABILITY CHARACTERISTICS OF A SERIES OF RINGTAIL-BODY COMBINATIONS AT MACH NUMBERS OF 0.8 - 4.5		
4. DESCRIPTIVE NOTES (Type of report and inclusive dates) Technical Report		
5. AUTHOR(S) (First name, middle initial, last name) Charles E. Brazzel James H. Henderson Joseph C. Craft		
6. REPORT DATE 12 May 1970	7a. TOTAL NO. OF PAGES 83	7b. NO. OF REFS 10
8a. CONTRACT OR GRANT NO.  8. PROJECT NO. (DA) 1S222901A206 AMC Management Structure Code No. * 5221. 11. 148 4		9a. ORIGINATOR'S REPORT NUMBER(S) RD-TR-65-7
		9b. OTHER REPORT NO(S) (Any other numbers that may be assigned this report) AD _____
10. DISTRIBUTION STATEMENT This document is subject to special export controls and each transmittal to foreign govern- ments or foreign nationals may be made only with prior approval of this Command, ATTN: AMSMI-RD.		
11. SUPPLEMENTARY NOTES None	12. SPONSORING MILITARY ACTIVITY Same as No. 1	
13. ABSTRACT  An analysis is made of experimentally determined stability characteristics of a series of ringtails in combination with bodies of revolution. Results of the analysis show ringtails to be efficient stabilizing devices, when missile overall diameter is limited.		

DD FORM 1473  
1 NOV 66REPLACES DD FORM 1473, 1 JAN 64, WHICH IS  
OBSOLETE FOR ARMY USE.UNCLASSIFIED  
Security Classification

75

UNCLASSIFIED

Security Classification

KEY WORDS	LINK A		LINK B		LINK C	
	ROLE	WT	ROLE	WT	ROLE	WT
Ringtails Bodies of revolution Tube-launched configurations Mach numbers 0.8 - 4.5 Longitudinal stability characteristics						

UNCLASSIFIED

Security Classification



**SUPPLEMENTARY**

**INFORMATION**



DEPARTMENT OF THE ARMY  
HEADQUARTERS UNITED STATES ARMY MISSILE COMMAND  
REDSTONE ARSENAL, ALABAMA 35809

AMSML-RDK

SUBJECT: Errata for Report No. RD-TR-65-7, entitled "Longitudinal Stability Characteristics of a Series of Ringtail-Body Combinations at Mach Numbers of 0.8-4.5"

TO: Recipients of Subject Report

It is requested that the following changes be made in all copies of the subject report:

Page 50, change ordinate scale designation to read  $\left(\frac{\Delta C_{N_a}}{B^2 - 1}\right)$ .

Page 42, Figure 12(b), add the ordinate scale designation  $\Delta C_{N_a}$  (T13S-T13).

Page 42, Figure 12(c), add the ordinate scale designation  $\Delta C_{N_a}$ .

APPROVED:

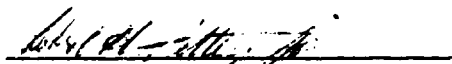
  
ROBERT H. PETTEY, JR.  
Acting Director  
Advanced Systems Laboratory  
Research & Engineering Directorate

AD-871756