

UNCLASSIFIED

AD NUMBER

AD871449

LIMITATION CHANGES

TO:

Approved for public release; distribution is unlimited.

FROM:

Distribution authorized to U.S. Gov't. agencies and their contractors; Critical Technology; MAY 1970. Other requests shall be referred to Naval Ordnance Laboratory, White Oak, MD. This document contains export-controlled technical data.

AUTHORITY

no1 ltr dtd 15 nov 1971

THIS PAGE IS UNCLASSIFIED

20

NOLTR 70-87

AD871449

AD NO. —  
DDC FILE COPY

40-FOOT FREE-FALL TEST CARRIAGE  
(Feasibility Study of Carriage Use for  
MIL-STD-331 Test 103)

By  
V. DeVost

NOL

8 MAY 1970

DDC  
RECEIVED  
JUL 13 1970  
RECEIVED

UNITED STATES NAVAL ORDNANCE LABORATORY, WHITE OAK, MARYLAND

NOLTR 70-87

ATTENTION

This document is subject to special export controls and each transmittal to foreign governments or foreign nationals may be made only with prior approval of NOL.

NOLTR 70-87

40-FOOT FREE-FALL TEST CARRIAGE  
(Feasibility Study of Carriage Use for MIL-STD-331 Test 103)

Prepared by:

V. DeVost  
Environment Simulation Division

ABSTRACT: A 1500-pound, high impact steel carriage is intended for use in screening live-loaded fuzes and components during production under impact conditions equivalent to those specified in the MIL-STD-331 Forty-Foot Drop Test. The test items are mounted inside the carriage to protect them from accidental damage. Each of three mounting spaces will accommodate test items up to four inches in diameter and eight inches long. Three fuzes may be tested, each in a different orientation, in a single drop. Impacts are about 10,000g peak and 0.3 ms duration.

PUBLISHED 8 MAY 1970

U. S. NAVAL ORDNANCE LABORATORY  
WHITE OAK, MARYLAND

NOLTR 70-87

8 May 1970

40-FOOT FREE-FALL TEST CARRIAGE  
(Feasibility Study of Carriage Use for MIL-STD-331, Test 103)

This carriage, intended for testing live-loaded fuzes and components, will result in procedures that are safer, simpler and more economical than present methods that require the use of inert munitions as test carriages. The new carriage provides better control of the test conditions and impact parameters. Damage to test items that is incidental to the screening of these items for manufacturing defects is avoided. The test method meets the essential requirements of Test 103 of MIL-STD-331 for munitions weighing 500 pounds or more. The carriage will house most enclosed bomb and projectile fuzes currently in large scale production under Navy contract.

Work on the development of the free-fall test carriage was one of several projects undertaken in support of NOL Task A35 532/WF17 353 502 Problem 204 and Task A532 5323/246 00 003. The test concept was originated by R. L. Brodell of the Air and Surface Evaluation Department. Design of the test carriage was the joint effort of J. W. Simkins of the Product Engineering Department, and V. DeVost of the Environmental Evaluation Department.

The opinions and conclusions are those of the Environmental Evaluation Department.

GEORGE G. BALL  
Captain, USN  
Commander

*V. M. Korty*  
V. M. KORTY  
By direction

NOLTR 70-87

CONTENTS

	Page
INTRODUCTION . . . . .	1
DESCRIPTION. . . . .	1
General . . . . .	1
Forging . . . . .	2
Lifting Bridle. . . . .	2
Components Wells. . . . .	2
Impact Adapter (Optional) . . . . .	3
TEST PROCEDURES. . . . .	3
TEST-CARRIAGE IMPACT . . . . .	3
DISCUSSION AND CONCLUSIONS . . . . .	4

ILLUSTRATIONS

Figure	Title
1	Forty-Foot Free-Fall Test Carriage
2	Test Carriage Components
3	Test Carriage Fabrication Details
4	Sample Oscillogram of Carriage Impact
5	Spectra of 40-Foot Free-Fall Impacts

TABLES

Table	Title
1	40-Foot Free-Fall Test Carriage General Specifications
2	Comparison of Carriage and Bomb Impacts

REFERENCES

- (a) MIL-STD-331, Fuze and Fuze Components, Environmental and Performance Tests For, 10 Jan 1966
- (b) NOLTR 67-151, Shock Spectra Measurements Using Multiple Mechanical Gages, 20 Sep 1967
- (c) NOLTR 68-158, VHg Impact Test Set, 10 Sep 1968

## INTRODUCTION

1. The need has existed for some time for a simplified, safe, and economical shock-test method to screen live-loaded fuzes and components for manufacturing defects. The need is especially pressing today with the heavy increase in fuze production. The principal problems with the present method of testing, Test 103 of reference (a), are: the requirement that an inert munition (or equal) be used as a test carriage for each fuze or component tested and that each drop be made with the munition in a different orientation. Rigging and handling for each test is difficult and time-consuming.

2. Once a fuze has been released for production, having met the pertinent requirements of MIL-STD-331, the safety and ruggedness of the design should have been established. Subsequent testing in compliance with the 40-foot drop requirement (Test 103) should be solely for the purpose of screening components for manufacturing defects. The 40-Foot Free-Fall Test Carriage is intended for this purpose. The new test method eliminates the need for the many sizes and shapes of munitions normally used as test carriages and reduces the number of drops necessary to meet the essential requirements of Test 103 from five to two, and possibly one (see paragraph 11). Impact repeatability is improved considerably over impacts produced by dropping munitions in several orientations.

## DESCRIPTION

### GENERAL

3. Special features of the free-fall test carriage, Figure 1, are high impact strength, one-piece construction, crush-proof housing of the test items (except for tests requiring direct impact against the test item), and a single drop orientation. The forging contains three component wells: one vertical, one at 45°, and one at 90° (horizontal). The wells protect the test items from accidental damage during the tests. Three items may be tested in one drop. To duplicate drops in which the munition impacts on its fuze, a special adapter that bolts to the bottom of the carriage is suggested. The adapter should be easy to remove after a test. The adapter is considered optional — its use, except in rare cases, would be more applicable to design testing than to production testing.

4. The carriage is dropped 40 feet, the height specified in reference (a). In tests other than those requiring direct impact

against the fuze, the carriage is dropped onto a steel plate producing a complex steel-on-steel shock. The initial (fundamental) pulse is approximately 10,000g peak and 0.3 ms duration. The general specifications of the tester are listed in Table 1. The carriage is described in detail in the following paragraphs; the items are keyed to Figure 2. Dimensional and fabrication details are presented in Figure 3.

FORGING

5. The carriage is a solid, 1500-pound billet forged from 4340 steel and heat-treated to 31 Rockwell C hardness. The hardness is in the optimum free machining and high impact strength region of the material. The billet is 30 inches long and 16 inches in diameter. The outer surface finish, except for the striking surface, is 250 microinches. The impacting surface has a six-foot spherical radius and a machined finish of 125 microinches. The spherical radius of six feet proved to be the best of several tried to produce a fundamental shock pulse high enough in amplitude to meet most munition requirements, and to maintain relatively close shock pulse repeatability.

LIFTING BRIDLE

6. The test carriage must hang plumb before it is dropped to ensure that it will impact against its spherical surface. The spherical bottom of the carriage provides adequate tolerance for oblique impacts since the carriage can land as much as four degrees off axis and still produce a full impact. The bridle used to lift the carriage is designed to ensure that the carriage will hang within one degree of axial when it is ready to drop.

7. The bridle consists of three wire rope slings that attach to three lifting hooks mounted in wells to protect them from being knocked out of alignment when the carriage is battered about after impact. The hooks allow for easy removal of the bridle to facilitate mounting of components in the vertical well. The bridle is limited to 13 inches in length, to prevent it from hanging over the edge of the carriage where it could accidentally be kinked or severed. Unless it is improperly dropped, the carriage cannot rebound and land upside down.

COMPONENT WELLS

8. The chief purpose of the tester is to subject a test component to a high impact without exposing it unnecessarily to damage other than that resulting from initial impact of the carriage. For protection, the test components are mounted in wells eight inches deep and seven inches in diameter with base holes four inches in diameter and a minimum of eight inches long. Each well is vented. (Explosive elements in the components may actuate during impact.)

9. Components are mounted on adapter rings or suitable fixtures. The bottom of each well contains four equally spaced 3/4-10 tapped holes on a 5.5-inch bolt circle. Four 3/4-inch sockethead bolts are sufficient to hold the fixture and test item.

IMPACT ADAPTER (OPTIONAL)

10. Some screening tests may require that the test item be dropped directly against the impacting plate. This may be done by using adapters as shown schematically in Figure 2, views B and C. There are four 3/4-10 tapped holes on the bottom of the carriage to accommodate adapters. The holes are equally spaced on an 8.5-inch diameter bolt circle. The adapters should contain several blast vent holes.

TEST PROCEDURES

11. The procedures for testing items using the free-fall carriage conform as closely as possible to the essential requirements of Test 103 of reference (a). The drops and procedures recommended are as follows:

a. Exposed Fuzes and Components. Three drops are made. One drop each is made using the impact adapters with the test items mounted as shown in Figure 2-B and -C. A third drop is made with the test items mounted in each well as shown in Figure 2-A, except that a single test item is mounted in the vertical well and that both the vertical and 45° test items are mounted nose up.

b. Enclosed Fuzes and Components. Two drops are made. One drop is made with test items mounted in each well as shown in Figure 2-A. The second drop is made with the test items mounted in the vertical and 45° wells, but opposite from the orientation of the test items previously dropped. As specified in Test 103 of reference (a), each test item should be impact tested only once.

c. All Fuzes and Components. As an alternate to procedures a and b, five fuzes or components may be tested in a single drop by mounting two fuzes back-to-back in the vertical and 45° wells — see vertical well, Figure 2-A.

TEST-CARRIAGE IMPACT

12. Because of practical considerations the test-carriage impact had to be less severe than the highest munition impact produced in a 40-foot free-fall drop. This would be an impact of a flat-ended munition, e.g. an artillery projectile, landing on its base. Achieving flat impacts, either with a test carriage or munition in free fall, is extremely difficult and the shocks produced are considered too severe for tests used to screen production components.

13. The new test carriage produces an impact consisting of a fundamental pulse of approximately 10,000g peak and 0.3 ms duration. The peak of the pulse is repeatable to within ±15 percent. The shape of the fundamental pulse cannot be simply defined because of superimposed high frequency shock. The shock is complex in character, containing frequencies ranging from approximately 3000 Hz



to 20,000 Hz. This is typical of the response to impact of many hard-case munitions. A sample oscillogram of the impact is shown in Figure 4. A spectrum of the shock measured with mechanical gages, reference (b), is shown in Figure 5. For comparison, Figure 5 contains a spectrum of the 40-foot guided drop tester shock, also measured with mechanical gages.

14. To estimate the highest impact produced by munitions dropped as specified in MIL-STD-331, reference (a), 40-foot free-fall drop tests were conducted on several representative hard-case munitions. The samples consisted of Mk 80 series low drag bombs: 250-pound Mk 81, 500-pound Mk 82 and 1000-pound Mk 83. All bombs were dropped in a horizontal orientation to produce the highest shock. The shock was measured near the center of gravity of each bomb. Table 2 compares the peaks of the bomb impacts with those of the test carriage.

#### DISCUSSION AND CONCLUSIONS

15. Use of the 40-Foot Free-Fall Test Carriage to screen fuzes and components for manufacturing defects is considered feasible and meets the essential requirements of Test 103, MIL-STD-331. The principal advantages of the tester are:

- a. Low unit cost and minimal maintenance — see paragraph 16.
- b. Better repeatability and better control of test conditions than is possible using Test 103 procedures.
- c. More adaptable for general use by laboratories and contractors than the Test 103 method.

16. The unit cost of the new test carriage is approximately \$3000; a production lot of five carriages would reduce the unit cost by approximately 20 percent. Either cost figure is relatively small when compared with the cost of most high impact test facilities, and with the cost of tests which require the use of a wide variety of expendable test vehicles and complex test procedures. Munition carriages normally survive about five drops; the high impact steel carriage proposed for screening tests has an estimated life expectancy of thousands of drops. The test carriage described could therefore result in a substantial saving in production testing and provide a uniform and reliable method for accepting and rejecting munition fuzes and fuze components.

17. Improvements in the state of the art in shock measuring techniques over the last few years have made it possible to better determine the essential parameters of shock. A new look should be taken into methods used for many years to test production as well as development components. The study described in this report represents a small but important effort to apply new techniques to old problems in the interest of simplifying current test procedures and reducing cost.

18. Results of the study conducted on the free-fall carriage suggest similar studies in areas that may prove effective in reducing costs and simplifying test procedures; several of immediate interest are being considered. They are described briefly in the following paragraphs.

a. Test 103, reference (a). Measure fuze free-fall shock environment under actual service conditions and with a large enough number of munition samples to better define what the level of shock should be for development and production testing. Based on these measurements, find a feasible means of emplacing a 40-foot free-fall impacting plate that will produce an adequate shock and obviate the need for a reinforced concrete foundation.

b. Determine the margin of safety that exists in explosive components that have passed a 40-Foot Guided Free-Fall Drop Tester impact or a VHg Tester impact, reference (c). This would require that measurements be made of impacts produced by flat-ended projectiles dropping 40 feet and landing flat-end first on steel decks or by bomb impacts at higher velocities against rigid ship structures.

c. Test 209, reference (a). Measure the fuze shock environment under conditions simulating hard impacts after missile pull-off from aircraft on arrested landing. Based on these measurements, develop a feasible laboratory method to test munition components for safety.

NOLTR 70-87



Fig. 1 Forty-Foot Free-Fall Test Carriage

NOLTR 70-87

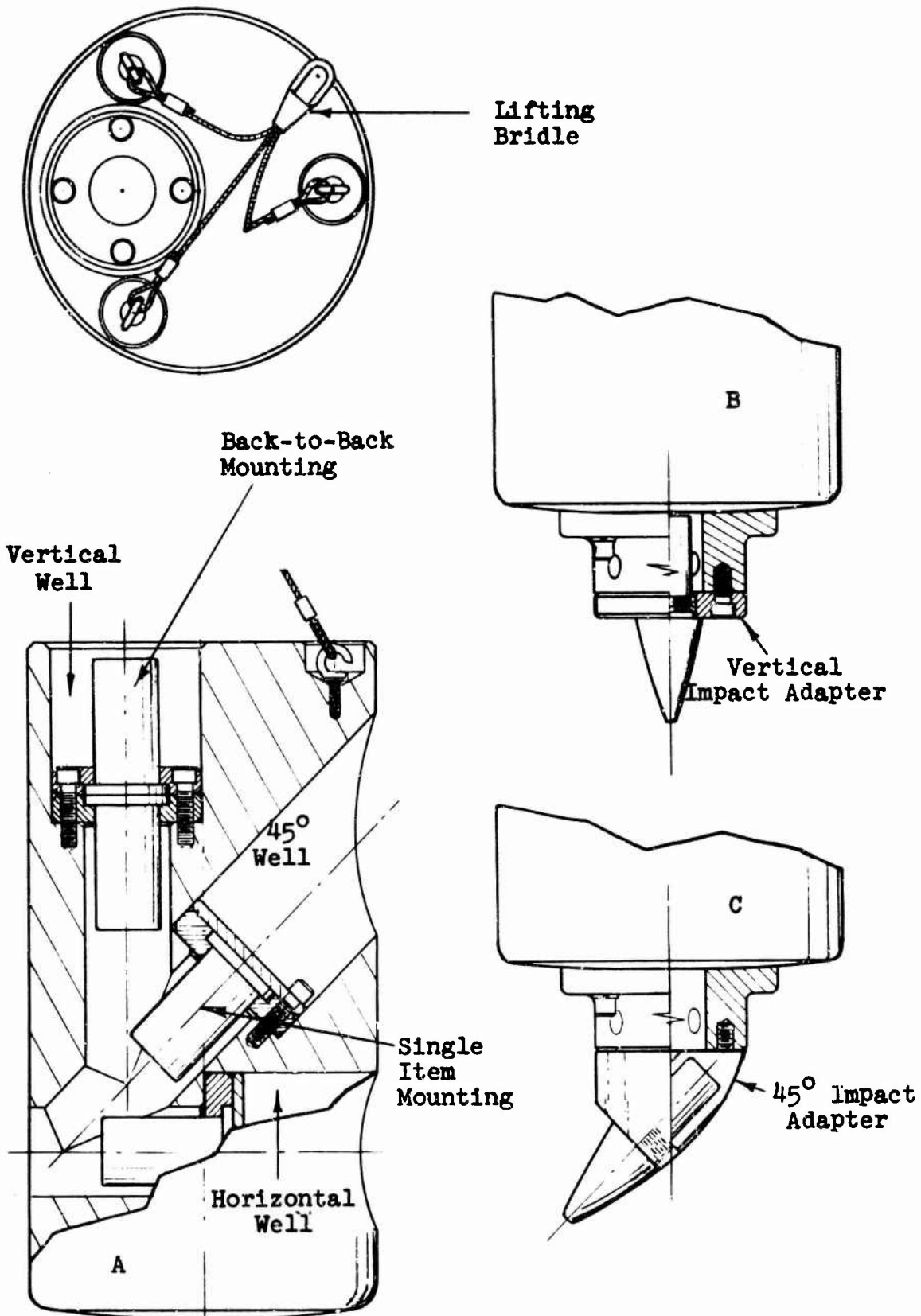

Fig. 2 Test Carriage Components

NOLTR 70-87

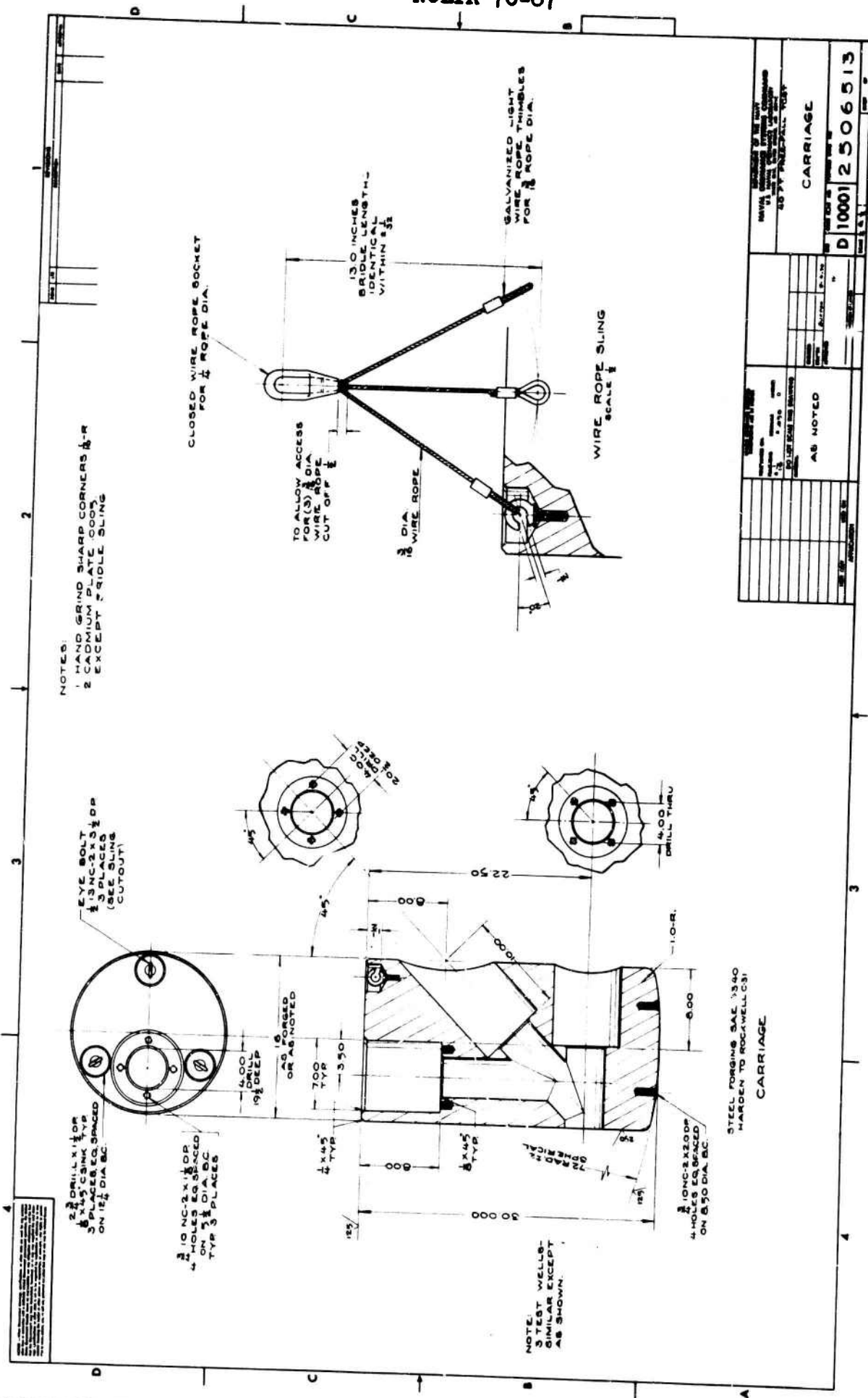

Fig. 3 Test Carriage Fabrication Details

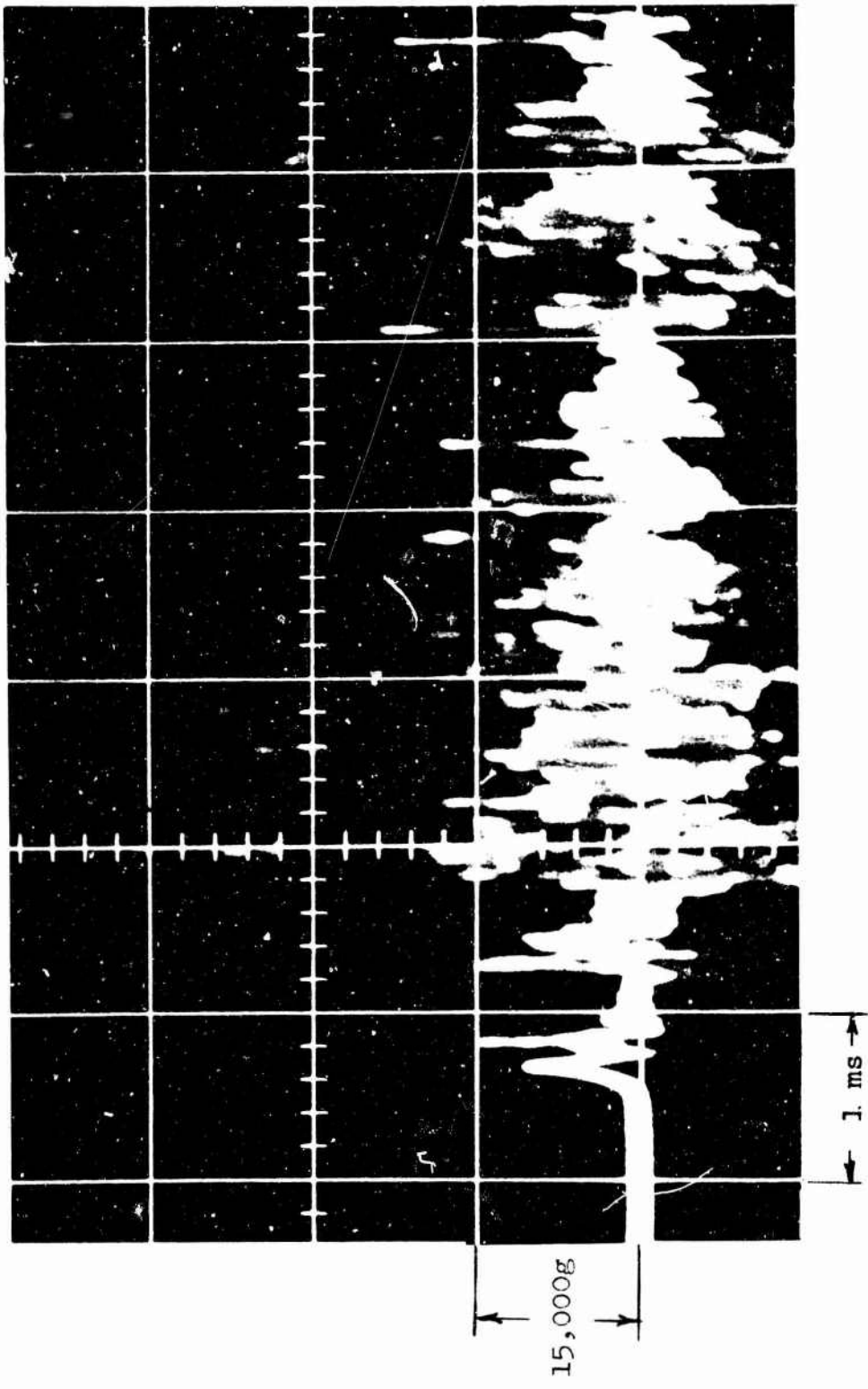

Fig. 4. Sample Oscillogram of Carriage Impact

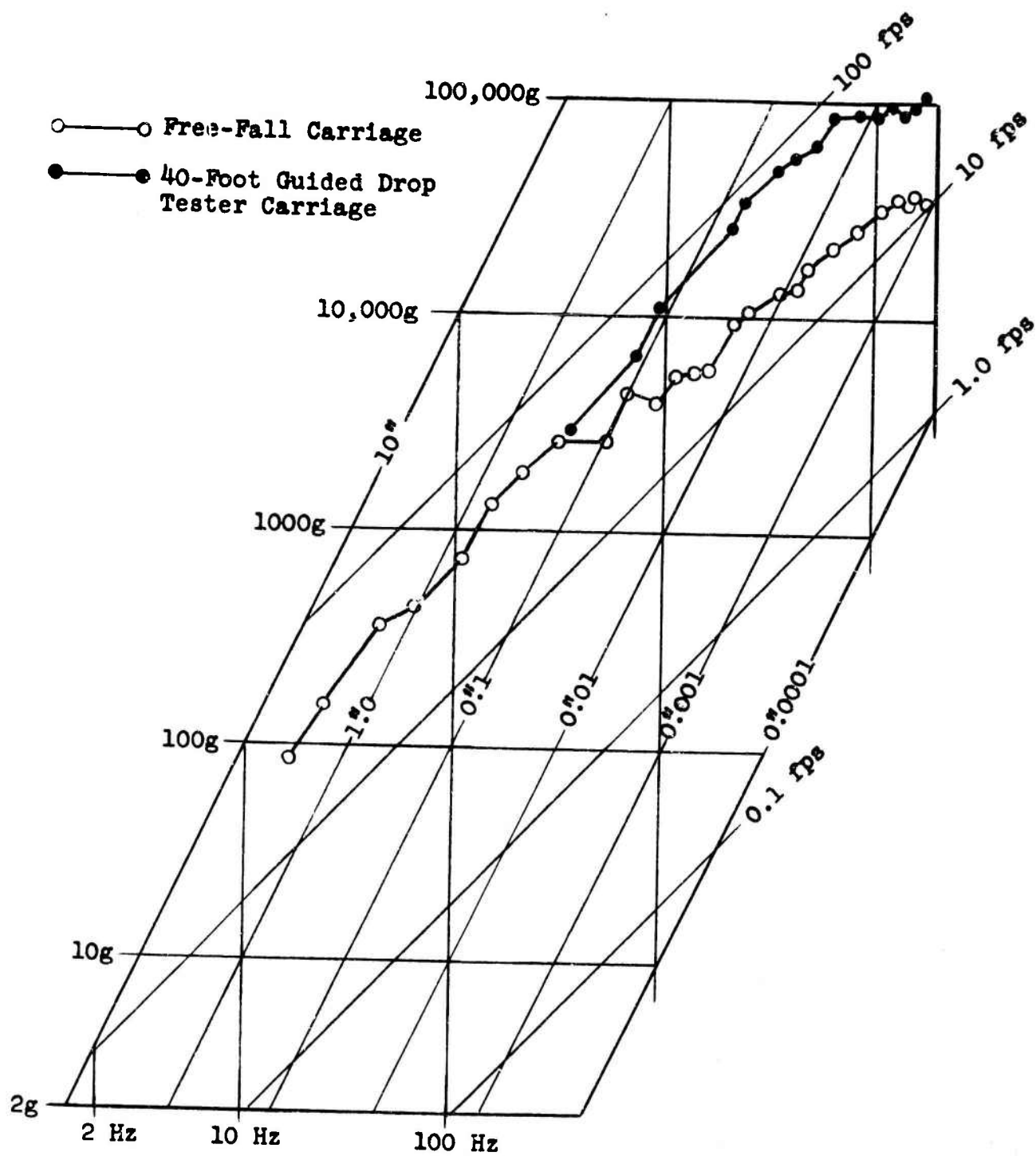

Fig. 5 Spectra of 40-Foot Free-Fall Impacts

NOLTR 70-87

Table 1

40-FOOT FREE-FALL TEST CARRIAGE  
GENERAL SPECIFICATIONS

Size: 30 inches high by 16 inches diameter

Weight: Carriage — 1500 pounds

Material: AISI 4340 steel forging; 31 Rockwell C hardness

Payload Capacity: 100 pounds (recommended to maintain shock repeatability)

Mounting Space: Three wells — 8 inches deep by 7 inches in diameter; vertical, 45° and 90°

Mounting Holes: Four 3/4-10 tapped holes equally spaced on 5-inch bolt circle.

Impacting Material: 3-inch mild steel plate, 207 Brinell hardness, mounted on 2-foot thick, reinforced concrete foundation

Maximum Drop Height: 40 feet

Impact: Complex shock consisting of fundamental 10,000g, 0.3 ms pulse (±15 percent) and high frequency ringing of from 15,000g to 20,000g

Table 2

COMPARISON OF CARRIAGE AND BOMB IMPACTS

Drop No.	Item Dropped	Weight (lb)	Shock Peak (g)
1	Free-Fall Carriage	1500	8,500
2	" "	"	10,000
3	" "	"	9,300
4	Mk 81 Bomb	250	3,680
5	Mk 82 Bomb	500	3,060
6	Mk 83 Bomb	1000	1,330



**UNCLASSIFIED**

Security Classification

DOCUMENT CONTROL DATA - R & D		
<i>(Security classification of title, body of abstract and indexing annotation must be entered when the overall report is classified)</i>		
1. ORIGINATING ACTIVITY (Corporate author) <b>U. S. Naval Ordnance Laboratory White Oak, Silver Spring, Maryland 20910</b>		2a. REPORT SECURITY CLASSIFICATION <b>Unclassified</b>
		2b. GROUP
3. REPORT TITLE <b>40-FOOT FREE-FALL TEST CARRIAGE (Feasibility Study of Carriage Use for MIL-STD-331 Test 103)</b>		
4. DESCRIPTIVE NOTES (Type of report and inclusive dates)		
5. AUTHOR(S) (First name, middle initial, last name) <b>V. F. DeVost</b>		
6. REPORT DATE <b>8 May 1970</b>	7a. TOTAL NO. OF PAGES <b>11</b>	7b. NO. OF REFS <b>3</b>
8a. CONTRACT OR GRANT NO.	9a. ORIGINATOR'S REPORT NUMBER(S) <b>NOLTR 70-87</b>	
b. PROJECT NO. <b>Task A35 532/WF17 353 502 Pr 204</b>		
c. <b>Task A532 5323/246 00 003</b>		
d.	9b. OTHER REPORT NO(S) (Any other numbers that may be assigned this report)	
10. DISTRIBUTION STATEMENT <b>This document is subject to special export controls and each transmittal to foreign governments or foreign nationals may be made only with prior approval of NOL.</b>		
11. SUPPLEMENTARY NOTES		12. SPONSORING MILITARY ACTIVITY
13. ABSTRACT <b>A 1500-pound, high-impact steel carriage is intended for use in screening live-loaded fuzes and components during production under impact conditions equivalent to those specified in the MIL-STD-331 Forty-Foot Drop Test. The test items are mounted inside the carriage to protect them from accidental damage.</b>		

DD FORM 1473 (PAGE 1)

1 NOV 65  
S/N 0101-807-6801

**UNCLASSIFIED**

Security Classification

14 KEY WORDS	LINK A		LINK B		LINK C	
	ROLE	WT	ROLE	WT	ROLE	WT
SHOCK						
SHOCK TESTER						
HIGH IMPACT						
EXPLOSIVES TESTING						
PRODUCTION SCREENING						