

UNCLASSIFIED

AD NUMBER

AD862973

LIMITATION CHANGES

TO:

Approved for public release; distribution is unlimited.

FROM:

Distribution authorized to U.S. Gov't. agencies and their contractors; Critical Technology; DEC 1969. Other requests shall be referred to Air Force Flight Dynamics Laboratory, Attn: FDFR, Wright-Paterson AFB, OH 45433. This document contains export-controlled technical data.

AUTHORITY

AFFDL ltr, 21 Oct 1974

THIS PAGE IS UNCLASSIFIED

ARCHIVE COPY  
DO NOT LOAN

DRAG AND PERFORMANCE CHARACTERISTICS OF  
SEVERAL FLEXIBLE AERODYNAMIC DECELERATORS  
AT MACH NUMBERS FROM 1.5 TO 6.0



R. W. Rhudy

ARO, Inc.

*not cleared  
for public  
release  
Jan 20, 75*

*This document has been approved for public release  
its distribution is unlimited.  
Per AF letter  
dt'd 2 June, 75  
signed William D. Cole*

December 1969

DISTRIBUTION LIMITED TO U. S. GOV'T AGENCIES  
ONLY; Test and Evaluation; 12 Nov. 71. Other  
requests for this document must be referred  
to Director, Air Force Flight Dynamics Lab.,  
Attn: FDFR. Wright-Patterson AFB,  
Ohio 45433.

PER TAB 72-21, dated 1 November, 1972.

VON KÁRMÁN GAS DYNAMICS FACILITY  
ARNOLD ENGINEERING DEVELOPMENT CENTER  
AIR FORCE SYSTEMS COMMAND  
ARNOLD AIR FORCE STATION, TENNESSEE

AEDC TECHNICAL LIBRARY



5 0720 00032 7296

# ***NOTICES***

When U. S. Government drawings specifications, or other data are used for any purpose other than a definitely related Government procurement operation, the Government thereby incurs no responsibility nor any obligation whatsoever, and the fact that the Government may have formulated, furnished, or in any way supplied the said drawings, specifications, or other data, is not to be regarded by implication or otherwise, or in any manner licensing the holder or any other person or corporation, or conveying any rights or permission to manufacture, use, or sell any patented invention that may in any way be related thereto.

Qualified users may obtain copies of this report from the Defense Documentation Center.

References to named commercial products in this report are not to be considered in any sense as an endorsement of the product by the United States Air Force or the Government.

**DRAG AND PERFORMANCE CHARACTERISTICS OF  
SEVERAL FLEXIBLE AERODYNAMIC DECELERATORS  
AT MACH NUMBERS FROM 1.5 TO 6.0**

**R.W. Rhudy  
ARO, Inc.**

This document has been approved for public release  
its distribution is unlimited. *Per AF letter  
dtg 24 June, 75  
Signed William  
C. Cole*

This document is subject to special export controls and each transmittal to foreign governments or foreign nationals may be made only with prior approval of Air Force Flight Dynamics Laboratory (FDFR), Wright-Patterson AF Base, Ohio 45433.

DISTRIBUTION LIMITED TO U. S. GOV'T AGENCIES  
ONLY: Test and Evaluation; 12 Nov. 71. Other  
requests for this document must be referred  
to Director, Air Force Flight Dynamics Lab.,  
Attn: FDFR. Wright-Patterson AFB,  
Ohio 45433.  
PER TAB 72-21, datd 1 November, 1972.

## FOREWORD

The work reported herein was done at the request of the Air Force Flight Dynamics Laboratory (AFFDL) (FDFR), Air Force Systems Command (AFSC), under Program Element 62201F, Project 6065, Task 05.

The results of the tests presented were obtained by ARO, Inc. (a subsidiary of Sverdrup & Parcel and Associates, Inc.), contract operator of the Arnold Engineering Development Center (AEDC), AFSC, Arnold Air Force Station, Tennessee, under Contract F40600-69-C-0001. The tests were conducted from August 13 through 15, 1969, under ARO Project No. VT0031, and the manuscript was submitted for publication on October 29, 1969.

Information in this report is embargoed under the Department of State International Traffic in Arms Regulations. This report may be released to foreign governments by departments or agencies of the U.S. Government subject to approval of Air Force Flight Dynamics Laboratory (FDFR), or higher authority within the Department of the Air Force. Private individuals or firms require a Department of State export license.

This technical report has been reviewed and is approved.

Eugene C. Fletcher  
Lt Colonel, USAF  
AF Representative, VKF  
Directorate of Test

Roy R. Croy, Jr.  
Colonel, USAF  
Director of Test

This document has been approved for public release  
its distribution is unlimited.

Per AF letter  
dtg 24 June 75 - signed  
William D. Cole

### ABSTRACT

An experimental investigation was conducted at Mach numbers from 1.5 to 6.0 to determine the drag and stability characteristics of several flexible aerodynamic decelerators located in the wake of double-strut-mounted forebodies. Data are presented which show a decrease in drag with an increase in free-stream Mach number and/or a decrease in  $x/d$  for both guide surface decelerators and for a ballute. Because of differences in calibration techniques, riser line length, and test equipment, a 50- to 70-percent lower value of drag coefficient was obtained on a series of supersonic X decelerators when compared to previous tests. The present data do, however, agree reasonably well with drag data for a full-scale decelerator. An indication of the parachute stability is given in tabular form. All of the present data were obtained at a free-stream dynamic pressure of 1.0 psia and static pressures corresponding to pressure altitudes ranging from 70,000 to 130,000 ft.

This document has been approved for public release  
its distribution is unlimited. *Rev AF letter dt'd  
24 June, 75 signed  
William O. Cole*

This document is subject to special export controls and each transmittal to foreign governments or foreign nationals may be made only with prior approval of Air Force Flight Dynamics Laboratory (FDFR), Wright-Patterson AF Base, Ohio 45433.

DISTRIBUTION LIMITED TO U.S. GOVT AGENCIES  
ONLY: Test and Evaluation. 12 NOV 71. Other  
requests for this document must be referred  
to DIRECTOR, AIR FORCE FLIGHT DYNAMICS  
LAB, ATTN: FDFR WRIGHT-PATTERSON  
AFB, OHIO 45433  
PER TAB

*72-21, dt'd 1 Nov, 72*

## CONTENTS

	<u>Page</u>
ABSTRACT . . . . .	iii
NOMENCLATURE . . . . .	vi
I. INTRODUCTION . . . . .	1
II. APPARATUS	
2.1 Wind Tunnel . . . . .	1
2.2 Test Articles . . . . .	1
2.3 Instrumentation . . . . .	2
III. TEST PROCEDURE . . . . .	3
IV. RESULTS AND DISCUSSION . . . . .	3
V. CONCLUSIONS . . . . .	4
REFERENCES . . . . .	4

## APPENDIXES

### I. ILLUSTRATIONS

#### Figure

1. Forebody and Strut Details	
a. Strut Details . . . . .	9
b. Tunnel Installation Sketch . . . . .	9
c. Winch Assembly Modifications . . . . .	10
d. Forebody Configurations 1 and 2 . . . . .	11
e. Forebody Configurations 3 and 4 . . . . .	12
2. Parachute Photographs	
a. Configurations of Differing Porosity: 1 through 4 . . . . .	13
b. Configurations with Differing Internal Supports: 250, 254, and 256 . . . . .	14
c. Configurations 088, 080, and 065 . . . . .	15
d. Configurations 034, 284, and 286 . . . . .	16
e. Configurations 241 and 752 . . . . .	17
3. Variation of Drag Coefficient with Mach Number for Decelerators of Differing Porosity Located in the Wake of a Symmetrical Wedge, Flat-Plate Model, $x/d = 9$ . . . . .	18
4. Performance Data for Supersonic X Configurations Located in the Wake of a Cone-Cylinder	
a. Variation of Drag Coefficient with Mach Number . . . . .	19
b. Shadowgraphs at $x/d = 8$ . . . . .	20
c. Schlieren Photograph from Tests Reported in Ref. 8, $M_\infty = 3.0$ , $x/d = 8$ , Configuration 2250 . . . . .	21
5. Variation of Drag Coefficient with Mach Number for Guide Surface Decelerators Located in the Wake of a Simulated Ejection Seat . . . . .	22
6. Variation of Drag Coefficient with Mach Number for a Ballute Decelerator in the Wake of a Cone-Cylinder-Flare Model (Configuration 4065) . . . . .	23

## II. TABLE

I. Summary of Test Conditions, Reference Dimensions, and Stability . . .	24
--	----

## NOMENCLATURE

$C_D$	Drag coefficient of parachute, measured drag force/ $q_\infty S$
$D$	Design projected diameter of inflated parachute canopy, in.
$d$	Forebody base diameter or reference dimension, in.
$M_\infty$	Wind tunnel free-stream Mach number
$q_\infty$	Wind tunnel free-stream dynamic pressure, psia
$S$	Reference area, $\pi D^2/4$ , in. <sup>2</sup>
$x$	Distance from base of forebody to the parachute canopy inlet, in.



## SECTION I INTRODUCTION

An experimental investigation was conducted in the 40-in. supersonic tunnel (Gas Dynamics Wind Tunnel, Supersonic (A)) of the von Kármán Gas Dynamics Facility (VKF) to determine the drag, shock-wave standoff distance, and stability characteristics of several flexible aerodynamic decelerators. The decelerators were tested at several positions in the wake of various centerbodies which were supported by a strut spanning the test section. The tests were conducted at free-stream Mach numbers from 1.5 to 6.0 and at a constant free-stream dynamic pressure of 1.0 psia. The present tests are a follow-on to earlier experiments conducted on similar decelerators and which were reported in Refs. 1 through 10.

Selected results are presented showing the effects of Mach number, location in the wake, and parachute design on the average drag. Stability characteristics, which refer only to the oscillatory motion of the parachute with respect to the forebody (observed in schlieren motion pictures), are summarized in tabular form.

## SECTION II APPARATUS

### 2.1 WIND TUNNEL

Tunnel A is a continuous, closed-circuit, variable density wind tunnel with an automatically driven, flexible-plate-type nozzle and a 40- by 40-in. test section. The tunnel can be operated at Mach numbers from 1.5 to 6 at maximum stagnation pressures from 29 to 200 psia, respectively, and stagnation temperatures up to 750°R ( $M_{\infty} = 6$ ). Minimum operating pressures range from about one-tenth to one-twentieth of the maximum at each Mach number. A description of the tunnel and airflow calibration information may be found in Ref. 11.

### 2.2 TEST ARTICLES

#### 2.2.1 Forebody Models and Support System

The model support system consisted of a full-tunnel-span strut to which forebodies were attached and through which the support line for the decelerators passed (Figs. 1a and b, Appendix I). The drag tensiometer and winch assembly (used for varying the location of the decelerators aft of the forebodies) were located in a vacuum tank mounted to the tunnel sidewall. The decelerator attachment line, either 300-lb tensile strength nylon or Dacron<sup>®</sup>, passed through the forebodies, around a pulley, through the strut, and attached to the tensiometer and winch assembly (Fig. 1a). While the overall system used for the present tests was the same as that used in previous tests (e.g., Ref. 8), two of the pulleys which had sleeve bearings were replaced with roller-bearing pulleys. The attachment of the tensiometer was also modified to allow more freedom of movement so it could seek the proper angle with respect to the applied load. The winch assembly details and the above changes are shown in Fig. 1c. The vacuum tank and support strut internal pressures were monitored during the test. These pressures indicated

that small leaks were present which could not be eliminated. While the data of Ref. 6 indicate that a reduction in drag coefficient could result from large air leaks into the forebody wake, it is felt that the effect of the small leaks on the present data was insignificant.

Four forebodies (Figs. 1d and e) were used during the tests to investigate the performance of the decelerators in the wake of a particular configuration. A particular series of decelerators was tested in the wake of only one of the forebodies. Forebody configuration 1 (Fig. 1d) was a wedge-block combination and was made as thin as possible to minimize the wake size. Configuration 2 (Fig. 1d) was a 13-deg half-angle, cone-cylinder forebody, 2 in. in diameter. Configurations 3 and 4 (Fig. 1e) consisted of the above cone-cylinder, to which was attached either a simulated ejection seat or a 70-deg half-angle, conical flare.

### 2.2.2 Decelerator Models

The parachutes were designed and constructed by AFFDL. Because of the number of configurations tested and the fact that the present tests were a follow-on to previous tests of the same or similar configurations, a complete description of the decelerators has not been included in this report. The decelerators are adequately described in Refs. 1 through 10. It was noted, however, that there was, at least in one case, a difference between the construction of the decelerators for the present tests and that of previous tests. As pointed out in a later section (Section IV), the riser lines on configuration 2250 of the present tests were longer than those of the same configuration during the previous tests (Ref. 8). Photographs of the configurations for which drag data are presented are shown in Fig. 2, and the reference dimensions and series variables are tabulated in Table I (Appendix II).

## 2.3 INSTRUMENTATION

Parachute drag measurements were made with a 60-lb tensiometer located in the winch assembly. A time-history of the dynamic drag output from the tensiometer was recorded on an oscillograph, and the average drag values were measured with low response force instrumentation. The tensiometer was calibrated by repeatedly loading and unloading weights (from 0 to 60 lb and back to 0) in 5-lb increments with the entire system just as it was used for testing. After a linear scale factor, which varied with the type of attachment line used, was applied to these results, the precision of the drag measurements was estimated to be within  $\pm 6$  percent of full scale (i.e.,  $\pm 3.6$  lb). For previous tests (e.g., Ref. 8), the tensiometer was calibrated by loading in two ranges (from 0 to 30 lb and from 0 to 60 lb) and only in the direction of increasing load. From the repeatability of these calibrations, the accuracy of the previous drag measurements was estimated to be within 4 percent (Ref. 8).

Parachute performance was monitored with two high-speed, 16-mm motion-picture cameras (one for side motion pictures and one for shadowgraph photography), and additional photographic results were obtained with still cameras mounted in the shadowgraph system and next to the test section windows.

### SECTION III TEST PROCEDURE

Before each test run, the parachute canopy and suspension lines were packed in a deployment bag which was suspended near the base of the forebody model by a pull cord routed from the rear of the bag through the tunnel sector. The pull cord was held taut during the tunnel start, and when the desired test conditions were established, a sharp pull on the cord removed the bag. Parachute location behind the forebody was set by the remotely operated winch assembly using reference marks on the tunnel windows.

A summary of the test conditions, decelerator performance, and data reduction reference dimensions is given in Table I. The stability results presented in this table were derived from evaluations of the photographic data.

### SECTION IV RESULTS AND DISCUSSION

In order to extend, from previous tests, the information on the effect of forebody configuration on the decelerator drag coefficient, parachute configurations 001 through 004 were tested with the minimum forebody (configuration 1). These data, along with data from previous tests, are shown as a function of Mach number in Fig. 3. The previous data were obtained in the wake of forebody configuration 2 (previously designated configuration 1) at an  $x/d = 7$ . The present data, using the same reference dimensions ( $d = 2$  in.), were obtained at approximately  $x/d = 9$ ; however, this difference in axial location is felt to be unimportant because the present forebody was designed to minimize the wake size. The effect of the reduction in forebody wake size was to reduce the general level of  $C_D$  by approximately 30 percent. All of the present data at a given Mach number (decelerator configurations 001, 002, 003, and 004) are within the estimated precision of the drag measurement.

The variation in drag coefficient with Mach number for a series of "supersonic X" decelerators is shown in Fig. 4a. The last digit in the configuration number for this series of decelerators refers to the number of internal webs in the canopy (refer to photographs in Fig. 2b). These data, in Fig. 4a, show that the drag coefficient was decreased by increasing the number of webs and/or by increasing the free-stream Mach number. Within the range of axial locations tested, an increase in  $x/d$  caused very little change in drag. The data from previous tests (solid symbols) have the same trends with Mach number and  $x/d$  but are 50 to 70 percent higher than the present data. These differences in drag were probably caused by a combination of several factors: (1) the different calibration techniques used during the present tests, (2) slightly longer riser lines on the present tests as compared to the previous tests, (3) in conjunction with item 2, differences in the flow field as indicated by the change in shock-wave shape between the previous test and the present (Figs. 4b and c), and (4) the modifications made to the winch assembly as noted in Section 2.2. Reasonable agreement was obtained, however, between the present tests and a previous test on a full-scale parachute, configuration 250, in the AEDC Propulsion Wind Tunnel, Supersonic (16S) in the Propulsion Wind Tunnel Facility (PWT).

Two configurations of "guide surface" decelerators were tested in the wake of a simulated ejection seat. These decelerators, one of which had eight "cores" (configuration 3088) and the other 12 (configuration 3080), are pictured in Fig. 2c. Figure 5 shows that an increase in Mach number caused a decrease in drag coefficient, whereas an increase in  $x/d$  had the opposite effect. The two configurations produced the same drag at an  $x/d$  of 5.0, but the one with the greater number of cores gave slightly higher values at  $x/d = 7.5$ . Configuration 3080 was not tested at  $x/d = 4.0$ . The reference dimension for these tests was the width of the simulated seat ( $d = 4.0$  in.).

The variation in drag coefficient with a change in Mach number and/or in axial location for a "ballute" decelerator in the wake of a cone-cylinder-flare is shown in Fig. 6. The data trends for this configuration were the same as shown in the previous figure, i.e., an increase in Mach number or a decrease in  $x/d$  decreased the drag.

The oscillations of the parachutes were observed in the shadowgraph motion pictures, and an evaluation of the stability is tabulated in Table I. The determination of relative stability was arbitrarily chosen to be (1) oscillations of less than  $\pm 2$  deg—very stable, (2) oscillations between  $\pm 2$  and  $\pm 5$  deg—stable, and (3) oscillations greater than  $\pm 5$  deg—unstable. In some cases, the shadowgraph motion pictures were taken only at selected Mach numbers and  $x/d$ 's; however, where possible, the results of previous tests and the reference report are listed for the same or similar conditions to the present tests.

## SECTION V CONCLUSIONS

The drag data obtained during the present tests may be summarized as follows:

1. A reduction in drag with an increase in free-stream Mach number and/or decrease in distance from the forebody to the parachute was obtained on both guide surface decelerators and a ballute.
2. Because of differences in calibration techniques, riser line length, and test equipment, the measured drag on a series of supersonic X decelerators was reduced by approximately 50 to 70 percent from previous data. Reasonable agreement was obtained, however, between present data and results from a test of a full-scale decelerator.

## REFERENCES

1. Deitering, J.S. "Investigation of Flexible Parachute Model Characteristics at Mach Numbers [from 1.5 to 6." AEDC-TR-62-185 (AD331941), October 1962.
2. Deitering, J.S. "Performance of Flexible Parachute Models at Mach Numbers from 1.5 to 4." AEDC-TR-62-234 (AD333536), December 1962.
3. Deitering, J.S. "Performance of Flexible Aerodynamic Decelerators at Mach Numbers from 1.5 to 6." AEDC-TR-63-119 (AD338412), July 1963.

4. Deitering, J.S. "Wind Tunnel Investigation of Flexible Parachute Model Characteristics at Mach Numbers 1.5 to 5." AEDC-TR-63-263 (AD346344), January 1964.
5. Deitering, J.S. and Hilliard, E.E. "Wind Tunnel Investigation of Flexible Aerodynamic Decelerator Characteristics at Mach Numbers 1.5 to 6." AEDC-TR-65-110 (AD464786), June 1965.
6. Sims, L.W. "The Effects of Design Parameters and Local Flow Fields on the Performance of Hyperflo Supersonic Parachutes and High Dynamic Pressure Parachute Concepts." AFFDL-TR-65-150 (AD476520), Vol. I, October 1965.
7. Myers, A.W. and Hahn, J.S. "Drag and Performance Characteristics of Flexible Aerodynamic Decelerators in the Wake of Basic and Modified Arapaho "C" Test Vehicle Configurations at Mach Numbers from 2 to 5." AEDC-TR-67-75 (AD813808), May 1967.
8. Myers, A.W. "Drag and Performance Characteristics of Flexible Supersonic Decelerator Models at Mach Numbers from 2 to 6." AEDC-TR-67-224 (AD822880), November 1967.
9. Myers, A.W. "Drag and Performance Characteristics of Flexible Aerodynamic Decelerators in the Wakes of Double-Strut Mounted Forebodies at Mach Numbers from 2 to 5." AEDC-TR-67-260 (AD824245), December 1967.
10. Galigher, L.L. "Aerodynamic Characteristics of Supersonic X Parachutes at Mach Numbers of 2.1 and 4.0." AEDC-TR-69-8 (AD846695), January 1969.
11. Test Facilities Handbook (Seventh Edition). "von Kármán Gas Dynamics Facility, Vol. 4." Arnold Engineering Development Center, July 1968.

**APPENDIXES**  
**I. ILLUSTRATIONS**  
**II. TABLE**

All Dimensions in Inches  
Not to Scale

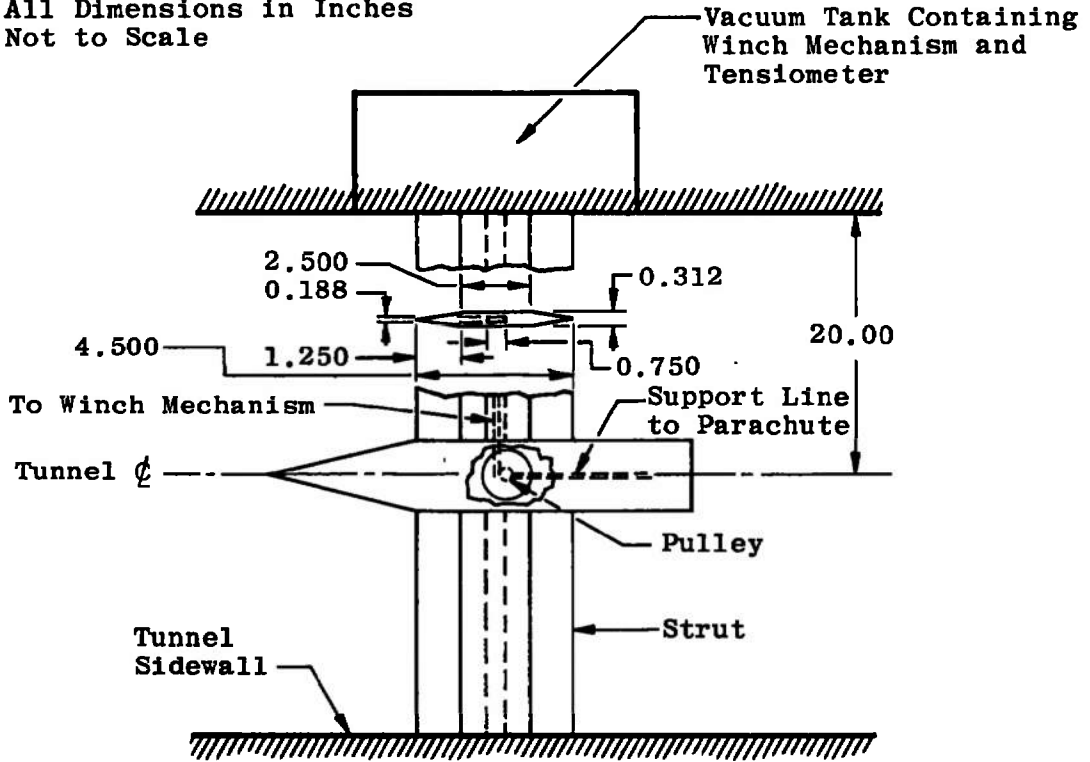

a. Strut Details

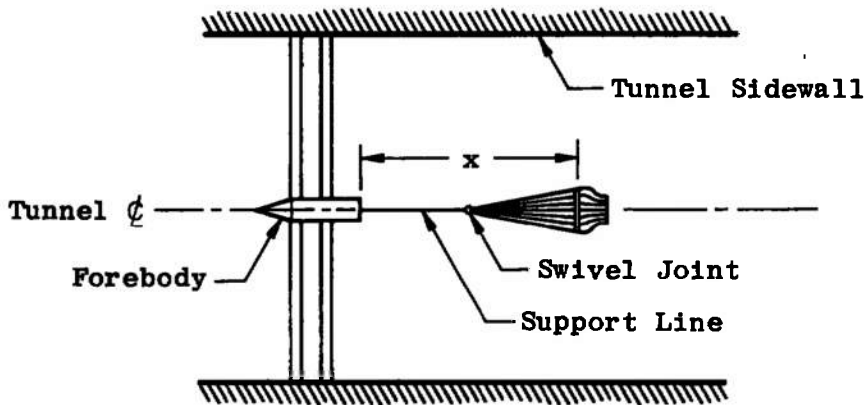

b. Tunnel Installation Sketch  
Fig. 1 Forebody and Strut Details

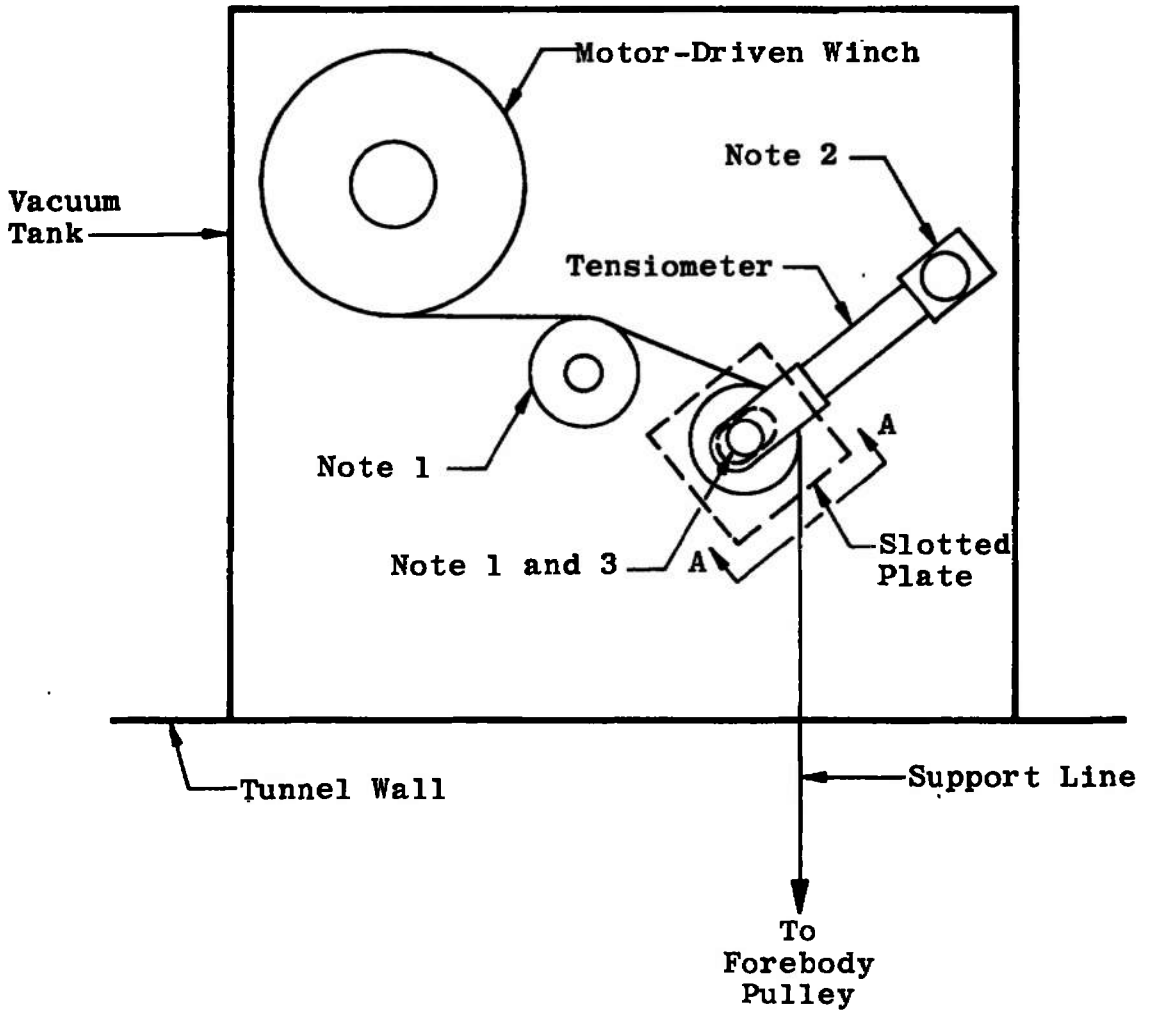
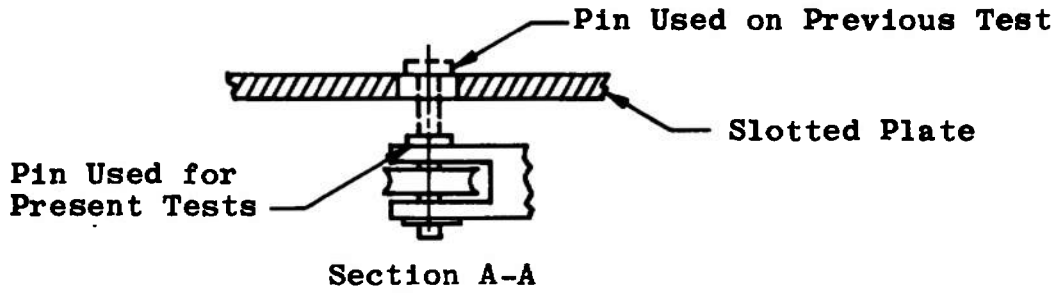

Notes:

1. Replaced Sleeve Bearing Pulley with Roller-Bearing Pulley
2. Replaced Pin with Ball Socket
3. Shortened Pin to Allow Freedom of Movement

c. Winch Assembly Modifications  
Fig. 1 Continued



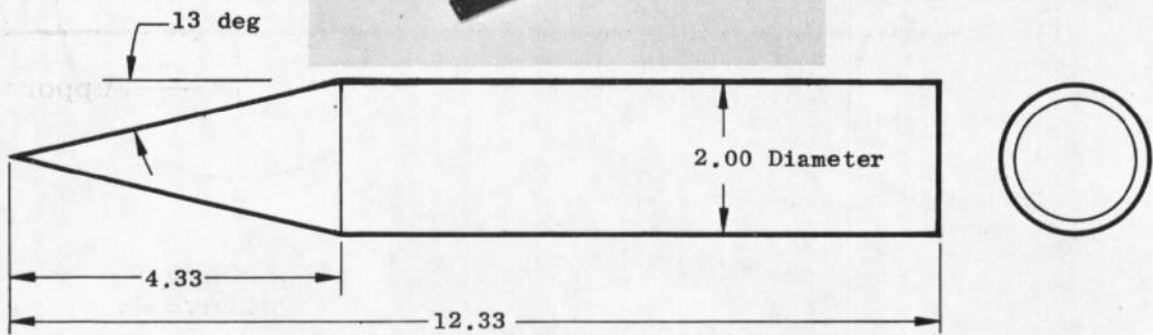
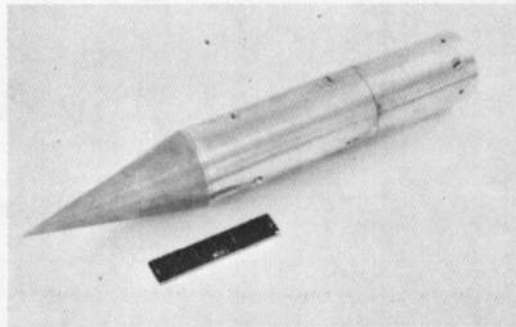
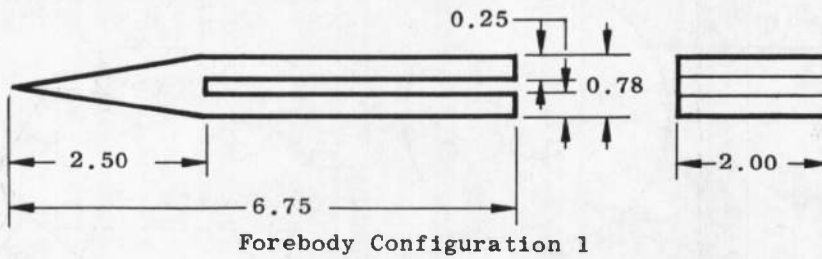
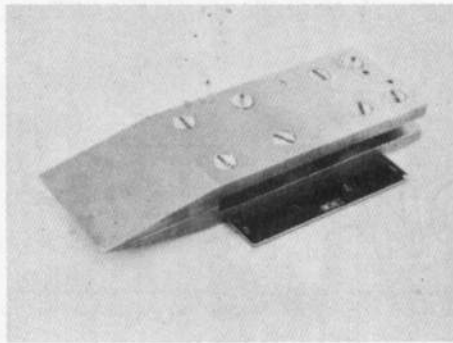

All Dimensions in Inches  
 unless Specified Otherwise  
 Not to Scale

d. Forebody Configurations 1 and 2  
 Fig. 1 Continued

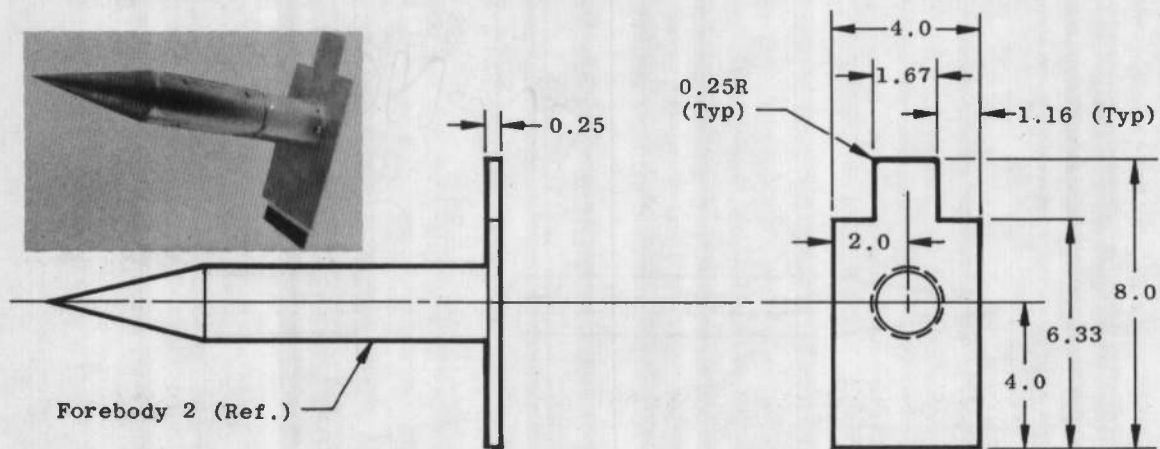

Forebody Configuration 3

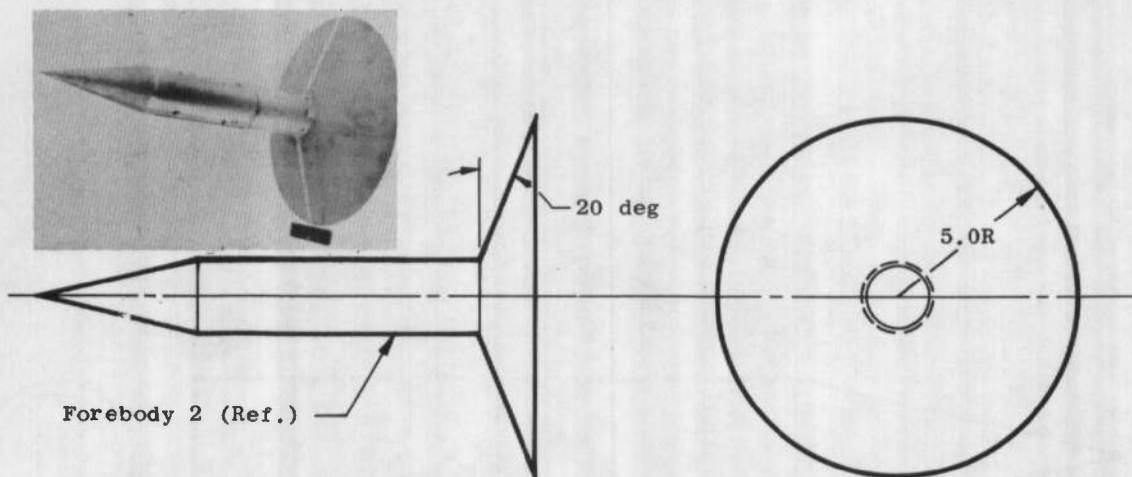

All Dimensions in Inches  
Not to Scale

Forebody Configuration 4

e. Forebody Configurations 3 and 4  
Fig. 1 Concluded

Parachute  
Configuration/Porosity

001/15 percent

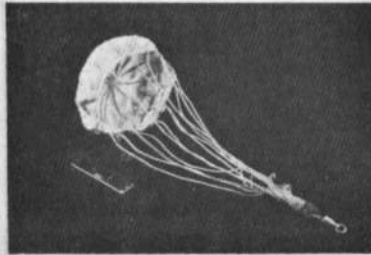

002/10 percent

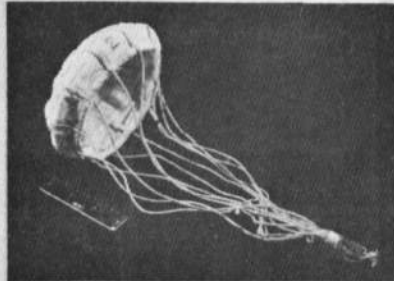

003/5 percent

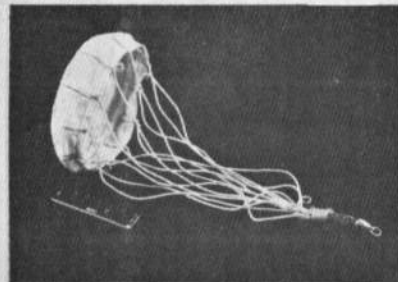

004/20 percent

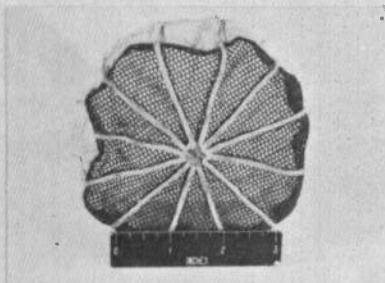
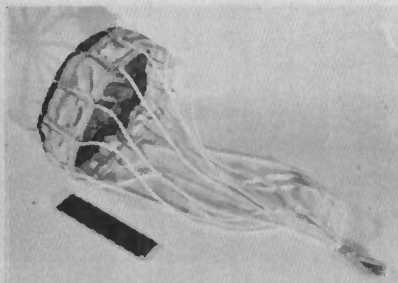

a. Configurations of Differing Porosity: 1 through 4  
Fig. 2 Parachute Photographs

Parachute  
Configuration

250

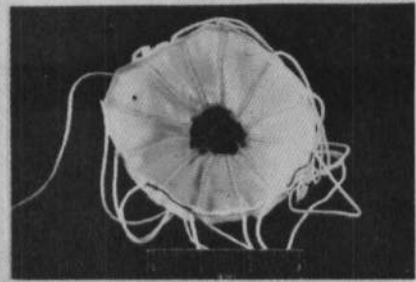
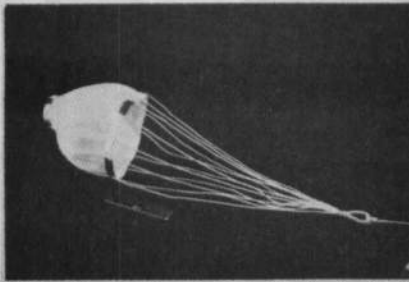

254

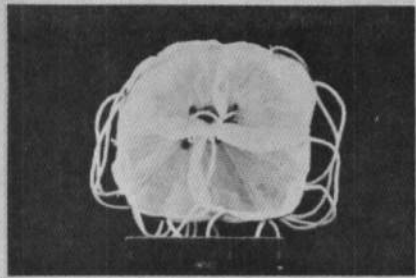
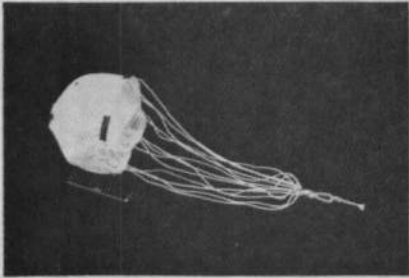

256

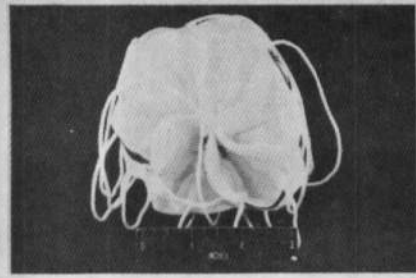
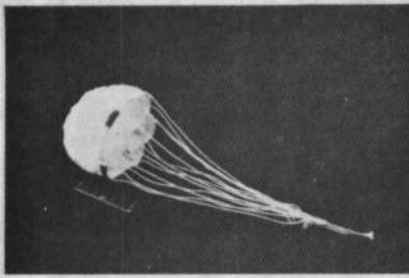

b. Configurations with Differing Internal Supports: 250, 254, and 256  
Fig. 2 Continued

Parachute  
Configuration

088

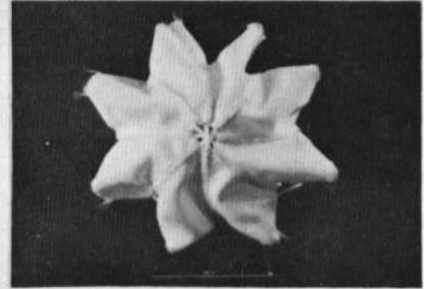
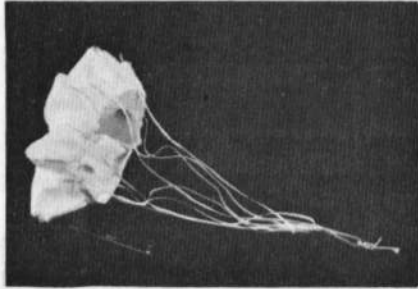

080

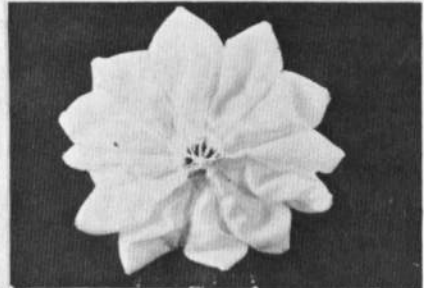
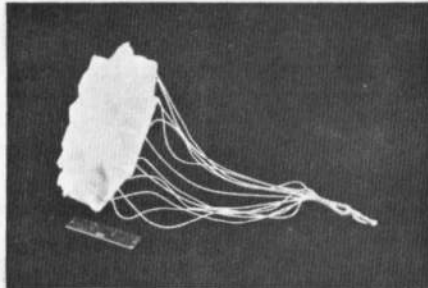

065



c. Configurations 088, 080, and 065  
Fig. 2 Continued

Parachute Configuration

034

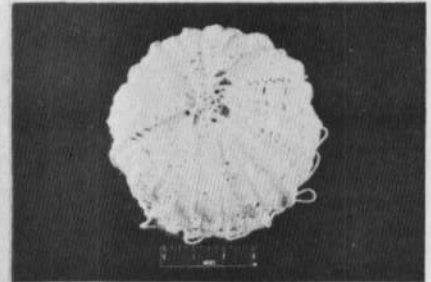
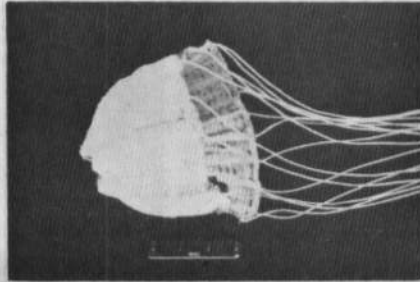

284

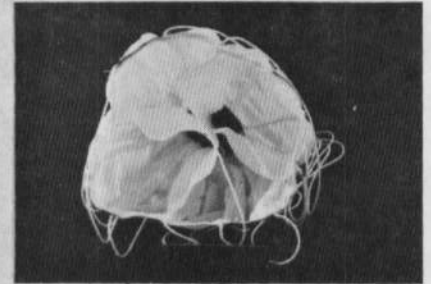
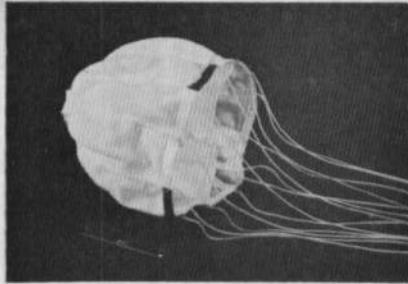

286

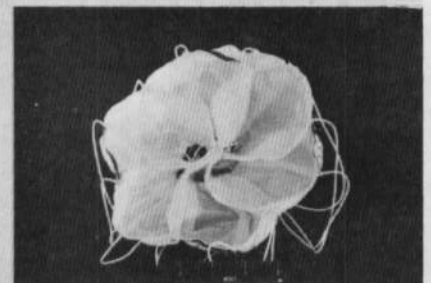
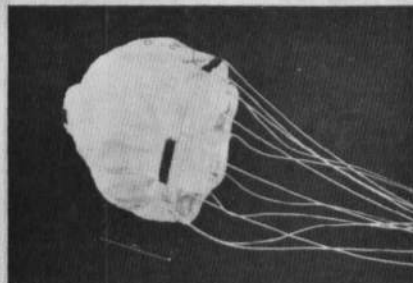

d. Configurations 034, 284, and 286  
Fig. 2 Continued

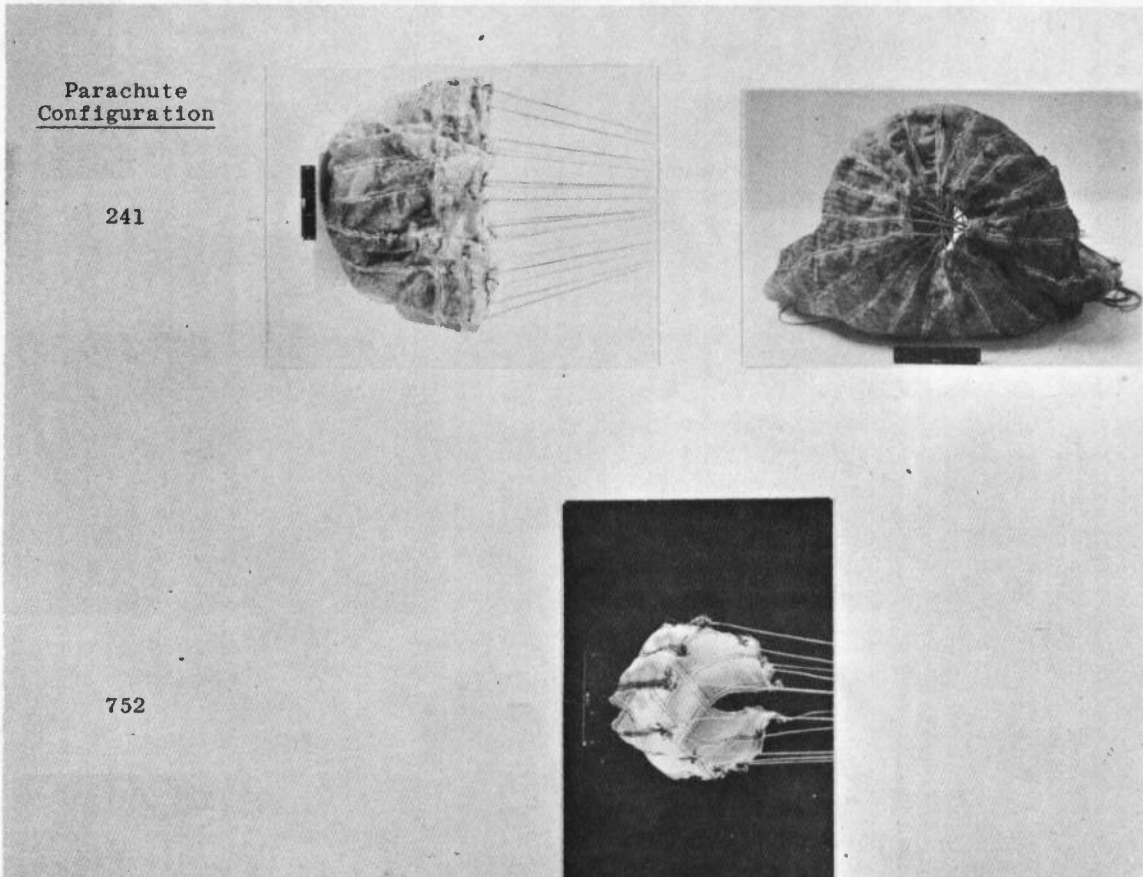

e. Configurations 241 and 752  
Fig. 2 Concluded

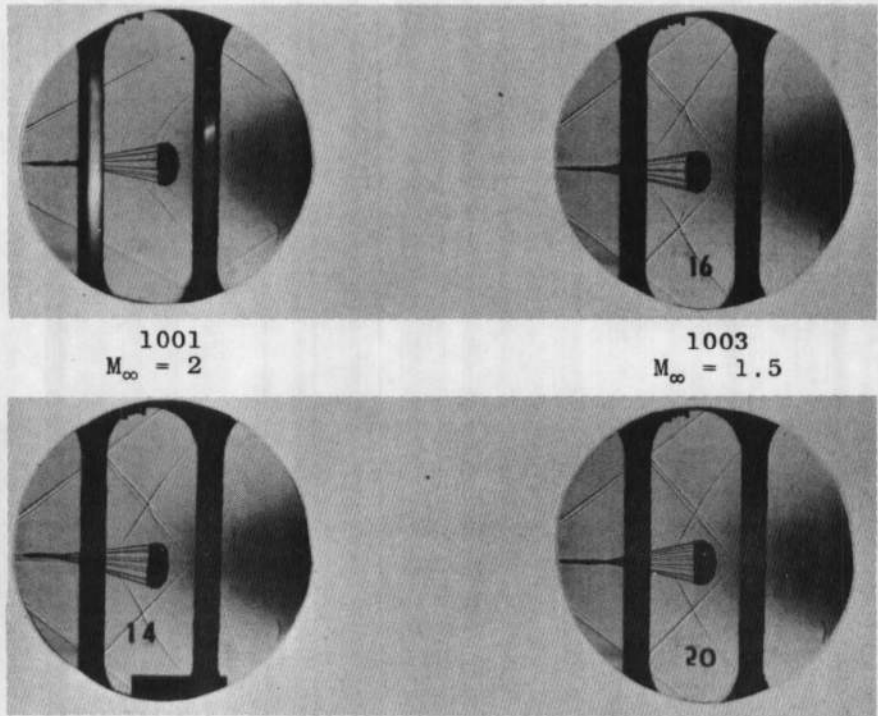

1001  
 $M_\infty = 2$

1003  
 $M_\infty = 1.5$

1002  
 $M_\infty = 1.5$

1004  
 $M_\infty = 1.5$

Sym	Configuration	Porosity, percent
○	1001	15
□	1002	10
◇	1003	5
△	1004	20

Solid Sym, Ref. 5 Data  
at  $x/d = 7$  with Forebody  
2 (Previously Designated I)

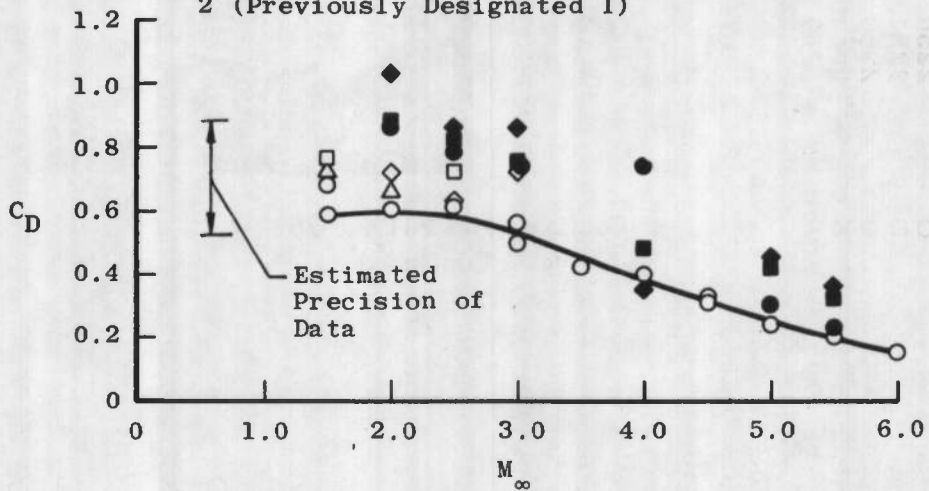
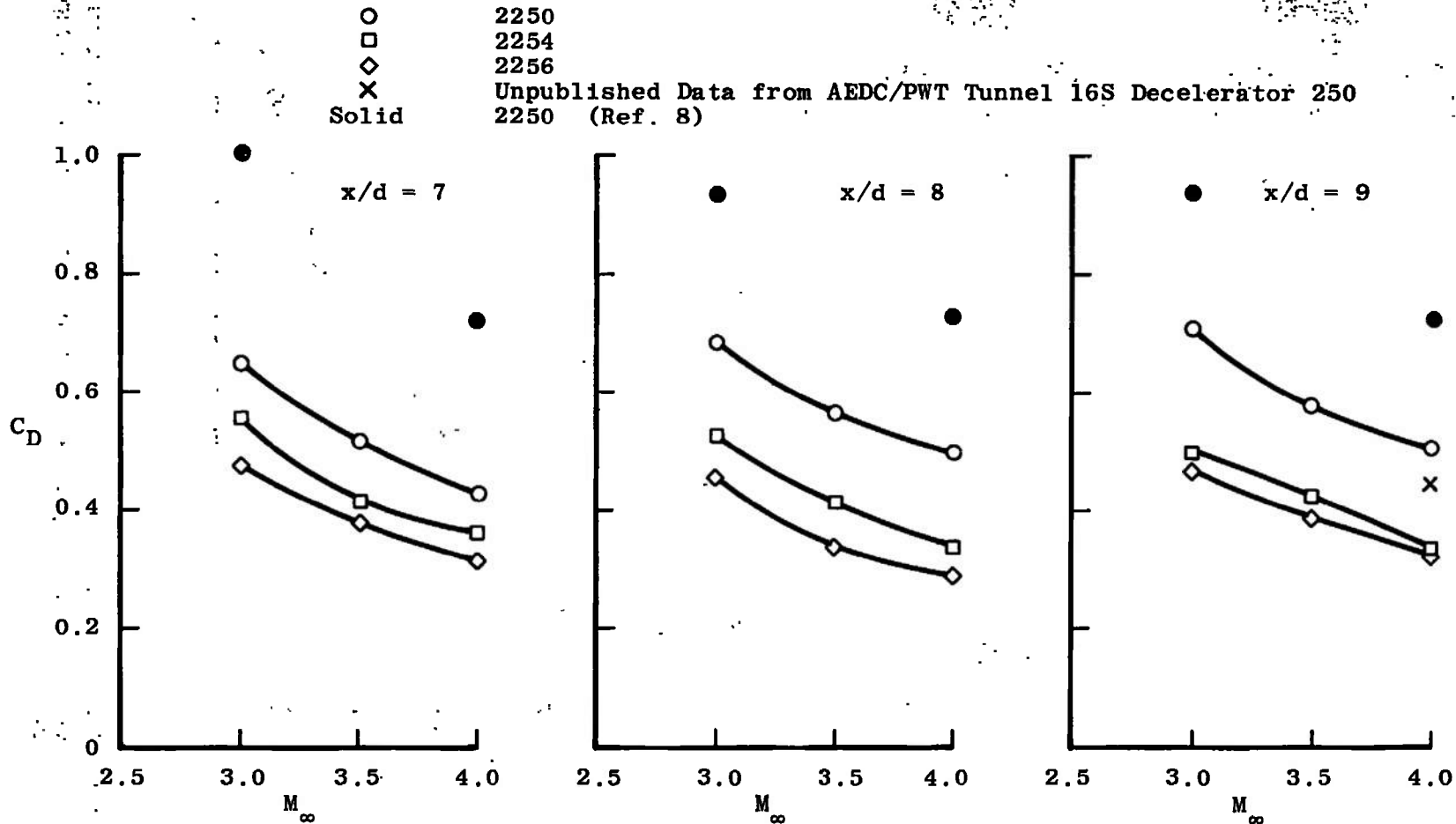

Fig. 3 Variation of Drag Coefficient with Mach Number for Decelerators of Differing Porosity Located in the Wake of a Symmetrical Wedge, Flat-Plate Model,  $x/d = 9$



Sym	Configuration
○	2250
□	2254
◇	2256
X	Unpublished Data from AEDC/PWT Tunnel 16S Decelerator 250
Solid	2250 (Ref. 8)



a. Variation of Drag Coefficient with Mach Number  
 Fig. 4 Performance Data for Supersonic X Configurations Located in the Wake  
 of a Cone-Cylinder Model

Configuration

2250

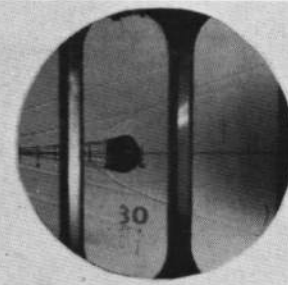
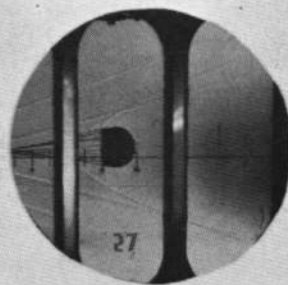
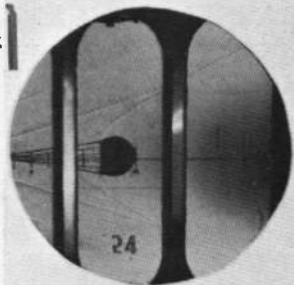

2254

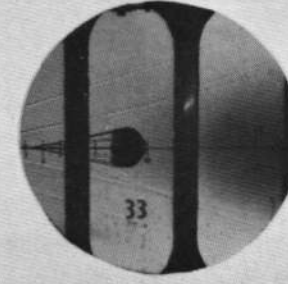
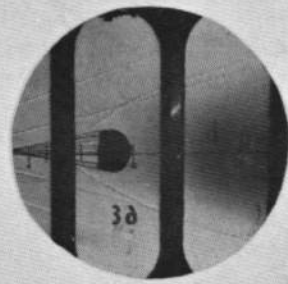
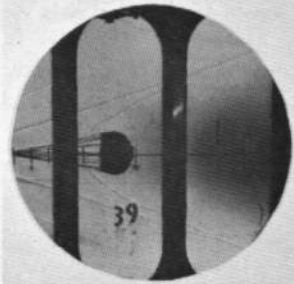

2256

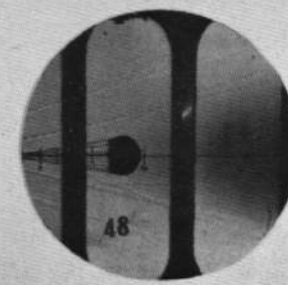
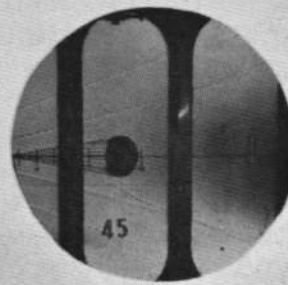
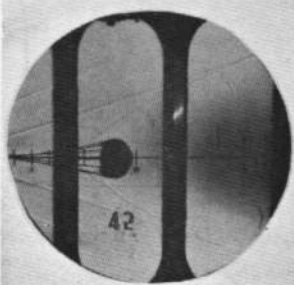

$M_\infty = 3$

$M_\infty = 3.5$

$M_\infty = 4$

b. Shadowgraphs at  $x/d = 8$   
Fig. 4 Continued

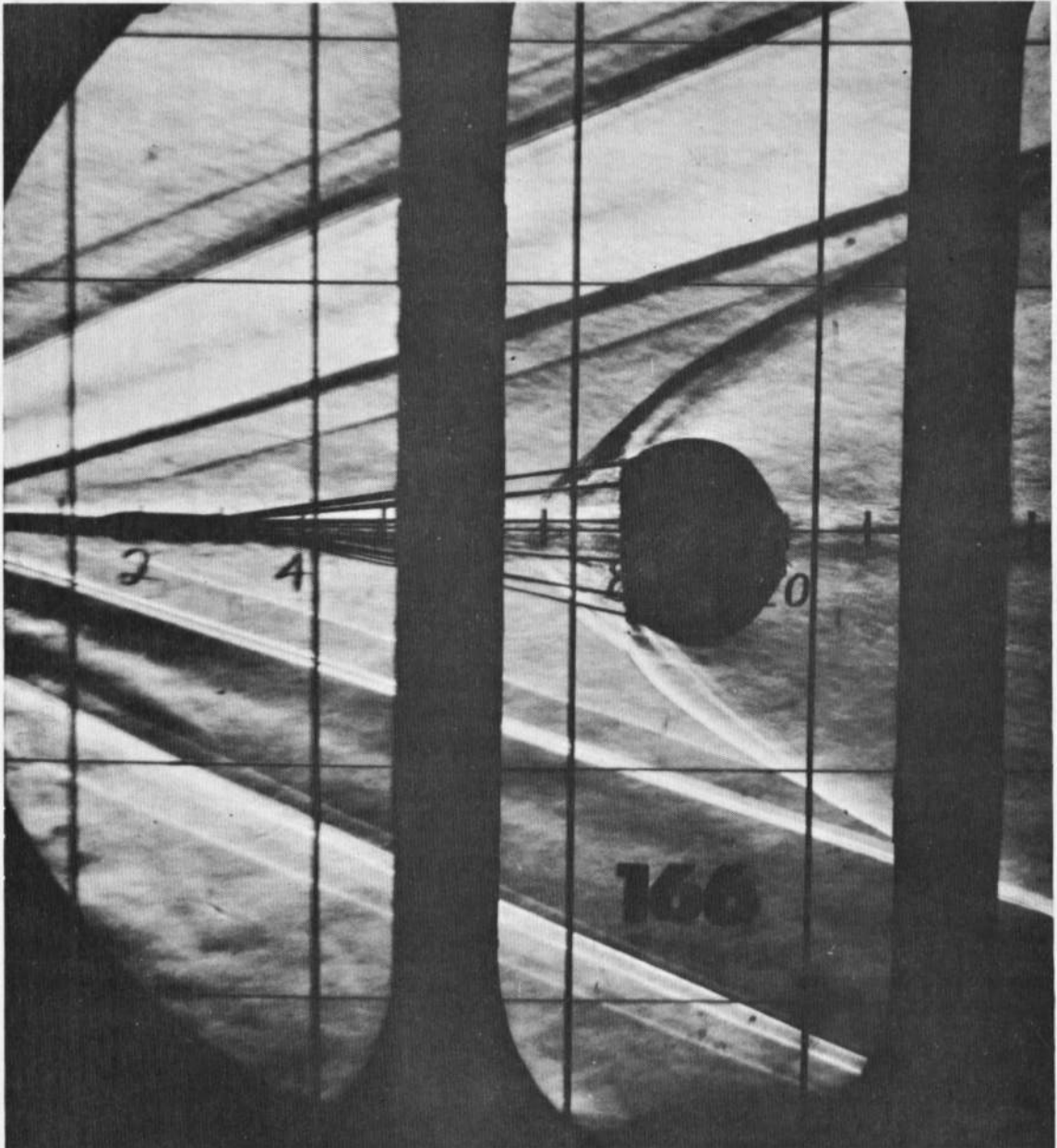

c. Schlieren Photograph from Tests Reported in Ref. 8,  $M_\infty = 3.0$ ,  
 $x/d = 8$ , Configuration 2250

Fig. 4 Concluded

Configuration

3088  
 $M_\infty = 2.5$

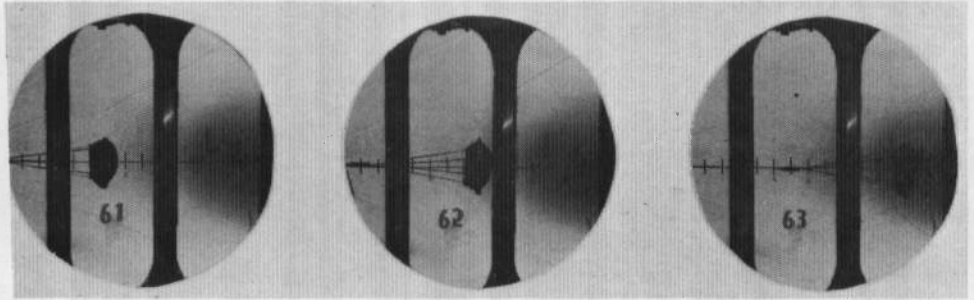

$x/d = 4$

3080  
 $M_\infty = 2.5$

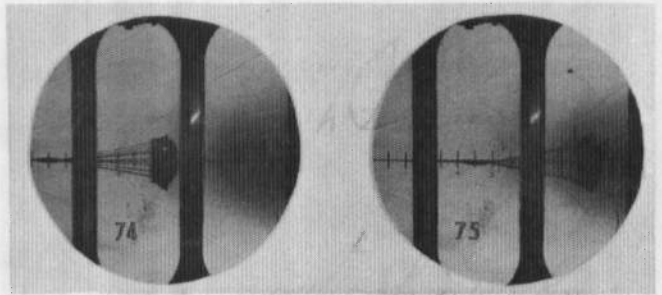

$x/d = 5$

$x/d = 7.5$

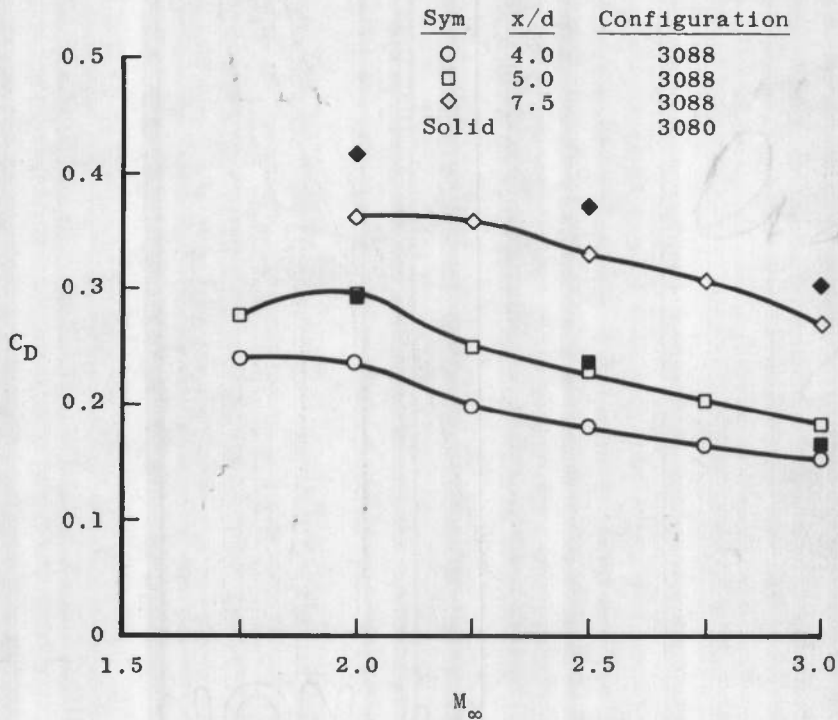

Fig. 5 Variation of Drag Coefficient with Mach Number for Guide Surface Decelerators Located in Wake of Simulated Ejection Seat

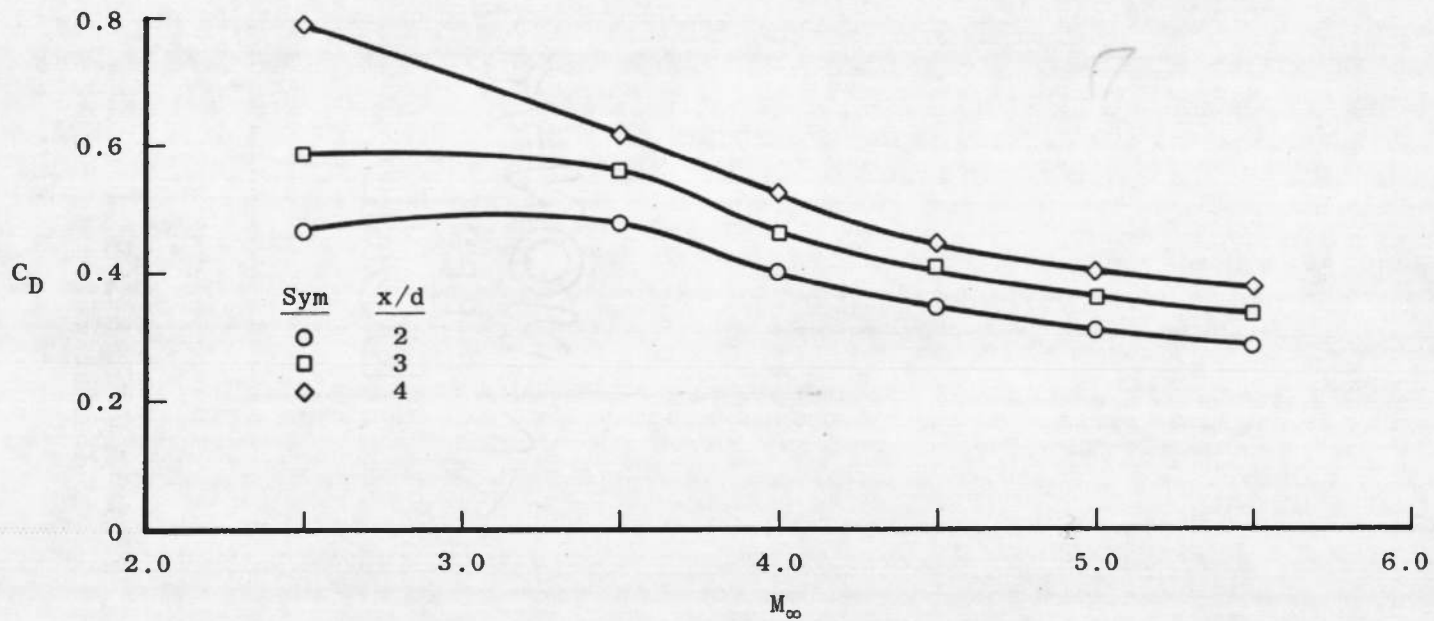
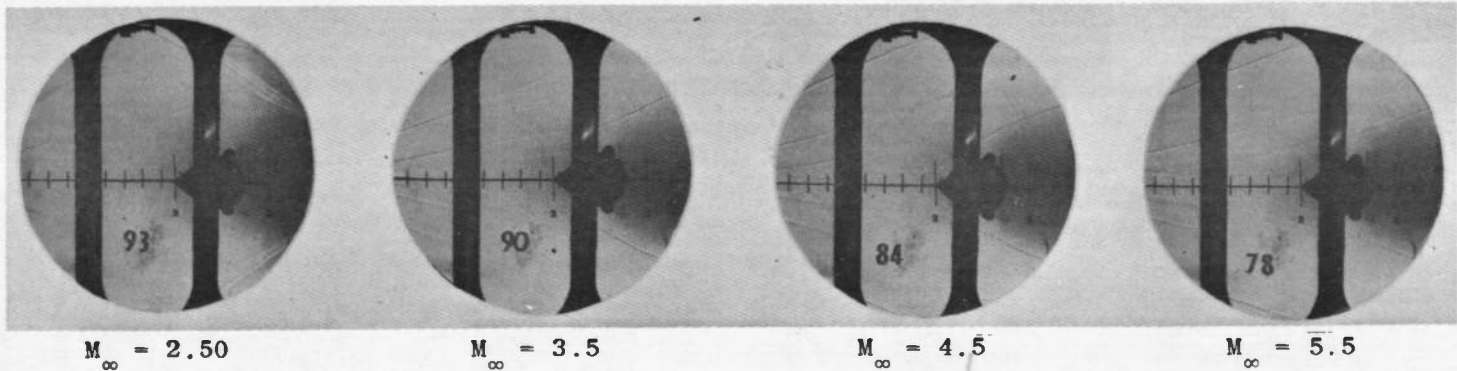

Fig. 6 Variation of Drag Coefficient with Mach Number for a Ballute Decelerator in the Wake of a Cone-Cylinder-Flare Model (Configuration 4065)



DOCUMENT CONTROL DATA - R & D

(Security classification of title, body of abstract and indexing annotation must be entered when the overall report is classified)

1. ORIGINATING ACTIVITY (Corporate author) Arnold Engineering Development Center ARO, Inc., Operating Contractor Arnold Air Force Station, Tennessee 37389	2a. REPORT SECURITY CLASSIFICATION <b>UNCLASSIFIED</b>
	2b. GROUP N/A

3. REPORT TITLE  
DRAG AND PERFORMANCE CHARACTERISTICS OF SEVERAL FLEXIBLE AERODYNAMIC DECELERATORS AT MACH NUMBERS FROM 1.5 TO 6.0

4. DESCRIPTIVE NOTES (Type of report and inclusive dates)  
August 13 through 15, 1969 - Final Report

5. AUTHOR(S) (First name, middle initial, last name)  
R. W. Rhudy, ARO, Inc.

*This document has been approved for public release and its distribution is unlimited. Per AF 24 June 75 Signed William O'cale*

6. REPORT DATE December 1969	7a. TOTAL NO. OF PAGES 30	7b. NO. OF REFS 11
---------------------------------	------------------------------	-----------------------

8a. CONTRACT OR GRANT NO. F40600-69-C-0001 b. PROJECT NO. 6065 c. Program Element 62201F d. Task 05	9a. ORIGINATOR'S REPORT NUMBER(S) AEDC-TR-69-263
	9b. OTHER REPORT NO(S) (Any other numbers that may be assigned this report) N/A

10. DISTRIBUTION STATEMENT ~~This document is subject to special export controls and each transmittal to foreign governments or foreign nationals may be made only with prior approval of Air Force Flight Dynamics Laboratory (FDFR), Wright-Patterson Air Force Base, Ohio 45433.~~

11. SUPPLEMENTARY NOTES Available in DDC.	12. SPONSORING MILITARY ACTIVITY Air Force Flight Dynamics Laboratory (FDFR), Wright-Patterson AF Base, Ohio 45433
--	--

13. ABSTRACT  
An experimental investigation was conducted at Mach numbers from 1.5 to 6.0 to determine the drag and stability characteristics of several flexible aerodynamic decelerators located in the wake of double-strut-mounted forebodies. Data are presented which show a decrease in drag with an increase in free-stream Mach number and/or a decrease in x/d for both guide surface decelerators and for a ballute. Because of differences in calibration techniques, riser line length, and test equipment, a 50- to 70-percent lower value of drag coefficient was obtained on a series of supersonic X decelerators when compared to previous tests. The present data do, however, agree reasonably well with drag data for a full-scale decelerator. An indication of the parachute stability is given in tabular form. All of the present data were obtained at a free-stream dynamic pressure of 1.0 psia and static pressures corresponding to pressure altitudes ranging from 70,000 to 130,000 ft.

DISTRIBUTION LIMITED TO U. S. GOV'T AGENCIES ONLY; Test and Evaluation; 12 Nov. 71. Other requests for this document must be referred to Director, Air Force Flight Dynamics Lab., Attn: FDFR, Wright-Patterson AFB, Ohio 45433.

~~This document is subject to special export controls and each transmittal to foreign governments or foreign nationals may be made only with prior approval of Air Force Flight Dynamics Laboratory (FDFR), Wright-Patterson Air Force Base, Ohio 45433.~~

PER TAB 72-21, dated 1 November, 1972.

14. KEY WORDS	LINK A		LINK B		LINK C	
	ROLE	WT	ROLE	WT	ROLE	WT
deceleration						
aerodynamics						
drag						
stability						
wind tunnels						
supersonic flow						
hypersonic flow						
1. Decelerators	-	-	Drag			
2 " "	-	-	Stability			
3 Parachutes	-	-	" "			
4 " "	-	-	Drag			
1 - 15.						