

UNCLASSIFIED

AD NUMBER
AD861531
NEW LIMITATION CHANGE
TO Approved for public release, distribution unlimited
FROM Distribution authorized to U.S. Gov't. agencies and their contractors; Administrative/Operational Use; 08 AUG 1969. Other requests shall be referred to Office of the Adjutant General, Department of the Army, Washington, DC 20310.
AUTHORITY
AGO D/A ltr dtd 29 Apr 1980

THIS PAGE IS UNCLASSIFIED

**THIS REPORT HAS BEEN DELIMITED  
AND CLEARED FOR PUBLIC RELEASE  
UNDER DOD DIRECTIVE 5200.20 AND  
NO RESTRICTIONS ARE IMPOSED UPON  
ITS USE AND DISCLOSURE.**

**DISTRIBUTION STATEMENT A**

**APPROVED FOR PUBLIC RELEASE,  
DISTRIBUTION UNLIMITED.**



DEPARTMENT OF THE ARMY  
OFFICE OF THE ADJUTANT GENERAL  
WASHINGTON, D.C. 20310

IN REPLY REFER TO

AD 861531

AGDA (M) (22 Oct 69) FOR OT UT 693182

5 November 1969

SUBJECT: Operational Report - Lessons Learned, Headquarters, 12th Signal Group, Period Ending 31 July 1969

SEE DISTRIBUTION

1. Subject report is forwarded for review and evaluation in accordance with paragraph 5b, AR 525-15. Evaluations and corrective actions should be reported to ACSFOR OT UT, Operational Reports Branch, within 90 days of receipt of covering letter.
2. Information contained in this report is provided to insure appropriate benefits in the future from lessons learned during current operations and may be adapted for use in developing training material.

BY ORDER OF THE SECRETARY OF THE ARMY:

*Kenneth G. Wickham*

KENNETH G. WICKHAM  
Major General, USA  
The Adjutant General

1 Incl  
as

DISTRIBUTION:

Commanding Generals  
US Continental Army Command  
US Army Combat Developments Command  
Commandants  
US Army War College  
US Army Command and General Staff College  
US Army Air Defense School  
US Army Armor School  
US Army Aviation School  
US Army Engineer School  
US Army Field Artillery School  
US Army Infantry School  
US Army Ordnance School  
US Army Quartermaster School  
US Army Signal School

NOV 21 1969

UNCLASSIFIED REPORT  
DISTRIBUTION NO FOREIGN WITHOUT APPROVAL OF  
ASSISTANT CHIEF OF STAFF FOR FORCE DEVELOPMENT  
(ARMY) ATTN FOR OT UT. WASHINGTON, D.C. 20310

DEPARTMENT OF THE ARMY  
Headquarters, 12th Signal Group  
APO 96308

SCCPV-PGOI

8 August 1969

SUBJECT: Operational Report of Headquarters, 12th Signal Group for Period  
Ending 31 July 1969.

SEE DISTRIBUTION

1. Section 1, Operations: Significant Activities:

a. 12th Signal Group was composed of the following units as of 31 July 1969. An organizational diagram is attached as inclosure one.

- (1) HHD, 12th Signal Group
- (2) Da Nang Signal Battalion
- (3) 37th Signal Battalion composed of the following:
  - (a) HHD, 37th Signal Battalion (Spt)
  - (b) Company A (Spt)
  - (c) Company C (Spt)
  - (d) Company D/43rd (Spt)
  - (e) 337th Signal Company (R/R)
- (4) 63rd Signal Battalion composed of the following:
  - (a) HHC, 63rd Signal Battalion (Rad Cab)
  - (b) 596th Signal Company (Spt)
  - (c) 588th Signal Company (Spt)
  - (d) Company B/37th (Spt)
  - (e) 270th Signal Company (CA)
  - (f) 17th Cable Platoon (CC)

b. During the period 1 May through 31 July the following significant activities occurred within this command.

FOR OT UT

693182

Inclosure

SCCV-FGOI

SUBJECT: Operational Report of Headquarters, 12th Signal Group for Period Ending 31 July 1969.

(1) CMI Team: The 12th Signal Group Headquarters organized a CMI Team to inspect subordinate units within the Group. The units inspected gained an impartial evaluation of their readiness posture and now knowledge of correct maintenance procedures.

(2) Requisition of an additional UH-1 helicopter: On 2 May 1969 the Group Aviation Section received an additional UH-1 helicopter raising the total number of aircraft assigned the Group to four. This additional aircraft greatly extended the Group Aviation Section's support capability to subordinate units within the Group.

(3) Phu Bai Dial Telephone Exchange Expansion: The installation of a 1000 line addition to the PHB DTE began with the arrival of a 12 man installation team from the Gustav Hirsch Organization (GHO) in mid-May. The completion of the 1000 line addition will enable the PHB DTE to extend dial service to 600 additional customers in this area and still remain within the engineering maximum of 80% commitment of available lines. Of these 600 new mainlines, approximately 180 class A and 420 class C lines will be available for use.

(4) Change of Group Commanders: On 10 June the 12th Signal Group changed Commanders at a ceremony held at the Group Headquarters in Phu Bai. Colonel Albert B. Crawford Jr., formerly Chief of Communications Systems Engineering and Management Agency (CSEMA) 1st Signal Brigade, replaced Colonel Mitchel Goldenthal. Colonel Goldenthal departed to assume the position of Deputy Commander, USASTRATCOM Europe.

(5) PLL Assistance: A MECOM representative arrived at this headquarters on 17 June to assist units within the Group with Prescribed Load List (PLL) problems. The significant feature of this assistance is that the MECOM representative assisted and counseled each PLL clerk while working with the PLL records. Personnel involved with PLL gained greater knowledge of procedures and were able to obviate deficiencies as a result of this assistance from MECOM.

(6) Revetting of SYSCON: A twelve foot high revetment around the SYSCON and COMCENTER building was completed during the last week of June. This revetment provides protection to these structures against shrapnel and blast damage from indirect fire weapons.

(7) Group Redesignation: On 1 July the I Corps Tactical Zone Signal Group was officially redesignated as the 12th Signal Group by Headquarters, USASTRATCOM GO 123.

(8) Change of Command at HHD, 12th Signal Group: On 5 July, 1LT Eugene C. Supak assumed command of HHD from Cpt John H. Ringelspugh, who departed for assignment with the 63rd Signal Battalion.

INCL

SCCPV-PGOI

SUBJECT: Operational Report of Headquarters, 12th Signal Group for Period Ending 31 July.

(9) Completion of Phu Bai Combat Telephone Directory: The PHB Combat Telephone Directory was completed by the Terminal Division, 12th Signal Group and forwarded to the 63rd Signal Battalion for distribution in mid-July. This directory will enable PHB DTE users to rapidly locate and contact specific subscribers without using an operators assistance.

2. Section 2, Lessons Learned: Commanders Observations, Evaluations, and Recommendations:

a. Personnel and Administrative:

(1) Decrease in time required for return of RECAP Options for Prospective Reenlistees.

(a) OBSERVATION: During the past quarter three members of the 12th Signal Group who expressed their desire to reenlist failed to do so because they had not received firm option commitments before their DEROS dates.

(b) EVALUATION: The failure of this Group to retain these individuals and perhaps similiar failures throughout Vietnam, due to a needless administrative lag, has had and will continue to have an adverse effect upon the service by depleting the core of professional soldiers which is critically needed to train and mold into an effective force the short term volunteers and conscriptees upon whom the Army relies to fill its ranks.

(c) RECOMMENDATION: That consideration be given to a policy reform designed to ensure the fastest possible return of RECAP options to prospective reenlistees. The maximum time suggested for the processing and return of RECAP options is two weeks.

(2) Reproduction of Messages:

(a) OBSERVATION: In most instances, messages are received in a single copy from Headquarters, 1st Signal Brigade. In some cases this burned copy is poorly reproduced and occasionally it is almost impossible to read the contents because the copy is black and smudged. Most messages have some importance to our battalions and consequently have to be reproduced by use of a typewriter because the messages are not reproduceable by other means due to the color of the print or because of the condition mentioned above.

(b) EVALUATION: Much time is utilized copying and proofreading these messages. It must be assumed other headquarters are likewise plagued with this problem. Receiving sufficient copies from higher headquarters would preclude duplication of effort at the lower intermediate headquarters.

(c) RECOMMENDATIONS: That instead of each group headquarters utilizing a clerk to reproduce, proofread and assemble messages, that this reproduction be accomplished at Brigade Headquarters. Net result would be saving of manpower of 6 clerks in the various group headquarters, as opposed to only 1 clerk at the higher headquarters.

INCL

SCJFY-PCOI

SUBJECT: Operational Report of Headquarters, 12th Signal Group for Period  
Ending 31 July 1969.

b. Operations:

(1) Documentation of Cable Installations

(a) OBSERVATION: When new cable plants are installed or existing plants are modified, adequate records and maps are often not made or updated. After the personnel involved in the installation have left, the lack of accurate record makes circuit activations or troubleshooting difficult and may in extreme cases cause unnecessary duplication of existing installations.

(b) EVALUATION: The lack of accurate cable records and maps leaves communications personnel blindfolded when changes are necessary. The lack of accurate maps showing cable and splice locations makes maintenance of cable plants more difficult, and not knowing the locations makes the task of protecting cables from damage by construction work almost impossible.

(c) RECOMMENDATION: Command emphasis must be placed on cable records. Site OIC's must realize the necessity of accurate cable records, updated whenever changes are made. Construction units must maintain As-Built drawings to be turned over to the Project Engineer when the project is complete; and the O & M units must update drawings whenever the cable plant is changed. Accurate records will provide more efficient utilization of existing installations and provide a factual data base for determining any requirement for expansion.

(2) Technical Assistance for AN/TTC-7 Switchboards

(a) OBSERVATION: Personnel maintaining AN/TTC-7 Manual Central Offices, in its various configurations, are not using the proper lamp in the universal cord circuits.

(b) EVALUATION: In each technical assistance visit to communications sites using the AN/TTC-7 switchboard, 48 volt lamps have been found in the supervisory light of the universal cord circuits instead of the 6 volt lamp which should be used. The use of the 48 volt lamp limits the current flow through the relay and causes marginal operation of the relay. In several cases, the current was limited to the non-operate current value of the relay.

(c) RECOMMENDATION: Each universal cord circuit receive a weekly operational check which will include a measurement of the current flowing through the supervisory lamp. This test will discover 48 volt lamps that have been erroneously inserted in the supervisory lights thereby avoiding marginal performances of the supervisory relays.

(3) Tech Control Reporting Channels

(a) OBSERVATION: It has been noted that as the average reporting time improves the average restoral time decreases.

SCCPV-PGOI

SUBJECT: Operational Report of Headquarters, 12th Signal Group for Period Ending 31 July 1969.

(b) EVALUATION: Rapid reporting of an outage alerts personnel at higher positions of control so that lateral coordination can immediately be effected to restore circuits to traffic. Many times reporting channels are slow because these reporting channels are through command channels.

(c) RECOMMENDATION: That reporting channels for circuit and system outages be handled through a tech control reporting system. Command channel reporting should not be eliminated but the two channels should be separate to serve their intended purposes.

(4) Tuning of TRC-24 Equipment

(a) OBSERVATION: The operators in many instances use short cut procedures when tuning AN/TRC-24 equipment. This procedure restores the system to traffic but over a period of time the system reliability and quality is adversely affected.

(b) EVALUATION: Operators of TRC-24 system should request down time in order to go through a complete line up of the equipment by the manuals to improve system reliability and quality.

(c) RECOMMENDATION: That extracts be made from the manual describing the steps to be taken on the line up of TRC-24 and that a complete line up be accomplished as often as down time can be granted.

(5) Patrol of Cable Line

(a) OBSERVATION: Patrolling cable lines can be accomplished more effectively from the air.

(b) EVALUATION: During the week of 18 May the cable running from Phu Bai to Camp Eagle was cut almost daily, usually in the late afternoon. A group helicopter was used daily to fly along the cable to keep it under continual observation during the critical hours. The first time this method was used, three ARVN Soldiers were observed digging up the cable. One of the three was apprehended through coordination between the aircraft crew and personnel on the ground.

(c) RECOMMENDATION: That aircraft be used whenever possible to maintain observation of cable which is being frequently cut.

c. Training:

(1) Weapons Familiarization

(a) OBSERVATION: It has been noted that many individuals assigned to this HQ had gone past the six month period since they had last fired their individual weapon. These individuals are detailed to pull perimeter guard duty approximately every seven days, therefore it is essential that



SCCFV-PGOI

SUBJECT: Operational Report of Headquarters, 12th Signal Group for Period  
Ending 31 July 1969.

they familiarize as often as possible. Due to the nature of the work of the individuals of this HQ, it is difficult for them to receive all the necessary training that they should have.

(b) EVALUATION: The importance of perimeter guard duty dictates that every individual should have complete confidence in his weapon.

(c) RECOMMENDATION: Individuals should familiarize and zero their weapons as soon as possible after arriving in-country. This HQ has set up a training program which allows all individuals to fire every two months. Priority is given to new personnel in the headquarters.

d. Intelligence - NONE

e. Logistics:

(a) OBSERVATION: Subordinate units of this headquarters are experiencing an extremely high deadline rate of amplifier AM3349, FSN 5820-076-4771.

(b) EVALUATION: The primary reason for the high deadline rate is the non-availability of repair parts for these amplifiers. In addition, Direct Support Maintenance Units and General Support Maintenance Units have been unable to receive repair parts to restore deadline amplifiers. The lack of these repair parts has forced subordinate units to turn in the unserviceable amplifiers and requisition new replacements. The replacement amplifiers have not been received by requisitioning units and the units continue to experience a shortage of this equipment.

(c) RECOMMENDATION: The amplifier AN-3349 should be made a Closed Loop Item and sufficient quantities be made available on hand at DSU's to facilitate a direct exchange on unserviceable amplifiers.

f. Organization: NONE

g. Other: NONE

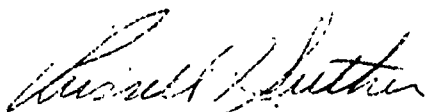

RUSSELL J. SUTHER  
LTC, SIC  
Acting Commander

1 Incl  
as

DISTRIBUTION:

2 - CINCUSARPAC  
1 - CG, USASTRATCOMPAC  
3 - CG, USARV  
10 - CG, 1st Sig Bde

SUCCPV-OP-SD (8 Aug 69) 1st Ind  
SUBJECT: Operational Report of Headquarters, 12th Signal Group for Period  
Ending 31 July 1969, CS CSRG-65 (1.1)

DA, HQ, 1st Signal Brigade (USAS A.CC1), APO 96384 2 September 1969

TO: Commanding General, United States Army Vietnam, ATTN: AVEGC-DST, APO 96375

1. Subject report is forwarded in accordance with USARV Regulation 525-15.  
2. This headquarters has reviewed the report and concurs in it with the following comments and/or exceptions concerning referenced paragraphs:

a. Paragraph 2a(1), page 3. Non-concur. Statistics maintained by this headquarters do not reveal undue delay in administration or processing of reenlistment options, nor that there is a need for consideration of a policy change at this time.

b. Paragraph 2a(2), page 3. Coordination between this headquarters and 12th Signal Group has been accomplished. This problem will be rectified in the future.

c. Paragraph 2b(3), page 4. The two reporting channels mentioned in the recommendation are now separate. First channel is through technical control, the second is through circuit/system control. The circuit/system channel follows the chain of command but is a communication reporting channel for lateral coordination.

d. Paragraph 2b(4), page 5. Necessary downtime is normally granted for valid reasons. If system is properly maintained equipment can normally be tested while in a spare stack configuration on a routine maintenance basis.

e. Paragraph 2c, page 6. Instructions for establishing a direct exchange at the provisional DSU ELH shops are being issued under the provisions of para 14-8 AR 711-16.

FOR THE COMMANDER:

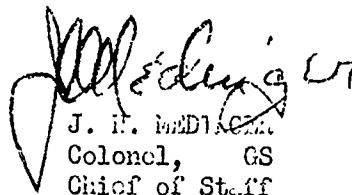
  
J. H. MEDLOCK  
Colonel, GS  
Chief of Staff

Cc: Assistant Chief of Staff for Force Development, Department of the Army,  
Washington, D. C. 20310  
Commanding General, United States Army Strategic Communications Command  
ATTN: SCC-OPS- T, Fort Huachuca, Arizona 85613  
Commanding Officer, 12th Signal Group, APO 96308

NOT REPRODUCIBLE

AVHGC-DST (8 Aug 69) 2d Ind  
SUBJECT: Operational Report of Headquarters, 12th Signal Group for  
Period Ending 31 July 1969, RCS CSFOR-65 (R1)

HEADQUARTERS, UNITED STATES ARMY, VIETNAM, APO San Francisco 96375 13 SEP 1969

THRU: Commanding General, United States Army Strategic Communications  
Command-Pacific, APO 96557

TO: Commander in Chief, United States Army, Pacific, ATTN: GPOP-DT,  
APO 96558

This headquarters has reviewed the Operational Report-Lessons Learned  
for the quarterly period ending 31 July 1969 from Headquarters, 12th  
Signal Group and concurs with the report as indorsed.

FOR THE COMMANDER:

  
B. A. GOODWIN  
CPT, AGC  
Assistant Adjutant General

Cy furn:  
12th Sig Gp  
1st Sig Bde

SCCP-OP (8 Aug 69) 3d Ind  
SUBJECT: Operational Report of Headquarters, 12th Signal Group for Period  
Ending 31 July 1969, RCS CSFOR-65 (R1)

Headquarters, U. S. Army Strategic Communications Command-Pacific, APO  
San Francisco 96557 24 SEP 1969

TO: Commander in Chief, United States Army, Pacific, ATTN: GPOP-DT,  
APO 96558

1. Subject report is forwarded in accordance with AR 525-15.
2. This headquarters has reviewed and concurs with subject report as indorsed.

FOR THE COMMANDER:

FRANK C. MAHIN  
COL, GS  
Chief of Staff

GPOP-DT (8 Aug 69) 4th Ind  
SUBJECT: Operational Report of HQ, 12th Signal Group for  
Period Ending 31 July 1969, RCS CSFOR-65 (R1)

HQ, US Army, Pacific, APO San Francisco 96558 29 SEP 69

THRU: Commanding General, US Army Strategic Communications  
Command, Fort Huachuca, Arizona 85613

TO: Assistant Chief of Staff for Force Development,  
Department of the Army, Washington, D. C. 20310

This headquarters concurs in subject report as indorsed.

FOR THE COMMANDER IN CHIEF:



D. A. TUCKER  
CPT. AGC  
ASST AG

Cy furn:  
DA, ACSFOR  
CG, USASTRATCOM-PAC

SCC-PO-CERA (8 Aug 69) 5th Ind  
SUBJECT: Operational Report of HQ, 12th Signal Group for Period Ending  
31 July 1969, RCS CSFOR-65 (R1)

Headquarters, US Army Strategic Communications Command, Fort Huachuca,  
Arizona 85613 **10 OCT 1969**

TO: Assistant Chief of Staff for Force Development, Department of  
the Army, Washington, D. C. 20310

This Headquarters has evaluated subject report and forwarding indorse-  
ments and concurs in the report as indorsed.

FOR THE COMMANDER:

*Robert A. Mall*  
ROBERT A. MALL  
Captain, AGC  
Asst Adj Gen

CF:  
CG, USASTRATCOM-PAC

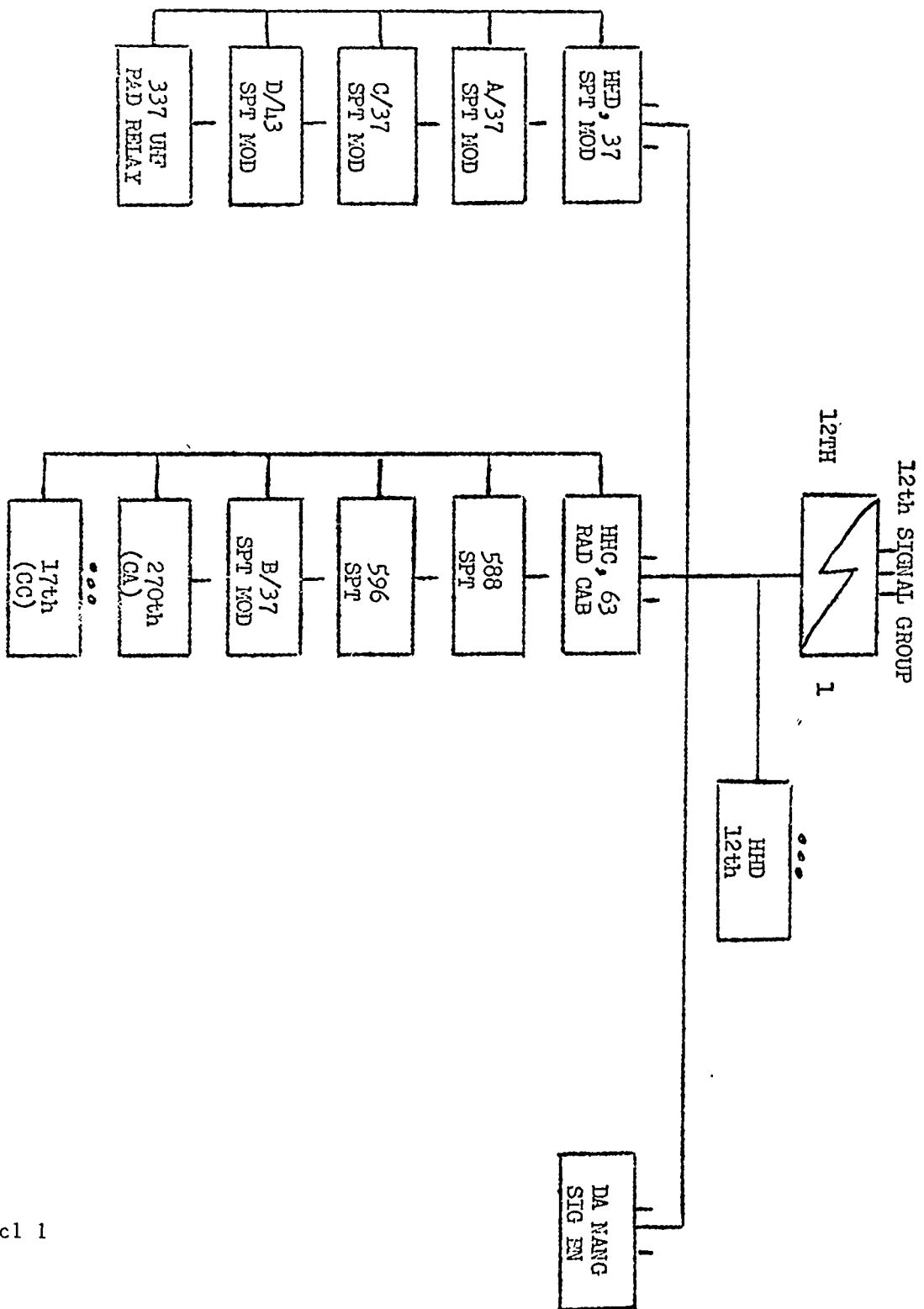

Incl 1

UNCLASSIFIED

Security Classification

DOCUMENT CONTROL DATA - R & D		
<i>(Security classification of title, body of abstract and indexing annotation must be entered when the overall report is classified)</i>		
1. ORIGINATING ACTIVITY (Corporate author) HQ, OACSFOR, DA, Washington, D.C. 2031G		2a. REPORT SECURITY CLASSIFICATION UNCLASSIFIED
		2b. GROUP
3. REPORT TITLE Operational Report - Lessons Learned, HQ, 12th Signal Group		
4. DESCRIPTIVE NOTES (Type of report and inclusive dates) Experiences of unit engaged in counterinsurgency operations, 1 May 69 to 31 July 69.		
5. AUTHOR(S) (First name, middle initial, last name) CO, 12th Signal Group		
6. REPORT DATE 8 August 1969	7a. TOTAL NO. OF PAGES 15	7b. NO. OF REFS
8a. CONTRACT OR GRANT NO.	9a. ORIGINATOR'S REPORT NUMBER(S) 693182	
b. PROJECT NO		
c. N/A	9b. OTHER REPORT NO(S) (Any other numbers that may be assigned this report)	
d.		
10. DISTRIBUTION STATEMENT		
11. SUPPLEMENTARY NOTES N/A	12. SPONSORING MILITARY ACTIVITY OACSFOR, DA, Washington, D.C. 20310	
13. ABSTRACT		

DD FORM 1473  
1 NOV 65

UNCLASSIFIED

Security Classification