

UNCLASSIFIED

AD NUMBER
AD857678
NEW LIMITATION CHANGE
TO Approved for public release, distribution unlimited
FROM Distribution authorized to U.S. Gov't. agencies and their contractors; Administrative/Operational use; July 1969. Other requests shall be referred to Dept. of Army, Fort Detrick, Attn: Technical Release Branch/TID, Frederick, Maryland 21701.
AUTHORITY
BDRL, d/a ltr, 29 Sep 1971.

THIS PAGE IS UNCLASSIFIED

AD

TECHNICAL MANUSCRIPT 545

A LABORATORY  
FOR STUDYING THE EFFECT OF SOLAR  
AND SIMULATED SOLAR RADIATION  
ON AIRBORNE MICROORGANISMS

Richard F. Berendt  
Everett L. Neff, Jr.  
Emerson L. Dorsey

JULY 1969

STATEMENT #2 UNCLASSIFIED

This document is subject to special export controls and each transmittal to foreign governments or foreign nationals may be made only with prior approval of Dept. of Army, Fort Detrick, ATTN: Technical Release Branch/TID, Frederick, Maryland 21701

DEPARTMENT OF THE ARMY  
Fort Detrick  
Frederick, Maryland

D D C  
RECEIVED  
SLP 8 1969  
RECEIVED

AD857678

ACCESSION NO.	
CPSTI	WHITE SECTION <input type="checkbox"/>
DDC	BUFF SECTION <input checked="" type="checkbox"/>
UNANNOUNCED	<input type="checkbox"/>
JUSTIFICATION	
DISTRIBUTION/AVAILABILITY CODES	
POST.	AVAIL. and/or SPECIAL
2	

Reproduction of this publication in whole or in part is prohibited except with permission of the Commanding Officer, Fort Detrick, ATTN: Technical Releases Branch, Technical Information Division, Fort Detrick, Frederick, Maryland, 21701. However, DDC is authorized to reproduce the publication for United States Government purposes.

DDC AVAILABILITY NOTICES

Qualified requesters may obtain copies of this publication from DDC.

Foreign announcement and dissemination of this publication by DDC is not authorized.

Release or announcement to the public is not authorized.

DISPOSITION INSTRUCTIONS

Destroy this publication when it is no longer needed. Do not return it to the originator.

The findings in this publication are not to be construed as an official Department of the Army position, unless so designated by other authorized documents.

DEPARTMENT OF THE ARMY  
Fort Detrick  
Frederick, Maryland 21701

TECHNICAL MANUSCRIPT 545

A LABORATORY FOR STUDYING THE EFFECT OF SOLAR AND  
SIMULATED SOLAR RADIATION ON AIRBORNE MICROORGANISMS

Richard F. Berendt

Everett L. Neff, Jr.

Emerson L. Dorsey

Experimental Aerobiology Division  
AEROBIOLOGY & EVALUATION LABORATORIES

Project 1B562602A080

July 1969

ABSTRACT

A three-component laboratory has been constructed to study the effect of solar or simulated solar radiation on airborne microorganisms. A 45-foot transit tube having one surface of sunlight-transmitting glass was designed for the study of dynamic aerosols of no more than 10 minutes' age. A 650-liter revolving dodecagon with a periphery, constructed with the same glass is used to study aerosols aged 2 minutes to more than 24 hours. This facility is illuminated either by a heliostat on the roof that reflects natural sunlight or by a xenon light located under the apparatus. Animals can be exposed to aerosols irrespective of the light source with either transit tube or drum. Studies of the action spectrum of light can be carried out in a 20-liter chamber illuminated by 30- or 90-nm bandwidths of light provided by a plasma light-diffraction grating system. The increments of light may be selected from a total range of 300 to 2,500 nm. The method of data acquisition and some preliminary experiments are described.

## I. INTRODUCTION\*

The germicidal activity of ultraviolet and shorter-wavelength radiation has been firmly established by many investigators.<sup>1-7</sup> Most of these investigators have shown that the most active wavelengths are found in the area of greatest absorption by nucleic acids. The wavelengths of greatest activity are shorter than 300 nm, which are less than the shortest solar radiation that strikes the earth's surface. Except for the phenomenon of photoreactivation,<sup>8-11</sup> little attention has been given to the effect of wavelengths longer than 300 nm.

Recently, natural and simulated sunlight have been shown to be detrimental to airborne microorganisms.<sup>12,13</sup> Preliminary investigations carried out in our laboratories with both natural and simulated solar radiation have emphasized the need for research on the biological effect of sunlight on airborne microorganisms, and it is for this purpose that our solar radiation laboratory has been constructed.

Three major research objectives were established for the design of our laboratory:

- 1) The study of irradiated airborne microorganisms shortly after dissemination (aged 0 to 10 minutes).
- 2) The study of irradiated airborne microorganisms for periods as long as 24 hours after dissemination.
- 3) The determination of the biological action spectrum of sunlight and the subsequent determination of the mechanism of inactivation.

In order to initiate experimental approaches designed to attain the three major objectives, several subsidiary requirements were established:

- 1) Provision for environmental control, such as temperature and relative humidity.
- 2) A system for the exposure of laboratory animals to the infectious aerosols.
- 3) A system for the acquisition of important physical measurements, such as radiation intensity and wavelength, temperature, and relative humidity.
- 4) Because the study of hazardous organisms was contemplated, provision for the safe operation of all facilities.

---

\* This report should not be used as a literature citation in material to be published in the open literature. Readers interested in referencing the information contained herein should contact the senior author to ascertain when and where it may appear in citable form.

## II. APPARATUS

Three specific apparatus systems were designed for studying the effect of radiation on microorganisms. These are briefly described and data representing the type of information that can be obtained using one of these systems are presented.

### A. TRANSIT TUBE

To achieve the first objective, the study of short-aged irradiated clouds, a 45 foot transit tube was constructed that consisted of three straight sections (Fig. 1) about 15 feet long connected by U-shaped elbows. The tube has a polygonal cross section approximately equivalent in area to a cylinder of 6 inches in diameter. The device is located on the south wall of the building and has an outer face of two sheets of 7910 Vycor\* glass separated by a nitrogen-filled space of about 1 inch. Irradiation of aerosols moving through the device is possible for at least a 2-hour period at any time of year on clear days. On the inside of the building, the tube is fitted with hinged doors that contain sensor exposure or sampling ports. Temperature is maintained by circulating water through the doors and side walls. For the partial control of light intensity, five sets of screens of different mesh are provided to cover the glass windows. These may be used to attenuate the incident light to values ranging from 11 to 65% of the non-screened glass.

Light intensity over a range of 300 to 2,500 nm is measured with a special 12-thermopile sensor assembly (Fig. 2). Ten of the 12 thermopiles are fitted with interference filters that allow measurement of the energy in selected ranges; the other two measure the total energy. An identical sensor is used to determine light intensity in the rotating drum system that is described later.

Certain problems have hindered the use of this device. Primarily, these involve devising techniques for producing turbulent flow and maintaining airtight seals around the doors. The discovery, however, that the revolving drum system can be used for studying aerosols of as early as 2 minutes of age has turned our attention away from the transit tube toward this more useful device.

### B. MONOCHROMATIC LIGHT CHAMBER

The monochromatic light chamber was constructed to study the effect of selected radiation bands on airborne microorganisms.

---

\* Corning Glass Company, Corning, N.Y.

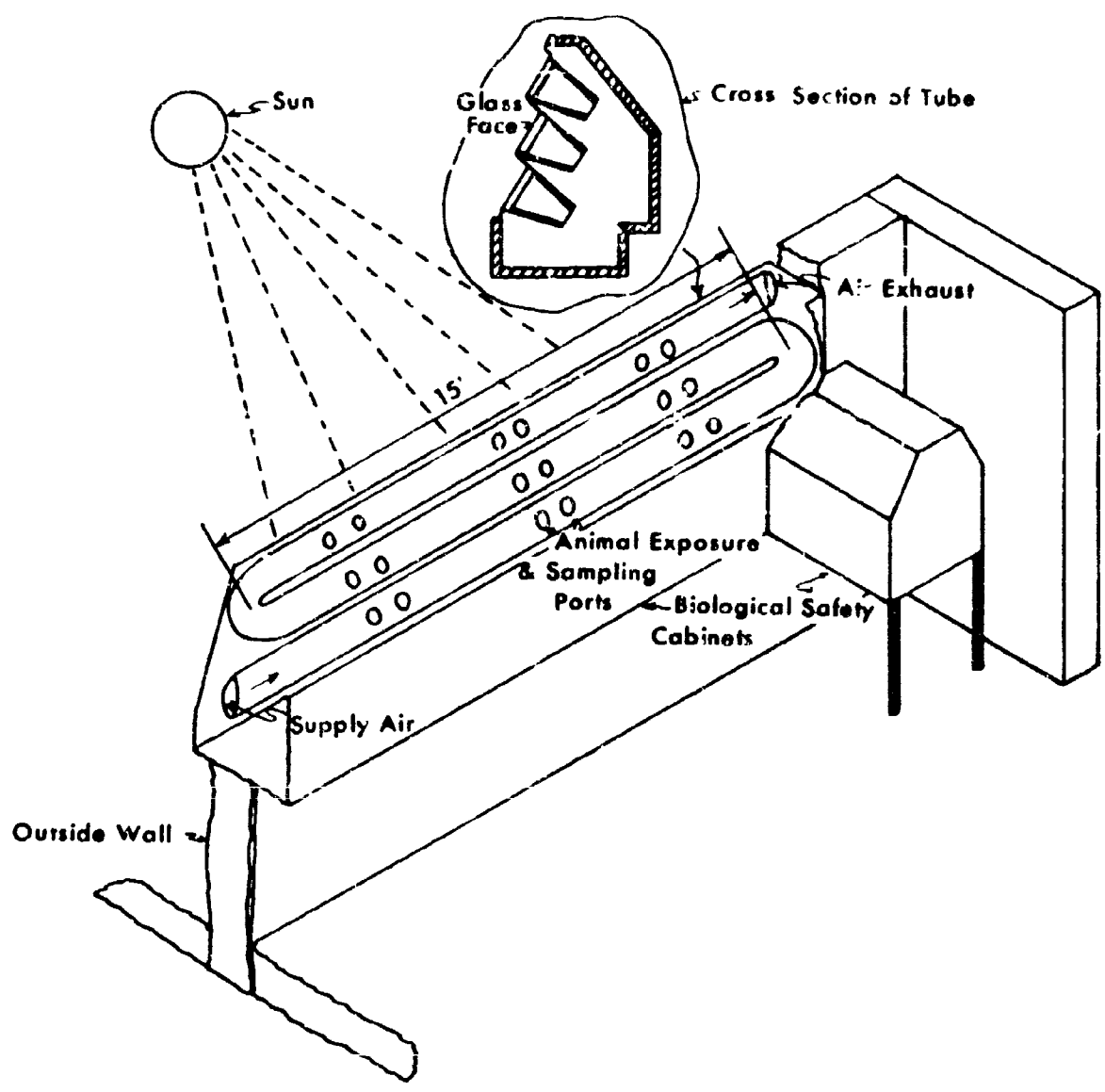

FIGURE 1. Natural Sunlight Transit Tube.



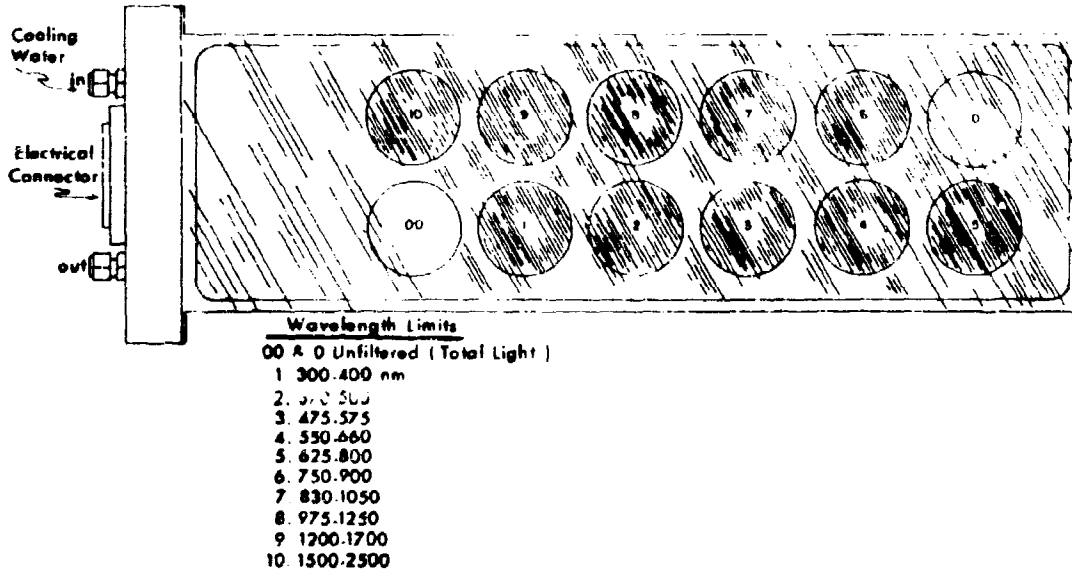

FIGURE 2. Solar Radiation Spectral Energy Sensor.

Its major application will be that of explaining the underlying mechanisms of phenomena observed with the transit tube and the rotating drum system.

The aerosol unit of this system is a 20-liter chamber. Temperature is controlled by circulating conditioned brine through channels in the sides of the chamber. On or near the floor of the chamber are mounted sensors for measuring light intensity, temperature, and dew point. The unit is too small for animal exposure.

The top of the chamber is Vycor glass to permit passage of light generated by the monochromator, located on the floor above the chamber. Figure 3 is a schematic diagram of the entire system that illustrates the spatial relationships of components. The vertical distance from the directing mirror to the aerosol test chamber is approximately 12 feet.

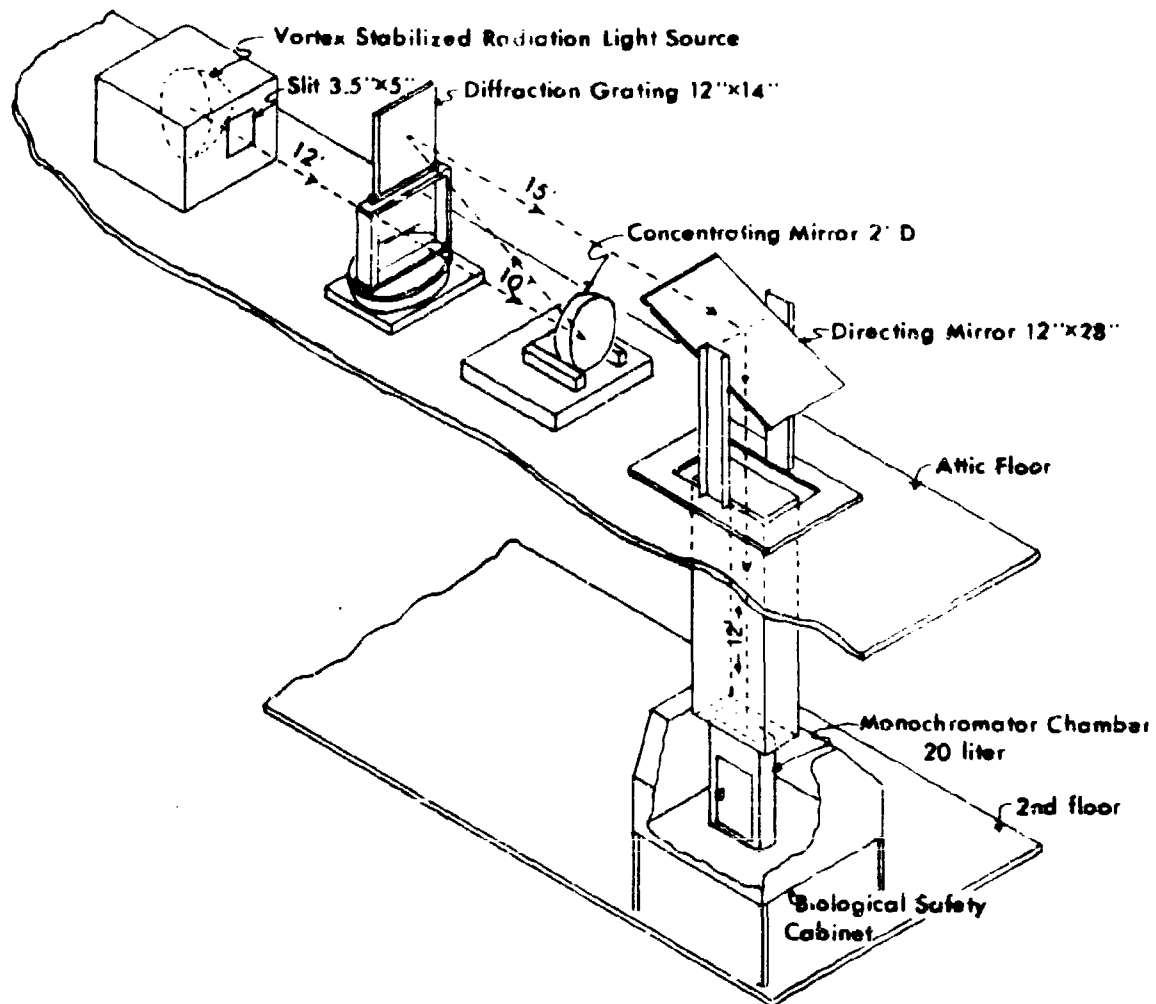

FIGURE 3. Monochromator Chamber System.

The monochromator system is located on the attic floor. The essential parts of this system are a vortex-stabilized radiation source,\* an entrance slit, a concave concentrating mirror, a set of diffraction gratings, and a flat directing mirror. In addition, light-attenuation screens and optical filters are provided.

\* Giannini Scientific Corporation, Santa Ana, California.

The radiation source is a high-intensity plasma arc unit in which argon is used as the plasma gas. The entrance slit measures 3.5 inches wide by 5 inches high. Interposed in the light path is the diffraction grating system that provides the desired spectral increments.

Two 12- by 14-inch diffraction gratings are employed in this system. One, a 400-lines/mm grating, provides 90-nm wide bands of illumination between 900 and 2,500 nm. The other, a 1,200-lines/mm grating, provides 30-nm bands between 290 and 950 nm. The desired bandwidth is selected by rotating the grating on its index table; selection to within 0.3 and 0.1 nm, respectively, can be achieved.

The system is also equipped with optical filters to reduce second-order effects and attenuation screens to aid in the control of light intensity. The desired increment of the spectrum provided by the grating is reflected downward into the aerosol chamber by the flat mirror.

#### C. HELIOSTAT - REVOLVING DRUM SYSTEM

To study irradiated aerosols of up to 24 hours' age, a heliostat - revolving drum system was fabricated. The use of the revolving drum for the study of aerosols has been reported by Goldberg et al.<sup>14</sup> The essential components of this system are shown in Figure 4. The aerosol device is a revolving dodecagon with a volume of 650 liters, enclosed in a biological safety cabinet system. Each of the 12 surfaces on the periphery consists of panes of Vycor glass. The drum can be operated at any one of six preset speeds ranging from 2 to 7 rpm. Dissemination, sampling, and measurement of such physical factors as temperature, dew point, and light intensity are accomplished through one of the 14-inch hubs of the drum. The light sensor employed is identical to that installed in the transit tube. Six 4-inch ports are drilled in the other hub plate to permit animal exposure. Sample assessment is accomplished within the attached hood system.

Provisions for studying both natural and simulated solar radiation have been made with this system. Solar radiation is simulated by a 10-kilowatt xenon lamp\* mounted directly beneath the drum. A glass plate cuts off emissions at wavelengths below 300 nm. A five-position switch permits the choice of total light intensities ranging from about 500 to 1,300  $\text{mcal cm}^{-2} \text{min}^{-1}$ . Further control of light intensity is provided by the use of attenuation screens as for the transit tube.

Natural sunlight is directed into the drum through several layers of Vycor glass from a fixed mirror mounted on a platform fastened to the roof of the building. The fixed mirror reflects an image directed into it from a 5- by 10-foot front-surface tracking mirror that is also

\* Osram Gesellschaft, Berlin, West Germany.

mounted on the platform. This mirror and the tracking equipment that controls it compose the heliostat system. The tracking sensors are mounted in the shaft that leads downward from the roof. The whole system is constructed to allow either direct tracking of the sun or the collection of skylight ahead of or behind the sun. Additional control of light intensity is provided by light-attenuation screens. After the cover that protects the heliostat system has been moved out of the way, the entire system can be controlled from a console located in the drum room. The loss of light intensity resulting from passage through several layers of glass has been estimated at about 50%.

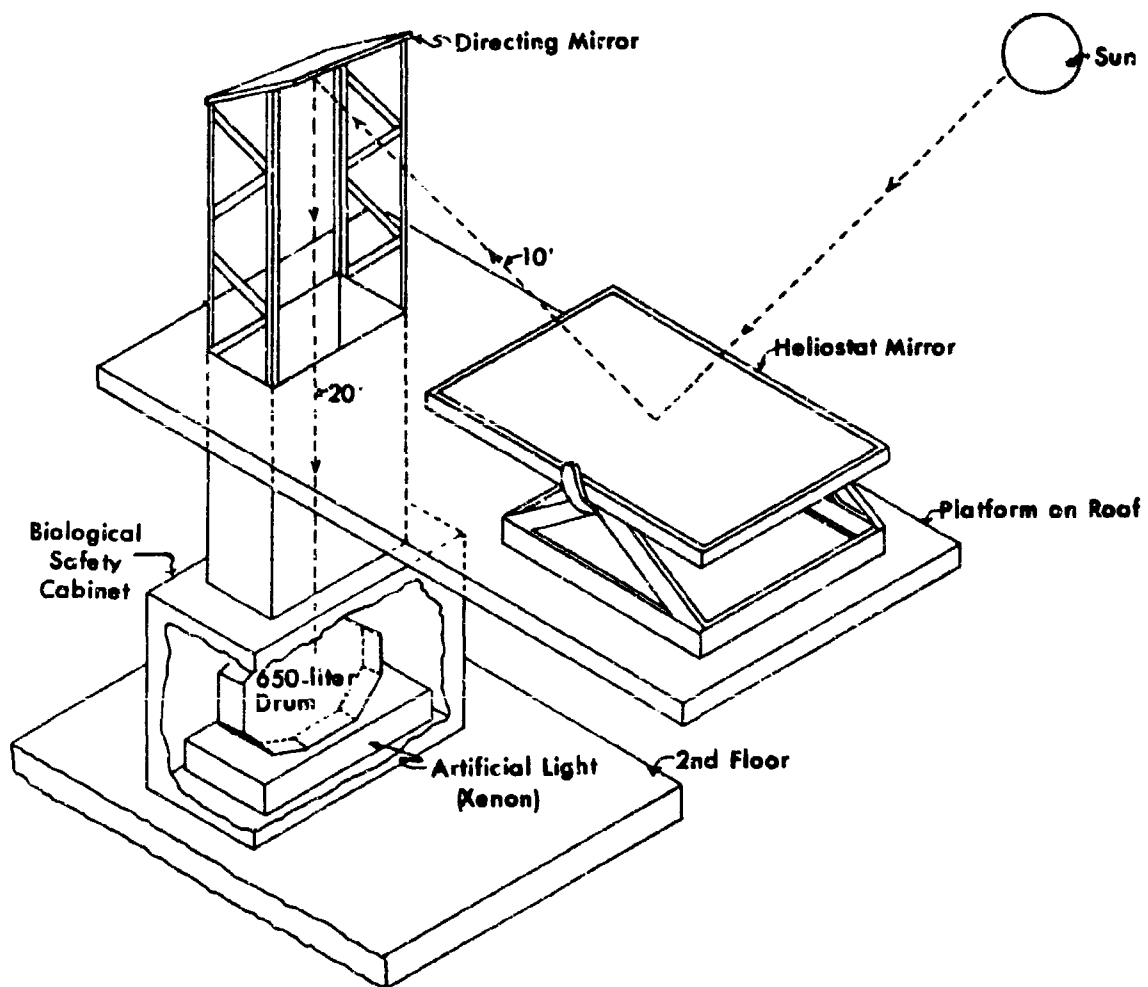

FIGURE 4. Heliostat and Revolving Drum System.

The question of the relationship of the xenon light to natural sunlight is often raised. Figure 5 shows a representative set of curves of intensity plotted against wavelength for both kinds of light. It seems that the xenon source as operated in this system is deficient in what may possibly be the most important area, the near UV. For research purposes, however, the artificial light has the advantage of being much more constant, because it is not affected by atmospheric clouds or changes in air mass.

A comparison of major characteristics of the three devices is presented in Table 1. Of the three devices discussed, the transit tube has been the most troublesome to operate. The primary difficulty has been obtaining sufficient turbulence to produce reasonably homogeneous flow at all points in the tube cross section. Because we have been able to obtain homogeneous dispersion of aerosols in the revolving drum in about 2 minutes, we have concentrated our attention upon the heliostat - revolving drum system as our primary device for determining solar radiation effects. The monochromatic light system will be used to elucidate the mechanisms of the effects seen with the larger device.

As already indicated, the heliostat - revolving drum system has been, thus far, the most useful apparatus of the three types mentioned. A number of preliminary studies have been conducted in which aerosols of selected organisms have been exposed to either natural or simulated sunlight. Preliminary research findings made in the presence of natural and xenon light seem to be interesting. In almost every case, the aerosol decay rate of irradiated organisms appeared to increase after a certain period of time had elapsed. The time and rate varied with the species of microorganism and light intensity. Representative decay curves are shown in Figure 6 for irradiated Escherichia coli and Serratia marcescens. It is obvious that the shape of the decay curves for the irradiated organisms is different than that for the nonirradiated organisms. Further illustration of this is given in Table 2, which shows the decay rates for the two organisms calculated for the 2- to 16-minute and 16- to 64-minute periods. The rates for the dark controls decrease after 16 minutes, whereas they increase for the irradiated cells. This difference suggests that the effect of irradiation on airborne microorganisms involves mechanisms of inactivation supplementary to those observed in the dark, and the total inactivation is the product of two different kinds of reactions. These findings also suggest that the mathematical expressions for decay rate commonly employed are not applicable to irradiated cells, and new formulations are needed.

The comparison of the spectrum of xenon light with that of sunlight has already been discussed. A very important point, however, is the comparative response of airborne organisms to the natural and artificial sources of irradiation. Figure 7 is a graphic representation of the response of E. coli to sunlight of approximately the same intensity and other environmental conditions as shown in the previous figures for

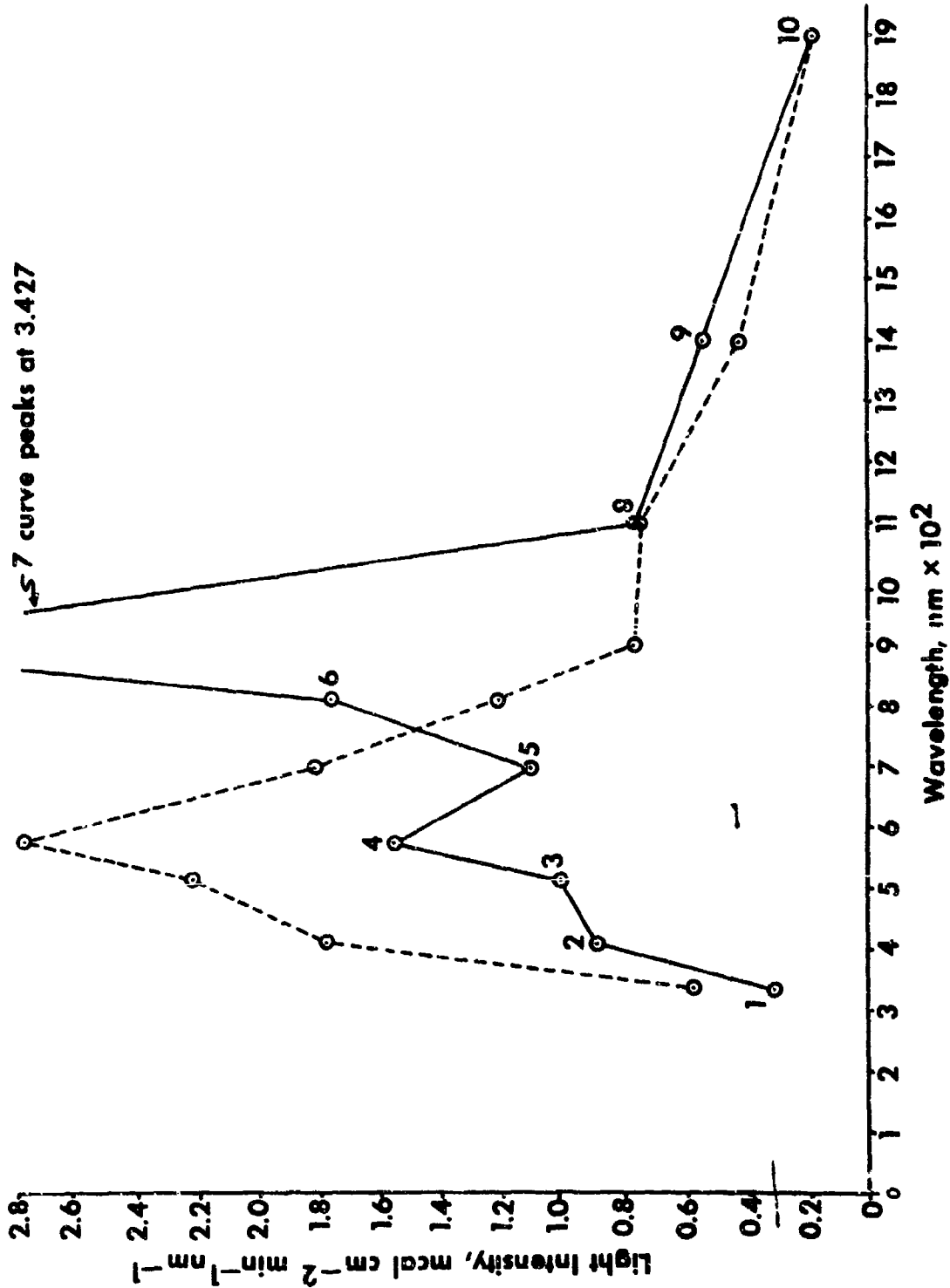

FIGURE 5. Spectral Irradiance of the Sun and of the Xenon Light.  
 Sun at noon, air mass 1.1 - - -. Xenon lamp "g" setting, sensor No. 6465 —.

TABLE 1. COMPARISON OF COMPONENTS OF THE SOLAR RADIATION LABORATORY

Characteristic	Transit Tube	Heliostat- Drum	Monochromator
Capacity, liters	NA	650	20
Temperature range, C	-10 to +40 for all units		
Relative humidity range, %	12 to 95±5 for all units		
Maximum age of aerosols	approx 10 min	24 hours	approx 1 hour
Natural light	Yes	Yes	No
Artificial light	No	Yes	Yes
Light intensity control	Poor	Moderate	Good
Wavelength control	None	Partial	Good
Animal exposure	Yes	Yes	No

TABLE 2. EFFECT OF AEROSOL AGE ON DECAY RATE OF IRRADIATED SERRATIA MARCESCENS AND ESCHERICHIA COLI

Organism	Light Intensity, <sup>a</sup> / mcal cm <sup>-2</sup> min <sup>-1</sup>	Decay Rate over Indicated Periods, %/minute	
		2 to 16 Min	16 to 64 Min
<u>S. marcescens</u>	0	2.06	1.92
	70	10.19	14.88
<u>E. coli</u>	0	5.26	1.94
	70	18.66	19.10

a. Light intensity measured from 300 to 400 nm.

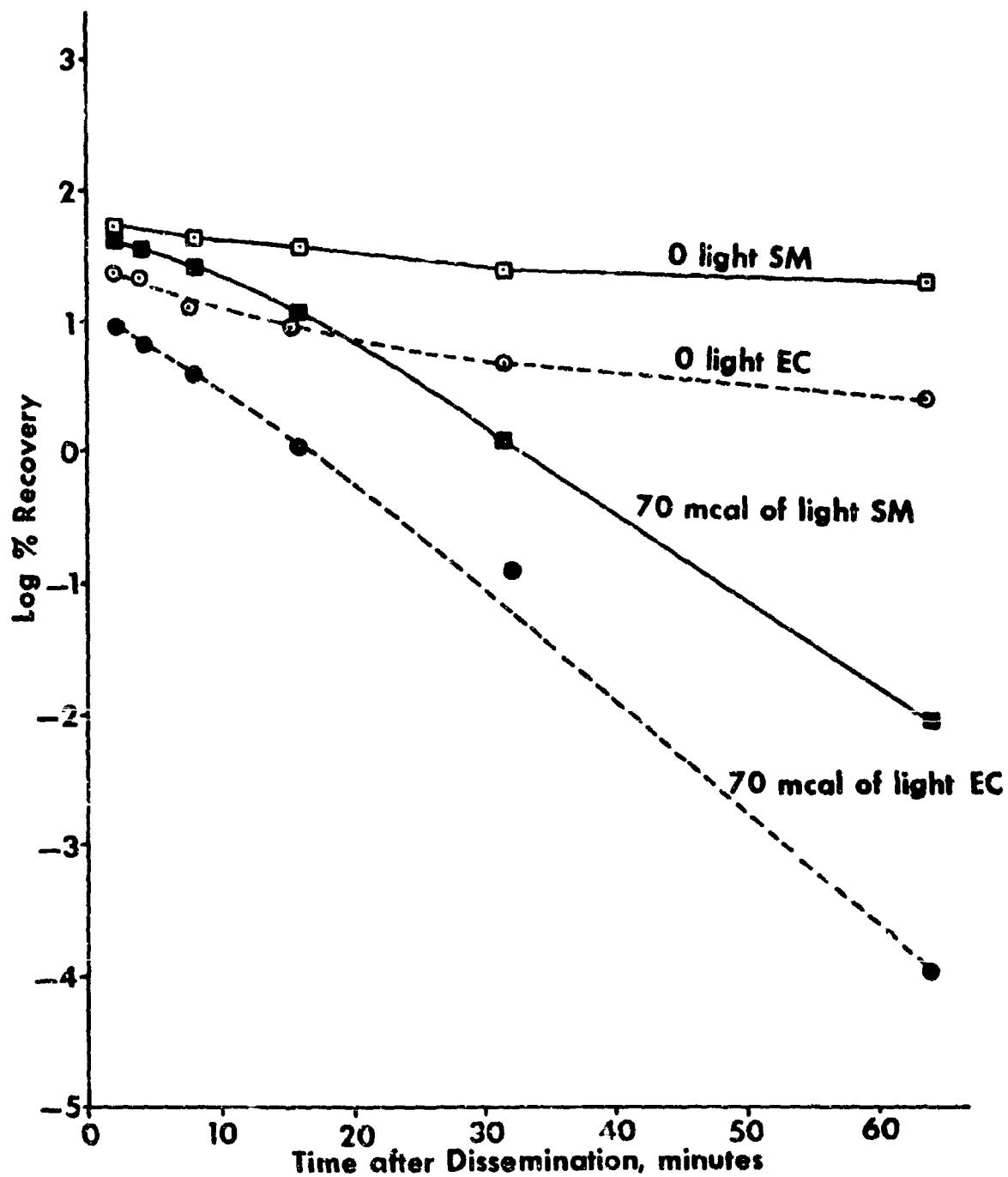

FIGURE 6. Effect of Irradiation upon Viable Recovery of *Escherichia coli* and *Serratia marcescens*. Source: xenon light, 70 F, 60% RH.



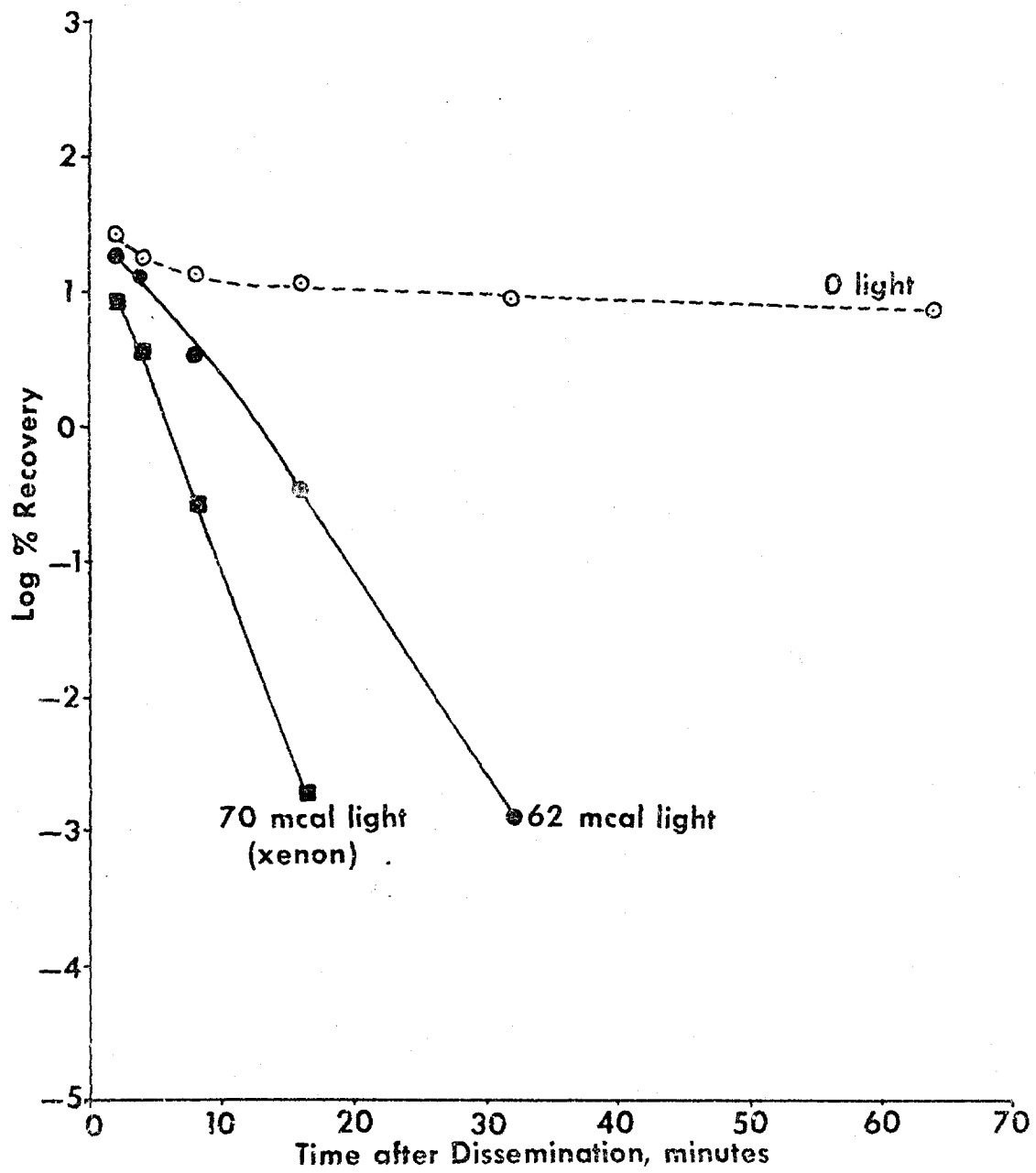

FIGURE 7. Effect of Irradiation upon the Viable Recovery of *Escherichia coli*.  
Source: natural sunlight, 66 F, 60% RH.

xenon light. The suspensions employed in these tests contained uranine dye. The response to the two kinds of light seems to be very similar, with the decay pattern being essentially the same.

The second finding is that of the marked sensitivity of irradiated cells to sodium fluorescein. In our laboratories, this material is frequently used as a mass tracer of the aerosol. Calculation of physical loss of fluorescein permits the determination of biological death rate by simple means. Figure 8 illustrates the toxic effect of uranine on aerosols of *E. coli*. Although a reaction of small magnitude was seen in the dark, the effect on irradiated cells was much greater. The results suggest that the reaction may be due to a radiation-induced change in the dye that causes it to become toxic for the airborne bacteria. This hypothesis is consistent with the recent findings of Foote,<sup>15</sup> who has investigated the mechanism of radiation-induced toxicity and has shown that otherwise innocuous compounds may become toxic after exposure to radiation. The possibility of adverse effects upon airborne microorganisms resulting from the interaction of radiation with various substrates will be investigated further.

#### D. DATA ACQUISITION

Finally, the method of obtaining and processing physical data is very important in the study of solar radiation. Physical information from both transit tube and revolving drum laboratories is acquired by an electronic system in which the data are punched on paper tape for ultimate computer analysis. The data consist of the 12 channels of radiation intensity, dew point, temperature, and, in the case of the tube, airflow rate. In addition, temperature, dew point, and total and integrated light intensities for all three laboratories are displayed on recorders for the investigators' immediate information. Because the wavelength of light in the monochromatic light system is controlled, it was not necessary to provide a complex electronic system to acquire data, so total light intensity, temperature, and dew point are displayed on recorders.

The mathematical techniques required for processing data have not yet been fully developed. This problem is exceedingly complex and involves (i) a method for reducing the quantity of physical data to manageable proportions and (ii) the correlation of observed biological effects with the various physical phenomena.

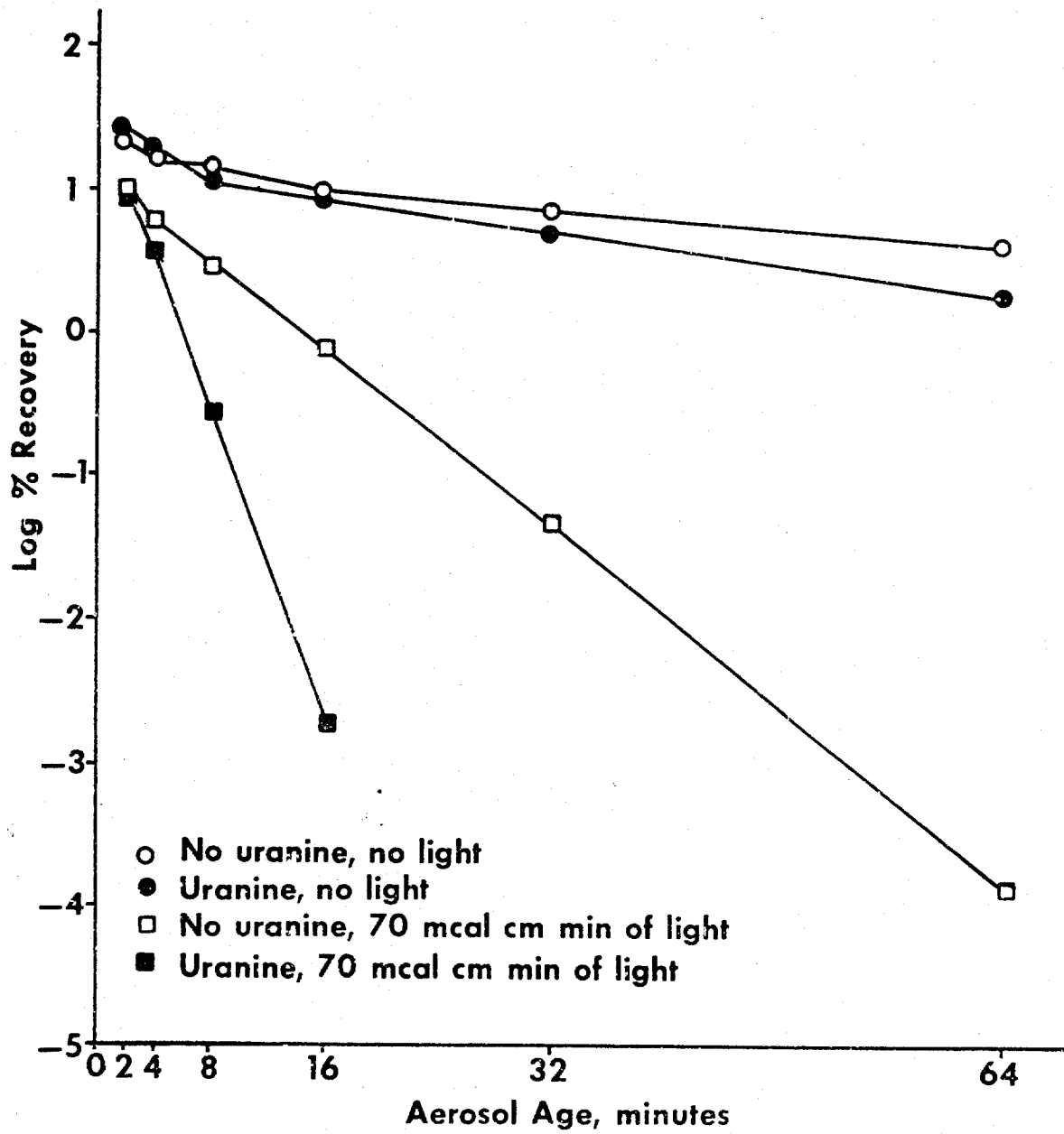

FIGURE 8. Effect of Tracer and Light on Recovery of *E. coli*.  
Source: xenon light, 70 F, 60% RH.

LITERATURE CITED

1. Coblantz, W.W.; Fulton, H.R. 1924. Germicidal action of ultra-violet radiation. Bur. Stand. Sci. Papers 19:641-680.
2. Gates, F.L. 1929. A study of the bactericidal action of ultraviolet light. J. Gen. Physiol. 13:231-260.
3. Wychoff, R.W.G. 1930. Killing of certain bacteria by X-rays. J. Exp. Med. 52:435-446.
4. Wychoff, R.W.G. 1930. Killing of colon bacilli by X-rays of different wave lengths. J. Exp. Med. 52:769-780.
5. Wychoff, R.W.G.; Rivers, M. 1930. The effect of cathode rays upon certain bacteria. J. Exp. Med. 51:921-932.
6. Hollaender, A.; Claus, W.D. 1936. Bactericidal effect of ultra-violet radiation on Escherichia coli in liquid suspensions. J. Gen. Physiol. 19:753-765.
7. Lea, D.E.; Haines, R.B. 1940. The bactericidal action of ultra-violet light. J. Hyg. 40:162-171.
8. Hertel, E.Z. 1904. Allg. Physiol. 4:1. Cited in Seliger, H.H.; McElroy, W.D. 1965. Light: Physical and biological action. Academic Press, New York.
9. Witkin, E.M. 1946. Inherited differences in sensitivity to radiation in Escherichia coli. Proc. Nat. Acad. Sci. US 32:59-68.
10. Kelner, A. 1949. Photoreactivation of ultraviolet-irradiated Escherichia coli with special reference to the dose-reduction principle and to ultraviolet-induced mutation. J. Bacteriol. 58:511-522.
11. Kelner, A. 1951. Action spectra for photoreactivation of ultraviolet-irradiated Escherichia coli and Streptomyces griseus. J. Gen. Physiol. 34:835-852.
12. Beebe, J.M.; Pirsch, G.W. 1958. Response of airborne species of Pasteurella to artificial radiation simulating sunlight under different conditions of relative humidity. Appl. Microbiol. 6:127-138.
13. Beebe, J.M. 1959. Stability of disseminated aerosols of Pasteurella tularensis subjected to simulated solar radiation at various humidities. J. Bacteriol. 78:18-24.

14. Goldberg, L.J.; Watkins, H.M.S.; Boerke, E.E.; Chatigny, M.A. 1958. The use of a rotating drum for the study of aerosols over an extended period of time. *Amer. J. Hyg.* 68:85-93.
15. Foote, C.S. 1968. Mechanisms of photosensitized oxidation. *Science* 162:963-970.

Unclassified

Security Classification

DOCUMENT CONTROL DATA - R & D		
<i>Security classification of title, body of abstract and indexing annotation must be entered when the overall report is classified</i>		
1. ORIGINATING ACTIVITY (Corporate author)		2a. REPORT SECURITY CLASSIFICATION
Department of the Army Fort Detrick Frederick, Maryland 21701		Unclassified
2b. GROUP		
3. REPORT TITLE		
A LABORATORY FOR STUDYING THE EFFECT OF SOLAR AND SIMULATED SOLAR RADIATION ON AIRBORNE MICROORGANISMS		
4. DESCRIPTIVE NOTES (Type of report and inclusive dates)		
5. AUTHOR(S) (First name, middle initial, last name)		
Richard F. Berendt Everett L. Neff, Jr. Emerson L. Dorsey		
6. REPORT DATE	7a. TOTAL NO. OF PAGES	7b. NO. OF REFS
July 1969	21	15
8a. CONTRACT OR GRANT NO.		8b. ORIGINATOR'S REPORT NUMBER(S)
A. PROJECT NO 1B562602A080		Technical Manuscript 545
9.		9c. OTHER REPORT NO(S) (Any other numbers that may be assigned this report)
4.		
10. DISTRIBUTION STATEMENT		
Qualified requesters may obtain copies of this publication from DDC. Foreign announcement and dissemination of this publication by DDC is not authorized. Release or announcement to the public is not authorized.		
11. SUPPLEMENTARY NOTES		12. SPONSORING MILITARY ACTIVITY
		Department of the Army Fort Detrick Frederick, Maryland 21701
13. ABSTRACT		
A three-component laboratory has been constructed to study the effect of solar or simulated solar radiation on airborne microorganisms. A 45-foot transit tube having one surface of sunlight-transmitting glass was designed for the study of dynamic aerosols of no more than 10 minutes' age. A 650-liter revolving dodecagon with a periphery constructed with the same glass is used to study aerosols aged 2 minutes to more than 24 hours. This facility is illuminated either by a heliostat on the roof that reflects natural sunlight or by a xenon light located under the apparatus. Animals can be exposed to aerosols irrespective of the light source with either transit tube or drum. Studies of the action spectrum of light can be carried out in a 20-liter chamber illuminated by 30- or 90-nm bandwidths of light provided by a plasma light-diffraction grating system. The increments of light may be selected from a total range of 300 to 2,500 nm. The method of data acquisition and some preliminary experiments are described. )		
14. Key Words		
Aerosols Solar radiation Biological inactivation Aerosol chambers Inactivation mechanism Xenon radiation		

DD FORM 1473

REPLACES DD FORM 1473, 1 JAN 60, WHICH IS OBSOLETE FOR ARMY USE.

Unclassified

Security Classification