

UNCLASSIFIED

AD NUMBER
AD857482
NEW LIMITATION CHANGE
TO Approved for public release, distribution unlimited
FROM Distribution authorized to U.S. Gov't. agencies and their contractors; Administrative/Operational Use; 15 FEB 1969. Other requests shall be referred to Office of the Adjutant General, Department of the Army, Washington, DC 20310.
AUTHORITY
AGO D/A ltr dtd 29 Apr 1980

THIS PAGE IS UNCLASSIFIED

**THIS REPORT HAS BEEN DELIMITED
AND CLEARED FOR PUBLIC RELEASE
UNDER DOD DIRECTIVE 5200.20 AND
NO RESTRICTIONS ARE IMPOSED UPON
ITS USE AND DISCLOSURE.**

DISTRIBUTION STATEMENT A

**APPROVED FOR PUBLIC RELEASE;
DISTRIBUTION UNLIMITED.**



DEPARTMENT OF THE ARMY
OFFICE OF THE ADJUTANT GENERAL
WASHINGTON, D.C. 20310

AGDA (M) (13 Aug 69) FOR OT UT 691256

18 August 1969

SUBJECT: Operational Report - Lessons Learned, Headquarters, 160th Signal Group, Period Ending 31 January 1969

SEE DISTRIBUTION

1. Subject report is forwarded for review and evaluation in accordance with paragraph 5b, AR 525-15. Evaluations and corrective actions should be reported to ACSFOR OT UT, Operational Reports Branch, within 90 days of receipt of covering letter.
2. Information contained in this report is provided to insure appropriate benefits in the future from lessons learned during current operations and may be adapted for use in developing training material.

BY ORDER OF THE SECRETARY OF THE ARMY:

KENNETH G. WICKHAM
Major General, USA
The Adjutant General

1 Incl
as

DISTRIBUTION:

Commanding Generals
US Continental Army Command
US Army Combat Developments Command
Commandants
US Army War College
US Army Command and General Staff College
US Army Signal School
US Army Southeastern Signal School

Copies furnished:
Office, Chief of Staff, US Army
Deputy Chiefs of Staff
Chief of Research and Development
Assistant Chiefs of Staff
Chief of Engineers
Commanding Generals
US Army STRATCOM
US Army Electronics Command

UNCLASSIFIED REPORT

DISTRIBUTION NO FOREIGN WITHOUT APPROVAL OF
ASSISTANT CHIEF OF STAFF FOR FORCE DEVELOPMENT
(ARMY) ATTN FOR OT UT. WASHINGTON, D.C. 20310

SEP 2 1969

AD 857482

25

DEPARTMENT OF THE ARMY
HEADQUARTERS, 160TH SIGNAL GROUP
APO San Francisco 96491

SCCPV-UG-OP

15 February 1969

SUBJECT: Operational Report - Lessons Learned of 160th Signal Group for
Period Ending 31 January 1969, RCS CSFOR-65(R1).

SEE DISTRIBUTION

1. Section 1, Operation: Significant Activities.

a. General. This is the seventh report to be submitted by this Group since its arrival in the Republic of Vietnam (RVN) on 30 April 1967. The organization, mission, and functions of the Group remain unchanged except as outlined in paragraph 1g below.

b. Personnel. The Group's assigned strength continued to be below the required and authorized strength levels. However, the replacement system proved more effective. There were 3023 personnel assigned as of the end of the reporting period, which was an increase of 79 over the previous quarter.

(1) During this reporting period, the Group processed 488 incoming and 410 outgoing enlisted personnel as follows:

UNIT	NOV		DEC		JAN		TOTAL		NET QTR	
	GAIN	LOSS	GAIN	LOSS	GAIN	LOSS	GAIN	LOSS	GAIN	LOSS
HHD	9	7	6	2	9	7	24	16	8	-
40th	18	17	11	9	14	14	43	40	3	-
44th	34	28	49	58	53	47	136	133	3	-
69th	48	43	47	53	47	49	142	145	-	3
221st	29	18	20	12	11	1	60	31	29	-
1st Sig Cn	21	9	17	16	30	11	68	36	32	-
USATF	5	3	4	2	4	4	13	9	4	-
SEAPC	0	0	1	0	1	0	2	0	2	-

FOR DT UT
691256

Inclosure

SCCPV-UG-OP

SUBJECT: Operational Report - Lessons Learned of 160th Signal Group for
Period Ending 31 January 1969, RCS CSFOR-65(R1).

(2) The Group also processed 34 incoming and 37 outgoing officer
personnel as follows:

UNIT	NOV.		DEC		JAN		TOTAL		NET QTR	
	GAIN	LOSS	GAIN	LOSS	GAIN	LOSS	GAIN	LOSS	GAIN	LOSS
HHD	1	3	1	3	5	2	7	8	-	-1
69th	1	5	4	3	1	1	6	9	-	-3
44th	1	1	2	2	3	1	6	4	+2	-
40th	0	1	0	0	1	1	1	2	-	-1
221st	1	0	2	0	5	2	8	2	+6	-
1st Sig Cn	2	3	0	6	4	2	6	11	-	-5
USATF	0	0	0	1	0	0	0	1	-	-1
SEAPC	0	0	0	0	0	0	0	0	0	0

(3) During the quarter enlisted promotion allocations were distributed
as follows:

UNIT	E9	E8	E7	E6	E5	E4	TOTAL	LAST QTR
HHD	0	0	1	2	12	19	34	31
40th	0	0	2	3	26	159	190	76
44th	0	0	3	8	83	194	288	99
69th	0	0	6	11	39	127	183	154
221st	0	0	1	4	15	30	50	25
1st Sig Cn	0	0	1	1	12	4	18	30
USATF	0	0	0	0	4	7	11	8
SEAPC	0	0	0	0	1	1	2	4

SCCPV-UG-OP

SUBJECT: Operational Report - Lessons Learned of 160th Signal Group for
Period Ending 31 January 1969, RCS CSFOR-65(R1).

(4) During this period, the following awards were approved for Group personnel:

	NOV	DEC	JAN	TOTAL	LAST QTR
LOM			1	1	2
SM				0	1
BSM "V"	1			1	0
BSM	2	11	11	24	53
AIR MEDAL				0	3
ACM "V"				0	0
ACM	7	14	20	41	40
PHM				0	0
TOTAL	10	25	32	67	99

(5) As of 31 Jan 1969, the assigned strength for the Group Headquarters was as follows:

OFF	WO	ENL	TOTAL	LAST QTR
28	4	120	152	158

(6) The following information office (IO) program statistics are furnished:

(a) 20 IO press releases and accompanying photographs were forwarded to the 1st Signal Brigade; many of these releases were printed in the Army Times, Stars and Stripes, Army Reporter and various other newspapers. The 160th Signal Group Information Officer personally directed and filmed 3 color motion picture hometown television releases, thereby establishing the Group as the first unit within the 1st Signal Brigade to have submitted filmed Hometown News Releases (HTNR). 129 radio tapes were prepared for Thanksgiving and Christmas stateside radio releases.

SCCPV-UG-OP

SUBJECT: Operational Report - Lessons Learned of 160th Signal Group for Period Ending 31 January 1969, RCS CSFOR-65(R1).

(b) 646 hometown news releases (DA Form 1526) were forwarded to 1st Signal Brigade, 195 in November 1968, 206 in December 1968, and 245 in January 1969.

(c) The quota assigned by the 1st Brigade for the reporting period was 807 HTNR's. During this period the Group filled 81% of its quota.

(7) Key personnel of the Group headquarters include:

(a) Commanding Officer - Colonel Richard W. Swenson.

(b) Deputy Commander - Lieutenant Colonel Stanley J. Duarte.

(c) S-1 Adjutant - Captain Glen E. Butcher.

(d) Operations Officer - Lieutenant Colonel Howard R. Sage.

(e) S-4 - Major William G. Mills.

(f) Plans and Training Officer - Captain Robert K. Matsumoto

(g) Chief, Systems Engineering and Control Office - Captain Douglas J. Behnke.

(h) Chief, Commcen Engineering and Analysis Office - Captain William J. Anderson.

(i) Telephone Management Officer - Major Jackie L. Manbeck.

(j) Command Sergeant Major - Sergeant Major James Ah Quin.

c. Operations. This section of the report is dividdd into areas of functional responsibility.

(1) Telephone Management.

(a) The following telephone communications facilities are operated by Group units at locations indicated:

<u>FACILITY</u>	<u>LOCATION</u>
Long Binh DTE (5000 Line Capacity)	Long Binh
MACV DTE (3000 Line Capacity)	Saigon (MACV HQS)

SCCPV-UG-OP

SUBJECT: Operational Report - Lessons Learned of 160th Signal Group for
Period Ending 31 January 1969, RCS CSFOR-65(R1).

<u>FACILITY</u>	<u>LOCATION</u>
Tiger DTE (2000 Line Capacity)	Saigon (MACV I)
Saigon LD Switchboard (660 Line Capacity)	Saigon (TSN AB)
MACV EAC (200 Line Capacity)	Saigon (MACV HQS)
USARV EAC (100 Line Capacity)	Long Binh (USARV HQS)

(b) Telephone System Projects included:

1 Installation and move of telephone systems for Headquarters, 1st Aviation Brigade; Headquarters, 506th Field Depot; Army Communication Operation Center, 1st Signal Brigade; Headquarters, 1st Logistical Command; USARV Tactical Operation Center; 972d Signal Battalion; Headquarters, USA Engineer Construction Agency; Headquarters, Vietnam Regional Exchanges; and cut-over to new cable facilities serving Headquarters of 1st Signal Brigade and the 44th Medical Brigade.

2 The Deer Dial Telephone Exchange was eliminated on 25 January 1969. This DTE served the Free World Military Assistance Organization (FWMAO) subscribers in and around the FWMAO compound, Saigon. Elimination was accomplished by converting the 145 Deer lines to Tiger DTE service and retermination of trunks on the Deer Switchboard to the Tiger DSA switchboard.

3 Expansion of the MACV Dial Telephone Exchange from 2000 to 3000 lines had been completed last quarter (12 October 1968). To further improve service, a redistribution of mainlines was accomplished during the period of 9 November 1968 to 14 December 1968. A total of 553 telephone numbers was changed to relieve the congested hundred groups in the original 2000 line plant.

4 Elimination of over 44,000 feet of unserviceable and abandoned cable and over 45,500 feet of spiral-four cable from the Saigon/Cholon area. The Saigon area has a very complex cable plant, which includes many old cables installed by the French, RVN civil and military agencies, and U.S. Government agencies. The removal of the old cables facilitates new construction and cable maintenance efforts; the program will continue for an indefinite period.

5 The percentage of class "A" service was reduced from 33% to 31.3%

SCCPV-UG-OP

SUBJECT: Operational Report - Lessons Learned of 160th Signal Group for
Period Ending 31 January 1969, RCS CSFOR-65(R1).

during the reporting period. This figure represents the overall percentage for Long Binh, MACV, and Tiger Dial Telephone Exchanges.

6 In November the first tandem switching center, Bang Pla, was activated. This has greatly improved service between Vietnam and Thailand subscribers.

7 Completion of the following cable construction projects:

<u>LOCATION</u>	<u>(PAIR) SIZE</u>	<u>(FEET) AMOUNT</u>
Free World Compound (Distribution, Saigon)	200 & 300	8,900
Tropo Scatter Radio Site (54th Artillery Gp, Long Binh)	50	2,700
U.S. Embassy (Distribution, Saigon)	100	1,400
1st Logistics Command Communications Center (Distribution, Long Binh)	25	300
2nd Signal Group Area (Distribution, Long Binh)	25, 50, 100	3,010
1st Aviation Brigade TOC (Distribution, Long Binh)	50	200
Microwave Site to IV Corps Tactical Operation Center (Tic Cable, Can Tho)	200	2,050
United States Army Vietnam Tactical Operations Center, Long Binh Park & EAC Frame (Distribution, Long Binh)	200 & 400	1,400
Joint U.S. Public Affairs Office I (JUSPAO) to JUSPAO II (Distribution, Saigon)	50	2,100
		<u>22,060</u>

8 Engineering completed on the following cable projects during the reporting period:

SCCPV-UG-OP

SUBJECT: Operational Report - Lessons Learned of 160th Signal Group for
Period Ending 31 January 1969, RCS CSFOR-65(R1).

<u>LOCATION</u>	<u>(PAIR) SIZE</u>	<u>(FEET) AMOUNT</u>
2nd Signal Group Area (Distribution, Long Binh)	25, 50, 100	3,010
1st Logistics Command Communications Center (Distribution, Long Binh)	25	300
MACV MDF to Site Octopus (Major VHF/MW/Tropo Site) (Tie, Saigon)	400	23,000
MACV MDF to AUTOSEVOCOM MDF (Tie, Saigon)	200	250
AUTOSEVOCOM (Distribution, Saigon)	25 & 50	12,000
USARV HQS Secure Voice (Distribution, Long Binh)	50	1,500
MACV DTE to Tiger DTE (Tie, Saigon)	100	23,000
Elimination of Tiger House Frame (Cross-connect point)(Saigon)		
Tiger DTE Area (Distribution, Saigon)	300	1,075
MACV DTE to Tiger DTE (Tie, Saigon)	400	21,000
JUSPAO and Old Brinks PX (Distribution, Saigon)	25	2,000
JGS Compound (Distribution, Saigon)	50	900
USAID I Area (Distribution, Saigon)	100	6,000
506th Field Depot (Distribution, Long Binh)	200	4,000

SCCPV-UG-OP

SUBJECT: Operational Report - Lessons Learned of 160th Signal Group for Period Ending 31 January 1969, RCS CSFOR-65(R1).

<u>LOCATION</u>	<u>(PAIR) SIZE</u>	<u>(FEET) AMOUNT</u>
Tiger DTE to USAID II (Distribution, Saigon)	25	2,900
1st Aviation Brigade TOC (Distribution, Long Binh)	50	200
Long Binh DTE to Long Binh Communications Center (Tie, Long Binh)	100	5,300
		<hr/>
		106,435

(2) Communication Center Engineering and Analysis.

(a) The second quarter ending 31 January was characterized by a decrease in all precedence categories of manual teletype traffic and a decrease in all precedence categories for manual data traffic. The decrease of manual teletype traffic was a result of the deactivation of the Saigon Area COMCEN (SACC) which had been accomplished late last quarter (15 October 1968), the Combined Intelligence Center's Vietnam Terminal (CICV) on 20 November 1968, and the TASE/MIBARS COMCEN on 17 January 1969. The volume of data traffic is expected to increase in the third quarter due to the increased usage of data to handle large volumes of statistical and logistical information. An increase in data traffic is also expected due to the implementation of magnetic tape data equipment at the Data Management Agency. No foreseeable problems are forecast at the present time from the further increase in data traffic.

(b) A comparison of manual teletype and data traffic are shown below:

MANUAL TELETYPE TRAFFIC

	<u>Send</u>	<u>Receive</u>	<u>Total</u>
Messages Previous Quarter	478,094	646,660	1,124,754
Messages This Quarter	408,134	535,083	943,217

MANUAL DATA TRAFFIC

Cards Previous Quarter	2,632,053	4,830,051	7,462,104
Cards This Quarter	2,316,777	4,256,578	6,573,355

SCCPV-UG-OP

SUBJECT: Operational Report - Lessons Learned of 160th Signal Group for .
Period Ending 31 January 1969, RCS CSFOR-65(R1).

(c) There was a considerable improvement this quarter in the message precedence assignment. There are still, however, quite a few high precedence messages containing unusually high group counts.

(d) The handling time for originate teletype traffic increased in all precedence categories from the previous quarter. This increase was affected through a change in reporting of message counts. The new reporting system has eliminated service messages, channel checks, quality control tests, multiple transmissions, and other COMMCEN control messages. These COMMCEN Control messages have been very short, and when these messages are included with other originate traffic totals, they substantially reduced handling times for report purposes. By eliminating these messages, a more accurate figure of handling times is obtained. Many high precedence messages that are originated at USARV and MACV Common User Communications Centers are multi-page, multi-section in length; these also contribute directly to higher handling times. Originate handling times should improve next quarter as a result of continuing operator and supervisory training within each facility.

(e) The handling time for terminated teletype traffic decreased for all precedence categories except for Flash which remained the same. The strong command emphasis that has been placed on using the AUTODIN system whenever possible, has helped reduce the terminate handling times.

(f) The service rate for the second quarter reflects an overall decrease. The improvement is attributed to increased command emphasis on preparing letter perfect originate tapes. There are still service messages being received from non-AUTODIN connected stations which should service their last relay and not the originating terminal. OIC notes are presently being sent to those stations that are servicing improperly. If this procedure does not cut down on the number of improper services, command action will be required.

(3) Systems Engineering & Control

(a) During the reporting period the VHF and the Pulse Code Modulation (PCM) carrier equipments formed four Defense Communications Systems (DCS) and eleven Corps Area Communications Systems (CACS) multichannel radio links. They were as follows:

<u>SYSTEM DESIGNATOR</u>	<u>TERMINAL LOCATIONS</u>
77UHM4	Long Binh - Saigon
77UHP6	Tan Son Nhut - Dian

SCCPV-UG-OP

SUBJECT: Operational Report - Lessons Learned of 160th Signal Group for
Period Ending 31 January 1969, RCS CSFOR-65(R1).

SYSTEM DESIGNATOR

TERMINAL LOCATIONS

77UH1G	Tan Son Nhut - Cu Chi
77UH17	Saigon - Nha Be
CAW19	Tan Son Nhut - Cu Chi
CAW39	Tan Son Nhut - Dian
CAW40	Long Binh - Phu Loi
CAW41	Saigon - Nha Be
CAW42	Long Binh - Long Thanh North
CAW46	Long Binh - Bien Hoa
CCA24	Gia Dinh - Long Binh
CCA25	Gia Dinh - Long Binh
CCA28	Gia Dinh - Long Binh
CCA26	Gia Dinh - Saigon Port
CCA50	Tan Son Nhut - Blair House

(b) There were two cable carrier Corps Area Communications Systems using PCM equipment:

SYSTEM DESIGNATOR

TERMINAL LOCATIONS

CAR20	Long Binh - Plantation
CAR21	Long Binh - Plantation

(c) There were two DCS and seven CACS microwave (AN/TRC-29) systems in operation providing the following radio links:

SYSTEM DESIGNATOR

TERMINAL LOCATIONS

77UMG3	Long binh - Tan Son Nhut
77UM4T	Long Binh - Gia Dinh

SCCFV-UG-OP

SUBJECT: Operational Report - Lessons Learned of 160th Signal Group for
Period Ending 31 January 1969, RCS CSFOR-65(R1).

<u>SYSTEM DESIGNATOR</u>	<u>TERMINAL LOCATIONS</u>
CAM90	Long Binh - Lai Khe
CAM91	Long Binh - Bien Hoa
CAM92	Long Binh - Long Thanh North
CAM94	Long binh - Dian
CCM95	Long Binh - Gia Dinh
CCM97	Long Binh - Gia Dinh
CCM99	Long Binh - Saigon

(d) The three DCS and one CACS SHF tropospheric scatter systems in operation were as follows:

<u>SYSTEM DESIGNATOR</u>	<u>TERMINAL LOCATIONS</u>
77UT2Y	Tan Son Nhut - Can Tho
77UT73	Tan Son Nhut - Lang Bien Mt
77UT89	Tan Son Nhut - Pr Line
CAT02	Long Binh - Dong Tam

(e) No defense Communications Systems (DCS) were in operation using AN/TCC-7 carrier equipment.

(f) Six AN/GRC-10 radios were committed to provide minimum essential communications as follows:

<u>SYSTEM DESIGNATOR</u>	<u>TERMINAL LOCATIONS</u>
CCH37	Long Binh - Sigma (Thu Duc)
CCH41	JGS Compound - Hqs MACV
CCH47	Long Binh - Cat Lai

(g) Two radio systems (AN/MRC-69) from the Free World Forces Compound in Cholon-Saigon to MACV Saigon were in operation as follows:

SCCPV-UG-OF

SUBJECT: Operational Report - Lessons Learned of 160th Signal Group for Period Ending 31 January 1969, RCS CSFOR-65(R1).

SYSTEM DESIGNATOR

TERMINAL LOCATIONS

CCH45

Free World Forces - Hqs MACV

CCH46

Free World Forces - Hqs MACV

(h) During the period 1 November to 31 January, 1116 circuit engineering orders were processed; 895 were for DCS and 221 were for CACS circuits.

(i) During December, elements of the 160th Signal Group were tasked to provide communications support for Operation Holly, the Bob Hope Show. In addition to renovating the speaker system at the show site, the 160th coordinated the activation of several circuits to be used throughout Mr. Hope's visit to Vietnam.

(j) Also during December 1968 and January 1969, elements of the 160th Signal Group, in conjunction with the 2nd Signal Group, provided signal support for operation "Chicago Fire". This involved the installation and operation of stations in the MACV Command HF RATT and MACV Command SSB nets.

(k) Control of the Long Binh terminals of the microwave systems listed in paragraph (c) and the tropospheric scatter systems listed in paragraph (d) came under the operational control of the 160th Signal Group on 1 Nov 68. The 77UHM4T system between Long Binh and MACV Hqs was deactivated on 23 Jan 69.

(4) Pictorial Operations: Special photographic projects of dignitaries visiting Vietnam during this reporting period included:

(a) Still and motion picture coverage of Operation Holly, 15 December 1968 - 2 January 1969. Approximately 16,800 feet of MOPIC was shot of Bob Hope and his supporting cast.

(b) Still and motion picture coverage of General James Woolnough, CG CONARC, during his inspection tour of military installations.

(c) Still and motion picture coverage of Reverend Billy Graham and Archbishop Terrence Cooke during their visits to Long Binh on Christmas Day 1968.

(d) Still and motion picture coverage of the release of three American prisoners of war by the Viet Cong on 1 Jan 1969 to a team of selected American officers. A representative from SEAPC was the official Army photographer for this event. Photographs and motion picture footage

SCCPV-UG-OP

SUBJECT: Operational Report - Lessons Learned of 160th Signal Group for Period Ending 31 January 1969, RCS CSFOR-65(R1).

taken during the event were available to all news media within hours through official USARV and MACV channels. The motion picture footage was forwarded to DA the same day, and the still photographs the following day after local requirements had been met.

d. Training.

(1) In a continuing effort to maintain improved training programs throughout the Group, eighteen training inspections of subordinate units were conducted by Group Headquarters personnel during the reporting period.

(2) Personnel of this Group participated in the following training programs:

(a) Enlisted personnel successfully completed the following courses conducted at the US Army Training Facility (USATF) - 1st Signal Brigade (USASTRATCOM): AN/TRC-110/117 Operators Course - 7; Cable Splicers Course - 14; Teletype Circuit Restoral Course - 8; Technical Facility Controller Course - 1.

(b) Eleven EM received projectionist licenses after having completed a course of instruction on the 16 mm projector conducted by the Southeast Asia Pictorial Center at Long Binh and Tan Son Nhut.

(c) Seven PLL (Prescribed Load List) clerks and one officer attended three separate PLL training courses.

(d) Training for Group officers and warrant officers with less than five years active commissioned/warrant service was conducted on a consolidated basis at Group level. Group officers in the Long Binh area participated in the program. Those Group officers stationed in the Saigon area were invited to participate. Subjects presented included: Officer Efficiency Reports, I.G. Inspections, Generator and Motor Maintenance, and Material Readiness. In addition, monthly classes for applicable officers are conducted by subordinate battalions on relevant mission - essential topics.

(e) Weekly NCO Training classes for E-5s and E-6s with less than fifteen years service continued during the reporting period and covered a wide range of topics including: Enlisted Efficiency Reports, Property Accountability, and Requisitioning.

(f) An extensive formal and informal on-the-job training program continued throughout the reporting period in order to provide training in

SCCPV-UG-OP

SUBJECT: Operational Report - Lessons Learned, of 160th Signal Group for Period Ending 31 January 1969, RCS CSFOR-65(R1).

depth and/or cross training in related MOS's where critical MOS shortages exist. Personnel received formal on-the-job training in the following MOSs: 31E, 31J, 31L, 31M, 31S, 32D, 32F, 32G, 34C, 36C, 36E, 41E, 41F, 52B, 63B, 71B, 72B, 72C, 76L, 76U and 84G.

(g) Two NCOs attended a two day artillery observer course conducted by Headquarters, Long Binh Post.

(h) Two NCOs attended a seven week Automatic Multiple Addressee Routing System (AMARS) training program held at Phu Lam, RVN.

(i) Eight EM attended an orientation on the IBM 360/20 presented in Long Binh by Mr. Bill Shuty, an IBM technical representative.

(3) There are two major training problem areas:

(a) Although Group sites in Long Binh and Saigon have IBM 360/20 equipment, replacement personnel are arriving in-country lacking proper training on this equipment. 72B personnel have been receiving on-the-job training, in as much as functional training on this equipment is not presently provided.

(b) Warrant officers, MCS 721A, and enlisted personnel, MOS 72B, often are not fully qualified, as required by AR 380-41, in COMSEC accounting due to inadequate training and experience. There is no formal schooling available for Communications Security (COMSEC) accountants. Moreover, in CONUS, 72B personnel receive only a brief orientation on COMSEC accounting during their formal MOS schooling; and, warrant officers from Naval and Air Force enlisted ranks often have had no prior experience in COMSEC accounting.

(4) US Army Training Facility operations:

(a) Fourteen (14) different courses were conducted during this reporting period. These fourteen courses produced a total of eight hundred and forty (840) students.

(b) Curriculum courses are currently: Cable Splicer, AN/GRC-106 Operator and Maintenance, Pulse Code Modulation (PCM) (AN/TRC-110/117 - AN/GRC-50) Operator, AN/GRC-163 O&M, VHF/Carrier (AN/TRC-24) Operator, AN/GRC-50 Maintenance, Cryptographic Maintenance (KL-7, KW-7) Radar (AN-PPS-5) Operator and Maintenance, Switchboard Operator, Teletype Circuit Restoral, Technical Control, Telephone Key Systems Maintenance and AUTODIN Mode V Maintenance courses.

SCCPV-UG-OP

SUBJECT: Operational Report - Lessons Learned of 160th Signal Group for Period Ending 31 January 1969, RCS CSFOR-65(R1).

e. Intelligence:

(1) Group units continued tactical defense of their installations and facilities throughout the Republic of Vietnam.

(2) There were no enemy initiated incidents involving personnel of the Group.

(3) No major equipment damages were reported.

(4) A renewed effort by the Group units in searching Local National hires before and just prior to leaving the area has helped to avoid any attempts at sabotage.

f. Logistics:

(1) The Group continued its beautification and revetment program at Camp Gerry. A covered walkway was constructed between the command building and the SYSCON building. Revetments were built around four BOQ buildings. Two existing revetments around BOQ buildings were rebuilt.

(2) The Group continued its dust control project by using an oil base peneprime solution on highly traveled areas such as motor pools, PX area, and roadways to reduce the dust.

g. Organization. Assignment of Group units is as outlined in USASTRAFCOM General Orders (GO) 158, dated 17 Sep 1968; 241, dated 19 Nov 1968, and 1st Signal Brigade General Orders 164, dated 12 May 1967; 294, dated 12 Aug 1967; and 676, dated 22 Aug 1968.

(1) Only one US Army Strategic Communications Command General Order (GO) was received by this headquarters during the reporting period. GO 241, 19 Nov 68, activated the 1st Signal Center (COMSEC Logistic Support) and deactivated the 49th, 213th, 446th, 455th, and 786th Signal Detachments. The mission of the 1st Signal Center (COMSEC Logistics Support) is to provide communications security, logistics support to Headquarters, USMACV: US Army Forces in Vietnam; and other forces under the provisions of AR 380-10 when directed by COMUSMACV.

(2) The following is a list of assigned and attached units:

(a) Assigned:

1 40th Signal Battalion (Construction)

2 44th Signal Battalion

SCCPV-UG-OP

SUBJECT: Operational Report - Lessons Learned of 160th Signal Group for
Period Ending 31 January 1969, RCS CSFOR-65(R1).

3 69th Signal Battalion

4 1st Signal Center (COMSEC Logistics Support)

5 Southeast Asia Pictorial Center

6 United States Army Training Facility - 1st Signal Brigade (USASTRATCOM)

7 221st Signal Company (Pictorial)

(b) Attached:

1 Cryptologistics Section, 53d General Support Group (per 1st Signal
Brigade General Order 302, dated 16 August 1967).

2 Cryptologistics Section, 80th General Support Group (per 1st
Signal Brigade General Order 302, dated 16 August 1967).

h. Ground Defense:

(1) The Group Commander continued to serve as Sector Commander of one of the four major subdivisions of Long Binh Post (LBP) for ground defense planning and control. Sector units continued to perform their assigned ground defense mission in an effective and efficient manner.

(2) The 160th Signal Group Sector, which covers approximately five square miles is subdivided into five sub-sectors. Command and control of sub-sector units is exercised through both FM radio and land line communication. Each sub-sector maintains a 50 man mobile reaction force which is capable of performing blocking or reinforcing missions. In addition, the Sector has five platoon size blocking forces dedicated to occupying and holding designated areas within the Sector. Forward observer training was conducted in December for all sub-sector units in order to have trained personnel readily available to call in and direct artillery so as to destroy the enemy forward of the LBP perimeter.

2. Section II, Lessons Learned: Commander's Observation, Evaluation, and Recommendations.

a. Personnel: None

b. Operations:

SCCPV-UG-OP

SUBJECT: Operations Report - Lessons Learned of 160th Signal Group for
Period Ending 31 January 1969, RCS USFOR-65(R1).

(1) Automated Cable Records for Restoral.

(a) Observation: The problem of restoring critical communications in a major cable outage could be expedited if a current listing of the priority circuits and their corresponding cable pairs is readily available to System/Circuit Technical Control Centers.

(b) Evaluation: Down time on critical circuits from damaged cable can be minimized if an accurate reference to pairs in use is available to the circuit control agencies as a guide for priority restorals. Instances have occurred in which such a list has allowed restoration priorities (i.e., immediate restoral, alternate routing, or scheduled restorals) to be initiated without jeopardizing mission requirements; consequently, extensive critical circuit outages have been prevented and circuit control has been maintained. Such a list can be produced in several copies and easily updated using a data machine's capability to "print-out" cable pairs and their corresponding usage.

(c) Recommendation: Automated cable records should be established to provide more efficient and responsive circuit restoral procedures.

(2) Radio dispatch:

(a) Observation: Desirability of radio dispatch control of Telephone Installation and Repair Teams in metropolitan areas, as in Saigon, and large installations.

(b) Evaluation: The wide dispersion of telephone plant and communication sites in unfamiliar metropolitan areas, such as the Saigon/Cholon complex and large geographical areas create problems in controlling the operating teams. Changes in primary tasks, delays, and rescheduling of teams result in inefficient utilization of materials and personnel; consequently, continuous changes in situations result in excessive work back-log, duplication of effort and inadequate control of the repair teams. Versatility and maneuverability of the repair teams are required to meet fluctuating critical communication requirements. In addition, during periods of increased enemy activity, movement of personnel is restricted, often for extended periods, and dispatches are subject to cancellation or reschedule based upon the extent of enemy activity. This can only be realized if the Installation and Repair Teams are radio controlled.

(c) Recommendation: Telephone Installation and Repair Teams be provided with radio dispatch control in unfamiliar metropolitan areas and large installations to ensure reasonably efficient utilization of limited resources and to provide timely response to changes in mission requirements.

SCCPV-UG-OP

SUBJECT: Operations Report - Lessons Learned of 160th Signal Group for
Period Ending 31 January 1969, RCS CSFOR-65(R1).

(3) MOS For Installation and Repair

(a) Observation: Telephone installation and repair personnel, key-set repairmen, as well as the ordinary pole lineman are identified by the 36C MOS. Consequently, it is impossible to properly allocate qualified personnel to meet the varied field unit requirements.

(b) Evaluation: In an effort to upgrade mission performance, all available personnel must be properly utilized. It has been noted that qualified personnel have been relegated to perfunctory duties such as making cross-connects or filling out records and reports. It is essential that the limited number of qualified personnel available in Vietnam, who are trained and experienced, be properly screened and assigned. The single 36C MOS description does not properly identify the separate skill groups within the rating; consequently, assignment to field units is often not reflective of the actual requirement.

(c) Recommendation: That the 36C MOS be re-evaluated, and new categories be established to separate installation and repair personnel and key-set repairmen from the ordinary pole linemen. An addition to the existing 36C MOS is needed to properly assign and monitor skill development of these different categories.

c. Training.

(1) Non-associated MOS's at USATF

(a) Observation: Increasing numbers of student personnel at USATF arrive for schooling possessing non-associated MOS's.

(b) Evaluation: Although many of the students have demonstrated a sincere desire to learn and put in a tremendous effort to acquire new skills, they are at a disadvantage from the start. These personnel in unrelated MOS's generally fall behind and are dismissed from the course. Every conceivable effort is made to train these personnel to include special assistance, homework, study hall, and counselling sessions.

(c) Recommendation: Increased emphasis at all command levels to stress course pre-requisites at interviews with potential students prior to their enrollment will help alleviate this problem.

d. Intelligence: None

e. Logistics: None

SCCPV-UG-OP

SUBJECT: Operations Report - Lessons Learned of 160th Signal Group for
Period Ending 31 January 1969, RCS CSFOR-65(R1).

- f. Organization: None
- g. Escape, Evasion, and Survival: None
- h. Other: None

1 Incl



RICHARD W. SWENSON
COL, SigC
Commanding

DISTRIBUTION:

- 9 - CG, 1st Sig Bde
- 3 - CG, USARV ATTN: AVHGC-DST APO 96375
- 2 - CINCUSARPAC ATTN: GOP-DT APO 96558
- 1 - CG USASTRATCOM-PAC SCHOFIELD BRKS APO 96557

SCCPV-OP-CC (15 Feb 69) 1st Ind
SUBJECT: Operational Report - Lessons Learned of 160th Signal Group
For Period Ending 31 January 1969, RCS CSFOR-05 (RI)

DA, HQ, 1st Signal Brigade (USARV REGO.), APO 96384 28 February 1969.

TO: Commanding Officer, United States Army Vietnam, AVICC-BST,
APO 96375

1. Subject report is forwarded in accordance with USARV Regulation 525-15.

2. The report has been reviewed by this headquarters and is concurred in with the following comments and/or exceptions concerning referenced paragraphs.

a. Paragraph 1c(3)(b), p.14. Warrant officers, MOS 721A appointed from Army enlisted ranks are qualified in CO.SEC accounting. However, concur in the remainder of this paragraph.

b. Paragraphs 1c(2)(b) 1 and 2, p.16. The establishment of the 1st Signal Center (CO.SEC Logistics Support) was contingent upon use of spaces in the two units mentioned in referenced paragraphs. Therefore, as of the date of establishment of the 1st Signal Center by USARV REGO General Order 241, dated 19 November 1968, these units ceased to exist. A Brigade general order to this effect will be published.

c. Paragraph 2b(1), p.17. Automation of cable records is an area which is very worthy of consideration and is being investigated for implementation in Vietnam by this headquarters. If there is sufficient demand in Vietnam for such a system, it will be incorporated into the Brigade Data Automation Request (DAR).

d. Paragraph 2b(3), p.18. The evaluation of the 36C MOS is a CONARC/DA responsibility and cannot be accomplished at this level. This headquarters however, does recommend that the problems stated in this paragraph be studied by CONARC/DA to see if solutions are necessary. It should additionally be noted that the duty description of a 36C does not include key set telephone installation and repair and that these personnel are required to perform these duties since theirs is the most closely associated MOS. A course in the maintenance of this set is, however, carried on at the United States Army Signal Training Facility in Vietnam.

e. Paragraph 2c(1), p.18. Command action has been initiated on this problem. It has been discussed at the 1st Signal Brigade Commander's Conference, USARV Signal Officers Conference, and by 1st Signal Brigade letter, dated 14 February 1969, Subject: "Unqualified or Improperly Equipped Students" which has been sent to all major and subordinate com-

SCCRV-OF-CC

28 February 1969

SUBJECT: Operational Report - Lessons Learned of 160th Signal Group
for Period Ending 31 January 1969, MCS CSFGA-65 (RI)

mands who utilize the United States Army Signal Training Facility in
Vietnam.

FOR THE COMMANDER:

1 Incl
160th Sig Gp Org Diagram

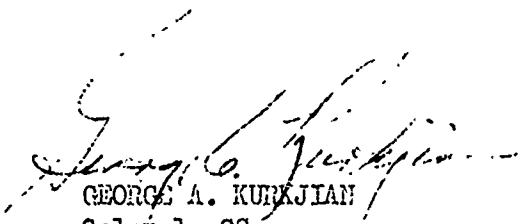
GEORGE A. KURKJIAN
Colonel, GS
Chief of Staff

CF:
Assistant Chief of Staff for Force Development, Department of the Army,
Washington D.C. 20310
Commanding General, United States Army Strategic Communications Command,
ATTC: SCC-GS-PM, Fort Huachuca, Arizona 85613
Commanding Officer, 160th Signal Group, AFO 96491

AVHGC-DST (15 Feb 69) 2d Ind
SUBJECT: Operational Report-Lessons Learned of 160th Signal Group
for Period Ending 31 January 1969, RCS CSFOR-65 (R1)

HEADQUARTERS, UNITED STATES ARMY, VIETNAM, APO San Francisco 96375 **19 MAR 1969**

THRU: Commanding General, United States Army, STRATCOM-PAC, APO 96557

TO: Commander in Chief, United States Army, Pacific, ATTN: GPOP-DT,
APO 96558

1. This headquarters has reviewed the Operational Report-Lessons Learned for the quarterly period ending 31 January 1969 from Headquarters, 160th Signal Group.

2. Comments follow:

a. Reference item concerning Radio dispatch, page 17, paragraph 2b(2); concur. The 1st Signal Brigade is preparing a Purchase Request and Contract for a system to be used in the Saigon area.

b. Reference item concerning MOS For Installation and Repair, page 18, paragraph 2b(3), and 1st Indorsement, paragraph 2d. Concur in unit recommendation and comments contained in 1st Indorsement, that an evaluation of the 36C MOS be conducted at CONARC/DA.

FOR THE COMMANDER:

Cy furn:
160th Sig Gp
1st Sig Bde

W. C. ARNTZ
CPT, AGC
Assistant Adjutant General

SCCP-OP (15 Feb 69) 3rd Ind

SUBJECT: Operational Report - Lessons Learned of 160th Signal Group for
Period Ending 31 January 1969

Headquarters, U. S. Army Strategic Communications Command-Pacific, APO
San Francisco 96557 JUL 25 1969

TO: Commander in Chief, United States Army, Pacific, ATTN: GPOP-DT,
APO 96558

1. Subject report is forwarded in accordance with AR 525-15.
2. This headquarters has reviewed and concurs with subject report as indorsed.

FOR THE COMMANDER:



FRANK C. MAHIN
Colonel, GS
Chief of Staff

GPOP-DT (15 Feb 69) 4th Ind
SUBJECT: Operational Report of HQ, 160th Sig Gp for Period
Ending 31 January 1969, RCS CSFOR-65 (R1)

HQ, US Army, Pacific, APO San Francisco 96558 4 AUG 69

TO: Assistant Chief of Staff for Force Development,
Department of the Army, Washington, D. C. 20310

This headquarters has evaluated subject report and forward-
ing indorsements and concurs in the report as indorsed.

FOR THE COMMANDER IN CHIEF:

D. A. TUCKER
CPT. AGC
ASST AG

160TH SIGNAL GROUP

MISSION: TO PROVIDE COMMUNICATIONS ELECTRONICS SUPPORT TO HEADQUARTERS MACV, HEADQUARTERS USARV, AND OTHER MAJOR HEADQUARTERS IN THE SAIGON/CHOLON AND LONG BINH COMPLEX, AND OTHER SPECIAL SIGNAL AND PICTORIAL SUPPORT ON A COUNTRY-WIDE BASIS.

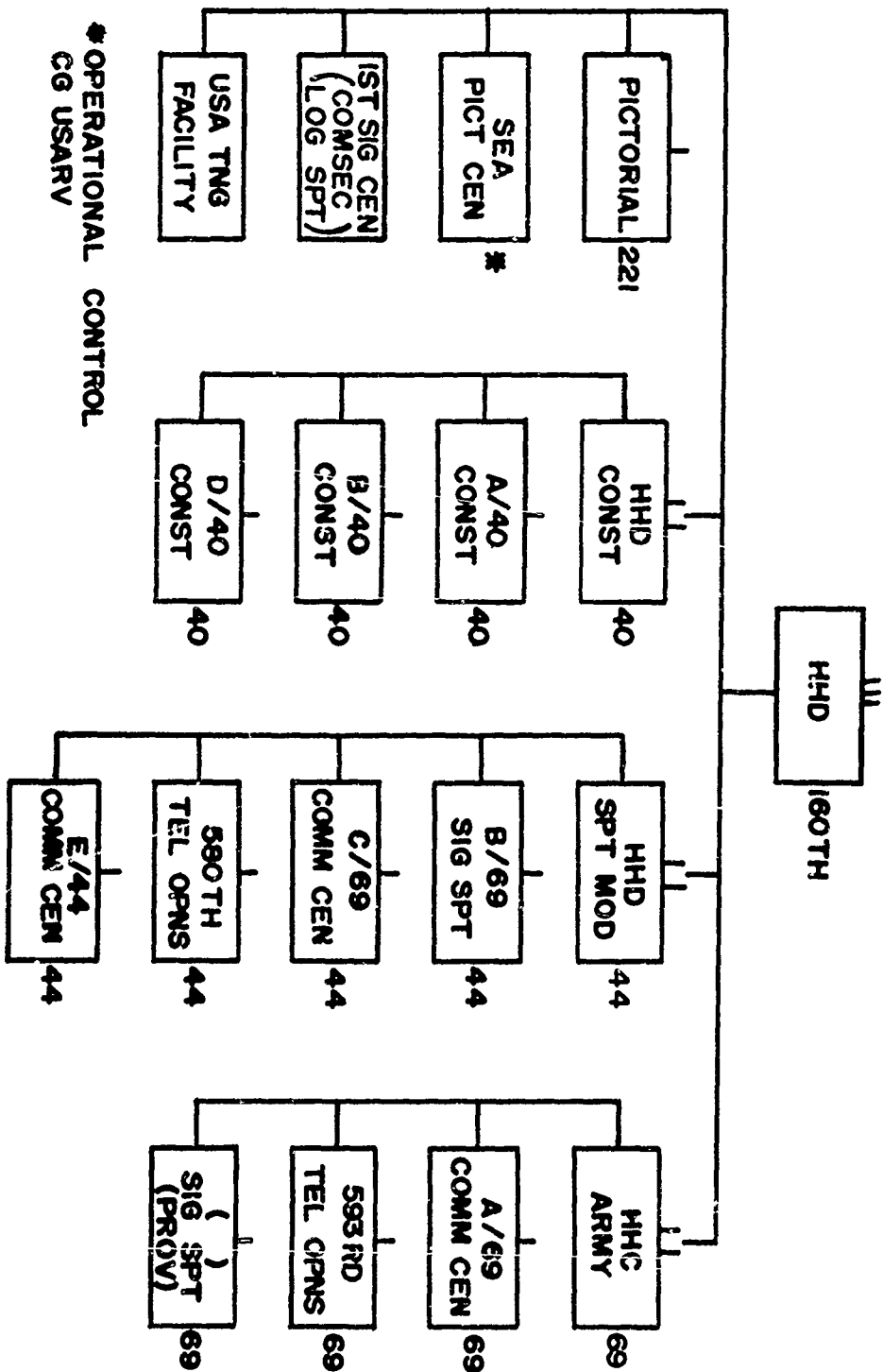

Inclosure 1'

UNCLASSIFIED

Security Classification

DOCUMENT CONTROL DATA - R & D

(Security classification of title, body of abstract and indexing annotation must be entered when the overall report is classified)

1. ORIGINATING ACTIVITY (Corporate author) HQ, OACSFOR, DA, Washington, D. C. 20310		2a. REPORT SECURITY CLASSIFICATION UNCLASSIFIED	
		2b. GROUP	
3. REPORT TITLE Operational Report - Lessons Learned, Hq, 160th Signal Group			
4. DESCRIPTIVE NOTES (Type of report and inclusive dates) Experiences of unit engaged in counterinsurgency operations, 1 Nov 68 to 31 Jan 69.			
5. AUTHOR(S) (First name, middle initial, last name) CO, 160th Signal Group			
6. REPORT DATE 15 February 1969		7a. TOTAL NO. OF PAGES 28	7b. NO. OF REFS
8a. CONTRACT OR GRANT NO.		9a. ORIGINATOR'S REPORT NUMBER(S) 691256	
b. PROJECT NO.		9b. OTHER REPORT NO(S) (Any other numbers that may be assigned this report)	
c. N/A			
d.			
10. DISTRIBUTION STATEMENT			
11. SUPPLEMENTARY NOTES N/A		12. SPONSORING MILITARY ACTIVITY OACSFOR, DA, Washington, D.C 20310	
13. ABSTRACT			