

UNCLASSIFIED

AD NUMBER
AD855582
NEW LIMITATION CHANGE
TO Approved for public release, distribution unlimited
FROM Distribution authorized to U.S. Gov't. agencies and their contractors; Critical Technology; 22 DEC 1969. Other requests shall be referred to Air Force Human Resources Laboratory, ATTN: HRT, Wright-Patterson AFB, OH 45433.
AUTHORITY
AFHRL ltr dtd 2 Aug 1971

THIS PAGE IS UNCLASSIFIED

AD855582



**FLIGHT SIMULATORS  
A REVIEW OF THE RESEARCH AND  
DEVELOPMENT**

*HORACE H. VALVERDE*

JULY 1966

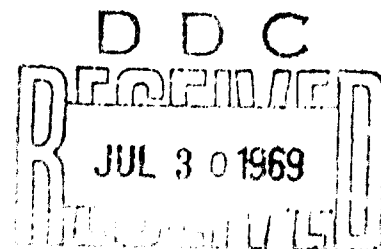

This document is subject to special export controls and each transmittal to foreign governments or foreign nationals may be made only with prior approval of Aerospace Medical Research Laboratories, Wright-Patterson Air Force Base, Ohio 45433.

AEROSPACE MEDICAL RESEARCH LABORATORY  
AEROSPACE MEDICAL DIVISION  
AIR FORCE SYSTEMS COMMAND  
WRIGHT-PATTERSON AIR FORCE BASE, OHIO

ACCESSION NO.	
CFSTI	SECTION <input type="checkbox"/>
DDC	SECTION <input checked="" type="checkbox"/>
UNANNOUNCED	<input type="checkbox"/>
JUSTIFICATION:	
BY	
DISTRIBUTION/AVAILABILITY CODES	
DATE	AVAILABILITY
2	

## NOTICES

When US Government drawings, specifications, or other data are used for any purpose other than a definitely related Government procurement operation, the Government thereby incurs no responsibility nor any obligation whatsoever, and the fact that the Government may have formulated, furnished, or in any way supplied the said drawings, specifications, or other data, is not to be regarded by implication or otherwise, as in any manner licensing the holder or any other person or corporation, or conveying any rights or permission to manufacture, use, or sell any patented invention that may in any way be related thereto.

Federal Government agencies and their contractors registered with Defense Documentation Center (DDC) should direct requests for copies of this report to:

DDC  
Cameron Station  
Alexandria, Virginia 22314

Non-DDC users may purchase copies of this report from:

Chief, Storage and Dissemination Section  
Clearinghouse for Federal Scientific & Technical Information (CFSTI)  
Sills Building  
5285 Port Royal Road  
Springfield, Virginia 22151

Organizations and individuals receiving reports via the Aerospace Medical Research Laboratories' automatic mailing lists should submit the addressograph plate stamp on the report envelope or refer to the code number when corresponding about change of address or cancellation.

Do not return this copy. Retain or destroy.

ERRATA - July 1969

The following corrections apply to Technical Report No. AMRL-TR-68-97, Flight Simulators—A Review of the Research and Development.

Page 16

The two figures are reversed; therefore, reverse the titles, including figure numbers; i. e., change "Figure 14. Computer Generated Geometrical Patterns" to read "Figure 15. Link All-Electronic Night-Landing Display" and change "Figure 15. Link All-Electronic Night-Landing Display" to read "Figure 14. Computer Generated Geometrical Patterns."

Page 24

In title for figure 25, change "SMK-22" to read "SMK-23."

AEROSPACE MEDICAL RESEARCH LABORATORY  
AEROSPACE MEDICAL DIVISION  
AIR FORCE SYSTEMS COMMAND  
WRIGHT-PATTERSON AIR FORCE BASE, OHIO

AMRL-TR-68-97

**FLIGHT SIMULATORS  
A REVIEW OF THE RESEARCH AND  
DEVELOPMENT**

*HORACE H. VALVERDE*

This document is subject to special export controls and each transmittal to foreign governments or foreign nationals may be made only with prior approval of Aerospace Medical Research Laboratories, Wright-Patterson Air Force Base, Ohio 45433.

## Foreword

This study was initiated by the Behavioral Sciences Laboratory of the Aerospace Medical Research Laboratories, Aerospace Medical Division, Wright-Patterson Air Force Base, Ohio. The work was performed as in-house research in support of Project 1710, "Human Factors in the Design of Training Systems," and Task 171003, "Human Factors in the Design of Systems for Operator Training and Evaluation." Dr. Gordon A. Eckstrand, Chief of the Training Research Division, was the Project Scientist. Dr. Donald E. Meyer, Chief of the Operator Training Branch, was the Task Scientist. The research reported herein was begun in October 1967 and was completed in March 1968.

The author acknowledges the technical guidance of Mr. A. T. Gill of the Simulation Techniques Branch, Behavioral Sciences Laboratory, and Mr. R. J. Heintzman of the Flight Simulator Branch, Systems Engineering Group, in the preparation of the visual simulation portion of Section II. Acknowledgments is also made of the consultation provided by Mr. Carl F. McNulty and Mr. Don Gum of the Simulation Techniques Branch, Behavioral Sciences Laboratory, in the preparation of Section V, Computers. The valuable contributions to this study by Mr. J. J. O'Connell, Link Group, General Precision Systems, Inc., and Mr. E. L. Noonan, Curtis-Wright Corp., are appreciated.

This technical report has been reviewed and is approved.

C. H. KRATOCHVIL, Colonel, USAF, MC  
Commander  
Aerospace Medical Research Laboratories

## **Abstract**

This report presents a general review of the research and development of flight simulators and related areas sponsored by military and other government agencies since 1949. The use of simulators for flight training is emphasized. The report does not consider mathematical models and space flight simulators. The topics include: (1) Visual and Motion Simulation, (2) Transfer of Training, (3) Utilization and Evaluation, and (4) Computers. An annotated bibliography of unclassified technical reports reviewed is included for each of the topics. The Defense Documentation Center accession number for each report is provided to facilitate the acquisition of microfilm copies of desired documents by United States military and other government agencies.

## Table of Contents

<i>Section</i>	<i>Page</i>
I. INTRODUCTION.....	1
Background.....	1
Definition.....	4
The Annotated Bibliography.....	7
II. VISUAL AND MOTION SIMULATION.....	10
Introduction.....	10
Visual Simulation.....	11
Visual Systems.....	12
Image Storage.....	13
Model System.....	13
Film System.....	14
Transparency System.....	14
Computer Systems.....	15
Image Pickup.....	15
Optical Probe.....	17
The Point Light Source Projection System.....	17
Flying Spot Scanner.....	17
Image Relay.....	17
Image Display.....	18
The Light Valve Projector.....	19
The Schmidt Projector.....	19
The Refractive Projector.....	19
Projection Screens.....	19
Visual Simulation Studies.....	19
Motion Simulation.....	26
Motion Simulation Studies.....	27
Conclusions.....	30
Annotated Bibliography – Visual and Motion Simulation.....	32



## Table of Contents--(continued)

<i>Section</i>	<i>Page</i>
<b>III. TRANSFER OF TRAINING.....</b>	<b>60</b>
Introduction.....	60
Synthetic Trainers Versus Operational Equipment.....	60
The Problem of Individual Differences.....	61
The Presumed Value of Flight Trainers.....	63
Conclusions.....	71
The Criterion Measure.....	71
The Subjects.....	71
The Instructor.....	71
The Instructional Sequence.....	72
Annotated Bibliography -- Transfer of Training.....	72
<b>IV. UTILIZATION AND EVALUATION.....</b>	<b>84</b>
Introduction.....	84
Utilization.....	84
Evaluation.....	86
Conclusions.....	87
Annotated Bibliography -- Utilization and Evaluation.....	88
<b>V. FLIGHT SIMULATOR COMPUTERS.....</b>	<b>110</b>
Introduction.....	110
Analog Computers.....	110
Digital Computers.....	111
Hybrid Simulation.....	112
Analog.....	112
Digital.....	112
Future Developments.....	113
Conclusions.....	113
Annotated Bibliography -- Flight Simulator Computers.....	114
<b>APPENDIXES</b>	
Appendix I -- Visual Information Requirements for Flight Tasks.....	126
Appendix II -- Flight Training Simulators.....	129

## List of Figures

<i>Figure</i>	<i>Page</i>
1. The Sanders Teacher (Flight Trainer).....	2
2. The Eardly-Billings Oscillator (Flight Trainer).....	2
3. The First Link Trainer.....	3
4. A Small Special-Purpose Research Simulator.....	5
5. An Aircraft Systems Engineering Test Simulator (F-111A).....	6
6. The Link T-4 Trainer (T-37) Used in the Air Training Command Undergraduate Pilot Training Program.....	6
7. The Link T-7 Trainer (T-38) Used in the Air Training Command Undergraduate Pilot Training Program.....	7
8. Conductron Cockpit Flight Training Simulator (C-5 Cargo Transport).....	8
9. Diagram of Flight Simulator with Visual and Motion Simulation.....	11
10. Aircraft Attitudes.....	12
11. The Visual System.....	13
12. Three-Dimensional Model and Optical Probe.....	14
13. Link Variable Anamorphic Motion Picture (VAMP) System.....	15
14. Computer Generated Geometrical Patterns.....	16
15. Link All-Electronic Night-Landing Display.....	16
16. Physical Configuration of a Bead Lens Optical Probe.....	17
17. Schematic of a Point Light Source.....	18
18. The Light Valve Projector.....	19
19. The Schmidt Projector.....	20
20. The Projectors and Translucent Screen (Ref. 5).....	21
21. Link Trainer 1-CA-2 SNJ (P-1) with Cyclorama.....	21
22. The Runway Image (Ref. 101).....	22
23. Plan View of Trainer Room Showing Location of Projection Mechanism, Screen, and SNJ Link Trainer.....	23
24. An All-Optical, Color Television Visual Simulation (Refs. 13, 14).....	23
25. Composite View of the SMK-22 Attachment Showing Front and Rear Projection.....	24

## List of Figures—(continued)

<i>Figure</i>	<i>Page</i>
26. The C-135 Flight Simulator with the SMK-23 Visual Attachment.....	25
27. Visual Simulator Trainer Attachment, Type SMK-43/F37A-T, Typical Installation.....	25
28. Navy Basic Instrument Trainer, Link 1-CA-1 (Nav BIT).....	27
29. Motion Platform Configuration Isometric.....	28
30. The Link Trainer, ME-1.....	29
31. Human Centrifuge – Aerospace Medical Research Laboratories.....	30
32. The Dynamic Escape Centrifuge – Aerospace Medical Research Laboratories.....	31
33. Layout of General Purpose Airborne Simulator Systems.....	31
34. Factors to be Considered in the Design of a Visual Device.....	32
35. Degree of Simulation of Trainer to Cost and Transfer of Training Value.....	61
36. The Link Trainer, AN-T-18.....	78
37. The Link Trainer, C-8.....	63
38. The Link Trainer, C-11.....	66
39. The Link B-47 Simulator.....	68
40. The Curtiss-Wright B-50 Simulator.....	85
41. Typical Flight Simulator Block Diagram.....	110
42. The UDOFT System.....	111
43. B-47E Flight Simulator (S-6A).....	129
44. B-50D Flight Simulator (S-1).....	129
45. B-52G Flight Simulator (T-1).....	130
46. B-66B Flight Simulator (MB-20).....	130
47. C-97A Flight Simulator (S-4).....	131
48. C-118A Flight Simulator (MB-11).....	131
49. C-119G Flight Simulator (S-10A).....	132
50. C-130A Flight Simulator (MB-12).....	132
51. KC-97G Flight Simulator (MB-27).....	133

## List of Figures (continued)

<i>Figure</i>	<i>Page</i>
52. KC-135A Flight Simulator (MB-26).....	133
53. F-86D Flight Simulator (MB-23A).....	134
54. F-100A Flight Simulator (MB-3).....	134
55. F-100C Flight Simulator (MB-22).....	135
56. F-101B Flight Simulator (MB-40).....	135
57. F-102A Flight Simulator (MB-5).....	136
58. F-106A Flight Simulator (MB-42).....	136
59. F-102 Cockpit Procedure Trainer (MF-9).....	137
60. F-105 Cockpit Procedure Trainer (MF-13).....	137
61. T-33A Cockpit Procedure Trainer (MF-1).....	138
62. T-37A Instrument Flight Trainer (T-4).....	138
63. T-37A Instrument Flight Trainer.....	139
64. T-38 Instrument Flight Trainer (T-7).....	139
65. Instrument Flight Trainer, Jet Propelled Aircraft (C-11B,C).....	140

## Explanation of Terms

Analog Computer	A computer that operates on the principle of measuring, as distinguished from counting, in which the measurements obtained (voltages, resistances, etc.) are translated into desired data.
AT-6	A former designation for the T-6 Trainer Aircraft. Navy version: SNJ.
Attrition Rate	A rate, usually expressed as a percentage, reflecting the loss of personnel or equipment due to defined causes in a given period of time.
Azimuth	Bearing in the horizontal plane, usually expressed as an angle, clockwise from true north, grid north, or magnetic north, from 0° to 360°.
Bandwidth	That portion of a frequency spectrum that is required or made available for proper transmission of the signal of interest.
Bank	The attitude of an aircraft when its lateral axis is inclined with respect to the horizon. Bank is the position normally assumed by an aircraft when making a turn, to prevent skidding, hence to turn the aircraft.
Bit	Generally, the arbitrary designation for a unit of information capacity of a storage device. As applied to television, it is the smallest resolvable element of a scanning line.
Buffeting	The knocking about sustained by an aircraft surface when turbulence is encountered, especially under conditions of compressibility. The irregular oscillations that result from this circumstance.
Centrifuge	A device for inducing artificial gravity by means of centrifugal force, used in testing the ability of flying personnel to withstand above-normal gravitational (G) forces.
Contact Flying	A method of flying in which the pilot determines the attitude and position of his aircraft by visual reference to the horizon, to landmarks, or to clouds.
Digital Computer	A computer that operates by using numbers to express all the quantities and variables of a problem; operates on the principle of counting, as distinguished from measuring.
Dutch Roll	A combined yawing and rolling motion of an airplane caused by rough air.
G-Forces	A G is the measure or value of the gravitational pull of the earth or of a force required to accelerate or decelerate any freely movable body at the rate of approximately 32.16 feet per second. In referring to the G-forces exerted upon the human body, the direction of the force is relevant to problems of blackout and redout. The force is referred to as so many G's of footward acceleration or headward acceleration, of chest-to-back acceleration, or back-to-chest acceleration. A positive G is a G-force exerted upon the human body as a result of headward acceleration. A negative G is a G-force exerted upon the human body as a result of footward acceleration.

## Explanation of Terms—(continued)

Hybrid Computer	Combines analog computer speed, flexibility, and direct communication capability with digital memory, logic, and accuracy. Permits overall computational economy and efficiency.
IFR	Instrument flight rules. The collection of rules which govern flight procedures under instrument conditions. In instrument flying, navigation is carried out by the use of flight and navigational instruments without visual reference to the ground.
Kinesthetic Receptors	See Proprioceptors.
Line of Sight	The straight line between eye and target in gunnery, bombing, or rocket firing.
Mach	The speed of a relatively moving body or a part thereof, as measured by the speed of sound in the medium in which it moves, indicated by a number; for example, mach 1 is equal to the speed of sound, mach 1.5 is equal to one and one-half times the speed of sound, etc. Named for the Austrian physicist, Ernst Mach, 1838-1916.
Mockup	A model, often full-sized, of an aircraft, other piece of equipment, or installation, designed to expose its parts for study, training, or testing.
Phugoid Oscillation	A slow or long-period longitudinal oscillation of an aircraft.
Pitch	The movement of an aircraft about its lateral axis.
Proprioceptors	Includes kinesthetic receptors and vestibular receptors. Kinesthetic receptors are sense organs located in the muscles, tendons, and joints. These receptors are important in the control of movement. Vestibular receptors are located in the nonauditory inner ear (the vestibule) and they are stimulated by head movements. These receptors are important in dynamic and static balance.
Raster	A predetermined pattern of scanning lines which provides substantially uniform coverage of an area of a display surface.
Resolution, Horizontal	The amount of resolvable detail in the horizontal direction of a television picture. It is usually expressed as the number of distinct vertical lines (alternately black and white) which can be seen in a horizontal dimension equal to the picture height. A sharp and clear picture which shows small details has good or high resolution. A soft or blurred picture in which small details are indistinct has poor or low resolution.
Resolution, Vertical	The amount of resolvable detail in the vertical direction of a television picture. It is usually expressed as the number of distinct horizontal lines (alternately black and white) which can be seen in a test pattern.
Roll	The movement of an aircraft about its longitudinal axis.
Servomechanism (Servo)	A mechanism in which control of position, speed, power output, etc., is effected by a device that automatically changes or corrects, or helps to

## Explanation of Terms—(continued)

	change or correct, such position, speed, power, etc., in accordance with a predetermined setting or manipulation.
Simulator, Flight	A device that simulates a desired condition or set of conditions of actual flight. Used especially for training purposes, but also includes research and systems test simulators. In a broad sense, the term includes centrifuges and recently, the airborne flight simulator.
Slant Range	The line-of-sight range between two points not at the same elevation.
SNJ	The Navy designation for the T-6 trainer aircraft (Texan).
Stanine Score	From standard nine. A separate rating or score formerly used for each of Air Force Specialties, designed to predict the aptitude of a person. The scores are obtained by converting raw scores received on a battery of aptitude tests to a standard score that ranges from 1 to 9.
Syllabus	A list of the main topics, references, training aids, objectives, etc., in a course of instruction.
T-6	The first and most widely used of modern single engine advanced trainer aircraft. It was popularly called the "Texan" (the Navy SNJ). It is now obsolete.
Vestibular Receptors	See Proprioceptors.
VFR	Visual flight rules. Rules restricting the flying of aircraft under conditions of contact flying to given minimum altitudes and limits of visibility.
Yaw	The movement of an aircraft about its vertical axis.

## SECTION I. Introduction

### BACKGROUND .

At least as early as 1910, two crude flight trainers called the "Sanders Teacher" and the "Earlly-Billing Oscillator" were used for flight training in England. The Sanders Teacher was described in the December 10, 1910 issue of *Flight International*. A description of this trainer, in part, was reprinted in a recent issue of the *Connecting Link*\* as follows:

Those wishing to take up aviation either as a recreation or a profession find many drawbacks at the commencement of their undertaking, but one of the most formidable, especially to those not blessed with a long purse, is the risk of smashing the machine while endeavoring to learn how to control and fly it.

Even the most apt pupil is certain to find himself in difficulties at some time or another during his probation, and owing to lack of skill the machine is necessarily sacrificed to save his life, or at least to prevent a serious accident. The invention, therefore, of a device which will enable the novice to obtain a clear conception of the workings of the control of an aeroplane, and of the conditions existent in the air, without any risk personally or otherwise, is to be welcomed without a doubt. Several have already been constructed to this end, and the Sanders Teacher is the latest to enter the field.

The aim and object of an invention of this kind is naturally to render tuition safe to the pupil while at the same time giving him confidence. Now there is a tendency to design such an apparatus merely for purposes of balance and without any real resemblance to an actual aeroplane, while the very balance is so exaggerated that the pupil is placed under conditions that are in no way so arduous in free flight.

. . . All these details are standard parts of the Sanders biplane and can be substituted if desired by the same parts of any other type of aeroplane. Thus, the purchaser of a Teacher is buying parts which can be used later if he wishes in the construction of a machine and his outlay can therefore scarcely be considered an extravagant one.

In 1917, a trainer was developed in France which was based on a pivoted fuselage and the device produced variations of response and feel with assumed speed. The trainer also included engine noise, rudder-aileron crossover, and a simple visual approach. Canada, Great Britain, and the United States continued the development of flight trainers during the years following World War I.

In the United States, Edwin A. Link developed his first flight trainer in 1929. The Link trainer was developed during a period of accelerated aviation progress based on technological advances which permitted aircraft designers to produce larger and safer aircraft. Airplanes were built which could fly higher and faster than ever before, but as the technology advanced, the complexity of the aircraft increased. The introduction of instrument flying, for example, resulted in a new need for qualified pilots. Since "blind flying" training in the actual aircraft was both dangerous and uneconomical, research and development of ground trainers were undertaken to alleviate the problem.

---

\**The Connecting Link*. Link Group, General Precision Systems, Inc., Binghamton, New York, Vol. 5, Number 1, 1963, pp. 10-11.



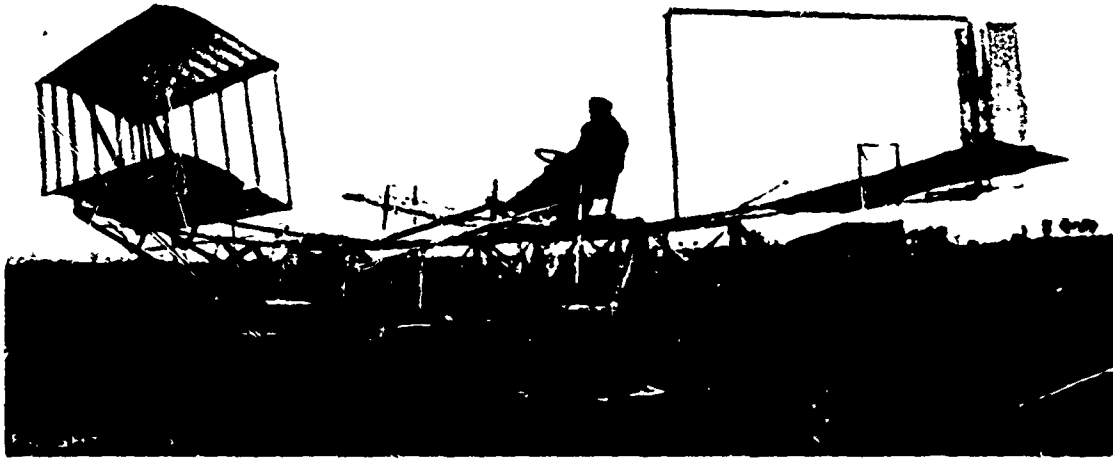

**Figure 1. The Sanders Teacher (Flight Trainer)**

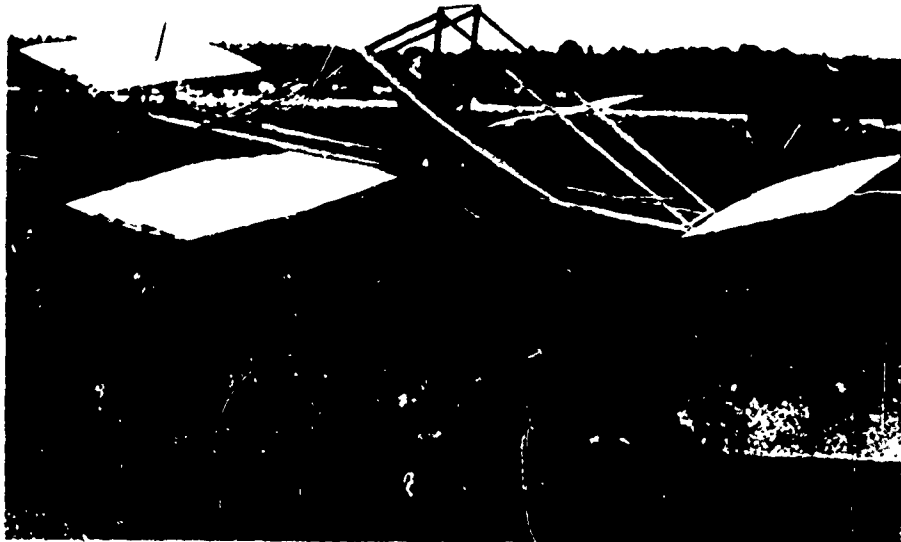

**Figure 2. The Eardly-Billings Oscillator (Flight Trainer)**

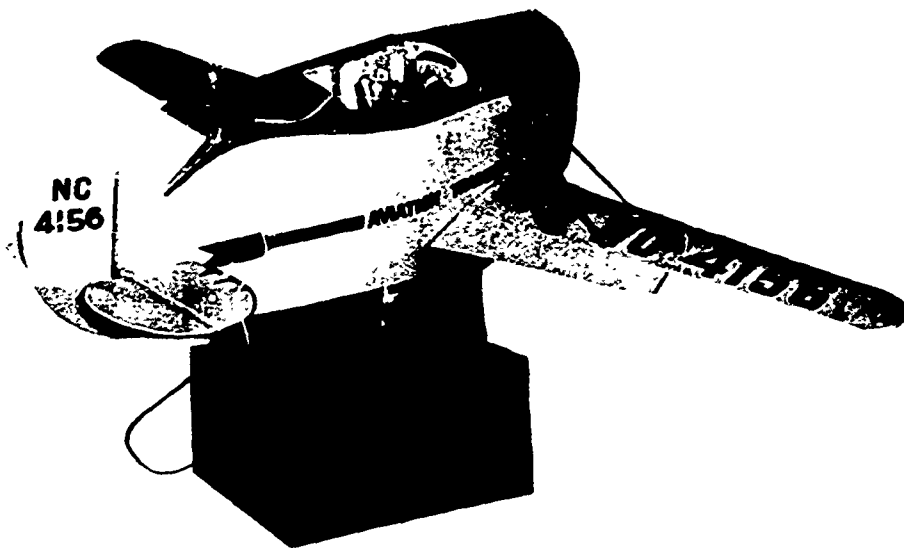

Figure 3. The First Link Trainer

By the time World War II began, the Link trainer had been already accepted and it was used extensively in civil aviation. Also, the armed forces adopted the trainer and utilized it on a large scale. Flight trainers of that period were principally mechanically activated procedures trainers and although hard data on their effectiveness is lacking, their contribution to military aviation training was apparently acceptable.

With the advent of analog computers by the late 1940's, modern training simulators became a possibility. In addition, improvements in these simulators were realized because of information derived from servo systems and components which were developed during World War II. Thus, the historical facts tend to support Westbrook's (154) position that:

Those using research and development simulators can thank training simulator people for providing the motivation for and the development of the techniques and experiments necessary for what is used. Much of the literature on simulation in past years now relates to this area . . . .

Under the joint sponsorship of the Air Force and Navy, research in digital computer speed and other characteristics was initiated in 1950 by the Moore School of Electrical Engineering at the University of Pennsylvania. It was found that a digital computer of adequate capability for flight simulators did not exist. As a result, designs for an acceptable digital computer were developed by the school staff. Also, under the sponsorship of the Air Force and Navy, by 1960, a prototype system called the Universal Digital Operational Flight Trainer (UDOFT), based on the Moore School of Engineering designs was constructed by the Sylvania Electric Products, Inc. (180).

Recent research by the Electronic Systems Laboratory, Massachusetts Institute of Technology (186), indicates that a combined analog-digital computer system may be more efficient than the

all-digital simulation. Tests demonstrated that this hybrid system maintained good fidelity at solution rates as low as 1 per second as compared to 20 per second for the all-digital simulation. Information on hybrid and other computer systems is contained in the annotated bibliography, Section V of this report.

#### DEFINITION

Since World War II, the use of the term simulator has been used increasingly by training personnel to denote flight trainers, possibly because of the development of advanced electronic research and systems simulators. For example, prior to, and during, World War II, generally, a training medium that permitted practice which could be substituted for actual practice in operational situations, was called a trainer. In 1945, Wolfle (156) said:

In this memorandum any device used to give a student *information about* a piece of equipment or a process will be called a training aid. Cut-away models, wall charts and motion pictures are examples. In contrast, a device on which a man can actually build up skill will be called a trainer.

Later, however, the terms simulator, synthetic trainer, and operational flight trainer appear to cause some confusion in the literature on flight simulators. For example, in 1954, Miller (136) distinguished between simulators and trainers when he said "Trainers and simulators are designed and used both for training and for evaluation of trainees." Muckler, et al (138), in 1956, said in part "In these experiments the technique used was to study transfer effects from *more than one simulator* to a single operational aircraft." However, in discussing the experiments, the authors used the terms simulator and synthetic trainer to denote the same training medium.

In explaining what simulation means, Cagne (123) said:

First of all, as has already been implied, a simulator attempts to represent a real situation in which operations are carried out. (By "operations" is meant a set of events in which a man or men interact with machines or with their environment to bring about a particular result.) Big or small, complex or simple, the simulator is believed by its designer, and hopefully, by its users, to provide exact representation of certain parts of the real "operational situation." In this respect a simulator is often distinguished from a trainer. While a simulator is often used for training, there are trainers which do not represent any specific real situation, and which are not designed to do so . . . .

In 1960, Miller (137) recognized two types of simulators: (1) job-segment trainers, and (2) full simulators. According to Miller, job-segment trainers are simulators with restricted training capability. For example, simulators which only teach instrument landings or simulators constructed to provide training in air-to-air refueling are job-segment trainers.

Parker and Downs (141) identified two types of simulators used in training pilots and other aircrew members: (1) aircraft flight simulators, and (2) full-mission simulators. The aircraft flight simulator contains all control display dynamics and, in some cases, visual and motion cues. The trainee, however, cannot practice complete missions. The full-mission simulator permits the trainee to practice a complete tactical mission. The terms simulator and trainer are not used interchangeably by the authors.

Actually, flight simulators fall into several distinct categories. They may be classified as (1) research simulators, (2) aircraft systems test simulators, and (3) training simulators. In this report, the terms flight trainer, operational flight trainer, and synthetic flight trainer are used interchangeably and they are, thus, subsumed under the category of flight training simulators.

A wide variety of simulators are used for research problems and the simulator configurations depend upon the areas to be investigated. A research simulator may be a replica of a cockpit or a mockup of an entire aircraft. The degree of simulation desired may be either engineering or psychological depending upon the nature of the investigation.

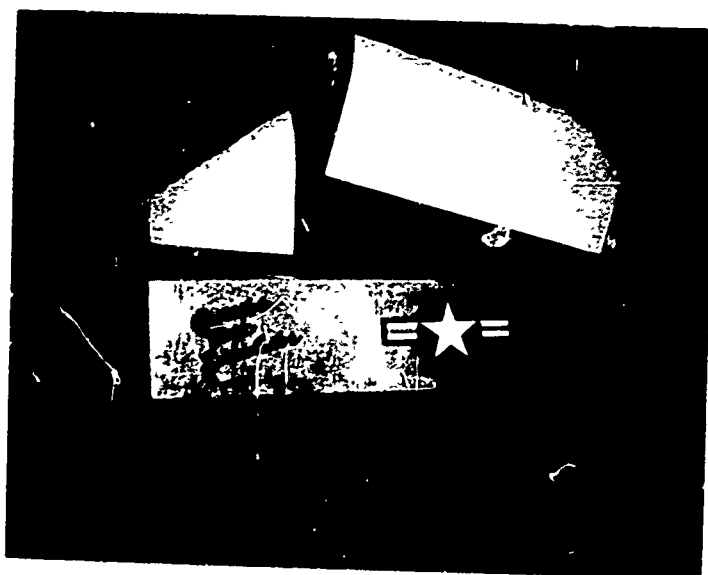
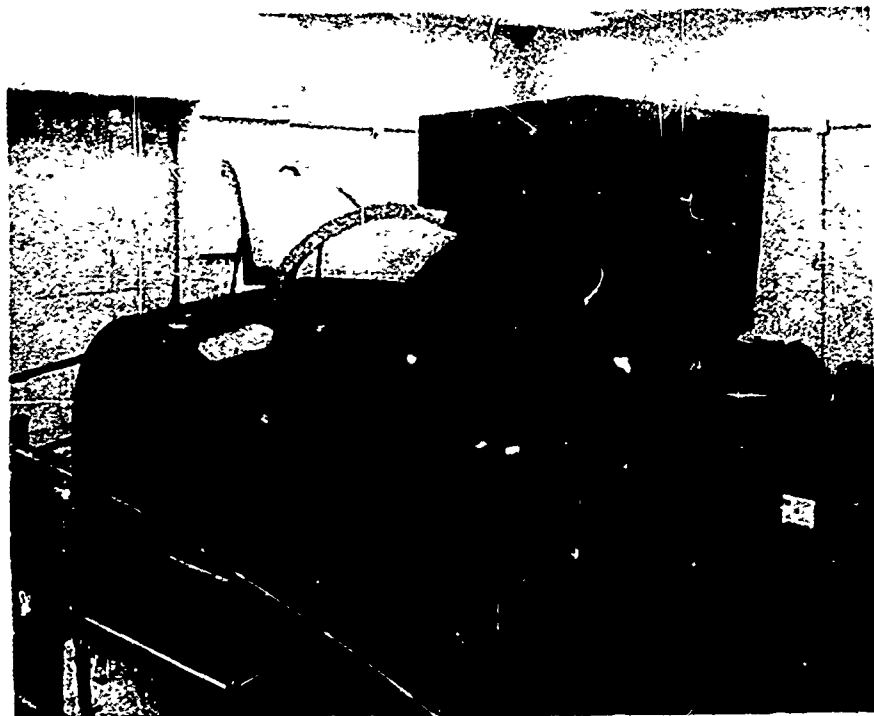

Figure 4. A Small Special-Purpose Research Simulator

Systems engineering test simulators are used in the development and testing of new aircraft systems, and they usually require a high degree of engineering fidelity in simulation. These simulators are modified as required to keep abreast of all changes in the aerodynamic design and configuration of the aircraft being developed.

Flight training simulators have progressed from the relatively simple devices in use prior to World War II to the present expensive, computerized, operational trainers that closely simulate actual aircraft. As these simulators become more sophisticated and costly, their training value, which previously had been assumed, was questioned, particularly in the armed forces. As described in Section III, numerous transfer of training studies were undertaken following World War II in an effort to determine the value of these simulators in flight training. Although the results of a number of studies were largely controversial, the value of the trainers for increasing flight proficiency and reducing flight time continued to be generally accepted. In discussing this aspect of training simulators, Westbrook (154) in 1964 said:

As a matter of fact, however, numerous analyses have shown that these trainers can quickly save far more than they cost in reducing expensive flight time needed to maintain pilot proficiency particularly in such areas as instrument flight and simulated emergencies.



**Figure 5. An Aircraft Systems Engineering Test Simulator (F-111A)**

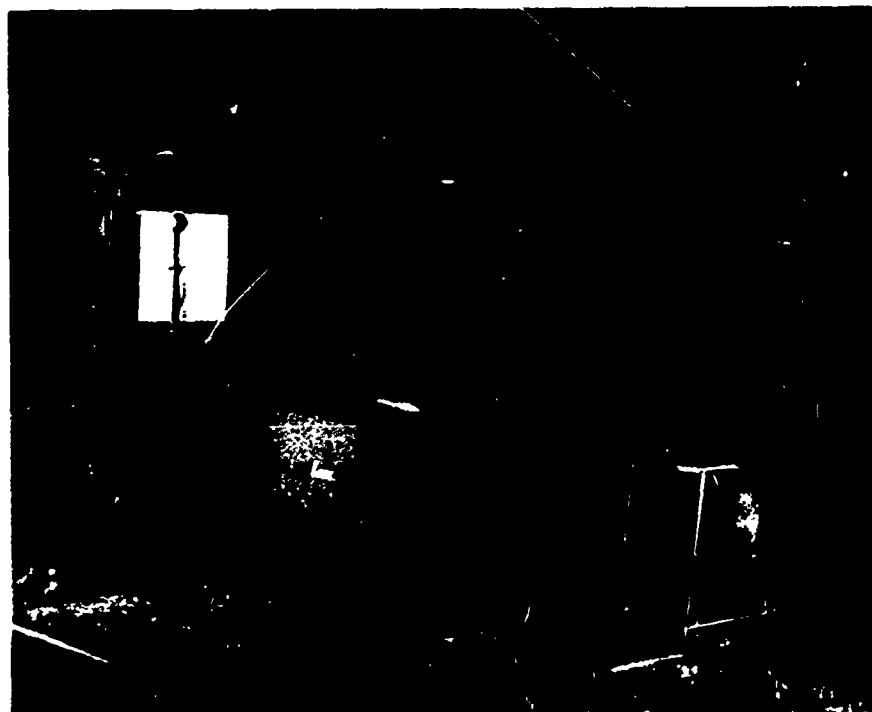

**Figure 6. The Link T-4 Trainer (T-37) Used in the Air Training Command Undergraduate Pilot Training Program**



**Figure 7. The Link T-7 Trainer (T-38) Used in the Air Training Command Undergraduate Pilot Training Program**

In the U. S. Air Force, flight simulators are classified as: (1) Flight Simulators, (2) Instrument Flight Trainers, and (3) Cockpit Procedure Trainers.\* Simulators which represent these three classes are shown in Appendix II. Figure 8 is a schematic of a new cockpit flight training simulator built by Conductron-Missouri to train Air Force pilots of the Lockheed-Georgia C-5 cargo transport. Cab compartment at left exactly duplicates the aircraft's flight crew stations. The remaining cabinets accommodate electronics for the total simulator complex. The system's "master brain" — a pair of digital computers operating as one unit — is in the console at the bottom right corner of the room.

#### **THE ANNOTATED BIBLIOGRAPHY**

The purpose of the annotated bibliography contained in this report is to provide a convenient source of unclassified information concerning the various types of flight simulators. The references are intended to convey only a general brief of the content of the cited technical reports which should provide both research and training personnel with sufficient information to enable them to decide whether any particular item warrants further reading. It is suggested that conclusions should not be based solely upon the abstracts since often the complete reports contain certain reservations or qualifications concerning the obtained results.

The annotated bibliography was selected from unclassified government sponsored technical reports for the years 1949 through 1967. Two reports (156, 115) published in 1945 are included, however, as topics of historical interest to the study of flight training simulators. No attempt was made to complete an exhaustive listing of all reports published during the period covered; in-

---

\*Technical Order 43-1-3, *Special Training Devices*. U. S. Air Force, August 1966.

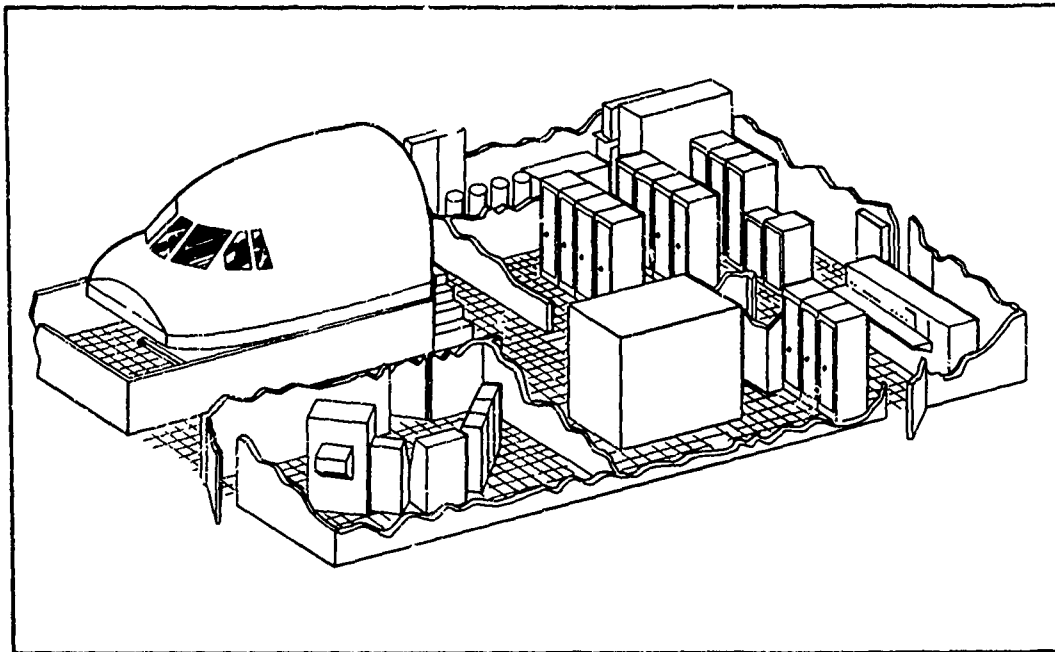

**Figure 8. Conduction Cockpit Flight Training Simulator (C-5 Cargo Transport)**

stead, only selected reports considered to be of general interest and application to flight simulators and computers were included.

The approach used in preparing the annotated bibliography was a thorough review of all relevant information concerning government sponsored research. The Defense Documentation Center (DDC) files were searched in all subject areas listed. All reports prepared by the now defunct Air Force Human Resources Research Center (HRRRC) and Air Force Personnel and Training Research Center (AFPTRC) were reviewed. All publications of the Aerospace Medical Research Laboratories (AMRL) library were screened. In addition, a large collection of reports which had been gathered by the Training Research Division, Behavioral Sciences Laboratory (Aerospace Medical Research Laboratories) was examined. The references were selected primarily from research on flight simulators; however, technical reports on simulators used for space research and training were not included.

When known, the contractual agencies are parenthetically included in the references. Also, the DDC accession number is included for each reference contained in the annotated bibliography and microfilm copies of these publications are free of charge to government agencies and their contractors. In most cases, the abstracts included in the various sections of this report are those prepared by the authors. Abstracts were prepared for reports which contained none. Books and articles referenced in this report which are not available through DDC, or do not specifically apply to the area of flight simulators, are included as footnotes.

For those readers who are unfamiliar with DDC, the following information about its organization and function is provided: DDC is the central facility of the Department of Defense (DoD) for secondary distribution of technical reports of research, development, test and evaluation

sponsored by DoD. DDC acquires technical documents, stores them for retrieval, announces them for official use, and supplies microfilm copies of them without charge to government agencies and their registered contractors and grantees. It assigns an accession number prefixed by the letters AD (Accession Document) for each report received since 1952. Previous reports are prefixed by the letters ATI (Air Technical Index). DDC does not serve the general public, but provides DoD reports which have no security or distribution limitations to the Clearinghouse for Scientific and Technical Information of the Department of Commerce which offers them for sale to the public. The annual accessions exceed 50,000 reports.



## SECTION II.

# Visual and Motion Simulation

### INTRODUCTION

In general, flight training simulators have been developed as an aid in training pilots in cockpit familiarization and in normal and emergency procedures. The long use of these simulators in civilian and military aviation training indicates general acceptance of their value in certain critical areas of flight training. However, flight trainers do not typically simulate such stimuli as external (extra-cockpit) cues, G- forces, or changes in bodily orientation resulting from changes in the simulated aircraft attitude. For this reason, it may be said that only part-training is possible in trainers which do not provide visual and motion cues.\* Various studies have been made as to the value of these cues in flight training and the results indicate that visual and motion cues should be simulated. However, more conclusive data are needed to justify the additional costs involved. Smode, Hall, and Meyer (153), in their comments on visual displays for flight trainers, said:

Apparently, for student pilots, at least, even very crude contact displays have considerable training value, provided that "good" instruction is given in relation to the device. Quality of instruction may substitute for absent contact cues in many instances.

The cues that the pilot uses while flying an aircraft are:

- a. Visual cues
  - (1) Instrument reading
  - (2) External visual information
- b. Aural cues
- c. Motion cues from the aircraft motion and control feel

All of these cues may be simulated in flight simulators in various degrees of sophistication.

It appears, however, that widespread acceptance of the value of visual and motion simulation in training, as yet, has not been achieved. For example, in a recent study by Hall, Parker, and Meyer (125), a survey was made at six different flying training locations to assess the training value and acceptance of visual attachments and cockpit motion capability in flight simulators. The training value of visual simulation could not be evaluated because the visual attachments were inoperative at all bases visited. These devices were not used for extended periods of time because of maintenance problems and a lack of spare parts. While motion capability was available, and usable at all the bases visited, it appeared that, in most instances, its use was optional with the instructor. The survey showed much disagreement existed among the instructors as to the value of motion capability in flight simulators. However, they did indicate general agreement in that motion simulation was not realistic.

This section considers the simulation of external visual cues and includes information on various types of systems and components used in visual simulation. Motion may be induced either visually or physically and, in fact, some simulators use both forms of motion simulation to re-

---

\*Motion cues refer to stimuli which act upon the kinesthetic and vestibular receptors of the proprioceptive-cerebellar system.

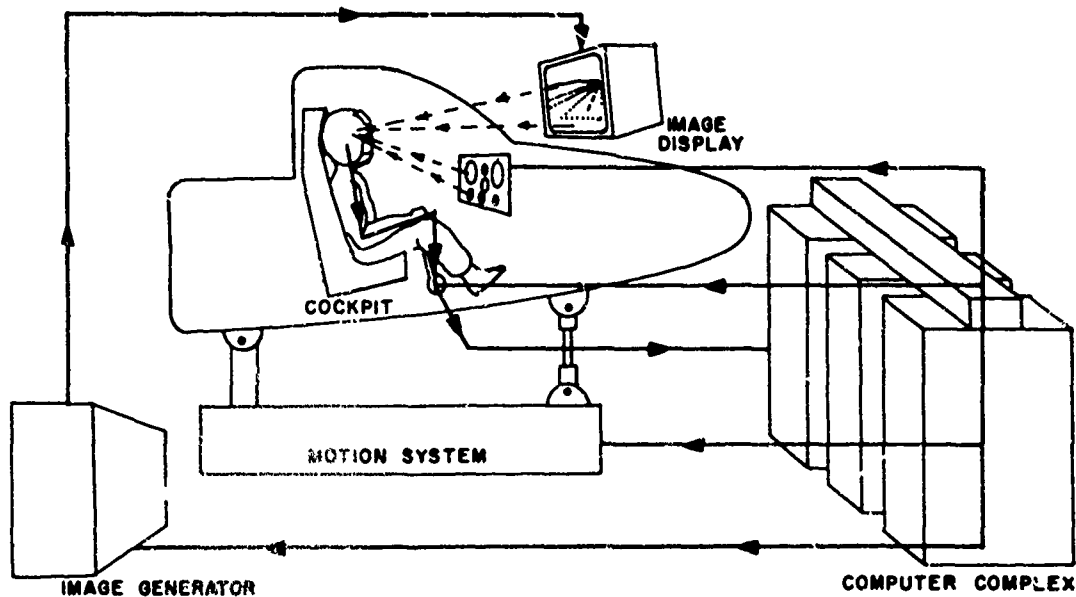

Figure 9. Diagram of Flight Simulator with Visual and Motion Simulation

produce various aircraft attitudes. In the annotated bibliography, studies which relate primarily to visually simulated motion are included under Visual Simulation and studies which concern actual movement (motion platforms, control handling, rotation, buffeting, etc.) are included under Motion Simulation.

#### VISUAL SIMULATION

Pilots require certain types and amounts of extra-cockpit information during contact flight. The information needed includes: (1) pitch and roll relative to the earth's surface and yaw relative to line of flight over the ground; (2) position of aircraft-elevation relative to the earth's surface - - azimuth and slant range relative to a point on the earth's surface; (3) changes in position of aircraft; and (4) rate of change in attitude and position of aircraft. Aircraft attitudes of pitch, roll, and yaw are represented in the figure below:

Lybrand, et al (22), listed various flight tasks used in a visual landing system in terms of those subtasks which require external cockpit visual information. The list is presented in Appendix I of this report.

Burke (6) presented a similar list of subtasks utilized in visual landing systems. His list, however, includes taxi, and parking subtasks. Both studies summarize the extra-cockpit visual information needed by the pilot to perform safely and effectively such flight tasks. The information is summarized as follows:

1. Attitude of aircraft - axial orientation of three rotational axes of aircraft; pitch and roll relative to the earth's surface; yaw relative to line of flight (ground track). These attitudes are graphically presented in figure 10.

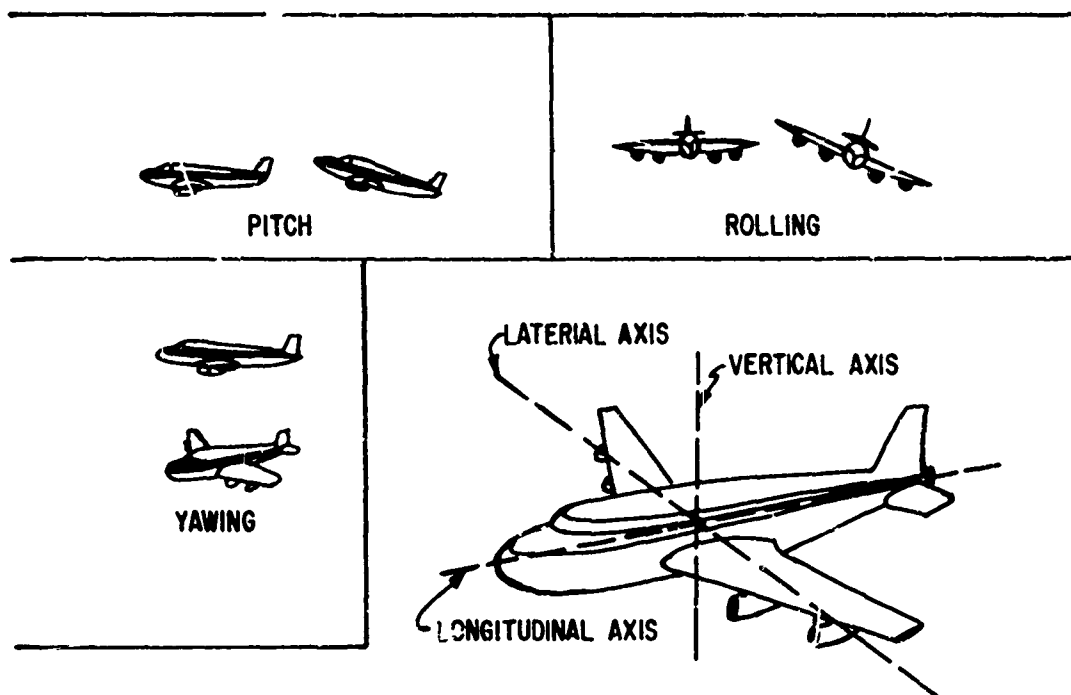

Figure 10. Aircraft Attitudes

2. Position of aircraft – elevation relative to the earth's surface; azimuth and slant range relative to a point (runway) on the earth's surface.
3. Changes in attitude and position of aircraft.
4. Rate of change in attitude and position of aircraft.

The development of external visual simulation has progressed from the early simple graphic devices to the complex visual attachments in use today. A high degree of impetus for research in this area is attributed to: (1) the need for a high degree of engineering simulation in systems development and (2) the need to provide more "real world" cues in pilot training simulators. Many pilots have expressed the criticism that flight simulators do not fly or sound like the actual aircraft.

#### VISUAL SYSTEMS

Visual simulation techniques have been developed to provide effective simulated real-world visual environment for flight simulators. In the past, particular attention was given to techniques for training commercial and military conventional aircraft pilots in takeoff, landing, and low-level flight. The development of Vertical Short Takeoff and Landing (V/STOL) aircraft caused further demands on simulation technology. The advent of manned space flight has resulted in new and more exacting requirements for realistic visual simulation. In addition, visual simulation techniques are used as a research tool for configuration management, mission profile determination, and evaluation of equipment design.

Although great progress has been achieved in the development of visual simulation devices, they still are subject to serious limitations and deficiencies which require further research. Some

visual simulation problems are: (1) marginal image quality because of poor resolution and picture noise, (2) limited operating parameters in viewing angle, area of the visual envelope, and on ground picture fidelity, and (3) tendency of the visual system to emphasize the inability of the simulator to duplicate aircraft flight responses.

In this report, the visual system is divided into four areas: (1) image storage, (2) image pick-up, (3) image relay, and (4) image display. The various types of devices for each area are shown below:

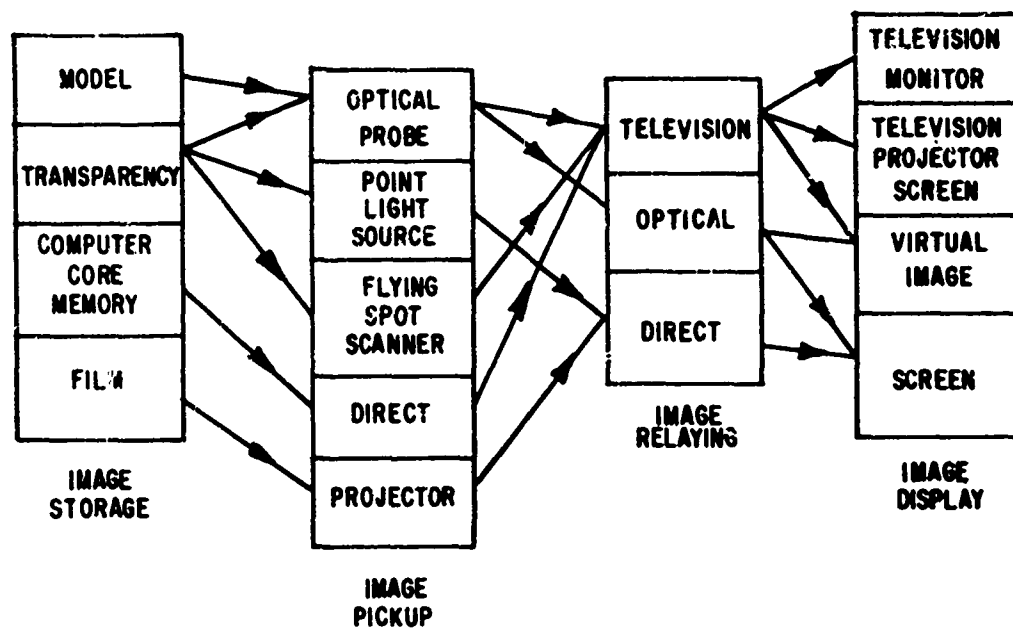

#### Image Storage

A visual system requires some form of information storage which can be picked up and relayed to a display. Four forms of image storage have been used in visual simulation as follows:

- a. Model System
- b. Film Projection System
- c. Transparency System
- d. Computer System

#### Model System

The three-dimensional model has been used as a source for the simulation of terrain relief, and cultural features such as airports, buildings, railroads, etc. The model provides a good image source because of its realistic perspective; however, fidelity of reproduction of detail in simulated flight is a serious problem. The Aerospace Medical Research Laboratories (Simulation Techniques Branch) is presently conducting research in an effort to improve the quality of model reproduction. The research model is shown below.

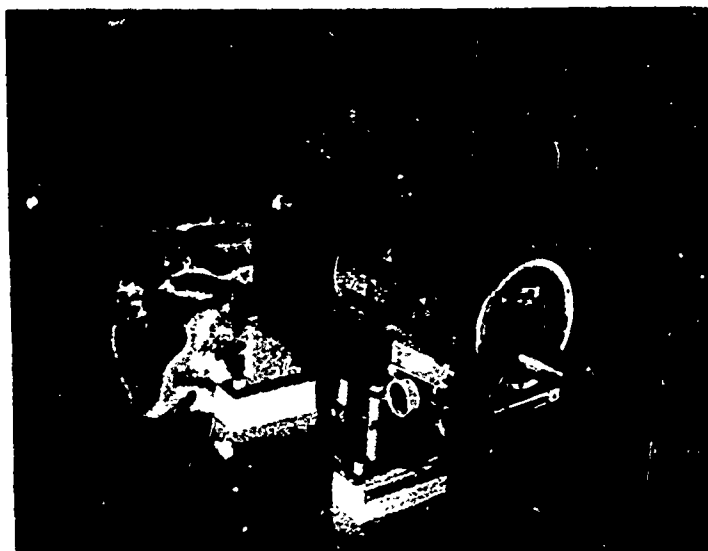

**Figure 12. Three-Dimensional Model and Optical Probe**

#### **Film System**

Motion picture film may be used for visual simulation information storage purposes. For example, the substitution of film for the three-dimensional model can eliminate the scale factor limitation of the model. The storage capability of film provides at least a 20:1 increase in storage over the model system. However, film provides only a two-dimensional representation of a three-dimensional scene. While the two-dimensional representation of film may be satisfactory for distant scenes, correction distortions and attitude effects must be applied. The main disadvantage of motion picture film in visual simulation and training is its pre-programmed or "set in concrete" nature. Of course, film presentations can be advantageously utilized for static training conditions, but costly trailers must provide a more versatile training environment.

#### **Transparency System**

The transparency approach to visual simulation has several advantages over other information storage systems. These are cost, size and flexibility. The cost of a transparency is low as compared to other image storage systems. The size of the transparency is an advantage because higher scale factors can be obtained with comparable resolution. For example, a transparency less than a square foot can store the same information as a large 12' x 4' model. It is flexible because any terrain area may be simulated by reading out transparency of that area.

Transparency image storage has certain disadvantages when used for visual simulation. For example, the transparency is two-dimensional and does not realistically display terrain relief or provide for other three-dimensional visual requirements. Also, at a lower simulated altitude, the resolving power of the transparency rapidly decreases, particularly during the final simulated landing stages. Another disadvantage is that the resolving power of the system is diminished with altitude as a result of the reduction of the area of the transparency display.

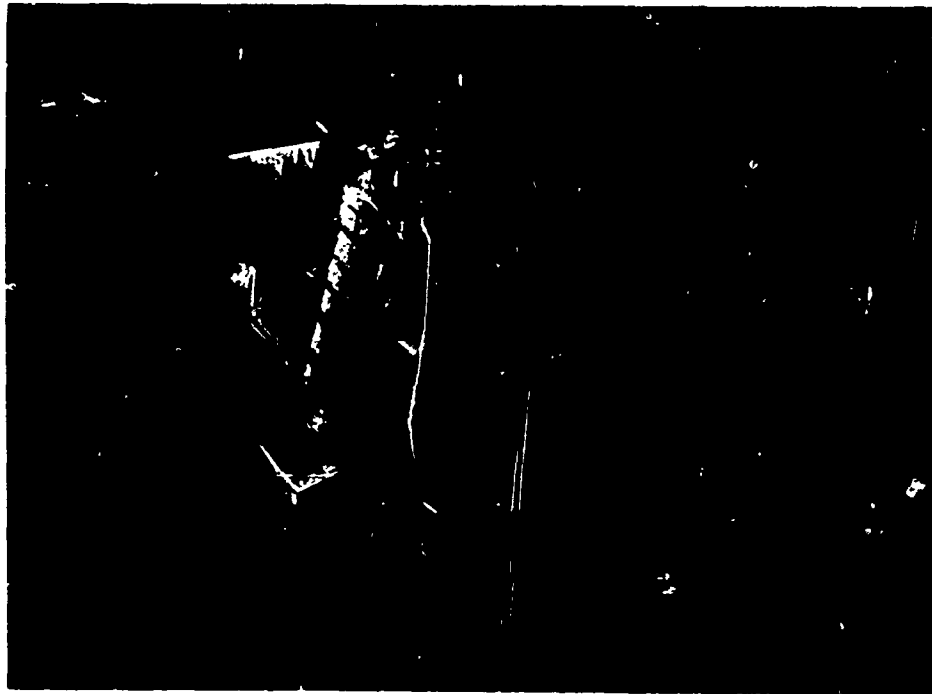

Figure 13. Link Variable Anamorphic Motion Picture (VAMP) System

#### Computer Systems

In the core memory of a computer, the stored image is a synthetically generated mathematical model of the terrain. Computer generated displays already are capable of three-dimensional displays. Some of these computer generated geometrical patterns developed by General Electric Company, are shown in figure 14. The two drawings of an aircraft carrier represent perspective changes during an approach.

Unfortunately in its present state of development, computer storage of the real scene is not practical. To store information contained on a ten-inch two-dimensional color transparency would require approximately  $3.75 \times 10^9$  bits of information, assuming a film resolution at 50 lines per millimeter, eight shades of gray and three colors.

If information storage could be provided at a minimum, computer image generation would be feasible. A combination of digital and analog computation provides a display of an approach and landing light pattern on a television screen as shown in figure 15. The Link All-Electronic Night Landing System is an example of this type of computer image generator.

Another technique which may be investigated involves the mixing of digital computer and transparency or model storage. The objective of this research would be to alleviate the problem of excessive computer storage capacity and, thus, make it possible to concentrate storage in particular areas of interest.

#### IMAGE PICKUP

As we have already observed, the basic consideration in visual simulation involves the use of image storage devices. The next devices to be considered are those which pick up the images. After the images are picked up, they are relayed to the display. Refer again to figure 11.



**Figure 14. Computer Generated Geometrical Patterns**

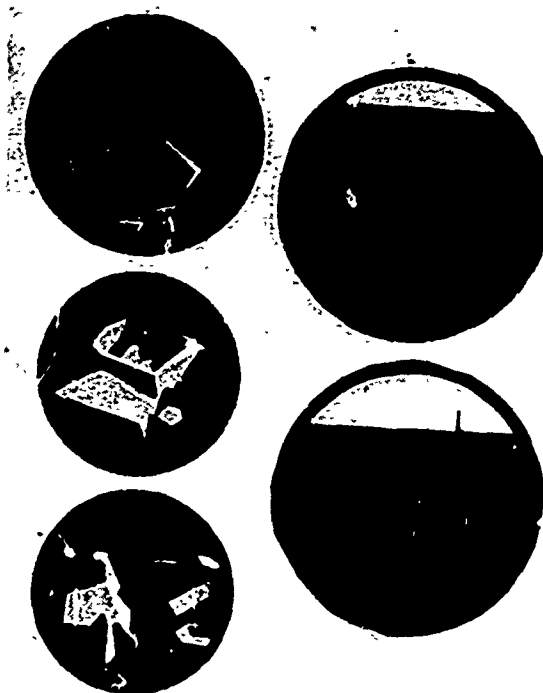

**Figure 15. Link All-Electronic Night-Landing Display**

### Optical Probe

In general, the model system uses an optical pickup (optical probe). The optical probe picks up the image and also provides aircraft pitch, roll, and yaw simulation. Optical probes also can be used for picking up images from a transparency.

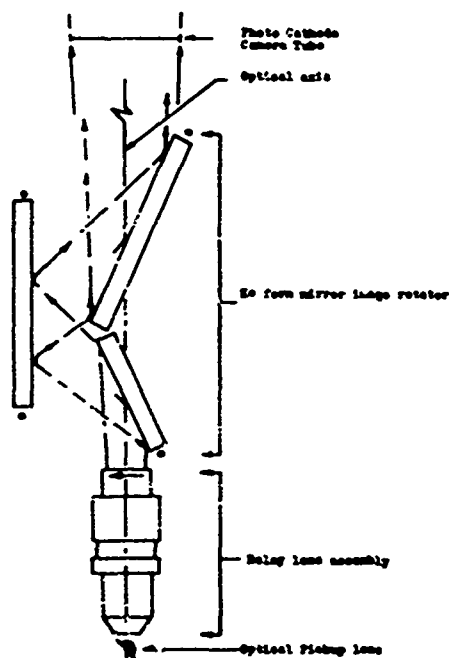

Figure 16. Physical Configuration of a Bead Lens Optical Probe

### The Point Light Source Projection System

The point light source projection system is designed to serve as a direct projection wide angle image pickup for visual simulation. That is, the device displays visual information from a transparency onto a screen with a point source of light. The system's direct projection and wide field of view are desirable features; however, it also has disadvantages which include: (1) distortion, (2) low light level, (3) limited visual envelope, and (4) marginal resolution.

### Flying Spot Scanner

The flying spot scanner, which uses a cathode ray tube to read out a transparency, is another technique of image pickup. It scans the transparency in the form of a television raster and the information is read out with photomultipliers. Perspective, pitch, and altitude information are generated by shaping of the raster.

### IMAGE RELAY

Image relay may be accomplished directly (e.g., point light source), optically (e.g., optical probe), and by television. In comparison to direct and optical image relay, television represents a very complicated method of image relay. It serves as a light amplifier between the image pick-up and the image display of visual simulation systems utilizing television techniques.

The two most important factors in judging the performance of a television system are resolution and noise. Resolution refers to the ability of the system to resolve, transmit, and display the



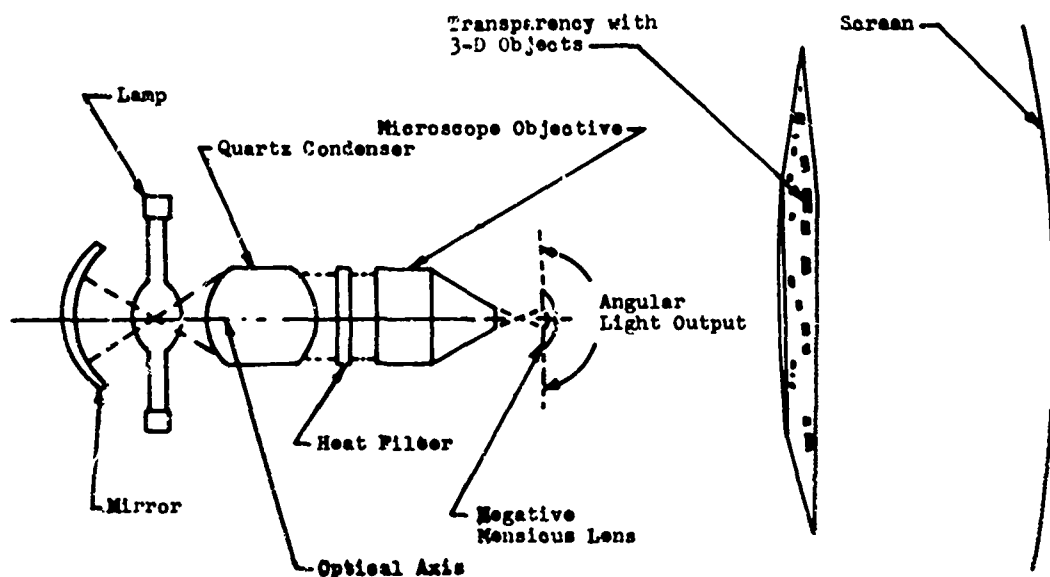

Figure 17. Schematic of a Point Light Source

image. Resolution of the image is limited by the bandwidth of the system. Bandwidth represents a measure of the quantity of picture information which the television system can process in a given unit of time. System noise is a measure of the amount of unnecessary or unrelated picture information as compared to the related picture information. These two factors (resolution and system noise) greatly influence the quality of the displayed image.

As yet, the problem of whether to use monochrome (black and white) or color has not been resolved. For example, color adds realism and possibly provides visual information not shown with monochrome, but color television presents certain problems that are not present in monochrome systems. In general, color television has poorer resolution, higher noise, and less brightness and density. In addition, the color system is less reliable and it is more difficult to align and maintain. Discounting esthetic values, unless training objectives require color discriminations, the use of color television is presently uneconomical.

#### IMAGE DISPLAY

Image displays should receive careful consideration in the development and use of visual simulation devices. The television monitor, projector and screen, and virtual image are types of displays. The virtual image is the most recent display to be used in visual simulation and, thus, it is the least familiar of the displays. It images the picture at, or near infinity in contrast to the monitor and screen which image the picture on the surface of the device. One aspect of the device is that the viewer does not sense the presence of the screen.

Several types of television projectors are used in visual simulation. However, they vary widely in cost, degree of resolution, and maintenance requirements. The types of projectors which may be used are light valve, Schmidt optical system, and refractive.

### The Light Valve Projector

The light valve projector has the highest light output and, generally, the highest resolution. It is also more costly, as well as more difficult and expensive to maintain. This projector combines the instantaneous feature of the cathode ray tube with the light efficiency of the film projector.

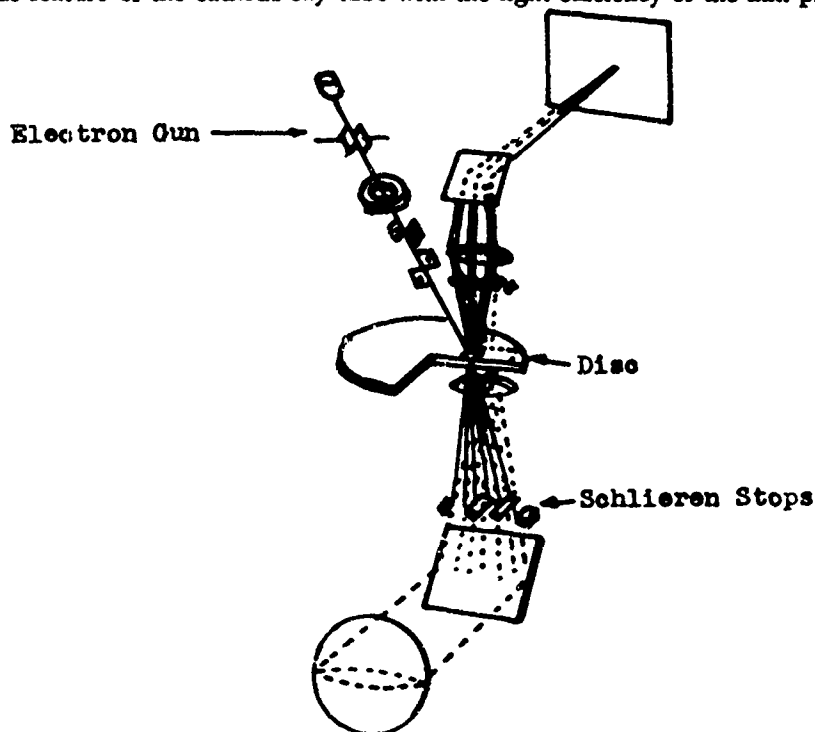

Figure 18. The Light Valve Projector

### The Schmidt Projector

The Schmidt projector was designed to project the image from the face of a cathode ray tube. It is less expensive and easier to maintain than the light valve. On the other hand, the Schmidt projector has a lower light output and a limited resolution as compared to the light valve.

### The Refractive Projector

The refractive projector uses a cathode ray tube and refractive optics to display the image. It is easy to maintain and costs less than other projectors. However, in terms of light output, the refractive projector is very inefficient.

### Projection Screens

Many types of both front and rear screens are available for displaying projected images, and some are more efficient than others. For example, front projection screens are considered to be more desirable than rear projection screens for use in visual simulation. Rear projection screens are inefficient, reduce image resolution, and greater brightness appears in the center than in other areas of the screen.

### VISUAL SIMULATION STUDIES

Flexman (112), 1949, devised a visual system for teaching landings in the School Link Trainer. A blackboard which could be rotated around its horizontal axis was placed in front of the trainer. An extension arm permitted the instructor to stand by the trainer and control the rotation of the

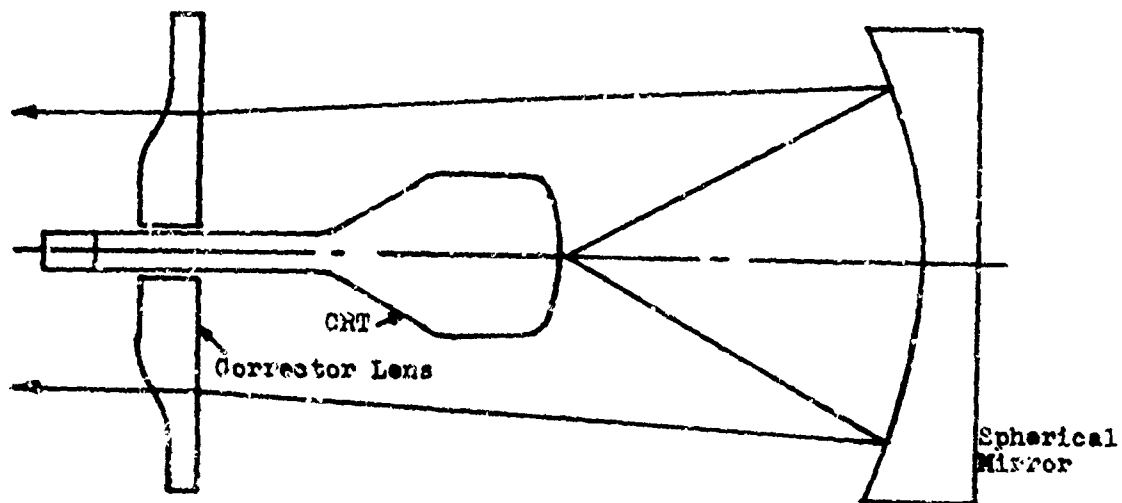

Figure 19. The Schmidt Projector

blackboard about its horizontal axis. A perspective view of the runway was drawn with white chalk on the blackboard. An ordinary window shade directed by a horizontal line, was connected to the blackboard by means of pulleys, levers, and cords. Thus, as the angle of the blackboard was being reduced to the horizontal, the shade would come down faster than the adjacent end of the runway. For example, as the student glided the trainer, the instructor starting with the blackboard at approximately a forty-five degree angle, reduced the angle gradually to simulate an approach to the runway. The blackboard was varied to simulate various conditions of approaches.

The visual landing system also utilized a cyclorama which was set up around the trainer. The cyclorama consisted of white cotton airplane fabric draped on a steel framework. A black tape seam on the fabric served as the horizontal reference line.

In 1951, Fell (5) described the development of a visual display designed to be used with any contact flight simulator. The purpose of the display was to teach the approach to landing maneuver and the system used two film projectors and a translucent screen.

Payne, et al (101), 1954, described a pictorial display designed to teach approaches to landings in a flight simulator. The device included a landing display projector and a screen. A Navy 1-CA-2 SNJ (P-1)\* Link trainer, with cyclorama, was modified to accommodate the pictorial display. The runway image was formed in the projector by means of a fixed-point light source shining through a movable cut-out of a runway and onto a translucent screen. The runway image could be viewed from the trainer cockpit, located on the other side of the screen. The image as it appeared during an approach is shown below.

\*The Navy SNJ trainer and the Air Force P-1 trainer are the same devices (Link Trainer 1-CA-2).

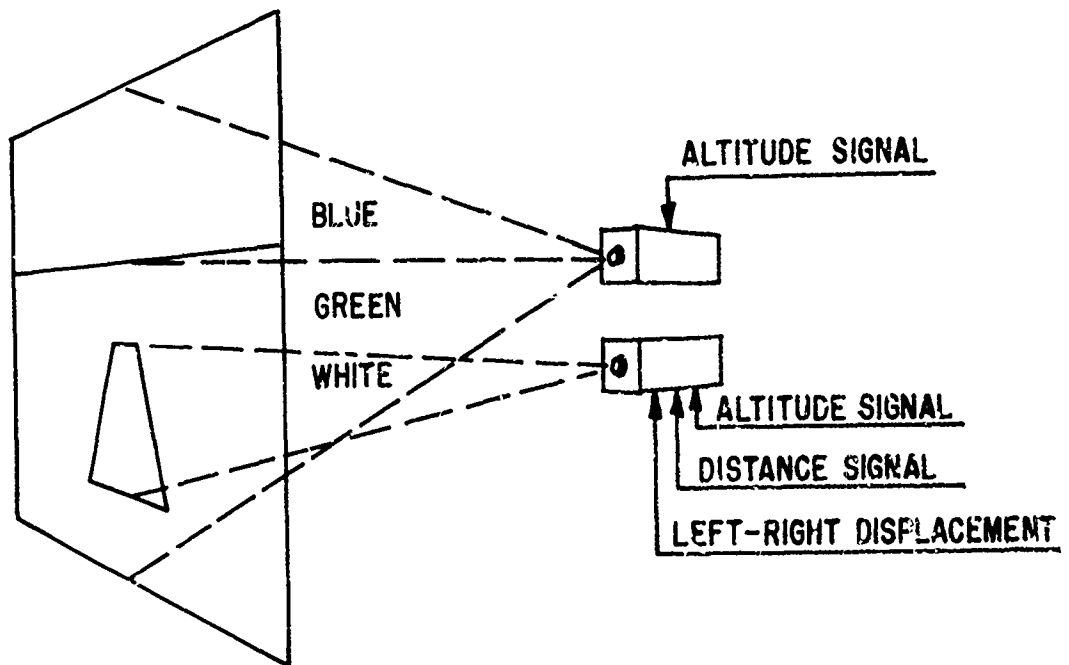

Figure 20. The Projectors and Translucent Screen (Ref. 5)

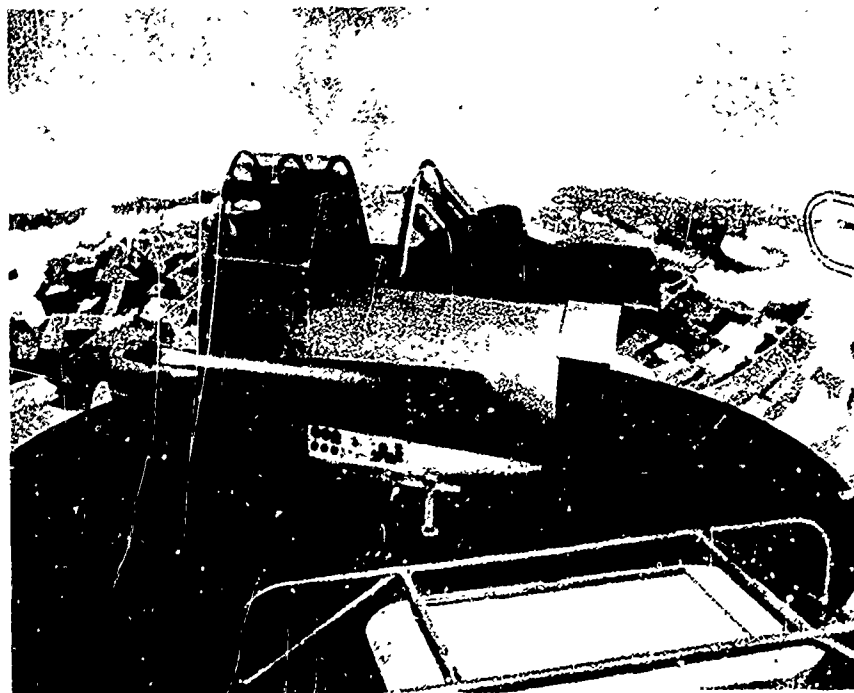

Figure 21. Link Trainer 1-CA-2 SNJ (P-1) with Cyciorama

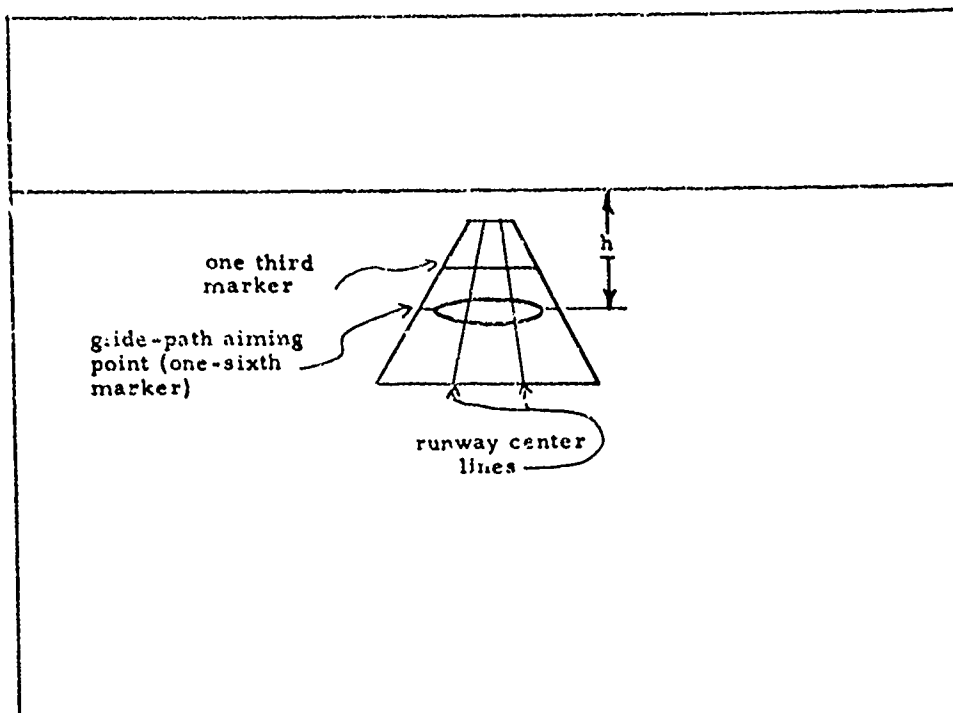

Figure 22. The Runway Image (Ref. 101)

The runway cut-out unit was mounted on a modified automatic recorder (crab). The crab moved on a smooth platform and its direction of movement was controlled by the heading of the Link trainer. The platform could move up and down in relation to the fixed light source and the platform elevation was controlled by the Link trainer altimeter system. As a simulated approach to a landing was made, the runway image showed changes in the trainer's heading, position, and altitude to the simulated runway. A graphic presentation of the equipment layout is shown below.

The United States Air Force (USAF) first became concerned with visual flight simulation in 1954 when a contract was awarded for the development of a terrain presentation attachment. The objective of the program was to design and develop an all optical, full-color visual simulation. The design concept used mirrors and lenses to relay an image from a three-dimensional model to a spherical screen in front of the cockpit. The direct optical approach was used because of the resolution limitations of closed circuit television (13, 14). During the design phase, it became apparent that the system was extremely inefficient, and would provide only a very dim image.

The SMK-22 (32), which used closed circuit television, became the first visual flight simulation attachment developed under the sponsorship of the USAF. It was designed to simulate low visibility, low ceiling, and night time conditions during takeoff and landings.

The SMK-23 Visual Simulator Trainer Attachment (7) was designed to aid the training of pilots in the critical aspects of takeoff and landing. It provides both day and night visual simulation and it could be used for training in different weather conditions. The device consists of a three-dimensional terrain model mounted on an endless belt which is viewed by a sequential color television camera through a servo-driven optical probe. The attachment is self-contained requiring only flight information from the simulator. The device was designed to be used with several different types of flight simulators.

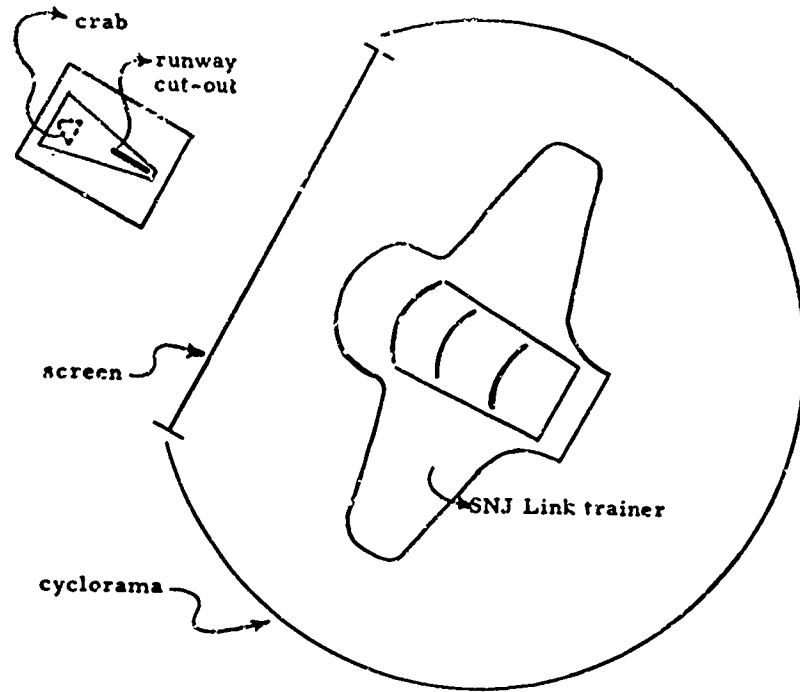

**Figure 23. Plan View of Trainer Room Showing Location of Projection Mechanism, Screen, and SNJ Link Trainer**

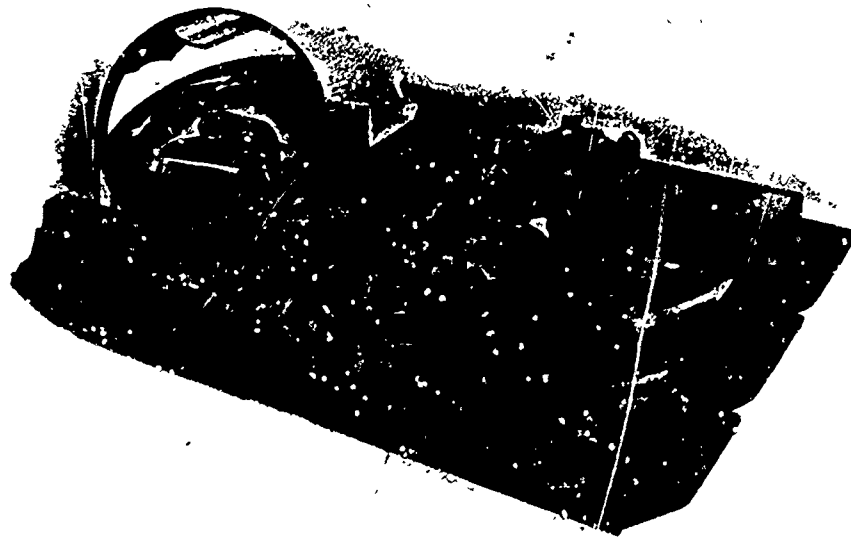

**Figure 24. An All-Optical, Color Television Visual Simulation (Refs. 13, 15)**

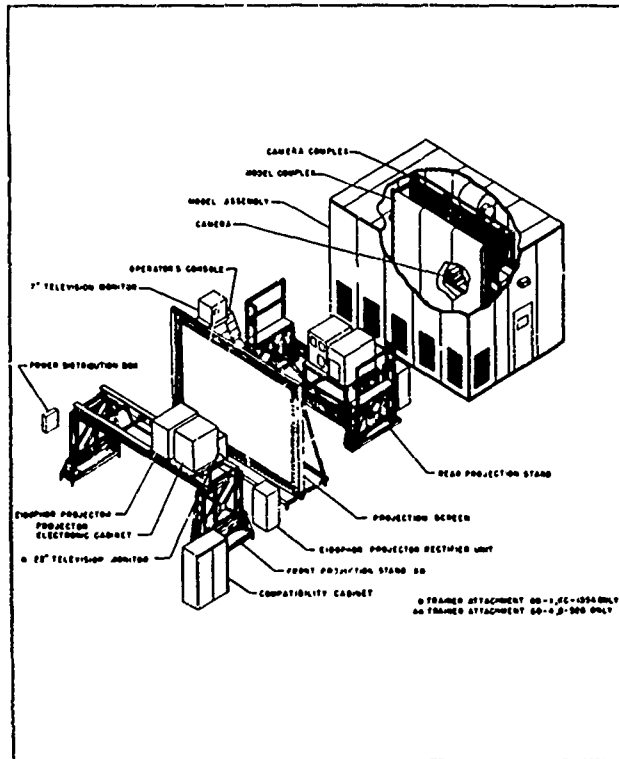

**Figure 25. Composite View of the SMK-22 Attachment Showing Front and Rear Projection**

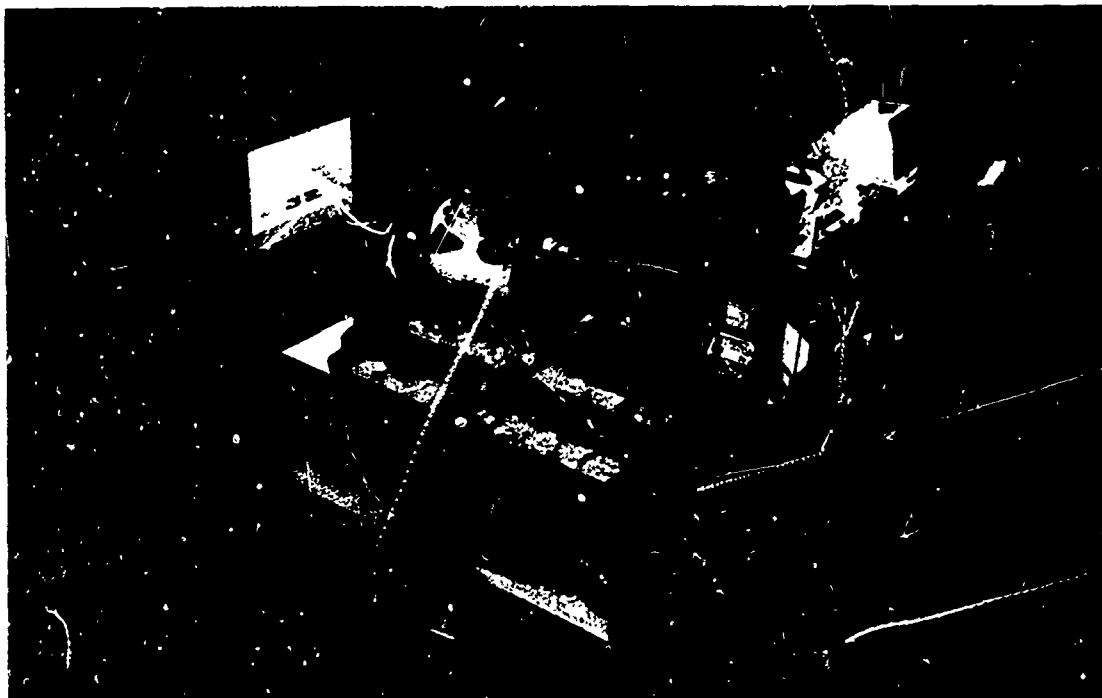

**Figure 26. The C-135 Flight Simulator with the SMK-23 Visual Attachment**

The SMK-43 Visual Simulator Trainer Attachment (33) was originally designed for the USAF as a night simulation device, but it was later expanded to also include day simulation. A flying spot scanner and an optical system scan the color slide transparency. The information is relayed in color by television onto a rear projection screen where it is viewed by a pilot trainee. A monochrome display of the scene is available at the instructor's console. The displayed image moves in response to roll, pitch, heading, longitudinal, and altitude movement of the flight simulator.

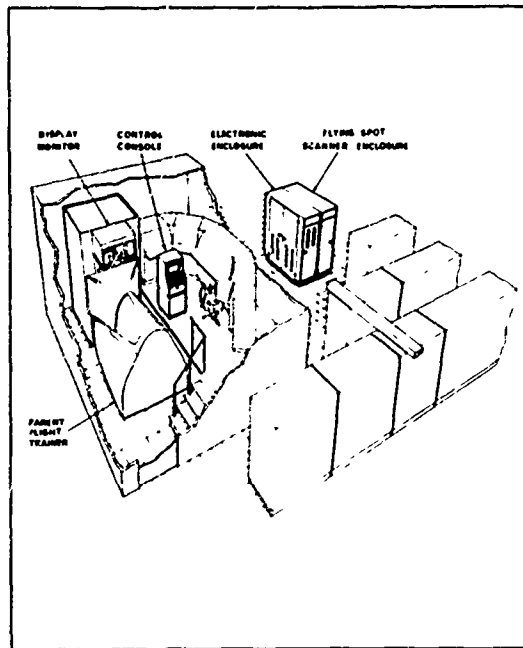

Figure 27. Visual Simulator Trainer Attachment, Type SMK-43/F37A-T, Typical Installation

The value of these visual simulation attachments is considerably reduced because of undesirable picture quality and poor maintainability of the systems. Various problems were encountered because the technology associated with these developments was not sufficiently advanced to support the development of the operational hardware without extensive exploratory work. The U. S. Air Force is presently conducting research in an effort to improve picture quality and other deficient areas in visual simulation. Also, the SMK-23 is being modified to improve its simulation quality.

Burke (6) described a visual landing system developed by Douglas Aircraft Company to be used with the DC-8 flight training program. This visual attachment is a part of the DC-8 flight simulator and it was developed for the purpose of training crews in normal and emergency procedures in day and night, and through fog and storm. The visual landing system includes the simulator aircraft controls, a television camera, projector and screen, a control and track system, and a replica of an airport.

In a study by Pfeiffer, Clark, and Danaher (29), in 1963, an external visual display was used with the F-100 simulator. The display included a television system, two slide projectors, and an instructor's console. The apparatus was used in the F-100/151 fixed gunnery experiment which is briefly considered in Section III.



The Navy sponsored a series of studies by the deFlores Company, Inc. which were designed to determine the usefulness of the point light source in presenting visual displays required for various training devices. These studies are identified by the Naval Training Devices Center Report numbers NTDC 1628-1 through 1628-11. Several of these reports directly related to flight operator training are included in the annotated bibliography (37, 38, 39). In general, the point source system device consists of the point source of light, the display-object, the screen, and the supporting structure and mechanisms required to move the display-object relative to the point source. The display-object is a black and white or color transparency.

The use of television and the Spectocom Head-up Display were reported in a series of visual simulation studies (8) by Bell Helicopter Company for the Joint Army-Navy Aircraft Instrumentation Research Program (JANAIR). The studies were performed in both the simulator and the helicopter. The simulator studies investigated pilot performance as a function of: (1) the use of director symbols and changes in grid texture; (2) the presentation of flight information on vertical tapes; and (3) digital readout of flight information augmenting the contact analog. The helicopter flight studies also examined the use of television with the Spectocom display for use as a total IFR in-flight helicopter display.

Care should be exercised in the selection of visual simulation devices (or any other training media) to ensure that the requirements of the real task objectives can be best achieved by use of the hardware under consideration. Since limitations and deficiencies exist, some compromise will be required. For example, if a very large visual envelope is needed, a larger and more expensive generator will be required. However, if a small envelope will suffice, the size and cost of the image generator can be reduced. Therefore, some knowledge of the capabilities and limitations of the visual devices is needed in order to weigh each factor and to select the equipment which is best suited for fulfillment of the training requirements. The annotated bibliography includes studies which provide research information on television cameras (16), high resolution television systems (17), display evaluation techniques (3, 4, 9, 10, 18) and image generation (20, 35, 36).

#### **MOTION SIMULATION**

Aircraft motion occurs within any of six degrees of freedom. Three of these degrees of freedom are in rotation around the axes of pitch, roll, and yaw. The other three are in translation along these axes in a longitudinal, lateral, or vertical direction. The aircraft's oscillations, vibrations, jerks, buffets, accelerations, decelerations, etc., can be described in one or more of these degrees of freedom.

In normal flight, the pilot uses visual cues to make continual adjustments while controlling the aircraft and also he receives cues from vehicular motion and changes in his body position. Apparently these visual and proprioceptive (motion) cues become more important as experience in flying tasks increases.

The early Link trainers provided motion which simulated bank, pitch, spin, turn, and yaw. However, when electronic simulators were developed following World War II, the consensus was that motion cueing was unnecessary. As Flexman\* said ". . . seat-of-the-pants flying was considered to be obsolete."

However, the advent of electronic simulators did not convince everyone that motion cues were no longer necessary in ground simulator training. Perhaps these cues could provide realism

\*Flexman, R. E. Man In Motion. *The Connecting Link*. 1966, 3 (1), 12-18 (General Precision, Inc., Link Group, Binghamton, New York).

in simulators which would contribute to the trainee's performance in the aircraft. However, the extent to which cueing should be incorporated into simulators was debatable. As a result, some research studies were conducted to investigate the problem.

#### **MOTION SIMULATION STUDIES**

A study by Wilcoxon and Davy (10), in 1954, described an experimental investigation of the effectiveness of rough air simulation in basic instrument and radio range procedure training. The rough air simulation consisted of mild pitching and rolling movements in two flight trainers: the Link 1-CA-2 SNJ Operational Flight Trainer (OFT) and the Link 1-CA-1 Navy Basic Instrument



**Figure 28. Navy Basic Instrument Trainer, Link 1-CA-1 (Nav BIT)**

Trainer (Nav BIT). The OFT subjects received rough air during all syllabus periods or during only one basic instrument and one radio procedure period. The NavBIT subjects received only the rough air schedule. The control groups for both trainers received no rough air simulation. The rough air simulation did not contribute to greater proficiency in either the trainers or in the SNJ aircraft. The rough air simulation seemed to add more realism to the training situation which resulted in a more favorable student attitude toward the trainers. The authors concluded that while rough air simulation is considered to be unnecessary, the inclusion of the simulation may be justified because of its "face validity."

A motion platform of the Grumman Motion Research Simulator, shown in figure 29, was described by Ruocco, Vitale, and Benfari (107). Three hydraulic servos position the points A, B, and C in a plane. Points A and B move differentially for roll, point C moves for pitch, and all three move simultaneously for vertical motion and any combination of pitch, roll, and heave can be achieved within the mechanical limitations of the motion platform.

A study by Townsend (109), 1955, indicated that the addition of motion is a desirable simulator feature. The ME-1 Link trainer used in the elevation was capable of a maximum cockpit

movement of  $5.5^\circ$  of pitch with no roll, and  $8.5^\circ$  of roll with no pitch. Pilots' opinions, which were not supported by experimental evidence, indicated that the motion capability increased the value of the trainer above all others that they had flown.

Vomaske, Sadoff, and Drinkwater (80) reported a National Aeronautics and Space Administration (NASA) study based on pilots' opinions on adverse and favorable aileron-induced yawing moments at various Dutch-roll damping levels. The authors concluded that the results of the fixed-base simulator test were about the same as for the actual flight results. Therefore, the absence of motion cues (in the simulator) did not markedly affect pilot opinion, possibly because of the strengthened visual cues presented.

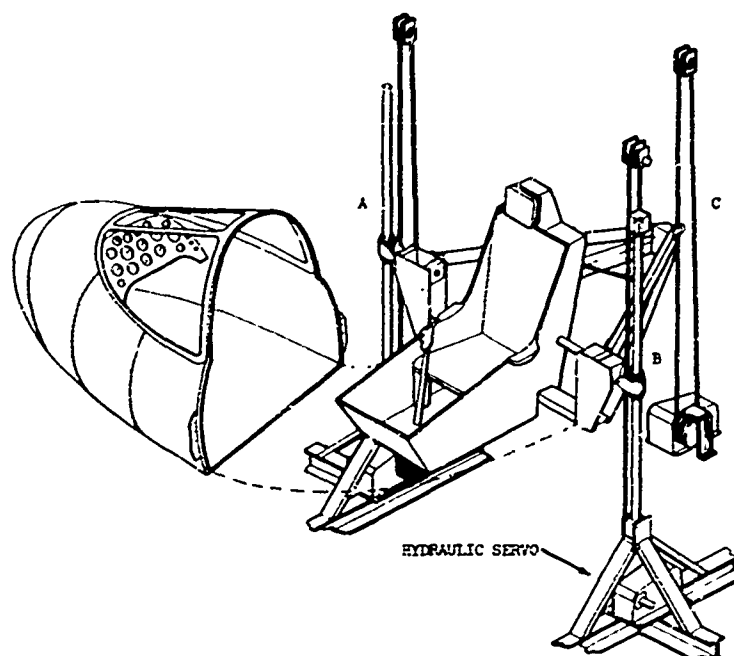

Figure 29. Motion Platform Configuration Isometric

Another NASA study by Creer, Steward, Merrick, and Drinkwater (53) distinguishes between what they call a mandatory stimulus and a desirable stimulus. The authors conclude that for certain aircraft characteristics, some form of motion must be provided if realistic simulation is to be achieved. On the other hand, there are various response characteristics for which fixed-base simulation should be sufficient.

Brown, Johnson, and Mungall (48), 1960; Federsen (58), 1962; and Ruocco, Vitale, and Benfari (107), 1965, found that the incorporation of motion in simulators enhanced performance. However, Brown, Kuehnel, Nicholson, and Futterweit (49), 1960, reported that work with a fixed-base simulator provides as good a basis for the prediction of pilot performance as do investigations using a centrifuge.

Research by NASA, compared the capabilities of test pilots in flight over a wide range of conditions under six degrees of motion with those on various fixed-base and moving-base simulators. In general, the conclusions indicate that motion cues in simulators are necessary only



Figure 30. The Link Trainer, ME-1

when they improve control of the vehicle or interfere with satisfactory performance. The studies emphasize that there is a distinction between mandatory and desirable cues. Thus, it seems that motion cues might be classified as "need to have" and "nice to have." These studies were summarized by Rathert, Creer, and Douvillier (73), 1959; Rathert, Creer, and Sadoff (74), 1961.

Caro and Isley (84) reported a study in which the Whirlymite Helicopter Trainer was used. This device differed from other flight trainers in that it used real world visual, auditory, and proprioceptive stimuli associated with actual contact flight. The performance of the experimental group was superior to the control group in the actual helicopter.

The demand for centrifuge facilities has continually increased over the past decade because of the advanced developments in aerospace systems. These developments in supersonic aircraft and space vehicles have increased the need for research on man's tolerance to flight stress. The results of the research may then be used as a basis for both vehicle and personnel equipment development. In addition, the centrifuge may be a valuable tool in aerospace systems tests by permitting tests of procedures, life support, control, restraint, escape, aircrew compartment construction, and instrumentation display during exposure to dynamic force environments. These motion simulators permit training of crew members to develop manual and mental skills which may increase the probability of appropriate responses to the performance requirements of a mission. Seven centrifuge studies (49, 51, 52, 61, 62, 71, 77) are included in the annotated bibliography of this section.

The Aerospace Medical Research Laboratories' human centrifuge with four cantilever trusses is shown in figure 31. The superstructure and cab were constructed by S. Morgan Smith Company, York, Pennsylvania. This centrifuge was "retired" in 1962 after 13 years of continuous service. It

has been replaced by the Dynamic Escape Simulator, shown in figure 32, which was constructed by the Franklin Institute, Philadelphia, Pennsylvania under the sponsorship of the Aerospace Medical Research Laboratories. The Dynamic Escape Simulator is basically a human centrifuge, designed to produce as closely as possible, the complex acceleration profiles of flight and emergency escape from present and proposed aerospace vehicles. It can be used as a simple centrifuge, escape simulator, disorientation device, six degrees of freedom simulator, and also for multi-stress tests.

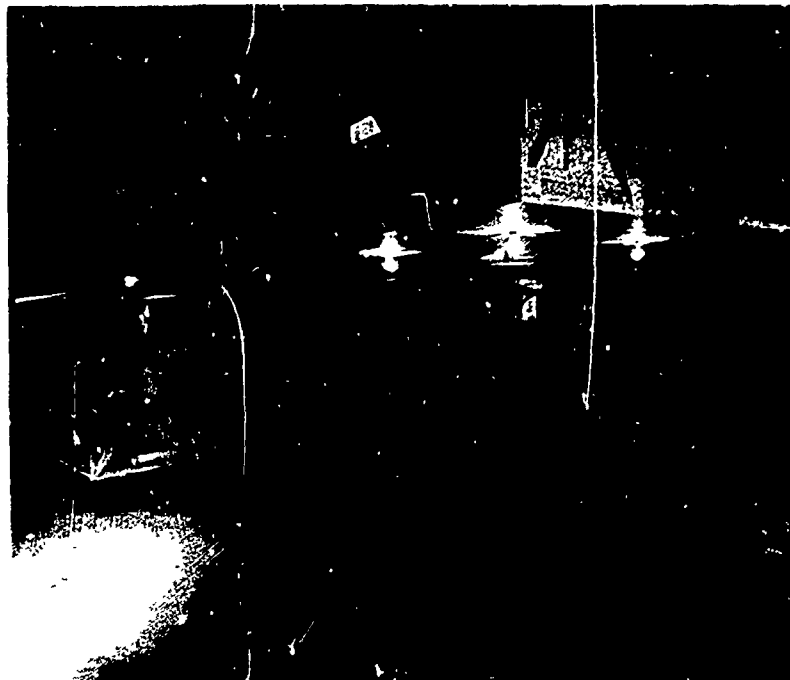

**Figure 31. Human Centrifuge — Aerospace Medical Research Laboratories**

Human centrifuge research is also conducted at the U. S. Naval Air Development Center (NADC), Johnsville, Pennsylvania. The centrifuge facility at the Aviation Medical Acceleration Laboratory contains a centrifuge which consists of a 50 ft. arm with a 10 ft. by 6 ft. oblate spheroid gondola mounted at the end.

Although airborne simulators are not considered to be within the scope of this report, several studies (64, 65, 66, 76) are included in the annotated bibliography as topics of related interest. The need for this flight-testing tool is based on the design requirements for modern high performance aircraft. A test airplane may be used to conduct research in the design of cockpit controls as well as the aircraft's response to the controls. For example, the control system of a jet trainer may be modified to permit simulation of more advanced aircraft. Thus, the airborne simulators may be used to acquaint pilots with the control characteristics of newly developed fighter aircraft.

#### **CONCLUSIONS**

In normal flight, the pilot uses both visual and motion cues while controlling the aircraft; however, the need for simulating these cues in flight trainers often has been questioned. External visual displays are only a part of flight training and the effectiveness of these devices may be as much a function of the fidelity of the simulator with which they are used as it is a function of the

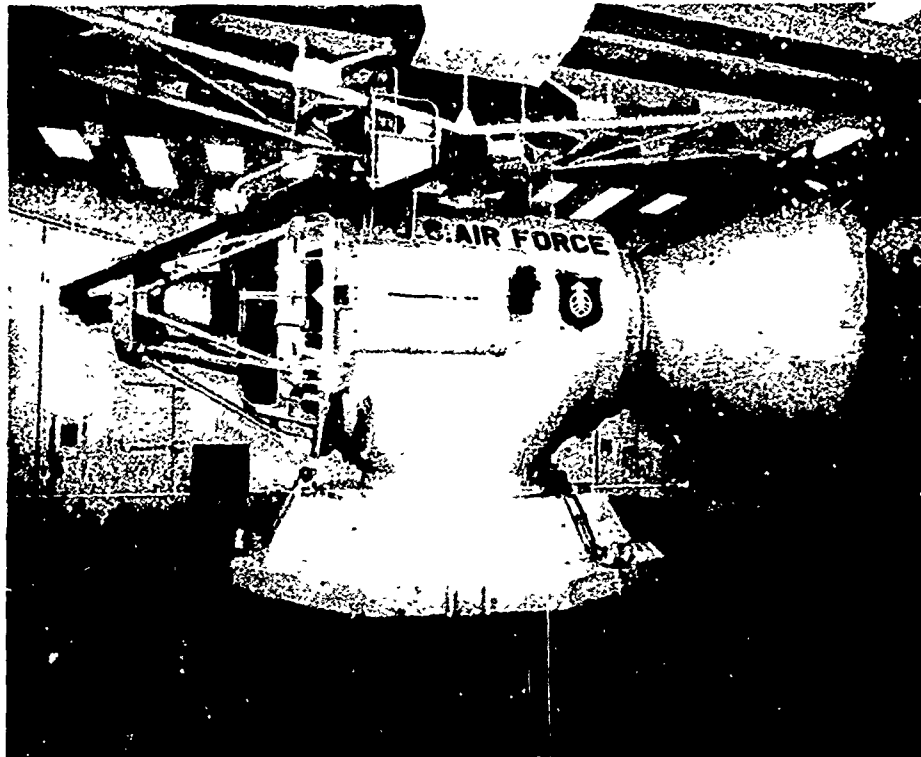

Figure 32. The Dynamic Escape Centrifuge -- Aerospace Medical Research Laboratories

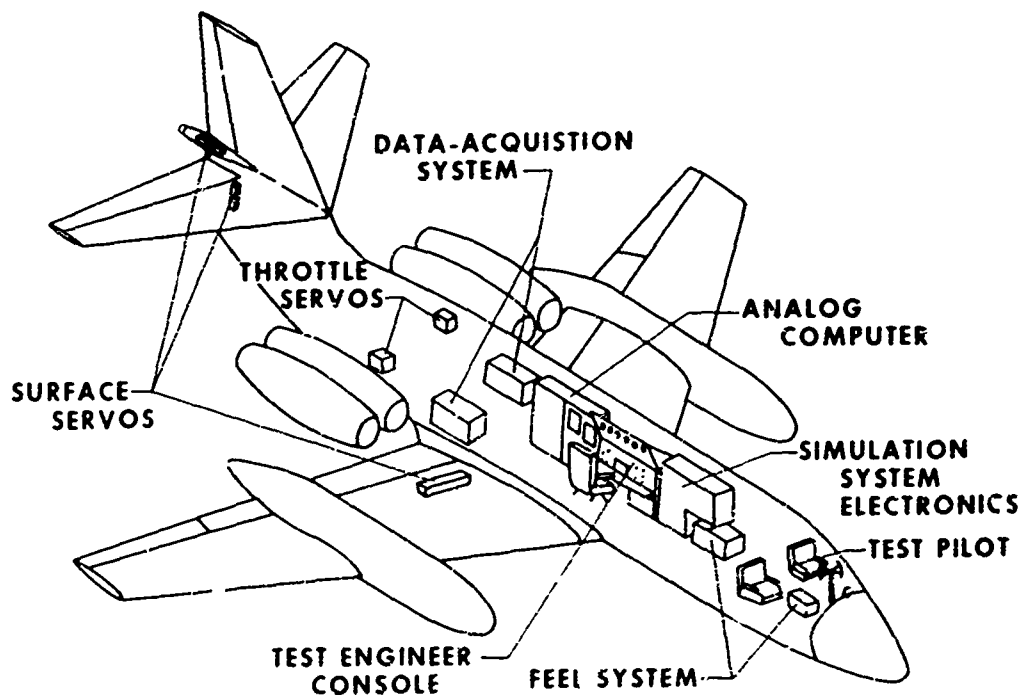

Figure 33. Layout of General Purpose Airborne Simulator Systems

visual displays. Also, the value of contact displays may depend upon the quality of instruction, attitudes toward the trainer, and other variables. The factors which should be considered in the design of a visual device are shown below:

FACTORS AFFECTING DESIGN OF VISUAL DEVICE	
AREA	FACTORS TO BE CONSIDERED
IMAGE STORAGE	SIZE VISUAL ENVELOPE COLOR OR MONOCHROME TWO OR THREE DIMENSIONAL IMAGE PHYSICAL SIZE STORAGE DEVICE IMAGE DETAIL
IMAGE PICKUP	RESOLUTION PHYSICAL SIZE PICKUP ELEMENT FIELD OF VIEW DYNAMIC RESPONSE
IMAGE RELAY	RESOLUTION BANDWIDTH (CAPACITY) COLOR OR MONOCHROME
IMAGE DISPLAY	FIELD OF VIEW RESOLUTION COMPATIBILITY WITH COCKPIT AND MOTION SYSTEM IMAGE FOCUS DISTANCE

Figure 34. Factors to be Considered in the Design of a Visual Device

Some studies indicate that motion cues in flight trainers are not necessary, while other studies suggest that such cues are desirable. However, a review of the literature indicates wide acceptance of the flight trainer as an effective medium for procedures training. The addition of visual and motion cues does not necessarily make the trainer more acceptable to pilots.

Perhaps too much reliance has been placed upon opinions when more factual information is needed. For example, what should the flight trainer teach? Are the objectives of the syllabus based upon a behavioral analysis of the actual performance requirements? If a training simulator, provided with visual and motion cues, is used only as a procedures trainer, it may be possible that procedures instruction capability is all that is required of the trainer. Thus, if not needed, additional cues unnecessarily increase the costs of training. On the other hand, a trainer utilization problem is apparent if the cues are necessary to achieve valid training objectives, but are not used for that purpose.

#### ANNOTATED BIBLIOGRAPHY — VISUAL AND MOTION SIMULATION

##### VISUAL SIMULATION

1. Abbott, B. A. and Dougherty, Dora J. *Contract Analog Simulator Evaluation: Altitude and Groundspeed Judgments*. Office of Naval Research, Washington, D. C. (Bell Helicopter Company, Fort Worth, Texas), Technical Report No. D228-421-015, March 1964, 134 pp, AD 467 203.

This report summarizes work which was accomplished during the first phase of evaluation of the JANAIR vertical display. The purpose of this study was to determine the accuracy with which

altitude and ground speed could be interpreted from the existing display. The display presentation was "open loop," i.e., no control task was required of the experimental subjects. Pertinent applied maneuver variables were presented. These included heading, ground speed, rate of turn, vertical speed and altitude. The influence of the test variables are discussed. Recommendations are made for use and redesign of this type of display.

2. Anderson, H. E., Jr. and Streeter, E. *Study, Aircraft Weapon System Trainer Instructor Station Display and Recording Systems*. Naval Training Devices Center, Port Washington, New York (American Institutes for Research, Los Angeles, California) Technical Report: NTDC-TR-1086-1, 209 pp, AD 464 614.

The objective of this study is to derive the functional requirements for the design and/or procurement of mission-oriented nonrepeating display and recording systems that will optimize instructor performance in five classes of naval aircraft weapon system trainers. This study provides a critique of the various display and recording systems available, or in the "breadboard" stage, and also an instructor information requirements analysis for each of the five classes of aircraft weapon system trainers. Integration of the results of these two analyses provide the basis for the type of display and recording systems recommended for each class of aircraft weapon system trainer. The main result of these analyses is the widespread use of an all-electronic cathode-ray tube display system for tactical, track and procedural information. In addition, this type of system could be extended to allow for playback capability for debriefing and would also offer the greatest possibility for growth and use with digital computers. This study also includes a survey of display techniques which provides a summary and abstracts of the various types of display techniques available as of 1962.

3. Baxter, J. R. and Workman, J. D. *Review of Projected Displays of Flight Information and Recommendations for Further Development*. Australian Defence Scientific Service, Aeronautical Research Laboratories, Melbourne, Australia Report ARL/HE 2, August 1962, 78 pp, AD 608 843.

Five projected displays of flight information proposed by organizations in the United States, England and Australia were reviewed and compared in respect to information content, simplicity and compatibility with the outside world. All five were shown to have associated problems of various types. A series of new displays, based on similar concepts but designed to eliminate the less desirable features of the others, were therefore proposed for simulator and flight evaluation. These new displays vary in respect to the type of flight director provided, and a complete test program was prepared to evaluate them in detail.

4. Basinger, J. D. and Holden, L. D. *Development of Measurement Techniques for Evaluation of a Visual Simulation System*. Aerospace Medical Research Laboratories, Wright-Patterson Air Force Base, Ohio (Systems Research Laboratories, Inc., Dayton, Ohio), Technical Report: AMRL-TR-67-90, June 1967, 139 pp, AD 820 280.

The purpose of this study was to develop evaluation techniques for visual simulation and to obtain an improved display for the SMK-23 Visual Simulator Attachment. In the past, evaluation techniques have been developed for television subsystems, but have not included the optical probe. This report documents techniques developed for the evaluation of the optical probe using the television camera as the measuring instrument. This permits the evaluation of the optical probe as it is actually used in the Visual Simulator. The evaluation includes resolution, depth of field, and flatness of field. To improve the picture quality of the SMK-23, different optical probes were



evaluated and the sequential color television system was modified to 1029-line, high resolution monochrome television. In the original SMK-23, system performance is limited by the bead lens optical probe. This probe limits the resolution, depth of field, and flatness of field of the final display. The Librascope optical probe overcomes these limitations and is recommended to replace the bead. The conversion of the SMK-23 to monochrome television greatly improves the resolution capabilities of the system, and also eliminates the color misregistration that is inherent in the original system. By using both the monochrome system and Librascope optical probe, the light available to the pickup tube is greatly increased. This permits the use of a less sensitive and less expensive image orthicon pickup tube and improves signal-to-noise ratio.

5. Bell, J. M. *A Landing Display for Use with a Contact Flight Simulator*. U. S. Naval Special Devices Center, Port Washington, New York (Department of Psychology, University of Illinois), Technical Report: SDC 71-16-18, March 1951, 19 pp, AT1 107 647.

One of the most difficult maneuvers to learn in a contact flying syllabus, in terms of time spent on it, is the approach to landing. If this maneuver could be taught successfully in a synthetic trainer, the usefulness of the trainer would be greatly extended. This report presents a mathematical analysis of the visual perspective cues that occur during an approach to a landing and the application of this theory to the design of an actual training device. Employing five mathematical equations developed during the study, a functional contact landing display was designed that could be used with any contact flight simulator. The changes in the image were made automatically in accordance with the simulated flight path of the trainer.

6. Burke, R. O. *A Preliminary Evaluation of the Link Visual Landing System Mark IV*. Masters Thesis, University of Wyoming, Laramie, Wyoming, January 1959, 141 pp, AD 214 308.

From the analysis of this study, it appears that the Visual Landing System tends to increase the training value of the DC-8 simulator. It is not possible to state that only the "most important" training needs utilize the visual system, but a majority of them do. Many of the "intermediate" and "less" important items of training needs are also presented through the use of visual cues. The importance of training items may change as a result of the perfection of equipment, refinement of training procedures, and/or experience in the aircraft. As a result of such changes, the usefulness of the Visual Landing System could become more or less meaningful. Further, if the consensus is followed that all simulator flights should be as realistic as possible and follow the normal "real life" sequence, then it must be concluded that the Visual Landing System aids in presenting this type of program.

7. Cohen, E., Woodson, R. A., Mackinnon, D. D., and French, H. W. *"Day-Night" Visual Simulator Trainer Attachment: Type SMK-23/F73A-T (Prototype)*. Systems Engineering Group, Wright-Patterson Air Force Base, Ohio, (Link Group, Systems Division, General Precision, Inc., Binghamton, New York), Technical Report: SEG-TR-67-10, March 1967, 34 pp, AD 817 665.

The requirement for flight training equipment, which simulates visual phenomena, normally encountered in take-offs, approaches, and landings, has long been recognized by the United States Air Force. It was not until the era of this prototype that the state-of-the-art progressed to the level at which training equipment could practicably and realistically reproduce the visual aspects of terminal flight conditions, in addition to the instrument flight indications normally available in instrument trainers and flight simulators. This report contains an account of the approaches, techniques, and equipments utilized in developing the prototype "Day-Night" Visual System. This

system represents a practical milestone in the design of visual simulation systems using relief models and closed loop television transfer techniques. The "Day-Night" Visual Simulator, Trainer Attachment, Type SMK-23/F37A-T, when combined with a flight simulator provides pilot trainees with a more realistic and complete simulation of the critical phases of the flight problem.

8. Dougherty, Dora J. *Final Technical Report, JANAIR Contract 4429(M)*. Joint Army and Navy Aircraft Instrumentation Research (JANAIR), (Bell Helicopter Company, Fort Worth, Texas), Technical Report No. D228-100-011, February 1966, 30 pp, AD 645 492.

The simulator studies were oriented about improvement and information augmentation of the contact analog. They were performed in the JANAIR/Bell Dynamic Flight Simulator and examined pilot performance as a function of: (1) the use of director symbols and changes in grid texture, (2) presentation of flight information on vertical tapes, (3) the use of digital read-out of flight information. Flight studies examined the spectocom head-up display and television in flight situations in the JANAIR research helicopter. Recommendations for solution to these problems are presented in the correspondingly appropriate technical reports. Technical reports of all researches performed under the contract have been issued and are reviewed in this document.

9. Emery, J. H. and Dougherty, Dora J. *Contact Analog Simulator Evaluation: Climbout, Low Cruise and Descent Maneuvers*. Joint Army and Navy Aircraft Instrumentation Research (Bell Helicopter Company, Fort Worth, Texas), Technical Report No. D228-421-017, May 1964, AD 603 744.

This study was designed to evaluate the contact analog vertical display which is an electronically generated encoded representation of the real world capable of presenting sensed information for altitude, airspeed, heading, pitch and roll. Encoded ground position and flight path symbols are also capable of being generated. Pilot subjects performed simulated helicopter flight maneuvers which included lift-offs, climbout, cruise and approach. The study was conducted in the Bell Helicopter Company dynamic helicopter simulator. The task was performed on different conditions of display content, glideslope angle and heading. Measures of performance included absolute integrated error of climb and approach airspeed, glideslope angle deviation, maximum vertical deviation from glideslope, fore/aft and lateral position error at hover, and vertical speed and altitude at hover, analyses of the results are presented and discussed, recommendations for display content for similar maneuvers in the research helicopter (RH-2) are presented.

10. Emery, J. H. and Dougherty, Dora J. *Contact Analog Simulator Evaluation: Vertical Display with Horizontal Map Display*. Joint Army and Navy Aircraft Instrumentation Research (Bell Helicopter Company, Fort Worth, Texas), Technical Report No. D228-421-020, October 1964, 39 pp, AD 612 465.

Evaluation was made of the pilot's ability to navigate and to perform simulated helicopter terminal area maneuvers using contact analog vertical display symbology alone and in the presence of the horizontal map display. Combinations of the grid, flight pathway and ground position indicator (GPI) on the vertical display with and without the map display were investigated. Performance measures were taken of the terminal area maneuvers including the landing approach, transition to hover, hover and touchdown. In general, the cruise position of the flight could be accomplished as well when using the basic grid plane on the vertical display in the presence of the map display as when additional symbology (pathway and GPI) was presented on the vertical display. Performance on the approaches and transition to hover scores indicated

improved performance with the additional information provided by the pathway and the GPI. It was concluded that precision of performance could be improved with the pathway and GPI navigation features on the vertical display but successful accomplishment of terminal area maneuvers was not entirely dependent upon this information.

11. Emery, J. H., Koch, C. A., and Curtin, J. G. *Contact Analog Simulator Evaluation: Investigations of Director Symbols, Display Alteration, and the Presentation of Secondary Flight Information*. Joint Army and Navy Aircraft Instrumentation Research (Bell Helicopter Company, Fort Worth, Texas), Technical Report No. D228-420-008, January 1967, 122 pp, AD 647 201.

The experimental work was performed within the flight simulation laboratory and made use of a dynamic platform programmed with UH-1 helicopter equations of motion. Three areas of research were conducted. One area included a series of experiments evaluating the use of different types of director symbols in the contact analog. Another area included a series of experiments to improve performance on basic maneuvers. A third area of investigation studied the display of secondary flight information with the contact analog. Experimental results are reported and discussed.

12. Federal Aviation Agency. *Flight Simulator Tests of Altitude-Coded Lights*, Washington, D. C., (Applied Psychology Corporation, Arlington, Virginia), Technical Report No. 8, March 1962, 29 pp, AD 602 423.

A regularly flashing, fixed-frequency light and a light giving altitude information by means of dot-dash signals were compared in terms of their usefulness to pilots who were trying to judge the relative altitude and vertical flight path of a simulated intruder aircraft. Standardized problems were constructed for a modified F-100/151 flight simulator, and included three rates of altitude change, approaches from left and right, and a number of collisions and misses. Accuracy in determining both relative altitude and vertical flight path of the intruder was better with the altitude-coded light than with the regularly-flashing, fixed-frequency light. With both kinds of lights, pilots became less accurate in judging relative altitude, but more accurate in judging vertical flight path, as the rate of altitude change increased.

13. Fox, P. L. *Design Study for Trainer, Visual Flight Attachment for Aircraft Flight Simulators*. Wright Air Development Center, Wright-Patterson Air Force Base, Ohio (Rheem Manufacturing Company). WADC Technical Report 57-137, Part I, March 1957, 133 pp, AD 216 438.

Design of a comprehensive visual display system to be attached to and used in conjunction with a fixed-based electronic flight simulator is described. The recommended design concept is based upon a rotary-sweep optical system capable of generating an extremely wide-angle presentation using narrow-angle techniques. Validity and feasibility of the system have been established through the engineering study program and experimental development conducted at Rheem-Philadelphia facilities. As the attachment of the system to the simulator will be accomplished by established techniques, this subject has not been discussed in detail as part of this study. The optical system is currently being subjected to a detailed mathematical analysis by a competent optical engineering firm for confirmation of the first-order design. Subject to the results of this mathematical analysis, it has been concluded that Phase II of the proposed visual flight attachment system should be started. An outline of the work for this phase is included.

14. Fox, P. L. *Design Study for Trainer Visual Flight Attachment for Aircraft Simulators*. Wright Air Development Center, Wright-Patterson Air Force Base, Ohio (Rheem Manufacturing Company), WADC TN 57-137, Part II, September 1958, 57 pp, AD 216 437.

The report is the result of an intensive search for a solution to the many difficult optical, geometrical, and mechanical problems involved in providing a display of sufficient scope and realism to make the trainer a positive and significant tool in the accomplishment of its intended function. Continuing study of these problems since the report was issued has resulted in further classification of the functional requirements and in the development of advanced techniques which permit certain important and desirable modifications in the system concept. These modifications are the substance of the present supplement to the original report. (WADC TN 57-137, Part I.)

15. Girod, C. V., Jr. and Pourciau, L. L. *Study and Development of Television Projector Video Amplifier Techniques*. Aerospace Medical Research Laboratories, Wright-Patterson Air Force Base, Ohio, (GPL Division, General Precision, Inc., Pleasantville, New York), Technical Report: AMRL-TR-67-61, July 1967, 47 pp, AD 660 912.

To determine the most suitable technique to provide a wideband (30-mc) high level (150 volts, peak-to-peak) video amplifier for use with experimental and developmental television projectors, various techniques for obtaining wideband amplification were investigated. The techniques investigated were: shunt, series and combination peaking, distributed amplification, negative feedback, and modulated radio frequency carrier. The primary problem was that of providing wideband amplification and high output level to a load that consisted of a resistor in parallel with various unavoidable capacitances which result from stage output capacitance, stray and wiring capacitances, and the input capacitance of the driven device. The capacitance limits the bandwidth of the amplifier, inversely proportional to the resistor-capacitance product. The study resulted in the design and construction of a solid-state video amplifier, employing a combination of feedback and peaking techniques, which meets the required performance characteristics. The amplifier provides a bandwidth of 30 Hz, a gain of 300 and an output capability of 150 volts.

16. Harshbarger, J. H. *Color Signal Source for Visual Simulation*. Aerospace Medical Research Laboratories, Wright-Patterson Air Force Base, Ohio, (Systems Research Laboratories, Inc., Dayton, Ohio), Technical Report: AMRL-TR-66-116, September 1966, 43 pp, AD 645 140.

A specialized color closed-circuit television camera system was developed as a source of high-quality signals to be used in simulation display device research programs. The system employs three vidicon camera tubes in conjunction with a unique optical and beam-splitting system. Camera configuration permits the system to be used as a three-color pickup, a multichannel monochrome signal source, or a high performance monochrome television signal source. The camera system contains four major units: camera, camera control, video inverter, and power supply unit. The camera is mounted on a special framework which also serves as a model or test chart support. The camera control, power supply, and color television monitor are placed in a rack cabinet. Wherever possible, standard circuit modules of high quality are employed in the system; this design approach provides a high degree of reliability even though the system represents a new approach to color television camera design.

17. Harshbarger, J. H. *Development of a High Resolution Research Television System*. Aerospace Medical Research Laboratories, Wright-Patterson Air Force Base, Ohio, (Systems Research Laboratories, Inc., Dayton, Ohio), AMRL-TR-65-235, December 1965, 18 pp, AD 630 941.

As a basis for the evaluation of high resolution television displays for their possible application to visual simulation training technique, a high resolution television system was developed to

provide high quality signals which will drive the display devices which were to be evaluated. As a result of previous research, a 1029-scanning line television system had been developed. Limitations in this single camera arrangement restricted the research which could be conducted into high resolution devices. A larger, higher quality system was required to carry the research study to greater levels of performance with less effort lost due to maintenance and adjustment. The system constructed combines newly purchased devices modified as required for the application together with some specially developed items and other government furnished equipment which was modified and integrated into the system. The design approach which led to the particular system concept is explained also. The equipment itself is described in detail with schematics and interconnection diagrams provided for special pieces of equipment. The effort is considered successful, as documented by photographs of displays achieved through the system.

18. Harshbarger, J. H. *Test and Evaluation of Electronic Image Generation and Projection Devices - Volume I - Evaluation Technique*. Aerospace Medical Research Laboratories, Wright-Patterson Air Force Base, Ohio, (Systems Research Laboratories, Incorporated, Dayton, Ohio), AMRL-TR-65-116 (I), August 1965, 39 pp, AD 623 908.

The report describes a method for evaluation of all types of displays in terms of resolution, brightness, and contrast ratio. The technique employs a television camera to replace human observation. This method thereby translates the characteristics of the display to measurable electronic waveforms. The waveforms are displayed on an oscilloscope where they may be analyzed directly and photographed, thus providing known standards of measurements in terms of electrical units rather than depending upon human judgment as a comparison standard. Direct evaluation may be applied to any display. The observer television camera furnished data which are an expression of the display fidelity. Brightness is measured by a photometer. These terms are subsequently interrelated in an expression of the contrast ratio attainable at various resolution and brightness levels. The analytical evaluation, especially applicable to cathode ray tube (CRT) display, obtains data through examination of the minute scanning spot as it traverses the image area. Analysis of the beam spot behavior enables one to predict the ultimate CRT capabilities without generating a complete display. Results of the analytical study are expressed so that they may be completely checked by application of the direct method to the full display. These methods of evaluation are adaptable to displays of every type as standard measurement technique.

19. Harshbarger, J. H. and Basinger, J. D. *Test and Evaluation of Electronic Image Generation and Projection Devices - Volume II - Evaluation of Television Systems*. Aerospace Medical Research Laboratories, Wright-Patterson Air Force Base, Ohio, (Systems Research Laboratories, Incorporated, Dayton, Ohio), AMRL-TR-65-116 (II), November 1965, 137 pp, AD 628 693.

This report presents data from an evaluation of the 7WP4 Projection Cathode Ray Tube (CRT) operated in the high resolution mode of 1029-line scanning configuration to produce a suitable display for simulation training. The capabilities of the CRT were first predicted by theoretical analysis conducted while the tube was in actual operation, then the actual display was analyzed to confirm the theoretical predictions. The test image projected on a screen was viewed by an observer television camera to reduce the displayed image to electronic waveforms which formed the basis for an accurate evaluation. The results obtained during the practical evaluation of the CRT in all ways confirmed the theoretical predictions. The CRT showed a resolution potential greater than the 800-line prediction, with a high level of brightness, and adequate grey scale linearity. Spot size was found to vary inversely with the scanning speed; line width is reduced at the faster scanning rates. Resolving capability, limited by spot size, is shown related to both brightness and scanning.

20. Harshbarger, J. H. and Gill, A. T. *Development of Techniques for Evaluation of Visual Simulation Equipment*. Aerospace Medical Research Laboratories, Wright-Patterson Air Force Base, Ohio, (Systems Research Laboratories, Inc., Dayton, Ohio), AMRL-TDR-64-49, August 1964, 149 pp, AD 607 880.

In Phase I of this report, a study of large area image display by projection television was undertaken to involve techniques of suitable image generation for astronautical flight simulation training. It was necessary to develop a technique to evaluate projected images. The display provided by the research apparatus, the closed-circuit television system from an F-151 Fixed Gunnery Trainer, was evaluated; and performance characteristics of the 7WP4 performance in an ultra-high resolution television system revealed the tube to be unsuited to high resolution service. In Phase II of this report, the projector in F-151 television system is converted from a conventional 525-line system to a high resolution 1029-line system. The 525-line format operated at 30 frames per second, with a horizontal scanning frequency of 15.75 kc and a vertical scanning frequency of 60 cps. In the 1029-line system, the frame rate and vertical scanning frequency were retained, but the horizontal scanning frequency was changed to 30.87 kc. The vertical sweep generator, sweep protection, and projection control circuits were duplicated; a video amplified and horizontal sweep generator were developed; and volume of the control equipment was reduced from 144 to 32 cubic feet. Performance of the 7WP4 tube exceeded the prediction: limiting horizontal resolution is 650 to 700 lines with a well defined vertical raster. Research indicates that a study into basic CRT characteristics is in order, particularly for use in display devices.

21. Izzo, L. L. and Cubberly, H. A. *Optical Spot Size Study for Data Extraction from a Transparency*. Aerospace Medical Research Laboratories, Wright-Patterson Air Force Base, Ohio, (CBS Laboratories, Division of Columbia Broadcasting System, Stamford, Connecticut), AMRL-TR-65-175, September 1965, 70 pp, AD 628 588.

A breadboard model scanner using coherent light to generate a small optical spot for data extraction from a transparency was constructed. Using the technique developed, a capability of distinguishing 256 lp/mm and 30 shades of grey from light to dark was demonstrated. The system consists of a laser light source, a beam expander, a beam normalizer, a rotating optical scanning system to cover a 2-inch wide transparency, a transparency holder, a light collector and a photomultiplier assembly including video amplifier and high voltage power supply. These system components are basically "off-the-shelf" items.

22. Lybrand, W. A., Havron, M. D., Hartner, W. B., Scarr, H. A., and Hackman, R. C. *Simulation of Extra-Cockpit Visual Cues in Contact Flight Transition Trainers*. Air Force Personnel and Training Research Center, Lackland Air Force Base, Texas, February 1958, Technical Report: AFPTRC-TR-58-11, AD 152 123.

Provides information needed to make recommendations regarding the visual cues which should be presented in prototype visual attachments to flight simulators. A secondary objective was to determine information and control design characteristics of instructional facilities required for optimal training utilization of the devices. The major areas concerned are transition training of experienced pilots to fighter, fighter-bomber and interceptor approach, landing, and go-around flight tasks. The study shows a serious lack of reliable, empirically derived information regarding the nature and functioning of extra-cockpit cues. A conceptual approach to the problem, developed in the study, allows a meaningful integration of available research knowledge and operational experience regarding visual cues.

23. Lybrand, W. A., Havron, M. D., Hartner, W. B., Scarr, H. A., and Hackman, R. C. *Simulation of Extra-Cockpit Visual Cues in Contact Flight Transition Trainers*. (Appendix I) Air Force Personnel and Training Research Center, Lackland Air Force Base, Texas, February 1958, Technical Report: AFPTRC-TR-58-11, AD 152 124.

Contains references which contribute to the understanding of the role of extra-cockpit visual cues in contact flight and information which the authors used for recommendations on certain characteristics of visual attachments to flight simulators. The appendix contains: (1) a preface which facilitates the use of the appendix; (2) Bibliography – Part I, of publications examined, but not formally abstracted; (3) Bibliography – Part II, lists publications examined during the extension period of the study and articles examined during the main study which were not listed in Part I for appendix organizational reasons which are not valid for the present appendix; (4) Bibliography of Confidential Publications, publications classified as Confidential which were reviewed during the research. The titles are unclassified; and (5) includes abstracts of applicable publications.

24. McGrath, J. J. and Borden, G. J. *Geographic Orientation in Aircraft Pilots: A Research Method*. Joint Army and Navy Aircraft Instrument Research Committee, (Human Factors Research, Inc., Los Angeles, California), Technical Report 751-2, September 1964, 59 pp, AD 605 893.

A methodological experiment was conducted using 24 pilots as experimental subjects. After a briefing, a chart study period, and a practice run, the subject attempted to maintain geographic orientation while sitting in the cockpit viewing one of the motion pictures. The experimental task required the subject to draw his ground track on an aeronautical chart, and upon periodic demand to indicate his exact navigational position. Each subject performed the task twice, a different flight route being used each time. The subjects were divided into three groups of eight. One group was given no navigational information other than the visual cues in the motion picture scene; the second group was given speed and elapsed time information; and the third group was given speed, time, and heading information to supplement the visual information. The results showed that individual differences in orientation performance were very large and performance scores were markedly skewed. There were no statistically significant differences between the performances of the three groups of subjects; there was no significant difference between performances on the two different routes.

25. McGrath, J. J., Osterhoff, W. E., Seltzer, M. L., and Borden, G. J. *Geographic Orientation in Aircraft Pilots: Methodological Advancement* Joint Army-Navy Aircraft Instrument Research Committee, (Human Factors Research, Inc., Los Angeles, California), Technical Report 751-5, October 1965, 45 pp, AD 624 616.

The report describes a revision in a cinema method of simulating low-altitude flight. Cockpit instruments used in dead reckoning were activated and synchronized with the motion picture scene. The throttle control was linked to the projector motor to provide the pilot with control of the simulated speed of the aircraft. An automated response system was devised to provide more accurate performance measurement, and the experimental procedure was revised to provide a more effective practice session prior to test sessions. A methodological study showed that the new experimental method improved geographic orientation in pilots during simulated flight.

26. Molnar, A. R. and Lybrand, W. A. *Basic Development Accomplished on Wick Angle, Non-Programmed, Visual Presentations – Vol. I*. U. S. Naval Training Device Center, Port Washing-

ton, New York, (Carmody Corporation, Buffalo, New York), Technical Report: NTDC 404, April 1959, 142 pp, AD 227 192.

This report provides the first summary of the efforts undertaken in the development of wide-angle, non-programmed visual presentation. The study also includes recommendations for additional investigations to define and detail the requirements for presentation of visual cues, because little is known about the visual-perceptual laws especially in dynamic situations. Results of the study are contained in two volumes: the report proper (Volume I) and its supporting appendix (Volume II). Abstracts and a bibliography of materials, from which the content of the report was drawn, are presented in the appendix as a secondary source for the use of design engineers.

27. Molnar, A. R. and Lybrand, W. A. *Basic Development Accomplished on Wide-Angle, Non-Programmed, Visual Presentations -- Vol. II -- Appendix*. U. S. Naval Training Device Center, Port Washington, New York, (Carmody Corporation, Buffalo, New York), Technical Report: NTDC 404, April 1959, 195 pp, AD 227 193.

Volume I presents a discussion and evaluation of equipment and techniques used in visual presentations. General descriptions of the major basic approaches are discussed. Brief descriptions of devices utilizing these approaches, their components and their advantages and limitations are presented. Part I also contains a summary and formulation of functional design criteria which should be considered in the design of visual presentation equipment for training purposes. Finally, recommendations for research and development areas are discussed.

Volume II consists of abstracts of various documents pertaining to visual presentations. The abstracts cover the design approach, training purpose and characteristics, description of useful components and a brief summary of the reports reviewed. An alphabetical listing of useful references is also presented. A summary of the information obtained from the state-of-the-art questionnaire is also presented.

28. Naish, J. M. *Simulation of Visual Flight, with Particular Reference to the Study of Flight Instruments*. Royal Aircraft Establishment, Farnborough, England. Technical Note No. 1.A.P.1099, August 1959, 29 pp, AD 232 600.

The pilot's forward view in flight is discussed with a view to formulating the requirements for a visual background, to be used in the study of flight instruments. Systems of visual flight simulation are reviewed and it is shown that the appearance of the external world may be simulated in a very compact manner by extending the known principle of an edge-viewed ground pattern, using a novel television technique, with the addition of a simulated sky. The ground pattern is formed by projection from a transparency, representing the chosen terrain, which is endowed with movements of translation and rotation such as to permit complete freedom of maneuver within the area covered. An industrial television camera, mounted with freedom of rotation about two axes, is used to look across the ground pattern from a point of variable height and the resulting picture, which has six degrees of freedom -- conveniently arranged to be compatible with the outputs of a conventional aircraft simulator, is presented on a large projection screen before the simulator cockpit, thus permitting head freedom and binocular viewing. Night or day conditions may be simulated and the visibility range is variable, but vertical ground features are not included. Details of construction are given and values presented for the chosen field of view, scale and viewing distance. Picture quality for the moving scene is discussed in relation to the essential characteristics, which are texture, resolution, engineering accuracy, perspec-



tive geometry, contrast, depth of focus and horizon characteristics. Tolerances or values are indicated for these parameters and brief economic details are given.

29. Pfeiffer, M. G., Clark, W. C., and Danaher, J. W. *The Pilot's Visual Task. A Study of Visual Display Requirements*. U. S. Naval Training Device Center, Port Washington, New York, (Courtney and Company, Philadelphia, Pennsylvania), Technical Report NTDC 783-1, March 1963, 117 pp, AD 407 440.

An analysis was made of the perceptual characteristics of the pilot's visual world while performing various flight tasks. These were compared with the perceptual characteristics made available by typical nonprogrammed visual displays attached to flight trainers. An experiment was then conducted in the F-100 simulator equipped with the 151 visual attachment to determine training effects. It was determined that, even among experienced subjects, performance significantly improved, both with regard to (1) the detection of inflight emergencies and (2) the maintenance of aerodynamic stability. Recommendations are made for improvements in external flight simulators.

30. Quatse, J. T. *A Visual Display System Suitable for Time Shared Use*. Office of the Secretary of Defense, (Carnegie Institute of Technology, Pittsburgh, Pennsylvania), June 7, 1965, 72 pp, AD 803 912

A visual display facility is being integrated with the time-shared G-21 multi-processor system at Carnegie Institute of Technology. Initially, three consoles will time-share an 8K regeneration memory which is addressable as main memory by the G-21 processors. More consoles can be added as the need arises. This paper documents the visual display system design. The primary design objectives were to develop and exploit a representation of displayed information which was suitable, economically and functionally, to time-shared use. The adopted representation permits a set of common editing operations to be completely controlled by relatively inexpensive console circuits. During these operations, no processor intervention is required. When processor intervention is required, the dual purpose of the memory module, as both regeneration memory and processor memory, permits a close partnership between the processors and the human console user.

The television camera is synchronized with the roll, pitch, yaw, vertical, and lateral motions of the aircraft so that the television presentation and its motion relative to the stationary cockpit accurately simulates the appearance of a runway at night. Visual simulation begins at breakout and, provided that the aircraft stays close to the approach path, continues to touchdown and roll-out.

31. Sgro, J. A. and Dougherty, Doris J. *Contact Analog Simulator Evaluations: Hovering and Air Taxi Maneuvers*. Bell Helicopter Co., Fort Worth, Texas for Office of Naval Research, Technical Report D228-421-016, July 1963, 109 pp, AD 424 485.

This study represents the second in a series of evaluations of the JANAIR vertical display. Four basic configurations (basic grid plane, basic grid plane with ground position indicator, basic grid plane with pathway, basic grid plane with pathway plus parastrips) which could be incorporated into a vertical display are evaluated, four subjects (5s) were required to perform three basic flight maneuvers. These maneuvers were presented at various assigned flight conditions for all display configurations. The three maneuvers were: (1) hovering, (2) takeoff, hover and touchdown, and (3) takeoff, air taxi and touchdown. Performance measures pertinent to each maneuver were evaluated for each display. These were recorded graphically and also in terms

of integrated absolute error. Analysis of the findings indicates that (1) the configuration of basic grid plane with pathway, and of basic grid plane with pathway plus tarstrips, were most effective for the hovering maneuvers and also for the takeoff, air taxi and touchdown maneuvers (2) for the takeoff, hover, and touchdown maneuver, the displays differed with respect to the various responses being recorded. The configuration of the basic grid plane produced the best performance for vertical velocity for the touchdown maneuvers.

32. Smith, G. *Trainer Attachment, Visual Simulator SMK 22/F37A-T*. Aeronautical Systems Division, Wright-Patterson Air Force Base, Ohio, (Fairchild Stratos Corporation, Wyandanch, New York), Technical Documentary Report: ASD-TDR-63-335, October 1963, 25 pp, AD 425 682.

The Trainer Attachment, Visual Simulator, SMK-22/F37A-T when combined with a Flight Simulator provides training in low visibility landings and takeoffs. Specifically, the Visual Simulator provides a dynamic stimulation of the pattern of the runway and approach lights which the pilot must use to guide the aircraft when transferring from instrument flight control to visual contact flight. Configuration "A" airport lighting with strobe lights, high intensity lights, and runway markers is simulated on a 30-foot neoprene conveyor belt moving in synchronism with aircraft speed. The pilot occupies his normal place in the flight simulator and performs instrument flight maneuvers in the standard manner. For landings it is assumed that the aircraft is flying under normal conditions; the initial phase of the approach (either precision radar or ILS) is under way, and the airplane is close to the desired flight path and in the proper attitude. When the approach becomes "visual" the pilot views the simulated approach and runway lights in a closed circuit television monitor located in front of him and above the instrument panel. The television camera is synchronized with the roll, pitch, yaw, vertical, and lateral motions of the aircraft so that the television presentation and its motion relative to the stationary cockpit accurately simulates the appearance of a runway at night. Visual simulation begins at breakout and, provided that the aircraft stays close to the approach path, continues to touchdown and roll-out.

33. Smith, G. *Trainer Attachment Visual Simulator SMK-43/F37A-T*. Systems Engineering Group, Wright-Patterson Air Force Base, Ohio, (Dalco Electronics Corporation, Norwood, New Jersey), Technical Report: SEG-TR-65-60, December 1965, 80 pp, AD 476 542.

Trainer Attachment, Visual Simulator SMK-43/F37A-T was designed to train and monitor pilots in the visual concepts of transitioning from instrument flight rules to visual flight rules at low altitudes and low-visibility day and night conditions when landing or taking off. Using a unique design, a trapezoidal raster of variable line spacing (functions of parent trainer's altitude and position) on a flying spot scanner tube furnishes a light source which is focused on a two-dimensional plane transparency of an airfield complex to generate red, blue, and green signals. These signals, when used with colored projection tubes utilizing normal rasters, provide a projected colored image in true perspective on the rear of a translucent screen mounted in front of the pilot. The pilot views the front of the screen through a large lens which makes the image appear to be at a great distance, adding realism to the display. The presentation image is made to move in response to roll, pitch, heading, longitudinal and altitude movements of the parent trainer enabling the pilot to experience the visual cues associated with flying.

34. Soxman, E. J. *Development of Thin Film Electroluminescent Display Techniques*. Aerospace Medical Research Laboratories, Wright-Patterson Air Force Base, Ohio, (Signatron, Inc., Coleta, California), Technical Report: AMRL-TR-67-1, April 1967, 23 pp, AD 655 903.

This report summarizes the design, fabrication and characteristics of a new thin film electro-luminescent (EL) display device of the cross-grid matrix type. The design called for an active area of approximately 7 inches x 7 inches containing at least 256 x 256 elements. The new panel was to provide maximum individual element size and be capable of generating a brightness of 100 ft-L when driven at 100 percent duty cycle. Under these conditions, the cross-suppression ratio was to exceed 10,000 to 1 even though no supplementary nonlinear suppression layer was employed. The panel was to be designed to single color operation essentially independent of drive voltage and frequency. In order to use a scan mode of drive, the high frequency excitation characteristics were to be determined. One goal was to achieve low voltage and high frequency response. It was also desired to provide for superimposed visual presentations, for example, by using the display panel as a screen for rear projected images.

35. Stoner, L. D., Horton, J. A., and Carson, E. R. *Simulation Image Generation - Vol. I - Study of Television Camera and Optical Pickup from Scale Relief Models*. Aerospace Medical Research Laboratories, Wright-Patterson Air Force Base, Ohio, (Goodyear Aerospace Corporation, Akron, Ohio), Technical Report: AMRL-TR-66-18 (Vol. 1), February 1966, 243 pp, AD 485 304 L.

Simulation devices for high-speed low-level flight, approach, and landing are considered deficient in one or more of the areas of (1) depth of field, (2) resolution, (3) perspective, and (4) shading. Phase I of this study program is an investigation of these problems as they relate to an optical-pickup/three-dimensional-model/television-system type of visual-image generator. The problems are examined in detail, and solutions or optimization techniques are offered for advancing the state of the art. Ten approaches - six with a single television channel in black-and-white and four in multiple-tube system with Scheimpflug-plane adaptive optics and a multiple-tube system with electronic data compilation of the equivalent high-resolution pickup plane are developed more fully; these are the recommended designs, representing state-of-the-art advances for improving depth of field. For available high-resolution television systems, it is possible to design a practical optical-pickup image generator whose apparent resulting display resolution is essentially limited by the television characteristics for all typical conditions of probe-model relationships and simulated vehicle attitudes.

36. Stoner, L. D. and Keates, D. T. *Simulation Image Generation - Vol. II - Study of Transparency and Stylized Image Techniques; Virtual Image Display*. Aerospace Medical Research Laboratories, Wright-Patterson Air Force Base, Ohio, (Goodyear Aerospace Corporation, Akron, Ohio), Technical Report: AMRL-TR-66-18, Vol. II, April 1967, 91 pp, AD 485 304 L.

Phase II of the study is an investigation continuing from Phase I (AMRL-TR-66-18 - Vol. I). Phase II investigates depth of field, resolution, perspective, and shading as related to flying spot scanner (FSS) and stylized visual image generation. Goodyear Aerospace also designed, fabricated, and tested a lightweight infinity optics display. The GAC study extended the definitions of FSS systems to include scanning pickups, with suitable light sources, conventional pictorial transparencies, and the coupling optics sub-system with analysis of problem areas and recommendations for improving the state of the art. An analysis was made of typical stylized image generation requirements from a viewer and equipment standpoint. This analysis leads to recommendations for improved languages and mechanics and for optimization of the system with respect to viewers characteristics. Reviewed in this study are equipment concepts and hardware and especially the need for video-data storage devices capable of operating in real time with ordinary and high-resolution TV equipment.

37. U. S. Naval Training Device Center. *Evaluation of Experimental Point Sources on Transparencies for Helicopter Hovering Flight Simulation Device 2FH2*. Port Washington, New York, (The deFlorez Company, Inc., Englewood Cliffs, New Jersey), Technical Report: NTDC 1628-11, February 1959, 85 pp, AD 235 883.

The visual display produced by the point light source and transparency originally furnished for Device 2FH2, an experimental helicopter hovering flight simulation device, and the visual display produced by a new light source and transparency for that device were evaluated by pilots. These evaluations were then compared to determine the relative merits of the original set and the new set of components. An appraisal of the usefulness of such a device for training was obtained also. The improved resolution obtained with the new light source is preferable to the greater brightness of the original one. The photographic techniques used in preparing the new transparency result in a more realistic display than that obtained with the wholly hand-decorated original transparency. The dished shape of the new transparency is much more rigid than the old one but detracts somewhat from the realism. Three-dimensional objects give the most important cues in the display with horizon and earth texture next in importance. The distortion known as "bowl effect" is the most objectional distraction. Simulation of all sorts of ambient weather conditions is greatly to be desired for training purposes. Some cockpit motion, even though limited, will add significantly to the effectiveness of the display.

38. U. S. Naval Training Device Center. *The Application of Point Source Projection Techniques to Helicopter Low-Altitude Navigation Training*. Port Washington, New York, (The deFlorez Company, Inc., Englewood Cliffs, New Jersey), Technical Report: NTDC 1628-3, March 1959, 43 pp, AD 235 880.

This report describes the results of a study to determine if a satisfactory visual presentation can be obtained with point light source techniques for application to a helicopter low altitude navigational trainer. The scope and the important elements of the problem were determined through interviews with pilots as well as from the requirements of the contract specification. A very promising point source projection system has been devised for use in helicopter low altitude navigational training. It is recommended that this system be evaluated through the experimenter described.

39. U. S. Naval Training Device Center. *The Development, Application, and Study of the Point Light Source Technique - Device 2FH4*. Port Washington, New York, (The deFlorez Company, Inc., Englewood Cliffs, New Jersey), Technical Report: NTDC 1628-16, September 1963, 96 pp, AD 435 547.

Device 2FH4 was designed and developed to provide a research, development and evaluation tool for studying problems associated with a flight simulator requiring visual presentation. This report is the final engineering, operation and maintenance report for the complete device and includes a discussion of the principles involved in the operation of the device 2FH4 and its application to the point light source visual presentation technique. The maintenance section of the report contains instructions on routine inspection, general maintenance, lubrication procedures, and a trouble-shooting guide for analysis and locating typical problems which may confront maintenance personnel charged with maintaining device 2FH4.

40. Whittenberg, J. A. and Wise, J. E. *Feasibility for Research of Visual Attachments for Dynamic Flight Simulators, Report No. 2: Requirements and State-of-the-Art Evaluation*. Federal

Aviation Agency, Systems Research and Development Service, Washington, D. C., 1963, 108 pp, AD 401 129.

This report identifies human factors research requirements for visual attachments to dynamic flight simulators, evaluates the state-of-the-art in visual simulation techniques for meeting these requirements, and discusses, within the context of a research and development cycle, alternative study settings (e.g., laboratory, simulation, and field) for investigating different types of human factors problems associated with visual cues and pilot performance. Current research problems dealing with visual cues and pilot performance during terminal flight and ground phases are grouped according to the nature of the task involved and types of variables related to the performance of these tasks. Three categories were used for grouping current problems:

1. *Detection/Identification Requirements:* Problems in this group are concerned with the photometric/colorimetric properties of airport and aircraft lights and markings as the independent variables. These studies contribute to the design and development of marking and lighting components and systems.

2. *Guidance Requirements:* Problems in this area deal with the alignment, spacing and configuration properties of airport lights and markings as the independent variables. These studies contribute to the design and development of airport lighting and marking patterns.

3. *Pilot Related Variables:* Problems in this area involve studies on the effects of such variables as pilot fatigue, work load, and operating environment on pilot performance during terminal flight and ground phases. These studies contribute to the development of pilot selection and training programs and to policies regulating pilot procedures and performance standards.

This classification procedure is used as a guide in establishing visual simulation requirements and criteria.

41. Wilkerson, L. E. and Matheny, W. G. *Discrimination and Control of Pitch, Roll and Yaw with a Grid to Encode the Ground Plane.* Office of Naval Research, (Bell Helicopter Corporation, Fort Worth, Texas), Technical Report: D228-421-003, January 1960, 17 pp, AD 234 786.

The basic assumption underlying a contact analogue display is that it will transmit information to the pilot in a manner which embodies the necessary and sufficient cues resident in the real world. It is believed that this real world abstraction, in order to elicit the correct responses, must create identity relationships analogous to those existing between the operator and his observed real world and permit his "reading out" the required information with the necessary precision. One of the cues needed in this picture is a presentation of the ground plane. Performance of eighteen flight naive subjects in controlling pitch, roll and yaw was measured in a helicopter simulator, a projected grid pattern being used to encode the ground plane. The principal independent variable was the orientation of the grid or heading of the aircraft. The subject's task was to "fly" straight and level while maintaining a prescribed heading. Three trials were given on each orientation. An analysis of the RMS data showed that differences in orientation of the grid plane did not affect tracking performance. The analysis of the reversal scores showed a trend toward fewer reversals with less spread when operating on the 45 degree orientation than when operating on either the 0 or 30 degree orientation. The implications of these findings are discussed.

## MOTION SIMULATION

42. A'Harrah, R. C. and Schick, J. P. *An Investigation of Low-Altitude, High Speed Flying and Riding Qualities of Aircraft*. North American Aviation, Inc., Columbus, Ohio, (for Bureau of Naval Weapons), February 1963, 111 pp, AD 403 044.

The results of a combined flight program and ground-based dynamic flight simulator study of the handling and riding qualities problems associated with low-altitude, high-speed flight are presented. Wide variations of longitudinal stability and control characteristics were pilot evaluated and pilot performance was measured for a terrain following task flown at varying levels of atmospheric turbulence. Pilot iso-opinion mappings of longitudinal static and dynamic stability for various control systems are shown, with regions exhibiting pilot induced oscillation (PIO) tendencies denoted. Pilot tolerance to gust-induced acceleration is established along with the influence of stability, control and turbulence on pilot performance.

43. A'Harrah, R. C. *Low Altitude, High-Speed Handling and Riding Qualities*. Advisory Group for Aeronautical Research and Development, North Atlantic Treaty Organization, Paris, France, Report 443, April 1963, 44 pp, AD 431 320.

The results of a combined flight and ground based dynamic flight simulator study of the handling and riding qualities problems associated with low-altitude, high-speed flight are presented in this paper. Wide variations of the longitudinal stability and control characteristics, which can be considered representative of current and future strike aircraft, were pilot evaluated. The influence of these stability and control characteristics, as well as the effects of low altitude turbulence on the pilots' terrain following performance, were measured. The results of this comprehensive investigation are presented in terms of iso-opinion and iso-performance boundaries defining the desired and required combinations of stability and control parameters for low-altitude, high-speed flight. These acceptance boundaries are significantly different from the boundaries presently defined in the military specifications. Combinations of vehicle and control system characteristics, which tend to become unstable when coupled with the pilots' response (i.e., pilot induced oscillations), have been defined.

44. Army Materiel Command. *Development of Fixed-Wing Basic Instrument Flight Simulator, Device Z-B-12A*. Prepared by the University of Pittsburgh, Army Materiel Research Staff, Washington, D. C., Technical Information Report 33,34.3, August 1965, 8 pp, AD 472 583.

Device Z-B-12A is a fixed-wing single-engine aircraft trainer with radio aids. It is used to teach pilot trainees navigation instrument flying by presenting them with a conventional blind flying instrument panel activated realistically by a transistorized analog computer. The computer is fed with position and rate data from the pilot controls and solves the aerodynamic and thermodynamic equations that activate the instruments. The flight characteristics of the device are generally similar to those of the U-8D (L-23) aircraft but with engines combined as a single reciprocating engine driving a variable-pitch propeller. Connected to the flight computer is a ten-station radio-aids unit with integral track recorder. The recorder continuously and accurately plots the flight path of the simulated aircraft within one or two areas, as selected (80 by 80 nautical miles or 160 by 160 nautical miles). The ten radio stations, five VHF/VOR, three LF/ADF, and two fan markers, are positionable anywhere in the area covered by the recorder under the control of the instructor. The trainer can set an ILS station with any runway heading and enable simulated ILS and GCA approaches to be made by using standard ILS marker configurations, localizer patterns, and glide-slope angles.

45. Assadourian, A. *Ground Simulator Studies of a Small Side-Located Controller in a Power Control System*. National Advisory Committee for Aeronautics, Washington, D. C. Research Memorandum L58B14, April 23, 1958, 27 pp, AD 156 848.

An investigation was made to determine the operating characteristics of a small side-located control stick with the use of a ground simulator incorporating a power control system. The simulator or pitch chair was designed to produce the pitching motion associated with the short-period mode of an airplane. The short-period dynamic characteristics of the simulator were adjustable so that a large number of airplane flight conditions could be simulated. The quality of the control system using the side-located controller was determined by the ease and precision with which various tracking maneuvers could be accomplished by the pilot. A general opinion of all the pilots operating the pitch chair was that they were favorably impressed with their ability to track precisely with the small side-located controller provided the control-system characteristics were desirable.

46. Bell Helicopter Corporation. *Results of Engineering Test Made on the Franklin Institute Dynamic Flight Simulator*. Fort Worth, Texas, Report No. D228-370-001, April 1960, 48 pp, AD 236 660.

The purpose of these tests was to determine velocity limits, acceleration limits, magnitude and frequency of unwanted signals. Particular attention was given to the lower frequency, large excursion signals presented to the platform by the computer during the simulated flight. It is felt that signals such as these are more representative of the actual motion of the helicopter. Conclusions were that the existing distance available for acceleration is very near optimum in most channels. Most of the noise noted had a definite frequency component of 2 cps., the platform natural frequency in most channels. In most cases larger servo valves will improve maximum velocities and accelerations obtainable, as the largest percentage of the hydraulic pressure drop is produced by the servo valve, with very little pressure remaining to accelerate the load. Many modifications were made to improve the performance of the platform during the test. The results shown in this report represent the optimum obtained from these modifications.

47. Breul, H. T. *Simulator Study of Low Speed VTOL Handling Qualities in Turbulence (Final Report)*. Bureau of Naval Weapons, Washington, D. C., (Grumman Aircraft Corporation, Bethpage, New York), Grumman Research Report RE-238, February 1966, 62 pp, AD 477 949.

An experimental study was performed to determine, from the pilot's point of view, the effects of certain stability derivatives, atmospheric turbulence, and control power on the handling qualities of VTOL craft. Using a flight simulator, qualified pilots evaluated over 450 configurations in the task of moving the craft from one hover spot to another. The simulator consisted of a cockpit providing motion in roll and pitch and an optical display system providing an illusion of motion in the remaining four degrees of freedom. The primary conclusion drawn from the study is that speed stability, either lateral or longitudinal, strongly influences a hovering vehicle's control power and angular rate damping requirements. Furthermore, lateral and longitudinal requirements are found to be similar, when the effects of speed stability are taken into account.

48. Brown, B. P., Johnson, H. I., and Mungall, R. G. *Simulator Motion Effects on a Pilot's Ability to Perform a Precise Longitudinal Flying Task*. National Aeronautics and Space Administration, Washington, D. C., Technical Note: NASA TN D-367, May 1960, 10 pp, AD 236 265.

A program was conducted on the NASA normal acceleration and pitch (NAP) simulator to determine the effect that body-motion cues have on the pilot's ability to perform a precision

close-coupled tracking task. These tests were conducted with heavy stick-force gradient and with zero-stick-force gradient over a range of longitudinal stability conditions. Pilots controlled the simulator from both a fixed and a moving cockpit. The results indicate that there was improvement in pilot performance due to motion cues over the stability range tested. The motion cues appreciably improved the performance of both pilots when the feel forces were absent. The pilots always preferred to be supplied with motion cues. In the absence of feel forces, confusion was exhibited by one pilot as to the proper direction to execute control when bodily-motion cues were not provided.

49. Brown, J. L., Kuehnel, H., Nicholson, F. T., and Futterweit, A. *Comparison of Tracking Performance in the TV-2 Aircraft and the ACL Computer/AMAL Human Centrifuge Simulation of this Aircraft*. U. S. Naval Air Development Center, Johnsville, Pennsylvania, Report: NADC-MA-6016/NADC-AC-6008, 7 November 1960, 66 pp, AD 250 129.

The analysis of a preliminary experiment does not indicate any advantage in the use of the centrifuge for the study of pilot tracking performance in a maneuvering aircraft when the maximum linear accelerations are on the order of 5 G. Anomalous angular motions of the centrifuge, which in this experiment caused disorientation and nausea of the subject pilots, probably served to offset any advantage gained by the inclusion of the acceleration forces in the simulation. For the tracking tasks used in the present experiment, the results of work with a static, or fixed base, simulator provided just as good a basis for prediction of the way in which pilots would perform a specific task in the aircraft as did work performed on the centrifuge.

50. Brugh, R. L. and McHugh, J. G. *Flight Simulator Study of Human Performance During Low-Altitude, High-Speed Flight*. U. S. Army Transportation Research Command, Fort Eustis, Virginia, (North American Aviation, Inc., Columbus, Ohio), TRECOT Technical Report 63-52, November 1963, 101 pp, AD 429 114.

An investigation of the influence of low-altitude high-speed flight conditions on inflight operator performance of surveillance-centered tasks is reported. Six Army pilots and four Army observers "flew" approximately 278 hours on simulated three-hour missions involving five RMS gust intensity levels and two airspeeds. The flights were made in a moving base simulator that had a total travel of approximately 12 feet, and acceleration capability of  $\pm 6$  G, a functional control system, and an associated analog computer for obtaining solutions to equations of motion of a mechanized aircraft. Data were analyzed in terms of human performance aspects of the missions.

51. Clark, C. C. and Woodling, C. H. *Centrifuge Simulation of the X-15 Research Aircraft*. U. S. Naval Air Development Center, Johnsville, Pennsylvania, Report No. 9, 10 December 1960, 33 pp, AD 233 340.

These X-15 centrifuge programs have demonstrated the potentialities of the centrifuge simulator, particularly under conditions of closed loop pilot-computer control or centrifuge dynamic control flight simulation, for the study of pilot tolerance, restraint, instruments, controls, vehicle controllability, control techniques, and training. Although the centrifuge has only three degrees of freedom of control and hence can only partially simulate the three linear and three angular accelerations of unconstrained flight, it has been possible to simulate the principal forces operating on a pilot and hence, to "fly an aircraft before it is built." This new technique of centrifuge flight simulation under pilot control should now join the previous techniques of mathematical design, wind tunnel testing, static control simulation, and flight in other aircraft in contributing



to the development of the design of all new and particularly high performance aircraft and space vehicles. This technique requires a large computer, but it is noted that the centrifuge has already been operated in a preliminary way through telephone line linkage to a computer in Langley, Virginia, 250 miles away. It is visualized that centrifuge dynamic control simulation would follow the airplane manufacturer's developmental work utilizing static simulation to confirm the adequacy of the design. By the use of telephone lines or microwave linkage, the manufacturer's computer, already utilized for the static simulation work, might be utilized in the centrifuge control loop.

52. Creer, B. Y., Smedal, H. A., and Wingrove, R. C. *Centrifuge Study of Pilot Tolerance to Acceleration and the Effects of Acceleration on Pilot Performance*. National Aeronautics and Space Administration, Washington, D. C., Technical Note: NASA TN D-337, November 1960, 35 pp, AD 245 411.

Describes a research program designed to measure the effects of various sustained accelerations on the control performance of pilots on the Aviation Medical Acceleration Laboratory centrifuge, U. S. Naval Air Development Center, Johnsville, Pennsylvania. The experimental setup consisted of a flight simulator with the centrifuge in the control loop. The pilot performed his control tasks while being subjected to acceleration fields such as might be encountered by a forward-facing pilot flying an atmosphere entry vehicle. The study showed there could be marked decreases in pilot tracking performance with increases in the magnitude of the impressed accelerations. Pilot comments indicated that in order to have the same level of control over the vehicle, an increase in the vehicle dynamic stability is required with increases in the magnitude of the acceleration impressed on the pilot. It appears that a great deal of additional research work is warranted in investigating the effects of sustained acceleration on the pilot performance. The study indicated quite clearly the improvement in tolerance to acceleration times which can be realized through relatively minor improvements in the pilot's restraint system. Pilot comments indicated a unanimous preference for the two-axis class of side control over the three-axis class. The pedal controls used in this study resulted in effective yaw control for most acceleration fields of this investigation.

53. Creer, B. Y., Stewart, J. D., Merrick, R. B., and Drinkwater, F. J., II. *A Pilot Opinion Study of Lateral Control Requirements for Fighter-Type Aircraft*. National Aeronautics and Space Administration, Washington, D. C., NASA Memo 1-29-59A, 1959, AD 213 632.

In the investigation, both a fixed and rolling simulator were used and an actual flight test was made. The results of this study were the determination of two fundamental parameters which affect pilot opinion of the aircraft roll performance. In addition, a handling qualities criterion was formulated for the lateral control fighter aircraft flying in their combat speed range.

54. Douvillier, J. G., Jr. and Coate, R. E. *The Coordinate-Transformation Equations for a Piloted Flight Simulator with Several Degrees of Freedom*. National Aeronautics and Space Administration, Washington, D. C., NASA Technical Note D-1150, January 1962, 24 pp, AD 270 086.

A method for developing coordinate-transformation equations for a multiple-degree-of-freedom flight simulator is presented. The equations are applicable in particular to a five-degree-of-freedom piloted flight simulator. In general, however, the method of their development is applicable to transformation equations for other, similar simulators of fewer or of more degrees of freedom. Because the NASA simulator has a very limited range of displacement in one of its

modes of motion, the equations are written for four degrees of freedom. Examination of the singularities of the equations showed it possible to reproduce any combination of four of the six components of motion, three angular and three linear, of the vehicle being simulated. In most cases, there is more than one way to simulate each combination, the most desirable way determined by the restrictions imposed by the singularities of the equations.

55. Douvillier, J. G., Jr., Turner, H. L., McLean, J. D., and Heinle, D. R. *Effects of Flight Simulator Motion on Pilots' Performance of Tracking Tasks*. National Aeronautics and Space Administration, Washington, D. C., Technical Note: NASA-TN-D-143, February 1960, 34 pp, AD 231 341.

In the design of cockpit-instrument displays flight simulators are used extensively for preliminary studies and for much of the advanced development. Yet, little is known about the differences in pilots' tracking performance between actual flight and simulated flight. The effect of motion of a flight simulator on pilots' performance of a tracking task was investigated by comparing the air-to-air tracking performance of two pilots in flight, on a motionless flight simulator, and a flight simulator free to roll and to pitch. Two different attack displays were used. It was found in tracking a maneuvering target that: (1) The results from the moving flight simulator resembled the results from flight much more than did those from the motionless simulator; and (2) That in flight the conventional circle-dot display was superior to a drone display. For simpler tracking tasks it was not possible to detect these differences.

56. Durand, T. S. *Theory and Simulation of Piloted Longitudinal Control In Carrier Approach*. Systems Technology, Inc., Hawthorne, California, (For Bureau of Naval Weapons), STI Technical Report No. 130-1, March 1965, 76 pp, AD 464 703.

This report covers the second phase of a program investigating piloting control problems in carrier approach and landing operations. Analyses and experiments were performed to determine the causes of the pilot's inability to control altitude, which is often described as the reason for a (minimum) limiting usable carrier approach airspeed. The analyses indicate that an altitude tracking performance defect is encountered at a certain speed assuming the pilot controls pitch attitude with elevator and altitude with throttle. The speed at which this theoretical problem is encountered seems to match well with flight test determined minimum carrier approach speeds for several aircraft. Thus, the cause/effect relationship is clearly inferred. However, there is then considerable question as to why alternative piloting techniques which eliminate the problem are not used. To investigate such inferences and questions and to lend credence to the analyses, piloted simulation experiments were devised, implemented, and run. The trials and tribulations attending satisfactory fixed-base simulation with a minimum of equipment were encountered early. The steps finally taken to achieve suitable realism are described, as are the detailed results. In general, the results tend to support the theory, and shed some light on possible reasons for pilots' preference for an apparently inferior control technique.

57. Faye, A. E., Jr. *Attitude Control Requirements for Hovering Determined Through the Use of a Piloted Flight Simulator*. Ames Research Center, Moffett Field, California, National Aeronautics and Space Administration, Technical Note: NASA TN D-792, April 1961, 20 pp, AD 254 163.

A piloted simulator investigation has been conducted to establish attitude control requirements for hovering flight. Realistic controllability boundaries of control power and damping values were established about each of the three axes, one at a time, under ideal conditions.

These single-axis boundaries shifted and became more restrictive when simultaneous control about two axes was presented the pilot, with the controls harmonized, or when gyroscopic coupling was added. Gyroscopic coupling between the pitch and yaw freedom of motion resulted in a rapid deterioration of controllability with increasing amounts of gyroscopic coupling, especially when the damping was reduced to low values. The results of a comparison of simulator controllability with flight indicates good correlation between the simulator two-axes results and the VTOL airplane all-axes results.

58. Feddersen, W. E. *The Role of Motion and Its Contribution to Simulation Validity*. Bell Helicopter Company, Fort Worth, Texas for Army-Navy Instrumentation Program, Report No. D228-429-001, April 1962, 88 pp, AD 281 855.

The use of a motion simulator in the evaluation and testing of display and instrumentation concepts which are central to the objectives of the Army-Navy instrumentation program (ANIP) poses the same question, to what extent does the device allow a valid evaluation of the developments under consideration. The ultimate in validity would be achieved when operator behavior in the simulator corresponds precisely to control behavior in the system being simulated which, in this case, is a helicopter in all of its flight modes. Since it is unrealistic to expect exact behavior correspondence in the two situations the task is one of determining the extent or degree of approximation. This report summarizes the results of a series of three investigations, both simulator and flight test, designed to determine the relative proficiency allowed by motion information in the simulator in a hovering flight mode and, secondly, to determine with approximate measures the degree to which control behavior in the helicopter is approximated by behavior in the simulator when the tasks are equivalent. The proficiency results are reported in terms of integrated absolute error scores about the various axes defining the hovering task, and the behavioral data, are presented in the form of auto-correlation functions.

59. Gerdes, R. M., and Weick, R. F. *A Preliminary Piloted Simulator and Flight Study of Height Control Requirements for VTOL Aircraft*. National Aeronautics and Space Administration, Washington, D. C., Technical Note D-1201, February 1962, 20 pp, AD 272 130.

A fixed-base piloted flight simulator was used in a preliminary investigation of requirements for VTOL aircraft altitude control. Pilot opinion ratings were used to determine the relationships of control sensitivity, and control power to damping for both normal flight and satisfactory control characteristics, control power should be capable of producing at least 1.2 G upward acceleration for normal flight and at least 1.05 G for the augmentation failure flight condition. A minimum damping level is about  $-0.35$  per second for normal flight. Flight results obtained with three VTOL aircraft were in reasonable agreement with the simulator data. The influence of control response time constant and ground effect in shifting basic pilot opinion boundaries was also investigated on the simulator. Control response time constant restricts the control boundaries, particularly in the case where high control power and low damping levels or both exist. Introduction of positive ground effect characteristics into the height-control system resulted in a marked improvement in pilot-opinion ratings. However, it was found that additional damping was required to cope with the oscillatory hovering behavior induced at levels of control power above 1.2 G. Negative ground effect was responsible for a rapid deterioration in height controllability; excessive sink rates were developed when negative ground effect was combined with low control power.

60. Guedry, F. E. and Graybiel, A. *Rotation Devices, other than Centrifuges and Motion Simulators*. Armed Forces-National Research Council on Bio-Astronautics, National Academy of Sci-

ences — National Research Council, Washington, D. C., Publication 902, 1961, 40 pp, AD 262 435.

This report deals with rotation devices used in studying the role of the semicircular canals and otolith organs in aerospace flight. Most of these devices have limited capability as flight simulators but are instrumented for controlling and recording the dynamic performance of the rotary structure and for measuring electrophysiological and behavioral responses of the subjects. The greater number are to stimulate the semicircular canals, organs uniquely structured to respond to angular accelerations. The otolith organs, which are stimulated by linear accelerations, respond to change in body (head) position with respect to the direction of gravity or any inertial force of sufficient magnitude. Brief descriptions of these rotation devices and where they are located are given in the report.

61. Hardy, J. D. and Clark, C. C. *The Development of Dynamic Flight Simulation*. U. S. Naval Air Development Center, Johnsville, Pennsylvania, Report No. 1, 4 December 1958, 19 pp, AD 216 508.

In any simulation, the required compromises with the actual condition of flight place important restrictions on the usefulness of the simulation. No simulation can be more than an approximate reproduction of flight. The compromises that must be accepted are many. In a marginally stable aircraft, less compromise can be accepted, and in particular, it is desirable to have acceleration inputs to the pilot in addition to those afforded by indications of instruments. The need for acceleration inputs was mentioned by Pecoraro (1) in 1954 who noted that "In all simulation experiments, it is understood that some compromise must be made. In this case, it was felt that physiological cues to the inertial forces are missing. But a human centrifuge could be useful for additional study if desired and necessary." It is perhaps safe to say that until the marginally stable aircraft became an important instrument of flight research, the necessity of presenting the pilot with acceleration forces was not clear. However, with the desire of man to go higher into space and at greater and greater speeds, the problem of acceleration became an increasingly important one. It is the incorporation of the acceleration forces into the flight simulator that is the burden of this report. As predicted by Pecoraro this has involved the use of a human centrifuge.

62. Hyde, A. S. *Man-Rated Centrifuges: A National Survey with Design Considerations and Recommendations for Future Devices*. Aerospace Medical Research Laboratories, Wright-Patterson Air Force Base, Ohio, AMRL Memorandum B-55, September 1963, 27 pp, AD 419 380.

It has been the thesis of this memorandum-report that the need for man-rated centrifuges will continue to increase, that more devices of this type will be proposed and built within the next decade, and that performance (and cost) of these devices will also continue to increase. Categories of use of man-rated centrifuges have been presented and compared to our national capabilities; our capabilities were found to be less than our needs. In order to transmit experience gained by the author in establishing specifications for man-rated centrifuges, information was offered relating to major trade-offs that influence final design configuration, cost and usefulness of these devices.

63. Kennedy, P. J. and Fimmel, R. O. *Unbalance Indicating Instrumentation for Flight Simulator*. Headquarters, Signal Corps Engineering Laboratories, Fort Monmouth, New Jersey, November 1955, 10 pp, AD 80 687.

The purpose of this memorandum is to illustrate the application of strain gages, as a sensing

element for indicating unbalance of the "whirler," a flight simulator consisting of a rotating arm 12 feet in diameter with meteorological instruments mounted on the tip of the arm for testing at high velocity, and the principles involved in the design of the Dynamic Strain Gage Indicator. A balancing system for use with a flight simulator was required as a safety device to indicate excessive unbalance. A system was designed using strain gages as the sensing element, a cutoff relay to trip the ignition system and a strain indicator to indicate the unbalance. Mounting the strain gages on the stationary leg of the whirler mount eliminated the need for slip rings which greatly simplified the installation. The system has been installed and is giving satisfactory operation.

64. Kidd, E. A., Bull, G., and Harper, R. P., Jr. *In-Flight Simulation — Theory and Application*. Advisory Group for Aeronautical Research and Development, North Atlantic Treaty Organization, Paris, France. Report 368, April 1961, 40 pp, AD 446 170.

Simulation techniques are applied to the problems of determining aircraft handling qualities. Analog computers, fixed-base simulators, and various other ground machines are discussed. In particular, the theory and actual techniques of in-flight simulators of the variable-stability type are considered. The conclusion is drawn that the solution of the various problems of handling-qualities requirements and of control systems development requires the use of ground-based simulators and in-flight simulators as complementary tools. There is still work to be done in the establishment of handling-qualities requirements and control system development. Ad hoc problems in particular airplane design developments will need to be solved. Knowledge of human control capabilities in new and demanding flight regimes is required. The difficulties in obtaining adequate pilot familiarization, training, and proficiency maintenance in the new types of high-performance aircraft are increasing. The solutions to these problems require the use of ground-based simulators and flying simulators as complementary tools. Each has special virtues which should be carefully and fully exploited.

65. McGregor, D. M. and Wood, A. D. *An Investigation of the Effects of Lateral Directional Control Cross-Coupling on Flying Qualities Using a V/STOL Airborne Simulator*. National Aeronautical Establishment, Ottawa, Canada, Report: LR-390, December 1963, 16 pp, AD 428 236.

A handling qualities investigation was undertaken to determine the variation of pilots' opinion on V/STOL aircraft lateral-directional control cross-coupling effects. A visual flight task which included hovering, accelerating and decelerating transitions, and steep approaches was used to give the pilots a realistic function to perform while assessing the various configurations. The results indicate quite a small area on the control cross-coupling graph over which the pilots' ratings were in the normal operation region but a very large region for emergency operation. A preference was indicated in both these regions for negative roll due to the pilots' yaw command input and the shape of the emergency operation region showed that the pilots were more readily able to cope with favourable yaw due to roll input.

66. McGregor, D. M. *The Influence of Aircraft Size on Control Power and Control Sensitivity Requirements — A Comparison of Results from Two Variable Stability Helicopters*. National Aeronautical Establishment, Ottawa, Canada, Report LR-459, July 1966, 27 pp, AD 805 418.

A flight research programme was undertaken to determine control power and control sensitivity requirements during a visual hovering and low speed approach task using a small variable stability helicopter. Minimum levels of directional control power for satisfactory handling qualities were found, while optimum values of control sensitivity as well were determined for the

roll and pitch controls. The angular rate damping played an important role in determining these maxima. The results are compared with those obtained from a significantly larger research vehicle and indicate that lower sensitivities and powers were found satisfactory in the smaller simulator. This result is opposite to predictions obtained by application of the "weight sensitive" scaling laws contained in current V/STOL aircraft recommendations and helicopter specification.

67. Miller, J. W. and Goodson, J. E. *A Note Concerning "Motion Sickness" in the 2-FH-2 Hover Trainer*. U. S. Naval School of Aviation Medicine, U. S. Naval Air Station, Pensacola, Florida, Research Report No. 1, 20 February 1958, 18 pp, AD 204 234.

A review was made of the development of Device 2-FH-2, including two evaluations. These evaluations pointed with no little concern to the problem of "motion sickness" experienced in the simulator. The writers feel that the hypotheses offered by others to the effect that these symptoms were elicited by the conflict between visual cues of motion and static physiological cues is false. The problem seems to lie in one or a combination of several modes of distortion: There exist both static and dynamic distortions in the projected scenery; there are errors in the perceived directional changes of motion; and there are dynamic errors in the perceived angular rate of motion. These distortions are pointed out herein and suggestions are made as to how they might be alleviated.

68. Newell, F. D. *Ground Simulator Evaluations of Coupled Roll-Spiral Mode Effects on Aircraft Handling Qualities*. Air Force Flight Dynamics Laboratory, Wright-Patterson Air Force Base, Ohio, (Cornell Aeronautical Laboratory, Inc., Buffalo, New York), CAL Report No. TC-1921-F-1, March 1965, 46 pp, AD 468 857.

A systematic investigation of the lateral handling qualities of fighter aircraft on an enroute IFR mission was made in a fixed-base ground simulator. The suitability of a wide range of roll and spiral mode root locations was examined with particular emphasis placed upon determining the effects of complex roll-spiral roots. The complex roll-spiral roots were produced with several feasible combinations of stability derivatives. Interaction effects of the Dutch roll mode roots were examined, including the effects of the proximity of these roots to the complex roll-spiral mode roots. Assessment of the flying qualities is reported in terms of the evaluation comments and ratings given by two pilots. In general the complex roll-spiral configurations that were evaluated were too difficult to control in roll to consider their handling quality characteristics as acceptable for fighter aircraft.

69. Palmer, W. E. *A Flight Simulator Study of the Lateral-Directional Stability Requirements of Piloted Air Vehicles*. North American Aviation, Inc., Columbus, Ohio, for Bureau of Naval Weapons, Technical Report NA 61H-241, March 31, 1961, 27 pp, AD 264 752.

A stationary flight simulator study was made of the primary factors which affect pilot opinion of the lateral-directional stability of contemporary aircraft. The results indicate the degree of acceptability of damping, airspeed indicators, mach number, rate-climb indicators, altimeters, oscilloscopes. Pilots, open-ended turns. Dutch roll. A stationary flight simulator study was made of the primary factors which affect pilot opinion of the lateral-directional stability of contemporary aircraft. The results indicate that the degree of acceptability of the lateral-directional characteristics of any aircraft can be predicted for a wide range of configurations by use of two correlation parameters. One parameter specifies the minimum required damping of the lateral oscillation, and the other specifies the maximum allowable control yawing moment.

70. Perry, D. H. and Burnham, J. *A Flight Simulation Study of Difficulties in Piloting Large Jet Transport Aircraft through Severe Atmospheric Disturbances*. Ministry of Aviation, Aeronautical Research Council, Report C. P. No. 906, September 1965, 52 pp, AD 813 961.

A ground based flight simulator, having motion freedoms in pitch and roll, has been used to study the difficulties of flying a representative jet transport aircraft through severe storm turbulence. Random atmospheric disturbances of RMS velocity 15 ft/sec, combined with longer term draughts in the vertical plane of up to 200 ft/sec were studied during flight on instruments. Most pilots had surprisingly little difficulty in controlling the aircraft despite the severe conditions represented. Some, who made power and trim changes freely however, tended to set up long period oscillations in speed and flight path, similar to those which have been reported in flight. The results provide a useful experimental demonstration of the validity of current rough air flying techniques.

71. Pryor, A. J., Eggleston, L. A., and Johnson, R. K. *Summary of Cost and Time Required for Modifications and Conversions on the USAF School of Aerospace Medicine Human Centrifuge and Rotational Flight Simulator*. Southwest Research Institute, San Antonio, Texas, Technical Report: SWR1-03-1787, December 1965, 16 pp, AD 627 430.

A study was made of the fire hazards peculiar to the equipment and operation of the USAF School of Aerospace Medicine human centrifuge and rotational flight simulator at Brooks Air Force Base, Texas. The study was based on present Air Force standards and recommendations were outlined in previous reports where hazards exceeded acceptable limits. The report contains cost and time estimates for the accomplishment of the recommendations referred to above.

72. Randel, R. J., Jr. *Vibrations in Helicopters: Training Considerations*. Wright Air Development Center, Wright-Patterson Air Force Base, Ohio, Technical Note: WADC 59-61, March 1959, 7 pp, AD 212 314.

Helicopter instructor pilots were interviewed individually to analyze in detail the role that vibrations play in piloting helicopters. Information was gathered which indicated that vibrations are utilized as cues in both normal control and the detection and diagnosis of system malfunctions. Training considerations are discussed and recommendations made for a relatively gross simulation of each of the several classes of vibrations in a proposed helicopter instrument trainer.

73. Rathert, G. A., Jr., Creer, B. Y., and Douvillier, J. G., Jr. *Use of Flight Simulators for Pilot-Control Problems*. National Aeronautics and Space Administration, Washington, D. C., NASA Memo: 3-6-59A, February 1959, 14 pp, AD 210 526.

Comparisons were made between actual flight results and results obtained with fixed and moving flight simulators in a number of phases of flying airplanes with a wide range of characteristics. These results were used to study the importance of providing motion stimuli in a simulator in order that the pilot operate the simulator in a realistic manner. Regions of airplane characteristics where motion stimuli are either mandatory or desirable are indicated.

74. Rathert, G. A., Jr., Creer, B. Y. and Sadoff, M. *The Use of Piloted Flight Simulators in General Research*. Advisory Group for Aeronautical Research and Development, North Atlantic Treaty Organization, Paris, France. Report 365, April 1961, 25 pp, AD 404 196.

A number of direct correlations between flight and various types of simulators have been examined in problem areas of interest for research on advanced transports and manned space-

craft. Where the characteristics are such that the vehicle is satisfactory or easy to fly, even the simplest forms of simulation are effective. The addition of motion cues is required in two general circumstances: (1) Where the motion cue helps the pilot by supplying a necessary lead or anticipation cue, as in coping with a lightly damped or unstable vehicle or a sluggish control system, and (2) Where the motion cue realistically hinders the pilot in making a desired control motion, as in using a very powerful or sensitive control system. A reasonable judgment of whether such cues will be needed in a given simulation can be made by inspecting the comparisons on the design-criteria charts in the reports referenced. If levels of acceleration stress greater than about 4g are anticipated they should be included in the simulation; however, the exaggerated or spurious motion cues encountered in closed-loop operation on a centrifuge must be taken into account. Additional simulation techniques, such as measurements of performance and physiological condition and use of the human pilot analog, are often a necessary supplement to the subjective opinion of the pilot.

75. Seckel, E., Hall, I. A. M., McRuer, D. T., and Weir, D. H. *Human Pilot Dynamic Response in Flight and Simulator*. Wright Air Development Center, Wright-Patterson Air Force Base, Ohio, (Princeton University and Control Specialists, Inc.), Technical Report: WADC TR-57-520, August 1958, 58 pp, AD 130 988.

This report presents the results of an effort to determine the difference in pilot tracking behavior resulting from differences between flight and ground simulator control environments. The investigation has been centered on an experiment designed to estimate the quasi-linear describing functions and linear correlations of several pilots when engaged in lateral and longitudinal tracking tasks with random appearing forcing functions. A Navion aircraft functioned as the controlled element in the flight environment and the same airplane, with aircraft dynamics generated with analog computer techniques, provided the ground simulator controlled element. Statistical analyses of describing function and linear correlation data revealed that: (1) Individual run phase angle (in degrees), amplitude ratio (in db), and linear correlation data are approximately normally distributed about their mean values for all runs, (2) The mean values of pilot's describing functions in longitudinal flight and simulator control exhibit significant differences in both amplitude ratio and phase angle, (3) The mean values of pilot's describing functions in lateral flight and simulator control exhibit significant differences in phase angle and no significant differences in amplitude ratio, (4) Significant differences between flight and simulator linear correlations were present for both lateral and longitudinal control, (5) The flight and simulator variances for lateral amplitude ratio and lateral and longitudinal phase were significantly different. No significant differences appeared between flight and simulator variances for longitudinal amplitude ratio and lateral and longitudinal linear correlation.

76. Smith, R. E. *A Comparison of V/STOL Aircraft Directional Handling Qualities Criteria for Visual and Instrument Flight Using an Airborne Simulator*. National Aeronautical Establishment, Ottawa, Canada. Report LR-465, September 1966, 46 pp, AD 813 767.

The directional handling qualities criteria for an instrument approach task in controlled turbulence were determined using an airborne V/STOL simulator, and compared with the results for a visual approach task, to show that instrument flight demanded more stringent criteria. Increasing the weathercock stability, in the presence of turbulence, required significantly larger values of damping. These minimum directional damping levels, which were dependent on the task, were apparently determined by the aircraft's response to turbulence as shown by the good correlation obtained between pilot ratings and theoretical criteria based on the aircraft's turbu-



lence response. Existing recommendations for minimum damping levels did not correlate with the experimental results, but the recommendations for minimum directional response were found to be adequate for normal operation. Theoretical criteria from a pilot-aircraft synthesis were correlated with pilot ratings and provided a useful insight into the possible behaviour of the pilot while flying an approach task in turbulence.

77. Snyder, C. J. *Centrifuge Design of the X-20 (Dyna-Soar) Crew Station*. Aeronautical Systems Division, Wright-Patterson Air Force Base, Ohio, Technical Report: ASD-TDR-63-338, July 1963, 29 pp, AD 416 730.

Centrifuge simulation tests of the X-20 crew station were conducted to evaluate the design and determine man's ability to fly the vehicle under anticipated stresses. The simulator built for this program consisted of an instrument panel and controls that were, in most respects, physically identical to those of the X-20, and a prototype ejection seat that was installed in the same position relative to the instrument panel as in the actual X-20 vehicle. Test subjects wore the full pressure suit and the restraint system was that developed for the X-20. The six X-20 pilots served as test subjects. Tests were conducted under static and dynamic conditions with the suit unpressurized and pressurized. Results of tests were recorded on analog strip charts and motion pictures, and pilot opinions were recorded on magnetic tape and debriefing questionnaires. A Development Engineering Inspection held at the conclusion of the test program resulted in several minor modifications to the crew station. An analysis of the test results indicated, however, that man could perform necessary control functions in the crew station of the X-20 vehicle under conditions of maximum g-forces anticipated during boost, as simulated on the centrifuge.

78. Soliday, S. M. *Effects of Task Loading on Pilot Performance During Simulated Low-Altitude High-Speed Flight*. U. S. Army Transportation Research Command, Fort Eustis, Virginia, (North American Aviation, Inc., Columbus, Ohio), USATRECOM Technical Report 64-69, February 1965, 79 pp, AD 614 243.

The effects of task loading on pilot performance during simulated low-altitude, high-speed flight were studied, approximately 210 hours of flight were made by experienced pilots in a moving-base simulator that had a total vertical travel of 12 feet and an acceleration capability of  $\approx 6G$ . The flights were made over several types of terrain at several airspeeds under different conditions of navigation task and emergency task loading. Medium heavy turbulence was simulated for all flights. Data were analyzed in terms of human performance aspects of the missions. Pilots' reaction time did not change under the different experimental conditions, indicating that they were equally alert and could perform physical and mental tasks equally well under all conditions. There was no evidence of fatigue under any condition. Several measures showed that learning continued throughout the experiment.

79. Tremblay, H. G., Brown, J. L., and Futterweit, A. *Application of Harmonic Analysis in a Study of Tracking Performance in the TV-2 Aircraft and in Centrifuge and Stationary Simulations of that Aircraft*. U. S. Naval Air Development Center, Johnsville, Pennsylvania, Technical Report NADC-AC-6406, 30 April 1964, 28 pp, AD 602 178.

Piloting performance in a continuous tracking task was studied in an aircraft, in human centrifuge simulations controlled by a computer simulation of the aircraft, and in a stationary simulation. Continuous records of elevator and aileron control surface deflections were subjected to a power spectral density analysis. Results indicate that there is a reduction in the contribu-

tions of high frequency components of power, successively, from the static simulation to the centrifuge simulations, to the aircraft itself. The power spectral density function for performance in a centrifuge simulation is more like that for the aircraft than is the power spectral density function in a static simulation.

80. Vomaske, R. F., Sadoff, M., and Drinkwater, F. J. *The Effect of Lateral-Directional Control Coupling on Pilot Control of an Airplane as Determined in Flight and in a Fixed-Base Flight Simulator*. National Aeronautics and Space Administration, Washington, D. C., NASA TN D-1141, November 1961, 44 pp, AD 285 889.

A flight and fixed-base simulator study was made of the effects of aileron-induced yaw on pilot opinion of aircraft lateral-directional controllability characteristics. A wide range of adverse and favorable aileron-induced yaw was investigated in flight at several levels of Dutch-roll damping. The flight results indicated that the optimum values of aileron-induced yaw differed only slightly from zero for Dutch-roll damping from satisfactory to marginally controllable levels. It was also shown that each range of values of aileron-induced yawing moment considered satisfactory, acceptable, or controllable increased with an increase in the Dutch-roll damping. The increase was most marked for marginally controllable configurations exhibiting favorable aileron-induced yaw. Comparison of fixed-base flight simulator results with flight results showed agreement, indicating that absence of kinesthetic motion cues did not markedly affect the pilots' evaluation of the type of control problem considered in this study. The results of the flight study were recast in terms of several parameters which were considered to have an important effect on pilot opinion of lateral-directional handling qualities, including the effects of control coupling. Results of brief tests with a three-axis side-arm controller indicated that for control coupling problems associated with highly favorable yaw and cross-control techniques, use of the three-axis controller resulted in a deterioration of control relative to results obtained with the conventional center stick and rudder pedals.

## SECTION III.

# Transfer of Training

### INTRODUCTION

The appraisal of any training medium must consider how effectively transfer of training is achieved from the device to the operational task. Thus, the value of a synthetic trainer in a pilot training program depends upon the extent of transfer from the trainer to the flying tasks. Concerning this principle, Gagné (123) said:

When one inquires about the effectiveness of a device for training, one is really asking about transfer of learning to some criterion.

Transfer may occur when there is a similarity between two activities either in substance or procedure. Anything which can be learned can be transferred including such things as attitudes, a feeling of self-confidence, learning sets, and interests, as well as skills, facts, and other items generally thought of as constituting school work. Transfer may be quite specific, as when elements of one learning situation occur in identical or similar form in another.

Transfer may be either positive or negative. Positive transfer takes place when the acquisition of one skill facilitates the acquisition of another skill. Negative transfer occurs when the acquisition of one skill interferes with the acquisition of another skill. It is hoped that responses from a desired set of stimulus conditions in a trainer will transfer positively to the operational situation. One of the most important variables which determines whether transfer will be positive or negative is the degree of similarity of the stimuli and responses in the two tasks.

One of the ways to increase transfer is to make it clear to the learner that what he is learning can be transferred to other situations. In this respect, the attitude of the instructor as to the value of the trainer is extremely important. A training program should not only provide for acquisition of factual knowledge and motor skills; it also should promote favorable attitudes on the part of the trainee toward the training he receives. If the trainee develops unfavorable attitudes toward the instruction and training equipment, the attitudes may carry over (transfer) to the operational tasks.

### SYNTHETIC TRAINERS VERSUS OPERATIONAL EQUIPMENT

Although it may be generally considered that actual operational components are the most valid types of training equipment, it is not so in every case. Operational training and testing have several disadvantages which include: (1) high equipment costs; (2) malfunctions are difficult to insert; and (3) safety hazards. Therefore, it is considered that to practice certain skills, a trade-off in favor of a synthetic trainer may be advantageous.

Miller (136) distinguished between engineering simulation and psychological simulation. That is, engineering simulation duplicates the functional characteristics of the operational equipment within very close tolerance specifications while psychological simulation is related to transfer of training from the simulator to the operational equipment. As the degree of engineering simulation increases, the costs rise at an increasing rate. An oversimplification of the relationship between the degree of engineering simulation, cost, and transfer of training value by Miller is shown in Figure 35. Thus, it is necessary that practical decisions about training media must depend upon compromises between economic and training objectives. A trainer need not be an exact replica of the operational equipment to have training value. The most important consideration is its degree of transfer to the real tasks.

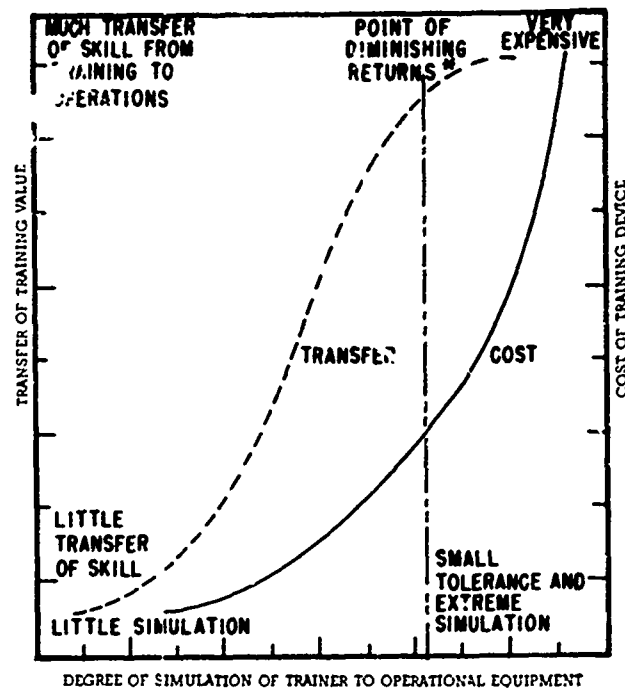

\*This is the point the designer wants to determine. It is getting the most training value per dollar cost.

Figure 35. Schematic Relationship between Degree of Engineering Simulation, Cost, and Transfer of Training Value — Motivation assumed to be constant and high (From R. B. Miller)

#### THE PROBLEM OF INDIVIDUAL DIFFERENCES

In dealing with this training problem, it should be realized that there are vast differences in the technological environments of trainees from various backgrounds. In addition, individual differences exist among trainees regardless of pre-military vocations. The U. S. Army General Classification Test (AGCT) results obtained in World War II, presented in figure 36, show the pronounced individual differences within and among various groups.\* The titles represent the civilian occupations of personnel prior to Army service. For example, some lumberjacks scored higher on the AGCT than some lawyers or teachers. Thus, it appears evident that the chosen career field of an individual does not necessarily indicate his intellectual capacity. Also, measures such as the Airman Qualifying Examination (AQE) and the Air Force Qualifying Test (AFOQT) do not assess motor skills ability. However, it may be logically inferred that individual differences in motor skills proficiency exist to the same degree among individuals as do verbal or other differences. It should not be assumed that a high score on a classification test will unequivocally result in a high performance score by the trainee. For example, at an Air Force flying training base, the author obtained a Pearson product moment coefficient of correlation of .32 for the AFOQT Pilot Composite scores vs. pilot performance scores (N=147). A correlation this low has a forecast efficiency of only about 5%. Thus, a student may obtain a high score on a verbal aptitude test, but the lack of opportunity to practice motor skills prior to entry into training may seriously handicap his training progress.

\*Thorndike, R. L. and Hagen, Elizabeth. Measurement and Evaluation in Psychology and Education. John Wiley and Sons, Inc., New York, New York, 1961.

PERCENTILE

<i>Occupation</i>	10	25	50	75	90
Accountant	114	121	129	138	143
Teacher	110	117	124	132	140
Lawyer	112	118	124	132	141
Bookkeeper	108	114	122	129	138
Chief-clerk	107	114	122	131	141
Draftsman	99	109	120	127	137
Postal clerk	100	109	119	126	136
Clerk, general	97	108	117	125	133
Radio repairman	97	108	117	125	136
Salesman	94	107	115	125	133
Store manager	91	104	115	124	133
Tool maker	92	101	112	123	129
Stock clerk	85	99	110	120	127
Machinist	86	99	110	120	127
Policeman	86	96	109	118	128
Electrician	83	96	109	118	124
Meat cutter	80	94	108	117	126
Sheet metal worker	82	95	107	117	126
Machine operator	77	89	103	114	123
Automobile mechanic	75	89	102	114	122
Carpenter	73	86	101	113	123
Baker	69	83	99	113	123
Truck driver	71	83	98	111	120
Cook	67	79	96	111	120
Laborer	65	78	93	108	119
Barber	66	79	93	109	120
Miner	67	75	87	103	119
Farm worker	61	70	86	103	115
Lumberjack	60	70	85	100	116

(By permission of John Wiley and Sons, Inc., New York, N. Y.)

Figure 36. AGCT Standard Scores by Occupation (World War II)

In the Air Force Undergraduate Pilot Training program, commendable progress has been achieved in providing for academic individual differences among the trainees in the past few years. Perhaps research should now be conducted to determine to what extent flight simulators may be used advantageously to improve trainee motor skills ability. It may not be easy to accomplish, but if the trainees' input academic knowledges and motor skills abilities can be determined, it may be possible to provide the training necessary for them to achieve proficiency in the operational tasks. Thus:

$$I + T = M$$

Where I = Input knowledge or skill; T = training; and M = mastery.

Since transfer of training to actual tasks is the desired objective in the use of any training course, the instruction should be presented in a meaningful context that facilitates optimum learning. However, Hall, Parker, and Meyer (125) said:

Simulator training within the Air Force is conducted under highly variable circumstances. This applies both to inter- and intra-training unit practices. Some units give simulator training in a block before airtime; others intersperse the two kinds of lessons. There also is inconsistency in the position which simulator training occupies within the overall program. The freedom permitted IP's to conduct training results in many different training practices. Often because of the necessity for training a large number of items, only very limited opportunity is provided for repetition of materials . . .

#### THE PRESUMED VALUE OF FLIGHT TRAINERS

As noted in Section I, during World War II flight trainers found wide acceptance in the Armed Forces. Concerning the presumed value of these trainers, Smith, Bacon, Cook, and Maeers (112) said:

Their manufacturers and users believe they are realistic substitutes for the actual aircraft and for actual flight; that their use materially reduced training costs and releases aircraft for operational employment; that accidents and wastage can be avoided in training; and that the emergency procedure training made possible by the flight simulator can cut down accidents and deaths in subsequent flying operations.

Since prior to 1949, no hard data obtained by the Armed Forces on trainer effectiveness are readily available, it may be assumed that the value of flight trainers was accepted on the basis of common sense. That is, since the trainers simulated various flight conditions, transfer of training should logically take place. Certainly, the savings in flight costs, safer practice in emergency procedures and other advantages reinforced the belief in the value of flight trainers.

Williams and Flexman (112) reported the results of a study on the evaluation of the SNJ operational flight trainer (OFT) in 1949. The purpose of the study was to determine if certain aspects of basic contact flight training could be learned successfully in a synthetic trainer. Twelve University of Illinois students divided into two matched groups were used as subjects. The trainer group performed maneuvers both in the SNJ OFT and in the aircraft. The control group performed maneuvers in the aircraft only. The 12-hour syllabus included cockpit procedure, basic contact air work, and traffic pattern flying. The results showed that the simulator group (1) required 874 fewer task trials, or 62% savings; (2) made 1511 fewer errors, or 75% savings; and (3) used 44 fewer air hours or 62% savings. The estimated training cost for the control group was \$3,572 and \$1,572 for the trainer group.

An exploratory study by Brown, Matheny, and Flexman (83), in 1950, was designed to determine what problems were involved in teaching certain ground reference maneuvers (landings, forced landings, and pylon eights) in the School Link trainer. Also, an evaluation of the effects of such training on pilot trainee performance in light aircraft was attempted. A perspective drawing of a runway was sketched on a blackboard which served as an aid in teaching landings. A grid pattern drawn on another blackboard was used to teach forced landings and pylon eights. The experimental and control groups consisted of only ten subjects each. The results for landings indicated that errors made in learning to land a light aircraft can be significantly reduced as a result of previous School Link practice. No conclusions were given for forced landings and pylon eights because insufficient data were collected for these two maneuvers.

Also, 1950, Page and Lyon (100) described a study of the relationship between overall objective scores on specific maneuvers following four hours of instruction in the SNJ Cycloramic Link and flight grades obtained by the same students in Stage "A" training. However, the value of Stage "A" grades as a criterion of performance, the reliability of the scoring device, and the validity of the selected test maneuvers are questioned by the authors. Recommendations are made for modifying the experimental design with a view toward further investigation of the possibility of predicting student performance.

In 1952, Poe and Lyon (103) reported a study to determine the contribution of instruction in the SNJ Cycloramic Link Trainer during Pre-Flight School to flight proficiency in the initial stages of flight training. One group was given the regular Pre-Flight School curriculum and another group had five periods of instruction in the SNJ trainer. Very small differences between the groups were found on any of the criteria. It was concluded that the SNJ trainer instruction did not affect proficiency during the initial stages of flight training.

Matheny, Williams, Dougherty, and Hasler (98) reported a study in 1953 which was designed to determine: (1) whether transfer of training would occur from the P-1 (SNJ) Link Trainer to the T-6 aircraft for specific maneuvers; and (2) if transfer did occur, whether the amount of transfer achieved was different for two groups that had learned the tasks in the P-1 Link Trainer with different amounts of elevator control stick pressure.\*

One group learned the maneuver of climbing and gliding in the P-1 Link trainer with elevator control stick pressure near zero. A third or control group practiced the maneuvers only in the aircraft.

A significant amount of transfer occurred for the glide maneuver only. No significant difference in amount of transfer from trainer to aircraft was demonstrated for the two experimental groups.

Examination of the two tasks leads to the hypothesis that transfer of training in this situation depends more upon a correspondence between the sequence or pattern of control forces required in trainer and aircraft than it does upon a correspondence between the absolute amounts of control force required.

An experimental evaluation of a contact flight simulator (P-1) was described by Flexman, Townsend, and Ornstein (91) in 1954. Aviation cadets were used as subjects at Goodfellow Air Force Base, Texas. Two groups of students were selected from various classes. The simulator trained group was given 100 hours of T-6 flying time plus 40 hours of P-1 contact simulator

---

\*The Air Force P-1 trainer and the Navy SNJ trainer are the same devices. Also, the SNJ and the T-6 are the Navy and Air Force designations for the same aircraft.

time; the control group received 130 hours of T-6 time and no P-1 simulator time. The results of the study indicate that the efficiency of instruction in Primary Pilot Training may be greatly improved by the incorporation of contact flight simulator into the experimental program. The results of the study were:

1. Students who received 100 hours flying time plus practice in a simulator were as proficient on flight checks as students who received 130 hours flying time and no practice in a simulator.
2. Examination of instructors' records and opinions indicated that simulator trained students were significantly superior to nonsimulator trained students in flight proficiency.
3. Attrition and accident data in both Primary and Basic phases of training indicated no adverse effects attributable to the 30 hours reduction in the T-6 flying time of the simulator trained student.

The second part of the Goodfellow study concerning the value of the P-1 was reported in late 1954 (99). An analysis was made of the effectiveness of the P-1 in teaching specific components of contact and instrument flying skills. Maneuvers, dimensions, and families of maneuvers, were investigated and the contribution of simulator training to each was determined.

Experimental subjects were selected during Pre-Flight to provide a sample representative of the distribution of Pilot Stanines\* (3-9) in the aviation cadet population. A randomly selected half of the students at each stanine level composed the simulator (experimental) group; the other half composed the nonsimulator (control) group.

The contact portion of the Primary Pilot Training Syllabus consisted of 40 flying proficiency lessons. The simulator group completed each lesson in the simulator prior to performing that lesson in the T-6. The nonsimulator group received no simulator training, but were required to complete all T-6 lessons. The simulator group received instrument ground training in the P-1 simulator. The nonsimulator group received instrument ground training in the Link AN-T-18 and C-8 instrument trainers.

The simulator-trained group was given 100 hours of T-6 flying time plus 20 hours of instrument and 40 hours of contact simulator time. The control group received 130 hours of T-6 time plus 25 hours of instrument time in the Link C-8 and AN-T-18 instrument trainers, but no time in the P-1. Both groups received practically the same content and methods of instruction and extraneous conditions were as closely controlled as possible.

The results of this study support and expand the implications of the first study in this series. Both studies indicate that training which utilizes the P-1 simulator is effective. Simulator training appears to be most effective with respect to maneuvers in which the performance does not exceed the design limitations of the trainer and maneuvers which are heavily weighted with "procedural" components.

Payne, et al (101), in 1954, reported a study designed to test the effectiveness of: (1) a contact landing display developed for use in connection with the Cycloramic Link Trainer, and (2) a program of instruction called principles training which is tailor-made to meet the requirements of the above training device. Subjects used in the experiment were flight-naive students learning to make their first approaches in the SNJ aircraft. A modified I-CA-2 SNJ Link trainer

---

\*See "Stanines" in Explanation of Terms.



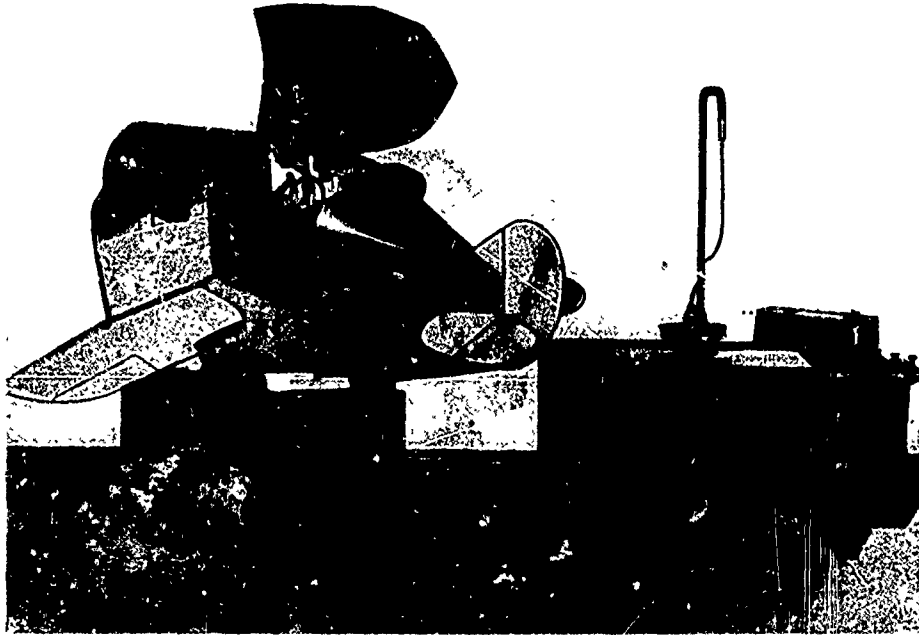

**Figure 36. The Link Trainer, AN-T-18**

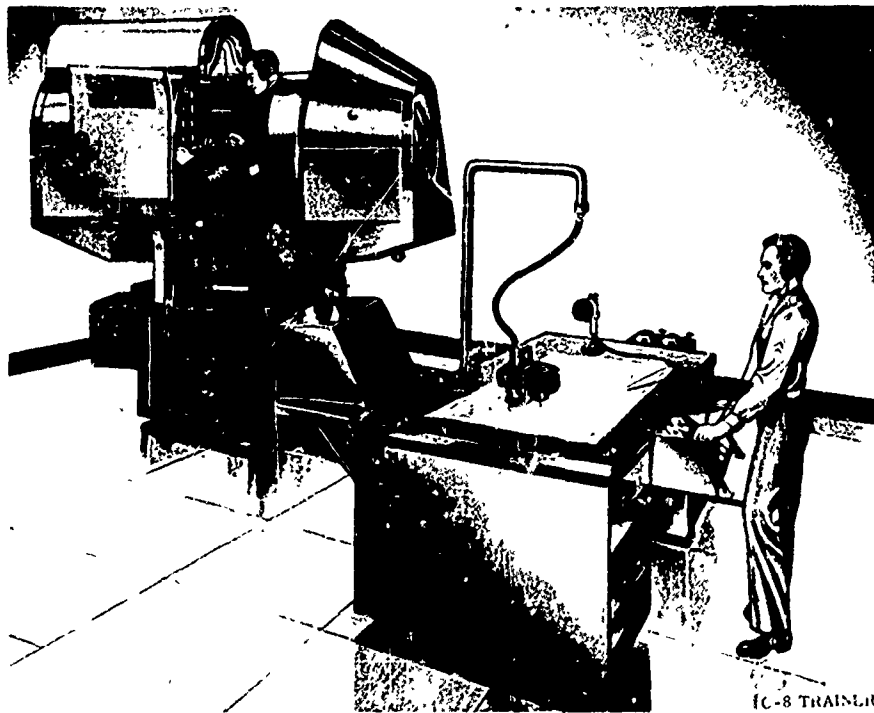

**Figure 37. The Link Trainer, C-8**

(with cyclorama, similar to the Air Force P-1) was used in the experiment. The display was a closed loop projection system and the runway image projected on the screen showed changes of the simulator with respect to the runway image. A control and experimental group of students were both given training in the principles of approach and landing through lectures and demonstration flights. The control group went on to qualify in the aircraft whereas the experimental group qualified on approaches in the trainer first and then went on to the aircraft. The students who used the device: (1) required 61% fewer trials in the aircraft and made 74% fewer errors than the students who did not use the device and (2) showed an over-all superior ability to handle the aircraft in both approach and landing.

Another contact landing display study by Creelman (86), in 1955, concerned a Navy contact approach trainer which had been evaluated under routine training. A contact landing display and Cyclorama visual display were used with the Link SNJ Trainer. One experimental group of subjects was given flight training in the trainer, with simulated contact landing, before flying the actual aircraft. Another experimental group was shown films of contact landings and also the runway image simulated by the landing device. A control group received practice in the actual aircraft only. The results indicated that the group receiving instruction in the trainer with the contact landing display achieved significantly higher ratings on approaches. This group also required fewer practice landings during pre-solo stage and fewer unsatisfactory check flights than did the other groups.

Adams and Hufford (81), in 1961, reported a study designed to determine if perceptual pre-training on contact landing cues influences acquisition of contact landing skills in the Navy Contact Analog Landing Research Tool (Device 20-L-10a). Naive subjects were first presented a flight training program which taught basic flight principles before the subjects flew the experimental equipment. Experimental subjects were trained on a landing display and they were required to judge the presence or absence of errors in the landing pattern, and if an error was present, to judge its type and initiating cause. The pre-training was followed by criterion flights in the Contact Analog Landing Research Tool. The control group had only the criterion flights. The perceptual-verbal pre-training had no apparent effect on the subject's subsequent learning of the contact landings in the trainer, where he was required to make responses related to the visual presentations. No significant differences were found between groups or measures of criterion performance, and it was concluded that the perceptual-verbal pre-training methods used did not justify the development of part-task training devices for learning the relationships present in complex visual cues. It is possible, however, that the pre-training might have caused the subjects to become preoccupied with the visual display, and, thus fail to timeshare scanning of the contact world adequately with critical cues on the instrument panel.

A study by Woolman (113), in 1955, concerned the training value of two flight trainers, the C-11 Link Trainer and the B-47 Link Simulator. Students who were provided only B-47 simulator training were about as proficient as students who were given both C-11 trainer and B-47 simulator training. The findings suggest that if C-11 training were deleted, there would be no significant loss in the quality of the B-47 student product. The results also indicate greater transfer from the B-47 simulator to the aircraft than from the C-11 trainer to the simulator. In addition, the findings suggest that it is feasible to predict air performance from B-47 simulator performance.

In 1957, Dougherty, Houston, and Nicklas (89) reported a study in which five groups of private pilots were trained to fly and perform a series of normal and emergency procedures in the SNJ aircraft. For each group  $N=10$ . Four groups received five periods of ground instruction

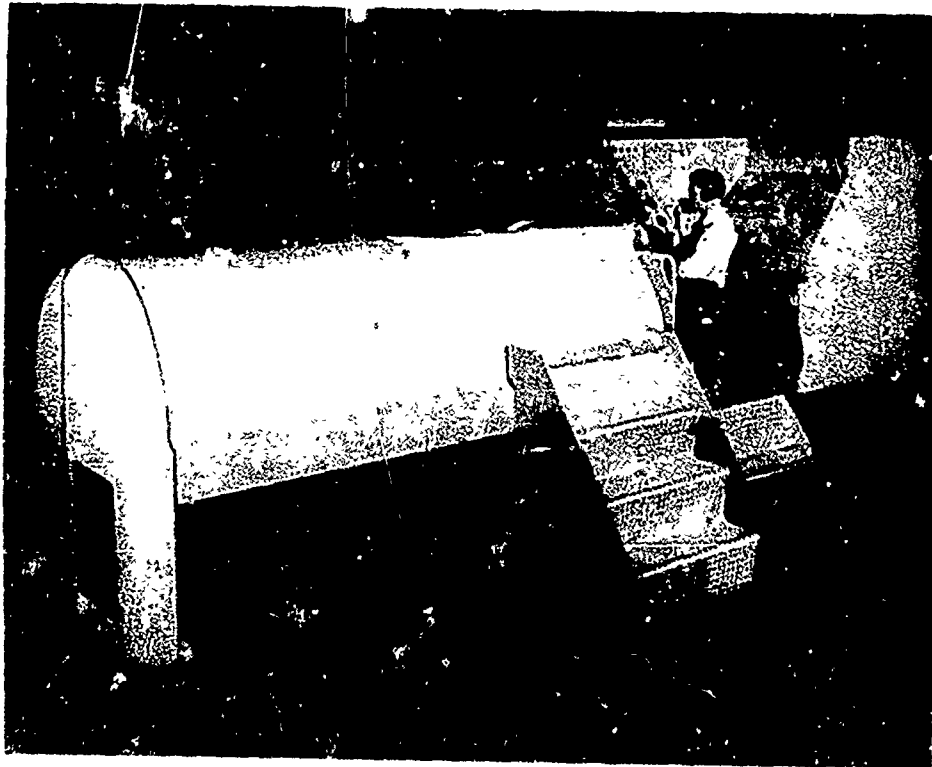

**Figure 38. The Link Trainer. C-11**

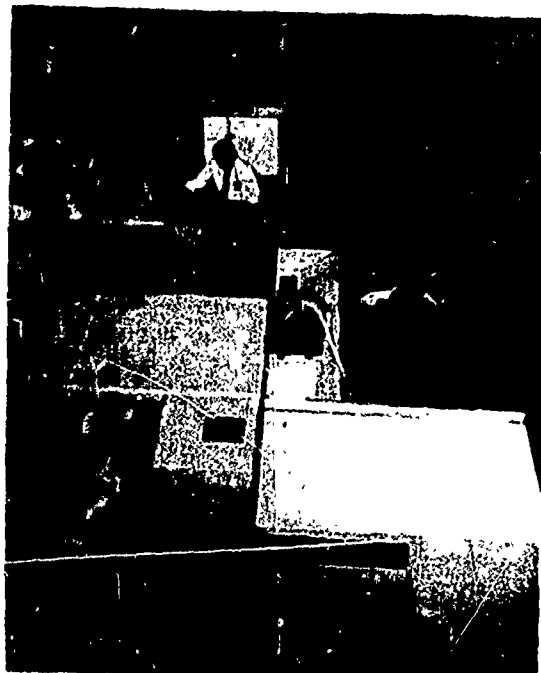

**Figure 39. The Link B-47 Simulator**

with each group trained on a different training device. This instruction was followed by five periods of in-flight training in the SNJ aircraft. The fifth group was given ten periods of instruction entirely in the SNJ aircraft. The following training devices were used:

a. SNJ Link Trainer (1-CA-2) with cyclorama and referred to as the OFT. According to the authors, this trainer most clearly duplicated the real aircraft.

b. The SNJ Link Trainer with the flight system disconnected, but the engine, electrical and hydraulic systems functioned as in a procedures trainer.

c. A simple photographic life-size mockup of the SNJ aircraft cockpit. Photographs of the instrument, side, and floor panels were mounted on plywood so that all instruments and controls were in their proper positions.

d. The SNJ as a procedures trainer similar to the one described in paragraph b, above, but with the added task of maintaining level flight on the altitude indicator.

The subjects in all groups were given the same training on complex procedural and flight maneuvers. The performance was recorded and scored as procedural and flight errors. Performance was significantly better for the experimental groups on the first air trial than it was for the control group. The performance for subjects trained in the procedures trainer and the OFT was almost identical.

A comparison of the performance of the experimental groups on the first air trial, following five periods of ground training, with performance of the control group after five training periods in the air, indicated that procedures can be learned as effectively on the ground as in the air.

The following conclusions were given:

a. Each of the ground training devices made a significant contribution to learning in-flight procedures.

b. An operational flight trainer and a procedures trainer make equally effective contributions to training.

c. Under the experimental conditions, training on an operational flight trainer or a procedures trainer does not significantly differ from the same amount of training in the aircraft itself.

d. Training on procedural tasks alone does not adversely affect performance on flight tasks when both are simultaneously required in the aircraft.

e. Time sharing while learning procedures does not facilitate the in-flight performance of procedures and flight skills.

Another study of whole-task simulators versus part-task simulators was reported by Adams, Hufford, and Dunlop (82), in 1960. The study was a laboratory experiment in which the effectiveness of training in whole-task and part-task procedures was investigated. A hypothetical toss-bomb maneuver was used in which the trainees were required to cope with a high level of activity. The SNJ OFT was used in the experiment. Ten procedural items were performed in conjunction with the continuous requirement of flying the trainer. The control group practiced the complete maneuver on each trial in the dynamic, whole-task configuration of the trainer. A static version of the trainer was used by the experimental group. Both groups were administered a common set of criterion trials where the maneuver was practiced in the whole-task configuration of the trainer. This was a continuation of practice for the control group, but for the

experimental group it was the first time that flight control and procedural responses were combined in the whole maneuver in a time-shared relationship.

The experimental group had a lower proficiency in procedures than the control group on the first trial. On the second trial, the two groups had about the same proficiency level in procedures. This equivalency was obtained for the remaining criterion trials. No significant differences were found for flight control measures of ability.

The implications of this study for operational Navy pilot training, according to the authors, are:

a. Cockpit procedures trainers can be effective training devices but cautions in their use are suggested. They can be used in training any procedural sequence, such as engine start, which does not require concurrent flight control of the aircraft. For in-the-air normal and emergency procedures, it is recommended that training in a cockpit procedures trainer be followed by a nominal amount of whole-task practice. For some procedures, it might be safe to do this in the aircraft. An Operational Flight Trainer could provide this integrative practice for all procedures and, of course, be perfectly safe.

b. A cockpit procedures trainer does not yield an accurate measure of a pilot's proficiency in procedures. The evidence is that the score in procedures derived from the part-task trainer is a spuriously high index of proficiency in the whole-task where concurrent flight control is required.

The authors indicated that the experiment applied only to the original learning of procedures. Also, cockpit procedures trainers may be useful in the maintenance of procedures proficiency by pilots with prior practice in the aircraft or the operational flight trainer, although empirical evidence to support the hypothesis is lacking.

A follow-on study by Hufford and Adams (93), in 1961, concerned the relearning of a whole-task in which subjects from the above experiment were required to relearn the same maneuver after a ten-month interval of no practice. Part-task training reduced the number of trials required to regain whole-task proficiency. The authors concluded that the use of part-task trainers should be followed by integrative whole-task training to permit trainees to regain lost timesharing skill. Thus, in these last cited studies, it is advised that part-task training be followed by whole-task practice.

Pfeiffer, Clark, and Danaher (29), in 1963, conducted an experiment in the F100/151 Fixed Gunnery Trainer to determine if timesharing training would improve intruder detection performance. Although only 10 subjects were used in the experiment, the results indicated that timesharing training could be beneficial even for experienced pilots.

A more extensive follow-on experiment was later conducted in 1965, by Gabriel, Burrows, and Abbot (92) using 60 marine pilots as subjects. The subjects were divided into upper and lower experience groups. The experimental group received eight hours of training in a simple contact simulator plus approximately four hours of tachistoscopic instrument speed-reading training. The control group did not receive this training. Comparisons were made on criterion flying tasks in the A-1 Operational Flight Trainer (2F76) with a programmed film sequence visual attachment. The timesharing group showed significantly better ability to detect the extra-cockpit (intruder) emergencies than the control group.

Caro and Isley (84), in 1966, reported a study to determine whether the use of a synthetic helicopter flight trainer would improve subsequent primary flight performance of trainees at the

U. S. Army Primary Helicopter School. It was found that the device-trained subjects, when compared with subjects who were not trained on the device, were significantly less likely to be eliminated from subsequent primary helicopter training for reasons of flight skills deficiency. Measures of relative performance during primary flight training indicated that the device-trained group soloed the helicopter earlier and made better flight grades during the pre-solo phase of training than did the control group.

In an experiment sponsored by the Federal Aviation Administration, the instructional effectiveness of different types of ground trainers in general aviation pilot training was assessed. Data were obtained and evaluated by three participating schools offering flight training programs: Miami-Dade Junior College (102); Middle Tennessee State University (95); and Ohio State University (85). The results of the experiment indicated that some transfer from the trainer to aircraft occurred. Although two of the schools did not recommend substitution of trainer time for aircraft dual instruction, all considered the trainer to be effective in teaching voice communications, radio procedures, and cross-country navigation.

As in the case of a number of other transfer of training studies, because of the small number of subjects used, the lack of information given on criteria measures used, and the possible intrusion of unidentified variables, the results should be interpreted with caution. For example, Crook (87), in his summary of the experiment, indicated that the flight instructor influenced the student's achievement more than did the variations in syllabus or trainer.

#### CONCLUSIONS

The various studies on transfer of training from the flight simulator to the actual aircraft have sometimes resulted in contradictory results. The reason for the disparity in findings may have been due to variables which were not assessed in the experiments. Some of these variables are as follows:

1. *The Criterion Measure.* Most of the performance measures used in the cited experiments were judgmental in nature and, thus, highly subjective evaluation instruments. The need for more objective measures based upon desired terminal behaviors continues to pose a problem in the assessment of performance in all training areas. In the past, only isolated attempts have been undertaken to measure performance by other than rating methods or cognitive paper-and-pencil tests.

2. *The Subjects.* The value of paper-and-pencil aptitude tests to match subjects for a performance experiment is debatable. There must be individual differences in motor skills just as there are in any other human endeavor and the low correlations obtained between paper-and-pencil tests and performance criteria seem to support this assumption. It is acknowledged, of course, that an aptitude test, although poorly correlated with the performance criterion, may be the best predictor of success available. It is important to consider, however, that a high pilot aptitude score obtained by a student does not necessarily mean that he will receive high performance grades in pilot training. The motivation and attitude of the student toward the simulator may also affect his learning of the specified tasks.

3. *The Instructor.* The instructor plays an extremely important role in transfer of training experiments. His biases, attitudes, abilities, motivation, etc., bear upon the learning situation. If he exhibits disdain for the trainer, the student will likely reflect this attitude. A capable instructor can provide the student with supplementary information which will increase the effectiveness of a trainer even though it has only minimal cues. Concerning this instructor ability, Muckler, et al (138), said:

In a somewhat more general manner, it has been proposed that instructor ability and fidelity are related in an inverse manner.

$$\text{fidelity of simulation} \times \text{instructor ability} = k$$

where  $k$  is some desired transfer effect.

This says, in effect, that, as fidelity increases, the necessary level of instructor ability may decrease, and, conversely, as fidelity decreases instructor ability must increase. Further, the multiplicative relationship imposes the reasonable restriction that neither can be zero. Since there is no direct data on this issue, any postulated relationship must, of course, be highly speculative.

Often the simulator instructor does not give instruction in the aircraft. For this reason instructional techniques may vary widely between simulator and aircraft training which may adversely affect a transfer of training experiment. In considering the possibilities of such instructional differences, Williams and Flexman (112) said:

In routine flight training it is well known that performance which pleases one instructor has a good chance of displeasing some other instructor. To the extent that this would occur in the transition from trainer to aircraft the value of what is learned in the trainer would diminish.

4. *The Instructional Sequence.* The transfer of training studies considered in this section have used at least two variations in training sequences for the simulator and the aircraft. For example, in one study, the entire block of simulator instruction was given prior to any training in the aircraft (89); in another study, simulator training was alternated with actual flight training (91). Wilcoxon, Davy, and Webster (111) found greater savings in favor of the block technique in terms of working days. Thus, opinion has varied as to the value of block versus alternating sequences. However, as Wochman (113) suggested, further research is needed to determine which technique is most effective.

#### ANNOTATED BIBLIOGRAPHY — TRANSFER OF TRAINING

81. Adams, J. A. and Hufford, L. E. *Effects of Programmed Training on the Learning of Contact Landing Skills.* U. S. Naval Training Skills. U. S. Naval Training Device Center, Port Washington, New York, Technical Report NTDC 297-3, 28 April 1961, 37 pp., AD 264 377.

This project consisted of an experiment on the effect of one type of perceptual (open-loop) training on the learning of contact landing. Thirty non-pilots, divided equally into two matched groups, participated. The experimental group received perceptual training with a programmed visual display; the control group did not receive this training. As criterion trials, both groups performed contact landings in an operational flight trainer equipped with a non-programmed visual attachment. The results indicated that the programmed presentation evaluated did not contribute to the learning of contact landings. The implications of the findings, and research issues in the evaluation of visual attachments and of pilot performance are discussed.

82. Adams, J. A., Hufford, L. E., and Dunlop, J. M. *Part- Versus Whole-Task Learning of a Flight Maneuver.* U. S. Naval Training Device Center, Port Washington, New York, (University of Illinois), Technical Report NTDC 297-1, 21 June 1960, 53 pp., AD 242 580.

The purpose of this report was to examine to what effect the learning of "procedures" in isolation from "flight control" tasks has on subsequent learning and performance of the "total-

task." More specifically, the contribution of part-task training to total task training, and the many variables that enhance or diminish this contribution, have never been measured. It was the purpose of this experiment to examine this problem rigorously from both the qualitative and quantitative viewpoint.

Analysis of whole-task performance revealed that only on the first trial was part-task group less proficient than a group that learned two types of tasks concurrently. And even then, this inferiority was shown only on the procedural aspects of the whole-task. As for the flight control tasks, they were performed equally well by both groups on the very first whole-task trial.

83. Brown, E. L., Matheny, W. G., and Flexman, R. E. *Evaluation of the School Link as an Aid in Teaching Ground Reference Maneuvers*. U. S. Navy, Special Devices Center, Port Washington, New York, (University of Illinois, Urbana, Illinois), Technical Report: SDC-71-16-7, March 1951, AD 657 473.

Describes a preliminary study in a series to evaluate the School Link Trainer for teaching ground reference maneuvers. Twenty students divided into two groups were rated on 15 actual landings of an aircraft, half having had three hours of previous practice in the Link with a simulated display of a runway as it looks during landing; half had no Link time. Errors per trial are recorded for each group and interpreted regarding transfer from the Link pre-training. Sample work sheets for rating landings are appended. Some additional data were gathered for nine students on other maneuvers.

84. Caro, P. W., Jr. and Isley, R. N. *Helicopter Trainee Performance Following Synthetic Flight Training*. The Department of the Army, (The George Washington University, Human Resources Research Office, HumRRO Division No. 6, Alexandria, Virginia), Professional Paper 7-66, November 1966, 15 pp, AD 646 157.

In a study to determine whether the use of a synthetic helicopter flight training device would improve the subsequent primary flight performance of trainees at the U. S. Army Primary Helicopter School, two groups were trained to "fly" a captive helicopter mounted on a ground effects machine. The device had the approximate handling characteristics of a free-flying vehicle, yet it allowed the trainees to obtain "Aeronautical Experience" not otherwise possible at their level of training. It was found that the device-trained controls were significantly less likely to be eliminated from subsequent primary helicopter training for reasons of flight skills deficiency. Further, measures of relative performance during primary flight training indicated the device-trained group soloed the helicopter earlier and made better flight grades during the pre-solo phase of training than did the controls. Implications of the device concepts investigated in this study are illustrated.

85. Chapman, G. C. *An Experimental Assessment of a Ground Pilot Trainer in the General Aviation*. Aircraft Development Service, Federal Aviation Agency, Washington, D. C., (The Ohio State University, Columbus, Ohio), Technical Report: FAA-ADS-63, February 1966, 73 pp, AD 653 736.

Three groups of subjects were trained to private pilot proficiency. Each group used a ground pilot trainer in a specified manner in an effort to determine how many hours of ground pilot trainer time can be substituted for aircraft dual instruction. Results of training time required were compared between groups and to a fourth control group not using a trainer. The group that used the trainer the greatest amount before going to the aircraft had significantly less time



at private pilot certification and solo. The primary cause for the significant success is attributed to the instructors' influence rather than trainer wage, however. When groups were compared by their total flight time added to ground pilot trainer time (or observer) the fourth control group had the least total time in training. Results are considered to be inconclusive. Ten pilots were also trained to instrument pilot proficiency using a ground pilot trainer in an effort to determine the minimum number of flight hours required to reach certification standards. The average times required were near the minimums currently required by F.A.R.'s Pilots with less than total flying experience requirements were as successful as those with high experience levels. Further study is necessary to determine if the total experience requirements can be lowered in the F.A.R.'s.

86. Creelman, J. A. *Evaluation of Approach Training Procedures*. U. S. Naval School of Aviation Medicine, Naval Air Station, Pensacola, Florida, 17 October 1959, 19 pp, AD 89 997.

The training effectiveness of a contact approach trainer was evaluated under routine training conditions within the framework of Navy primary flight training. The device had previously been developed and evaluated. It was found that subjects who were given instruction in the trainer before attempting landings in the airplane learned the task of landing earlier than a control group. It was suggested that the trainer may prove effective in such a program.

The results of the present report indicate that the group receiving instruction in the trainer received significantly higher ratings on approaches, fewer practice landings during pre-solo stage, and fewer unsatisfactory check flights than did the control group.

87. Crook, W. G. *Experimental Assessment of Ground Trainers in General Aviation Pilot Training*. Federal Aviation Administration, Aircraft Development Service, Washington, D. C., Final Report: FAA-ADS-67-5, April 1967, 28 pp, AD 652 371.

An evaluation was conducted to compare the effectiveness of different types of ground trainers when used in the private pilot flight training program. One objective was to determine standards for identifying ground trainers in which instruction would be acceptable toward pilot certification requirements. A second objective was to determine how much time in a trainer might be substituted for actual flight time. No specified design or operational standard for ground trainers is recommended. Results showed that average total airplane time to reach private pilot proficiency was reduced by 16%. A 15% substitution of trainer time for airplane instruction time is recommended in the approved 35-hour primary flight curriculum requirements.

88. Demaree, P. G., Normal, D. A., Matheny, W. G. *An Experimental Program for Relating Transfer of Training to Pilot Performance and Degree of Simulation*. U. S. Naval Training Device Center, Port Washington, New York, (Life Sciences, Inc., Fort Worth, Texas), Technical Report: NTDC 1388-1, June 1965, 66 pp, AD 471 806.

The relationship between the degree of simulation and the resulting transfer of training for piloting tasks in flight simulators represents an area of investigation in which relatively few studies have been conducted to date and consequently, for which little empirical data is available. The UDOTT (Universal Digital Operational Flight Trainer Tool) provides an opportunity for studies to be conducted of specific characteristics of pilot trainers and the corresponding training effectiveness. The computational capabilities of the UDOTT and the flexibility it provides in regard to the modification of characteristics of simulated jet fighter aircraft, offer an opportunity for pilot training research to be conducted in which specific modi-

fications or reductions in the degrees of simulation are introduced as experimental variables in an organized program of studies of the transfer of training of piloting skills and techniques. Initial investigations and a pilot performance study have been conducted with respect to the use of the UDOFTT computer in conjunction with a real-time input-output capability to an instrumented jet fighter cockpit. The rationale, methodology, and outline for a series of pilot training research studies have been developed in conjunction with the determination of effective means for use of the UDOFTT, including the recording and computation of objective performance measures.

89. Dougherty, D. J., Houston, R. C., and Nicklas, D. R. *Transfer of Training in Flight: Procedures from Selected Ground Training Devices to the Aircraft*. U. S. Naval Training Device Center, Port Washington, New York, (University of Illinois, Urbana, Illinois), Technical Report: NTDC 71-16-16, 1 September 1957, 91 pp, AD 149 547.

The study was designed to provide the basis for decisions concerning the relative training effectiveness of a number of training tools for the task of training pilots in normal and emergency procedures in new aircraft. From the results it is evident that the all important training task involved in transitioning to a new aircraft is training in normal and emergency procedures. It is equally apparent that there are a number of ways that this training can be accomplished. In this study a photographic mockup of the cockpit, a partly activated trainer, an aircraft flight simulator and the combination of a part task (procedures trainer) and time shared tracking task were used on equivalent groups. The following results were obtained:

1. All four methods provided good learning situations.
2. The groups trained on procedures trainers and the flight simulator showed the highest degree of transfer to the first air trial. Neither method was superior in this respect. In fact these groups performed as well as the group which practiced in the aircraft for five trials.
3. The photo mockup provided the best learning situation as measured by performance in the ground situation.

90. Flexman, R. E. and Latham, A. J. *Use of a Contact Flight Simulator in Training of Basic Student Pilots*. Human Resources Research Center, Lackland Air Force Base, Texas, Research Note Pilot: 52-1, April 1952, 5 p. AD 76 421.

Ten airmen who had no previous pilot experience were taken to the University of Illinois to act as students in the training of the ten flight instructors from the Pilot Training Research Laboratory. This research note presents information on student performance which, while incidental to the primary purpose of the activity (instructor training) and unsuitable for statistical analysis, contains interesting implications for training research. A large proportion of the pre-solo maneuvers and skills appeared to have been learned in the P-1 trainer by the rather highly selected sample of men utilized. The extent to which these can be learned by regular cadet samples, what other skills can be so gained, and the best combination of trainer and aircraft time, are topics which require a major and rigorously controlled investigation.

91. Flexman, R. E., Townsend, J. C., and Ornstein, G. N. *Evaluation of a Contract Flight Simulator When Used in an Air Force Primary Pilot Training Program - Part 1. Over-all Effectiveness*. Air Force Personnel and Training Research Center, Lackland Air Force Base, Texas, Technical Report AFPTRC TR-54-38, 8 September 1954 23 pp, AD 53 730.

This study was conducted to investigate the contribution which might be expected from the use of contact flight simulators in one area of pilot training. Little was known concerning the effectiveness of such devices for teaching contact flight training. It was felt that the results of this project would have important implications for future planning of training programs and procurement of training equipment. The results of this study indicated that the efficiency of instruction in the Primary Pilot Training program may be greatly improved by the incorporation of a contact flight simulator into the experimental training program. Simulators with higher fidelity have been developed since the design of the movable, vacuum operated, flight simulators used in this study. These more recent simulators, all of the fixed electronic type, do not, however, provide the cues necessary for contact flight simulation. The results of this study suggested that consideration be given to development and evaluation of visual cue system for contact flight simulation in fixed type simulators.

92. Gabriel, R. F., Burrows, A. A., and Abbott, P. E. *Using a Generalized Contact Flight Simulator to Improve Visual Time-Sharing*. U. S. Naval Training Device Center, Port Washington, New York, (Douglas Aircraft Company, Inc., Long Beach, California), Technical Report NTDC 1428-1, April 1965, 73 pp, AD 619 047.

Thirty Marine A-4 pilots were given eight carefully-designed time-sharing training sessions in a simple, generalized visual flight simulator and then compared with a control group on performance in the highly specific A-4 operational flight trainer equipped with a visual display. Results indicated improved ability to detect simulated mid-air collision hazards without compromising performance in the other flight tasks. Such training therefore is recommended as an aid in reducing the mid-air collision hazard.

93. Hufford, L. E. and Adams, J. A. *The Contribution of Part-Task Training to the Relearning of a Flight Maneuver*. U. S. Naval Training Device Center, Port Washington, New York, (University of Illinois, Urbana, Illinois), Technical Report: NTDC 297-2, 22 March 1961, 44 pp, AD 259 505.

The purpose of this study was to determine the contribution of part-task training to the relearning of a whole-task. An experiment was performed using subjects who had learned the whole-task (a simulated bomb-tool maneuver) during participation in the previous study, "Part-Versus Whole-Task Learning of a Flight Maneuver," (TR NTDC-297-1) but had lost proficiency as a result of a ten-month interval of non-practice. Half the subjects obtained part-task refresher training only. Results revealed that while part-task training could not completely substitute for the whole-task training, it substantially reduced the number of whole-task trials needed.

94. Johnson, J. H. *An Evaluation of a Device Designed to Teach the Principles of Trimming an Aircraft*. U. S. Naval Aviation Medical Center, Pensacola, Florida, Special Report No. 61-1, 25 January 1961, 9 pp, AD 255 282.

During the first week of primary training a group (experimental group) of students received special training with a device designed to teach the principles of trimming an aircraft. They were compared with a matched group (control group) who received no special training. The experimental group were able to learn to manipulate the device at a rapid rate with very few errors. There was no one particular outstanding difference in performance between the experimental group and the control group. However, more of the differences that did occur were favorable to the experimental group. This was especially true of students with high aptitude. There was much

more variability of performance later on in the training program among the experimental group. It may be, therefore, that the training device makes possible quicker recognition of the potential of students.

95. Lanier, H. M. and Putler, E. D. *An Experimental Assessment of a Ground Pilot Trainer in General Aviation*. Aircraft Development Service, Federal Aviation Agency, (Middle Tennessee State University, Murfreesboro, Tennessee), Technical Report: FAA-ADS-64, February 1966, 31 pp, AD 653 733.

An experiment was conducted by Middle Tennessee State University to assess the teaching effectiveness of a government furnished ground pilot trainer utilized in instruction designed to develop primary and instrument flight proficiencies. The design of the private pilot study required the selection of three groups of candidates, differential employment of the ground trainer with each of these three groups, and comparison of the measures of training progress and attained proficiency versus a comparison group of pilot candidates taught by the usual methods, i.e., without use of a ground trainer. The instrument rating experiment required the selection of ten pilots, all with minimum IFR experience, to be trained to flight performance required for instrument rating, utilizing the ground trainer combined with flight instruction. Ground trainer instructional hours and aircraft instructional hours required to develop proficiency in primary flight ability and instrument rating ability are reported. An analysis of the data revealed that the ground trainer does not reduce the total number of instructional hours necessary to achieve flight proficiencies but the trainer does reduce the number of aircraft instructional hours ordinarily required in the acquisition of such proficiency. The ground trainer was found to be of most value in developing navigational competence and command ability.

96. Mahler, W. R. and Bennett, G. K. *Psychological Studies of Advanced Naval Air Training: Evaluation of Operational Flight Trainers*. U. S. Naval Special Devices Center, Port Washington, New York, (Psychological Corporation, New York, New York), Technical Report: SDC 969-1-1, September 1950, 152 pp, AD 643 499.

Two operational flight trainers, one for the PBM (two-engine seaplane) and one for the PB4Y (four-engine seaplane) were evaluated. Results showed: (1) with regard to flight time, there are no savings during the familiarization phase, but during the instrument stage, some flight instruction can be saved; (2, with regard to student proficiency, there are fewer serious errors and fewer total errors on most maneuvers; (3) the most effective use of operational flight trainers is in providing a superior type of briefing; and (4) the authors believe more research should be done on maintenance proficiency, training on emergencies, and the transition from one aircraft to another.

97. Mahler, W. R. and Bennett, G. K. *Special Devices in Primary Flight Training: Their Training and Selection Value*. Special Devices Center, Port Washington, New York, (The Psychological Corporation, New York, New York), Technical Report: SDC 151-1-18, 31 August 1949, 121 pp, ATI 64 943.

Results of the study indicate that the types of synthetic flight training studied tended to reduce the number of accidents and the number of flight failures. Accidents were reduced by approximately two-fifths. Flight failures were reduced by approximately one-third. A very slight reduction, one-half hour of flight per student, in amount of extra flight time was found among those given synthetic training. The differences in mean check flight grades were negligible.

Roughly equivalent results were obtained from the three rather different types of synthetic training. In the opinion of the authors, the results justify neither the abandonment of synthetic training nor the immediate full-scale incorporation of such training into the regular syllabus. Continuation of research activities are recommended. Improvement in the criteria of flight performance is highly desirable.

98. Matheny, W. G., Williams, A. C., Dougherty, Dora, and Hasler, S. G. *The Effect of Varying Control Forces in the P-1 Trainer Upon Transfer of Training to the T-6 Aircraft*. Human Resources Research Center, Lackland Air Force Base, Texas, Technical Report 53-31, September 1953, 5 pp, AD 22 980.

The study was concerned with evaluating whether subsequent performance in learning climb and glide maneuvers in T-6 aircraft was affected by differential amounts of control stick pressure used during previous training in a P-1 Link Trainer. Three groups of subjects received flight training in climbs and glides in the T-6 aircraft. Two of these groups were given a program of training in these maneuvers in a synthetic flight trainer (Link P-1) prior to their training in these maneuvers in the T-6. One of these two "simulator" groups learned the maneuvers in the P-1 with the force required on the elevator control adjusted to correspond as closely as possible to the control force characteristic of the T-6. The other group learned the maneuver in the P-1 with the elevator control force adjusted to a minimum value. The third group, a control group, learned the maneuver only in the T-6 aircraft. Performance in the T-6 was assessed through determining the number of trials required during T-6 training to achieve a specified standard of performance in executing climb and glide maneuvers. The groups given simulator training achieved the standard criterion performance in the glide maneuver in a fewer number of trials than did members of the control group, these differences being statistically significant. Performance of the "simulator" groups in the climb maneuver was also superior to that of the control group, although inasmuch as these differences did not achieve statistical significance, unequivocal conclusions regarding the effect of simulator training in the climb maneuver cannot be drawn.

99. Ornstein, G. N., Nichols, I. A., and Flexman, R. E. *Evaluation of a Contact Flight Simulator When Used in an Air Force Primary Pilot Training Program: Part II. Effectiveness of Training on Component Skills*. Air Force Personnel and Training Research Center, Lackland Air Force Base, Texas, Technical Report: AFPTC TR-54-110, 6 December 1954, 12 pp, AD 62 373.

This report presents an analysis of the effectiveness of the P-1 simulator in teaching specific components of contact and instrument flying skills. Specifically maneuvers, dimensions, and families of maneuvers are investigated and the contribution of simulator training to each is ascertained. The results of this study support and expand the implications of the first study in this series. Both studies indicate that training which utilizes the P-1 simulator is effective. This second study indicates, however, differential effectiveness of simulator training for various maneuvers and components of flight performance. Simulator training appears to be most effective with respect to maneuvers the performance of which does not exceed the design limitations of the trainer and maneuvers which are heavily weighted with "procedural" components.

100. Page, H. E. and Lyon, V. W. *Performance in the SNJ Cycloramic Link and its Relationship to Subsequent Performance in Stage "A" of Flight Training*. U. S. Naval School of Aviation Medicine, Pensacola, Florida, Preliminary Report: NM-001-058, OS, 1 November 1950, ATI 94 301.

A study was made of the relationship between objective scores on specific maneuvers after five hours of instruction in the SNJ Cycloramic Link Trainer and flight grades achieved by the

same students in Stage "A" training. The value of the Stage "A" grades as a flight performance criterion, the reliability of the scoring device, and the validity of the selected test maneuvers were questioned. Recommendations were made for modifying the experimental design which could be used for further investigation into the possibility of predicting student performance.

101. Payne, T. A., Dougherty, Dora J., Hasler, S. G., Skeen, J. R., Brown, E. L., and Williams, A. C. *Improving Landing Performance Using a Contact Landing Trainer*. U. S. Navy, Special Devices Center, Port Washington, New York, (University of Illinois, Urbana, Illinois), Technical Report: SDC 71-16-11, 1 March 1954, 32 pp, AD 121 200.

Reports a method for teaching approaches to a landing in a synthetic flight trainer. Subjects were 12 university male students, between the ages of 18 and 25. The students were randomly assigned to an experimental group or control group, six to a group. The experimental group learned to make approaches in the 1-CA-2 and then relearned this task in an SNJ aircraft. The control group learned to make approaches only in the SNJ. A comparison of the performance of the two groups in the SNJ showed: (1) the experimental group required 61% fewer approaches (trials) in the SNJ than did the control group in order to achieve a standard level of proficiency in making approaches. (2) the experimental group made 74% fewer errors in the SNJ than did the control group. A special method of instruction called principles of training was used throughout. Students were required to learn the principles involved in the approach task. Results of the experiment show that: (1) This method of teaching approaches could be profitably used in routine flight training, saving time, money, and probably lives. (2) It should be particularly helpful with borderline students who are having difficulty with approach. (3) The use of principles training is essential to the success of the method. The application of principles training in this case can be made with sufficient specificity and detail that it should prove no problem in routine use. (4) It may be possible to adapt this technique to the teaching of carrier approaches.

102. Phillips, C. R., Jr. *An Experimental Assessment of a Ground Pilot Trainer in General Aviation*. Aircraft Development Service, Federal Aviation Agency, Washington, D. C., (Miami-Dade Junior College, Miami, Florida), Technical Report: FAA-ADS-61, January 1961, 98 pp, AD 653 729.

Experimental flight training was conducted in conjunction with a commercial model ground trainer to determine its effectiveness in contributing to the proficiency level normally obtained by students undergoing a rigidly controlled flight syllabus without use of synthetic training device. Differential levels of training with the ground trainer was prescribed for three experimental groups of students. All students in the experimental groups were permitted to accelerate their individual learning with respect to their demonstrated proficiency. Results indicate that no appreciable reduction in total aircraft training time was in evidence, particularly in view of the additional hours of training performed in the ground trainer. However, aircraft time was reduced from 50 hours to 43 hours but at the cost of ground trainer time. A second phase of the experimental program involving use of the trainer was the instrument training for a control group of students having Private Pilot qualifications. Additionally, physical features and equipments of the trainer were evaluated and comments are involved in the discussion.

103. Poe, A. C. and Lyon, V. W. *The Effectiveness of the Cycloramic Link Trainer in the U. S. Naval School, Pre-Flight*. U. S. Naval School of Aviation, Naval Air Station, Pensacola, Florida, Report Number: NM 001 058. 07. 01, 17 March 1952, 9 pp, ATI 149 911.

The purpose of this study was to determine the contribution of instruction in the SNJ Cycloramic Link during Pre-Flight School to flight proficiency in the initial stages of flight training. Flight instruction does not begin until this academic pre-flight course has been completed. The procedure consisted of the random selection of two groups of students. One, the Academic Group, had the regular Pre-Flight School curriculum. The performance of these two groups during the initial stages of flight training was compared on five criteria. These were: The number of flight attritions in each group, the number of Student Pilot Disposition Boards convened to consider flight deficiencies in each group, the number of extra flights necessary for each group to reach flight proficiency standards, instructional flight grades, and check flight grades. Very small differences between the groups were found on any of the criteria and none of these were statistically significant. The conclusion was reached that instruction in the SNJ Cycloramic Link during the Pre-Flight School did not affect proficiency during the initial stages of flight training. The recommendation was made that such instruction be omitted and it was suggested that the SNJ Cycloramic Links be transferred to NAAS Whiting Field for direct use in primary flight training.

104. Prophet, W. W. *The Importance of Training Requirements Information in the Design and Use of Aviation Training Devices*. Department of the Army, (Human Resources Research Office, George Washington University), Professional Paper: 8-66, December 1966, 3 pp, AD 645 961.

Included is a brief description of an experiment in which one group of pilots trained on an expensive (\$100,000) cockpit procedures trainer; the second group trained in a mockup which cost \$100; a third group received all their training in the aircraft. Their performance served as a baseline against which the transfer of the device training administered to the two trainer groups could be evaluated. The mockup group performed as well as the trainer group on all procedures. The effectiveness of both trainers was shown to be high by comparing the aircraft trials of the trainer and mockup groups with those of the control group. It is emphasized that a great deal of beneficial training can be realized from devices which may lack much in physical fidelity, but have the task fidelity necessary to transfer of training. Also the point is taken that the training program is the important factor.

105. Ritchie, M. L. and Flanes, L. F. *An Experimental Analysis of Transfer Effects Between Contact and Instrument Flight Training*. Federal Aviation Agency, Washington, D. C., (Ritchie, Inc., Dayton, Ohio), June 1964, 30 pp, AD 818 553.

Thirty-nine students learned to fly straight and level and to make level turns on instruments and on contact in a study designed to measure the effects of instrument experience in the airplane and in a Link Trainer on the subsequent learning of contact flight and instruments in the airplane. Instrument flight was shown to be harder to learn than contact flight. On instruments, straight and level was the difficult task to learn and heading was the limit most often exceeded. On contact flight, turns were the most difficult task and no one limit accounted for the majority of the errors. Learning to maneuver in the Link Trainer reduced the time to learn subsequently to fly the maneuvers in both contact and instruments, but the difference was not statistically significant. A greater reduction was obtained with instruments learned in the airplane before learning contact and relearning instruments. Relevance of the findings to other studies are discussed and recommendations for further study are made.

106. Rugocco, J. N., Vitale, P. A., and Benfari, R. C. *Kinetic Cueing in Simulated Carrier Approaches*. U. S. Naval Training Device Center, Port Washington, New York, (Grumman Aircraft

Engineering Corporation, Bethpage, New York), Technical Report: NTDC 1432-1, 28 April 1965, 90 pp, AD 617 689.

Pairs of matched pilots were trained using a flight simulator in a carrier landing maneuver under two conditions – kinetic and static. The two conditions were identical except that in the kinetic mode cockpit motion was provided. Kinetic cueing significantly improved performance in terms of percentage of successful landings, altitude error, time outside the flight path, and variability of pilot inputs. The statically trained group showed a decrement in performance which persisted throughout training and transferred to the criterion flights which involved cockpit motion. Results clearly indicate that kinetic cueing is a valuable and desirable adjunct to flight airborne simulation systems.

107. Ruocco, J. N., Vitale, F. A., and Benfari, R. C. *Kinetic Cueing in Simulated Carrier Approaches – Supplement I – Study Details*. Naval Training Device Center, Port Washington, New York, (Grumman Aircraft Engineering Corporation, Bethpage, Long Island, New York), Technical Report: NTDC 1432-1-S1, 28 April 1965, 196 pp, AD 618 756.

Pairs of matched pilots were trained using a flight simulator in a carrier-landing maneuver under two conditions – kinetic and static. Technical Report NTDC 1432-1 is a summary report of this study (see Reference 106). This is a supplement for the technical reader providing detailed information on the equipment used, on the experimental design, and on the reduction of data.

108. Taylor, L. W., Jr. and Day, R. E. *Flight Controllability Limits and Related Human Transfer Functions as Determined from Simulator and Flight Tests*. National Aeronautics and Space Administration, Washington, D. C., Technical Note: NASA TN D-716, May 1961, 65 pp, AD 256 073.

A simulator study and limited flight tests were performed to determine the levels of static stability and damping necessary for pilot control of the pitch, roll, and yaw attitudes of a vehicle for a short period of time. Novel piloting techniques were found which enabled the pilot to control the airplane at conditions that were otherwise uncontrollable. The influence on the controllability limits of the more important aerodynamic coefficients and other factors, such as learning and interruption of the pilot's display, was also investigated. Information concerning human transfer functions applicable to marginally controllable tasks is presented which should aid in assessing the controllability of any specific configuration.

109. Townsend, J. C. *Evaluation of the Link, ME-1, Basic Instrument Flight Trainer*. Air Force Personnel and Training Research Center, Lackland Air Force Base, Texas Development Report AFPTRC-TN-56-84, June 1956, 80 pp, AD 113 519.

The Link, ME-1, basic instrument flight trainer was evaluated during a 17-week period. More than 70 individuals, representing all levels of skill in piloting conventional and jet aircraft, flew the trainer during the evaluation. Twenty-two of these subjects were given structured training, which consisted of an hour ride on each of four successive days, during which time their performance was measured on a flight check which had been developed by the evaluation team. The results of the evaluation indicated that the ME-1 was rated average in housing requirements, excellent in instructional facilities, above-average in unloading, installing and calibrating, excellent in maintenance, below-average in human engineering, average in engineering, excellent in validity and stability of performance curves, excellent in cockpit motion and rough air capability, and excellent in manning requirements. Evaluative opinion by all persons who "flew" the



trainer was generally highly favorable. On the basis of training effectiveness and economy of maintenance during the evaluation, the ME-1 is recommended for acceptance as a satisfactory generalized basic instrument flight trainer.

110. Wilcoxon, H. C. and Davy, E. *Fidelity of Simulation in Operational Flight Trainers - Part I - Effectiveness of Rough Air Simulation*. Special Devices Center, Port Washington, New York, (The Psychological Corporation, New York, New York), Technical Report: SDC 99-2-3, 25 January 1954, 8 pp, AD 140 998.

The study investigated the effect of rough air simulation on basic instrument and radio range procedure training (Stage D Basic Flight Training). Results: (1) Performance in the aircraft on basic instrument and radio range procedures reveal no significant differences between groups trained with rough air and those not; (2) No differences were found in number of flights required to complete the syllabus; (3) Rough air simulation does seem to add reality to the trainer and increases student acceptance of it. Acceptability of a trainer to students and training personnel seems to be a factor which should be weighed in considering design of flight trainers. Acceptance should and can be achieved through designs which contribute to training. Rough air is not a necessary element in basic instrument and radio navigation training, and is therefore not economically justified.

111. Wilcoxon, H. C., Davy, E., and Webster, J. C. *Evaluation of the SNJ Operational Flight Trainer*. U. S. Navy, Special Devices Center, Port Washington, New York, Technical Report: SDC-99-2-1, March 1954, AD 88 988.

This study presents an extensive evaluation of the SNJ Operational Flight Trainer. Two broad problem areas were investigated: (1) how much transfer of training can be obtained through the use of the trainer, and (2) the development of improved utilization techniques. The evaluation was conducted primarily by comparing the trainer with other trainers while performance was measured against a "no-trainer" condition. The results are treated in terms of comparative flight proficiency exhibited by groups of subjects utilizing the various trainers.

112. Williams, A. C., Jr. and Flexman, R. E. *An Evaluation of the Link SNJ Operational Trainer as an Aid in Contact Flight Training*. Special Devices Center, Office of Naval Research, Port Washington, New York, (University of Illinois and Link Aviation, Inc.), Technical Report: SDC 71-13-3, 1949, AD 136 300.

An investigation to determine whether certain aspects of basic flight training could be successfully learned in a flight trainer. The conclusions were: (1) training in the SNJ Operational Flight Trainer resulted in saving flight training time in the aircraft, (2) the saving in time achieved averaged 7 hours and 14 minutes per student for the syllabus used, (3) the saving in training time for the entire population of such students lies somewhere within the limits of 4 hours and 47 minutes and 8 hours and 47 minutes.

113. Woolman, M. *Some Effects of Synthetic Trainers in a B-47 Training Program*. Training Analysis and Development Division, McConnell Air Force Base, Kansas, Final Project Report, 22 February 1955, 27 pp, AD 76 533.

This study concerns the training value of two synthetic flight trainers; (1) the C-11 Link Trainer, and (2) the B-47 Simulator. Students who were provided only B-47 Simulator training

were about as proficient as students who were given both C-11 Simulation training. The finding suggests that if C-11 training were deleted, there would be no significant loss in the quality of the B-47 student product. The results also indicate greater transfer from the B-47 Simulator to the aircraft than from the C-11 trainer to the simulator. Also the findings suggest that it is feasible to predict air performance from B-47 Simulator performance.

## SECTION IV.

# Utilization and Evaluation

### INTRODUCTION

This section primarily concerns the utilization and evaluation of training flight simulators. In the flight training area, many technical reports have been published which describe flight trainer effectiveness, utilization, and performance measurement. The purpose of this section is to present a selected annotated bibliography of those reports which may be of interest to military or civilian personnel engaged in synthetic flight training.

There are many types of simulators used in military and civilian aviation training programs throughout the country. These range from expensive, sophisticated electronic devices, with visual and motion simulation, to relatively simple and economical part-task trainers. For this reason, it is not surprising that some attempts have been made to determine what constitutes proper utilization of these trainers. For example, Meyer, et al (132) indicated that at some Air Force installations certain complex simulators were being used as procedures trainers because of inoperative motion and visual capabilities. It would appear that in the interest of economy, that a relatively inexpensive procedures trainer could be used for this purpose.

The primary consideration in simulator training should concern the use of valid objectives in the development of the syllabus. How and for what reason are the training devices obtained for training purposes? Is the media selection made as a result of specific requirements based upon behavioral objectives, or is the selection made based on the hopeful desire that all training contingencies will be covered? If the objectives reflect desired task behaviors, it should be possible to determine with reasonable assurance whether any training media is being properly utilized. If the major attribute of a training device is its high cost, or "gold plate," a second look at the training objectives should be taken. Unfortunately, the reader will find little useful information on this subject in the cited literature, which indicates a need for the development of sound guidelines for media selection and utilization.

### UTILIZATION

Edgerton, et al,\* presented a guide for the synthetic study of training aids which may be generalized to flight trainers. The report may be of value in developing methods for the following: (1) who should do the study; (2) what instruments should be used; and (3) procedures for summarizing results and making recommendations. Sample blanks and observers' check list, the SDC-ONR Evaluation Procedure, and a manual for using the procedure are appended.

A comprehensive handbook on the utilization of simulators (126) was published in 1953. The handbook contains discussion on installation, maintenance, and checkout for malfunction and appropriateness of the simulator; methods of instruction; organization of the simulator section; and methods for studying the effectiveness of simulator training. Since many innovations in training and computer technology have occurred since 1953, there is a need to update this simulator handbook.

An overview of flight simulator utilization was prepared by Smith, Bacon, Cook, and Maeers (150) in 1954. Most of the simulator problems experienced at that time are present today. An

---

\*Edgerton, H. A., Heinemann, R. F. D., and Gray, E. J. *Construction of the 1953 Form of the Evaluation Procedure for Training Aids and Devices*. Office of Naval Research, Special Devices Center, Technical Report: SDC-383-2-2, January 1953, AD 221 528.

interesting item considered by the authors was the cost involved in simulator training. For example, a detailed breakdown of operating costs for the B-50 aircraft and B-50 simulator at that time was given. The total per hour operational costs for the B-50 aircraft was \$423.00 as compared with \$68.00 for the B-50 simulator. The authors point out that production and operating costs are directly affected by the simulator utilization program. Also, it is very important at pre-contract and manufacturing stages, to have sound information on the number and kinds of components to be simulated, and the degree of flexibility of tolerance permissible since these factors influence initial costs more directly.

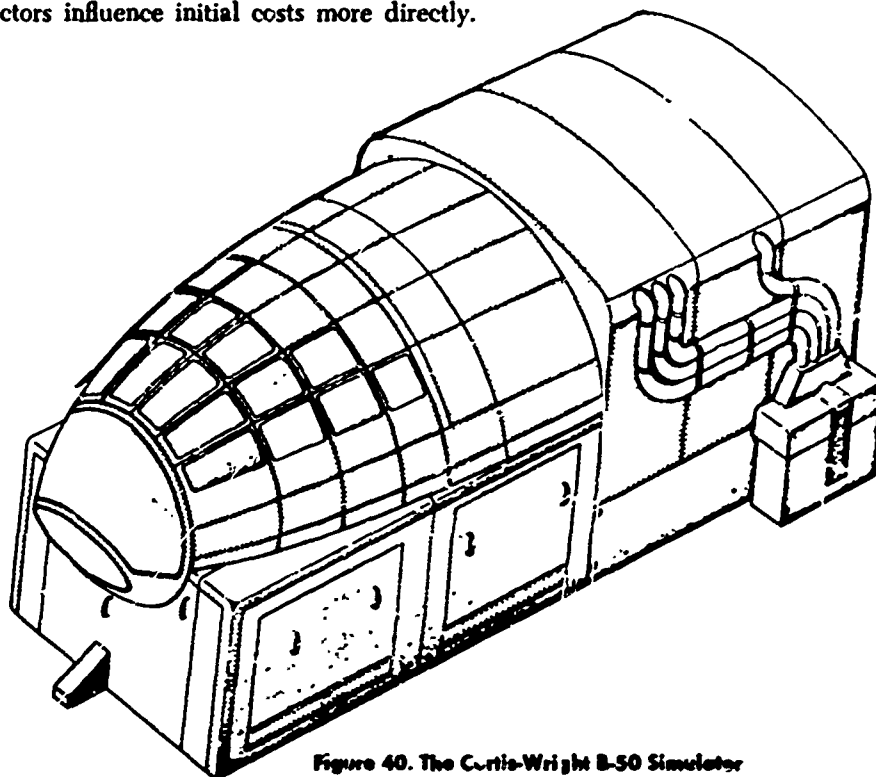

Figure 40. The Curtiss-Wright B-50 Simulator

Jones and Dubois (127) described and evaluated a rating method for the selection of flight procedures for B-50 simulator courses. Three groups of experienced flight personnel chose out of 30 training areas the 20 areas in which their crews needed the most and the least additional training. The data included mean ratings for training areas, agreement within and between the judgments of flight personnel and flight instructors as to the relative importance of the areas.

The instructor activity in operational flight trainers was studied by Casperson and Channel (116) for the purpose of improving the capabilities of such devices, many of the findings apply generally to the Operational Flight Trainer program. The authors recommended: (1) establishment of programs and training of instructors; (2) formalization of the syllabus material; and (3) possible simplification of the devices.

Colman, Davis, and Courtney (118) reported a study, in 1962, on the utilization potential of operational flight trainers toward the reduction of aircraft accidents based on the concept of an aircraft as a man-machine system. The study recommends certain specific action in the areas of: (1) instructional techniques; (2) syllabus construction; (3) instructor selection; (4) utilization of trainer equipment; and (5) design of operational flight trainers.

Meyer, et al (132), conducted an experiment to determine the effects of simulator training to criterion proficiency upon time required in the aircraft. Data were also collected on proficiency levels attained, self-confidence levels, individual estimates of capability, and sources from which that capability was derived. Subjects for the experiment were 48 airline captains transitioning into the DC-8 aircraft. Data obtained from student reactions to questionnaire items are interpreted to indicate that: (1) simulators can be used to further reduce requirements for training time in the aircraft; and (2) simulators can be used to evaluate performance that is indicative of performance in the aircraft.

### EVALUATION

The evaluation of flight simulators has several different connotations. For example, a trainer may be evaluated as to its validity, efficiency and practicability. A valid simulator is one that teaches what it is supposed to teach. This implies that practice on the trainer must "transfer" or carry over to the operational equipment. Generally, however, evaluation considered in this section concerns studies in which efficiency and practicability were determined by opinion surveys, check lists, and assessment of performance. Transfer of training studies are not included since these are treated in Section II.

Some evaluative studies have been conducted to determine the employment capability and suitability of flight simulators for training purposes. Specific areas of investigation included:

1. Capability of the simulator to provide suitable training in operational techniques and procedures used in the actual aircraft.
2. Suitability of maintenance and logistics required to sustain daily operation.
3. Installation and initial check out of the simulator including facility requirements and man-hour requirements.

The Air Proving Ground Command (now Air Proving Ground Center) has tested the employment and suitability of various simulators. Reports cited in the annotated bibliography include tests of the C-130A Flight Simulator (162), KC-135A Flight Simulator (164), KC-97G Flight Simulator (163), B-66B Trainer Simulator (161), and B-52B Flight Simulator (160). These simulators are shown in Appendix II.

A report by Pomarolli (172) describes the effectiveness of the Link I-CA-1 Naval Basic Instrument Trainer (NavBIT). The study concerned student perception of and attitudes toward the trainer. The findings are based on student reactions and on an extensive search of the pertinent literature. The author concludes that the trainer adequately fulfills its purpose of teaching procedures, scan, and reading of instruments.

With the advent of World War II, this country was confronted with the formidable task of training thousands of young men as combat pilots. A major research problem at that time involved the development of sound methods for the selection of flying training candidates and the prediction of success by means of aptitude testing early in the training program. A concentrated effort was made to develop more objective evaluation measures rather than to rely on subjective methods which had been, and still are used. For a summary of this research goal, the reader is referred to the study by Ericksen,\* published in 1952.

---

\*Ericksen, S. C. *A Review of the Literature on Methods of Measuring Pilot Proficiency*. Human Resources Research Center, Lackland Air Force Base, Texas, Research Bulletin 52-25, August 1952, 24 pp. AD 169 181.

An important contribution to the design of scoring and recording devices in flight simulators was made by Danneskiold (167) in 1955. He emphasized the need for diagnostic performance grading as opposed to proficiency measures and reviewed mechanical scoring devices which permitted measurements related to control movements.

Also, Danneskiold described an objective method for grading the performance of students in flight trainers. This method, called the Basic Instrument Check, is discussed with respect to its reliability and validity in predicting pilot proficiency.

The feasibility of oscillographic recording of pilot performance was reported by Swanson (176) in 1957. He believed that the usual method of recording observations on evaluation forms and flight checks could be improved. He discussed the integration of a Photon 6-channel oscillograph with the B-52 Flight Simulator for measuring and evaluating the feasibility of measuring pilot performance in it.

Automated systems of performance measurement for simulators and other complex equipment seem to present certain advantages. Angell, Shearer, and Berliner (165) listed some of the advantages as follows:

1. More objective measures are provided by automatic equipment than by fallible human observers, and with an increase in objectivity, all of the purposes of performance measurement are more directly and more accurately fulfilled.
2. Automatic equipment has the capability of providing evaluation information of a more detailed nature than is easily available by other observational methods.
3. Evaluations may be made very rapidly by high-speed automatic equipment, and this has implications for training effectiveness and for assignment procedures.
4. Training equipment may be used to its maximum capability with the incorporation of measuring instruments of relatively small cost and size.

Demaree, Norman, and Matheny (88), in 1965, reported on initial investigations and a pilot performance study conducted with respect to the use of the Universal Digital Operational Flight Trainer Tool (UDOFTT) computer in conjunction with a real-time input-output capability to an instrumented jet fighter cockpit. The rationale, methodology, and outline for a series of pilot training research studies have been developed in conjunction with the determination of effective means for use of the UDOFTT, including the recording and computation of objective performance measures.

#### **CONCLUSIONS**

The data obtained from training research literature indicate that the utilization and proficiency evaluation of flight simulators should be further improved. The objectives for flight simulator training programs should clearly reflect the behaviors of flying training that can best be taught in the simulator.

Many instructors and other training personnel consider the simulators to be useful aids in flight instruction, but their opinions differ widely as to how these simulators should be used. Structured interviews with instructor pilots indicate that, generally, instructors are divided in their opinions as to the value of simulators in pilot training programs. Some instructors believe that simulators are valuable training media, while others disapprove of their use. Some instructors also feel that trainers should faithfully simulate the actual aircraft.

Some progress is being accomplished in performance scoring methods in exploratory research. Objective recording devices, in-flight telemeters, motion pictures, and television have been used. However, these devices were generally too heavy, bulky, and expensive (especially in training aircraft) for widespread application to training performance evaluation. It is possible that in the near future economical microminiaturization of automatic scoring devices will facilitate the achievement of objective performance testing in flight training programs.

#### ANNOTATED BIBLIOGRAPHY -- UTILIZATION AND EVALUATION

##### UTILIZATION

114. Ammerman, H L. and Melching, W. H. *The Derivation, Analysis, and Classification of Instructional Objectives*. Department of the Army, (Human Resources Research Office, George Washington University, Alexandria, Virginia), HumRRO Technical Report: TR-66-4, May 1966, 58 pp, AD 633 474.

An examination of the methods, terms and criteria associated with the determination of student performance objectives was made in order to synthesize and apply the relatively new developments in Human Factors research on this subject. Education and training research literature on the subject was examined to identify procedures currently being used or proposed. A survey of eight Army service schools was conducted to determine procedures employed by instructional personnel in determining course content. On the basis of data obtained, important problems arising in connection with the development of objectives are identified and analyzed. A system for analyzing instructional objectives by identifying factors that influence their meaningfulness and usefulness was developed. Types of student performance objectives are listed, and a classification scheme for terminal objectives is suggested. The classification is based on five factors on which a statement of an objective may vary, affecting the nature of the student action description and the communicability of the statement itself. The variety of terms associated with objectives are discussed.

115. Brown, J. S. and Weitz, J. *A Pre-Validation Study of Pilot Selection Test Situations Using the Link Trainer*. 27th AAF Base Unit, AAF School of Aviation Medicine, Randolph Field, Texas, Report No. 1, 24 August 1945, 12 pp, AD 236 415.

The purpose of the study was to determine the feasibility of using the Link Trainer (AN-T-18) and stationary targets for pilot selection test situations of varying degrees of difficulty. A technique was developed for objectively scoring an individual's ability to manipulate the Link Trainer with the hood removed. The subject's task was to fly the Link so that a beam of light, projected from the trainer would fall upon one or more of a series of stationary photoelectric targets. Eight test situations, varying in difficulty, were administered to groups of from 25 to 100 aviation cadets under conditions similar to those employed with the standard AAF psychomotor classification tests. Two of the test conditions were found to be too easy to differentiate clearly between individuals of different abilities. Six of the conditions, however, were neither too easy nor too difficult, and yielded data of adequate reliability.

116. Casperson, R. C. and Channel, R. C. *Use of the Operational Flight Trainer*. U. S. Naval Training Device Center, Port Washington, New York, (Dunlap and Associates, Inc., Stamford, Connecticut), Technical Report: NTDC-1734-00-1, May 1957, 66 pp, AD 643 498.

Instructor activity in an operational flight trainer was studied for the purpose of improving the training capabilities of these devices. The study was confined to the P2V-5 and F9F-5 OBT's in the training command in fleet training. However, many of the findings apply generally to the

operational flight trainer program. Sample problems designed to test the maximum capabilities of the trainers were conducted at several installations. The results of the study suggest the following recommendations:

1. Single instructor operation of an OFT is feasible, if GCA and flight malfunctions are separated. Otherwise a second operator and/or minor equipment modifications should be made.
2. In order to improve the training capabilities of the OFT and its crew, instructors should be given extensive formal training in teaching techniques and should be given a separate rating from the maintenance technicians.
3. Improved utilization of the training capabilities of the OFT should result if a formalized training syllabus, incorporating instruction schedule, problems, scoring, and recording techniques accompanies each trainer as part of its standard equipment. This syllabus should be made an integral part of the training curriculum when it is assigned to a particular installation.
4. If operational flight trainers currently in the field continue to be used as procedures trainers, they can be simplified by the elimination of many unused components. This would serve to reduce maintenance and increase reliability of operation.

117. Chambers, A. N. *Human Engineering Recommendations for a Synthesized Helicopter Simulator*. Wright Air Development Center, Wright-Patterson Air Force Base, Ohio, (American Institute for Research, Pittsburgh, Pennsylvania), June 1955, 78 pp, AD 84 789.

The objective of human engineering design recommendations was to determine the minimal training equipment required for various stages of training and the utilization of this equipment to obtain optimal training and transfer of training to the operational situation. The recommendations represent psychological considerations from the standpoint of efficiency of training and as such may conflict with engineering considerations. Recommendations are based on task analysis of the pilot's job to determine the essential discriminations, decisions, and responses required of a pilot to fly a helicopter.

118. Colman, K. W., Davis, C. G., and Courtney, D. *The Operational Flight Trainer in Aviation Safety*. U. S. Naval Training Device Center, Port Washington, New York, (Courtney and Company, Philadelphia, Pennsylvania), Technical Report: NTDC 520-1, July 1962, 57 pp, AD 287 905.

This is a study of the utilization potential of operational flight trainers (OFT) toward the reduction of aircraft accidents based on the concept of an aircraft as a man-machine system. Both "materiel errors" and "pilot errors" are perceived as the result of inadequate interaction between the pilot and his aircraft in all modes of flight. Beginning with an analysis of jet aircraft accidents, this study also includes intensive interviews with experienced pilots as well as personal observations of current simulator utilization. This study recommends certain specific action in the areas of: (1) Instructional techniques; (2) Syllabus construction; (3) Instructor selection; (4) Utilization of OFT equipment; and (5) Design of OFT. In addition to detailed insights into the nature of accident-producing situations and into the training that is needed to reduce their occurrence, the study provided the background knowledge and the techniques for the development of a training syllabus that would enable the OFT instructor to provide realistic emergency training even if he were not a pilot with first-hand operational experience in the given aircraft.

119. Demaree, R. G. *Development of Training Equipment Planning Information*. Aerospace Medical Laboratory, Aeronautical Systems Division, Wright-Patterson Air Force Base, Ohio, (Psy-



chological Research Associates, Arlington, Virginia), Technical Report: ASD TR-61-533, October 1961, 101 pp, AD 287 326.

In the development of Air Force systems, the timely procurement and delivery of training equipment is essential. Many human factors and engineering considerations enter into the determination as to what items of training equipment will best serve the purposes of a particular system. This report attempts to take proper account of both the engineering and human factors considerations but places special emphasis upon the latter. The report is divided into seven sections entitled: Introduction, An Overview of Training Equipment Planning, Training Functions for Various Types of Training Equipment, Training Equipment Utilization, Training Equipment Effectiveness Characteristics, Training Equipment Cost, and TEPI Development. The appendices cover: Explanation of Terms, The Personnel Subsystem and Its Elements, and a Selected Bibliography. Liberal use is made of graphic and tabular presentations to illustrate the principles presented.

120. Dinsmore, Ruth A. and DuBois, P. H. *A Preliminary Study of Learning in the B-50D Flight Simulator*. Human Resources Research Laboratories Bolling Air Force Base, Washington, D. C., HRRL Memo Report No. 26, July 1952, 18 pp, ATI 180 385.

This study shows that considerable learning takes place in the B-50D simulator; it provides no evidence that skills acquired in the simulator are transferred to operations in the aircraft. The evidence presented here, and the conclusions drawn, pertain specifically to performances, by trainees, within the simulator. Considerable caution should be exercised in generalizing any conclusions reached in this report to aircraft operations. The findings presented here are based on the analysis of the training records of 47 crews trained in the B-50D Flight Simulator at Walker AFB. All crews studied completed their simulator training between 1 November 1951, and 30 June 1952. Twenty-four of these crew completed the Basic Course, and 23, the Advanced course. Data from the Basic and Advanced Courses are treated separately throughout this report. Except for two training areas, engine malfunctions and general crew teamwork, data for Aircraft Commanders and Flight Engineers are also treated separately. All significant statistical results are reported both graphically and numerically. No estimates of statistical reliability are presented in this study. The circumstances under which it was accomplished necessarily limited it to being an exploratory research project, with emphasis on the location of trends.

121. Doppelt, F. F. *A Program for the Spatial Disorientation Demonstrator*. USAF School of Aerospace Medicine, Brooks Air Force Base, Texas, Technical Report: SAM-TR-65-66, October 1965, 9 pp, AD 474 455.

In order to better delineate the flight profile situations to be programmed into the simulator, a questionnaire was given to 55 rated pilots at the Instructor Pilot Instrument School (IPIS) at Randolph AFB, Texas. The questionnaire is a relatively simple one and allows for many comments by the individual filling it out. Vertigo and spatial disorientation were used interchangeably throughout the questionnaire. They were defined to the pilots as either (1) the sensation of rotating or whirling around, which implies a subjective sensation of rotating with respect to the environment or vice versa; or (2) a false or incorrect impression of one's position in space with respect to the surface of the earth. The information obtained from the pilots was used to propose a program for the spatial disorientation demonstrator.

122. Fancher, P. S., Larrow, V. L., Jennings, J. R., and Spencer, M. M. *A Study of Engine Simulation Methods for Operational Flight Trainers*. U. S. Naval Training Device Center, Port Wash-

ington, New York, (Institute of Science and Technology, University of Michigan, Ann Arbor, Michigan), Technical Report: NTDC 822-1, October 1960, 147 pp, AD 424 149.

The first phase of an investigation to determine optimum equations to be used in engine simulators for operational flight trainers has shown that current methods of designing such simulators do not use theoretical equations, but instead use empirical equations which result from the application of various curve-fitting techniques to known engine performance data. A program to develop suitable theoretical equations has been started. Existing methods of simulating engines on analog computing equipment have been examined and analyzed in terms of complexity, flexibility, and accuracy. The methods considered include not only those in use by OFT (Operational Flight Trainer) manufacturers but also others proposed by or in use by various research and development organizations. Several methods of generating functions of two variables have been thoroughly examined, and design formulas applicable for specified error tolerance have been developed.

123. Gagne, R. M. *Training Devices and Simulators: Some Research Issues*. Air Force Personnel and Training Research Center, Lackland Air Force Base, Texas, Technical Report: AFPTRC TR-54-16, May 1954, 13 pp, AD 39 946.

Describes and clarifies some research issues relevant to the development, use and evaluation of training devices and simulators. A distinction is made between performance measurement and performance improvement. Also training devices and simulators are defined. Research opportunities on methodology include job analysis, training, proficiency measurement, and criterion development. Research opportunities on theory include structure of skills, the determinants of human variability, relationships of set and motivation to learning, and mechanisms of transfer of learning. A training device must either train or measure something. It cannot be justified on the basis of looks or similarity to an operational situation.

124. Cebhard, R., Gradijan, J. M., and Brooks, F. *Handbook for the Consideration of Training Functions During Design of Operational Equipment*. Naval Training Device Center, Port Washington, New York, (Dunlap and Associates, Inc., Washington, D. C.), NTDC Technical Report: 1450-2, July 1965, 82 pp, AD 625 828.

The handbook was prepared on a one-year study of how training considerations should be made during operational system design. For many systems, categories of operations can be defined according to whether on-system practice will normally be provided during mission fulfillment; can be provided at some degradation to mission or equipment; can be provided if additional equipment (not essential to functioning of the basic machine) simulates the external environment, or can be provided if internal state modification possibilities have been incorporated into the basic machine. Beyond this operation categorization scheme, many factors, called training tradeoffs, which must be considered in the allocation of training resources are discussed.

125. Hall, E. R., Parker, J. F., Jr., and Meyer, D. E. *A Study of Air Force Flight Simulator Programs*. Aerospace Medical Research Laboratories, Wright-Patterson Air Force Base, Ohio, (BioTechnology, Inc., Arlington, Virginia), Technical Report: AMRL-TR-67-111, June 1967, 113 pp, AD 818 957.

This report describes flight simulator utilization and training practices within the U. S. Air Force. Data are presented concerning simulator training objectives, curricula, instructional methods, personnel, and support factors which affect utilization and program effectiveness. Informa-

tion relating to the acceptance of flight simulators by pilot training personnel is included. In addition, recommendations and research issues are presented for improving the effective utilization of existing flight simulators and for the development of future simulator training requirements and programs.

126. Human Factors Operations Research Laboratories. *Flight Simulator Utilization Handbook*. Air Research and Development Command, Bolling Air Force Base, Washington, D. C., HFORL Report No. 42, August 1953, 227 pp, AD 21 359.

This simulator handbook has been written to provide practical assistance and to be a source of usable ideas for training personnel assigned the task of developing and operating a flight simulator program. It is also intended as an informative report for persons having an administrative or scientific interest in such programs, but no immediate contact with them. It is a record of experiences met in developing and conducting simulator programs. It is a summarization of pertinent knowledge in the fields of psychology and education which is applicable in flight simulator training. Most of the general principles, and all the specific examples have been derived from three programs: these are Strategic Air Command's B-50 and B-47, and Military Air Transport Command's C-97 simulator programs. The handbook is an accumulation of the knowledge, experience, and insights of all those who participated. It was compiled in 1953.

127. Jones, E. R. and DuBois, P. H. *The Use of Expert Judgments in the Development of Flight Simulator Training Courses*. Air Force Personnel and Training Research Center, Lackland Air Force Base, Texas, Research Report: AFPTTC-TN-55-14, July 1955, 20 pp, AD 72 653.

Presents research developments based on judgments of aircraft commanders, pilots, and flight engineers concerning their squadrons' training needs. Although the aircraft (the B-50D) involved in this study is not a new type, the method can be used with any plane for which pertinent information is unavailable from other sources. A basic list of 30 training areas was obtained from standing operating procedures for the B-50, instrument manuals, flight safety publications, individual Form 14's and a listing by selected B-50 crew members. Aircraft commanders, pilots, and flight engineers were asked to indicate those areas in which comparable crews of their squadrons needed the most and least training. The respondents, 28 aircraft commanders, 27 pilots, and 27 flight engineers, were all relatively proficient crew members. Their combined judgments were obtained for each of the 30 items. These provided rankings of the relative importance of various procedures for training, together with estimates of the agreement of the judges and of the agreement among various groups of judges. The combined judgments on the training needs of B-50 flight crews showed a relatively high degree of stability. It could be expected that another group of expert judges of equal size would give approximately the same importance rankings to the various areas. When the rankings were compared with scores on the rating form filled out by the instructors after each simulator flight, it was found that the procedures in which the crew members felt they needed training were generally those in which the instructors rated them as weak.

128. Kidd, E. A., Bull, G., and Harper, R. P., Jr., *In-Flight Simulation - Theory and Application*. Advisory Group for Aeronautical Research and Development, Paris, France, April 1961, 36 pp, AD 446 170.

Simulation techniques are applied to the problems of determining aircraft handling qualities. Analog computers, fixed-base simulators, and various other ground machines are discussed.

In particular, the theory and actual techniques of in-flight simulators of the variable-stability type are considered, the conclusion is drawn that the solution of the various problems of handling-qualities requirements and of control systems development requires the use of ground-base simulators and in-flight simulators as complementary tools.

129. Killian, D. C. *Survey of Training Characteristics of the B-52 Flight Simulator*. Air Force Personnel and Training Research Center, San Antonio, Texas, Technical Note: AFPTRC-TN-56-69, June 1956, 26 pp, AD 109 180.

The primary aim of this survey was to investigate all information sources at Castle Air Force Base to determine functional characteristics which might be included in the B-52C and B-52D Flight Simulators to improve the training capabilities of these simulators. A secondary aim of this survey was to provide information which might be helpful in retrofitting Models B, C, and D of the B-52 simulators. The information for this survey was gathered from five sources: B-52 SAC Aircraft Incident Reports; Recommendations by the Officer in Charge (OIC), Flight Simulator Section; Flight Instructor Comments; Training Crew Comments; Boeing Aircraft Company Engineering Change Proposals (ECPs). The materials gathered in the survey have been summarized in terms of their relevance to: systems operation; special mission elements simulation; fidelity of performance; and fidelity of physical characteristics.

130. Kurtzberg, J. M. *Dynamic Task Scheduling In Flight Simulators*. Aerospace Medical Research Laboratories, Wright-Patterson Air Force Base, Ohio, (Barroughs Corporation, Paoli, Pennsylvania), Technical Documentary Report: AMRL TDR-65-17, February 1963, 45 pp, AD 402 383.

This report deals with the possible mechanization of dynamic task scheduling flight simulators, i.e., developing a Task-Sequencer. Attention is focused on the possible application of some of the heuristic programming techniques and an evaluation of their worth for that specific purpose is made. Two main applications for a Task-Sequencer are defined. The first involves the traditional training of students (flight crews) for flight vehicle operation, termed the operation-teaching mode. The second is for the development of tactical skill, i.e., crew decision-making capabilities, termed the tactic-teaching mode. Algorithms for task sequencing in real time are formulated for both of these classes of applications. The only possible benefits in employing a heuristic programming scheme appear to exist when it is used for an ancillary role in the tactic-teaching mode. A procedural training model is developed in detail for the operation-teaching mode. This includes development of specific task flow diagrams and associated scoring charts. Finally, recommendations are made for further work.

131. Lamont, J. N. *Annotated Bibliography on Flight Simulators*. Directorate of Biosciences Research, Defence Research Board, Ottawa, Canada, August 1960, 25 pp, AD 247 344.

This bibliography is a list of unclassified reports, articles, and other material referring to flight simulators. It is likely to be of use to Service personnel who have some responsibility in connection with the acquisition, evaluation and use of these devices for the training of aircraft pilots and crews. Simulators used for other purposes, such as research into problems of aircraft design or the training of individual crew members other than the pilot, are not referred to here. In collecting items for the bibliography the compiler searched the literature of psychology, education, and training, but not of engineering. Hence the emphasis is on the simulator as a training device and the references deal only with the utility of the simulator in contributing to effective

training, not with its maintainability nor its cost, nor any other aspect of its effectiveness purely as a piece of electromechanical equipment.

132. Meyer, D. E., Flexman, R. E., Van Gundy, E. A., Killian, D. C., and Lanahan, C. J. *A Study of Simulator Capabilities in an Operational Training Program*. Aerospace Medical Research Laboratories, Wright-Patterson Air Force Base, Ohio, Technical Report: AMRL-TR-67-14, May 1967, 48 pp, AD 658 308.

The experiment was conducted to determine the effects of simulator training to criterion proficiency upon time required in the aircraft. Data were also collected on proficiency levels attained, self-confidence levels, individual estimates of capability and sources from which that capability was derived. Subjects for the experiment were 48 airline captains transitioning into the DC-8 aircraft. The subjects were equally assigned to experimental and control treatment groups. Subjects in the experimental group were trained in the DC-8 simulator for as much time as required to satisfy their instructors that they could perform the required maneuvers in the simulator at the same level of proficiency required to pass the final qualifications check in the aircraft. The control group was trained using the standard curricula which required a fixed time in the simulator. Data obtained from student reactions to questionnaire items are interpreted to indicate that (1) simulators can be used to further reduce requirements for training time in aircraft; and (2) simulators can be used to evaluate performance that is indicative of performance in the aircraft.

133. Miller, R. B. *A Method for Determining Human Engineering Design Requirements for Training Equipment*. Wright Air Development Center, Wright-Patterson Air Force Base, Ohio, (The American Institute for Research, Pittsburgh, Pennsylvania), Technical Report: WADC-TR-53-135, June 1953, 17 pp, AD 15 848.

This report summarizes and integrates three other Technical Reports, each of which plays a role in a procedure intended to determine the human behavioral requirements of complex training devices. These reports are WADC Technical Reports 53-136, *Handbook on Training and Training Equipment Design*; 53-137, *A Method for Man-Machine Task Analysis*; 53-138, *Human Engineering Design Schedule for Training Equipment*. It is intended that the procedures described in these reports will help bring to bear, in a systematic way, the contributions of psychology and psychologists to the design of training devices and their optimal use. The following two phases which constitute the procedure are summarized: a method for performing a behavioral analysis of man-machine tasks; the application of a human engineering design schedule to the planning or improvement of a training device. A brief description is given of the *Handbook on Training and Training Equipment Design* and its applicability to the procedures described above. These materials and procedures are designed for use by trained personnel in the preparation of recommendations concerning the design and use of complex training devices.

134. Miller, R. B. *Human Engineering Design Schedule for Training Equipment*. Wright Air Development Center, Wright-Patterson Air Force Base, Ohio, (American Institute for Research, Pittsburgh, Pennsylvania), Technical Report: WADC TR-53-138, June 1953, 24 pp, AD 14 768.

This report is an organization of several hundred considerations which, from the human engineering standpoint, are important to the relevance and efficiency of training equipment. These considerations are applicable to a training device during initial planning, specification, proto-

type, or production model stages of trainer development. The items of the Design Schedule are grouped under the following main topics: 1. Designing a Trainer to Use as a Demonstrator of Principles; 2. Controls; 3. Displays; 4. Control-Display Interactions; 5. Programs; 6. Scoring and Error Analysis; 7. Motivation of the Student; 8. Conditions of Practice and Learning; 9. Facilities for the Instructor; 10. Research Data on the Task.

135. Miller, R. B. *Handbook on Training and Training Equipment Design*. Wright Air Development Center, Wright-Patterson Air Force Base, Ohio, (American Institute for Research, Pittsburgh, Pennsylvania), Technical Report: WADC TR-53-136, June 1953, 339 pp, AD 16 859.

This *Handbook* is intended to aid in preparing recommendations on the design and use of training equipment. As such, it permits cross referencing to a companion report, WADC Technical Report 53-138, *Human Engineering Design Schedule for Training Equipment*. The contents of the *Handbook* include learning and transfer theory, principles applicable to problems of training, and bibliographic references. One principle theme which is developed is that different kinds of tasks, and different degrees of learning have different implications for transfer of training and the best form of presenting knowledge of results. Stages of learning are analyzed in detail, as are the variables in "knowledge of results." The principal sections are titled: I. Human Learning - An Overview; II. The Role of the Instructor in Training; III. The Trainer as a Demonstrator of Principles; IV. The Use of Knowledge of Results; V. The Problem of Simulation; VI. The Problem of Motivation; VII. Preparing the Specifications for a Training Device. The many problems indicated as requiring further research in the field of human learning and training suggest the importance of "programmatic" studies. These materials, in conjunction with WADC TR-53-137, *A Method for Man-Machine Task Analysis*, and WADC TR-53-135, *A Method for Determining Human Engineering Design Requirements for Training Equipment*, are designed for use by trained personnel.

136. Miller, R. B. *Psychological Considerations in the Design of Training Equipment*. Wright Air Development Center, Wright-Patterson Air Force Base, Ohio, (The American Institute for Research, Pittsburgh, Pennsylvania), Technical Report: WADC TR-54-563, December 1954, 137 pp, AD 71 202.

A training device is a machine whose purpose is to teach job skills which will transfer to operational situations. As such, the human factors involved in efficient learning and transfer of training are considerations essential to economy and training value of trainer design. The report presents a number of considerations and recommendations for trainer design under the following topics: I. Some principle concepts in learning and transfer of learning; II. Problems of physical simulation; III. Stage of learning and degree of physical simulation; IV. Knowledge of results and scoring; V. Recording procedures; VI. Proficiency measurement; VII. The design of the instructor's station; VIII. The trainer as demonstrator of principles; IX. Outline of steps in designing a training device.

137. Miller, R. B. *Task and Part-Task Trainers and Training*. Wright Air Development Division, Wright-Patterson Air Force Base, Ohio, (American Institute for Research, Pittsburgh, Pennsylvania), Technical Report: WADD TR-60-469, June 1960, 90 pp, AD 245 652.

Because enough simulators for sufficient and varied practice in job skills are rarely available, simpler devices are needed for training parts of tasks. In addition, learning total jobs one step at a time may be more efficient. Procedures for dividing total performance requirements into

training segments lending themselves to distinctive types of trainers are described. Principal variables in the division are phase of learning and time-sharing of activities. Risks of improper part-task training are detailed and principles for reducing such risks are proposed. Classes of trainers identified are: I. Familiarization Trainers, II. Instructed-Response Trainers, and III. Automatized Skill Trainers. Essential training and human engineering variables are described for each of the above classes of devices. Potentialities of the Class II device are emphasized.

138. Muckler, F. A., Nygaard, J. E., Kelly, L. I., and Williams, C., Jr. *Psychological Variables in the Design of Flight Simulators for Training*. Wright Air Development Center, Wright-Patterson Air Force Base, Ohio, (Aviation Psychology Laboratory, University of Illinois), Technical Report: WADC TR-56-369, January 1959, 132 pp, AD 97 130.

In the design, construction, and utilization of synthetic training devices, two general problem areas have been frequently contracted. The first of the areas is the degree of fidelity of physical simulation that may be achieved between the flight training device and the operational aircraft. This properly has been the concern of simulator design engineers, and it has been termed the problem of physical simulation. The second problem area is based on the ultimate criterion of any synthetic training device; the training value that results from the use of the device. This fundamentally is a psychological problem of transfer of training from the device to the aircraft that involves the psychological similarity between trainer and aircraft tasks. It is termed the problem of psychological simulation. The existing training research literature on flight trainers and simulators is evaluated, and a number of experimental programs are suggested. Motivational, instructional, and methodological variables are considered. Conventional theories of transfer of training are evaluated in terms of their predictive efficacy in the area of fidelity of psychological simulation.

139. Mulhern, J. J. *The Physical and Functional Characteristics of Flight Control Systems Simulators*. U. S. Naval Air Development Center, Johnsville, Pennsylvania, 28 April 1959, 13 pp, AD 128 066.

It was the initial objective of this task to make a survey of flight control system simulator currently serving the aircraft industry, to determine the types of problems handled by simulator investigations, the simulation techniques currently practiced, and to obtain detailed information on the design parameters considered essential by contractors for adequate simulation of specific problems. The second objective following from the results of the first includes an evaluation of the validity and applicability of design parameters currently considered in flight control systems simulation work, the significance of parameters ordinarily omitted, and recommendations concerning the desirability and practicality of including these parameters in the design of simulators. This report covers phase I of this task which consists primarily of determining the physical and functional characteristics of flight control simulation. The basis for most of this preliminary information was obtained from field trips to aircraft contractors and Government agencies.

140 Newell, F. D. *Criteria for Acceptable Representation of Airplane Dynamic Responses in Simulators Used for Pilot Training*. U. S. Naval Training Device Center, Port Washington, New York, (Cornell Aeronautical Laboratory, Buffalo, New York), Technical Report: NTDC 1146-1, October 1962, 80 pp, AD 297 838.

This report establishes the application of measured pilot sensitivities to airplane dynamic-response characteristics, and to Aviation Weapon System Trainer acceptance criteria. Reasons

why simulators should be subjected to transient response tests, the origin and applicability of handling qualities evaluation data, and the evaluation pilot are discussed. A specific discussion of each important longitudinal and lateral-directional handling qualities parameter is given. Pilot sensitivity to each parameter is determined. On the basis of pilot sensitivities determined from the study, accuracy requirements for simulators are given and discussed. A fundamental premise of the study is that the simulator reproduce the dynamics of the aircraft well enough so that the pilot in training will use the same techniques in the simulator as he will in the aircraft.

141. Parker, J. F., Jr. and Downs, Judith E. *Selection of Training Media*. Aeronautical Systems Division, Wright-Patterson Air Force Base, Ohio. (Psychological Research Associates Matrix Corporation, Arlington, Virginia), Technical Report: ASD TR-61-473, September 1961, 94 pp, AD 271 483.

The selection of training media in support of military training programs represents an important area of concern. Training equipment exercises considerable influence on the way in which training programs are conducted, upon their effectiveness in accomplishing objectives, and upon the total cost of the program. This report is designed to assist a training analyst faced with the problem of selecting specific training aids and devices to be used in support of the development of the personnel subsystem of a military system. The translation of statements of desired personnel performance and capabilities, as presented in Qualitative and Quantitative Personnel Requirements Information and task analysis documents into training objectives is discussed. The effectiveness of various training media in meeting specific training objectives is indicated and justified in terms of available objective evidence. An example is presented illustrating the manner in which training media are selected in support of a typical Air Force operator position.

142. Perry, D. H., Warton, L. H., and Welbourne, C. E. *A Flight Simulator for Research into Aircraft Handling Characteristics*. Royal Aircraft Establishment, Ministry of Aviation, Farnborough, England, Technical Report 66373, December 1966, 47 pp plus 37 figures, AD 818 390.

The technical features of a piloted flight simulator, used in the study of aircraft handling qualities, are described. The equipment includes an analogue computer, several visual simulation systems using both direct optical and electronic techniques, and hydraulically driven motion systems for providing the pilot with acceleration cues. Some comments on the effectiveness of these devices for simulating piloted flight are included.

143. Pinsky, W. J. G. *The Flight Simulator in Aircraft Control and Design*. Advisory Group for Aeronautical Research and Development, North Atlantic Treaty Organization, Paris, France, Report 71, August 1956, 53 pp, AD 158 804.

The possibilities of simulating manually controlled flight are discussed and the principal types of flight simulators are described. Particular attention is given to the importance of realistic visual and physical flight impressions. It is shown that useful conclusions on the handling characteristics of an aircraft can be drawn from experiments on relatively simple simulators. This is illustrated by results obtained on the RAE aiming-flight simulators. It is suggested in conclusion that a flight simulator can be a very powerful tool for the design optimization of aircraft control systems, if sufficiently realistic sensations of flight are simulated. Flight tests will, however, be always necessary as the final check and for the exploratory aerodynamic phenomena, which the simulator cannot predict but only accept as data.



144. Power, J. K. *Some Considerations in the Use of Flight Simulators in the Supersonic Transport Program*. Federal Aviation Agency Aircraft Development Service, Washington, D. C., (Paper presented to ASME Second International Simulation Conference, Los Angeles, California, March 4-6, 1963), 15 pp, AD 629 874.

Simulators provide an effective tool to augment flight research in support of wind-tunnel, analytical, operational, and hardware research for future supersonic transport aircraft. In addition, new simulator research techniques are extremely valuable in developing FAA certification regulatory and operation techniques and to assist in the evaluation and selection of SST aircraft designs.

145 Reid, Lloyd. *The Design of a Facility for the Measurement of Human Pilot Dynamics*. Institute for Aerospace Studies, University of Toronto, Canada, UTIAS Technical Note No. 95, June 1965, 58 pp, AD 627 570.

The report describes the modification of the UTIAS CF-100 flight simulator and the development of a data analysis technique in order to study human operators in a realistic flight environment. The operator forms part of a closed loop system which may consist of one or two degrees of freedom. A method of analyzing data obtained from short record runs is presented which is similar to the well known cross-correlation, cross-power spectral density method.

146. Root, R. T. *An Annotated Bibliography of Research on Training Aids and Training Devices*. (Human Resources Research Office, Training Methods Division, George Washington University, Washington, D. C.), August 1957, Staff Memorandum, 118 pp, AD 637 219.

An annotated bibliography of training aids and devices. Special consideration has been given to the use of training aids and devices in the military services. It includes articles, reports, and books from psychological, military, and educational literature. The titles were selected and the abstracts were prepared from publications of the armed services, publications of the American Psychological Association, other American professional journals, and publications of the Canadian and British governments. No extensive effort was made to review the foreign literature on the subject. The bibliography contains only unclassified abstracts and was surveyed up to 1 December 1956.

147. Rulon, P. J. and Horowitz, M. W. *A Training Analysis of the Pilot's Task in Transitioning to Jet VTOL Aircraft*. U. S. Naval Training Devices Center, Port Washington, New York, (Educational Research Corporation, Cambridge, Massachusetts), Technical Report: NTDC TR-74-1, September 1959, 54 pp, AD 231 477.

An analysis of Vertical Take-Off and Landing (VTOL) flight training problems was undertaken. The study consisted primarily of discussions with technical and pilot personnel, examination of test flight reports, and observation of VTOL aircraft were still in the development stage, the study was necessarily anticipatory and opportunistic. However, an attempt was made to provide data most relevant to horizontal attitude VTOL. A number of factors were found to make the task of flying VTOL aircraft exceptionally difficult. The more important of these were: (1) Need for great precision in controlling aircraft, especially during transition from the hovering to the aerodynamic mode; (2) Poor visibility from the cockpit during certain flight modes; (3) Variations in display-control relationships and instrument responsiveness and sensitivity as a function of flight mode; and (4) Inadequate instrumentation for determining whether aircraft is sustained by thrust or aerodynamic control. Solutions of these problems are considered

in terms of better instrumented and human engineered VTOL aircraft; previous helicopter training; the use of 2-place VTOL training aircraft; and selected training devices.

148. Schohan, B. *Human Factors Recommendations for the Design of Cockpit Procedures Trainers*. Wright Air Development Center, Air Research and Development Command, Wright-Patterson Air Force Base, Ohio, (American Institute for Research, Pittsburgh, Pennsylvania), Technical Report: WADC TR-58-327, September 1958, 49 pp, AD 110 424.

The cockpit procedures trainer (CPT) appears to have promising potential as a training aid to teach pilots knowledge about aircraft systems, nomenclature and location of cockpit controls and displays, and procedures required to operate aircraft safely. This report is intended to aid design engineers by presenting first a discussion of the cockpit procedures trainer's role in training, and second, a set of human engineering recommendations pertinent to the design of such trainers for fighter-type jet aircraft

149. Siskel, M., Jr. and Smith, W. D. *A Preliminary Training Study of the H-34 Cockpit Procedures Trainer*. U. S. Army Aviation Human Research Unit, Fort Rucker, Alabama, (Human Resources Research Office, George Washington University, Alexandria, Virginia), Research Memorandum 6, October 1960, 20 pp, AD 489 301 L.

The study concerns normal pre-flight and post-flight cockpit procedures for the H-34 helicopter. Two separate programs of instruction were established for use with the H-34 Cockpit Procedures Trainer (CPT). A third program of instruction was given exclusively in the helicopter as a part of the regularly scheduled transition training. One conclusion of the experiment was that a substantial increase in the efficiency of learning cockpit procedures for the H-34 helicopter can be effected by administering three hour of pre-aircraft training in the H-34 Cockpit Procedures Trainer.

150. Smith, A. H., Bacon, E. A. H., Cook, T. W. and Maeers, S. P. *The Problem of the Utility of the Flight Simulator*. Defence Research Medical Laboratories, Toronto, Ontario, DRML Report No. 154-33-67-1, July 1954, 146 pp, AD 39 421.

A general survey of the flight simulator field was undertaken to provide useful information pertinent to conducting a simulator program and to set up a fund of data for use in research on simulators. The topics discussed include their origin and current status, their evaluation, the development of a program, and major research questions. Most of the main problem areas in the use of flight simulators are indicated. This report calls for careful study to determine if it is possible to obtain satisfactory results from simulation without simulating everything that can be simulated. The expense involved in building exact simulators of individual aircraft could be greatly reduced if some kind of "general aircraft" simulator could be used to get the same training results. The authors conclude that much research can and should be carried out in the field of flight simulation.

151. Smith, B. J. *Task Analysis Methods Compared for Application to Training Equipment Development*. U. S. Naval Training Device Center, Fort Washington, New York, Technical Report: NTDC 1218-5, September 1965, 140 pp, AD 475 879.

Personnel aspects of modern military systems under development include criteria for selection, for technical manuals, and for training and training equipment, at the least. But these aspects must be somehow translated from human terms, such as the basic abilities for selection,

and the learning phase and type for training. The many methods of task analysis developed for this structuring of behavior into system specification differ widely in the aspect to which they are tailored, in the scope of behavior analyzed, in basic task taxonomy, and even in terminology. The purpose of this study was to compare the differences in the features these methods have in common, to examine the theoretical or empiric foundation, and to identify which features are included by some but excluded by others. The focus has been on the applicability to training and training equipment device task analysis requirements. A "single-thread" example of part of a real but unidentified fire control system has been followed throughout.

152. Smode, A. F., Gruber, A., and Ely, J. H. *Human Factors Technology in the Design of Simulators for Operator Training*. U. S. Naval Training Device Center, Port Washington, New York, (Dunlop and Associates, Inc., Stamford, Connecticut). Technical Report: NTDC 1103-1, 18 December 1963, 185 pp, AD 432 028.

This report presents an organized body of information useful for dealing with those human factors problems frequently encountered in the development of the weapons system trainer. Emphasis is given throughout to the general problems involved in developing the complete training system rather than to the analysis of details specific to given training systems. It summarizes basic human factors information which influences the design and construction of training devices. Successive chapters of the report are devoted to determining training needs, developing the environment for learning, understanding simulation requirements for training, developing a measurement capability, and discussing the human engineering problems in trainer design. As it provides a considerable background of human factors information pertinent to the synthetic ground environment, this report will be of interest to individuals directly concerned with weapons system training programs, preparing trainer specifications, developing training standards, and testing and evaluating simulation equipment.

153. Smode, A. F., Hall, E. R. and Meyer, D. E. *An Assessment of Research Relevant to Pilot Training*. Aerospace Medical Research Laboratories, Wright-Patterson Air Force Base, Ohio, (Bio-Technology, Inc., Arlington, Virginia), Technical Report: AMRL-TR-66-196, November 1966, 241 pp, AD 804 600.

This report presents a critical review and interpretation of the considerable amount of research data that have either direct or indirect implications for the training of pilots. The purpose is to organize systematically the research findings from the human performance and the training research literature that are pertinent to pilot training, and, based on the status of research in defined areas, to identify researchable issues. Successive portions of the report deal with studies on the definition of the pilot's job, the acquisition of flying skills, performance measurement, simulation and transfer of training operational components of the pilot's job, and the maintenance of flying proficiency. In addition, attention is given to studies concerned with improving training systems and recent innovations in training methods are reviewed. As it provides a considerable background of information directly concerned with pilot training, this report will be of interest to individuals involved in any aspect of flight training.

154. Westbrook, C. B. *Background of Piloted Simulator Development*. Air Force Flight Dynamics Laboratory, Research and Technology Division, Wright-Patterson Air Force Base, Ohio, TM 64-28, August 1964, 13 pp, AD 457 592.

In this paper a review is made of the piloted simulation facilities commonly used in the United States. An attempt is made to classify these facilities and to understand how and why

these facilities are needed and came into being and how they are used. Some thoughts on the philosophy of use of simulation are offered and conclusions presented. In recent years the use of piloted simulators has become more and more widespread in the research and development process. In this paper a review is made of the simulation facilities in use in the aerospace industry and related organizations. An attempt is made to classify these facilities and to understand how and why these facilities are needed and came into being, and how they are used. It is hoped that this collection of information, the codifications, and the conclusions may be of benefit to those who use and are planning to use simulation facilities.

155. Williams, A. C., Jr. and Adelson, M. *Some Considerations in Deciding About the Complexity of Flight Simulators*. Basic Pilot Research Laboratory, Air Force Personnel and Training Research Center, Goodfellow Air Force Base, Texas, Technical Report: AFPTRC-TR-54-106, 1954, 29 pp, AD 62 986.

The concept of a variable characteristic simulator (VCS) arose as a possible method for solving a complex and persistent problem. The problem is what fidelity of simulation is required of a flight simulator? Data relating limits to the training value of devices were not available. It was current practice, therefore, to adopt the hypothesis that the simulator should simulate the aircraft as faithfully as the state of the art would permit. Thus, where faithful simulation of the aircraft is necessary, it will be achieved; where it is not necessary, no harm would be done. This policy was successful so long as the simulators produced under it afforded an economic or proficiency advantage. In attempting to develop the rationale behind the concept of a variable simulator, the authors were confronted with the task of sorting out various factors that enter into the decision to use a simulator in flight training programs. There were a number of factors that interacted in complex ways. As a consequence the authors were led to attempt a formal analysis of the problem. The analysis yielded little that was new but did show clearly where the gaps in the author's knowledge were and what had to be done before rational decisions with respect to simulators could be made.

156. Wolfe, D. *The Use and Design of Synthetic Trainers for Military Training*. Applied Psychology Panel, National Defense Research Committee, Office of Scientific Research and Development, OSRD Report No. 5246, July 8, 1945, 33 pp, ATI 35 346.

A good trainer has three essential characteristics: (1) Practice on the trainer leads to substantial improvement on the equipment the men are being trained to operate; (2) A good trainer provides reliable information on the quality of the men's performance; and (3) Mechanically and electrically it is as simple and rugged as possible. It is necessary to plan carefully an instructional program using a trainer. Simply telling men to practice for a while sometimes results in loss of skill instead of a gain. The factors to be controlled in a trainer program are:

1. The men being trained should be informed of the meaning of their task.
2. Difficulty of practice should be controlled.
3. The amount of improvement possible on the trainer should be considered.
4. A variety of practice materials should be available.
5. Practice on the trainer should be coordinated with the rest of the training program.
6. Practice should be properly distributed in time.
7. Practice should be carefully supervised.

8. Scoring records should be used to motivate the men and help in coaching them.
9. The men should be made to want to learn.

Instructions for the proper use of a trainer should be prepared as the trainer is being developed, and distributed with it. Trainers possess some advantages over real equipment for practice: (1) they are generally safer, more economical and more readily available; (2) on a trainer, it is possible to break up a complex task into simpler elements; and (3) it is usually easier to give men exact information about their errors and successes on a trainer than on real equipment.

The steps to follow in developing a new trainer or in evaluating an existing one are outlined in the report.

157. Wright Air Development Division. *Uses of Task Analysis in Deriving Training and Training Equipment Requirements*. Wright Air Development Division, Wright-Patterson Air Force Base, Ohio, Technical Report: WADD TR-60-593, December 1960, 61 pp, AD 252 946.

The requirements for and uses of task information in developing requirements for training equipment are discussed in a series of seven papers by the human factors subcontractors involved in the development of three complex electronic reconnaissance systems. The papers deal with the purposes, content, sources, and recording of task information in establishing training requirements, selecting training equipment, and developing proficiency measures. A final paper describes in detail the approach taken on these issues with the AN/ULD-1 system.

158. Khignesse, L. B. *Selective Survey of French Developments in Flight Simulators and Flight Instruments - 1. Flight Simulators*. Wright Air Development Center, Wright-Patterson Air Force Base, Ohio, (University of Illinois), Technical Note: WADC TN-57-378, June 1958, 19 pp, AD 142 130.

A selective survey of French developments in aircraft and missile simulation was conducted. The survey covered the characteristics of a flight simulator for a primary trainer of the conventional engine type, three types of helicopter simulators, and a simulator for an air-to-ground or ground-to-ground missile. The simulators are less elaborate and expensive than their American counterparts and, for this reason, might be of particular interest to designers and users of simulators in the United States where the trend has been toward greater complexity and cost. Certain of the simulators permit easy change of simulated flight characteristics so that the same device can be used in training for proficiency in more than one model of a basic aircraft type. American simulators tend to be relatively rigid in this regard at the present time, with extensive modifications required to change flight characteristics. All of the devices have systems for simulating aspects of the external visual environment. Reliable point-source projection systems are used throughout.

## EVALUATION

159. Aerospace Medical Research Laboratories. *Development of an Automatic Monitoring System for Flight Simulators*. Wright-Patterson Air Force Base, Ohio, (Curtis-Wright Corporation, East Paterson, New Jersey), Technical Documentary Report: MRL-TDR-62-47, May 1962, 102 pp, AD 283 008.

The design study of an automatic monitoring system for flight simulators is presented. System basic functions are: (1) recording and playback, and (2) evaluation and scoring. The recording and playback facilities allow the recording of pertinent parameters of a simulated flight

mission. The recording of any part or all of the mission can be played back into the flight simulator for re-enactment at any desired time. Objective evaluation and scoring of the trainee is accomplished by comparison of monitored parameters to the programmed criteria. Student errors in performance are printed by the device onto a cue sheet readily accessible to the instructor. Functional flexibility, the degree of automation required, size, and complexity of the simulator to be monitored are the factors that most affect the design.

160. Air Proving Ground. *Final Report on Operational Suitability of B-52B Flight Simulator, Type S-9*. Eglin Air Force Base, Florida, 18 June 1956, 35 pp, AD 97 633.

The B-52B Flight Simulator, Type S-9, is an effective ground training device to teach crews (pilot and co-pilot) a part of B-52 flight training in emergency situations, normal preflight and inflight procedures, instrument flying, and flying proficiency. It accurately simulates cockpit configuration, instrument and systems operation, and most of the performance characteristics of the aircraft. Trainer simulation of aircraft flight control and trim forces is marginal.

Design of the simulator permits problem-free installation and calibration; however, housing requirements are exacting and should be closely followed. The flight simulator has a creditable in commission rate. It has been utilized almost 12 hours a day since installation. Maintenance requirements are stringent, and the in commission rate and fidelity of performance are dependent on the quality of maintenance.

161. Air Proving Ground Command. *Final Report on Employment and Suitability Test of the B-66B Trainer-Simulator, Type MB-20*. Eglin Air Force Base, Florida, 27 December 1956, 20 pp, AD 110 800.

The Type MB-20 B-66B Trainer-Simulator is an effective training device for instructing pilots in normal preflight and inflight procedures, instrument procedures, simulated operational mission profiles, and emergency situations. It simulates with acceptable realism the B-66B cockpit configuration, the operation of the majority of the aircraft and instrument systems, and most of the performance characteristics of the aircraft. The simulation of control of the aircraft during flight is not completely realistic; however, satisfactory training can be accomplished. The trainer-simulator has a high in commission rate. Housing requirements for the trainer-simulator are stringent and must be followed closely. Maintenance requirements are exacting, and the in commission rate and quality of performance are dependent on the quality of the maintenance provided.

162. Air Proving Ground Command. *Final Report on Employment and Suitability Test of the C-130A Flight Simulator, Type MB-12*. Eglin Air Force Base, Florida, 10 July 1957, 46 pp, AD 293 927.

The C-130A flight simulator, Type MB-12, is an effective training device for instructing pilots, co-pilots, and flight mechanic technicians in proper pre-flight inspection, starting, run-up, and take-off procedures; normal and emergency flight operating techniques; all phases of instrument flying; and radio communications procedures. It simulates, to a high degree, cockpit configuration, instrument and systems operation, and most of the performance characteristics of the aircraft. Flight control simulation is not completely realistic; however, satisfactory training can be accomplished. The flight simulator has an excellent in commission and utilization rate. Maintenance requirements are exacting and the in commission rate and fidelity of performance are dependent on the availability of spare parts and the quality of maintenance.

163. Air Proving Ground Command. *Final Report on Employment and Suitability Test of the KC-97G Flight Simulator, Type MB-27*. Eglin Air Force Base, Florida, 24 September 1956, 27 pp, AD 108 048.

The KC-97G Flight Simulator, type MB-27, is an effective ground training device which is a duplication of cockpit, controls, and instruments of a KC-97G aircraft. The operation of all controls, switches, levers and instruments very closely simulate those of the actual aircraft. The flight simulator offers valuable training to the flight crew (pilot, co-pilot, and flight engineer) in transition, ground and air emergency procedures, and all phases of instrument flight. It is indicated the average transition time required in the aircraft, per crew, can be substantially reduced by utilization of the simulator. The design of the simulator permits problem-free installation, if housing requirements have been met. Housing requirements are exacting. If they are not followed, utilization of the flight simulator will decline while supply and maintenance requirements will increase. The flight simulator has a very high in commission rate. The test item averaged 17 hours of training utilization per day during the testing; however, such utilization can only be achieved with properly trained maintenance personnel and an adequate supply system. This is particularly significant when it is considered that there are no schools now in the Air Force for training simulator maintenance personnel. This problem is further complicated by a lack of AFSC division to facilitate identification of simulator operators and simulator maintenance personnel.

164. Air Proving Ground Command. *Final Report on Employment and Stability Test of the KC-135A Flight Simulator, Type MB-26*. Eglin Air Force Base, Florida, 5 November 1957, 31 pp, AD 293 933.

In general, the cockpit area of the KC-135A flight simulator, Type MB-26, is a realistic duplication of the cockpit of the KC-135A aircraft. Performance characteristics of the simulator closely parallel those of the actual aircraft, except for oversensitivity of lateral flight control reaction of the simulator at low airspeeds with flaps down. The simulator has an excellent in commission rate; however, logistical support of the simulator from sources other than the manufacturer has not been adequate. To exploit the high rate of utilization that the simulator can afford in a KC-135A training program, adequate logistical support and qualified maintenance personnel become prime prerequisites. Included are recommendations that greater realism be provided in the training of maintenance personnel and radio aids operators, together with recommendations regarding the timely provisioning of spare parts and the physical changes necessary to enhance cockpit similarity.

165. Angell, D., Shearer, J. W., and Berliner, D. C. *Study of Training Performance Evaluation Techniques*. U. S. Naval Training Device Center, Port Washington, New York, Technical Report: NTDC 1449-1, October 1964, 74 pp, AD 609 605.

The report discusses performance evaluation in the training environment, specifically in training situations involving the use of simulators and other complex training equipment. The important variables involved in developing a system of performance evaluation are seen as (1) types of behaviors; (2) types of measures or mensural indices; and (3) types of instruments for recording performance. Factors relating to these variables are discussed, and some of their interrelationships are delineated. Matrices which facilitate the consideration of interrelationships among the three variables are presented. An illustrative application of an automatic training/evaluation system is given.

166. Benenati, A. T., Hull, R., Korobow, N., and Nienaltowski. *Development of an Automatic Monitoring System for Flight Simulators*. Aerospace Medical Research Laboratories, Wright-Patterson Air Force Base, Ohio, (Curtis-Wright Corp., East Paterson, New Jersey), Technical Documentary Report: MRL-TDR-62-47, May 1962, 102 pp, AD 283 008.

The design study of an automatic monitoring system for flight simulators is presented. System basic functions are: (1) Recording and playback, and (2) Evaluation and scoring. The recording and playback facilities allow the recording of pertinent parameters of a simulated flight mission. The recording of any part or all of the mission can be played back into the flight simulator for re-enactment at any desired time. Objective evaluation and scoring of the trainee is accomplished by comparison of monitored parameters to the programmed criteria. Student errors in performance are printed by the device onto a cue sheet readily accessible to the instructor. Functional flexibility, the degree of automation required, size, and complexity of the simulator to be monitored are the factors that most affect the design.

167. Danneskiold, R. D. *Objective Scoring Procedure for Operational Flight Trainer Performance*. U. S. Naval Special Devices Center, Port Washington, New York, Technical Report: SDC-999-2-4, 15 February 1955, 99 pp, AD 110 925.

Instructor judgment of student progress in flight trainers while reliable over a period of time is not sensitive to the specifics of performance in any given training period. Thus the instructor is not able to provide the student with a meaningful analysis of his progress. However, considerable success has been achieved in measuring pilot proficiency in aircraft when the instructor is provided with a means of assessing the specific units of behavior which comprise total performance. The study was designed to:

1. Evaluate existing pilot proficiency measures and their applicability to flight training in terms of the following criteria.
  - a. Validity — The meaningfulness of the measures in terms of overall performance.
  - b. Reliability — the degree to which the measures are free of constant errors and personal bias.
  - c. Feasibility — the ease of use of the measures.
2. Develop, for typical flight trainers grading methods for use by instructors which meet the requirements of 1 above.
3. Determine the feasibility of mechanical scoring methods.

**RESULTS:** 1. The technique for assessing pilot performance in aircraft is feasible for measuring student progress in flight trainers.

2. Mechanical or automatic scoring methods are cumbersome and fail to measure total performance. Flight path recording instruments are of value as an adjunct to manual grading forms used by instructors.

3. Instructor scoring instruments for basic instrument, familiarization and procedures training in the SN<sub>1</sub>-OFT and F9F5-OFT were developed and appear in the appendix.

168. Havron, M. D. and Butler, L. F. *Evaluation of Training Effectiveness of the 2-FH-2 Helicopter Flight Trainer Research Tool*. U. S. Naval Training Device Center, Port Washington, New



York, (Psychological Research Associates, Arlington, Virginia), Technical Report: NTDC-1915-00-1, 1 April 1957, 140 pp, AD 125 465.

The Device 2-FH-2 Helicopter Hovering Research Tool was developed as an engineering prototype to determine the feasibility of a nonprogrammed visual display for training in hovering and other maneuvers performed near the ground. Later, its capabilities were extended to permit simulation of high altitude maneuvers without extensive modification of the flight computer system. The device uses a point light source to project images from a transparency plate containing objects and scenery to a wide angle screen surrounding the cockpit. In an initial appraisal, instructors flew the device and were interviewed. Responses and examination of the H-Stage Training Syllabus indicated that the low-altitude plate then installed would permit practice in about half the A-Stage maneuvers. Lack of fidelity was noted, but this did not appear sufficiently serious to indicate that the device would have no training value. Instructors recommended further investigation of the operational capabilities of the device. This as a report of the methods used and the results obtained for the recommended investigation.

169. Krendel, E. S. and Bloom, J. W. *The Natural Pilot Model for Flight Proficiency Evaluation*. U. S. Naval Training Device Center, Port Washington, New York, (Engineering Psychology Branch, Franklin Institute, Philadelphia, Pennsylvania), Technical Report: NTDC 323-1, 15 April 1963, 70 pp, AD 410 805.

This report presents the development and rationale for a new approach to pilot proficiency measurement in operational flight trainers. It is based on a "natural pilot model" that identifies three criteria as being of prime importance to the understanding and measurement of pilot performance: Consistency of system performance, human adaptability, and least effort in skilled performance. By means of these criteria — which arose from an effort to apply the servo-mechanism theory of skilled performance to the study of pilot proficiency — the investigators believe that the traditional impediments to valid measurement will be removed; and that the characteristics that most crucially differentiate the good from the poor pilot will be measured. Ways of quantifying these criteria and the implications to training and further research are discussed.

170. Krumm, R. L. and Farina, A. J., Jr. *Effectiveness of Integrated Flight Simulator Training in Promoting B-52 Crew Coordination*. Aerospace Medical Research Laboratories, Wright-Patterson Air Force Base, Ohio, (American Institute for Research, Pittsburgh, Pennsylvania), Technical Documentary Report: MRL-TDR-62-1, February 1962, 79 pp, AD 275 891.

This report represents the findings of a study designed to assess the value of a B-52 flight simulator electronically linked to a T-2A navigator trainer in promoting crew coordination. Seventy-five SAC aircrews undergoing B-52 transition training at Castle Air Force Base were used as subjects. Integrated and non-integrated simulator training of these crews was contrasted. The results as indicated by certain of the measures used enable a favorable recommendation to be made regarding the effectiveness of the B-52 integrated crew trainer. Special attention is devoted to a discussion of two aspects of communication, pattern and volume, and the relation of these aspects to crew coordination.

171. Newell, F. D. and Schelhorn, A. E. *Dynamir Test Program for Weapon System Trainers — Summary Report, Phase IV*. Naval Training Device Center, Port Washington, New York, (Cornell Aeronautical Laboratory, Inc., Buffalo, New York) Technical Report: NTDC 318-4, 2 June 1961, 90 pp, AD 262 667.

This report is a technical summary of a study which determined the valuable use of dynamic test procedures for evaluating and acceptance testing operational flight trainers and weapon system trainers. Discussion of the background upon which the decisions as to what parameters should be measured and how closely they should compare to airplane characteristics is given. The implementation of dynamic testing is depicted and then demonstrated by the results of tests performed on both A.C. carrier and D.C. computers of representative simulators. Among the several forms of dynamic testing that could be used, prime emphasis is placed upon transient response techniques for the over-all simulator testing and both transient response and frequency response techniques for evaluating servo components of the simulator computer. Means for determining handling qualities and performance characteristics are displayed.

172. Pomaroli, R. S. *The Effectiveness of the Naval Air Basic Instrument Trainer*. U. S. Naval Aviation Medical Center, Pensacola, Florida, Special Report No. 65-7, 5 November 1965, 47 pp, AD 627 218.

The study evaluated the effectiveness of the naval basic instrument trainer (NAVBIT) as it is currently used in the basic and radio instrument navigation-stages of basic flight training. Findings are based on a detailed study of individual student reactions and on an intensive search of the pertinent literature. The study indicates that the Naval basic instrument trainer is doing an effective job as an aid to teaching instrument flight, and that the expenditure for a more elaborate simulator would not be justified in terms of increased effectiveness. It also points out that the students themselves feel that the Link trainer is adequately fulfilling its basic purpose of teaching procedures, scan, and the reading of instruments.

173. Rockway, M. R. *A Survey of Pilots' Opinions of the C-97 Flight Simulator*. Wright Air Development Center, Wright-Patterson Air Force Base, Ohio, Technical Note: WCRD-TN-53-38, April 1953, 6 pp, AD 62 899.

A conference was held in March 1953 to consider the control-pressure question. Because of the great amount of interest in the fidelity-of-simulation requirements of training devices, the results of a small study performed to provide information for the conference are reported here. A questionnaire was administered to 30 rated pilots who had flown both the C-97 Flight Simulator and the C-97 airplane. The primary purpose of the survey was to determine the effect of certain control-loading deviations in the simulator upon its training value. A number of questions were asked which referred to other aspects of the simulator; therefore, the response data presented in this report may be considered as a limited evaluation of the simulator as a whole.

174. Smith, J. F. *Measurement of All-Weather Interceptor Pilot Performance (F-86D): I. Development of a Planned Simulator Ride and Flight Check Booklet*. Air Force Personnel and Training Research Center, Randolph Air Force Base, Texas, Technical Memorandum: OL-TM-57-6, July 1957, 66 pp.

Describes the process used in formulating a planned simulator ride for use in collecting data in the research project, definitions of maneuvers and items included therein, procedures used in administering the ride to subjects, and the various recording methods used in obtaining the data. The end product of the planned simulator ride was a flight check called the Standard Flight Check.

175. Swain, A. D. *Guide for the Design and Evaluation of the Instructor's Station in Training Equipment*. Wright Air Development Center, Wright-Patterson Air Force Base, Ohio, (The Amer-

ican Institute for Research), Technical Report: WADC-TR-54-564, AD 71 203.

The purpose of this "Instructor's Station Guide" is two-fold: to provide (1) procedures for the collection of data on the design of instructor's station equipment, and (2) a method to aid in the evaluation and in the design of existing or proposed instructor's stations. This report is intended mainly for: (1) the specialist with a professional background in the theoretical and practical problems of training, and psychology of learning; and (2) the training specialist whose actual experience with the design and use of training programs and training devices has given him an awareness from a practical point of view of the qualifications sometimes necessary to general principles which must cover a large variety of circumstances.

176. Swanson, A. M. *Notes on Simulator Instrumentation for Measurement of Pilot Proficiency*. Air Force Personnel and Training Research Center, Randolph Air Force Base, Texas, Technical Memorandum: CL-TM-57-3, May 1957, 43 pp, AD 159 938.

Describes the investigation of the feasibility of obtaining pilot proficiency measures from oscillographic records of pilot performance in the B-52 simulator. A photon six-channel oscillograph was obtained to make preliminary tests in the study. The memorandum discusses the integration of the recording equipment with flight simulator and the development of a plan for obtaining appropriate data to evaluate the utility of instrumentation in the measurement of pilot performance in the simulator.

177. Townsend, J. C. and Bamford, H. E. *Evaluation of Attitude Instrument Flying Proficiency Based on Performance in a Flight Simulator*. Air Force Personnel and Training Research Center, Basic Pilot Research Laboratory, Goodfellow Air Force Base, Texas, Staff Research Memorandum, September 1954, 5 pp, AD 102 991.

Several solutions to the problem of flight training evaluation of a pilot in a single place aircraft, who, of necessity, must fly solo, are considered:

1. The check pilot could evaluate the student while flying in close formation with him. Readings from the instruments of the check pilot's plane, plus subjective estimates of the student's performance by the check pilot, would constitute flight check data. However, instrument readings in the observer plane, would in many instances, be different from those in the student plane for various reasons.

2. The student might be evaluated by means of automatic or semi-automatic flight performance recording equipment in the student's plane and use the recordings as data for later evaluation. However, such recording devices are not only costly and bulky, but can be shown to measure only a part of the information relevant to pilot proficiency.

3. Evaluate the student in terms of some outside criteria such as the number of hits made by him on the target or his ability to reach the objectives designated for the flight. These techniques, however, may yield scores that are of low reliability from day to day and are of little value for evaluating individuals.

4. The authors propose that the solution to the problem is the estimation of the student's performance in the aircraft from measurements of his performance in a flight simulator.

To test the value of a simulator for this purpose, the performances of 64 pilot trainees were evaluated in the SNJ flight simulator and the T-6 aircraft with one measurement each morning and one measurement each afternoon on two successive days. The results of the comparisons

seemed to support the feasibility of evaluating altitude instrument flying proficiency from scores obtained in a flight simulator

NOTE: This memorandum is an informal paper intended to record opinions and preliminary reports of studies which later may have been modified or rescinded.

178. Verdi, A. P. *Measurement of All-Weather Interceptor Pilot Performance (F-86D): IV. Simulator Reliability, Maintenance and Operation*. Air Force Personnel and Training Research Center, Randolph Air Force Base, Texas, Technical Memorandum: OL-TM-57-9, July 1957, 73 pp.

One of a series describing the results of a research project directed at measurement of F-86D interceptor pilot performance. As part of the project, an F-86D simulator was used to measure the performance of a group of combat-qualified F-86D pilots. Describes the simulator environment to which these pilots were exposed and examines various problems encountered in the use of the simulator as a performance-measuring device. It was concluded that certain simulator characteristics vary to an excessive degree from desired standards. The high malfunction rate made the administration and scoring of the flight check difficult and time consuming. Priority should be given to design of more stable and reliable simulators.

## SECTION V. Flight Simulator Computers

### INTRODUCTION

In general, flight simulators for pilot training consist of a replica of an aircraft cockpit, an instructor's console, and a computer to solve the aircraft flight equations as shown in the block diagram in figure 41. As the trainee flies the simulator, the cockpit controls (by means of transducers) provide inputs to the computer. The computer values, in turn, are fed to instruments and indicators of trainee and instructor. Also, the instructor may simultaneously introduce conditions such as engine failure, rough air, or icing, by manipulating controls at his station. These inputs are assimilated by the computer and the effects on the simulated behavior of the aircraft are produced. Thus, training is accomplished under both normal and abnormal conditions.

Prior to World War II, simple air-activated Link instrument trainers were used in flight training. The development of these trainers progressed to electrically controlled types and then to

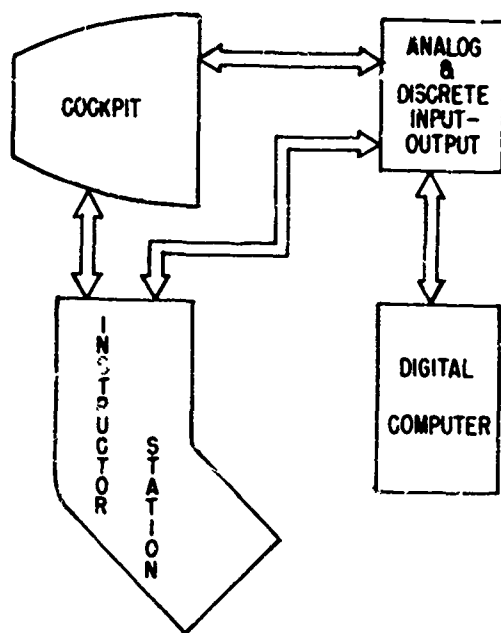

Figure 41. Typical Flight Simulator Block Diagram

simulators which used electronic and electromechanical analog computing elements. Further simulation developments made possible the use of an aircraft mathematical model with aircraft data programmed on a special purpose analog computer to implement a full-mission simulator.

### ANALOG COMPUTERS

As early as 1935, an electrical device for solving longitudinal stability equations was developed by Mueller at Massachusetts Institute of Technology. In an article published in 1936,\* he

\*Mueller, R. R. An Electrical Device for Solving the Equations of Longitudinal Motions. *Journal of Aeronautical Sciences*, March 1936.

predicted the potential of the device for real time, hand controls, and pilot training research. The development of differential analyzers progressed rapidly during World War II and for several years thereafter. By 1948, analog computers had become a reality and the availability of these computers made possible the development of modern flight simulators.

Although analog-computer-driven simulators were very effective, the characteristic of the analog approach and the design of the special purpose computer made simulator changes difficult and time-consuming. If a part or system were added, deleted, or replaced in the simulator, the analog computer was similarly affected. In addition, other desirable characteristics such as a poor small-signal response and performance degradation with age were prevalent.

### DIGITAL COMPUTERS

With the advent of the digital computer, the feasibility of its use for the central computing element was investigated because of its advantages over analog computers such as programming and model solution flexibility and superior precision and resolution. The digital computer's inherent go-no-go characteristics offered certain maintenance advantages. The solution would be consistently accurate from one day to the next and would not be affected by component degradation. However, if a failure did occur in the computer, the entire simulation would be likely to fail.

Research in the field of flight simulation through the use of digital computers began in 1950 by the Moore School of Engineering of the University of Pennsylvania under the sponsorship of the Air Force and Navy (201, 202, 203, 204). One result of the study was the logical design of the Universal Digital Operational Flight Trainer (UDOFT). The remaining design and prototype construction of the UDOFT were completed by Sylvania Electric Products, Inc., in 1960. This effort was conducted under a joint Air Force-Navy contract (180).

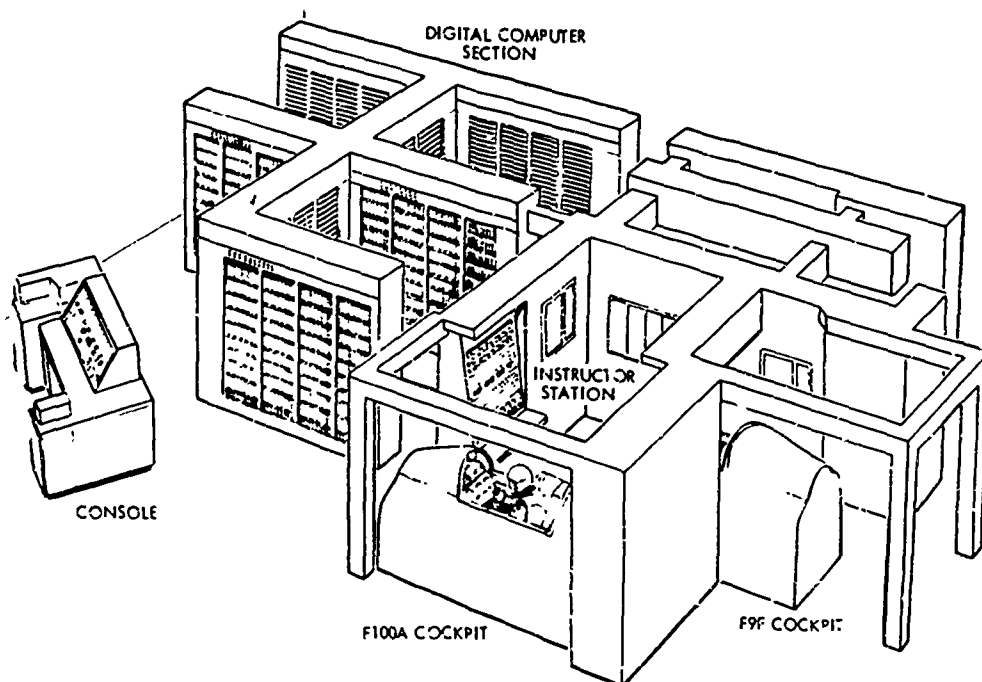

Figure 42. The UDOFT System

The UDOFT consisted of a high-speed (5 microsecond basic cycle time) general-purpose digital computer, input/output conversion equipment, two aircraft cockpit mockups (F-100A and F-9F-2), and instructor consoles. The UDOFT was designed to investigate a wide variety of vehicles ranging from a hypersonic orbiting and re-entry vehicle to a submarine. Andresen and Ewing (182) pointed out that as digital computer techniques evolved and advances in design lowered the cost of computation, a trend toward the use of digital simulation in flight trainers has been established. A single digital computer can be applicable to many flight trainer problems which will eliminate the requirement for special-purpose control computers.

#### **HYBRID SIMULATION**

There are many simulation problems that can be equally solved by either analog or digital computers. However, these computers are basically different in their operating characteristics and in some areas the two techniques supplement each other. Leger (196) has listed the principal characteristics of the two types of computers as follows:

##### **Analog**

1. Running speed is high.
2. Accuracy is limited.
3. The inclusion of operating system hardware into the simulation is relatively straightforward.
4. As problem complexity increases, accuracy decreases and reliability becomes a severe problem.
5. Output data are available as directly-plotted permanent graphs, which, while providing limited accuracy, can be monitored while the run is proceeding and interpreted immediately.
6. Some types of operations are awkward or nearly impossible to carry out on an analog computer (e.g., certain arbitrary functions, particularly functions of more than one variable are very troublesome).

##### **Digital**

1. Running speed is limited, particularly when the simulated system involves high frequency phenomena so that high sampling frequency is required for adequate representation.
2. Precision is excellent and may run as high as six to ten decimal digits.
3. Operating system hardware cannot be directly connected to the digital computer.
4. As problem complexity increases the principal effect is an increased running time.
5. Output data are usually obtained to high accuracy on punched cards, magnetic tape, or printed tabulations. The cards or tape permit further processing at a later time if desired, but there is usually no real equivalent to the instantaneously plotted permanent graph of the analog computer.
6. The digital computer is extremely flexible with respect to the types of operations it can perform. Functions of several variables can be generated easily.

Under Navy sponsorship, the Electronic Systems Laboratory of the Massachusetts Institute of Technology investigated the use of analog-digital computers for operational flight trainers. As a result, a number of designs were developed and several analog-digital systems were tested. In

1958, it was demonstrated that it was feasible to use high-speed, time-shared analog computing elements under digital sequence control (212).

An Air Force sponsored design study by the Electronic Systems Laboratory (M.I.T.) was conducted to determine the systems design of a combined analog-digital computer appropriate for real-time simulation of complex dynamic systems (186). A program based on the functional characteristics of the hybrid computer was prepared and development work was accomplished on high-speed analog computing elements.

The results of the above study were sufficiently promising to warrant the construction of a solid-state analog subsystem with analog equipment solving a linearized model, used in conjunction with a small PDP-1 digital computer supplying the nonlinear corrections. To demonstrate its capabilities, an F-100A simulation was implemented on the hybrid system. The tests showed that the digital computer iteration rate could be reduced as low as one per second as compared to 20 iterations per second for another digital simulation of the F-100A.

#### **FUTURE DEVELOPMENTS**

Although initial trends in the computer industry from 1960 indicated that many computers would soon be available for the small and medium class of simulation, the larger class such as supersonic, multiengine aircraft weapon systems and future space vehicles still presented a problem. Three approaches have been formulated for handling this class of simulation as follows: (1) the use of parallel processors to achieve the speed and necessary memory capacity; (2) the use of a yet to be developed high-speed large capacity computer capable of handling, independently, an entire large simulation; and (3) the use of hybrid analog-digital computer, functioning with each domain handling the part of the whole problem for which it is best suited.

Future research efforts by the Air Force will include the development of computer aided techniques for producing future flight simulator aerodynamic mathematical model. The method is intended to produce, from a rigorous mathematical model, an adequate and efficient simulator model based on the specified performance criteria for the simulator. The system could be used to develop sound criteria simulator performance data for use in the acceptance test of simulators. After the system is developed, work could be conducted to determine simulator performance requirements based on a criterion of training effectiveness.\*

#### **CONCLUSIONS**

In a relatively short period of history, rapid progress has been achieved in the development of computer techniques which are applicable to flight simulators. However, the need still exists for defining the problem and selecting the most suitable techniques. In many applications, hybrid computer techniques are less complex and are capable of better dynamic response than an all-digital system. While the pilot trainee is the heart of any training situation, the computer and simulation program is certainly the heart of any simulation system.

---

\*Gum, Don R. *Trends in Digital Flight Simulation for Training*. A paper presented at the National Aerospace Electronics Conference, May 15, 1967, Dayton, Ohio.



## ANNOTATED BIBLIOGRAPHY -- FLIGHT SIMULATOR COMPUTERS

179. Aerospace Medical Laboratory. *A Study Program for Simulator Component Interconnections*. Aeronautical Systems Division, Wright-Patterson Air Force Base, Ohio, (Curtis-Wright Corporation, East Paterson, New Jersey), Technical Report: ASD TR-61-71, April 1961, 28 pp, AD 262 512.

Component interconnecting techniques, patching logic and component distribution were developed which can be incorporated into the designs of training simulators. The techniques developed are to attain flexibility and versatility of general purpose computers for simulators to lessen the arduous operations presently incurred whenever alterations to an existing system are required. Emphasis was placed on providing a means to accomplish this desired result without increasing the size or space required for any given cabinet. In fact, using the techniques derived herein, the cabinet size and space needed has been cut down. A hermaphrodite body type of connector was selected utilizing crimp type pins and sockets, affixed to standard lengths of wire which in turn are inserted into the prescribed holes in the connector body as dictated by the electrical circuit design.

180. Aerospace Medical Research Laboratories. *The UDOFT Flight Simulation System*. Aerospace Medical Research Laboratories, Wright-Patterson Air Force Base, Ohio, (Sylvania Electric Products, Inc., Needham, Massachusetts), Technical Documentary Report: AMRL-TDR-63-133, December 1963, 280 pp, AD 431 205.

UDOFT (Universal Digital Operational Flight Trainer) represents the first full-scale application of a high-speed, general-purpose digital computer to the real-time flight simulation problem. Through the use of the stored program digital computer, simulation of different aircraft is accomplished by changing the computer program. This flexibility is the key to the realization of the full advantages of the digital control system, as compared to the conventional analog control system, in this application. Basically a high-speed, general-purpose digital computer, the UDOFT computer represents an advancement in the design of real-time control computers. With the use of dual, 4096-word, random-access, magnetic core memories, the basic instruction time for the UDOFT computer is five microseconds. To interface with the analog environment of a flight compartment, the UDOFT computer is equipped with a special-purpose, real-time input-output capability.

Use of the computer in a simulation system demanded the preparation of programs for applying the computer to the solution of the mathematical model of the real-world system under consideration. Such programs were written for the F-100A and the F9F-9. Extensive qualification testing was performed to ensure proper and complete simulation of these aircraft.

181. Air Materiel Command. *Flight Simulator; Three Degrees of Freedom*. Wright-Patterson Air Force Base, Ohio, (Armour Research Foundation of Illinois Institute of Technology, Chicago, Illinois), Final Report, February 18, 1953, 335 pp, AD 33 231.

An extended investigation was undertaken to prepare design and performance specifications for a Flight Simulator of Three Degrees of Freedom, to test a single degree of freedom model based on the preliminary designs developed during both periods of the program, and to prepare performance specifications, based on preliminary mechanical design, system computations, and electronic circuit designs, for smaller degree of freedom simulator, referred to as Simulator III.

The proposed mechanical construction of Simulator III is described, and the structural analysis required to predict its mechanical behavior is discussed. The required instrumentation is described in general, typical circuits are presented and discussed, and performance limitations are calculated.

The main body of the report is devoted to descriptions, discussions, performance predictions, and resulting conclusions. The detailed developments and calculations are presented in the appendices.

182. Andresen, V. W. and Ewing, D. *A Study of Digital Computers for a Real Time Training Simulation Research System*. Aerospace Medical Research Laboratories, Wright-Patterson Air Force Base, Ohio, (IIT Research Institute, Chicago, Illinois), Technical Documentary Report: AMRL-TDR-64-22, May 1964, 103 pp, AD 601 649.

In the study phase of the project to provide a general purpose laboratory facility for use in research in training simulation techniques, digital computer systems and interface equipments were evaluated for the application. Criteria for the system evaluation were obtained from previous studies involving the F100A aircraft and EROS vehicle flight simulations using the UDOFT computer facility. Requirements for the computer hinge on a real time operating capability which stresses high computation rates. Significant characteristics include: (1) An operating rate in excess of 75,000 instructions per second on flight simulation problems, (2) A memory capacity of at least 8,000 words; (3) A computer word length of at least 24 bits, and (4) At least three index registers. The result of the study phase is a recommendation of the Packard Bell 440 as the central computer of the simulation system; and as an alternative, a recommendation of the faster SDS 9300 computer is made provided its higher cost and later delivery time are acceptable. The recommended interface equipment will include a multiplexed analog-to-digital conversion subsystem capable of digitizing 32 input channels to 13 bits at a rate in excess of 35,000 conversions per second, a dual resolution digital-to-analog conversion system supplying 64 analog outputs to analog equipment, 72 sense inputs, 72 control outputs, and a digital interval timer.

183. Balkink, E. B. and Sovine, D. M. *Analog Computer Mechanization of a Tilt-Wing V. OL Aircraft*. Wright Air Development Division, Wright-Patterson Air Force Base, Ohio, Technical Note: WADD TR-59-344, July 1960, 93 pp, AD 246 530.

This report was initiated as the result of the stability and control characteristics of a Vertical Takeoff and Landing aircraft. The contract called for a simulation to be of at least one type VTOL (Vertical Takeoff and Landing aircraft). The tilt-wing type was chosen because it seemed to be the most complicated. In the early stages of the work it was realized that a simulation of this nature could be made only by large scale use of analogue computing equipment. The techniques used in simulating a tilt-wing Vertical Takeoff and Landing aircraft are summarized. A "cockpit" from which the pilot could "fly" the aircraft was included. Both longitudinal and lateral modes were used, and wing-tilt was possible. Relatively few of the usual linearizing assumptions were made, thus it was possible to "fly" the aircraft through the transition from hover to normal flight and back to hover. The data taken during simulated flights were delivered to Cook Research Laboratories for evaluation and reporting as specified by the terms of the contract.

184. Castle, R. A., Gray, A. I., and McIntyre, W. *Simulation of Helicopter and V/STOL Aircraft - Volume III, Part I - Computational Methods, Analog*. U. S. Naval Training Device Cen-

ter, Port Washington, New York, (Melpar, Inc., Falls Church, Virginia), Technical Report: NTDC 1205-3, May 1964, 142 pp, AD 607 737.

This report demonstrates methods of mechanizing the equations of motion of helicopters and V/STOL aircraft by the use of analog computing equipment. The equations of motion of these aircraft are presented in NAVTRADEVGEN Technical Reports 1205-1, -2 (AD 601 022, AD 602 427), and this report assumes a knowledge of such equations by the reader. The report reviews and discusses criteria for the selection of analog computer type as 60 cycle and 400 cycle, and choice of carrier, as well as specific computer components. A helicopter and a tilt-wing V/STOL are selected for computer mechanization and the presentation of computer flow diagrams which may be typical computer diagrams used in the analog simulation of such aircraft are discussed.

185. Connelly, M. E. *Computers for Aircraft Simulation*. Massachusetts Institute of Technology, Cambridge, Massachusetts, Report 7591-F 2, (For U. S. Naval Training Device Center), December 15, 1959, 112 pp, AD 245 519.

This report is the concluding work on a one-year study of the equations of motion and the computing techniques used in the aerodynamics computer section of Operational Flight Trainers. A review of the characteristics of basic 60 cps, 400 cps, and DC analog computing techniques is presented with emphasis on the relative applicability of these techniques to the unique requirements of the OFT problem. It is concluded that 400 cps techniques would give more than acceptable performance and would offer substantial advantages with respect to cost, size, maintenance and power consumed. In conclusion, several suggestions are made concerning OFT acceptance procedures, the matching of the OFT to the actual aircraft, and standardization.

186. Connelly, M. E. and Fedoroff, O. *A Demonstration Hybrid Computer for Real-Time Flight Simulation*. Aerospace Medical Research Laboratories, Wright-Patterson Air Force Base, Ohio, (Massachusetts Institute of Technology, Cambridge, Massachusetts), Technical Report: AMRL-TR-65-97, June 1965, 185 pp, AD 618 706.

A hybrid, real-time simulation facility has been designed, constructed, and demonstrated, using as a test vehicle the complete aerodynamic and engine equations for a high performance military aircraft. The analog-digital configuration employs peripheral analog equipment to represent a linear, skeleton version of the aircraft and the PDP-1 digital computer to carry out engine simulation, decision management, and corrections for nonlinear effects. To provide an all-digital reference against which the hybrid simulation could be compared, the aircraft model, which in general scope is identical to the F-100A model used in the UDOFT studies, was also simulated on the PDP-1 alone. It was found that the solution rate of 20 per second employed in the all-digital study could be reduced to one per second without deleterious effects when the hybrid configuration was used. Such a reduction demonstrates that supplementing a digital computer by relatively inexpensive analog peripheral equipment in the manner suggested substantially increases the real-time capacity of the digital computer in complex simulation applications.

187. Fancher, P. S., Larrowe, V. L., Jennings, J. R., and Spencer, M. M. *A Study of Engine Simulation Methods for Operational Flight Trainers*. U. S. Naval Training Device Center, Port Washington, New York, (Institute of Science and Technology, University of Michigan, Ann Arbor, Michigan), Technical Report: NTDC 822-1 (3591-8-T), October 1960, 147 pp, AD 424 149.

The first phase of this investigation to determine optimum equations to be used in engine simulators for operations in flight trainers has shown that current methods of designing such simulators do not use theoretical equations, but instead use empirical equations which result from the application of various curve-fitting techniques to known engine performance data. A program to develop suitable theoretical equations has been started. Existing methods of simulating engines on analog computing equipment have been examined and analyzed in terms of complexity, flexibility, and accuracy. The methods considered include not only those in use by OFT (Operational Flight Trainer) manufacturers but also others proposed by or in use by various research and development organizations. Several methods of generating functions of two variables have been thoroughly examined, and design formulas applicable for specified error tolerance have been developed.

188. Greenwood, D. T. *An Extended Euler Angle Coordinate System for Use with All-Attitude Aircraft Simulator*. Wright Air Development Division, Wright-Patterson Air Force Base, Ohio, (University of Michigan, Ann Arbor, Michigan), Technical Report: WADD TR-60-372, August 1960, 22 pp, AD 249 068.

This report considers the problem of finding a suitable coordinate system for representing aircraft orientation. The new extended Euler angle system is compared with other coordinate systems (ordinary Euler angle system, reversed Euler angle system, and quaternion system), particularly with respect to the output variables and the amount of analog computer equipment required for simulator representation. The extended Euler angle system required the most important equipment but has the advantage of being an all-attitude system with outputs convenient for cockpit display.

189. Cum, D. R. and Knoop, Patricia A. *Automated Input/Output Diagnostics for a Real-Time Simulation Research System*. Aerospace Medical Research Laboratories, Wright-Patterson Air Force Base, Ohio, Technical Report: AMRL-TR-66-133, October 1966, 166 pp, AD 655 771.

This report describes in detail a library of automated diagnostic programs for the input/output portion of a Real-Time Simulation Research System, and discusses the application of such a library of programs for the acceptance testing of simulation systems and subsequent preventive and diagnostic maintenance. The programs designed and coded to operate on a Raytheon 440 computer, which is part of the Real-Time Simulation Research System in the Simulation Techniques Branch of the Aerospace Medical Research Laboratories. Their functional designs are applicable, however, to a wide range of digital computers and associated analog-discrete input/output equipment. This report includes some background material on training-simulation in general and a description of the Real-Time Simulation Research System for which the programs were specifically designed and coded. The programs themselves are explained from the functional standpoint, including the objectives and specific operational features of each. The described diagnostic programs apply only to the real-time input/output portions of the simulation system. Their recommended use, therefore, is to supplement, not replace, present test procedures; since a complete test must naturally include computer diagnostics and tests for non-real-time input/output equipment used in the preparation of programs.

190. Howe, R. M. *A Study of the Computer Section of Flight Simulators*. Engineering Research Institute, Department of Aeronautical Engineering, University of Michigan, (For Wright Air Development Center), October 1954, 17 pp, AD 60 155.

This report summarizes the results of a fifteen-month study of the computer section of training type flight simulators. A previous report described the results of the first nine months of the study program. In the previous report are given a number of specific recommendations growing out of the original study program. Work since then has led the authors to emphasize further these recommendations, which are included again in the present report. In addition, several recommendations with respect to specifications for dynamic performance of the trainer have been added in the present report. In order to help develop realistic dynamic specifications for flight-trainer performance a number of studies of the flight-equations of the F-86D and B-47 aircraft were carried out. Specifically, computer solutions of both the lateral and longitudinal linearized flight equations of the F-86D have been obtained from a high-accuracy direct current electronic differential analyzer. These solutions were compared with flight-test data and results are summarized in a technical report. In addition both the F-86D and B-47D longitudinal equations, including all important nonlinearities, were simulated on the same direct current equipment. Results of these tests are presented in another report.

191. Howe, R. M. *An Investigation of Flight Equation Requirements for Simulators of Aircraft Up to Mach 3.5*. Wright Air Development Center, Wright-Patterson Air Force Base, Ohio, (The University of Michigan, Ann Arbor, Michigan), Technical Note: WADC TN-57-144, March 1957, 41 pp, AD 201 834.

This report summarizes the results of an investigation of the computer-section requirements of flight simulators for aircraft up to Mach 3.5 in performance capabilities. Included in the report are the flight equations which, it is felt, represent the best mechanization of the required computations. The source, expected range in value, effect on the aircraft response, and estimated tolerance requirements for the lateral and longitudinal stability derivatives are presented. The effect of inertia coupling terms is discussed, as well as recommendations regarding which terms should be included in the simulator. A survey of the effect of aerodynamic heating and the probable simulator requirements which it may introduce is given. Finally, the expected dynamic performance range, both in regard to limiting velocities and accelerations, and infrequencies, is presented.

192. Howe, R. M. *Coordinate Systems for Solving the Three-Dimensional Flight Equations*. Wright Air Development Center, Wright-Patterson Air Force Base, Ohio, (The University of Michigan, Ann Arbor, Michigan), Technical Note: WADC TN-55-747, June 1956, 41 pp, AD 111 582.

The choice of coordinate systems and the methods of coordinate resolution are extremely important in designing the computer section of flight simulators. In this report the six-degree-of-freedom flight equations are presented in the body-axis system and the general equations for aerodynamic forces and moments are given. Next, the six-degree-of-freedom flight equations are rederived, using wind axes for the three translational degrees of freedom. Finally, the alternative use of body-axis Euler angles, wind-axis Euler angles, or direction cosines for coordinate transformations is discussed. It is concluded that the combined coordinate system which uses wind axes for translational and body axes for rotational equations is the best. Choice of coordinate transformation methods depends on the requirements of the simulation. Example computer circuits and recordings of computer solutions for the F-86D are presented.

193. Howe, R. M. and Lemm, R. G. *A Standardized Computer for Solving the Three-Dimensional Flight Equations*. Wright Air Development Center, Wright-Patterson Air Force Base, Ohio,

(University of Michigan, Ann Arbor, Michigan), Technical Note: WADC TN-59-283, May 1959, 59 pp. AD 227 996.

The results of a study conducted for the purpose of standardizing the computer sections of flight simulators are presented in this document. The study is based upon data for airplane types ranging from high performance fighters to large transport aircraft in order to fulfill a requirement for simulation of all airplanes. A standard formulation and mechanization of the flight equations, except those for aerodynamic coefficients, is proposed for the simulation of all types of conventional aircraft. Since the relationships defining the aerodynamic coefficients differ considerably for different types of aircraft, no general standardization of the aerodynamic computations appears possible. However, a limited standardization of the longitudinal aerodynamics is presented. Separate computer layouts are given for the lateral aerodynamic computations for the aircraft studied as guides to the types and amounts of equipment required. Estimates of the computer component performance requirements are presented. It is concluded that the standardization of the computers will be more easily accomplished if aircraft manufacturers adopt standard forms for aerodynamic data presentation. Aeroelastic effects are found to be best simulated when aerodynamic data are presented as functions of dynamic pressure rather than altitude.

194. Kamm, L. J., Sherertz, P. C., and Stefan, L. E. *An Electronic Two-Variable Function Generator*. Wright Air Development Division, Wright-Patterson Air Force Base, Ohio, (Convair, a Division of General Dynamics Corporation, San Diego, California), Technical Report: WADC TR-59-546, March 1960, 40 pp, AD 236 964.

This report describes a transistorized bi-variable function generator developed by Convair-San Diego. The function is specified by the storage of 441 equally spaced ordinates. Bi-linear interpolation is employed to determine Z values between the stored ordinates. Each ordinate is specified by voltage, the voltages being obtained from a divider chain with outputs at each one percent step between plus and minus full scale. The independent variables, X and Y, select by an analog to digital converter and logic circuitry the four ordinates surrounding the point (x, y) and simultaneously develop in time division form, signals for bi-linear interpolation between the corner points. The voltages of the selected ordinates are switched by precision transistor switches into the interpolation circuits, where the output is generated. Function set-up is accomplished by patch cord connection of ordinate switches to voltage taps. Exclusive of power supplies and metering circuits, the function generator occupies about two cubic feet and requires about 60 watts. Substantial reduction in size would be practical in a production model.

195. Knoop, Patricia A. *The Application of Schur's Algorithm to the Derivation of Optimal Numerical Integration Techniques for Digital Flight Simulation*. Aerospace Medical Research Laboratories, Wright-Patterson Air Force Base, Ohio, Technical Report: AMRL-TR-67-3, March 1967, 39 pp, AD 654 320.

This report describes the derivation and application a computer-oriented technique for synthesizing numerical integration methods which are optimal on the basis of stability alone. The local growth of propagated error during a numerical integration and its affect on stability is explored. Also, a unique approach for deriving both classical and nonclassical integration methods is presented. Schur's algorithm is used to formulate the search for an optimal kth-order integration method as a non-linear programming problem suitable for computer implementation. First and second order methods which are optimal on the basis of stability alone are derived. Finally, the technique developed in this study is used to derive the "stability ranges" for several well

known integration formulae for purposes of evaluating their adequacy for a given simulation problem.

196. Leger, R. M. Requirements for Simulation of Complex Control Systems. In *Proceedings of First Flight Simulation Symposium*, White Sands Proving Ground, New Mexico, WSPG Report 9, September 1957, pp 125-131, AD 143 964.

Discusses the problem of simulating complex control systems by means of combined analog-digital computing equipment. Emphasis is placed on simulation in real time with the inclusion of operating system hardware in the simulation. The analog-digital and digital-analog converting equipment required for such a simulation must meet strict accuracy requirements while remaining within the state-of-the-art if such a simulation is to be successful. These requirements are considered in some detail. Some special techniques for increasing the accuracy of the simulation are briefly discussed.

197. Lovell, C. C. and Farquar, J. A. *Man-Machine Simulation of V/STOL Operations*. Air Proving Ground Center, Eglin Air Force Base, Florida, Technical Report: APCG-TR-66-8, February 1966, 27 pp, AD 478 330.

This report presents the findings of a study based on the results of APGC Project 69BT11, Support Requirements for Employment of V/STOL Aircraft. The study was concerned with the feasibility of simulating V/STOL operations with a computer model so that a broader spectrum of operational considerations could be evaluated than would be practical in a field test. In addition, the possibility of extrapolating from limited test results to a broader, more complex framework of operations was considered. The simulation developed in this study was considered highly successful as a first venture, and was designed so that it could be expanded to higher levels of sophistication, as well as extended to further operational considerations. The model is presented in detail in the report.

198. McIntyre, W. *Simulation of Helicopter and V/STOL Aircraft - Volume II - V/STOL Analysis Report*. U. S. Naval Training Device Center, Port Washington, New York, (Melpar, Inc., Falls Church, Virginia), Technical Report: NTDC 1205-2, September 1963, AD 602 427.

The report promotes an understanding of V/STOL analysis for simulation purposes and develops equations of motion compatible to either analogue or real time digital solution. A general set of equations of motion are developed in which axis systems and aerodynamic coefficients are minimized. Equations of motion are then developed for five different V/STOL aircraft wherein the need for additional axis systems and aerodynamic coefficients for a particular V/STOL configuration is developed. The SC-142A tilt-wing and the VZ-4DA tilt-duct aircraft are used to illustrate equation development. Equations are presented though not painstakingly developed for the X-19 tilt-prop, the XV-5A fan-in-wing and the P-1127 rotating thrust. A great deal of the symbology used for these different V/STOL aircraft is used just as presented by the respective manufacturers in order that verifying data might be available in the proper form at the earliest possible time. At present it appears that the equations developed will comprise a maximum requirement. Terms in these equations which prove in flight test to be sufficiently small, will be discarded. Analysis of flight test data may enable simulation with less rigorous equations but no such simplification can now safely be made.

199. McNeal, R. N. *Development of an Input/Output Technique for Integrated Circuit Simulation Computers*. Aerospace Medical Research Laboratories, Wright-Patterson Air Force Base,

Ohio, (Melpar, Inc., Falls Church, Virginia), Technical Report: AMRL-TR-67-74, July, 1967, AD 660 847.

The basic system requirements and the overall system design technique for an input/output system are described based on an input/output technique developed to interface between integrated circuit computers and simulation systems. Four general types of signals are processed by this input/output system: discrete inputs, discrete outputs, analog inputs, and analog outputs. This study has determined that integrated circuits are readily adaptable to performing the digital functions in the input/output system, but the analog signal conversion requirements of these systems are not within present linear integrated circuit capabilities. It is anticipated that the linear integrated circuit development will have progressed to the point of making integrated circuit converters feasible within the next year.

200. Meissner, L. P. and McCormick, E. F. Evaluation of Analog and Digital Computers for Flight Simulation. In *Summary Progress Report - Volume IV - Computers*, LaBudde, C. D., Editor, (pp. 11-47) Advisory Board on Simulation, University of Chicago, February 1953, AD 21 806.

This volume contains the results of the work on computers and their role in dynamic systems engineering of unitary aerial weapons. It considers the application of both general purpose and specialized computers to dynamic systems engineering, and, in particular, to flight simulation. Specifications for a special purpose computer, referred to as a dynamic systems synthesizer, used in flight simulation have been included. A survey of existent computational systems has been made, and the results of the survey are summarized.

201. Naval Training Device Center, *Design of Digital Flight Trainers*. Naval Training Device Center, Port Washington, New York, (Moore School of Electrical Engineering, University of Pennsylvania, Philadelphia, Pennsylvania), Research Division Report 54.08, 1 July 1953, 54 pp, AD 35 066.

During the period covered by this report, major emphasis has been placed on three important topics. First, the logical structure of a serial machine using a serial memory has been laid out in almost complete detail. At the same time, the equations of motion of the F9F have been studied in detail to determine all its possible characteristic frequencies. These two projects have permitted not only a more exact determination of the size of the envisaged prototype trainer, but also the time required to compute one quadrature interval and the maximum quadrature interval allowed by the best available quadrature formulas. Finally, a new quadrature method has been synthesized which is simpler but believed to be equally powerful to the former.

202. Naval Training Device Center. *Universal Digital Operational Flight Trainers, Final Report 1958-1959*. Naval Training Device Center, Port Washington, New York, (Moore School of Electrical Engineering, University of Pennsylvania, Philadelphia, Pennsylvania), 31 January 1960, 137 pp, AD 249 232.

The basic design of the digital computer for the actuation of a multiple-cockpit digital operational flight trainer is given. This computer system consists of a magnetic drum holding the program and one computer per cockpit which "listens in" on the program and selects those portions that are of interest to it. This is the arrangement when all the aircraft simulated are of the same type. If the aircraft are of different types, a drum is required for each cockpit computer. The cockpit computer design is described in some detail. The design is based on solid state



circuits. The arithmetic unit is designed for automatic floating-point arithmetic, addition time of 5 microseconds, multiplication time of 10 microseconds and division time of 15 microseconds on the basis of conservative circuit speed estimates.

203. Naval Training Device Center. *Universal Digital Operational Flight Trainers*. Naval Training Device Center, Port Washington, New York, (Moore School of Engineering, University of Pennsylvania, Philadelphia, Pennsylvania), Report 58-27, 31 October 1958, 94 pp, AD 203 708.

The universal operational flight trainer (UDOFT) designed at the Moore School of Electrical Engineering for the U. S. Naval Training Devices Center is now being built. Since 1950 when the effort began, many problems have been studied and solved sufficiently well to warrant construction of UDOFT.

In the course of the design studies, many different possibilities for each feature were considered, reasons pro and con listed, and those features selected that represent what might be called an approximation to an optimum design.

In this report history and progress are given, and recommendations on the two parts of the work of the preceding year: (1) The design of a digital flight trainer to actuate more than one cockpit, and (2) The development of methods of approximating aerodynamic functions that are functions of more than one variable.

204. Naval Training Device Center. *Design of Digital Flight Trainers*. Naval Training Device Center, Port Washington, New York, (Moore School of Electrical Engineering, University of Pennsylvania, Philadelphia, Pennsylvania), Research Division Report 54-09, September 6, 1953, 190 pp, Port Washington, New York, (Moore School of Electrical Engineering, University of Pennsylvania, Philadelphia, Pennsylvania), Research Division Report 54-09, September 6, 1953, 190 pp, AD 35 065.

Operational Flight Trainers have been used for many years in the training of airplane pilots. The computers used in all existing Trainers are of the analog type. The question arose whether recent high-speed digital computers can be used more advantageously; since they can solve certain systems of equations faster than analog machines. The design of a digital Operational Flight Trainer required the development of three phases: (1) mathematical techniques for fast but accurate solution of the flight equations, (2) the logical structure of a special-purpose digital machine capable of ultra high-speed computation, and (3) reliable circuits not only for the digital computer but for conversion to and from analog form, multiplexing, and cockpit information.

It is clear from this and preceding reports that a digital flight trainer is inherently feasible and that a first prototype should be built. In addition to proving feasibility, a prototype Trainer would assist in improving the design and render feasible the actuation of more than one cockpit using a single digital computing machine.

205. Nigro, B. J. *Study of Numerical Integration Techniques for Real-Time Digital Flight Simulation*. Aerospace Medical Research Laboratories, Wright-Patterson Air Force Base, Ohio, (Bell Aerosystems Company, Buffalo, New York), Technical Report: AMRL-TR-67-4, March 1967, 238 pp, AD 654 307.

A comprehensive and rigorous mathematical analysis of numerical integration techniques for real-time digital flight simulation is presented. Accuracy and efficiency of methods as well as stability of numerical solutions are examined in detail. These investigations allow the subject of

"best" integration methods and their derivation to be pursued. "Best" methods based on accuracy/efficiency and on stability were developed; in addition, the Stability Chart and Z-Transform approaches are examined. This study allows certain evaluational techniques to be derived. Notable among these are a technique for evaluating any integration method and a technique for deriving a "best" method for a given digital flight simulation problem. A demonstration section is included wherein the utility of these techniques is established.

206. Ordnance Mission. *Proceedings of First Flight Simulation Symposium, November 1956*. Ordnance Mission, White Sands Proving Ground, New Mexico, WSPG Special Report 9, September 1957, 256 pp, AD 143 964.

These proceedings are the result of the nation's first flight simulation symposium, held at White Sands Proving Ground on 14, 15, 16 November 1956. Only those papers which were unclassified are being published here, but unclassified abstracts of classified papers are included in the contents. Most of the papers concern problems in the evaluation of missiles and other dynamic systems. Requirements and achievements in realistic simulation with particular regard to the solution of complex problems for advanced missile systems were discussed. Some papers also concern new equipment and arrangements.

207. Perry, E. L. *Submicrosecond Simulation Computer Study Program - Part II - Preliminary Design and System Synthesis*. Aerospace Medical Research Laboratories, Wright-Patterson Air Force Base, Ohio, (Sylvania Electric Products, Inc., Needham, Massachusetts), Technical Documentary Report: MRL-TDR-62-27 (II), October 1962, 126 pp, AD 230 628.

The results of a research program to determine the preliminary design and system configuration of a high-speed simulation computer are described. Bench tests and analytical study of circuits utilizing Fairchild 2N 709 transistor have shown that the propagation delay through the basic diode-transistor NAND logic circuit will be approximately 4 nanoseconds. The memory study and tests have supported the use of ferrite cores for the storage of bulk program data. These cores may be sensed non-destructively at a two-megacycle rate by means of a flux-direction sensing technique. A fast scratch-pad memory is provided to compensate for the characteristically slow writing rate (250KC) associated with the non-destructive read-out memory. The computer described is designed to achieve a 0.75  $\mu$ s floating point addition operation time using these circuits and memories. The system organization will permit the computer to be applied to a variety of real-time simulation problems without any change in its basic structure. A variety of input/output equipment can be attached to the basic computer to adapt it to any particular simulation need. Memory quantity may be specified in module sizes of 4 thousand words. A rapid access optional drum memory may be used to reduce the amount of random-access storage for certain types of simulation applications. An independent search feature and input/output operations, which do not interrupt the execution of the main program, serve to increase the effective computing capability of the system.

208. Rasmussen, S. B. *Analog Function Generator*. Wright Air Development Center, Wright-Patterson Air Force Base, Ohio, (Palo Alto Research and Development Laboratory, Link Aviation, Inc., Palo Alto, California), Technical Report: WADC TR-59-439, February 1960, 55 pp, AD 233 563.

The primary purpose of the function generator herein described is to generate a variable  $z = f(x, y)$  as a function of two independent variables;  $(x, y)$  are represented as analog d-c volt-

ages. The function is stored in the manner of a square 21x21 matrix consisting of discrete voltages which are manually selected by making appropriate patch board connections to a precision transformer powered by a 1000 - cps square wave source. To interpolate between these voltages, they are applied to a ceramic resistance film at discrete points placed in equidistant rows and columns. The connections to the resistance film are made through flexible pigtailed. A specially developed relinear servomechanism is used to position the film element so that its displacement is proportional to one of the input variables ( $x$ ), while a second servomechanism positions a sliding contact onto the resistance film in response to the resistance film, the output voltage of the sliding contact equals  $z = f(x, y)$ . In order to have the output variable represented by a d-c voltage, a scheme for synchronous demodulation is incorporated. The equipment is capable of 1.0% accuracy, 5 cps frequency response, requires 100 watts of power, and is adaptable for generating many other types of function.

209. Riordan, W. J., Ed. *Summary Progress Report: Vol. II. Flight Tables on Simulation*. University of Chicago, Chicago, Illinois, February 1953, 149 pp, AD 16 193.

Flight tables are a necessary part of a Dynamic Systems Engineering Facility (DSEF) primarily because such a facility will have to solve simulation problems involving motion-sensitive elements of the air vehicle system whose mathematical characteristics are not readily available. In such studies flight tables can be used in two categories of problems: (1) open loop subsystem testing, and (2) closed loop system simulation.

Conclusion reached by the Board may be summarized as follows: (1) Flight tables will be used principally for homing studies; (2) Three-axis tables of more than one size will be necessary to cover the requisite size and speed range; (3) the Board should not undertake a flight table development program, but should watch the progress of tables now under development; (4) the computer used with a flight table must be studied, for it may be a limitation on flight table performance.

210. Schelhorn, A. E. *A Study of the Dynamic Response Characteristics of Flight Simulators*. Wright Air Development Center, Wright-Patterson Air Force Base, Ohio, (Cornell Aeronautical Laboratory, Inc., Buffalo, New York), WADC Technical Report 59-98, April 1959, 100 pp, AD 210 566.

The ability of a flight simulator to solve the characteristic flight equations of an aircraft is dependent upon the dynamic and small motion performance of the mechanical, electronic and servo elements of the simulator computer. One AC analog simulator and one DC analog simulator were tested for small amplitude longitudinal dynamic response utilizing pulse, ramp, step, sinusoidal and square wave inputs. The purpose of the tests was to determine and analyze the over-all dynamic performance and the component results of the testing, prepare a specification establishing requirements, tests and tolerances for dynamic response of future flight simulators. This report contains an analysis of the dynamic performance of the computers and various components utilized in the simulators tested. Representative copies of oscillograph records taken at the simulators, showing computer response to the various inputs are included. Requirements, tests and tolerances utilized in preparation of the specification are presented and discussed in the report.

211. Trugub, E. G., Coffee, M. F. and Russell, C. E. *Simulation of Helicopter and V/STOL Aircraft, Vol. II. Part II. Computational Methods, Digital*. U. S. Naval Training Device Center, Port Washington, New York, (Selpar, Inc., Falls Church, Virginia), Technical Report NTDC 1205-3, August 1963, 112 pp, AI 807 738.

This report was written with the purpose of demonstrating the methods of mechanizing the equations of motion of helicopters and V/STOL aircraft by digital computing equipment. The report is based on the mechanization of the final equations developed in volumes I and II of this report and assumes a knowledge of them. A general treatment of mathematical methods of analysis and of digital computer techniques is presented. The mathematical models developed in volumes I and II for helicopters, both single and tandem rotor, and for V/STOL aircraft are presented in a digitally applicable form. Recommendations are given for computer memory size and for computer sophistication based on the findings of the study reported.

212. U. S. Naval Training Device Center. *An Experimental Analog-Digital Flight Simulator*. U. S. Naval Training Device Center, Port Washington, New York, (Massachusetts Institute of Technology, Cambridge, Massachusetts), Technical Report: NTDC 45-2, December 1959, 115 pp, AD 234 504.

This report describes one of two demonstration systems which were designed, built, and tested to determine the feasibility of combining analog and digital elements in a computer suitable for solving, in real time, a set of non-linear differential equations such as those pertaining to aircraft flight. Data and programming instructions, and all calculations except integration with respect to time, were performed by the digital section; integration and generation of manually-adjusted control signals were accomplished in the analog section. Whirlwind I, with its versatile input-output system, constituted the digital portion of this experimental flight simulator. Signals were transmitted between the digital and analog elements via analog gates and a time-shared decoder and encoder. The set of equations used described flight at a fixed altitude and at speeds varying about a mean value of Mach .7. The system could be operated at a maximum solution rate of sixty per second; the results were generally in agreement with values obtained from an all-digital study performed at 1/72 real time and much greater precision. At a solution rate of thirty per second the responses were in most instances acceptable, and it therefore appears that a more complex set of equations describing flight at all altitudes and speeds, including landing and take-off, could be solved by this technique. The effects of reduced precision in the decoding and encoding operations were observed; round-off to less than six bits produced completely erroneous results. Finally, this experimental system provided useful information regarding the more important characteristics of the various components, information which should be useful in designing new and improved systems.

213. Young, D. D. *Two-Variable Function Generation for Analog Flight Simulation*. Masters Thesis, Air Force Institute of Technology, Wright-Patterson Air Force Base, Ohio, March 1958, 85 pp, AD 161 831.

The functions which describe the coefficients in the nonlinear equations of aircraft performance are generated by two-variable analog function generators. The analog computer uses these coefficients in the solution of the flight equations used to "fly" a simulator. A faster, more versatile function generator must be developed if the flight simulator is going to be used to simulate flight of future high-performance aircraft, missiles, and space vehicles. Almost all of the six described theoretical methods of all-electronic-two-variable function generation have the potential capability of being developed into a "universal" function generator that can replace the servo-driven systems. The new methods of electronic-two-variable function generation now under development exhibit no serious problems or limitations in flexibility and frequency response. Theoretical designs appear capable of overcoming the latent problem of low accuracy resolution; however, actual construction may indicate a need for minor design modifications.

## APPENDIX I.

# Visual Information Requirements for Flight Tasks

### 1. Take-off Flight Task

#### *Sub-Task*

- a. Position aircraft on correct side and line up with runway.
- b. Maintain directional control,
- c. Assume appropriate "fly-off" attitude.
- d. Establish initial climb attitude.
- e. Maintain appropriate climb attitude.

#### *Visual Information Requirement*

- a. Position of front and longitudinal axis of aircraft with respect to center-line of runway.
- b. Line of roll relative to center-line of runway.
- c. Position of two rotational axes (pitch, roll) relative to earth surface; position of yaw axis to line of flight (ground track).
- d. Same as c.
- e. Same as c.

### 2. Initial Approach — Pattern

#### *Sub-Task*

- a. Line up with outside of active runway.
- b. Maintain heading and altitude.
- c. Close to established "break" position.\*

#### *Visual Information Requirement*

- a. Line of flight relative to outside edge of runway; position of pitch and roll axes relative to earth surface and yaw axis to line of flight.
- b. Line of flight relative to outside edge of runway; elevation of aircraft with respect to earth surface; position of pitch and roll axes relative to earth surface; yaw axis relative to line of flight.
- c. Line of flight relative to pre-determined point on earth surface; position of pitch and roll axes relative to earth surface; yaw axis relative to line of flight.

### 3. First 180 — Pattern

#### *Sub-Task*

- a. Determine appropriate "break" position.

#### *Visual Information Requirement*

- a. Position in space (horizontal planes: fore-aft, lateral) relative to pre-determined point on earth surface; position of pitch and roll axes relative to earth surface and yaw axis relative to line of flight.

\*The pattern and "break" position varies among the different Commands at different times. At the time that this information was collected at Tyndall Air Force Base, Florida, the pattern was a modified overhead 360°, with the "break" being made 1000 feet short of the runway.

- b. Roll into level turn to the left.
- c. "Play" turn to achieve desired radius of turn and maintain altitude.
- d. Roll-out 180 from runway heading (Downwind Leg) at recommended lateral distance from runway.

- b. Rate of change in position of roll axis relative to earth surface; position of pitch axis relative to earth surface and yaw axis to line of flight.
- c. Same as b; position in space (three planes: fore-aft, horizontal, vertical) with respect to runway.
- d. Same as c.

#### 4. Second 180 — Pattern

##### *Sub-Task*

- a. Determine and fly to appropriate position for turn-in to final approach.
- b. Roll into descending turn to the left.
- c. "Play" turn to roll-out aligned with runway at recommended altitude and slant range.

##### *Visual Information Requirement*

- a. Position of pitch and roll axes with respect to earth surface; position in space in three translational planes (fore-aft, lateral, vertical); position of yaw axis relative to line of flight.
- b. Rate of change in position of roll and pitch axes relative to earth surface and yaw axis to line of flight.
- c. Rate of change in position in space in three translational planes relative to position of runway; rate of change in roll and pitch axes relative to earth surface; position of yaw axis relative to line of flight.

#### 5. Final Approach

##### *Sub-Task*

- a. Coordinate flight and power controls to establish recommended glide path.
- b. Correct for wind-drift as required.
- c. Maintain recommended glide path to permit a safe touchdown on first third of runway on correct side.
- d. Decide whether or not to go-around.

##### *Visual Information Requirement*

- a. Rate of change in position in space in three translational planes relative to position of runway (rate of closure); position of roll and pitch axes relative to earth surface; position of yaw axis relative to line of flight.
- b. Position of roll axis relative to earth surface; position of yaw axis relative to line of flight.
- c. Same as a.
- d. Same as a.

## 6. Go-Around (If Necessary)

### *Sub-Task*

- a. Establish safe airspeed.
- b. Maintain heading.
- c. Clear to right of runway.
- d. Fly flight path parallel to outside edge of runway.
- e. Roll into climbing turn to the left to pattern altitude after passing far end of runway.
- f. Fly pattern.

### *Visual Information Requirement*

- a. Position of pitch and roll axes relative to earth surface; position of yaw axis relative to line of flight.
- b. Line of flight relative to position of runway.
- c. Position of pitch and roll axes relative to earth surface; position of yaw axis relative to line of flight; line of flight relative to position of runway.
- d. Same as c.
- e. Rate of change in position of roll and pitch axes relative to earth surface; position of yaw axis to line of flight; position in space (three translational planes) relative to runway position.
- f. Same as for Flight Tasks 3, 4, and 5 – First 180, Second 180 and Final Approach.

## 7. Landing

### *Sub-Task*

- a. Execute "flare-cut" or establish proper attitude at correct range and elevation from runway.
- b. Maintain appropriate pre-touchdown attitude.
- c. Roll-out of wind correction and align aircraft with center-line of runway on correct side.
- d. Lower nose wheel and maintain directional control.
- e. Use braking action as required to slow and stop aircraft prior to reaching end of runway.

### *Visual Information Requirement*

- a. Rate of change in position of roll and pitch axes relative to earth surface; position of yaw axis relative to line of flight; rate of change in position in space in fore-aft and vertical translation relative to runway position.
- b. Position of pitch and roll axes relative to earth surface; position of yaw axis relative to line of flight.
- c. Rate of change in position of roll axis relative to earth surface and/or yaw axis relative to line of flight.
- d. Line of roll relative to center-line of runway.
- e. Position in fore-aft translational space with respect to position of far end of runway.

**APPENDIX II.**  
**Flight Training Simulators**

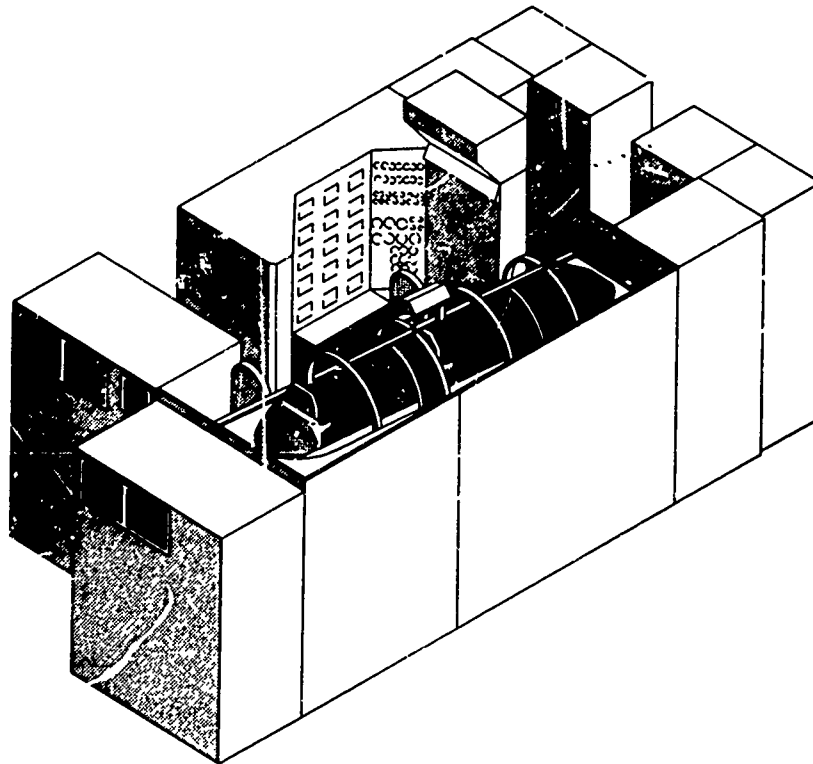

**Figure 43. B-47E Flight Simulator (S-6A) -- Link Division, General Precision Corp.**

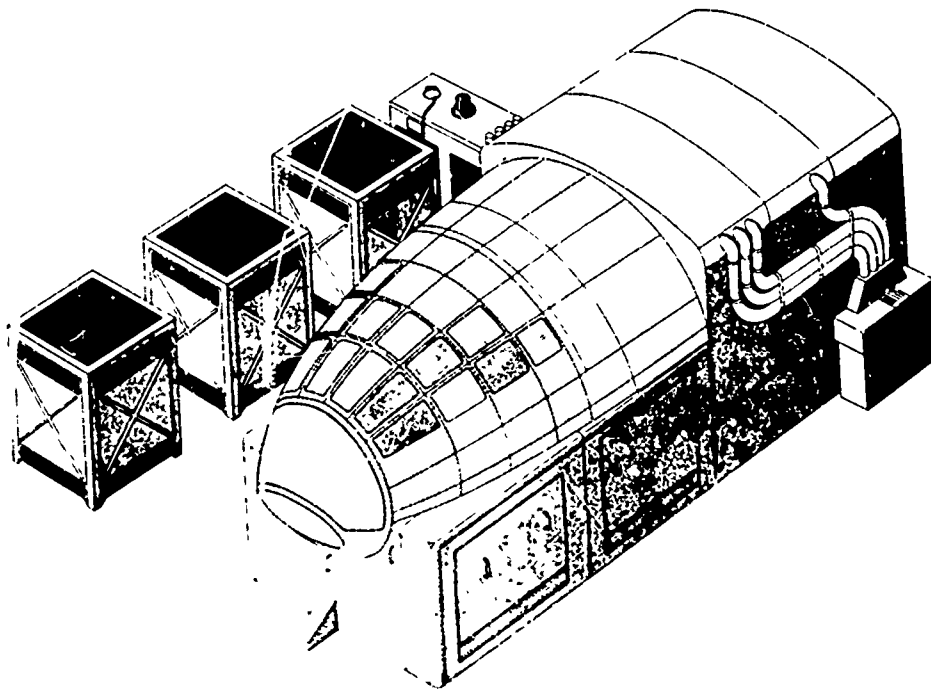

**Figure 44. B-50D Flight Simulator (S-1) -- Curtis-Wright Corp.**



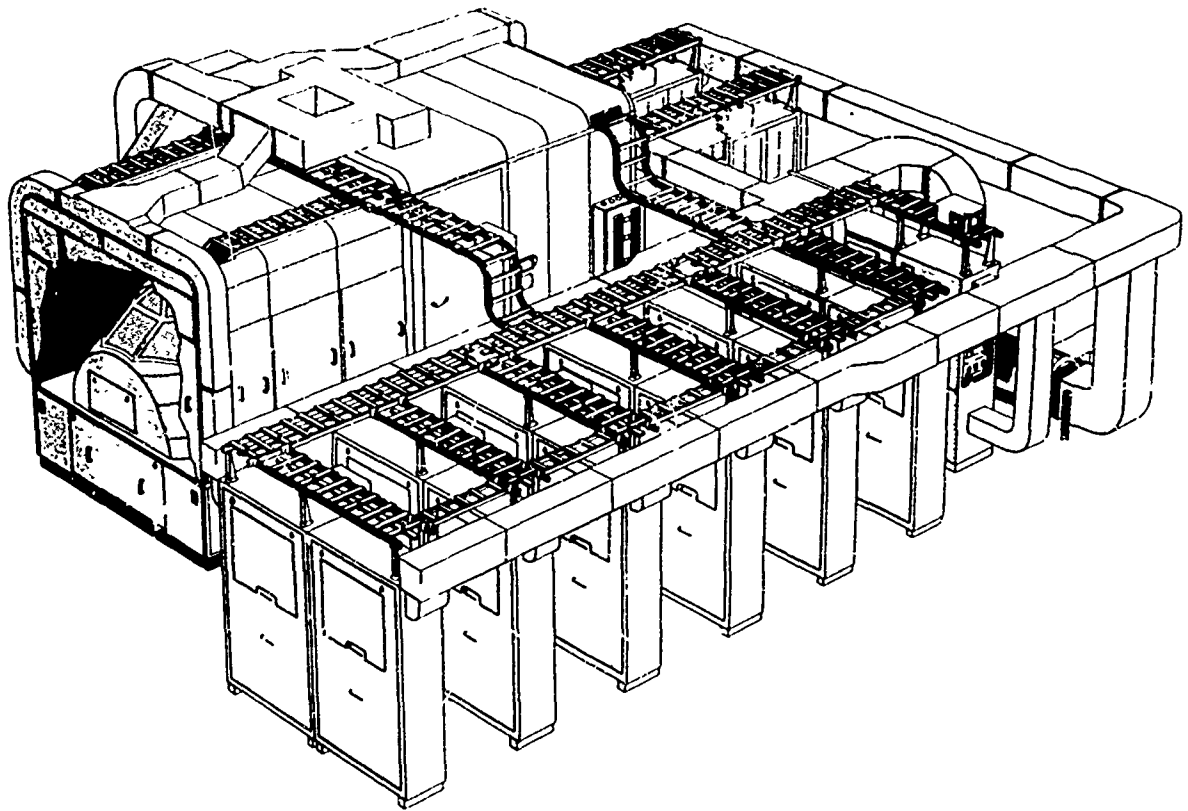

Figure 45. B-52G Flight Simulator (T-1) -- Curtis-Wright Corp.

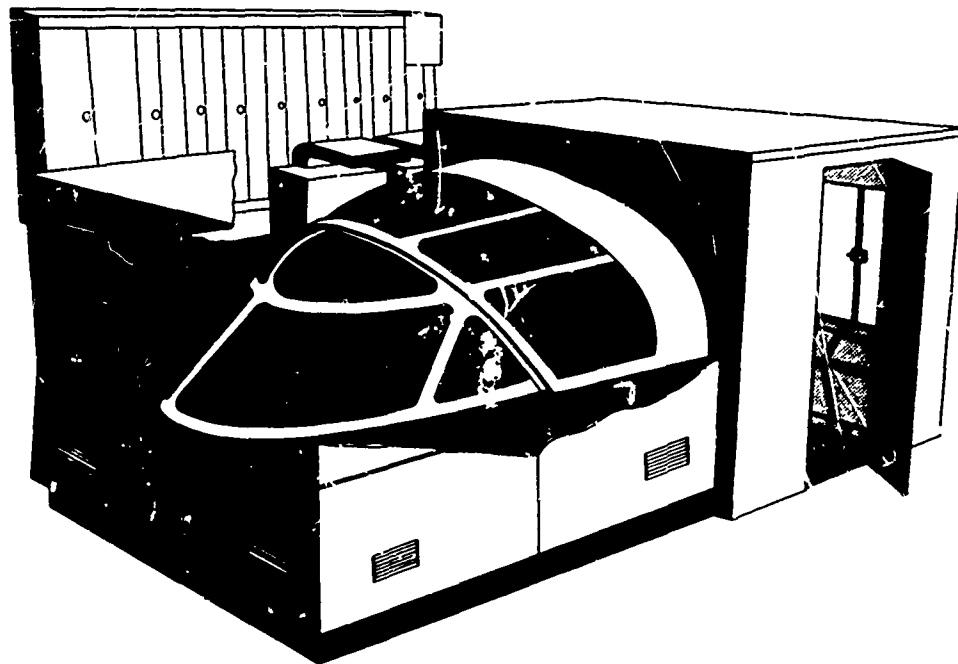

Figure 46. B-66B Flight Simulator (MB-20) -- ACF Industries, Inc.

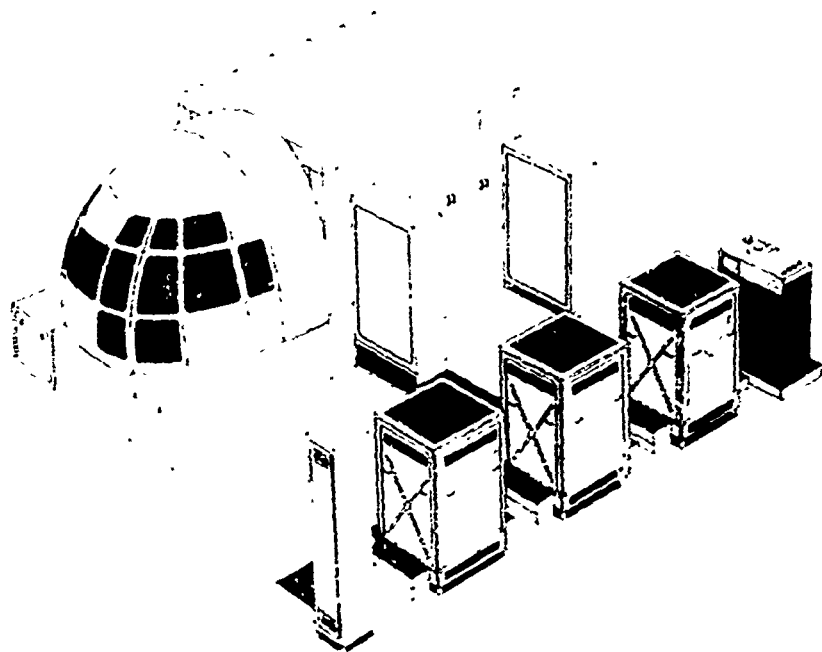

Figure 47. C-97A Flight Simulator (S-4) – Curtis-Wright Corp.

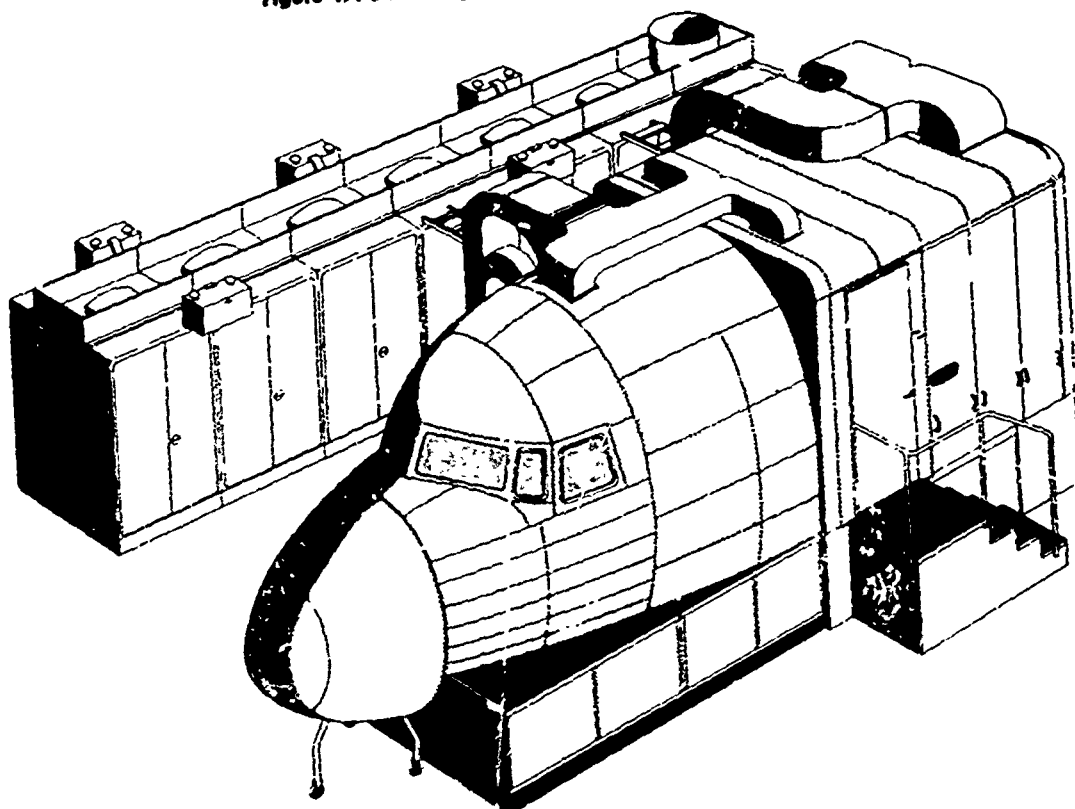

Figure 48. C-118A Flight Simulator (MB-11) – Curtis-Wright Corp.

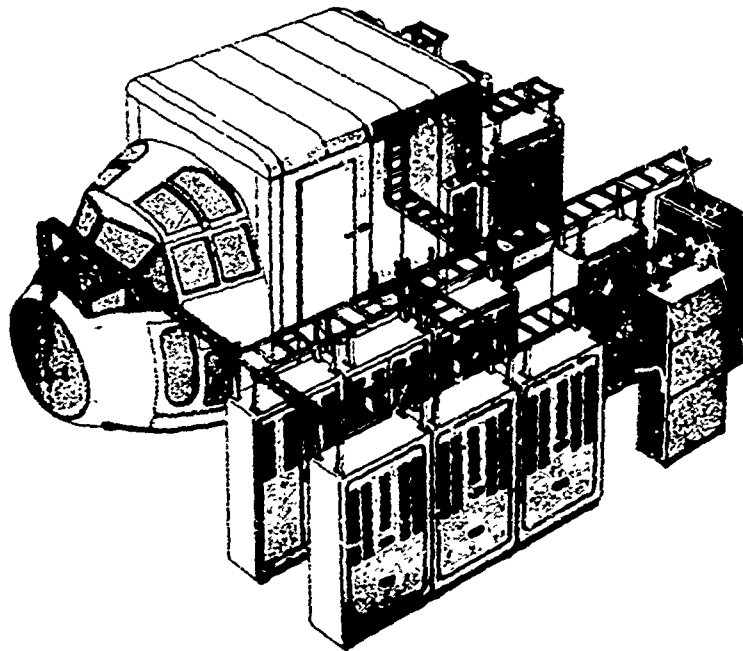

Figure 49. C-119G Flight Simulator (S-10A) – Curtis-Wright Corp.

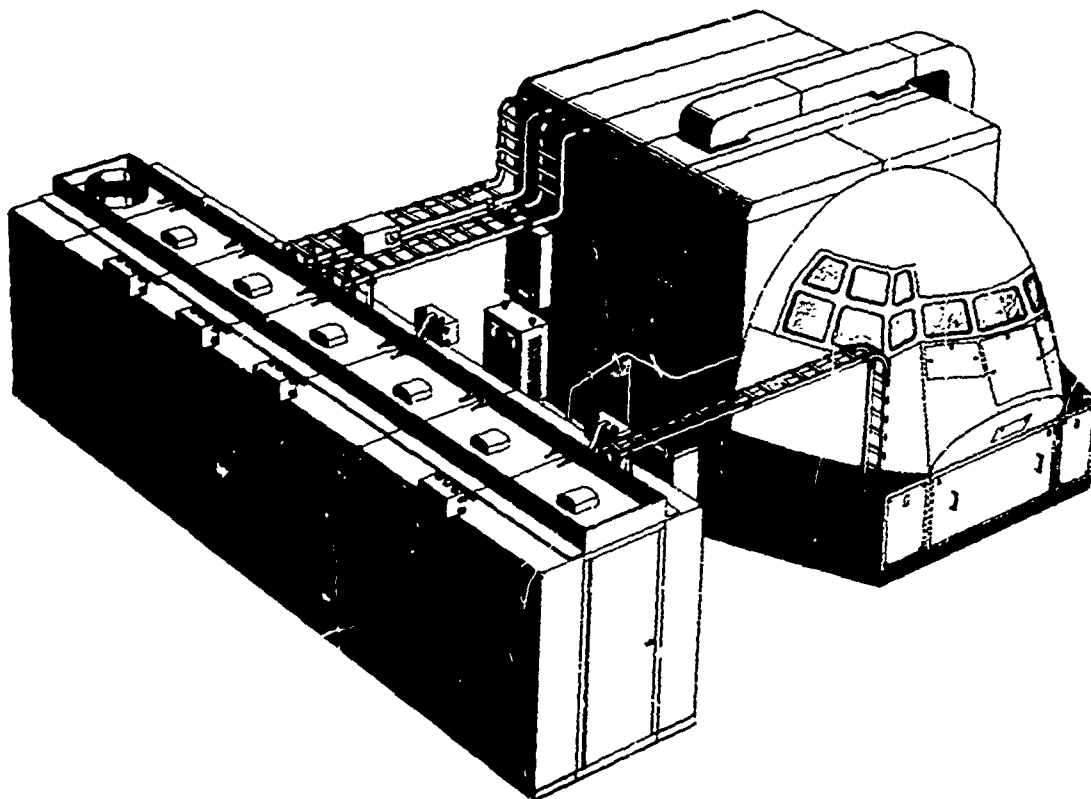
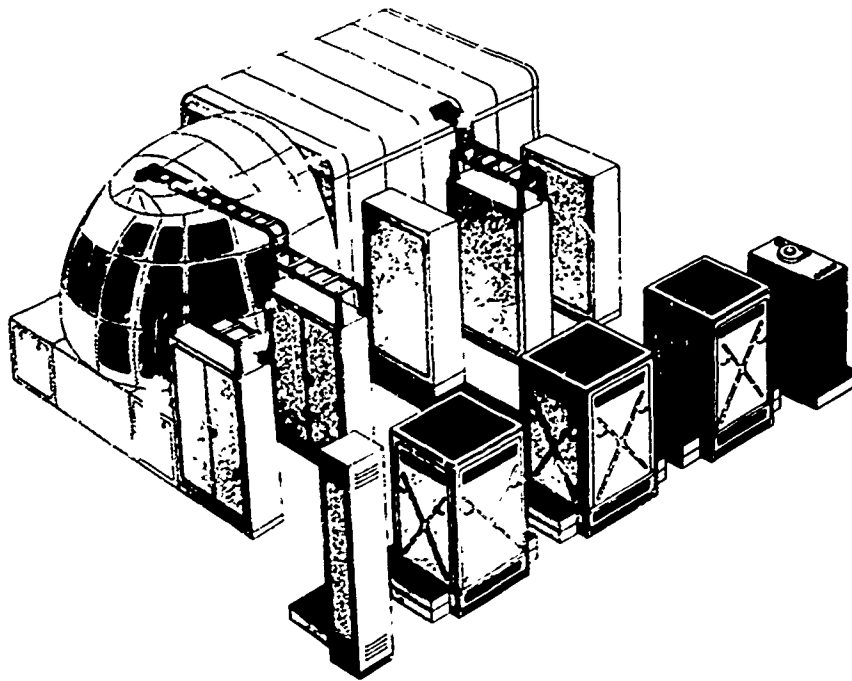
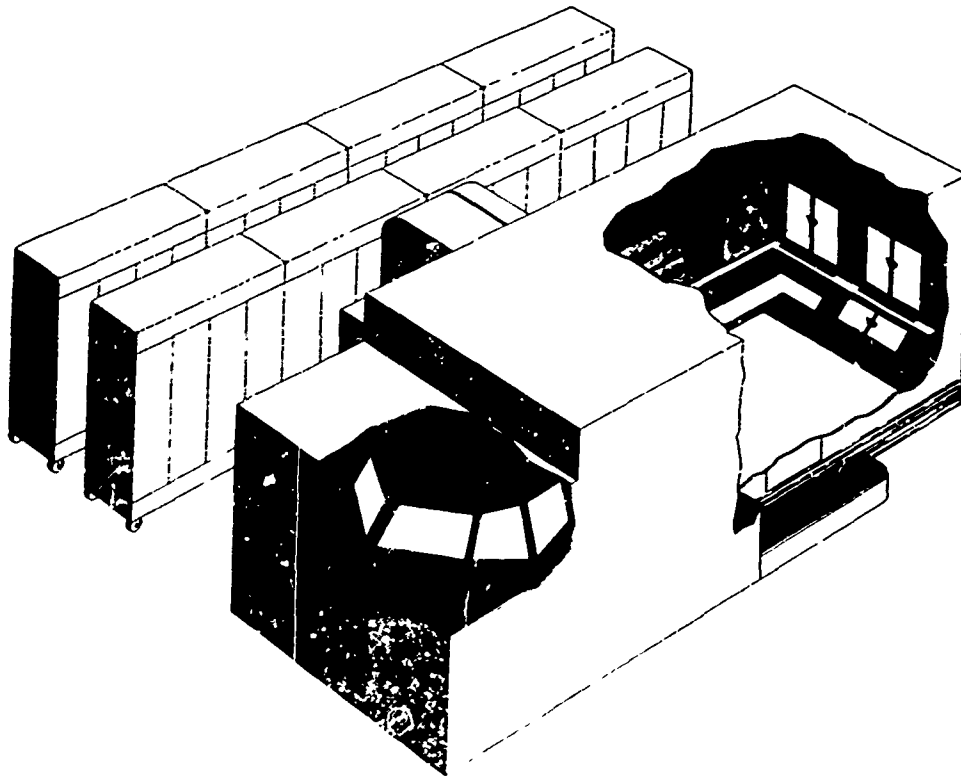

Figure 50. C-130A Flight Simulator (AB-12) – Curtis-Wright Corp.



**Figure 51. KC-97G Flight Simulator (MB-27) – Curtis-Wright Corp.**



**Figure 52. KC-135A Flight Simulator (MB-26) – ACF Industries, Inc.**

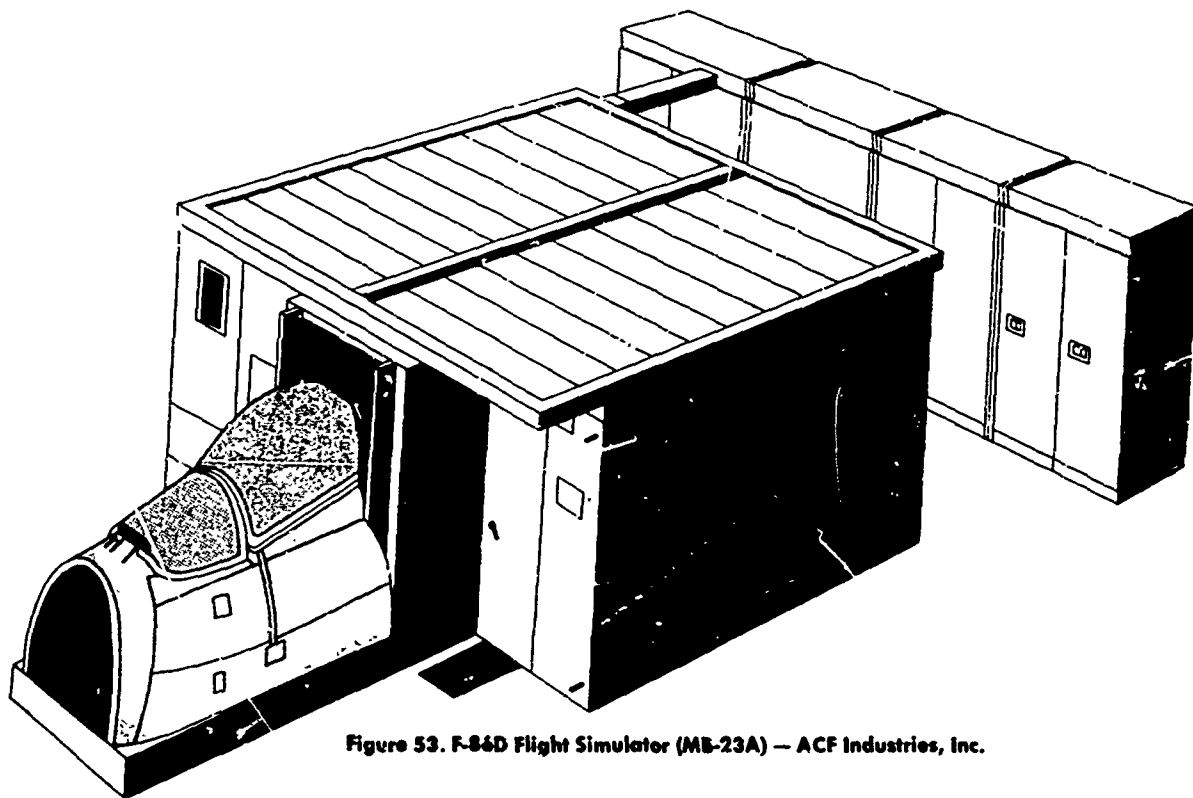

Figure 53. F-86D Flight Simulator (MB-23A) — ACF Industries, Inc.

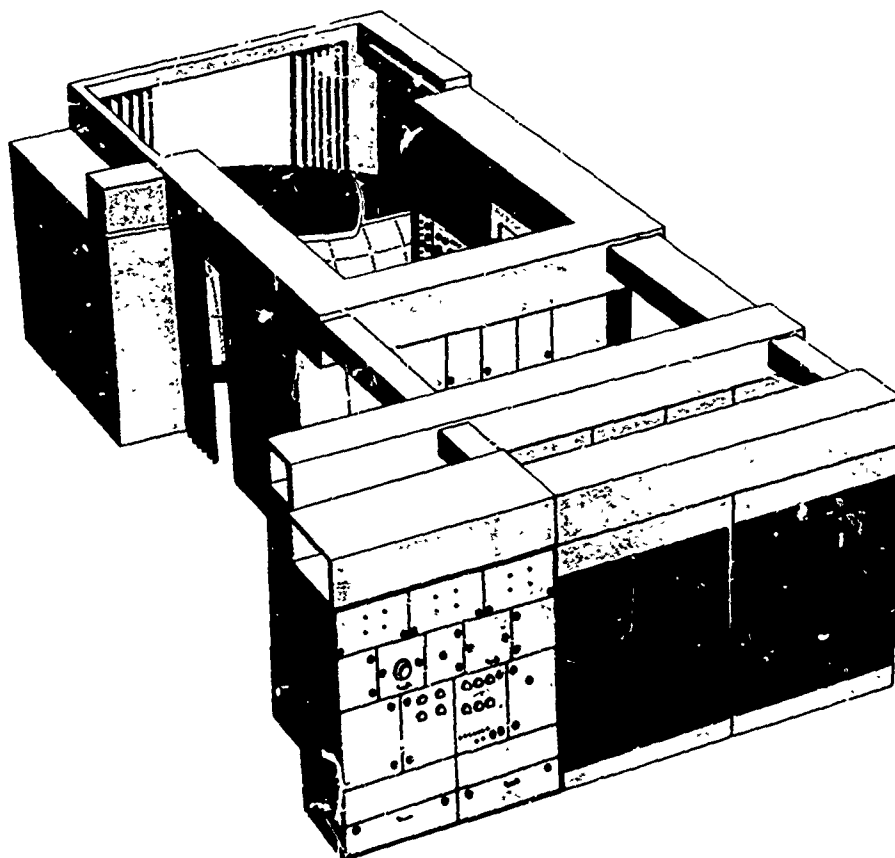

Figure 54. F-100A Flight Simulator (MB-3) — Union Switch and Signal

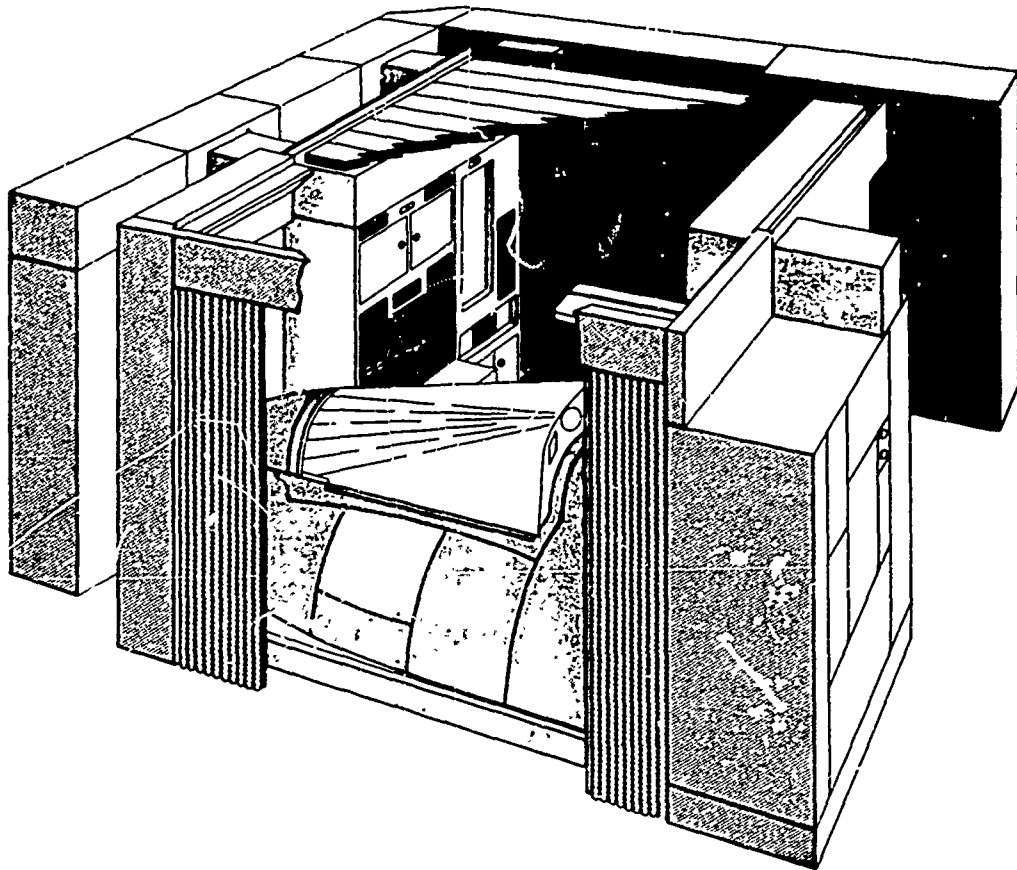

Figure 55. F-100C Flight Simulator (MB-22) — Union Switch and Signal

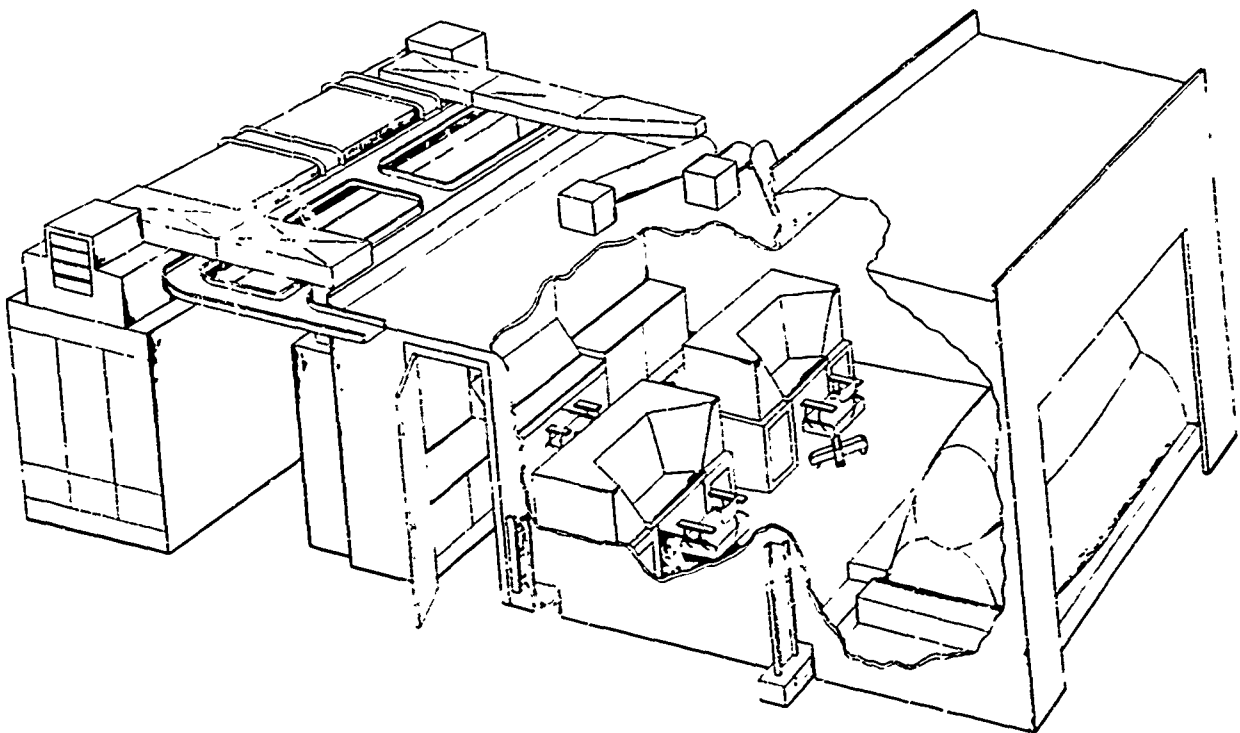

Figure 56. F-101B Flight Simulator (MB-40) — Melpar, Inc.

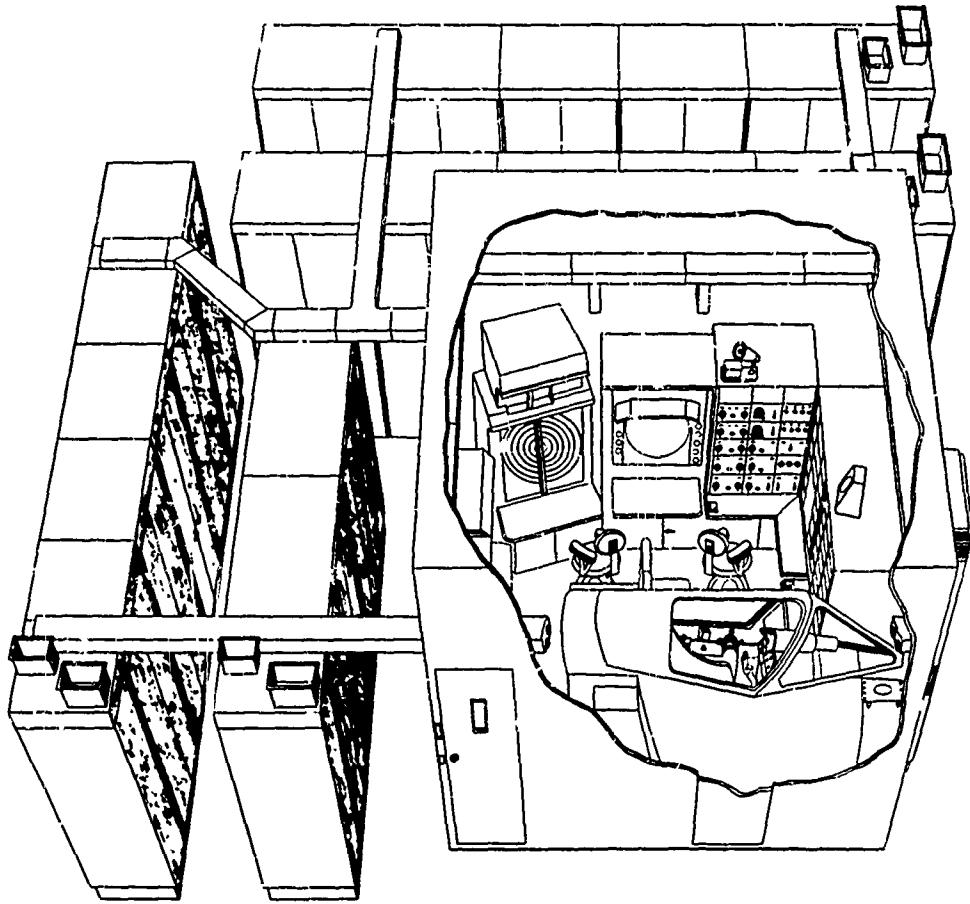

Figure 57. F-102A Flight Simulator (MB-5) — Link Division, General Precision, Inc.

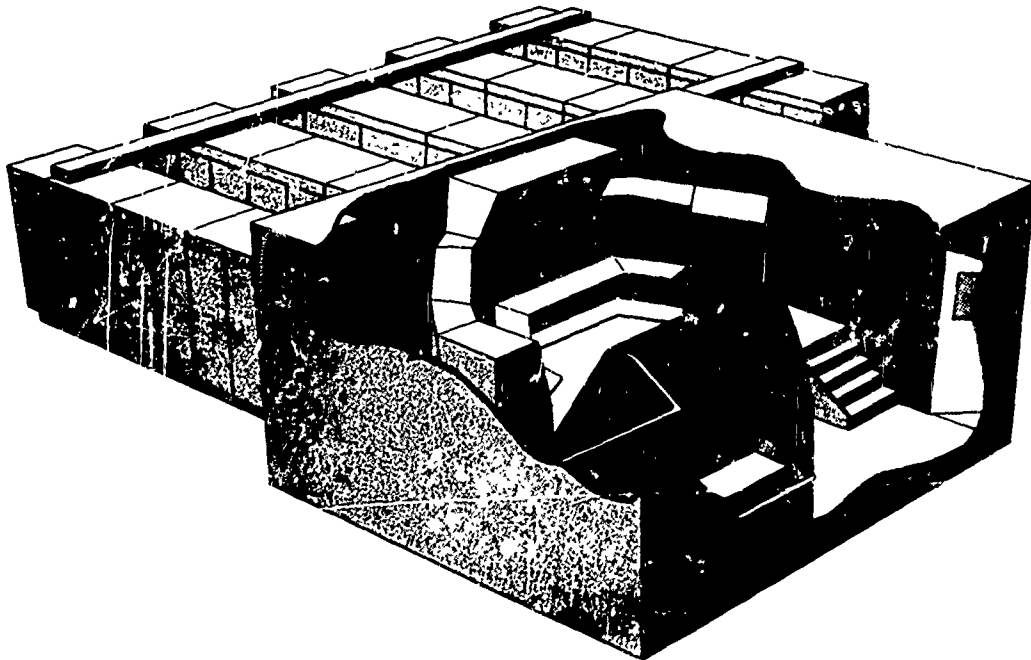

Figure 58. F-106A Flight Simulator (MB-42) — Link Division, General Precision, Inc.

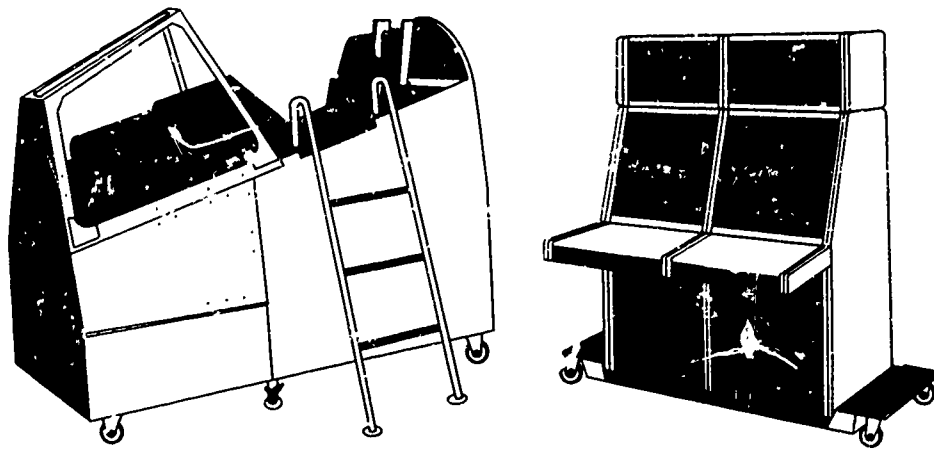

Figure 59. F-102A Cockpit Procedure Trainer (MF-9) — Newton Corp.

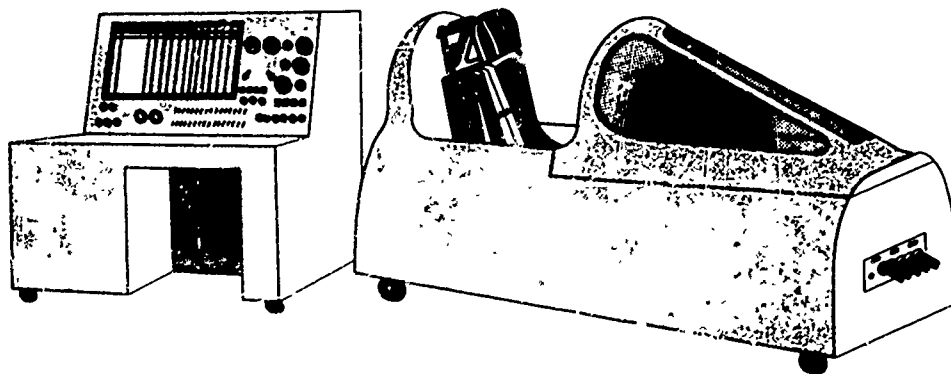

Figure 60. F-105 Cockpit Procedure Trainer (MF-13) — Burttek, Inc.



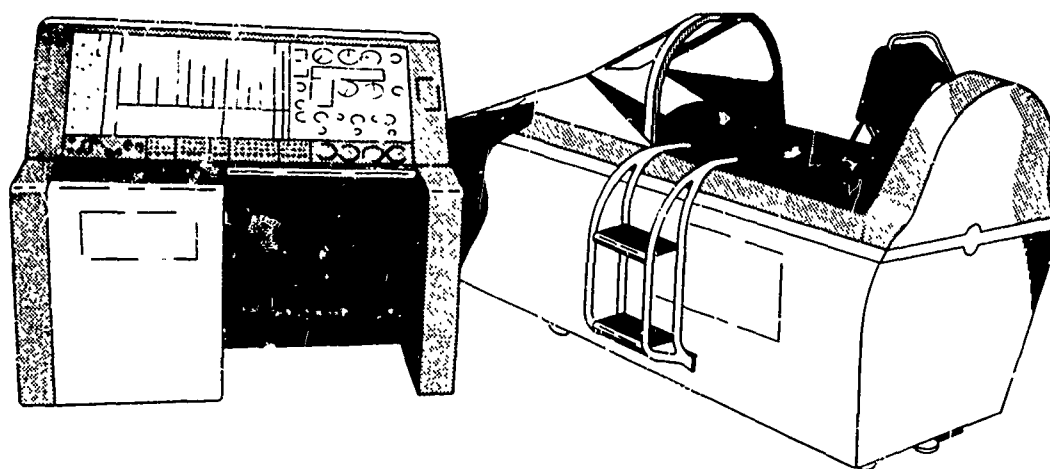

Figure 61. T-33A Cockpit Procedure Trainer (MF-1) — Stanley Aviation, Inc.  
Also Burttek, Inc.

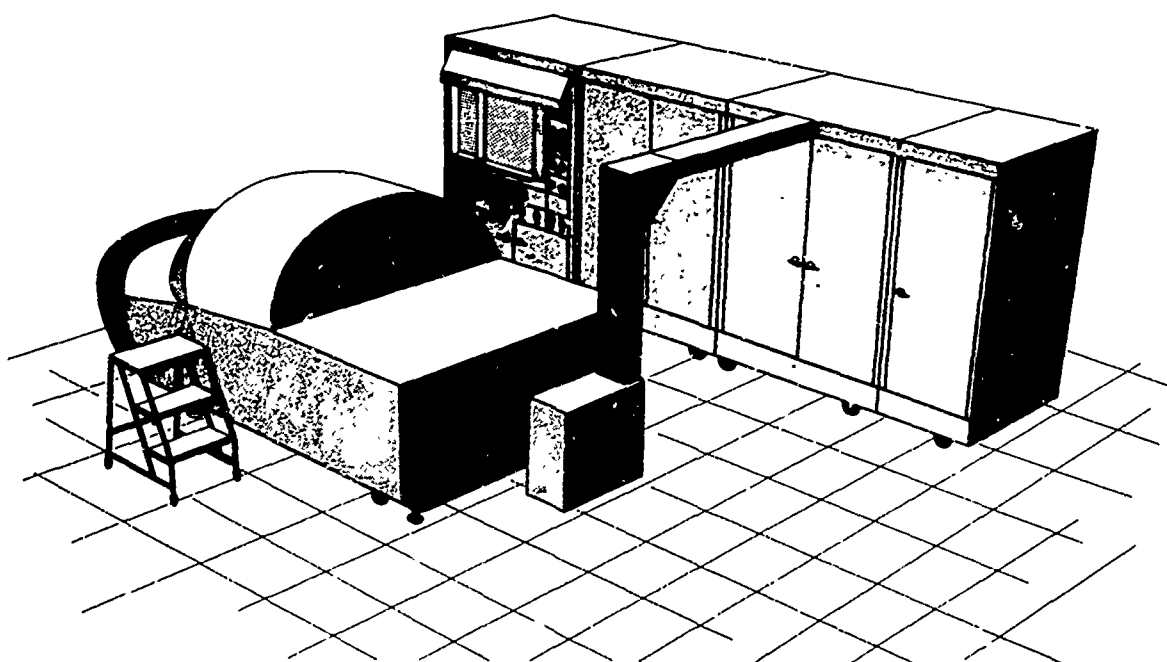

Figure 62. T-37A Instrument Flight Trainer (T-4) — Link Division, General Precision, Inc.

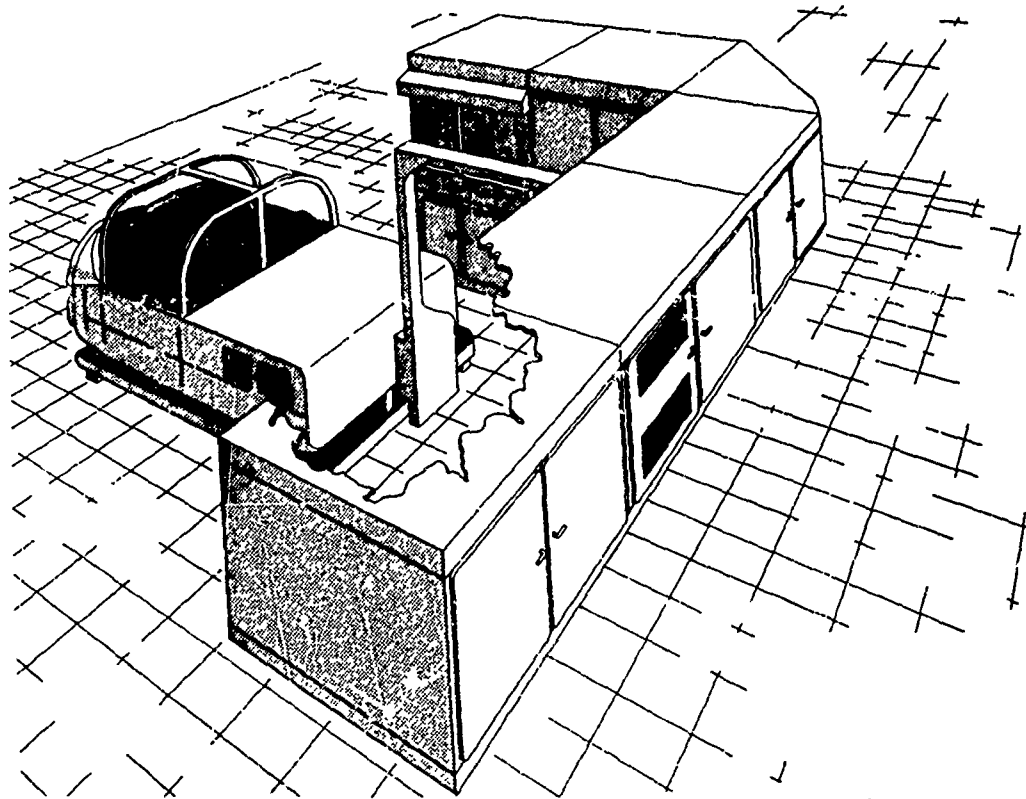

Figure 63. T-37A Instrument Flight Trainer — Link Division, General Precision, Inc.

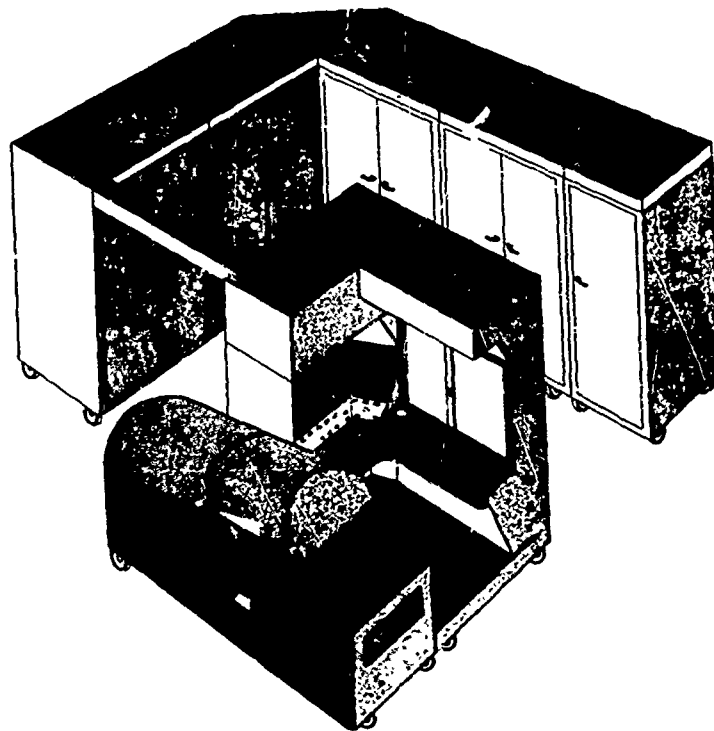
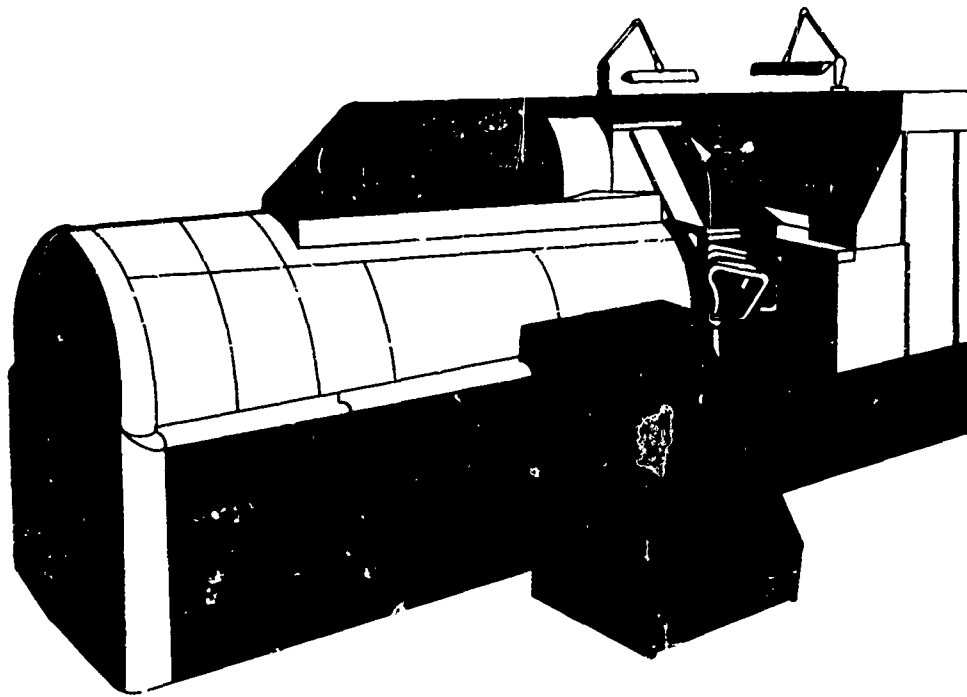

Figure 64. T-38 Instrument Flight Trainer (T-7) — Link Division, General Precision, Inc.



**Figure 65. Instrument Flight Trainer, Jet Propelled Aircraft (C-11B, C) — Link Division, General Precision, Inc.**

Security Classification

## DOCUMENT CONTROL DATA - R &amp; D

(Security classification of title, body of abstract and indexing annotation must be entered when the overall report is classified)

1. ORIGINATING ACTIVITY (Corporate author) Aerospace Medical Research Laboratories, Aerospace Medical Division, Air Force Systems Command, Wright-Patterson Air Force Base, Ohio 45433		2a. REPORT SECURITY CLASSIFICATION UNCLASSIFIED	
		2b. GROUP N/A	
3. REPORT TITLE FLIGHT SIMULATORS: A REVIEW OF THE RESEARCH AND DEVELOPMENT			
4. DESCRIPTIVE NOTES (Type of report and inclusive dates) Final Report, October 1967-March 1968			
5. AUTHOR(S) (First name, middle initial, last name) Horace H. Valverde			
6. REPORT DATE July 1968	7a. TOTAL NO. OF PAGES 140	7b. NO. OF REFS 213	
8a. CONTRACT OR GRANT NO.  b. PROJECT NO. 1710 c. Task No. 171003 d.		9a. ORIGINATOR'S REPORT NUMBER(S) AMRL-TR-68-97	
9b. OTHER REPORT NO(S) (Any other numbers that may be assigned this report)			
10. DISTRIBUTION STATEMENT This document is subject to special export controls and each transmittal to foreign governments or foreign nationals may be made only with prior approval of Aerospace Medical Research Laboratories, Wright-Patterson Air Force Base, Ohio 45433.			
11. SUPPLEMENTARY NOTES		12. SPONSORING MILITARY ACTIVITY Aerospace Medical Research Laboratories, Aerospace Medical Div., Air Force Systems Command, Wright-Patterson AFB, OH 45433	
13. ABSTRACT This report presents a general review of the research and development of flight simulators and related areas sponsored by military and other government agencies since 1949. The use of simulators for flight training is emphasized. The report does not consider mathematical models and space flight simulators. The topics include: (1) Visual and Motion Simulation, (2) Transfer of Training, (3) Utilization and Evaluation, and (4) Computers. An annotated bibliography of unclassified technical reports reviewed is included for each of the topics. The Defense Documentation Center accession number for each report is provided to facilitate the acquisition of microfilm copies of desired documents by United States military and other government agencies.			

DD FORM 1 NOV 65 1473

Security Classification

14 KEY WORDS	LINK A		LINK B		LINK C	
	ROLE	WT	ROLE	WT	ROLE	WT
Flight simulators Flight trainers Visual simulation Motion simulation Transfer of training Trainer utilization Trainer evaluation Computers Bibliographies						

**SUPPLEMENTARY**

**INFORMATION**

IDENTIFICATION	FORMER STATEMENT	NEW STATEMENT	AUTHORITY
AD-855 582 Aerospace Medical Research Lab., Wright-Patterson AFB, Ohio. Final rept. Oct 67-Mar 68. Rept. no. AMRL-TR-68- 97	No Foreign without approval of Commander, Aerospace Medical Research Labs., Wright-Patterson AFB, Ohio.	No Foreign without approval of Air Force Human Resources Laboratory, Attn: HRT, Wright-Patterson AFB, Ohio.	AMRL, USAF ltr, 22 Dec 69