

UNCLASSIFIED

AD NUMBER
AD854544
NEW LIMITATION CHANGE
TO Approved for public release, distribution unlimited
FROM Distribution authorized to U.S. Gov't. agencies and their contractors; Critical Technology; FEB 1969. Other requests shall be referred to Air Force Space and Missile Systems Organization, Los Angeles AFB, CA 90045.
AUTHORITY
samso ltr, 19 jan 1972

THIS PAGE IS UNCLASSIFIED

BOEING



AD854544

DDC
RECEIVED
JUL 3 1963
C

SEATTLE, WASHINGTON

346

SAMSO-TR-69-168

A

REV LTR A

THE **BOEING** COMPANY

CODE IDENT. NO. S1205

NUMBER T2-3557-1

TITLE: Final Test Report - Static Confirmation Tests -
LSM-306 (Minteman III)

ORIGINAL RELEASE DATE 7/1/69 FOR THE RELEASE DATE OF SUBSEQUENT REVISIONS, SEE THE REVISIONS SHEET. FOR LIMITATIONS IMPOSED ON THE DISTRIBUTION AND USE OF INFORMATION CONTAINED IN THIS DOCUMENT, SEE THE LIMITATIONS SHEET.

MODEL WS-133B

PREPARED UNDER:

ISSUE NO. _____

CONTRACT NO. AF 04 (692) -791

ISSUE TO _____

IR&D

PREPARED BY J. Tancredi

J. Tancredi

David W. Womack

E. W. MacCott

J. Davis

J. Wilson

D. Sabin

G. Pains

SUPERVISED BY James R. Anderson

G. S. Sloger

SUPERVISED BY W. A. Mills

W. A. Mills

APPROVED BY J. E. Edison

J. E. Edison

DISTRIBUTION LIMITATION: This document is subject to special export controls and each transmittal to foreign governments or foreign nationals may be made only with prior approval of Space and Missile Systems Organization (AFSC) ~~(SAMS)~~. The distribution of this report is limited because it contains technology restricted by Mutuals Security Acts.

A

SMSD, Los Angeles SHEET 1 AFB, Calif 90045

#31

MICROFILMED 2 / 1 / 69

DISCLAIMER NOTICE

**THIS DOCUMENT IS BEST QUALITY
PRACTICABLE. THE COPY FURNISHED
TO DTIC CONTAINED A SIGNIFICANT
NUMBER OF PAGES WHICH DO NOT
REPRODUCE LEGIBLY.**

**BEST
AVAILABLE COPY**

THE **BOEING** COMPANY

LIMITATIONS

Distribution Limitation:

This document is subject to special export controls and each transmittal to foreign governments or foreign nationals may be made only with prior approval of Space and Missile Systems Organization (AFSC) (~~SECRET~~). The distribution of this report is limited because it contains technology restricted by Mutuals Security Acts.

A
↑

This document is controlled by Structures Technology -
Minuteman Missile Stress 2-5513-1

All revisions to this document shall be approved by the above noted organization prior to release.

ACTIVE SHEET RECORD											
SHEET NUMBER	REV LTR	ADDED SHEETS				SHEET NUMBER	REV LTR	ADDED SHEETS			
		SHEET NUMBER	REV LTR	SHEET NUMBER	REV LTR			SHEET NUMBER	REV LTR	SHEET NUMBER	REV LTR
1	A					223					
2	A					224					
3	A					225					
4						226					
5						227					
6						228					
7	A					229					
8						230					
						231					
100						232					
101						233					
102						234					
103						235					
104						236					
105						237					
106						238					
107						239					
108						240					
						241					
200						242					
201						243					
202						244					
203						245					
204						246					
205						247					
206						248					
207						249					
208						250					
209						251					
210						252					
211						253					
212											
213											
214						300					
215						301					
216						302					
217						303					
218						304					
219						305					
220						306					
221						307					
222						308					

ACTIVE SHEET RECORD

SHEET NUMBER	REV LTR	ADDED SHEETS				SHEET NUMBER	REV LTR	ADDED SHEETS			
		SHEET NUMBER	REV LTR	SHEET NUMBER	REV LTR			SHEET NUMBER	REV LTR	SHEET NUMBER	REV LTR
309						416					
310						417					
311						418					
312						419					
313						420					
314						421					
315						422					
316						423					
317						424					
318						425					
319						426					
320						427					
321						428					
322						429					
323						430					
324						431					
325						432					
326						433					
327						434					
328						435					
329						436					
330						437					
331						438					
332						439					
						440					
						441					
400						442					
401						443					
402						444					
403						445					
404						446					
405						447					
406						448					
407						449					
408						450					
409						451					
410						452					
411						453					
412						454					
413						455					
414						456					
415											

ACTIVE SHEET RECORD											
SHEET NUMBER	REV LTR	ADDED SHEETS				SHEET NUMBER	REV LTR	ADDED SHEETS			
		SHEET NUMBER	REV LTR	SHEET NUMBER	REV LTR			SHEET NUMBER	REV LTR	SHEET NUMBER	REV LTR
500						541					
501						542					
502						543					
503						544					
504						545					
505						546					
506						547					
507						548					
508						549					
509						550					
510						551					
511						552					
512						553					
513						554					
514						555					
515						556					
516						557					
517						558					
518						559					
519						560					
520						561					
521						562					
522						563					
523						564					
524						565					
525						566					
526						567					
527						568					
528						569					
529						570					
530						571					
531						572					
532						573					
533											
534											
535						600					
536						601					
537						602					
538						603					
539						604					
540						605					

ACTIVE SHEET RECORD											
SHEET NUMBER	REV LTR	ADDED SHEETS				SHEET NUMBER	REV LTR	ADDED SHEETS			
		SHEET NUMBER	REV LTR	SHEET NUMBER	REV LTR			SHEET NUMBER	REV LTR	SHEET NUMBER	REV LTR
606						649					
607						650					
608						651					
609						652					
610						653					
611						654					
612						655					
613						656					
614						657					
615						658					
616						659					
617						660					
618											
619						700					
620						701					
621						702					
622						703					
623						704					
624						705					
625						706					
626						707					
627						708					
628						709					
629						710					
630						711					
631						712					
632						713					
633						714					
634						715					
635						716					
636						717					
637						718					
638						719					
639						720					
640						721					
641						722					
642						723					
643						724					
644						725					
645											
646											
647											
648											

ACTIVE SHEET RECORD											
SHEET NUMBER	REV LTR	ADDED SHEETS				SHEET NUMBER	REV LTR	ADDED SHEETS			
		SHEET NUMBER	REV LTR	SHEET NUMBER	REV LTR			SHEET NUMBER	REV LTR	SHEET NUMBER	REV LTR
800	A										
801											
802											
803											
804											
805											
806											
807											
808											
809											
900											
901											
902											

REVISIONS			
LTR	DESCRIPTION	DATE	APPROVAL
A	<p>Add or revise the "Distribution Limitation and Justification" statement on Sheets 1, 2 and 901 (Form DD 1473). Revise Sheets 3 and 7 to identify active document pages.</p> <p>Add customer assigned report number "SAMSO-TR-69-168" to sheets 1, 2 and 901.</p> <p>This revision in response to and in compliance with SAMSO letter SMOKP/6-6-7/C. Humphrey/4571, AF04(694)-791.</p>		<p><i>[Handwritten Signature]</i> <i>[Handwritten Date]</i></p>

1.0 GENERAL INFORMATION

1.1 ABSTRACT

This document provides the final test report for the Structural Static Confirmation Tests of integrated structural components of the Minuteman LGM 30G missile. The primary purposes of the test program were to: 1) confirm structural compatibility of integrated structure, 2) determine ultimate load capability, 3) obtain load deflection characteristics. Static tests were conducted on integrated Stage III/PBV R&D and Operational stackups and Stage II Fwd/ II-III Interstage/Stage III stackup. Various critical combinations of external and internal pressure, axial load, moment, shear and heat were applied to the structure simulating the silo launch condition and powered flight conditions.

1.2

LIST OF KEY WORDS

Confirmation Test	PBPS
Flight Condition	PBV -
Integrated Test	Programmed Loads
II-III Interstage	Programmed Temperatures
Joint Stiffness	Re-Entry System
Launch Condition	R/S Frustum
MGS	R/S Shroud
Minuteman	Stage III Motor
Missile Section Stiffness	Stage III/PBV Separation Joint
Mod 7E	Static Test
PBCS	

USE FOR TYPEWRITTEN MATERIAL ONLY

USE FOR TYPEWRITTEN MATERIAL ONLY

	SECT
1.3 TABLE OF CONTENTS	-
1.0 GENERAL INFORMATION	
1.1 ABSTRACT	100
1.2 LIST OF KEY WORDS	100
1.3 TABLE OF CONTENTS	101
1.4 SUMMARY	104
1.5 TEST OBJECTIVES	107
1.6 TEST FACILITIES	107
1.7 TEST DATA	107
2.0 STAGE III/PBV R&D LAUNCH CONDITION TESTS (332-L)	
2.1 TEST SPECIMEN	200
2.2 TEST SETUP	200
2.3 INSTRUMENTATION	200
2.4 TEST CONDITIONS	200
2.5 TEST PROCEDURE	201
2.6 TEST RESULTS	201
2.7 TEST CONCLUSIONS	201
3.0 STAGE III/PBV OPERATIONAL LAUNCH CONDITION TEST (333-L)	
3.1 TEST SPECIMEN	300
3.2 TEST SETUP	300
3.3 INSTRUMENTATION	300
3.4 TEST CONDITIONS	300
3.5 TEST PROCEDURE	300
3.6 TEST RESULTS	301
3.7 TEST CONCLUSIONS	301

SECT

USE FOR TYPEWRITTEN MATERIAL ONLY

1.3	TABLE OF CONTENTS (Continued)	
4.0	STAGE III/PEV BAD FLIGHT CONDITION TESTS	
4.1	TEST SPECIMEN	400
4.2	TEST SETUP	400
4.3	INSTRUMENTATIONS	400
4.4	TEST CONDITIONS	400
4.5	TEST PROCEDURES	401
4.6	TEST RESULTS	401
4.7	TEST CONCLUSIONS	401
5.0	STAGE III/PEV OPERATIONAL FLIGHT CONDITION TESTS (333-F)	
5.1	TEST SPECIMEN	500
5.2	TEST SETUP	500
5.3	INSTRUMENTATION	500
5.4	TEST CONDITIONS	501
5.5	TEST PROCEDURES	502
5.6	TEST RESULTS	503
5.7	TEST CONCLUSIONS	503
6.0	II-III INTERSTAGE FLIGHT CONDITION TESTS (345-F)	
6.1	TEST SPECIMEN	600
6.2	TEST SETUP	600
6.3	INSTRUMENTATION	600
6.4	TEST CONDITIONS	600
6.5	TEST PROCEDURES	601
6.6	TEST RESULTS	601
6.7	TEST CONCLUSIONS	601

SECRET

1.3	TABLE OF CONTENTS (Continued)	
7.0	MINUTEMAN III STIFFNESS DETERMINATION TESTS	
7.1	TEST DESCRIPTION AND TEST SPECIMEN	700
7.2	TEST SETUP	700
7.3	TEST CONDITIONS	701
7.4	INSTRUMENTATION	701
7.5	DATA ACQUISITION AND REDUCTION	701
7.6	TEST RESULTS	701
7.7	ROTATION ERROR	703
7.8	CONCLUSIONS AND RECOMMENDATIONS	706
8.0	SAMPLE CALCULATIONS--LOADS	800
8.1	SILG LAUNCH CONDITION TEST CALCULATIONS--LOADS	800
8.2	FLIGHT CONDITION TEST CALCULATIONS--LOADS	804
9.0	REFERENCES	900

USE FOR TYPEWRITTEN MATERIAL ONLY

1.4 SUMMARY

The R&D configuration tests (332 Series tests) and the Operational configuration tests (333 Series tests and 345-F tests) successfully sustained the 100% level test loads without failure or evidence of detrimental yielding. The test specimens which were subjected to the failure test conditions successfully sustained loads in excess of 100% test loads before failure.

Based on the successful test results documented herein, the Static Confirmation Test Program demonstrated that the new Minuteman III missile components will sustain launch and powered flight loads without failure or detrimental yielding and satisfied the objectives of the test program.

A summary of ultimate capability of missile components demonstrated by destruction tests are shown in the table below. The values are stated in terms of percentages of two sets of design ultimate load criteria: (1) design ultimate loads per test plan and, (2) design ultimate loads per BSD Exhibit 66-6A

SUMMARY OF MAXIMUM APPLIED LOADS				
MISSILE STRUCTURAL COMPONENT	FLIGHT LOAD CONDITION 1		LAUNCH LOAD CONDITION 2	
	% OF DESIGN ULTIMATE LOADS PER			
	TEST PLAN 3	BSD 66-6A 4	TEST PLAN 3	BSD 66-6A 4
MGS	120	97	137	128
PBPS	119	100	135	127
STG III FWD. SKIRT	119	100	135	131
II-III INTERSTAGE	132	116	See Reference 10 Section 4	
1	Flight Loads consist of combined axial compression, shear & bending mom.			
2	Launch Loads consist of combined axial compression plus overpressure.			
3	Design ultimate test loads (reference 1) were based on loads resulting from final flight trajectories and launch environments.			
4	BSD EXHIBIT 66-6A loads were based on early preliminary flight trajectories and launch environment.			

A summary of the test program including applied test loads is shown in Table 1.4-1 page 106. Table 1.4-2 page 107, shows the maximum loads applied to each missile section.

Stiffness determination tests were conducted on all test stack-ups to obtain load-deflection characteristics. This phase of the test program is presented in Section 7 beginning on page 700. Stiffness results are tabulated in Tables 7.6-1 through 7.6-5 on pages 720 through 723. Conclusions and recommendations are as follows:

1. The local rotation or bulging of the Minuteman joints has been identified as an important contributor to the stiffness of joints.
2. The joint rotation effect can lead to erroneous readings with the present method of electronic deflection indicator (EDI) measurement.
3. Stiffness measurements on future testing should include instrumentation to measure local rotation of the EDI attachment clips.

USE FOR TYPECASE ONLY

1.4 SUMMARY (Continued)

4. The test stiffness values obtained for the Stage III motor and the joints forward of the Stage III motor should be used in future analytical studies.
5. The test stiffness values for the II-III interstage and the missile sections forward of the third stage motor should not be used without correcting for joint rotation.
6. It is recommended that further analysis be performed to establish models for stiffness evaluation of Minuteman missile joints.

USE FOR TYPEWRITTEN MATERIAL ONLY

TABLE 1.4-1 SUMMARY

TEST NUMBER	TEST DATE	TEST SPECIMEN	TEST CONDITIONS	MAXIMUM APPLIED T		
				P _{kips}	M _{in-kips}	V _{kt}
332-L	7-9-68	R/S FRUSTUM & SHROUD MOD 7E, MGS, PBPS STAGE III FWD. SKIRT	SILO LAUNCH (STAGE I IGNITION)	54.63	---	---
333-L	7-18-68	R/S FRUSTUM & SHROUD MGS, PBPS, STAGE III FWD SKIRT	SILO LAUNCH TO DESTRUCTION	76.8	---	---
332-F (a)	6-20-68	R/S FRUSTUM & SHROUD,	WIND SHEAR (MAX qα)	15.2	827	12.7
332-F (b)	6-18-68	MOD 7E, MGS, PEPS, STAGE III MOTOR	WIND SHEAR (MAX qα)	15.2	841	12.8
333-F	6-5-68 PHASE I	R/S FRUSTUM & SHROUD, MGS, PBPS, STAGE III MOTOR	WIND SHEAR (MAX qα) MAX. AXIAL LOAD FACTOR STAGE II IGNITION (58.6 SEC)	20.9 18.5 26.0	1460.8 526.6 754.1	15.4 5.1 8.3
	6-11-68 PHASE II	R/S FRUSTUM, MGS, PBPS, STAGE III MOTOR	STAGE II IGNITION (68.6 SEC) STAGE II BURNOUT STAGE III IGNITION STAGE III THRUST TERM.	25.0 12.9 20.55 22.11	755.0 15.5 186.2 41.76	8.2 0.9 1.7 0.3
	6-25-68 DESTRUCT	SAME AS FOR PROGRAM- MED TEST, PHASE I	DESTRUCTION	24.81	1535	16.3
345-F	4-10-68	STAGE III MOTOR, II-III INTERSTAGE STAGE II FWD SKIRT	WIND SHEAR (MAX qα) MAX. AXIAL LOAD FACTOR STAGE II IGNITION STAGE II BURNOUT	68.2 88.2 106.9 50	2530 650 1122 227	10.3 2.3 3.9 0.0
		SAME AS FOR PROGRAM- MED TEST	DESTRUCTION	87.6	3291	13.3

1 ▽ STAGE III MOTOR INTERNAL PRESSURE

2 ▽ A TEST NUMBER SCHEME WAS ESTABLISHED BASED ON THE FOLLOWING EXAMPLE:

332-L
 └── SILO LAUNCH CONDITION
 └── SECTION 32 (MOD 7E) INCLUDED
 └── MINUTEMAN III MISSILE

A

SUMMARY OF TEST PROGRAM

LOADS APPLIED TEST LOADS						HEAT	FAILURE LOCATION	REPORT SECTION
W in-kips	V kips	R ₁ psi	P psi	AZIMUTH	STATION			
---	---	---	22.14	---	219.3"	NO	NONE	2.0
---	---	---	30.80	---	225.3"	NO	BUCKLING IN THE MGS, PBPS AND STAGE III FWD.	3.0
27	12.75	28	---	0° 0'	225.3"	NO	NONE	4.0
41	12.83	28	---	36° 30'	225.3"	NO	NONE	4.0
60.8	15.4	28	---	36° 30'	257.4"	YES	NONE DURING PROGRAMMED PORTION	5.0
26.6	5.5	28	---	36° 30'	257.4"	YES		
54.1	8.1	28	---	36° 30'	257.4"	YES		
55.0	8.2	28	---	36° 30'	257.4"	YES		
15.5	0.93	28	---	36° 30'	257.4"	YES		
26.2	1.73	561	---	36° 30'	257.4"	YES		
41.76	0.376	628	---	36° 30'	257.4"	---	---	---
35	16.1	28	---	36° 30'	257.4"	NO	AFT END OF STAGE III MOTOR CASE	---
30	10.32	28	---	70°	359"	YES	NONE	6.0
50	2.9	28	---	70°	359"	YES		
22	3.53	28	---	70°	359"	YES		
27	0.0	28	---	70°	359"	YES		
91	13.3	28	---	70°	359"	NO		

B

USE FOR DRAWING AND HANDPRINTING — NO TYPEWRITTEN MATERIAL

MISSILE SECTION	TEST	MISSILE SITUATION	MAX. LINE LOAD AZIMUTH	MAX. APPLIED LOADS				
				FLIGHT COND.		LAUNCH COND.		
				P (kip)	M (in-kip)	V (kip)	F (kip)	P (psi)
SHROUD	333-F FAILURE	221.6	36° 30'	14.78	959.1	16.1	55.9	30.80
	333-L FAILURE	221.6	36° 30'	17.0	265.3	5.6		
FRUSTUM	333-F PROG PHASE I	221.6	36° 30'				21.2	
	333-L FAILURE	221.6	36° 30'					
MOD 7E	332-F (a)	225.3	0°	15.2	827	12.75	54.8	22.4
	332-L	225.3	0°					
MGS	333-F FAILURE	238.5	36° 30'	21.51	1231	16.1	79.1	31.28
	333-L FAILURE	238.5	36° 30'					
PBPS	333-F FAILURE	257.4	36° 30'	24.81	1535	16.1	82.4	32.0
	333-L FAILURE	257.4	36° 30'					
STG III FWD SKIRT	333-L FAILURE	272.0	36° 30'	24.81	1535	16.1	82.4	32.5
	333-L FAILURE	272.0	36° 30'					
STG III MOTOR	333-F FAILURE	320.8	36° 30'	63.82	2556	16.1		
	345-F FAILURE	320.8	70°	87.60	2763	13.3		
II-III INTERSTG	345-F FAILURE	359.0	70°	87.6	3251	13.3		

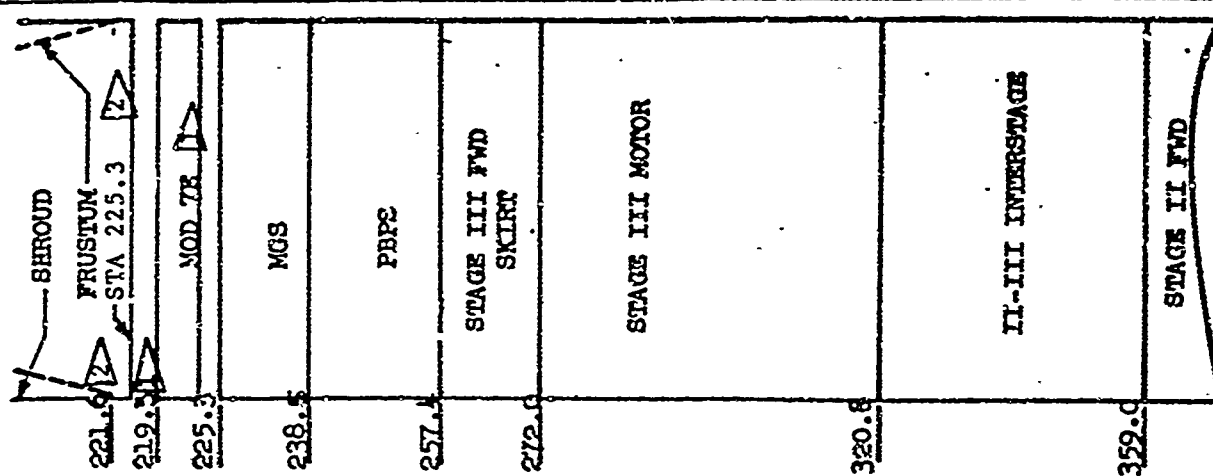

TABLE 1.4.-2
332-L&F CONFIGURATION ONLY
FOR 333 CONFIGURATIONS
MAXIMUM APPLIED LOADS BY SECTION

1.5 TEST OBJECTIVES

The test objectives were:

- a. To confirm that the Stage III/PBV primary structures are structurally compatible in the launch and powered flight environment and that the Stage II/II-III Interstage/Stage III structures are structurally compatible in the powered flight environment.
- b. To determine the ultimate capability of the test specimen by continuing to increase the loads for the critical condition until the specimen fails.
- c. To obtain the load-deflection characteristics of the test specimen.

1.6 TEST FACILITIES

The tests were conducted at Boeing Structures Laboratory Facilities Kent, Washington by the Structural Test Engineering Group with technical assistance from Boeing Minuteman Structures Technology.

1.7 TEST DATA

All instrumentation data and monitored loads were recorded and reduced by the aid of a computer. The recorded data is shown in T2-3656-1 through -4 (reference 2) and T2-3657-2 (reference 3) and T2-3657-3 (reference 4). Only selected data is shown plotted in this document. All strain gage data shown in this document are the incremental strains (converted to stress) from an original condition at which the strain gages were zeroed. The test procedure paragraph in each section indicates the zero gage reading condition. In all cases, the effect of the PBCS internal dead weights has been zeroed out. Data obtained before and after installing these dead weights is given in the data reports (references 2, 3 and 4). In all plots of stress vs. test load, the test load is the planned percentage of test load at that increment at which the gages were read. Actual test loads at these increments are shown in the test condition subsections. The above considerations generally had negligible effects on the results of this document though, where they were significant, they were included.

USE FOR TYPEWRITTEN MATERIAL ONLY

2.0 STAGE III/PBV R&D LAUNCH CONDITION TESTS (332-L)

2.1 TEST SPECIMEN

The 332-L Test Specimen consisted of the aft section of the R/S including a portion of the Shroud (G.E. part number 67J53362G1, S/N G031B), the R/S Frustum (67J55705G1, S/N G031B) and a V-Band Assembly (67J54865, S/N G031B). Also included were a Mod 7E wafer (25-61767-20), an MGS section (Autonetics part number 8537-4000C1-1, S/N BTU 0200), a PBPS section (Autonetics 8537-5000C1-1, S/N A4X0009), a Stage III/FIV Separation Joint (25-60282-1, S/N 0000017), a Stage III Motor Forward Skirt (AGC 1143927) and an operational Stage III forward R/W cap (25-62157-1) with attach base (AGC 1146695-7). Figures 2.1-1 thru 2.1-10 show the test specimen which was complete in all details affecting structural strength, stiffness and load distribution except for the omission of insulation. The assembled integrated specimen is shown in Figure 2.2-3. A cross section of the specimen giving the dimensional survey locations is shown in Figure 2.1-11 and the dimensional survey is shown in Tables 2.1-1 thru 2.1-5.

2.2 TEST SETUP

Figure 2.2-1 shows a schematic of the test setup. The complete specimen with load adaptors was enclosed in a pressure tank (shown in Figure 2.2-2). The setup with the pressure tank omitted is shown in Figure 2.2-3. Pressurized water, between the tank and sealed specimen, provided the overpressure loads. This water pressure acting vertically on the Shroud and Shroud adaptor provided 100% of the shroud axial compression load. The Frustum axial load was supplied by a vertical pressure component acting on the Frustum load adaptor and by an internal jack loading thru an evenner system. Lead weights applied constant axial load to the internal structure of the PBCS. The pressure and jack loads were controlled by a manually operated servo control system.

2.3 TEST INSTRUMENTATION

Strain gage channels were located and identified as shown in Figures 2.3-1 thru 2.3-5. Photographs of selected strain gage installations are given in Figures 2.3-6 thru 2.3-12. Test data were recorded at each increment of applied load and are shown in reference 3.

2.4 TEST CONDITIONS

The Launch condition loads of axial compression and overpressure were applied in increments to 100% of test load (from reference 1). The PBCS internal structure was loaded with 2.0 kips on the MGS bulkhead and 3.3 kips suspended from the PBPS internal beams. The test setup load geometry is shown in Figure 2.4-1. Figures 2.4-2 thru 2.4-6 present the planned and actual test loads of overpressure and compression.

USE FOR TYPEWRITTEN MATERIAL ONLY

2.5 TEST PROCEDURE

The strain gages were zeroed, with the internal dead weights and the load heads on the specimen, prior to filling the tank with water. Two hours and 20 minutes later the strain gages were read after the tank had been filled. The test was then run in increments to 100% load (from reference 1). After unloading the pressure and compression loads, zero load gage readings were taken. The gages were again read after the water was drained.

2.6 TEST RESULTS

Selected strain gage data are shown plotted in Figures 2.6-1 thru 2.6-9. A tabulation of all test data acquired is given in reference 3. The strain gage data and visual inspection verified that the specimen had successfully sustained the test loads without loss of structural capability.

2.7 TEST CONCLUSIONS

This test, on the R & D configuration, showed that the R/S/Mod 7E/MGS specimen was capable of withstanding 100% of the launch load environment specified in reference 1. The relatively low stresses in the Mod 7E and a comparison of the stresses in the adjacent structures in this test with their stress levels in the 333-L failure test (see section 3.6) indicates that a minimum gage R & D specimen could also sustain these loads and would have an ultimate capability similar to the operational configuration.

USE FOR TYPEWRITTEN MATERIAL ONLY

USE FOR TYPEWRITTEN MATERIAL ONLY

2.1 TEST SPECIMEN

SHEET 202

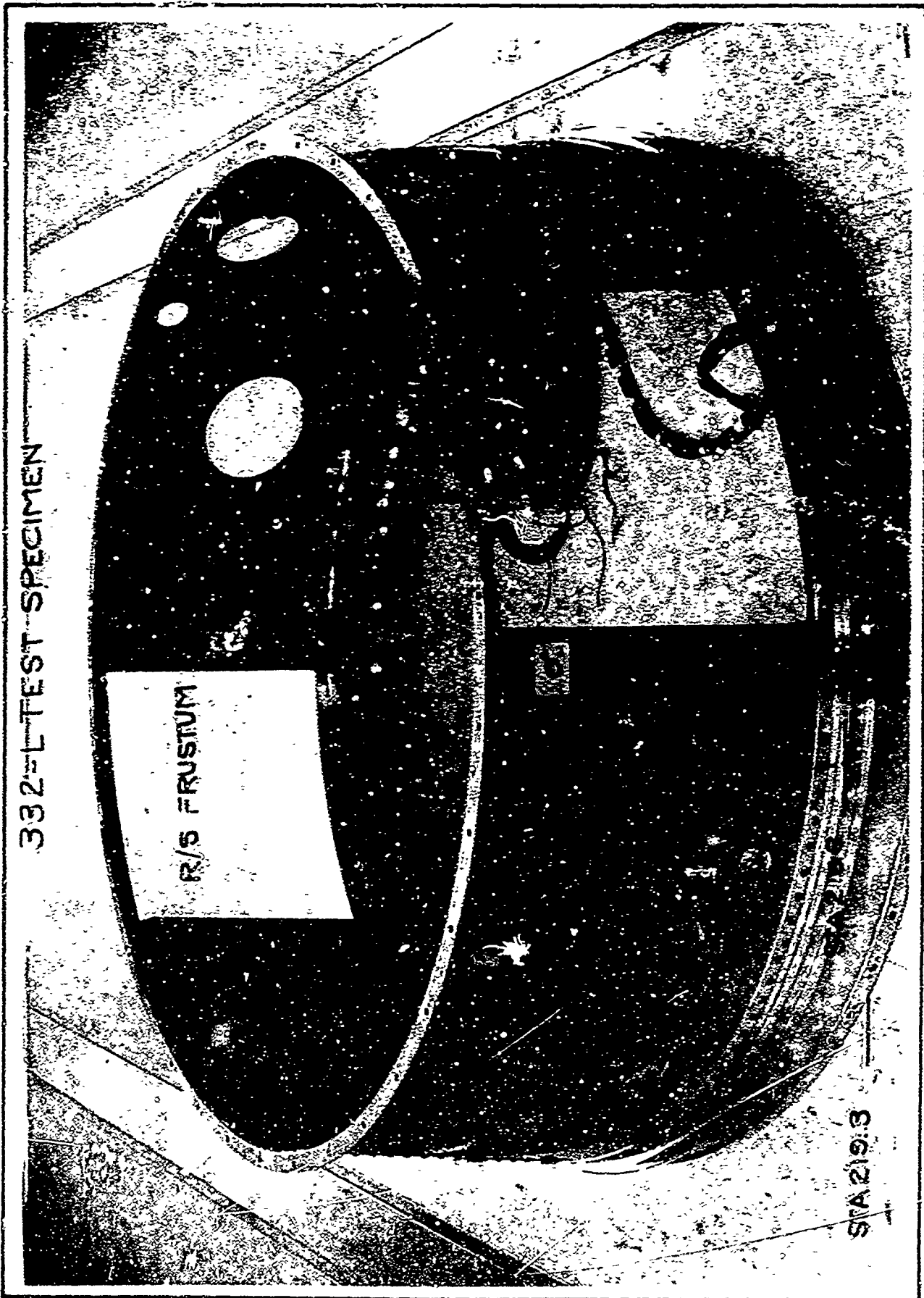

332-L TEST SPECIMEN

R/S FRUSTUM

STA 219.3





SHEET 204

FIG. 2.1-2



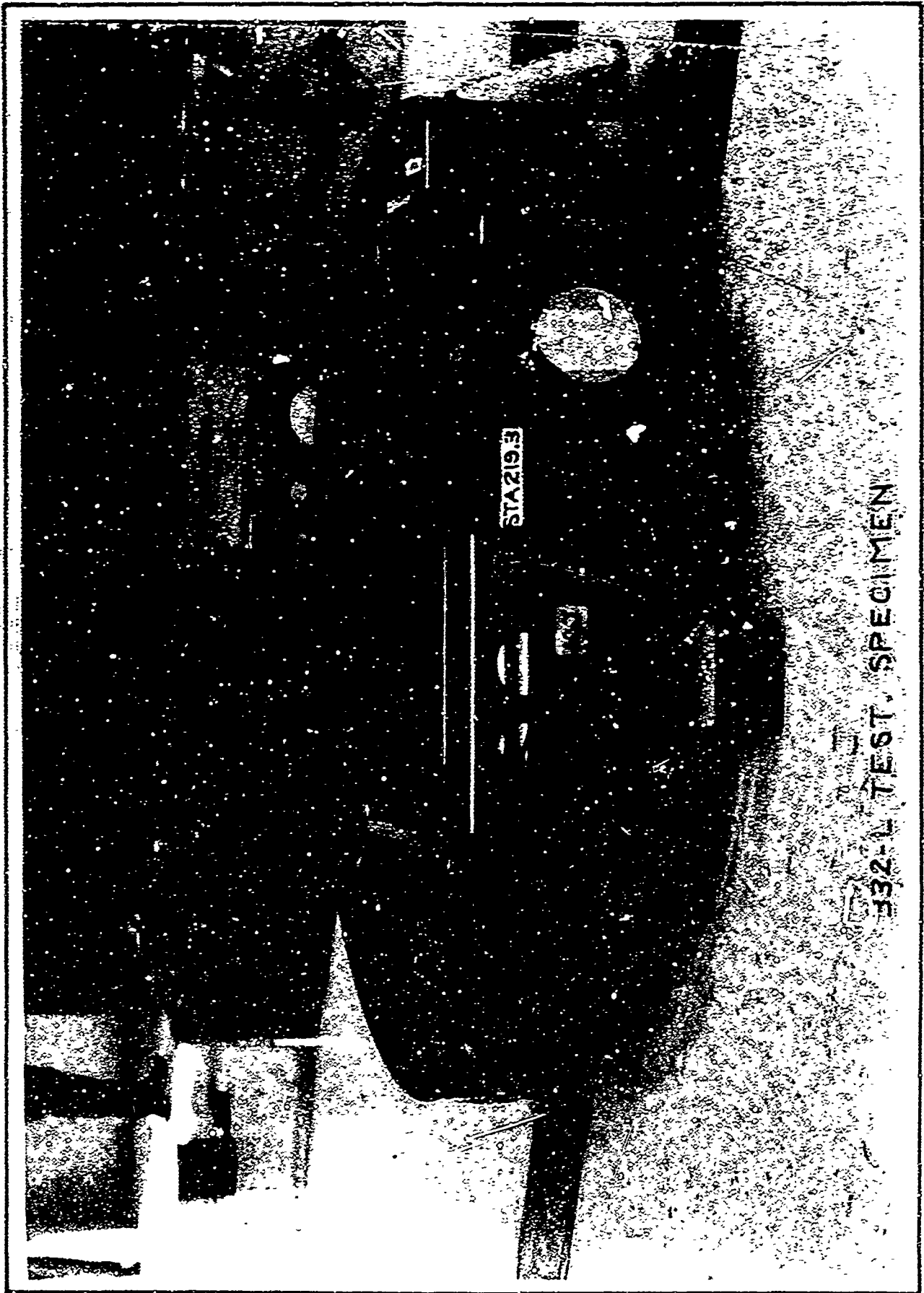

132-1 TEST SPECIMEN

SHEET 205

FIG. 2.1-3



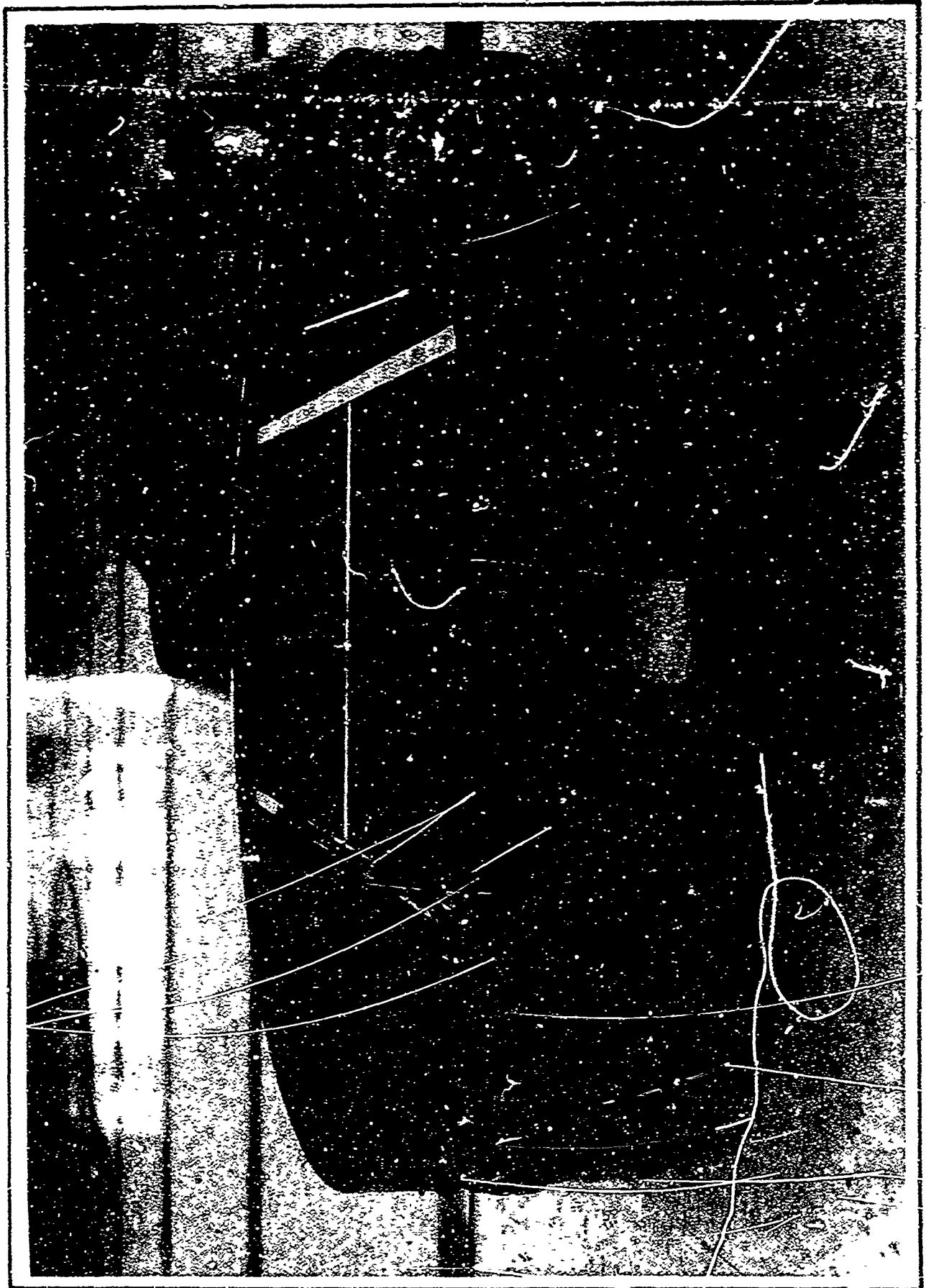

SHEET 206

FIG. 2.1-4





SHEET 207

FIG. 2.1-5



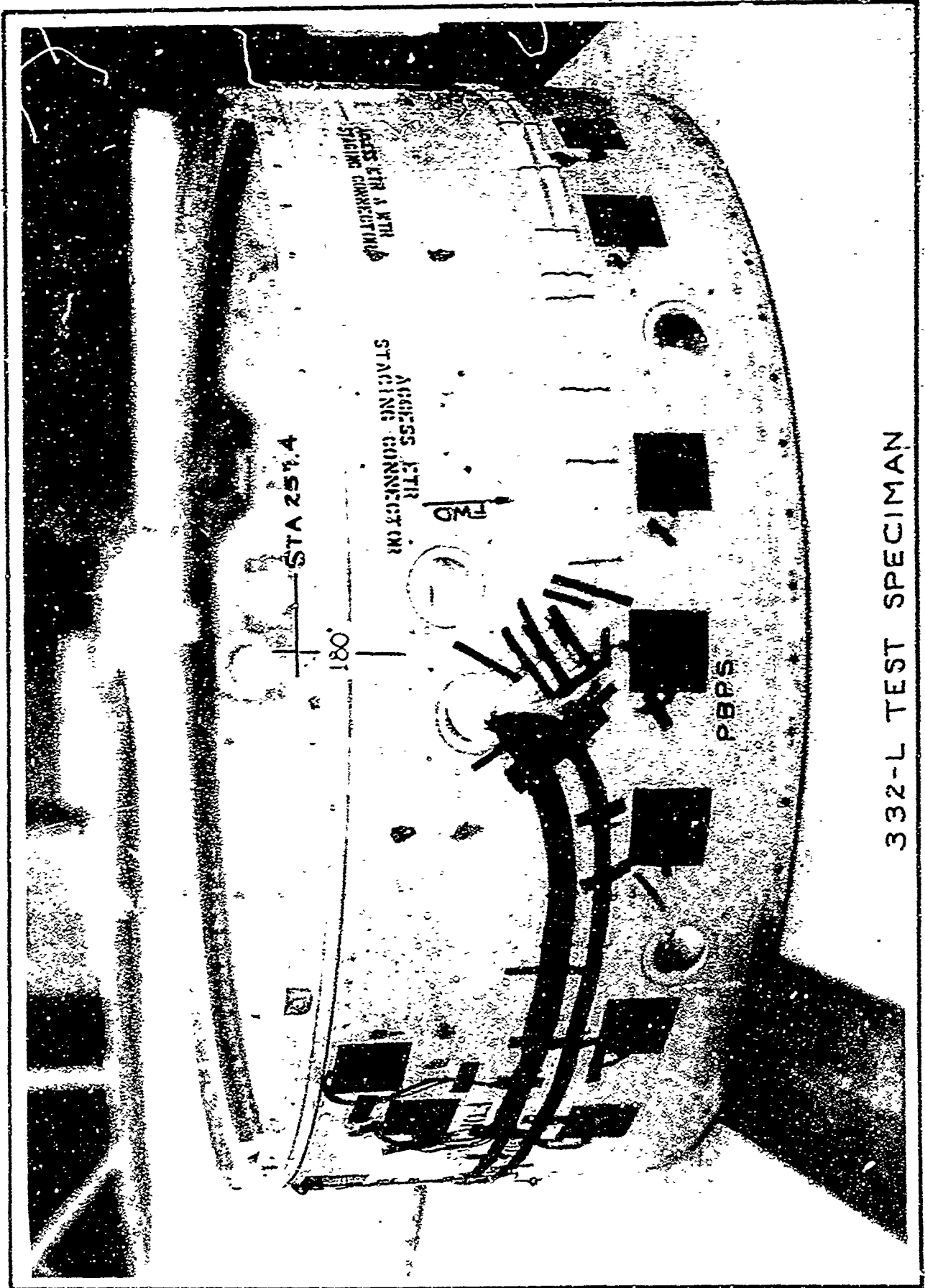

332-L TEST SPECIMAN





SHEET 209

FIG. 2.1-7





SHEET 210

FIG. 2.1-8



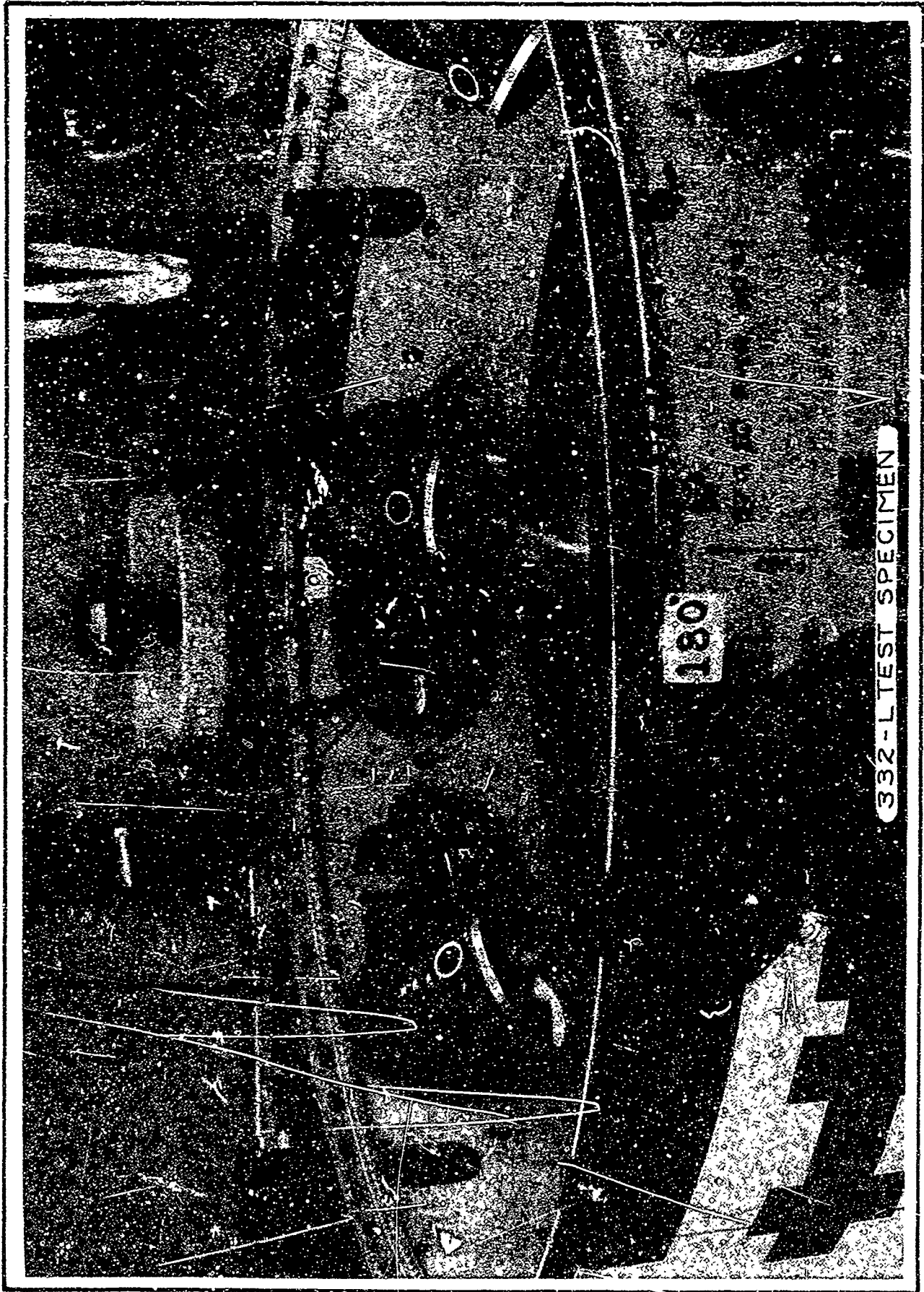

SHEET 211

FIG. 2.1-9



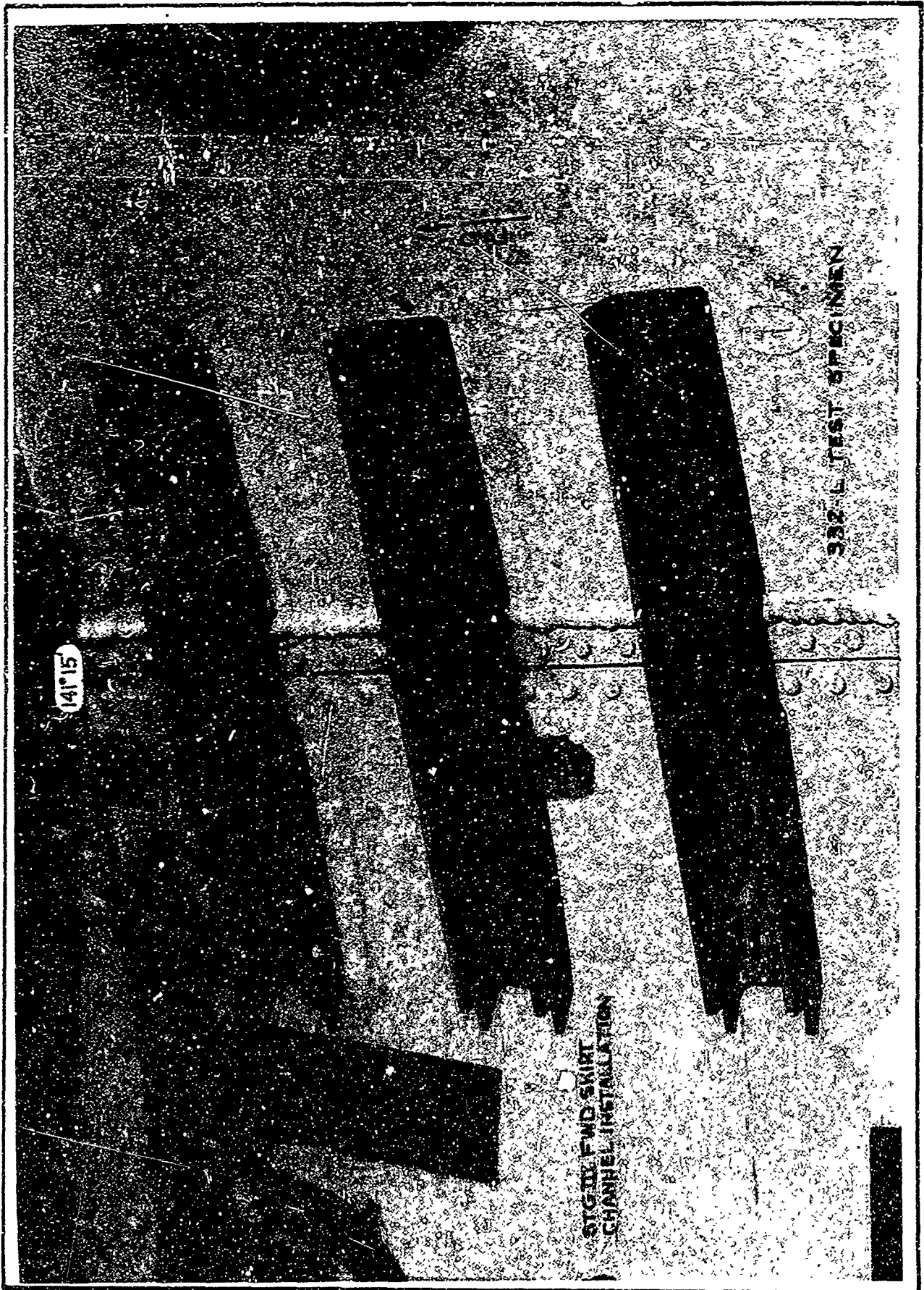

14115

332-L TEST SPECIMEN

STGIII FWD SKIRT
CHANNEL INSTALLATION

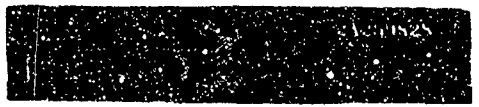

USE FOR DRAWING AND HANDPRINTING — NO TYPEWRITTEN MATERIAL

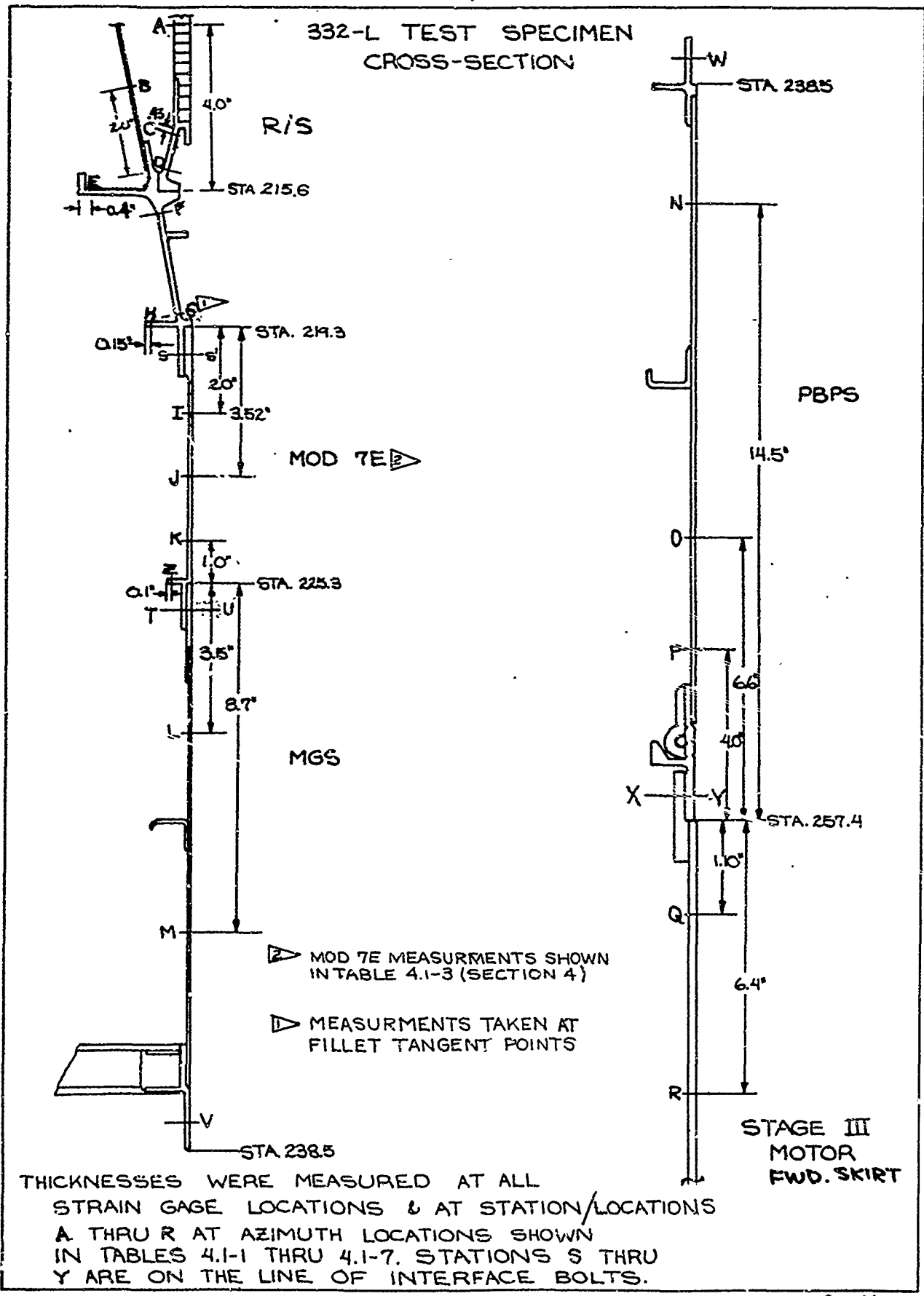

MGS SECTION S/N BTU 0200 LAUNCH										
LOCATION IN DEGREES	STRAIN GAGE NO.	STA. L 228.8	STRAIN GAGE NO.	STA M 234.0	STA U FWD RING	STA V AFT RING				
0	300	.100	301	.100	.092	.106				
20	302	.100		.100						
37	303	.101	304	.101						
56	305	.101		.102						
60					.101	.107				
73	306	.101		.101						
90	307	.101	308	.100						
107	309	.101		.101						
120					.107	.109				
124	310	.101		.101						
142	311	.101		.101						
160	312	.101		.101						
180	313	.102	314	.101	.101	.108				
203	315	.101		.101						
240					.089	.116				
255	316	.102		.100						
285	317	.101		.101						
300					.086	.118				
304	318	.100		.100						
322	319	.100		.100						
340	320	.100		.100						

SEE FIGURE 2.1-12 FOR STATION LOCATIONS

STA. 228.0

COPIED	INITIALS	DATE	REV BY INITIALS	DATE	TITLE	MODEL
	KSW	5/16/65			DIMENSIONAL SURVEY MGS SECTIONS - LAUNCH M ² STATIC CONFIRMATION TEST	TABLE 2.1-3
CHECK	SDW	5/21/65				
APPD						
APPD						

REV LTR _____

BOEING NO. T2-3657-1

SH 216

STAGE III FWD SKT - LAUNCH																
INITIALS	DATE	REV BY INITIALS	DATE	TITLE	MODEL	LOCATION DEGREES	S.G. NUMBER	STA. Q	S.G. NUMBER	STA. K						
COD'ED	KSW	KEDGE		DIMENSIONAL SURVEY STAGE III FWD SKT- LAUNCH M ² STATIC CONFIRMATION TEST	TABLE 2.1-5	0°		258.42		263.8	STA. Q FWD. RING	LOCATION DEGREES	S.G. NO.	BTA Q		
CHECK	SDW	SEPG						22°		.157					532	258.42
APPD								67°		.155	501	.156	.128		534	--
APPD								82°		.156	503	.156	.125		533	.156
								97°		.155	504	.156			532	.157
								127°		.156	505	.156			531	.157
								142°		.155	506	.155	.117		530	.156
								143°		.157	507	.157				
								157°		---	508	.157				
								172°		---	517					
								↑	-2.0in.	---						
								↓	-4.0in.	.157						
								↓	-6.0in.	.157						
								↓	-8.5in.	.158						
						172°	-11.0in	.157								
						187°		.157	518	.158						
						202°		.158	519	.158	.120					
						247°		.158	521	.158						
						262°		.158	522	.158	.122					
						277°		.157	523	.158						
						307°		.156	524	.156						
						323°		.157	525	.157	.128					
						337°			526	.157						

REV 1TR

BOEING NO. T2-3657-1
SH 218

USE FOR TYPEWRITTEN MATERIAL ONLY

2.2 TEST SETUP

USE FOR DRAWING AND HANDPRINTING --- NO TYPEWRITTEN MATERIAL.

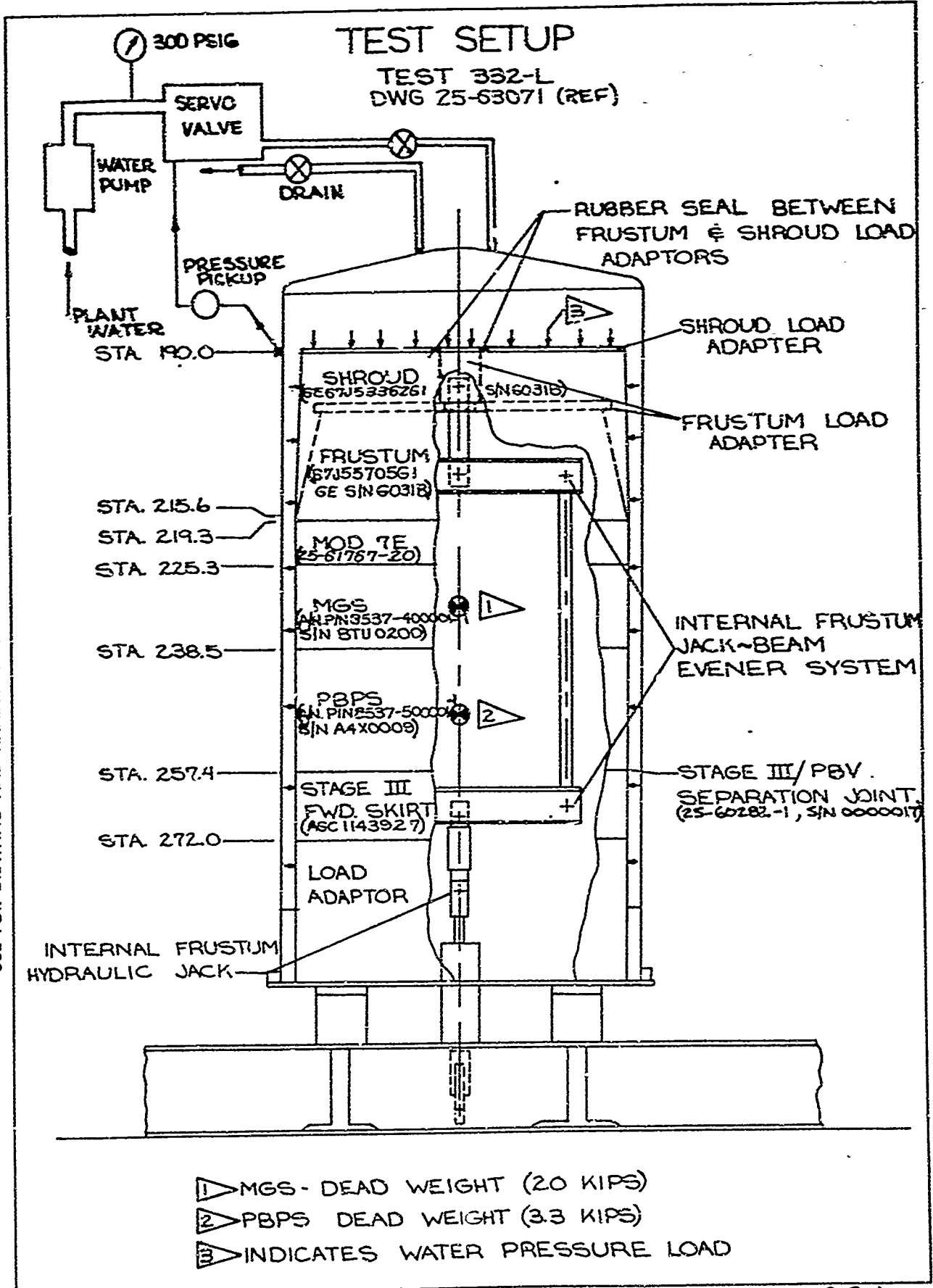

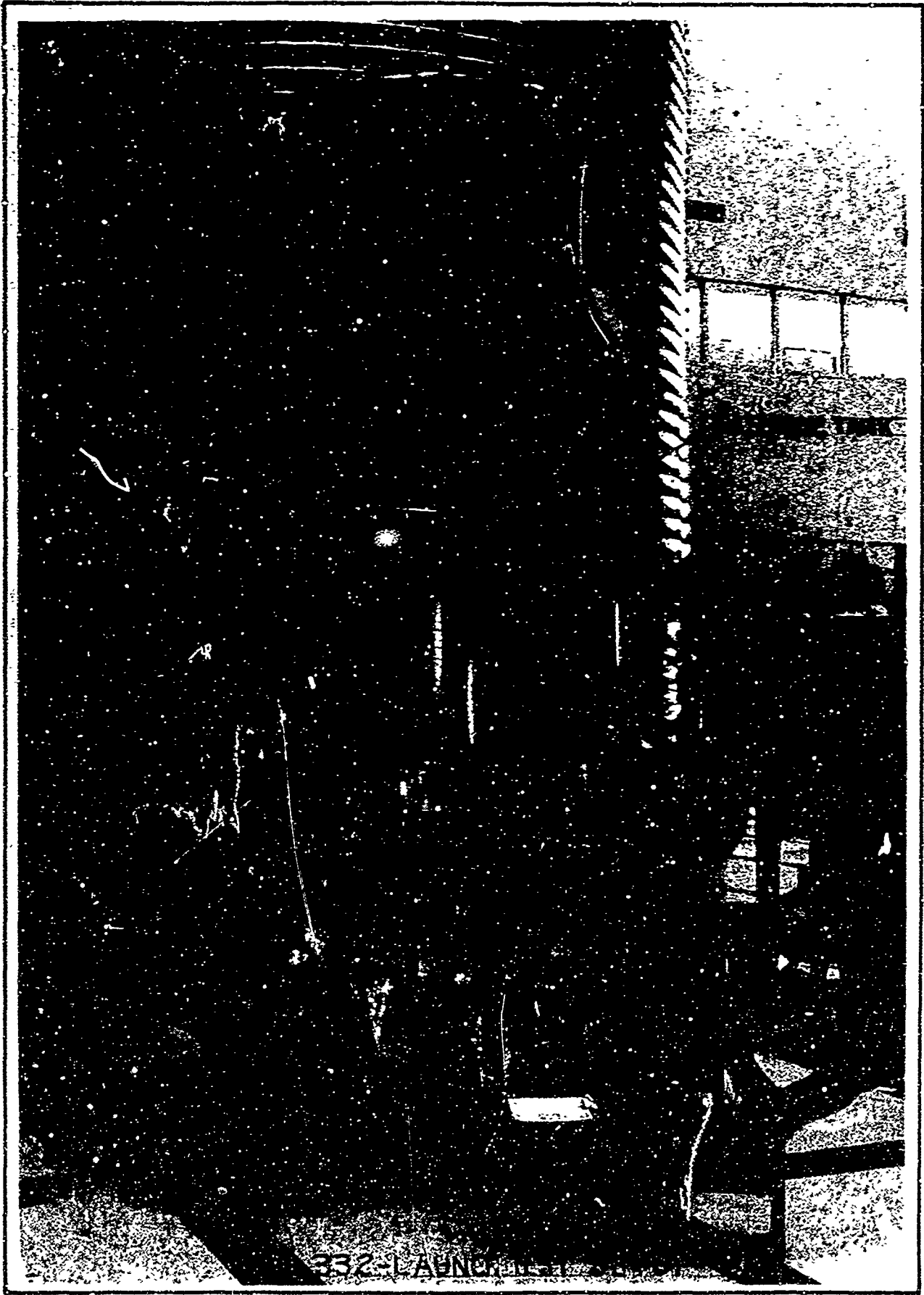

SHEET 221

FIG. 2.2-2





SHEET 222

FIG. 2,2-3

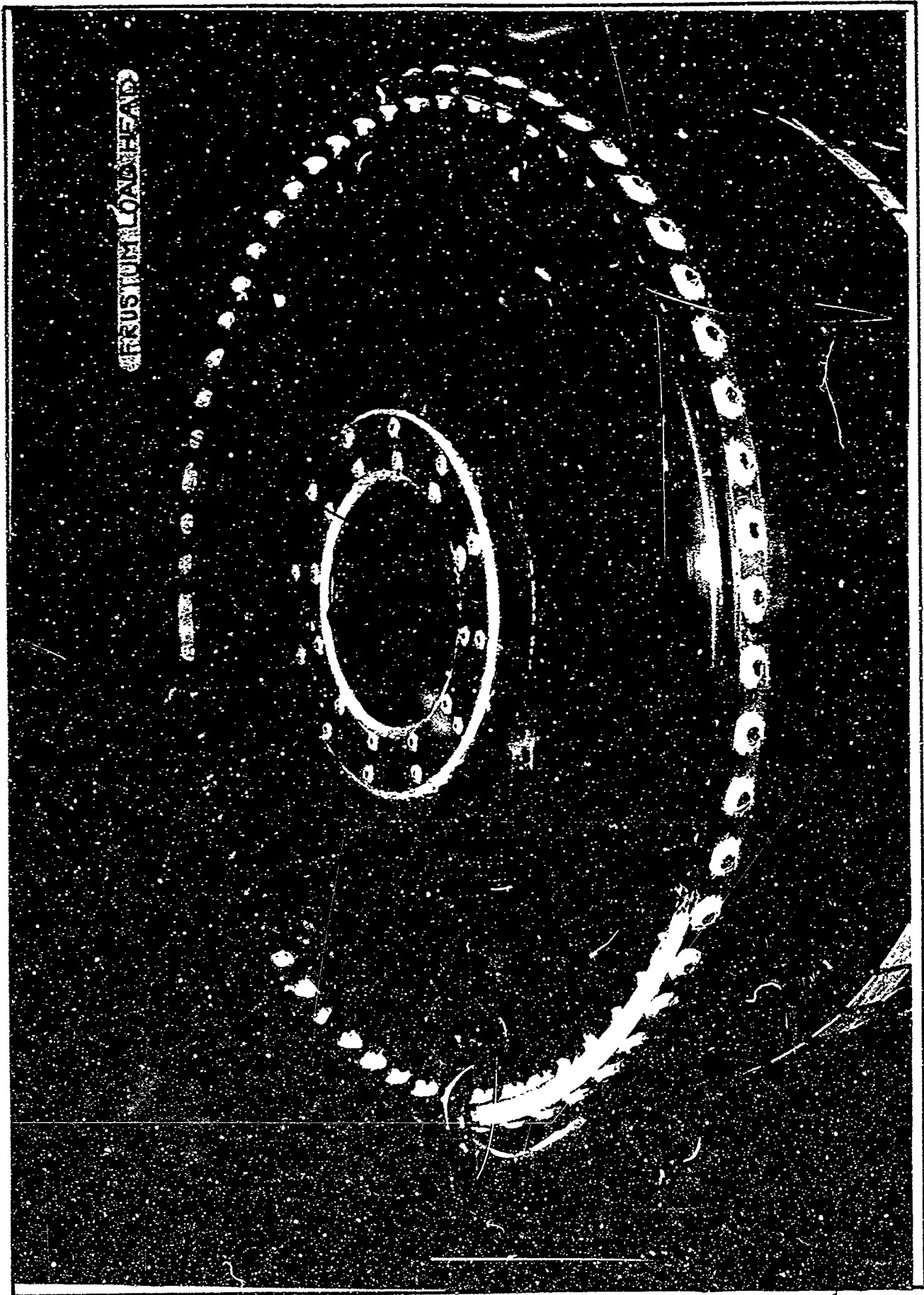

SHEET 223

FIG.2.2-4

USE FOR TYPEWRITTEN MATERIAL ONLY

2.3 TEST INSTRUMENTATION

USE FOR DRAWING AND HANDPRINTING — NO TYPEWRITTEN MATERIAL

R/S FRUSTUM INSTRUMENTATION - TEST #32-L

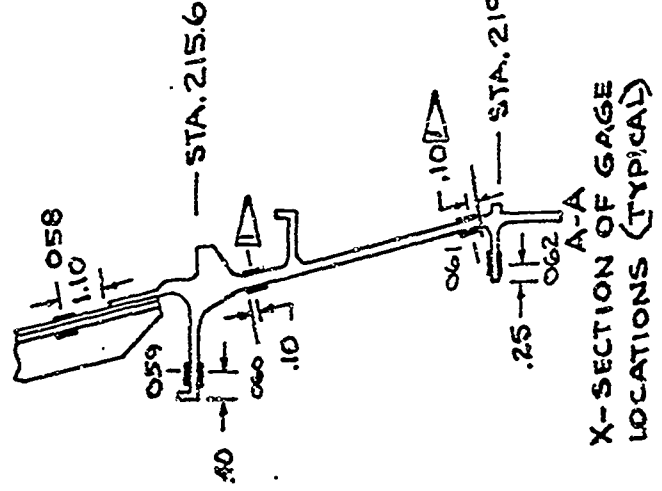
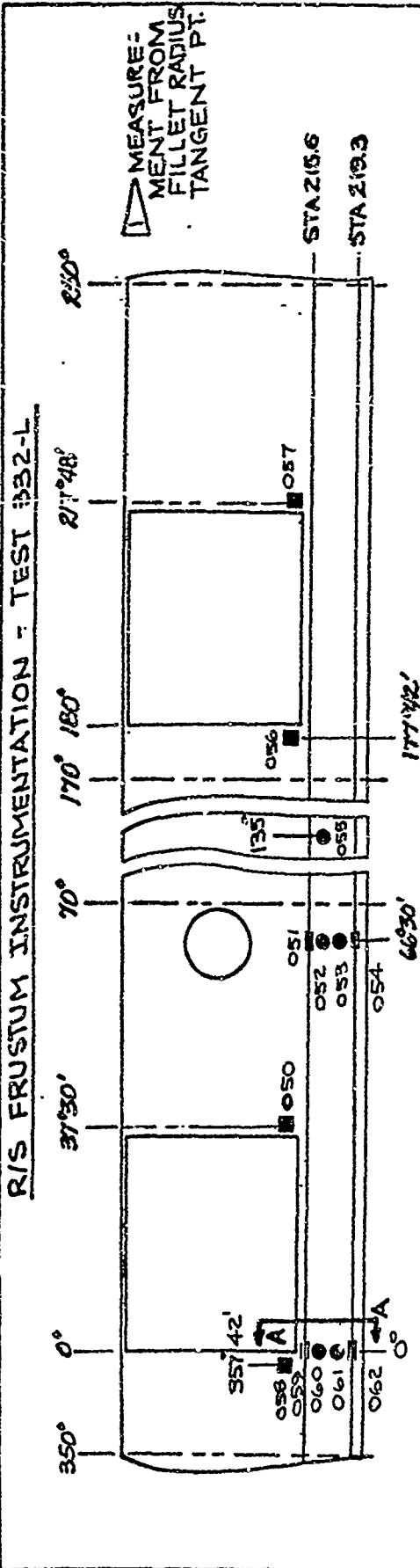

BIAXIAL GAGE DIMENSIONING KEYS:

ALL EXCEPT R/S
DIMENSION

AZIMUTH

R/S
DIMENSION

AZIMUTH

TEST REPORT KEY:

- UNIAxIAL GAGES
- OUTSIDE ONLY
- BACK TO BACK
- BIAXIAL GAGES
- OUTSIDE ONLY
- BACK TO BACK
- CIRCUMFERENTIAL GAGES
- ▷ OUTSIDE ONLY
- = FORE AND AFT ON FLANGES

DATA REPORT KEY:

XXX X X
LOCATION NUMBER

NO LETTER =
OUTSIDE GAGE
I OR I = INSIDE GAGE

A = AXIAL ORIENTATION
C = CIRCUMFERENTIAL ORIENTATION

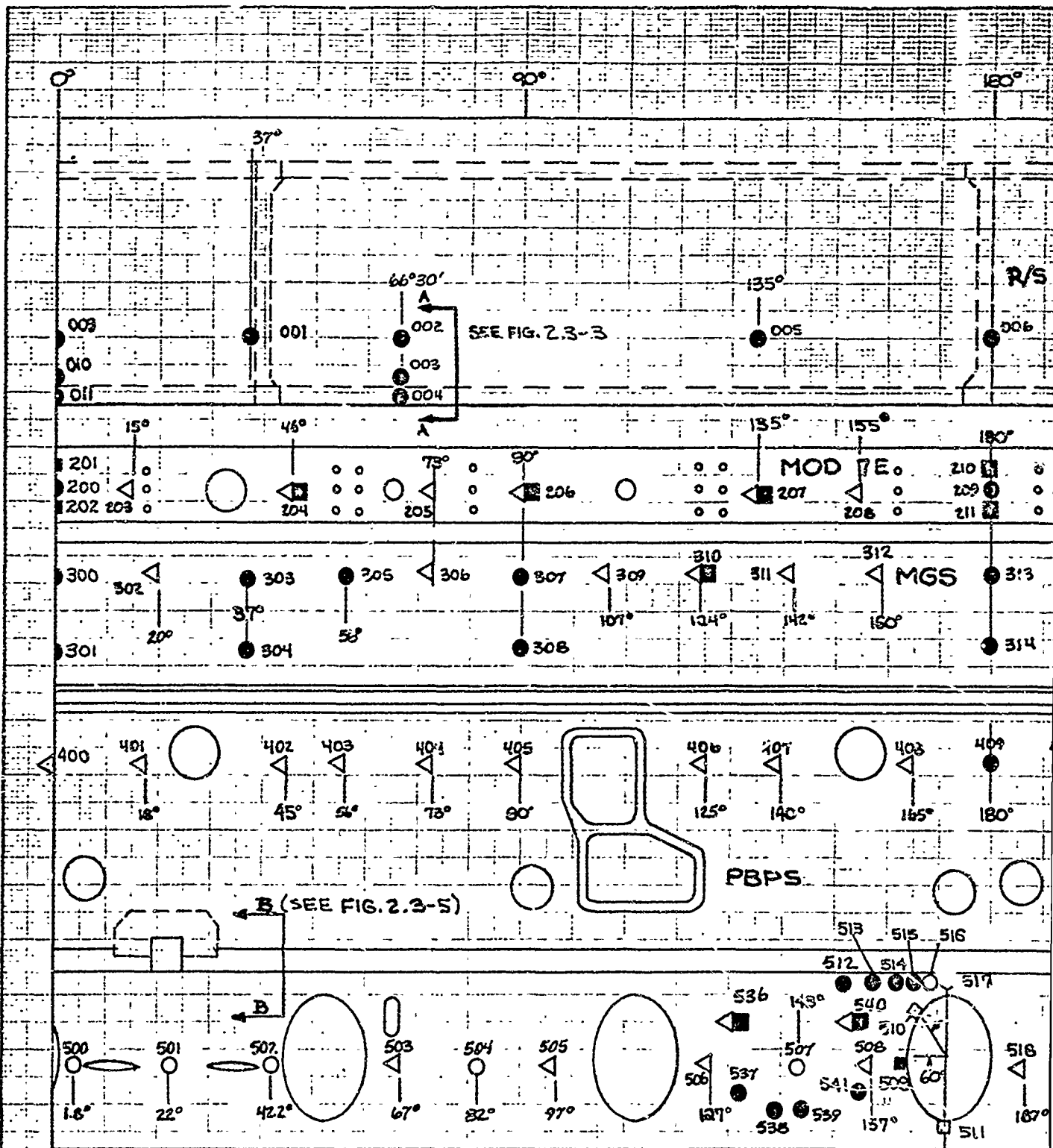

INSTRUMENTATION KEY

LONGITUDINAL STRAIN GAGES:

- ◻ OUTSIDE
- ◼ BACK TO BACK

CIRCUMFERENTIAL STRAIN GAGES:

- ◁ OUTSIDE

BIAxIAL STRAIN GAGES:

- OUTSIDE
- BACK TO BACK

◁ SEE FIGURE 2.3-1 FOR R/S FRUSTUM INSTRUMENTATION

A

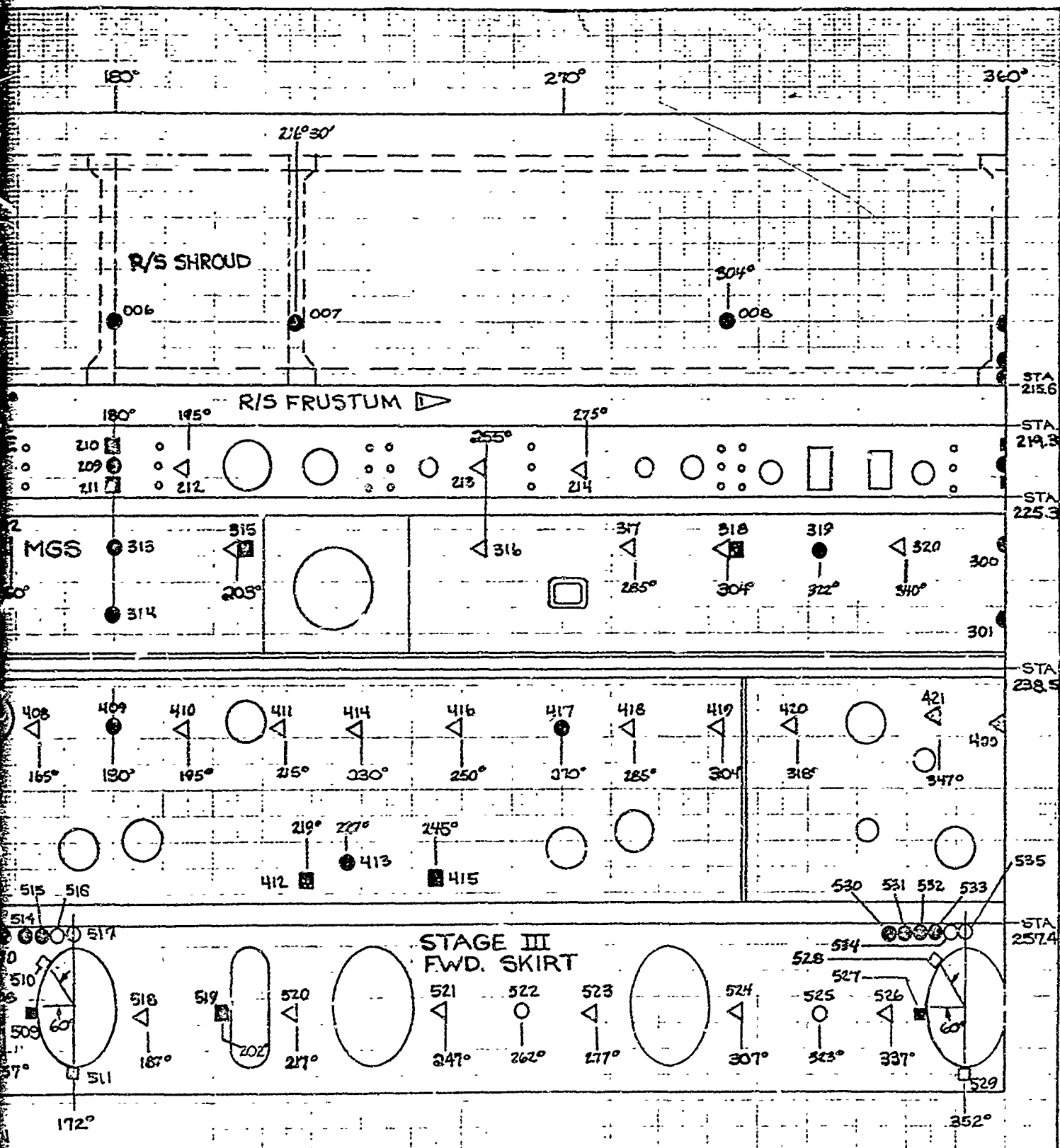

	INITIALS	DATE	R.V. BY INITIALS	DATE	TITLE	MODEL
CALC	<i>RS</i>	7/27/6			332-L TEST INSTRUMENTATION STRAIN GAGE IDENTIFICATION	
CHECK						
APPD						
APPD						

REV LTR _____
U7 4041 7000 REV 6.84

BOEING NO. T2-3657-1
SH 226

FIG. 2.3-2
B

USE FOR DRAWING AND HANDPRINTING — NO TYPEWRITTEN MATERIAL

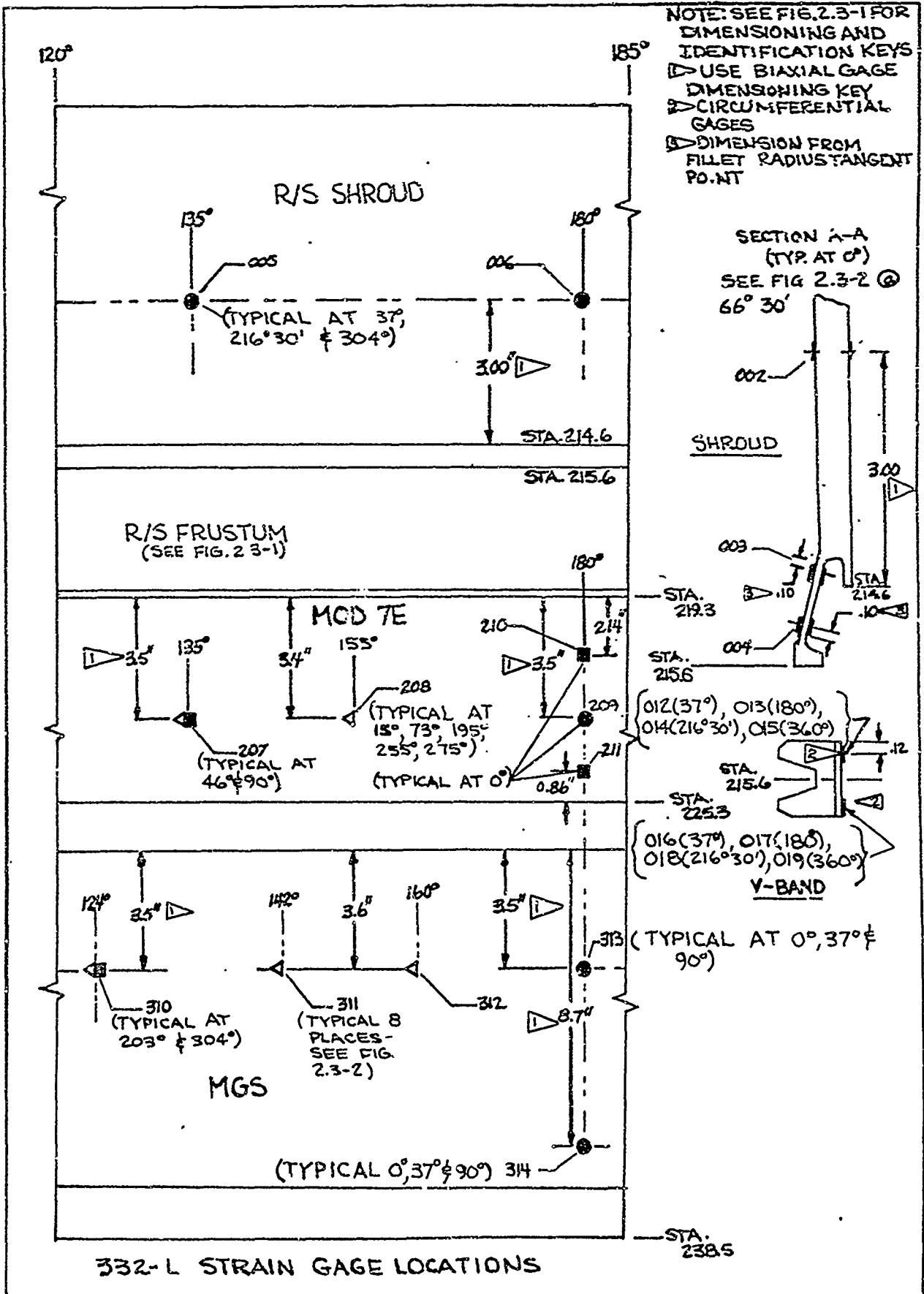

TENT RING
GAGE LOCATIONS

GAGE NO.	422	423	424
AZIMUTH	0°	45°	310°

NOTE: ALL GAGES ARE CIRCUMFERENTIAL
KEY: FORWARD GAGE - C
AFT GAGE - Ci

USE FOR DRAWING AND HANDPRINTING — NO TYPEWRITTEN MATERIAL

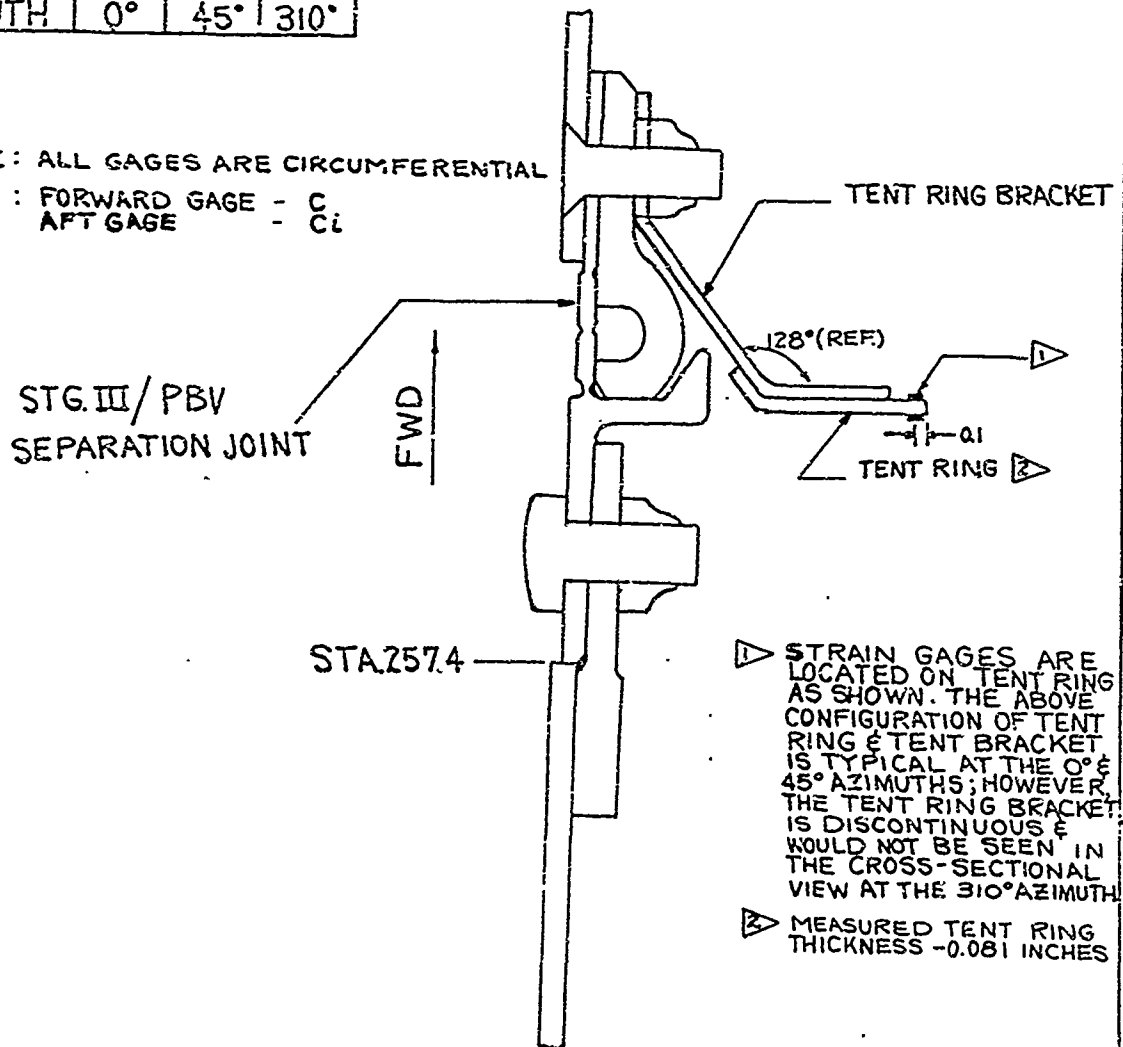

▷ STRAIN GAGES ARE LOCATED ON TENT RING AS SHOWN. THE ABOVE CONFIGURATION OF TENT RING & TENT BRACKET IS TYPICAL AT THE 0° & 45° AZIMUTHS; HOWEVER, THE TENT RING BRACKET IS DISCONTINUOUS & WOULD NOT BE SEEN IN THE CROSS-SECTIONAL VIEW AT THE 310° AZIMUTH.

▷ MEASURED TENT RING THICKNESS -0.081 INCHES

VIEW BB(45°)
(FIG 2.3-2)

332-LAUNCH INSTRUMENTATION
TENT RING

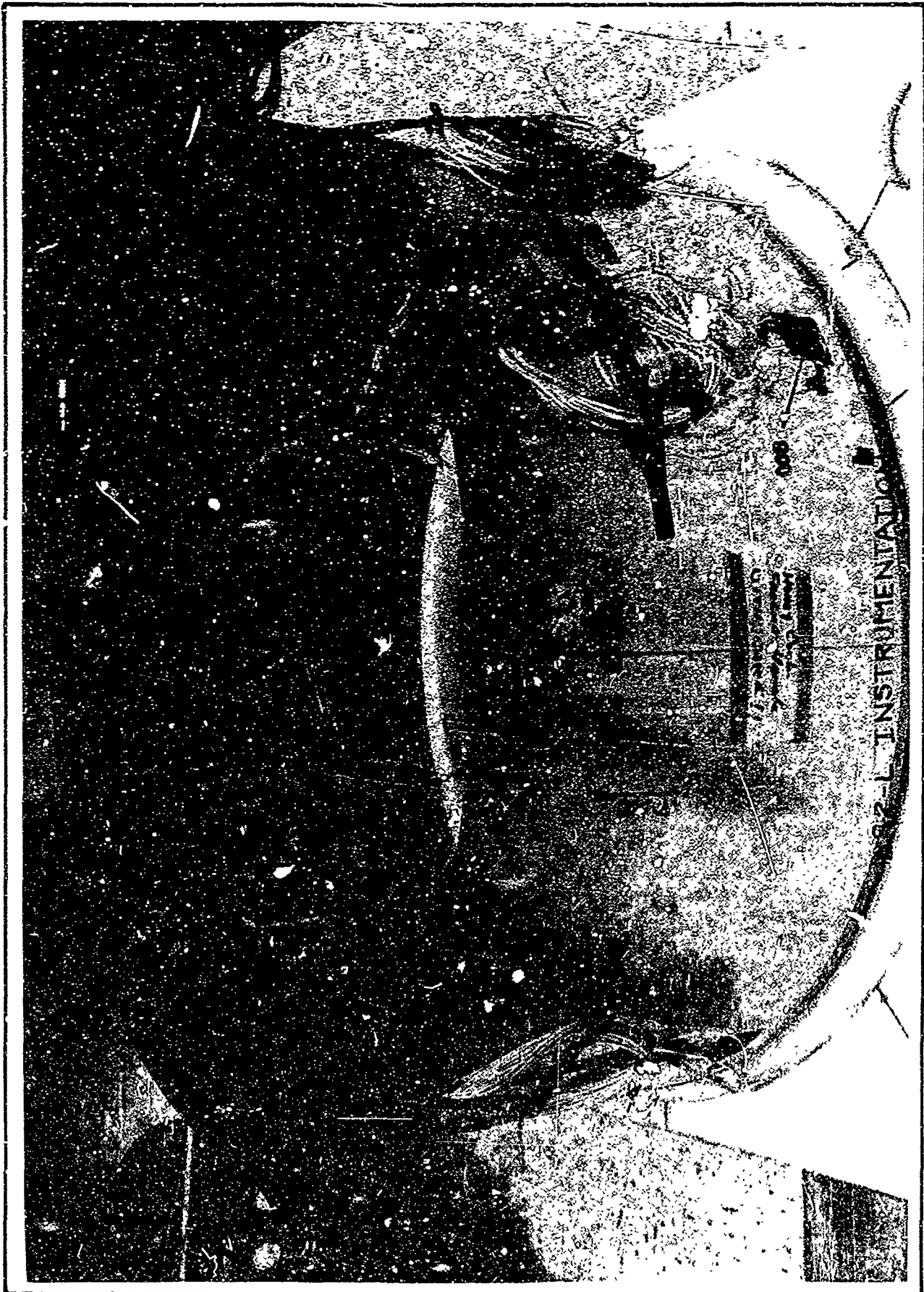

SHEET 230

FIG. 23-6

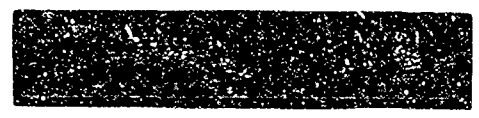

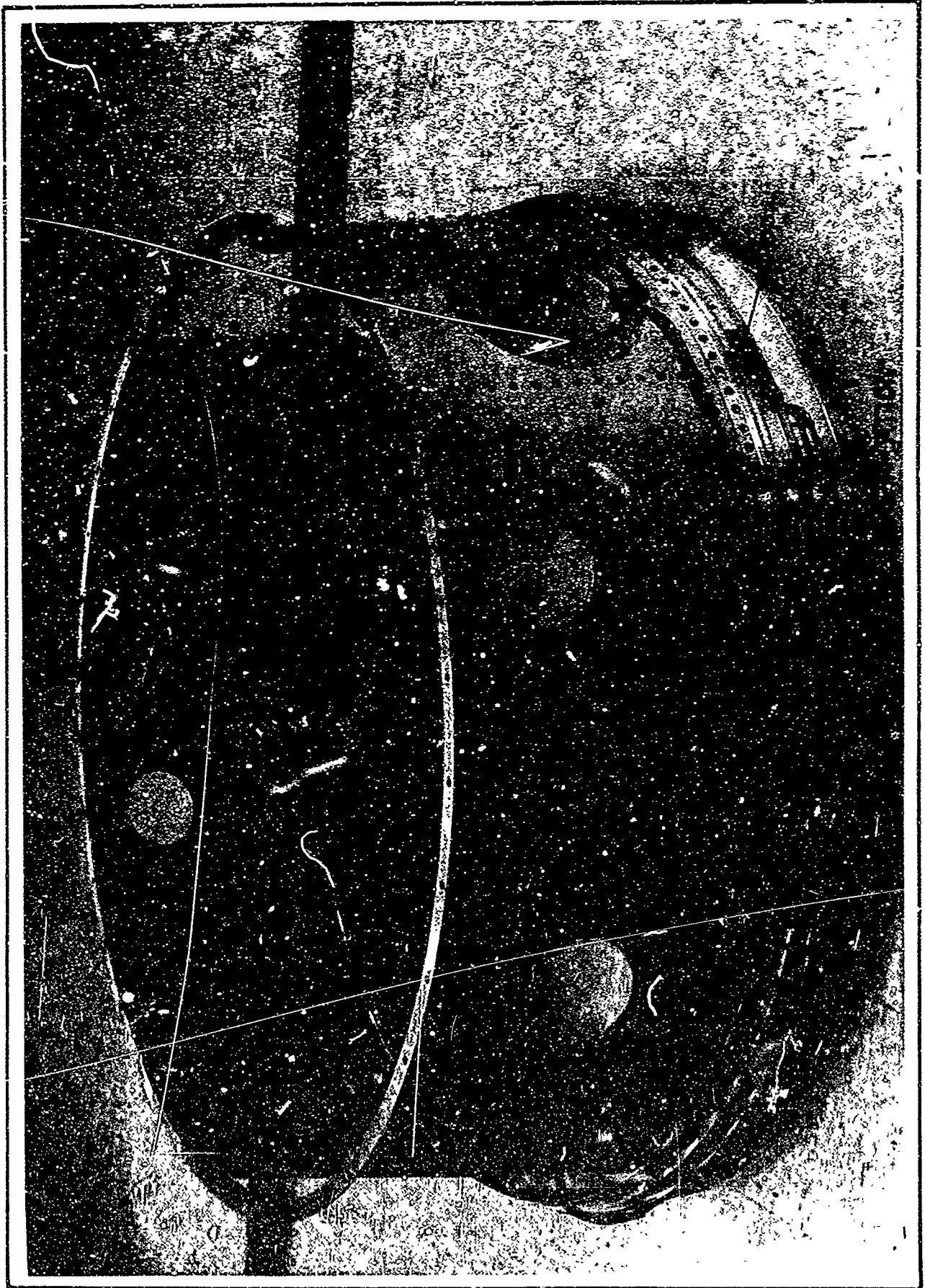

SHEET 231

FIG. 2.3-7



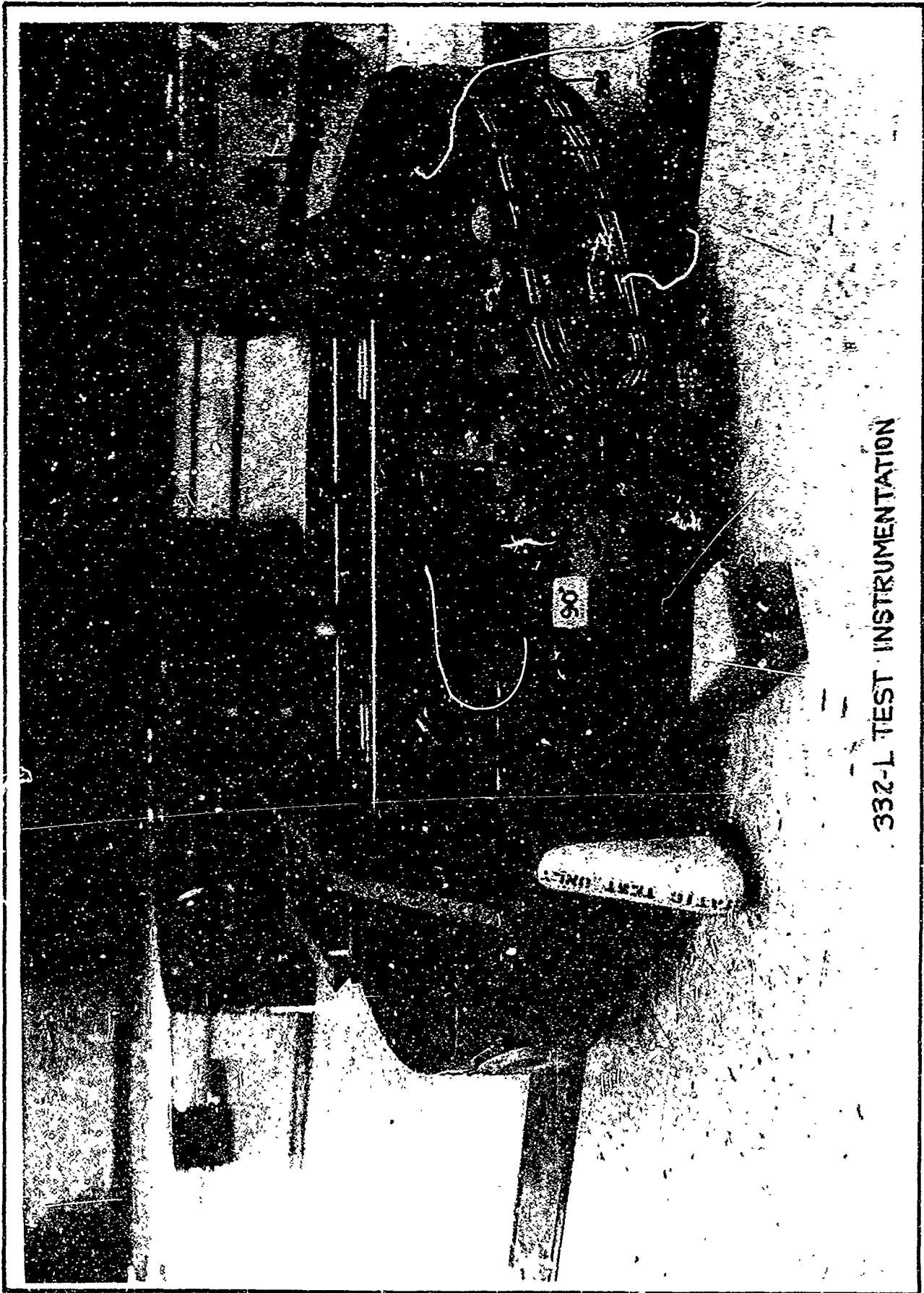

332-L TEST INSTRUMENTATION

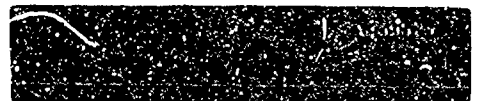

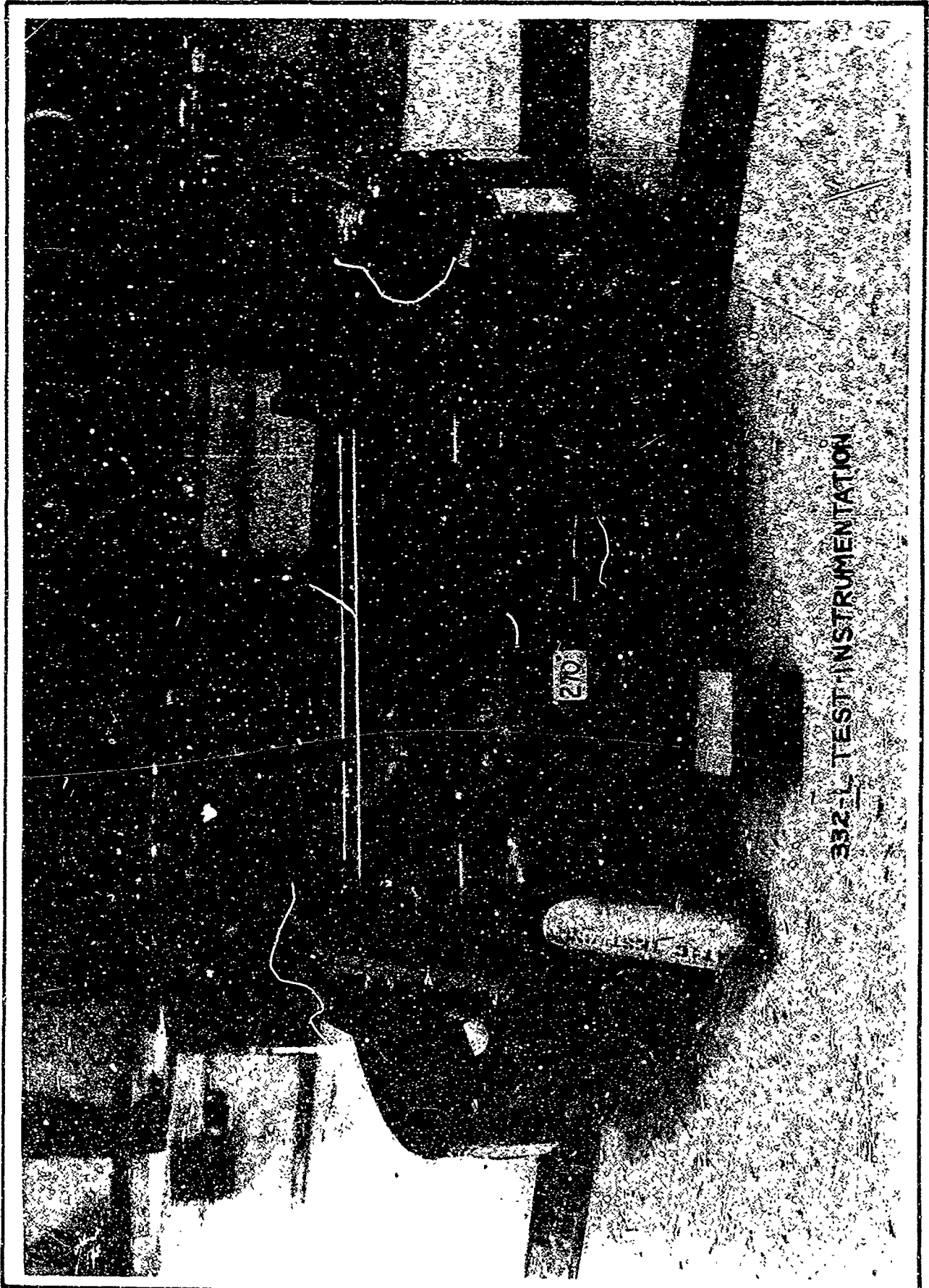

SHEET 233

FIG. 2.3-9

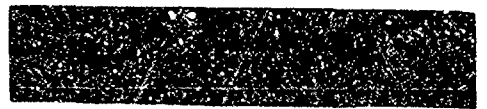

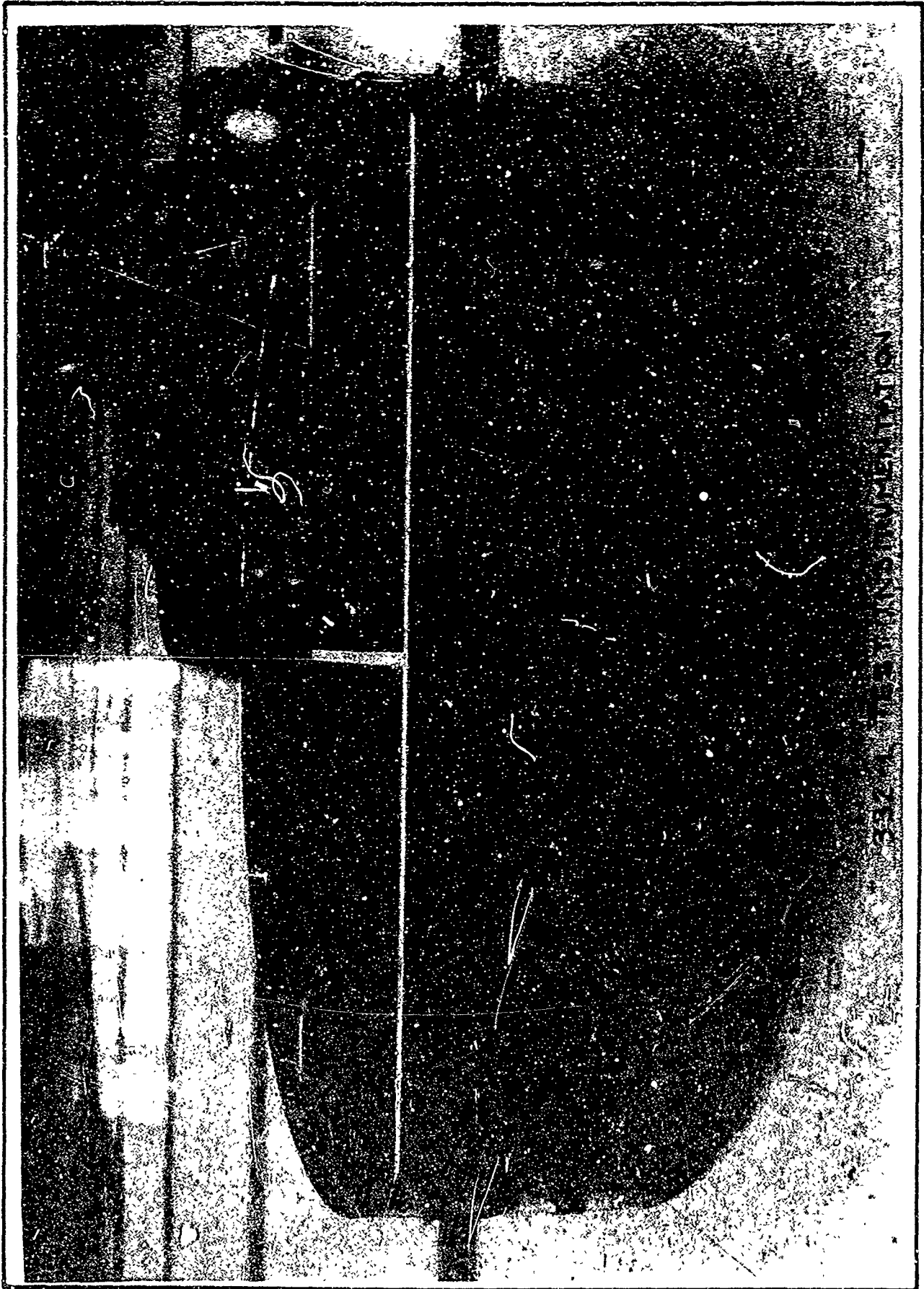

SHEET 234

FIG. 23-10



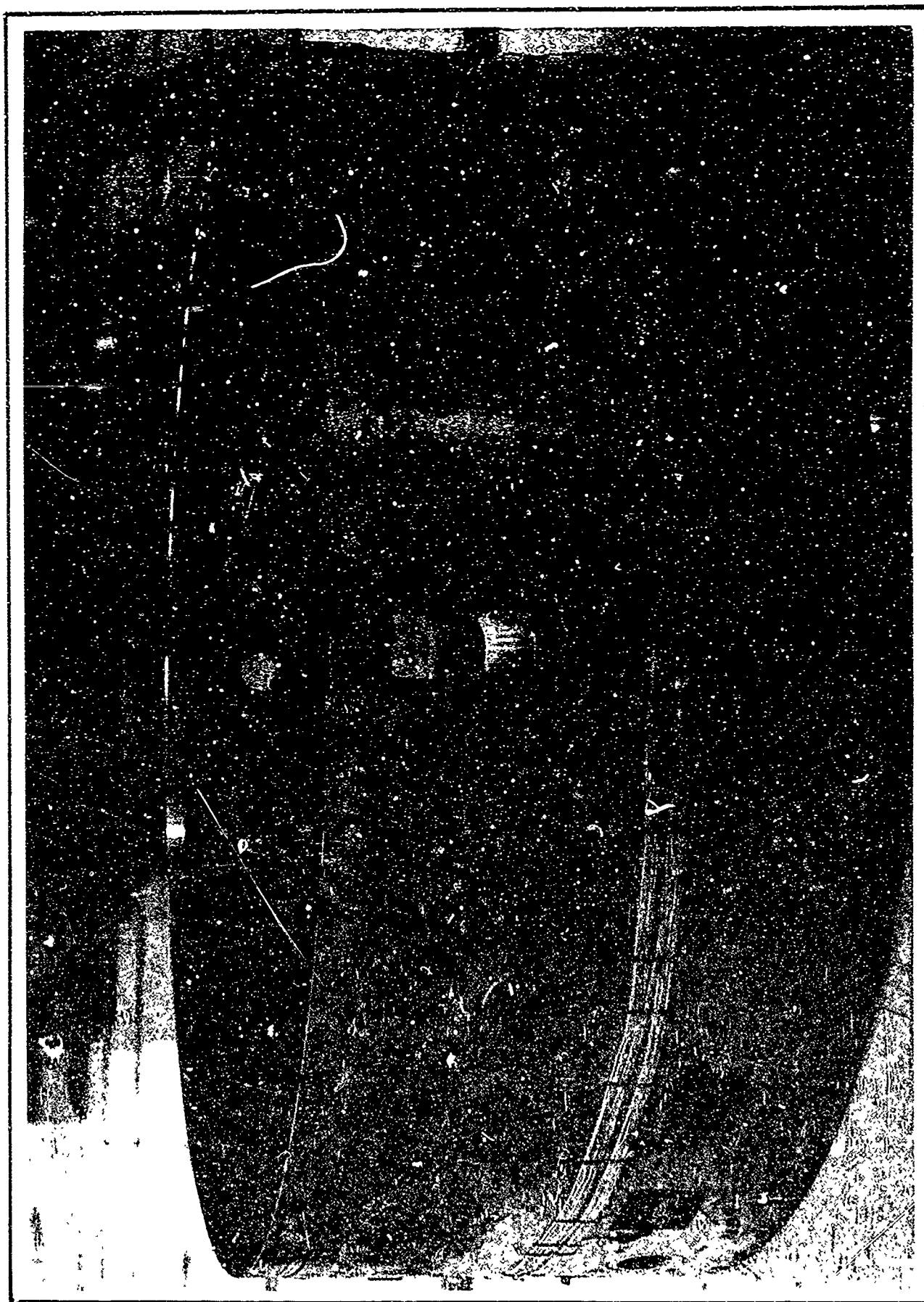

SHEET 235

FIG. 2.3-11

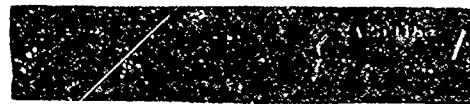

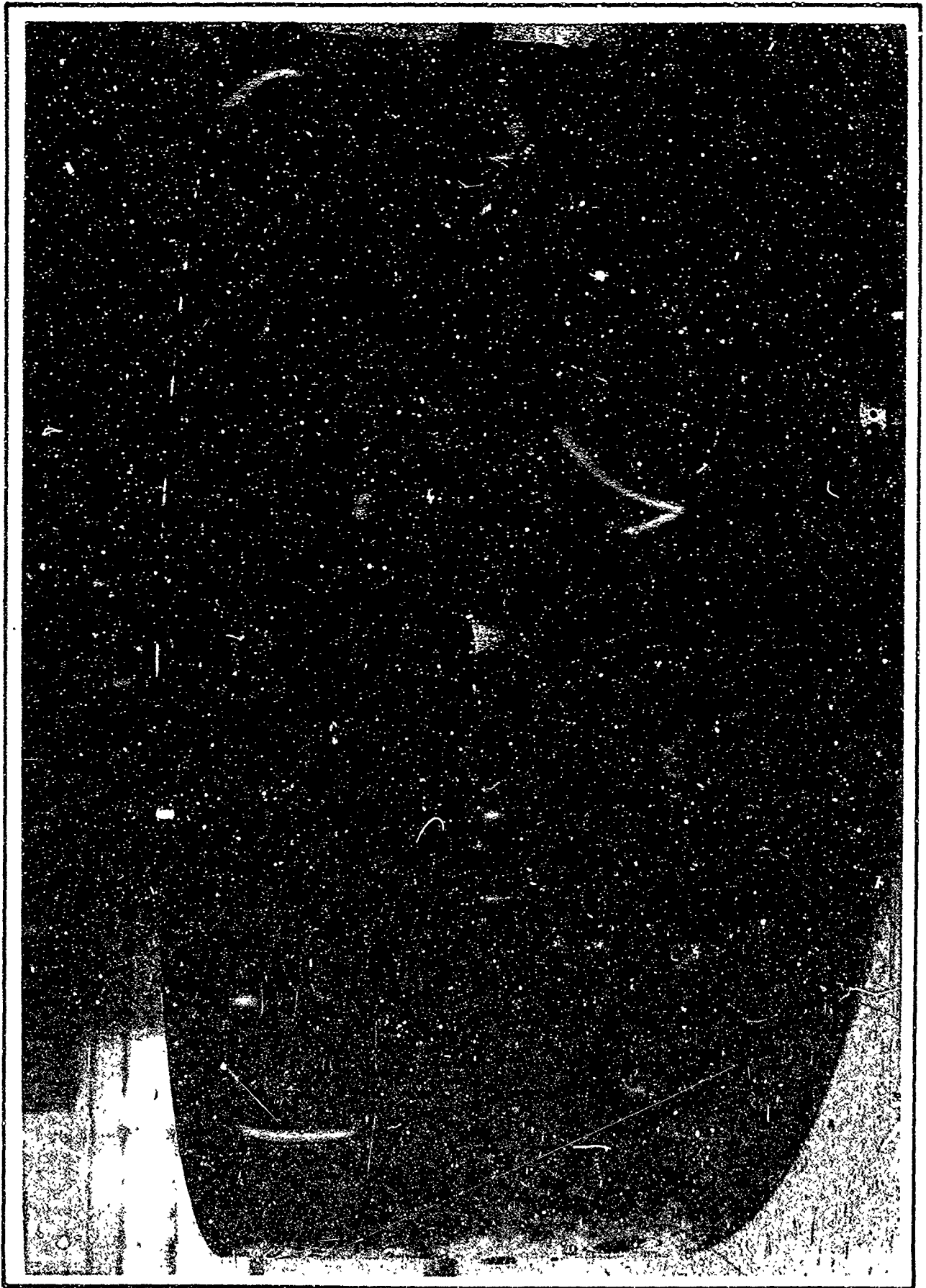

SHEET 236

FIG. 2.3-12



USE FOR TYPEWRITTEN MATERIAL ONLY

2.4 TEST CONDITIONS

SHEET 237

USE FOR DRAWING AND HANDPRINTING — NO TYPEWRITTEN MATERIAL

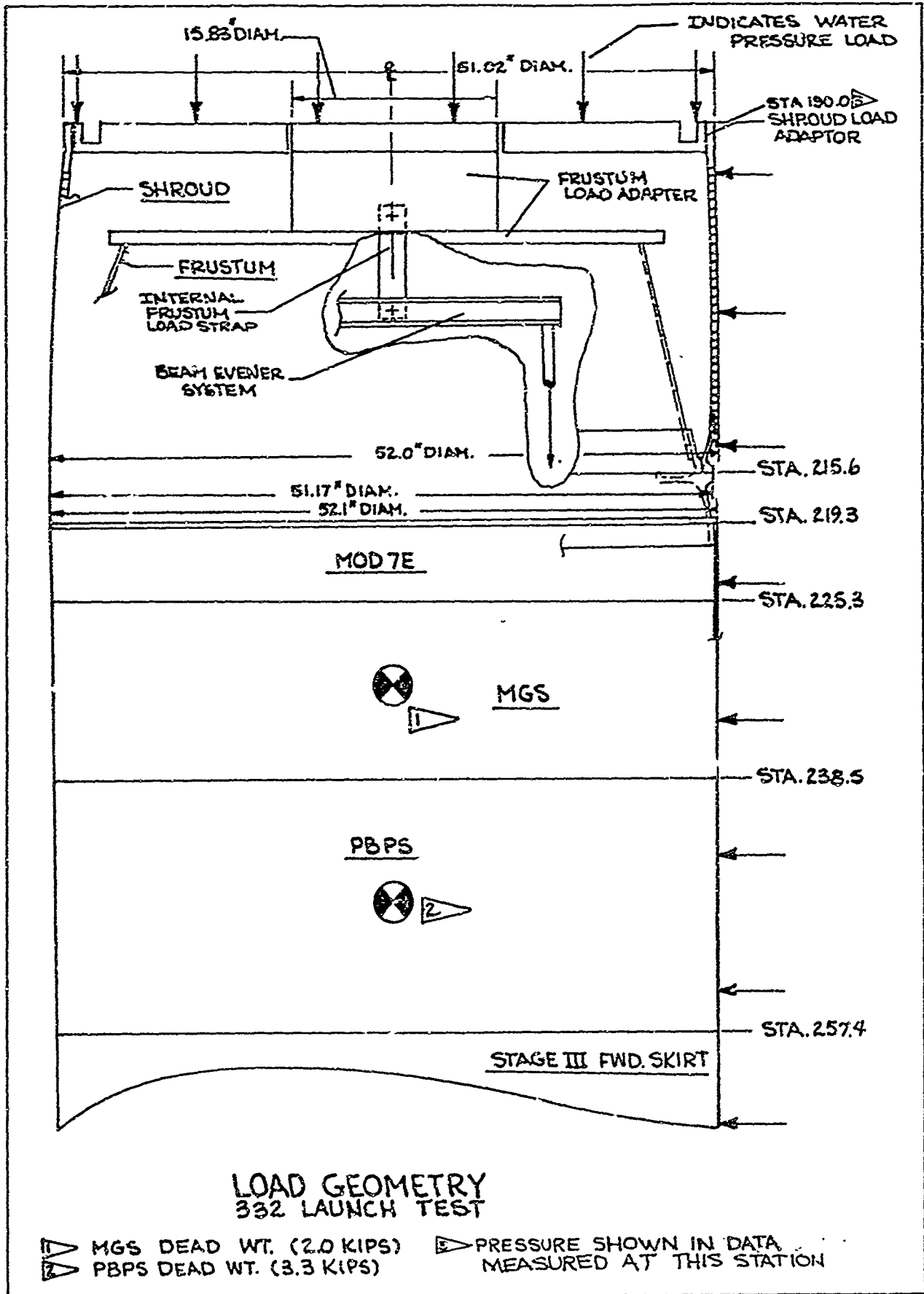

PERCENT LOAD	0%	20%	40%	60%	80%	90%	100%
PROGRAMMED ~ KIPS	0	8.06	16.12	24.18	32.24	36.27	40.30
ACTUAL ~ KIPS	1.93	8.21	16.22	23.87	31.74	36.06	39.75

AXIAL COMPRESSION
STA. 215.6 SHROUD

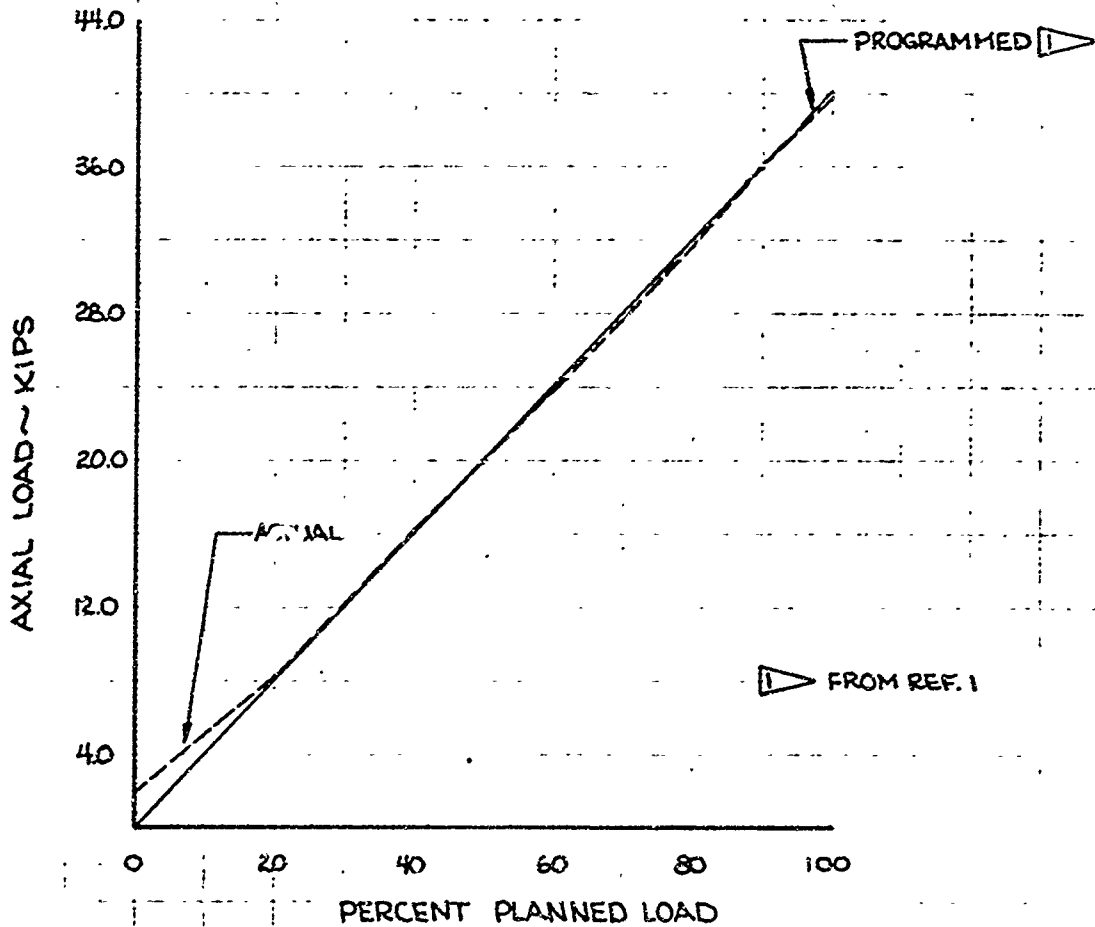

	INITIALS	DATE	REV BY INITIAL	DATE	TITLE	MODEL
CALC	<i>MDW</i>	11-4-8			332-L LAUNCH TEST PROGRAMMED AND ACTUAL AXIAL LOAD VS. PERCENT LOAD STATION 215.6 ~ SHROUD	
CHECK	GDW	11-6-8				
APPD						
APPD						

U3 4013 8000 REV 1/66

FIG. 24-2

REV LTR _____

BOEING NO T2-3657-1
SH 239

PERCENT LOAD	0%	20%	40%	60%	80%	90%	100%
PROGRAMMED KIPS	0	2.96	5.92	8.88	11.84	13.32	14.80
ACTUAL ~KIPS	1.37	3.02	6.09	8.99	11.95	13.51	15.03

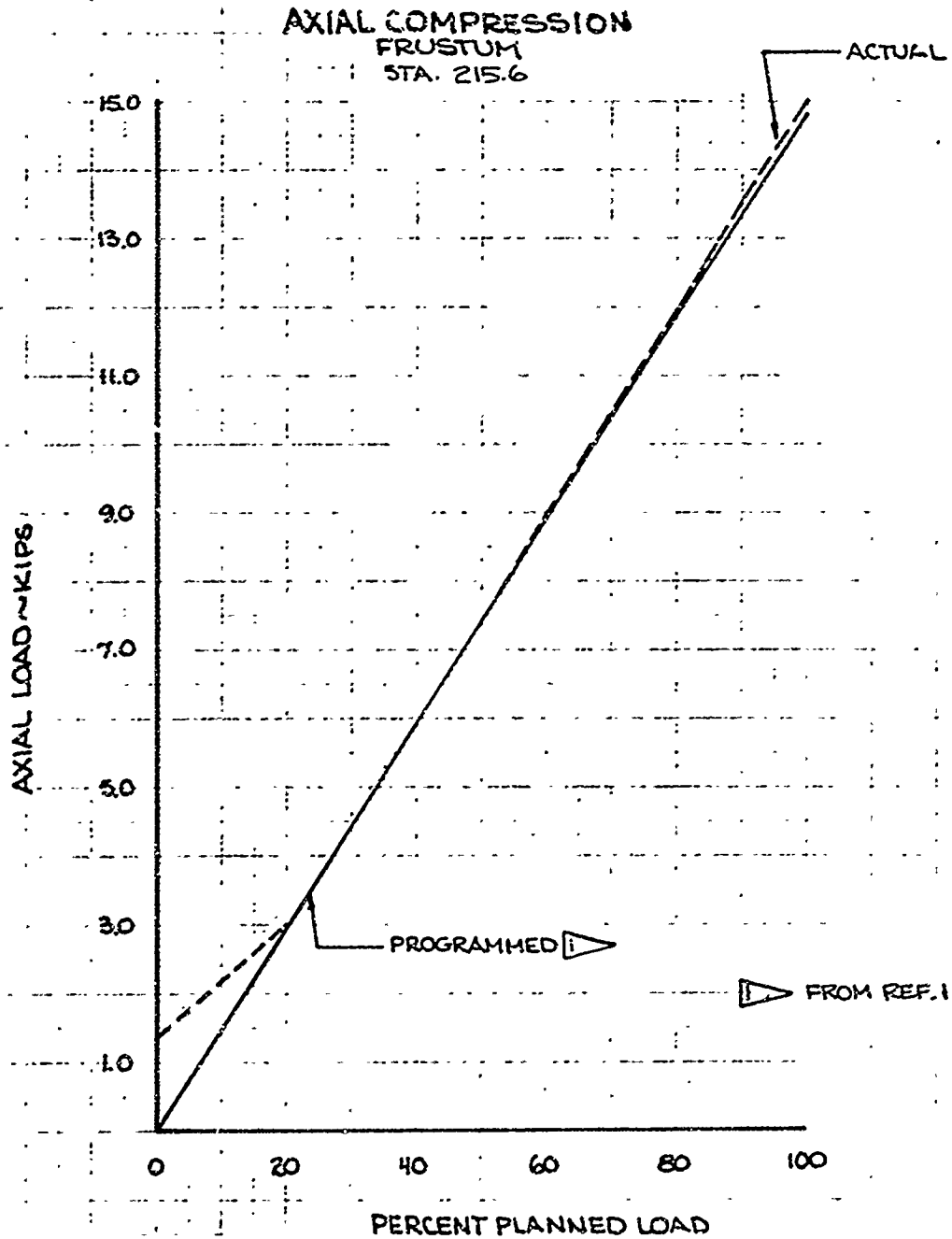

	INITIALS	DATE	REV BY INITIAL	DATE	TITLE	MODEL
CALC	BDW	11-11-8			332-L LAUNCH TEST PROGRAMMED ACTUAL AXIAL LOAD VS. PERCENT LOAD STATION 215.6 FRUSTUM	
CHECK	BDW	11-6-8				
APPD.						
APPD.						

U3 4012 8000 REV 1/66

REV LTR _____

BOEING NO T2-3657-1
SH 240

FIG. 2.4-3

PERCENT LOAD	0%	20%	40%	60%	80%	90%	100%
PROGRAMMED ~ KIPS	0	11.02	22.04	33.06	44.08	49.59	55.1
ACTUAL ~ KIPS	3.30	11.23	21.31	32.86	43.69	49.57	54.73

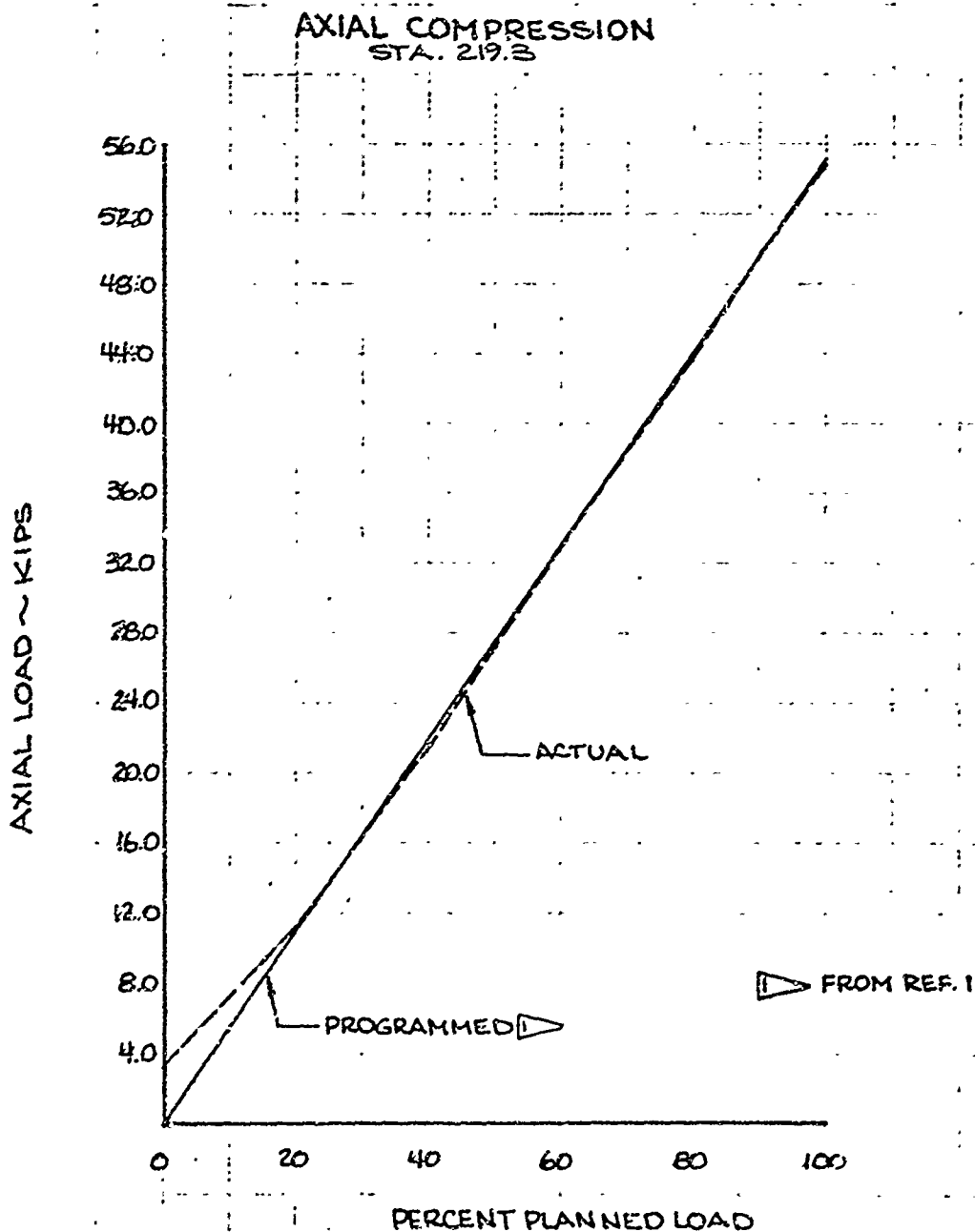

	INITIALS	DATE	REV BY INITIAL	DATE	TITLE	MODEL
CALC	<i>[Signature]</i>	11-4-8			332-L LAUNCH TEST PROGRAMMED & ACTUAL AXIAL LOAD VS. PERCENT LOAD. STATION 219.3	
CHECK	GDW	11-5-8				
APPD.						
APPD.						

U3 4013 8000 REV 1/66

FIG 2.4-4

REV LTR _____

BOEING NO T2-3657-1
SH 241

PERCENT LOAD	0%	20%	40%	60%	80%	90%	100%
PROGRAMMED ~ PSI	0	4.46	8.92	13.38	17.84	20.07	22.3
ACTUAL ~ PSI	1.79	5.17	9.48	13.59	17.86	20.15	22.14

OVERPRESSURE
STA. 219.3

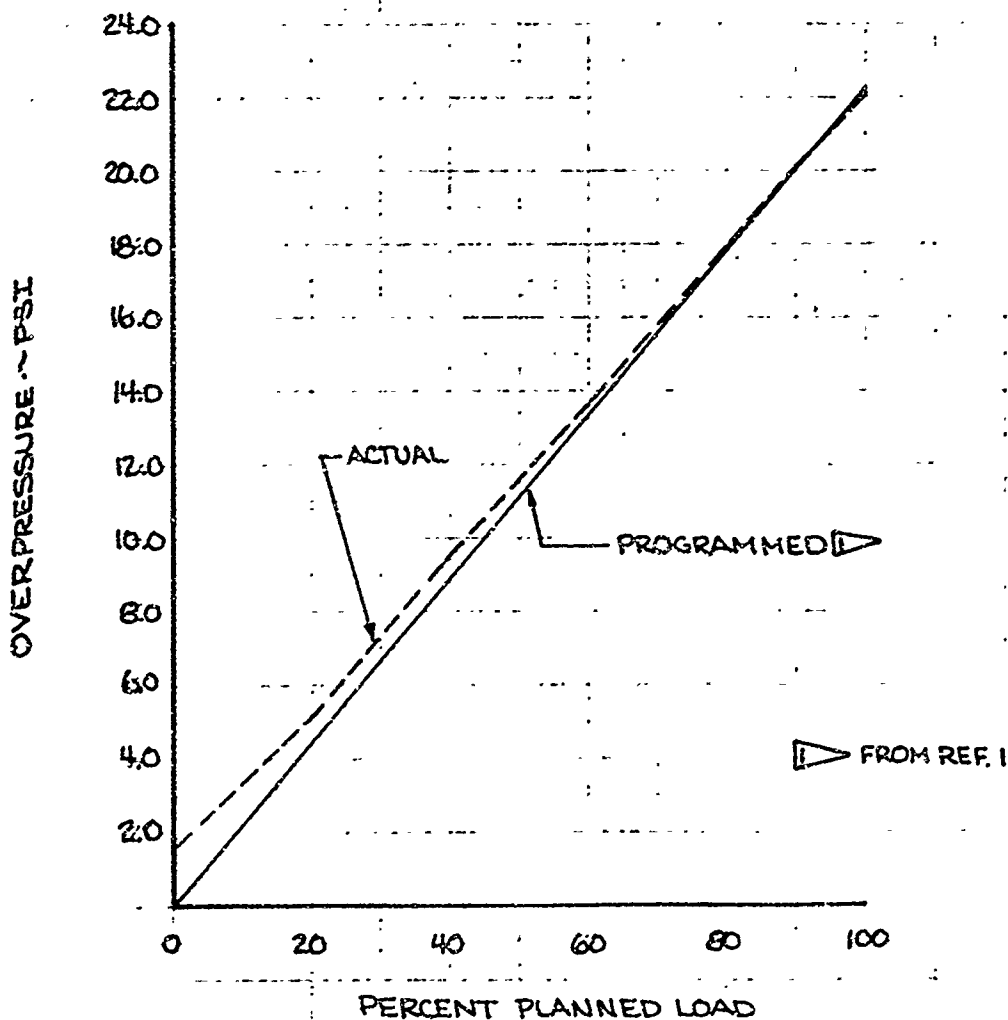

	INITIALS	DATE	REV BY INITIAL	DATE	TITLE	MODEL
CALC	<i>MLW</i>	11-4-5			332-L LAUNCH TEST PLANNED AND ACTUAL OVERPRESSURE ~ STATION 219.3	
CHECK	<i>JBT</i>	1-6-8				
APPD.						
APPD.						

U3 4013 8000 REV 1/66

FIG. 2.4-5

REV LTR _____

BOEING NO T2-3657-1
SH 242

332-L 100% TEST LOADS VS MISSILE STATION

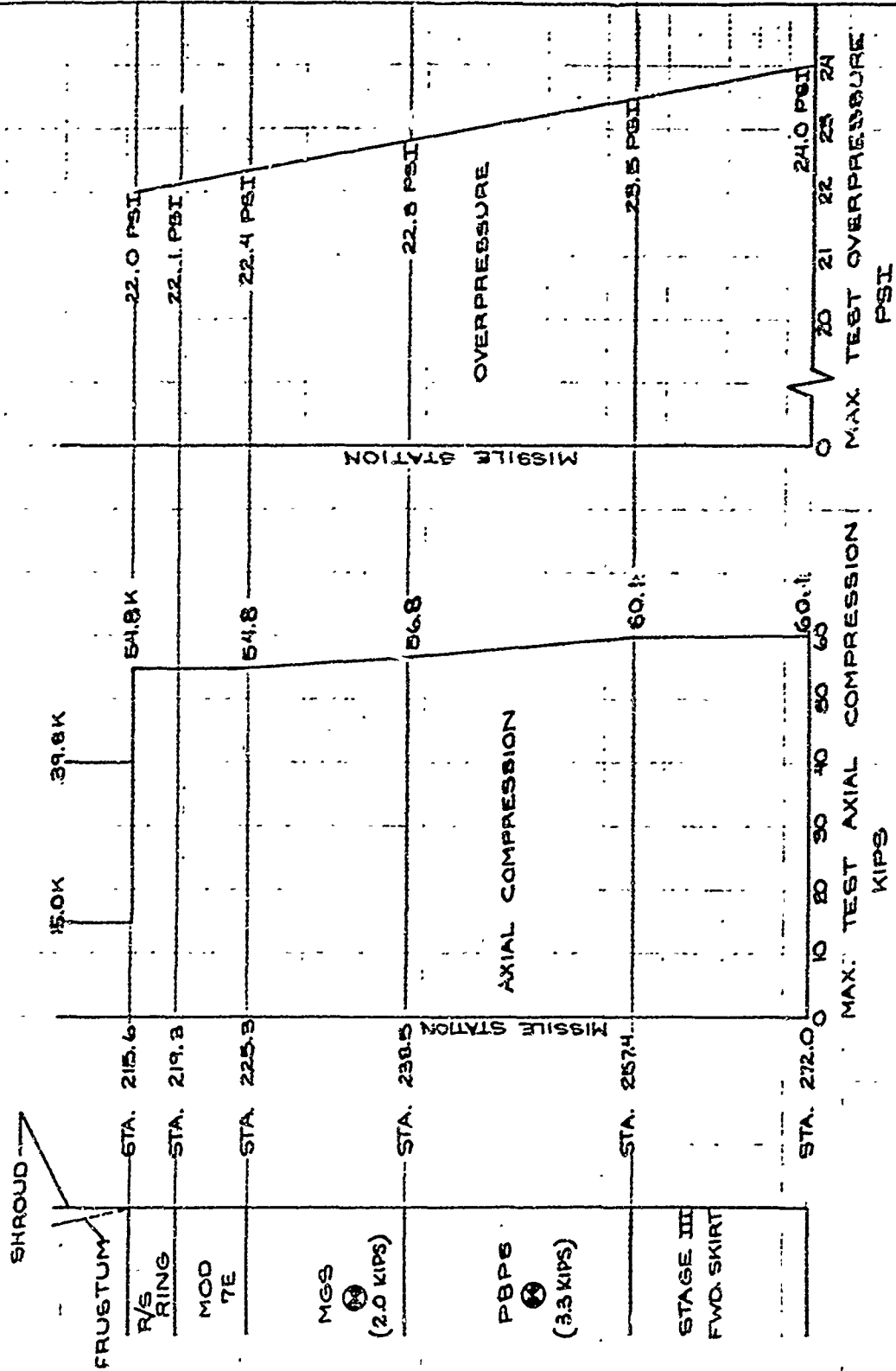

INITIALS	DATE	REV BY INITIAL	DATE	TITLE	MODEL
GDW	9-9-68			332-L LAUNCH TEST APPLIED AXIAL COMPRESSION AND OVERPRESSURE (AT MAX. LOAD) VS. MISSILE STATION	
JPT	11-6-8				

U3 4013 8000 REV 1/66

FIG. 2.A-6

REV ITR _____

BOEING NO T2-3657-1
SH. 243

USE FOR TYPEWRITTEN MATERIAL ONLY

2.6 TEST RESULTS

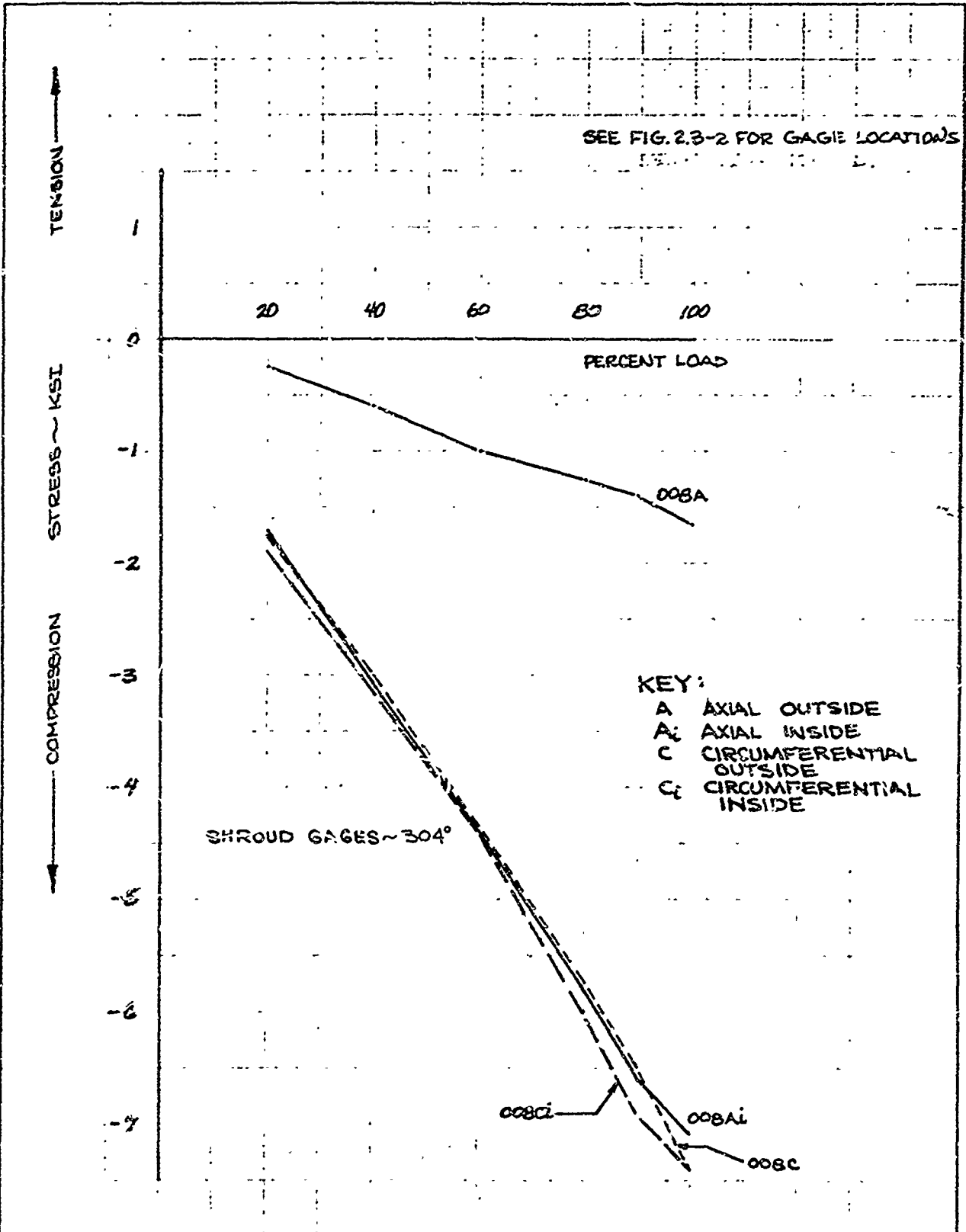

	INITIALS	DATE	REV BY INITIAL	DATE	TITLE	MODEL
CALC	RAW	9/16/8			332-L(LAUNCH) 100% TEST STRAIN GAGE READING SHROUD ~ 304°	
CHECK	YSLW	10/14/8				
APPD						
APPD						

U3 4013 8000 REV 1/66

FIG. 2.6-1

REV LTR _____

BOEING NO T2-3657-1
SH. 245

SEE FIG. 2.3-1 FOR GAGE LOCATION KEY

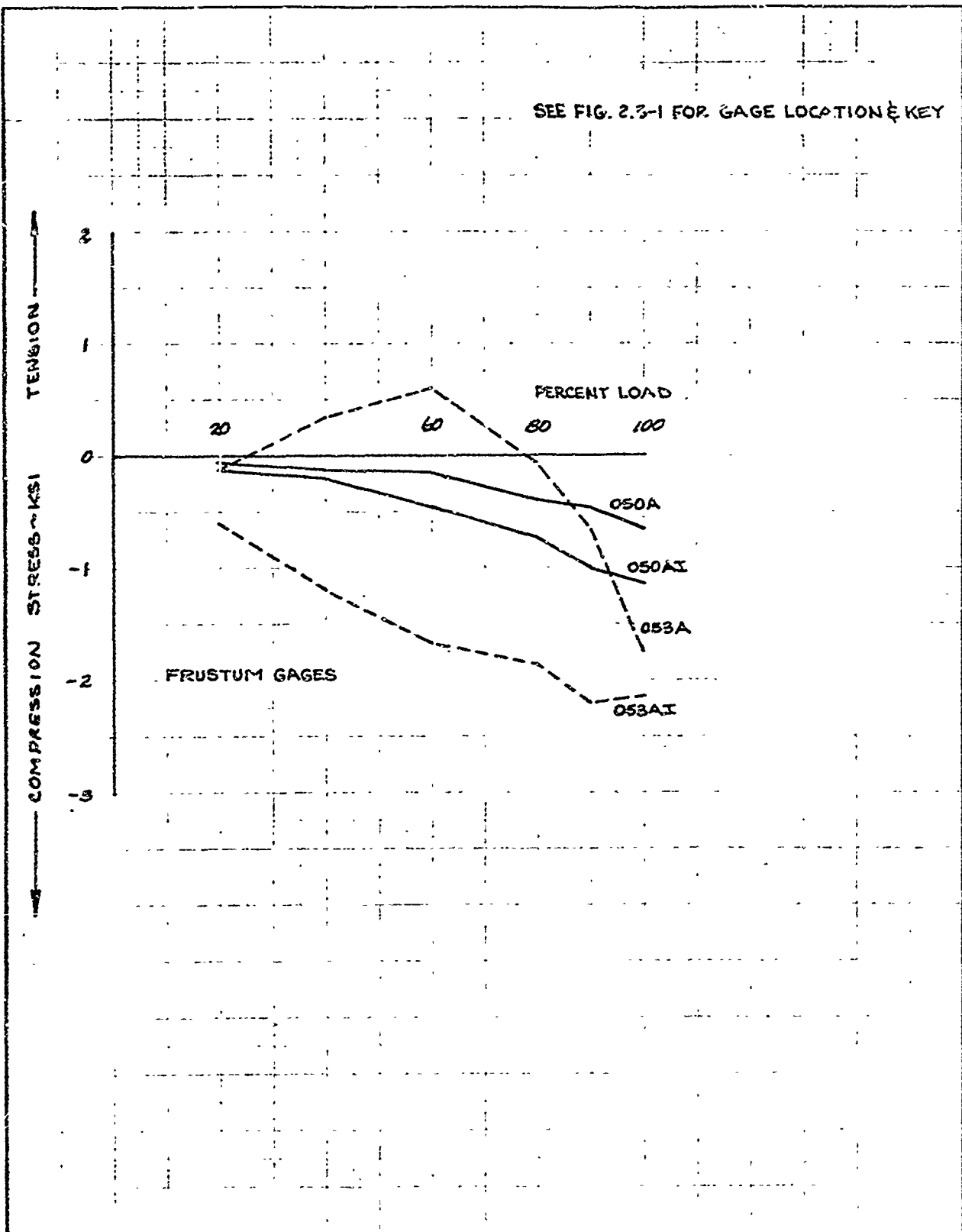

	INITIALS	DATE	REV BY INITIAL	DATE	TITLE	MODEL
CALC	KAM	9/16/8			3324(LAUNCH) 100% TEST STRAIN GAGE READING FRUSTUM ~ 37° & 66°30'	
CHECK	GDW	01/4/8				
APP'D.						
APP'D.						

U3 4013 8000 REV 1/66

FIG.2.6-2

REV LTR _____

BOEING NO T2-3657-1
SH 246

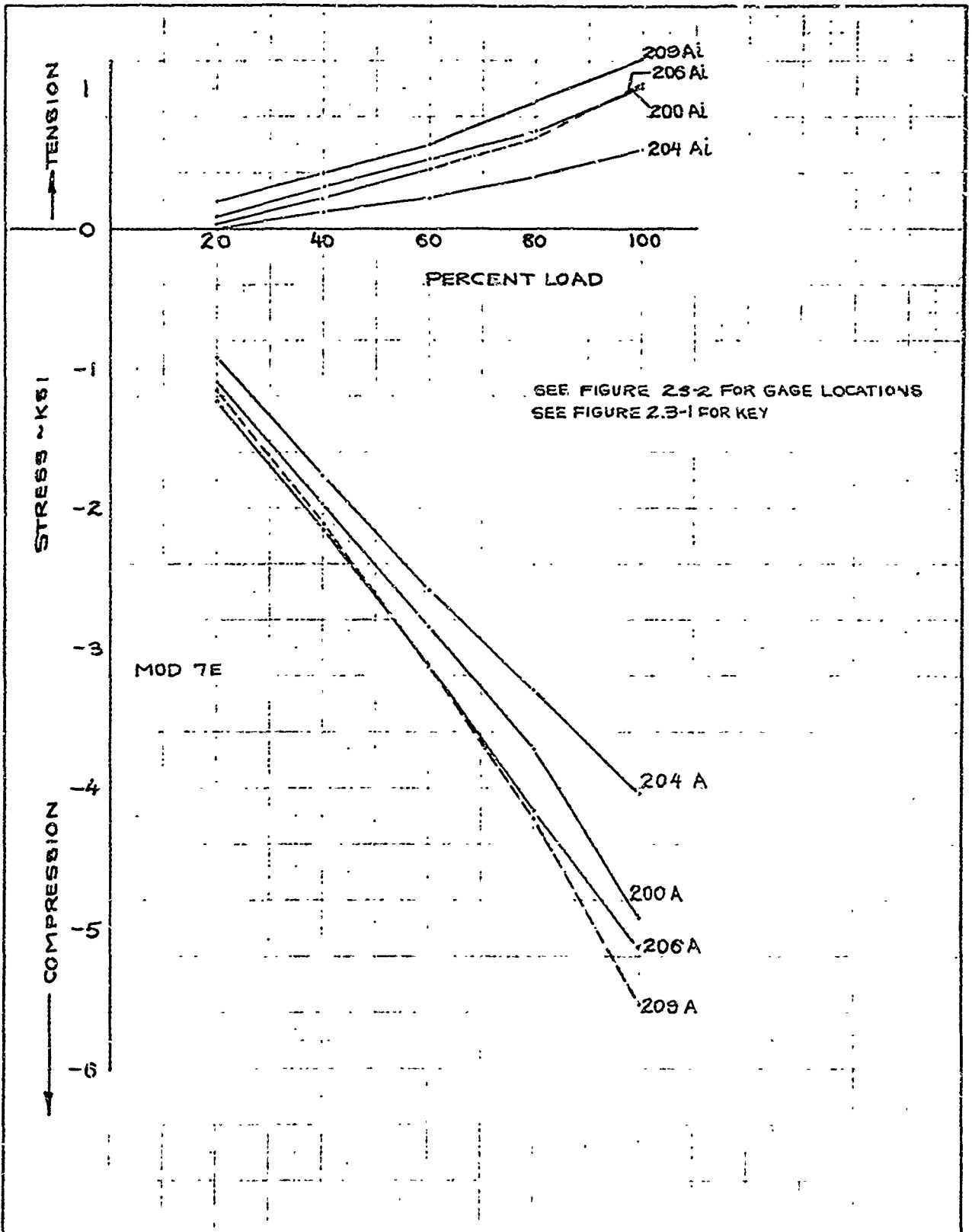

	INITIALS	DATE	REV BY INITIAL	DATE	TITLE	MODEL
CALC	GDW	09-8-8			332L(LAUNCH)100% TEST STRAIN GAGE READINGS MOD 7E	
CHECK	RWC	10-14-8				
APPD.						
APPD.						

U3 4013 8000 REV 1/66

FIG. 2.6-3

REV LTR _____

BOEING NO. T2-3657-1
SH 247

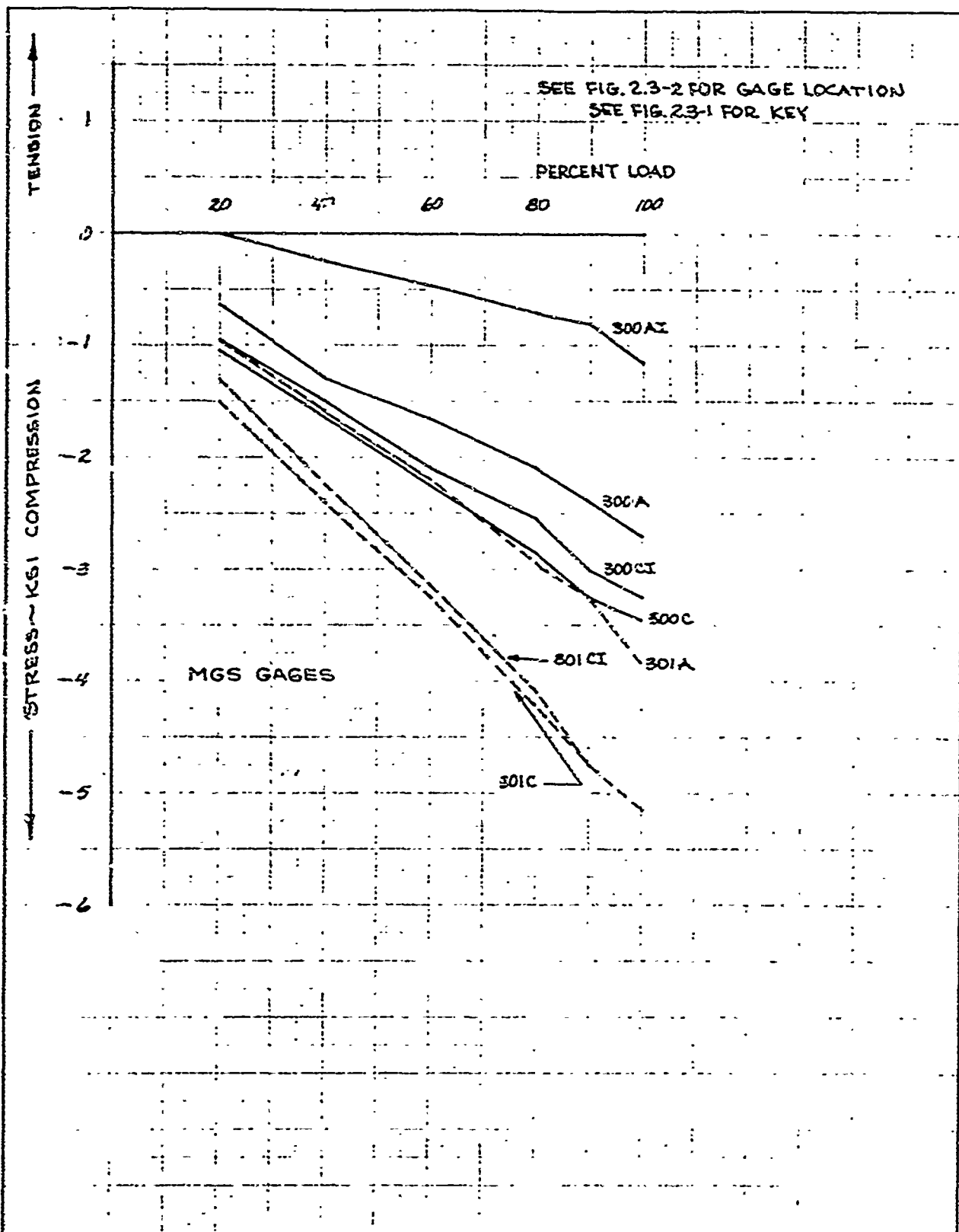

	INITIALS	DATE	REV BY INITIAL	DATE	TITLE	MODEL
CALC	ROW	9/16/68			332L(LAUNCH) 100% TEST STRAIN GAGE READING MGS ~ 0°	
CHECK	GDW	10/14/68				
APPD.						
APPD.						

U3 4013 8000 REV 1/66

FIG.2.6-4

REV LTR _____

BOEING NO T2-3657-1
SH 248

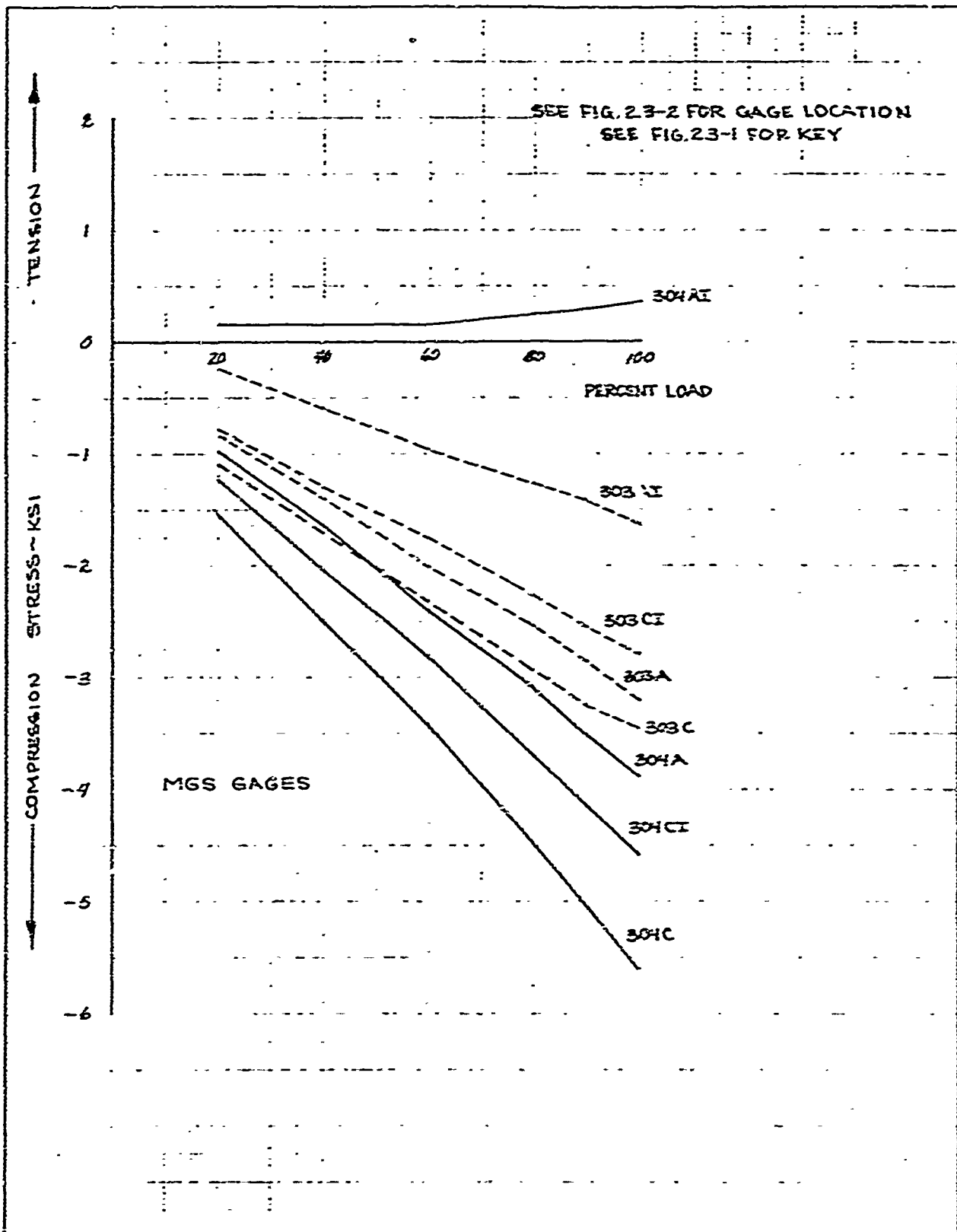

	INITIALS	DATE	REV BY INITIAL	DATE	TITLE	MODEL
CALC	Rev	9/16/18			332-L(LAUNCH) 100% TEST STRAIN GAGE READING MGS ~ 37°	
CHECK	GDW	9/18/18				
APPD.						
APPD.						

U3 4013 2000 REV 1 00

REV LTR _____

BOEING NO T2-3657-1
SH 249

FIG. 2.6-5

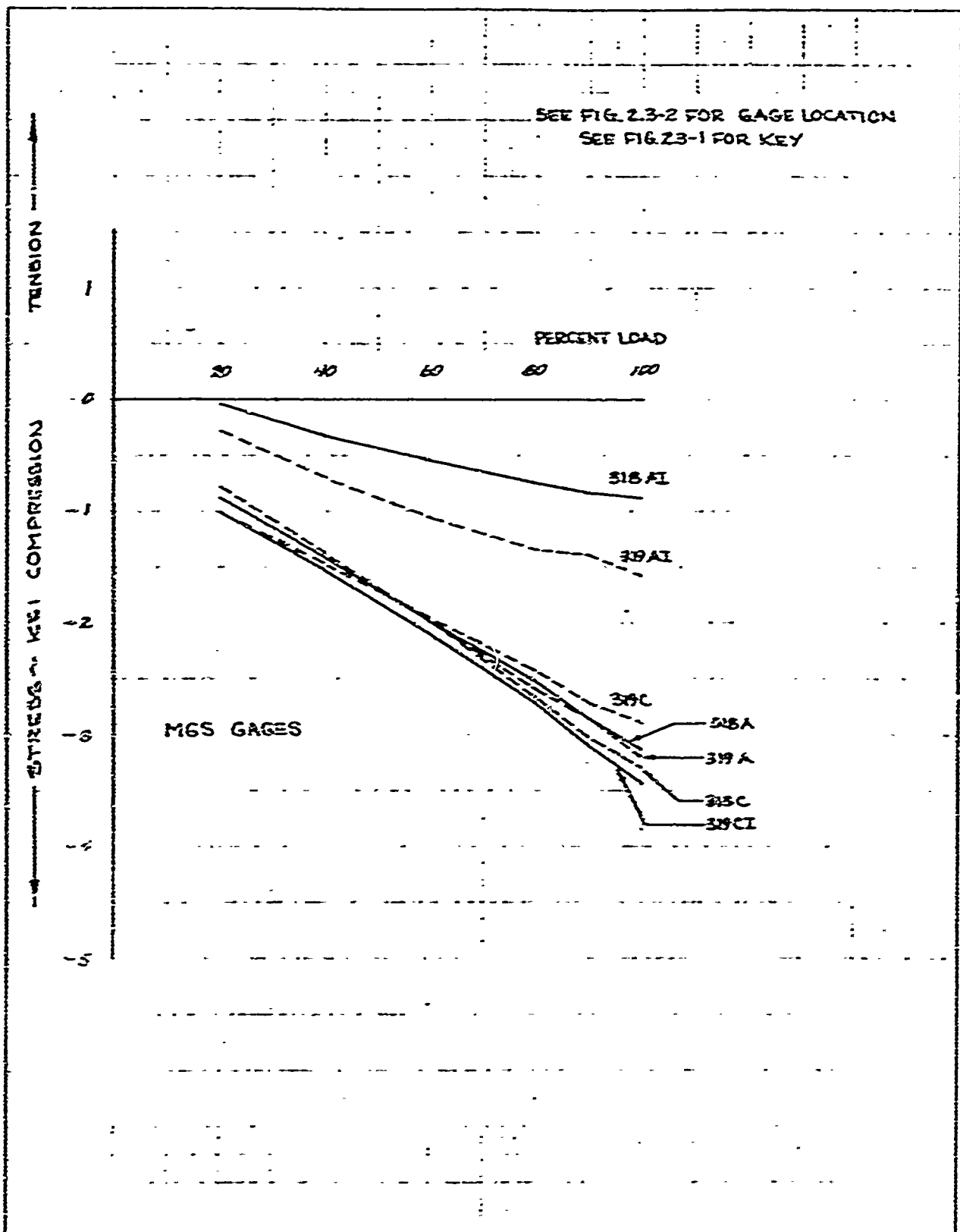

	INITIALS	DATE	REV BY INITIAL	DATE	TITLE	MODEL
CALC	Row	9/16/53			332-L(LAUNCH) 100% TEST STRAIN GAGE READING MGS ~ 304° & 322°	
CHECK	G.D.H.	9/16/53				
APPD.						
APPD.						

CG 4013 B200 REV 1 52

FIG. 2.6-6

REV ITR _____

BOEING NO T2-3657-1
SH 250

SEE FIG. 23-2 FOR GAGE LOCATION
SEE FIG. 23-1 FOR KEY

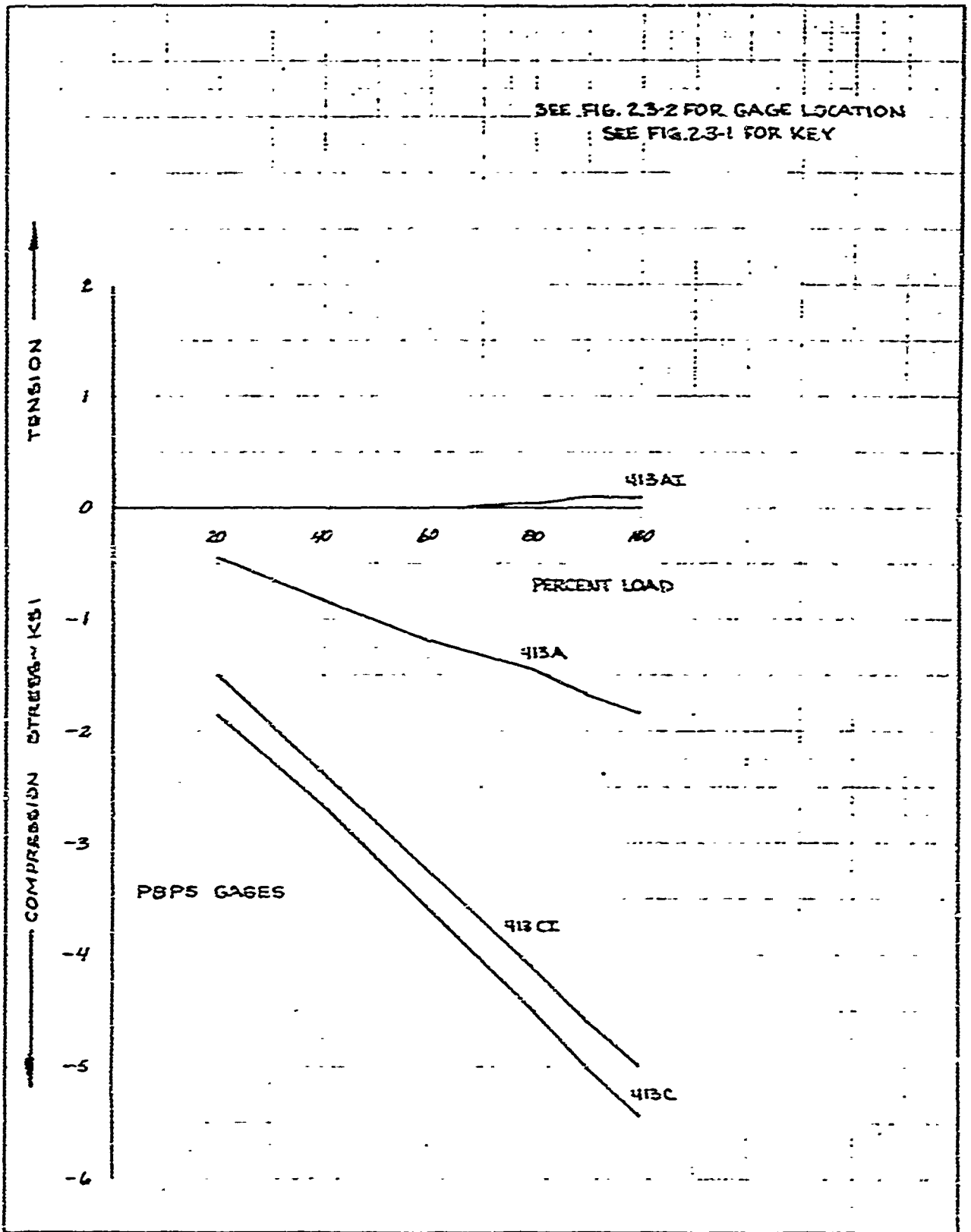

	INITIALS	DATE	REV BY INITIAL	DATE	TITLE	MODEL
CALC	ROW	9/16/68			332(LAUNCH) 100% TEST STRAIN GAGE READING PBPS - 227°	
CHECK	GDW	10/18/68				
APPD.						
APPD.						

UD 413 5000 REV 1 EN

REV iTR _____

BOEING / NO T2-3657-1
SH 251

FIG. 26-7

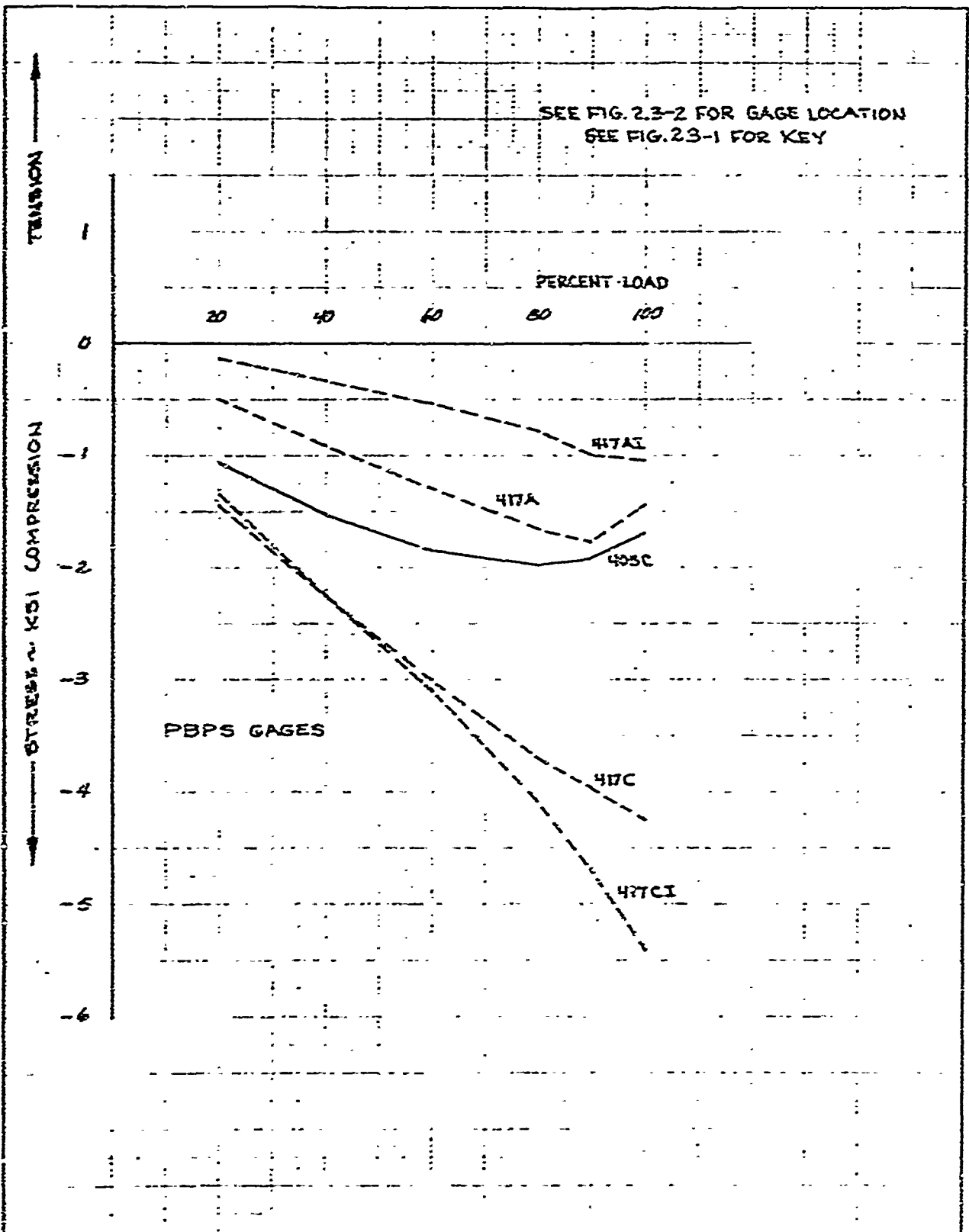

	INITIALS	DATE	REV BY INITIAL	DATE	TITLE	MODEL
CALC	POW	9/16/8			332(LAUNCH) 100% TEST STRAIN GAGE READINGS PBPS ~ 90° & 270°	
CHECK	GDW	10/4/8				
APPD.						
APPD.						

UD 4013 8000 REV 1

REV LTR _____

BOEING NO T2-3657-1
SH 252

FIG. 2.68

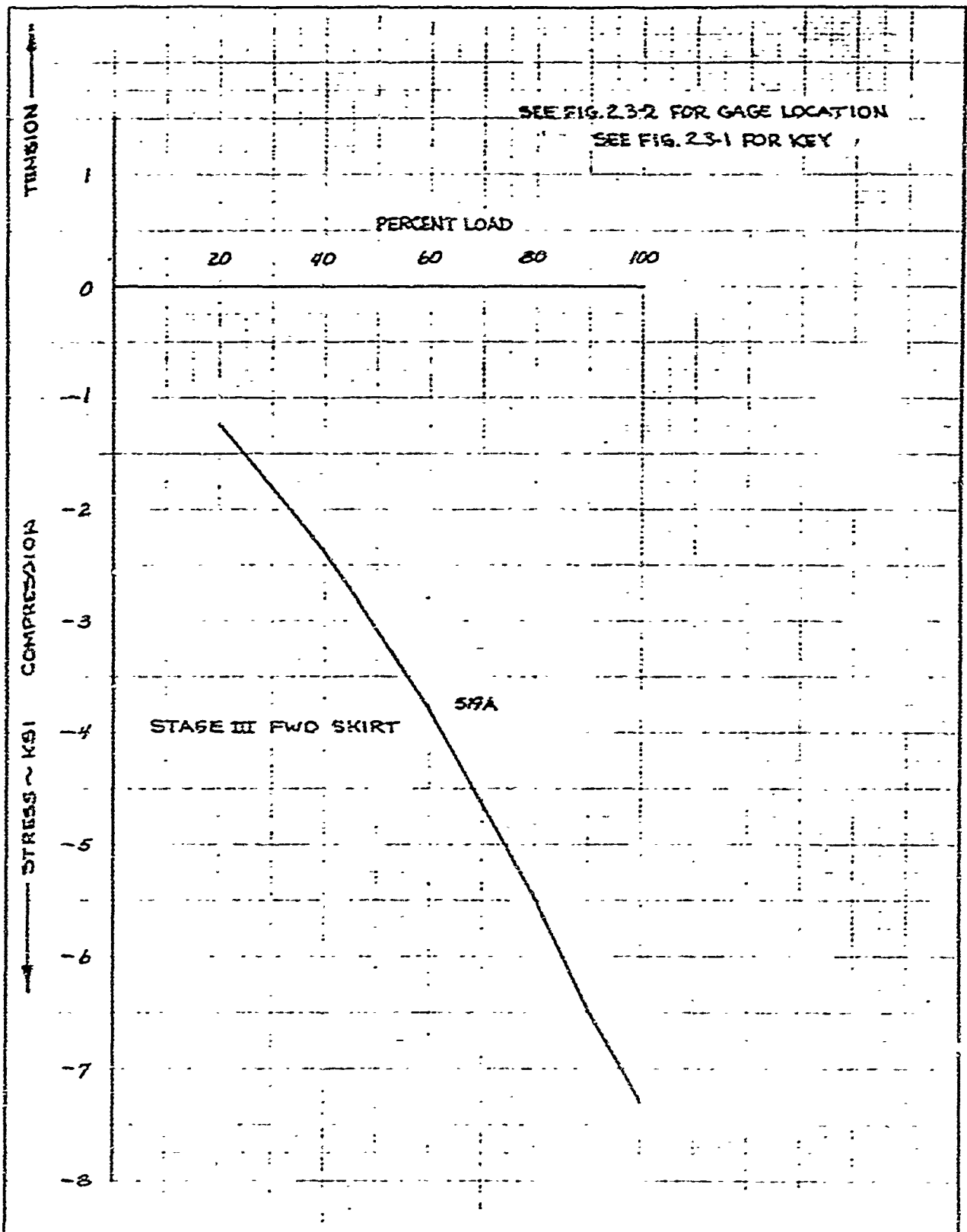

	INITIALS	DATE	REV BY INITIAL	DATE	TITLE	MODEL
CALC	ROH	9/16/68			332-L(LAUNCH) 100% TEST STRAIN GAGE READING STAGE III. FWD. SKIRT ~202°	
CHECK	ROH/B	11/14/68				
APPD.						
APPD.						

UJ 4013 5000 REV 1/66

FIG. 2.6-9

REV LTR _____

BOEING NO T2-3657-1
SH 253

3.0 STAGE III/PBV OPERATIONAL LAUNCH CONDITION FAILURE TEST (333-L)

3.1 TEST SPECIMEN

The 333-L test specimen used the same hardware described in Section 2.1 with the exception of the MOD 7E wafer which is not included in the operational configuration. See Section 2.1 for description, photographs and dimensional surveys of the test specimen. Figure 3.2-2 shows the integrated specimen sealed with a coat of sealant,

3.2 TEST SETUP

Figure 3.2.1 shows a schematic of the test setup. Figure 3.2-2 shows a photograph of the setup before installation of the pressure tank. The complete specimen with load adaptors was enclosed in a pressure tank. Pressurized water, between the tank and sealed specimen, provided the overpressure loads. This water pressure acting vertically on the Shroud and Shroud adapter provided 100% of the shroud axial compression load. The Frustum axial load was supplied by a vertical pressure component acting on the Frustum load adaptor and by an internal jack loading thru an evenner system. Lead weights applied constant axial load to the internal structure of the PBCS. The pressure and jack loads were controlled by a manually operated servo control system.

3.3 TEST INSTRUMENTATION

Strain gage channels were located and identified as shown in Section 2, Figures 2.3-1 through 2.3-5, except for the omission of the MOD 7E and its gages. Test data were recorded at each increment of applied load up to 100% test loads. Above 100% test load, loading was continuous (manually) and gages were read continuously (approximately once each 1.5 seconds).

3.4 TEST CONDITIONS

The Launch condition loads of axial compression and overpressure were applied in increments of 100% of test load (from reference 1). Loads were then increased continuously to failure. The PBCS internal structure was loaded with 2.0 kips on the MGS bulkhead and 3.3 kips suspended from the PBPS internal beams. The test setup load geometry is shown in Figure 3.4-1. Figures 3.4-2 through 3.4-5 present the planned and actual test loads of overpressure and compression.

3.5 TEST PROCEDURE

The strain gages were zeroed, with the internal dead weights and the load heads on the specimen, prior to filling the tank with water. Two hours later, after filling the tank with water, the strain gages were again read. The test was then run with loads applied incrementally to 100% load. Loads above 100% were then applied continuously to fail-

USE FOR TYPEWRITTEN MATERIAL ONLY

3.5 TEST PROCEDURE (CONT.)

ure. When additional load could no longer be supported the loads were brought back to zero where zero gage readings were taken before and after the water was drained.

3.6 TEST RESULTS

Figures 3.6-1 thru 3.6-11 show photographs of the buckled specimen. Selected strain gage data are shown in Figures 3.6-12 through 3.6-22. A tabulation of all test data acquired is given in Reference 3. Inspection of the test data showed that initial buckling occurred in the PBPS section at 118% of test load between 220° and 270° in both the forward and aft bays (See Figures 3.6-19, 3.6-20). At 120% load, further buckling appeared in the PBPS between 73° and 90° (See Figure 2.6-21). The specimen continued to carry load to approximately 135% of test load when the MGS and Stage III forward skirt buckled. On inspection extensive buckling was found in both bays of the MGS between 285° and 73° (thru 0°). A single buckle was found in the Stage III forward skirt between 180° and the Raceway Cutout. Strain gages in these areas of the MGS and Stage III forward skirt are among the plots shown. The operational Stage III forward skirt R/V cap which had sustained the 332-L loads also sustained the 135% loads in this test. The following table summarizes the ultimate loads sustained by each specimen and the loads at which initial buckling occurred in the PBPS.

SECTION	STATION	LOADS AT FAILURE	
		PRES. (psi)	COMP. (kips)
R/S	225.3	30.80	77.1
MGS	236.5	31.3 (27.16)	79.1 (68.46)
PBPS	257.4	32.0 (27.94)	82.4 (71.76)
STG. III			

() indicates loads at which initial buckling occurred in the PBPS.

3.7 TEST CONCLUSION

The test specimen sustained the ultimate loads (approximately 137% of the reference 1 loads) shown in paragraph 3.6. These loads were also higher than the BSD Exhibit 66-6A design ultimate silo launch loads

USE FOR TYPEWRITTEN MATERIAL ONLY

3.7 TEST CONCLUSIONS (CGNT.)

as is shown in the following table:

STATION	BSD LOADS		% OF BSD LOADS AT FAILURE	
	OVER PRES. (psi)	COMPRESSION (kips)	OVERPRESSURE	AXIAL COMPRESSION
225.3	22.6	71.4	136%	108%
238.5 *	23.0	74.6	136.5%	106%
257.4	23.6	79.0	136%	104%

The two percentages given above (one for overpressure and one for compression) can be used to conservatively calculate (assuming uniform cylindrical sections) an equivalent single percentage of the BSD loads. The overpressure load, being the more critical, has the greatest effect on the equivalent single ultimate percentage, though the affect of each load also depends on the structure geometry. The following ultimate capabilities were calculated. See Section 8 for calculations.

SECTION	TEST SPECIMEN ULTIMATE CAPABILITY (% OF BSD LOADS)
MGS	128%
PBPS	127%
STAGE III PWD SKIRT	131%

The above results are not adjusted for a minimum gage specimen. Conservative calculations using a t^3 relationship and assuming a uniform specimen of the highest recorded thickness in the buckled areas give the following results.

SPECIMEN	TEST GAGE (IN)	MINIMUM GAGE (IN)	REDUCTION FACTOR ($\propto t^3$)	CAPABILITY OF MINIMUM GAGE (% BSD)
MGS	.101	.099	.94	120%
PBPS	.115	.113	.95	121%
STAGE III SKIRT	.158	.150	.85	112%

A minimum gage specimen therefore, would be capable of supporting the reference 1 loads and the BSD Exhibit 66-6A design ultimate loads. Conservative ultimate capabilities of test specimen sections are as shown in the above table.

* BSD load interpolated from loads at 225.3 and 257.4.

USE FOR TYPEWRITTEN MATERIAL ONLY

USE FOR TYPEWRITTEN MATERIAL ONLY

3.2 TEST SETUP

USE FOR DRAWING AND HANDPRINTING — NO TYPEWRITTEN MATERIAL

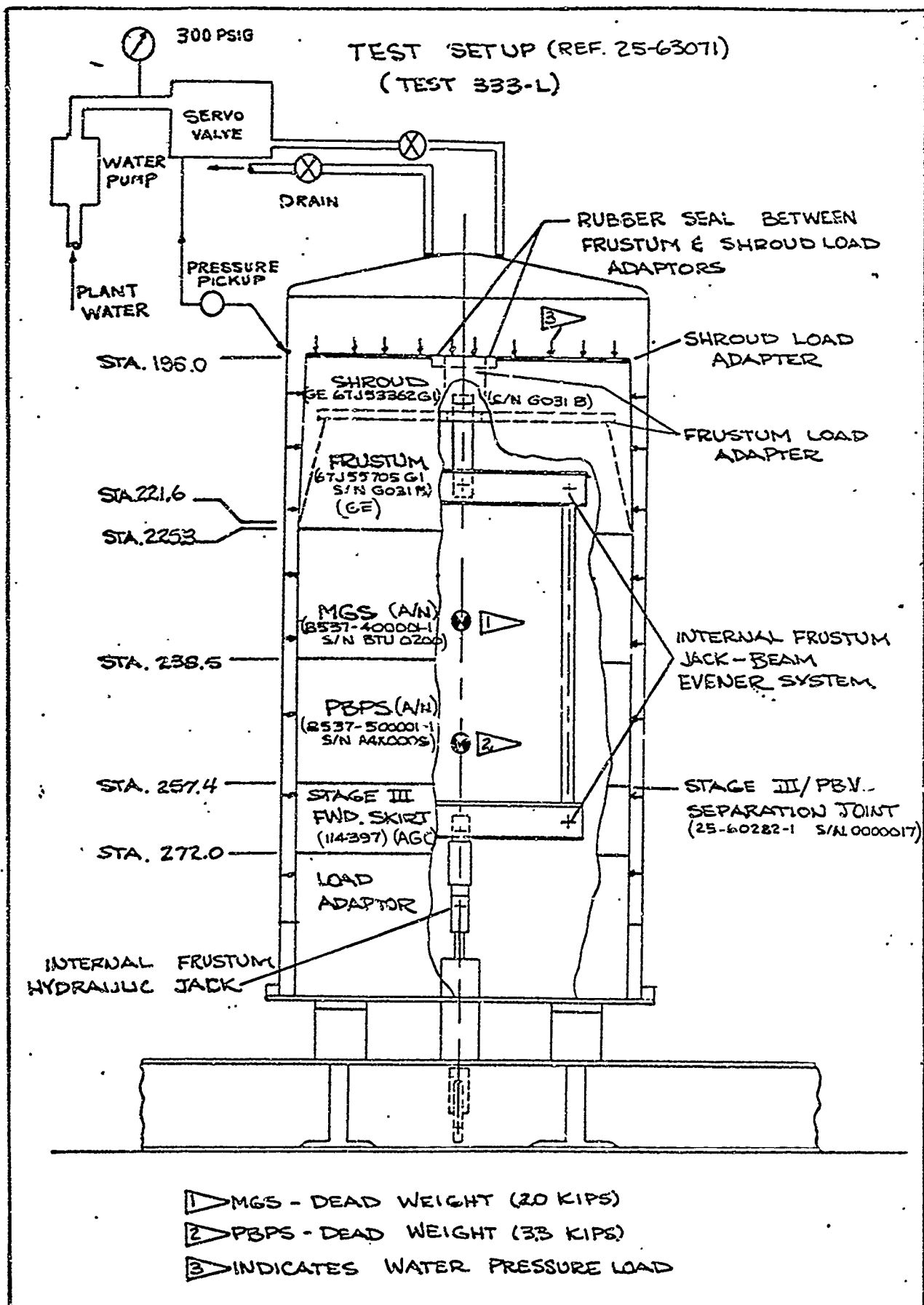

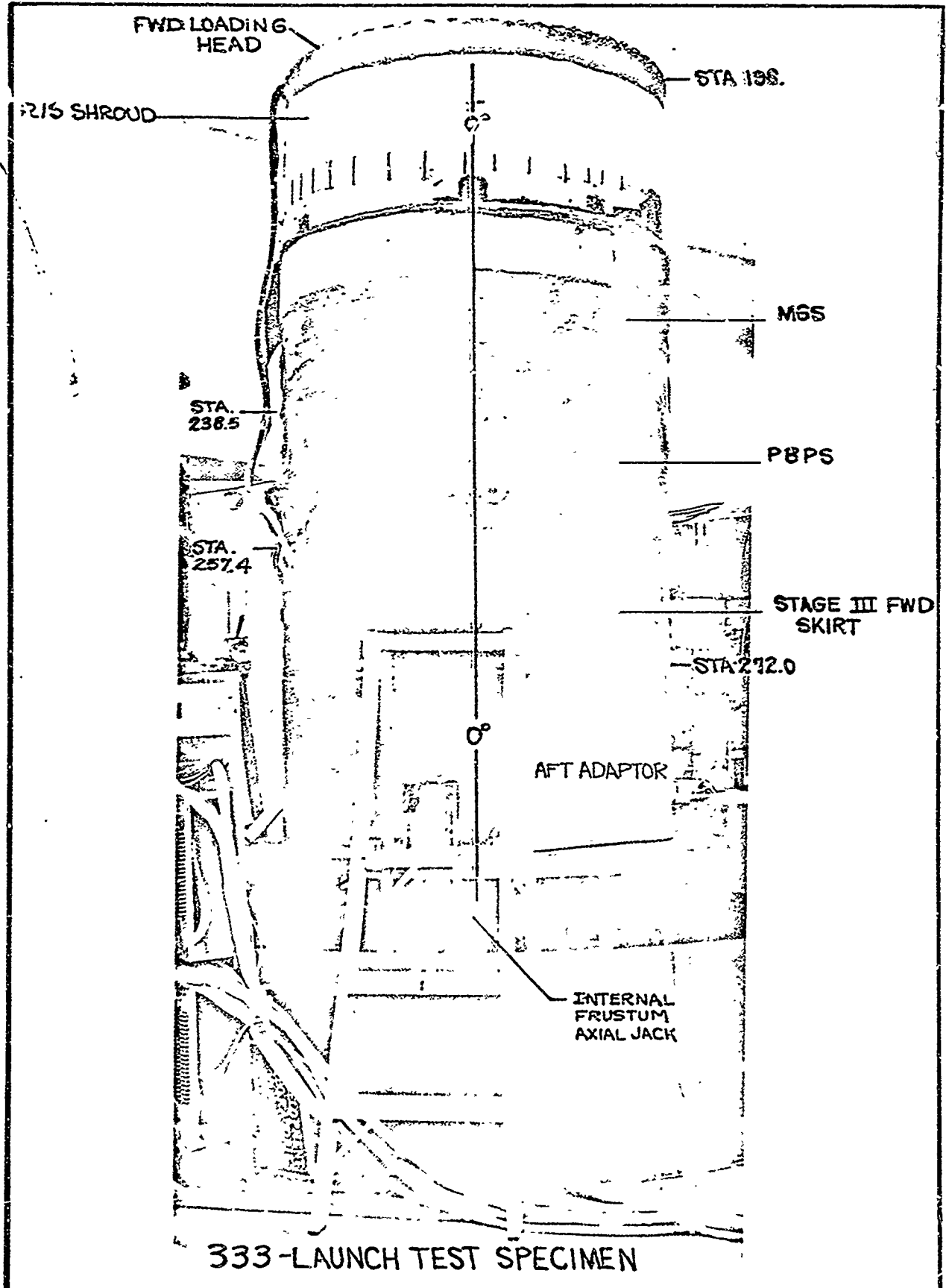

333-LAUNCH TEST SPECIMEN

USE FOR TYPEWRITTEN MATERIAL ONLY

3.4 TEST CONDITIONS

USE FOR DRAWING AND HANDPRINTING — NO TYPEWRITTEN MATERIAL

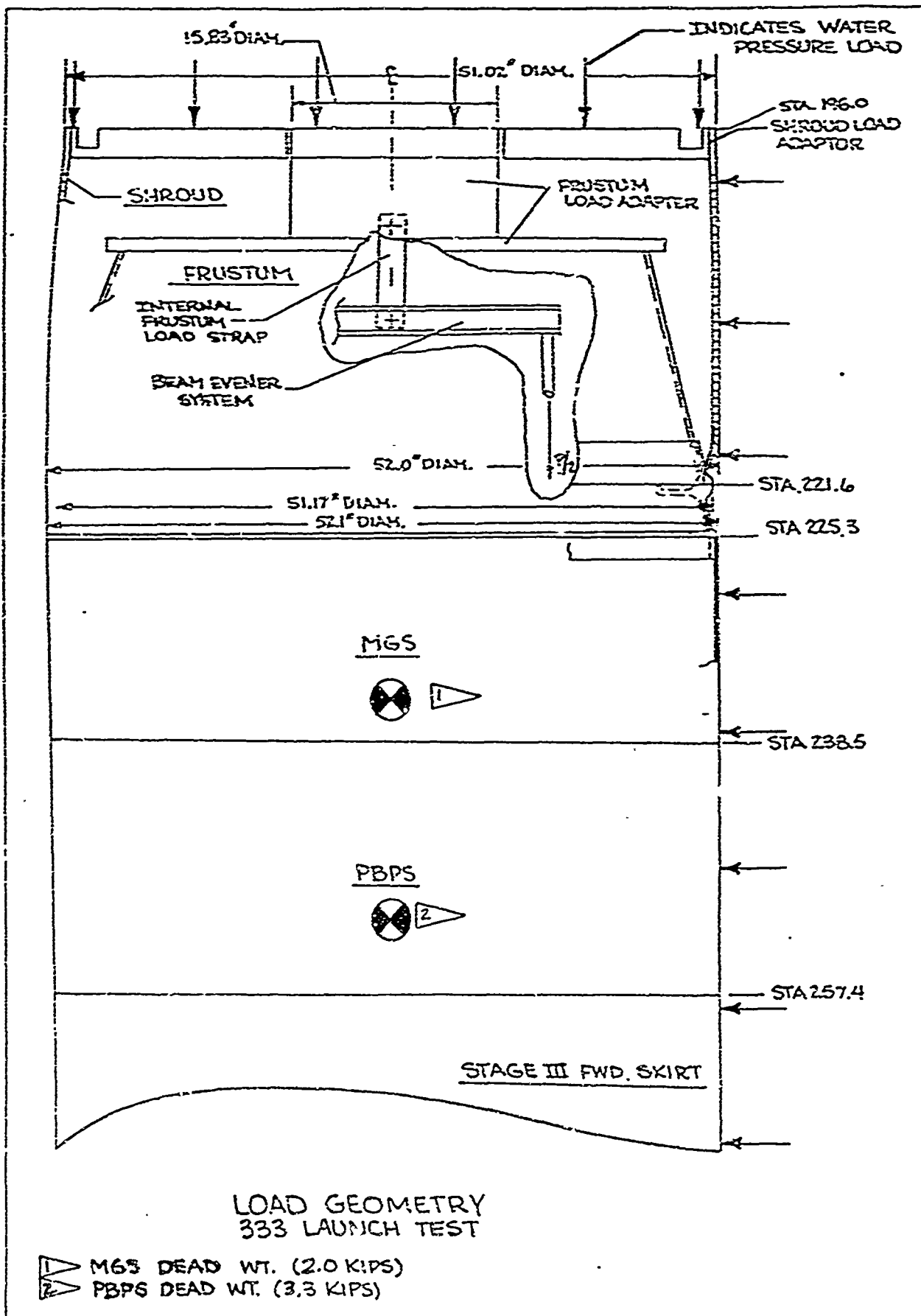

USE FOR TYPEWRITTEN MATERIAL ONLY

333-LAUNCH FAILURE LOADS													
% Load	PLANNED LOADS					APPLIED LOADS					OVER-PRESSURE (PSI) (STA.) (225.3)		
	AXIAL COMPRESSION					AXIAL COMPRESSION (KIPS)							
	SHROUD (STA.) (221.6)		FRUSTUM (STA.) (221.6)		TOTAL (STA.) (225.3)	SHROUD (STA. 221.6)		FRUSTUM (STA. 221.6)		TOTAL (STA.) (225.3)			
	Po	DD.Wt.	Po	DD.Wt.	TOTAL	Po	DD.Wt.	Po	DD.Wt.	TOTAL			
20	8.06	2.96	11.02	4.5	8.71	0.6	9.31	1.35	1.05	1.04	3.44	12.75	5.76
40	16.12	5.92	22.04	9.0	16.46	0.6	17.06	2.49	1.05	2.87	6.41	23.47	9.43
60	24.18	8.88	33.06	13.5	24.08	0.6	24.68	3.60	1.05	4.66	9.31	33.99	14.03
80	32.24	11.84	44.08	18.0	34.54	0.6	35.14	4.78	1.05	6.48	12.31	47.45	18.34
90	36.27	13.32	49.59	20.25	35.94	0.6	36.54	5.34	1.05	7.26	13.65	50.19	20.41
100	40.30	14.8	55.1	22.5	39.80	0.6	40.40	5.90	1.05	8.34	15.29	55.69	21.49
110	44.33	16.28	60.61	24.75	44.01	0.6	44.61	6.52	1.05	9.29	16.86	61.47	24.75
120	48.36	17.76	66.12	27.0	43.29	0.6	48.79	7.13	1.05	10.32	18.50	67.29	27.00
125	50.37	18.50	68.87	29.12	50.60	0.6	50.80	7.42	1.05	10.63	19.10	69.90	28.12
130	52.39	19.24	71.63	29.25	52.37	0.6	52.97	7.65	1.05	11.23	19.93	72.90	29.25
135	54.40	19.98	74.38	30.37	54.46	0.6	55.06	8.04	1.05	11.68	20.77	75.83	30.37
136.9	55.17	20.26	75.43	30.80	55.27	0.6	55.87	8.17	1.05	12.01	21.23	77.10	30.80

△ Po-AXIAL COMPRESSION RESULTING FROM OVERPRESSURE
REFER TO FIGURE 3.4-5 FOR CORRELATION OF LOADS AT OTHER MISSILE STATIONS.

▽ SEE SECTION 8.1 FOR SAMPLE CALCULATIONS.

333 - LAUNCH FAILURE LOADS BY MISSILE STATION

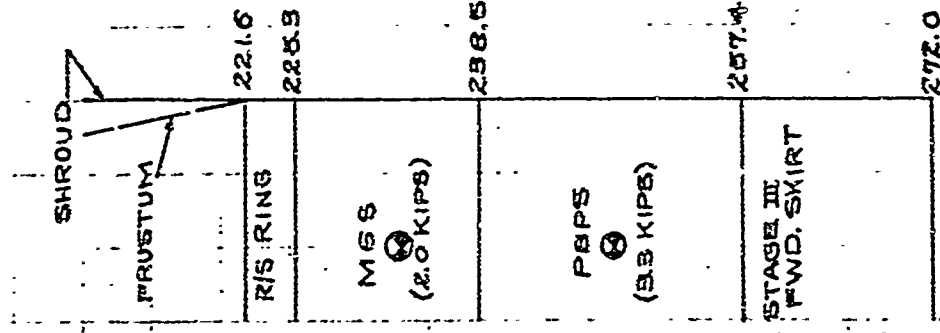
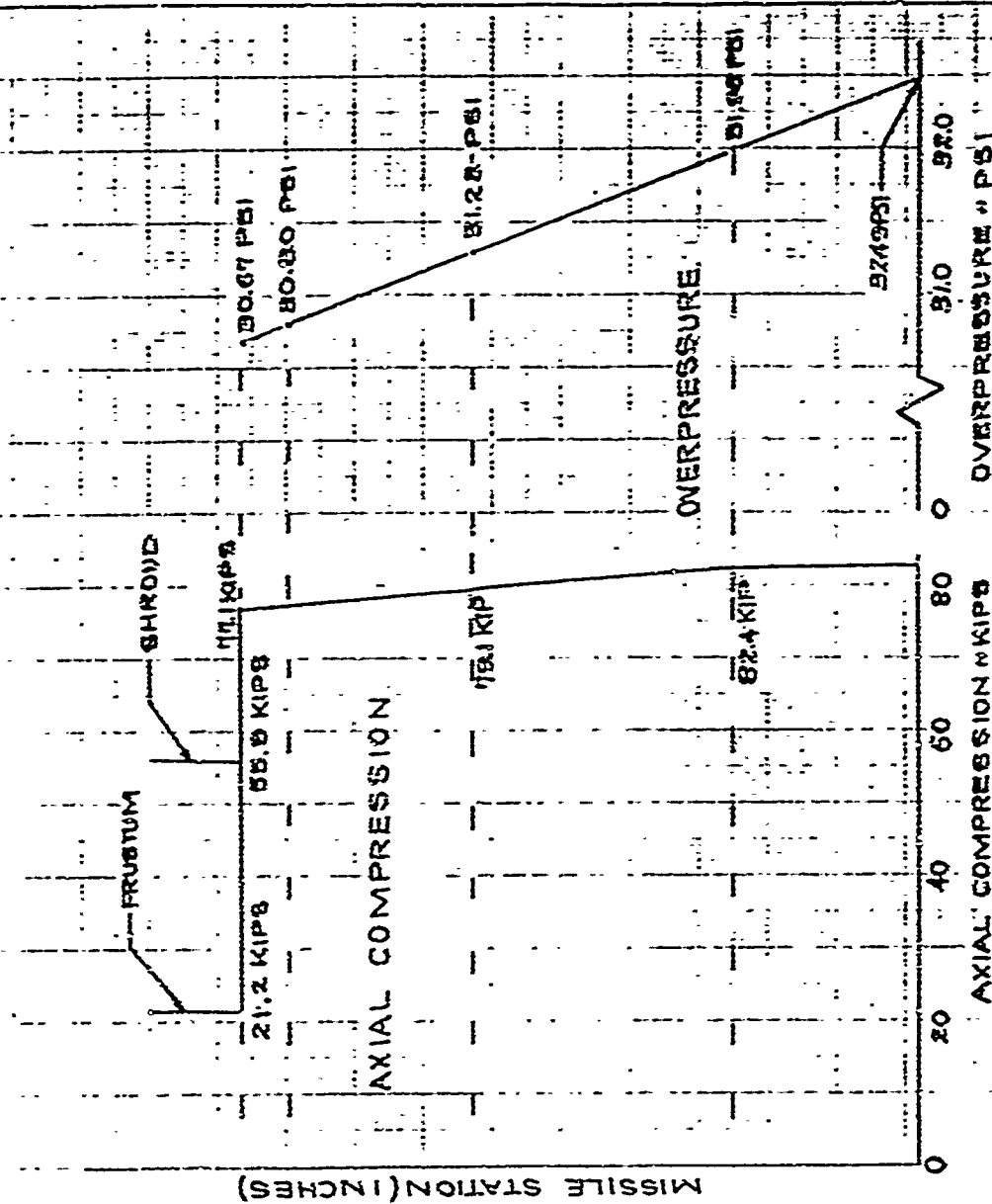

NOTE:
HYDR. JACK LOAD ON FRUSTUM = 12.01 KIPS
PRESSURE RECORDED AT DATUM (STA. 106.0) = 20.75 PSI

	INITIALS	DATE	REV BY INITIAL	DATE	TITLE	MODEL
CALC	SDW	11-8-8			333-L(LAUNCH) FAILURE TEST, LOADS OF AXIAL COMPRESSION & OVERPRESSURE APPLIED AT FAILURE VS. MISSILE STATION.	
CHECK	JET	11-8-8				
APPD.						
APPD.						
APPD.						

U3 4013 8000 REV 1-66

REV LTR _____

BOEING NO. T2-3657-1
SH 309

FIG. 8.4-2

USE FOR TYPEWRITTEN MATERIAL ONLY

3.6 TEST RESULTS

SHEET 310

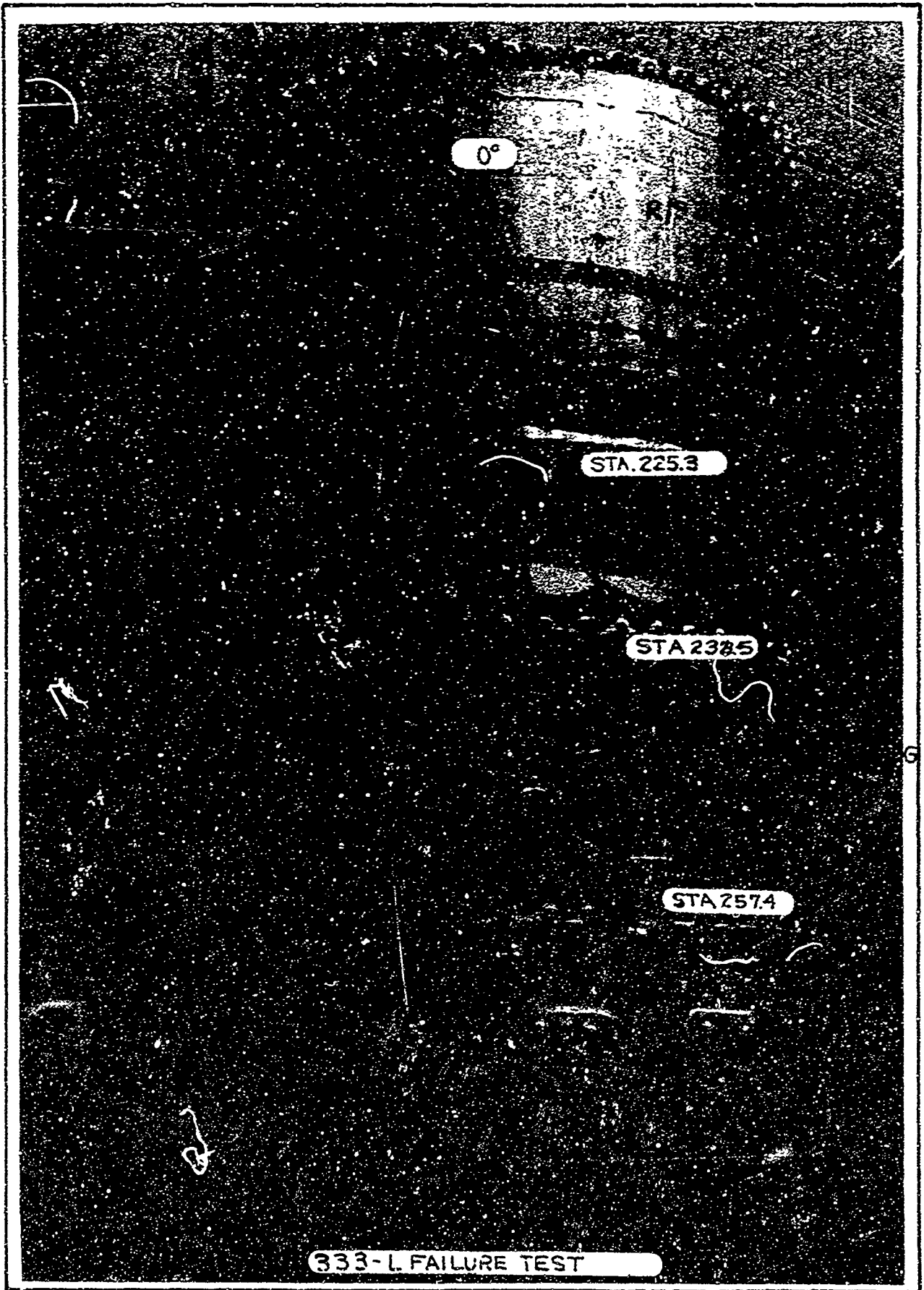

SHEET 311

FIG. 3.6-1



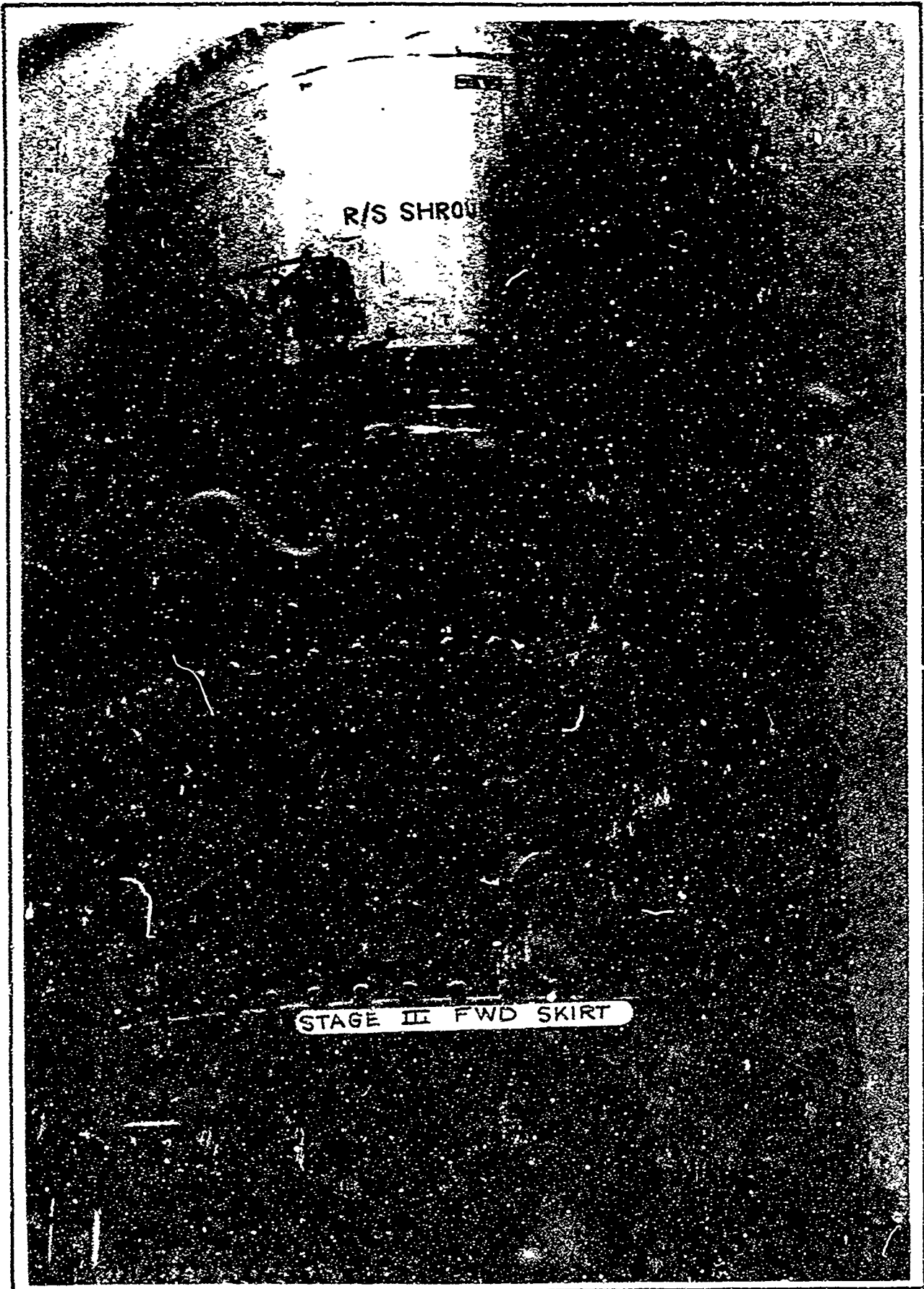

SHEET 312

FIG. 3.6-2



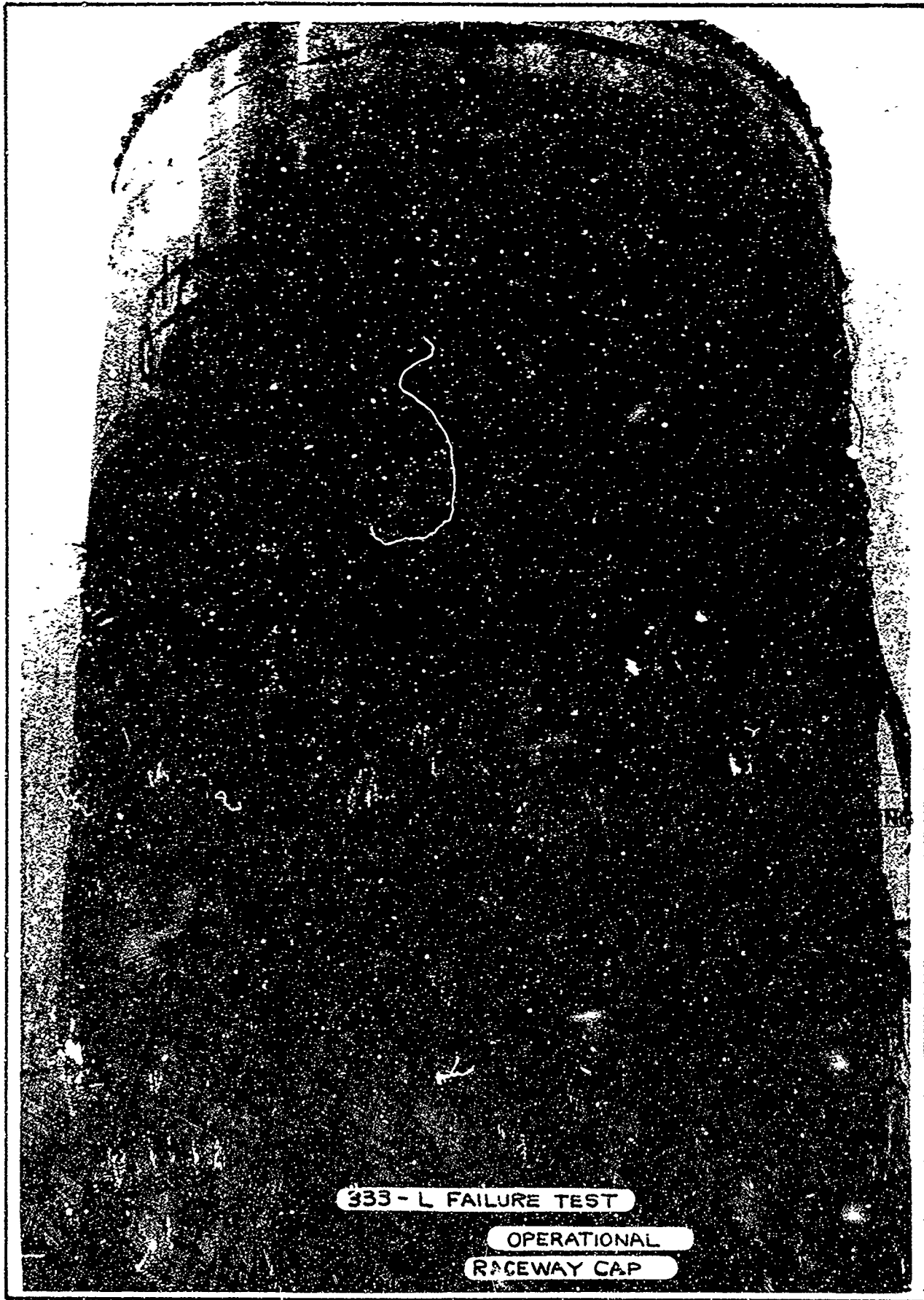

SHEET 313

FIG. 3.6-3



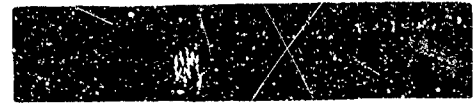
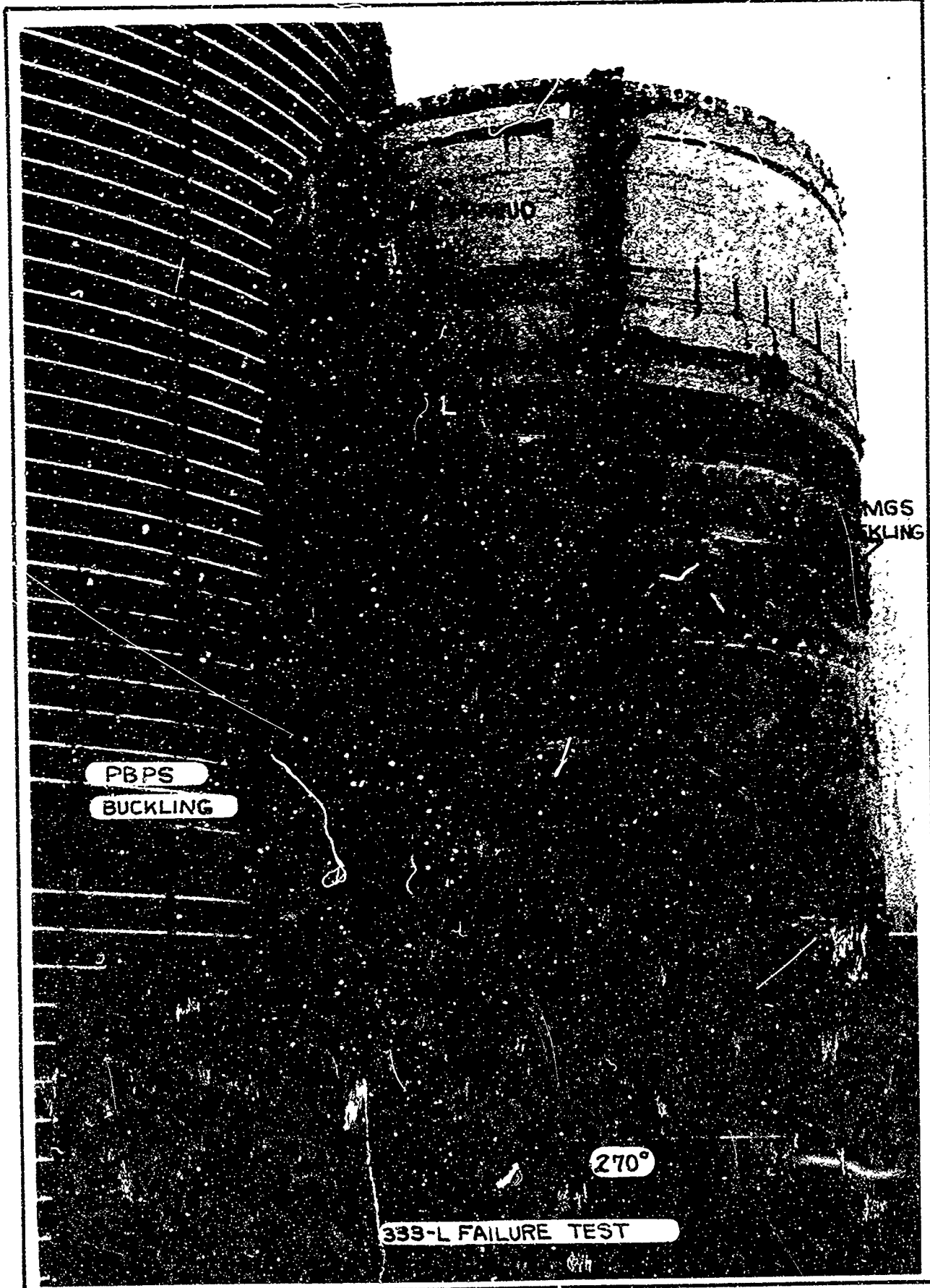

NUMBER T2-3657-1
REV LTR

THE **BOEING** COMPANY

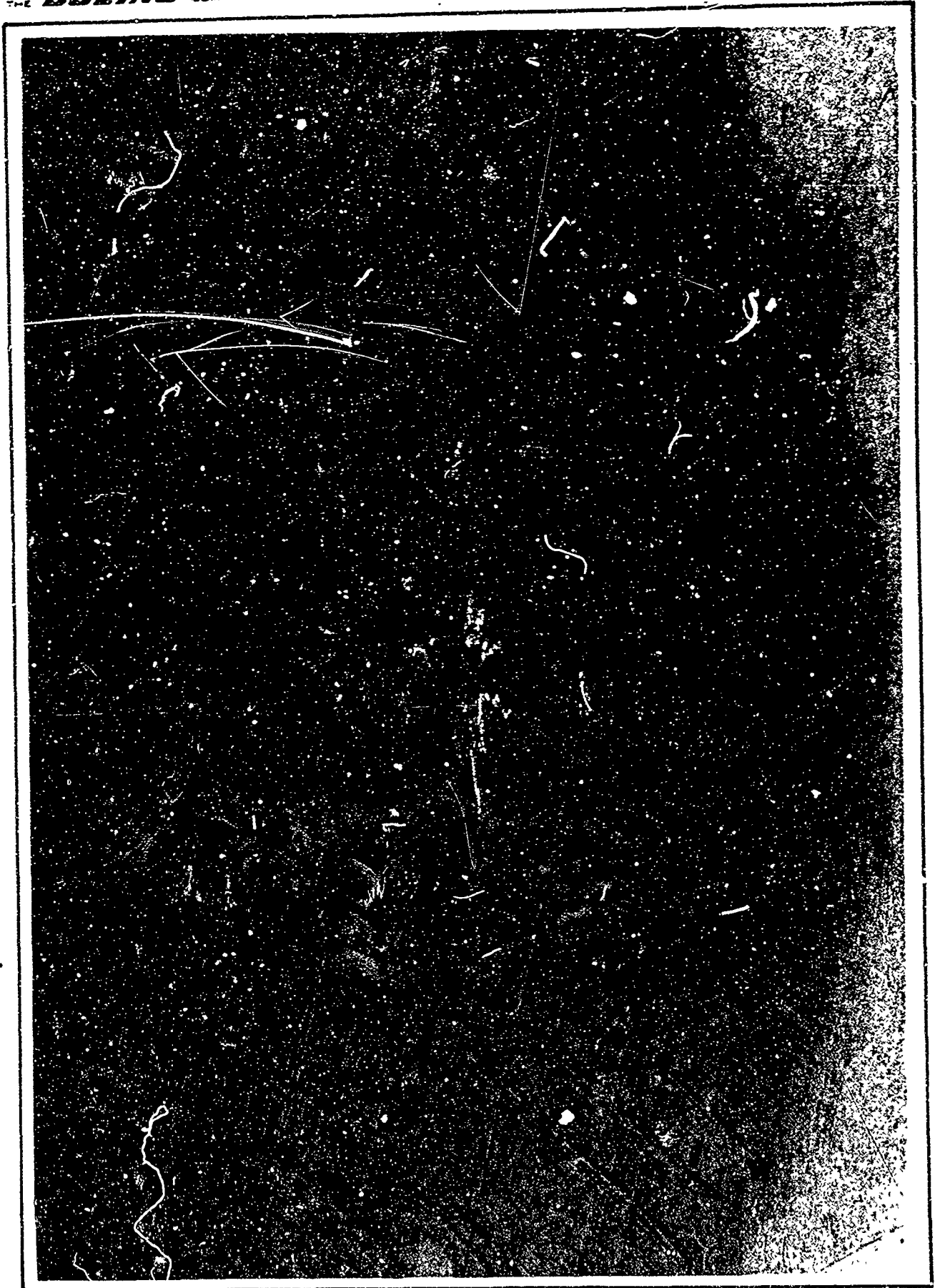

SHEET 315

FIG. 3.6-5

U3 4802 1434 ORIC, 4-65



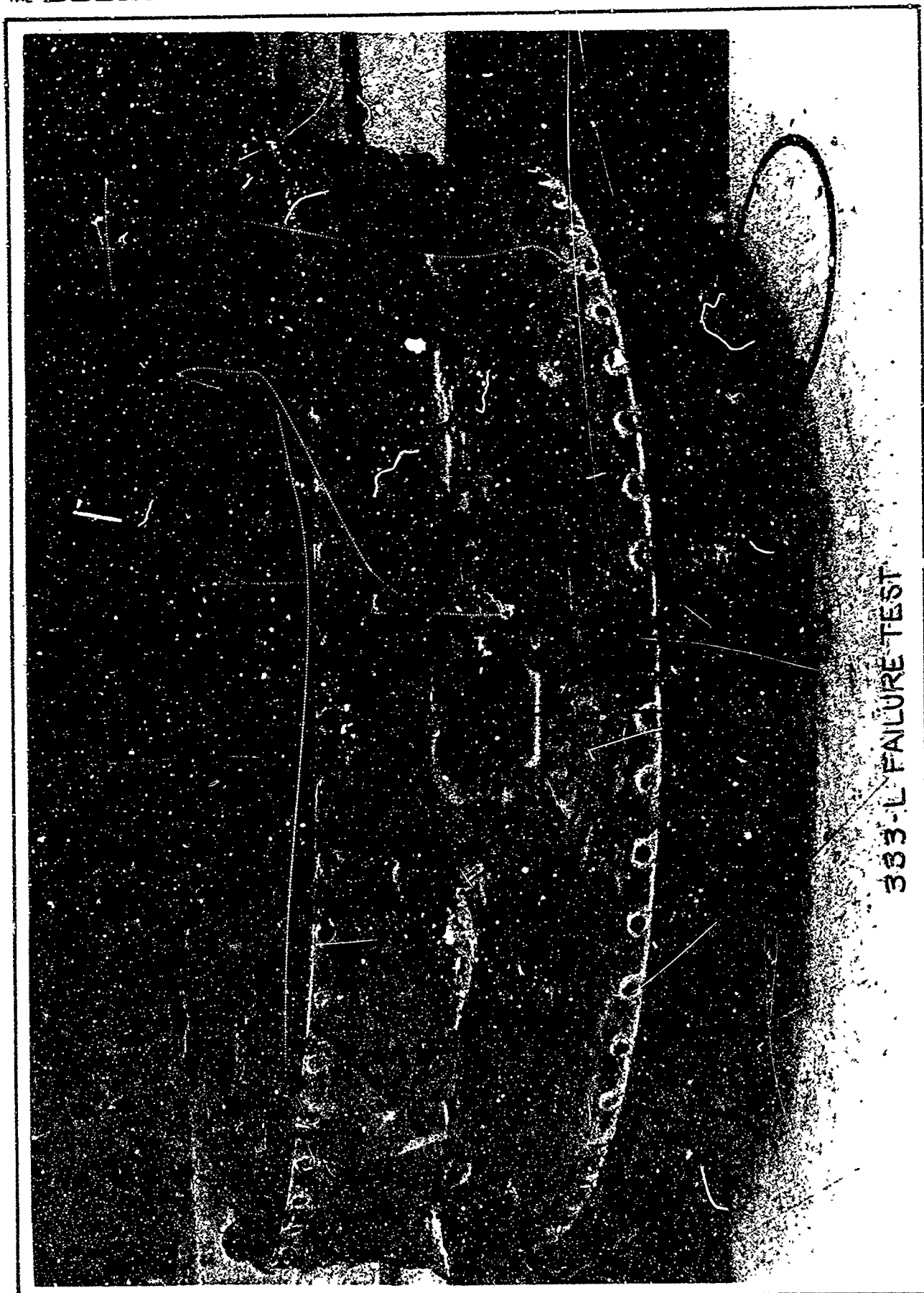

333-L FAILURE TEST

SHEET 316

FIG. 3.6-6

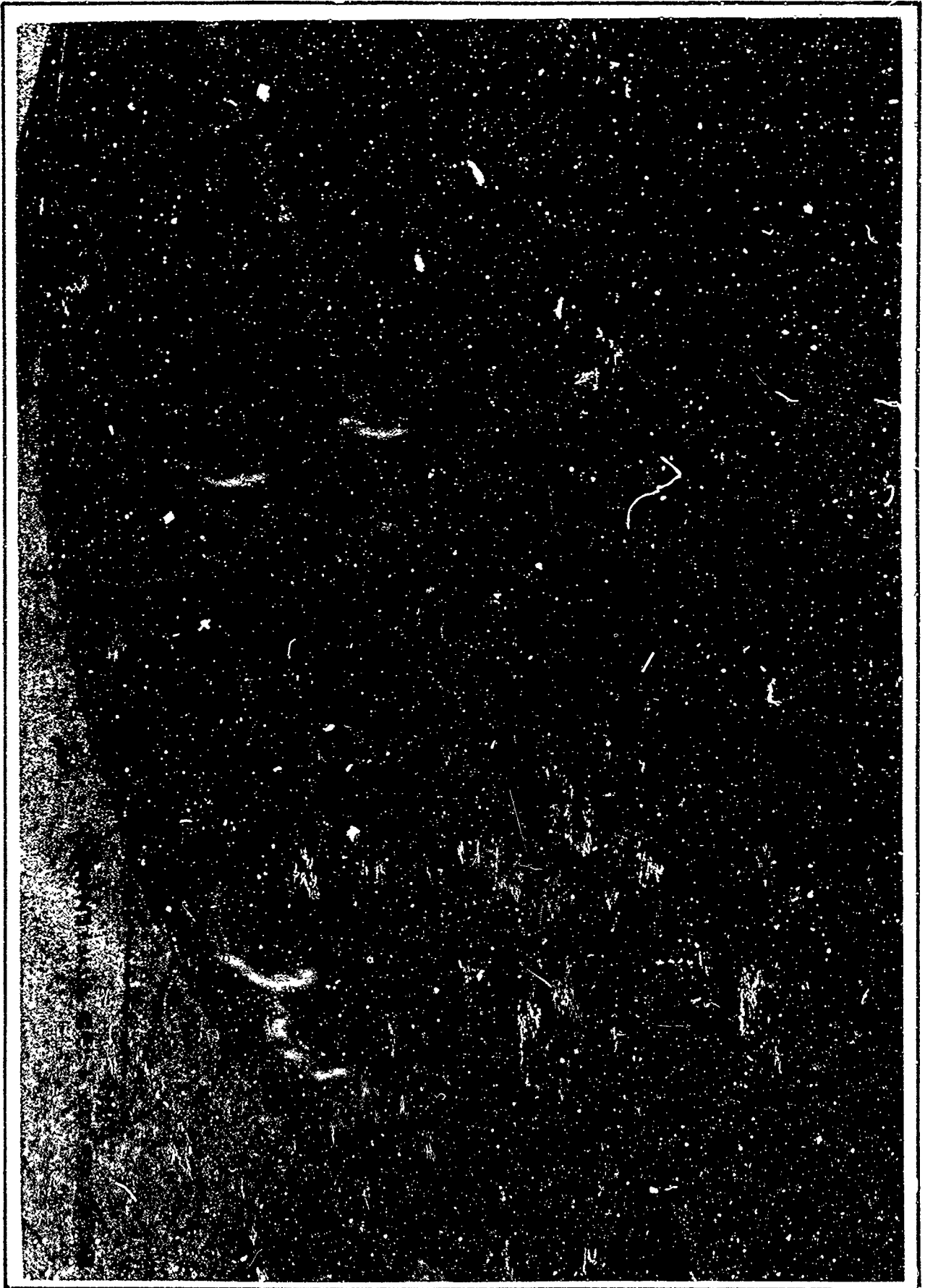

SHEET 317

FIG. 3.6-7





335-L FAILURE TEST

SHEET 318

FIG. 3.6-8



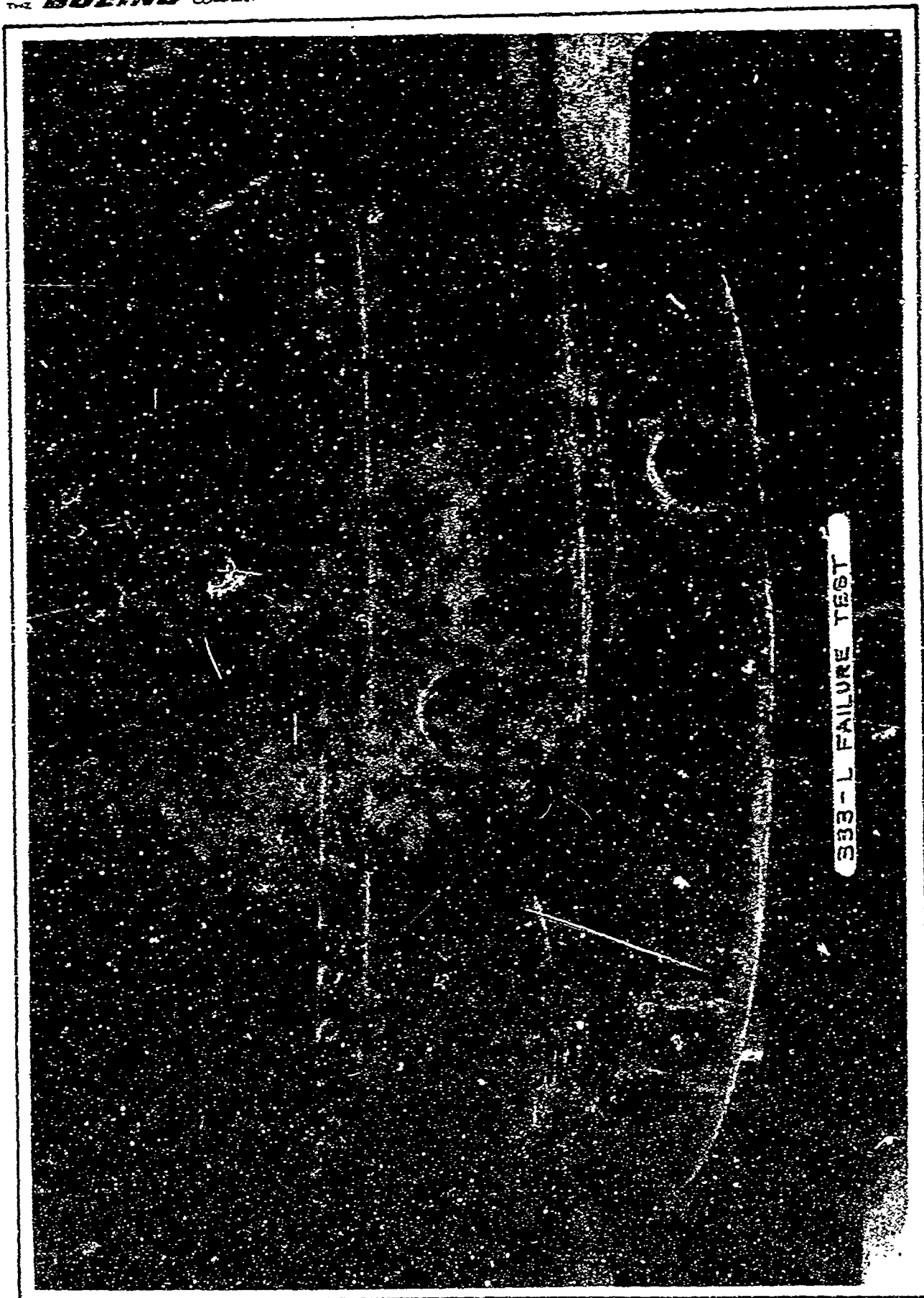

SHEET 319

FIG. 3.6-9



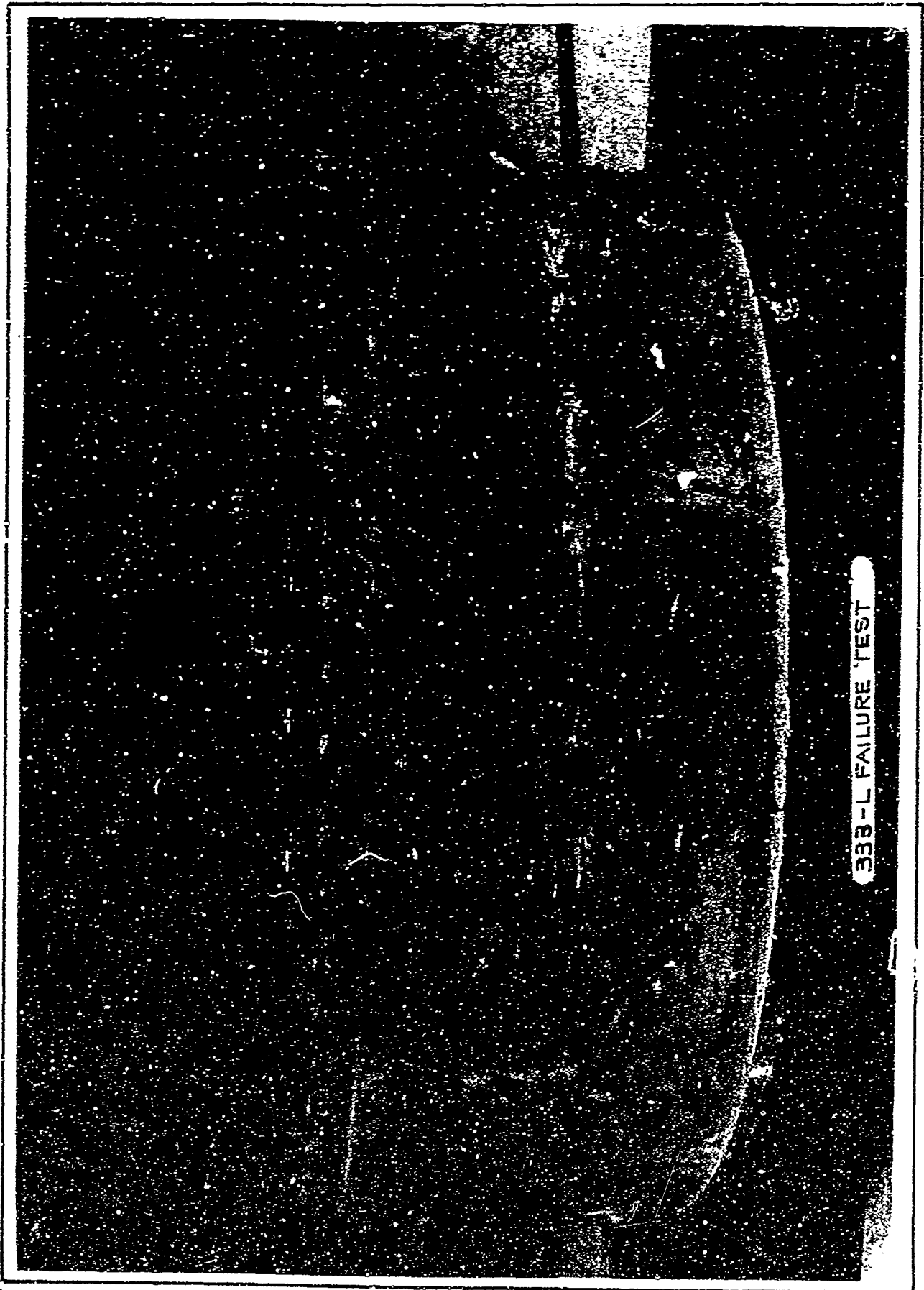

333-L FAILURE TEST

SHEET 320

FIG.3.6-10



SHEET 321

FIG. 3.6-11

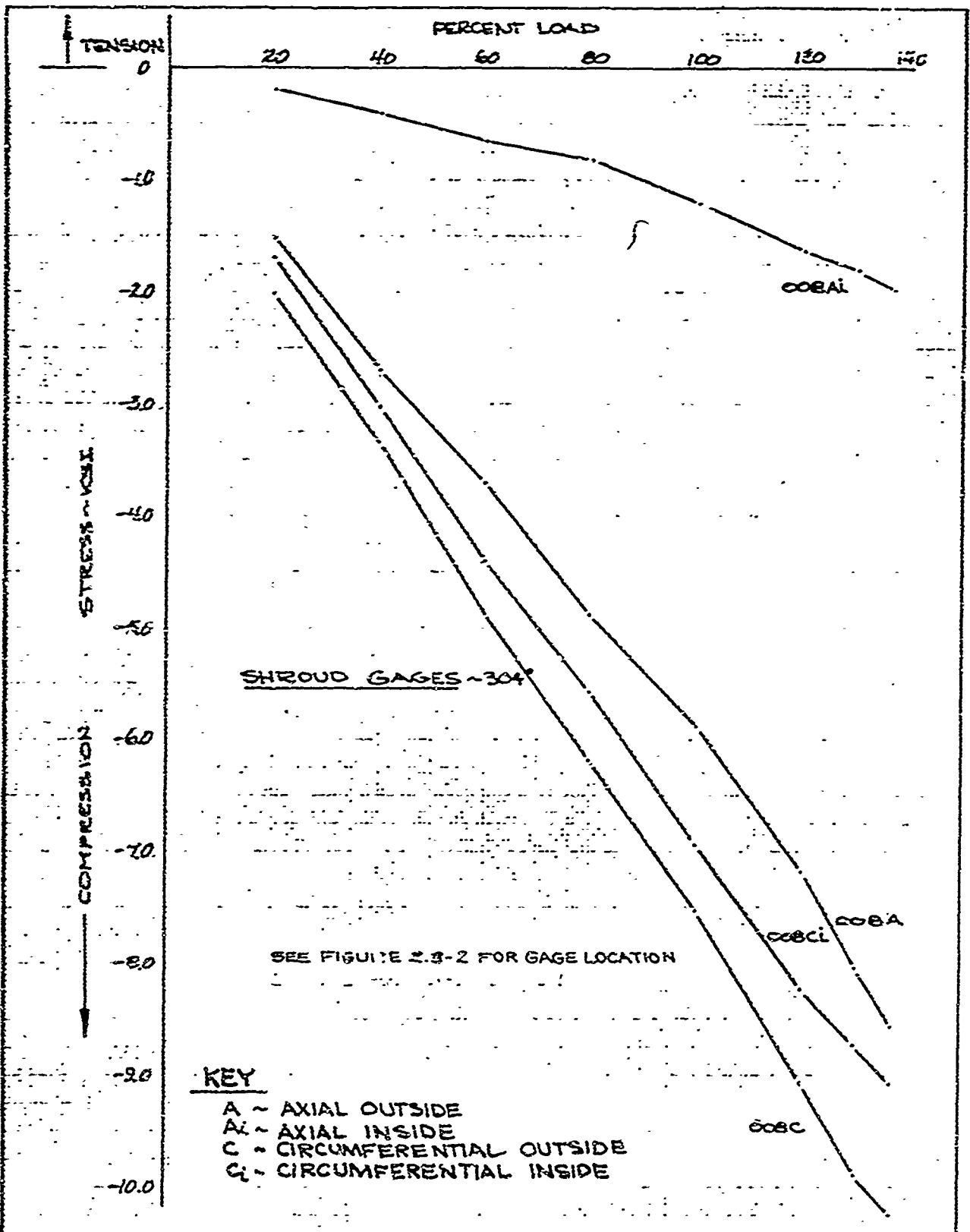

	INITIALS	DATE	REV BY INITIAL	DATE	TITLE	MODEL
CALC	RDW	10/1-8			333-L FAILURE TEST STRAIN GAGE READINGS SHROUD ~304°	
CHECK	GDW	11/118				
APPD.						
APPD.						

U3 4013 8000 REV 1/66

REV LTR _____

BOEING NO. T2-3657-1
 SH. 322

FIG. 3.6-12

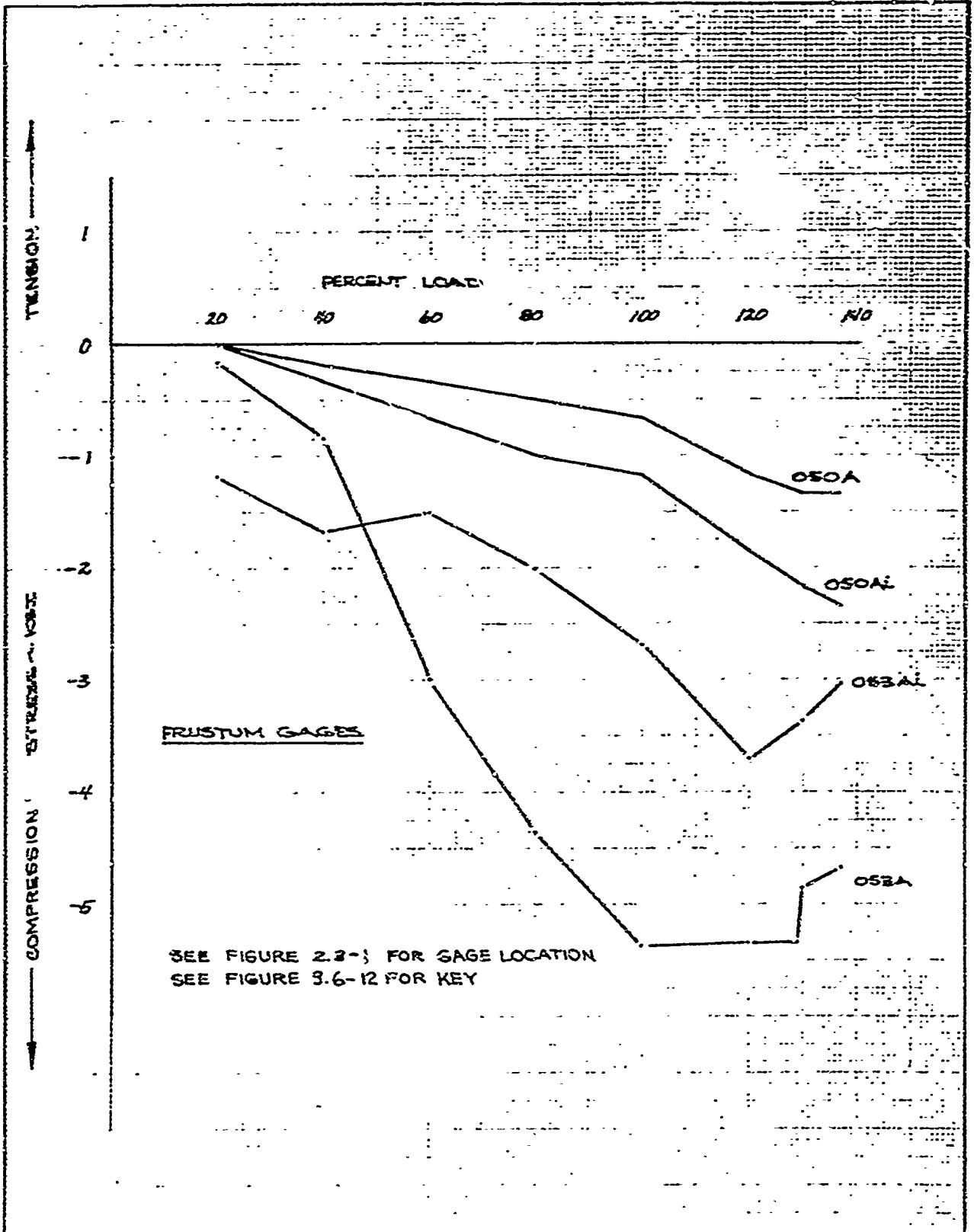

SEE FIGURE 2.2-3 FOR GAGE LOCATION
 SEE FIGURE 3.6-12 FOR KEY

	INITIALS	DATE	REV BY INITIAL	DATE	TITLE	MODE.
CALC	Row	10/1-8			333-L FAILURE TEST STRAIN GAGE READINGS FRUSTUM	
CHECK	SDW	11/1/8				
APPD.						
APPD.						

U3 4013 8000 REV 1/66

REV LTR _____

BOEING NO. T2-3657-1
 SH. 323

FIG. 3.6-13

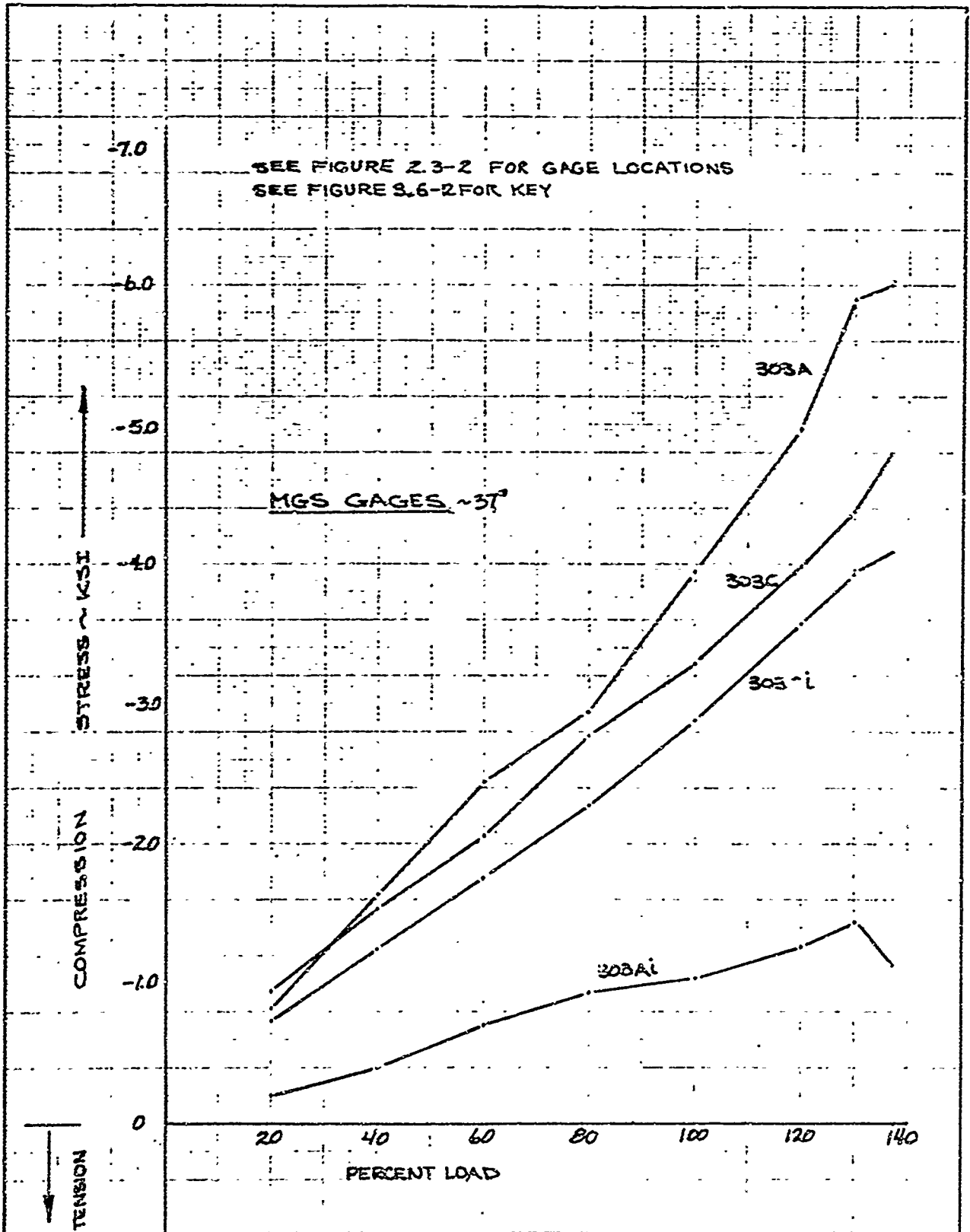

	INITIALS	DATE	REV BY INITIAL	DATE	TITLE	MODEL
CALC	Row	10/1/8			333-L FAILURE TEST STRAIN GAGE READINGS 37° MGS	
CHECK	GDW	11/1/8				
APPD.						
APPD.						

UJ 4013 8000 REV 1/66

REV LTR _____

FIG. 3.6-14

BOEING NO. T2-3657-1
SH. 324

SEE FIGURE 2.3-2 FOR GAGE LOCATIONS
SEE FIGURE 3.6-12 FOR KEY

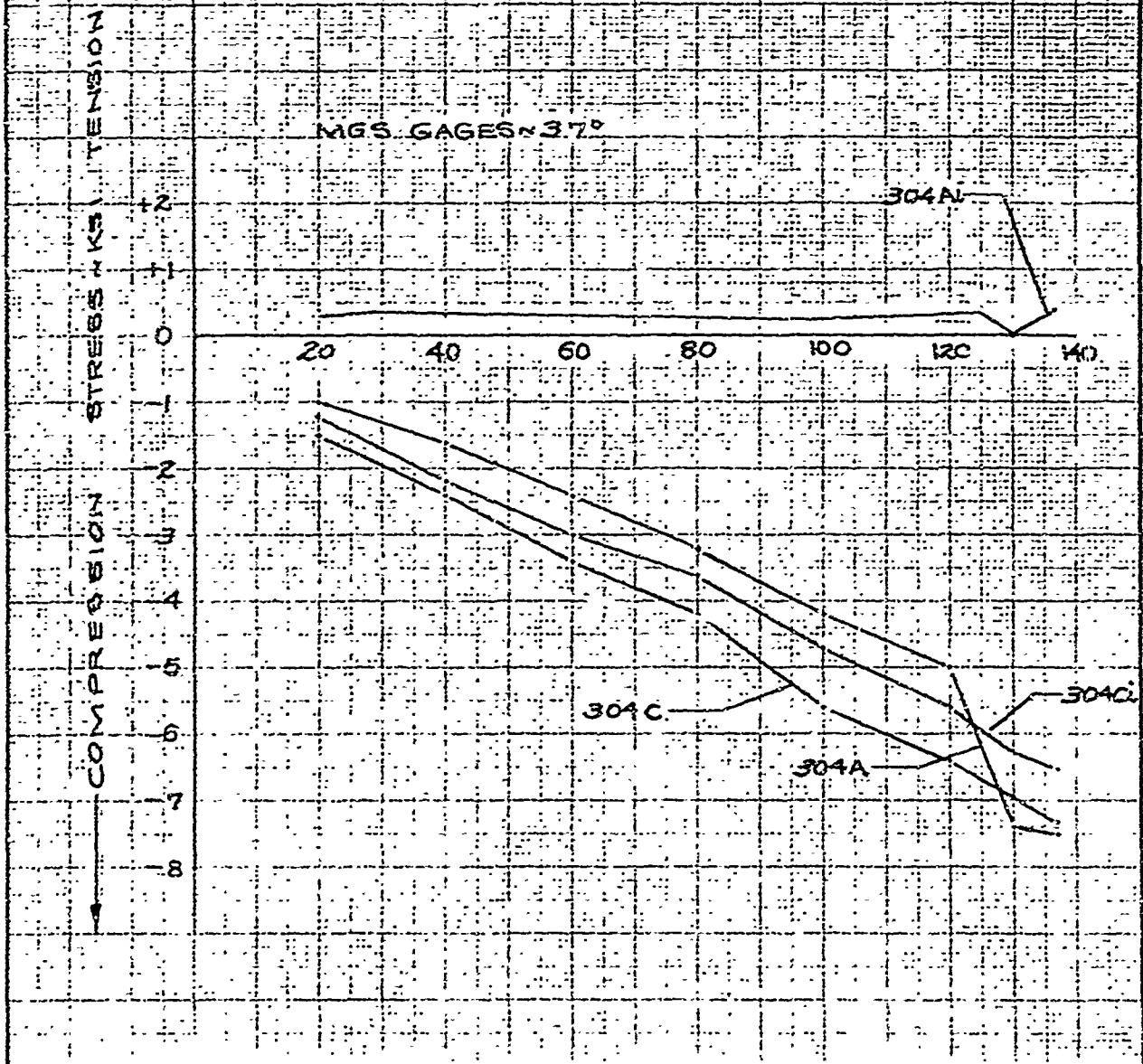

	INITIALS	DATE	REV BY INITIAL	DATE	TITLE	MODEL
CALC	GDW	10-30-8			333-L FAILURE TEST STRAIN GAGE READINGS MGS ~37°	
CHECK	NET	11-6-8				
APPD.						
APPD.						

U3 4013 8000 REV. 1/66

FIG. 3.6-15

REV LTR _____

BOEING NO. T2-3657-1
SH. 325

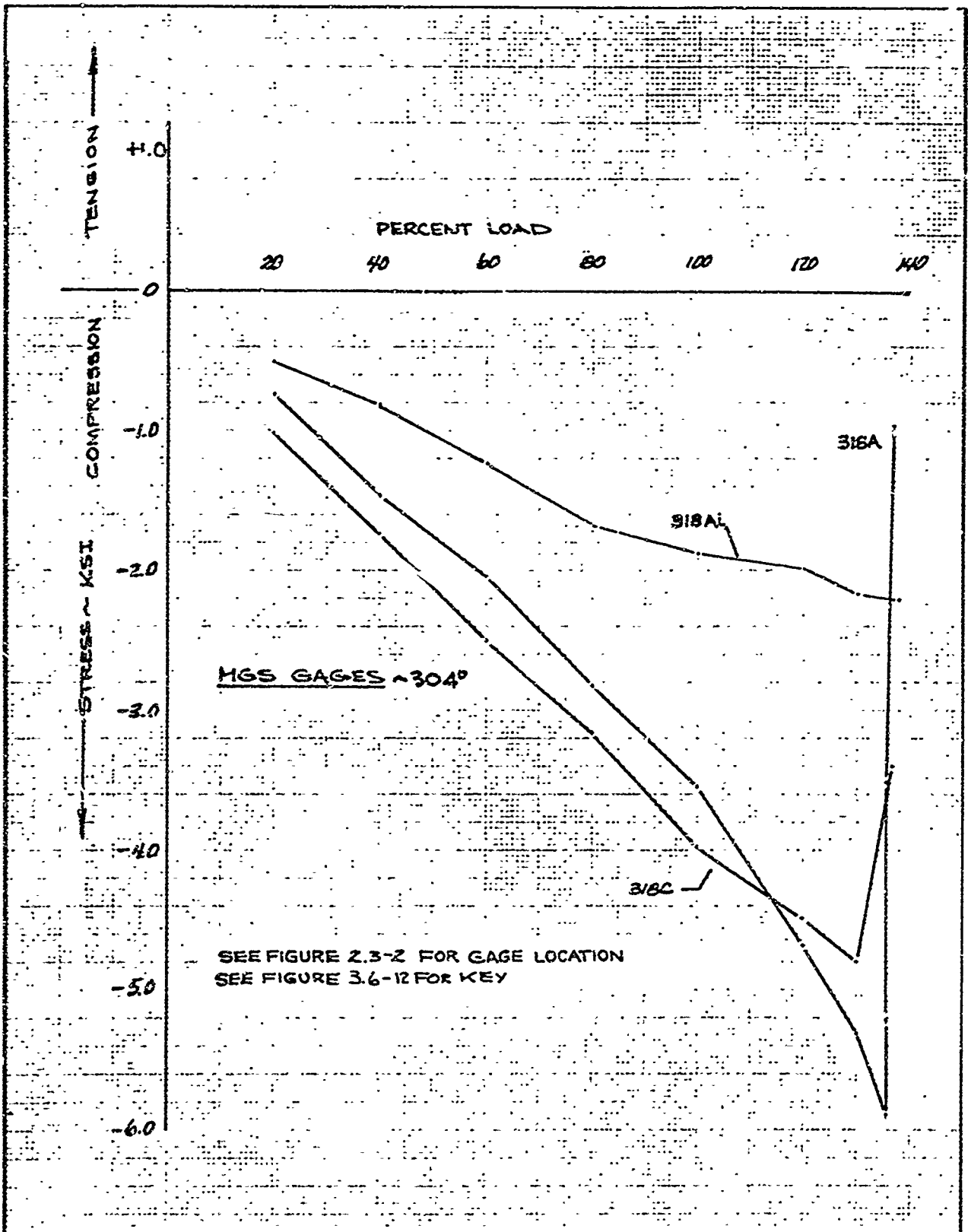

	INITIALS	DATE	REV BY INITIAL	DATE	TITLE	MODEL
CALC	GDW	10/1-8			333-L FAILURE TEST STRAIN GAGE READINGS MGS ~304°	
CHECK	GDW	11/6-8				
APPD.						
APPD.						

U3 4013 8000 REV 1/66

REV ITR _____

BOEING NO. T2-3657-1
SH. 326

FIG. 3.6-16

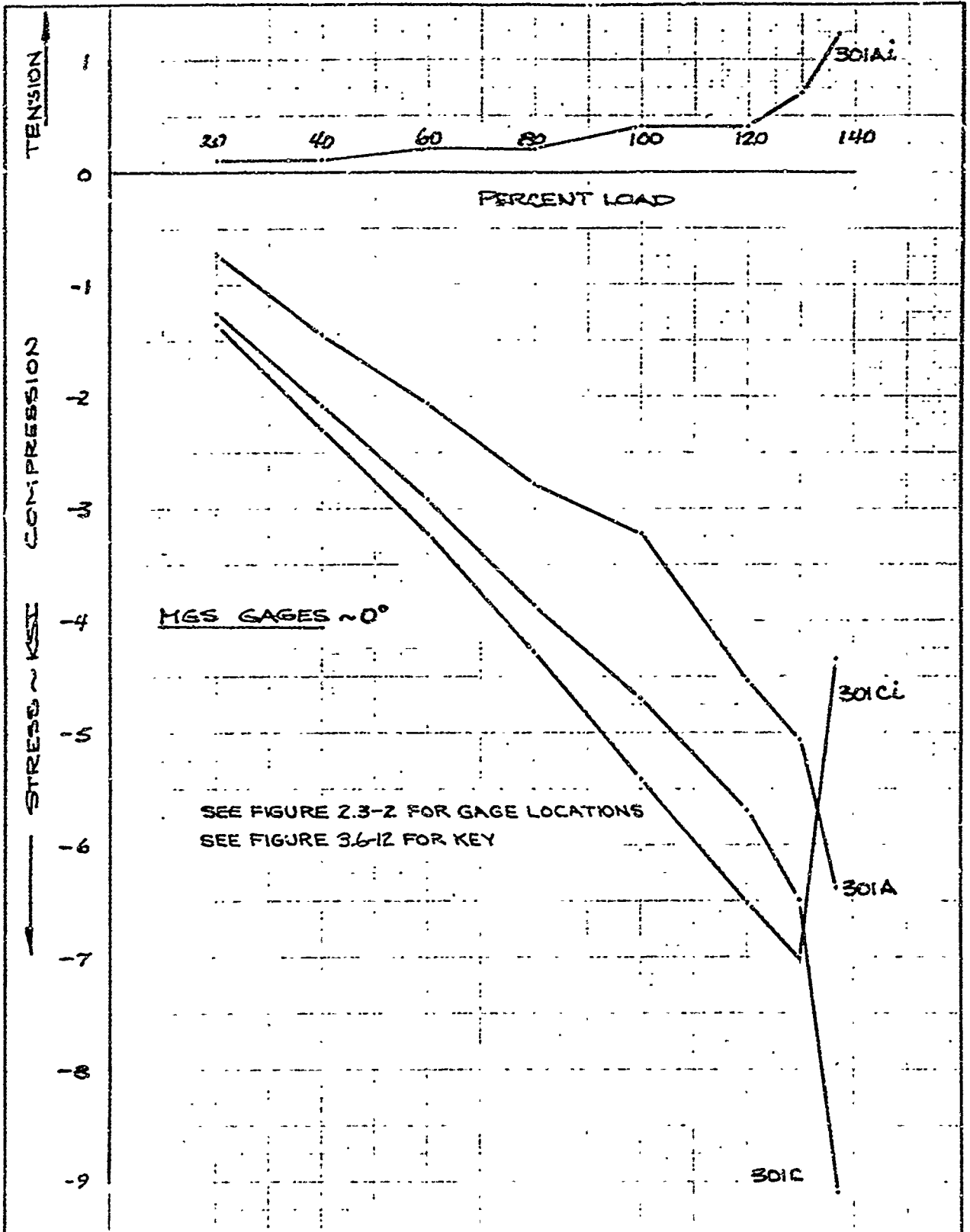

INITIALS	DATE	REV BY INITIAL	DATE	TITLE	MODEL
CAIC	Row	10-1-8		333-L FAILURE TEST STRAIN GAGE READINGS MGS ~ 0°	
CHECK	BW	11-48			
APPD.					
APPD.					

UJ 4013 8000 REV 1/66

FIG. 3.6-17

REV LTR _____

BOEING NO. T2-3657-1
SH. 327

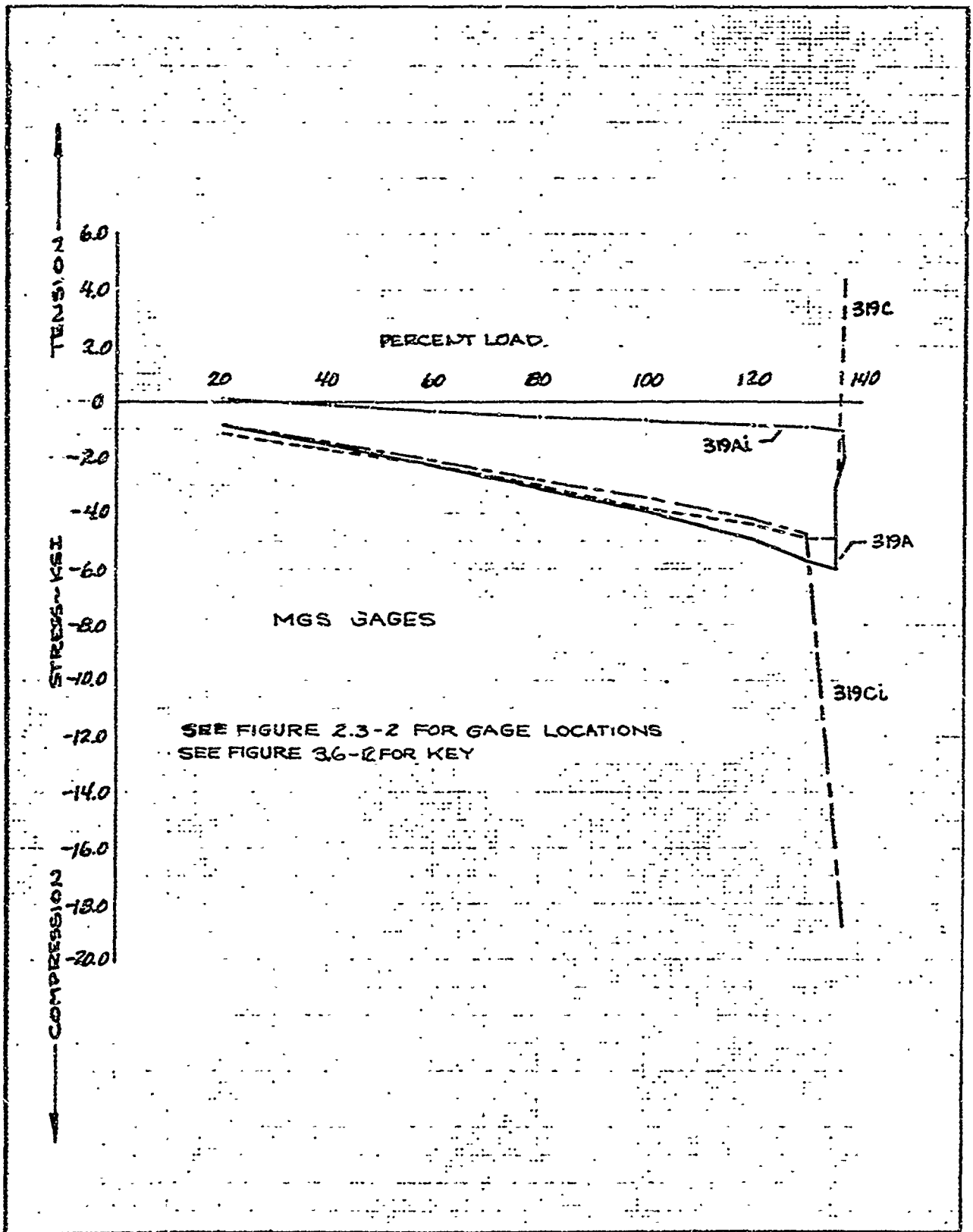

	INITIALS	DATE	REV BY INITIAL	DATE	TITLE	MODEL
CALC	GDW	10/1-8			333-L FAILURE TEST STRAIN GAGE READINGS MGS ~ 319°	
CHECK	GDW	11/6/8				
APPD.						
APPD.						

U3 4013 8000 REV 1/66

FIG. 3.6-18

REV LTR _____

BOEING NO. T2-3657-1
SH. 328

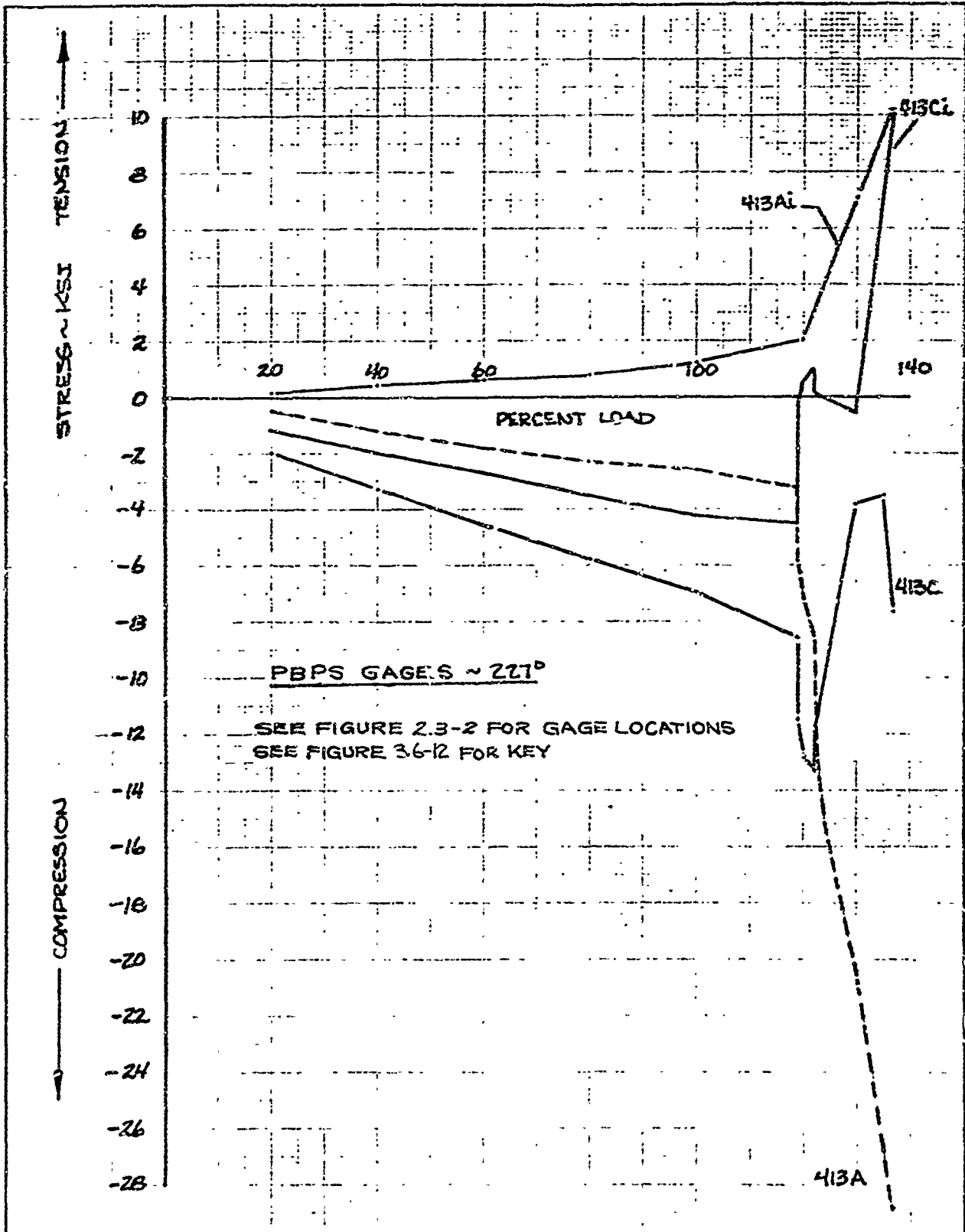

	INITIALS	DATE	REV BY INITIAL	DATE	TITLE	MODEL
CALC	<i>Row</i>	<i>10/1-8</i>			333-L FAILURE TEST STRAIN GAGE READINGS PBPS ~ 227°	
CHECK	<i>GDW</i>	<i>11/4/8</i>				
APPD.						
APPD.						

U3 4013 8000 REV 1/66

FIG. 3.6-19

REV LTR _____

BOEING NO. TZ-3657-1
SH. 329

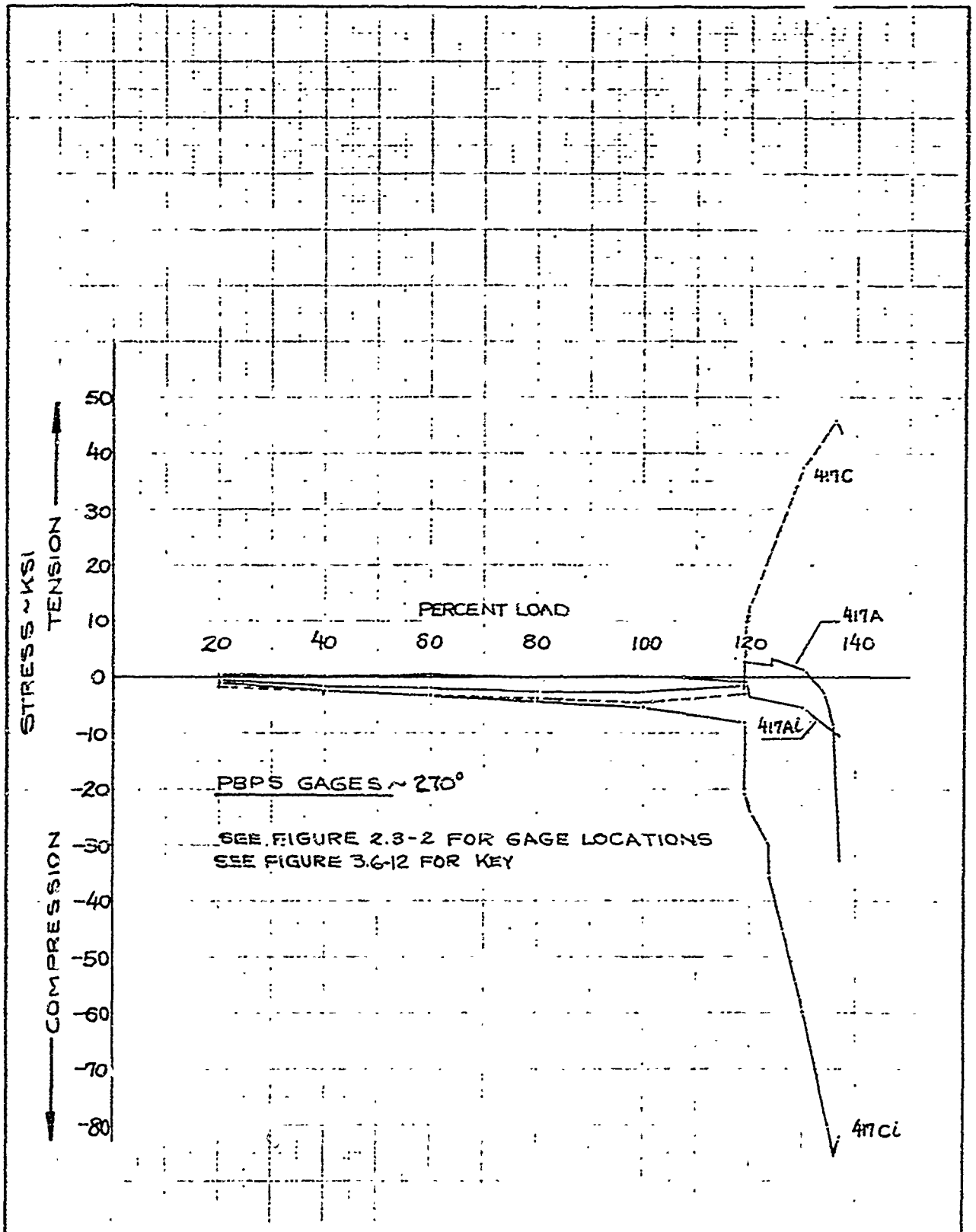

	INITIALS	DATE	REV BY INITIAL	DATE	TITLE	MODEL
CALC	GOW	10/1/8			333-L FAILURE TEST STRAIN GAGE READINGS PBPS ~ 270°	
CHECK	JET	11/4/8				
APPD.						
APPD.						

U3 4013 8000 REV 1/66

FIG. 3.6-20

REV LTR _____

BOEING NO. T2-3657-1
SH 330

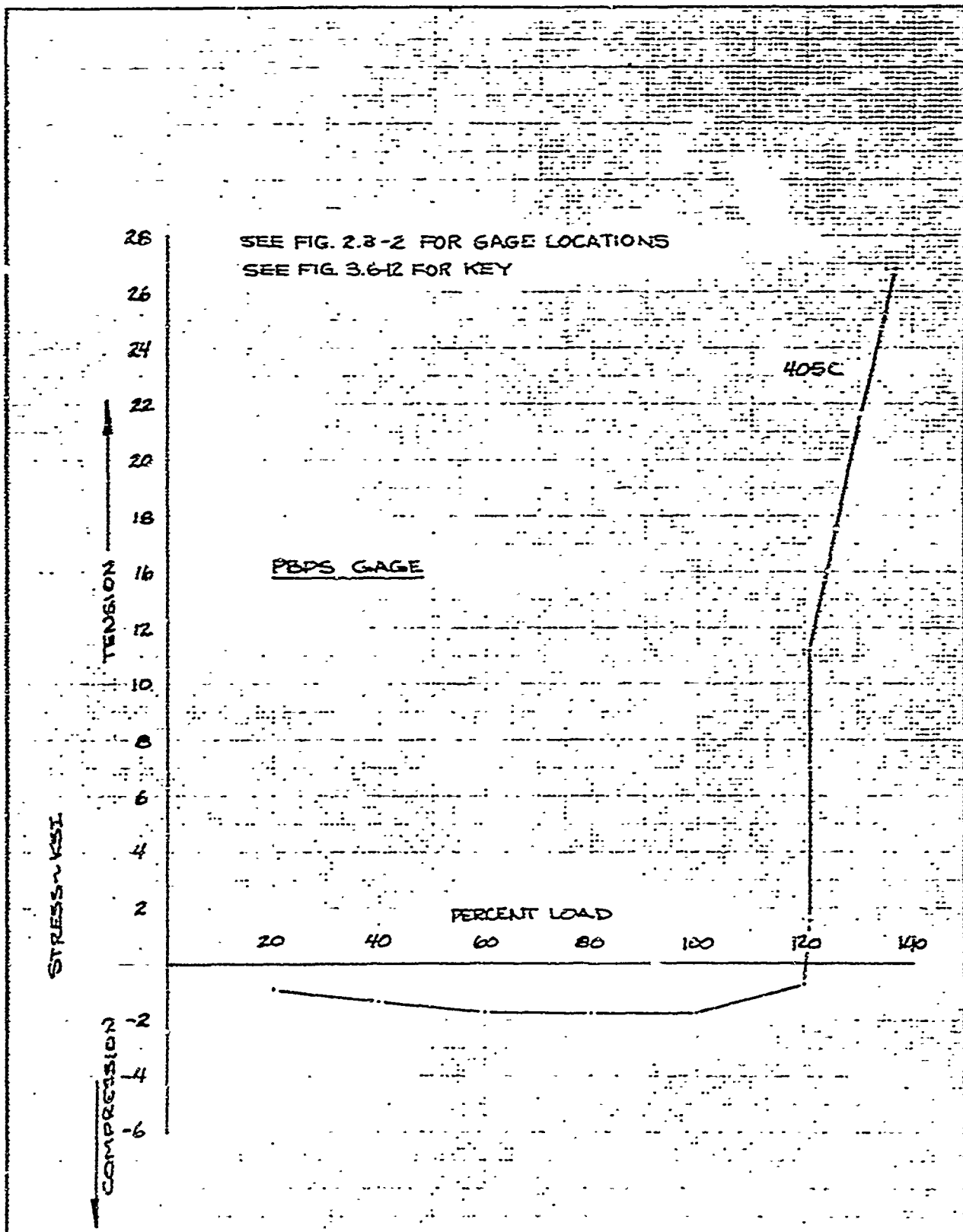

	INITIALS	DATE	REV BY INITIAL	DATE	TITLE	MOSEL
CALC	ROW	10/1-8			333-L FAILURE TEST STRAIN GAGE READINGS PBPS ~ 90°	
CHECK	GDW	11/4/8				
APPD.						
APPD.						

113 4013 8000 REV 1, '56

REV LTR _____

FIG. 3.6-21

BOEING NO T2-3657-1
SH. 331

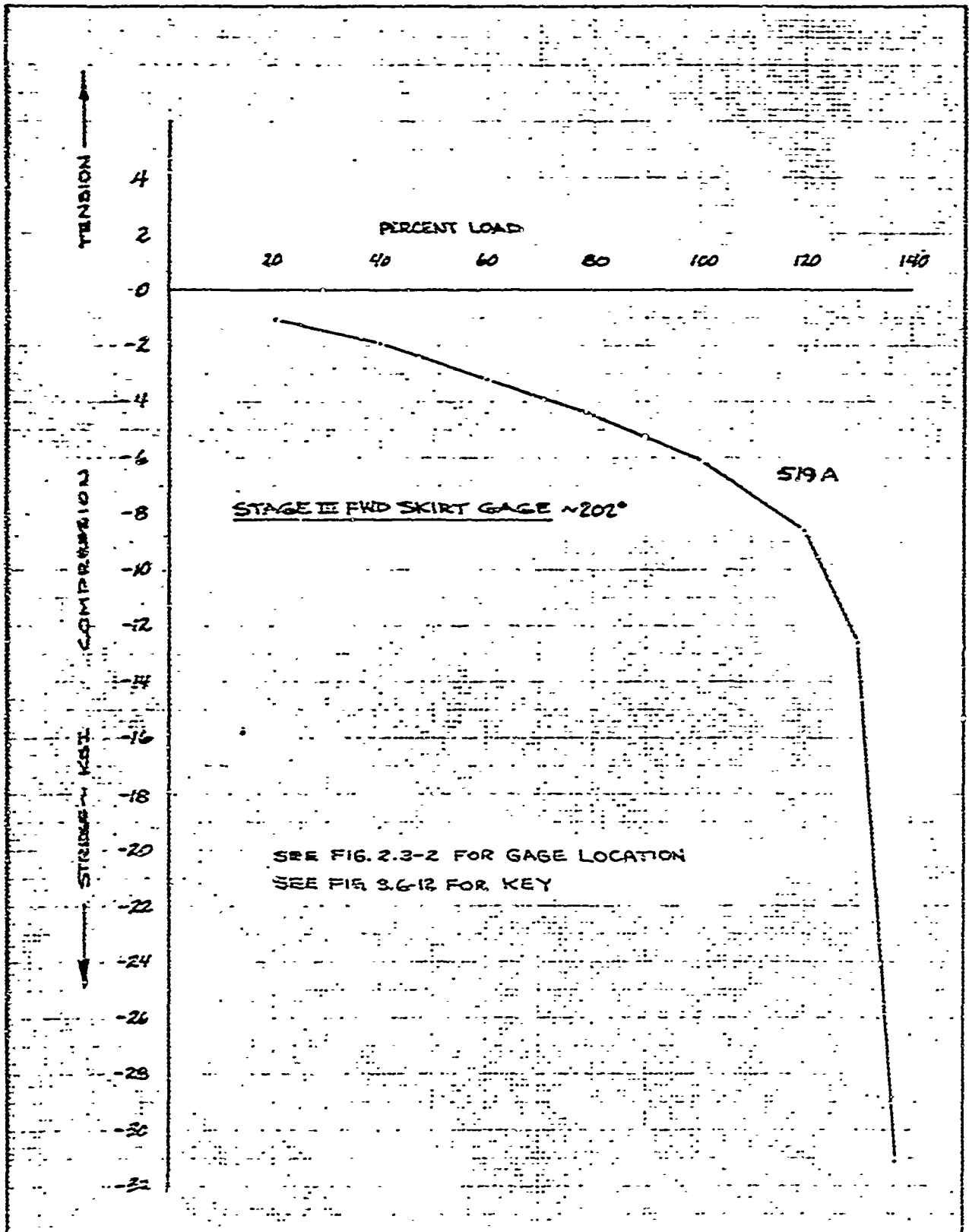

	INITIALS	DATE	REV BY INITIAL	DATE	TITLE	MODEL
CALC	RDW	10/1-8			333-L FAILURE TEST STRAIN GAGE READINGS STG. III FWD. SKIRT ~202°	
CHECK	GDW	11/4/8				
APPD.						
APPD.						

UJ 4013 8000 REV 1/66

FIG. 3.6-22

REV LTR _____

BOEING NO. T2-3657-1
SH. 332

4.0 STAGE III/PBV R&D FLIGHT CONDITION TESTS (332-F)

4.1 TEST SPECIMEN

The 332-F Test Specimen consisted of the aft section of the R/V including a portion of the Shroud (GE Part Number 67J53362G1, S/N G031A), the R/S Frustum (GE 67J55705G1, S/N G031A) and a V-Band assembly (GE 67J54865, S/N G031A). Also included were a Mod 7E wafer (25-61767-20), an MGS Section (Autonetics Part Number 8537-400001-1, S/N BTJ 0201), a PBPS Section (A/N 8537-500001-1, A/N A4X0011), a Stage III/PBV Separation Joint (25-60262-1, S/N G000031), and an empty Stage III motor (AGC 1144233-9, S/N 0000019) with an aft dome closure plate (AGC 1144231-1). Figures 4.1-1 through 4.1-9 show the test specimen which was complete in all details affecting structural strength, stiffness, and load distribution. All raceway covers and insulation were omitted from the test specimen. A cross-section of the specimen giving the dimensional survey locations is shown in Figure 4.1-10 and the dimensional survey results are shown in Tables 4.1-1 through 4.1-6.

4.2 TEST SETUP

Figure 4.2-1 shows a schematic of the test setup. Loading heads and adapters were used to introduce loads to the specimen. A lateral jack introduced the shear load through the forward shroud loading head. Four longitudinal jacks applied an axial load and a pure couple component of the moment to the shroud. Two longitudinal jacks applied an axial load to the frustum. A seventh longitudinal jack applied axial compression through the aft dome closure plate of the Stage III motor. Lead weights applied constant axial load to the internal structure of the PBCS. The empty Stage III motor was internally pressurized to 28 psi with water in order to simulate the increased buckling capability of an operational motor. All loads were programmed through the SDS 910 computer and applied by servo-controlled jacks. The test was conducted in a test cell as a safety precaution. Photographs of the test setup are shown in Figures 4.2-2 through 4.2-7.

4.3 TEST INSTRUMENTATION

During the 332-F Tests, selected strain gages were read. The strain gage channels were located and identified as shown in Figures 4.3-1 through 4.3-4. Test data, including load cell readings, were recorded at the end of each increment of applied load and are shown in reference 4.

4.4 TEST CONDITIONS

Prior to the static flight condition tests a set of 16 stiffness tests were conducted with this specimen. See section 7.0 for details of these tests. The wind shear maximum q_{∞} loads of axial compression, moment and shear were applied at room temperature, in increments, to 100% of the reference 1 test loads. Conditions 332-F (a) and 332-F (b), per reference 1, applied the maximum line load at the 0° and 36°30' azimuths respectively. The PBCS internal structure was loaded with 2.0 kips on

4.4 TEST CONDITIONS (CONT.)

the MGS bulkhead and 3.3 kips suspended from the PBPS internal beams. A stabilizing internal pressure of 28 psi was applied to the Stage III motor during both tests. The test setup load geometry is shown in Figure 4.4-1. Figures 4.4-2 to 4.4-7 present the reference and planned loads vs. the actual test load of axial compression, moment and shear for both tests.

4.5 TEST PROCEDURE

The strain gages were zeroed with the load of the dead weights on the specimen. Strain gage readings, due to dead weights only, were recorded during the setup assembly. Test 332-F(b) was run first. Due to faulty excess error signals in the automatic load dump system, 3 runs were conducted prior to successfully reaching 100% test load. Two tests were run to 70% load and one to 90% load when the automatic dumps occurred. In the first test to 70% load the stage III motor was inadvertently left unpressurized. In all following tests however, the motor was internally pressurized to 28 psi just prior to loading. On the fourth run the loads were successfully increased incrementally to 100% loads. After rotating the specimen the 332-F(a) test was run following the same procedure as in the 332-F(b) test. Two runs were necessary since the first try was discontinued at 50% load to find the reason for improper loading in one jack.

4.6 TEST RESULTS

Selected strain gage data are shown plotted in figures 4.6-1 through 4.6-16. A tabulation of all test data acquired is given in reference 3. The strain gage data and visual inspection after each test verified that the specimen, had successfully sustained the test loads with no detrimental yielding.

4.7 TEST CONCLUSIONS

The successful conduct of test conditions 332-F(a) and 332-F(b) satisfies the objectives of reference 1 test plan and structurally confirms that the integrated Stage III/PBV stackup structurally sustains 100% test ultimate loads during the wind shear maximum q_{∞} flight condition. Though the specimen was only loaded to 100% loads the strain gage data showed that the R/S/Mod 7E/MJS integrated structure was not dangerously stressed and therefore, minimum gage R&D specimens would also be expected to sustain the 100% test loads.

USE FOR TYPEWRITTEN MATERIAL ONLY

USE FOR TYPE WRITING MATERIAL ONLY

4.1
TEST SPECIMEN

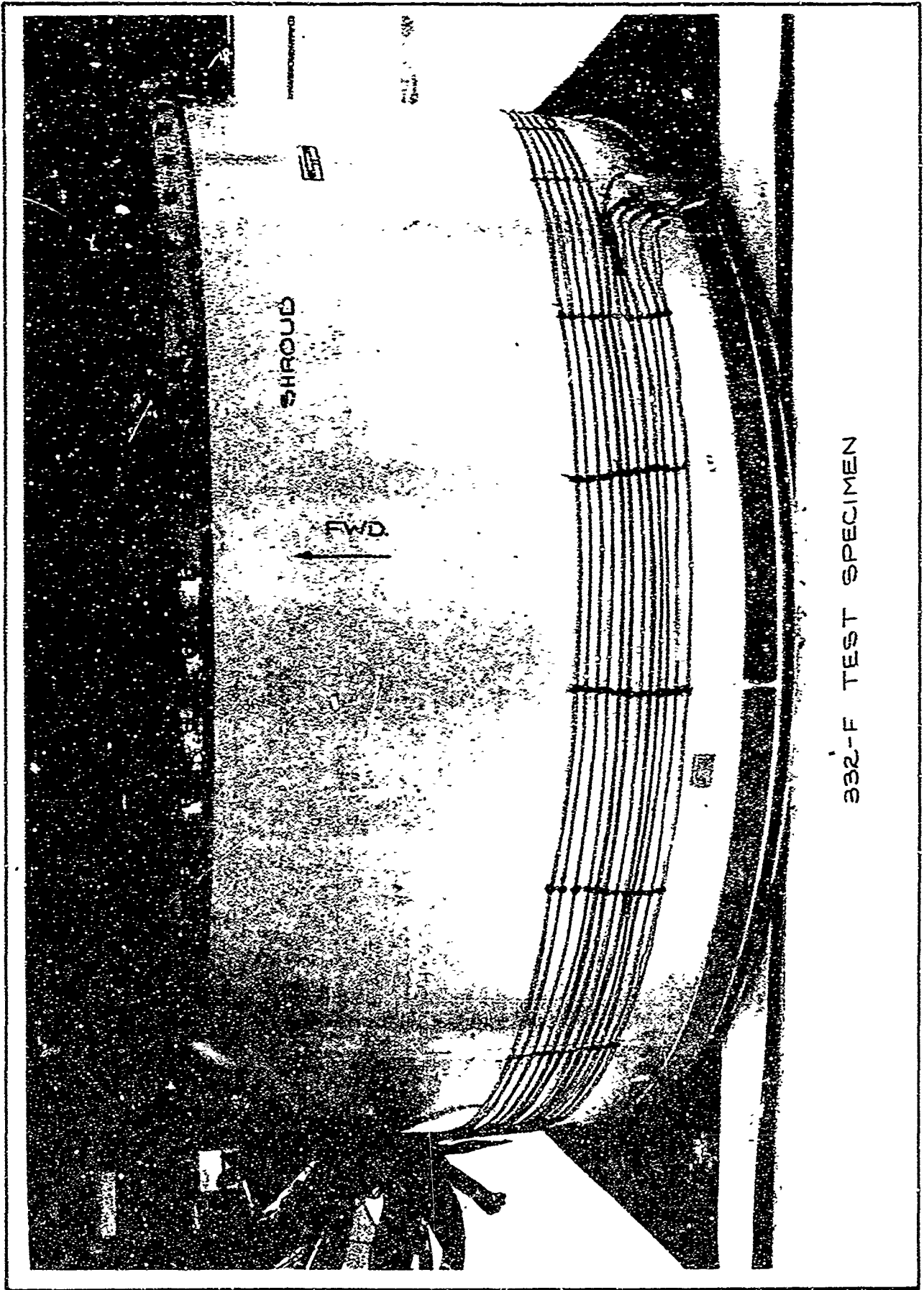

SHEET 403

FIG. 4.1-1

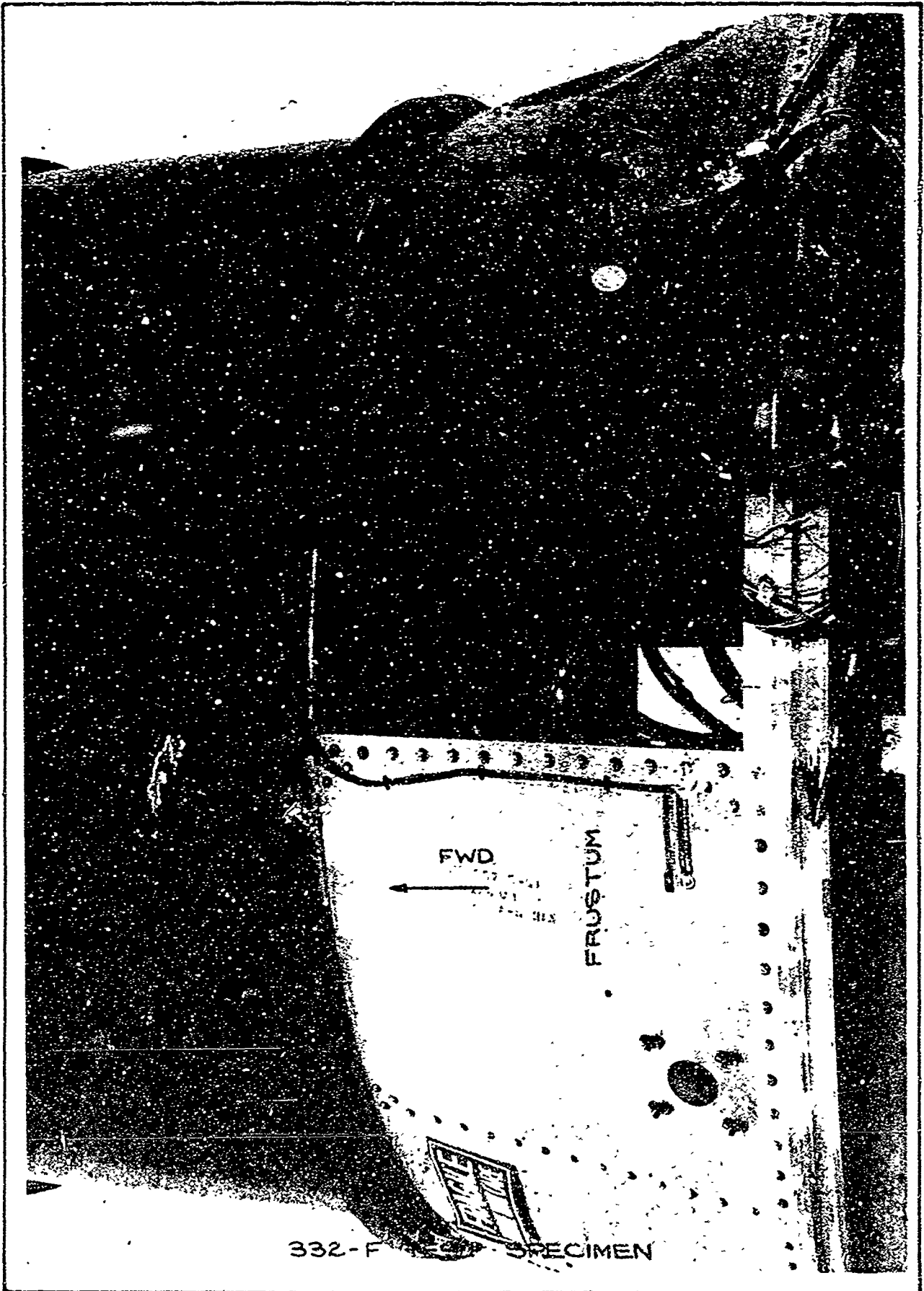

332-F SPECIMEN

SHEET 404

FIG. 4.1-2

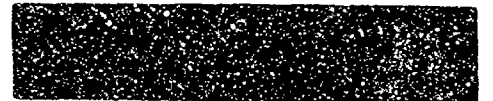



SHEET 405

FIG. 4.1-3

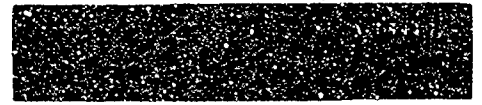



SHEET 406

FIG. 4.1-4

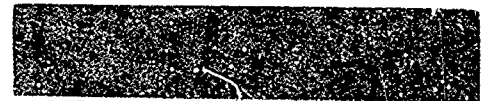

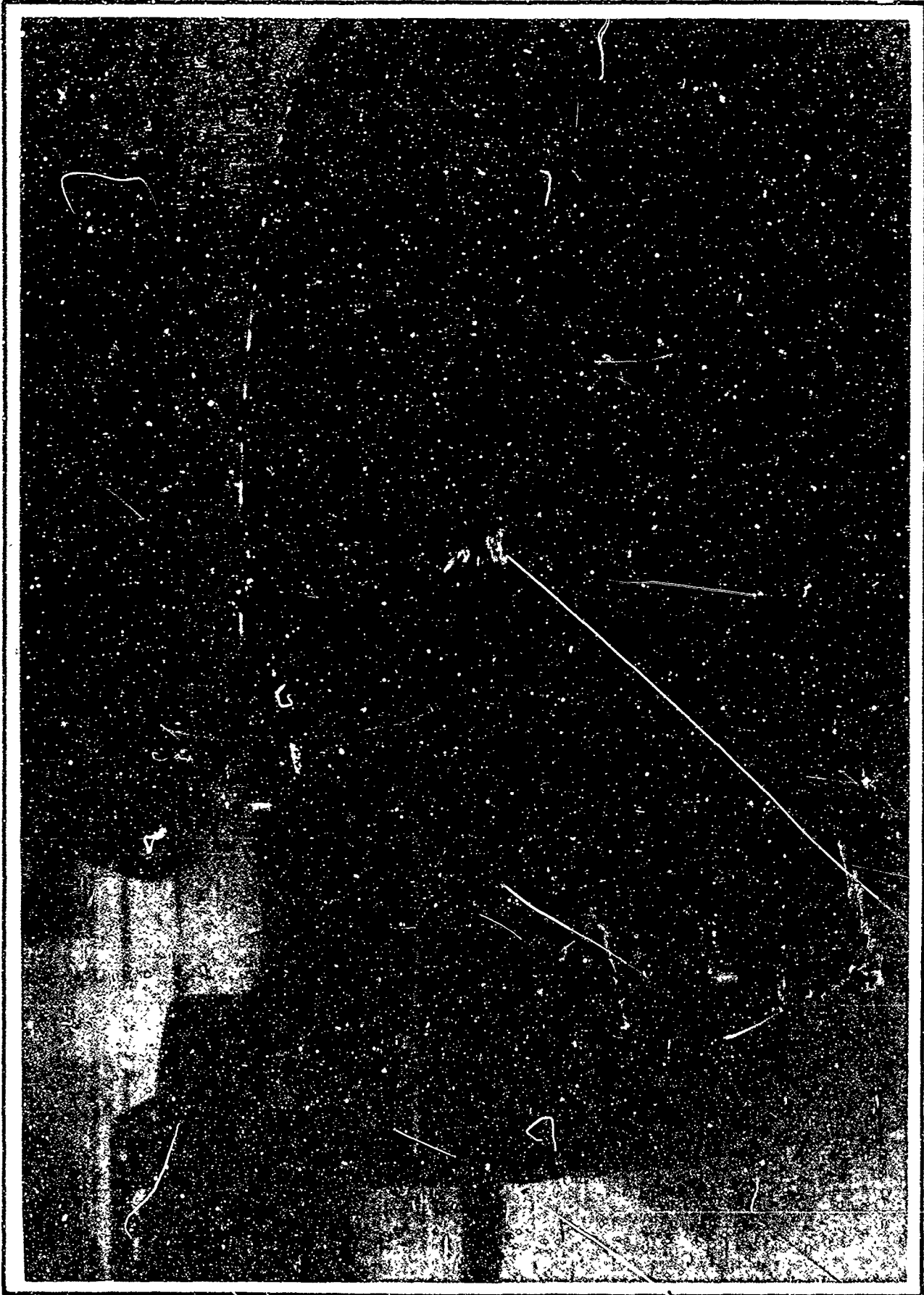

SHEET 407

FIG. 4.1-5

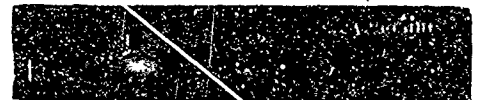

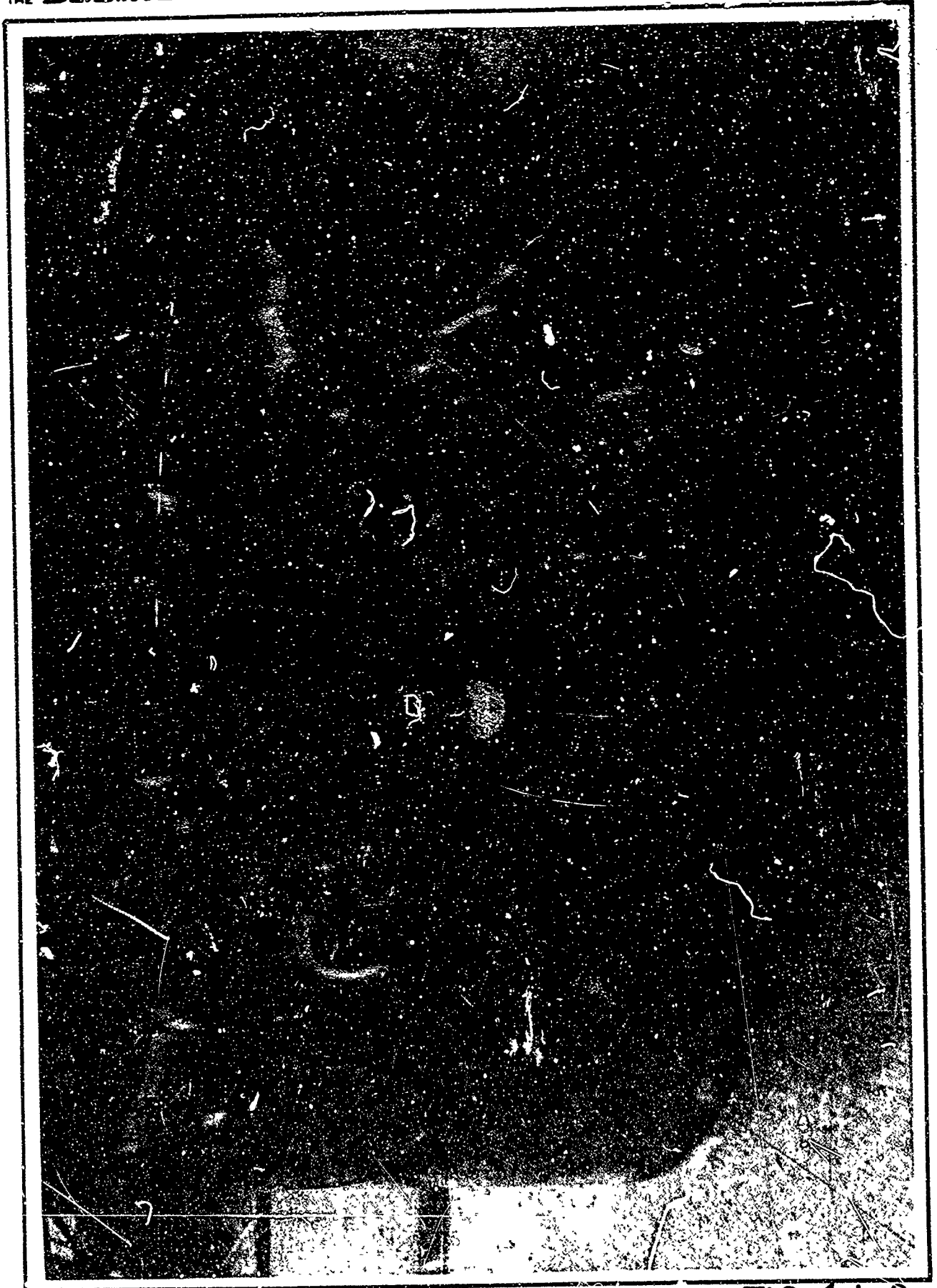

SHEET 408

FIG. 4.1-6

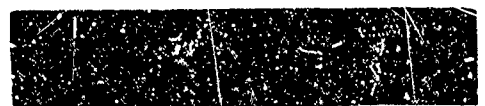

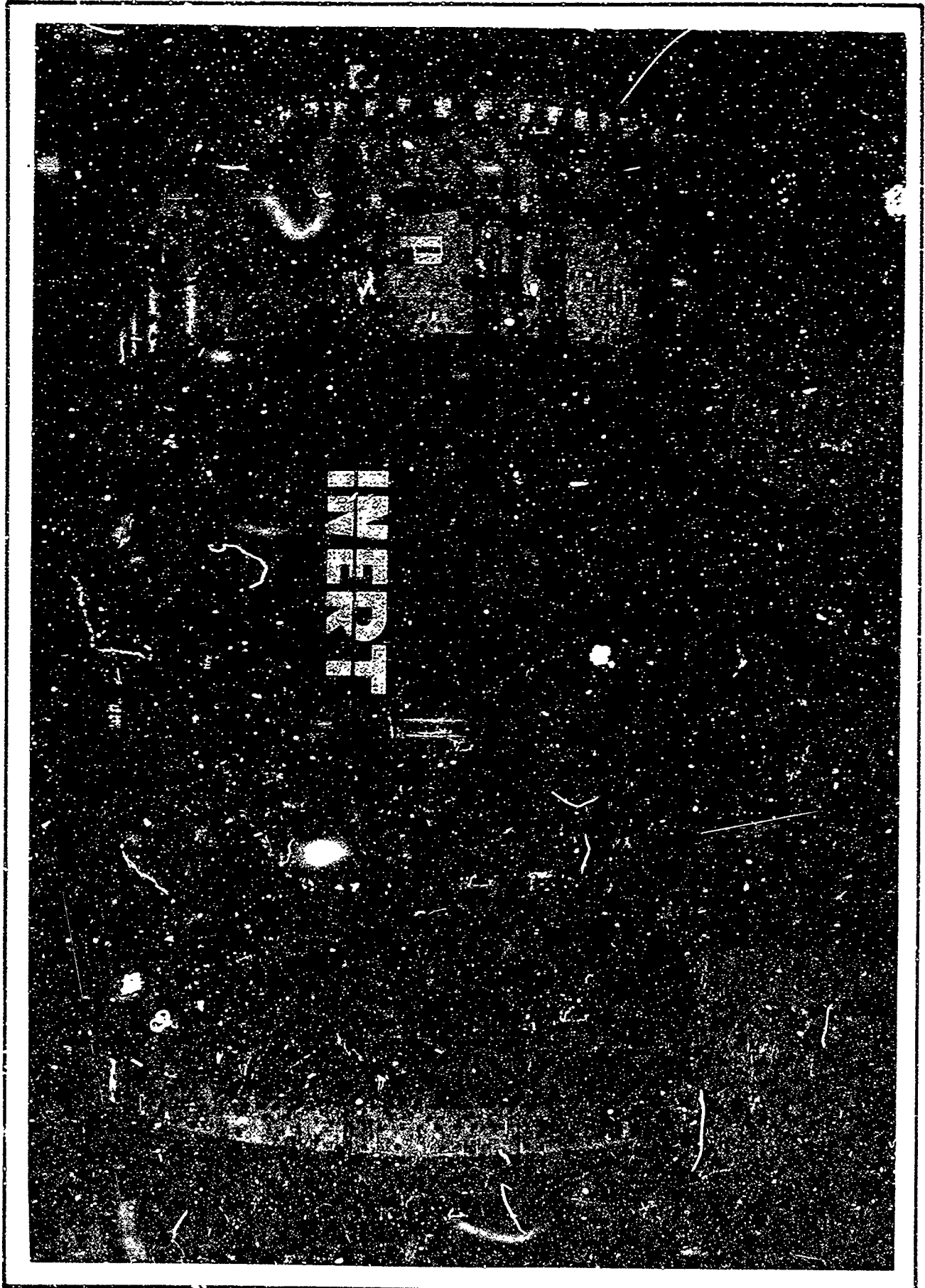

SHEET 409

FIG. 4.1-7



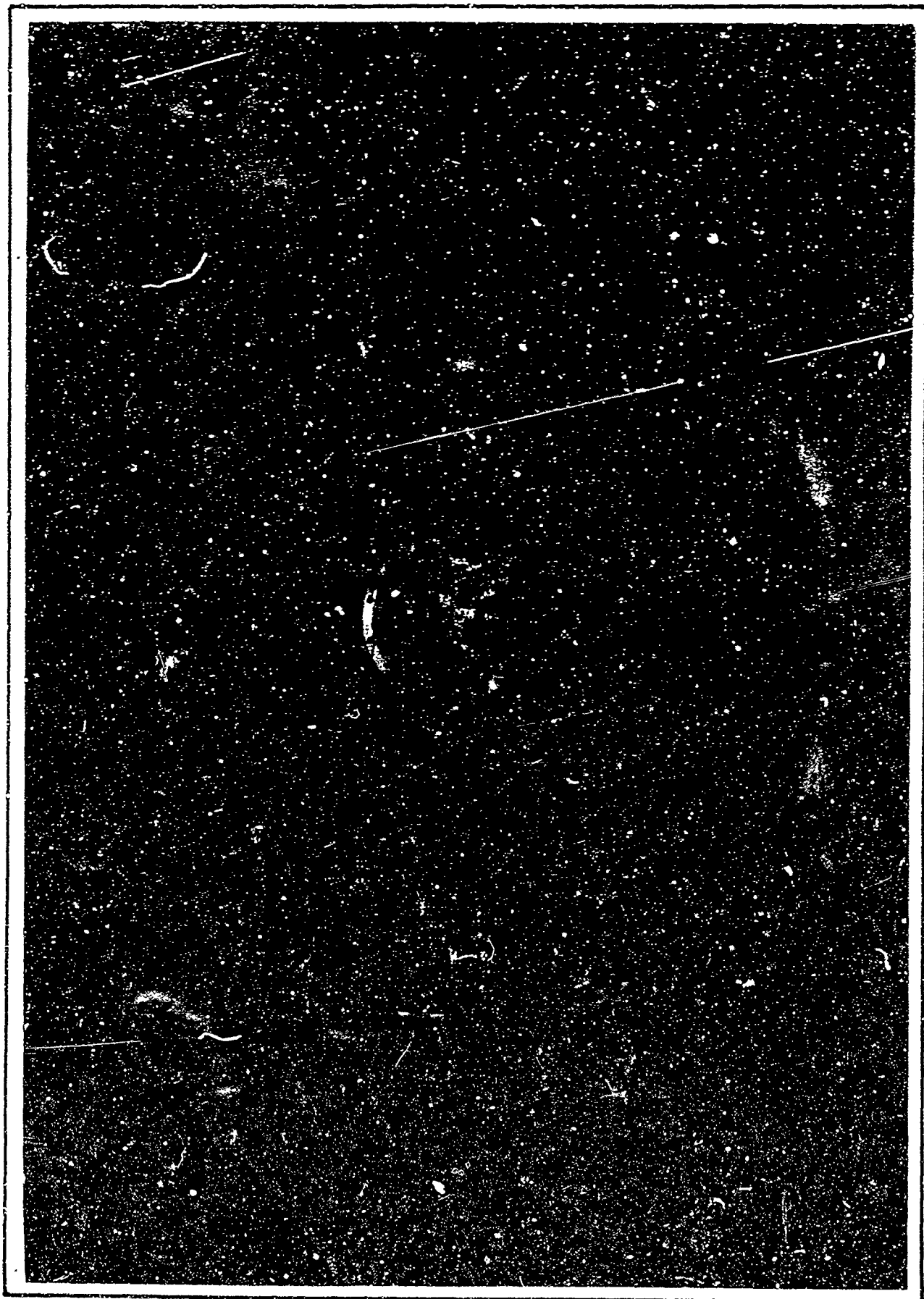

SHEET 410

FIG. 4.1-8



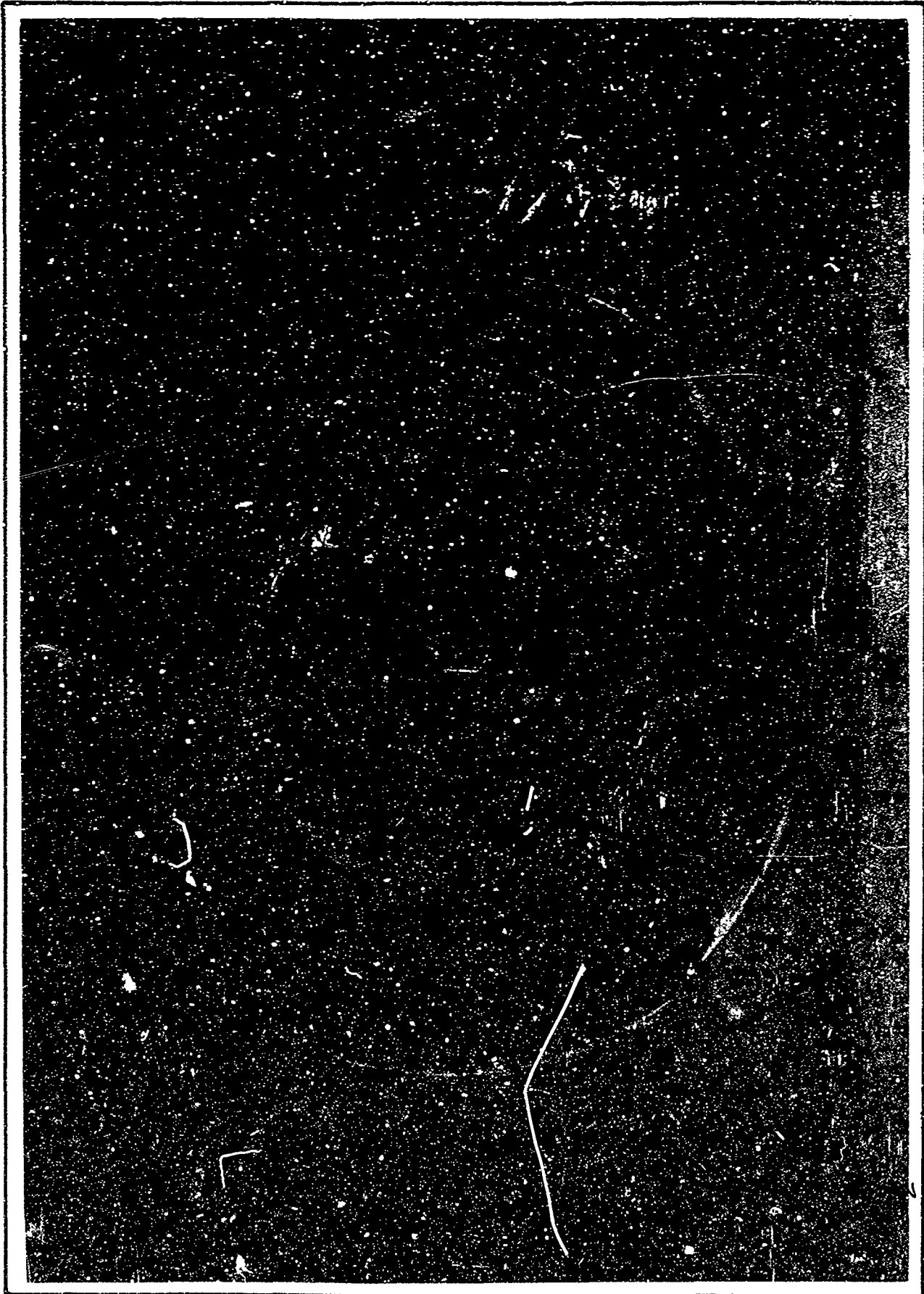

SHEET 411

FIG. 4.1-9



USE FOR DRAWING AND HANDPRINTING — NO TYPEWRITTEN MATERIAL

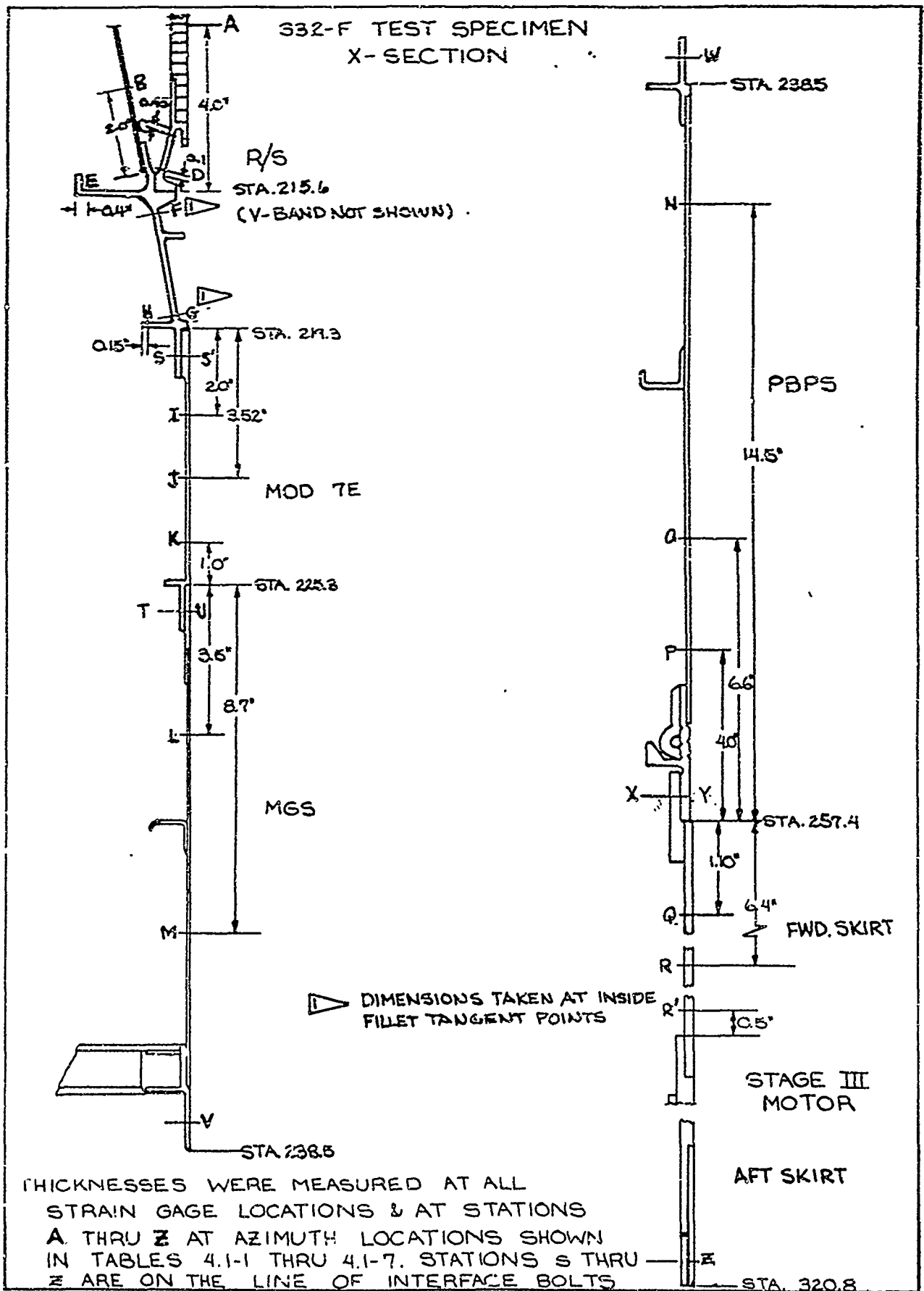

MGS SECTION - 332F FLIGHT TEST

INITIALS	DATE	REV BY INITIALS	DATE	TITLE	MODEL	
COPIED	KSW	SEP 65		DIMENSIONAL SURVEY MGS SECTION - 332F M ² STATIC CONFIRMATION TEST (S/N 201)	TABLE A.1-4	
CHECK	GDVI	SEP 65				
APPD						
APPD						
LOCATION DEGREES	STRAIN GAGE NO.	STA. L 228.8	STRAIN GAGE NO.	STA. M 234.0	STA. U FWD RING	STA. V AFT RING
0	350	.105	351	.104	.103	.115
20	352	.104		.105		
37	353	.105	354	.105		
56	355	.104		.104		
60					.100	.114
73		.104		.104		
107		.104		.104		
120					.101	.116
127		.103	356	.102		
142		.103		.102		
160		.103		.103		
180	360	.102		.102	.099	.112
203		.102		.102		
240					.100	.115
255		.103		.102		
285		.102		.102		
300					.103	.123
304						
307	357	.103		.104		
340	358	.103		.104		SEE FIGURE 4.1-10
350	359	.104		.104		

REV LTR _____

BOEING NO. T2-3657-1
416

PBPS - 332F FLIGHT TEST													
INITIALS	DATE	REV BY INITIALS	DATE	TITLE	MODEL	LOCATION	STA. P 253.4	S.G. NO.	STA. O 250.8	S.G. NO.	STA. N 242.9	STA. W FWD RING	STA. Y AFT RING
						0°				450	0.115	0.115	0.147
						22° 45'		451	0.117				
						+1.75"		452	0.117				
						+3.0 "		453	0.116				
						+4.5 "		454	0.117				
						+7.0 "		455	0.117				
						39°		456	0.116				
						46°				457	0.116		
						56°				458	0.116		
						60°						0.113	0.151
						65°		459	0.117		0.117		
						90°					0.117		
						120°							
						125°					0.118		
						145°			0.117				
						180°			0.118				
						215°					0.118	0.115	0.148
						217°		460	0.118				
						240°							
						245 / 246			0.118 / -		- / .118	0.113	0.146
						270					0.119		
						300°						0.114	0.147
						304°			0.119		0.119		
						323 / 325			.117 / -		- / .116		

REV LTR _____

BOEING NO. T2-3657-1
417

DIMENSIONAL SURVEY
PBPS - 332F
M² STATIC CONFIRMATION TEST
TABLE 4.1-5

USE FOR TYPEWRITTEN MATERIAL ONLY

4.2
TEST SETUP

332 F TEST SETUP

DWG 25-63070-1, 2, & 3

USE FOR DRAWING AND HANDPRINTING — NO TYPEWRITTEN MATERIAL

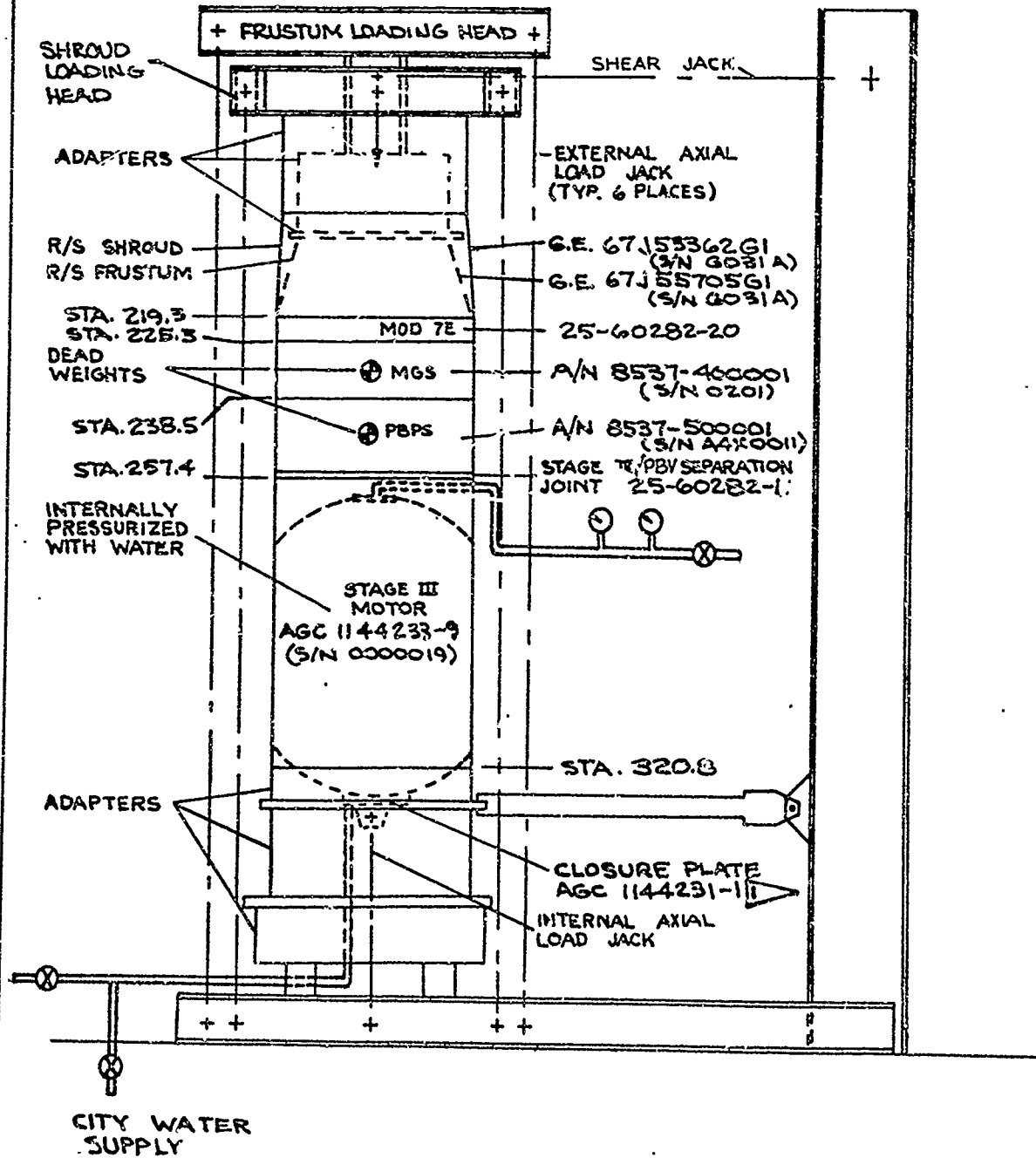

ALTERED TO
25-63406-81

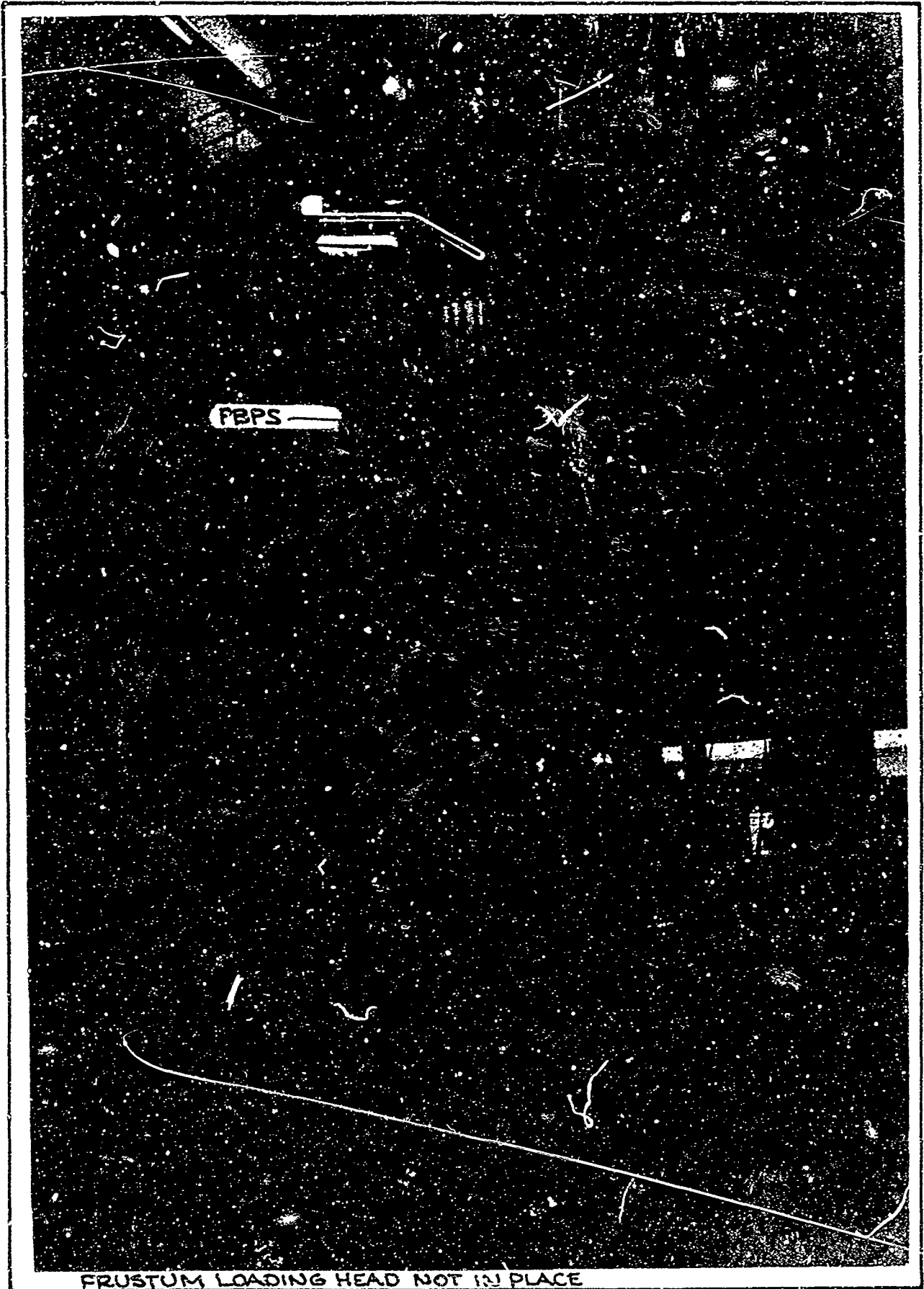

FRUSTUM LOADING HEAD NOT IN PLACE

SHEET 421

FIG. 4.2-2



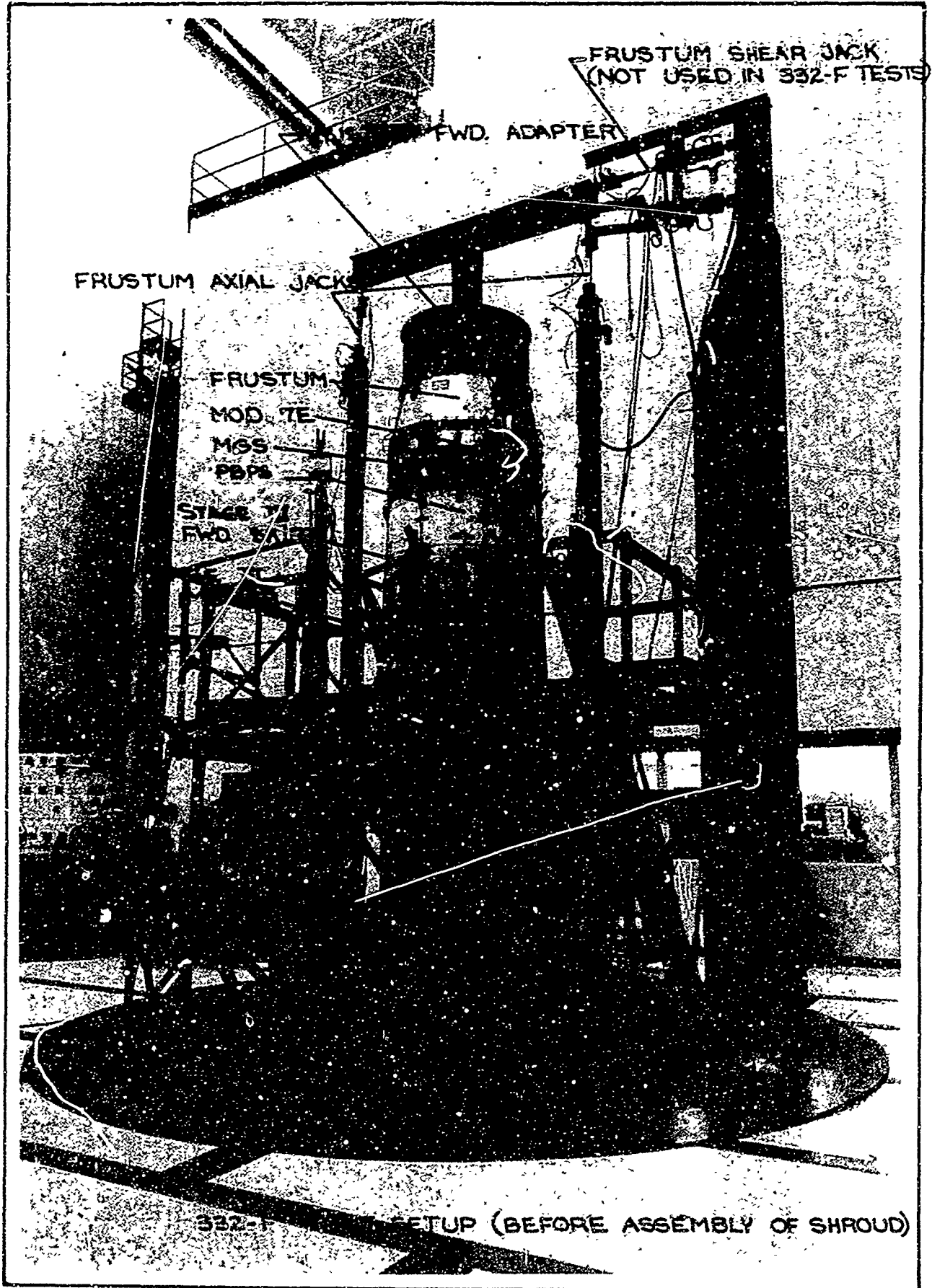

SHEET 422

FIG. 4.2-3

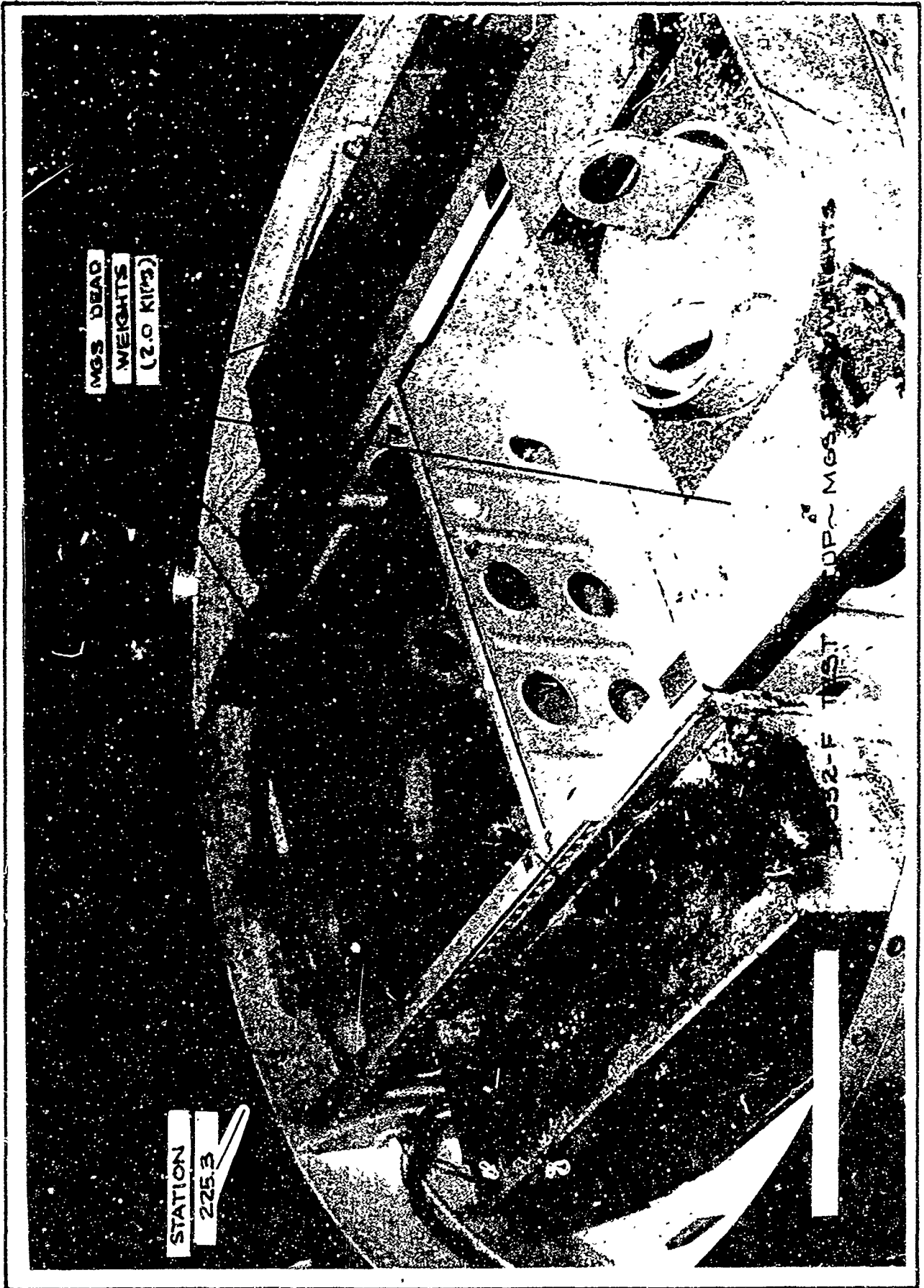

SHEET 423

FIG. 4.2-4

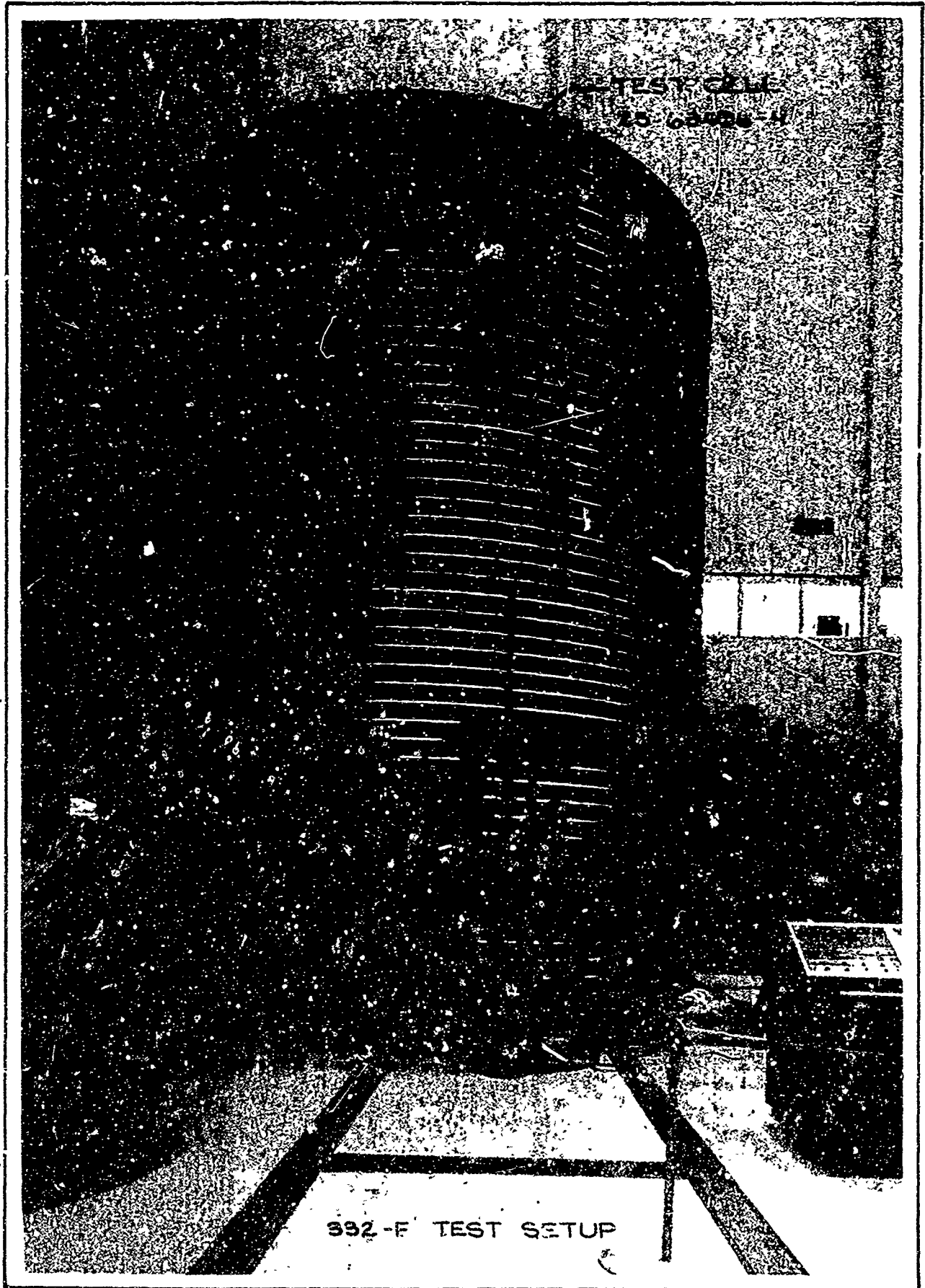

392-F TEST SETUP

SHEET 424

FIG. 4.2-5

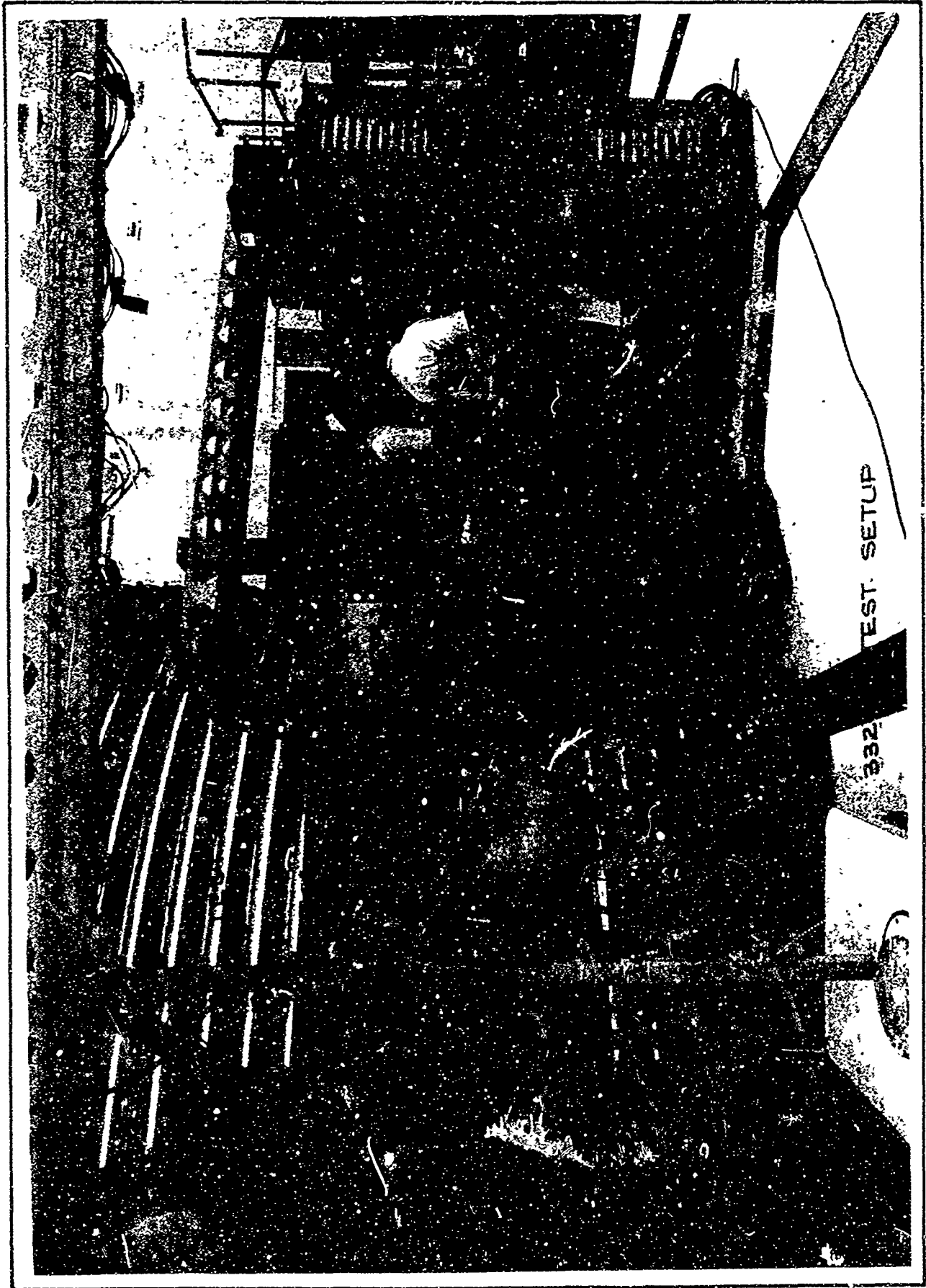

SHEET 425

FIG. 4.2-6



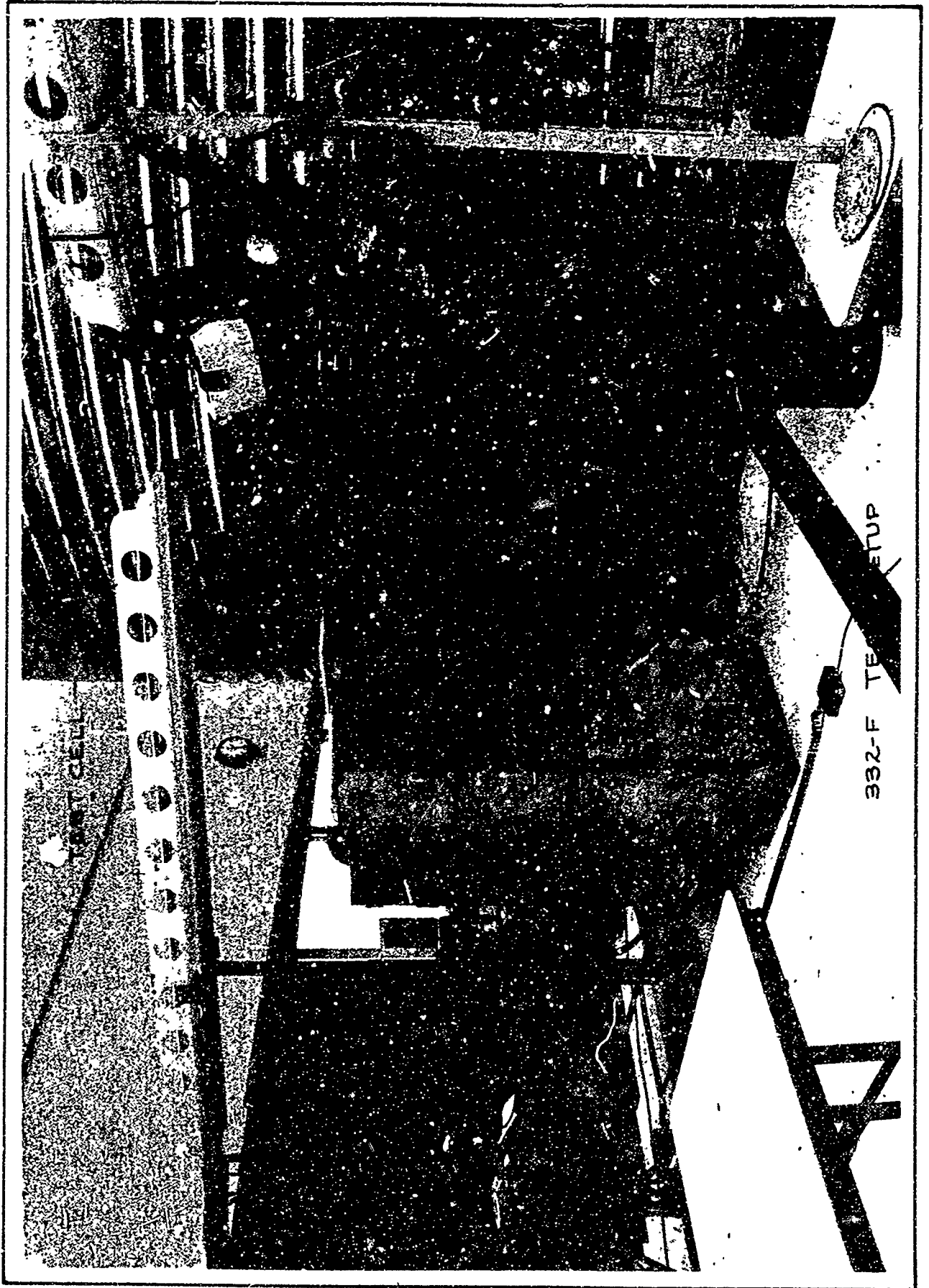

SHEET 426

FIG. 42-7



USE FOR TYPEWRITTEN MATERIAL ONLY

4.3

TEST INSTRUMENTATION

USE FOR DRAWING AND HANDPRINTING — NO TYPEWRITTEN MATERIAL

R/S FRUSTUM INSTRUMENTATION - TEST 332-F

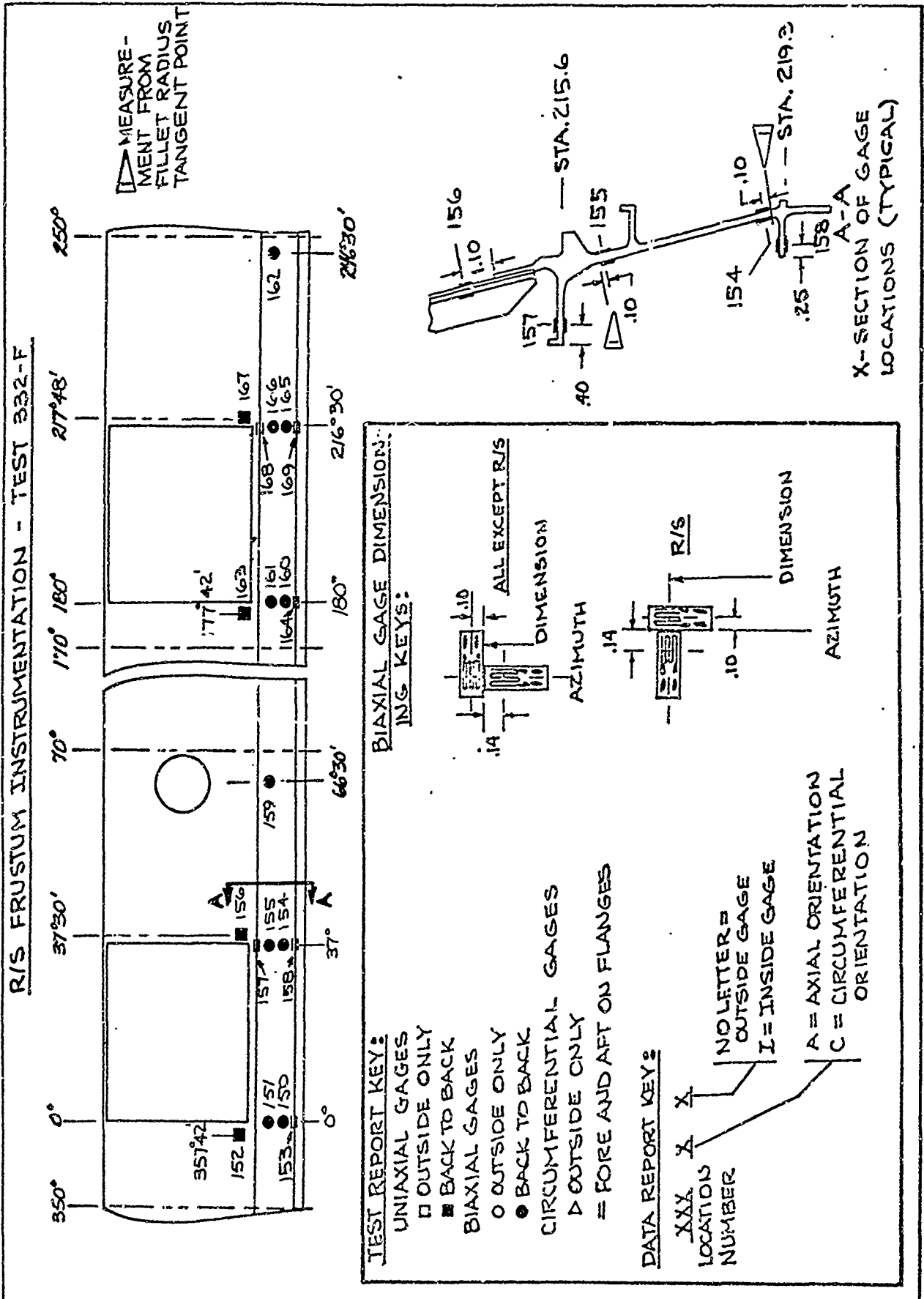

TEST REPORT KEY:

- UNIAxIAL GAGES
- ◻ OUTSIDE ONLY
- BACK TO BACK
- BIAxIAL GAGES
- OUTSIDE ONLY
- BACK TO BACK
- CIRCUMFERENTIAL GAGES
- △ OUTSIDE ONLY
- ≡ FORE AND AFT ON FLANGES

DATA REPORT KEY:

- XXX X X X
LOCATION NUMBER
- NO LETTER = OUTSIDE GAGE
- I = INSIDE GAGE
- A = AxIAL ORIENTATION
- C = CIRCUMFERENTIAL ORIENTATION

BIAxIAL GAGE DIMENSIONING KEYS:

- ▲ ALL EXCEPT R/S
- ▲ DIMENSION
- ▲ AZIMUTH
- ▲ R/S
- ▲ DIMENSION
- ▲ AZIMUTH

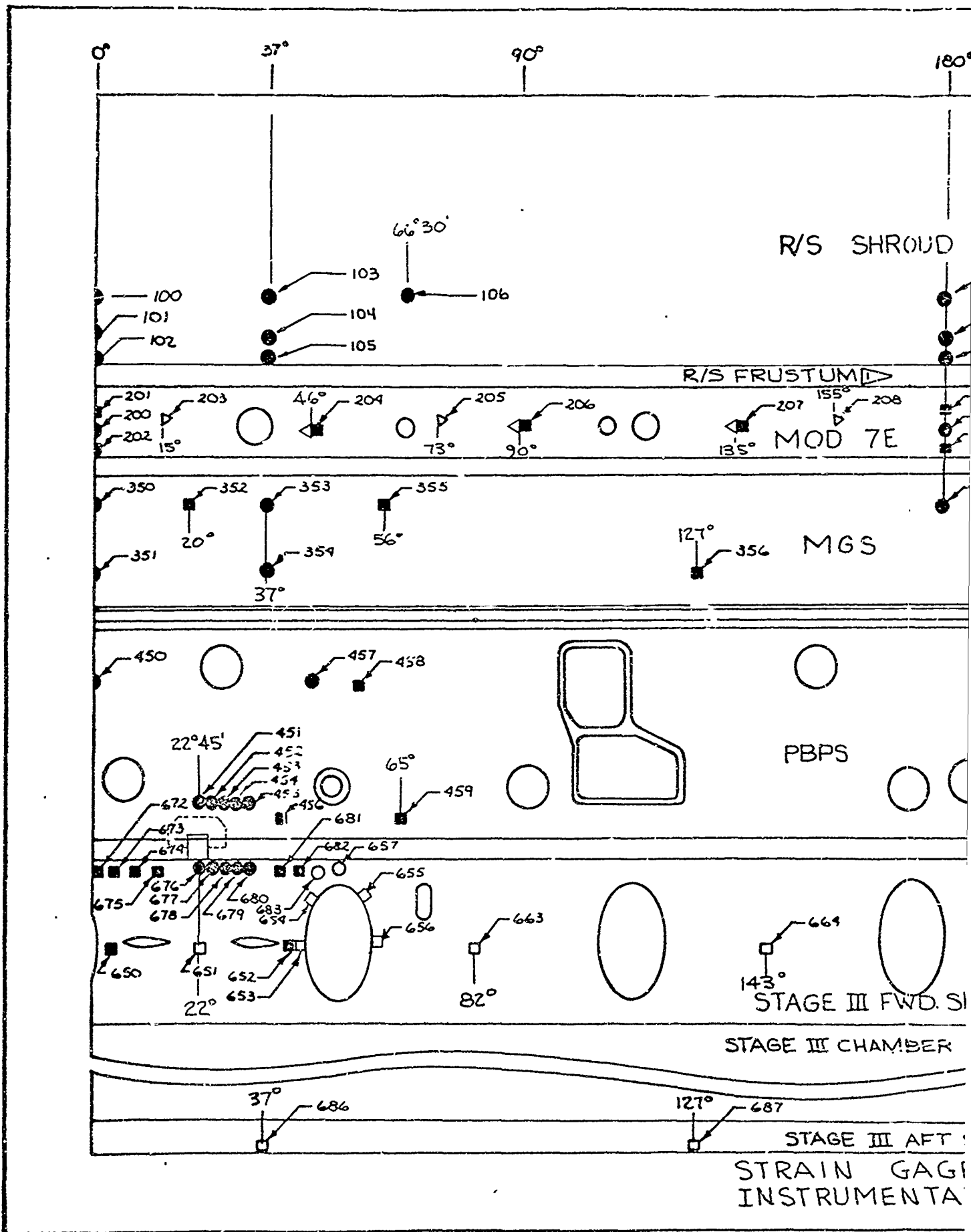

REV LTR _____

USE FOR DRAWING AND HANDPRINTING — NO TYPEWRITTEN MATERIAL

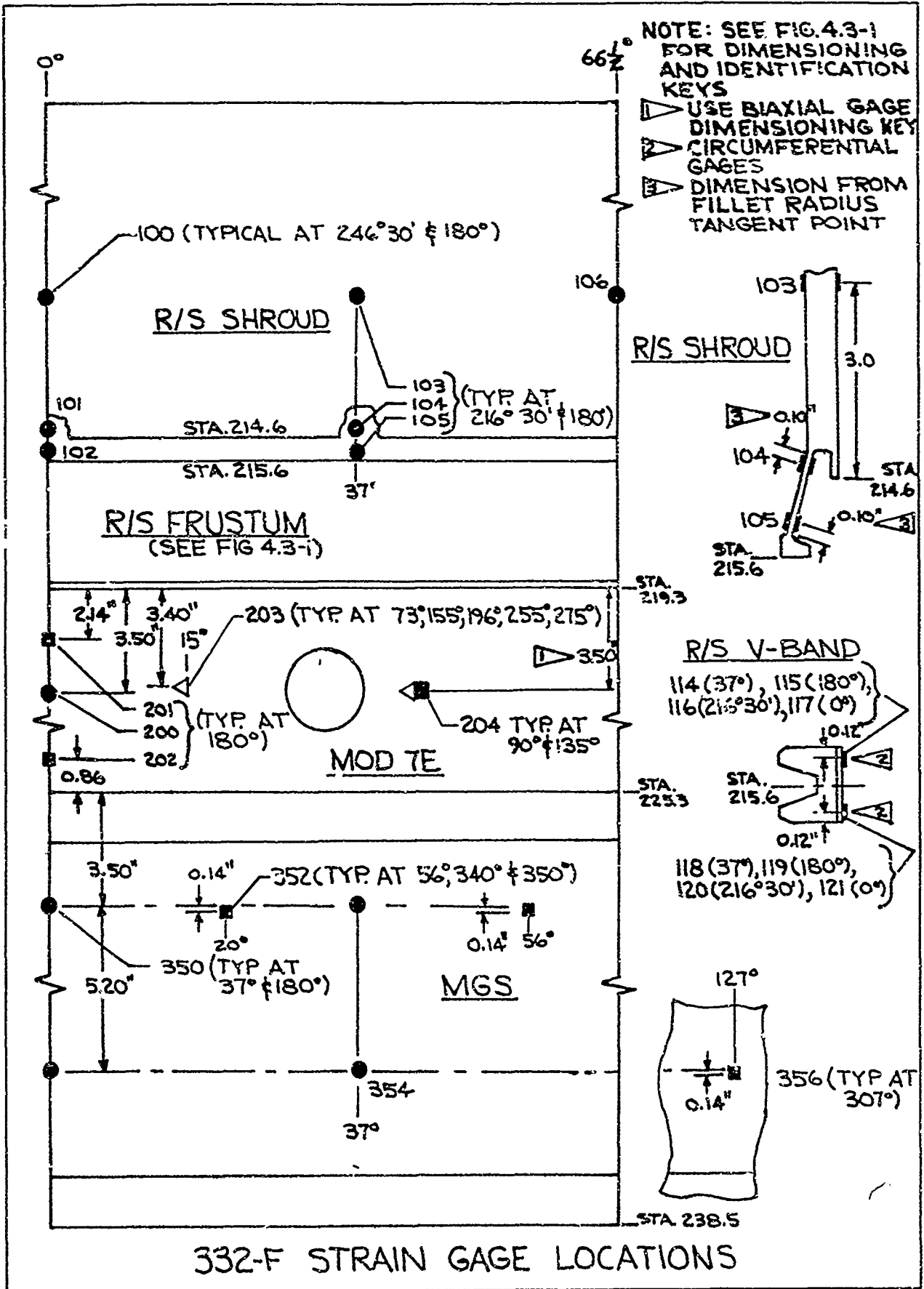

TEST 332-F STRAIN GAGE LOCATIONS

USE FOR DRAWING AND HANDWRITING --- NO TYPEWRITTEN MATERIAL

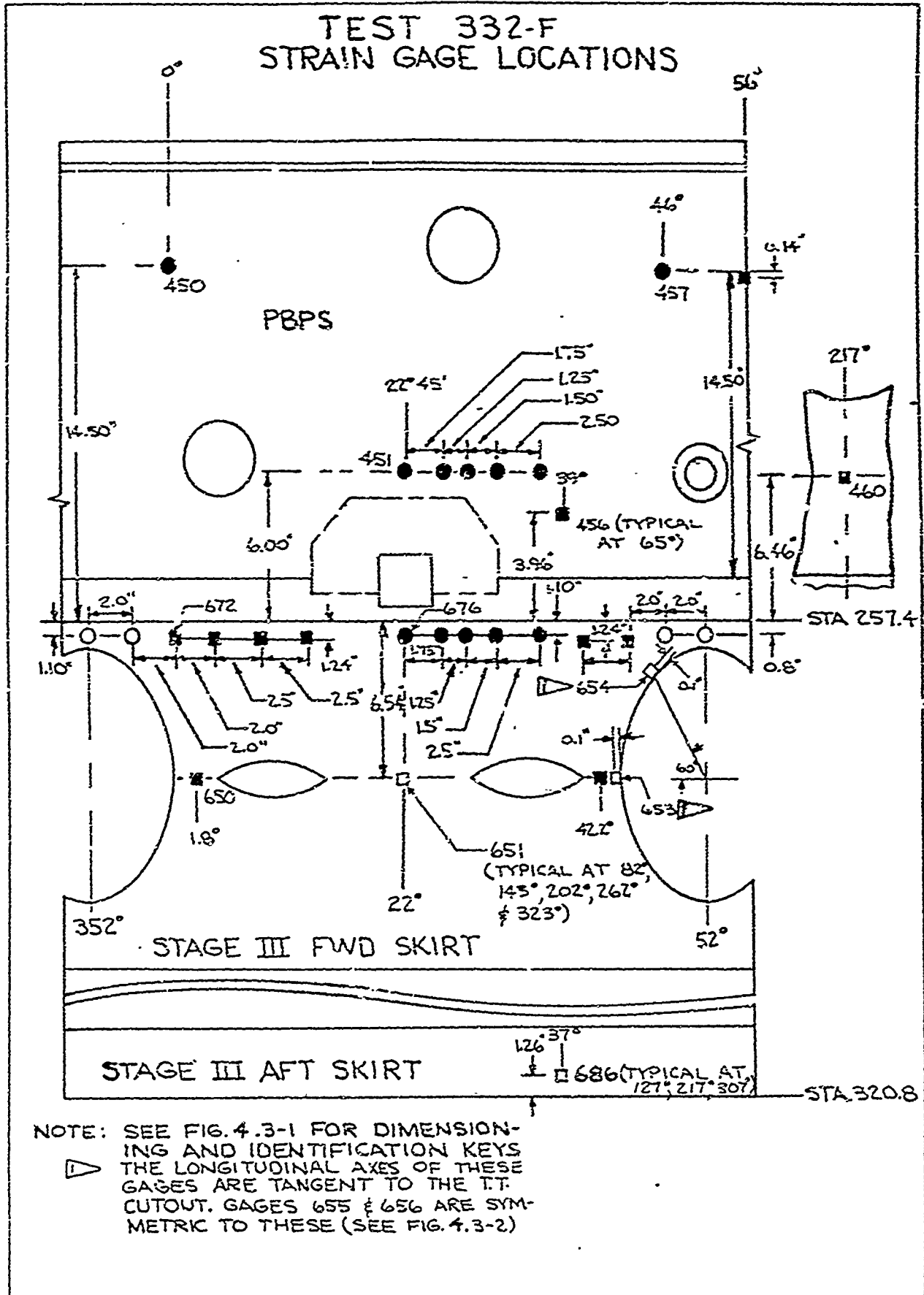

USE FOR TYPEWRITTEN MATERIAL ONLY

4.4

TEST CONDITIONS

LOAD GEOMETRY 332-F TEST

USE FOR DRAWING AND HANDPRINTING — NO TYPEWRITTEN MATERIAL

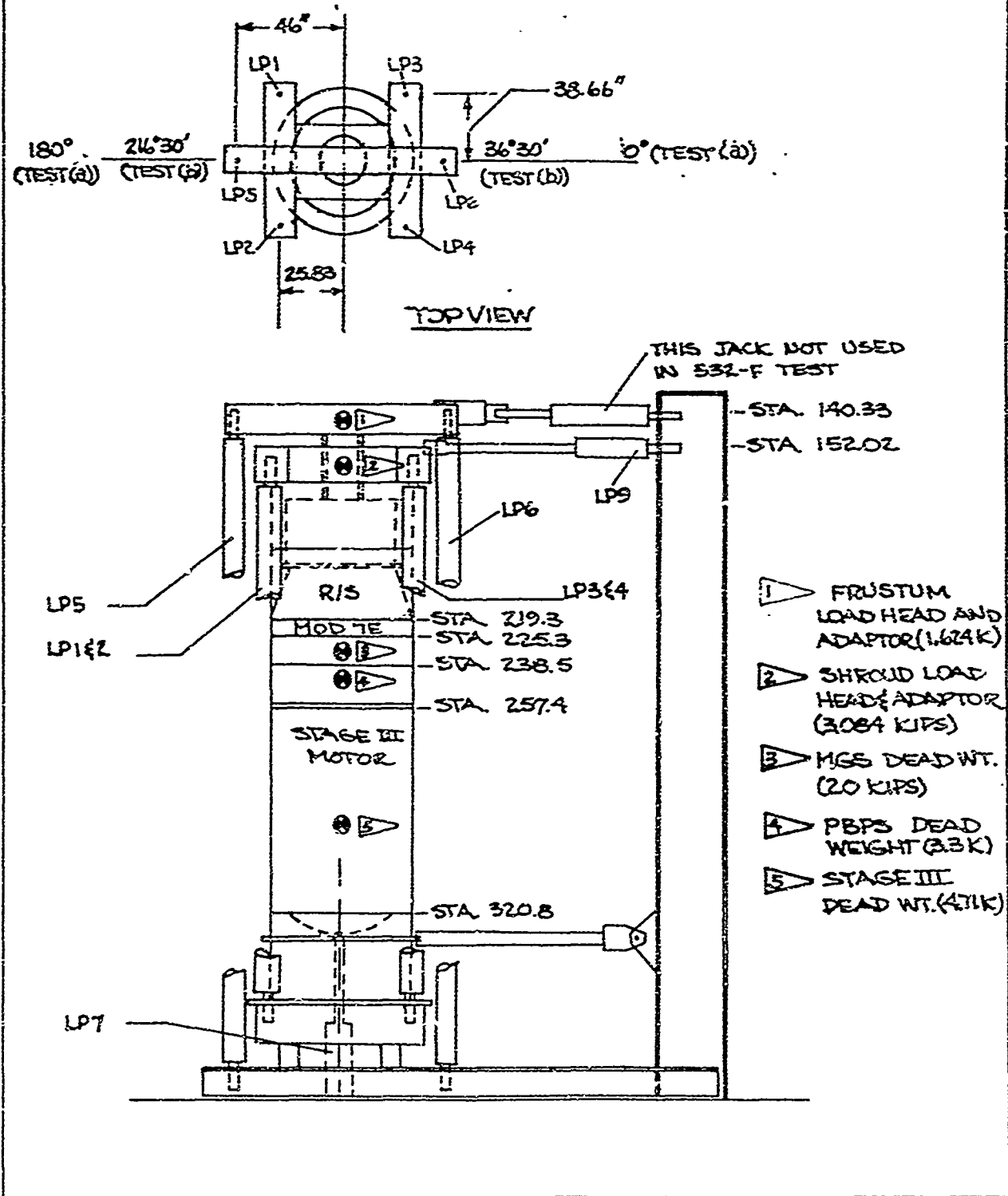

PERCENT TEST	0	30	50	70	80	90	100
PROGRAMMED KIPS	0	4.56	7.60	10.64	12.16	13.68	15.20
APPLIED -KIPS	0	4.5	7.7	10.6	12.2	13.7	15.2

▷ FROM REFERENCE 1

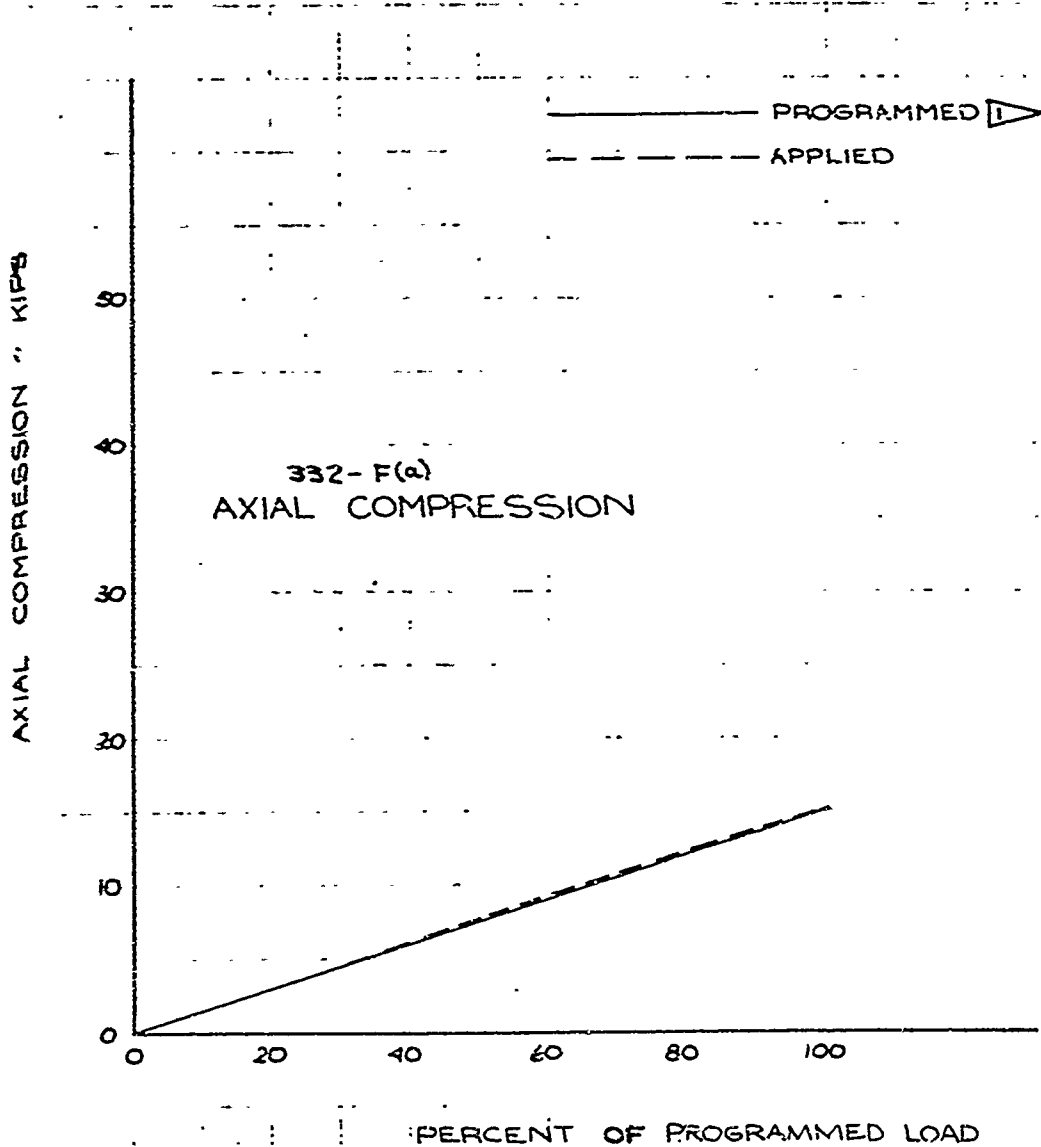

	INITIALS	DATE	REV BY INITIAL	DATE	TITLE	MODEL
CALC	J.A.G.	9-2-68			332-F(a) (MAXIMUM LINE LOAD @ 0°) PROGRAMMED & APPLIED COMP- RESSION VS % LD. - STA. 225.3	FIG. 4.4-2
CHECK	RPS	9-18-68				
APPD.						
APPD.						

U3 4013 1000 REV 1/66

REV LTR _____

BOEING NO T2-3657-1
SH 434

PERCENT TEST	0	30	50	70	80	90	100
PROGRAMMED ~ IN-KIPS	0	256	428	599	685	770	856
APPLIED ~ IN-KIP	0	267	425	596	703	791	827

▶ SEE REFERENCE 1

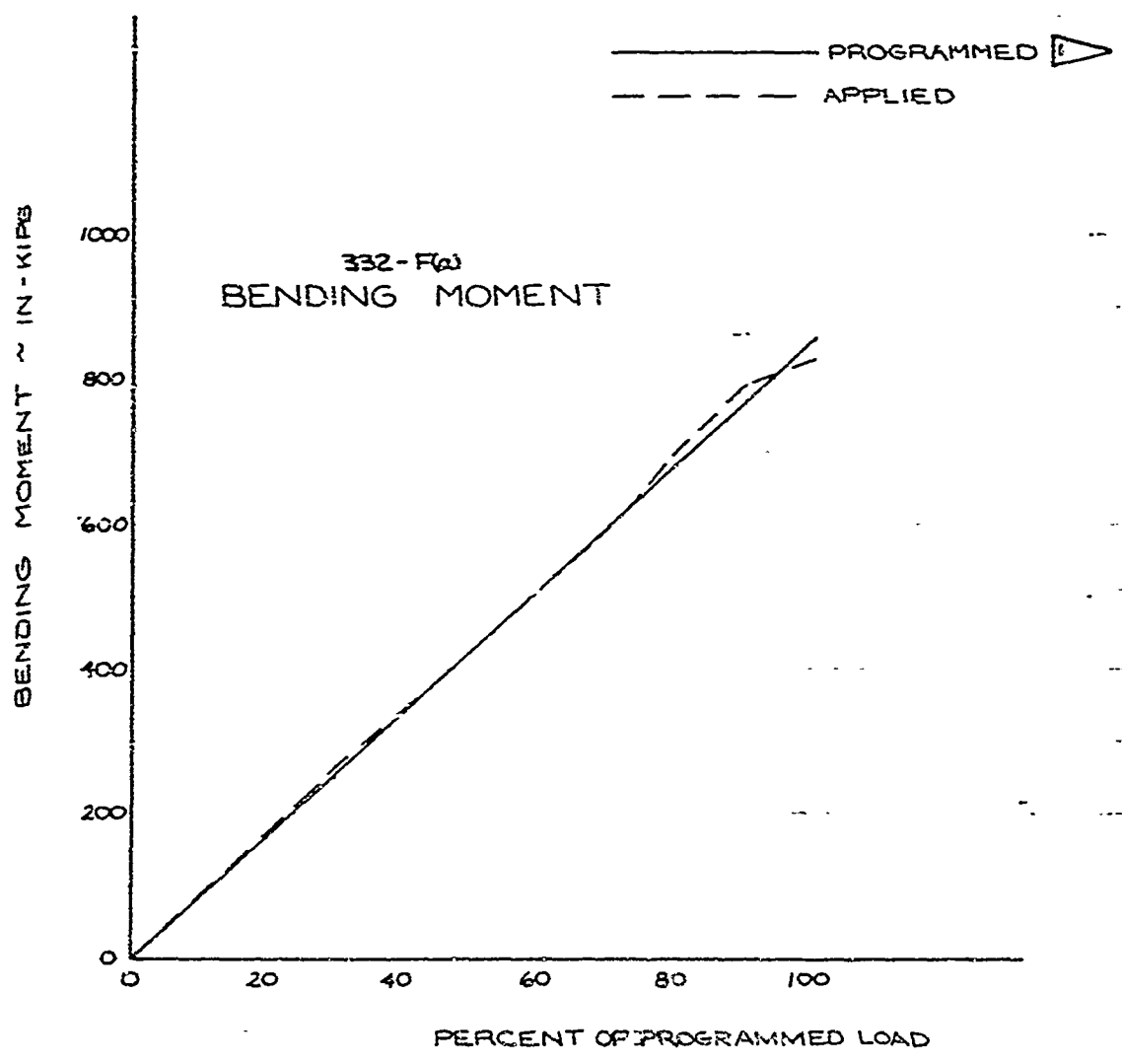

	INITIALS	DATE	REV BY INITIAL	DATE	TITLE	MODEL
CALC	JAG	9-2-68			332-F(a) (MAXIMUM LINE LOAD @ 0°) PROGRAMMED & APPLIED MOMENT VS. % MOM - STATION 225.3	FIG. 4.4-3
CHECK	RPS	9-18-68				
APPD.						
APPD						

U3 4013 8000 REV 1-66

REV LTR _____

BOEING NO T2-3657-1
SH 435

PERCENT TEST	C	30	50	70	80	90	100
PROGRAMMED ~ KIPS	0	3.91	6.52	9.12	10.42	11.73	13.03
APPLIED ~ KIPS	0	3.97	6.50	9.12	10.51	11.61	12.75

FROM REFERENCE 1

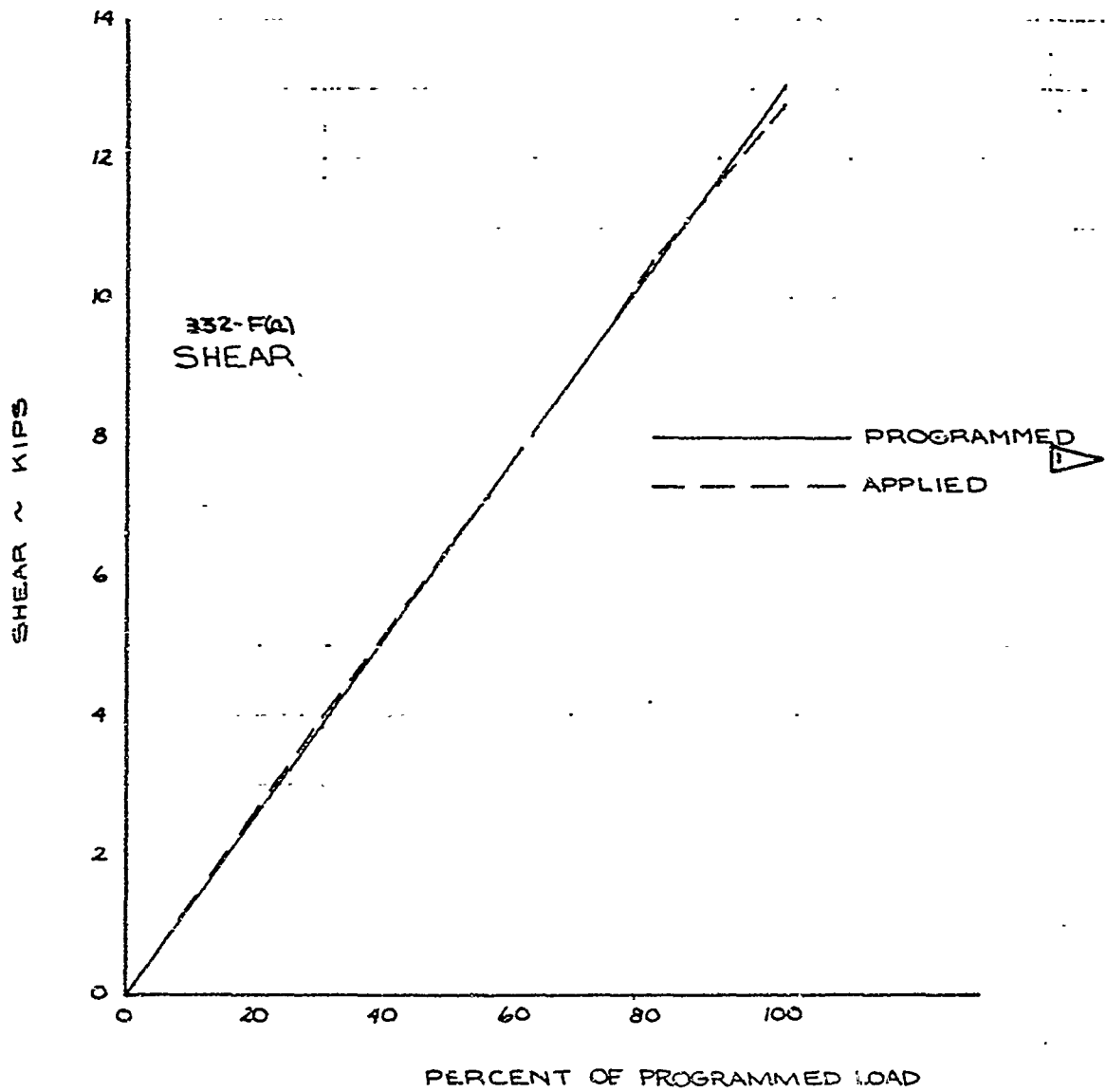

	INITIALS	DATE	REV BY INITIAL	DATE	TITLE	MODEC
CALC	J.A.G.	9-2-68			332-F(a) (MAXIMUM LINE LOAD @ 0°) PROGRAMMED & APPLIED SHEAR VS % SHEAR - STATION 225.3	FIG 44-4
CHECK	RPS	9-18-68				
APPD.						
APPD.						

U3 4013 8000 REV 1/66

REV LTR _____

BOEING NO T2-3657-1
SH 436

PERCENT TEST	0	30	50	70	80	100
PROGRAMMED ~ KIPS	0	4.86	7.60	10.64	12.36	15.20
APPLIED ~ KIPS	0	4.5	7.6	10.5	12.0	15.2

FROM REFERENCE 1

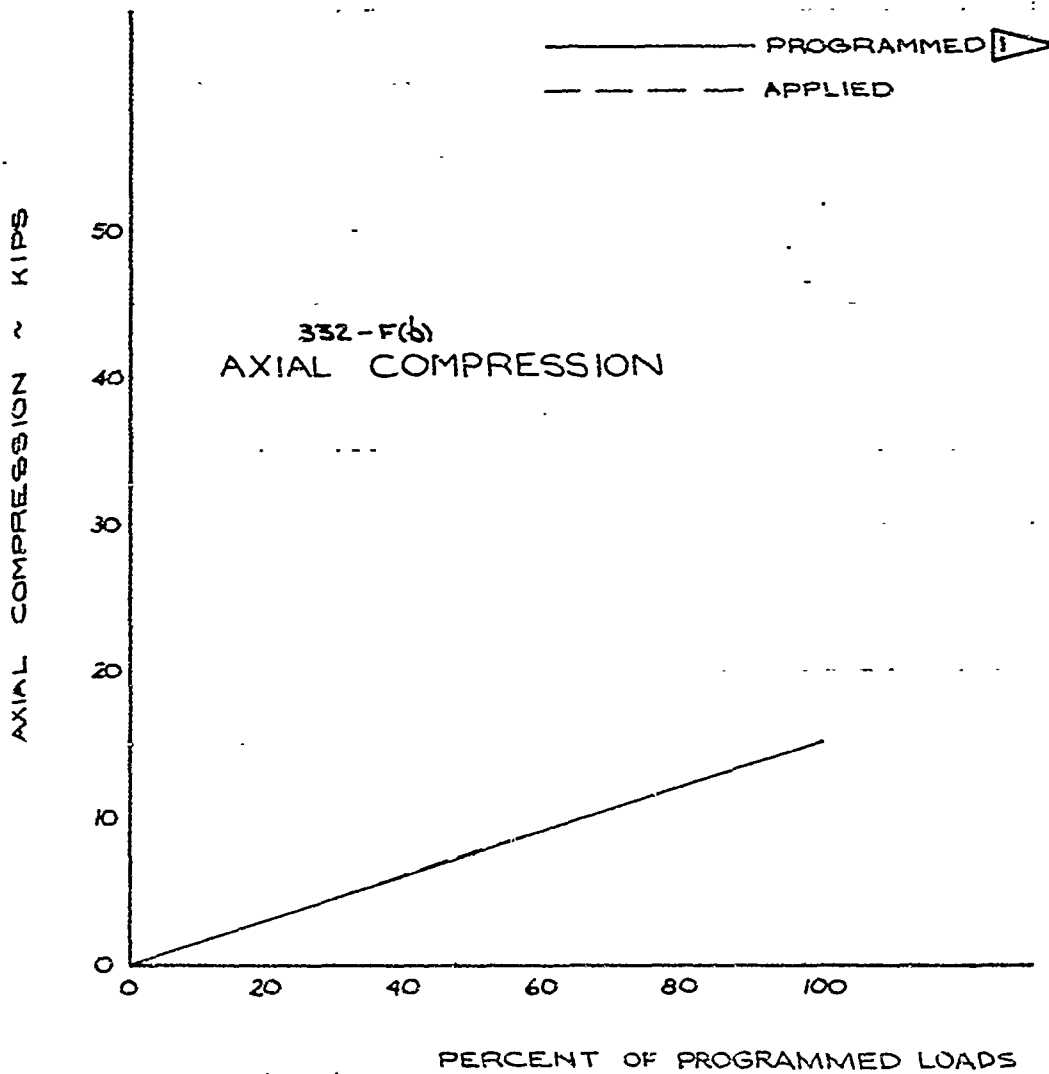

	INITIALS	DATE	REV BY INITIAL	DATE	TITLE	MODEL
CALC	JAG.	9-2-68			332-F(b) FLIGHT TEST ~ % LD. VS. PROGRAMMED AND APPLIED AXIAL LOADS ~ STATION 225.3	FIG. 4.4-5
CHECK	RPS	9-18-68				
APPD.						
APPD.						

U3 4013 8000 REV 1/66

REV LTR _____

BOEING NO T2-3657-1
SH 437

PERCENT TEST	0	30	50	70	80	100
PROGRAMMED IN-KIPS	0	2568	428	5992	6848	856
APPLIED IN-KIPS	0	271	420	581	686	841

▷ FROM REFERENCE:

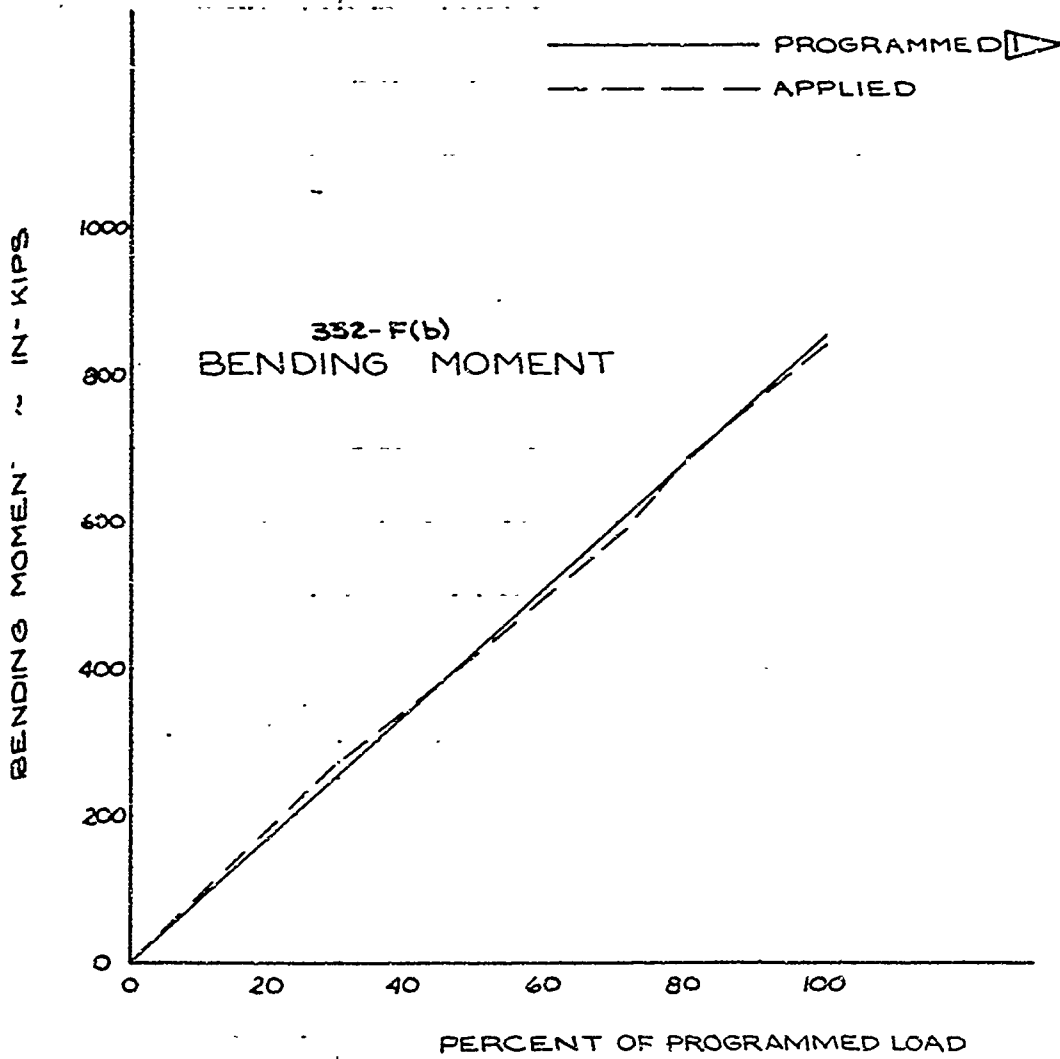

	INITIALS	DATE	REV BY INITIAL	DATE	TITLE	MODEL
CALC	J.A.G.	9-2-68			332-F(b) FLIGHT TEST PROGRAMMED AND APPLIED MOM. VS. % LOAD ~ STA. 225.3	FIG 44-6
CHECK	RPS	9-18-68				
APPD.						
APPD.						

U3 401J 8000 REV 1/66

REV LTR _____

BOEING NO T2-3657-1
SH 438

PERCENT TEST	0	30	50	70	80	100
PROGRAMMED ~ KIPS	0	3.91	6.52	9.12	10.42	13.03
APPLIED ~ KIPS	0	4.09	6.42	8.86	10.43	12.83

▷ FROM REFERENCE 1

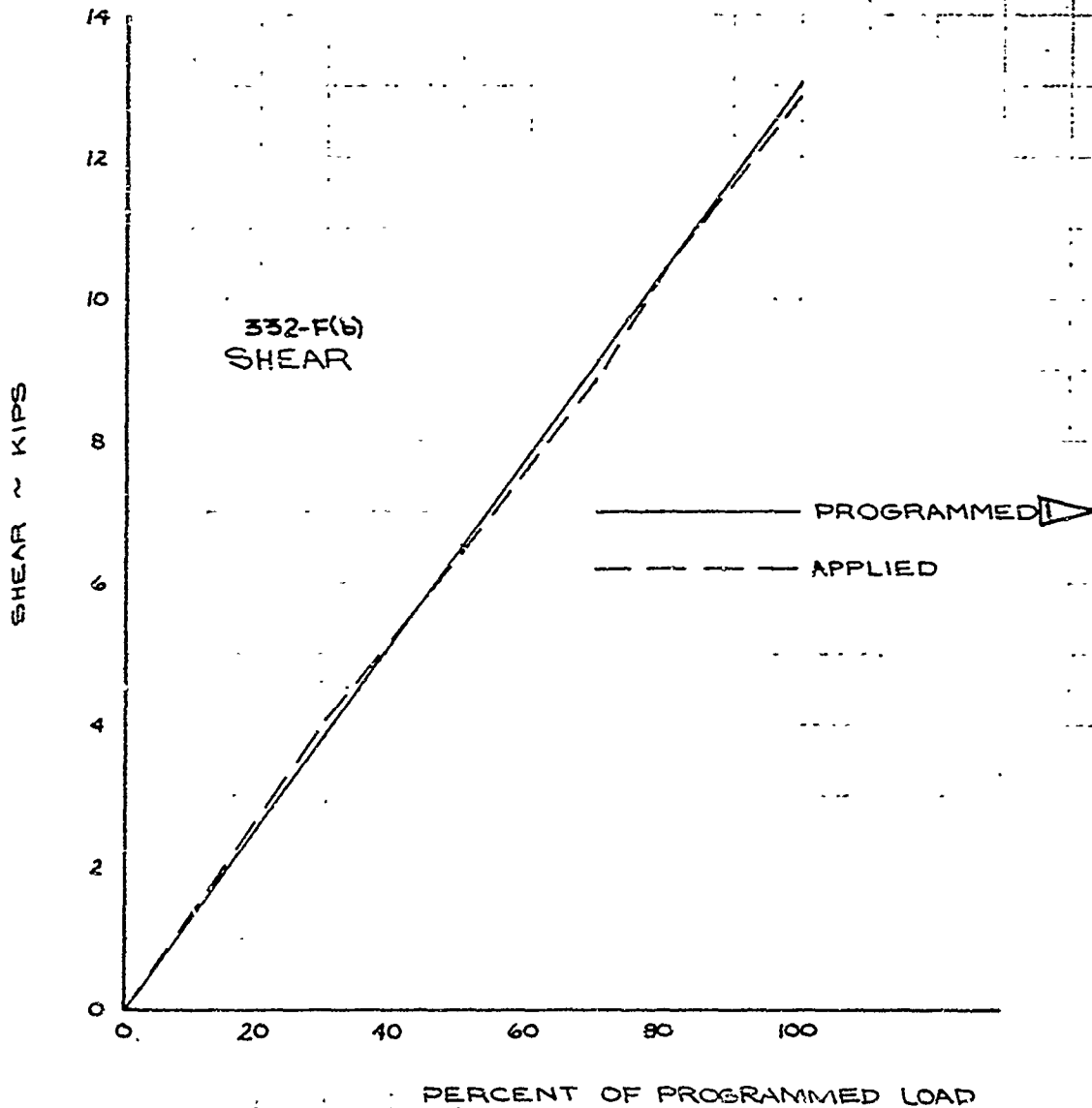

	INITIALS	DATE	REV BY INITIAL	DATE	TITLE	MODEL
CALC	J.A.G.	9-2-68			332-F(6) FLIGHT TEST PROGRAMMED AND APPLIED SHEAR VS % LOAD STA. 2253	FIG. 4.4-7
CHECK	RPS	9-18-8				
APPD.						
APPD.						

U3 4013 8000 REV 1/66

REV LTR _____

BOEING NO T2-3657-1
SH 439

USE FOR TYPEWRITTEN MATERIAL ONLY

4.6
TEST RESULTS

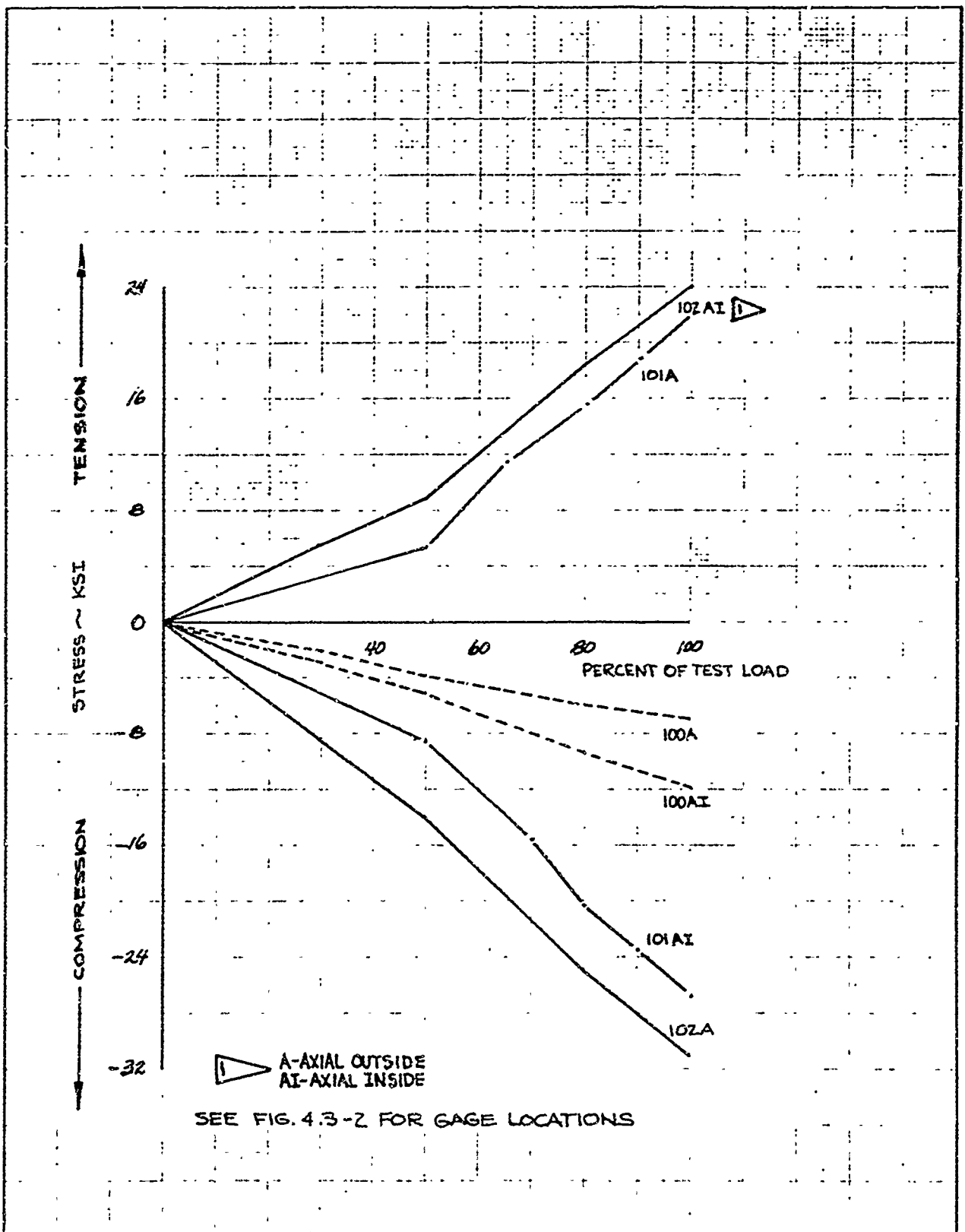



	INITIALS	DATE	REV BY INITIAL	DATE	TITLE	MODEL
CALC	<i>RAW</i>	8-23-8			332- F(2) (0° AZIMUTH) TEST STRAIN GAGE READINGS SHROUD ~ 0°	FIG. 4.6-1
CHECK	<i>RSW</i>	8-26-8				
APPD.						
APPD.						

U3 4013 8000 REV 1/66

REV ITR _____

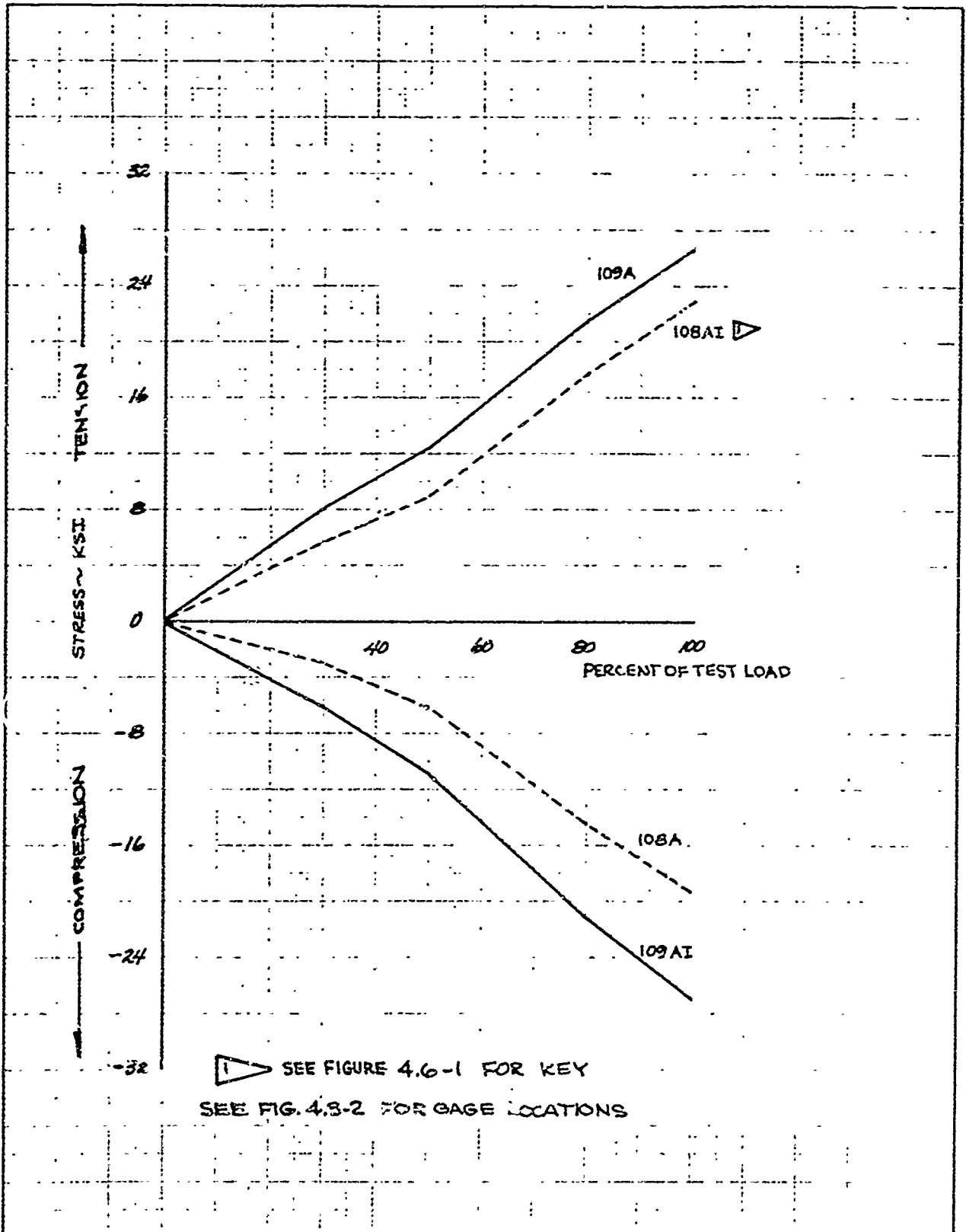
BOEING NO TL-3651-1
SH 4-41



 SEE FIGURE 4.6-1 FOR KEY
 SEE FIG. 4.8-2 FOR GAGE LOCATIONS

	INITIALS	DATE	REV BY INITIAL	DATE	TITLE	MODEL
CALC	<i>Pat</i>	8-3-8			332- F(a) (0° AZIMUTH) TEST STRAIN GAGE READINGS SHROUD ~ 180°	FIG. 4.6-2
CHECK	<i>PDW</i>	9-26-8				
APPD.						
APPD.						

U3 4013 6000 REV 1/56

REV LTR _____

BOEING | NO T2-3657-1
 | SH 4.42

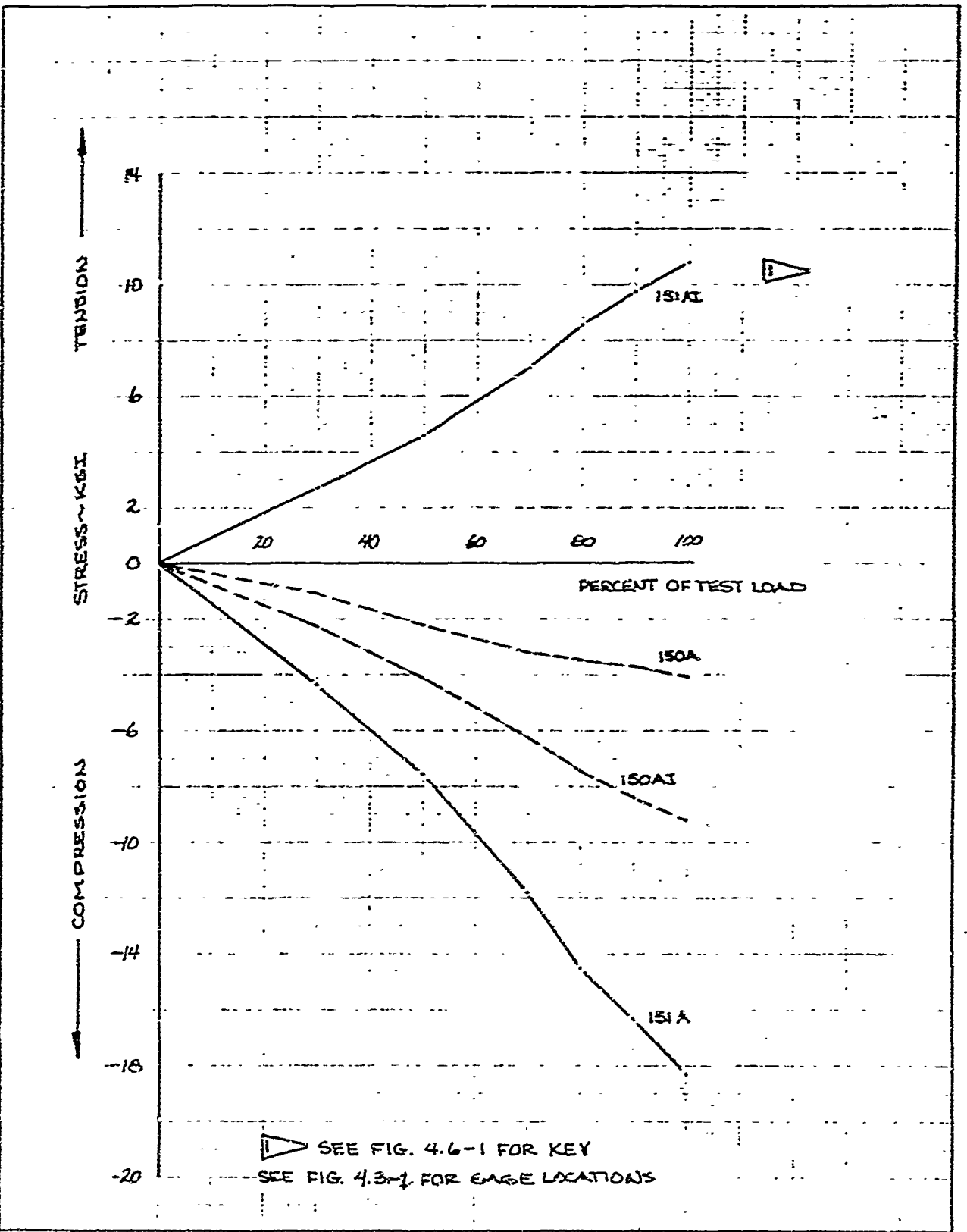

	INITIALS	DATE	REV BY INITIAL	DATE	TITLE	MODEL
CALC	RPW	8-23-8			332-F(2) (0° AZIMUTH) TEST STRAIN GAGE READINGS FRUSTUM ~ 0°	FIG. 4.6-3
CHECK	JET	8-23-8				
APPD.						
APPD.						

U3 4013 8000 REV 1/66

REV LTR _____

BOEING NO T2-3657-1
SH 443

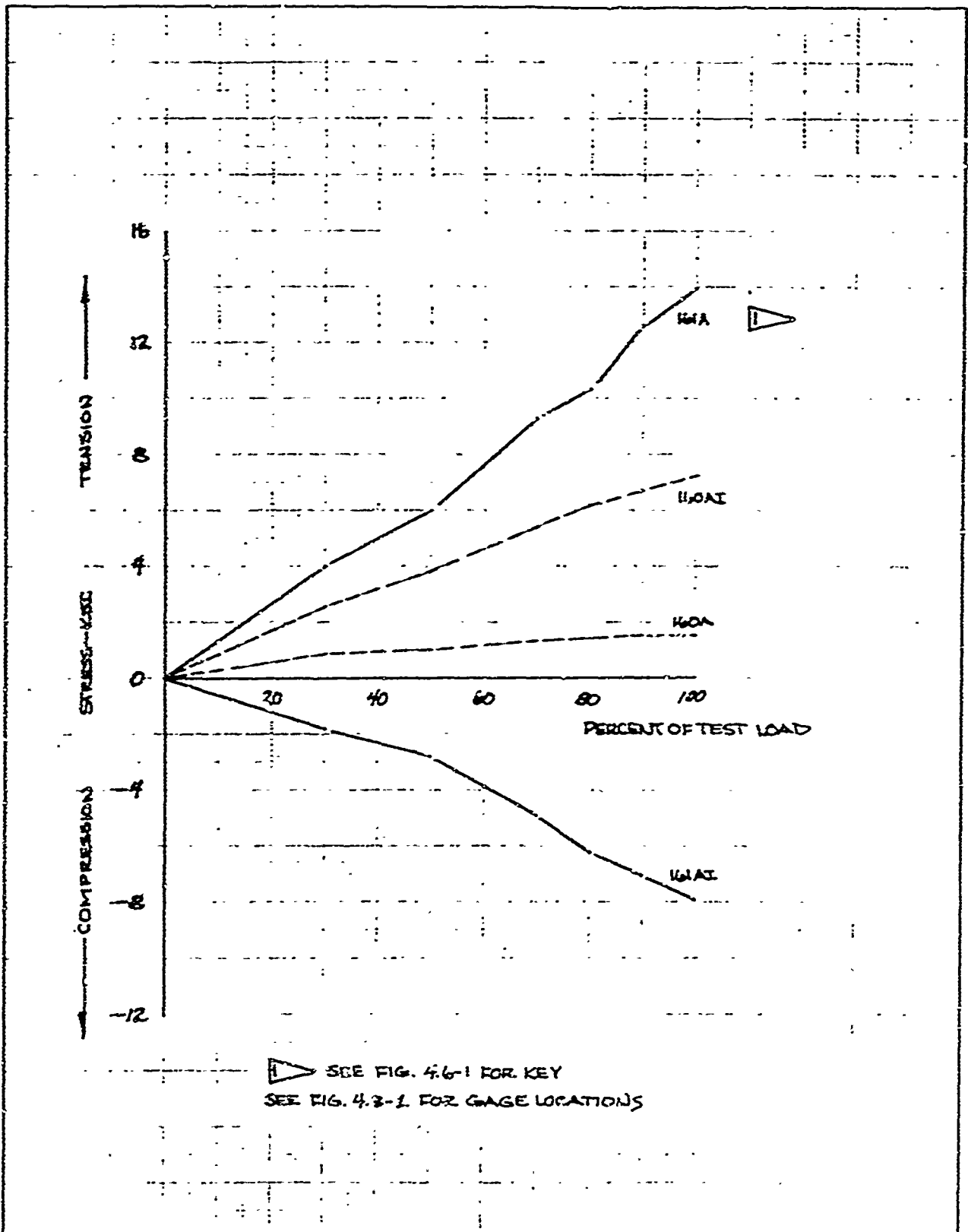

SEE FIG. 4.6-1 FOR KEY
 SEE FIG. 4.3-1 FOR GAGE LOCATIONS

	INITIALS	DATE	REV BY INITIAL	DATE	TITLE	MODEL
CALC	RAW	8-23-8			332-F(2) (0° AZIMUTH) TEST STRAIN GAGE READINGS FRUSTUM ~180°	FIG. 4.6-4
CHECK	JET	8-23-8				
APPD.						
APPD.						

U3 4013 8000 REV 1/66

REV LTR _____

BOEING | NO T2-3657-1
 | SH. 4.44

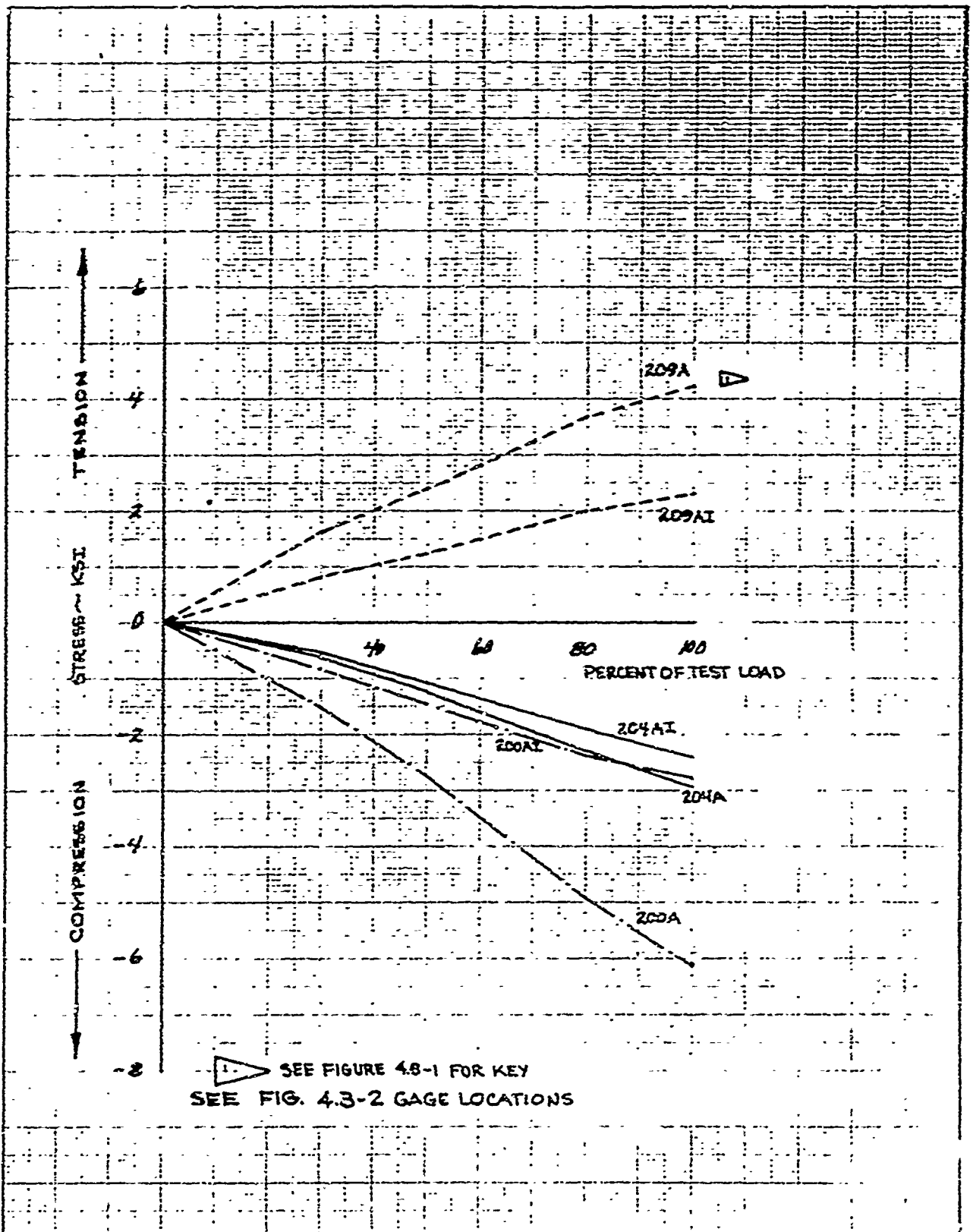

	INITIALS	DATE	REV BY INITIAL	DATE	TITLE	MODEL
CALC	<i>SNW</i>	8-23-8			332-F(2) (0° AZIMUTH) TEST STRAIN GAGE READINGS MOD TE	FIG 4.6-5
CHECK	<i>SNW</i>	8-26-8				
APPD.						
APPD.						

U3 4013 8000 REV 1/66

REV LTR _____

BOEING NO. T2-3657-1
SH 445

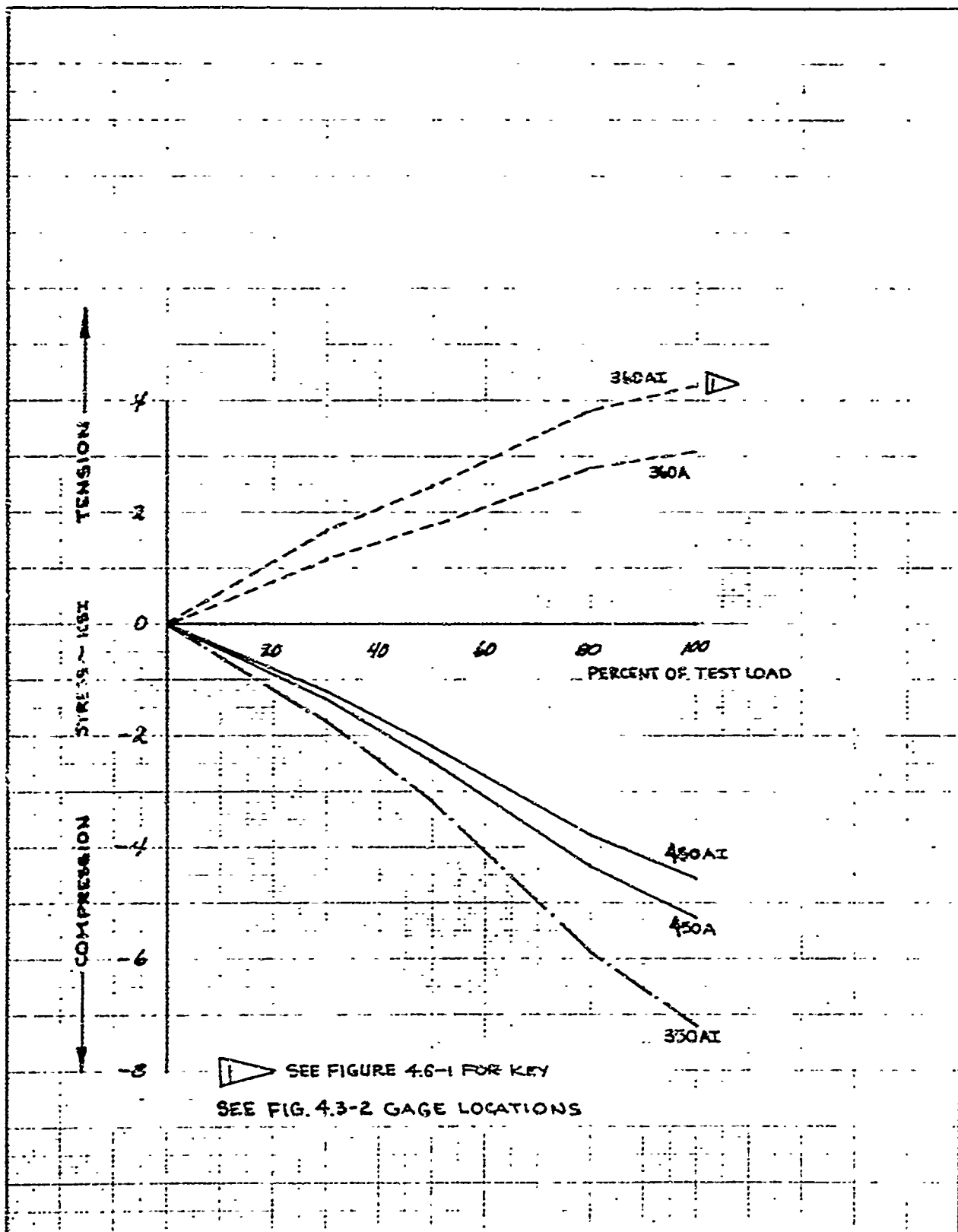

	INITIALS	DATE	REV BY INITIAL	DATE	TITLE	MODEL
CALC	<i>RW</i>	8-23-8			332- F(2) (0° AZIMUTH) TEST STRAIN GAGE READINGS MGS & PBPS	FIG. 4.6-6
CHECK	<i>DNW</i>	8-26-8				
APPD.						
APPD.						

US 4013 8000 REV 1/66

REV LTR _____

BOEING NO T2-3657-1
SH. 4.46

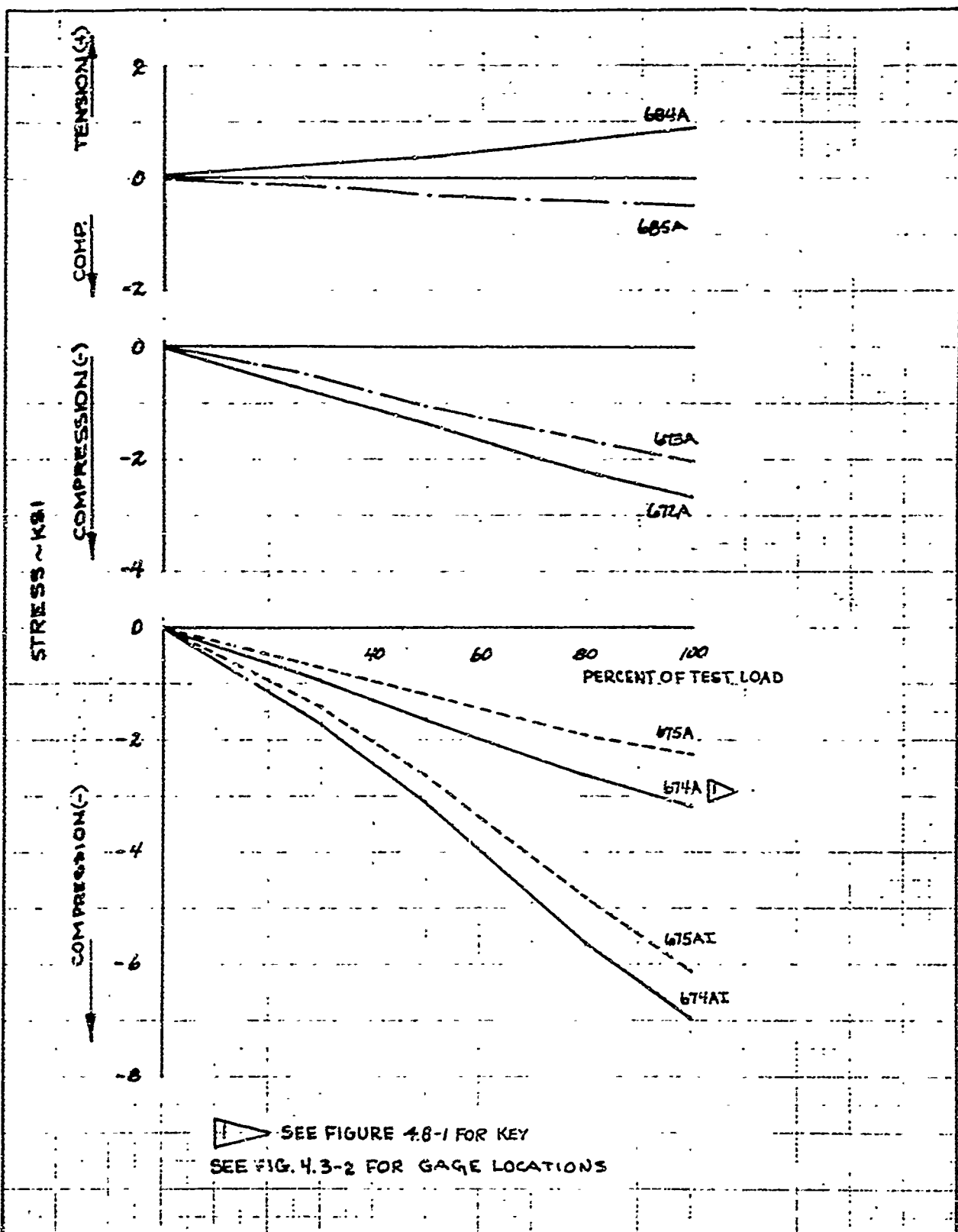

	INITIALS	DATE	REV BY INITIAL	DATE	TITLE	MODEL
CALC	RAW	8-23-8			332- F(a) (0° AZIMUTH) TEST STRAIN GAGE READINGS STAGE III FWD. SKIRT	FIG. 4.6-9
CHECK	RAW	8-25-8				
APPD.						
APPD.						

U3 4013 8000 REV 1/66

REV LTR _____

BOEING NO T2-3657-1
SH 447

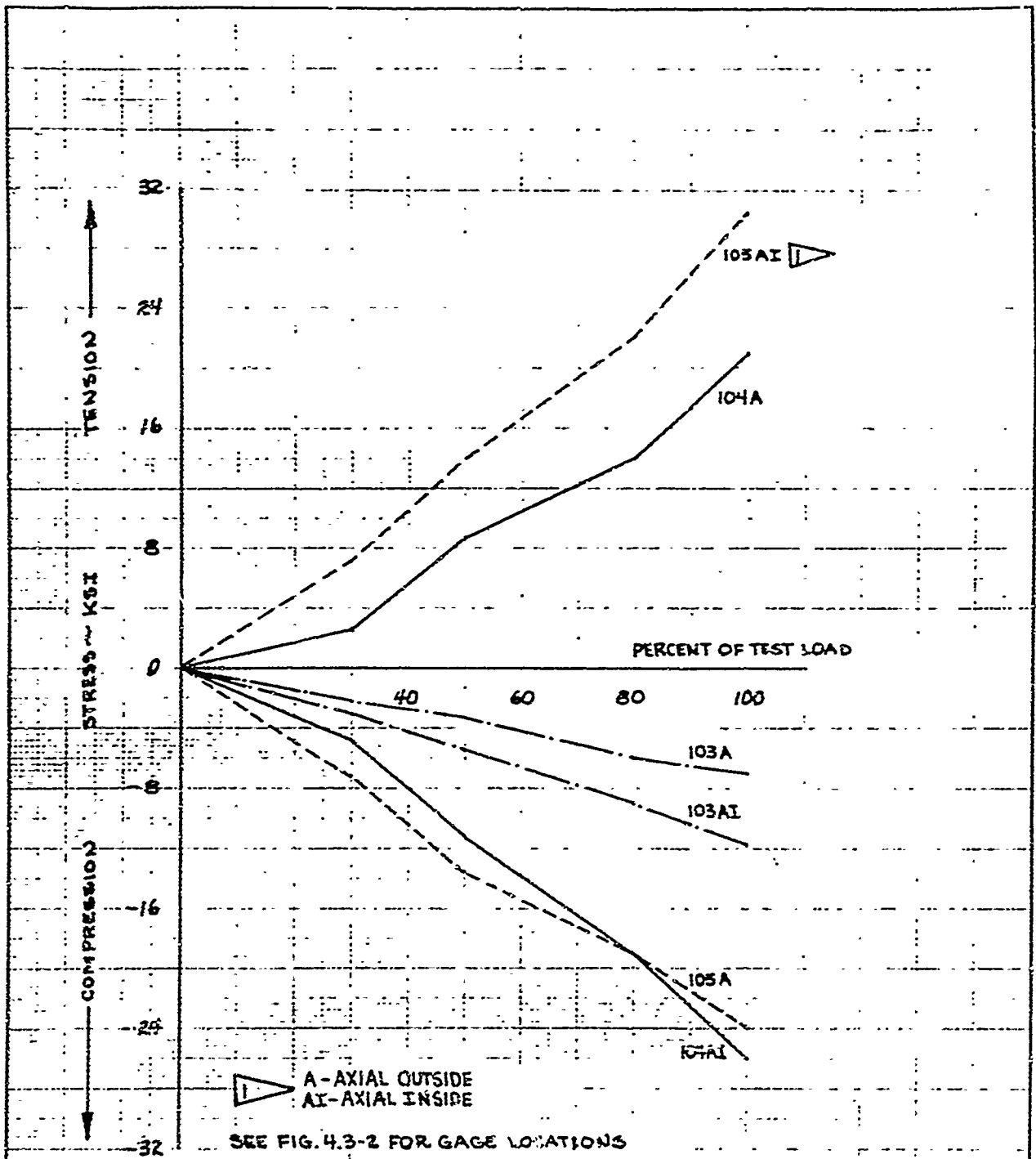



	INITIALS	DATE	REV BY INITIAL	DATE	TITLE	MODEL
CALC	RAW	8-23-68			332- F(b) (36° 30' AZIMUTH) TEST STRAIN GAGE READINGS SHROUD ~ 37°	FIG. 4.6-8
CHECK	MDW	8-26-68				
APPD.						
APPD.						

U3 4013 8000 REV 1/65

REV LTR _____

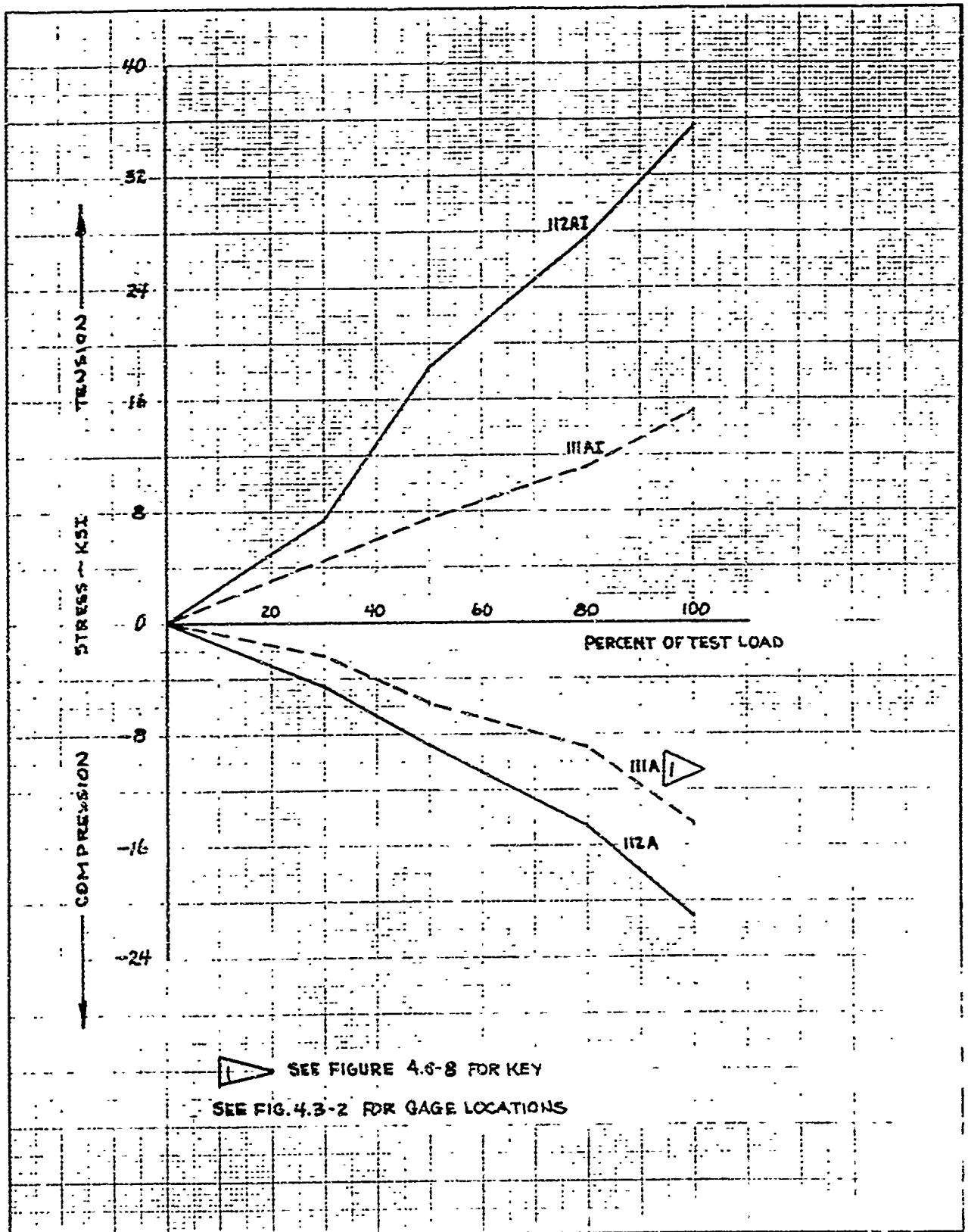
BOEING NO T2-3657-1
SH 448



 SEE FIGURE 4.6-8 FOR KEY
 SEE FIG. 4.3-2 FOR GAGE LOCATIONS

	INITIALS	DATE	REV BY INITIAL	DATE	TITLE	MODEL
CALC	POW	8-23-8			332- F(b) (36° 30' AZIMUTH) TEST STRAIN GAGE READINGS SHROUD-216° 30'	FIG 4.6-8
CHECK	POW	8/26/8				
APPD.						
APPD.						

UD 4013 8000 REV 1/66

REV LTR _____

BOEING NO T2-365-1
 SH 449

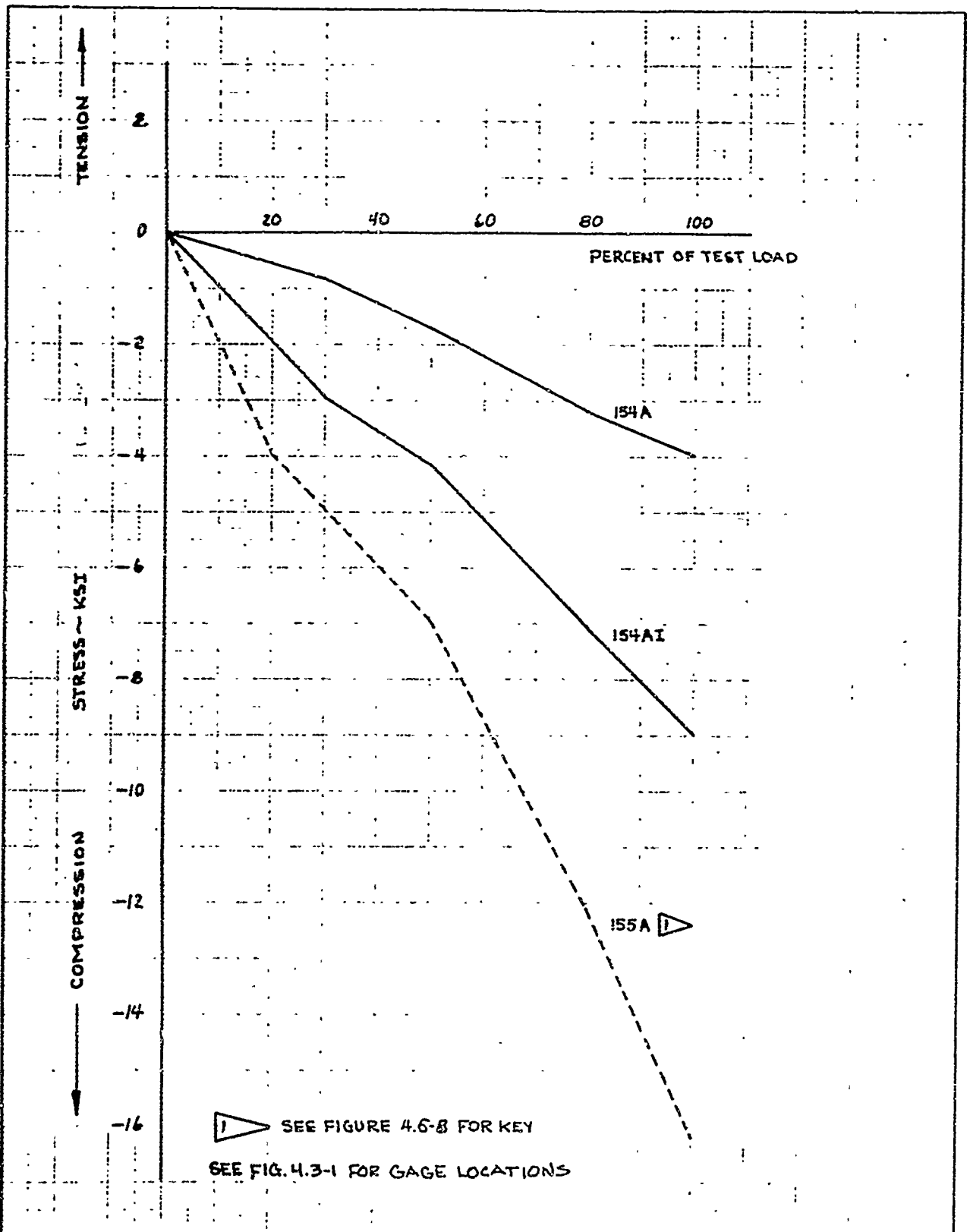

	INITIALS	DATE	REV BY INITIAL	DATE	TITLE	MODEL
CALC	<i>Raw</i>	8-23-58			332- F(b) (36° 30' AZIMUTH) TEST STRAIN GAGE READINGS FRUSTUM ~ 37°	FIG. 4.6-10
CHECK	<i>FDW</i>	8-26-58				
APPD.						
APPD.						

U3 4013 8000 REV 1/66

REV LTR _____

BOEING NO. T2-3657-1
ISH 450

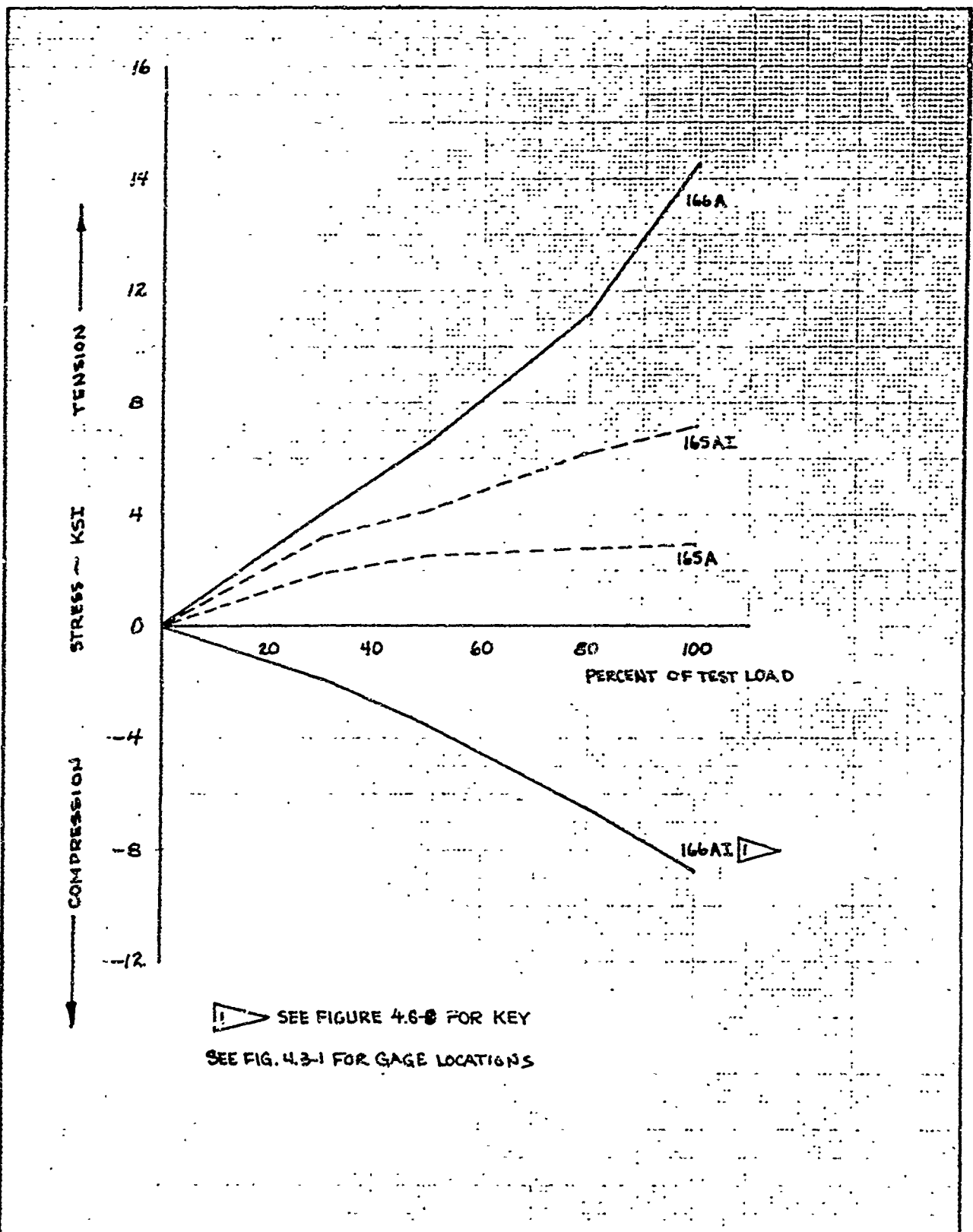

SEE FIGURE 4.6-8 FOR KEY

SEE FIG. 4.3-1 FOR GAGE LOCATIONS

	INITIALS	DATE	REV BY INITIAL	DATE	TITLE	MODEL
CALC	<i>Row</i>	8-23-8			332- F(b) (36° 30' AZIMUTH) TEST STRAIN GAGE READINGS FRUSTUM ~ 216° 30'	FIG. 4.6-11
CHECK	<i>Row</i>	8-26-8				
APPD.						
APPD.						

U3 4013 8000 REV 1/66

REV LTR _____

BOEING NO. T2-3657-1
SH. 451

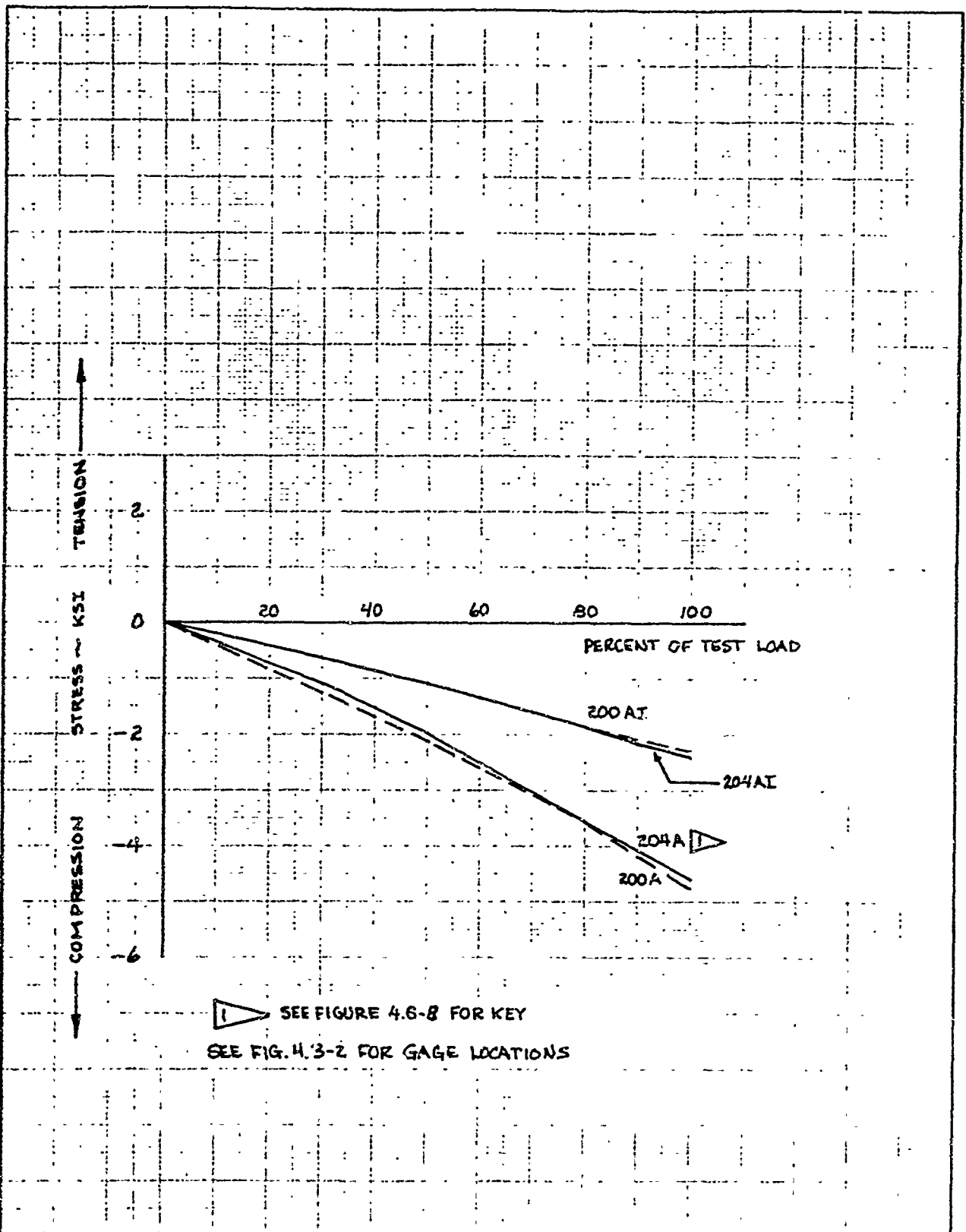

	INITIALS	DATE	REV BY INITIAL	DATE	TITLE	MODEL
CALC.	ROW	8-23-8			332- F(b) (36° 30' AZIMUTH) TEST STRAIN GAGE READINGS MOD TE	FIG. 4.6-12
CHECK	MDW	8-26-8				
APPD.						
APPD.						

U3 4013 8000 REV 1/66

REV LTR _____

BEING NO T2-3657-1
 SH 452

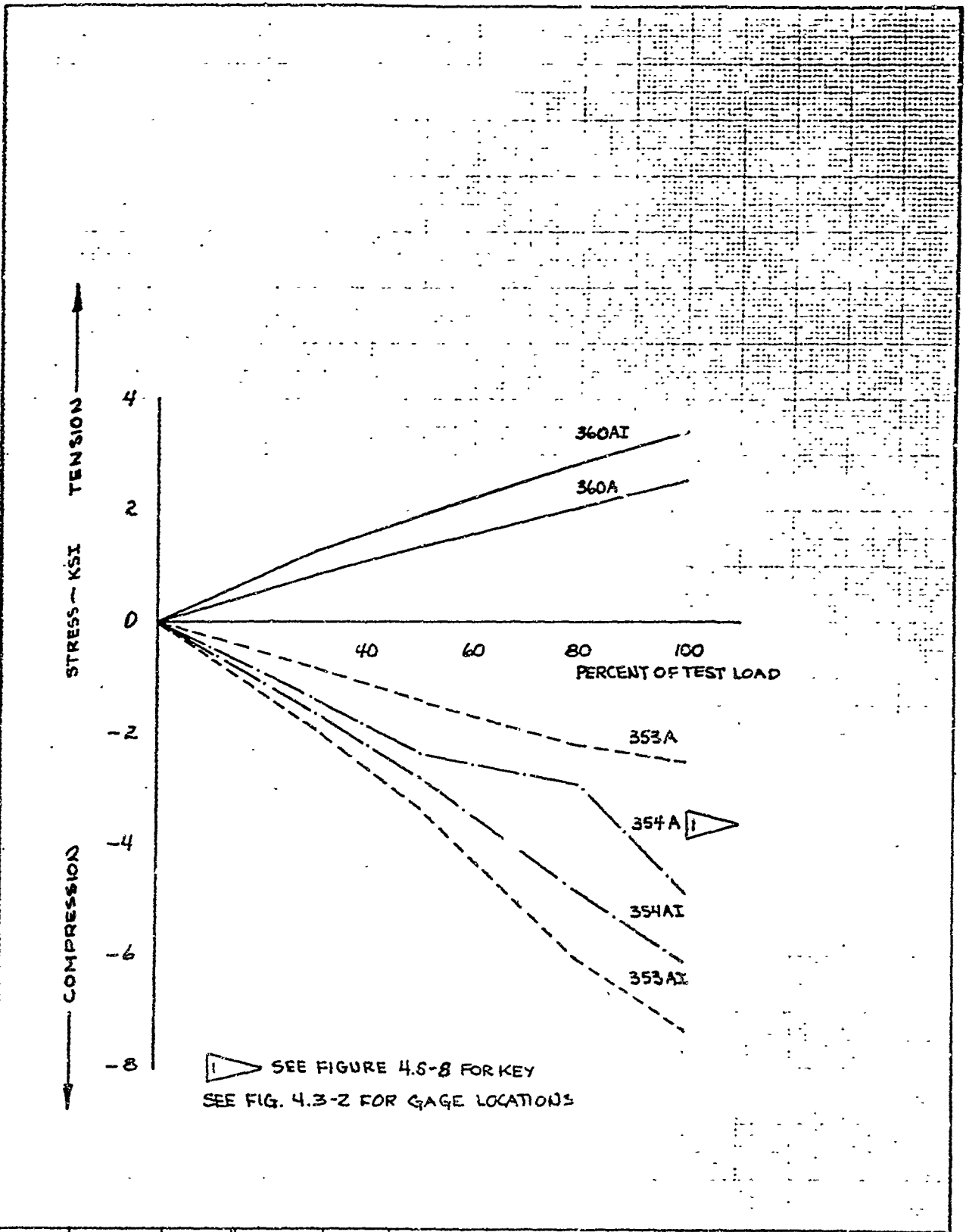

	INITIALS	DATE	REV BY INITIAL	DATE	TITLE	MODEL
CALC	Raw	8-23-8			332- FCB (36° 30' AZIMUTH) TEST STRAIN GAGE READINGS MGS ~ 37° & 180°	FIG. 4.6-13
CHECK	ADW	5-26-9				
APPD.						
APPD.						

U3 4013 2000 REV 1/66

REV LTR _____

BOEING NO T2-3657-1
SH 453

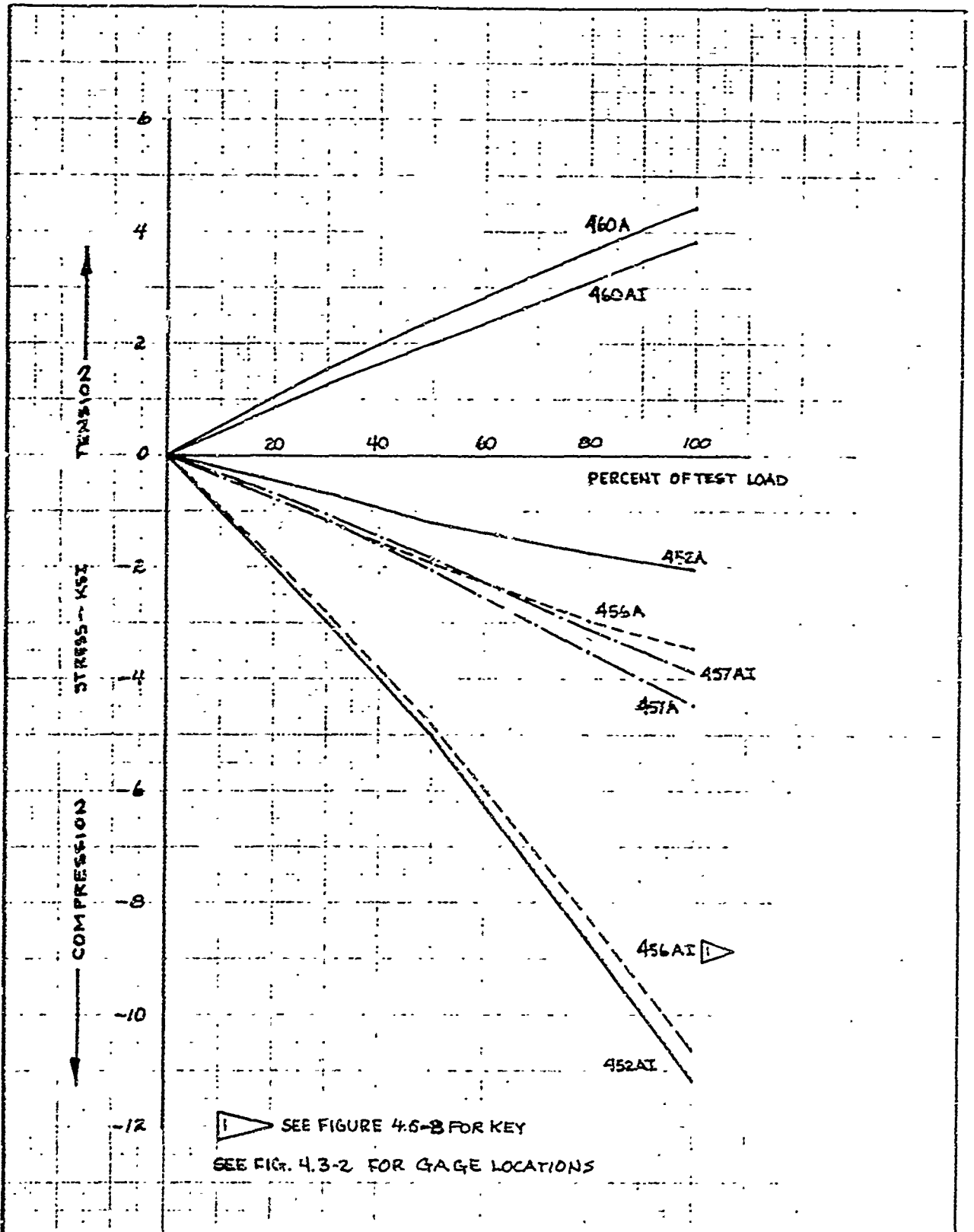

	INITIALS	DATE	REV BY INITIAL	DATE	TITLE	MODEL
CALC.	RDW	8-23-8			332- F(b) (36° 30' AZIMUTH) TEST STRAIN GAGE READINGS PBPS	FIG. 4.6-1A
CHECK	RDW	8-26-8				
APPD.						
APPD.						

U3 4013 8000 REV 1/66

REV LTR _____

BOEING NO T2-3657-i
 SH 454

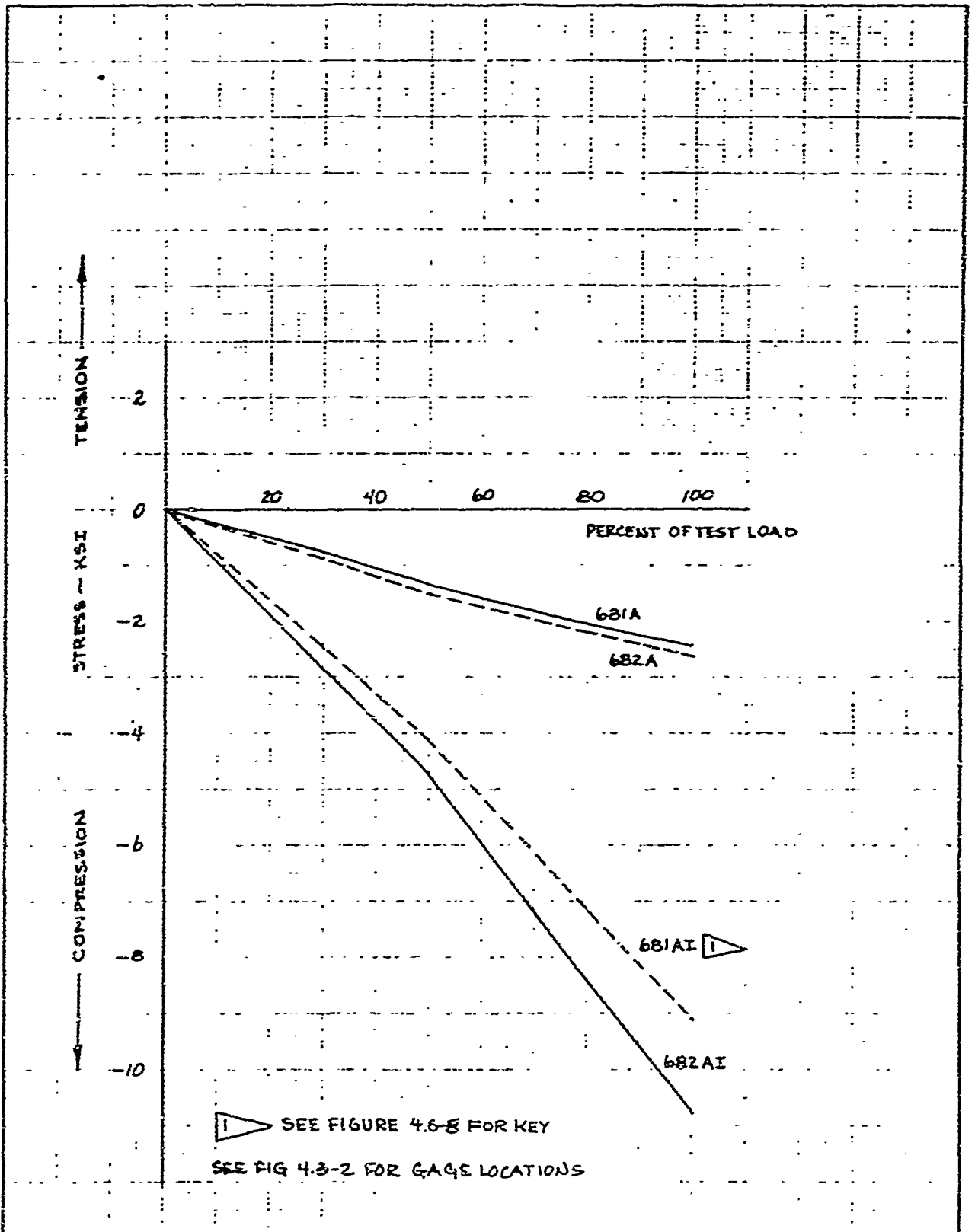



	INITIALS	DATE	REV BY INITIAL	DATE	TITLE	MODEL
CALC	Row	8-23-8			332- F(b) (36° 30' AZIMUTH) TEST STRAIN GAGE READINGS STAGE III FWD. SKIRT	FIG. 4.6-15
CHECK	ADW	8-25-8				
APPD.						
APPD.						

UJ 4013 8000 REV 1/66

REV ITR _____

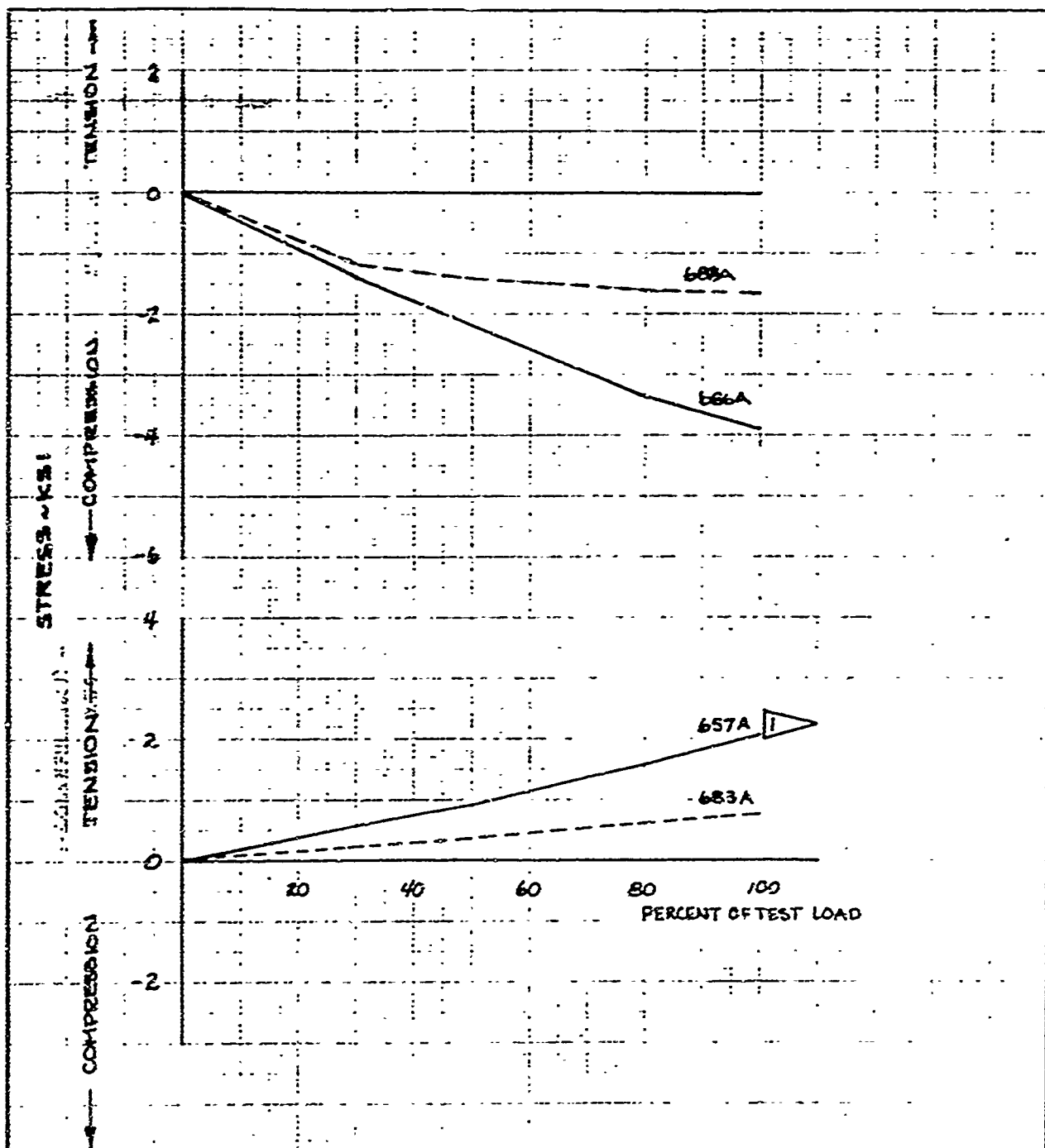
BOEING NO. T2-3657-1
 SH. 455



 SEE FIGURE 4.8-8 FOR KEY
 SEE FIG. 4.3-2 FOR GAGE LOCATIONS

	INITIALS	DATE	REV BY INITIAL	DATE	TITLE	MODEL
CALC	Raw	8-23-8			332- F(b) (36' 30' AZIMUTH) TEST STRAIN GAGE READINGS STAGE III FWD. SKIRT	FIG. 4.6-16
CHECK	MDW	3-26-8				
APPD.						
A.PPD.						

US 4013 8000 REV 1/66

REV LTR _____

BOEING NO. T2-3657-1
 SH 456

5.0 STAGE III/PBV OPERATIONAL FLIGHT CONDITION TESTS (333-F)

5.1 TEST SPECIMEN

The 333-F test specimen used the same hardware described in section 4.1 with the exception of the MOD 7E wafer which is not included in the operational configuration. See section 4.1 for description, photographs and dimensional surveys of the test specimen.

5.2 TEST SETUP

Three test setups were used: Phase I, Phase II and Failure conditions. Figure 5.2-1 shows a schematic of the Phase I and Failure test setups. Figure 5.2-2 shows the Phase II test setup. The Phase I and the Failure test runs introduced loads through the Shroud and the Frustum. In these two tests two lateral jacks introduced the shear load through the forward loading heads. Four longitudinal jacks applied an axial load and a pure couple component to the Shroud. Two longitudinal jacks applied an axial load and a pure couple component to the Frustum. A seventh longitudinal jack applied axial compression thru the aft dome closure plate of the Stage III motor.

The Phase II test setup did not use an R/S Shroud and therefore, all loads thru the R/S were introduced thru the Frustum in the setup described above.

The Phase I and Phase II tests used heat lamps to supply the required temperatures. See Figures 5.2-3, 5.2-4 and 5.2-5 for photographs of the heat jig and lamps. The heat lamps were removed for the failure test and the Shroud replaced (it had been removed for Phase II) to give the setup shown in Figure 5.2-6.

In the Phase II test a Kobe Triplex Pump was used to provide the necessary water pressure inside the Stage III motor to simulate operating pressures. In the Phase I and Failure tests the 28 psi stabilizing pressure was supplied by the city water pressure.

Lead weights applied constant axial load to the PBCS structure. All jack and pump pressure loads were programmed thru the SDS 910 Computer and applied thru a servo-controlled system. Heating was manually controlled using control thermocouples and Ignitron Power Controllers shown in Figure 5.2-7.

5.3 TEST INSTRUMENTATION

Strain gages, located and identified in Figures 5.3-1, 5.3-2, 5.3-3 and 5.3-4, were recorded during all of the 333-F tests. During the programmed Phase I and Phase II tests data thermocouples, located at each gage location in heated zones and at locations shown in Figures 5.3-5 thru 5.3-10, were also read. Test data and load cell readings were recorded at the rate of 192 channels per second (each channel read approximately every 2 seconds) except up to 100% of the Failure test, when they were read at the end of each increment of applied load. These recordings are shown in reference 4.

5.4 TEST CONDITIONS

5.4.1 PROGRAMMED POWERED FLIGHT ENVIRONMENT

Phase I and Phase II of the Programmed Test applied the continuous loads and heat of the powered flight environment from the critical wind shear max. q_{∞} condition thru the Stage III thrust termination condition. Loads and temperatures were from reference 1 with the exception of the 5 second hold of the wind shear condition (30-35 seconds) and the immediate reduction of the loads after the Stage II Ignition condition in Phase I and the Stage III Ignition condition in Phase II (see 5.4.1 Figures and reference 5). The Phase I portion of the powered flight environment test included the "shroud on" conditions of Wind Shear, Maximum Axial Load Factor, Stage II Ignition (2 possible conditions) and Stage II Burnout. The actual loads were generally higher than planned except during the low load condition prior to Stage II Burnout when loads were lower than planned. The Stage III motor was internally pressurized to 28 psi to simulate the added stability of a motor with propellant. A load of 21.5 kips was applied to the aft boss of the Stage III motor to reduce the tension load at the Stage III motor aft interface. Figures 5.4.1-1 thru 5.4.1-11 show Phase I load geometry, loads and wind shear condition line loads. Figures 5.4.1-12 thru 5.4.1-17 show control thermocouple locations and typical temperature history curves during the test. Figure 5.4.1-18 shows data and control thermocouple response to the heat environment at t=58.6 seconds of test time.

The Phase II portion of the powered flight environment test included the "shroud off" conditions of Stage III Ignition and Stage III Thrust Termination. The actual loads were slightly lower than planned and the Stage III motor internal pressure (simulating motor burn pressures) reached its peak value later than planned. Figures 5.4.1-19 thru 5.4.1-27 show the Phase II load geometry, loads and Stage II ignition line loads. Figures 5.4.1-28 and -29 show control thermocouple temperature history curves during the test. Figure 5.4.1-30 show data and control thermocouple response to the heat environment at t= 25.7 seconds of test time.

5.4.2 FAILURE CONDITION

The critical Wind Shear condition loads (from reference 1) were increased incrementally to failure. Testing was at room temperature with 28 psi internal stabilizing pressure in the Stage III motor. The load geometry was the same as that shown for the programmed Phase I test as shown in Figure 5.4.1-1. Figures 5.4.2-1 thru 5.4.2-4 show the test loads. A maximum load of 34.3 kips (at 120%) instead of the reference 1 planned load of 21.5 kips was applied to the Stage III motor aft dome to further reduce the tension load at the aft Stage III Motor interface. Though loads were not increased over 120% during the test (failure was at 120%) the planned loading after reaching 120% was to have changed so as to reduce the bending loads on the Stage III motor. This would have been done by increasing moment only by increasing the pure couple

USE FOR TYPEWRITTEN MATERIAL ONLY

5.4.2 FAILURE CONDITION (CONT.)

from the longitudinal jacks. The shear would have been held constant at its 120% value (as would have been the aft dome load of 34.3 kips) but the axial compression load would have increased proportionally.

5.5 TEST PROCEDURE

5.5.1 PROGRAMMED POWERED FLIGHT ENVIRONMENT

PHASE I

After internally pressuring the Stage III motor to 28 psi, the strain gages were zeroed with the load of the dead weights, the loading heads and the water on the specimen. An axial preload was then applied to the specimen to offset the weight of the loading heads. The SDS 910 computer programmer and the manually operated heat controllers were synchronized at the start to provide correct coincidence of heat and loads throughout the test. The heat and loads programs were then run continuously through the critical conditions of powered flight from wind shear thru Stage II burnout. Zero gage readings were taken after the Stage III motor case pressure had been released and the specimen had cooled to room temperature.

PHASE II

After removing the Shroud, the strain gages were again zeroed with the load of the water, the frustum loading head and the internal dead weights on the specimen. A preload was applied to the specimen to offset the frustum loading head weight. Prior to test time zero Stage III Motor internal pressure was increased to an initial 350 psi so that the required pressure at Stage III ignition could be reached in 25.7 seconds of test time. After applying the initial motor pressure the temperature program was begun at -60 sec. of test time in order that the specimen would be at the required temperature at 25.7 sec. of test time (Stage III ignition). Due to a discrepancy between two pressure readout systems monitoring the Stage III motor pressure a hold of approximately one minute was necessary at test time zero. When the discrepancy was explained and remedied (a valve had not been opened) the test was continued from test time zero with the initiation of the computerized jack loading program. The test was then run to conclusion as planned.

5.5.2 WIND SHEAR CONDITION FAILURE TEST

The heating jig was removed from the Phase II test and the Shroud and Shroud load head were reassembled to the specimen. After the stabilizing Stage III Motor Case pressure of 28 psi was applied the strain gages were zeroed with the internal dead weights and loading head dead weights on the specimen. A preload, unloading the loading head dead weights, was then applied, and the gages were read. Loading was applied incrementally with the gages read at the end of each increment of applied load.

USE FOR TYPEWRITTEN MATERIAL ONLY

5.6 TEST RESULTS

The test specimen successfully sustained the heat and loads of the powered flight environment as shown in section 5.4.1 (Phase I and Phase II test conditions). Figures 5.6-1 thru -4 show selected strain gage data plotted thru 35 seconds of Phase I test time (the wind shear condition was held between 30 and 35 seconds of test time). Most strain gage data was lost before reaching the next critical condition at $t = 53.6$ seconds because of the effect of high temperature on the strain gage bonds. Because of this no gage data are shown for the Phase II portion of testing. This strain gage data and a visual inspection showed that the test specimen successfully sustained the test heat and loads without loss of structural capability. A tabulation of all test data acquired is given in Reference 4.

The failure test was run by increasing the wind shear condition loads in increments to failure. Failure occurred in the Stage III Motor case at 120% of the test loads as shown in section 5.4.2. Loads were per Reference 1 except for the increase in the Stage III Motor aft dome load from 21.5 kips to 34.3 kips. Figures 5.6-5 thru 5.6-11 show strain gage data up to 110% of test loads when the last recordings were taken. Figures 5.6-12 thru -14 are photographs of the failure. Failure occurred on a horizontal plane (sta 311.8 at the 37° azimuth) in the Stage III Motor Case between 301° and 127°. As shown in Figure 5.6-14, this is in the Y-joint transition area just below the rubber fillet runout. This area was not expected to fail and had been loaded to higher line loads in previous tests on other motor cases.

5.7 TEST CONCLUSIONS

The integrated R/S /PBCS/Stage III structure was shown to be adequate for the heating and loads environment of powered flight as specified in Reference 1. Actual loads sustained by the specimen are shown in section 5.4.1.

In the failure test the Stage III motor case failed unexpectedly at 120% of Reference 1 test loads. It had been expected that the motor case and aft skirt would sustain enough load to force a failure forward of the Stage III motor (In the R/S, PBCS or Stage III forward skirt). However, an improperly prepared bond (found later in tests to be understrength) near the aft equator, between internal longitudinal filaments and the rubber fillet extension, allowed separation of layers to occur. The external failed layers were left unsupported thus reducing greatly their load carrying capability and resulting in a local instability failure. A failure analysis has been prepared by the Aerojet General Corporation, Sacramento, and submitted to SAMSO/TRW -- Reference 6.

The failure test showed that the R/S /PBCS / Stage III forward skirt integrated test specimen is capable of sustaining at least 120% of Reference 1 test loads. Actual loads at failure are shown in section 5.4.2. The maximum loads applied to the PBV section, though approximately 120% of Reference 1 loads, were between 97% (at R/S-MGS interface) and 100% (at Stage III/PBV Separation Joint) of the BSD Exhibit 66-6A Design Ultimate line loads. At the Stage III/PBV Separation Joint the maximum applied line load was 100.7 per cent of the Figure A ultimate line load requirement.

USE FOR TYPEWRITTEN MATERIAL ONLY

USE FOR TYPEWRITTEN MATERIAL ONLY

5.2 TEST SETUPS

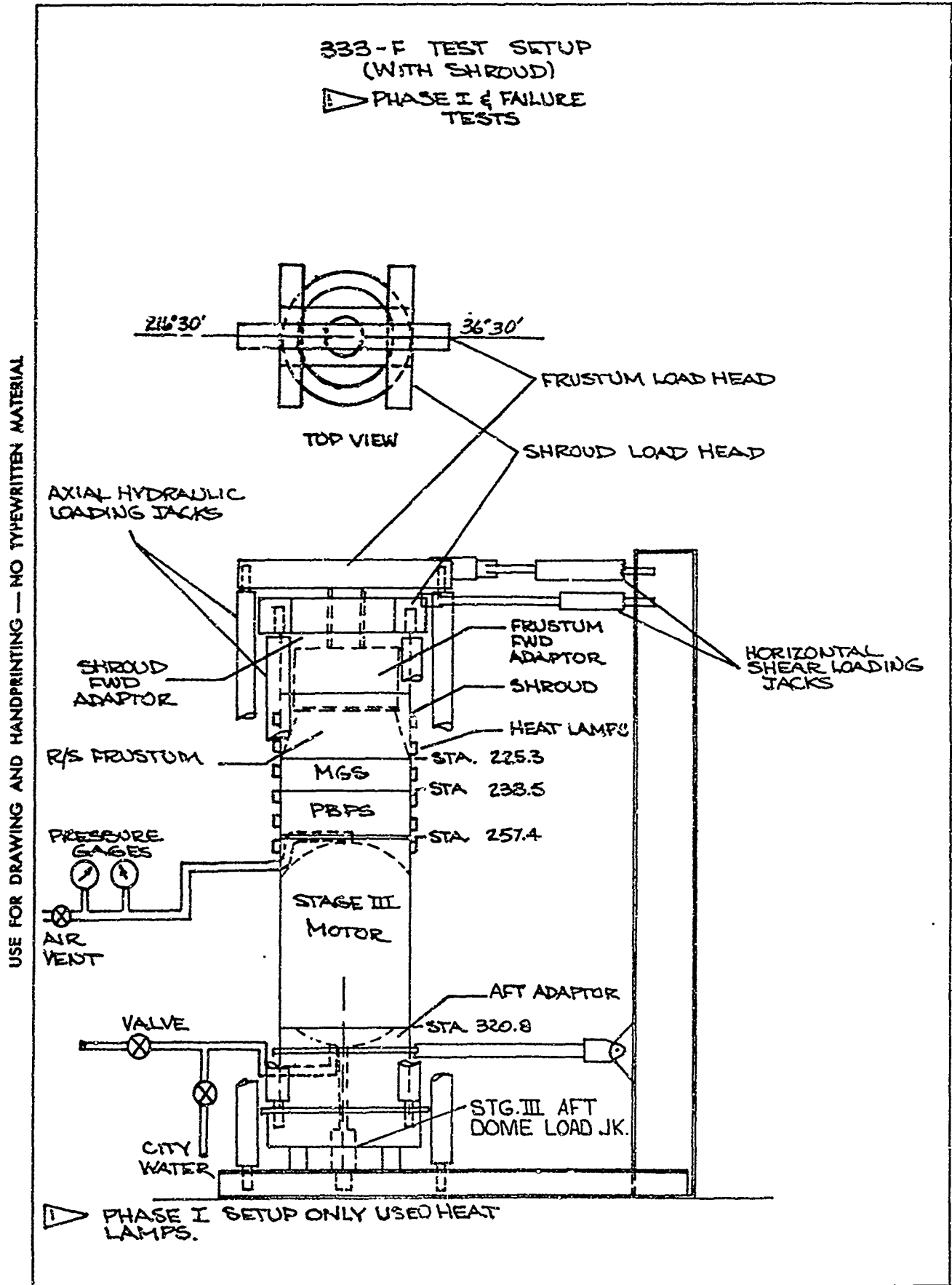

USE FOR DRAWING AND HANDPRINTING — NO TYPEWRITTEN MATERIAL

333-F TEST SETUP
(FRUSTUM ONLY)
PHASE II

USE FOR DRAWING AND HANDPRINTING — NO TYPEWRITTEN MATERIAL

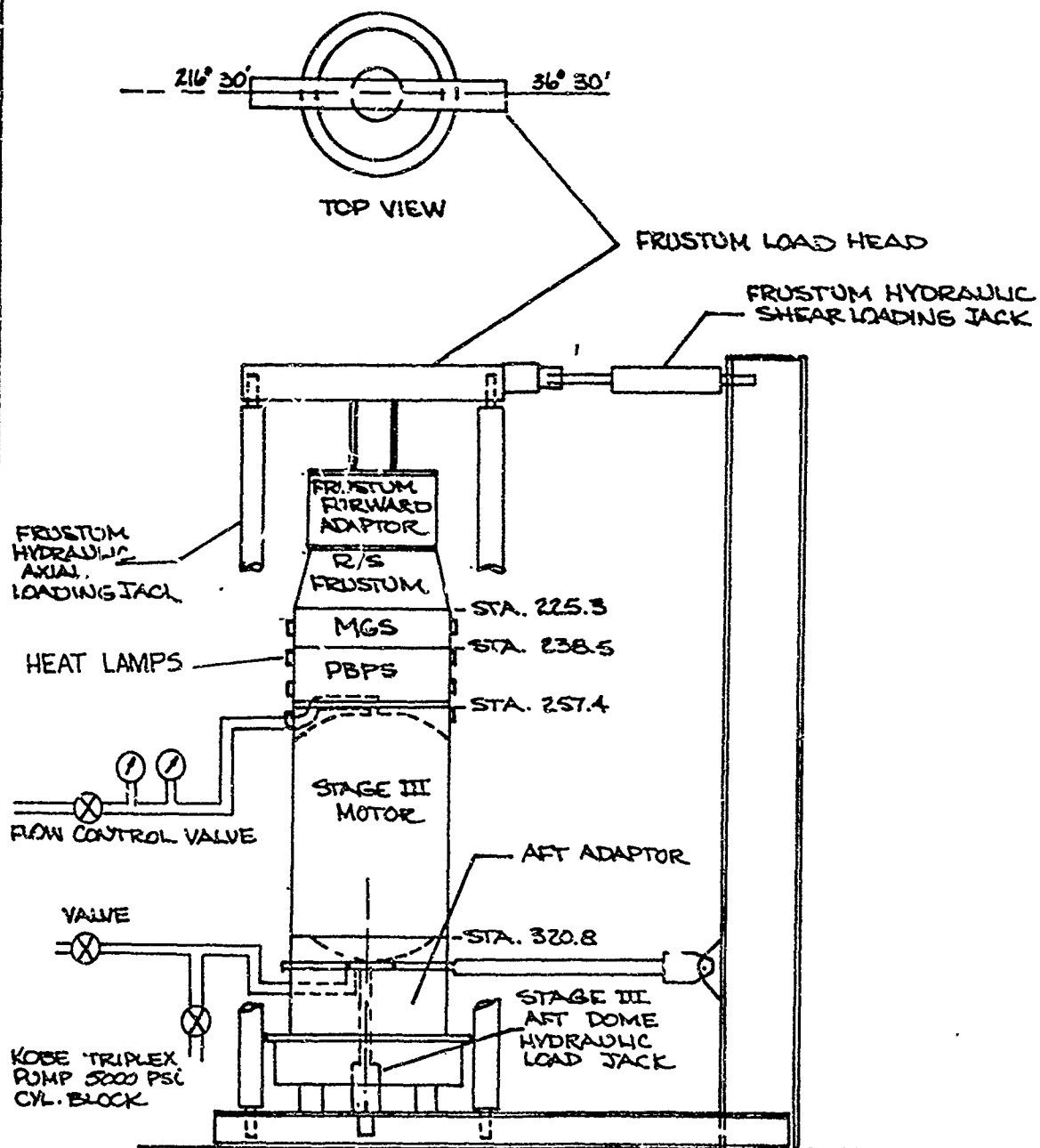

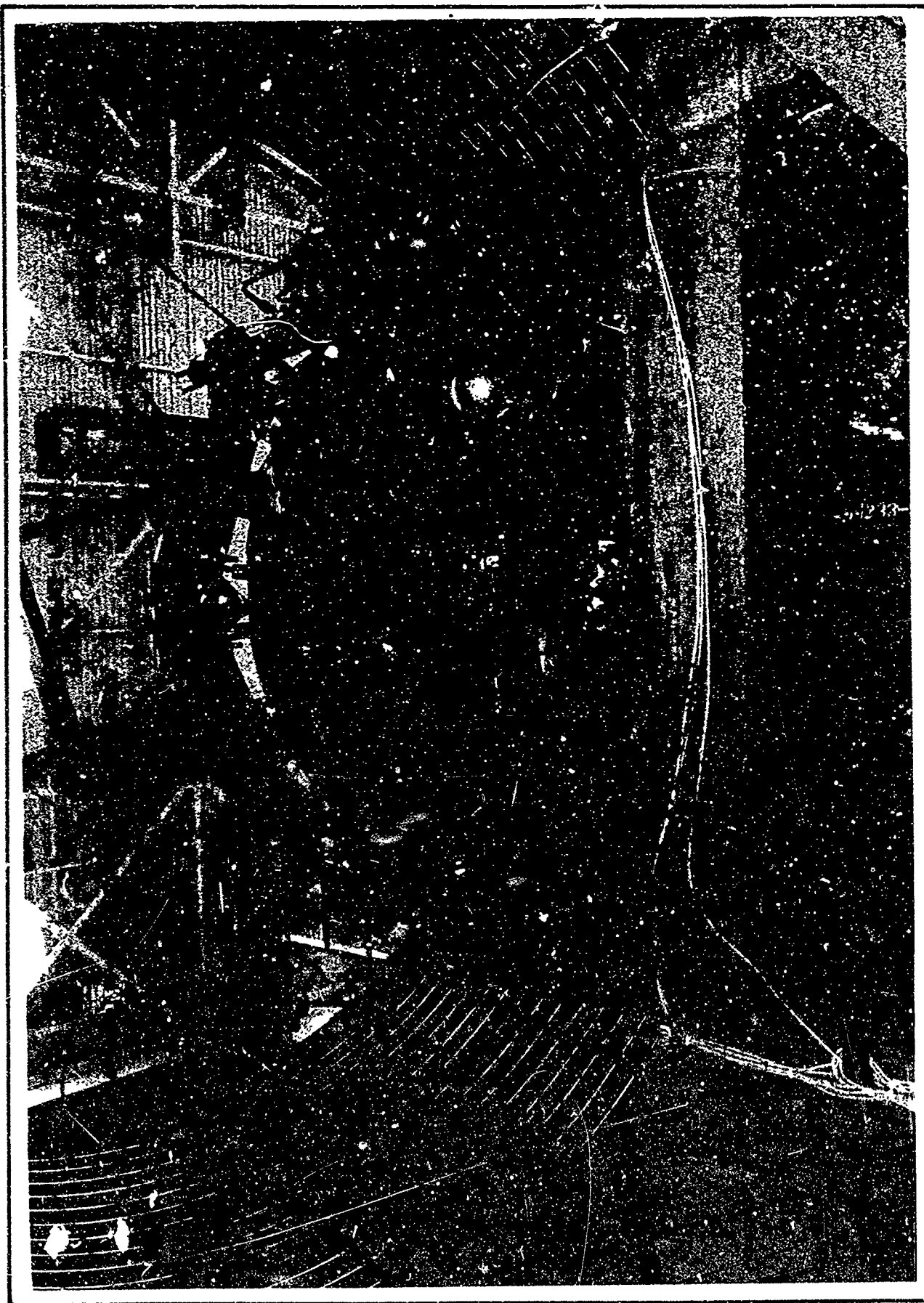

SHEET 507

FIG. 5.2-3

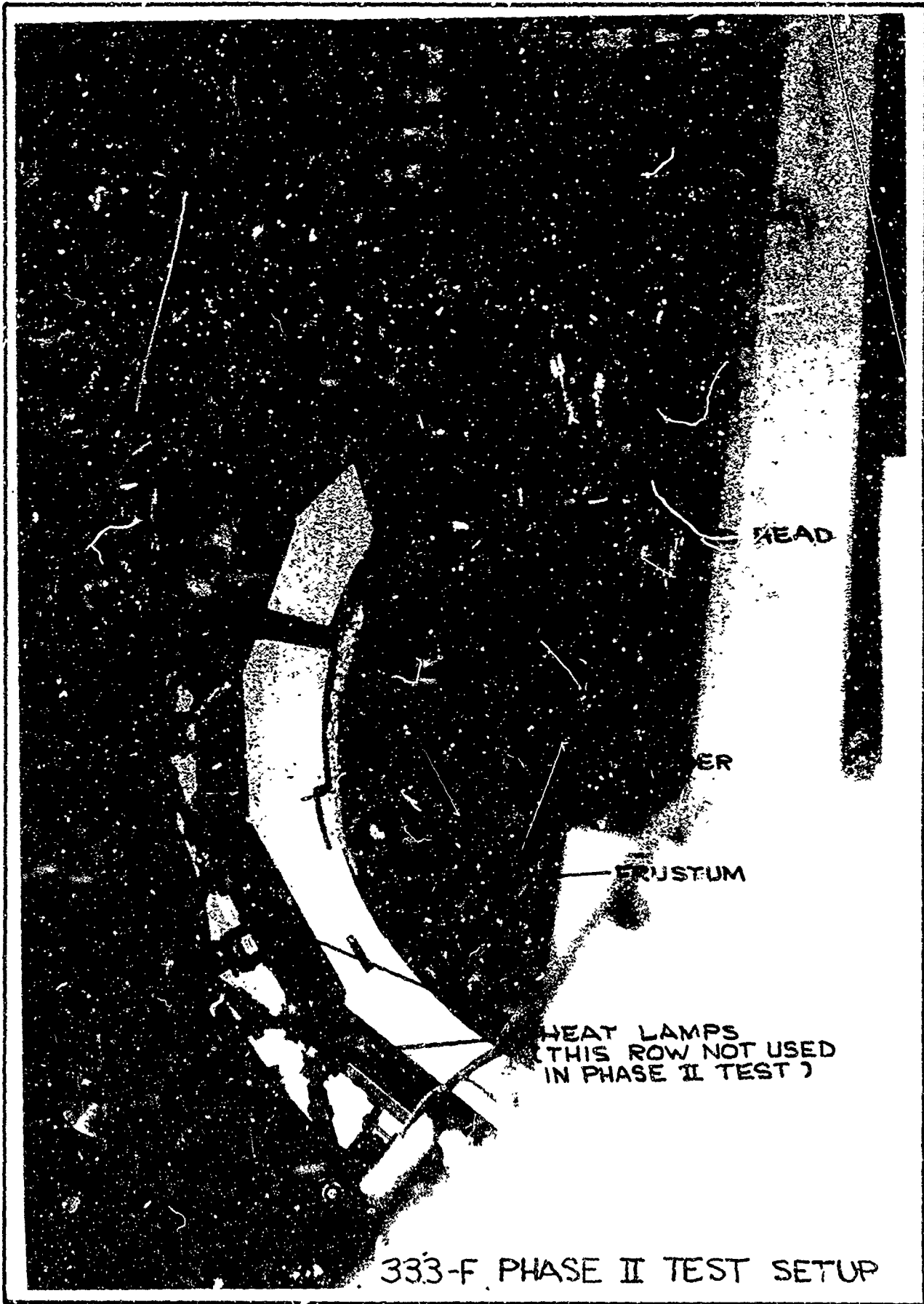

SHEET 508

FIG. 5.2-4



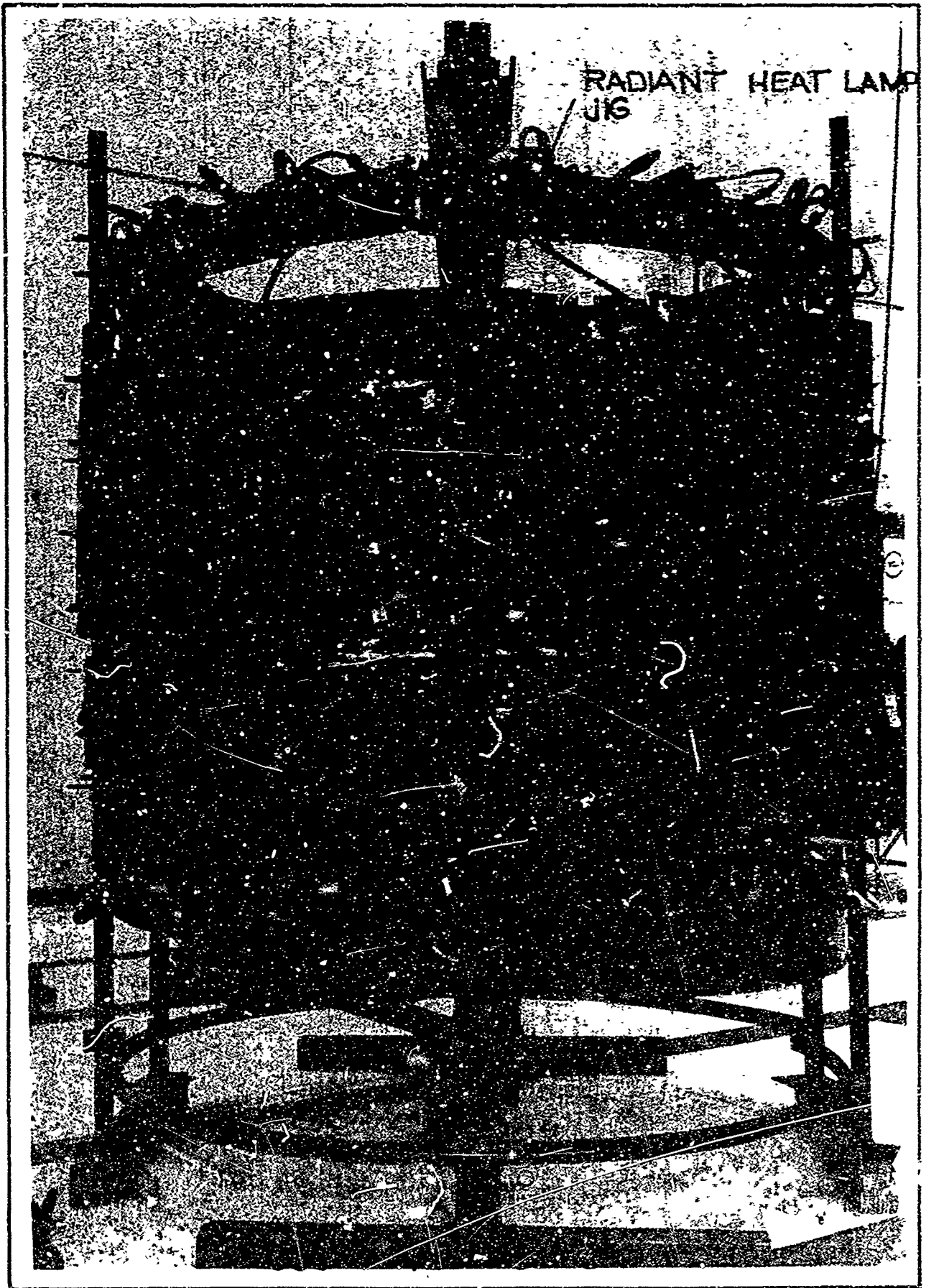

SHEET 509

FIG. 5.2-5

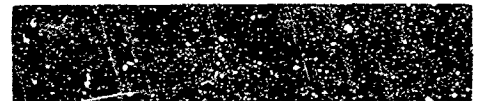



SHEET 510

FIG. 5.2-6





SHEET S11

FIG. 5.2-7



USE FOR TYPEWRITTEN MATERIAL ONLY

5.3 TEST INSTRUMENTATION

USE FOR DRAWING AND HANDPRINTING — NO TYPEWRITTEN MATERIAL

R/S FRUSTUM INSTRUMENTATION - TEST 335-F

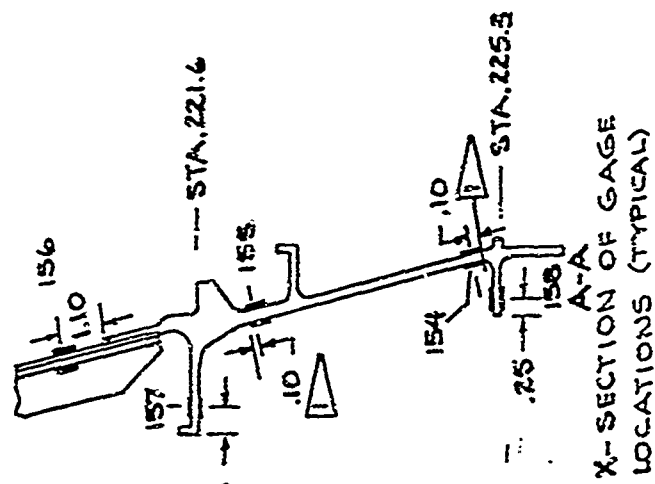
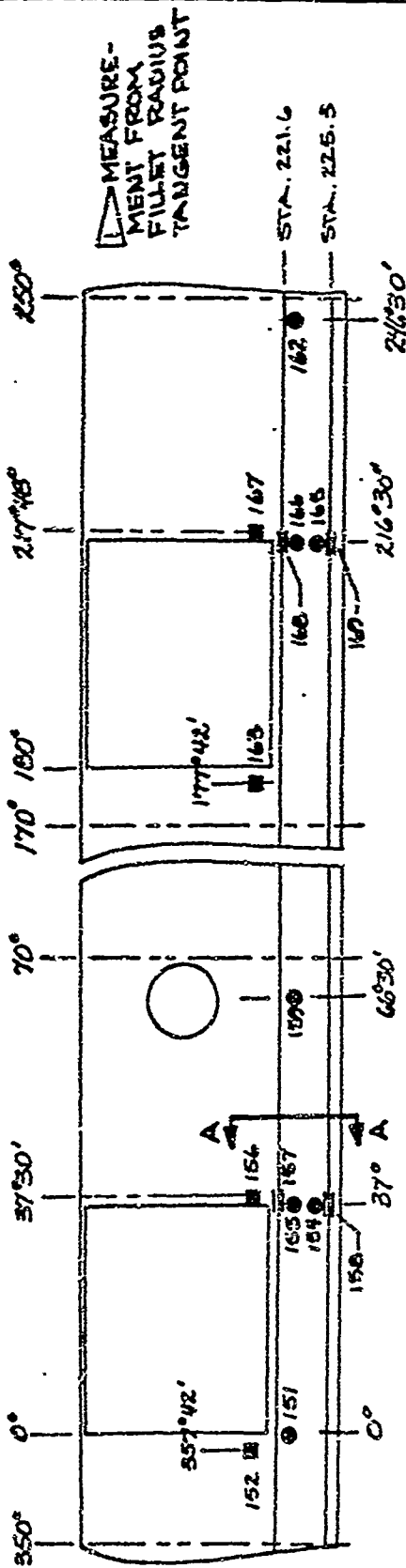

X-SECTION OF GAGE LOCATIONS (TYPICAL)
A-A

TEST REPORT KEY:

- UNIAxIAL GAGES
- OUTSIDE ONLY
- BACK TO BACK
- BIAXIAL GAGES
- OUTSIDE ONLY
- BACK TO BACK
- CIRCUMFERENTIAL GAGES
- ▷ OUTSIDE ONLY
- = FORE AND AFT ON FLANGES

DATA REPORT KEY:

XXX X X
LOCATION NUMBER

NO LETTER = OUTSIDE GAGE
I = INSIDE GAGE

A = AXIAL ORIENTATION
C = CIRCUMFERENTIAL ORIENTATION

BIAXIAL GAGE DIMENSIONING KEYS:

INSTRUMENTATION KEY:

- UNAXIAL GAGES
 □ OUTSIDE ONLY
 ■ "BACK TO BACK"

- BIAXIAL GAGES
 ○ OUTSIDE ONLY
 ● "BACK TO BACK"

TEST 333-
 STRAIN GAGE IDE

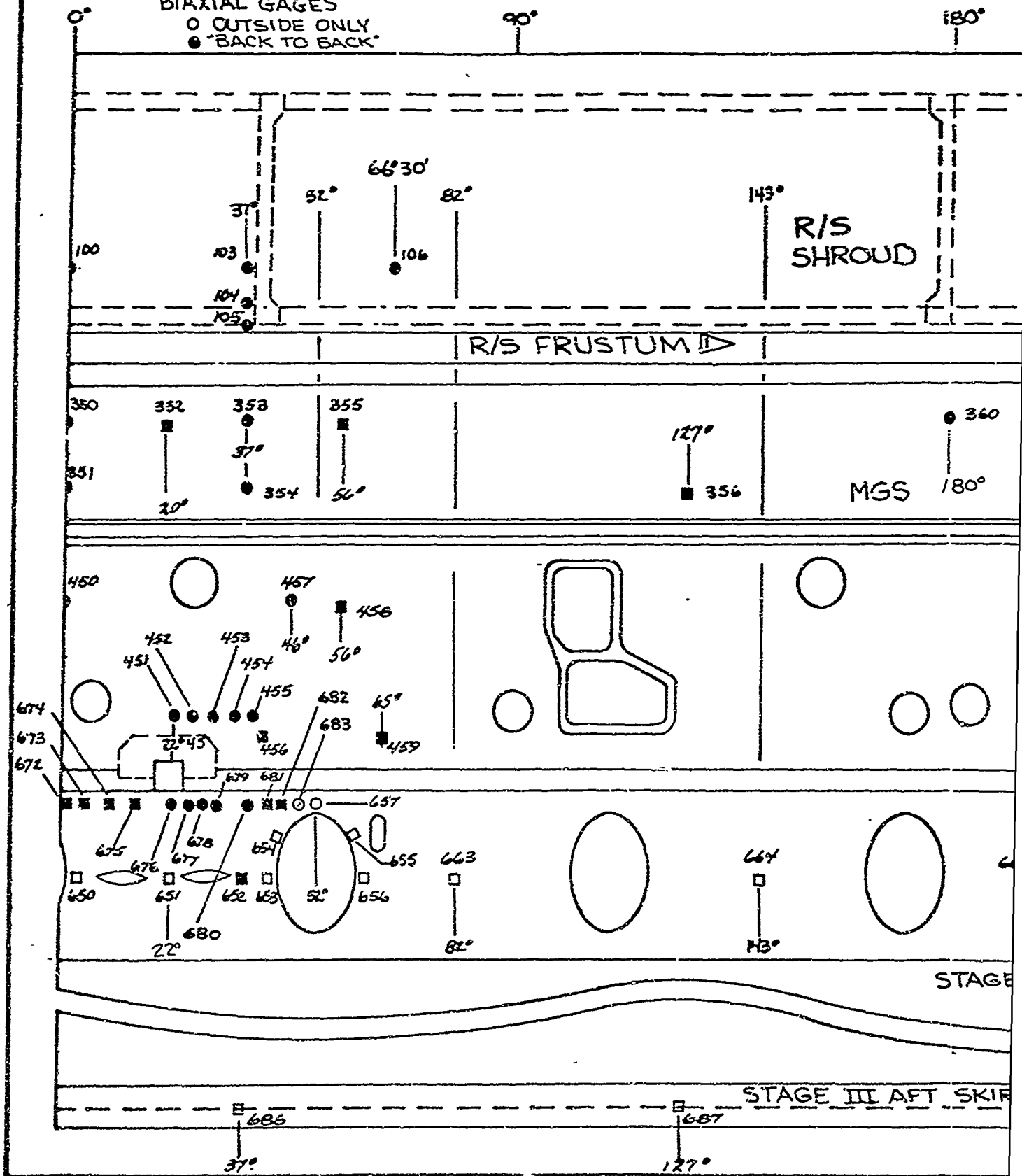

REV LTR _____

A

T 333-F
AGE IDENTIFICATION

SEE FIGURE
5.3-1 FOR
R/S FRUSTUM
GAGES.

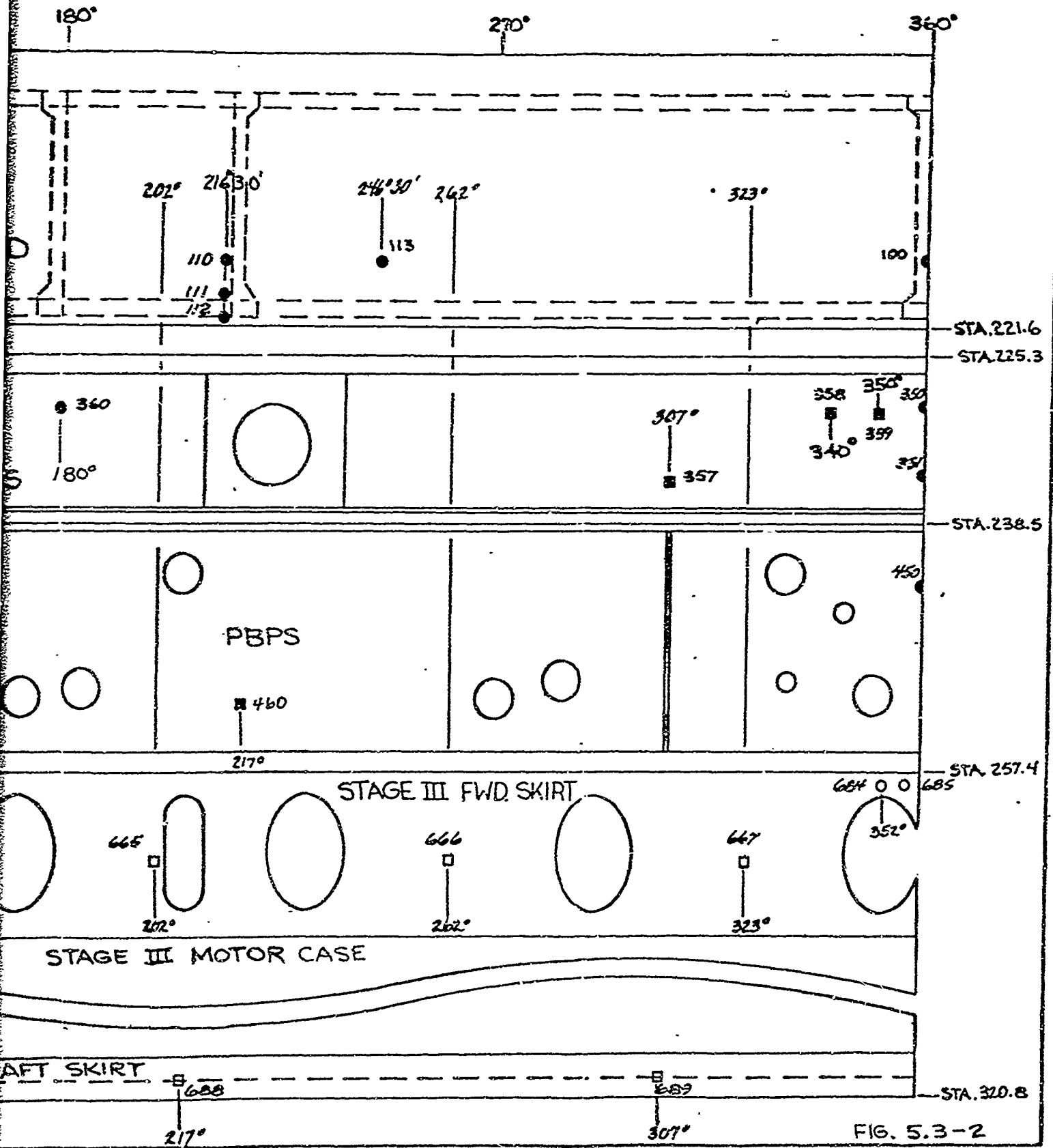
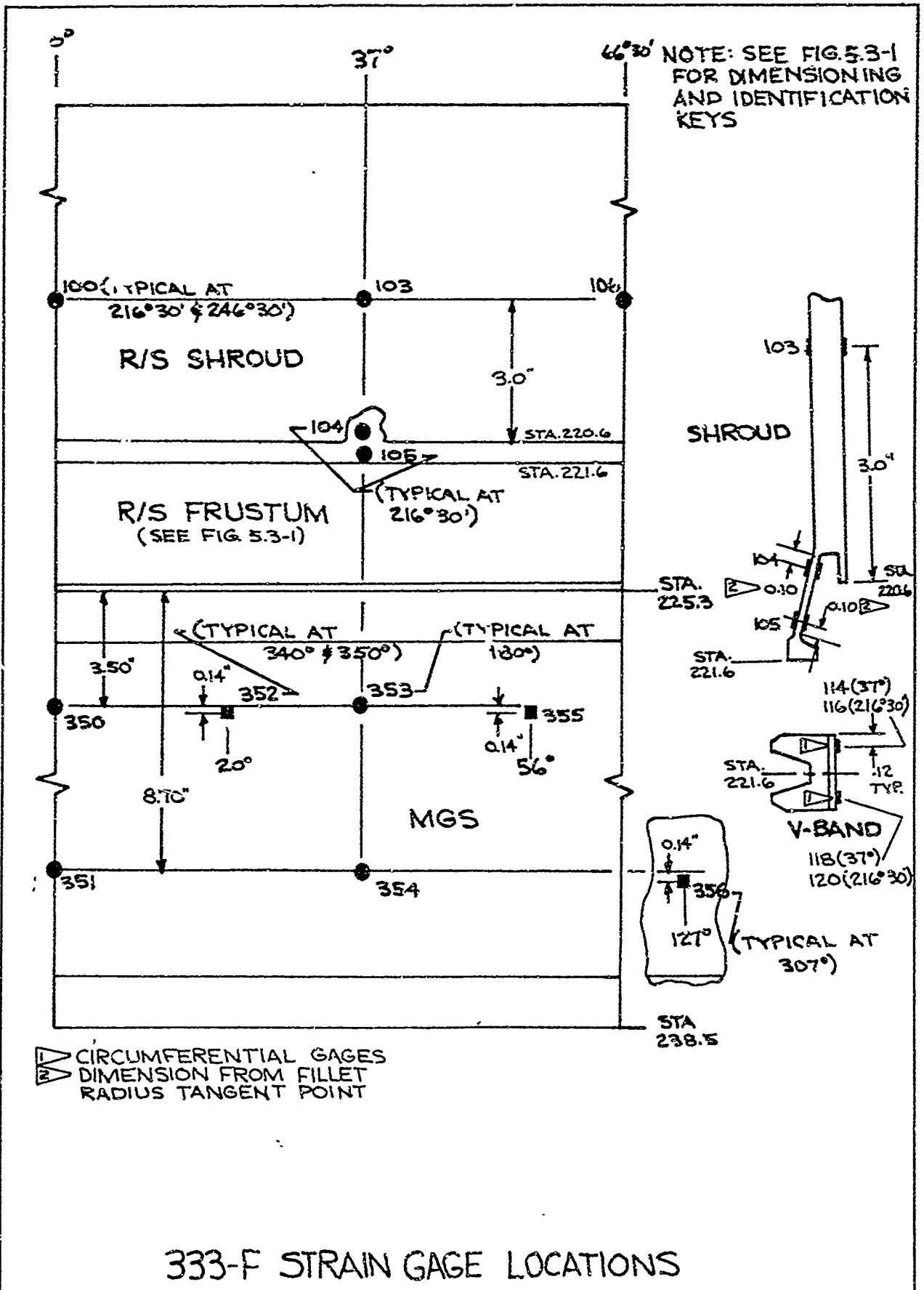

FIG. 5.3-2

BOEING NO. T2-3657-1
SH 514

B

USE FOR DRAWING AND HANDPRINTING — NO TYPEWRITTEN MATERIAL



USE FOR DRAWING AND HANDPRINTING - NO TYPEWRITTEN MATERIAL

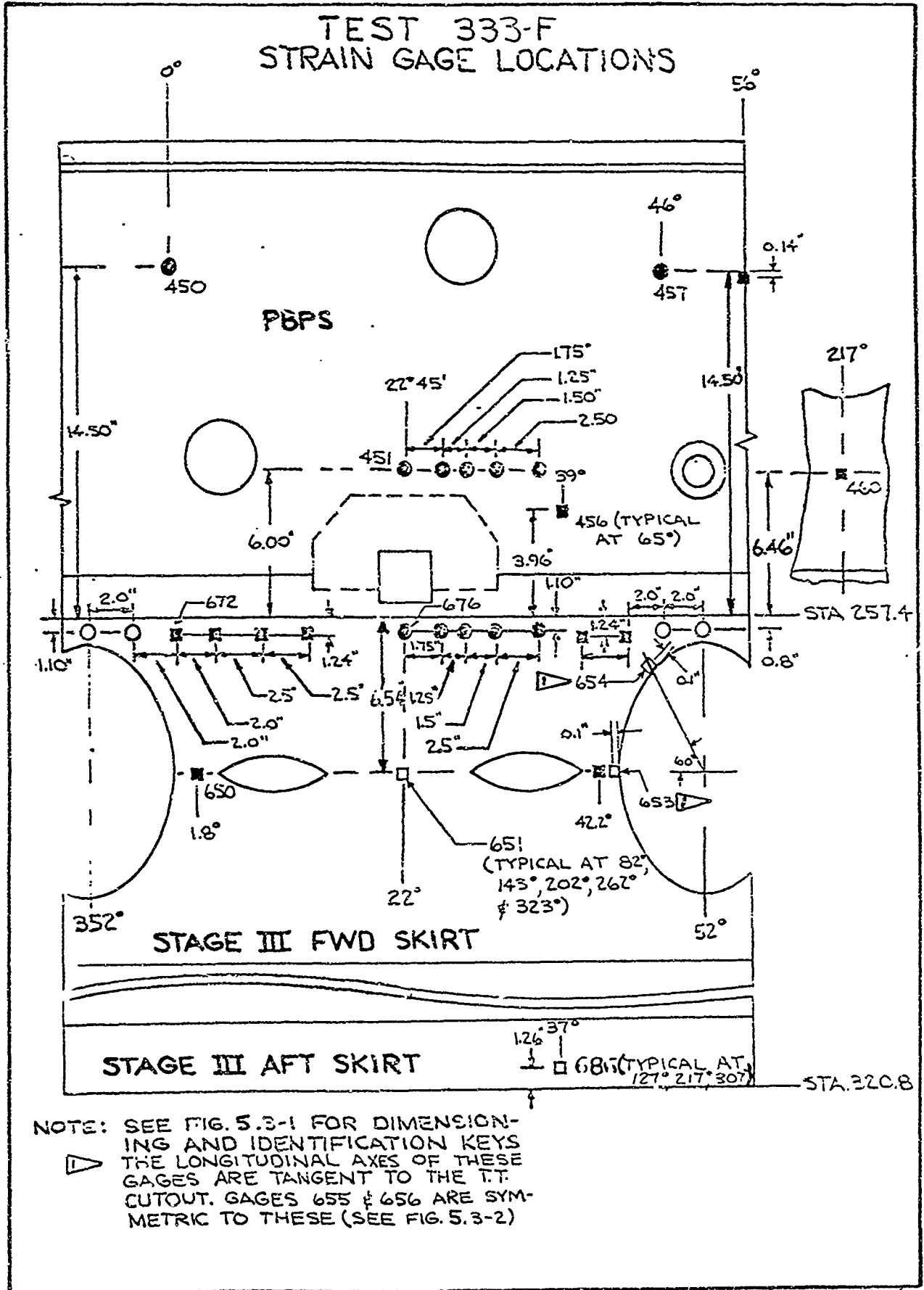

USE FOR DRAWING AND HANDPRINTING — NO TYPEWRITTEN MATERIAL

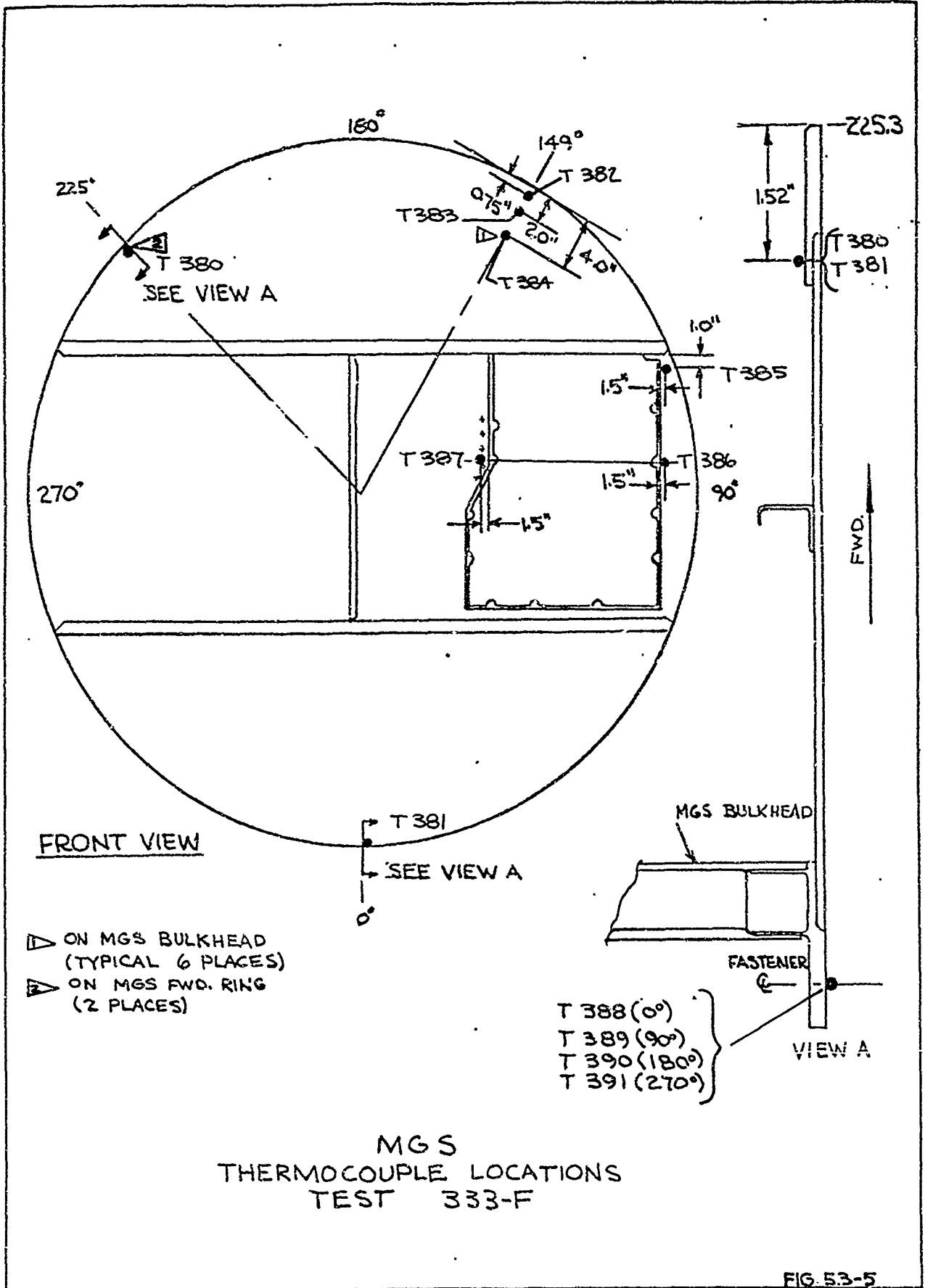

USE FOR DRAWING AND HANDPRINTING — NO TYPEWRITTEN MATERIAL

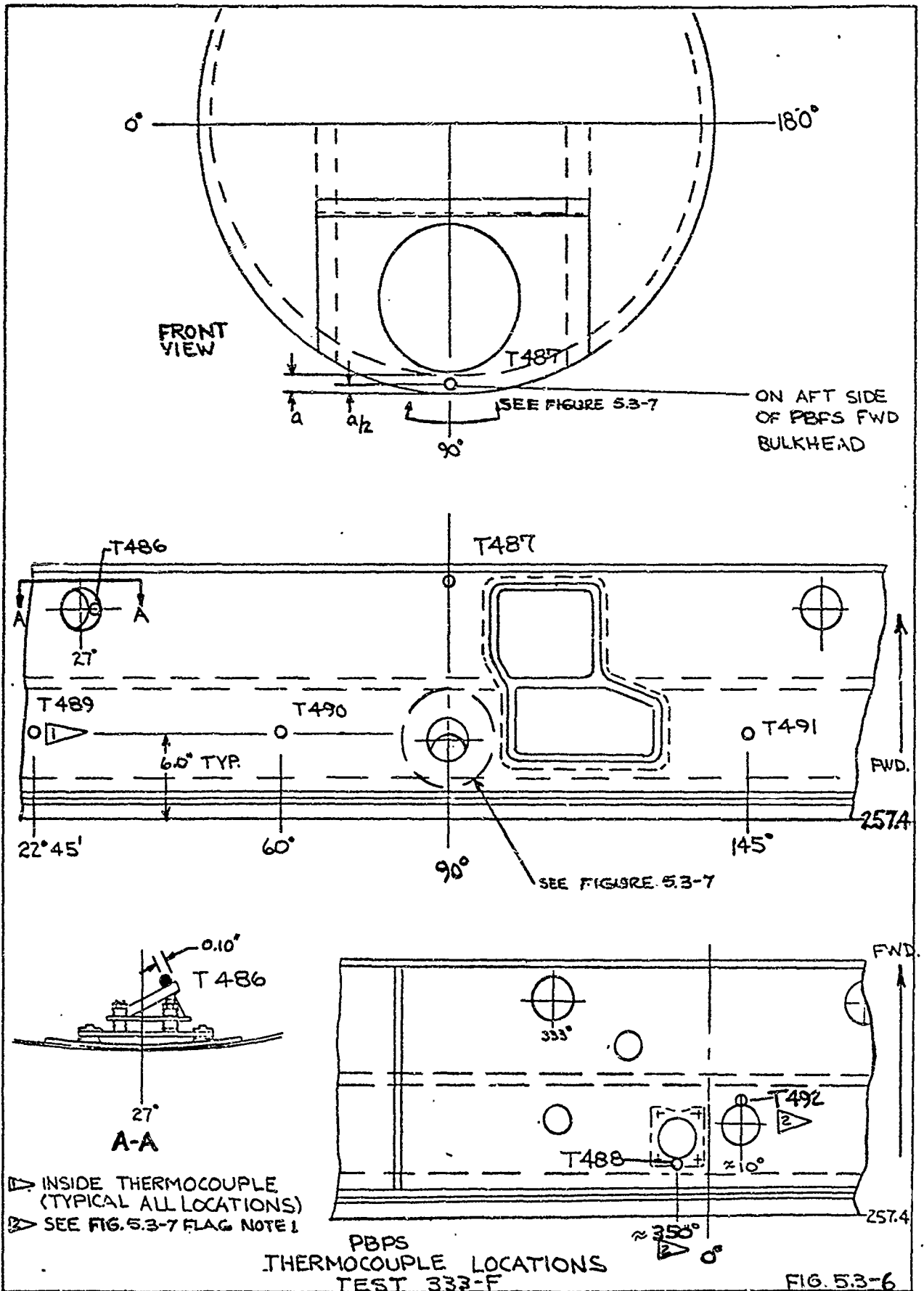

USE FOR DRAWING AND HAND-PRINTING — NO TYPEWRITTEN MATERIAL

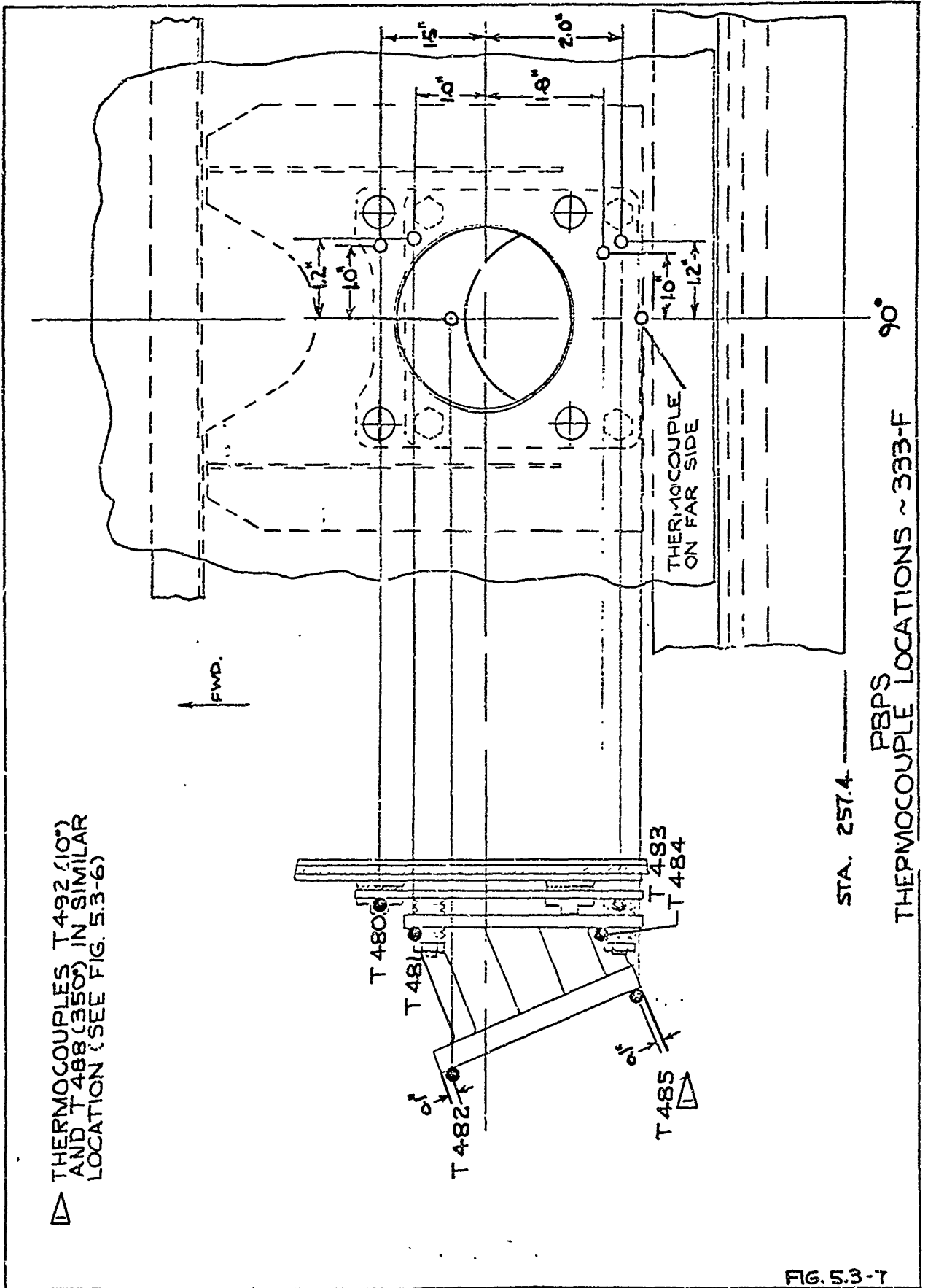

THERMOCOUPLES T492 (10°)
AND T488 (350°) IN SIMILAR
LOCATION (SEE FIG. 5.3-6)

THERMOCOUPLE
ON FAR SIDE

STA. 257.4

PBPS
THERMOCOUPLE LOCATIONS ~ 333-F

FIG. 5.3-7

USE FOR DRAWING AND HANDPRINTING — NO TYPEWRITTEN MATERIAL

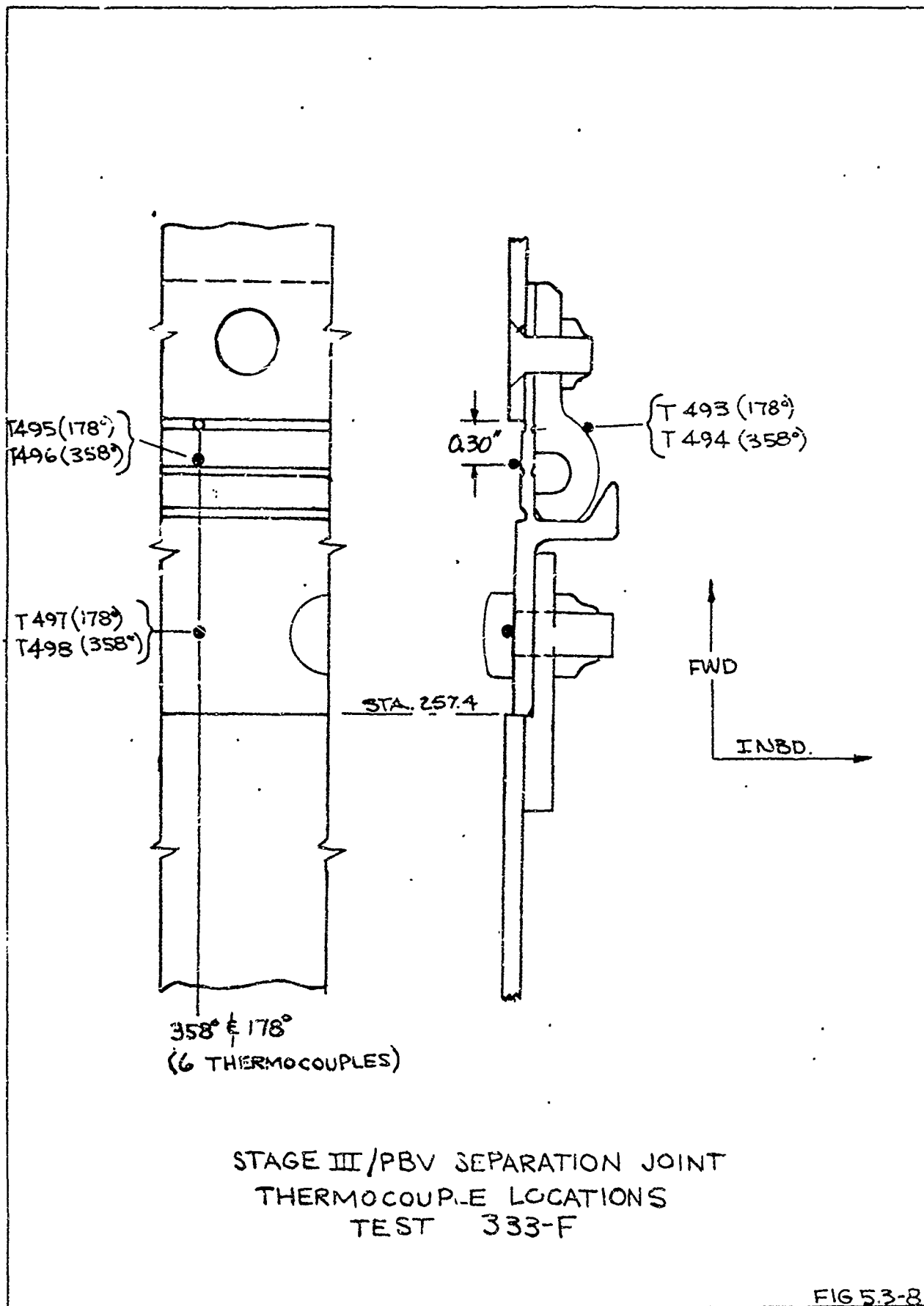

USE FOR DRAWING AND HANDPRINTING — NO TYPEWRITTEN MATERIAL

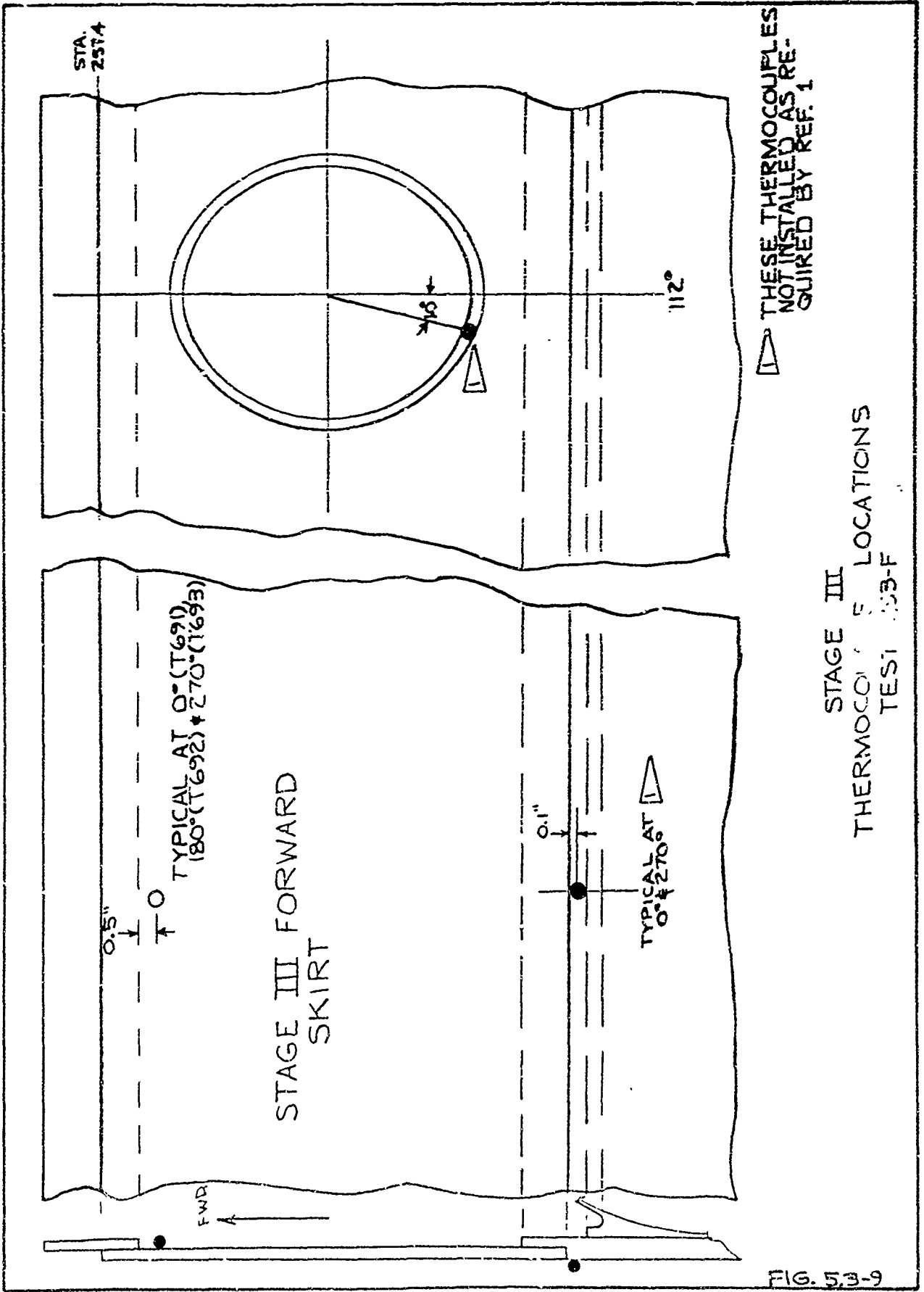

USE FOR DRAWING AND HANDPRINTING — NO TYPEWRITTEN MATERIAL

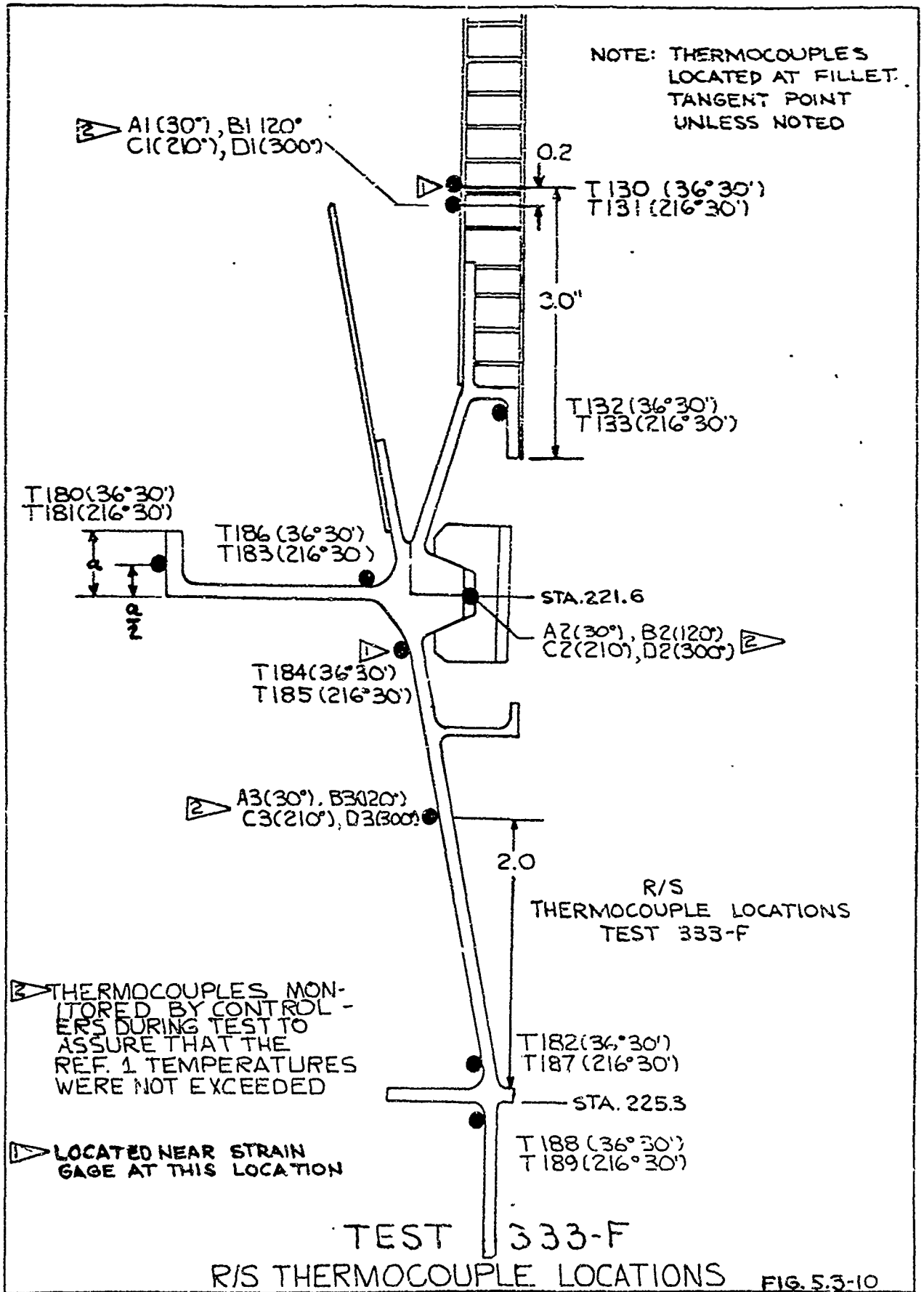

USE FOR TYPEWRITTEN MATERIAL ONLY

5.4.1
PROGRAMMED POWERED FLIGHT ENVIRONMENT
(HEAT AND LOAD TEST)

SHEET 523

LOAD GEOMETRY 333 F TEST
WITH SHROUD (PHASE I AND
FAILURE)

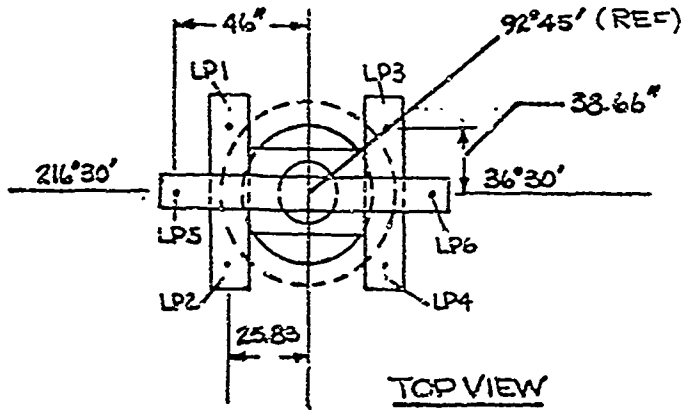

TOP VIEW

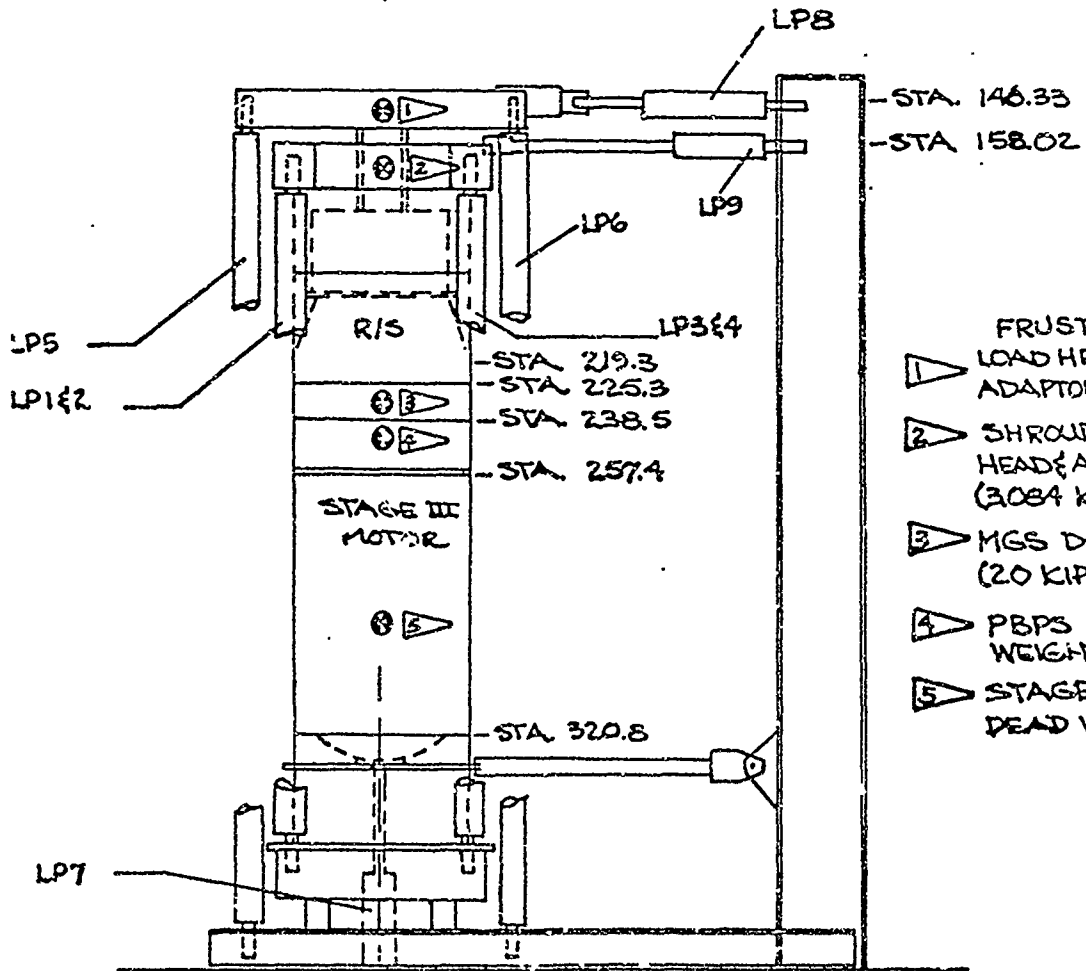

- 1 ▽ FRUSTUM LOAD HEAD AND ADAPTOR (1.624K)
- 2 ▽ SHROUD LOAD HEAD & ADAPTOR (3084 KIPS)
- 3 ▽ MGS DEAD WT. (20 KIPS)
- 4 ▽ PBPS DEAD WEIGHT (23K)
- 5 ▽ STAGE III DEAD WT. (4.71K)

USE FOR DRAWING AND HANDPRINTING — NO TYPEWRITTEN MATERIAL

TEST TIME - SEC	0	35	50	58.6	68.6	78.5	122
PROGRAMMED KIPS	0	11.3	12.4	4.9	3.8	0	0
ACTUAL KIPS	0.38	11.8	12.7	5.7	3.3	0.366	0.30

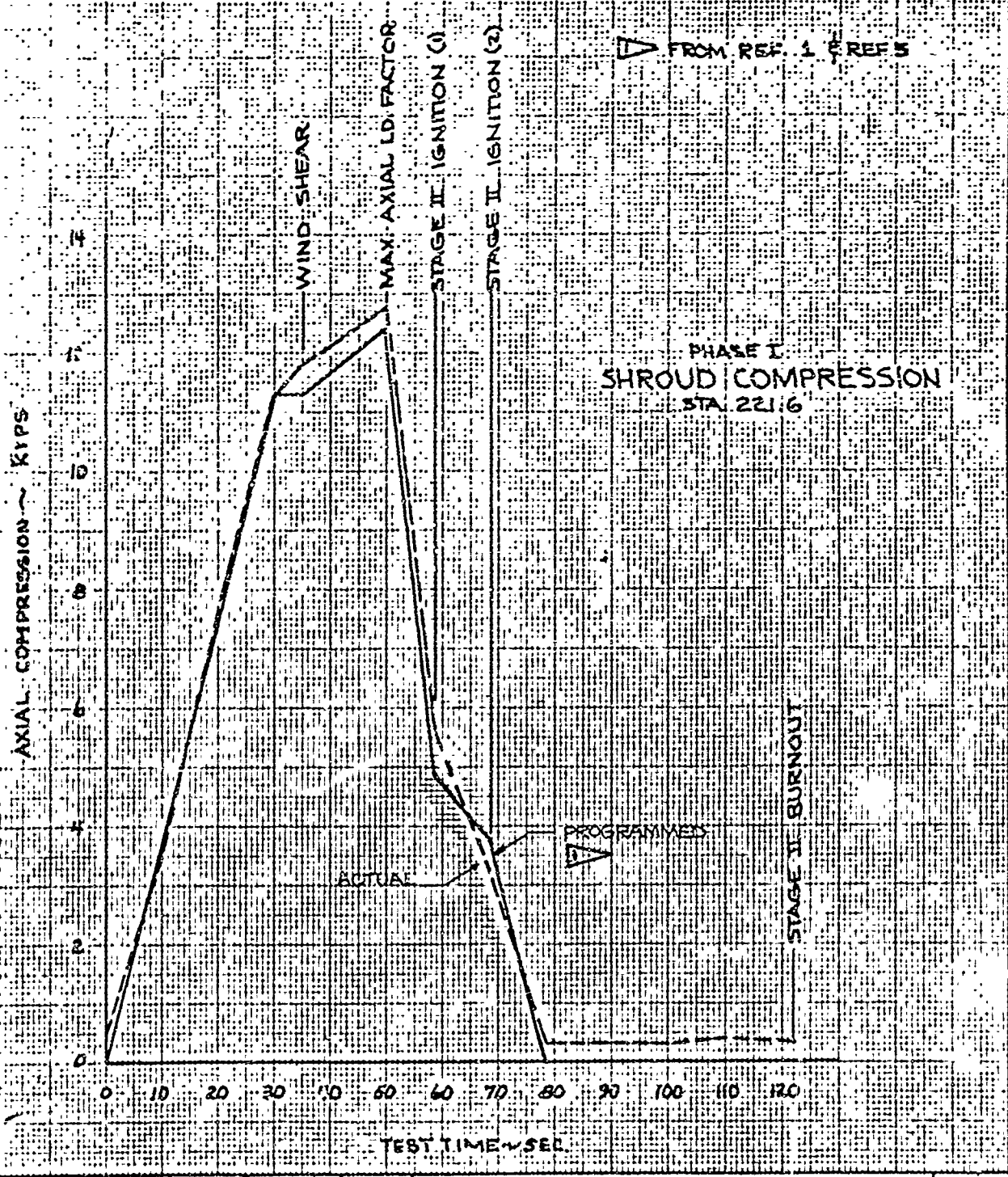

INITIALS	DATE	REV BY INITIAL	DATE	TITLE	MODEL
CAIC	8/19/68			333-F PROGRAMMED TEST. PHASE I PLANNED & ACTUAL AXIAL COMP. VS. TIME SHROUD. STATION. 221.6	FIG. 541-2
CHECK	8/19/68				
APPD.					
APPD.					

U3 4013 8000 REV 1/66

REV LTR _____

BOEING NO T2-3657-1
SH. 525

TEST TIME~SEC	0	35	50	58.6	68.6	78.6	122
PROGRAMMED IN K	0	798.1	196.7	390.1	87.2	0	0
ACTUAL	42.9	882.4	304.7	448.4	196.5	76.73	68.7

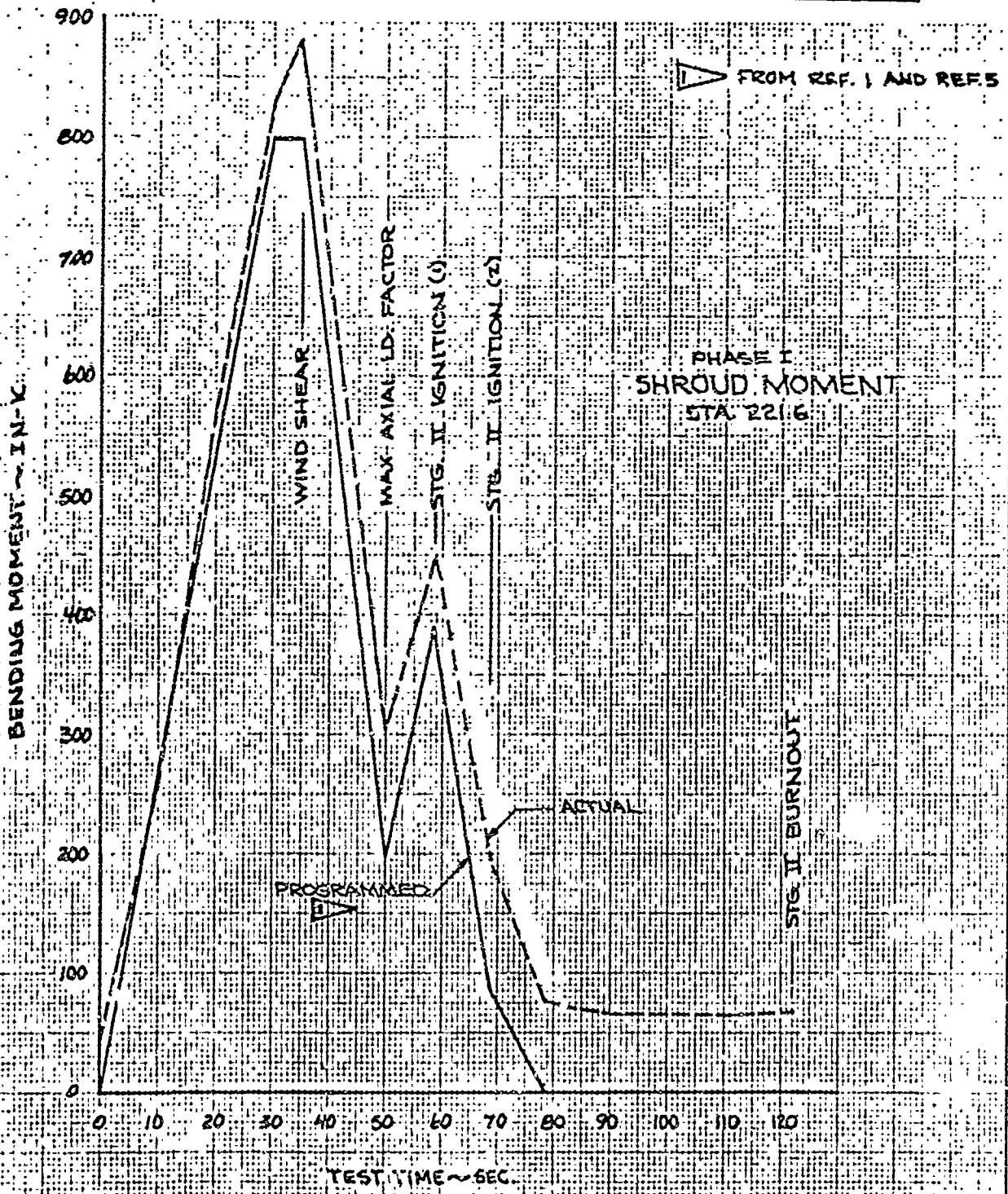

	INITIALS	DATE	REV BY INITIAL	DATE	TITLE	MODEL
CAIC	EPW	8-29-8			333-F PROGRAMMED TEST. PHASE I PLANNED & ACTUAL MOMENT VS. TIME SHROUD. STATION 221.6	FIG. 54.1-3
CHECK	EWJ	30 AUG 9				
APPD.						
APPD.						

U3 4013 8000 REV 1/68

REV LTR _____

BOEING NO. T2-3657-1
SH. 526

TEST TIME ~ SEC	0	35	50	58.6	68.6	78.6	122
PROGRAMMED	0	13.5	3.3	4.5	1.7	0	0
ACTUAL	0.51	14.9	5.1	5.5	3.0	1.06	0.93

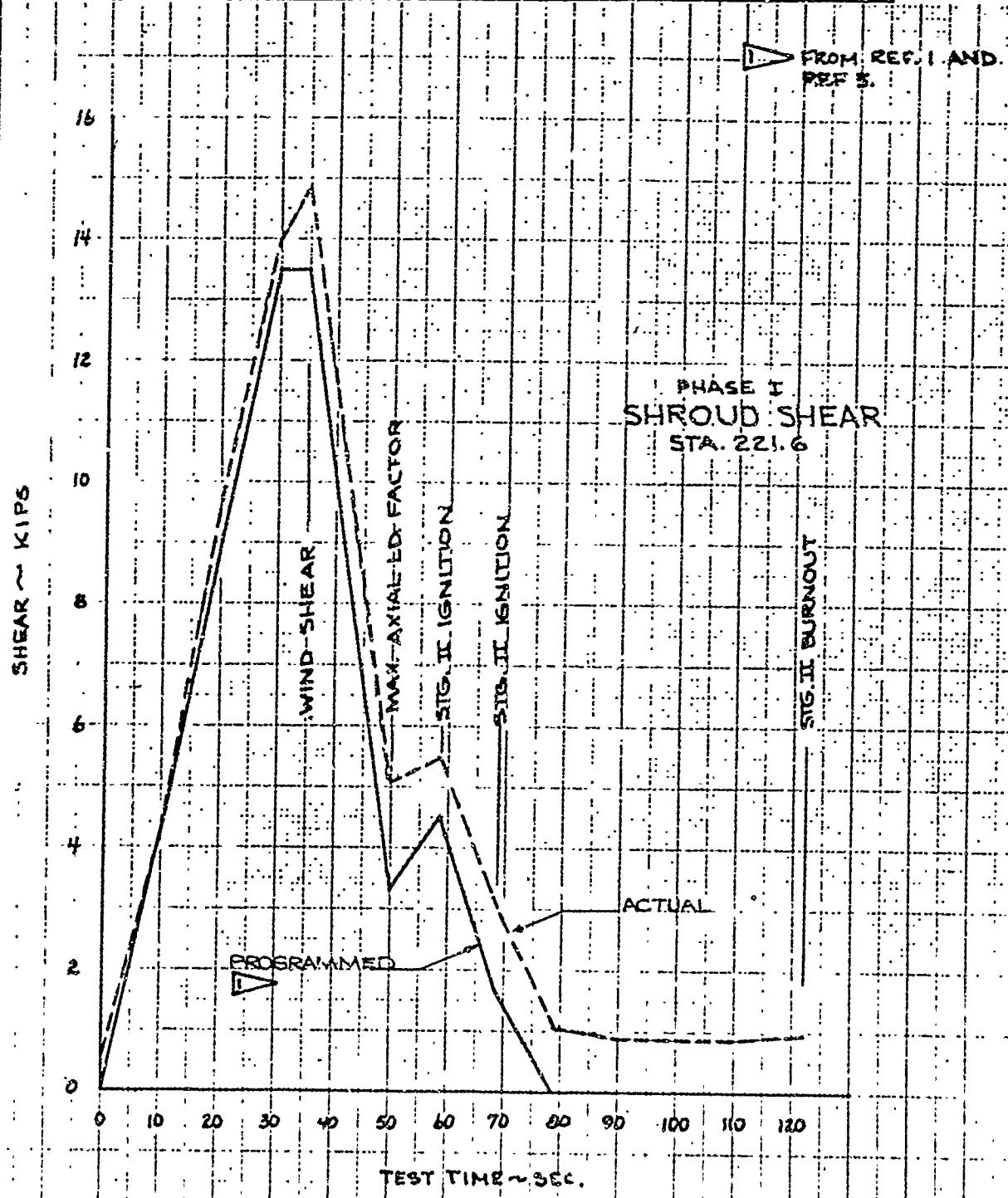

	INITIALS	DATE	REV BY INITIAL	DATE	TITLE	MODEL
CALC	<i>RW</i>	8-29-8			333-F PROGRAMMED TEST, PHASE I PLANNED & ACTUAL SHEAR VS. TIME SHROUD. STATION 221.6	FIG. 5A.1-4
CHECK	<i>JAW</i>	30/06/8				
APPD.						
APPD.						

U3 4013 8000 REV 1/66

REV LTR _____

BOEING NO T2-3657-1
SH 527

TEST TIME ~ SEC.		0	35	50	58.6	68.6	78.6	122
PROGRAMMED	KIPS	0	3.7	0	16.1	17.2	7.1	7.1
ACTUAL	KIPS	.208	3.8	4.00	15.1	17.0	7.3	7.2

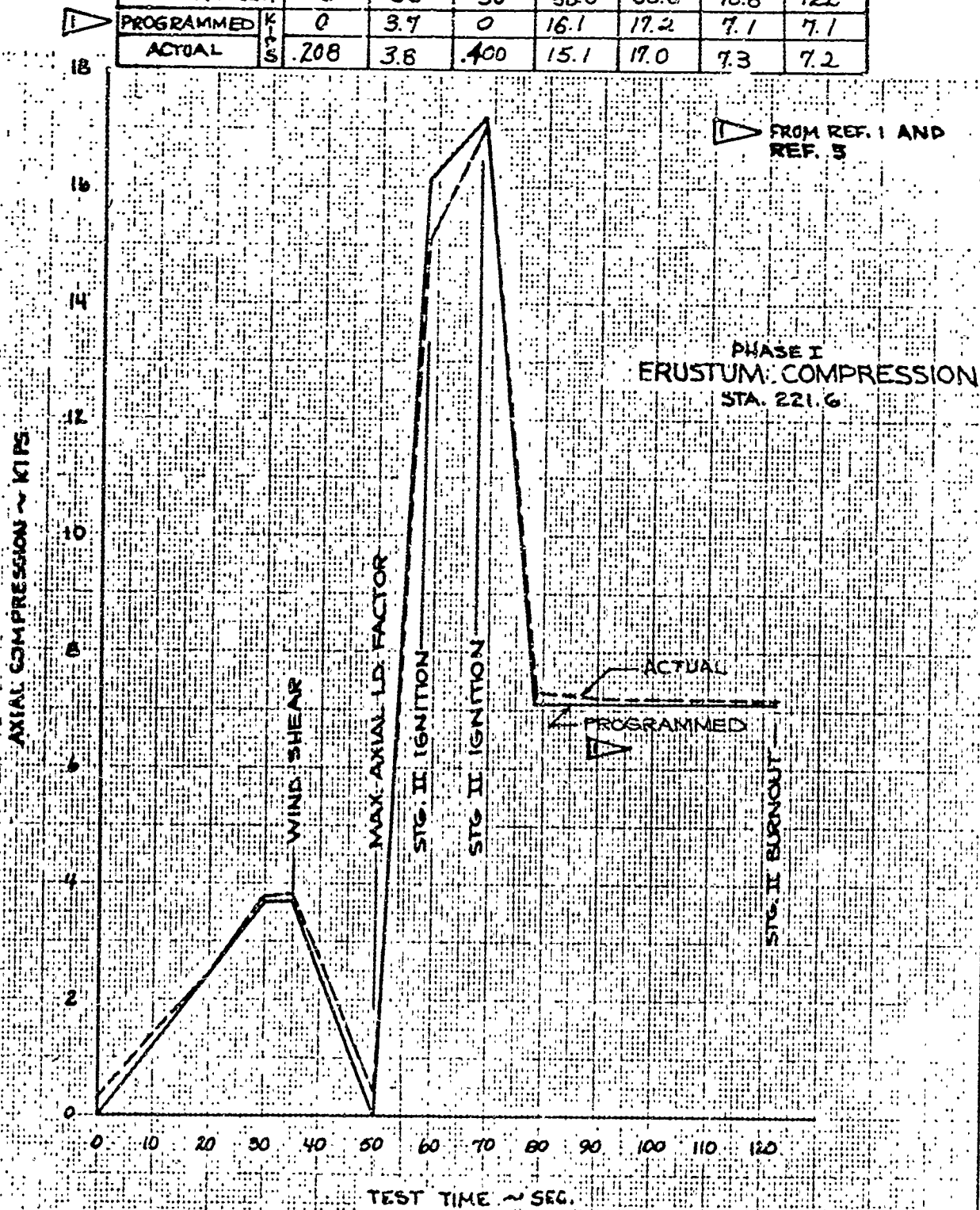

	INITIALS	DATE	REV BY INITIAL	DATE	TITLE	MODEL
CALC	<i>Paul</i>	8-29-8			333-F PROGRAMMED TEST, PHASE I PLANNED & ACTUAL AXIAL COMP. VS. TIME FRUSTUM. STATION 221.6	FIG. 5.4.1-5
CHECK	<i>BSW</i>	30 AUG 80				
APPD.						
APPD.						

U3 4013 8000 REV 1/66

REV LTR _____

BOEING NO T2-3651-1
SH. 528

TEST TIME ~ SEC	0	55	50	58.6	68.6	78.6	122
PROGRAMMED	0	0	0	49.2	352.1	76.0	76.0
ACTUAL	17.7	28.5	24.0	15.7	2663	3248	86.5

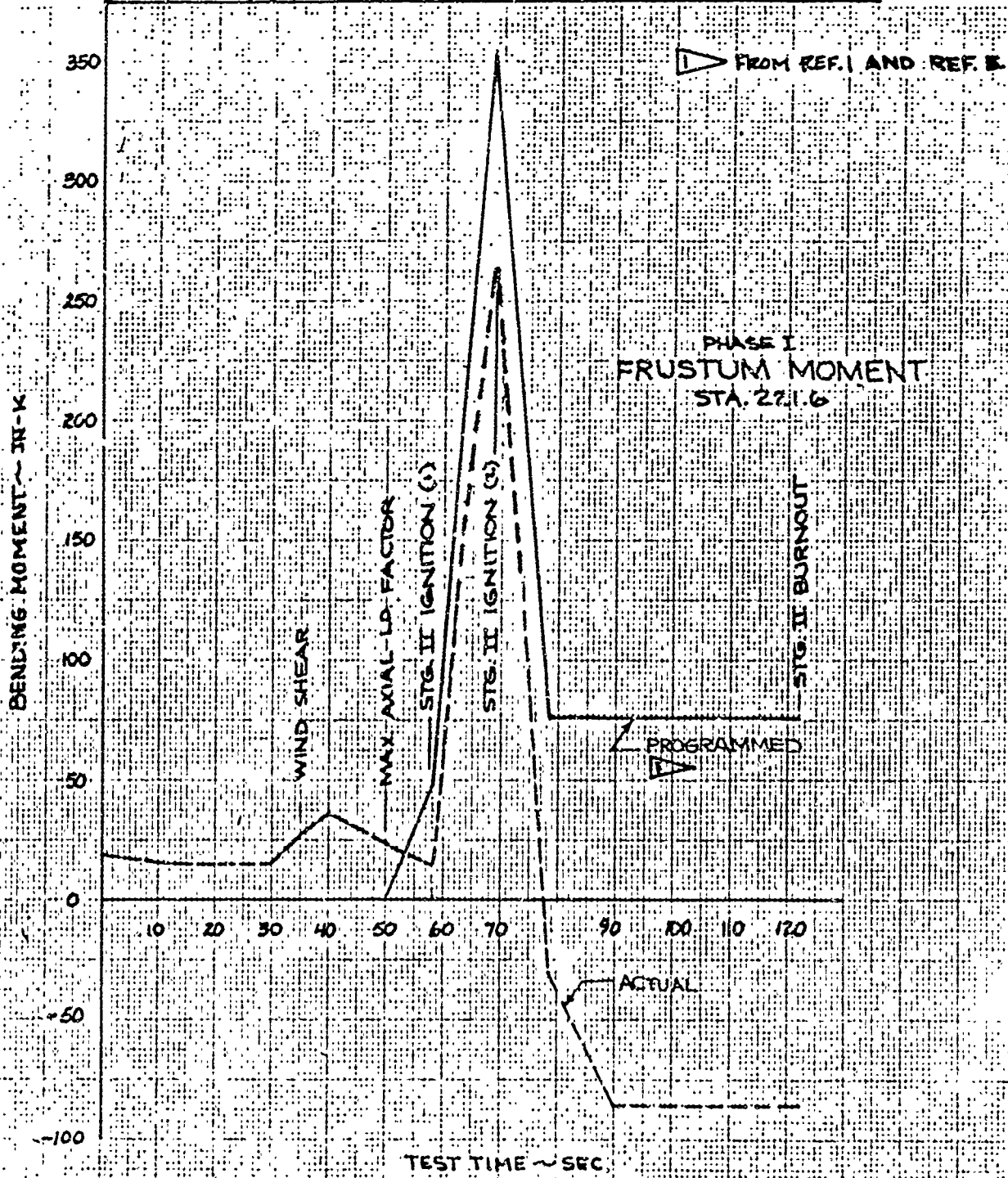

	INITIALS	DATE	REV BY INITIAL	DATE	TITLE	MODEL
CALC	Row	8-27-8			333-F PROGRAMMED TEST, PHASE I PLANNED & ACTUAL MOMENT VS TIME FRUSTUM. STATION 221.6	FIG. 54.1-6
CHECK	Row	30 AUG 8				
APPD.						
APPD.						

U3 4013 8000 REV 1/66

REV LTR _____

BOEING NO T2-3657-1
SH. 529

TEST TIME - SEC.	0	35	50	58.6	68.6	78.6	122
PROGRAMMED	0	0	0	3.13	5.99	2.04	2.04
ACTUAL	.36	.49	.42	2.6	5.6	0.693	0

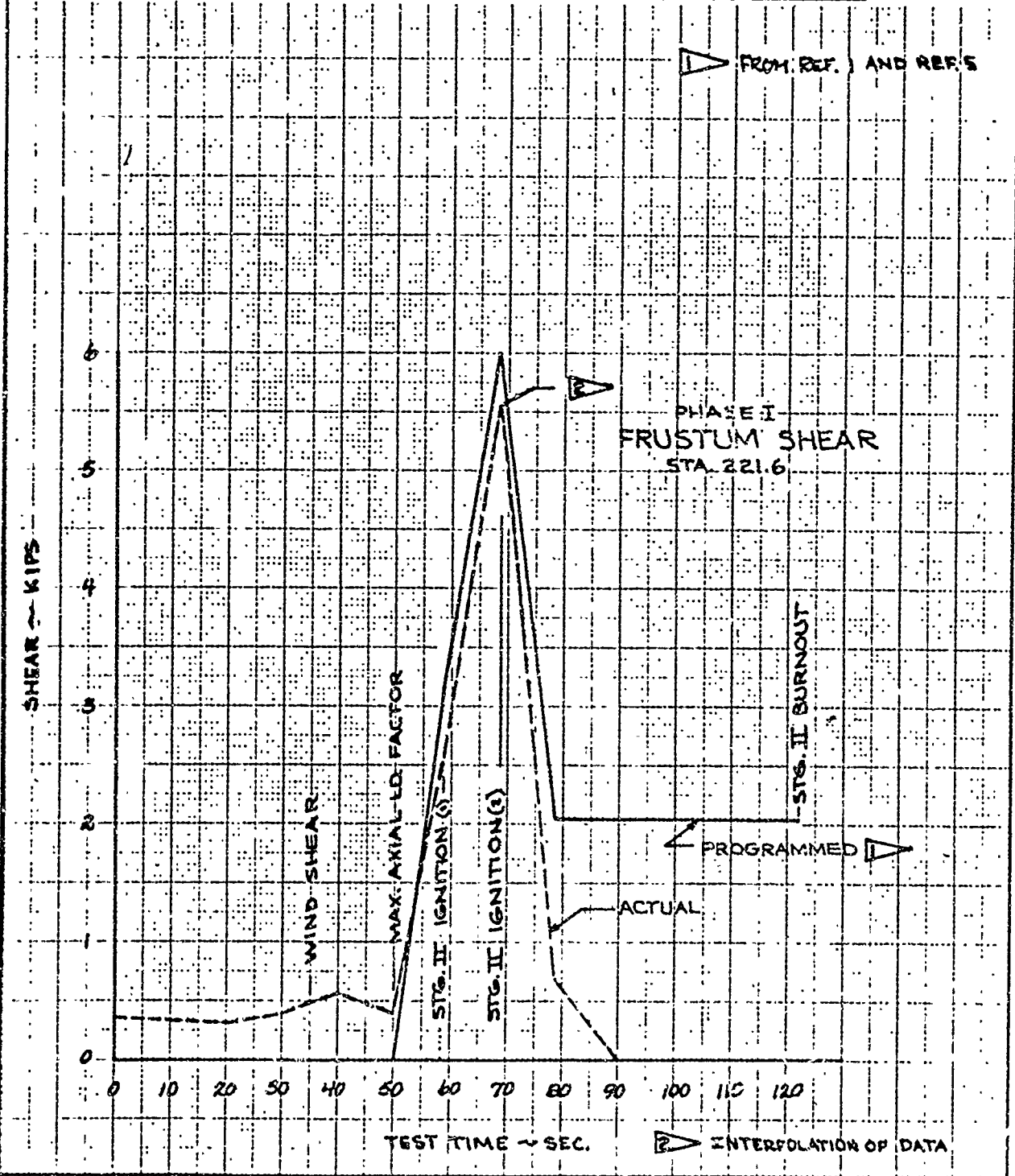

	INITIALS	DATE	REV BY INITIAL	DATE	TITLE	MODEL
CALC	<i>REW</i>	9-29-8			933-F PROGRAMMED TEST. PHASE I PLANNED & ACTUAL SHEAR VS TIME FRUSTUM, STATION 221.6	FIG. 541-7
CHECK	<i>MBUS</i>	30 AUG 89				
APPD.						
APPD.						

UJ 4013 8000 REV 1/66

REV LTR _____

BOEING NO T2-3657-1
SH 530

TEST TIME ~ SEC	0	35	50	58.6	68.6	78.6	122
PROGRAMMED KIPS	5.3	20.3	18.7	26.3	26.3	12.4	12.4
ACTUAL KIPS	5.9	20.9	18.5	26.0	25.6	13.0	12.9

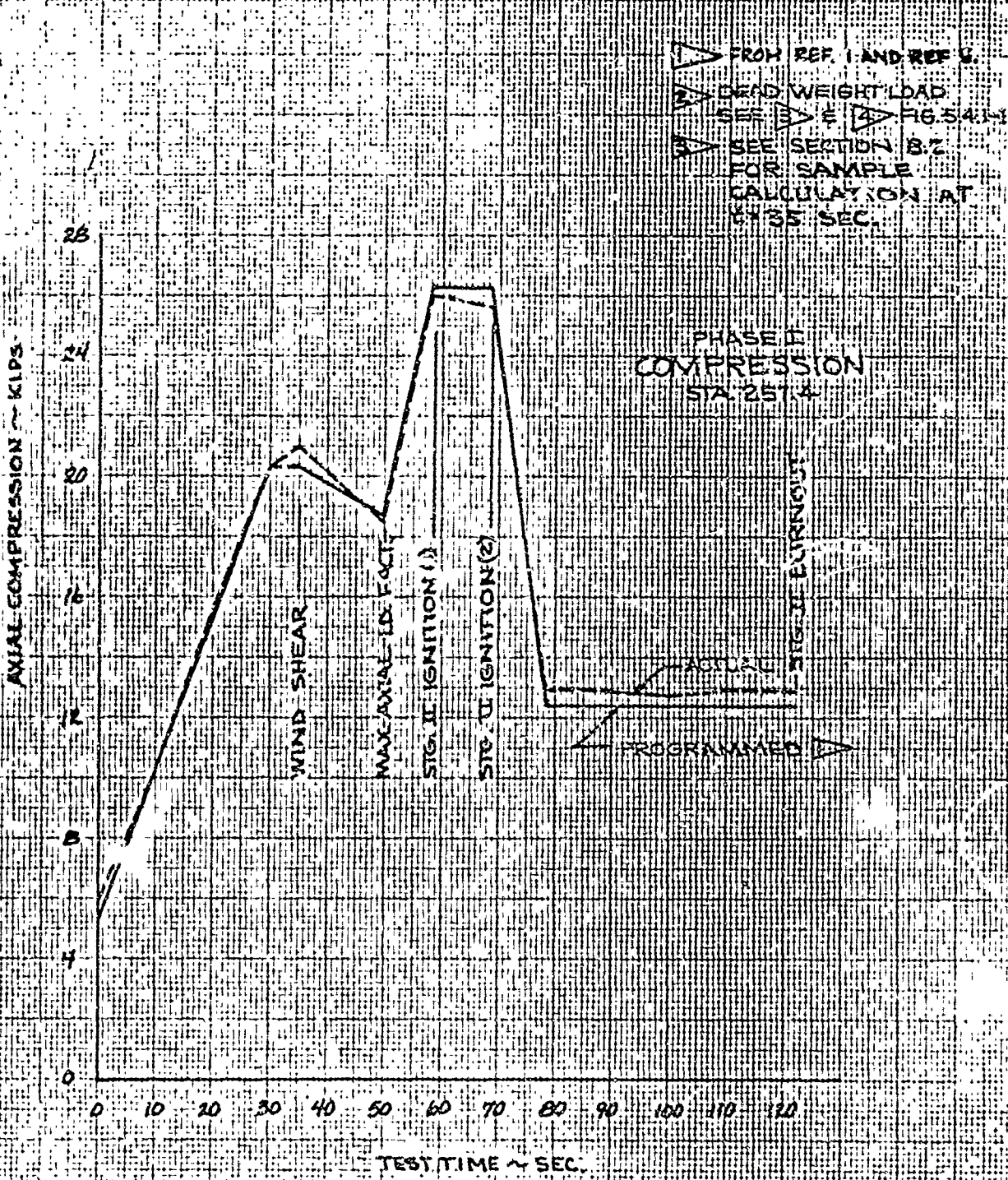

	INITIALS	DATE	REV BY INITIAL	DATE	TITLE	MODEL
CALC	<i>PLW</i>	8-29-6			333-F PROGRAMMED TEST, PHASE I PLANNED & ACTUAL AXIAL COMP. VS. TIME STATION 257.4	FIG. 541-8
CHECK	<i>LDW</i>	20AD68				
APPD.						
APPD.						

U3 4013 8000 REV 1/66

REV LTR _____

BOEING NO. T2-3657-1
SH. 531

TEST TIME ~ SEC	0	35	50	58.6	68.6	78.6	122
PROGRAMMED IN	0	1282.5	315.4	713.6	713.6	149.0	149.0
ACTUAL	108.6	1461.0	526.6	754.1	755.0	107.2	15.5

FROM REF. 1 AND REF. 2
 SEE SECTION 8.2
 FOR SAMPLE CALCULATION AT $t=35$ SEC.

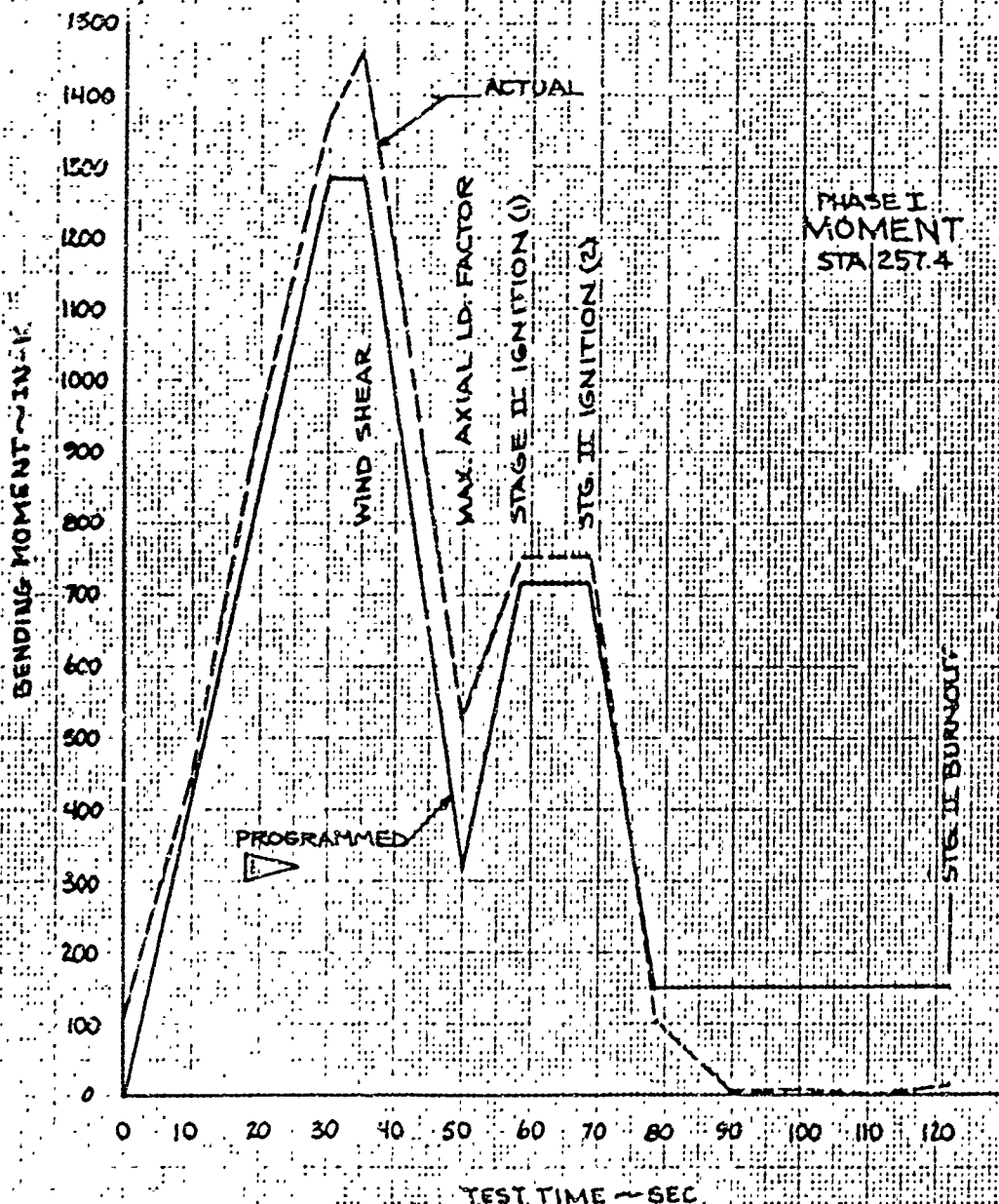

PHASE I
 MOMENT
 STA 257.4

	INITIALS	DATE	REV BY INITIAL	DATE	TITLE	MODEL
CALC	<i>Law</i>	6-27-8			333-F PROGRAMMED TEST. PHASE I PLANNED & ACTUAL MOMENT VS TIME STATION 257.4	FIG. 541-9
CHECK	<i>Law</i>	8-1-8				
APPD.						
APPD.						

U3 4013 8000 REV 1/66

REV LTR _____

BOEING NO T2-3657-1
 SH. 532

TEST TIME ~ SEC.		0	35	50	58.6	68.6	78.6	122
PROGRAMMED	K	0	13.5	3.31	7.65	7.65	2.04	2.0
ACTUAL	S	.86	15.4	5.5	8.1	8.2	1.75	.93

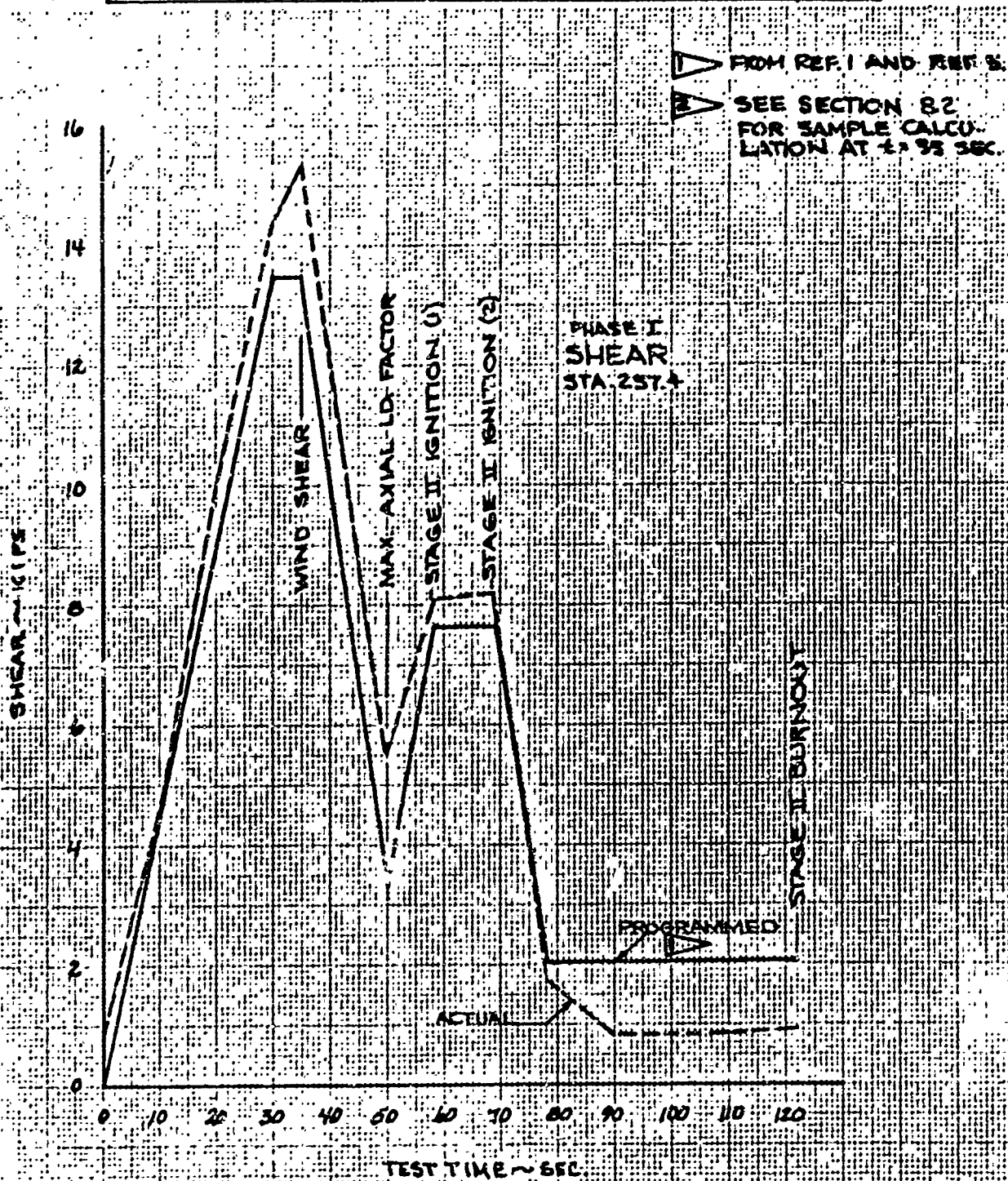

	INITIALS	DATE	REV BY INITIAL	DATE	TITLE	MODEL
CALC	RLW	8-29-68			333-F PROGRAMMED TEST, PHASE I PLANNED & ACTUAL SHEAR VS TIME STATION 257.4	FIG. 54.10
CHECK	RLW	30 AUG 68				
APPD.						
APPD.						

UJ 4013 8000 REV 1/64

REV LTR _____

BOEING NO T2-3657-1
SH. 533

PHASE I WIND SHEAR (1.35 SEC) LINE LOAD

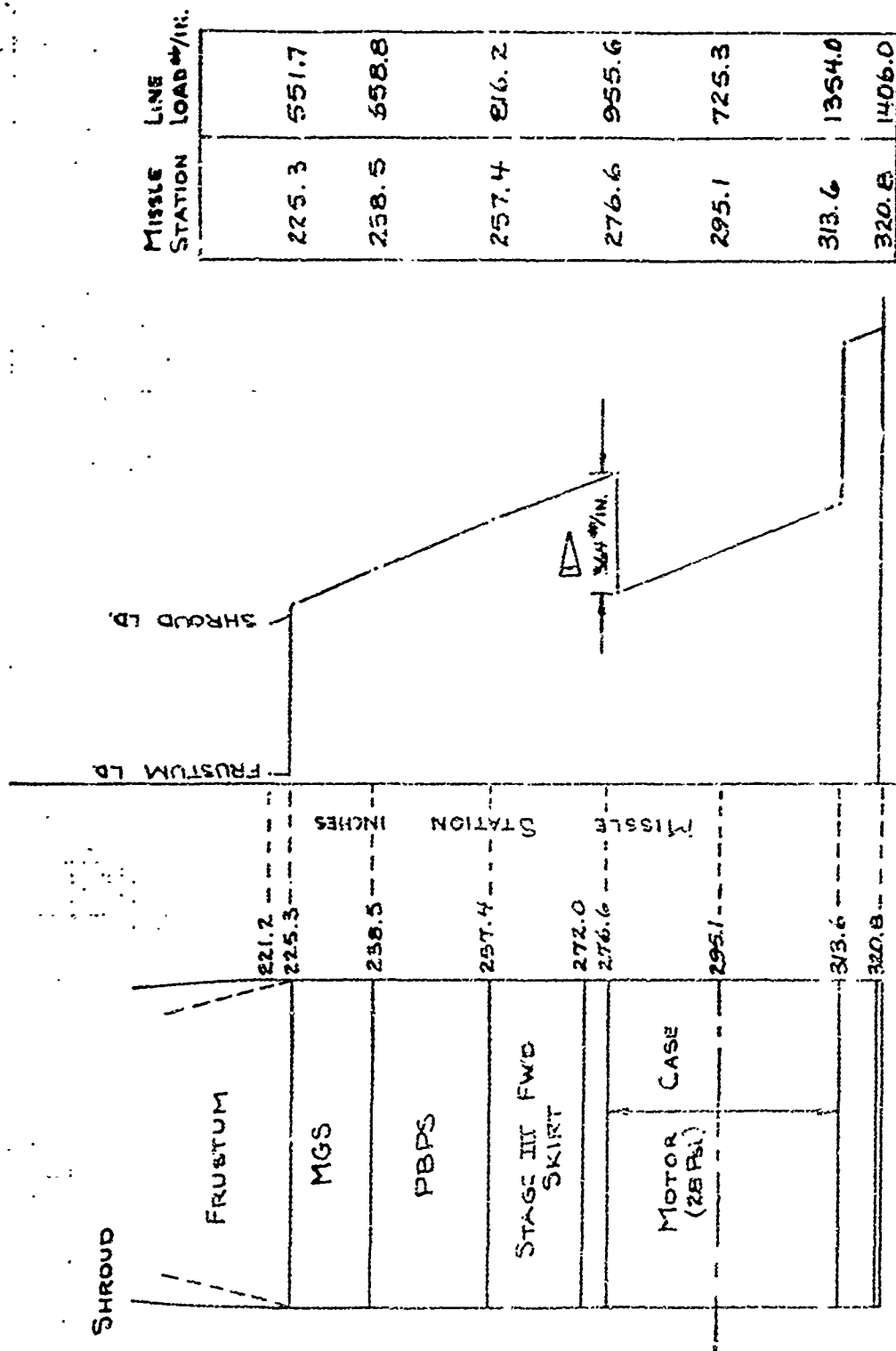

200 400 600 800 1000 1200 1400 1600
 COMPRESSIVE LINE LOAD #/IN (36° 30' AZI.)

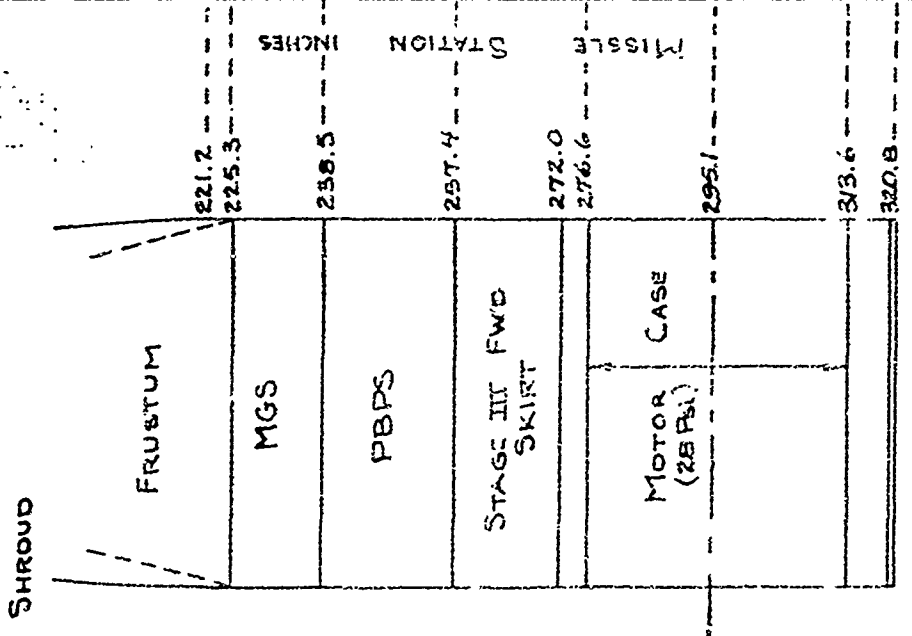

RESULT OF STAGE III
 MIN. CASE PRESSURE

	INITIALS	DATE	REV BY INITIAL	DATE	TITLE	MODEL
CALC	KIDW	AUG 23 5			333-F PROGRAMMED TEST APPLIED LINE LOAD VS. MISSILE STATION. PHASE I (WIND SHEAR LOADS)	FIG. 511-11
CHECK	DET	11/7/8				
APPD.						
APPD.						

UJ 4013 8000 REV 1/66

REV LTR _____

BEING NO T2-3657-1
 BY E27

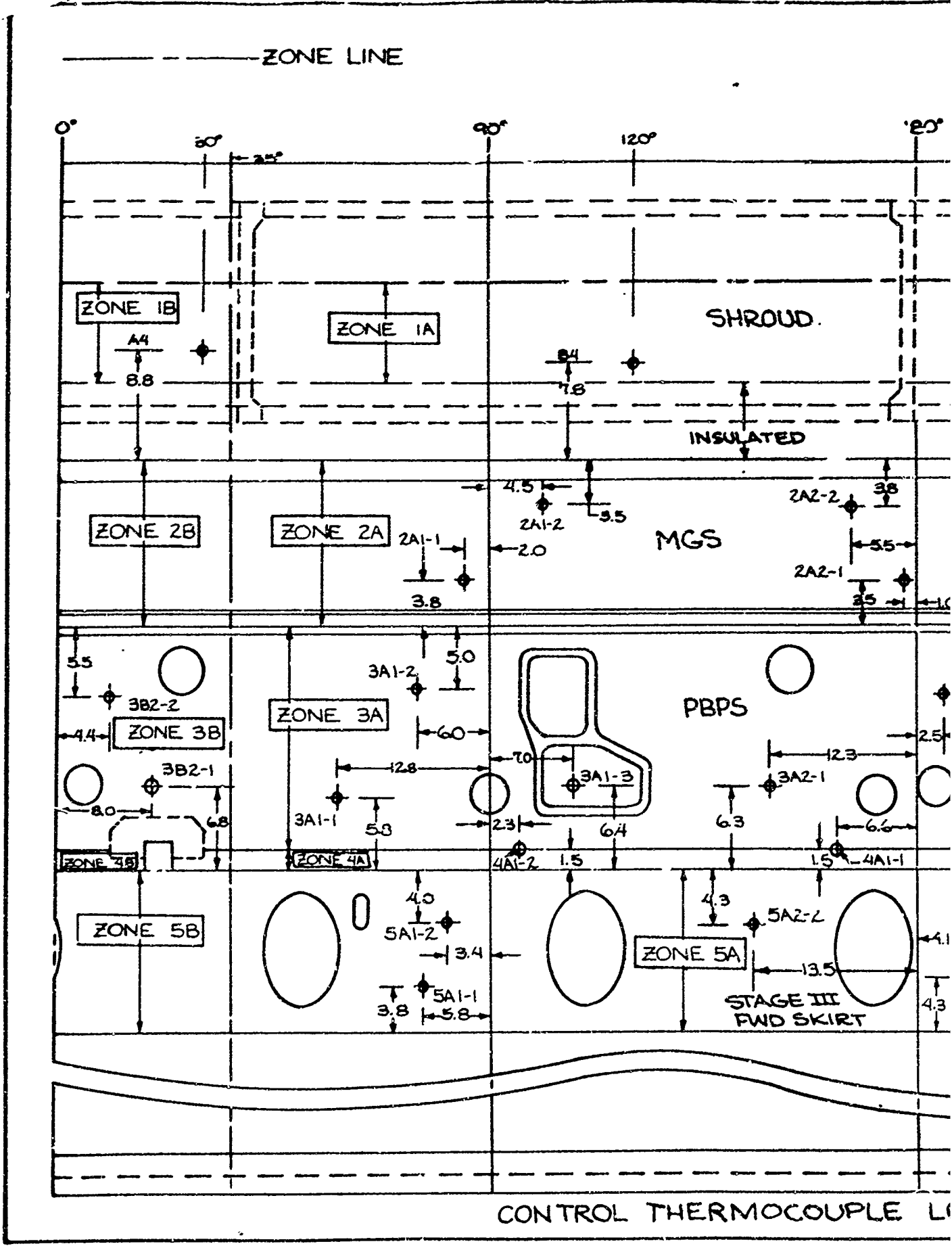

REV LTR

THE HIGHEST READING THERMOCOUPLE OF THE TWO WITHIN EACH ZONE WAS USED AS THE CONTROL FOR THAT ZONE. SEE FIGURES 5.4.1-13 THRU 5.4.1-17 FOR TYPICAL CONTROL THERMOCOUPLE TEMPERATURE HISTORY CURVES.
ALL T/C ARE OUTSIDE

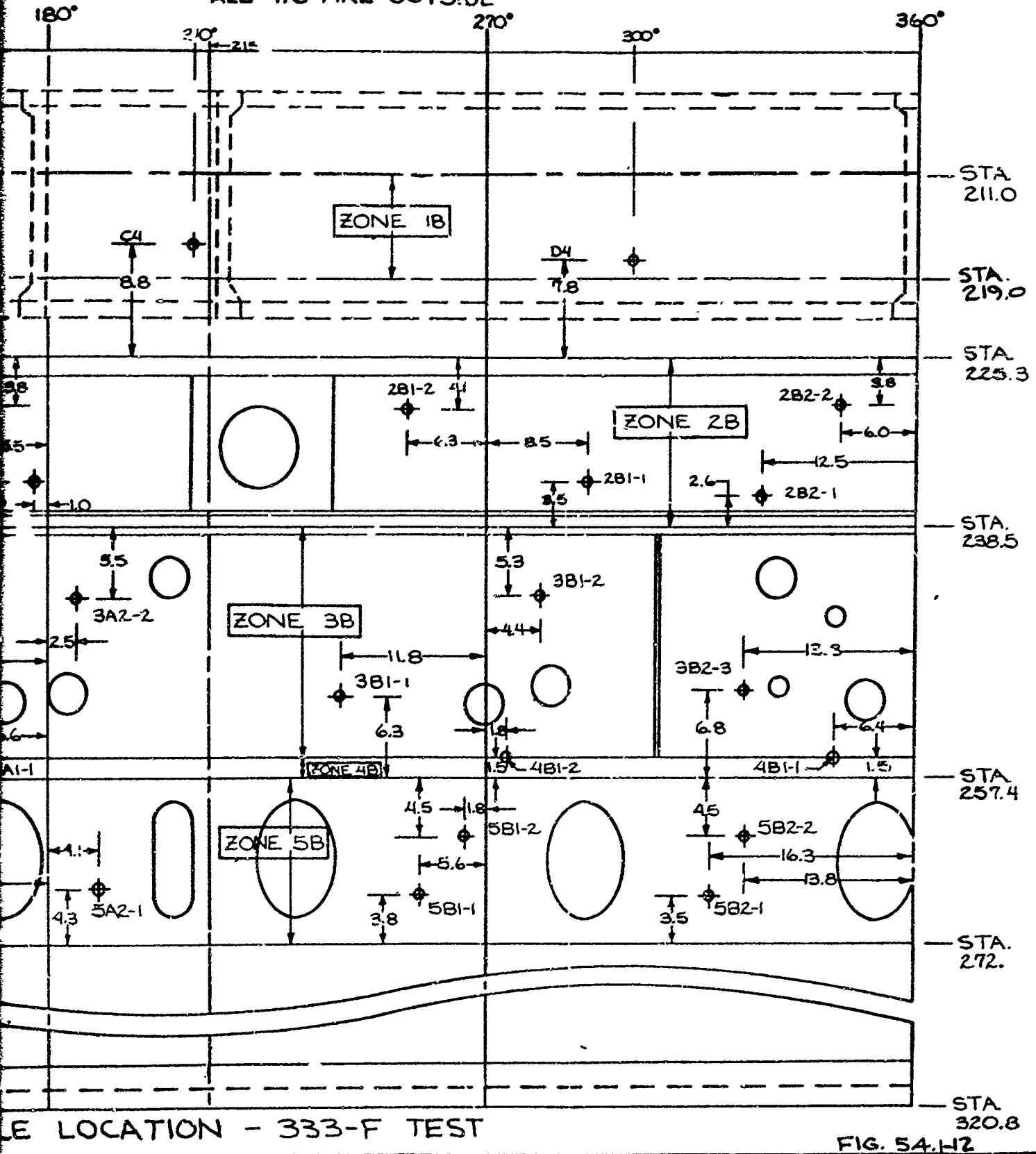

LOCATION - 333-F TEST

FIG. 54.H2

BOEING NO. T2-3657-1
SH 535

B

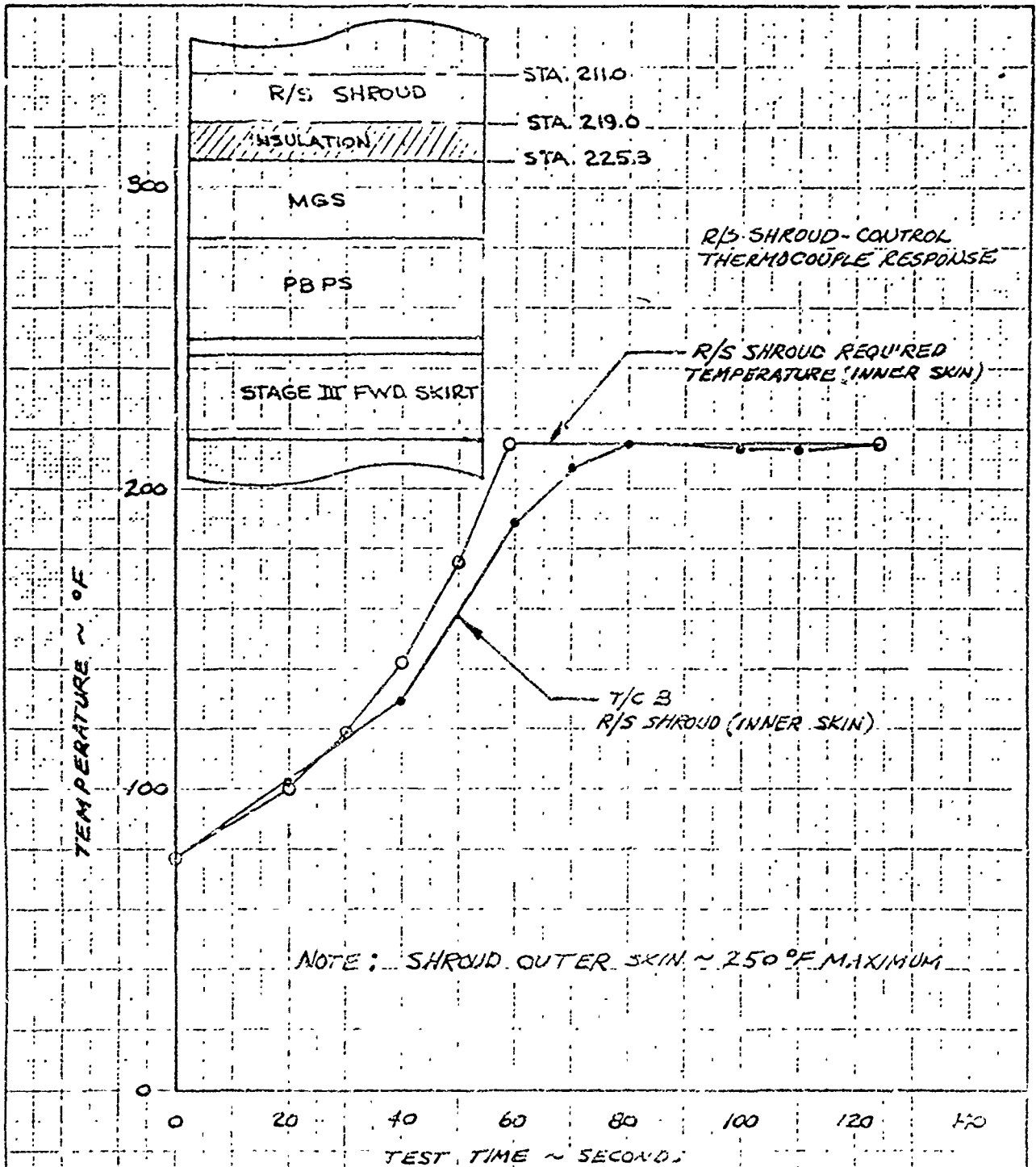

	INITIALS	DATE	REV BY INITIAL	DATE	TITLE	MODEL
CALC	DLH	4/21/66			MM III 333-F TEST PHASE I CONTROL TEMPERATURE- R/S SHROUD - HEAT ZONE I	FIG. 5413
CHECK	MUD	✓				
APPD						
APPD						

UJ 4013 EUCO REV 1/66

REV LTR. _____

ORIGIN NO T2-3657-1
511 536

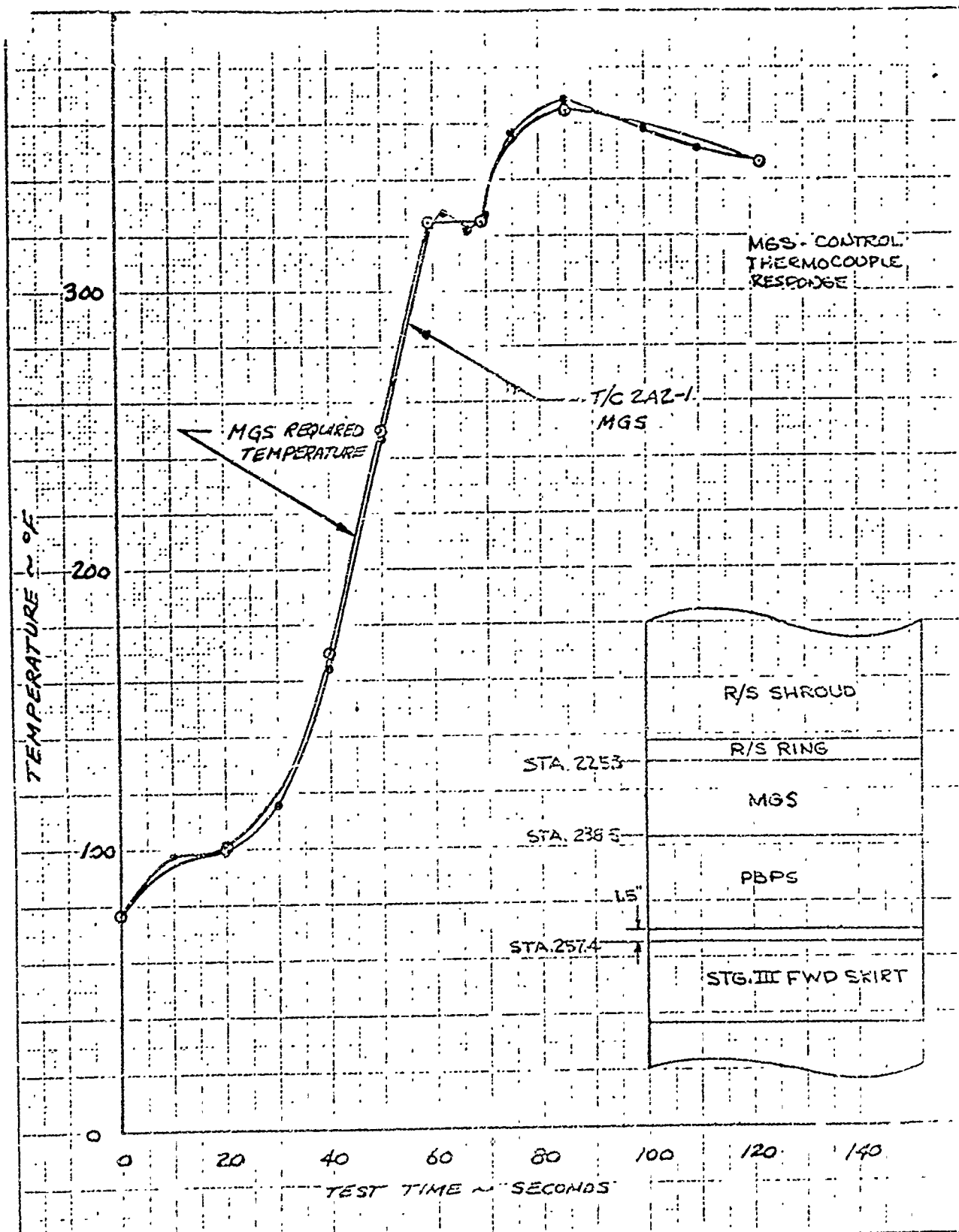

	INITIALS	DATE	REV BY INITIAL	DATE	TITLE	MODEL
CALC	DLH	6/27/66			MM III 333-F TEST PHASE I CONTROL TEMPERATURE - MGS - HEAT ZONE 2	FIG. SA-14
CHECK	MUD	/				
APPD						
APPD						

U3 4015 EWA REV 1/66

REV LTR _____

DDJING NO T2-3657-1
SH 537

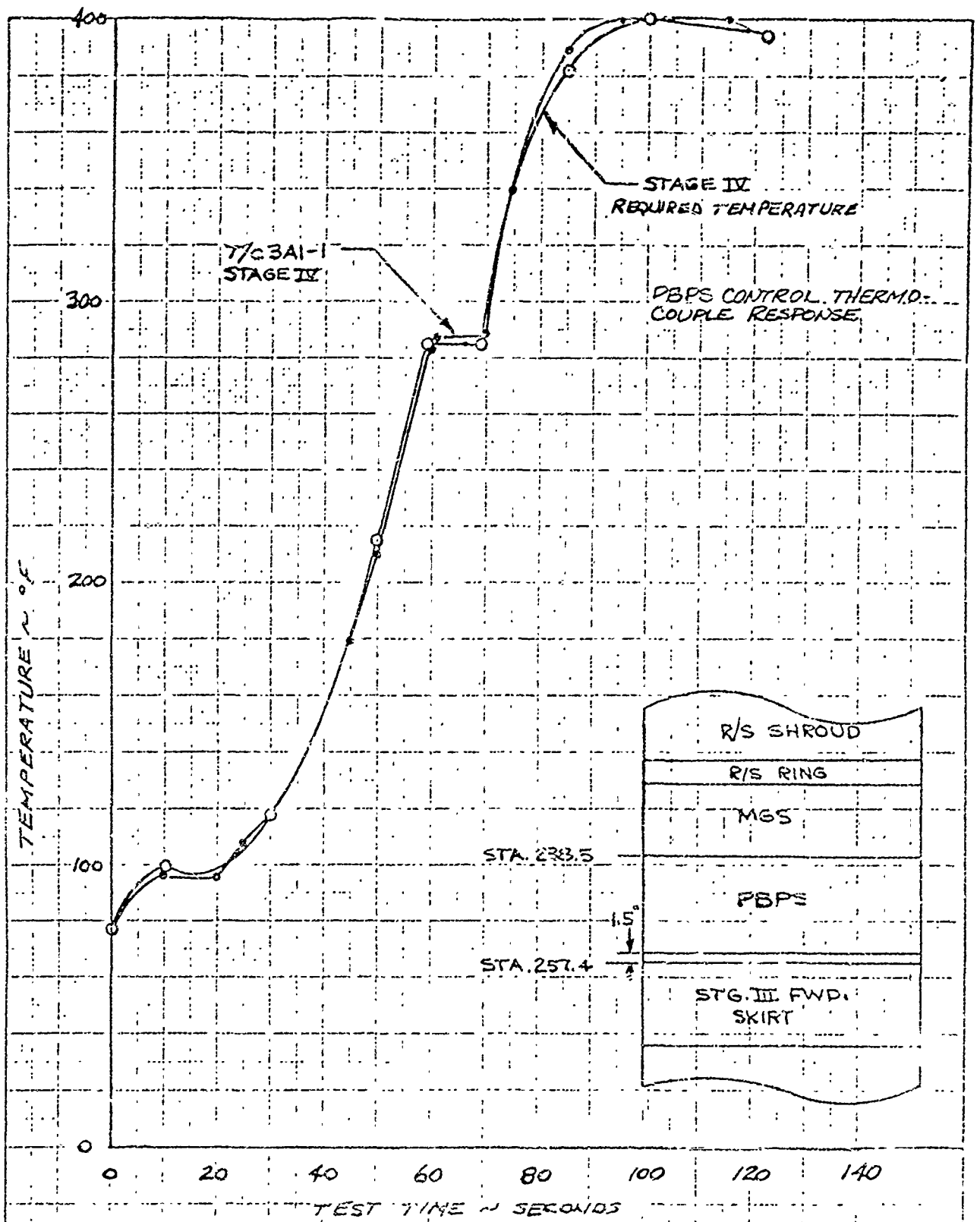

	INITIALS	DATE	REV BY INITIAL	DATE	TITLE	MODEL
CALC	DLH	6/27/66			MM III 333-F TEST PHASE I CONTROL TEMPERATURE- PBPS - HEAT ZONE 3	FIG. 5.4.15
CHECK	MUD	✓				
APPD						
APPD						

UJ 4013 2-0 REV 1/66

REV LTR. _____

BOEING NO T2-3657-1
SH 539

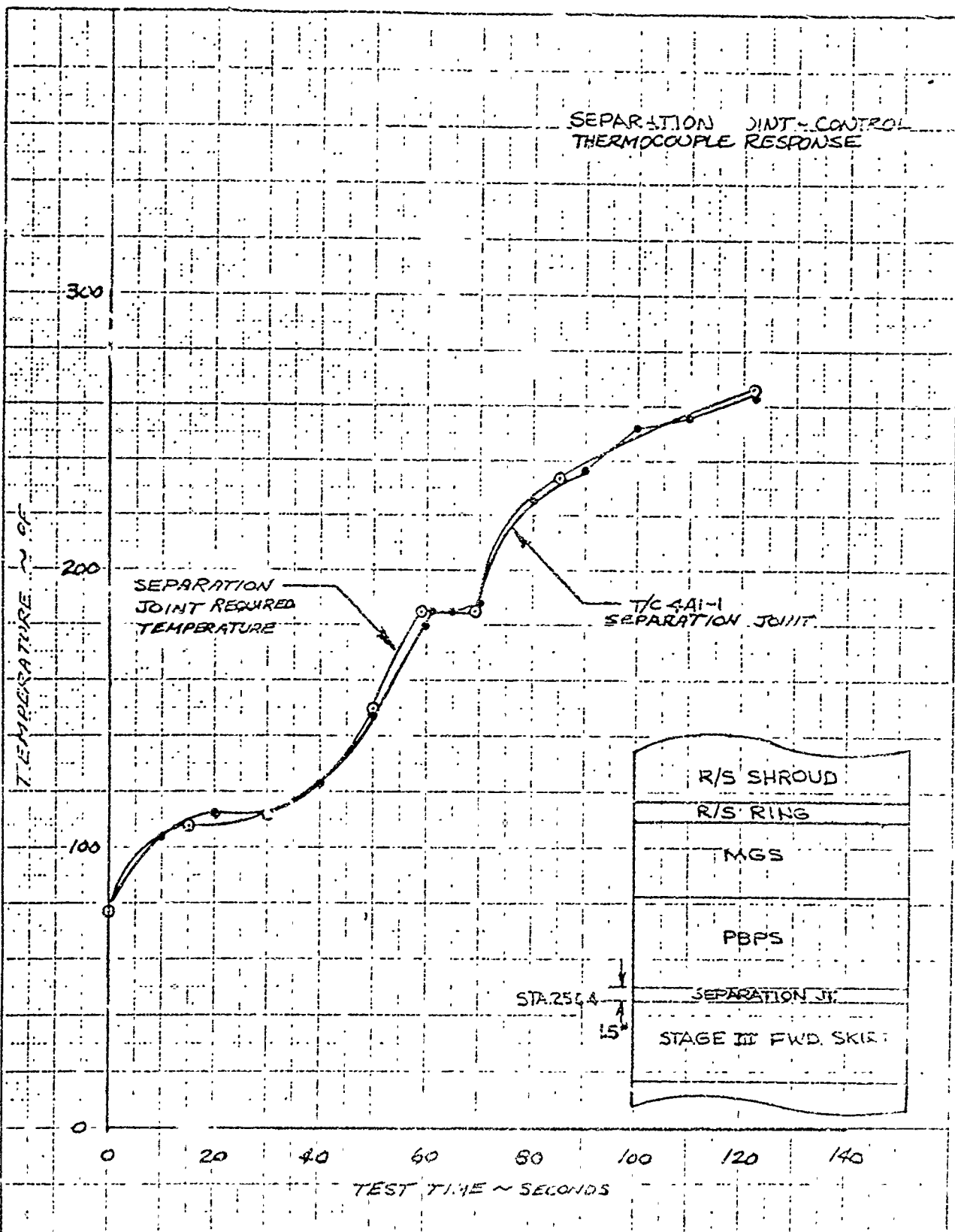

BOEING NO T2-3657-1
SH 539

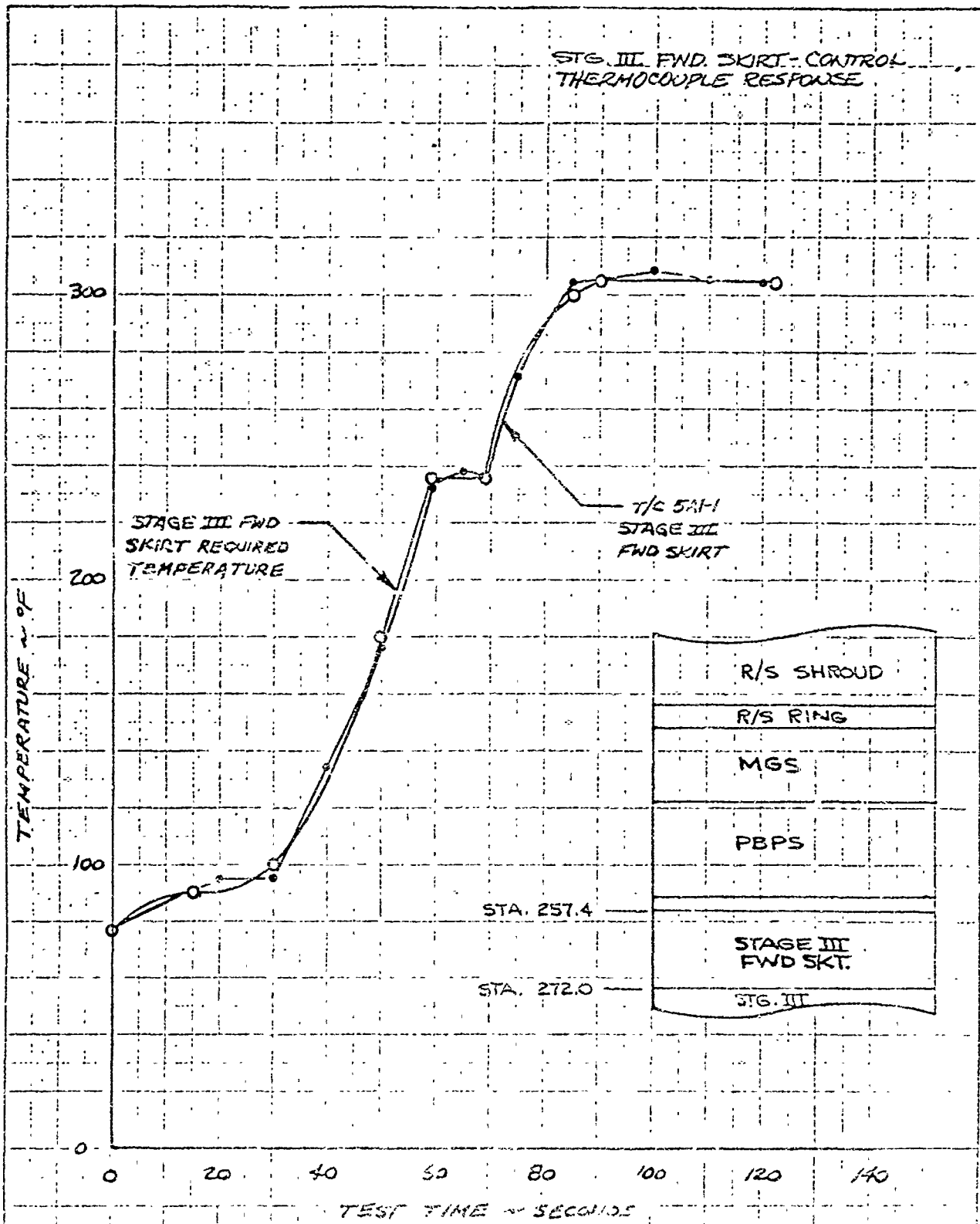

	INITIALS	DATE	REV BY INITIAL	DATE	TITLE	MODEL
CALC	DLH	7/1/68			MM III 333-F TEST PHASE I CONTROL TEMPERATURE STAGE III FWD SKIRT - HEAT ZONE 5	
CHECK	MLD	✓				FIG
APPD.						
APPD.						
						5AH1

U3 4213 FWSO REV 1/66

REV LTR _____

ENGINEING NO T2-3657-1
SH 540

▷ CONTROL THERMOCOUPLE

333-F PROGRAMMED P
THERMOCOUPLE READIN
58.6 SECONDS OF TEST T

KEY
● OUTSIDE
○ INSIDE

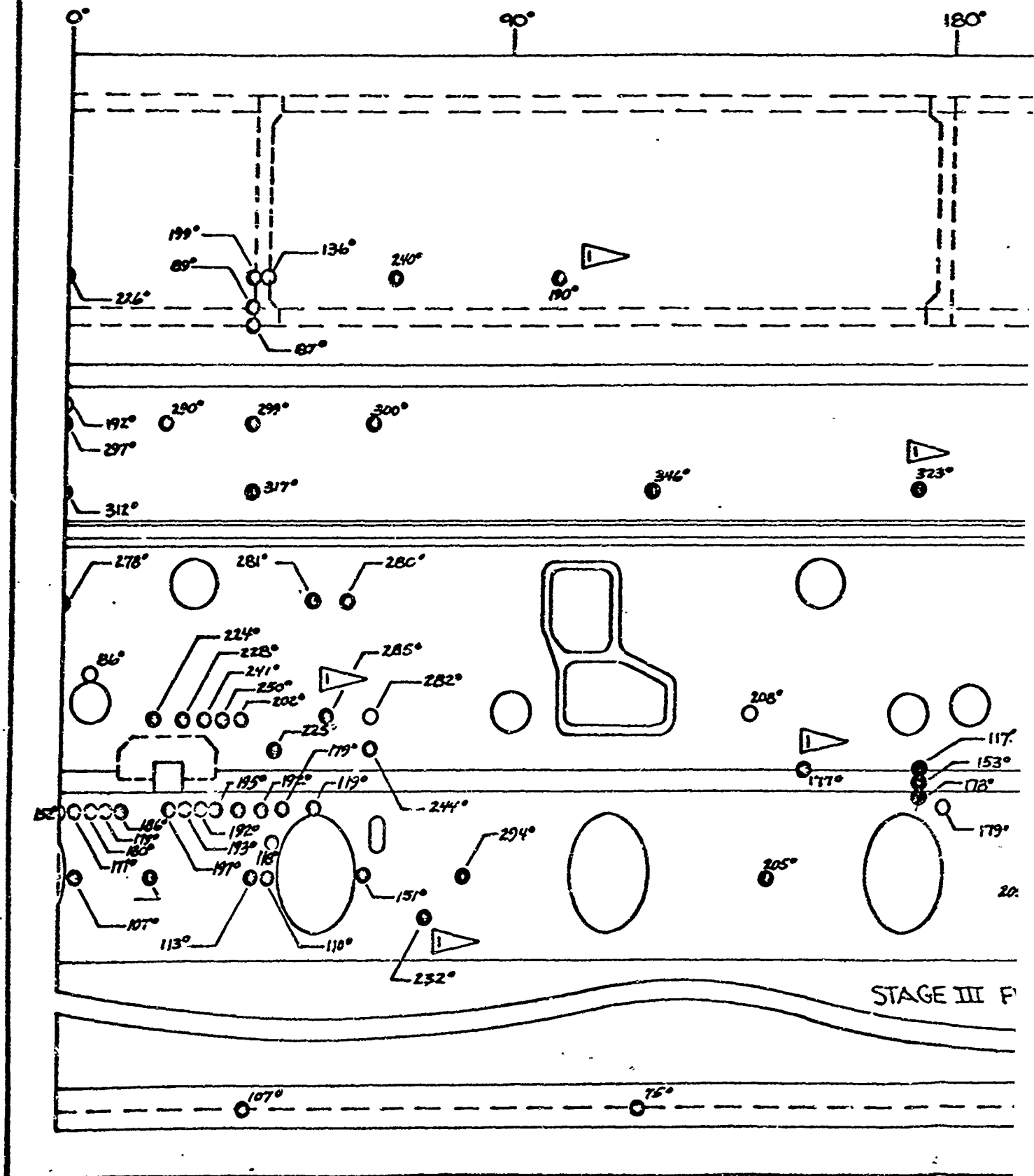

REV LTR _____

RAMMED PHASE I
 TABLE READINGS AT
 END OF TEST TIME

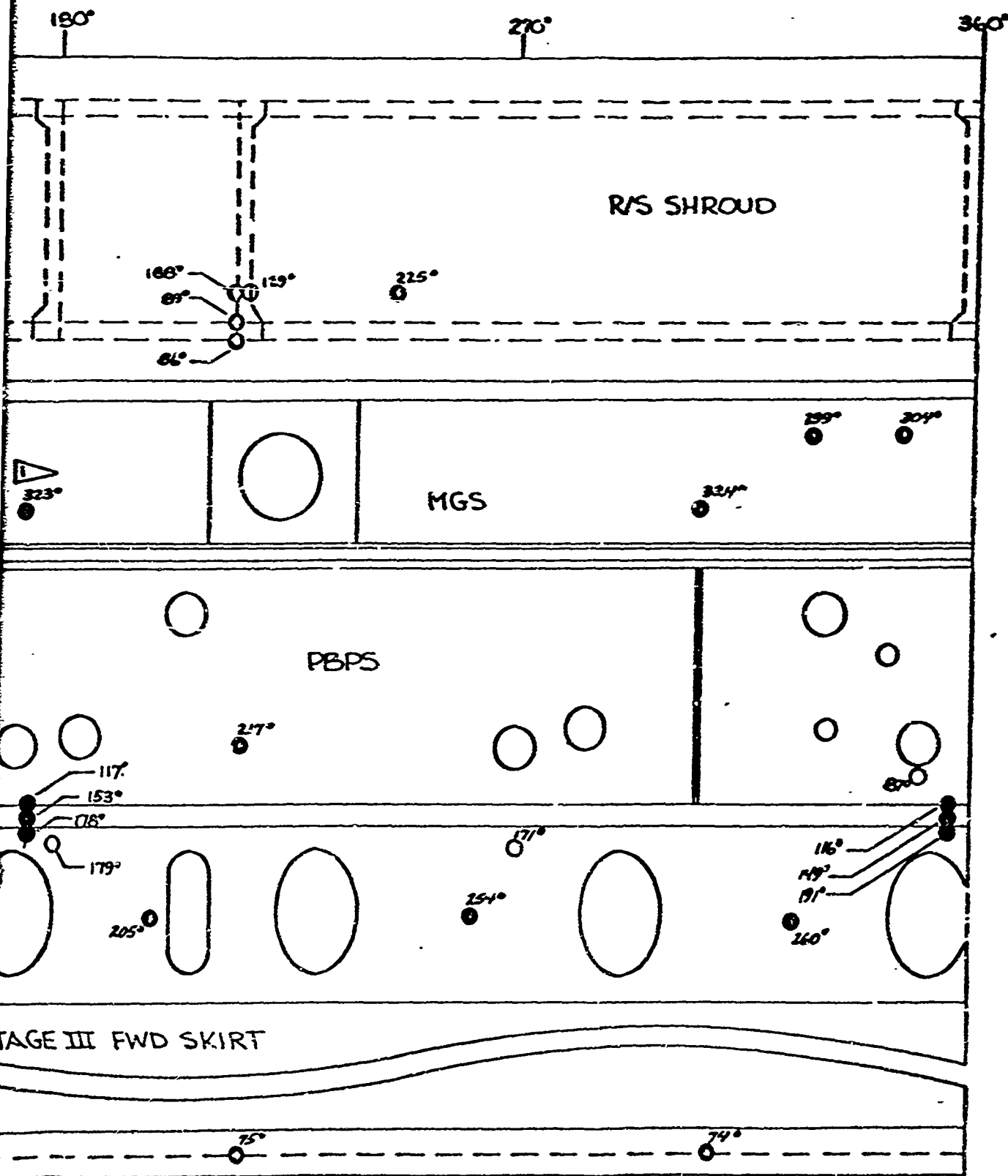
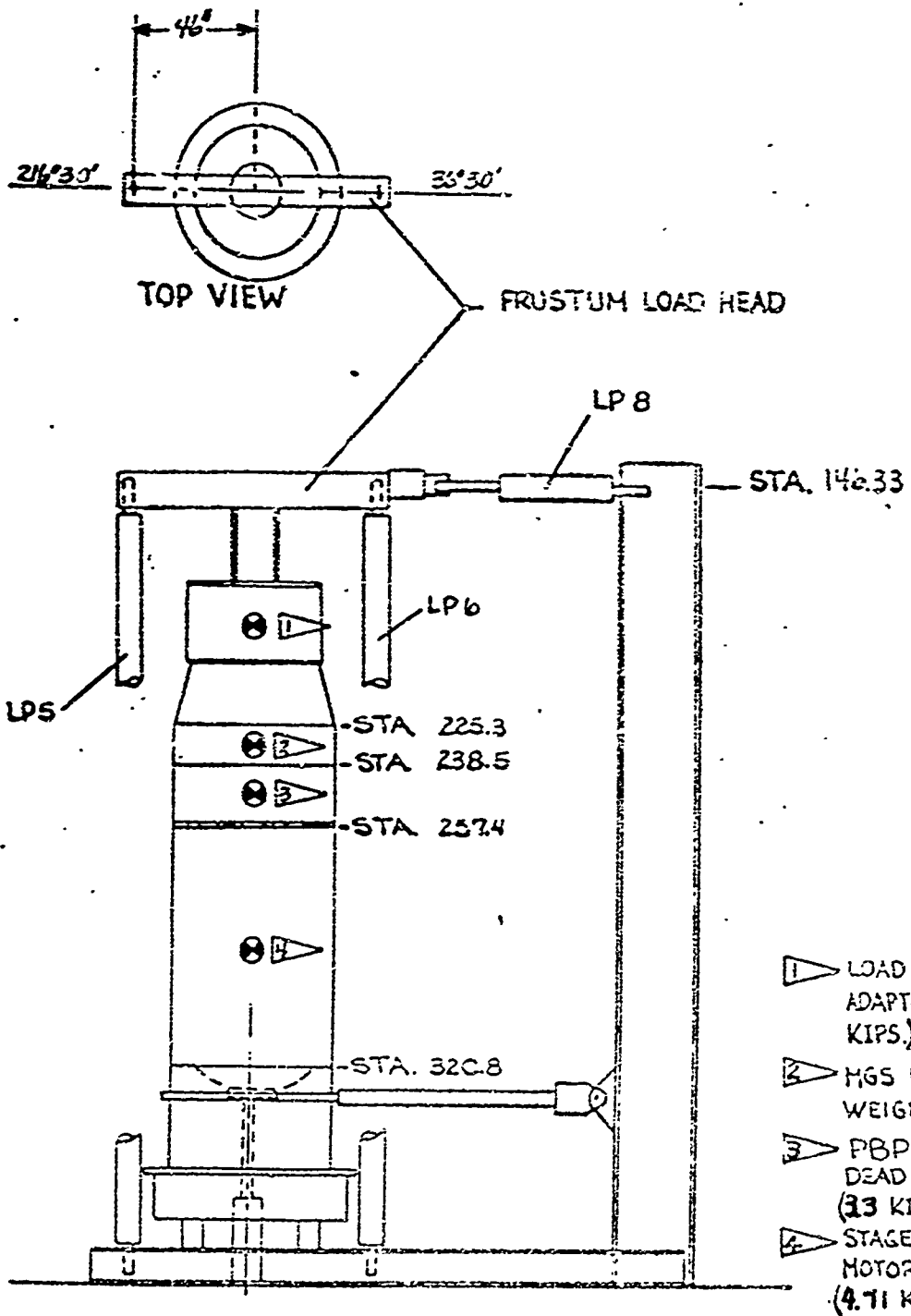

FIG. 5.4.1-18

LOAD GEOMETRY
(FRUSTUM ONLY)
PHASE II



USE FOR DRAWING AND HANDPRINTING — NO TYPEWRITTEN MATERIAL

333-F TEST

TEST TIME ~ SEC.	0	25.7	35.7	50	70	77
PROGRAMMED R_1	0	16.1	8.70	11.70	15.25	17.40
ACTUAL P_S	0.068	15.25	9.11	11.46	15.65	16.81

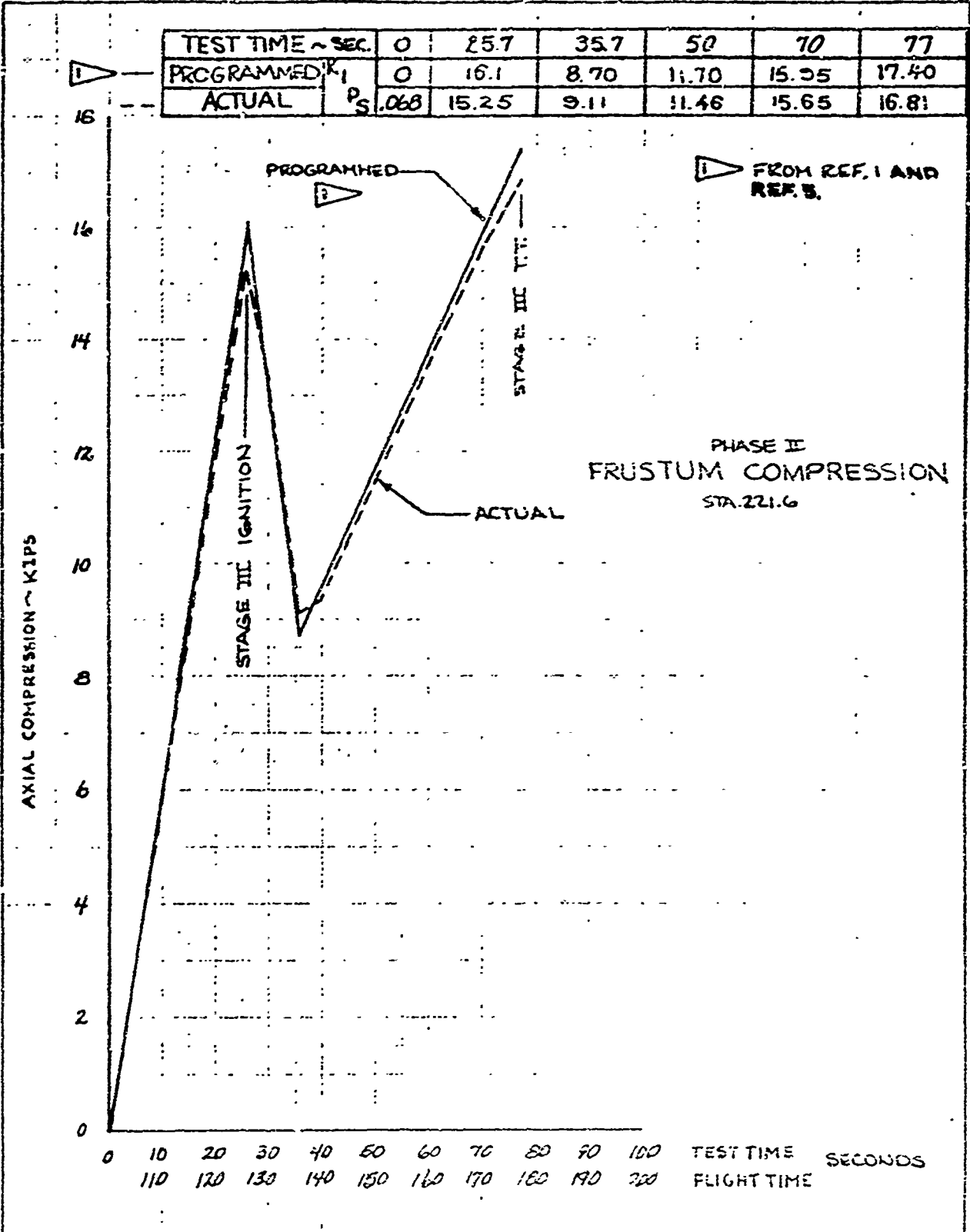

	INITIALS	DATE	REV BY INITIAL	DATE	TITLE	MODEL
CALC	AW	8-29-58			333-F PROGRAMMED TEST-PHASE II PLANNED & ACTUAL AXIAL COMPRESSION VS. TIME. FRUSTUM STATION 221.6	FIG. 54.1-20
CHECK	AW	30 AUG 58				
APPD						
APPD						

US 4013 (200) REV 1/66

REV LTR _____

BOEING NO TZ-3657-1
SH 543

TEST TIME-SEC.	0	257	357	50	10	77
PROGRAMMED P_s	0	132.9	29.80	29.8	29.8	29.8
ACTUAL P_s	0	124.1	38.11	28.5	28.5	28.3

FROM REF. 1 AND REF. 5

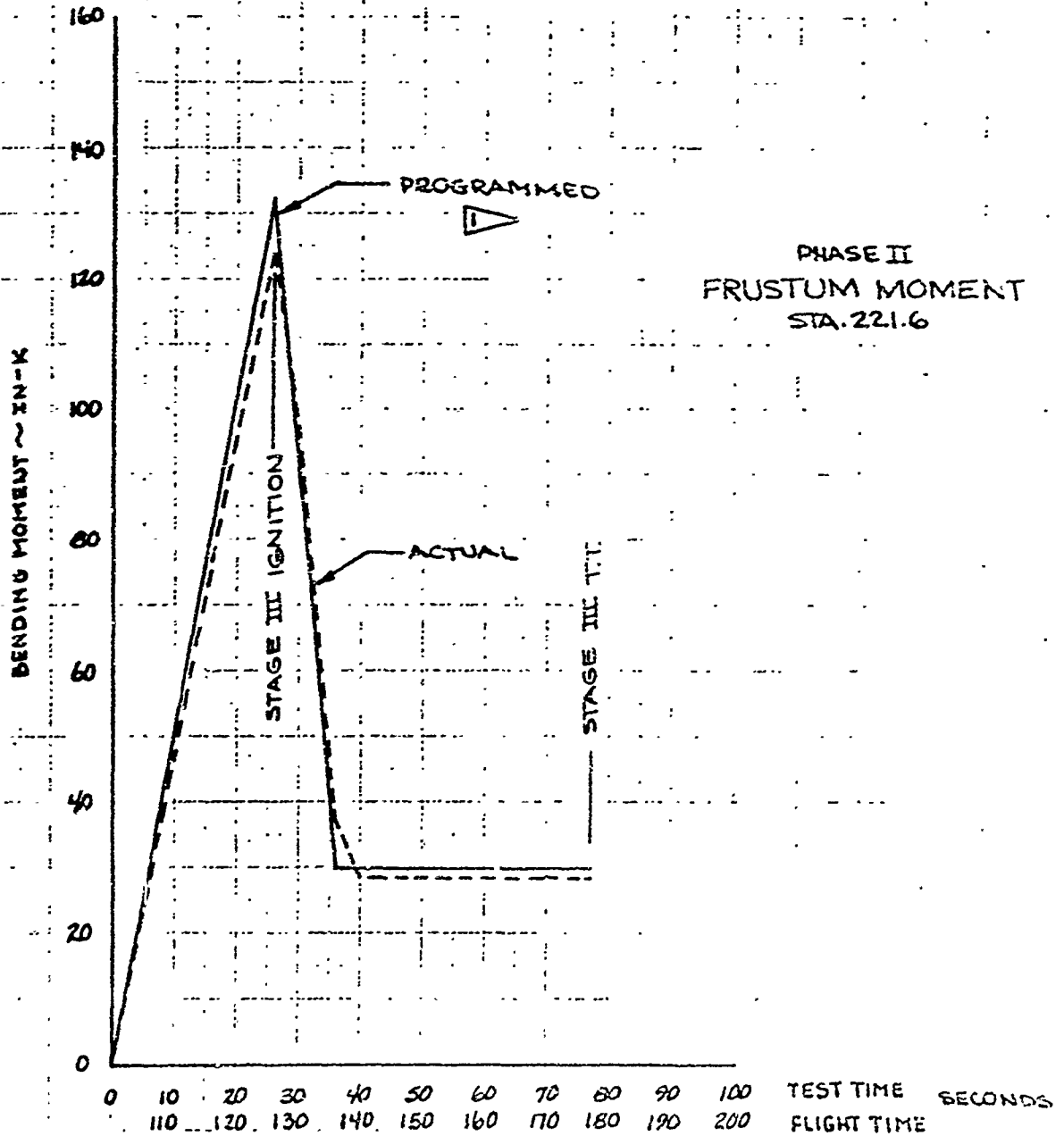

	INITIALS	DATE	REV BY INITIAL	DATE	TITLE	MODEL
CALC	RAW	8-29-8			333-F PROGRAMMED TEST PHASE II PLANNED & ACTUAL MOMENT VS TIME FRUSTUM STATION 221.6	FIG. 54.21
CHECK	MDW	30 AUG 8				
APPD.						
APPD.						

U3 4013 6000 REV 1/66

REV LTR. _____

BOEING NO T2-3657-1
SH. 544.

TEST TIME ~ SEC	0	25.7	35.7	50	70	77
PROGRAMMED K_p	0	1.79	0.371	0.371	0.371	0.371
ACTUAL K_p	0	1.73	0.488	0.379	0.379	0.376

FROM REF. 1 AND REF. 5.

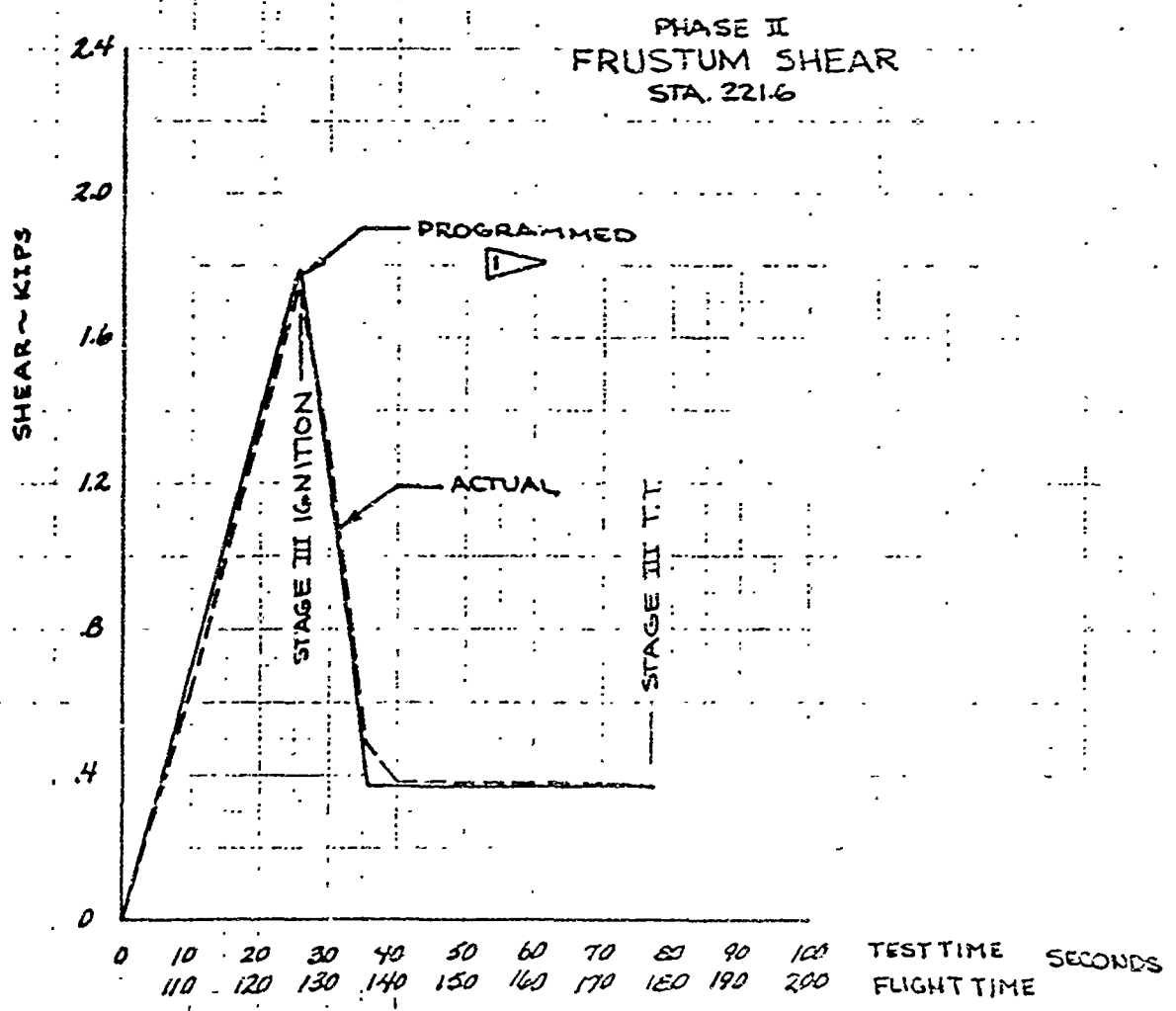

	INITIALS	DATE	REV BY INITIAL	DATE	TITLE	MODEL
CALC	RAW	8-29-8			333-F PROGRAMMED TEST - PHASE II PLANNED & ACTUAL SHEAR VS. TIME FRUSTUM - STATION 221.6	FIG. 5-4.1-22
CHECK	YBW	30 AUG 8				
APPD.						
APPD.						

U3 4613 8000 REV 1/66

REV LFR _____

BOEING NO T2-3657-1
SH 545

TEST TIME ~ SEC	0	25.7	35.7	50	70	77
PROGRAMMED K_1	530	21.40	4.0	17.0	21.22	22.7
ACTUAL P_s	537	20.55	14.41	16.76	20.95	22.11

1 FROM REF 1 AND REF 5
 2 DEAD WEIGHT LOAD
 SEE 3 OF
 FIGURE 5.4.1-19

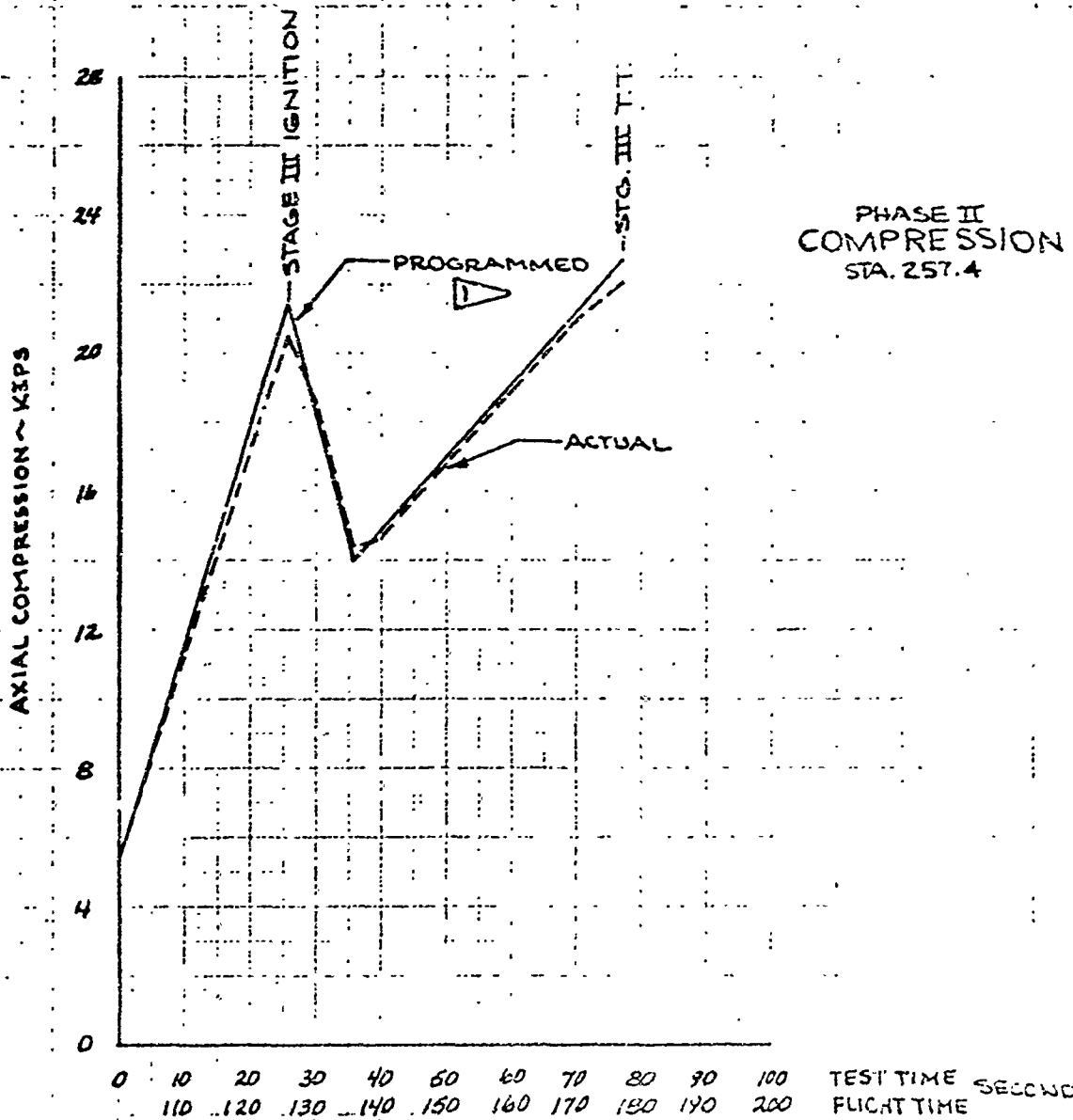

	INITIALS	DATE	REV BY INITIAL	DATE	TITLE	MODEL
CALC	RAW	8-29-8			333-F PROGRAMMED TEST PHASE II PLANNED & ACTUAL COMPRESSION VS. TIME STATION 257.4	FIG 54-73
CHECK	RAW	8-29-8				
APPD.						
APPD.						

U3 4013 8000 REV 1/66

REV LTR _____

BOEING NO T2-3657-1
SH 54-3

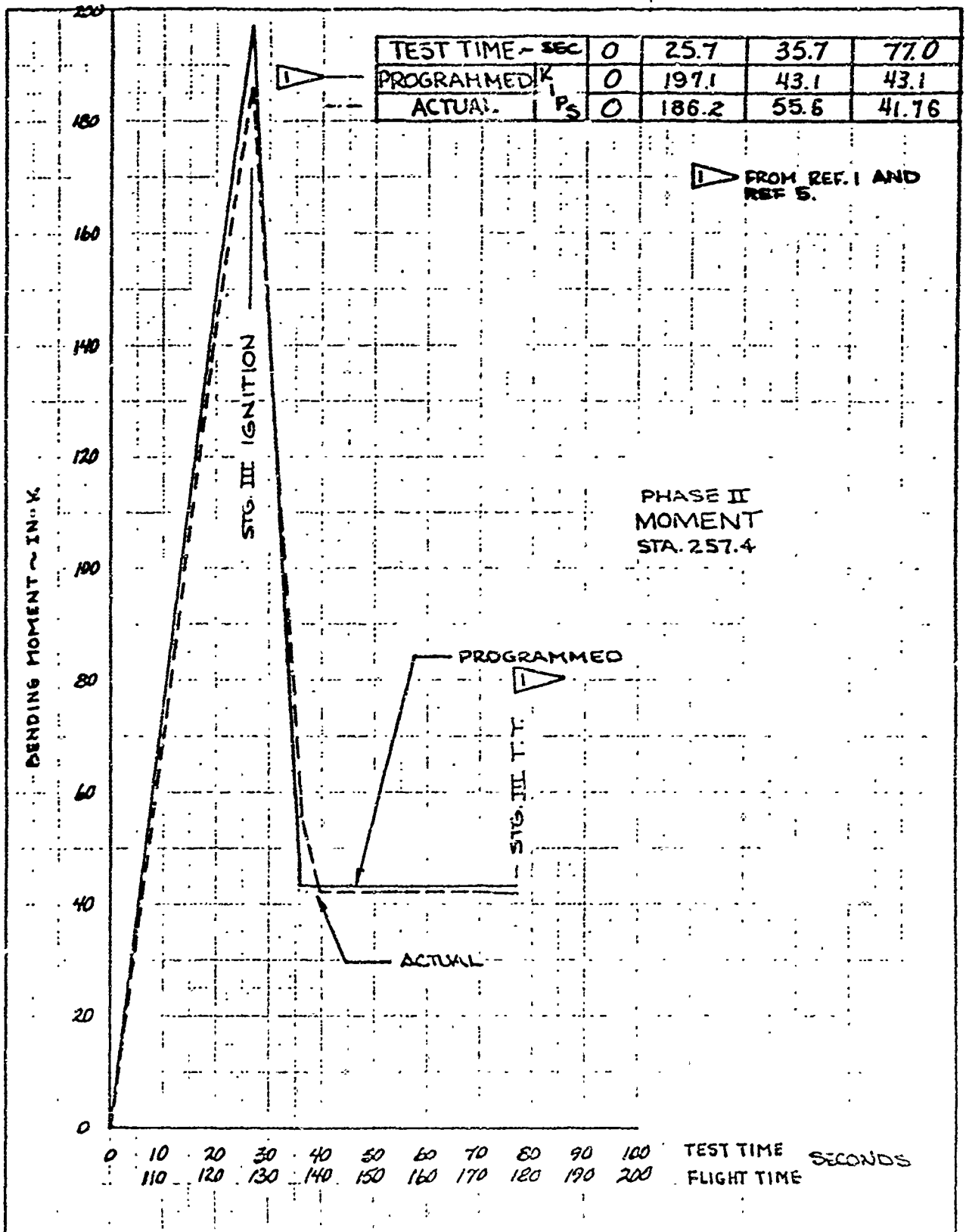

	INITIALS	DATE	REV BY INITIAL	DATE	TITLE	MODEL
CALC	<i>Law</i>	8-29-68			533-F PROGRAMMED TEST - PHASE II PLANNED AND ACTUAL MOMENT VS TIME STATION 257.4	FIG. 54.124
CHECK	<i>Law</i>	8-29-68				
APPD.						
APPD.						

U3 4013 8000 REV 1/66

REV LTR _____

BOEING NO T2-3657-1
SH 547

TEST TIME ~ SEC	0	25.7	35.7	50	70	77
PROGRAMMED K_p	0	1.79	0.371	0.371	0.371	0.371
ACTUAL P_s	0	1.73	0.448	0.379	0.379	0.376

FROM REF. 1 AND REF. 5.

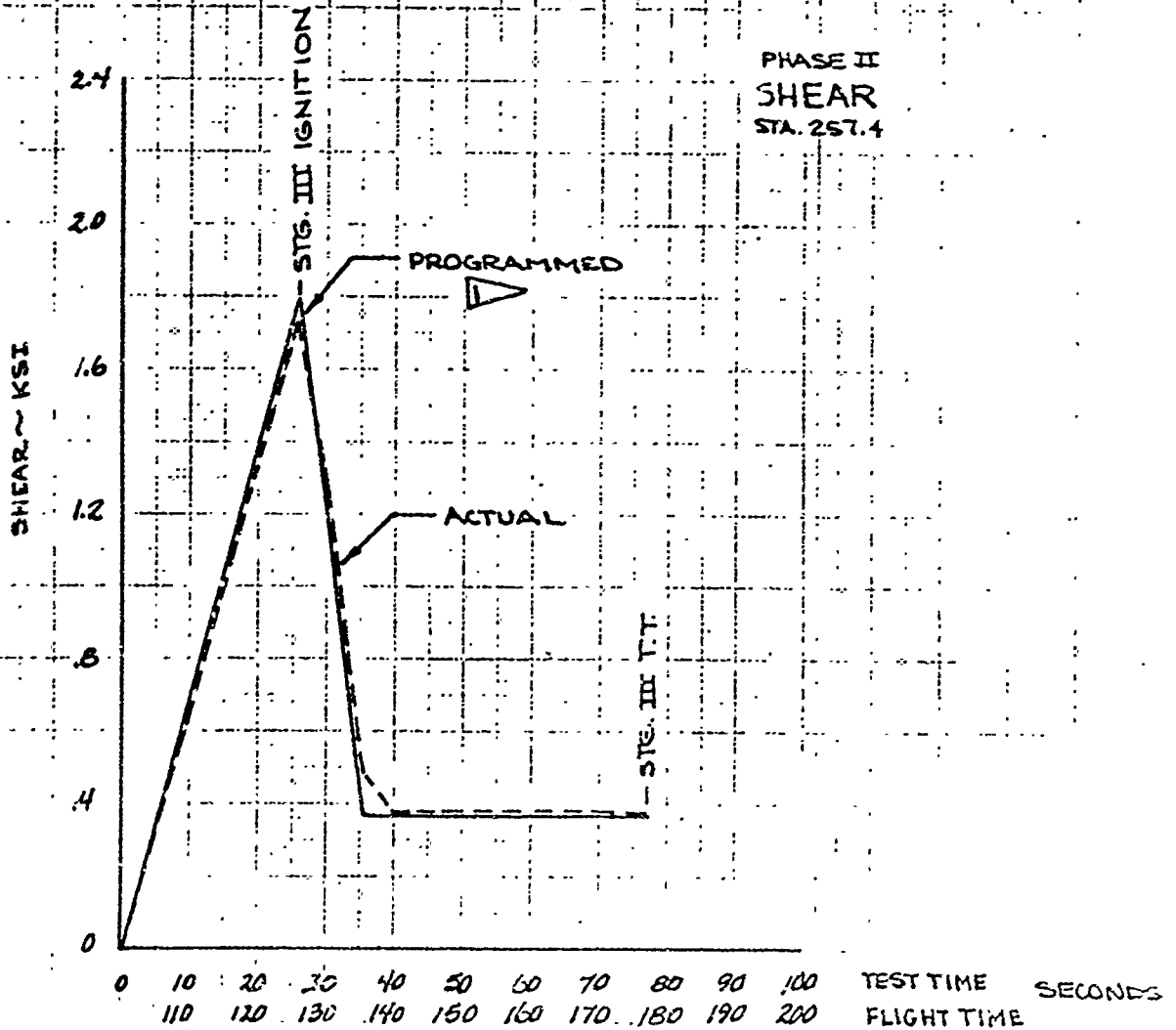

	INITIALS	DATE	REV BY INITIAL	DATE	TITLE	MODEL
CALC	SW	8-29-8			333 - F PROGRAMMED TEST-PHASE II PLANNED & ACTUAL SHEAR VS. TIME STATION 257.4	FIG. 54-25
CHECK	SW	30 Aug 8				
APPD.						
APPD.						

U3 4013 8000 REV 1/66

REV LTR _____

BOEING NO T2-3657-1
SH 548

TEST TIME ~ SEC	0	10	20	25.7	35.7	40	50	60	77	95
PLANNED PRESS. ~ PSI	350	469	587	655	655	655	655	655	655	0
ACTUAL PRESS. ~ PSI	354	425	501	561	614	624	632	634	628	475

PER REF. 1, EXCEPT FOR VALUES FROM TEST TIME 0 TO TEST TIME 25.7 BECAUSE OF THE NECESSITY OF AN INITIAL PRESSURE (550 PSI) IN ORDER THAT THE PUMP MIGHT SUPPLY 655 PSI BY TEST TIME 25.7.

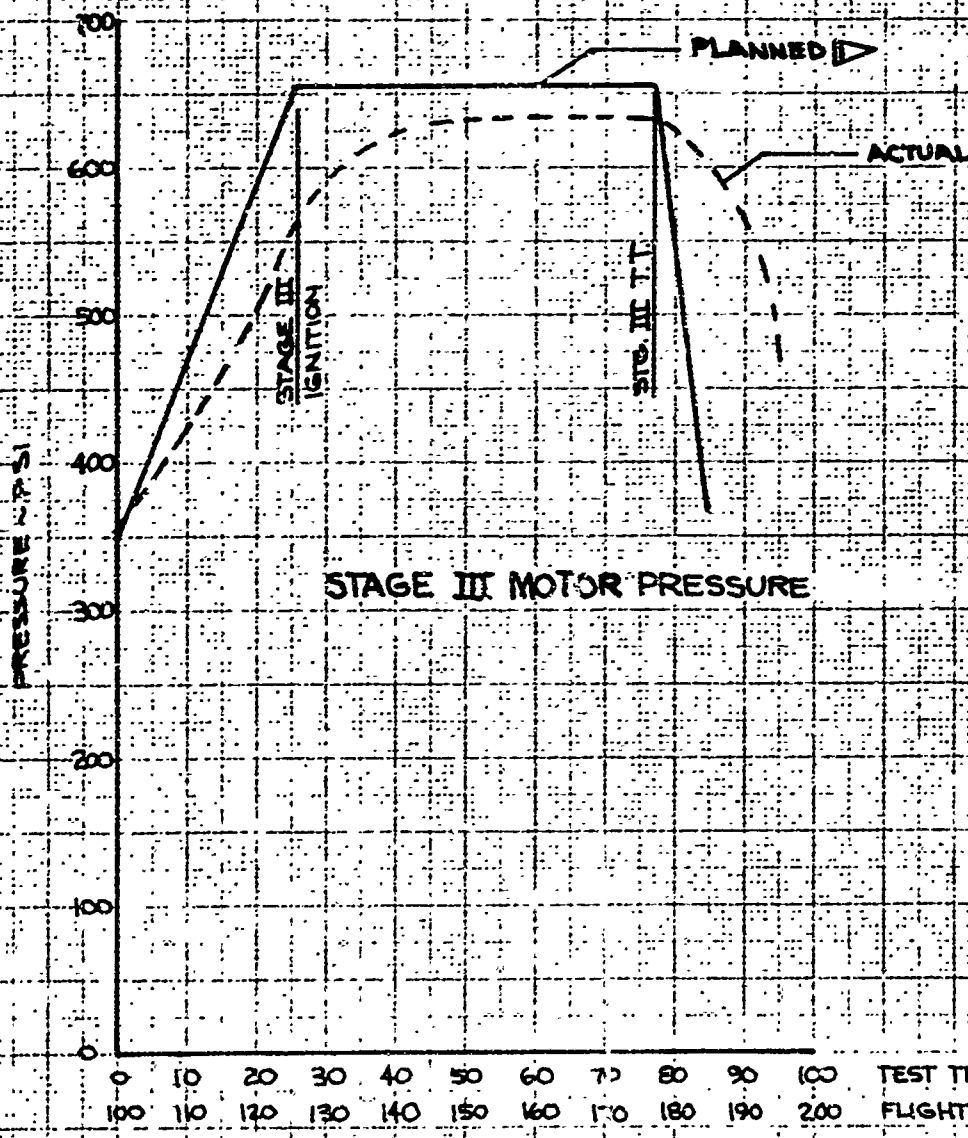

	INITIALS	DATE	REV BY INITIAL	DATE	TITLE	MODEL
CALC	GDW	30 Sep 68			333-F PROGRAMMED TEST ~ PHASE II STAGE III MOTOR CASE PLANNED AND ACTUAL INTERNAL PRESSURES VS. TIME	FIG. 5A.1-26
CHECK	RET	1 Oct. 68				
APPD.						
APPD.						

US 4013 8000 REV. 1/66

REV ITR _____

BOEING NO. T2-3657-1
SH. 549

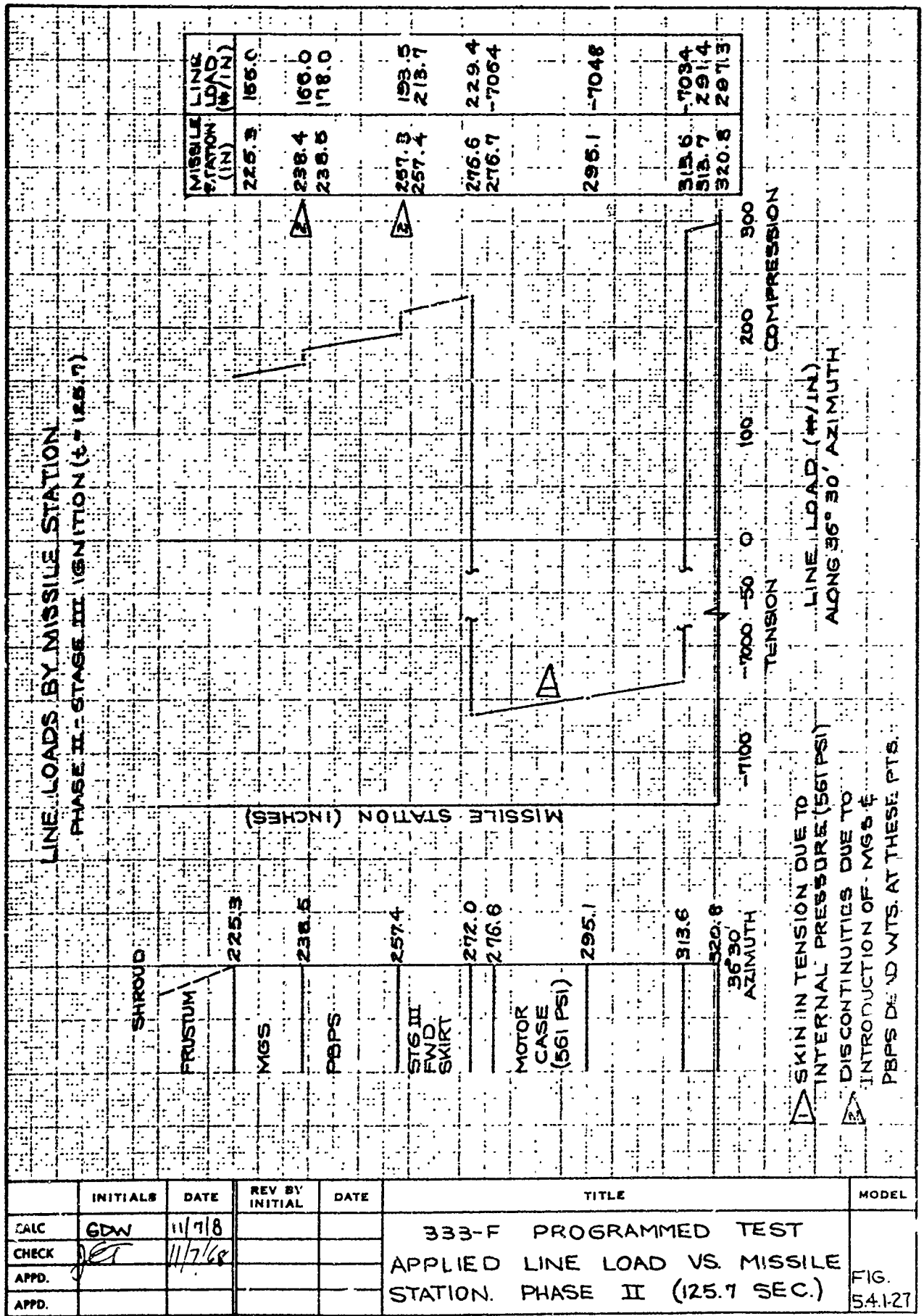

INITIALS	DATE	REV BY INITIAL	DATE	TITLE	MODEL
CALC	GDW	11/7/68		333-F PROGRAMMED TEST APPLIED LINE LOAD VS. MISSILE STATION. PHASE II (125.7 SEC.)	FIG. 54-127
CHECK	JET	11/7/68			
APPD.					
APPD.					

U3 4013 8000 REV. 1/56

REV LTR _____

BOEING NO. T2-3651-1
SH 550

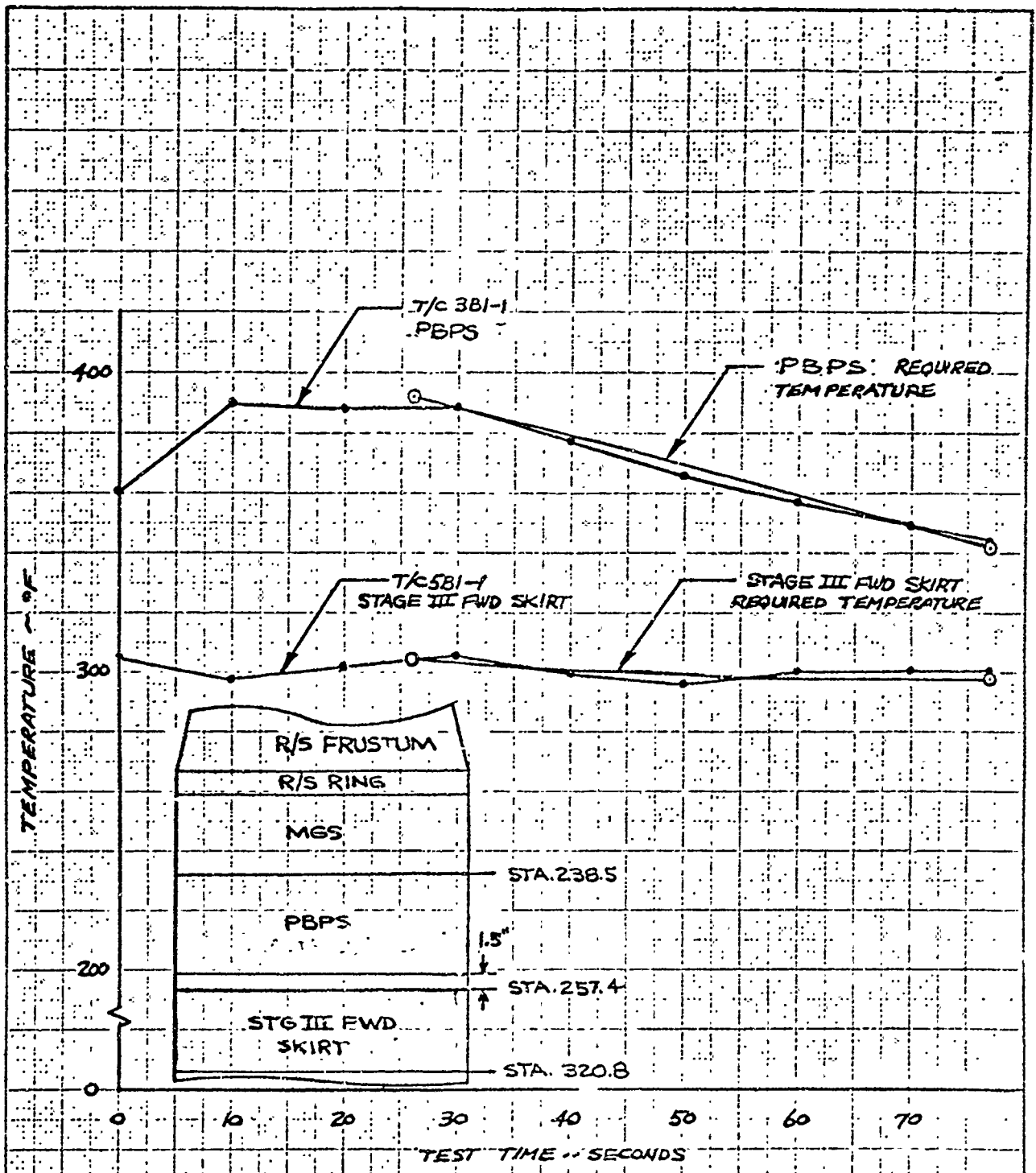

	INITIALS	DATE	REV BY INITIAL	DATE	TITLE	MODEL
CALC	DLH	6/16/68			MM III 333-F TEST PHASE II CONTROL TEMPERATURES - PBPS AND STAGE III FWD SKIRT	FIG. 54.128
CHECK	MUD	V				
APPD.						
APPD.						

UJ 4013 E000 REV 1/60

REV LTR _____

DOEING NO. T2-3657-1
SH. 55.1

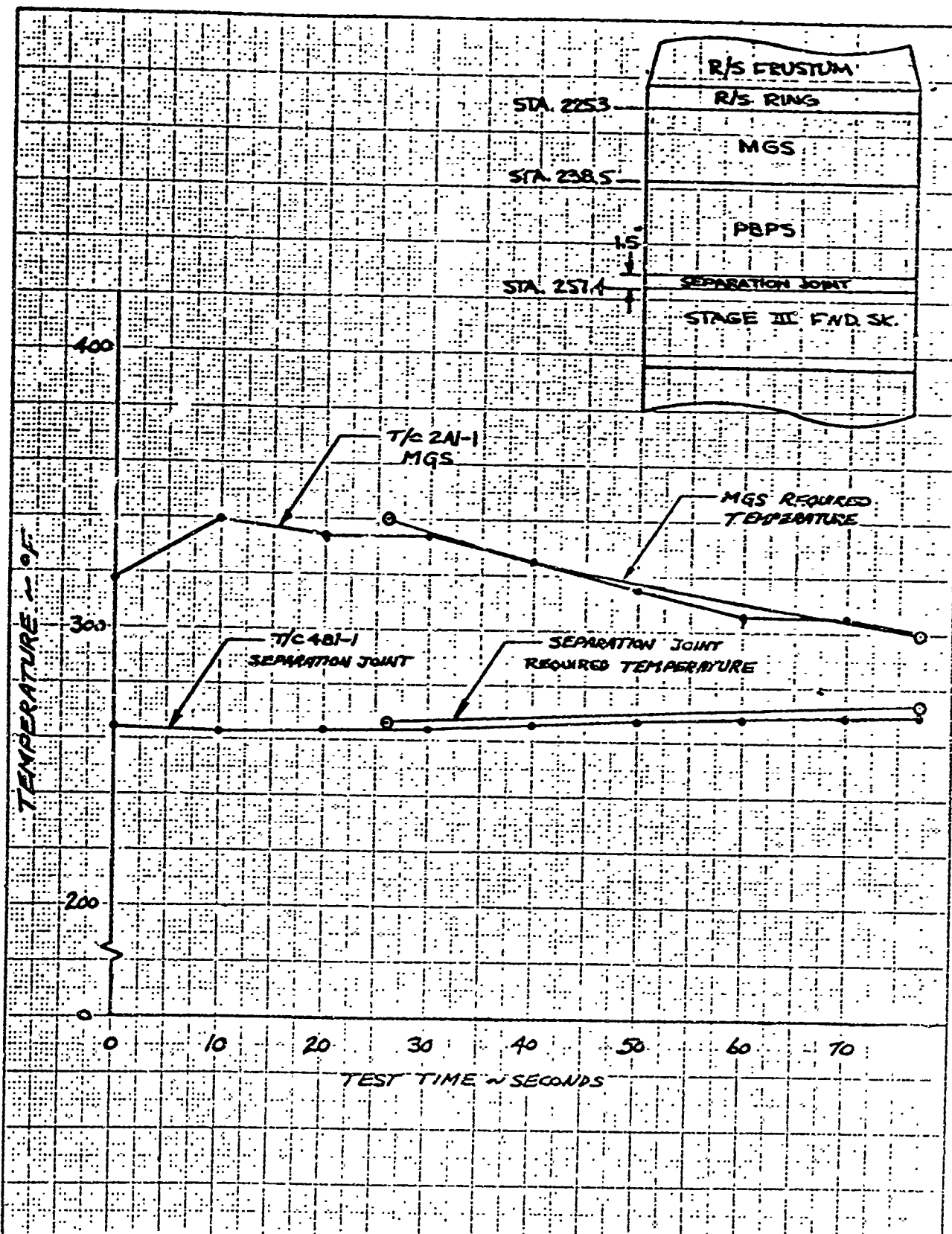

	INITIALS	DATE	REV BY INITIAL	DATE	TITLE	MODEL
CALC	DLH	6/18/66			MM III 333-F TEST PHASE II CONTROL TEMPERATURES - MGS AND STAGE III-PBV SEPARATION JOINT	FIG. 54.129
CHECK	MUD	✓				
APPD.						
APPD.						

UT 013 8000 REV. 1/66

REV LTR _____

DOEING NO. T2-3657-1
SH. 55?

ADDED PHASE II
READINGS AT
OF TEST TIME

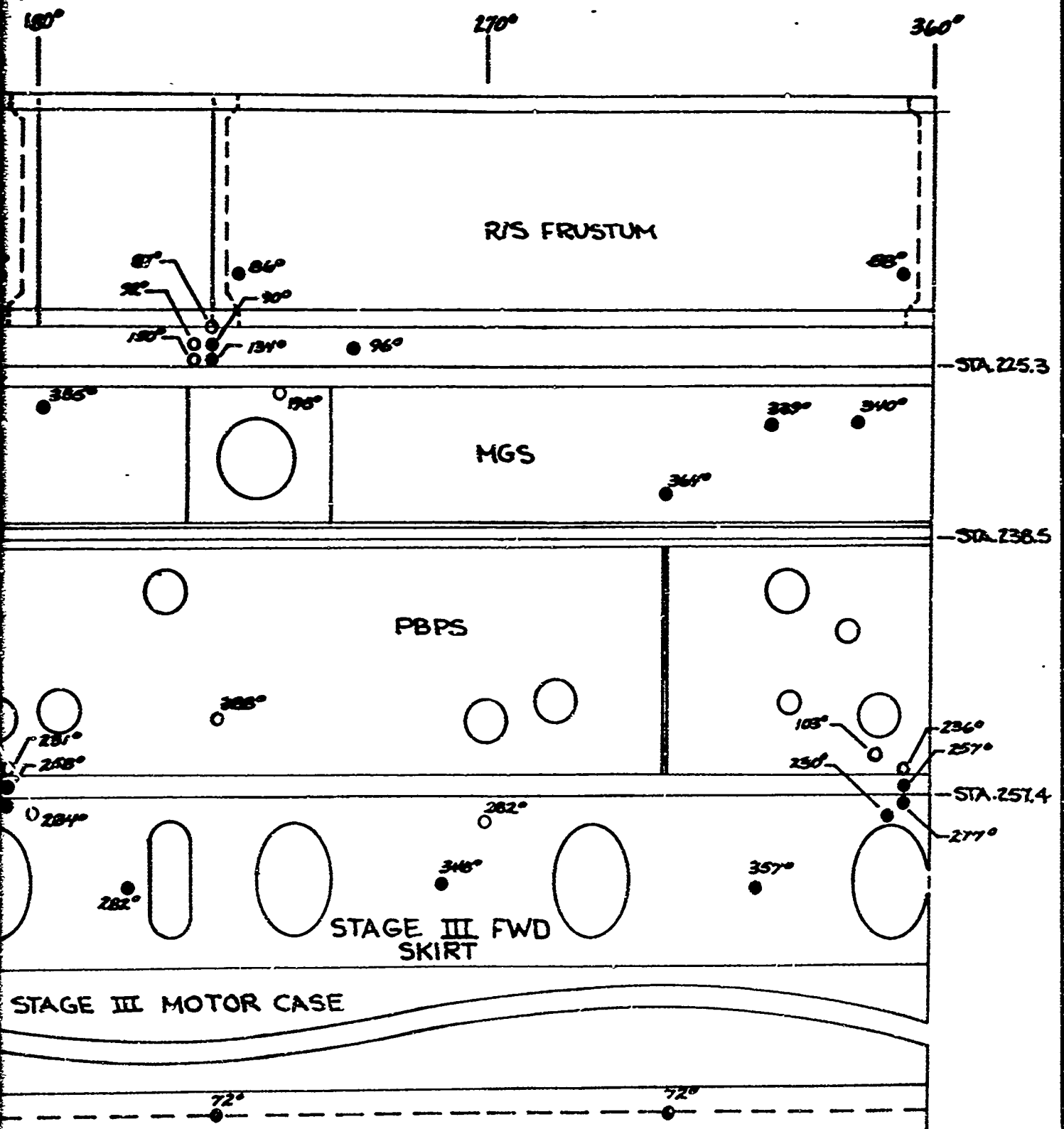

FIG. 54.1-30

BOEING | NO. T2-3657-1
| SH 553

B

USE FOR TYPEWRITING MATERIAL ONLY

5.4.2 FAILURE TEST CONDITIONS

STA	PERCENT		0%	50%	80%	100%	110%	120%
257.4	PROGRAMMED	KIPS	530 ¹	12.90 ²	17.40 ³	20.50	22.00 ³	23.54 ³
	ACTUAL	KIPS	5346	12.90	17.67	20.71	22.39	24.81
	% OF PROGRAMMED 100% LOAD		26.1%	62.9%	86.2%	101.0%	109.2%	121.0%
225.3	PLANNED	KIPS	0	7.6	12.16	15.2	16.72	18.24
	ACTUAL	KIPS	.046	7.6	12.37	15.4	17.1	19.51
	% OF PROGRAMMED 100% LOAD		0.3%	50.0%	81.4%	101.3%	112.5%	128.4%

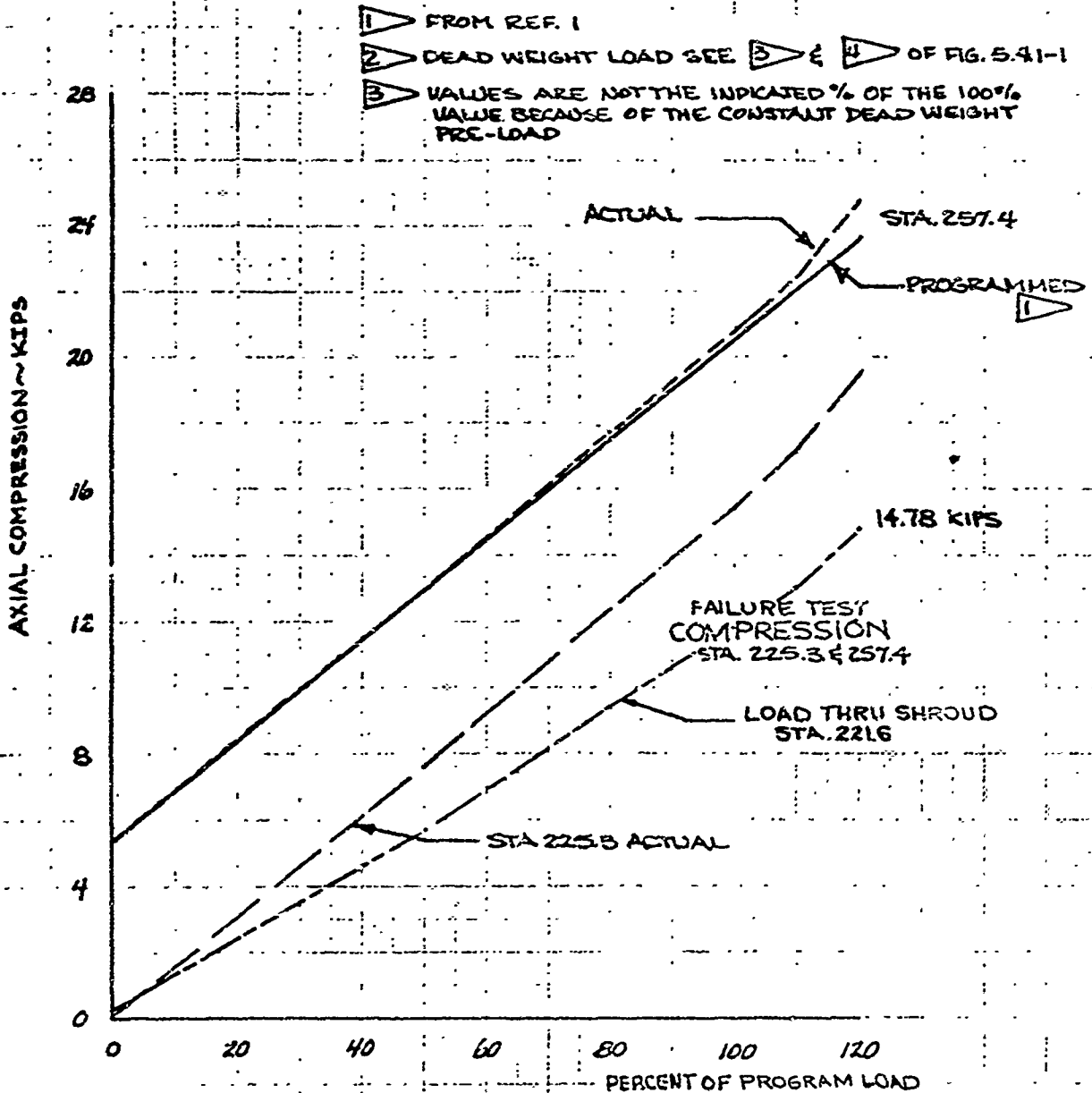

	INITIALS	DATE	REV BY INITIAL	DATE	TITLE	MODEL
CAIC	RAW	8-29-8			333 - F FAILURE TEST PLANNED & ACTUAL AXIAL COMP. VS. %LOAD STATIONS 225.3 & 257.4	FIG. 5.42-1
CHECK	ADW	8-30-8				
APPD.						
APPD.						

U3 4013 2050 REV 1/66

REV LTR _____

BOEING NO. T2-3657-1
 SH. 555

STA	PERCENT		0%	50%	80%	100%	110%	120%
257.4	PROGRAMMED	IN	0	646.5	1034.4	1293	1422.3	1551.6
	ACTUAL	IP	33.3	636.1	1052.	1290	1411.4	1535
	% OF PROGRAMMED 100% LOAD	%	2.6%	49.2%	81.4%	99.8%	102.4%	119%
225.3	PROGRAMMED	IN	0	427.9	684.64	856	944.4	1027
	ACTUAL	IP	21.5	420.1	701.33	852.8	934.4	1018.2
	% OF PROGRAMMED 100% LOAD	%	2.5%	49.1%	81.9%	99.6%	109.2%	118.25%

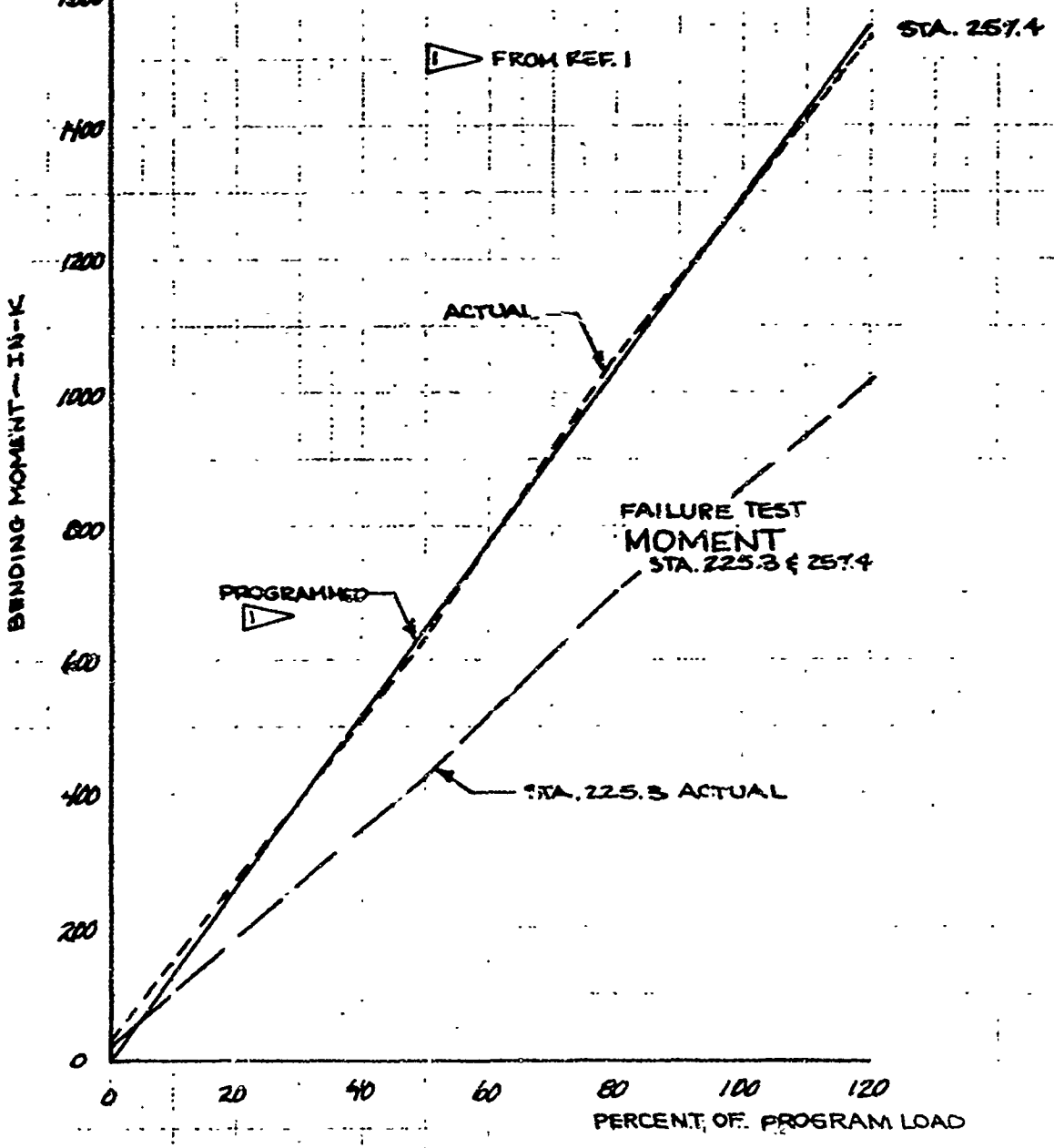

	INITIALS	DATE	REV BY INITIAL	DATE	TITLE	MODEL
CALC	<i>[Signature]</i>	9-29-8			333-F FAILURE TEST PLANNED & ACTUAL MOMENT VS. % LOAD STATION 225.3 & 257.4	FIG. 542-2
CHECK	<i>[Signature]</i>	8-30-8				
APPD.						
APPD.						

U3 4013 8000 REV 1/66

REV LTR _____

BOEING NO T2-3657-1
SH 556

PERCENT	0%	50%	80%	100%	110%	120%
PROGRAMMED	0	6.81	10.90	13.62	14.98	16.34
ACTUAL	3.68	6.73	11.08	13.62	14.86	16.10
% OF PROGRAMMED 120% LOAD	.27%	49.4%	81.4%	100%	109.1%	118.2%

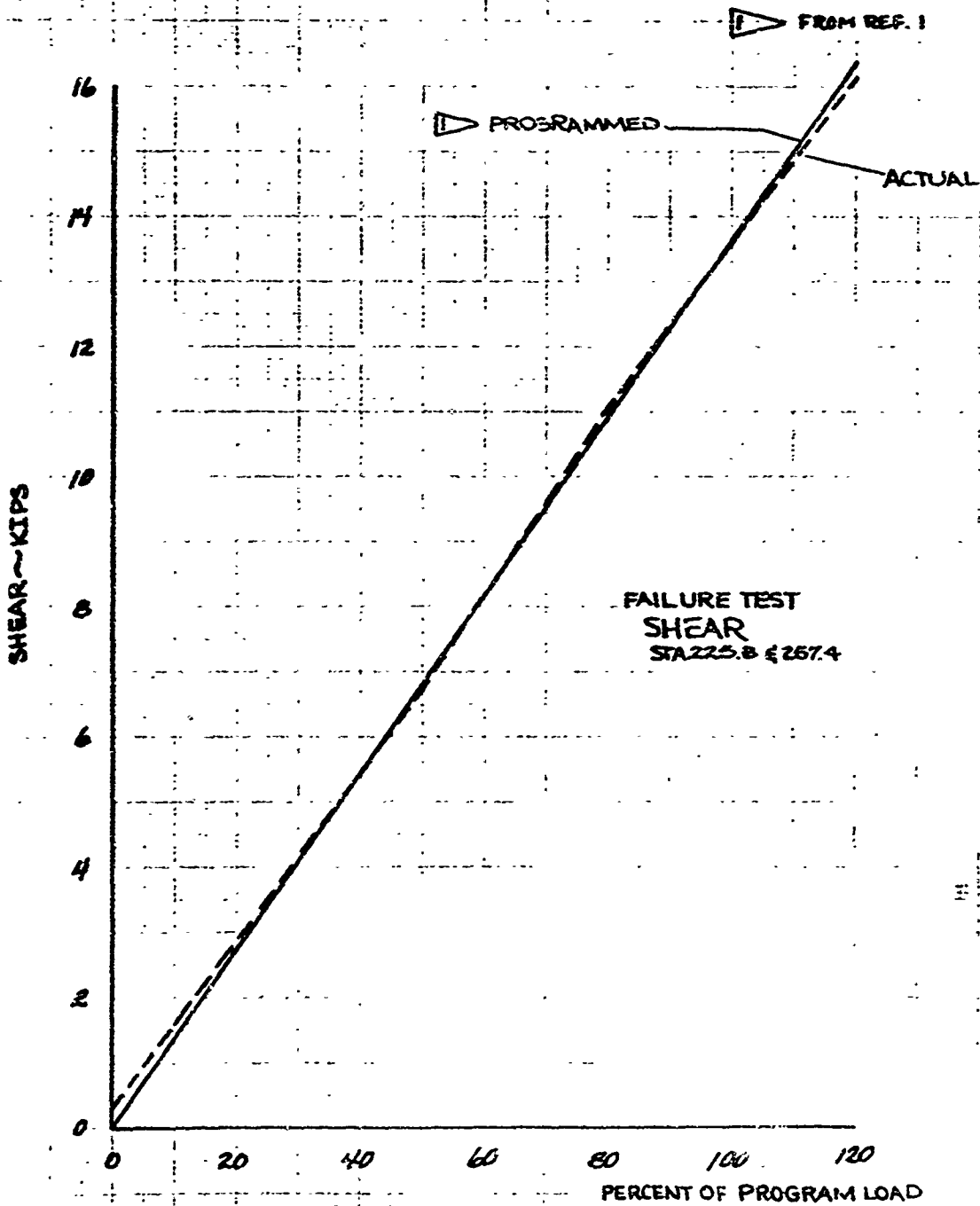

	INITIALS	DATE	REV BY INITIAL	DATE	TITLE	MODEL
CALC	<i>AW</i>	8-19-8			333-F FAILURE TEST PLANNED AND ACTUAL SHEAR VS. PERCENT LOAD STATIONS 225.3 & 257.4	FIG. 54.2-3
CHECK	<i>SW</i>	8-30-8				
APPD.						
APPD.						

U3 4013 8000 REV 1/66

REV LTR. _____

BOEING NO T2-3657-1
SH 557

333-F FAILURE TEST MAXIMUM LINE LOAD

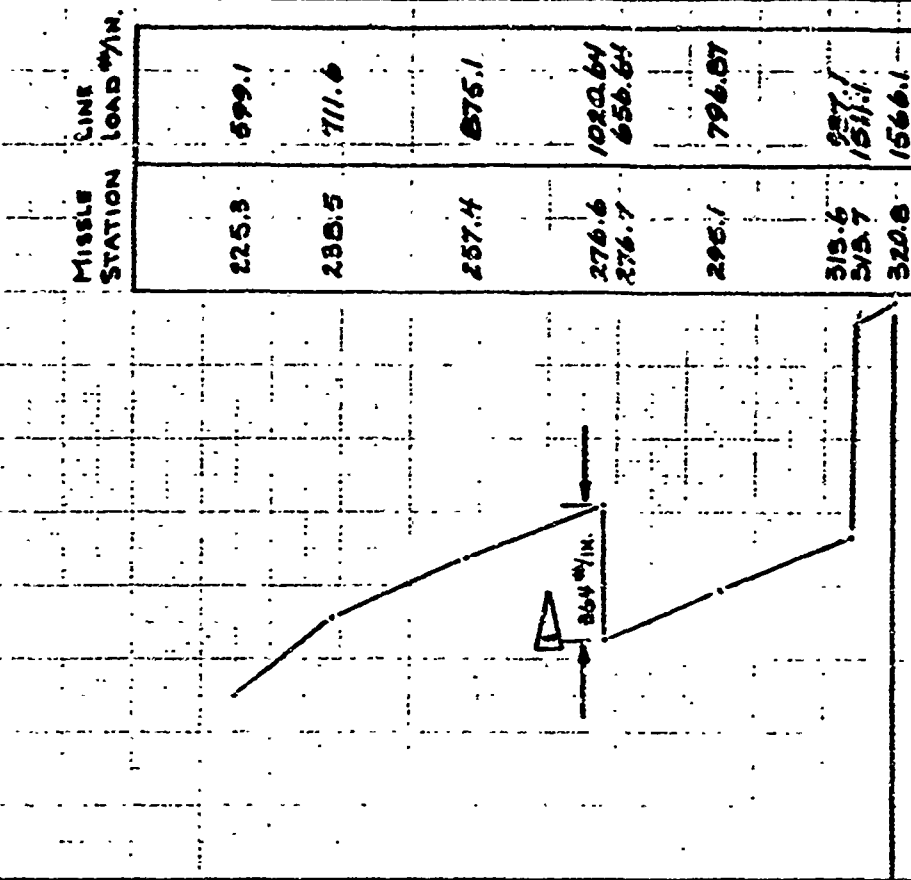

200 400 600 800 1000 1200 1400 1600
 COMPRESSIVE LINE LOAD #/IN. (36° 30' AZL.)

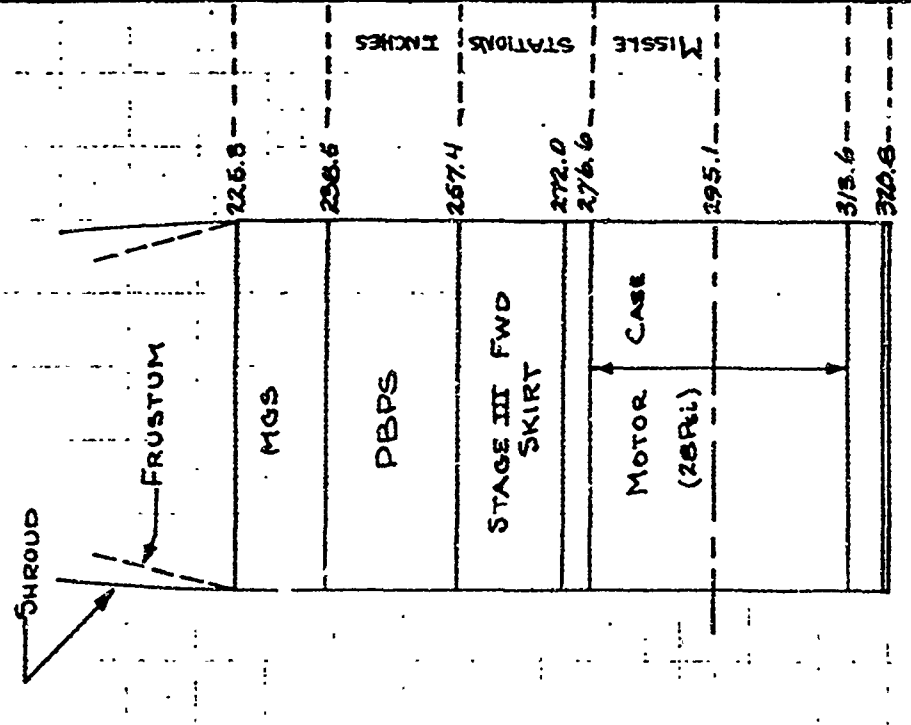

RESULT OF STAGE III
 MOTOR CASE FAILURE

INITIALS	DATE	REV BY INITIAL	DATE	TITLE	MODEL
GDW	23 Aug 68			333-F FAILURE TEST APPLIED LINE LOAD VS. MISSILE STATION. LOADS AT FAILURE	FIG. 542-4
CHECK	HOW	9-10-68			
APPD.					
APPD.					

U3 401J 8000 REV 1/66

REV LTR. _____

BOEING NO T2-3657-1
 SH 558

USE FOR TYPEWRITTEN MATERIAL ONLY

5.6 TEST RESULTS

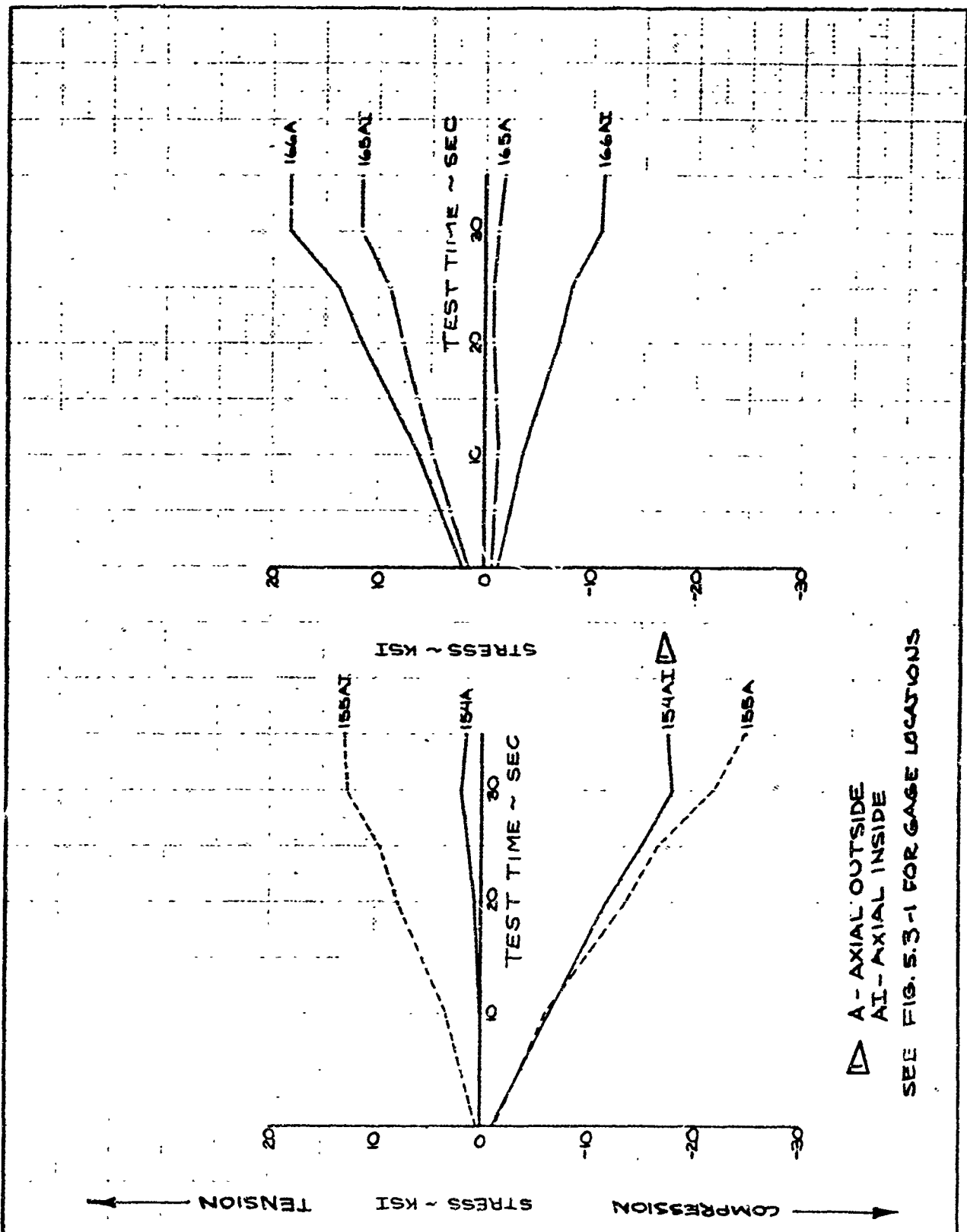

△ A - AXIAL OUTSIDE
 AI - AXIAL INSIDE
 SEE FIG. 5.3-1 FOR GAGE LOCATIONS

	INITIALS	DATE	REV BY INITIAL	DATE	TITLE	MODEL
CALC	<i>[Signature]</i>	8-30-68			333 - F PROGRAMMED TEST STRESS VS. TEST TIME FRUSTUM GAGES PHASE I	FIG. 5.6-1
CHECK	<i>[Signature]</i>	9-4-68				
APPD.						
APPD.						

US 4013 8600 REV 1/66

REV LTR _____

BOEING NO T2-3657-1
 SH 560

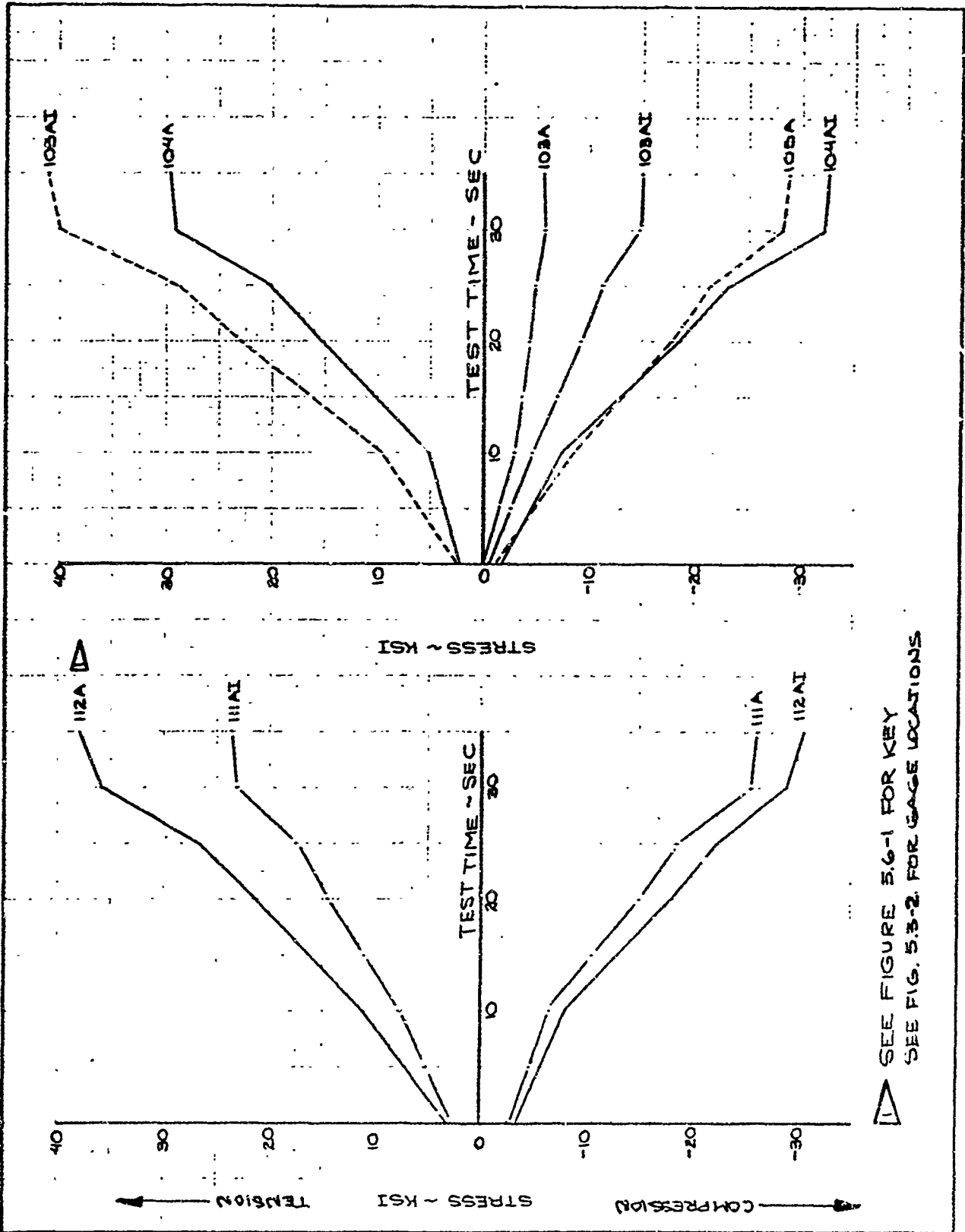

SEE FIGURE 5.6-1 FOR KEY
 SEE FIG. 5.3-2 FOR GAGE LOCATIONS

	INITIALS	DATE	REV BY INITIAL	DATE	TITLE	MODEL
CALC	<i>[Signature]</i>	8-30-68			333-F PROGRAMMED TEST STRESS VS. TEST TIME SHROUD GAGES PHASE I	FIG. 5.6-2
CHECK	<i>[Signature]</i>	9-4-68				
APPD.						
APPD.						

U3 4013 8000 REV 1/66

REV LTR _____

BOEING NO T2-3657-1
 SH 561

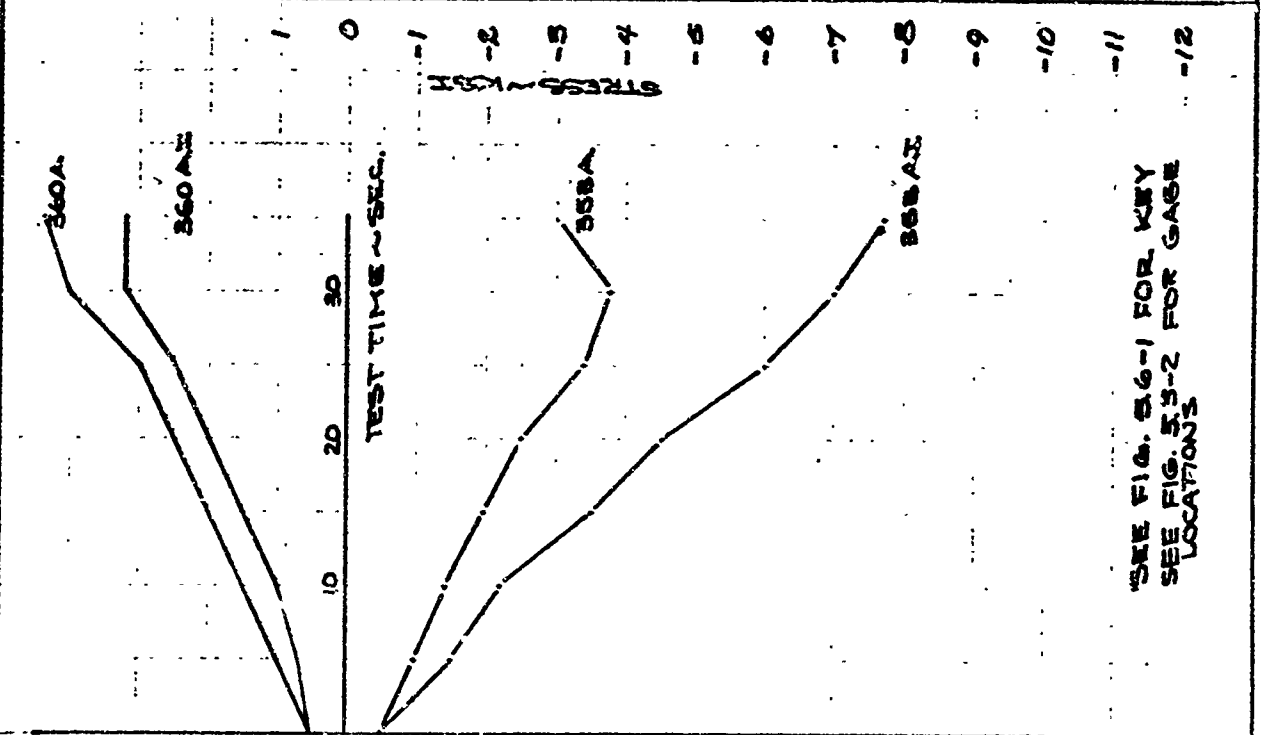
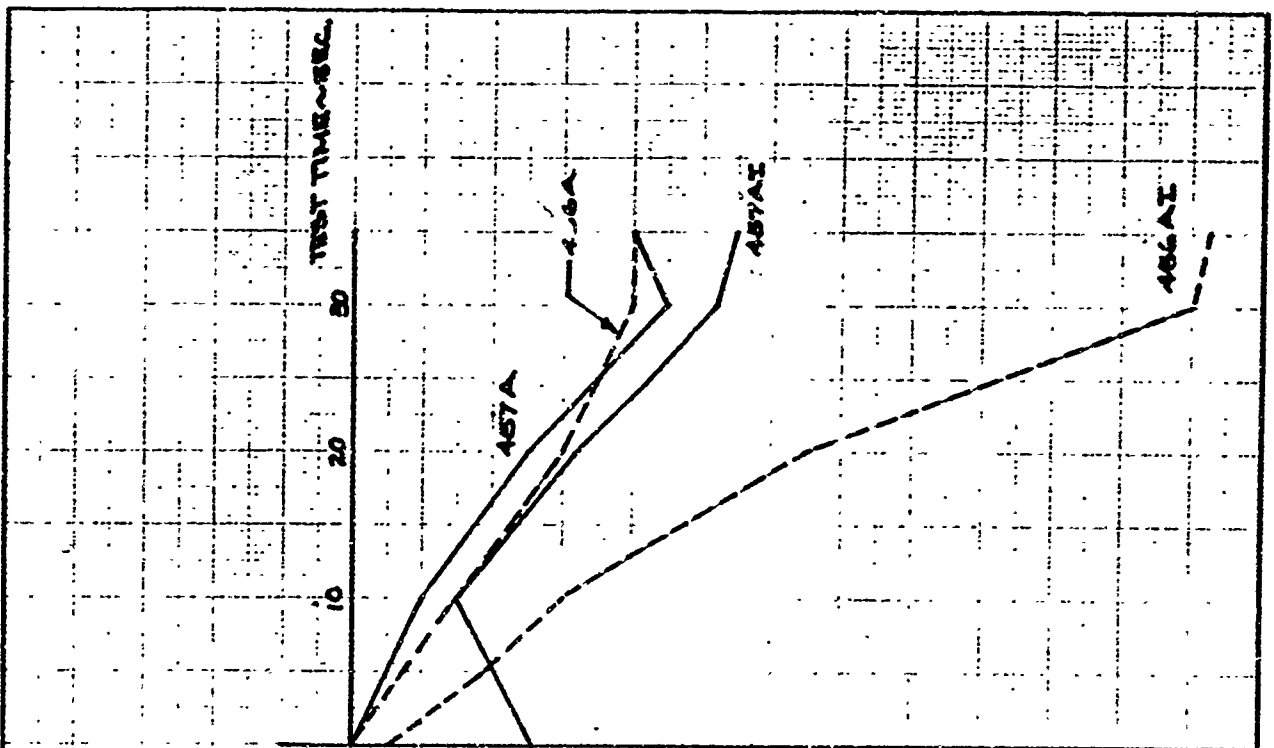

SEE FIG. 5.6-1 FOR KEY
SEE FIG. 5.5-2 FOR GAGE
LOCATIONS

STRESS & KSI
TENSION
COMPRESSION

	INITIALS	DATE	REV BY INITIAL	DATE	TITLE	MODEL
CALC	SW	15-10-8			333 - F PROGRAMMED TEST STRESS VS. TEST TIME STAGE III & PBPS GAGES PHASE I	FIG. 5.6-3
CHECK	SDW	11-10-8				
APPD.						
APPD.						

U3 4013 8000 REV 1/66

REV LTR _____

BOEING NO T2-3657-1
SH 562

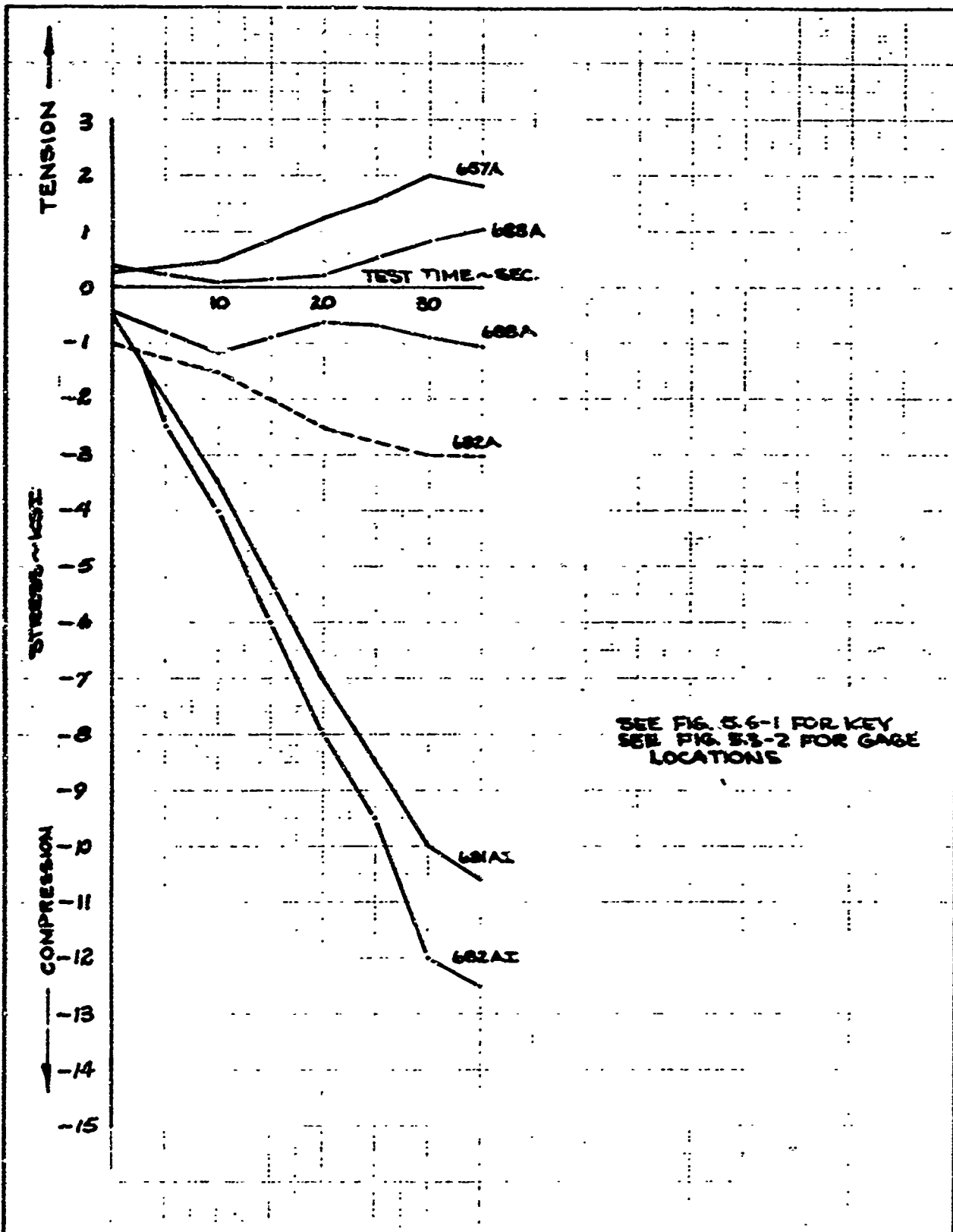

	INITIALS	DATE	REV BY INITIAL	DATE	TITLE	MODEL
CALC.	<i>PLW</i>	25 Oct 68			333-F PROGRAMMED TEST STRESS VS. TEST TIME STAGE III GAGES PHASE I	FIG. 5.6-4
CHECK	<i>ST</i>	5 Nov '8				
APPD.						
APPD.						

UJ 4013 8000 REV. 1/66

REV LTR _____

BOEING NO. T2-3657-1
SH. 563

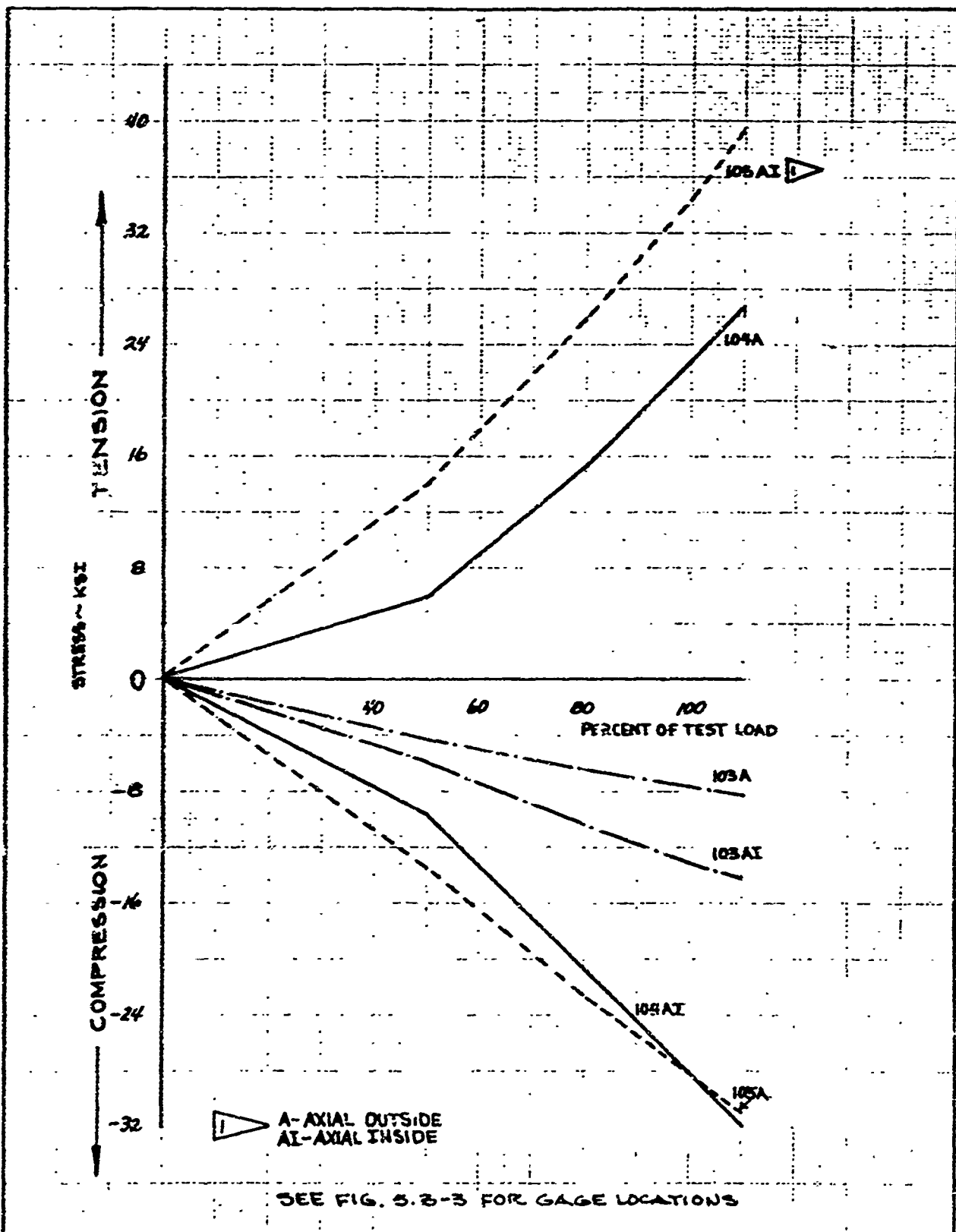



	INITIALS	DATE	REV BY INITIAL	DATE	TITLE	MODEL
CALC	<i>RAW</i>	8-23-8			333-F FAILURE TEST STRAIN GAGE READINGS SHROUD GAGES	FIG. 56-5
CHECK	<i>SDW</i>	8-26-9				
APPD.						
APPD.						

U3 4013 8000 REV 1/66

REV LTR _____

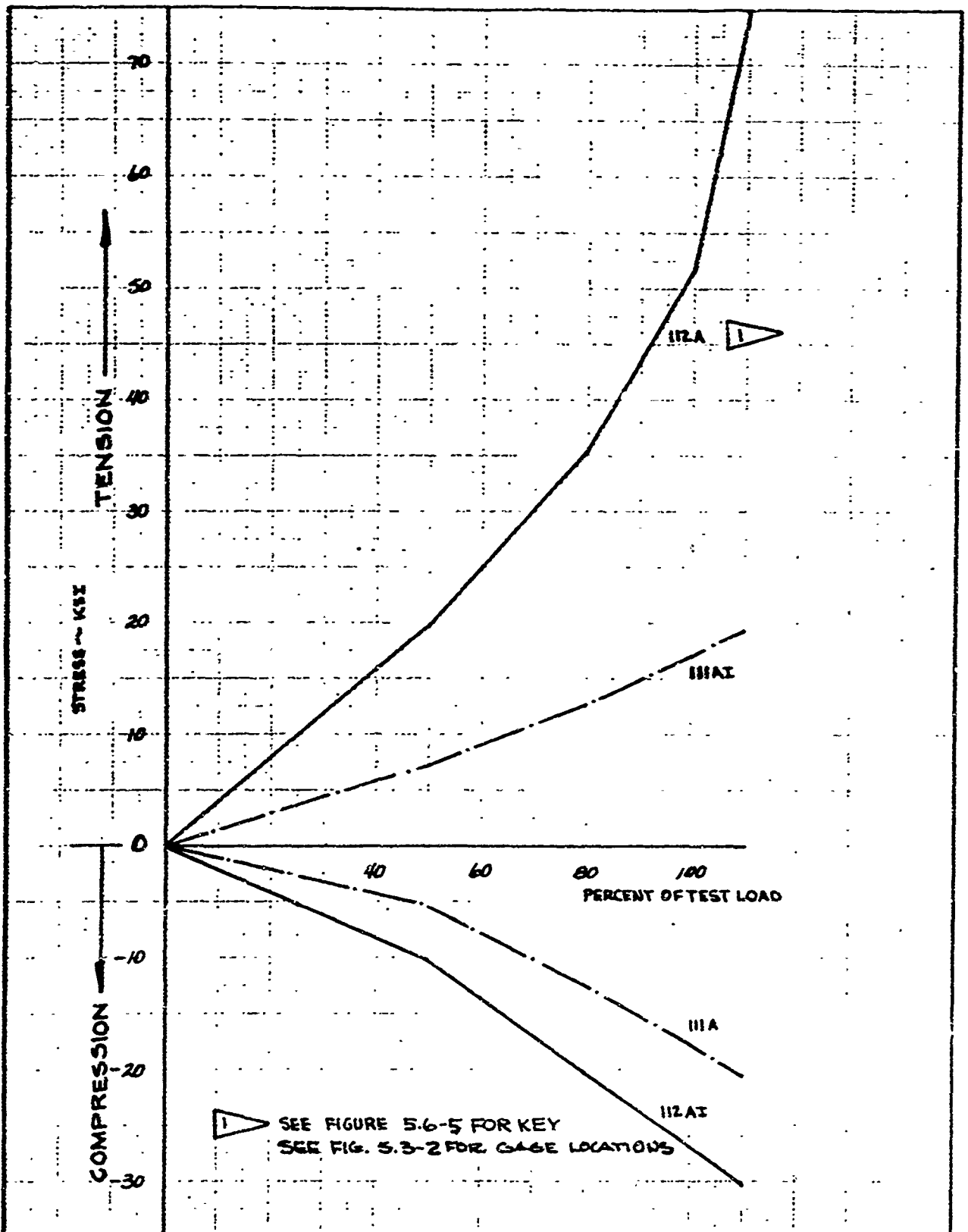
BOEING NO T2-3657-1
SH. 56.4



 SEE FIGURE 5.6-5 FOR KEY
 SEE FIG. 5.3-2 FOR GAGE LOCATIONS

	INITIALS	DATE	REV BY INITIAL	DATE	TITLE	MODEL
CALC	Raw	8-23-8			333-F FAILURE TEST STRAIN GAGE READINGS SHROUD GAGES	FIG. 5.6-6
CHECK	EDW	8-26-8				
APPD.						
APPD.						

U3 4013 8000 REV 1/66

REV LTR. _____

BOEING NO T2-3651-1
 SH 565

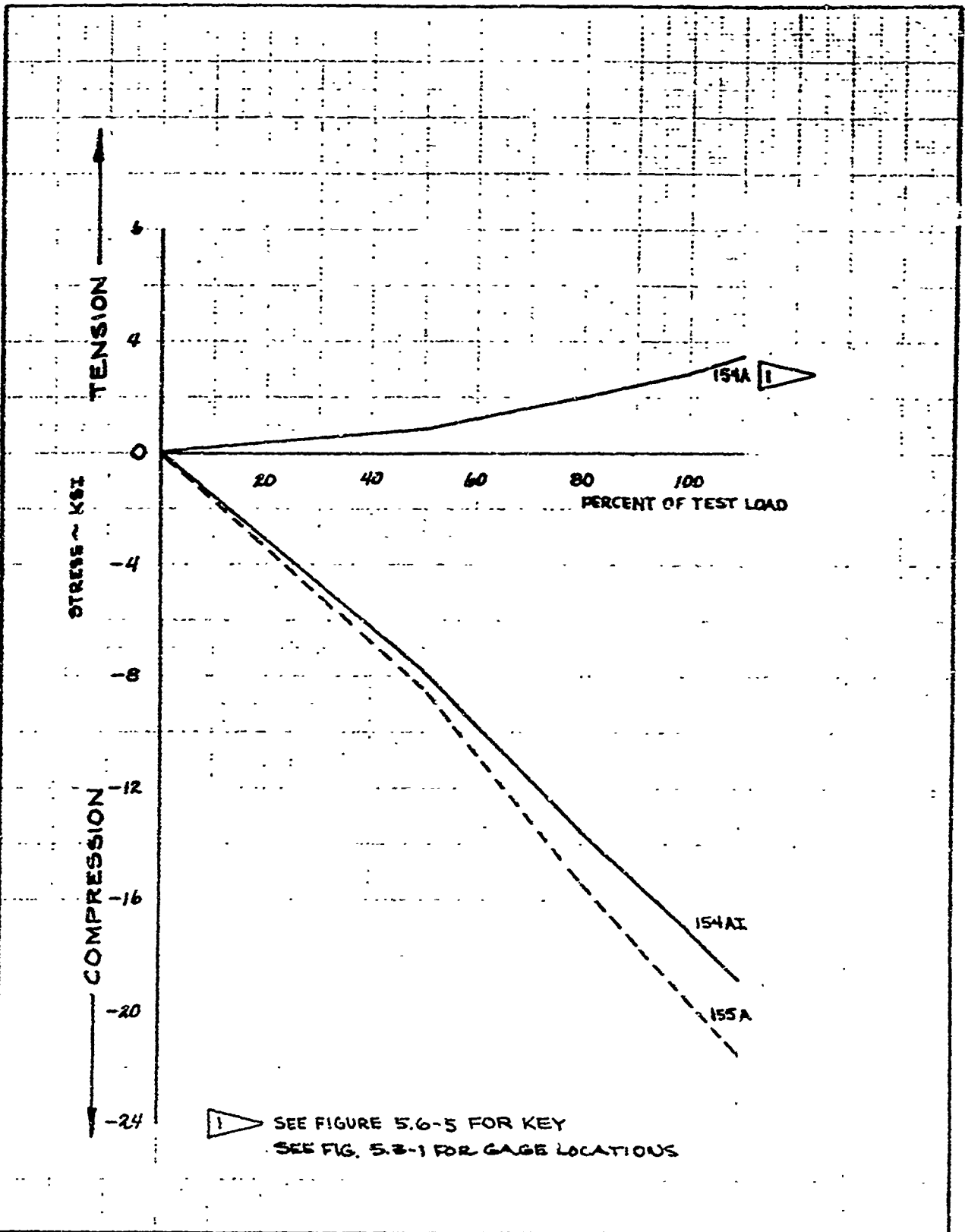



	INITIALS	DATE	REV BY INITIAL	DATE	TITLE	MODEL
CALC	PSW	8-23-8			333-F FAILURE TEST STRAIN GAGE READINGS FRUSTUM GAGES	FIG. 56-7
CHECK	PSW	8-26-8				
APPD.						
APPD.						

U3 4013 8000 REV 1/66

REV LTR _____

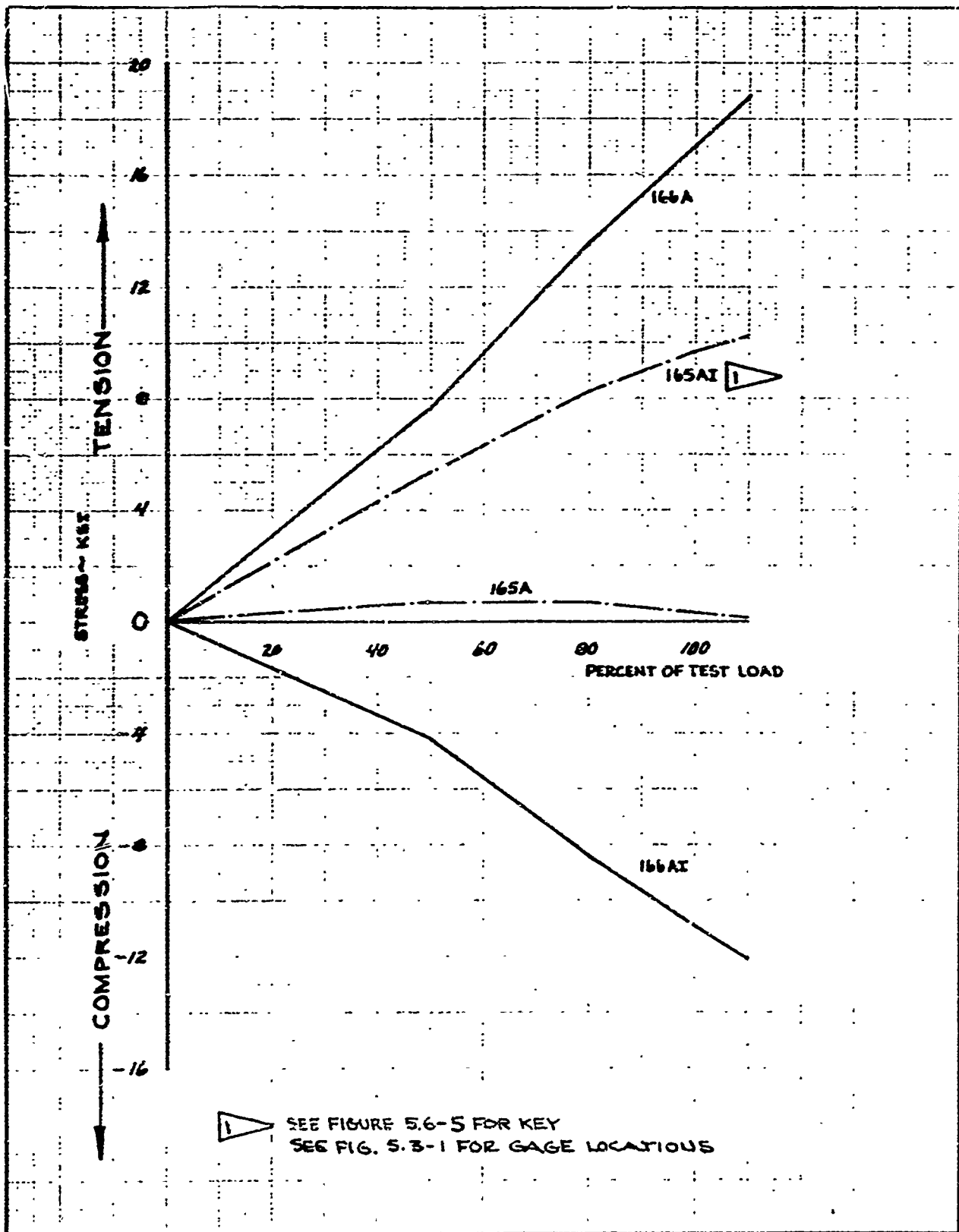
BOEING NO T2-3657-1
SH 566





 SEE FIGURE 5.6-5 FOR KEY
 SEE FIG. 5.3-1 FOR GAGE LOCATIONS

	INITIALS	DATE	REV BY INITIAL	DATE	TITLE	MODEL
CALC	<i>RAW</i>	8-23-8			333-F FAILURE TEST STRAIN GAGE READINGS FRUSTUM GAGES	FIG 5.6-E
CHECK	<i>MDW</i>	8-26-8				
APPD.						
APPD.						

U3 4013 8000 REV 1/66

REV LTR _____

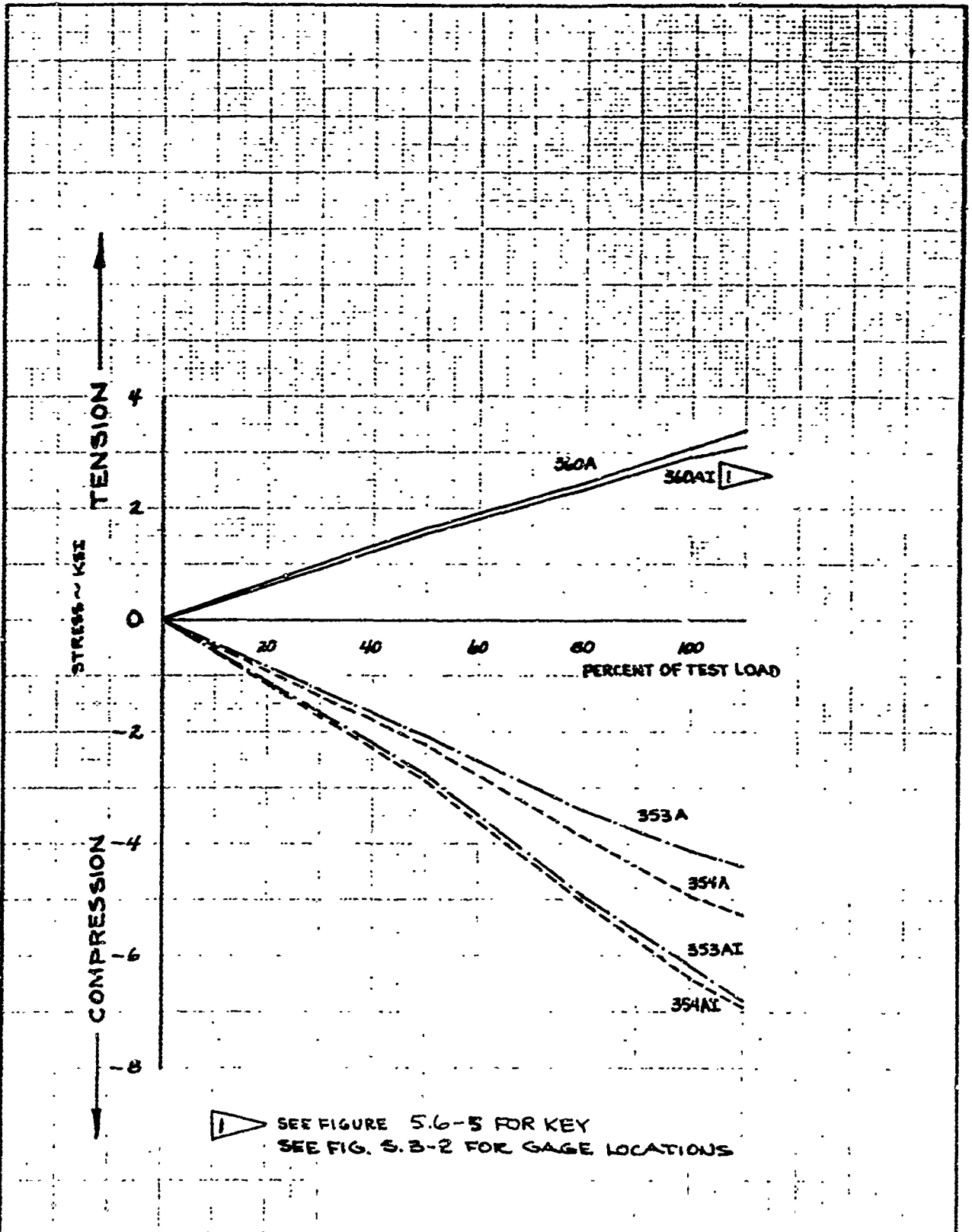
BOEING NO T2-3657-1
 SH 56.7



	INITIALS	DATE	REV BY INITIAL	DATE	TITLE	MODEL
CAIC	<i>Raw</i>	8-23-8			333-F FAILURE TEST STRAIN GAGE READINGS MGS GAGES	FIG. 5.6-9
CHECK	<i>YNW</i>	8-28-8				
APPD.						
APPD						

U3 4013 8000 REV 1/66

REV LTR _____

BOEING NO T2-3657-1
SH 568

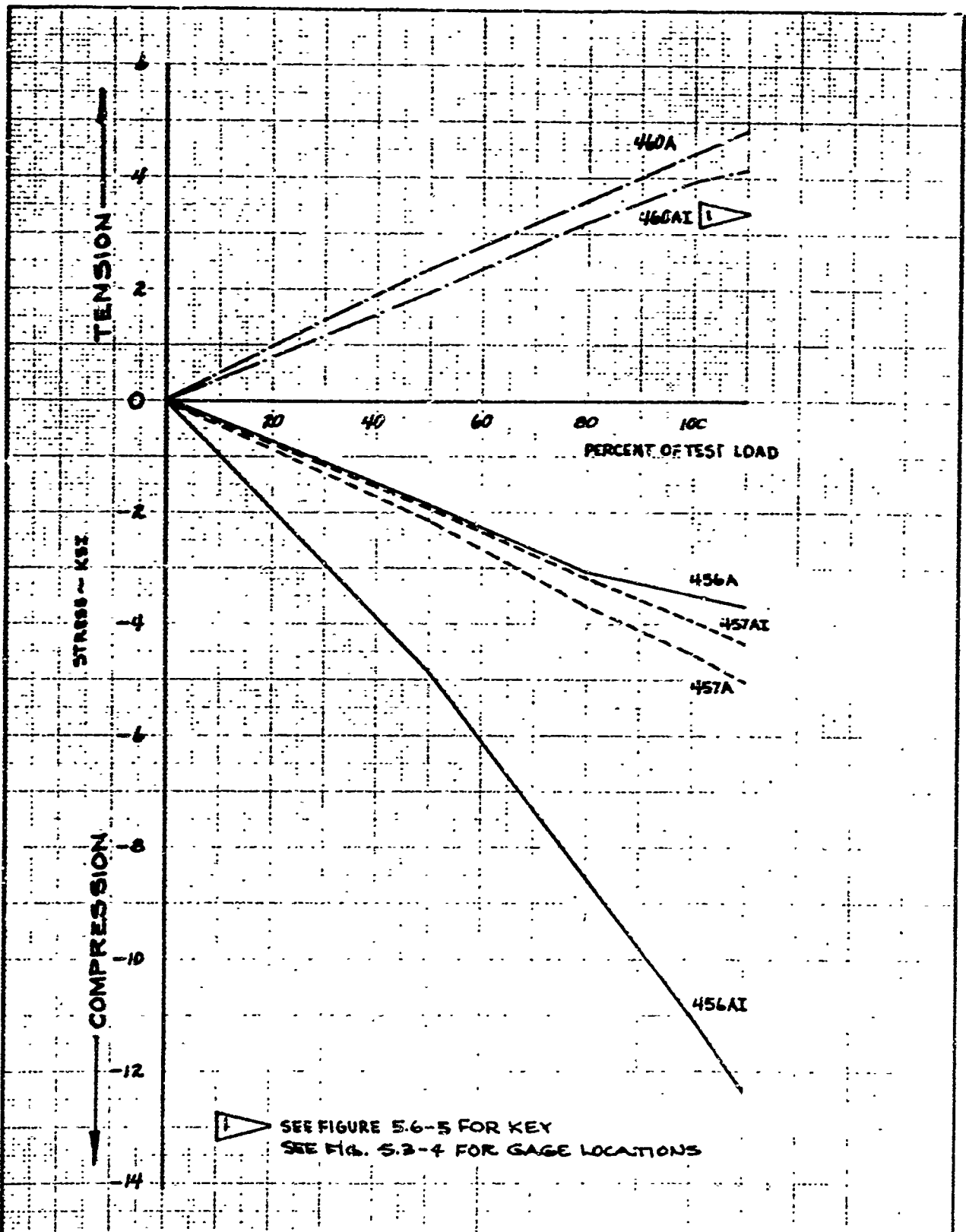

	INITIALS	DATE	REV BY INITIAL	DATE	TITLE	MODEL
CALC	<i>Call</i>	8-23-8			333-F FAILURE TEST STRAIN GAGE READINGS PBPS GAGES	FIG. 5.6-10
CHECK	<i>Call</i>	8-26-8				
APPD.						
APPD.						

U3 4013 8000 REV 1/66

REV LTR _____

BOEING NO T2-3657-1
SH 569

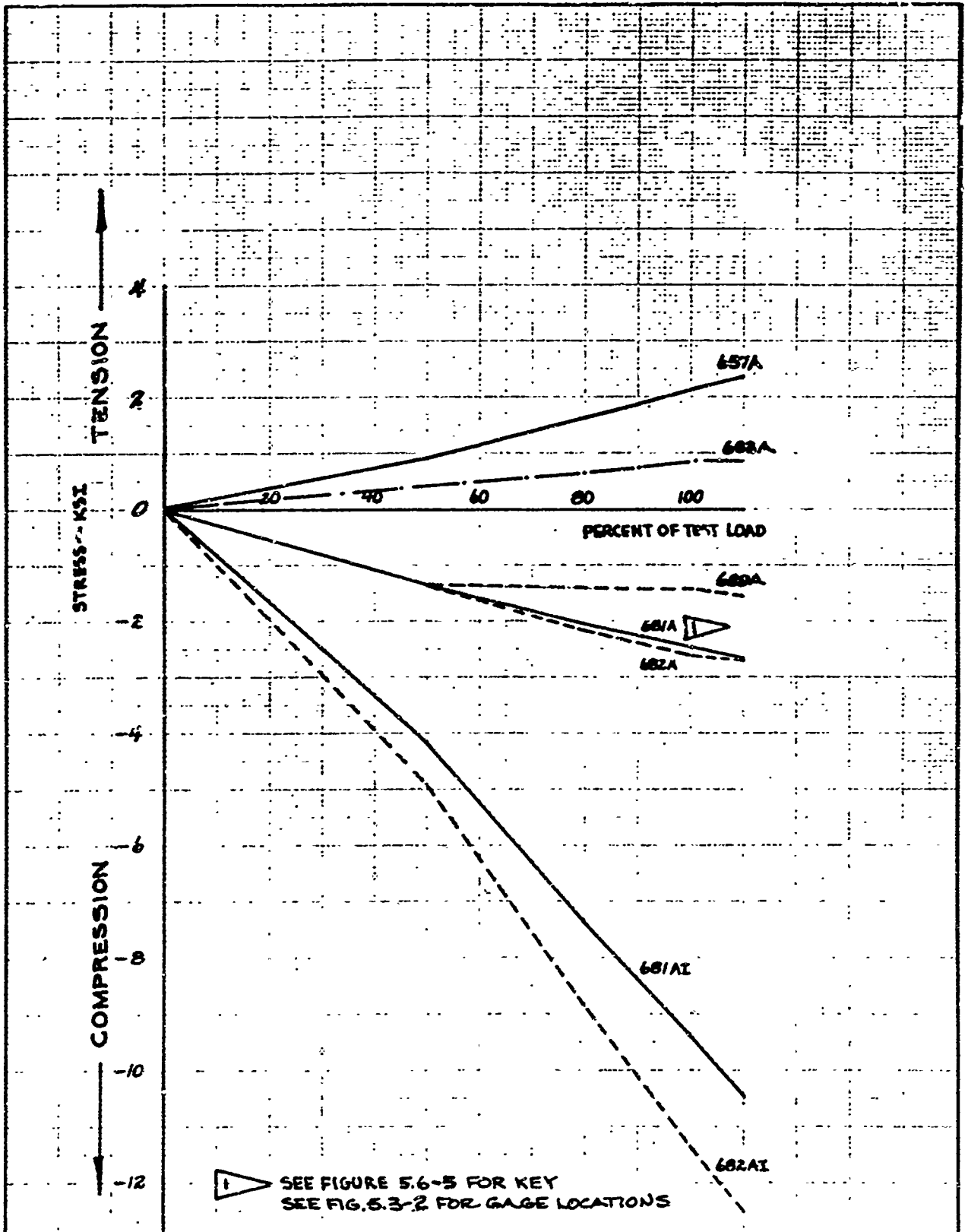

	INITIALS	DATE	REV BY INITIAL	DATE	TITLE	MODEL
CALC	<i>AW</i>	8-23-8			333-F FAILURE TEST STRAIN GAGE READINGS STAGE III FWD. SKIRT GAGES	FIG. 5.6-11
CHECK	<i>AW</i>	8-26-8				
APPD.						
APPD.						

U3 4013 8000 REV 1/66

REV LTR _____

BOEING NO. T2-3657-1
SH. 570

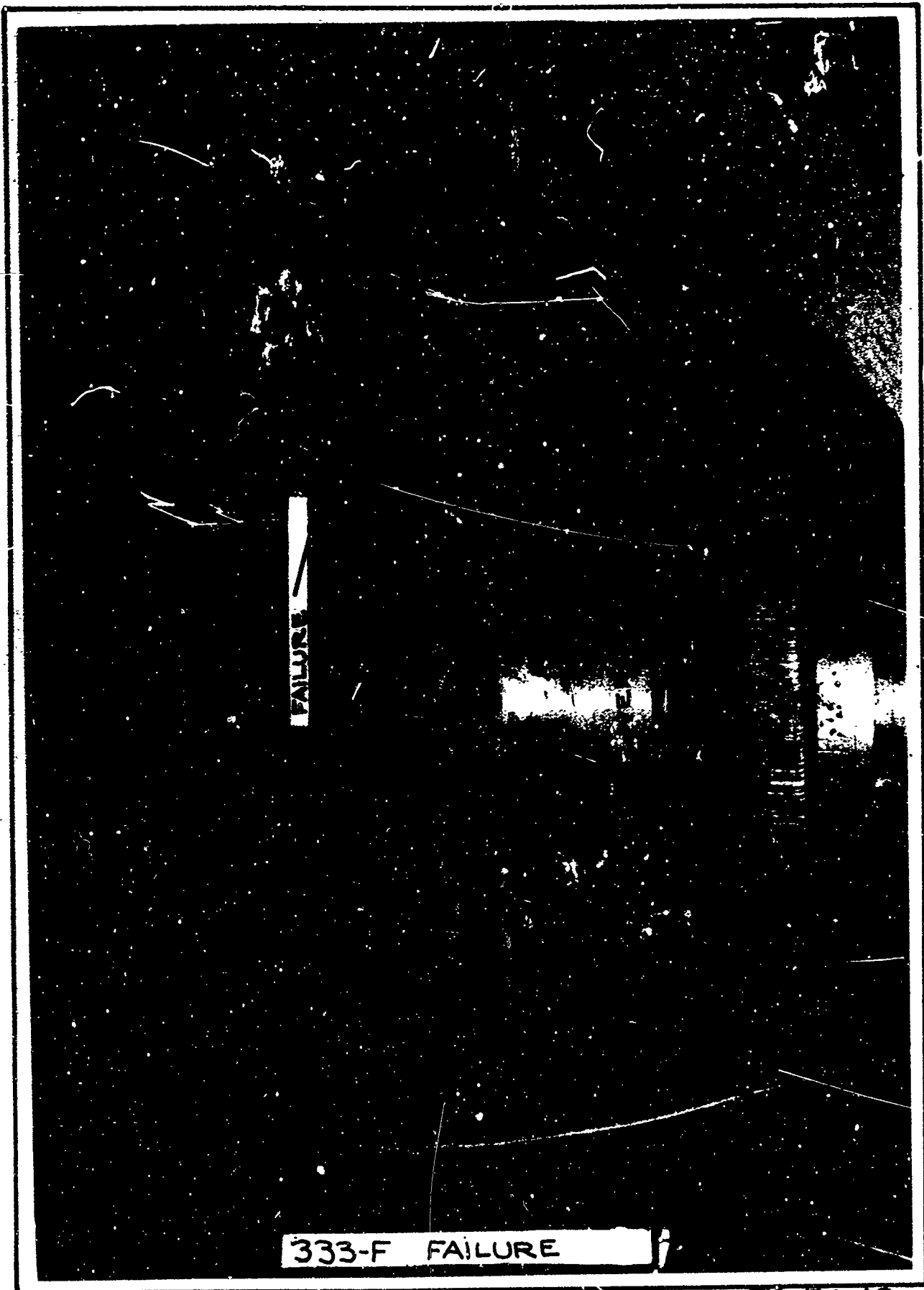

SHEET 571

FIG. 5.6-12



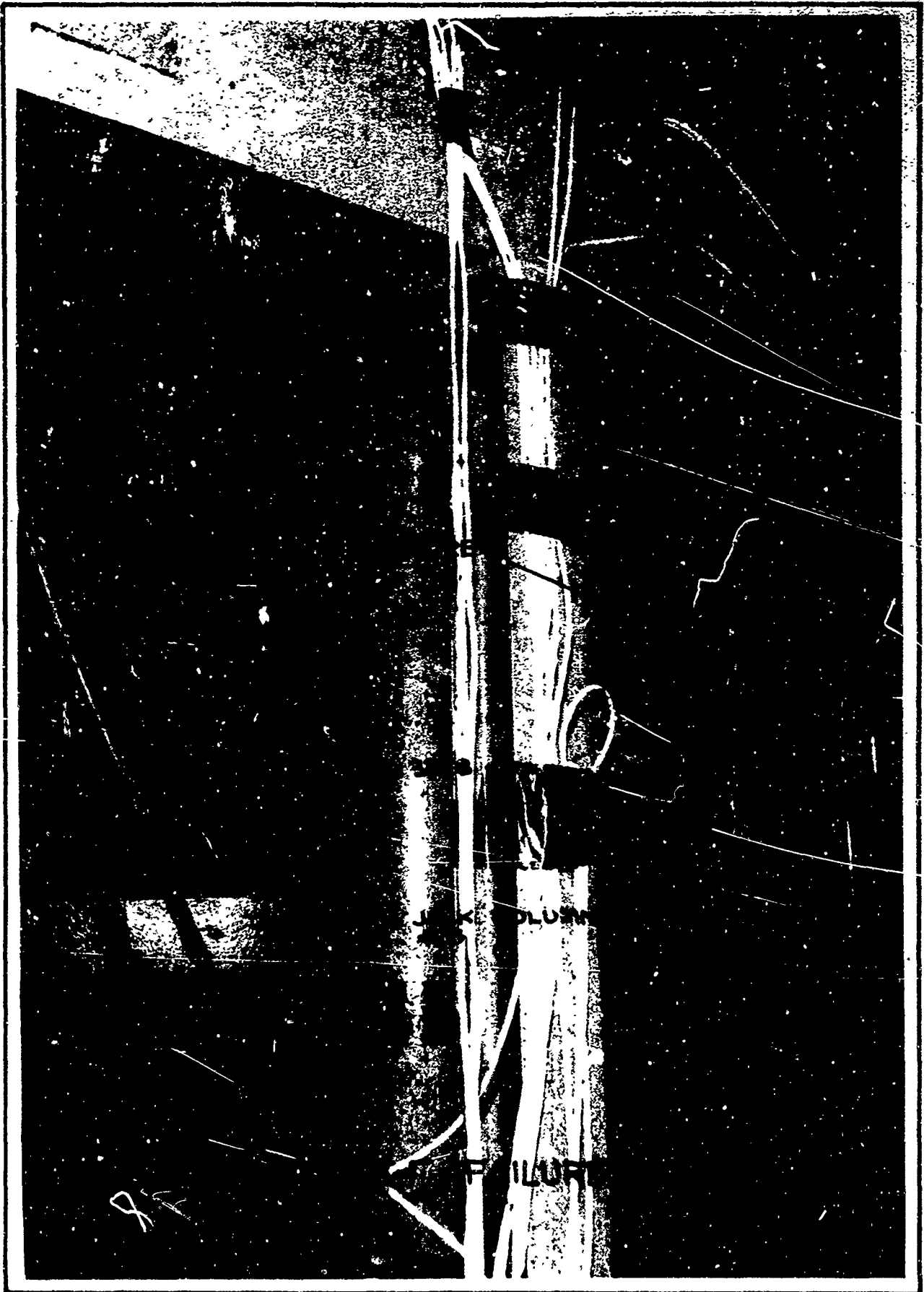

SHEET 572

FIG. 5.6-13



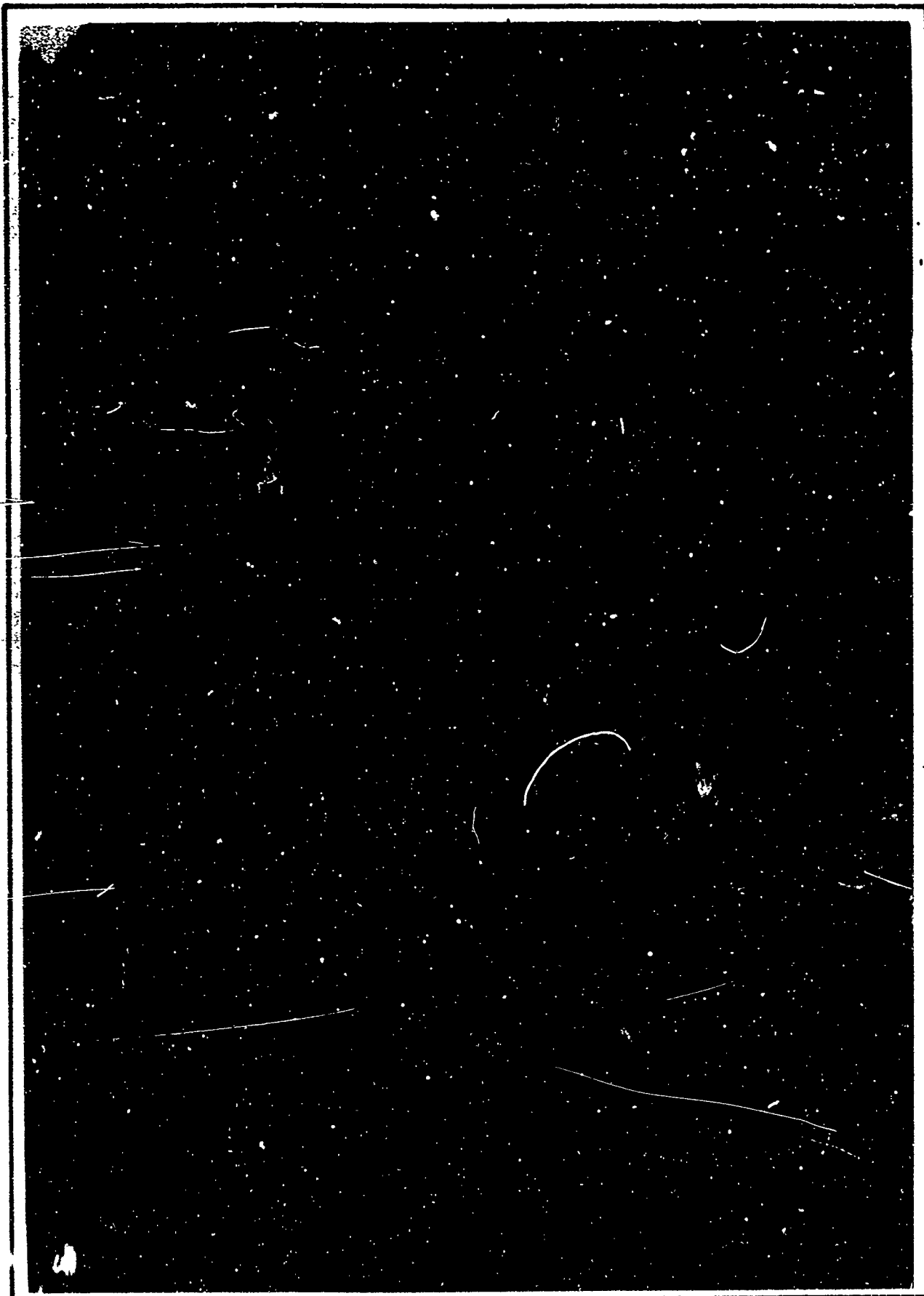

SHEET 513

FIG. 5.6-14



6.0 II-III INTERSTAGE FLIGHT CONDITION TESTS (345-F)

6.1 TEST SPECIMEN

The 345-F Test Specimen consisted of a Stage II forward skirt and dome cut from a fired motor case (AGC Part Number 384041-9, S/N 806693), a II-III Interstage (Boeing Part Number 25-60327-2, S/N 0000103) and an empty Stage III motor (AGC Part Number 1144233-9, S/N 0000020) with an aft dome closure plate (AGC Part Number 1144231-1). Figures 6.1-1 through 6.1-3 show the test specimen components which were complete in all details affecting structural strength, stiffness and load distribution. All raceway covers and insulation were omitted from the test specimen. A cross-section sketch of the specimen shell giving locations at which thicknesses were obtained is shown in Figure 6.1-4. The dimensional survey of material thicknesses is shown in Tables 6.1-1 through 6.1-4.

6.2 TEST SETUP

A schematic drawing of the test setup is shown in Figure 6.2-1. Loading heads and adaptors were used to introduce loads to the specimen. A horizontal jack introduced the shear load through the forward loading head. Four longitudinal jacks applied axial loads and a pure couple component of the moment. A fifth longitudinal jack applied axial compression through the aft dome closure of the Stage III motor. All hydraulic jack loads were controlled by load cells and automatic load controllers utilizing servo valves. The empty Stage III motor was pressurized with water to simulate the increased buckling capability of a full motor. In the programmed heat and load test, heat lamps were arranged in zones and controlled manually with Ignitron Power Controllers. The tests were conducted in a test cell as a safety precaution. Photographs of the programmed and failure test setups are shown in Figures 6.2-2 and 6.2-3 respectively.

6.3 TEST INSTRUMENTATION

Strain gage channels were located as shown in Figures 6.3-1, 6.3-2 and 6.3-3. Additional photographic coverage of the II-III Interstage instrumentation is included to complement the drawings. Figures 6.3-4 and 6.3-5 show the instrumentation along the maximum compression and maximum tension azimuths respectively. The instrumentation added to the hat section is shown in Figure 6.3-6. In the programmed heat and load test, data thermocouples were located at all strain gage locations and at other locations as shown in Figures 6.3-7 and 6.3-8. Data, including load cells and pressure transducers, were recorded at a rate of 192 channels per second in the programmed heat and load test and at the end of each increment of applied load in the failure test. Load cell strain gage and thermocouple data are shown in reference 2.

6.4 TEST CONDITIONS

Prior to the programmed flight test, a set of four stiffness tests were conducted. See Section 7.0 for details of these tests.

USE FOR TYPEWRITTEN MATERIAL ONLY

6.4.1 PROGRAMMED POWERED FLIGHT ENVIRONMENT

The programmed test applied the continuous heat and loads of the powered flight environment from the critical conditions of wind shear max. ~~q~~ through the Stage II burnout condition. The test setup loading geometry is shown in Figure 6.4.1-1. The actual test loads of axial compression, moment and shear are compared with the programmed loads (from reference 1) in Figures 6.4.1-2 through 6.4.1-5. The maximum line load was at the seventy degree azimuth. Eleven heating zones, each containing two control thermocouples, were manually controlled with Ignitron Power Controllers. Figures 6.4.1-6 through 6.4.1-10 present the programmed (from reference 1) vs. actual heating as shown by the control thermocouples. Figure 6.4.1-11 is a pictorial tabulation of data and control thermocouple readings at t=85 seconds of test time.

6.4.2 WIND SHEAR CONDITION FAILURE TEST

The failure test, conducted at room temperature, applied the critical loads of the wind shear maximum ~~q~~ condition (from reference 1) in increments to failure. Maximum line load was at the seventy degree azimuth. Figures 6.4.2-1 through 6.4.2-3 show the applied loads and compare them with the planned loads. Figure 6.4.2-4 compares average line loads at failure with line loads derived from design ultimate loads as specified in the appropriate Figure A and BSD exhibit.

During the two flight load tests the Stage III motor was internally pressurized with water to 28 psi.

6.5 TEST PROCEDURE

6.5.1 PROGRAMMED POWERED FLIGHT ENVIRONMENT

After internally pressurizing the Stage III motor with water, the strain gages were zeroed with the load of the dead weights and water on the specimen. The load and heat programs were then begun and run continuously through the critical load conditions of powered flight. Automatic load programmers and manually operated heat programmers were synchronized at the start to provide correct coincidence of heat and loads throughout the test. Zero gage readings were taken after the Stage III motor case internal pressure had been released and the specimen had cooled to room temperature.

6.5.2 WIND SHEAR CONDITION FAILURE TEST

Following removal of the heating fixtures, the Stage III motor was again pressurized and the strain gages were zeroed with the dead weights on the specimen. The loading of the specimen and the recording of data was done incrementally. The loading proceeded to failure, at which time the jack loads were automatically dumped. After releasing the pressure in the Stage III motor, the strain gages were again read with only the dead weights of the fixture and water on the specimen.

USE FOR TYPEWRITTEN MATERIAL ONLY

6.6 TEST RESULTS

The test specimen successfully sustained the heat and loads of the powered flight environment (from Reference 1) as shown in section 6.4.1. Selected strain gage data are shown plotted, through 40 seconds of test time, in Figures 6.5-1 thru 6.5-3. (Most strain gage data after 45 seconds, was lost because of the effect of high temperature on the strain gage bonds). This strain gage data and a visual inspection showed that the test specimen successfully sustained the test heat and loads without loss of structural capability.

The failure test was run by increasing the wind shear condition loads in increments to failure. Failure occurred at 132% of the test loads as shown in Section 6.4.2. Figure 6.5-5, -6 and -7 show the buckling pattern in the aft bay of the II-III interstage. The buckling was centered about the 70° azimuth of maximum line load and included 180° of the II-III interstage aft bay. Figures 6.5-8, -9 and -10 show buckling of the internal stiffening rings. The angle overpressure ring and hat section nodal ring were damaged throughout the section of buckled skin. Selected strain gage data are shown in Figure 6.5-11 thru 6.5-17. These data indicated initial buckling occurred between 115% and 120% of test loads in the II-III interstage aft bay. Figure 6.5-18 shows the local skin bending as indicated by strain gages in the area of initial buckling. See Reference 1 for the test data.

6.7 TEST CONCLUSIONS

The failure load of 132% of Reference 1 loads is equivalent to 116.8%* of the Figure A 6560 wind shear maximum q_{∞} design ultimate loads at missile station 359. By analysis this failure load is reduced to 111%* for a minimum gage specimen. The Stage III aft skirt/II-III interstage/Stage II forward skirt integrated structure is therefore considered to have satisfied the Figure A 6560 DUL requirements for flight condition critical load. The integrated specimen was also shown to be adequate for the heating and loads environment of powered flight as specified in Reference 1.

*See Section 8, sheets 806 to 809 inclusive for calculations.

USE FOR TYPEWRITTEN MATERIAL ONLY

6.1

TEST SPECIMEN

SHEET 603

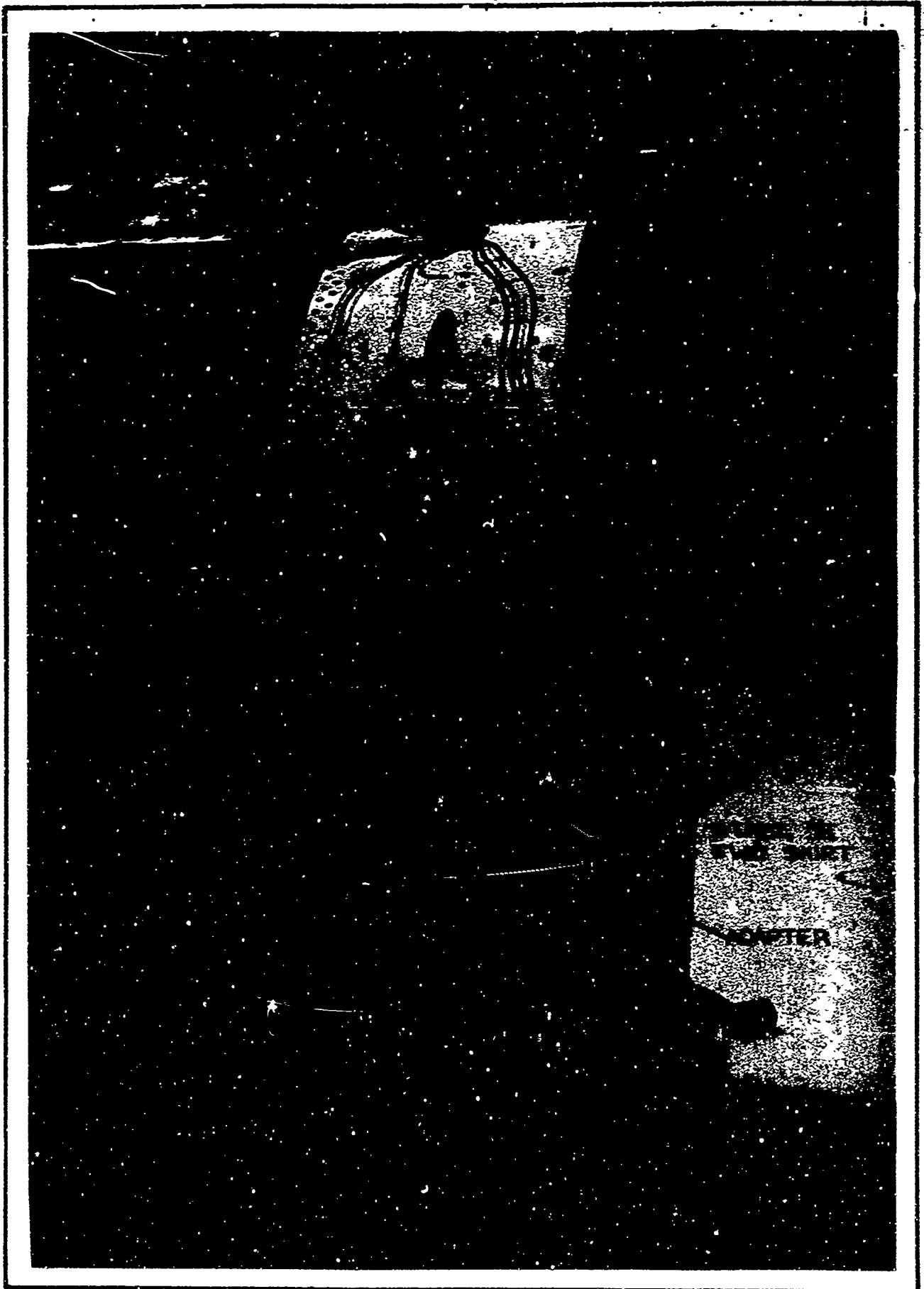

SHEET 604

FIG. 6.1-1



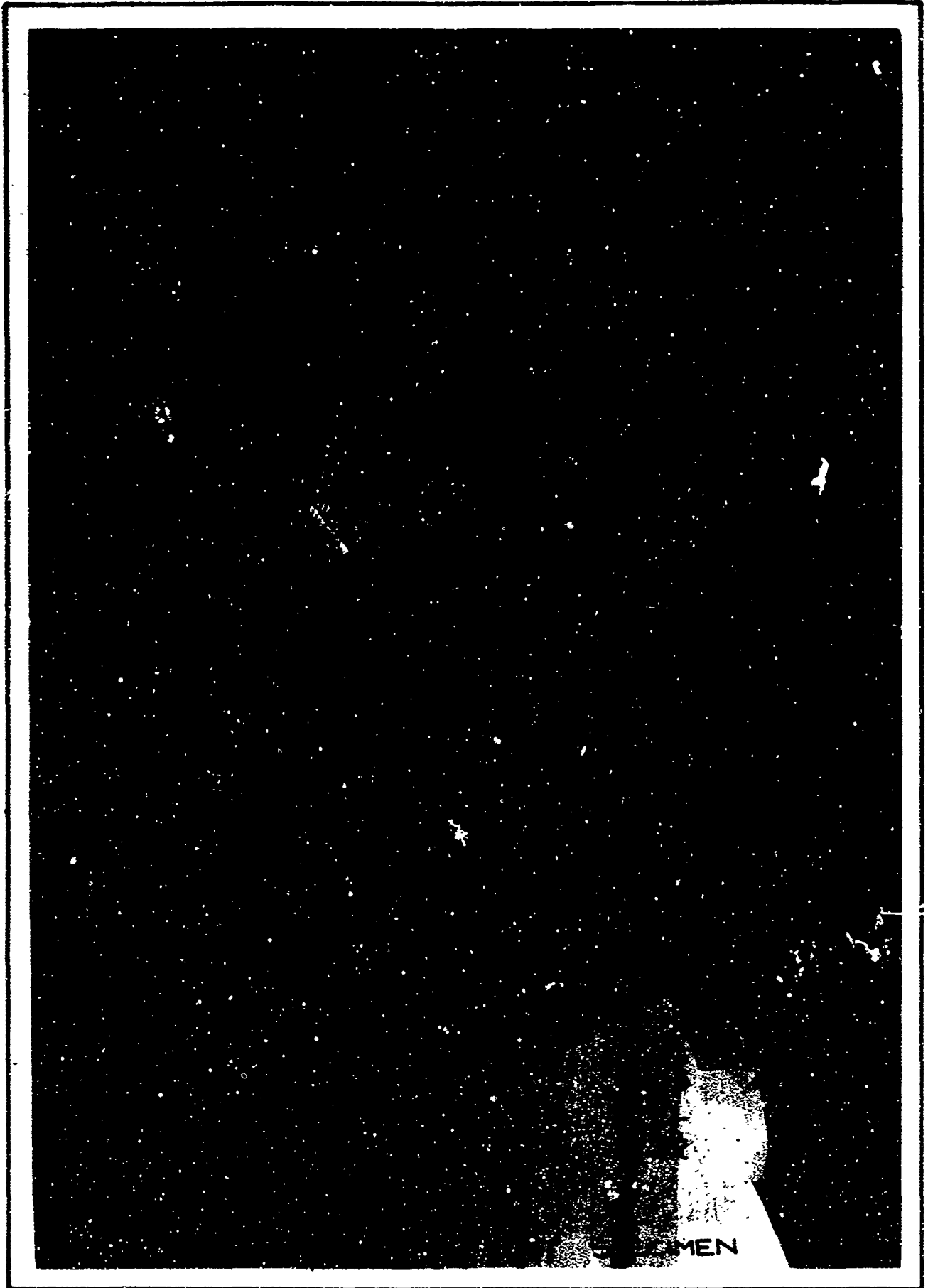

SHEET 605

FIG. 6.1-2



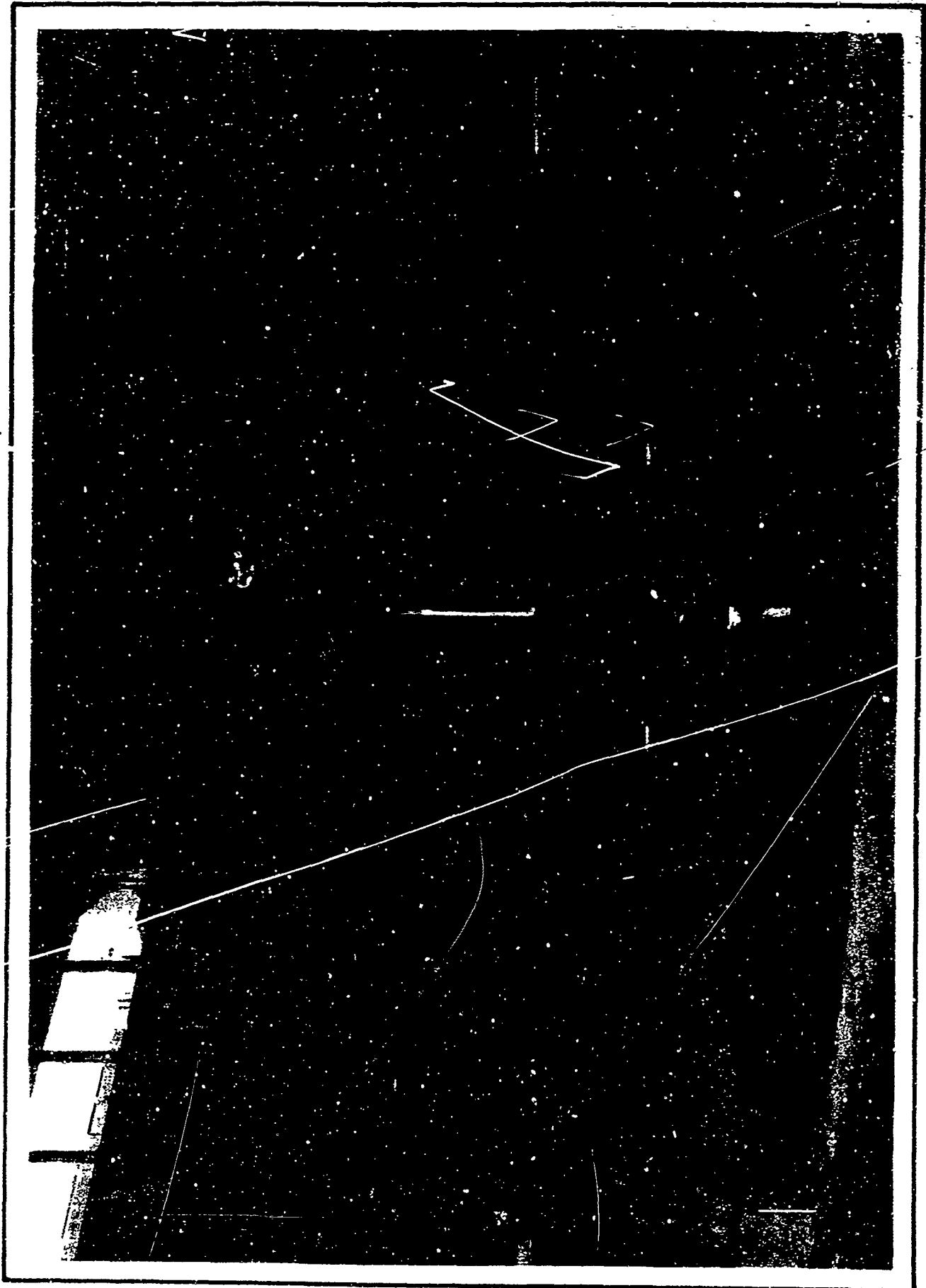

SHEET 606

FIG. 6.1-3



USE FOR DRAWING AND HANDPRINTING — NO TYPEWRITTEN MATERIAL

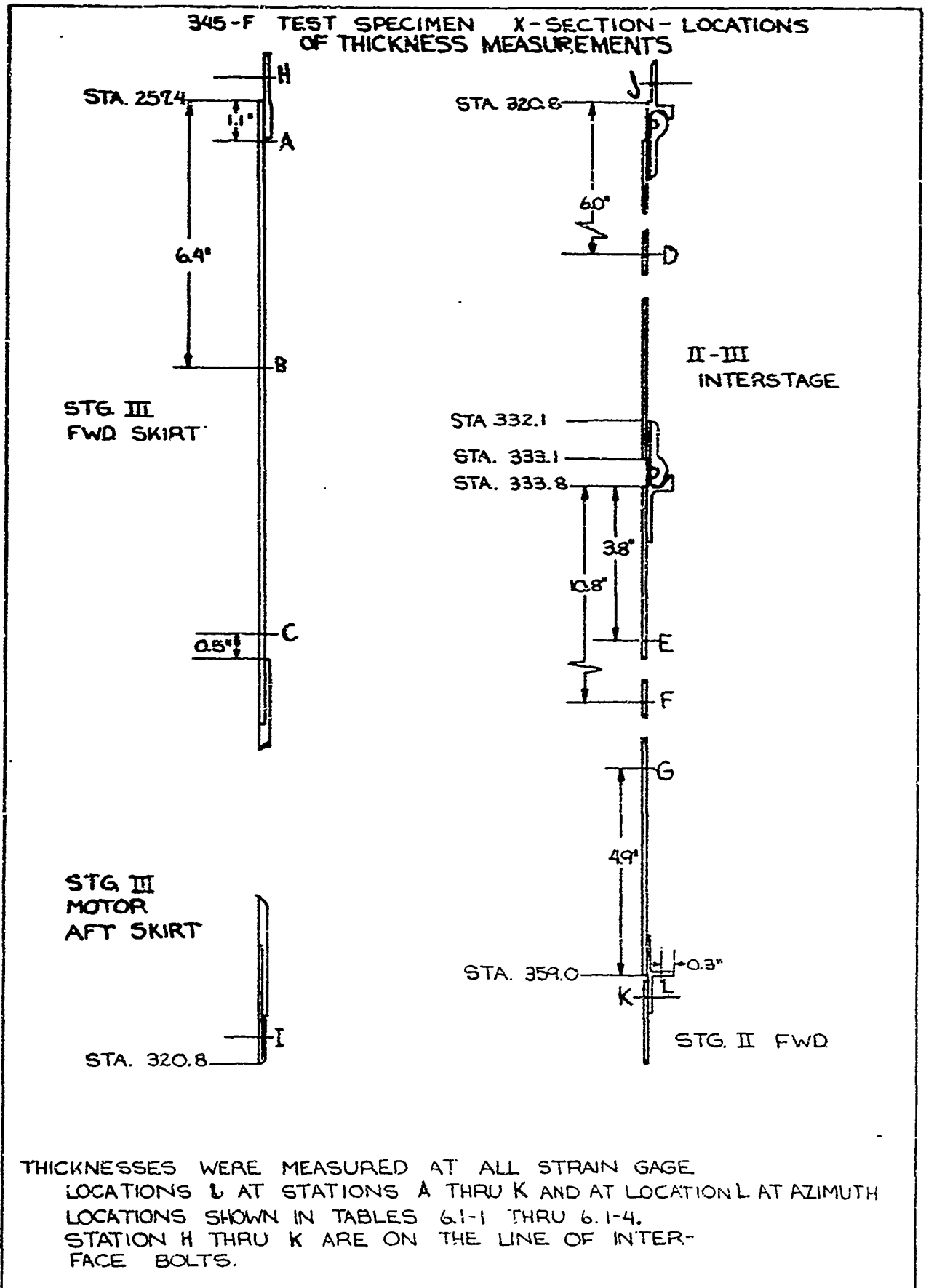

STAGE III MOTOR - 345F FLIGHT TEST
PRE-TEST DIMENSIONAL SURVEY

COPIED	INITIALS	DATE	REV BY INITIALS	DATE	TITLE	MODEL			
CHECK	KSW	SEP 69			DIMENSIONAL SURVEY STAGE III MOTOR - 345F M ² STATIC CONFIRMATION TEST S/N 0000020	TABLE 6.1-3			
APPD									
APPD									
LOCATION DEGREES	STA. A 258.5	S.G. NO.	STA. B 263.8	STA 263.9+			STA. C 269.8	STA. H FWD RING	STA. I AFT RING
0°								.142	.251
352+2in	.155								
+4in	.155								
+6in	.155								
+8.5in	.155								
+11.0in	.155								
22°	.155	610		.155			.155		
+1.8in	.155								
+3.0in	.155								
+4.5in	.155								
+7.0in	.155								
52°-6.0in	.155								
-4.0in	.155								
52°					.155				
60°						.143			
65°	.155				.155				
82°	.155	616		.155	.155				
99°	.155				.155				
120°						.136			
127°	.155				.155				
145°	.155	617		.155	.155		.245		
157°	.155				.155				
180°						.143			

ALL DIMENSIONS IN INCHES
1 SEE FIGURE 6.1-1

REV LTR _____

NO T2-3657-1
610

STAGE III MOTOR - 345F FLIGHT TEST
PRE-TEST DIMENSIONAL SURVEY

LOCAL- TION DEGREES	S.G. NO.	STA. A 258.5	S.G. NO.	STA. B STA 263.8	STA. C See FIG. 6.1-4	STA. H FWD RING	S.G. NO.	STA. I AFT RING	STA 319.5+	TITLE	MODEL
187°		.155		.155	.155			.240			
202°		.155	620	.155	.155						
219°		.155		.155	.155						
220°											
240°						.143		.240			
247°		.155		.155	.155						
260°								.247			
262°		.155	622	.155	.155						
277°		.155		.155	.155						
300°											
307°		.155		.155				.254			
323°		.155	624	.155	.155						
337°		.155		.155	.155						
341°							639		.247		
78°											
52 +2.0in	631	.155								.238	
+4.0in	632	.155									
+6.0in	633	.155									
+8.5in	634	.155									
+11.0in	635	.155									
71°											.240
161°											.240
251°											.241

COPIED	KSW	SEP 68			DIMENSIONAL SURVEY STAGE III MOTOR - 345F M ² STATIC CONFIRMATION TEST S/N 000020	TABLE 61-4
CHECK	GDW	SEP 68				
APPD						
APPD						

REV LTR _____

BOEING NO. T2-3657-1
SH 611

USE FOR TYPEWRITTEN MATERIAL ONLY

6.2

TEST SETUP

SHEET 612

345-F TEST SET-UP

DWG. 25-63243

USE FOR DRAWING AND HANDPRINTING — NO TYPEWRITTEN MATERIAL

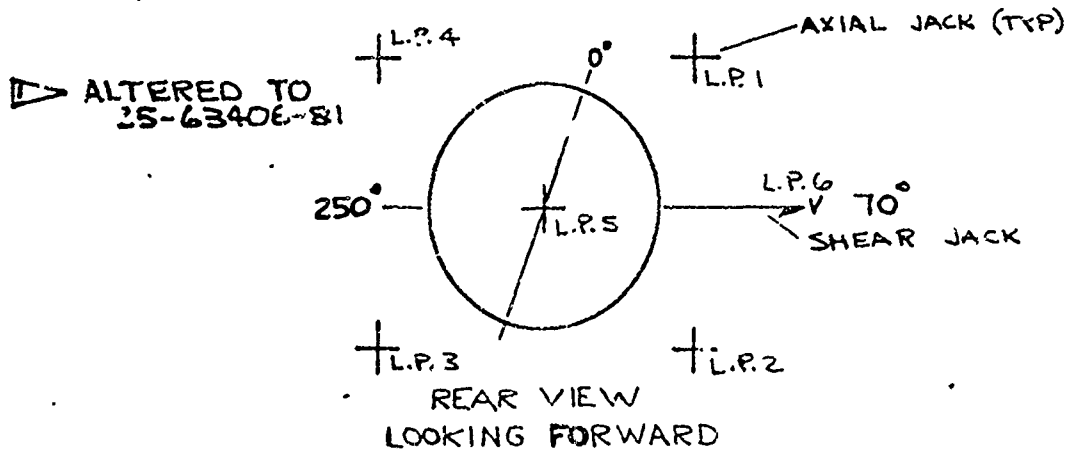
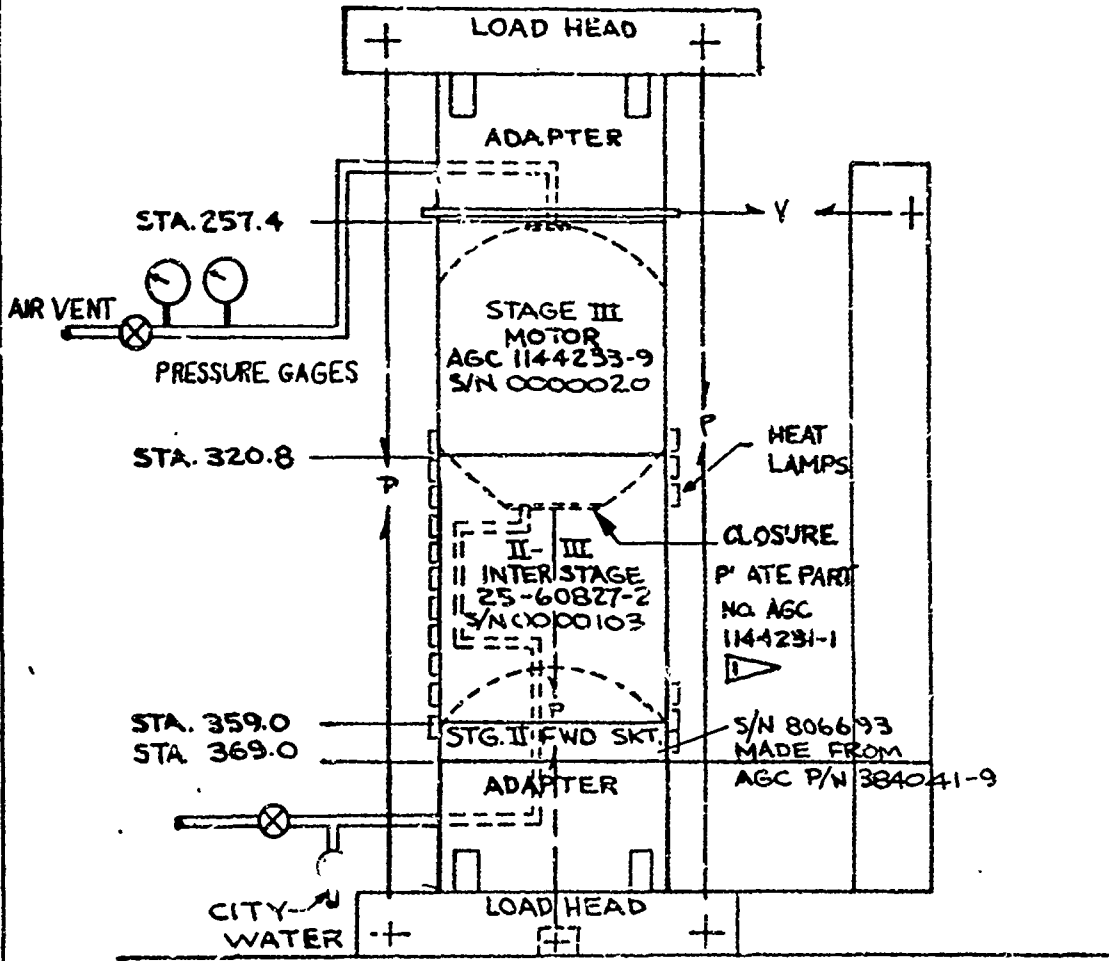

FIG. 62-1



SHEET 614

FIG. 6.2-2



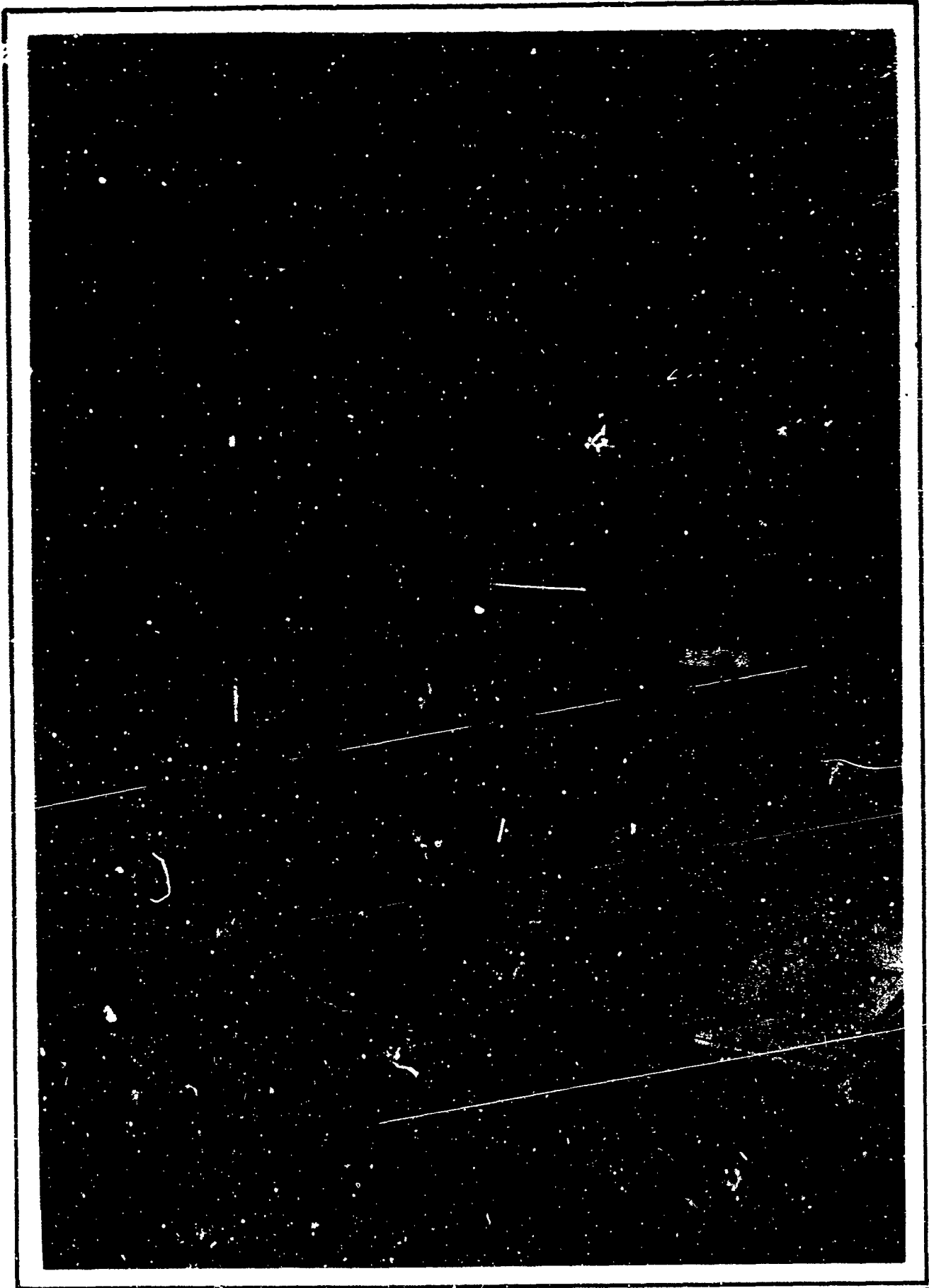

SHEET 615

FIG. 6.2-3



USE FOR TYPEWRITTEN MATERIAL ONLY

6.3

TEST INSTRUMENTATION

SHEET 616

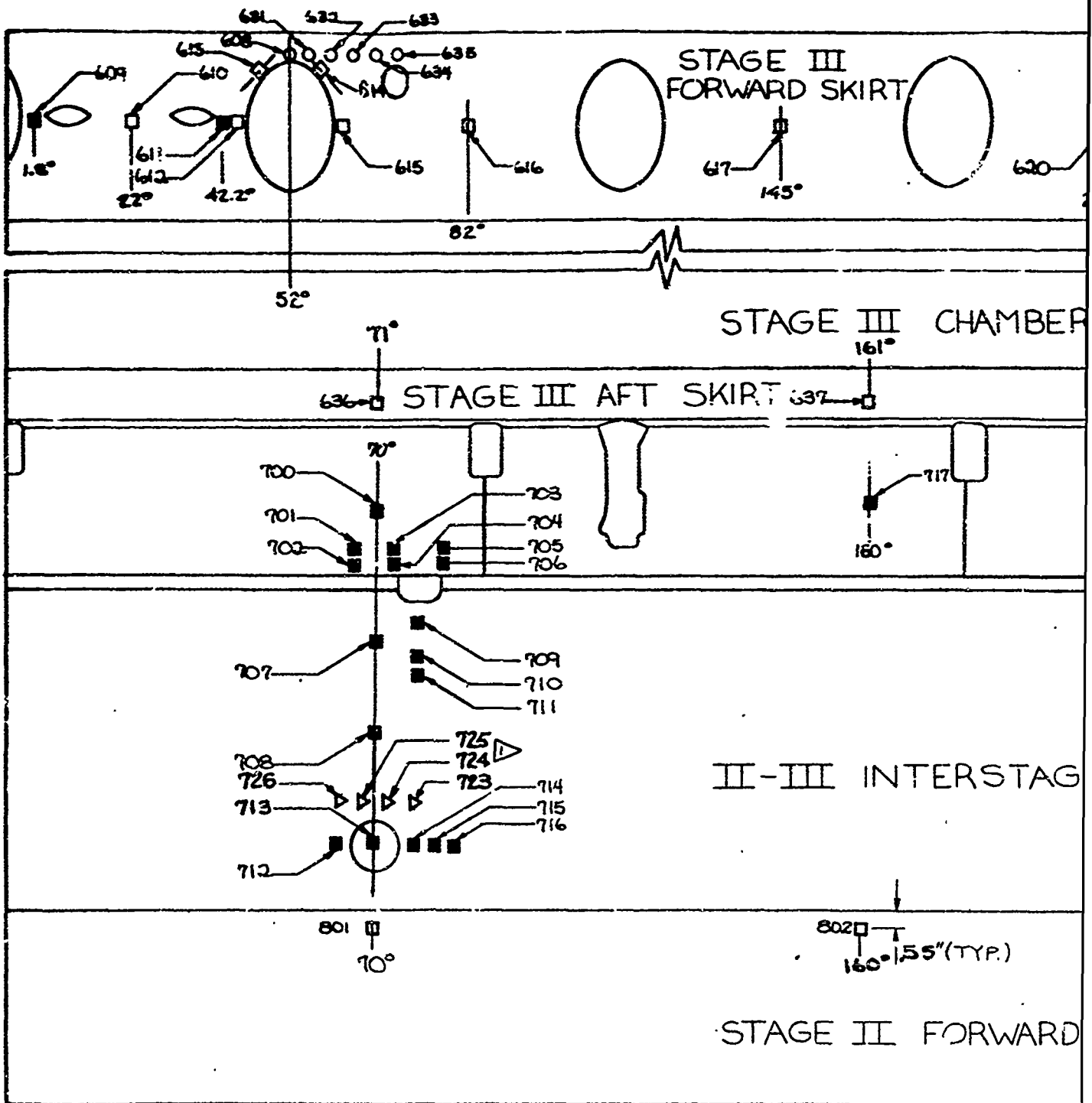

▷ SEE FIGURE 6.3-2 FOR DETAIL OF LOCATIONS

STRAIN GAGE IDENTIFICATION

INSTRUMENTATION KEY

- UNIAxIAL GAGES
- OUTSIDE ONLY
- "BACK TO BACK"
- BIAXIAL GAGES
- OUTSIDE ONLY

▷ CIRCUMFERENTIAL GAGES

INSTRUMENTATION

REV LTR



STA. 257.4

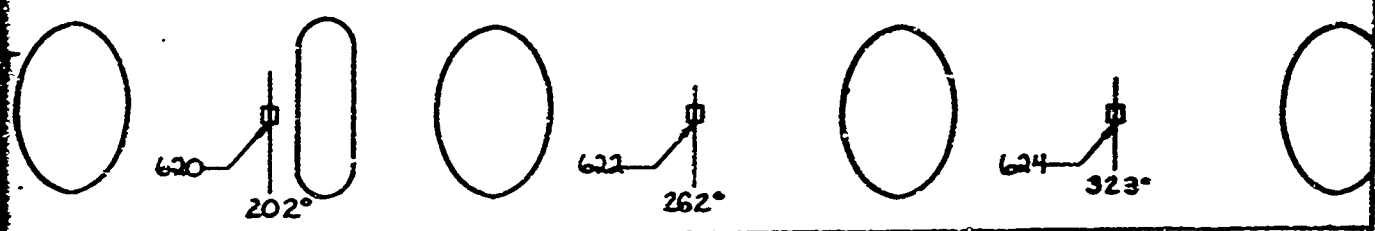

CHAMBER

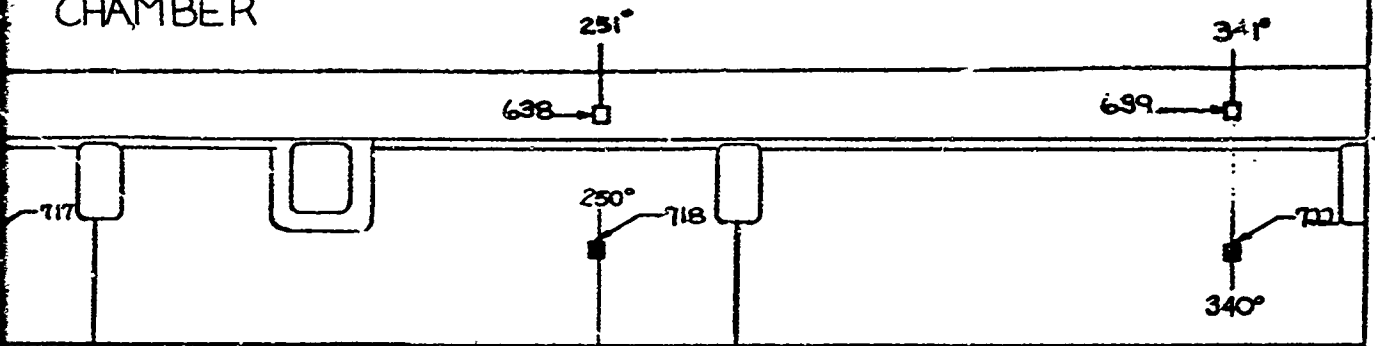

STA. 320.8

INTERSTAGE

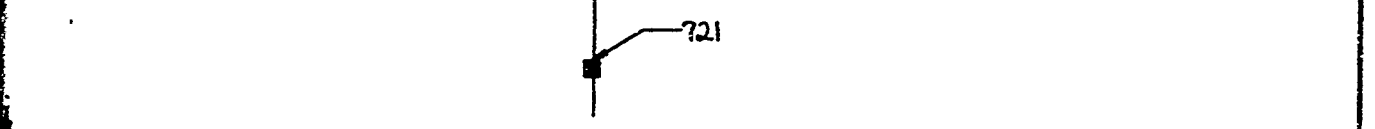

STA. 359.0

55"(TYP.)

FORWARD SKIRT

GAGE IDENTIFICATION

DATA REPORT KEY

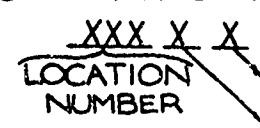

- NO LETTER - OUTSIDE GAGE
 - i = INSIDE GAGE
 - A - AXIAL ORIENTATION, EXCEPT: 613, 614
 - C - CIRCUMFERENTIAL ORIENTATION
- FIG. 6.3-1

ORIENTATION ~ TEST 345-F

ESTERLINE NO. TZ-3657-1
SH 6:7

B

USE FOR DRAWING AND HANDPRINTING — NO TYPEWRITTEN MATERIAL

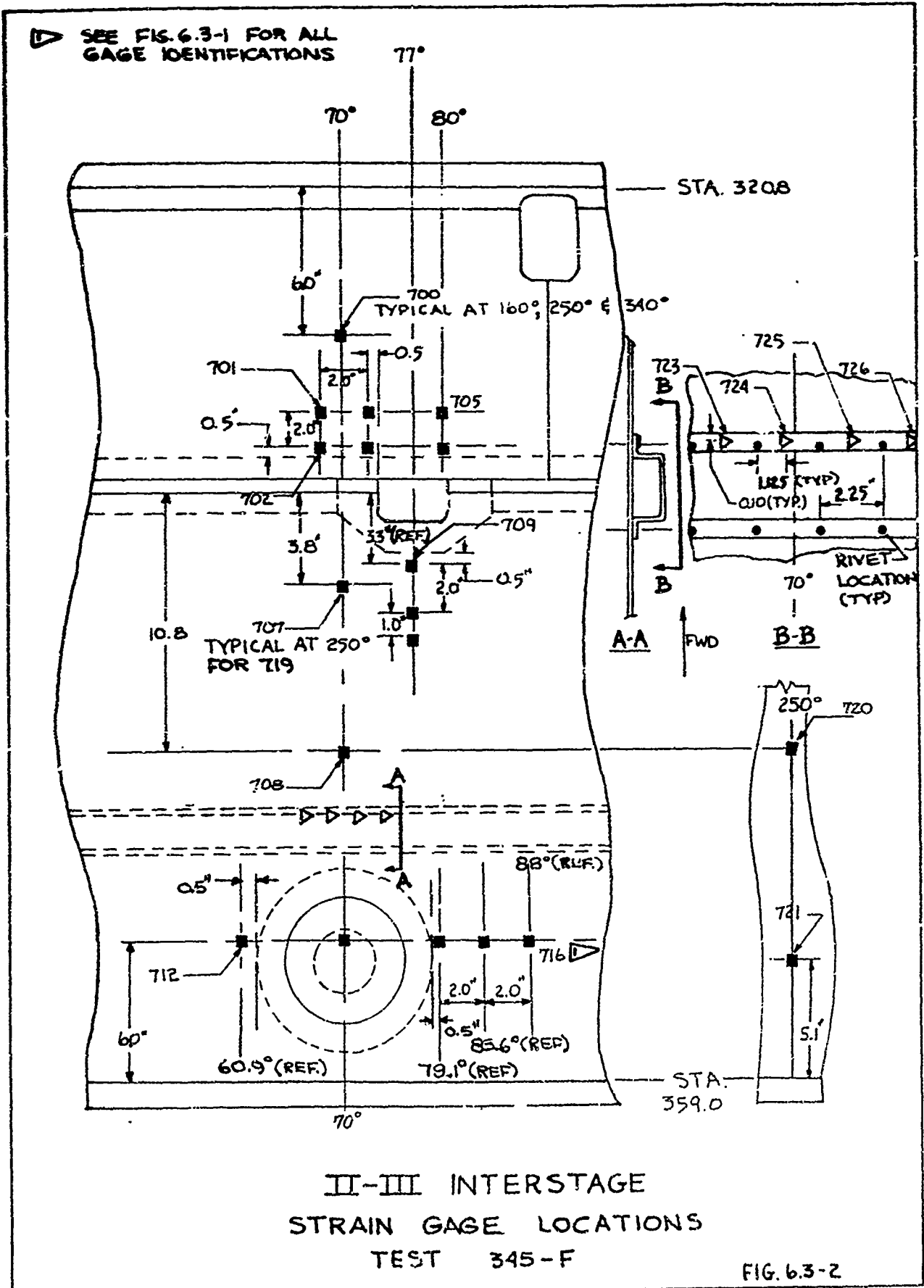

USE FOR DRAWING AND HANDPRINTING --- NO TYPED MATERIAL

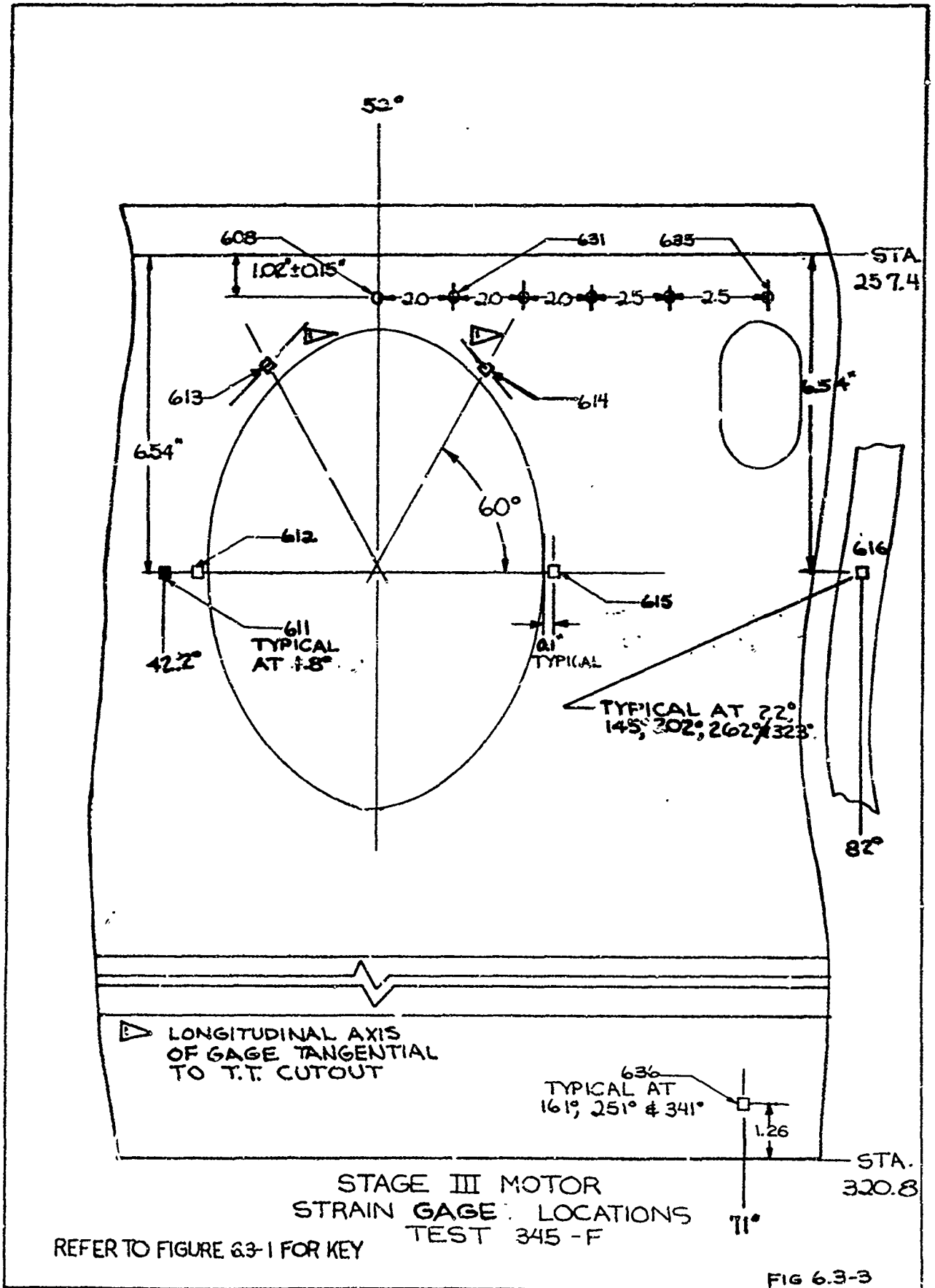



SHEET 620

FIG. 6.3-4



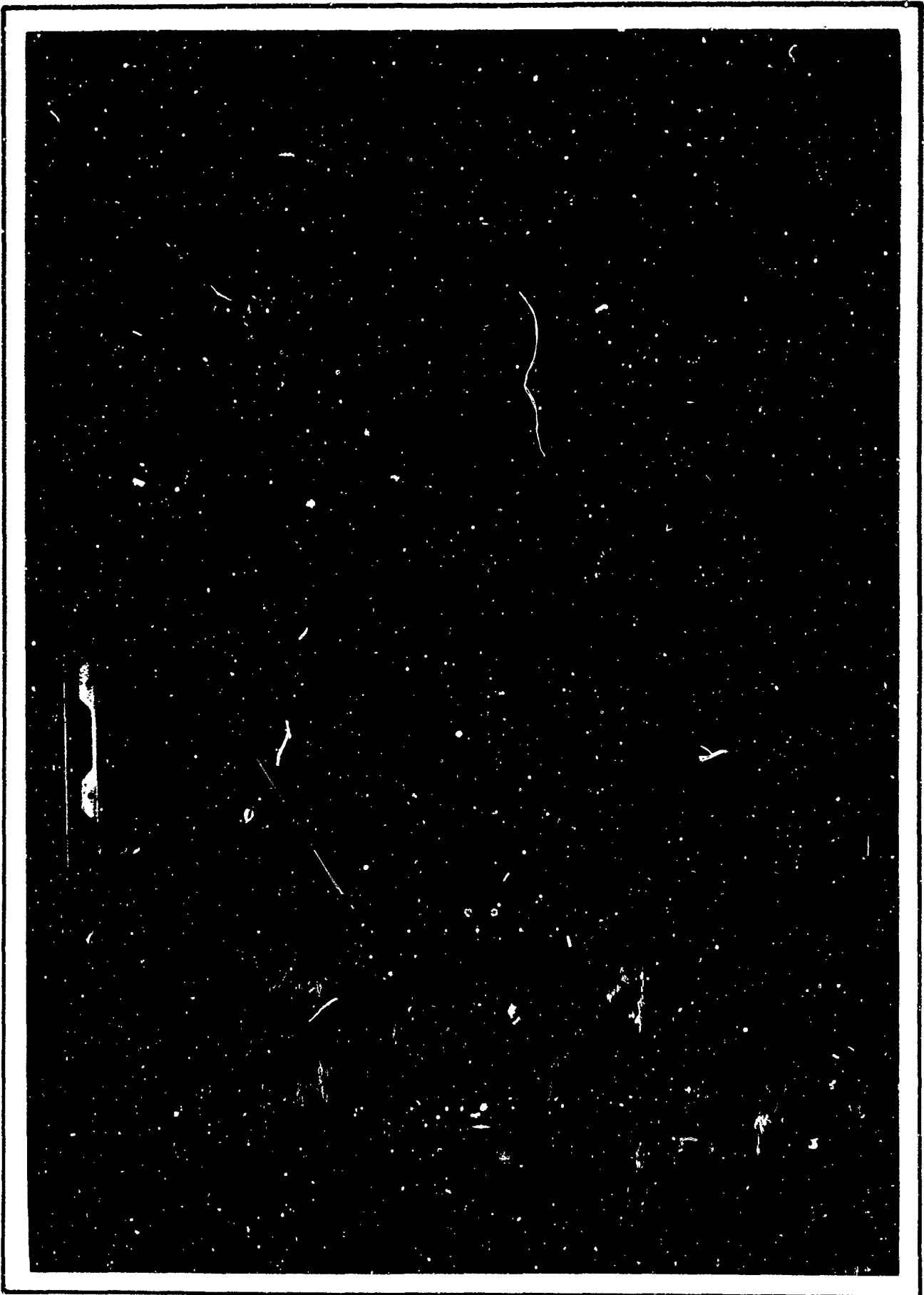

SHEET 621

FIG. 6.3-5



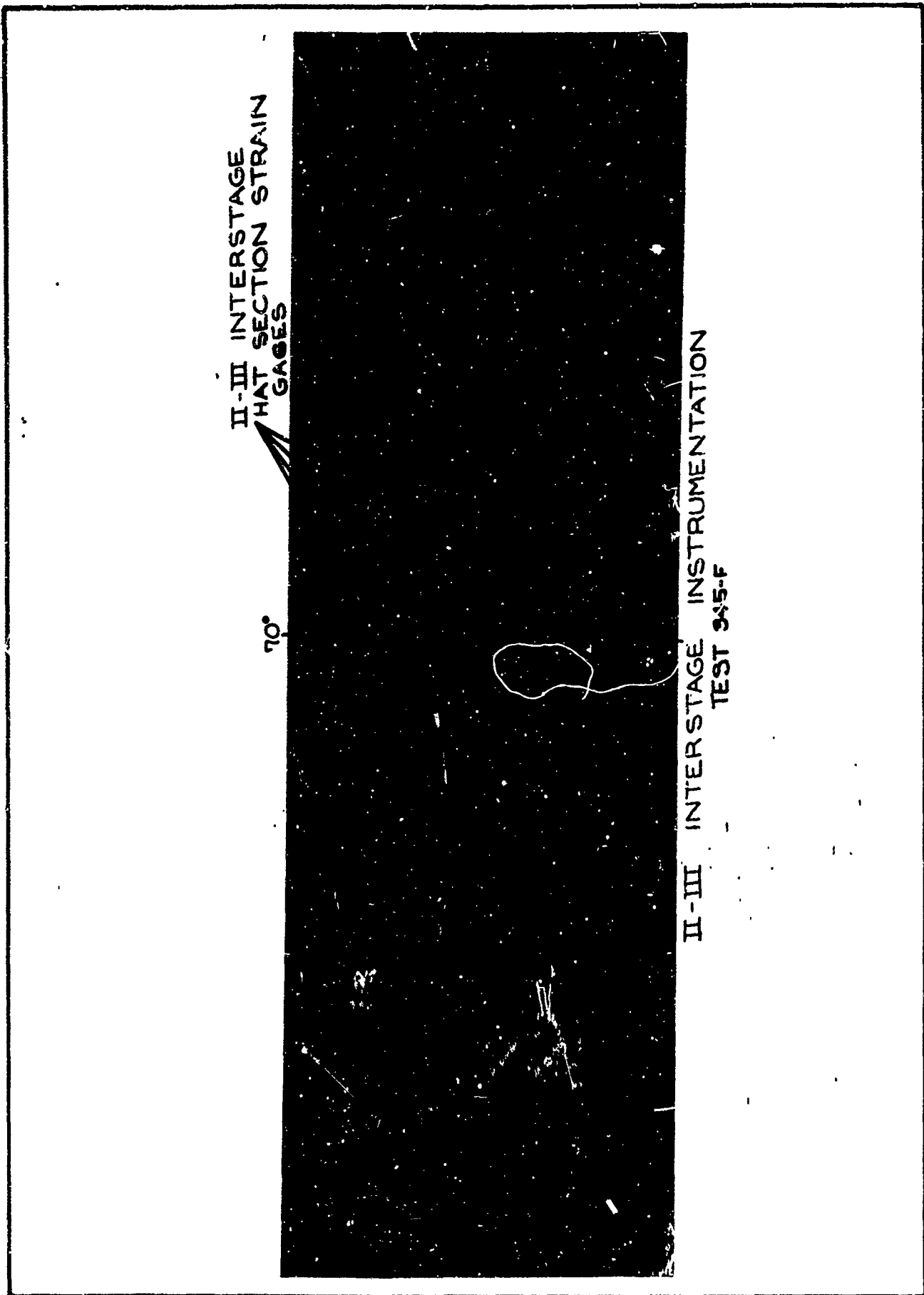

SHEET 622

FIG. 6.3-6



THERMOCOUPLE IDENTIFICATION		AZIMUTH						
		45°	85°	135°	225°	280°	315°	320°
MISSILE STATION	317.8	T640		T641	T642		T643	
	326.8	T723						T729
	345.0		T724			T726		
	360.5	T805		T806	T807		T808	

- THERMOCOUPLE INSIDE
- THERMOCOUPLE OUTSIDE

USE FOR DRAWING AND HANDPRINTING — NO TYPEWRITTEN MATERIAL

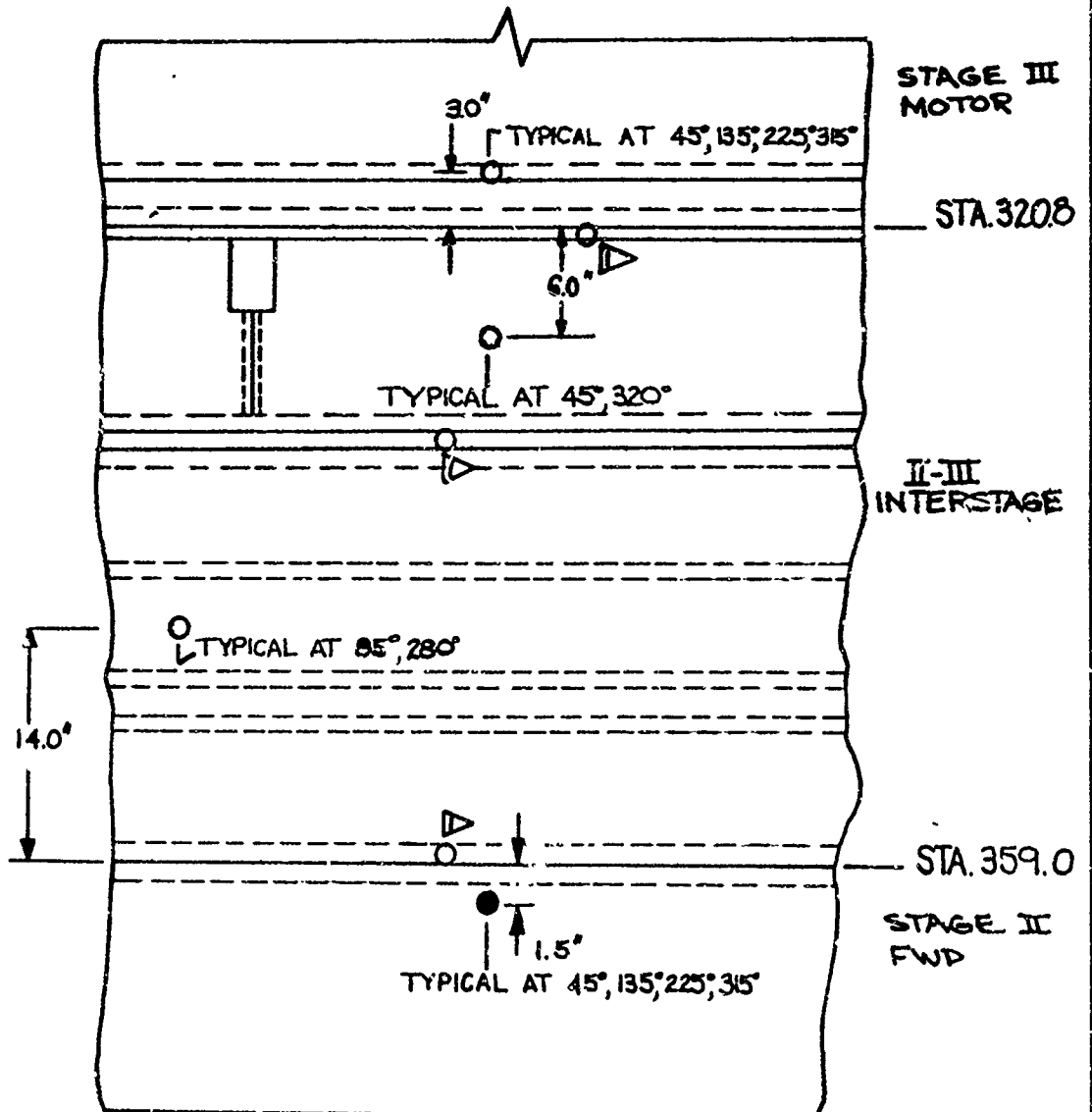

DATA THERMOCOUPLE LOCATIONS 345-F TEST

▷ SEE FIGURE 6.3-8 FOR DETAIL

FIG. 6.3-7

USE FOR DRAWING AND HANDPRINTING — NO TYPEWRITTEN MATERIAL

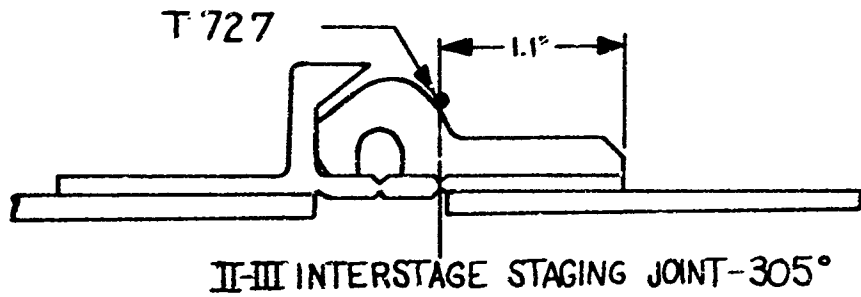
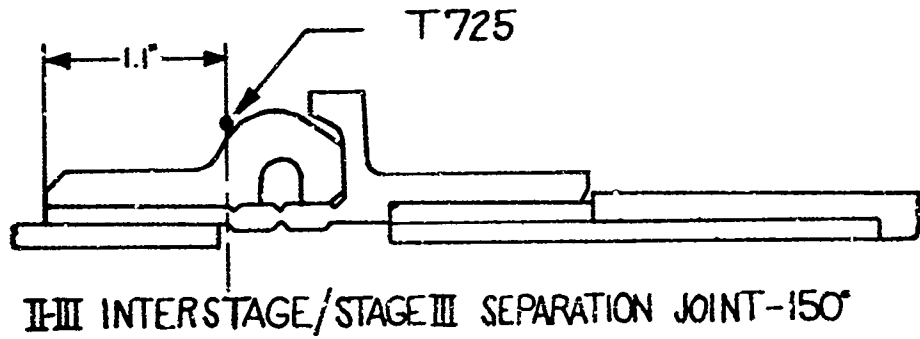

FWD →

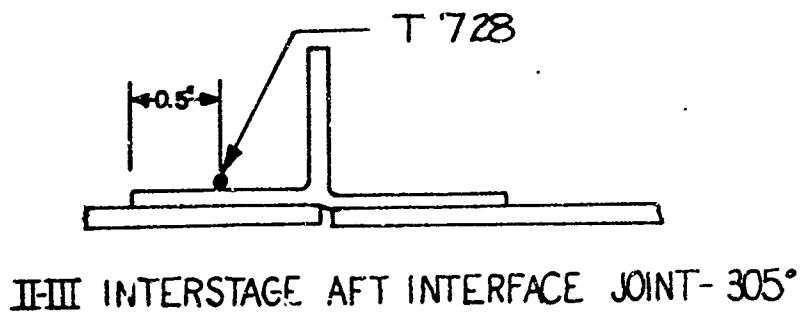

II III INTERSTAGE THERMOCOUPLE LOCATIONS
ON JOINTS ~ TEST 345-F

FIG. 6.3-8

USE FOR TYPEWRITTEN MATERIAL ONLY

6.4.1
TEST CONDITIONS
PROGRAMMED HEAT AND LOAD TEST

SHEET 625

345-F TEST LOADING ORIENTATION

USE FOR DRAWING AND HANDPRINTING — NO TYPEWRITTEN MATERIAL

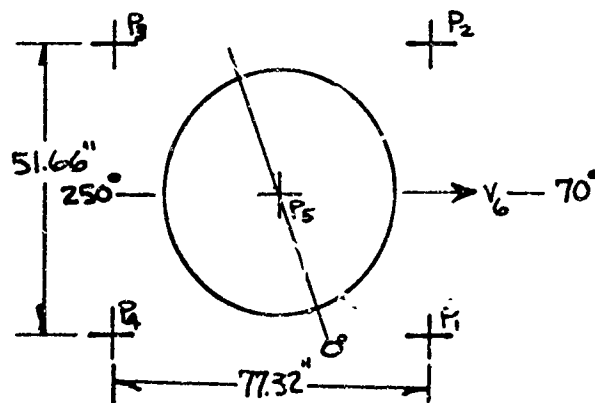
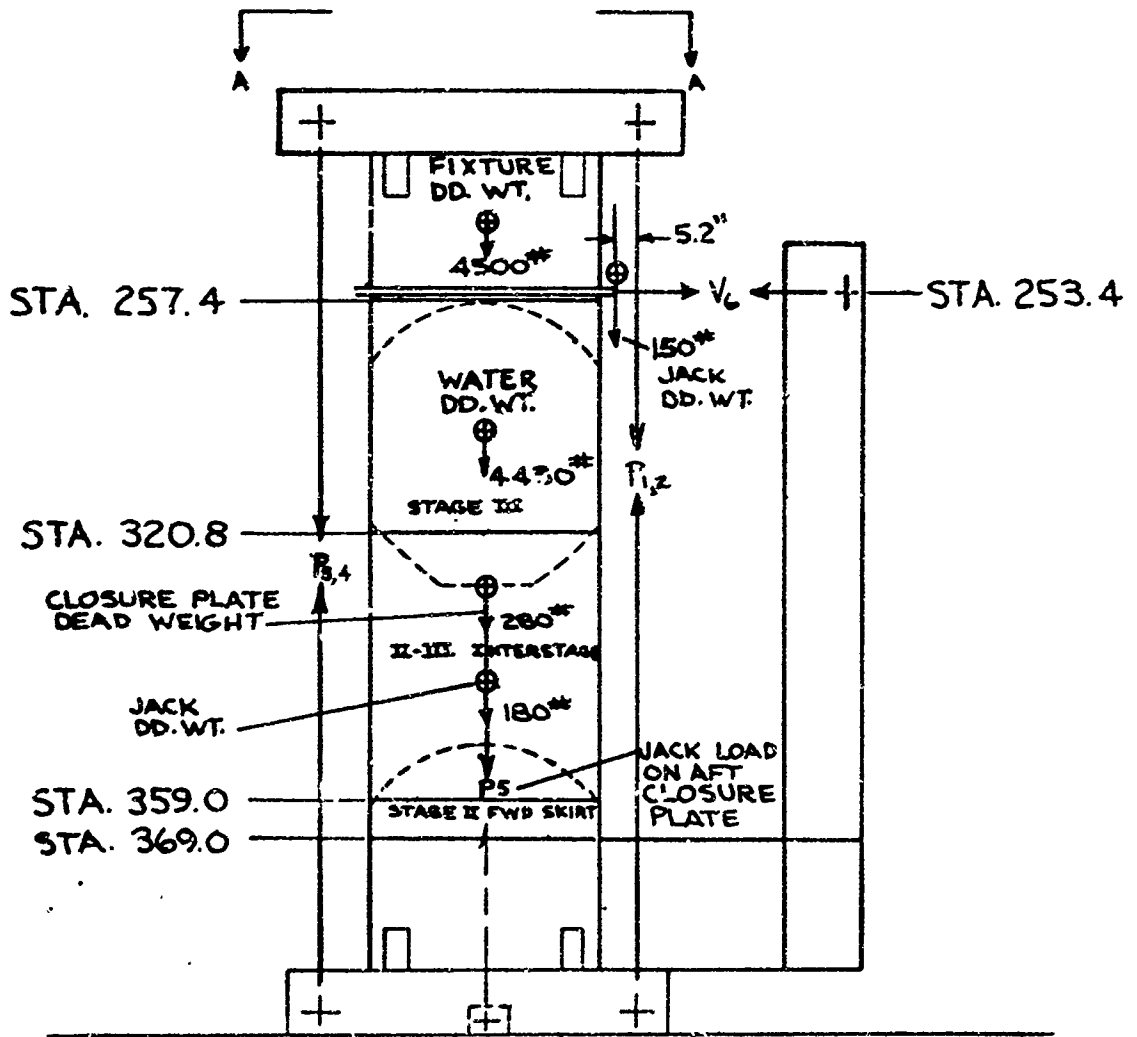

SECTION A-A

FIG. 6.4.1-1

TEST TIME (SEC.)	10	20	30	35	50	58.6	70	80	90	100	110	120	122
PROGRAMMED ∇	19	37.9	56.9	66.4	85.5	105.5	96.2	86.4	77.5	68.6	59.7	50.8	42.0
APPLIED	13.6	38.6	58.1	68.2	88.2	106.9	96.3	86.9	78.4	70	61.1	51.3	50.0

∇ 1 BASED ON REF. 1.
 ∇ 2 WATER DEAD WEIGHT IN STAGE III MOTOR

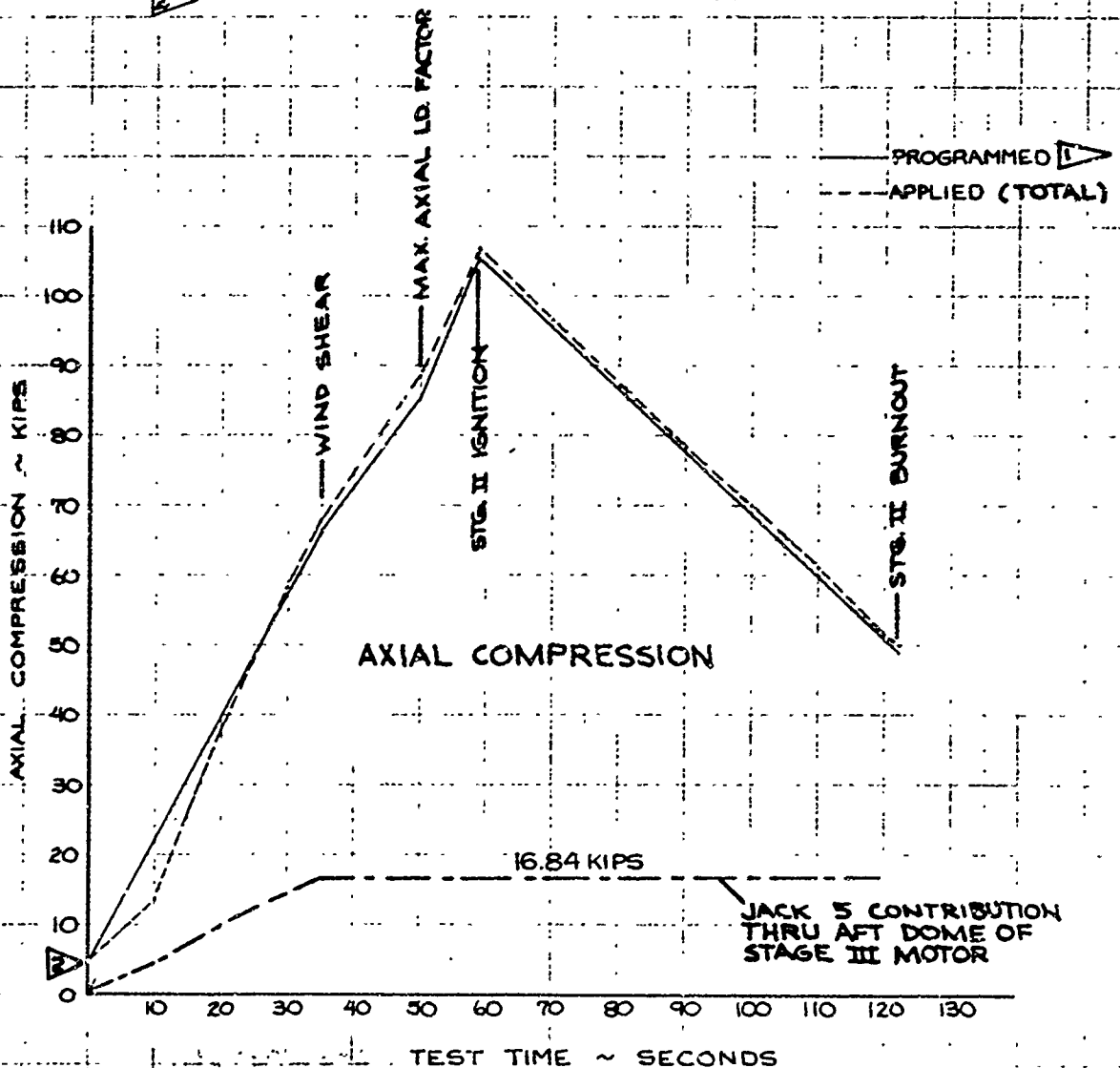

	INITIALS	DATE	REV BY INITIAL	DATE	TITLE	MODEL
CALC	JAG	6-12-8			TEST 345 - F PROGRAMMED & APPLIED AXIAL LDS. VS. TEST TIME - STATION 3590	FIG 641-2
CHECK	LDW	9-16-9				
APPD.						
APPD.						

U3 4013 8000 REV 1/66

REV LTR _____

BOEING NO T2-365T-1
 SH 627

TEST TIME (SEC.)	10	20	30	35	50	56.6	70	80	90	100	110	120	122
PROGRAMMED IN-K	712	1424	2137	2493	584	1108	949	809	669	530	390	250	222
APPLIED IN-K	695	1387	2183	2530	630	1122	972	821	685	555	409	264	227

BASED ON REF. 1.

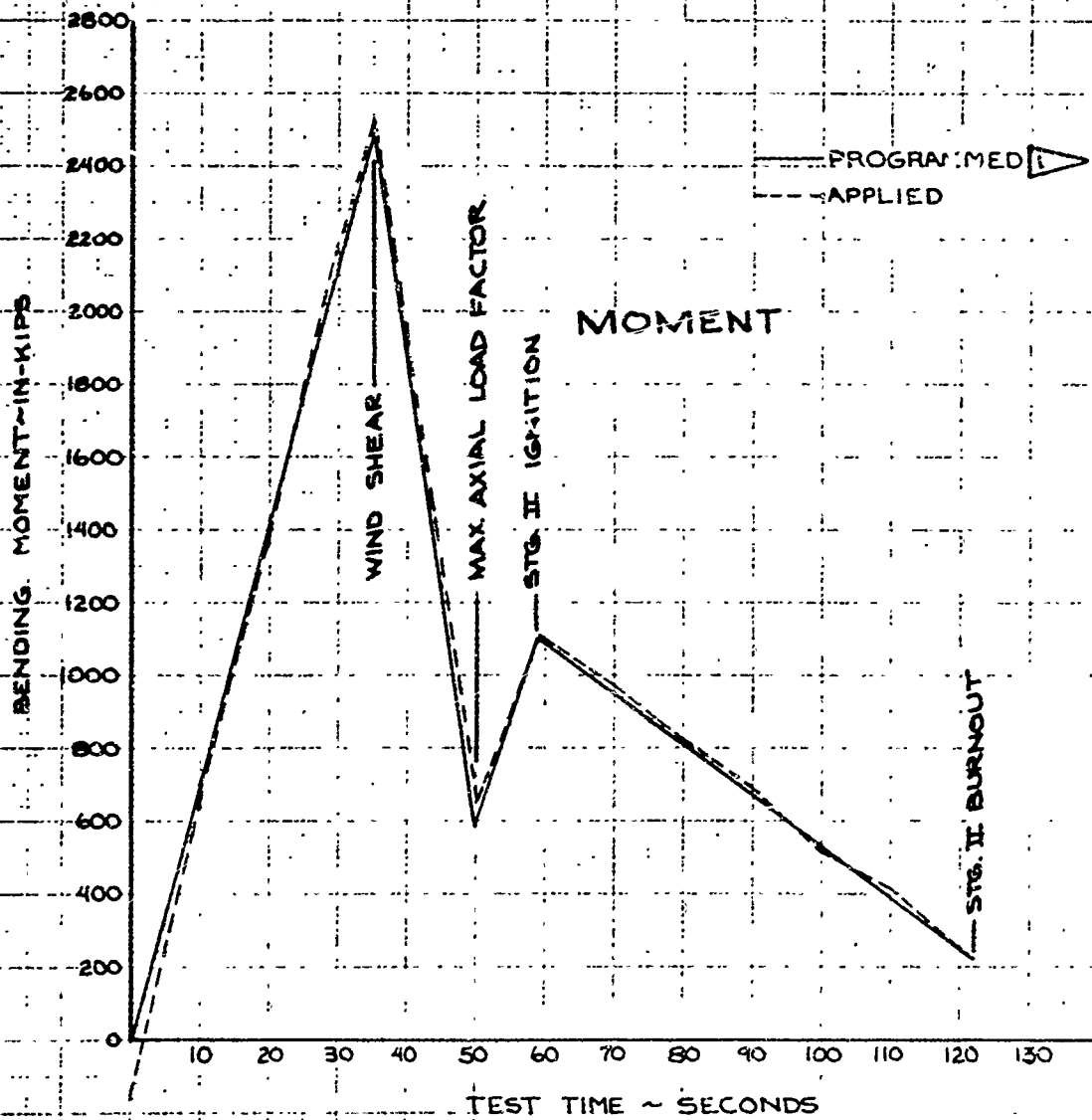

	INITIALS	DATE	REV BY INITIAL	DATE	TITLE	MODEL
CALC	JBG	6-12-8			TEST 345-F PROGRAMMED & APPLIED MOMENT VS. TEST TIME - STATION 359.0641-3	FIG
CHECK	GDW	9-16-9				
APPD.						
APPD.						

U3 4013 8000 REV 1/66

REV LTR _____

BOEING NO T2-3657-1
SH 628

TEST TIME (SEC.)	10	20	30	35	50	58.6	70	80	90	100	110	120	122
PROGRAMMED \blacktriangleright	2.88	5.77	8.66	10.1	2.06	3.50	2.87	2.32	1.78	1.23	.68	.13	0
APPLIED	2.78	5.88	8.77	10.32	2.19	3.53	2.88	2.29	1.74	1.2	.63	.02	0

\blacktriangleright BASED ON REF. 1.

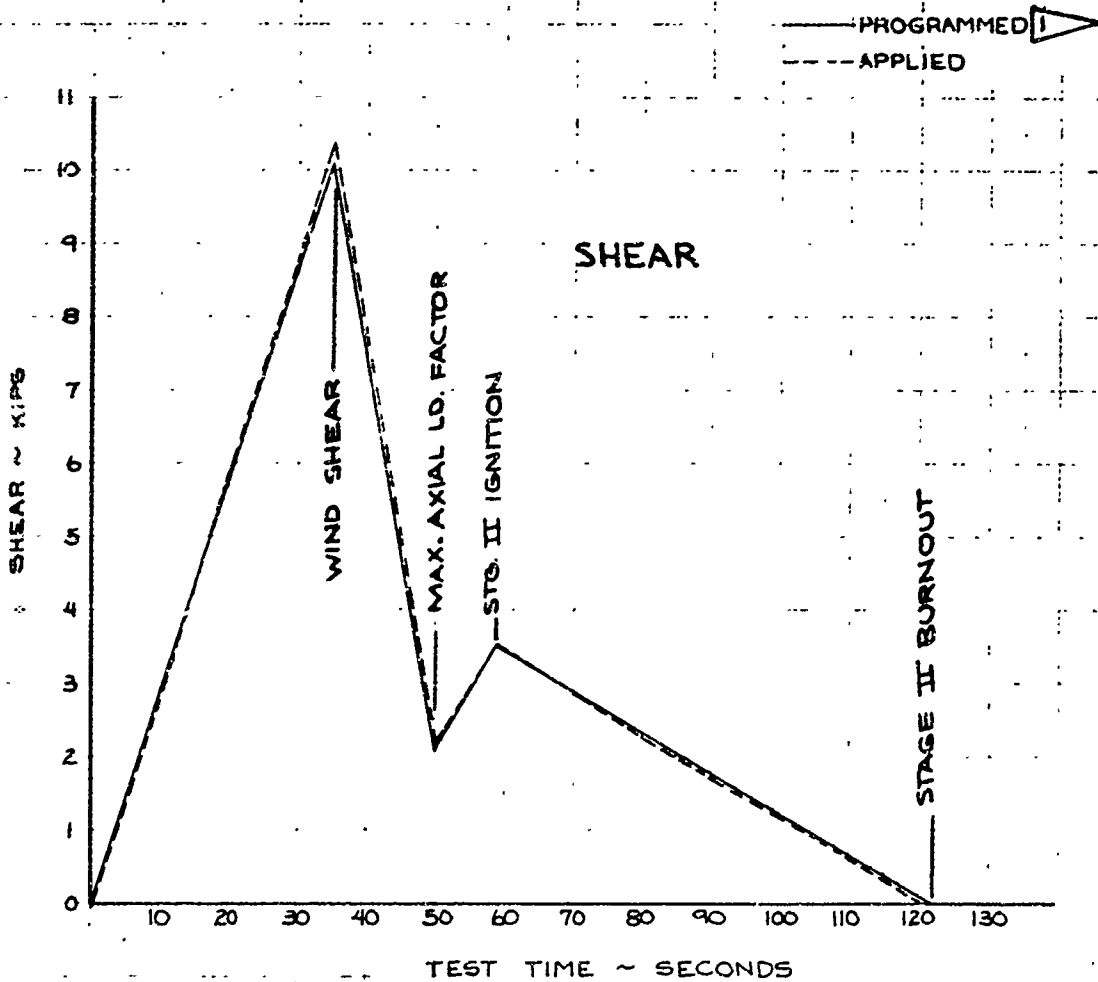

	INITIALS	DATE	REV BY INITIAL	DATE	TITLE	MODEL
CALC	JAG	6-12-8			TEST 345-F PROGRAMMED & APPLIED SHEAR VS. TEST TIME - STATION 359.0	FIG 641-4
CHECK	GDW	9-6-8				
APPD.						
APPD						

U2 4013 EMD REV 1/66

REV LTR _____

BOEING NO T2-3657-1
SH 629

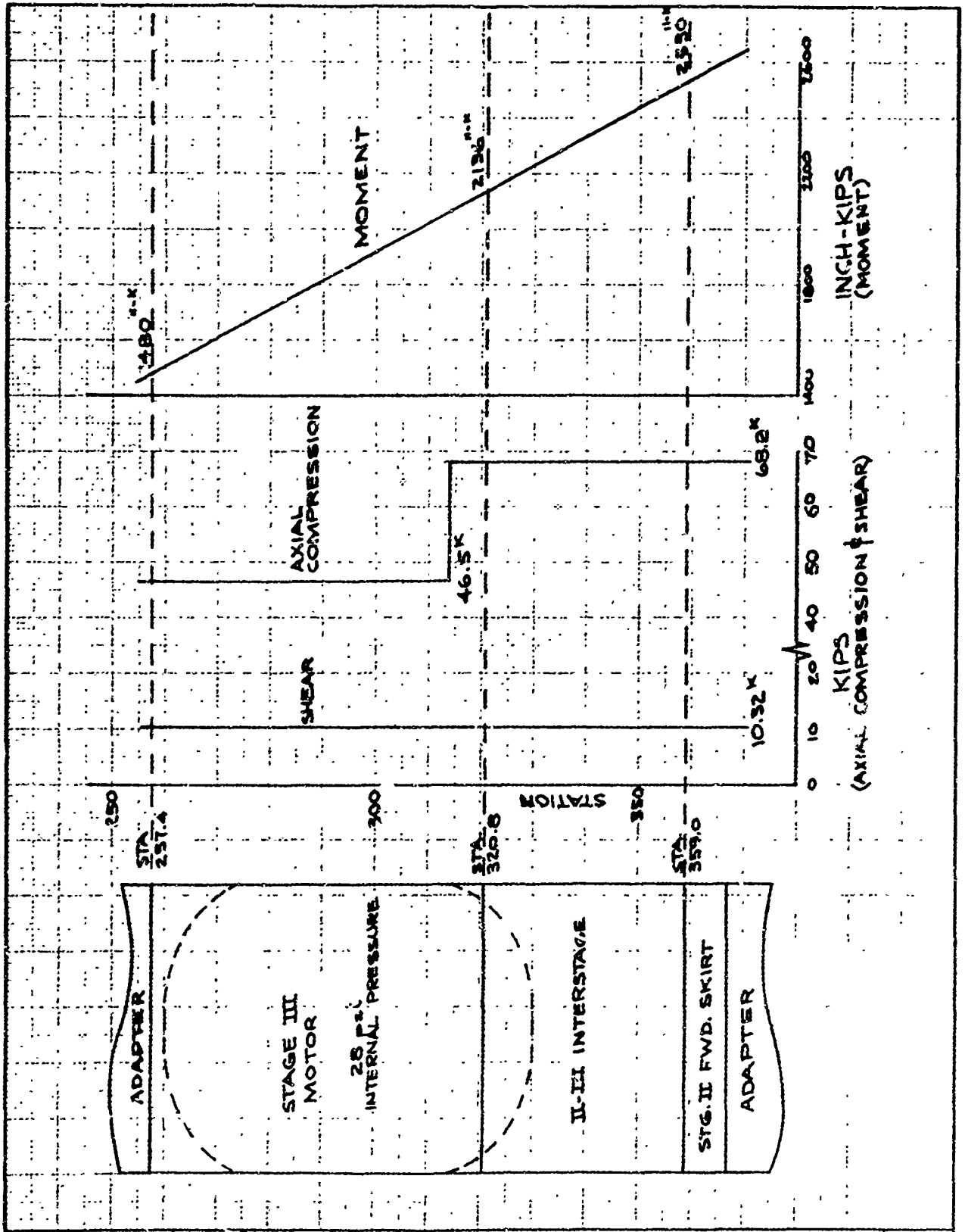

	INITIALS	DATE	REV BY INITIAL	DATE	TITLE	MODEL
CALC	JET	6/7/58			TEST 345-F FLIGHT PROFILE APPLIED LOADS @ t=35sec LOADS VS. STATION (WIND SHEAR MAX 8K CONDITION)	FIG 6411-5
CHECK	GPW	2/16/58				
APPD.						
APPD.						

U3 4013 8000 REV 1/66

REV LTR _____

BOEING NO. T2-3657-1
SH. 630

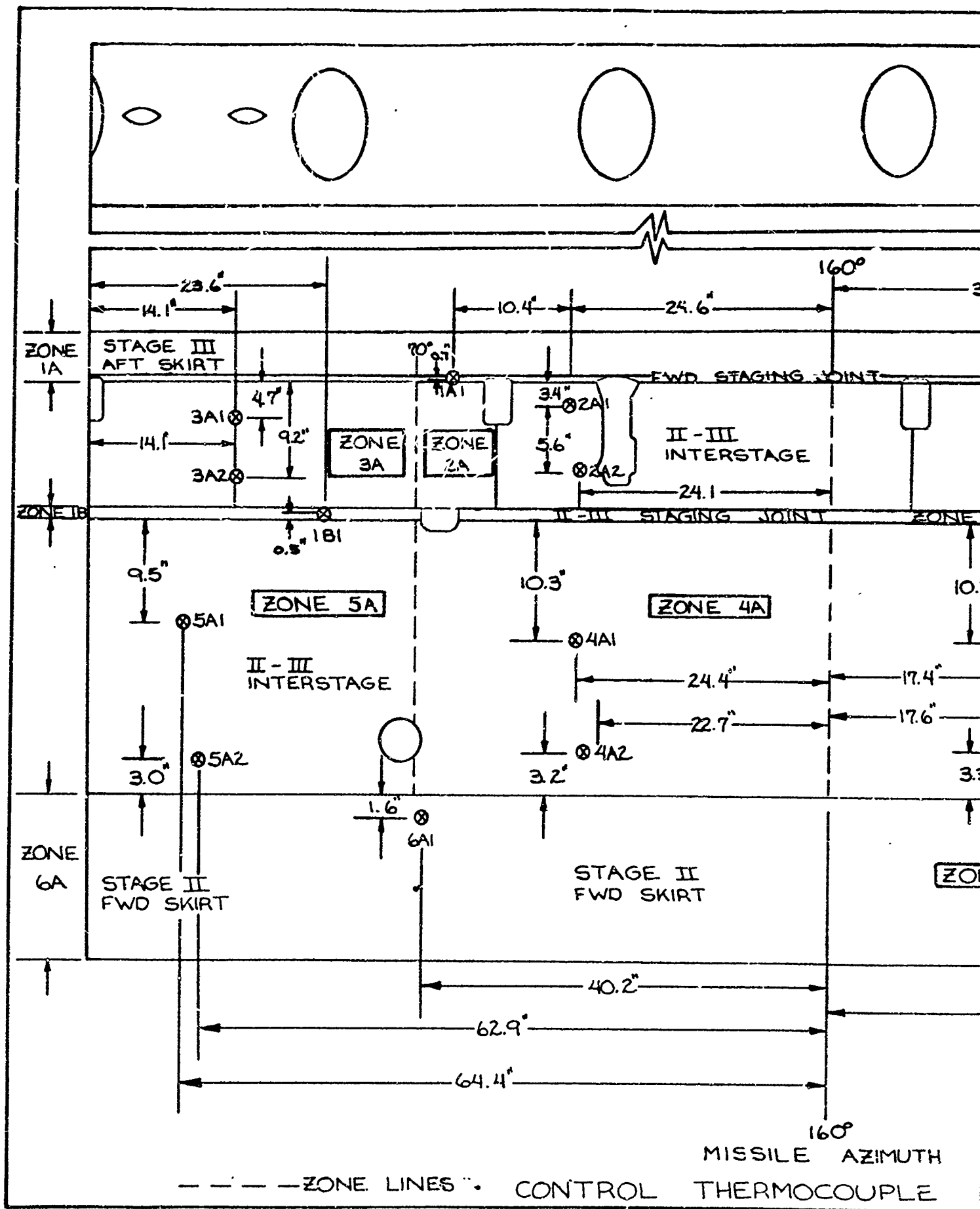

REV LTR _____

A

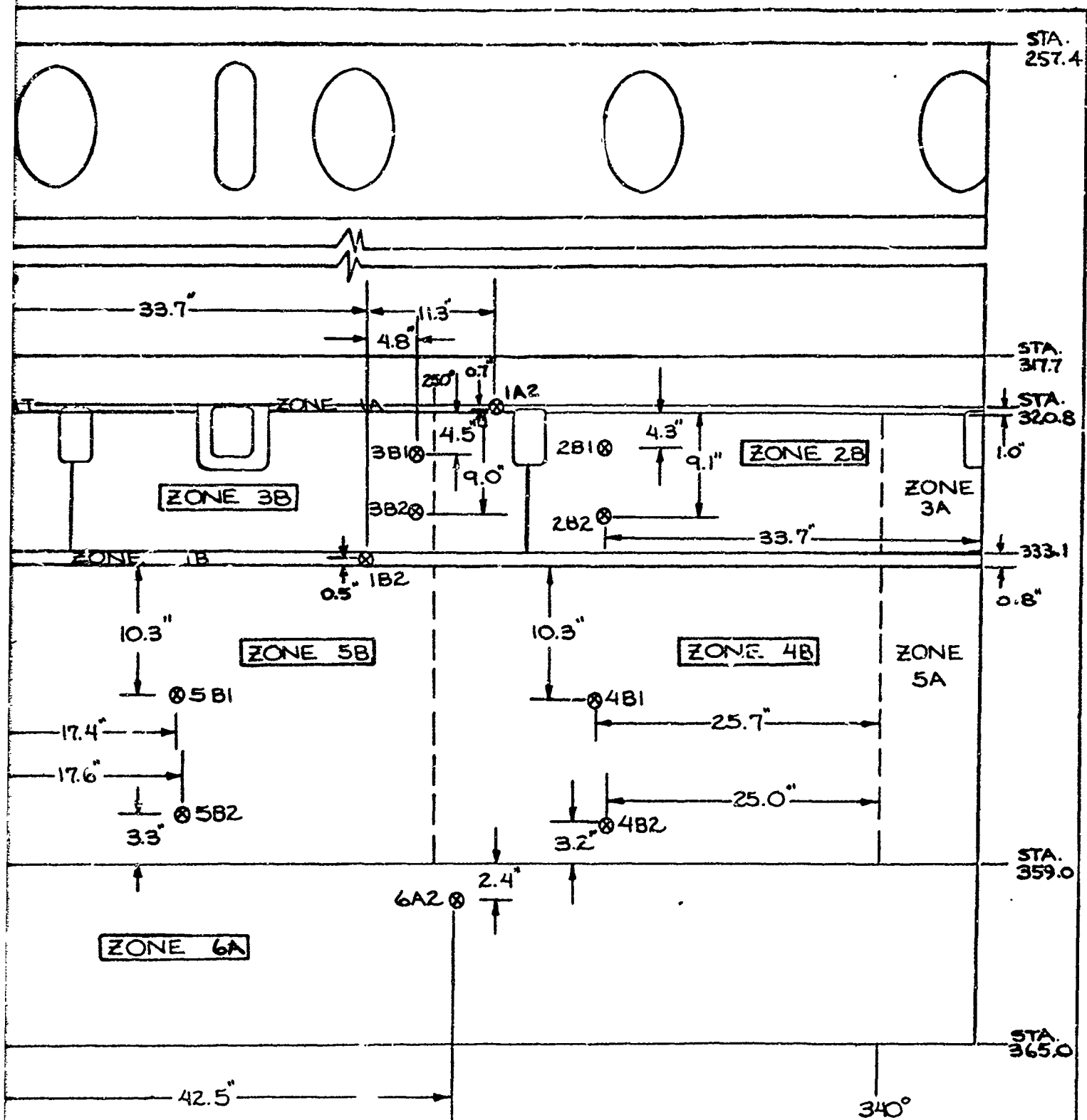

THE HIGHEST READING THERMOCOUPLE, OF THE TWO WITHIN EACH ZONE, WAS USED AS THE CONTROL FOR THAT ZONE. SEE FIGURES 6.4.1-7 THRU 6.4.1-10 FOR THE TEMPERATURE HISTORY CURVES FOLLOWED BY THE CONTROL THERMOCOUPLES.

THERMOCOUPLE LOCATIONS - TEST 345-F

FIG. 6.4.1-6

BOEING NO. TZ-3657-1
 SH 651

B

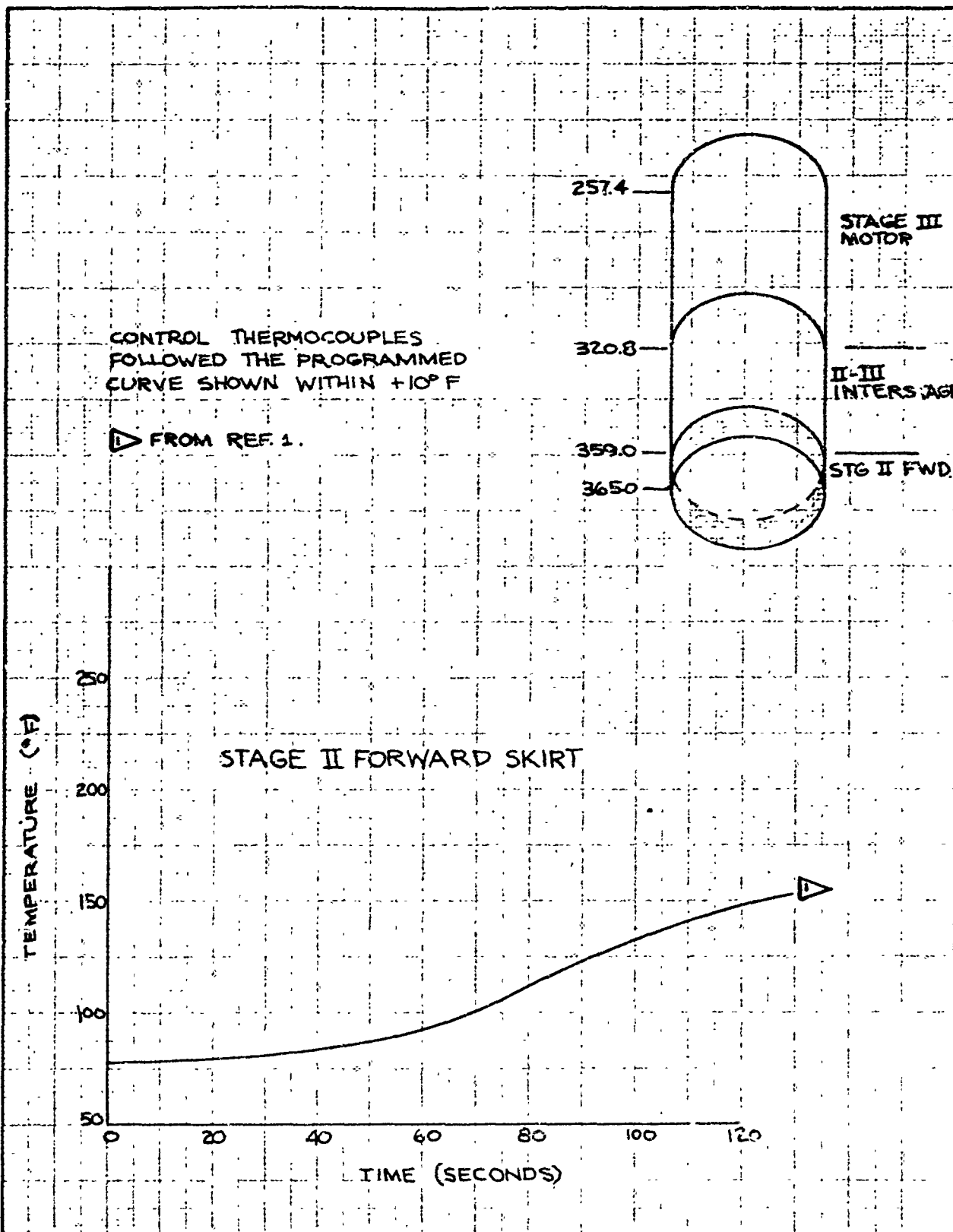

	INITIALS	DATE	REV BY INITIAL	DATE	TITLE	MODEL
CALC	JET	8/16/8			345-F PROGRAMMED TEST PLANNED & ACTUAL TEMPERATURES STAGE II FORWARD SKIRT	FIG. 6.4.1-7
CHECK	MDW	9-16-8				
APPD.						
APPD.						

U3 4013 8000 REV 1/66

REV LTR _____

BOEING NO T2-3657-1
SH 637

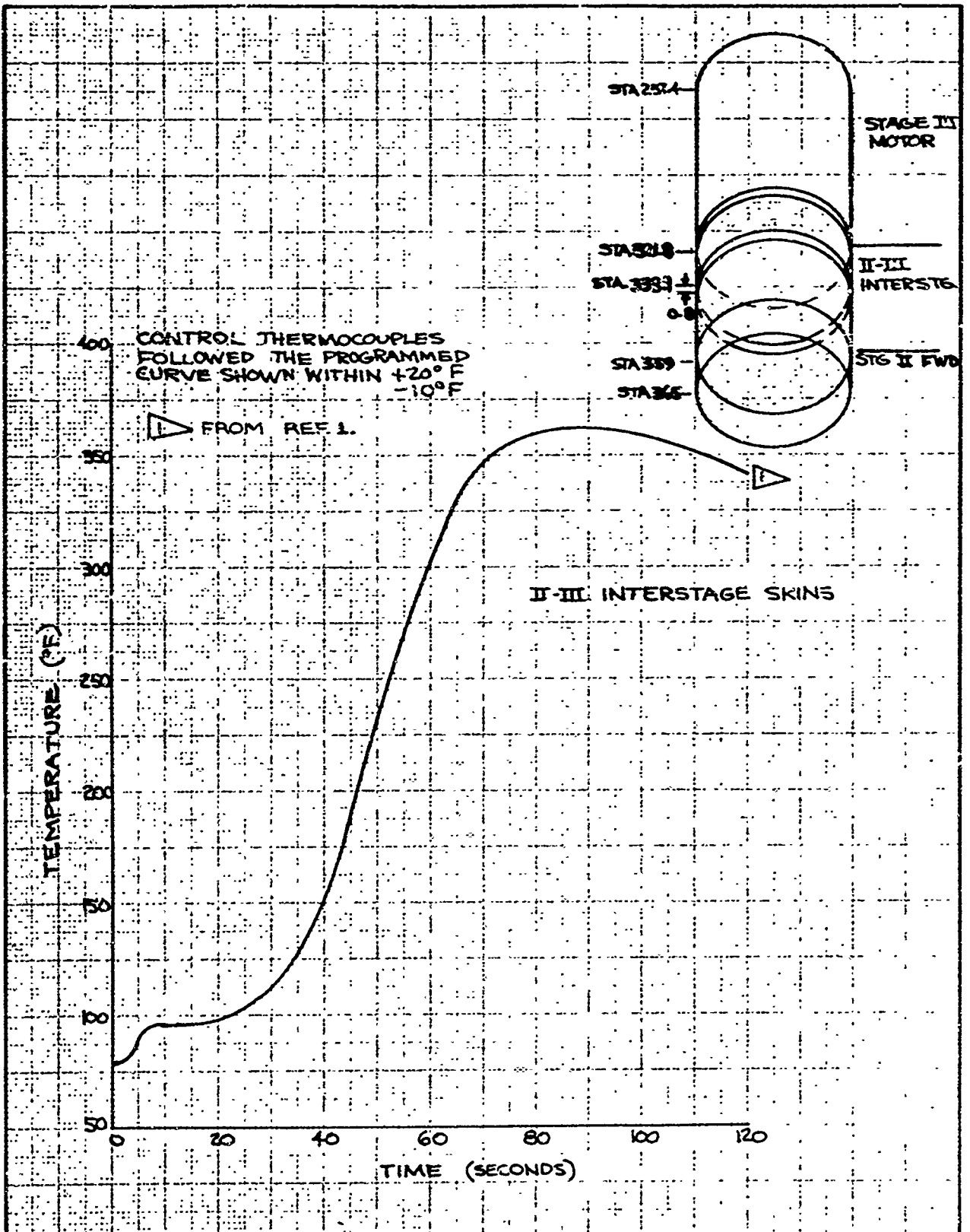

	INITIALS	DATE	REV BY INITIAL	DATE	TITLE	MODEL
CALC	DET	8/16/68			345-F PROGRAMMED TEST PLANNED & ACTUAL TEMPERATURES II-III INTERSTAGE SKINS	FIG. 6.4.1-8
CHECK	PSW	8/16/68				
APPD.						
APPD.						

U3 4013 8000 REV. 1/66

REV LTR _____

BOEING NO T2-3657-1
SH. 633

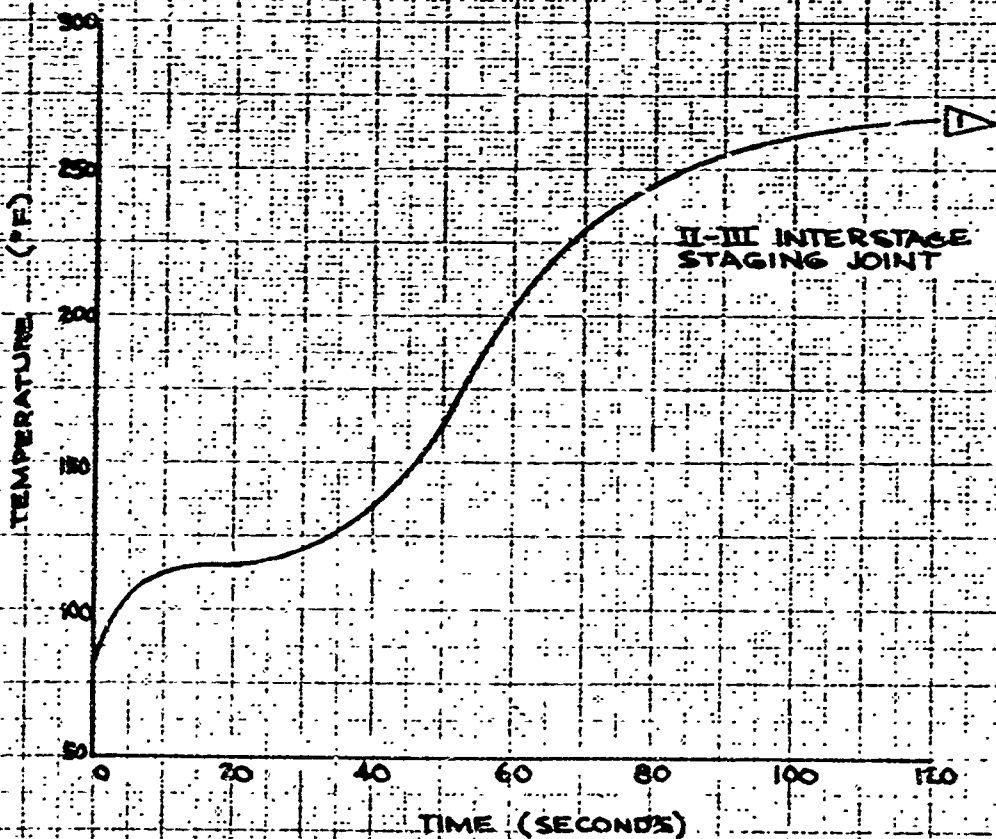
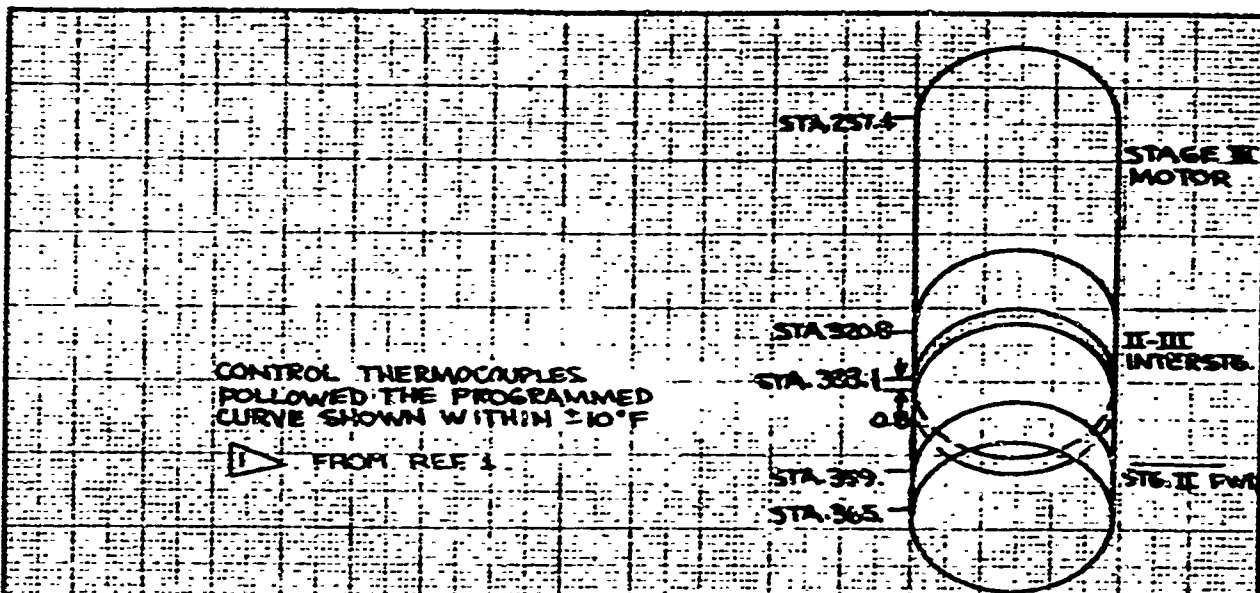

INITIALS	DATE	REV BY INITIAL	DATE	TITLE	MODEL
ALC	8/6/69			345-F PROGRAMMED TEST PLANNED AND ACTUAL TEMPERATURES STAGING JOINT	FIG. 64.1-9
CHECK	9/16/69				
APPD.					
APPD.					

US 4013 8000 REV 1/66

REV LTR _____

BOEING NO. T2-3657-1
SH. 622

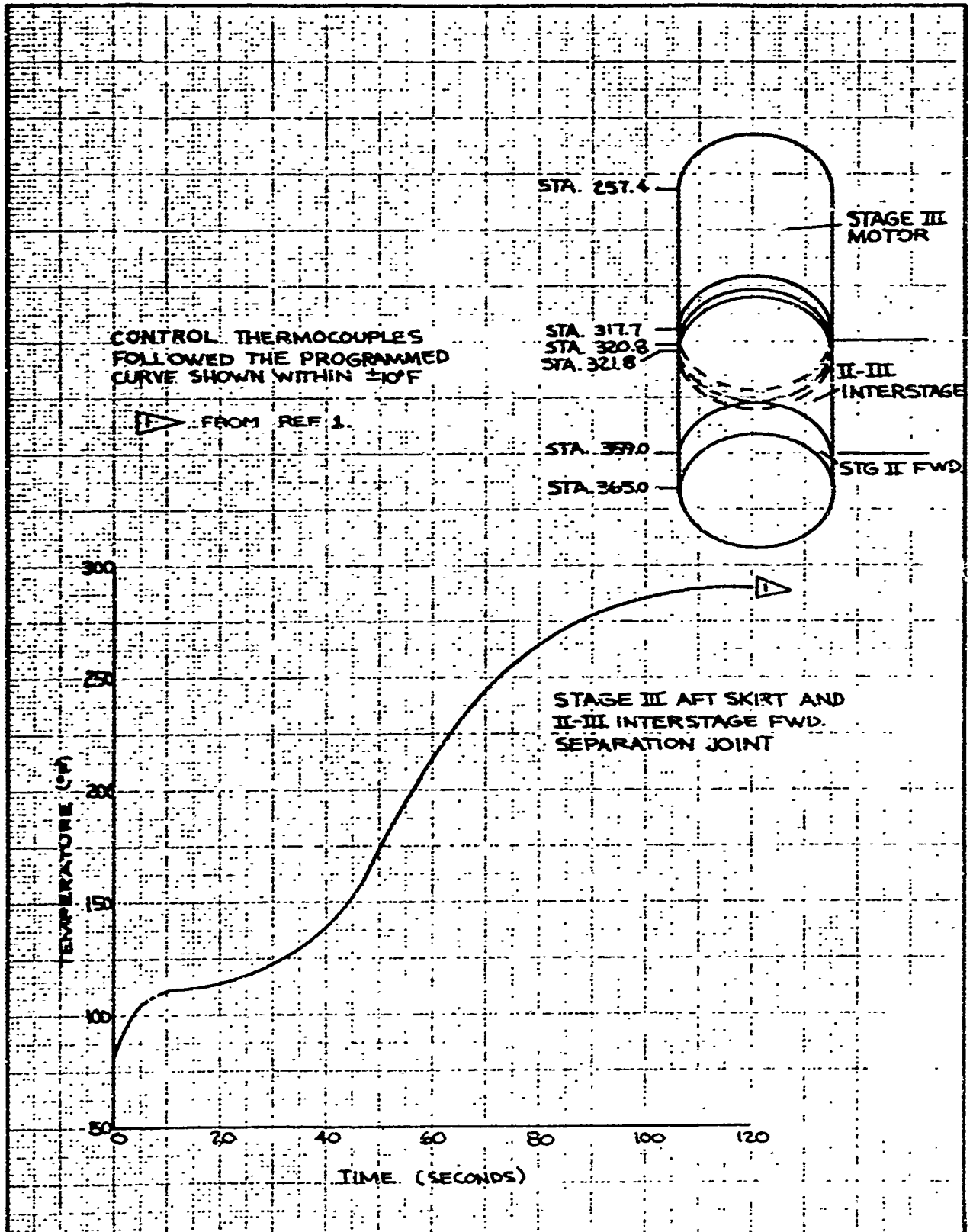





	INITIALS	DATE	REV BY INITIAL	DATE	TITLE	MODEL
CALC	DET	8/16/69			345-F PROGRAMMED TEST PLANNED & ACTUAL TEMPERATURES STAGE III AFT SKIRT	6.4-1-10
CHECK	DMT	8/16/69				
APPD.						
APPD.						

U3 4C13 9000 REV 1/66

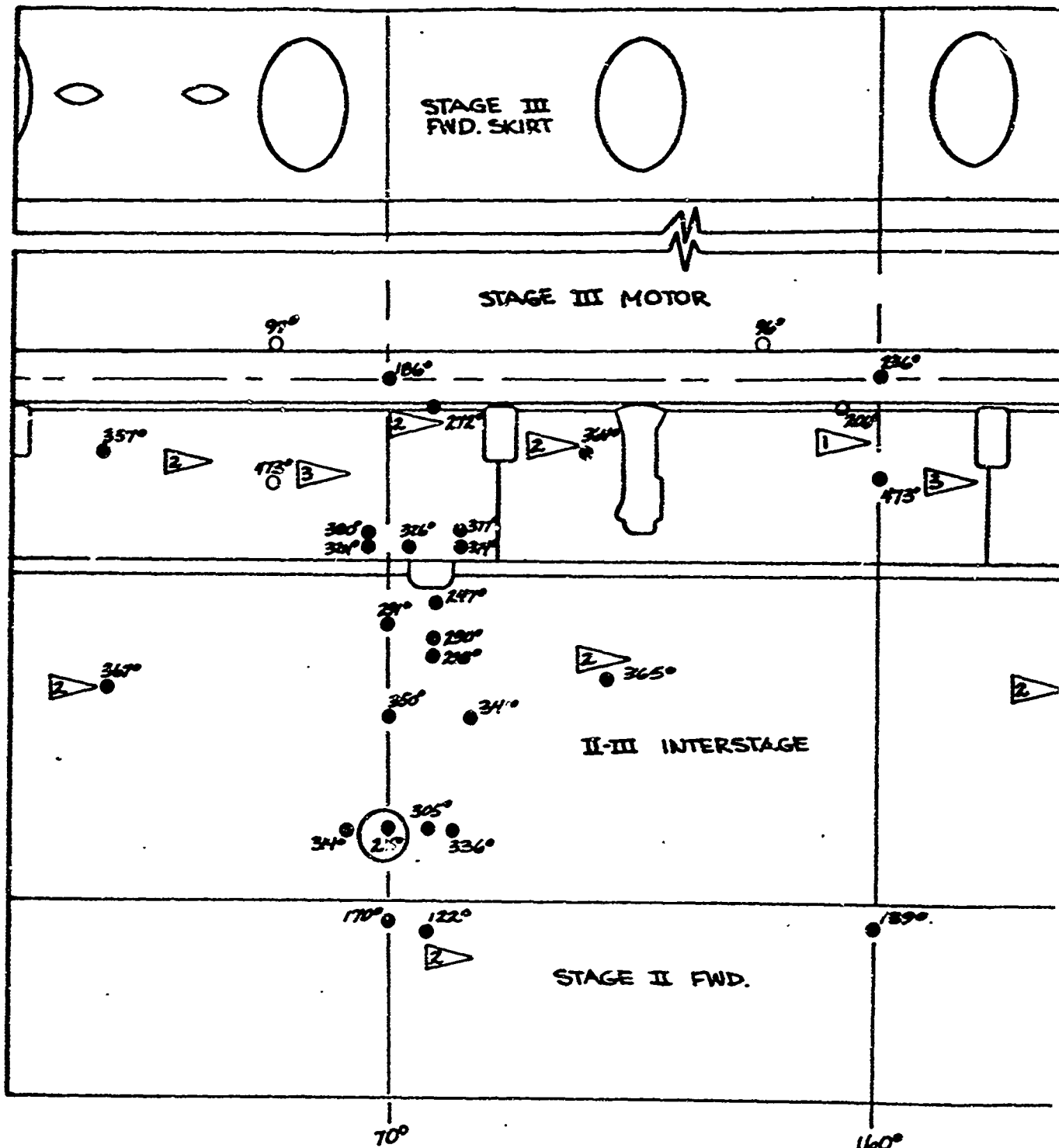
REV LTR _____

BOEING NO. 72-3657-1
SH 655



ALL GAGES ARE LOCATED ON SKIN EXCEPT AS INDICATED IN  REFER TO FIG. 6.3-7 FOR GAGE LOCATIONS
 CONTROL THERMOCOUPLES (SEE FIG. 6.4.1-6)
 LOCAL HIGH TEMPERATURES PROBABLY DUE TO MIS-
 LOCATION OF INDIVIDUAL HEAT LAMPS

ALL THERMOCOUPLE VALUES IN °F
 ○ INSIDE GAGE ● OUTSIDE GAGE

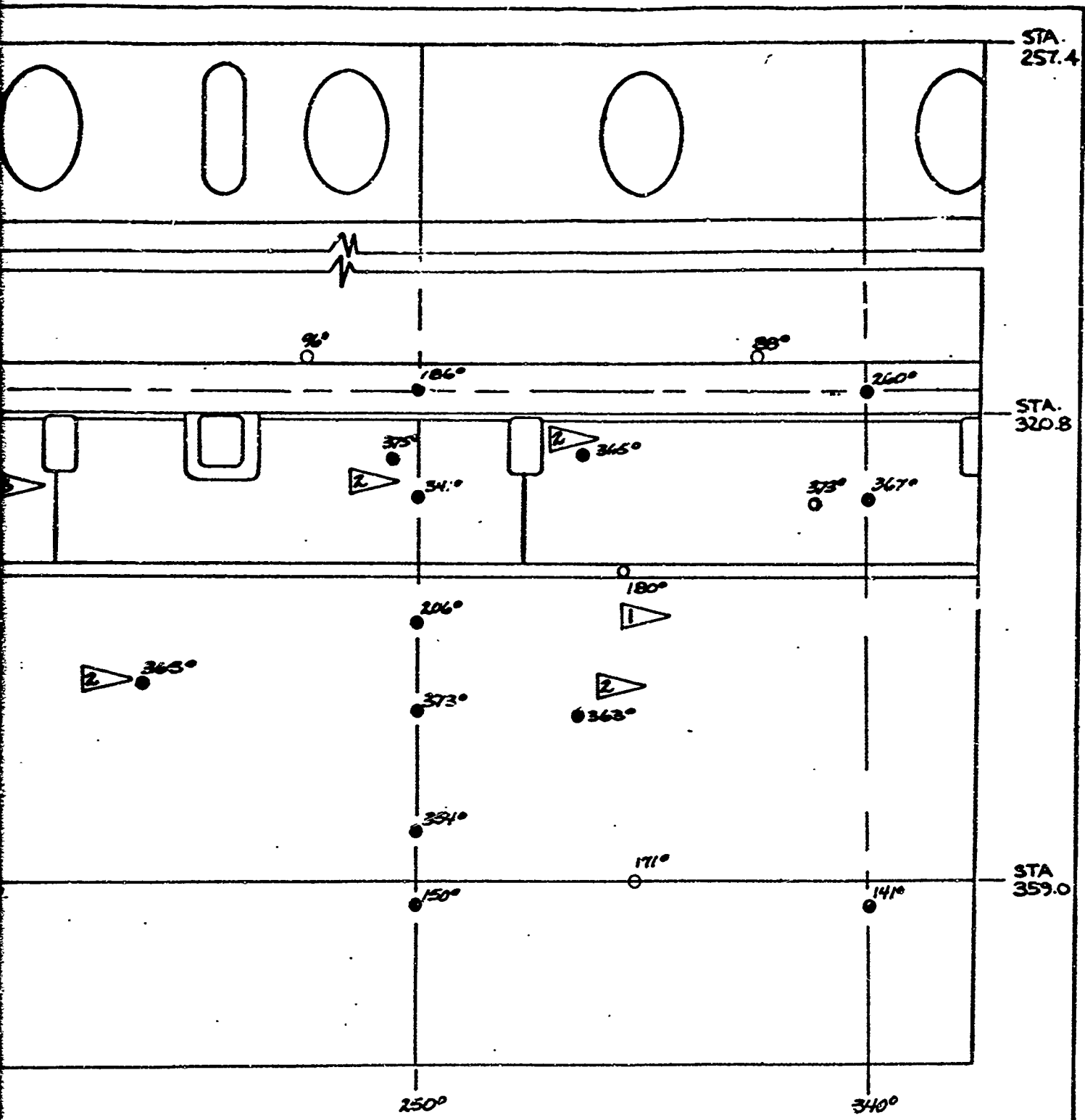

345-F TEST THERMOCOUPLE READINGS
AT t = 85 SECONDS OF TEST TIME

FIG. 6.4.1-11

BOEING	NO. T2-3657-1
	SH 636

B

USE FOR TYPEWRITTEN MATERIAL ONLY

6.4.2

TEST CONDITIONS

FAILURE TEST

SHEET 627

PERCENT TEST	0	20	40	60	80	90	100	105	110	115	120	125	130
PROGRAMMED ^{KIPS} ∇	0	133	266	398	531	598	664	61.7	73.0	76.4	79.7	83.0	86.3
APPLIED LOAD-KIPS	0	13.2	26.6	40.8	51.0	60.7	67.5	70.6	74.2	77.6	81.0	84.3	87.6
% OF PLANNED 100% LOAD		19.9	40	61.4	61.3	91.4	101.7	106.3	111.7	116.9	122.0	128.9	131.9

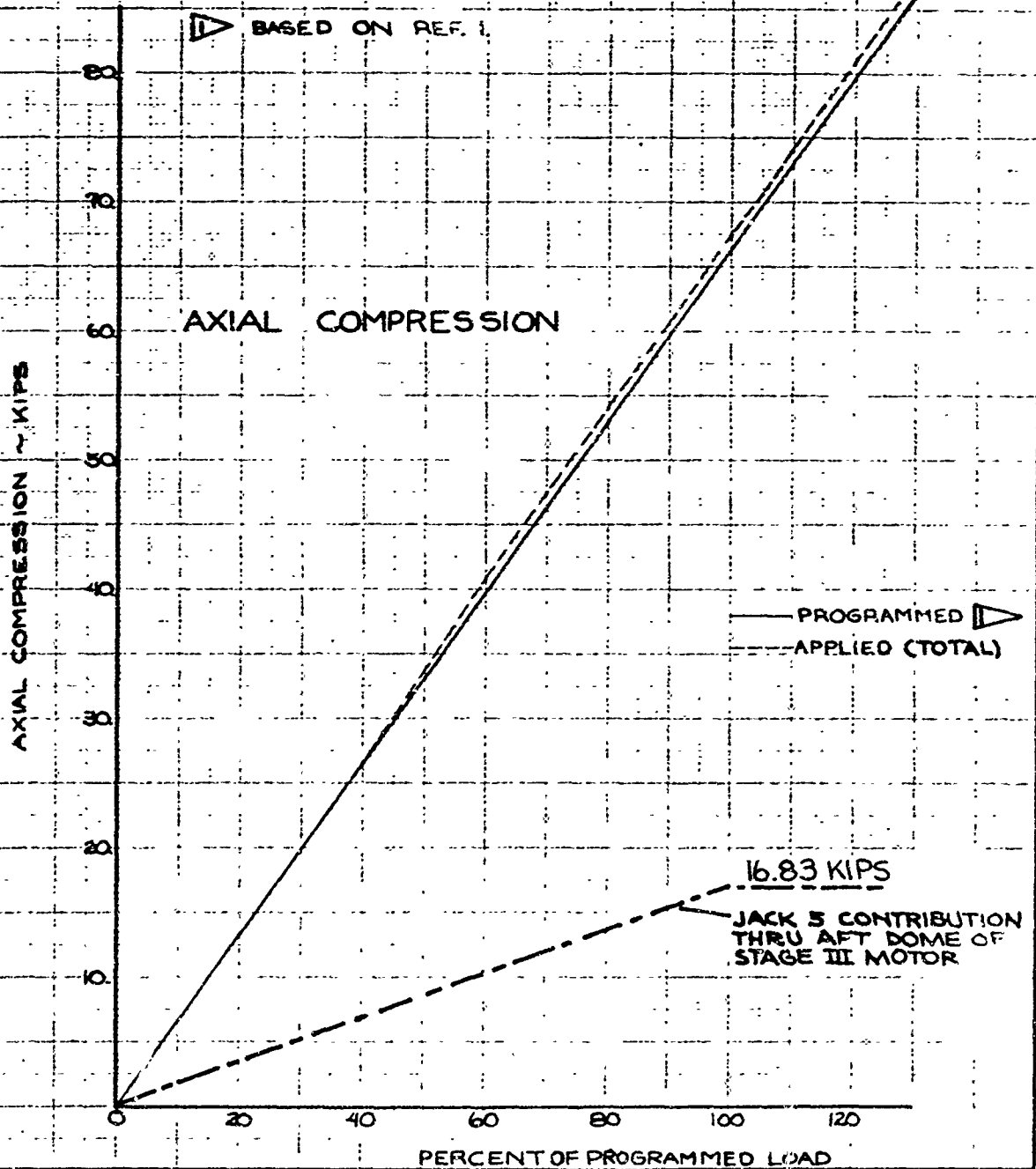

	INITIALS	DATE	REV BY INITIAL	DATE	TITLE	MODEL
CALC	JAG	6-19-8			3-15-F FAILURE TEST PROGRAMMED & APPLIED AXIAL LOADS VS. PERCENT LOAD - STA 359.0	FIG 6.4.2-1
CHECK	JDW	9-16-8				
APPD.						
APPD.						

U3 4013 8090 REV. 1/66

REV LTR _____

BOEING NO T2-3657-1

SH 638

PERCENT TEST	0	20	40	60	80	90	100	105	110	115	120	125	130
PROGRAMMED ∇ IN-KIP	0	499	997	1496	1994	2244	2493	2618	2742	2867	2992	3116	3241
APPLIED MOM. IN-KIP	0	450	1004	1541	2039	2287	2538	2654	2773	2920	3046	3172	3291
% OF PLANNED 100% MOM		18.0	40.3	61.8	81.5	91.7	101.8	106.5	112.0	117.1	122.2	127.2	132.0

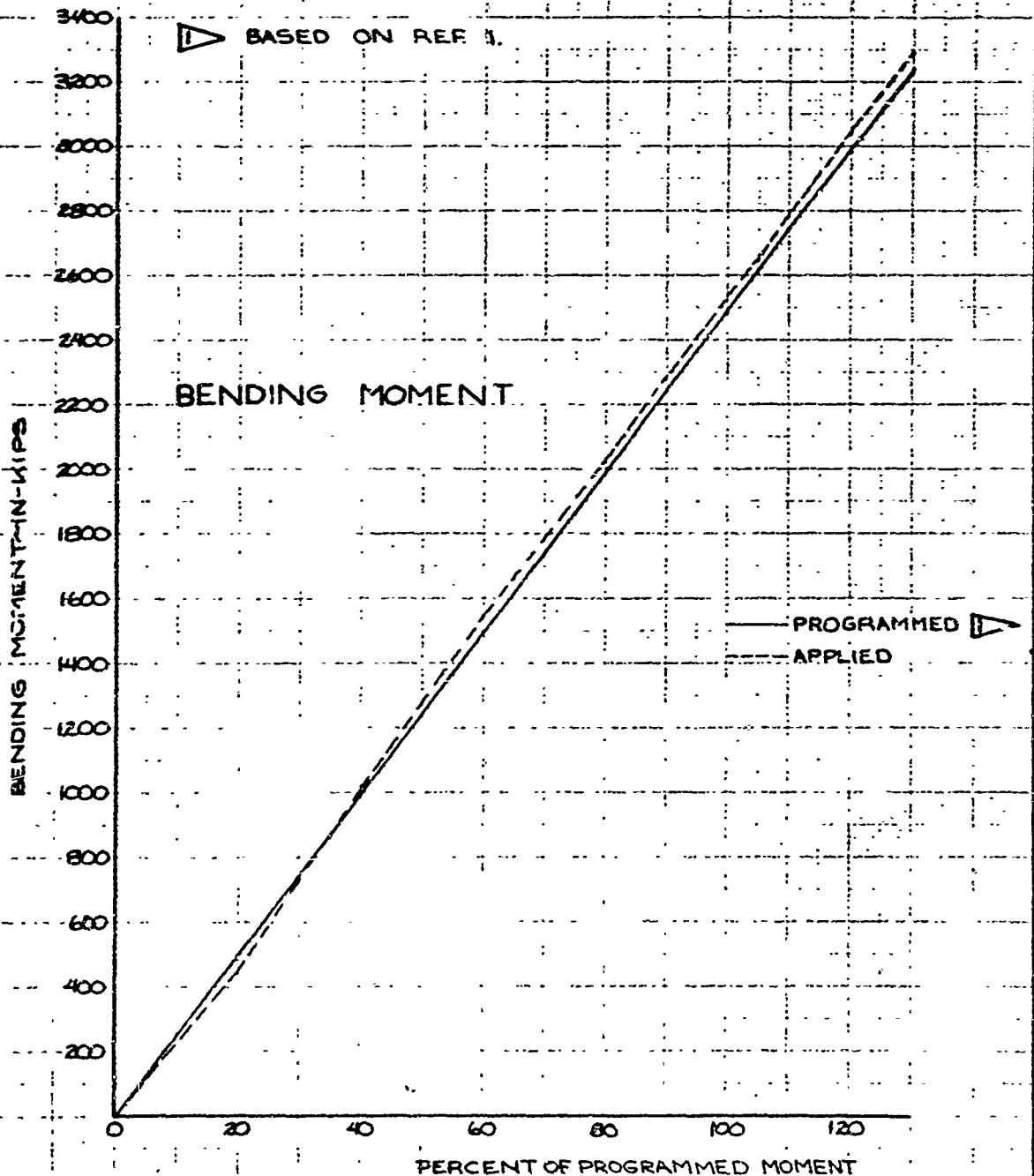

	INITIALS	DATE	REV BY INITIAL	DATE	TITLE	MODEL
CALC	JAG	6-19-8			345-F FAILURE TEST PROGRAMMED & APPLIED MOMENT VS. PERCENT MOMENT STA. 359.0	FIG. 64.2-2
CHECK	JDW	9-16-8				
APPD.						
APPD.						

U3 4013 8000 REV 1/66

REV LTR _____

BOEING NO T2-3657-1
SH 623

PERCENT TEST	0	20	40	60	80	90	100	105	110	115	120	125	130
PROGRAMMED ^{KIPS} ∇	0	2.09	4.04	6.06	8.08	9.09	10.1	10.6	11.1	11.68	12.12	12.62	13.1
APPLIED ^{KIPS}	0	2.05	4.11	6.32	8.25	9.32	10.31	10.76	11.33	11.83	12.36	12.89	13.3
% OF PLANNED 100%		20.3	40.7	62.6	81.7	92.3	102.1	106.5	112.2	117.1	122.4	127.6	131.7

∇ BASED ON REF. 1.

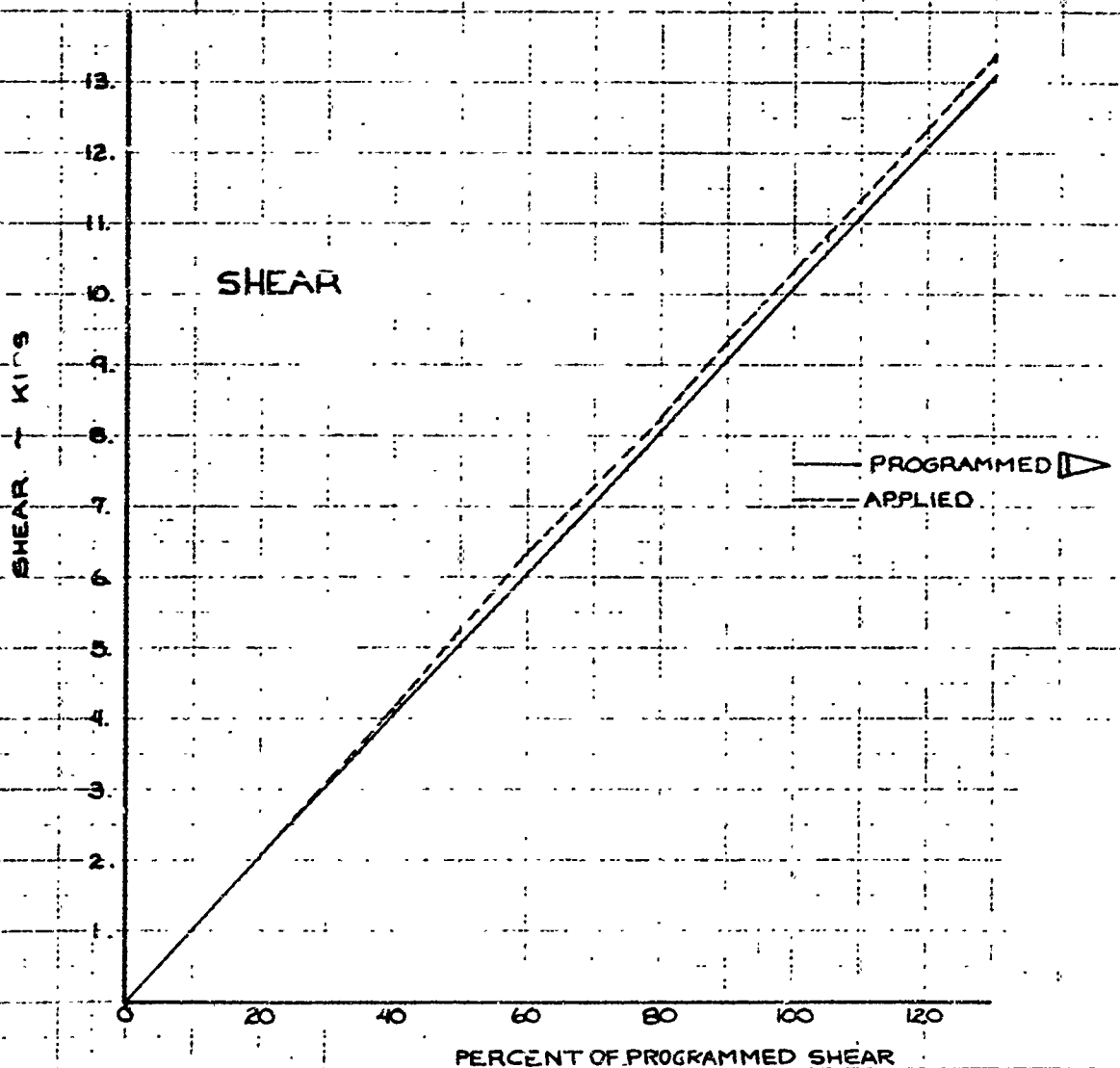

	INITIALS	DATE	REV BY INITIAL	DATE	TITLE	MODEL
CALC	JAG	6-19-5			345-F FAILURE TEST PROGRAMMED & APPLIED SHEAR VS. PERCENT SHEAR- STA. 359.0	
CHECK	ADWT	9-16-9				
APPD.						
APPD.						

FIG. 64.2-3

U3 4013 8000 REV 1/66

REV LTR _____

BOEING NO T2-3657-1
SH 640

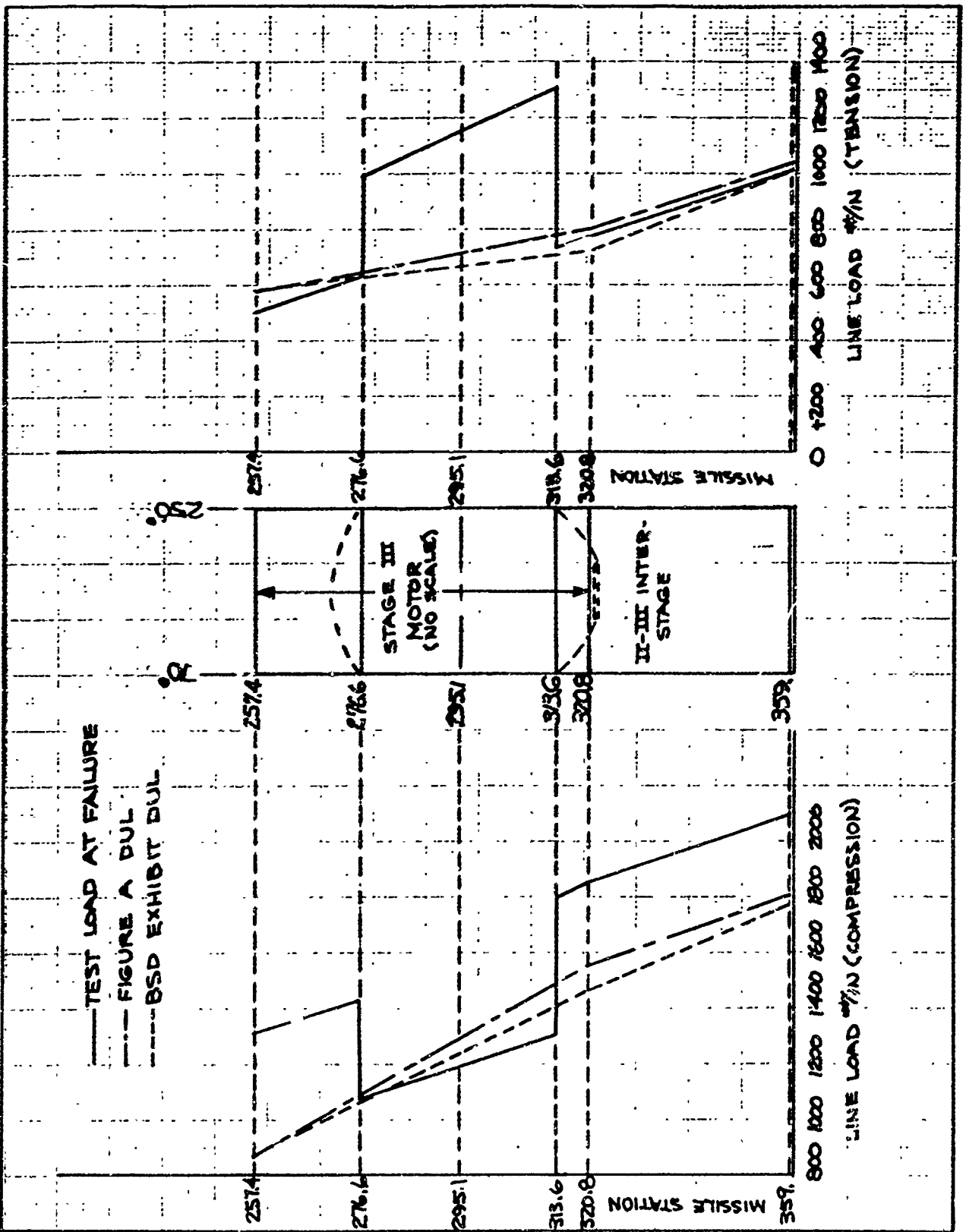

				TITLE	MODEL
CAIC	JET	JUNE 29		345 TEST LINE LOADS AT FAILURE DESIGN ULTIMATE LINE LOADS VS. MISSILE STATION	FIG. 642-4
CHECK	JET	JUL 8			
APPD.					
APPD.					

U3 4013 8000 REV 1/66

REV LTR _____

BOEING NO T2-3657-1
 SH 641

USE FOR TYPEWRITTEN MATERIAL ONLY

6.5
TEST RESULTS

SHEET 642

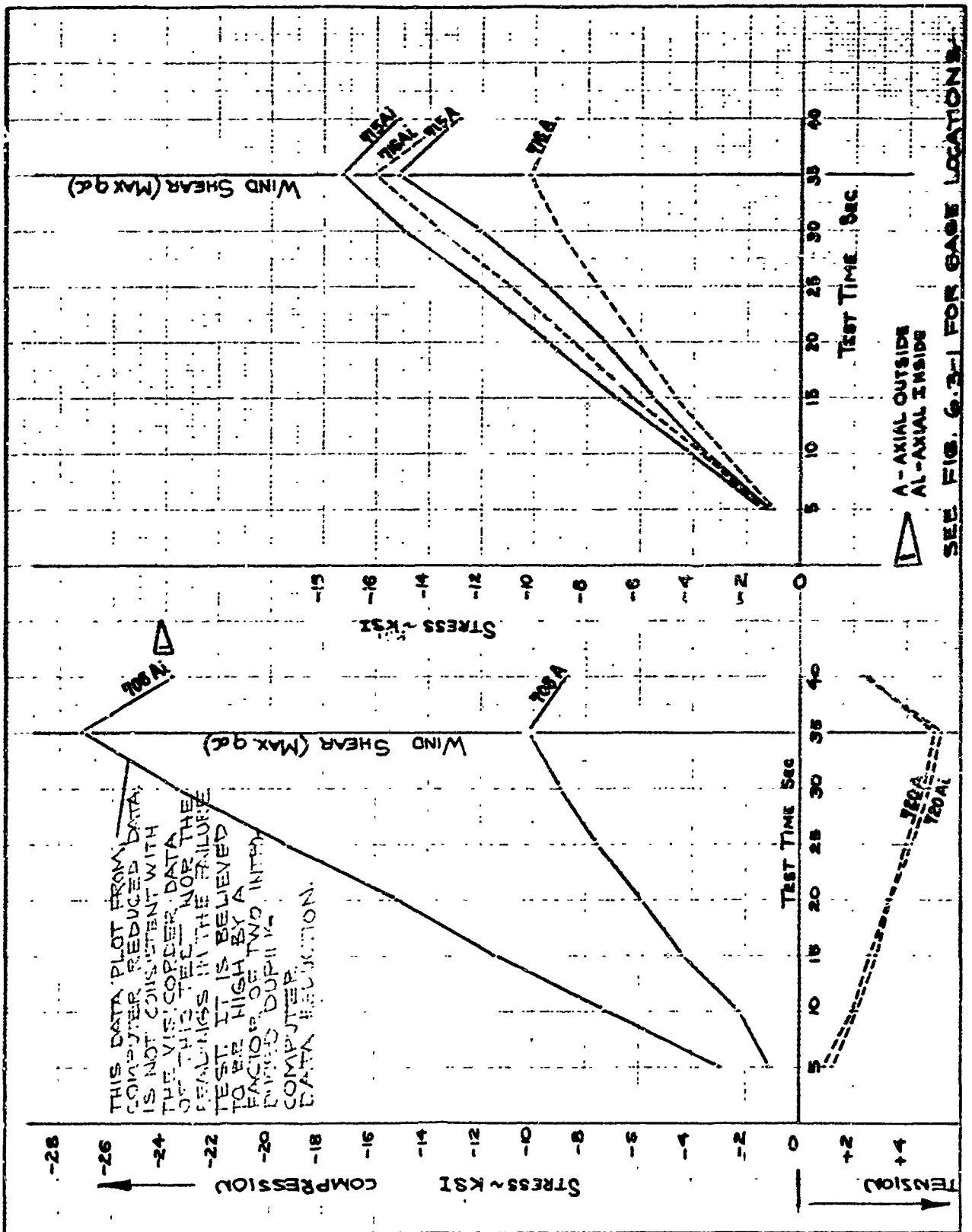

SEE FIG. 6.3-1 FOR GAGE LOCATIONS

THIS DATA PLOT FROM COMPUTER REDUCED DATA IS NOT CONSISTENT WITH THE VISCOPLASTIC DATA OF THIS TEST. FOR THE REASONS IN THE FAILURE TEST, IT IS BELIEVED TO BE HIGH BY A FACTOR OF TWO IN THE DURING DUPLICATION. COMPUTER DATA REDUCTION.

	INITIALS	DATE	REV BY INITIAL	DATE	TITLE	MODEL
CALC	<i>WJL</i>	7-24-64			345-F PROGRAMMED HEAT AND LOAD TEST STRAIN GAGE READINGS	FIG. 6.5-1
CHECK	<i>WJL</i>	8/4				
APPD.						
APPD.						

U3 4013 8000 REV 1/66

REV ITR _____

BOEING NO T2-3657-1
SH 642

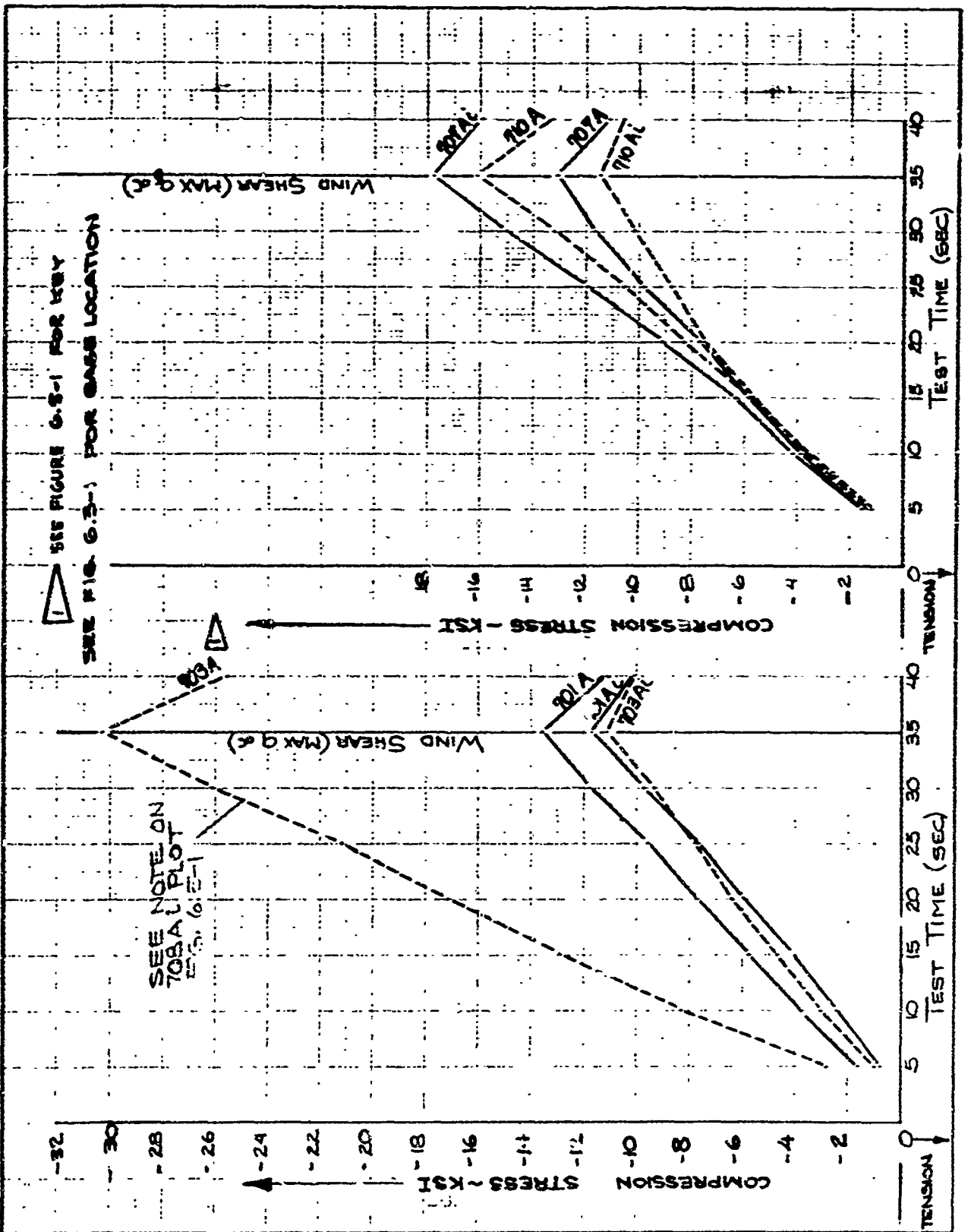

	INITIALS	DATE	REV BY INITIAL	DATE	TITLE	MODEL
CALC	<i>WJL</i>	7-24-64			345-F PROGRAMMED HEAT AND LOAD TEST STRAIN GAGE READINGS	FIG. 6.5-2
CHECK	<i>RET</i>	8-17				
APPD.						
APPD.						

U3 4013 8000 REV 1/66

REV LTR _____

BOEING NO. T2-3657-1
SH 644

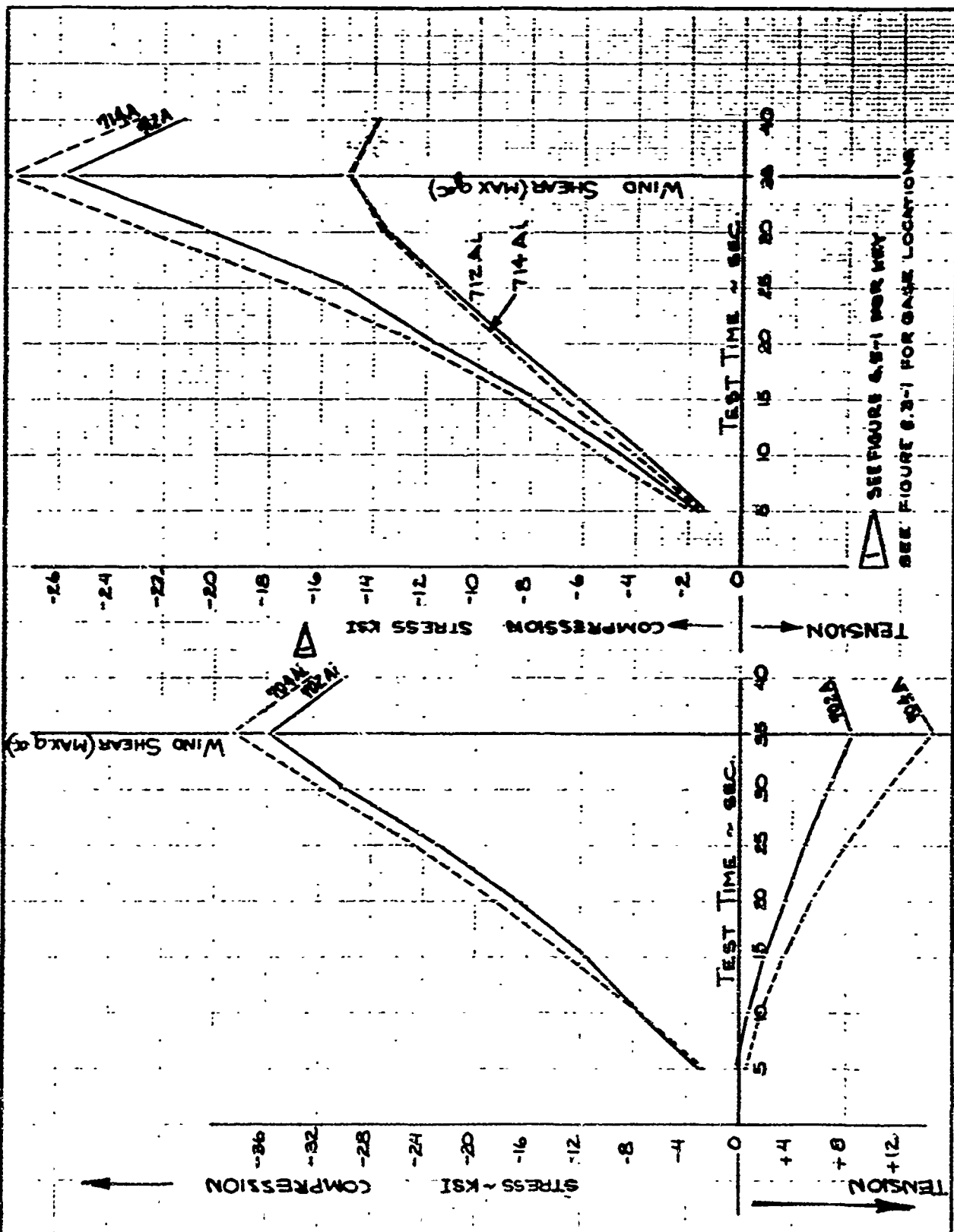

	INITIALS	DATE	REV BY INITIAL	DATE	TITLE	MODEL
CALC	<i>MDW</i>	3-5-8			345-F PROGRAMMED HEAT AND LOAD TEST STRAIN GAGE READINGS	FIG. 6.2-3
CHECK	<i>JRT</i>	1-19				
APPD.						
APPD.						

U3 4013 8000 REV 1/66

REV LTR _____

BOEING NO T2-3657-1
SH 64E

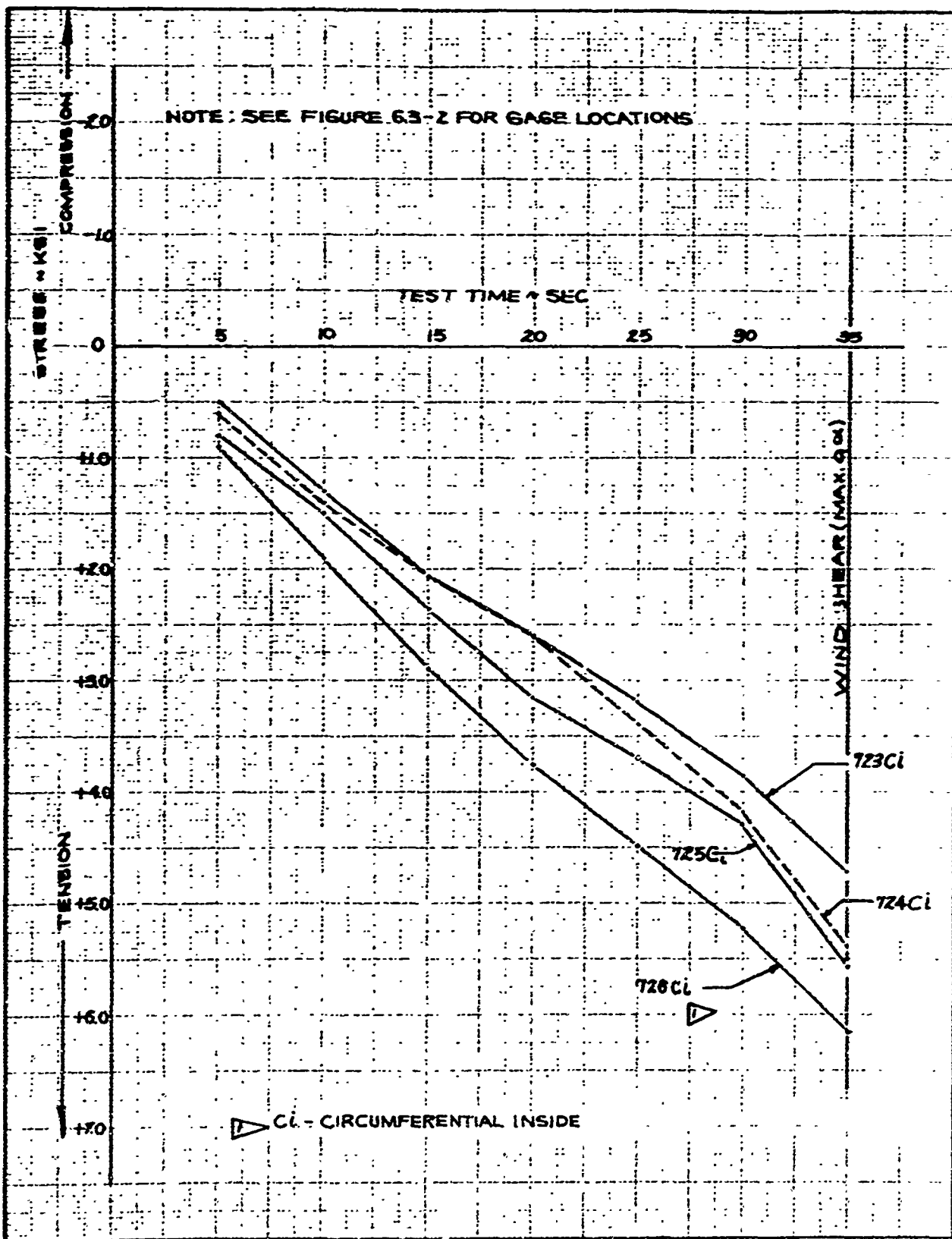

	INITIALS	DATE	REV BY INITIAL	DATE	TITLE	MODEL
CALC	GDW	11-12-8			345-F PROGRAMMED HEAT AND LOAD TEST STRAIN GAGE READINGS	FIG. 6.5-4
CHECK	NET	11-12-8				
APPD.						
APPD.						

US 4013 8000 REV. 1/66

REV LTR _____

BOEING NO. T2-3657-1
SH. 646

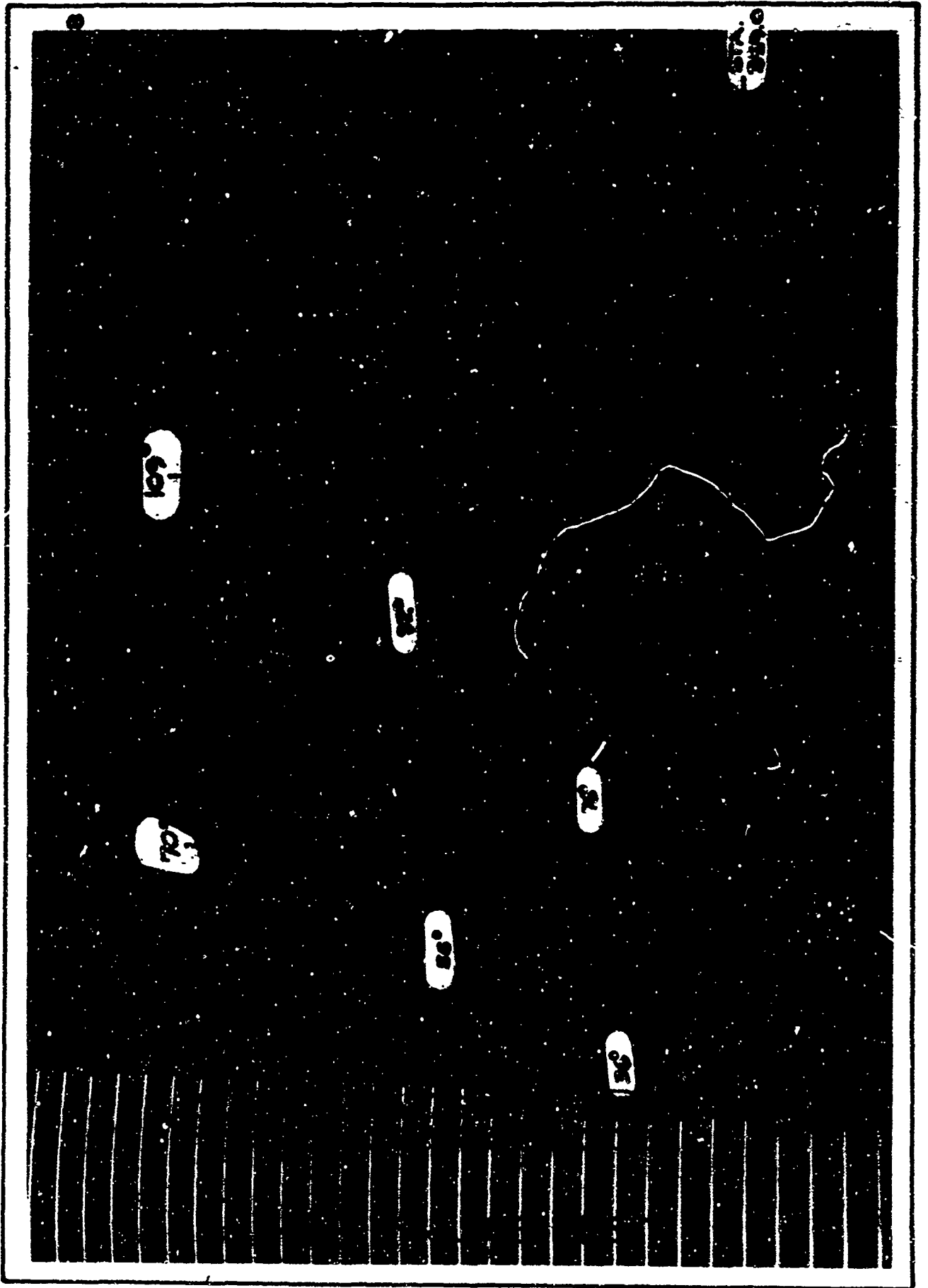

SHEET 647

FIG. 6.5-5





345-F FAILURE TEST

SHEET 648

FIG. 6.5-6



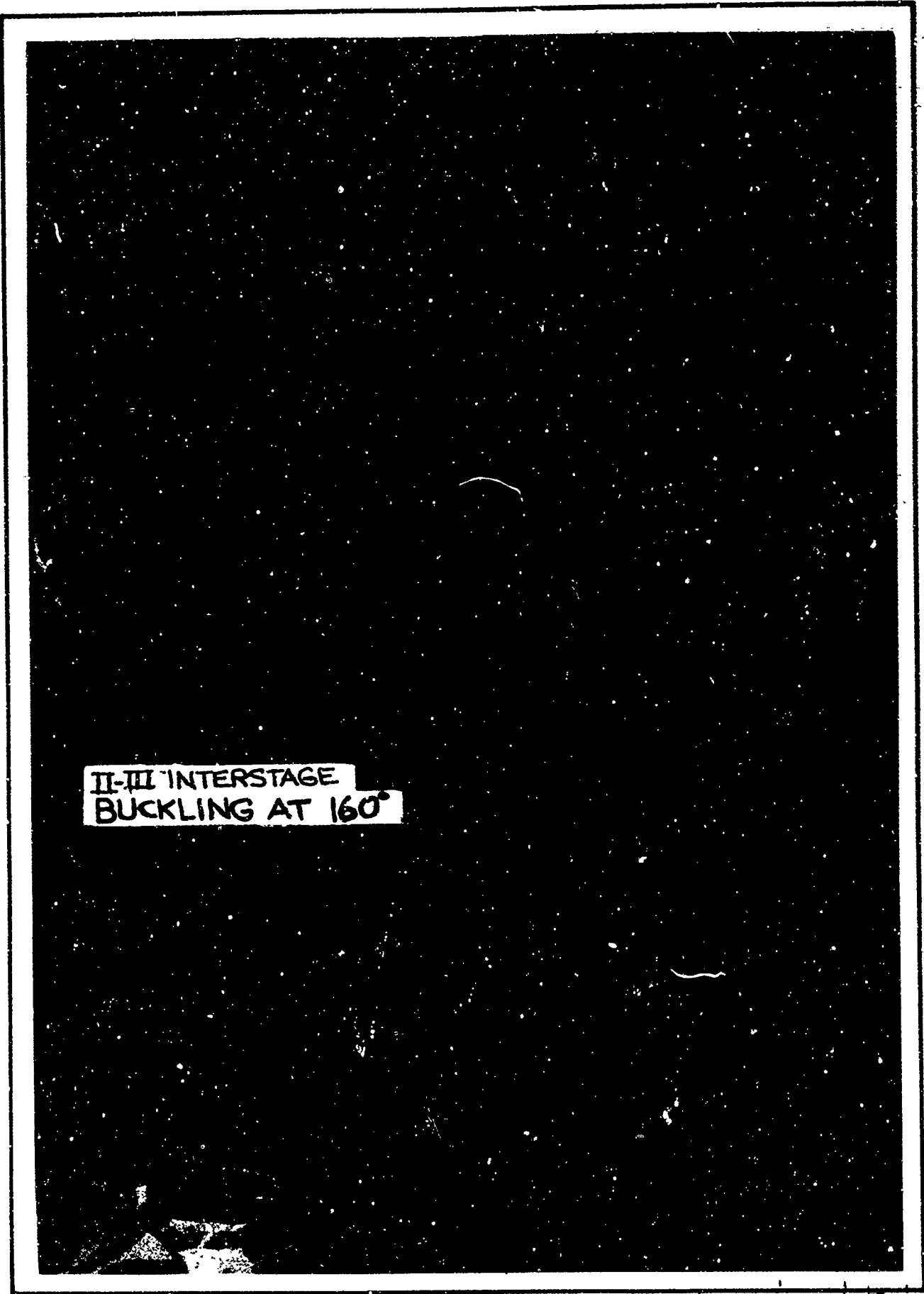

II-III INTERSTAGE
BUCKLING AT 160°



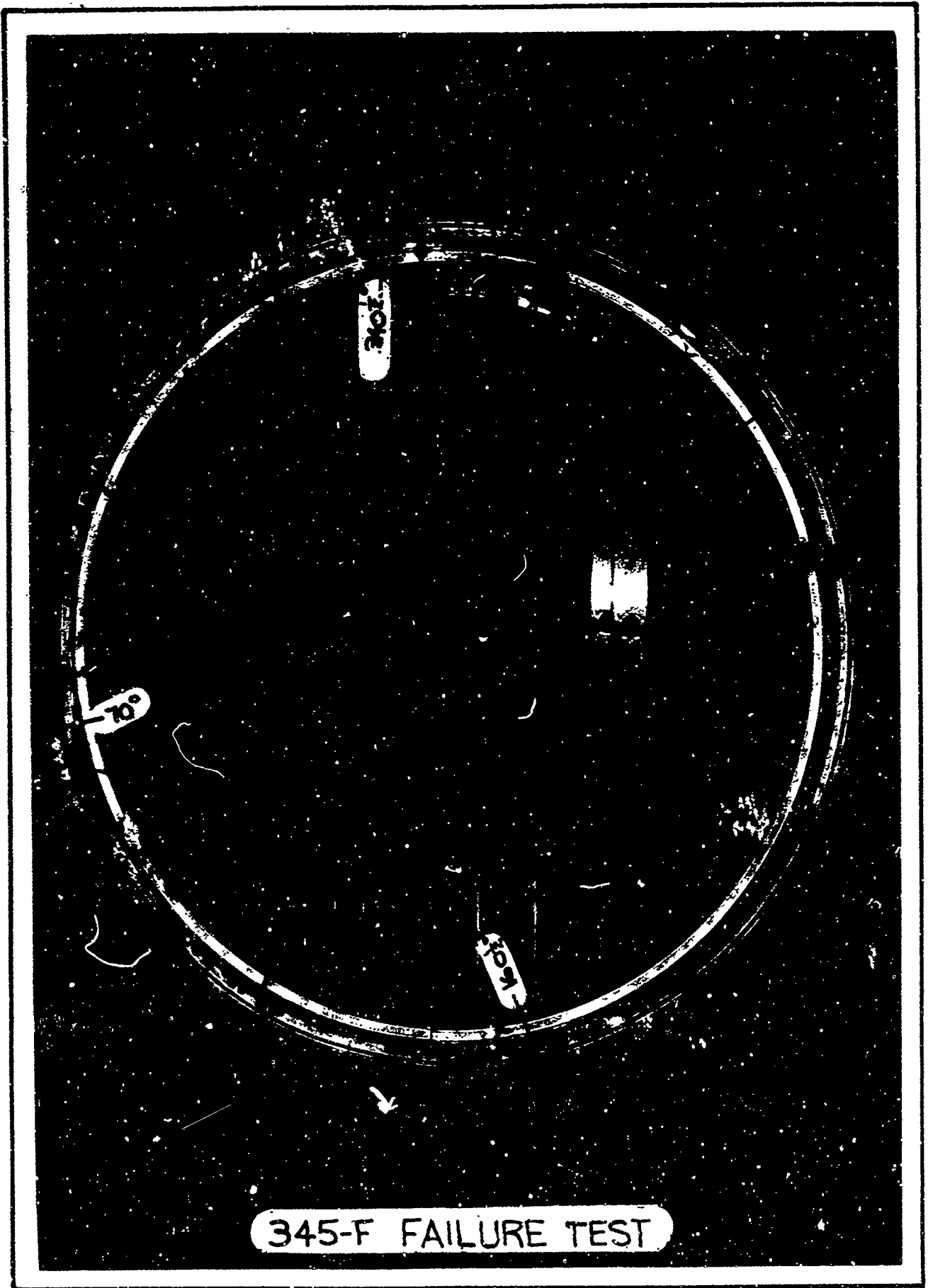

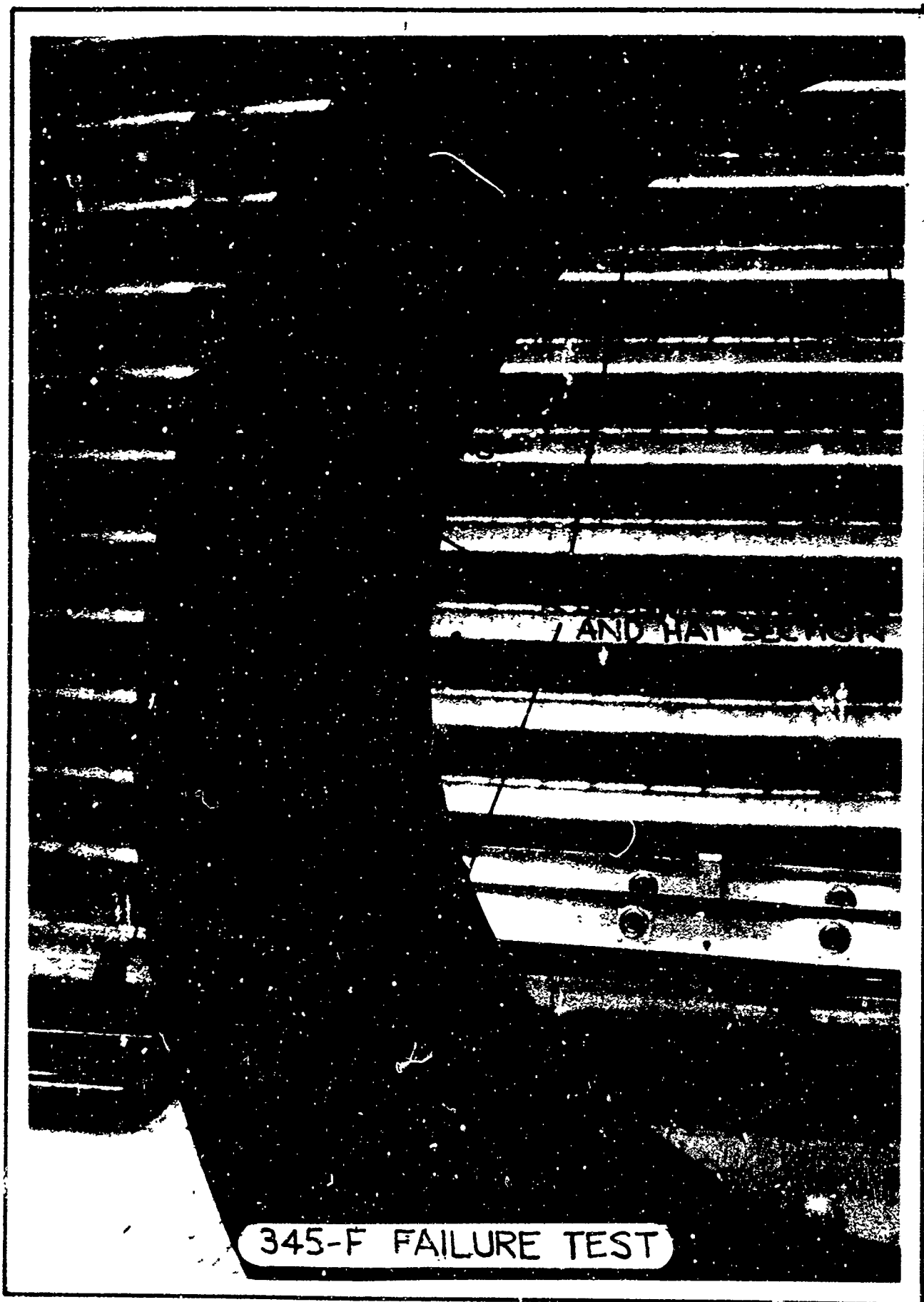

345-F FAILURE TEST

SHEET 651

FIG. 6.5-9



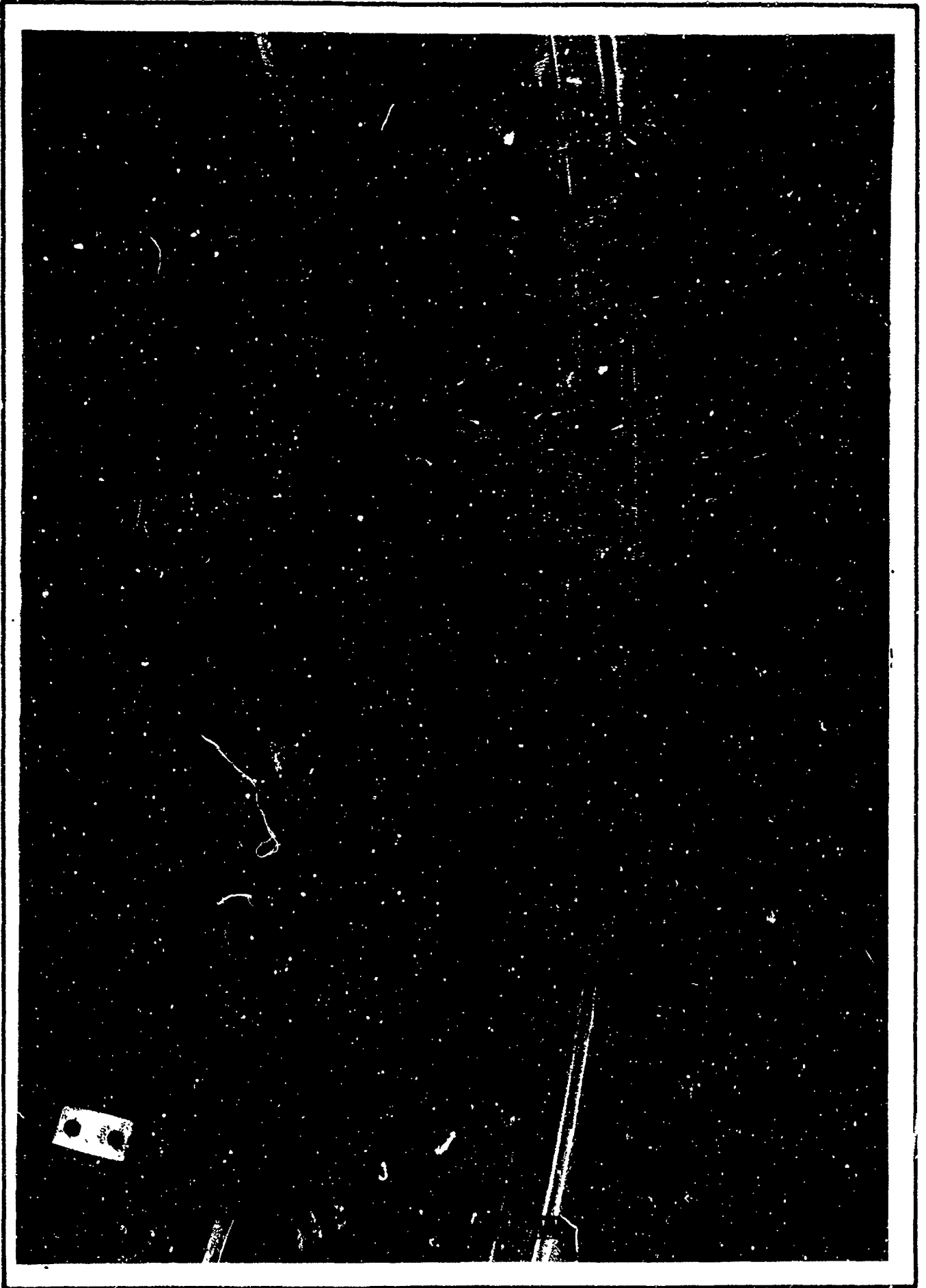

SHEET 652

FIG. 6.5-10

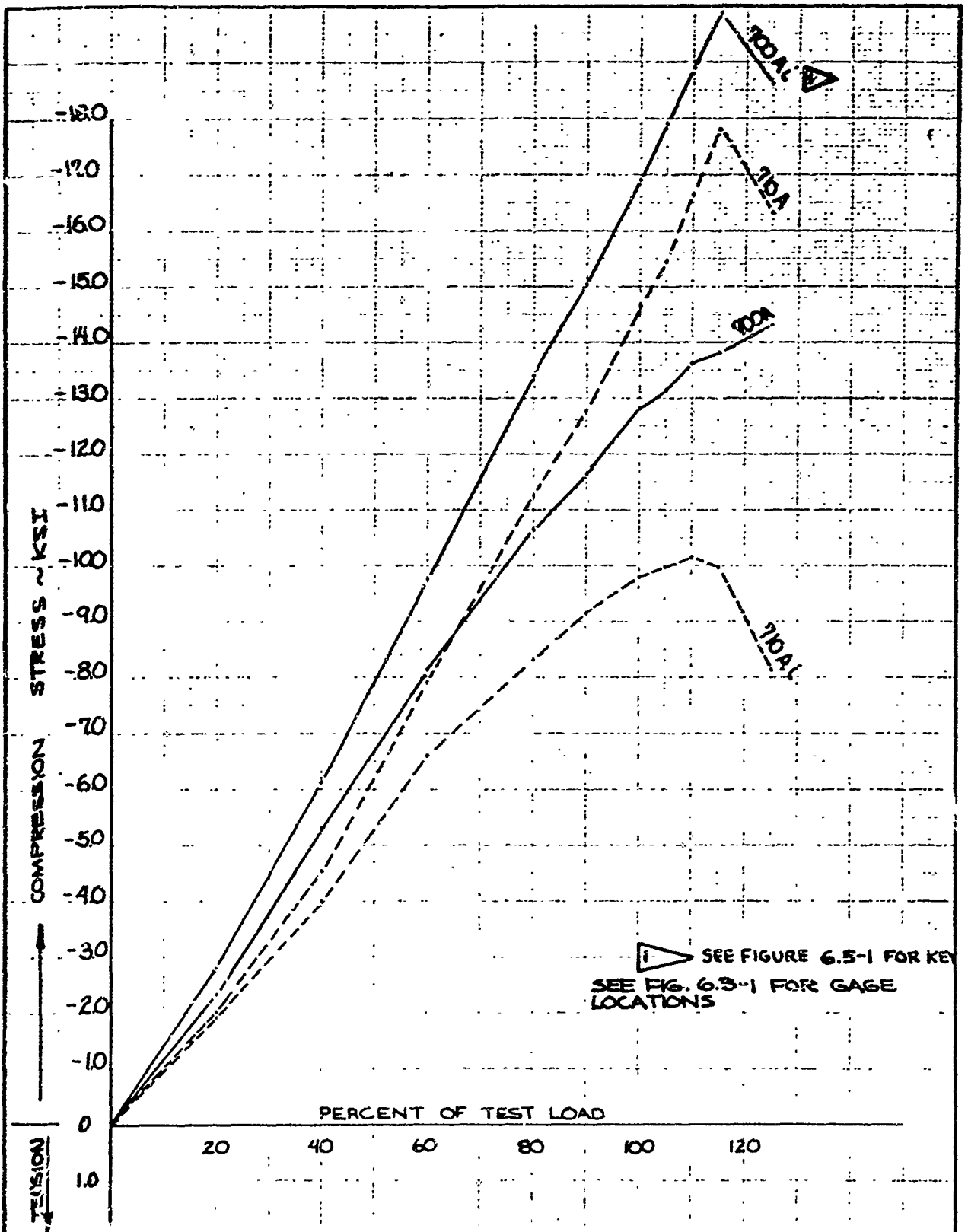

SEE FIGURE 6.5-1 FOR KEY
SEE FIG. 6.5-1 FOR GAGE
LOCATIONS

	INITIALS	DATE	REV BY INITIALS	DATE	TITLE	MODEL
CALC	GDWB-7-5				345-F FAILURE TEST STRAIN GAGE READINGS	FIG. 6.5-11
CHECK	WET	8-17				
APPD.						
APPD.						

US 4013 8000 REV 1/66

REV LTR _____

BOEING NO T2-3657-1
SH 6E3

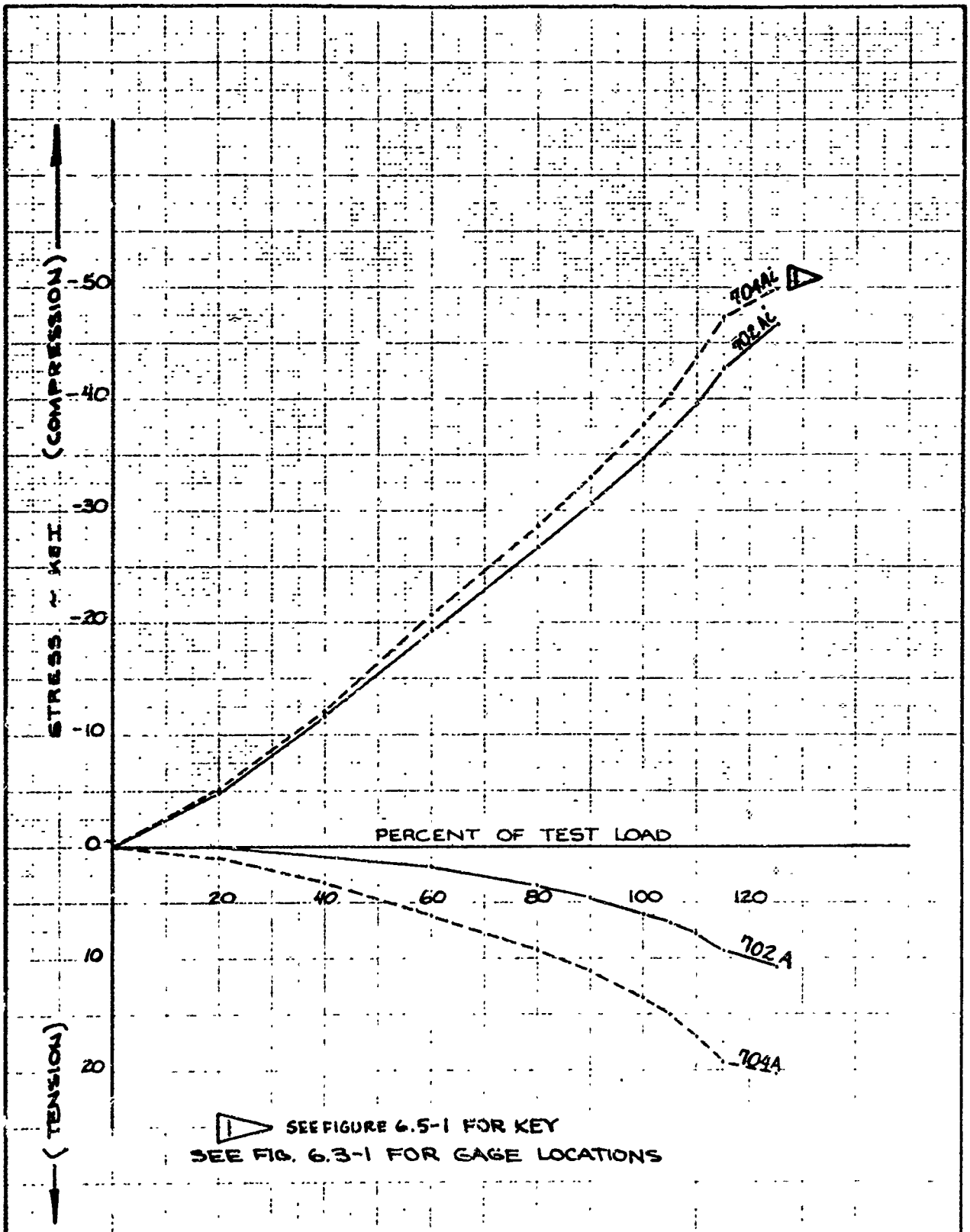

SEE FIGURE 6.5-1 FOR KEY
SEE FIG. 6.3-1 FOR GAGE LOCATIONS

	INITIALS	DATE	REV BY INITIAL	DATE	TITLE	MODEL
CALC	SPS	7/17/66			345-F FAILURE TEST STRAIN GAGE READINGS	6.5-12
CHECK	GNW	5-19-66				
APPD.						
APPD.						

U3 4013 9000 REV 1/66

REV LTR _____

BOEING NO T2-3657-1
SH 654

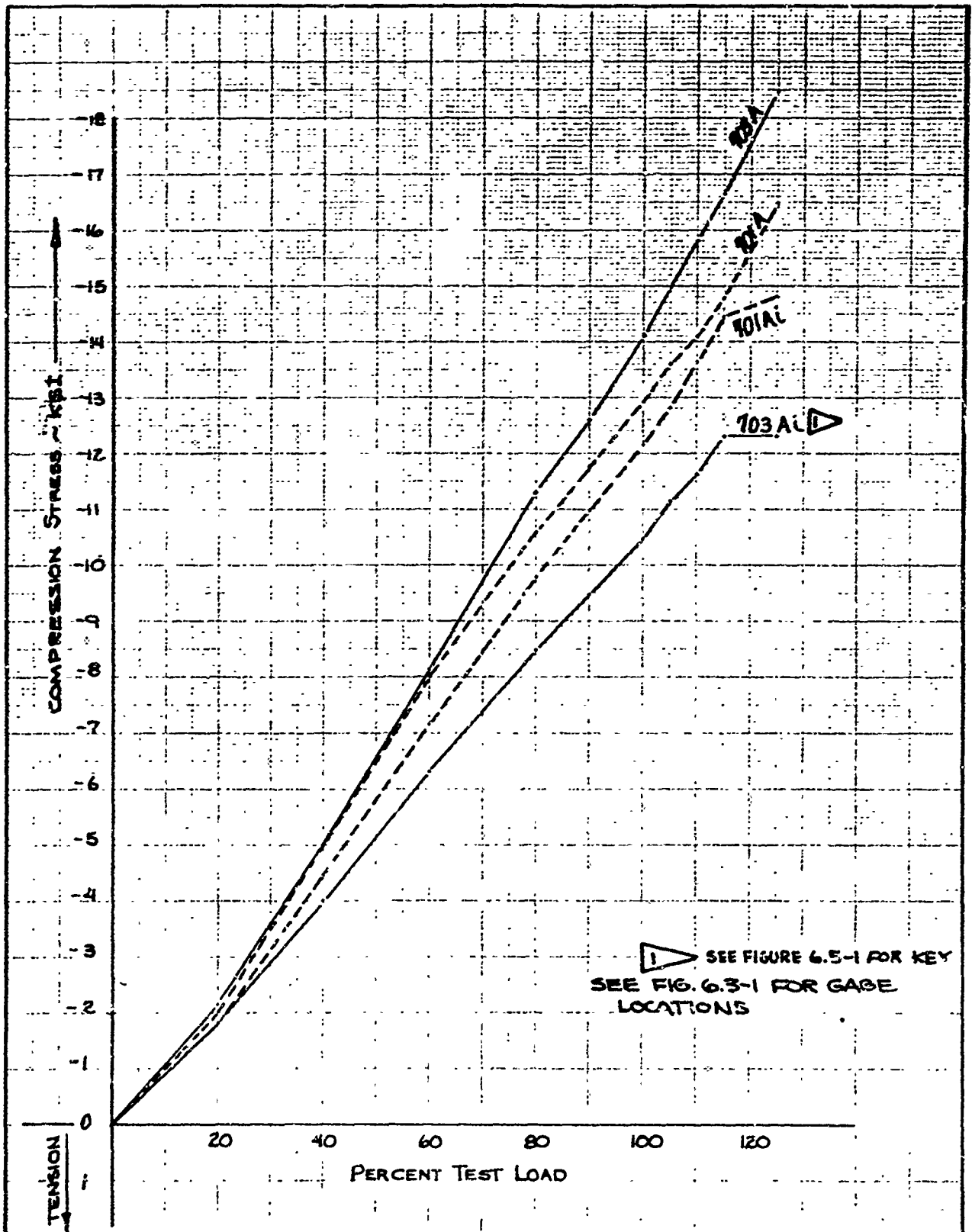

SEE FIGURE 6.5-1 FOR KEY
SEE FIG. 6.3-1 FOR GAGE
LOCATIONS

	INITIALS	DATE	REV BY INITIAL	DATE	TITLE	MODEL
CALC	<i>[Signature]</i>	7/17			345-F FAILURE TEST STRAIN GAGE READINGS	6.5-13
CHECK	<i>[Signature]</i>	9/16/64				
APPD.						
APPD.						

U3 4013 8000 REV 1/66

REV LTR _____

BOEING NO T2-3657-1
SH 65E

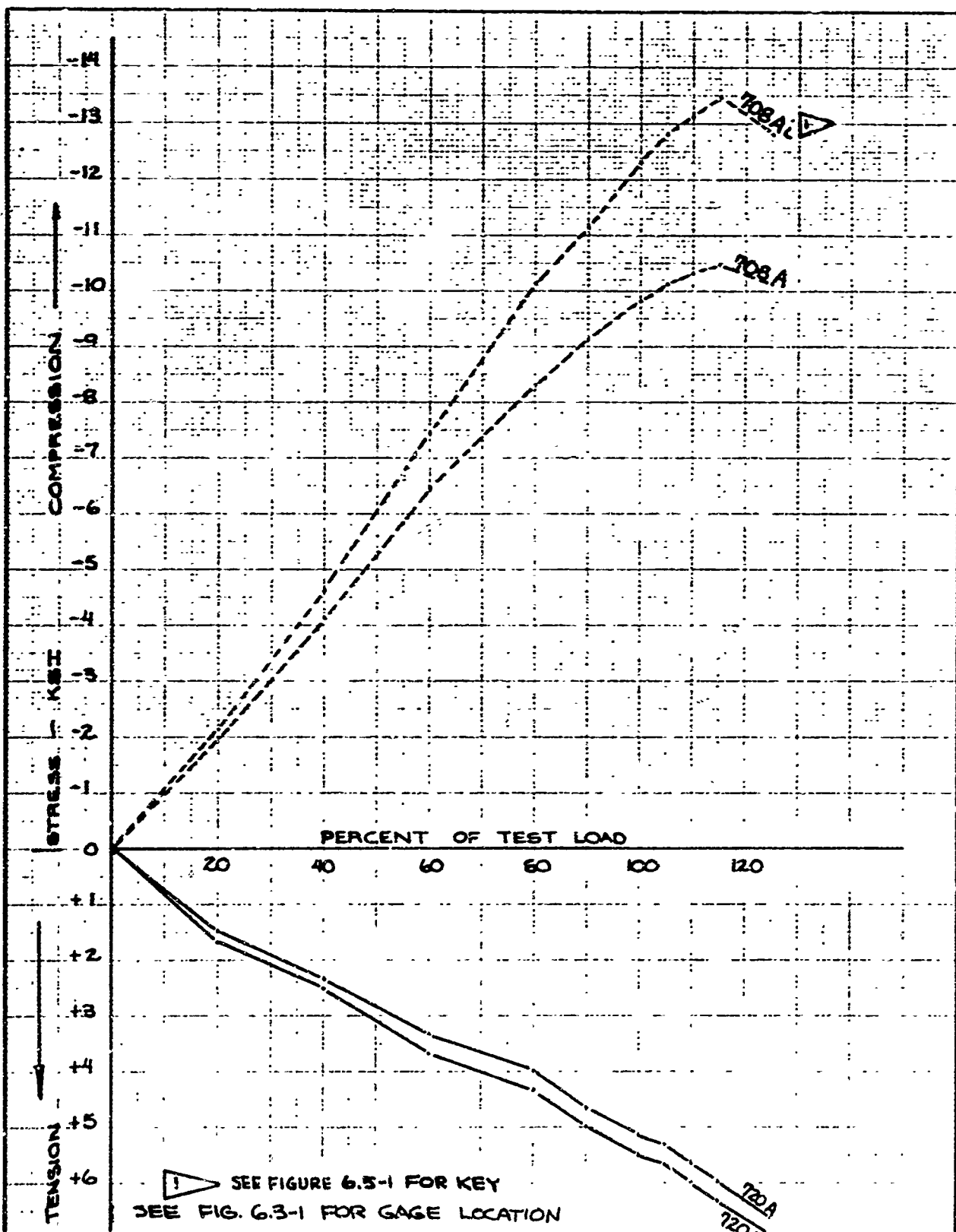

	INITIALS	DATE	REV BY INITIAL	DATE	TITLE	MODEL
CALC	JAG	8-78			345-F FAILURE TEST STRAIN GAGE READINGS	FIG. 6.5-14
CHECK	JDW	2-16-81				
APPD.						
APPD.						

U3 4013 8000 REV 1/66

REV LTR _____

BOEING NO T2-3657-1
SH 656

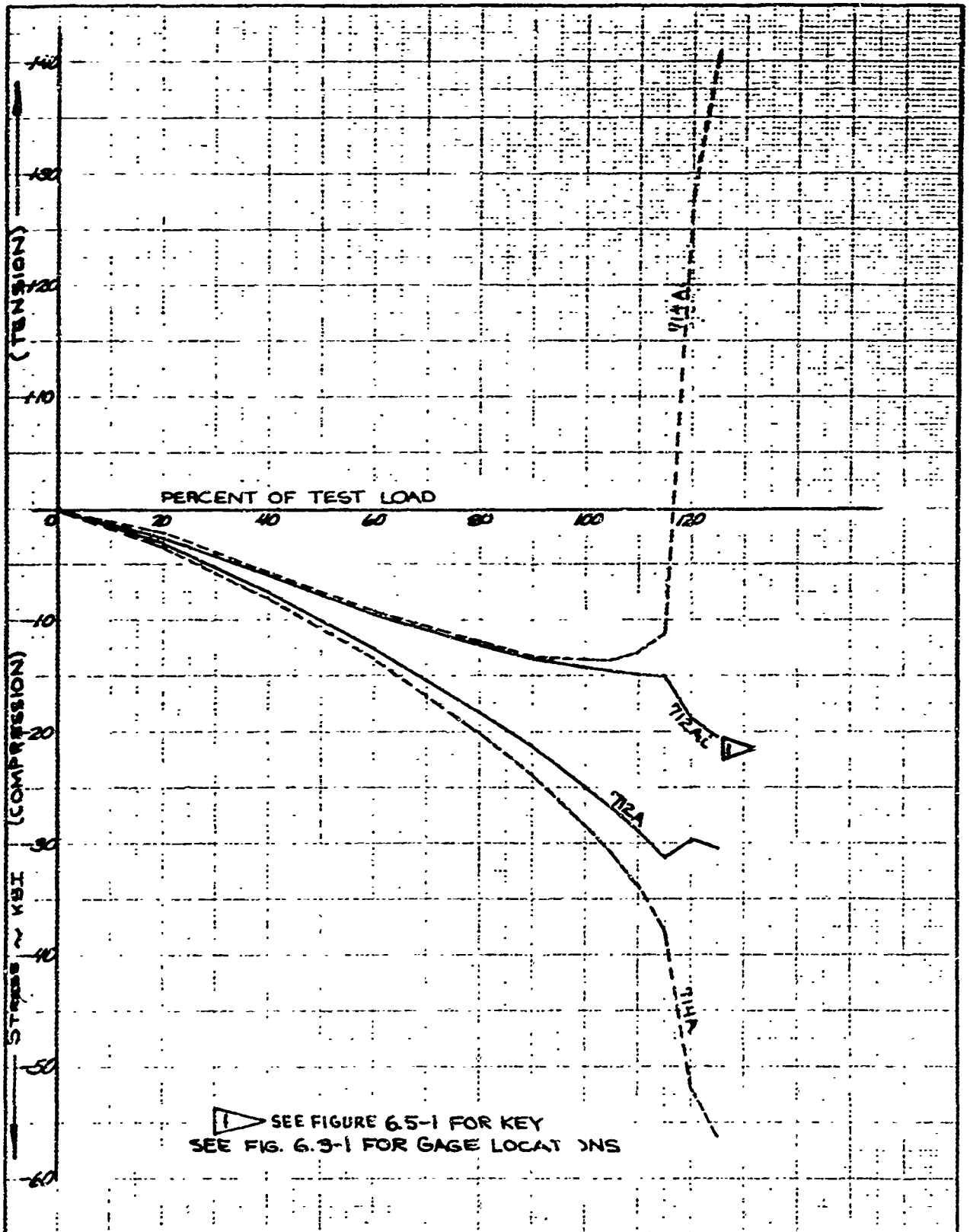

	INITIALS	DATE	REV BY INITIAL	DATE	TITLE	MODEL
CALC	<i>[Signature]</i>	9/17/63			345-F FAILURE TEST STRAIN GAGE READINGS	6.5-15
CHECK	<i>[Signature]</i>	9/16/64				
APPD.						
APPD.						

U3 4013 6000 REV 1/66

REV LTR _____

BOEING NO T2-3657-1
SH 657

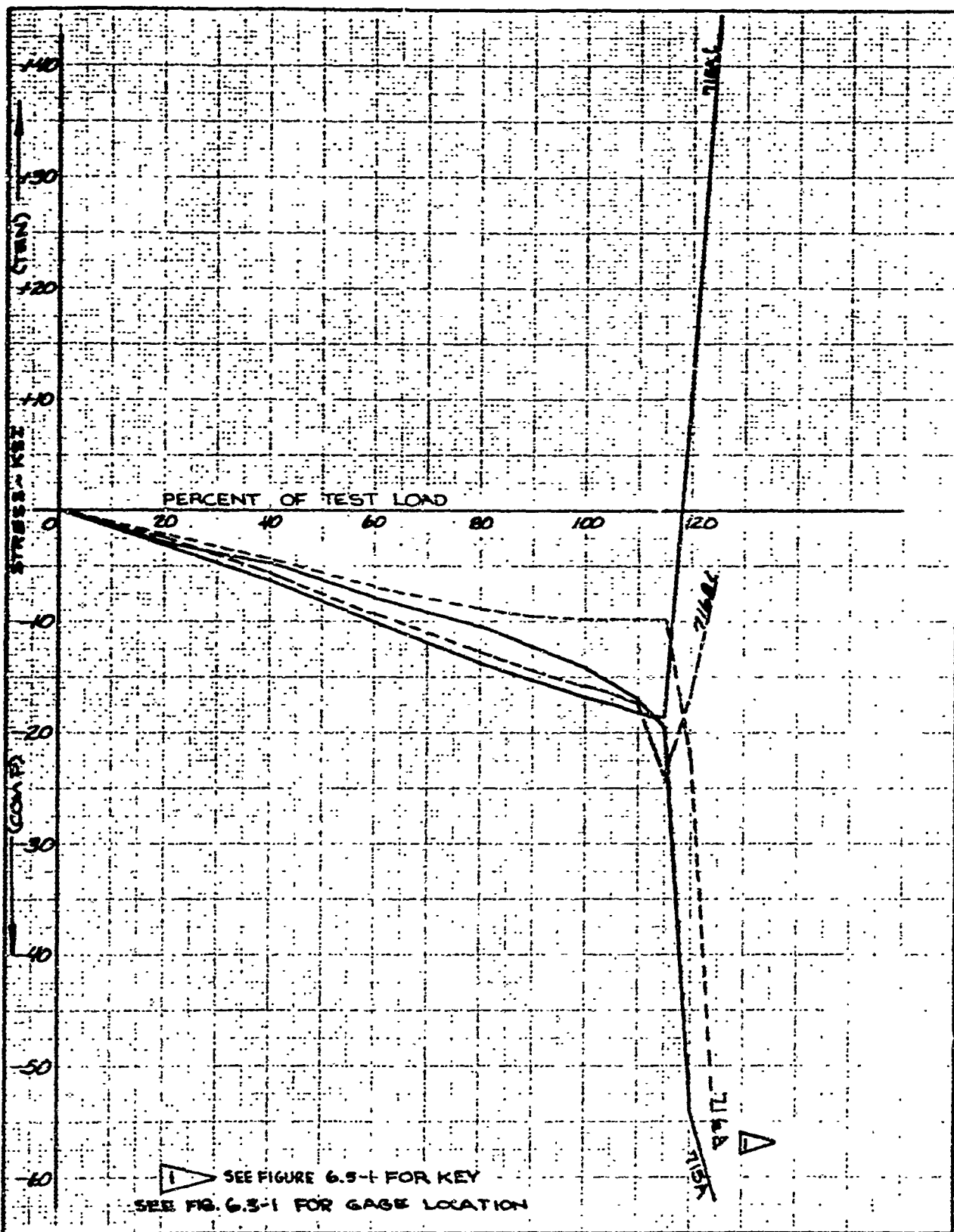

	INITIALS	DATE	REV BY INITIAL	DATE	TITLE	MODEL
CALC	<i>SLB</i>	<i>7/16/65</i>			345-F FAILURE TEST STRAIN GAGE READINGS	65-16
CHECK	<i>SLB</i>	<i>9/16/65</i>				
APPD.						
APPD.						

US 4013 8000 REV. 1/66

REV LTR _____

BOEING NO. T2-3657-1
SH. 65E

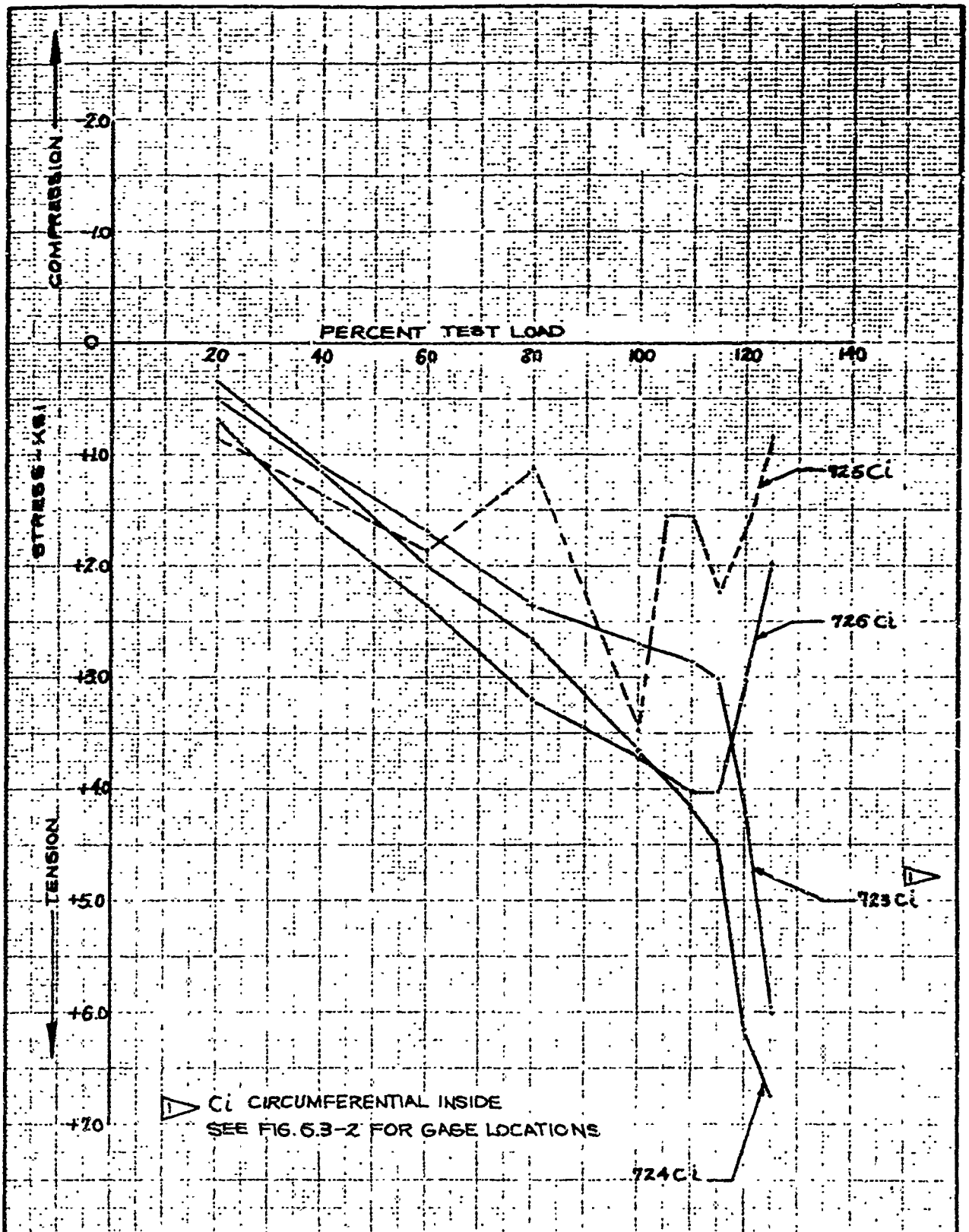

	INITIALS	DATE	REV BY INITIAL	DATE	TITLE	MODEL
CALC	GDW	11-12-8			345-F FAILURE TEST STRAIN GAGE READINGS	FIG, 6.5-17
CHECK	JET	11-12-8				
APPD.						
APPD.						

U3 4013 8000 REV. 1/66

REV LTR _____

BOEING NO. T2-3657-1
SH 659

BENDING MOMENT - IN-LBS PER INCH OF CIRCUMFERENCE

Key - SG - STRAIN GAGE
SEE FIG. 6-3-1 FOR GAGE LOCATIONS

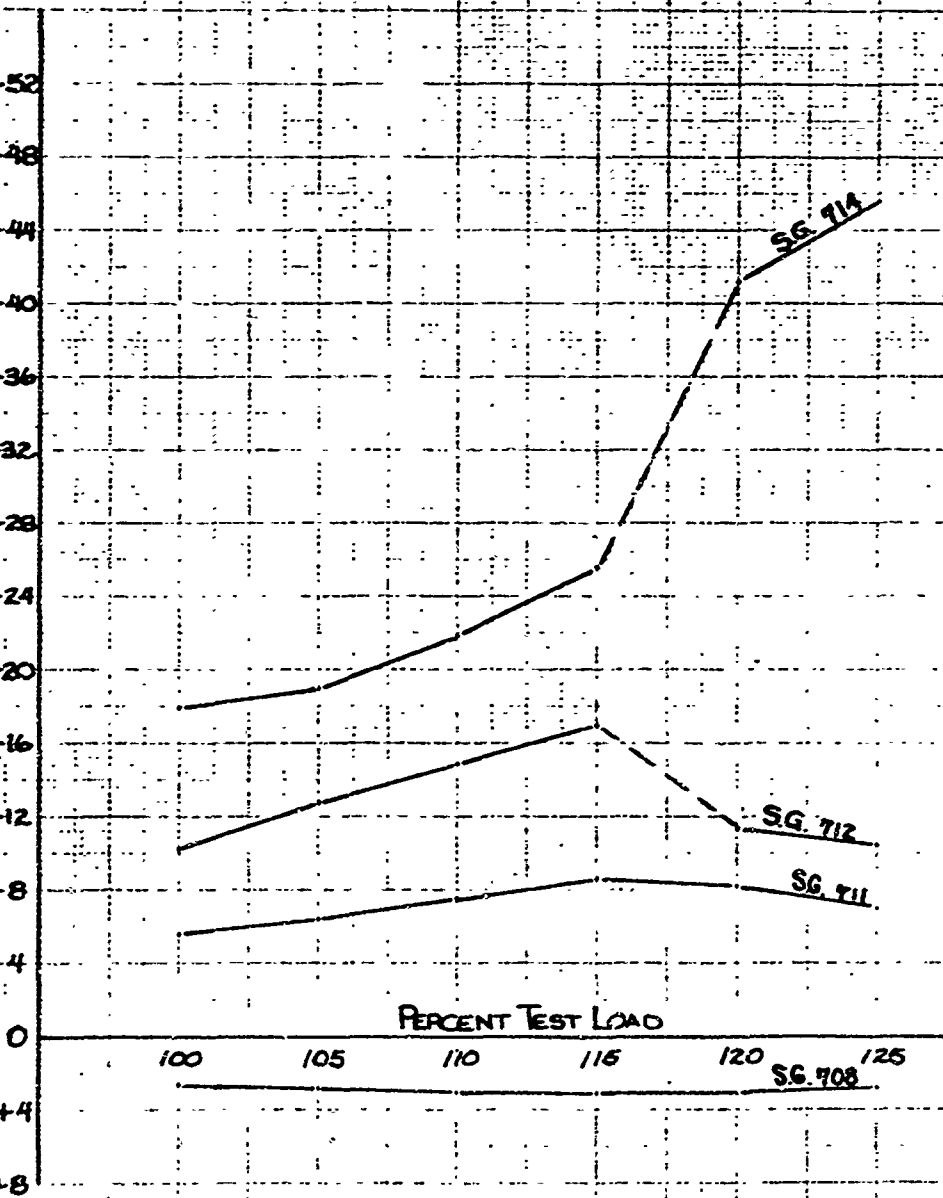

	INITIALS	DATE	REV BY INITIAL	DATE	TITLE	MODEL
CALC	<i>WDL</i>	<i>7-25-59</i>			345-F FAILURE TEST LOCAL SKIN BENDING VERSUS PER- CENT ULTIMATE LOAD	6.5-13
CHECK	<i>ST</i>	<i>8-19</i>				
APPD.						
APPD.						

U3 4013 8000 REV 1/65

REV LTR _____

BOEING NO T2-3 657-1
SH 660

7.0 MINUTEMAN III STIFFNESS DETERMINATION TESTS

7.1 TEST DESCRIPTION AND TEST SPECIMEN

The stiffness determination tests consisted of the evaluation of the load-deflection characteristics for those sections and joints of the Minuteman III missile above the Stage II motor case. The tests were denoted as the 345-F, 332-F, and 333-F tests. For the 345-F test, the II-III interstage was the primary test area. See paragraph 6.1, page 600, for a detail description of the test specimen.

The upper sections were tested in two distinctive configurations. Test 332-F had the MOD 7E wafer inserted, whereas in test 333-F the MOD 7E wafer was removed. In addition, the latter two stacks were tested in the shroud on and shroud off configurations. Shroud on and shroud off indicates load application through the R/S shroud for the former and through the R/S Frustum for the latter. The five test specimens are schematically shown in Figure 7.1-1. See paragraph 4.1, page 400, for a detail description of the test specimen 332-F.

Four runs were conducted on each test specimen. The four runs consisted of combinations of loads in the gapped and butted joint conditions. The gapped joint condition was tested under a pure tension load, a pure bending load, and a combined compression, bending and shear load. The butted joint condition was tested only under the combined compression, bending, and shear load. Table 7.1-1 summarizes for each test the load conditions and the joints and/or sections tested. In conjunction with this table, the test specimens are illustrated in Figures 7.1-2 through 7.1-6.

The gapped joint condition was obtained during assembly as approximately one-half the maximum measured gap that occurs at each interface joint under a tension load. The tension load was just large enough to bottom out the interface bolt holes on the interface bolts. A compression load just large enough to eliminate the gap at the interface joints established the butted joint condition. Gaps were measured and recorded after each run to determine if joint slip had occurred and if regapping was required prior to the next run.

7.2 TEST SETUP

Hydraulic jacks were used to apply the axial, bending, and shear loads. The jacks were connected to a load distribution head which in turn was connected to the forward end of the test specimen. The aft end of the test specimen was connected to a fixed load distribution head. Figure 7.2-1 is a schematic of the load head geometry.

For tests 345-F, 332-F (shroud on), and 333-F (shroud on), four vertical jacks were used to apply the axial and bending loads. Uniform jack loads produced axial tension or compression, while differential jack loads produced bending. A fifth horizontal jack produced the shear load. The jack locations for each test are shown in Figures 7.1-2, 7.1-3, and 7.1-5. Two vertical jacks were used to apply the axial and bending loads for tests 332-F (shroud off) and 333-F (shroud off). Uniform jack loads produced axial tension or compression, while differential jack loads produced bending. A third horizontal jack produced the shear load. The jack locations for each test are shown in Figures 7.1-4 and 7.1-6.

7.3 TEST CONDITIONS

Figure 7.3-1 shows the load sequence for each test run. The type of loading per run was discussed in Section 7.1. The maximum prescribed values for the loads are given in Reference 1.

7.4 INSTRUMENTATION

Deflections were measured by electronic deflection indicators (EDI's). A discussion of the method of operation of an EDI is contained in Reference 7. There were eight EDI's around the circumference of each datum (section or joint) to be tested, with two exceptions. In the 332-F (shroud off) and 333-F (shroud off) tests, dual gages were mounted at each of the circumferential locations (Figures 7.14 and 7.16). Thus the erroneous deflection due to the rotation of the post mount on the R/S Frustum was accounted for and eliminated from the measured deflection.

Post type mounts, bonded to the skin surface, were the attachment points for the EDI's in test 345-F. The EDI's at alternate datums were .3 and .5 inches from the skin surface with the exception of run #4, datum 4 as shown in Figure 7.1-2. Where the section or joint span exceeded the EDI span, a wire extension was used to connect the EDI to the post mount. For this test the EDI plus wire was calibrated as a unit. In all other tests (excluding the shroud off R/S Frustum attachment point), a clip type mount was bonded to the skin surface such that all EDI's were approximately .05 inches from the skin surface. Again wire connectors were used, where required, to attach the EDI's between clips. However, the EDI's were calibrated separately and a correction factor based on the deflection of the wire was applied to the EDI deflection to obtain the joint or section deflection.

7.5 DATA ACQUISITION AND REDUCTION

The jack loads and EDI deflections were recorded at selective time intervals on a SDS 910 computer. A library tape is produced in addition to a preliminary copy of the data. Subsequently, the data are converted into a Fortran tape for use by a principal loads and deflections program on the IBM 7094. The program (described in Reference 7) produces punched cards and plots of axial force versus axial deflection and moment versus rotation for each time increment. A second program uses selective punched cards to yield stiffness values based on the minimization of the square of the deflection or load error.

7.6 TEST RESULTS

7.6.1 SAMPLE REDUCED DATA - STAGE III MOTOR CASE

As an example of the type of reduced data produced by the principal loads and deflections program, selective points generated for the Stage III Motor case are plotted in Figures 7.6-1 and 7.6-2. Stiffness values are tabulated on the figures and converted to AE and EI values in Table 7.6-3. The process

7.6.1 SAMPLE REDUCED DATA - STAGE III MOTOR CASE (Continued)

by which displacements measured by EDI's at eight locations around the circumference are converted into an angular rotation, is illustrated in Figure 7.6-3. From test 333-F, three increments of deflection corresponding to three load increments taken during the moment application of run #4 are plotted around the circumference of the cylinder. The plane (shown as a line in the side view) for which the square of the deflection error is a minimum is generated by the principal loads and deflections program. The rotation angle corresponding to this plane in addition to the maximum and minimum angles using any two EDI's (excluding the two EDI's at the neutral axis) are plotted vs. moment in Figure 7.6-4. Figure 7.6-4 shows the scatter of data that might be expected from measuring stiffness from two gages as opposed to the eight used in this test.

7.6.2 TEST VALUES OF AE AND EI

Tables 7.6-1 through 7.6-5 summarize the results of the stiffness evaluation tests. The stiffness values obtained through the process described in Section 7.5 were multiplied by the appropriate section or joint length to give values of AE and EI. Also included in the tables are average values and theoretical values. The theoretical values were obtained from Reference 8, except as indicated. The joints were assumed to be comprised of two uniform shell segments, butted at the joint and continuous. The error introduced by this assumption is discussed in Section 7.7. Table 7.6-6 lists the geometry and stiffness properties of all components.

USE FOR TYPEWRITTEN MATERIAL ONLY

7.7 ROTATION ERROR

In the process of interpreting the preliminary results of runs #1, #2, and #3 of test 345F, it became apparent that the EDI Deflection output was deviating from the anticipated output. The problem area seemed to be an erroneous displacement component due to rotation of the post mount that was superimposed on the membrane displacement component. To confirm this theory and to provide correction information, the radial location of the EDI's of datum 4 for run #4 were changed as indicated in Figure 7.12. The underlying assumptions for the changes were as follows:

- 1) A comparison of EDI output would be made between runs #3 and #4 of datum 4. The choice of section measurements for comparison, as opposed to joint measurements, was made because it was felt the section would not be greatly influenced by the gapped versus butted configuration.
- 2) The EDI at D4-202 would remain at the same radial location as in run #3. Thus a comparison of plots of line load versus EDI D4-202 deflection output for the two runs could substantiate assumption 1).
- 3) If 2) verified 1), then the five EDI's that were .5 inches from the shell surface during run #3, and .3 inches from the shell surface during run #4, could be used to calculate post rotation. With the post rotation known, the deflection of the neutral surface could be calculated.
- 4) The EDI at D4-25 was mounted on the shell surface. Thus, the calculated rotations of 3) plus the output of D4-25 run #3 could be used to predict deflections of the shell surface. The predicted deflections could be compared with the measured deflections of D4-25 to verify the technique.
- 5) With test rotation angles available, a theoretical model could be developed. This model could then be used to predict the rotations of other datums.

Implementation of the technique was not entirely successful. Assumption 1) was somewhat questionable, although there was reasonable compatibility from 2). The model of 5) was not completed satisfactorily. Positive results were provided by 3) and 4). The stiffnesses, corrected for post rotation error, were comparable with theory as indicated in Table 7.6-1. In addition, the skin mounted EDI proved superior to the post mounted EDI's. Therefore, in succeeding tests a clip mount was utilized and in the shroud off series, dual gages were used. The complexity of the rotation problem was not apparent at this point.

Examination of the behavior of two cylindrical shells in the vicinity of a joint reveals the nature of the rotation error. Schematics of the joints are shown in Figures 7.12, 7.13, 7.14, 7.15 and 7.16. An illustrative example indicating the basic characteristics of such joints is shown in Figure 7.7-1. Also shown is the deformation of the joint under a tensile load. Localized

7.7 ROTATION ERROR (Continued)

bending, caused by the load transfer through the joint, induces post rotation which in turn produces the erroneous EDI component of displacement. The magnitude of the error for the idealization of Figure 7.7-1 is given by

$$\text{EDI error} = \left(\frac{t_1}{2} + .3\right) \theta_1 + \left(\frac{t_2}{2} + .3\right) \theta_2$$

Further investigation reveals that the original model to predict joint stiffnesses employed an approximation that was too simplified, i.e. that joints consisted of continuous cylinders butted at the joint. The joint of Figure 7.7-1 exhibits not only this pure membrane extension, but also the contribution of the bending rotation to the membrane extension.

$$\delta \text{ rotation} = \left(\frac{t_1 + t_2}{2}\right) \theta_3 + \left(\frac{t_2 + t_3}{2}\right) \theta_4$$

This deflection exerts a significant softening of the joint. Preliminary conclusions may be summarized as follows:

- 1) The theoretical stiffness values for the joints should be considerably smaller (a softer or less stiff joint) than those shown in Tables 7.6-1, 7.6-2, 7.6-3, 7.6-4 and 7.6-5. This is due to the effect of the additional membrane deflection caused by localized bending rotation.
- 2) The EDI deflection output is in error due to the rotation of the clip or post mount about the neutral surface of the cylindrical shell. This error is large for the post-mounted EDI's. For short spans, even the clip mounted EDI's may be significantly in error. For long spans, the rotational deflection is small compared to the overall deflection and thus the error should be small.
- 3) The rotational error of 2), for the idealization of Figure 7.7-1 effects EDI output such that test stiffness values for joints are softer than theory and sections are stiffer than theory. This is confirmed in Section 7.6.2.

To rectify these problem areas, two complementary investigations are required. The present inadequate model used to calculate theoretical joint stiffnesses, tabulated in Section 7.6.2 should be replaced by a model which incorporates the coupling of axial and bending stiffnesses. Such a model would be a better physical representation of the joint and would produce smaller theoretical stiffness values (or softer joints). Secondly, the same model should generate the local rotation at each clip or post location. Thus the existing test data could be extrapolated to the neutral surface of the shell and subsequently yield improved individual stiffnesses.

7.7 ROTATION ERROR (Continued)

The accomplishment of the above objectives is in progress. Supplementary tests to produce additional test values for local rotations were performed. A more sophisticated model to idealize the joint is under development. The model employs the stiffness method of structural analysis with advanced cylindrical shell elements. The use of offset nodes to couple axial and bending stiffnesses simulates the load transmission through the joint. Although the model is in the development stage, preliminary data verifies its adequacy.

The rotation error would appear to have a detrimental effect on all test values of AE and EI. However, for the Stage III motor case and the joints of tests 332F and 333F the effect is minimal. In both cases the displacement component due to rotation is small compared to the displacements to be measured when the clip mounts are close to the skin surface.

Two sources of information supply verification for the Stage III motor case. Reference 9 is a test report on the Stage III/BV separation joint. Data contained in this report indicates that the slope per unit line load at the forward clip location on the Stage III motor case (Station 258.3) is approximately -1.2×10^{-5} radians/lb/in. Preliminary data from a model of the joint used in the stiffness method of analysis indicates an angle of -1.5×10^{-5} radians/lb/in. At the aft clip location (Station 317.9), this model predicts a rotation of $.1 \times 10^{-5}$ radians/lb/in. From the analytical model data, the relative angle that has reduced EDI output is -1.6×10^{-5} radians/lb/in. This contribution to the EDI output is less than two percent. Although the magnitude of this angle may be somewhat in question, it is important to note that the correction for clip rotation tends to increase deflections. Thus the test values of AE and EI in Table 7.63 for the Stage III motor case will decrease when clip rotation is taken into account.

The error introduced into the EDI measurements is directly proportional to the magnitude of the rotational component of displacement and inversely proportional to the displacement to be measured. Thus the error is decreased when the measured displacement is large, the rotation is small and/or the offset distance of the EDI from the neutral surface is small. The first and last variables are known, but the magnitude of the rotation is a function of the geometry of the joint, the load, and the clip location relative to the joint. Preliminary test and theoretical data form a basis for the following estimates of percent error due to clip rotation. The joints of tests 332F and 333F are least affected by clip rotation due to large displacements relative to the rotation component, and the small EDI offset. For these joints, the test values of AE and EI in Tables 7.62 and 7.63 may be up to twenty percent too small.

The sections of test 332F and all stiffnesses except the II-III interstage forward bay of test 345F are more seriously affected by rotation error. The rotation is a significant part of the deflection measured. The former because the measured deflections are small. The latter because the EDI's are offset from the skin surface on post mounts which accentuates the rotation displacement component. The test values of AE and EI may be up to fifty percent too small for the joints and up to one hundred percent too large for the sections.

USE FOR TYPEWRITTEN MATERIAL ONLY

7.8 CONCLUSIONS AND RECOMMENDATIONS

1. The stiffness tests were completed satisfactorily with stiffness data obtained on all missile sections and joints forward of the second stage motor.
2. Joint rotation has been identified as an important contributor to the stiffness of the joints.
3. The method of stiffness measurement used in this test should be modified on future tests to incorporate instrumentation to measure local rotation of the EDI attachment clips.
4. It is recommended that the test stiffness values for the third stage motor and the joints forward of the third stage be used in future analytical studies.
5. The test stiffness values for the 2-3 interstage and the missile sections forward of the third stage motor should not be used without correcting for joint rotation.
6. It is recommended that further analysis be performed to establish models for stiffness evaluation of Minuteman joints.

USE FOR TYPEWRITTEN MATERIAL ONLY

USE FOR DRAWING AND HANDPRINTING — NO TYPEWRITTEN MATERIAL

TEST 332F
(SHROUD ON)

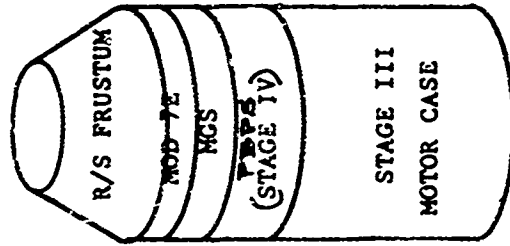
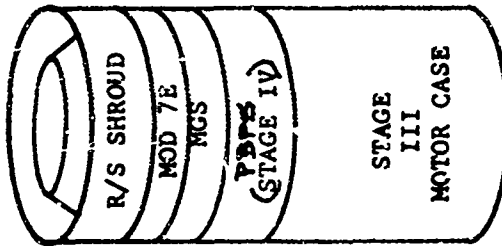

TEST 332F
(SHROUD OFF)

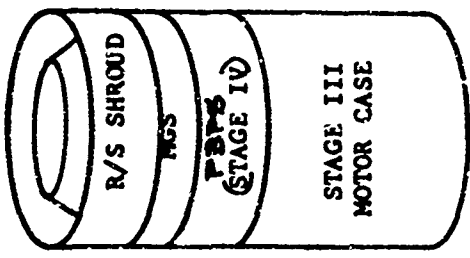

TEST 333F
(SHROUD ON)

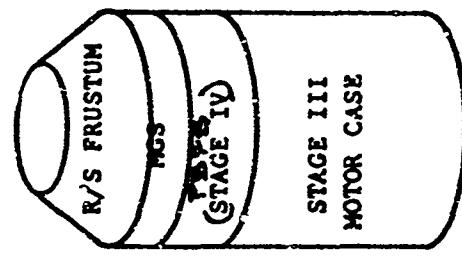

TEST 333F
(SHROUD OFF)

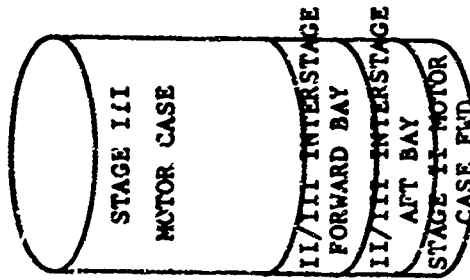

TEST 345F

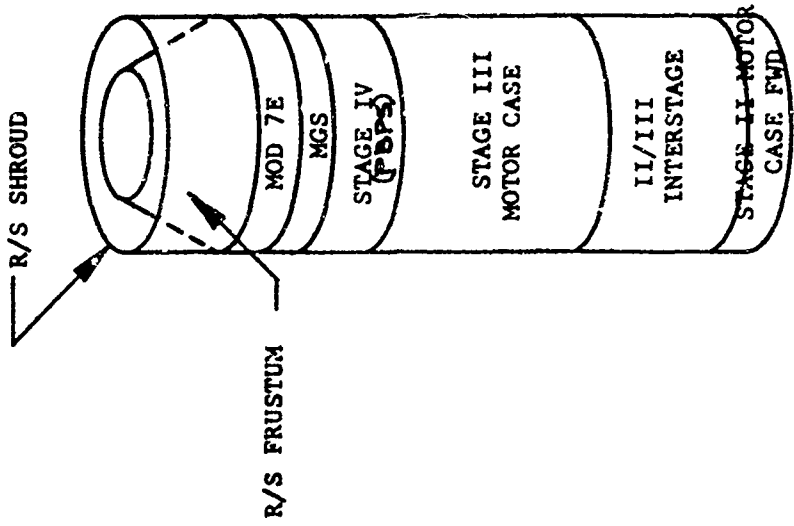

TYPICAL R&D FLIGHT
CONFIGURATION
(NOT A TEST STACKUP)

FIGURE 7-1 TEST SPECIMENS

REV 1TR _____

U3 4288 2001 ORIG. 5-65

BOEING

NO. T2-3657-1

SH 707

TABLE 7.1-1 STIFFNESS EVALUATION TESTS-CONDITIONS & ITEMS TESTED

TEST	LOAD CONDITION	JOINTS AND SECTIONS TESTED
345F	#1. Pure tension, joints gapped #2. Pure bending, joints gapped #3. Compression, bending, shear joints gapped #4. Compression, bending, shear joints butted	D1. II-III interstage aft inter-face joint D2. II-III interstage aft bay D3. II-III interstage staging joint D4. II-III interstage forward bay D5. II-III interstage/stage III separation joint
332F (shroud on)	#1. Pure tension, joints gapped #2. Pure bending, joints gapped #3. Compression, bending, shear joints gapped #4. Compression, bending, shear joints butted	D1. Stage IV motor case D2. MGS/PDPS interface ring D3. MGS D4. MOD 7E/MGS Interface joint D5. MOD 7E Wafer D6. RS aft/MOD 7E wafer inter-face ring
332F (shroud off)	#1. Pure tension, joints gapped #2. Pure bending, joints gapped #3. Compression, bending, shear joints gapped #4. Compression, bending, shear joints butted	D6. R/S aft/MOD 7E wafer interface ring
333F (shroud on)	#1. Pure tension, joints gapped #2. Pure bending, joints gapped #3. Compression, bending, shear joints gapped #4. Compression, bending, shear joints butted	D1. Stage III aft interface ring D2. Stage III motor case D3. Stage III/PW separation joint D4. R/S aft/MGS interface joint
333F (shroud off)	#1. Pure tension, joints gapped #2. Pure bending, joints gapped #3. Compression, bending, shear joints gapped #4. Compression, bending, shear joints butted	D4. R/S aft/MGS interface joint

USE FOR DRAWING AND HANDPRINTING — NO TYPEWRITTEN MATERIAL

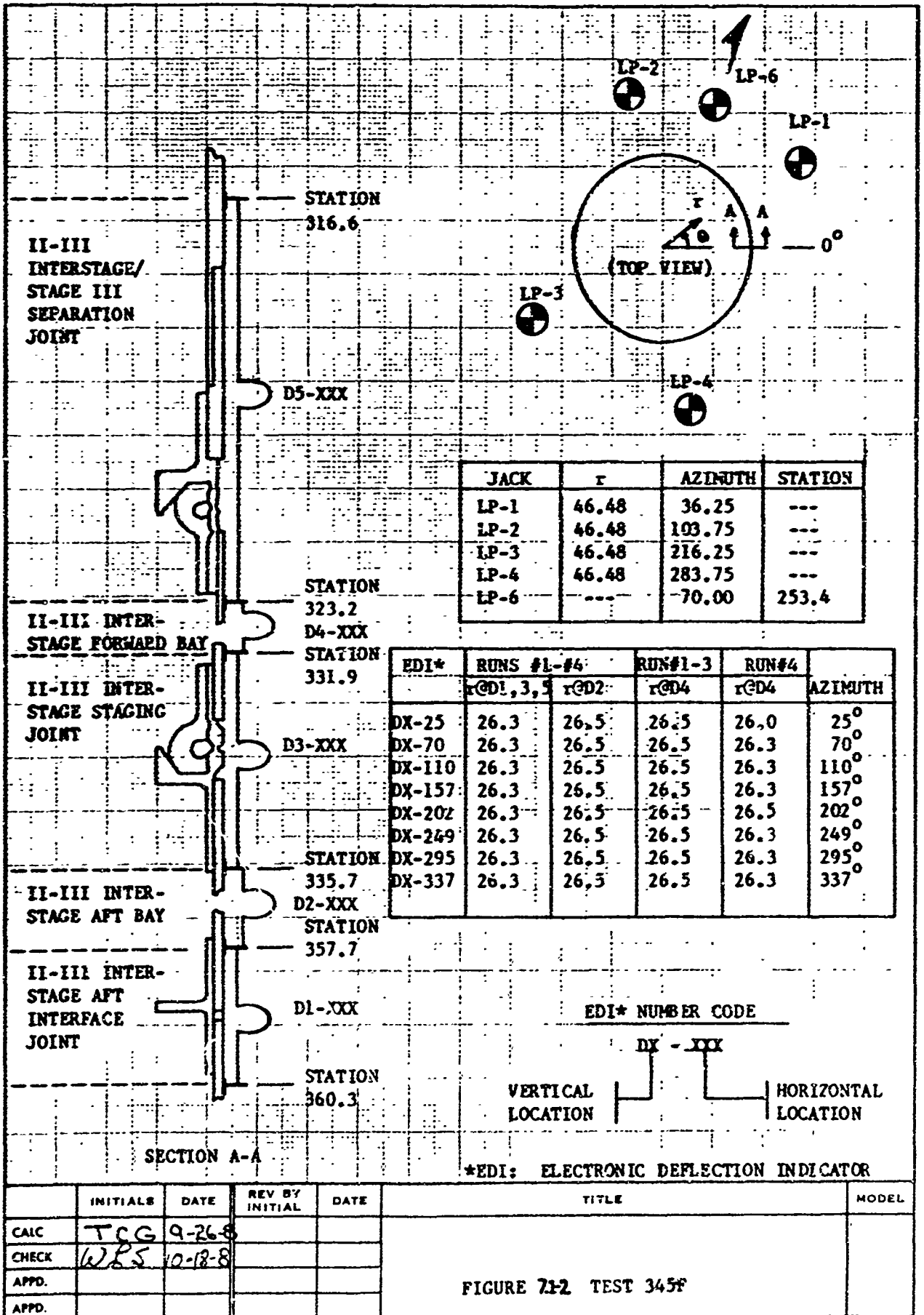

U3 4013 8000 REV 1/66

REV LTR _____

BOEING NO T2-3657-1
SH 709

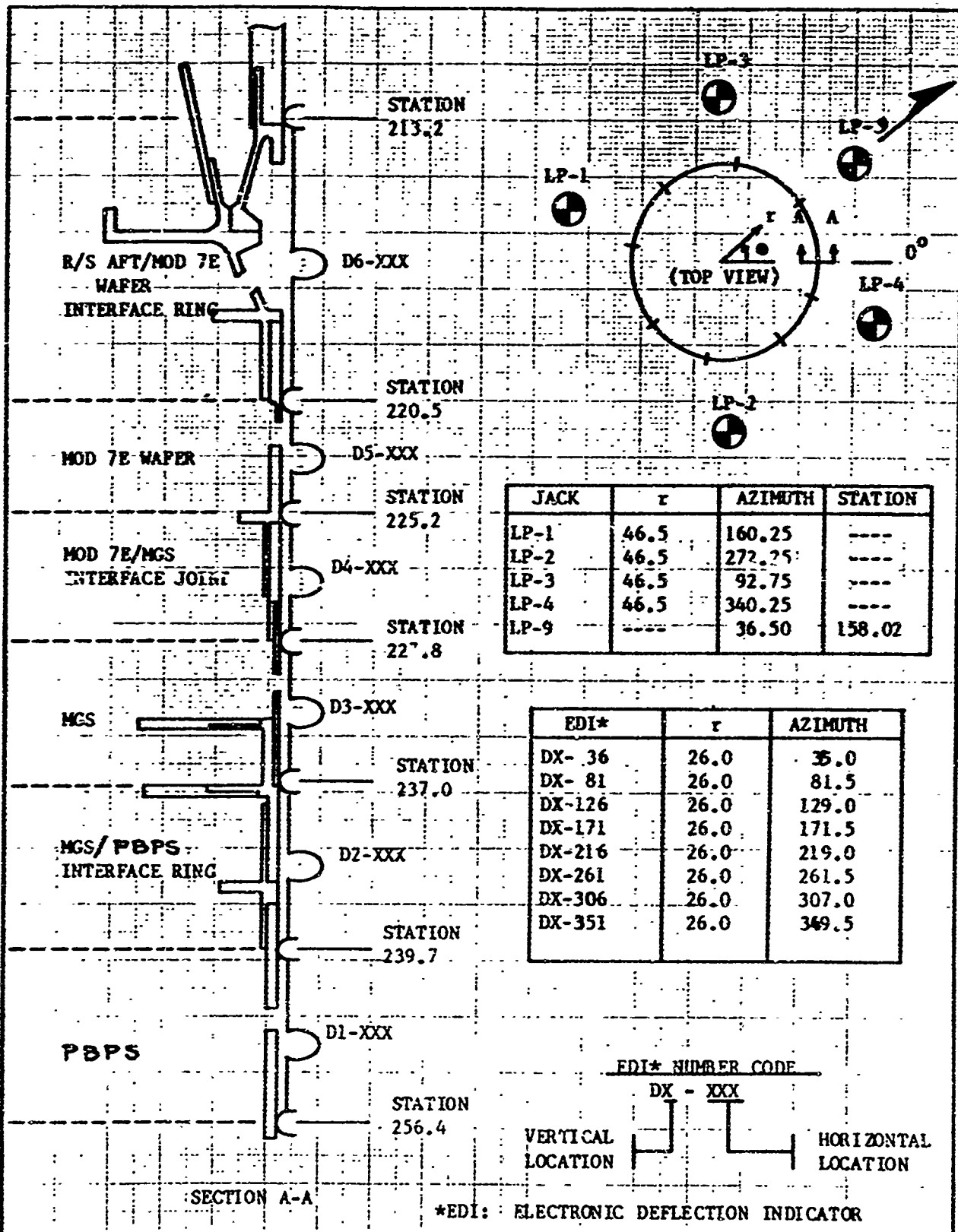

JACK	r	AZIMUTH	STATION
LP-1	46.5	160.25	----
LP-2	46.5	272.25	----
LP-3	46.5	92.75	----
LP-4	46.5	340.25	----
LP-9	----	36.50	158.02

EDI*	r	AZIMUTH
DX-36	26.0	35.0
DX-81	26.0	81.5
DX-126	26.0	129.0
DX-171	26.0	171.5
DX-216	26.0	219.0
DX-261	26.0	261.5
DX-306	26.0	307.0
DX-351	26.0	349.5

*EDI: ELECTRONIC DEFLECTION INDICATOR

	INITIALS	DATE	REV BY INITIAL	DATE	TITLE	MODEL
CALC.	TCC	9-26-58			FIGURE 713 TEST 332F (SHROUD ON)	
CHECK	(W) S.	10-18-58				
APPD.						
APPD.						
APPD.						

U3 4013 8000 REV 1/66

REV LTR _____

BOEING NO T2-3657-1
SH 710

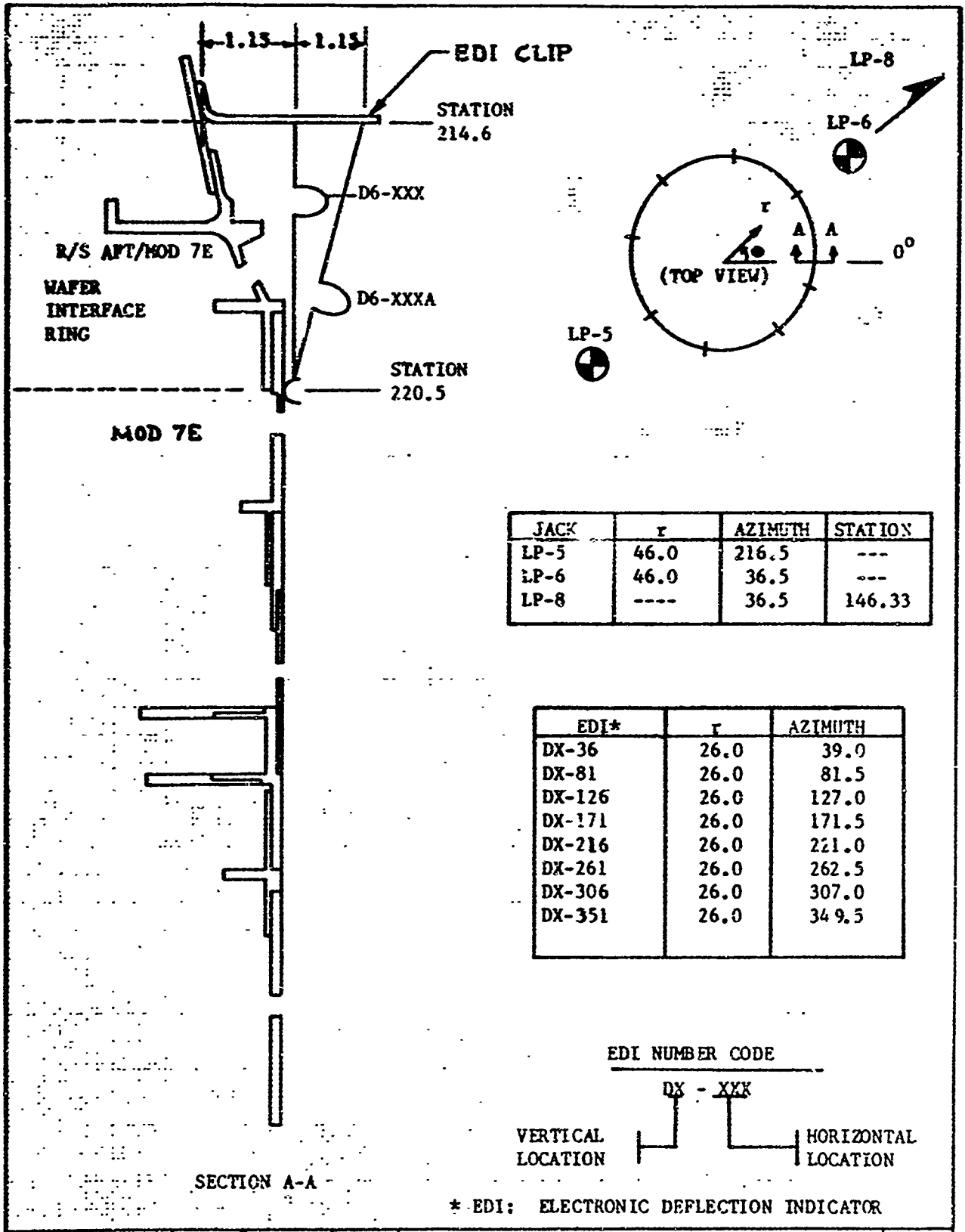

JACK	r	AZIMUTH	STATION
LP-5	46.0	216.5	---
LP-6	46.0	36.5	---
LP-8	----	36.5	146.33

EDI*	r	AZIMUTH
DX-36	26.0	39.0
DX-81	26.0	81.5
DX-126	26.0	127.0
DX-171	26.0	171.5
DX-216	26.0	221.0
DX-261	26.0	262.5
DX-306	26.0	307.0
DX-351	26.0	349.5

	INITIALS	DATE	REV BY INITIAL	DATE	TITLE	MODEL
CAIC	TCG	9-26-8			FIGURE 714 TEST 332F (SHROUD OFF)	
CHECK	W/S	10-18-8				
APPD.						
APPD.						

U3 4013 8000 REV 1/66

REV LTR. _____

BOEING NO T2-3657-1
SH 711

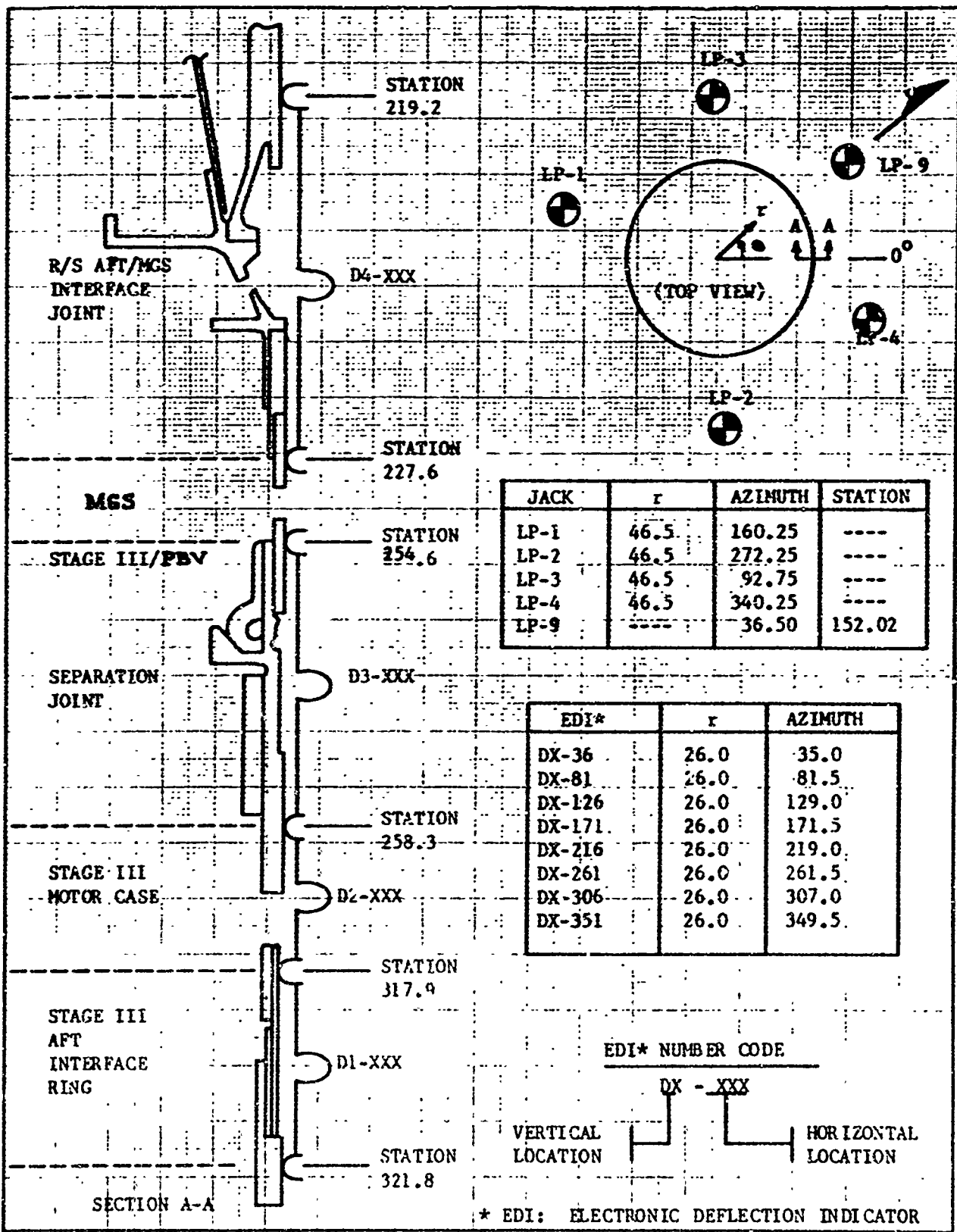

JACK	r	AZIMUTH	STATION
LP-1	46.5	160.25	----
LP-2	46.5	272.25	----
LP-3	46.5	92.75	----
LP-4	46.5	340.25	----
LP-9	----	36.50	152.02

EDI*	r	AZIMUTH
DX-36	26.0	35.0
DX-81	26.0	81.5
DX-126	26.0	129.0
DX-171	26.0	171.5
DX-216	26.0	219.0
DX-261	26.0	261.5
DX-306	26.0	307.0
DX-351	26.0	349.5

EDI* NUMBER CODE

DX - XXX

VERTICAL LOCATION

HORIZONTAL LOCATION

* EDI: ELECTRONIC DEFLECTION INDICATOR

	INITIALS	DATE	REV BY INITIAL	DATE	TITLE	MODEL
CALC	TCG	9-26-8			FIGURE 715 TEST 333F (SHROUD ON)	
CHECK	WLS	10-18-8				
APPD.						
APPD.						

US 4013 5000 REV 1/66

REV LTR _____

BOEING NO T2-3657-1
SH 712

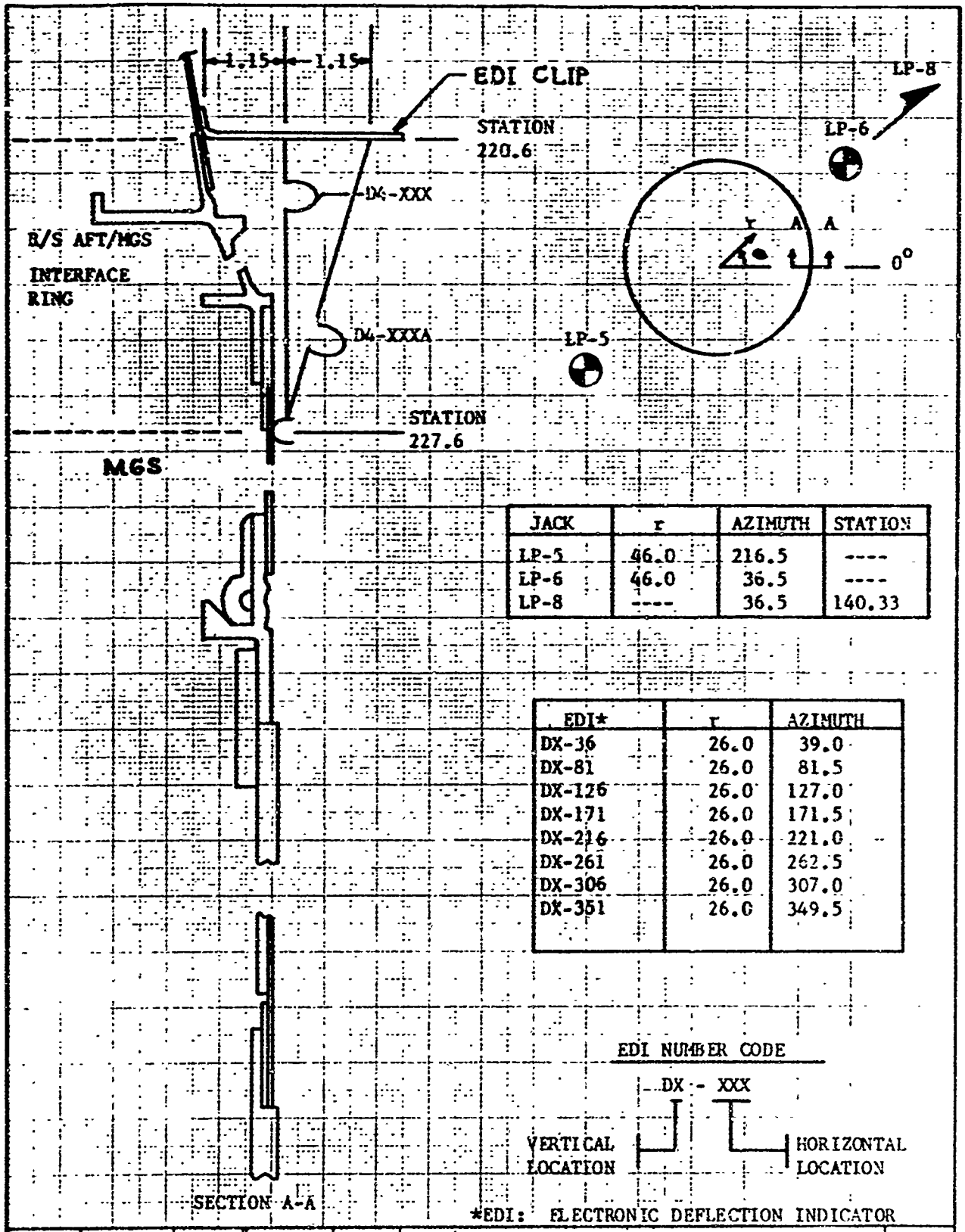

JACK	r	AZIMUTH	STATION
LP-5	46.0	216.5	----
LP-6	46.0	36.5	----
LP-8	----	36.5	140.33

EDI*	r	AZIMUTH
DX-36	26.0	39.0
DX-81	26.0	81.5
DX-126	26.0	127.0
DX-171	26.0	171.5
DX-216	26.0	221.0
DX-261	26.0	262.5
DX-306	26.0	307.0
DX-351	26.0	349.5

	INITIALS	DATE	REV BY INITIAL	DATE	TITLE	MODEL
CALC	TCG	9-28-8			FIGURE 716 TEST 333F (SHROUD OFF)	
CHECK	WFS	10-18-8				
APPD.						
APPD.						

U3 4613 8000 REV 1/66

REV LTR _____

BOEING NO T2-3657-1
SH 713

USE FOR DRAWING AND HANDPRINTING — NO TYPEWRITTEN MATERIAL

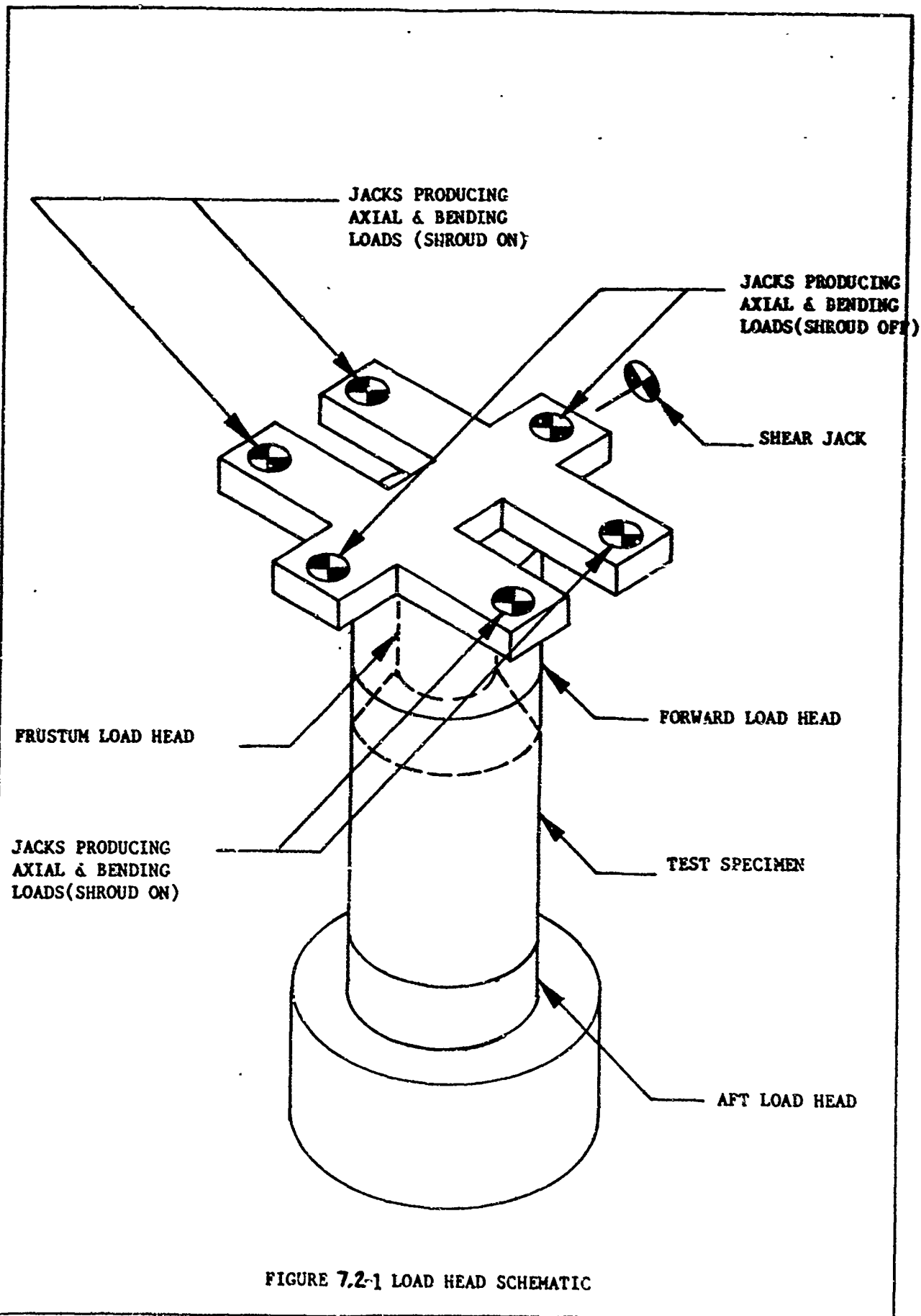

FIGURE 7.2-1 LOAD HEAD SCHEMATIC

REV LTR _____

U3 4288 2001 ORIG. 5 65

BOEING

NO. T2-3657-1

SH 714

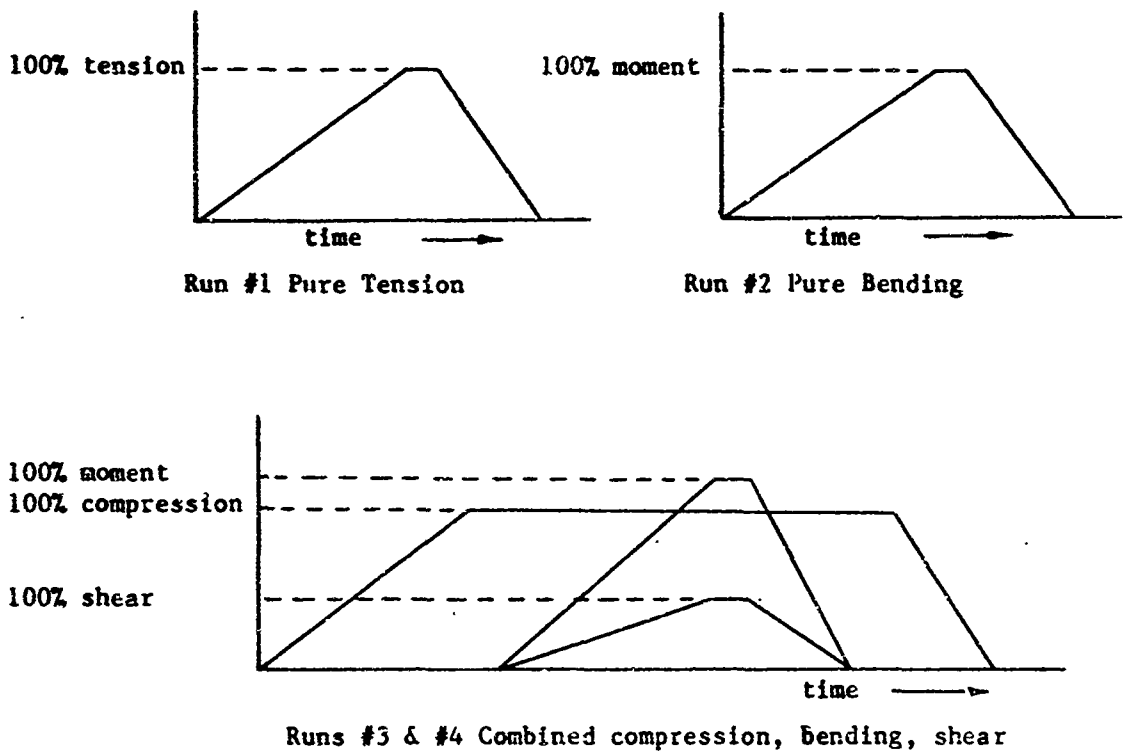

USE FOR TYPEWRITTEN MATERIAL ONLY

FIGURE 7.31 LOAD SEQUENCE

P vs δ

TEST 333-F (SHROUD ON)

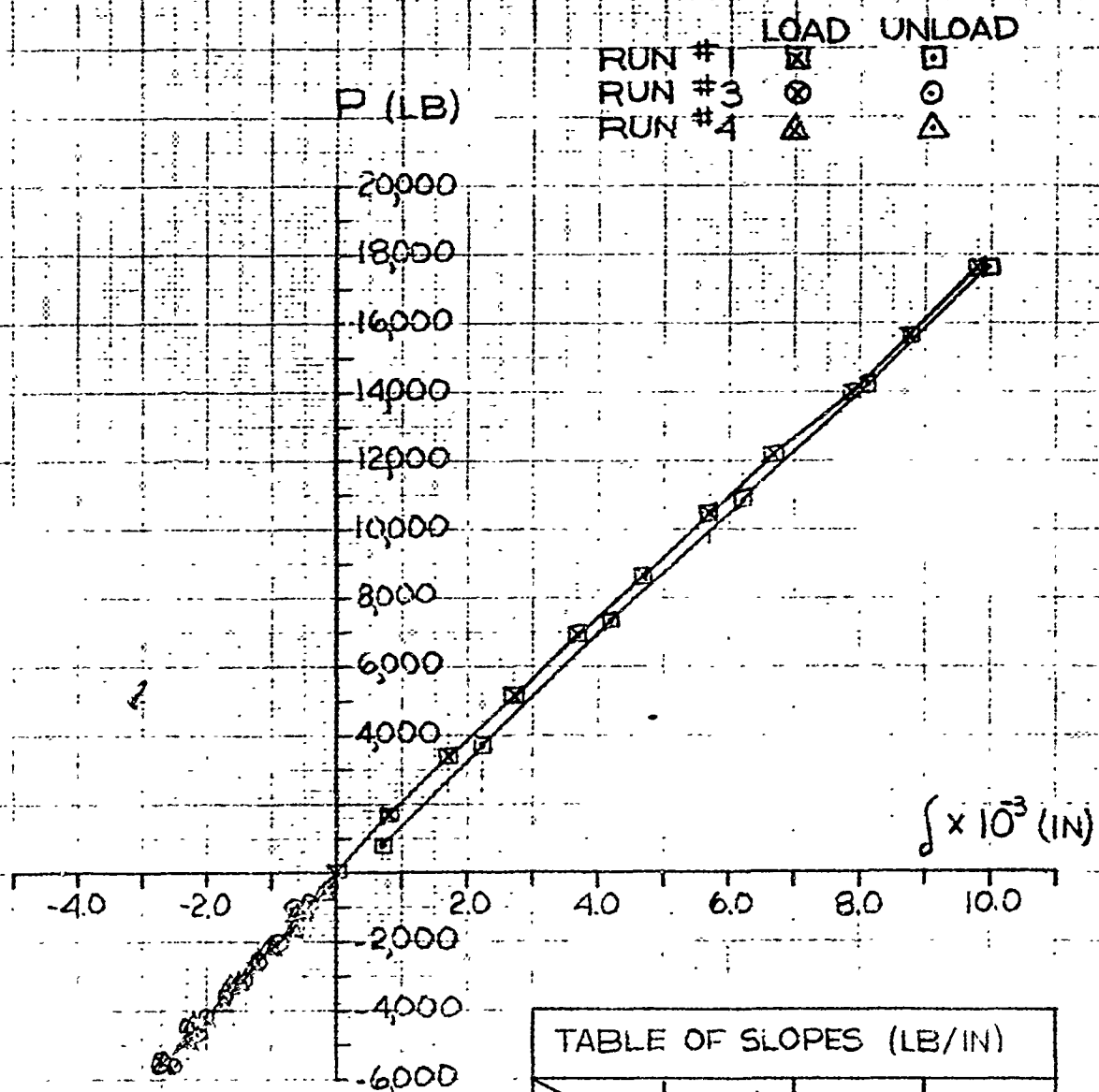

TABLE OF SLOPES (LB/IN)			
	RUN #1	RUN #3	RUN #4
LOAD	1.75(10) ⁶	2.01(10) ⁶	2.06(10) ⁶
UNLOAD	1.81(10) ⁶	1.98(10) ⁶	1.98(10) ⁶

NOTE: DEFLECTIONS MEASURED FROM STATION 358.3 TO STATION 317.9 (SEE FIG 7.1-5)

	INITIALS	DATE	REV BY INITIAL	DATE	TITLE	MODEL
CALC	WJS	11-11-8			FIGURE 7.6-1 PLOT OF AXIAL LOAD vs. DISPLACEMENT, STAGE III MOTOR CASE. TEST 333F (SHROUD ON)	
CHECK	WJS	11-11-8				
APPD.						
APPD.						

U3 4013 8000 REV 1/66

REV ITR _____

BOEING NO T2-3657-1
SH 716

TEST 333F (SHROUD ON)

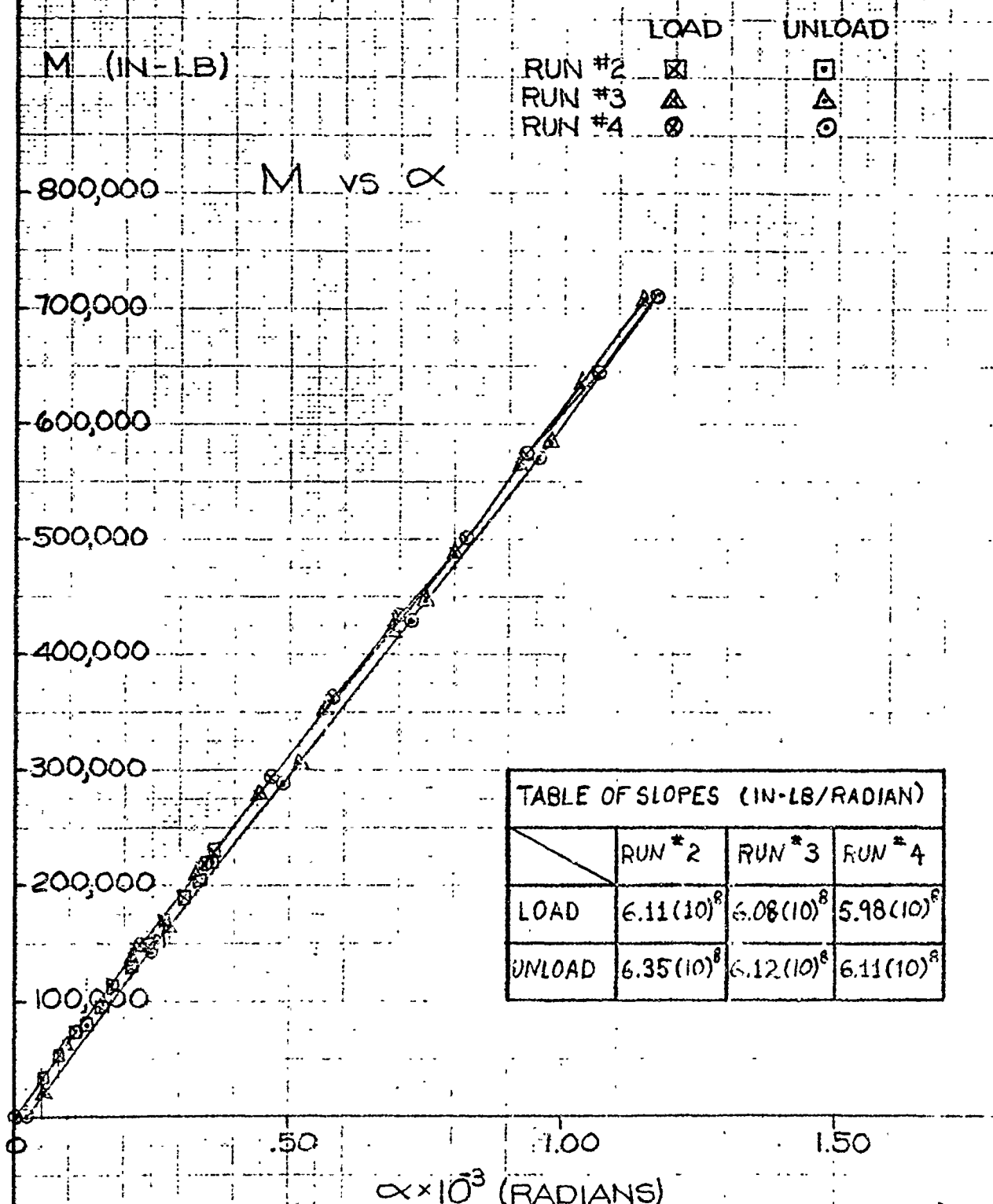

	RUN #2	RUN #3	RUN #4
LOAD	$6.11(10)^8$	$6.08(10)^8$	$5.98(10)^8$
UNLOAD	$6.35(10)^8$	$6.12(10)^8$	$6.11(10)^8$

NOTE: DEFLECTIONS MEASURED FROM STATION 358.3 TO STATION 317.9 (SEE FIGURE 7.1-E)

	INITIALS	DATE	REV BY INITIAL	DATE	TITLE	MODEL
CALC	AMS	11-11-8			FIGURE 7.6-2. PLOT OF BENDING MOMENT vs. ROTATION, STAGE III MOTOR CASE. TEST 333F (SHROUD ON)	
CHECK	WFS	11-11-8				
APPD.						
APPD.						

U3 4013 8000 REV 1/66

REV LTR _____

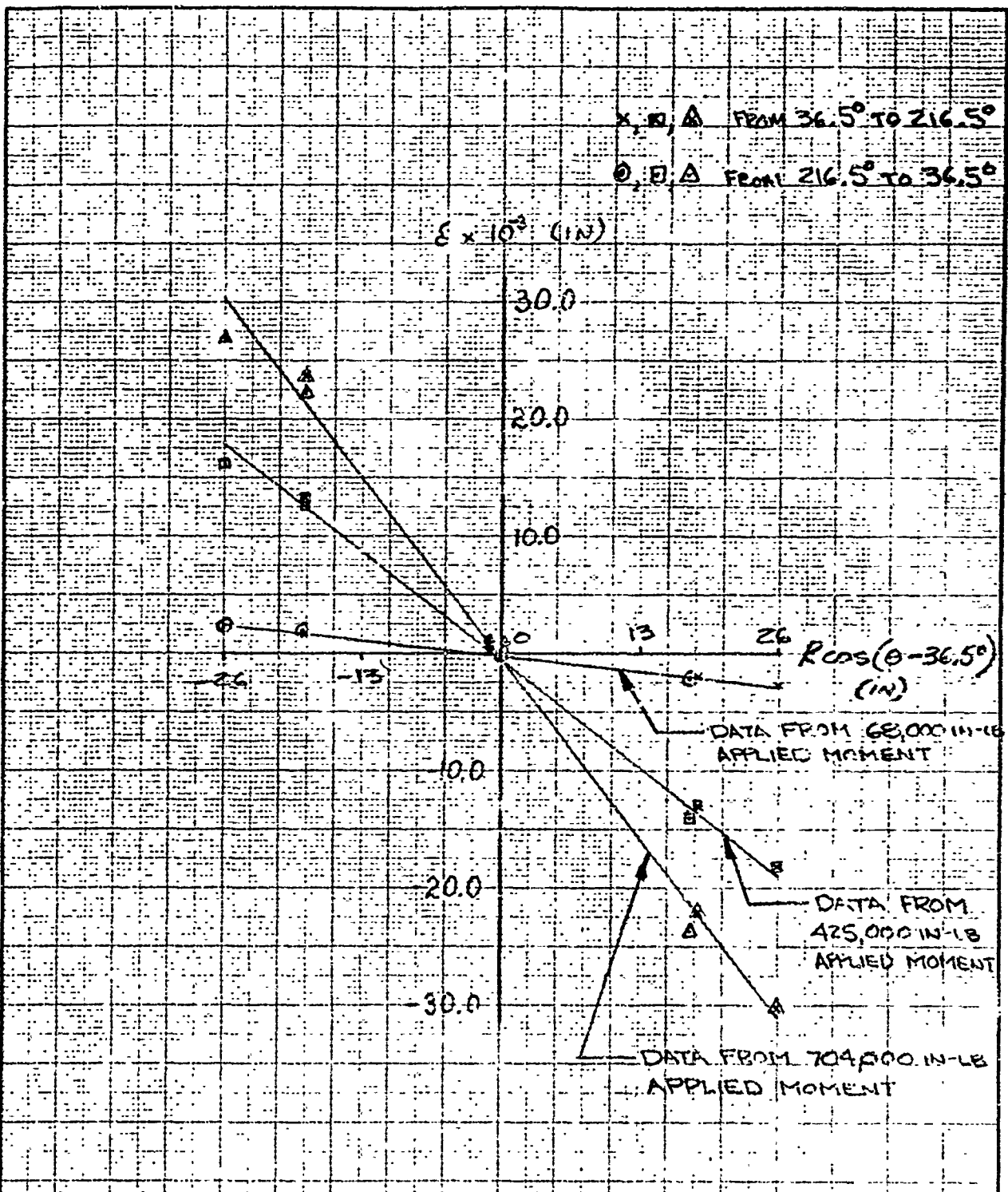

NOTE: SOLID LINE INDICATES BEST FIT SLOPE THROUGH POINTS

	INITIALS	DATE	REV BY INITIAL	DATE	TITLE	MODEL
CALC	WRS	10-18-8			FIGURE 7.6-3 PLOT OF INCREMENTS OF EDI DISPLACEMENT vs. RADIUS FOR THREE INCREMENTS OF BENDING MOMENT. PAGE III MOTOR CASE TEST 333F (SHROUD ON) RUN #4	
CHECK	WRS	10-18-8				
APPD.						
APPD.						

U3 4013 8000 REV 1/66

REV LTR _____

BOEING NO. T2-3657-1
SH 7E

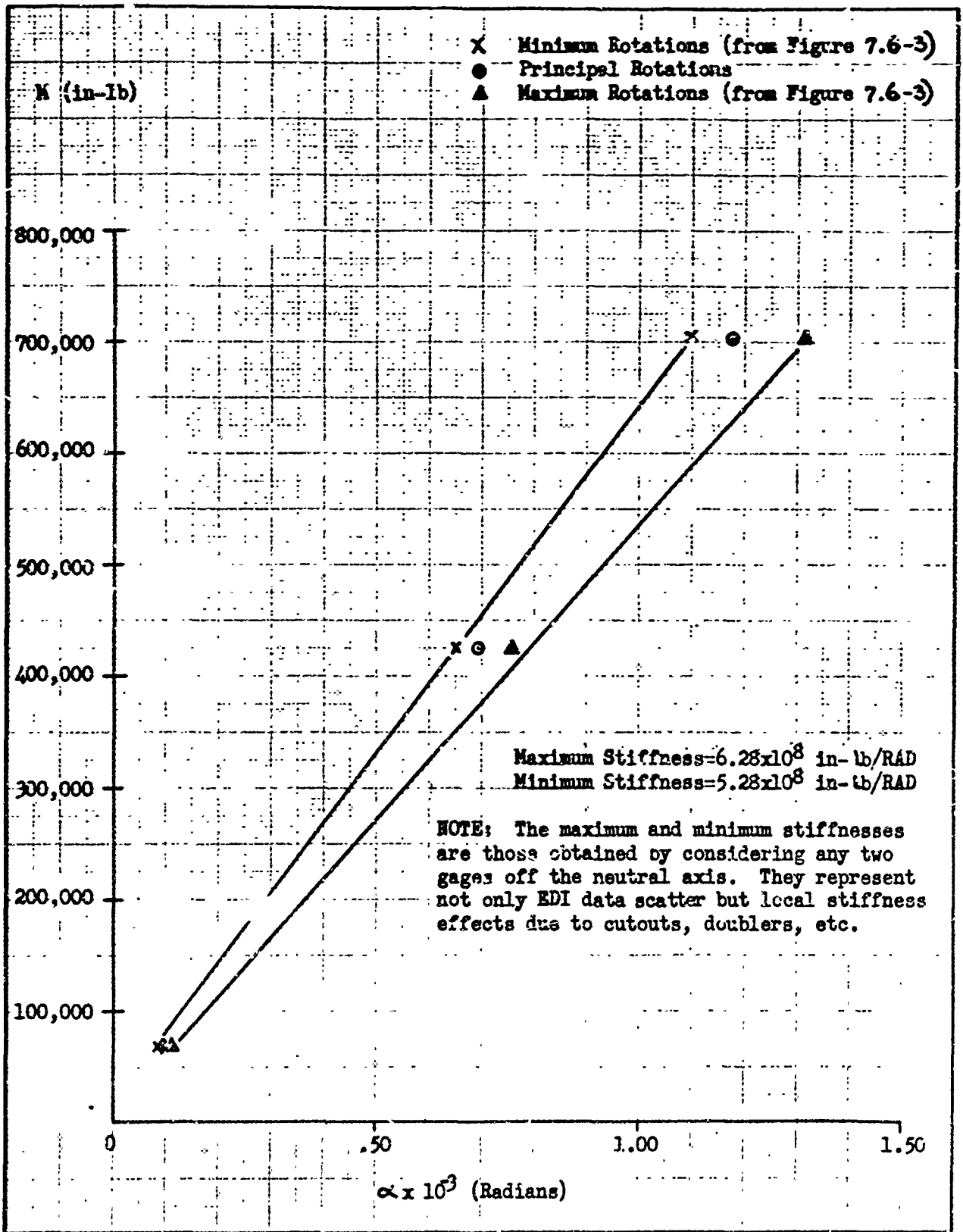

	INITIALS	DATE	REV BY INITIAL	DATE	TITLE	MODEL
CALC	WPS	10-18-8			FIGURE 7.6-4 PLOT OF BENDING MOMENT vs. ROTATIONS FROM FIGURE 7. STAGE III MOTOR CASE. TEST 333-F (SERUOD ON) RUN #4	
CHECK	WPS	10/22/8				
APPD.						
APPD.						

U3 4015 8000 REV 1/66

REV ITR _____

BOEING NO. T2-3657-1
 SH. 719

USE FOR DRAWING AND HANDPRINTING — NO TYPEWRITTEN MATERIAL

TABLE 7.6-1 AE AND EI FROM TEST 345F

MISSILE SECTION	Run #1 Pure Tension	Run #2 Purc Bending	Run #3 Comb- ined Load- ing-Gapped	Run #4 Comb- ined Loading -Butted	AVERAGE	Theoretical Values
II-III inter- stage/stage III separa- tion joint	AEX10 ⁻⁸	---	.558	.568	.494 +.074 -.137	1.50
	EIX10 ⁻¹⁰	.859	.647	1.36	.956 +.404 -.309	5.02
II-III inter- stage forward bay	AEX10 ⁻⁸	---	3.01 *	3.01 *	2.51 * +.50 -1.00	2.02
	EIX10 ⁻¹⁰	5.12 *	8.91 *	8.91 *	7.65 * +1.26 -2.53	6.79
II-III inter- stage stag- ing joint	AEX10 ⁻⁸	---	.574	.635	.529 +.106 -.151	1.96
	EIX10 ⁻¹⁰	1.10	1.07	1.37	1.18 +.19 -.11	6.60
II-III inter- stage aft bay	AEX10 ⁻⁸	---	3.14	3.12	3.00 +.14 -.27	1.92
	EIX10 ⁻¹⁰	10.7	8.95	8.45	9.37 +.1.33 -.92	6.49
II-III inter- stage aft interface joint	AEX10 ⁻⁸	---	.346	.596	.416 +.18 -.109	2.31
	EIX10 ⁻¹⁰	1.26	.975	1.36	1.20 +.16 -.225	7.80

*Corrected for rotation (Refer to Section 7.7)

USE FOR DRAWING AND HANDPRINTING — NO TYPEWRITTEN MATERIAL

TABLE 7.6-2 AE AND EI FROM TEST 332P (SHROUD ON)

MISSILE SECTION		RUN #1 PURE TENSION	RUN #2 PURE BRIDGING	RUN #3 COMBINED LOADING GAPPED	RUN #4 COMBINED LOADING BUTTED	AVERAGE	THEORETICAL VALUES
R/S aft/ MOD 7E wafer inter-face ring	AEX10 ⁻⁸	.206	---	.243	.238	.229 +.014 -.023	.411
	EIX10 ⁻¹⁰	---	.861	.851	.866	.859 +.007 -.008	1.40
MOD 7E wafer	AEX10 ⁻⁸	2.08	---	2.38	2.27	2.25 +.13 -.17	1.17
	EIX10 ⁻¹⁰	---	4.76	5.67	5.81	5.42 +.39 -.66	3.92
MOD 7E/MGS interface joint	AEX10 ⁻⁸	.232	---	.251	.251	.244 +.007 -.012	1.10
	EIX10 ⁻¹⁰	---	.878	.764	.883	.843 +.041 -.078	3.69
MGS	AEX10 ⁻⁸	2.24	---	2.35	2.34	2.31 +.04 -.07	1.04
	EIX10 ⁻¹⁰	---	6.04	5.92	5.90	5.95 +.09 -.03	3.50
MGS/ PDPS interface ring	AEX10 ⁻⁸	.243	---	.261	.257	.254 +.007 -.011	1.04
	EIX10 ⁻¹⁰	---	.874	.860	.865	.867 +.007 -.007	3.50
PDPS	AEX10 ⁻⁸	1.90	---	2.11	2.07	2.03 +.08 -.13	1.04
	EIX10 ⁻¹⁰	---	6.32	7.99	5.92	6.73 +1.26 .41	3.50

USE FOR DRAWING AND HANDPRINTING — NO TYPEWRITER MATERIAL

TABLE 7.6-3 AE AND EI FROM TEST 333F (SHROUD ON)

MISSILE SECTION		Run #1 Pure Tension	Run #2 Pure Bending	Run #3 Combined Loading-Capped	Run #4 Combined Loading-Rupted	AVERAGE	Theoretical Values
R/S aft/MGS interface joint	AEX10 ⁻⁸	.307	---	.342	.337	.329 +.013 -.022	.445
	EIX10 ⁻¹⁰	---	1.06	1.06	1.12	1.08 +.04 -.02	1.51
Stage III/IV separation joint	AEX10 ⁻⁸	.356	---	.400	.374	.376 +.024 -.020	1.095
	EIX10 ⁻¹⁰	---	1.20	1.16	1.45	1.27 +.18 -.11	3.69
Stage III motor case	AEX10 ⁻⁸	1.04	---	1.20	1.23	1.16 +.07 -.12	1.30 ^{***}
	EIX10 ⁻¹⁰	---	3.64	3.62	3.56	3.61 +.03 -.05	4.36 [*]
Stage III aft interface ring	AEX10 ⁻⁸	1.04	---	.955	.987	.995 +.040 -.045	1.432
	EIX10 ⁻¹⁰	---	2.83	2.30	2.51	2.55 +.28 -.25	4.64

* Aerojec Letter 3110:4675, dated 22 March 1968
** Calculated from Aerojet EI value, using EI/AE = R²/2

USE FOR DRAWING AND HANDPRINTING --- NO TYPEWRITTEN MATERIAL

TABLE 7.6-4 AE AND EI FROM TEST 332F (SHROUD OFF)

MISSILE SECTION	Run #1 Pure Tension	Run #2 Pure Bending	Run #3 Com-bined Load-ing-Gapped	Run #4 Com-bined Load-ing-Butted	AVERAGE	Theoretical Values
	R/S aft/MOD 7E wafer interface ring	.515	---	.501		
	---	1.87	2.26	3.26	2.47 +.79 -.60	.666

TABLE 7.6-5 AE AND EI FROM TEST 330F (SHROUD OFF)

MISSILE SECTION	Run #1 Pure Tension	Run #2 Pure Bending	Run #3 Com-bined Load-ing-Gapped	Run #4 Com-bined Load-ing-Butted	AVERAGE	Theoretical Values
	R/S aft/MGS interface ring	.526	---	.495		
	---	1.39	1.31	1.67	1.458 +.21 -.15	.756

USE FOR DRAWING AND HANDPRINTING — NO TYPEWRITTEN MATERIAL

TABLE 7.6-6

GEOMETRY AND STIFFNESS PROPERTIES FROM REF. 8

COMPONENT	r IN	t IN	E-6 X10 ⁻⁶ LB/IN ²	EI-10 X10 ⁻² LB-IN ²	EA-6 X10 ⁻⁶ LB
MOD 7E	25.9	0.110	6.5	3.92	116.6
MISSILE GUIDANCE SET	25.944	0.112	6.5	3.5	104.0
POST BOOST PROPULSION SYSTEM	25.944	0.112	6.5	3.5	104.0
STAGE III MOTOR				4.38*	130.0**
II-III INTERSTAGE FORWARD	25.941	0.118	10.5	6.795	202.0
II-III INTERSTAGE AFT	25.944	0.112	10.5	6.489	191.7

* Aerojet Letter 3110:4675, dated 22 March 1968

** Calculated from Aerojet EI value, using $EI/AE = R^2/2$

REV LTR _____

U3 4288 2001 ORIG. 5-65

BOEING

NO. T2-3657-1

SH 724

USE FOR DRAWING AND HANDPRINTING — NO TYPEWRITTEN MATERIAL

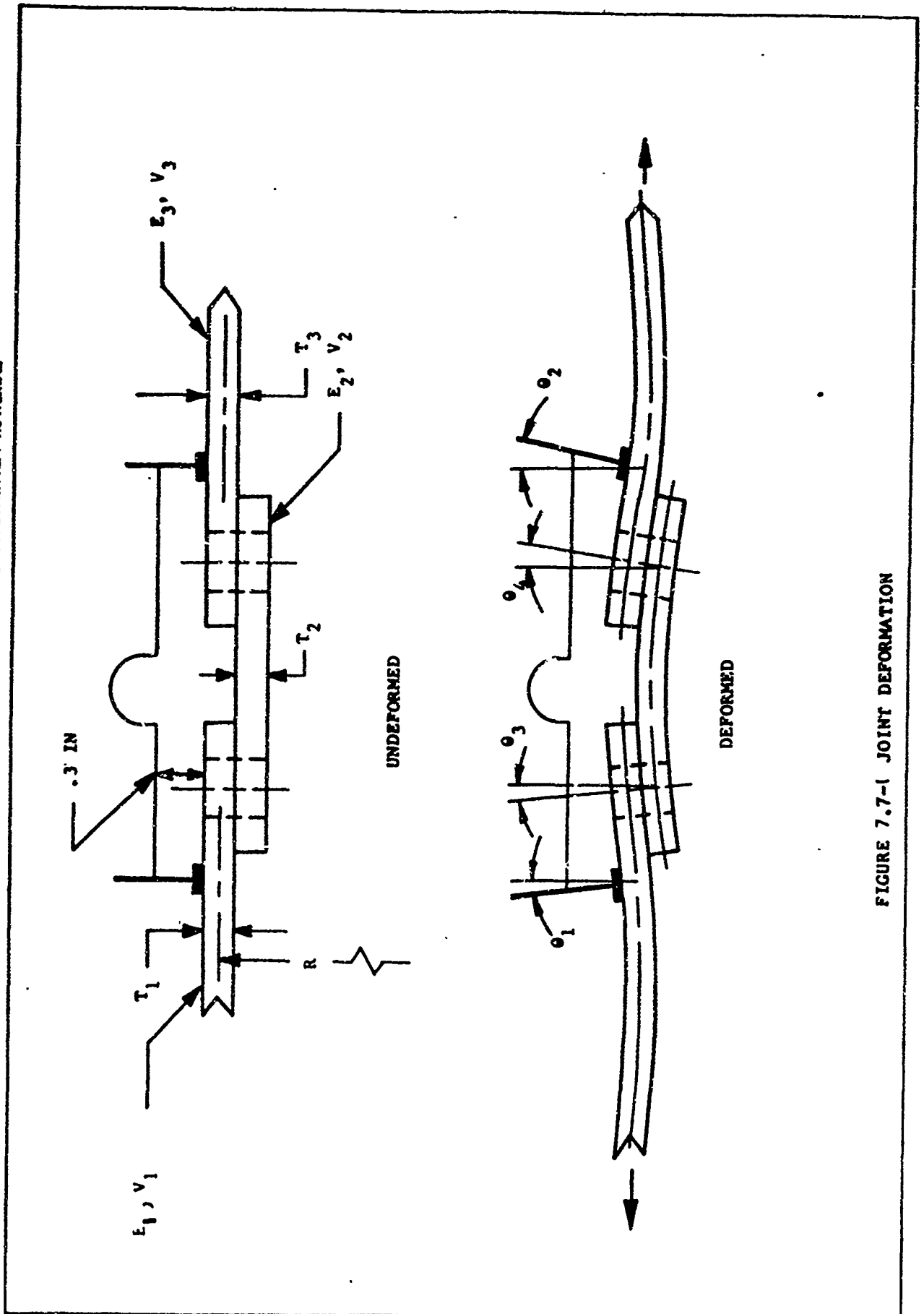

REV LTR _____

US 4268 2001 OR G 3 55

BOEING

NO. T2-3657-1

SH 725

FIGURE 7.7-1 JOINT DEFORMATION

8.0 SAMPLE CALCULATIONS—LOADS

8.1 LAUNCH TEST CALCULATIONS—LOADS

CALCULATION OF THE 333-L FAILURE OVERPRESSURE (Δp) AND AXIAL COMPRESSION (P) LOADS AT STATION 225.3 ARE SHOWN. THE RECORDED OVERPRES. (AT STATION 196.0) AND HYDRAULIC JACK COMPRESSION LOAD ARE FROM REFERENCE 3. THE LOAD GEOMETRY IS SHOWN IN FIGURE 3.4-1. IN CALCULATING THE AXIAL COMPRESSION DUE TO OVERPRESSURE IN THE V-BAND AREA (AROUND STATION 221.6) IT WAS ASSUMED THAT THE R/S RING WAS COVERED WITH SEALANT TO A DIAMETER OF 51.17."

OVERPRESSURE (Δp)

$$\Delta p_{225.3} \text{ (PSI)} = \Delta p_{196} \triangleright + (\text{STA. 225.3} - \text{STA. 196}) (\text{DENSITY OF H}_2\text{O})$$

$$\Delta p_{225.3} = 29.75 + \frac{(225.3 - 196.0) 62.4}{177.8}$$

$$\Delta p_{225.3} = 30.80 \text{ PSI}$$

AXIAL COMPRESSION LOADS

A PORTION OF THE FRUSTUM AXIAL COMPRESSION AND ALL BUT THE SHROUD LOAD ADAPTOR WEIGHT OF THE SHROUD AXIAL COMPRESSION RESULTS FROM THE OVERPRESSURE.

DUE TO THE OVERPRESSURE (P_b)

$$P_{b225.3} = P_{b\text{SHROUD}} + P_{b\text{FRUSTUM}}$$

$$P_{os} \text{ (lbs)} = \Delta p_{196} (\text{AREA})_1 + \Delta p_{208.3} (\text{AREA})_2 - \Delta p_{220.6} (\text{AREA})_3$$

$$P_{os} = 29.75 \left[(51.02)^2 - (15.83)^2 \right] \frac{\pi}{4} + \left[\frac{2(29.75) + .888}{2} \right] \left[(52)^2 - (51.02)^2 \right] \frac{\pi}{4} - (30.66) \left[(52.0)^2 - (51.17)^2 \right] \frac{\pi}{4}$$

$$P_{os} \text{ (KIPS)} = 54.94 + 2.39 - 2.06$$

$$P_{os} = 55.27 \text{ KIPS}$$

$$P_{of} \text{ (lbs)} = \Delta p_{196} (\text{AREA}) + \Delta p_{220.6} (\text{AREA})_4$$

$$P_{of} = 29.75 (15.83)^2 \frac{\pi}{4} + (30.74) \left[(52.1)^2 - (51.17)^2 \right] \frac{\pi}{4}$$

$$P_{of} = 8.17 \text{ KIPS}$$

	INITIALS	DATE	REV BY INITIALS	DATE	TITLE	MODEL
CALC	GDW	11-8-8			SAMPLE CALCULATIONS—LOADS 333 - LAUNCH TEST	
CHECK	JET	11-19-8				
APPD.						
APPD.						

SAMPLE CALCULATIONS (CONT.)

THE TOTAL AXIAL COMPRESSION THRU THE SHROUD

$$P_T (KIPS) = 55.27 + 0.6 \triangleright$$

$$P_T = 55.87 \text{ KIPS}$$

\triangleright WEIGHT OF THE SHROUD LOAD ADAPTOR

THE TOTAL AXIAL COMPRESSION THRU THE FRUSTUM

$$P_T (KIPS) = 8.17 + 1.05 \triangleright + 12.01 \triangleright$$

$$P_T = 21.23 \text{ KIPS}$$

\triangleright WEIGHT OF THE FRUSTUM LOAD ADAPTOR.

\triangleright LOAD INTRODUCED BY FRUSTUM HYDRALIC JACK. (DATA-REF.3)

AT STATION 225.3 THE FRUSTUM & SHROUD AXIAL COMPRESSION LOADS HAVE COMBINED DIRECTLY:

$$P_{225.3} (KIPS) = 55.87 + 21.23$$

$$P_{225.3} = 77.1 \text{ KIPS}$$

THE FOLLOWING SAMPLE CALCULATIONS REDUCE THE FAILURE LOADS OF AXIAL COMPRESSION & OVERPRESSURE TO A COMPARABLE PERCENTAGE OF THE BSD EXHIBIT 66-6A DESIGN ULTIMATE LAUNCH LOADS.

THE CALCULATIONS FOR THE MGS SECTION AT STATION 225.3 ARE SHOWN:

LOADS	OVERPRESSURE (PSI)	AXIAL - COMPRESSION (KIPS)
BSD EXHIBIT	22.6	71.5
TEST FAILURE LOADS	30.8	77.1

THE MGS IS MADE OF MAGNESIUM WITH A MODULUS OF ELASTICITY (E) OF 6.5×10^6 $\frac{\text{LBS.}}{\text{IN.}}$

	INITIALS	DATE	REV BY INITIALS	DATE	TITLE	MODEL
CALC	GDW	11-3-8	GDW	11-21-8	SAMPLE CALCULATIONS 333-LAUNCH TEST.	
CHECK	JET	11-9-8				
APPD.						
APPD.						

SAMPLE CALCULATIONS (CONT)

RADIUS = 26 INCHES

$L_1 = 3.54$ INCHES

$L_2 = 5.50$ INCHES

THE OVERPRESSURE RING ALLOWS THE L_2 TO BE USED TO CALCULATE THE CRITICAL VALUE OF OVERPRESSURE.

THE MINIMUM GAGE = .099 INCHES OF THE SECTION

MGS SECTION

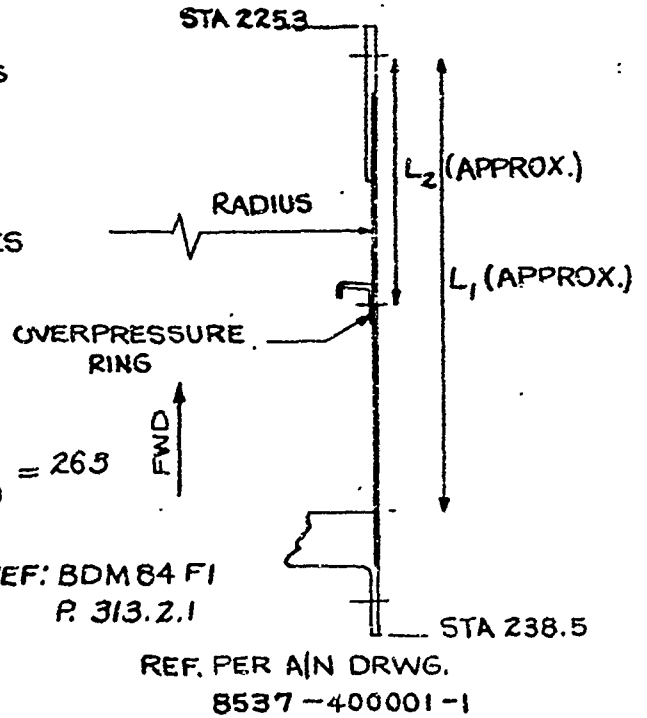

CRITICAL AXIAL COMPRESSION

$$\frac{L_1}{R} = \frac{3.54}{26} = 0.367 \quad \frac{R}{t_{MIN.}} = \frac{26}{0.099} = 265$$

$$F_c \left(\frac{1}{IN} \right) = (E) (1.85 \times 10^{-3}) \quad \leftarrow \text{REF: BDM 84 F1 P. 313.2.1}$$

$$F_c = 6.5 \times 10^6 (1.85 \times 10^{-3})$$

$$F_c = 12.03 \times 10^3 \frac{\#}{IN^2}$$

$$P_{CR} (KIPS) = 2\pi (R) (t_{MIN.}) (F_c)$$

$$P_{CR} = 2\pi (26) (.099) (12.03 \times 10^3)$$

$$P_{CR} = 194 \text{ KIPS}$$

CRITICAL OVERPRESSURE

$$Z_L = \frac{(L_2)^2 (.937)}{(R) (t_{MIN.})} \quad \leftarrow \text{REF. BDM 84 F1 P. 323.2.1}$$

$$Z_L = \frac{(5.4)^2 (.937)}{(26) (.099)}$$

	INITIALS	DATE	REV BY INITIALS	DATE	TITLE	MODEL
CALC	GDW	11-12-8	GDW	11-21-8	SAMPLE CALCULATIONS 333-L TEST	
CHECK	JET	11-19-8				
APPD.						
APPD.						

SAMPLE CALCULATIONS (CONT.)

$$Z_L = 10.59$$

$K_Y = 4.5$ REF: BDM 84 F1 ASSUME SIMPLY
PAGE 323.2.1 SUPPORTED EDGES

$$P_{CR} \text{ (PSI)} = \frac{.925 (K_Y) (t_{MIN})^3 E}{(R) (L_2)^2}$$

$$P_{CR} = \frac{(.925)(4.5)(.099)^3(6.5 \times 10^6)}{(26)(5.5)^2}$$

$$P_{CR} = 33.35 \text{ PSI}$$

USING THE INTERACTION FORMULA FOR DETERMINING CAPABILITY,
WE FIND X% OF BSD TO GIVE SAME CAPABILITY AS THE
FAILURE LOADS.

$$\left[\left(\frac{22.6 X}{33.35} \right)^{1.2} + \left(\frac{71.5 X}{194} \right)^{1.2} \right]^{.83} = \left[\left(\frac{30.8}{33.35} \right)^{1.2} + \left(\frac{77.1}{194} \right)^{1.2} \right]^{.83}$$

$$(.678 X)^{1.2} + (.368 X)^{1.2} = (.925)^{1.2} + (.398)^{1.2}$$

$$X^{1.2} (.627 + .301) = (.911) + (.331)$$

$$X^{1.2} = 1.34$$

$$X = 1.28$$

IN PERCENT,

$$X\% = 128 \% \text{ BSD DUL}$$

	INITIALS	DATE	REV BY INITIALS	DATE	TITLE	MODEL
CALC	GDW	11-21-81			SAMPLE CALCULATIONS 333 - LAUNCH TEST	
CHECK	JET	11-19-81				
APPD.						
APPD.						

8.2 FLIGHT TEST CALCULATIONS—LOADS

8.2.1 333-F TEST CALCULATIONS

CALCULATIONS OF AXIAL COMPRESSION, BENDING MOMENT & SHEAR LOADS ON THE SPECIMEN AT STATION 257.4 AT 35 SECONDS OF PHASE I ARE SHOWN BELOW. THE JACK LOADS WERE TAKEN FROM REF. 4. SEE FIG. 5.4.1-1 FOR GEOMETRY.

HYDRALIC JACK NO.	1	2	3	4	5	6	7	8	9
LOAD (KIPS)	2.79	2.78	1.54	1.61	1.20	1.01	16.72	.495	14.865

AXIAL COMPRESSION LOADS

$$P \text{ (KIPS)} = \sum_{i=1}^6 (\text{HYD. JACK})_i + 2.0 + 3.3 + 3.084 + 1.624 \triangle$$

$$P = 10.93 + 5.3 + 4.71$$

$$P = 20.94 \text{ KIPS}$$

\triangle THE 2.0 KIPS & 3.3 KIPS DEAD WEIGHTS SIMULATE THE INTERNAL STRUCTURE LOADS OF THE MGS & PBPS RESPECTIVELY. THE SHROUD & FRUSTUM LOAD ADAPTORS APPLY LOADS OF 3.084 KIPS & 1.624 KIPS.

BENDING MOMENT

$$M \text{ (IN-KIPS)} = \text{COUPLE-MOMENTS} + \text{SHEAR MOMENT}$$

$$M = \left[\sum \text{JACKS (3 \& 4 - 1 \& 2)} \right] 25.83 + \left[\sum \text{JACK (6-5)} \right] 46 + (257.4 - 158.02) \text{JACK 9} + (257.4 - 146.35) \text{JACK 8}$$

$$M = (-2.42) 25.83 + (-.19) 46 + 99.38 (14.865) + (111.05) .495$$

$$M = 1461.0 \text{ IN-KIPS}$$

SHEAR THE 14.86 KIPS ON THE SHROUD & .495 KIPS ON THE FRUSTUM (JACKS 9 & 8) COMBINE AT STATION 225.3 TO GIVE A SHEAR OF 15.36 KIPS.

	INITIALS	DATE	REV BY INITIALS	DATE	TITLE	MODEL
CALC	GDW	11-14-8			SAMPLE CALCULATIONS—LOADS 333 - F PROGRAMMED TEST	
CHECK	ET	11-19-8				
APPD.						
APPD.						

SAMPLE CALCULATION (CONT.)

CALCULATION OF THE LINE LOAD ON THE SPECIMEN ALONG THE AZIMUTH OF THE MAXIMUM LINE LOAD (36°30' AZIMUTH) IS SHOWN. THE LOADS USED ARE FROM THE WIND SHEAR CONDITION AT STATION 257.4.

$$\text{LINE LOAD} \approx q \left(\frac{\text{lbs}}{\text{IN}} \right) = \frac{\text{AXIAL COMP.}}{\text{CIRCUMFERENCE}} + \frac{\text{BEND. MOM.} \cos(36^\circ 30' - \theta)}{\text{AREA}}$$

CIRCUMFERENCE AND AREA ARE OF THE CROSS SECTION AT STATION 257.4. THE RADIUS IS 26 INCHES. $\theta = 36^\circ 30'$

$$q_{\text{MAX.}} = \frac{2094}{163} + \frac{1461.0 \cos 0^\circ}{2124}$$

$$q_{\text{MAX.}} = 128.5 + 687.7$$

$$q_{\text{MAX.}} = 816.2 \frac{\text{lbs.}}{\text{IN}}$$

	INITIALS	DATE	REV BY INITIALS	DATE	TITLE	MODEL
CALC	GDW	11-14-8			SAMPLE CALCULATIONS 333-F PROGRAMMED TEST	
CHECK	ET	11-19-8				
APPD.						
APPD.						

82.2 345-F TEST CALCULATIONS - LOAD CAPABILITIES

CALCULATIONS TO REDUCE THE FAILURE LOADS OF AXIAL COMPRESSION, BENDING MOMENT & SHEAR TO AN EQUIVALENT PERCENTAGE OF THE FIGURE A 6560 DESIGN ULTIMATE LOADS ARE AS FOLLOWS:

$L_1 = 10.51$ INCHES $E = 10.7 \times 10^6$ FOR AL
 $R = 26.0$ INCHES $\frac{L}{R} = .404$ $\frac{R}{t_{MIN}} = 238$

II-III INTERSTG.
AFT BAY

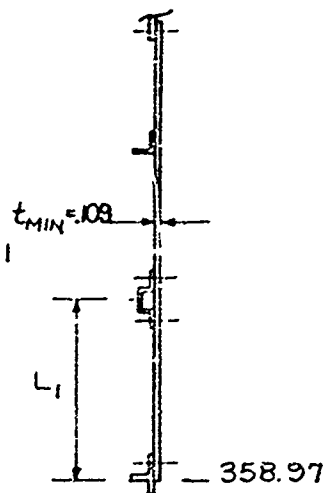

CRITICAL AXIAL COMPRESSION

$F_C \left(\frac{\text{lbs}}{\text{IN}^2} \right) = (1.60 \times 10^{-3}) (E)$ ← REF. BDM 84 F1
PAGE 313.2.1

$F_C = 17.12 \times 10^3 \frac{\text{lbs}}{\text{IN}^2}$

$P_{CR} = F_C (2\pi) R (t_{MIN})$

$P_{CR} (\text{KIPS}) = 2\pi (R) (t_{MIN}) F_C$

$P_{CR} = 2\pi (26) (.109) (17.12 \times 10^3)$

$P_{CR} = 305$ KIPS

REF. DRWG. PER BOEING
25-60827

CRITICAL BENDING MOMENT

$F_B \left(\frac{\text{lbs}}{\text{IN}^2} \right) = 2.12 \times 10^{-3} (E)$ ← REF. BDM 84 F1
PAGE 316.2.1

$F_B = 2268 \times 10^3 \frac{\text{lbs}}{\text{IN}^2}$

$M_{CR} (\text{IN-KIPS}) = F_B (\pi R^2) (t_{MIN})$

$M_{CR} = 5248$ IN - KIPS

CRITICAL SHEAR

$F_V = (1.4) (1.07) (E)$ ← REF. BDM 84 F1
PAGE 319.2.1.1

$F_V = 16.03 \times 10^3 \frac{\text{lbs}}{\text{IN}^2}$

$V_{CR} = F_V (\pi) R (t_{MIN})$

$V_{CR} = 1426$ KIPS

	INITIALS	DATE	REV BY INITIALS	DATE	TITLE	MODEL
CALC.	WONACOTT	11-15-8			SAMPLE CALCULATIONS 345-F FAILURE TEST LOAD CAPABILITIES	
CHECK	ET	11-19-8				
APPD.						
APPD.						

SAMPLE CALCULATIONS (CONT.)

TABULATION OF FAILURE LOADS & FIGURE A (100%) LOADS AT STA. 359.

	AXIAL COMP.	BEND. MOM.	SHEAR
FAILURE LOADS	87.6 KIPS	3291 IN-KIPS	13.3 KIPS
FIGURE A LOADS	62.8 KIPS	3,000 IN-KIPS	12 KIPS

USING INTERACTION FORMULA FOR DETERMINING CAPABILITY, WE FIND X% OF THE FIG. A LOADS THAT GIVE THE SAME CAPABILITY AS THE FAILURE LOADS.

$$\left[\frac{62.8X}{305} + \frac{3000X}{5248} + \frac{12X}{142.6} \right] = \left[\frac{87.6}{305} + \frac{3291}{5248} + \frac{13.3}{142.6} \right]$$

$$X = 1.168$$

$$\% \text{ FIG. A} = 116.8 \%$$

CALCULATIONS FOR THE REDUCED CAPABILITY OF A MINIMUM GAGE SECTION ARE AS FOLLOWS:

$$t_{\text{MIN.}} (\text{IN}) = .109$$

$$t_{\text{ACTUAL}} (\text{IN}) = .111$$

TO CALCULATE THE CRITICAL VALUES OF AXIAL COMPRESSION, BENDING MOMENT & SHEAR USING ACTUAL THICKNESS.

$$\frac{L}{R} = .404 \quad \frac{R}{t_{\text{ACT}}} = 234$$

CRITICAL AXIAL COMPRESSION

$$F_c \left(\frac{\text{lbs}}{\text{IN}^2} \right) = 1.68 \times 10^{-3} (E) \quad \leftarrow \text{REF: BDM84F1 PAGE 313.2.1}$$

$$F_c = 17.98 \times 10^3 \frac{\text{lbs.}}{\text{IN}^2}$$

$$P_{\text{CR}} (\text{KIPS}) = F_c (2\pi) R (t_{\text{ACT}})$$

$$P_{\text{CR}} = (17.98 \times 10^3) (2\pi) (26) (.111)$$

	INITIALS	DATE	REV BY INITIALS	DATE	TITLE	MODEL
CALC.	GDW	11-18-8	GDW	11-22-8	SAMPLE CALCULATIONS 345-F FAILURE TEST	
CHECK	JET	11-19-8				
APPD.						
APPD.						

SAMPLE CALCULATIONS (CONT.)

$P_{CR} = 326 \text{ KIPS}$

CRITICAL BENDING MOMENT

$F_B \left(\frac{\text{lbs}}{\text{IN}^2} \right) = 2.17 \times 10^{-3} (E)$ ← REF. BDM 84 F 1
PAGE 316.2.1

$F_B = 23.22 \times 10^3 \frac{\text{lbs}}{\text{IN}^2}$

$M_{CR} (\text{IN-KIPS}) = F_B (\pi R^2) (t_{ACT})$

$M_{CR} = 23.22 \times 10^3 (\pi 26^2) (.111)$

$M_{CR} = 5471 \text{ IN-KIPS}$

CRITICAL SHEAR

$F_V \left(\frac{\text{lbs}}{\text{IN}^2} \right) = 1.4 (1.1) (E) \times 10^{-3}$ ← REF. BDM 84 F 1
PAGE 319.2.1.1

$F_V = 16.48 \frac{\text{lbs}}{\text{IN}^2}$

$V_{CR} (\text{KIPS}) = F_V (\pi)(R)(t_{ACT})$

$V_{CR} = 149.2 \text{ KIPS}$

A TABULATION OF THE CRITICAL VALUES DETERMINED FROM t_{ACT} CALCULATION ABOVE & t_{MIN} CALCULATIONS IN A PREVIOUS SECTION IS SHOWN:

CASE	GAGE	CRIT AXIAL COMP.	CRIT. BEND. MOM.	CRIT. SHEAR
t_{MIN}	.109 IN.	305 KIPS	5248 IN-KIPS	142.6 KIPS
t_{ACT}	.111 IN.	326 KIPS	5471 IN-KIPS	149.2 KIPS

FIGURE A 6560 DUL, SHOWN ON SHEET 807 COMPLETES THE VALUES NEEDED FOR THE RATIO OF THE INTERACTION FORMULAS OF CAPABILITIES.

	INITIALS	DATE	REV BY INITIALS	DATE	TITLE	MODEL.
CALC.	WOLFGOTT	11-18-8			SAMPLE CALCULATIONS 345-F FAILURE TEST	
CHECK	JST	11-19-8				
APPD.						
APPD.						

SAMPLE CALCULATIONS (CONT.)

$$\text{MIN. GAGE FACTOR (\%)} = \frac{\frac{\Sigma(\text{FIG. A LOADS})}{t_{\text{ACT. CRITICAL LOADS}}}}{\frac{\Sigma(\text{FIG. A LOADS})}{t_{\text{MIN. CRITICAL LOADS}}}}$$

$$\text{MIN. GAGE FACTOR} = \frac{\left(\frac{62.8}{326} + \frac{3000}{5471} + \frac{12}{149.2} \right)}{\left(\frac{62.8}{305} + \frac{3000}{5248} + \frac{12}{142.6} \right)}$$

MIN. GAGE FACTOR = 0.952

CAPABILITY OF A MINIMUM GAGE SPECIMEN

.952 (116.8) = 111 % FIG. A DUL

	INITIALS	DATE	REV BY INITIALS	DATE	TITLE	MODEL
CALC	GDW	11-18-81			SAMPLE CALCULATIONS 345-F TEST	
CHECK	JET	11-19-81				
APPD.						
APPD.						

9.0 REFERENCES

1. D2-16696-1, "Detail Test Plan-Static Confirmation Tests LGM-30G (Minuteman III)." Revision B, March 1968, The Boeing Company, Seattle, Washington.
2. T2-3656-1 through -4, "Test and Data Report-Static Confirmation Tests LGM-30G II-III Interstage." Revision A, September 1968, The Boeing Company, Seattle, Washington.
3. T2-3657-2 and -3, "Test Data-Static Confirmation Silo Launch Condition Tests (332-L and 333-L partial) - LGM-30G", and "Test Data - Static Confirmation Silo Launch Condition Tests (333-L completed) - LGM-30G", respectively. 196, The Boeing Company, Seattle, Washington.
4. T2-3657-4 and -5, "Test Data-Static Confirmation Flight Condition Tests (332-F and 333-F partial) - LGM-30G", and "Test Data - Static Confirmation Flight Condition Tests (333-F completed) - LGM-30G", respectively. 196, The Boeing Company, Seattle, Washington.
5. Letter 2-5513-10-141, May 6, 1968. The Boeing Company to SAMSO/TRW. Subject: Minuteman III Static Confirmation Test 333-F Flight Load Profile revision.
6. "Failure Analysis of Boeing Structural Test No. 333-F". 2 August 1968, SRO Stress Group, Aerojet-General Corporation, Sacramento, California.
7. D2-30876-1, "Analysis of Load-Deflection Data from Wing VI Static Confirmation Tests." January 19, 1966, The Boeing Company, Seattle, Washington.
8. D2-16763-1, "Structural Dynamic Characteristics-Operational LGM-30G Missile Configurations (U) July 21, 1967 (SECRET RESTRICTED DATA), The Boeing Company, Seattle, Washington.
9. T2-3671-1, "Final Test Report-Static Development Test Stage III/ Stage IV Separation Joint, Figure A 6553" (unpublished). The Boeing Company, Seattle, Washington.
10. T2-3673-1, "Final Test Report-Static Development Test 2-3 Interstage, ETR 6560." May 1968, The Boeing Company, Seattle, Washington.

USE FOR TYPEWRITTEN MATERIAL ONLY

Unclassified

Security Classification

NUMBER T2-3657-1
REV LTR A

DOCUMENT CONTROL DATA - R&D

(Security classification of title, body of abstract and indexing annotation must be entered when the overall report is classified)

1. ORIGINATING ACTIVITY (Corporate author) The Boeing Company P. O. Box 3985 Seattle, Washington		2a. REPORT SECURITY CLASSIFICATION Unclassified	
		2b. GROUP	
7. REPORT TITLE FINAL TEST REPORT -- STATIC CONFIRMATION TESTS LCM-30G (MINUTEMAN III)			
4. DESCRIPTIVE NOTES (Types of report and inclusive dates) Final Test Report 9 March 1968 to 18 July 1968			
5. AUTHORS (First name, middle initial, last name) James E. Tancreto John Claus Gary D. Wonacott Wayne L. Salus			
6. REPORT DATE 7 February 1969		7a. TOTAL NO. OF PAGES 335	7b. NO. OF REFS 10
8a. CONTRACT OR GRANT NO. AF04(694)-791		9a. ORIGINATOR'S REPORT NUMBERS T2-3657-1	
b. Project No. WS 133			
c.		9b. OTHER REPORT NO(S) (Any other numbers that may be associated with this report) SAMSO-TR-69-168	
d.			
10. DISTRIBUTION STATEMENT This document is subject to special export controls and each transmittal to foreign governments or foreign nationals may be made only with prior approval of Space and Missiles Systems Organization (AFSC) (3164) Naval Air Station, San Diego, California <i>SAMSO, Los Angeles AFB, Calif 90045</i>			
11. SUPPLEMENTARY NOTES The distribution of this report is limited because it contains technology restricted by Mutual Security Acts.		12. SPONSORING MILITARY ACTIVITY SAMSO Horton Air Force Base San Bernardino, California	
13. ABSTRACT This document provides the final test report for the Structural Static Confirmation Tests of integrated structural components of the Minuteman LGM 30G missile. The primary purposes of the test program were to: 1) confirm structural compatibility of integrated structure, 2) determine ultimate load capability, 3) obtain load deflection characteristics. Static tests were conducted on integrated Stage III/PBV R&D and Operational stackups and Stage II Fwd/ II-III Interstage/Stage III stackup. Various critical combinations of external and internal pressure, axial load, moment, shear and heat were applied to the structure simulating the silo launch condition and powered flight conditions.			

Security Classification

14. KEY WORDS	LINK A		LINK B		LINK C	
	ROLE	WT	ROLE	WT	ROLE	WT
Confirmation Test Flight Condition Integrated Test II-III Interstage Joint Stiffness Launch Condition MGS Minuteman Missile Section Stiffness Mod 7E PECS PBPS PBV Programmed Loads Programmed Temperatures Re-Entry System R/S Frustum R/S Shroud Stage III Motor Stage III/PBV Separation Joint Static Test						