

THIS REPORT HAS BEEN DELIMITED
AND CLEARED FOR PUBLIC RELEASE
UNDER DOD DIRECTIVE 5200.20 AND
NO RESTRICTIONS ARE IMPOSED UPON
ITS USE AND DISCLOSURE.

DISTRIBUTION STATEMENT A

APPROVED FOR PUBLIC RELEASE;
DISTRIBUTION UNLIMITED.

FOR OFFICIAL USE ONLY

DEPARTMENT OF THE ARMY
OFFICE OF THE ADJUTANT GENERAL
WASHINGTON, D.C. 20310



IN REPLY REFER TO

AD 844657

AGAM-P (M) (21 Nov 68) FOR OT UT 683338

25 November 1968

SUBJECT: Operational Report - Lessons Learned, Headquarters, 34th
Engineer Group (Const), Period Ending 31 July 1968

SEE DISTRIBUTION

1. Subject report is forwarded for review and evaluation in accordance with paragraph 5b, AR 525-15. Evaluations and corrective actions should be reported to AGSFOR OT UT, Operational Reports Branch, within 90 days of receipt of covering letter.
2. Information contained in this report is provided to insure that the Army realizes current benefits from lessons learned during recent operations.
3. To insure that the information provided through the Lessons Learned Program is readily available on a continuous basis, a cumulative Lessons Learned Index containing alphabetical listings of items appearing in the reports is compiled and distributed periodically. Recipients of the attached report are encouraged to recommend items from it for inclusion in the Index by completing and returning the self-addressed form provided at the end of this report.

BY ORDER OF THE SECRETARY OF THE ARMY:

1 Incl
as

Kenneth G. Wickham
KENNETH G. WICKHAM
Major General, USA
The Adjutant General

D D C
RECORDED
DEC 16 1968
A

DISTRIBUTION:

- Commanding Generals
 - US Continental Army Command
 - US Army Combat Developments Command
- Commandants
 - US Army Command and General Staff College
 - US Army Engineer School

UNCLASSIFIED REPORT

DISTRIBUTION NO FOREIGN WITHOUT APPROVAL OF
ASSISTANT CHIEF OF STAFF FOR FORCE DEVELOPMENT
(ARMY) ATTN FOR OT UT WASHINGTON, D.C. 20310

Protective marking cancelled when
separated from inclosure.

FOR OFFICIAL USE ONLY

DISTRIBUTION (Cont'd)

Copies furnished:

Office, Chief of Staff, US Army

Deputy Chiefs of Staff

Chief of Engineers

Chief of Research and Development

Assistant Chiefs of Staff

Research Analysis Corporation

Defense Documentation Center

Security Officer, Hudson Institute

Commanding Officers

US Army Limited War Laboratory

US Army Logistics, Doctrine Systems & Readiness Agency

34th Engineer Group (Const)

ACCESSION IN	
CFSTI	WRITE SECTION <input type="checkbox"/>
DDC	REF SECTION <input checked="" type="checkbox"/>
UNCLASSIFIED	<input type="checkbox"/>
CLASSIFICATION	
BY	
DISTRIBUTION/AVAILABILITY CODES	
DIST.	AVAIL. AC/IC SPECIAL
2	

FOR OFFICIAL USE ONLY

DEPARTMENT OF THE ARMY
HEADQUARTERS 34TH ENGINEER GROUP (CONST)
APO San Francisco 96291

EGF-OP

1 August 1968

SUBJECT: Operational Report of HQ, 34th Engineer Group (Const) for
Period Ending 31 July 1968, RCS, CSFOR-65(R1)

Commander-in-Chief, US Army Pacific, ATTN: GPOP-DT, APO 96558
Commanding General, US Army Vietnam, ATTN: AVHGC-DST, APO 96375
Commanding General, 20th Engineer Brigade, ATTN: AVBI-OS, APO 96491

1. Section 1, Operations: Significant Activities

a. Command:

(1) During the reporting period, Headquarters 34th Engineer Group (Const) remained located at Vung Tau, South Vietnam. The major activities of the Group continued to include operational support to Second Field Force Vietnam (IIFORGEV) and IV ARVN Corps, road and bridge upgrading (LOC's), providing minimum essential requirements (MER) to incoming and relocating units, base construction, quarry operations, and support to the Revolutionary Development Support Program.

(2) COL William C. Stewart continued to command the Group throughout the period.

(3) Organization Structure:

(a) On 20 May 68, the 702d Engr Det (PD) was assigned to the 34th Engr Gp. The unit is presently located in Dong Tam, attached to the 93d Engr Bn (Const) and is engaged in power distribution system construction at that location,

(b) On 17 Jun 68, the 93d Engr Bn (Const) HQ moved from Long Thanh North to Dong Tam. Presently, the entire unit is located at Dong Tam where it is constructing facilities for the 9th Inf Div.

(c) On 1 Jul 68, the 31st Engr Bn (Cbt), the 573d Engr Co (FB), and the 617th Engr Co (PB) were reassigned to the 159th Engr Gp (Const). This reassignment of units occurred with a corresponding change in Area of Responsibility (AOR) for the 34th Engr Gp.

FOR OT UT
683338

Inclosure

FOR OFFICIAL USE ONLY

FOR OFFICIAL USE ONLY

EGF-OP

1 August 1968

SUBJECT: Operational Report of HQ, 34th Engineer Group (Const) for Period Ending 31 July 1968, RCS,CSFOR-65(R1)

(d) On 1 Jul 68, the 67th Engr Co (DT) was attached to the 93d Engr Bn (Const). The unit was formerly attached to the 36th Engr Bn (Const). The 67th Engr Co (DT) HQ is now located in Long Tam.

(e) On 1 Jul 68, the 523d Engr Co (PC) was reassigned from the 18th Engr Bde to the 34th Engr Gp, replacing the 536th Engr Det (PC) which was reassigned from the 34th Engr Gp to the 18th Engr Bde on the same date. The 523d Engr Co (PC) HQ is located in Vung Tau.

(f) The 34th Engr Gp organization chart as of 31 July 68 is attached as inclosure 1.

(4) Area of Responsibility: The Group area of responsibility (AOR) was changed by the expansion of the 159th Engr Gp AOR in the vicinity of Bear Cat and Xuan Loc areas. The current Group AOR includes all of IV Corps Tactical Zone, Long An Province, part of Gia Dinh Province, Phouc Tuy Province, Rung Sat Special Zone, Vung Tau Special Zone, and Phu Quoc Island. Inclosure 2 portrays the current Group AOR.

b, Personnel, Administration, Morale and Discipline:

(1) At the end of the reporting period the strength was:

	<u>O</u>	<u>WO</u>	<u>EM</u>	<u>TOTAL</u>
AUTH	172	33	4204	4409
ASGD	173	27	4037	4237

(2) During the reporting period the Group rotated approximately 29% of its total authorized strength. Critical personnel shortages as of 31 July are listed below:

<u>GRADE</u>	<u>JOB DESCRIPTION</u>	<u>MOS</u>	<u>AUTH</u>	<u>ASGD</u>
E4	Mason	51D2	37	10
E6-E9	Construction Supervisor	51H4	94	38
E4	Plumber	51K2	112	27
E4	Electrician	52F2	113	32
E6-E7	Supply Sergeant	76Y4	29	12

(3) 152 personnel extended their FST during the reporting period (as of 20 July).

FOR OFFICIAL USE ONLY

FOR OFFICIAL USE ONLY

EGF-OP

1 August 1968

SUBJECT: Operational Report of HQ, 34th Engineer Group (Const) for
Period Ending 31 July 1968, RCS,CSFOR-65(R1)

(4) The following awards were presented to 34th Engr Gp personnel:

MEDALS

Silver Star	1
Legion of Merit	0
Air Medal	5
Bronze Star Medal with "V" for Valor	4
Bronze Star Medal for Achievement/Service	45
Joint Service Commendation Medal	2
Army Commendation Medal with "V" for Valor	37
Army Commendation Medal for Achievement/Service	72
Purple Heart	13
Certificate of Achievement	46

(5) The following promotions were made during the reporting period:
E8 - (2), E7 - (5), E6 - (22), E5 - (343), E4 - (565).

(6) A daily average of 742 Local National Permanent Hire personnel were paid a total of 13,183,749 \$VN during the period for work on projects throughout the Group ACR. A daily average of 292 Local National daily hire unskilled personnel were paid a total of 1,675,273 \$VN. Both categories continued to serve a useful function by releasing military personnel for more specialized tasks.

(7) The Group's career counseling and reenlistment program attained increased success with the assignment of a second full time career counselor to Group Headquarters. During the previous reporting period Jan - Mar 68 the Group's 1st Term RA reenlistment rate was 33.3% while the first term RA reenlistment rate for the current reporting period was 53%.

(8) (a) The Information Program of the 34th Engineer Group was greatly expanded during the reporting period.

1 Distribution of the Group bi-weekly newspaper, the "Delta Developer", containing command information material, stories of significant events throughout the Group, awards, as well as other items of interest to the command, has been increased from 1500 to 2000 copies per issue.

FOR OFFICIAL USE ONLY

FOR OFFICIAL USE ONLY

EGF-OP

1 August 1968

SUBJECT: Operational Report of HQ, 34th Engineer Group (Const) for Period Ending 31 July 1968, RCS, CSFOR-65(R1)

2 Publication of the new 76th Engineer Battalion newspaper, the "Seahorse", has been put into effect under the guidance of the Group Information Officer.

3 Additional expansion of the Group Information Program was accomplished by using the facilities of network television to cover unusually important engineer accomplishments. Using USARV information facilities, taped interviews were made of engineer personnel in the field. Also, using USARV information capabilities, photographic teams and motion picture teams have visited operations - providing both immediate coverage, as well as a "selling point" for the civilian news media.

(b) The 34th Group, at the suggestion of the Group Commander, has developed a job satisfaction program. Designed to increase morale and pride in individual accomplishments, the program has great possibilities for all engineer units. At the completion of a job, all personnel who worked on the project are photographed standing in front of the completed project. Photographs are reproduced for each man in the picture, and distributed to the men. It is felt that this program helps each man to identify more closely with his work, and it gives each man a pictorial history of what he had done during his tour in Vietnam.

(9) The Blank Card Theory of Morale Analysis has proven itself during the past quarter to be an outstanding means of communication between the lower ranking EM and the Command structure of the 34th Engineer Group.

(a) The purpose of the Blank Card Theory of Morale Analysis is:

- 1 To obtain an objective basis upon which to analyze morale.
- 2 To offer the soldier a completely anonymous means of presenting his complaints and venting his hostility.
- 3 To inform the commander of morale problems.

(b) The prerequisites of the Blank Card Theory of Morale Analysis are:

- 1 The chaplain must have established a high degree of rapport with the company commander involved.
- 2 Some degree of rapport is needed with the 1SG.
- 3 At least a two month time span in which the above can be accomplished.
- 4 Approval of the battalion commander.

FOR OFFICIAL USE ONLY

FOR OFFICIAL USE ONLY

EGF-OP

1 August 1968

SUBJECT: Operational Report of HQ, 34th Engineer Group (Const) for
Period Ending 31 July 1968, RCD, CSFOR-65(R1)

(c) A simple procedure is followed in the application of the Blank Card Theory of Morale Analysis:

1 In conjunction with the Character Guidance lecture the chaplain gives each soldier a blank card and asks him to write down any grievances which he has. The soldier is told to list his grievances; to be specific; to print, not write; and not to sign his name. The class is told that the cards will be given to the company commander. The soldier is told to print "NONE" on his card if he has no complaints.

2 The chaplain must be careful to limit his instructions to the class. His instructions should be memorized verbatim and should not vary in presentation. This procedure must be followed to avoid coloring the response on the cards.

3 The chaplain allows ample time for each soldier to write down his grievances, takes up the cards and presents a quick tabulation of the results to the class.

4 The chaplain gives cards to the company commander and discusses each card with him. The chaplain points out to the CO that this is a carte blanche procedure and that much of the time the complaints are nothing more than a venting of hostility.

5 The chaplain carefully tabulates the total number of cards and the number of each type of complaints, eg.: 50 Chow complaints

25 NCO complaints

10 Officer complaints

15 Laundry complaints

13 No time off complaints

20 Mail complaints

6 The chaplain leaves the cards with the company commander and carries the tabulation to the battalion commander.

(10) No unusual disciplinary problems were experienced during the reporting period.

c. Intelligence and Counter Intelligence: The chief sources of intelligence information concerning enemy activity continued to be II FORCEV INTSUMs, PERINTREPs, the USARV Weekly Combat Intelligence and Security Review and 9th Div (US) INTSUMs. Additional intelligence

FOR OFFICIAL USE ONLY

FOR OFFICIAL USE ONLY

EGF-OP

1 August 1968

SUBJECT: Operational Report of HQ, 34th Engineer Group (Const) for Period Ending 31 July 1968, RCS, CSFOR-65(R1)

summaries were obtained from Senior Advisor IV RVN Corps Tactical Zone, 164 AVN Gp and Phuoc Tuy Province Sector Headquarters. This information was supplemented by intelligence obtained by direct liaison between the Group's battalions and local tactical units having area responsibility and was further supplemented by SPOTREPs from the Group's units which were in sporadic contact with the enemy. Engineer reconnaissance of routes QL-4 and QL-15 and information from tactical units having area responsibility provided daily information of interdictions on these two routes. Engineer reconnaissance of other LOCs and planned project sites continued to be on an "as required" basis. Group HQ remained physically located in the Vung Tau Sub-Area. The 53d Gen Spt Gp, responsible for the overall defense of the sub-area, provided INTSUMs for the local area.

d. Plans, Operations, and Training:

(1) Operational Support:

(a) During the period 51.6% of the total Group effort was expended on operational support missions. There continued to be three basic types of operational support missions:

1 Direct support to combat operations.

2 Deliberate construction to support future operations.

3 Troop and equipment support to MACV and II FFORCEV units for construction and maintenance of existing roads, airfields and other facilities.

(b) Operation Pinnaroo: On this operation, the 36th Engr Bn (Const) organized a five-plow land clearing task force to support the 1st Australian Task Force in clearing selected areas near the Long Hai Mountains. The operation began on 1 Apr 68 and ended on 3 Mar 68 with 1,125 acres being cleared. A discussion of land clearing with Rome Plows is contained in inclosure 3.

(c) Operation Giant Swath: The 86th Engr Bn (Cbt) Land Clearing Team supported the 1st Inf Div on this operation near Lai Khe. The operation began on 27 Apr 68 and finished on 27 Jun 68 with 10,617 acres being cleared.

(d) Operation Duong Cau Dan (Peoples Road): On this operation, the 86th Engr Bn (Cbt) in support of the 9th Inf Div provided two companies for the upgrading of QL-4 between My Thuat, north of My Tho junction with LTL-6A. The mission is described in more detail in paragraph 1d(2)(c)1 of the Lines of Communication section of this report.

FOR OFFICIAL USE ONLY

FOR OFFICIAL USE ONLY

EGF-OP

1 August 1968

SUBJECT: Operational Report of HQ, 34th Engineer Group (Const) for Period Ending 31 July 1968, RCS, CSFOR-65(R1)

(e) Operation Land Clearing - Route 15: The 86th Engr Bn (Cbt) is supporting the 9th Inf Div on this land clearing operation. The operation consists of clearing selected areas along Route QL-15 between Ba Ria and Long Binh. Clearing began on 12 Jul 68, and as of 31 Jul, 2,475 acres had been cleared.

(f) Airfields: The 34th Engr Gp worked on five deliberate operational support airfields during the reporting period:

1 Can Tho Airfield: The 69th Engr Bn (Const) completed the rehabilitation of the old deteriorated FSP runway by construction of a new runway consisting of a sand/asphalt sealing layer overlaid with M8A1 matting. The airfield has a Type II, C-130 capability.

2 Vi Thanh Airfield: The 69th Engr Bn (Const) continued to upgrade this airfield to Type II, C-130 capability. The original airfield consisted of rice paddy clay surfaced with gravel. The completed airfield will consist of M8A1 matting on a sand/asphalt sealing layer. Twelve hundred feet have been completed as of 31 July.

3 Binh Duc Airfield: Upgrading of the existing 1,500 foot rice paddy clay base, laterite capped airfield continued by the 86th Engr Bn (Cbt). The new runway will have a Type II, C-123 capability and will consist of M8A1 matting overlaying a lime stabilized clay base with a sand/asphalt sealing course. This is the first use of clay/lime stabilization by a 34th Engr Gp unit in airfield construction. 250 feet of runway were completed on 31 Jul 68.

4 Luscombe Airfield: The 36th Engr Bn (Const) continued to upgrade the original Type I, C-130 airfield to a Type II, C-130 capability in support of the 1st Australian Task Force. The finished airfield will consist of a laterite base surfaced with a DBST. On 31 Jul 68, 2,700 feet were completed.

5 Ben Tre Airfield: The 31st Engr Bn (Cbt) began upgrading the existing Type II C-7A runway to Type II C-123 capability on 25 May 68. The original runway consisted of a clay base surfaced with crushed rock. The 31st Engr Bn is currently placing a sand/asphalt sealing layer and surfacing with AM-2 matting. On 31 Jul 68, 1,100 feet were completed.

(g) Miscellaneous Construction and Maintenance Projects in support of MACV and II FFORCEV units included:

1 Long Hai: Elements of the 36th Engr Bn (Const) provided technical assistance and a small construction force to the 5th Special Forces for construction of berms, towers and buildings.

FOR OFFICIAL USE ONLY

FOR OFFICIAL USE ONLY

EGF-OP

1 August 1968

SUBJECT: Operational Report of HQ, 34th Engineer Group (Const) for Period Ending 31 July 1968, RCS, CSFOR-65(R1)

2 Beh Luc Fire Support Base: Elements of the 86th Engr Bn (Cbt) completed rehabilitation of the fire support base. A revetment was relocated, new drainage structures were constructed, and the road network was rehabilitated using clay/lime stabilization.

3 Dong Tam: Elements of the 93d Engr Bn (Const) completed the construction of protective structures for the Medical Unit Self-Sustaining (MUST) Hospital in support of the 3d Surgical Hospital.

4 Phu Quoc Island: Elements of the 36th Engr Bn (Const) continued quarrying, jungle clearing for the expansion of POW facilities, rehabilitating POW camp access roads, and the drilling of wells. In addition, an airfield access road was completed and the erection of four water tanks was initiated.

5 Vung Tau: Elements of the 36th Engr Bn (Const) constructed revetment security walls for an Integrated Wideband Communications System.

6 Tan An: Elements of the 86th Engr Bn (Cbt) supported the 1st Signal Brigade by excavating 4000 meters of trench 1.5 meters deep for the emplacement of communications cable.

7 Xuan Loc: Elements of the 86th Engr Bn (Cbt) excavated 2,460 met of trench, 1.2 meters deep for the emplacement of communications cable in support of the 39th Signal Group.

(h) Operational support bridge missions in support of II FFORCEV included the following:

1 Tan An: Elements of the 617th Engr Co (PB) installed a 160' Double Triple, Class 55 Bailey Bridge at XS 568667 in support of the 9th Inf Div.

2 Route QL-20: Elements of the 573d Engr Co (FB) and the 31st Engr Bn (Cbt) installed 230' of M4T6 Float Bridge at YT 482340.

(2) Lines of Communication: Emergency road repair and deliberate road restoration continued. A total of 13.5% effort was expended on LOCs during the period. Work accomplished by Group units included:

(a) Route QL-15 (Vung Tau to Kien Hoa - Phouc Tuy Province Boundary): The upgrading of this National Highway to MACV standards by elements of the 36th Engr Bn (Const) continued. During the period, work continued on drainage structures, selected sections were widened and approximately 3.25 kilometers were paved with hot-mix asphalt.

FOR OFFICIAL USE ONLY

FOR OFFICIAL USE ONLY

EGF-OP

1 August 1968

SUBJECT: Operational Report of HQ, 34th Engineer Group (Const) f.
Period Ending 31 July 1968, RCS, CSFOR-65(R1)

(b) Route LTL-2 - QL-1 (Xuan Loc to Black Horse): Elements of the 31st Engr Bn (Cbt) continued the effort originally provided by the departed 27th Engr Bn (Cbt) in upgrading this section of highway to MACV standards. Work accomplished consisted of widening, shaping, and base preparation.

(c) Route QL-4: Group units upgraded this National Route from My Tho junction with LTL-6A to Can Tho to withstand the summer monsoon season. In addition a large amount of effort was expended by the Group in the repair of interdictions along the route. General road maintenance continues.

1 QL-4 (My Tho junction (LTL-6A) to My Thuan Ferry Landing): Elements of the 86th Engr Bn (Cbt) upgraded this route to an allweather, two-way, Class 25 road during the period. The upgrading was considered an operational support mission and was given the name "Operation Duong Cau Dan (Peoples Road)". The project consisted of repairing potholes with cold-mix asphalt and surfacing 36 kilometers of road with DBST.

2 QL-4 (Vinh Long to Can Tho): Along this section of road, elements of the 69th Engr Bn (Const) worked in conjunction with the Ministry of Public Works (MPW) and ARVN Engineers in the repairing of potholes and craters, the driving of sheet pile along the canal side of the road to prevent further erosion, and placing a DBST and SBST where required.

(d) Route LTL-22 and LTL-25. Elements of the 93d Engr Bn (Const) performed continuous maintenance on these access routes to Dong Tam from Route QL-4 and My Tho to insure passage of essential military traffic.

(e) Xuan Loc Bypass: Elements of the 31st Engr Bn (Cbt) initiated construction of two bypasses around Xuan Loc for military traffic in support of the 11th Armored Cavalry Regiment.

(f) Cau Co May: Elements of the 36th Engr Bn (Const) and the 617th Engr Co (FB) installed 290' of Double-Single Bailey Bridge at YS 379573. The original concrete bridge had been partially destroyed and an Eiffel had been installed over the gap. The Class 12 Eiffel bridge was removed by a CH-54 Skycrane. The present classification of the bridge is Class 30.

(g) Ap Thu Luu Bridge: Elements of the 36th Engr Bn (Const) constructed a MACV standard bridge at YS 401600 as a part of the Tactical Bridge Removal and Replacement Program.

(h) Long Thanh North Bridge: Elements of the 86th Engr Bn (Cbt) initiated construction of a MACV standard bridge to replace a destroyed bridge at YS 140917. The project was later transferred to the 159th Engr Bn (Const) upon change of AORs.

FOR OFFICIAL USE ONLY

FOR OFFICIAL USE ONLY

EGF-OP

1 August 1968

SUBJECT: Operational Report of HQ, 34th Engineer Group (Const) for
Period Ending 31 July 1968, RCS, CSFOR-65(R1)

(3) Barge Off-loading Facilities: The joint ARVN, MFW, and the US program of constructing and operating barge off-loading sites in the DELTA which was initiated to support the LOC program during the last period, continued. During this period, elements of the 86th Engr Bn (Cbt) constructed a barge off-loading site at My Tho and initiated construction of another at Tan An. Elements of the 536th Engr Det (FG) supported the construction at My Tho and began construction of the Vinh Long barge off-loading site in support of the 69th Engr Bn (Const). During the period the 86th Engr Bn operated the off-loading site at My Thuan and the 93d Engr Bn operated the site at Dong Tam.

(4) Base Construction:

(a) Elements of the 34th Engr Gp continued construction of cantonment facilities for approximately 59,000 men at the following locations: Ba Ria, Can Tho, Cao Lanh, Dong Tam, Ham Tan, Phu Quoc Island, Soc Trang, Vinh Dong, Vi Thanh, and Vung Tau. In addition, Group units were engaged in base construction at Bear Cat, Gia Ray, Long Giao, Long Thanh North, and Xuan Loc.

(b) Currently in the planning stage are base construction projects at the following new locations: Bac Lieu, Ben Tre, Ca Mau, Chau Doc, Go Cong, Long Xuyen, Moc Hoa, My Tho, Rach Gia, Sa Dec, and Tra Vinh.

(c) Construction of the permanent C-130 airfield and related support facilities continued at Vung Tau. The 4,500 foot bituminous concrete runway was completed along with 1,500 feet of overruns and 10 foot wide SBST shoulders along the entire 6,000 feet. During the last two weeks of the reporting period work was initiated on the new 8th Aerial Port Building and related aircraft and vehicular parking areas. When these facilities are completed it will give Vung Tau greatly increased cargo handling capability.

(d) The first of three 50,000 BBL welded steel bulk fuel storage tanks was completed this period. The remaining two tanks will be completed during the next period. These tanks, in conjunction with the nearby POL Jetty will make Vung Tau one of the major bulk fuel handling facilities in Vietnam.

(e) An indication of the magnitude of the 34th Engr Gp construction effort during the reporting period is given by the following:

- 1 Total CY of concrete placed: 10,050.
- 2 Total SF of wood frame buildings completed: 474,460.
- 3 Total SF of wood hutments (billets) completed: 101,488.

FOR OFFICIAL USE ONLY

FOR OFFICIAL USE ONLY

EGF-CP

1 August 1968.

SUBJECT: Operational Report of HQ, 34th Engineer Group (Const) for Period Ending 31 July 1968, RCS, CSFCR-65(R1)

4 Total CY of laterite excavated: 168,160.

5 Total CY of fill hauled: 372,200.

6 Ton. of rock produced: 125,500.

7 Tons of asphalt placed: 4,750.

(f) Uncompleted Raymond, Morrison, Knudsen-Brown, Root, Jones (RMK-BRJ) contract projects previously assigned to the 34th Engr Gp were still active. The basic problem identified in previous reports still existed: non-availability of construction materials which are not standard to the Army supply system.

(g) The 34th Engr Gp continued to monitor contract dredging within the Group AOR. Maintenance dredging of the Dong Tam turning basin continued throughout the reporting period and was 90% complete at the end of the reporting period. A total of 130,000 CM has been pumped out of the turning basin and spoiled into the My Tho river. At Can Tho a 750,000 CM land fill requirement was initiated and completed. At Vinh Long a 300,000 CM land fill requirement was initiated during the last month of the reporting period. A major mechanical breakdown on the dredge resulted in only 100,000 CM of the total requirement being pumped by the end of the reporting period.

(5) Design and Construction Engineering:

(a) The Group Engineer section has devoted most of its effort to the review of construction drawings produced by the battalions. Recent losses of highly trained personnel in the battalion operations sections and an increase in the number of non-standard buildings requiring design has required more time for review and corrective effort to be spent by the section. As a result of detailed review, many suggestions for improvement were passed on to the originating unit. The largest project reviewed was the plan for a new MACV standard bridge over the Cau Co May tidal estuary. This bridge is a 483' span which has an 31' center section of reinforced concrete T beams and 8 side spans utilizing steel stringers and precast deck panels. This will be the longest multi-span bridge constructed by any of the Group units.

(b) Revisions have been made to previously produced standard drawings to improve them for ease of construction, to change them as required by availability of materials and to adapt them to the needs of the customer. New designs for an aircraft control tower and float bridge protection system were also completed.

(c) A complete power distribution system was designed for the new 86th Engineer Bn base camp at My Tho

FOR OFFICIAL USE ONLY

FOR OFFICIAL USE ONLY

EGF-OP

1 August 1968

SUBJECT: Operational Report of HQ, 34th Engineer Group (Const) for Period Ending 31 July 1968, RCS, CSFOR-65(R1)

(d) The surveying and soils sections continued to support the battalions upon request. The soils section has devoted nearly all of its efforts toward maintaining quality control of clay-lime stabilization at the Binh Duc airfield. This project is the first large scale clay-lime stabilization project undertaken by the 34th Engr Gp. The survey section has been utilized for survey control on the Binh Duc airfield and the Ben Tre airfield which is being rehabilitated using AM2 aluminum landing mat.

(e) A survey of the Bac Lieu airfield was completed for the Senior Advisor, IV CTZ to determine the feasibility of upgrading the airfield using matting. Results of soils analysis revealed that the airfield could be upgraded to type II, C-123 traffic using M3A1 matting. The work will be done by ARVN Engineers.

(f) The Engineering Section made an engineering estimate of the feasibility of replacing the portion of QL-4 between Can Tho and Vinh Long with a new road instead of rehabilitating the existing road. Calculations indicated that in both material cost and engineer effort, the new road would be more economical. The design of the new road used the specifications of a MACV Standard Road while rehabilitation of the existing road was a modified MACV Standard Road of lesser quality.

(g) The Engineering Section studied the feasibility of using some native materials in buildings constructed by Army Engineers. Calculation indicated that the materials cost savings would be negligible and that the building would require additional training of US troops. Native carpenters and workers would, however have the required skills. The final conclusion was that native materials should not be incorporated in military construction unless imported materials could not be delivered for high priority projects.

(6) Training: During the reporting period, the following training programs were conducted over and above those required by USARV regulations.

(a) Personnel from the Group began attending the 18th Engr Bde equipment operators school. Instruction is being given operators on the 290 M wheeled tractor, D-7E tractor, 20 ton crane, and grader.

(b) Personnel from the 86th Engr Bn (Obt) participated in float bridge training conducted by the 573d Engr Co (FB).

(c) Generator operation and maintenance training was given to personnel of the 69th Engr Bn (Const). The training was given by a representative of the US Army Mobility Equipment Command.

e. Logistics and Maintenance:

FOR OFFICIAL USE ONLY

FOR OFFICIAL USE ONLY

EGF-OP

1 August 1968

SUBJECT: Operational Report of HQ, 34th Engineer Group (Const) for
Period Ending 31 July 1968, RCS, CSFOR-65(R1)

(1) Supply: Shortages of construction materials and transportation of these items continued to be a problem. With increased construction effort being focused in the Delta, a large influx of materials was needed, primarily lumber (1x and 2x material) to support cantonment projects. Since Tet and the ensuing enemy activity, such lumber items have remained in short supply throughout the entire country. When material was available, transportation assets were hard-pressed to meet resupply rates to some areas. (Dong Tam is presently consuming in excess of 150,000 BF/week.) This will continue to be a problem for the foreseeable future. The Group is endeavoring to forecast requirements more accurately and to submit requisitions far enough in advance to allow timely delivery to work sites. An acceptable solution has been to provide the supply source with a copy of the project directives as well as approved BOMs as soon as they become available.

(2) Maintenance: The Group continued to experience a fairly constant deadline rate of all items of equipment during the reporting period. The USARV goals of 10% for critical items and 5% overall were maintained with the Group averaging 9.47% and 4.40% respectively. The continued low deadline rate was the direct result of continued command emphasis on operator maintenance and training, and obtaining repair parts through the use of Material Readiness Expeditors (MREs). During the reporting period the Group continued to maintain a full time MRE for the purpose of obtaining repair parts from property disposal yards, cannibalization points and organic units. The acquisition of parts from other than normal supply channels detracted from the unit's maintenance supervision capability, however this continued to be justified when the supply system was unable to supply the necessary repair parts.

f. Force Development:

(1) Company A, 86th Engr Bn (Cbt) was relocated from Bear Cat (YT 16/01) to Camp Viking (Binh Duc) (XS 4945) during June to develop Camp Viking into the new 86th Engr Bn (C)(A) base camp.

(2) The remainder of the 93d Engr Bn (HQ, A&D Companies) were relocated during June and July from Long Thanh North (YS 15'98) to provide additional engineer support to develop Dong Tam base (XS 4243). As the aviation and troop M&R facilities were completed, the emphasis was shifted to base construction for the 9th US Inf Div.

(3) On 1 July 1968 the 31st Engr Bn (C)(A), the 573d Engr Co (FB) and the 617th Engr Co (FB) were reassigned to the 159th Engr Gr (Const).

(4) On 1 July 1968 the 523d Engr Co (FC) was assigned to the Group and the 536th Engr Det (FC) was reassigned to the 18th Engr Bde.

FOR OFFICIAL USE ONLY

FOR OFFICIAL USE ONLY

EGF-OP

1 August 1968

SUBJECT: Operational Report of HQ, 34th Engineer Group (Const) for Period Ending 31 July 1968, RCS, CSFOR-65(R1)

(5) Company C, 69th Engr Bn was relocated from Dong Tam (XS 4549) to Binh Tuy (1S 8116) in July to construct MER facilities for the Binh Tuy Logistical Support Activity (LSA) and the new cantonment for the 69th Engr Bn (Const).

(6) Companies B & D of the 86th relocated from an operational support mission on QL-4 (People's Road) to Long Tan (XS 4243) during July to assist the 93d Engr Bn (Const) in base development construction for the 9th US Inf Div.

(7) The Group force structure remained well balanced for the accomplishment of its assigned missions, and was in fact greatly improved with the addition of the 523d Fort Construction Company.

g. Command Management: Aviation continued to be the critical item in maintaining effective command and control over the widely dispersed Group units. Aviation support was greatly improved this period reducing the problem.

h. Communications:

(1) During the reporting period the Group Communications Section began the installation of a Group-wide Tactical Telephone and Landline Teletypewriter system. The radioteletype system which has been in use since October 1967 had proven to be inadequate for this headquarters' needs. Because of nonavailability of optimum traffic frequencies, communications with subordinate battalions and the 20th Engineer Brigade were possible only a few hours of the day and not at all at night. The Landline Teletypewriter System is as follows:

(a) Service with the 20th Engineer Brigade began in May 1968, and with the 31st Engineer Battalion in June 1968. Circuit reliability is about 85% as compared with 10% on radio. In June a total of 116 messages were handled by the 34th Engineer Group Commcenter.

(b) Service to the 69th, 86th and 93d Engineer Battalions is expected to begin within the next sixty days. Service to the 36th Engineer Battalion will begin within 90 days.

(c) Cryptographic accounting is being decentralized to better accommodate the change over to the new cryptographic accounting procedures. As of 31 July, the 31st and 86th Battalions had accounts, and the account for the 69th Engineer Battalion was pending.

(2) The 34th Engineer Group Tactical Telephone Network is expanding rapidly. With the announced cutback in the number of Class A telephones authorized, telephonic communications have been somewhat hampered. The

FOR OFFICIAL USE ONLY

FOR OFFICIAL USE ONLY

EGF-OP

1 August 1968

SUBJECT: Operational Report of HQ, 34th Engineer Group (Const) for Period Ending 31 July 1968, RCS, CSFOR-65(R1)

unique dispersion of the elements within the 34th Engineer Group AOR results in over 95% of all telephone calls originated being to distant exchanges. Class C telephones are of little value in this situation. Consequently, a network of sole-user speech plus circuits has been installed with subordinate and higher headquarters to accommodate both the above mentioned teletypewriters and the Tactical Telephone System. All circuits have been approved by USARV and only the 86th Battalion remains to be connected. This will be installed within the next 5 days. This system has noticeably improved the inter-office communications and greatly supplements the common user circuits which are becoming increasingly more crowded.

i. 523d Engineer Company (Port Construction):

(1) Command:

(a) The unit continued to be commanded by CPT Alton A Clark.

(b) The unit was attached to the 34th Engineer Group (Const) APO San Francisco 96291 for operational control effective 1 July 1968.

(2) Personnel:

(a) At the end of the reporting period the personnel strength was:

	<u>O</u>	<u>WO</u>	<u>EM</u>	<u>TOTAL</u>
AUTH	12	1	214	227
ASCD	8	1	187	196

(b) During the reporting period 10% of the unit's personnel rotated to CONUS.

(c) During the quarterly period ending 31 July 1968 there were 25 Awards and Decorations given to individuals of this unit. The Army of the Republic of Vietnam presented one individual of this unit with the Technician Second Class Award. There was one IG complaint, no Class I or Class II offenses, and no AWOL's during this period.

(d) Personnel with the 523d Engineer Company (PC) received 11 Delinquency Reports, 4 Field Grade Article 15's and 16 Company Grade Article 15's.

(3) Operations:

FOR OFFICIAL USE ONLY

FOR OFFICIAL USE ONLY

EGF-OP

August 1968

SUBJECT: Operational Report of HQ, 34th Engineer Group (Const) for
Period Ending 31 July 1968, RCS, CSFR-65(R1)

(a) The 523d Engineer Company (FC) during the last quarter engaged in 78 working days and 7 days of training. The training consisted of classes on pertinent military subjects, personal hygiene and familiarization with individual and crew-served weapons.

(b) The principal operational activities taking place during this reporting period were as follows.

1 Causeway Bridge No 2 (CR 0923): The entire project was completed on 24 June 1968 when the concrete protective sleeves were placed around all 36 H-pile in the two piers. Scouring by tidal action has stabilized at the design depth.

2 Repair of Bridge (L-1-322 (BR 9520): A total of 6440 cubic yards of laterite were hauled for the by-pass road adjacent to the pier. Four (4) 48-inch corrugated metal culverts, 52 feet long, were placed in the by-pass to accommodate the anticipated water flow. This phase of the bridge repair was completed 8 June 1968. Work was completed on the repair of the damaged south pier on 7 June 1968. Pile driving operations for bents 3 and 4 were completed on 14 June 1968 with the driving of twelve 18-inch diameter 60-foot long hollow pipe piles. Work was initiated on the forming for the pile caps. The entire project was turned over to the 536th Engineer Detachment (FC) on 23 June 1968.

3 Flight Control Tower, Lane Army Heliport: The entire project was completed on 4 June 1968 when the tower was turned over to the Post Engineer Using Unit. All dry rotted timbers had been replaced, the cab area expanded to allow for the installation of a prefabricated cab unit, all of the wooden portions of the tower were painted with a sealer and finish coat of paint, concrete pads were placed for generator equipment, and a shed was built for equipment shelter and protection.

4 AUTOCSEVCCOM Facility (CR 0721): A total of 700 cubic yards of laterite and 3-inch minus were backfilled and compacted on the site. A reinforced concrete pad and 2350 concrete blocks were placed for the Switch Building. The roofing, external framework, and interior framing were completed on 13 June 1968. The remaining work, to include interior finishing, electrical and mechanical work, and painting has been delayed by the lack of materials. The remaining work on the project was turned over to the 536th Engineer Detachment (FC) on 1 July 1968.

5 Tandem Switch, Vung Chau Mountain (CR 0419): A total of 1,230 cubic yards of laterite backfill was placed for the initial site preparation. This was followed by the placement of a 700 cubic yard reinforced concrete retaining wall. The foundation footers were placed and additional backfill brought in to bring the site to finished grade. Construction was halted due to the lack of the prefabricated "Pascoe" Building. The remaining work was turned over to C Company of the 84th Engineer Battalion on 1 July 1968

FOR OFFICIAL USE ONLY

FOR OFFICIAL USE ONLY

EGF-07

1 August 1968

SUBJECT: Operational Report of HQ, 34th Engineer Group (Const) for Period Ending 31 July 1968, RCS, CSFOR-65(R1)

6 Ammo Barge Off-Loading Facility (CR 0924): Site preparation was initiated by the hauling of 9,000 cubic yards of sand. This project was turned over to the 536th Engineer Detachment (FC) on 1 July 1968.

7 Operational Support:

a Maintenance of LST Beach - Hauled 350 cubic yards of armor rock and blast rock for a 250 foot sea wall.

b Furnished security forces for RMK-BRJ Rock Quarry, Airfield security, and Red Beach Recreational Area.

c Bridge 442-3: Designed a 100-foot Class 55 bridge for the RVN Engineers. Furnished construction support by driving six (6) 30-foot, 18-inch hollow-pipe piles, furnished a 16 S concrete mixer and a 20-ton crane (CR 0329).

d Operation Cochise: Placed 36 feet of MAT6 balk on Bridge 442-5 to upgrade it to a class 60 bridge. 600 cubic yards of blast rock were hauled for 14 by-pass roads on Route QL-442.

e Vinh Long (XS 0433): 31 batter piles were driven for a timber pile wharf. Five LCM VIII's with supplies were unloaded.

f Vung Tau (YS 3048): Supported the 544th Engineer Company (CS) with welders. Twenty (20) EM were supplied to the 36th Engineer Bn (Const) for security guards during a recent convoy to Dong Tam.

8 Minor Task Assignments:

a Maintenance of Barge Quay: replaced 5,000 board feet of the 12"x12" timbers in the fender system on the fence of the concrete apron.

b Furnished a concrete mixer (16 S) with operator to Vinnell Corp and 5th Transportation Command.

c Furnished diving support to 5th Transportation Command, 159th Transportation Bn, 394 Transportation Bn, 1098th and 544th Transportation Companies (Medium Boat).

d Drafting and survey support were furnished to the 5th Transportation Command.

e Equipment and operator support were furnished during the restoration of the Red Beach recreation area with 5 ton tractors and 25 ton trailers, a 20-ton crane, a scoop loader, and D-7E tractors.

FOR OFFICIAL USE ONLY

FOR OFFICIAL USE ONLY

EGF-OP

1 August 1968

SUBJECT: Operational Report of HQ, 34th Engineer Group (Const) for Period Ending 31 July 1968, RCS, CSFOR-65(R1)

f Supported the 84th Engineer Bn with personnel and equipment to include surveyors, a 15-ton tractor with 55-ton trailer, D-7E tractors, scoop loaders, dump trucks, and 20-ton cranes.

g Extracted 72 DP-2 sheetpiles from cofferdam at Causeway Bridge No 1.

2 Unit Movement:

a The unit received its initial alert orders for movement on 7 June 1968. The advance party consisting of Officers, NCO's, and Enlisted Personnel left Qui Nhon (CR 0721) and arrived in Vung Tau (YS 3048) on 10 July 1968. Effective 1 July 1968, 1 Officer, 6 NCOs, and 42 Enlisted Men of the 523d Engineer Company (PC) formed a detachment which was designated the 536th Engineer Detachment (Fort Construction). The 523d Engineer Company (PC) equipped the detachment with the property which they were to pick up upon arrival in Vung Tau. The former 536th Engineer Detachment (PC) located in Vung Tau transferred all personnel and equipment to the 523d Engineer Company (PC), thus eliminating the relocation of some equipment and personnel.

b The floating equipage of the unit, consisting of four barges and one LCM VIII's departed Qui Nhon on 8 July 1968. Two of the work barges were left in Vung Rho Bay. The remaining barges and LCM-8 arrived in Vung Tau on 13 July 1968.

c The remaining personnel boarded AB&T Barges 567 and 611 on 18 July respectively. Barge 567 with 73 personnel stopped in Vung Rho and offloaded the two work barges before proceeding onto Vung Tau. Both barges arrived in Vung Tau 25 July 1968. Off-loading of the barges was completed on 27 July 1968.

d The unit is currently 70% committed and expects to be 100% committed by 20 August 1968.

(4) LOGISTICS:

(a) The company continued to experience a great deal of difficulty in procuring needed supplies for its projects. Work on two projects stopped completely due to the lack of materials: the AUTOSEVOCOM Building (CR 0721) and the Tandem Switch Building (CR 0419). The Ammo Barge Off-loading Facility (CR 0924) has been delayed because the ZP sheetpile was not available. The sheetpile has been on order since December 1967 by higher headquarters. This has also caused a delay in the construction planning of the sheetpile bulkhead which has had an approved construction directive since December 1967.

FOR OFFICIAL USE ONLY

FOR OFFICIAL USE ONLY

EGF-OP

1 August 1968

SUBJECT: Operational Report of HQ, 34th Engineer Report (Const) for
Period Ending 31 July 1968, RCS, CSFOR-65(R1)

(b) This unit has not been able to procure its TCE barges and bridge erection boats. Since moving to the Mekong Delta area, these shortages have become critical due to requirements to move men, equipment, and construction materials to widely dispersed job sites. With the authorized equipment, the unit could maintain three independent pile driving operations where it can now operate only two at reduced efficiency.

(5) CIVIC AFFAIRS: The following Civic Action projects were undertaken by this company during the cited period, with an expenditure of 100 manhours and 610 equipment hours.

(a) A water tower was constructed for the local Vietnamese hospital in Qui Nhon (CR 0721).

(b) Assisting the Kim Chau Orphanage (BR 9535) with construction and installation of additional recreational equipment.

(c) Hauled fill for the site development and relocation of a mortar damaged church

(d) Upgraded the 100-foot Kim Chau Orphanage bridge (BR 9535) from a Class 4 to a Class 20 bridge using salvage sheetpile and dunnage from the ships moored in Qui Nhon Harbor.

2. Section 2, Lessons Learned: Commander's Observations, Evaluations, and Recommendations

a. Personnel. None

b. Operations.

(i) Clay-lime Stabilization.

(a) OBSERVATION. Mixtures of clay and lime are highly susceptible to changes in moisture content after compaction is obtained. Allowing a clay-lime mixture to dry after it is compacted causes severe cracking and deterioration. This then requires that the mixture be scarified, moistened, and recompacted.

(b) EVALUATION. Severe shrinkage cracks which develop in compacted clay-lime mixtures decrease the ability of the material to withstand traffic loadings. Water percolating into the base course will collect in the shrinkage cracks and cause a pumping action to occur. The result is that the subgrade will soften and fail under loading.

FOR OFFICIAL USE ONLY

FOR OFFICIAL USE ONLY

EGF-OP

1 August 1968

SUBJECT: Observation Report of HQ, 34th Engineer Group (Const) for
Period Ending 31 July 1968, RCS, CSFOR-65(R1)

(c) RECOMMENDATION. Compacted clay-lime mixtures must be covered with a bituminous or other waterproof seal within 24 hours after bluetopping to prevent the escape of moisture and the development of large shrinkage cracks which cause the base course to fail.

(2) Customer Relations.

(a) OBSERVATION. An LST Ramp was designed and built for MSTs use. Although the plans were approved by one MSTs representative prior to construction, another representative looked at the finished product and stated that the facility could not be used. Alteration was necessary.

(b) EVALUATION. Customer liaison is especially important where a facility is one-of-a-kind to the customer. Some proof of liaison is useful as personnel changes may occur before completion.

(c) RECOMMENDATION. The signature block on construction drawings should contain a place for a customer's representative to indicate approval or a letter of approval should be required which would be entered in the project folder, thus preventing conflicts from arising at a later date.

(3) Wharf Construction.

(a) OBSERVATION. The use of MAT6 balk as a combination stringer and decking material can greatly speed wharf and pier construction.

(b) EVALUATION. To expedite operations in the construction of pile wharves, decking can be laid down on the pile caps and the crane moved forward to the next bent. This reduces the pile driver idle time. In order to insure the safety of the pile driving crew and equipment it is necessary to secure the stringers and decking to the pile and pile cap. After the crane has moved out several bents, considerable difficulty is encountered in placing the transverse and lateral bracing system to the pile. This requires the removing of the decking to get to the bracing. Instead of permanently affixing the decking to the stringers and stringer to the pile caps, the entire operation can be expedited by using MAT6 balk as a combination stringer and decking material.

(c) RECOMMENDATION. That MAT6 balk be used as a combination stringer and decking material to expedite wharf and pier construction.

(4) Placement of Concrete Pier Caps Over Water.

(a) OBSERVATION. When placing concrete over deep water or at heights where a "tinker-toy" scaffold system becomes impractical, the construction of a semi-permanent base approximately six feet below the bottom of the forms can greatly speed up operations. This system is

FOR OFFICIAL USE ONLY

FOR OFFICIAL USE ONLY

EGF-OP

1 August 1968

SUBJECT: Operational Report of HQ, 34th Engineer Group (Const) for
Period Ending 31 July 1968

equally applicable to "H" piles and hollow tube piles and can be modified for use with timber piles by using one-inch bolts to scab intermediate supports below the cap.

(b) EVALUATION. When working over deep water it is impractical to use a tinker-toy scaffold system or construct a temporary heavy construction bracing system to support the load of the forms and concrete. To solve this problem when using 18-inch hollow-pipe pile, holes were cut in each of the parallel hollow-pipe piles prior to filling them with concrete so that a piece of 12" channel could pass through the pile and parallel to the ground or water. This 12" channel extended a sufficient distance to allow a 12" H-pile to rest on the flange of the channel section and run parallel to the longitudinal axis of the concrete forms and approximately six feet below the forms. This formed a stable platform capable of supporting the forms and concrete. A "T" Jack bracing system was used which allowed the forms to be easily stripped.

(c) RECOMMENDATIONS. That a semi-permanent base be utilized when placing concrete over water or at heights where a "tinker-toy" scaffold would prove impractical to expedite concrete placement.

(5) Use of Mica for Marking Piles and Timbers.

(a) OBSERVATION. Mica may be used in place of crayon and soapstone at job sites for marking cutoff lines on piles and timbers.

(b) EVALUATION. Mica is sometimes easily obtained in the field and gives an easily readable mark.

(c) RECOMMENDATION. That mica be used for marking cutoff lines on piles and timber when it is easily obtainable.

(6) Use of 40mm and 105 mm Shell Casings as Permanent and Temporary Bench Marks.

(a) OBSERVATION. The use of 40mm and 105 mm shell casings for bench marks eliminates the use of large monuments. These casings are often readily available in the field and expedite survey work.

(b) EVALUATION. The use of 40mm and 105mm shell casing as an expedient for bench marks is advisable in certain areas because of the nonavailability of concrete monuments. When sunk in the ground they are very hard to remove or disturb. Being made of brass they resist rust and corrosion and are excellent near salt water. The percussion cap in the center of the casing provides an accurate point for reference. If the marks are to remain for a significant length of time, numbers can be imprinted on the surface.

FOR OFFICIAL USE ONLY

FOR OFFICIAL USE ONLY

EGF-OP

1 August 1968

SUBJECT: Operational Report of HQ, 34th Engineer Group (Const) for
Period Ending 31 July 1968, RCS, CSFOR-65(R1)

(c) RECOMMENDATION. That 40mm and 105mm shell casings be used as expedient bench marks.

- c. Training. None
- d. Intelligence. None
- e. Logistics. None
- f. Organization. None
- g. Other.

(1) Maintenance:

(a) Track Adjustment Seal on D7E Tractors.

1 OBSERVATION. A problem was encountered with failure of the track adjustment seals on D7E tractors assigned to the 86th Land Clearing Team.

2 EVALUATION. Track adjustment seals were failing on the D7E tractors of the 86th Engineer Battalion Land Clearing Team. The Rome Plow blade mounted on the tractors extends farther from the tractor than the regular bull blade. This redistributes the weight on the tracks which in turn causes the track adjustment seals to fail.

3 RECOMMENDATION. That heavy leather gasket material be obtained and track adjustment seals be made from it. Use of this material has eliminated the problem.

(2) Communications:

(a) AM Radio Communications.

1 OBSERVATION. The AN/GRC-19 radio has proven inadequate for the Group's needs.

2 EVALUATION. The 31st Engineer Battalion was assigned to the 34th Engineer Group directly from CONUS from April to July 1968. The 31st Battalion was equipped with the AN/GRC-106 when it arrived in country and was the only unit in the 34th Engineer Group to have this radio. The 31st Engineer Battalion had instant success with the AN/GRC-106 and was able to communicate with subordinate companies anywhere in the IV CTZ and the lower half of the III CTZ. Because of the high power and ease of operation, the AN/GRC-106 provided effective communication with elements up to 200 miles distant, 24 hours a day. Due to the wide dispersion of

FOR OFFICIAL USE ONLY

FOR OFFICIAL USE ONLY

EGF-OP

1 August 1968

SUBJECT: Operational Report of HQ, 34th Engineer Group (Const) for Period Ending 31 July 1968, RCS, CSFOR-65(R1)

units within the 34th Engineer Group AOR, this equipment is definitely needed to improve communications between Group Headquarters, Battalion Headquarters, and Company Headquarters. The AN/GRC-19 is totally unsatisfactory in providing this needed communication. By the use of two frequencies, one in the 10 MHz range and one in the 25 MHz range it is possible to achieve both distance communications and local coverage equivalent to the FM series radios with one set

3 RECOMMENDATION. That the AN/GRC-106 replace the AN/GRC 19 as soon as possible.

(b) Maintenance of the RC-292 Antenna System.

1 OBSERVATION. The climatic conditions of Vietnam cause RC-292 antenna elements to corrode rapidly.

2 EVALUATION. The corrosive atmosphere in the theater, particularly near the seacoast, causes the RC-292 antenna elements to corrode from the inside out. The average element life is from three to five months. A continuous stream of requisitions is required to insure that a sufficient number of element sections are on hand to meet operational requirements.

3 RECOMMENDATION. That the inside of the RC-292 Antenna elements be heavily painted to reduce corrosion and eliminate the continuous supply of replacement elements required to maintain serviceable antennas.

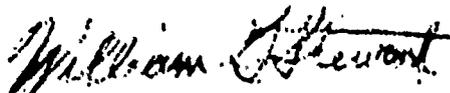

WILLIAM G STEWART
Colonel, CE
Commanding

3 Incl

1. Gp Organization Chart
2. Gp AOR Map
3. Land Clearing with Rome Plows

Copies Furnished:

- 6 - USAECAV(P), ATTN: AVCC-P&O (Courier)
- 1 - CO, 31st Engr Bn (Mail)
- 1 - CO, 36th Engr Bn (Courier)
- 1 - CO, 69th Engr Bn (Courier)
- 1 - CO, 86th Engr Bn (Courier)
- 1 - CO, 93d Engr Bn (Courier)
- 1 - CO, 523d Engr Co (Courier)
- 1 - CO, 573d Engr Co (Mail)
- 1 - CO, 617th Engr Co (Mail)
- 1 - CO, 536th Engr Co (Mail)

FOR OFFICIAL USE ONLY

BLANK PAGE

AVBL-OS (1Aug68) 1st Ind

SUBJECT: Operational Report of HQ, 34th Engineer Group (Const) for Period
Ending 31 July 1968, RCS CSFOR-65 (R1)

DA, Headquarters 20th Engineer Brigade, APO 96491 SEP 23 1968

TO: Commanding General, US Army Vietnam, ATTN: AVAGC-DST, APO 96375

1. Submitted in accordance with USARV Regulation 525-15 dated 13 April 1968.
2. Subject report for the 34th Engineer Group has been reviewed and is considered adequate.

FOR THE COMMANDER:

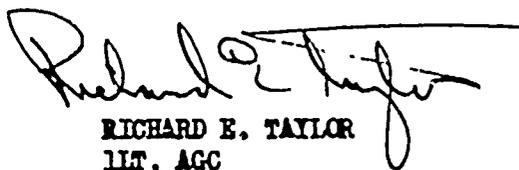
RICHARD E. TAYLOR
LIT, AGC
Assistant Adjutant

Copies Furnished:

- 2 - ACSFOR-DA
- 1 - USAES, Ft Belvoir
- 1 - CG, 8th US Army, ATTN: Engr
- 1 - CG, 18th Engr Bde

AVHGC-DST (1 Aug 68) 2d Ind
SUBJECT: Operational Report of HQ, 34th Engineer Group (Const) for
Period Ending 31 July 1968, RCS, CSFOR-65 (RI)

MAJ Klingman/ds/LSH 4433

HEADQUARTERS, UNITED STATES ARMY, VIETNAM, APO San Francisco 96375

TO: Commander in Chief, United States Army, Pacific, ATTN: GPOP-DT,
APO 96558

21 OCT 1968

1. This headquarters has reviewed the Operational Report-Lessons Learned for the quarterly period ending 31 July 1968 from Headquarters, 34th Engineer Group (Const).

2. Comments follow:

a. Reference item concerning customer relations, page 20, paragraph 2b(2): Concur with the recommendation. However, customer approval is required only to assure that the facility to be constructed is complete and usable.

b. Reference item concerning AM radio communications, page 22, paragraph g(2). Under the USARV SSB conversion program, the AN/GRC-106 is replacing the AN/GRC-19. Based on established priorities, 20th Engineer Brigade units should begin receiving the replacement item during the third quarter FY 69.

c. Reference item concerning maintenance of the RC-292 antenna system, page 23, paragraph g(b): Concur. Painting the inside of elements of the RC-292 antenna system is a positive measure to prevent corrosion.

d. Reference item concerning logistics, page 18, paragraph li(4): Concur with the comments pertaining to ZP sheetpile, TOE barges, and bridge erection boats.

(1) The unit has been informed that limited quantities of sheetpile are available and will be issued to units with validated requisitions.

(2) There are no records at USAICCV of any requisitions for barges. This is a nonstockage item and will have to be requisitioned from CCNUS. This headquarters has advised all engineer brigades to reconcile their requisitions for barges.

AVHGC-DST (1 Aug 68) 2d Ind
SUBJECT: Operational Report of HQ, 34th Engineer Group (Const) for
Period Ending 31 July 1968, RCS, CSFOR-65 (R1)

(3) USAMECOM has advised this headquarters that bridge section
boats are available. The unit has been advised to requisition these
items.

FOR THE COMMANDER:



A.R. GUENTHER
CPT. AGC
ASST. ADJUTANT GENERAL

Cy Turn:
HQ 20th Engr Bde
HQ 34th Engr Gp

GPOP-DT (1 Aug 68) 3d Ind
SUBJECT: Operational Report of HQ, 34th Engr Gp (Const) for Period
Ending 31 July 1968, RCS CSFOR-65 (R1)

HQ, US Army, Pacific, APO San Francisco 96558 15 NOV 1968

TO: Assistant Chief of Staff for Force Development, Department of the
Army, Washington, D. C. 20310

This headquarters has evaluated subject report and forwarding indorse-
ments and concurs in the report as indorsed.

FOR THE COMMANDER IN CHIEF:

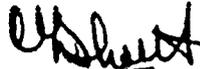
C. L. SHORTT
CPT, AGC
Asst AG

34TH ENGINEER GROUP ORGANIZATION

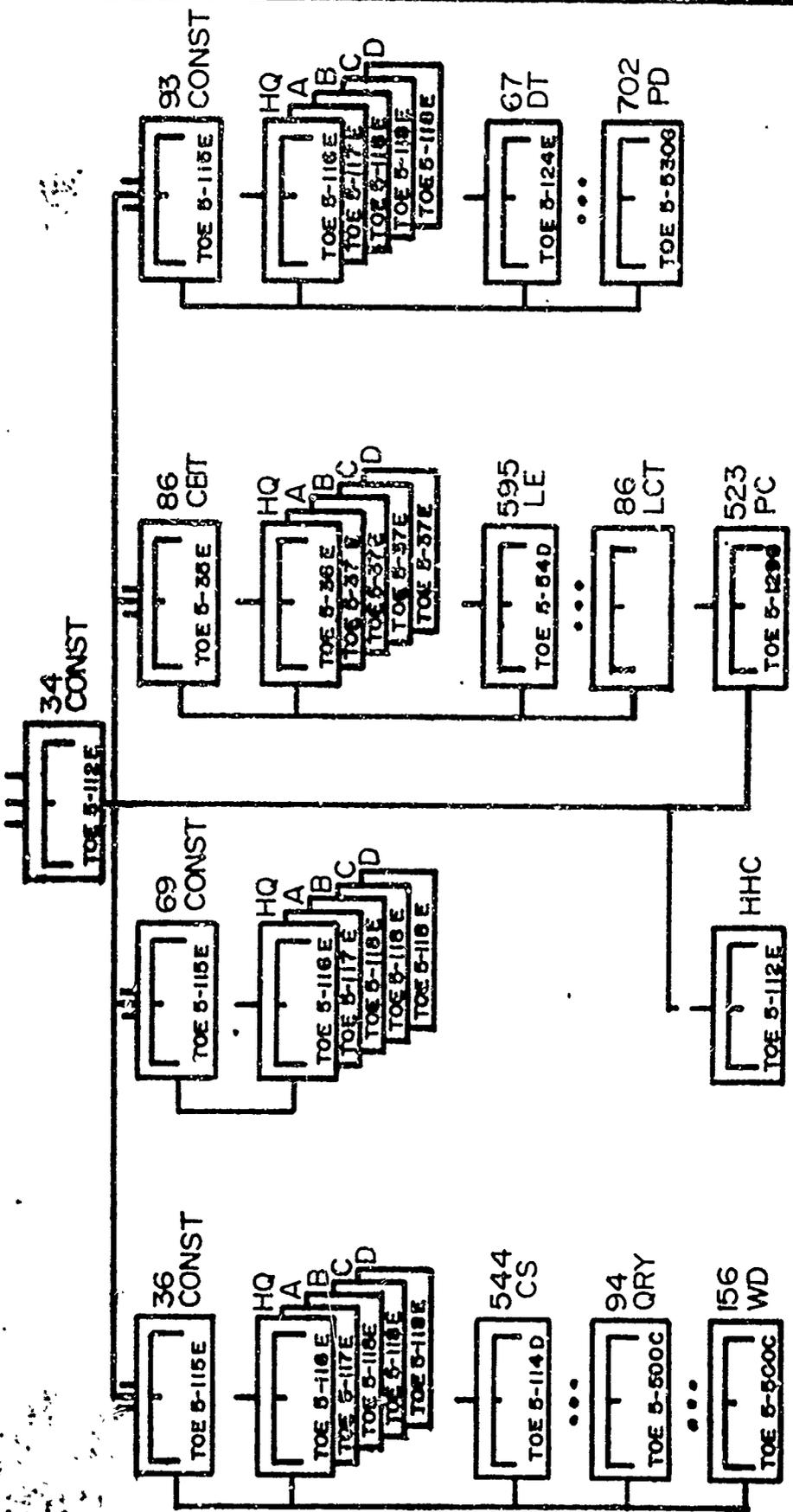

AS OF 31 JULY 68

INCL 1

20

NOT REPRODUCIBLE

31 JUL 68

34TH ENGR GP SECTOR

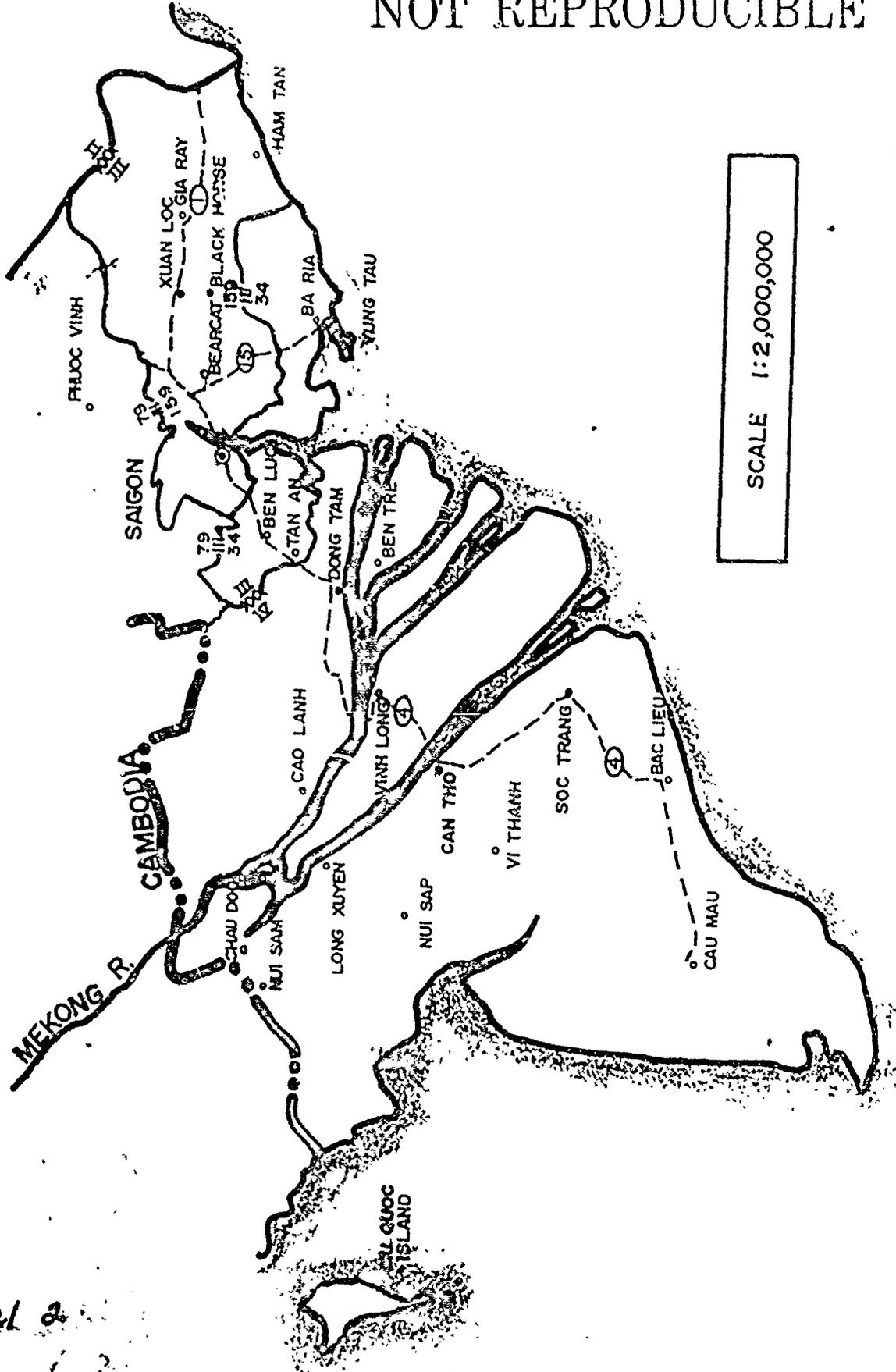

SCALE 1:2,000,000

Final 2

LAND CLEARING WITH ROME PLOWS

1. Land Clearing Operations depend on many factors. In addition to the wetness of the ground, which is covered below, the following also effects production.

- a. Age of tractor
- b. Hardness of wood
- c. Enemy activity
- d. Operator's technique
- e. Presence or absence of bamboo

2. Following chart is a guideline for judging the relation of effectiveness of a tractor. Figures are in terms of number of acres per plow per 10 hour workday.

a. TYPE GROWTH	JUNGLE		RUBBER TREES	
	CUT	CUT & WINDROW	CUT	CUT & WINDROW
Light	10	5	11	6
Medium	9	4	10	5
Heavy	7	3	9	4

b. The above figures should be reduced by the following percentages depending on wetness of ground.

Dry: 0%
Med: 20% - 50%
Wet: 50% - 80%

3. Two tractors pulling a US Navy anchor chain can clear 30 to 180 acres per day in light to medium rubber. In very small rubber and brush, the trees and brush will bend and spring back up after the chain passes over them.

4. Cuts should be made so that cut material falls away from uncut timber.

5. Very large trees should be left standing; they provide less cover for the enemy while vertical.

UNCLASSIFIED

Security Classification

DOCUMENT CONTROL DATA - R & D

(Security classification of title, body of abstract and indexing annotation must be entered when the overall report is classified)

1. ORIGINATING ACTIVITY (Corporate author)

HQ, OACSFOR, DA, Washington, D.C. 20310

2a. REPORT SECURITY CLASSIFICATION

For Official Use Only

2b. GROUP

3. REPORT TITLE

Operational Report - Lessons Learned, HQ, 34th Engineer Group (Const) (U)

4. DESCRIPTIVE NOTES (Type of report and inclusive dates)

Experiences of unit engaged in counterinsurgency operations, 1 May - 31 Jul 68

5. AUTHOR(S) (First name, middle initial, last name)

CO, 34th Engineer Group (Const)

6. REPORT DATE

1 August 1968

7a. TOTAL NO. OF PAGES

31

7b. NO. OF REFS

8a. CONTRACT OR GRANT NO.

a. PROJECT NO.

N/A

c.

d.

8b. ORIGINATOR'S REPORT NUMBER(S)

683336

8c. OTHER REPORT NO(S) (Any other numbers that may be assigned this report)

10. DISTRIBUTION STATEMENT

11. SUPPLEMENTARY NOTES

N/A

12. DURING MILITARY ACTIVITY

OACSFOR, DA, Washington, D.C. 20310

13. ABSTRACT

31

DD FORM 1473
1 NOV 68

UNCLASSIFIED

Security Classification

The following items are recommended for inclusion in the Lessons Learned Index:

ITEM 1

* SUBJECT TITLE _____

** FOR OT UT # _____

***PAGE # _____

ITEM 2

SUBJECT TITLE _____

FOR OT UT # _____

PAGE # _____

ITEM 3

SUBJECT TITLE _____

FOR OT UT # _____

PAGE # _____

ITEM 4

SUBJECT TITLE _____

FOR OT UT # _____

PAGE # _____

ITEM 5

SUBJECT TITLE _____

FOR OT UT # _____

PAGE # _____

* Subject Title: A short (one sentence or phrase) description of the item of interest.

** FOR OT UT # : Appears in the Reply Reference line of the Letter of Transmittal. This number must be accurately stated.

***Page # : That page on which the item of interest is located.

----- FOLD -----

DEPARTMENT OF THE ARMY

POSTAGE AND FEES PAID
DEPARTMENT OF THE ARMY

OFFICIAL BUSINESS

Office of the Assistant Chief of Staff for
Force Development

ATTN: Operational Reports Branch
Headquarters, Department of the Army
Washington, D.C. 20310

STAPLE

STAPLE

DA Label 18, 1 APR 99 PREVIOUS EDITIONS OF THIS LABEL ARE OBSOLETE.

----- FOLD -----