

UNCLASSIFIED

AD NUMBER
AD840581
NEW LIMITATION CHANGE
TO Approved for public release, distribution unlimited
FROM Distribution authorized to U.S. Gov't. agencies and their contractors; Administrative/Operational Use; AUG 1968. Other requests shall be referred to Air Force Flight Dynamics Lab., Wright-Patterson AFB, OH 45433.
AUTHORITY
AFFDL ltr, 29 Dec 1978

THIS PAGE IS UNCLASSIFIED

THIS REPORT HAS BEEN DELIMITED  
AND CLEARED FOR PUBLIC RELEASE  
UNDER DOD DIRECTIVE 5200.20 AND  
NO RESTRICTIONS ARE IMPOSED UPON  
ITS USE AND DISCLOSURE.

DISTRIBUTION STATEMENT A

APPROVED FOR PUBLIC RELEASE;  
DISTRIBUTION UNLIMITED.

AFFDL-TR-67-140

AD 240581

**DESIGN CRITERIA FOR THE PREDICTION AND  
PREVENTION OF PANEL FLUTTER**

**VOLUME I: CRITERIA PRESENTATION**

*CLARK E. LEMLEY*

*McDonnell Douglas Corporation*

TECHNICAL REPORT AFFDL-TR-67-140

AUGUST 1968

This document is subject to special export controls and each transmittal to foreign governments or foreign nationals may be made only with prior approval of the Air Force Flight Dynamics Laboratory (FDL), Wright-Patterson AFB, Ohio 45433.

AIR FORCE FLIGHT DYNAMICS LABORATORY  
AIR FORCE SYSTEMS COMMAND  
WRIGHT-PATTERSON AIR FORCE BASE, OHIO

NOTICES

When Government drawings, specifications, or other data are used for any purpose other than in connection with a definitely related Government procurement operation, the United States Government thereby incurs no responsibility nor any obligation whatsoever; and the fact that the Government may have formulated, furnished, or in any way supplied the said drawings, specifications, or other data is not to be regarded by implication or otherwise as in any manner licensing the holder or any other person or corporation, or conveying any rights or permission to manufacture, use, or sell any patented invention that may in any way be related thereto.

OFFICIAL	SECTION	<input type="checkbox"/>
CONFIDENTIAL	SECTION	<input checked="" type="checkbox"/>
SECRET	SECTION	<input type="checkbox"/>
DATE OF DECLASSIFICATION		
CLASSIFICATION		
2		

This document is subject to special export controls and each transmittal to foreign governments or foreign nationals may be made only with prior approval of the Air Force Flight Dynamics Laboratory (FDDS), Wright-Patterson AFB, Ohio.

The distribution of this report is limited because it contains the development of improved design criteria for the prevention of panel flutter applicable to future aerospace systems.

Copies of this report should not be returned to the Research and Technology Division unless return is required by security considerations, contractual obligations, or notice on a specific document.

## ABSTRACT

The program described in this report was performed to bring together all available data from wind tunnel test, flight test, vibration test, thermal test and theoretical investigations to form comprehensive panel flutter design criteria. Procedures were developed which are applicable to the environment and various panel structural arrangements for transonic, supersonic, and hypersonic aircraft; aerospace reentry vehicles, and boosters.

This report (Volume I) presents a set of criteria for the design of flutter-free panels. The design procedure provides for initially establishing the required thickness at neutral stability of a flat, unstressed, unswept panel. Thickness corrections are then made to account for various parameters that are known to affect panel flutter boundaries.

Volume II presents the results of background investigations and supplemental analyses that provide the bases for establishing the criteria of Volume I. An extensive bibliography is also presented in Volume II.

AFFDL-TR-67-140

**DESIGN CRITERIA FOR THE PREDICTION AND  
PREVENTION OF PANEL FLUTTER**

**VOLUME I: CRITERIA PRESENTATION**

*CLARK E. LEMLEY*

**This document is subject to special export controls and each transmittal to foreign governments or foreign nationals may be made only with prior approval of the Air Force Flight Dynamics Laboratory (FDDS), Wright-Patterson AFB, Ohio 45433.**

## FOREWORD

This report, prepared by the Structural Dynamics Department of the Engineering Technology Division of McDonnell Douglas Corporation, covers work performed under Air Force Contract AF33(615)-5295. The contract was sponsored by the Air Force Flight Dynamics Laboratory, Air Force Systems Command, Wright-Patterson Air Force Base, Ohio. This work was done to provide improved panel flutter design criteria for aircraft and aerospace vehicles as part of the exploratory research program of the Air Force Systems Command. This research was conducted under Project No. 1370, "Dynamic Problems in Flight Vehicles," and Task No. 137003, "Prediction and Prevention of Aerothermoelastic Problems." This report covers work conducted from August 1966 to November 1967. The work was administered by Mr. Michael H. Shirk of the Vehicle Dynamics Division.

The program was managed by Dr. Norman Zimmerman. Dr. Clark E. Lemley was the principal investigator. Significant technical contributions to the program were made by Mr. Bobby R. Scheller, Structural Dynamics Engineer.

The manuscript was released by the author in January 1968 for publication.

This technical report has been reviewed and is approved.

*Walter J. Mykytow*

WALTER J. MYKYTOW  
Asst. for Research and Technology  
Vehicle Dynamics Division

## TABLE OF CONTENTS

SECTION	PAGE
I INTRODUCTION . . . . .	1
II PARAMETERS THAT AFFECT PANEL FLUTTER BOUNDARIES. . . . .	3
1. Parameters Included in These Criteria. . . . .	3
2. Other Parameters . . . . .	6
III DESIGN CRITERIA. . . . .	7
1. Step (1) - Flight Data, $l/w$ . . . . .	9
2. Step (2) - "Flat" Panel Design . . . . .	11
3. Step (3) - Thickness Requirement . . . . .	14
4. Step (4) - Angle of Attack . . . . .	31
IV RELATED AREAS. . . . .	37
1. Built-Up Isotropic Panels. . . . .	37
2. Negligible Inplane Edge Restraints . . . . .	38
V SPECIAL CONSIDERATIONS . . . . .	39
1. Factors of Safety. . . . .	39
2. Panels Recommended for Closer Study. . . . .	43
3. Some Minimum Weight Configurations . . . . .	43
4. The Role of Testing in Panel Design. . . . .	45
VI SAMPLE DESIGNS AND EVALUATION OF CRITERIA. . . . .	46
1. Panel Design Problems. . . . .	46
2. Evaluation of Design Criteria. . . . .	48
REFERENCES . . . . .	50



LIST OF FIGURES

NO.	TITLE	PAGE
1.	Mach Number Correction Factor Versus Mach Number. . . . .	8
2.	Plot of $q/r(M)$ Versus Mach Number with Parametric Variation in Altitude. . . . .	10
3.	"Baseline" Design Curve . . . . .	12
4.	Aerodynamic Parameter $q/r(M)$ Versus $l/w$ with Variation in Structural Parameter $E \left(\frac{t_B}{l}\right)^3$ . . . . .	13
5.	Flat Panel Design Curves. . . . .	15
6.	Thickness Correction Factor For Curvature . . . . .	16
7.	Thickness Correction Factor for Flow Angularity . . . . .	18
8.	Thickness Correction Factor for a Simply Supported Panel. . . . .	19
9.	Thickness Correction Factor for Inplane Stress (Tension) . . . . .	20
10.	Thickness Correction Factor for Inplane Stress (Compression) . . . . .	23
11.	Critical Inplane Compression Load for Clamped Panel, $N_y = 0$ . . . . .	24
12.	Critical Inplane Compression Load for Clamped Panel, $N_x = N_y$ . . . . .	25
13.	Critical Inplane Compression Load for Simply Supported Panel, $N_y = 0$ . . . . .	26
14.	Critical inplane Compression Load for Simply Supported Panel, $N_y = N_x$ . . . . .	27
15.	Relationship Between $\frac{d_0}{t_B}$ , $\Delta p$ , and Panel Geometric-Physical Characteristics . . . . .	29
16.	Thickness Correction Factor for Differential Pressure . . . . .	30
17.	Critical Differential Temperature of Clamped Panel with Restrained Edges . . . . .	32
18.	Critical Differential Temperature of Simply Supported Rectangular Panel with Restrained Edges . . . . .	33
19.	Thickness Correction Factor for Differential Temperature . . . . .	34

LIST OF FIGURES (Continued)

NO.	TITLE	PAGE
20.	Thickness Correction for an Enclosed Cavity . . . . .	35
21.	Honeycomb Configuration for Analyzing Stiffness . . . . .	37
22.	Orientation of a Rectangular Panel for Minimum Weight . . . . .	44
23.	Orientation of Stiffeners to Obtain Higher Flutter Speed. . . . .	44
24.	Panel Configuration for Sample Design Number 1. . . . .	46
25.	Panel Configuration for Sample Design Number 2. . . . .	47

TABLES

I.	Grouping of Parameters that Affect Flutter Speed. . . . .	9
II.	Recommended Panel Flutter Safety Factors. . . . .	42

SYMBOLS

D	Plate Bending stiffness $\left( = \frac{Et^3}{12(1-\nu^2)} \right)$
d	Cavity depth
$d_0$	Static deflection
E	Modulus of elasticity
$f(M)$	Mach number correction factor
$h_0$	Crown height of curved panel
$l$	Panel length (streamwise)
M	Mach number
N	Curvature parameter $\left( = \frac{h_0}{t_B} \right)$
$N_x$	Inplane load $(= \sigma_x t)$ per unit length in the x-direction
$N_y$	Inplane load $(= \sigma_y t)$ per unit length in the y-direction
$P_{cav}$	Cavity pressure
$\Delta p$	Differential pressure between opposite panel surfaces
q	Dynamic pressure $(= \frac{1}{2} \rho V^2)$
R	Radius of curvature
s	Core thickness, honeycomb panel
t	Panel thickness
$\Delta T$	Differential temperature
V	Velocity
w	Panel width
$\alpha$	Angle of attack of panel
$\alpha_T$	Thermal coefficient of expansion
$\beta$	Compressibility parameter $(= \sqrt{M^2 - 1})$
$\theta$	Sector angle of cylindrically curved panel

A	Yaw or sweep angle
v	Poisson's ratio
$\rho$	Mass density of air
$\sigma$	Inplane stress
$\phi$	Nondimensional panel flutter parameter $\left[ = \left( \frac{r(M) E}{q} \right)^{1/3} \frac{t}{l} \right]$

#### SUBSCRIPTS

B	Baseline
b	Buckling
cav	Cavity
C	Corrected
cr	Critical
D	Design value
eq	Equivalent
f	Face sheet, honeycomb panel
L	Local
max	Maximum
N	Curvature
$\Delta p$	Differential pressure
ss	Simply supported
$\Delta T$	Differential temperature
x	x-direction (parallel to air flow)
y	y-direction (perpendicular to air flow)
A	Yaw or sweep
-	Free stream

## SECTION I

### INTRODUCTION

Panel flutter is a self-excited, aeroelastic instability that may occur when a panel is exposed to a supersonic airstream. During flutter the panel oscillates in a direction normal to its plane and the amplitude of motion usually increases until limited by inplane stresses. The consequences of panel flutter cannot be reliably predicted, but the serious effects that have been encountered include very high noise levels within occupied compartments as well as panel failure due to fatigue.

A considerable amount of work, both experimental and theoretical, has been done during the last two decades not only to obtain insight into the phenomenon but to develop procedures for the prediction and prevention of panel flutter. This report presents the results of an extensive investigation to determine the state of the art in panel flutter, and from that basis, to formulate a comprehensive set of design criteria. The investigation consisted not only of literature review but also of personal consultation with individuals who have made significant contributions in the field. The report further brings together data from wind tunnel test, flight test, vibration test and theoretical investigation, and presents methods that have been developed to provide procedures, criteria, and guidelines for designing panels.

The criteria may be applied directly under the following conditions:

- (a) The skin panels are of uniform thickness and rectangular in shape.
- (b) All edges are supported, that is, either clamped or simply supported.
- (c) The panels are flat or cylindrically curved.
- (d) Inplane (membrane) stress may exist in the panel whether due to flight loading, unequal static pressures on the two faces, or unequal temperature between the panel and its support structure.
- (e) A small volume of air may be contained behind the panel (cavity effect).
- (f) The flow conditions (Mach number and dynamic pressure) local to the surface of the panels are known.
- (g) Flow angularity (yaw or sweep) across the face of the panel is known.
- (h) The inplane (membrane) restraint exerted on the panel at the supported edges is considered to be fully effective; the supports do not yield and thereby allow stress buildup in the panel.

The treatment of conditions not covered above are discussed later in this Volume. The work is presented in two volumes. Volume I is the working document that explains the design approach and presents panel design criteria. Volume II presents background information that has provided the basis for development of the criteria.

Volume I is organized in a manner that permits the designer to arrange his data in a logical manner and then proceed step by step with panel design.

Section II presents brief discussions of the parameters that are taken into account in panel design; this provides the designer with better insight into some of the problem areas.

Section III presents the design approach together with the charts and curves to be used in establishing panel physical parameters.

Section IV discusses several areas that are closely related to the criteria of Section III although not specifically covered there.

Section V describes some special considerations in the panel design problem; notable in this section are margins of safety and design of panels in critical locations.

Section VI presents two examples of typical panel design problems that illustrate the application of the design criteria. In addition, panel thicknesses obtained with these criteria are compared with actual modifications that were made to remedy two previous incidences of panel flutter; it is indicated that the criteria would have provided flutter-free panels of the approximate gauges that were used for the final fixes.

The notation and symbols that are used in Volume I are defined at the beginning of this volume.

## SECTION II

### PARAMETERS THAT AFFECT PANEL FLUTTER BOUNDARIES

This Section presents a discussion of the parameters that affect the flutter speeds of skin panels. The first group of parameters listed, items (a) through (l) are sufficiently well understood to be included in this set of design criteria. This volume presents sufficient data to support complete panel design, but detailed discussions of the parameters and their treatment is given in Volume II. The remaining factors, listed under Other Parameters, are known to affect flutter speeds but criteria cannot be presented at this time because theoretical results are inconclusive and experimental data are incomplete.

#### 1. Parameters Included in These Criteria

The following are taken into account in the application of the panel design criteria:

##### a. Dynamic Pressure (q)

The aerodynamic forces that cause panel flutter are, in the flight regimes that are adapted to analysis, proportional to dynamic pressure. It has proven to be advantageous to include the dynamic pressure directly in primary design parameters. This trend has been followed in these criteria and therefore dynamic pressure is implicit in the application of the criteria.

##### b. Mach Number (M)

The Mach number of the impinging airstream has a strong influence on the spatial distribution, magnitude, and time-phasing of the aerodynamic pressures that are exerted on a vibrating panel. This criterion presents a Mach number correction factor  $f(M)$  that is derived from experimental data and replaces the usual compressibility factor  $\sqrt{M^2 - 1}$  between  $M = 1$  and  $M = 2$ . The basis for the Mach number correction factor is given in Section III of Volume II.

##### c. Angle-of-Attack ( $\alpha$ )

If a panel is inclined to the prevailing airstream, the flow conditions at the surface of the panel (local conditions) are different from those of the free stream; furthermore a static airload  $\Delta p$  may be induced if the volume behind the panel is not vented to the stream. The effect of the angle of attack is taken into account by using local values of  $M$  and  $q$  and by taking into account the differential pressure.

d. Length-to-Width Ratio ( $l/w$ )

The planform dimensions of a panel affect flutter boundaries in the sense that an increase in streamwise length (width constant) is destabilizing. The length-to-width parameter  $l/w$  has been chosen as a primary design parameter and the  $l/w$  effect is implicit in the criteria presentations.

e. Flow Angularity ( $\Lambda$ )

The flutter speed of a rectangular panel changes when the panel is yawed to the free streamwind velocity. Both theory and experiment show that flow angularity is somewhat stabilizing when  $l/w > 1$  but is strongly destabilizing when  $l/w < 1$ . These criteria call for thickness increase to account for flow angularity when  $l/w < 1$ ; the criterion tends to be conservative for  $l/w > 1$  in that no thickness decrease is called out to account for flow angularity. These guides are based on data that is presented in Section III of Volume II.

f. Edge Conditions

A simply supported (unstressed) panel flutters at a lower airspeed than a panel with clamped edges. The clamped panel is used as a standard in these criteria, and a correction is shown to account for simply supported edges. For real panels, the edge conditions usually lie somewhere between the two extremes and guidelines are presented for treating the intermediate cases.

g. Curvature

Many applications of skin panels require simple, cylindrical curvature in one direction. The frequencies of the lower modes, and hence flutter speeds, may be different from those of the equivalent flat panel. These criteria treat the simply curved panel configuration in which stream flow passes axially (i.e., parallel to a generator) along the panel. The curvature in this case tends to raise the flutter boundary. The case in which flow is perpendicular to the generators of a singly curved panel is not covered in these criteria but is discussed in Section III of Volume II.

h. Buckling

Panel buckling is a condition in which inplane compressive stresses cause some (in most cases the lower) modal frequency to be reduced to zero. While buckled, the structure is described as being in a state of indifferent equilibrium; experience has shown that the flutter speed of a panel on the verge of buckling (in which large static deflections have not yet occurred) has a minimum value very near this critical stress condition. The basis for the criterion presented here is the experimental evidence that a buckled panel required about twice the thickness for stability of an unstressed panel. Further discussions are given in Volume II.



i. Inplane Stress ( $\sigma$ )

As stated in the previous paragraphs, the critical compressive stress causes a panel to flutter at very nearly its lowest flutter speed. In addition, compressive inplane stress less than critical causes a flutter speed that is larger than the buckled value but smaller than the flutter speed for the unstressed panel; likewise tensile stress causes a larger flutter speed and is therefore stabilizing. Inplane stress may be caused by vehicle loads, temperature change or may be built in during manufacture. These criteria account for various combinations of streamwise and cross-stream stresses on the assumption that the stress is uniform along each edge.

j. Differential Temperature ( $\Delta T$ )

A difference in temperature between a panel and its supporting structure causes thermal stresses that are compressive when the panel is hotter and tensile when the structure is hotter. These stresses are assumed to be uniform if the panel temperature is uniform and are treated by the methods developed for inplane stresses discussed previously. The criterion considers only the case of compressive thermal stress.

k. Differential Pressure ( $\Delta p$ )

Differential pressure denotes a condition whereby different static pressures exist on the two surfaces of a panel. The primary effect on panel flutter is due to the inplane stresses that are induced in resisting the pressure difference. For flat panels, the induced stresses are always tensile regardless of whether  $\Delta p$  acts inward or outward, and by (i) above would raise flutter speeds. The criteria presented in this report apply to flat panels. (If a cylindrically curved panel of radius  $R$  and thickness  $t$  is subjected to  $\Delta p$ , the circumferential stress is approximated by  $\sigma = \frac{R\Delta p}{t}$ ; it is compressive if  $\Delta p$  acts inward and tensile if  $\Delta p$  acts outward. The computed value of stress can be used as described in (i) above).

l. Cavity Effect

Air that is entrapped in a sealed-off volume behind a panel acts as a mechanical spring to increase the effective stiffness, and hence the frequency, of the fundamental panel mode. Some higher ordered modes are also affected but to a negligible degree. The cavity therefore diminishes the separation between modal frequencies and may lower the speed at which panel flutter occurs. In accounting for this effect, the cavity volume is interpreted as the gross volume of the constrained air, thus leading to the equivalent cavity depth

$$d = \frac{\text{actual cavity volume}}{lw}$$

The volume is not to be construed as the projected volume directly beneath the panel unless this is the volume actually enclosed.

## 2. Other Parameters

The following parameters have been treated in the literature and are known to affect panel flutter speeds; as noted previously, however, reliable quantitative design guides cannot yet be formulated.

### a. Orthotropicity

A panel that has unequal bending stiffnesses in orthogonal directions is described as being orthotropic. The condition of orthotropicity may be caused by beading or corrugation stiffening.

### b. Damping

Mechanical damping may be caused by friction in built up structures, by material losses, or by the application of commercially available damping material. Although damping does provide a mechanism for energy absorption, and hence might always be expected to raise flutter speeds, there are also cases in which friction lowers flutter speeds by introducing a phase shift between flutter critical vibration modes. Therefore the overall role of damping requires better definition.

### c. Boundary Layer

The boundary layer adjacent to the exposed panel surface has been shown to appreciably raise flutter speeds under certain flow conditions. However, knowledge at the present time precludes criteria formulation.

### SECTION III

#### DESIGN CRITERIA

The set of criteria presented here is an attempt to substantially reduce the uncertainty that has been inherent in existing design techniques by incorporating existing knowledge in a revised and reoriented set of design guidelines. The design criteria are based on stability boundaries, that is, the condition of no flutter is the basis for design. Factors of safety in design are not included in this section but are discussed separately in Section V.

The nondimensional panel flutter parameter

$$\phi = \left[ \frac{\beta E}{q} \right]^{1/3} t/l$$

has gained wide usage and is used in these criteria with some modification. In its most familiar application to flat panels, the critical value of  $\phi$  is specified as a function of length-to-width ratio [see (1)\* for example] and any combination of  $\beta$ ,  $q$ ,  $E$ ,  $t$  and  $l$  giving the specified  $\phi$  will cause a panel to be neutrally stable.

Note, however, that as  $M$  approaches the value 1,  $\beta$  approaches zero. This untenable situation would require that the panel have prohibitively large thickness to prevent flutter at low transonic Mach numbers. In this document, therefore,  $\beta$  has been replaced by a Mach number correction factor  $f(M)$  that is derived from published experimental data. The function  $f(M)$  is shown versus Mach number in Figure 1, and is seen to coincide with  $\beta$  for  $M > 2$ . (This curve was derived from experimental data obtained with a panel for which  $l/w = 0.5$  and is discussed in Section III of Volume II; as additional data become available it may be possible to define the variation in  $f(M)$  with  $l/w$ .) The nondimensional panel flutter parameter that will be used in this set of criteria thus has the modified form

$$\phi_B = \left[ \frac{f(M) E}{q} \right]^{1/3} \left( \frac{t_B}{l} \right)$$

and  $t_B$  is a "baseline" design thickness. These concepts are described in the following paragraphs.

The design procedure is oriented for the designer who must specify a panel thickness that will preclude flutter throughout the vehicle flight environment. To this end, the designer must first be furnished data in the following three basic categories:

- (a) Flight conditions

\* Numbers indicate references at the end of this volume.

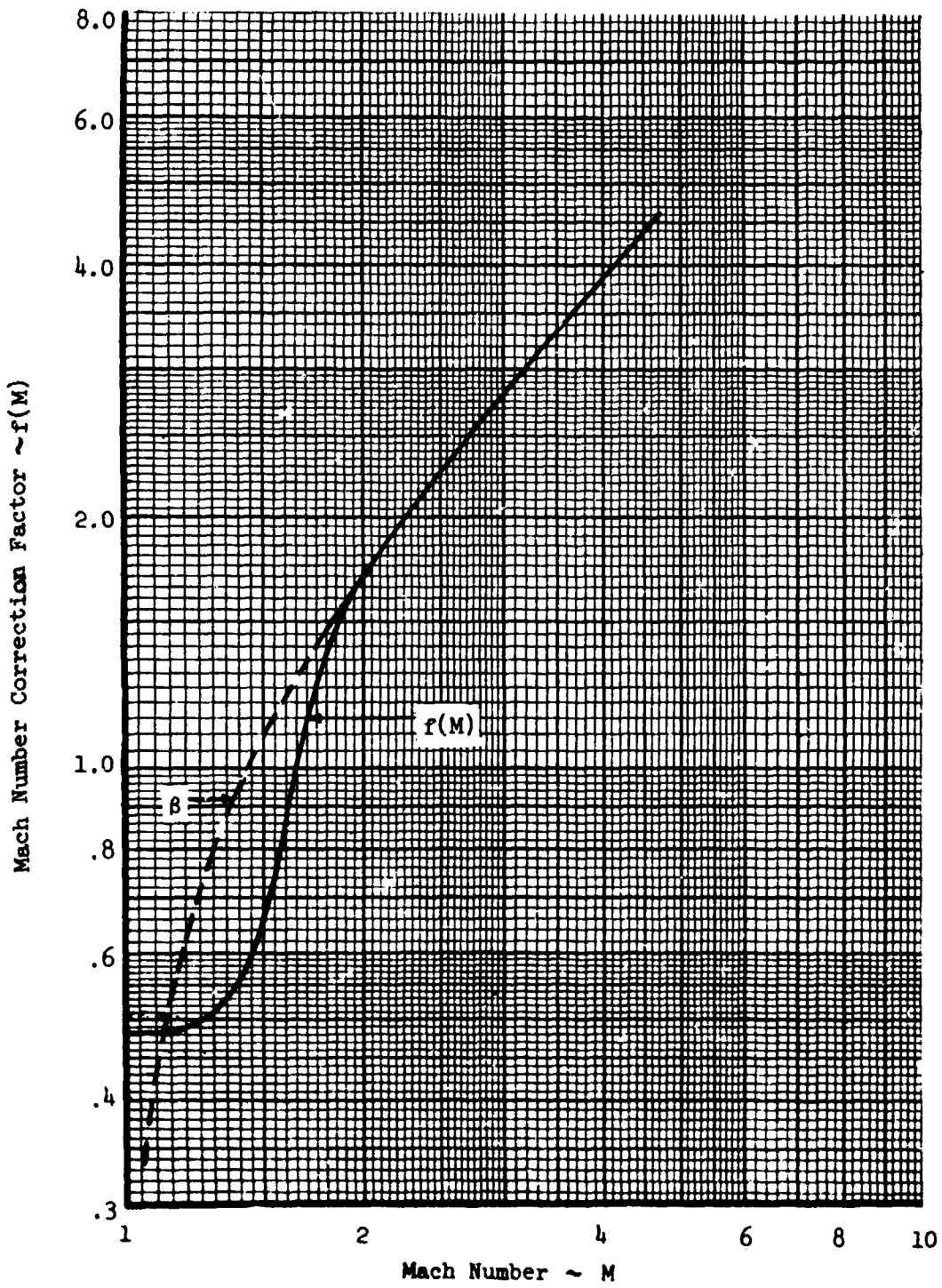

Figure 1 - Mach Number Correction Factor Versus Mach Number

(b) Physical Data and Geometry

(c) Environmental Conditions

The parameters that were discussed in Section I are now separated and grouped in Table I within these three categories.

Table I  
GROUPING OF PARAMETERS THAT AFFECT FLUTTER SPEED

(a) Flight Conditions	(b) Physical Data and Geometry	(c) Environmental Conditions
Mach number	Young's modulus	Inplane stress
Dynamic pressure	Length	Differential pressure
Angle-of-attack	Width	Differential temperature
Flow angularity	Length-to-width ratio	
	Curvature	
	Cavity	
	Edge conditions	
	Thickness (to be determined)	

The remainder of this section is used to describe step-by-step procedures that account for the above listed parameters in the overall set of criteria.

1. Step (1) - Flight Data,  $l/w$

The known quantities that enable the beginning of design are

Mach number ( $M$ )  
Dynamic pressure ( $q$ )  
Planform dimensions, length ( $l$ ), and width ( $w$ )

and are to be used as follows:

- (a) Establish the aerodynamic quantity  $[q/f(M)]$  for the flight envelope of the vehicle. Since the designer usually possesses flight data as altitude-Mach number or he can easily convert to this form, this step is facilitated by plotting the data directly on the prepared graph of Figure 2. This figure was constructed by using  $f(M)$

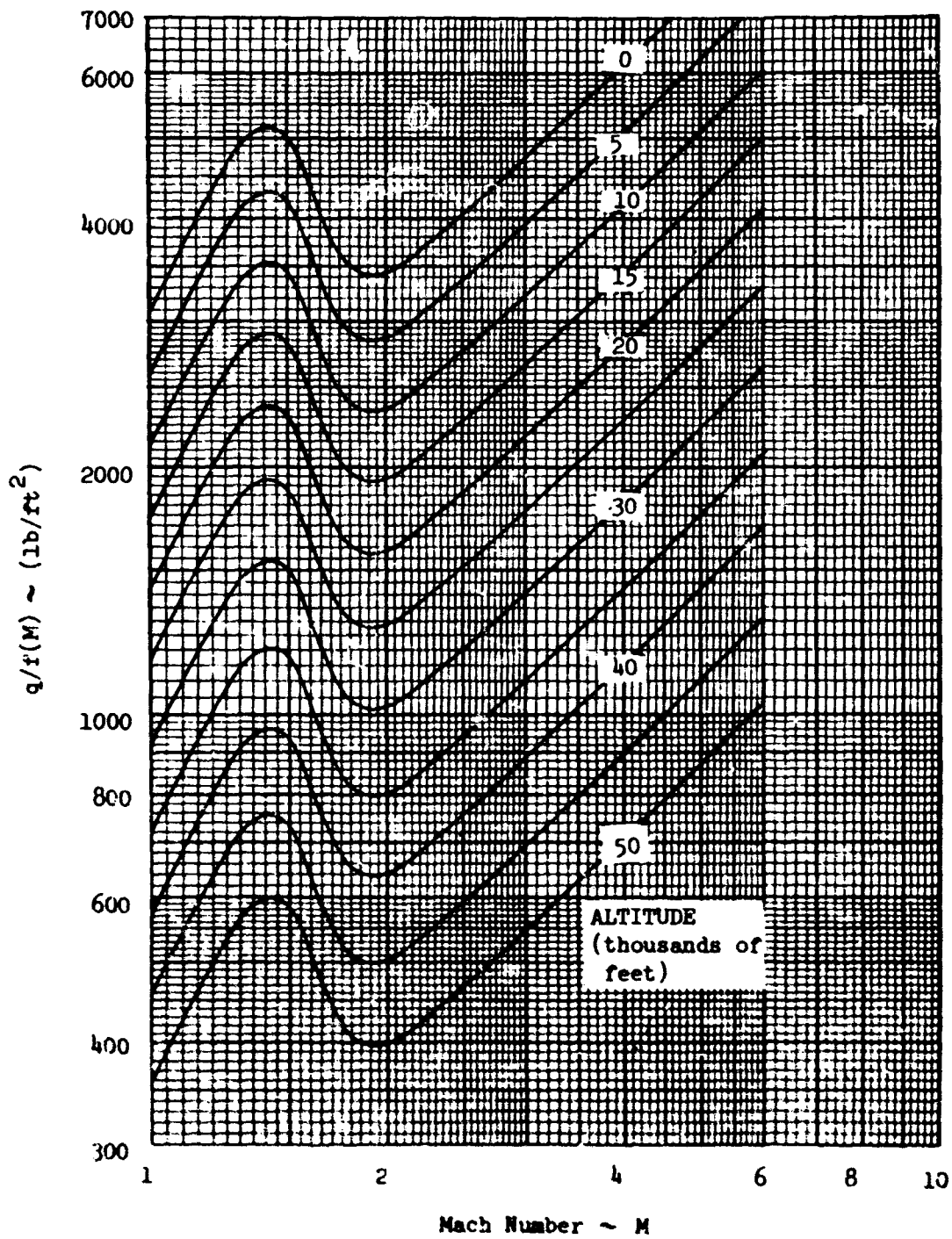

Figure 2 - Plot of  $q/f(M)$  Versus Mach Number with Parametric Variation in Altitude

from Figure 1 together with pertinent dynamic pressure-Mach number relationships from Reference 2. The most adverse panel flutter environment usually occurs at  $[q/f(M)]_{\max}$  although other trajectory points may require investigation. Any other flight loading condition, either aerodynamic or thermal, that can cause panel buckling must be considered in the design. If the panel will be flown at or very near zero angle of attack, proceed to step (2).

- (b) If the panel will be inclined to the airstream, go to step (4) before continuing with step (2) below.

## 2. Step (2) - "Flat" Panel Design

Proceed with the assumption that the panel will be clamped on all edges, flat, unswept and unstressed. Determine the panel thickness  $t_B$  that is required for neutral stability from the flight data used in step (1). (Thickness corrections for deviations from the ideal flat conditions will be made in step (3).)

The value  $t_B$  is obtained by using the "baseline" panel flutter parameter  $\phi_B$  that is shown in Figure 3. This parameter, which is of the same nondimensional form that is now widely accepted, is

$$\phi_B = \left( \frac{f(M) E}{q} \right)^{1/3} \left( \frac{t_B}{l} \right)$$

This plot is adapted from experimental data given in References 1 and 3 together with a theoretical extrapolation from plots given in Reference 4. It is expedient to rewrite the parameter as follows:

$$\phi_B^3 = \left( \frac{f(M)}{q} \right) \times E \left( \frac{t_B}{l} \right)^3$$

and by using the data from Figure 3, the relationships shown in Figure 4 are obtained. This data, plotted in the form that shows  $[q/f(M)]$  as the ordinate (as it also was in Figure 2) presents the opportunity of graphically determining the value of  $t_B$  required for neutral stability. In addition to the flight path data that was developed in step (1), it is assumed that the quantities

Modulus (E),  
length (l),  
width (w)

have also been specified.

We now combine Figures 2 and 4 by matching the ordinates to obtain the composite graph shown as Figure 5. Given the maximum value of  $[q/f(M)]$  from step (1) and the length-width ratio  $l/w$ , the required value of the structural term

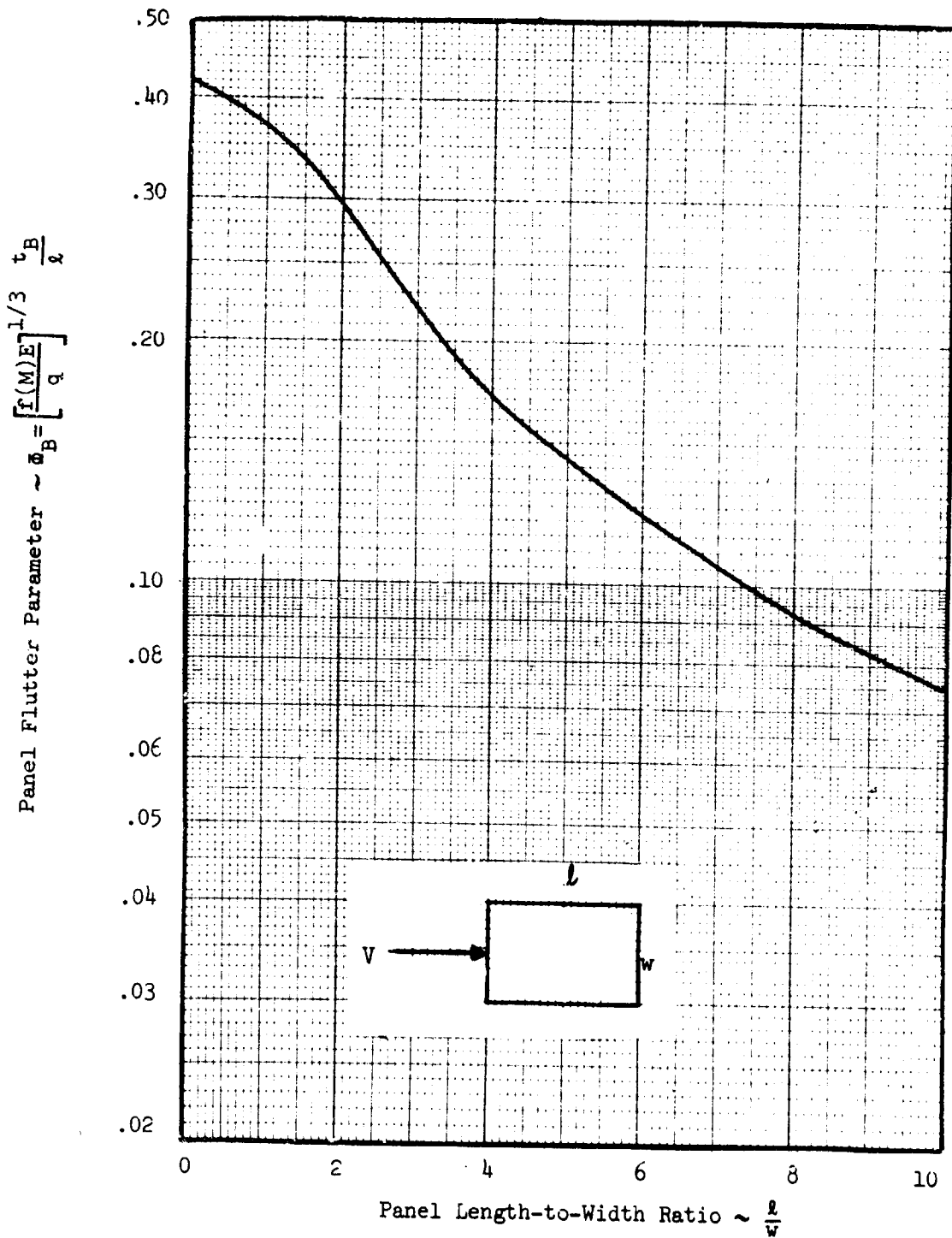

Figure 3 - "Baseline" Design Curve



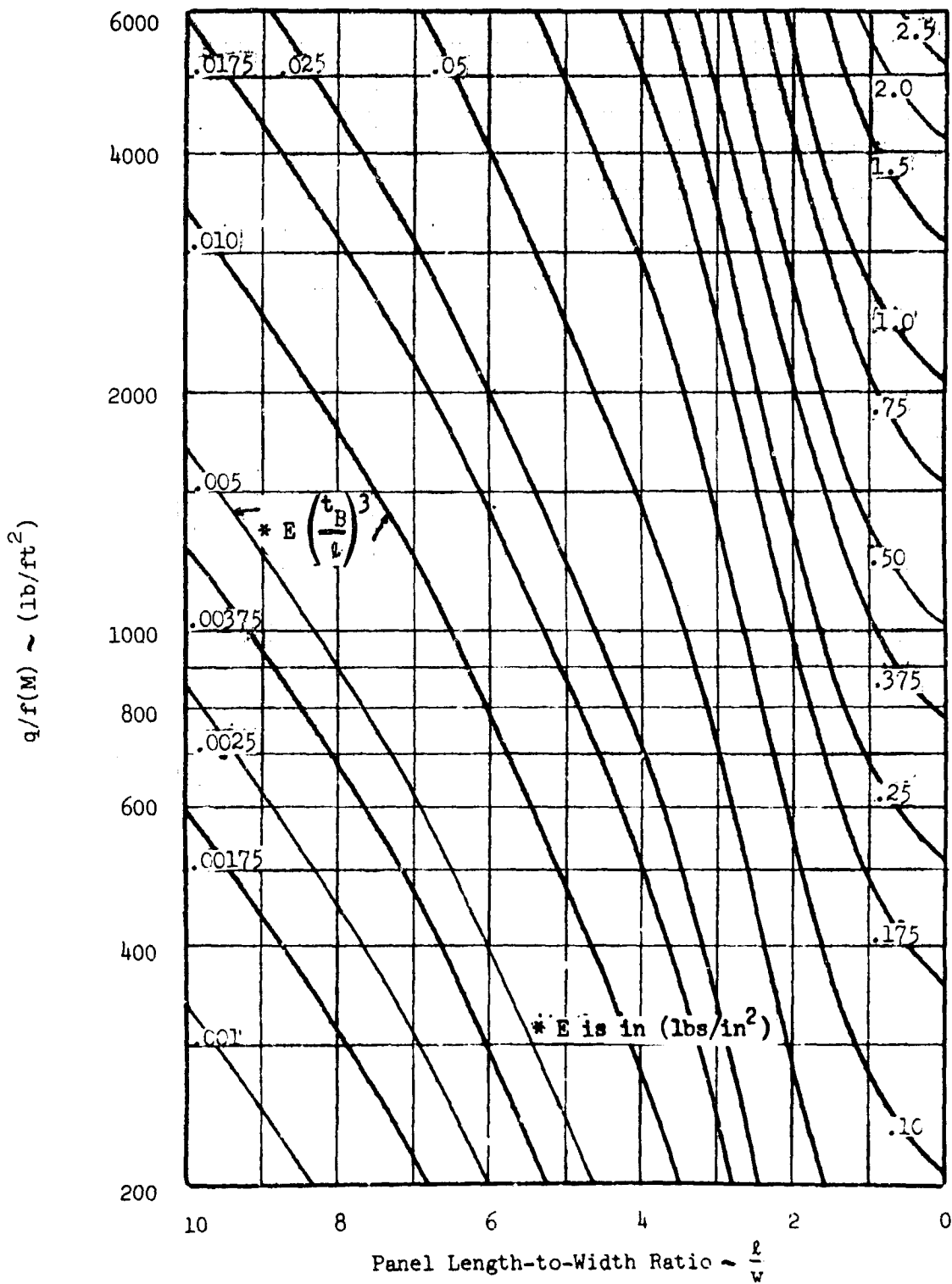

Figure 4 - Aerodynamic Parameter  $q/f(M)$  versus  $l/w$  with Variation in Structural Parameter  $E \left( \frac{t_B}{l} \right)^3$

$$E \left( \frac{t_B}{\ell} \right)^3$$

is found from the intersection of two lines that are constructed as explained in the following sample design case:

[An example problem is shown in Figure 5 for a typical flight envelope that has been drawn on Curve (B) to establish  $[q/f(M)]_{\max}$ . A horizontal line is passed through this peak value. A vertical line is drawn on Curve (A) through the value of  $\ell/w$  for the subject panel ( $\ell/w = 3$  in the sample problem). The intersection of the two lines is found, by interpolation, to be

$$E \left( \frac{t_B}{\ell} \right)^3 = 0.31$$

so that the "baseline" design thickness for the sample design is

$$t_B = (0.31/E)^{1/3} \ell.$$

This concludes the second step.

### 3. Step (3) - Thickness Requirement

The flat panel thickness value  $t_B$  has now been established. If the anticipated service condition of the panel happens to be flat, clamped, unswept and unstressed, then the design is complete, and  $t_B$  is the panel thickness required for neutral stability. This is unlikely, however.

We direct our attention back to the parameters that were listed in Columns (b) and (c) of Table I. We assume that each of the parameters that is not yet accounted for will cause a change in panel stability that can be represented by a correction in panel thickness. If the parameter destabilizes the panel, then panel thickness should be increased; likewise a stabilizing effect would cause a decrease in required panel thickness. It was assumed, in establishing thickness correction factors that are shown in the remaining figures, that interaction between parameters is small compared to the primary influence of a parameter itself. This step results in a corrected thickness  $t_C$  obtained from  $t_B$  and the thickness correction factors.

Thickness correction factors and procedures for their determination are as follows:

Curvature

$t_N/t_B$

Figure 6

Procedure:

Determine the baseline thickness  $t_B$ . For a cylindrically curved panel with the flow orientation shown on Figure 6, determine the crown height distance  $h_0$  from the geometrical relationship

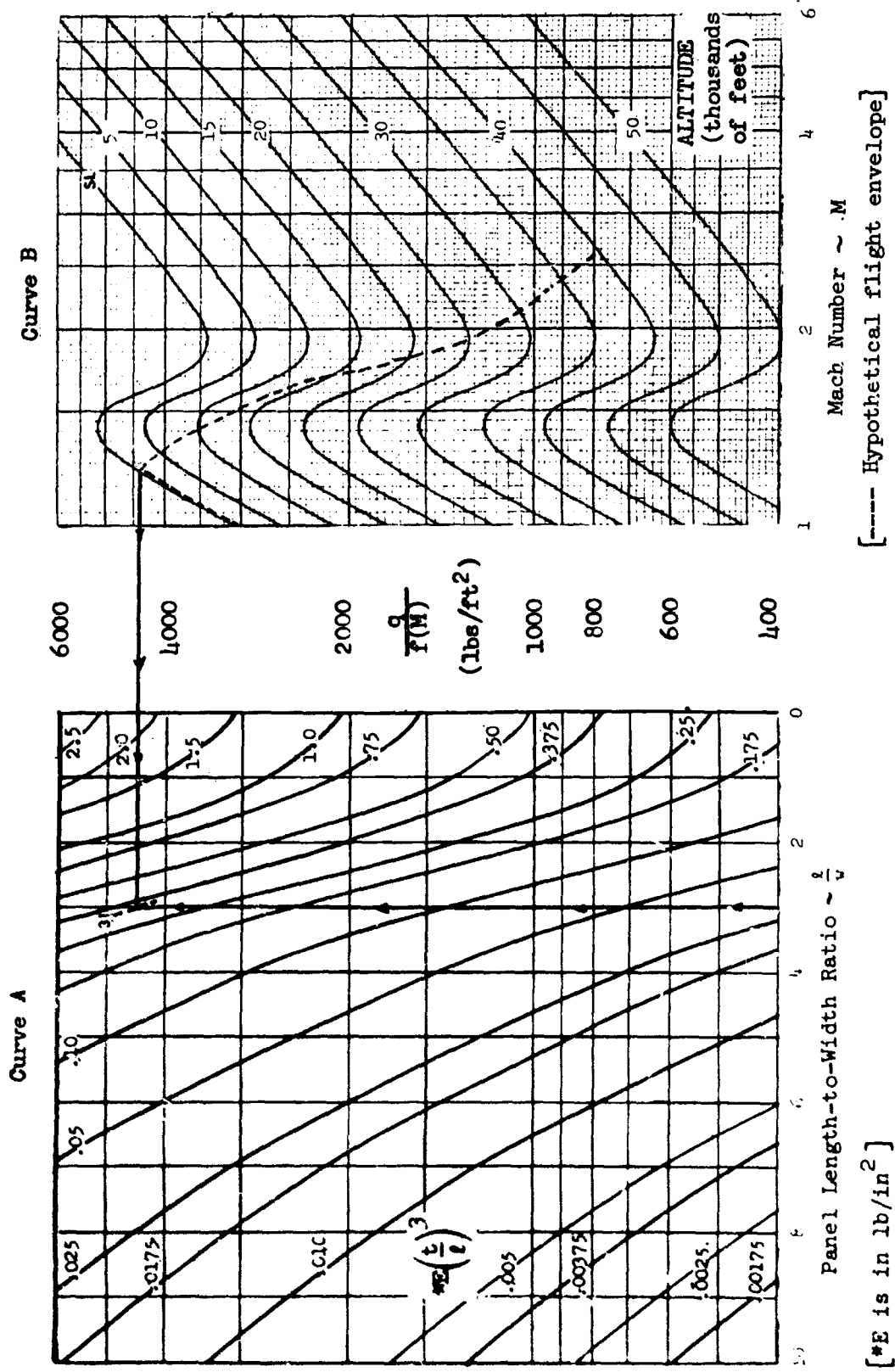

Figure 5 - Flat Panel Design Curves

Thickness Correction Factor  $\sim \frac{t_N}{t_B}$

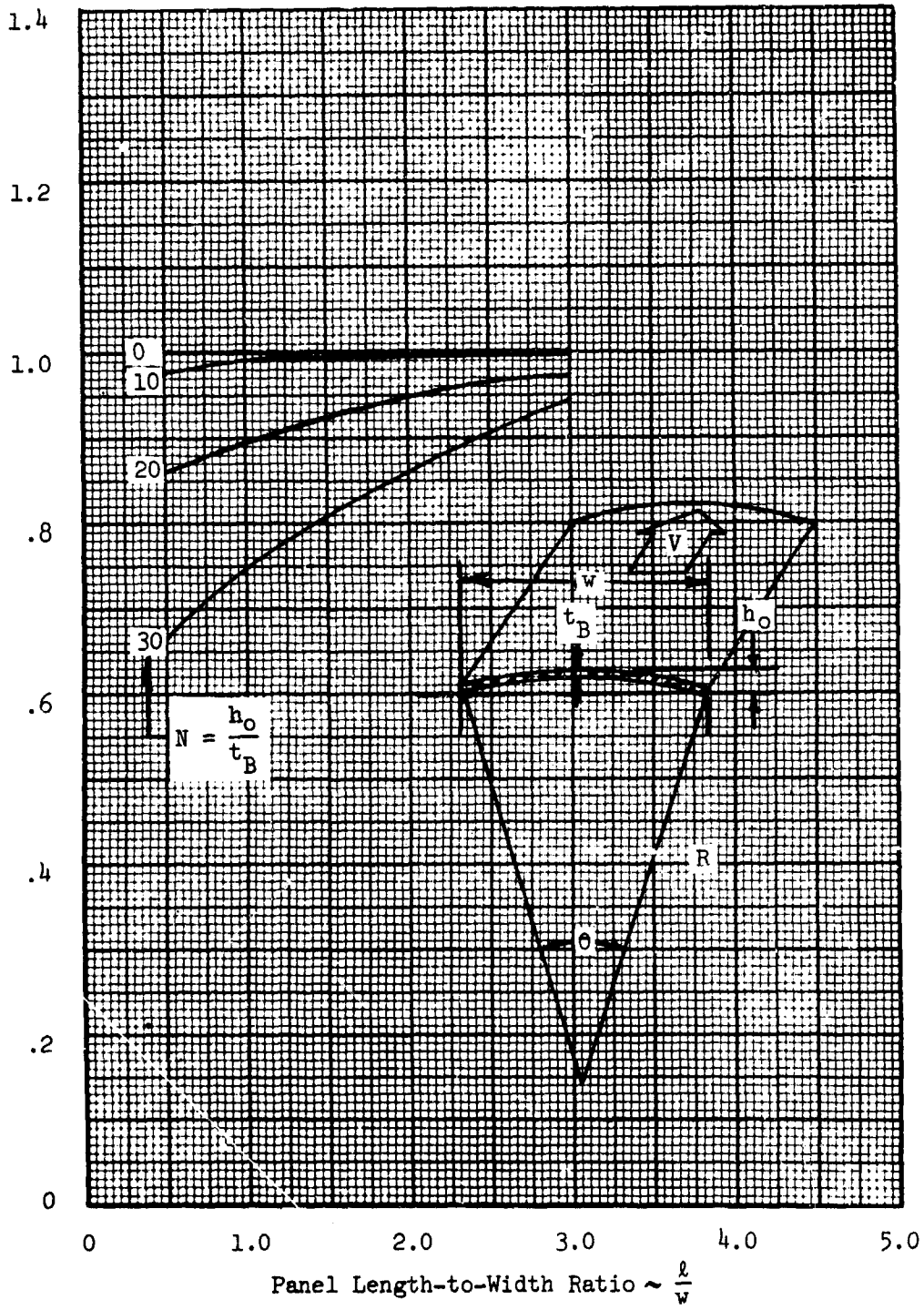

Figure 6 - Thickness Correction Factor for Curvature

$$h_o = R (1 - \cos \frac{\theta}{2}) = R - \sqrt{R^2 - (\frac{w}{2})^2}$$

Compute the curvature parameter

$$N = h_o/t_B$$

and enter Figure 6 to obtain  $t_N/t_B$ .

Sweep (yaw)

$t_\Lambda/t_B$

Figure 7

Procedure:

Make thickness correction for flow angularity  $\Lambda$  only if  $l/w < 1$ . The dimension  $l$  is the one most nearly aligned with the flow since the correction  $t_\Lambda/t_B$  is only applied to rectangular panels when  $\Lambda \leq 45^\circ$ . The thickness correction factor is obtained from Figure 7. (The effect of flow angularity for  $l/w > 1$  is shown in Volume II to be slightly stabilizing; therefore no thickness correction is recommended.)

Simply-supported Edges

$t_{ss}/t_B$

Figure 8

Procedure:

Use this correction if panel edge supports are less than fully clamped. The baseline thickness  $t_B$  assumes clamped edges and Figure 8 provides a thickness correction  $t_{ss}/t_B$  for a panel whose edges are not restrained in rotation. For intermediate cases, choose a value of the correction factor between 1 and the value of  $t_{ss}/t_B$ . The value chosen will depend on the method by which the panel is attached to support structure. For example, closely spaced rivets or screws would justify the use of a value of 1.0, whereas sparsely spaced fasteners would call for a value near the curve. In most cases the clamped edge approximation is believed to be adequate.

Inplane Stress (tension)

$t_\sigma/t_B$

Figure 9

Procedure:

Tensile stress is stabilizing and is most easily handled as an apparent increase in the panel modulus in the amount

$$E_{\text{effective}} = E \left( 1 + \frac{N_x}{N_{x_{cr}}} \right)$$

A thickness correction factor has been derived from this relationship and is presented in Figure 9 as a plot of  $t_\sigma/t_B$  versus  $N_x/N_{x_{cr}}$ . The

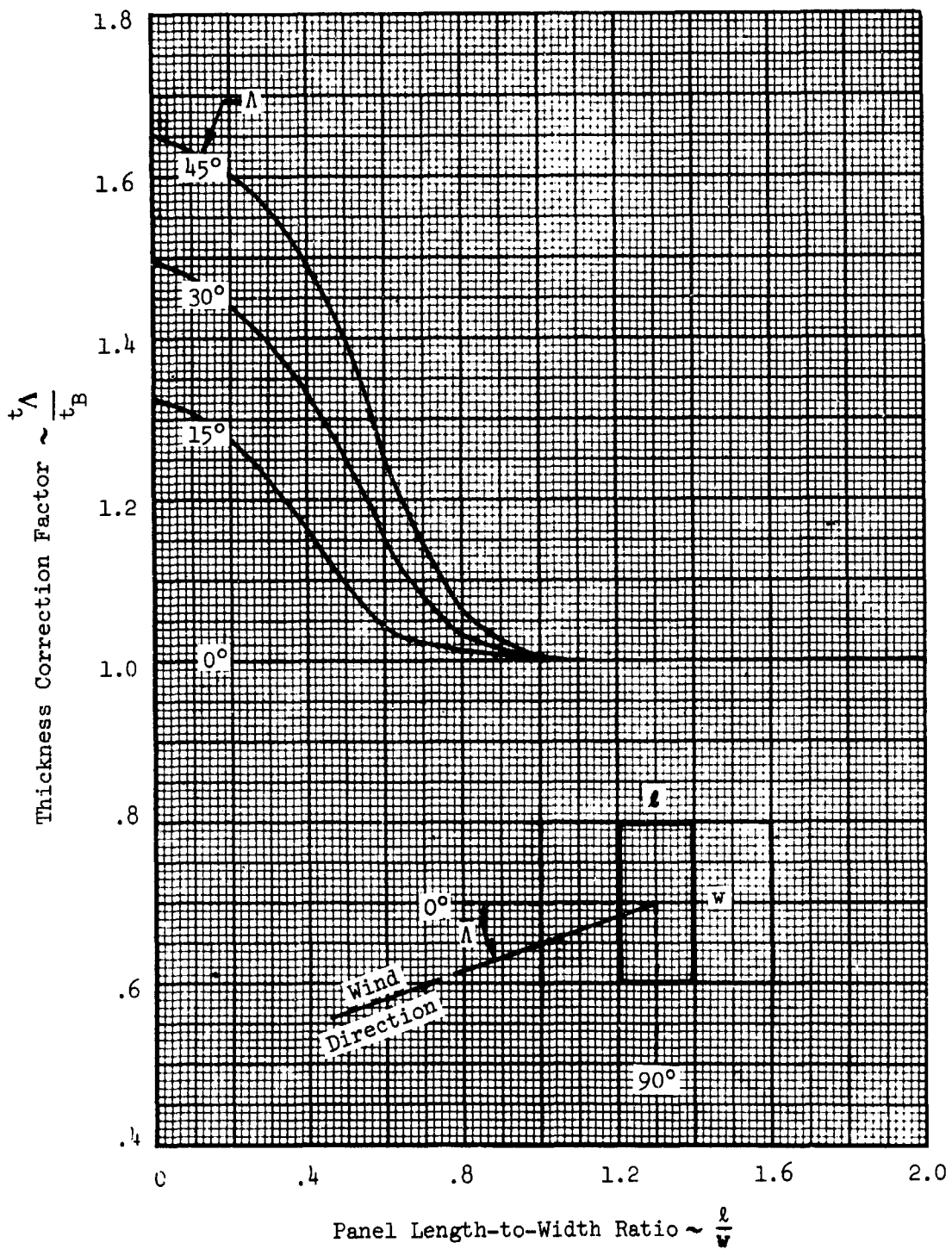

Figure 7 - Thickness Correction Factor for Flow Angularity

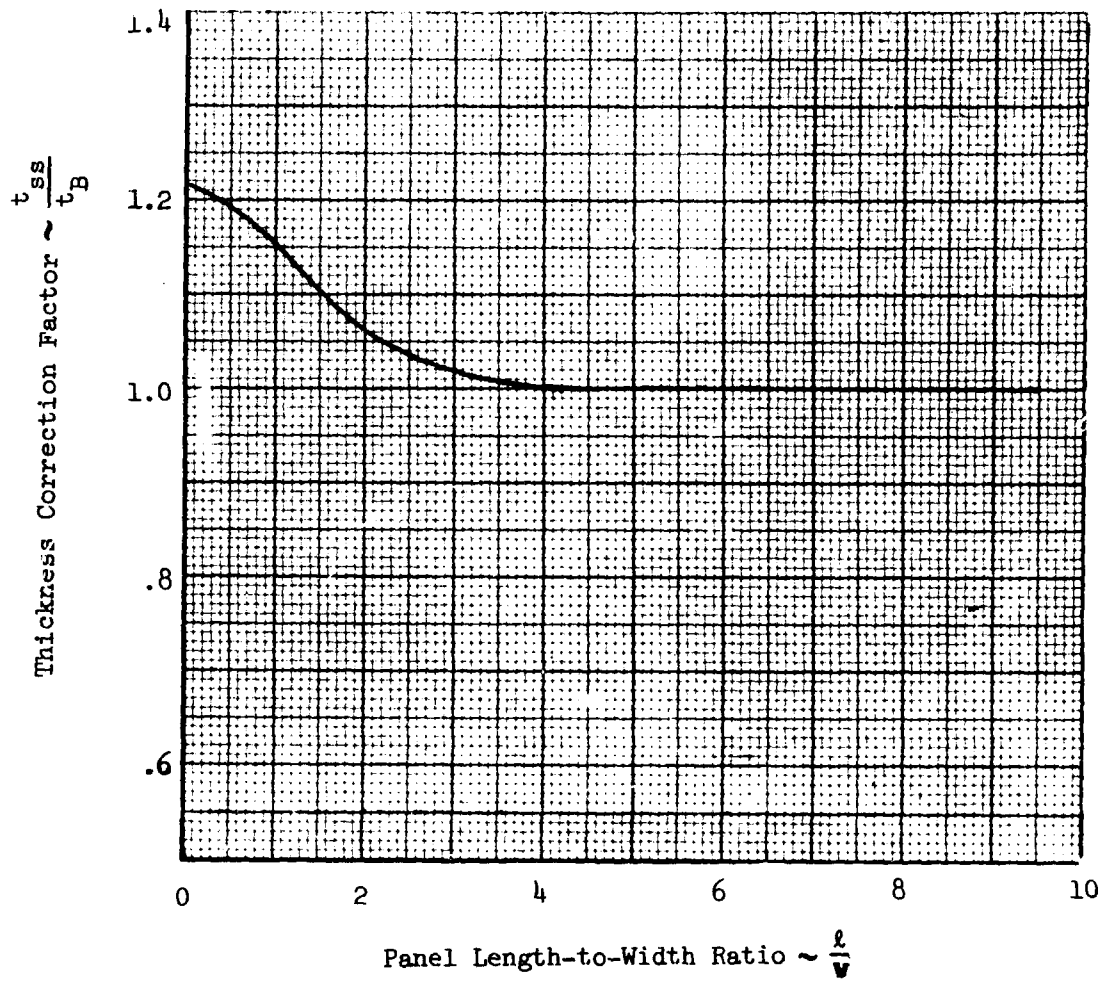

Figure 8 - Thickness Correction Factor for a Simply Supported Panel

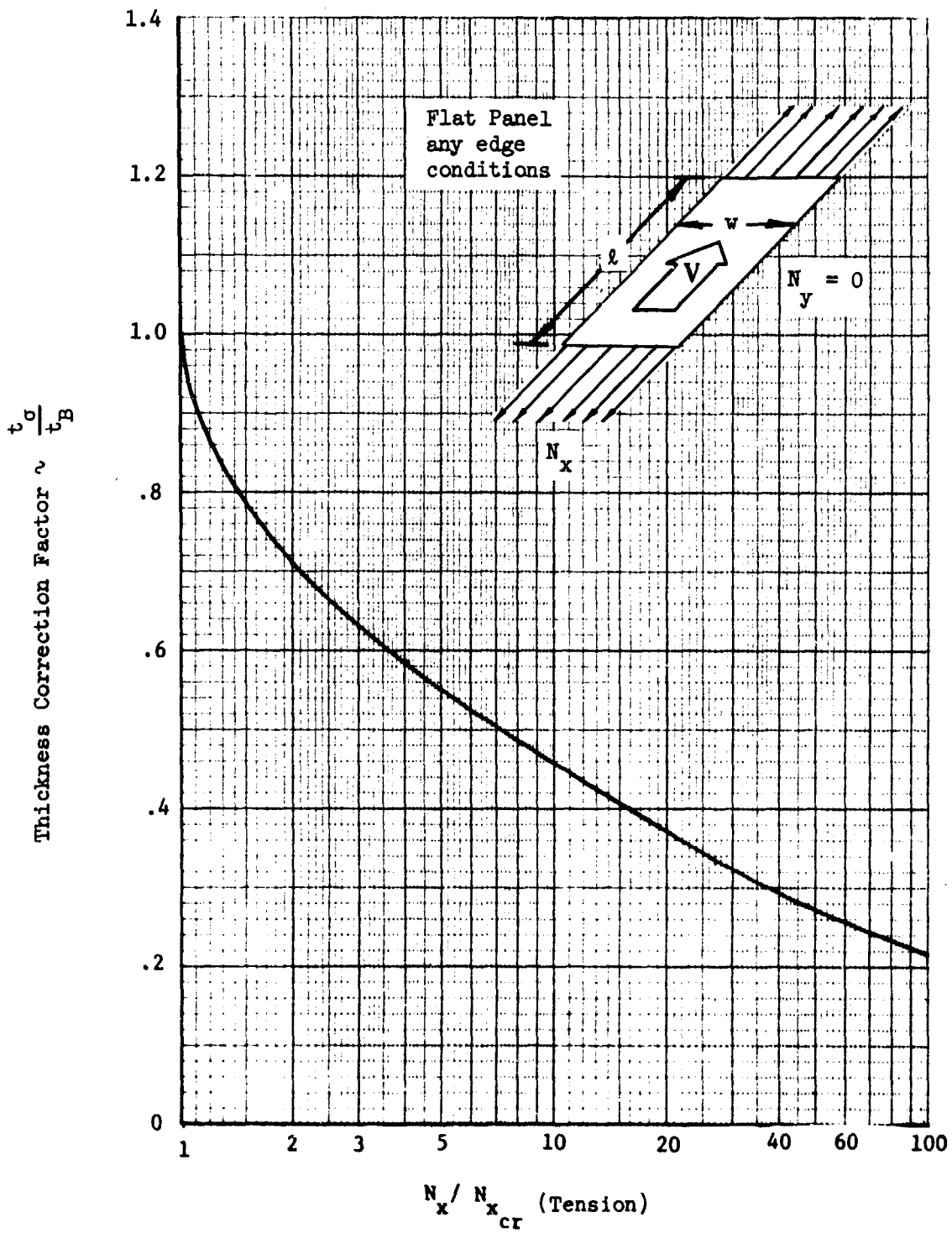

Figure 9 - Thickness Correction Factor  
for Stress (Tension)



tension load is applied in the stream direction and the cross-stream load is zero; it is recommended, however, that this correction be used even if tension load also occurs in the cross stream direction.

(The designer may obtain values of  $N_{x_{cr}}$  from Figures 11 and 13.)

Inplane Stress (compression)  $t_{\sigma}/t_B$

Figure 10  
Figures 11, 12,  
13, 14

**Procedure:**

The method of obtaining the thickness correction for longitudinal compressive stress is accomplished in three steps:

- (1) Determine the anticipated inplane loads  $N_x$  (streamwise) and  $N_y$  (cross-stream) that will occur during the critical portion of flight.
- (2) Determine the critical value of streamwise load  $N_{x_{cr}}$  for the panel based upon edge conditions,  $l/w$ , and the ratio  $N_y/N_x$ . (For aid in determining  $N_{x_{cr}}$ , see item (4) below.)
- (3) Using the computed value  $N_x/N_{x_{cr}}$ , enter Figure 10 and obtain the thickness correction factor  $t_{\sigma}/t_B$ . (On the basis of experimental data that is discussed in Volume II, the curve of Figure 10 assumes that the critical flutter speed occurs when panel compressive stress is between 80% and 100% of the still air buckling stress. Therefore the flat portion between  $N_x/N_{x_{cr}} = 0.8$  and 1.0 provides maximum thickness correction. The remainder of the curve is obtained by adjusting the values of the theoretical curve shown in Figure 20 of Volume II downward to 0.8  $N_x/N_{x_{cr}}$ .)
- (4) Figures 11, 12, 13 and 14 have been included to assist in determining  $N_{x_{cr}}$ . These curves present  $N_{x_{cr}}/(\pi^2 D/l^2)$  versus  $l/w$  for clamped and simply supported panels for the loading conditions  $N_y = 0$  and  $N_y = N_x$ . It is recommended that the designer interpolate among the four cases if he feels that his panel edge supports and loading do not identically match any of the examples presented. (As an example, suppose that a panel of  $l/w = 3$  is estimated to have edge bending stiffness that is roughly intermediate between simply supported and clamped edge conditions; furthermore, the inplane stress at the critical flight condition is estimated to be  $N_y = 0.5N_x$ . Linear interpolation gives a value

$$N_{x_{cr}}/\frac{\pi^2 D}{l^2} = 33.3$$

as indicated by the following chart.)

Demonstration of Linear Interpolation  
to Obtain

Value of  $N_{xcr} / \frac{\pi^2 D}{l^2}$   
for panel with  $l/w = 3$

SS*	Cl**
$N_y = 0$	
23	65
(Figure 13)	(Figure 11)

Average

↓

44  
(Intermediate  
edge restraint)

SS	Cl
$N_y = N_x$	
10	35
(Figure 14)	(Figure 12)

Average

↓

22.5  
(Intermediate  
edge restraint)

AVERAGE YIELDS

$$N_{xcr} / \frac{\pi^2 D}{l^2} = 33.3$$

(Intermediate edge  
restraint and  $N_y = 0.5 N_x$ )

SS\*- Simply Supported Edges  
Cl\*\*- Clamped Edges

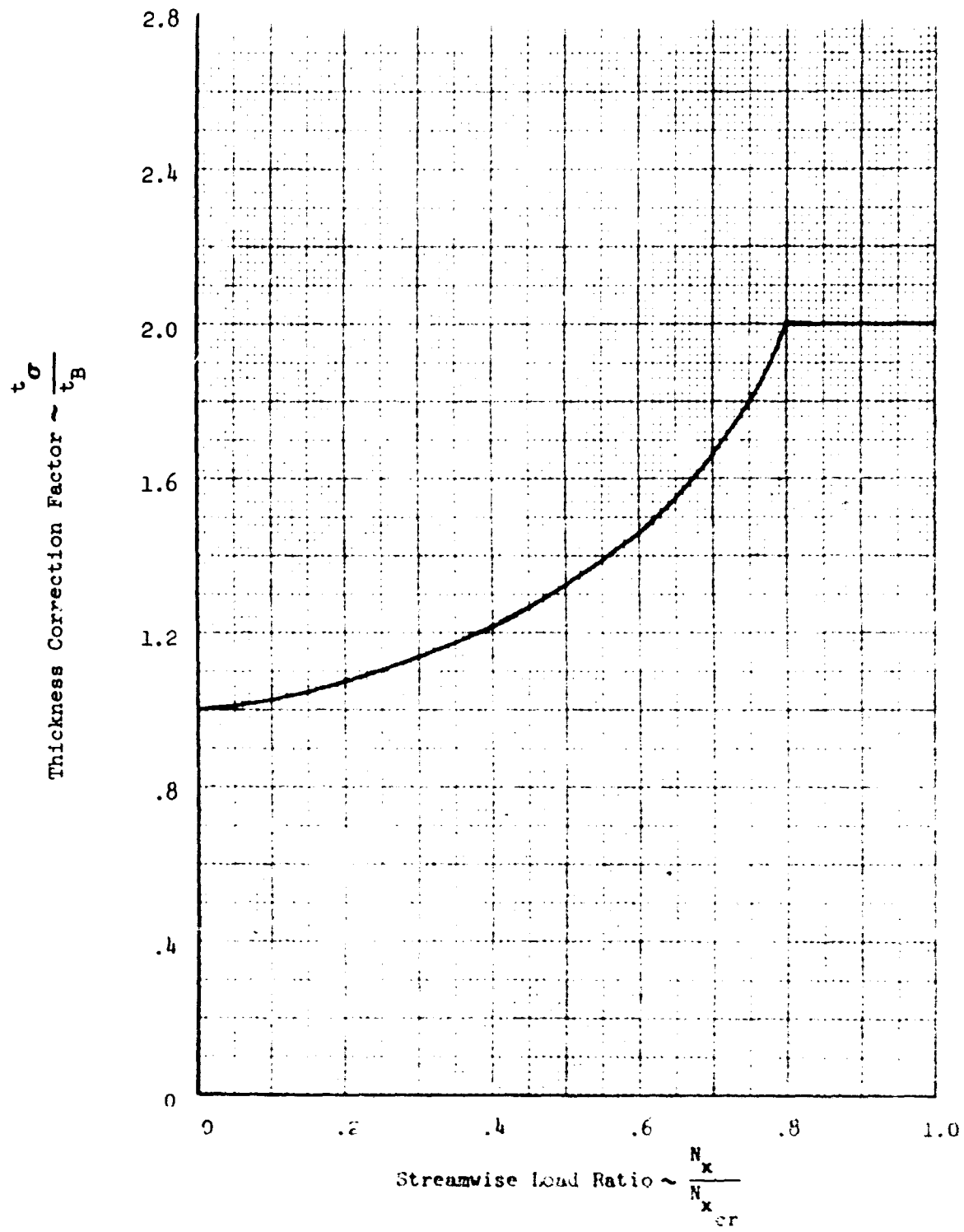

Figure 10 - Thickness Correction Factor for Inplane Stress (Compression)

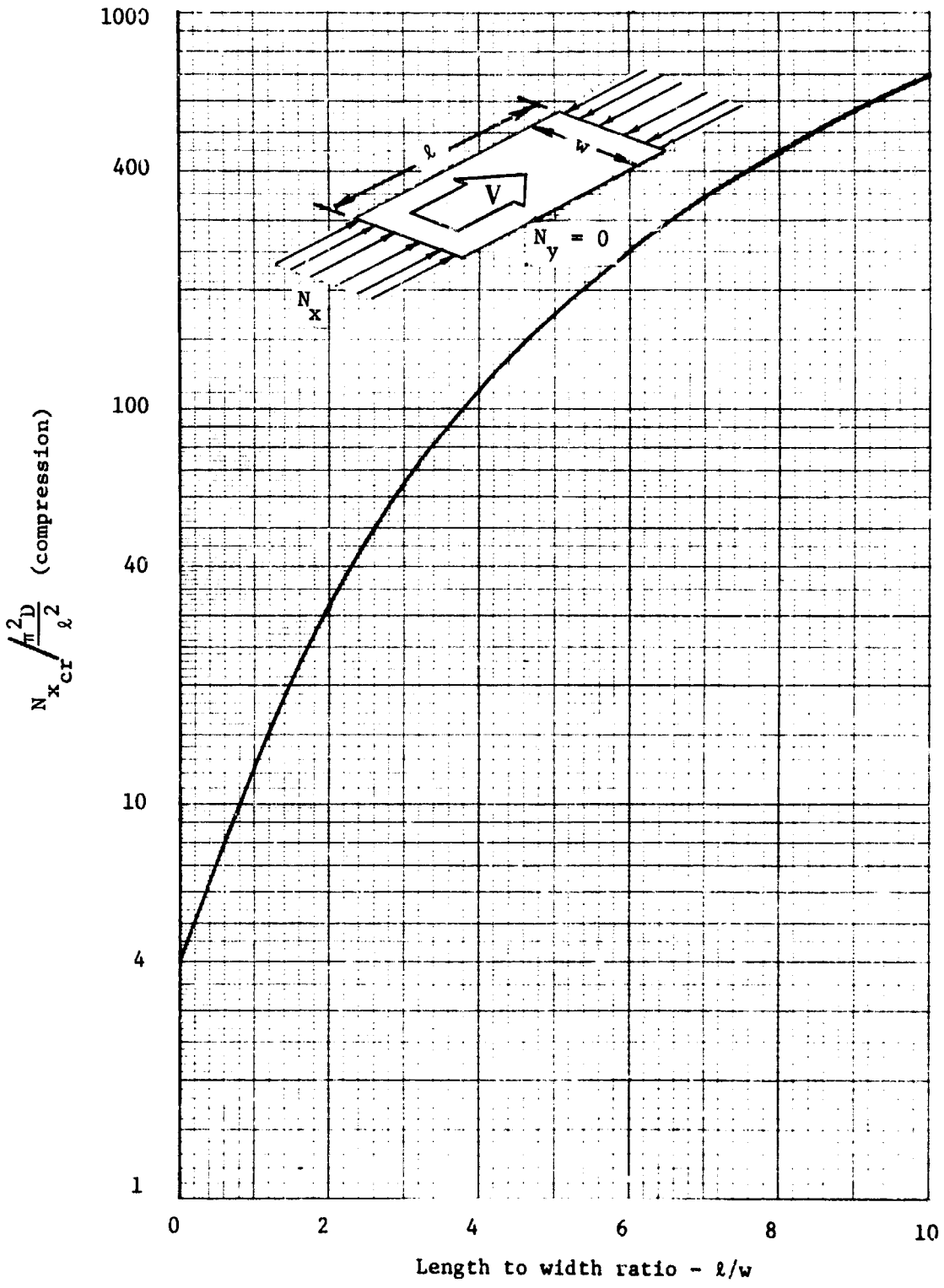

Figure 11 - Critical Inplane Compression Load for Clamped Panel,  $N_y = 0$

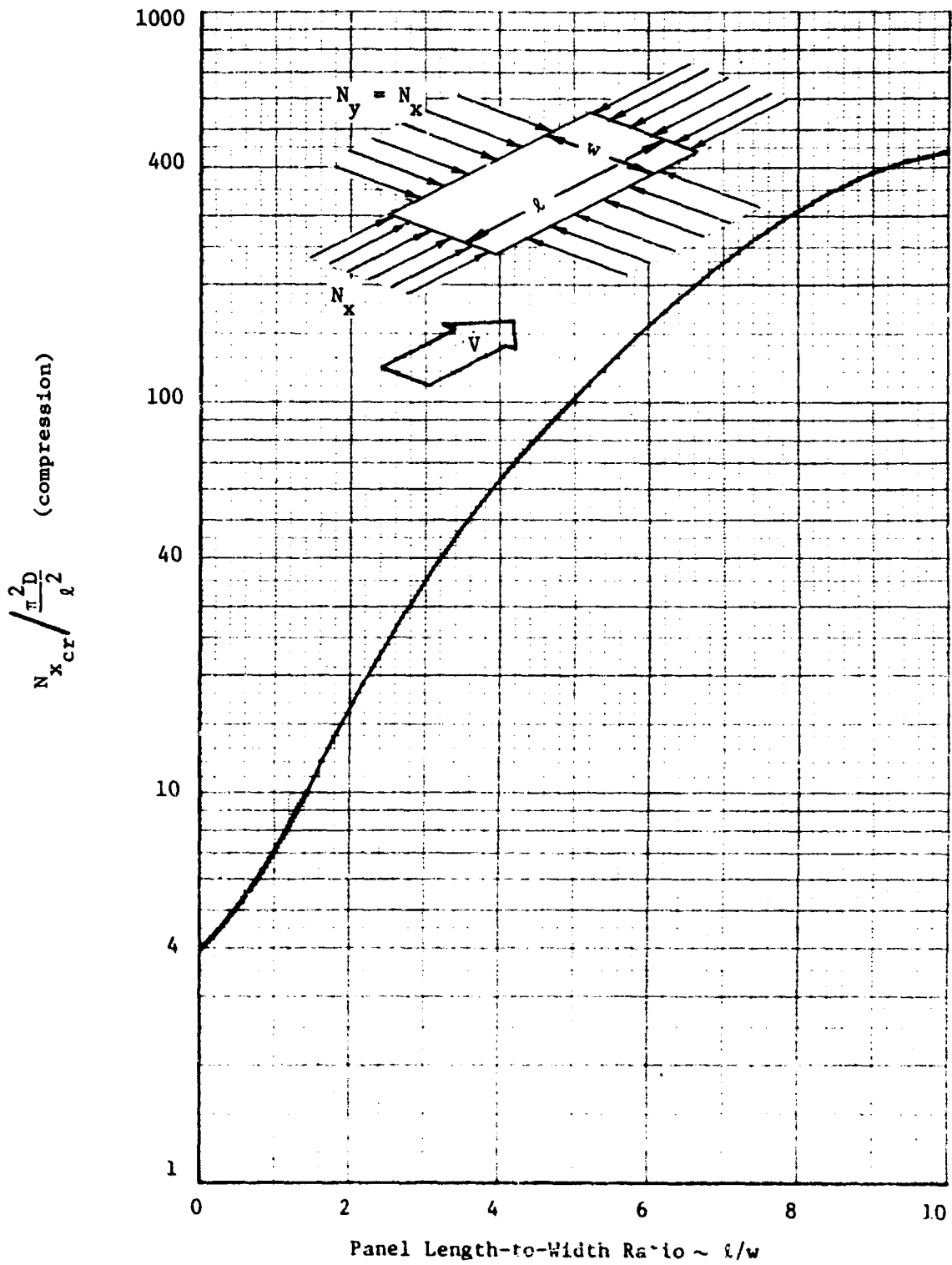

Figure 12 - Critical Inplane Compression Load for Clamped Panel,  $N_x = N_y$

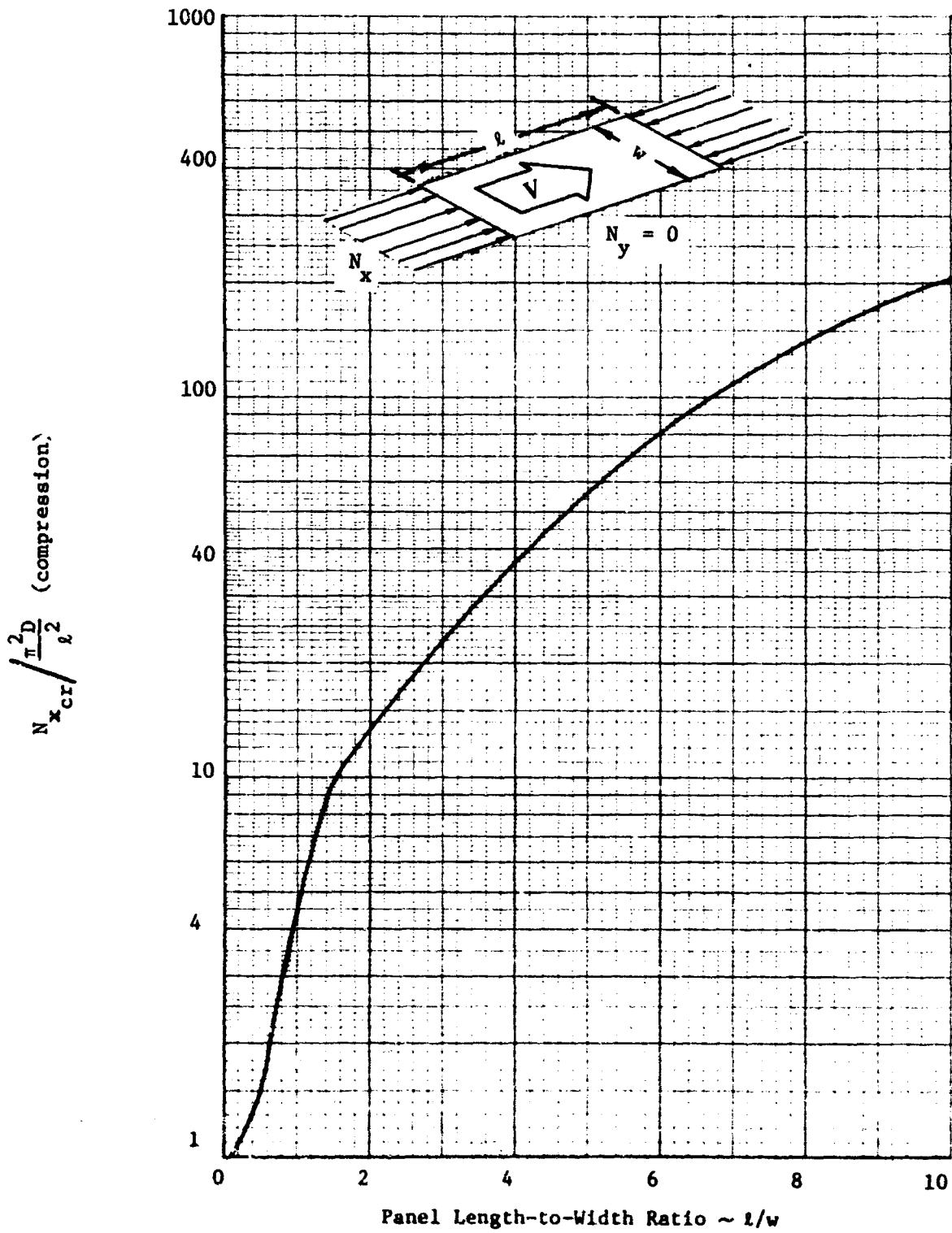

Figure 13 - Critical Inplane Compression Load for Simply Supported Panel,  $N_y = 0$

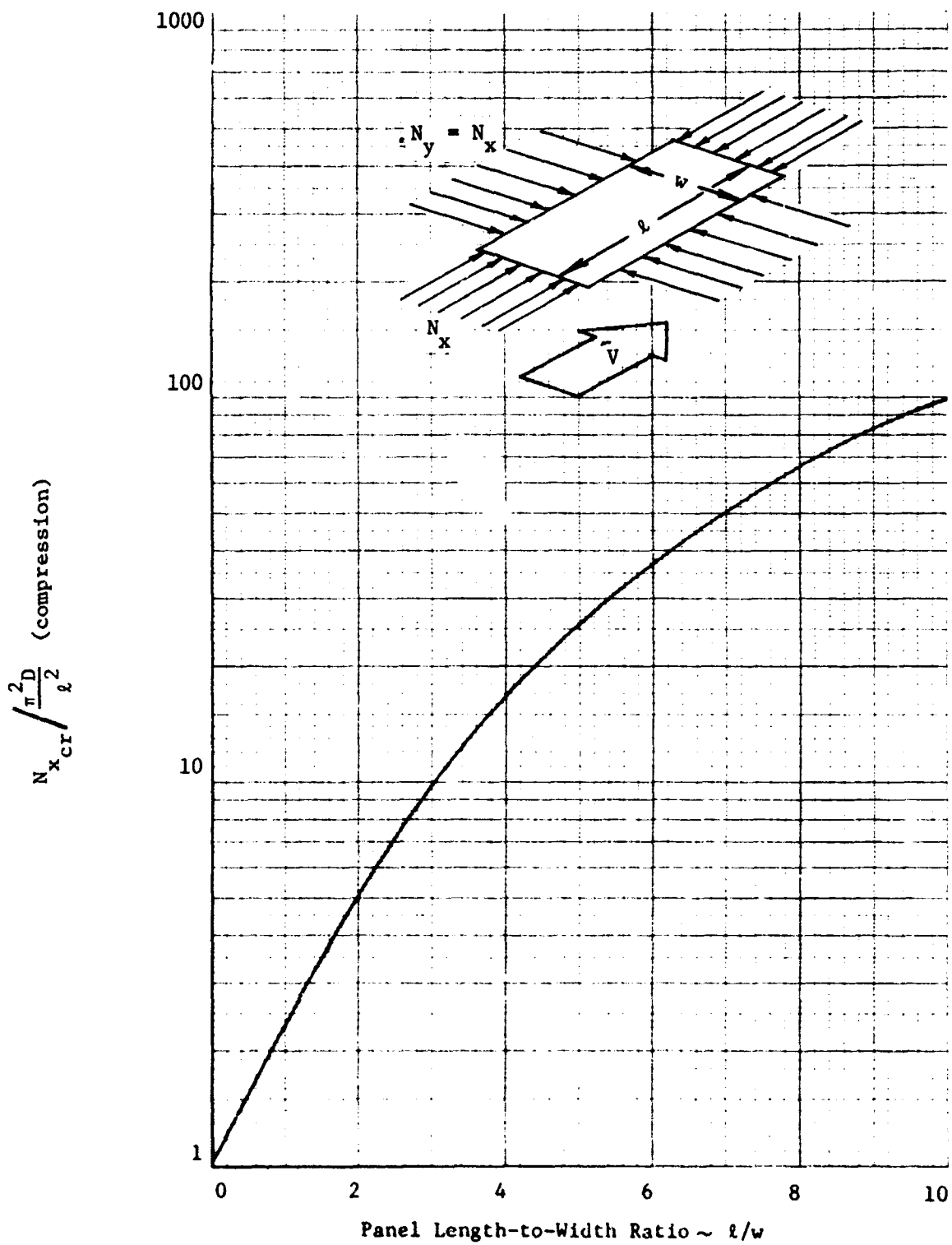

Figure 14 - Critical Inplane Compression Load for Simply Supported Panel,  $N_y = N_x$

Buckling

$$t_b/t_B$$

Figures 11, 12,  
13, 14

Procedure:

Experimental evidence from studies of inplane stress indicate that the lowest flutter speed for a stressed panel occurs when  $N_x$  is at or near  $N_{x_{\text{buckling}}}$ . Therefore, a panel that will be buckled during the critical portion of its flight requires a thickness correction  $t_b/t_B = 2$ . (This is the maximum correction factor from the curve of Figure 10.). Assume that  $N_{x_{\text{buckling}}} = N_{x_{\text{cr}}}$  so that critical load values can be obtained from Figures 11, 12, 13, and 14.

Differential Pressure

$$t_{\Delta p}/t_B$$

Figure 15  
Figure 16

Procedure:

To account for unequal pressures on opposite faces of a flat panel,

- (1) Compute the value of the parameter  $\Delta p/E \left( \frac{t_B}{l} \right)^4$  from the design data; with  $l/w$  enter Figure 15 to find the parameter  $d_o/t_B$ .
- (2) With the value of  $d_o/t_B$  and  $l/w$ , enter Figure 16 to find the thickness correction factor  $t_{\Delta p}/t_B$ .

Differential Temperature  $t_{\Delta T}/t_B$

Figures 17, 18  
Figure 19

Procedure:

This correction applies to a panel whose edges are restrained against inplane motion; the panel temperature is higher by an amount  $\Delta T$  than its supporting structure. The critical value of differential temperature  $\Delta T_{\text{cr}}$  is that value at which the panel buckles.



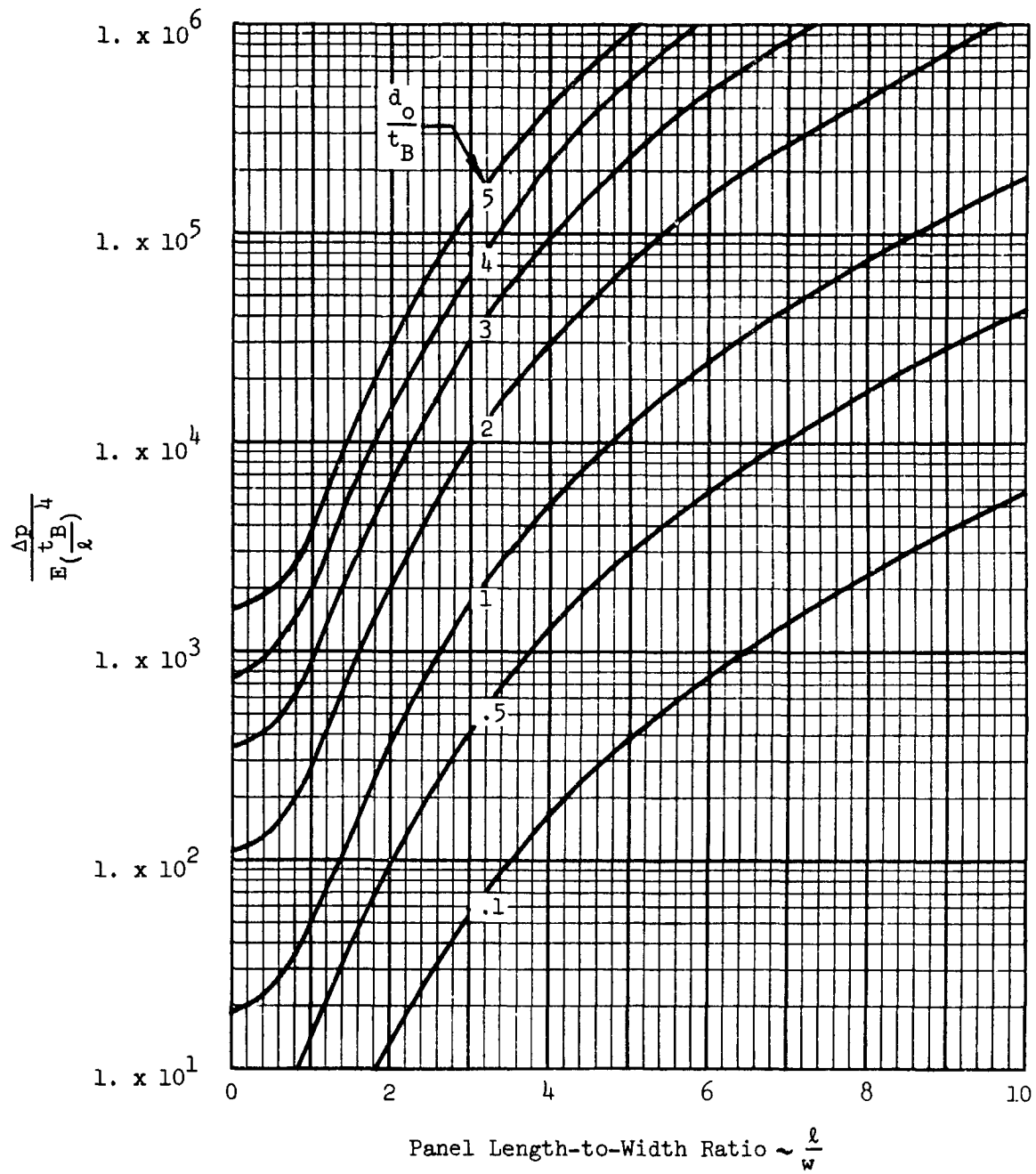

Figure 15 - Relationship Between  $\frac{d_0}{t_B}$ ,  $\Delta p$ , and Panel Geometric-Physical Characteristics

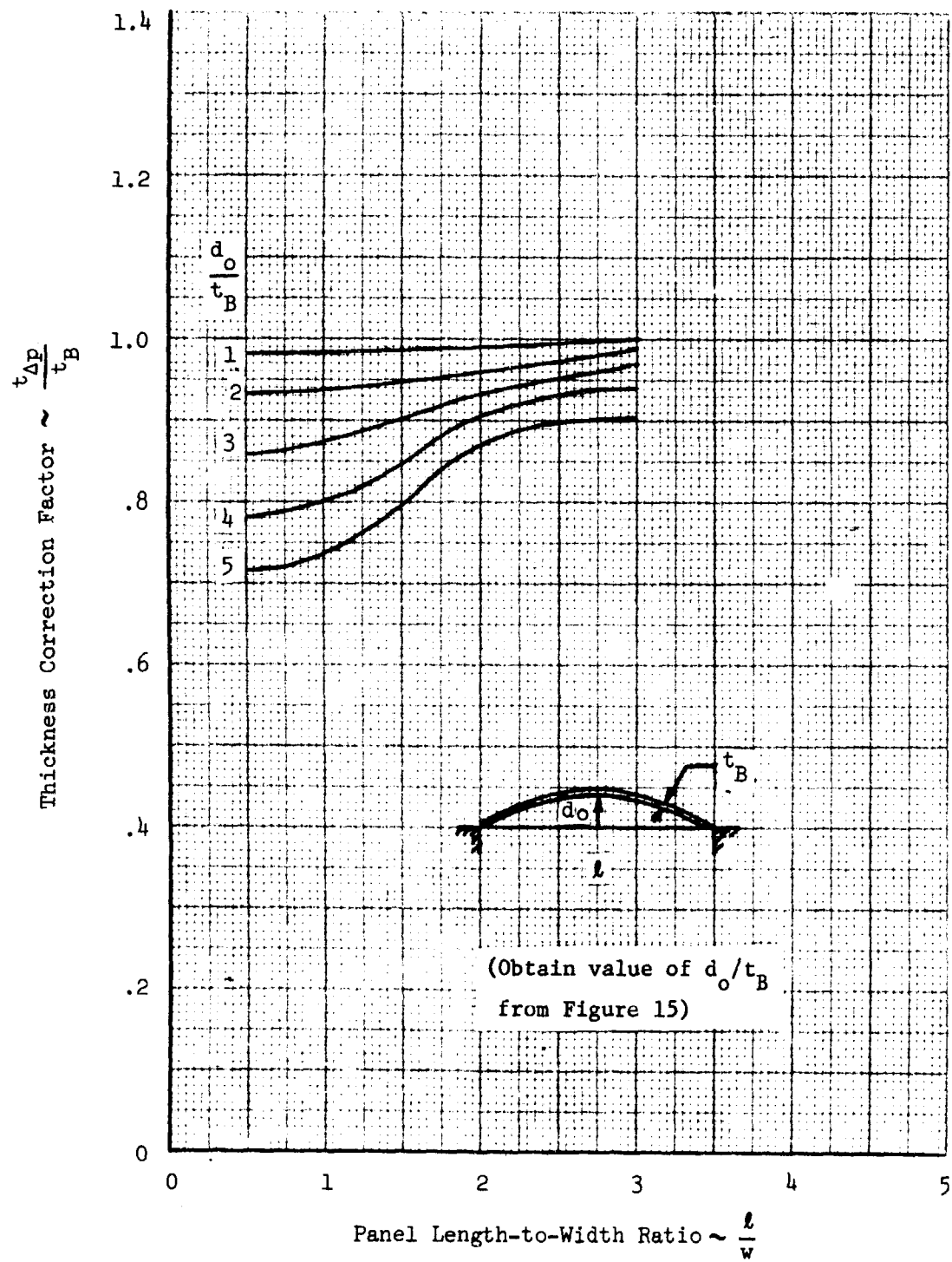

Figure 16 - Thickness Correction Factor for Differential Pressure

(1) Enter Figure 17 or 18 with  $\ell$ ,  $t_B$  and  $\ell/w$  to determine  $\alpha_T \Delta T_{cr}$  in which  $\alpha_T$  is the thermal coefficient of expansion for panel material.

(2) Compute  $\Delta T / \Delta T_{cr}$  and enter Figure 19 to find  $t_{\Delta T} / t_B$ .

Cavity

$t_{cav} / t_B$

Figure 20

Procedure:

This correction applies if the panel encloses a volume of air that is not vented to the atmosphere. The volume of the cavity is written in the form  $(\ell wd)$  in which  $d$  is an equivalent cavity depth. Compute the quantity

$$p_{cav} (\ell^4 / Dd)$$

and enter Figure 20 to determine  $t_{cav} / t_B$ .

Determination of Corrected Thickness  $t_C$

The final value of thickness  $t_C$  is obtained by multiplying all thickness correction factors by the "baseline" thickness, viz.,

$$t_C = t_B (t_1 / t_B) (t_2 / t_B) \dots (t_i / t_B)$$

The maximum value of the corrected thickness is limited to

$$t_C = 2 \left( \frac{t_A}{t_B} \right) t_B$$

Use of the factor 2 as a maximum value recognizes that the "worst case" flutter susceptibility cannot be compounded; this fact is substantiated by experimental data as shown in the plots of Reference 3 for example. Flow angularity, however, does influence flutter boundaries even at the minimum flutter speeds.

4. Step (4) - Angle of Attack

If the panel is inclined to the airstream then the angle of attack  $\alpha$  is used to establish local values of Mach number ( $M_L$ ) and dynamic pressure ( $q_L$ ). The quantity

$$[q/f(M)]_L = q_L / f(M_L)$$

must be computed for a sufficient portion of the flight envelope to insure that the critical (maximizing) value is obtained. This value is then used to enter Curve (a) of Figure 5, and hence to determine the value of  $E \left( \frac{t_B}{l} \right)^3$ .

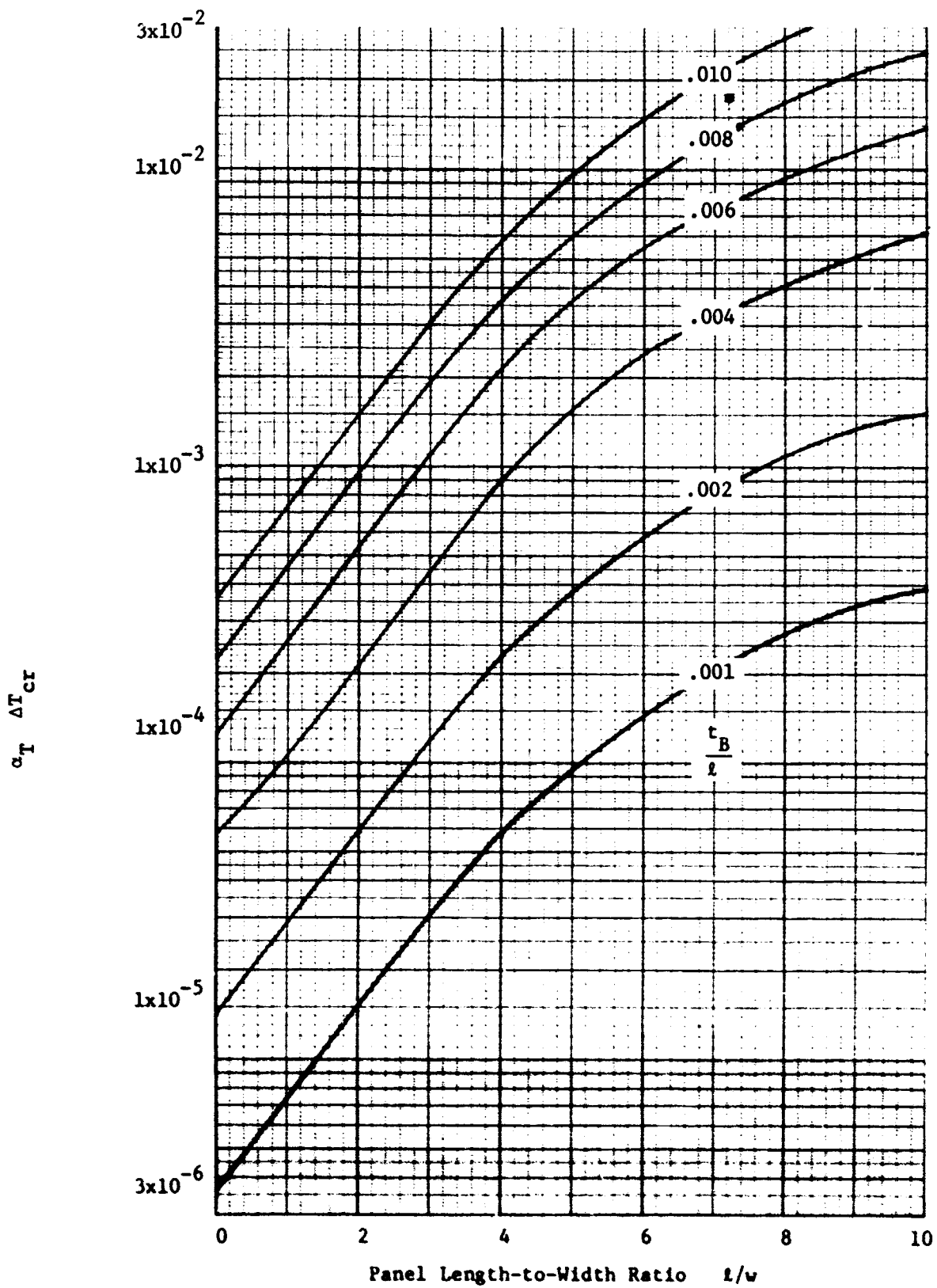

Figure 17 - Critical Differential Temperature of Clamped Panel with Restrained Edges

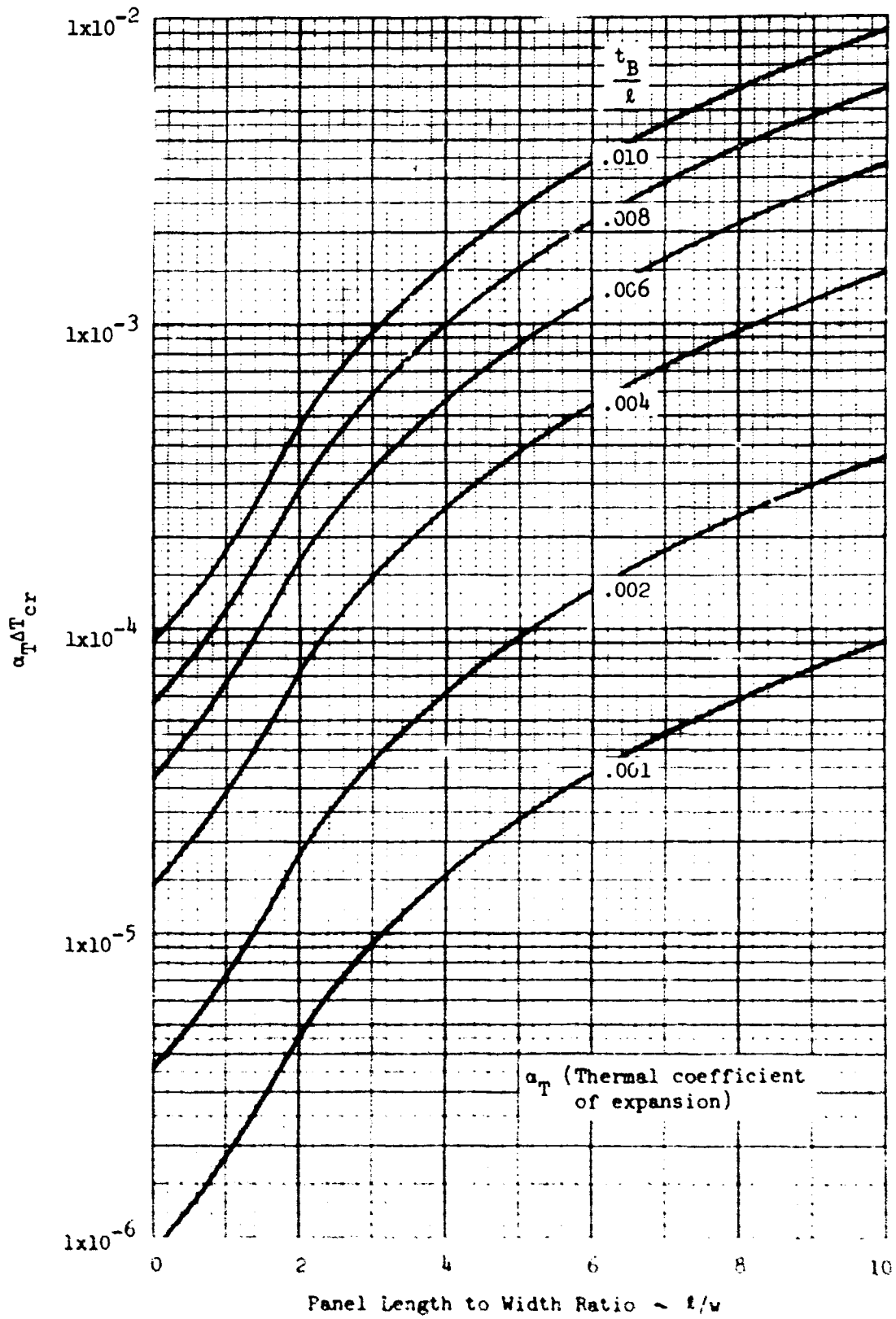

Figure 18 - Critical Differential Temperature of Simply Supported Rectangular Panel with Restrained Edges

Thickness Correction Factor  $\sim \frac{t_{\Delta T}}{t_B}$

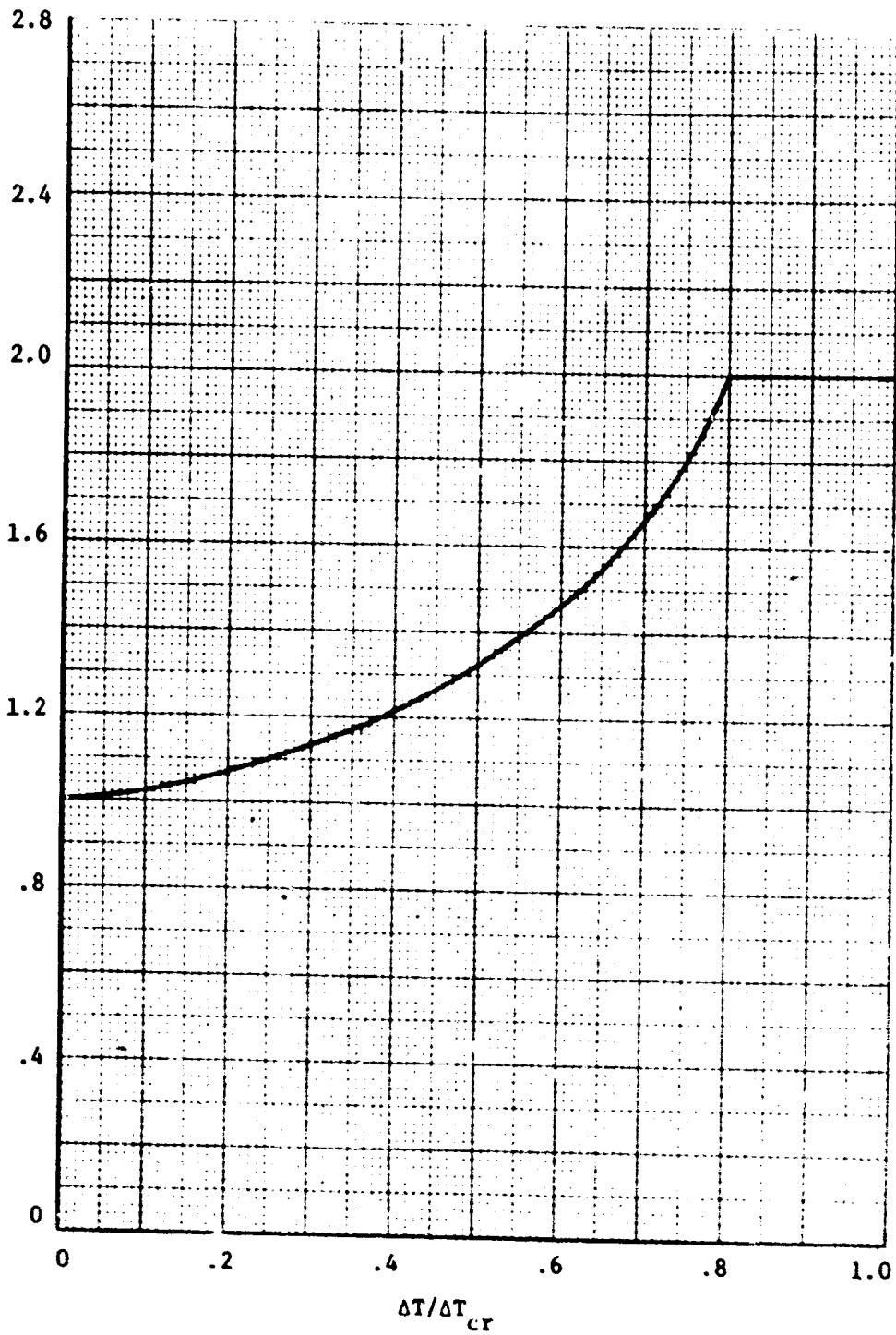

Figure 19 - Thickness Correction Factor for Differential Temperature

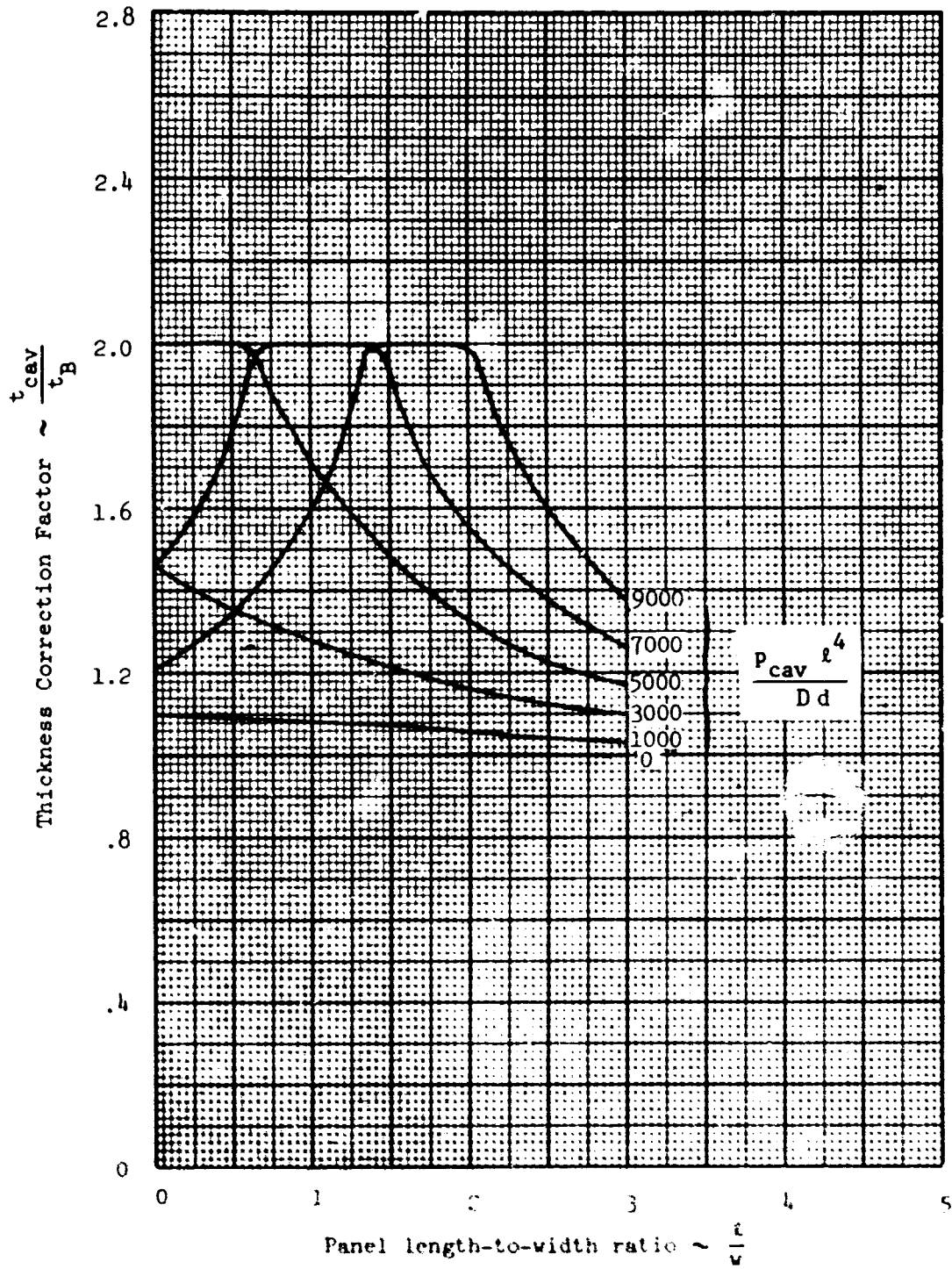

Figure 20 - Thickness Correction For an Enclosed Cavity

(It is suggested that the conversion from free stream to local be obtained by using directly charts of  $(q/\beta)_L / (q/\beta)_\infty$  such as shown in Figure 3(a) of Reference 5.)

The design now proceeds back to Step (2).



## SECTION IV

### RELATED AREAS

The conditions under which the criteria in this report are directly applicable are discussed in Section I. The purpose of this Section is to discuss certain areas in which the criteria are not directly applicable, but may be used indirectly to design flutter-free panels. These closely related areas include (1) built-up isotropic panels (such as honeycomb), and (2) panels whose edge supports do not restrain inplane motion. Before discussing these conditions individually, the designer is reminded that the dominating factor that determines panel flutter behavior is the inter-relationship of the natural frequencies. Therefore, if analyses (or the judgment and experience of the designer) are able to predict how the panel still air frequencies will behave, the trend of the variation in flutter speed can be estimated by one of the assumed mode methods described in Section IV, Part 2 of Volume II.

#### 1. Built-Up Isotropic Panels

The most important example of a built-up, isotropic panel is honeycomb which consists of a low density core (middle layer) sandwiched between two flat face sheets. The core serves to stabilize the relative positions of the face sheets in a structural configuration that is much more rigid in bending than is a single panel with the combined thickness of the two faces. A flexural stiffness that is analogous to the plate stiffness  $D$  for a flat panel is obtained from the Young's modulus  $E$ , the face sheet thickness  $t_f$ , the core thickness  $s$  and by neglecting the bending rigidity of the core.

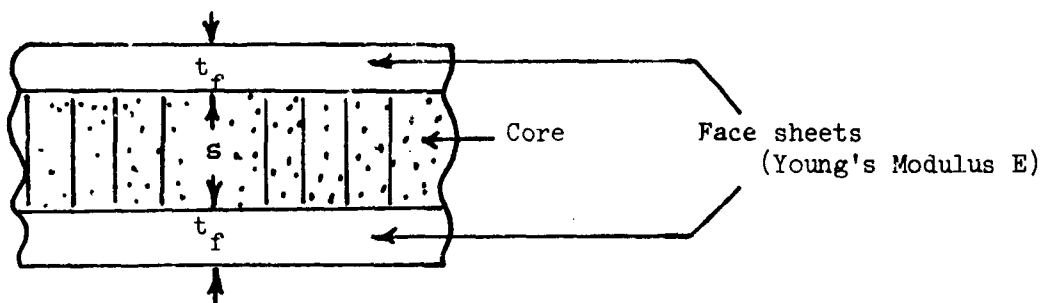

Figure 21 -Honeycomb Configuration  
for Analyzing Stiffness

Figure 21 shows the honeycomb configuration. The equivalent plate bending stiffnesses are

(a) if  $t_f$  and  $s$  are of the same order of magnitude,

$$D_h = \frac{E}{2(1-\nu^2)} \left[ t_f (s + t_f)^2 + \frac{1}{3} t_f^3 \right]$$

and

(b) if  $s \gg t_f$ ,

$$D_h = \frac{E}{2(1-\nu^2)} t_f s^2 .$$

These stiffnesses lead to the following equivalent thicknesses (for a flat plate):

(a)  $t_f$  and  $s$  same order of magnitude,

$$t_{eq}^3 = 6 t_f (s + t_f)^2 + 2t_f^3$$

and

(b)  $s \gg t_f$ ,

$$t_{eq}^3 = 6 t_f s^2$$

Frequencies of the equivalent uniform thickness skin panel would not be the same, but the frequency ratios between modes would be, i.e., we preserve basic stiffness level and frequency ratios. Once the equivalent thickness has been obtained, criteria charts can be used as before.

## 2. Negligible Inplane Edge Restraint

If the edge support structures offer negligible inplane restraint (as, for example, in the case of a heat shield panel that is allowed to expand thermally), the basic criteria are even easier to apply. Under this condition no corrections need be made for any effects resulting from induced inplane stress. Thus no correction is needed for induced inplane stress resulting from flight loading, differential pressure, or differential temperature.

## SECTION V

### SPECIAL CONSIDERATIONS

Previous sections have presented criteria for the design of panels that will be free of flutter even though subjected to environments and conditions that are known to affect flutter boundaries. This section presents further guidance and assistance in accomplishing the final design in certain areas that cannot be as clearly defined. These areas include safety factors, panels recommended for closer study, weight saving, and use of testing as a design tool.

#### 1. Factors of Safety

The criteria presented in Section III include a certain degree of conservatism, as a result of encompassing some scatter in basic test data (see, for example, Figure 4 of Volume II). Consequently, the design thickness obtained from using the criteria is expected to be slightly greater than required for a given set of designing conditions. Inasmuch as the amount of such conservatism cannot be defined, the design thickness obtained from Section III is considered as the "neutral" value to which additional margins against flutter must be added. This subsection discusses panel flutter margins, and presents some guidelines that will be useful in establishing a design philosophy.

Factors of safety are imposed to provide assurance of design integrity in spite of uncertainties in basic theory, as well as the possibility of unexpected and/or underestimated environmental conditions. Panel flutter, being a relatively new discipline, is not as well understood as the classical lifting surface flutter. Furthermore, a greater number of parameters significantly affect panel flutter boundaries and some of these are difficult to assess prior to flight. The aerospace designer is always faced with the problem of trading off weight against mission objectives and crew safety. In the case of panel flutter, the need for a rationale to assist in design decisions is clearly evident.

There are three basic considerations which must logically be accounted for in establishing a flutter margin philosophy, namely, the uncertainties involved, the consequences of a panel flutter, and the consequences of over-design. These are discussed below and are followed by a set of guidelines recommended for incorporating safety factors in panel design.

#### a. Uncertainties Involved

The various factors that may cause uncertainties in determining flutter boundaries are as follows:

- (1) Accuracy of Analytical Predictions - The ability of the basic analytical tools depends upon how well the mechanisms are understood and how well the mathematical idealizations describe the mechanisms.

- (2) Ability to Predict Values of the Parameters that Affect Panel Flutter - The parameters can be separated into two basic groupings with a distinct line of demarcation between them. The first grouping contains those parameters whose values can be predicted with a high confidence level. These include the vehicle Mach-altitude flight envelope and the panel material properties, length, width, thickness, sweep, and curvature. The other grouping, well separated from the first, contains those parameters whose values are more nebulous and more difficult to predict. These include parameters such as induced inplane loads, differential pressure, differential temperature, angle of attack, boundary layer, as well as any remaining parameters discussed in Section III.

b. Consequences of Panel Flutter

The consequences of panel flutter encompass a very wide spectrum and are listed below in the order of increasing severity:

- (1) No Deleterious Effects - Experience indicates that some panels may flutter for prolonged periods of time without adverse effects.
- (2) Undesirable Noise Only - Some panels on flight vehicles may flutter and be bothersome only because of the noise generated by the flutter.
- (3) Fatigue Cracks Develop, Requiring Panel Replacement - Panel flutter amplitude and time duration may combine to cause fatigue damage; this normally requires panel replacement, repair, or modification.
- (4) Panel Fails in Flight - No Significant Influence on Mission or Flight Safety - Failure may occur on a panel serving only a minor functional role; its loss does not result in subsequent damage to other important vehicle components.
- (5) Panel Failure in Flight Jeopardizes Mission and Flight Safety - Failure may occur on panel serving a major functional role. Or, failure of an otherwise insignificant panel may result in subsequent damage to some other important vehicle component.

c. Consequences of Overdesign

Overdesign adds unnecessary weight thus imposing unwarranted performance penalties on the vehicle. Certainly the failure of some panels on a vehicle can have serious consequences, and panel integrity would be the overriding consideration from a flight safety standpoint. However, the temptation to make the same kind of trade-offs and to use the same safety factors for all panels would cause intolerable performance penalties, and should be avoided.

d. Recommended Safety Factors

It is now necessary to incorporate the previous basic considerations into a workable set of design guidelines. Obviously all panels on a vehicle

will not be considered safety-of-flight critical; likewise, all panels will not be considered noncritical. In a similar sense, the condition of a panel during flight can be estimated more reliably in some cases than in others. Therefore, a rationale is required that assigns different safety factors to the different panels and the foregoing considerations suggest that a workable set of guidelines may be set up in a matrix format with the rows representing the degree of uncertainty of the panel condition and the columns representing weight/safety tradeoffs. This format was employed in the preparation of Table II, where recommended panel flutter safety factors are presented.

In using Table II, the designer multiplies the thickness determined from the criteria of Section III by an appropriate factor to obtain a specified design thickness. The table has purposely been made flexible enough to encompass varying depths of preliminary investigation which the designer might wish to employ during various phases of vehicle design. The minimal depth (Baseline Design Criteria only) might be employed in the early advanced design phase where time limitations permit only cursory studies. In the detailed design phase the designer will probe more extensively into the problem and will employ the overall criteria to a much greater extent (Baseline Criteria, plus all applicable corrections and careful assessment of the parameters involved). In addition to these extremes, intermediate depths of investigations are included. The bases for selection of the numerical values assigned for the safety factors are discussed in the following paragraphs.

The factors 3.75 and 2.25 at the upper right of Table II are the maximum recommended safety factors obtained by accounting for uncertainties in all the parameters that affect flutter boundaries beyond baseline design. The "worst case" to be guarded against in practice depends on the length-to-width ratio. When  $l/w < 1$ , a worst case may be caused for example by a combination of buckling and flow angularity; buckling, without sweep requires that the baseline panel thickness be doubled (see Figure 10). The maximum thickness correction factor due to sweep for a panel of very low  $l/w$  (i.e.,  $l/w \rightarrow 0$ ) is 1.65 and occurs for  $\Lambda = 45^\circ$  (see Figure 7). Inasmuch as safety of flight is involved, a velocity margin of 20% is provided by applying an additional factor 1.13 to the thickness. Therefore, the thickness multiplier  $2 \times 1.65 \times 1.13 \cong 3.75$  is used for the case  $l/w < 1$  when no knowledge is assumed for any parameters other than flight conditions and baseline panel properties. The flow angularity correction becomes 1.0 when  $l/w \geq 1.0$  (see Figure 7); thus the corresponding thickness multiplier for  $l/w \geq 1$  is  $2.0 \times 1.13 \cong 2.25$

The factors 1.70 (for  $l/w < 1$ ) and 1.30 (for  $l/w \geq 1$ ) at the upper left were obtained by using approximately 25% of the thickness margins used for the most conservative case discussed in the preceding paragraph. It is felt justified to dismiss the possibility that a worst combination of conditions would prevail and inasmuch as the panel is noncritical, the justification reflects a tradeoff in accepting the remote possibility of minor panel flutter incidences in order to avoid excessive weight penalties.

The factor 1.00 at the lower left represents the opposite extreme from the most conservative factor (3.75). It assumes full use of the criteria and the consequences of panel flutter would be minor.

TABLE II

RECOMMENDED PANEL FLUTTER SAFETY FACTORS

CRITERIA THICKNESS SPECIFIED BY:	TRADE OFF	
	Weight	Safety of Flight
	NON-CRITICAL (Excessive weight penalties override minor consequences of panel flutter.)	CRITICAL (Serious consequences of panel failures override weight penalties.)
1. Baseline Design Criteria only.	1.70 ( $l/w < 1$ ) 1.30 ( $l/w \geq 1$ )	3.75 ( $l/w < 1$ ) 2.25 ( $l/w \geq 1$ )
2. Baseline Design Criteria plus use of sweep correction.	1.30	2.25
3. Baseline Design Criteria plus use of both sweep and curvature corrections.	1.30	2.25
*4. Baseline Design Criteria plus use of all corrections from Section III. Requires careful assessment of all parameters involved.	1.00	**1.25

DECREASING  
↓  
UNCERTAINTIES

\*The corrected thickness  $t_C$  obtained from the complete criteria of Section III cannot exceed twice the baseline value  $t_B$  (see Section III, Part 3)

\*\*The design thickness  $t_D$  for this case need not exceed  $3.75 t_B$  for  $l/w < 1$  or  $2.25 t_B$  for  $l/w \geq 1$ .

NOTE: The safety factors presented herein are not to be construed as specification requirements. The use in design of safety factors other than required by formal specifications should be requested through the procuring agency.

The factor 1.25 at the lower right is based on a velocity margin of 40% instead of the 20% velocity margin used for other Critical cases. This is based on the premise that careful assessment of all parameters involved does not necessarily insure that the assessed values are the same as the actual values encountered in flight and may result in a worse actual environment than the predicted environment. The other Critical cases (20% velocity margin) have already assumed the worst possible environment.

The other factors shown in Table II are natural extensions of the factors established for line 1 and they fall between the extremes at the corners of the matrix.

All of the factors shown in Table II are believed to be consistent with the present state-of-the-art and the various tradeoffs which must be realistically included in panel design.

NOTE: The safety factors presented herein are not to be construed as specification requirements. The use in design of safety factors other than required by formal specifications should be requested through the procuring agency.

## 2. Panels Recommended for Closer Study

Panels that are not designed to carry static or maneuvering loads are often made very thin to preserve weight; as a consequence, such panels are found to be the source of many noise problems and fatigue failures. Therefore, it is recommended that all non-structural panels receive close scrutiny.

Some panels may be designed initially in anticipation of some inflight stabilizing condition (such as pressurization or tension stress). The possibility of a temporary or permanent change in the anticipated condition should be considered in initial design.

Built-up panels are usually sufficiently stiff in bending that they only need cursory investigations. Therefore, the single thickness panel should receive most of the designer's attention.

Although sufficient data were not available to define a criterion for boundary layer in this report, some designers believe that aft fuselage panels are not susceptible to flutter because of the thicker boundary layer. It is hoped that further research will soon clarify the problem of boundary layer.

## 3. Some Minimum Weight Configurations

The following weight savings ideas may be employed to advantage:

- (a) Less thickness is required to preclude flutter if the panel is incorporated into the design with the short side in the stream-wise direction rather than the long side (see Figure 22).

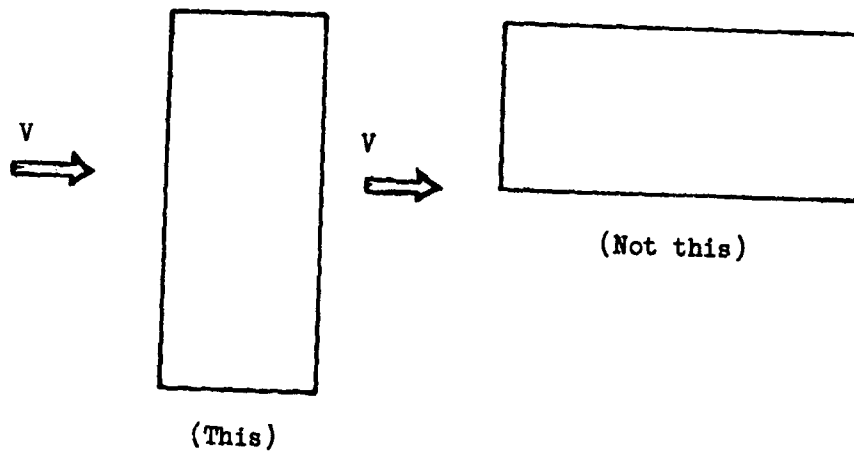

Figure 22. Orientation of a Rectangular Panel for Minimum Weight

- (b) Stiffeners or corrugations running streamwise will result in lighter structure to prevent panel flutter (see Figure 23).

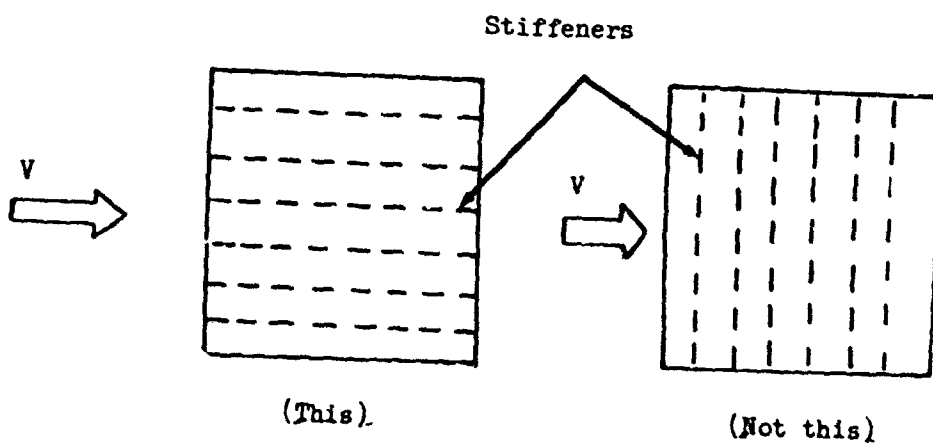

Figure 23. Orientation of Stiffeners to Obtain Higher Flutter Speed



#### 4. The Role of Testing in Panel Design

Testing should be used to verify panel integrity when a design is not covered by existing criteria or as justification for specifying lesser thicknesses than those specified by the criteria.

Panel flutter is caused by an intricate interaction between structural and aerodynamic forces. Furthermore the panel dynamics, and hence flutter speeds, may be influenced by flight conditions and vehicle loads; therefore a careful assessment of the extent to which actual service conditions can be simulated in the laboratory is the first step toward defining a meaningful test program. Air loads, thermal stresses, Mach number, and panel geometry, for example, may all combine to influence the minimum flutter speed.

Vibration tests and wind tunnel tests are of primary interest here and their uses are discussed in the following paragraphs:

##### (a) Vibration Tests

A large portion of the uncertainty in panel flutter analysis can be traced directly to structural causes; that is, the structural analysis is inadequate to accurately predict panel dynamics. Therefore, the structural features that determine panel dynamics can be conveniently checked by a direct measurement of the panel natural frequencies. A panel test fixture that incorporates as many parameters as are deemed necessary can be employed (1) to check the accuracy of the theory used or (2) to obtain natural frequencies (and possibly mode shapes) for use in flutter analysis. The vibration test may provide sufficient confidence that design may proceed without further tests; if not, a wind tunnel test may be required.

##### (b) Wind Tunnel Tests

A wind tunnel test provides the closest simulation of flight conditions that can be attained on the ground and therefore also provides the greatest assurance of design integrity. The cost may be very large, however, and the usefulness of the test is directly related to the degree of flight simulation that is attained. The designer will consider scaling, choice of wind tunnel, type of fixture, measurement of parameters, and related problems. Mach number cannot be scaled so that the flight Mach numbers of concern must be duplicated in the wind tunnel. Aerodynamic heating can be induced artificially as can inplane stresses and differential pressure. In many respects the formulation of a good wind tunnel test program poses problems as formidable as the prototype design itself. However, the results of the test should provide a very high level of confidence in the final design.

SECTION VI  
 SAMPLE DESIGNS AND EVALUATION  
 OF CRITERIA

This concluding section deals with application of the criteria to panel design problems and is divided into two parts. The first part traces the step-by-step design of two hypothetical panels for a particular flight trajectory. The second part applies the criteria to two actual instances of panel flutter and the results are compared with the fixes that were made to correct the flutter conditions.

1. Panel Design Problems

The use of the thickness correction curves presented in Section III will be demonstrated with two hypothetical design problems. The flight path of the vehicle is shown in Figure 5 where a maximum value of  $q/f(M)$  is obtained at sea level for  $M = 1.15$ . In the sample design problems that follow, the panels will be assumed to have zero angle of attack so that corrections for local flow conditions will not be included.

- (a) Find the thickness required to prevent flutter of the aluminum panels, shown in Figure 24, which is representative of a panel on a wing or stabilator yawed to the free stream flow.

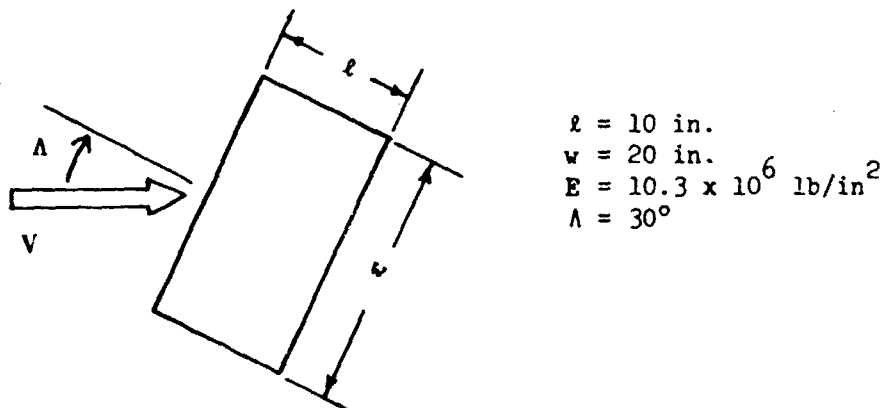

Figure 24. Panel Configuration for Sample Design Number 1

Using Figure 5 with a  $\frac{l}{v}$  of  $1/2$  yields a value of

$$E \left( \frac{B}{l} \right)^3 = 1.92$$

from which the "baseline" thickness is determined as

$$t_B = l \sqrt[3]{\frac{1.92}{E}} = .057 \text{ in.}$$

(It should be noted that E is Young's modulus in lb/in<sup>2</sup> in the above equation)

The required thickness,  $t_R$ , is obtained by multiplying  $t_B$  by the thickness correction factor for yaw,  $t_A/t_B$ . The value of  $t_A/t_B$  determined from Figure 7 is 1.24 which results in a  $t_R$  of

$$t_R = \frac{t_A}{t_B} t_B = (1.24)(.057) = .071 \text{ in.}$$

- (b) Assuming a curved steel panel orientated with the flow as shown in Figure 25

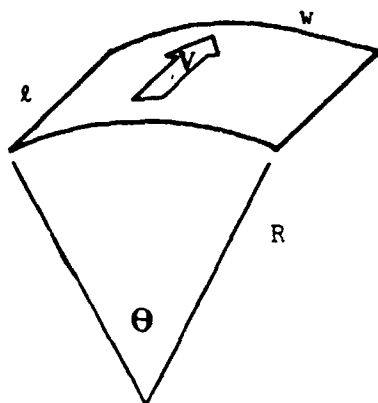

$$\begin{aligned} l &= 10 \text{ in.} \\ w &= 20 \text{ in.} \\ R &= 100 \text{ in.} \\ E &= 30 \times 10^6 \text{ lb/in}^2 \\ A &= 0 \end{aligned}$$

Figure 25. Panel Configuration for Sample Design Number 2

find the panel design thickness for a noncritical installation.

Using the value of  $E \left( \frac{t_B}{l} \right)^3$  of 1.92 obtained from sample problem (a) results in a "baseline" panel thickness of

$$t_B = l \sqrt[3]{\frac{1.92}{E}} = .040 \text{ in}$$

The curvature parameter  $N = \frac{h_o}{t_B}$  is computed from

$$N = \frac{h_o}{t_B} = \frac{R - \sqrt{R^2 - \left(\frac{w}{2}\right)^2}}{t_B} = R \left( 1 - \cos \frac{\theta}{2} \right)$$

which gives a value of  $N = 12.5$  for this case.

Using Figure 6, the thickness correction factor for curvature

$\left( \frac{t_N}{t_R} = .95 \right)$  is obtained. By using the noncritical safety fac-

tor 1.30 obtained from item 3 of Table II, the design thickness of the panel is determined from

$$t_D = (.95)(1.30)(.040) = .0495$$

In the above design problems it should be noted that additional thickness correction factors would have to be included to account for the effect of in-plane stress, differential pressure, cavity, edge conditions, or local flow conditions.

## 2. Evaluation of Design Criteria

Two cases of panel flutter that have occurred on different supersonic aircraft are studied here; the available data for these cases is used in the design criteria of Section III to arrive at recommended thicknesses which are then compared with actual "fixes" that were made to alleviate the flutter problems.

### (a) First Case, Flat Panel

Location - Side fuselage, vicinity of cockpit

Symptoms - Noise and fatigue cracks

Panel Length - 6.50 in.

Length-to-width ratio - approx. .32

Young's Modulus -  $10 \times 10^6$  psi

Skin thickness - .032 in.

Most severe flutter conditions -  $M=1.25$

$h=8k$  ft.

$[q/f(M)]_{cr} [q/f(M)]_{cr}$  - approx. 3,400 p.s.f. (from Figure 5)

$$E \left( \frac{t_B}{l} \right)^3 = 1.6 \text{ psi (from Figure 5)}$$

$$t_B = \left( \frac{1.6}{10^7} \right)^{1/3} l = .0054l$$

$$t_B = .035 \text{ inch}$$

In this case there is neither sweep ( $\Lambda=0$ ) nor curvature ( $N=0$ ), and the panel is judged to be noncritical. Therefore the safety factor 1.30 from line 3 of Table II is judged to be applicable and yields a design thickness

$$t_D = 1.30 (.035)$$

$$= .045 \text{ inch}$$

(The flutter problem with this case was apparently solved by increasing the panel thickness from .032 to .050 inch.)

### (b) Second Case, Curved Panel

Location - upper fuselage, vicinity of cockpit

Symptom - Noise

Panel Length - 11.25 inch

$l/w$  - 0.55

Young's Modulus -  $10 \times 10^6$  p.s.i.

Skin thickness - 0.03 inch  
Flight condition at flutter -  $M=1.2$   
 $h=20k$  ft.

$$[q/f(M)]_{cr} = 2000 \text{ p.s.f.}$$

$$E \left( \frac{t_B}{\ell} \right)^3 = 0.9$$

$$t_B = \left( \frac{0.9}{10^7} \right)^{1/3} \ell = .0045\ell = .05 \text{ in.}$$

$$\text{Curvature} - N = \frac{h\alpha}{t_B} = 10.4$$

$$t_N/t_B = 0.98 \text{ (Figure 6)}$$

Safety factor - 1.30 (noncritical panel)

$$t_D = 0.98 (1.30) 0.05 = .064 \text{ in.}$$

(The "fix" in this case was made by adding a .03 inch doubler panel thus raising the total thickness to 0.06 inch.)

The two cases cited above are based on very limited amounts of data and serve only to indicate how the criteria predictions compare with actual flutter experiences. The results show that the criteria give thicknesses that are in reasonable agreement with the actual thickness modifications that were made to alleviate the flutter problems. If the criteria had been available and applied in the manner indicated, the panels would presumably have been flutter-free.

#### REFERENCES

1. Hess, R. W., "Preliminary Results of an Experimental Study of the Effects of Compressive Stress on Panel Flutter," NASA, Langley Working Paper LWP-177, January 1966.
2. Condensed Table of Atmospheric Properties for the 1959 ARDC Model Atmosphere (Ref. AFCRC-TR-59-267 AFSIG No. 115).
3. Kordes, E. E., Tuovila, W. J. and Guy, L. D., "Flutter Research on Skin Panels," NASA Technical Note D-451, September 1960.
4. Dugundji, J., "Theoretical Considerations of Panel Flutter at High Supersonic Mach Numbers," MIT (ASRL) TR 134-1, August 1965.
5. Olsen, James J., "Local Aerodynamic Parameters for Supersonic and Hypersonic Flutter Analyses," AFFDL -TR-65-183, October 1965.
6. Durvasula, Somayajulu, "Flutter of Simply Supported Parallelogrammic Flat Panels in Supersonic Flow," AIAA Paper No. 66-474.

UNCLASSIFIED

Security Classification

DOCUMENT CONTROL DATA - R & D		
<i>(Security classification of title, body of abstract and indexing annotation must be entered when the overall report is classified)</i>		
1. ORIGINATING ACTIVITY (Corporate author)		2a. REPORT SECURITY CLASSIFICATION
McDonnell Douglas Corporation Box 516, St. Louis, Missouri 63166		UNCLASSIFIED
		2b. GROUP
3. REPORT TITLE		
Design Criteria for the Prediction and Prevention of Panel Flutter; Vol I, Criteria Presentation		
4. DESCRIPTIVE NOTES (Type of report and inclusive dates)		
Final Report		
5. AUTHOR(S) (First name, middle initial, last name)		
Clark E. Lemley		
6. REPORT DATE	7a. TOTAL NO. OF PAGES	7b. NO. OF REFS
August 1968	50	6
8a. CONTRACT OR GRANT NO.	8b. ORIGINATOR'S REPORT NUMBER(S)	
Contract AF33(615)-5295	AFFDL-TR-67-140, Vol I	
b. PROJECT NO. 1370	9b. OTHER REPORT NO(S) (Any other numbers that may be assigned this report)	
c. Task 137003		
d.		
10. DISTRIBUTION STATEMENT This document is subject to special export controls and each transmittal to foreign governments or foreign nationals may be made only with prior approval of the Air Force Flight Dynamics Laboratory (FDDS), Wright-Patterson AFB, Ohio 45433.		
11. SUPPLEMENTARY NOTES		12. SPONSORING MILITARY ACTIVITY
		Air Force Flight Dynamics Laboratory (FDDS) Wright-Patterson AFB, Ohio 45433
13. ABSTRACT The program described in this report was performed to bring together all available data from wind tunnel test, flight test, vibration test, thermal test and theoretical investigations to form comprehensive panel flutter design criteria. Procedures were developed which are applicable to the environment and various panel structural arrangements for transonic, supersonic, and hypersonic aircraft; aerospace re-entry vehicles, and boosters.		
<p>This report (Volume I) presents a set of criteria for the design of flutter-free panels. The design procedure provides for initially establishing the required thickness at neutral stability of a flat, unstressed, unswept panel. Thickness corrections are then made to account for various parameters that are known to affect panel flutter boundaries.</p> <p>Volume II presents the results of background investigations and supplemental analyses that provide the bases for establishing the criteria of Volume I. An extensive bibliography is also presented in Volume II.</p>		

DD FORM 1473  
1 NOV 66

UNCLASSIFIED

Security Classification

UNCLASSIFIED

Security Classification

14. KEY WORDS	LINK A		LINK B		LINK C	
	ROLE	WT	ROLE	WT	ROLE	WT
Panel flutter Design criteria Transonic Supersonic Hypersonic Aircraft Reentry vehicles Boosters						

UNCLASSIFIED

Security Classification