

UNCLASSIFIED

AD NUMBER

AD829984

LIMITATION CHANGES

TO:

Approved for public release; distribution is unlimited.

FROM:

Distribution authorized to DoD only;  
Administrative/Operational Use; APR 1968. Other  
requests shall be referred to NASA Marshall  
Space Flight Center, AL.

AUTHORITY

USAEDC ltr, 12 Jul 1974

THIS PAGE IS UNCLASSIFIED

*cy*

**ALTITUDE DEVELOPMENTAL TESTING OF THE  
J-2 ROCKET ENGINE IN PROPULSION ENGINE  
TEST CELL (J-4) (TEST J4-1801-16)**



This document is approved for public release  
its distribution is unlimited.

*Per AF Little dt'd  
12 July 74 signed  
W. H. O. C. H. E.*

**C. H. Kunz**

**ARO, Inc.**

**April 1968**

PROPERTY OF U. S. AIR FORCE  
AEDC LIBRARY  
AF 40(600)1200

Each transmittal of this document outside the Department of Defense must have prior approval of NASA, Marshall Space Flight Center (I-E-J), Huntsville, Alabama.

This document is subject to special export controls and each transmittal to foreign governments or foreign nationals may be made only with prior approval of NASA, Marshall Space Flight Center (I-E-J), Huntsville, Alabama.

**LARGE ROCKET FACILITY  
ARNOLD ENGINEERING DEVELOPMENT CENTER  
AIR FORCE SYSTEMS COMMAND  
ARNOLD AIR FORCE STATION, TENNESSEE**

PROPERTY OF U. S. AIR FORCE  
AEDC LIBRARY  
AF 40(600)1200

AEDC TECHNICAL LIBRARY



7999 1E000 0220 5  
5 0720 00031 6861

# ***NOTICES***

When U. S. Government drawings specifications, or other data are used for any purpose other than a definitely related Government procurement operation, the Government thereby incurs no responsibility nor any obligation whatsoever, and the fact that the Government may have formulated, furnished, or in any way supplied the said drawings, specifications, or other data, is not to be regarded by implication or otherwise, or in any manner licensing the holder or any other person or corporation, or conveying any rights or permission to manufacture, use, or sell any patented invention that may in any way be related thereto.

Qualified users may obtain copies of this report from the Defense Documentation Center.

References to named commercial products in this report are not to be considered in any sense as an endorsement of the product by the United States Air Force or the Government.

ALTITUDE DEVELOPMENTAL TESTING OF THE  
J-2 ROCKET ENGINE IN PROPULSION ENGINE  
TEST CELL (J-4) (TEST J4-1801-16)

This document is not to be released for public release  
if distribution is unlimited.

*Per AF Letter dt 2  
12 July 74 Signed  
William O. Cole.*

C. H. Kunz  
ARO, Inc.

Each transmittal of this document outside the Department of Defense must have prior approval of NASA, Marshall Space Flight Center (I-E-J), Huntsville, Alabama.

This document is subject to special export controls and each transmittal to foreign governments or foreign nationals may be made only with prior approval of NASA, Marshall Space Flight Center (I-E-J), Huntsville, Alabama.

**FOREWORD**

The work reported herein was sponsored by the National Aeronautics and Space Administration (NASA), Marshall Space Flight Center (MSFC) (I-E-J), under System 921E, Project 9194.

The results of the tests presented were obtained by ARO, Inc. (a subsidiary of Sverdrup & Parcel and Associates, Inc.), contract operator of the Arnold Engineering Development Center (AEDC), Air Force Systems Command (AFSC), Arnold Air Force Station, Tennessee, under Contract AF40(600)-1200. Program direction was provided by NASA/MSFC; engineering liaison was provided by North American Aviation, Inc., Rocketdyne Division, manufacturer of the J-2 rocket engine, and Douglas Aircraft Company, manufacturer of the S-IVB stage. The testing reported herein was conducted on November 14, 1967, in Propulsion Engine Test Cell (J-4) of the Large Rocket Facility (LRF) under ARO Project No. KA1801. The manuscript was submitted for publication on January 26, 1968.

Information in this report is embargoed under the Department of State International Traffic in Arms Regulations. This report may be released to foreign governments by departments or agencies of the U. S. Government subject to approval of NASA, Marshall Space Flight Center (I-E-J), or higher authority. Private individuals or firms require a Department of State export license.

This technical report has been reviewed and is approved.

Harold Nelson, Jr.  
Captain, USAF  
AF Representative, LRF  
Directorate of Test

Roy R. Croy, Jr.  
Colonel, USAF  
Director of Test

## ABSTRACT

Five firings of the Rocketdyne J-2 rocket engine (S/N J-2047) were conducted in Test Cell J-4 of the Large Rocket Facility. These firings were accomplished during test period J4-1801-16 at pressure altitudes of approximately 100,000 ft at engine start to investigate S-II/S-V (1) fuel pump operation during the start transient at lower than minimum model specification inlet pressure, (2) thrust chamber pressure buildup rate with low starting energy, and (3) gas generator and augmented spark igniter temperature transients with warmest and coldest expected thrust chamber temperatures as predicted from the AS-501 countdown demonstration. Engine operation was satisfactory for all firings. The accumulated firing duration was 46.2 sec.

This document is subject to special export controls and each transmittal to foreign governments or foreign nationals may be made only with prior approval of NASA, Marshall Space Flight Center (I-E-J), Huntsville, Alabama.

This document is classified "Confidential" and is not to be released without the approval of the appropriate authority.

Public release

*Per A.F. Letter  
dated 12 July 74 signed  
William O. Cole.*

## CONTENTS

	<u>Page</u>
ABSTRACT . . . . .	iii
NOMENCLATURE . . . . .	vii
I. INTRODUCTION . . . . .	1
II. APPARATUS . . . . .	1
III. PROCEDURE . . . . .	7
IV. RESULTS AND DISCUSSION . . . . .	8
V. SUMMARY OF RESULTS . . . . .	13
REFERENCES . . . . .	14

## APPENDIXES

## I. ILLUSTRATIONS

Figure

1. Test Cell J-4 Complex . . . . .	17
2. Test Cell J-4, Artist's Conception . . . . .	18
3. Engine Details . . . . .	19
4. S-IVB Battleship Stage/J-2 Engine Schematic . . . . .	20
5. Engine Schematic . . . . .	21
6. Engine Start Logic Schematic . . . . .	22
7. Engine Start and Shutdown Sequence . . . . .	23
8. Engine Start Conditions for Pump Inlets, Start Tank, and Helium Tank . . . . .	25
9. Engine Ambient and Combustion Chamber Pressure, Firing 16A . . . . .	27
10. Thermal Conditioning History of Engine Components, Firing 16A . . . . .	28
11. Engine Transient Operation, Firing 16A . . . . .	30
12. Fuel Pump Start Transient Performance, Firing 16A . . . . .	34
13. Fuel Pump NPSH during Start Transient, Firing 16A . . . . .	35
14. Engine Ambient and Combustion Chamber Pressure, Firing 16B . . . . .	36

<u>Figure</u>	<u>Page</u>
15. Thermal Conditioning History of Engine Components, Firing 16B . . . . .	37
16. Engine Transient Operation, Firing 16B . . . . .	39
17. Fuel Pump Start Transient Performance, Firing 16B . . . . .	43
18. Fuel Pump NPSH during Start Transient, Firing 16B . . . . .	44
19. Engine Ambient and Combustion Chamber Pressure, Firing 16C . . . . .	45
20. Thermal Conditioning of Engine Components, Firing 16C . . . . .	46
21. Engine Transient Operation, Firing 16C . . . . .	48
22. Thrust Chamber Temperature Effect on Engine Start Transient (Firings 16B and 16C) . . . . .	52
23. Fuel Pump Start Transient Performance, Firing 16C . . . . .	54
24. Fuel Pump NPSH during Start Transient, Firing 16C . . . . .	55
25. Engine Ambient and Combustion Chamber Pressures, Firing 16D . . . . .	56
26. Thermal Conditioning History of Engine Components, Firing 16D . . . . .	57
27. Engine Transient Operation, Firing 16D . . . . .	59
28. Fuel Pump Start Transient Performance, Firing 16D . . . . .	63
29. Fuel Pump NPSH during Start Transient, Firing 16D . . . . .	64
30. Engine Ambient and Combustion Chamber Pressures, Firing 16E . . . . .	65
31. Thermal Conditioning History of Engine Components, Firing 16E . . . . .	66
32. Engine Transient Operation, Firing 16E . . . . .	68
33. Fuel Pump Start Transient Performance, Firing 16E . . . . .	70
34. Fuel Pump and Oxidizer Pump NPSH during Firing 16E . . . . .	71



II. TABLES	<u>Page</u>
I. Major Engine Components . . . . .	72
II. Summary of Engine Orifices . . . . .	73
III. Engine Component Replacements (between Tests J4-1801-15 and J4-1801-16) . . . . .	73
IV. Engine Purge and Component Conditioning Sequence . . . . .	74
V. Summary of Test Requirements and Results . . . . .	75
VI. Engine Valve Timings . . . . .	76
VII. Engine Performance Summary . . . . .	77
III. INSTRUMENTATION . . . . .	78
IV. METHODS OF CALCULATIONS (PERFORMANCE PROGRAM) . . . . .	91

#### NOMENCLATURE

A	Area, in. <sup>2</sup>
ASI	Augmented spark igniter
ES	Engine start, designated as the time that helium control and ignition phase solenoids are energized
GG	Gas generator
MOV	Main oxidizer valve
NPSH	Net positive suction head, ft
STDV	Start tank discharge valve
$t_0$	Defined as the time at which the opening signal is applied to the start tank discharge valve solenoid
VSC	Vibration safety counts, defined as engine vibration in excess of 150 g rms in a 960- to 6000-Hz frequency range

**SUBSCRIPTS**

<b>f</b>	<b>Force</b>
<b>m</b>	<b>Mass</b>
<b>t</b>	<b>Throat</b>

## SECTION I INTRODUCTION

Testing of the Rocketdyne J-2 rocket engine using an S-IVB battleship stage has been in progress since July 1966 at AEDC in support of the J-2 engine application on the Saturn IB and Saturn V launch vehicles for the NASA Apollo Program. The five firings reported herein were conducted during test period J4-1801-16 on November 14, 1967, in Propulsion Engine Test Cell (J-4) (Figs. 1 and 2, Appendix I) of the Large Rocket Facility (LRF) to accomplish objectives which include investigation of S-II/S-V (1) fuel pump operation during the start transient at lower than minimum model specification inlet pressure, (2) thrust chamber pressure buildup rate with low starting energy, and (3) gas generator and augmented spark igniter temperature transients with warmest and coldest expected thrust chamber temperatures as predicted from the AS-501 countdown demonstration. These firings were accomplished at pressure altitudes of approximately 100,000 ft (geometric pressure altitude, Z, Ref. 1) at engine start and with S-II interstage/engine temperature conditioning targets.

Data collected to accomplish the test objectives are presented herein. Copies of all data obtained during this test period have been previously supplied to the sponsor, and copies are on file at AEDC. The results of the previous test period are presented in Ref. 2.

## SECTION II APPARATUS

### 2.1 TEST ARTICLE

The test article was a J-2 rocket engine (S/N J-2047) (Fig. 3) designed and developed by Rocketdyne Division of North American Aviation, Inc. The engine uses liquid oxygen and liquid hydrogen as propellants and has a thrust rating of 225,000 lb<sub>f</sub> at an oxidizer-to-fuel mixture ratio of 5.5. An S-IVB battleship stage was used to supply propellants to the engine, although the firings of this test period were in support of the J-2 engine application on the S-II stage, which has different fuel and oxidizer supply fluid dynamic characteristics. A schematic of the battleship stage is presented in Fig. 4.

Listings of major engine components and engine orifices for this test period are presented in Tables I and II, respectively (Appendix II). No engine modifications were performed since the previous test period.

Component replacements performed since the previous test period are presented in Table III. The thrust chamber heater blankets were in place during this test period, although they were not utilized.

### 2.1.1 J-2 Rocket Engine

The J-2 rocket engine (Figs. 3 and 5, Ref. 3) features the following major components:

1. Thrust Chamber - The tubular-walled, bell-shaped thrust chamber consists of an 18.6-in. -diam combustion chamber (8.0 in. long from the injector mounting to the throat inlet) with a characteristic length ( $L^*$ ) of 24.6 in., a 170.4-in.<sup>2</sup> throat area, and a divergent nozzle with an expansion ratio of 27.1. Thrust chamber length (from the injector flange to the nozzle exit) is 107 in. Cooling is accomplished by the circulation of engine fuel flow downward from the fuel manifold through 180 tubes and then upward through 360 tubes to the injector.
2. Thrust Chamber Injector - The injector is a concentric-orificed (concentric fuel orifices around the oxidizer post orifices), porous-faced injector. Fuel and oxidizer injector orifice areas are 25.0 and 16.0 in.<sup>2</sup>, respectively. The porous material, forming the injector face, allows approximately 3.5 percent of total fuel flow to transpiration cool the face of the injector.
3. Augmented Spark Igniter - The augmented spark igniter unit is mounted on the thrust chamber injector and supplies the initial energy source to ignite propellants in the main combustion chamber. The augmented spark igniter chamber is an integral part of the thrust chamber injector. Fuel and oxidizer are ignited in the combustion area by two spark plugs.
4. Fuel Turbopump - The turbopump is composed of a two-stage turbine-stator assembly, an inducer, and a seven-stage axial-flow pump. The pump is self lubricated and nominally produces, at rated conditions, a head rise of 35,517 ft (1225 psia) of liquid hydrogen at a flow rate of 8414 gpm for a rotor speed of 26,702 rpm.
5. Oxidizer Turbopump - The turbopump is composed of a two-stage turbine-stator assembly and a single-stage centrifugal pump. The pump is self lubricated and nominally produces, at rated conditions, a head rise of 2117 ft (1081 psia) of liquid oxygen at a flow rate of 2907 gpm for a rotor speed of 8572 rpm.
6. Gas Generator - The gas generator consists of a combustion chamber containing two spark plugs, a pneumatically operated

control valve containing oxidizer and fuel poppets, and an injector assembly. The oxidizer and fuel poppets provide a fuel lead to the gas generator combustion chamber. The high energy gases produced by the gas generator are directed to the fuel turbine and then to the oxidizer turbine (through the turbine crossover duct) before being exhausted into the thrust chamber at an area ratio ( $A/A_t$ ) of approximately 11.

7. Propellant Utilization Valve - The motor-driven propellant utilization valve is mounted on the oxidizer turbopump and bypasses liquid oxygen from the discharge to the inlet side of the pump to vary engine mixture ratio.
8. Propellant Bleed Valves - The pneumatically operated fuel and oxidizer bleed valves provide pressure relief for the boiloff of propellants trapped between the battleship stage prevalves and main propellant valves at engine shutdown.
9. Integral Hydrogen Start Tank and Helium Tank - The integral tanks consist of a 7258-in.<sup>3</sup> sphere for hydrogen with a 1000-in.<sup>3</sup> sphere for helium located within it. Pressurized gaseous hydrogen in the start tank provides the initial energy source for spinning the propellant turbopumps during engine start. The helium tank provides a helium pressure supply to the engine pneumatic control system.
10. Oxidizer Turbine Bypass Valve - The pneumatically actuated oxidizer turbine bypass valve provides control of the fuel turbine exhaust gases directed to the oxidizer turbine in order to control the oxidizer-to-fuel turbine spinup relationship. The fuel turbine exhaust gases which bypass the oxidizer turbine are discharged into the thrust chamber.
11. Main Oxidizer Valve - The main oxidizer valve is a pneumatically actuated, two-stage, butterfly-type valve located in the oxidizer high pressure duct between the turbopump and the main injector. The first-stage actuator positions the main oxidizer valve at the 14-deg position to obtain initial thrust chamber ignition; the second-stage actuator ramps the main oxidizer valve full open to accelerate the engine to main-stage operation.
12. Main Fuel Valve - The main fuel valve is a pneumatically actuated butterfly-type valve located in the fuel high pressure duct between the turbopump and the fuel manifold.
13. Pneumatic Control Package - The pneumatic control package controls all pneumatically operated engine valves and purges.

14. **Electrical Control Assembly** - The electrical control assembly provides the electrical logic required for proper sequencing of engine components during operation.
15. **Primary and Auxiliary Flight Instrumentation Packages** - The instrumentation packages contain sensors required to monitor critical engine parameters. The packages provide environmental control for the sensors.

### 2.1.2 S-IVB Battleship Stage

The S-IVB battleship stage is approximately 22 ft in diameter and 49 ft long and has a maximum propellant capacity of 46,000 lb of liquid hydrogen and 199,000 lb of liquid oxygen. The propellant tanks, fuel above oxidizer, are separated by a common bulkhead. Propellant pre-valves, in the low pressure ducts (external to the tanks) interfacing the stage and the engine, retain propellant in the stage until being admitted into the engine to the main propellant valves and serve as emergency engine shutoff valves. Propellant recirculation pumps in both fuel and oxidizer tanks are utilized to circulate propellants through the low pressure ducts and turbopumps before engine start to stabilize hardware temperatures near normal operating levels and to prevent propellant temperature stratification. Vent and relief valve systems are provided for both propellant tanks.

Pressurization of the fuel and oxidizer tanks was accomplished by facility systems using hydrogen and helium, respectively, as the pressurizing gases. The engine-supplied gaseous hydrogen and gaseous oxygen for fuel and oxidizer tank pressurization during S-II flight were routed to the respective facility venting systems.

## 2.2 TEST CELL

Test Cell J-4, Fig. 2, is a vertically oriented test unit designed for static testing of liquid-propellant rocket engines and propulsion systems at pressure altitudes of 100,000 ft. The basic cell construction provides a 1.5-million-lbf-thrust capacity. The cell consists of four major components (1) test capsule, 48 ft in diameter and 82 ft in height, situated at grade level and containing the test article; (2) spray chamber, 100 ft in diameter and 250 ft in depth, located directly beneath the test capsule to provide exhaust gas cooling and dehumidification; (3) coolant water, steam, nitrogen (gaseous and liquid), hydrogen (gaseous and liquid), and liquid oxygen and gaseous helium storage and delivery systems for operation of the cell and test article; and (4) control building,

containing test article controls, test cell controls, and data acquisition equipment. Exhaust machinery is connected with the spray chamber and maintains a minimum test cell pressure before and after the engine firing and exhausts the products of combustion from the engine firing. Before a firing, the facility steam ejector, in series with the exhaust machinery, provides a pressure altitude of 100,000 ft in the test capsule. A detailed description of the test cell is presented in Ref. 4.

The battleship stage and the J-2 engine were oriented vertically downward on the centerline of the diffuser-steam ejector assembly. This assembly consisted of a diffuser duct (20 ft in diameter by 150 ft in length), a centerbody steam ejector within the diffuser duct, a diffuser insert (13.5 ft in diameter by 30 ft in length) at the inlet to the diffuser duct, and a gaseous nitrogen annular ejector above the diffuser insert. The diffuser insert was provided for dynamic pressure recovery of the engine exhaust gases and to maintain engine ambient pressure altitude (attained by the steam ejector) during the engine firing. The annular ejector was provided to suppress steam recirculation into the test capsule during steam ejector shutdown. The test cell was also equipped with (1) a gaseous nitrogen purge system for continuously inerting the normal air in-leakage of the cell; (2) a gaseous nitrogen repressurization system for raising test cell pressure, after engine cutoff, to a level equal to spray chamber pressure and for rapid emergency inerting of the capsule; and (3) a spray chamber liquid nitrogen supply and distribution manifold for initially inerting the spray chamber and exhaust ducting and for increasing the molecular weight of the hydrogen-rich exhaust products.

An engine component conditioning system was provided for temperature conditioning engine components. The conditioning system utilized a liquid hydrogen-helium heat exchanger to provide cold helium gas for component conditioning. Engine components requiring temperature conditioning were the thrust chamber, crossover duct, start tank discharge valve, and main oxidizer valve second-stage actuator. Helium was routed internally through the crossover duct and tubular-walled thrust chamber and externally over the start tank discharge valve. The main oxidizer valve second-stage actuator was chilled by opening the prevalues and permitting oxidizer into the engine.

### 2.3 INSTRUMENTATION

Instrumentation systems were provided to measure engine, stage, and facility parameters. The engine instrumentation was comprised of (1) flight instrumentation for the measurement of critical engine param-

eters and (2) facility instrumentation which was provided to verify the flight instrumentation and to measure additional engine parameters. The flight instrumentation was provided and calibrated by the engine manufacturer; facility instrumentation was initially calibrated and periodically recalibrated at AEDC. Appendix III contains a list of all measured test parameters and the locations of selected sensing points.

Pressure measurements were made using strain-gage-type pressure transducers. Temperature measurements were made using resistance temperature transducers and thermocouples. Oxidizer and fuel turbopump shaft speeds were sensed by magnetic pickup. Fuel and oxidizer flow rates to the engine were measured by turbine-type flowmeters which are an integral part of the engine. The propellant recirculation flow rates were also monitored with turbine-type flowmeters. Engine side loads were measured with dual-bridge, strain-gage-type load cells which were laboratory calibrated before installation. Vibrations were measured by accelerometers mounted on the oxidizer injector dome and on the turbopumps. Primary engine and stage valves were instrumented with linear potentiometers and limit switches.

The data acquisition systems were calibrated by (1) precision electrical shunt resistance substitution for the pressure transducers, load cells, and resistance temperature transducer units; (2) voltage substitution for the thermocouples; (3) frequency substitution for shaft speeds and flowmeters; and (4) frequency-voltage substitution for accelerometers.

The types of data acquisition and recording systems used during this test period were (1) a multiple-input digital data acquisition system (MicroSADIC®) scanning each parameter at 40 samples per second and recording on magnetic tape; (2) single-input, continuous-recording FM systems recording on magnetic tape; (3) photographically recording galvanometer oscillographs; (4) direct-inking, null-balance potentiometer-type X-Y plotters and strip charts; and (5) optical data recorders. Applicable systems were calibrated before each test (atmospheric and altitude calibrations). Television cameras, in conjunction with video tape recorders, were used to provide visual coverage during an engine firing, as well as for replay capability for immediate examination of unexpected events.

## 2.4 CONTROLS

Control of the J-2 engine, battleship stage, and test cell systems during the terminal countdown was provided from the test cell control room. A facility control logic network was provided to interconnect the



engine control system, major stage systems, the engine safety cutoff system, the observer cutoff circuits, and the countdown sequencer. A schematic of the engine start control logic is presented in Fig. 6. The sequence of engine events for a normal start and shutdown is presented in Figs. 7a and b. Two control logics for sequencing the stage pre-valves and recirculation systems with engine start for simulating engine flight start sequences are presented in Figs. 7c and d.

### SECTION III PROCEDURE

Pre-operational procedures were begun several hours before the test period. All consumable storage systems were replenished, and engine inspections, leak checks, and drying procedures were conducted. Propellant tank pressurants and engine pneumatic and purge gas samples were taken to ensure that specification requirements were met. Chemical analysis of propellants was provided by the propellant suppliers. Facility sequence, engine sequence, and engine abort checks were conducted within a 24-hr time period before an engine firing to verify the proper sequence of events. Facility and engine sequence checks consisted of verifying the timing of valves and events to be within specified limits; the abort checks consisted of electrically simulating engine malfunctions to verify the occurrence of an automatic engine cutoff signal. A final engine sequence check was conducted immediately preceding the test period.

Oxidizer dome, gas generator oxidizer injector, and thrust chamber jacket purges were initiated before evacuating the test cell. After completion of instrumentation calibrations at atmospheric conditions, the test cell was evacuated to approximately 0.5 psia with the exhaust machinery, and instrumentation calibrations at altitude conditions were conducted. Immediately before loading propellants on board the vehicle, the cell and exhaust-ducting atmosphere was inerted. At this same time, the cell nitrogen purge was initiated for the duration of the test period, except for the engine firing. The vehicle propellant tanks were then loaded, and the remainder of the terminal countdown was conducted. Temperature conditioning of the various engine components was accomplished as required, using the facility-supplied engine component conditioning system. Engine components which required temperature conditioning were the thrust chamber, the crossover duct, start tank discharge valve, and main oxidizer valve second-stage actuator. Table IV presents the engine purges and thermal conditioning operations during the terminal countdown and immediately following the engine firing.

## SECTION IV RESULTS AND DISCUSSION

### 4.1 TEST SUMMARY

Five firings of the J-2 rocket engine (S/N J-2047) were conducted during test period J4-1801-16 on November 14, 1967, for a total firing duration of 46.2 sec. The total accumulated firing duration for this engine at AEDC to date is 202.7 sec; this is the result of 14 engine starts. Testing was accomplished at pressure altitudes of approximately 100,000 ft with thermal conditioning of selected engine components to S-II interstage/engine temperature targets predicted from the AS-501 countdown demonstration. Each engine firing was preceded by a 1-sec fuel lead.

Test requirements and specific test results are summarized in Table V. Start and shutdown transient times for selected engine valves are presented in Table VI. Figure 8 shows engine start conditions for pump inlets, start tank, and helium tank. Specific test objectives and a brief summary of results obtained for each firing are presented as follows:

<u>Firing</u>	<u>Test Objectives</u>	<u>Results</u>
16A	Conduct a 30-sec firing to evaluate (1) thrust chamber pressure buildup rate and fuel pump high level stall margin with low start energy and (2) fuel pump start transient operation at lower than minimum model specification inlet pressure.	Combustion chamber pressure attained 550 psia at $t_0 + 2.081$ sec. A conservative fuel pump stall margin was maintained/during the start transient. Fuel pump operation with reduced inlet pressure was satisfactory.
16B	Conduct a 5-sec firing to evaluate (1) fuel pump low level stall margin, (2) gas generator and augmented spark igniter temperature transients with high starting energy, minimum fuel pump inlet pressure, and warmest expected thrust chamber as predicted from the AS-501 countdown demonstration, and (3) fuel pump operation at lower than minimum model specification inlet pressure.	A conservative fuel pump stall margin was maintained during the start transient. Augmented spark igniter ignition was detected 155 msec after engine start. Post-test inspection revealed no augmented spark igniter erosion. The gas generator outlet temperature experienced an initial peak of 1700°F and a second peak of 1880°F. Fuel pump operation with reduced inlet pressure was satisfactory.

<u>Firing</u>	<u>Test Objectives</u>	<u>Results</u>
16C	Conduct a 5-sec firing to evaluate gas generator and augmented spark igniter transient temperature with high starting energy, with coldest expected thrust chamber as predicted from the AS-501 countdown demonstration and lower than minimum model specification fuel pump inlet pressure.	The gas generator outlet temperature experienced an initial peak of 1955°F with no second peak. Augmented spark igniter ignition was detected 125 msec after engine start.
16D	Conduct a 5-sec firing to evaluate fuel pump low level stall characteristics at near the maximum model specification inlet pressure with low starting energy.	A conservative fuel pump stall margin was maintained during the start transient. Fuel pump operation with near maximum model specification inlet pressure was satisfactory.
16E	Conduct a firing to be terminated 400 msec after main-stage solenoid energized to evaluate fuel and oxidizer pump operation at lower than minimum model specification inlet pressure.	Fuel and oxidizer pump operation at reduced inlet pressure was satisfactory.

Chemical analysis of the liquid oxygen used during this test period was made as a result of concern for possible nitrogen dilution expressed during the previous test periods reported in Ref. 2. The pre-test analysis of the oxygen supplied to the vehicle revealed a nitrogen content of 0.67 percent.

The presentation of the test results in the following sections will consist of a discussion of each engine firing with pertinent comparisons. The data presented will be those recorded on the digital data acquisition system, except as noted.

## 4.2 TEST RESULTS

### 4.2.1 Firing J4-1801-16A

Firing 16A was 30.07 sec in duration with a propellant utilization valve excursion from null to closed at approximately  $t_0 + 11$  sec. Test cell pressure and combustion chamber pressure during the firing are presented in Fig. 9. Pressure altitude at engine start was 94,000 ft and attained a maximum of 93,000 ft during engine main-stage operation. Fuel lead duration was 1.00 sec. Thermal conditioning of selected engine components before engine start was accomplished as shown in Fig. 10.

Engine start and shutdown transients of primary engine parameters are shown in Fig. 11. Thrust chamber pressure buildup rate was such that main-stage operation was attained at  $t_0 + 2.081$  sec (indicated by the time required for combustion chamber pressure to attain 550 psia). Fuel pump start transient performance (Fig. 12) shows a conservative stall margin was maintained during the start transient. Fuel pump inlet pressure at engine start was 26.3 psia (1.7 psi lower than minimum model specification). The net positive suction head (NPSH) available to the fuel pump during the start transient is presented in Fig. 13 and compared to minimum model specification NPSH values (Ref. 5). The minimum NPSH required to prevent cavitation during the start transient was not available from the engine manufacturer; however, fuel pump operation under these conditions was satisfactory.

Movement of the second stage of the main oxidizer valve began during main chamber ignition ( $t_0 + 1.026$  sec). This is inconsistent with previously observed S-II low energy starts at AEDC (Ref. 2), in which the main oxidizer valve was observed to start its second-stage movement before main chamber ignition. Also, this movement (firing 16A) was coincident with the beginning of 88 msec of engine vibration (VSC).

Engine steady-state performance data are presented in Table VII. The data presented are for a 1-sec average of test measurements obtained from  $t_0 + 29$  sec to  $t_0 + 30$  sec and were computed using the Rocketdyne PAST 640 modification zero performance program. Engine test measurements required by the program and the program equations are presented in Appendix IV. Calculated thrust from these data was 2.9 percent higher than rated. Also, the data indicated that the gas generator oxidizer supply orifice was slightly oversized and that the oxidizer turbine bypass orifice was slightly undersized.

#### 4.2.2 Firing J4-1801-16B

Firing 16B was 5.09 sec in duration with the propellant utilization valve in the null position. Test cell pressure and combustion chamber pressure during the firing are presented in Fig. 14. Pressure altitude at engine start was 106,000 ft and attained a maximum of 101,000 ft during engine main-stage operation. Fuel lead duration was 1.01 sec. Thermal conditioning of selected engine components before engine start was accomplished as shown in Fig. 15.

Engine start and shutdown transients of primary engine parameters are shown in Fig. 16. The gas generator outlet temperature experienced an initial peak of 1700°F and a second peak of 1880°F (Fig. 16f). Augmented spark igniter ignition was detected 155 msec after engine start. Post-test inspection revealed no augmented spark igniter erosion. Fuel pump start transient performance data are presented in Fig. 17. These data are compared with the nominal stall inception curve and show a conservative stall margin was maintained during the start transient. Fuel pump inlet pressure at engine start was 25.7 psia (2.3 psi lower than minimum model specification). The net positive suction head available to the fuel pump during the start transient is presented in Fig. 18 and compared to minimum model specification NPSH values. Fuel pump operation under these conditions was satisfactory. Vibration safety counts (VSC) were recorded for 20 msec during main chamber ignition.

#### 4.2.3 Firing J4-1801-16C

Firing 16C was 5.09 sec in duration with the propellant utilization valve in the null position. Test cell pressure and combustion chamber pressure during the firing are presented in Fig. 19. Pressure altitude at engine start was 106,000 ft and attained a maximum of 100,000 ft during engine main-stage operation. Fuel lead duration was 1.01 sec. Thermal conditioning of selected engine components before engine start was accomplished as shown in Fig. 20.

Engine start and shutdown transients of primary engine parameters are presented in Fig. 21. Test conditions for firing 16C were selected to repeat conditions for firing 16B, except for thrust chamber temperature (the test variable), firing 16B having the warmest expected thrust chamber and firing 16C having the coldest expected thrust chamber for S-II/S-V flights, as predicted from the AS-501 countdown demonstration. Actual conditioning attained for these two firings, as indicated in Table V, was essentially the same except for the average thrust chamber temperature, which was approximately 80°F colder on firing 16C. Augmented spark igniter ignition was detected 125 msec after engine start, as compared to

155 msec on firing 16B. Gas generator ignition occurred at  $t_0 + 0.654$  sec, as compared to  $t_0 + 0.664$  sec on firing 16B. A further comparison of these firings shows that during the bootstrap transient period, firing 16C experienced lower (1) gas generator chamber pressure (Fig. 22a), (2) oxidizer pump spin speed (Fig. 22b), and (3) hydraulic torque across the main oxidizer valve, as indicated by the differential pressure between the oxidizer pump discharge and the main combustion chamber (Fig. 22c). This reduction in hydraulic torque allowed the main oxidizer valve to begin its second-stage ramp during main chamber ignition ( $t_0 + 0.992$  sec), 254 msec faster than on firing 16B. This faster movement prevented the gas generator from experiencing a second peak as on firing 16B (Fig. 22d).

Fuel pump start transient performance is presented in Fig. 23. These data are compared with the nominal stall inception curve and show a conservative stall margin was maintained during the start transient. Fuel pump inlet pressure at engine start was 25.8 psia (2.2 psi lower than minimum model specification). The net positive suction head available to the fuel pump is presented in Fig. 24 and compared to minimum model specification NPSH values. Fuel pump operation under these conditions was satisfactory. Vibration safety counts (VSC) were recorded for 93 msec during main chamber ignition.

#### 4.2.4 Firing J4-1801-16D

Firing 16D was 5.09 sec in duration with the propellant utilization valve in the null position. Test cell pressure and combustion chamber pressure during the firing are presented in Fig. 25. Pressure altitude at engine start was 110,000 ft and attained a maximum of 102,000 ft during engine main-stage operation. Fuel lead duration was 1.01 sec. Thermal conditioning of selected engine components before engine start was accomplished as shown in Fig. 26.

Engine start and shutdown transients of primary engine parameters are shown in Fig. 27. Fuel pump start transient performance data are presented in Fig. 28 and compared with the nominal stall inception curve. These data indicate that a conservative stall margin was maintained during the start transient. Fuel pump inlet pressure at engine start was 42.3 psia (3.7 psi less than maximum model specification). The fuel pump NPSH during the start transient is presented in Fig. 29 and is compared to the maximum model specification values. Fuel pump operation under these conditions was satisfactory. Vibration safety counts (VSC) were recorded for 38 msec during main chamber ignition.

#### 4.2.5 Firing J4-1801-16E

Firing 16E was 0.87 sec in duration with the propellant utilization valve in the null position. Test cell pressure and combustion chamber pressure during the firing are presented in Fig. 30. Pressure altitude at engine start was 110,000 ft. Fuel lead duration was 1.01 sec. Thermal conditioning of selected engine components before engine start was accomplished as shown in Fig. 31.

Engine start and shutdown transients of primary engine parameters are shown in Fig. 32. The fuel pump start transient performance data are compared with the nominal stall inception curve (Fig. 33) and show a conservative stall margin was maintained during the firing. Fuel pump inlet pressure at engine start was 24.4 psia (3.6 psi lower than minimum model specification). The net positive suction head available to the fuel pump during the start transient is presented in Fig. 34a and compared to the minimum model specification values. Fuel pump operation under these conditions was satisfactory. Oxidizer pump inlet pressure at engine start was 28.3 psia (6.7 psi lower than minimum model specification). The net positive suction head available to the oxidizer pump is presented in Fig. 34b and compared to the minimum model specification values. Oxidizer pump operation under these conditions was satisfactory.

### SECTION V SUMMARY OF RESULTS

The results of these five firings of the J-2 engine conducted in Test Cell J-4 are summarized as follows:

1. Fuel pump operation was satisfactory with inlet pressures as low as 3.6 psi below minimum model specification.
2. The main oxidizer valve second-stage initial movement was (1) 254 msec faster with the coldest expected thrust chamber (firing 16C) as compared with the warmest expected thrust chamber (firing 16B) (temperatures predicted from the AS-501 countdown demonstration), and (2) inconsistent with previous low energy S-II starts.
3. A conservative fuel pump stall margin was maintained during all five engine start transients.

4. The gas generator outlet temperature experienced an initial peak of 1955°F with high starting energy, with coldest expected thrust chamber (as predicted from the AS-501 countdown demonstration) and with lower than minimum model specification fuel pump inlet pressure. Post-test inspection revealed no augmented spark igniter erosion.

#### REFERENCES

1. Dubin, M., Sissenwine, N., and Wexler, H. "U. S. Standard Atmosphere, 1962." December 1962.
2. Counts, H. J. "Altitude Development Testing of the J-2 Rocket Engine in Propulsion Engine Test Cell (J-4) (Tests J4-1801-13 through J4-1801-15)" AEDC-TR-68-16, February 1968.
3. "J-2 Rocket Engine, Technical Manual Engine Data." R-3825-1, August 1965.
4. Test Facilities Handbook (6th Edition). "Large Rocket Facility, Vol. 3." Arnold Engineering Development Center, November 1966.
5. "Engine Model Specification Liquid-Propellant Rocket Engine-Rocketdyne Model J-2." R-2158cS, January 1966.



**APPENDIXES**

- I. ILLUSTRATIONS**
- II. TABLES**
- III. INSTRUMENTATION**
- IV. METHODS OF CALCULATIONS (PERFORMANCE PROGRAM)**

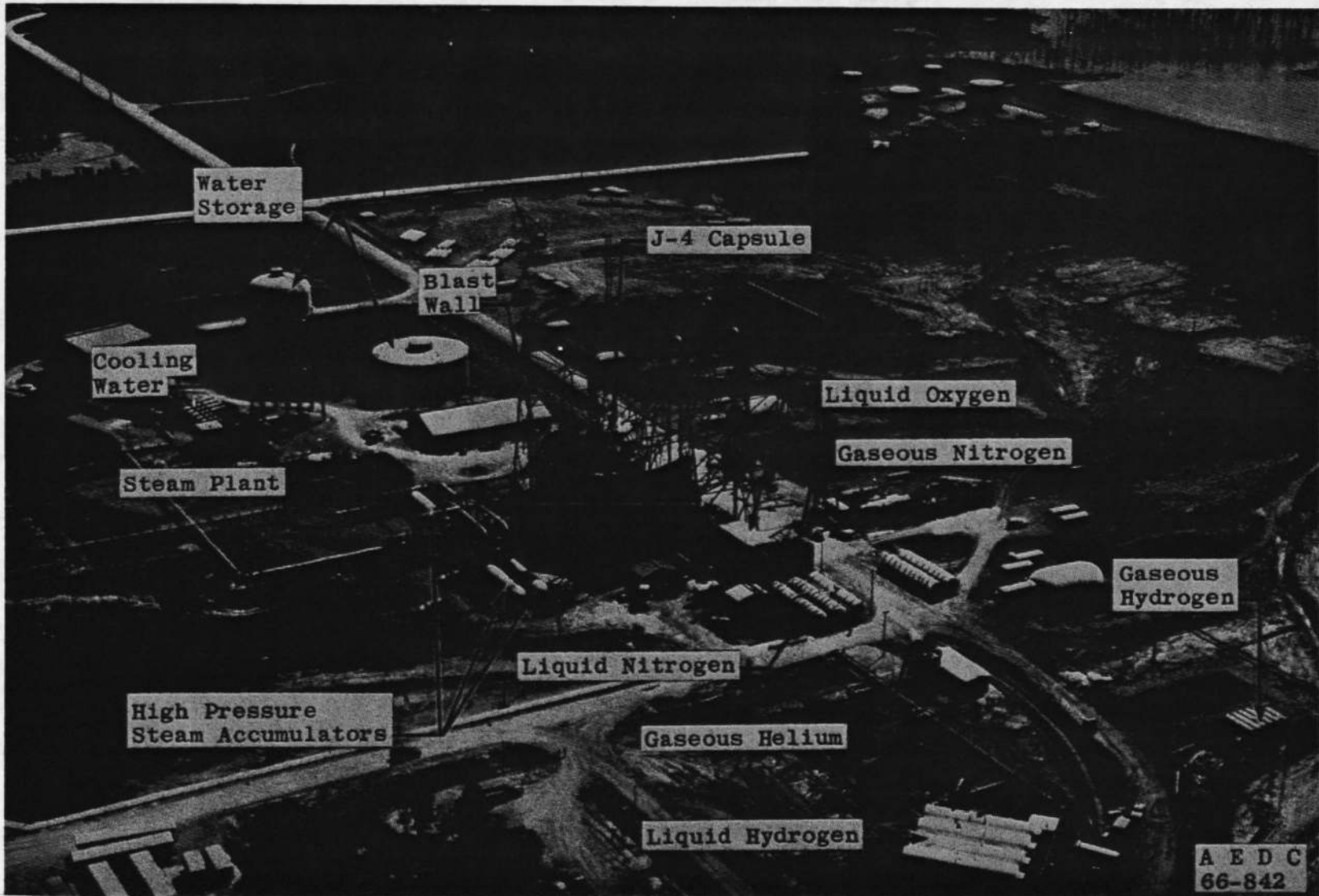

Fig. 1 Test Cell J-4 Complex

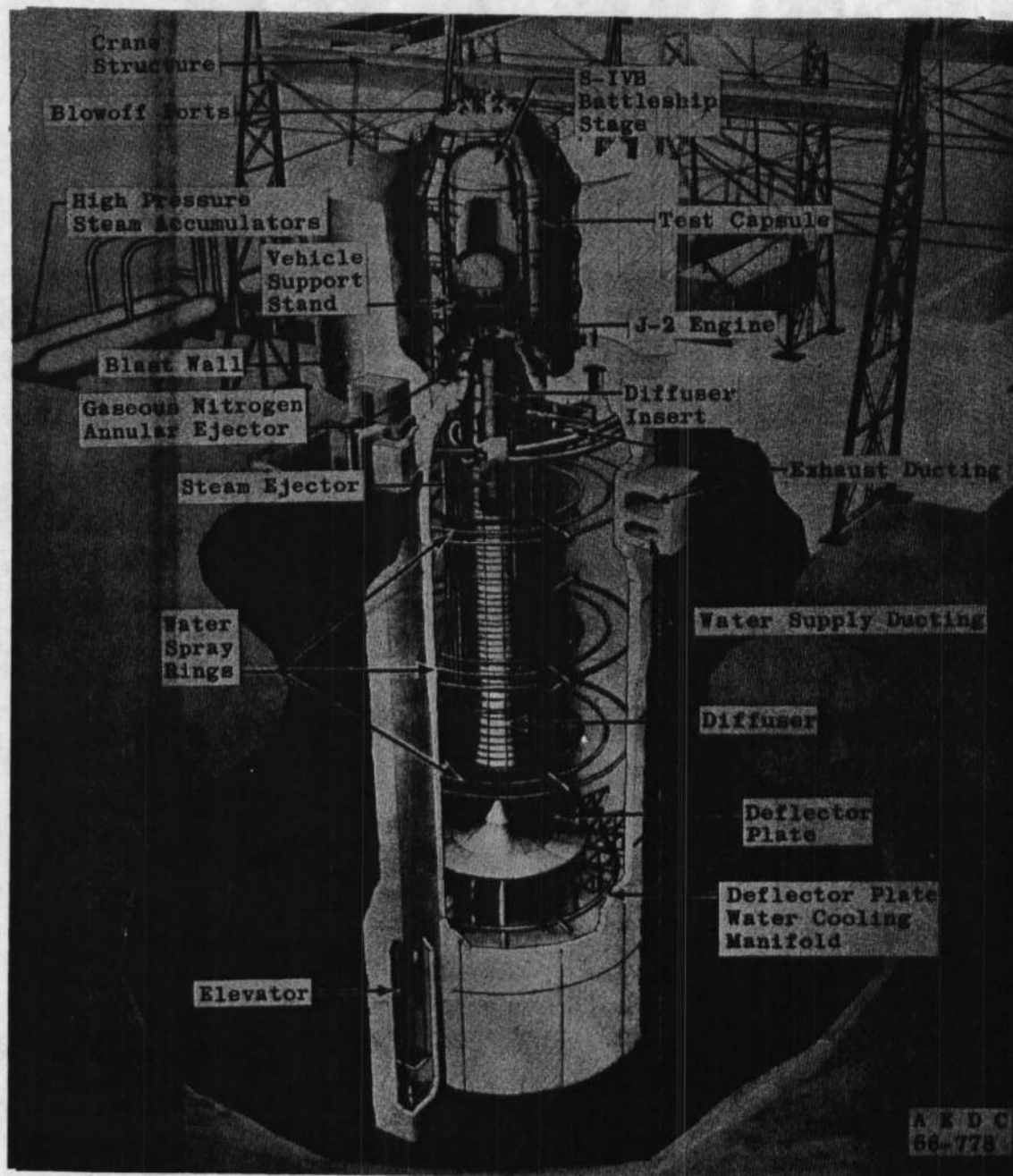

Fig. 2 Test Cell J-4, Artist's Conception

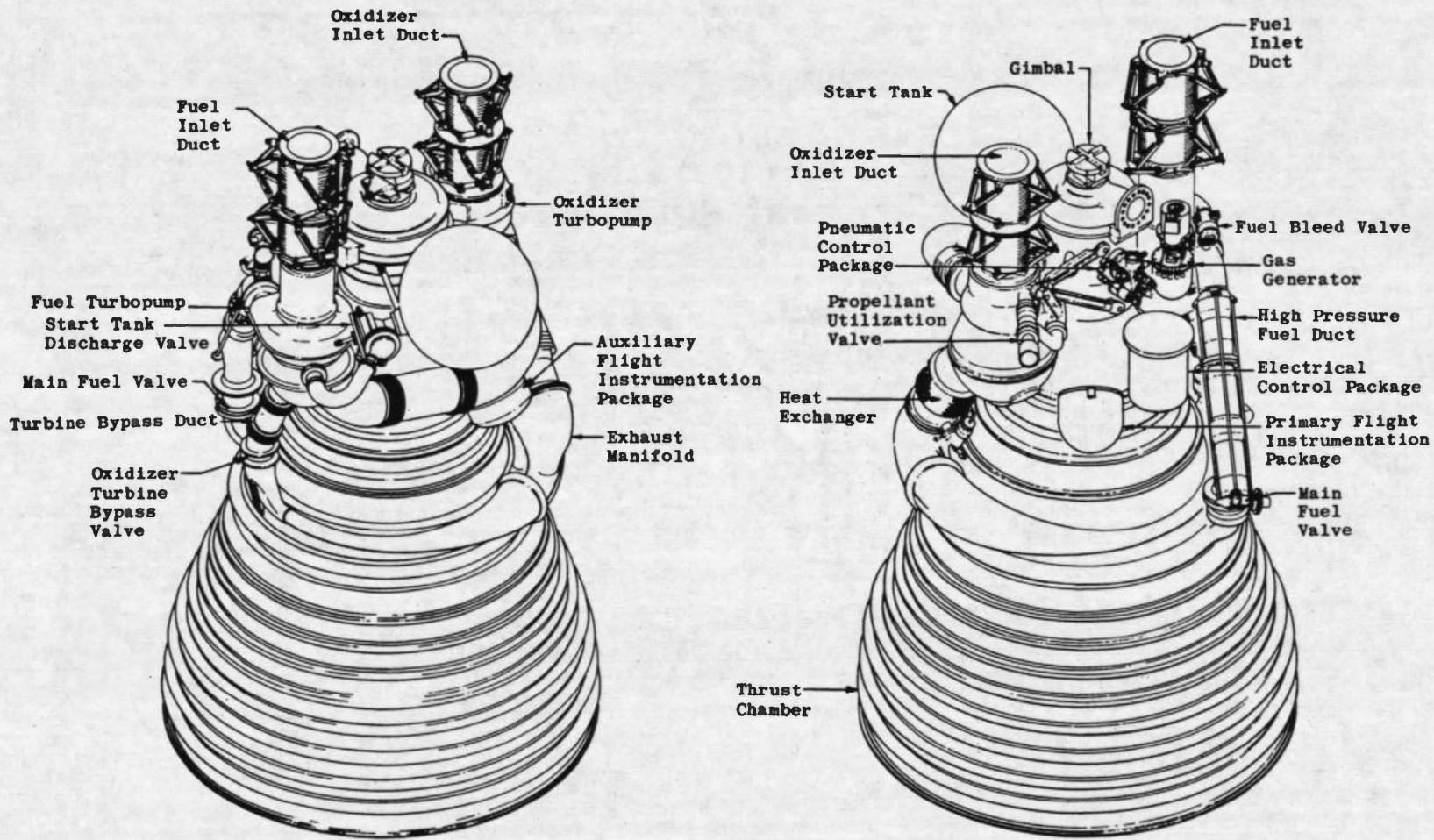

Fig. 3 Engine Details

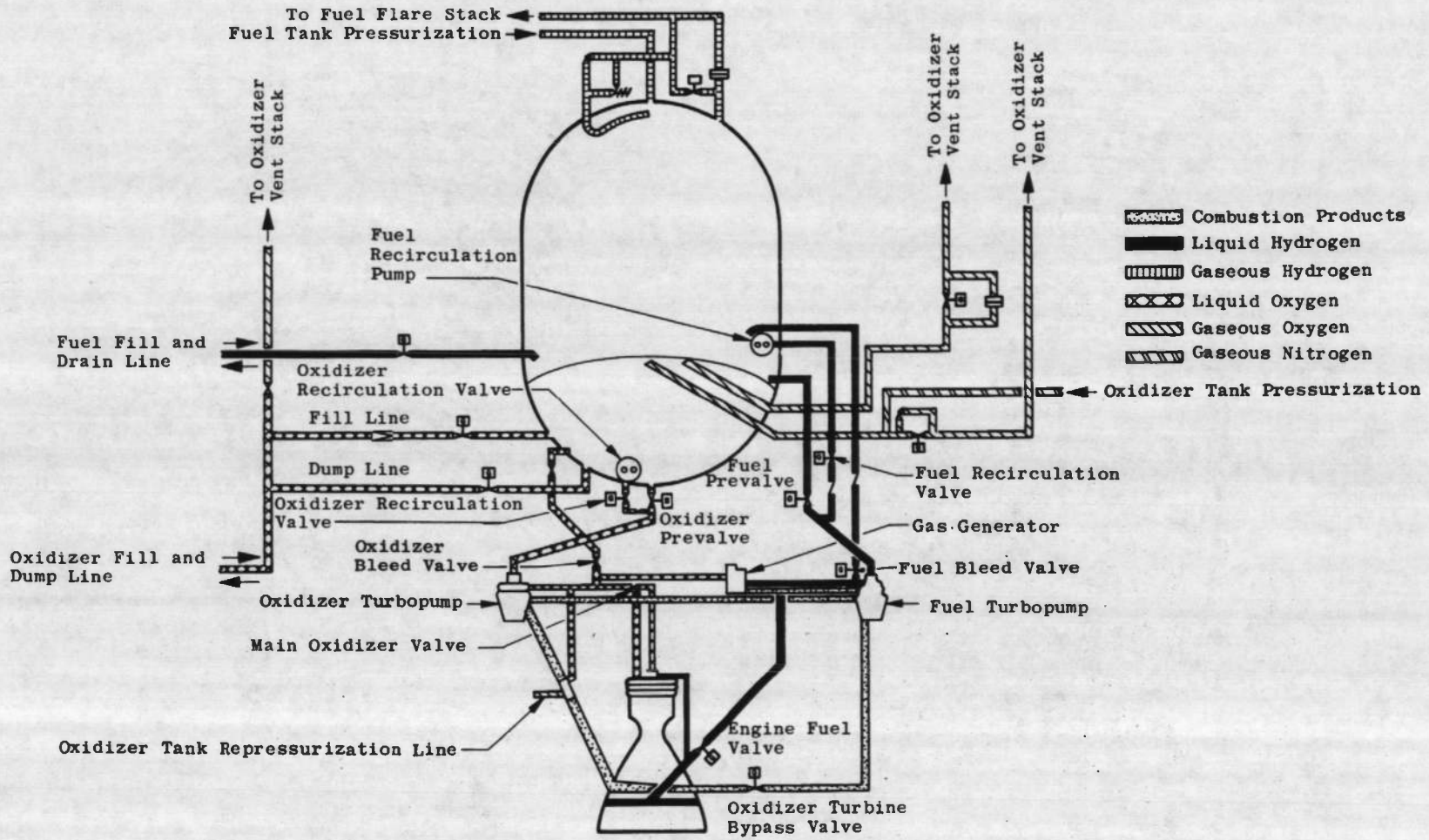

Fig. 4 S-IVB Battleship Stage/J-2 Engine Schematic

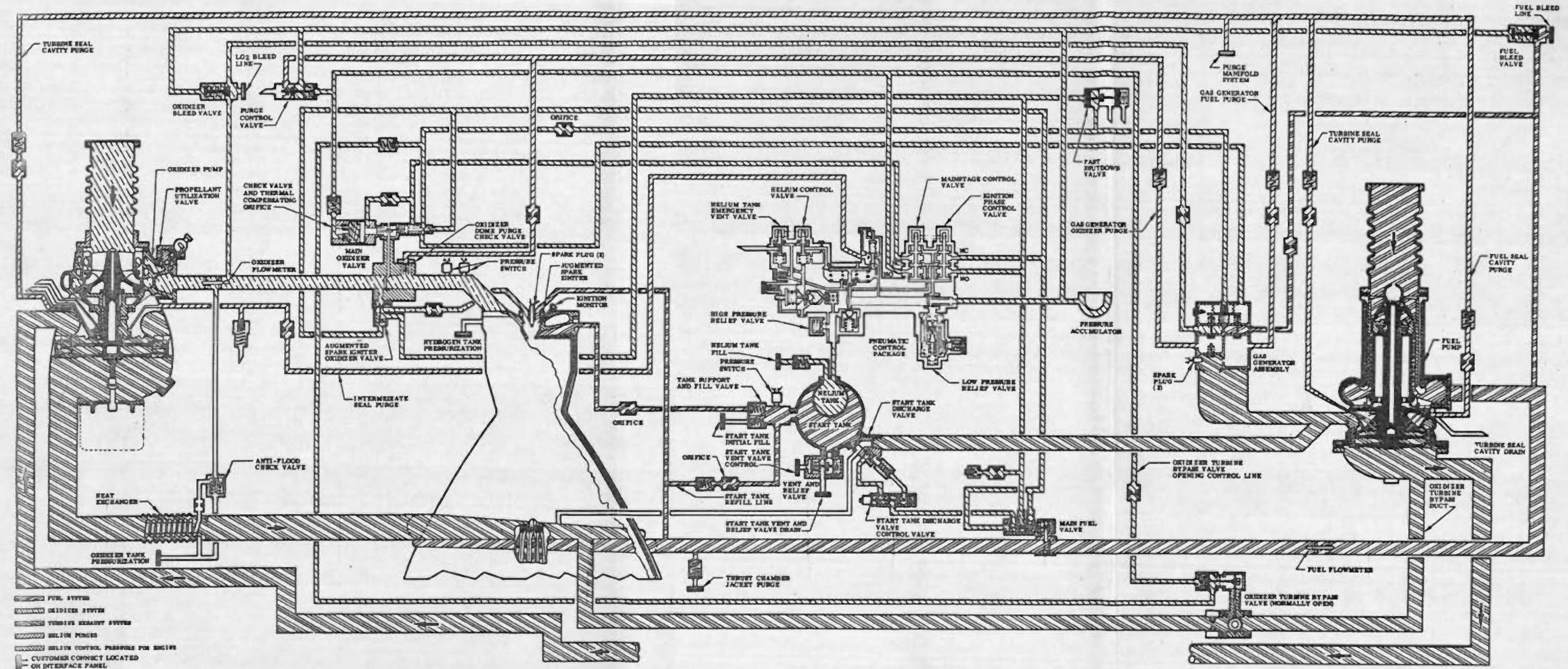

Fig. 5 Engine Schematic

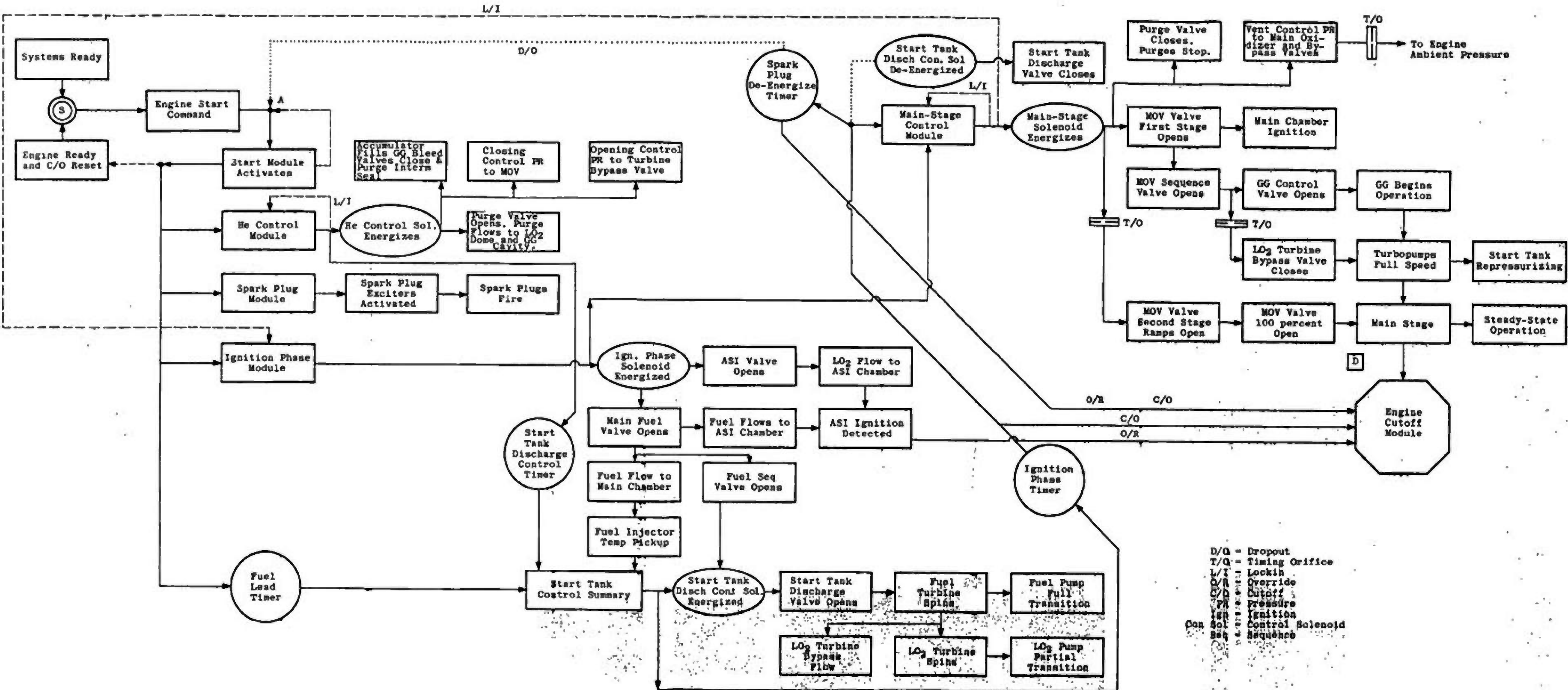
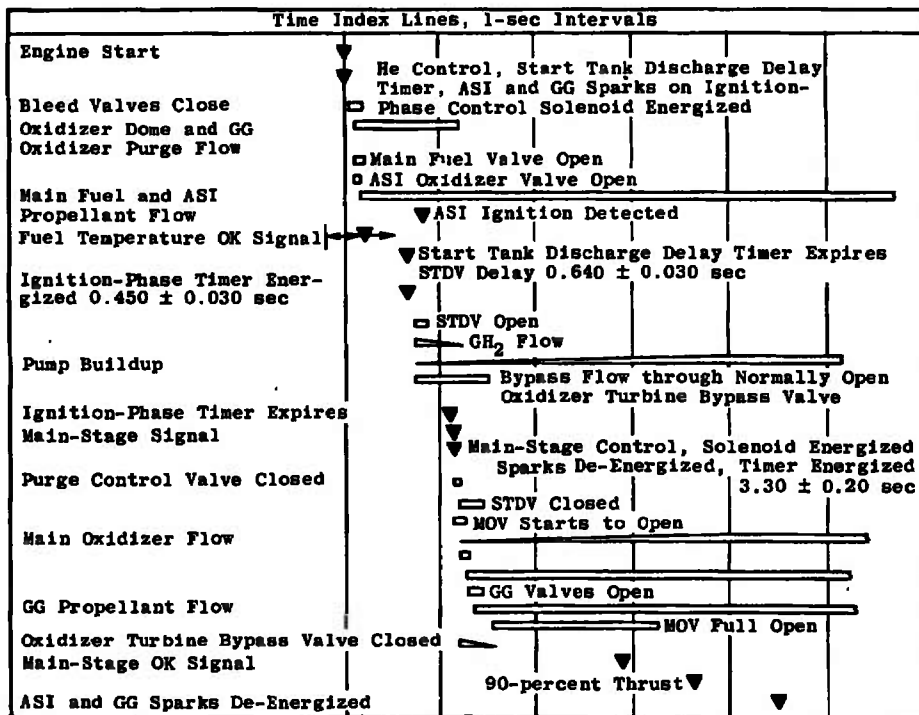
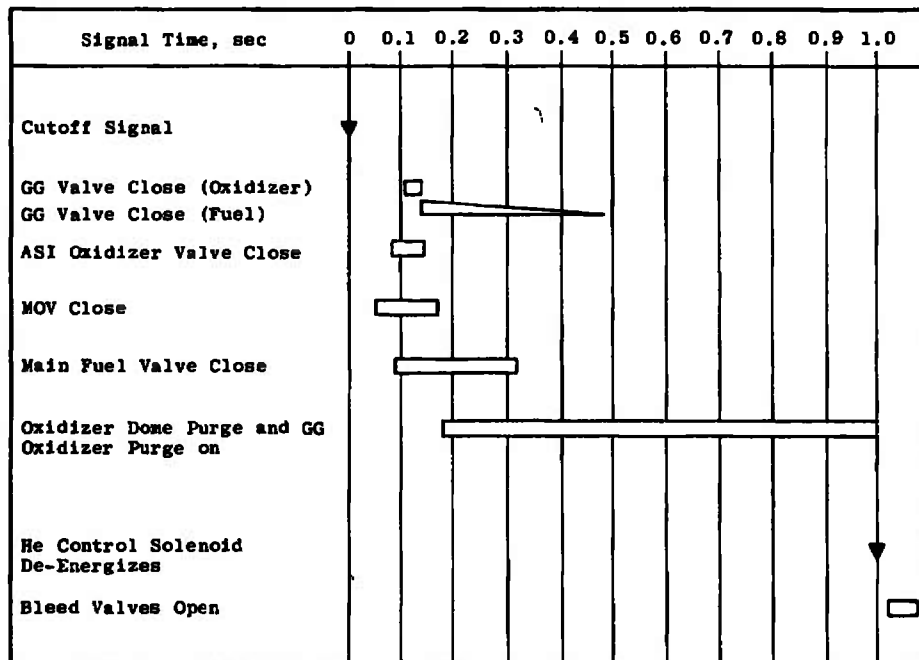

Fig. 6 Engine Start Logic Schematic



a. Start Sequence



b. Shutdown Sequence

Fig. 7 Engine Start and Shutdown Sequence



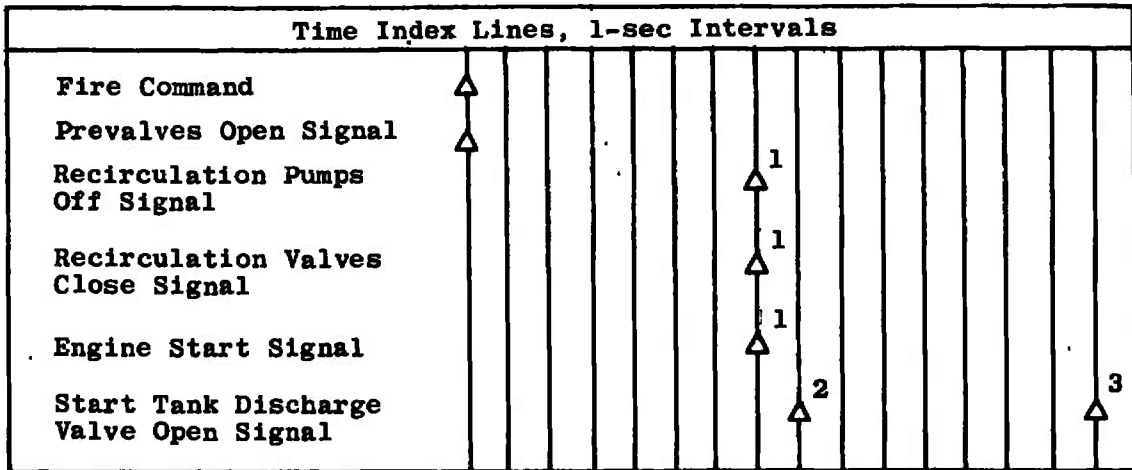

- <sup>1</sup>Nominal Occurrence Time (Function of Prevalves Opening Time)
- <sup>2</sup>One-sec Fuel Lead (S-II/S-V and S-IVB/S-IB)
- <sup>3</sup>Eight-sec Fuel Lead (S-IVB/S-V and S-IB Orbital Restart)

c. Normal Logic Start Sequence

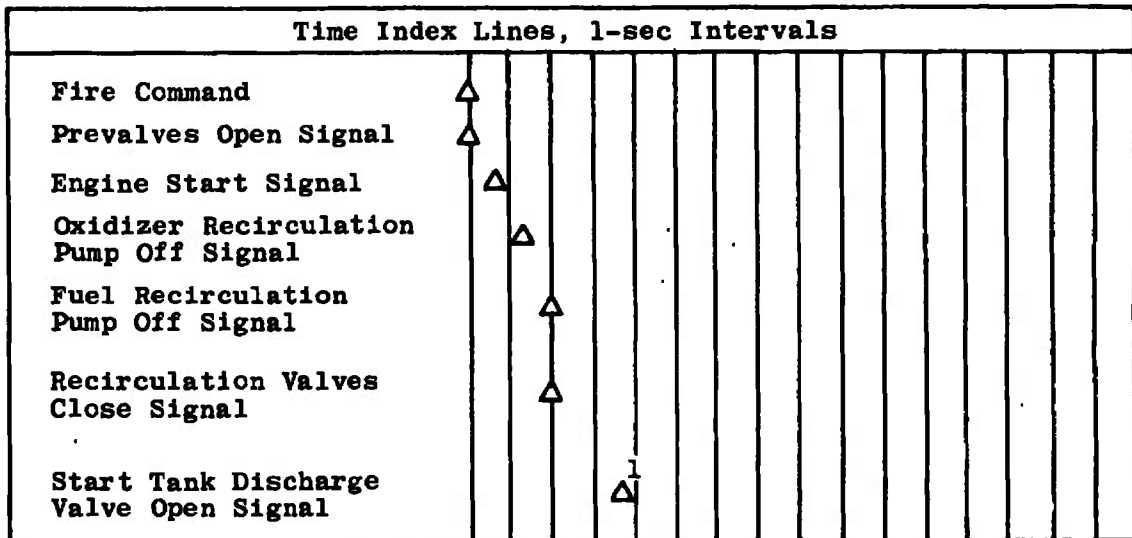

- <sup>1</sup>Three-sec Fuel Lead (S-IVB/S-V First Burn)

d. Auxiliary Logic Start Sequence

Fig. 7 Concluded

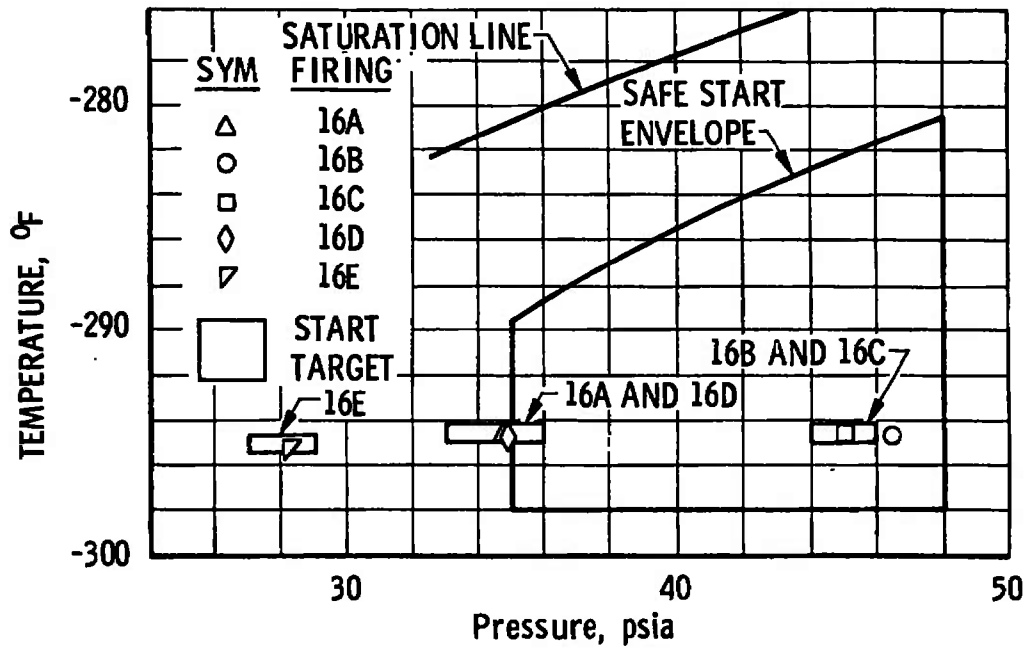

a. Oxidizer Pump Inlet

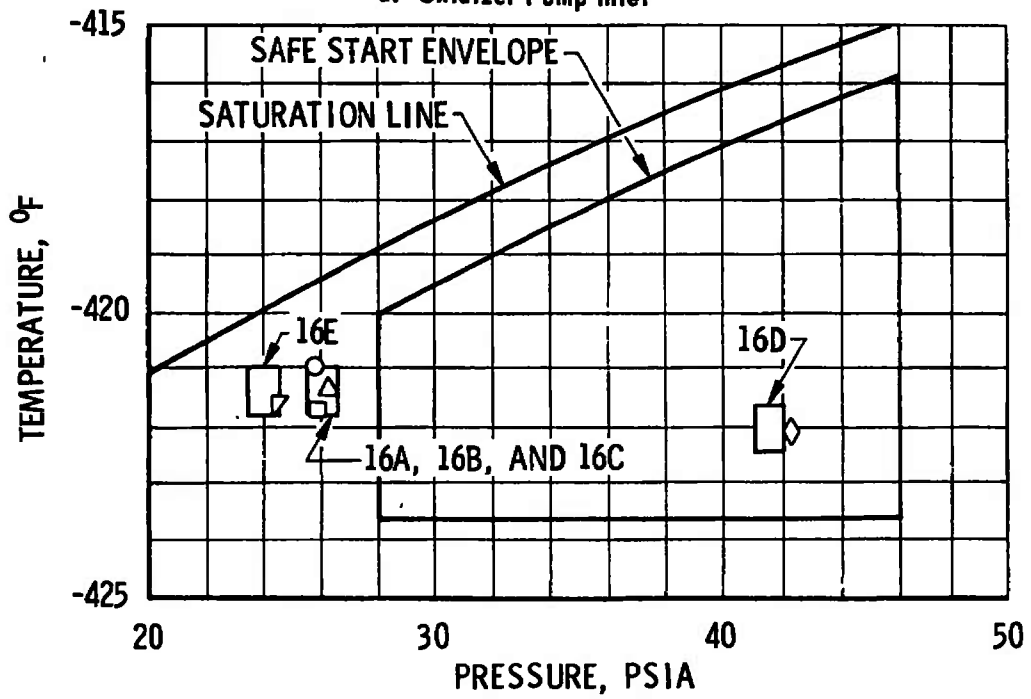

b. Fuel Pump Inlet

Fig. 8 Engine Start Conditions for Pump Inlets, Start Tank, and Helium Tank

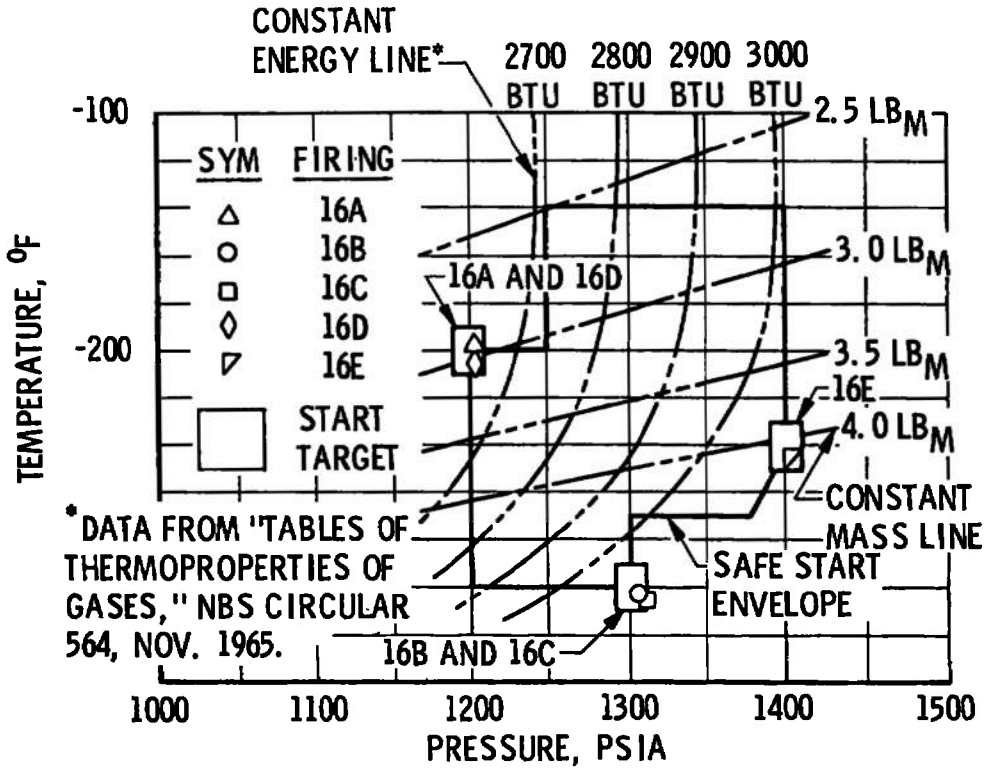

c. Start Tank

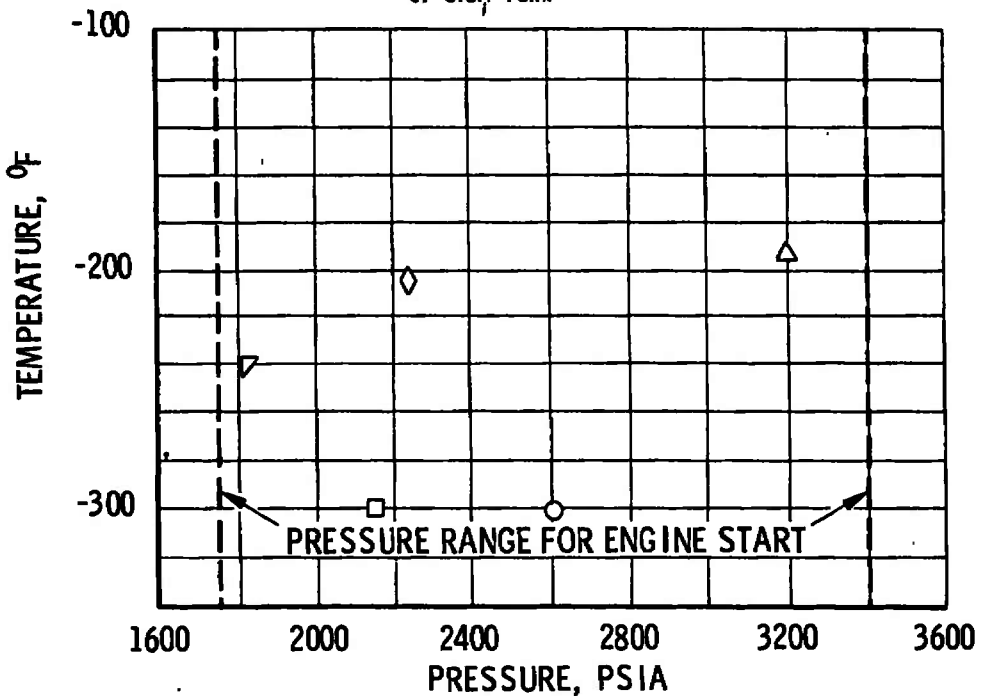

d. Helium Tank

Fig. 8 Concluded

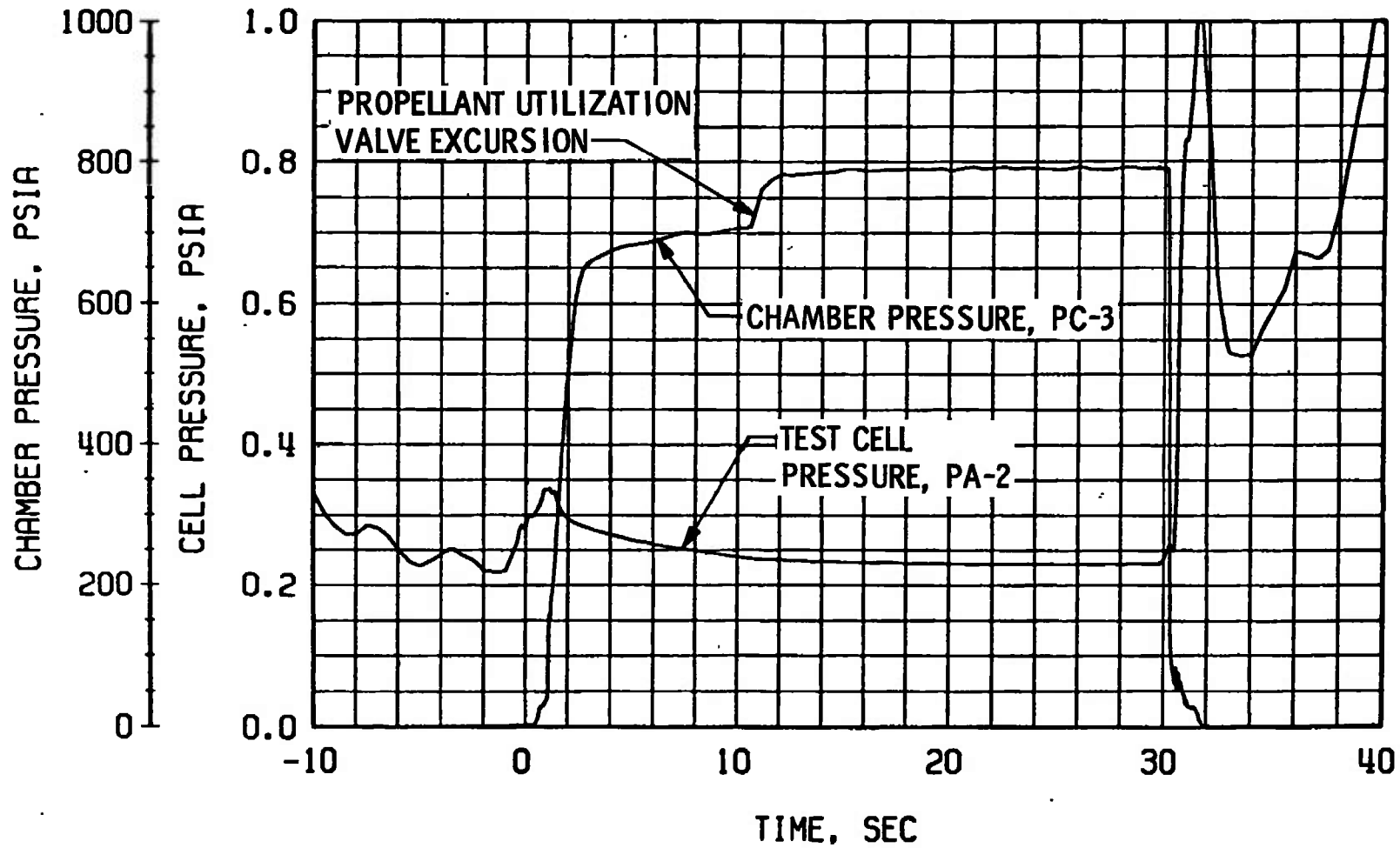
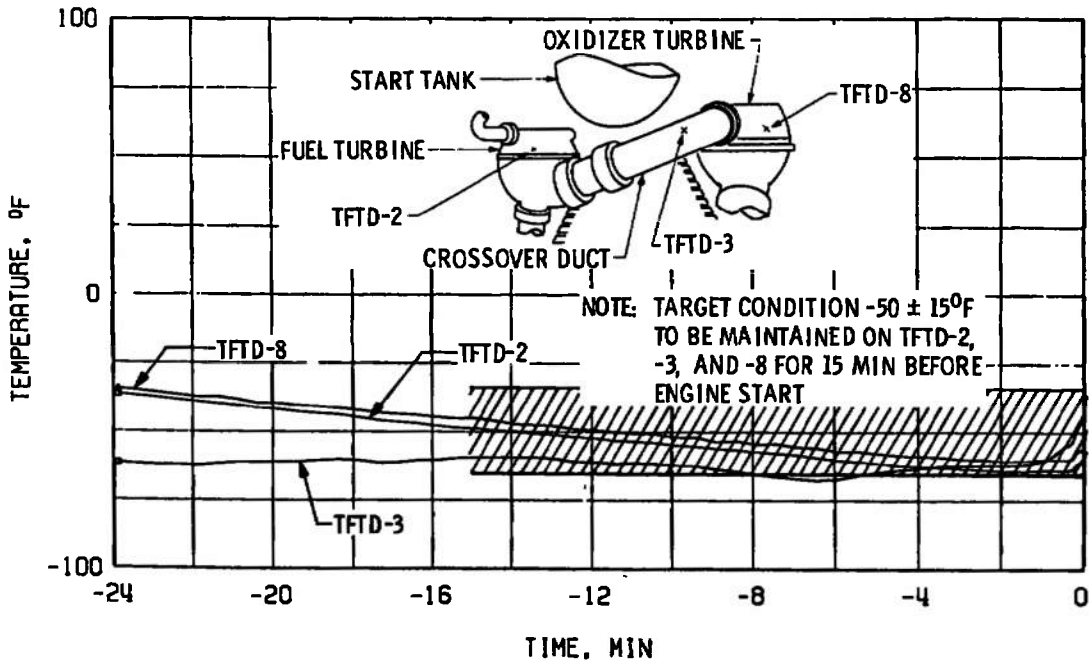
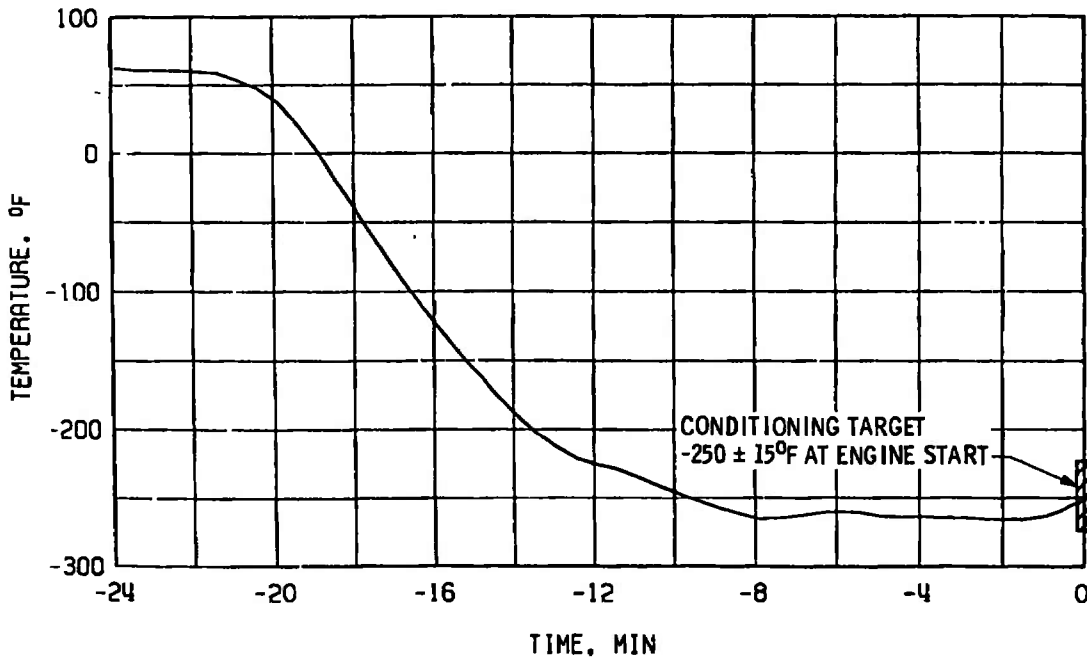

Fig. 9 Engine Ambient and Combustion Chamber Pressures, Firing 16A



a. Crossover Duct, TFTD



b. Thrust Chamber Throat, TTC-1P

Fig. 10 Thermal Conditioning History of Engine Components, Firing 16A

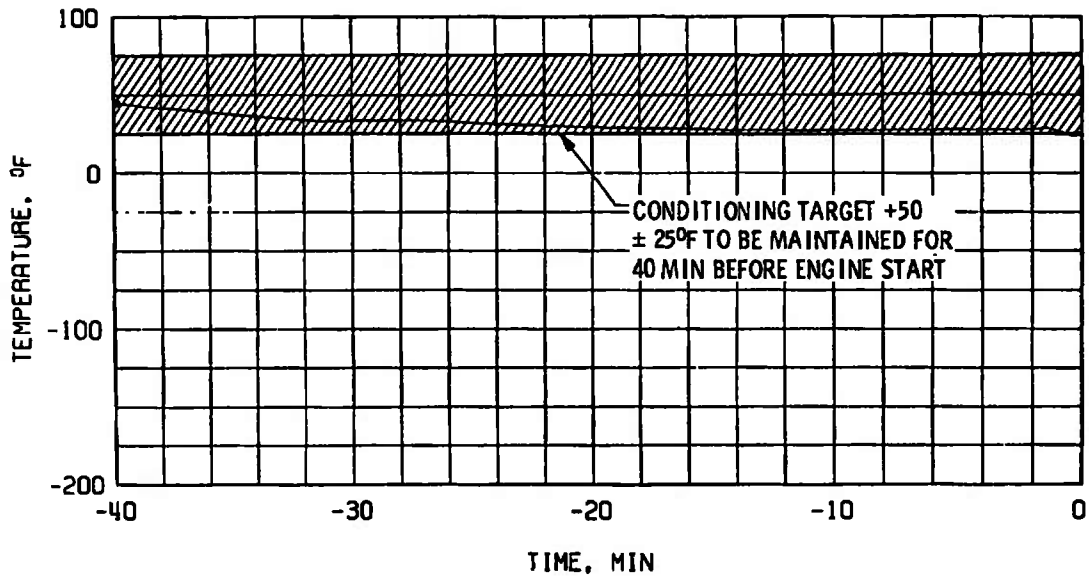

c. Start Tank Discharge Valve, STDVOC

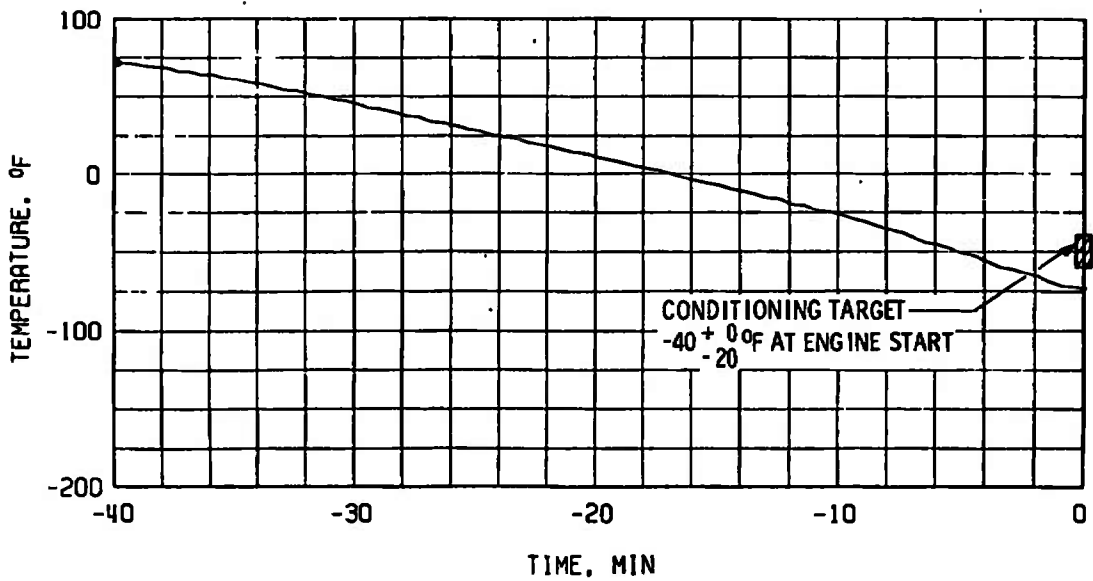

d. Main Oxidizer Valve Second-Stage Actuator, TSOVC-2

Fig. 10 Concluded

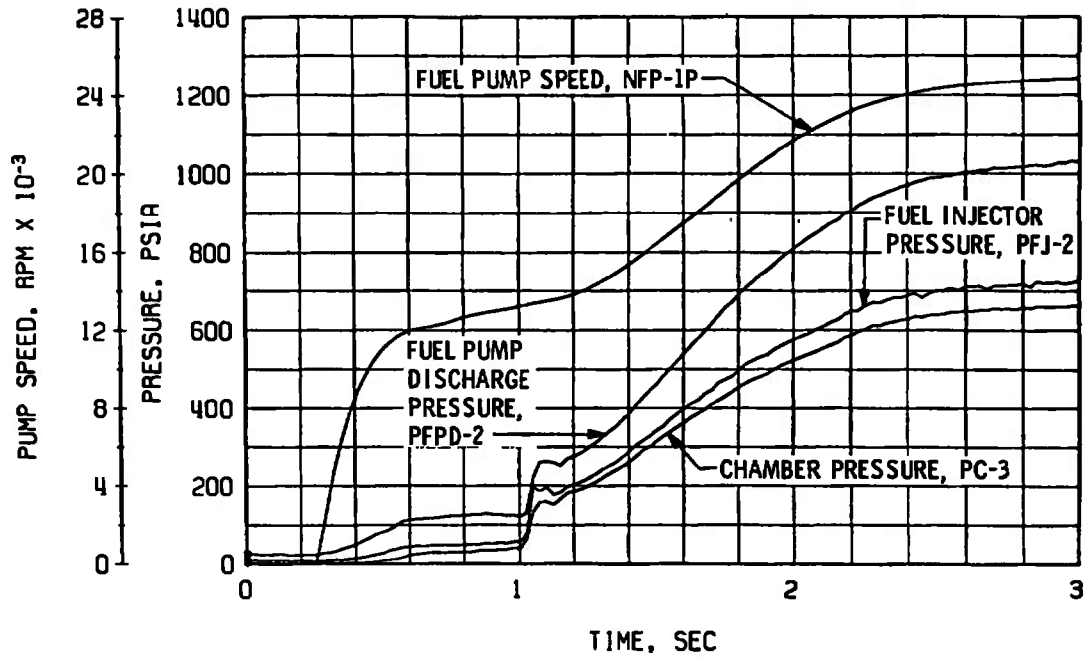

a. Thrust Chamber Fuel System, Start

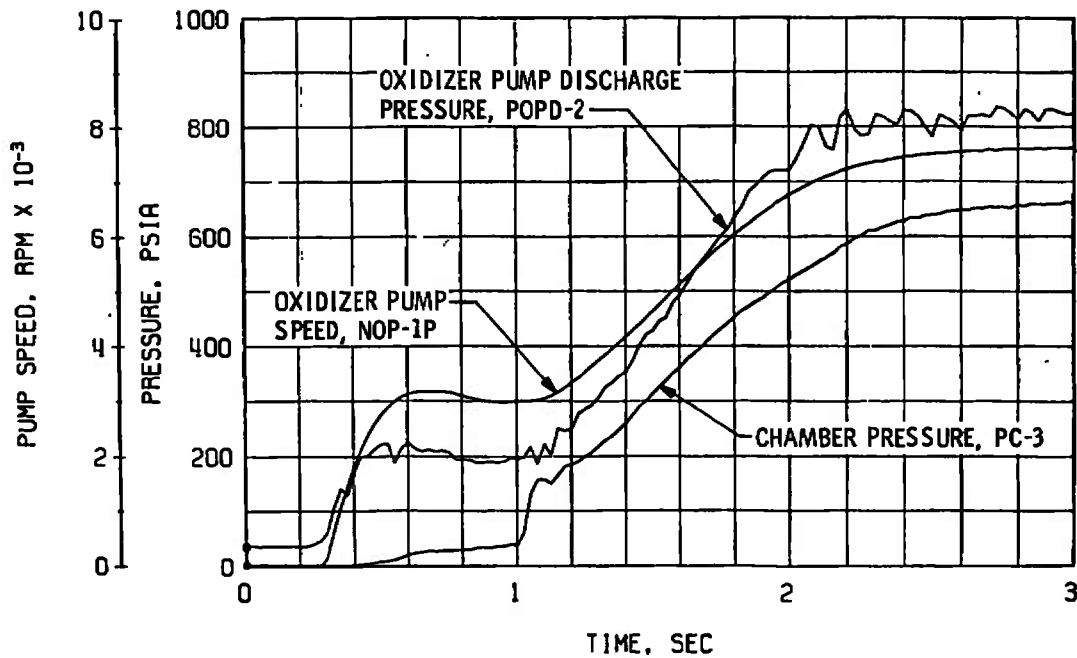

b. Thrust Chamber Oxidizer System, Start

Fig. 11 Engine Transient Operation, Firing 16A

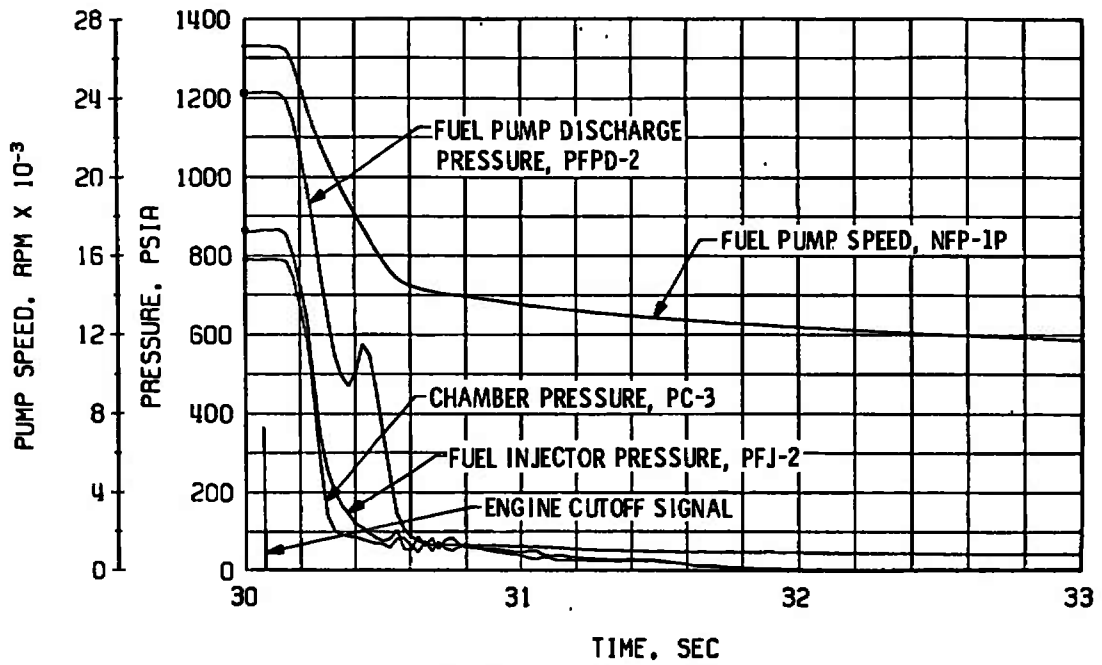

c. Thrust Chamber Fuel System, Shutdown

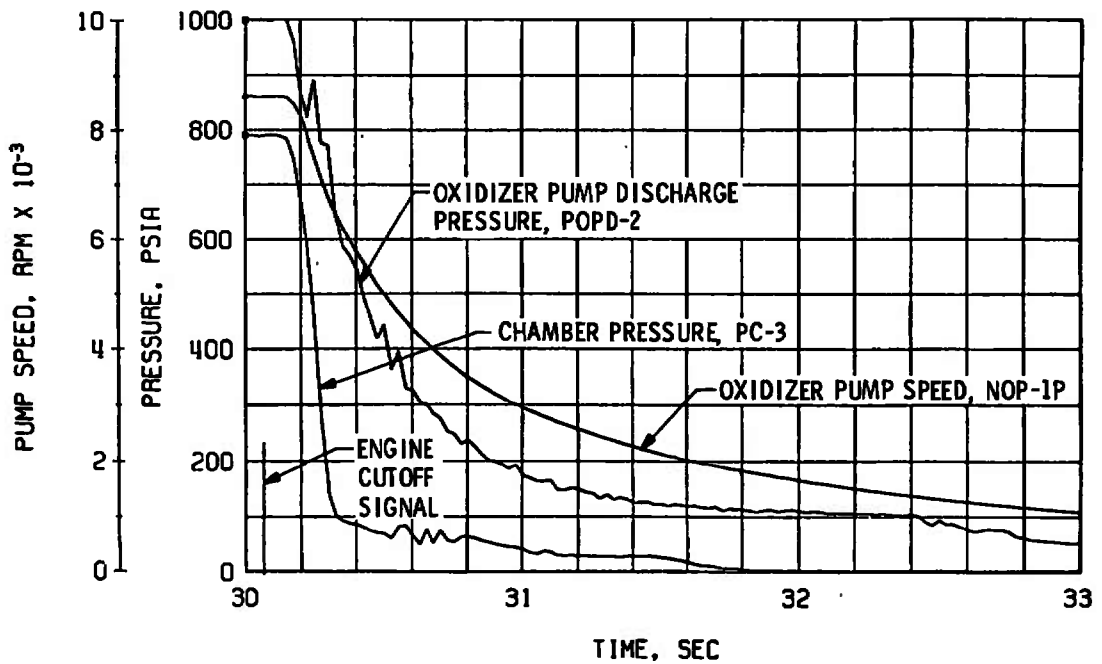

d. Thrust Chamber Oxidizer System, Shutdown

Fig. 11 Continued



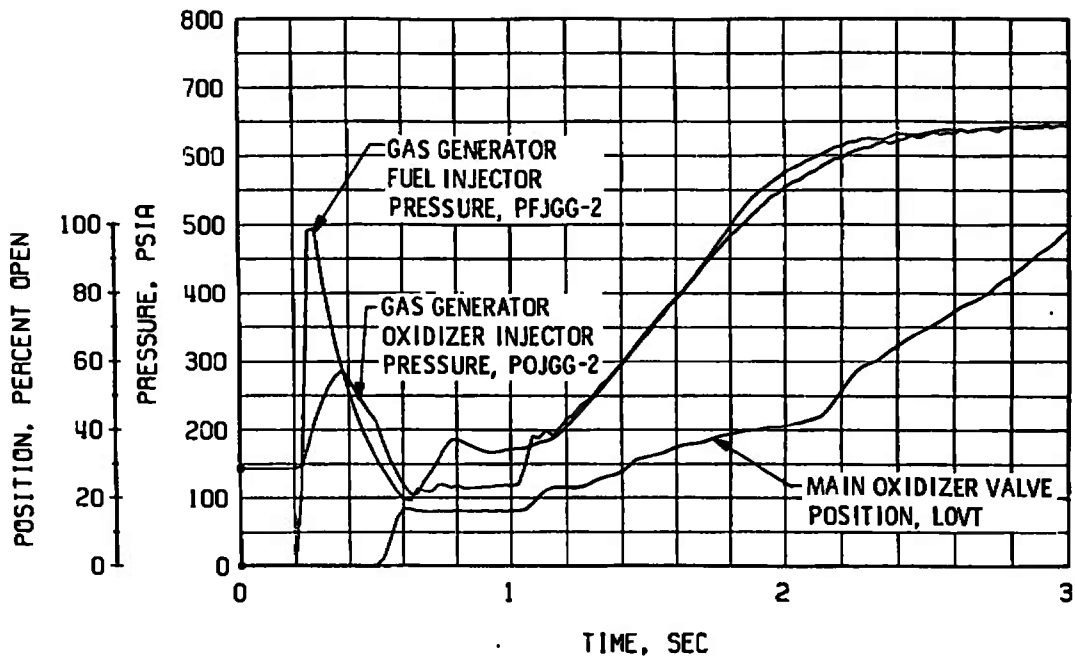

e. Gas Generator Injector Pressures and Main Oxidizer Valve Position, Start

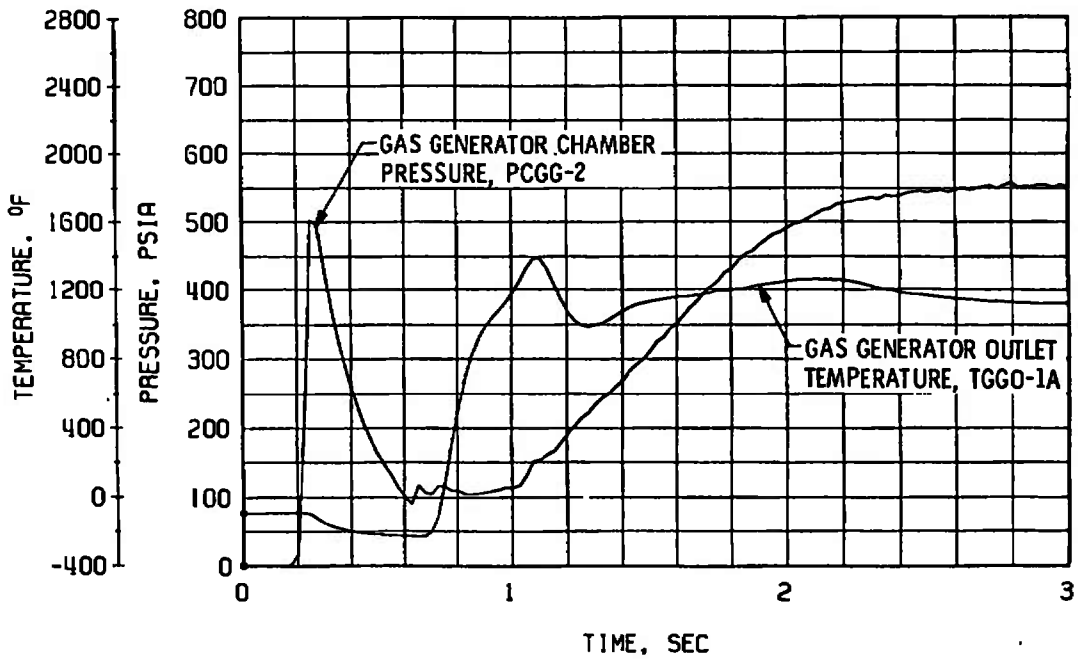

f. Gas Generator Chamber Pressure and Temperature, Start

Fig. 11 Continued

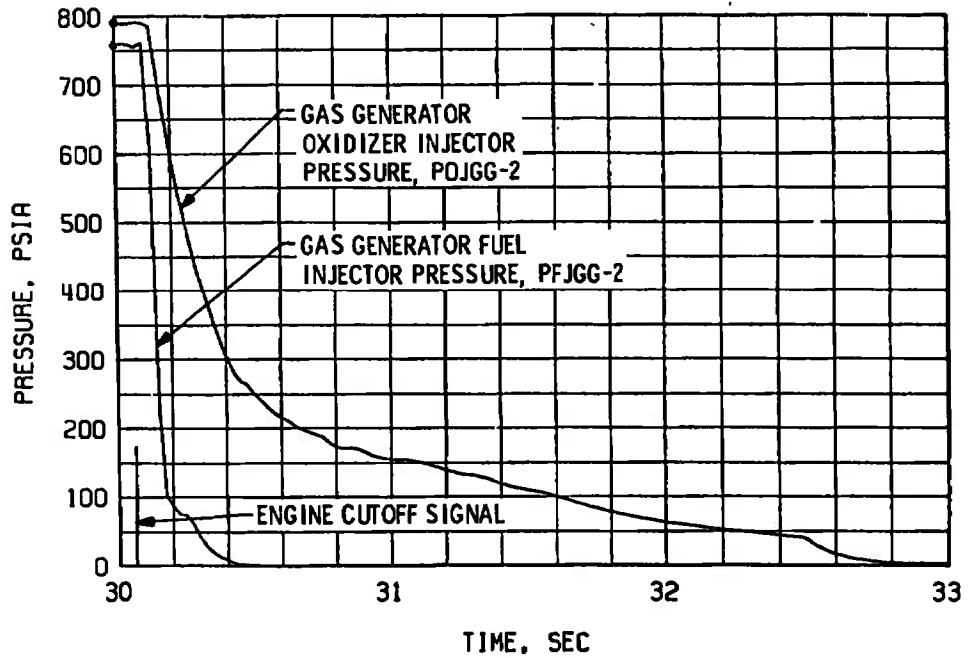

g. Gas Generator Injector Pressures, Shutdown

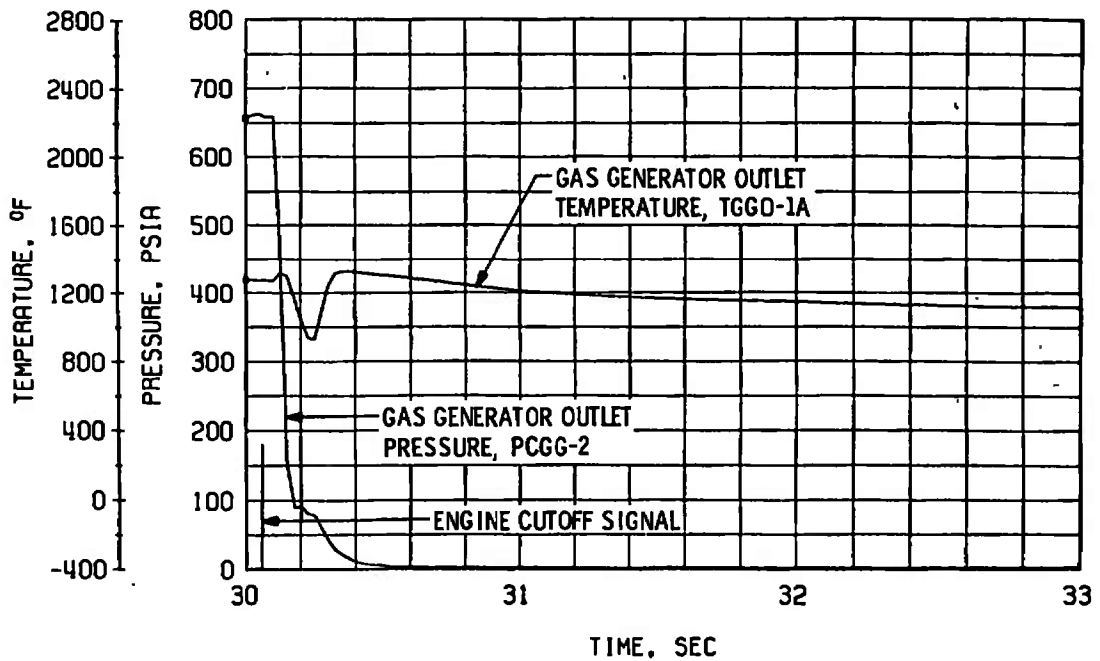

h. Gas Generator Chamber Pressure and Temperature, Shutdown

Fig. 11 Concluded

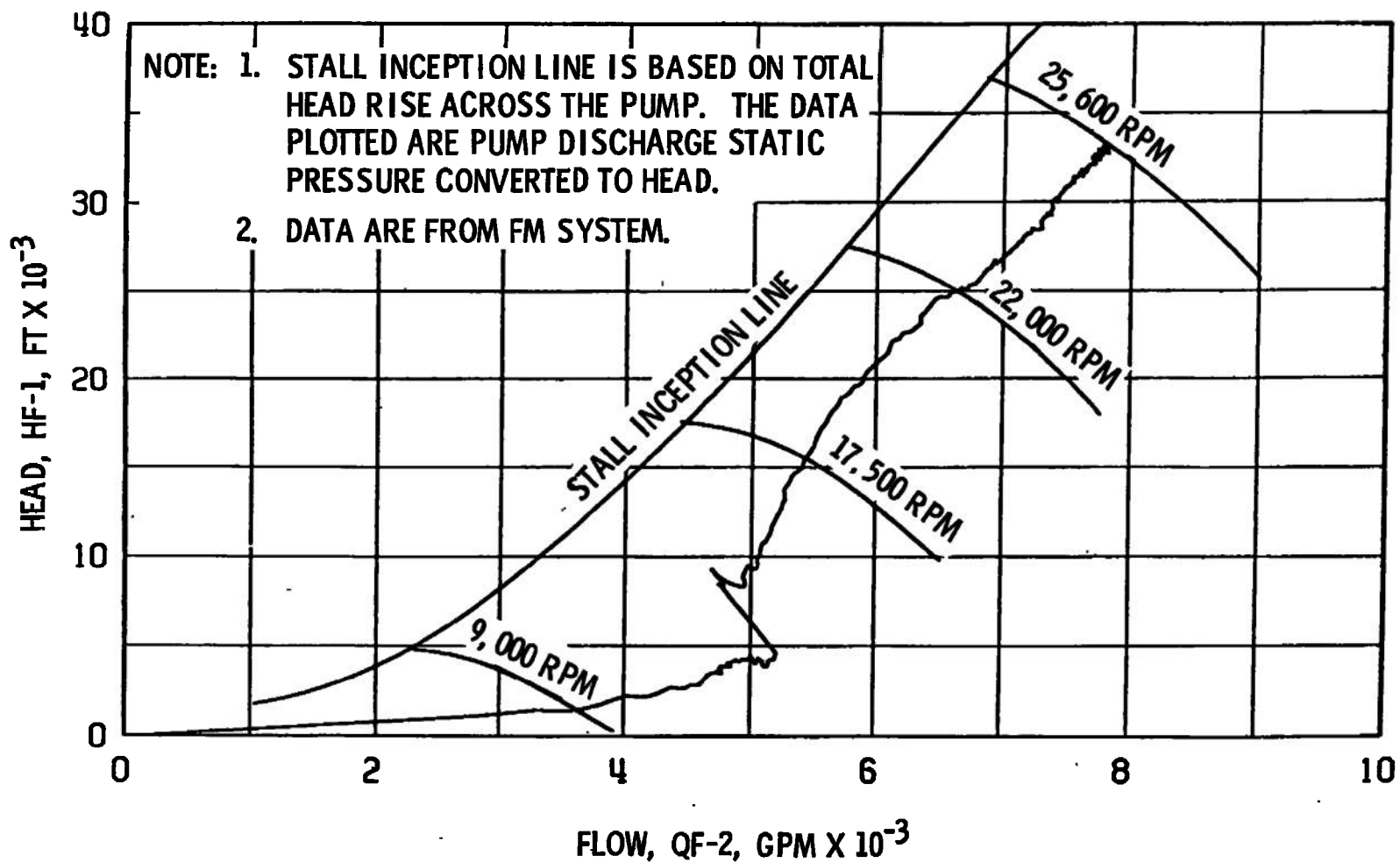

Fig. 12 Fuel Pump Start Transient Performance, Firing 16A

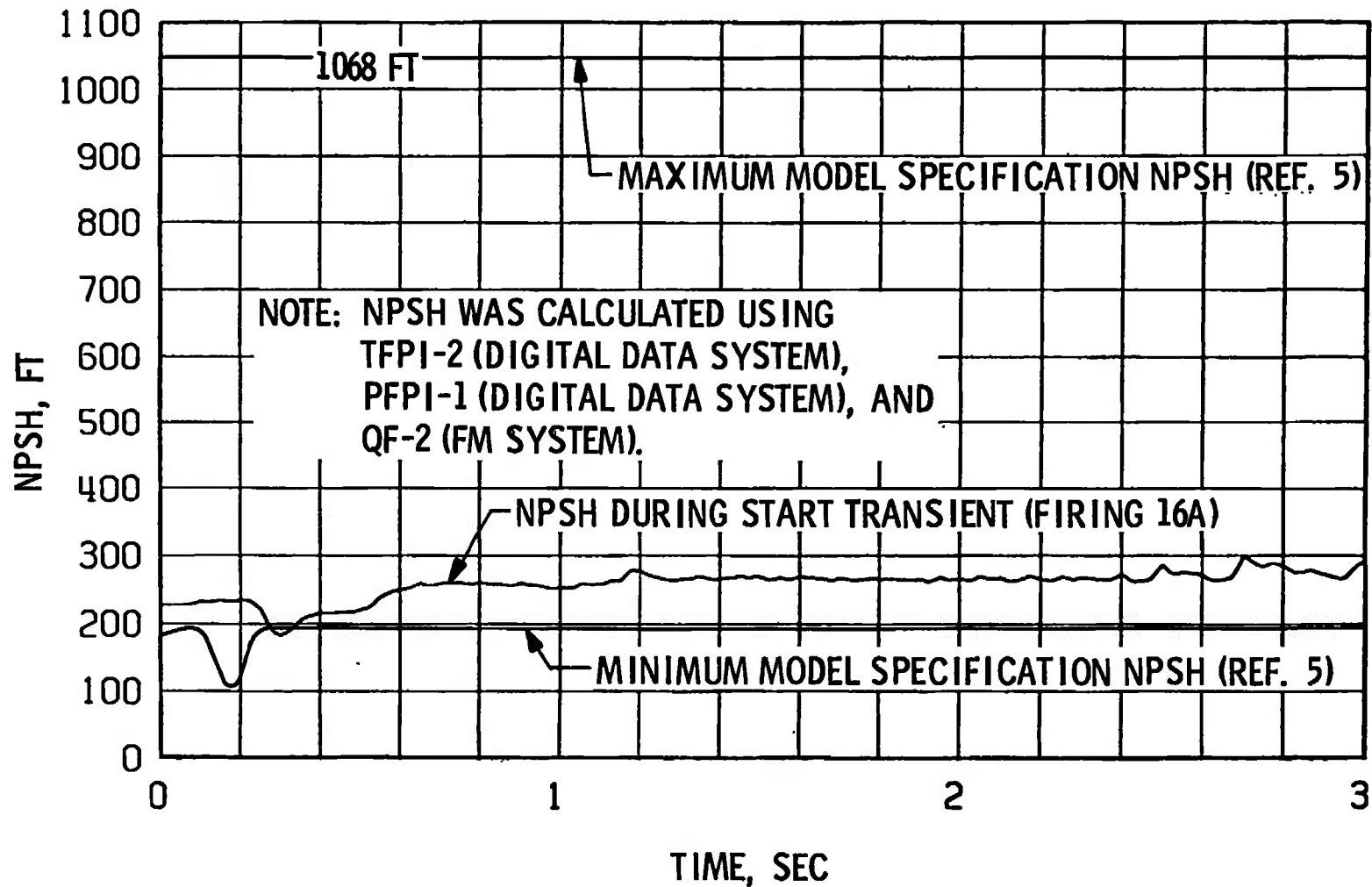

Fig. 13 Fuel Pump NPSH during Start Transient, Firing 16A

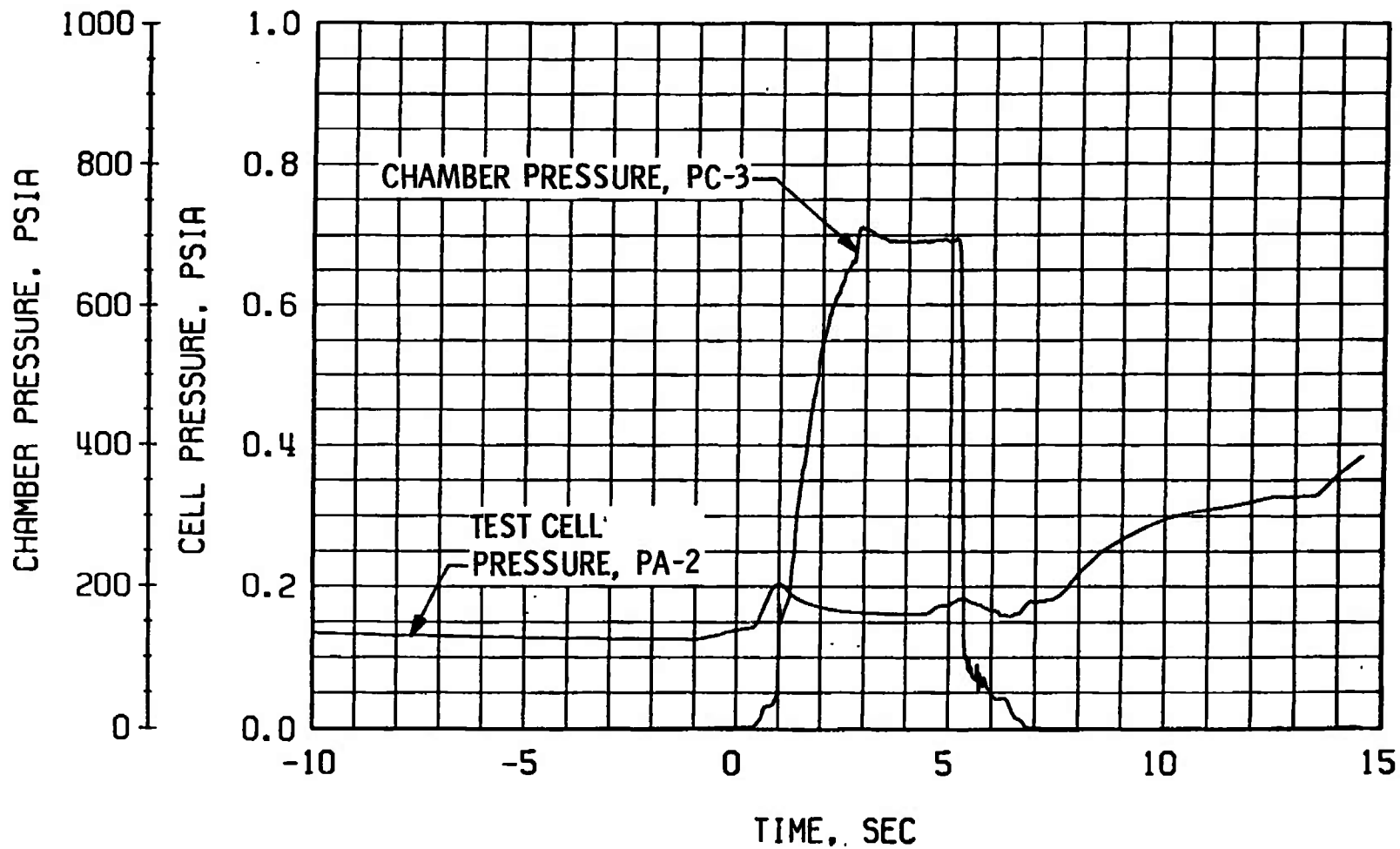
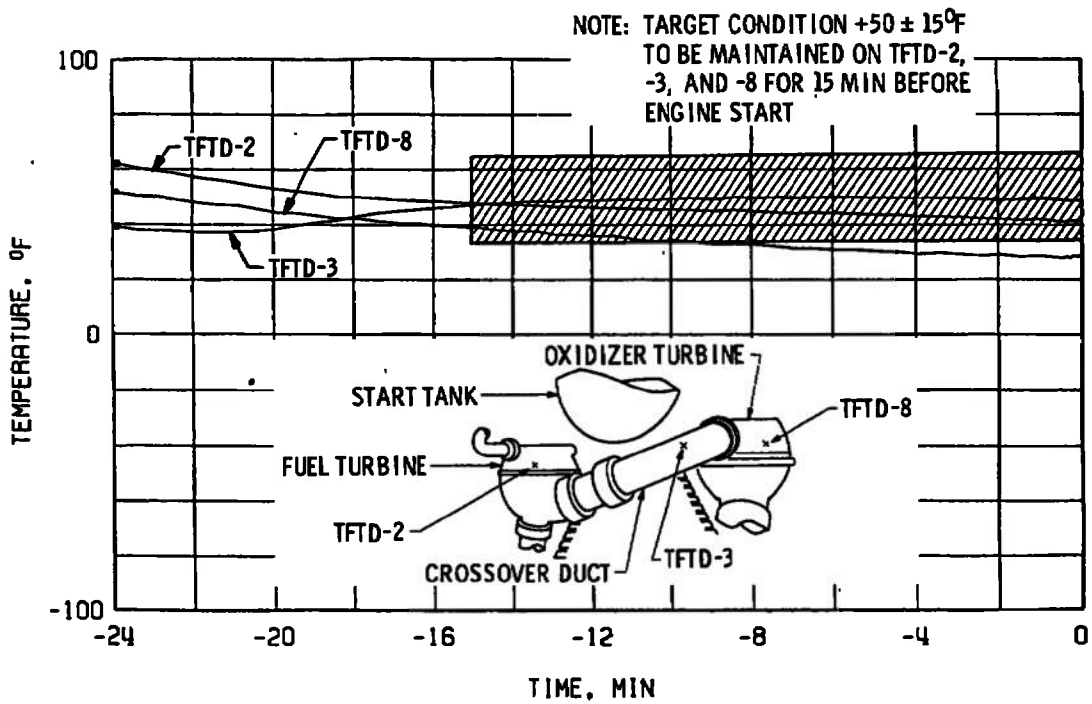
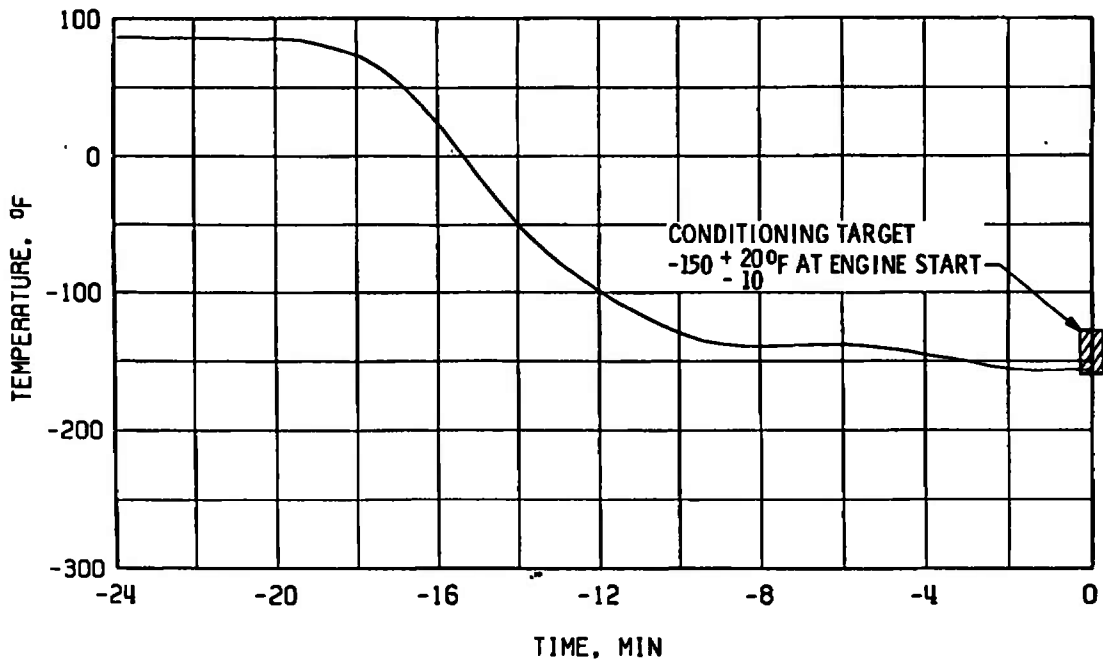

Fig. 14 Engine Ambient and Combustion Chamber Pressure, Firing 16B



a. Crossover Duct, TFTD



b. Thrust Chamber Throat, TTC-1P

Fig. 15 Thermal Conditioning History of Engine Components, Firing 16B

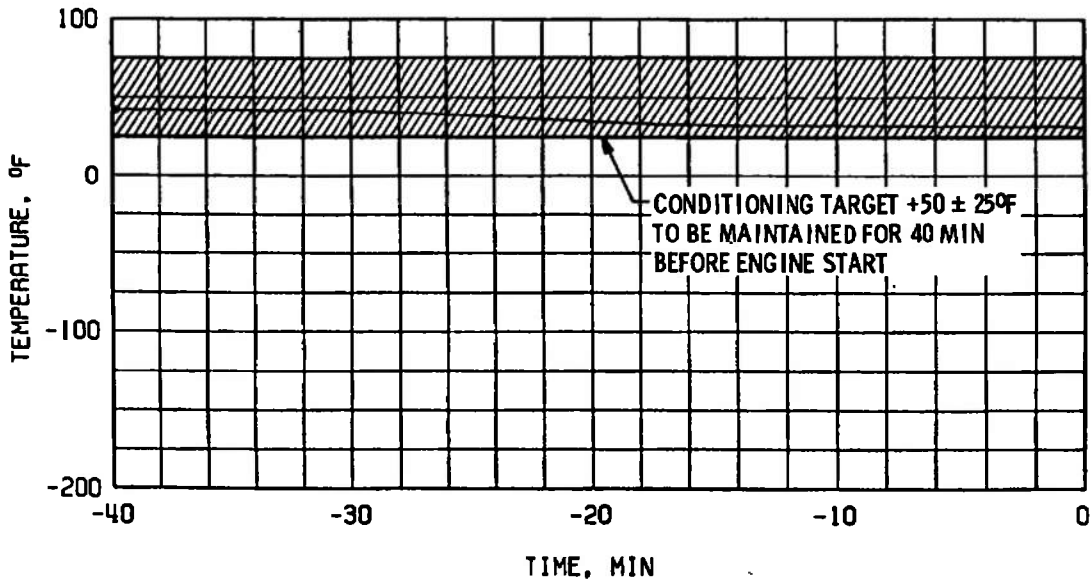

c. Start Tank Discharge Valve, STDVOC

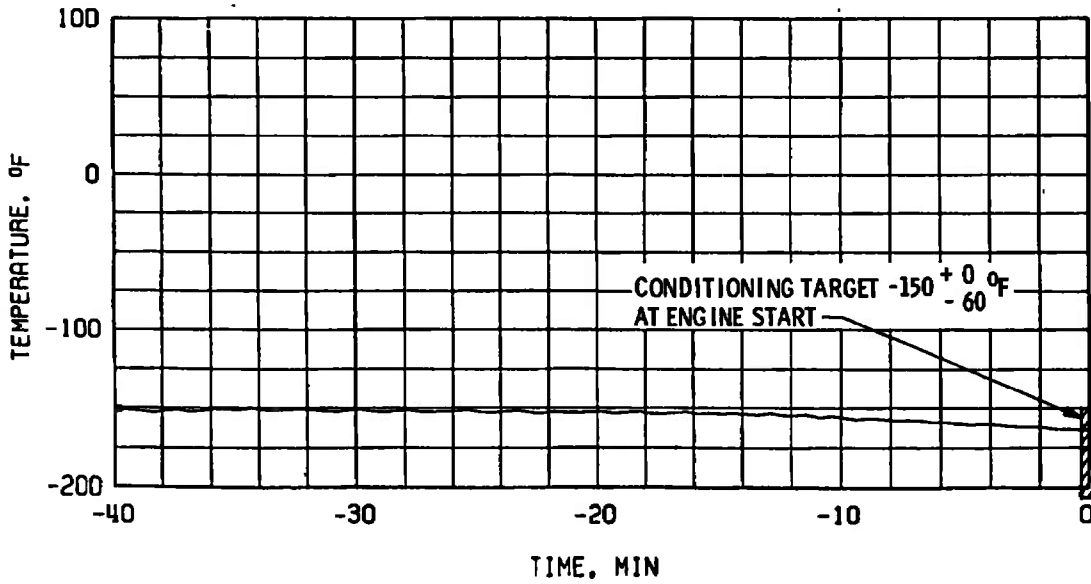

d. Main Oxidizer Valve Second-Stage Actuator, TSOVC-1

Fig. 15 Concluded

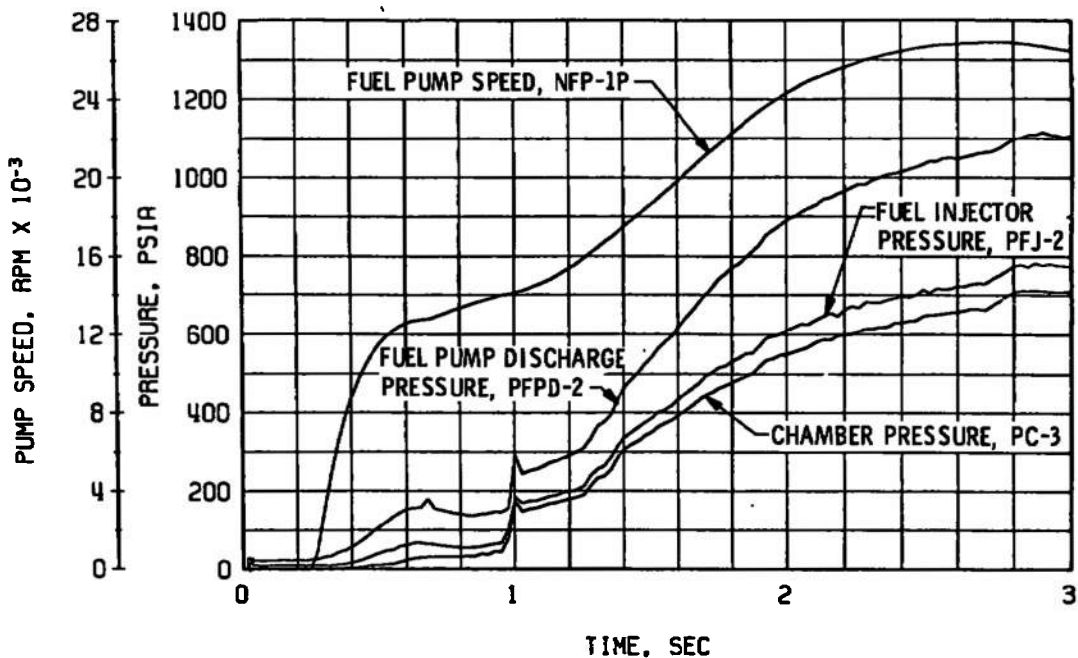

a. Thrust Chamber Fuel System, Start

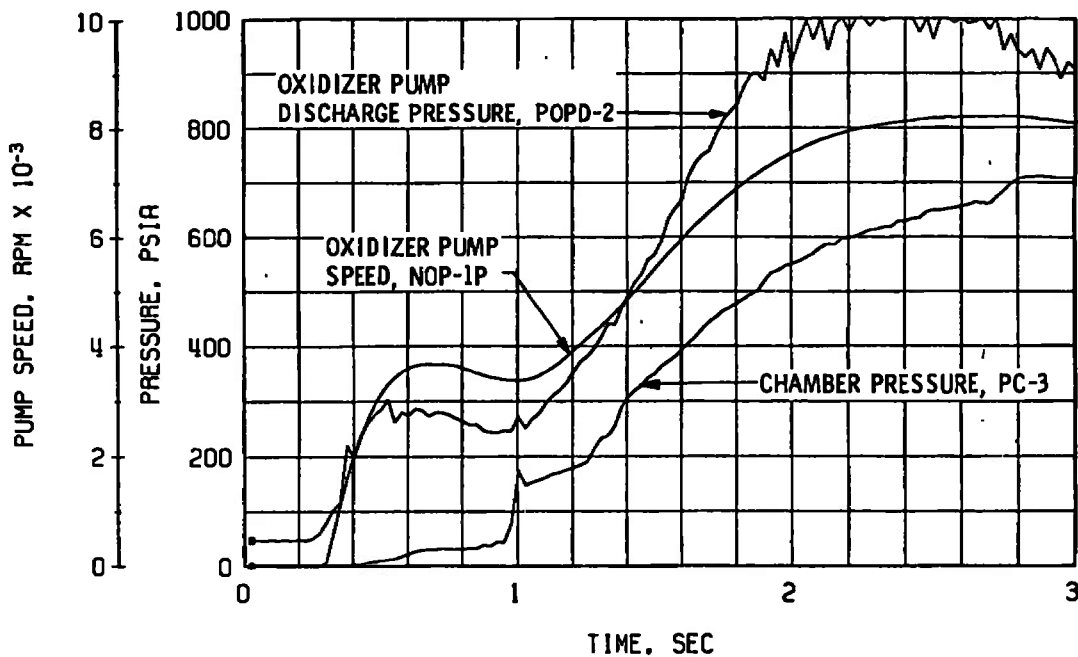

b. Thrust Chamber Oxidizer System, Start

Fig. 16 Engine Transient Operation, Firing 16B



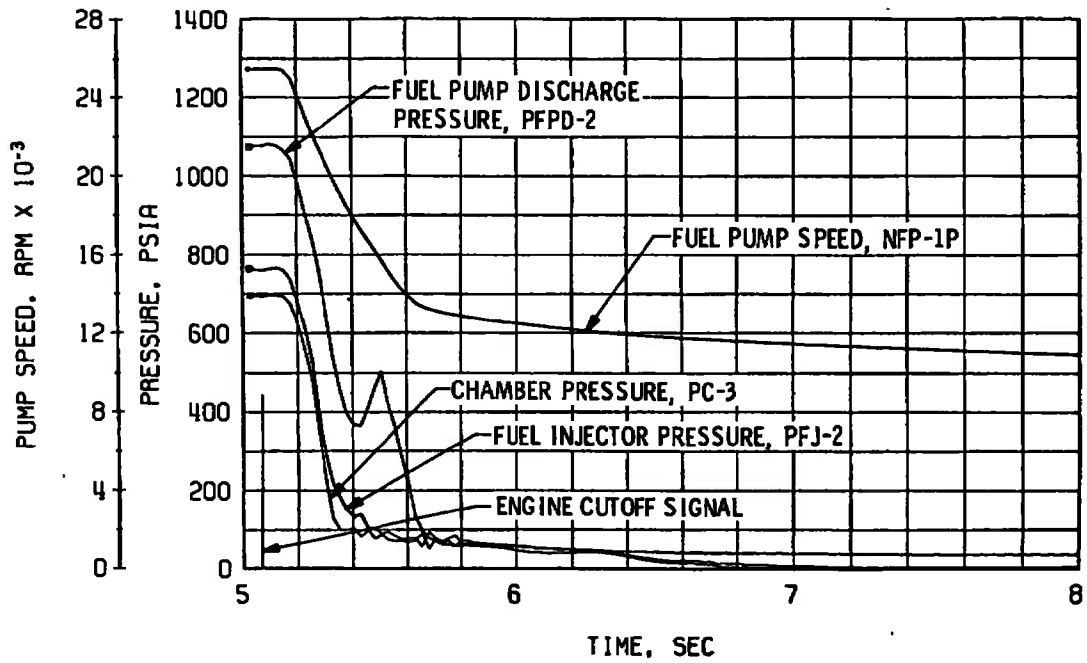

c. Thrust Chamber Fuel System, Shutdown

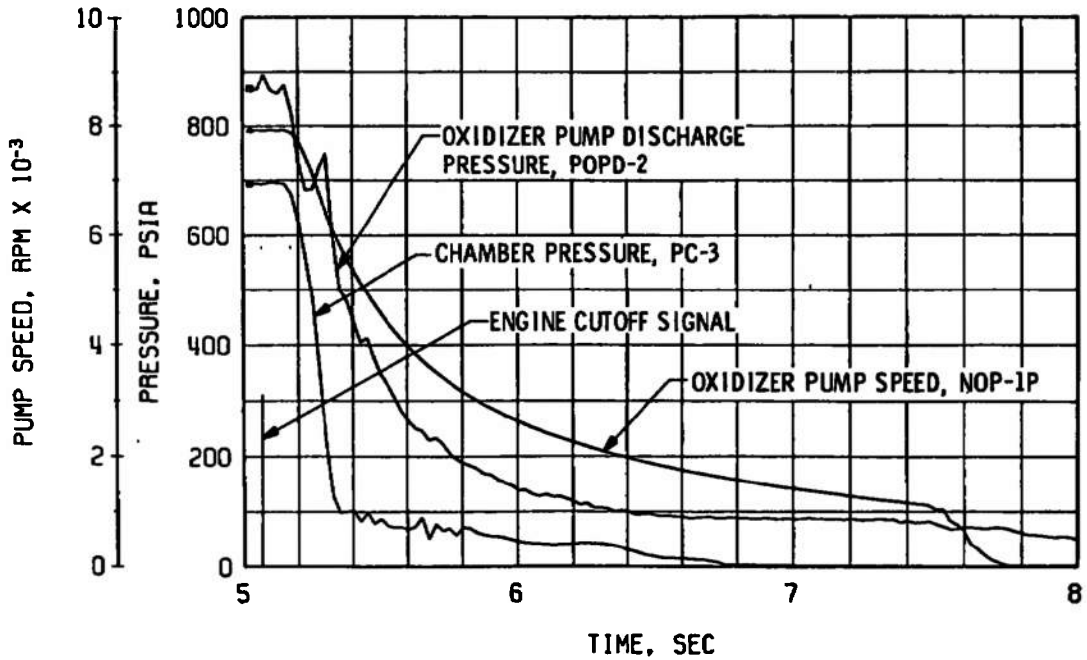

d. Thrust Chamber Oxidizer System, Shutdown

Fig. 16 Continued

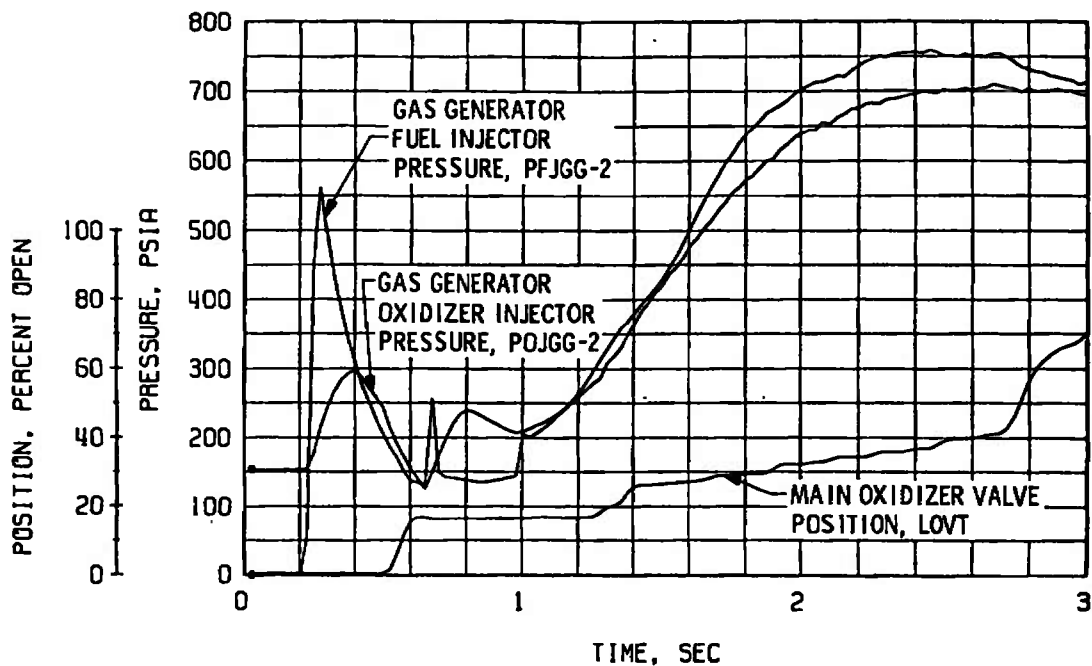

e. Gas Generator Injector Pressures and Main Oxidizer Valve Position, Start

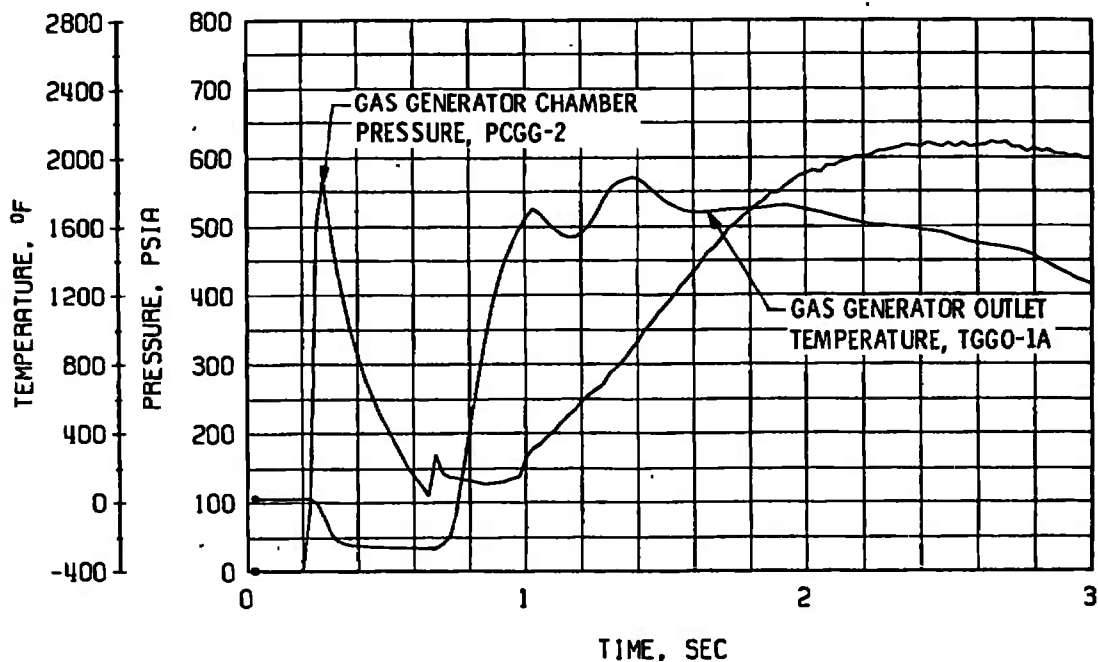

f. Gas Generator Chamber Pressure and Temperature, Start

Fig. 16 Continued

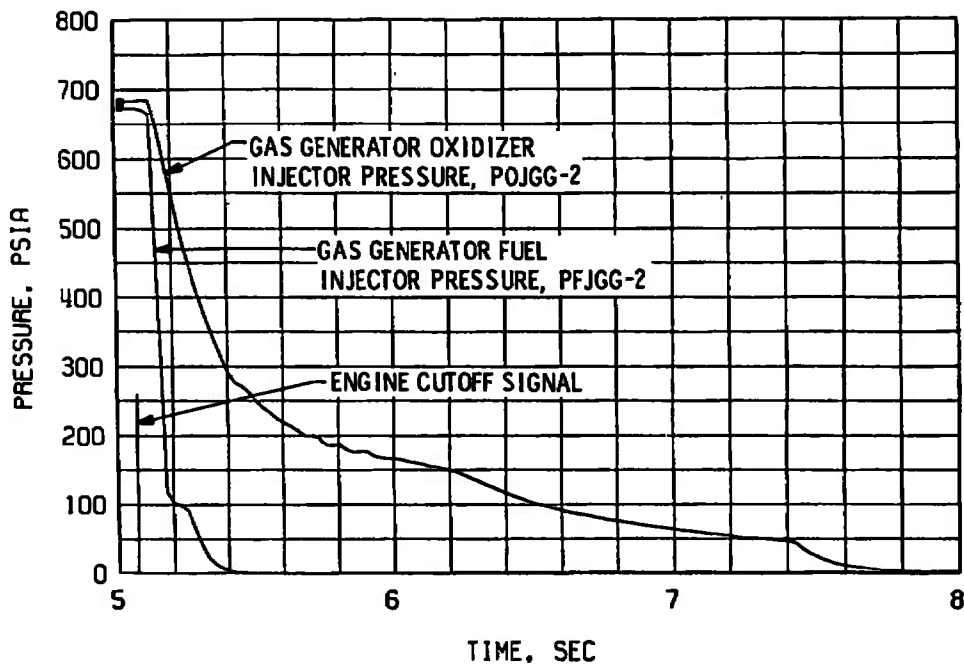

g. Gas Generator Injector Pressures, Shutdown

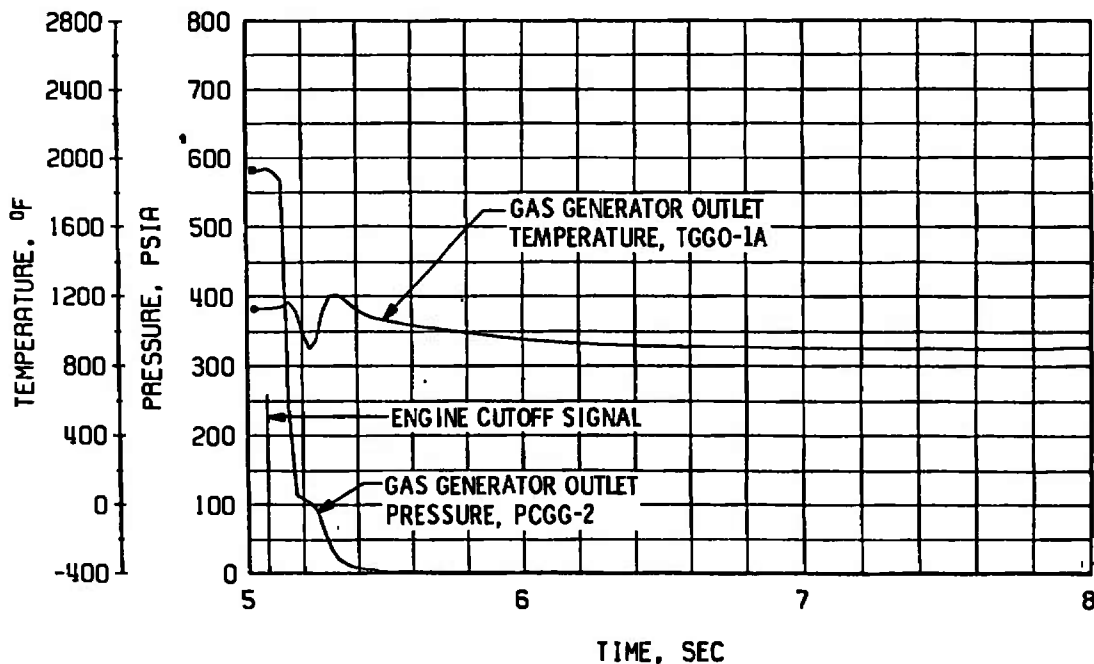

h. Gas Generator Chamber Pressure and Temperature, Shutdown

Fig. 16 Concluded

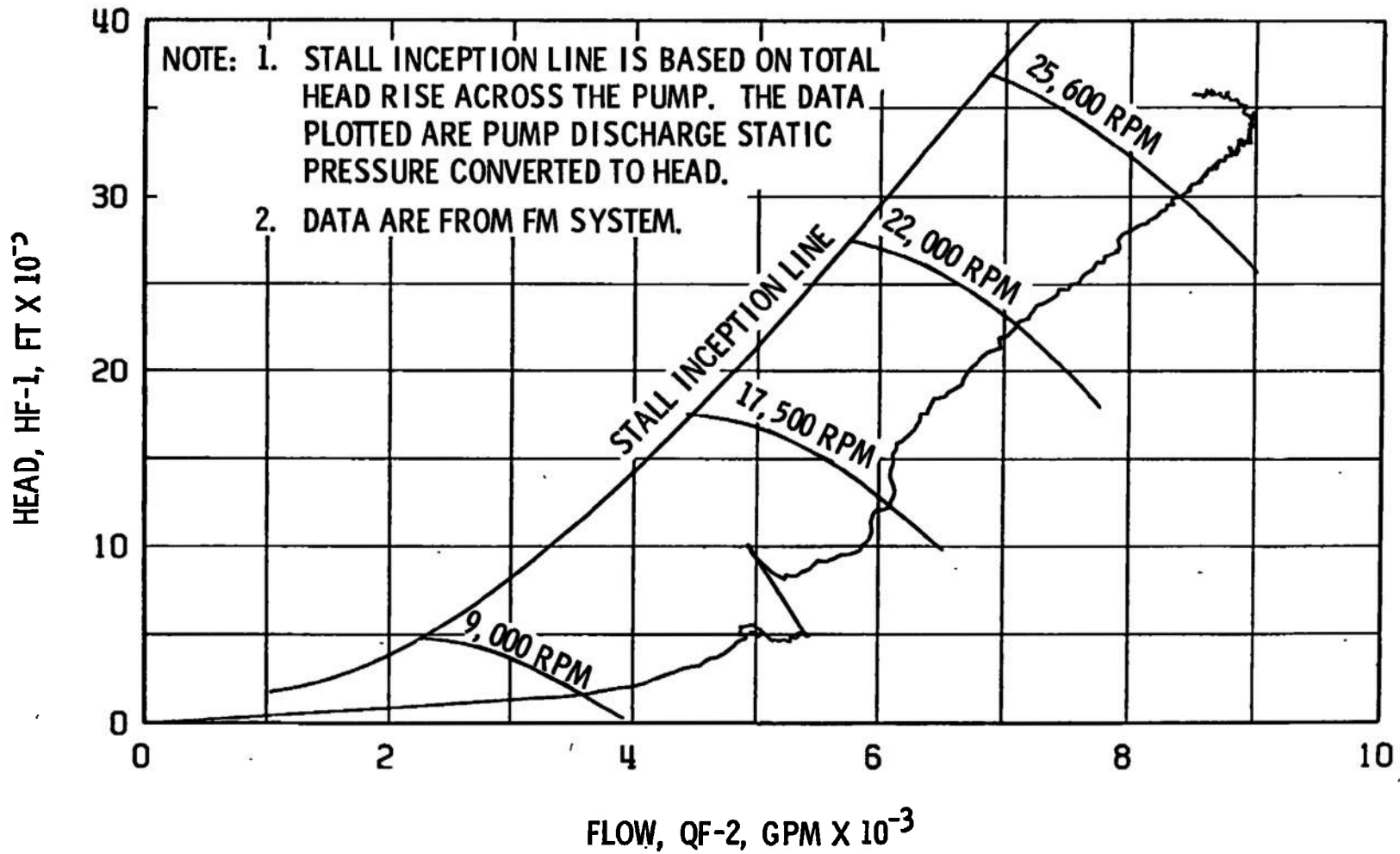

Fig. 17 Fuel Pump Start Transient Performance, Firing 16B

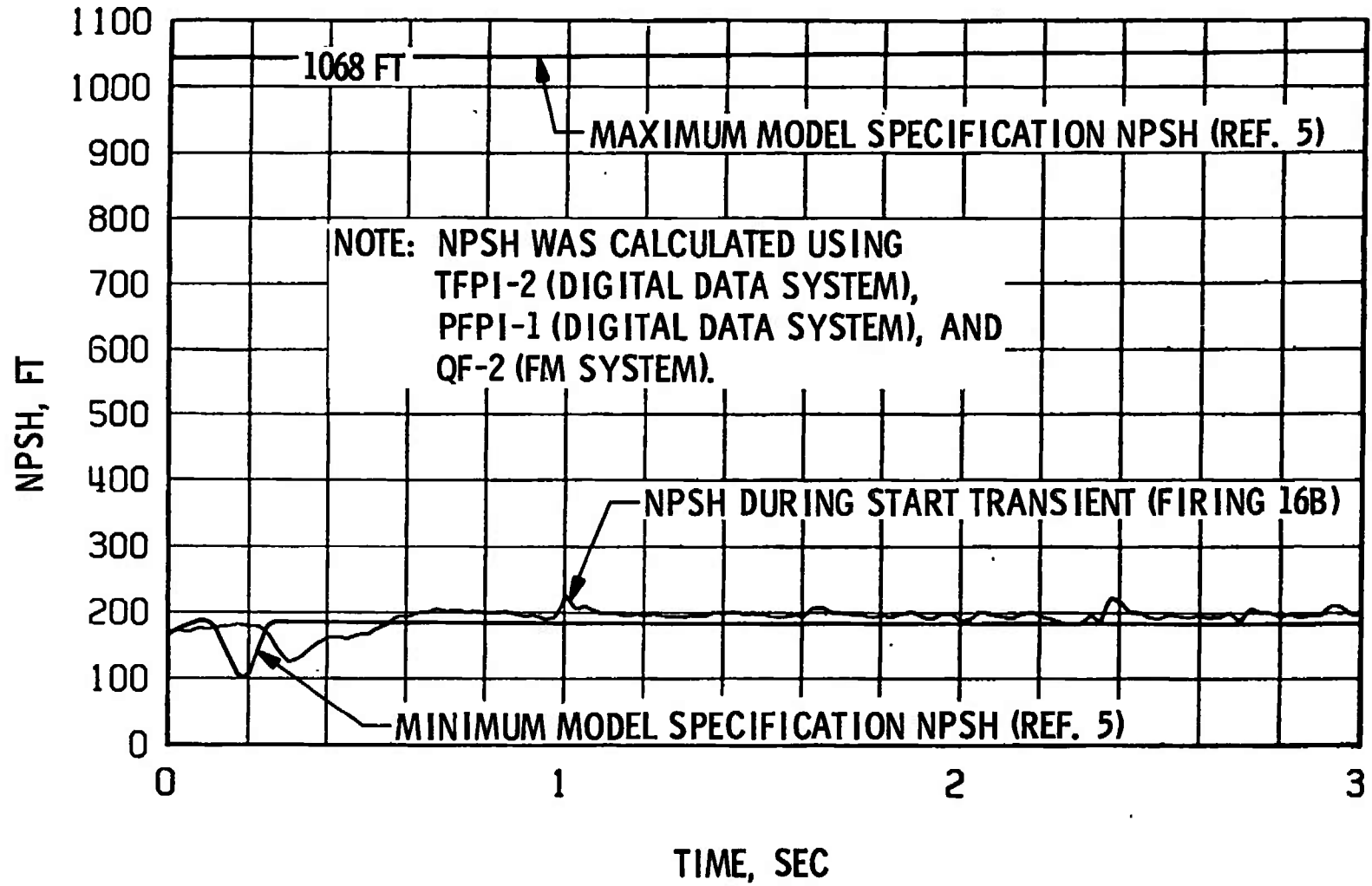

Fig. 18 Fuel Pump NPSH during Start Transient, Firing 16B

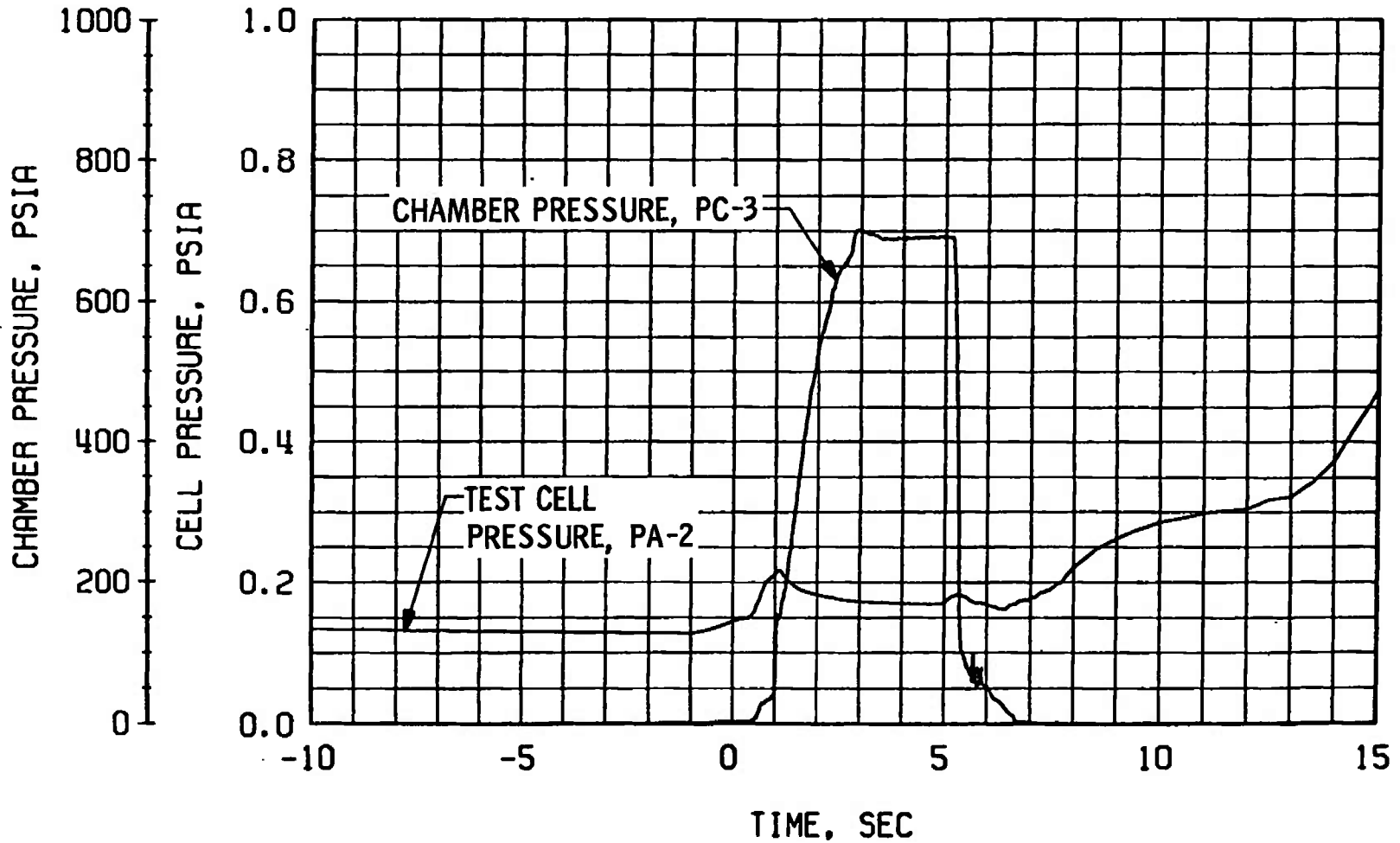

Fig. 19 Engine Ambient and Combustion Chamber Pressure, Firing 16C

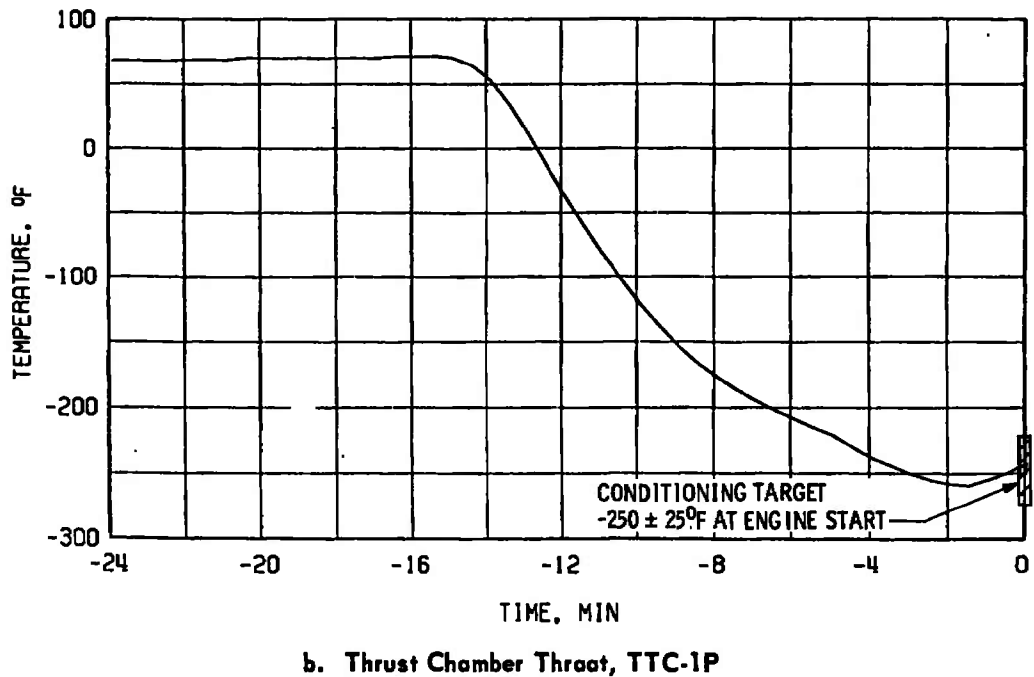
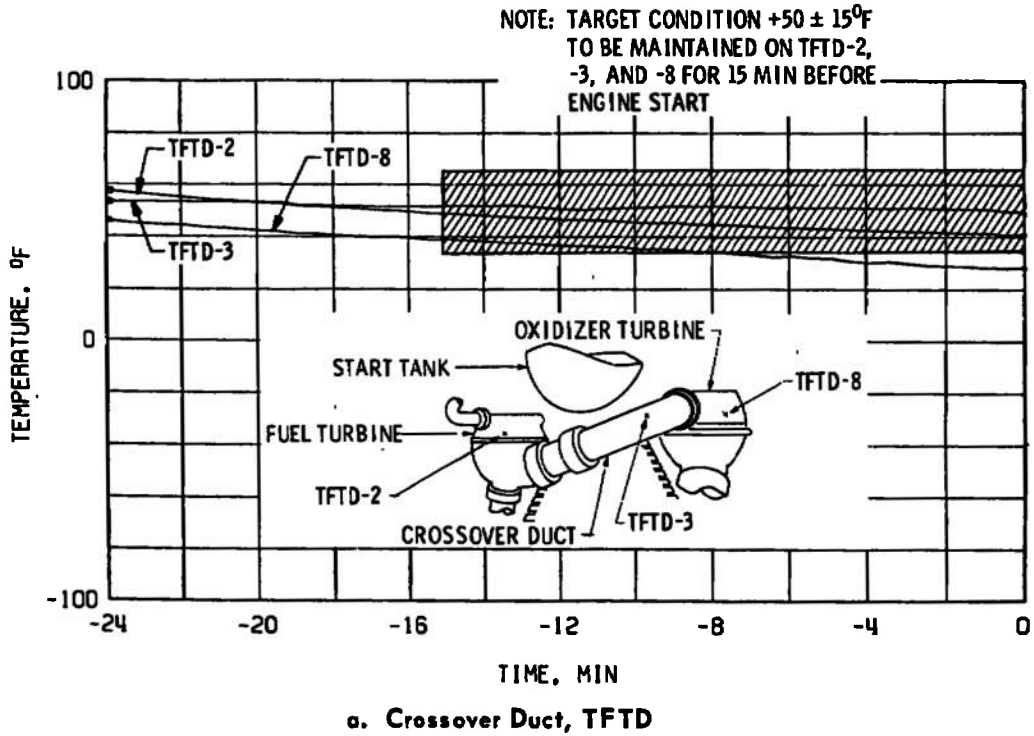
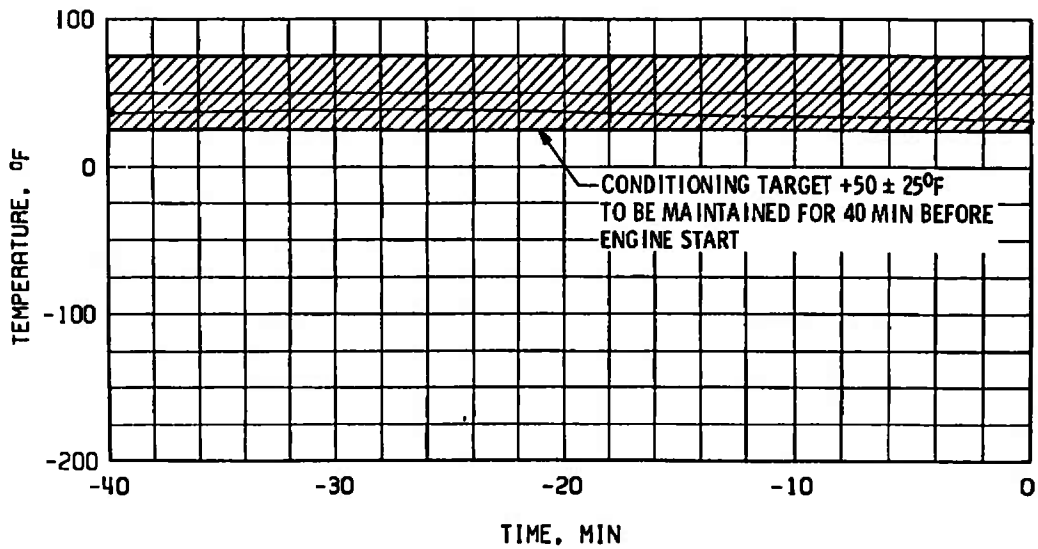
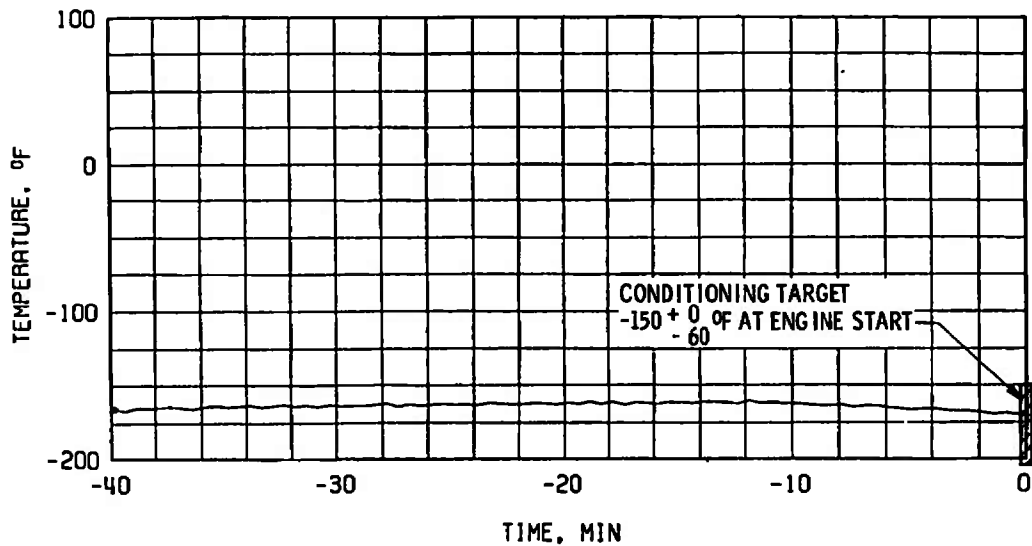

Fig. 20 Thermal Conditioning of Engine Components, Firing 16C



c. Start Tank Discharge Valve, STDVOC



d. Main Oxidizer Valve Second-Stage Actuator, TSOVC-1

Fig. 20 Concluded



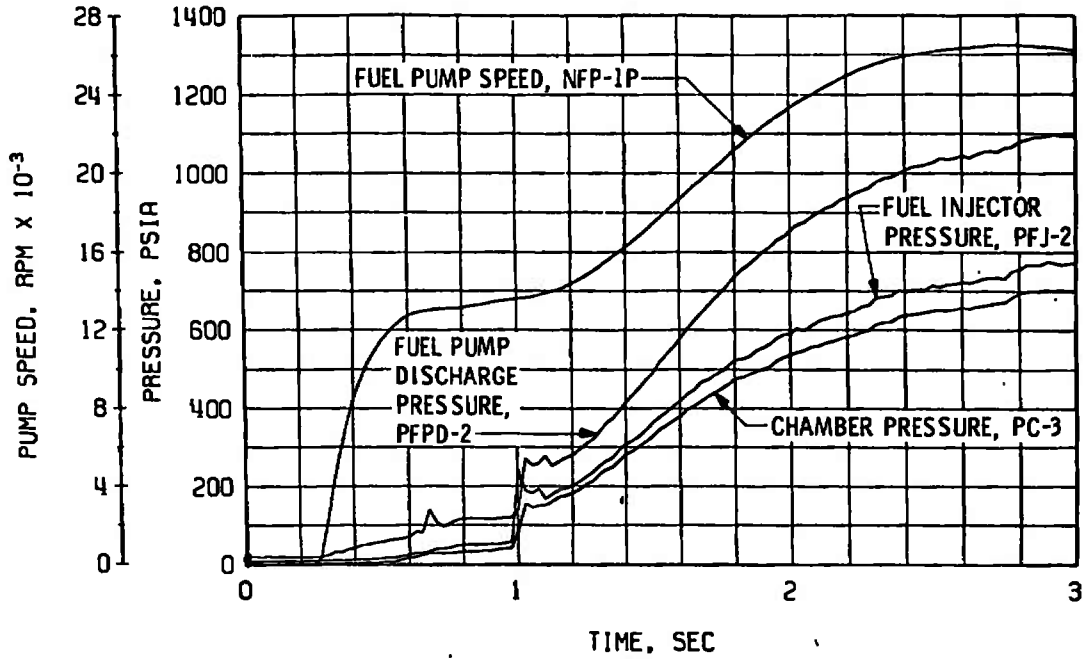

a. Thrust Chamber Fuel System, Start

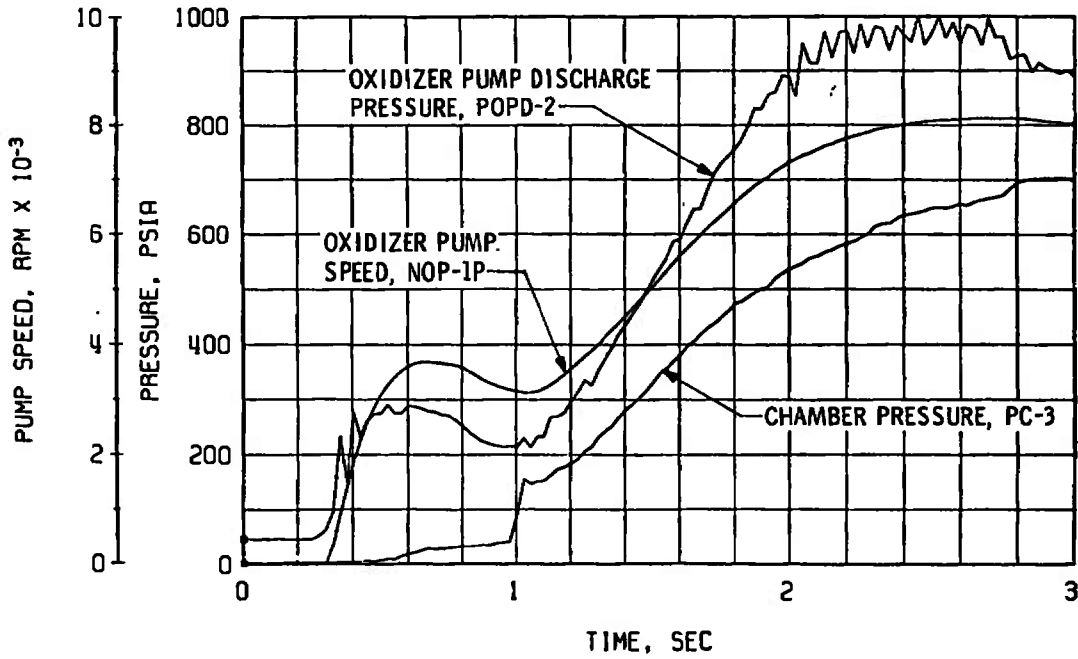

b. Thrust Chamber Oxidizer System, Start

Fig. 21 Engine Transient Operation, Firing 16C

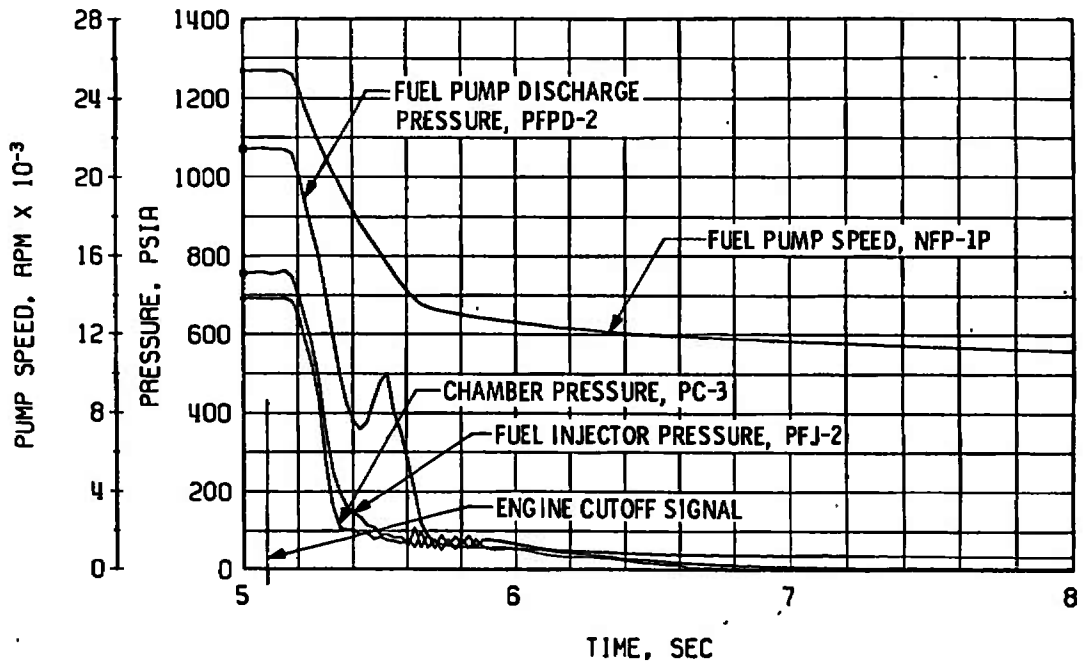

c. Thrust Chamber Fuel System, Shutdown

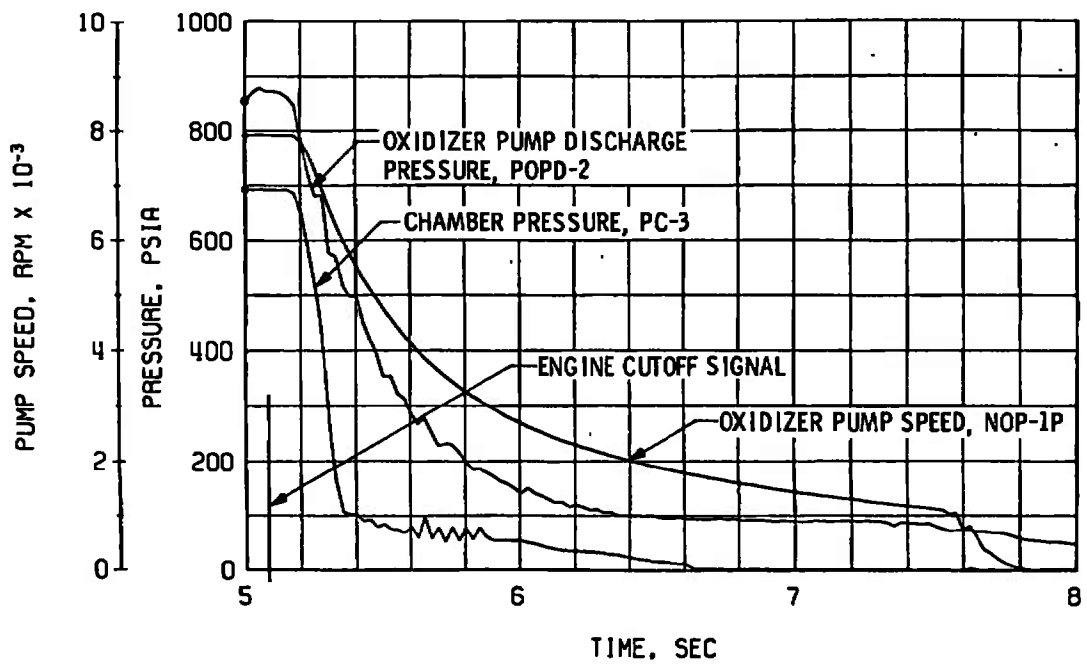

d. Thrust Chamber Oxidizer System, Shutdown

Fig. 21 Continued

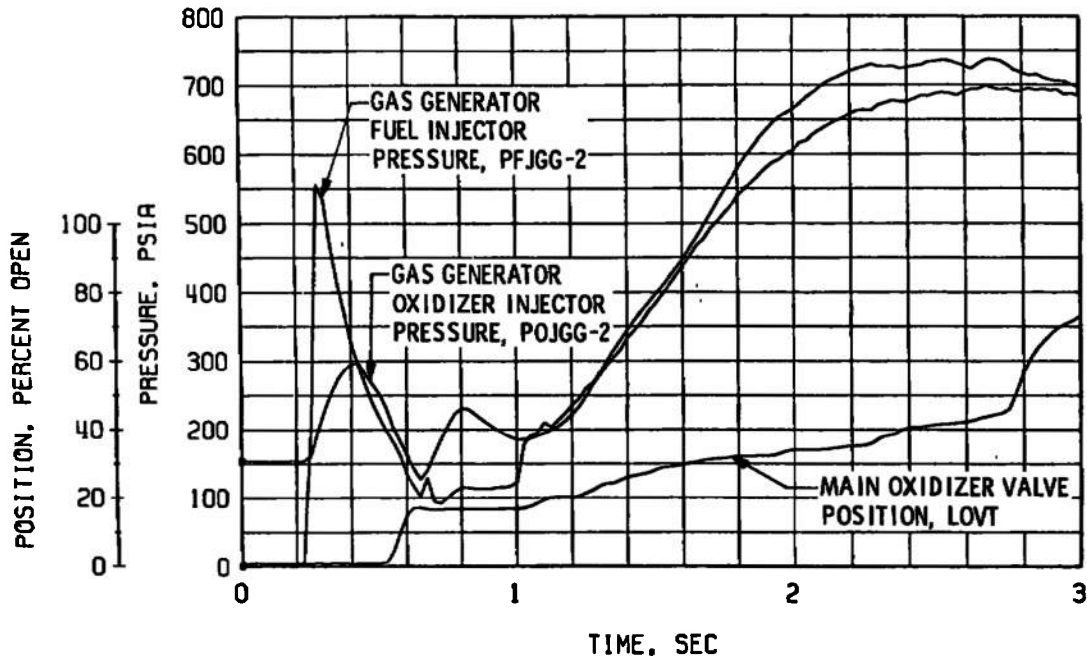

e. Gas Generator Injector Pressures and Main Oxidizer Valve Position, Start

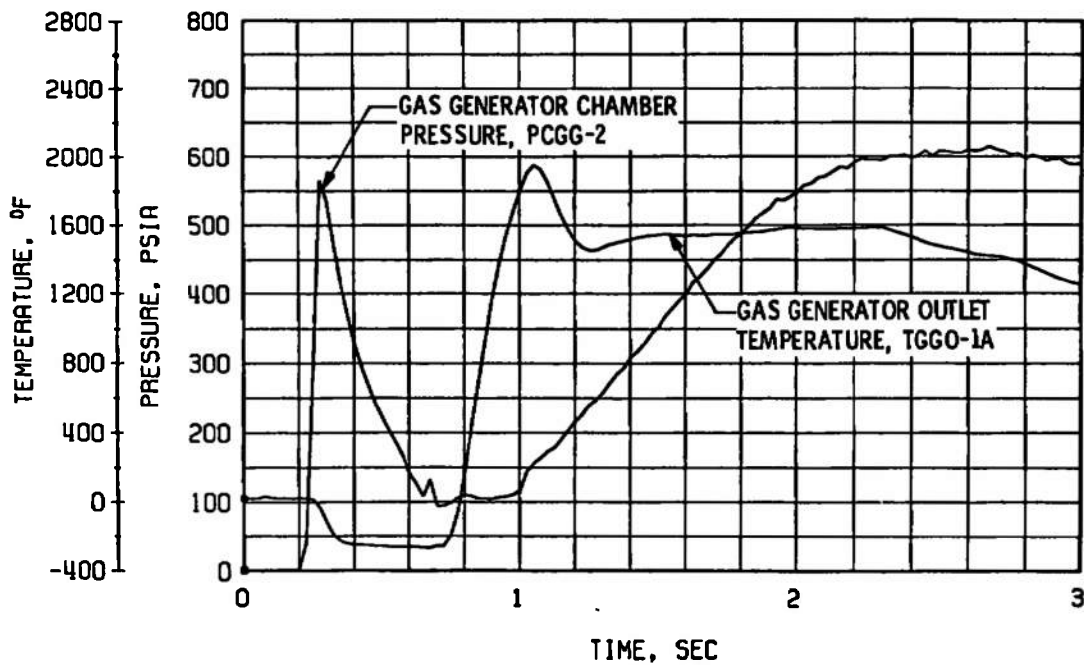

f. Gas Generator Chamber Pressure and Temperature, Start

Fig. 21 Continued

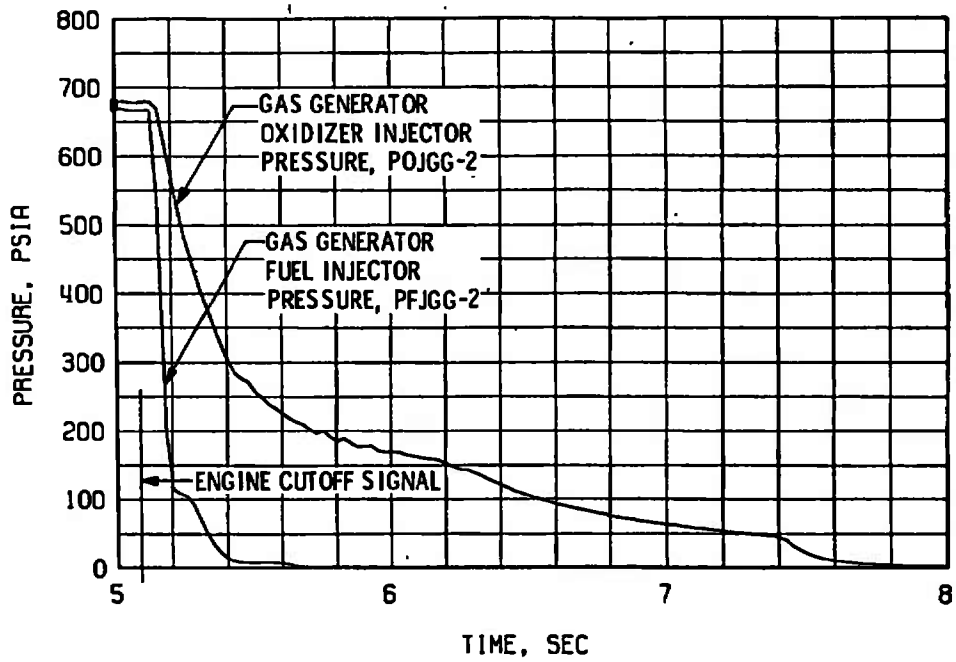

g. Gas Generator Injector Pressures, Shutdown

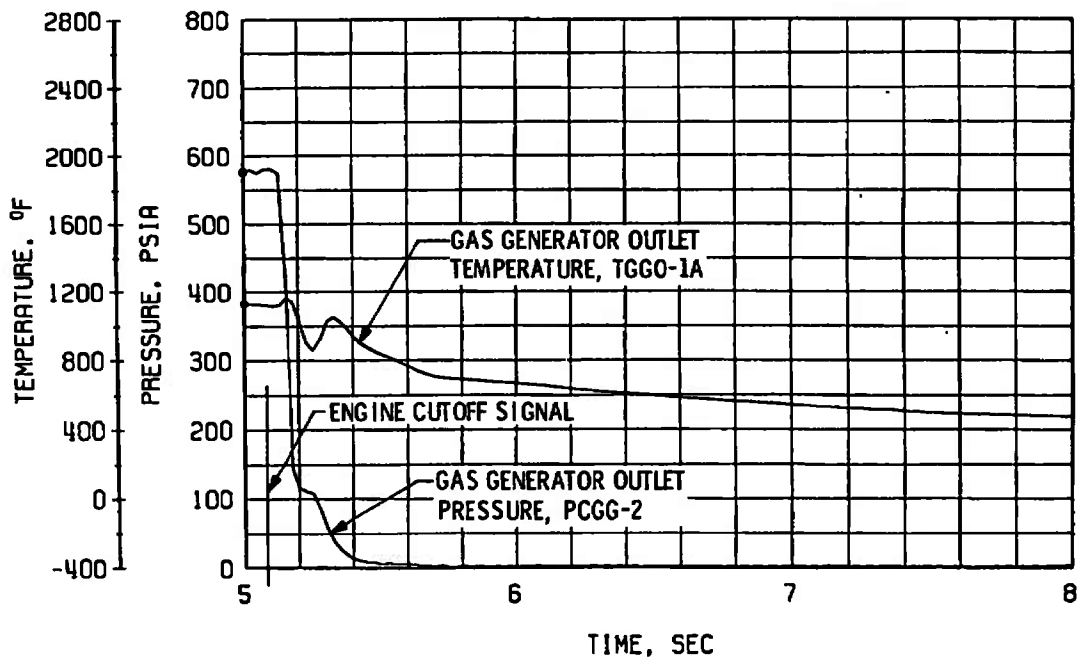

h. Gas Generator Chamber Pressure and Temperature, Shutdown

Fig. 21 Concluded

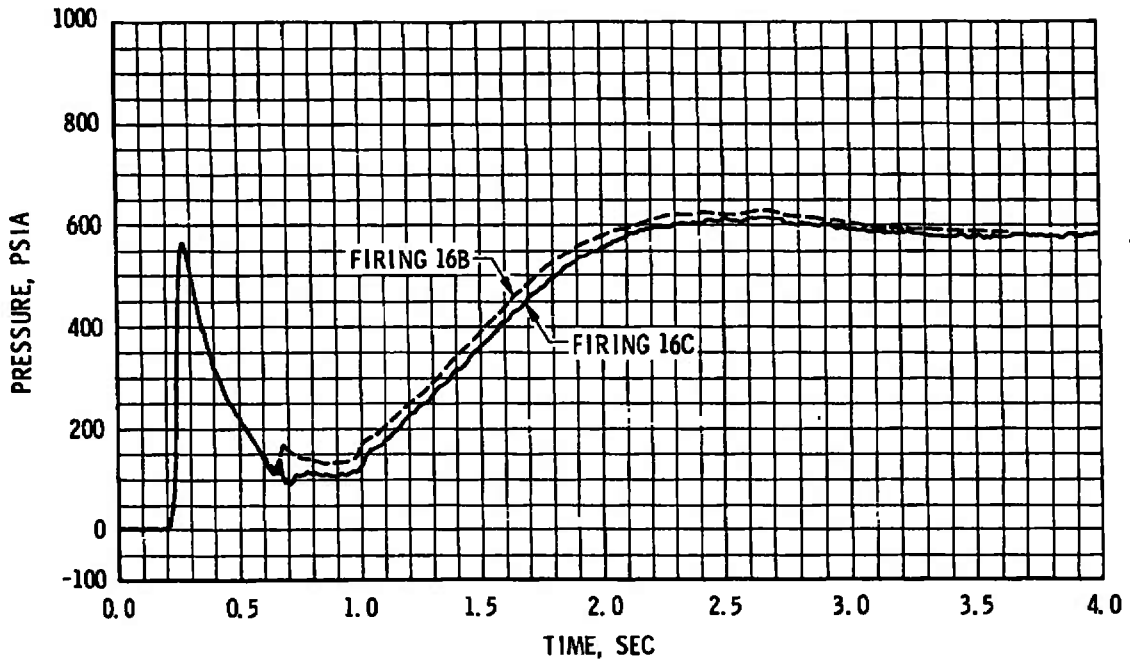

a. Gas Generator Chamber Pressure

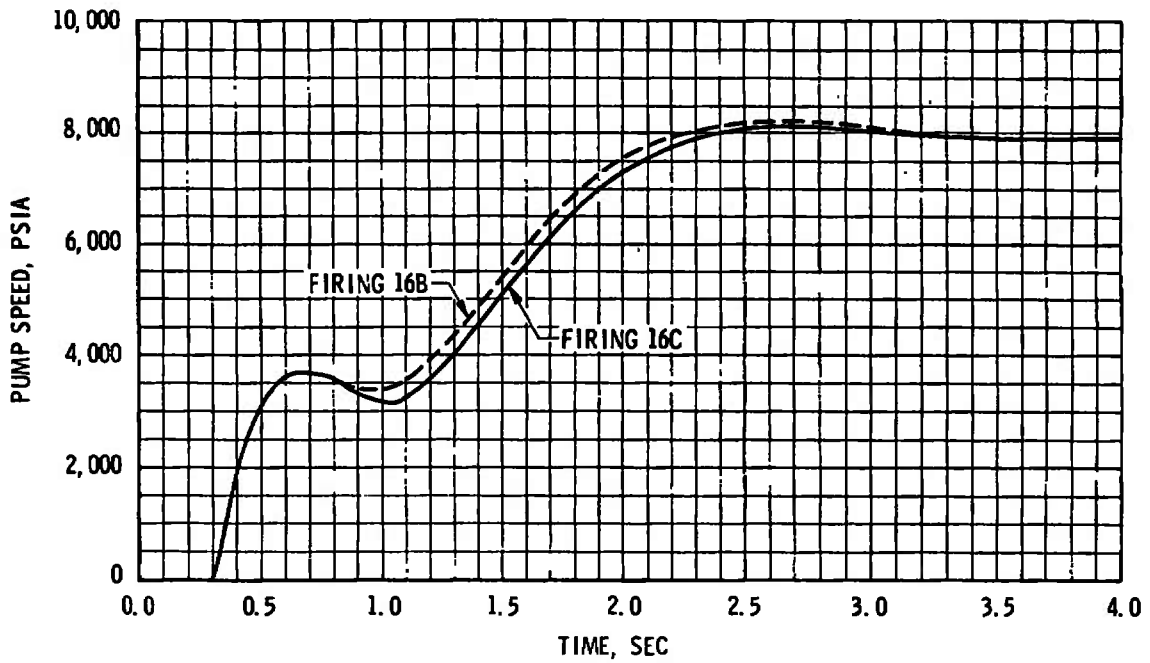

b. Oxidizer Pump Speed

Fig. 22 Thrust Chamber Temperature Effect on Engine Start Transient (Firings 16B and 16C)

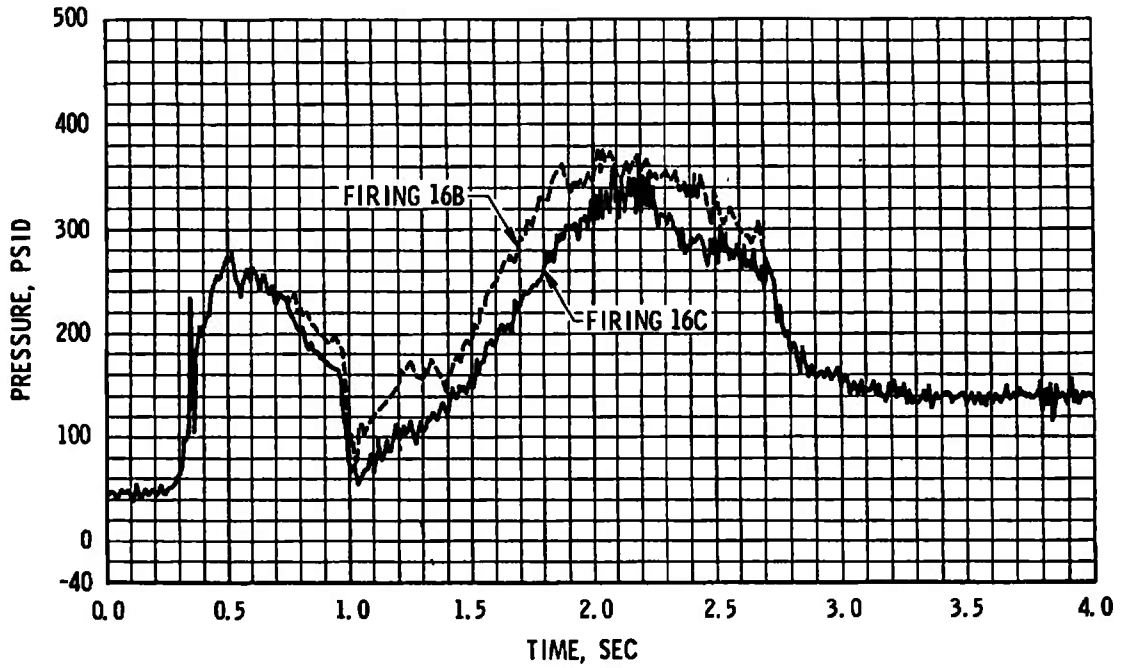

c. Differential Pressure across Main Oxidizer Valve

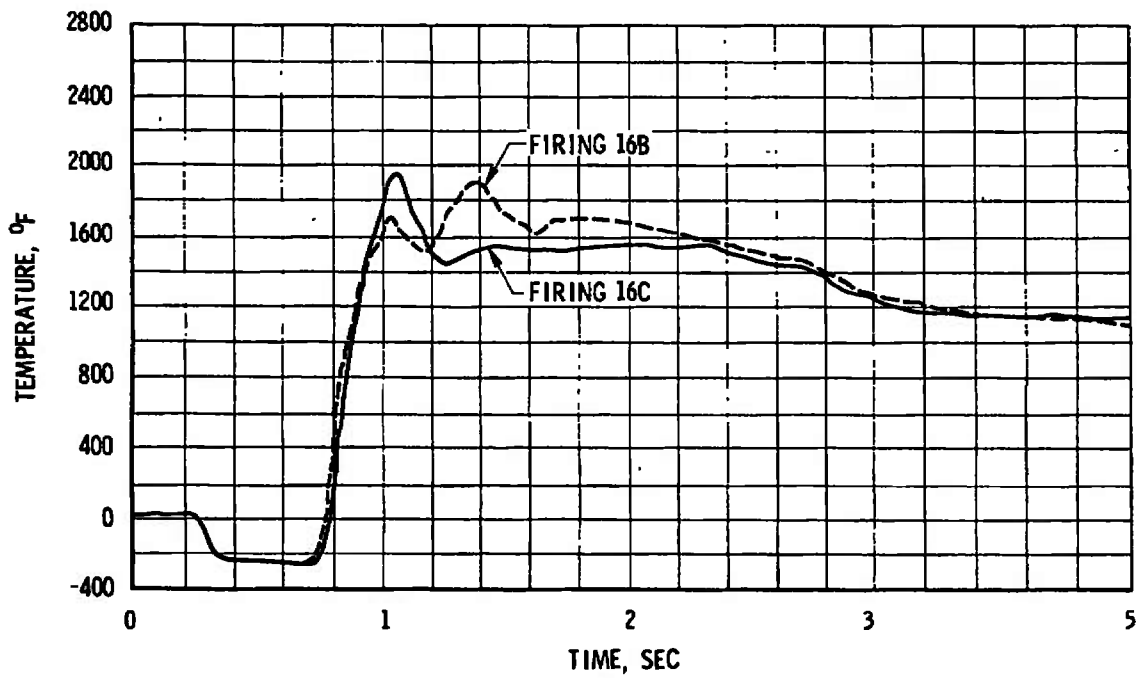

d. Gas Generator Outlet Temperature

Fig. 22 Concluded

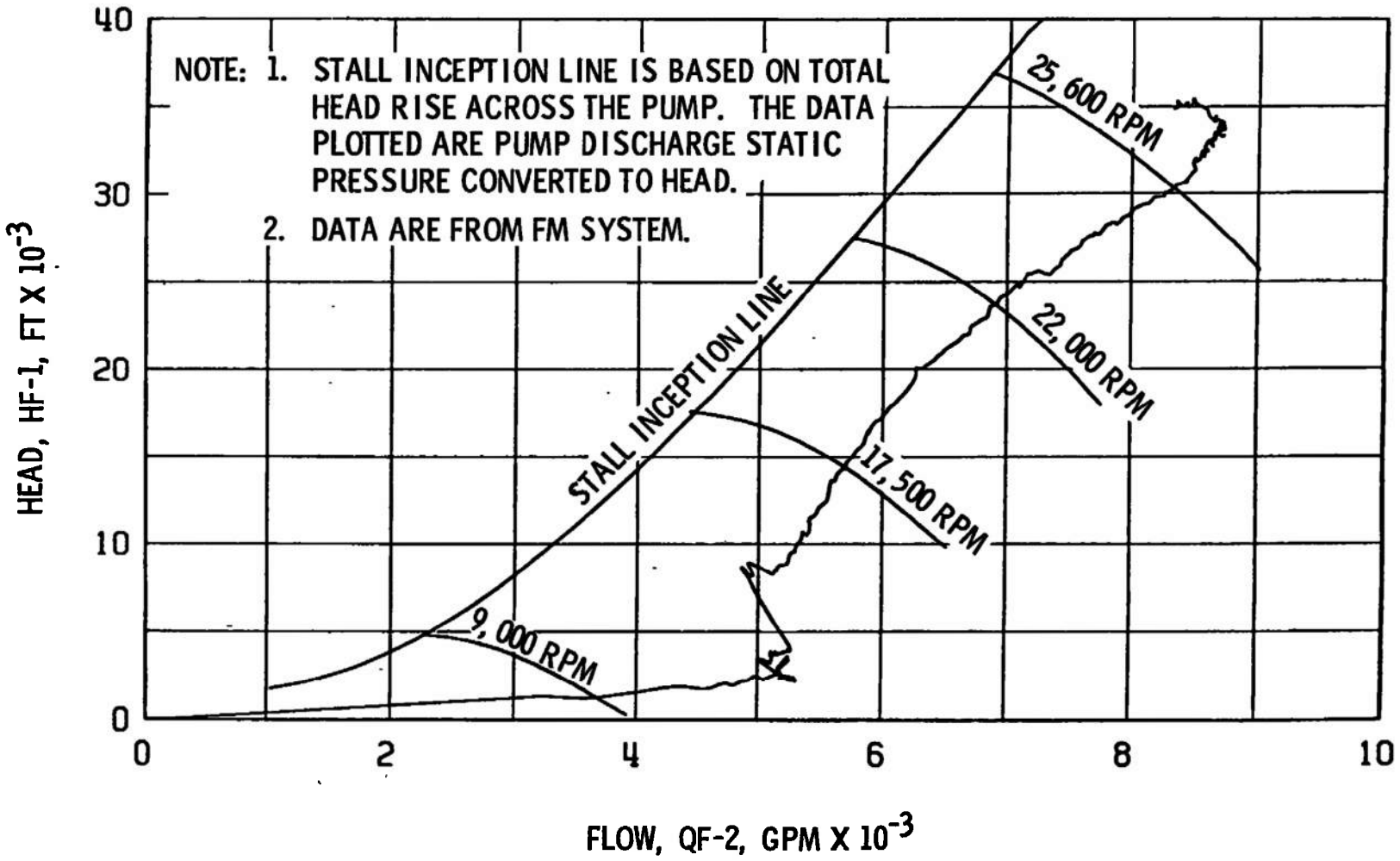

NOTE: 1. STALL INCEPTION LINE IS BASED ON TOTAL HEAD RISE ACROSS THE PUMP. THE DATA PLOTTED ARE PUMP DISCHARGE STATIC PRESSURE CONVERTED TO HEAD.  
2. DATA ARE FROM FM SYSTEM.

Fig. 23 Fuel Pump Start Transient Performance, Firing 16C

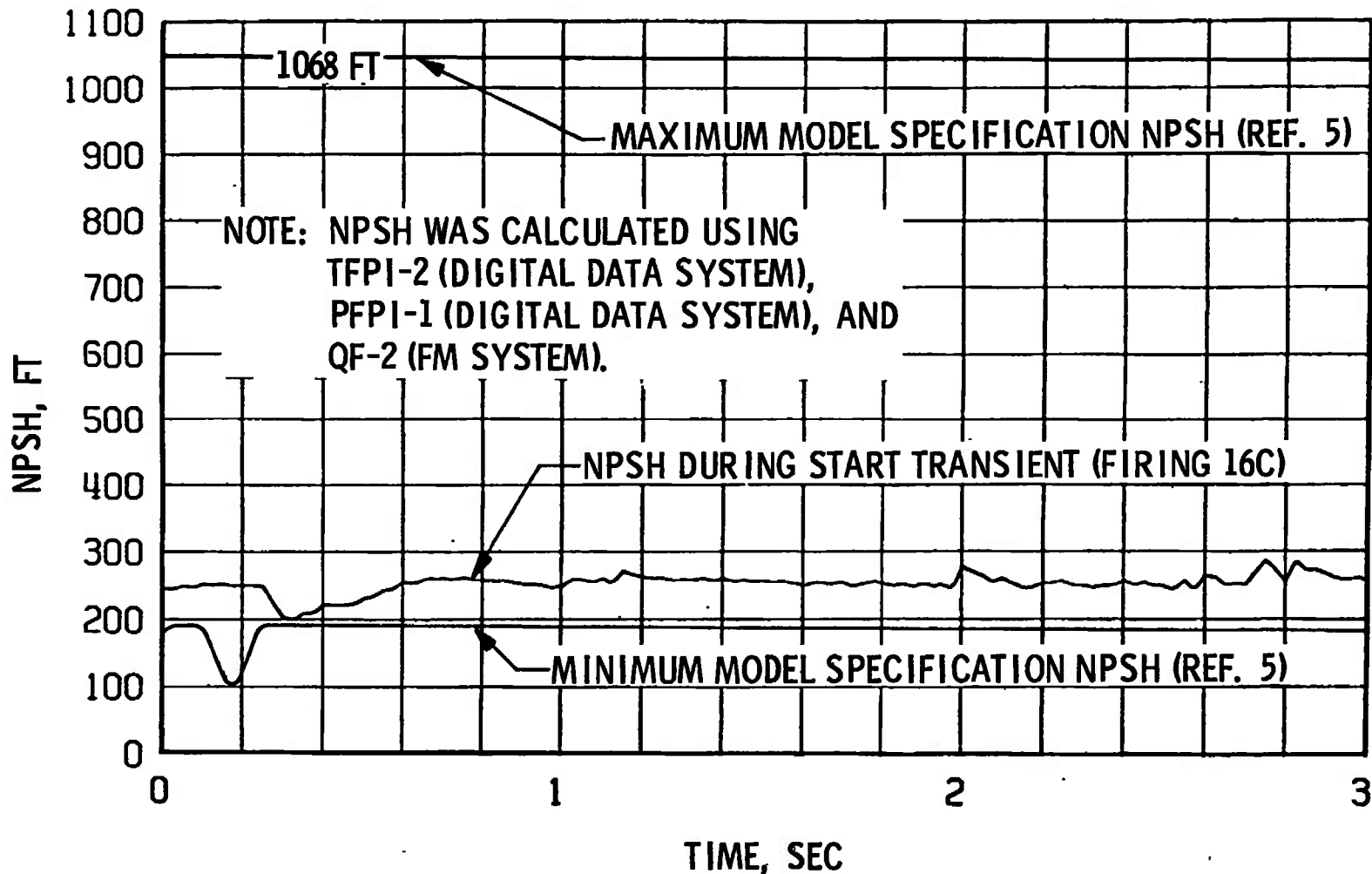

Fig. 24 Fuel Pump NPSH during Start Transient, Firing 16C



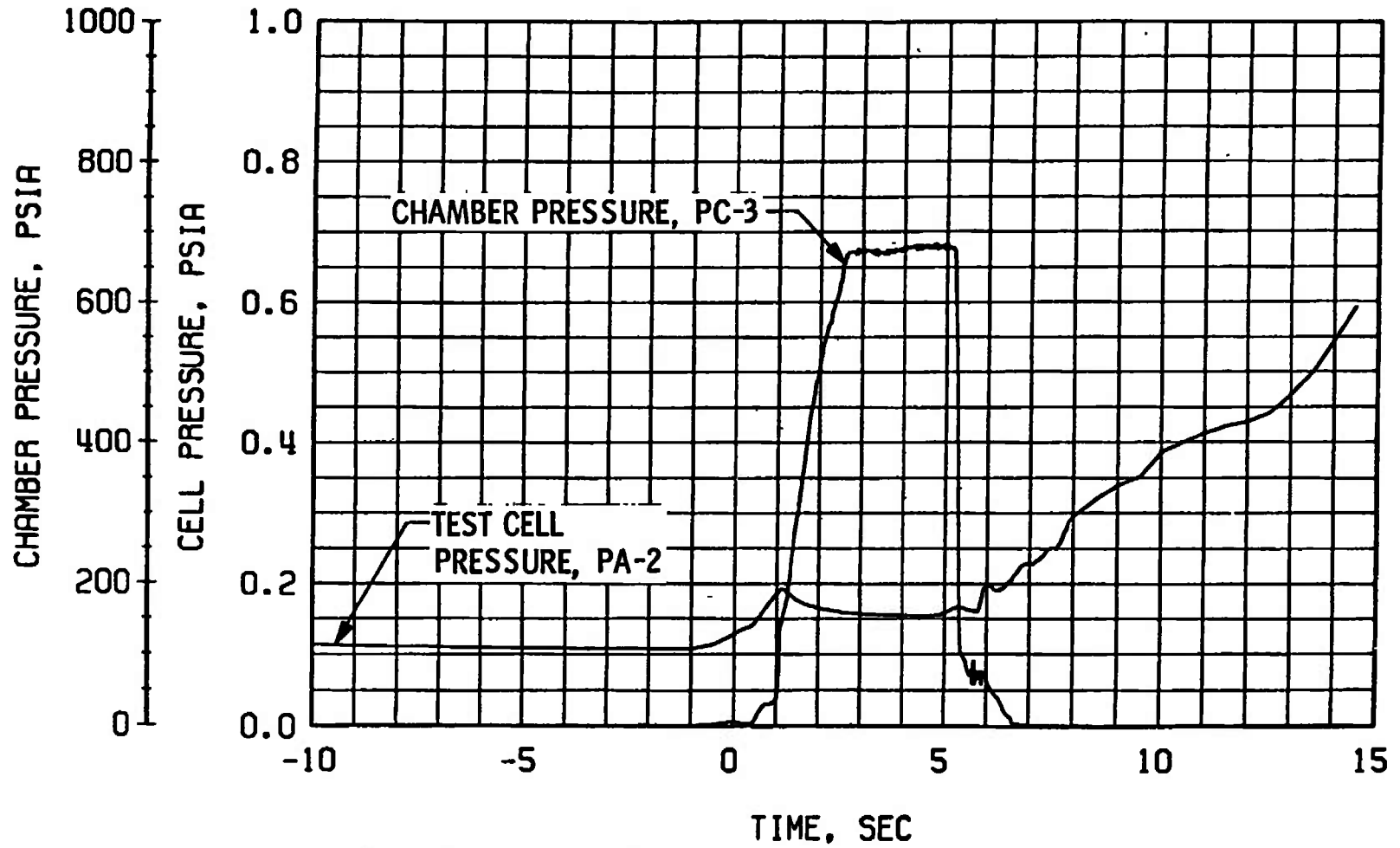
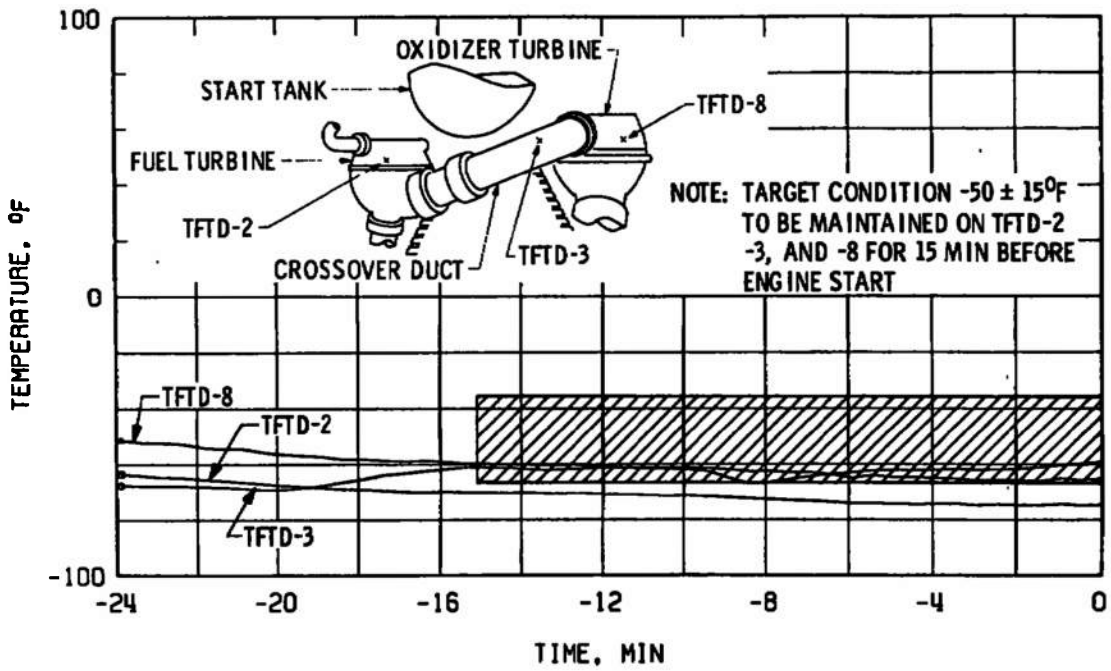
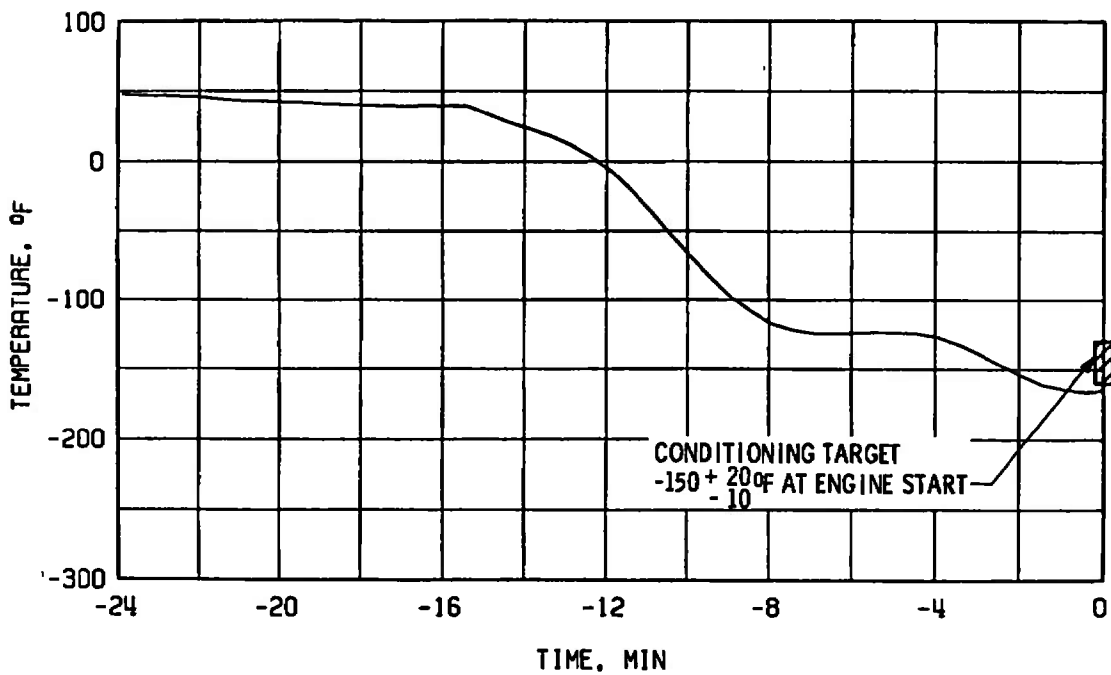

Fig. 25 Engine Ambient and Combustion Chamber Pressures, Firing 16D



a. Crossover Duct, TTFD



b. Thrust Chamber Throat, TTC-1P

Fig. 26 Thermal Conditioning History of Engine Components, Firing 16D

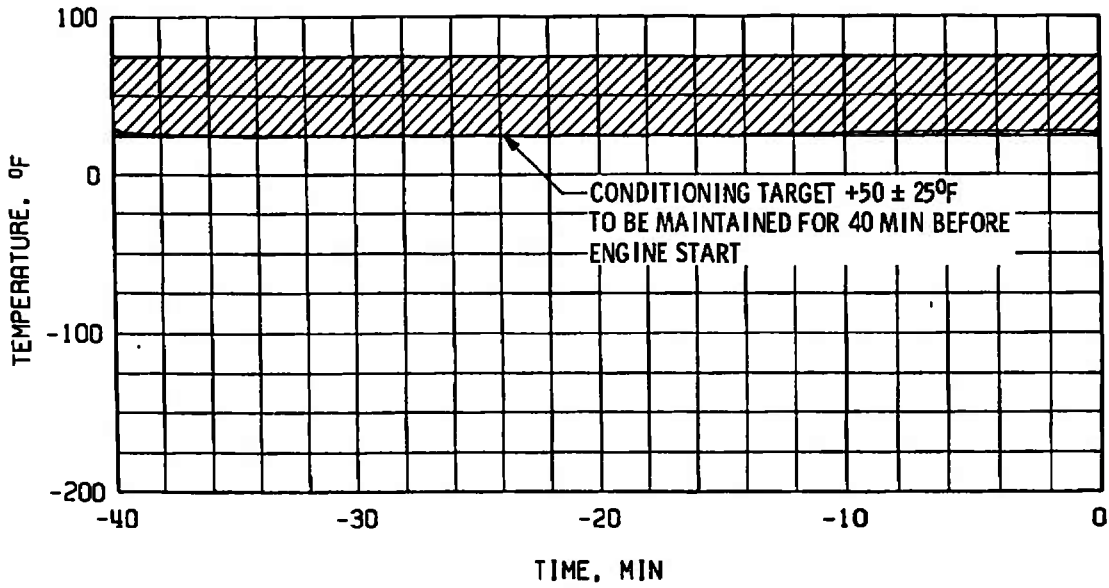

c. Start Tank Discharge Valve, STDVOC

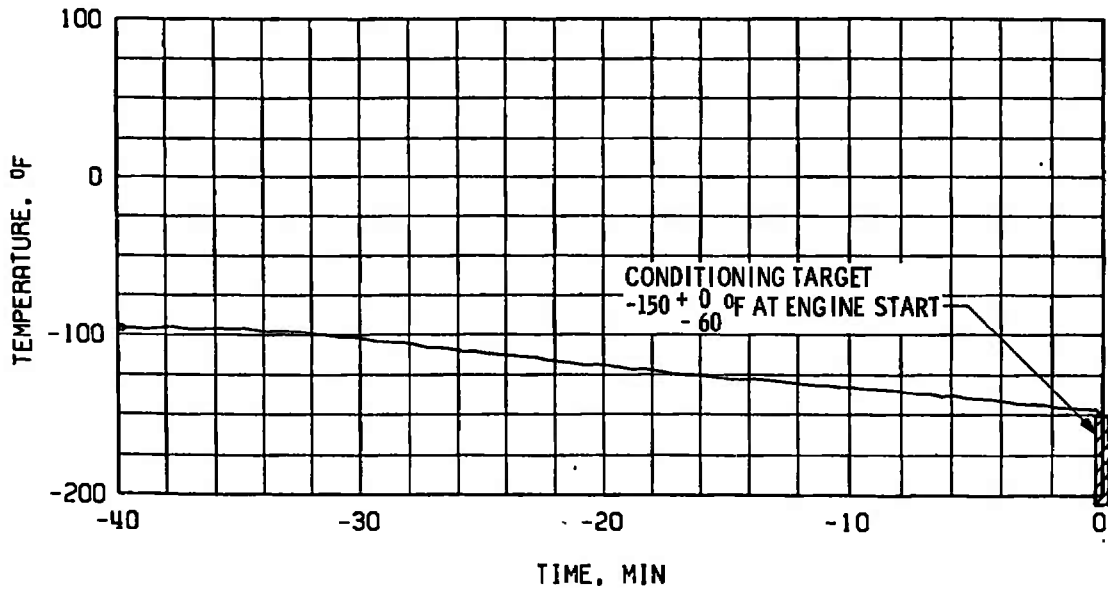

d. Main Oxidizer Valve Second-Stage Actuator, TSOVC-1

Fig. 26 Concluded

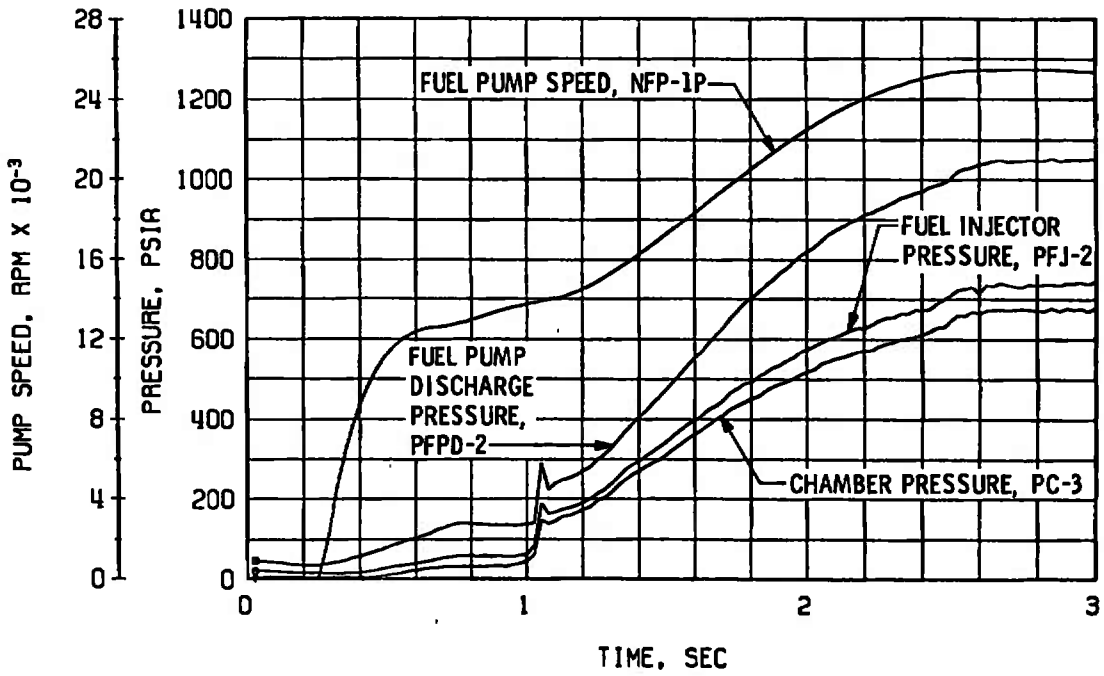

a. Thrust Chamber Fuel System, Start

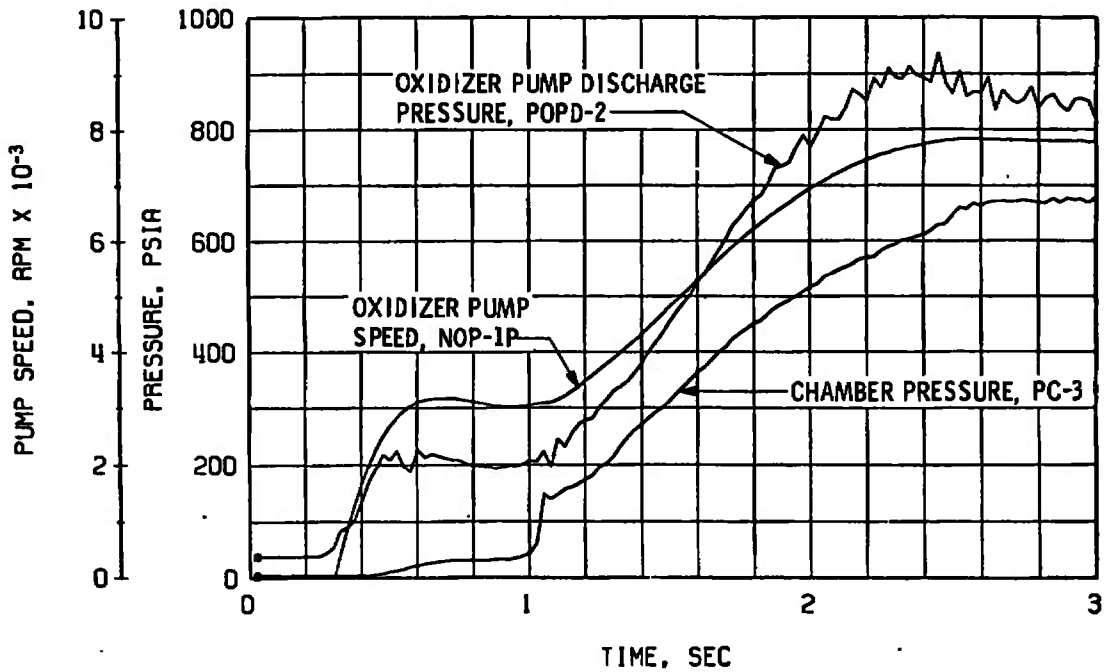

b. Thrust Chamber Oxidizer System, Start

Fig. 27 Engine Transient Operation, Firing 16D

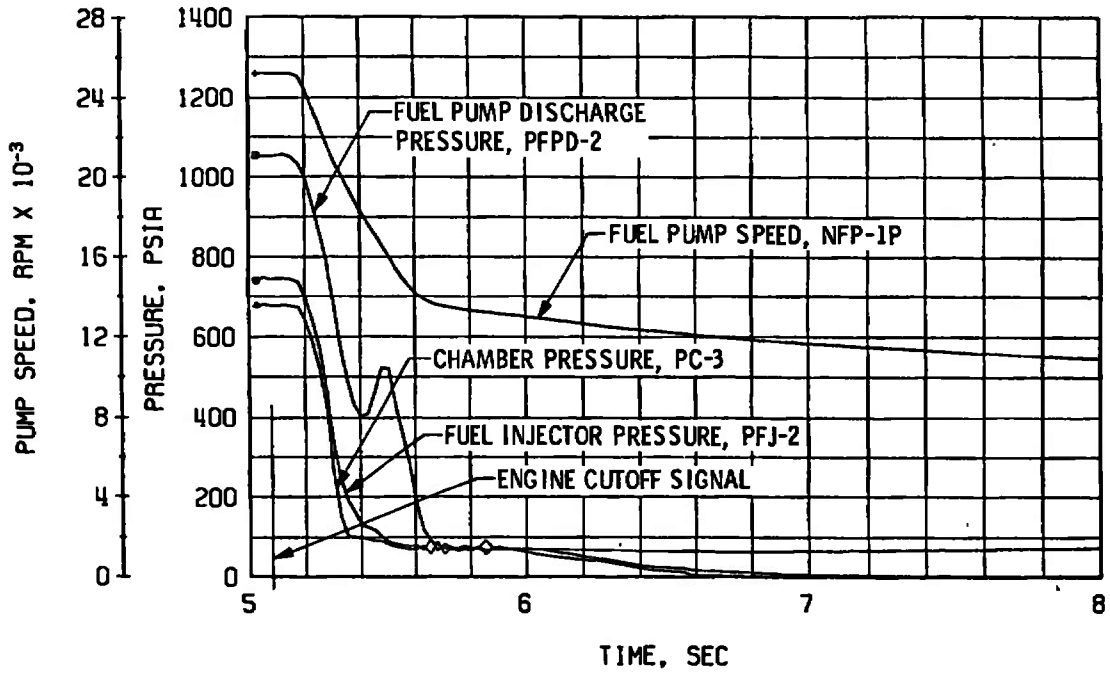

c. Thrust Chamber Fuel System, Shutdown

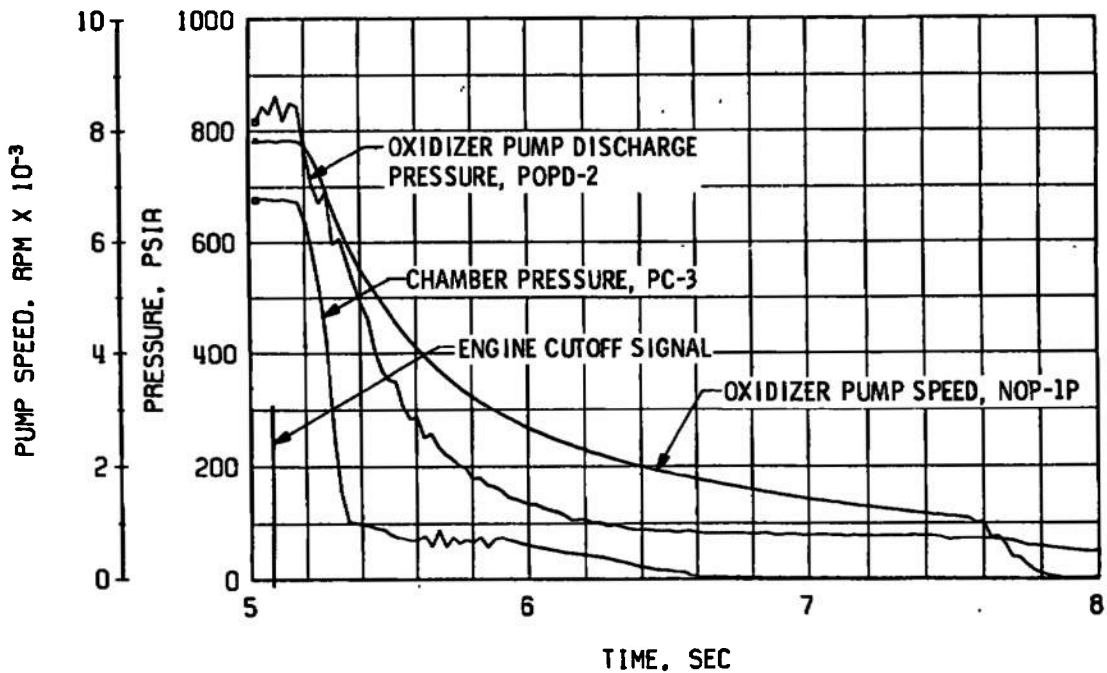

d. Thrust Chamber Oxidizer System, Shutdown

Fig. 27 Continued

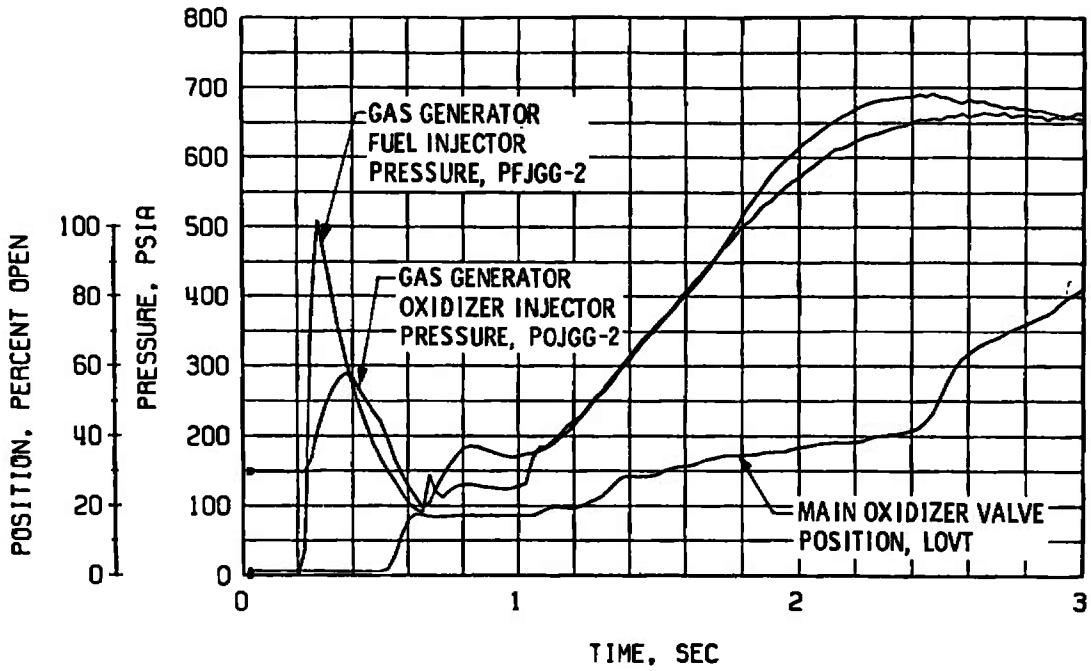

e. Gas Generator Injector Pressures and Main Oxidizer Valve Position, Start

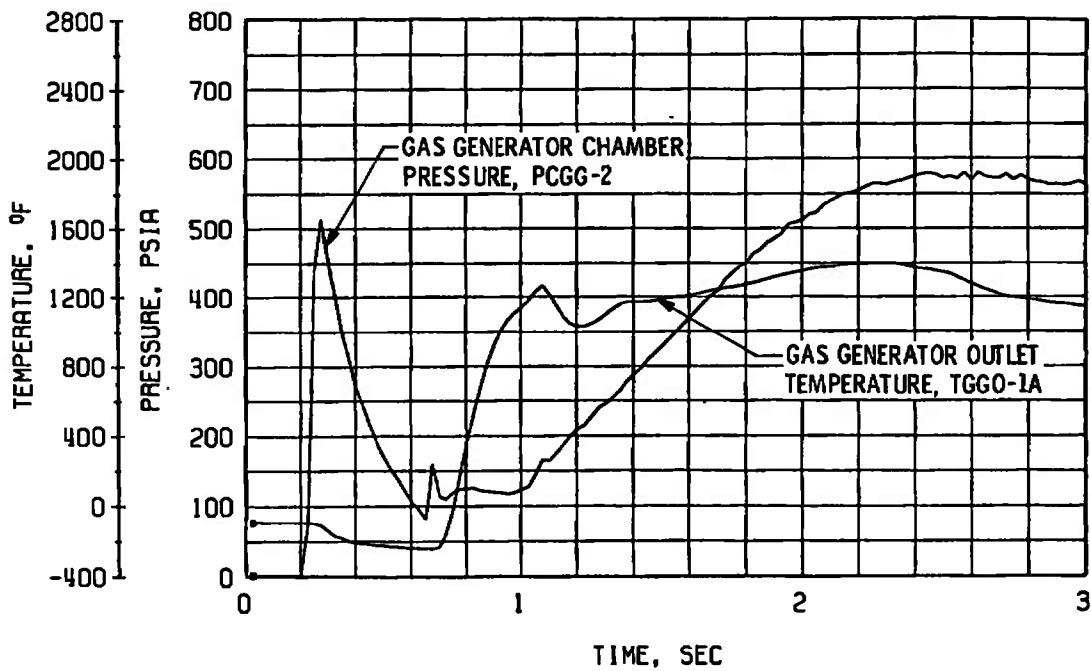

f. Gas Generator Chamber Pressure and Temperature, Start

Fig. 27 Continued

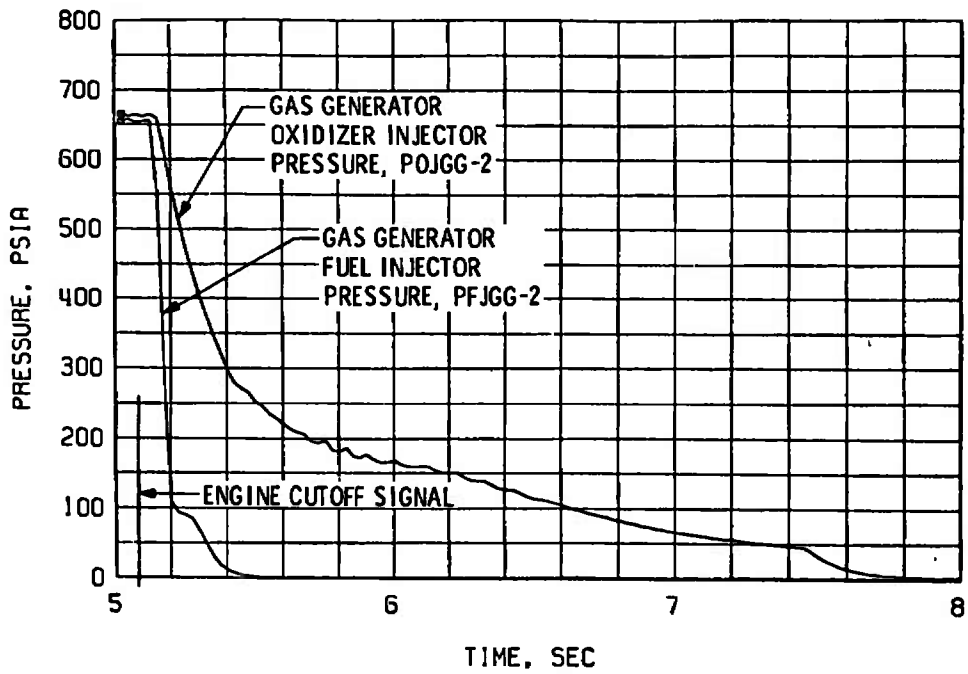

g. Gas Generator Injector Pressures, Shutdown

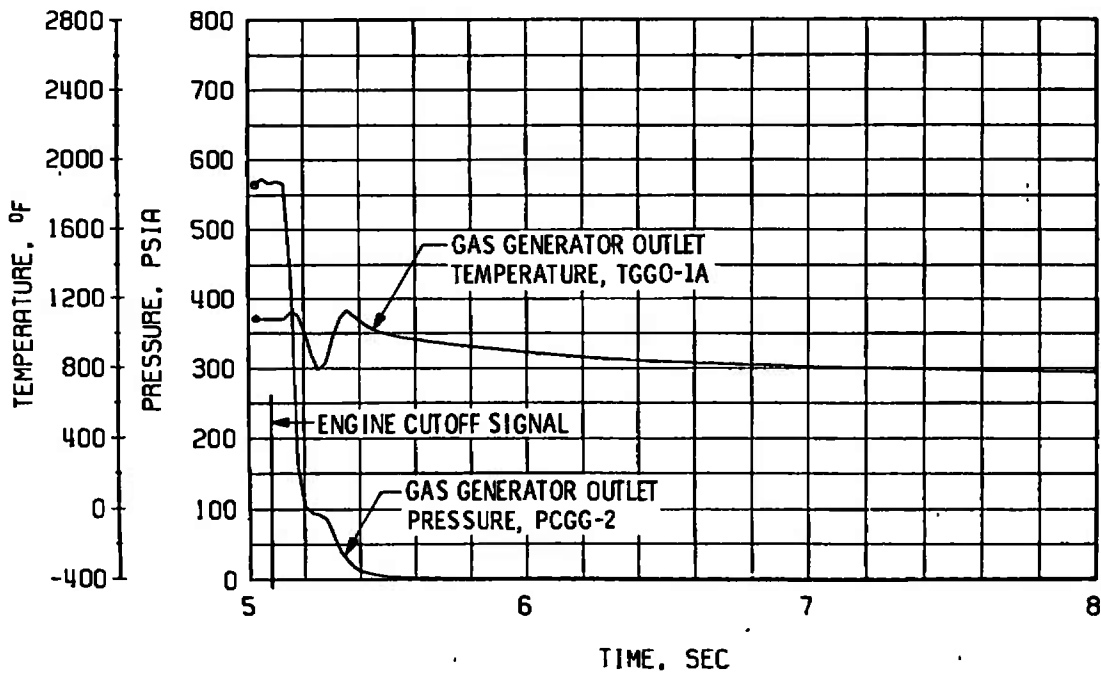

h. Gas Generator Chamber Pressure and Temperature, Shutdown

Fig. 27 Concluded

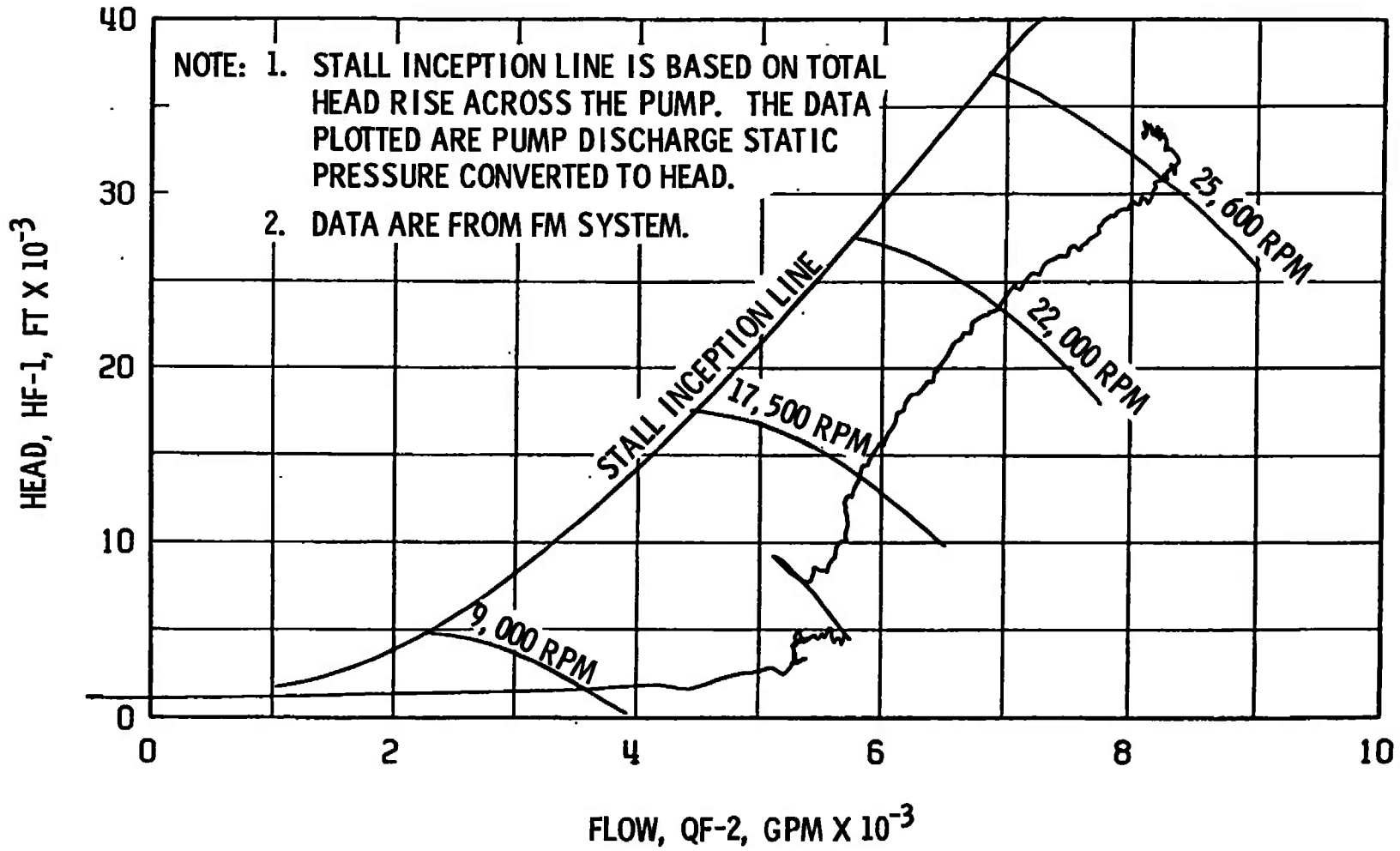

Fig. 28 Fuel Pump Start Transient Performance, Firing 16D



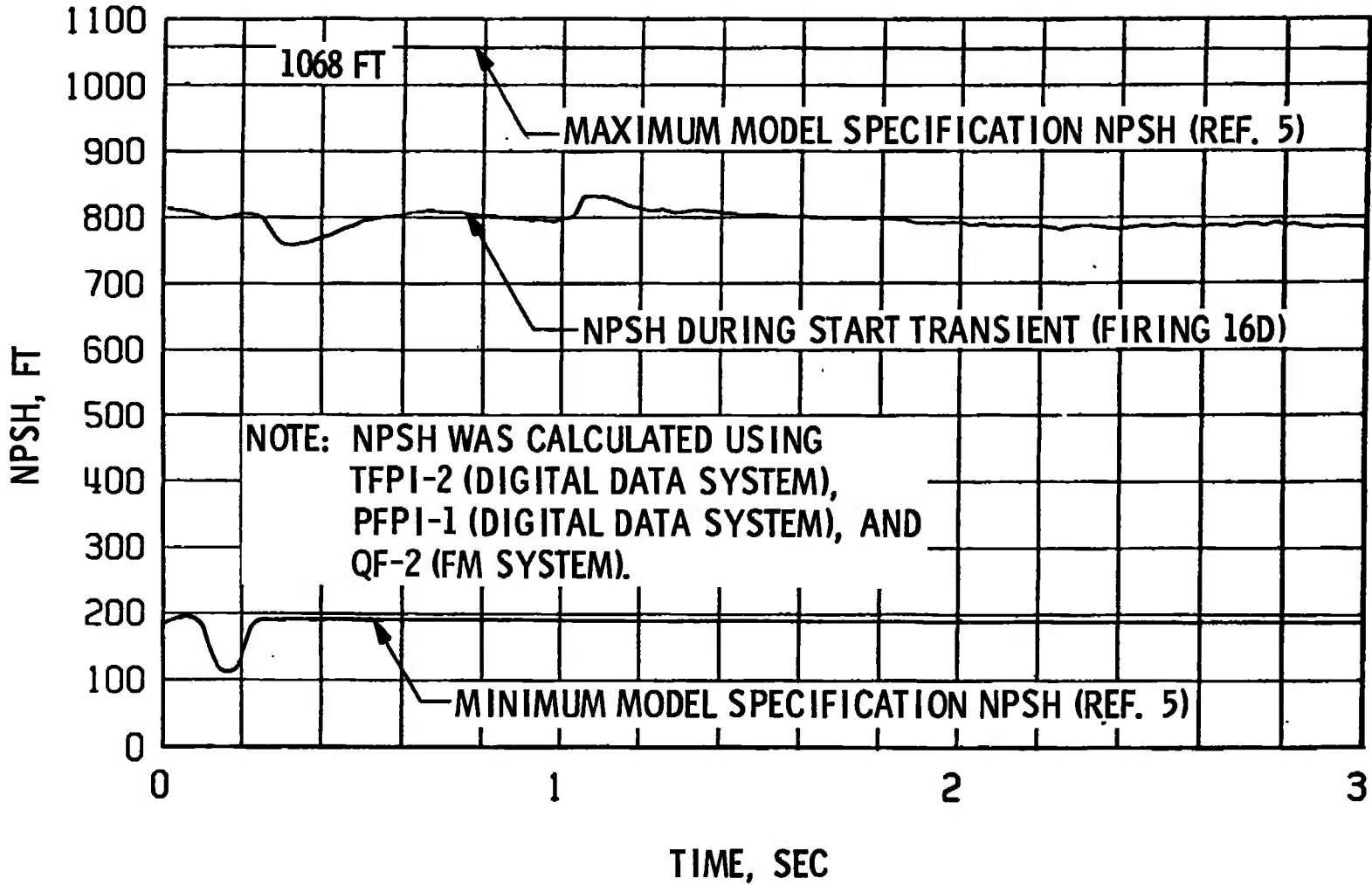

Fig. 29 Fuel Pump NPSH during Start Transient, Firing 16D

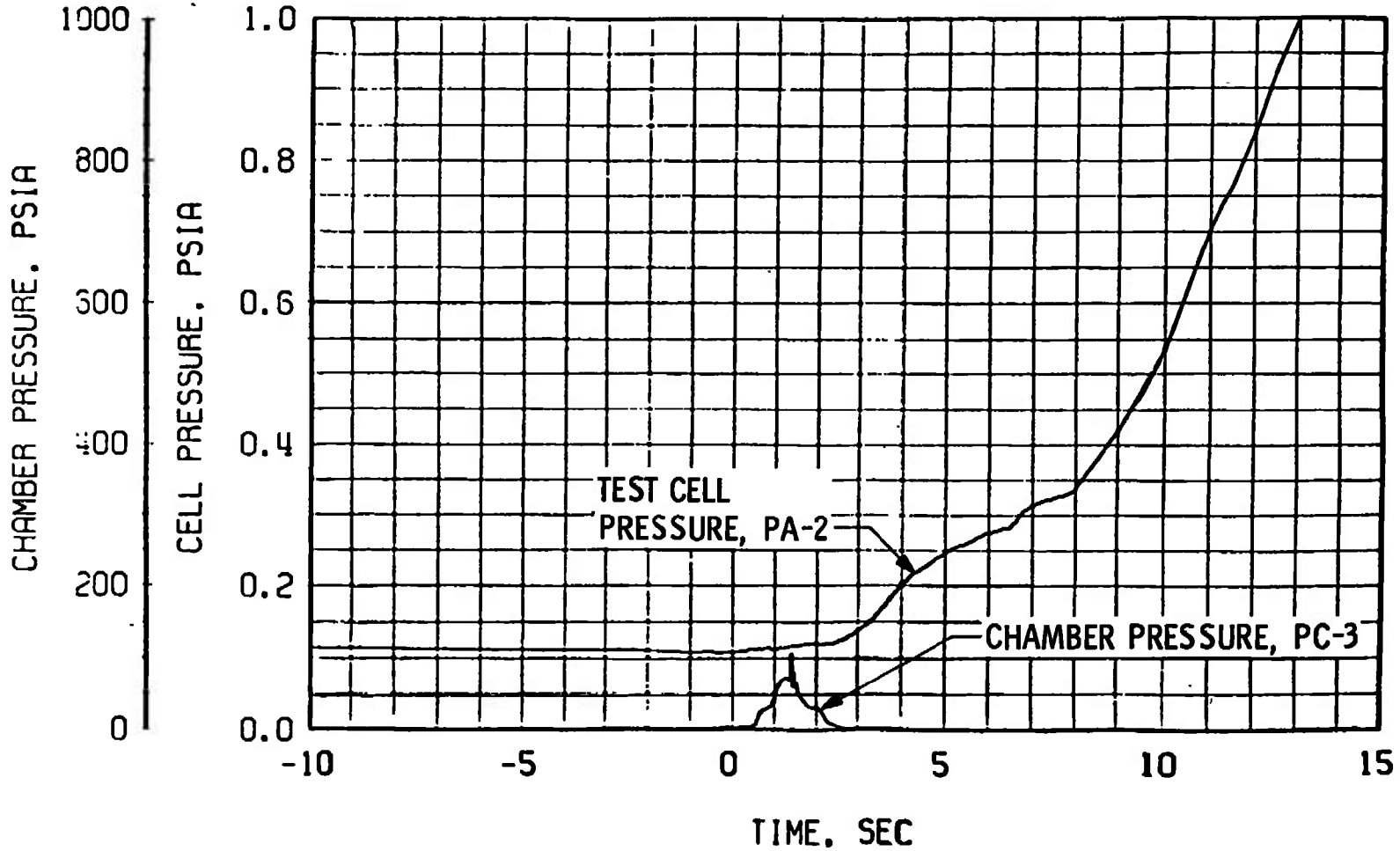
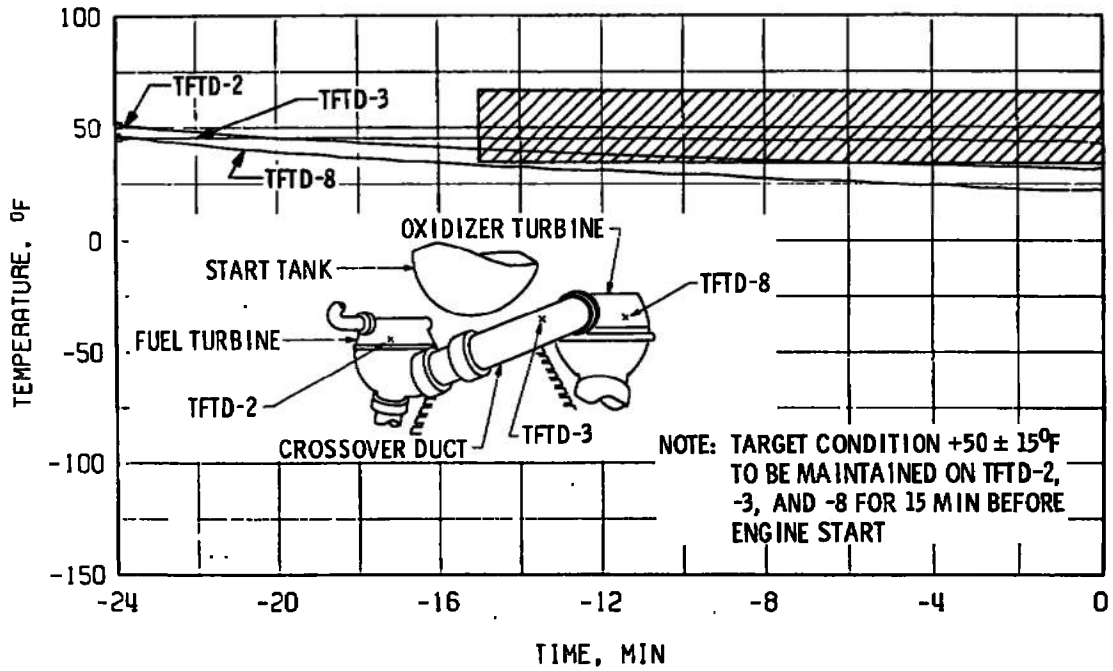
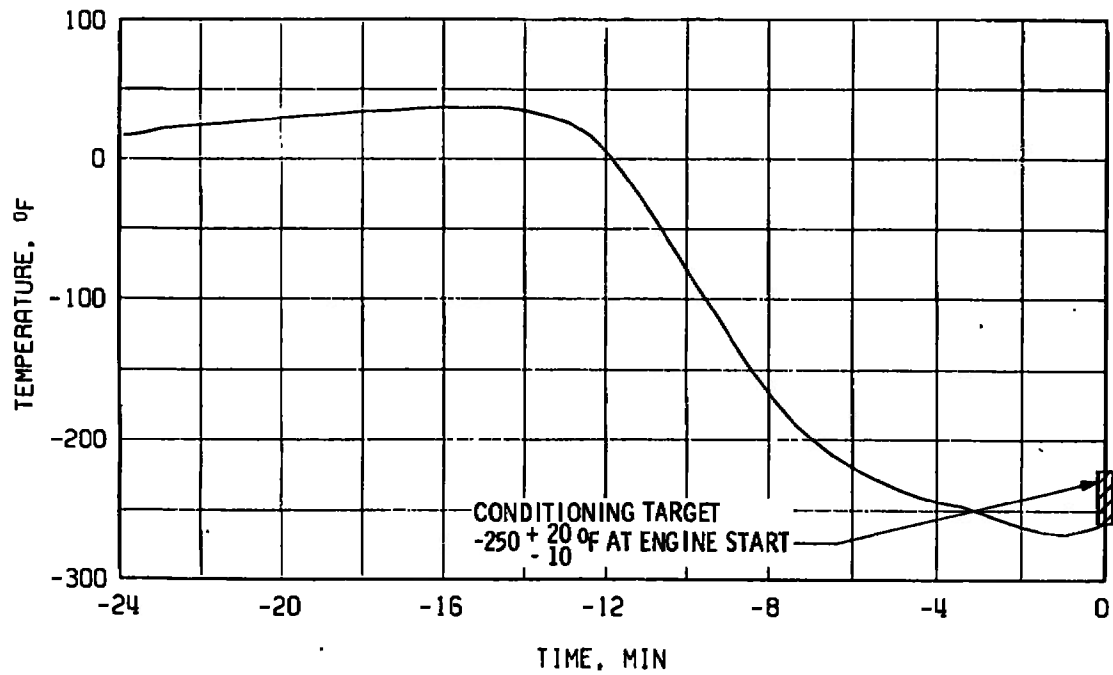

Fig. 30 Engine Ambient and Combustion Chamber Pressures, Firing 16E



a. Crossover Duct, TFTD



b. Thrust Chamber Throat, TTC-1P

Fig. 31 Thermal Conditioning History of Engine Components, Firing 16E

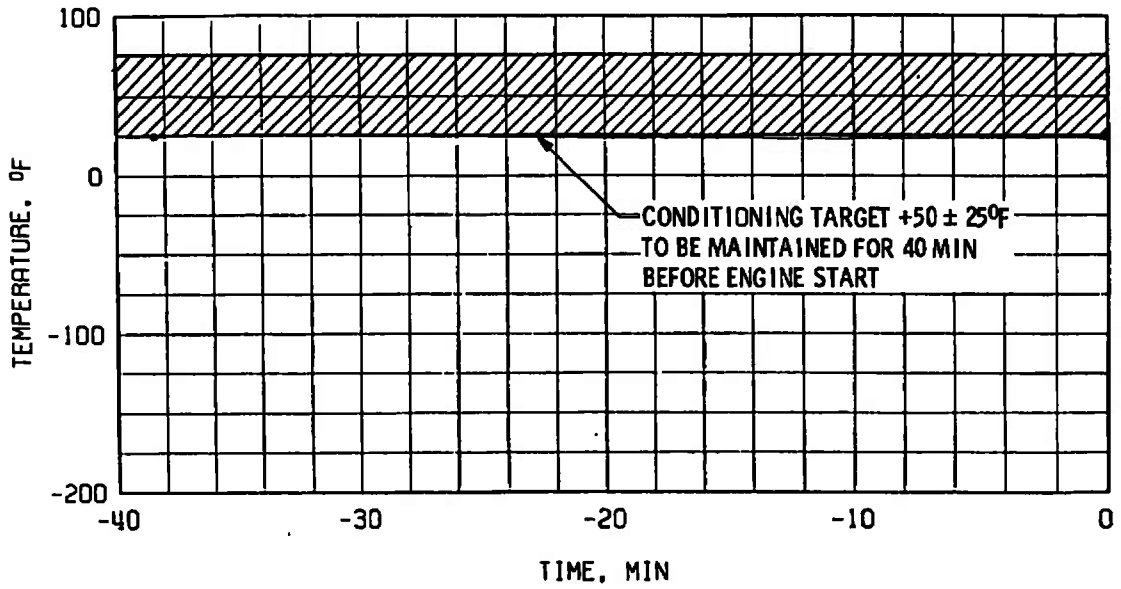

c. Start Tank Discharge Valve, STDVOC

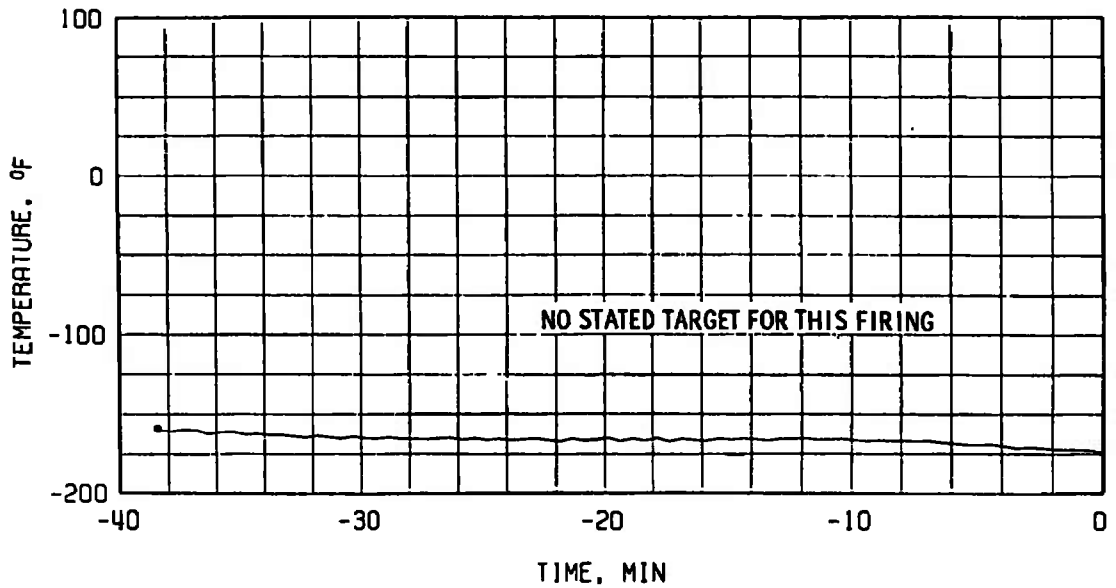

d. Main Oxidizer Valve Second-Stage Actuator, TSOVC-1

Fig. 31 Concluded

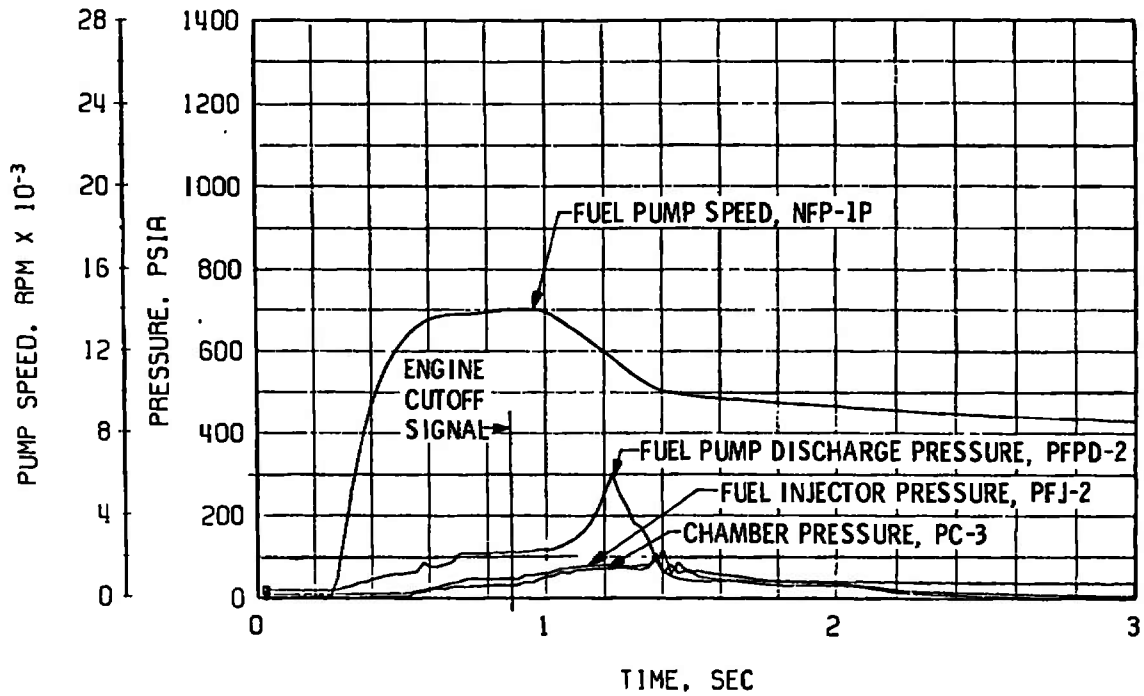

a. Thrust Chamber Fuel System

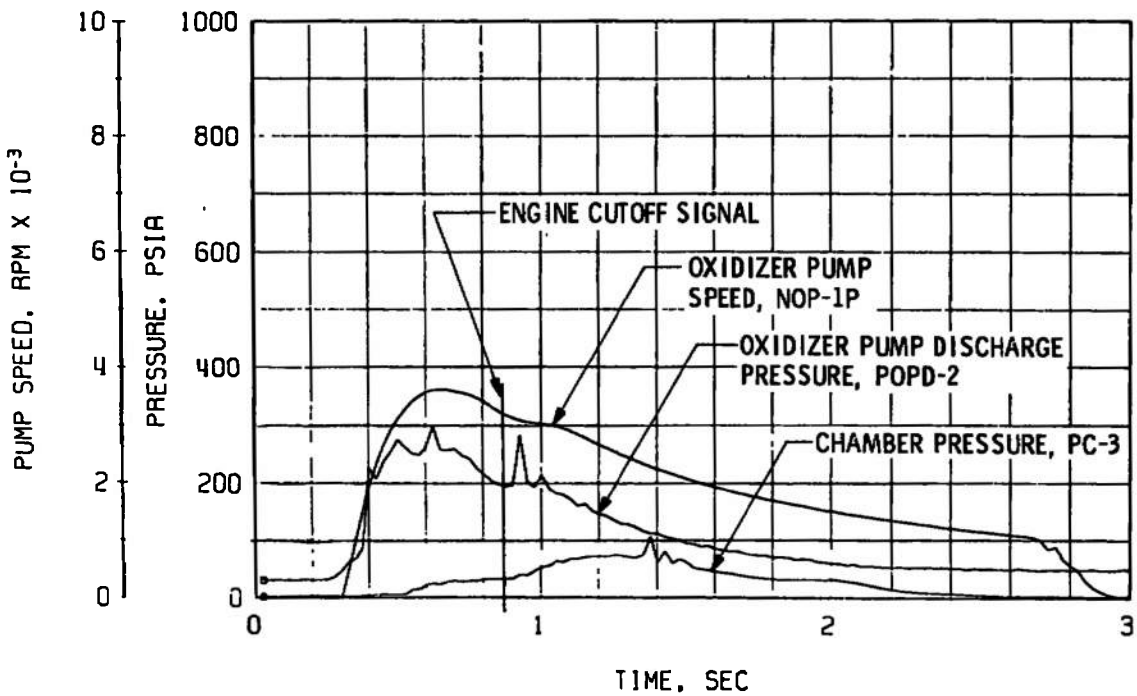

b. Thrust Chamber Oxidizer System

Fig. 32 Engine Transient Operation, Firing 16E

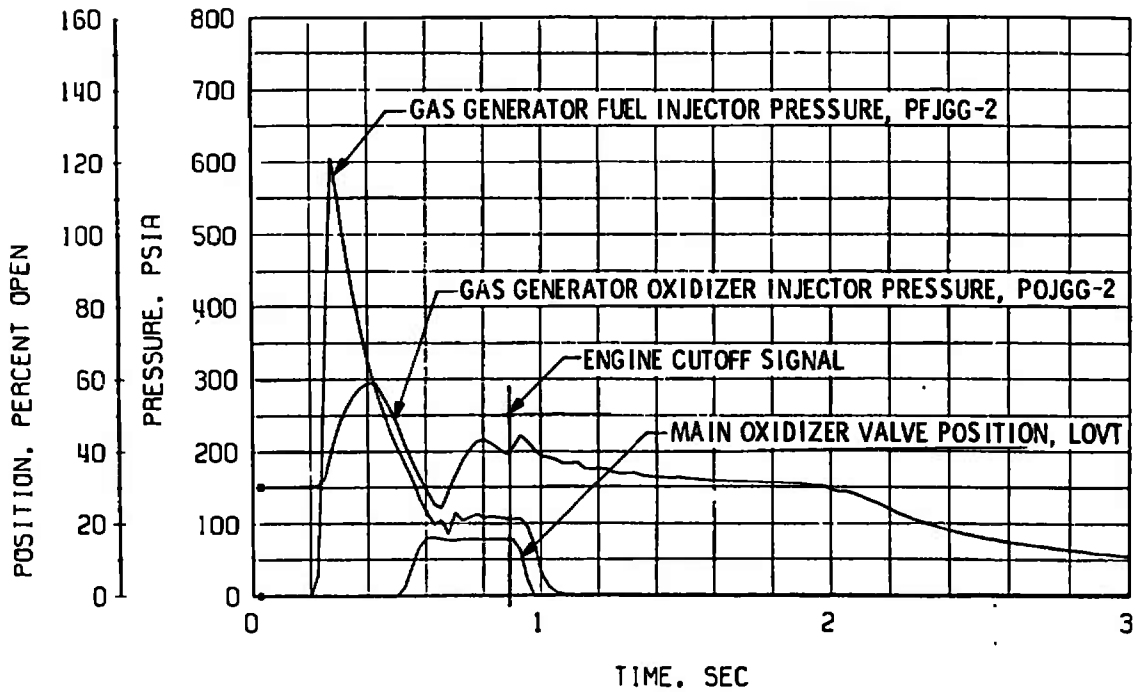

c. Gas Generator Injector Pressures and Main Oxidizer Valve Position

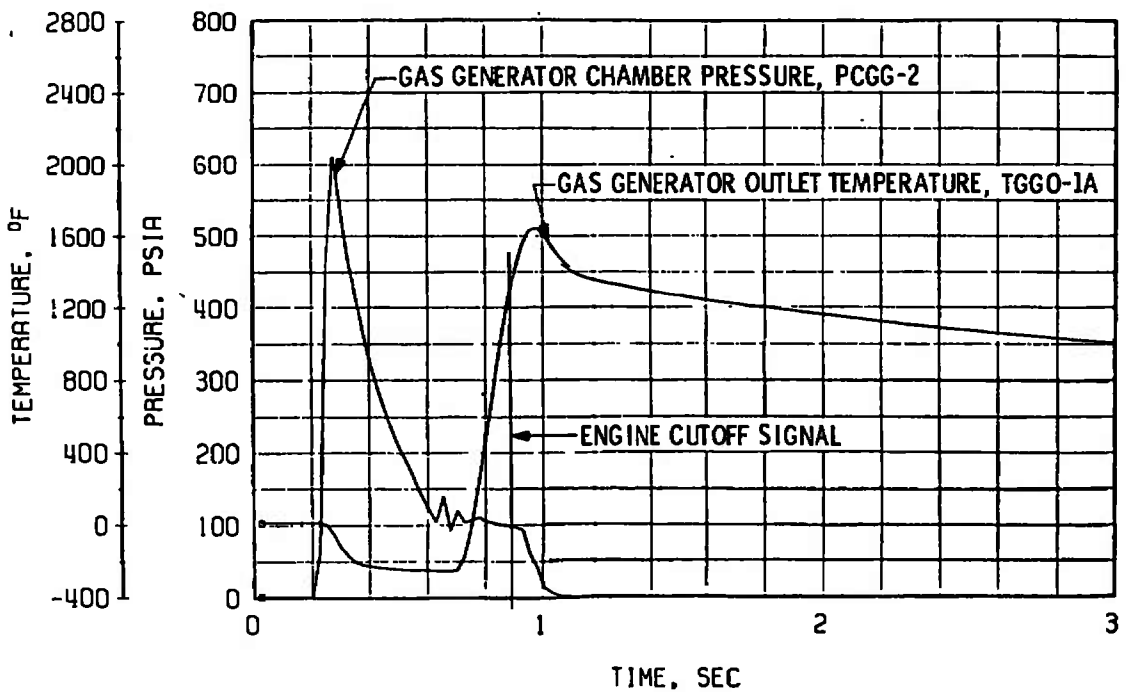

d. Gas Generator Chamber Pressures and Temperature

Fig. 32 Concluded

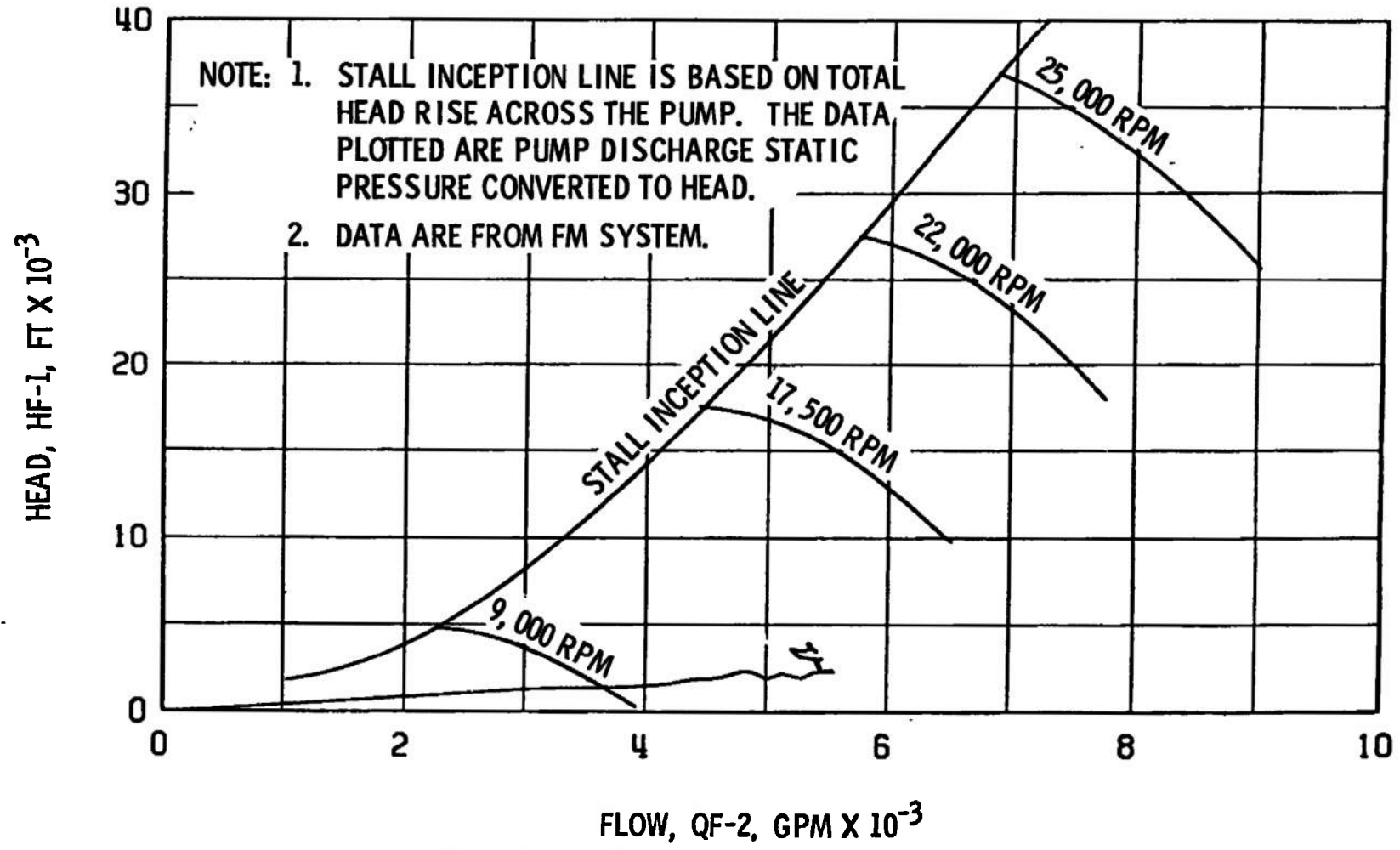
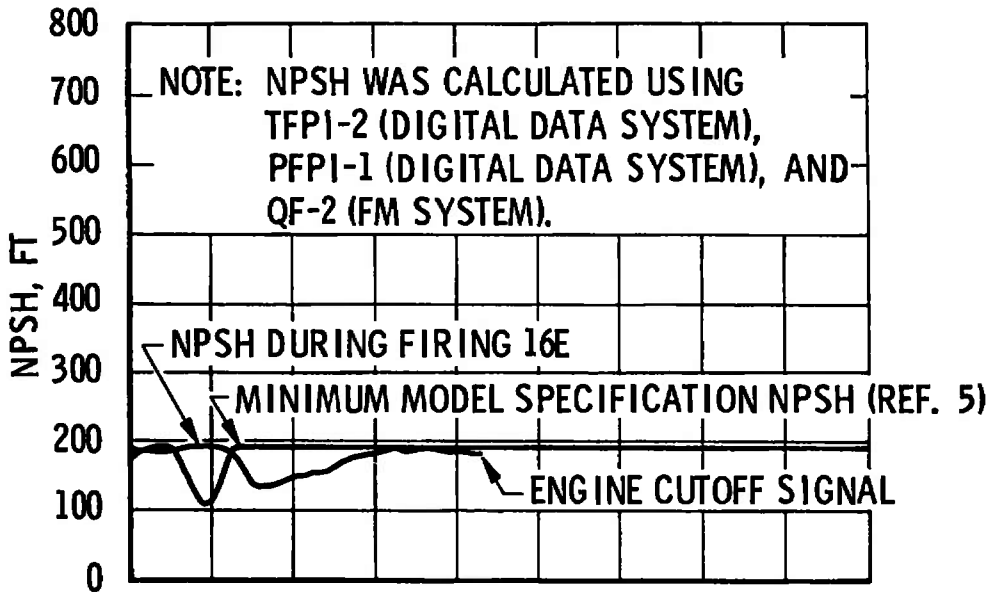
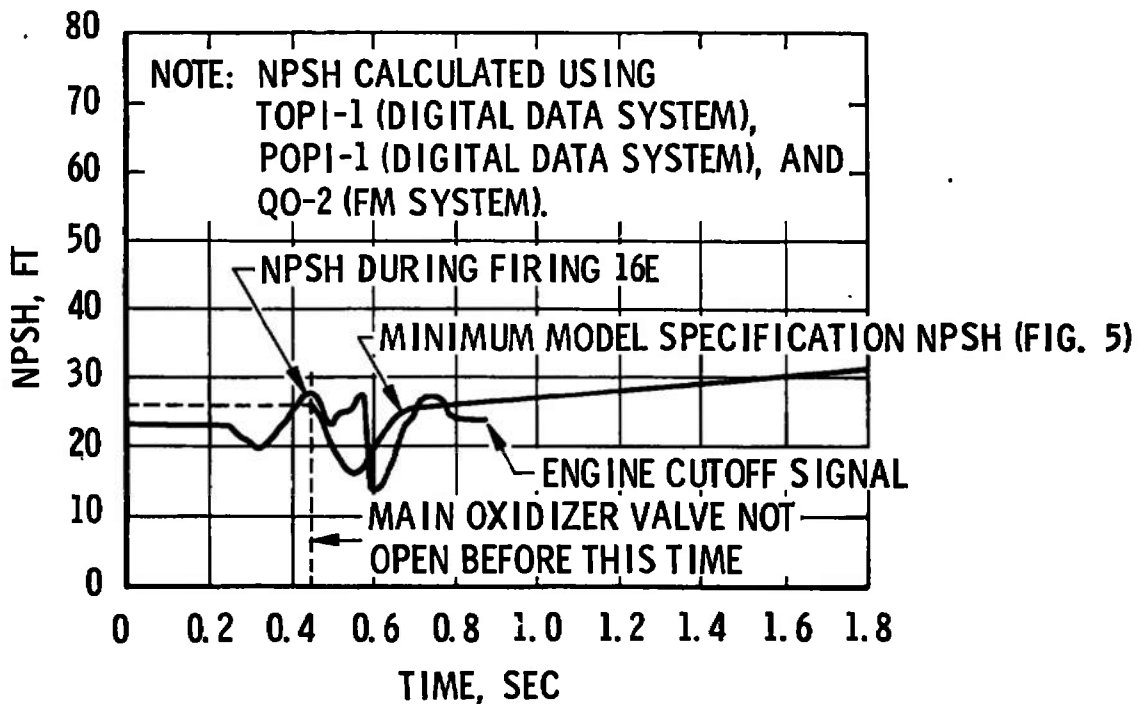

Fig. 33 Fuel Pump Start Transient Performance, Firing 16E



a. Fuel Pump



b. Oxidizer Pump

Fig. 34 Fuel Pump and Oxidizer Pump NPSH during Firing 16E



**TABLE I**  
**MAJOR ENGINE COMPONENTS**

Part Name	P/N	S/N
Thrust Chamber Body	206600-31	4072755
Thrust Chamber Injector Assembly	208021-11	4071421
Fuel Turbopump Assembly	459000-171	4078258
Oxidizer Turbopump Assembly	458175-71	6616135
Start Tank	303439	0038
Augmented Spark Igniter	206280-81	4078806
Gas Generator Fuel Injector and Combustor	308360-11	2008734
Gas Generator Oxidizer Injector and Poppet Assembly	303323	4076827
Helium Regulator Assembly	556948	4072709
Electrical Control Package	502670-11	4078604
Primary Flight Instrumentation Package	703685	4077391
Auxiliary Flight Instrumentation Package	703680	4077313
Main Fuel Valve	409120	4062472
Main Oxidizer Valve	409973	4077271
Gas Generator Control Valve	309040	4076768
Start Tank Discharge Valve	306875	4081218
Oxidizer Turbine Bypass Valve	409930	4081831
Propellant Utilization Valve	251351-11	4068732
Main-Stage Control Valve	555767	8284307
Ignition Phase Control Valve	555767	8284305
Helium Control Valve	NA5-27273	340919
Start Tank Vent and Relief Valve	557818	4062234
Helium Tank Vent Valve	NA5-27273	340918
Fuel Bleed Valve	309034	4077233
Oxidizer Bleed Valve	309029	4076750
Augmented Spark Igniter Oxidizer Valve	308880	4089946
Pressure Actuator Shutdown Valve Assembly	557817	4067200
Pressure Actuator Purge Control Valve	557823	4075865
Start Tank Fill/Refill Valve	558000	4072899
Fuel Flowmeter	251225	4076564
Oxidizer Flowmeter	251216	4077137
Fuel Injector Temperature Transducer	NA5-27441	12350
Restartable Ignition Detect Probe	NA5-27298T2	329

**TABLE II  
SUMMARY OF ENGINE ORIFICES**

Orifice Name	Part Number	Diameter, in.	Date Effective	Comments
Gas Generator Fuel Supply Line	RD251-4107	0.468	*	
Gas Generator Oxidizer Supply Line	RD251-4106	0.268	*	
Oxidizer Turbine Bypass Valve Nozzle	RD273-8002	1.319	*	
Main Oxidizer Valve Closing Control	556443	0.0267	October 7, 1967	Nonthermostatic Orifice
Oxidizer Turbine Exhaust Manifold	RD251-9004	10.000	*	
Augmented Spark Igniter Oxidizer Supply Line	406361	0.150	October 20, 1967	

\*Installed before Engine Delivery to AEDC

**TABLE III  
ENGINE COMPONENT REPLACEMENTS  
(BETWEEN TESTS J4-1801-15 AND J4-1801-16)**

Replacement	Completion Date	Component Replaced
UCR*-007324	November 8, 1967	Ignition Detect Probe

\*UCR - Unsatisfactory Condition Report

**TABLE IV  
ENGINE PURGE AND COMPONENT CONDITIONING SEQUENCE**

AEDC-TR-68-43

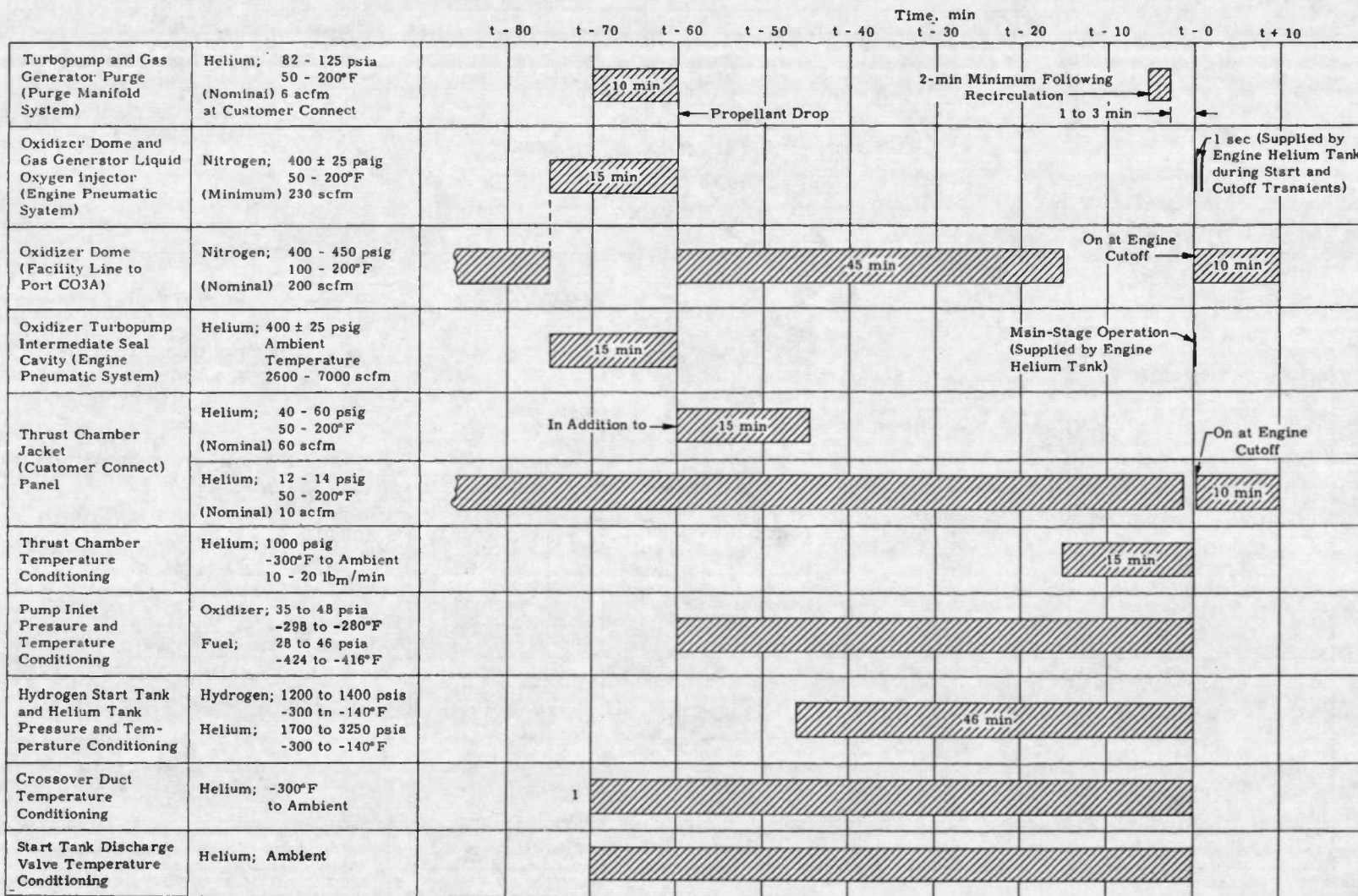

<sup>1</sup>Conditioning temperature to be maintained for the last 30 min of pre-fire.

**TABLE V**  
**SUMMARY OF TEST REQUIREMENTS AND RESULTS**

Firing Number, J4-1801-	16A		16B		16C		16D		16E		
	Target	Actual	Target	Actual	Target	Actual	Target	Actual	Target	Actual	
Firing Date/Time of Day, hr	11-14-67	1244	11-14-67	1419	11-14-67	1533	11-14-67	1744	11-14-67	1834	
Pressure Altitude at Engine Start, ft	---	94,000	---	106,500	---	108,000	---	110,000	---	109,500	
Firing Duration, sec	30.0	30.074	5.0	5.088	8.0	5.088	5.0	5.088	M/S* + 0.4	0.872	
Fuel Pump Inlet Conditions at Engine Start	Pressure, psia	25.5 <sup>+1</sup> <sub>-0</sub>	28.3	25.5 <sup>+1</sup> <sub>-0</sub>	25.7	25.5 <sup>+1</sup> <sub>-0</sub>	25.6	41.0 <sup>+1</sup> <sub>-0</sub>	42.3	23.5 <sup>+1</sup> <sub>-0</sub>	24.4
	Temperature, °F	-421.4 ± 0.4	-421.3	-421.4 ± 0.4	-421.0	-421.4 ± 0.4	-421.7	-422.0 ± 0.4	-422.1	-421.4 ± 0.4	-421.8
Oxidizer Pump Inlet Conditions at Engine Start	Pressure, psia	33 <sup>+1</sup> <sub>-0</sub>	34.8	45 ± 1	46.4	45 ± 1	45.1	35 ± 1	34.8	28 ± 1	28.3
	Temperature, °F	-294.5 ± 0.4	-294.7	-294.6 ± 0.4	-294.8	-294.5 ± 0.4	-294.6	-294.5 ± 0.4	-294.6	-295.0 ± 0.4	-295.2
Start Tank Conditions at Engine Start	Pressure, psia	1200 ± 10	1204	1300 ± 10	1304	1300 ± 10	1311	1200 ± 10	1205	1400 ± 10	1402
	Temperature, °F	-200 ± 10	-187.0	-300 ± 10	-302.9	-300 ± 10	-306.1	-200 ± 10	-206.4	-240 ± 10	-244.8
Helium Tank Conditions at Engine Start	Pressure, psia	---	3206	---	2509	---	2150	---	2241	---	1829
	Temperature, °F	---	-199	---	-300	---	-301	---	-204	---	-240
Thrust Chamber Temperature Conditions at Engine Start, °F	Throat	-250 ± 25	-251	-150 <sup>+20</sup> <sub>-10</sub>	-156	-250 ± 25	-243	-150 <sup>+20</sup> <sub>-10</sub>	-163	-250 <sup>+20</sup> <sub>-10</sub>	-258
	Average	---	-215	---	-173	---	-255	---	-177	---	-272
Crossover Duct Temperature at Engine Start, °F	TFTD-2	-50 ± 15	-61	+50 ± 15	41	+50 ± 15	41	-50 ± 15	-75	+50 ± 15	32
	TFTD-3	-50 ± 15	-43	+50 ± 15	46	+50 ± 15	49	-50 ± 15	-59	+50 ± 15	42
	TFTD-8	-50 ± 15	-58	+50 ± 15	28	+50 ± 15	27	-50 ± 15	-85	+50 ± 15	22
Main Oxidizer Valve Closing Control Line Temperature at Engine Start, °F	---	1.1	---	-15.1	---	-32.0	---	-19.4	---	-40.3	
Main Oxidizer Valve Second-Stage Actuator Temperature at Engine Start, °F	-40 <sup>+0</sup> <sub>-20</sub>	-74	-150 <sup>+0</sup> <sub>-60</sub>	-164	-150 <sup>+0</sup> <sub>-60</sub>	-171	-150 <sup>+0</sup> <sub>-60</sub>	-150	---	-174	
Fuel Lead Time, sec	1.0	1.001	1.0	1.009	1.0	1.009	1.0	1.008	1.0	1.009	
Propellant in Engine Time, min	40		60		60		60		30		
Propellant Recirculation Time, min	10	15.95	10	14.47	10	10.47	10	10.47	10	10.46	
Prevalve Sequencing Logic	Normal	Normal	Normal	Normal	Normal	Normal	Normal	Normal	Normal	Normal	
Bootstrapped Line Temperature at Engine Start, °F	TOBS-1	---	30.8	---	17.7	---	9.1	---	-31.5	---	-29.4
	TOBS-2	---	13.2	---	-12.6	---	-21.0	---	-13.2	---	-37.1
	TOBS-3	---	-8.7	---	-23.5	---	-24.2	---	-22.2	---	-35.9
Start Tank Discharge Valve Opening Temperature at Engine Start, °F	+50 ± 25	24	+50 ± 25	30	+50 ± 25	31	+50 ± 25	28	+50 ± 25	23	
Vibration Safety Count Duration (msec) and Occurrence Time (sec) from t <sub>0</sub>	---	66	---	19	---	93	---	38	---	---	
	---	1.024	---	0.972	---	0.978	---	1.007	---	---	
Gas Generator Outlet Temperature, °F	Initial Peak	---	1389	---	1702	---	1954	---	1283	---	1649
	Second Peak	---	---	---	1880	---	---	---	1396	---	---
Main Chamber Ignition (P <sub>c</sub> = 100 psia) Time, sec (Ref. t <sub>0</sub> )	---	1.029	---	0.977	---	0.960	---	1.023	---	---	
Main Oxidizer Valve Second-Stage Initial Movement, sec (Ref. t <sub>0</sub> )	---	1.026	---	1.248	---	0.992	---	1.026	---	---	
Main-Stage Pressure No. 2, sec (Ref. t <sub>0</sub> )	---	1.780	---	1.697	---	1.699	---	1.698	---	---	
550-psia Chamber Pressure Attained, sec (Ref. t <sub>0</sub> )	---	2.081	---	1.875	---	2.058	---	2.112	---	---	
Propellant Utilization Valve Position at Engine Start, deg	Null	Null	Null	Null	Null	Null	Null	Null	Null	Null	
	Closed	Closed	---	---	---	---	---	---	---	---	

\*Main-Stage Signal

**TABLE VI  
ENGINE VALVE TIMINGS**

TABLE VI  
ENGINE VALVE TIMINGS

Firing Number J4-1801-	Start																							
	Start Tank Discharge Valve						Main Fuel Valve			Main Oxidizer Valve First Stage			Main Oxidizer Valve Second Stage			Gas Generator Fuel Poppet			Gas Generator Oxidizer Poppet			Oxidizer Turbine Bypass Valve		
	Time of Opening Signal	Valve Delay Time, sec	Valve Opening Time, sec	Time of Closing Signal	Valve Delay Time, sec	Valve Closing Time, sec	Time of Opening Signal	Valve Delay Time, sec	Valve Opening Time, sec	Time of Opening Signal	Valve Delay Time, sec	Valve Opening Time, sec	Time of Opening Signal	Valve Delay Time, sec	Valve Opening Time, sec	Time of Opening Signal	Valve Delay Time, sec	Valve Opening Time, sec	Time of Opening Signal	Valve Delay Time, sec	Valve Opening Time, sec	Time of Closing Signal	Valve Delay Time, sec	Valve Closing Time, sec
18A	0	0.138	0.128	0.447	0.092	0.248	-1.001	0.051	0.085	0.447	0.057	0.080	0.447	0.578	1.943	0.447	0.110	0.030	0.447	0.183	0.083	0.447	0.220	0.285
18B	0	0.138	0.136	0.447	0.086	0.237	-1.009	0.059	0.069	0.447	0.055	0.088	0.447	0.799	2.205	0.447	0.121	0.028	0.447	0.185	0.078	0.447	0.208	0.287
18C	0	0.138	0.135	0.445	0.086	0.236	-1.008	0.061	0.070	0.445	0.057	0.080	0.445	0.547	2.425	0.445	0.118	0.029	0.445	0.191	0.073	0.445	0.212	0.275
18D	0	0.136	0.130	0.448	0.085	0.248	-1.008	0.080	0.070	0.448	0.058	0.070	0.448	0.580	2.230	0.448	0.118	0.030	0.446	0.183	0.075	0.448	0.231	0.290
18E	0	0.135	0.143	0.445	0.068	0.238	-1.009	0.061	0.075	0.445	0.057	0.075	0.445	---	---	0.445	0.120	0.030	0.445	0.192	0.090	0.445	0.227	---
Pre-Fire Final Sequence	0	0.099	0.111	0.448	0.092	0.245	-0.884	0.048	0.069	0.448	0.050	0.053	0.448	0.522	1.420	0.448	0.083	0.032	0.448	0.137	0.070	0.448	0.207	0.285

Firing Number J4-1801-	Shutdown														
	Main Fuel Valve			Main Oxidizer Valve			Gas Generator Fuel Poppet			Gas Generator Oxidizer Poppet			Oxidizer Turbine Bypass Valve		
	Time of Closing Signal	Valve Delay Time, sec	Valve Closing Time, sec	Time of Closing Signal	Valve Delay Time, sec	Valve Closing Time, sec	Time of Closing Signal	Valve Delay Time, sec	Valve Closing Time, sec	Time of Closing Signal	Valve Delay Time, sec	Valve Closing Time, sec	Time of Closing Signal	Valve Delay Time, sec	Valve Closing Time, sec
16A	30.074	0.124	0.312	30.074	0.061	0.172	30.074	0.050	0.030	30.074	0.028	0.018	30.074	0.280	0.430
18B	5.088	0.138	0.372	5.088	0.052	0.190	5.088	0.054	0.025	5.088	0.031	0.014	5.088	0.213	0.410
18C	5.088	0.138	0.377	5.088	0.050	0.193	5.088	0.053	0.022	5.088	0.031	0.013	5.088	0.245	0.380
16D	5.088	0.131	0.347	5.088	0.053	0.184	5.088	0.081	0.020	5.088	0.032	0.015	5.088	0.288	0.440
18E	0.872	0.111	0.328	0.872	---	---	0.872	0.070	0.029	0.872	0.039	0.020	0.872	---	---
Pre-Fire Final Sequence	---	0.086	0.245	---	0.048	0.130	---	0.083	0.024	---	0.058	0.019	---	0.203	0.522

- Notes: 1. All valve signal times are referenced to  $t_0$ .  
 2. Valve delay time is the time required for initial valve movement after the valve "open" or valve "closed" solenoid has been energized.  
 3. Final sequence check is conducted without propellant and within 12 hr before testing.  
 4. Data reduced from oscillogram.

**TABLE VII**  
**ENGINE PERFORMANCE SUMMARY**

Firing Number J4-1801-		16A	
		Site	Normalized
Overall Engine Performance	Thrust, lbf	231,500	229,500
	Chamber Pressure, psia	776.5	766.8
	Mixture Ratio	5.566	5.546
	Fuel Weight Flow, lb <sub>m</sub> /sec	82.1	81.3
	Oxidizer Weight Flow, lb <sub>m</sub> /sec	456.8	450.7
	Total Weight Flow, lb <sub>m</sub> /sec	538.9	532.0
Thrust Chamber Performance	Mixture Ratio	5.766	5.747
	Total Weight Flow, lb <sub>m</sub> /sec	532.1	525.2
	Characteristic Velocity, ft/sec	7988	7992
Fuel Turbopump Performance	Pump Efficiency, percent	74.3	74.3
	Pump Speed, rpm	26660	26460
	Turbine Efficiency, percent	59.6	59.5
	Turbine Pressure Ratio	7.20	7.20
	Turbine Inlet Temperature, °F	1250	1230
	Turbine Weight Flow, lb <sub>m</sub> /sec	6.76	6.71
Oxidizer Turbopump Performance	Pump Efficiency, percent	80.3	80.2
	Pump Speed, rpm	8614	8560
	Turbine Efficiency, percent	47.1	47.0
	Turbine Pressure Ratio	2.63	2.63
	Turbine Inlet Temperature, °F	822	806
	Turbine Weight Flow, lb <sub>m</sub> /sec	6.10	6.06
Gas Generator Performance	Mixture Ratio	0.971	0.959
	Chamber Pressure, psia	658.9	652.2

- Notes: 1. Site data are calculated from test data.  
 2. Normalized data are corrected to standard pump inlet and engine ambient pressure conditions.  
 3. Input data are test data averaged from 29 to 30 sec.  
 4. Site and normalized data were computed using the Rocketdyne PAST 640 modification zero computer program.

**APPENDIX III  
INSTRUMENTATION**

The instrumentation for AEDC test J4-1801-16 is tabulated in Table III-1. The location of selected major engine instrumentation is shown in Fig. III-1.

**TABLE III-1  
INSTRUMENTATION LIST**

<u>AEDC Code</u>	<u>Parameter</u>	<u>Tap No.</u>	<u>Range</u>	<u>Micro-SADIC</u>	<u>Magnetic Tape</u>	<u>Oscillo-graph</u>	<u>Strip Chart</u>	<u>X-Y Plotter</u>
	<u>Current</u>		<u>amp</u>					
ICC	Control		0 to 30	x		x		
IIC	Ignition		0 to 30	x		x		
	<u>Event</u>							
EECL	Engine Cutoff Lockin		On/Off	x		x		
EECO	Engine Cutoff Signal		On/Off	x	x	x		
EES	Engine Start Command		On/Off	x		x		
EFBVC	Fuel Bleed Valve Closed Limit		Open/Closed	x				
EFJT	Fuel Injector Temperature		On/Off	x		x		
EFPVC/O	Fuel Prevalve Closed/Open Limit		Closed/Open	x		x		
EHCS	Helium Control Solenoid		On/Off	x		x		
EID	Ignition Detected		On/Off	x		x		
EIPCS	Ignition Phase Control Solenoid		On/Off	x		x		
EMCS	Main-Stage Control Solenoid		On/Off	x		x		
EMP-1	Main-Stage Pressure No. 1		On/Off	x		x		
EMP-2	Main-Stage Pressure No. 2		On/Off	x		x		
EOBVC	Oxidizer Bleed Valve Closed Limit		Open/Closed	x				
EOPVC	Oxidizer Prevalve Closed Limit		Closed	x		x		
EOPVO	Oxidizer Prevalve Open Limit		Open	x		x		
ESTDCS	Start Tank Discharge Control Solenoid		On/Off	x	x	x		
RASIS-1	Augmented Spark Igniter Spark No. 1		On/Off			x		
RASIS-2	Augmented Spark Igniter Spark No. 2		On/Off			x		
RGGS-1	Gas Generator Spark No. 1		On/Off			x		
RGGS-2	Gas Generator Spark No. 2		On/Off			x		
	<u>Flows</u>		<u>gpm</u>					
QF-1A	Fuel	PF	0 to 9000	x		x		
QF-2	Fuel	PFFA	0 to 9000	x	x	x		
QF-2SD	Fuel Flow Stall Approach Monitor		0 to 9000	x		x		
QFRP	Fuel Recirculation		0 to 160	x				
QO-1A	Oxidizer	POF	0 to 3000	x		x		
QO-2	Oxidizer	POFA	0 to 3000	x	x	x		
QORP	Oxidizer Recirculation		0 to 50	x			x	
	<u>Forces</u>		<u>ib<sub>f</sub></u>					
FSP-1	Side Load (Pitch)		±20,000	x		x		
FSY-1	Side Load (Yaw)		±20,000	x		x		
	<u>Heat Flux</u>		<u>Watts Sr. cm<sup>2</sup></u>					
RTCEP	Radiation Thrust Chamber Exhaust Plume		0 to 7	x				
	<u>Position</u>		<u>Percent Open</u>					
LFVT	Main Fuel Valve		0 to 100	x		x		
LGGVT	Gas Generator Valve		0 to 100	x		x		
LOTBVT	Oxidizer Turbine Bypass Valve		0 to 100	x		x		



TABLE III-1 (Continued)

<u>AEDC Code</u>	<u>Parameter</u>	<u>Tap No.</u>	<u>Range</u>	<u>Micro-SADIC</u>	<u>Magnetic Tape</u>	<u>Oscillo-graph</u>	<u>Strip Chart</u>	<u>X-Y Plotter</u>
	<u>Position</u>		<u>Percent Open</u>					
LOVT	Main Oxidizer Valve		0 to 100	x	x	x		
LPUTOP	Propellant Utilization Valve		0 to 100	x		x	x	
LSTDVT	Start Tank Discharge Valve		0 to 100	x		x		
	<u>Pressure</u>		<u>psia</u>					
PA1	Test Cell		0 to 0.5	x		x		
PA2	Test Cell		0 to 1.0	x	x			
PA3	Test Cell		0 to 5.0	x			x	
PC-1P	Thrust Chamber	CG1	0 to 1000	x			x	
PC-3	Thrust Chamber	CG1A	0 to 1000	x	x	x		
PCGG-1P	Gas Generator Chamber Pressure		0 to 1000	x	x	x		
PCGG-2	Gas Generator Chamber	GG1A	0 to 1000	x				
PFASIJ	Augmented Spark Igniter Fuel Injection		0 to 1000	x				
PFJ-1A	Main Fuel Injection	CF2	0 to 1000	x		x		
PFJ-2	Main Fuel Injection	CF2A	0 to 1000	x	x			
PFJGG-1A	Gas Generator Fuel Injection	GF4	0 to 1000	x				
PFJGG-2	Gas Generator Fuel Injection	GF4	0 to 1000	x		x		
PFMI	Fuel Jacket Inlet Manifold	CF1	0 to 2000	x				
PFPC-1A	Fuel Pump Balance Piston Cavity	PF5	0 to 1000	x				
PFPD-1P	Fuel Pump Discharge	PF3	0 to 1500	x				
PFPD-2	Fuel Pump Discharge	PF2	0 to 1500	x	x	x		
PFPI-1	Fuel Pump Inlet		0 to 100	x				x
PFPI-2	Fuel Pump Inlet		0 to 200	x				x
PFPI-3	Fuel Pump Inlet		0 to 200		x	x		
PFPS-1P	Fuel Pump Interstage	PF6	0 to 200	x				
PFPRPO	Fuel Recirculation Pump Outlet		0 to 60	x				
PFPRPR	Fuel Recirculation Pump Return		0 to 50	x				
PFST-1P	Fuel Start Tank	TF1	0 to 1500	x		x		
PFST-2	Fuel Start Tank	TF1	0 to 1500	x				x
PFUT	Fuel Tank Ullage		0 to 100	x				
PFVI	Fuel Tank Repressurization Line Nozzle Inlet		0 to 1000	x				
PFVL	Fuel Tank Repressurization Line Nozzle Throat		0 to 1000	x				
PHECMO	Pneumatic Control Module Outlet		0 to 750	x				
PHEOP	Oxidizer Recirculation Pump Purge		0 to 150	x				
PHES	Helium Supply		0 to 5000	x				
PHET-1P	Helium Tank	NN1	0 to 3500	x		x		
PHET-2	Helium Tank	NN1	0 to 3500	x				x
PHRO-1A	Helium Regulator Outlet	NN2	0 to 750	x	x			
POBSC	Oxidizer Bootstrap Conditioning		0 to 50	x				
POBV	Gas Generator Oxidizer Bleed Valve	GO2	0 to 2000	x				
POJ-1A	Main Oxidizer Injection	CO3	0 to 1000	x				

TABLE III-1 (Continued)

<u>AEDC Code</u>	<u>Parameter</u>	<u>Tap No.</u>	<u>Range</u>	<u>Micro-SADIC</u>	<u>Magnetic Tape</u>	<u>Oscillo-graph</u>	<u>Strip Chart</u>	<u>X-Y Plotter</u>
	<u>Pressure</u>		<u>psia</u>					
POJ-2	Main Oxidizer Injection	CO3A	0 to 1000	x		x		
POJGG-1A	Gas Generator Oxidizer Injection	GO5	0 to 1000	x		x		
POJGG-2	Gas Generator Oxidizer Injection	GO5	0 to 1000	x				
POPBC-1A	Oxidizer Pump Bearing Coolant	PO7	0 to 500	x				
POPD-1P	Oxidizer Pump Discharge	PO3	0 to 1500	x				
POPD-2	Oxidizer Pump Discharge	PO2	0 to 1500	x	x	x		
POPI-1	Oxidizer Pump Inlet		0 to 100	x				x
POPI-2	Oxidizer Pump Inlet		0 to 200	x				x
POPI-3	Oxidizer Pump Inlet		0 to 100			x		
POPSC-1A	Oxidizer Pump Primary Seal Cavity	PO6	0 to 50	x				
PORPO	Oxidizer Recirculation Pump Outlet		0 to 115	x				
PORPR	Oxidizer Recirculation Pump Return		0 to 100	x				
POTI-1A	Oxidizer Turbine Inlet	TG3	0 to 200	x				
POTO-1A	Oxidizer Turbine Outlet	TG4	0 to 100	x				
POUT	Oxidizer Tank Ullage		0 to 100	x				
POVCC	Main Oxidizer Valve Closing Control		0 to 500	x	x			
POVI	Oxidizer Tank Repressurization Line Nozzle Inlet		0 to 1000	x				
POVL	Oxidizer Tank Repressurization Line Nozzle Throat		0 to 1000	x				
PPUVI-1A	Propellant Utilization Valve Inlet	PO8	0 to 1000	x				
PPUVO-1A	Propellant Utilization Valve Outlet	PO9	0 to 500	x				
PTCFJP	Thrust Chamber Fuel Jacket Purge		0 to 100	x				
PTCP	Thrust Chamber Purge		0 to 15	x				
PTPP	Turbopump and Gas Generator Purge		0 to 250	x				
	<u>Speeds</u>		<u>rpm</u>					
NFP-1P	Fuel Pump	PFV	0 to 30,000	x	x	x		
NFRP	Fuel Recirculation Pump		0 to 15,000	x				
NOP-1P	Oxidizer Pump	POV	0 to 12,000	x	x	x		
NORP	Oxidizer Recirculation Pump		0 to 15,000	x				
	<u>Temperatures</u>		<u>°F</u>					
TA1	Test Cell (North)		-50 to +800	x				
TA2	Test Cell (East)		-50 to +800	x				
TA3	Test Cell (South)		-50 to +800	x				
TA4	Test Cell (West)		-50 to +800	x				
TAIP-1A	Auxiliary Instrument Package		-300 to +200	x				
TBPM	Bypass Manifold		-325 to +200	x				
TBSC	Oxidizer Bootstrap Conditioning		-350 to +150	x				
TECP-1P	Electrical Controls Package	NSTIA	-300 to +200	x				x
TFASIJ	Augmented Spark Igniter Fuel Injection	IFT1	-425 to +100	x		x		
TFASIL-1	Augmented Spark Igniter Line		-300 to +200	x				x
TFASIL-2	Augmented Spark Igniter Line		-300 to +300	x				x

TABLE III-1 (Continued)

<u>AEDC Code</u>	<u>Parameter</u>	<u>Tap No.</u>	<u>Range</u>	<u>Micro-SADIC</u>	<u>Magnetic Tape</u>	<u>Oscillo-graph</u>	<u>Strip Chart</u>	<u>X-Y Plotter</u>
<u>Temperatures</u>			<u>°F</u>					
TFBV-1A	Fuel Bleed Valve	GFT1	-425 to -375	x				
TFD-1	Fire Detection		0 to 1000	x			x	
TFJ-1P	Main Fuel Injection	CFT2	-425 to +250	x	x	x		
TFPD-1P	Fuel Pump Discharge	PFT1	-425 to -400	x	x	x		
TFPD-2	Fuel Pump Discharge	PFT1	-425 to -400	x				
TFPDD	Fuel Pump Discharge Duct		-320 to -300	x				
TFPI-1	Fuel Pump Inlet		-425 to -400	x				x
TFPI-2	Fuel Pump Inlet		-425 to -400	x				x
TFRPO	Fuel Recirculation Pump Outlet		-425 to -410	x				
TFRPR	Fuel Recirculation Pump Return Line		-425 to -250	x				
TFRT-1	Fuel Tank		-425 to -410	x				
TFRT-3	Fuel Tank		-425 to -410	x				
TFST-1P	Fuel Start Tank	TFT1	-350 to +100	x				
TFST-2	Fuel Start Tank	TFT1	-350 to +100	x				x
TFTD-1	Fuel Turbine Discharge Duct		-200 to +800	x				
TFTD-2	Fuel Turbine Discharge Duct		-200 to +1000	x			x	
TFTD-3	Fuel Turbine Discharge Duct		-200 to +1000	x			x	
TFTD-3R	Fuel Turbine Discharge Line		-200 to +900	x				
TFTD-4	Fuel Turbine Discharge Duct		-200 to +1000	x				
TFTD-5	Fuel Turbine Discharge Duct		-200 to +1400	x				
TFTD-6	Fuel Turbine Discharge Duct		-200 to +1400	x				
TFTD-7	Fuel Turbine Discharge Duct		-200 to +1400	x				
TFTD-8	Fuel Turbine Discharge Duct		-200 to +1400	x			x	
TFTI-1P	Fuel Turbine Inlet	TFT1	0 to 1800	x			x	
TFTO	Fuel Turbine Outlet	TFT2	0 to 1800	x				
TGGO-1A	Gas Generator Outlet	GGT1	0 to 1800	x	x	x		
THET-1P	Helium Tank	NNT1	-350 to +100	x				x
TNODP	LO <sub>2</sub> Dome Purge		0 to -300	x				
TOBS-1	Oxidizer Bootstrap Line		-300 to +250	x				
TOBS-2	Oxidizer Bootstrap Line		-300 to +250	x				
TOBS-2A	Oxidizer Bootstrap Line		-300 to +250	x				
TOBS-2B	Oxidizer Bootstrap Line		-300 to +250	x				
TOBS-3	Oxidizer Bootstrap Line		-300 to +250	x				
TOBS-4	Oxidizer Bootstrap Line		-300 to +250	x				
TOBV-1A	Oxidizer Bleed Valve	GOT2	-300 to -250	x				
TOPB-1A	Oxidizer Pump Bearing Coolant	POT4	-300 to -250	x				
TOPD-1P	Oxidizer Pump Discharge	POT3	-300 to -250	x	x	x	x	
TOPD-2	Oxidizer Pump Discharge	POT3	-300 to -250	x				
TOPI-1	Oxidizer Pump Inlet		-310 to -270	x				x
TOPI-2	Oxidizer Pump Inlet		-310 to -270	x				x
TORPO	Oxidizer Recirculation Pump Outlet		-300 to -250	x				
TORPR	Oxidizer Recirculation Pump Return		-300 to -140	x				

TABLE III-1 (Continued)

<u>AEDC Code</u>	<u>Parameter</u>	<u>Tap No.</u>	<u>Range</u>	<u>Micro-SADIC</u>	<u>Magnetic Tape</u>	<u>Oscillo-graph</u>	<u>Strip Chart</u>	<u>X-Y Plotter</u>
<u>Temperatures</u>								
			<u>°F</u>					
TORT-1	Oxidizer Tank		-300 to -287	x				
TORT-3	Oxidizer Tank		-300 to -287	x				
TOTI-1P	Oxidizer Turbine Inlet	TGT3	0 to 1200	x			x	
TOTO-1P	Oxidizer Turbine Outlet	TGT4	0 to 1000	x				
TOVL	Oxidizer Tank Repreaurization Line Nozzle Throat		-300 to +100	x				
TPCC	Pre-Chill Controller		-425 to -300	x				
TPIP-1P	Primary Instrument Package		-300 to +200	x				
TSC2-1	Thrust Chamber Skin		-300 to -500	x				
TSC2-2	Thrust Chamber Skin		-300 to +500	x				
TSC2-3	Thrust Chamber Skin		-300 to +500	x				
TSC2-4	Thrust Chamber Skin		-300 to +500	x				
TSC2-5	Thrust Chamber Skin		-300 to +500	x				
TSC2-6	Thrust Chamber Skin		-300 to +500	x				
TSC2-7	Thrust Chamber Skin		-300 to +500	x				
TSC2-8	Thrust Chamber Skin		-300 to +500	x				
TSC2-9	Thrust Chamber Skin		-300 to +500	x				
TSC2-10	Thrust Chamber Skin		-300 to +500	x				
TSC2-11	Thrust Chamber Skin		-300 to +500	x				
TSC2-12	Thrust Chamber Skin		-300 to +500	x				
TSC2-13	Thrust Chamber Skin		-300 to +500	x			x	
TSC2-14	Thrust Chamber Skin		-300 to +500	x				
TSC2-15	Thrust Chamber Skin		-300 to +500	x				
TSC2-16	Thrust Chamber Skin		-300 to +500	x				
TSC2-17	Thrust Chamber Skin		-300 to +500	x				
TSC2-18	Thrust Chamber Skin		-300 to +500	x				
TSC2-19	Thrust Chamber Skin		-300 to +500	x				
TSC2-20	Thrust Chamber Skin		-300 to +500	x				
TSC2-21	Thrust Chamber Skin		-300 to +500	x				
TSC2-22	Thrust Chamber Skin		-300 to +500	x				
TSC2-23	Thrust Chamber Skin		-300 to +500	x				
TSC2-24	Thrust Chamber Skin		-300 to +500	x				
TSOVAL-1	Oxidizer Valve Cloaing Control Line		-200 to +100	x				
TSOVC-1	Oxidizer Valve Actuator Cap		-325 to +150	x				
TSTC	Start Tank Conditioning		-350 to +150	x				
TSTDVOC	Start Tank Discharge Valve Opening Control Port		-350 to +100	x				
TTC-1P	Thrust Chamber Jacket (Control)	CS <sub>1</sub>	-425 to +500	x				
TTCEP-1	Thrust Chamber Exit		-425 to +500	x				
TXOC	Crossover Duct Conditioning		-325 to +200	x				

TABLE III-1 (Concluded)

<u>AEDC Code</u>	<u>Parameter</u>	<u>Tap No.</u>	<u>Range</u>	<u>Micro-SADIC</u>	<u>Magnetic Tape</u>	<u>Oscillo-graph</u>	<u>Strip Chart</u>	<u>X-Y Plotter</u>
			<u>g's</u>					
UFPR	Fuel Pump Radial 90 deg		±200		x			
UOPR	Oxidizer Pump Radial 90 deg		±200		x			
UTCD-1	Thrust Chamber Dome		±500		x	x		
UTCD-2	Thrust Chamber Dome		±500		x	x		
UTCD-3	Thrust Chamber Dome		±500		x	x		
U1VSC	No. 1 Vibration Safety Counts		On/Off				x	
U2VSC	No. 2 Vibration Safety Counts		On/Off				x	
			<u>Volts</u>					
VCB	Control Bus		0 to 36	x			x	
VIB	Ignition Bus		0 to 36	x			x	
VIDA	Ignition Detect Amplifier		9 to 16	x			x	
VPUTEP	Propellant Utilization Valve Excitation		0 to 5	x				

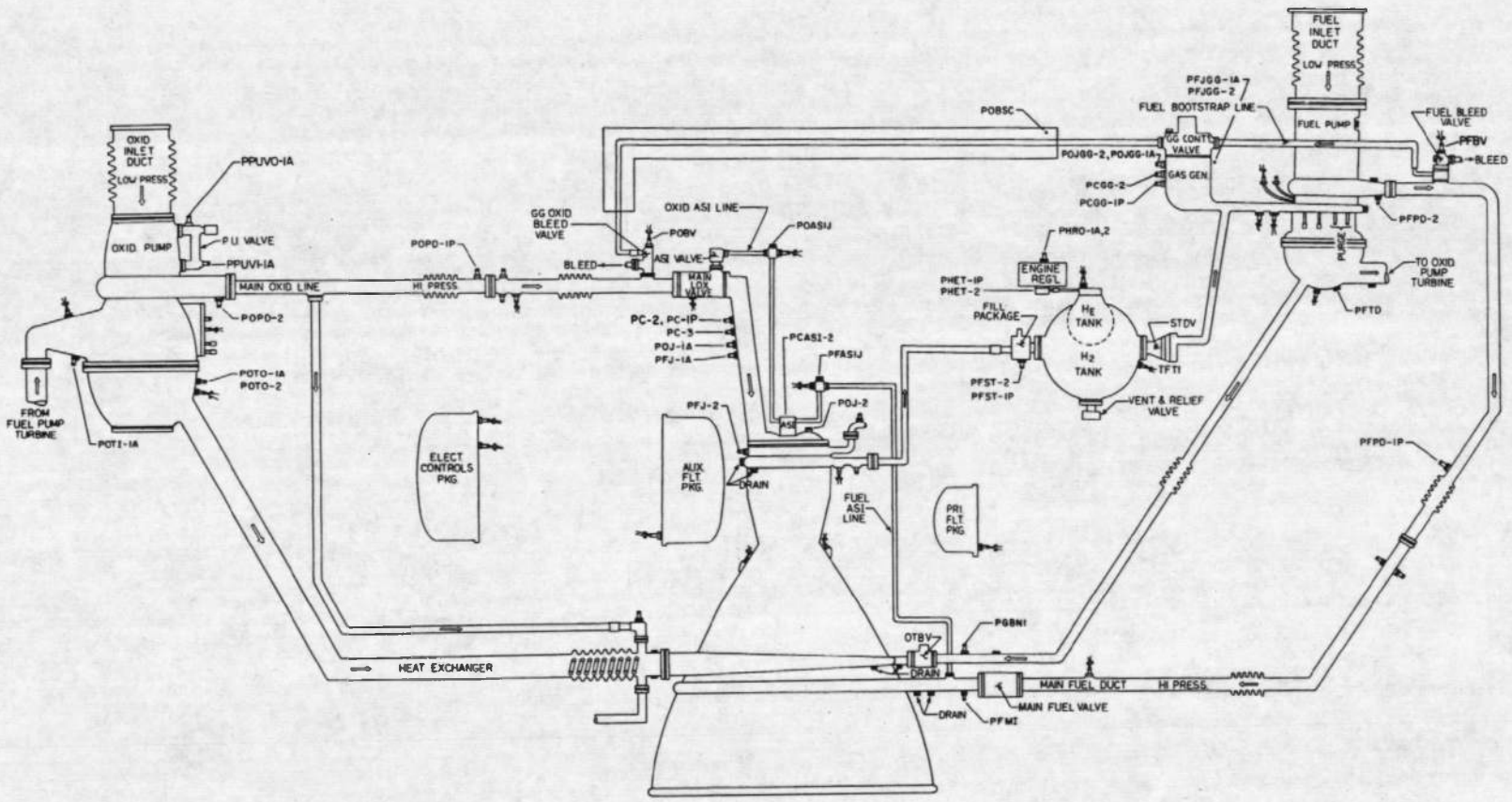

a. Engine Pressure Tap Locations  
 Fig. III-1 Instrumentation Locations

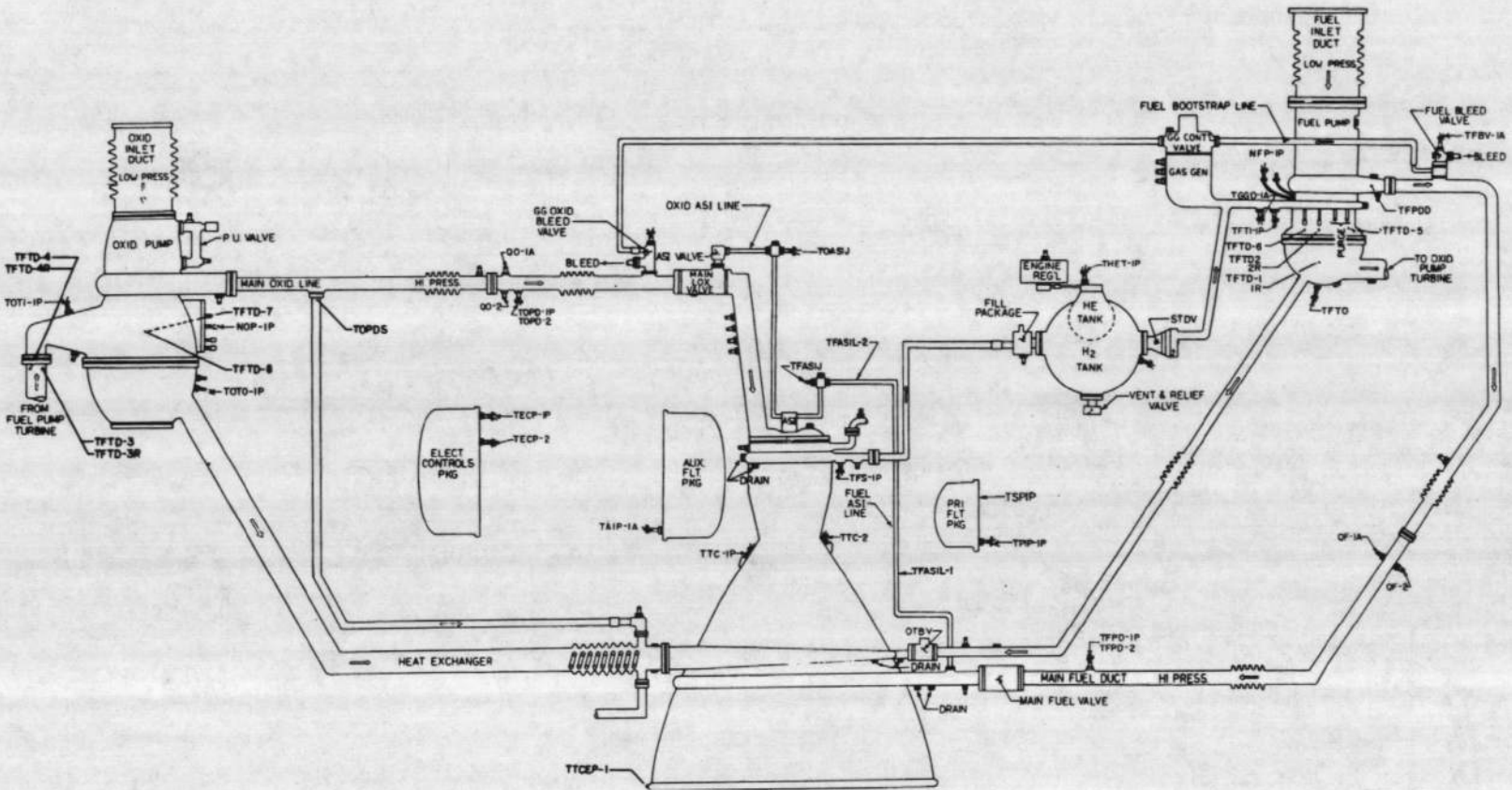

b. Engine Temperature, Flow, and Speed Instrumentation Locations  
 Fig. III-1 Continued

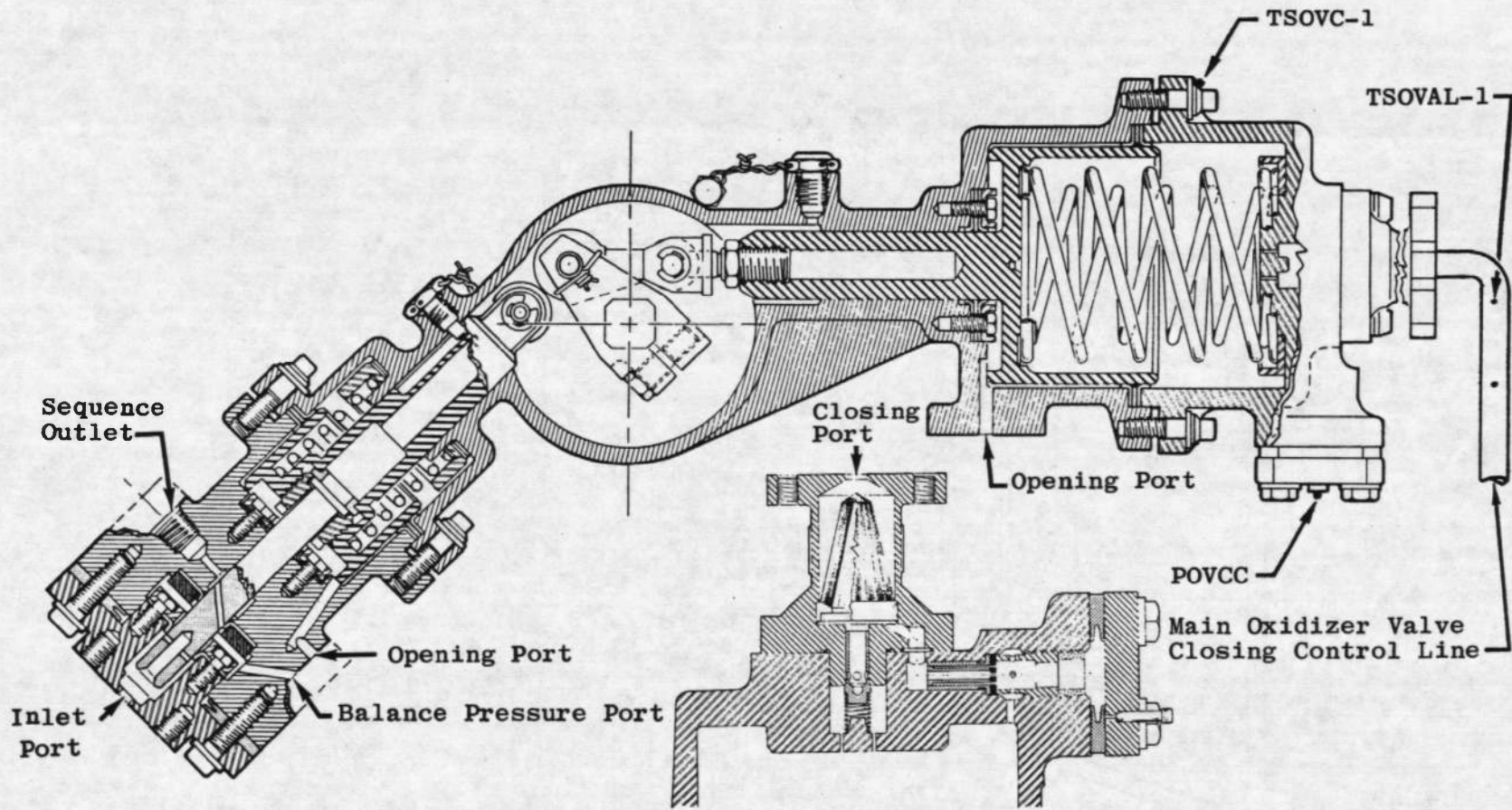

c. Main Oxidizer Valve  
Fig. III-1 Continued



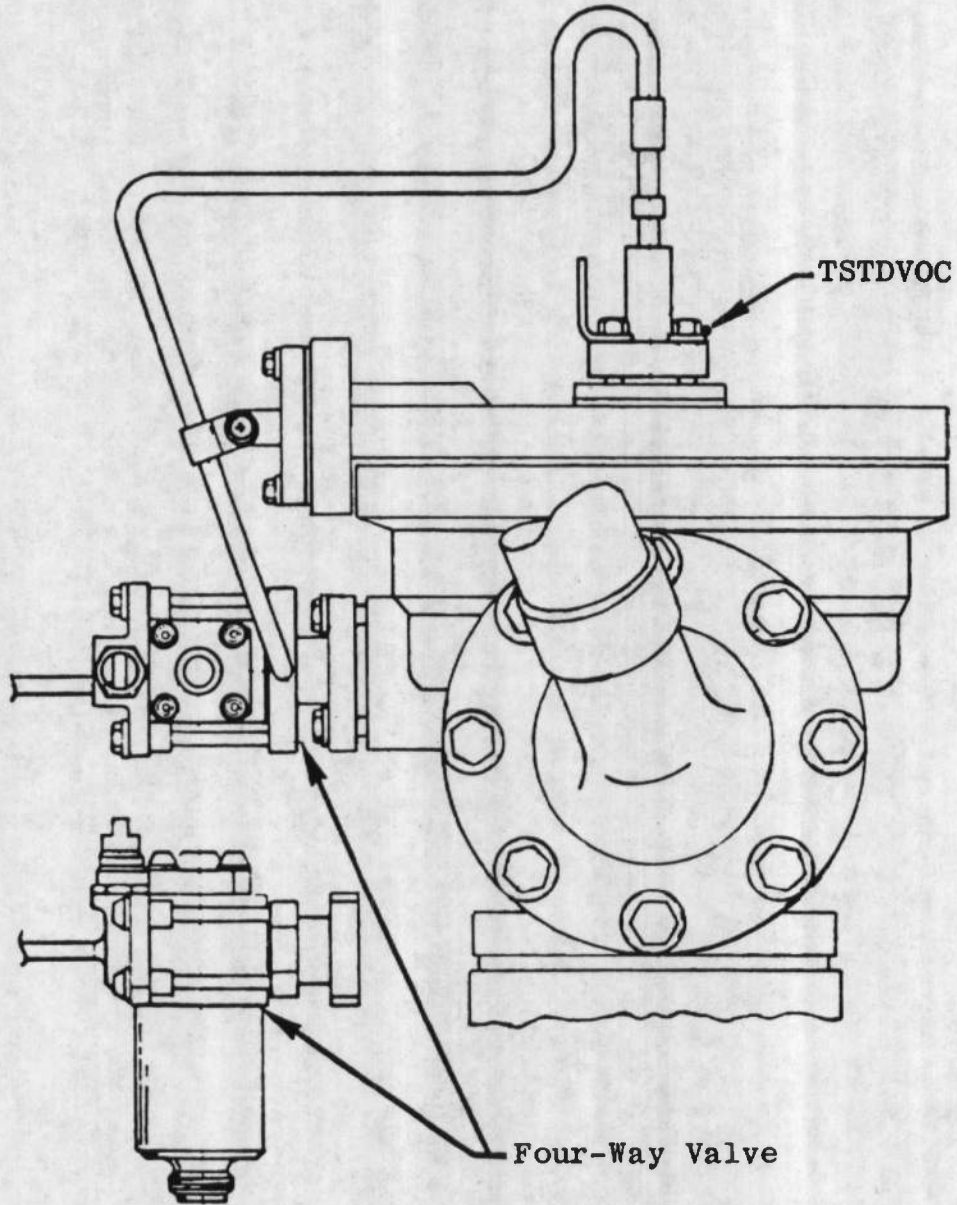

d. Start Tank Discharge Valve  
Fig. III-1 Continued

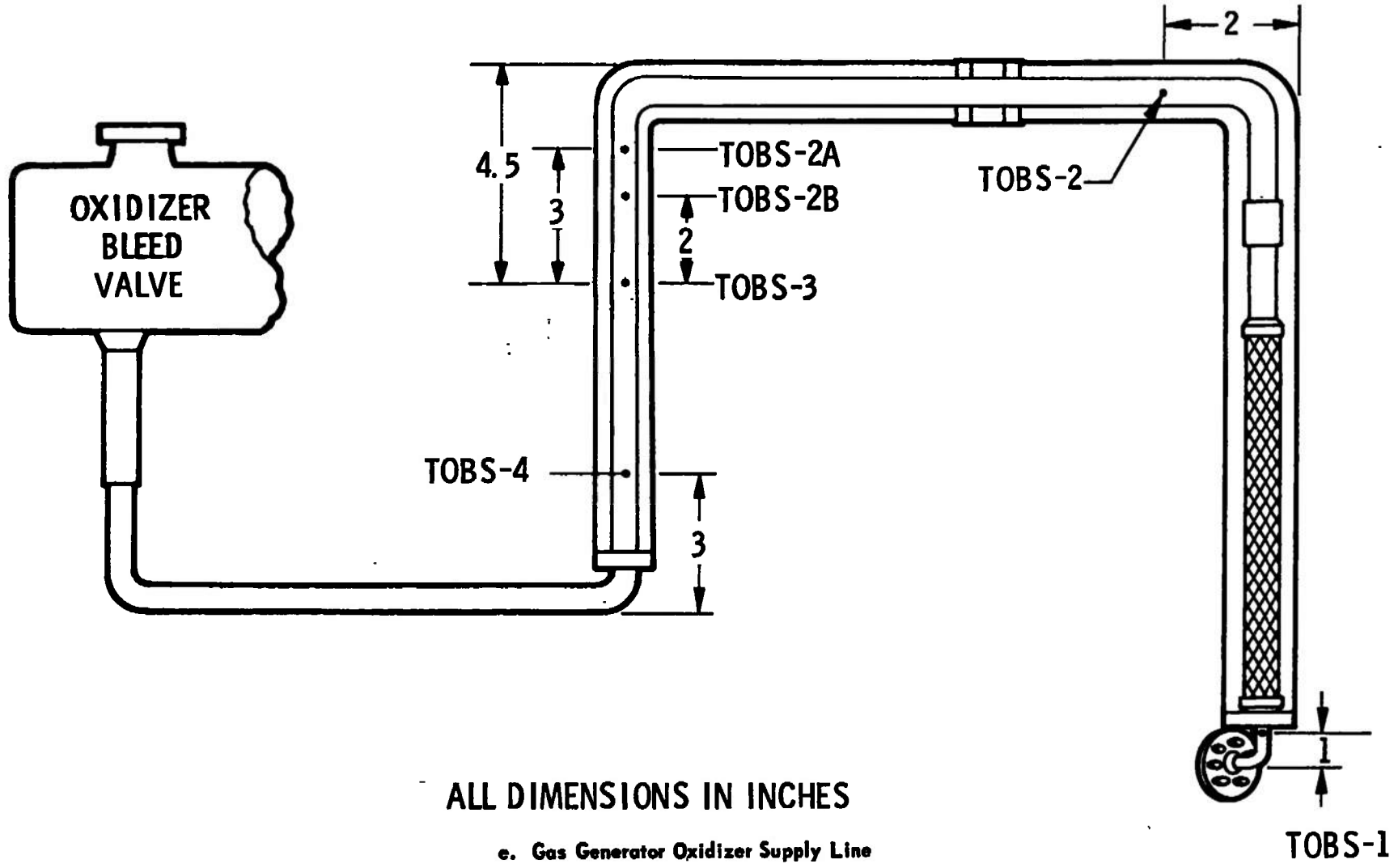

ALL DIMENSIONS IN INCHES

e. Gas Generator Oxidizer Supply Line

Fig. III-1 Continued

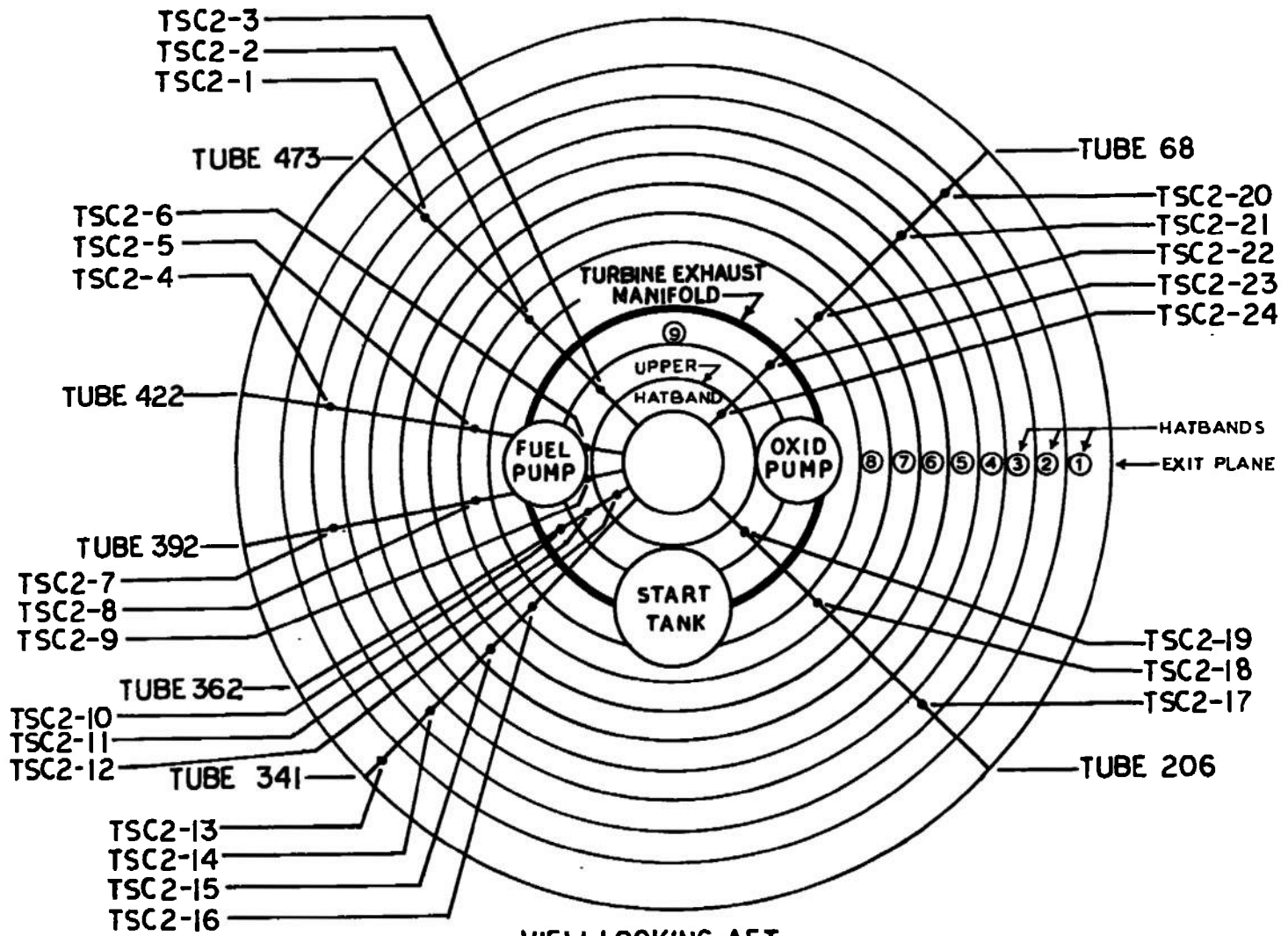

VIEW LOOKING AFT

f. Thrust Chamber  
Fig. III-1, Concluded

**APPENDIX IV  
METHODS OF CALCULATIONS (PERFORMANCE PROGRAM)**

**TABLE IV-1  
PERFORMANCE PROGRAM DATA INPUTS**

Item No.	Parameter
1	Thrust Chamber (Injector Face) Pressure, psia
2	Thrust Chamber Fuel and Oxidizer Injection Pressures, psia
3	Thrust Chamber Fuel Injection Temperature, °F
4	Fuel and Oxidizer Flowmeter Speeds, Hz
5	Fuel and Oxidizer Engine Inlet Pressures, psia
6	Fuel and Oxidizer Pump Discharge Pressures, psia
7	Fuel and Oxidizer Engine Inlet Temperatures, °F
8	Fuel and Oxidizer (Main Valves) Temperatures, °F
9	Propellant Utilization Valve Center Tap Voltage, volts
10	Propellant Utilization Valve Position, volts
11	Fuel and Oxidizer Pump Speeds, rpm
12	Gas Generator Chamber Pressure, psia
13	Gas Generator (Bootstrap Line at Bleed Valve) Temperature, °F
14	Fuel* and Oxidizer Turbine Inlet Pressure, psia
15	Oxidizer Turbine Discharge Pressure, psia
16	Fuel and Oxidizer Turbine Inlet Temperature, °F
17	Oxidizer Turbine Discharge Temperature, °F

\*At AEDC, fuel turbine inlet pressure is calculated from gas generator chamber pressure.

## NOMENCLATURE

A	Area, in. <sup>2</sup>
B	Horsepower, hp
C*	Characteristic velocity, ft/sec
C <sub>p</sub>	Specific heat at constant pressure, Btu/lb/°F
D	Diameter, in.
H	Head, ft
h	Enthalpy, Btu/lb <sub>m</sub>
M	Molecular weight
N	Speed, rpm
P	Pressure, psia
Q	Flow rate, gpm
R	Resistance, sec <sup>2</sup> /ft <sup>3</sup> -in. <sup>2</sup>
r	Mixture ratio
T	Temperature, °F
TC*	Theoretical characteristic velocity, ft/sec
W	Weight flow, lb/sec
Z	Pressure drop, psi
β	Ratio
γ	Ratio of specific heats
η	Efficiency
θ	Degrees
ρ	Density, lb/ft <sup>3</sup>

## SUBSCRIPTS

A	Ambient
AA	Ambient at thrust chamber exit
B	Bypass nozzle

BIR	Bypass nozzle inlet (Rankine)
BNI	Bypass nozzle inlet (total)
C	Thrust chamber
CF	Thrust chamber, fuel
CO	Thrust chamber, oxidizer
CV	Thrust chamber, vacuum
E	Engine
EF	Engine fuel
EM	Engine measured
EO	Engine oxidizer
EV	Engine, vacuum
e	Exit
em	Exit measured
F	Thrust
FIT	Fuel turbine inlet
FM	Fuel measured
FY	Thrust, vacuum
f	Fuel
G	Gas generator
GF	Gas generator fuel
GO	Gas generator oxidizer
H1	Hot gas duct No. 1
H1R	Hot gas duct No. 1 (Rankine)
H2R	Hot gas duct No. 2 (Rankine)
IF	Inlet fuel
IO	Inlet oxidizer
ITF	Isentropic turbine fuel
ITO	Isentropic turbine oxidizer
N	Nozzle
NB	Bypass nozzle (throat)

NV	Nozzle, vacuum
O	Oxidizer
OC	Oxidizer pump calculated
OF	Outlet fuel pump
OFIS	Outlet fuel pump isentropic
OM	Oxidizer measured
OO	Oxidizer outlet
PF	Pump fuel
PO	Pump oxidizer
PUVO	Propellant utilization valve oxidizer
RNC	Ratio bypass nozzle, critical
SC	Specific, thrust chamber
SCV	Specific thrust chamber, vacuum
SE	Specific, engine
SEV	Specific, engine vacuum
T	Total
T <sub>o</sub>	Turbine oxidizer
TEF	Turbine exit fuel
TEFS	Turbine exit fuel (static)
TF	Fuel turbine
TIF	Turbine inlet fuel (total)
TIFM	Turbine inlet, fuel, measured
TIFS	Turbine inlet fuel isentropic
TIO	Turbine inlet oxidizer
t	Throat
V	Vacuum
v	Valve
XF	Fuel tank repressurant
XO	Oxidizer tank repressurant

## PERFORMANCE PROGRAM EQUATIONS

## MIXTURE RATIO

## Engine

$$r_E = \frac{W_{EO}}{W_{EF}}$$

$$W_{EO} = W_{OM} - W_{XO}$$

$$W_{EF} = W_{FM} - W_{XF}$$

$$W_E = W_{EO} + W_{EF}$$

## Thrust Chamber

$$r_C = \frac{W_{CO}}{W_{CF}}$$

$$W_{CO} = W_{OM} - W_{XO} - W_{GO}$$

$$W_{CF} = W_{FM} - W_{XF} - W_{GF}$$

$$W_{XO} = 0.8 \text{ lb/sec}$$

$$W_{XF} = 1.8 \text{ lb/sec}$$

$$W_{GO} = W_T - W_{GF}$$

$$W_{GF} = \frac{W_T}{1 + r_G}$$

$$W_T = \frac{P_{TIF} A_{TIF} K_7}{TC * TIF}$$

$$K_7 = 32.174$$

$$W_C = W_{CO} + W_{CF}$$

## CHARACTERISTIC VELOCITY

## Thrust Chamber

$$C^* = \frac{K_7 P_c A_t}{W_C}$$

$$K_7 = 32.174$$



14. KEY WORDS	LINK A		LINK B		LINK C	
	ROLE	WT	ROLE	WT	ROLE	WT
J-2 rocket engines Saturn altitude testing performance fuel pump operation thrust chamber pressure temperature transients						
<i>1. Rocket motors -- J-2.</i>						
<i>2 " " -- Perform</i>						
<i>16-3</i>						