

UNCLASSIFIED

AD NUMBER

AD823395

LIMITATION CHANGES

TO:

Approved for public release; distribution is unlimited.

FROM:

Distribution authorized to U.S. Gov't. agencies and their contractors; Critical Technology; NOV 1967. Other requests shall be referred to Rome Air Development Center, Attn: RADC/EMATE, Griffiss AFB, NY 13441-5700. This document contains export-controlled technical data.

AUTHORITY

USAF RADC ltr dtd 17 Sep 1971

THIS PAGE IS UNCLASSIFIED

RADC-TR-67-549



AD823395

ELECTRON BEAM ANALYSIS TECHNIQUES

A. S. Gilmour, Jr.
R. J. Myers
H. Veron

Cornell Aeronautical Laboratory, Inc.

TECHNICAL REPORT NO. RADC-TR-67-549

November 1967

This document is subject to special export controls and each transmittal to foreign governments, foreign nationals or representatives thereto may be made only with prior approval of RADC (EMATE), GAFB, N. Y. The distribution of this document is limited under the U.S. Export Control Act of 1949.

Rome Air Development Center
Air Force Systems Command
Griffiss Air Force Base, New York

When US Government drawings, specifications, or other data are used for any purpose other than a definitely related government procurement operation, the government thereby incurs no responsibility nor any obligation whatsoever; and the fact that the government may have formulated, furnished, or in any way supplied the said drawings, specifications, or other data is not to be regarded, by implication or otherwise, as in any manner licensing the holder or any other person or corporation, or conveying any rights or permission to manufacturer, use, or sell any patented invention that may in any way be related thereto.

Do not retain this copy. Retain or destroy.

ELECTRON BEAM ANALYSIS TECHNIQUES

A. S. Gilmour, Jr.

R. J. Myers

H. Veron

Cornell Aeronautical Laboratory, Inc.

This document is subject to special export controls and each transmittal to foreign governments, foreign nationals or representatives thereto may be made only with prior approval of RADC (EMATE), GAFB, NY 13440.

FOREWORD

This final report was prepared by Cornell Aeronautical Laboratory, Inc., P.O. Box 235, Buffalo, New York, under Contract F30602-67-C-0020, Project No. 5573, Task No. 557303, covering the period 15 August 1966 to 15 August 1967. The report is identified by the contractor as No. UB-2333-E-2. The study was under the overall direction of Dr. A. S. Gilmour, Jr.

RADC Project Engineer was R. H. Chilton (EMATE).

The objective of this contract is to determine the feasibility of a nonintercepting electron beam probe (an atomic, molecular, or ionic beam injected normal to an electron beam) for obtaining the properties of linear and injected crossed-field electron beams as used in microwave tubes.

Information in this report is embargoed under the U.S. Export Control Act of 1949, administered by the Department of Commerce. This report may be released by departments or agencies of the U.S. Government to departments or agencies of foreign governments with which the United States has defense treaty commitments. Private individuals or firms must comply with Department of Commerce export control regulations.

This technical report has been reviewed and is approved.

Approved:

R H Chilton
R. H. CHILTON
Project Engineer
Electron Devices Section

Approved:

Alfred W. Parker
BARRETT B. TOWNSEND
Colonel, USAF
Chief, Surveillance & Control
Division

FOR THE COMMANDER:

Irving J. Gabelman
IRVING J. GABELMAN
Chief, Advanced Studies Group

ABSTRACT

The feasibility of using a nonintercepting electron beam probe for obtaining the properties of linear electron beams as used in microwave tubes has been demonstrated. The nonintercepting probe employs the technique of injecting an atomic, molecular, or ionic beam normal to the electron beam and the determination of the electron beam properties from the photon emissions resulting from the interactions of the two beams. The use of this technique for analyzing crossed-field beams should be feasible because the density of crossed-field beams is about two orders of magnitude greater than that of the linear beam that has been studied. The major problem anticipated in the analysis of crossed-field beams is in the instrumentation of a crossed-field device. Through the use of miniaturized probing beam generators and fiber optics it is anticipated that this instrumentation problem will be solved.

CONTENTS

<u>Section</u>		<u>Page</u>
	FOREWORD	iii
I	INTRODUCTION	1
II	TECHNICAL DISCUSSION	4
	A. APPARATUS	4
	1. Vacuum System	4
	2. Electron-Beam Generation System	7
	3. Mechanical Scanner	8
	4. Atomic-Beam Generator	11
	B. RESULTS	24
	1. Analysis of Interaction of Beams	24
	2. Experimental Results	29
	C. RECOMMENDATIONS FOR THE ANALYSIS OF CROSSED-FIELD BEAMS	35
	1. Miniaturization of Atomic-Beam Generator	36
	2. Observation of Interaction of Probing Beam with Electron Beam	38
III	SUMMARY	39

ILLUSTRATIONS

<u>Figure</u>		<u>Page</u>
1	Technique Being Used for Generation of Probing Beam . . .	3
2	Electron Beam Analyzer for Project PROBE	5
3	Vacuum System of Beam Analyzer	6
4	Electron Gun and Associated Apparatus	9
5	Beam Scanning Mechanism	10
6	Atomic Beam Apparatus (Without Beam-Defining Aperture)	12
7	Scale Drawing of the Atomic Beam Generator	13
8	Relation of Cathode and Collimator Size to Beam Shape . . .	15
9	Densitometer Traces of the Stainless Steel Deposits from a Glass Screen	17
10	Igniter Circuit	18
11a	TR-180 Secondary Output Across Tektronix P6015 High Voltage Probe	20
11b	TR-180 Secondary Output on Igniter Electrode, No Ensuing Vacuum Arc	20
11c	TR-180 Secondary Output on Igniter Electrode with Ensuing Vacuum Arc	20
12	Power Supply for Pulsed Vacuum Arc	21
13	Current and Voltage as a Function of Time for a Pulsed Arc on Bismuth	23
14	Density of Atomic Beam as a Function of the Arc Current, I_a , the Atomic Weight, M , the Distance from the Arc Cathode, r , and the Beam Velocity, u_a	27
15	Paths Followed by Ionized and Neutral Streams After Leaving Probing Beam Generator	30
16	Baffling System Used to Help Make Interaction of Beams Observable	32

ILLUSTRATIONS (Cont.)

<u>Figure</u>		<u>Page</u>
17	Photograph of Results of Early Interaction Experiment . .	34
18	Miniaturized Atomic-Beam Generator	37
19	Circuit for Driving Miniaturized Atomic-Beam Generator	37

EVALUATION

A thorough knowledge of the behavior of the electron flow in microwave tubes is an essential factor in designing new tubes.

Various techniques have been used to physically determine the properties of electron beams. The probing of linear electron beams is well at hand; however, lack of satisfactory techniques to probe an injected crossed field beam without disturbing it prompted this effort.

Cornell Aeronautical Labs (CAL) proposed the non-intercepting electron beam probe to meet this need. This report covers the feasibility studies made on the technique in conjunction with the simpler linear electron beam case.

Now that the feasibility has been established, the next step is to apply the technique to the cross-field case and eventually make the methods and results available to microwave tube designers and manufacturers to be applied to the next generation of microwave tubes.

R. H. Chilton
R. H. CHILTON
Project Engineer

1. INTRODUCTION

In microwave, electron-beam devices the manner of generation and degree of control of the beam is of the utmost importance if optimum interaction between the beam and the slow-wave circuit is to be obtained. The behavior of the electron beam in most devices is complex enough so that it is not possible to perform a meaningful analytical study of its behavior. For this reason, experimental studies must be performed if optimum results are to be obtained. Present experimental techniques for determining the performance of electron beams are such that they change the potential distribution in the beam. Their application is, therefore, limited to the analysis of beams, such as drifting linear beams, which will not be seriously affected by the perturbation of potential distribution.

The objective of the project described herein (Project PROBE) is to develop a technique for probing beams, which does not cause an appreciable disturbance in the beams, even though these beams may exist in strong electric and/or magnetic fields. The approach being pursued for probing these beams is that of using atomic, molecular, or ionic beams directed normal to the electron beam under study. This approach was selected after ruling out the possibilities of using electron or photon beams as probing beams. The electron probing beam is not being considered because of the complex interactions of scattered electrons with magnetic focusing fields. Photon beams, such as those emitted by lasers, are not feasible at the present time because the amount of light scattered by the electrons at the electron concentration of interest is too small to make meaningful analyses possible.

In the CAL technique, electrons in the beam under study excite particles in the probing beam which, upon returning to the ground state, emit photons. The intensity of the photon emission is proportional to the densities of the electron beam and the probing beam. Thus, a visible display of the current density as a function of position in the electron beam results

from the interaction of the two beams. By suitable choices of the geometry and density of the probing beam, disturbances of the electron beam are negligible.

Care must be taken in selecting the species of particles to be used for the probing beam. In particular, particles from low-vapor-pressure materials must be selected to avoid disturbances of the electron beam by ion neutralization, which would accompany the use of high-vapor-pressure materials. Thus, it is necessary to consider probing beams and probing-beam collectors which have accommodation coefficients close to unity. As is described in the Technical Discussion, the technique being used on Project PROBE for meeting the requirement for a high accommodation coefficient is to use the metallic-atom beam generated by a vacuum arc. Figure 1 shows that the plasma plume from the arc is caused to impinge on a plate containing an aperture for defining the probing beam. The result of the interaction of this probing beam with the electron beam is a thin, planar light source, the intensity of which is thought to be directly proportional to the current density in the electron beam. Measurements of the density of the electron beam as a function of position in a plane normal to the axis of the light beam will, therefore, be possible. Measurement of the beam density as a function of axial position will be made by moving the probing beam along the electron beam and photographically recording the light generated.

This report describes the development of a beam analyzer in which to perform the probing experiments, the development of the atomic beam generator, and the results obtained from the probing experiments.

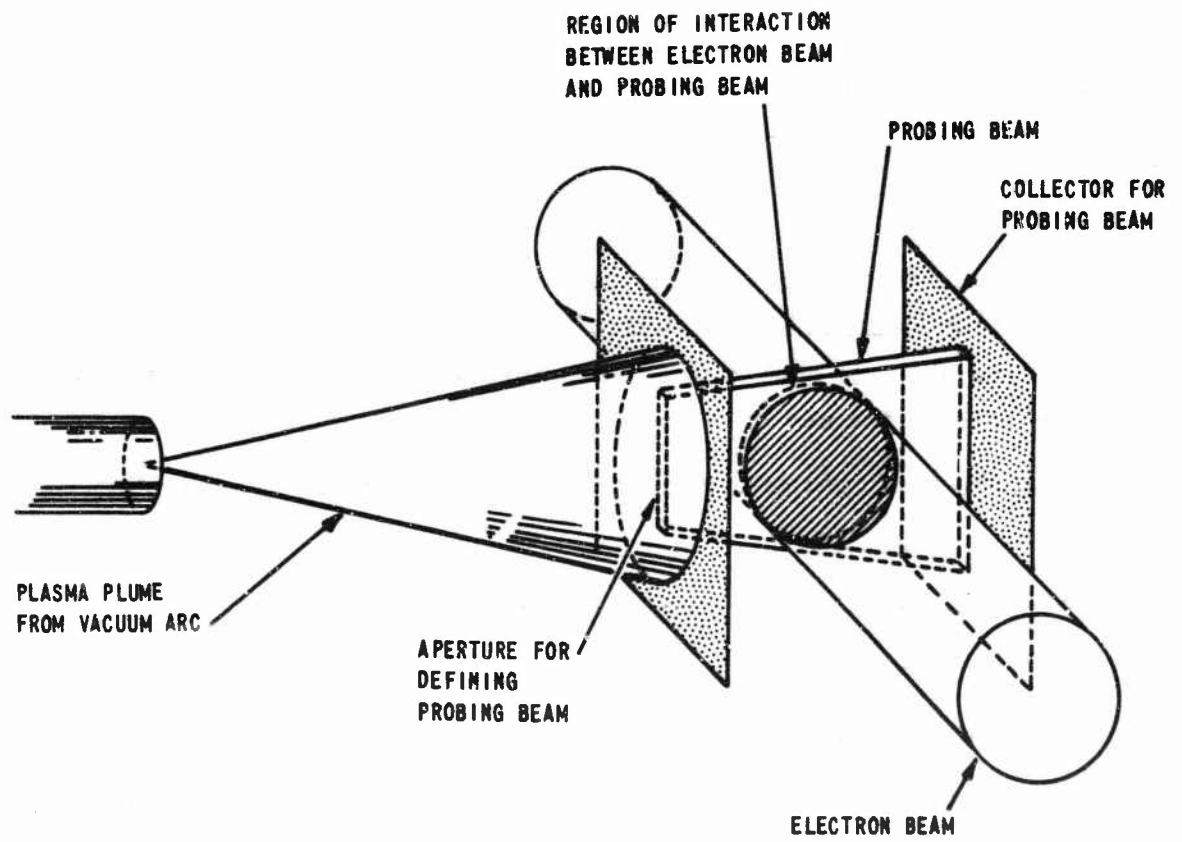

Figure 1 TECHNIQUE BEING USED FOR GENERATION OF PROBING BEAM

II. TECHNICAL DISCUSSION

A. APPARATUS

The beam analyzer that has been constructed, as shown in Figure 2, is more sophisticated than would be required simply to show that light can be generated by causing an atomic beam to interact with an electron beam. It is the intention, on PROBE, to use this analyzer to relate the intensity and eventually, the spectrum of the light generated by the interactions of the beams to the characteristics of the electron beam. In addition, it is planned that calibration of future atomic-beam generators can be performed using this analyzer and that the generators can be used for analyzing beams, such as crossed-field electron beams, which heretofore have not been investigated. Of course, the ultimate goal is to obtain improved performance of microwave tubes through the use of this new beam-analysis technique.

The analyzer consists, primarily, of four important components:

1. Demountable vacuum system.
2. Electron-beam generation system.
3. Mechanical beam scanner.
4. Atomic-beam generator.

Each of these components is discussed separately in the following paragraphs.

1. Vacuum System

The vacuum system for the analyzer has been designed and constructed to provide maximum versatility while making possible the attainment of low ultimate pressures comparable to those found in medium and high power microwave tubes. As is shown in Figure 3, the primary portion of the vacuum system is pumped by a 75 μ /sec Vac-Ion Pump. With this pump, pressures in the low 10^{-8} Torr range are readily achieved even though it is not possible to bake the analyzer because of its size and configuration. The electron-gun portion of the system is pumped by an 8 μ /sec

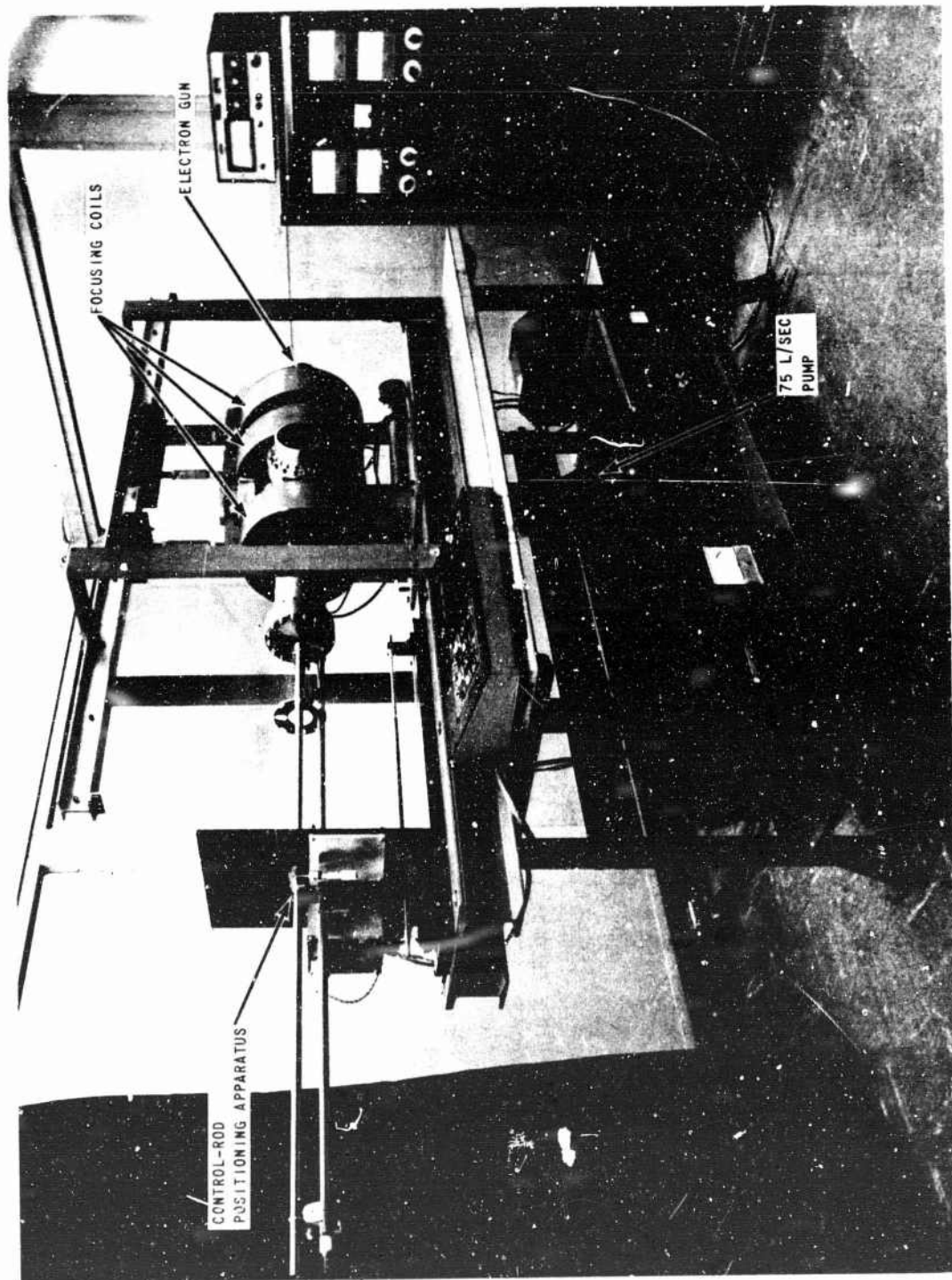

Figure 2 ELECTRON BEAM ANALYZER FOR PROJECT PROBE

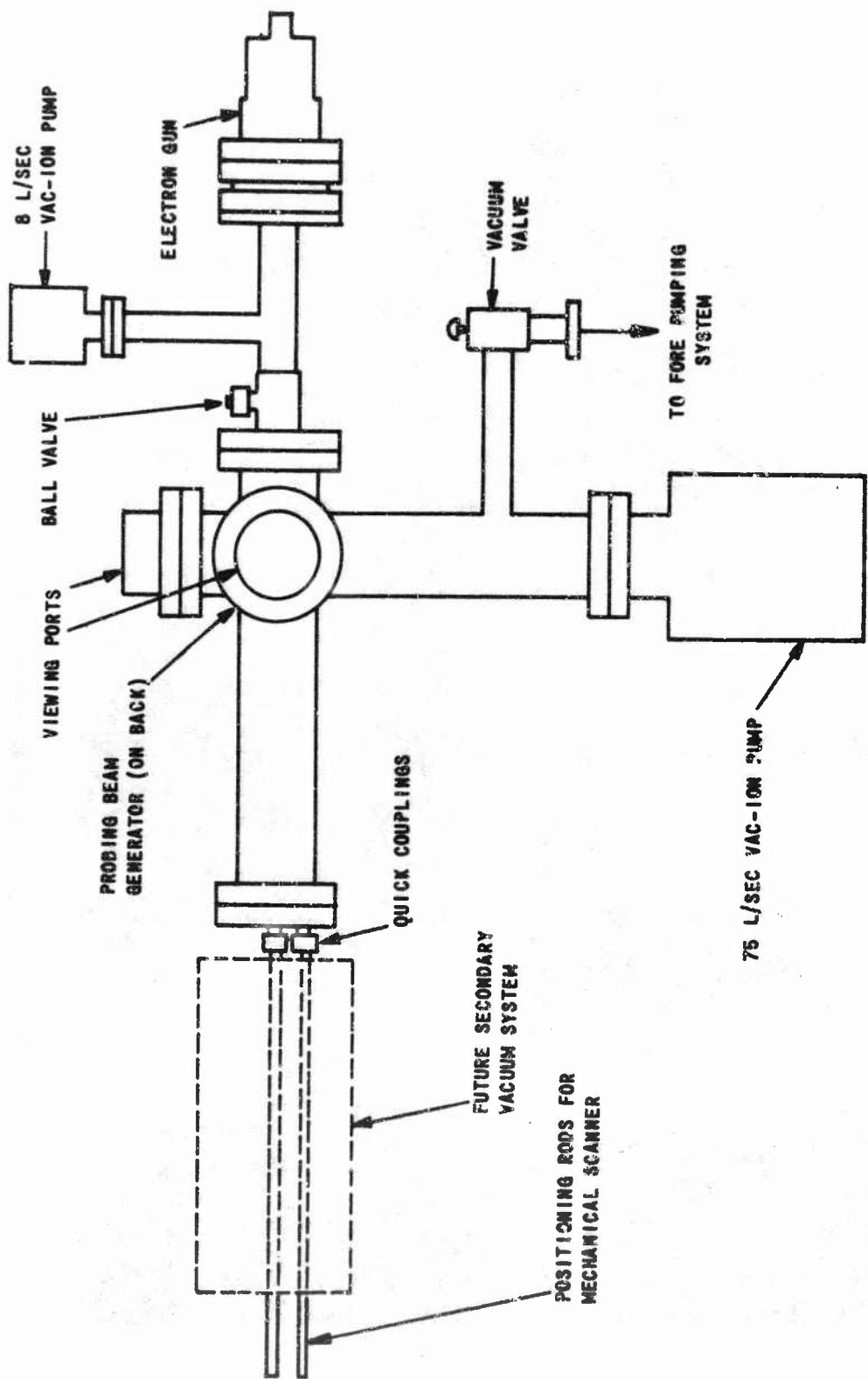

Figure 3 VACUUM SYSTEM OF BEAM ANALYZER

Vac-Ion Pump and is isolated from the primary vacuum system by a high-vacuum ball valve of the type developed by one of the authors and described in detail elsewhere.¹ Many different measurements in the electron beam are planned and, for these measurements to be related to each other, they must be carried out on the same beam. Since it is anticipated that several modifications will be made in the beam probing apparatus in the process of developing the new probing technique using atomic beams, the ball valve² is used so that the drift tube containing the beam probing apparatus can be exposed to air without damaging the cathode.

The portions of the mechanical analyzer inside the vacuum system are controlled by polished stainless-steel rods sliding through the quick couplings shown in Figure 3. These rods are coated with a film of Dow-Corning high-vacuum compound as a lubricant. It is anticipated that as development of the atomic-probing-beam technique progresses, a secondary vacuum system, as shown in Figure 3, will be added to the analyzer. As is described in Reference 1, the reason for using this secondary system is to prevent the release of adsorbed gas into the primary vacuum system as the control rods are moved into the vacuum systems.

2. Electron-Beam Generation System

The selection of the electron-beam being used on PROBE was based on a number of factors. The most important consideration was the requirement that it should be possible to analyze the beam using the new atomic-beam technique as well as using conventional proven techniques, to provide a means for calibrating the new probe. Since conventional techniques, such as the pin-hole type scanner, can be used only on linear, drifting beams,

¹A. S. Gilmour, Jr. and D. D. Hallock, "A Demountable Beam Analyzer for Studying Magnetically Confined Electron Beams," *Advances in Electron Tube Techniques*, Volume 2, Pergamon Press, 1963.

²When the valve is open, the beam can be passed through the aperture in the ball. When the valve is closed, the drift tube can be opened to atmospheric pressure while the cathode is kept in a high vacuum.

the decision was made to use an electron gun and focusing system of the type normally used on klystrons or traveling-wave tubes.

The second requirement placed on the electron-beam system was that the beam should be large enough so that the overall characteristics of the interactions of the two beams could be determined without the aid of auxiliary equipment such as magnifying lenses. A third requirement was that the electron-beam voltage should be adjustable over the range in which most microwave tubes operate, that is, from 0 to at least a few tens of kilovolts.

Because of its availability and because it satisfied the three requirements described in the preceding paragraphs, the Varian K 820 electron gun, shown in Figure 4, was selected for use on the analyzer. This gun is rated at 150 KV and has a nominal microperveance of 2.4. With the focusing coil arrangement being used on the analyzer the diameter of the electron beam in the interaction region was 1/2 inch.

3. Mechanical Scanner

The mechanical scanner being used on the analyzer was provided by the Rome Air Development Center and was developed under Contracts AF 30(602)-1692 and AF 30(603)-2573 at Cornell University. This scanner was used for direct measurements of the current density as a function of position in the electron beam. A brief description of the mechanical scanner is given in the following paragraphs.

The portion of the scanner used inside the vacuum system is shown in Figure 5. The beam-collecting area on the scanner is a molybdenum plate that is carbonized to reduce the emission of secondary electrons. A 0.010-inch aperture in the center of this plate allows a small fraction of the beam to pass through the collecting plate to a Faraday cage. The Faraday cage is part of the center conductor of a coaxial line so that injected r-f currents, as well as the current density in the unmodulated beam, can be measured. The plate can be moved horizontally by rotating the bottom rod while vertical motion is produced in a similar manner by rotating the side

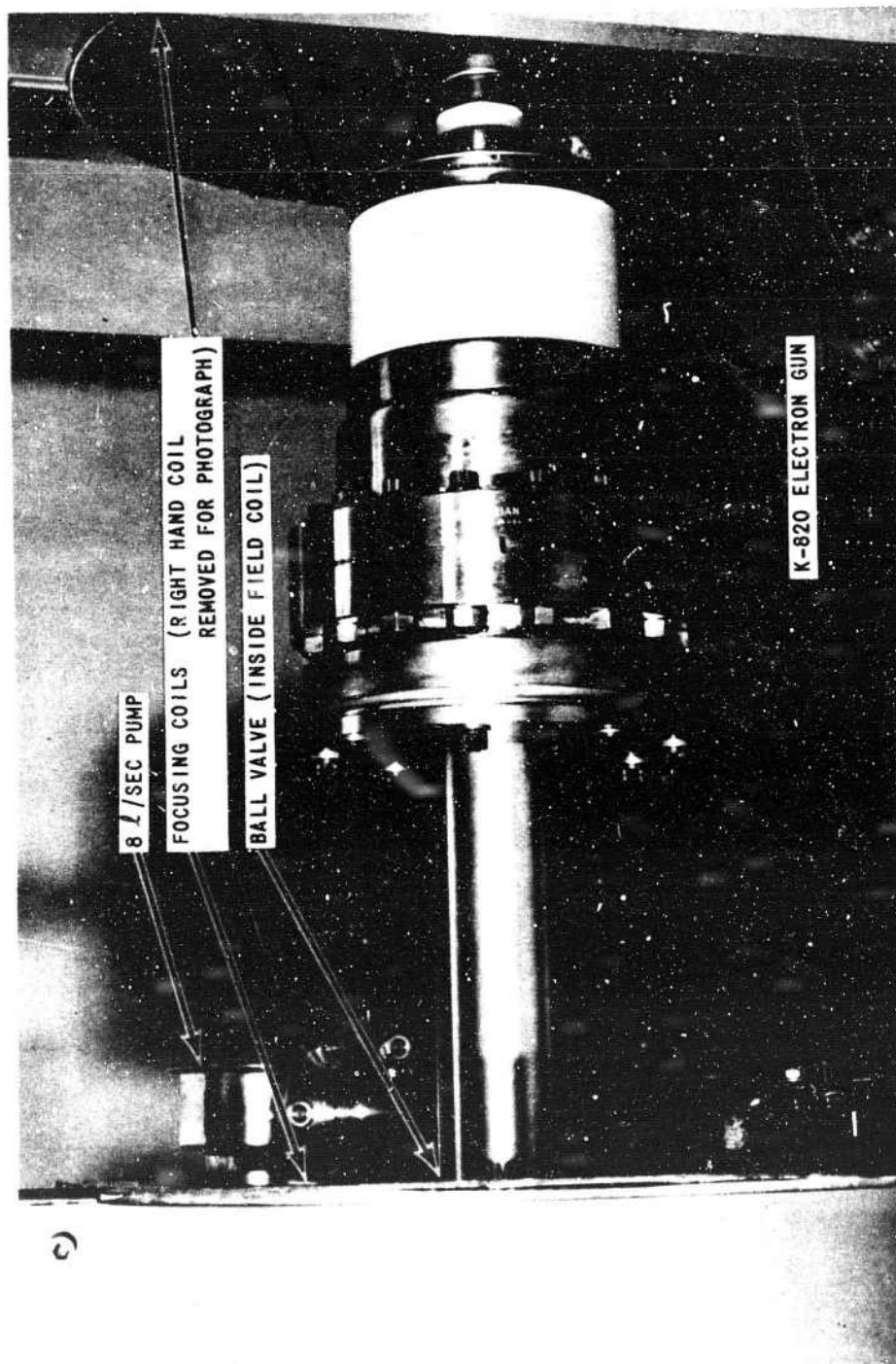

Figure 4 ELECTRON GUN AND ASSOCIATED APPARATUS

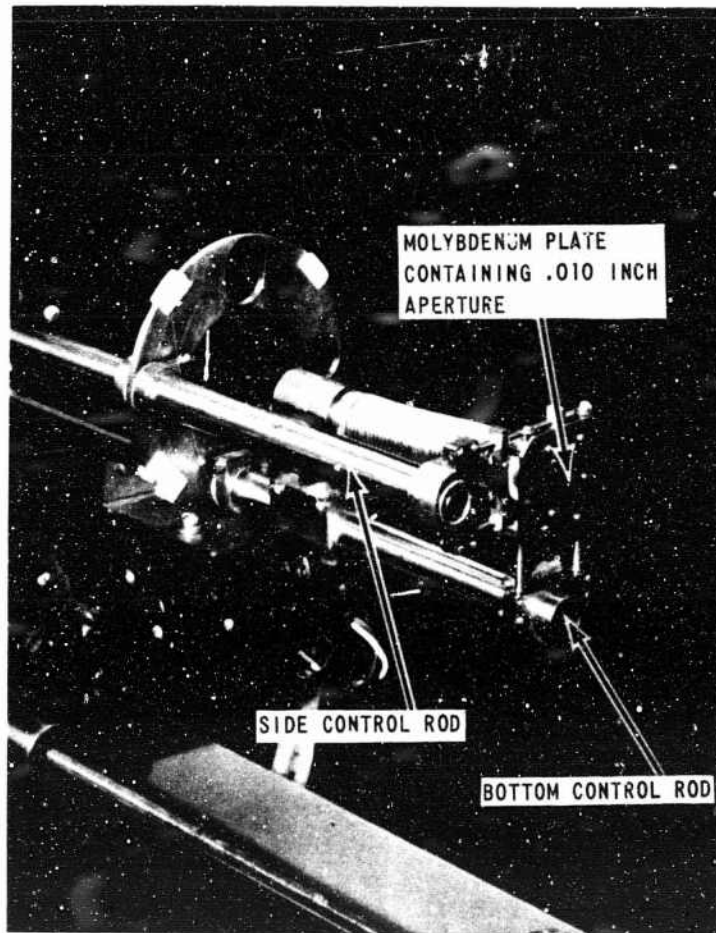

Figure 5 BEAM SCANNING MECHANISM

rod. Teflon bearings, which are used to prevent binding between the stainless steel parts, are attached to the back of the plate and they slide on the lever arms attached to the side and bottom rods during horizontal and vertical motion. Although rotational motions are converted to translational motions in positioning the cage, the motion can be considered to be linear, since the distances moved are small compared to the lengths of the lever arms. A plate to center the scanner inside the drift tube is attached to the positioning rods behind the collecting plate. The centering plate is guided by a Teflon bearing that moves along a guide rail inside the drift tube and is prevented from touching the wall of the drift tube by spring-loaded Teflon blocks.

The control mechanism for the positioning rods was shown in Figure 1. The scanning mechanism can be moved axially by using a gear and rack arrangement. The angular position of the rods is adjusted by means of micrometers, with the micrometer that sets the horizontal position of the scanner being equipped with a motor drive. Reversing switches cause the motor to sweep the scanner back and forth across the beam automatically. To provide a voltage proportional to the horizontal position of the scanner, a ten-turn helipot is geared to the motor. This voltage can be applied to the X input of an X-Y recorder. The current from the Faraday cage can be used to produce a voltage drop across the input resistor of a General Radio electrometer. This voltage is amplified by the electrometer to provide a Y input to the recorder proportional to the current to the Faraday cage. It is also possible to arrange helipots to provide a voltage proportional to either the X or Z position of the scanner. This makes it possible to measure the beam current as a function of any one of the three positional parameters in a single scan.

4. Atomic-Beam Generator

A photograph of the atomic-beam apparatus used in early beam analyzing experiments on Project PROBE is shown in Figure 6. The beam-generator portion of the apparatus is shown in the scale drawing in Figure 7. Formation of the atomic beam is achieved by first striking a vacuum arc on the cathode of the beam generator. The vacuum arc is started by the evaporation and ionization, with a high-voltage pulse applied to the igniter electrodes,

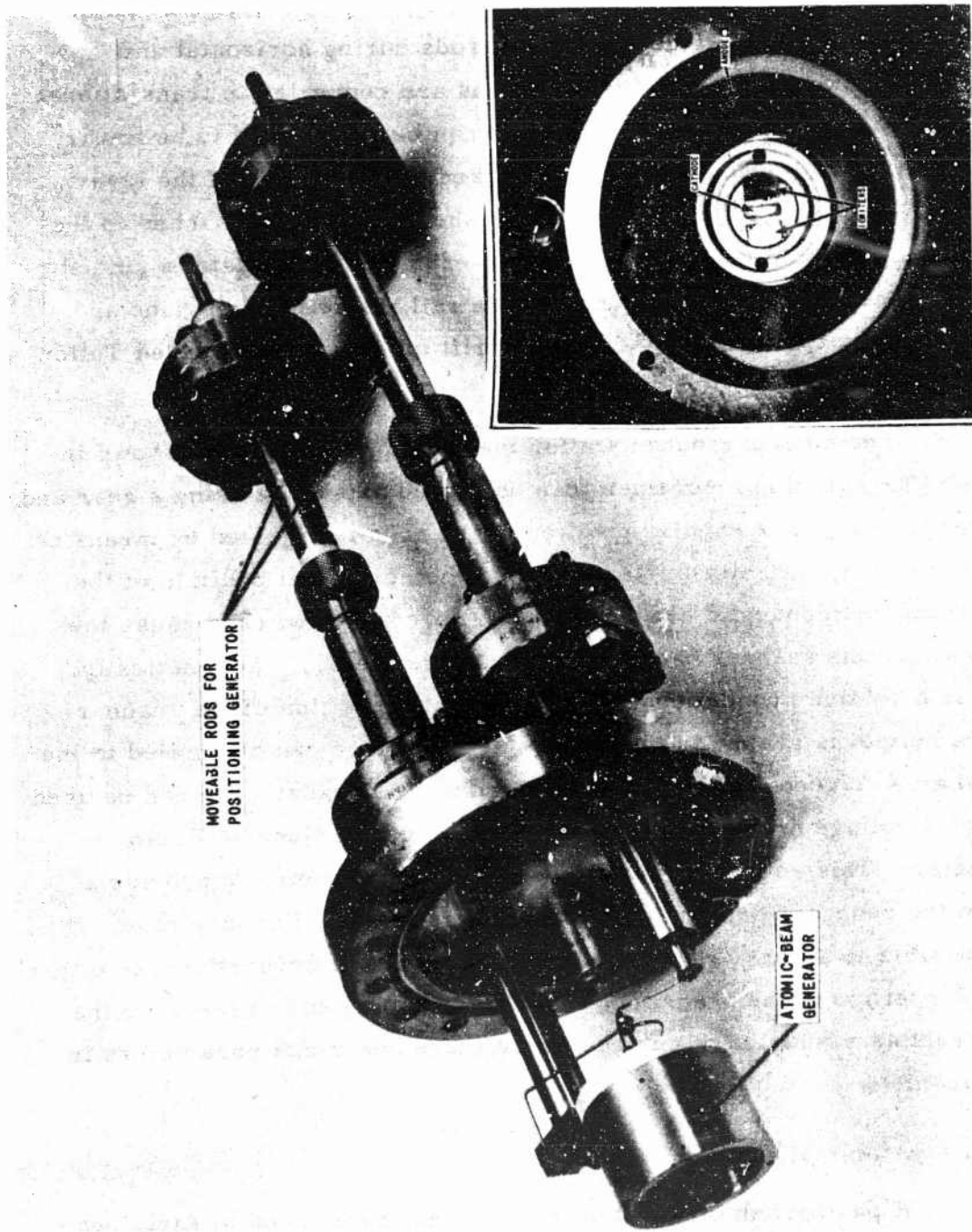

Figure 6 ATOMIC BEAM APPARATUS (WITHOUT BEAM-DEFINING APERTURE)

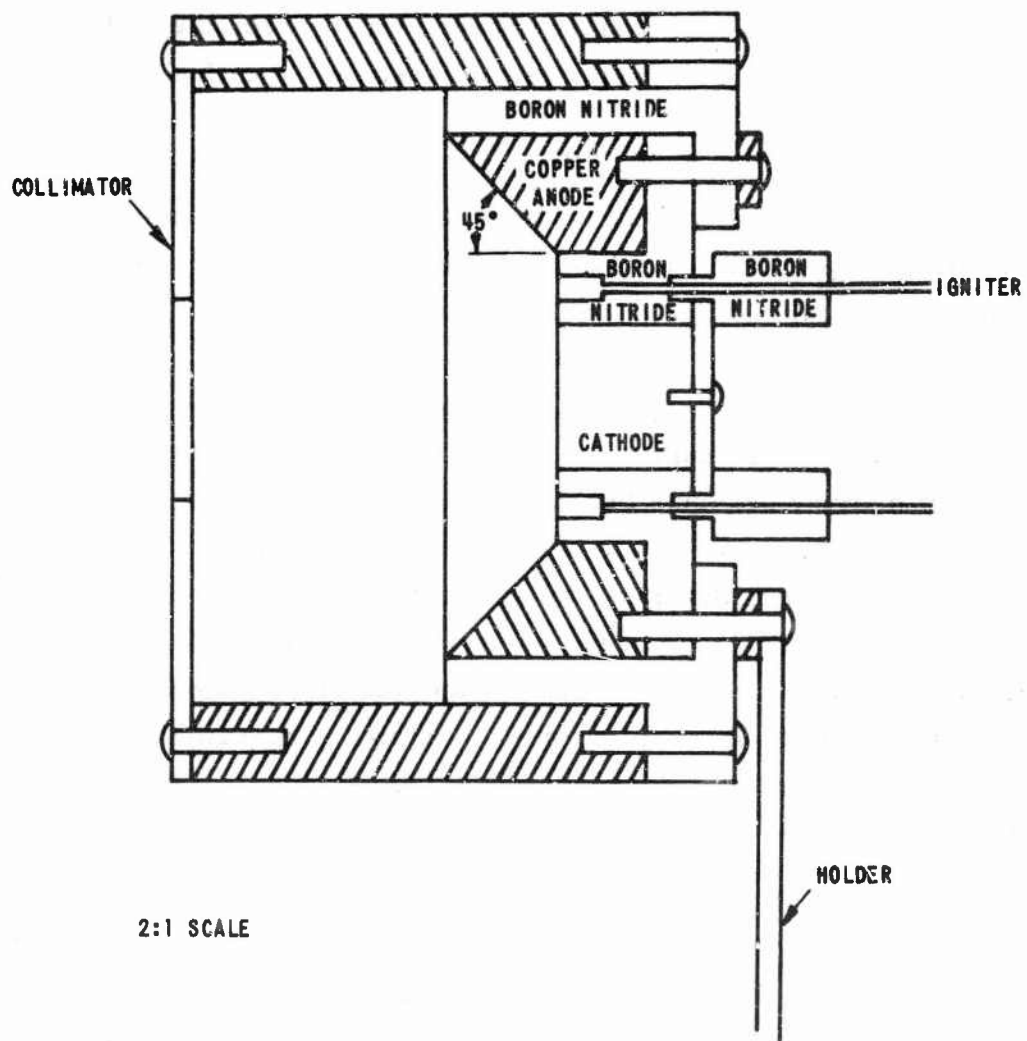

Figure 7 SCALE DRAWING OF THE ATOMIC BEAM GENERATOR

of a small amount of deposited metal from the surface of the insulator surrounding the igniter along with some of the cathode metal that is adjacent to the insulator. Subsequently, with the initial burst of metallic plasma and with the application of an appropriate voltage drop between the cathode and the anode, a sustained vacuum arc is established on the cathode.

a. Atomic-Beam Formation

The plasma cloud from the vacuum arc consists of approximately 90 percent neutral particles and, if left uncollimated, has the shape of a conical plume with an axis normal to the face of the arc cathode. By using an electrode configuration, as shown in Figure 1, a metallic plasma cloud, under proper collimation, can be used to generate a thin sheet-like probing beam. Various kinds of metallic-atom beams can be obtained simply by changing the cathode material. To determine the effect of a collimator on the shape of the plasma beam, a 5.77 mm by 14.77 mm rectangular collimator was attached to the copper frame of the beam generator. The cathode used was a stainless-steel cylinder with a 3/8-inch (9.53 mm) diameter. A glass slide was placed one inch from the collimator so that after several hours of vacuum-arc operation a dense rectangular-like deposit was formed on the glass slide. The metallic deposit appeared to have the same physical characteristics as stainless steel.

In order to obtain quantitative information as to the shape of the plasma beam so that it could be used as a probe, a geometric or ray tracing analysis was performed. Figure 8 shows a geometric representation of the cathode, the collimator, the glass screen, and the beam. Also in Figure 8, accompanying the ray diagram, is a plot of the intensity of a hypothetical beam as a function of position. It can readily be shown that

$$S' = \frac{X_2}{X_1} (Y - d) + d$$

$$S = \frac{X_2}{X_1} (Y + d) - d$$

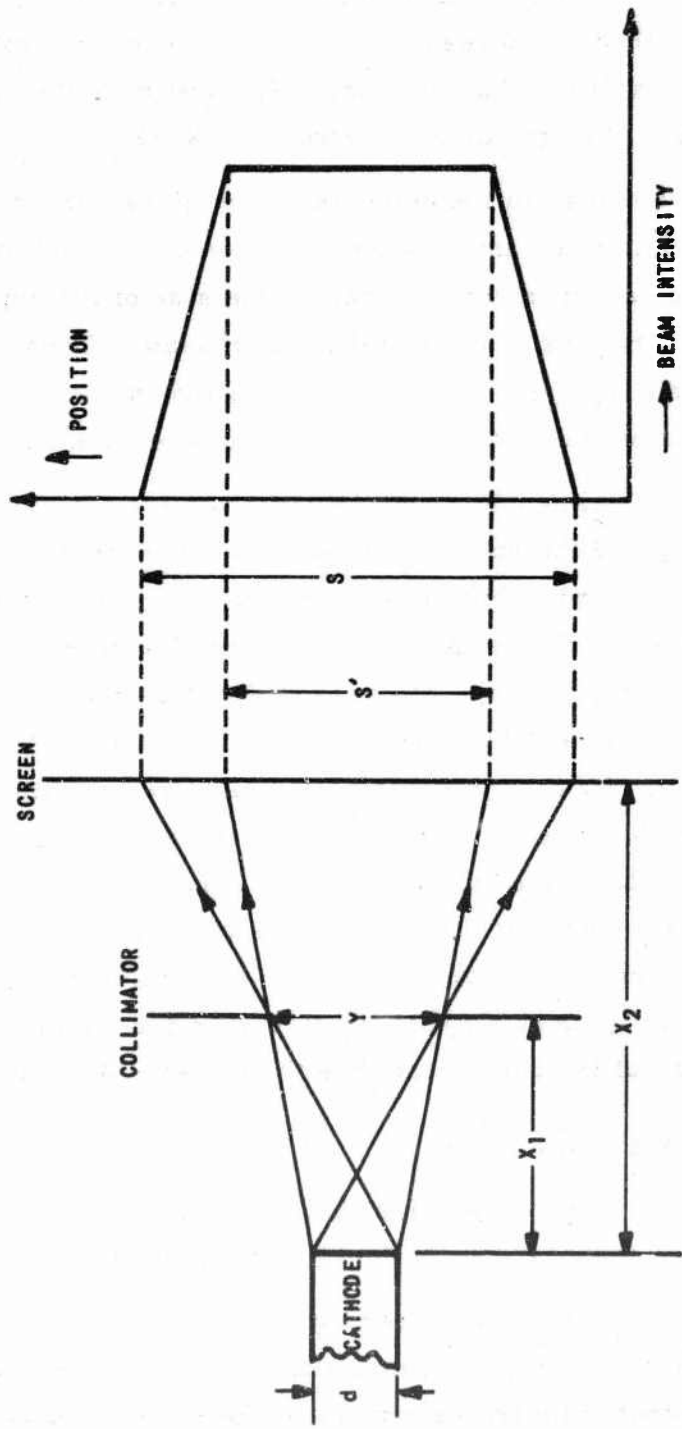

Figure 8 RELATION OF CATHODE AND COLLIMATOR SIZE TO BEAM SHAPE

where, as indicated in Figure 8, S' is the width of the umbra region of the beam, S is the width of both the penumbra and umbra regions, X_2 is the distance from the cathode to screen, X_1 is the distance from cathode to collimator, Y is the width of the collimator slit, and d is the diameter (or width) of the cathode. For the data reported here $X_2/X_1 = 2$.

The size of the deposits on the glass screen would indicate the size of the metallic beam incident on the screen. A densitometer trace of the deposit was obtained in order to determine size of the deposit which, in turn, determined the size of the metallic atom beam. These densitometer traces are shown in Figure 9. Each trace shows the intensity of the beam deposit as a function of position after several hours of vacuum arc operation.

The dimensions previously given for the vacuum-arc cathode, collimator, and the ratio X_2/X_1 were selected to give a beam with a height (S'_h) of 20 mm and a thickness (S'_t) of 2 mm. To obtain the corresponding values for S , use of the above formulas yielded an S_h of 39.0 mm, and S_t of 21.0 mm. Measuring the height from the densitometer trace we obtain an S'_h of 19.3 mm and S_h of 38.0 mm, which is in good agreement with the calculated values. On the other hand, the measured thickness was S'_t equal to 8.8 mm and S_t equal to 22.6 mm. The penumbra region is in good agreement with the calculation but the umbra region is in disagreement. This may be due to the fact that the cathode was circular (9.53 mm diameter) and that the arc prefers to operate on the outer circumference of the cathode so that the atom beam is more susceptible to edge effects along the shorter dimension (5.77 mm) of the collimator than the longer (14.77 mm).

b. Arc Ignition

The high-voltage ignition pulse is supplied by an EG & G model TR 180 trigger transformer in the circuit shown in Figure 10.

In order to obtain repetitive ignition of the vacuum arc during each pulse from the trigger transformer, the circuitry was so arranged that the output from the secondary of the EG & G transformer was allowed to ring (with an approximate frequency of 100 kc) at high peak values

SCALE: 0.55 CM/VERTICAL DIVISION
DENSITOMETER SLITS SET AT 0.5 μ

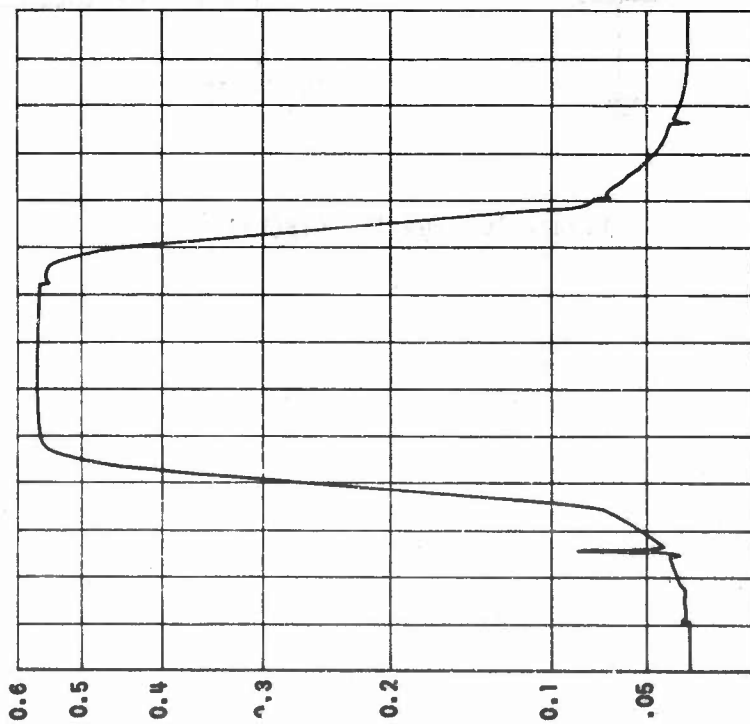

a) INTENSITY AS A FUNCTION OF RADIAL
POSITION (IN ELECTRON BEAM)

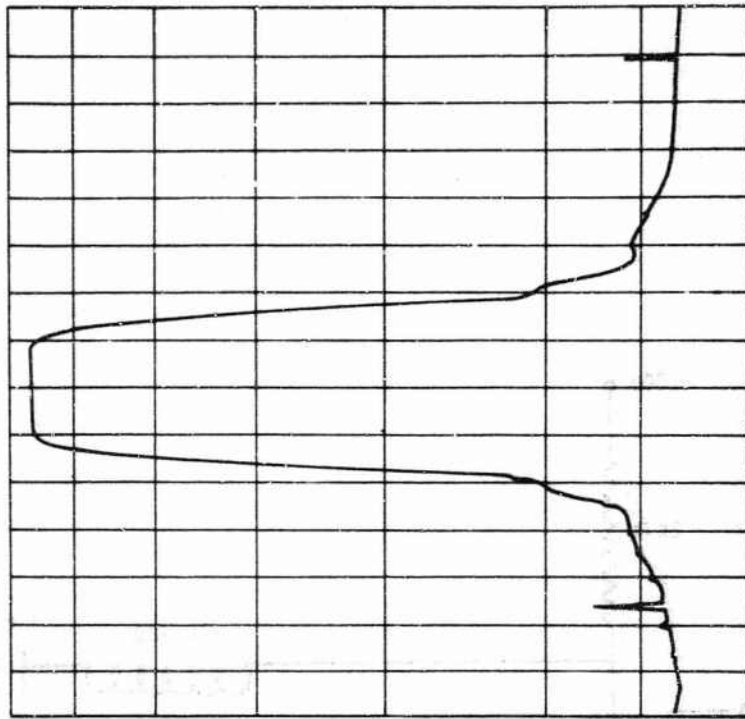

b) INTENSITY AS A FUNCTION OF AXIAL
POSITION (IN ELECTRON BEAM)

Figure 9 DENSITOMETER TRACES OF THE STAINLESS STEEL DEPOSITS
FROM A GLASS SCREEN

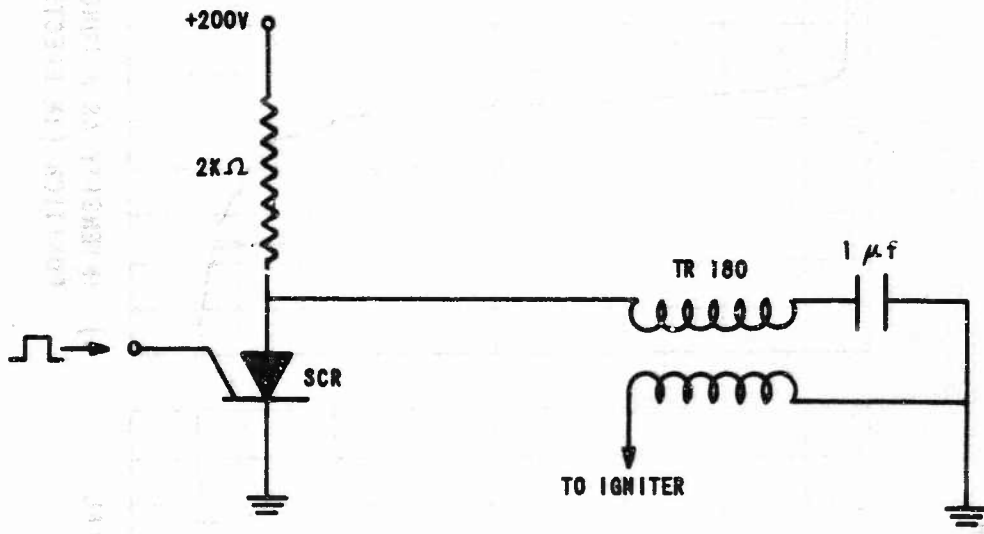

Figure 10 IGNITER CIRCUIT

of voltage (greater than 15 KV) with a $3\mu\text{sec.}$ duration. The ringing from the secondary is shown in Figure 11a where the output from the secondary was placed across a Tektronix type P6015 high voltage probe. The ringing mode was purposely excited so that several sparks from the igniter electrode to the cathode would occur during one single pulse from the TR 180 to give the vacuum arc more than one opportunity to ignite. The corresponding multiple sparks from the igniter electrode, operating in the ringing mode, are shown in Figure 11b. When the vacuum arc strikes, there is no ringing from the secondary of the TR 180 as shown in Figure 11c. Also from Figure 11c, it appears that the vacuum arc did not strike with the first spark from the igniter electrode which is supporting evidence that the igniter should generate several sparks for each pulse in order to reliably ignite the vacuum arc. With this arrangement a reliable pulse rate of 60 pulses per second and greater was obtained.

c. Arc Power Supplies

In the first experiments on Project PROBE a pulsed atomic beam was used in attempts to probe the pulsed electron beam from the Varian K 820 electron gun shown in Figure 4. To this end, a pulse forming network (PFN) was designed and constructed in order to obtain a pulsed vacuum arc. The PFN was driven by a dc power supply and was triggered by arc ignition as indicated in the schematic diagram in Figure 12. Because of expected large current pulses, the PFN was designed to have a small characteristic impedance (about 4 ohms). The inductors were wound with No. 10 copper wire on one long, solid piece of 2.5-inch diameter paper-based phenolic. The necessary capacitors were then attached between the inductors. Each inductance was about 4 microhenries and the capacitance of each 2 KV capacitor was 0.25 microfarad. Eleven stages were used and the last stage was open-circuited. The PFN was placed in a metal box and grounded for shielding purposes.

Figure 12 shows simultaneously the output voltage from the PFN and the total current through a bismuth arc as functions of time. If the pulse length is defined between half-max points, we see from the current

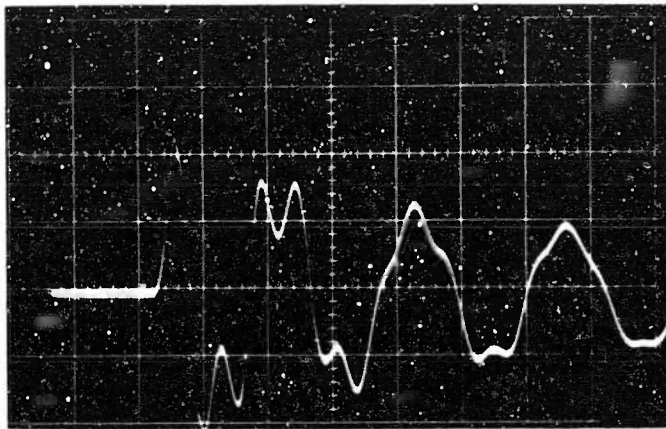

Figure 11a TR-180 SECONDARY OUTPUT
ACROSS TEKTRONIX P6015 HIGH
VOLTAGE PROBE

TIME: 5 μ sec/cm
VOLTAGE: 10 KV/cm

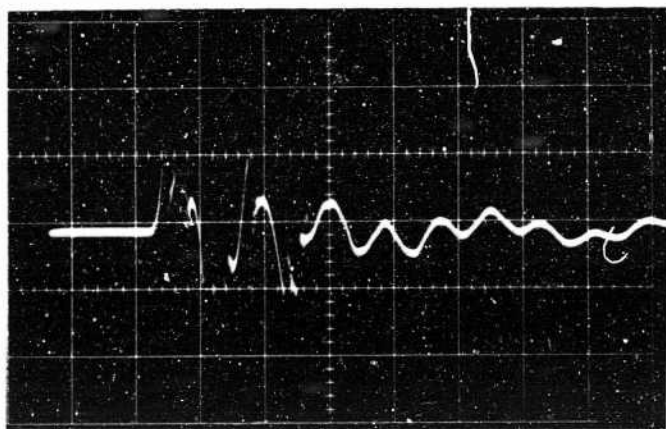

Figure 11b TR-180 SECONDARY OUTPUT
ON IGNITER ELECTRODE, NO EN-
SUING VACUUM ARC

TIME: 5 μ sec/cm
VOLTAGE: 5 KV/cm

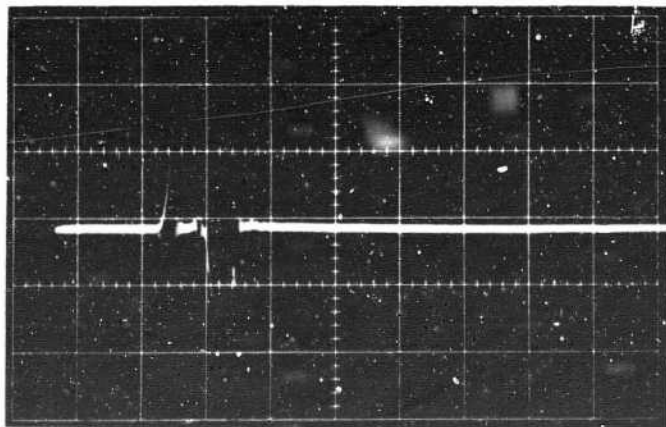

Figure 11c TR-180 SECONDARY OUTPUT
ON IGNITER ELECTRODE WITH EN-
SUING VACUUM ARC

TIME: 5 μ sec/cm
VOLTAGE: 5 KV/cm

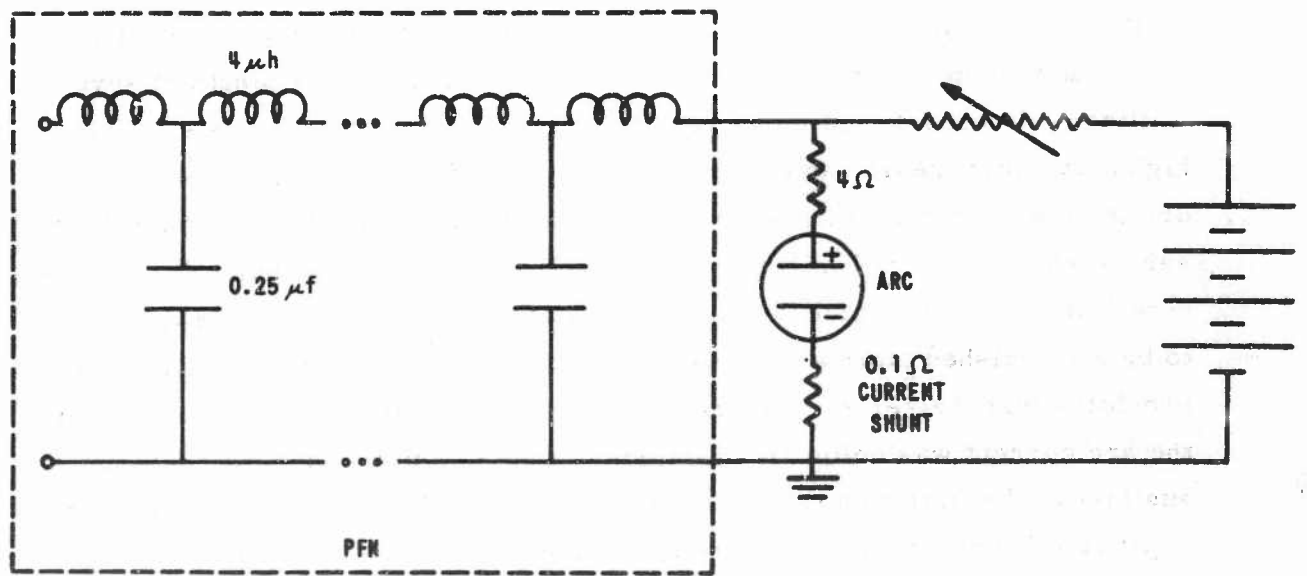

Figure 12 POWER SUPPLY FOR PULSED VACUUM ARC

trace in Figure 13 that a 20 microsecond pulse of bismuth plasma is readily obtained. It should also be noted, however, that the output voltage from the PFN does not fall to one-half of its maximum value as it should because of an impedance mismatch at the output of the PFN due to the arc impedance and the current shunt. This is not considered to be a serious problem. The reason for choosing a 20 microsecond pulse length for the PFN was that a 10 microsecond pulse length was used for the electron gun. It was planned that the electron-beam pulse would be timed to interact with the "clean" portion of the atomic beam pulse.

As will be described later in this report in Section B entitled RESULTS, several beam probing experiments were performed with a dc electron beam and with a probing beam having a pulse length of several milliseconds operated at pulse repetition frequencies up to 100 pps. This high duty cycle (nearly unity) probing beam was formed quite simply by driving the atomic beam generator with a high-power dc power supply in series with a current limiting resistor. The probing-beam pulse length was determined solely by mechanisms in the vacuum arc which caused the arc to be extinguished after a finite period of time. The arc self extinguished providing that the series limiting resistor was adjusted to a value such that the arc current was below the minimum value at which a dc arc could be sustained. Even though the arc pulse length varied from pulse to pulse, the repetition frequency was high enough to prevent an observable flicker in the light generated by the probing beam.

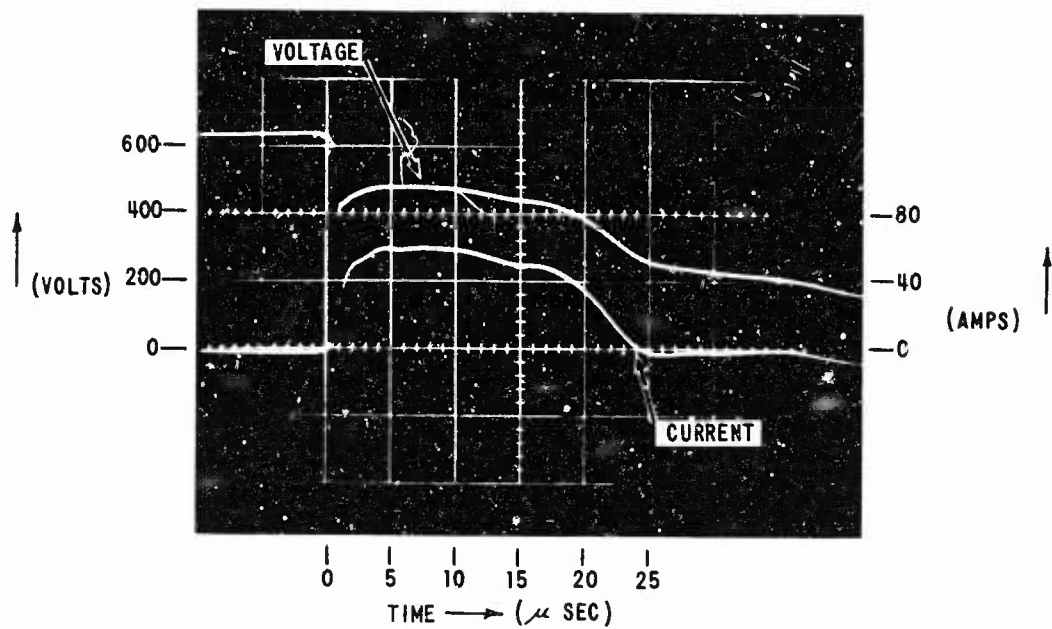

Figure 11 CURRENT AND VOLTAGE AS A FUNCTION OF TIME FOR A PULSED ARC ON BISMUTH

B. RESULTS

The following section contains an analysis of the interaction of the atomic probing beam with an electron beam to show that the interaction should produce adequate photon emissions from which the density of the electron beam as a function of position can be determined. Experimental results from beam probing experiments are also given.

1. Analysis of Interaction of Beams

In the region of interaction between the electron beam and the probing beam, the number of electrons exciting atoms per unit volume per unit time may be written as¹

$$\dot{n}_e = -n_a q n_e u_e \quad (1)$$

where

- n_a = density of atoms (number per cm^3),
- n_e = density of electrons (number per cm^3),
- q = excitation (excluding ionization) cross section of atoms (cm^2),
- u_e = velocity of electrons (cm/sec).

The rate of emission of visible photons (photons/ cm^3/sec , \dot{n}_p) is not equal to the rate at which electrons excite atoms, \dot{n}_e , because some photons are emitted in the infrared or in the ultraviolet regions. However, these rates will be taken as being approximately equal for the purposes of obtaining an order of magnitude estimate for \dot{n}_p . Multiplying \dot{n}_p by the volume, v , of the interaction region to obtain the total rate of emission of visible photons, the following may be obtained:

$$\dot{n}_p v = n_a q \frac{I}{e} t \quad (2)$$

where I is the current in the electron beam, e is the electronic charge, and t is the distance the electron beam travels in the probing beam, that is, t is the thickness of the probing beam.

¹See, for example, S. C. Brown, "Basic Data of Plasma Physics," John Wiley and Sons, Inc. and The Technology Press, 1959, pp. 2-3.

The atomic density, n_a , can be determined from the characteristics of the arc diode as follows:

It has been found experimentally that the density in the plume from the vacuum arc has a distribution that is approximately cosinusoidal (i.e., $n_a = n_{a0} \cos \theta$) as is shown below.

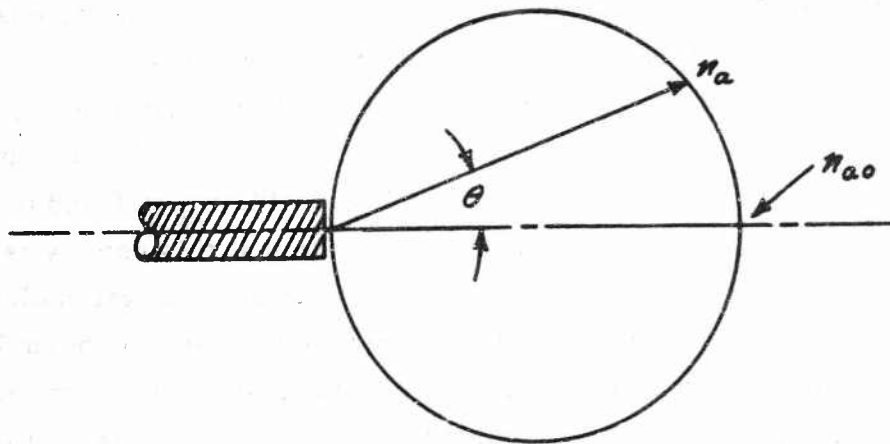

The emission rate of cathode material, \dot{m} , in Kg/sec is related to n_a and the plume velocity u_a through

$$\dot{m} = 1.66 \times 10^{-27} M \int_A n_a u_a \cdot dA \quad (3)$$

The constant in Equation (3) is the atomic mass unit and M is the atomic weight of atoms in the probing beam. The area, A , over which the integral in (3) is to be evaluated is the surface through which the cathode material is emitted. By choosing a hemispherical surface for A , then $u_a \cdot dA$ is $u_a dA$ and Equation (3) becomes

$$\dot{m} = 1.66 \times 10^{-27} M \pi r^2 n_{a0} u_a \text{ Kg/sec} \quad (4)$$

where r is the radius of the hemispherical surface. Because only the portion of the vacuum-arc plume near the axis will be used for the probing beam, the value of n_{a0} in Equation (4) is the value required for n_a in Equation (2). In virtually all of CAL's experiments with vacuum arcs, it has been observed that the rate of utilization of the cathode, m_c is 0.2×10^{-6} Kg

per coulomb of charge passed through the arc. Denoting the arc current as I_a , then \dot{m} can be written as the product $I_a m_c$ and so, Equation (4) can be rewritten as

$$n_{ao} = 0.384 \times 10^{20} \frac{I_a}{Mr^2 u_a} \text{ atoms/cm}^3 \quad (5)$$

Equation (5) is plotted in Figure 14 to illustrate the density of the atomic beam as a function of the arc and beam parameters. For example, assuming that a gold ($M=197$) probing beam is used, that the arc current, I_a , is 197 amperes (for convenience in using Figure 14), that the distance, r , from the arc cathode to the beam being analyzed is 10 cm and that the velocity of the probing beam is 10^6 cm/sec, then, from Figure 14, n_{ao} is found to be nearly 4×10^{11} atoms/cm³. It is interesting to note that this density is three orders of magnitude greater than the density of ambient gas molecules at a pressure of 10^{-8} Torr. If, now, the current in the electron beam being probed is 10 amperes, if the thickness of the probing beam is 0.1 cm and if excitation cross section, q , is assumed to be 10^{-16} cm²¹ then, from Equation (2), the $\dot{n}_p v$ product is 2.5×10^{14} photons per second. Making the highly pessimistic assumption that only 10^{13} per second of these photons are in the visible region, then the emission from one side of the interaction region would be approximately one foot-lambert for CW interaction and 10^{-5} foot-lambert for interaction pulsed with a duty cycle of .001. The average scotopic (well-dark-adapted) eye can readily detect about 3×10^{-6} foot-lamberts,² so that the light generated by the interaction of the two beams would be visible to the extent that even small variations in the electron beam density should be observable. In addition, for quantitative measurements, the amount of light generated would be sufficient to make possible photographic recordings of electron-beam cross sections.

It should be noted that there are a number of variables that can be adjusted to compensate for smaller beam currents or smaller beam sizes

¹ Estimated on the basis of data available for other metals.

² Leverenz, H. W., "An Introduction to Luminescence of Solids," John Wiley and Sons, Inc., New York, 1950, pp. 298-299.

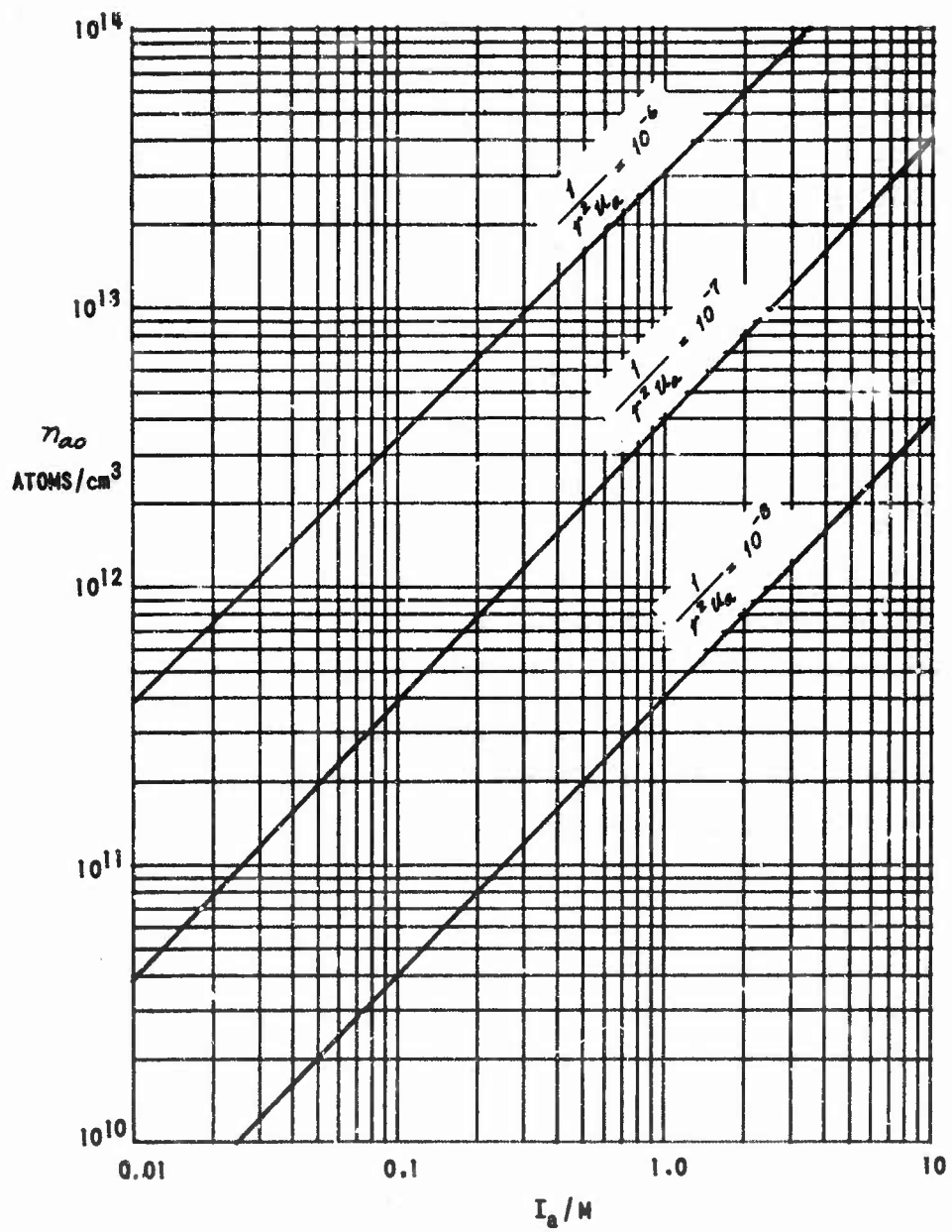

Figure 14 DENSITY OF ATOMIC BEAM AS A FUNCTION OF THE ARC CURRENT, I_a , THE ATOMIC WEIGHT, M , THE DISTANCE FROM THE ARC CATHODE, r , AND THE BEAM VELOCITY, u_a .

than those chosen for the preceding computation. For example, two orders of magnitude increase in brightness can be obtained by reducing r to 1 cm.

In addition to the brightness computations, an estimate will be made of the amount of disturbance that will be caused in the electron beam as a result of its interaction with the probing beam. First of all, there is scattering of electrons by the atoms. The amount of scattering can be computed using Equation (1), which can be integrated to yield

$$n_e = n_{e0} e^{-n_a q t} \quad (7)$$

where n_{e0} is the number density of the electron beam as it enters the interaction region and n_e is the number density upon leaving the interaction region. Using the value of n_{a0} of 4×10^{11} atoms/cm³ previously computed, the value of the exponent in Equation (7) is 10^{-5} (the total cross section¹ of 10^{-15} cm², rather than the excitation cross section of 10^{-16} cm², is used for computing scattering) and so, less than one electron in 10^4 will be scattered as a result of interaction with the probing beam. The effect of the atoms on the electron beam can thus be considered to be negligible.

Secondly, there is the possibility that the atomic beam will disturb the electron beam if a large fraction of the atoms are ionized by impact with electrons. Assuming that the ionization cross section of gold is on the order of 10^{-16} cm², then the rate of ion formation is the same as the rate of photon emission and, for the conditions given by Equations (6), is about 2.5×10^{14} ions/second. It is interesting to note that this number is less than one percent of the number of atoms per second in the probing beam. The minimum velocity of the ions is the velocity of the probing beam (that is, 10^6 cm/sec), so that the maximum density of the ions in the probing beam is 2.5×10^9 per cm³. Acceleration of the ions by electric fields in the interaction region will reduce the ion density below 2.5×10^9 /cm³. Since the electron density, computed on the basis of the numbers given in Equation (6) and an electron energy of 5000 ev, is about 2×10^{10} /cm³, the neutralizing effect of the ions would be negligible.

¹ This value is estimated on the basis of data given for other metals in Massey and Burhop, "Electronic and Ionic Impact Phenomena," Oxford, London, 1952, p. 11.

2. Experimental Results

While all parts of the analyzer described in Section A operated very nearly according to expectations during initial beam-probing experiments, no interaction of the electron beam with the atomic beam was observed. Among the modifications made to the experiment to make the interaction visible were the following (not necessarily in chronological order):

a. Light Baffling

While the level of radiation from the interaction of the probing beam with the electron beam may have been as high as was predicted in the previous section entitled "Analysis of Interaction of Beams," optical radiation by a number of sources caused the ambient light level to be high enough in the region where the desired interaction was anticipated to completely mask radiation from the interaction of the beams. Radiation from the Penning discharge in the 75 μ /s Vac Ion Pump, which was located directly on the line of sight from the viewing port to the beam interaction region, was the most intense source of background radiation. Other sources were: the de-excitation of metallic-beam atoms on the collector for these atoms; the atomic-beam generator (light leaving the arcing region through the beam forming aperture); the interaction of the electron beam with ambient gas in the vacuum system; fluorescence of insulating surfaces (glass and boron nitride) when bombarded by high-energy electrons; and radiation from atoms and ions excited in the beam generator. In fact, interestingly enough, it was possible to differentiate between streams of ionized and neutral atoms in the probing beam by observing the radiation from these streams and thus observing the paths followed by these streams after the probing beam emerged from the generator. As is shown in Figure 15, the neutral portion of the beam was observed to move in a straight line directly across the electron beam. Variations in the magnetic field level had no effect on the neutral stream. The ionized portion of the stream was observed not to cross the electron beam, but instead to move parallel to the magnetic field lines and to be intercepted by the mechanical scanner. As the magnetic field level was changed, the distance that the ionized stream extended out of the beam generator was observed to change.

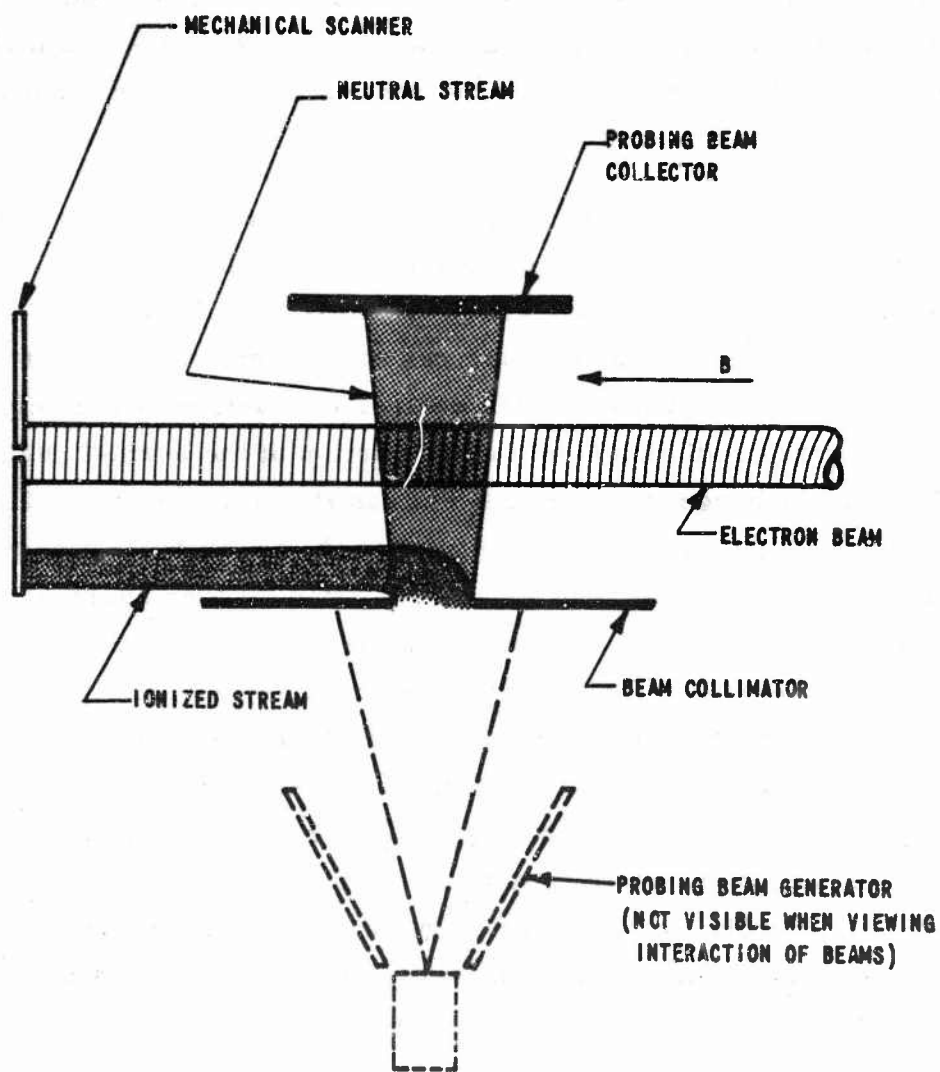

Figure 15 PATHS FOLLOWED BY IONIZED AND NEUTRAL STREAMS AFTER LEAVING PROBING BEAM GENERATOR

Through the appropriate positioning of aquadag-coated stainless steel baffles, some of which are shown in Figure 16, the light from the Vac Ion radiation, the de-excitation radiation, the radiation from the atomic-beam generator, and the fluorescence of insulating surfaces was essentially eliminated in the beam interaction region. Of course, the only way to minimize radiation from the interaction of the electron beam with ambient gas has been to keep the pressure as low as possible. Normal operating pressures are in the high 10^{-8} Torr to low 10^{-7} Torr range. The use of aquadag on appropriately shaped aperture-defining plates helped to reduce interference from radiation emitted by atoms excited in the atomic beam generator. The main portion of this interference, however, was eliminated by controlling the operating conditions of the atomic beam generator. The aperture defining plates helped in reducing the radiation from the ionized stream and the remainder of the stream was eliminated by placing the cathode of the beam probing generator at the potential (ground) of the vacuum chamber and of the mechanical scanner. Operation of the generator was then achieved by pulsing the anode positive.

b. Control of Atomic Beam

Two conflicting requirements make the control of the atomic beam critical. To reduce radiation from atoms excited in the atomic beam generator it has been found necessary to reduce the arc current and the density of the plasma plume. On the other hand, to maximize the interaction of the probing beam with the electron beam it is necessary to maximize the density of the probing beam and this means, as was shown in Equation (5) and in Figure 4, that the current through the arc should be maximized. After experimenting with a high-voltage pulsed electron beam (5 to 15 KV) and with relatively high current materials (that is, materials requiring several tens of amperes of current for arc establishment) such as gold and stainless steel and after experimenting with barium at high current levels during which experiments no interaction with the electron beam was observed, the desired interaction was finally observed with a low voltage (400 volts) dc electron beam and with barium at an arc-current level of only two amperes. At this low current the level of radiation from atoms excited in the beam generator was extremely low and it must be concluded, tentatively at least, that reducing radiation from generator-excited atoms is more important than increasing the probing beam density by increasing the arc current.

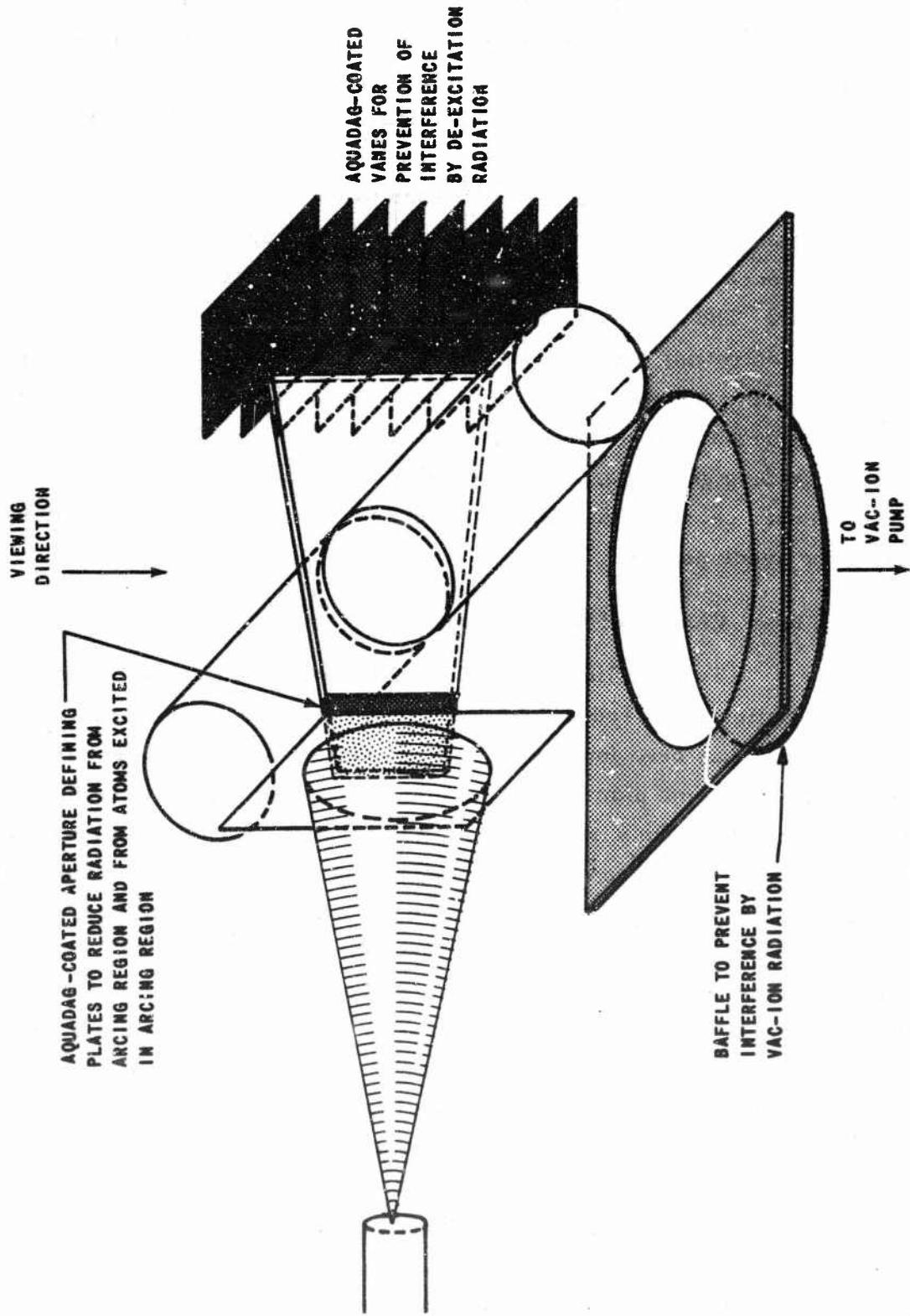
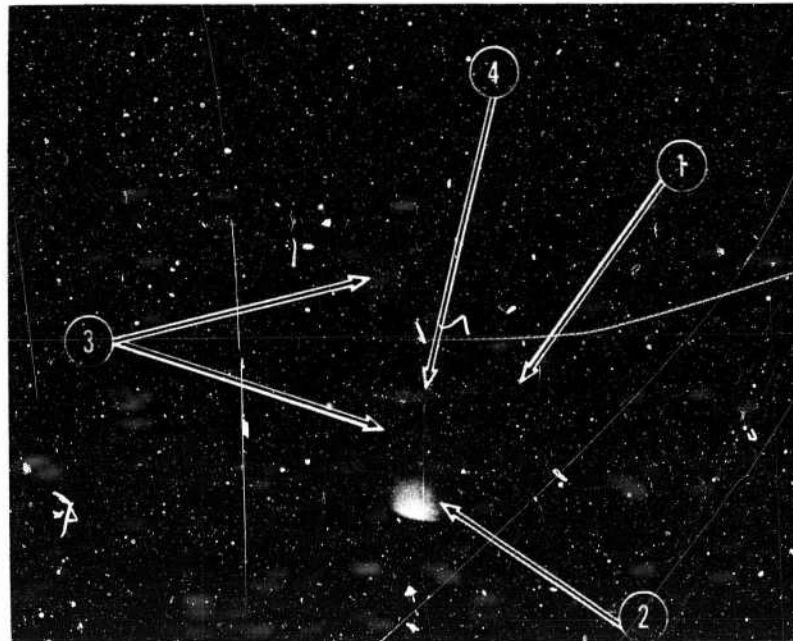

Figure 16 BAFFLING SYSTEM USED TO HELP MAKE INTERACTION OF BEAMS OBSERVABLE

It should also be mentioned that, in the initial experiments in which no results were obtained, the atomic beam generator was like that shown in Figure 7 with no magnetic field coil being used to help direct and focus the plasma plume from the arc. A field coil consisting of ten turns of wire, wound coaxially with the cathode was added to the generator and was excited by the current through the arc. The coil was made very small in diameter, so that the magnetic field generated would be concentrated in the beam generator and would not perturb the electron beam under study. The effect of the self-excited field coil was quite large when arc currents of several tens of amperes were used in conjunction with gold and stainless steel arcs. With the two-ampere barium arc, however, only a few tens of gauss were generated by the coil and the effect of this small field was probably negligible.

Shown in Figure 17 is a photograph, which was obtained by exposing film with a speed of 3000 for a period of 2 minutes, of the results of one of the first successful interaction experiments. This photograph is very informative since it shows, quite clearly, many of the effects and many of the light sources described in preceding paragraphs. The interaction of the electron beam with gas in the vacuum system is clearly visible as a horizontal streak of light across the photograph. The bright region at the bottom of the figure resulted from radiation from the probing beam after it left the probing beam generator (not shown in the photograph). The light region at the top of the photograph and part of the light region in the center of the photograph resulted from the reflection by light baffles of some of the light generated when the atomic beam impinged on its collector (also not shown in the photograph). The actual region of interaction of the electron beam with the atomic beam is the sausage-shaped region in the center of the figure. The reason for the large registration of the interaction region in the photograph is that the aperture defining the probing beam was very large. In later experiments, the aperture was reduced in width and correspondingly the width (distance along the electron beam) of the interaction region was reduced to about 2 millimeters. Unfortunately, although the interaction is observable with the eye, it has not yet been possible to obtain photographs or photo-multiplier information concerning the interaction.



- 1 INTERACTION OF ELECTRON BEAM WITH AMBIENT GAS
- 2 RADIATION FROM PROBING BEAM
- 3 REFLECTIONS FROM LIGHT BAFFLES
- 4 DESIRED INTERACTION

Figure 17 PHOTOGRAPH OF RESULTS OF EARLY INTERACTION EXPERIMENT

During experiments with the long interaction region shown in Figure 17 and with experiments in which the interaction region was about 2 millimeters long, a careful search was made for an effect of the probing beam on the electron beam by using the mechanical scanner in the beam analyzer. The scanner was positioned so that the 0.010 inch aperture was on the axis of the electron beam. The dc current arriving at the Faraday cage in the scanner was examined with and without the probing beam generator in operation. No change was observed in the level of the cage current. Effects of the probing beam on the electron beam would have been evidenced by changes, resulting from ion neutralization of the electron beam, in the current to the cage.

C. RECOMMENDATIONS FOR THE ANALYSIS OF CROSSED-FIELD BEAMS

For a given voltage of operation the density of crossed-field electron beams is normally much higher than the density of a linear klystron beam of the type used in the Project PROBE experiments (one-half inch diameter beam from Pierce electron gun with a microperveance of about 2.5). The two reasons for the higher density are: (1) that the perveance of the crossed-field gun is about an order of magnitude greater than the perveance of the Pierce gun, and (2) that the focusing fields in the crossed-field beam device are large enough so that the cross-sectional area of the crossed-field beam is an order of magnitude smaller than the cross-sectional area of the klystron beam. The higher perveance and the smaller area combine to make the density of the crossed-field beam about two orders of magnitude greater than that of the linear beam. This should, of course, produce a more pronounced interaction for the crossed-field beam case than for the linear beam. The main problem that is anticipated in analyzing crossed-field beams is in the instrumentation of a device containing the beam. Without disturbing the electron beam, the probing-beam generator must be adapted to the device and means must be provided for viewing the interaction of the probing beam with the electron beam. While it is not possible at the present time to specify the exact technique for instrumenting any given crossed-field device, techniques that will probably be required and problems that must be faced, regardless of the configuration of the device, can be discussed.

1. Miniaturization of Atomic-Beam Generator

Because the atomic-beam generator used on Project PROBE is far too large to be used with crossed-field beams, consideration has been given to the miniaturization of the generator. Shown in Figure 18 is a large-scale drawing of one possible configuration of a miniaturized generator. It will be noted that no igniter electrode is shown in the drawing. Instead of using the high-voltage arc ignition technique that has been used on Project PROBE, an ignition technique that was discovered on a CAL internal research program nearly three years ago and which has recently been the subject of renewed investigation on Project PROBE and on an electric propulsion program, will be used. In using this technique, a film of cathode material is formed between the anode and the cathode on the surface of the insulator separating the two electrodes. When a sufficient amount of current is caused to pass through the metallic film through the use of a circuit such as that shown in Figure 19, a portion of the film is evaporated to create a metallic plasma in the region between the cathode and the anode. During the ensuing vacuum arc a sufficient amount of cathode material is deposited on the cathode-to-anode insulator to form a film for the initiation of a subsequent arc. A brief discussion explaining the operation of the circuit in Figure 19 will assist in understanding the operation of the miniaturized beam generator. Assuming that a high conductivity film exists on the cathode-to-anode insulator, then a trigger signal to the silicon controlled rectifier (SCR) will connect the capacitor, C, to the beam generator through inductor, L, and resistor, R_2 . Normally, only a small portion of the energy stored in the capacitor is required to initiate the arc so most of the energy is used to produce the atomic probing beam. The function of the inductor is to insure that the SCR is turned off at the end of each capacitor-discharge cycle. Resistor, R_2 , serves to limit the current through the arc and R_3 causes the SCR to go into conduction and, therefore, causes voltage to be applied to the beam generator even though the film on the cathode-to-anode insulator doesn't provide a path of low enough resistance to force the SCR into conduction.

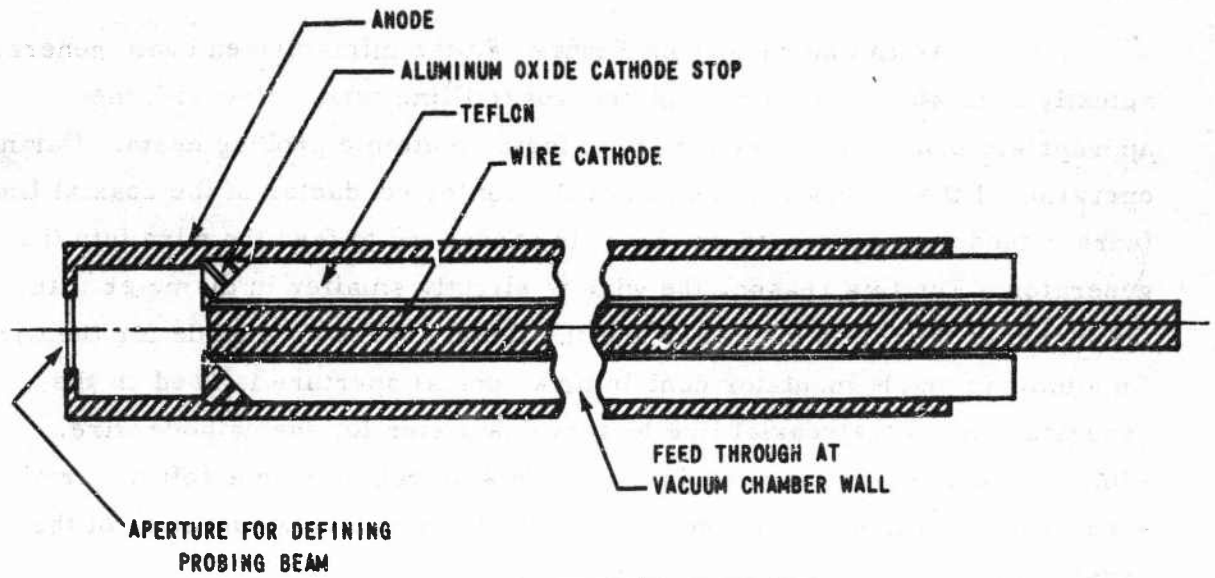

SCALE APPROXIMATELY 10:1

Figure 18 MINIATURIZED ATOMIC-BEAM GENERATOR

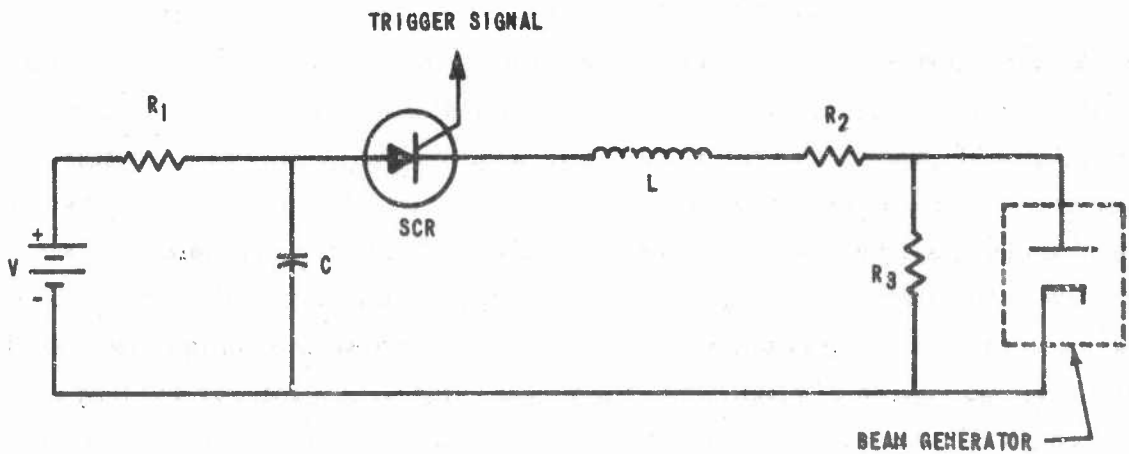

Figure 19 CIRCUIT FOR DRIVING MINIATURIZED ATOMIC BEAM GENERATOR

As can be seen from Figure 18, the miniaturized beam generator actually consists of a teflon-insulated coaxial line terminated with the appropriate insulator and electrode to form an atomic probing beam. During operation of the generator, the end of the center conductor of the coaxial line (wire cathode) is consumed so that it is necessary to feed the wire into the generator. For this reason, the wire is slightly smaller in diameter than the inside of the teflon insulation and the teflon serves as a guide for the wire. An aluminum oxide insulator containing a conical aperture is used on the generator end of the coaxial line to serve as a stop for the cathode wire. Aluminum oxide must be used as a cathode stop rather than a soft material such as boron nitride to prevent excessive ablation during operation of the generator.

The diameter of the miniaturized beam generator is expected to be very small (between 1/16 and 1/8 inch in preliminary versions and smaller if required in later versions) and the outer conductor can be flexible braid of the type normally used on coaxial cables. Therefore, it is expected that the generator can easily be positioned in a crossed-field device for probing the electron beam.

2. Observation of Interaction of Probing Beam with Electron Beam

On Project PROBE, ports were positioned to facilitate viewing of the interaction of the probing beam with the electron beam. On crossed-field devices, because of the configuration of the r-f circuit and the magnetic field, it will probably not be possible to locate viewing ports in positions that are convenient for observing the beam interaction. Thus, alternate viewing techniques must be devised. The possibility exists, for example, of using a system of mirrors arranged so that viewing would be possible from either the collector or the gun end of the device. A promising technique that would avoid the problems of alignment that would exist with a mirror system is that of using fiber optics. For example, it would appear that a Fiberscope made by the American Optical Company could be adapted directly to many crossed-field devices. This device contains a light source that could be used for the initial alignment of the viewing end of the fiber optics system as well as for the proper positioning of the atomic-beam generator.

III. SUMMARY

In summary, the results obtained to date on Project PROBE have demonstrated the feasibility of analyzing linear electron beams of the type used in klystrons and traveling-wave tubes. Because the density of crossed-field beams is about two orders of magnitude greater than that of the linear beam presently being used, it is anticipated that the interaction between an atomic probing beam and a crossed-field beam will be relatively easy to detect. The major problem anticipated in the analysis of crossed-field beams is in the instrumentation of a crossed-field device. Several suggestions concerning possible probing arrangements are contained in this report. Final selection of a probing technique should be made after a detailed examination has been made of the device to be analyzed.

UNCLASSIFIED

Security Classification

DOCUMENT CONTROL DATA - R & D

(Security classification of title, body of abstract and indexing annotation must be entered when the overall report is classified)

1. ORIGINATING ACTIVITY (Corporate author) Cornell Aeronautical Laboratory, Inc. P.O. Box 235 Buffalo, N.Y. 14221		2a. REPORT SECURITY CLASSIFICATION Unclassified	
		2b. GROUP	
3. REPORT TITLE ELECTRON BEAM ANALYSIS TECHNIQUE			
4. DESCRIPTIVE NOTES (Type of report and inclusive dates) Final Report 15 August 1966 - 15 August 1967			
5. AUTHOR(S) (First name, middle initial, last name) A. S. Gilmour, Jr. R. J. Myers H. Veron			
6. REPORT DATE November 1967		7a. TOTAL NO. OF PAGES 50	7b. NO. OF REFS 4
8a. CONTRACT OR GRANT NO. F30602-67-C-0020		9a. ORIGINATOR'S REPORT NUMBER(S) UB-2333-E-2	
b. PROJECT NO. 5573			
c. Task No. 557303		9b. OTHER REPORT NO(S) (Any other numbers that may be assigned this report) RADC-TR-67-549	
d.			
10. DISTRIBUTION STATEMENT This document is subject to special export controls and each transmittal to foreign governments, foreign nationals or representatives thereto may be made only with prior approval of RADC (EMATE), GAFB, NY 13440.			
11. SUPPLEMENTARY NOTES R. H. Chilton Project Engineer (EMATE) AG315 330-4251		12. SPONSORING MILITARY ACTIVITY Rome Air Development Center (EMATE) Griffiss Air Force Base, New York 13440	
13. ABSTRACT The feasibility of using a nonintercepting electron beam probe for obtaining the properties of linear electron beams as used in microwave tubes has been demonstrated. The nonintercepting probe employs the technique of injecting an atomic, molecular, or ionic beam normal to the electron beam and the determination of the electron beam properties from the photon emissions resulting from the interactions of the two beams. The use of this technique for analyzing crossed-field beams should be feasible because the density of crossed-field beams is about two orders of magnitude greater than that of the linear beam that has been studied. The major problem anticipated in the analysis of crossed-field beams is in the instrumentation of a crossed-field device. Through the use of miniaturized probing beam generators and fiber optics it is anticipated that this instrumentation problem will be solved.			

UNCLASSIFIED

Security Classification

14.

KEY WORDS

Microwave Tube
Klystron
Crossed-field Amplifier

LINK A

LINK B

LINK C

ROLE

WT

ROLE

WT

ROLE

WT

UNCLASSIFIED

Security Classification