

UNCLASSIFIED

AD NUMBER

AD802403

LIMITATION CHANGES

TO:

Approved for public release; distribution is unlimited.

FROM:

Distribution authorized to U.S. Gov't. agencies and their contractors; Critical Technology; JUL 1966. Other requests shall be referred to Air Force Materials Laboratory, ATTN: MAAM, Wright-Patterson AFB, OH 45433.

AUTHORITY

AFSC ltr dtd 2 Mar 1972

THIS PAGE IS UNCLASSIFIED

AD0802403

AFML-TR-66-120

**K_{IC} and (W/A) FRACTURE TOUGHNESS PROPERTIES OF
AFC-77 STAINLESS STEEL**

SIDNEY O. DAVIS
AIR FORCE MATERIALS LABORATORY

and

ROGER M. NIEMI
MONSANTO RESEARCH CORPORATION

TECHNICAL REPORT AFML-TR-66-120
JULY 1966

This document is subject to special export controls and each transmittal to foreign governments or foreign nationals may be made only with prior approval of MAAM, Air Force Materials Laboratory.

**AIR FORCE MATERIALS LABORATORY
RESEARCH AND TECHNOLOGY DIVISION
AIR FORCE SYSTEMS COMMAND
WRIGHT-PATTERSON AIR FORCE BASE, OHIO**

20080815 267

NOTICES

When Government drawings, specifications, or other data are used for any purpose other than in connection with a definitely related Government procurement operation, the United States Government thereby incurs no responsibility nor any obligation whatsoever; and the fact that the Government may have formulated, furnished, or in any way supplied the said drawings, specifications, or other data, is not to be regarded by implication or otherwise as in any manner licensing the holder or any other person or corporation, or conveying any rights or permission to manufacture, use, or sell any patented invention that may in any way be related thereto.

All (or any) of the items compared in this report were commercial items that were not developed or manufactured to meet any Government specification, to withstand the tests to which they were subjected, or to operate as applied during this study. Any failure to meet the objectives of this study is no reflection on any of the commercial items discussed herein or on any manufacturer.

Copies of this report should not be returned to the Research and Technology Division unless return is required by security considerations, contractual obligations, or notice on a specific document.

**K_{IC} and (W/A) FRACTURE TOUGHNESS PROPERTIES OF
AFC-77 STAINLESS STEEL**

AD 802 403

SIDNEY O. DAVIS
AIR FORCE MATERIALS LABORATORY

and

ROGER M. NIEMI
MONSANTO RESEARCH CORPORATION

This document is subject to special export controls and each transmittal to foreign governments or foreign nationals may be made only with prior approval of MAAM, Air Force Materials Laboratory.

FOREWORD

This report was prepared by Mr. Sidney O. Davis, Materials Information Branch, Materials Applications Division, Air Force Materials Laboratory, Research and Technology Division, Air Force Systems Command, Wright-Patterson Air Force Base, Ohio, and Mr. Roger M. Niemi of Monsanto Research Corporation, Dayton, Ohio. This program was conducted under Project No. 7381 "Materials Applications," Task No. 738106, "Design Information Development."

This report covers work conducted from January 1965 to January 1966. The manuscript was released by the authors in April 1966 for publication as an RTD Technical Report.

This technical report has been reviewed and is approved.



D. A. SHINN
Chief, Materials Information Branch
Materials Applications Division
Air Force Materials Laboratory

ABSTRACT

The fracture toughness of AFC-77, a high strength stainless steel alloy, was determined with the center notch and single edge notch fracture toughness specimens at room temperature as a function of six tempering temperatures: 400, 700, 800, 900, 1000, and 1100°F. Tempering temperatures above 700°F produced poor values of plane strain fracture toughness. In addition the precracked charpy specimen was used to determine, for each tempering temperature, the testing temperature at which transition from relatively tough to relatively brittle behavior occurred. The optimum properties of AFC-77 were obtained at the 700°F temper. This was evident as a result of the analysis of the room temperature center notch, single edge notch and precrack charpy test results. The optimum room temperature properties were 182 KSI yield strength and 65 KSI $\sqrt{\text{in}}$ plane strain fracture toughness.

CONTENTS

SECTION		PAGE
I	INTRODUCTION	1
II	MATERIAL	2
III	MATERIAL HEAT TREATMENT	3
IV	SPECIMENS	4
V	TEST PROCEDURES	7
VI	RESULTS	14
VII	DISCUSSION	17
VIII	CONCLUSIONS	18
IX	REFERENCES	19
	Appendix I - Tables	21
	Appendix II - Curves	29

ILLUSTRATIONS

FIGURE		PAGE
1.	Microstructure of As-Received and Heat Treated AFC-77, 50 mil Sheet	3
2.	Test Specimens	5
3.	Subsize Precracked Charpy Test Specimen	6
4.	Precrack Charpy Specimens Fatigue Machine	8
5.	Elevated Temperature Tensile Test Set-up	9
6.	Center Notch Fracture Toughness Test Set-up	10
7.	Detail View of Fracture Toughness Test Set-up	11
8.	Single Edge Notch Fracture Toughness Test Set-up	12
9.	Precrack Charpy Impact Testing Fracture Toughness Machine	13
10.	800°F Temper Longitudinal Specimens Ductile-to-Brittle-Transition-Temperature Curve	30
11.	800°F Temper Transverse Specimens Ductile-to-Brittle-Transition-Temperature Curve	31
12.	900°F Temper Longitudinal Specimens Ductile-to-Brittle-Transition-Temperature Curve	32
13.	900°F Temper Transverse Specimens Ductile-to-Brittle-Transition-Temperature Curve	33
14.	1000°F Temper Longitudinal Specimens Ductile-to-Brittle-Transition-Temperature Curve	34
15.	1000°F Temper Transverse Specimens Ductile-to-Brittle-Transition-Temperature Curve	35
16.	1100°F Temper Longitudinal Specimens Ductile-to-Brittle-Transition-Temperature Curve	36
17.	1100°F Temper Transverse Specimens Ductile-to-Brittle-Transition-Temperature Curve	37
18.	Variation of K_{IC} With Tempering Temperatures	38

TABLES

TABLE		PAGE
I	AFC-77 Tensile Data	22
II	AFC-77 Percent Elongation Data	22
III	Center Notch Fracture Toughness Data for AFC-77	23-24
IV	Single Edge Notch Fracture Toughness Data	25
V	W/A in $\frac{\text{in}\cdot\text{lb}}{\text{in}^2}$ at Room Temperature	26
VI	W/A in $\frac{\text{in}\cdot\text{lb}}{\text{in}^2}$ at 210°F	26
VII	W/A in $\frac{\text{in}\cdot\text{lb}}{\text{in}^2}$ at 550°F	27
VIII	W/A in $\frac{\text{in}\cdot\text{lb}}{\text{in}^2}$ at 650°F	27
IX	Transition Temperatures	28

SECTION I

INTRODUCTION

The purpose of this investigation was to study the effect of tempering temperature on the toughness of AFC-77. This stainless steel alloy was recently developed under sponsorship of the Air Force Materials Laboratory as a high strength elevated temperature load-bearing material for structural applications. The alloy was developed by Crucible Steel Company under Contract AF 33(657)-8458.

AFC-77 is a low carbon Cr-Mo-Co martensitic stainless steel which is strengthened by precipitation reactions during tempering. Up to 900°F, its strength depends on carbide precipitation, and above 1000°F it is strengthened by precipitation of intermetallic compounds such as Fe₂Mo Laves phase and the Chi phase (References 6 and 7). Creep and stress-rupture tests previously conducted have shown it to be superior in comparison with such alloys as H-11 and PH15-7 Mo high strength steels. In order to more fully characterize the effect of tempering temperature on the room temperature properties of AFC-77, this program was initiated in collaboration with the Metals and Ceramics Division of the Air Force Materials Laboratory.

The following three different types of fracture toughness specimens were employed: 2 x 8 x 0.090-inch center notch, 2 x 8 x .090-inch single-edge notch, and 0.050-inch thick subsize precracked Charpy specimens. Testing was done at room temperature for all three types of specimens and additionally at elevated temperatures for the precracked Charpy specimens. Tensile specimens were also tested at room and elevated temperatures to correlate with the fracture toughness specimen results. The center notch specimen was selected because of its greater versatility in the testing of sheet materials. When properly used it allows calculation of K_{IC} and K_C , as well as a test value called notch strength, which is sometimes used as a convenient measure of the notch sensitivity behavior of a material. However, its versatility is somewhat offset by: the increased specimen size needed to meet the plane strain and plane stress state requirements when thick sections are tested, and the increased specimen fabrication cost and testing machine capacity requirements. The single edge notch specimen was chosen because it allows a smaller specimen for plane strain (K_{IC}) fracture toughness determination. The K_{IC} results obtained from the single edge notch specimen are considered to be slightly more accurate than those obtained with the center notch specimen, because it develops basically a plane strain state of stress. In this investigation, the single edge notch results were used to check the center notch K_{IC} results as well as to furnish additional plane strain fracture data.

Previous investigators have found the precracked Charpy specimen to be good for screening a large number of variables such as chemistry, heat treatment, and processing. In this investigation it was used to measure the transition behavior for various tempering temperatures and to see how well the results correlated with the center notch and single edge notch specimens. Among the advantages of this specimen are its low material requirements, low cost, and ease of data interpretation. In this program, the precracked Charpy specimen proved its value as a screening test yielding good qualitative material transition temperature behavior information at low overall cost. No attempt has been made in this program to apply any of the schemes for quantitatively correlating the precracked Charpy results with either G_C or G_{IC} , such as $EG_C \approx E(W/A) \approx K_C^2$.

Where

E = the modulus of elasticity of the material under test in (lb/in.²)

G_C = the strain energy released per unit surface area in (in.-lb)/in.²

(W/A) = the work done per unit surface area in $(\text{in.}\cdot\text{lb})/\text{in.}^2$

K_C = the plane stress fracture toughness in $(\text{lb}/\text{in.}^2)^{1/2} \sqrt{\text{in.}}$

The G_C , (W/A) and K_C terms in practical terminology are the resistance to fracture of a structural material.

SECTION II MATERIAL

The AFC-77 Material tested in this program was processed from an air-induction melted 15-ton heat of material. The heat (No. 46073) had the following chemical analysis:

$\frac{\text{C}}{0.15}$	$\frac{\text{Mn}}{0.10}$	$\frac{\text{P}}{0.01}$	$\frac{\text{S}}{0.008}$	$\frac{\text{Si}}{0.07}$	$\frac{\text{Ni}}{0.08}$	$\frac{\text{Cr}}{14.22}$	$\frac{\text{V}}{0.30}$
$\frac{\text{Mo}}{4.62}$	$\frac{\text{Cu}}{0.07}$	$\frac{\text{Al}}{0.03}$	$\frac{\text{Co}}{12.93}$	$\frac{\text{N}}{0.03}$	$\frac{\text{Fe}}{\text{Bal}}$		

The material was processed as follows:

Press forged from 10 x 18-inch ingots to 4-1/2 by 18-inch slabs. The slabs were then hot rolled to 5/8 by 18-inch sheet bars which in turn were hot rolled to 30 x 96 x .090-inch, and 36 x 96 x .050-inch sheet. Prior to shipping, the sheets were annealed at 2000°F, A.C., 500°F + 2 hr, pickled and stretch-leveled. As received, the material had stringers of free delta ferrite (Figure 1), which were not completely removed by heat treatment. Presently the effect of delta ferrite on the fracture properties is not known in detail.

SECTION III

MATERIAL HEAT TREATMENT

The material was sheared into blanks, rough machined and heat treated as follows: 1900°F for 1 hour, oil quenched, -110°F for 1/2 hour and tempered for 2 + 2 hours at tempering temperatures from 400 to 1100°F at 100°F intervals after the 700°F temper. These specimen blanks were grouped according to tempering temperature.



As-Received
1000 X

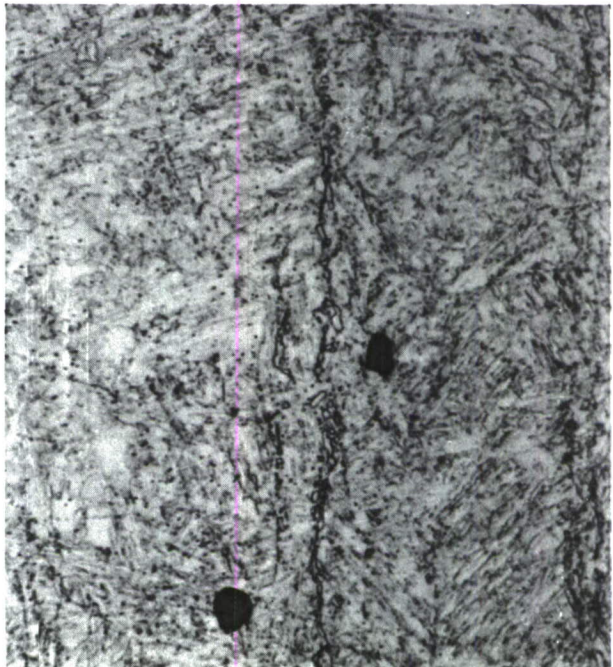

Tempered at 700° F
1000 X

Figure 1. Microstructure of As-Received and Heat Treated AFC-77, 50 mil Sheet

SECTION IV

SPECIMENS

TENSILE SPECIMEN

The tensile specimen is shown in Figure 2a

CENTER NOTCH SPECIMENS

The specimens were a nominal 2 inch x 8 inch x .090 inch with a fatigue cracked center notch. A specimen drawing is shown in Figure 2b also. The following steps were followed when preparing specimens:

1. Sheared to 2 x 8-inch blanks
2. Drilled 5/8-inch diameter pin holes
3. Heat treated as mentioned previously
4. Surface ground
5. Eloxed the center notch
6. Fatigue cracked to 1/3 of the width (W)
7. Heat tinted

It was observed that machining of the center notch after heat treating was extremely difficult.

Eloxing is expensive and is usually time-consuming. Also, fatigue cracks put in the specimens after heat treatment are difficult to control when the material has low fracture resistance. This difficulty was experienced and crack lengths of as low as 1/4 W were necessary for some specimens, but did not appear to affect the test results. Other investigators (Reference 1) have observed a slight difference in K_{IC} results between fatigue cracking before versus after heat treatment, with the former technique apparently yielding higher results. Therefore, in spite of the aforementioned difficulties, fatigue cracking before heat treatment should be done only as a last resort because of the possibility of inducing metallurgical changes.

The center notch specimens were tempered at 400, 700, 800, 900, 1000, and 1100°F and tested in both sheet directions.

SINGLE-EDGE NOTCH (SEN)

The SEN specimen was a 2 x 8 x .090-inch, W/2 type with a fatigue cracked flaw. Material supply precluded a complete series of specimens, but enough tests were run to compare with the results of the center notch tests. The test specimens were prepared according to the specimen drawing shown in Figure 2c in the same way as the center notch specimens were. A few 1 x 4 x .090-inch SEN specimens were tried, but problems occurred in fatigue cracking the specimens in tension-tension. Most of the specimens were so brittle they failed in the pinholes during fatigue cracking. Fatigue cracking the specimens as beams in bending would have been attempted, but the number of specimens remaining was so small as to preclude further effort on the 1 x 4-inch SEN specimens.

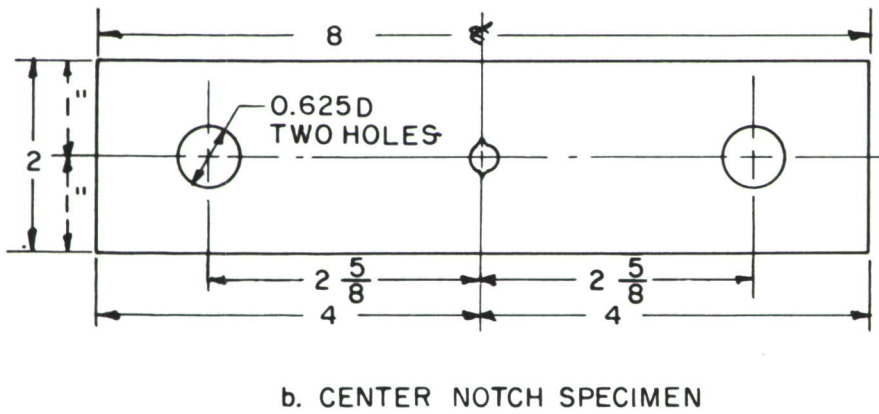
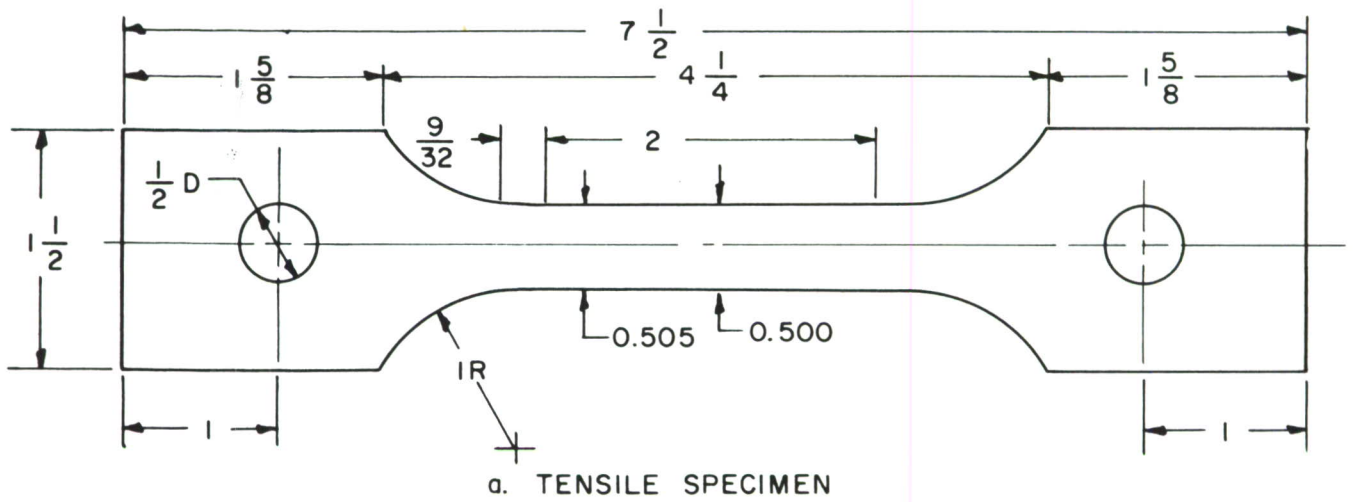

NOTCH DETAIL

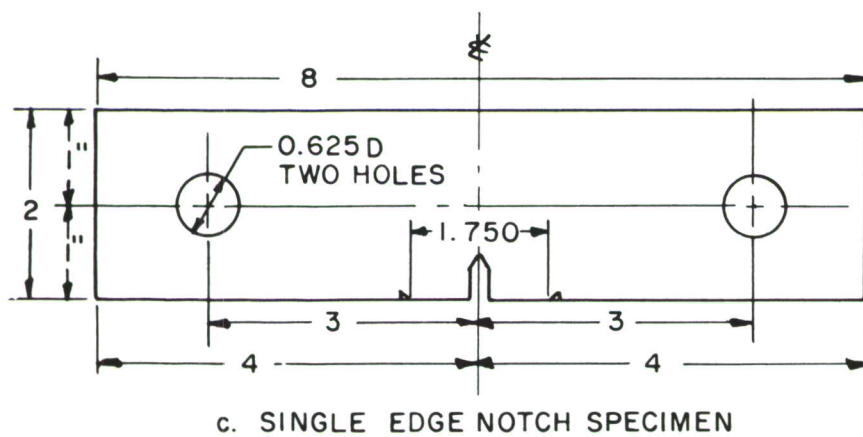
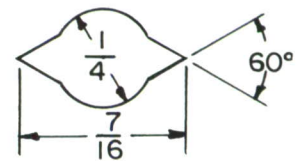

NOTCH DETAIL

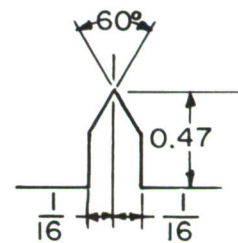

Figure 2. Test Specimens

All dimensions specified are in inches.

PRECRACKED CHARPY

About 350 Charpy specimens of standard dimensions except for thickness as shown in Figure 3 were prepared from .050 sheet. They were sheared into blanks and heat treated in batches with the center notch and single-edge notch specimens. After heat treating they were surface ground to remove possible surface contamination. The notches were ground in batches of about 40 specimens using a commercially available grinding fixture. After machining in the notches, the specimens were fatigue cracked to a depth of roughly .030 inch and a total crack depth of roughly .110 inches. This was done using a commercially available Manlabs, Inc.* unit as shown in Figure 4. This unit was designed for the purpose of fatigue cracking Charpy specimens. The machine controls the crack depth by monitoring the change in compliance as the crack grows. Again, as with the other specimens, most of the specimens required heat-tinting to delineate the fatigue crack.

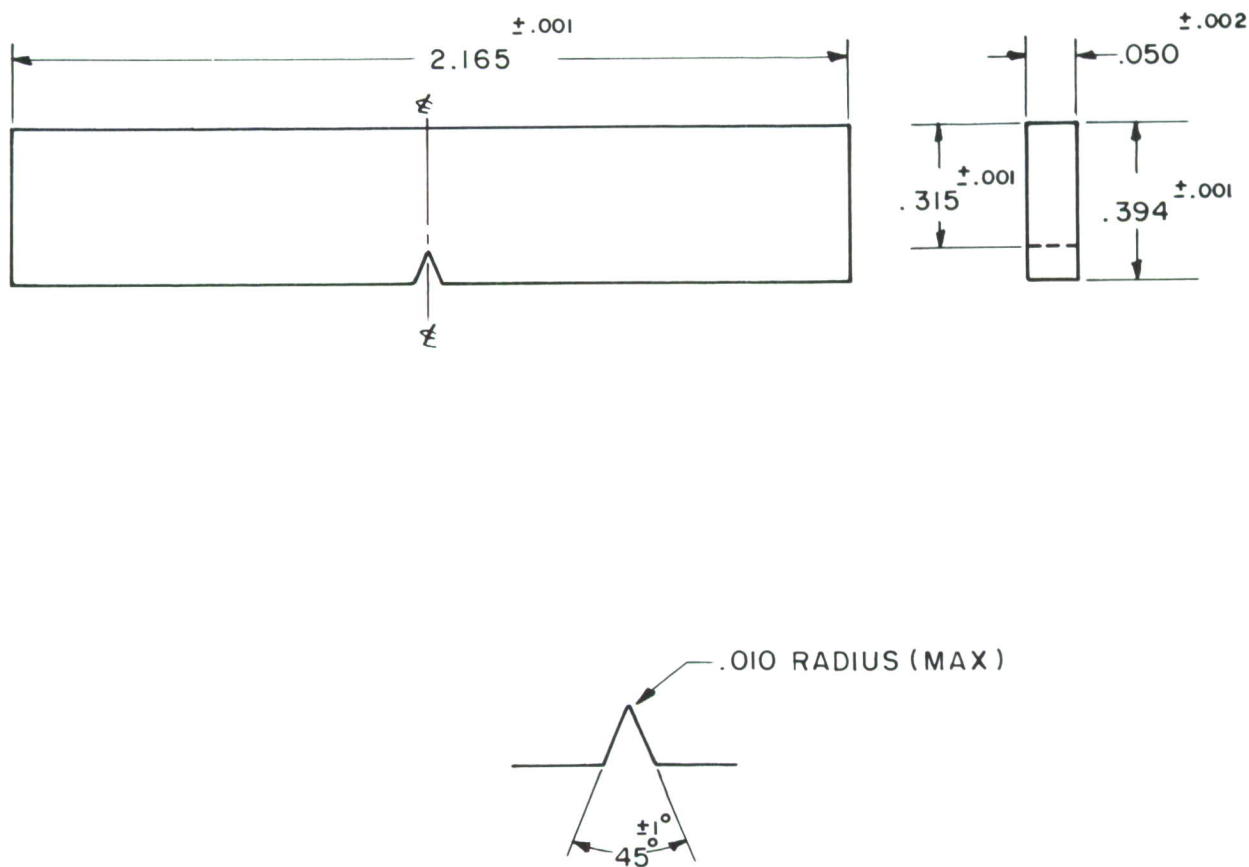

Figure 3. Subsize Precracked Charpy Test Specimen

All dimensions specified are in inches.

* Trade Name

SECTION V

TEST PROCEDURES

TENSILE TESTS

Tensile tests were run using 50 mil, 2-inch gage length sheet specimens to give correlation data for the fracture toughness tests.

These tests were made at 75, 200, 300, 400, 550 and 650°F on the Wiedemann FGT tensile testing machine shown in Figure 5, using the procedures recommended in the tentative ASTM specifications E8-61T and E21-58T.

Elevated temperature tests were made in a Marshall 3-zone furnace, also shown in Figure 5, with a thermocouple on both ends and the center of the gage length.

CENTER NOTCH TESTS

The specimens were tested to failure using a test set-up similar to the one shown in Figure 6. A loading rate less than 50 KSI/minute on the uncracked section was used. Crack growth was followed with a Boyle's type compliance gage as shown in Figure 7. Also, an acoustical probe was inserted in the notch as shown in detail in Figure 7. The operator listened for an acoustical pop-in with earphones shown in Figure 6 and recorded the load value at which it was heard on the load-compliance recorder. Although the specimens were relatively thin gage, compliance and acoustical pop-ins occurred on most of the specimens. This was probably because most of the specimens were quite brittle. Acoustical pop-ins were not used for K_{IC} calculations, they only served to provide a check on the compliance gage record and to substantiate whether a pop-in did indeed occur.

SINGLE-EDGE NOTCH TESTS

The specimens were tested on the Instron TTC test machine shown in Figure 8 using a strain gage beam, as shown attached to specimen in Figure 8, to sense the compliance change. The gage has a span of 1.750 inches and is fastened to the edge of the specimen using milled V-notches. The beam is used with the Instron strain gage preamplifier. The specimens were tested at a cross-head rate of .02 in./min. After testing the original fatigue crack length was measured with a toolmakers microscope to an accuracy of .001 inches. All testing was done at room temperature.

PRECRACKED CHARPY TESTS

The specimens were tested in a commercially available Manlabs 24 ft-lb impact machine, as shown in Figure 9. The machine has an accuracy of $\pm .01$ ft-lbs at the low end of the scale.

The standard test temperatures were 75, 210, 550 and 650°F. After the general transition pattern was obtained, tests at temperatures between these values were run to define the curve.

Thermocouples were spot welded to the surface of the specimen to accurately monitor the test temperature. The specimens were heated above the test temperature and allowed to cool under continuous monitoring to the test temperature while on the anvil in position. This was done to try to decrease scatter caused by test temperature variations.

Following the testing, the fatigue crack depth was measured with a toolmakers microscope. Lement et. al., (Reference 1) suggest a correction factor of $1/\cos^2\theta$ (W/A) for specimens

that crack at an angle; θ is the angle between the depth direction and the fracture direction. Theta is small, therefore $\cos^2 \theta < 1$ and $1/\cos^2 \theta > 1$. So our reported values, not corrected for angle fractures, are conservative. In our testing, about 10 percent of the specimens broke at an angle. This percentage was low because the specimens were accurately positioned on the anvil. In general, the angular fractured specimens had W/A values in excess of 2000 in.-lb/in.². This was considered adequate toughness.

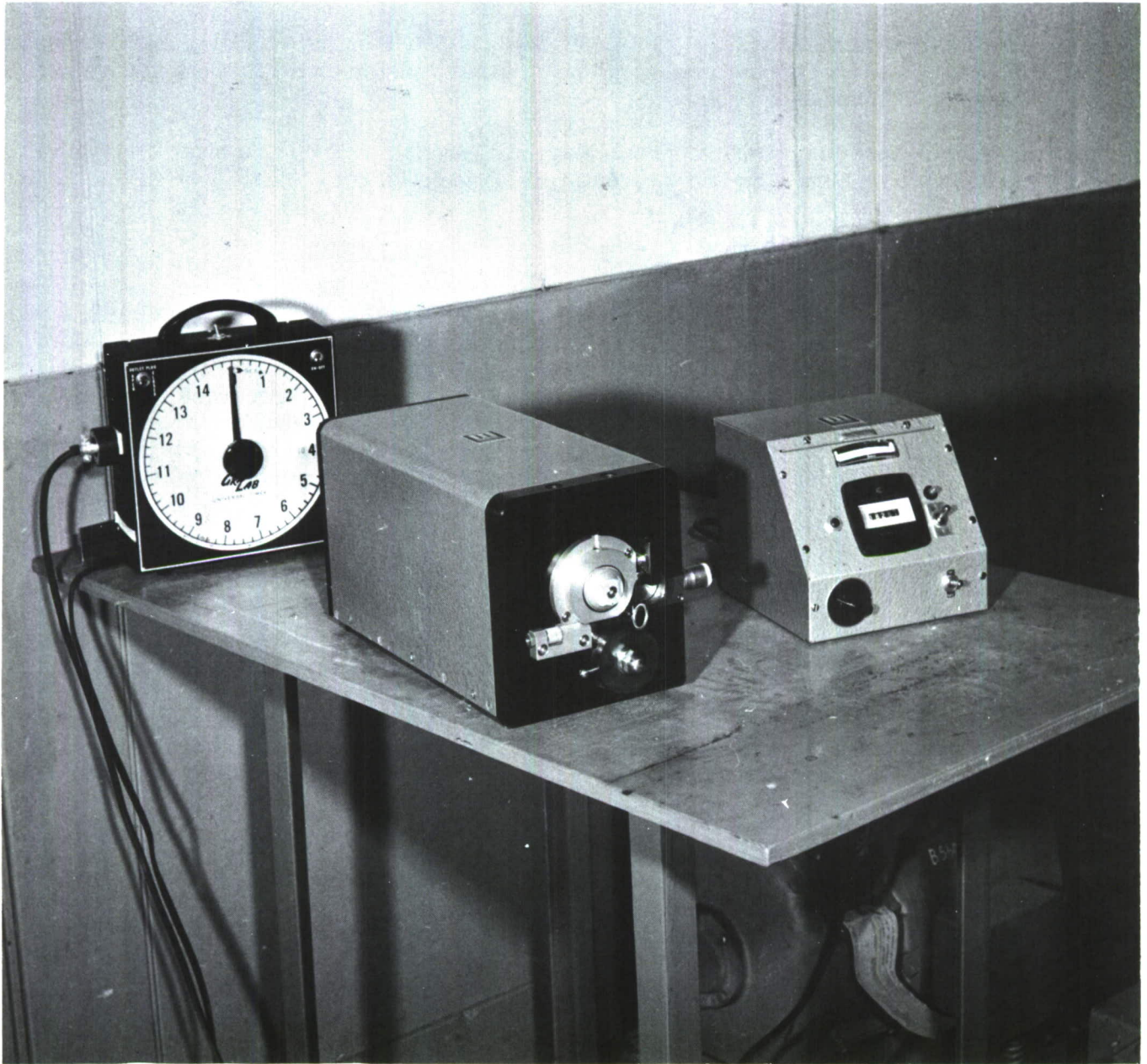

Figure 4. Precrack Charpy Specimens Fatigue Machine

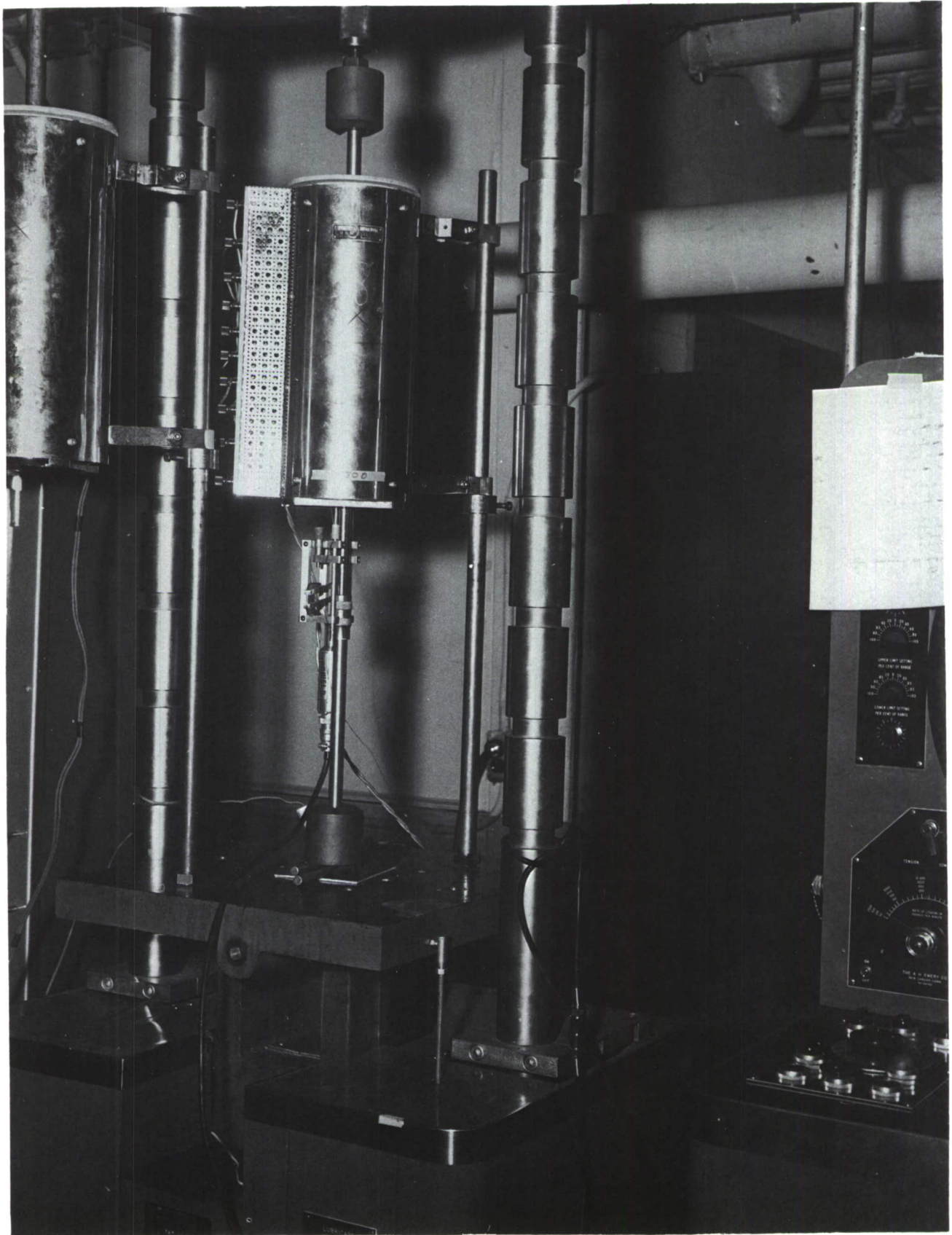

Figure 5. Elevated Temperature Tensile Test Set-up

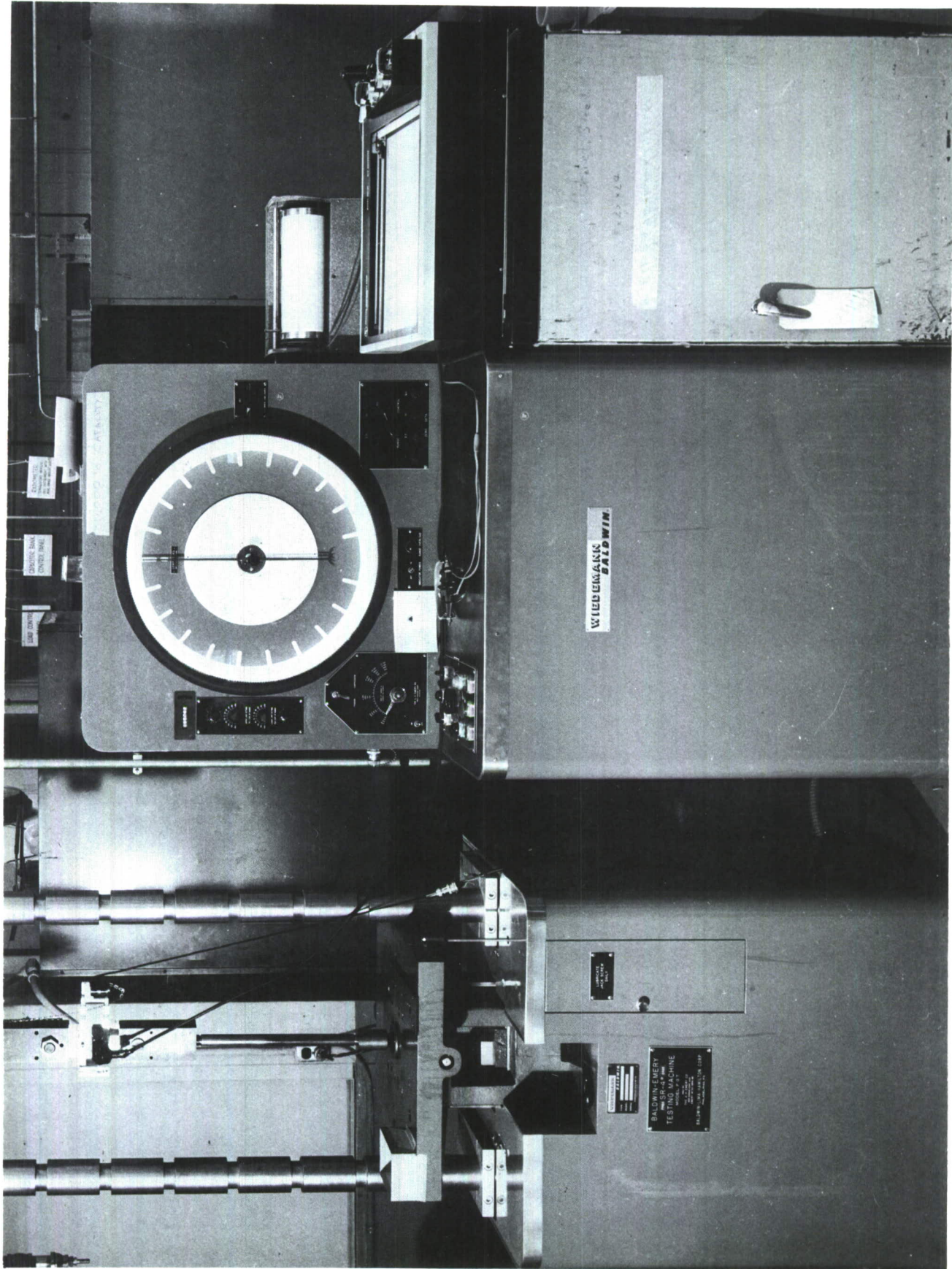

Figure 6. Center Notch Fracture Toughness Test Set-up

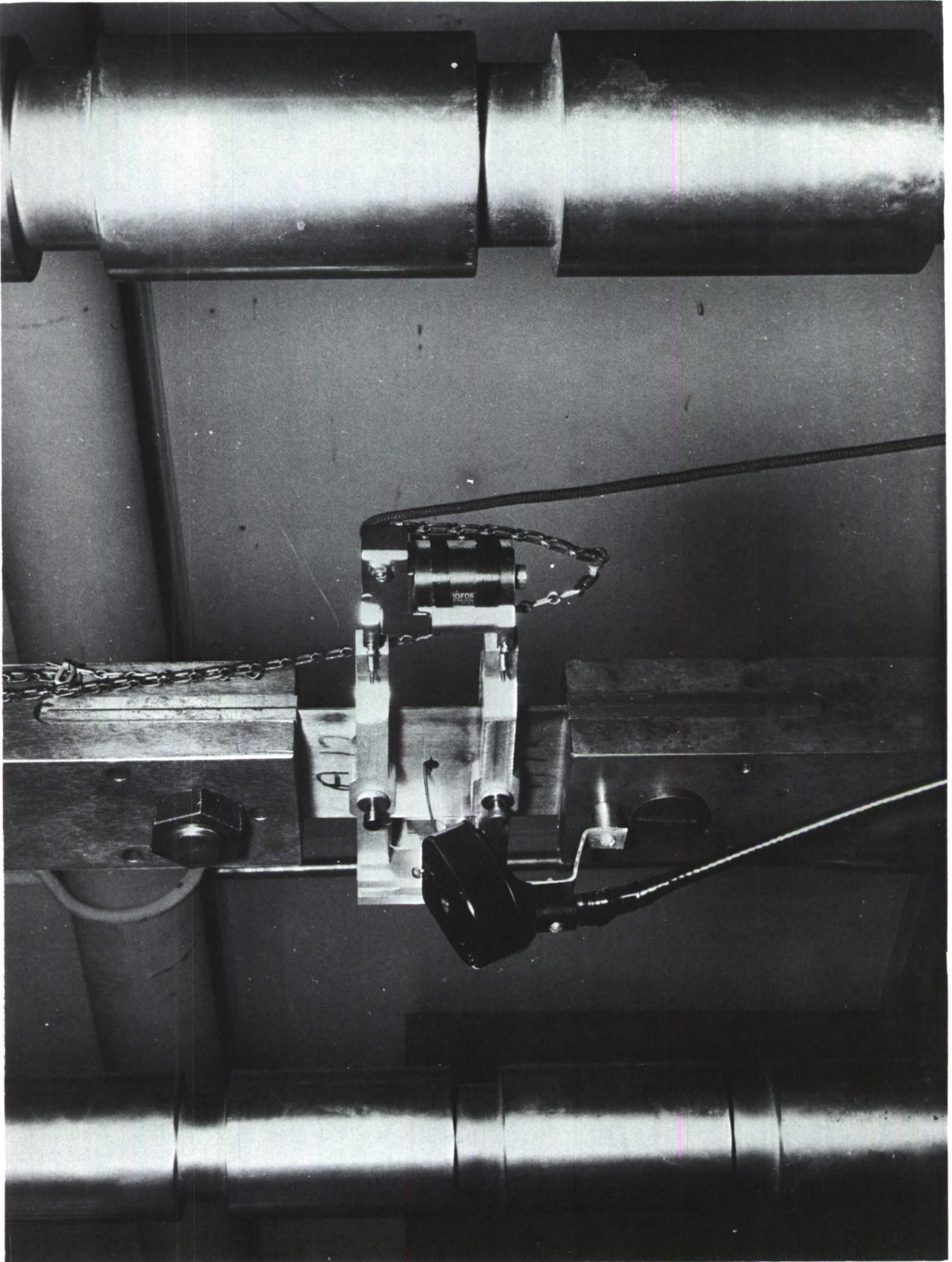
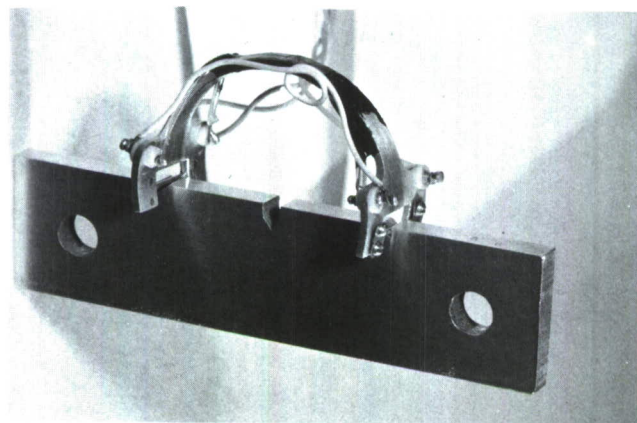

Figure 7. Detail View of Fracture Toughness Test Set-up



(a) Test Machine



(b) Single Edge Notch Specimen and Compliance Gage

Figure 8. Single Edge Notch Fracture Toughness Test Set-up

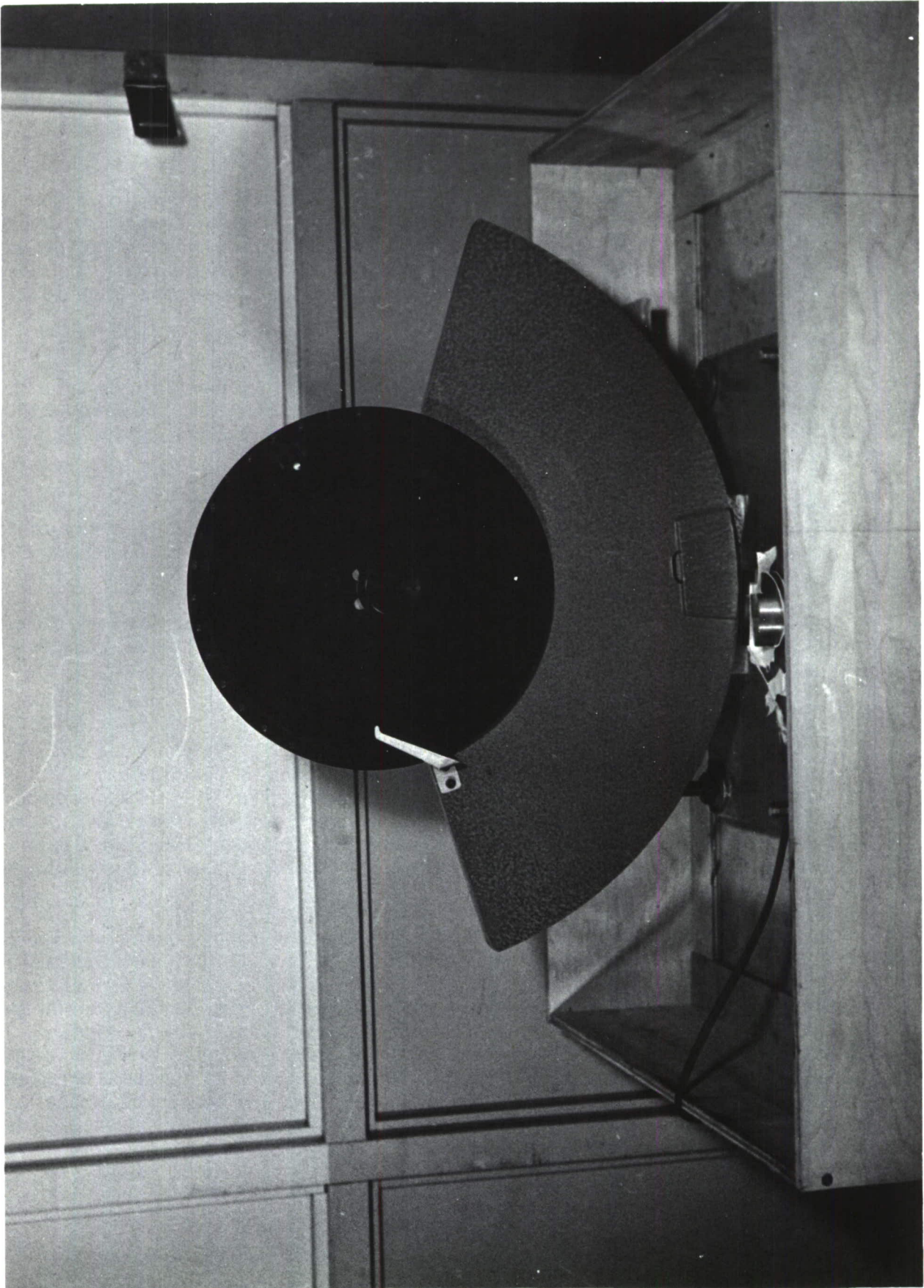

Figure 9. Precrack Charpy Impact Testing Fracture Toughness Machine

SECTION VI

RESULTS

TENSILE TESTS

The results of the tensile tests are shown in Table I. The yield strength generally increases with increasing tempering temperatures with maximum values of yield strength occurring with the 900 and 1000°F tempers for room temperature tests. This behavior is normal for AFC-77 and is not surprising in view of the varied and complex precipitation reactions occurring at the different tempering temperatures involved. As expected, it decreases with increasing test temperature from 75 to 650°F.

The ultimate strength gain at 75°F test temperature for the 700 to 1100°F tempering temperature range was approximately 30 KSI. At the 650°F test temperature for the same temper range, the ultimate strength gain as shown by the data in Table I was only 3 KSI. The 400, 700, 800 and 900°F tempers reach a minimum value and rebound, but this is most probably typical tensile data scatter.

No pattern was evident when comparing longitudinal to transverse yield strength values. The differences were largest at room temperature and decreased to amounts which could well be data scatter at 550 and 650°F test temperatures. Therefore, the values reported in Table I are averages for both directions.

Elongation values are listed in Table II. The consistent trend is for the data to decrease with increasing test temperature and tempering temperature. The reasons for the former trend are obscure at the present time from a metallurgical point of view.

CENTER NOTCH

The center notch fracture toughness test data is listed in Table III. The computer program previously described in AFML-TR-65-214 (Reference 8) was used to make the calculations. The program, very briefly, calculates K (uncorrected and corrected for plastic zone effects), gross and net stress, net stress to yield strength ratio (so-called notch strength), and plastic zone size. All three features of the program were utilized in this investigation. For a particular test, the first line is K_{IC} and the second is K_C data; obviously, K_{IC} is always the lower of the two values.

The effect of higher tempering temperatures on the fracture toughness behavior of AFC-77 is obvious by looking at the nominal ratios in the Table. This ratio, also called the notch strength ratio, is $P_{max}/B(W-2a_0)/\sigma_y$ where B is the thickness and $2a_0$ is the original crack length. For tempers above 800°F it drops from 1/3 to 1/5 of its value of ~ 1.0 at 400 and 700°F tempering temperatures. The corresponding K values of the specimens tempered at 800°F and above are very low. In fact, the pop-in load was often either very close to or was the maximum load. Actually, the specimens often failed completely without any deviation from linearity. With the more brittle tempers (800°F and above), those few specimens whose K_{IC} was calculated using the load at deviation from linearity yielded data which was indistinguishable from the K_{IC} 's calculated from the load at pop-in.

SINGLE-EDGE NOTCH (SEN)

The data for the SEN tests are listed in Table IV. On the low toughness specimens, 800°F temper and above, the fatigue crack length was kept between 1/4W and 1/3W because control was lost as the fatigue crack approached the recommended 1/3W length. Other investigators

(References 2 and 3) have demonstrated that K_{IC} values are not affected by a/W in this range of $1/3$ to $1/4$ provided that the proper equation is used for the calculation of K_{IC} . The K_{IC} calculations were based on Srawley's compliance calibration (Reference 4):

$$\frac{K^2}{\sigma^2 W} = f(a/W)$$

where

$$\sigma = \frac{\text{load}}{B \cdot W}$$

and "a" is the total crack length. The actual equation used for calculation of K_{IC} was (Reference 3):

$$K_{IC}^2 = \frac{P^2}{(1-\nu^2)WB^2} \left[7.59(a/W) - 32(a/W)^2 + 117(a/W)^3 \right]$$

which is simply a closed approximate expression which fits the curve generated by the above expression for $0.25 < a/W < 0.40$.

The average K_{IC} values of the SEN tests correlated extremely well with the center notch tests for all of the tempering temperatures.

PRE-CRACKED CHARPY

Tables V to VIII list the W/A values for the four standard test temperatures: room temperature, 210°F, 550°F and 650°F.

At room temperature, W/A shows a steady decline from 2100 in.-lb/in.² longitudinally for the 400°F temper to 1500 in.-lb/in.² for a 700° temper. Then, for both directions, the data drop off to an average of 150 in.-lb/in.² for the 800 to 1100°F temper conditions. In general, the longitudinal specimens had higher fracture resistance than the transverse ones, but the effect was not quantitatively consistent. In a few cases, however, the difference was extremely great. These differences usually occurred at temperatures near the ductile-to-brittle-transition temperature.

At 210°F test temperature an unusual and unexplainable situation arose with respect to the transition temperature. The transition temperature as shown in Table IX for the longitudinal direction of the 800, 1000, and 1100°F tempers was exceeded in the precrack Charpy test as shown in Table VI, but not for the 900°F temper condition. As a consequence, the precrack Charpy fracture resistance for 800, 1000, 1100°F tempers were higher than the 900°F temper. Conversely, in the transverse direction only those tempers up through the 800°F temper regained their fracture resistance, as compared with 1000 and 1100°F tempers for longitudinal results in Table VI. For the higher tempering temperatures, the W/A values increased only slightly above 900°F temperature for 210°F test temperature for the transverse specimens.

At the 550°F test temperature all tempers had good fracture resistance. The average values increased, as expected, from the 210°F tests. However, from 550 to 650°F the W/A values started to decrease. From the 550 and 650°F tests, the longitudinal values were higher than the transverse.

Ductile-to-Brittle-Transition-Temperature curves are presented in Figures 10 to 17 for those tempers with transition temperature at or above room temperature. All numbers in the legend box on Figures 10 through 17 indicate the number of specimens tested for each associated data point. The vertical lines perpendicular to short horizontal lines on each curve

show maximum and minimum W/A values for appropriate data point. Examination of these graphs shows that the transition temperature increases with increasing tempering temperature. For AFC-77 the rate of change of slope in the steep slope region of the transition range is high as well as the data scatter. To arrive at a transition temperature, the criterion was adopted wherein the transition temperature is the temperature at which 1/2 of the average 600°F W/A value was reached. The 600°F test temperature on the abscissa was chosen because all of the curves (Figures 10 through 17) level out by then. This is an arbitrary method, but the standard size Charpy criteria of 10-15 ft-lbs were too high to be applicable to this type of test. The results, as a consequence of using the above criterion, are summarized in Table IX.

SECTION VII

DISCUSSION

Previous test programs have shown a marked reduction in standard Charpy V-notch impact values for tempers of 850°F and above, thus qualitatively indicating a decrease in toughness. These findings were quantitatively substantiated by the fracture toughness results of this program as summarized in Figure 18, which is a compendium of all the K_{IC} values generated. Since the single edge notch and center notch specimens yielded comparable values, results from both are included in the average values shown in Figure 18. Inspection of Figure 18 indicates that there seems to be no essential difference in K_{IC} between the 400 and 700°F tempers, the difference being well under 5 percent for both directions. The 900, 1000, and 1100°F tempers exhibit the same general behavior with the exception of transverse specimens tempered at 1000°F, which are similar to the results from the longitudinal specimens tempered at 1000°F and must therefore be regarded with a certain degree of suspicion.

On the basis of room temperature tensile and percent elongation data (Tables I and II respectively) the details of the above fracture toughness behavior are not entirely predictable. For instance, longitudinal specimens tempered at 900°F exhibited the highest percent elongation of any of the tempers, as well as the highest room temperature yield strength. Also, there is essentially no difference in yield strength between the 800 and 1100°F tempers, although the differences in ultimate tensile strength are rather significant, with the 1100°F temper giving 270 KSI versus 240 KSI for the 800°F temper. Since the percent elongation is lower for the 1100°F temper, it would appear that the strain hardening exponent is greater for this tempering temperature than for 800°F. Obviously with AFC-77, attempts to "guestimate" relative values of fracture toughness on the basis of ordinary tensile properties would meet with dismal failure as analysis of the data indicates.

Comparison of Table V with Figure 18 shows that the precracked Charpy specimen results, qualitatively demonstrate the dramatic drop in fracture resistance as the tempering temperature is raised from 700 to 900°F. This is also quantitatively shown by the center notch and single edge notch specimen results. This fact points up rather convincingly the value of the precracked Charpy specimen as a quick, economical screening test, but it also helps to demonstrate the need for the more quantitative type of fracture toughness test in design.

The influence of the thickness to the plastic zone ($\frac{t}{r_p}$) on resultant K_{IC} values has been discussed in Reference 5. Note that (Table III) for the 400°F and 700°F tempers ($\frac{t}{r_p}$) was roughly 4 while the net section stress to yield stress ratio never exceeded 0.54. At the more brittle tempers, ($\frac{t}{r_p}$) ranged between 20 and 40 while the net stress to yield strength ratio was roughly 0.20. Other investigators (Reference 5) have suggested that for steels ($\frac{t}{r_p}$) should be at least 8 for distinct pop-in occurrence. At the 400 and 700°F tempers, several distinct pop-ins occurred with the ($\frac{t}{r_p}$) of roughly 4. Those specimens which did not exhibit a distinct pop-in yielded readily interpretable deviations from linearity, from which K_{IC} values were calculated which agreed nicely with those determined from pop-in.

To recapitulate, this investigation was concerned with after rolling and subsequent specific heat treatment (1900°F austenitizing treatment for 1 hour, oil quenched, -110°F for 1/2 hour and followed by various tempering temperatures for 2 + 2 hours), the effect of tempering

temperature and which one seems to be the most promising. It is possible that a different prior treatment would give increased toughness with the desirable higher yield strength level.

SECTION VIII

CONCLUSIONS

The room temperature properties of AFC-77 (austenitized at 1900°F for 1 hour, oil quenched, refrigerated at -110°F for 1/2 hour, and tempered for 2 + 2 hours from 400 to 1100°F) show that optimum results as determined by this program were obtained with the 700°F temper. The optimum properties were 182 KSI yield strength and 65 KSI $\sqrt{\text{in}}$ plane strain fracture toughness. The room temperature fracture properties at the 900, 1000, and 1100°F tempers were too low to contemplate the use of this material at heat treatment specified for high strength applications where fracture resistance is important at low temperatures. For elevated temperature applications, the fracture resistance is much improved as shown from the analysis of the Charpy results in this report. For elevated temperature applications, of which AFC-77 was developed, it has several desirable properties such as good tensile strength retention, attractive creep and stress rupture properties, excellent oxidation and corrosion resistance.

SECTION IX

REFERENCES

1. B. S. Lement, K. Kreder, H. Tushman, Investigation of Fracture Toughness in High Strength Alloys, ASD-TDR-62-868, Part II, January 1964, p. 25.
2. E. A. Steigerwald and G. L. Hanna, Development of Standardized Test Methods to Determine Plane Strain Fracture Toughness, AFML-TR-65-213, June 1965.
3. W. F. Brown and J. E. Srawley, Fracture Toughness Testing, NASA Technical Note, NASA TN D-2599, January 1955.
4. J. E. Srawley, M. H. Jones, and B. Gross, Experimental Determination of the Dependence of Crack Extension Force on Crack Length Force Single Edge Notch Tension Specimen, proposed NASA Technical Note, draft number E-2392.
5. E. A. Steigerwald, and G. L. Hanna, Influence of Test Conditions of the Determination of Plane Strain Fracture Toughness for Sheet Specimens, Engineering Report ER 5817, TRW Inc.
6. B. R. Banerjee and J. J. Hauser, Fracture Micromechanics in High-Strength Steels and Titanium, AFML-TDR-64-182, July 31, 1964.
7. A. Kasak, V. K. Chandhok, J. H. Moll and E. J. Dulis, Development of High-Strength, Elevated-Temperature, Corrosion-Resistance Steel, ASD-TDR-63-766, September 1963.
8. Sidney O. Davis, Nathan G. Tupper, Roger M. Niemi, Center Notch Plane Strain K_{IC} Fracture Toughness Properties of Several High-Strength Steel Alloys, AFML-TR-65-214, October 1965.

APPENDIX I: TABLES

TABLE I

AFC-77 TENSILE DATA

Tempering Temperature in °F	Test Temperature in °F					
	75	200	300	400	550	650
400	*174	162	171	169	---	---
	**235	229	230	236	---	---
700	182	167	174	159	157	143
	235	225	227	229	234	235
800	190	180	179	170	171	166
	240	234	232	232	237	241
900	212	193	201	188	177	172
	255	247	242	235	237	241
1000	209	208	208	202	198	192
	265	257	247	244	240	240
1100	191	190	192	196	197	191
	270	262	256	249	241	238

*Yield Strength in KSI

**Tensile Strength in KSI

TABLE II

AFC-77 PERCENT ELONGATION DATA

Tempering Temperature in °F		Test Temperature (°F)					
		75	200	300	400	550	650
400	L	9.1	8.5	---	---	---	---
	T	---	---	6.2	6.8	---	---
700	L	7.8	7.8	6.7	6.5	6.0	---
	T	---	6.8	---	---	---	8.6
800	L	7.5	7.4	---	7.0	6.3	6.1
	T	---	---	7.3	---	---	---
900	L	9.5	9.2	8.0	7.4	6.2	---
	T	---	---	5.8	---	7.0	---
1000	L	7.2	7.8	7.4	6.0	---	4.5
	T	---	---	---	---	5.3	4.9
1100	L	6.1	6.0	5.0	6.0	5.0	5.3
	T	---	7.4	---	6.3	6.3	---

NOTE: All Data for a 2-Inch Gage Length.

L = Longitudinal Specimen

T = Transverse Specimen

TABLE III.
CENTER NOTCH FRACTURE TOUGHNESS DATA FOR AFC - 77

TEMPERATURE IN °F	CRACK INITIAL	LENGTH FINAL	WIDTH	THICKNESS	LOAD	GROSS STRESS	NOMINAL STRESS	NET STRESS	YIELD STRESS	NOMINAL RATIO	NET RATIO	LENGTH/ WIDTH	PLASTIC ZONE	TOUGHNESS K	
400	L	1.053	1.967	0.0877	10.50	60.87	90.76	90.76	174.00	0.98	0.52	0.33	0.0238	64.40*	
			1.967	0.0877	19.65	113.91	245.13	169.86	174.00	0.98	1.41	0.33	0.0219	168.89	
			1.967	0.0882	10.10	58.22	87.35	87.35	174.00	174.00	0.97	0.50	0.33	0.0219	62.06
			1.967	0.0882	19.60	112.98	169.52	169.52	174.00	174.00	0.97	1.42	0.33	0.0219	169.08
			1.964	0.0870	8.40	49.16	72.91	72.91	174.00	174.00	1.02	0.42	0.33	0.0148	51.63
			1.964	0.0870	20.40	119.39	177.06	177.06	174.00	174.00	1.02	1.50	0.33	0.0148	179.06
	T	1.084	1.956	0.0874	10.70	62.59	93.22	93.22	174.00	174.00	1.02	0.54	0.33	0.0251	65.94
			1.956	0.0874	20.40	119.33	177.73	177.73	174.00	174.00	1.02	1.54	0.33	0.0251	181.82
			1.946	0.0882	10.30	60.01	90.40	90.40	174.00	174.00	1.02	0.52	0.34	0.0234	63.94
			1.946	0.0882	20.20	117.69	177.29	177.29	174.00	174.00	1.02	1.48	0.34	0.0234	176.05
			1.961	0.0873	10.80	63.09	93.62	93.62	182.00	182.00	1.00	0.51	0.33	0.0229	66.25
			1.961	0.0873	21.05	122.96	182.48	182.48	182.00	182.00	1.00	1.37	0.28	0.0184	174.29
700	L	1.016	1.969	0.0880	10.80	62.33	86.23	86.23	182.00	0.94	0.47	0.31	0.0233	59.65	
			1.969	0.0880	21.45	123.79	171.26	171.26	182.00	0.94	1.41	0.31	0.0233	178.10	
			1.956	0.0871	11.10	65.15	94.81	94.81	182.00	182.00	0.99	0.52	0.31	0.0233	66.66
			1.956	0.0871	21.00	123.26	179.38	179.38	182.00	182.00	0.99	1.49	0.31	0.0233	185.10
			1.965	0.0878	9.10	52.75	77.95	77.95	182.00	182.00	0.99	0.43	0.32	0.0155	55.16
			1.965	0.0878	21.10	122.30	180.73	180.73	182.00	182.00	0.99	1.30	0.31	0.0224	167.12
	T	1.026	1.946	0.0882	11.00	64.09	93.29	93.29	182.00	182.00	1.00	1.46	0.33	0.0216	65.42
			1.946	0.0882	21.50	125.26	182.34	182.34	182.00	182.00	1.00	1.46	0.33	0.0216	182.42
			1.962	0.0871	10.40	60.86	90.88	90.88	182.00	182.00	1.01	0.50	0.33	0.0216	64.42
			1.962	0.0871	21.00	122.89	183.50	183.50	182.00	182.00	1.01	1.42	0.33	0.0216	179.30
			1.955	0.0872	6.50	38.13	55.22	55.22	190.00	190.00	0.34	0.29	0.31	0.0068	38.76
			1.955	0.0872	7.65	44.87	64.99	64.99	190.00	190.00	0.34	0.36	0.31	0.0068	48.12
800	L	0.624	1.960	0.0869	7.34	43.09	62.95	62.95	190.00	0.33	0.33	0.32	0.0090	44.36	
			1.960	0.0869	7.34	43.09	62.95	62.95	190.00	190.00	0.33	0.33	0.32	0.0090	44.60
			1.957	0.0860	7.25	43.08	63.13	63.13	190.00	190.00	0.33	0.33	0.32	0.0090	44.49
	T	0.631	1.963	0.0883	6.36	36.69	54.00	54.00	190.00	0.35	0.28	0.32	0.0066	44.88	
			1.963	0.0883	7.76	44.77	65.88	65.88	190.00	190.00	0.35	0.28	0.32	0.0066	38.15
			1.963	0.0883	7.76	44.77	65.88	65.88	190.00	190.00	0.35	0.35	0.32	0.0066	47.37

*First line is K_{IC} and second line is K_{IC}

TABLE III. (Contd)
CENTER NOTCH FRACTURE TOUGHNESS DATA FOR AFC - 77

TEMPERATURE IN °F	CRACK INITIAL	LENGTH FINAL	WIDTH	THICKNESS	LOAD	GROSS STRESS	NOMINAL STRESS	NET STRESS	YIELD STRESS	NOMINAL RATIO	NET RATIO	LENGTH/ WIDTH	PLASTIC ZONE	TOUGHNESS K
900	L	0.573	1.963	0.0873	5.30	30.93	43.68	43.68	212.00	0.23	0.21	0.29	0.0033	30.44
		0.573	1.963	0.0873	5.93	34.60	49.43	48.87	212.00	0.23	0.23	0.31	0.0037	34.60
		0.599	1.962	0.0871	5.42	31.72	45.65	45.65	212.00	0.22	0.22	0.32	0.0030	32.03
		0.599	1.962	0.0871	5.42	31.72	45.65	45.65	212.00	0.22	0.22	0.32	0.0030	32.17
		0.624	1.953	0.0873	4.80	28.15	41.37	41.37	212.00	0.20	0.20	0.32	0.0030	29.14
	T	0.624	1.953	0.0873	5.16	30.26	44.47	44.47	212.00	0.21	0.21	0.32	0.0032	31.37
		0.620	1.957	0.0885	4.98	28.75	42.10	42.10	212.00	0.20	0.20	0.32	0.0032	29.66
		0.620	1.957	0.0885	4.98	28.75	42.10	42.10	212.00	0.20	0.20	0.32	0.0032	29.72
		0.649	1.964	0.0880	4.62	26.73	39.91	39.91	212.00	0.19	0.19	0.33	0.0029	28.31
		0.649	1.964	0.0880	4.62	26.73	39.91	39.91	212.00	0.19	0.19	0.33	0.0029	28.32
1000	L	0.633	1.959	0.0867	5.36	31.56	46.61	46.61	209.00	0.22	0.22	0.32	0.0040	32.93
		0.633	1.959	0.0867	5.36	31.56	46.61	46.61	209.00	0.22	0.23	0.32	0.0040	33.46
		0.624	1.959	0.0888	4.96	28.51	41.85	41.85	209.00	0.20	0.20	0.32	0.0032	29.52
		0.624	1.959	0.0888	5.61	32.25	48.61	47.34	209.00	0.23	0.23	0.33	0.0038	34.50
		0.652	1.963	0.0874	5.20	30.31	45.39	45.39	209.00	0.22	0.22	0.33	0.0038	32.20
	T	0.652	1.963	0.0874	5.20	30.31	45.39	45.39	209.00	0.22	0.22	0.33	0.0038	32.25
		0.594	1.958	0.0862	4.70	27.85	39.99	39.99	209.00	0.19	0.19	0.30	0.0029	28.01
		0.594	1.958	0.0862	5.23	30.99	45.37	44.50	209.00	0.21	0.22	0.32	0.0029	31.97
		0.635	1.959	0.0884	4.66	26.91	39.83	39.83	209.00	0.19	0.19	0.32	0.0029	28.15
		0.635	1.959	0.0884	5.15	29.74	44.01	44.01	209.00	0.21	0.21	0.31	0.0029	32.07
1100	L	0.606	1.960	0.0868	4.70	27.63	39.99	39.99	209.00	0.20	0.19	0.31	0.0029	28.10
		0.606	1.960	0.0868	4.94	29.04	42.03	42.03	209.00	0.20	0.20	0.31	0.0029	29.72
		0.611	1.956	0.0871	5.12	30.05	43.72	43.72	191.00	0.23	0.23	0.31	0.0042	30.74
		0.611	1.956	0.0871	5.12	30.05	43.72	43.72	191.00	0.23	0.23	0.31	0.0042	31.14
		0.591	1.961	0.0877	5.07	29.48	42.19	42.19	191.00	0.22	0.22	0.30	0.0039	29.54
	T	0.591	1.961	0.0877	5.07	29.48	42.19	42.19	191.00	0.22	0.22	0.30	0.0039	29.54
		0.646	1.960	0.0874	4.90	28.60	42.67	42.67	191.00	0.22	0.22	0.33	0.0040	30.43
		0.646	1.960	0.0874	5.04	29.42	43.89	43.89	191.00	0.23	0.23	0.33	0.0040	30.23
		0.575	1.961	0.0882	4.60	26.60	37.64	37.64	191.00	0.20	0.20	0.29	0.0030	26.24
		0.575	1.961	0.0882	5.08	29.37	41.57	41.57	191.00	0.22	0.22	0.29	0.0030	30.10
T	0.622	1.953	0.0870	4.52	26.60	39.05	39.05	191.00	0.20	0.20	0.32	0.0033	27.50	
	0.622	1.953	0.0870	4.97	29.25	42.93	42.93	191.00	0.22	0.22	0.32	0.0033	30.63	
	0.522	1.958	0.0880	4.34	25.19	34.35	34.35	191.00	0.18	0.18	0.27	0.0024	23.52	
	0.522	1.958	0.0880	4.94	28.67	39.10	39.10	191.00	0.20	0.20	0.27	0.0024	29.30	
	0.522	1.958	0.0880	4.94	28.67	39.10	39.10	191.00	0.20	0.20	0.27	0.0024	29.30	

TABLE IV

SINGLE EDGE NOTCH FRACTURE TOUGHNESS DATA

Temper & Direction		$2a_o$ (in.)	Width (in.)	Thickness (in.)	P_{IC} Kips	K_{IC}^* KSI $\sqrt{\text{in.}}$	Obtained by
400	L	.712	1.927	.087	3.52	62.6	Deviation
400	T	.623	1.926	.086	4.95	74.4	Deviation
		.624	1.926	.085	3.00	45.8	Deviation
700	L	.653	1.927	.087	4.21	66.8	Deviation
		.629	1.927	.087	4.44	67.1	Deviation
700	T	.609	1.923	.086	2.72	39.8	Pop-in
		.621	1.927	.086	4.70	70.4	Deviation
800	L	.592	1.932	.086	3.05	43.0	Pop-in
		.577	1.933	.087	3.0	40.4	Maximum Load
		.693	1.931	.086	2.75	47.2	Pop-in
800	T	.598	1.932	.085	2.92	41.9	Pop-in
		.602	1.932	.087	2.35	33.4	Pop-in
900	L	.628	1.931	.088	2.13	31.4	Pop-in
		.604	1.931	.086	2.00	29.0	Pop-in
		.588	1.931	.087	1.94	26.7	Pop-in
900	T	.544	1.932	.087	1.85	23.3	Pop-in
		.577	1.932	.086	1.80	24.5	Deviation
1000	L	.529	1.931	.086	2.08	25.7	Pop-in
		.587	1.931	.085	2.12	30.0	Maximum Load
		.506	1.932	.085	2.18	26.1	Pop-in
1000	T	.606	1.931	.086	2.24	32.5	Pop-in
		.604	1.931	.086	1.88	27.0	Pop-in
1100	L	.526					
1100	L	.526	1.931	.087	2.16	26.5	Pop-in

* (Poisson's ratio utilized to calculate K_{IC})

TABLE V
 (W/A) IN $\frac{\text{in.}\cdot\text{lb}}{\text{in.}^2}$ AT ROOM TEMPERATURE

	Tempering Temperature in °F							
	400	500	600	700	800	900	1000	1100
Longitudinal*								
	2500	1800	1725	1800	175	125	250	100
	2050	1800	1800	1350	300	100	175	100
	2025	1850	1625	1875	275	75	100	125
	<u>2000</u>	<u>1800</u>	<u>1625</u>	<u>1325</u>	<u>250</u>	<u>100</u>	<u>300</u>	<u>125</u>
Avg	2150	1800	1675	1575	250	100	200	100
Transverse								
	1925	1500	1625	1600	150	75	50	100
	1625	1700	1500	1050	100	100	75	100
	2375	1925	1725	1200	75	150	50	75
	<u>2500</u>	<u>1475</u>	<u>1850</u>	<u>1125</u>	<u>100</u>	<u>100</u>	<u>50</u>	<u>50</u>
Avg	2100	1650	1675	1250	100	100	50	75

* Major axis is parallel to the rolling direction

TABLE VI
 (W/A) IN $\frac{\text{in.}\cdot\text{lb}}{\text{in.}^2}$ AT 210°F

	Tempering Temperature in °F							
	400	500	600	700	800	900	1000	1100
Longitudinal								
	2000	2150	1850	1525	1600	225	1325	1050
	2650	1825	2250	1800	1875	350	925	975
	2125	2400	1775	1725	1725	150	1425	1075
	<u>2150</u>	<u>1550</u>	<u>2000</u>	<u>1800</u>	<u>1300</u>	<u>275</u>	<u>1150</u>	<u>975</u>
Avg	2225	1975	2000	1700	1625	250	1200	1025
Transverse								
	2175	2125	1750	1150	1500	175	75	175
	1750	1775	925	1900	1100	210	125	125
	1625	1625	1700	1550	1375	---	100	150
	<u>2000</u>	<u>1875</u>	<u>1800</u>	<u>1525</u>	<u>--</u>	<u>---</u>	<u>175</u>	<u>175</u>
Avg	1900	1850	1550	1525	1325	200	125	150

TABLE VII
 (W/A) IN $\frac{\text{in.-lb}}{\text{in.}^2}$ AT 550°F

	Tempering Temperature in °F					
	600	700	800	900	1000	1100
Longitudinal						
	2100	1525	1725	2050	1400	1350
	1825	2025	1800	1700	1600	1800
	1700	1675	1800	1800	1625	1275
	1700	2300	2350	--	1575	1375
Avg	<u>1825</u>	<u>1875</u>	<u>1925</u>	<u>1850</u>	<u>1550</u>	<u>1425</u>
Transverse						
	1675	2200	1275	1800	1400	1025
	1675	2100	1975	1500	1475	1025
	1625	2000	1500	1725	1550	950
	--	1675	1450	1650	1725	1025
Avg	<u>1650</u>	<u>1875</u>	<u>1550</u>	<u>1675</u>	<u>1525</u>	<u>1025</u>

TABLE VIII
 (W/A) IN $\frac{\text{in.-lb}}{\text{in.}^2}$ AT 650°F

	Tempering Temperature				
	700	800	900	1000	1100
Longitudinal					
	1725	1525	1600	1125	1225
	1725	2075	1875	1500	1300
	1475	1625	1675	1450	1300
	2125	1900	1650	1450	1175
Avg	<u>1700</u>	<u>1700</u>	<u>1700</u>	<u>1375</u>	<u>1250</u>
Transverse					
	1550	1650	--	1800	1225
	1525	1450	--	1350	900
	1500	1550	--	1425	1300
	1450	1850	--	1400	950
Avg	<u>1500</u>	<u>1625</u>	<u>--</u>	<u>1500</u>	<u>1100</u>

TABLE IX
TRANSITION TEMPERATURES

Temper and Direction	Approximate Transition Temperature in °F	Based upon a W/A* Value of:
800 Longitudinal	155	925
800 Transverse	180	800
900 Longitudinal	235	900
900 Transverse	275	800
1000 Longitudinal	160	750
1000 Transverse	300	750
1100 Longitudinal	190	650
1100 Transverse	300	525

Other subzero tests for longitudinal specimens have shown that the transition temperature for a 400°F temper is below -11°F, that of 500°F is around -110°F, and a 600°F temper has a transition temperature between -110°F and room temperature.

* All W/A values are in in.-lb/in.²

APPENDIX II: CURVES

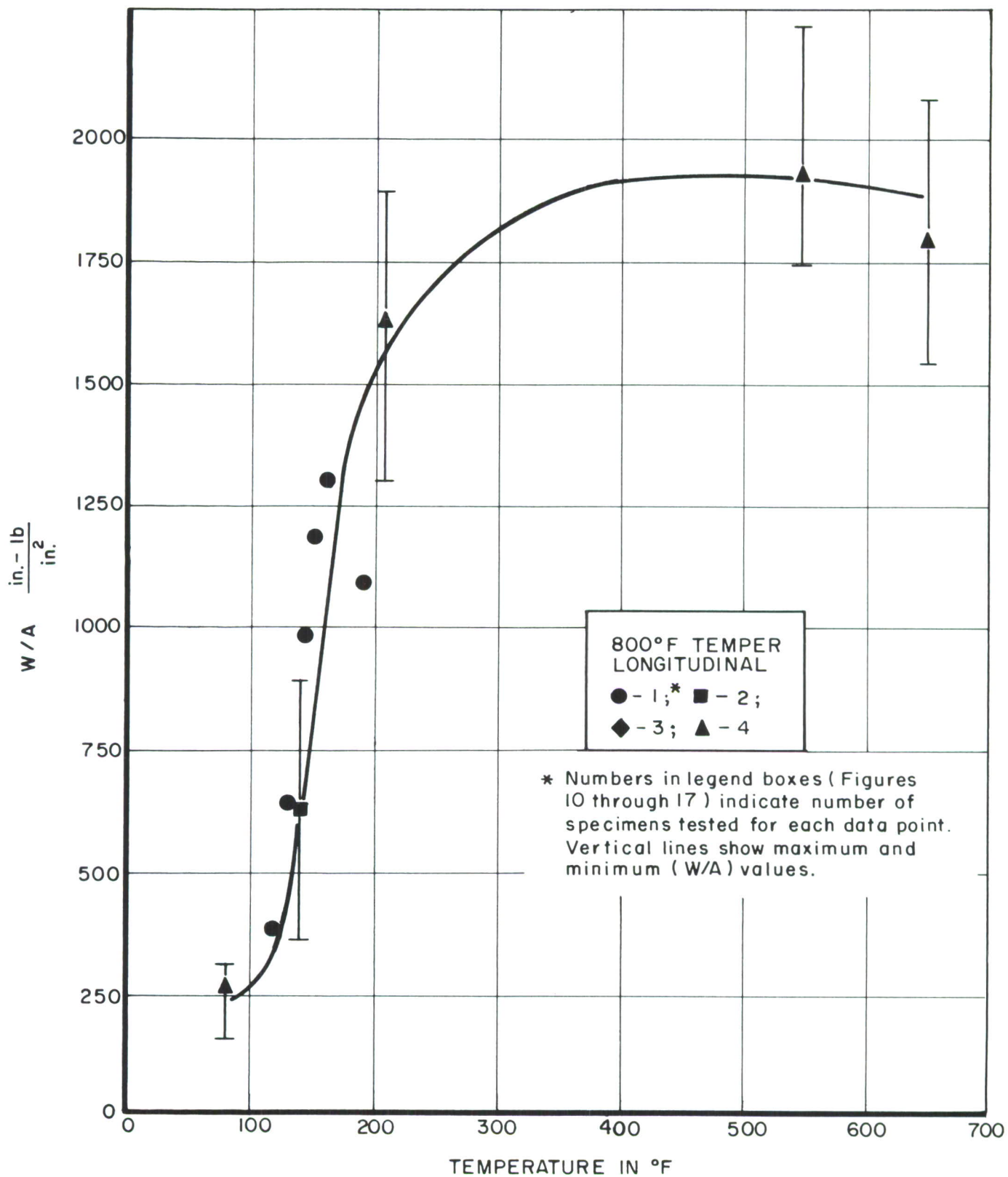

Figure 10. 800° F Temper Longitudinal Specimens Ductile-to-Brittle-Transition-Temperature Curve

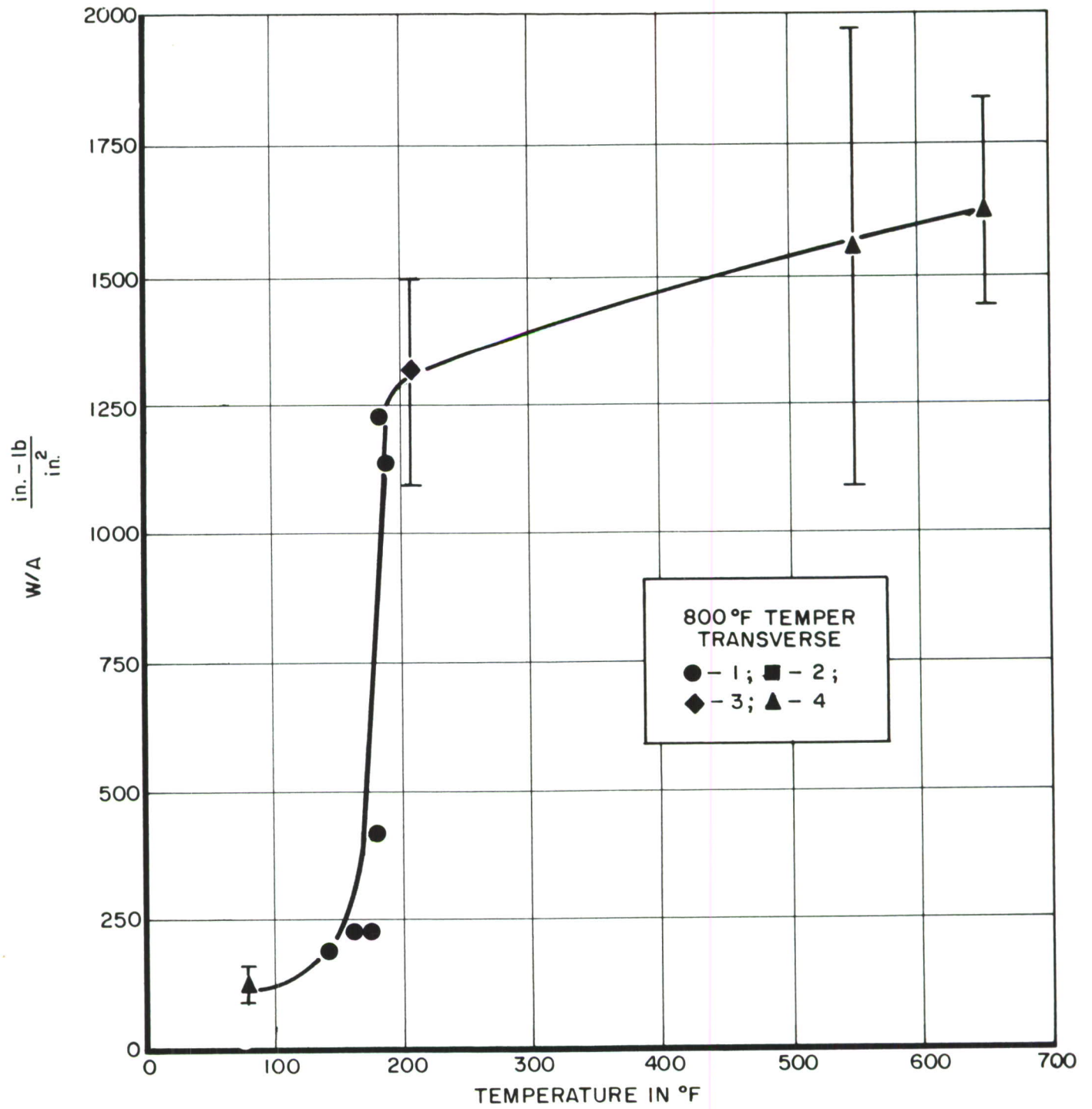

Figure 11. 800° F Temper Transverse Specimens Ductile-to-Brittle-Transition-Temperature Curve

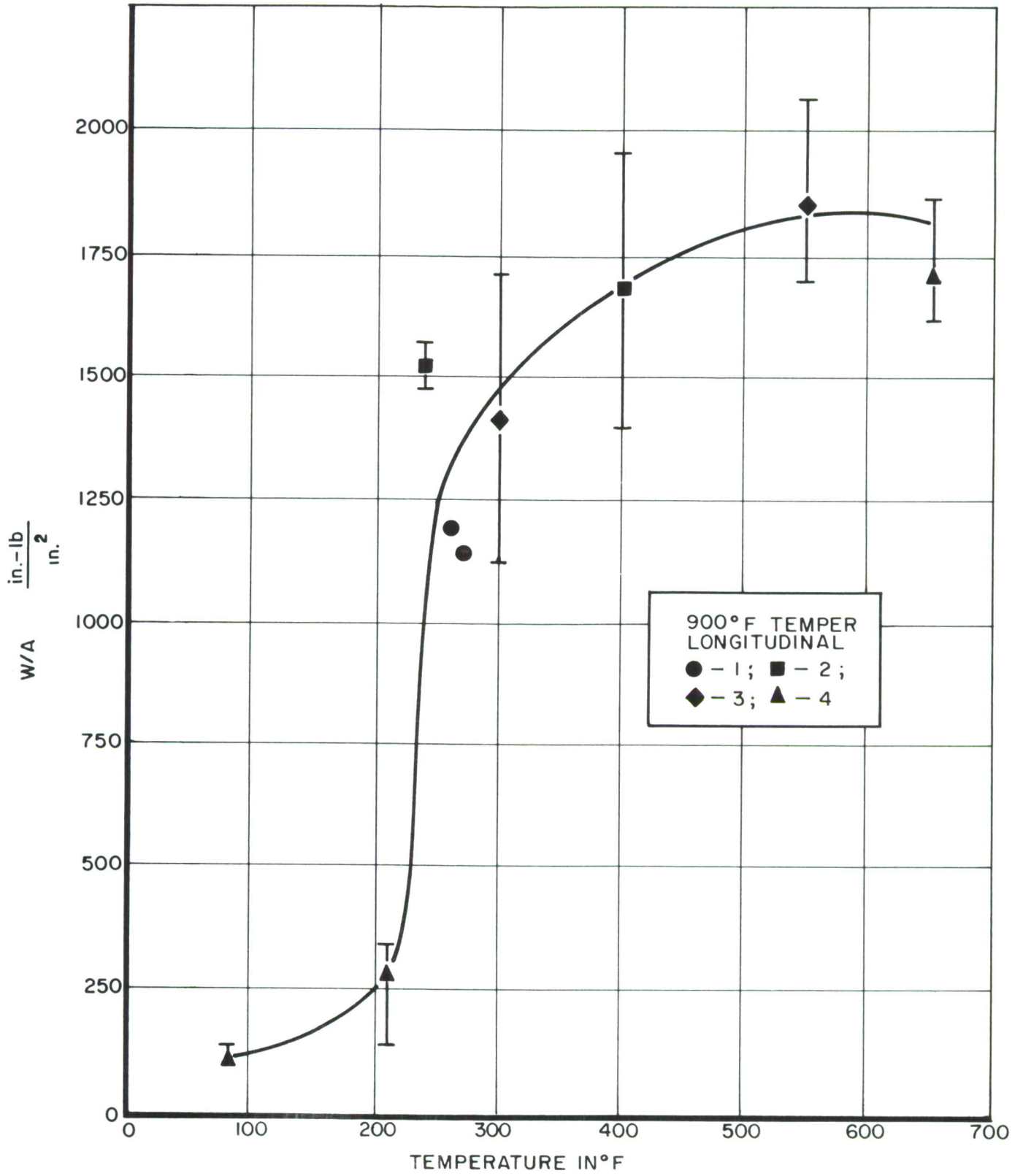

Figure 12. 900° F Temper Longitudinal Specimens Ductile-to-Brittle-Transition-Temperature Curve

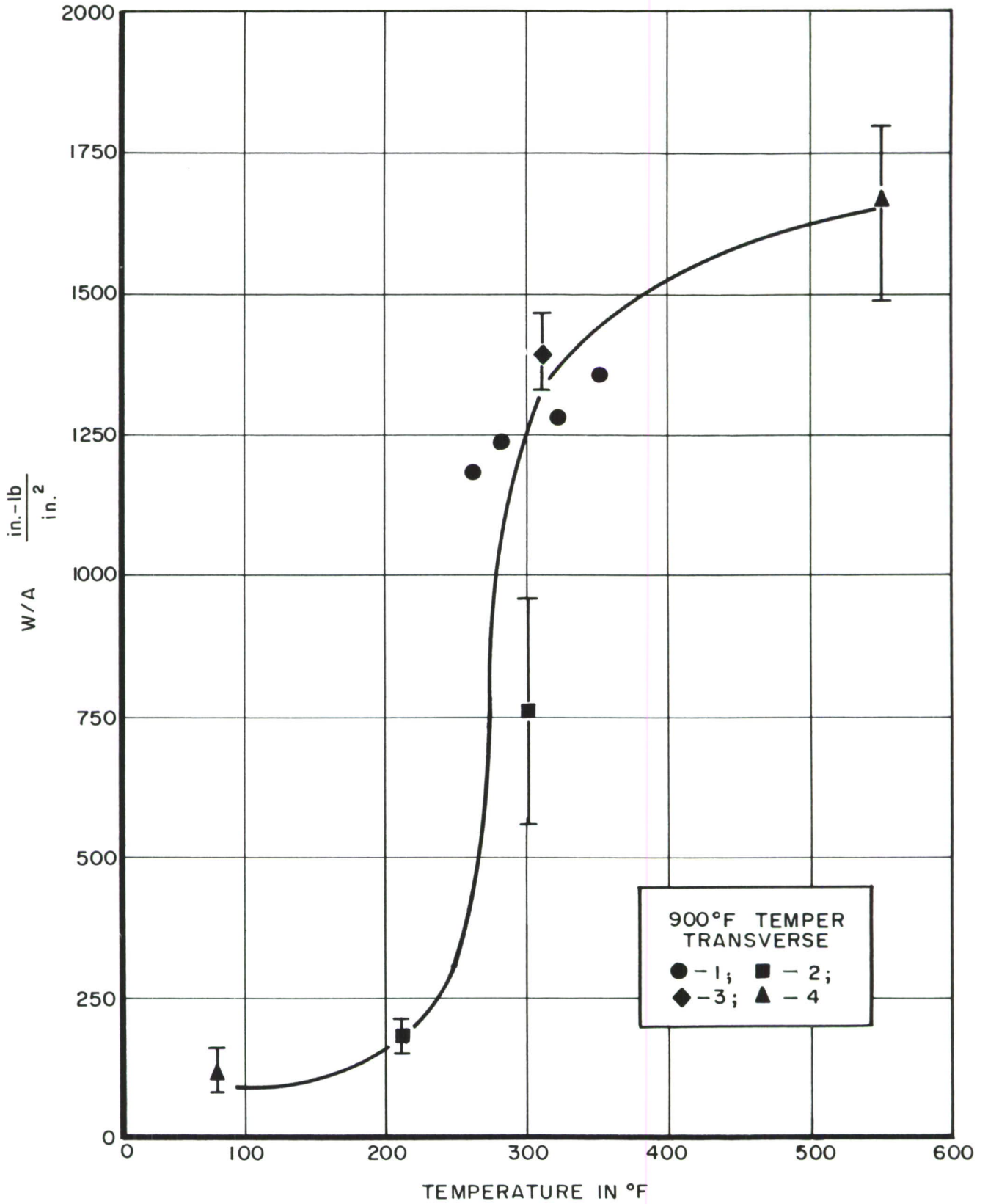

Figure 13. 900° F Temper Transverse Specimens Ductile-to-Brittle-Transition-Temperature Curve

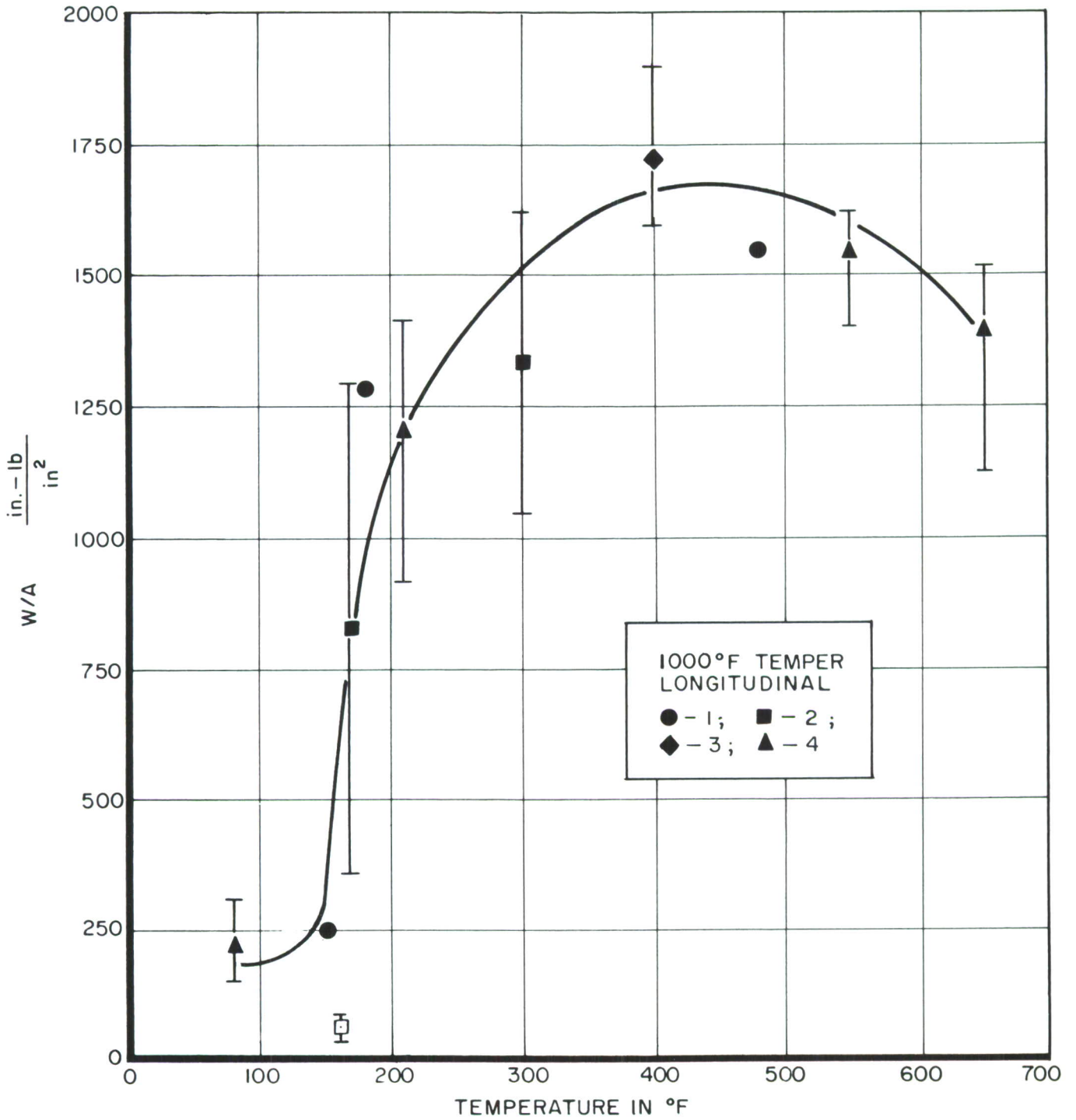

Figure 14. 1000° F Temper Longitudinal Specimens Ductile-to-Brittle-Transition-Temperature Curve

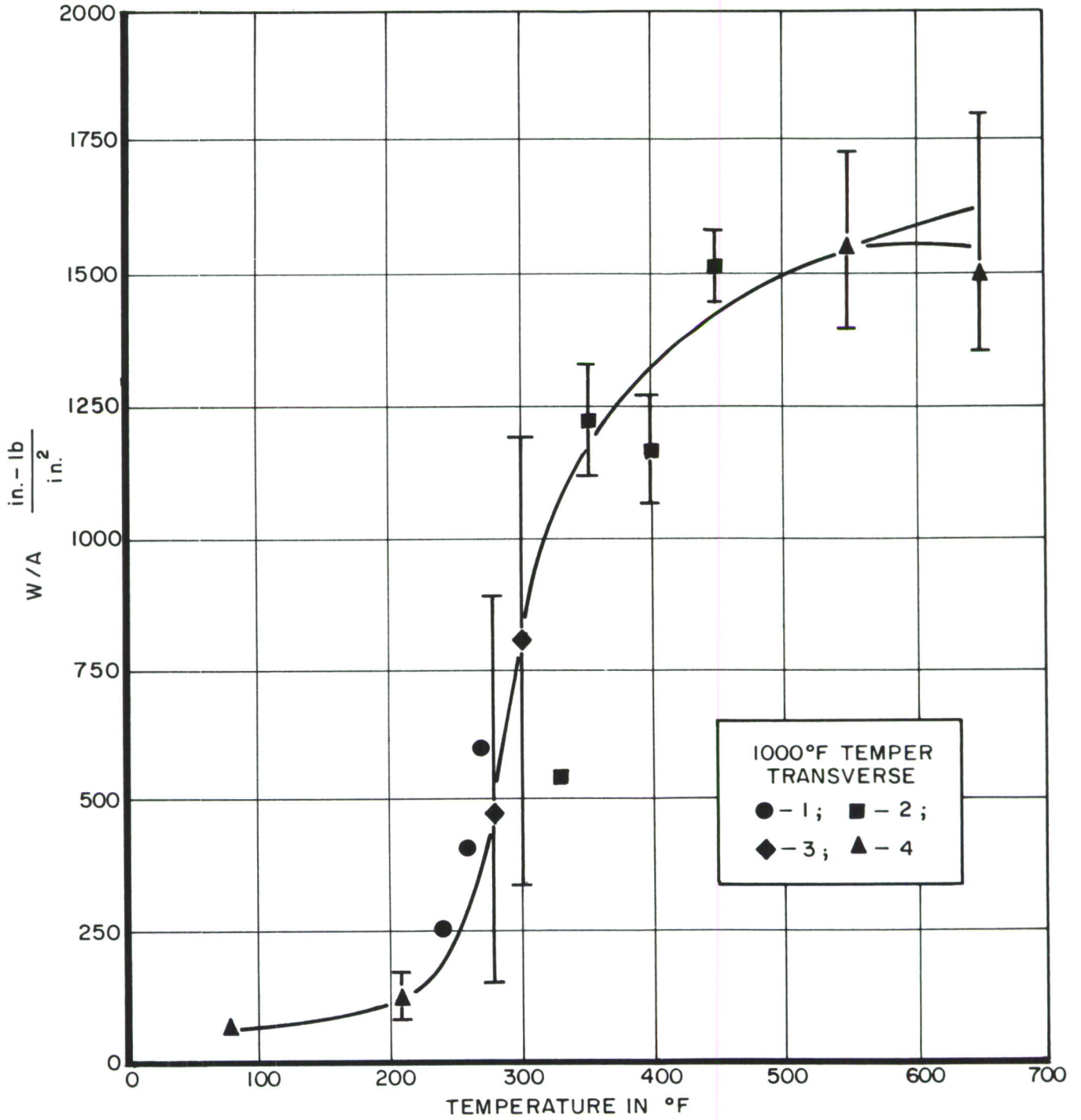

Figure 15. 1000° F Temper Transverse Specimens Ductile-to-Brittle-Transition-Temperature Curve

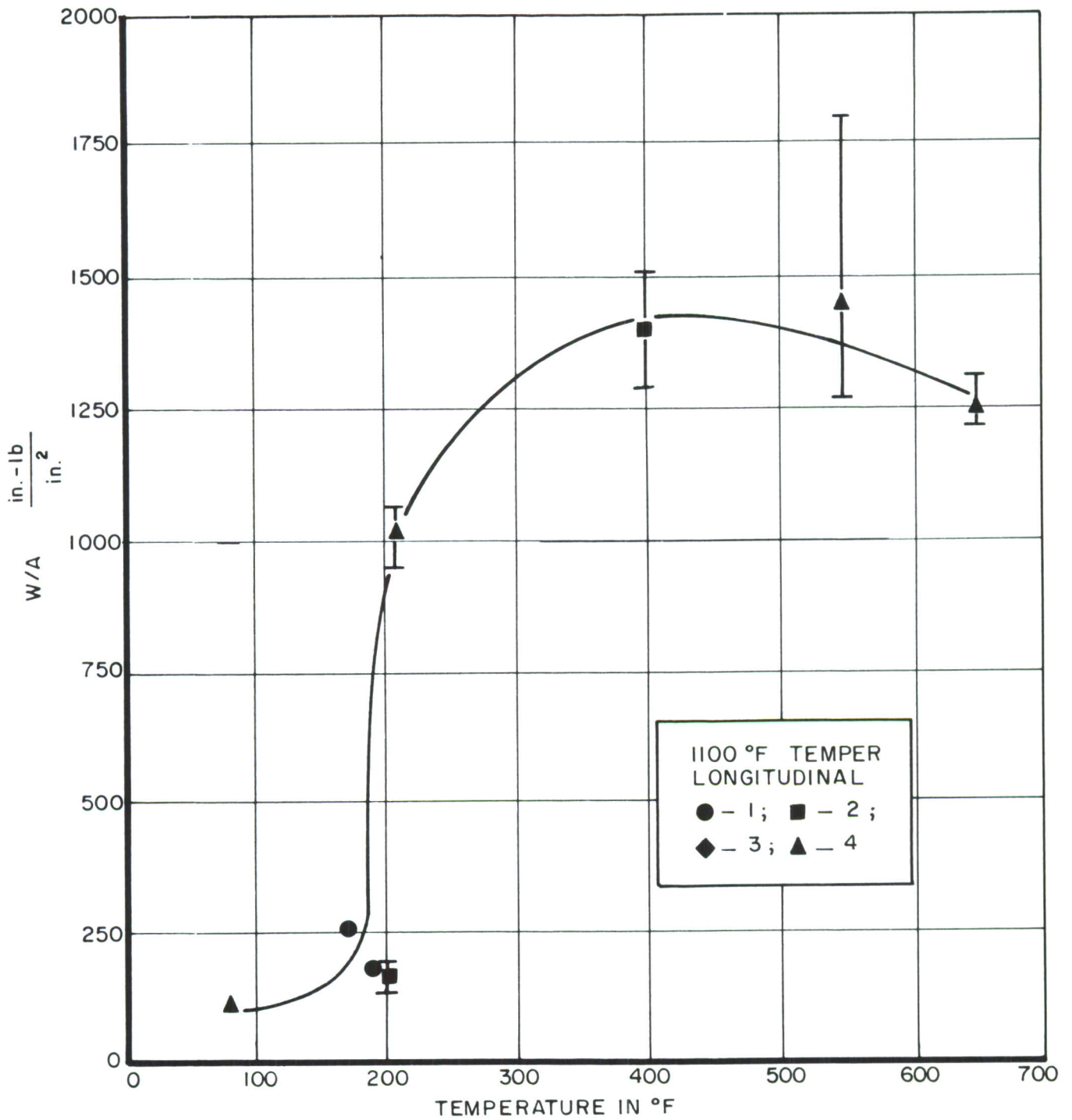

Figure 16. 1100° F Temper Longitudinal Specimens Ductile-to-Brittle-Transition-Temperature Curve

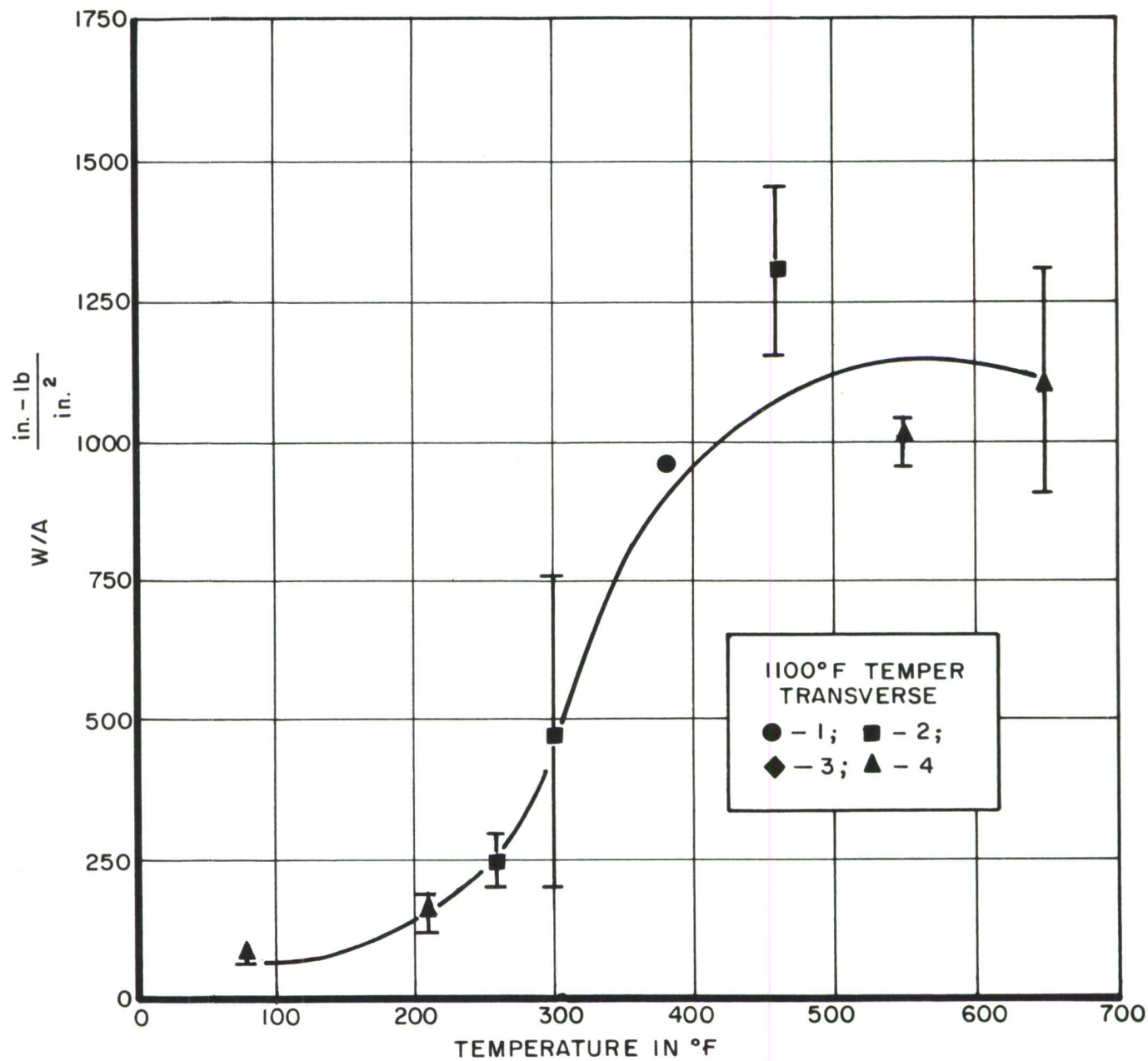

Figure 17. 1100° F Temper Transverse Specimens Ductile-to-Brittle-Transition-Temperature Curve

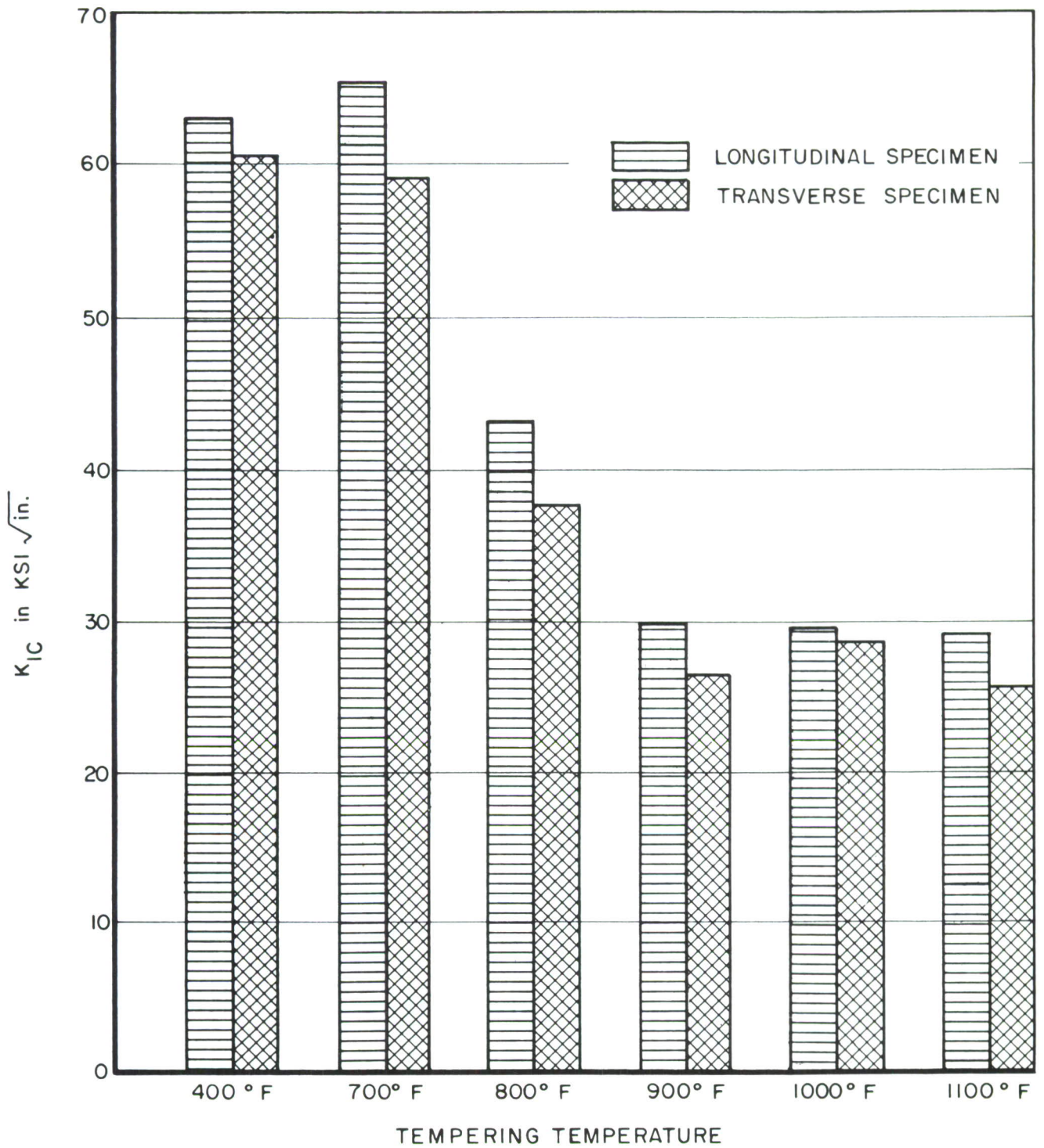

Figure 18. Variation of K_{IC} With Tempering Temperatures

DOCUMENT CONTROL DATA - R&D		
<i>(Security classification of title, body of abstract and indexing annotation must be entered when the overall report is classified)</i>		
1. ORIGINATING ACTIVITY <i>(Corporate author)</i> Materials Information Branch Materials Application Division Air Force Materials Laboratory, W-PAFB, Ohio		2 a. REPORT SECURITY CLASSIFICATION Unclassified
		2 b. GROUP
3. REPORT TITLE K_{IC} AND (W/A) FRACTURE TOUGHNESS PROPERTIES OF AFC-77 STAINLESS STEEL		
4. DESCRIPTIVE NOTES <i>(Type of report and inclusive dates)</i> This report covers work conducted from January 1965 to January 1966.		
5. AUTHOR(S) <i>(Last name, first name, initial)</i> Davis, Sidney O. Niemi, Roger M. Tupper, Nathan G.		
6. REPORT DATE July 1966	7 a. TOTAL NO. OF PAGES 47	7 b. NO. OF REFS 8
8 a. CONTRACT OR GRANT NO.	9 a. ORIGINATOR'S REPORT NUMBER(S) AFML-TR-66-120	
b. PROJECT NO. 7381		
c. Task No. 738106	9 b. OTHER REPORT NO(S) <i>(Any other numbers that may be assigned this report)</i>	
d.		
10. AVAILABILITY/LIMITATION NOTICES This document is subject to special export controls and each transmittal to foreign governments or foreign nationals may be made only with prior approval of MAAM, Air Force Materials Laboratory.		
11. SUPPLEMENTARY NOTES	12. SPONSORING MILITARY ACTIVITY Air Force Materials Laboratory Wright-Patterson Air Force Base, Ohio	
13. ABSTRACT <p>The fracture toughness of AFC-77, a high strength stainless steel alloy, was determined with the center notch and single edge notch fracture toughness specimens at room temperature as a function of six tempering temperatures: 400° F, 700° F, 800° F, 900° F, 1000° F, and 1100° F. Tempering temperatures above 700° F produced poor values of plane strain fracture toughness. In addition the precracked charpy specimen was used to determine, for each tempering temperature, the testing temperature at which transition from relatively tough to relatively brittle behavior occurred. The optimum properties of AFC-77 were obtained at the 700° F temper. This was evident as a result of the analysis of the room temperature center notch, single edge notch and precrack charpy test results. The optimum room temperature properties were 182 KSI yield strength and 65 KSI√in plane strain fracture toughness.</p>		

14. KEY WORDS	LINK A		LINK B		LINK C	
	ROLE	WT	ROLE	WT	ROLE	WT
Plane Strain Fracture Toughness High Strength Stainless Steel						
Precracked Charpy Toughness AFC-77 Steel Alloy K _{IC} and (W/A) Fracture Data						

INSTRUCTIONS

1. ORIGINATING ACTIVITY: Enter the name and address of the contractor, subcontractor, grantee, Department of Defense activity or other organization (*corporate author*) issuing the report.

2a. REPORT SECURITY CLASSIFICATION: Enter the overall security classification of the report. Indicate whether "Restricted Data" is included. Marking is to be in accordance with appropriate security regulations.

2b. GROUP: Automatic downgrading is specified in DoD Directive 5200.10 and Armed Forces Industrial Manual. Enter the group number. Also, when applicable, show that optional markings have been used for Group 3 and Group 4 as authorized.

3. REPORT TITLE: Enter the complete report title in all capital letters. Titles in all cases should be unclassified. If a meaningful title cannot be selected without classification, show title classification in all capitals in parenthesis immediately following the title.

4. DESCRIPTIVE NOTES: If appropriate, enter the type of report, e.g., interim, progress, summary, annual, or final. Give the inclusive dates when a specific reporting period is covered.

5. AUTHOR(S): Enter the name(s) of author(s) as shown on or in the report. Enter last name, first name, middle initial. If military, show rank and branch of service. The name of the principal author is an absolute minimum requirement.

6. REPORT DATE: Enter the date of the report as day, month, year; or month, year. If more than one date appears on the report, use date of publication.

7a. TOTAL NUMBER OF PAGES: The total page count should follow normal pagination procedures, i.e., enter the number of pages containing information.

7b. NUMBER OF REFERENCES: Enter the total number of references cited in the report.

8a. CONTRACT OR GRANT NUMBER: If appropriate, enter the applicable number of the contract or grant under which the report was written.

8b, 8c, & 8d. PROJECT NUMBER: Enter the appropriate military department identification, such as project number, subproject number, system numbers, task number, etc.

9a. ORIGINATOR'S REPORT NUMBER(S): Enter the official report number by which the document will be identified and controlled by the originating activity. This number must be unique to this report.

9b. OTHER REPORT NUMBER(S): If the report has been assigned any other report numbers (*either by the originator or by the sponsor*), also enter this number(s).

10. AVAILABILITY/LIMITATION NOTICES: Enter any limitations on further dissemination of the report, other than those

imposed by security classification, using standard statements such as:

- (1) "Qualified requesters may obtain copies of this report from DDC."
- (2) "Foreign announcement and dissemination of this report by DDC is not authorized."
- (3) "U. S. Government agencies may obtain copies of this report directly from DDC. Other qualified DDC users shall request through _____."
- (4) "U. S. military agencies may obtain copies of this report directly from DDC. Other qualified users shall request through _____."
- (5) "All distribution of this report is controlled. Qualified DDC users shall request through _____."

If the report has been furnished to the Office of Technical Services, Department of Commerce, for sale to the public, indicate this fact and enter the price, if known.

11. SUPPLEMENTARY NOTES: Use for additional explanatory notes.

12. SPONSORING MILITARY ACTIVITY: Enter the name of the departmental project office or laboratory sponsoring (*paying for*) the research and development. Include address.

13. ABSTRACT: Enter an abstract giving a brief and factual summary of the document indicative of the report, even though it may also appear elsewhere in the body of the technical report. If additional space is required, a continuation sheet shall be attached.

It is highly desirable that the abstract of classified reports be unclassified. Each paragraph of the abstract shall end with an indication of the military security classification of the information in the paragraph, represented as (TS), (S), (C), or (U).

There is no limitation on the length of the abstract. However, the suggested length is from 150 to 225 words.

14. KEY WORDS: Key words are technically meaningful terms or short phrases that characterize a report and may be used as index entries for cataloging the report. Key words must be selected so that no security classification is required. Identifiers, such as equipment model designation, trade name, military project code name, geographic location, may be used as key words but will be followed by an indication of technical context. The assignment of links, rules, and weights is optional.