

AD-787 518

CONCEPTUAL COMBAT FOOTWEAR STUDY

J. L. MacDonald, et al

IIT Research Institute

Prepared for:

Army Natick Laboratories

April 1974

DISTRIBUTED BY:

**NTIS**

National Technical Information Service  
U. S. DEPARTMENT OF COMMERCE  
5285 Port Royal Road, Springfield Va. 22151

## UNCLASSIFIED

SECURITY CLASSIFICATION OF THIS PAGE (When Data Entered)

REPORT DOCUMENTATION PAGE		READ INSTRUCTIONS BEFORE COMPLETING FORM
1. REPORT NUMBER 75-9-CEML (CPLSEL-125)	2. GOVT ACCESSION NO.	3. RECIPIENT'S CATALOG NUMBER <b>AD-787518</b>
4. TITLE (and Subtitle) CONCEPTUAL COMBAT FOOTWEAR STUDY		5. TYPE OF REPORT & PERIOD COVERED Final Report
7. AUTHOR(s) J. L. MacDonald and E. Swider		6. PERFORMING ORG. REPORT NUMBER IITRI Project No. E6267
9. PERFORMING ORGANIZATION NAME AND ADDRESS IIT Research Institute 10 West 35th Street Chicago, Illinois 60616		8. CONTRACT OR GRANT NUMBER(s) DAAG17-73-C-0147
11. CONTROLLING OFFICE NAME AND ADDRESS U. S. Army Natick Laboratories Kansas Street Natick, Massachusetts 01760		10. PROGRAM ELEMENT, PROJECT, TASK AREA & WORK UNIT NUMBERS 6.2 1J662713DJ40 01.013
14. MONITORING AGENCY NAME & ADDRESS (if different from Controlling Office)		12. REPORT DATE April 1974
		13. NUMBER OF PAGES
		15. SECURITY CLASS. (of this report) Unclassified
		15a. DECLASSIFICATION/DOWNGRADING SCHEDULE
16. DISTRIBUTION STATEMENT (of this Report) Approved for public release; distribution unlimited.		
17. DISTRIBUTION STATEMENT (of the abstract entered in Block 20, if different from Report)		
18. SUPPLEMENTARY NOTES Reproduced by NATIONAL TECHNICAL INFORMATION SERVICE U S Department of Commerce Springfield VA 22151		
19. KEY WORDS (Continue on reverse side if necessary and identify by block number) See reverse side.		
20. ABSTRACT (Continue on reverse side if necessary and identify by block number.) A series of footwear uppers and outsole concepts are presented to provide expedient donning and doffing and aid in improving traction effectiveness for the foot soldier. Manufacturing processes and material use relative to the concepts are studied and prototype models constructed which indicate compatibility with production requirements and utilization. Three concepts were then selected and final design versions (continued on reverse side)		

DD FORM 1473

JAN 73

EDITION OF 1 NOV 65 IS OBSOLETE

UNCLASSIFIED

SECURITY CLASSIFICATION OF THIS PAGE (When Data Entered)

## UNCLASSIFIED

SECURITY CLASSIFICATION OF THIS PAGE(When Data Entered)

KEY WORDS	LINK A		LINK B		LINK C	
	Role	Wt.	Role	Wt.	Role	Wt.
DESIGN		8		8		8
DEVELOPMENT		8		8		8
FOOTWEAR		9				9
BOOTS (FOOTWEAR)		9				9
COMBAT FOOTWEAR		9				9
WEAR		4				
WEAR RESISTANCE		4				
CONCEPTS (FOOTWEAR)				9		
QUICK-CLOSURE SYSTEM				9		
DONNING				4		
DOFFING				4		
FIELD CONDITIONS				4		4
TRACTION AIDS						9
TRACTION DEVICES						9
TRACTION SYSTEM						9
OUTSOLE DESIGN						9
ENVIRONMENTAL CONDITIONS						4
TERRAIN TESTS						4

20. Abstract (continued)  
 conceived and constructed. These models incorporate one version  
 of a quick closure upper with three different versions of traction  
 aided molded outsoles.

ia

UNCLASSIFIED

SECURITY CLASSIFICATION OF THIS PAGE(When Data Entered)

Approved for public release;  
distribution unlimited.

AD

TECHNICAL REPORT

75-9-CEML

CONCEPTUAL COMBAT FOOTWEAR STUDY

by

J. L. MacDonald

and

E. Swider

IIT Research Institute  
10 West 35th Street  
Chicago, Illinois 60616

Contract No. DAAG17-73-C-0147  
IITRI Project No. E6267

Project Reference:  
LJ662713DJ40

Series:  
CPLSEL-125

April 1974

Clothing and Personal Life Support Equipment Laboratory  
U. S. ARMY NATICK LABORATORIES  
Natick, Massachusetts 01760

*il*

## FOREWORD

During the last three decades, the improvement in military footwear has been primarily for the purpose of comfort, durability, wear, health and blast protection. This effort has required the development and use of new materials and manufacturing processes. The result of the effort has enabled the configuration of outsole shapes through molding, thereby eliminating the welting process, and providing a significantly better outsole to upper bond. Another significant advance is reflected in the design of the tropical boot with improved ventilation to combat the incidence of foot fungus. The cold-weather boot, the blast resistant boot and the spike resistant boot are also evidence of improved footwear for special purpose use.

This report describes a program of work that has been conducted to evolve footwear concepts with improved closure and traction characteristics. The designs which were evolved are based upon an empirical approach using both conventional and recently evolved materials, subjective experience and laboratory model behavior for information. The design concepts selected herein are intended to increase the wearer's ability to attain rapid donning and doffing capabilities and to aid in foot locomotion over a prescribed variety of environmental conditioned terrains.

The work was performed during the 12-month period, 30 March 73 to 1 April 74, under the guidance of Project Officer, Joseph E. Assaf, U. S. Army Natick Laboratories and covers conceptual footwear studies of quick-closure systems and traction aids and fabrication of prototype footwear. The work was performed by IIT Research Institute, Chicago, Illinois, under Project Reference LJ662713DJ40 through Contract No. DAAG17-73-C-0147.

The Project Officer wishes to acknowledge the valued suggestions of Dr. Malcolm C. Henry, Chief, Chemical Products Research and Engineering Division, and the aid and guidance of Mr. Douglas S. Swain, Footwear Technologist at NLABS relative to design considerations.

## TABLE OF CONTENTS

	<u>Page</u>
1. INTRODUCTION.....	1
2. DESIGN CRITERIA.....	1
A. Quick-Closure System.....	2
B. Traction System and Outsole Design.....	2
3. LITERATURE AND PATENT SEARCH.....	3
4. CONCEPT DESIGN.....	5
A. Quick-Closure Concepts.....	5
(1) Hook and Loop Concepts.....	6
a. Mil-Quick A.....	6
b. Mil-Quick B.....	9
c. Mil-Quick C.....	9
(2) Zipper Concept.....	9
a. Zip-Wrap.....	13
b. Zip-Up.....	17
(3) Buckle-Up Concept.....	17
a. Buckle-Up A.....	17
b. Buckle-Up B and C.....	18
(4) Options.....	18
a. Replaceable Strap.....	18
b. Alternative Fastening.....	23
B. Traction Concepts.....	23
(1) Hard Terrain Surface Concepts.....	25
a. Flexible Carrier for Hobs or Cleats..	25
b. Traction Pad.....	31
<u>1</u> Traction Pad A.....	31
<u>2</u> Traction Pad B.....	31
c. Edge Grippers.....	31
<u>1</u> Saw Edge Sole and Heel Gripper....	34
<u>2</u> Saw Edge Heel Gripper.....	34
<u>3</u> Storable Sole Gripper.....	34

TABLE OF CONTENTS (cont'd)

	<u>Page</u>
d. Cleats and Spikes (Retractable and Convertible).....	39
<u>i</u> Cleats in Molded Pockets.....	40
<u>2</u> Foldable Spike Plates.....	40
<u>3</u> Retractable Grippers.....	40
<u>4</u> Retractable Heel Spikes.....	46
<u>5</u> Spikes with an Add-on Outsole.....	46
(2) Soft Terrain Surface Concepts.....	46
a. Bear Paw.....	50
b. Inflatable Overshoe.....	52
5. FABRICATION STUDIES AND MATERIAL INVESTIGATIONS...	52
A. Molding Outsoles.....	52
B. Upper Manufacture .....	54
C. Traction Aid Manufacture.....	54
D. Closure Manufacture.....	55
E. Hook and Loop Material Evaluation .....	57
6. FINAL MODELS.....	60
A. Concept No. 1.....	67
(1) Manufacture and Assembly.....	71
B. Concept No. 2 .....	73
(1) Manufacture and Assembly.....	76
C. Concept No. 3.....	76
(1) Manufacture and Assembly.....	79
7. CONCLUSIONS AND RECOMMENDATIONS.....	79
APPENDIX A LIST OF PATENTS.....	84
APPENDIX B LIST OF REFERENCES.....	87
APPENDIX C LIST OF SUPPLIERS.....	90

## LIST OF ILLUSTRATIONS

<u>Figure No.</u>		<u>Page</u>
1	Mil-Quick A (Drawing).....	7
2	Mil-Quick A (Photograph).....	8
3	Mil-Quick B (Drawing).....	10
4	Mil-Quick B (Photograph).....	11
5	Mil-Quick C (Photograph).....	12
6	Zip-Wrap (Drawing).....	14
7	Zip-Wrap (Photograph).....	15
8	Zip-Up (Photograph).....	16
9	Buckle-Up A (Photograph).....	19
10	Buckle-Up B (Photograph).....	20
11	Buckle-Up C (Photograph).....	21
12	Replaceable Strap (Photograph).....	22
13	Alternative Fastenings (Photograph).....	24
14	Along-the-Foot Traction Device (Drawing).....	26
15	Along-the-Foot with Alternate Fastener (Drawing).....	27
16	Across-the-Foot Traction Device (Drawing) ..	28
17	Along-the-Foot Traction Device (Photograph)...	29
18	Across-the-Foot Traction Device (Photograph)..	30
19	Traction Pad A (Drawing).....	32
20	Traction Pad B (Drawing).....	33
21	Saw Edge Sole and Heel Gripper A (Drawing)....	35
22	Saw Edge Sole and Heel Gripper B (Drawing)....	36
23	Saw Edge Heel Gripper (Drawing).....	37
24	Storable Sole Gripper (Drawing).....	38
25	Cleats in Molded Pockets (Drawing).....	41
26	Model of Cleats in Molded Pockets (Photograph)	42
27	Folded Spike Plate (Drawing).....	43
28	Wilson Concept (Photograph).....	44
29	Retractable Gripper A (Drawing).....	45
30	Retractable Gripper B (Drawing).....	47
31	Retractable Heel Spikes (Drawing).....	48
32	Spikes with Add-on Outsole (Drawing).....	49



LIST OF ILLUSTRATIONS (cont'd)

<u>Figure No.</u>		<u>Page</u>
33	Bear Paw (Drawing).....	51
34	Inflatable Overshoe (Drawing).....	53
35	Gripper with Hardweld on Contact Surface (Drawing).....	56
36	Test Fixture for Hook and Loop Material (Photograph).....	58
37	Close-Up of Anvil on Test Fixture, Material in Closed Position (Photograph).....	59
38	Peel Force vs. Wear for 2" Wide Hook and Loop Fastener - Dry Condition (Drawing).....	62
39	Peel Force vs. Wear for 2" Wide Hook and Loop Fastener - Wet Condition (Drawing).....	63
40	Various Hook and Loop Tape Samples Painted with a Mud Slurry - A and B (Photograph).....	64
41	Peel Force vs. Wear for 1" Wide Hook and Loop Fastener - Dry Condition (Drawing).....	66
42	Along-the-Foot Concept No. 1 (Photograph)....	68
43	Along-the-Foot Assembly Concept No. 1 (Drawing).....	69
44	Position of Integral Components Concept No. 1 (Photograph).....	72
45	Cleats in Molded Pockets Concept No. 2 (Drawing).....	74
46	Cleats in Molded Pockets Concept No. 2 (Photograph).....	75
47	Position of Integral Components Concept No. 2 (Photograph).....	77
48	Retractable Gripper Outsole for Size 9R U. S. MIL-5 Last Concept No. 3 (Drawing) ....	78
49	Retractable Gripper Outsole Concept No. 3 (Photograph).....	80
50	Position of Integral Components Concept No. 3 (Photograph).....	81
<u>Table No.</u>		
1	Hook and Loop Samples.....	61
2	Experimental Data for 2" Wide Hook and Loop Fastener-Muddy Condition.....	65
3	Concept No. 1.....	71

## ABSTRACT

A series of footwear uppers and outsole concepts are presented to provide expedient donning and doffing and aid in improving traction effectiveness for the foot soldier.

Manufacturing processes and material use relative to the concepts are studied and prototype models constructed which indicate compatibility with production requirements and utilization. Three concepts were then selected and final design versions conceived and constructed. These models incorporate one version of a quick-closure upper with three different versions of traction aided molded outsoles.

## CONCEPTUAL COMBAT FOOTWEAR STUDY

### 1. INTRODUCTION

This research program is concerned with the development of conceptual designs to evolve quick closure uppers and traction devices for U. S. Army Leather Combat Boots. To best illustrate the concepts, the program has furnished samples of material, and material combination in a series of preprototype models for purposes of evaluation to aid in the design and selection of final prototypes. The sponsoring agency, U. S. Army Natick Laboratories (NLABS), then selected final prototypes which have been manufactured and delivered in accordance with the contract DAAG17-73-C-0147-P00002.

This document is the final report on that program. The report contains, in summary form, the supportive effort which was required to establish a judgment basis from which the concepts were evolved. The report presents the preliminary concepts, discusses the NLABS selected versions, and describes in detail the design and manufacture of the three delivered prototype models. These models are discussed in adequate detail to permit manufacture by program independent sources. Appendices are included for specific information on literature sources and material vendors.

The report composition roughly parallels the method of approach used on the program which consists of:

- Establishment of design criteria
- Literature and patent search
- Concept design
- Manufacture and delivery of final prototypes

The work reported herein is the result of the combined efforts of a military-industrial team formed from personnel of NLABS, Ro-Search, IITRI and selected material vendors.

### 2. DESIGN CRITERIA

The objective of the program is to produce footwear concepts for quick closure uppers to permit easy donning and doffing and traction aiding devices to permit operating efficiency on many types of surfaces.

Certain design requirements were established in the Request for Procurement and required by the government for use on the program.

A. Quick-Closure System

- A closure system is required that will permit easy opening and closing and be capable of quick and easy donning and doffing under field conditions both when wearer is barehanded and while wearing handwear. Donning or doffing shall be accomplished within 10 seconds.
- Use of combat footwear leather and gusset leather in accordance with Military Specifications MIL-L-3122, dated 5 August 1971, Treatment A, and MIL-L-10867D, dated 17 December 1970, Treatment A.
- Upper footwear systems to be compatible with outsole traction systems.
- The foot section of the footwear shall be built around the U. S. Army MIL-V Last, and the finished system shall result in proper fit, anchoring the heel of the foot to the boot to keep slippage at the heel to a minimum while walking.
- Maximize water resistance.
- Maintain M-1 Standard Combat Boot comfort and motor activity limits.
- Consider good style and appearance.
- Maintain reliability of fastener to wear, snagging, and inadvertant opening.

B. Traction System and Outsole Design

- Increase traction on ice, snow, sand, rocks, and mud with minimum accumulation in tread pattern (Modified to emphasize ice and hard packed snow).
- Compatible with upper design.
- Consider both off-boot and integral with outsole design.
- Dual mode design for storage and use.
- Compatible with vehicle foot pedals.
- Maintain load distribution over plantar surface of foot.
- No compromise to water resistance.
- Consider sole flexure and flexure point.
- Consider problems of secondary fragments and spike resistance.

### 3. LITERATURE AND PATENT SEARCH

A literature and patent search was included as part of the program effort. The purpose of the search was to obtain information on footwear designs, design rationale, materials and manufacturing processes as applied to this program. The search was limited to a ten-year period from 1963. This search complements a search to 1950 conducted for an IITRI industrial client in 1969. NLABS has an authorized copy of the bibliography resulting from that search.

The patent search was conducted from the source document "U. S. Department of Commerce, Patent Office, Manual of Classification," which permitted a selection by title and abstract on the basis of class and subclass listing a total of 96 patents. These patents were ordered and reviewed in detail. The titles of these patents are included in Appendix A with an asterisk adjacent to the ones which are felt to be the most applicable. The U. S. Patent lists were searched for:

#### Class 36 Boots, Shoes and Leggings

##### Sub-classes

2.5	Boots and Shoes
7.7	Antislipping Sandals, Heelless, Overshoes
7.6	Sandals Antislipping
45	Uppers
50	Closures
51	Elastic
52	Buttonhole pieces
53	Slit stays
54	Tongue pieces
59	Antislipping Devices
61	Disengaging
62	Detachable
64	Clamping
65	Screw
66	Attached Fasteners
67	Calks

Copies of all patents listed in the appendix are available to NLABS upon request.

The literature search employed key word selection from annotated reference lists, contemporary publication files, manufacturers' reference data, and personal information from program staff, consultants, and vendors. Annotated source documents were searched on a Computer Search Center program, NTIS (National Technical Information Service), U. S. Department of Commerce.

Source information was interrogated by key word category for:

- Adhesives
- Footwear manufacturing
- Rubber, molded
- Traction Devices
- Boots and Shoe Closures
- Soles and Sole patterns (Vibram, Montagnablock, Rocciablock, Dufour, or Defour and Melangit)
- Vitale Bramani

A total of approximately 100 publications were reviewed for the program, a list of the 15 most informative is noted in Appendix B. Copies are available to NLABS upon request.

Other sources reviewed by individuals were:

Libraries:

The John Crerar Library  
Chicago Public Library  
Skokie Public Library

Finally, sources were searched including:

Sporting Goods Manufacturers' Catalogs  
Sporting Magazines  
Footwear Manufacturers' Catalogs  
Footwear Hardware Catalogs

Shoe hardware and material manufacturers have also been contacted to explore alternative means of quickly closing the uppers. Letters of inquiry were mailed to fifteen manufacturers inquiring about various production buckles, hooks, loops, eyelets, snaps, and latches.

A variety of samples and catalogs have been received. Some of the most promising and appropriate hardware samples were incorporated into boot closures and were presented to NLABS upon completion.

In summarizing the Patent and Literature search, the authors feel that the original objectives were attained. Information was obtained for design approaches and candidate materials. A variety of samples were also received. Some of the most promising were incorporated into boot closures and were presented to NLABS for consideration. It is noteworthy also from our examination of the literature, that the only technical base for outsole design relative to a traction effect pertains to sliding surface friction response. Such a base is not totally adequate for military use which must consider an all-terrain environment.

The influence of the outsole tread pattern on deformable surfaces is primarily determined on a subjective basis by both military and civilian users. Civilian application of outsole patterns tend to duplicate existing patterns such as the Vibram pattern that has strong popular appeal due to testimonials by expert mountain climbers. Molded patterns for both cemented and directly molded outsoles go so far as to duplicate clearance allowances for automatic nailing equipment when nails are not used in the attachment process.

#### 4. CONCEPT DESIGN

The development of a quick-closure upper and outsole traction aid was accomplished in an iterative process. This process consisted of graphically presenting, through sketches and drawings, a series of concepts for both subsystems (closures and traction aids) and then constructing initial models. The models varied in substance from crude to relatively sophisticated models dependent upon the availability of materials, equipment, and production technology.

Selection was then made of the most promising, and additional models were constructed from more detailed instructions and drawings. After the third generation of preliminary models, a final selection was made for the deliverable contract line items (CLIN).

##### A. Quick-Closure Concepts

Three quick-closure concepts are described in this section. The concepts include closures which incorporate hook and loop material, zippers, and multiple belts and buckles. Further, a solution is presented to replace worn belts or straps and for an alternate or emergency closure fastening.

(1) Hook and Loop Concept

The hook and loop concept employs a two-piece material which is attached to opposite sides of a closure and pressed together in intimate contact. Small hooks 1/32 to 1/16 of an inch high on one piece are entangled into a loose loop or felt-like material on the other piece during the pressing action. Resistive forces are generated when the materials are being separated due to interference between the hooks and loops.

The desirable features of the hook and loop fastener concept include:

- Easily variable adjustment to compensate for lower foot size difference and individual needs and preference of lower calf fit. (Paratrooper use)
- Very rapid donning and doffing.
- Good style and appearance. (Troop acceptance)

The undesirable features are:

- Strap replacement is a depot maintenance function. (Later models consider this problem)
- Long term behavior in the field is unknown for hook and loop material.
- Peel strength requirements for hook and loop designs have not been established. Tests indicate the 1 psi to 2 psi peel available may not be enough to resist military environment. Conversely, peel strength may be adequate. Field evaluation is required to determine potential service life.
- Hook and loop material creates a noise when unfastening, and one can postulate a tactical situation where the noise may be detrimental.

a. Mil-Quick A

This design eliminates regular eyelets and shoe laces and includes the following: (See Figure 1 and 2)

- Wide leather top cuff lined with hook and loop fastener for incremental adjustment
- Instep strap for incremental adjustment
- Vamp strap for one-time adjustment

The bellows tongue eliminates the use of eyelets but requires the strap termination and the strap loop to be sewn on the upper.



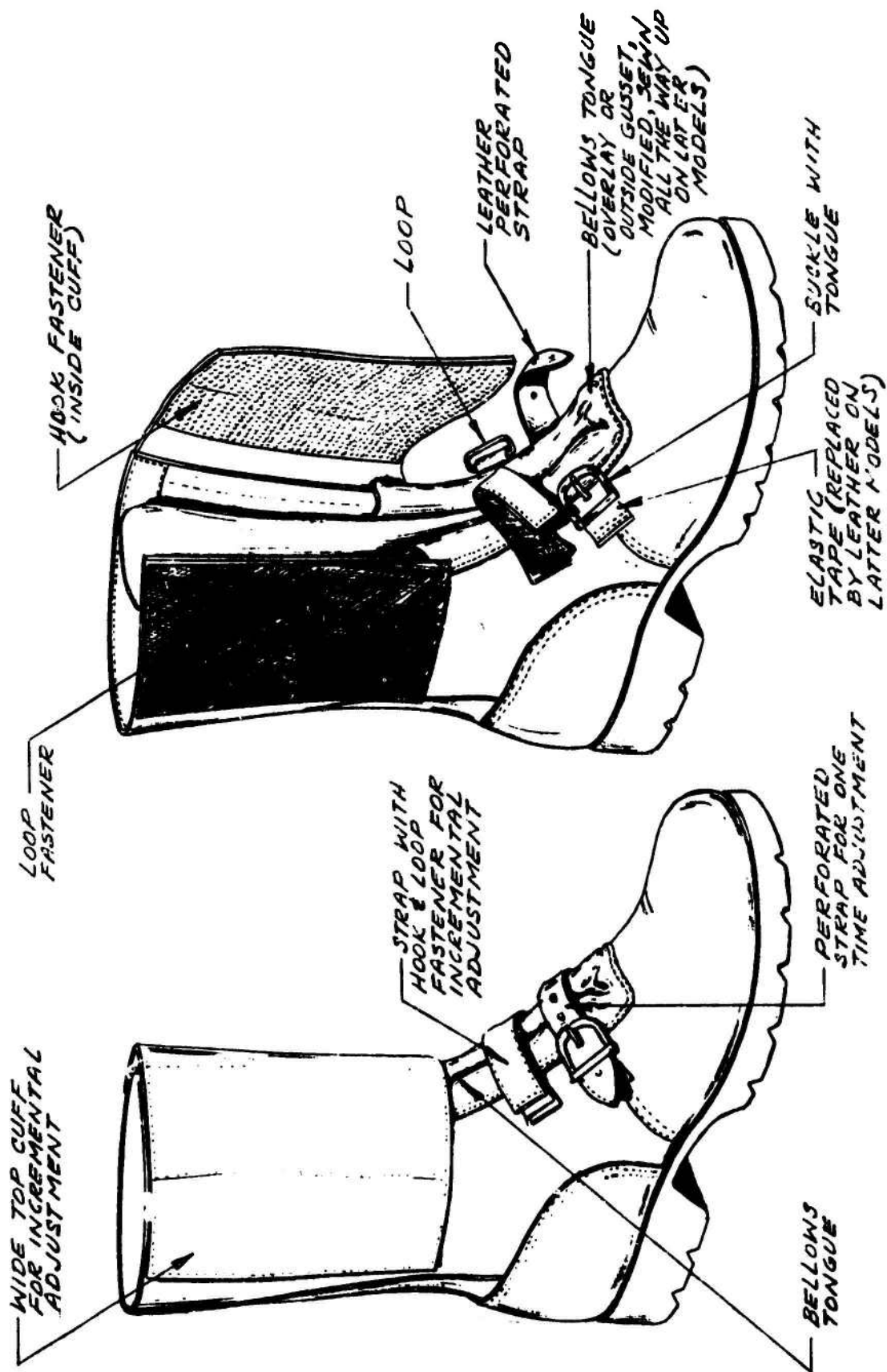

MIL-QUICK A  
 DRAWING NO. F6267-B-001  
 11TRI JULY 1973  
 FIGURE 1



Figure 2 MIL-QUICK A

Two strap designs are available. One is to lay the strap directly over the instep and secure the end with a hook and loop fastener, buckle, snap system, or other device. Such a design requires a fastener like the hook and loop to develop in single shear, the full resistive load to separation forces at the hook and loop interface. This design is not illustrated as a narrow strap, but the design would be similar to the cuff of Figure 1.

The other strap is a double-lay design threading through a metal strap loop which distributes the separation load between the layed and returned sections of strap. The strap thereby requires only one-half the shear force to be developed in the hook and loop material when compared to the single-lay design.

b. Mil-Quick B

This design reduces the regular eyelet and lace function. The basic design difference is in the tongue which is sewn conventionally as an inside gusset with a reversed edge. This design permits the installation of pierced eyelets at the gusset/upper edge without compromising water resistance.

The July prototype Mil-Quick B drawing number E6267-B-002, Figure 3 and 4 illustrate one version of this style. The two lower pair of eyelets are retained for installation of a short shoe lace. This lace is adjusted during the first donning to suit the individual's size and should not require adjustment for a long time if not for the life of the boot. The instep strap with hook material on the loose end is assembled by threading through an elongated eyelet and securing the loose end to a patch of pile material at the base of the strap.

c. Mil-Quick C

This is a minor variant of the previously described models. Mil-Quick C, Figure 5 embodies two elongated eyelets in addition to the wide cuff. The lower vamp strap can again be size-adjusted in an initial fitting, and thereafter can remain closed during subsequent donning and doffing.

(2) Zipper Concept

The design premise of the zipper concept is also to produce a closure compatible with the full range of calf sizes for each upper pattern. As the zipper is inherently a fixed size closure, this problem was circumvented by retaining the laces. The initial fitting is obtained by closing the zipper and then securing the laces for the

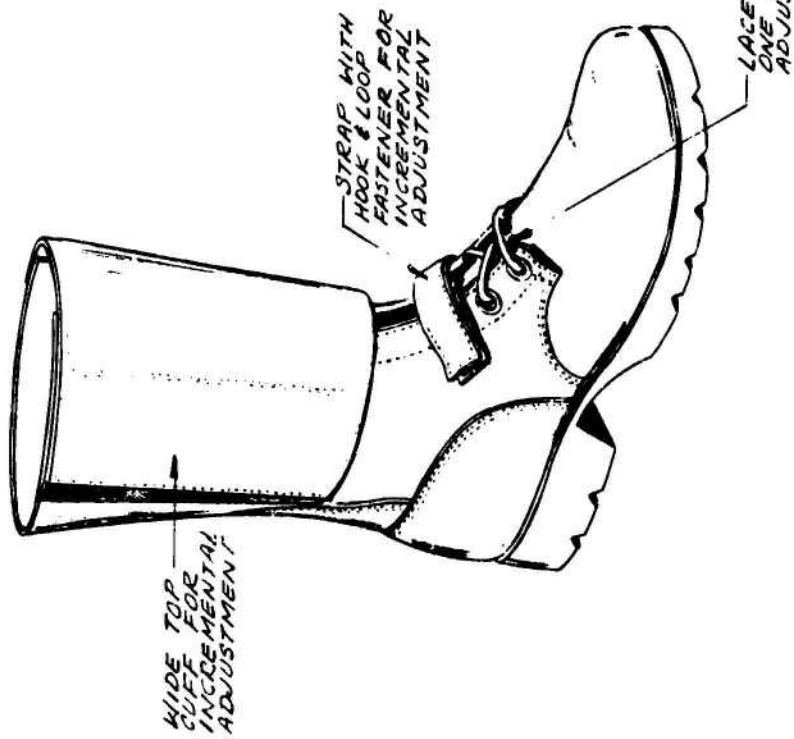
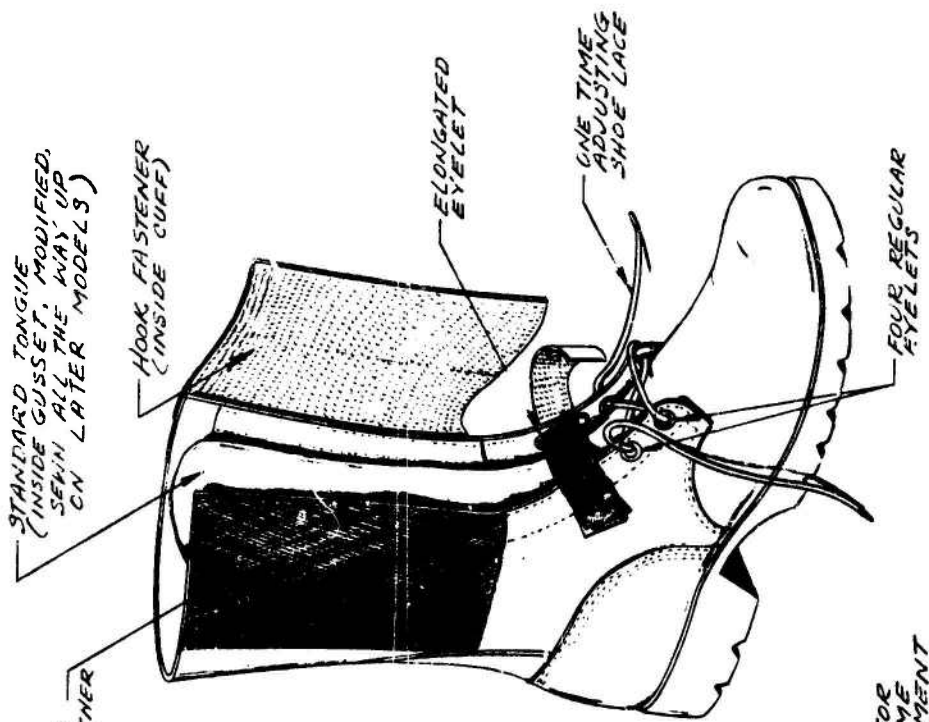

MIL-QUICK B  
DRAWING NO. 62267-B-002  
11/81 JULY 1973  
FIGURE 3



Figure 4 MIL-QUICK B



Figure 5 MIL-QUICK C

desired calf fit. Subsequent donning and doffing are then accomplished with the zipper.

The advantages of the zipper concept are:

- The most rapid donning and doffing concept after initial fitting.
- The "closer to standard" look may have better troop acceptance. (Many Army Standard and Corcoran Jump Boots have been modified with zippers by troops at their own expense.)

The disadvantages of the zipper concept are:

- Difficult to design without a stress (wear) concentration at the permanently closed end of the zipper.
- Poor water resistance.
- In the event of zipper failure in the open position, it is difficult to provide an acceptable secondary fastening for temporary use.
- Service life must be evaluated. Separation forces on the order of 100 pounds per linear inch seems to be adequate. Wear and tendency toward inadvertent opening should be determined.

a. Zip-Wrap

The Zip-Wrap design, Figures 6 and 7, provides several features to overcome the inherent problems related to zippers. A long zipper (12 inch) is inserted on the inside of the foot at the top of the vamp and progresses toward the rear of the leg in an upward spiral until the top of the zipper terminates at the top edge of the upper on the outside of the boot. The zipper is closed or opened in a single smooth motion.

Design variations are available to increase water resistance and reduce the possibility of catching material during closure. These designs essentially provide for covering of the zipper teeth with a shield material. On zippers which are sewn on the outside of the upper, the upper pattern is cut so the material butts together on the same line as the closed zipper teeth will form. On inside sewn closures, an extra piece of shield material is sewn to cover the inside of the boot portion of the zipper.

An optional elastic gore, Figure 8, is sewn on the inside of the boot over the lower 2 inches of the zipper termination to reduce stresses on the zipper when inserting the foot.

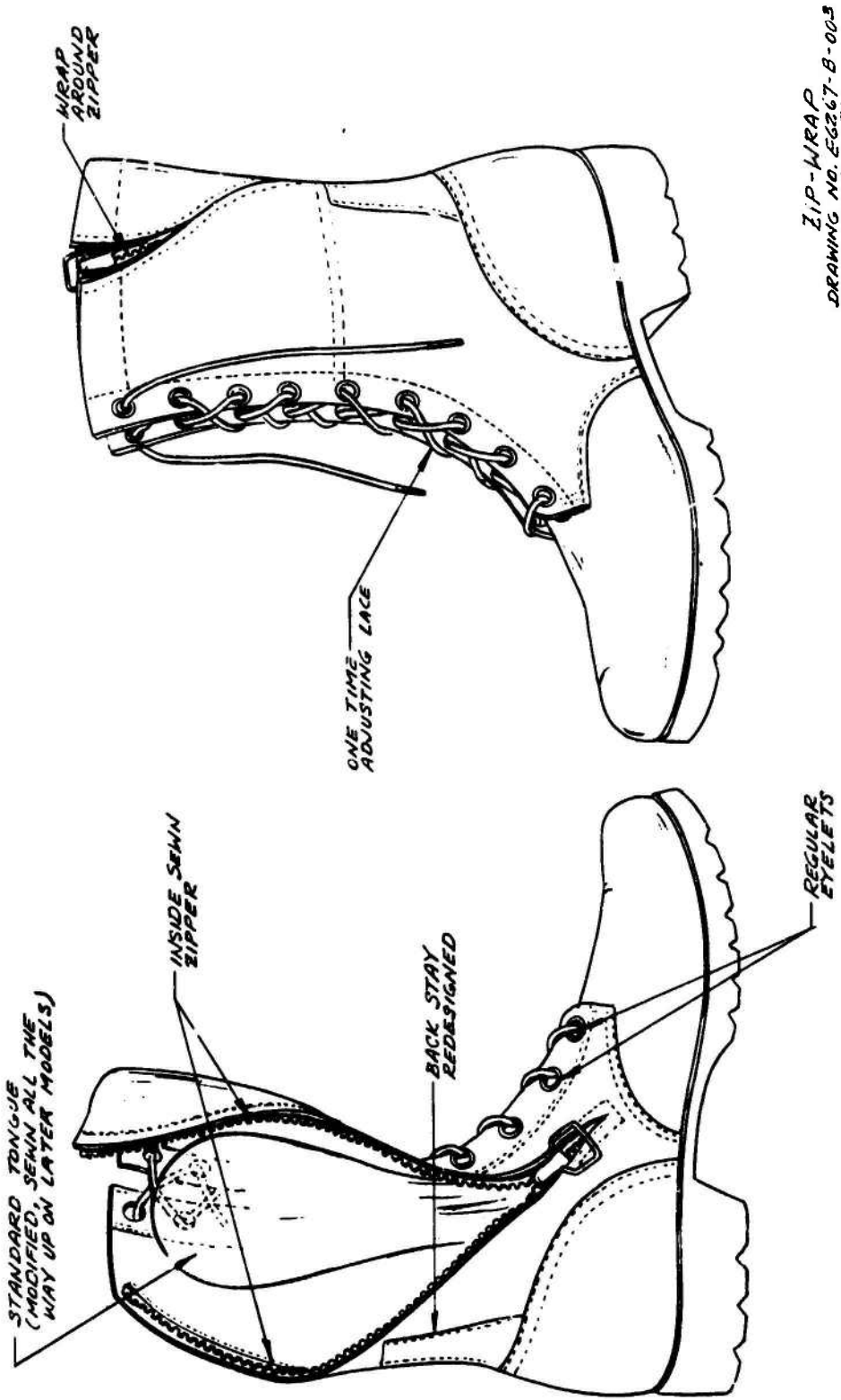

ZIP-WRAP  
 DRAWING NO. EG267-B-003  
 17121 JULY - 1973  
 FIGURE 6





Figure 7 ZIP-WRAP



Figure 8 ZIP-UP

## b. Zip-Up

The Zip-Up version, Figure 8, provides two short zippers installed on both sides of the quarter. The closed end of the zipper is installed low on the side in the center of the instep and proceeds in a straight line to the top of the upper, midway on the side of the calf. There is some possibility that a design can be evolved with a single side-opening zipper but the two-opening design should remain faster during donning and doffing due to the larger foot opening.

The previous section's discussion on zipper installation also pertains to this closure version.

## (3) Buckle-Up Concept

The Buckle-Up quick-closure is dependent upon the locking forces generated with a two-bar buckle and one-inch-wide cloth strap to resist opening of the upper. An array of four or five buckle-strap assemblies are positioned across the quarter opening from the top to the vamp end of the quarter replacing the normal nine-or ten-unit string of lace eyelets. As the buckle and strap termination are stitched to the outside of the upper, a bellows (outside gore) tongue variation can also be considered in place of the conventional (inside gore) tongue.

The advantages of the Buckle-Up concept are:

- Acceptable donning and doffing speed
- The multiple strap design permits a wide range of fit control
- System remains functional with some missing elements (Self-redundant)
- Many optional features are available for a specific design (Bellows gusset, alternate fastener system)

The disadvantages of the buckle concept are:

- Large number of elements may increase cost over other concepts
- Strength requirements for strap have not been established (For Buckle-Up B, see hook and loop comments)

## a. Buckle-Up A

The Buckle-Up A prototype considers, in addition to the above, the design problems of strap retention during donning and doffing and storage of the loose strap end after buckling.

The illustrated version, Figure 9, shows a pad of loop material (from hook and loop) with a thickness such that the combination of strap and pad must be forcibly threaded through the buckle bars for initial assembly. When the straps are loose, the oversized section is then prevented from unthreading unless a similar force, oriented to pass through the buckle bars is regenerated. To secure the strap, the loose end is captured by hand and retained by reversing the lay and positioning the loop material onto a pad of hook material. This pad is located adjacent to the sewn strap end making an assembly of the bottom strap over the top strap for the storage position.

b. Buckle-Up B and C

The Buckle-Up B and C prototypes are similar in appearance to Buckle-Up A but employ metal loops in the B version (inside gore) or elongated eyelets in the C version (outside gore) instead of the double-bar buckle, Figures 10 and 11. Boot closure is accomplished by threading a strap from one side of the boot, across the tongue gore opening through an opening fixed to the opposite quarter. The strap is then pulled tight, relayed across the opening and secured in a hook and loop material termination. This concept depends upon the hook and loop patch to generate resistive forces and could probably be included with the hook and loop material concepts.

(4) Options

Two options for use with the quick-closure systems are available if desired. Each option is concerned with models requiring narrow straps. The first option offers a replaceable strap, and the second provides a means for emergency fastening.

a. Replaceable Strap

Early models of the Buckle-Up had one end of the strap permanently stitched to the boot, and this may be a potential design deficiency. Experience with lace boots indicates that strap wear may occur before the useful life of the major components. Therefore, a provision has been made for a replaceable strap, Figure 12. This strap end design laps two sections of loop and pile such that the material is in double shear and resists load in excess of 20 pounds with a 3/4-inch x 1-inch patch. Preliminary tests indicate that a resistive load of this magnitude is adequate for this semi-permanent strap terminus.

Further, a design which depends upon special material for function, such as straps with pile or loop ends, should consider, in addition to useful life, the problems of



Figure 9 BUCKLE UP A



Figure 10 BUCKLE UP B



Figure 11 BUCKLE UP C



Figure 12 REPLACEABLE STRAP



logistics (supply) and the use of alternate systems. Supply problems can be circumvented through the use of the replaceable strap. The issuance of extra straps and the supply room or depot stocking as currently accomplished with laces should be adequate.

b. Alternative Fastening

In the event of strap loss and the failure of all resupply elements, an alternative system could be available that was not dependent upon hook and loop material. To some measure, the ingenuity of the user combined with usually available material like various adhesive and nonadhesive tapes, twine, wire, laces, vegetation, etc., can be expected to solve such a problem. However, the discrete installation of additional hardware (eyelets, hooks, loops, etc.) not employed in the primary fastening function can serve to support such alternative solutions by providing lace or tie points at the strap terminations employing hook and loop material. Figure 13 shows additional hardware which could be used with alternative systems.

B. Traction Concepts

The traction concepts which are presented in the following text represent design suggestions for overcoming the tactical environment encountered by foot soldiers in the field. The terrain surfaces and subsurfaces which have been considered are ice, hard-packed snow, mud, and sand. Traction effectiveness in high grass and boggy ground have also been considered.

The design of traction devices has been restricted to elements which can be manufactured integral with the sole or carried as an add-on device in other personal equipment. The criteria for being integral is self-storable on the footwear upper or in the outsole material. The program was not concerned with new material development intended to improve hard surface friction coupling between sole and terrain.

During the design process of the program, it became apparent that the wide disparity in physical properties of the considered terrain material obviated the possibility of producing a single traction device capable of operating effectively for all of the anticipated conditions.

Communication with NLABS' monitors, however, indicated NLABS' majority interest was in overcoming the ice and hard-packed snow terrain. Accordingly, the ensuing design concepts emphasize locomoting on ice and hard-packed snow

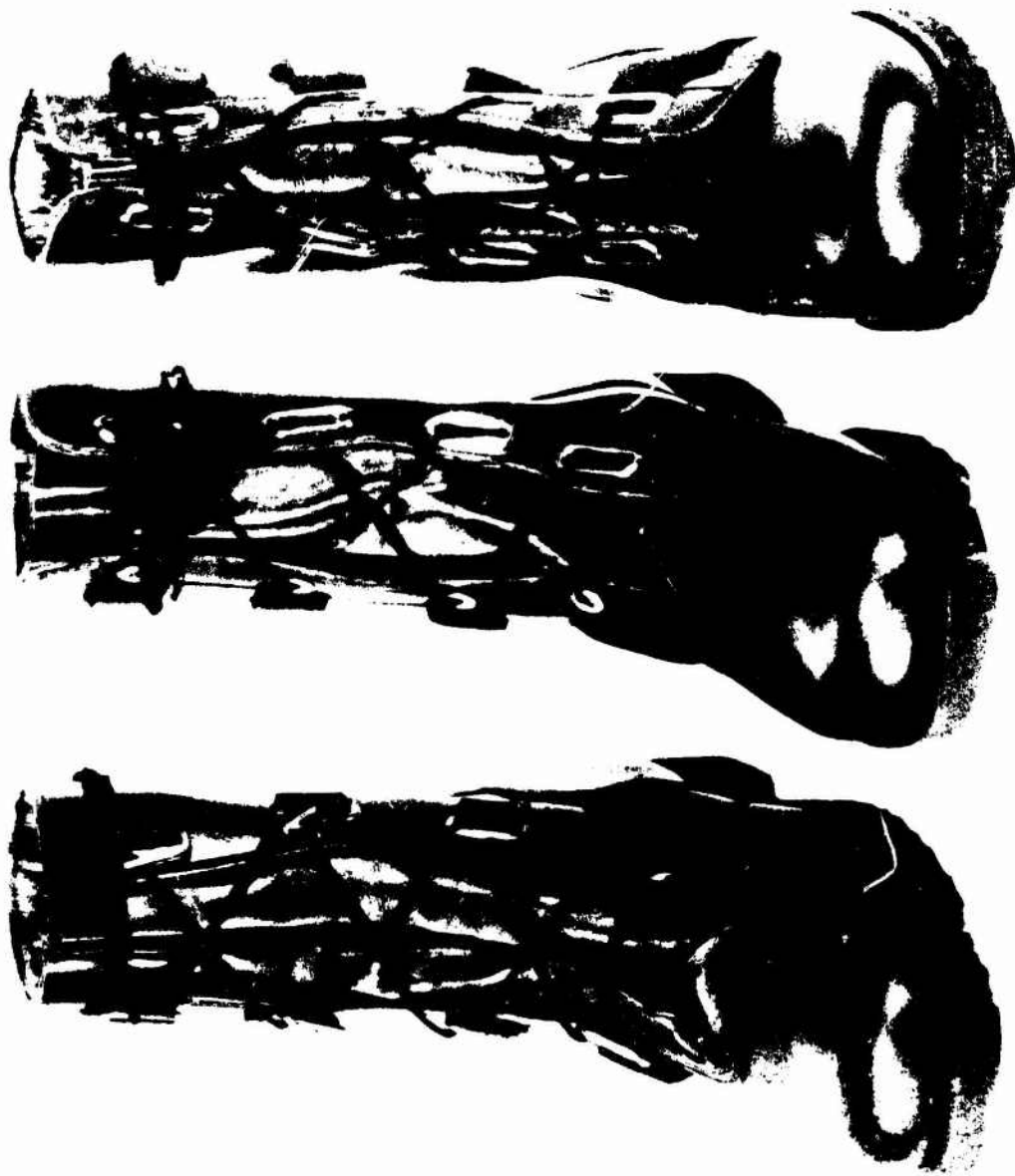

Figure 13 ALTERNATIVE FASTENINGS

with several candidate devices, while only two devices address the low strength terrain problem, (i.e., sand, soft snow, and boggy ground).

(1) Hard Terrain Surface Concepts

Locomotion on ice and hard-packed snow is aided primarily by the use of hard wear resistant points on surfaces which penetrate the terrain surface. Traction is then improved through an increased ability of the individual to transmit shear forces at the footwear/terrain surface interface. Several versions of this concept are presented in the following section. They include flexible carriers with attached points and surfaces, rigid point carriers, storable individual cleats and cleat or point arrays.

a. Flexible Carrier for Hobs or Cleats

A class of traction devices has been devised based upon a flexible carrier system. The carrier has the hard high-wear-resistant metal hobs or points attached which will improve traction. Interference points are generated when the unit pressure exerted by the hobs causes failure of the surface material in the bearing contact area. The surface of the carrier adjacent to the mating portion of the boot outsole is textured and interacts with the outsole pattern to reduce relative motion (slipping) at that interface.

Integrally molded carrier attachment points provided with hinged and quick-disconnect fasteners are illustrated to permit removal for long-term pack storage.

The on footwear storage is accomplished by disengaging one end of the carrier and laying it over the top of the instep/vamp area.

When the carrier is in the stored position, it is anticipated that wear will occur on the leather of the upper. To circumvent this wear, the relative motion between the carrier and upper leather will be absorbed by a protective pad of a wear resistant elastometric material such as rubber or plastic. The pad design is also expected to act as a carrier retainer in the stored position during locomotion.

Several versions are illustrated in the drawings of Figures 14, 15 and 16 while photographs, Figures 17 and 18, show models provided to NLABS for evaluation of the flexible-chain concept. The materials selected for these initial prototypes are readily available from stock. Future prototypes should, however, consider a more

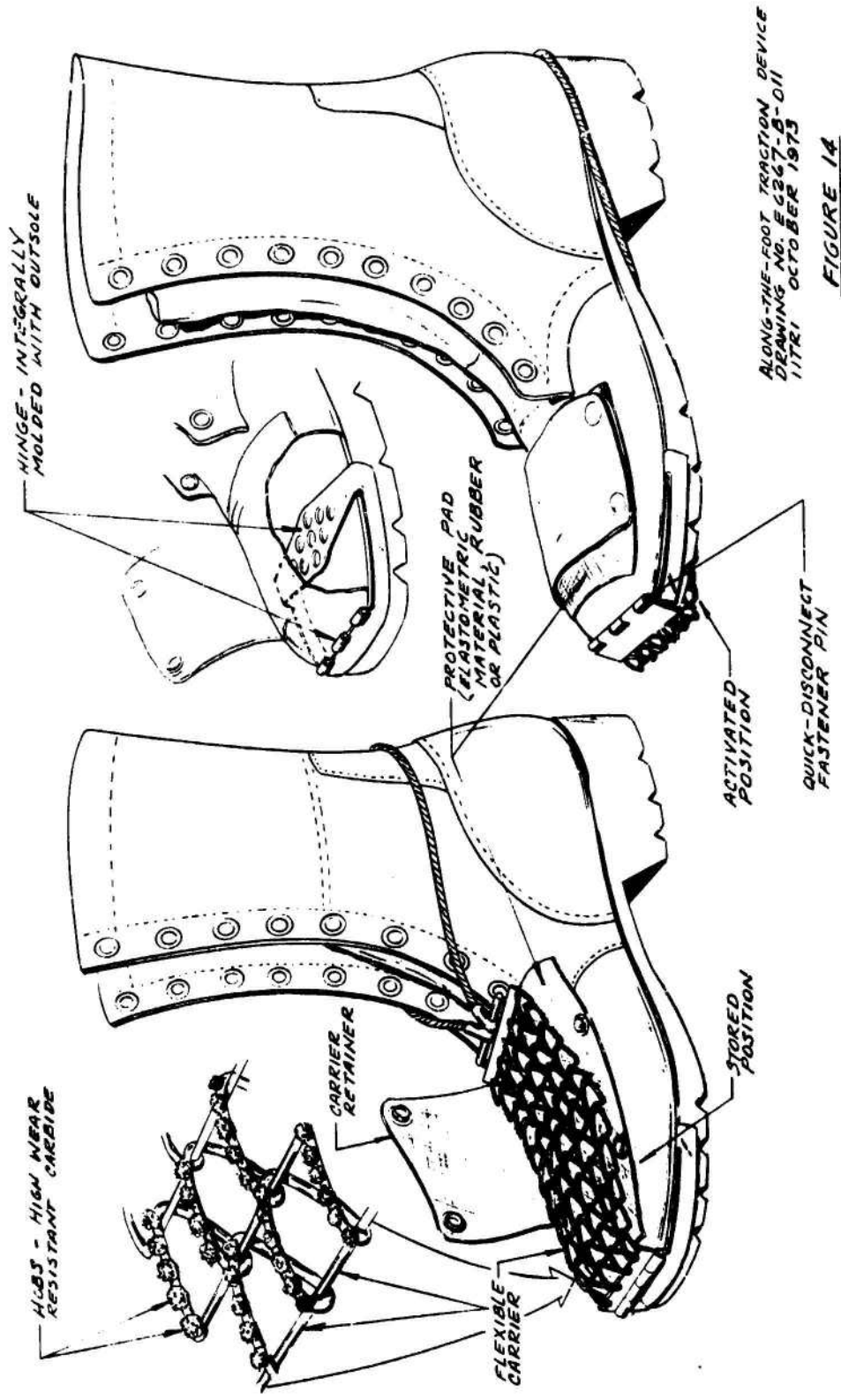

ALONG-THE-FOOT TRACTION DEVICE  
 DRAWING NO. E 4367 A-D11  
 11171 OCTOBER 1973

FIGURE 14

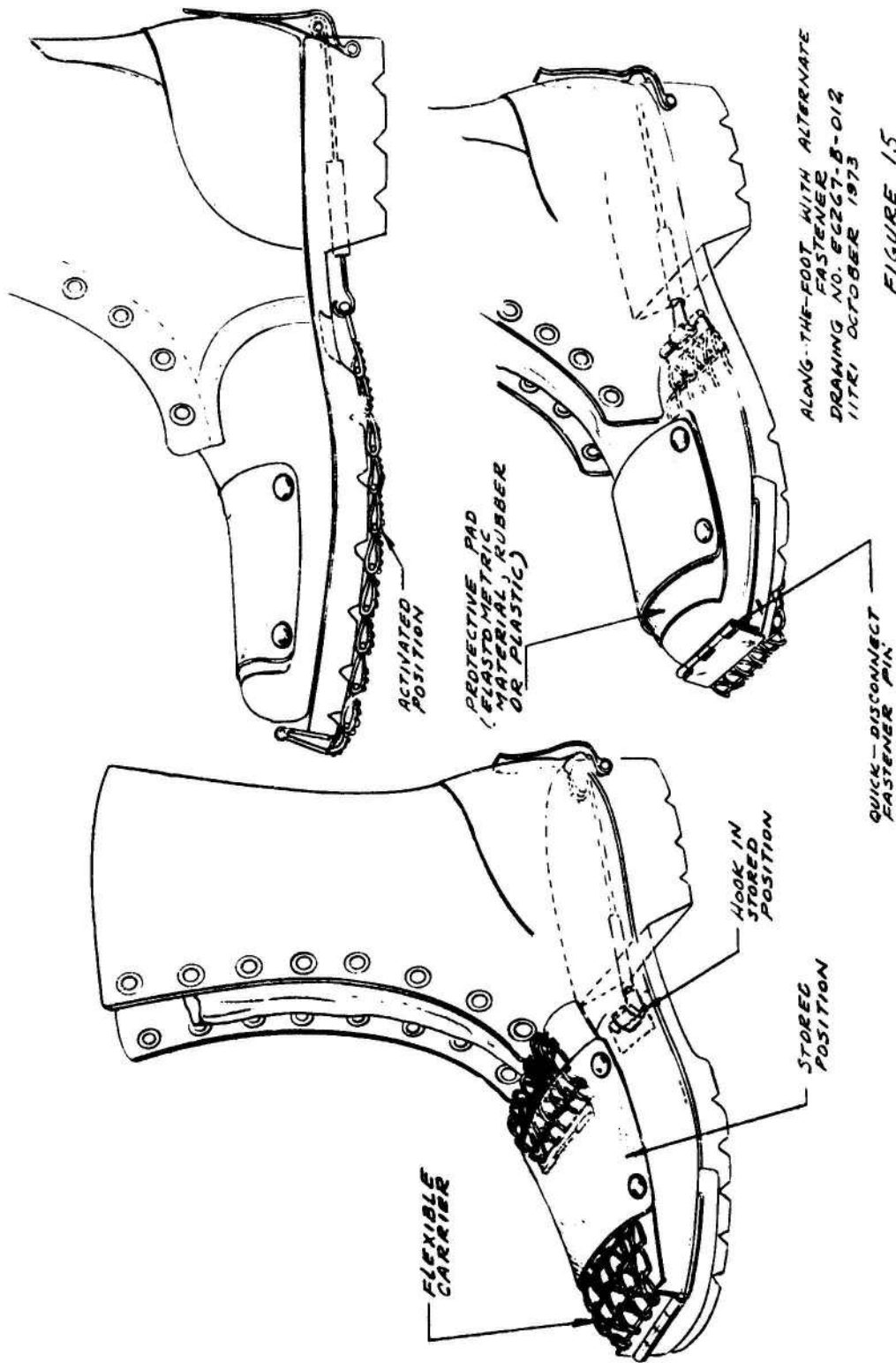

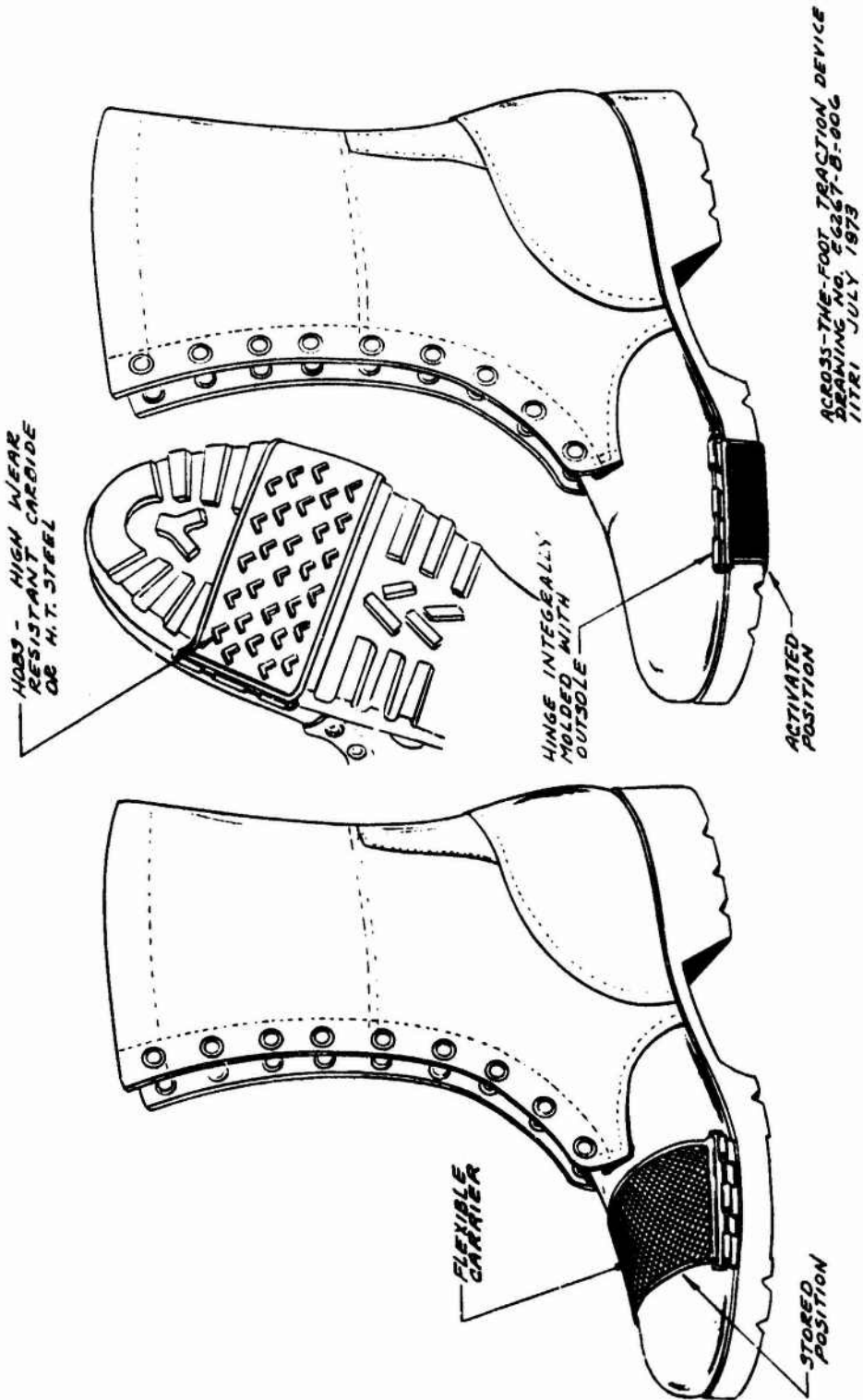

ACROSS-THE-FOOT TRACTION DEVICE  
 DRAWING NO. E 6267-B-006  
 11191 JULY 1973

FIGURE 16

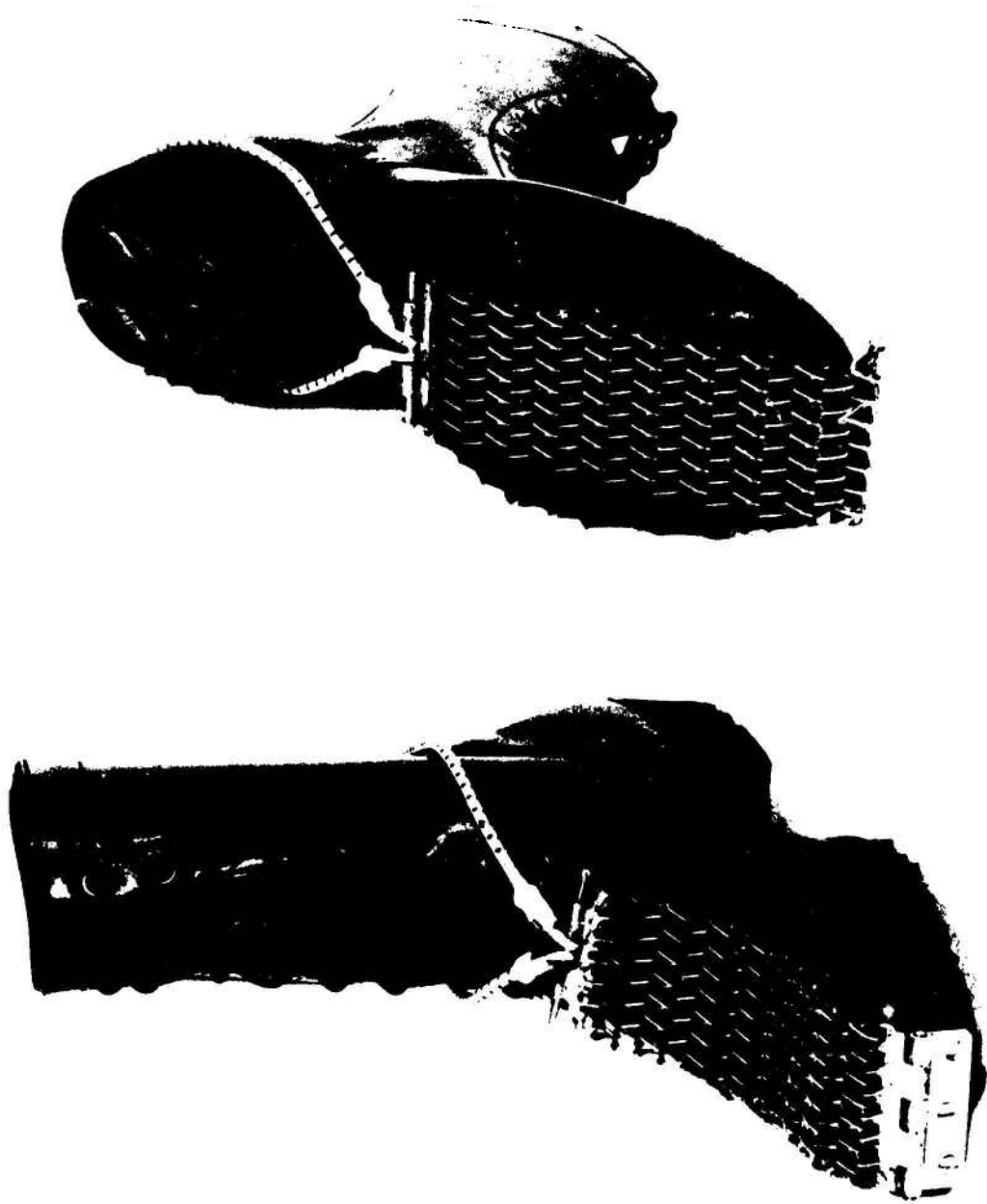

Figure 17 ALONG-THE-FOOT TRACTION DEVICE

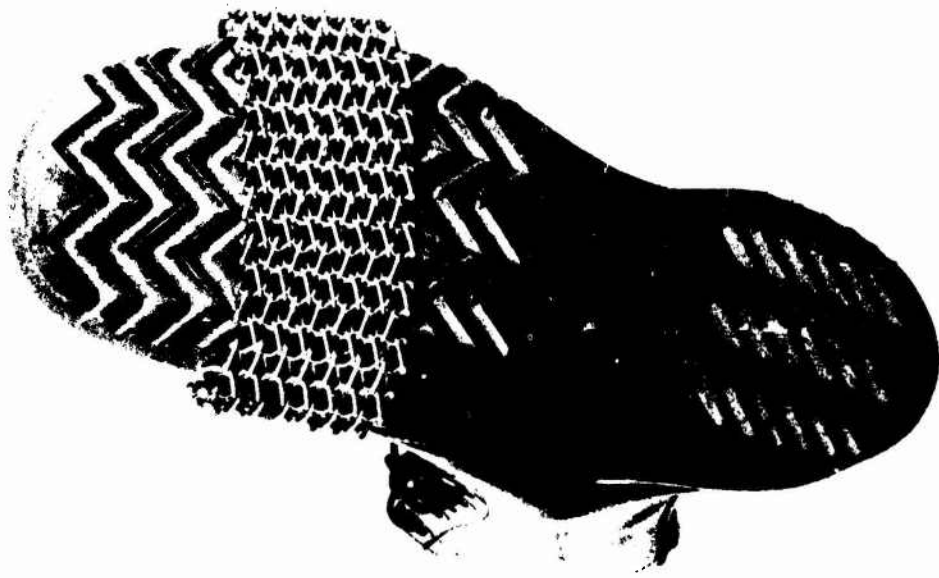

Figure 18 ACROSS-THE-FOOT TRACTION DEVICE



integrated design between carrier and outsole and terrain. Such a design, if cost effective, may require a specially fabricated carrier rather than commercial chain.

#### b. Traction Pad

A concept is presented consisting of an outsole with a reversible or removable traction pad. The traction pad consists of an elastometric form containing integrally cast high wear material. The material forms the wear surface of a molded calk or hob and provides traction forces through deformation and shear of the footpath media. A softer medium is deformed by the total calk body while a firm or hard medium is deformed by the hardened wear surface. Tractive shear forces are generated when the side of the calk is forced against the walls or matching irregularities of the surface deformation.

Interface shear loads between the outsole and the traction pad are transmitted by contact forces through mating patterns.

##### 1 Traction Pad A

The A design of Figure 19 is stored on the top of the foot and must be fabricated of thin, flexible material to adequately interface with the outsole and the vamp/instep storage area. The flexible material fastened to the rear of the traction pad provides the tensile force necessary to retain the pad in the operating and stored positions.

##### 2 Traction Pad B

The B design, Figure 20, is configured in a thicker than conventional outsole with the traction device a separate but integral part. The device is secured by a simple hook which holds the elastic forepart solidly to the sole material. The rear of the device is formed into a ball section which can be rotated to reverse the traction pad, thereby exposing the hard surfaced calks.

#### c. Edge Grippers

The class of device termed edge grippers is devised from edge cutting devices such as dies for cutting sheet stock, (i.e., insole stock) or as the gunbase shear element which resists recoil forces in artillery weapon systems. The edge is serrated to assure that a high unit force is available to create the deformation or local failure preliminary to transmitting shear effectively. An attractive feature of edge type devices is that attachment to the outsole can be made with a minimal modification

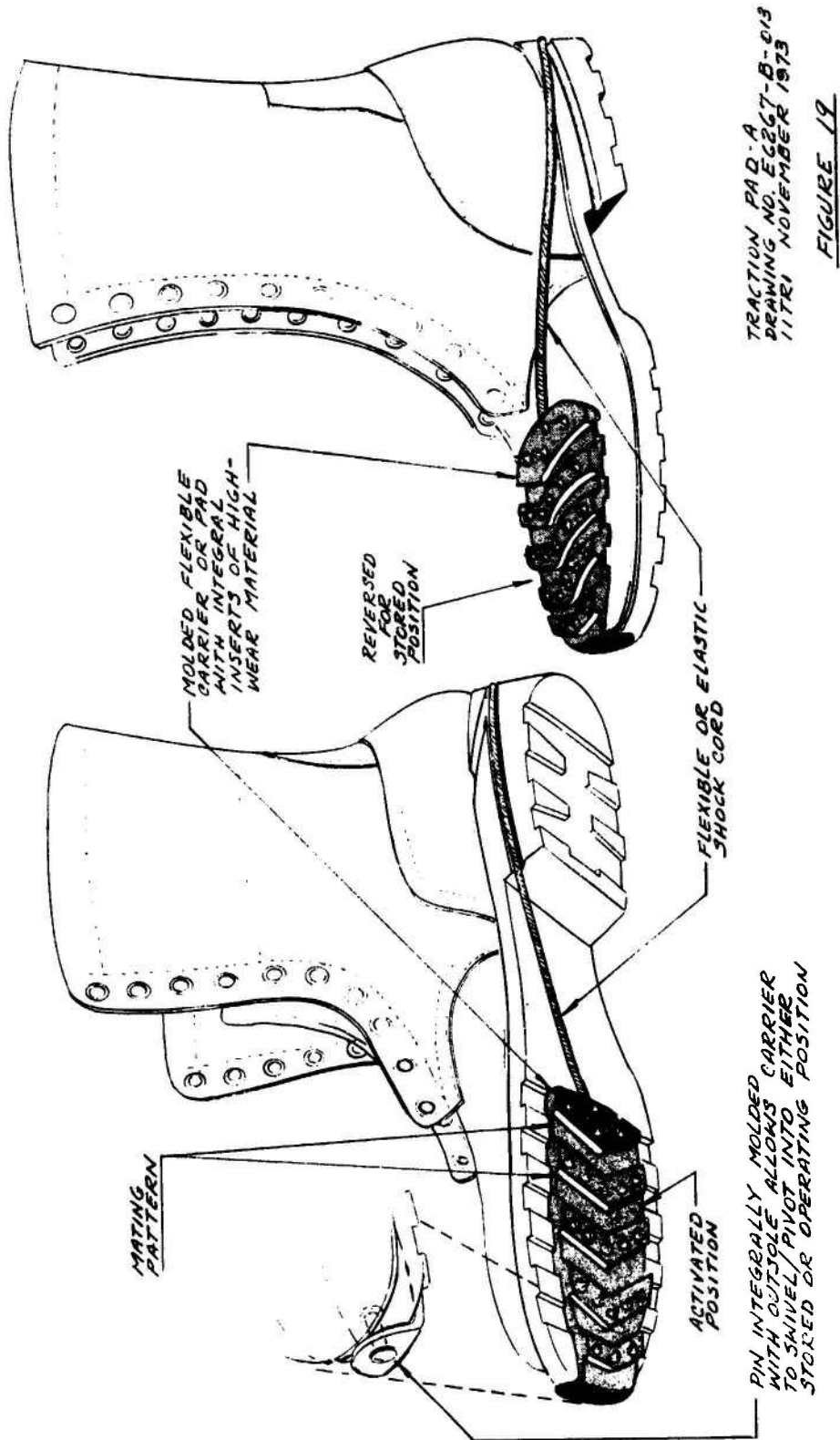

TRACTION PAD - A  
 DRAWING NO. EG267-B-013  
 11TR1 NOVEMBER 1973  
 FIGURE 19

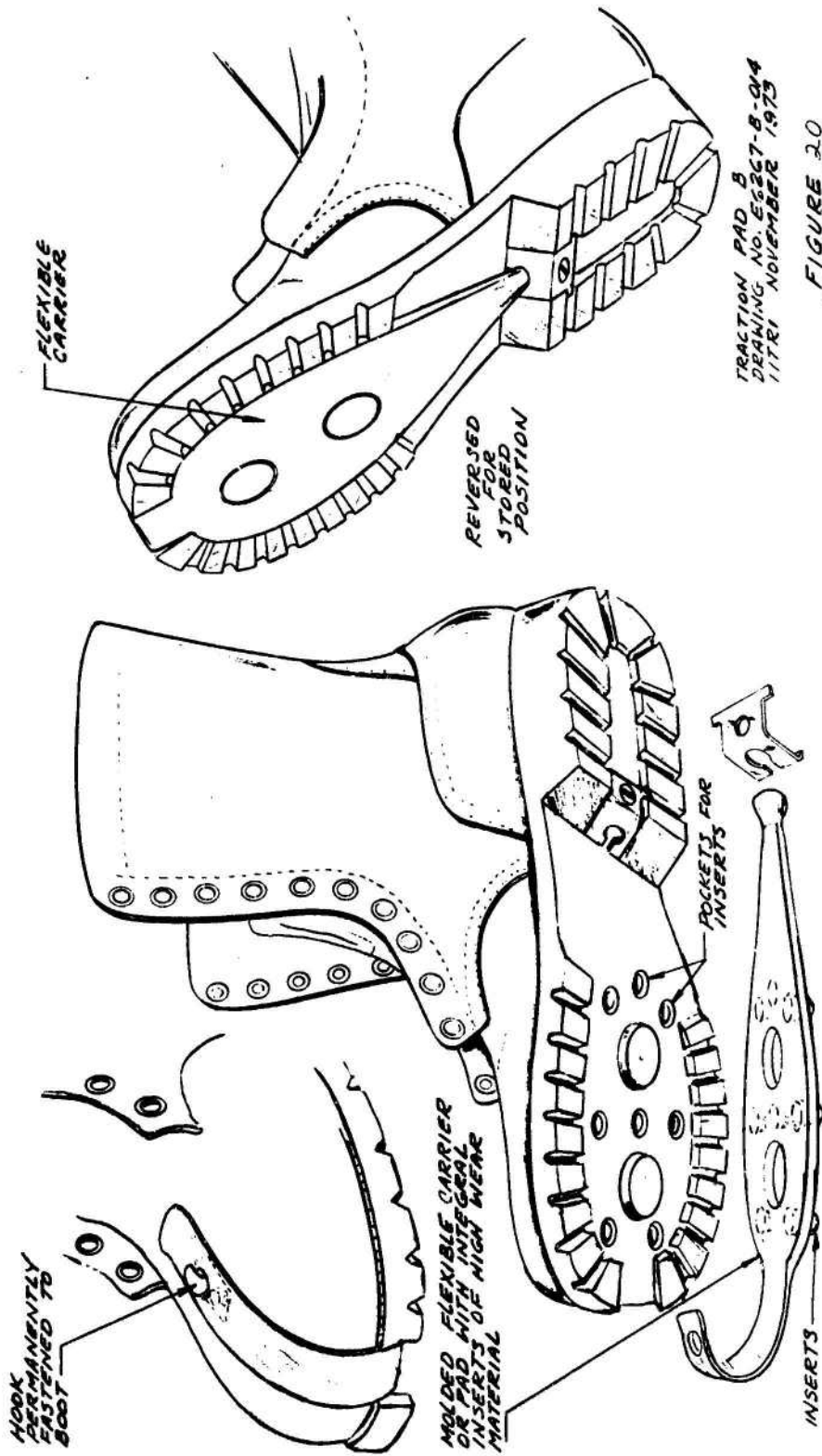

TRACTION PAD B  
 DRAWING NO. 65267-B-Q4  
 1171 NOVEMBER 1973

FIGURE 20

of outsole characteristics. Sole pattern, flexure, elasticity and normal friction qualities can remain essentially the same as an unmodified boot.

### 1 Saw Edge Sole and Heel Gripper

This device, Figures 21 and 22, is actuated by positioning a cam over lock so the device pivots at the rear hinge and extends below the surface of the outsole. The throw of the cam lock controls the displacement of the device. Operation of the gripper depends upon normal foot loads being transmitted by the cam lock and hinge point through the cantilevered structure which reacts on the terrain surface. As the beam deflects, the forepart of the outsole also contacts the surface. Load transfer during the footstep and at push-off is, therefore, shared between the outsole and gripper. The relative motion between outsole and device is also inherently self-cleaning. The trade-offs between an adequately deformed surface material and comfort during wear and locomotion will determine an acceptable beam design, primarily stiffness. Several models of advanced prototypes may have to be evaluated.

### 2 Saw Edge Heel Gripper

The heel gripper version shown in Figure 23 is intended for use in conjunction with a device on the forepart of the sole. Although the relative needs for traction of the forepart vs. the heel have not been clearly defined, it is obvious that for some gait/terrain conditions both an initial heel strike and toe push-off are present. Therefore, if a significant change in an individual's gait is not acceptable then traction aids at both the sole and heel are probably necessary.

The heel gripper is held in place by an over center locking pin placed axially through the heel. One end of the pin bears against the main serrated section of the device clamping the device against pins which are molded integrally within the heel. Upon release of the locking pin, the pins may be repositioned in the upper section of the two-position groove causing the serrated teeth to extend beyond the heel material ready to provide additional traction.

### 3 Storable Sole Gripper

The storable sole gripper, Figure 24, is a device for use on the forepart of the foot to improve traction on hard-packed snow and ice.

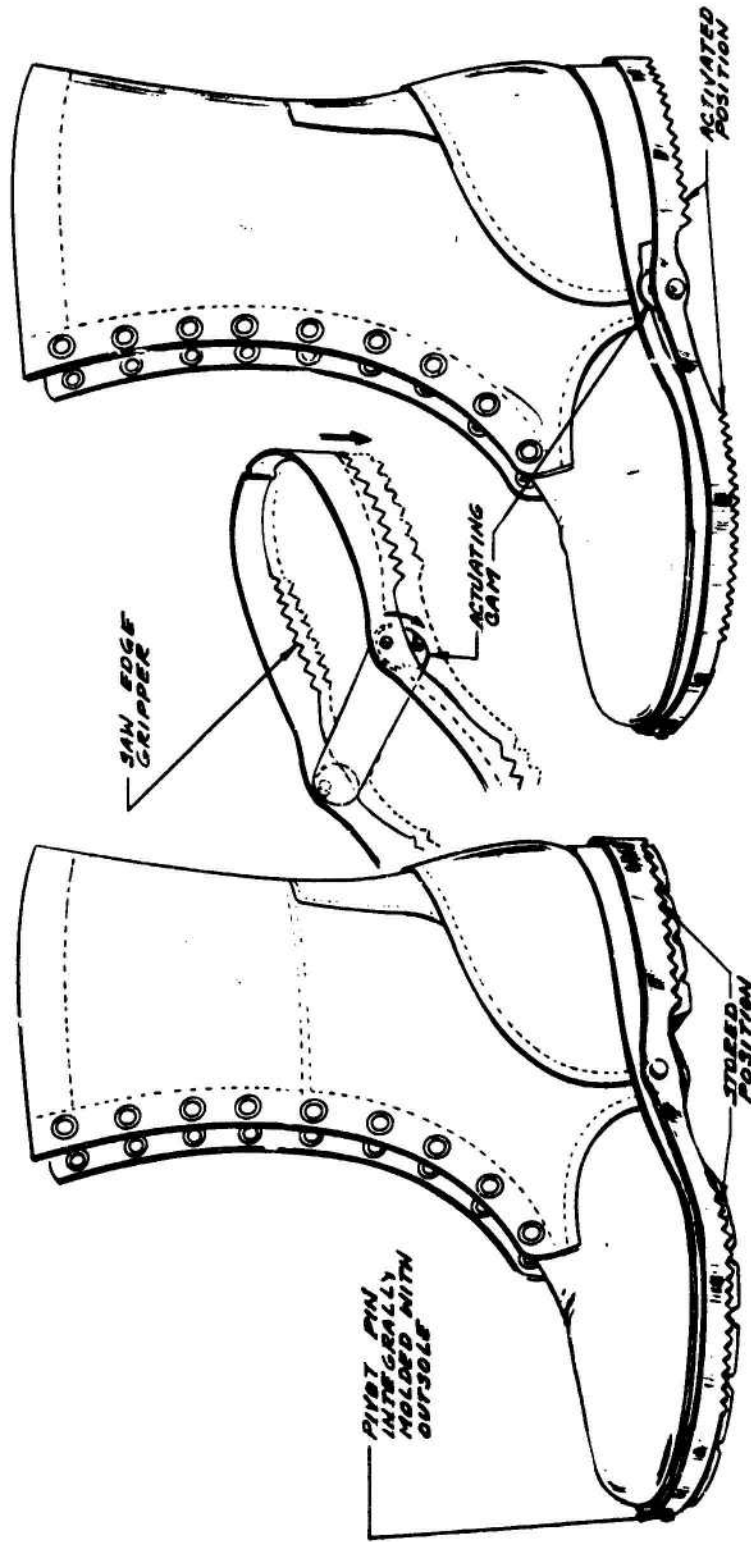

SAN EDGE SOLE AND HEEL GRIPPER-A  
 DRAWING NO. E6267-B-D13  
 11/17/71 OCTOBER 1972

FIGURE 2.1

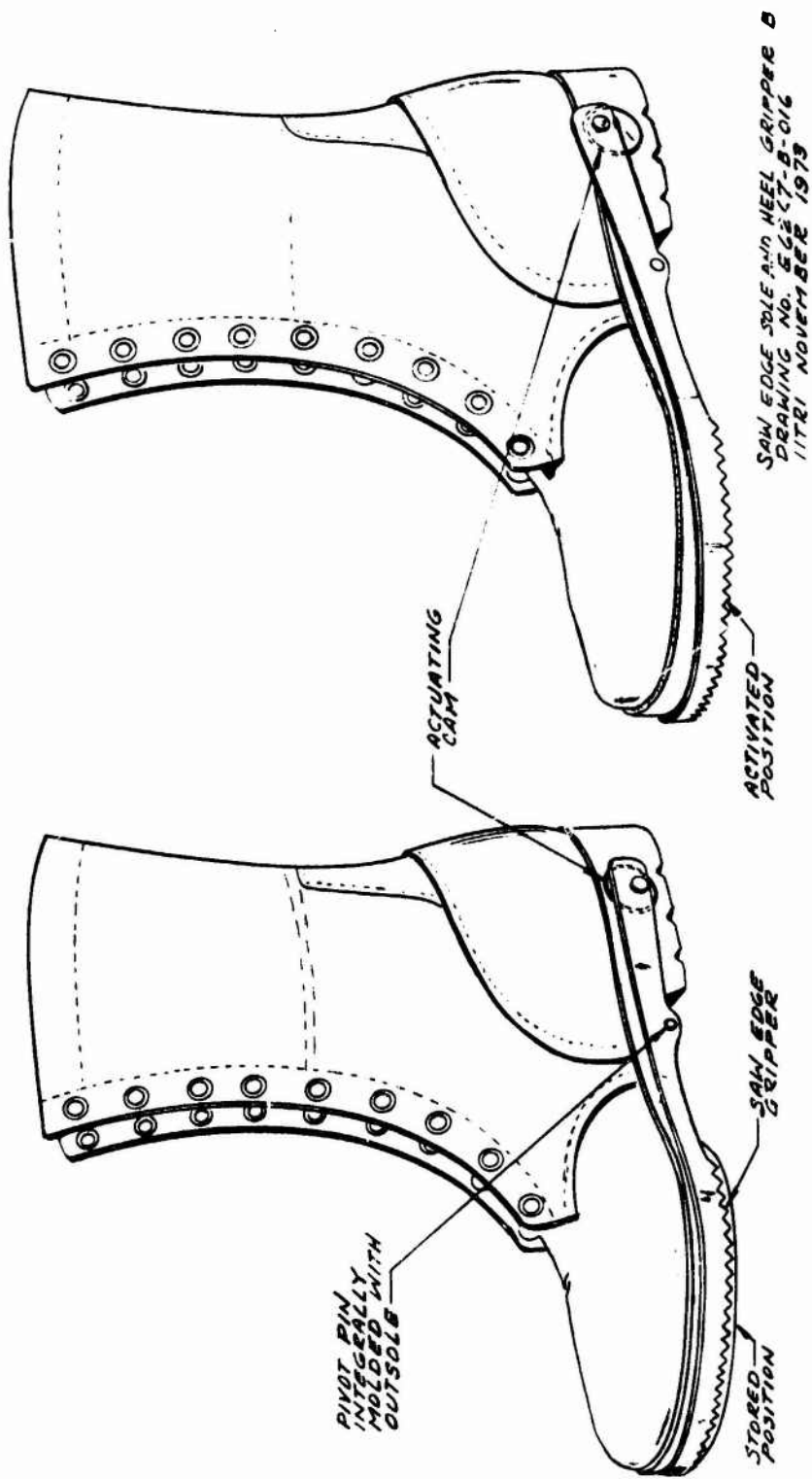
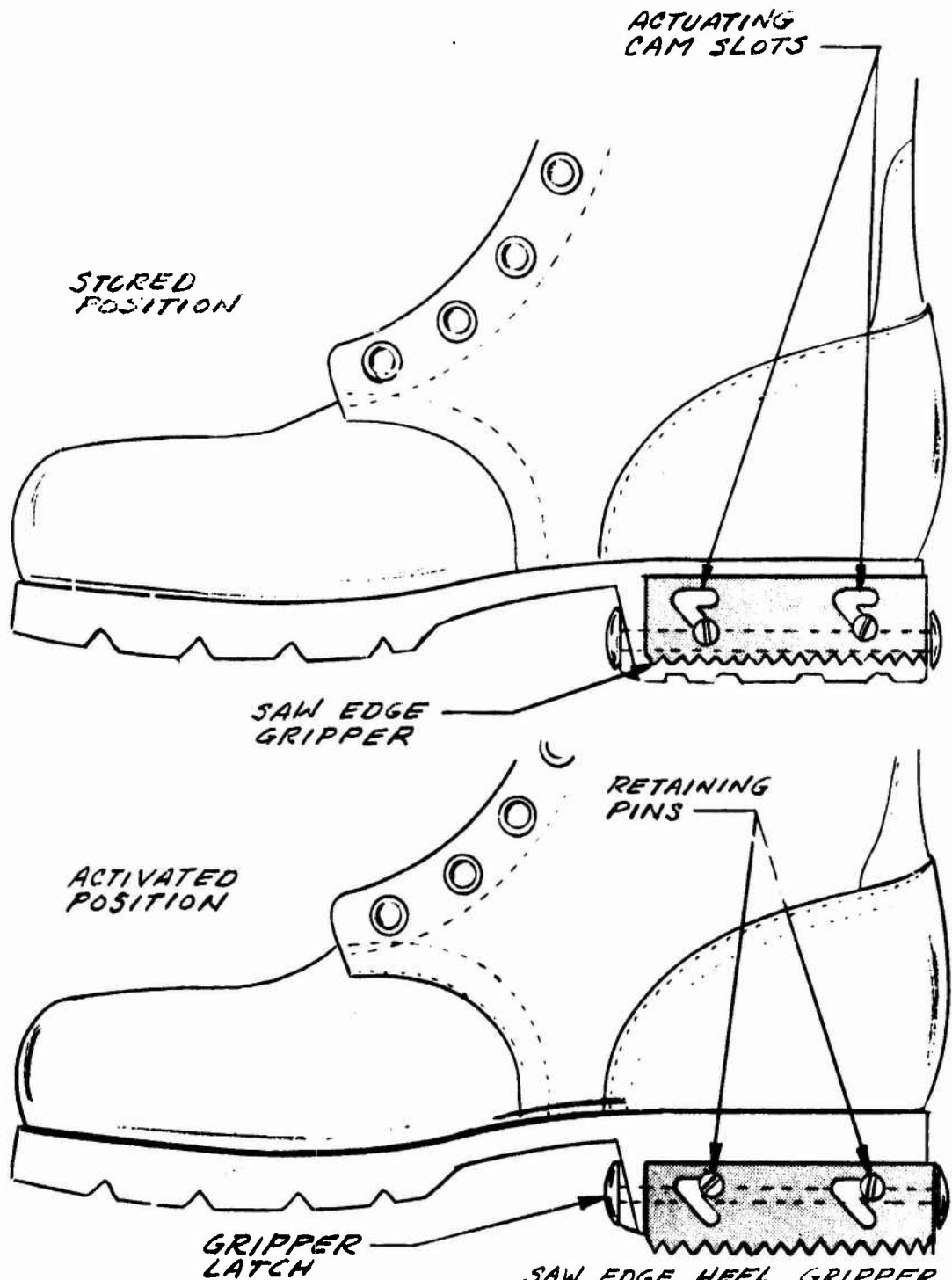
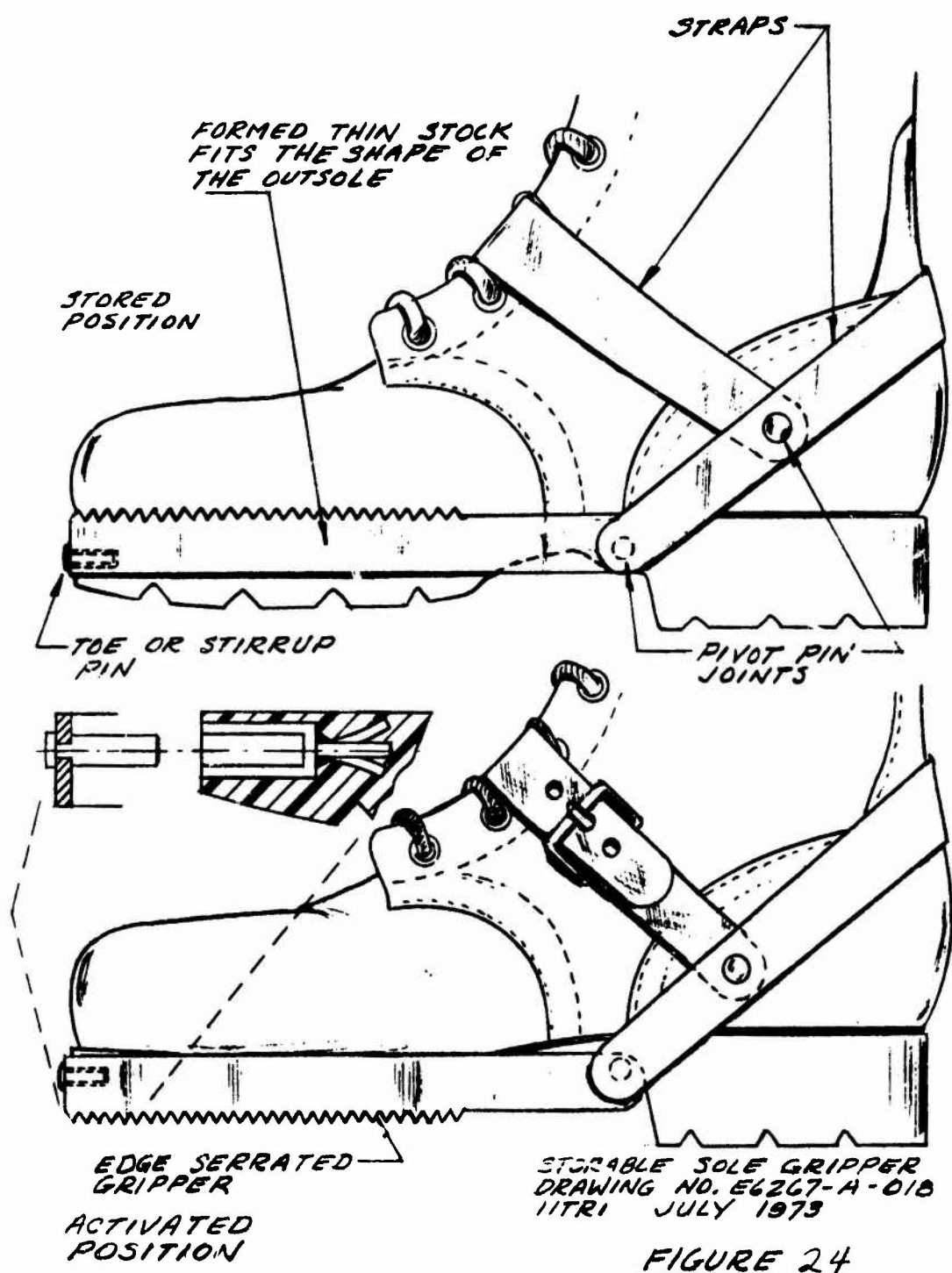

FIGURE 2.2



SAW EDGE HEEL GRIPPER  
 DRAWING NO. E6267-A-017  
 IITRI JULY 1973

FIGURE 23





The main beam has a serrated edge and would be manufactured from relatively thin stock formed to fit the shape of the outsole. The teeth in the serrated edge will consist of wear-resistant materials either from hard weld buildup or brazed pieces of stock.

It is anticipated that a range of widths and lengths in the military tariff can be accommodated by one size of gripper.

In the traction position, the vertical and traction loads are transmitted to the footwear through a toe and stirrup pin. These pins assure engagement with the surface through the offset location on the main beam.

The device is held in place on the footwear by an arrangement of straps secured around the heel and instep by fasteners. The strap arrangement is pin-jointed to permit reversal of the strap location which is required for the obverse installation.

The storage position is attained after removal of the device from the traction position by installation on the opposite foot with the traction surface facing upward as shown in the illustration. Installation on the opposite foot is required because the shape or hand of the main beam changes when the device is turned over.

#### d. Cleats and Spikes (Retractable and Convertible)

Retractable cleats and spikes are designed primarily to provide effective locomotion over soft ice and hard-packed snow. The design of the outsole and integral support hardware will be segmented to retain sole flexure.

The traversing of hard ice in these outsole arrays which contain a relatively few long points may be unacceptable. Such a design requires a midsole or sub-plate system capable of distributing load to the foot in a manner that is acceptable to the wearer. The design would result in a stiffer sole adequate for ice work but which should be fatiguing during a forced march over conventional terrain when the points are retracted.

The crampon, a device available to the government, is a sample of the design requirements for this type of load transfer. The ice points are fixed to a stiff sub-plate which in turn is buckled to footwear. The crampon, however, is removed and stored when not required.

### 1 Cleats in Molded Pockets

The version shown in Figure 25 depends on the point array and configuration for traction and the integrally molded support beam for vertical load transfer into the foot system. The photograph of Figure 26 shows a simple model to illustrate the concept.

The operation of the system requires actuation of each cleat into the traction position where it is retained through a component of the vertical force and due to an interference fit with the elastometric material of the pocket. An alternative to this cleat retention is to provide a spring loaded contact (not illustrated) as a means to generate the friction load necessary to prevent rotation during use. Forced rotation into the storage position would clear the cleats so the footwear can be used on conventional floors and terrain.

### 2 Foldable Spike Plates

A traction device is shown in Figure 27 that is based upon a model, Figure 28, provided by Mr. A. F. Wilson of NIABS. The design includes two arrays of spikes hinged at the sole and heel which are secured in both the traction and storage position by rotary locks. These locks may require a simple tool to operate.

In the traction position, both the ball of the foot and heel area are provided with traction aids. These aids are shown mounted on a stiff metal plate which will distribute the load on the outsole resulting in a more uniform foot load.

In the storage position, the plate is nested with clearance over the footwear contact surface. This clearance will provide for considerable outsole wear before contact can be made with a flat hard-surfaced terrain or floor system.

An optional elastometric coating can be added to the rear of the spike plates to decrease the chance of damaging finished flooring when they are in the stored position.

### 3 Retractable Grippers

A device for use on ice and hard-packed snow with small grippers (hobs) is shown in Figure 29. The Retractable Grippers A are attached to spring wire forms which are assembled within grooves contained in the outsole material for the storage position. Operation of the traction element is accomplished by rotation of the front loop from the rear storage location to the

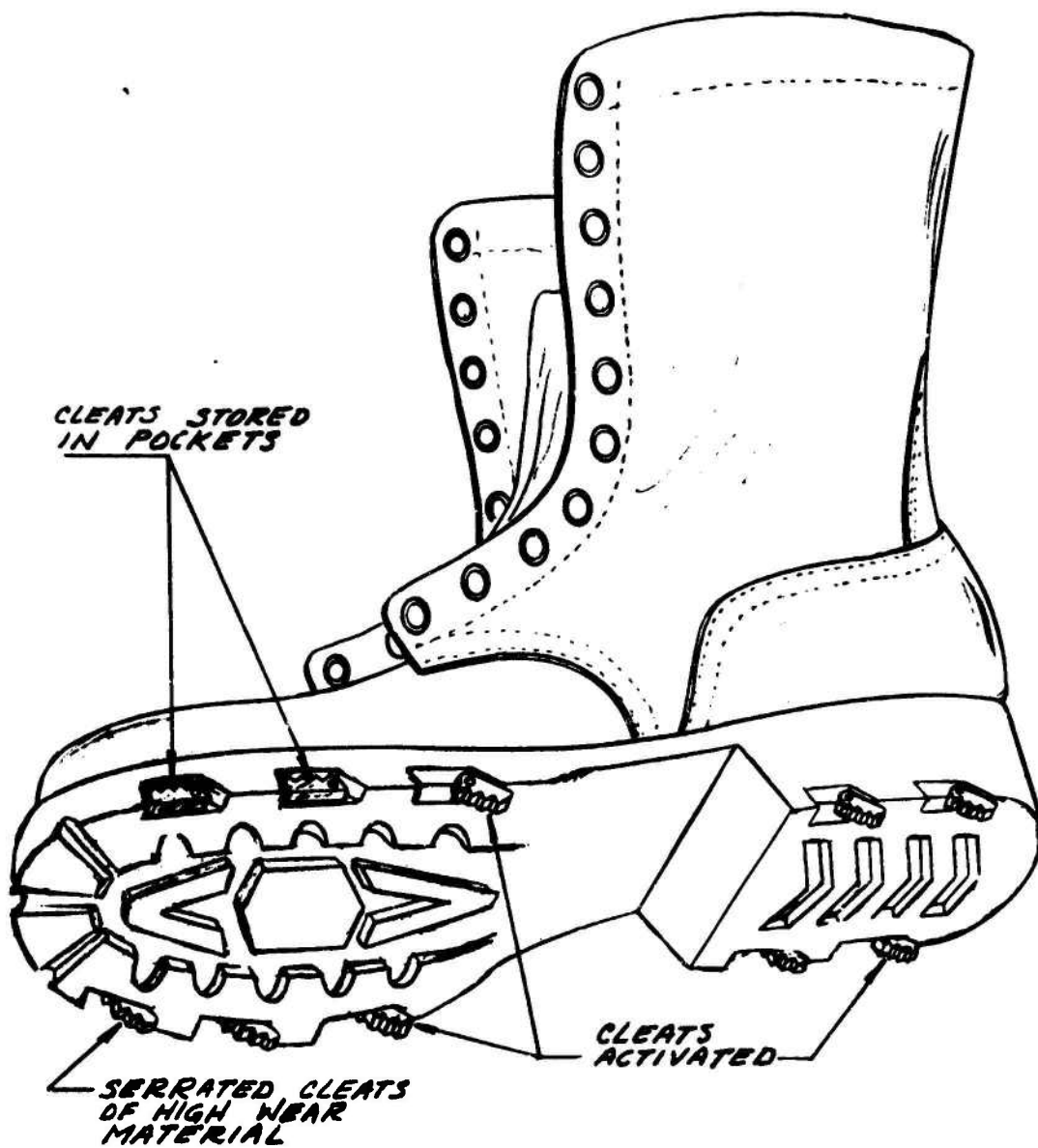

CLEATS IN MOLDED POCKETS  
DRAWING NO. EG267-A-019  
11TR1 NOVEMBER 1973

FIGURE 25



Figure 26 MODELS OF CLEATS IN MOLDED POCKETS

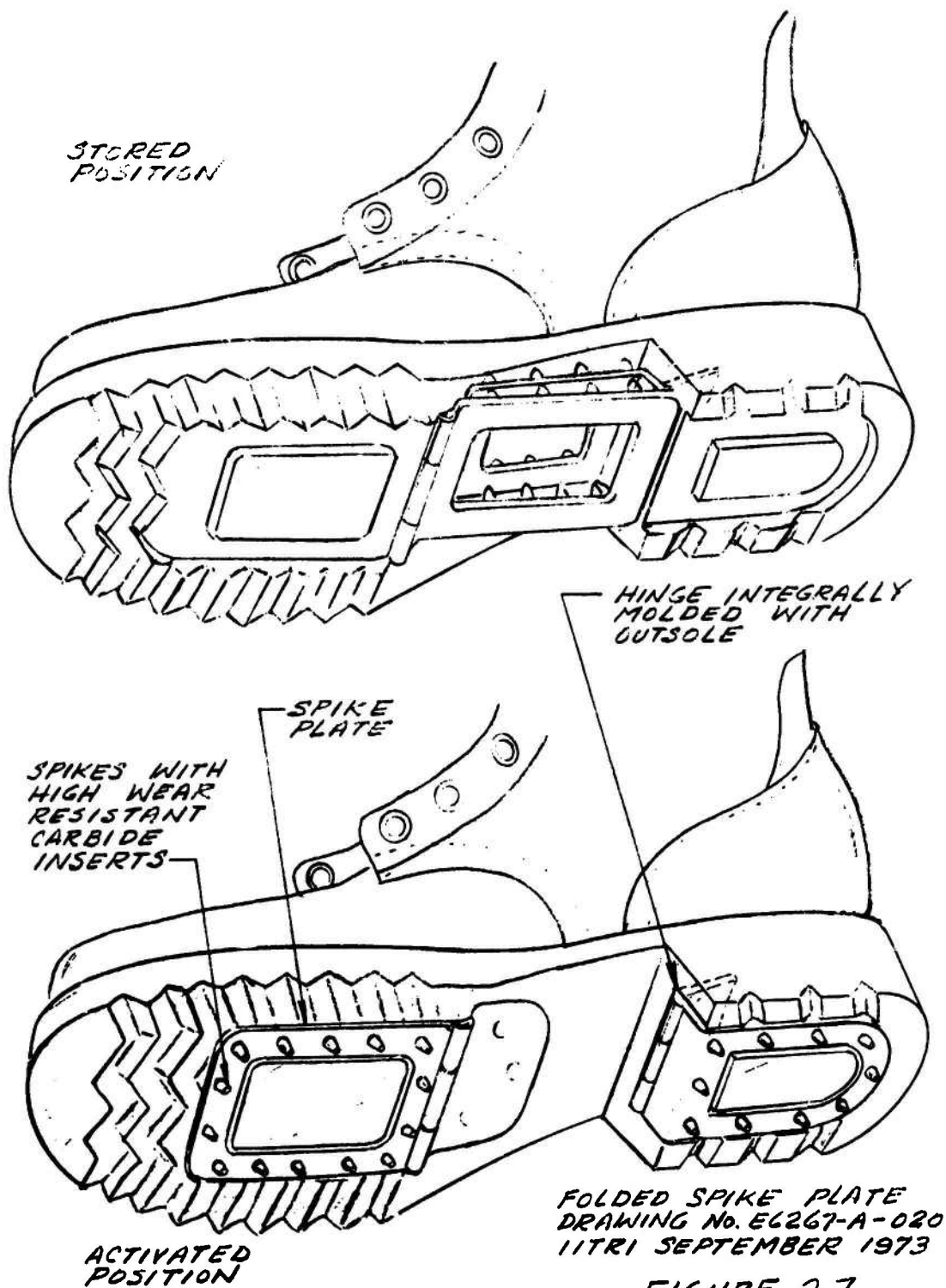

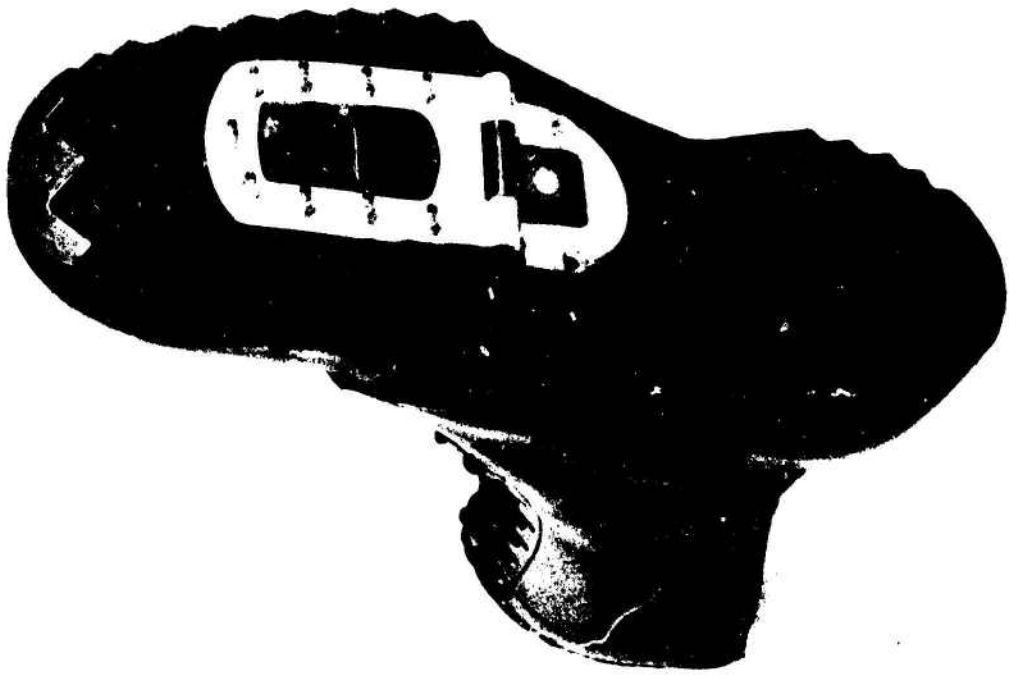

Figure 28 WILSON CONCEPT

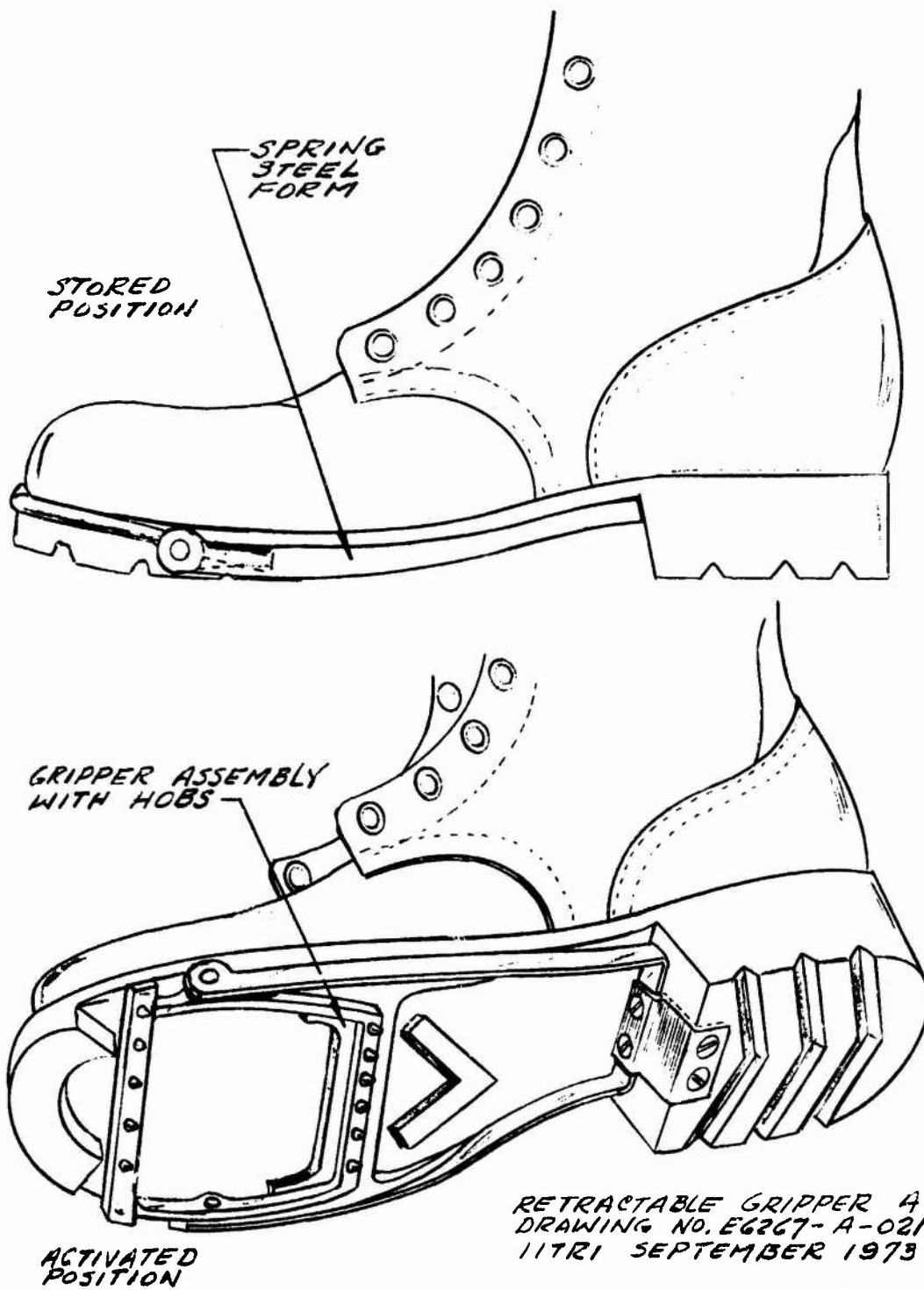

FIGURE 29

traction position on the front of the outsole. The rear loop is lifted from its storage position by the action of the cam ends of the front loop around hinge points. Interaction forces between the outsole, the loops, and the ground maintain the loops in the traction position.

Another version of retractable grippers is shown in Figure 30. In this B version, four sets of integrally molded grippers are concealed in the outsole, two in the forepart and two in the heel. The grippers are positioned or stored by a simple rotational movement against frictional resistance. A snap lock or detent system will be incorporated to ensure the bias position.

#### 4 Retractable Heel Spikes

The retractable heel spikes shown in Figure 31 are again intended for use with an ancillary device on the forepart of the boot. The storage position shows the spikes retracted with a normal wear provision in outsole material before contact is established on hard surfaces. The traction position is attained by removing the plate insert contained in the heel from the bottom location thus permitting the spike plate to extend beyond the heel. The plate insert is then relocated on top of the spike plate as part of the transmission path of the spike force.

Retention of the spike plate is by direct interference with other components while the plate insert retention will be by a spring loaded detent (not shown).

#### 5 Spikes with an Add-on Outsole

A version, Figure 32, containing an array of fixed hobs or spikes molded in a midsole shape can be converted by the addition of an "add-on" outsole. This concept has been used to protect floors from golf spikes. Outsole attachment is illustrated by buckles and straps but could be secured through a wide variety of methods; some typical candidates are suggested by the attachment methods presented in other sections of this document.

#### (2) Soft Terrain Surface Concepts

Soft terrain surfaces inhibit an individual's tractive ability by yielding under normal footwear contact forces. The yielding requires an abnormal gait to maintain locomotion. Large muscular forces are required to overcome the surface media's cohesion and adhesion and fatigue results.

The design criteria considered to reduce these forces are by increasing the size of the footprint and through material selection. Two concepts of increased area footwear



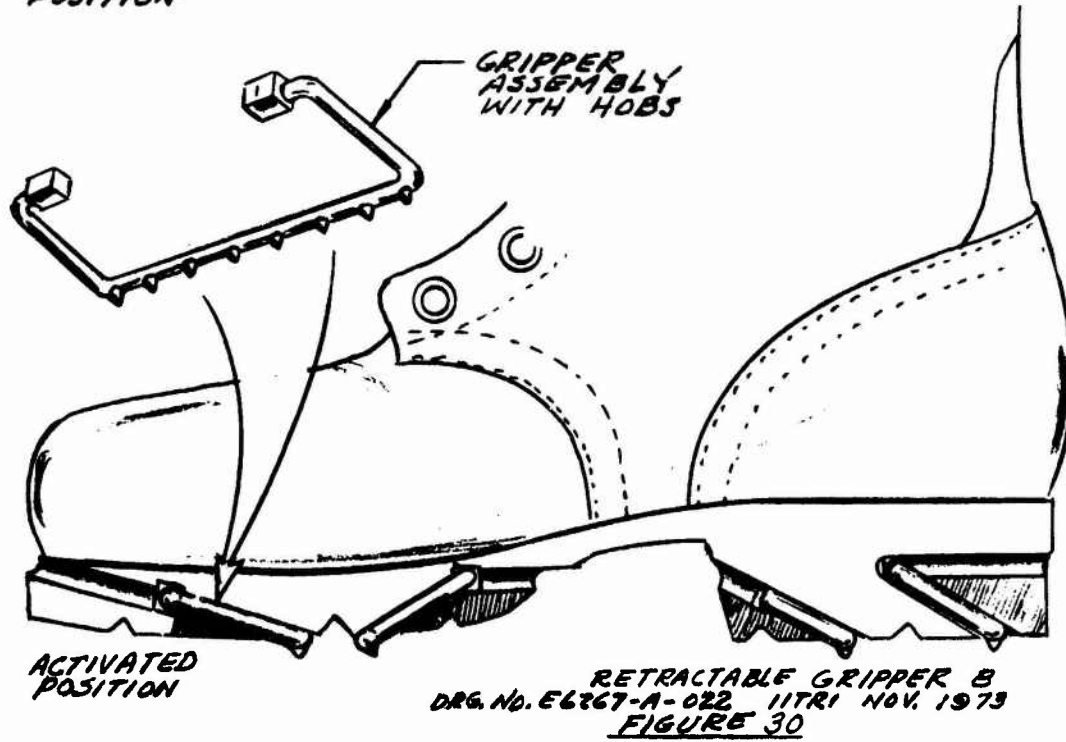
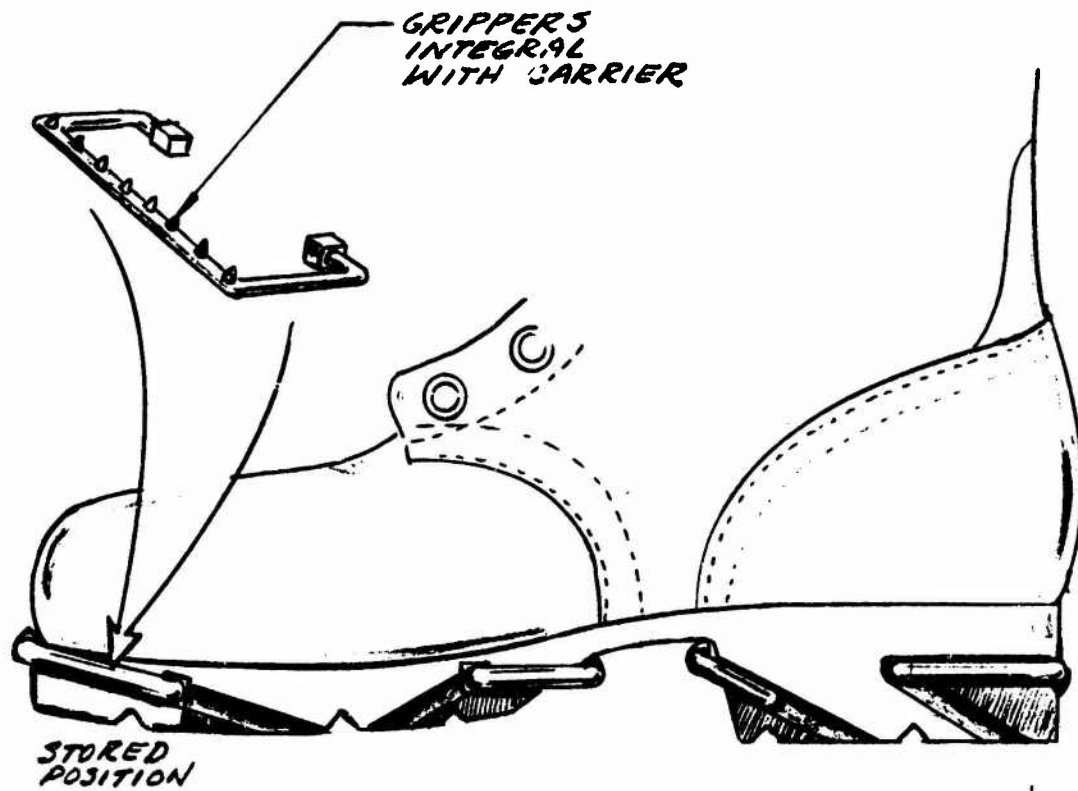

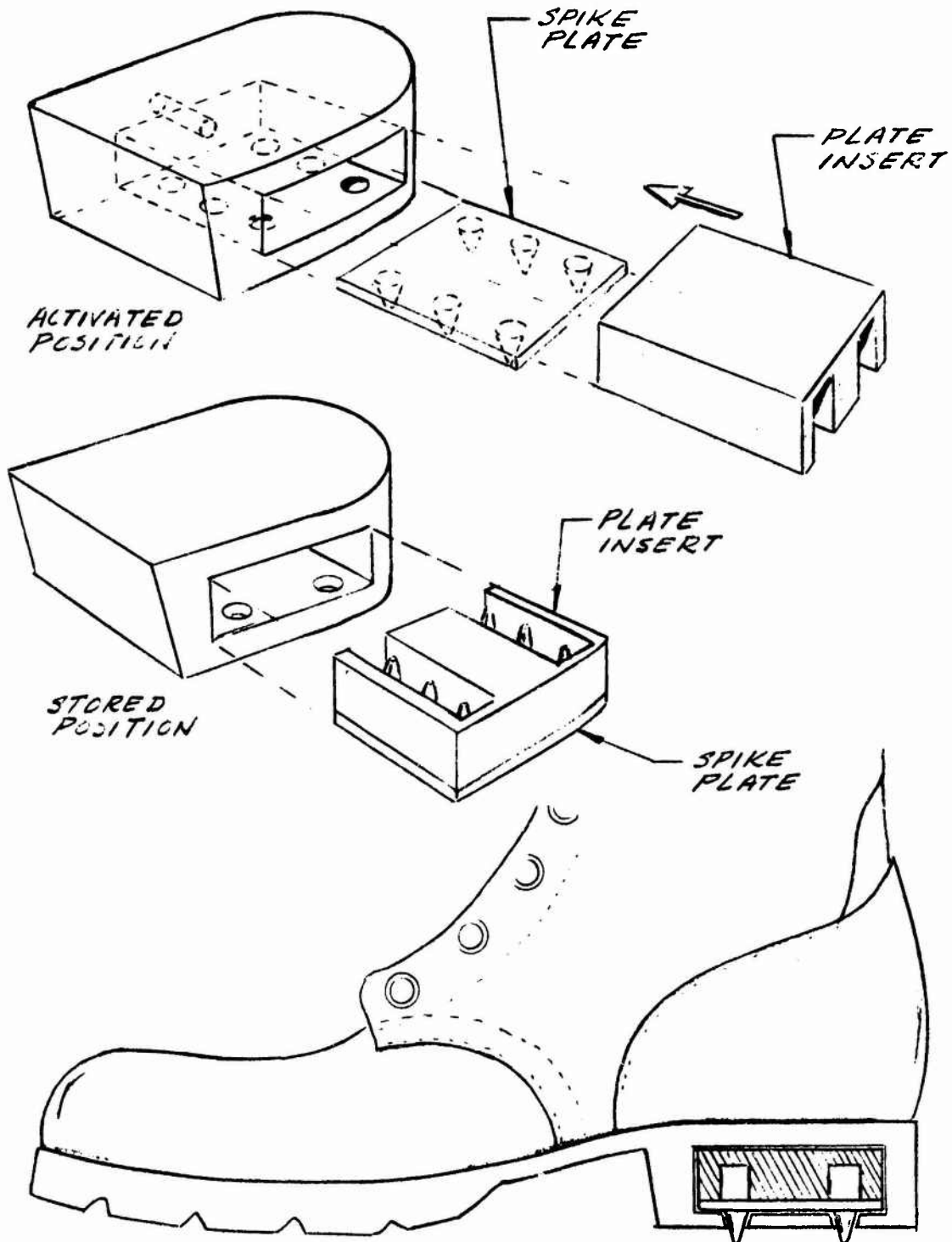

RETRACTABLE HEEL SPIKES  
 DRAWING NO. EG267-A-023  
 IITRI JULY 1973

FIGURE 31

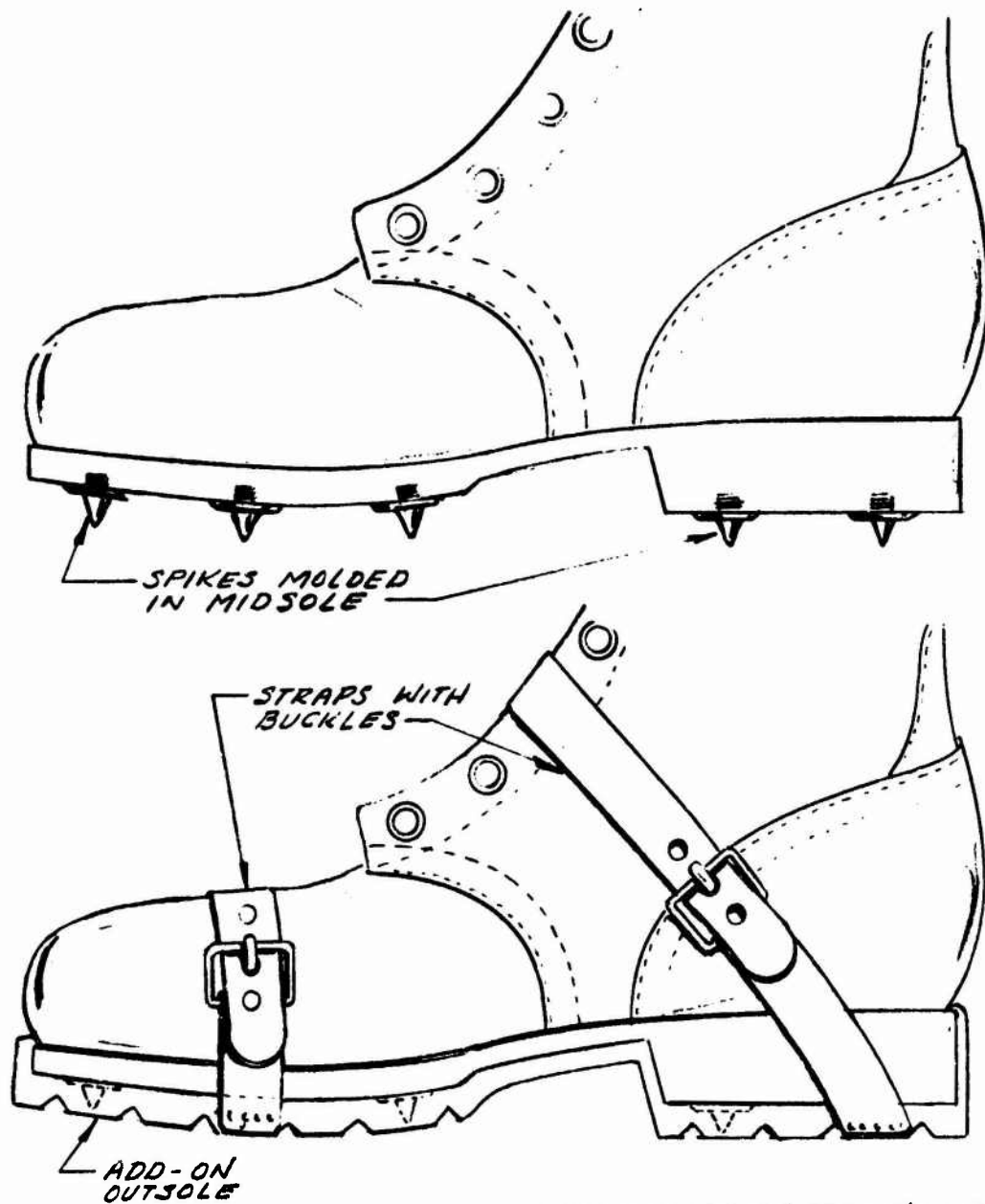

SPIKES WITH AN ADD-ON OUTSOLE  
DRAWING NO. EG267-A-024  
11TRI JULY 1973

FIGURE 32

are presented. These concepts are designed as inflatables to reduce the storage problem, although many other versions are possible to overcome soft road surfaces.

Typical terrain material which is structurally weak or unstable includes loam, bog, snow, sand, and certain clays and silts that have been pulverized to fine particles or powder.

The maximum force transmitted to the surface media would be from equipment bearing troops with a single footprint force of 200 to 300 pounds dependent upon the individual. Such a force in a media with a 1-pound/square-inch bearing capacity such as dry, loose sand would require an outsole area of 1.4 to 2.1 square feet. The sand medium also exhibits poor shear strength, and foot locomotion with add-ons with a large increase in footprint area would require developing a load transferral gait to minimize shear. Such a gait would probably appear similar to a stride with snow shoes or skis. Binding, inflation pressures, structural load distribution, and wear surface material are some of the problems pertaining to the design of inflatable footwear.

a. Bear Paw

The Bear Paw of Figure 33 is a rigidized tube attached by cords to a shoe binding. The tube has an inflation pressure which is suitable for locomotion on a five-psi surface media. The device would be used for traversing crusted snow, boggy ground, and dense sand.

The effective area of the Bear Paw can be significantly increased if the center section is enclosed, thereby permitting locomotion over media with a strength of less than 5 psi. Enclosure, however, increases the potential of material adhering to or being carried on the footwear, resulting in the rapid onset of fatigue. A view in Figure 33 illustrates a bag worn over the Bear Paw and attached above the knee which should inhibit material build up.

The bag would be fabricated from a glass reinforced plastic and could be designed to resist the hazards associated with an open barren environment where the major threat is the load bearing surface media. Traversing brush or thorny terrain where the incidence of puncture is high would, in turn, be a difficult environment to resist.

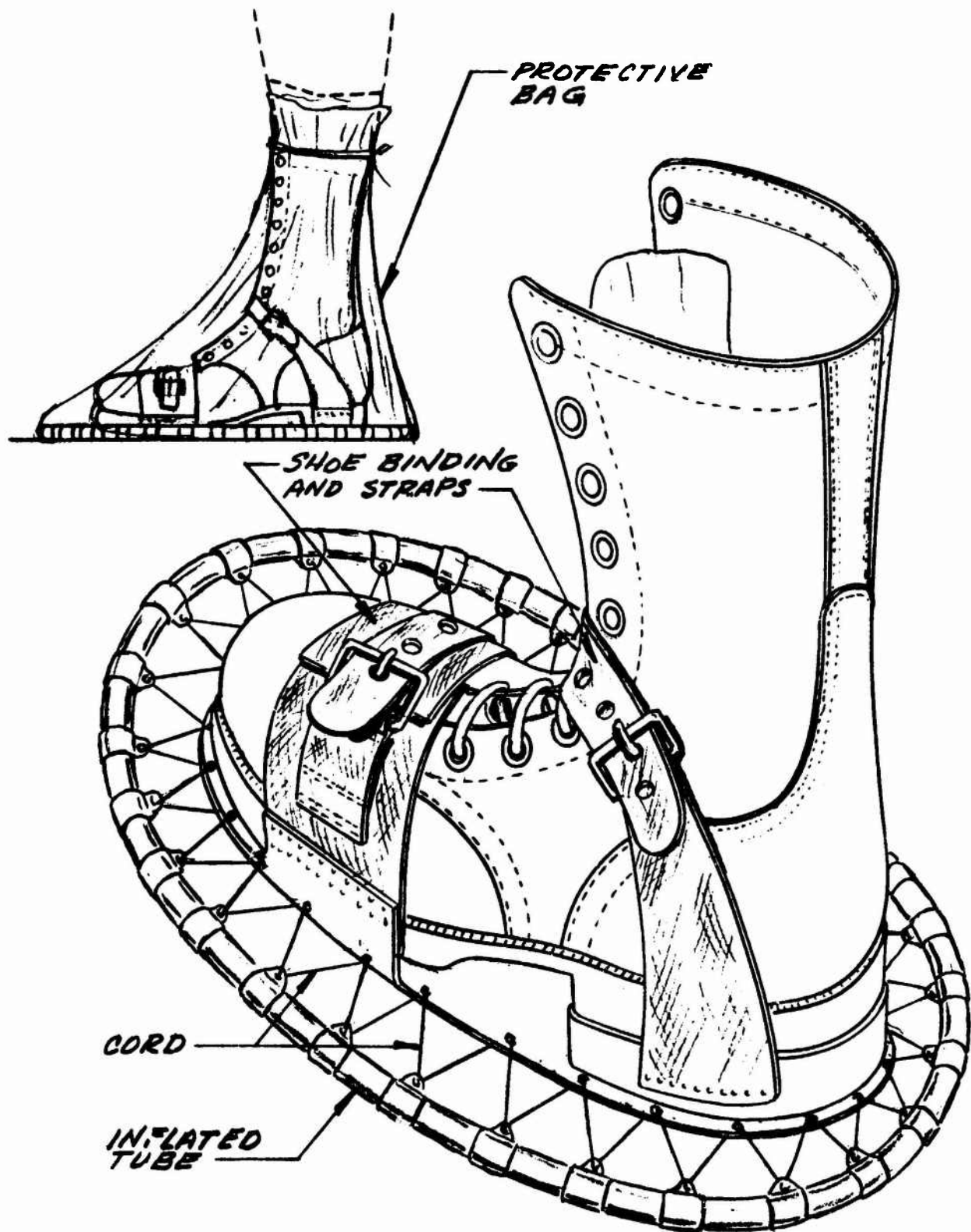

BEAR PAW  
DRAWING NO. E6267-A-025  
IITRI OCTOBER 1973

FIGURE 33

b. Inflatable Overshoe

An inflatable overshoe, as shown in Figure 34, has the potential of enabling locomotion over surface terrain with compressive and shear strengths on the order of 0.5 to 1 psi for a single foot loading of 250 pounds.

The cell shape, internal pressure and material strength will all be significant elements in determining if the pretensioning stresses will be able to support the necessary man/equipment load without employing compression members in the design. Should compression members be required, the ability to package the device in a small space would be compromised.

5. FABRICATION STUDIES AND MATERIAL INVESTIGATIONS

A series of subtasks were undertaken to investigate the problems attendant with materials and the manufacturing process as applied to quick-closure uppers and traction aids.

A. Molding Outsoles

The program considered prototype manufacturing by Direct Molded Sole (DMS), a biscuit molding technique presently employed for the Standard Combat Boot. This process was used for outsole attachment and inclusion of elements or devices within the outsole material. This method was elected over an injection process because the inclusion of elements or components in the flow path of the outsole material during the filling of the cavity was anticipated to require development.

Adequate preheating of components and maintenance of molding compound in the liquid or suitably viscous state during flow could, however, make the injection process a likely candidate for manufacture.

As experienced with the DMS process, maintaining the final position of the traction elements with the outsole material was difficult anyway. Misalignment forces are present in the die cavity during closure of the sole piston due probably to one of two causes. The first is that the final thickness between the outsole and the bottom of the lasted upper is not controlled with great accuracy, and interference with the inclusion is possible. The second fact is that the biscuit is still semi-solid and capable of transmitting structural load. It was necessary to cut biscuit patterns to approximate the outsole shape, thereby reducing the interference loads during closure. Premolded semi-cured biscuits would alleviate this problem and make the DMS process acceptable for production.

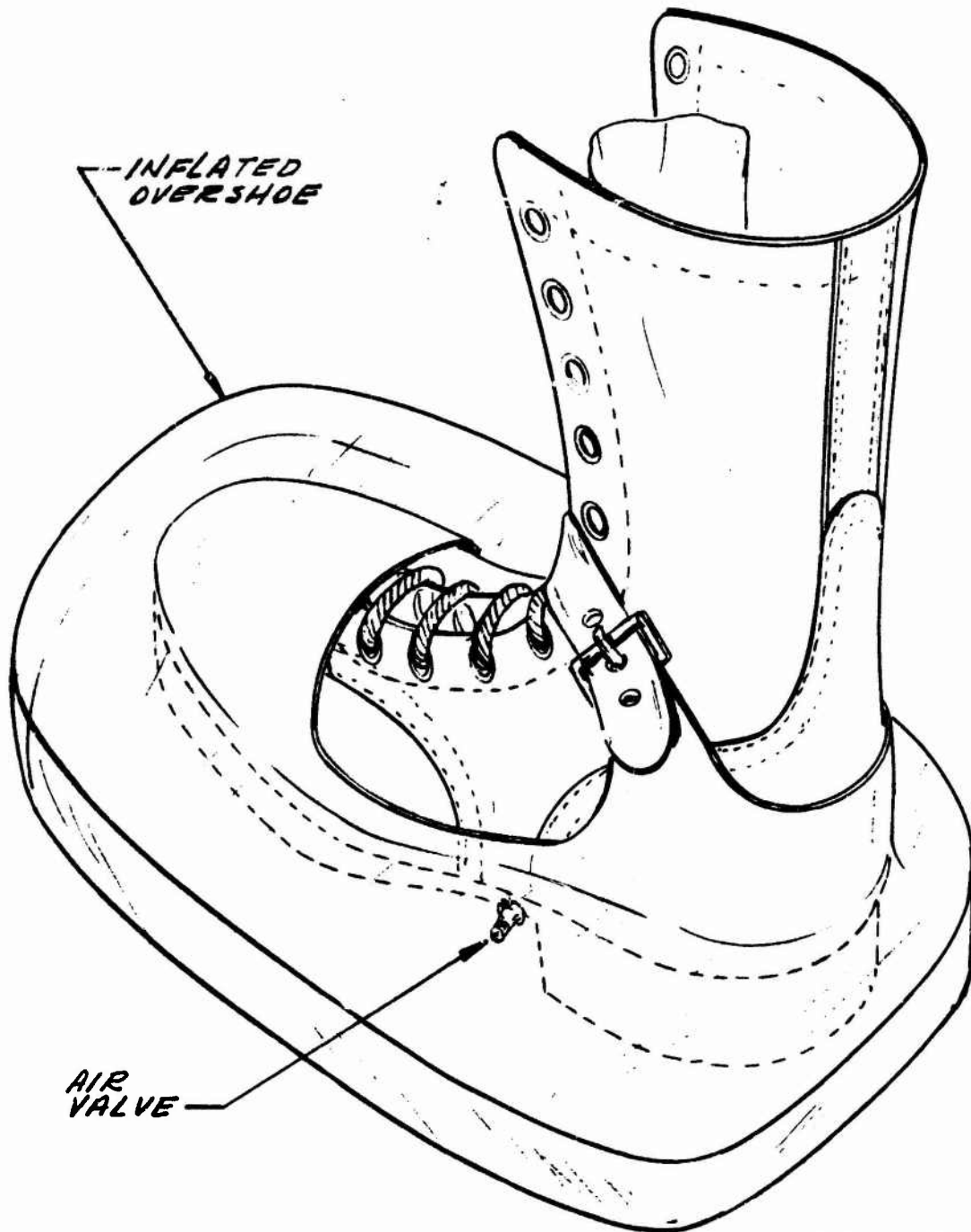

INFLATABLE OVERSHOE  
DRAWING NO. E6267-A-026  
IITRI NOVEMBER 1973  
FIGURE 34

Either process at this time seems feasible; no real extreme problems are anticipated, but the detailed effort attendant with tooling for positioning and reduction of intracavity forces for the finally elected boot/outsole molding process must be worked out.

The models manufactured on this program required considerable hand labor but demonstrate the feasibility of the DMS process.

#### B. Upper Manufacture

Contract requirements legislated the use of military specified leather as upper material. The process employed for prototype manufacture was the conventional die cutting of upper patterns where suitable existing pattern forms were available. Special patterns were cut by hand. Preparation of the upper is not anticipated to deviate from standard practice.

The costs of leather in general and especially of high quality kid leather for the manufacture of balloon gussets led to a survey of poromeric material status. This material is well qualified for gussets and may be required as a substitute.

The advantages of poromeric materials are: they are reasonably similar to leather in breathability; they are a closed cell material making them strongly resistant to staining, and hardening or curling, as leather does when the preservatives and lubricants are lost. Material loss due to pattern scrap is also less because the material has even edges unlike natural hides. Costs, however, must be considered on the basis of the ambient market due to the general economic state which creates wide variances. A boot specification for gusset material could include poromerics on the basis of performance, thereby letting each vendor make the judgment of effectiveness for his case.

Poromeric material manufacturers and material status information is presently in a changing state and the reader is referenced to current literature for supplier and cost data.

#### C. Traction Aid Manufacture

The materials considered for traction devices include those for components which are integrally molded with the outsole, or are assembled with other components.



The footwear traction design requires materials and components which can structurally resist the molding environment during manufacture, and also withstand severe abrasion forces at the terrain surface during use.

Manufacturing processes that pertain to the three selected concepts of this program are not anticipated to be a problem during production. Manufacture of a chain mesh belt by automatic methods for physical location and joining by welding can reduce unit costs. The present technique requires hand welding due to the relatively low volume and consumer demand for a wide range of wire size and types of belt.

As a measure of expediency, the designs and manufacture of the selected models have been based upon machine shop practice and availability of materials rather than production. Production design is anticipated to accommodate stamping and forming processes for manufacture of such elements as the insert of the cleat design, chain mesh terminations, and the body of the gripper to reduce weight and decrease costs.

One other technique not commonly employed in the shoe industry which may be considered is the welding or flame deposition of hard material to a surface for wear resistance. A sample gripper dimensioned for fabrication by stamping with the contact area surfaced with hardweld (Rockwell "C-60") is shown in Figure 35. This technique can be used to provide wear resistant lugs or cleats to the base material including both ferrous and stainless steels. Designs can, therefore, be made which do not require heat-treatable grades of steel in the noncontacting areas of the structure.

#### D. Closure Manufacture

A wide variety of closure devices and materials were investigated for incorporation into an upper design including belts, buckles, metal loops, eyelets, stem and loop, and hook and loop materials.

The fastening techniques used are essentially some form of adhesive or piercing and subsequent securing by rivets or thread.

Adhesives are used to laminate natural and synthetic material combinations. They are used to bond inside surfaces such as lining or for the attachment of outsoles or attachment of the uppers to insole during lasting as a temporary or ancillary fastening preparatory to molding. This latter technique reduces the chance of nail ends encroaching on the plantar contact area of the insole.

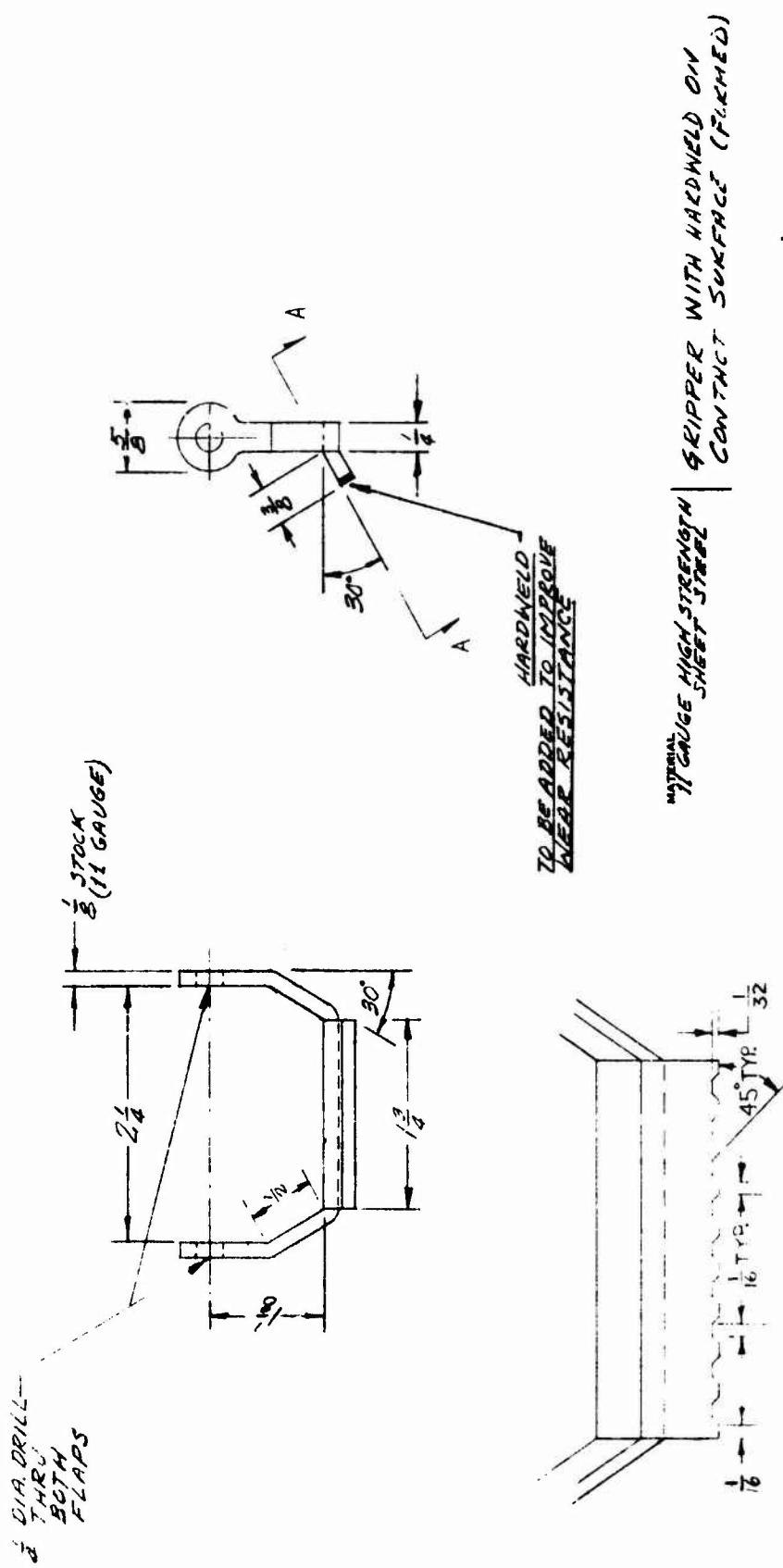

Figure 35

Thermal set adhesives offer a wide choice of temporary and permanent fastening applications. Surface preparation for use of adhesives on leather to reduce surface oil and promote "tooth" are usually destructive and great care must be exercised to be sure the finished footwear physical characteristics and appearance are not affected.

Fabrication of the upper closure system is anticipated to be accomplished by some variation of these processes which are conventional with the footwear industry and are not expected to be a significant issue when applied to the attachment of a quick-closure system.

Fastening devices and materials were then studied to determine if their use in a closure system would result in marginal or inadequate performance.

Several devices and materials were employed on this program as noted above, and most were found to be demonstrably adequate. Some commercial items, such as speed hooks and some loops should be qualified for military use. Their strength and method of attachment could be improved for body motions which require extreme deformation of the upper and maximum forces to maintain closure (i.e., squatting, rapid deceleration).

The consideration of hook and loop material as a closure candidate, however, required the assessment of the materials' fatigue performance in the absence of available engineering data.

#### E. Hook and Loop Material Evaluation

A simple test program was evolved, equipment was designed and built and an evaluation of hook and loop material adequacy was performed. The test equipment and test samples are shown in Figure 36 and 37.

Criteria for adjudging performance were based upon the degradation of the opening or peel force of new material over an anticipated life cycle of two years. Assuming four closures per day and a safety factor of two, a test was established to determine the material's ability to withstand 3000 repetitive closure cycles without a significant reduction in peel force. The peel force was used as a criterion because it is the weakest force in the system, and peeling is the method most likely to inadvertently open the closure. The shear and tensile response of the material are on the order of 5 to 10 psi and not considered to be a problem for military requirements of body forces and motion which influence footwear closure.

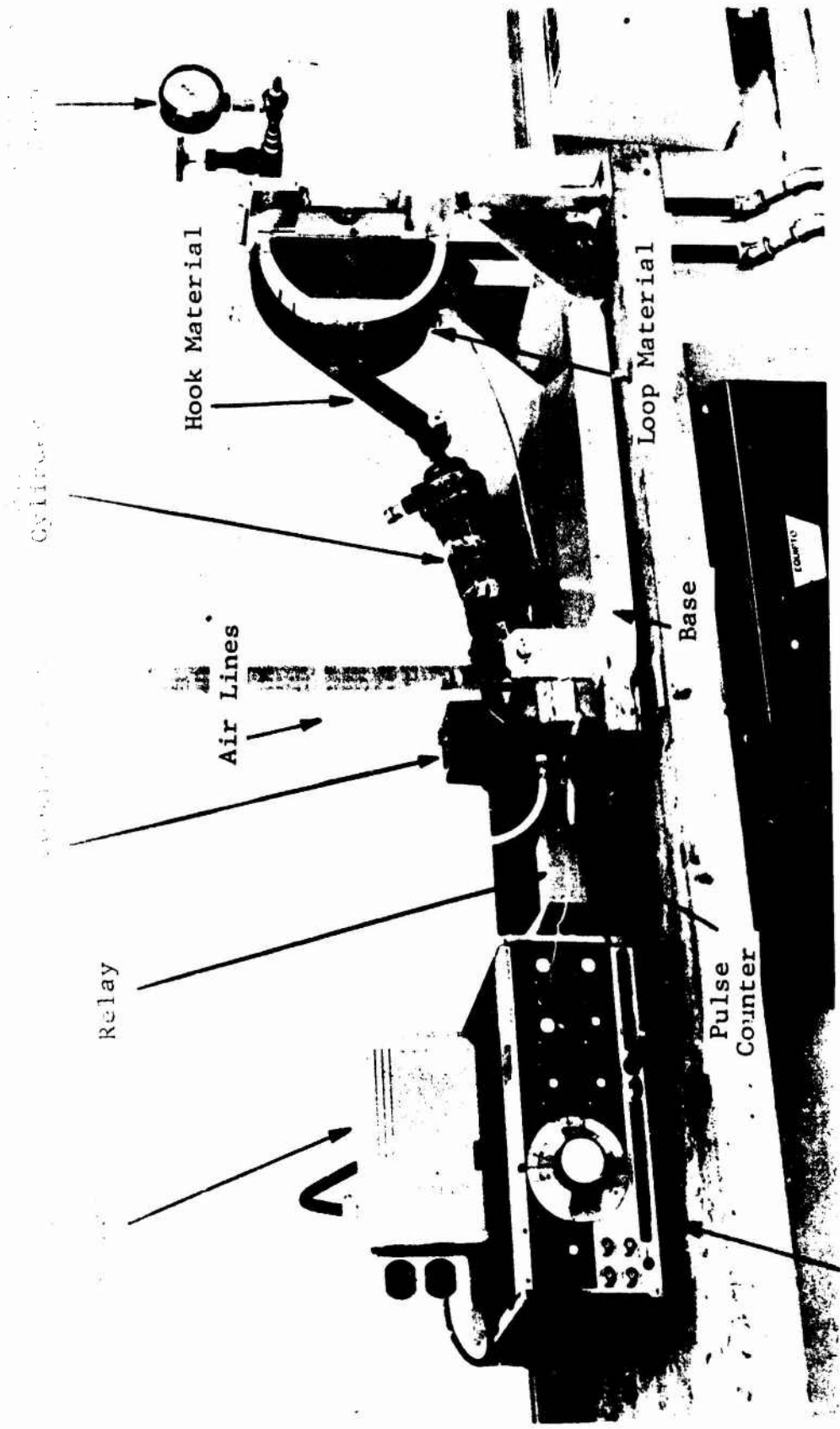

Waveform Generator

Figure 36 TEST FIXTURE FOR HOOK AND LOOP MATERIAL.

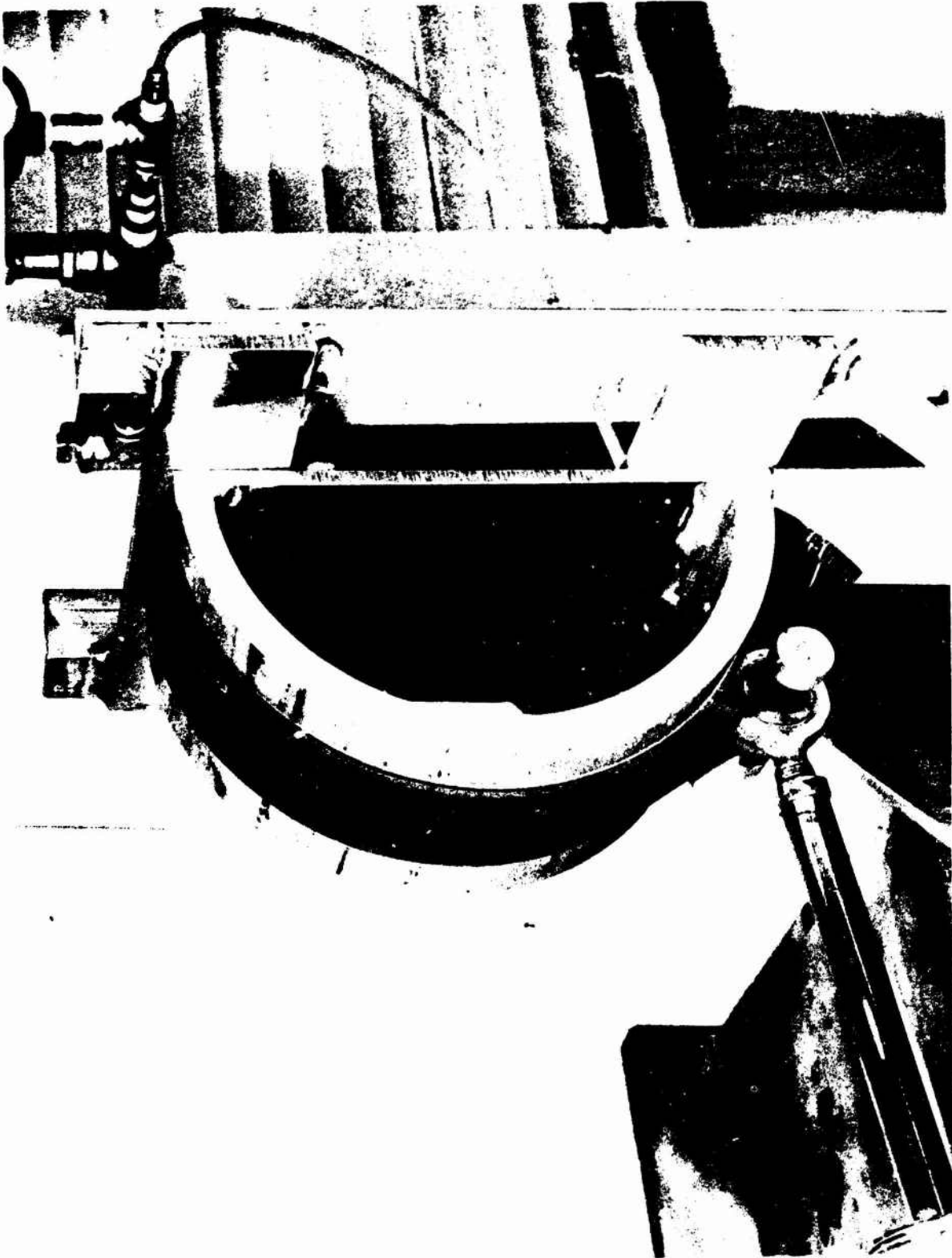

Figure 37 CLOSE-UP OF ANVIL ON TEST FIXTURE,  
MATERIAL IN CLOSED POSITION

The hook and loop material was tested in all nylon, all polyester, polyester hook and nylon loop, and nylon hook and nomex loop combinations for a variety of hook sizes ranging from #65 (.008" dia.) to #100 (.0125" dia.). The materials were tested in belts of one-and two-inch widths for dry, water wet, mud dry, and mud wet conditions. A series of 17 samples, Table 1, were tested.

Results of the experiment indicate the peel forces for the two-inch-wide test samples, ranging from two pounds in the original condition to one pound in the degraded condition, can be expected for all but one of the materials. Figures 38 and 39 are based on the arithmetic means of a series of four replicate runs of each test and indicate that all hook and loop materials are suitable dependent upon the final design (contact area). One reservation is noted as applied to wet nylon/nylon configurations where peel force reductions on the order of 50% were recorded in the wet but new condition and continued to degrade in the wet and used condition.

Tests with mud, Mississippi Buckshot Clay, Figure 40, did not seem to degrade response any further than the experience in the wet condition, Table 2, and returned to dry condition response after brushing.

The initial one-inch-wide samples which were tested yielded data of similar range (i.e., one-half the value of the two-inch-wide samples) but had greater scatter. A subsequent series of one-inch sample tests reduced the data scatter, Figure 41.

## 6. FINAL MODELS

The footwear models or final prototypes presented in this section represent versions of the concepts which were presented in the previous text. These versions include one style of leather upper and three styles of traction aids combined into three integrated footwear models. The models are lasted and bottomed semi-manually. Bottoming is accomplished with the aid of Direct Molded Sole (DMS) equipment to prove feasibility of mass production.

The models incorporate commercially available hardware and fastening material. Suggested vendor sources are contained in Appendix C.

The outsoles of the models do not incorporate the optimum material for the design but rather is the product of a "trade-off" between available bottoming equipment and material which is compatible with the Ro-Search DMS process. This is particularly true for the versions of Concept No. 2 and No. 3 which have thick soles. These versions could be

Table 1

HOOK AND LOOP SAMPLES

<u>No.</u>	<u>Width Inches</u>	<u>Hook Part No.</u>	<u>Loop Part No.</u>	<u>Manufacturer</u>
1	2	Nylon 200-080-660-0199-AA	Nylon 200-001-660-0199-AA	Velcro Corp.
2	2	Polyester 200-084-330-0199-AB	Nylon 200-001-330-0199-AA	Velcro Corp.
3	2	Polyester SJ3405 Hook D	Polyester SJ3404-2"	3-M Company
4	2	Nylon 200-065-0106-AA	Nylon 200-001-660-0199-AA	Velcro Corp.
5	1	Nylon 100-080-660-0199-AA	Nomex 200-001-660-0199-AA	Velcro Corp.
6	1	Same as No. 5	(Nylon/Nomex)	
7	1	Nylon 100-080-660-0199-AA	Nylon 100-001-660-0199-AA	Velcro Corp.
8	1	Polyester 100-080-660-0199-AA	Polyester 100-001-660-0199-AA	3-M Company
9	2	Same as No. 1	(100% Nylon)	
10	2	Same as No. 1	(100% Nylon)	
11	2	Same as No. 1	(100% Nylon)	
12	2	Same as No. 2	(Polyester/Nylon)	
13	2	Same as No. 3	(100% Polyester)	
14	2	Same as No. 3	(100% Polyester)	
15	1	Same as No. 5	(Nylon/Nomex)	
16	1	Same as No. 7	(100% Nylon)	
17	1	Same as No. 8	(100% Polyester)	

- Sample 1 - 100% Nylon
- Sample 2 - Hook Polyester
- △ Sample 3 - 100% Polyester
- Sample 4 - 100% Nylon

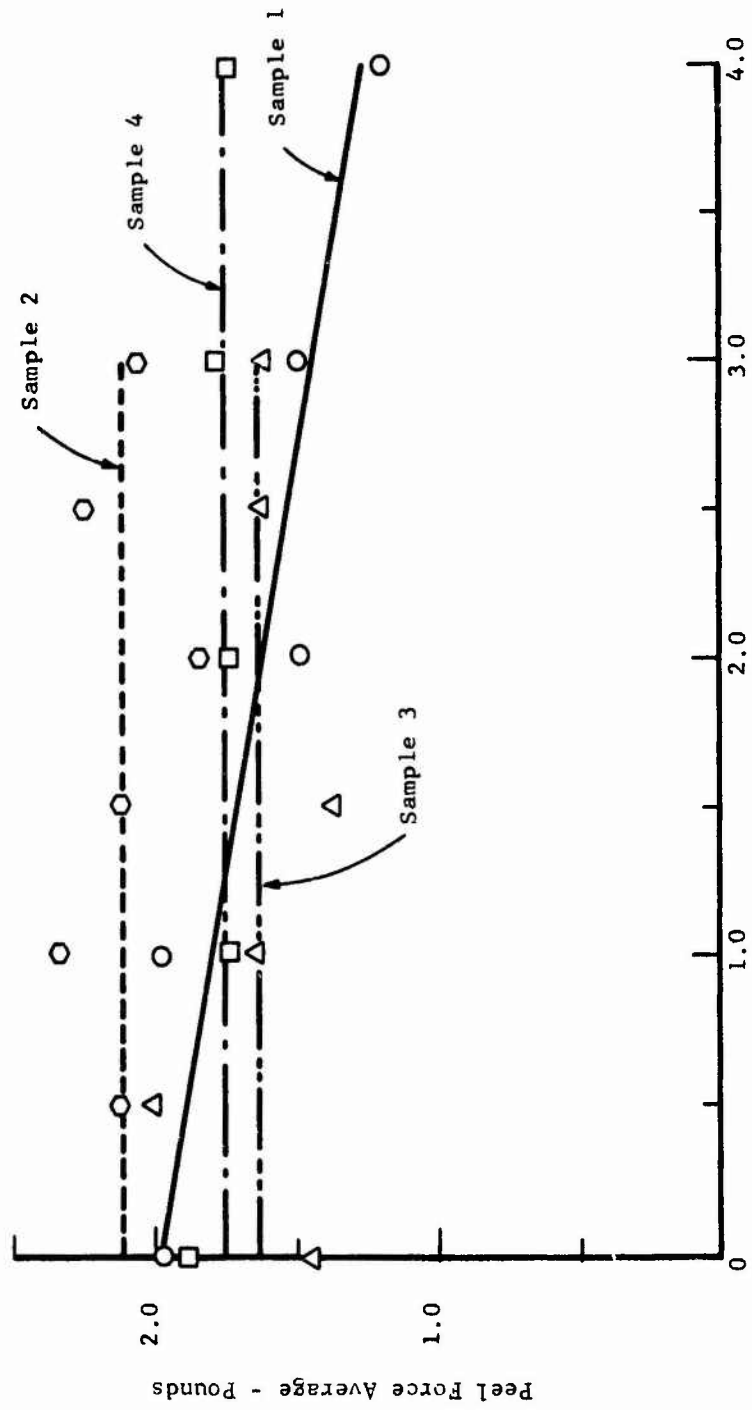

PEEL FORCE VS. WEAR FOR 2" WIDE HOOK AND LOOP FASTENER - DRY CONDITION  
 Cycles  $\times 10^3$   
 Figure 38



- Sample 1 - 100% Nylon, Dry
- △ Sample 3 - 100% Polyester, Dry
- Sample 9 - 100% Nylon, Wet
- Sample 14 - 100% Polyester, Wet

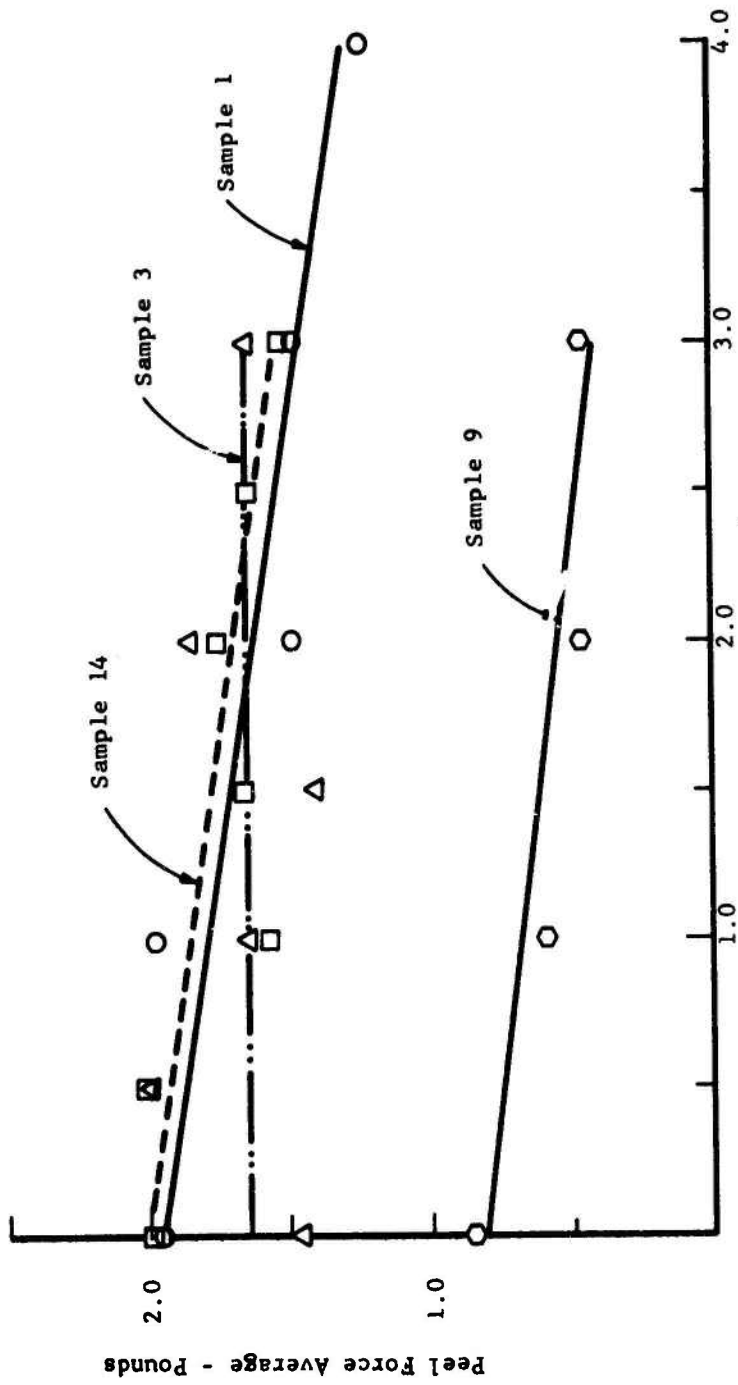

PEEL FORCE VS. WEAR FOR 2" WIDE HOOK AND LOOP FASTENER - WET CONDITION  
 Cycles 1 x 10<sup>3</sup>  
 Figure 39

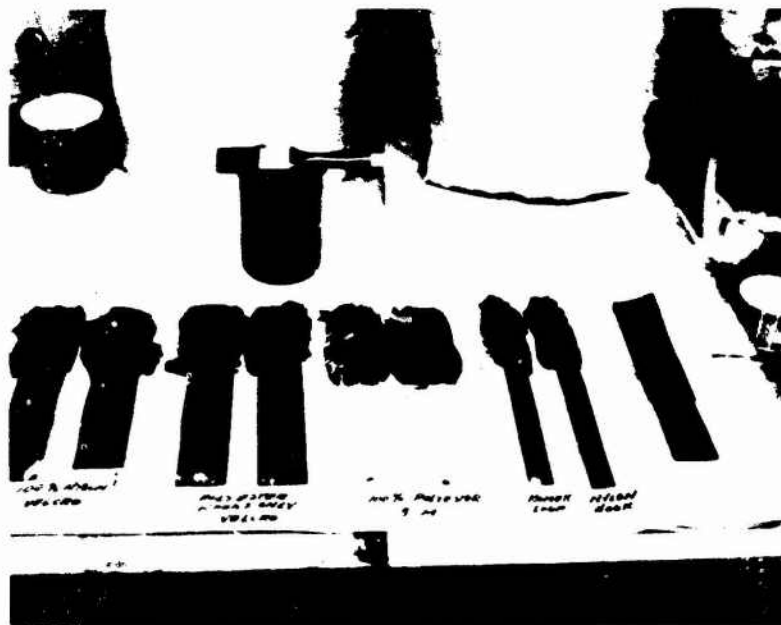

A

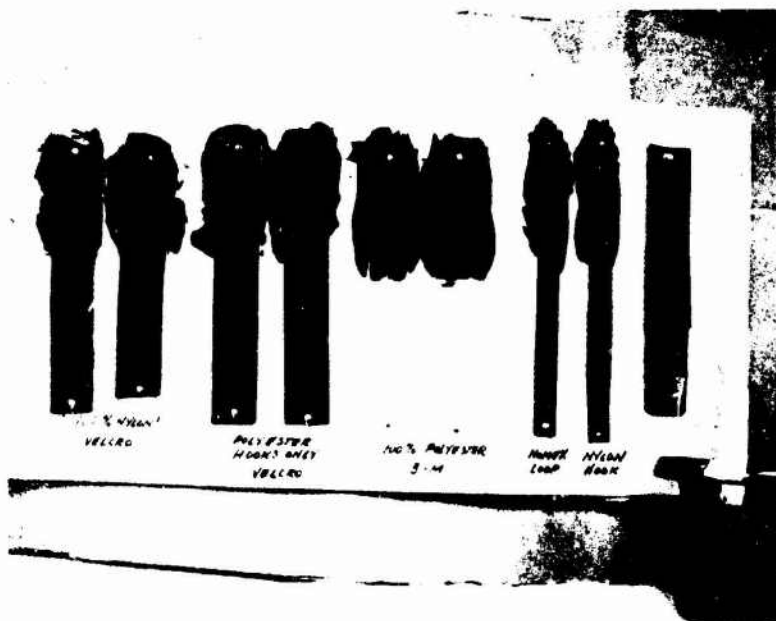

B

Figure 40 VARIOUS HOOK AND LOOP TAPE SAMPLES  
PAINTED WITH A MUD SLURRY



Table 2  
 EXPERIMENTAL DATA FOR 2" WIDE HOOK AND LOOP FASTENER  
 MUDDY CONDITION

Sample No. Condition	10		11		12		13	
	Actual Readings Lbs.	Arith- metic Mean Lbs.	Actual Readings Lbs.	Arith- metic Mean Lbs.	Actual Readings Lbs.	Arith- metic Mean Lbs.	Actual Readings Lbs.	Arith- metic Mean Lbs.
Original	1.5 to 2.0 1.5 to 2.5 1.75 to 2.25	1.92	1.5 to 2.0 1.75 to 2.25 1.5 to 2.0	1.92	1.75 to 3.0 1.5 to 2.75 1.5 to 3.0	2.25	2.0 to 2.5 2.5 to 2.75 2.0 to 2.75	2.42
Fastener Apart Mud Dried	0.5 to 0.75 0.5 to 0.75	0.63			1.0 to 1.5 0.8 to 1.5 1.0 to 1.5	1.21	0.5 0.4 0.5	0.47
Hooks Dried and Brushed	1.5 to 1.75 1.5 to 1.75	1.63	1.5 to 1.75 1.0 to 2.0 1.5 to 1.75	1.58	2.0 to 2.5 2.25 to 2.5 2.0 to 2.0	2.21	1.0 to 2.0 1.25 to 1.75 1.0 to 1.75	1.46
Hooks and Loops Dried and Brushed	1.75 to 2.0 1.75 to 2.25 1.75 to 2.25	1.92	1.75 to 2.0 1.85 to 2.0 1.5 to 2.25	1.88	2.5 to 3.25 3.0 to 3.5 2.5 to 3.0	2.96	1.75 to 2.25 1.75 to 2.5 2.0 to 2.5	2.12

- Sample 15 - 100% Nylon Nomex
- △ Sample 16 - 100% Nylon
- Sample 17 - 100% Polyester

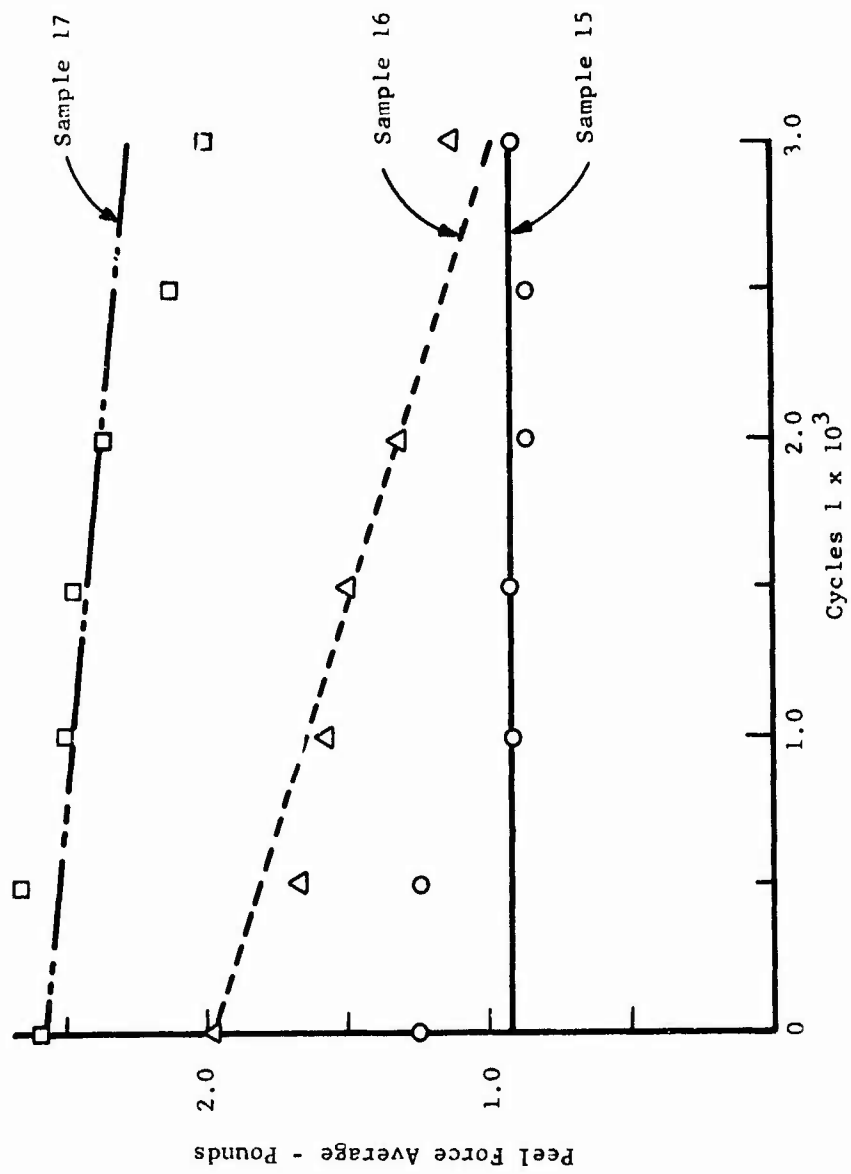

PEEL FORCE VS. WEAR FOR 1" WIDE HOOK AND LOOP FASTENER - DRY CONDITION

Figure 41

better demonstrated in a blown outsole material with a weight that was comparable with the Standard Boot.

The following text describes the prototypes and discusses the related manufacturing. The test is illustrated by drawing and through photograph of the prototypes during fabrication. A total of 20 pair of final prototypes were delivered on the contract. This amount includes 9 pair each of Concept No. 1 and of Concept No. 2, and 2 pair of Concept No. 3.

A. Concept No. 1

Concept No. 1 is a version of the Along-the-Foot with Alternate Fastener of Figure 15. The final version, Figure 42, incorporates the Mil-Quick A hook and loop upper with a lugged chain as a traction aid. The outsole is shown in Along-the-Foot Assembly, drawing E6267-D-100, Figure 43, which requires a set of modified MIL-V upper patterns with a chain pocket, a MIL-V insole pattern and metal parts for the basic footwear construction. Other material necessary for construction includes a tongued buckle for use with a one-inch strap and a military specified Nitrile outsole compound with a specific gravity of 1.2. All other needed material (thread, adhesives, dye, etc.) can be identified from the specification MIL-B-43481B describing the DMS Black Leather Men's Combat Boot.

The Mil-Quick A upper in the final version consists of a standard, 10-1/2-inch-length upper with a box toe, vamp, quarters, back stay, counter, and counter pocket design which is fairly close to the present combat boot. The model differs by deleting the lace eyelets entirely and replacing the tongue with an outside or balloon gusset which is completely stitched from the instep to the top of the quarter. The upper is closed by a series of two one-inch-wide belts and a 5-1/2-inch-wide cuff. One belt, pierced for a tongued single-bar buckle, secures the bottom of the quarters across the instep/vamp area. This belt is intended to be adjusted one time only for fit and should not require readjustment except for an injury such as a swollen or enlarged foot. The second belt and 5-1/2-inch-wide cuff are secured with hook and loop material. The hook material is sewn to the leading edge of the narrow belt with the loop material adjacent. The belt is then threaded through a metal loop secured to the opposite side of the instep and turned back on itself so the hook material is in contact with the loop material. Interference between these hooks and the mating loops provides the fastening forces. The 5-1/2-inch-wide cuff, located at the top edge of the boot, has hook material sewn



Figure 42 CONCEPT NO. 1

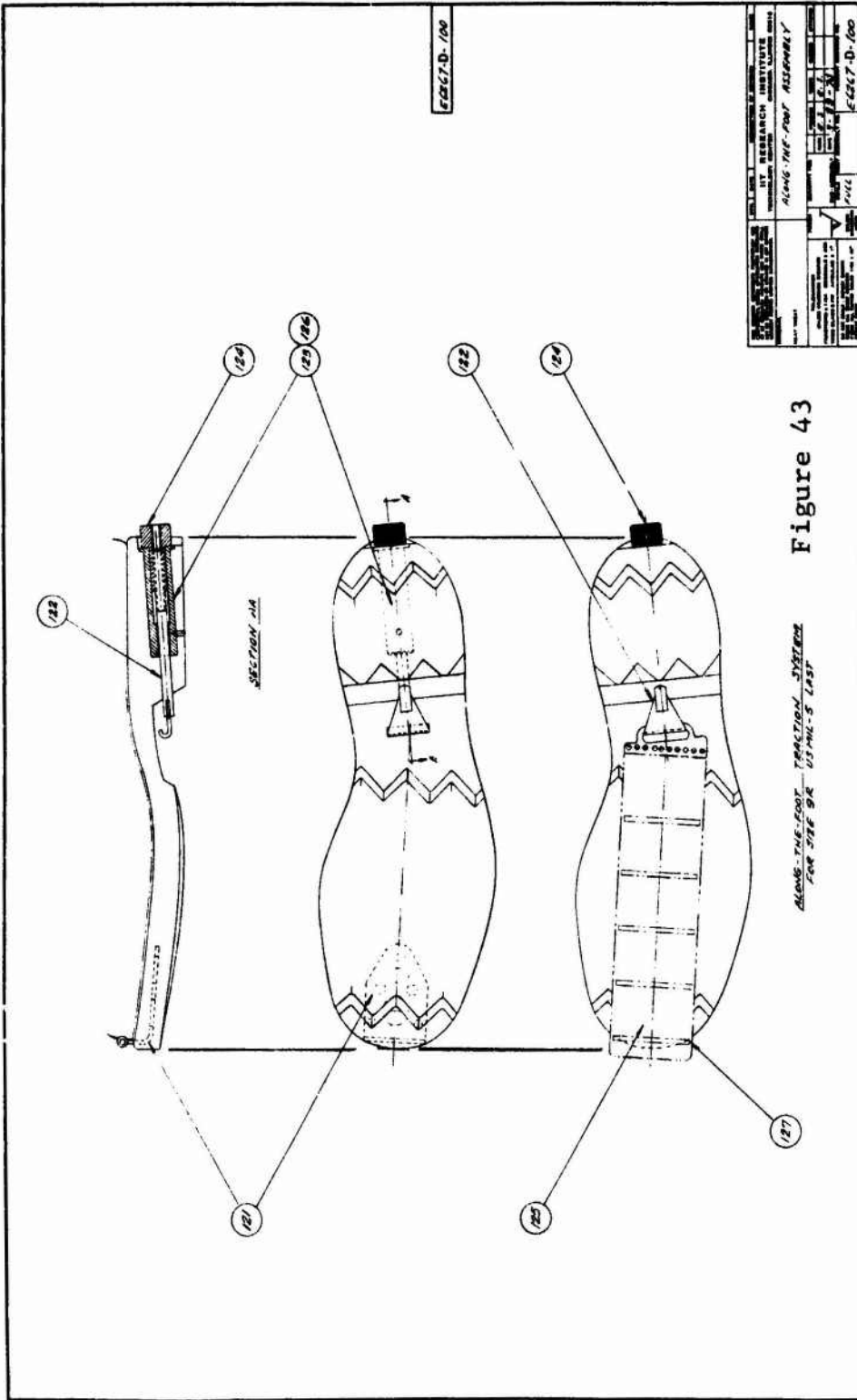

Figure 43

on the inside surface of a flap, attached to the inside quarter. Attachment is accomplished by wrapping the loose flap over the outside quarter until contact is established over the surfaces of the mating hook and loop materials.

The upper is neat in appearance and has a strong resemblance to contemporary footwear in the vamp area. This is noticed especially when the pant leg is worn outside of the boot. The boot upper should also find acceptance among military personnel on the basis of appearance in addition to the quick donning and doffing characteristics.

Donning and doffing are extremely rapid for a high upper boot. Donning over socks without blousing the pant leg can be accomplished in under 10 seconds per pair. Doffing is faster and on the order of five seconds per pair.

Water resistance is also improved with the full-stitched balloon tongue. The additional materials in the cuff and tongue should provide more resistance to penetration (i.e., spiked booby traps) but will also tend to retain body heat and may be warmer during wear.

Fastening forces on the basis of preliminary tests seem to be adequate for the anticipated use environment during ground locomotion.

The selected traction aid outsole concept is a flexible carrier or chain mesh emplaced along the bottom of the outsole which is secured at the toe and instep area of the boot.

In this final version, the traction aid incorporates integrally molded attachment parts providing quick-disconnect ends, one of which is adjustable for fit. The flexible carrier has high wear resistant metal lugs or hobs attached which improve traction through increased shear with the surface media. Interference points are generated when the unit pressure exerted by the lugs during transmission of body force cause failure of the surface in bearing. The chain mesh surface of the carrier adjacent to the mating portion of the boot outsole is textured and interacts with the outsole pattern to reduce slipping. Pretensioning the chain mesh also assures transmission of shear loads to the integrally molded end fixities.

Two storage modes are available in this concept. The first mode requires the instep end of the chain to be unfastened and provides a pocket to store the chain on-foot.



The second mode requires disassembly of both chain ends which permits storage in an off-foot location such as a back-pack.

(1) Manufacture and Assembly

Construction of the footwear models closely follows the conventional process. The patterns are used to mark the leather, lining, and hook and loop material which is then cut and lasted over a MIL-V last into an upper form. The assembly of the buckle is part of that process.

Preparatory to the bottoming of the boot, two metal components, Figure 44, of the lugged chain traction aid assembly are located within the mold cavity. Reference is made to Table 3 which lists the required metal parts for this concept. The Hinge Plate, drawing E6267-B-121, is secured to the bottom of the lasted upper by light tacking. The Heel Sleeve Assembly, drawing E6267-C-126, is then fitted with a spacer or filler plug to prevent filling the inside volume with compound.

Table 3

CONCEPT NO. 1

<u>Qty.</u>	<u>Drawing No.</u>	<u>Description</u>
	E6267-D-100	Along the Foot Assembly
2	E6267-B-121	Hinge Plate
2	E6267-B-122	Chain Hook
2	E6267-B-123	Heel Sleeve
2	E6267-B-124	Heel Adjuster Knob
2	E6267-B-125	Chain Assembly (right and left)
2	E6267-C-126	Heel Sleeve Assembly
2	E6267-A-127	Hinge Pin

Note: Along-the-Foot Traction Aid Parts List for 1 Pair (Drawings and upper pattern have been furnished to NLABS under separate cover).

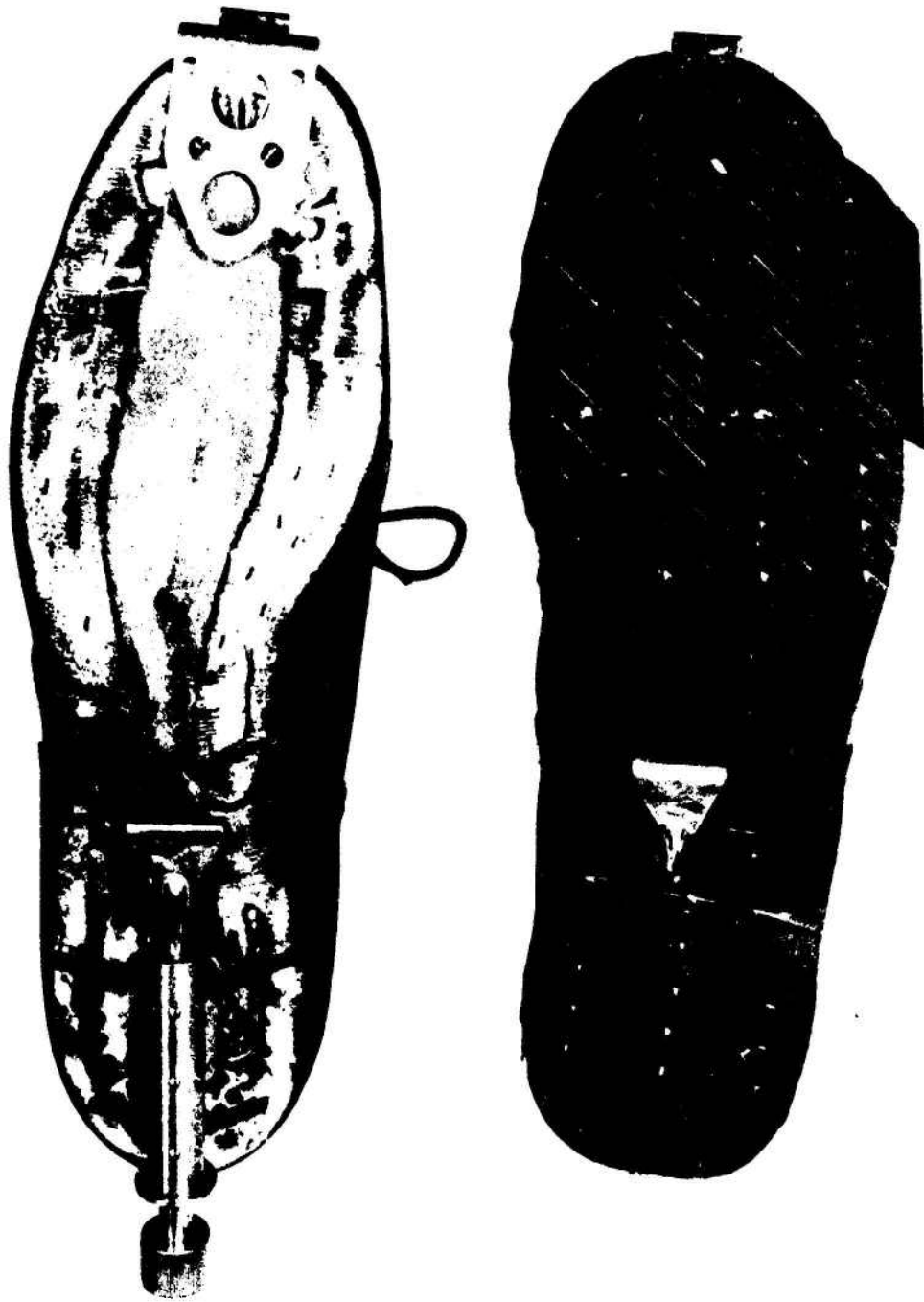

Figure 44 POSITION OF INTEGRAL COMPONENTS CONCEPT NO. 1

The upper is then assembled into the molding machine which contains the bottom shape. The bottom cavity is formed by a sole piston (new chevron design) and modified side mold assemblies. The modifications consist of machining these parts to retain the position of the Hinge Plate and the filler end of the Heel Sleeve Assembly.

Bottoming is accomplished with specially precut segments of Nitrile biscuits placed in the model cavity for molding in the conventional manner. Care must be exercised to assure prepositioning of components as the holding device (roll pins), which inhibit movement of the forepart of the Heel Sleeve Assembly, are hand emplaced and subject to change during die closure. (Production tooling would eliminate unacceptable displacements of these integrally molded components.) Upon release of the dies, the bottomed boot is withdrawn and the plug removed from the Heel Sleeve. The excess rubber flash is removed and the footwear finished in accordance with the military specification.

The traction aid can now be assembled (in the appropriate hand) as shown on the Along-the-Foot Assembly, Figure 43, drawing E6267-D-100. Assembly is initiated with a Chain Hook, drawing E6267-B-122 and a Heel Adjuster Knob, drawing E6267-B-124 being installed in the boot heel.

The Chain Assembly, E6267-B-125, is secured with the hand removable Hinge Pin, drawing E6267-A-127 so that the chain lugs will be in contact with the terrain surface when the footwear is worn. The assembly is completed by laying the Chain Assembly along the boot bottom until it can be engaged with the adjustable Chain Hook. The Heel Adjuster Knob is then rotated to tighten the Chain Assembly to the wearer desired tension.

#### B. Concept No. 2

Concept No. 2 was selected from the illustrated, Cleats in Molded Pockets of Figure 25, discussed earlier. This final version shown in Figure 45, Cleats in Molded Pockets, drawing E6267-D-200 and the prototype model photograph, Figure 46 also incorporate the Mil-Quick A upper.

The upper is essentially the same as the Concept No. 1 differing only in the deletion of the chain pocket. All other upper aspects are identical, and reference is made to the previous discussion for additional information.



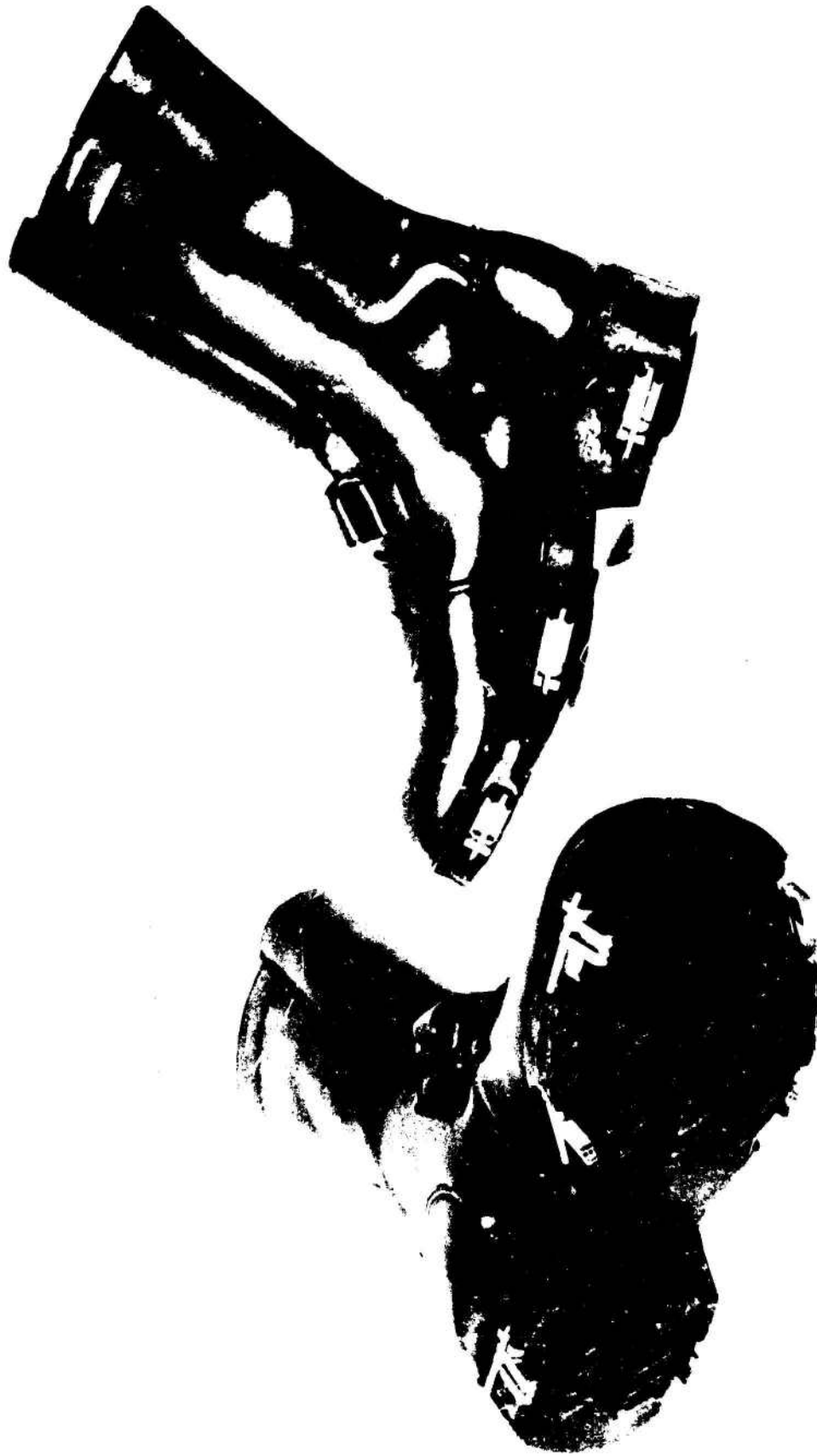

Figure 46 CLEATS IN MOLDED POCKETS CONCEPT NO. 2

The final version of the traction aid is a set of six individual self-storable cleat assemblies contained in an insert which is integrally molded in the outsole. The cleats are retained in both the stored and traction positions by a cantilevered spring lock. This lock is opened and the cleat rotated to the desired position and resecured when the cleat function is changed.

The integrally molded insert acts in the dual capacity of positioning the cleat and as a transferral device for loads.

#### (1) Manufacture and Assembly

The preparation for bottom molding requires the pre-positioning of the inserts, Figure 47, within the mold relative to the cavity surfaces and the bottom of the lasted upper. To accomplish this, the side molds are modified to accommodate filler plugs that locate the inserts and prevent the insert cavity from filling with outsole compound during molding. A set of wire forms, see Figure 47, are emplaced with the inserts to aid in maintaining their positions while being subjected to forces due to sole piston motion (closing).

Nitrile biscuits are cut in shapes to suit the traction aid inclusion, side molds, piston pattern, and the molding process is then completed.

The boot is removed from the DMS machine after curing and finished in the usual procedure to remove flash. Care must be exercised when scouring in the area of the insert to prevent damage to the pocket edges and retainer spring. (see Figure 45).

The cleats, Figure 45, are assembled by inserting the pin end of the cleat into the insert cavity after the retainer spring is deflected. The cleat is then rotated to use or storage position as desired and secured by engaging the retainer spring in the appropriate slot on the head of the cleat.

#### C. Concept No. 3

Concept No. 3 is derived from the Retractable Gripper of Figure 30. The final version also incorporated the Mil-Quick A upper as described in Concept No. 1, but again, without the chain pocket. The model's outsole configuration is shown in Figure 48, Retractable Gripper, drawing E6267-D-300. This assembly shows all of the metal parts required to



Figure 47 POSITIONING OF INTEGRAL COMPONENTS





construct one-half of a pair of boots. The reader is referenced to the text of Concept No. 1 for detailed description of the uppers. A photograph of the final versions is shown in Figure 49.

The traction aids for Concept No. 3 are a four-member set of hinged retractable grippers on each boot. The grippers are retained in the operating and storage positions by a friction lock which is molded into the outsole. The grippers are metal forms that incorporate hardened material at the contact surface. They are designed in a configuration so normal body weight will cause the surface failure of hard packed ice and snow. This embedment into the surface provides the interference between outsole system and terrain material that is necessary to transmit locomotion shear and inhibit sliding. The grippers are intimately nested with the outsole shape in the storage and use positions to inhibit potential interaction with brush or other material which may catch and cause a misstep.

#### (1) Manufacture and Assembly

Bottom molding of Concept No. 3 requires prepositioning the four-tube Weldment Assemblies for molding within the outsole cavity, Figure 50. It is essential that each tube assembly position be maintained with respect to the outside surface of the finished outsole to assure adequate gripper location or nesting in the functional and storage positions. Tube Weldment location is assured by inserting four removable pins in the sole piston which serve both to locate and to plug the inside of the tube during molding.

### 7. CONCLUSIONS AND RECOMMENDATIONS

The preceding text, in addition to the drawings and models which have been furnished to NLABS on this contract, has demonstrated the feasibility of designing footwear versions with quick-closure uppers that incorporate traction aids. Further, the footwear has the potential of being applied for combat use. Much development work, however, remains to be accomplished before an acceptable model is ready to be incorporated into the military procurement system. Traction effectiveness, environmental behavior, wearing comfort, and troop acceptance are areas to be investigated.



Figure 49 RETRACTABLE GRIPPER OUTSOLE CONCEPT NO. 3

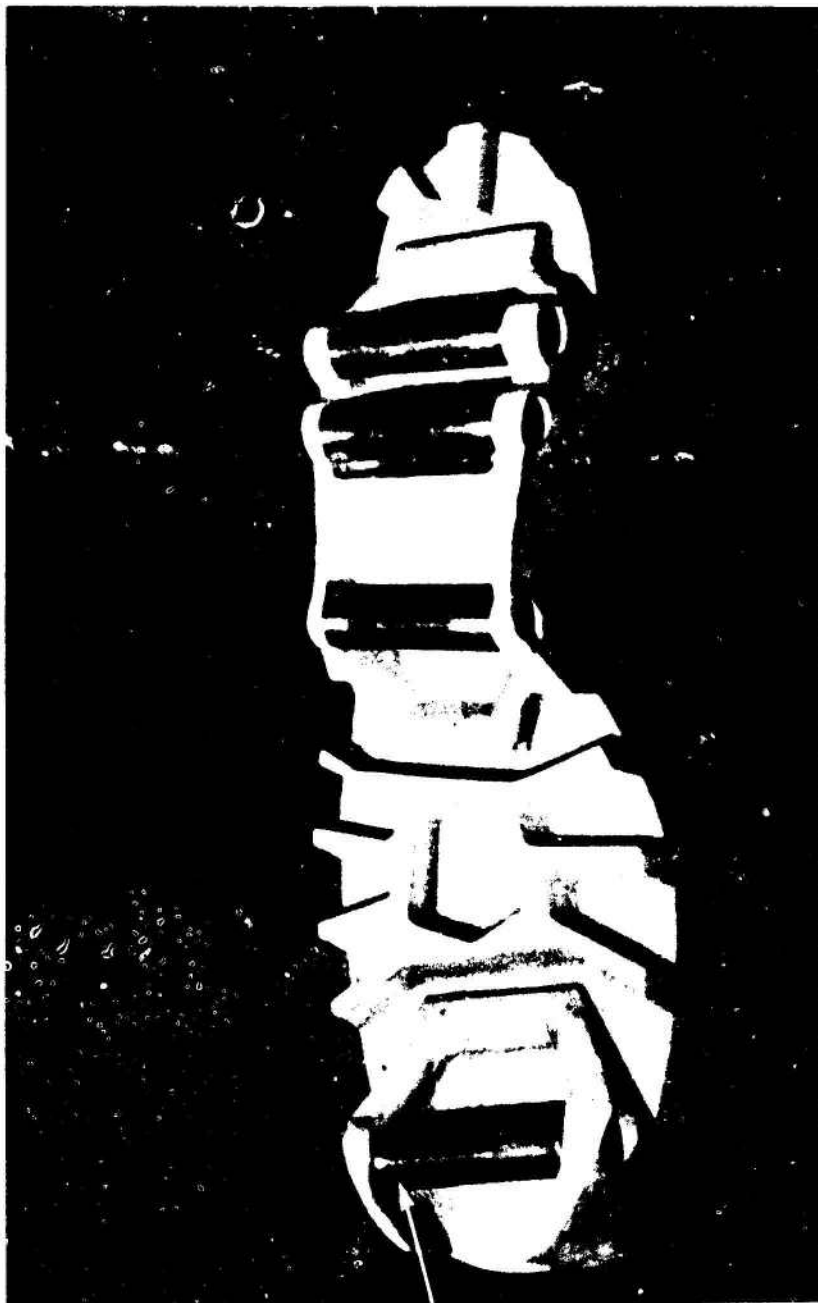

Figure 50 POSITION OF INTEGRAL COMPONENTS CONCEPT No. 3

Inserts simulated for clarity

The evaluation process for footwear is based primarily upon subjective wear tests and requires small lot production to obtain models. These tests, in conjunction with a preliminary evaluation on the NLABS Traction Device\* to obtain some basic engineering information, should provide sufficient data for any required design modification.

Accordingly, the authors recommend the initiation of wear tests for the specified concepts. These tests should be designed to identify the major deficiencies of the development models. A series of model/test iterations should then produce an engineering prototype suitable for field evaluation and subsequent production.

The authors also recommend the further investigation of inflatable footwear. The availability of a lightweight add-on which would provide a capability of effectively locomoting a soft (sand, snow, or bog) terrain surface is very attractive. The technology in materials seems sufficiently advanced that footwear designs can be provided to traverse structurally weak roadways. Design criteria are, however, lacking in this area and must be developed before this premise can be further supported.

Finally, the feasibility of incorporating molded enclosures which can function as attachment points for add-on devices has been demonstrated. These attachment locations have an application for any special purpose footwear device such as ski binding, pole climbing irons, landing shock attenuators, snow shoes and mountain boots. These devices, however, may require a thick sole (up to 1 inch) for proper installation. Accordingly, two other recommendations are made. The first is to investigate the development of a strong lightweight material for use with the molding process (injection or biscuit). Suggestions for the material are lightweight fillers, controlled foams, sandwich construction, and fiber reinforcement.

The second suggestion is to determine the tactical requirements for locomotion requiring special purpose footwear and to then enter the design and development phase for devices.

---

\* A device available in the C&PLSEL Rubber Laboratory

APPENDIX A  
LIST OF PATENTS

## APPENDIX A

List of patents, and their titles, reviewed.

1973

3,793,751	Retractable Spike Golf Shoe
* 3,754,340	Devices for Attaching Heels to Shoe Soles
* 3,717,238	Ski Boot Traction Device
3,731,406	Sport Shoe with Quickly Removable Spikes
3,722,112	Ski Boot Construction
* 3,717,943	Mud Resistant Elastomers
* 3,716,931	Retractable Spike for Golf Shoe
3,710,486	Shoe Lace Securing Apparatus

1972

3,638,337	Shoe Cleat Construction
3,631,614	Antislip Footpiece
3,672,077	Shoe Construction and Method
3,668,791	Fastener for Ski Boots and the Like Footwear
3,668,792	Breakaway Athletic Safety Shoe
3,656,245	Athletic Shoe Cleat
* 3,693,271	Built-in Retractable Ice Spur Device for Shoe Heels
* 3,691,659	Non-Slip Safety Sole Clampons
3,685,173	Crampon
* 3,685,174	Detachable Cleats

1971

3,609,888	Bowling Overshoe
3,616,552	Antiskid Footwear
* 3,618,235	Adjustable Footwear
3,619,916	Athletic Shoe
* 3,623,244	Calked Loggers, Boots
3,626,610	Sport Shoe
3,629,962	Shoe Outsole
* 3,552,043	Wear-Resisting Spikes for Shoe
3,561,139	Ski Boot and Stay Therefor
3,581,414	Athletic Shoe Safety Traction Sole Cleats
* 3,583,083	Traction Implement
3,594,930	Antislip Cam

1970

3,509,646	Shoe
3,494,055	Non-Slip Shoe
3,491,464	Ski Boots
3,545,107	Boot and Shoe Construction
3,545,106	Ski Boot with Mechanism for Tightening the Closure Flaps
* 3,526,976	Interchangeable Sports Shoe
3,526,977	Safety Shoelaces
3,513,571	Football Shoe

APPENDIX A (cont'd)

1969

- \* 3,464,127 Cleated Wading Sandal
- 3,478,447 Shoe Heel with Rotatable Lift
- \* 3,486,248 Overshoe for Spiked Shoe
- 3,432,945 Replaceable Heels for Shoe
- 3,444,632 Resilient Shoe Sole
- \* 3,452,457 Shoe Fastener
- 3,455,038 Renewable Heel for Footwear

1968

- 3,408,752 Sport Boot
- 3,418,733 Shoelace Anchor
- 3,363,342 Ski Boot
- 3,377,723 Adjustable Golf Shoe Heel
- 3,389,481 Expandable Shoe
- 3,403,461 Football Cleat
- \* 3,410,005 Golf Shoe

1967

- 3,355,823 Skid Protector for Footwear
- \* 3,359,659 Detachable Antislipping Device for Shoes
- 3,295,230 Anti-Skid Soles
- 3,299,544 Shoe Heel
- \* 3,327,412 Outsole Having Calks and Method of Manufacturing the Same
- \* 3,328,901 Detachable Golf Cleats
- \* 3,343,283 Retractable Anti-Slip Device for Shoe Heels
- \* 3,303,586 Track Shoe
- \* 3,321,850 Studs for Boots or Shoes
- 3,327,410 Athletic Shoe with Integral Flexible Ankle Support
- 3,333,304 Lacing Device
- 3,316,662 Safety Traction Athletic Shoe Soles
- 3,354,561 Athletic Shoe Having Rotatable Cleat Means
- \* 3,302,227 Method of Producing a Short Shoe Bottom with Fitting Therein

1966

- \* 3,229,389 Gripping Attachment for Boots
- 3,284,931 Sport Shoe
- 3,237,322 Resilient Sole Having Self-Cleaning Suction Cups
- \* 3,237,323 Golf Spike Receptacles and Anchor Plate Combination
- \* 3,267,593 Replaceable Spike for Shoe
- \* 3,258,863 Safety Footwear for Bath or Shower
- 3,259,950 Tensioning Device for a Ski Boot
- 3,262,167 Closure for Footwear Having Interconnected Rotatable Members
- 3,266,112 Permanent Magnet Fastener
- 3,279,015 Shoelace Apparatus

APPENDIX A (cont'd)

1965

\* 3,182,407 Ice Creeper  
 3,193,950 Fastening Means for Shoe Laces  
 3,218,737 Closure for Shoe or Boot Top  
 3,224,118 Ski Boot  
 \* 3,170,251 Antiskid Attachment for Shoes  
 \* 3,214,850 Ice Creeper  
 \* 3,195,246 Spike for Shoes

1964

3,137,952 Shoe Fastening Means  
 3,162,962 Binder Strip for Shoe Uppers  
 3,133,363 Receptacle for Athletic Shoe Cleat or Spike  
 \* 3,133,364 Cleat for Football Shoe

1963

\* 3,095,657 Traction Footwear  
 \* 3,075,307 Shoe Attachment  
 \* 3,076,273 Footwear Traction Attachment  
 \* 3,082,550 Ice Creeper  
 3,078,600 Shoe Construction  
 3,108,385 Tying Means for Shoes and Boots  
 3,084,460 Foot Conforming Shoe Upper  
 3,076,274 Cushion Boot  
 3,099,885 Anti-Slip Device for Boots  
 3,110,971 Anti-Skid Textile Shoe Sole Structures

\* Patents which are most applicable



APPENDIX B  
LIST OF REFERENCES

## APPENDIX B

### List of reference articles reviewed.

1. E. I. DuPont DeNemours Company (Inc.), The Language of Rubber, Elastomer Chemicals Department, Wilmington, Delaware, January 1963.
2. Moakes, R. C. W., "Wear Assessment of Rubber Blends as Soling Compositions", Journal of the IRI, August 1971.
3. Payne, A. R. and Whittaker, R. E., "Recent Developments in the Use of Polymers in Footwear", Journal of the IRI, June 1970.
4. Wilson, A. F. and Mahoney, P. J. (U. S. Army Natick Laboratories, Natick, Mass.) "Development of Techniques for Evaluating the Frictional Properties of Rubber Sole and Heel Compounds", Report No. 71-6-CE, May 1970, AD-713868.
5. Robinson, Danny E. (Aerospace Medical Research Laboratory, Wright Patterson AFB, Ohio) "Horizontal Static Forces Exerted by Men Standing in Common Working Positions on Various Frictions", January 1971, AD-720252.
6. Feoktistov, V. N., Blitman, A. M. and Ryazantseva, L. V., "Development of a New Method for Determining the Wear Resistance of Rubbers", National Technical Information Service, Springfield, Virginia, February 1969, AD-694880.
7. Mahoney, P. J. (U. S. Army Natick Laboratories, Natick, Mass.), "Investigation of Methods for Improving the Frictional Properties of Rubber Compounds Used in Footwear", Report No. 72-2-CE (CPISEL-88), July 1971, AD-733312.
8. Henrie, Gordon C., Major (USAF, Tactical Air Command, Eglin AFB, Florida) "Ventile Anti-Exposure Suit", June 1968, AD-838627.
9. "Individual Combat Clothing and Equipment", Status Report of USMC, Project 42-68-02, Quantico, Virginia, July 1969, AD-854462L.
10. "Walkin' Shoes", Michigan Natural Resources, 1972.
11. Elfes, Gene, "Always Put Your Best Foot Forward", The American Rifleman, November 1930.

APPENDIX B (cont'd)

12. Camp, J. B., Captain, "Quick Donning Flight Boot", TAC Test 67-234, USAF TALC vs. Air Force, 1968.
13. Quinby, Harold R., Pacemakers of Progress, (Chapter 7), Hide and Leather Publishing Company, Chicago, Illinois, 1946.
14. Napadensky, H. and Zaker, T. A., (Armor Research Foundation) "Dynamic Response of Shoe to High Rates of Loading", Final Report, IITRI Project D246 for U. S. Army Corps of Engineers Cold Regions Research and Engineering Laboratory, Contract No. DA-11-190-ENG-127, 1962.
15. Fey, E., Pilkey, W. and Estes, P., "Structural Analysis of Polar Icebreaker Bows", p. 11, IITRI Final Report, Project J6127 for U. S. Coast Guard Headquarters, Icebreaker Design Branch, Contract No. TGC-20035-A, 1968.

APPENDIX C

LIST OF SUPPLIERS FOR  
MATERIALS USED IN FINAL MODELS

HOOK AND LOOP FASTENER

Used in final samples of boots

Hook Tape R.C.U. #84  
#200-084-330-0199 AB

Napped Loop Tape  
#200-001-330-0199 AA

Velcro Corporation  
681 Fifth Avenue  
New York, New York 10022

Other Supplier

3M Company  
Industrial Specialties Division  
3M Center  
St. Paul, Minnesota 55101

METAL BELT

Used in final samples of boots

#B60-38-14 Balanced Weave Belt  
Ashworth Brothers, Incorporated  
P. O. Box 278  
Winchester, Virginia 22601

Other Supplier

Cambridge Wire Cloth Company  
Cambridge, Maryland 21613

LOOP

Used by Ro-Search in fabricating the Mil-Quick A

#3543 - Steel Nickle Plated Loop

E. E. Weller Company  
253 Georgia Avenue  
Providence, Rhode Island 02905

Other Suppliers

C & C Button and Trimming Company, Incorporated  
American Shoe Specialties Company, Incorporated  
318 West 39th Street  
New York, New York 10018

APPENDIX C (cont'd)

Hollander Metal Products Corporation  
Bridgeport 1, Connecticut

BUCKLE

Used by Ro-Search in fabricating the Mil-Quick A

#E-2634 - Black Buckle

Essex Shoe Supply  
P. O. Box 398  
142 Will Drive  
Kenton, Massachusetts 02021

Other Suppliers

C & C Button and Trimming Company, Incorporated  
American Shoe Specialties Company, Incorporated  
318 West 39th Street  
New York, New York 10018

Rhode Island Buckle Company  
192 Georgia Avenue  
Providence, Rhode Island 02905

Hollander Metal Products Corporation  
Bridgeport 1, Connecticut