

UNCLASSIFIED

SECURITY CLASSIFICATION OF THIS PAGE (When Data Entered)

REPORT DOCUMENTATION PAGE		READ INSTRUCTIONS BEFORE COMPLETING FORM
1. REPORT NUMBER 4067	2. GOVT ACCESSION NO.	3. RECIPIENT'S CATALOG NUMBER AD-785 833
4. TITLE (and Subtitle) SAFE DESIGN AND OPERATION OF DEEP-OCEAN SIMULATION FACILITIES		5. TYPE OF REPORT & PERIOD COVERED
		6. PERFORMING ORG. REPORT NUMBER 4067
7. AUTHOR(s) Ralph B. Allnut, Harold B. Prucha		8. CONTRACT OR GRANT NUMBER(s)
9. PERFORMING ORGANIZATION NAME AND ADDRESS Naval Ship Research and Development Center Bethesda, Md. 20034		10. PROGRAM ELEMENT, PROJECT, TASK AREA & WORK UNIT NUMBERS NCEL WR-1-0039 NSRDC Indirect Overhead
11. CONTROLLING OFFICE NAME AND ADDRESS Naval Civil Engineering Laboratory Washington, D.C.		12. REPORT DATE June 1974
		13. NUMBER OF PAGES 81
14. MONITORING AGENCY NAME & ADDRESS (if different from Controlling Office) Director of Naval Laboratories with NAVFAC and NAVSHIPS Washington, D.C.		15. SECURITY CLASS. (of this report) UNCLASSIFIED
		15a. DECLASSIFICATION/DOWNGRADING SCHEDULE
16. DISTRIBUTION STATEMENT (of this Report) APPROVED FOR PUBLIC RELEASE: DISTRIBUTION UNLIMITED		
17. DISTRIBUTION STATEMENT (of the abstract entered in Block 20, if different from Report)		
18. SUPPLEMENTARY NOTES reproduced by NATIONAL TECHNICAL INFORMATION SERVICE U. S. Department of Commerce Springfield VA 22151		
19. KEY WORDS (Continue on reverse side if necessary and identify by block number) Deep-Sea Simulation Facilities Effects of Underseas Pressure Pressure Tanks Pressure Vessel Closures Underseas Technology Underseas Machinery Underseas Engineering Safety of Pressure Tank Facilities <p style="text-align: right;">(See reverse side)</p>		
20. ABSTRACT (Continue on reverse side if necessary and identify by block number) Existing deep-sea simulation facilities are discussed, emphasizing specifications, design, fabrication, installation, operation, and maintenance of the facilities with particular consideration given to their safe design and operation subject to current practical constraints. Where possible reference is made to existing Government and professional codes and specifications which may apply. This report is intended to be a reference that will provide information concerning acquisition and safe operation of facilities suitable for hydrostatic testing of structures and equipment to be used in the ocean depths.		

DD FORM 1 JAN 73 1473

EDITION OF 1 NOV 68 IS OBSOLETE
S/N 0102-014-6601

UNCLASSIFIED

SECURITY CLASSIFICATION OF THIS PAGE (When Data Entered)

UNCLASSIFIED

SECURITY CLASSIFICATION OF THIS PAGE (When Data Entered)

Block 19

Operation of Deep Sea Simulation Facilities

Maintenance of Deep Sea Simulation Facilities

Control Systems for Pressure Tanks

Hydrostatic Pressure Tank

UNCLASSIFIED

SECURITY CLASSIFICATION OF THIS PAGE (When Data Entered)

The Naval Ship Research and Development Center is a U. S. Navy center for laboratory effort directed at achieving improved sea and air vehicles. It was formed in March 1967 by merging the David Taylor Model Basin at Carderock, Maryland with the Marine Engineering Laboratory at Annapolis, Maryland.

Naval Ship Research and Development Center
Bethesda, Md. 20034

MAJOR NSRDC ORGANIZATIONAL COMPONENTS

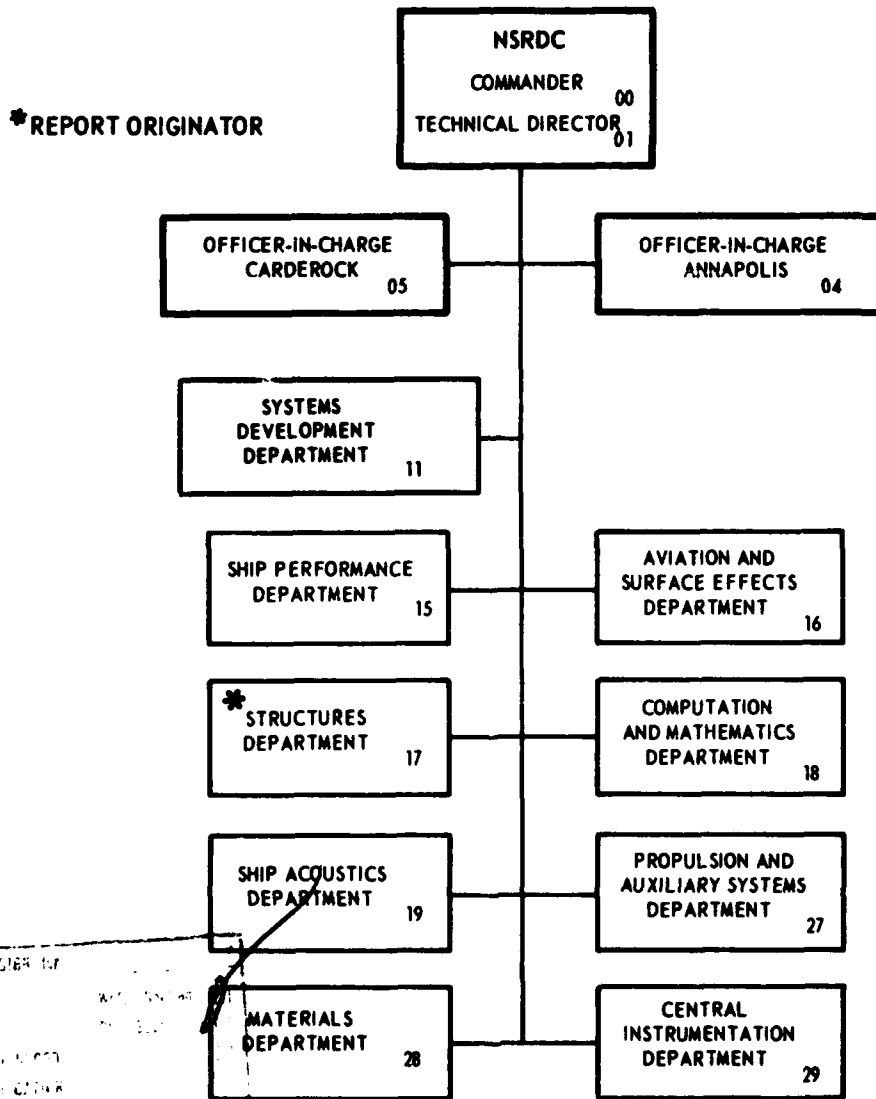

ACQUISITION BY

NTIS
CBC
UNIVERSITY MICROFILMS
SERIALS ACQUISITION

BY
DATE

Div.

A

11-a

FOREWORD

This report about deep-ocean simulation facilities represents the views and specific experiences of the authors and may not represent an official Navy view. The material covers a broad range of technical disciplines, and it is not intended to provide in-depth coverage of all facets. Hopefully, the reader will be provided guidance for obtaining more detailed information in areas which may be of particular interest.

TABLE OF CONTENTS

	Page
ABSTRACT	1
ADMINISTRATIVE INFORMATION	1
INTRODUCTION	1
BACKGROUND	2
SURVEY OF EXISTING FACILITIES	2
PRESENT STATUS	4
BASIC CRITERIA	7
CONSTRAINTS	7
URGENCY AND FUNDING	7
LOCATION	10
TRANSPORTATION	10
PROCUREMENT AND MANUFACTURING	11
TANK DESIGN	11
SHAPE AND ORIENTATION	11
TANK CONFIGURATION	12
DESIGN FACTORS	18
Fatigue Life	18
Brittle Fracture	19
Erosion and Corrosion	20
OPENINGS, CLOSURES, AND SEALS	22
PENETRATIONS AND FEEDTHROUGHS	28
MATERIAL SELECTION	28
COST FACTORS	30
SAFETY FACTORS	31
EXPERIMENTAL STRESS ANALYSIS	32
THEORETICAL STRESS ANALYSIS	33
TANK MANUFACTURE	33
FEASIBILITY	33
MATERIAL	33
FABRICATION	35
INSPECTION AND QUALITY CONTROL	37
Radiography	37
Liquid Penetrant	37
Magnetic Particle	37

	Page
Ultrasonics	38
TANK INSTALLATION AND ACCEPTANCE TESTING	38
PERIPHERAL OR ANCILLARY EQUIPMENT	39
PUMPS	39
PIPES	40
VALVES	43
ACCUMULATORS	45
REFRIGERATION AND HEAT EXCHANGERS	48
SAFE OPERATION OF FACILITY	49
TEST SUPERVISOR	49
INSPECTION BEFORE TESTING	49
EXCLUSION AREAS	49
PROTECTIVE WALLS AND MISSILE PENETRATION	50
HARD VERSUS SOFT CYCLING	51
CONTROLLED IMPLOSIONS	52
EMERGENCY PROCEDURES	52
RECORDKEEPING	53
PROOF-TESTING	53
MAINTENANCE OF FACILITY	54
PERIODICAL NONDESTRUCTIVE TESTS	54
CONTROL OF REPAIRS	54
AMORTIZATION	55
FAILURES OF HIGH-PRESSURE VESSELS	55
INTRODUCTION	55
BRITTLE FAILURES	56
FATIGUE FAILURES	56
FAULTY DESIGN	56
ACCIDENTS	59
CONTROL SYSTEM FAILURES	59
FAILURE OF CONVERTED SURPLUS GUNS	60
HAZARDOUS JET STREAMS	60
EXOTIC APPLICATIONS	60
SYSTEM SAFETY REVIEW	60
SAFETY REVIEW	60
EXTENT OF SAFETY REVIEW AND ANALYSIS PROCEDURES	60

	Page
CLEARING HOUSE FOR SYSTEM FAILURES	61
HOUSING FOR DEEP-OCEAN SIMULATION FACILITIES	62
PRESSURE-TANK ROOM	62
PUMPROOM	62
FIRE PREVENTION	63
MODEL INSTRUMENTATION	65
DATA ACQUISITION ROOM	65
PRESSURE-CONTROL ROOM	65
METALLURGICAL LABORATORY	68
SPECIMEN TESTING	68
SEAWATER AND OIL STORAGE TANKS	68
HANDLING FACILITIES	69
STORAGE AREAS	69
REFERENCES	70

LIST OF FIGURES

1 – Deep-Sea Simulation Facilities; Diameter of 1-Foot or Greater	3
2 – Deep-Submergence Test Facility	5
3 – Cross Sectional View of Deep-Sea Simulation Facility	6
4 – Model of Submarine Instrumented with Strain Gages Being Installed in a Pressure Tank	13
5 – Solid Wall Welded Tank with Segmented Clamp-Closure Ring	15
6 – Multilayer Tank with Closure Head Secured by Threaded Plug	16
7 – Large-Diameter, High-Pressure Tank with Thick Forged and Machined Cylinder with Outer Cylindrical Rings, Shrunk over Inner Cylinder	17
8 – Yoke-Type Tank—No Welding	17
9 – Correlation of Charpy V-Notch Impact Values to Thickness of HY-80 Steel Plates	21
10 – Large-Diameter, High-Pressure Spherical Tank with Interlocking Grooves and Fingers Secured by Radial Pins for Closure	23
11 – Large-Diameter, High-Pressure Cylindrical Tank with Wedge or Shear Bar Closure	25

	Page
12 – Floating O-Ring Seal, Installed in Tank with Segmented Breach Yoke Closure	26
13 – Naval Ship Research and Development Center Feedthrough for High-Pressure Application, 20,000 PSI	29
14 – Typical Stress-Prediction Contours Generated by Computer	34
15 – High-Pressure, Large-Capacity, Two-Speed, Five-Piston Pump	41
16 – High-Pressure Portable Pump and Control System, from 15,000 to 40,000 PSI	42
17 – High-Pressure, Large-Diameter Monel Piping with Large Radius Bends, 12,000 PSI Cyclic Seawater Service	44
18 – Cyclic Loading System	46
19 – Large, High-Pressure Pump, Accumulator, and Piping	47
20 – Brittle Fracture of Pressure Tank	58
21 – Data Acquisition Room	66
22 – Pressure Control Room	67

LIST OF TABLES

1 – Basic Considerations in Determining Pressure-Tank Requirements	8
2 – Basic Considerations in Determining Ancillary Mechanical Equipment Requirements	9
3 – Kinds of Failures	57
4 – Incidents Categorized by Causes of Failure	57

ABSTRACT

Existing deep-sea simulation facilities are discussed, emphasizing specifications, design, fabrication, installation, operation, and maintenance of the facilities with particular consideration given to their safe design and operation subject to current practical constraints. Where possible reference is made to existing Government and professional codes and specifications which may apply. This report is intended to be a reference that will provide information concerning acquisition and safe operation of facilities suitable for hydrostatic testing of structures and equipment to be used in the ocean depths.

ADMINISTRATIVE INFORMATION

The work described herein was initiated by the Naval Civil Engineering Laboratory and was funded by Navy engineering and development funds under NCEL WR-1-0039, Naval Ship Research and Development Center Task 66001, and NSRDC indirect technical overhead funds.

INTRODUCTION

This report has been prepared because a reference is needed that will give information concerning acquisition and safe operation of facilities suitable for hydrostatically testing structures and equipment for use in the ocean depths. It will not cover man-rated "hyperbaric facilities" with their complex life support system nor "ocean test ranges." Many of the *recommendations and practices discussed evolved before appropriate Governmental or professional society design and operational codes were established.* References are made to the codes now in existence.

A deep-ocean simulation facility is normally a land site in which structures, machinery, equipment, prototypes, or models are exposed to such environments as pressure, temperature, seawater corrosion, contamination, or combinations thereof which may affect the equipment or structure during use in the ocean. Existing pressure vessels used for deep-ocean simulation studies, characteristically, have designed operating pressures ranging from several hundred to 30,000 psi, are capable of simulating ocean depths of 30,000 ft or more, and have inside diameters ranging from 1 in. to approximately 30 ft and lengths of as much as 75 ft. Hydrostatic loads are developed in the tanks by pumping with freshwater, seawater, or oil.

Facilities simulating deep-sea conditions provide a means of verifying the reliability and safety of hardware systems and subsystems before they are tried under actual service conditions. Failures can be corrected, and better engineering designs can be made and developed before service at sea. This is particularly important for deep-sea systems; since failures at sea, attended by possible loss of life or the necessity of aborting expensive operations at sea, can result in postponement or curtailment of important programs.

In determining the specific requirements and establishing the basic criteria for the facility, the user should keep in mind that testing at high pressures inevitably involves risk; acceptable levels of risk and associated margins of safety must be determined, based on realistic appraisals. From the standpoint of failure probability, an unmanned, remotely located, test facility, barely adequate to perform one test, would represent the low limit of reliability because the probability of failure would be high. Were it possible to construct a vastly oversized facility, redundantly fitted with all conceivable safeguards, and to interlock and operate it at stress levels so low it would withstand an infinite number of loading cycles at very low temperatures, the probability of failure would approach zero. A host of constraints, many of which are discussed herein, precludes attainment of high reliability through overdesign. The best means of assuring a safe facility, therefore, is restricted to careful design, painstaking quality-control procedures throughout manufacture and installation, thorough and independent failure-analysis review before commencing operation of the facility, and periodic safety review after operations have begun.

BACKGROUND

SURVEY OF EXISTING FACILITIES

In assessing the present state of technology for deep-ocean simulation facilities, it is desirable to determine the numbers and types of existing facilities as well as their use, design considerations, and safe operation. A comprehensive survey of all facilities existing in the United States together with a projection of foreseeable needs was first conducted by the Navy in 1967. The results have been published in Reference 1, Parts 1 and 3, better known by the acronym AUTODOTS, derived from Automated Deep-Ocean Tank Simulation, because the summary listing is computerized. This work has been updated by a survey sponsored by the National Council on Marine Resources and Engineering Development, and an updated listing was published by the Catholic University of America in 1970.² Both surveys have indicated that approximately one-half of the tanks available in Government and private installations, well in excess of 125, are very small, having diameters of 1 ft or less. The basic diameter-pressure characteristics of these tanks are shown by Figure 1. Two additional summaries of facilities which include deep-ocean simulation facilities are given in References 3 and 4. Projected new deep-sea simulation facility requirements are included in Reference 5.

¹Allnut, R.B. et al., "Deep Sea Simulation Facilities," Parts 1 and 3, NSRDC Report 25 (1967). A complete listing of references is given on page 70.

²Heller, S.R., Jr., "Deep Ocean Simulation Facilities of the U.S.," Catholic University of America (1970).

³U.S. Naval Research Laboratory Shock and Vibration Center, "Index of Environmental Test Equipment in Government Establishments" (Nov 1967).

⁴Chief of Naval Material, "Navy Technical Facility Capability Register" (Apr, 1968).

⁵Johnson, J.W. and R.A. Fishkin, "Navy Requirements for RDT&E Test Facilities Through the 1970's," NSRDC Reports 2998-1 and 2998-2 (Mar 1969).

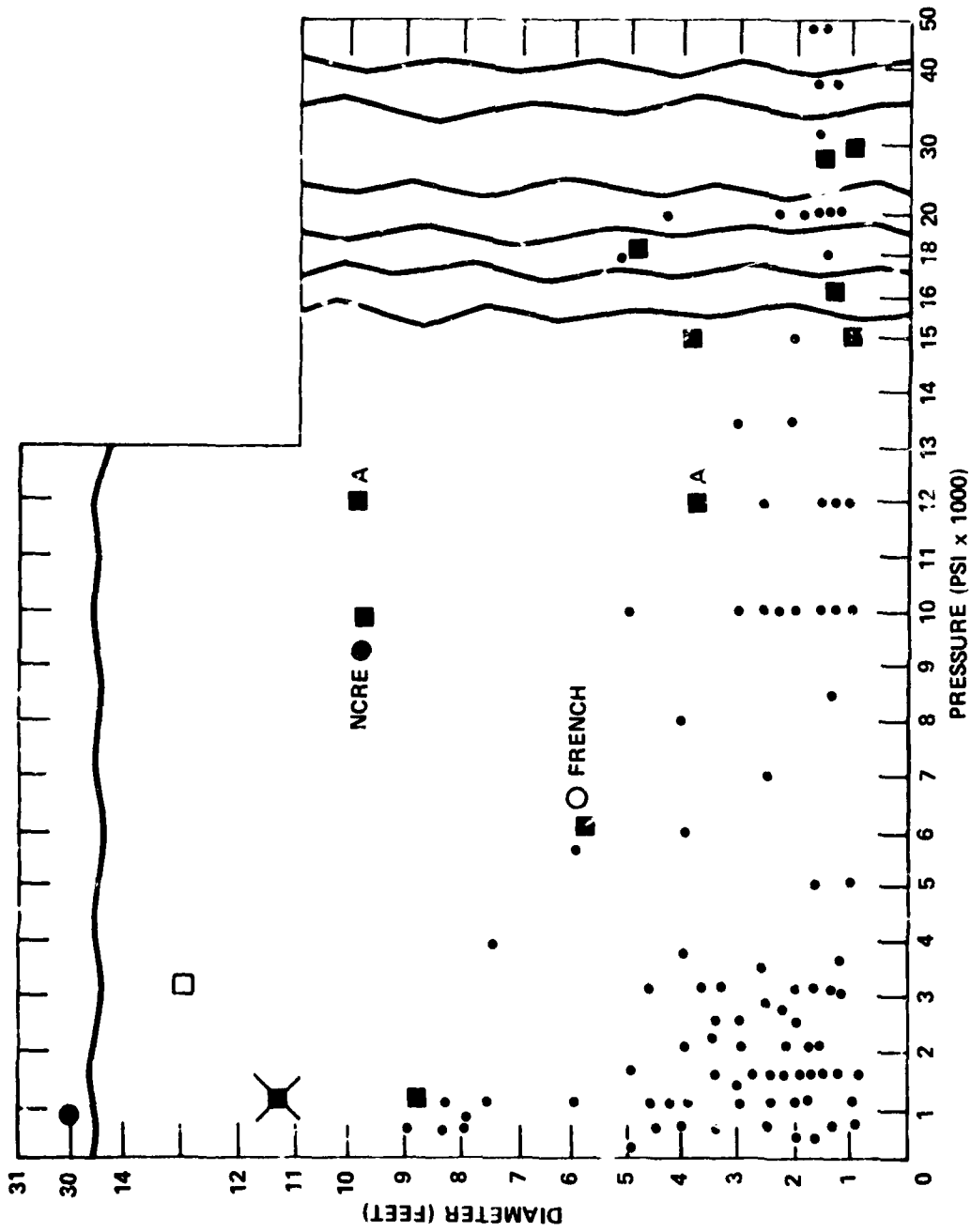

Figure 1 - Deep-Sea Simulation Facilities; Diameter of 1 Foot or Greater

PRESENT STATUS

In addition to the *basic* characteristics, such as diameter, length, static pressure, pressure medium, temperature, cyclic pressure, and rate of applying pressure, most facilities have special features that are augmented by ancillary equipment for accommodating most efficiently the type of tests for which the facility is primarily used. For example, testing submerged machinery requires some method of running machinery under load and no-load conditions and methods of removing heat generated by machinery. If cyclic testing is required, the facility must be designed to accommodate the necessary "hard" pressure cycles. Structural tests require facility provisions for sustaining impact loads due to implosions, resulting from the sudden collapse of test structures, and methods for monitoring strains and deflections of the structure during tests. When cyclic testing is required, methods for conducting both "hard" and "soft" cycling should be incorporated to provide means for increasing the fatigue life of the tank whenever test requirements permit. This is particularly important, since the cost of conducting cyclic tests is related to the rate at which a tank is worn out. Another use, for example, is tests of acoustic transducers when anechoic coatings are required on the tank walls. These are but few examples to illustrate the specialized aspects of these facilities.

The three most commonly used pressure fluids are petroleum oil, potable water, and seawater. Seawater may be either transported from a point at sea to the facility of the user or reconstituted by adding sea salt to potable water. The advantages of oil are that it is a nonconductor of electrical current; hence, oil is favored in testing highly instrumented structures, making insulation (waterproofing) of electrical strain gages and wiring a much easier task than it would be for use in water. The disadvantage of oil is that it introduces a fire hazard, and appropriate fire prevention systems must be added.

Generally speaking, there are four key parts to a deep-ocean simulation facility. They are the

1. Pressure tanks
2. Mechanical system, including pumps, pipes, and valve control equipment
3. Building
4. Instrumentation.

Most existing facilities are used primarily for specialized purposes; however, they may be adapted for other needs. Generally, when used for their designed purpose, they are less expensive and safer to operate. For the near future it is anticipated that new deep-sea simulation facilities will be limited to those fulfilling specialized needs. Figure 2 represents an existing facility of this type, used for verifying the structural design of new submarines prior to construction by testing scaled models and determining their collapse pressure. Figure 3 is a cross-sectional view, showing the arrangement of various parts of such a facility.

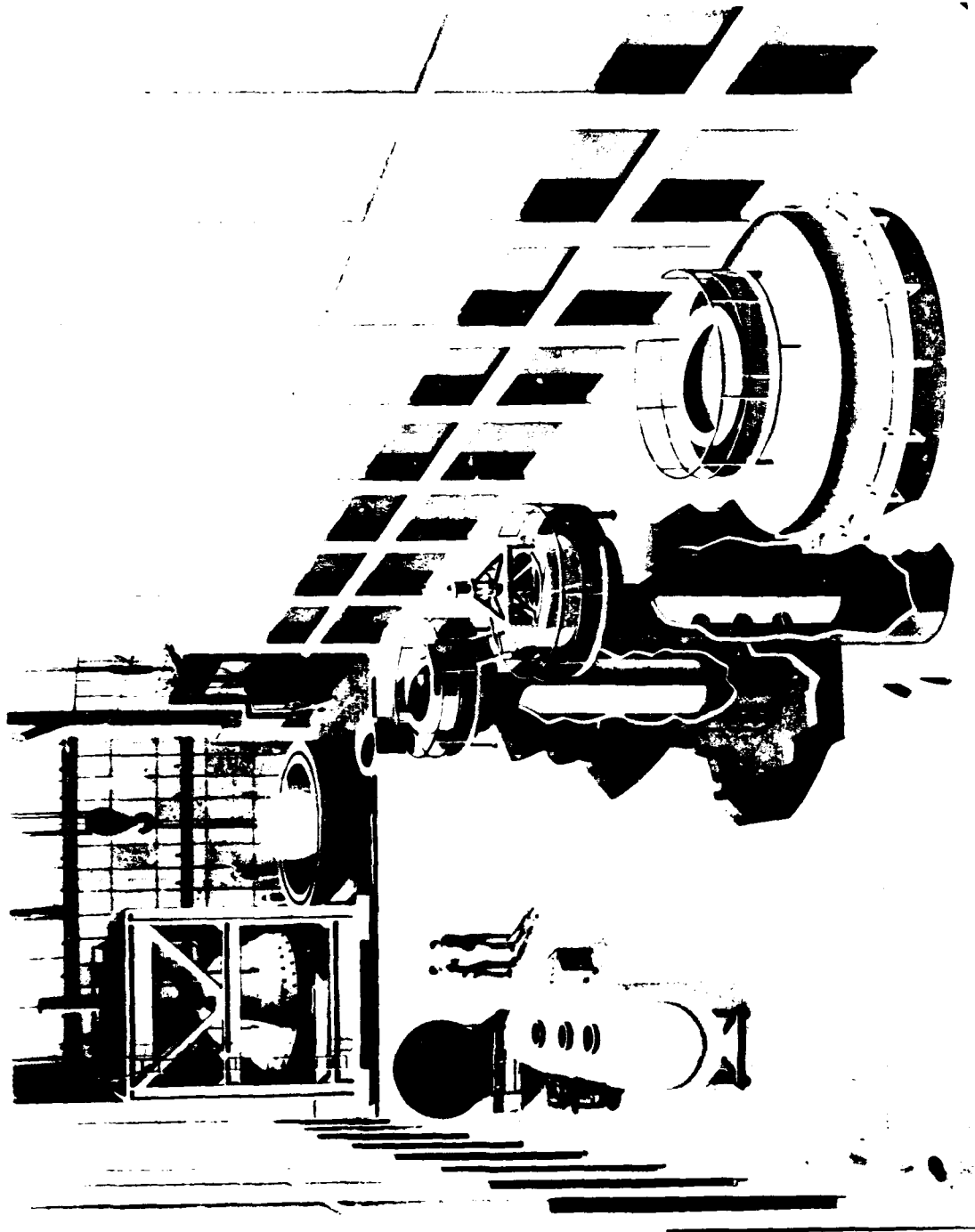

Figure 2 - Deep-Submergence Test Facility

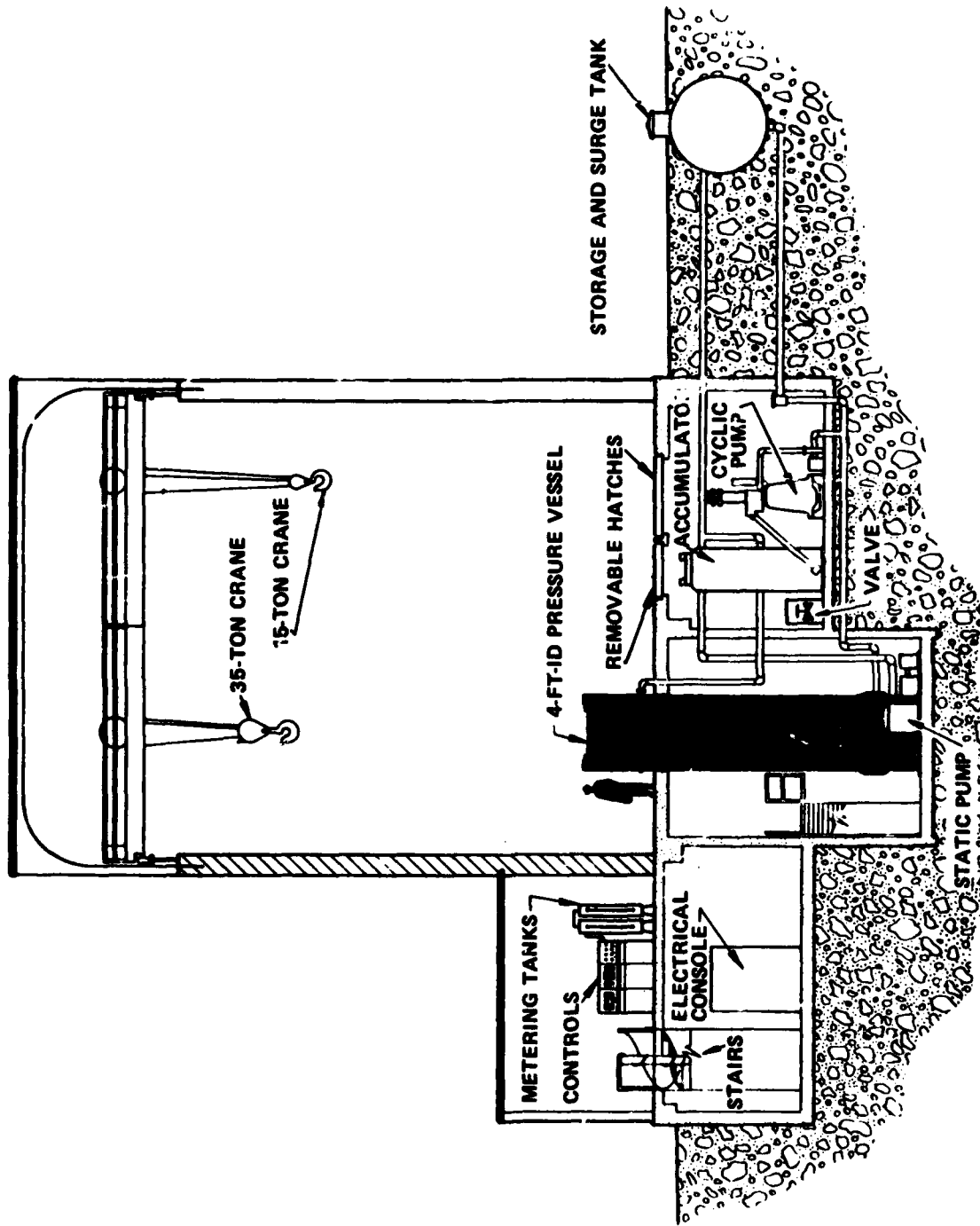

Figure 3 — Cross Sectional View of Deep-Sea Simulation Facility

BASIC CRITERIA

The first phase in establishing a deep-ocean simulation facility commences with recognizing a deficiency that inhibits timely and satisfactory development of technology and/or certification of essential hardware for use in the ocean depths. Once a deficiency is recognized, a complete set of basic criteria must be developed. This is a task normally performed by the principal user activity and is difficult for others to perform satisfactorily. These basic criteria must be related to needs and reconciled with a myriad of constraints in order to achieve a practical facility. The natural tendency to broaden requirements beyond actual need, not only as to size but also as to function, must be avoided; otherwise, both initial investment and operating costs will be increased unnecessarily. A well-defined rationale must be established to define how closely it is necessary to simulate actual prototype environmental conditions in the laboratory to achieve meaningful and reliable results. This rationale should be used in determining whether or not full-scale tests will be required and in obtaining appropriate scaling laws for the desired tests in order to determine facility size and ancillary equipment requirements. Although the current trend in developing advanced systems in many areas of technology has been to build large costly facilities, capable of simulating all of various environmental conditions which the full-scale systems may encounter in service, no such facility for deep-sea simulation has been built to date. Nevertheless, once purpose is determined, the maximum operating pressure and the maximum dimensions of the tank will have a significant effect upon costs, both initial and operational.

The value of a deep-sea simulation facility depends on how well it can simulate operational conditions and the degree to which the test results provide increased reliability and confidence for the prototype system tested. As a rule a great deal of judgment, experience, and technical expertise is involved in making decisions as to the type of facility that will fulfill these requirements in an efficient manner. Failing to do an adequate job at this stage can result in initial costs and operational and maintenance costs that will make the facility too expensive to use. Thus tradeoff studies are important in determining basic criteria for a required facility. A list of some of the basic considerations for determining pressure tank requirements is given in Table 1. Table 2 gives some of the basic considerations for determining requirements for ancillary mechanical equipment.

CONSTRAINTS

URGENCY AND FUNDING

When the primary objective of the sponsor is to acquire a facility for testing an urgently required military system or subsystem, the time allowed for designing and procuring a suitable test facility is minimal; however, MCON (military construction) plans must be initiated from 3 to 5 yr before the facility is required. In either event, future needs must be carefully

**TABLE 1 – BASIC CONSIDERATIONS IN DETERMINING
PRESSURE-TANK REQUIREMENTS**

Considerations	Requirements
Use	Collapse tests, shock loadings, explosive loadings
Shape	Spherical or cylindrical
Size	Length and diameter
Pressure	Maximum and minimum static, cyclic (rate), design, and working
Pressure Medium	Water, oil, seawater, gas, etc.
Temperature	Static (maximum and minimum)
Life	Fatigue life, anticipated usage, and design life
Head Features	Size and time required to open and close tank
Material	Strength, toughness, fabricability, cost
Weight	Foundations, transportation of
Orientation	Vertical horizontal
Seals	Zero leakage at all operating conditions
Penetrations	Size and locations
Feedthroughs	For instrumentation, etc.
Coatings	Insulation and corrosion protection, cladding, painting, anechoic
Safety	Design and construction, operational standards

TABLE 2 -- BASIC CONSIDERATION IN DETERMINING ANCILLARY MECHANICAL EQUIPMENT REQUIREMENTS

<p>GENERAL:</p>	<p>Pressure control system: static and/or cyclic Tank volume Model volume Maximum change of model volume due to pressure loading Maximum change of tank capacity due to tank expansion and fluid compression Model material Fluid media: oil, freshwater, saltwater (static and/or cyclic), and viscosity Temperature range of fluid Overpressure at all operating temperature Pipe flange and size</p>
<p>CYCLIC SYSTEM:</p>	<p>Pressure range Accuracy of pressure loading of tank pressure of model pressure Maximum flow rate from pump Cycle time Pressure program: levels and rate Flow program: maximum flow rate Bulk modulus of fluid media Entrained air in water Maximum velocity in pipes Pipe size: wall and lining Pipe sizes and flow rates: high pressure Size and location of tank pressurization and discharge ports</p>
<p>STATIC SYSTEM:</p>	<p>Pressure range Accuracy of pressure loading Maximum flow rate Time required to reach maximum pressure Location of static system pump</p>
<p>TRANSFER SYSTEM:</p>	<p>Flow rate Tank-fill time Location, size, and lining for fill port in tank Pump location</p>

assessed. Most of the existing deep-ocean simulation facilities owned by the Navy have been obtained to satisfy specific project needs. Recently, new man-rated facilities have been provided by MCON funds. These facilities were procured to fill a void that appeared when new technology or specific items of military hardware were being developed. In the future, if the degree of simulation required approaches closer to reality, the facilities required will become larger, more sophisticated, and expensive. The need for such facilities should be incorporated in all planning documents and should be clearly spelled out so that necessary funding for design and construction will be obtained in time for the anticipated need.

LOCATION

Where new deep-simulation facilities are to be located is a recurring question. Because of urgency and funding constraints, the acquisition of new test sites and/or buildings to house new facilities is not easily accomplished. Oftentimes, relatively minor alterations or additions to existing buildings are all that is permissible. Nevertheless, provision must be incorporated for protective barriers and exclusion areas. Regardless of constraints, there are advantages in erecting pressure tanks in proximity to an established research center that is supported with a well-equipped shop. Properly used, such facilities become valuable research tools; however, they must be located in proximity to a pool of competent research engineers, who are supported by skillful teams of technicians and mechanics. The availability of modern high-speed computers, coupled with a large pool of experienced and skilled analysts, greatly enhances the likelihood of most effective utilization of large, costly, deep-ocean simulation facilities. Further, if ever needed, super large facilities should be available—capable of full-scale testing, located with access to the sea, and having large-sized industrial support—such as a shipyard.

TRANSPORTATION

In procuring large-diameter, high-pressure tanks it must be determined whether or not the total weight and size of the tank will impose restrictions on transporting the fabricated tank or its parts from the plant of the manufacturer to the site of the facility. Because of both large size and heavy weight, the shipping costs of pressure-vessel components can be considerable, particularly if the sections are so large as to require a special vehicle, such as a barge, special rail cars, or drop-bed trucks, and/or a circuitous routing. To obtain a true comparison of bid prices, procurement contracts should require delivery and installation at the site in order to cover all necessary Federal, State, and local permits as well as to assure approved routings and modes of transportation for installation at the facility site. The capability for handling equipment at the facility site and the proximity of railroad terminals, wharfs, and connecting roadways imposes maximum size and weight limitations on the

various components that can be manufactured remotely and shipped to the test-facility site. If field fabrication is required, the problem arises of assuring that adequate quality control is maintained.

PROCUREMENT AND MANUFACTURING

Generally, Government procurement is based on the principle of purchasing any given item, system, or piece of equipment from the lowest bidder. Hence, the specifications must be written in a way that will encourage all qualified bidders with different manufacturing capabilities to bid and yet assure that all necessary requirements are met. The procurement problem for high-pressure facilities is more complicated. It is difficult without incurring premium costs to find a single contractor who has the varied expertise required for certifying material and fabrication as well as for exercising quality control of pressure tanks, high-pressure piping and valving systems, and buildings to assure a high quality, minimum cost, efficient operation, and low-maintenance requirements. This is especially true when pressures exceeding 6,000 psi are involved. The designers of deep-ocean simulation facilities sometimes overlook the limitations of the marketplace. Not only the practicality but also the effect must be considered of specifications upon competitive bidding and transportation, costs of plates, and quality control of material, welding and fabrication, e.g., large castings, forgings, extrusions, and rolled sections. A high degree of selectivity is required to assure that architects, engineers and fabricators are well-qualified in each of the specialized areas required.

TANK DESIGN

SHAPE AND ORIENTATION

Since initial construction and operating costs of a tank increase as a function of volume and pressure, one might conclude that the most efficient shape for a tank is spherical. However, most test structures are quasi-cylindrical, and the most practical and economical tank shape for most applications is cylindrical with either a spherical or ellipsoidal head. The tanks may be oriented in either the vertical or the horizontal direction.

The vertically oriented tank is usually located in a reinforced concrete vault in either bedrock or below grade level. Such installation provides the advantage of an exclusion area and a protective barrier for containing missile fragments in event of failure of high pressure elements of the system.

Another advantage of the vertically oriented tank is that heavily instrumented test models may be conveniently installed in it. It is not uncommon to attach as many as 1500 resistance-type strain gages with miles of delicate leads to these models and then to safely and easily install them in a tank having a minimum internal diameter only several

inches larger than the maximum outside diameter of the model. Figure 4 shows a model, instrumented with strain gages, being installed in a large vertical test tank. The models are customarily supported by an adapter so configured that the model and adapter plate, attached to each other, form part of the tank closure. When required it is practical to install a central shaft which supports numerous deflection-measuring gages inside the models. When tests require complete immersion of the model in the test media, they are simply supported within the tank by either a suspension or a simple stand resting on the bottom of the tank.

On the other hand, most machinery is designed and intended to be operated with its major dimensions and/or axis of rotation in a horizontal plane. The horizontal tank is generally selected for this kind of testing. For tanks which are installed in a horizontal position, installing a submerged structural model in the tank requires a sled or wheeled dolly which serves this purpose well; however, additional clearance will be required. With sufficient clearance, a buoyant model can be installed in a horizontal tank with a counterweighted, cantilevered support and external guide tracks. To close the tank, a gap or a removable section of track is part of the tank-closure arrangement. A second order effect is encountered since the model is cantilevered from its end support, and model buoyancy results in simple compressive stresses throughout the length of the model, excluding, of course, any possible asymmetric model. Flooding models can reduce this effect. When large machinery is to be tested, various adjuncts such as absorption dynamometers are required. These must be accurately aligned and rigidly supported in relation to the device being tested; consequently, an adequate foundation is required.

In addition to the previously described complexities and added costs for the horizontal tank, it is also necessary to empty it completely each time the tank is opened. In the vertical tank, however, the model can be removed for inspection after only a small portion of the pressure medium has been pumped down.

TANK CONFIGURATION

The current position is that adequate safety can be assured through certification of design, materials, and fabrication. At the onset, the designer selects a design that meets the specified need and avoids, insofar as possible, problems of high-stress concentrations; provides high confidence in prediction of stresses; utilizes tough nonbrittle materials; assures uniform material properties throughout; provides quick, full-diameter opening closures; and allows required penetrations. In connection with material certification, the first choice of materials is usually made from those of proven performance in similar applications and similar environments and the second choice is made from those of proven performance in various commercial applications. When it becomes necessary to use materials and components with which there has been little or no operational experience or use, a detailed justification, including the

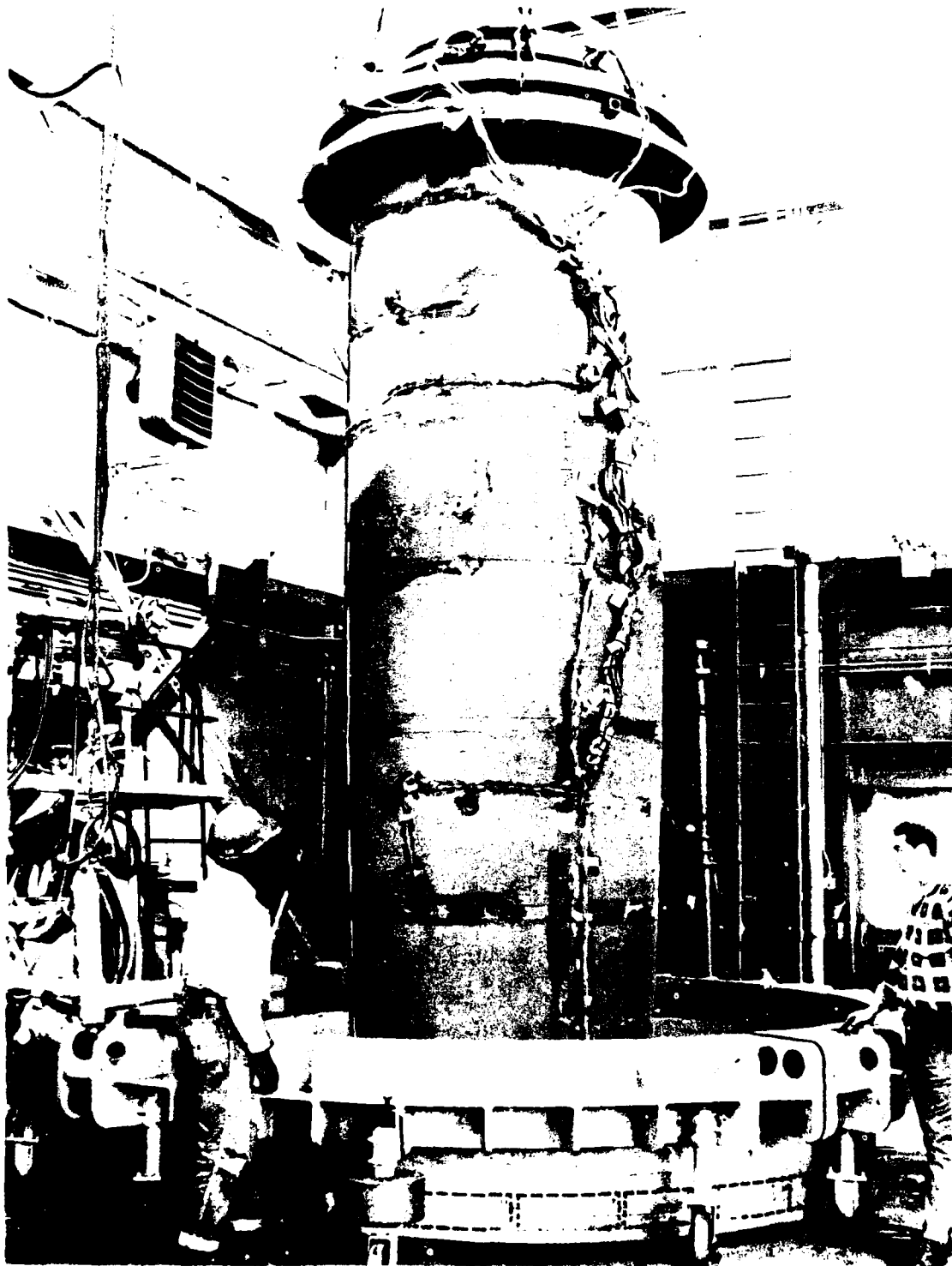

Figure 4 Model of Submarine Instrumented with Strain Gages Being Installed in a Pressure Tank

results of experimental tests, is required of the applicant for certification. Reference 6 outlines the certification procedures for existing and planned deep-ocean simulation facilities.

To accomplish this choice, various tank configurations, materials, closures, and construction concepts are used for high-pressure tanks. At present these range from conversion of 16-in. gun shells and gun barrels; simple cylinders, closed with flat plates held together with tie rods; thick cylindrical forgings with several layers shrunk over one another to form desired wall thickness; to multilayer all-welded construction. Keller⁷ discusses the state of the art of some various configurations, and Stachiw⁸ provides insight to relative merits of various designs.

Some typical tank configurations employed today are illustrated as follows.

Figure 5 shows a large-diameter, cylindrical tank of solid wall construction. The segments that form the cylindrical portion of the tank are welded together with both longitudinal and circumferential welds. Either the elliptical or spherical heads may be spun or the forged orangepeel segments may be welded together. Generally, plate thicknesses to 4 in. or slightly greater are used for this purpose for weldable materials.

Figure 6 shows a multilayer high-pressure tank. This design is advantageous when the ratio of diameter-to-wall thickness is 10 to 1 or less, and the required wall thickness exceeds 6 in. Reference 9 has described the multilayer concept when the thickness of the tank comprises many layers of steel, each progressively wrapped around a cylinder or inner layer by mechanical means. The layers are welded together at the longitudinal seams, which are staggered for each successive layer. The inner shell is made of material ranging from 1/2 to 3/4 in. in thickness; the outer layers, ranging from 1/4 to 3/8 in. in thickness. Small staggered vent holes are placed in each of the thin outer layers and essentially serve two purposes, (1) they provide a means of ensuring by gaging that good contact is achieved between successive layers, and (2) they provide an automatic pressure release in event that a throughcrack develops in the more highly stressed inner layer. This minimizes the possibility of a catastrophic failure caused by initiation of a small undetected crack.

Figure 7 shows a large-diameter, high-pressure tank with thick-forged and machined cylindrical sections, consisting of an outer cylindrical ring shrunk over an inner cylinder to obtain the required wall thicknesses. Generally, for the high-strength HY-80 and HY-100 steels, the maximum thickness of a single forging is limited to 9 in., preferably less, to maintain the desired toughness quality throughout the thickness.

⁶Naval Facilities Engineering Command, "Hyperbaric Facilities General Requirements for Material Certification," NAV FAC Report P-422 (May 1970).

⁷Keller, K.H., "High Pressure Test Chambers—State-of-the-Art," American Society of Mechanical Engineers 68-WA/UNT-8 (Dec 1968).

⁸Stachiw, J.D., "Pressure Vessel Concepts," Naval Civil Engineering Laboratory R666 (Mar 1970).

⁹Schmitz, E., "Multi-Layer Penstocks and High Pressure Wyes," American Society of Civil Engineers Proceedings, Paper 1344 (Aug 1957).

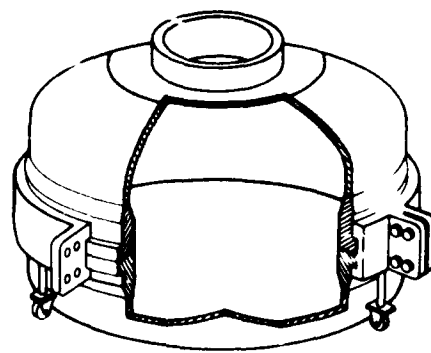
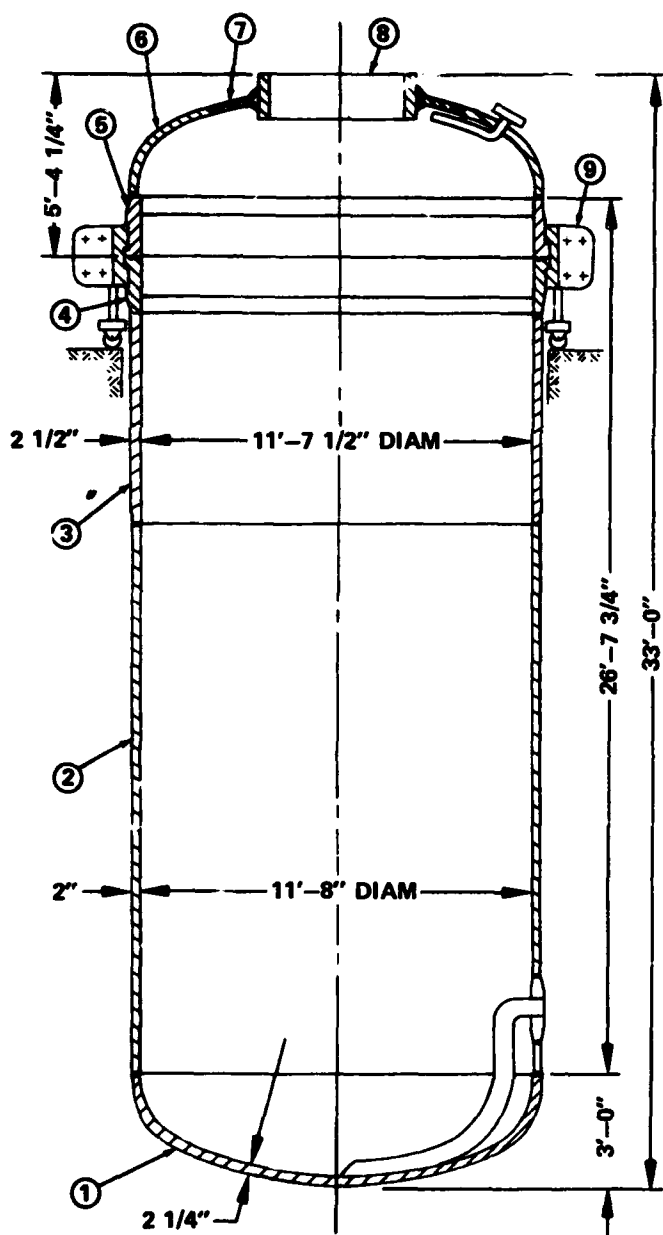

- 1 DISHED HEAD, STS
- 2 LOWER CYLINDER, STS
- 3 UPPER CYLINDER, STS
- 4 INSERT, C-MIL-S-18952, CLASS B
- 5 INSERT, C-MIL-S-18952, CLASS B
- 6 UPPER HEAD, STS
- 7 COLLAR, C-MIL-S-18952, CLASS B
- 8 PORT, C-MIL-S-18952, CLASS B
- 9 CLAMPING RING (4 SEGMENTS) C-MIL-S-18952, CLASS B

NOTE:
WORKING PRESSURE 1200 PSI

12-FT-DIAM, 1200-PSI TANK

Figure 5 – Solid Wall Welded Tank with Segmented Clamp-Closure Ring

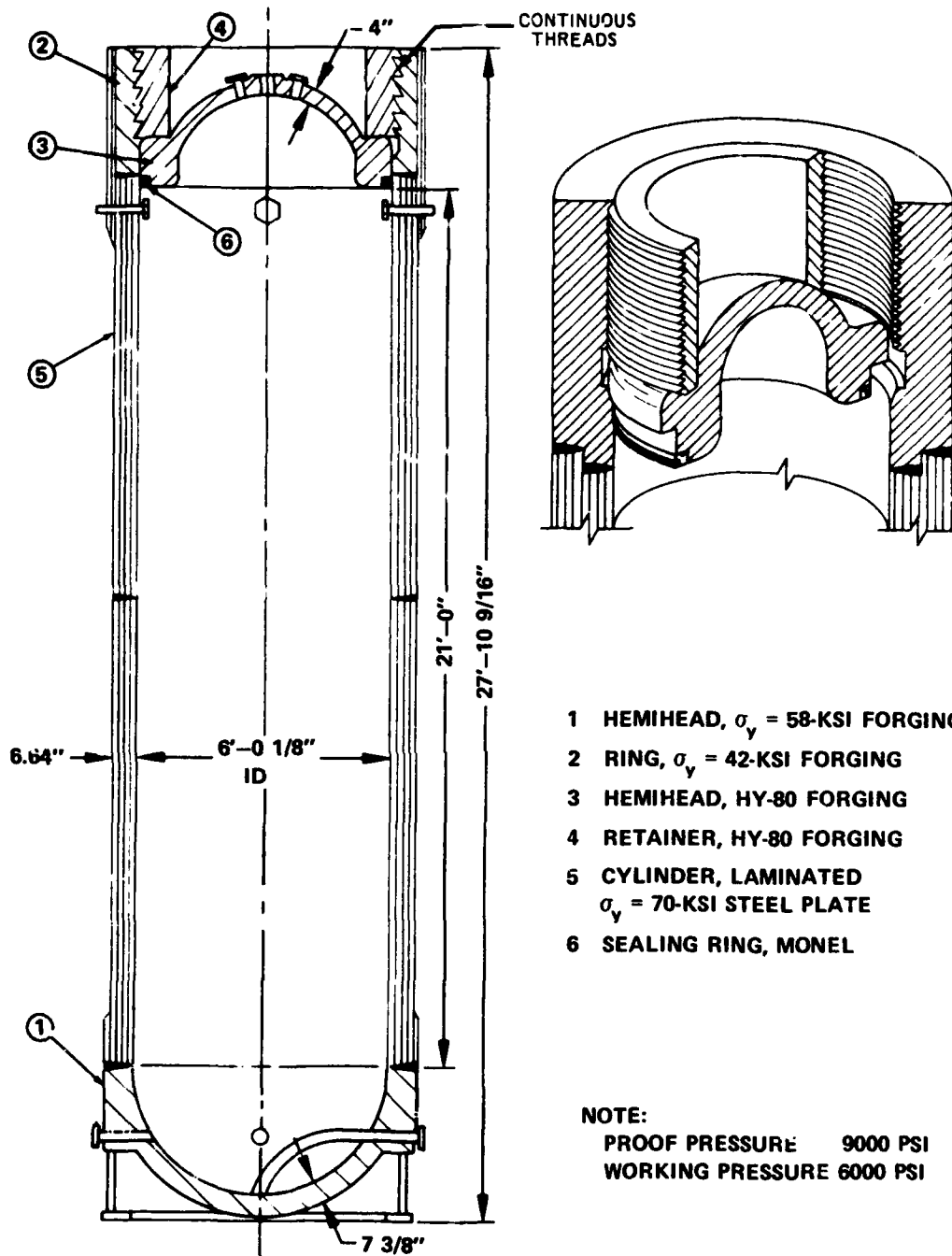

6-FT-DIAM, 6000-PSI TANK

Figure 6 – Multilayer Tank with Closure Head Secured by Threaded Plates

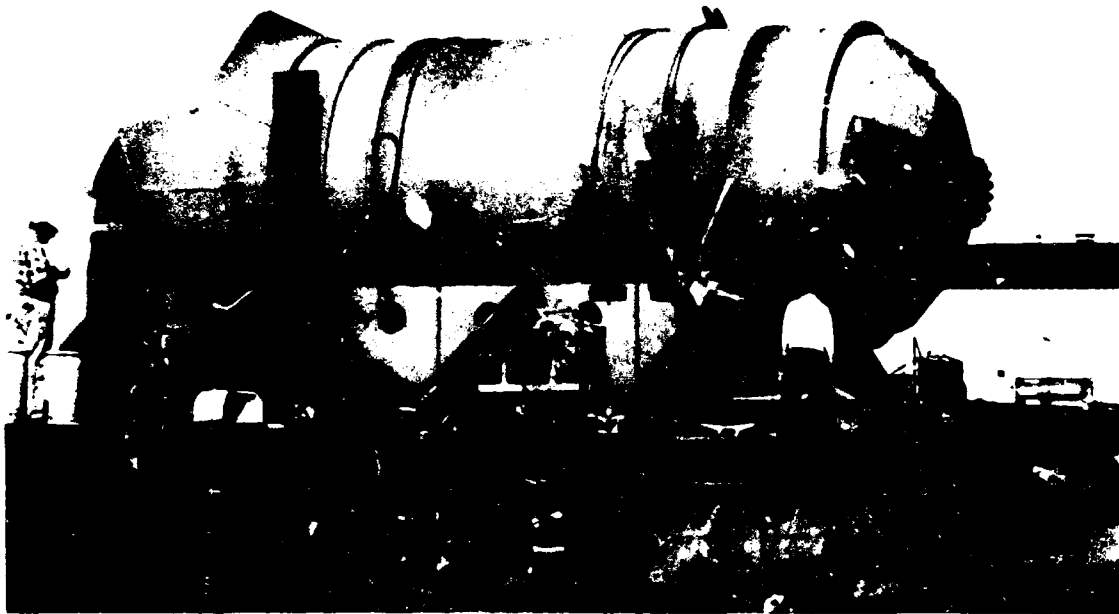

Figure 7 – Large-Diameter, High-Pressure Tank with Thick Forged and Machined Cylinder with Outer Cylindrical Rings, Shrunk over Inner Cylinder

PRESSURE TANK 5-FT-DIAM, 30,000 PSI

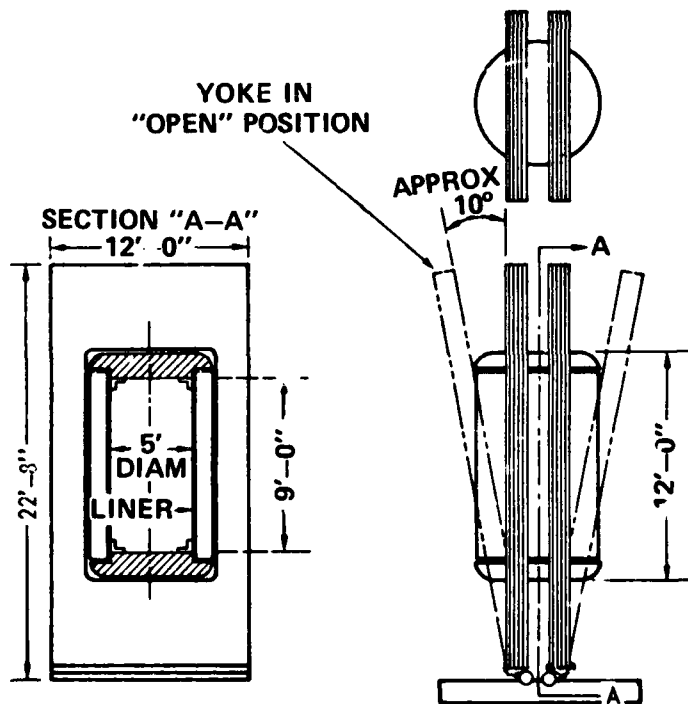

Figure 8 – Yoke-Type Tank—No Welding

Figure 8 shows the yoke-type of configuration where normally no welding is required. The tank consists of a cylinder, open at each end, which is sealed by a plug held in place by an external rectangular frame. This design separates the primary stresses into separate members, minimizes the effects of combined residual and welding stresses, and simplifies accurate stress analysis. However, care must be observed to assure that lateral instability of the yoke plates does not occur. Because of the configuration, the total required weight of steel is greater for this design, and the operation may require additional space and special handling mechanisms.

DESIGN FACTORS

With the basic criteria as a starting point, the tank designer should be able to consider possible modes of failure and to produce a design that will render the desired realistic life. Generally, the designer adequately treats the calculations for predicting strains and stresses and rupture based on inelastic yielding. With current finite element computer-oriented methods, accurate predictions of strain, deflection, and stress can be made; when the methods are applied to an appropriate failure theory, yield rupture can be predicted accurately.

Fatigue, defined as an initiation of a crack in a material as a result of repeated or cyclic loading, and the gradual propagation of the crack under additional cycles of loading must be considered if the number of load cycles are high, or, as in the case of most deep-sea simulation facilities, when the number of cycles are low because localized stresses are high enough to cause susceptibility to low-cycle fatigue at some finite number of cycles of loading. Although the use of high-strength steels allows higher stresses the low-cycle fatigue life of the structure is not increased and as a result may be critical. Generally, cracks initiated by fatigue can be detected before failure by surveillance and periodic inspection, provided a notch-tough material is used.

Fracture usually occurs rapidly and prematurely at relatively low operating pressures without warning and is usually initiated at the edge of a fatigue crack or other flaw in the base or weld material. Generally deep-sea simulation facilities should employ materials with adequate toughness at all operating conditions and temperatures to resist rapid fracture in the presence of cracks or flaws.

Certain elements of designs such as the cross frames, yoke tanks, and cylinder liners may be susceptible to instability failures. These require verification by the designer, and, if they cannot be predicted, model verification may be necessary. Various closure mechanisms may also require model verification.

Fatigue Life

As a rule of thumb, a tank designed to "hard-cycle" models for many years would have to be designed so that maximum primary stress levels reached would be about a third of those

tolerable in a tank designed for static tests only. Therefore, it is important that an estimate of the desired number of loading cycles be made. If the vessel is to be used for cyclical testing, a fatigue analysis is indicated. Even the tanks used only for static testing may accumulate actual fatigue failures if the number of pressure loadings are significant. Projected life should be estimated, based on the fatigue analysis, utilizing cumulative damage theory and the expected usage by the purchaser. The American Society of Mechanical Engineers (ASME) has provided a set of rules that may be applied to determine the advisability of performing a fatigue analysis. These rules appear in Paragraph N-415 of the 1968 edition of Section III and in Paragraph AD-160 of Section VIII, Division 2, of the ASME Code.^{10,11} The maximum peak stresses should be located by experimental measurement and/or analytical procedures. When special materials are used, actual test data may be used in lieu of Section III specifications. For example, test data from smooth and notched specimens of the tank material as well as test data for welded specimens representing the as-fabricated properties of the materials in seawater may be used.

Brittle Fracture

Deep-sea simulation facilities must be capable of employing test-pressure, media temperatures as low as 28 F. The nonductile transition temperatures (NDTT) for some types of steel, which may be used for tank construction, range from approximately -40 F to + 20 F. When load is applied to these steels at or near NDTT, very small flaws become crack initiators and catastrophic failure occurs. Generally, fracture protection is obtained by first selecting a suitable steel; second, applying rules developed for safe design, allowing temperature margins of 30, 60, or 120 deg; third, proper heat treatment during or after fabrication as required.

The degree of dynamic toughness or the ability of a material to resist rapid fracture due to crack propagation is measured in terms of the energy required to break a Charpy V-notch specimen, which in turn is related to drop-weighted tear and explosion-bulge tests. A most important condition, imposed to assure that no brittle material is used, supplements the Charpy V-notch tests by requiring 100-percent fibrous fracturing of the Charpy specimens. Although this is a difficult requirement to negotiate with the manufacturers, its achievement is reasonable, if requirements for material properties have been properly specified and fulfilled, and proper heat treatment has been followed. This factor is so important that materials failing to meet it should not be used in a pressure vessel. The location and direction at which Charpy specimens are taken must be defined to ensure that toughness is maintained throughout the

¹⁰ American Society of Mechanical Engineers, "ASME Boiler and Pressure Vessel Code Section III—Rules for Construction of Nuclear Vessels, Subcommittee of Boiler and Pressure Vessel Committee Report" (1968).

¹¹ American Society of Mechanical Engineers, "ASME Boiler and Pressure Vessel Code Section VIII, Division 2—Alternative Rules for Pressure Vessels" (1967).

material and that it is not brittle at midthickness. When high-strength HY-80 or HY-100 material thicknesses exceed from 6 to 8 in., there is likely to be some degradation of material properties; see Figure 9. Generally, thickness exceeding 9 in. may result in brittle material near midthickness for high-strength, weldable materials such as HY-80 and HY-100. Pellini and Puzak¹² have summarized available knowledge.

Erosion and Corrosion

Erosion is most likely to take place in the pumps, valves, and tank penetrations because the flow velocities of the pressurizing medium is highest in these regions. Erosion is caused by impingement of solid particles borne by the pressure media and by the collapse of air bubbles. Erosion can be controlled by minimizing flow velocities, by filtering pressure media, and by eliminating air from pressure media. Corrosion is due to electrolytic action; hence, the pressure medium should be as poor an electrolyte as possible. That is, seawater should be used only when absolutely essential to the test, and the system should be thoroughly flushed afterward. Likewise, whenever permissible, only oil should be used as a pressure medium for static tests. Corrosion is also minimized by avoiding the use of unlike materials in contact with each other, when such materials are known to produce significant potentials as indicated by the electrochemical series.

Mild steel and various alloys are susceptible to stress-corrosion cracking if subjected to severe tensile stresses, either residual or externally applied, depending on temperature and environment. Such cracks propagate in a plane perpendicular to the axis of tensile stress and can cause failure, even though the stress level is appreciably lower than that necessary to cause fracture in the absence of the corroding environment. In a corrosive environment, alternating or repetitive stress causes corrosion fatigue and cracking to occur, even under relatively small stress amplitudes. Oxygen and water vapor are believed to be contributory to corrosion failure, and hydrogen embrittlement may result. Care should be made in joining pipes, etc., to avoid stagnant areas where these elements may be trapped.

Tank liners are used either to obtain better corrosion resistance than could be obtained with the primary construction material or to provide a replaceable section in the event of wear, e.g., seal rings, erosion, or corrosion. Modern rubber-base coatings are available which provide economical low-maintenance means for protecting the interior of the tank from corrosive effects of seawater. An alternative is the use of Monel liners or Monel cladding. However, Monel is more expensive, and there is reluctance on the part of operators of Monel-lined tanks to use oil for fear that the contamination due to possible sulfur content of oil

¹²Pellini, W.S. and P.P. Puzak, "Fracture Safe Engineering Design of Steel Structures," Naval Research Laboratory Report 5920 (Aug 1968).

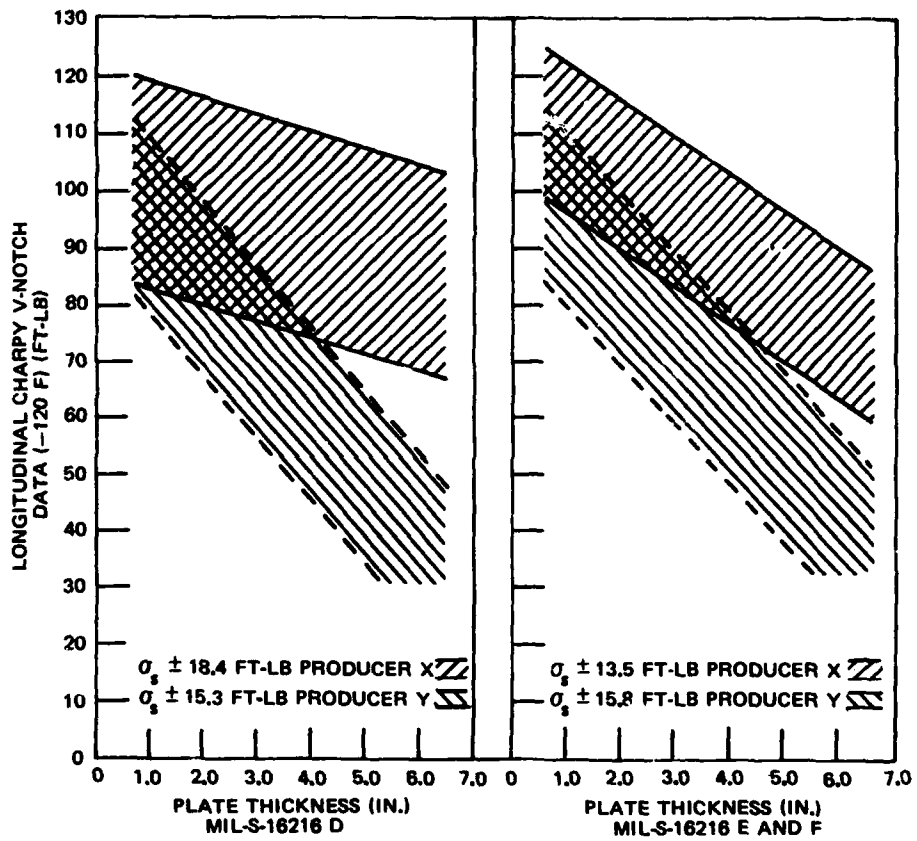

Figure 9 - Correlation of Charpy V-Notch Impact Values to Thickness of HY-80 Steel Plates

would make high-quality welding repairs difficult and expensive. For liners, two precautions are advised: (1) to deter corrosion, avoid incompatible materials; (2) provide sufficient strength so that the liner will withstand negative pressures that may be produced when the tank is drained or when a model is imploded.

OPENINGS, CLOSURES, AND SEALS

The necessity for full-diameter closures that can be opened and closed quickly and inexpensively has challenged the minds of designers and has resulted in a variety of different closures. Invariably, the closure represents one of the most critical areas because it usually requires fabrication of heavier sections, which may cause the material to lack uniform physical characteristics through its thickness—particularly toughness. Also, the shape of the closure may increase stresses in the form of sharp discontinuities, holes, roots of threads, etc. Therefore, it is mandatory that these areas receive special attention in stress analysis, specification, and quality control of material and fabrication as well as possible proof of acceptance through model tests or previous use.

The simplest way to manufacture a closure is to drill and tap holes in the pressure cylinder and to secure the head with a number of bolts, using a simple gasket as a seal. As an alternative, the top and bottom heads can both be secured to the pressure cylinder by a single set of through bolts. Many smaller tanks have functioned satisfactorily for years with this design being used; however, as tank diameters and operating pressures have increased, it has become more and more difficult to provide sufficient cross section in the bolts to withstand the tensile loads that would have to be resisted. Consequently various forms of closures have evolved.

To ensure efficient use of pressure tanks, the removable heads and closures must provide access to the full diameter of the tank. Simple closures were used for some of the earlier tank designs such as screw-on lids with either internal or external threads. For others, simple circumferential clamps were used that secured the lid to the tank. For yet others, a set of bolts was used for either holding the lid on the cylinder or for extending all the way through and clamping both base and lid to the cylinder. Figure 6 shows a refinement of the screw-on lid, resulting in a separate nonrotating top head, secured by a large, male, threaded plug. However, to prevent costly thread maintenance, it is necessary to provide special handling equipment to prevent galling of the thread. Yet another variation of threads is the stepped or segmented arrangement, similar to what is used in gun breaches, which requires only a quarter turn or less and eliminates galling. Care should be taken to avoid high stresses on the first few threads by providing relief on the first thread and variable clearance for the next few threads. Other types of threading include interlocking fingers with radial pins and shear blocks.

Figure 10 – Large-Diameter, High-Pressure Spherical Tank with Interlocking Grooves and Fingers Secured by Radial Pins for Closure

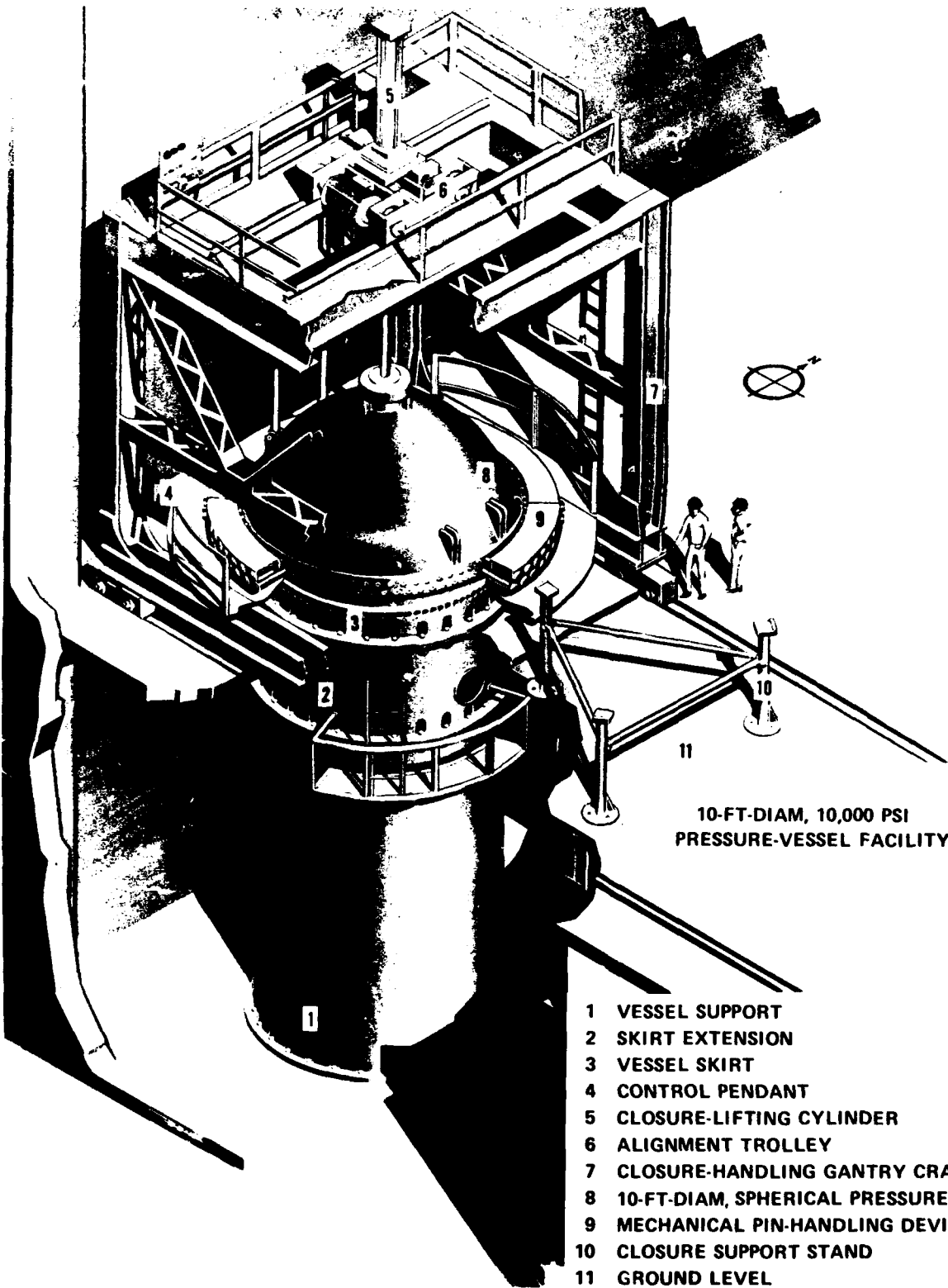

- 1 VESSEL SUPPORT
- 2 SKIRT EXTENSION
- 3 VESSEL SKIRT
- 4 CONTROL PENDANT
- 5 CLOSURE-LIFTING CYLINDER
- 6 ALIGNMENT TROLLEY
- 7 CLOSURE-HANDLING GANTRY CRANE
- 8 10-FT-DIAM, SPHERICAL PRESSURE VESSEL
- 9 MECHANICAL PIN-HANDLING DEVICE
- 10 CLOSURE SUPPORT STAND
- 11 GROUND LEVEL

Figure 10a – Artist's Conception

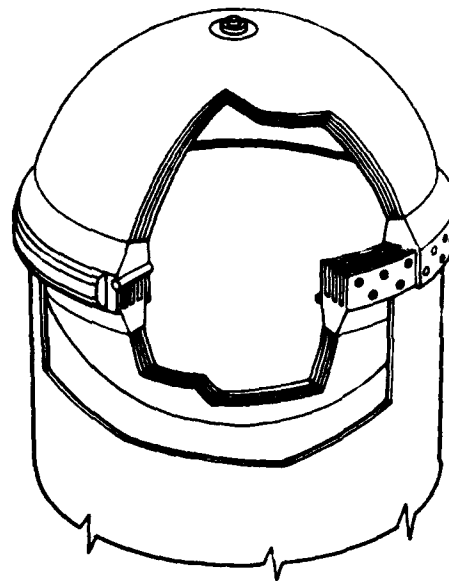
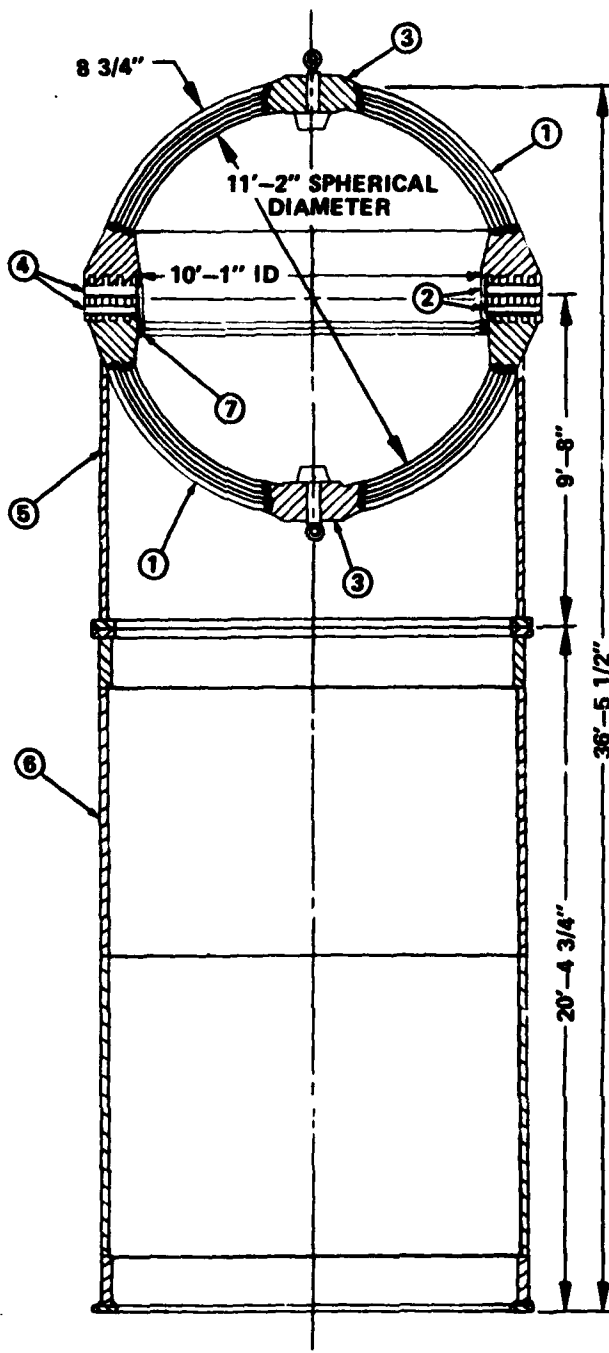

- 1 SHELL, LAMINATED, HY-100 STEEL PLATE
- 2 INTERLOCKING FINGER FORGINGS (TOP AND BOTTOM) HY-100
- 3 PENETRATION FORGING (TOP AND BOTTOM) HY-100
- 4 RADIAL TAPER PINS (86 REQUIRED) AISI 4340
- 5 SKIRT, HY-80
- 6 SUPPORT SKIRT, MILD STEEL
- 7 SEAL, MONEL

NOTE:
 PROOF PRESSURE 15,000 PSI
 WORKING PRESSURE 10,000 PSI

10-FT-DIAM, 10,000 PSI SPHERICAL TANK

Figure 10b - Cross Section

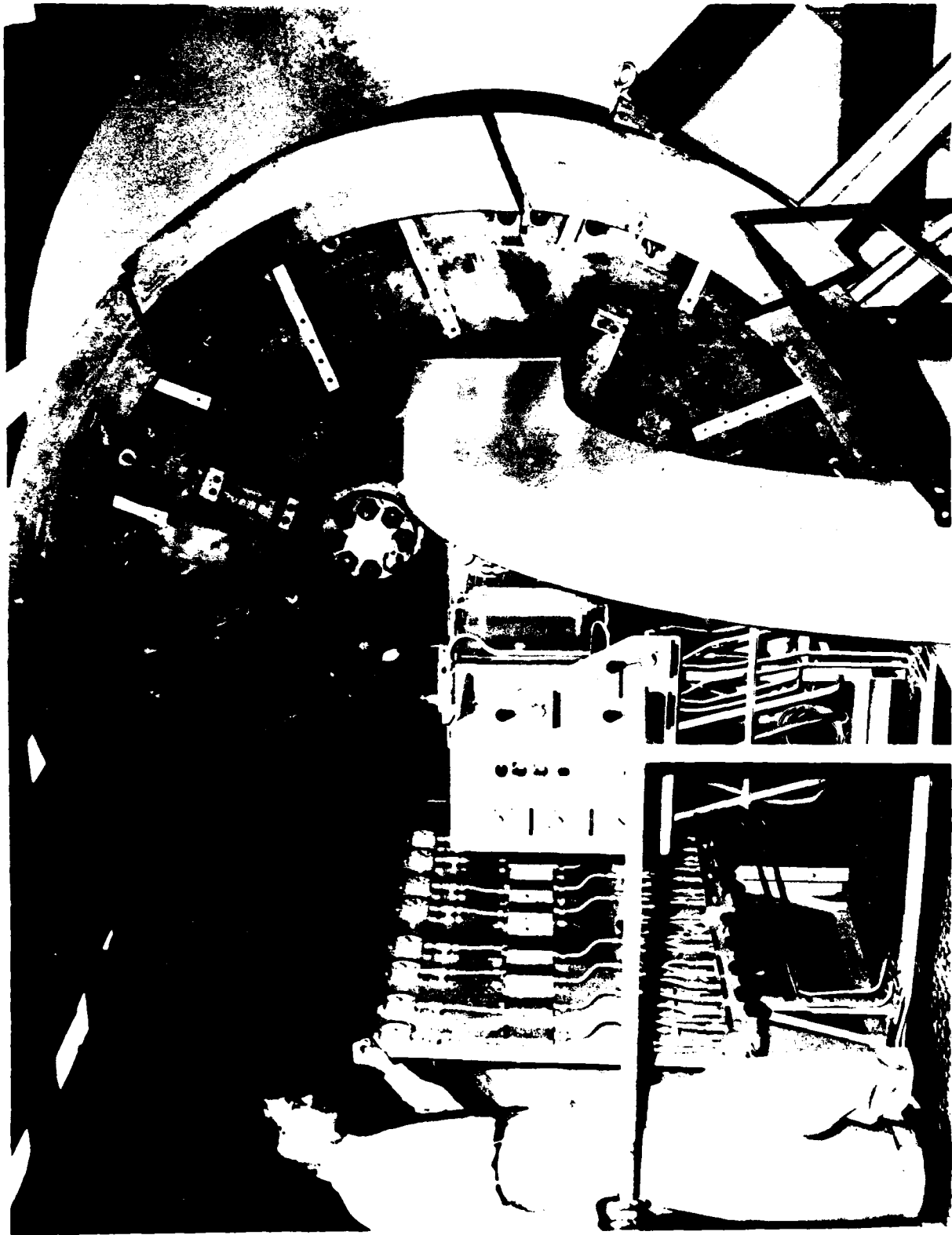

Figure 11 -- Large-Diameter, High-Pressure Cylindrical Tank with Wedge or Shear Bar Closure

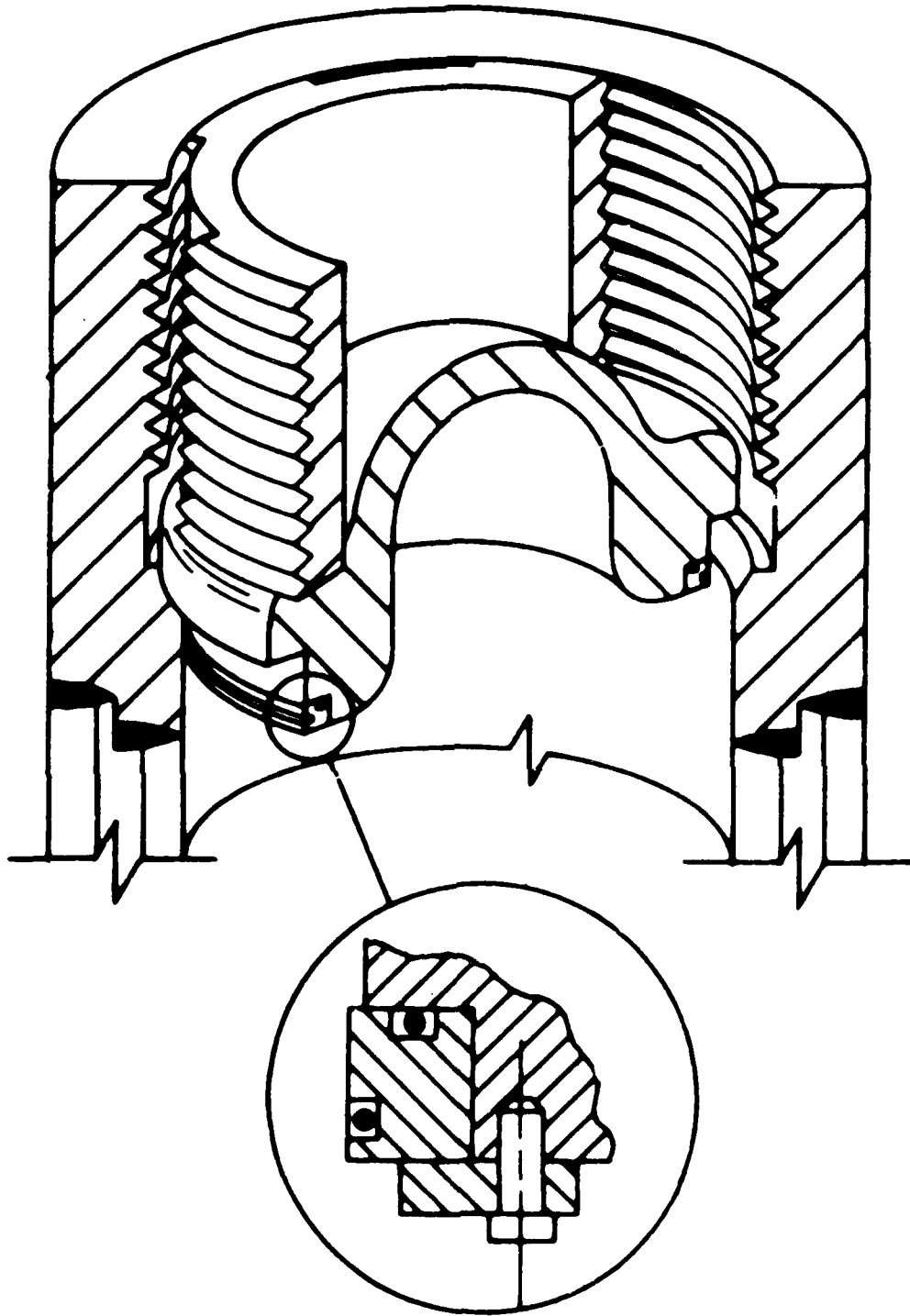

Figure 12 – Floating O-Ring Seal, Installed in Tank with Segmented Breach-Yoke Closure

As pressures are increased, especially for larger diameter tanks at high pressure, the design of closures may require considerable attention to avoid heavy sections which might create susceptibility to brittle fracture. The 10-ft-diam, spherical tank shown in Figure 10 utilizes a series of interlocking grooves and fingers, secured together with radially inserted pins so that each is subjected to shear loading as the tank is pressurized. Figure 11 shows a 10-ft-diam, cylindrical, horizontal tank installed, on which a series of wedges is used to clamp the removable head to the cylinder. Figure 8 shows another type of closure, which is a simple arrangement called a yoke tank. An open-ended cylinder forms the tank walls, while flat plates are used as the heads. An open rectangular frame serves to hold the two heads against the cylinder. To facilitate assembly, the opening in the frame or yoke is a little longer than the tank with both heads in place; wedges are used to take up the clearance. Although stress analysis for this design is simple, the actual behavior of the flat plates and the sliding action of the closure rings as the yoke stretches tend to add complexity to design details which are best worked out on small-scale tanks or models previous to design and construction of larger more costly tanks. For manufacturing, no complex forming or machining is necessary. The yoke design not only provides adequate cross section to withstand cyclical tensile stressing but minimizes the complexity of compound stresses otherwise developed in the pressure cylinder and heads. Designers, utilizing flat sheet steel to form yokes, are cautioned to ensure adequate stability in all planes and to design closure seals that will prevent fretting of sealing surfaces under either repeated loading or fatigue of seal rings. Since the yokes are rather large for a given tank size, twice as much building space must be provided. Ideally, for safety, these tanks should be isolated from operating personnel; vertical service tanks should be installed below the operating floor in a deep pit. It is a design requirement that no leakage occur at any pressure from zero to the maximum operating pressure.

Regardless of the closure, some relative motion between the cylinder and the closure head under pressure creates a sealing problem. The problem is aggravated when a tank is used for cyclical work. A most satisfactory seal has been developed, utilizing a self-energizing principle. The head proper is so fabricated that part of it fits with less than a 0.200-in. clearance inside the cylinder, ensuring initial compression of the O-rings. A recess in this projection contains the seal. An elastic seal ring is made by rolling bar stock into a ring and welding it closed. An elastomer O-ring is fitted into a groove on the upper surface of the seal ring, and a second elastomer O-ring is fitted into a circumferential groove in the O-ring. These grooves are so located that hydraulic pressure within the cylinder forces these O-rings, respectively, against the head and against the cylinder wall; see Figure 12. When the seal is installed in a tank that will be used for cyclical testing, lubricant is added through rifle-drilled passages and tubing to the rear of the seal ring.

PENETRATIONS AND FEEDTHROUGHS

Tank penetrations are required for various purposes, including pressurizing-system piping, instrumentation wiring, model power wiring, and model piping; usually, penetrations may be used interchangeably. The principal precautions to be taken with penetrations are to keep them small, as few in number as possible, and to locate them properly. Since some structural models require thousands of strain-gage leads, considerable development has taken place to minimize the number and size of openings required. A "feedthrough" design has been developed that permits approximately 2000 wires to pass through four 1-in-diam holes. Figure 13 shows this feedthrough. The feedthrough has been successfully used at pressures as high as 20,000 psi. The need for large-diameter access openings for special purposes must be reinforced and included in the basic tank head-cylinder design. Additional openings for specially instrumented feedthroughs and piping are generally required. Oftentimes, a single 4-in-diam opening, located in the head equipped with a specially designed feedthrough plug, can take the place of multiple openings for this purpose. Piping penetrations placed through the cylindrical walls of the tank are usually limited to 2 in. in diameter as far as is practicable. Corrosion resistant sleeves of appropriate thickness are inserted through the bored holes and are welded to the inside surface. These sleeves project a few inches into the tank and extend similarly above the outer surface. When machinery requiring appreciable amounts of alternating current is to be tested in a pressure tank, nonmagnetic material should be specified for the feedthrough bushings. This is necessary because a single, a-c carrying conductor, passing through magnetic material, may develop sufficient heat to destroy the insulation and to cause failure. Unless absolutely essential, viewports are not used. Generally, appropriately designed instrumentation, remote viewing, etc., precludes the need for viewports in these facilities.

MATERIAL SELECTION

The designer of a successful deep-ocean test facility must satisfy many constraints due to the practicabilities of funding, space limitations, manufacturing capabilities, and transportation problems. However, when it comes to selecting materials to be used in constructing high-pressure vessels, he must select only those materials having physical properties that can be reliably ascertained and which will retain suitable mechanical properties throughout the desired life of the facility. Also the materials selected should have uniform properties throughout the thickness of each section and the properties of each similar section should be closely matched. Very thick rolled or forged sections often exhibit marked differences between test specimens taken at or near the surfaces as compared to those taken from the center of the section. It is well known that proper quenching and tempering, rolling, and

**INSTRUCTIONS FOR MAKING A HIGH-PRESSURE ELECTRICAL PENETRATOR
FOR STRAIN GAGE CIRCUITS**

1. Drill solid 9/16-in Aminco® Super Pressure Plug to the dimensions shown.
2. Mount hollowed plug horizontally in a clamp or vise.
3. Draw size 27 Surlvn Coated Tinned Copper Wires** through the plug, singly or in groups, taking extreme care to keep the wires parallel and straight; 94 wires with an outside diameter of 0.026 in fit freely in the 5/16-in hole in the plug. The wires initially in place must be pulled tightly, and the ends must be anchored securely while additional wires are drawn through the plug. It is recommended that wires with different colored insulation, e.g., 10 red wires, 10 black wires, 10 green wires, etc., be used to facilitate locating the common ends.
4. Starting 12 in from the plug, in each direction, tape the bundle of wires together every 12 in.
5. Unfasten the ends of the wires and trim evenly. Mount the plug and 12 in of wire on both sides vertical and straight, with the tapered end of the plug pointing down.
6. Clean the inside of the plug and the wires several in on either side with trichlorethylene; the plug can be moved on the bundle to facilitate spreading the wires.
7. Mix a quantity of Hysol clear epoxy (Hysol Epoxi-Patch Kit 0151 clear) and pour into the top of the plug. Separate and spread the wires as much as possible with a probe to ensure that each wire is surrounded with epoxy. Refill the plug as the epoxy tends to settle and the entrapped air escapes. The bottom of the plug should be sealed around the wires with putty if the epoxy tends to run out. Make sure the wires are straight and parallel and allow the epoxy to harden for 24 hours.

* American Instrument Company, Silver Spring, Md.

**Can be supplied in 10 different colors by Belden Corporation, Chicago, Ill.

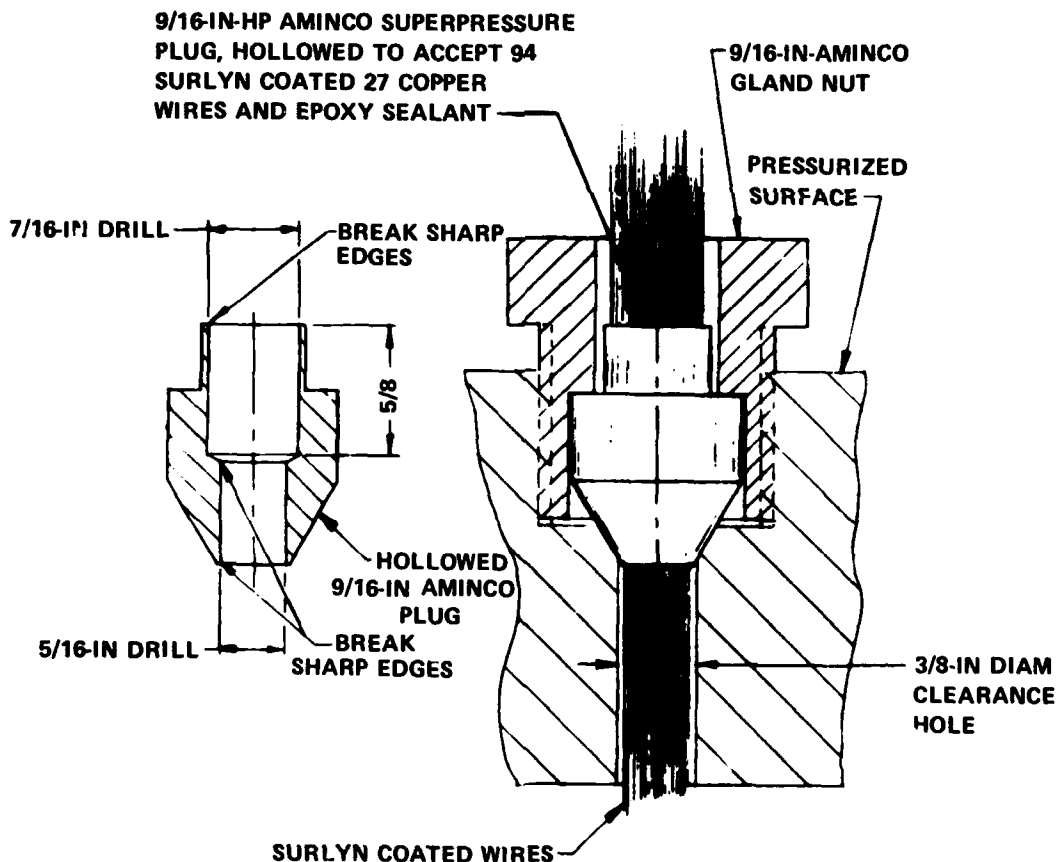

Figure 13 – Naval Ship Research and Development Center Feedthrough for High-Pressure Application, 20,000 PSI

forging toughens materials; however, the benefit is limited with thick sections, especially high-strength steels. Repeatedly rolling plates during manufacture sometimes results in slag inclusions and lamination in the sheets. Such flaws are unacceptable, and the material is rejected.

COST FACTORS

A significant portion of the cost of these facilities is spent for the materials and fabrication of the pressure tanks, including both large amounts of high-strength steel and, more so, stringent requirements of the specifications. High-strength steels cost much more per pound than ordinary carbon steel. The cost is due to limited production and to the high cost of the alloying materials such as nickel, which constitutes about 5 percent of the HY-130-150 alloy. In addition to an even higher nickel content, HY-180 steel also contains about 8 percent cobalt. The tougher steels are more difficult to work and require costly welding materials and procedures in order to achieve satisfactory strength and fatigue resistance. Some typical current prices for steel plates in the 1/2- to 4-in-thick range are

Steel Alloy:	Per Pound	
Carbon	\$0.14	CIRCA 1972 PRIOR TO LIFTING PRICE CONTROLS
HY-80	0.35	
HY-100	0.37	
HY-130-150	0.57	
HY-180	4.00	

Completely fabricated, large, high-pressure tanks have been procured at prices ranging from \$2 to \$4 per pound, whereas reactor vessel costs have ranged from \$12 to \$15 per pound because of their stringent specification requirements. The selection of materials and manufacturing requirements can be fruitful areas for a careful review of cost effectiveness.

When considering the price per pound of ultimate tensile strength, it appears that the lowest grade of material that will satisfy the design requirements will be the most economical. However, both ultimate strength and yield point of the more exotic materials are controllable more or less independently by proper heat treatment; consequently, the yield point may be made to approach the ultimate strength. By basing allowable working stresses on a percentage of the high yield point, a design can be sufficiently elastic and yet so use the potential properties of the material as to be more economical than they would by using lower grade material.¹³

Another fruitful area for potential cost savings is in manufacturing pressure vessels. Welding is a costly operation: ordinary carbon steel laid on by hand costs about \$8 per

¹³Harvey, I.F., "Pressure Vessel Design: Nuclear and Chemical Applications," D. Van Nostrand Company, Inc., Princeton, N.J. (1963).

pound. With machine welding, this cost is cut by a factor of approximately 10. When thick sections are butt-welded, current practice is to bevel the edges so as to produce a V-shape or J-groove and then to fill in the gap by making several welding passes. Minimizing the amount of welding can result in sizeable cost savings.

Carbon steel forgings cost about three times as much as rolled steel, and cast steel is half as expensive as a large forging. When very large forgings are required, the number of competitive suppliers becomes limited. Furthermore, the enhanced physical properties produced in smaller forgings cannot be attained throughout thickly sectioned forgings. Satisfactory castings may be produced, provided quality control and proper physical and chemical specifications and acceptance tests are obtained.

SAFETY FACTORS

Usually, a safety factor is an allowance for ignorance. The intention in using the factor is to produce a safe design without needing to understand and calculate the effects of multiple stresses upon a structure. Building a structure stronger than it needs to be to perform to a given set of criteria safely not only adds cost but may also make a given tank design impracticable to fabricate. The only ASME guide to pressure-vessel design (Section VIII, Division 1) before 1968 provided rules and tables for using materials based essentially upon a safety factor of 4 applied to tensile strength, unless the materials had a low-yield strength, when for ferrous metals allowable stresses were limited to five-eighths of yield strength.

Early in 1955, a special ASME Pressure Vessel Committee was organized to recommend logical criteria for the maximum allowable stresses for a variety of appropriate metals and evaluate the influence of materials, design, and other factors on the performance of pressure vessels. Before this committee could complete this assignment, an urgent need for a code for nuclear vessels was recognized. Obviously nuclear vessel operation requires ultrareliability because of the extreme cost, the serious consequences of a failure, and difficulty of shutting down for periodic nondestructive testing. A draft of Section III, entitled "Pressure Vessel Code, Rules for the Construction of Nuclear Vessels," resulted in 1962. The most recent edition used for pressure-tank applications is dated 1971. Subsequently the special committee returned to the original assignment, which culminated in 1968 in the issuance of Section VIII, Division 2, entitled, "Alternative Rules for Pressure Vessels." A recent edition used for pressure tank applications is dated 1971.^{14,15} Section VIII, Division 2, allows taking full advantage of technological progress by permitting use of thinner walls without sacrificing safety. If anything, safety is enhanced by imposition of rigorous requirements governing material

¹⁴American Society of Mechanical Engineers, "ASME Boiler and Pressure Vessel Code, Section III, Nuclear Power Plant Components" (1971).

¹⁵American Society of Mechanical Engineers, "ASME Boiler and Pressure Vessel Code, Section VIII, Pressure Vessels, and Division 2, Alternative Rules" (1971).

selection, structural design, and manufacture as well as provision of safeguards against brittle fracture. In essence, these rules lower the safety factor to 3 for tensile strength and to two-thirds of the yield strength. The design rules of Section III and Section VIII, Division 2, place heavy emphasis upon stress analysis in the design of pressure vessels. Thus, it is essential that the design and analysis efforts be closely coordinated; the resultant procedure has been termed "design by analysis." In 1969, ASME published a document that provided definitions and explanations of the strength theories, stress categories, and stress limits on which to base design procedures.¹⁶ Also the methods were explained for determining suitability of vessels and parts for cyclical loading.

In May of 1970 the Naval Facilities Engineering Command (NAVFAC) and the Naval Ship Systems Command (NAVSHIPS) adopted the ASME guides, discussed previously, governing the design of hyperbaric facilities; see Reference 6. The adaptation was done to provide contractors with a detailed account of practices usually acceptable to the Navy Material Certification Authority. In general, the use of Section III or Section VIII of the ASME Boiler and Pressure Vessel Code will govern the design of pressure-retaining elements. The bid documents will define the applicable sections and will delineate the modifications, if any, that apply to the code.

Inasmuch as many existing deep-ocean simulation facilities were designed and built long before publication of Section III or Section VIII, Division 2, and because of the many dominating constraints, the success of these facilities has been primarily attributable to the skills and experiences of their designers. However, continued safe operation warrants very serious consideration. Recognizing the existence of these facilities and seeking a means of ensuring continued safe operation with a high degree of confidence within an economical framework, NAVFAC is proposing, wherever feasible, to extend the material certification requirements for hyperbaric facilities to all Navy-owned deep-ocean simulation facilities.

EXPERIMENTAL STRESS ANALYSIS

A well-recognized method of determining and/or verifying doubtful directionality and magnitude of stresses is to build an instrumented model of a section of a structure and then to apply simulated loading, i.e., experimental stress analysis. Since large pressure tanks are quite costly, manufacturing and testing a conveniently scaled model is often justified. In developing the spherical tank shown in Figure 10, a 1/3-scale model proved invaluable. This model was constructed and proven satisfactory by using strategically placed strain gages; the

¹⁶American Society of Mechanical Engineers, "Criteria of the ASME Boiler and Pressure Vessel Code for Design by Analysis in Sections III and VIII, Division 2" (1969).

novel finger-closure and radial pin concept was developed and verified before the prototype tank was constructed. A draft version of Appendix II of the pressure vessel code was issued by ASME in May 1970 so as to establish guidelines for experimental stress analysis.¹⁷

THEORETICAL STRESS ANALYSIS

Until recently, theoretical stress analysis of pressure tanks was based on classical engineering mechanics "energy methods" or the Rayleigh-Ritz solution for predicting bending moments, deflections, and stresses in pressure arcs. With the advent of the computer, powerful numerical methods have been developed for accurately predicting the distribution of stresses and deflections throughout a pressure tank, including all structural discontinuities and details. Finite-element concepts have been employed for these computer programs. One of the more common, known as the "seal shell" computer program, is documented in Reference 18. Another computer program developed at the Center, designated ZPZ6, is capable of analyzing arbitrary thick bodies and shells of revolution for large-deflection, elastic-plastic treatment of arbitrary axisymmetric bodies, including the effects of contact, gap, or relative slip between mating structural components.¹⁹ Nonsymmetric problems, resulting from reinforced cylinder penetrations, are approximated as axisymmetric problems by replacing the penetrated cylinder with a "best equivalent" sphere. Figure 14 presents typical stress-prediction contour plots that are automatically generated by the computer.

TANK MANUFACTURE

FEASIBILITY

As designers are faced with the task of designing larger tanks with higher operating pressures, it is of increasing importance that they be well-informed concerning the capabilities and performance of various manufacturers. This is not only necessary to promote competitive bidding but to assure as well that the design is, in fact, feasible from the manufacturing standpoint.

MATERIAL

To ensure a safe facility, it is not sufficient to merely specify material appropriate for the application, there must be sufficient evidence to prove that the materials used have the proper chemistry of mechanical and toughness or impact properties for the intended service.

¹⁷ American Society of Mechanical Engineers, "Experimental Stress Analysis," Appendix II—Article II-1000 (May 1970).

¹⁸ American Society of Mechanical Engineers, "Stress Analysis Methods," Appendix A—Article A-1000 (May 1970).

¹⁹ Gifford, L.N., Jr., "Finite Element Analysis for Arbitrary Axisymmetric Structures," NSRDC Report 2641 (Mar 1968).

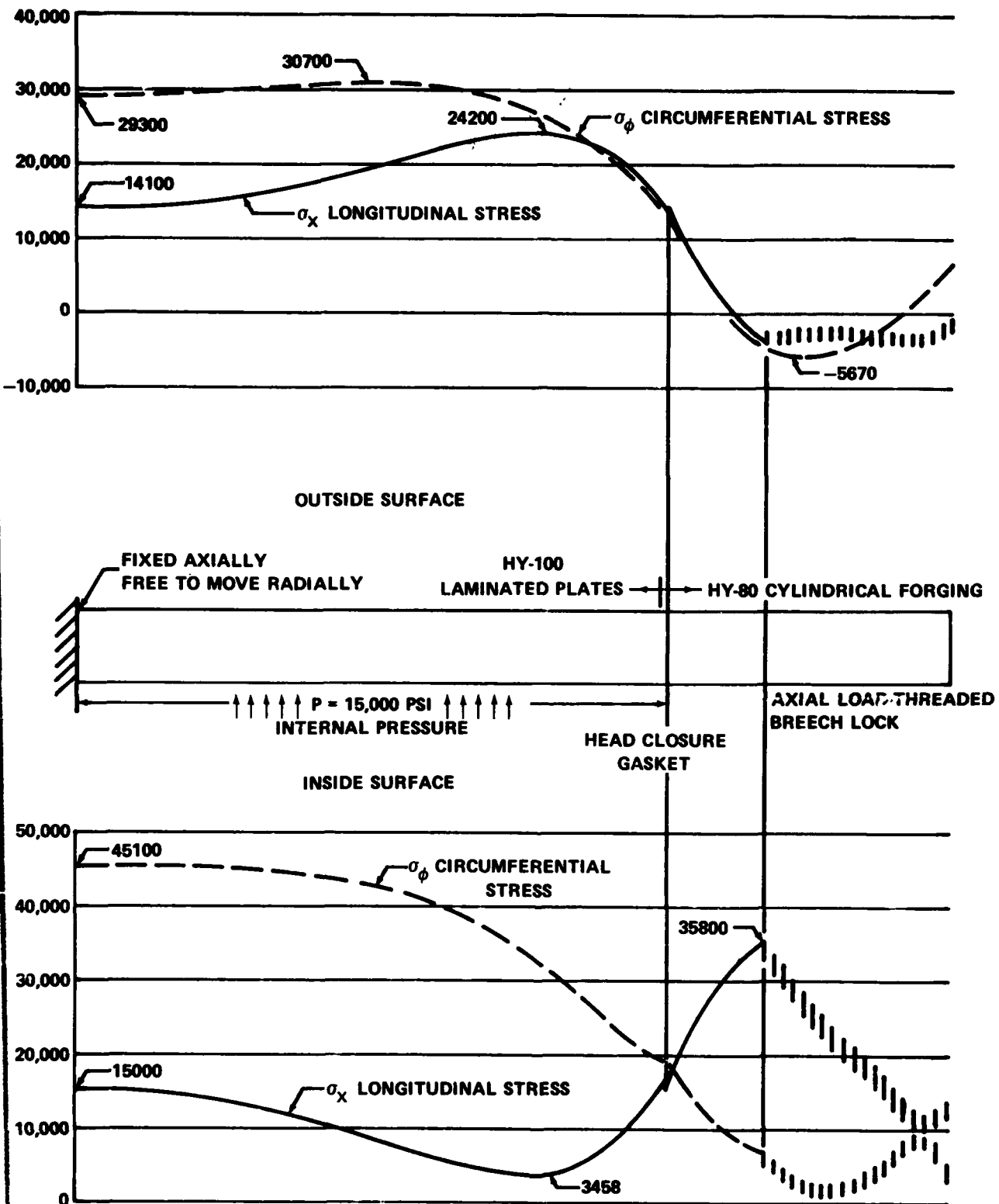

Figure 14 – Typical Stress-Prediction Contours Generated by Computer

The material must be traceable without question. Appropriate nondestructive testing must have been performed on all materials before fabrication, and there must be mill test reports verifying physical and chemical data. Examination of materials should be continued as fabrication progresses, i.e., the edges of all openings and all cut edges should be carefully examined to detect any defects that may be revealed. The specifications should be clear as to what inspection methods should be used and as to whether correction of defects is acceptable. An underthickness tolerance, if any is acceptable, should be specified.

The ASME rules for pressure vessels Section III and Section VIII, Division 2, give specific and detailed guidance as to the selection of coupons to be tested to assure attainment of minimum strength. The strength of the entire plate or forging is judged to be that of the minimum strength specimen. For determining the suitability of a given material for pressure tanks, a checkoff list, NAVFAC specification P422.1 for hyperbaric facilities, should be used.²⁰

Various ASTM standards provide guidance for determining various mechanical properties such as ASTM-STD E-8-66 for tension tests²¹ and ASTM-STD-E-73-64 for notch bar impact tests.²²

For tough high-strength materials such as HY-80, military specifications such as NAVSHIPS 0900-006-9010²³ provide guidance for fabrication, welding, and inspection. For these materials, military specification such as MIL-S-16216H²⁴ and MIL-S-23009A²⁵ define the chemistry of mechanical properties and toughness for plates and forgings, respectively.

FABRICATION

Following the careful inspection and acceptance of materials, it is important that all plates and forgings be suitably identified so that the individual identities are retained in the finished vessel. This information will facilitate inspection and is required by ASME rules. It should be documented and retained in user files for future safety reviews.

From a safety standpoint, the most critical area in manufacturing is welding. Consequently, rigorous requirements should be established so as to achieve a satisfactory facility. Specifically, for an area requiring special attention for deep-sea simulation facilities, issuance should be

²⁰Naval Facilities Engineering Command, "Hyperbaric Facilities," NAVFAC Specification P422.1, Pre-Material Certification Checklist (Jan 1971).

²¹American Society for Testing and Materials, "Tension Testing of Metallic Materials," ASTM-Standard E-8-66 (Feb 1966).

²²American Society for Testing and Materials, "Notch Bar Impact Test of Metallic Materials," ASTM Standard E-23-72 (1972).

²³Naval Ship Systems Command, "Fabrication, Welding and Inspection of HY-80 Submarine Hulls," NAVSHIPS 0900-006-9010 (Sep 1971).

²⁴Department of Defense, "Steel Plate, Alloy, Structural, High Yield Strength (HY-80 and HY-100)," Military Specification MIL-S-16216H (Feb 1963).

²⁵Department of Defense, "Steel Forgings Alloy, High Yield Strength (HY-80 and HY-100)," Military Specification MIL-S-23009A (Apr 1965).

made of adequate quality control programs and welding procedure specifications and qualification should be made of welding procedure specifications and welding operators. For instance all welds shall be 100-percent full penetration, and all butt and seam welds shall be 100-percent efficient. To insure this, it is required that the welders be thoroughly qualified in downhand, vertical, and overhead welding and that samples of their work, using the specified materials and procedures, be subjected to impact and bending tests. Section IX of the ASME Code treats extensively with such qualification requirements as well as welding and inspection procedures.²⁶ All welds in plates one-half inch or thicker and all circumferential welds in the pressure tank, regardless of thickness, shall be 100-percent⁺ radiographed. The use of wide welds to overcome poor fit must not be permitted. Binding welding of the joint surface to connect oversized root openings or errors in joint preparation shall not exceed a quarter of an inch.

Additional precautions, specified by ASME rules, require that electrodes, flux, and other welding materials be suitably identified and properly stored and handled. It is particularly important that precautions be taken to minimize absorption of water by low-hydrogen electrodes and flux.

When unacceptable defects are found in the welding, it is recommended that they be removed mechanically and that these areas be repaired by qualified welders, using qualified welding procedures. The repaired area should be reexamined as if it were an original weld. Repairs should not be accepted until all original requirements are completely satisfied.

As-deposited welding metal and associated heat-affected zone (HAZ) material shall exhibit the same minimum yield strength required for the corresponding base material. In addition, the toughness of the weld and HAZ material shall be determined by suitable tests. Tests for determining the suitability of welds are described by ASTM and military specifications such as for HY-80 MIL-STD-00418B(SHIPS)²⁷ and ASTM STD-E-16-64²⁸ to determine the mechanical properties and ductility of welds and welded joints, whereas Military Specification MIL-E-22200/1C²⁹ covers the properties and application of welding electrodes for these materials.

No cracking or fissuring shall be permitted. Suitable chemical and mechanical property, impact, and side-bending tests shall be performed for each heat, lot, or batch of welding electrodes or wire-flux combination used in fabrication.

²⁶ American Society for Mechanical Engineers, "Qualification Standard for Welding and Brazing Procedures, Welders, Brazers, and Welding and Brazing Operators," ASME Boiler and Pressure Vessel Code Section IX (1968 Edition).

²⁷ Department of Defense, "Mechanical Tests for Welded Joints," Military Specification-MIL-STD-00418B(SHIPS) (Nov 1967).

²⁸ American Society for Testing and Materials, "Free Bend Test for Ductility of Welds," ASTM Standard E-16-64 (1971).

²⁹ Department of Defense, "Electrodes, Welding, Mineral Covered, Iron Powder, Low Hydrogen Medium and High Tensile Steel, As-Welded a Stress Relieved Application," Military Specification, MIL-E-22200/1C (29 Jun 1962).

Section VIII, Division 2, of the ASME rules permits using quenched and tempered ferritic steels for fabricating components as well as complete pressure vessels. If heat-treated plates or forgings are to be used in the fabrication, the test specimens should be removed from the mid-section after such treatment. If necessary, prolongations must be provided for this purpose. In all cases, the base material to be used in preparing test specimens shall be subjected to the same heat treatments as the parent material in the completed pressure tank.

INSPECTION AND QUALITY CONTROL

There are four principle kinds of nondestructive tests that are customarily used to monitor the integrity of the materials, workmanship, and completed pressure vessel after its acceptance tests and periodically thereafter through its life. Detailed procedures are outlined in Reference 30.

Radiography

Radiography is useful for detecting flaws such as slag inclusions or cracks at any depth throughout the thickness of the plate, weld, or vessel, provided the flaw is not in a plane perpendicular to the penetrating rays. Examination of the exposed film requires a high degree of skill and a great deal of patience. It is quite time consuming.

Liquid Penetrant

A liquid is used, such as a thin oil having a low surface tension, in which are dissolved emulsifiers and sometimes fluorescent materials. Some manufacturers provide so-called developers. The purpose of these is to penetrate and to clearly reveal surface defects, either under normal or ultraviolet light, and then to allow easy removal by flushing with clear water so that satisfactory repairs can be made.

Magnetic Particle

Such testing is useful in checking for surface and subsurface discontinuities in magnetic materials. Lines of flux are established either by high magnetizing currents or by solenoids. Abnormalities of flux distribution are revealed by a surface covering of magnetic particles. A danger of using surface-contacting electrodes is that strikes may burn the surface being inspected, resulting in increased stress.

³⁰Department of Defense, "Military Standard Nondestructive Testing Requirements for Metals," MIL-STD 271D (SHIPS) (Mar 1965).

Ultrasonics

High-frequency sound waves are utilized, which are projected both perpendicularly and at an angle to the surface. These waves are reflected from the opposite surface or from hidden flaws. The total transient time is determined by the displacement shown on an oscillographic monitor as calibrated by suitable sample-test pieces. Considerable skill is required of the operator for evaluating findings. A lesser degree of skill suffices if the sole interest is in go and no-go flaws of modest size, such as 1/8-in. cracks.

For serious inspection of operating facilities, two or more of these methods of inspection usefully complement one another. All four of the foregoing inspection methods require that the surfaces be clean, smooth, and free of slag and foreign materials. When a tank is in service, this may involve sandblasting a protective coat of paint away in order to perform the inspection.

TANK INSTALLATION AND ACCEPTANCE TESTING

As mentioned previously, whenever cold water tests are to be conducted in a new facility, a cold water hydrostatic test should be specified as part of the acceptance procedure.

Before pressurizing, the tank should be properly vented and filled with chilled water, which should be circulated through the tank for 8 hr or more so that the temperatures of all parts of the tank will become essentially constant and the temperature of the inside walls will approach that of the chilled water. To minimize the temperature gradient through the wall thickness of the tank, an outer layer of insulation may be required.

After the tank and ancillary equipment are installed in the permanent location, initial pressurization and subsequent incrementation should take place as detailed for the warm water test. To guard against possible creep effects or crack growth, it is advisable to require that test pressure be maintained in the newly installed facility for 4 hr or so.

A well-designed and built tank should behave elastically, and only a small percentage of water should be added to raise the internal pressure each 1000 psi, provided that there is no leakage and that there are no pockets of air or gas to be compressed. Sometimes it is necessary to apply a vacuum to the tank for several hours before testing to remove excess air.

If at all practical, initial testing of the completed pressure vessel should be done at the manufacturing plant, and retesting should be done after final installation in the facility of the customer, using the following procedure.

1. Vent lines should be installed at the highest points so as to minimize the amount of air trapped and subsequently compressed.
2. The tank should be completely filled with water and allowed to stand until all parts of the tank and the water reach a constant temperature of 60 F for the first loading; before

final acceptance testing, the temperature of the tank should be lowered by ice if necessary to the lowest intended operating pressure, usually 32 F.

3. Strain gages should be affixed in various locations, including all those where higher than average stress is anticipated.

4. Approximately half of the maximum designed pressure should be applied, and the stresses indicated by all strain gages should be checked to see that they are within acceptable limits.

5. Pressure should be increased in steps approximating 10 percent of designed pressure, and all strain gage indications should be checked before the next increment is applied.

6. The maximum pressure applied should not be less than 1.25 times the designed or working pressure, usually 1.5 times the designed pressure, and should be measured at the top of the tank to assure that all portions of the tank are being subjected to the intentional overpressure. Maximum pressure should be maintained for several hours as proof against marginal safety.

7. Pressure should now be reduced to designed pressure, and all portions of the tank and fittings should be inspected for leaks.

8. Before applying pressure, an inspection should be made to assure that low-pressure fittings and piping are either blocked off or otherwise protected from the applied test pressure.

9. If for any reason, including accidental or intentional overpressurization, the vessel becomes permanently distorted to an extent visible to the unaided eye, it should be rejected.

PERIPHERAL OR ANCILLARY EQUIPMENT

PUMPS

Two basic high-pressure pumps are available on the market that are useful for developing the required high pressures. Both types utilize pistons for developing pressure; they differ only in the means of driving the pistons. The first type is patterned like boiler feed pumps and consists of a small-diameter piston coupled back to back with a much larger piston. Either compressed air or a lower pressure fluid drives the large piston while the small piston pumps on the pressurizing medium. Obviously the maximum pressure developed depends first on the pressure of the prime mover and the piston ratio less some loss for friction and valve operation. This pump is capable of producing pressures of as much as 80,000 psi; typically one developing as much as 40,000 psi with 90 lb of air delivers 12 cu in/min. As applied to deep-sea simulation facilities, this type will not last as long as cyclic service because its capacity is limited, and it requires a substantial house-air supply.

Larger capacity at high pressure and improved but limited life under cyclic testing is provided by the second type, the electric motor-driven pump. Rotary motion is converted to

reciprocal motion by a crankshaft. The use of multiple pistons decreases pulse amplitude as it increases the frequency of load pulses. Reduction gearing between the motor rotor and the crankshaft serves to reduce the torque required of the motor and allows the inertia of the motor rotor to act as a flywheel; its effect is reflected to the pistons as the square of the reduction ratio. If seawater is the fluid medium, Monel cylinder heads should be specified for the pump.

Figure 15 shows a five-piston pump, powered by a two-speed, 250/250-hp motor. Pumping capacity at high speed is nominally 50 gal/min to 6000 psi. At low speed, the capacity is halved, and the maximum pressure attainable increases to 12,000 psi. The more pistons in a given rated pump, the less will be the amplitude of pressure pulses that must be absorbed by surge dampers and/or accumulators. Pumps of the type illustrated are designed so that the pistons can be unloaded to facilitate starting the motor; nevertheless, friction and inertia are high enough to warrant selecting a motor that will develop high starting torque with only nominal inrush current so as to avoid inordinate voltage transients on the laboratory power supply.

Figure 16 shows a packaged portable pumping system, complete with all necessary control-indicating instruments, automatically capable of cyclically pressurizing a small test chamber between preset pressure limits. It utilizes a twin piston pump having a capacity and a pressure capability that may be either 13.77 gal/hr at 15,000 psi or 5.38 gal/hr at 40,000 psi, depending on the size of pistons installed. Automatic cyclic pressure controls are included.

In addition to the pressurizing pumps, conventional centrifugal pumps are normally provided to quickly transfer fluids between the pressure tanks, the refrigeration equipment, and the various storage tanks. This transfer equipment and its associated piping and valving cannot withstand high pressures and must be adequately safeguarded against accidental overpressures.

PIPES

Because of the pressures involved and because using seawater is mandatory for some tests conducted in deep-sea simulation facilities, design, fabrication, and acceptance testing of the entire piping system warrants the same attention as the pressure tank. Monel and Type-316 stainless steel perform satisfactorily in this service; however, it is recommended they be flushed promptly after being used for seawater. All of the larger diameter pressure-pipe runs should be carefully detailed and fabricated. Each length of pipe should be thoroughly cleaned and sealed before use.

In addition to selecting materials adequate for the intended service, the following precautions should be taken. Pipe runs should be so designed as to allow relative movement such as occurs when a tank is pressurized. Excessively restrained or inflexible pipe runs can cause

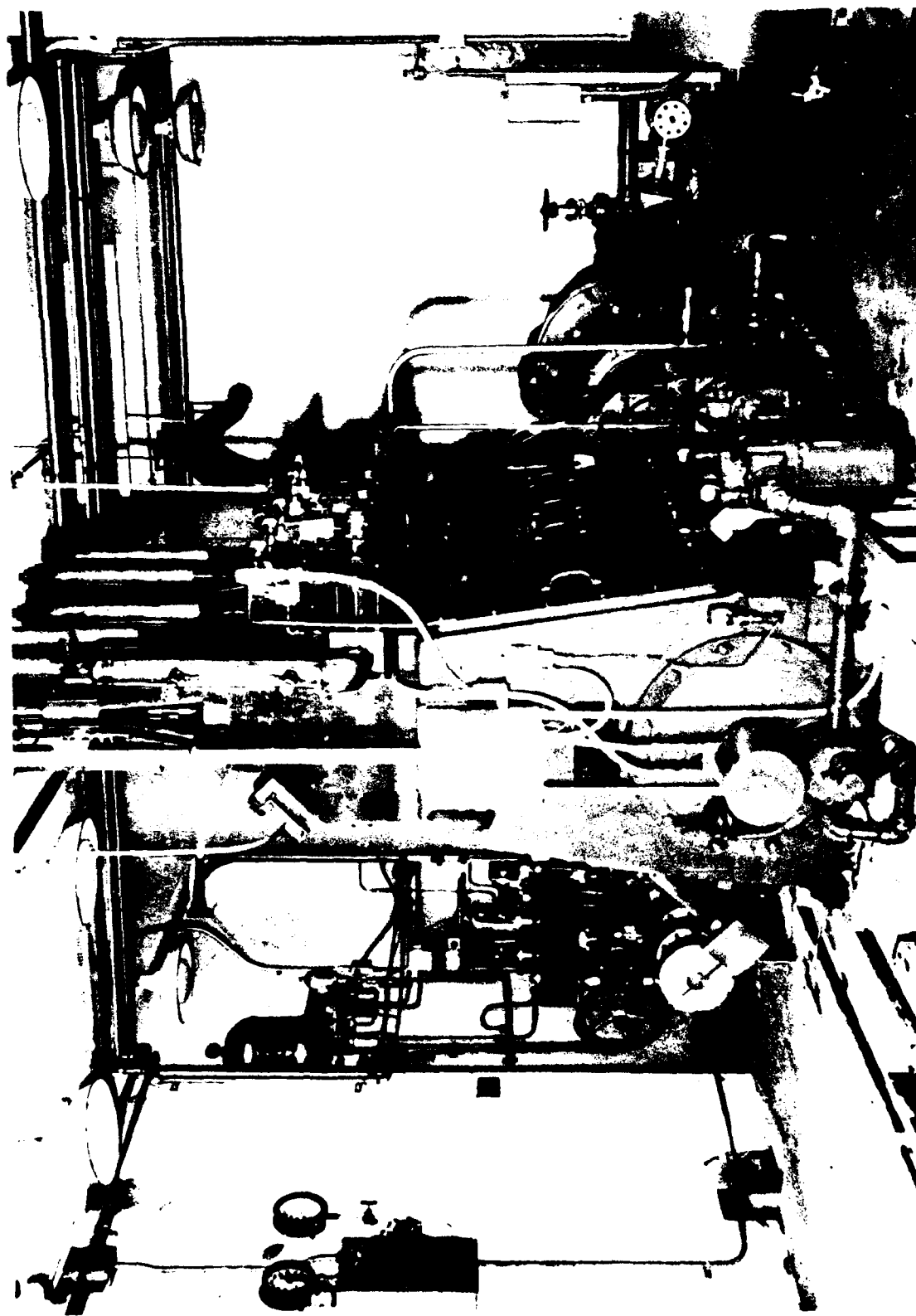

Figure 15 — High-Pressure, Large-Capacity, Two-Speed, Five-Piston Pump
(Delivers 50 gpm at 6,000 psi or 25 gpm at 12,000 psi.)



Figure 16 -- High-Pressure Portable Pump and Control System, from 15,000 to 40,000 PSI

hazardous stresses either at the tank penetrations or in the pipe. Pipes and tubes leading from accumulators or other sources of stored energy and large capacity pumps should be well secured so as to avoid whiplash if a fitting or joint fails.

When both large and small capacity pumps and two or more pressure tanks are installed at a single location, there is a tendency to provide interconnecting piping to allow interchangeability of pumps with the several tanks. To safeguard against pressurizing the wrong tank, there must be some foolproof method of interlocking. The best way of achieving this is to design the piping so that one or more lengths of it must be removed and reinstalled in the other line when delivery is changed from one tank to another.

Figure 17 shows a section of piping, designed with long-sweeping, right-angle bends and valves for 12 000-psi cyclical service. It was installed in 1966. The large-diameter piping was fabricated by drawing and reaming centrifugally cast Monel. Heavy, bolted, flang-end fittings were used first; however, since then a clamp-type Grayloc fitting has become available, utilizing only four bolts yet suitable for as much as 100,000 psi of service. These fittings may not, however, be suitable for piping subjected to external pressure. Note, particularly, the frequent fastenings of the thin-walled tubing, carrying both compressed air and hydraulic control fluid.

VALVES

The two large, light-colored cylinders with externally bolted heads appearing in the center of Figure 17 are pneumatically operated pressure-relief valves, provided to guard against overpressurizing the chamber. Pressure transducers generate the required signals to actuate solenoid control valves for carrying air to the cylinders and opening the appropriate relief valve. The two light-colored accumulators on the wall store sufficient air to ensure "fail safe" operation. The large pipe at the extreme right leads upward to an outdoor storage tank. The pipe in the lower center foreground leads to the pressure chamber and provides two-way flow for the pressure media. The pipe in the left lower foreground connects to the model and provides for flow of the pressure media in and out of the model. The check valve is installed between the model and tank supply lines to guard against applying positive internal pressure to the model exceeding that surrounding the model.

The large line in the extreme lower right of Figure 17 supplies high-pressure fluid from a large accumulator. After passing through the manually operated shutoff valve, the fluid is manifolded to two electrohydraulic servocontrol valves, one for tank and one for model and programmer; tank pressure is held constant. These are controlled by a remote controller and precisely regulate the differential pressure seen by the model. This system minimizes the pressure variations experienced by the tank while subjecting the model to whatever cyclic variations are required. The fatigue life of the tank is thereby enhanced. The large vertical cylinder atop the manifold is a surge damper, required on a 4-ft system only, to absorb fluid flow or to prevent water hammering as the servo valves function to cut off the flow.

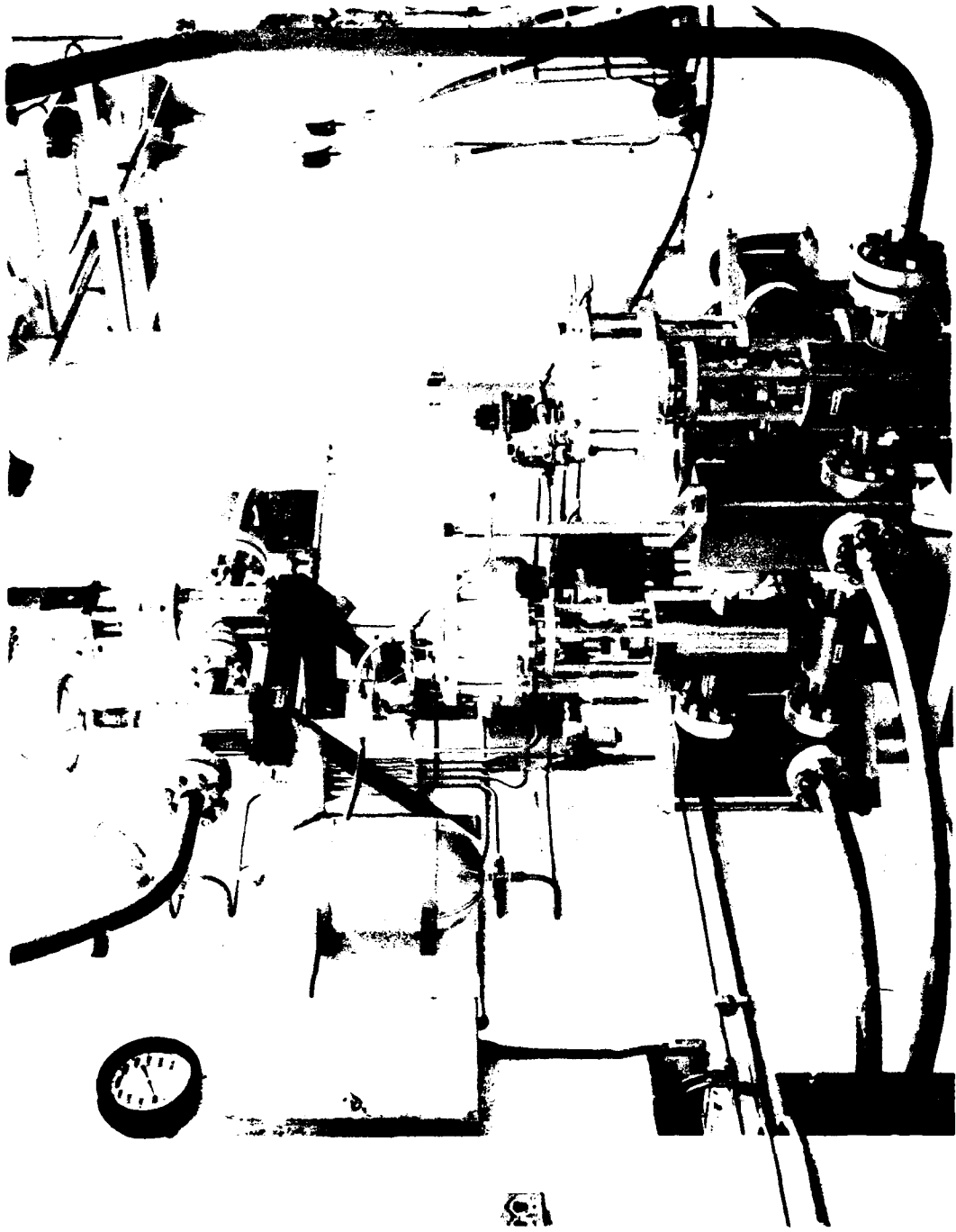

Figure 17 — High-Pressure, Large-Diameter Monel Piping with Large Radius Bends, 12,000 PSI Cyclic Seawater Service

Certain portions of the piping in the soft-cycling system are subjected to cyclic loadings with internal pressure excursions greater than those for the tank; hence, to avoid premature fatigue failure, it is recommended that piping and fittings be proportioned so that the ratio of maximum to yield stress is no more than one-fourth. Special care should also be required in selecting fittings and in fabricating the system to prevent crevices and voids in which water might stagnate and cause hydrogen embrittlement. Draft specification B31.7 of the USA Standards provides guidelines for the designing and fabricating high-pressure piping. It is believed B31.7 will be incorporated in the next revision of ASME Section III.

Figure 18 depicts a cyclic-loading system similar to that shown in Figure 17. This system, designed for soft cycling, has been patented.³¹

ACCUMULATORS

Filtering pressure pulsations and absorbing pressure waves is mandatory for deep-ocean simulation facilities in order to protect the piping from vibration as well as to protect the model and the entire system from unacceptable pressure variations. This is best accomplished in a separate chamber containing a suitable volume of compressed gas that is known as an accumulator. The large, vertical, 2-ft-ID cylinder, left of center in Figure 19, with a gross capacity of 200 gal is an accumulator designed for operation to 12,000 psi. It is lined with Monel for corrosion resistance, since seawater is used mostly in the system. The accumulator is equipped with probe-type, fluid-height indicators to aid in charging and operating. Initially one-fourth of the accumulator is filled with fluid which is locked in by a check valve in the inlet and a servocontrolled valve at the outlet. Nitrogen is used, and the minimum amount required to satisfactorily run a given test is pumped from standard bottles, each of which contains about 2 cu ft at 1800 or 1900 lb. Although there is no diaphragm or other separator, absorption by the fluid is small, and losses from this cause are negligible. Approximately 20 bottles of nitrogen are required for a single charge.

Where so large a volume of gas is compressed to 12,000 psi, a great deal of energy is contained, and its sudden release could be disastrous. The design and fabrication of this accumulator was given special attention to ensure a safe design. Maximum stresses were held to one-quarter of yield strength or better. The upper head is secured to the cylinder by a large ring of bolts and a sealed-diameter Grayloc seal, thus providing access for periodic internal inspection of all bolt threads, etc. The accumulator should be located so that all personnel can be excluded from it during operation.

³¹Day, P.P. and R.B. Allnutt, "Cyclic Pressure Loading System," U.S. Patent 3,196,677 (Nov 1962).

WHEN THE TANK IS PRESSURIZED TO P_{max} , THE TANK INPUT VALVE IS CLOSED. PRESSURE IS THEN APPLIED INSIDE THE MODEL. WHEN PRESSURE INSIDE THE MODEL REACHES P_{max} THE MODEL INPUT VALVE IS CLOSED. THE INTERLOCK SYSTEM THEN OPENS THE MODEL RELIEF VALVE. P_{model} IS THEN CONTROLLED BY THE TIME DELAY AND MODULATING UNITS WHICH IN TURN RESPOND TO THE TAPE INPUT INSTRUCTIONS.

SUBMARINE DEPTHS (p_s) ARE RECORDED ON MAGNETIC TAPE. AFTER AN OPERATIONAL PERIOD, THE TAPE IS REMOVED FROM THE SUBMARINE. THIS TAPE IS THE INPUT TO THE SERVOSYSTEM WHICH CONTROLS THE PRESSURE SYSTEM.

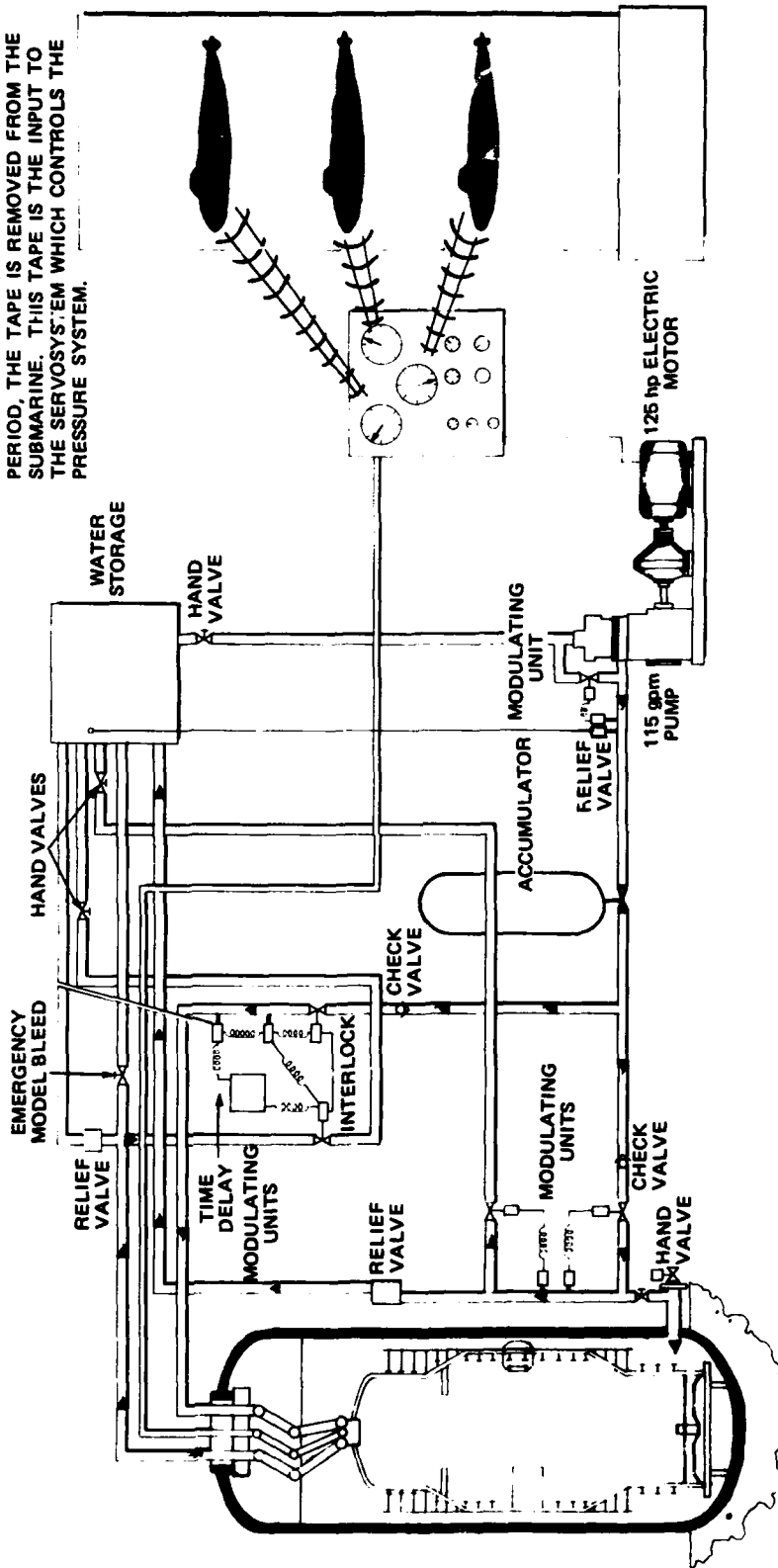

Figure 18 - Cyclic Loading System

The pressure in the tank is held constant at the maximum operating depth of the submarine (P_{max}). The pressure inside the model (P_{model}) is variable between 0 and P_{max} . Pressure equivalent to actual submarine depth (P_s) is maintained by varying P_{model} .

$$P_s = P_{max} - P_{model}$$

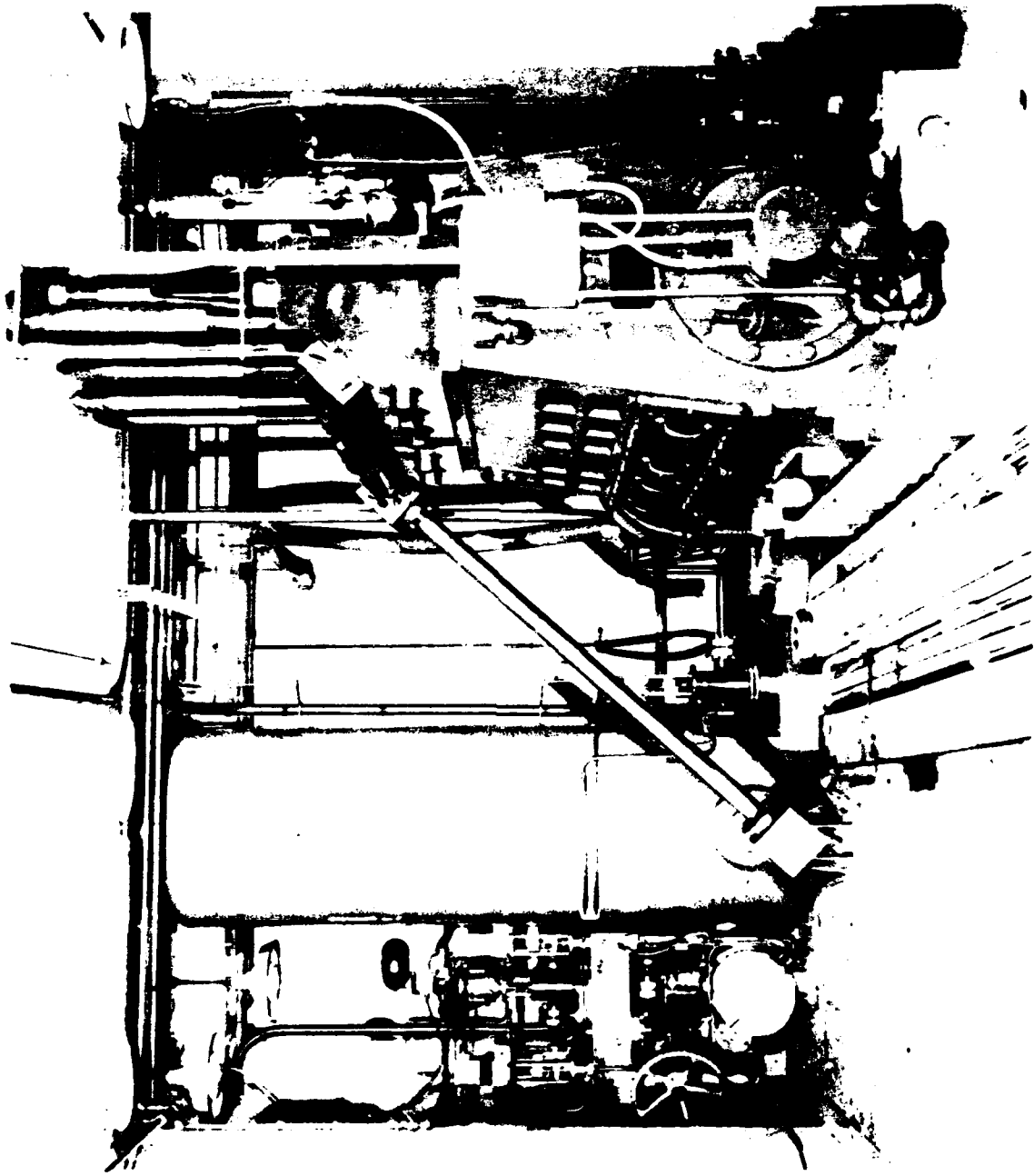

Figure 19 – Large, High-Pressure Pump, Accumulator, and Piping

REFRIGERATION AND HEAT EXCHANGERS

Early in the design process a statement is required as to acceptable temperature limits and rate of change required, the maximum rate of heat production, and the maximum total of heat anticipated. The lowest required operating temperature will determine requirements for heat exchangers or refrigeration equipment.

The major portion of the work done by the pumps and machinery upon the pressure media is converted to heat in the system, and about 50 percent of it is carried away by the pressure media. Therefore, sufficient refrigeration is required in most deep-ocean simulation facilities to remove the heat as well as to chill the media below ambient. A good estimating figure is 13,500 Btu or 1 1/8 tons of refrigeration needed for each horsepower of input. In addition chilling before testing may be necessary. Additional sources of heat are outside storage tanks exposed to the sun, which must be considered when sizing refrigerating equipment.

Several methods have been used to obtain the required cooling of the pressure media. The first and simplest consists of precooling the tank and fluid and adding ice to an insulated tank. It is possible to attain as low as 28 F by this method. The second method also involves precooling the fluid media and the tank, wrapping the exterior of the tank with hoses containing coolant, and insulating the tank and hoses. By this method about 42 F may be obtained. A more sophisticated variation of this method involves inserting specially designed cooling coils made of either low-carbon Type 316 stainless steel or Monel into the tank and providing inlet and outlet penetrations for circulation of refrigerant to a standard external refrigeration unit. The coils are designed to withstand the pressure environment of the tank, and a check valve in the inlet outlet wire prevents pressure reaching the refrigeration unit if a leak should occur in the cooling coils. This system is capable of lowering the pressure media and tank to 34 F without insulating the tank. A third method involves circulating the pressure media from the tank under pressure to an external heat exchanger and refrigeration unit. Care must be observed in protection and design of high pressure lines at low temperatures when employing this method. The first two methods are generally not acceptable for permanent long term use but can be used for one-of-a-kind tests.

Since thick test-tank walls are poor heat conductors, and laminated walls are poorer yet, it is impracticable to use external cooling jackets on large, high-pressure test facilities. However, such jackets are used on small tanks, otherwise there would be no room left inside the tank.

Using principals described previously, a system utilizes heat exchangers in the following manner. The surge tank water is cooled and then pumped on the intake side of the high-pressure pump, which is supplemented by refrigeration coils installed inside the test tank. The external, low-pressure piping connected to heat exchangers immersed in the high-pressure media must be protected against both possible failure of heat exchanger and admittance of

the high-pressure media. Flow-check valves, which are closely lined outside the tank as a precaution against a break in the coil, are installed in both inlet and outlet lines for protection.

SAFE OPERATION OF FACILITY

Conducting tests in deep-ocean simulation facilities is potentially hazardous because of the high pressures required and the large amounts of energy stored in the systems. Testing is seldom repetitious, and the kinds and sizes of models as well as the test requirements vary widely. Technicians, test mechanics, and riggers are required to install the model; to connect the various umbilicals, tubes, and pipes; to close the pressure tanks. Furthermore, the personnel within the operating crews change frequently. Under these circumstances, it is imperative that the likelihood of error be minimized and that each member of the operating crew be informed of exactly what is expected of him. The best way to do this is to prepare a written formal test plan, supplemented by appropriate illustrative matter. This plan should be thoroughly reviewed and approved by the cognizant test engineers before a test commences. One or more copies of the plan should be prominently posted for ready reference by all concerned.

TEST SUPERVISOR

A responsible individual should be named in each test plan, and he should be provided with a copy of it. He should be the one and only authority to whom all questions are referred that arise while the test is being prepared and conducted. He will provide answers and make required decisions. To minimize injury and/or property damage, he should be thoroughly prepared to cope with any emergency.

INSPECTION BEFORE TESTING

Before the test the supervisor should check all phases of the test, commencing with preparation of the facility and of the model. A final, critical inspection of all preparatory work listed on the test plan should be made before the high-pressure pumps are started.

EXCLUSION AREAS

The areas surrounding the pressure tank, high-pressure piping, pumps, valves, and accumulators are all hazardous during the performance of tests and should be so designated. Appropriate barriers, warning signs, and flashing red lights should be utilized to enforce exclusion of nonessential personnel from these areas. Only those designated by the test supervisor should be permitted within these areas during a test and only for a justifiable reason. Visual checking of performance of equipment as well as detection of unauthorized personnel in the exclusion areas can be accomplished with closed-circuit, TV-surveillance systems, strategically

placed and monitored at the pressure control console. Potential hazards from whipping and missiles on the operating floor of the test tanks should be guarded against by using shielding around high-pressure piping and penetrations. Lifting and transporting heavy weights over an operating facility and its high-pressure piping system should be prohibited so as to prevent triggering a casualty by accidentally dropping a heavy object.

When a common floor of operation is shared by two or more high-pressure tanks, it is impractical to cease all operations when only one tank is used for a test. With proper shielding, the hazard from whipping and missiles is removed; however, a shock wave hazard still exists. A significant amount of energy could be stored in air trapped in high-pressure piping or accumulators that would be released in the form of a shock wave upon failure. The radius at which the shock wave will be reduced to an overpressure of no more than 5 psi should be the minimum exclusion area. An overpressure of 5 psi is sufficient to displace people; however, it is not likely to seriously damage internal organs.

PROTECTIVE WALLS AND MISSILE PENETRATION

Exclusion areas and the walls and protective barriers of the equipment compartments and tank pits should be adequate to minimize potential hazards due to missiles created when equipment fails under high pressure. In a simple method believed to be conservative,³² an estimate is derived of the kinetic energy. This is done by assuming that the rupture pressure acts on the surface of the missile exposed to pressure during the time it takes the missile to move from its original position to a distance equal to the diameter of the opening generated by its removal.

The associated energy is

$$E = 0.0654D^3P = \text{energy in foot-pounds}$$

where D is the diameter of opening generated by removal of the missile in inches, and P is the pressure in the system at the time of rupture in pounds per square inch.

The associated initial velocity is

$$V_o = 2.05 \sqrt{\frac{PD^3}{W}} \text{ ft/sec}$$

where W is the weight of the missile in pounds.

The maximum vertical distance a missile could travel, given an initial velocity V_o , is

$$S = V_o t - 1/2 g t^2$$

where

$$t = \frac{V_o}{g}$$

³²Moore, C.V., "The Design of Barricades for Hazardous Pressure Systems" (Feb 1965).

and

$$S = \frac{1}{2} \frac{V_o^2}{g}$$

where S is distance in feet

V_o is initial velocity in feet per second

t is time in seconds

g is 32.2 ft/sec²

The depth to which a missile penetrates a missile barricade before coming to rest is given by

$$D^1 = KAV^1 R = \text{depth of penetration in feet}$$

where K is material constant or 4.76×10^{-3} cu ft/lb for reinforced concrete

A is section mass or $\frac{\text{weight of missile in pounds}}{\text{unit cross sectional area in square inches}}$

V^1 is velocity factor or $\log_{10} \left[1 + \frac{V_o^2}{215000} \right]$

R is the thickness ratio constant; the largest value it can have is 2.0.

Since scabbing (expulsion of the protective wall material from the opposite side of missile penetration) may occur if the missile penetration is greater than two-thirds of the wall thickness, the required wall thickness is assumed to be 1.5 times the calculated penetration depth. As an example, a large tank-steel plug, 2 ft in diameter and weighing 5 tons, ruptures at 10,000 psi. The calculated energy exceeds 9 million ft lb, and the initial velocity is $V_o = 241$ ft/sec; penetration of the reinforced-concrete protective barrier is 3.15 ft, and the minimum required wall thickness is 56.7 in. The initial velocity of smaller steel missiles, ranging from 0.1 to 50 lb, corresponding to valve stems, bonnets, etc., and having a length 5 times the diameter is $V_o = 194$ ft/sec, which can be contained by an 8.7-in-thick, or less, reinforced-concrete wall.

HARD VERSUS SOFT CYCLING

Hard cycling a test model is accomplished by varying the pressure in the test tank over the full range to which the model is subjected. The interior of the model may be filled either with inert gas or air and sealed or with water or oil and vented to the atmosphere. To withstand many such loading cycles, the pressure tank and all pressure piping, etc., would have to be designed to stress levels low enough to preclude fatigue failure. This may be required for some tests of exposed machinery and for certain types of structures, e.g., a thick-walled, glass-reinforced plastic (GRP) cylinder, for which the radial component of stress is an important contributor to failure and must be properly simulated. However, when absolutely

required, such tests are needlessly costly, either in running up the initial purchase cost or in accelerating the replacement of a pressure tank. When possible, soft cycling should be employed.

For soft cycling, the model is filled with the same fluid as is in the pressure tank. Then by using valving and appropriate controls, the pressure applied to the outside of the model is held essentially constant, while that inside the model is varied over the desired range. This system, described by U.S. Patent 3,196,677,³¹ allows the model to be stressed cyclically; however, very little pressure variation is experienced by the tank, thereby prolonging the life of the tank and increasing by a factor of 3 the maximum pressure at which fatigue tests can be safely conducted in a given tank.

CONTROLLED IMPLOSIONS

When underwater vehicles fail catastrophically at sea, they are so badly damaged due to the infinite potential energy of the sea that it is usually impossible to determine the point of origin of the failure. However, when a model is tested to failure in a pressure tank, the degree to which the structure is mutilated can be controlled. If the volume displaced by the model is small relative to the volume of the pressurized fluid in the tank, or if a sufficient head of inert gas or air is contained in the tank, a catastrophic failure of the model structure similar to that encountered in the ocean will occur. A catastrophic failure at high pressures of models constructed of relatively brittle materials such as glass produces shock waves and high-acceleration forces capable of tearing the pressure tank from its foundation. For this reason, restraint should be provided to prevent lateral displacement of the tank, and all piping connecting to the tank should be designed with sufficient flexibility to prevent all tearing loose.

From an operating standpoint, avoidance of catastrophic failures by controlled implosions is preferable since the tank and equipment are not subject to as severe shock waves and acceleration forces, and the amount of damage may be attenuated by sizing models so that they displace a major portion of the internal volume of the pressure tank. Thus, when failure of the model occurs, the increased volume caused by denting or rupturing, the model automatically reduces the pressure; therefore, the degree of damage to the model is limited, and the acceleration felt by the tank is reduced. In addition, the acceleration forces to which the tank is subjected can be further attenuated by filling the model structure with a suitable fluid and venting it to the atmosphere via a relatively small-diameter vent pipe.

EMERGENCY PROCEDURES

A complete system analysis should be performed, and an appropriate emergency procedure should be prepared, to treat with each potential hazard. These procedures should be

incorporated in the operational manual, and all personnel likely to be affected, as well as those required to effect the procedures, should become thoroughly familiar with them.

Some examples are a leak in the high-pressure boundary, pressure trapped in the tank, fire, and emergency shutdown of the high-pressure pumps.

RECORDKEEPING

An essential part of proper operation and maintenance of a high-pressure test facility is an adequate set of records that reflect the conditions of the facility. These should be in sufficient detail to permit an in-depth technical evaluation at any time of the suitability of the facility for continued high-pressure testing.

The records, maintained by the user, should provide a complete history of the facility. These should include:

Material Certification

Acceptance Test and Results

Inspection Reports, Original and Periodic

As-Built Drawings

As-Built Schematics

As-Built Bills of Material

Complete Maintenance Records—Including Breakdowns and Replacements

Complete *Cyclical Loading History—Type of Test (Static, Cyclic, Collapse, etc.)*

PROOF-TESTING

The whole reason for performing a hydrostatic overpressure test at acceptance is to try to avoid catastrophic failure during normal operations. Although the acceptance test is performed very cautiously and with extraordinary precautions, such as barring all but a minimal crew, the possibility of catastrophic failure exists; either the user or the manufacturer will be responsible, depending upon contractual agreements.

As mentioned previously, during acceptance, a warm hydrostatic water test, followed by a cold water test, is conducted at pressures to 1 1/2 times the designed, operating pressure. The question often arises, "Are additional hydrostatic tests required to assure safety?" Under certain conditions, a higher assurance of pressure-tank integrity may result, particularly with respect to resistance to brittle fracture. This is based on the rationale that (1) a warm water test at moderately elevated temperatures, relative to NDTT when the mode of fracture is entirely ductile, would allow plastic deformation to take place at the tips of undetected defects and might reduce the possibility of brittle failure at subsequent lower temperature tests, and (2) periodic overpressure hydrostatic tests might provide assurance that no cracks

greater than some critical length have developed in the pressure tank. However, for a tank designed with relatively tough materials, NDTT of the tank material is sufficiently less than the lowest operating test temperature of the tank, at least 60 F. Such tests are not warranted because they use up a significant portion of the fatigue life of the tank. Every high-pressure model test conducted in the tank is in effect a hydrostatic test and should be conducted with proper caution. Furthermore, it is difficult to determine when to schedule overpressure tests because it is impossible to calculate crack-growth rates and critical flaw size with certainty.

Careful periodic inspections, employing appropriate nondestructive testing procedures, should locate significant defects and allow their correction before they become critical.

MAINTENANCE OF FACILITY

PERIODICAL NONDESTRUCTIVE TESTS

Formal routine maintenance procedures should include periodic nondestructive tests (NDT) of the pressure vessel to assure detection of fatigue cracks and flaws and to follow their development. The frequency with which such inspections are made and the areas covered depend on the conservativeness of the entire design, the quality of fabrication, and the operating history. For areas known to be very highly stressed, it may be advisable to check with penetrative dyes in preparing model tests, especially when high pressures near the maximum designed operating pressure of the tank are expected. With conservative design and use, a dye-penetrant check of all accessible welds every several years may be adequate. In addition, checks should be made any time unusual or high-pressure collapse tests are made.

When the fatigue life of the tank is known to be short or questionable, frequent inspections are required. Inspection personnel for NDT's should be qualified and should perform in accordance with the standards established by ASME or other recognized authorities. The qualification records of the inspectors and the results of their tests, including review comments by the cognizant facility engineer, should be retained in the maintenance record file. Appropriate inspection drawings that locate all reportable indications of cracks and flaws together with appropriate checkoff sheets that reflect the extent of the inspection should be kept in the files.

CONTROL OF REPAIRS

Every repair of a pressure vessel and its associated piping and equipment should be performed by competent mechanics or technicians and should be noted in the maintenance records. The work should be inspected both in progress and after completion by a responsible facility engineer. No substitution for specified material or equipment should be permitted without complete engineering evaluation. Written work authorizations, completely

detailed and supplemented by appropriate engineering drawings, are required to ensure control of the repair work performed. All changes in a system shall be clearly indicated on the engineering drawings, and these must be kept up to date. A scheduled checkoff list for regular maintenance should be established and major overhauls earmarked.

AMORTIZATION

Budgeting for adequate maintenance through usage rates, accrual accounts or overhead accounts should be provided. Generally, Government fiscal policies do not permit charging for depreciation and replacement of wornout or obsolete high-pressure test facilities. Continued use of older facilities can increase the burden because of increased surveillance and maintenance requirements in conducting research. Older facilities may represent a safety hazard and, if so, should be replaced.

The life of a high-pressure tank may span only a few years, or it may last 20. As an average, a tank probably should be amortized in 10 to 15 yr. Inasmuch as deep-ocean simulation facilities are part of the national resources, their maintenance and replacement should be funded in a more systematic manner. The current effort on the part of NAVFAC³³ to assume responsibility for periodic certification of existing pressure tanks supports the contention that existing pressure tanks, regardless of origin, are an important part of the gross national product.

FAILURES OF HIGH-PRESSURE VESSELS

INTRODUCTION

A brief survey of failures of high-pressure vessels and systems was conducted in 1970 under sponsorship of the Naval Ship Research and Development Center to determine the nature and cause of failures experienced by others as an aid to ensure safe design; material selection; fabrication, inspection, and operation of high-pressure test facilities at the Center.³⁴ The main effort was limited to special purpose, high-pressure testing tanks and systems. When available, pertinent information about failures of industrial high-pressure systems and piping was included. An inquiry data sheet was sent to approximately 50 Government offices and private organizations to seek relevant information. This program was supplemented by discussions with persons having specific knowledge of failures as well as a limited review of

³³Naval Facilities Engineering Command, "Material Certification or Waiver for Existing Non-Man-Rated Hyperbaric Vessels and Existing Non-Man-Rated High-Pressure Tanks," Mark III (Oct 1970).

³⁴MPR Associates, Inc., "Survey of High Pressure Vessel and System Failure," prepared for Naval Ship Research and Development Center (Oct 1970).

pertinent literature. Information was obtained for 31 failures of systems or components listed in Table 3. Categorized causes of failures and number of times a condition contributed to failure is listed in Table 4.

BRITTLE FAILURES

Figure 20 shows a typical failure. The largest number of failures resulted from pressurization of vessels at or below NDTT of the material. Many failures occurred during the initial hydrostatic test, while others occurred during subsequent pressurizations. Eleven failures occurred during test or operation at temperatures lower than NDTT of the material, while in six other cases, inadequate notch toughness of the material was believed to have been a significant contributing factor.

These failures were attributable to one or more of the following causes.

Failure to control notch toughness

Failure to avoid loading at temperatures near NDTT

Improper heat treatment; in four cases, the material supplier failed to remove the material from the furnace quickly enough, and the required fast cooling did not occur

Failure to adequately inspect the material either during fabrication or after operation; in seven cases, undetected flaws including lamination, slag inclusions, and cracked welds initiated catastrophic failures in material that had poor notch toughness

In one case, a very small flaw caused by an arc strike on the outside of the vessel initiated the failure

Lack of appropriate post-welding heat treatment

Poor designs.

FATIGUE FAILURES

Fatigue cracking originating in highly stressed regions such as nozzles and closure threads was a contributing factor to failure in 10 cases. In one case, a test tank was used for hard cycling a series of models to failure, and this service exhausted the fatigue life of the tank.

FAULTY DESIGN

Either improper design details or overrating the vessels with unknown material properties caused four failures in overstressed regions. Four failures resulted from improper selection or use of materials.

TABLE 3 – KINDS OF FAILURES

Ammonia Converter	Nitrogen Storage Bottles
100-Ton Forging for a Pressure Vessel	Failure of Standard Bourdon Pressure Gages
ASTM A-302B Pressure Vessel	Catastrophic Failure of a Thick-Walled Pressure Vessel
Pressure Vessel for Chemical Processing	Conical Shock-Tube Failure
Spherical Blast Chamber	Pressure-Vessel Failure
Oil Storage Tank	Brittle Fracture of a Dished Head
CO Converter	Brittle Failure of a SA-202B Vessel
High-Pressure Air Flask	Large Pipe Failure Under Test
High-Pressure Gas Flask	O-Ring Failures, Two Incidents
One-Half Scale Model of a Pressure Vessel	Explosion of High-Pressure Air Piping
High-Pressure Test Vessel	Failure of a High-Pressure Elevator Tank Under Hydrostatic Test
Gun Barrel-Type Vessel	Failure of an Air Flask for Missile-Launching System
Summary of High-Pressure Pipe and Tubing Failures, Six Incidents	Steam Catapult Accumulator Failures
Rocket Motor Case	Failure of a 10-Cu-Ft Titanium Sphere
10,000-PSI Test Vessel	Primary System, Heavy Water Leak in Test Reactor
Supersonic Tunnel Air-Pressure Pipe	

TABLE 4 – INCIDENTS CATEGORIZED BY CAUSES OF FAILURE

Condition	Number of Times Condition Contributed to Failure
Inadequate Material-Notch Toughness	18
Undetected Flaws Existing before Installation	8
Lack of Appropriate Post-Weld Heat Treatment	8
Design Inadequacies and Fatigue Failures	14
Improper Material Selection	4
Inadequate or Improper Piping Restraints	4
Missiles and Jet Impingement	7
Poor Welds	2
Pressure Gage Failures	2
Control-System Malfunctions	3
Hydrogen Embrittlement	3
Failure of Converted Surplus Guns	2
Hydraulic Oil Fires	4
Laboratory Fires	2
Inadequate or Improper Maintenance Procedures	1
O-Ring Failures	2
Thermal Shock	2
Furnace-Sensitized Austenitic Stainless Steel	4
Use of Compressed Air Rather than Inert Gas	1

Reproduced from
best available copy.

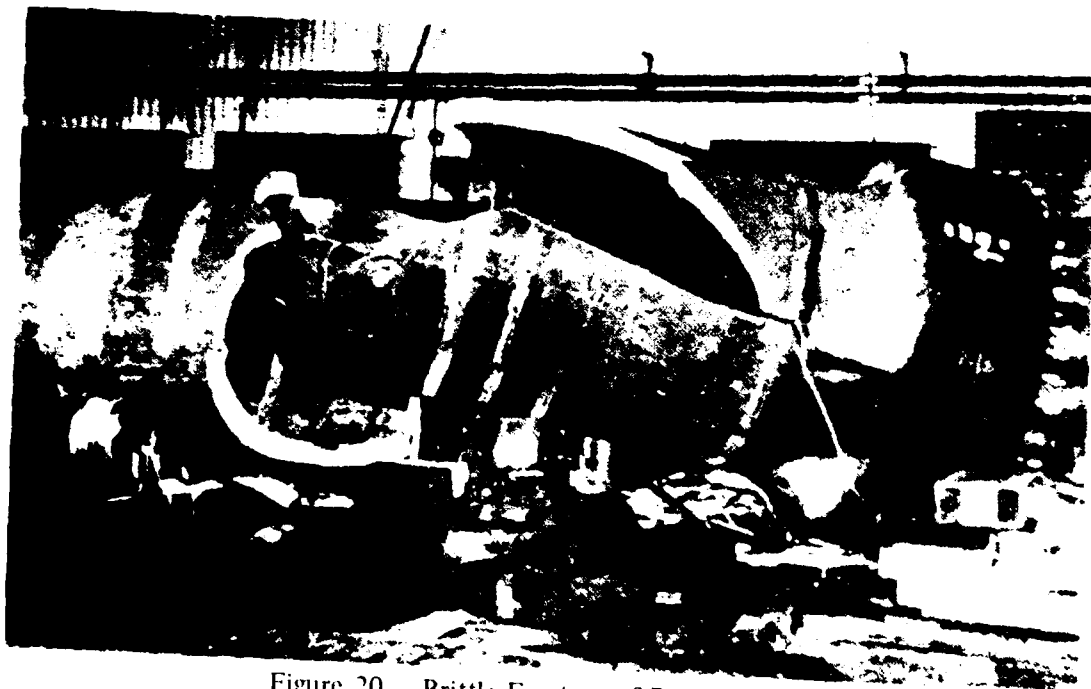

Figure 20 -- Brittle Fracture of Pressure Tank

ACCIDENTS

Accidents involving personal injury and one fatality were attributed to inadequate or improper piping restraints. In four accidents, pipe whipping resulted from fitting failures or inadequate piping restraint. In two cases, improperly located pipe supports restrained the piping in such a way as to overstress the tank connection during heatup and expansion of the piping. Three whipping accidents, including the fatality, occurred in small-diameter, 1400- to 2000-psi tubing and piping.

In six cases, potentially dangerous missiles in the form of valves, fittings, and pressure vessels were propelled by internal pressure and attained high velocities.

In two cases catastrophic failures of gas-loaded vessels and piping resulted from poor welding and inadequate quality control.

There were two reported instances of the Bourdon tubes failing in pressure gages.

Four cases involved hydraulic- or lubricating-oil fires. In one instance, lubricating oil became mixed with air in a compressor and caused an extensive fire. In another instance, there was an explosion in a hydropneumatic valve-actuating system that resulted in a fatality. In yet another incident, a heated oil line ruptured during routine testing of a hydraulic pump, filling the test area with oil vapor that ignited in an unknown manner.

There were two examples of fires at laboratories. In one instance, a heater-control failure caused ignition of hydrocarbon liquid; the resulting fire destroyed laboratory equipment. In another case a serious oil fire raged out of control for 8 hr, both because of lack of adequate firefighting equipment and of a plan for damage control in an area containing unaccustomed hazards.

In one instance, inadequate maintenance procedures allowed automatic drains, a safety-relief valve, and airflow distributors to malfunction; the end result was an explosion in high-pressure piping.

Backup- and O-rings, inadequate for the pressures and temperatures, failed in two instances. In one of these a jet of water was released during a hydrostatic test at 18,400 psi.

In another case, a number of steel accumulator vessels cracked due to the thermal shock of high-pressure steam impinging directly on the vessel walls.

In four incidents, furnace-sensitized, austenitic, stainless steels sustained severe stress-corrosion cracking in an environment containing chlorides and high concentrations of oxygen.

CONTROL SYSTEM FAILURES

In one instance, a test vessel was overpressurized and failed because of a malfunctioning overpressure safety valve and failure of the overpressure switch to shutdown the pressurizing pump.

FAILURE OF CONVERTED SURPLUS GUNS

Two pressure vessels constructed of surplus guns failed. In both instances, the type of material used and the mechanical properties were unknown to the user.

HAZARDOUS JET STREAMS

Any rupture of fluid-filled piping, even at pressures as low as 100 psi can have very serious consequences, e.g., violent displacement of a person. At only nominal pressures, fine streams can penetrate and tear flesh. Oil emitted through fine orifices or crevices becomes aerosolized at almost any pressure and can cause disastrous explosions, possibly followed by the release of large volumes of flaming oil. High-pressure jets of fresh or salt water can seriously damage equipment and can penetrate masonry walls. Jets of one-half diameter and more are very noisy, especially if they impinge on metallic surfaces. Such noise can cause individuals to panic.

EXOTIC APPLICATIONS

When testing models become more exotic than testing structures and relatively simple machinery, involving large quantities of gases such as hydrogen, oxygen, compressed air, steam, etc., *both the possibilities of failure and consequences thereof are greatly increased.* Under such circumstances stringent certification procedures are warranted and should be established.

SYSTEM SAFETY REVIEW

SAFETY REVIEW

Should a deep-ocean simulation test facility be placed in operation without an adequate safety analysis having been performed, design and fabrication defects may be exposed by the unpleasant experience of an accident investigation. A thorough safety analysis should be performed, preferably by an independent group of highly qualified engineers, as soon as practicable after installation of a test facility. For existing facilities that have not had such a review, it is strongly recommended that a review be performed. Periodic reviews may well be warranted for facilities that present potential hazards of an extraordinary kind.

EXTENT OF SAFETY REVIEW AND ANALYSIS PROCEDURES

The adequacy of the pressure tanks should be assessed for their rated pressure and temperature conditions, and the design and operation of the pressurizing systems should be

reviewed to assure that postulated system malfunctions and operator errors will not lead to conditions which exceed the pressure or temperature limits of the tank. For a properly designed and constructed facility as described in preceding sections of this report, all documentation should be readily available to enable this evaluation to be done quickly and inexpensively. In addition, existing operation and maintenance manuals will be checked.

The complete evaluation should include design, materials, fabrication, shop inspections, tests, operation, maintenance, and inservice examination of the tank plus whatever supplemental analyses and examinations may be required.

Since it may not be practical to review every piping element, fitting, valve, etc., in the system in sufficient detail to ensure that no component failure or malfunction could occur, a failure mode analysis may suffice. This analysis should determine whether the failure of a single component, a plausible operator error, or a systemwide failure such as loss of electric power could cause either overpressurization of the test tank or an unusual hazard to personnel.

Other matters related to overall safety should be evaluated, e.g.

1. Control of maintenance work and system modifications
2. Procedures for periodic inspection of pressure tanks
3. Selection and enforcement of exclusion areas to minimize the risk of personnel injured due to possible pipe whipping or missile hazards
4. Consequences of system components such as valves, fittings, pipings, etc., becoming missiles as a result of postulated failures; the effect of such missiles; and adequacy of the exclusion areas against possible missile hazards
5. Adequacy of fire-protection procedures

It is assumed that conventional industrial hazards associated with such items as lifting equipment, ladders and rigging, electrical equipment, etc., have been characterized elsewhere.

CLEARING HOUSE FOR SYSTEM FAILURES

An essential input for a thorough safety review is an analysis of all known failures. Not having information concerning this subject readily available, the Center sponsored a survey of high-pressure vessel and system failures as part of a safety review of several high-pressure test facilities. The survey was completed in 1970, and a summation of the more important findings appeared earlier in this dissertation. Establishment of a clearing house for collection and rapid dissemination of future casualty and failure analyses would be a valuable asset to the safe operation of all such facilities.

HOUSING FOR DEEP-OCEAN SIMULATION FACILITIES

PRESSURE-TANK ROOM

To control its environment, a pressure tank must be suitably sheltered. To facilitate installation of the tank and its operation, either a gantry or a bridge crane is justified. To limit the distance a projectile or jet stream can travel, the tank should be surrounded by earth and/or reinforced concrete. To limit the damage that can occur as a result of missile or jet impingement, the tank should be isolated. To contain all of the fluid that could be spilled in the event of a tank or fitting failure, a deep pit is an ideal solution. It is usually prohibitively costly to fully satisfy all of the preceding requirements. However, a good practical solution, especially if the tank is vertically oriented, is to provide a deep pit below-ground for the bulk of the tank. This allows an operating floor at or slightly aboveground. A sufficiently high industrial-type, aboveground building suffices as shelter. Protective barriers may be provided, and personnel exclusion areas may be designated.

Space should be provided to allow trucks, loaded with models, to enter the building; there should also be sufficient room near the pressure tank to instrument large models. The building columns should be sturdy enough to support an adequate bridge crane, having lift, span, and horizontal travel capability to service model preparation and tank operations.

Figure 4 shows a large, instrumented model being installed in a pressure tank. The building and the operating floor shown in Figure 2 serve several other large high-pressure tanks. The operating floor is heavily reinforced concrete, while the area underneath the operating floor is partially excavated and partitioned into individual tank pits of varying depths. Reinforced-concrete walls are used as partitions around each tank.

In addition to bridge cranes shown in Figure 3, high-capacity, forklift trucks and sturdy four-wheeled, open-bed trailers facilitate transportation and handling of the test models. Three- and five-ton powered hoists, supported on monorail trolleys, and pivoted jib cranes are also very useful adjuncts to high-pressure test facilities.

If large quantities of compressed gas are required for tests, and the volume of the building is such that sudden release of the gas can cause an overpressure exceeding 1 psi, hinged blowout panels should be provided to avoid serious damage to the building and occupants.

PUMPROOM

Because of both cost and hazard considerations, high-pressure piping runs should be as short as possible. Because of the possibility of disastrous failure of the pump, it should be isolated by either earth or reinforced concrete. However, high-pressure pumps require frequent servicing, which involves handling heavy components. These conditions are satisfied

by installing large, high-pressure pumps adjacent to the tank pits with compartmented walls of reinforced-concrete. A reinforced-concrete hatch cover, suitably sized, located over the pump, allows use of the bridge crane to install and service the pump.

If oil is to be used as a pressure medium, vapor-tight, incandescent lighting fixtures and totally enclosed electric motors are advisable for both the tank pit and the pumphouse. All spark-producing controls and starters should be either located in a separate room or provided with vapor-tight enclosures. It is preferable to locate motor-starting equipment in a separate room adjacent to the pumps so that performance can be checked without exposure to the hazards in the pumphouse.

Accumulators and control valves are an inseparable part of the high-pressure pumping system and must necessarily be located close to the pumps and the pressure tank, respectively. Accumulators should be housed in concrete enclosures, and areas in proximity to them should be designated exclusion areas during tests. The control valves must be readily accessible for maintenance. The requirements are satisfied by locating some or all of this kind of equipment in the pumphouse and the remainder in the tank pit. Figure 3 shows a good arrangement as well as separation of the various components of a high-pressure, test facility.

FIRE PREVENTION

The presence of large electrical machinery and equipment and the use of compressed air, hydraulically actuated controls, and oil as a pressure media increases the potential fire hazard. Fire occurring in proximity to high-pressure tanks and equipment can be very disastrous; consequently, adequate fire protection and firefighting procedures are imperative. Adequate fire protection includes a built in automatic fire-extinguishing system.

There are four principal ways to combat fire.

1. Cooling the fuel to less than the kindling point
2. Removing the oxygen supply
3. Separating the fuel from the oxidizer
4. Using chemicals that interfere with the chain reaction that takes place in combustion.

Available automatic systems based on each of these firefighting principles are available, and these may be classified as clean or dirty. The so-called clean systems use agents that may be considered costly but this is more than offset by minimal cleanup and secondary damage once actuated. The cheapest of all firefighting agents is water, which may be released in mist form or combined with chemicals to form foam; these are the dirty systems. In the presence of electrical systems, water also creates a shock hazard.

Automatic systems utilizing carbon dioxide as an extinguishing agent have had wide acceptance but are far from ideal since as much as 40 percent of room volume is required to

extinguish a fire, and CO₂ is toxic, even in relatively small percentages. The Underwriters' Laboratories, Inc., list carbon dioxide under Classification 5a as a toxic agent.

Chemical firefighting through the use of halogenated agents is gaining acceptance because the agents are clean and because considerably smaller concentrations are required than for CO₂. Dupont recommends only one of its line of halogenated products for firefighting; the trademark is "Freon FE 1301," also known as Halon 1301. It is claimed that it is a safe and effective fire-extinguishing agent against Class A, cellulosic materials; Class B, flammable liquids; and Class C, electrical fires. It is further claimed to be as much as three times more effective than carbon dioxide and most other halogenated agents and is equated to sodium-based dry powder in effectiveness.

The National Fire Protection Association (NFPA) adopted a tentative standard in May 1968 to serve as a guide for designing and installing fire-extinguishing systems using Halon 1301. This standard was officially adopted and issued in 1970.³⁵

Halon 1301 is a colorless, odorless, electrically nonconductive gas. It has only minor cooling ability. If dissipated too soon, cellulose materials in particular are apt to rekindle. Although it is less toxic than CO₂, it decomposes at 950 F, primarily into hydrogen fluoride, hydrogen bormide, and bromine. These decomposition products characteristically have sharp, acrid odors and are irritating, even in very low concentrations. The NFPA standard states, "In any proposed use of Halon 1301 where there is a possibility that men may be trapped in or enter into atmospheres made hazardous, suitable safeguards shall be provided to ensure prompt evacuation of and to prevent entry into such atmospheres and also to provide means for prompt rescue of any trapped personnel. Such safety items as personnel training, warning signs, discharge alarms, predischage alarms and breathing apparatus shall be considered."

As with any other fire-suppression system, maximum efficiency requires quick detection and rapid release of the agent. Detectors that operate on various characteristics of fire are available and should be selected to suit the specific installation. The types available include

1. Photoelectric--responds to visible smoke
2. Ionization--reacts to combustion gases; does not require heat, flame, or smoke
3. Infrared--senses infrared radiation, for use on rapidly developing fires
4. Fixed temperature--operates at preset temperature
5. Thermal--operates either on abnormal rate of rise or preset temperature.

Both detection and release of the agent require a dependable source of electric power. Without power, the agents are valueless. When there is a possibility of fire originating in

³⁵National Fire Protection Association, "Halogenated Extinguishing Agent Systems," National Fire Protection Association 12A (1970).

electrical machinery, circuit protection may function as far back as the primary breaker to the building. Consideration should be given to providing either an independent electrical circuit or an emergency battery supply.

The provision of an automatic fire-suppression system and compliance with NFPA requirements in regard to it are insufficient preparation for combating fire in a high-pressure-testing facility. Discussions should be held with the agency and/or local fire departments to establish acceptable procedures and to become familiarized with the potential hazards.

MODEL INSTRUMENTATION

Structural model preparation requires precise measurement and extensive instrumentation before the test as well as critical inspection, using various nondestructive test means, following the test. Sufficient space, adequate handling facilities, proper lighting, and humidity control are required for some or all of these operations and should be provided contiguous with the pressure tanks. Transportation of instrumented models any appreciable distance incurs the possibility of damaging delicate instrumentation.

DATA ACQUISITION ROOM

A single data acquisition room, centrally located with respect to two or more pressure tanks, enables easy allocation of data channels to each test, thus utilizing recording equipment more efficiently. Space is used economically as is the operating manpower.

Primary requirements for the room are: adequate isolation and protection in event of casualty in the high-pressure envelopes, temperature and humidity control, reliable communication with the tank operators, adequate lighting, and radio-frequency shielding when exceptionally sensitive recording equipment or digital conversion-transmission systems are used.

Figure 21 shows a data acquisition room and recording equipment that can accept data from 2000 strain gages. Permanently installed wiring terminates at patchboards near the feedthrough to locations at each pressure tank. Patchcords connect each recorder to receptacles which are permanently wired in. The control center allows the desired interconnections between recorders and patchboards.

PRESSURE-CONTROL ROOM

As a precautionary measure, individual control rooms have been provided for each major test tank at the Center. These are located so as to afford a degree of protection for the operator. Figure 22 shows such a room, and it shows a manual control console which is equipped with all of the necessary controls, remote TV monitors for exclusion areas, and a chart recorder to keep a permanent record of pressurizations. An automatic cyclic

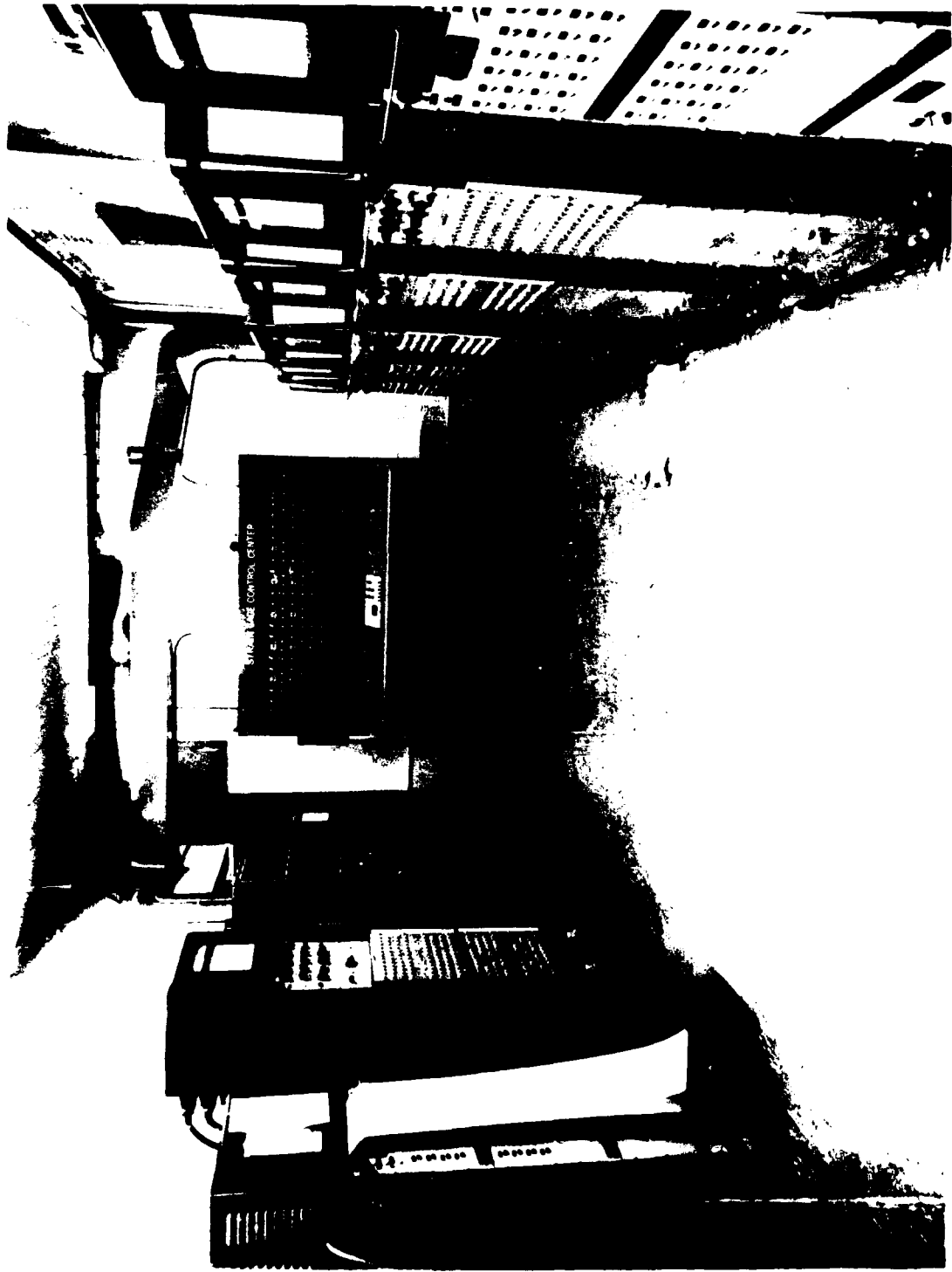

Figure 21 - Data Acquisition Room

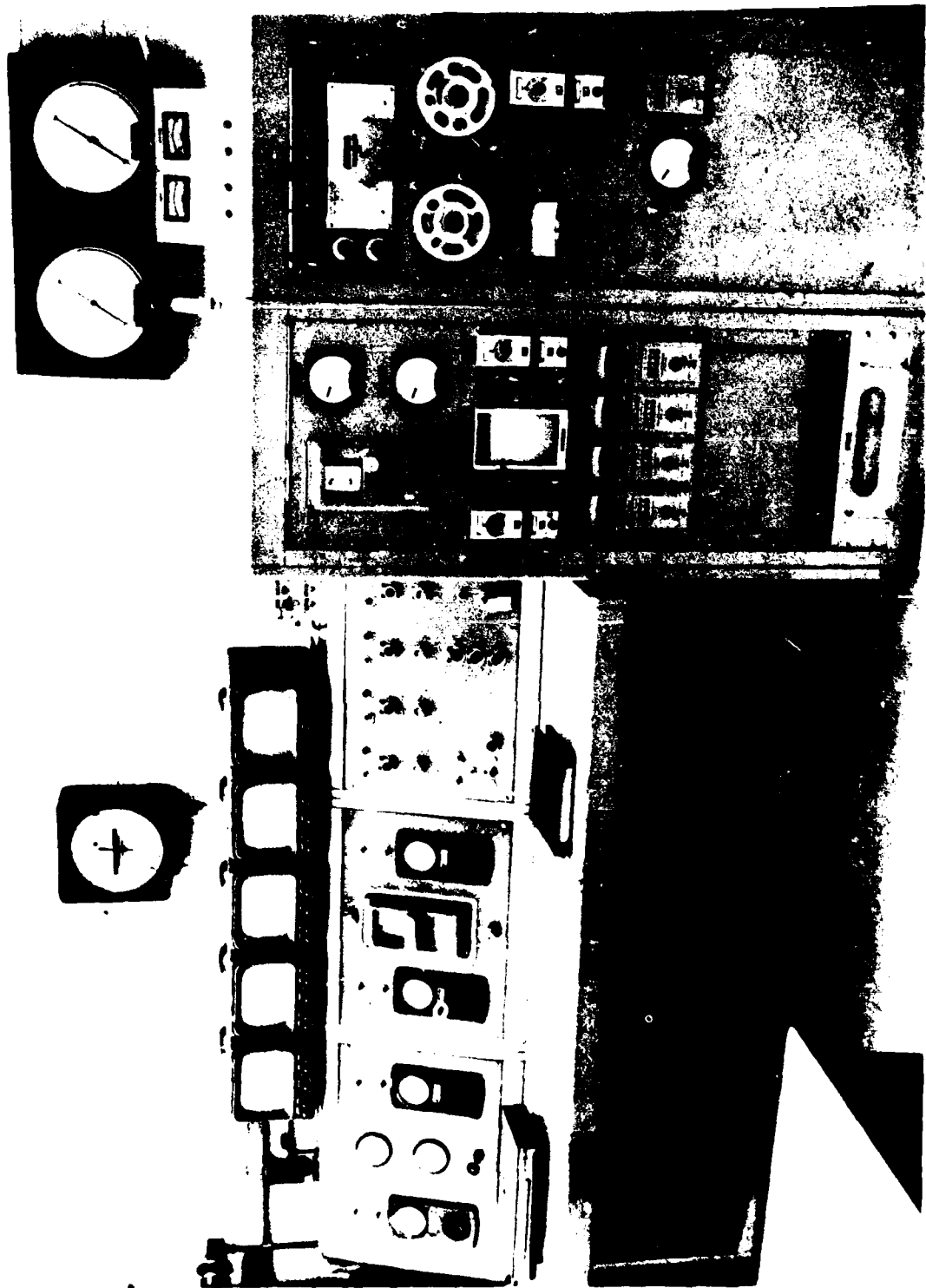

Figure 22 -- Pressure Control Room

pressure-control system has also been provided. This system utilizes punched tape; hence, any desired regular or randomly varying pressure program can be applied.

Since Bourdon-tube gages are susceptible to fatigue failure with serious consequences, established practice at the Center is to utilize them at only half-rated pressure for most applications. Valves are not to be used in a gageline, except on special setups and under supervision. Deadweight testers are used for calibrating gages, transducers, etc.

METALLURGICAL LABORATORY

An adequately equipped metallurgical laboratory also equipped for nondestructive testing and having at least one competent technician provides invaluable support in analyzing material failures, which is recommended as an essential adjunct to high-pressure, structural research.

SPECIMEN TESTING

The capability of preparing test specimens, the testing machines, and technical personnel to operate them accurately are essential requirements for accomplishing material certification, whether the material is used to fabricate pressure-testing facilities or the models to be tested in time.

SEAWATER AND OIL STORAGE TANKS

Storage tanks are preferred for reasons of economy to store both potable and seawater at most sites; when oil and seawater are used, tanks are mandatory. When ample space is available, and there are no esthetic objections, an aboveground tank farm may be the least expensive. In cold latitudes a nominal amount of heat may be necessary to prevent freezing, and an imperviously lined catch basin is mandatory in the event of oil storage-tank ruptures. An aboveground oil storage tank presents a serious fire hazard and must be kept a safe distance from the nearest building. For several reasons, underground oil storage tanks are preferred when possible.

When rock excavation is not involved, tanks may be buried at nominal cost, thus eliminating the need for tank heaters and minimizing the fire hazard in the case of oil. However, in times of high ground water, empty tanks become sufficiently buoyant to erupt violently from the ground; therefore, all tanks must be safely anchored.

Depending upon site location, it may be more economical to reconstitute seawater rather than to obtain it from the sea. Therefore, a means of mixing sea salts with freshwater, using minimum labor, should be provided in conjunction with seawater storage tanks.

Unless solids are desired in the seawater, a system is likely to prove a good investment for seawater as well as a filter system for oil. The maximum life, obtained before the seat

of a costly control valve is eroded to uselessness in one installation, is approximately 40 hr when unfiltered seawater is pumped through it at 11,000 psi.

HANDLING FACILITIES

Although adequate handling facilities are thoroughly justified on the basis of cost savings during installation of large high-pressure facilities, they are also necessary for adequate maintenance and are indispensable for the safe, economical handling of the many large, costly test models during preparation, installation, and removal after test.

Bridge and jib cranes, monorail hoists, forklifts, and flatbed trailers of suitable capacities are all required. When the item to be handled is extremely heavy, such as the head of a high-pressure, large-diameter tank, a gantry crane may be necessary.

STORAGE AREAS

Many of the materials needed to conduct deep-ocean research have long lead times for their procurement and frequently are available only in large quantities. To avoid delays that are too costly and to meet scheduled completion dates, it is necessary that many of these materials be stocked and that procurement for others initiated as soon as needs are recognized. Most sponsors request that their models be retained long after testing has been performed. In addition, many supports, jigs, and fixtures are fabricated in connection with various novel test requirements and must be retained for possible future use.

Sufficient and adequate indoor and outdoor storage areas in the general vicinity of deep-ocean environmental test facilities are essential requirements. A minimum of 10,000 sq ft of the outdoor storage area should be paved with concrete, and all of it should be flat and well drained. The poorest acceptable surface is stabilized soil. All storage areas should be well organized, and records of all stored items should be kept current. Accessibility to all items stored outdoors by trucks and cranes is essential.

REFERENCES

1. Allnutt, R. B. et al., "Deep Sea Simulation Facilities," Parts 1 and 3, NSRDC Report 2515 (Dec 1967).
2. Heller, S. R., Jr., "Deep Ocean Simulation Facilities of the U. S.," Catholic University of America (1970).
3. U. S. Naval Research Laboratory Shock and Vibration Center, "Index of Environmental Test Equipment in Government Establishments" (Nov 1967).
4. Chief of Naval Material, "Navy Technical Facility Capability Register" (Apr 1968).
5. Stinson, J. W. and R. A. Fishkin, "Navy Requirements for RDT&E Test Facilities Through the 1970's," NSRDC Reports 2998-1 and 2998-2 (Mar 1969).
6. Naval Facilities Engineering Command, "Hyperbaric Facilities General Requirements for Material Certification," NAVFAC Report P-422 (May 1970).
7. Keller, K. H., "High Pressure Test Chambers—State-of-the-Art," American Society of Mechanical Engineers 68-WA/UNT-8 (Dec 1968).
8. Stachiw, J. D., "Pressure Vessel Concepts," Naval Civil Engineering Laboratory R666 (Mar 1970).
9. Schmitz, E., "Multi-Layer Penstocks and High Pressure Wyes," American Society of Civil Engineers Proceedings, Paper 1344 (Aug 1957).
10. American Society of Mechanical Engineers, "ASME Boiler and Pressure Vessel Code Section VIII—Rules for Construction of Nuclear Vessels, Subcommittee of Boiler and Pressure Vessel Committee Report" (1968).
11. American Society of Mechanical Engineers, "ASME Boiler and Pressure Vessel Code Section VIII, Division 2—Alternative Rules for Pressure Vessels" (1967).
12. Pellini, W. S. and P. P. Puzak, "Fracture Safe Engineering Design of Steel Structures," Naval Research Laboratory Report 5920 (Aug 1968).
13. Harvey, J. F., "Pressure Vessel Design: Nuclear and Chemical Applications." D. Van Nostrand Company, Inc., Princeton, N. J. (1963).
14. American Society of Mechanical Engineers, "ASME Boiler and Pressure Vessel Code, Section III, Nuclear Power Plant Components" (1971).
15. American Society of Mechanical Engineers, "ASME Boiler and Pressure Vessel Code, Section VIII, Pressure Vessels, and Division 2, Alternative Rules" (1971).
16. American Society of Mechanical Engineers, "Criteria of the ASME Boiler and Pressure Vessel Code for Design by Analysis in Sections III and VIII, Division 2" (1969).

17. American Society of Mechanical Engineers, "Experimental Stress Analysis," Appendix II—Article II-1000 (May 1970).
18. American Society of Mechanical Engineers, "Stress Analysis Methods," Appendix A, Article A-1000 (May 1970).
19. Gifford, L. N., Jr., "Finite Element Analysis for Arbitrary Axisymmetric Structures," NSRDC Report 2641 (Mar 1968).
20. Naval Facilities Engineering Command, "Hyperbaric Facilities," NAVFAC Specification P422.1, Pre-Material Certification Checklist (Jan 1971).
21. American Society for Testing and Materials, "Tension Testing of Metallic Materials," ASTM-Standard E-8-66 (Feb 1966).
22. American Society for Testing and Materials, "Notch Bar Impact Test of Metallic Materials," ASTM-Standard E-23-64 (1972).
23. Naval Ship Systems Command, "Fabrication, Welding and Inspection of HY-80 Submarine Hulls," NAVSHIPS 0900-006-9010 (Sep 1971).
24. Department of Defense, "Steel Plate, Alloy, Structural, High Yield Strength (HY-80 and HY-100)," Military Specification MIL-S-16216H (Feb 1963).
25. Department of Defense, "Steel Forgings Alloy, High Yield Strength (HY-80 and HY-100)," Military Specification MIL-S-23009A (Apr 1965).
26. American Society for Mechanical Engineers, "Qualification Standard for Welding and Brazing Procedures, Welders, Brazers, and Welding and Brazing Operators," ASME Boiler and Pressure Vessel Code Section IX (1968 Edition).
27. Department of Defense, "Mechanical Tests for Welded Joints," Military Specification—MIL-STD-00418B(SHIPS) (Nov 1967).
28. American Society for Testing and Materials, "Free Bend Test for Ductility of Welds," ASTM Standard E-16-64 (1971).
29. Department of Defense, "Electrodes, Welding, Mineral Covered, Iron Powder, Low Hydrogen Medium and High Tensile Steel, As-Welded a Stress Relieved Application," Military Specification, MIL-E-22200/1C (29 Jun 1962).
30. Department of Defense, "Military Standard Nondestructive Testing Requirements for Metals," MIL-STD 271D(SHIPS) (Mar 1965).
31. Day, P. P. and R. B. Allnutt, "Cyclic Pressure Loading System," U. S. Patent 3,196,677 (Nov 1962).
32. Moore, C. V., "The Design of Barricades for Hazardous Pressure Systems," (Feb 1965).

33. Naval Facilities Engineering Command, "Material Certification or Waiver for Existing Non-Man-Rated Hyperbaric Vessels and Existing Non-Man-Rated High Pressure Test Tanks," Mark III (Oct 1970).

34. MPR Associates, Inc., "Survey of High Pressure Vessels and System Failure," prepared for Naval Ship Research and Development Center (Oct 1970).

35. National Fire Protection Association, "Halogenated Extinguishing Agent Systems," NFPA 12A (1970).