

AD-785 573

**U. S. ARMY HELICOPTER ELECTRICAL SYSTEM  
RELIABILITY AND MAINTAINABILITY INVESTI-  
GATION. VOLUME I. DOCUMENT DEFICIENCY  
ANALYSIS**

**Clifford E. Nord**

**Systems Associates, Incorporated**

**Prepared for:**

**Army Air Mobility Research and Development  
Laboratory**

**May 1974**

**DISTRIBUTED BY:**

**NTIS**

**National Technical Information Service  
U. S. DEPARTMENT OF COMMERCE  
5285 Port Royal Road, Springfield Va. 22151**

EUSTIS DIRECTORATE POSITION STATEMENT

The report is presented in two volumes. This volume (Volume I) gives a complete description of the investigation procedures and contains conclusions and recommendations, with their rationale. Volume II, "Supplemental Design Guide", contains only those recommendations which, if implemented, would improve the reliability and maintainability of future-generation Army helicopters.

This report and the accompanying Volume II are considered to provide an insight into the deficiencies which exist in the requirements documentation for helicopter electrical systems, and use of the recommended changes contained herein and in Volume II is encouraged.

However, it must be emphasized that carte blanche use of any requirement can never be as accurate as a very thorough analysis of requirements as they pertain to specific applications.

The Project Engineer for this effort was Mr. Richard I. Adams, Military Operations Technology Division.

DISCLAIMERS

The findings in this report are not to be construed as an official Department of the Army position unless so designated by other authorized documents.

When Government drawings, specifications, or other data are used for any purpose other than in connection with a definitely related Government procurement operation, the United States Government thereby incurs no responsibility nor any obligation whatsoever; and the fact that the Government may have formulated, furnished, or in any way supplied the said drawings, specifications, or other data is not to be regarded by implication or otherwise as in any manner licensing the holder or any other person or corporation, or conveying any rights or permission, to manufacture, use, or sell any patented invention that may in any way be related thereto.

Trade names cited in this report do not constitute an official endorsement or approval of the use of such commercial hardware or software.

DISPOSITION INSTRUCTIONS

Destroy this report when no longer needed. Do not return it to the originator.

ACCESSION for	
NTIS	White Section <input checked="" type="checkbox"/>
DIC	Buff Section <input type="checkbox"/>
UNCLASSIFIED	<input type="checkbox"/>
JUSTIFICATION	
BY	
DISTRIBUTION/AVAILABILITY CODES	
Dist.	AVAIL. and/or SPECIAL
A	

iiia

UNCLASSIFIED

AD 785 523

SECURITY CLASSIFICATION OF THIS PAGE (When Data Entered)

REPORT DOCUMENTATION PAGE		READ INSTRUCTIONS BEFORE COMPLETING FORM
1. REPORT NUMBER USAAMRDL-TR-73-97A	2. GOVT ACCESSION NO.	3. RECIPIENT'S CATALOG NUMBER
4. TITLE (and Subtitle) U.S. ARMY HELICOPTER ELECTRICAL SYSTEM RELIABILITY AND MAINTAINABILITY INVESTIGATION Volume I - Document Deficiency Analysis		5. TYPE OF REPORT & PERIOD COVERED Final Report
		6. PERFORMING ORG. REPORT NUMBER R73-011
7. AUTHOR(s) Clifford E. Nord		8. CONTRACT OR GRANT NUMBER(s) DAAJ02-73-C-0020
9. PERFORMING ORGANIZATION NAME AND ADDRESS Systems Associates, Inc. 444 West Ocean Boulevard Long Beach, California 90802		10. PROGRAM ELEMENT, PROJECT, TASK AREA & WORK UNIT NUMBERS Task 1F162203A11903
11. CONTROLLING OFFICE NAME AND ADDRESS Eustis Directorate U.S. Army Air Mobility R&D Laboratory Fort Eustis, Virginia 23604		12. REPORT DATE May 1974
		13. NUMBER OF PAGES <del>254</del> 264
14. MONITORING AGENCY NAME & ADDRESS (if different from Controlling Office)		15. SECURITY CLASS. (of this report) Unclassified
		15a. DECLASSIFICATION/DOWNGRADING SCHEDULE
16. DISTRIBUTION STATEMENT (of this Report)  Approved for public release; distribution unlimited.		
17. DISTRIBUTION STATEMENT (of the abstract entered in Block 20, if different from Report)		
18. SUPPLEMENTARY NOTES Volume I of a two-volume report  Reproduced by NATIONAL TECHNICAL INFORMATION SERVICE U S Department of Commerce Springfield VA 22151		
19. KEY WORDS (Continue on reverse side if necessary and identify by block number) Electrical Equipment    Maintainability    Human Factors Engineering Operation    Test Methods Data Acquisition    Environments Reliability    Safety Requirements    Quality Assurance		
20. ABSTRACT (Continue on reverse side if necessary and identify by block number) This investigation was performed in order to identify deficiencies in military specifications and standards concerning electrical systems in U.S. Army helicopters. The three areas of concern that have impact on helicopter reliability and maintainability are: design requirements; qualification test requirements, procedures, and practices; and quality assurance provisions and requirements.  264		

DD FORM 1 JAN 73 1473 EDITION OF 1 NOV 65 IS OBSOLETE

UNCLASSIFIED

SECURITY CLASSIFICATION OF THIS PAGE (When Data Entered)

**UNCLASSIFIED**

**SECURITY CLASSIFICATION OF THIS PAGE(When Data Entered)**

**Block 20**

The helicopters selected are the AH-1G Cobra, UH-1D/H Iroquois, OH-6A Cayuse, CH-47A Chinook, and the CH-54A Tarhe. Schematics of each model helicopter electrical system were analyzed, and a composite schematic was constructed to represent all circuits, equipments, and component parts of all models. This composite schematic provided a baseline system on which to build an electrical system documentation tree.

Documents were collected from DOD sources, supplemented by information from manufacturers' drawings and Army maintenance manuals. They were analyzed for application to the documentation tree and whether they required major revision, minor revision, deletion, or rewrite. Areas which lacked design documentation were identified for new documentation requirements.

Recommendations for new documents and for improvements are identified, and supplementary information to deficient documents is provided in Volume II of this report.

ii

**UNCLASSIFIED**

**SECURITY CLASSIFICATION OF THIS PAGE(When Data Entered)**

## SUMMARY

This investigation was performed to identify deficiencies in U.S. Army helicopter electrical system documentation. The scope of the effort was constrained to documentation pertinent to three classes of requirements which have impact on the reliability and maintainability of helicopters: (1) design requirements; (2) qualification test requirements, procedures, and practices; and (3) quality assurance provisions and requirements.

The results of this investigation are contained in two volumes: Volume I - Document Deficiency Analysis, and Volume II - Supplemental Design Guide. Figure 1 presents an overview of the total effort and illustrates the allocation of the various tasks into Volumes I and II.

The first major task was to analyze the electrical systems contained in the current inventory of U.S. Army helicopters. Five models were selected as representative of the total family of helicopters: AH-1G, UH-1D/H, OH-6A, CH-47A, and CH-54A. The equipments that comprise the electrical system of these helicopters were then aggregated into six functional categories: alternating current, battery, electrical controls, external power, direct current, and load circuit.

Within each of the six functional groups, component trees were developed to establish the dominant/subordinate relationships among them. This was followed by the development of a baseline electrical system which presents a composite of the design philosophies of all the Army helicopter designers. The development of this baseline system, in turn, is the basis for the design of the structure of the documentation tree included in Volume II of this report.

The next major task was to collect and classify over 200 documents, of which 124 were found to be pertinent; applicable documents were then evaluated against a structured set of deficiency criteria, and the potential degree of impact on reliability and maintainability was assessed. Those documents containing deficiencies with a potential major impact were then reevaluated to identify the alternative actions that the Army might take to reduce the impact and then to select the best of the alternatives.

Of the total of 124 pertinent documents, approximately 96 percent were found to be deficient in the area of reliability requirements, 90 percent in maintainability requirements, and 94 percent in reliability and maintainability demonstration requirements.

To correct the identified deficiencies, 5 new documents should be developed to fill the void in existing documentation. Additionally, 4 of the existing documents should be deleted. Of the remaining documents, 5 were judged adequate, 76 will require major revisions, and 27 should require only minor revisions. Sixteen documents are simple hardware category and were not subjected to an alternative evaluation and selection analysis.

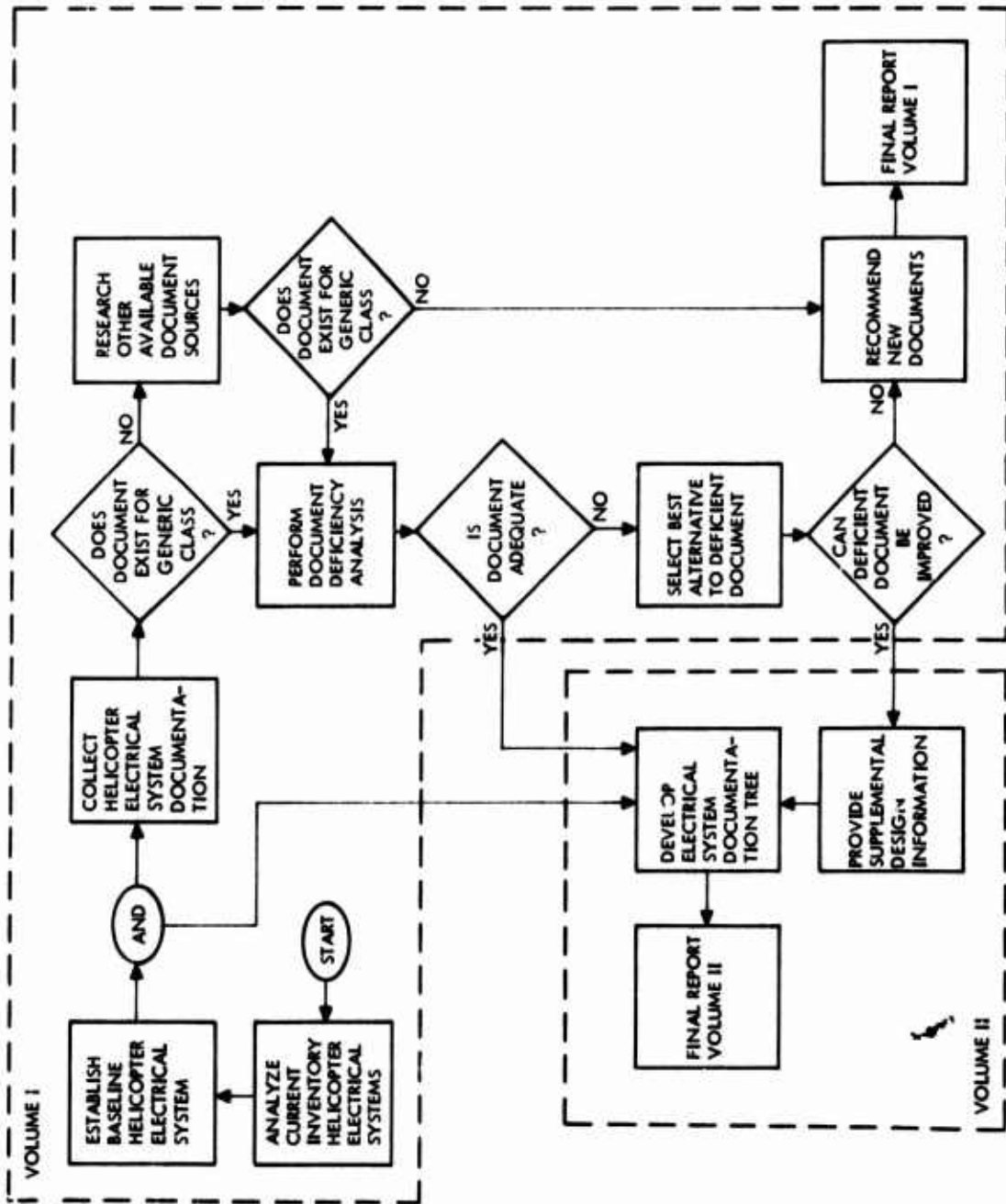

Figure 1. Electrical System Investigation Overview.

## TABLE OF CONTENTS

	<u>Page</u>
SUMMARY . . . . .	iii
LIST OF ILLUSTRATIONS . . . . .	vii
LIST OF TABLES . . . . .	ix
INTRODUCTION . . . . .	1
DERIVATION OF BASELINE ELECTRICAL SYSTEM . . . . .	2
DOCUMENT CLASSIFICATION . . . . .	37
Helicopter Technical Manuals . . . . .	37
Department of Defense Index of Specifications and Standards . . . . .	40
U. S. Army Aviation Systems Command . . . . .	40
Manufacturers' Detailed Design Specifications . . . . .	41
Documents Not Applicable . . . . .	41
DOCUMENT DEFICIENCY ANALYSIS . . . . .	56
Document Deficiency Criteria . . . . .	56
Design Requirements . . . . .	58
Test Requirements, Procedures and Practices . . . . .	60
Quality Assurance Requirements and Provisions . . . . .	62
Document Analysis . . . . .	63
ALTERNATIVE SELECTION ANALYSIS . . . . .	65
Evaluation Methodology . . . . .	65
Alternative Evaluation and Selection . . . . .	66
CONCLUSIONS . . . . .	112
RECOMMENDATIONS . . . . .	113
GLOSSARY . . . . .	116

**APPENDIXES**

I. Documents Analyzed . . . . .	118
II. Related Inapplicable Documents . . . . .	142
III. Related Reference Documents . . . . .	152
IV. Document Analysis . . . . .	156



## LIST OF ILLUSTRATIONS

<u>Figure</u>		<u>Page</u>
1	Electrical System Investigation Overview . . .	iv
2	AH-1G Alternating Current Circuit Schematic . . .	4
3	AH-1G Generator and Bus Circuit Schematic . . .	5
4	AH-1G Battery Circuit Schematic . . . . .	7
5	AH-1G External Power Circuit Schematic . . . . .	9
6	AH-1G Electrical Subsystem Block Diagram Tree . . .	10
7	UH-1D/H Alternating Current Circuit Schematic . . .	11
8	UH-1D/H Generator and Bus Circuit Schematic . . .	13
9	UH-1D/H Battery Circuit Schematic . . . . .	15
10	UH-1D/H External Power Circuit Schematic . . . . .	17
11	UH-1D/H Electrical Subsystem Block Diagram Tree . . .	19
12	OH-6A Electrical Subsystem Schematic . . . . .	21
13	OH-6A Electrical Subsystem Block Diagram Tree . . .	23
14	CH-47A Alternating Current Circuit Schematic . . .	25
15	CH-47A Direct Current Circuit Schematic . . . . .	27
16	CH-47A Electrical Subsystem Block Diagram Tree . . .	28
17	CH-54A Alternating Current Circuit Schematic . . .	29
18	CH-54A Direct Current Circuit Schematic . . . . .	33
19	CH-54A Electrical Subsystem Block Diagram Tree . . .	35
20	U. S. Army Helicopter Baseline Electrical System Block Diagram Tree . . . . .	36
21	Electrical System Design, Testing, and Quality Assurance Requirements and Provisions . . . . .	57
22	Electrical System Document Alternative Selection . . .	68

<u>Figure</u>		<u>Page</u>
23	Alternating Current Circuit Document Alternative Selection . . . . .	72
24	Battery Circuit Document Alternative Selection . . . . .	79
25	Electrical Control Circuit Document Alternative Selection . . . . .	81
26	External Power Circuit Document Alternative Selection . . . . .	82
27	Direct Current Circuit Document Alternative Selection . . . . .	83
28	Load Circuit Document Alternative Selection . . . . .	87
29	Electrical System Component Part Document Alternative Selection . . . . .	89
30	Document Alternative Selection Comparison . . . . .	111
31	Electrical System Document Deficiency Analysis . . . . .	159
32	Alternating Current Circuit Document Deficiency Analysis . . . . .	162
33	Battery Circuit Document Deficiency Analysis . . . . .	179
34	Electrical Controls Circuit Document Deficiency Analysis . . . . .	183
35	External Power Circuit Document Deficiency Analysis . . . . .	184
36	Direct Current Circuit Document Deficiency Analysis . . . . .	187
37	Load Circuit Document Deficiency Analysis . . . . .	195
38	Electrical Component Parts Document Deficiency Analysis . . . . .	199

LIST OF TABLES

<u>Table</u>		<u>Page</u>
I	Representative Army Helicopters . . . . .	2
II	Applicable Helicopter Technical Manuals . . . . .	38
III	Electrical System Documentation . . . . .	42
IV	Document Deficiency Matrix . . . . .	64

## INTRODUCTION

This investigation was performed in order to:

1. Determine the inherent electrical system documentation deficiencies that impact helicopter reliability and maintainability.
2. Improve deficient documents to reflect the U.S. Army helicopter operational environments.

Volume I of this report describes the various analytical activities that were performed with the primary intent of identifying the basic reliability and maintainability related deficiencies. These activities included:

1. Analysis of current-inventory helicopter electrical systems
2. Establishment of a baseline electrical system
3. Collection of electrical system documentation
4. Determination if applicable documentation existed for each electrical system generic classification
5. Identification of other document sources, i. e., commercial and manufacturer, where no existing military documentation was available
6. Performance of document deficiency analysis on all identified documentation
7. Selection of best alternatives to deficient documents
8. Recommendations for new documents

Volume II of this report is a supplemental design guide (SDG). If promulgated, the SDG will assist the designer of electrical systems and components in improving the reliability, availability, and maintainability of Army helicopters. The SDG contains a helicopter electrical system documentation tree which displays the interstitial relationships of these documents in the design of an electrical system.

## DERIVATION OF BASELINE ELECTRICAL SYSTEM

One objective of this investigation has been to develop a supplemental design guide (SDG). When implemented, this guide will serve to augment existing electrical system documentation in order to ensure that the reliability and maintainability of future electrical systems will not be degraded due to documentation deficiencies. It should be noted that in this context, documentation deficiency means either inadequate or nonexistent documents.

In order to provide an SDG of maximum use to the Army, the particular design philosophies of each of the existing helicopter suppliers must be considered. The baseline electrical system has been derived to satisfy this requirement. This baseline system is a composite design of all existing Army helicopter suppliers and therefore includes all of the generic types of components and functions represented by them.

The existing helicopter electrical systems used to develop the baseline system are shown in Table I.

**TABLE I. REPRESENTATIVE ARMY HELICOPTERS**

Designation	Popular Name	Manufacturer	Typical Mission Usage
AH-1G	Cobra	Bell Helicopter Company	Attack
UH-1D/H	Iroquois	Bell Helicopter Company	Utility
OH-6A	Cayuse	Hughes Tool Company	Observation
CH-47A	Chinook	Vertol Division — The Boeing Company	Cargo/Transport
CH-54A	Tarhe	Sikorsky Aircraft Division — United Aircraft Corp.	Cargo/Transport

The next step in the baseline system was to aggregate the electrical system into functional categories. The categories selected were:

- Alternating Current Circuit — Equipment whose function is to generate and control alternating current within the electrical system.
- Battery Circuit — Equipment, including batteries, whose function is to distribute stored electrical energy within the electrical system.

- **Electrical Controls Circuit** — Equipment whose function is to select and protect electrical circuits.
- **External Power Circuit** — Equipment whose function is to receive externally provided electrical power for ground operation.
- **Direct Current Circuit** — Equipment whose function is to generate and control direct current within the electrical system.
- **Electric Load Circuit** — Equipment whose functions are to control trim actuation, lighting, fire warning, instrumentation, weapons subsystems, communications, navigation, heating, and emergency equipment.

Figures 2 through 5 are the schematics of the AH-1G electrical subsystem reproduced from TM 55-1520-221-20, dated 10 September 1971 which were used to categorize the electrical subsystem into the functional groups previously described. Following this aggregation, a component "tree" is developed wherein each of the five functional groups is broken down into equipment and the component parts which comprise them. This tree format is a prerequisite to the development of the documentation tree wherein all pertinent documentation is ordered from the system down to the piece-part level. The AH-1G electrical subsystem tree is illustrated in Figure 6.

In similar fashion, the UH-1D/H schematics reproduced from TM 55-1520-210-20, dated 7 May 1969 are presented in Figures 7 through 10 and its tree is illustrated in Figure 11. The OH-6A schematic reproduced from TM 55-1520-214-20, dated 18 July 1969 and tree are shown as Figures 12 and 13 respectively. Figures 14 and 15 present the CH-47A electrical schematics reproduced from TM 55-1520-209-20, dated 29 May 1968, while the tree is shown as Figure 16. The CH-54A schematics reproduced from TM 55-1520-217-20-1/2, dated 24 April 1969, are provided in Figures 17 and 18 and the tree in Figure 19.

Upon completion of the five electrical system trees, a composite electric system tree was developed. This baseline system tree, illustrated in Figure 20, was then used as the basis for the electric system documentation tree presented in Volume II of this report.

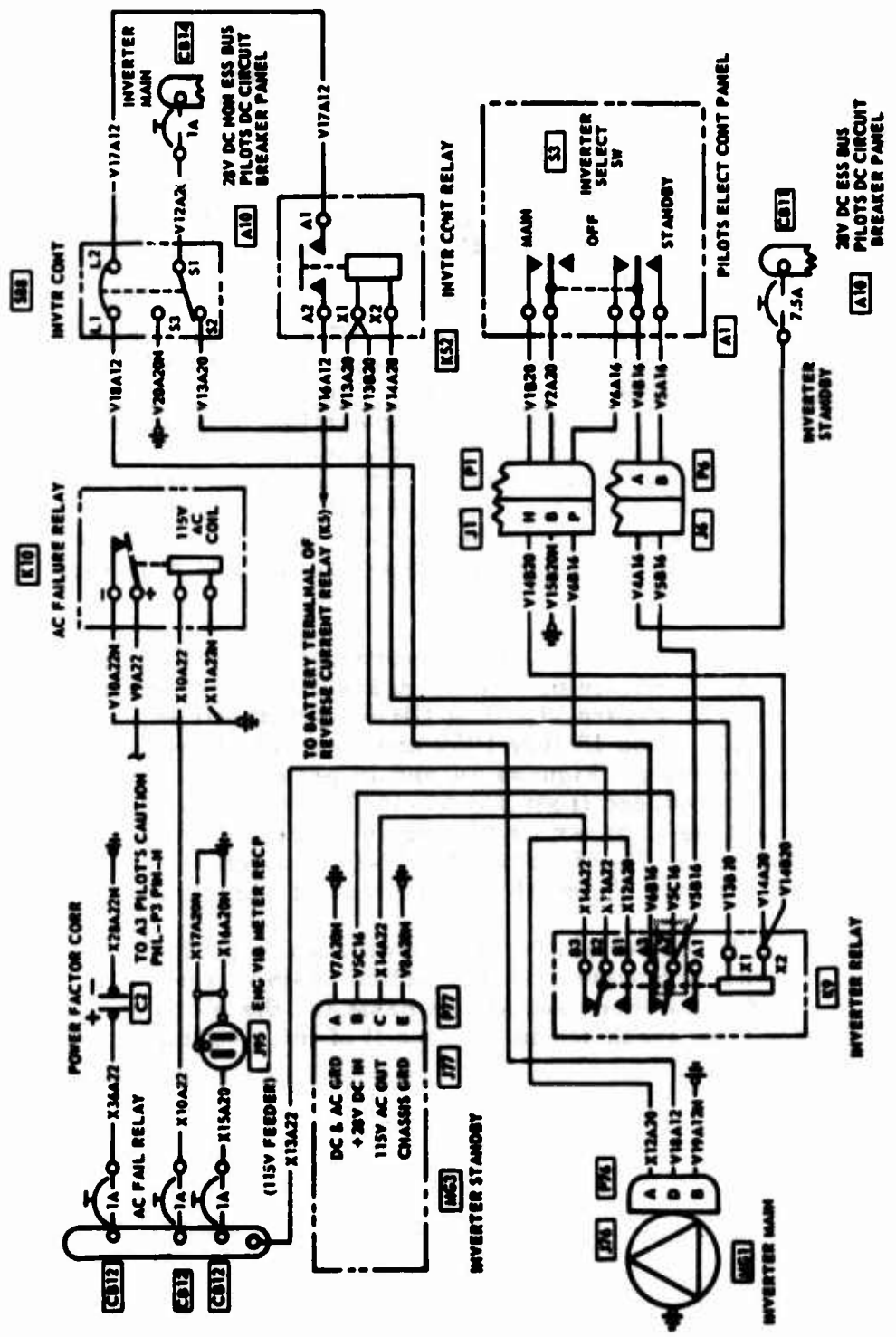

Figure 2. AH-1G Alternating Current Circuit Schematic.

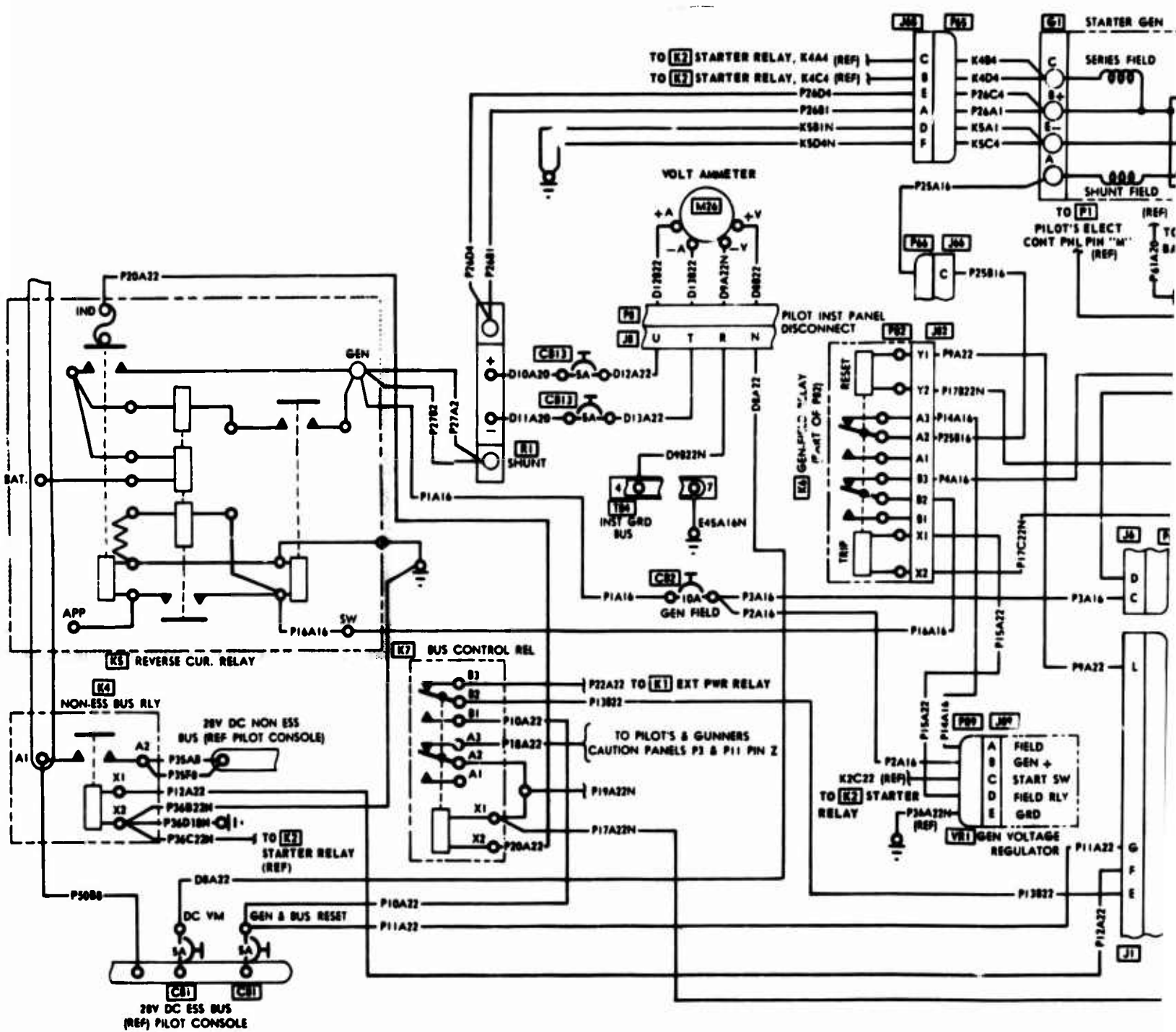
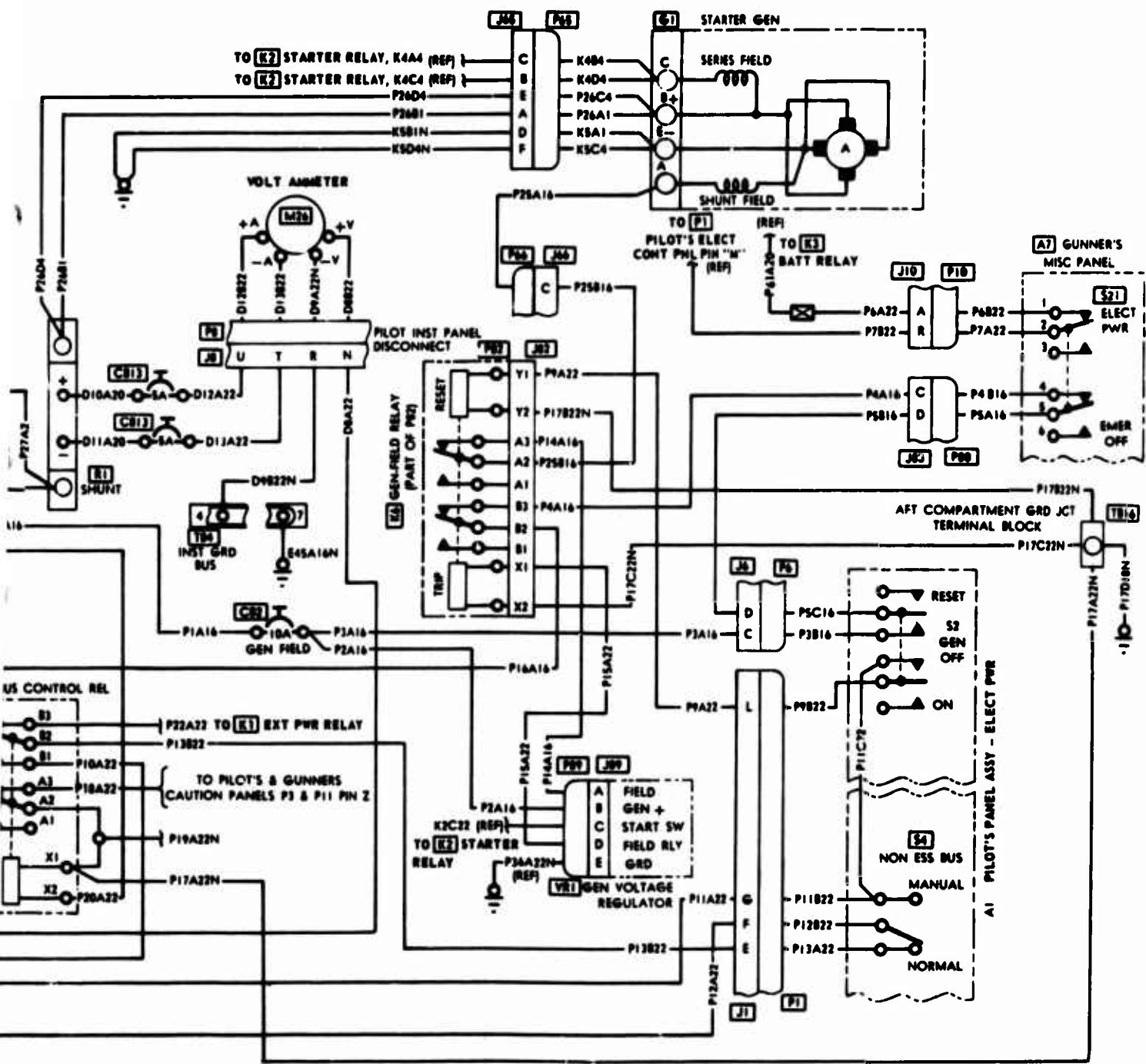

Figure 3. AH-1G Generator and Bus Circuit Schematic.





and Bus Circuit Schematic.

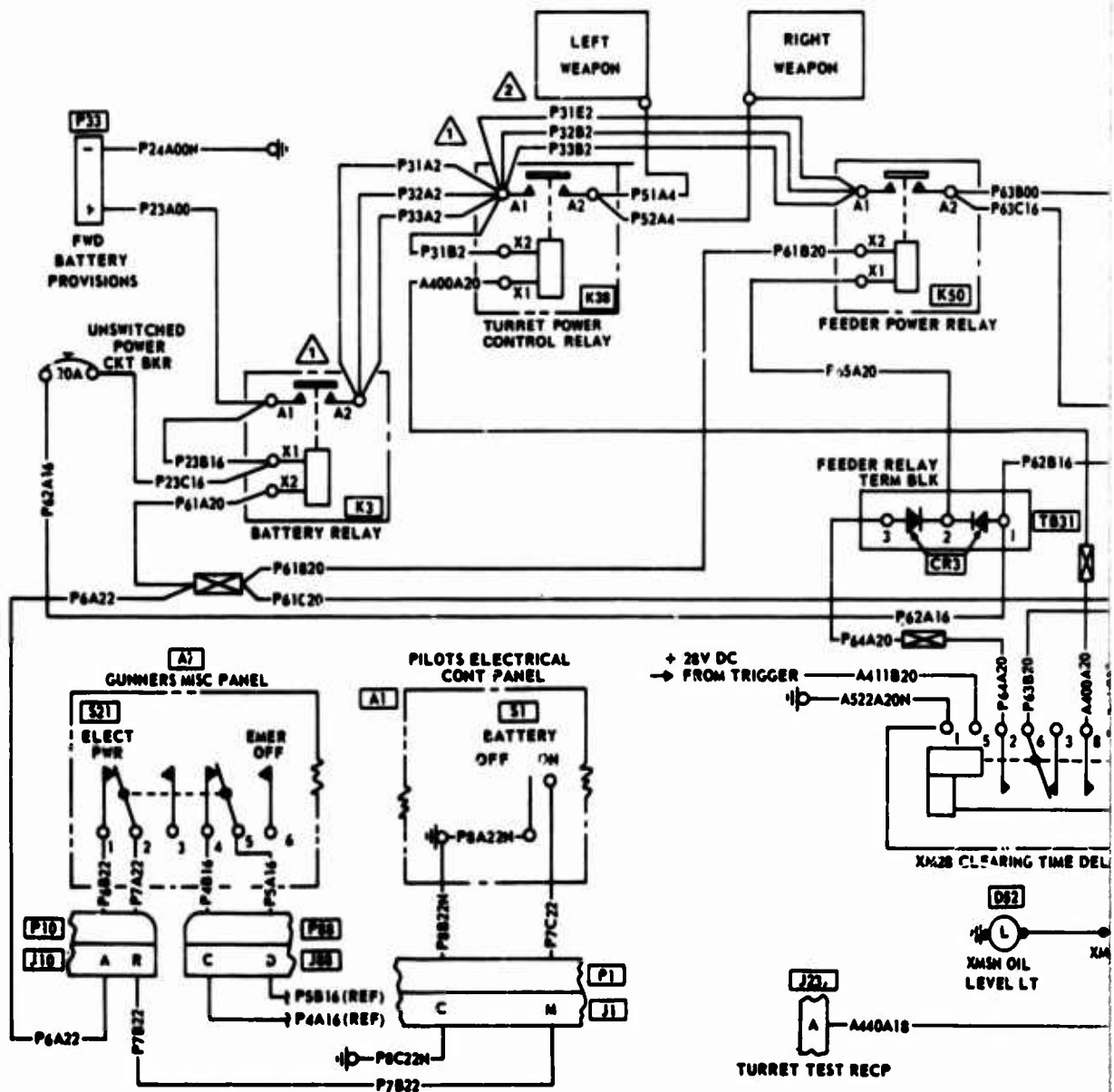
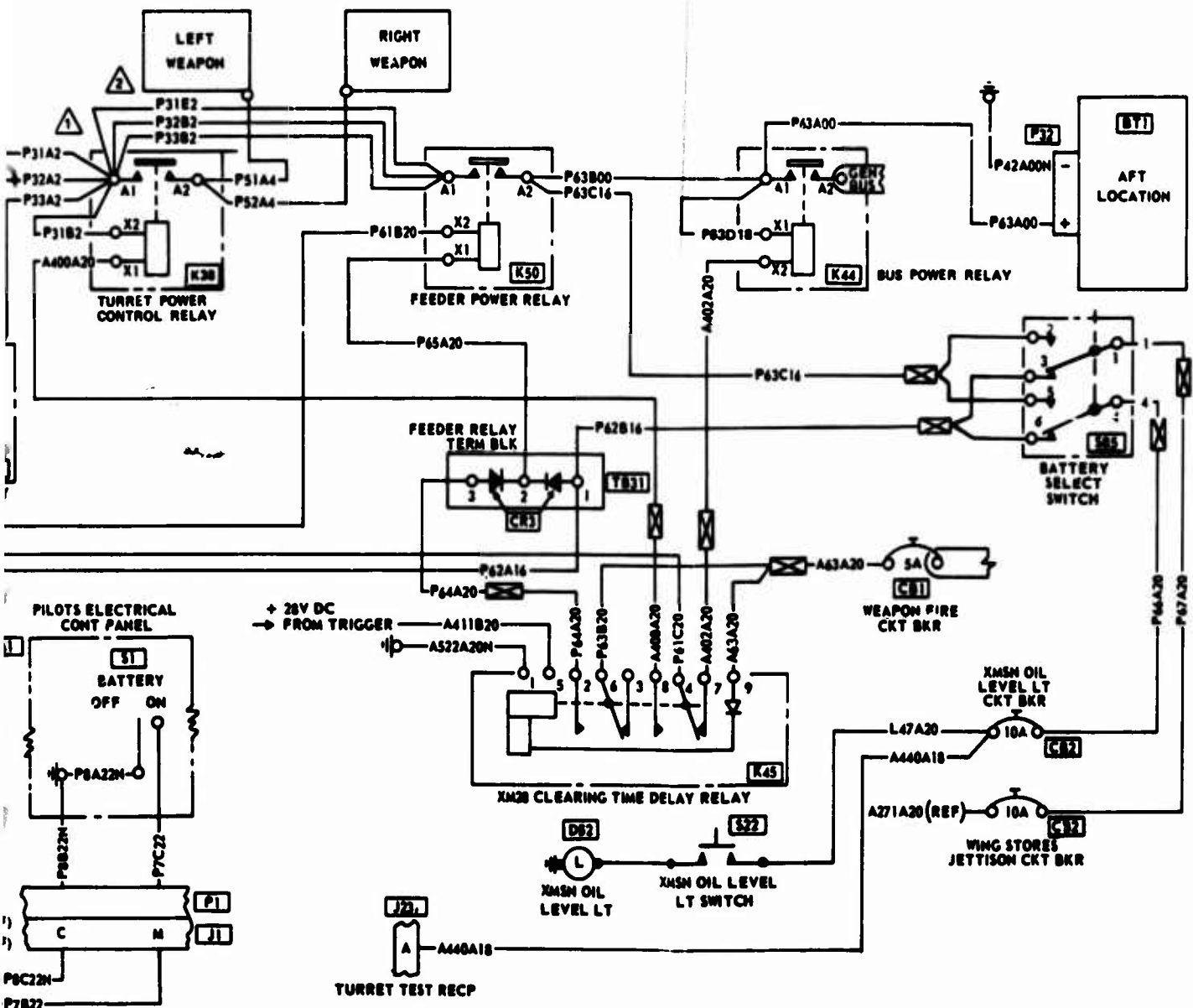

Figure 4. AH-1G Battery Circuit Schematic.

Preceding page blank



F-1G Battery Circuit Schematic.

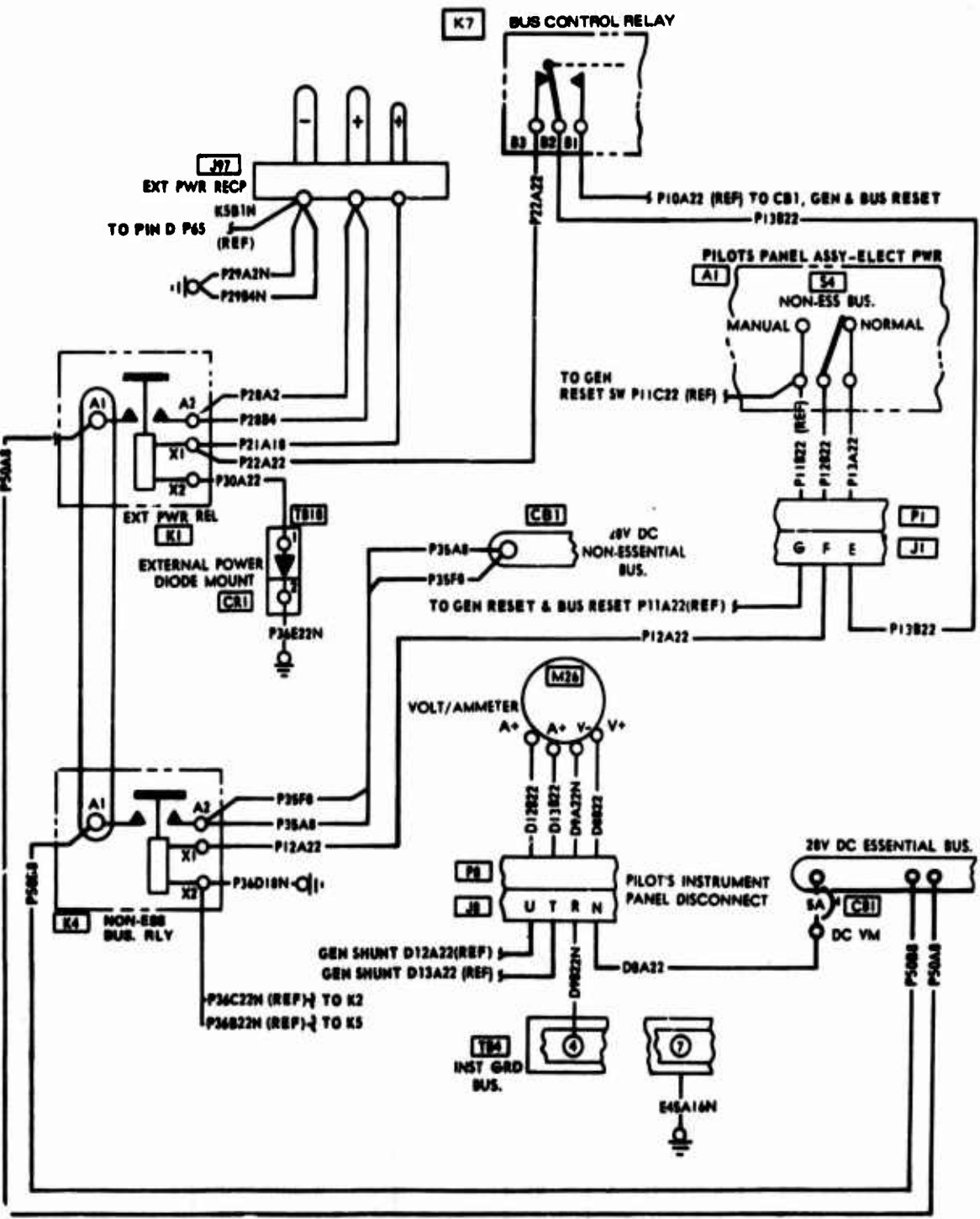

Figure 5. AH-1G External Power Circuit Schematic.

Preceding page blank

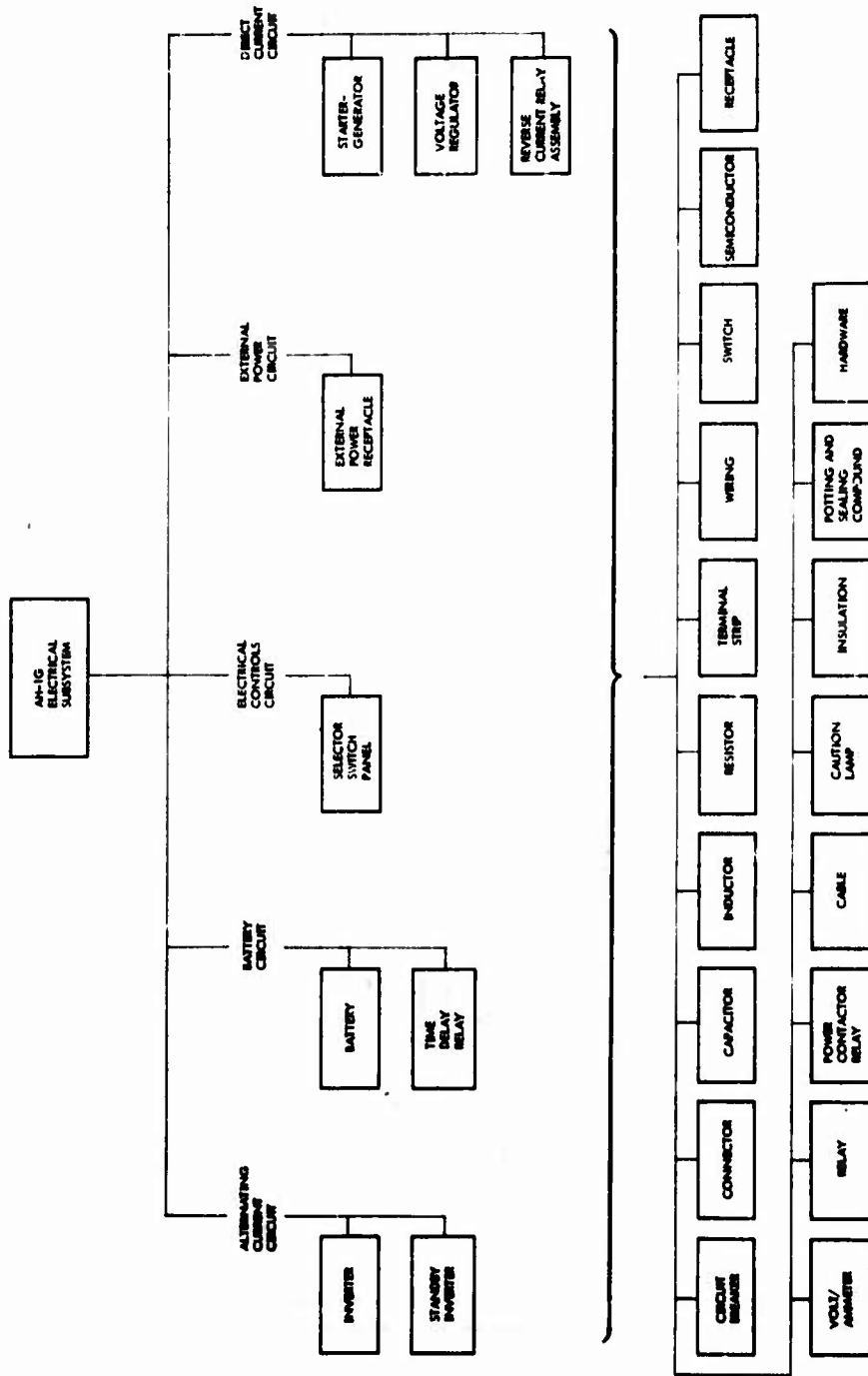

Figure 6. AH-1G Electrical Subsystem Block Diagram Tree.

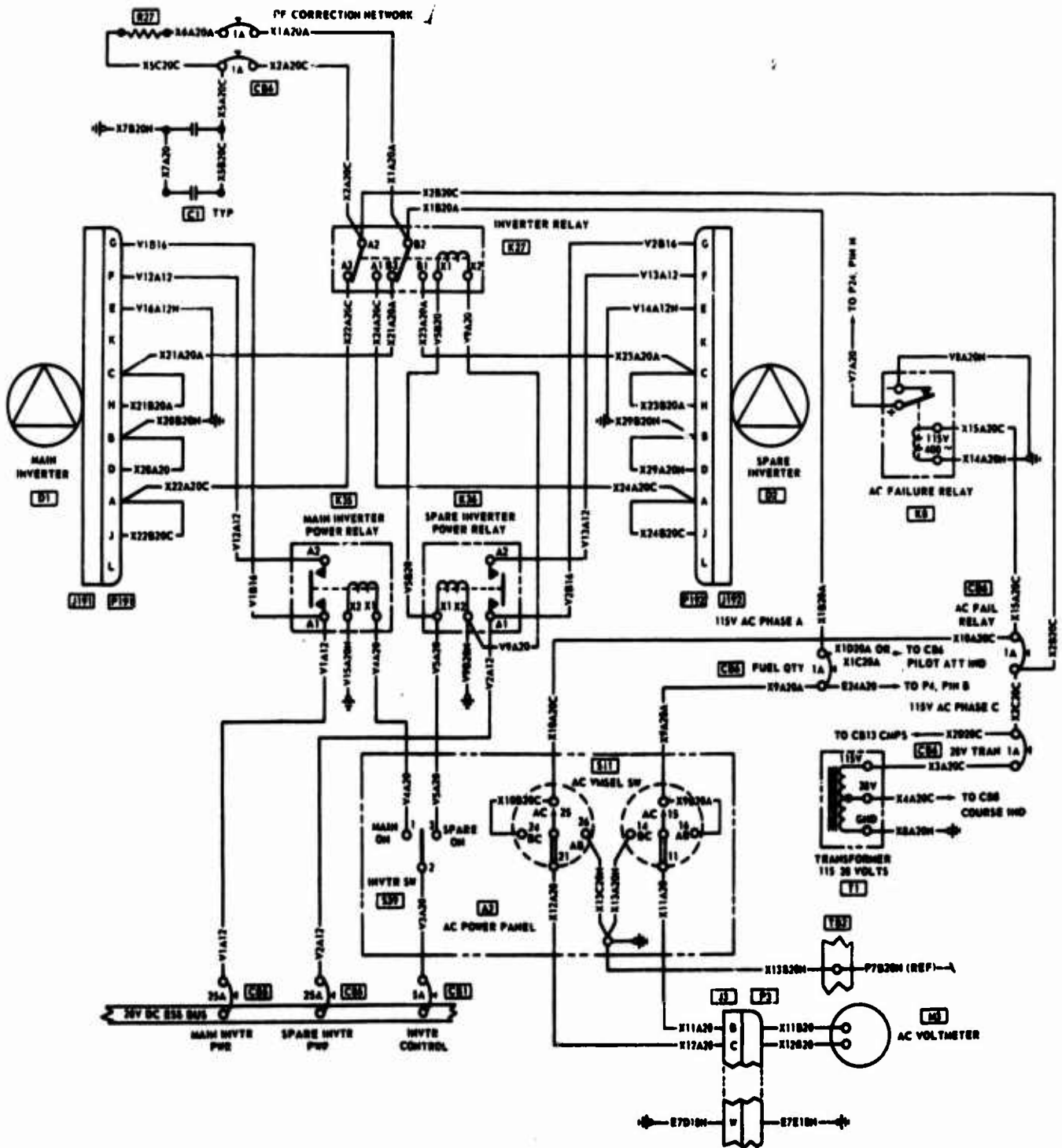

Figure 7. UH-1D/H Alternating Current Circuit Schematic.

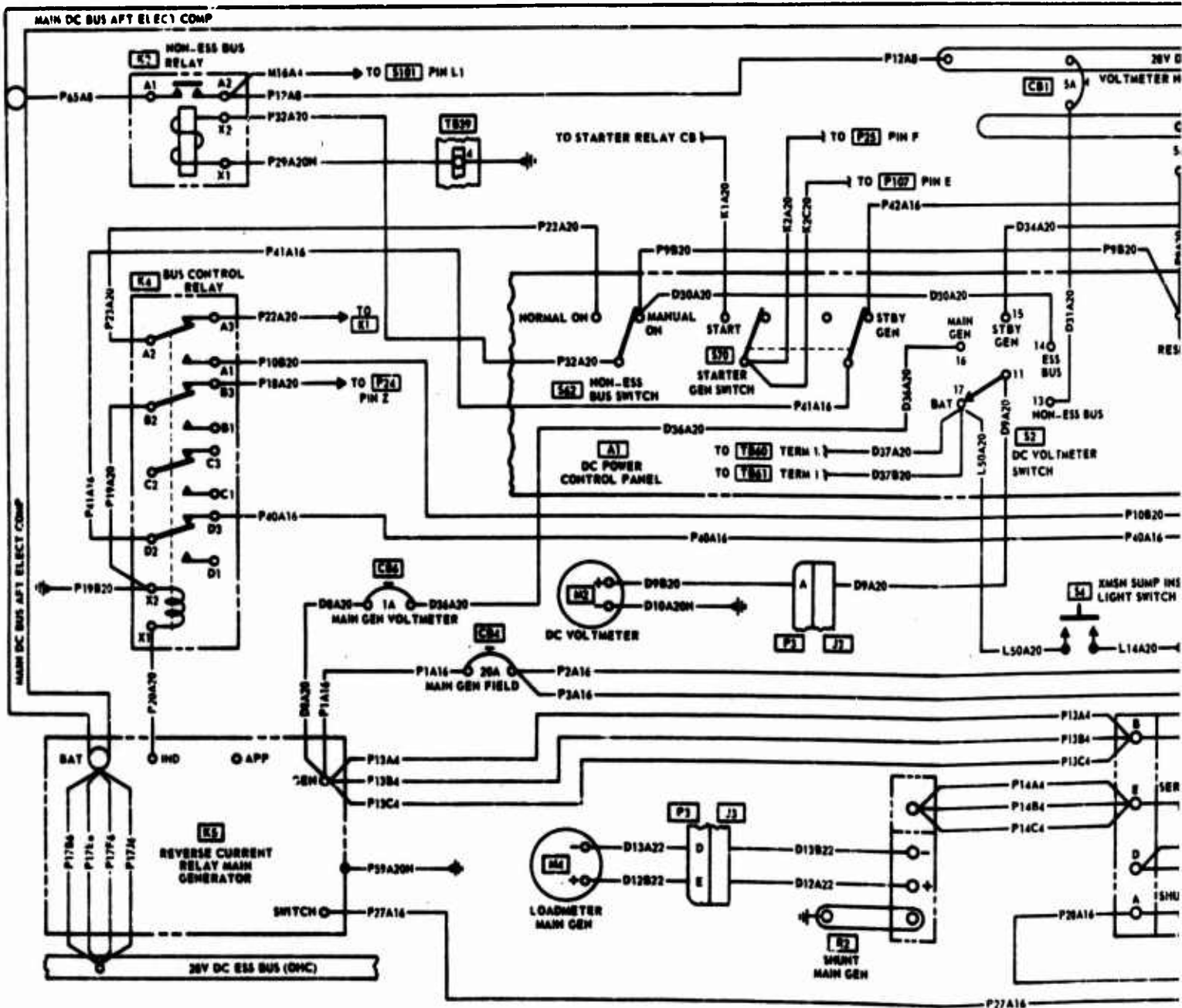
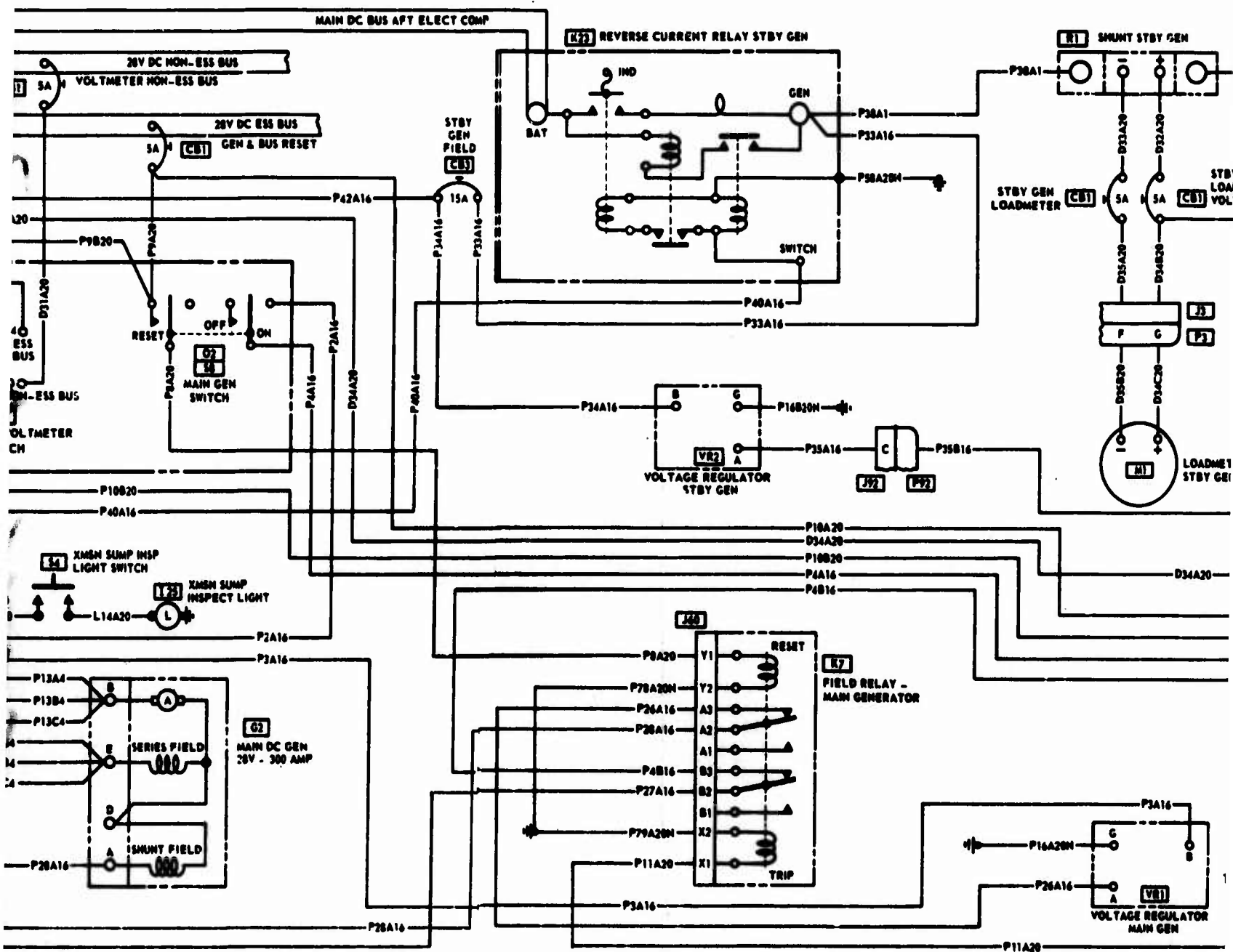
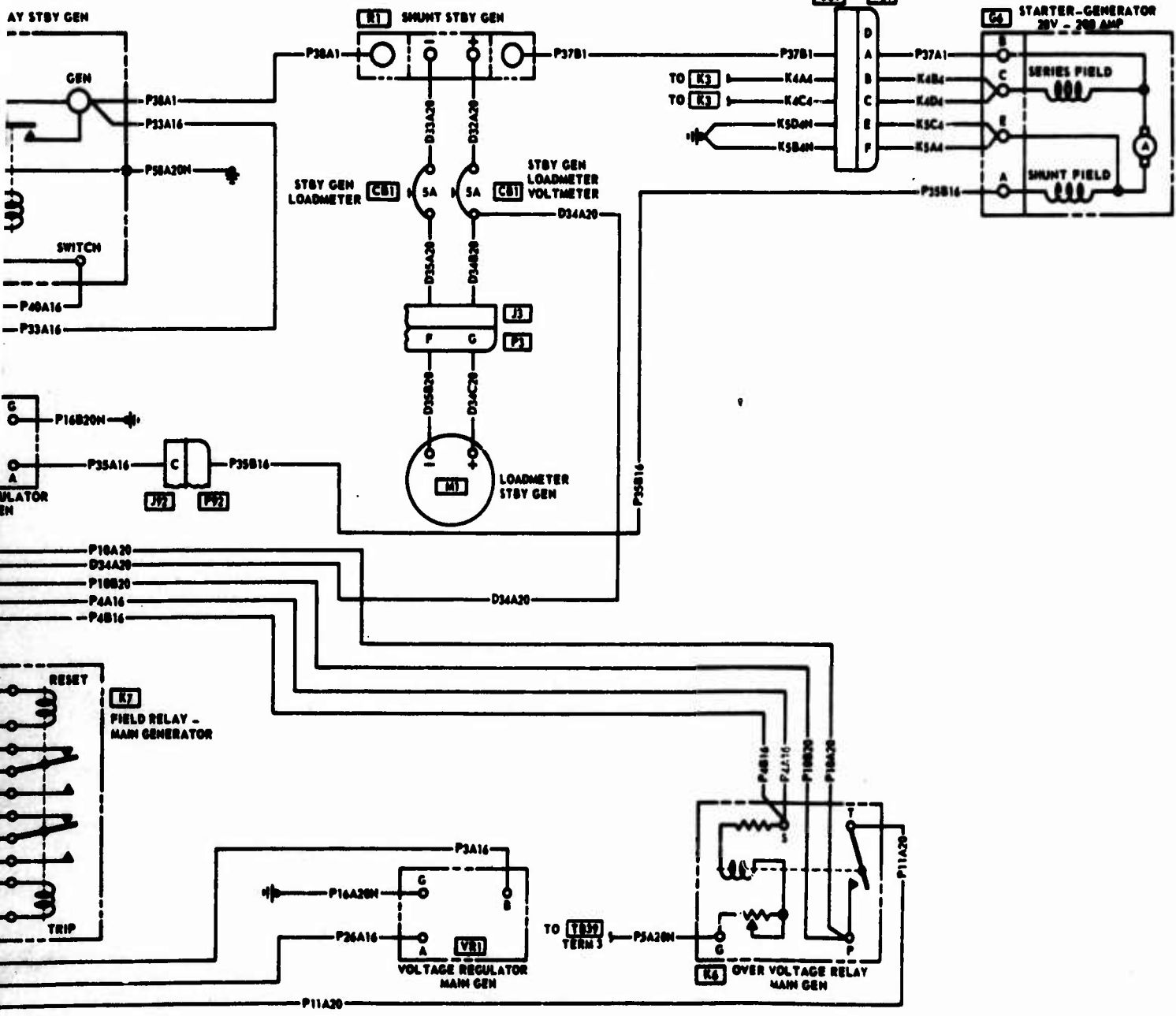

Figure 8. UH-1D/H Generator and Bus Circuit Schematic.

Preceding page blank







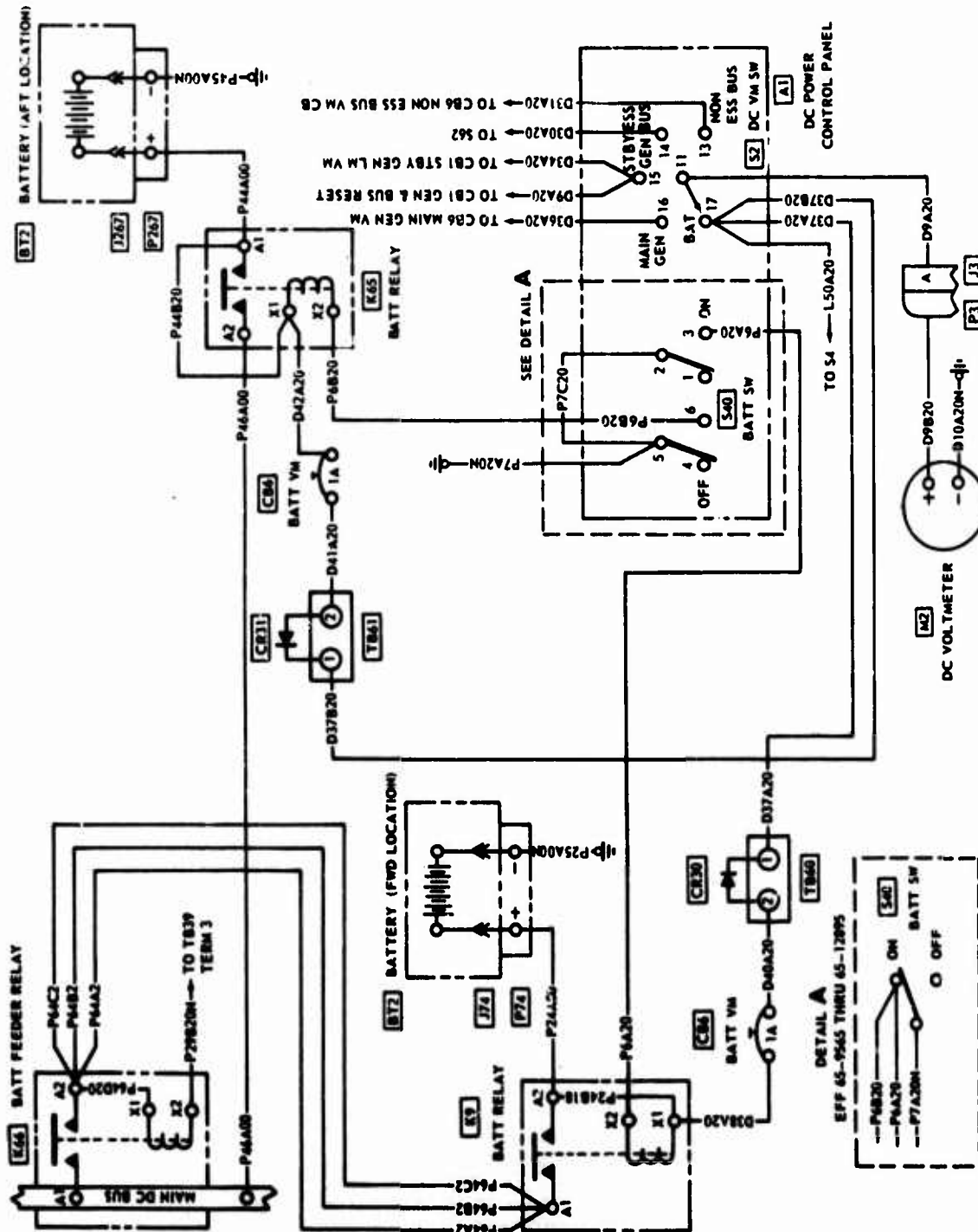

Figure 9. UH-1D/H Battery Circuit Schematic.

Preceding page blank

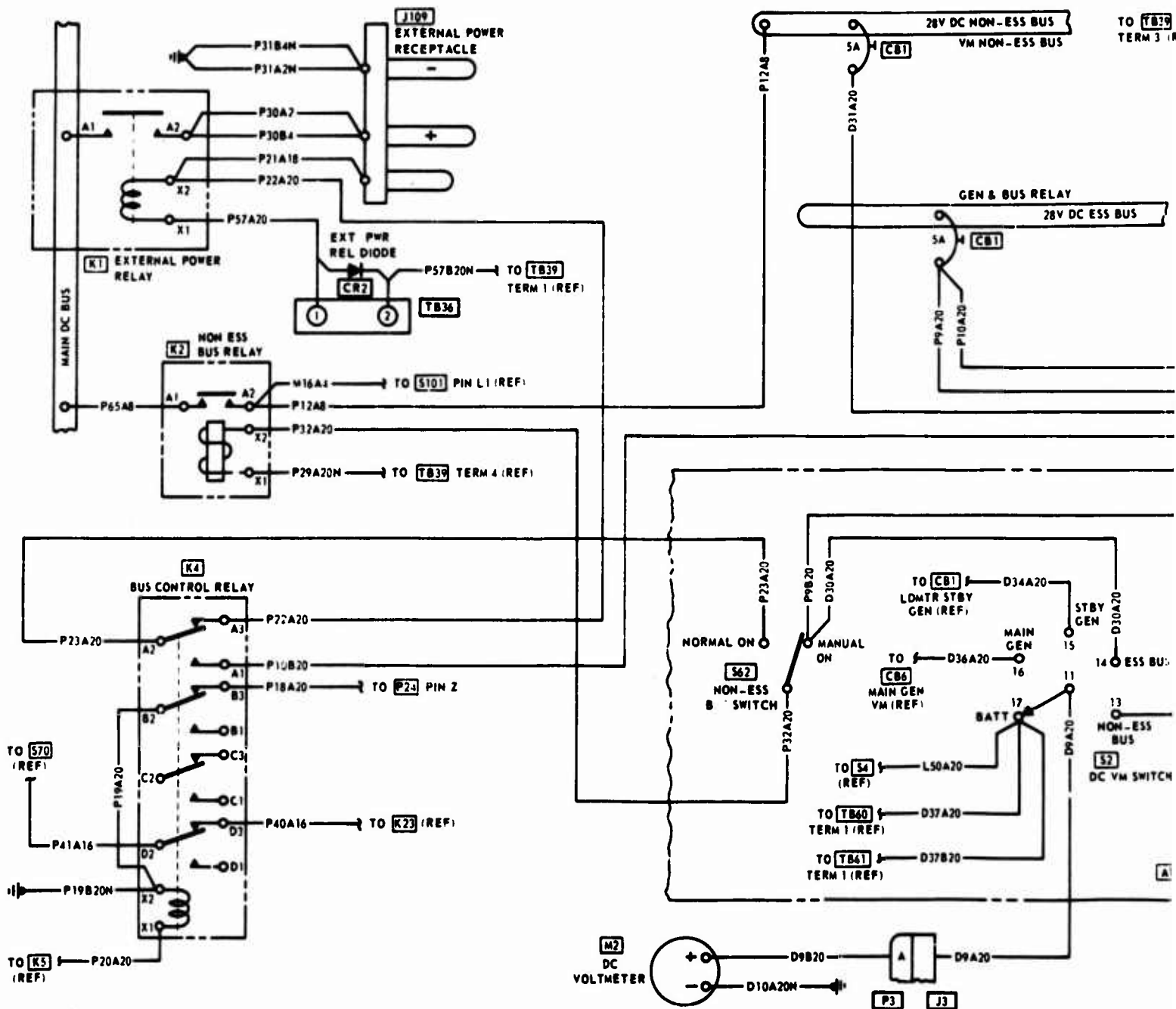
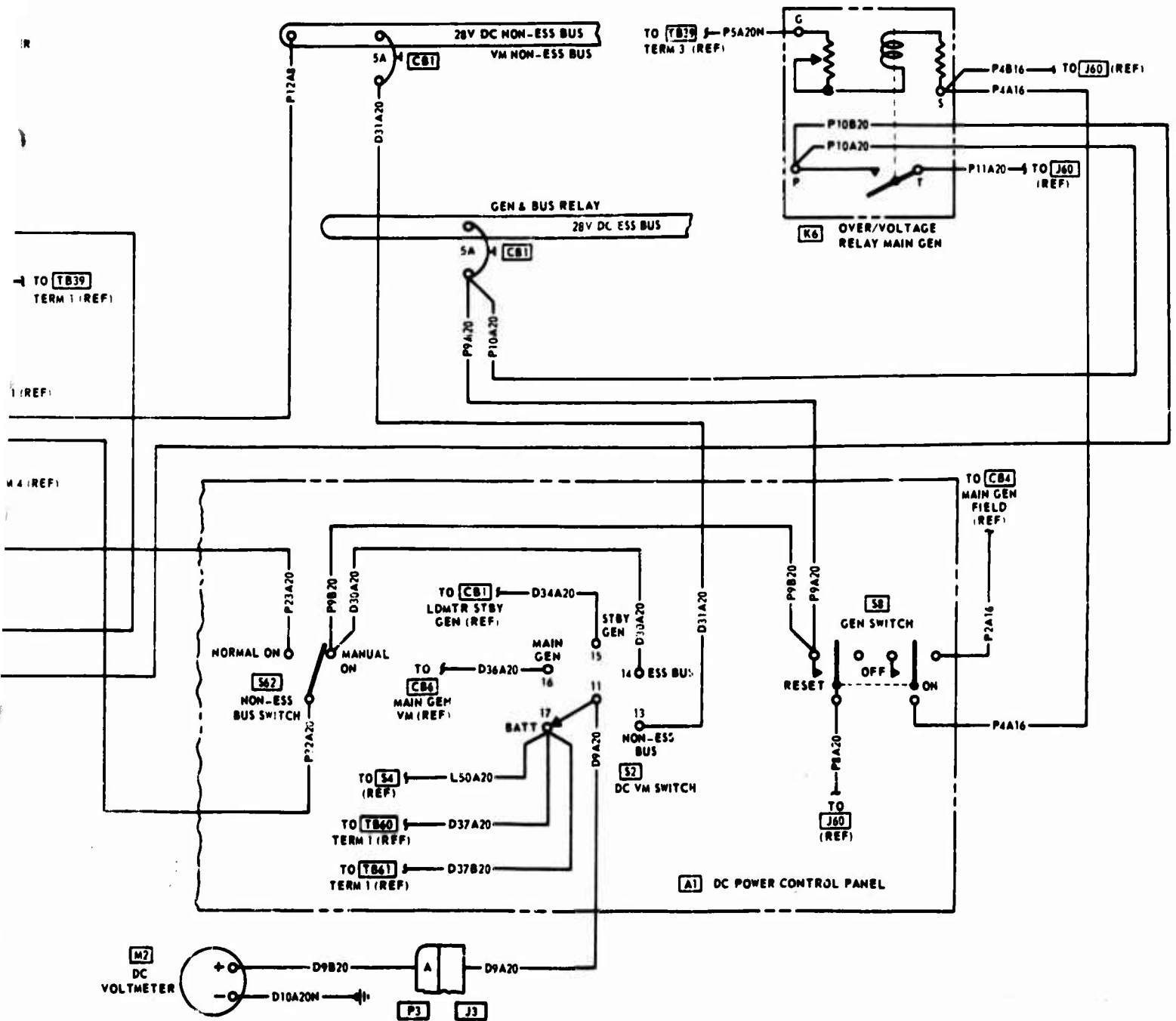

Figure 10. UH-1D/H External Power Circuit Schematic.

Preceding page blank



Power Circuit Schematic.

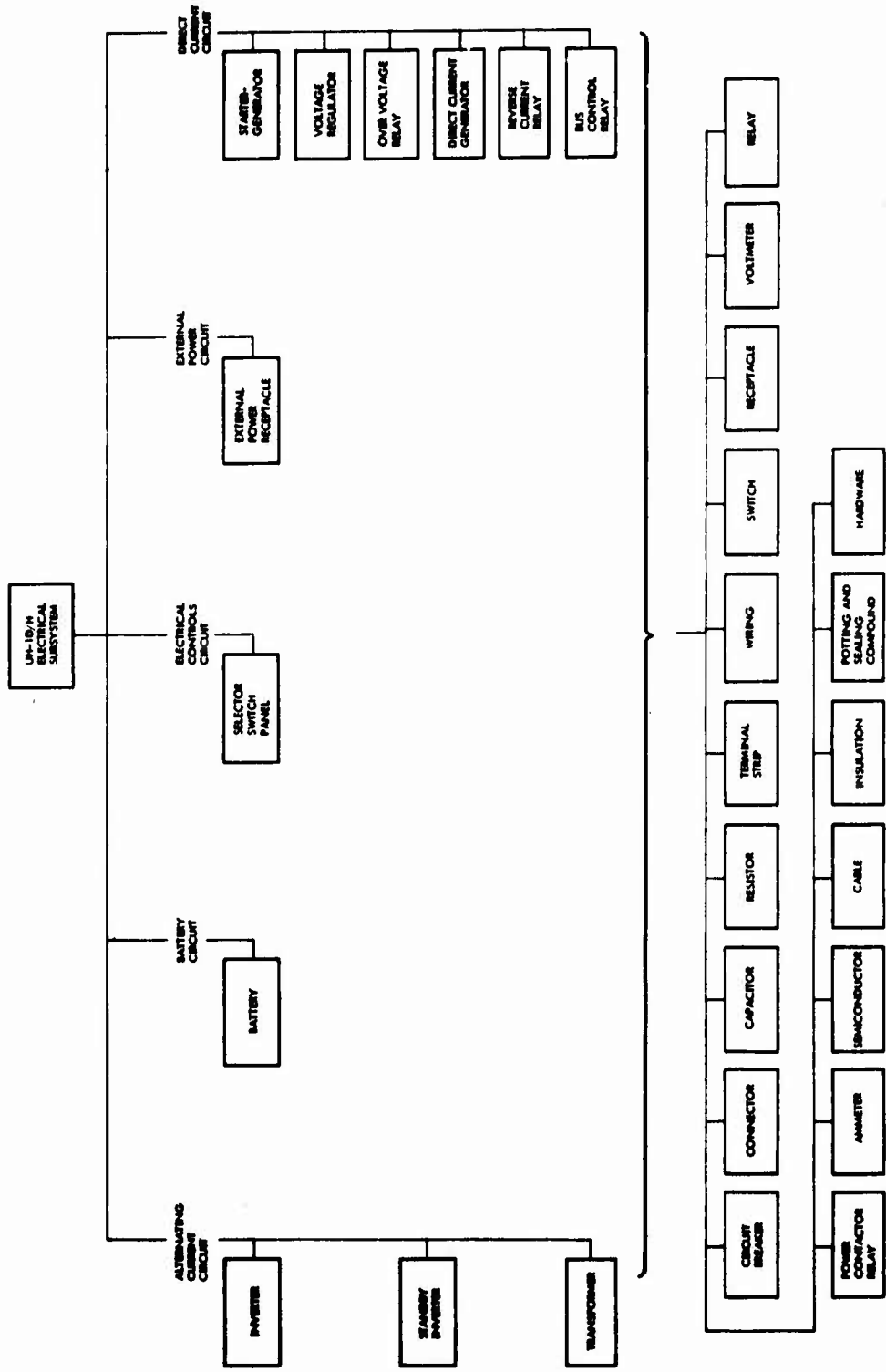

Figure 11. UH-1D/H Electrical Subsystem Block Diagram Tree.

Preceding page blank

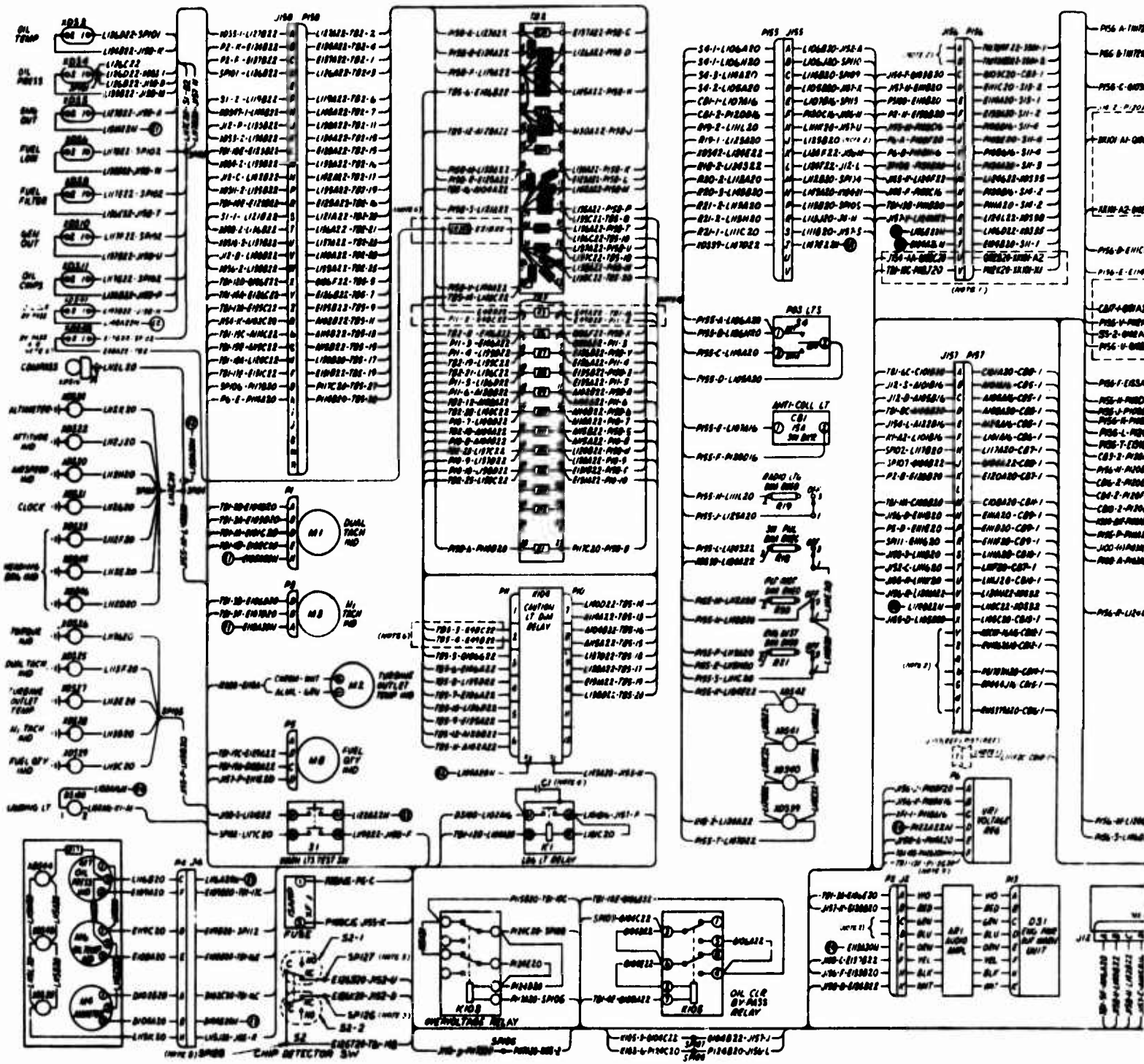
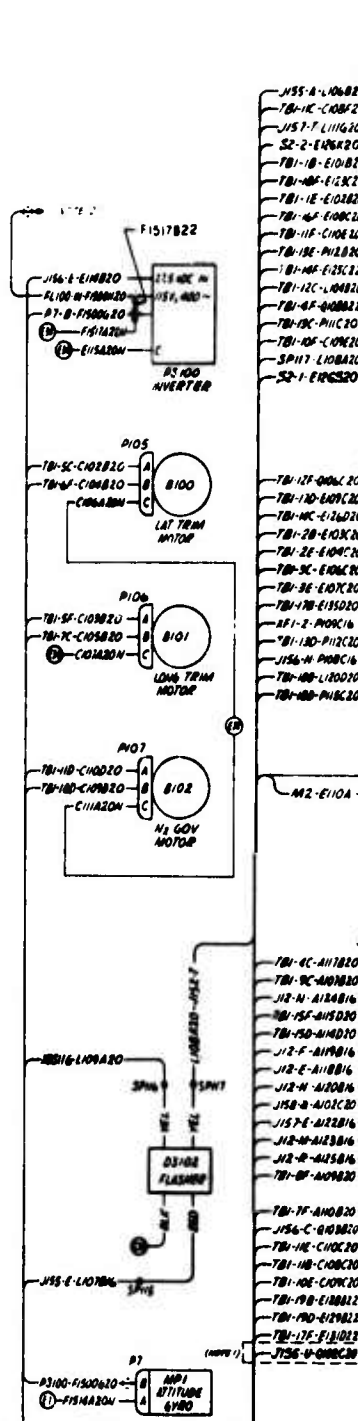
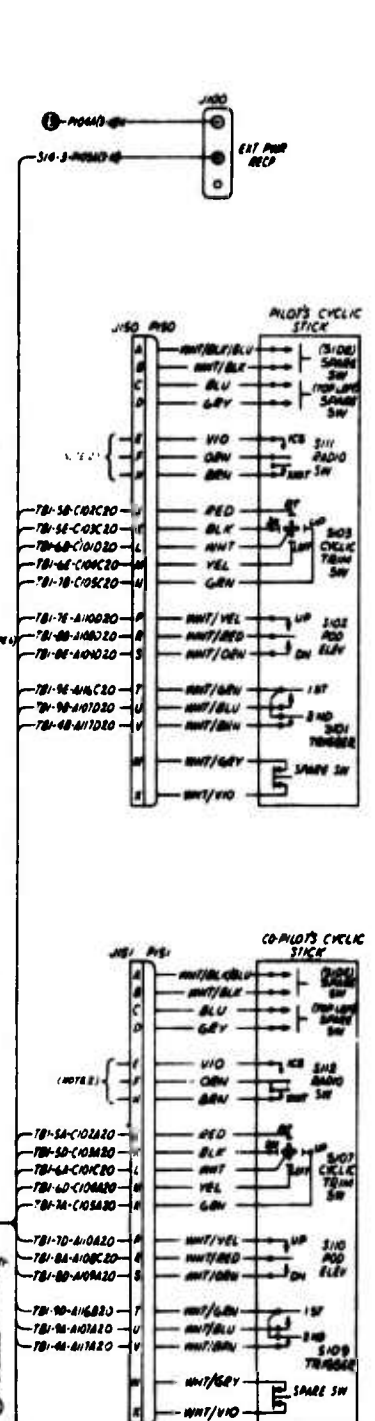
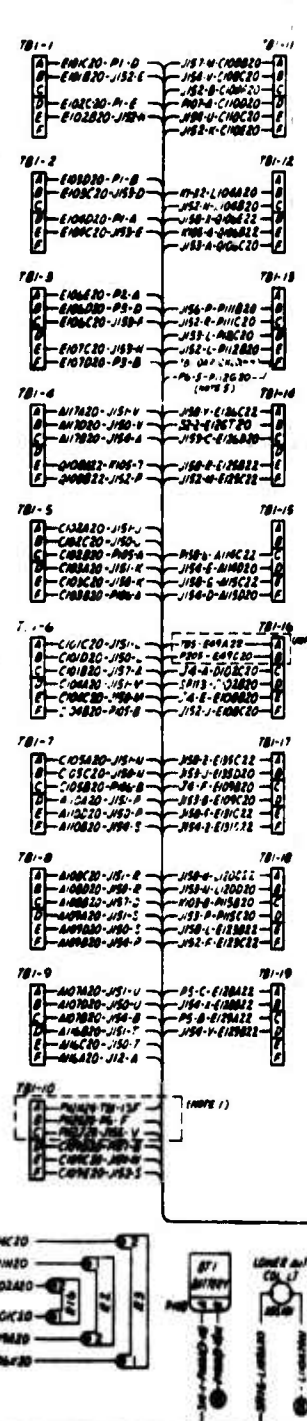
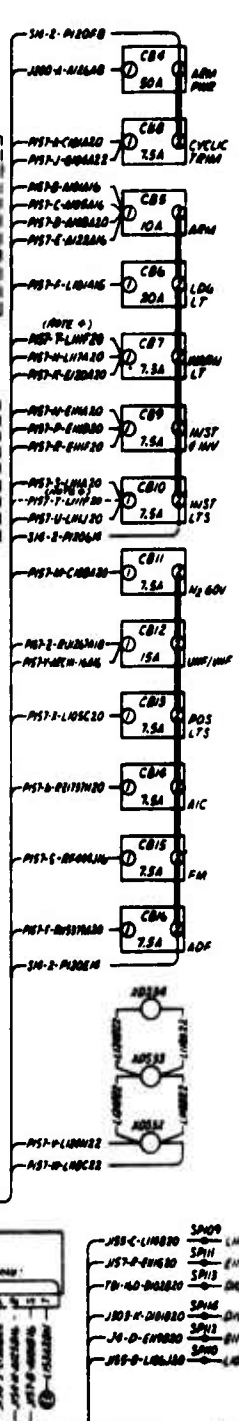
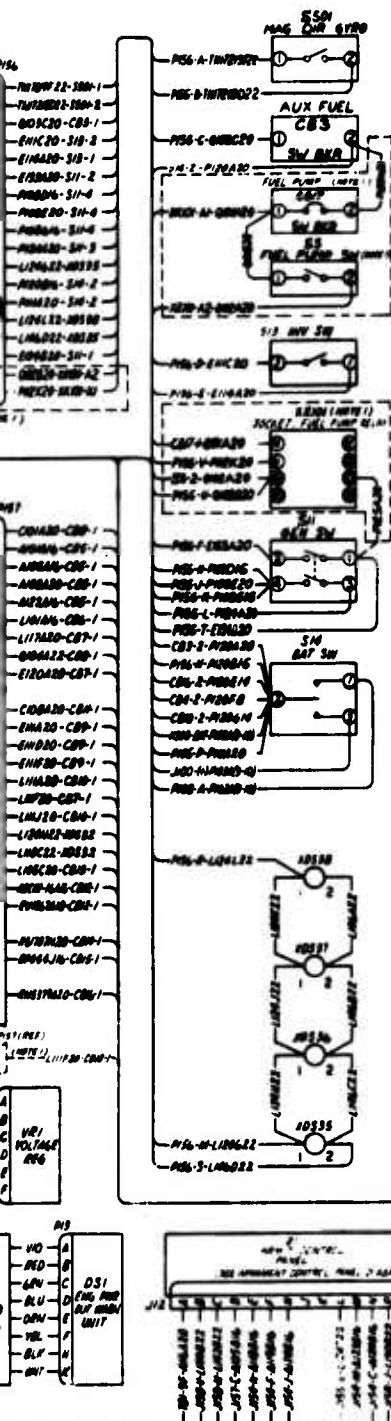
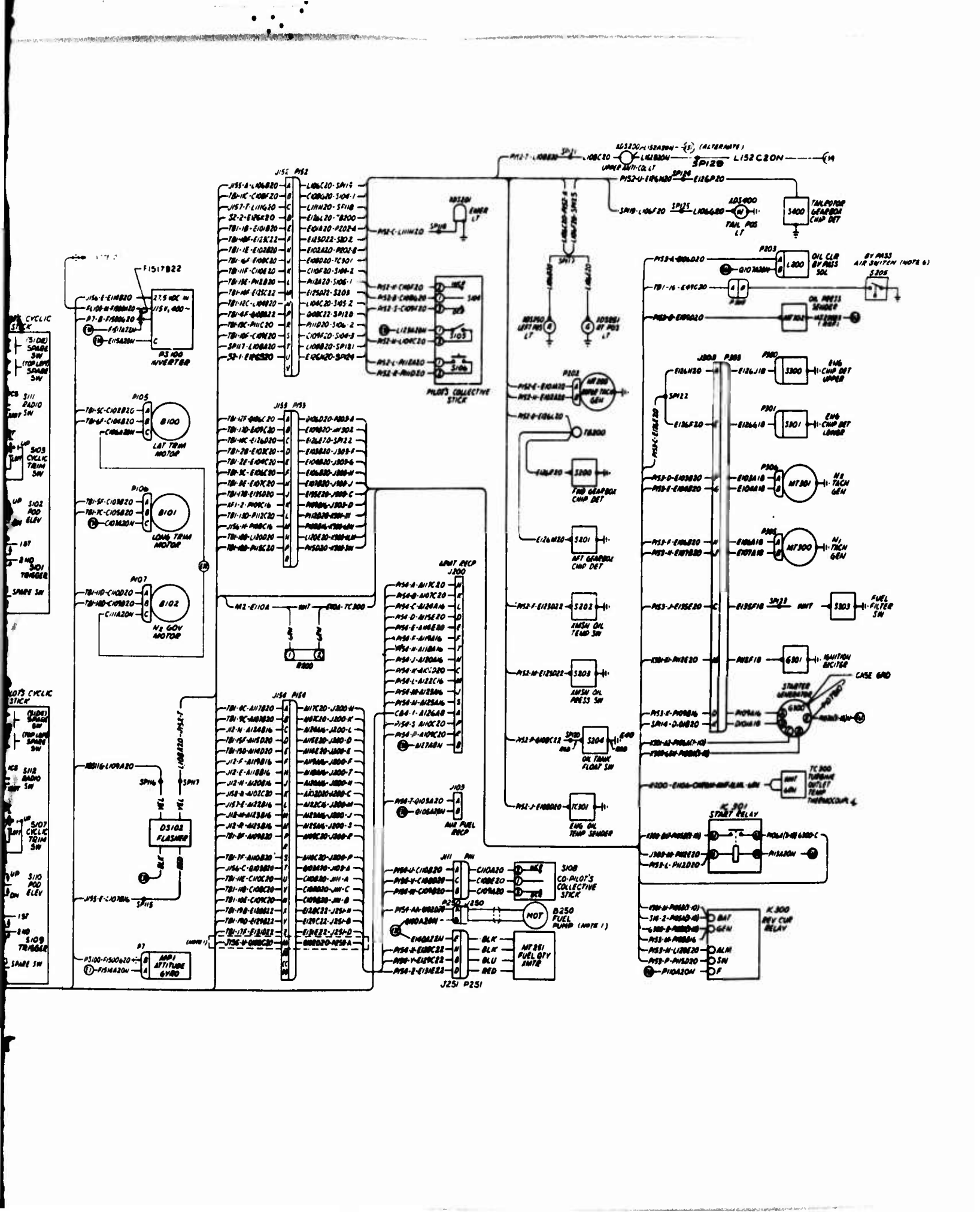

Figure 12. OH-6A Electrical Subsystem Schematic.







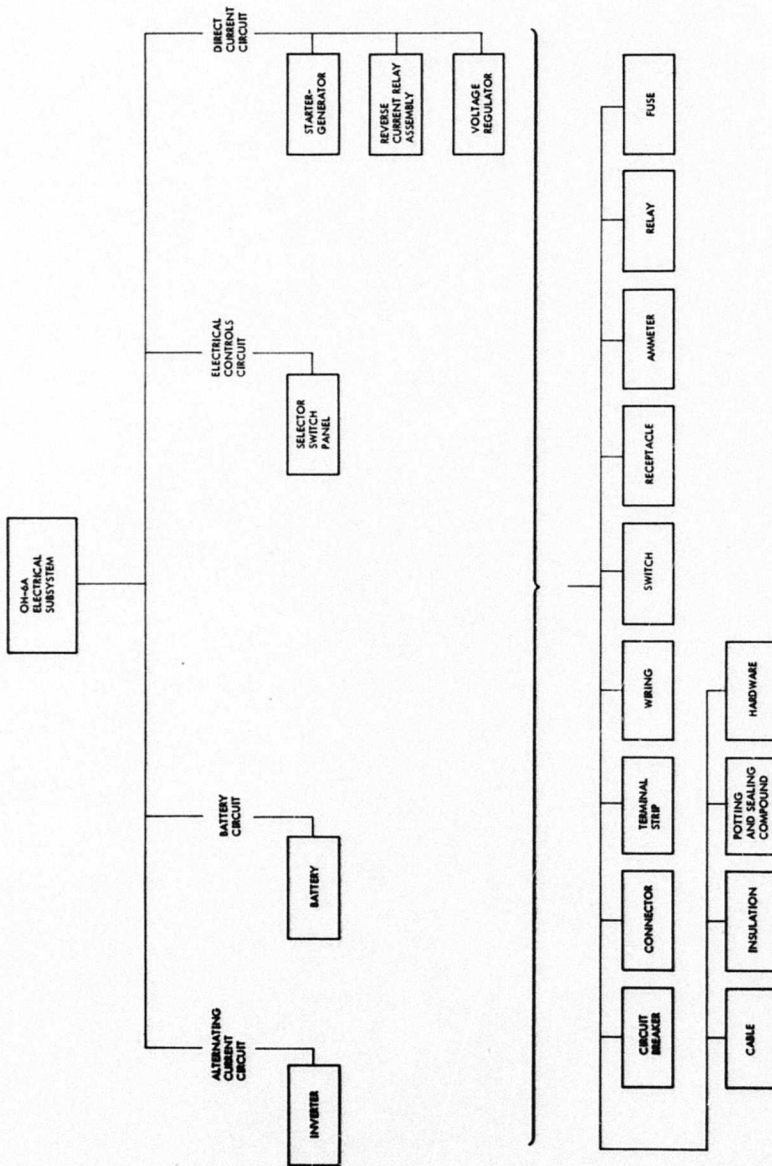

Figure 13. OH-6A Electrical Subsystem Block Diagram Tree.

Preceding page blank

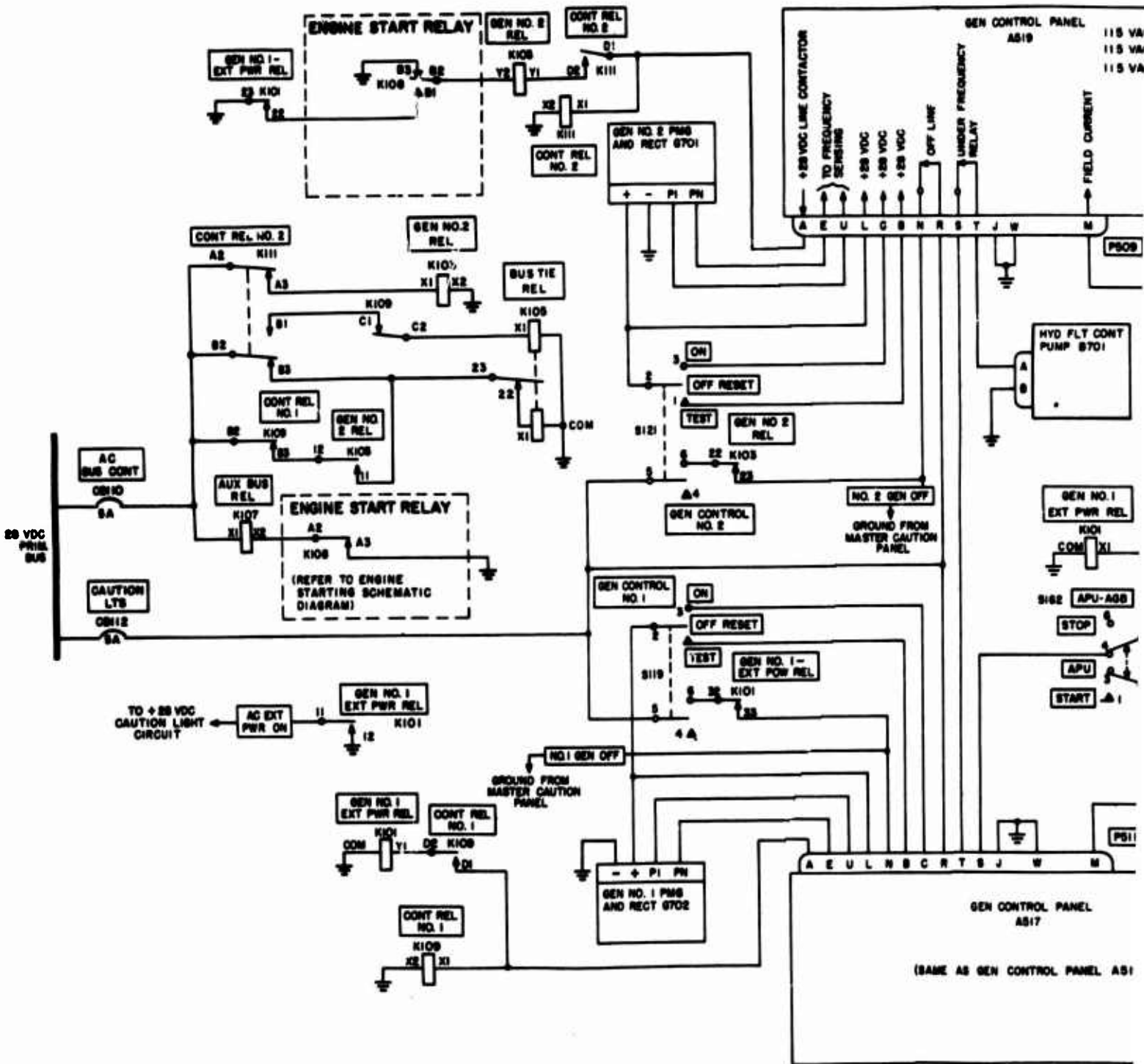
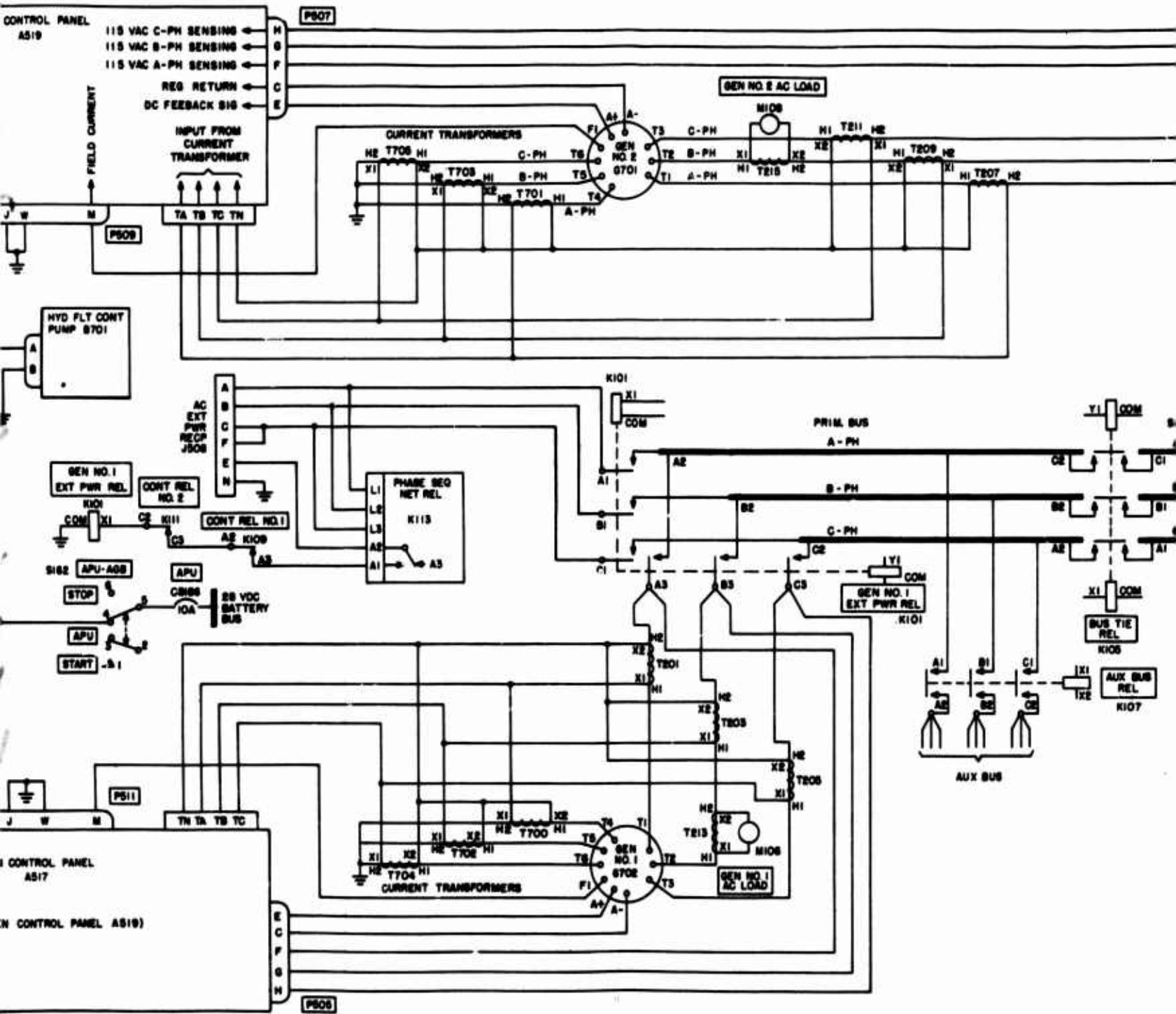
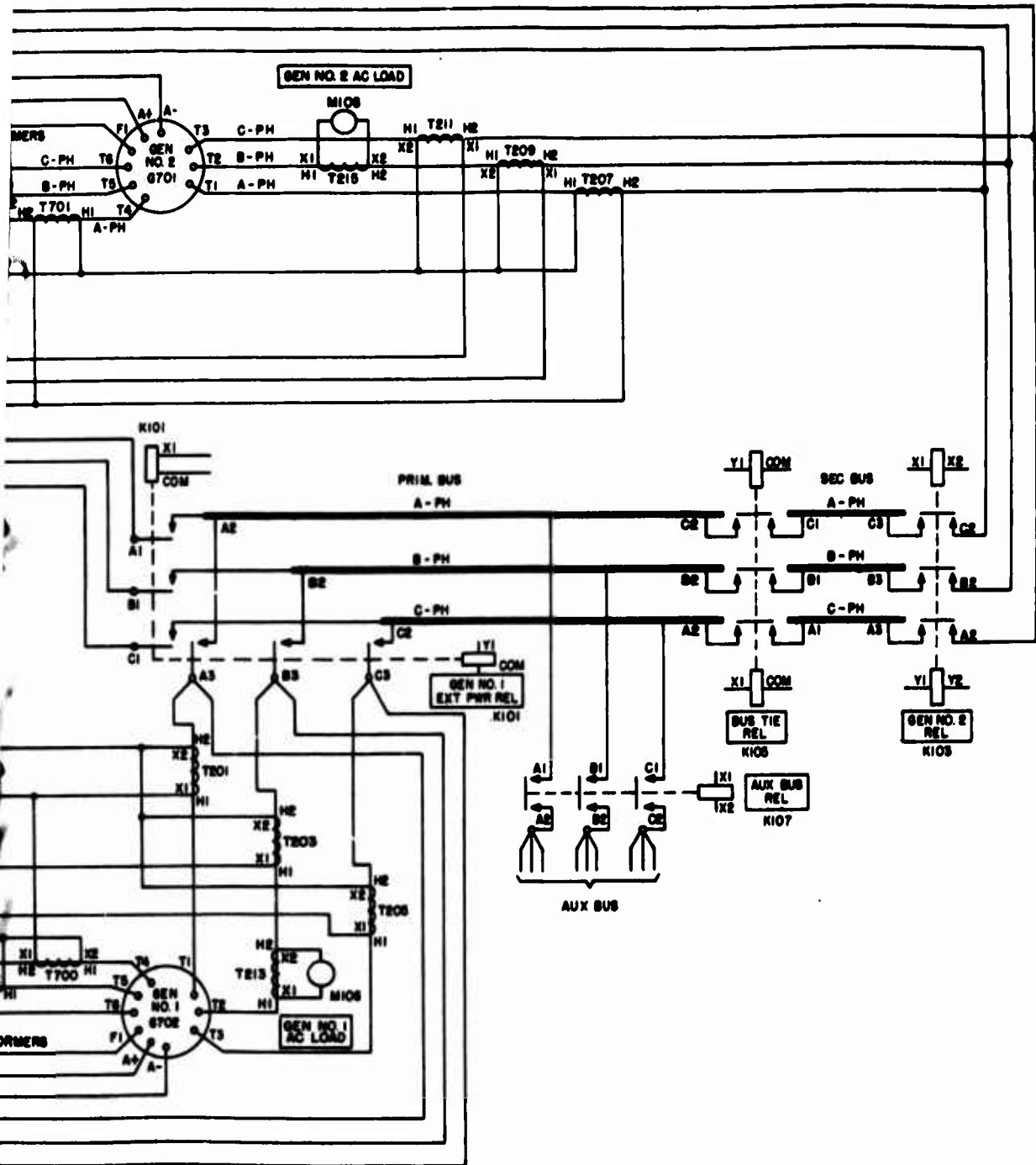

Figure 14. CH-47A Alternating Current Circuit Schematic.

Preceding page blank





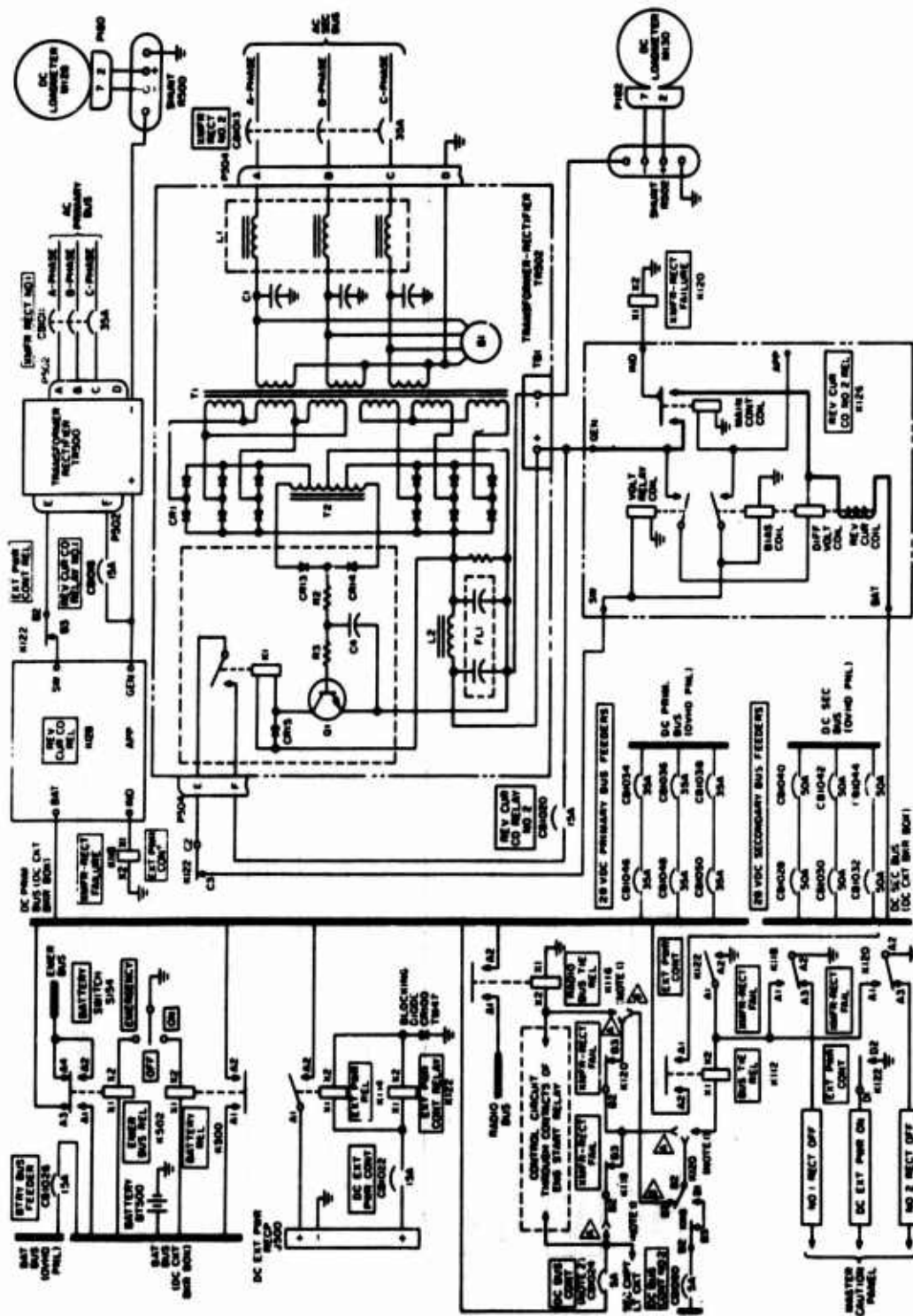

Figure 15. CH-47A Direct Current Circuit Schematic.

Preceding page blank

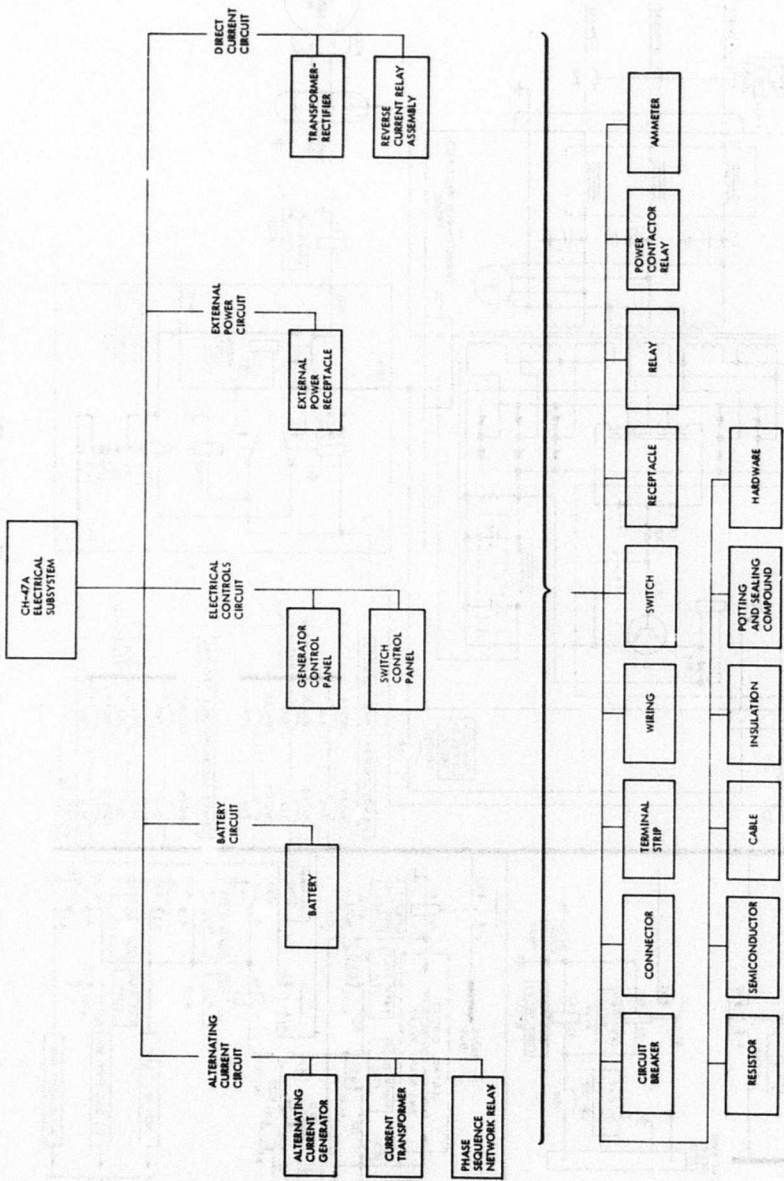

Figure 16. CH-47A Electrical Subsystem Block Diagram Tree.

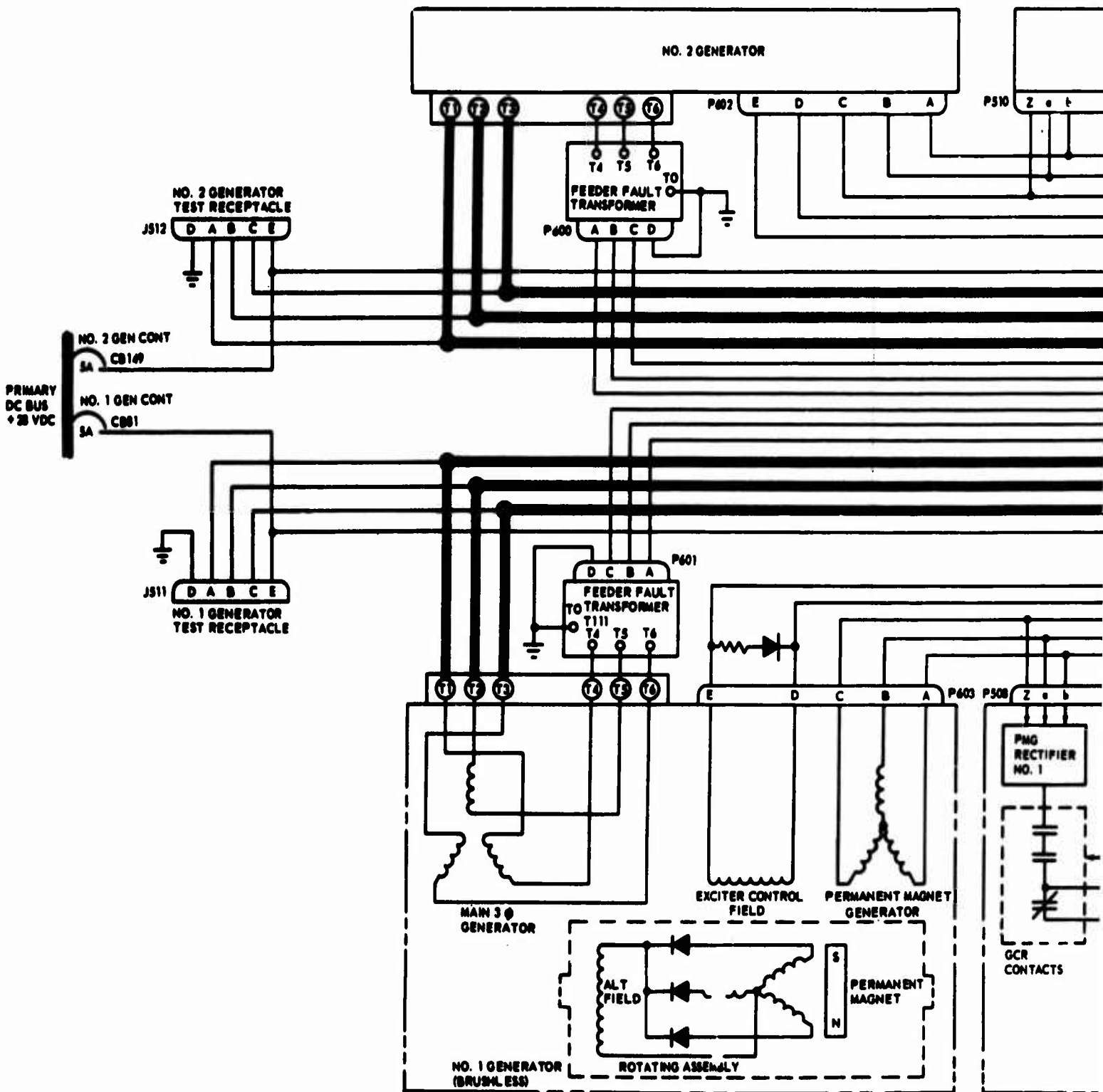
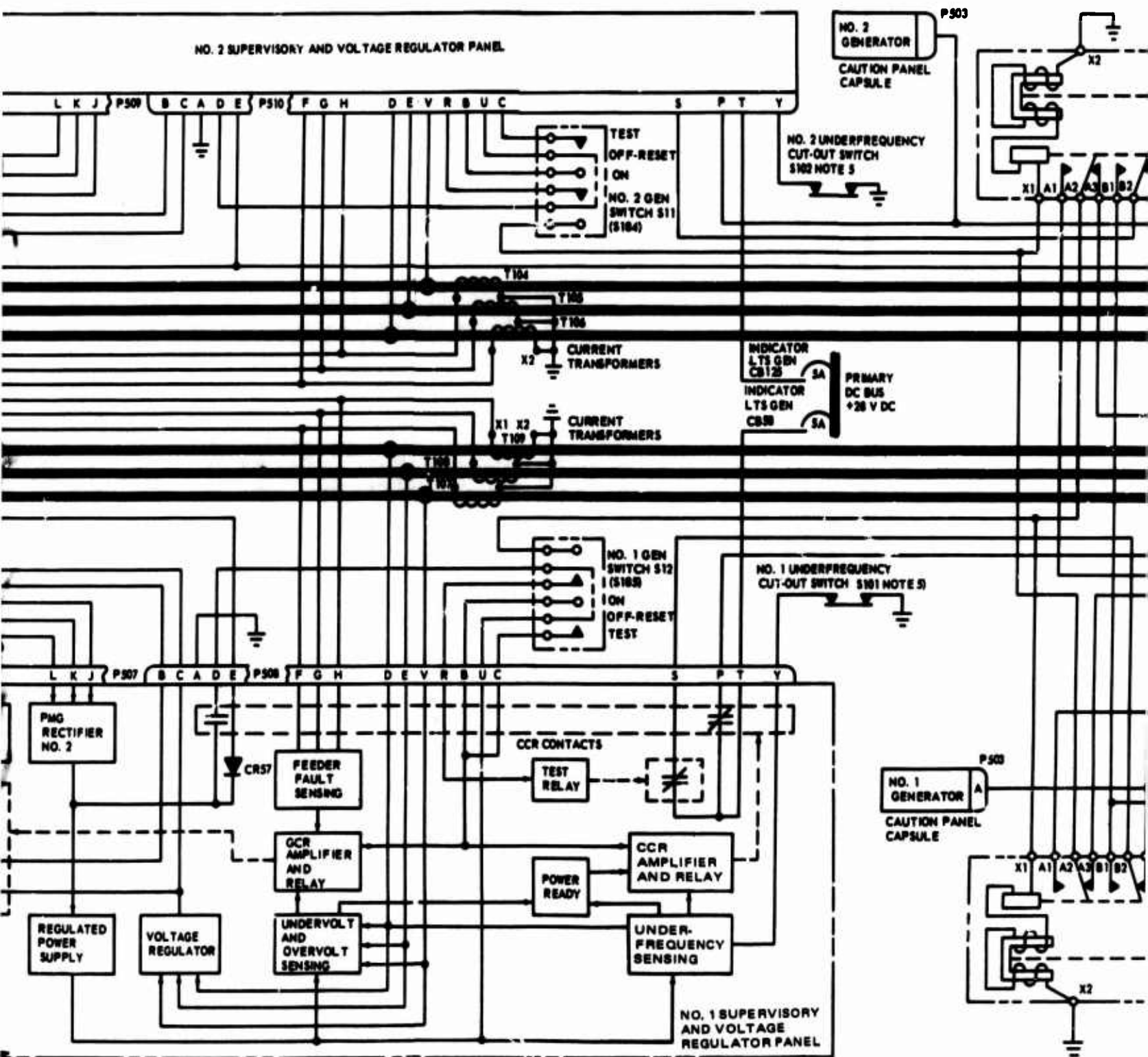

Figure 17. CH-54A Alternating Current Circuit Schematic.



NO. 2 SUPERVISORY AND VOLTAGE REGULATOR PANEL

NO. 2 GENERATOR  
CAUTION PANEL CAPSULE

NO. 2 UNDERFREQUENCY CUT-OUT SWITCH S102 NOTE 5

TEST  
OFF-RESET  
ON  
NO. 2 GEN SWITCH S11 (S184)

CURRENT TRANSFORMERS  
X1 X2  
CURRENT TRANSFORMERS  
X1 X2

INDICATOR LTS GEN CB12 SA  
INDICATOR LTS GEN CB3 SA  
PRIMARY DC BUS +28 V DC

NO. 1 GEN SWITCH S12 (S183)  
OFF-RESET  
TEST

NO. 1 UNDERFREQUENCY CUT-OUT SWITCH S101 NOTE 5

PMG RECTIFIER NO. 2

FEEDER FAULT SENSING

CCR AMPLIFIER AND RELAY

UNDERVOLT AND OVERVOLT SENSING

CCR CONTACTS  
TEST RELAY

POWER READY

CCR AMPLIFIER AND RELAY

UNDER-FREQUENCY SENSING

REGULATED POWER SUPPLY

VOLTAGE REGULATOR

NO. 1 GENERATOR  
CAUTION PANEL CAPSULE

NO. 1 SUPERVISORY AND VOLTAGE REGULATOR PANEL



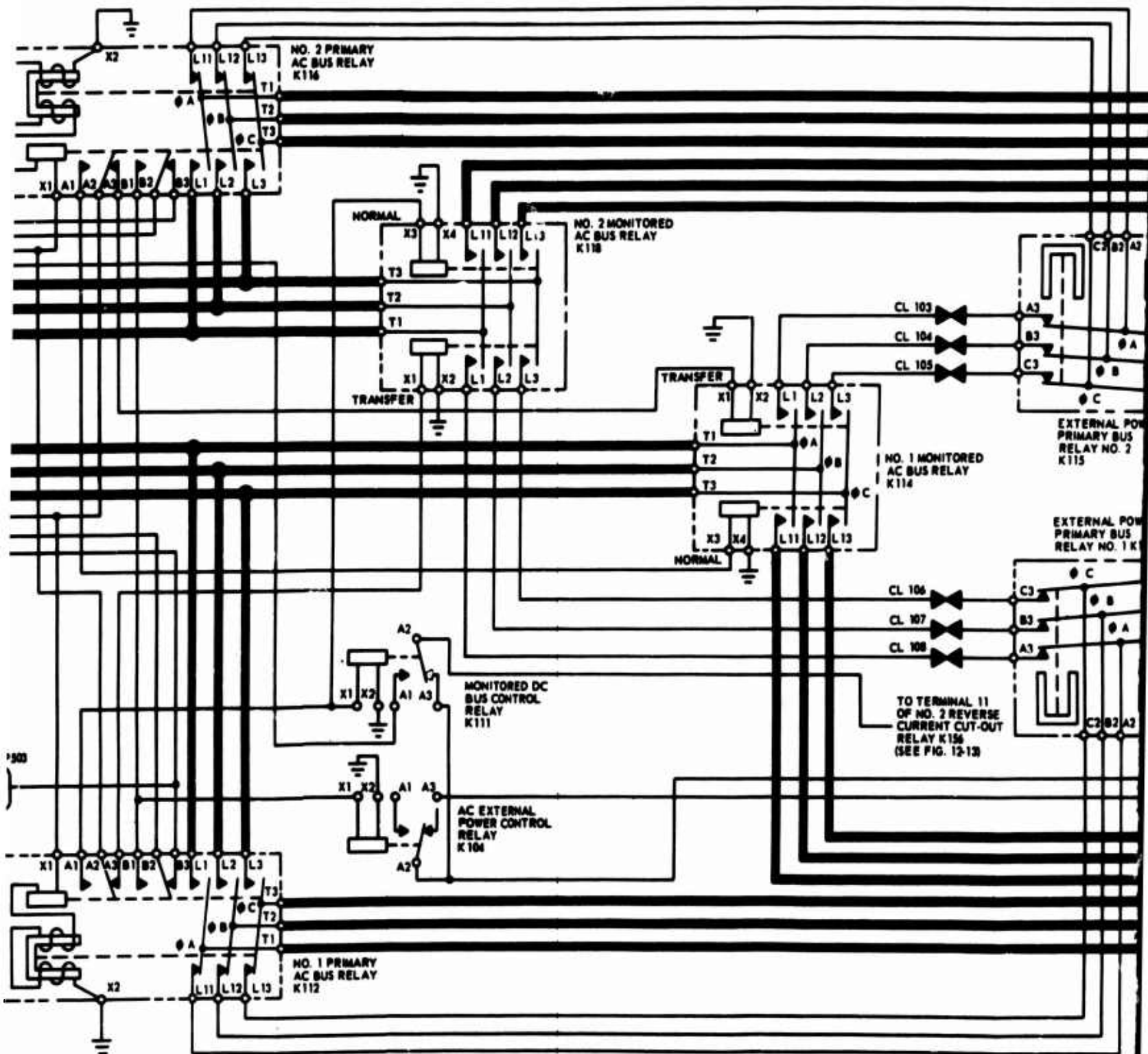

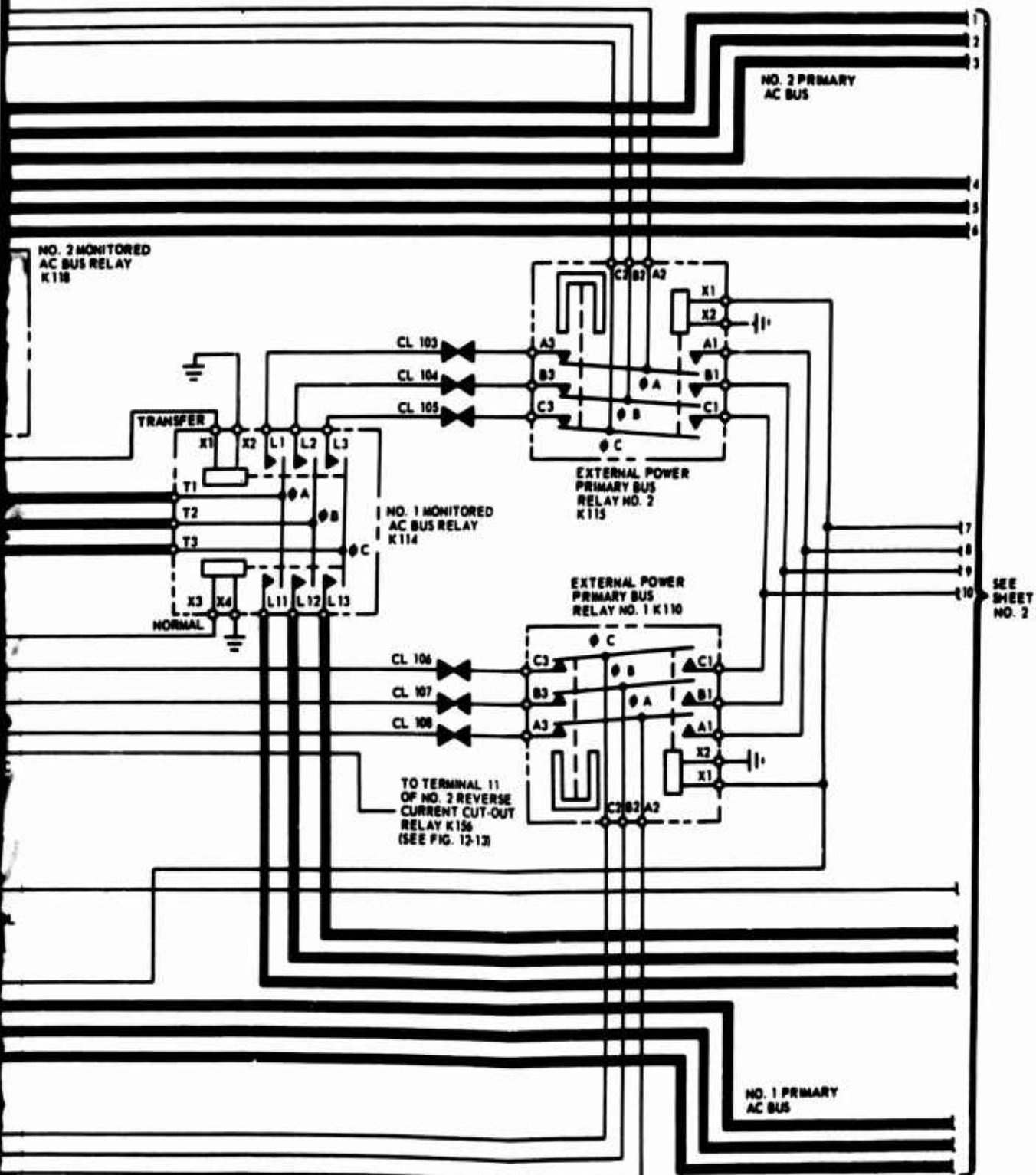

SEE SHEET NO. 1

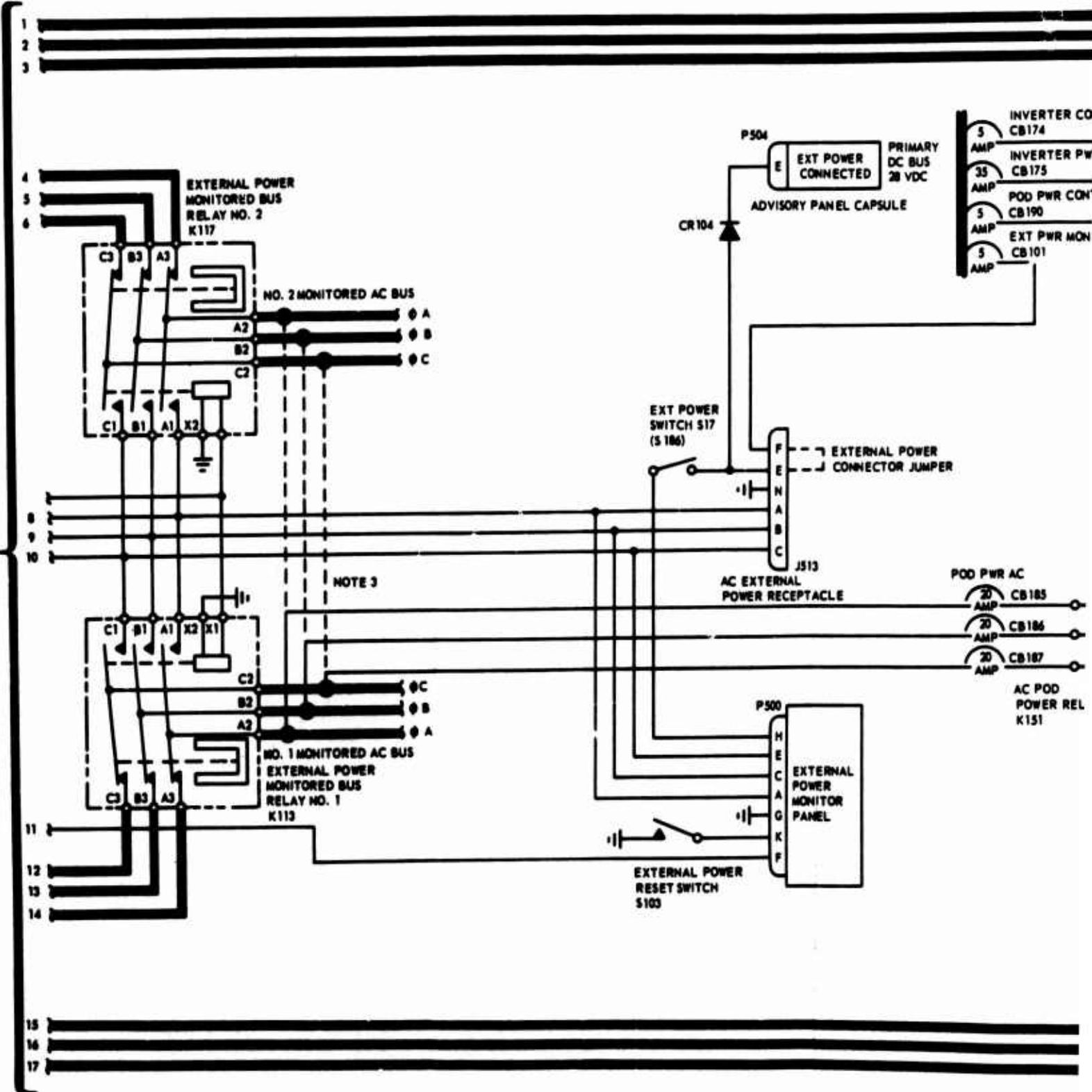
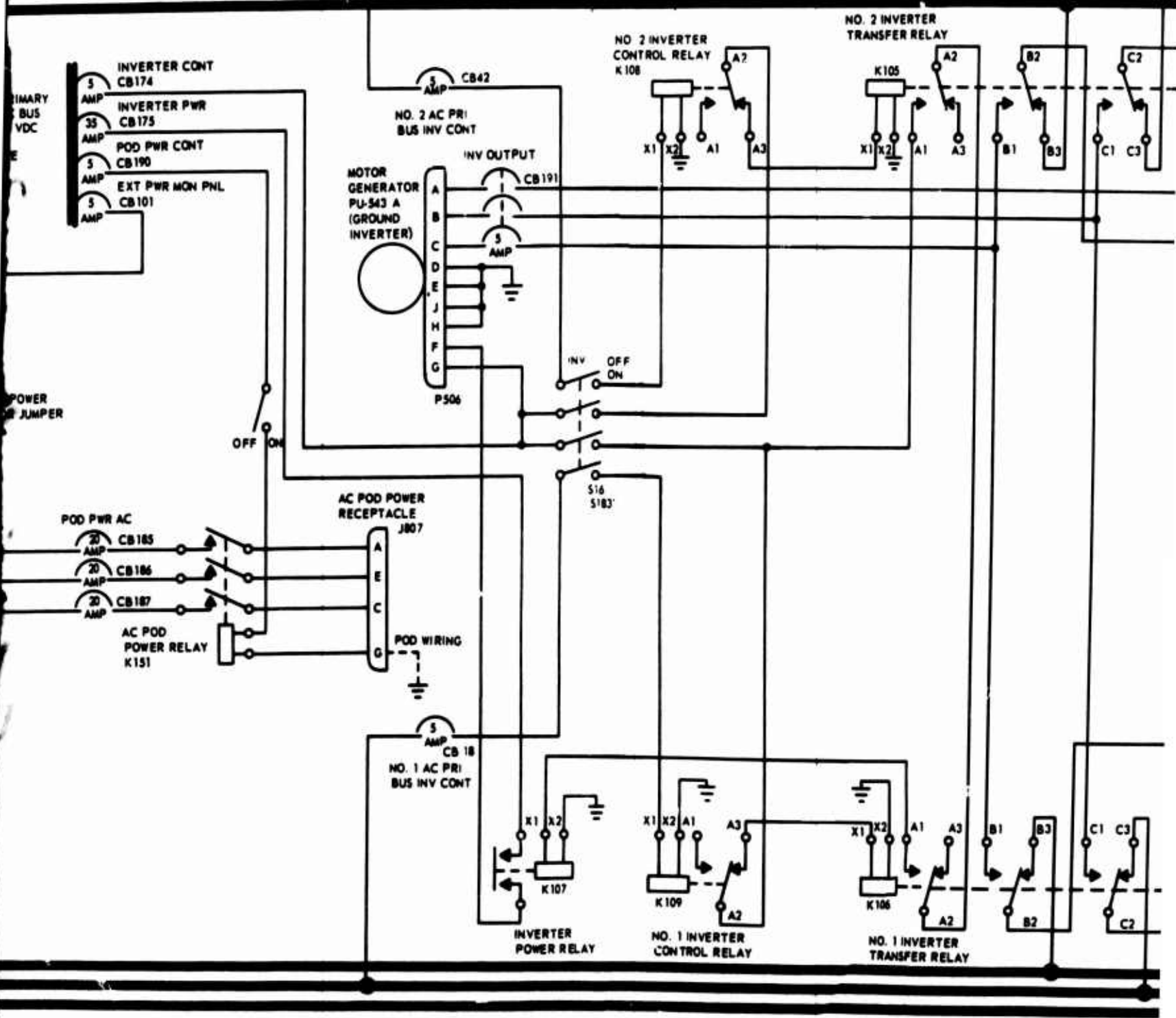
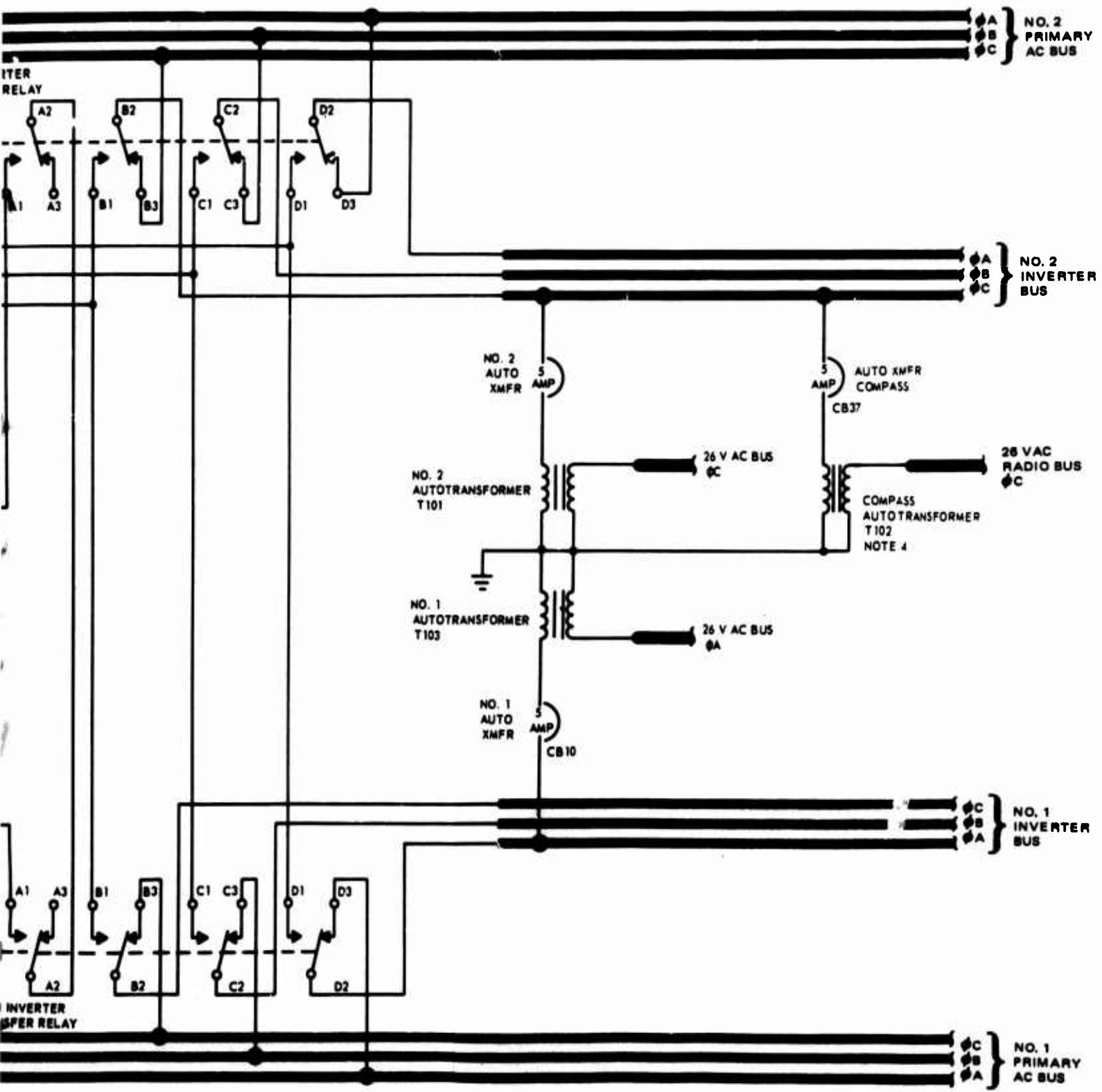

Figure 17 - Continued.

Preceding page blank





NO. 2 CONVERTER (TRANSFORMER-RECTIFIER)

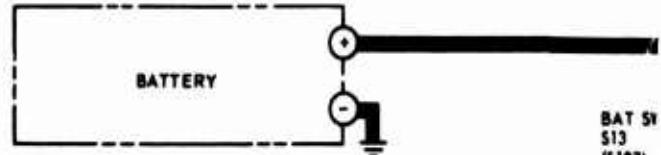
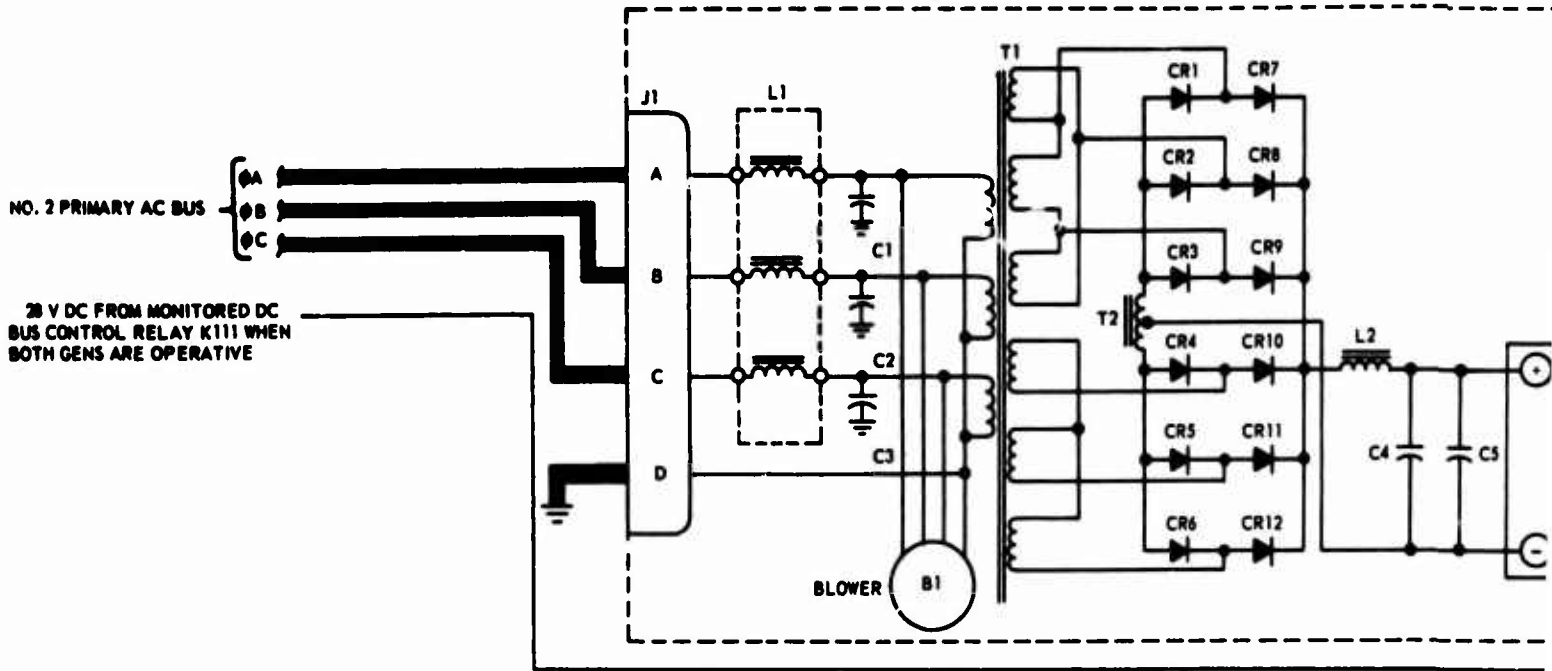

NO. 1 CONVERTER (TRANSFORMER-RECTIFIER)

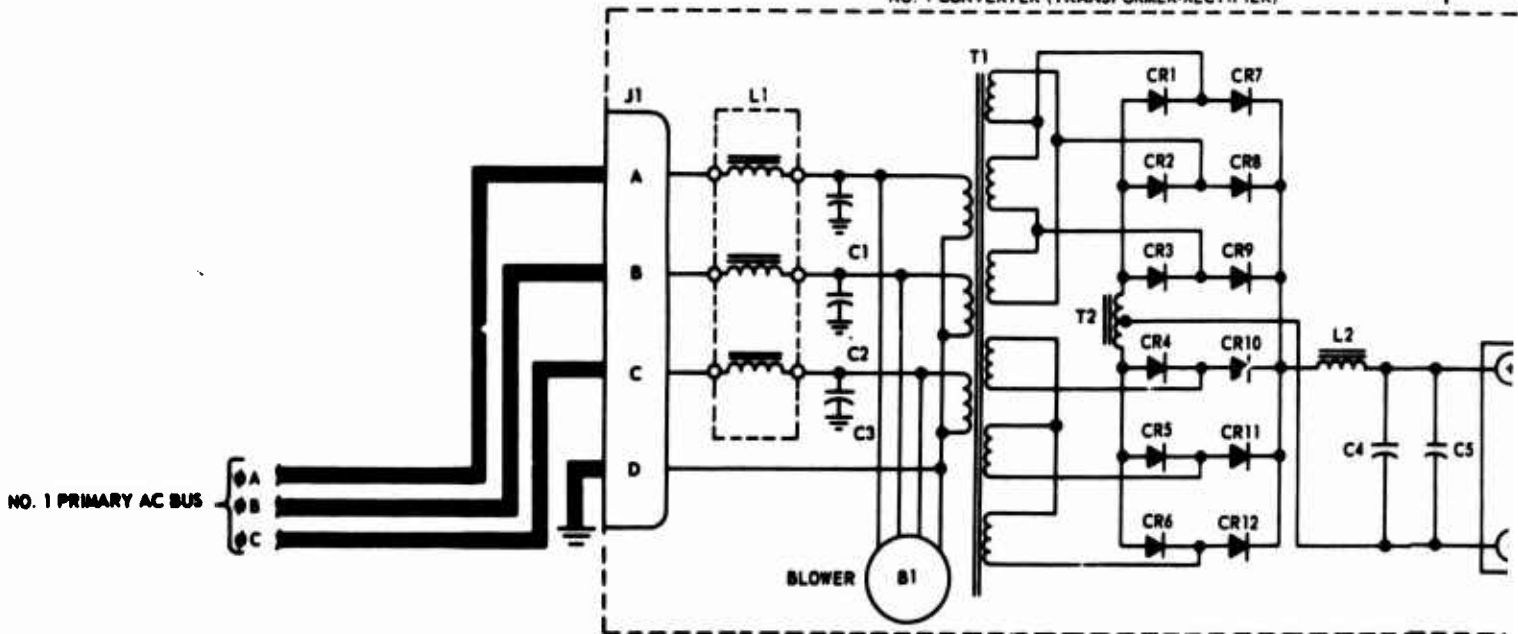
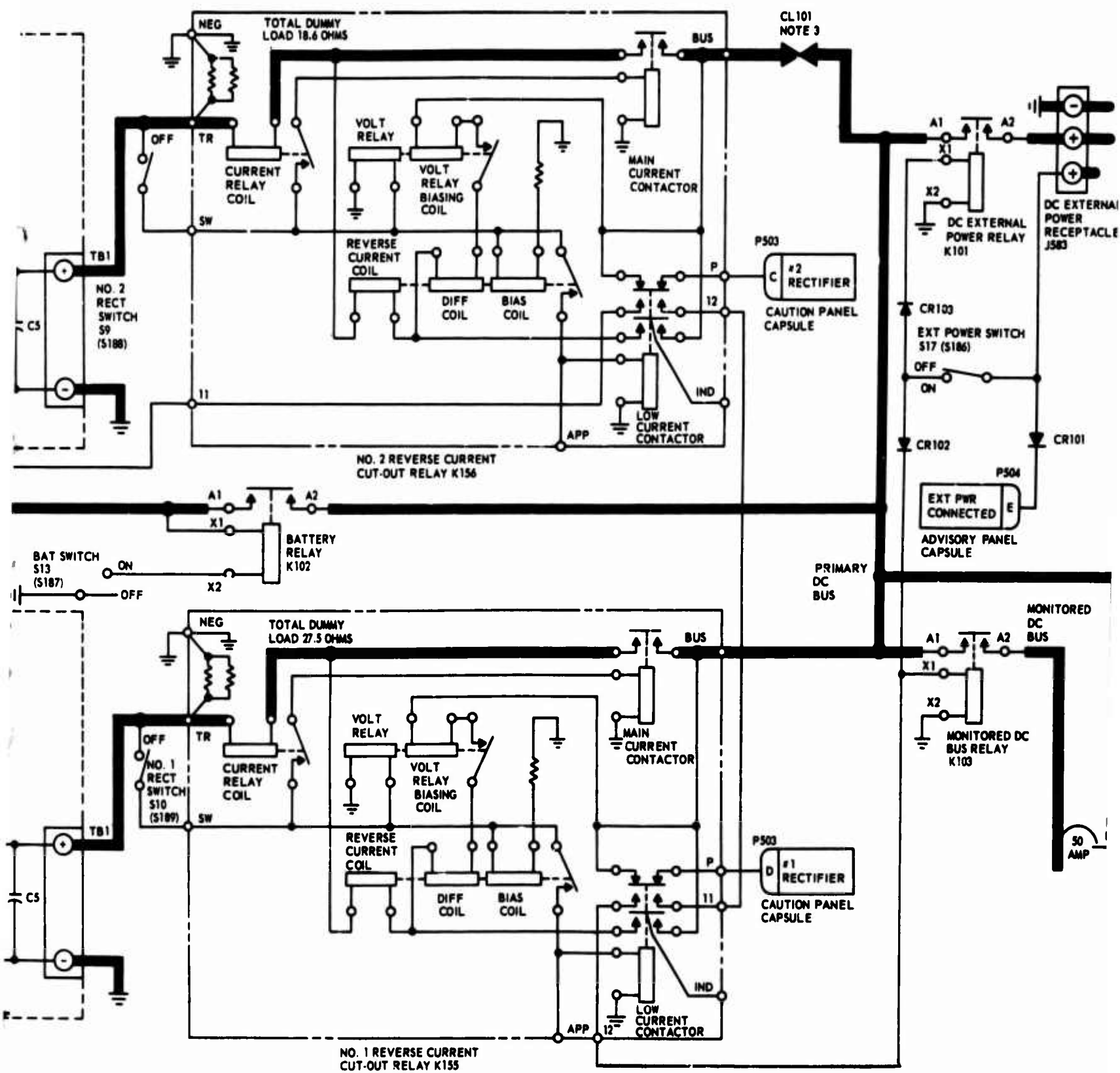
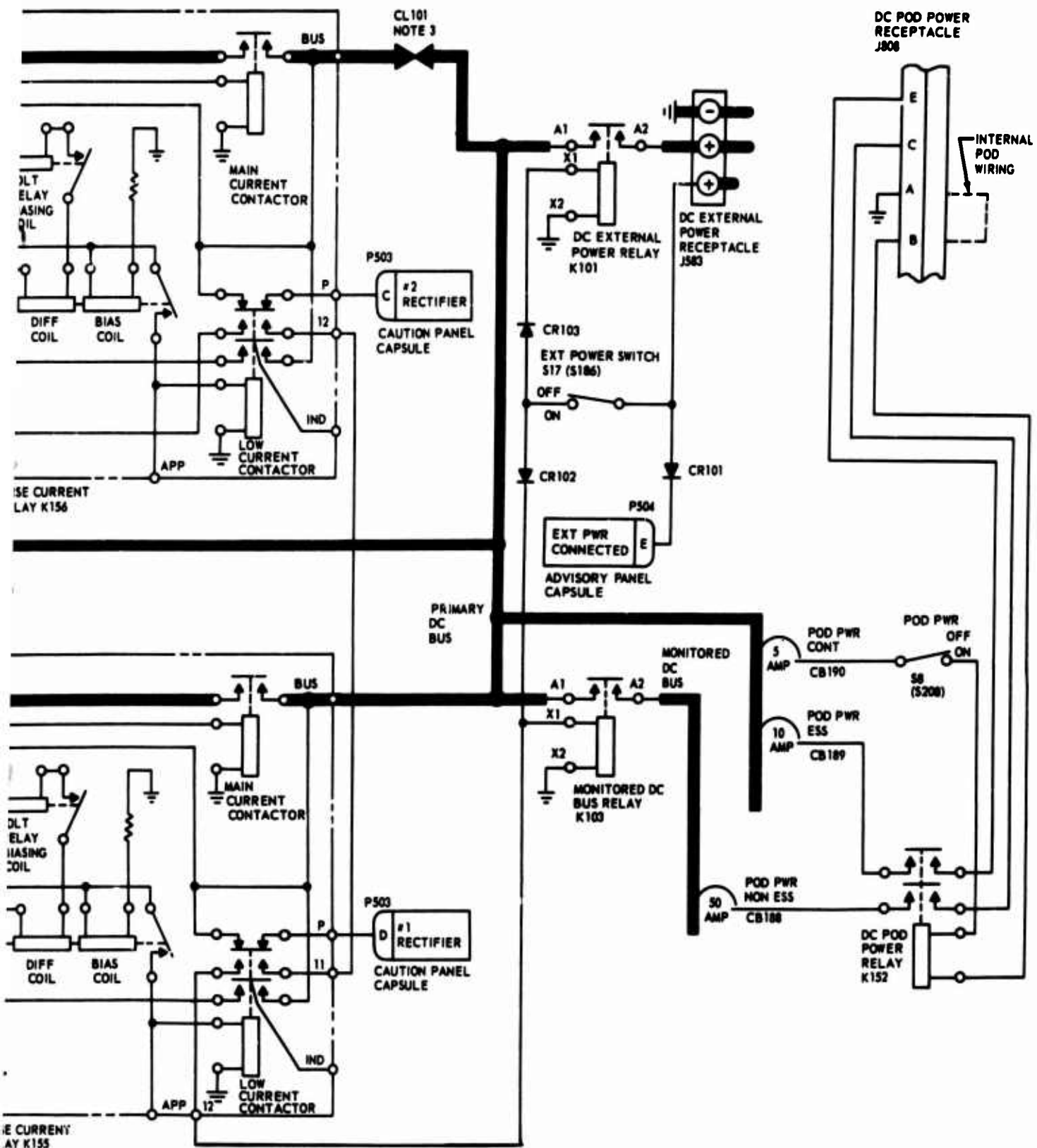

Figure 18. CH-54A Direct Current Circuit Schematic.







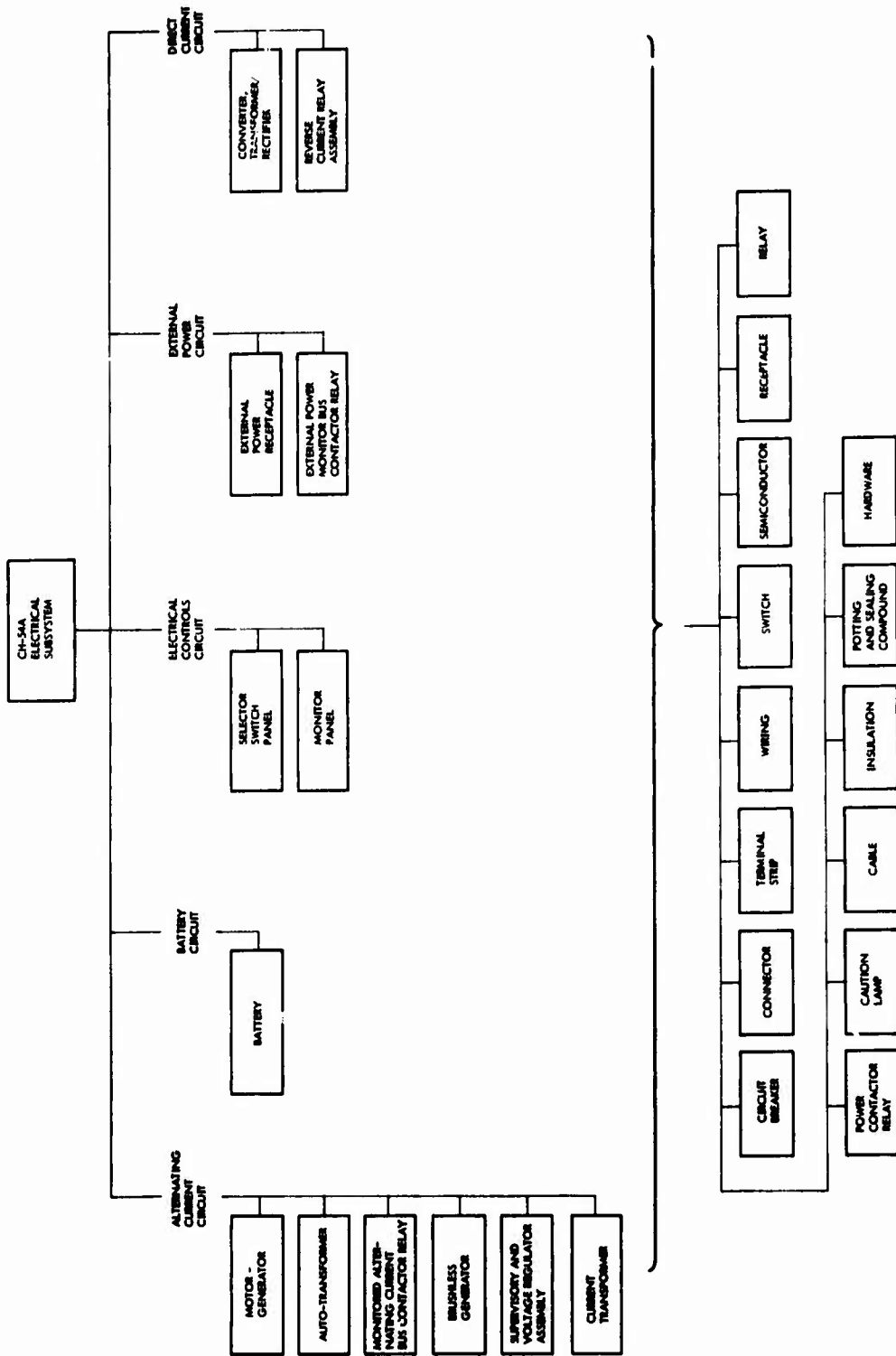

Figure 19. CH-54A Electrical Subsystem Block Diagram Tree.

Preceding page blank

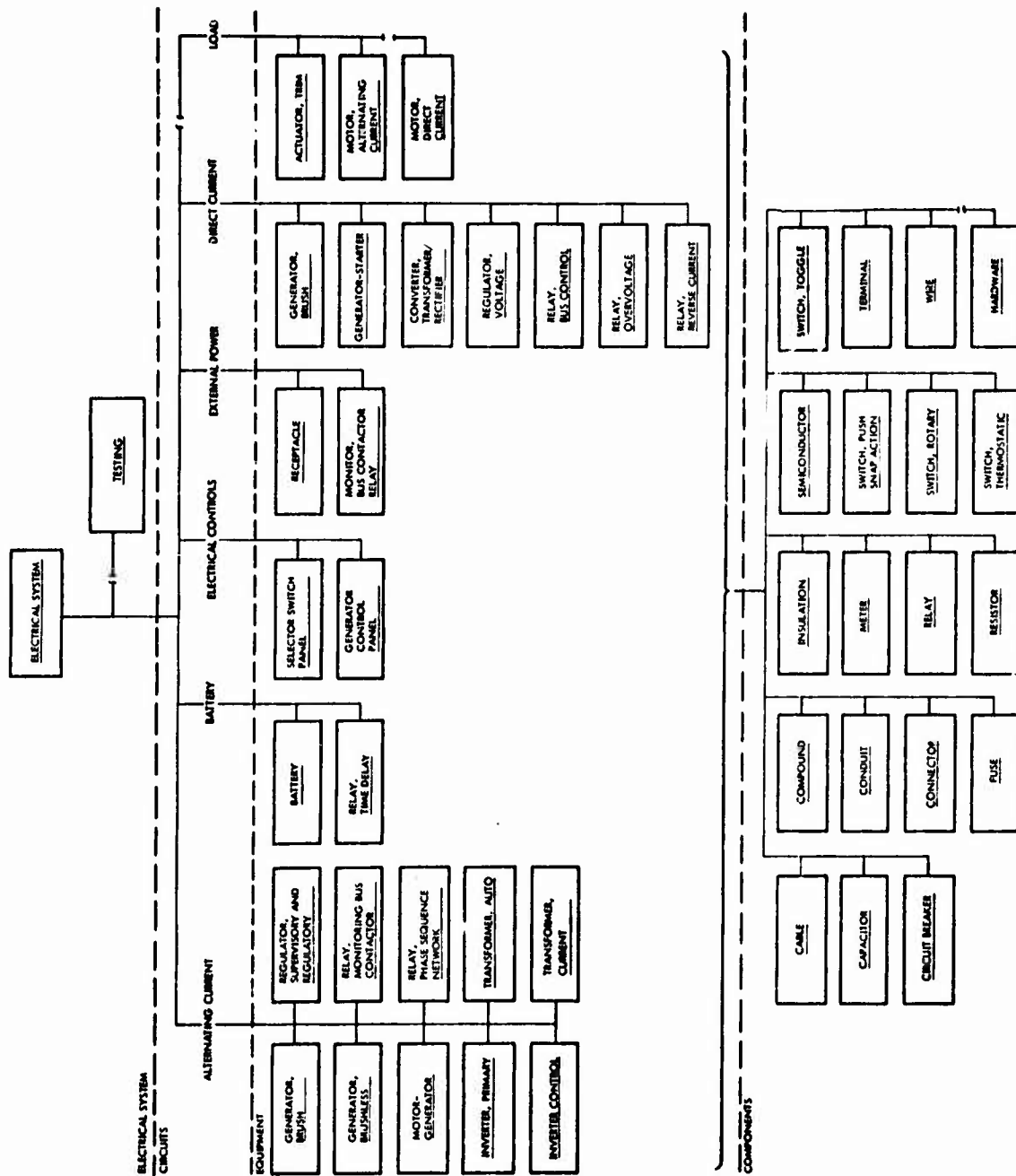

Figure 20. U.S. Army Helicopter Baseline Electrical System Block Diagram Tree.

## DOCUMENT CLASSIFICATION

During the electrical system documentation investigation, over 200 documents were identified, collected, sorted into generic classification groups, and analyzed for applicability to the Army helicopter electrical system. Appendix I lists those documents examined during this investigation. Of these 200 documents, 124 were determined to be applicable to one or more of the 5 representative helicopter types. The remaining documents were judged to be inapplicable to any of the representative helicopter types.

The documents examined were identified from the following sources:

1. Helicopter Technical Manuals (TM's)
2. Department of Defense Index of Specifications and Standards
3. Airframe manufacturers and component suppliers
4. U.S. Army Aviation Systems Command (AVSCOM), St. Louis, Missouri
5. Manufacturers' detailed design specifications for the CH-47A and CH-54A

### HELICOPTER TECHNICAL MANUALS

Following compilation of all pertinent documentation, the TM's applicable to the AH-1G, UH-1D/H, OH-6A, CH-47A, and CH-54A helicopters were reviewed to identify and classify each of the electrical system components. Table II lists the TM's that were utilized.

The helicopter repair parts manuals were used as the source documents for the applicable components list. These included:

- |            |                        |
|------------|------------------------|
| 1. AH-1G   | - TM 55-1520-221-20P   |
|            | - TM 55-1520-221-34P-1 |
| 2. UH-1D/H | - TM 55-1520-210-20P-2 |
|            | - TM 55-1520-210-34P-2 |
| 3. OH-6A   | - TM 55-1520-214-20P   |
|            | - TM 55-1520-214-35P   |
| 4. CH-47A  | - TM 55-1520-209-20P   |
|            | - TM 55-1520-209-34P-2 |
| 5. CH-54A  | - TM 55-1520-217-20P-2 |
|            | - TM 55-1520-217-35P-2 |

**TABLE II. APPLICABLE HELICOPTER TECHNICAL MANUALS**

Designation	Technical Manuals
AH-1G	<p>TM 55-1520-221-20, "Organizational Maintenance Manual, Army Model AH-1G Helicopter," dated 10 September 1971</p>
	<p>TM 55-1520-221-20P, "Organizational Maintenance Repair Parts and Special Tools List, Helicopter, Attack - AH-1G (Bell)," dated 1 June 1971</p>
	<p>TM 55-1520-221-34, "DS and GS Maintenance Manual, Army Model AH-1G Helicopter," dated 27 August 1971</p>
	<p>TM 55-1520-221-34P-1, "DS, GS and Depot Maintenance Repair Parts and Special Tools List, Helicopter, Attack - AH-1G (Bell)," dated June 1971</p>
UH-1D/H	<p>TM 55-1520-210-20, "Organizational Maintenance Manual: Army Model UH-1D/H Helicopter," dated 7 May 1969</p>
	<p>TM 55-1520-210-20P-2, "Organizational Maintenance Repair Parts and Special Tools List, Helicopter, Utility-Tactical Transport, UH-1A, UH-1B, UH-1C, UH-1D, UH-1H (Bell)," dated April 1971</p>
	<p>TM 55-1520-210-34, "DS and GS Maintenance Manual, Army Model UH-1D/H Helicopter, ' dated 10 September 1971</p>
	<p>TM 55-1520-210-34P-2, "DS and GS Maintenance and Repair Parts and Special Tools List, UH-1B, UH-1C, UH-1D, UH-1H, UH-1M (Bell)," dated December 1971</p>
OH-6A	<p>TM 55-1520-214-20, "Organizational Maintenance Manual," dated July 1969</p>
	<p>TM 55-1520-214-20P, "Organizational Maintenance Repair Parts and Special Tools List," dated May 1971</p>

TABLE II - Continued

Designation	Technical Manuals
CH-47A	TM 55-1520-214-35, "DS, GS, and Depot Maintenance Manual," dated July 1969
	TM 55-1520-214-35P, "DS, GS, and Depot Maintenance Repair Parts and Special Tools List," dated May 1971
	TM 55-1520-209-20-2, "Organizational Maintenance Manual, Army Model CH-47A Helicopter," dated May 1968
	TM 55-1520-209-20P, "Organizational Maintenance Repair Parts and Special Tools List, Helicopter, Cargo Transport, CH-47A, CH-47B, CH-47C (Vertol)," dated August 1971
	TM 55-1520-209-35-2, "DS, GS and Depot Maintenance Manual, Army Model CH-47A Helicopter," dated May 1968
CH-54A	TM 55-1520-209-34P-2, "DS and GS Maintenance Repair Parts and Special Tools List, Helicopter, Cargo Transport, CH-47A, CH-47B, CH-47C (Vertol)," dated August 1971
	TM 55-1520-217-20-1/2, "Organizational Maintenance Manual, CH-54A Helicopter," dated April 1969
	TM 55-1520-217-20P-2, "Organizational Maintenance Repair Parts and Special Tools List, Helicopter, Cargo Transport, CH-54A, CH-54B (Sikorsky)," dated July 1971
	TM 55-1520-217-35-1/2, "DS, GS and Depot Maintenance Manual, CH-54A Helicopter," dated April 1969
TM 55-1520-217-35P-2, "DS, GS and Depot Maintenance Repair Parts and Special Tools List, CH-54A (Sikorsky)," dated 23 April 1969	

Each component identified pertaining to the helicopter electrical system was identified by military standard (MS) number. Each standard was reviewed to determine if the standard was currently active for new designs or had been deemed inactive, cancelled or obsolete. These MS's were further reviewed to determine the military or federal specification that governs the design, testing, quality assurance requirements and provisions of the identified component. Each identified standard was then numerically sequenced and listed in Table III. This table displays the MS number, title, whether inactive, cancelled or obsolete for the new designs (indicated by an asterisk following the title), governing military or federal specification, and helicopter applicability. This latter categorization provides a ready cross-reference as to standardization of electrical systems component designs.

#### DEPARTMENT OF DEFENSE INDEX OF SPECIFICATIONS AND STANDARDS

The electrical system components identified during the analysis of the helicopter TM's were then used as the basis for research of the DODISS for applicable electrical system and component specifications. The alphabetical DODISS was surveyed to determine all military and federal specifications and standards applicable to that generic component type.

Some military specifications were noted to be interim specifications, as indicated by two zeros preceding the basic specification number. One such example is MIL-C-005015F (Navy), entitled, "Connectors, Electric, AN Type, General Specification For". The following legend is on the title page of this particular interim specification:

"This limited coordination Military specification has been prepared by the Naval Air Systems Command based upon currently available technical information, but it has not been approved for promulgation as a coordinated revision of Military Specification MIL-C-5015D. It is subject to modification. However, pending its promulgation as a coordinated Military specification, it may be used in procurement. "

In such instances, both the basic and interim documents were examined for possible applicability. Additionally, all processes, practices and procedures applicable to the design, quality assurance and testing of electrical and related systems were identified in the DODISS.

#### U. S. ARMY AVIATION SYSTEMS COMMAND

Design data were also sought from the U. S. Army Aviation Systems Command (AVSCOM), St. Louis, Missouri, for those component types

for which applicable military specifications could not be identified. These data were supplied in the form of microfiche transparencies from which the military specifications used in some part of the design process were identified.

#### MANUFACTURERS' DETAILED DESIGN SPECIFICATIONS

Detailed design specifications for the Boeing-Vertol CH-47A and Sikorsky CH-54A helicopters were reviewed to ascertain all military specifications and standards used in the design of these helicopters.

#### DOCUMENTS NOT APPLICABLE

All documents that were reviewed but considered to be inapplicable to the design of Army helicopter electrical systems are shown as Appendix II. Rationale is provided for the inapplicability of each document so classified.

Documents which impact the design of helicopter electrical systems but are not considered to be electrical system documents are shown as Appendix III. These documents are applicable to aircraft hardware, processes, packaging and inspection procedures. Aircraft piece part hardware, i. e. , grommets, boots, clamps, etc. , and testing documents were only analyzed in a cursory manner, as they are not amenable to the imposition of reliability and maintainability requirements. These documents are shown on the documentation tree, Volume II of this report. The inspection, packaging, and process documents also were only analyzed in a very cursory manner. These documents should be included at the aircraft level documentation tree analysis because of their inherent interrelationship with all the aircraft subsystems, i. e. , electrical, hydraulic, flight control, etc.

TABLE III. ELECTRICAL SYSTEM DOCUMENTATION

<u>Military Standard</u>		<u>Applicable MIL-Spec</u>	<u>Helicopter Applicability</u>				
Number	Title	Number	CH-47A	CH-54A	UH-1D/H	AH-1G	OH-6A
AN735	Clamp, Loop-Type Bonding	-	-	-	-	X	-
AN737	Clamp, Hose, Aircraft	MIL-C-6985	-	-	-	X	-
AN742	Clamp, Plain, Support, Loop-Type, Aircraft	MIL-C-8603	-	-	-	X	-
AN743	Bracket, Support Clamp	-	-	-	-	X	-
AN2552	Receptacle - External Power, 28 Volt DC	MIL-C-7974	X	X	X	X	X
AN3022	Switch - Toggle, Single Pole*	MIL-S-6745	-	-	X	-	-
AN3025	Cutout Relay, Aircraft Gen.*	MIL-C-5026	-	-	X	-	-
AN3053	Ferrule - Rigid Conduit	-	-	-	X	-	-
AN3054	Nut, Coupling, Electrical Conduit	-	-	-	X	-	-
AN3063	Elbow - Electrical Conduit	-	-	-	X	-	-
AN3064	Box Connector, Electrical*	-	-	-	X	-	-
AN3066	Nut, Plain, Hexagon, Conduit Coupling	-	-	-	X	-	-

\*Inactive, Cancelled, or Obsolete



TABLE III - Continued

<u>Military Standard</u>		<u>Applicable MIL-Spec</u>	<u>Helicopter Applicability</u>				
Number	Title	Number	CH-47A	CH-54A	UH-1D/H	AH-1G	OH-6A
AN3111	Ring - Bonding, Electrical Connector	-	-	-	X	X	-
AN3114	Receptacle, External Power	MIL-C-7974	X	X	-	-	-
AN3115	Receptacle - Airspeed Tube, Electrical	-	X	X	X	X	-
AN3116	Plug Assy - Instrument, Electrical	-	-	-	-	X	X
AN3117	Receptacle - Fuel Nozzle Grounding*	-	-	-	-	-	X
AN3155	Rheostat - Aircraft Power	MIL-R-6749	-	X	-	-	-
AN3156	Clamp - Battery Hold-Down	MIL-C-6783	-	-	X	-	-
AN3167	Actuator, Limit Switch Class B*	MIL-S-6744	-	-	X	X	-
AN3230	Switch - Five Hole Mounting - Single Pole Toggle*	MIL-S-6745	-	-	-	-	X
AN3371	Relay, 200 Amp, 1PST, Intermittent*	MIL-R-6106	-	-	-	-	X
AN342	Bushing, Cable, Adapter, Telescoping*	-	-	-	X	X	-

\*Inactive, Cancelled, or Obsolete

TABLE III - Continued

<u>Military Standard</u>		<u>Applicable MIL-Spec</u>	<u>Helicopter Applicability</u>				
Number	Title	Number	CH-47A	CH-54A	UH-1D/H	AH-1G	OH-6A
AN5534	Resistor - Thermocouple Lead Spool	MIL-R-7790	X	X	X	X	X
AN5538	Terminal - Thermocouple Lead Soldering	-	X	X	-	-	-
AN5539	Terminal - Thermocouple, Brass	-	X	-	-	-	-
AN5813	Tube - Pitot, Electrically Heated	MIL-T-5421	X	-	-	-	-
AN5816	Tube - Pitot Static, Straight	MIL-T-5421	-	X	-	-	-
MS3057	Clamp, Cable, Electrical Connector	MIL-C-5015	-	-	X	X	-
MS3100	Connector, Receptacle*	MIL-C-5015	X	X	X	X	-
MS3101	Connector, Plug*	MIL-C-5015	-	X	X	-	-
MS3102	Connector, Receptacle	MIL-C-5015	-	X	X	X	X
MS3105	Connector, Receptacle	MIL-C-5015	-	-	-	X	-
MS3106	Connector, Plug	MIL-C-5015	X	X	X	X	X
MS3108	Connector, Plug	MIL-C-5015	X	X	X	X	X
MS3110	Connector, Receptacle	MIL-C-26482	X	X	X	X	X
MS3112	Connector, Receptacle	MIL-C-26482	X	-	X	X	X

\*Inactive, Cancelled, or Obsolete

TABLE III - Continued

<u>Military Standard</u>		<u>Applicable MIL-Spec</u>	<u>Helicopter Applicability</u>				
Number	Title	Number	CH-47A	CH-54A	UH-1D/H	AH-1G	OH-6A
MS3114	Connector, Receptacle	MIL-C-26482	-	-	X	-	-
MS3115	Connector, Receptacle	MIL-C-26482	-	-	-	X	-
MS3116	Connector, Plug	MIL-C-26482	X	X	X	X	X
MS3119	Connector, Receptacle	MIL-C-26482	X	-	-	X	-
MS3120	Connector, Receptacle	MIL-C-26482	-	X	X	X	X
MS3122	Connector, Receptacle	MIL-C-26482	-	X	X	X	-
MS3124	Connector, Receptacle	MIL-C-26482	-	-	X	X	-
MS3126	Connector, Plug	MIL-C-26482	-	X	X	X	X
MS3127	Connector, Receptacle	MIL-C-81703	X	-	-	X	-
MS3181	Cover, Protective, Electric Connector Receptacle	MIL-C-26482	-	X	-	X	-
MS3193	Contact, Socket, Electric	MIL-C-23216	-	-	-	X	-
MS3367	Strap, Tiedown, Adjustable	MIL-S-23190	-	X	-	-	-
MS3373	Strip, Mounting, Nut Insulating	-	-	-	X	X	-
MS3400	Connector, Receptacle	MIL-C-005015	-	-	X	X	-

\*Inactive, Cancelled, or Obsolete

TABLE III - Continued

<u>Military Standard</u>		<u>Applicable MIL-Spec</u>	<u>Helicopter Applicability</u>				
Number	Title	Number	CH-47A	CH-54A	UH-1D/H	AH-1G	OH-6A
MS3406	Connector, Plug	MIL-C-005015	-	-	X	-	-
MS17411	Wire, Electric, Fluorocarbon - insulated	MIL-W-22759	-	-	X	-	-
MS17803	Contact, Electric Connector, Socket	MIL-C-23216	-	-	X	-	-
MS17829	Nut, Self-locking, Hexagon	MIL-S-23190	X	X	X	X	X
MS18029	Cover Assy, Electrical, for MS27212 Terminal Board Assy	-	-	X	X	X	-
MS18034	Strap, Cable, Adjustable, Plastic	MIL-S-23190	-	X	-	-	X
MS20659	Terminal, Lug, Crimp Style	MIL-T-7928	-	-	X	-	-
MS21104	Clamp, Loop, Cushioned, Wedge	MIL-C-8956	-	X	-	-	-
MS21105	Clamp, Loop, Cushioned, Wedge	MIL-C-8956	-	X	-	-	-
MS21122	Clamp, Loop, Cushioned, Wedge, Poly-tetrafluoroethylene	MIL-C-8956	-	X	-	X	-

\*Inactive, Cancelled, or Obsolete

TABLE III - Continued

<u>Military Standard</u>		<u>Applicable MIL-Spec</u>	<u>Helicopter Applicability</u>				
Number	Title	Number	CH-47A	CH-54A	UH-1D/H	AH-1G	OH-6A
MS21266	Grommet, Plastic, Edging	MIL-G-22529	-	-	-	X	-
MS21919	Clamp, Cushioned, Support	MIL-C-8603	X	X	X	-	-
MS21983	Inverter, 250VA	MIL-I-7032	-	-	X	-	-
MS24149	Relay, 10 Amp, 2PDT, Type I	MIL-R-6106	X	-	X	X	-
MS24166	Relay, 50 Amp, 1PST, Type II	MIL-G-22529	-	X	X	-	-
MS24170	Relay, 100 Amp, 2PST, Normally Open*	MIL-R-6106	-	X	-	-	-
MS24171	Relay, 200 Amp, 1PST, Normally Open, Type II	MIL-R-6106	X	X	X	-	-
MS24172	Relay, 200 Amp, 1PST, Normally Open, Type II	MIL-R-6106	-	-	X	-	-
MS24181	Relay, 50 Amp, 1PST, Normally Open, Type I	MIL-R-6106	-	X	X	-	-
MS24182	Relay, 100 Amp, 1PST, Type I	MIL-R-6106	-	-	-	X	-
MS24183	Relay, 200 Amp, 1PST, Normally Open, Type I	MIL-R-6106	-	-	-	X	-
MS24187	Relay, 50/25 Amp, 1PDT, Type II	MIL-R-6106	X	-	-	-	-

\*Inactive, Cancelled, or Obsolete

TABLE III - Continued

<u>Military Standard</u>		<u>Applicable MIL-Spec</u>	<u>Helicopter Applicability</u>				
Number	Title	Number	CH-47A	CH-54A	UH-1D/H	AH-1G	OH-6A
MS24192	Relay, 25 Amp, 3PST, Type II	MIL-R-6106	-	X	-	-	-
MS24331	Switch, Sensitive, Sealed*	MIL-S-6744	X	-	-	-	-
MS24420	Switch, Sensitive, Rotary Actuated*	MIL-S-6744	-	X	-	-	-
MS24496	Battery, Aircraft Storage	MIL-B-26220	-	X	-	-	-
MS24497	Battery, Aircraft Storage	MIL-B-26220	-	X	-	-	-
MS24498	Battery, Aircraft Storage	MIL-B-26220	-	-	X	-	-
MS24509	Circuit Breaker Aircraft, Trip Free, Toggle	MIL-C-5809	-	-	-	-	X
MS24523	Switch, Toggle, One Pole	MIL-S-3950	X	X	-	-	-
MS24524	Switch, Toggle, Two Pole	MIL-S-3950	X	X	X	-	-
MS24525	Switch, Toggle, Four Pole	MIL-S-3950	X	X	-	-	-
MS24568	Relay - 10 Amp, 4PDT, Sealed	MIL-R-6106	-	-	X	X	-
MS24658	Switch, Toggle, One Pole	MIL-S-3950	X	X	-	X	-
MS24659	Switch, Toggle, Two Pole	MIL-S-3950	X	X	-	X	-
MS24660	Switch, Toggle, Four Pole	MIL-S-3950	-	X	X	-	-

\*Inactive, Cancelled, or Obsolete

TABLE III - Continued

<u>Military Standard</u>		<u>Applicable MIL-Spec</u>	<u>Helicopter Applicability</u>				
Number	Title	Number	CH-47A	CH-54A	UH-1D/H	AH-1G	OH-6A
MS25002	Switch, Rotary, 28/115 Volts	MIL-S-6807	X	-	X	-	-
MS25024	Relay, 10 Amp, 4PDT, Sealed	MIL-R-6106	X	-	X	-	-
MS25026	Switch, Sensitive, 1PDT, Class 45*	MIL-S-8805	-	-	X	X	-
MS25028	Switch, Toggle, One Pole, Lever Locks, Unsealed*	MIL-S-3950	-	-	X	-	-
MS25035	Relay, 25 Amp, 1PST, Sealed	MIL-R-6106	X	-	-	-	-
MS25036	Terminal, Lug, Crimp Style, Copper	MIL-T-7928	-	-	X	X	X
MS25038	Gen., Tachometer and Synchronizing	Various	-	X	-	-	-
MS25039	Switch, Microphone, 5A-47A/AIC*	MIL-S-6744	-	-	X	X	X
MS25042	Cover, Electrical Connector, Plug, AN Type	MIL-C-5015	-	-	X	-	-
MS25043	Cover, Electrical, Receptacle, AN Type	MIL-C-5015	-	X	-	-	X
MS25044	Terminal Board, Two Stud	-	-	X	-	-	-

\*Inactive, Cancelled, or Obsolete

TABLE III - Continued

<u>Military Standard</u>		<u>Applicable MIL-Spec</u>	<u>Helicopter Applicability</u>				
Number	Title	Number	CH-47A	CH-54A	UH-1D/H	AH-1G	OH-6A
MS25068	Switch, Toggle, Four Pole, Sealed Toggle*	MIL-S-3950	-	-	X	-	-
MS25080	Terminal, Stud (ASG)	-	-	-	X	-	-
MS25083	Jumper Assy, Electric, Bonding and Current Return	-	-	X	X	-	-
MS25089	Switch, Push, Moisture Proof*	MIL-S-6743	X	X	X	X	-
MS25102	Switch, Toggle, One Pole, Unsealed*	MIL-S-3950	-	-	X	-	-
MS25103	Switch, Toggle, Two Pole, Unsealed*	MIL-S-3950	-	-	X	-	-
MS25105	Switch, Toggle, Three Pole, Unsealed*	MIL-S-3950	-	-	X	-	-
MS25106	Switch, Toggle, One Pole, Unsealed*	MIL-S-3950	-	-	-	-	X
MS25125	Switch, Toggle, One Pole, Sealed*	MIL-S-83731	-	-	-	-	-
MS25171	Nipple, Electrical Terminal (ASG)	-	X	X	X	X	X

\*Inactive, Cancelled, or Obsolete



TABLE III - Continued

<u>Military Standard</u>		<u>Applicable MIL-Spec</u>	<u>Helicopter Applicability</u>				
Number	Title	Number	CH-47A	CH-54A	UH-1D/H	AH-1G	OH-6A
MS25181	Splice, Electric, Permanent, Crimp Type	MIL-T-7928	-	-	X	X	X
MS25182	Plug, Electric, Aircraft Storage Battery	MIL-P-18148	X	X	X	-	-
MS25183	Connector, Plug, Electric, Potting Seal	MIL-C-5015	X	-	X	X	-
MS25189	Terminal, Lug, Flag Type Crimp Style, Copper, Class 1 (ASG)	MIL-T-7928	-	-	X	-	-
MS25190	Wire, Electric, 600 and 3000 Volt, Copper, Aircraft*	MIL-W-5086	-	-	X	-	X
MS25192	Cable, Electric, Aerospace Vehicle*	MIL-C-7078	-	-	X	-	-
MS25201	Switch, Toggle, Two Pole, Sealed*	MIL-S-3950	X	-	X	X	-
MS25226	Link, Terminal Connecting	-	-	X	X	X	-
MS25227	Strip, Mounting Nut Insulating	-	-	-	X	X	-

\*Inactive, Cancelled, or Obsolete

TABLE III - Continued

<u>Military Standard</u>		<u>Applicable MIL-Spec</u>	<u>Helicopter Applicability</u>				
Number	Title	Number	CH-47A	CH-54A	UH-1D/H	AH-1G	OH-6A
MS25244	Circuit Breaker, Trip-free, Push-pull	MIL-C-5809	X	X	X	X	-
MS25251	Plug, End Seal, Electric Connector	-	-	-	X	-	-
MS25253	Switch, Class E, Limit*	MIL-S-6743	-	X	-	-	-
MS25269	Relay, 5 Amp, 6PDT, Type I	MIL-R-6106	-	X	-	-	-
MS25271	Relay, 10 Amp, 4PDT, Class B8, Sealed	MIL-R-6106	-	X	-	-	-
MS25273	Relay, 10 Amp, 2PDT, Type I	MIL-R-6106	-	X	-	-	-
MS25274	Cap, Electrical	MIL-T-7928	-	-	X	-	-
MS25281	Clamp, Loop - Plastic, Wire Support	MIL-C-21563	-	-	X	X	X
MS25313	Cable, Electric, Aerospace Vehicle, 105°C Copper, Shield, Nylon Jacket*	MIL-C-7078	-	-	X	-	-
MS25381	Grommet, Mounting	-	X	-	-	-	-
MS25395	Relay, 5 Amp, 2PDT, Type I	MIL-R-6106	-	X	-	-	-

\*Inactive, Cancelled, or Obsolete

TABLE III - Continued

<u>Military Standard</u>		<u>Applicable MIL-Spec</u>	<u>Helicopter Applicability</u>				
Number	Title	Number	CH-47A	CH-54A	UH-1D/H	AH-1G	OH-6A
MS25435	Terminal-lug, Crimp-Style, Straight Type	MIL-T-7099	-	-	X	X	-
MS25437	Terminal-lug, Crimp-Style, Left Angle Type	MIL-T-7099	-	-	X	X	-
MS25438	Terminal-lug, Crimp-Style, Right Angle Type	MIL-T-7099	-	-	X	X	-
MS25457	Relay, Magnetic Latch, 10 Amp, 2PDT, Type I	MIL-R-6106	-	-	X	X	-
MS25674	Circuit Breaker, Trip Free, Push-Pull	MIL-C-5809	-	-	-	X	-
MS27212	Terminal Board, Assy, Molded-in-Stud, Electric	-	X	X	-	X	-
MS27400	Relay, Permanent Magnet Drive, 10 Amp, 4PDT,	MIL-R-6106	-	X	-	-	-
MS27401	Relay, Permanent, Magnet Drive, 10 Amp, 2PDT	MIL-R-6106	-	X	-	-	-
MS27407	Switch, Toggle, Two Pole	MIL-S-3950	X	X	-	-	-
MS27408	Switch, Toggle, Double Pole	MIL-S-3950	X	-	-	X	-

\*Inactive, Cancelled, or Obsolete

TABLE III - Continued

<u>Military Standard</u>		<u>Applicable MIL-Spec</u>	<u>Helicopter Applicability</u>				
Number	Title	Number	CH-47A	CH-54A	UH-1D/H	AH-1G	OH-6A
MS27418	Relay, 20 Amp, 3PST, Normally Open	MIL-R-6106	-	-	-	X	-
MS28005	Transmitter, Pressure, Synchro, Aircraft	Various	X	X	-	-	-
MS28034	Bulb, Temp., Electrical Resistance	MIL-B-7990	X	-	X	-	-
MS28042	Clamp, Mounting, Aircraft Instruments	MIL-C-6818	-	-	-	-	X
MS28939	Switch, Toggle, Momentary, Four Position On, Center Off	MIL-S-9419	-	X	-	-	-
MS29527	Valve, Fuel Shutoff, Solenoid Operated	MIL-V-8610	X	-	-	-	-
MS35058	Switch, Toggle, One Pole, Sealed*	MIL-S-83731	X	X	X	X	X
MS35489	Grommet, Rubber, Hot Oil and Coolant Resistant	MIL-G-3036	X	X	X	X	X
MS35490	Grommet, Rubber, Split, General Purpose	MIL-G-20699	X	X	-	-	-

\*Inactive, Cancelled, or Obsolete

TABLE III - Continued

<u>Military Standard</u>		<u>Applicable MIL-Spec</u>	<u>Helicopter Applicability</u>				
Number	Title	Number	CH-47A	CH-54A	UH-1D/H	AH-1G	OH-6A
MS35490	Grommet, Rubber, Split, General Purpose	MIL-G-20699	X	X	-	-	-
MS90310	Switch, Toggle, Miniature, Toggle Sealed, Single Pole, One Hole Mounting	MIL-S-8834	-	-	-	X	-
MS90335	Connector, Receptacle	MIL-P-7788	-	-	-	X	X
MS91587	Shunt, Instrument, External, 50-Millivolt, Style MSB	MIL-S-61B	X	-	X	-	-

\*Inactive, Cancelled, or Obsolete

## DOCUMENT DEFICIENCY ANALYSIS

This section presents the results of the analysis of military specifications pertaining to electrical systems, equipments, components, and procedures. The pertinent documents identified during the data collection tasks as being applicable to helicopter electrical systems were reviewed, with primary attention given to those areas that, by their deficiencies, have a potentially adverse effect on reliability and maintainability.

### DOCUMENT DEFICIENCY CRITERIA

One of the more important considerations in performing a document deficiency analysis is the interstitial relationship of the design, testing, and quality assurance requirements and provisions, and their effect upon the ultimate design and life cycle cost of the Army helicopter electrical system. Figure 21 displays this interstitial relationship and all of the various requirements that should be considered during the development, qualification, and production phases of the helicopter electrical system and the constituent components. Another important facet of this type of analysis is the understanding that the strict imposition of any one of these identified requirements or provisions may cause intolerable adverse effects on other parameters. Ultimately, the helicopter and its electrical system may be adversely affected to such a degree that the mission requirements will not be achieved.

Another factor used during this analysis was the degree that the ultimate design is governed by the applicable military specification. While this was not a requirement that is normally considered in reliability and maintainability analyses, it was considered during this analysis to the degree that technological advancements may be restricted by the military specification. Military specifications that are too specific in their requirements do not allow for technological advances. This could severely constrain the expected reliability growth of the system, equipment, or component.

The detailed criteria used to identify specific deficiencies in these documents were established by developing the specific requirements, as shown in Figure 21, that should be considered by the designer to meet or exceed the operational parameters of U.S. Army helicopters.

The primary areas in each document that have been reviewed for deficiencies are the:

- Design Requirements
- Qualification Test Requirements, Procedures and Practices
- Quality Assurance Requirements and Provisions

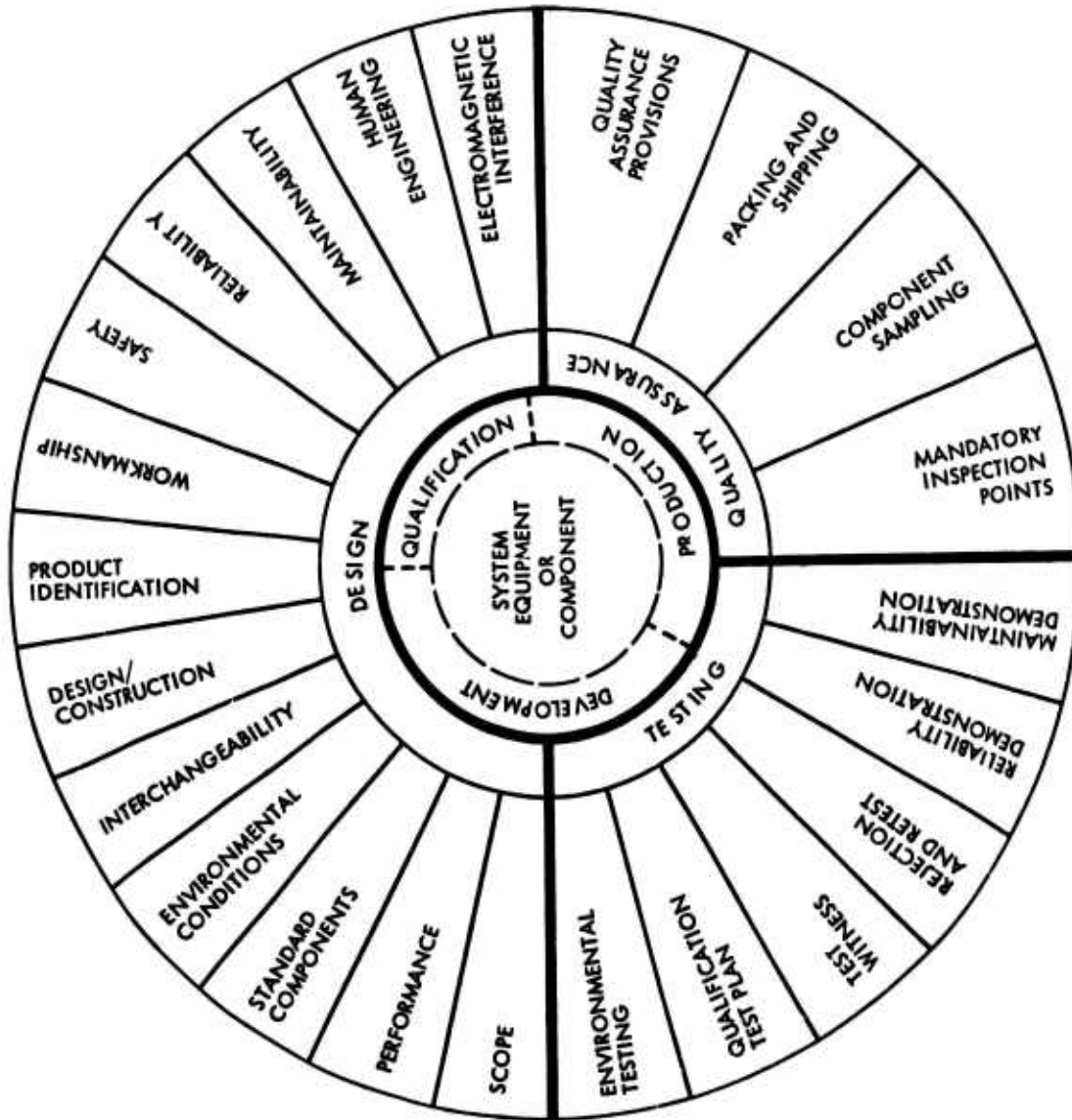

Figure 21. Electrical System Design, Testing, and Quality Assurance Requirements and Provisions.

## Design Requirements

The philosophy criteria used to analyze each document relative to design requirements are as follows:

1. Scope — Does the scope of the specification provide the designer with the types of applications for which the system, equipment or component is intended? If the specification is intended to apply only to ground-based applications, the operational stresses of a helicopter may exceed those provided by the specification. This could result in premature failure because operational parameters have been exceeded by use in the helicopter environment. On the other hand, if the intent of the specification is for a missile application, the design requirements may impose more than adequate reliability requirements, but the maintenance considerations may not be adequate for Army field use.
2. Performance — As with the scope, provisions must be made to ensure that the detailed operational requirements of the Army are considered by the designer. A mere listing of the performance parameters alone is not adequate unless these parameters are essentially the same as required by the operational use of the Army. A component or system can be built to meet or exceed the specification performance requirements and fail to meet the operational reliability or maintainability requirements.
3. Standard Components — Components on a Qualified Products List (QPL) are not necessarily qualified to the mission operational requirements of the Army. Standard component requirements should be related to the specific operational parameters that are expected to be experienced by the projected mission profile. Components that do not meet these requirements may fail prematurely when subjected to the Army helicopter operational environment.
4. Environmental Conditions — The requirements that are expressed in the military specification must be those that are imposed by the mission. Requirements that are expressed in quantitative values without reference to the expected service parameters are considered inadequate. Adverse environmental conditions such as high vibratory and extreme atmospheric conditions may cause insulation failures within electrical components and premature fatiguing or excessive wear. These factors must be adequately considered during the design of the components.



5. Interchangeability — The interchangeability requirements should consider the physical and functional parameters of the electrical system, equipment, and components to ensure all subsequent units are compatible and adequately interfaced with the electrical system and related systems. Components that are not completely interchangeable, both physically and functionally, may keep the helicopter and electrical system from achieving its operational availability requirements.
6. Design/Construction — The design and construction of the electrical system and its components, as governed by the military specification, must consider the projected operational parameters and environments to which the helicopter will be subjected. Additionally, the design requirements should not preclude the introduction of technological advancements impacting achievements of projected reliability growth.
7. Product Identification — Requirements for properly marking/identifying the components and/or equipments must be provided within the specification. These markings/identifications should include hazard or precautionary warnings, electrical ratings, interconnections, part numbers, and other pertinent data. Inadequately marked or identified components can contribute to personnel hazards and decreased availability due to increased maintenance times. The substitution of a different series of a similar type component may result in damage to the electrical system or decreased system reliability.
8. Workmanship — Workmanship requirements should be stated in clear and concise language that defines this requirement by reference to aircraft and electrical industry standards. The degradation of workmanship subsequent to reliability and maintainability demonstrations may result in the failure of the electrical system to maintain its operational availability.
9. Safety — Provisions should be included to impose systems safety programs as delineated in MIL-STD-882. Equipment designed without consideration for the safety of the operator and/or maintenance personnel or other components of the system or related systems could adversely affect the availability, or maintainability of the system. Poor safety features necessitate increased precaution during maintenance, resulting in increased maintenance man-hours expenditures.
10. Reliability — Reliability requirements stated quantitatively, as Mean-Time-Between-Failure (MTBF) values, are not considered to be adequate. An adequate reliability requirement is one that

is based on the projected mission requirements of the helicopter. Items designed to an MTBF value stated in a military specification may adversely affect the overall helicopter and/or system reliability requirement if the MTBF is not at least that required to meet the mission and/or system reliability.

11. Maintainability — Maintainability requirements must be stated with reference to the overall helicopter and/or system availability requirements. Consideration must also be given to the U.S. Army maintenance concepts, procedures, and practices. If these parameters are not considered, the item may not be compatible with the Army system and the helicopter availability and maintenance rates may be adversely affected.
12. Human Engineering — Human engineering requirements must consider the parameters delineated in MIL-STD-1472. Consideration should also be given to U.S. Army maintenance concepts, procedures, and practices. The absence of these considerations may have an adverse effect on the helicopter availability and maintenance man-hour expenditures.
13. Electromagnetic Interference — Provisions for eliminating or reducing electromagnetic interference must be included in all specifications for electrical and electronic equipments. False equipment failures induced by internally or externally generated electromagnetic energy will contribute to a lower system reliability.

#### Test Requirements, Procedures and Practices

The specific testing requirement criteria and philosophy used to conduct this analysis are as follows:

1. Environmental Testing — Each component of the electrical system should be subjected to environmental tests which simulate the Army operational environment. The test procedures of MIL-STD-810 and MIL-STD-202 should be used as representatives of the Army operational environment unless other knowledge is available for specific application. The effects of the environmental conditions, i.e., vibration, sand, and moisture, etc., on the reliability of the end item would identify inherent design weaknesses prior to the production phase.
2. Qualification Test Plan — A qualification test plan should include various categories of tests, as dictated by the design complexity, to ensure that the component meets or exceeds the design requirements imposed by military and detailed design specifications. The plan should provide for system compatibility, functional and flight testing of the component as required

by the design. The following statements define the rationale for qualification test plans which would adequately qualify the electrical system/components.

- a. System compatibility tests are necessary to ensure that all electrical system components and interfaces with other systems are compatible with the system operational and reliability requirements.
  - b. Functional tests are required to display that the component will perform its intended functions as required by the mission operating requirements.
  - c. Engineering flight tests should be imposed upon electrical systems and major components such as generators and bus tie equipment to ensure that the electrical system design is adequate and that any quality deficiencies will be identified prior to operational introduction.
3. Test Witness — The procuring activity should provide for test witnessing in those cases where the nature of the test or the inherent design of critical components require strict control. Other categories of tests should be witnessed on a random sampling basis by procuring activity representatives at the suppliers' or receiving activity sites. These representatives may be government personnel or manufacturing personnel designated by the procuring activity to perform the sampling. The witnessing of tests provides the Army with a high degree of assurance that the quality of the product is maintained such that the operational reliability is not degraded.
4. Rejection and Retest — Those components failing the initial qualification tests or subsequent sampling tests should be retested unless the failure can be isolated and categorized as a random failure. When a random failure occurs or a problem is encountered in the test procedures, the test should recommence from the point of the failure and a mathematical analysis should be initiated to compute the results of the tests. If the failure is of the category that would necessitate a major redesign of the component prior to qualification, or require a significant increase in sampling frequency, complete information should be furnished to the procuring agency representative prior to continuing the test or submitting the redesigned item to retest. This latter procedure should be strictly imposed upon those components whose failure may be deemed catastrophic to the electrical system operation.

5. Reliability Demonstration — A reliability demonstration is required to ensure that the operational reliability requirements imposed by the detailed specifications are met or exceeded in the projected operating environment. This demonstration should include a formal plan in accordance with the provisions of MIL-STD-785. This demonstration will provide the Army with the necessary degree of assurance that the operational reliability is attained. The degree that this requirement should be imposed is governed by the complexity, criticality, and reliability requirements of the component. In most cases the electrical system components reliability demonstration would be conducted at the systems level, with each component being individually analyzed.
  
6. Maintainability Demonstration — A maintainability demonstration (service) test is required to ensure that the operational availability and maintenance man-hour per flight hour requirements imposed by the detailed specification are met or exceeded in the projected operating environment. This demonstration should include a formal plan in accordance with the provisions of MIL-STD-473. This demonstration will provide the Army with the necessary degree of assurance that the operational quantitative values are attained. The degree that this requirement should be imposed is governed by the complexity, criticality, maintenance concept, and maintainability requirements of the component. In most cases the electrical system components maintainability demonstration would be conducted at the systems level, with each component being individually analyzed.

#### Quality Assurance Requirements and Provisions

The quality assurance requirements and provisions that should be considered as a minimum for Army helicopter electrical systems are as follows:

1. Quality Assurance Provisions — Quality assurance is required to ensure that the component is subjected to quality assurance provisions and standards that meet or exceed the requirements imposed by the military and detailed design specifications. Quality assurance plans should be developed and implemented in accordance with MIL-Q-9858. The implementation of such quality assurance programs serves to maintain high standards in the production of components and a high degree of reliability.
  
2. Packing and Shipping — Packing and shipping requirements should be imposed to protect the component from damage during shipment and storage. Procedures should be provided such that a random sampling of the packing and unpacking techniques are closely monitored. These requirements and provisions should

consider fragility of the component being procured by the specification. These procedures, when properly implemented, shall substantially reduce damage to the components during transit and storage and protect the component from environmentally-induced damage.

3. Component Sampling — Component sampling provisions and procedures should be imposed as delineated by MIL-STD-105. Infrequent sampling may allow defective components to be passed inadvertently. This could ultimately result in a potential degradation of the electrical system reliability and end item availability.
4. Mandatory Inspection Points — Certain critical phases of the manufacture and assembly processes require in-process inspections by designated quality assurance personnel. Provisions and procedures should be imposed to ensure that these checks/tests/inspections be made at designated intervals as dictated by the complexity and criticality of the component. The implementation of these procedures serves to substantially reduce failures caused by manufacturing errors.

#### DOCUMENT ANALYSIS

The electrical system documents identified during the data collection task were analyzed using the criteria and philosophy identified in the preceding discussion. This required a detailed analysis of each area identified as impacting the reliability and maintainability and/or the procedures and practices used to inspect and test the item being procured. Each document was analyzed to determine if ambiguities existed within the document and between it and other controlling documents. The documents were categorized by generic component type with respect to the baseline electrical system block diagram tree as shown in Figure 20.

The document provisions were then identified as being adequate or inadequate. The inadequate and nonexistent provisions were then rated as having one of the following impacts on the electrical system reliability, availability, and maintainability:

1. Major Impact — Those deficiencies which could result in a substantial degradation of the helicopter and electrical system reliability, availability, and/or maintainability.
2. Significant — Those deficiencies that could result in some degradation of the helicopter and electrical system reliability, availability, and/or maintainability.
3. Insignificant — Those deficiencies that may result in little or no degradation of the electrical system reliability, availability, and/or maintainability.

The document analysis is presented in Appendix IV of this volume. The documents reviewed included all amendments, revisions and supplements that were available during this analysis. These documents are presented in generic groupings to facilitate understanding of the whole analysis process. A short description of each deficiency and its reliability, maintainability and availability impact category are presented in a tabular format.

The summary results of the document analysis are shown as Table IV. This analysis has revealed that five of the 124 documents evaluated can be considered adequate with respect to reliability and maintainability.

TABLE IV. DOCUMENT DEFICIENCY MATRIX	
Parameter	% Deficient*
<u>Design Requirements:</u>	
● Design and Construction . . . . .	1.85
● Standard Components . . . . .	2.78
● Environmental Conditions . . . . .	34.26
● Interchangeability . . . . .	41.67
● Product Identification . . . . .	11.11
● Workmanship . . . . .	12.96
● Safety . . . . .	94.44
● Reliability Program . . . . .	90.74
● Maintainability Program . . . . .	89.81
● Human Engineering . . . . .	94.44
● Electromagnetic Interference . . . . .	37.04
●	
<u>Testing:</u>	
● Environmental Testing . . . . .	37.04
● Rejection and Retest . . . . .	68.52
● Test Witness . . . . .	5.56
● Reliability and Maintainability Demonstration . . . . .	94.44
<u>Quality Assurance Requirements:</u>	
● Quality Assurance Program . . . . .	87.04
● Responsibility for Inspection . . . . .	66.67
● Component Sampling . . . . .	3.70
*Deficiency percentage is based on the 108 electrical system related documents excluding testing, hardware, deleted and required new documents.	

## ALTERNATIVE SELECTION ANALYSIS

The objective of the alternative selection analysis was to determine the feasible alternative for each document found deficient during the document deficiency analysis. These alternatives are intended to reduce or eliminate the potential adverse impact on reliability and maintainability attributed to deficient documents.

### EVALUATION METHODOLOGY

The criteria used to evaluate and select the alternative to the deficient documents were established by analyzing the status of the documents, the specific deficiencies, the potential impact of the deficiencies on reliability and maintainability, and the availability of substitute documents. When two or more documents for the same component existed, either at the system, equipment or component levels, or any combination thereof, and an ambiguity in reliability and maintainability requirements was found to exist, a determination was then made as to which requirements should be imposed.

The degree of deficiency for each document was determined from the document deficiencies analyses shown in Appendix IV to this report. This degree of deficiency is then correlated into the document action required to remove the inherent reliability and maintainability document deficiency. Five alternatives were then considered when reviewing each document related to helicopter electrical systems:

No Action (None) – Document is adequate without revision.

Minor Revision – Document has some deficiencies that have a significant adverse impact on reliability and maintainability.

Major Revision – Document has numerous deficiencies that have a significant adverse impact on reliability and maintainability and can be remedied by an extensive rewrite of the document.

Delete – Document has numerous deficiencies that have a significant adverse impact on reliability and maintainability and a substitute document is available. Documents falling into this category were not analyzed further.

Issue New Document – For those areas where no document is presently available for the generic classification, a document should be issued.

Also, where one or more documents are available, the document that best suits the reliability and maintainability requirements of the Army was identified.

## ALTERNATIVE EVALUATION AND SELECTION

The alternative evaluation and selection of identified electrical system specifications were accomplished using the criteria established in the preceding "Evaluation Methodology" discussion. Using the generic classification groups previously established in this investigation, each generic class of document was evaluated to determine the action required by the Army to assure that the document adequately imposes helicopter reliability and maintainability related requirements.

The alternative evaluation selection and supporting rationale for electrical system documents for each generic classification of electrical subsystems are shown in columnar format in Figures 22 through 29. Figure 22 is the analysis of the system level documents, Figures 23 through 27 display equipment level documents for the five electrical subsystems. Figure 28 displays selected load equipment documents relating to aircraft trim control. Figure 29 displays electrical component parts, and are listed generically by alphabet. The columnar headings used in the alternative evaluation and selection analysis are as follows:

**Generic Classification** – Generic classification of item controlled by document.

**Document Number** – Military specification or standard number assigned to the document.

**Document Action** – Action required for the document being analyzed.

No Action (None)  
Minor Revision  
Major Revision  
Delete  
Issue New Document

**Preferred Document** – The document has been found to contain the least reliability and maintainability related deficiencies and can be improved by use of the Supplemental Design Guide, Volume II of this report.

- Signifies the preferred approach found during the analysis
- Signifies that an alternative to the approach was found during the analysis
- ▲ Signifies that this document should be deleted
- Signifies that a new document is required

**Rationale** – The supporting rationale for the selection action for each document.



The summary of the document selection analysis is shown as Figure 30. This analysis has shown that three-fourths of all the document and generic classifications considered require major revision to the documents. The recommendations for new documents are shown in the recommendation section of this volume. Recommendations to improve existing documents are shown as Volume II, "Electrical System Supplemental Design Guide." These recommendations, if promulgated, will eliminate the inherent reliability and maintainability document deficiencies.

GENERIC CLASSIFICATION	DOCUMENT NUMBER	DOCUMENT ACTION	PREFERRED DOCUMENT	RATIONALE
Electrical System	MIL-STD-704A	None	•	This document delineates characteristics of electric power supplied to airborne equipment at the terminals.
	MIL-B-5087B	Minor	•	This document is applicable to protection against stray electrical phenomena in aerospace electrical systems. Promulgation of the supplemental design recommendations provided in Volume II of this report will remove the reliability and maintainability deficiencies that are inherent in the document.
	MIL-W-5088E	Minor	•	This document is applicable to selection and installation of aircraft wire. Promulgation of the supplemental design recommendations provided in Volume II of this report will remove the reliability and maintainability deficiencies that are inherent in the document.
	MIL-E-6051D	None	•	This document is applicable to electro-magnetic compatibility, and does not contain any deficiencies which impact on reliability or maintainability.

Figure 22. Electrical System Document Alternative Selection.

GENERIC CLASSIFICATION	DOCUMENT NUMBER	DOCUMENT ACTION	PREFERRED DOCUMENT	RATIONALE
	MIL-E-7016D	None	•	This document is applicable to aircraft electric load and power source analysis, and does not contain deficiencies which impact on reliability or maintainability.
	MIL-E-7080B	Major	•	This document is applicable to selection and installation of electrical equipment in aircraft. Promulgation of the supplemental design recommendations provided in Volume II of this report will remove the reliability and maintainability deficiencies that are inherent in the document.
	MIL-E-25499C	Major	•	This document is applicable to design and installation of electrical systems for military aircraft. Promulgation of the supplemental design recommendations provided in Volume II of this report will remove the reliability and maintainability deficiencies that are inherent in the document.

Figure 22 - Continued.

GENERIC CLASSIFICATION	DOCUMENT NUMBER	DOCUMENT ACTION	PREFERRED DOCUMENT	RATIONALE
Testing/ Demonstration Requirements (Shown on tree in Volume II, but are not a part of final report SDG document improvement recommendations.)	MIL-T- 8679	Minor	•	This document is applicable to ground testing of helicopter systems and could be made applicable to U.S. Army helicopter requirements through minor changes to test requirements.
	MIL-T- 21200K	Major	•	This document is applicable to design and construction of equipment used in testing of aircraft electrical and electronic equipment at various maintenance levels.
	MIL-D- 2322A (AS)	Major	•	This Navy document is applicable to the demonstration of fixed- and rotary-wing aircraft systems including electrical. This document could be made applicable to U.S. Army helicopter requirements only through extensive changes to test requirements.

Figure 22 - Continued.

GENERIC CLASSIFICATION	DOCUMENT NUMBER	DOCUMENT ACTION	PREFERRED DOCUMENT	RATIONALE
	MIL-D-25381A (USAF)	Major	●	This Air Force document is applicable to flight testing of aircraft electrical systems. This document could be made applicable to U. S. Army helicopter requirements only through extensive changes to test requirements.
	MIL-E-25500B (USAF)	Major	●	This Air Force document is applicable to mockup testing of aircraft electrical systems. This document could be made applicable to U. S. Army helicopter requirements only through extensive changes to test requirements.
	MIL-E-5422 (ASG)	Delete	▲	This document is applicable to environmental testing of aircraft electronic equipment and is inactive for new design. Use MIL-STD-810 or MIL-STD-202.
	MIL-E-5272C (ASG)	Delete	▲	This document is applicable to environmental testing of all aircraft equipment and is inactive for new design. Use MIL-STD-810.
	MIL-STD-202D	None	●	This document is applicable to environmental and physical characteristics tests for electrical and electronic items - especially smaller parts.

Figure 22 - Continued.

GENERIC CLASSIFICATION	DOCUMENT NUMBER	DOCUMENT ACTION	PREFERRED DOCUMENT	RATIONALE
Generator, Brush	MIL-G-6099A	Major	o	This document is applicable to air-cooled ac generators for aircraft. Promulgation of the supplemental design recommendations provided in Volume II of this report will remove the reliability and maintainability deficiencies that are inherent in the document.
	MIL-G-6340A	Major	o	This document is applicable to a specific type of generator governed by MIL-G-6099A. Promulgation of the supplemental design recommendations provided in Volume II of this report will remove the reliability and maintainability deficiencies that are inherent in the document.
	MIL-G-21075	Major	o	This Navy document is applicable to single generator, constant frequency, alternating current generators with regulators for aircraft. Promulgation of the supplemental design recommendations provided in Volume II of this report will remove the reliability and maintainability deficiencies that are inherent in the document.

Figure 23. Alternating Current Circuit Document Alternative Selection.

GENERIC CLASSIFICATION	DOCUMENT NUMBER	DOCUMENT ACTION	PREFERRED DOCUMENT	RATIONALE
	MIL-G-25704A	Major	o	This Air Force document is applicable to constant frequency ac generator systems for aircraft. Promulgation of the supplemental design recommendations provided in Volume II of this report will remove the reliability and maintainability deficiencies that are inherent in the document.
Generator, Brushless	MIL-G-21480A (AS)	Minor	•	This Navy document is applicable to aircraft ac generators, including generator controls. Promulgation of the supplemental design recommendations provided in Volume II of this report will remove the reliability and maintainability deficiencies that are inherent in the document.
	MIL-E-23001A (AS)	Minor	o	This Navy document is applicable to variable-speed, constant-frequency (VSCF) generator systems for aircraft. Promulgation of the supplemental design recommendations provided in Volume II of this report will remove the reliability and maintainability deficiencies that are inherent in the document.

Figure 23 - Continued.

GENERIC CLASSIFICATION	DOCUMENT NUMBER	DOCUMENT ACTION	PREFERRED DOCUMENT	RATIONALE
Motor - Generator	None	Issue New Document	■	No specific document for motor generators to be installed in aircraft were found to exist.
Inverter, Primary	MIL-I-7032F	Minor	●	This document is applicable to rotary aircraft inverters to provide ac current at 400 Hertz. Promulgation of the supplemental design recommendations provided in Volume II of this report will remove the reliability and maintainability deficiencies that are inherent in the document.
	MIL-I-27273A	Minor	○	This document is applicable to static aircraft inverters to provide ac current at 400 Hertz. Promulgation of the supplemental design recommendations provided in Volume II of this report will remove the reliability and maintainability deficiencies that are inherent in the document.

Figure 23 - Continued.



GENERIC CLASSIFICATION	DOCUMENT NUMBER	DOCUMENT ACTION	PREFERRED DOCUMENT	RATIONALE
Inverter Control	MIL-C-6521 (USAF)	Major	●	This document is applicable to automatic changeover controls for inverters used in aircraft. Promulgation of the supplemental design recommendations provided in Volume II of this report will remove the reliability and maintainability deficiencies that are inherent in the document.
Regulator, Supervisory and Regulatory	MIL-R-6339 (USAF)	Major	○	This document is applicable to voltage regulators for ac generators specified by MIL-G-6099A. Promulgation of the supplemental design recommendations provided in Volume II of this report will remove the reliability and maintainability deficiencies that are inherent in the document.
Relay, Monitoring Bus Contactor	MIL-R-6466B	Major	●	This document is applicable to Type A-1 exciter protection relays for aircraft. Promulgation of the supplemental design recommendations provided in Volume II of this report will remove the reliability and maintainability deficiencies that are inherent in the document.

Figure 23 - Continued.

GENERIC CLASSIFICATION	DOCUMENT NUMBER	DOCUMENT ACTION	PREFERRED DOCUMENT	RATIONALE
	MIL-R - 7611 (USAF)	Major	o	This document is applicable to Type MA-1 400-Hertz armature relays for aircraft. Promulgation of the supplemental design recommendations provided in Volume II of this report will remove the reliability and maintainability deficiencies that are inherent in the document.
	MIL-R - 7649A	Major	o	This document is applicable to intermittent-duty, coil-latch type relays for use with alternators. Promulgation of the supplemental design recommendations provided in Volume II of this report will remove the reliability and maintainability deficiencies that are inherent in the document.
	MIL-R - 8373A (ASG)	Major	o	This document is applicable to Type D-1 400-Hertz relays for aircraft. Promulgation of the supplemental design recommendations provided in Volume II of this report will remove the reliability and maintainability deficiencies that are inherent in the document.

Figure 23 - Continued.

GENERIC CLASSIFICATION	DOCUMENT NUMBER	DOCUMENT ACTION	PREFERRED DOCUMENT	RATIONALE
	MIL-P-81653	Minor	●	This document is applicable to solid-state power controllers for advanced aircraft electrical systems. Promulgation of the supplemental design recommendations provided in Volume II of this report will remove the reliability and maintainability deficiencies that are inherent in the document.
Relay, Phase Sequence Network	None	Issue New Document	■	No specific document was found to exist for this type of relay.
Transformer, Auto	MIL-T-9219 (USAF)	Major	●	This document is applicable to 400-Hertz auto and stepdown power transformers for aircraft. Promulgation of the supplemental design recommendations provided in Volume II of this report will remove the reliability and maintainability deficiencies that are inherent in the document.

Figure 23 - Continued.

GENERIC CLASSIFICATION	DOCUMENT NUMBER	DOCUMENT ACTION	PREFERRED DOCUMENT	RATIONALE
Transformer, Current	MIL-T- 5383 (USAF)	Major	●	This document is applicable to Type B-1 current transformers used in 400-Hertz aircraft systems. Promulgation of the supplemental design recommendations provided in Volume II of this report will remove the reliability and maintainability deficiencies that are inherent in the document.
	MIL-T- 7210 (USAF)	Major	●	This document is applicable to Type D-2 transformers for use in 400-Hertz aircraft systems. Promulgation of the supplemental design recommendations provided in Volume II of this report will remove the reliability and maintainability deficiencies that are inherent in the document.

Figure 23 - Continued.

GENERIC CLASSIFICATION	DOCUMENT NUMBER	DOCUMENT ACTION	PREFERRED DOCUMENT	RATIONALE
Battery	MIL-B-6146	Major	o	This document applies to 28-volt shielded storage batteries for aircraft. Promulgation of the supplemental design recommendations provided in Volume II of this report will remove the reliability and maintainability deficiencies that are inherent in the document.
	MIL-B-6428A (USAF)	Major	o	This Air Force document applies to integrally shielded, lead-acid storage batteries for general use in aircraft. Promulgation of the supplemental design recommendations provided in Volume II of this report will remove the reliability and maintainability deficiencies that are inherent in the document.
	MIL-B-8565G (AS)	Minor	o	This Navy document applies to both acid and alkaline storage batteries, and also replacement cells in alkaline batteries for aircraft. Promulgation of the supplemental design recommendations provided in Volume II of this report will remove the reliability and maintainability deficiencies that are inherent in the document.

Figure 24. Battery Circuit Document Alternative Selection.

GENERIC CLASSIFICATION	DOCUMENT NUMBER	DOCUMENT ACTION	PREFERRED DOCUMENT	RATIONALE
	MIL-B-26220C (USAF)	Major	●	This Air Force document applies to nickel-cadmium storage batteries for aircraft. Promulgation of the supplemental design recommendations provided in Volume II of this report will remove the reliability and maintainability deficiencies that are inherent in the document.
Relay, Time Delay	None	Issue New Document	■	No specific document was found to exist for battery circuit time delay relays.

Figure 24 - Continued.

GENERIC CLASSIFICATION	DOCUMENT NUMBER	DOCUMENT ACTION	PREFERRED DOCUMENT	RATIONALE
Selector Switch Panel	None	Issue New Document	■	No specific document was found to exist for selector switch panels.
Generator Control Panel	None	Issue New Document	■	No specific document was found to exist for generator controls.
Protection Panel	MIL-P-26333A (USAF)	Delete	▲	This document is applicable to electrical system protection, but is inactive for new design.

Figure 25. Electrical Control Circuit Document Alternative Selection.

GENERIC CLASSIFICATION	DOCUMENT NUMBER	DOCUMENT ACTION	PREFERRED DOCUMENT	RATIONALE
Receptacle, External Power	MIL-C-7974A	Major	●	This document applies to cable assemblies which connect ground power to aircraft. Promulgation of the supplemental design recommendations provided in Volume II of this report will remove the reliability and maintainability deficiencies that are inherent in the document.
Monitor, Bus Contactor Relay	MIL-E-24021C	Major	●	This document applies to external power monitoring of both ac and dc supplied electrical power. Promulgation of the supplemental design recommendations provided in Volume II of this report will remove the reliability and maintainability deficiencies that are inherent in the document.
	MIL-P-81653 (AS)	Minor	●	This document applies to solid-state power controllers for advanced aircraft electrical systems. Promulgation of the supplemental design recommendations provided in Volume II of this report will remove the reliability and maintainability deficiencies that are inherent in the document.

Figure 26. External Power Circuit Document Alternative Selection.



GENERIC CLASSIFICATION	DOCUMENT NUMBER	DOCUMENT ACTION	PREFERRED DOCUMENT	RATIONALE
Generator, Starter	MIL-G-6162B	Minor	●	This document applies to dc generators and starter-generators for aircraft. Promulgation of the supplemental design recommendations provided in Volume II of this report will remove the reliability and maintainability deficiencies that are inherent in the document.
Generator, Brush	MIL-G-6162B	Minor	●	This document applies to dc generators and starter-generators for aircraft. Promulgation of the supplemental design recommendations provided in Volume II of this report will remove the reliability and maintainability deficiencies that are inherent in the document.
Converter, Transformer / Rectifier	MIL-C-7115D	Minor	●	This document applies to conversion of 400-Hertz ac to 28-volt dc for aircraft. Promulgation of the supplemental design recommendations provided in Volume II of this report will remove the reliability and maintainability deficiencies that are inherent in the document.

Figure 27. Direct Current Circuit Document Alternative Selection.

GENERIC CLASSIFICATION	DOCUMENT NUMBER	DOCUMENT ACTION	PREFERRED DOCUMENT	RATIONALE
	MIL-P-26517A (USAF)	Minor	o	This Air Force document applies to transformer-rectifier conversion of 400-Hertz current to 28-volt dc for aircraft. Promulgation of the supplemental design recommendations provided in Volume II of this report will remove the reliability and maintainability deficiencies that are inherent in the document.
Regulator, Voltage	MIL-R-6809	Major	o	This document applies to 30-volt regulators for aircraft dc generators. Promulgation of the supplemental design recommendations provided in Volume II of this report will remove the reliability and maintainability deficiencies that are inherent in the document.
	MIL-R-23761 (WEP)	Major	o	This document applies to 28-volt static voltage regulators for dc generators. Promulgation of the supplemental design recommendations provided in Volume II of this report will remove the reliability and maintainability deficiencies that are inherent in the document.

Figure 27 - Continued.

GENERIC CLASSIFICATION	DOCUMENT NUMBER	DOCUMENT ACTION	PREFERRED DOCUMENT	RATIONALE
Relay, Bus Control	MIL-R- 6463A	Major	•	This document is applicable to aircraft generation equalizer bus relays, Type A-1. Promulgation of the supplemental design recommendations provided in Volume II of this report will remove the reliability and maintainability deficiencies that are inherent in the document.
	MIL-P- 81653 (AS)	Minor	•	This document is applicable to solid-state power controllers for advanced aircraft electrical systems. Promulgation of the supplemental design recommendations provided in Volume II of this report will remove the reliability and maintainability deficiencies that are inherent in the document.
Relay, Overvoltage	MIL-C- 5026E	Minor	•	This document is applicable to aircraft engine generator direct current cutout relays. Promulgation of the supplemental design recommendations provided in Volume II of this report will remove the reliability and maintainability deficiencies that are inherent in the document.

Figure 27 - Continued.

GENERIC CLASSIFICATION	DOCUMENT NUMBER	DOCUMENT ACTION	PREFERRED DOCUMENT	RATIONALE
	MIL-P-81653 (AS)	Minor	•	This document is applicable to solid-state power controllers for advanced aircraft electrical systems. Promulgation of the supplemental design recommendations provided in Volume II of this report will remove the reliability and maintainability deficiencies that are inherent in the document.
Relay, Reverse Current	MIL-R-9162 (USAF)	Major	•	This document is applicable to dc generator reverse current relays. Promulgation of the supplemental design recommendations provided in Volume II of this report will remove the reliability and maintainability deficiencies that are inherent in the document.

Figure 27 - Continued.

GENERIC CLASSIFICATION	DOCUMENT NUMBER	DOCUMENT ACTION	PREFERRED DOCUMENT	RATIONALE
Actuator, Trim	MIL-A-8064B (USAF)	Minor	•	This document is applicable to electro-mechanical actuators used to move controls, landing gear, etc. Promulgation of the supplemental design recommendations provided in Volume II of this report will remove the reliability and maintainability deficiencies that are inherent in the document.
Motor, Alternating Current	MIL-A-23622 (WEP)	Minor	•	This document is applicable to electro-mechanical actuators used to move controls, landing gear, etc. Promulgation of the supplemental design recommendations provided in Volume II of this report will remove the reliability and maintainability deficiencies that are inherent in the document.
Motor, Alternating Current	MIL-M-7969C	Minor	•	This document is applicable to ac motors used in operating aircraft electrical load equipment; in particular, trim actuators. Promulgation of the supplemental design recommendations provided in Volume II of this report will remove the reliability and maintainability deficiencies that are inherent in the document.

Figure 23. Load Circuit Document Alternative Selection.

GENERIC CLASSIFICATION	DOCUMENT NUMBER	DOCUMENT ACTION	PREFERRED DOCUMENT	RATIONALE
Motor, Direct Current	MIL-M-8609B	Minor	•	<p>This document is applicable to dc motors used in operating aircraft electrical load equipment; in particular, trim actuators. Promulgation of the supplemental design recommendations provided in Volume II of this report will remove the reliability and maintainability deficiencies that are inherent in the document.</p>

Figure 28 - Continued.

GENERIC CLASSIFICATION	DOCUMENT NUMBER	DOCUMENT ACTION	PREFERRED DOCUMENT	RATIONALE
Cable	MIL-C-5756B	Minor	●	This document applies to 600-volt jacketed single-conductor wire for use in aircraft. Promulgation of the supplemental design recommendations provided in Volume II of this report will remove the reliability and maintainability deficiencies that are inherent in the document.
	MIL-C-7078C	Major	○	This document applies to electric cable installations in aerospace vehicles. Promulgation of the supplemental design recommendations provided in Volume II of this report will remove the reliability and maintainability deficiencies that are inherent in the document.
	MIL-C-7974A	Major	●	This document applies to cable assemblies used to connect ground power to aircraft. Promulgation of the supplemental design recommendations provided in Volume II of this report will remove the reliability and maintainability deficiencies that are inherent in the document.

Figure 29. Electrical System Component Part Document Alternative Selection.

GENERIC CLASSIFICATION	DOCUMENT NUMBER	DOCUMENT ACTION	PREFERRED DOCUMENT	RATIONALE
	MIL-C-27072A (USAF)	Major	o	This document applies to nonportable multi-conductor cable. Promulgation of the supplemental design recommendations provided in Volume II of this report will remove the reliability and maintainability deficiencies that are inherent in the document.
	MIL-C-27500A (USAF)	Major	o	This document applies to shielded and unshielded electrical cable for U.S. Air Force aircraft and missiles. Promulgation of the supplemental design recommendations provided in Volume II of this report will remove the reliability and maintainability deficiencies that are inherent in the document.
	MIL-C-55543A	Major	•	This document applies to flat multiconductor flexible unshielded cable for various military applications including aircraft. Promulgation of the supplemental design recommendations provided in Volume II of this report will remove the reliability and maintainability deficiencies that are inherent in the document.
Capacitor	MIL-STD-198C	None	•	This document is applicable to the selection and use of capacitors and does not contain any deficiencies which impact on reliability or maintainability.

Figure 29 - Continued.



GENERIC CLASSIFICATION	DOCUMENT NUMBER	DOCUMENT ACTION	PREFERRED DOCUMENT	RATIONALE
Circuit Breaker	MIL-C-5809F	Minor	●	This document applies to trip-free circuit breakers for aircraft. Promulgation of the supplemental design recommendations provided in Volume II of this report will remove the reliability and maintainability deficiencies that are inherent in the document.
	MIL-C-7079A (USAF)	Major	○	This document applies to nontrip-free circuit breakers used in aircraft propeller controls. Promulgation of the supplemental design recommendations provided in Volume II of this report will remove the reliability and maintainability deficiencies that are inherent in the document.
	MIL-C-8379A (ASG)	Minor	●	This document applies to electrically operated 3-pole circuit breakers for aircraft. Promulgation of the supplemental design recommendations provided in Volume II of this report will remove the reliability and maintainability deficiencies that are inherent in the document.

Figure 29 - Continued.

GENERIC CLASSIFICATION	DOCUMENT NUMBER	DOCUMENT ACTION	PREFERRED DOCUMENT	RATIONALE
Compound	MIL-S-8516C	Major	•	This document applies to synthetic rubber compounds used to seal and reinforce electric connections. Promulgation of the supplemental design recommendations provided in Volume II of this report will remove the reliability and maintainability deficiencies that are inherent in the document.
	MIL-S-23586C	Minor	•	This document applies to silicone rubber compounds for use on electrical connections. Promulgation of the supplemental design recommendations provided in Volume II of this report will remove the reliability and maintainability deficiencies that are inherent in the document.
	MIL-M-24041 (SHIPS)	Major	•	This document applies to potting compounds to make electrical connections watertight. Promulgation of the supplemental design recommendations provided in Volume II of this report will remove the reliability and maintainability deficiencies that are inherent in the document.

Figure 29 - Continued.

GENERIC CLASSIFICATION	DOCUMENT NUMBER	DOCUMENT ACTION	PREFERRED DOCUMENT	RATIONALE
Conduit	MIL-C-6136A	Major	●	This document applies to shielded electrical conduit for aircraft. Promulgation of the supplemental design recommendations provided in Volume II of this report will remove the reliability and maintainability deficiencies that are inherent in the document.
Connector	MIL-P-18148C	Major	●	This document applies to 2- and 4-wire electric plugs for aircraft storage batteries. Promulgation of the supplemental design recommendations provided in Volume II of this report will remove the reliability and maintainability deficiencies that are inherent in the document.
	MIL-C-21097C	Major	○	This document applies to multicontact connectors for printed wiring boards. Promulgation of the supplemental design recommendations provided in Volume II of this report will remove the reliability and maintainability deficiencies that are inherent in the document.

Figure 29 - Continued.

GENERIC CLASSIFICATION	DOCUMENT NUMBER	DOCUMENT ACTION	PREFERRED DOCUMENT	RATIONALE
	MIL-C-24308A	Major	•	This document applies to polarized shell miniature rack and panel connectors for use in aircraft. Promulgation of the supplemental design recommendations provided in Volume II of this report will remove the reliability and maintainability deficiencies that are inherent in the document.
	MIL-C-26482E	Major	•	This document applies to circular, miniature, quick-disconnect connectors for aircraft. Promulgation of the supplemental design recommendations provided in Volume II of this report will remove the reliability and maintainability deficiencies that are inherent in the document.
	MIL-C-26518B (USAF)	Minor	•	This document applies to environment resisting miniature rack and panel connectors for use in aircraft. Promulgation of the supplemental design recommendations provided in Volume II of this report will remove the reliability and maintainability deficiencies that are inherent in the document.

Figure 29 - Continued.

GENERIC CLASSIFICATION	DOCUMENT NUMBER	DOCUMENT ACTION	PREFERRED DOCUMENT	RATIONALE
	MIL-C-38300A (USAF)	Major	●	<p>This document applies to circular, multi-contact, high environment, quantitative reliability connectors for use in aircraft. Promulgation of the supplemental design recommendations provided in Volume II of this report will remove the reliability and maintainability deficiencies that are inherent in the document.</p>
	MIL-C-38999C	Major	○	<p>This document applies to circular, miniature, high-density, quick-disconnect, environment-resistant, removable crimp contact connectors. Promulgation of the supplemental design recommendations provided in Volume II of this report will remove the reliability and maintainability deficiencies that are inherent in the document.</p>
	MIL-C-55544A	Major	●	<p>This document applies to connectors used with flat flexible cable and round wire for use in aircraft. Promulgation of the supplemental design recommendations provided in Volume II of this report will remove the reliability and maintainability deficiencies that are inherent in the document.</p>

Figure 29 - Continued.

GENERIC CLASSIFICATION	DOCUMENT NUMBER	DOCUMENT ACTION	PREFERRED DOCUMENT	RATIONALE
	MIL-C-83723A (USAF)	Major	•	<p>This document applies to circular, environment-resisting connectors for aircraft. Promulgation of the supplemental design recommendations provided in Volume II of this report will remove the reliability and maintainability deficiencies that are inherent in the document.</p>
	MIL-C-23216C (NAVY)	Major	•	<p>This document applies to crimp and solder-type electric contacts for use in electrical connectors. Promulgation of the supplemental design recommendations provided in Volume II of this report will remove the reliability and maintainability deficiencies that are inherent in the document.</p>
	MIL-C-26636A (USAF)	Major	•	<p>This document applies to crimp-style electrical contacts for use in electrical connectors meeting aircraft environmental and temperature environments. Promulgation of the supplemental design recommendations provided in Volume II of this report will remove the reliability and maintainability deficiencies that are inherent in the document.</p>

Figure 29 - Continued.

GENERIC CLASSIFICATION	DOCUMENT NUMBER	DOCUMENT ACTION	PREFERRED DOCUMENT	RATIONALE
	MIL-C-39029	Major	o	This document applies to removable and nonremovable contacts for use in electrical connectors. Promulgation of the supplemental design recommendations provided in Volume II of this report will remove the reliability and maintainability deficiencies that are inherent in the document.
Fuse	MIL-F-5372C (ASG)	Major	•	This document applies to current limiter type fuses for aircraft. Promulgation of the supplemental design recommendations provided in Volume II of this report will remove the reliability and maintainability deficiencies that are inherent in the document.
	MIL-F-5373C (ASG)	Major	•	This document applies to fuseholders used in aircraft electrical circuits. Promulgation of the supplemental design recommendations provided in Volume II of this report will remove the reliability and maintainability deficiencies that are inherent in the document.

Figure 29 - Continued.

GENERIC CLASSIFICATION	DOCUMENT NUMBER	DOCUMENT ACTION	PREFERRED DOCUMENT	RATIONALE
Insulation	MIL-I-10B	Major	o	This document applies to ceramic-type electrical-insulating compounds used in electrical elements. Promulgation of the supplemental design recommendations provided in Volume II of this report will remove the reliability and maintainability deficiencies that are inherent in the document.
	MIL-I-631D	Major	o	This document applies to nonrigid synthetic-resin compounds having a wide range of insulation characteristics. Promulgation of the supplemental design recommendations provided in Volume II of this report will remove the reliability and maintainability deficiencies that are inherent in the document.
	MIL-P-997D	Major	o	This document applies to plastic insulating material. Promulgation of the supplemental design recommendations provided in Volume II of this report will remove the reliability and maintainability deficiencies that are inherent in the document.

Figure 29 - Continued.



GENERIC CLASSIFICATION	DOCUMENT NUMBER	DOCUMENT ACTION	PREFERRED DOCUMENT	RATIONALE
	MIL-I-3190B	Major	o	This document applies to flexible insulation sleeving used in various electrical installations. Promulgation of the supplemental design recommendations provided in Volume II of this report will remove the reliability and maintainability deficiencies that are inherent in the document.
	MIL-I-7444C	Major	o	This document applies to flexible, vinyl, plastic tubing used for electrical insulation. Promulgation of the supplemental design recommendations provided in Volume II of this report will remove the reliability and maintainability deficiencies that are inherent in the document.
	MIL-I-16923E	Major	o	This document applies to insulating compounds which embed or encase electronic parts. Promulgation of the supplemental design recommendations provided in Volume II of this report will remove the reliability and maintainability deficiencies that are inherent in the document.

Figure 29 - Continued.

GENERIC CLASSIFICATION	DOCUMENT NUMBER	DOCUMENT ACTION	PREFERRED DOCUMENT	RATIONALE
	MIL-I-18057A	Major	o	This document applies to silicone rubber-treated glass-fiber flexible insulation. Promulgation of the supplemental design recommendations provided in Volume II of this report will remove the reliability and maintainability deficiencies that are inherent in the document.
	MIL-I-22076B	Major	o	This document applies to very low temperature nonrigid tubing. Promulgation of the supplemental design recommendations provided in Volume II of this report will remove the reliability and maintainability deficiencies that are inherent in the document.
	MIL-I-22129C	Major	o	This document applies to nonrigid resin tubing. Promulgation of the supplemental design recommendations provided in Volume II of this report will remove the reliability and maintainability deficiencies that are inherent in the document.
	MIL-I-23053B	Major	•	This document applies to heat shrinkable insulation tubing for use in aircraft. Promulgation of the supplemental design recommendations provided in Volume II of this report will remove the reliability and maintainability deficiencies that are inherent in the document.

Figure 29 - Continued.

GENERIC CLASSIFICATION	DOCUMENT NUMBER	DOCUMENT ACTION	PREFERRED DOCUMENT	RATIONALE
	MIL-I-81550A	Major	●	This document applies to the embedment or encasement of electrical components used in aircraft. Promulgation of the supplemental design recommendations provided in Volume II of this report will remove the reliability and maintainability deficiencies that are inherent in the document.
Meter	MIL-A-6752A (ASG)	Major	●	This document applies to dc voltmeters, ammeters and loadmeters used in aircraft. Promulgation of the supplemental design recommendations provided in Volume II of this report will remove the reliability and maintainability deficiencies that are inherent in the document.
	MIL-V-6753A (ASG)	Minor	●	This document applies to ac voltmeters used in aircraft. Promulgation of the supplemental design recommendations provided in Volume II of this report will remove the reliability and maintainability deficiencies that are inherent in the document.

Figure 29 - Continued.

GENERIC CLASSIFICATION	DOCUMENT NUMBER	DOCUMENT ACTION	PREFERRED DOCUMENT	RATIONALE
Relay	MIL-R-5757F	Major	●	This document applies to relays used to make and break circuits in equipment used in aircraft. Promulgation of the supplemental design recommendations provided in Volume II of this report will remove the reliability and maintainability deficiencies that are inherent in the document.
	MIL-R-6106F (ASG)	Minor	●	This document applies to control relays for electrically operated equipment and devices. Promulgation of the supplemental design recommendations provided in Volume II of this report will remove the reliability and maintainability deficiencies that are inherent in the document.
Resistor	MIL-STD-199A	None	●	This document contains selected resistor types for DOD use in design and manufacture of military equipment.

Figure 29 - Continued.

GENERIC CLASSIFICATION	DOCUMENT NUMBER	DOCUMENT ACTION	PREFERRED DOCUMENT	RATIONALE
	MIL-R-11F	Major	o	<p>This document applies to insulated fixed resistors, style "RC". Promulgation of the supplemental design recommendations provided in Volume II of this report will remove the reliability and maintainability deficiencies that are inherent in the document.</p>
	MIL-R-22B	Major	o	<p>This document applies to wire-wound variable resistors, style "RP". Promulgation of the supplemental design recommendations provided in Volume II of this report will remove the reliability and maintainability deficiencies that are inherent in the document.</p>
	MIL-R-26E	Major	o	<p>This document applies to fixed wire-wound resistors, style "RW". Promulgation of the supplemental design recommendations provided in Volume II of this report will remove the reliability and maintainability deficiencies that are inherent in the document.</p>

Figure 29 - Continued.

GENERIC CLASSIFICATION	DOCUMENT NUMBER	DOCUMENT ACTION	PREFERRED DOCUMENT	RATIONALE
Semiconductor	MIL-S-19500E	Major	●	This document applies to semiconductor devices used in military equipment. Promulgation of the supplemental design recommendations provided in Volume II of this report will remove the reliability and maintainability deficiencies that are inherent in the document.
Switch, Push (Snap Action)	MIL-S-8805C	Major	●	This document applies to sensitive and push (snap action) switches for use in aircraft. Promulgation of the supplemental design recommendations provided in Volume II of this report will remove the reliability and maintainability deficiencies that are inherent in the document.
	MIL-S-6743	Delete	▲	These three documents have been cancelled and replaced by MIL-S-8805C and MIL-S-3950E. Although they are referenced in CH-47, CH-54, AH-1, UH-1, and OH-6 maintenance manuals, they have been omitted as pertinent documents and should be deleted.
	MIL-S-6744	Delete	▲	
	MIL-S-6745	Delete	▲	

Figure 29 - Continued.

GENERIC CLASSIFICATION	DOCUMENT NUMBER	DOCUMENT ACTION	PREFERRED DOCUMENT	RATIONALE
Switch, Rotary	MIL-S- 6746B	Minor	•	This document applies to shielded rotary aircraft ignition switches. Promulgation of the supplemental design recommendations provided in Volume II of this report will remove the reliability and maintainability deficiencies that are inherent in the document.
	MIL-S- 6807D	Major	•	This document applies to rotary switches in circuits with loads up to 10 amperes. Promulgation of the supplemental design recommendations provided in Volume II of this report will remove the reliability and maintainability deficiencies that are inherent in the document.
Switch, Thermostatic	MIL-S- 24236B	Major	•	This document applies to thermostatic switches for overheat protection for use in aircraft. Promulgation of the supplemental design recommendations provided in Volume II of this report will remove the reliability and maintainability deficiencies that are inherent in the document.

Figure 29 - Continued.

GENERIC CLASSIFICATION	DOCUMENT NUMBER	DOCUMENT ACTION	PREFERRED DOCUMENT	RATIONALE
Switch, Toggle	MIL-S-3950E	Major	●	This document applies to sealed toggle switches used in aircraft. Promulgation of the supplemental design recommendations provided in Volume II of this report will remove the reliability and maintainability deficiencies that are inherent in the document.
	MIL-S-8834C	Major	●	This document applies to positive break toggle switches for either ac or dc use in aircraft. Promulgation of the supplemental design recommendations provided in Volume II of this report will remove the reliability and maintainability deficiencies that are inherent in the document.
	MIL-S-9419D	Major	●	This document applies to 4-position, momentary ON, center OFF, positive action toggle switches for aircraft. Promulgation of the supplemental design recommendations provided in Volume II of this report will remove the reliability and maintainability deficiencies that are inherent in the document.

Figure 29 - Continued.



GENERIC CLASSIFICATION	DOCUMENT NUMBER	DOCUMENT ACTION	PREFERRED DOCUMENT	RATIONALE
Terminal	MIL-T-7099D	Major	•	This document applies to crimp-style aluminum and splice terminals for aluminum aircraft wire. Promulgation of the supplemental design recommendations provided in Volume II of this report will remove the reliability and maintainability deficiencies that are inherent in the document.
	MIL-T-7928F	Major	•	This document applies to crimp-style copper terminal lugs and conductor splices for aircraft copper wire. Promulgation of the supplemental design recommendations provided in Volume II of this report will remove the reliability and maintainability deficiencies that are inherent in the document.
Wire	MIL-W-5086B	Major	•	This document applies to electric wire which is suitable for aerospace installation including aircraft use. Promulgation of the supplemental design recommendations provided in Volume II of this report will remove the reliability and maintainability deficiencies that are inherent in the document.

Figure 29 - Continued.

GENERIC CLASSIFICATION	DOCUMENT NUMBER	DOCUMENT ACTION	PREFERRED DOCUMENT	RATIONALE
	MIL-W - 5846D	Major	●	This document applies to chromel and alumel thermocouple wire for use in aircraft. Promulgation of the supplemental design recommendations provided in Volume II of this report will remove the reliability and maintainability deficiencies that are inherent in the document.
	MIL-W - 7072B	Major	●	This document covers 600-volt insulated single aluminum conductors for aircraft. Promulgation of the supplemental design recommendations provided in Volume II of this report will remove the reliability and maintainability deficiencies that are inherent in the document.
	MIL-W - 8777C (ASG)	Major	●	This document applies to single-conductor copper wire, silicone-insulated, for use in aircraft. Promulgation of the supplemental design recommendations provided in Volume II of this report will remove the reliability and maintainability deficiencies that are inherent in the document.

Figure 29 - Continued.

GENERIC CLASSIFICATION	DOCUMENT NUMBER	DOCUMENT ACTION	PREFERRED DOCUMENT	RATIONALE
	MIL-W-16878D (NAVY)	Major	●	This document applies to insulated, high temperature copper wire for shipboard use, and in aircraft. Promulgation of the supplemental design recommendations provided in Volume II of this report will remove the reliability and maintainability deficiencies that are inherent in the document.
	MIL-W-22759C	Major	●	This document applies to electric wire used in aerospace electrical systems. Promulgation of the supplemental design recommendations provided in Volume II of this report will remove the reliability and maintainability deficiencies that are inherent in the document.
	MIL-W-25038D	Major	●	This document applies to fire-resistant electrical wire to function in aircraft fire emergencies. Promulgation of the supplemental design recommendations provided in Volume II of this report will remove the reliability and maintainability deficiencies that are inherent in the document.

Figure 29 - Continued.

GENERIC CLASSIFICATION	DOCUMENT NUMBER	DOCUMENT ACTION	PREFERRED DOCUMENT	RATIONALE
	MIL-W-81044A (AS)	Major	•	<p>This document applies to aircraft wire where a particular performance is required. Promulgation of the supplemental design recommendations provided in Volume II of this report will remove the reliability and maintainability deficiencies that are inherent in the document.</p>
	MIL-W-81381 (AS)	Major	•	<p>This document applies to wire for aerospace electrical systems where a particular performance is desired. Promulgation of the supplemental design recommendations provided in Volume II of this report will remove the reliability and maintainability deficiencies that are inherent in the document.</p>

Figure 29 - Continued.

NOTE: PERCENTAGES ARE BASED ON THE 112 PERTINENT ELECTRICAL SYSTEM RELATED DOCUMENTS ANALYZED AND THE 5 REQUIREMENTS IDENTIFIED AS NEEDING NEW DOCUMENTS. SIXTEEN DOCUMENTS ARE SIMPLE HARDWARE DOCUMENTS AND WERE NOT INCLUDED IN THE ALTERNATIVE SELECTION ANALYSIS

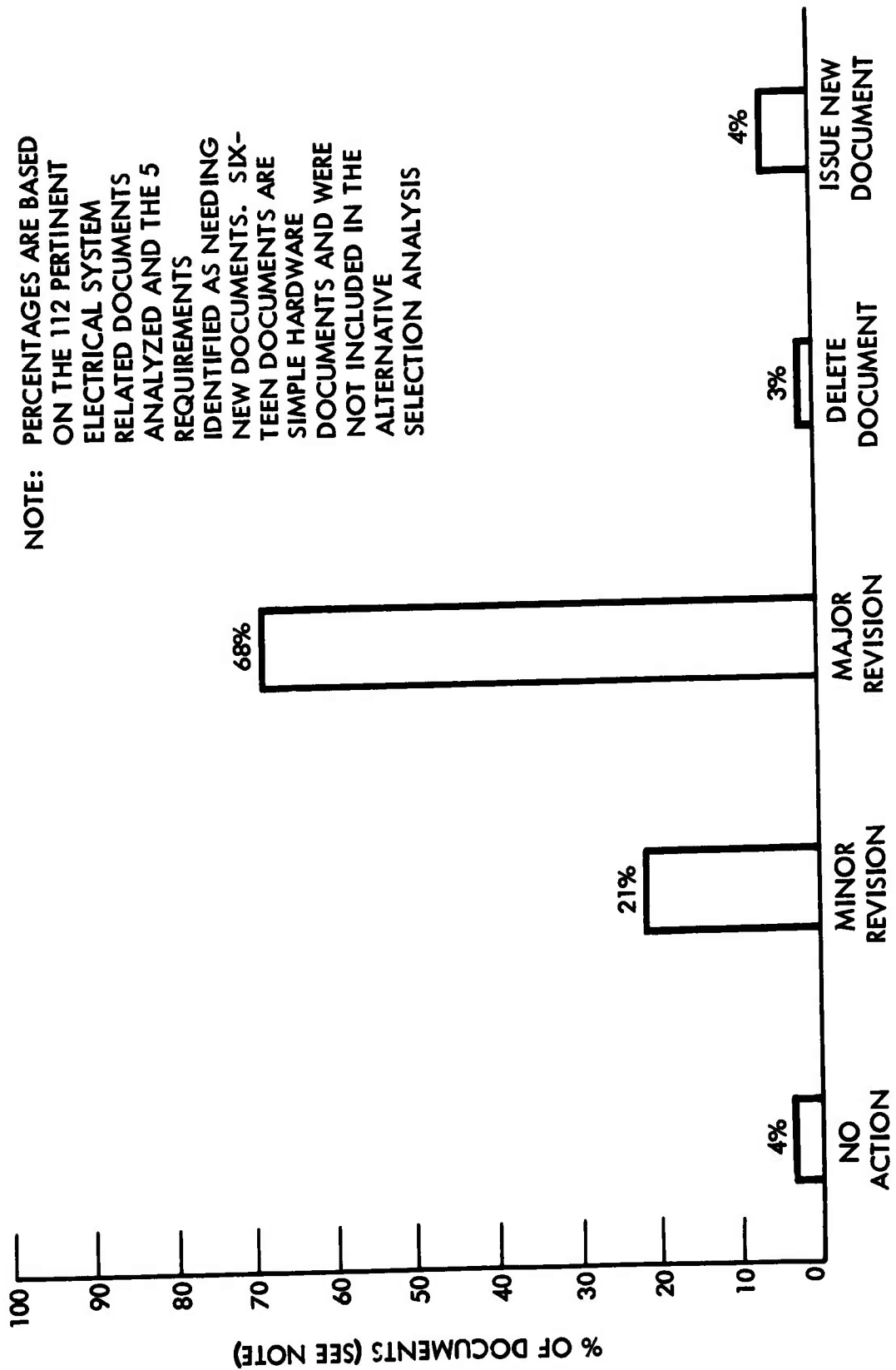

Figure 30. Document Alternative Selection Comparison.

## CONCLUSIONS

The most salient points discovered during this investigation are that existing helicopter electrical system and related documents were prepared without due consideration given to continuing technological advancements, reliability growth requirements, projected environmental usage, and the varied mission requirements as set forth by the procuring activity. Consequently, these documents were found to be inadequate to meet the U. S. Army mission related requirements for helicopters. The promulgation of the supplemental design information provided in Volume II of this report will provide for the implementation of mission requirements into the development, testing, and production of the electrical system, equipments and components. These conclusions are based on the following findings of this analysis:

1. Military specifications and standards governing the design of electrical system, hardware, and components do not consider the mission requirements of Army aircraft.
2. Numerous electrical system related documents identified as the governing military specifications for component parts for Army helicopters are not readily identifiable as having aircraft or aeronautical application.
3. In approximately 90 percent of electrical system related documents, such important design requirements as reliability, maintainability, and reliability and maintainability demonstration are not included in the document.
4. Those documents that do contain reliability and maintainability requirements do not contain provisions for considering the specific requirements of the Army aircraft mission requirements, i. e., a 2000-hour MTBF does not necessarily meet mission availability requirements.
5. MIL-E-25499C was initially identified as controlling the design of the electrical system for Army aircraft. However, due to the inherent generalities with respect to the design, testing, and quality assurance requirements, as they relate to reliability and maintainability, MIL-E-25499C is virtually nonusable as a governing document.
6. Almost without exception, the electrical system documents do not delineate environmental conditions and/or testing that consider the specific Army mission requirements. Some of the more prevalent exclusions are vibration, sand, and dust test requirements.

## RECOMMENDATIONS

The most important recommendation derived from this investigation is that military and detailed design specifications used to govern the development, qualification, and production of helicopter electrical systems/components, should provide design, testing, and quality assurance requirements and provisions that adequately reflect the Army helicopter mission requirements. Numerous recommendations to revise, update, or delete existing documents, and requirements for new documents related to the Army helicopter electrical systems, are summarized in this section. Detailed recommendations to remove the inherent reliability and maintainability related document deficiencies are presented in Volume II of this report.

The summary of specific recommendations that resulted from this investigation are as follows:

1. The supplemental design information presented in Volume II of this report should be promulgated to the greatest extent feasible including the:
  - a. Revision of the identified documents to include these reliability and maintainability related requirements.
  - b. Appendage of this information to all future detailed and electrical or component system specifications.
  - c. Preparation of new military specifications and standards to ensure that reliability and maintainability related requirements are adequately considered.
2. A specification should be generated and promulgated which delineates the test and demonstration requirements of Army aircraft. This document could be patterned after MIL-D-23222A (AS), which delineates the specific requirements of U. S. Navy helicopter demonstration tests.
3. Incorporate Army environmental and operational requirements into all applicable design, test, and quality assurance requirements for electrical system and related component part specifications.
4. New documents and revisions to existing documents that are intended to govern the design of aircraft or aeronautical electrical systems and related components should adequately identify aircraft or aeronautical applications in the "Scope" or "Intended Use" section of the document.

5. Detailed design and test requirements such as environmental conditions, reliability, maintainability, and reliability and maintainability demonstration should be imposed upon the contractor by the detailed or system specifications.
6. Military specifications should be developed for the five electrical system generic functions that are not governed by existing military documentation. These new documents, when developed, should be promulgated to the greatest extent feasible to ensure that all aircraft electrical system component designs meet or exceed the requirements of the Army. These proposed documents with their recommended scope are:
  - a. Motor-Generators – Govern the design of 115-VAC, 400-Hertz motor-generator type inverters to operate essential equipments for ground operations.
  - b. Generator Control Panels – Govern the general design requirements of helicopter electrical power generator selection including switches, monitoring devices, and caution indicators.
  - c. Selector Switch Panel – Govern the general design requirements of helicopter electrical power generation selection including switches, monitoring devices and caution indicators.
  - d. Phase Sequence Network Relays – Govern the general design requirements of phase sensing and sequence switching devices to ensure proper phasing of externally generated alternating current.
  - e. Time Delay Battery Relay – Govern the general design requirements of time delay relays to ensure that they remain activated for a specific interval.
7. The documents that have been declared inactive for new design by the U.S. Air Force and should be considered as candidates for cancellation are:
  - a. MIL-E-5272C, "Environmental Testing, Aeronautical and Associated Equipment, General Specification for"
  - b. MIL-E-5422E, "Testing, Environmental, Aircraft Electronic Equipment"
  - c. MIL-P-26333A (USAF), "Panel, Protection, Electrical System, AC Generator System, General Requirements for"



8. The following documents should be used as written. They have been found to be completely adequate with respect to reliability and maintainability related requirements.

- a. MIL-E-6051D, "Electromagnetic Compatibility", dated 5 July 1968
- b. MIL-E-7061D, "Electric Load and Power Source Capacity, Aircraft Analysis of", dated 15 April 1965
- c. MIL-STD-198C, "Capacitors, Selection and Use of", dated 29 September 1972
- d. MIL-STD-199A, "Resistors, Selection and Use of", dated 16 October 1972
- e. MIL-STD-704A, "Electrical Power, Aircraft, Characteristics and Utilization of", dated 5 May 1970

## GLOSSARY

Availability	A measure of the degree to which an item is in the operable and committable state at the start of the mission, when the mission is called for at an unknown (random) point in time.
Demonstrated	That which has been proven by the use of concrete evidence gathered under specified conditions.
Failure	The inability of an item to perform within previously specified limits.
Failure Rate	The number of failures of an item per unit measure of life (cycles, time, miles, events, etc., as applicable for the item).
Human Engineering	The area of human factors which applies scientific knowledge to the design of items to achieve effective man-machine integration and utilization.
Human Factors	A body of scientific facts about human characteristics. The term covers all biomedical and psychosocial considerations; it includes, but is not limited to, principles and applications in the areas of human engineering, personnel selection, training, life support, job performance aids, and human performance evaluation.
Inherent	Achievable under ideal conditions, generally derived by analysis, and potentially present in the design.
Maintainability	A characteristic of design and installation which is expressed as the probability that an item will be retained in or restored to a specified condition within a given period of time, when the maintenance is performed in accordance with prescribed procedures and resources.

Maintenance	All actions necessary for retaining an item in or restoring it to a specified condition.
Maintenance Man-Hours per Flight Hour	The number of maintenance hours expended per flight hour to keep the helicopter flying.
Mean-Time-Between-Failures (MTBF)	For a particular interval, the total functioning life of a population of an item divided by the total number of failures within the population during the measurement interval. The definition holds for time, cycles, miles, events, or other measures of life units.
Mean-Time-To-Repair (MTTR)	The total corrective maintenance time divided by the total number of corrective maintenance actions during a given period of time.
Quality Assurance	Quality control inspections subsequent to maintenance or manufacture at vendor or manufacturers' facilities.
Reliability	The probability that an item will perform its intended function for a specified interval under stated conditions.
Safety	The conservation of human life and its effectiveness, and the prevention of damage to items, consistent with mission requirements.

APPENDIX I  
DOCUMENTS ANALYZED

<u>DOCUMENT NUMBER</u>	<u>TITLE</u>
<u>MILITARY SPECIFICATIONS</u>	
MIL-I-10B	Insulating Compound, Electrical, Ceramic, Class L, 10 April 1967
MIL-R-11F	Resistors, Fixed, Composition (Insulated), 17 April 1967
MIL-C-17D	Cable, Radio Frequency, Coaxial, Dual Coaxial, Twin Conductor, and Twin Lead, 14 September 1964
MIL-R-22B	Resistors, Variable, Wire-Wound (Power Type), General Specification for, 10 September 1964
MIL-R-26E	Resistors, Fixed, Wire-Wound (Power Type), General Specification for, 11 July 1967
MIL-S-61B	Shunt, Instrument, External, 50 Millivolt (Lightweight Type), 21 October 1959
MIL-V-95B	Vibrators, Interrupter and Self-Rectifying, 29 December 1967
MIL-P-116E	Preservation, Methods of, 18 August 1967
MIL-T-152B	Treatment, Moisture-and Fungus-Resistant, of Communications, Electronic, and Associated Electrical Equipment, 6 June 1966
MIL-C-172C	Cases, Bases, Mounting, and Mounts, Vibration (For Use with Electronic Equipment in Aircraft), 20 October 1966
MIL-V-173C	Varnish, Moisture, and Fungus Resistant (For Treatment of Communications, Electronic and Associated Equipment), 5 November 1969
MIL-C-572G	Cords, Yarns and Monofilaments Organic Synthetic Fiber, 9 February 1972
MIL-W-583G	Wire, Magnet, Electrical, 6 March 1963

MIL-I-631D	Insulation, Electrical, Synthetic-Resin Composition, Non-Rigid, 20 June 1968
MIL-P-997D	Plastic Material, Laminated, Thermosetting, Electrical Insulation, Sheets, Glass, Cloth, Silicone Resin, 14 June 1968
MIL-D-1000	Drawings, Engineering and Associated Lists, 10 February 1969
MIL-R-2726A	Receptacles, Receptacle Plugs, Switch and Receptacles, and Outlets (Electrical), General Specification for, 14 August 1969
MIL-G-3036A	Grommets, Elastic, Hot-Oil and Coolant Resistant, 13 May 1965
MIL-M-3171C	Magnesium Alloy, Processes for Pretreatment and Prevention of Corrosion On, 11 July 1966
MIL-I-3190B	Insulation Sleeving, Electrical, Flexible, Treated, 2 March 1964
MIL-C-3432D	Cable and Wire, Electrical (Power and Control; Semi-Flexible, Flexible, and Extra Flexible, 300 and 600 Volts), 5 July 1966
MIL-C-3767B	Connectors, Plug and Receptacle, Electrical (Power, Bladed Type), General Specification for, 27 April 1970
MIL-S-3786C	Switch, Rotary (Circuit Selector, Low Current Capacity), General Specification for, 19 May 1971
MIL-W-3795B	Wire, Electrical (Tinsel), 12 November 1968
MIL-S-3950E	Switches, Toggle, Environmentally Sealed, General Specification for, 24 July 1972
MIL-E-4158D (USAF)	Electronic Equipment Ground, General Requirements for, 12 March 1969
MIL-S-5002C	Surface Treatments and Metallic Coatings for Metal Surfaces of Weapons Systems, 22 May 1968
MIL-C-5015D	Connectors, Electric, AN Type, General Specification for, 9 June 1970

MIL-C-005015F (Navy)	Connectors, Electric, AN Type, General Specification for, 18 October 1972, Interim Specification (Navy only)
MIL-C-5026E	Cutout Relay, Engine Generator, 18 January 1971
MIL-W-5086B	Wire, Electric, Hookup and Interconnecting, Polyvinyl Chloride-Insulated Copper or Copper Alloy Conductor, 16 December 1970
MIL-B-5087B	Bonding, Electrical, and Lightning Protection, for Aerospace Systems, 31 August 1970
MIL-W-5088E	Wiring, Aircraft, Selection and Installation of, 28 March 1972
MIL-T-5091	Transmission, Power, Constant Ratio, General Specification for, 1 December 1949
MIL-E-5272C	Environmental Testing, Aeronautical and Associated Equipment, General Specification for, 18 September 1970
MIL-T-5350	Transmitter, Synchro Operated, Aircraft, General Specification for, 18 June 1970
MIL-F-5372C	Fuse, Current Limiter, Aircraft, 20 April 1965
MIL-F-5373C	Fuseholders, Block Type, Aircraft, 24 January 1964
MIL-T-5383 (USAF)	Transformer, Current, Type D-1, 9 April 1954
MIL-T-5422E	Testing, Environmental, Aircraft Electronic Equipment, 15 November 1961
MIL-B-5423B	Boot, Dust and Water Seal (For Toggle and Push Button Switches and Rotary Actuated Switches), General Specification for, 3 February 1972
MIL-T-5438	Tester, Abrasion, Electric Cable, 19 December 1949
MIL-T-5583B	Transmitter, Position, 28-Volt DC, 24 September 1963

MIL-L-5667B	Lighting Equipment, Aircraft Instrument Panel, General Specification for Installation of, 4 February 1964
MIL-C-5756B	Cable and Wire, Power, Electric, Portable, 9 June 1972
MIL-R-5757F	Relay, Electrical (For Electronic and Communication Type Equipment), General Specification for, 28 January 1972
MIL-C-5809F	Circuit Breaker, Trip Free, Aircraft, General Specification for, 27 April 1972
MIL-W-5846B	Wire, Electrical, Chromel, and/or Alumel, Thermocouple, 26 May 1972
MIL-E-6051D	Electromagnetic Compatibility Requirements, Systems, 5 July 1968
MIL-P-6063A	Packaging of Batteries, Storage, Charged and Dry-Uncharged and Moist, General Specification for, 4 August 1964
MIL-G-6099A	Generators and Regulators, Aircooled A-C Aircraft, General Specification for, 15 April 1958
MIL-R-6106F	Relays, Electric, General Specifications for, 27 January 1970
MIL-C-6136A	Conduit, Electrical, Flexible, Shielded, Aluminum Alloy for Aircraft Installations, 10 December 1965
MIL-B-6146	Batteries, Storage, Shielded, General Specification for, 15 May 1950
MIL-G-6162B	Generators, 30 Volt, Direct Current, Aircraft Engine Driven, and Starter Generators, General Specification for, 15 February 1972
MIL-R-6339	Regulator, Voltage, Type L-4, 4 December 1969
MIL-G-6340	Generator, A-C, Type C-3, Aircraft, 12 July 1957
MIL-L-6363E	Lamp, Incandescent, Aviation Service, General Specification for, 27 May 1969

MIL-B-6428A	Batteries, Storage, Integrally Shielded, 28 October 1969
MIL-R-6463A	Relay, Generator Equalizer Bus, Type A-1, 31 December 1952
MIL-R-6466B	Relay Armature, Exciter Protection, Type A-1, 28 July 1965
MIL-L-6484C	Lights, Cockpit Utility, Aircraft, General Specification for, 15 July 1969
MIL-L-6503G	Lighting Equipment, Aircraft, General Specification for Installation of, 27 August 1970
MIL-C-6521 (USAF)	Control, Inverter Changeover, Type A-2, 8 September 1959
MIL-T-6616A	Transformer, Voltage Adjusting, Type C-1, 27 April 1953
MIL-L-6723B	Lights, Aircraft, General Specification for, 16 February 1962
MIL-L-6730	Lighting Equipment, Exterior, Installation of Aircraft (General Specification), 9 June 1950
MIL-S-6746B	Switch, Rotary, Shielded, Aircraft Ignition, 20 June 1963
MIL-R-6749	Rheostat, Aircraft Power (AN-R-14), 6 July 1950
MIL-A-6752A	Ammeters, Voltmeters, Loadmeters, Direct Current, 3 March 1958
MIL-V-6753A	Voltmeters, 0-150V, 330-1200 Cycle, Alternating Current, 24 November 1958
MIL-C-6783	Clamps, Battery Hold-Down, 23 June 1950
MIL-S-6807D	Switch, Rotary, Selector, Power, General Specification for, 25 September 1968
MIL-R-6809	Regulator, Voltage, 30V, D. C. Generator, General Specification for, 14 December 1965
MIL-C-6818C	Clamps, Instrument Mounting, Aircraft, 13 April 1962



MIL-S-6872B	Soldering Process, General Specification for, 14 June 1968
MIL-E-7016D	Electric Load and Power Source Capacity, Aircraft, Analysis of, 15 April 1965
MIL-I-7032F	Inverters, Aircraft, General Specification for, 14 October 1970
MIL-I-7071B	Indicator, Temperature, Thermocouple, Hermetically Sealed, General Specification for, 25 February 1972
MIL-W-7072B	Wire, Electric, 600V, Aluminum, Aircraft, General Specification for, 4 September 1962
MIL-C-7078C	Cable, Electric, Aerospace Vehicle, General Specification for, 9 August 1971
MIL-C-7079	Circuit Breakers, Non Trip-Free, General Specification for, 23 March 1967
MIL-E-7080B	Electric Equipment, Aircraft, Selection and Installation of, 29 April 1968
MIL-T-7099D	Terminals, Lug and Splice, Crimp Style Aluminum, for Aluminum Aircraft Wire, 23 August 1971
MIL-T-7101A	Transmission, Power, Constant Speed, General Specification (Aircraft 056), 20 November 1951
MIL-C-7115D	Converter, Aircraft, General Specification for, 10 March 1970
MIL-F-7179D	Finishes and Coatings, General Specification for Protection of Aerospace Weapons Systems, Structures, and Parts, 3 March 1969
MIL-T-7210	Transformer, Current, Type D-2, 5 May 1958
MIL-I-7444C	Insulation Sleeving, Electrical, Flexible, 22 September 1971
MIL-R-7611	Relay, Armature, Type MA-1, 5 April 1957

MIL-R-7649 Relay, Armature, Exciter-Control, 115/200 Volt, 3 Phase 4-Wire, 21 May 1953

MIL-G-7703C Guard, Switch, General Specification for, 9 February 1972

MIL-C-7762A Compasses, Installation of, 18 January 1967

MIL-P-7788D Panels, Information, Integrally Illuminated, 14 April 1967

MIL-R-7790 Resistor, Thermocouple Lead Spool, 27 December 1957

MIL-M-7793D Meters, Time Totalizing, 31 December 1969

MIL-F-7872C Fire and Overheat Warning Systems, Continuous, Aircraft, Test and Installation of, 18 November 1966

MIL-T-7928F Terminals, Lug and Splice, Conductor, Crimp Style, Copper, General Specification for, 19 July 1971

MIL-F-7929C Flashers, Lights, Aircraft, 10 April 1964

MIL-P-7968A Position Indicating Assemblies, Electrical, Wheels and Flaps, 23 March 1965

MIL-M-7969 Motor, Alternating Current, 400-Cycle, 115/200-Volt System, Aircraft, General Specification for, 25 May 1965

MIL-C-7974A Cable Assemblies, Plugs and Receptacles, External Power, 15 June 1961

MIL-C-7989B Covers, Light-transmitting, for Aeronautical Lights, General Specification for, 8 March 1971

MIL-A-8064B (USAF) Actuator and Actuating Systems, Aircraft, Electromechanical, General Requirements for, 22 January 1970

MIL-F-8180B Floodlight, Electric, Incandescent 28-Volts, 20 Watts, Type MB-1, 30 January 1967

MIL-R-8373A Relay, Current, Type D-1 (115-Volts, 400-Cycle, Single-Pole), 8 October 1963

MIL-C-8379A	Circuit Breaker, Electrically Operated, 3-Pole, Type A-1, 26 December 1957
MIL-I-8500B	Interchangeability and Replaceability of Component Parts for Aircraft and Missiles, 10 October 1960
MIL-H-8501A	Helicopter Flying and Ground Handling Qualities, General Requirements for, 3 April 1962
MIL-S-8516C	Sealing Compound, Synthetic Rubber, Electric Connectors, 21 June 1968
MIL-B-8565G	Batteries and Cells, Storage, Aircraft, 9 July 1971
MIL-C-8603	Clamp, Tube Support, Loop Type, 6 December 1968
MIL-M-8609B	Motors, D. C. , 28V System, Aircraft, General Specification for, 26 July 1965
MIL-V-8610A	Valve, Fuel Shut-off, Solenoid Operated, 11 December 1968
MIL-A-8625C	Anodic Coatings, for Aluminum and Aluminum Alloys, 13 March 1969
MIL-I-8700A	Installation and Test of Electronic Equipment in Aircraft, General Specification for, 1 May 1970
MIL-D-8706B	Data and Test of Electronic Equipment in Aircraft, General Specification for, 15 August 1968
MIL-W-8777C	Wire, Electrical, Silicone-Insulated, Copper, 600-Volt, 200°C, 11 April 1968
MIL-F-8785B	Flying Qualities of Piloted Airplanes, 7 August 1969
MIL-8805C	Switches and Switch Assemblies, Sensitive and Push (Snap Action), General Specification for, 22 May 1972
MIL-S-8834C	Switches, Toggle, Positive Break, Aircraft, General Specification for, 15 August 1969

MIL-S-8932	Switches, Pressure, Aircraft, General Specification for, 28 January 1965
MIL-C-8956A	Clamp, Loop, Tube Support, 22 May 1972
MIL-D-9129B	Discharger, Aircraft, Electrostatic, General Specification for, 8 November 1967
MIL-R-9162	Relay, Generator, Reverse Current, 120-Volt DC, 250 Amperes, Type Q-1, 29 September 1953
MIL-T-9212	Transformer, Power, Autotransformers, and Step Down, 400-Cycle, 4 June 1965
MIL-I-9343B	Indicator, Temperature, Thermocouple, Engine Exhaust, Type MJ-1, 15 October 1970
MIL-G-9398C	Generator Tachometer, Two-Pole, High Temperature, Aircraft, 30 June 1966
MIL-S-9419D	Switch, Toggle, Momentary, Four-Position ON, Center OFF, 10 August 1962
MIL-Q-9858A	Quality Program Requirements, 16 December 1963
MIL-M-10304D	Meters, Electrical Indicating Panel Type, Ruggedized, General Specification for, 27 April 1971
MIL-C-10544C	Connectors, Plug and Receptacle (Electrical, Audio, Waterproof, Ten Contact, Polarized), 31 August 1964
MIL-T-10727A	Tin-Plating, Electrodeposited or Hot-dipped, for Ferrous and Non-Ferrous Metals, 20 May 1959
MIL-P-11268G	Parts, Materials, Processes Used in Electronic Equipment, 1 April 1971
MIL-C-11796B	Corrossion Preventative, Petrolatum, Hot Application, 17 November 1971
MIL-C-12000F	Cable, Cord, and Wire, Electric; Packaging of, 10 September 1971
MIL-C-12520C	Connectors, Plug and Receptacle (Electrical, Waterproof), and Accessories, General Specification for, 5 November 1965

MIL-S-12883B	Sockets and Accessories for Plug-in Electronic Components, General Specification for, 22 March 1969
MIL-M-13231A	Marking of Electronic Items, 9 May 1960
MIL-C-13777F	Cable, Special Purpose, Electrical, General Specification for, 15 September 1969
MIL-C-13909B	Conduit, Metal, Flexible, Electrical, Shielded, 3 January 1963
MIL-F-14256D	Flux, Soldering, Liquid (Rosin Base), 20 December 1963
MIL-P-15024	Plates, Tags, and Bands for Identification of Equipment, 10 May 1971
MIL-F-15160E	Fuses, Instrument, Power and Telephone, 30 January 1971
MIL-S-15291C	Switch, Rotary, Snap Action, 15 January 1969
MIL-T-15659G	Terminal, Lug, Solder and Phosphor Bronze, 30 June 1967
MIL-F-15743A	Switch, Rotary, Enclosed, 3 September 1959
MIL-M-16034A	Meter, Electrical, Indicating (Switchboard and Portable Types), 19 June 1967
MIL-M-16125C	Meter, Electrical, Frequency, 2 November 1964
MIL-E-16298	Electric Machines Having Rotating Parts and Associated Repair Parts, Packaging of, 28 February 1964
MIL-E-16366D	Electrical Clamp, Lug, and Conductor Splices - Pressure Grip, 23 April 1964
MIL-W-16878D (Navy)	Wire, Electrical, Insulated, High Temperature, 15 June 1967
MIL-I-16923E	Insulating Compound, Electrical, Embedding, 19 July 1963
MIL-M-17275B	Meter, Electrical, Indicating, Direct Current, 14 April 1969

MIL-E-17555G	Electronic and Electrical Equipment, Accessories, and Repair Parts, Packaging and Packing of, 15 April 1970
MIL-M-18012B	Markings for Aircrew Station Displays and Configuration of, 20 July 1964
MIL-I-18057A	Insulation Sleeving, Electrical, Flexible, Glass Fiber, Silicone Rubber Treated, 21 May 1965
MIL-I-18079B	Installation of Angle of Attack and Sideslip Systems, 31 March 1969
MIL-C-18148C	Connector, Plug, Electrical, Quick-disconnect, Battery, 21 April 1972
MIL-L-18276C	Lighting, Aircraft Interior, Installation of, 25 April 1969
MIL-N-18307D (Navy)	Nomenclature for Electronic, Aeronautical, and Aeronautical Support Equipment, Including Ground Support Equipment, 15 September 1969
MIL-F-18327C	Filter, High Pass, Low Pass, Band Pass, Band Suppression, and Dual Functioning, General Specification for, 25 May 1966
MIL-A-19401	Actuator, Electromechanical, Rotary, For AS-473/ASB-1, 21 March 1956
MIL-S-19500E	Semiconductor Devices, General Specification for, 8 September 1952
MIL-A-19531	Aircraft, Maintenance and Engineering Inspection, 24 December 1958
MIL-G-20699A	Grommets, Rubber, Split, General Purpose, 21 August 1967
MIL-S-20708C	Synchros, General Specification for, 27 August 1969
MIL-G-21075	Generator System, Single Generator, Constant Frequency, Alternating Current, Aircraft, General Specification for, 12 March 1958
MIL-C-21097C	Connectors, Electrical, Printed-Wiring Board, General Purpose, General Specification for, 30 May 1972

MIL-T-21200K	Test Equipment for Use with Electronic and Electrical Equipment, General Specification for, 30 November 1971
MIL-G-21480A	Generator System, 400 Hertz, A-C, Aircraft, General Specification for, 24 August 1971
MIL-I-21557B	Insulation Sleeving, Electrical, Flexible, 19 July 1963
MIL-C-21565B	Clamp, Loop, Plastic, Wire Support, 9 August 1971
MIL-S-21604B	Switch, Rotary, Multipole and Selector, 1 to 10 Ampere, 6 May 1970
MIL-F-21608D	Ferrule, Shield Terminating, Crimp Style, 13 January 1971
MIL-C-21617	Connector, Plug and Receptacle-Electrical, Rectangular, Polarized Shell, Miniature Type, 5 March 1959
MIL-L-21652A	Light, Beacon, Anticollision Aircraft, General Specification for, 1 October 1964
MIL-I-22076B	Insulation, Tubing, Electrical, Non-Rigid, Vinyl, Very Low Temperature Grade, 2 August 1973
MIL-I-22129C	Insulation, Tubing, Electrical, Poly-tetrafluoroethylene Resin, Non-Rigid, 18 February 1965
MIL-C-22520D	Crimping Tools, Contact, Electric, Hand, General Specification for, 31 March 1971
MIL-G-22529A (AS)	Grommet, Plastic, 22 October 1968
MIL-C-22751D	Coating System, Epoxy-Polyamide, Chemical and Solvent Resistant, Process for Application of, 2 March 1971
MIL-W-22759C	Wire, Electric, Fluorocarbon-Insulated Copper or Copper Alloy, 20 November 1970
MIL-R-22973	Reliability Index Determination for Avionics Equipment Models, General Specification for, 16 October 1961

MIL-E-23001A	Electric Generating System, Variable Speed Constant Frequency Aircraft, General Specification for, 1 July 1968
MIL-I-23053B	Insulation Sleeving, Electrical, Heat Shrinkable, General Specification for, 24 March 1970
MIL-S-23190C	Strap, Tie Down, Electrical Components, 13 January 1971
MIL-C-23216C	Contacts, Electric Connector (Navy), General Specification for, 27 March 1972
MIL-A-23282B	Actuator, 3 March 1969
MIL-F-23419B	Fuses, Instrument Type, General Specification for, 18 November 1970
MIL-F-23447	Fire Warning Systems, Aircraft, Radiation Sensing Type, Test and Installation of, 14 September 1962
MIL-S-23586C	Sealing Compound, Electrical, Silicone Rubber, Accelerator Required, 12 June 1972
MIL-A-23622 (WEP)	Actuator, Aircraft Electromechanical, Linear, Direct Current, 15 April 1963
MIL-R-23761	Regulator, Voltage, Static, 28-Volt Direct Current Generator, General Specification for, 7 May 1963
MIL-E-24021C	Electric Power Monitors, External, Aircraft, 2 April 1965
MIL-M-24041	Molding and Potting Compounds, Chemically Cured, Polyurethane (Polyether Based), 15 March 1971
MIL-C-24308A	Connectors, Electric, Rectangular, Miniature Polarized Shell, Rack and Panel, General Specification for, 15 May 1972
MIL-S-24236B	Switches, Thermostatic (Metallic and Bimetallic), General Specification for, 25 August 1972
MIL-I-24391A	Insulation Tape, Electrical, Plastic, Pressure-Sensitive, 15 January 1972



MIL-W-25038D	Wire, Electrical, High Temperature and Fire Resistant, Aircraft, 10 January 1972
MIL-K-25049	Knob, Control, Equipment, Aircraft, 25 July 1960
MIL-C-25050A	Colors, Aeronautical Lights and Lighting Equipment, 2 December 1963
MIL-F-25173	Fastener, Control Panel, Aircraft Equipment, 23 November 1959
MIL-E-25366C	Electric and Electronic Equipment and System, Guided Missile, Installation of, General Specification for, 27 February 1961
MIL-L-25467C	Lighting, Integral, Aircraft Instrument, General Specification for, 29 May 1964
MIL-E-25499C	Electrical Systems, Aircraft, Design and Installation of, General Specification for, 23 March 1970
MIL-M-25500B	Mockup Testing, Electrical System, Piloted Aircraft and Guided Missile, General Requirements for, 27 October 1969
MIL-G-25704A	Generating System, A-C, Aircraft, General Specification for, 13 June 1968
MIL-C-25955	Connectors, Electrical, Environment Resisting, Miniature, With Snap-In Contacts, 5 February 1960
MIL-B-26220C (USAF)	Batteries, Storage, Aircraft, Nickel-Cadmium, General Specification for, 18 January 1971
MIL-F-26301C	Flashers, Position Light, Aircraft, 6 December 1967
MIL-P-26333A	Panel, Protection, Electrical System, AC Generator System, General Requirements for, 12 May 1959
MIL-C-26482E	Connectors, Electric, Circular, Miniature, Quick-Disconnect, Environment Resisting, 17 January 1972
MIL-C-26500D	Connectors, General Purpose, Electrical, Miniature, Circular, Environment Resisting, General Specification for, 26 January 1971

MIL-P-26517A (USAF)	Power Supply, Transformer-Rectifier, Aircraft, General Specification for, 10 March 1970
MIL-C-26518A	Connectors, Electrical, Miniature, Rack and Panel, Environment Resisting 200°C Ambient Temperature, 23 June 1972
MIL-G-26611B	Generator Tacometer, GEU-7/A, Miniature, 27 October 1969
MIL-C-26636A (USAF)	Contacts, Crimp Style, For Electrical Connectors, 21 September 1961
MIL-C-26637	Connectors, Coaxial, Radio Frequency, Series LT, General Specification for, 4 December 1963
MIL-C-27072A (USAF)	Cable, Special Purpose, Electrical, Multi-conductor, 7 August 1969
MIL-L-27160B	Lighting, Instrument, Integral, White, General Specification for, 4 December 1969
MIL-I-27273A	Inverter, Power, Static, General Specification for, 12 March 1970
MIL-T-27493A	Transformer, Variable, Single Phase, 400 Cycles, General Specification for, 30 October 1964
MIL-C-27500A	Cable, Electrical, Shielded and Unshielded, Aircraft and Missile, 24 February 1971
MIL-C-27699	Connector, Plug, Electrical Connector, Receptacle, Electrical (Heavy Duty, Waterproof), 2 October 1961
MIL-R-38100B (USAF)	Reliability and Quality Assurance Requirements for Established Reliability Parts, General Specification for, 15 June 1964
MIL-C-38300A	Connectors, Electrical Circular, Multi-contact, High Environment, Quantitative Reliability, General Specification for, 15 December 1970
MIL-M-38510A	Microcircuits, General Specification for, 2 November 1969

MIL-C-38999C	Connectors, Electrical, Circular, Miniature, High Density, Quick Disconnect, Environmental Resisting, Removable Crimp Type Contact, Reliability Assurance, 7 April 1972
MIL-C-39010B	Coils, Fixed, Radio Frequency, Molded, Established Reliability, General Specification for, 5 August 1968
MIL-C-39012B	Connectors, Coaxial, Radio-frequency, General Specification for, 9 April 1970
MIL-T-39013A	Transformers and Inductors (Audio and Power), Established Reliability for, 2 March 1970
MIL-C-39019A	Circuit Breakers, Magnetic, Low Power, Sealed, Trip-Free, General Specification for, 16 March 1971
MIL-C-39020	Crystal Units, Quartz, Established Reliability, General Specification for, 2 December 1964
MIL-F-39025	Filters, High Pass, Low Pass, Band Pass, Band Suppression, and Dual Functioning, Established Reliability, General Specification for, 24 February 1965
MIL-C-39029	Contacts, Electric, General Specification for, 6 April 1972
MIL-G-45204B	Gold Plating, Electrodeposited, 26 February 1971
MIL-I-45208A	Inspection System Requirements, 16 December 1963
MIL-C-45662A	Calibration System Requirements, 9 February 1962
MIL-S-45743C	Soldering, Manual Type, High Reliability, Electrical, Electronic, Instrument, Communication, and Radar for Aerospace, and Control Systems, Procedure for, 15 June 1970
MIL-E-45782B	Electrical Wiring, Procedures for, 28 December 1967

MIL-I-46058C	Insulating Compound, Electrical (For Coating Printed Circuit Assemblies), 25 March 1971
MIL-H-46355A	Human Engineering Requirements for Military Systems, Equipment, and Facilities, 29 March 1968
MIL-Q-50301 (MU)	Quality Control System, Requirements for, 6 May 1969
MIL-C-55021B	Cables, Twisted Pairs and Triples, Internal Hookup, General Specification for, 13 February 1970
MIL-P-55034A	Powered Magnetic Material, Molded, Stability of (For Cores Used in Electrical and Electronic Parts), 30 January 1963
MIL-C-55074D	Connector, Plug, Electrical U-185/G, Connector, Receptacle, Electrical U-186/G, Connector, Receptacle, Electrical U-187/G, Contact Assembly, Electrical, MX 3227/G, 15 May 1969
MIL-C-55081B	Connector, Plug, Electrical, U-176/G, Connector, Plug, Electrical, U-319/G, Connector, Receptacle, Electrical, U-121/G, Connector, Receptacle, Electrical, U-122/G, 22 May 1967
MIL-C-55116A	Connectors, Miniature Audio, Five Pin, 15 November 1965
MIL-B-55118A	Batteries, Storage (Cells), Vented, Nickel-Cadmium, 14 June 1971
MIL-B-55130	Batteries, Storage, Sealed, Nickel-Cadmium, 19 May 1961
MIL-T-55155A	Terminals, Feed-Thru (Insulated) and Terminals, Study (Insulated and Non-insulated), General Specification for, 27 October 1971
MIL-T-55156	Terminals, Lug, Splices, Conductor, Screw Type, General Specification for, 8 July 1965
MIL-T-55164A	Terminal Board, Molded, Barrier, Screw and Stud Types, and Associated Accessories, General Specification for, 22 July 1970

MIL-C-55181A	Connector, Plug and Receptacle, Intermediate (Electrical, Waterproof), General Specification for, 29 April 1968
MIL-C-55235	Connector, Coaxial, Radio Frequency, Series TPS, 2 July 1963
MIL-C-55302A	Connector, Printed Circuit Subassembly and Accessories, 15 August 1969
MIL-S-55433A	Switch Capsules, Dry Reed Type, General Specification for, 21 November 1968
MIL-C-55543A	Cable, Electrical, Flat Multiconductor, Flexible, Unshielded, 6 October 1971
MIL-C-55544A	Connectors, Electrical, Environment Resistant, For Use with Flexible Flat Conductor Cable and Round Wire, General Specification for, 25 June 1971
MIL-S-55556 (EL)	Specification, Preparation, Installation, and Acceptance of Electronics Equipment in Aircraft, 4 October 1967
MIL-G-62075	Generator System, Alternator Rectifier, 30/80 Amperes, 28-Volts, 22 November 1967
MIL-I-63026	Manual, Technical, for Army Aircraft, 2 September 1969
MIL-I-81023B	Inductor, 28V D.C. Laboratory Test, General Specification for, 6 December 1965
MIL-W-81044A	Wire, Electric, Crosslinked, Polyalkene Insulated, Copper, 30 November 1970
MIL-L-81174	Lights, Landing, Aircraft, Retractable, 20 January 1968
MIL-I-81219A	Indicator, Elapsed Time, Electrochemical, 6 August 1970
MIL-M-81260	Manual, Technical, Aircraft Maintenance, 18 May 1965
MIL-P-81279	Power Supply, Miniature, General Specification for, 1 August 1965

MIL-P-81338	Power Supply, Transistorized, Direct Current, Regulated, General Specification for, 18 November 1965
MIL-W-81381 (AS)	Wire, Electric, Polyimide-Insulated, Copper and Copper Alloy, 12 November 1970
MIL-C-81511C	Connector, Electrical, Circular, High Density, Quick Disconnect, Environment Resisting, and Accessories, General Specification for, 30 October 1970
MIL-M-81531	Marking of Electrical Insulating Materials, 2 May 1967
MIL-I-81550A	Insulating Compound, Electrical Embedding, Reversion Resistant Silicone, 9 March 1970
MIL-P-81653 (AS)	Power Controller, Solid State, General Specification for, 17 November 1969
MIL-C-83723A	Connectors, Electric, Circular, Environment Resisting, 30 June 1972
MIL-T-81768	Transformer-Rectifier, TEK-9/A24B-4(V), 30 November 1970

STANDARDS

MIL-STD-8C	Dimension and Tolerancing, 1 January 1968
MIL-STD-12C	Abbreviations for Use on Drawings, Specifications, Standards, and in Technical Documents, 15 June 1968
MIL-STD-100A	Engineering Drawing Practices, 1 October 1967
MIL-STD-104B	Limits for Electrical Insulation Color, 31 December 1970
MIL-STD-105D	Sampling Procedures and Tables for Inspection by Attributes, 20 March 1964
MIL-STD-106A	Mathematical Signs and Symbols for Use in Physical Sciences and Technology, 4 April 1969
MIL-STD-109B	Quality Assurance Terms and Definitions, 4 April 1969

MIL-STD-129E	Marking for Shipment and Storage, 20 April 1970
MIL-STD-130D	Identification Marking of U. S. Military Property, 30 July 1971
MIL-STD-143B	Standards and Specifications, Order of Precedence for the Selection of, 12 November 1969
MIL-STD-195	Marking of Connection for Electric Assemblies, 7 February 1958
MIL-STD-198C	Capacitor, Selection and Use of, 29 September 1972
MIL-STD-199A	Resistor, Selection and Use of, 16 October 1972
MIL-STD-202D	Test Methods for Electronic and Electrical Component Parts, 15 April 1970
MIL-STD-210A	Climatic Extremes for Military Equipment, 30 November 1958
MIL-STD-250C	Aircrew Station Controls and Displays for Rotary Wing Aircraft, 8 July 1958
MIL-STD-255A	Electric Voltages, Alternating and Direct Current, 29 January 1957
MIL-STD-280A	Definition of Item Levels, Item Exchange- ability, Models, and Related Terms, 7 July 1969
MIL-STD-411D	Aircrew Station Signals, 30 June 1970
MIL-STD-414	Sampling Procedures and Tables for Inspection of Variables for Percent 9 Defective, 11 June 1957
MIL-STD-417	Rubber Composition, Vulcanized General Purpose, Solid, 10 September 1957
MIL-STD-446B	Environmental Requirements for Electronic Component Parts, 2 September 1970
MIL-STD-454C	Standard General Requirements for Electronic Equipment, 1 May 1972

MIL-STD-461A	Electromagnetic Interference Characteristics, Requirements for Equipment, 9 February 1971
MIL-STD-462	Electromagnetic Interference Characteristics, Measurement of, 9 February 1971
MIL-STD-463	Definition and System of Units, Electromagnetic Interference Technology, 9 June 1966
MIL-STD-470	Maintainability Program Requirements (for Systems and Equipments), 21 March 1966
MIL-STD-471	Maintainability Demonstration, 9 April 1968
MIL-STD-473	Maintainability Verification/Demonstration Evaluation for Aeronautical Systems, 3 May 1971
MIL-STD-480	Configuration Control - Engineering Changes, Deviations, and Waivers, 30 October 1968
MIL-STD-490	Specification Practices, 1 February 1969
MIL-STD-681B	Identification Coding and Application of Hookup and Lead Wire, 6 February 1967
MIL-STD-686A	Cable and Cord, Electrical; Identification Marking and Color Coding of, 13 July 1972
MIL-STD-690	Failure Rate Sampling Plans and Procedures, 12 August 1971
MIL-STD-704A	Electric Power, Aircraft, Characteristics and Utilization of, 5 May 1970
MIL-STD-721B	Definition of Effectiveness Terms for Reliability, Maintainability, Human Factors, and Safety, 10 March 1970
MIL-STD-749B	Preparation and Submission of Data for Approval of Non-Standard Electronic Parts, 29 August 1969
MIL-STD-756A	Reliability Prediction, 5 May 1963
MIL-STD-757	Reliability Evaluation from Demonstration Data, 19 June 1964



MIL-STD-765A	Compass Swinging, Aircraft, General Requirements for, 4 January 1967
MIL-STD-778	Maintainability Terms and Definitions (Cancelled)
MIL-STD-781B	Reliability Tests Exponential Distribution, 28 July 1969
MIL-STD-785A	Reliability Program for Systems and Equipment Development and Production, 28 March 1969
MIL-STD-790C	Reliability Assurance Program for Electronics Parts Specifications, 18 April 1968
MIL-STD-794	Parts and Equipment, Procedures for Packing and Packaging of, 7 July 1972
MIL-STD-799 (AS)	Tabulated Wiring Data Lists and Pictorial Wiring Diagrams, 1 October 1969
MIL-STD-810B	Environmental Test Methods, 21 September 1970
MIL-STD-826A (USAF)	Electromagnetic Interference Test Requirements and Test Methods, 28 August 1963
MIL-STD-831	Test Reports, Preparation of, 28 August 1963
MIL-STD-863 (USAF)	Wiring Data, Preparation of, 12 March 1971
MIL-STD-875 (ASG)	Type Designation System for Aeronautical and Aeronautical Support Equipment, 1 November 1966
MIL-STD-882	System Safety, Program for Systems and Associated Subsystems and Equipment: Requirements for, 15 July 1969
MIL-STD-889A	Dissimilar Metals, 5 May 1972
MIL-STD-1285	Marking of Electrical and Electronic Parts, 10 August 1972
MIL-STD-1344	Test Methods, for Electrical Connectors, 5 May 1970
MIL-STD-1472A	Human Engineering Design Criteria for Military Systems, Equipment and Facilities, 15 May 1970

## STANDARDIZATION HANDBOOKS

MIL-HDBK-217A Reliability Stress and Failure Rate Data for  
Electronic Equipment, 30 December 1971

MIL-HDBK-472 Maintainability Prediction, 24 May 1957

## ARMY TECHNICAL MANUALS

TM 55-1520-209-20 Organizational Maintenance Manual, Army  
Model CH-47A Helicopter, May 1968

TM 55-1520-209-20P Organizational Maintenance Repair Parts  
and Special Tools List, Helicopter, Cargo  
Transport, CH-47A, CH-47B, CH-47C  
(Vertol), August 1971

TM 55-1520-209-34P DS and GS Maintenance Repair Parts and  
Special Tools List, Helicopter, Cargo  
Transport, CH-47A, CH-47B, CH-47C  
(Vertol), August 1971

TM 55-1520-209-35 DS, GS and Depot Maintenance Manual,  
Army Model CH-47A Helicopter, May 1968

TM 55-1520-210-20 Organizational Maintenance Manual: Army  
Model UH-1D/H Helicopter, 7 May 1969

TM 55-1520-210-20P Organizational Maintenance Repair Parts  
and Special Tools List, Helicopter, Utility-  
Tactical Transport, UH-1A, UH-1B,  
UH-1C, UH-1D, UH-1H (Bell), April 1971

TM 55-1520-210-34 DS and GS Maintenance Manual, Army  
Model UH-1D/H Helicopter, 10 September  
1971

TM 55-1520-210-34P DS and GS Maintenance and Repair Parts  
and Special Tools List, UH-1H, UH-1M  
(Bell), December 1971

TM 55-1520-214-20 Organizational Maintenance Manual,  
July 1969

TM 55-1520-214-20P Organizational Maintenance Repair Parts  
and Special Tools List, May 1971

TM 55-1520-214-35 DS, GS, and Depot Maintenance Manual,  
July 1969

TM 55-1520-214-35P DS, GS, and Depot Maintenance Repair  
Parts and Special Tools List, May 1971

TM 55-1520-217-20 Organizational Maintenance Manual,  
CH-54A Helicopter, April 1969

TM 55-1520-217-20P Organizational Maintenance Repair Parts  
and Special Tools List, Helicopter, Cargo  
Transport, CH-54A, CH-54B (Sikorsky)

TM 55-1520-217-35P-2 DS, GS, and Depot Maintenance Manual,  
CH-54A Helicopter, April 1969

TM 55-1520-221-20P Organizational Maintenance Repair Parts  
and Special Tools List, Helicopter, Attack -  
AH-1G (Bell), 1 June 1971

TM 55-1520-221-34 DS and GS Maintenance Manual, Army  
Model AH-1G Helicopter, 27 August 1971

TM 55-1520-221-34P DS, GS, and Depot Maintenance Repair and  
Special Tools List, Helicopter, Attack -  
AH-1G (Bell), June 1971

**APPENDIX II**  
**RELATED INAPPLICABLE DOCUMENTS**

The following military specifications were collected for review. Examination revealed that they did not have application to the helicopter electrical system report.

<u>DOCUMENT NUMBER</u>	<u>TITLE</u>	<u>APPLICATION</u>
MIL-C-17D	Cable, Radio Frequency; Coaxial, Dual Coaxial, Twin Conductor, and Twin Lead	Radio frequency transmission
MIL-S-61B	Shunt, Instrument, External, 50 Millivolt (Lightweight Type)	Nonaviation
MIL-V-95B	Vibrators, Interrupter and Self-Rectifying	Electronic equipment
MIL-C-172C	Cases; Bases, Mounting; and Mounts, Vibration (For Use with Electronic Equipment in Aircraft)	Use in helicopters not permitted
MIL-C-572G	Cords, Yarns and Monofilaments Organic Synthetic Fiber	Nonaviation
MIL-W-583G	Wire, Magnet, Electrical	Nonaviation
MIL-R-2726A	Receptacles, Receptacle Plugs, Switch and Receptacles, and Outlets (Electrical), General Specification for	Shipboard
MIL-C-3432D	Cable and Wire, Electrical (Power and Control; Semi-Flexible, Flexible, and Extra Flexible, 300 and 600 Volts)	Nonaviation
MIL-C-3767B	Connectors, Plug and Receptacle, Electrical (Power, Bladed Type), General Specification for	Nonaviation

MIL-S-3786C	Switch, Rotary (Circuit Selector, Low Current Capacity), General Specifications for	Airborne electronics/communications
MIL-W-3795B	Wire, Electrical (Tinsel)	Nonaviation
MIL-E-4158D (USAF)	Electronic Equipment Ground; General Requirements for	Ground electronics
MIL-C-5015D	Connectors, Electric, AN Type, General Specification for	Inactive for USAF procurement
MIL-C-005015F (Navy)	Connectors, Electric, AN Type, General Specification for	Interim specification (Navy only)
MIL-T-5091	Transmission, Power, Constant Ratio: General Specification for	Power plant system
MIL-E-5272C	Environmental Testing, Aeronautical and Associated Equipment, General Specification for	Inactive for Air Force new design
MIL-T-5422E	Testing, Environmental, Aircraft Electronic Equipment	Electronic, inactive for new design
MIL-T-5438	Tester, Abrasion, Electric Cable	Inactive for Air Force procurement
MIL-L-5667B	Lighting Equipment, Aircraft Instrument Panel, General Specification for Installation of	Aircraft lighting subsystem
MIL-L-6363E	Lamp, Incandescent, Aviation Service, General Specification for	Aircraft lighting subsystem
MIL-L-6484C	Lights, Cockpit Utility, Aircraft, General Specification for	Aircraft lighting subsystem
MIL-L-6503G	Lighting Equipment, Aircraft, General Specification for Installation of	Aircraft lighting subsystem

MIL-T-6616A	Transformer, Voltage Adjusting, Type C-1	Tetrahedron
MIL-L-6723B	Lights, Aircraft, General Specification for	Aircraft lighting subsystem
MIL-L-6730	Lighting Equipment, Exterior, Installation of Aircraft (General Specification)	Aircraft lighting subsystem
MIL-C-6818C	Clamps, Instrument Mounting, Aircraft	Aircraft instruments
MIL-S-6872B	Soldering Process, General Specification for	Non-electrical
MIL-I-7071B	Indicator, Temperature, Thermocouple, Hermetically Sealed, General Specification for	Turbine temperature
MIL-T-7101A	Transmission; Power, Constant Speed: General Specification for	Power plant accessories
MIL-C-7762A	Compasses, Installation of	Non-electrical
MIL-P-7788D	Panels, Information, Integrally Illuminated	Information display
MIL-R-7790	Resistor, Thermocouple, Lead Spool	Thermocouple leads
MIL-M-7793D	Meters, Time Totalizing	Equipment operating time
MIL-F-7872C	Fire and Overheat Warning Systems, Continuous, Aircraft, Test and Installation of	Engine, etc., fire warning
MIL-F-7929C	Flashers, Lights, Aircraft	Aircraft lighting subsystem
MIL-P-7968A	Position Indicating Assemblies, Electrical, Wheels and Flaps	Aircraft instruments
MIL-C-7989B	Covers, Light-Transmitting, for Aeronautical Lights, General Specification for	Aircraft lighting subsystem

MIL-F-8180B	Floodlight, Electric Incandescent, 28-Volts 20 Watts, Type MB-1	Aircraft lighting subsystem
MIL-V-8610A	Valve, Fuel Shut-off, Solenoid Operated	Aircraft fuel system
MIL-F-8785B	Flying Qualities of Piloted Airplanes	Fixed wing
MIL-S-8932	Switches, Pressure, Aircraft, General Specification for	Liquid pressure
MIL-I-9343B	Indicator, Temperature, Thermocouple, Engine Exhaust, Type MJ-1	Power plant
MIL-G-9398C	Generator Tachometer, Two-Pole, High Temperature, Aircraft	Engine RPM
MIL-M-10304D	Meters, Electrical Indicating Panel Type, Ruggedized, General Specification for	Field equipment
MIL-C-10544C	Connectors, Plug and Receptacle (Electrical, Audio, Waterproof, Ten Contact, Polarized)	Field equipment
MIL-C-12520C	Connectors, Plug and Receptacle (Electrical, Waterproof), and Accessories, General Specification for	Ground electronics
MIL-S-12883B	Sockets and Accessories for Plug-in Electronic Components, General Specification for	Electronics
MIL-C-13777F	Cable, Special Purpose, Electrical, General Specification for	Ground fire control
MIL-C-13909B	Conduit, Metal, Flexible, Electrical, Shielded	Military vehicles
MIL-F-14256D	Flux, Soldering, Liquid	Soldering
MIL-F-15160E	Fuses, Instrument, Power and Telephone	Instruments, telephones

MIL-S-15291C	Switch, Rotary, Snap Action	Shipboard
MIL-T-15659G	Terminal, Lug, Solder and Phosphor Bronze	Heavy equipment
MIL-F-15743A	Switch, Rotary, Enclosed	Shipboard
MIL-M-16034A	Meter, Electrical, Indicating (Switchboard and Portable Types)	Shipboard
MIL-M-16125C	Meters, Electrical, Frequency	Shipboard
MIL-E-16366D	Electrical Clamp, Lug, and Conductor Splices - Pressure Grip	Shipboard
MIL-M-17275B	Meter, Electrical, Indicating, Direct Current	Field equipment
MIL-I-18079B	Installation of Angle of Attack and Sideslip Systems	Aircraft instruments
MIL-L-18276C	Lighting, Aircraft Interior, Installation of	Aircraft lighting subsystem
MIL-F-18327C	Filters, High Pass, Low Pass, Band Pass, Band Suppression, and Dual Functioning, General Specification for	Audio
MIL-A-19401	Actuator, Electromechanical, Rotary, For AS-473/ASB-1	Radar antenna
MIL-S-20708C	Synchros, General Specification for	Fire control
MIL-I-21557B	Insulation Sleeving, Electrical Flexible	Shipboard
MIL-S-21604B	Switch, Rotary, Multipole and Selector, 1 to 10 Ampere	Shipboard
MIL-F-21608D	Ferrule, Shield Terminating, Crimp Style	RF cables



MIL-C-21617	Connectors, Plug and Receptacle-Electrical, Rectangular, Polarized Shell, Miniature Type	Shipboard
MIL-L-21652A	Light, Beacon, Anticollision Aircraft, General Specification for	Aircraft lighting subsystem
MIL-C-22520D	Crimping Tools, Contact, Electric, Hand, General Specification for	Electrical tools
MIL-A-23282B	Actuator	Torpedo
MIL-F-23419B	Fuses, Instrument Type, General Specification for	Electronic instruments
MIL-F-23447	Fire Warning Systems, Aircraft, Radiation Sensing Type, Test and Installation of	Navy aircraft
MIL-I-24391A	Insulation Tape, Electrical, Plastic, Pressure-Sensitive	Shipboard
MIL-C-22520D	Crimping Tools, Contact, Electric, Hand, General Specification for	Tools
MIL-C-25050A	Colors, Aeronautical Lights and Lighting Equipment	Aircraft lighting
MIL-L-25467C	Lighting, Integral, Aircraft Instrument, General Specification for	Aircraft lighting
MIL-E-25366C	Electric and Electronic Equipment and Systems, Guided Missiles, General Specification for	Missiles
MIL-C-25955	Connectors, Electrical, Environment Resisting, Miniature, With Snap-In Contacts	Inactive for new design
MIL-F-26301C	Flashers, Position Light, Aircraft	Aircraft lighting subsystem

MIL-P-26333A	Panel, Protection, Electrical System, AC Generator System, General Requirements for	Inactive for new design
MIL-C-26500D	Connectors, General Purpose, Electrical, Miniature, Circular Environment Resisting, General Specification for	Inactive for new design
MIL-G-26611B	Generator Tachometer, GEU-7/A Miniature	Turbine RPM
MIL-C-26637	Connectors, Coaxial, Radio Frequency Series LT, General Specification for	Audio transmission
MIL-L-27160B	Lighting, Instrument, Integral, White, General Specification for	Instrument lighting
MIL-T-27493A	Transformer, Variable, Single Phase, 400 Cycles, General Specification for	Aircraft lighting subsystem
MIL-C-27699	Connector, Plug, Electrical Connector, Receptacle, Electrical (Heavy Duty, Waterproof)	Outdoor cables
MIL-M-38510A	Microcircuits, General Specification for	Electronic
MIL-C-39010B	Coils, Fixed, Radio Frequency, Molded, Established Reliability, General Specification for	Audio/RF circuits
MIL-C-39012B	Connectors, Coaxial, Radio-frequency, General Specification for	Audio circuits
MIL-T-39013A	Transformers and Inductors (Audio and Power), Established Reliability for	Electronic
MIL-C-39019A	Circuit Breakers, Magnetic, Low Power, Sealed, Trip-Free, General Specification for	Electronic

MIL-C-39020	Crystal Units, Quartz, Established Reliability, General Specification for	Electronic
MIL-F-39025	Filters, High Pass, Low Pass, Band Pass, Band Suppression, and Dual Functioning, Established Reliability, General Specification for	Audio circuit
MIL-G-45204B	Gold Plating, Electrodeposited	Corrosion prevention
MIL-E-45782B	Electrical Wiring, Procedures for	Missiles
MIL-I-46058C	Insulating Compound, Electrical (For Coating Printed Circuit Assemblies)	Nonaviation
MIL-C-55021B	Cables, Twisted Pairs and Triples, Internal Hookup, General Specification for	Electronic
MIL-P-55034A	Powered Magnetic Material, Molded, Stability of (For Cores Used in Electrical and Electronic Parts)	Army field equipment
MIL-C-55074D	Connector, Plug, Electrical U-185/G, Connector, Receptacle, Electrical U-186/G, Connector, Receptacle, Electrical U-187/G, Contact Assembly, Electrical, MX 3227/G	Military communications
MIL-C-55081B	Connector, Plug, Electrical, U-185/G, Connector, Plug Electrical, U-319/G, Connector, Receptacle, Electrical, U-121/G, Connector, Receptacle, Electrical, U-122/G	Field equipment
MIL-C-55116A	Connectors, Miniature Audio, Five Pin	Audio circuit
MIL-B-55118A	Batteries, Storage (Cells), Vented, Nickel-Cadmium	Ground equipment

MIL-B-55130	Batteries, Storage, Sealed, Nickel-Cadmium	Ground equipment
MIL-T-55155A	Terminals, Feed Thru (Insulated) and Terminals, Stud (Insulated and Non-insulated), General Specification for	Nonaviation
MIL-T-55156	Terminals, Lug, Splices, Conductor, Screw Type, General Specification for	Nonaviation
MIL-T-55164A	Terminal Board, Molded, Barrier, Screw and Stud Types, and Associated Accessories, General Specification for	Nonaviation
MIL-C-55181A	Connectors, Plug and Receptacle, Intermediate (Electrical, Waterproof), General Specification for	Electronic
MIL-C-55235	Connectors, Coaxial, Radio Frequency, Series TPS	Audio circuit
MIL-C-55302A	Connectors, Printed Circuit Subassembly and Accessories	Nonaviation
MIL-S-55433A	Switch Capsules, Dry Reed Type, General Specification for	Nonaviation
MIL-G-62075	Generator System, Alternator Rectifier 30/80 Amperes, 28 Volts	Ground vehicles
MIL-L-81174	Lights, Landing, Aircraft, Retractable	Aircraft lighting subsystem
MIL-I-81219A	Indicator, Elapsed Time, Electrochemical	Equipment operating time
MIL-P-81338	Power Supplies, Transistorized, Direct Current, Regulated, General Specification for	Electronic

MIL-C-81511C

Connectors, Electrical,  
Circular, High Density,  
Quick Disconnect, Environ-  
ment Resisting, and Acces-  
sories, General Specification  
for

Inactive for  
new design

MIL-P-81279

Power Supply, Miniature,  
General Specification for

Electronics

MIL-T-81768

Transformer-Rectifier  
TEK-9/A24B-4(V)

Nuclear  
weapons

**APPENDIX III**  
**RELATED REFERENCE DOCUMENTS**

The following documents were valuable as reference documents. They are applicable to processes, marking, packaging, and inspection procedures.

<u>DOCUMENT NUMBER</u>	<u>TITLE</u>	<u>PURPOSE</u>
MIL-P-116E	Preservation. Method of	Corrosion control
MIL-T-152B	Treatment, Moisture and Fungus-Resistant of Communications, Electronic, and Associated Electrical Equipment	Moisture and fungus treatment
MIL-V-173C	Varnish, Moisture, and Fungus Resistant (For Treatment of Communications, Electronic and Associated Equipment)	Moisture and fungus treatment
MIL-D-1000	Drawings, Engineering, and Associated Lists	Drawing requirements
MIL-M-3171C	Magnesium Alloy, Processes for Pretreatment and Prevention of Corrosion On	Corrosion control
MIL-S-5002C	Surface Treatments and Metallic Coatings for Metal Surfaces of Weapons Systems	Cleaning metal surfaces
MIL-P-6063A	Packaging of Batteries, Storage, Charged and Dry-Uncharged	Battery shipping
MIL-F-7179D	Finishes and Coatings, General Specification for	Aircraft finishes
MIL-I-8500B	Interchangeability and Replaceability of Component Parts for Aircraft (Including Guided Missiles)	Includes electrical system

MIL-H-8501A	Helicopter Flying and Ground Handling Qualities, General Requirements for	Design requirements
MIL-A-8625C	Anodic Coatings, for Aluminum and Aluminum Alloys	Corrosion protection
MIL-I-8700A	Installation and Test of Electronic Equipment in Aircraft, General Specification for	Improved electronics
MIL-D-8706B	Data and Test of Electronic Equipment in Aircraft, General Specification for	Electronic equipment
MIL-Q-9858A	Quality Program Requirements	Supplies and services
MIL-T-10727A	Tin-Plating, Electrodeposited or Hot-dipped, for Ferrous and Non-Ferrous Metals	Preparation for soldering
MIL-P-11268G	Parts, Materials, Processes Used in Electronic Equipment	Shopping list
MIL-C-11796B	Corrosion Preventative, Petrolatum, Hot Application	Corrosion control
MIL-C-12000F	Cable, Cord, and Wire, Electric; Packaging of	Shipment and storage
MIL-M-13232A	Marking of Electronic Items	Marking material
MIL-P-15024	Plates, Tags, and Bands for Identification of Equipment	Includes electrical
MIL-E-16298	Electric Machines Having Rotating Parts, Packaging of	Shipment and storage
MIL-E-17555G	Electronic and Electrical Equipment, Accessories, and Repair Parts; Packaging and Packing of	Treatment, marking, shipping, and storage
MIL-M-18012B	Markings for Aircrew Station Displays and Configuration of	Letters, numerals

MIL-N-18307D (NAVY)	Nomenclature for Electronic, Aeronautical, and Aeronautical Support Equipment, Including Ground Support Equipment	Navy ground support
MIL-A-19531	Aircraft Maintenance and Engineering Inspection	Navy aircraft
MIL-STD-22256 (AER)	Reliability Requirements for Design of Electronic Equipment or Systems	Navy aircraft
MIL-C-22751D	Coating System, Epoxy-Polyimide, Chemical and Solvent Resistant, Process for Application of	Aircraft paint
MIL-R-22973	Reliability Index Determination for Avionics Equipment Models, General Specification for	Avionics models
MIL-R-38100B (USAF)	Reliability and Quality Assurance Requirements for Established Reliability Parts, General Specification for	Air Force R&M
MIL-I-45208A	Inspection System Requirements	Contractor procedure
MIL-C-45662A	Calibration System Requirements	Standardized calibration
MIL-S-45743C	Soldering, Manual Type, High Reliability Connections for Missile Systems, Procedures for	Missile wiring
MIL-H-46855A	Human Engineering Requirements for Military Systems, Equipment and Facilities	All military systems
MIL-Q-50301 (MU)	Quality Control System, Requirements for	Technical data
MIL-S-55556 (EL)	Specification, Preparation, Installation, and Acceptance of Electronics Equipment in Aircraft	Army aircraft



MIL-I-63026	Manual, Technical, for Army Aircraft	Aeronautical maintenance
MIL-I-81023B	Inductor, 28V D. C. Laboratory Test, General Specification for	Laboratory test
MIL-M-81260	Manual, Technical, Aircraft Maintenance	Navy aircraft
MIL-M-81531	Marking of Electrical Insulating Materials	Marking performance

## APPENDIX IV DOCUMENT ANALYSIS

This appendix provides the analysis of the electrical system documentation. The documents are divided into 8 major classifications.

- Electrical System Documents, Figure 31
- Alternating Current Circuit Documents, Figure 32
- Battery Circuit Documents, Figure 33
- Electrical Controls Circuit Documents, Figure 34
- External Power Circuit Documents, Figure 35
- Direct Current Circuit Documents, Figure 36
- Load Circuit Documents, Figure 37
- Electrical System Component Part Documents, Figure 38

The analysis is presented in columnar format; the columnar headings used in this analysis are as follows:

Generic Classification — Generic classification of item controlled by the document.

Document Number — Military specification or standard number assigned to the document, document title, all active revisions, amendments, and supplements and the dates of each.

Deficiency — Abbreviated deficiency terms are presented in this column. Abbreviated terms are used in Figures 31 through 38 for the purpose of brevity. A short description of these reliability/maintainability related deficiencies are as follows:

1. Performance. The document is devoid of requirements for the component to meet or exceed the performance requirements established by the mission profile.
2. Design. The document references other documents for the design requirements. This is considered inadequate.
3. Environmental Conditions. The document either does not address environmental conditions which are normally encountered by military helicopters, or merely implies the mission design requirements by stating performance or physical test values in nonspecific terms.

4. Interchangeability. The document is devoid of a requirement for similar assemblies, subassemblies, and replaceable parts to be interchangeable.
5. Standard Components. The document is devoid of a requirement to use standard components that consider the specific mission profile requirements.
6. Product Identification. The document is devoid of identifying features, i. e., nameplates or markings which identify the item governed by the specification.
7. Workmanship. The document is devoid of a workmanship requirement, or a standard is merely implied.
8. Safety. The document is devoid of safety requirements for personnel and equipment.
9. Reliability Program. The document is devoid of reliability program requirements that consider the mission requirements.
10. Maintainability Program. The document is devoid of maintainability program requirements that consider the mission requirements.
11. Electromagnetic Interference. The document is devoid of electromagnetic interference requirements for electrical components.
12. Human Engineering. The document is devoid of human engineering requirements.
13. Environmental Testing. The document is either devoid of environmental testing requirements or the requirements stated are not in consonance with MIL-STD-810 and/or MIL-STD-202.
14. Qualification Test Plan. The document does not require qualification testing or the test plan requirements are ambiguous.
15. Test Witness. The document does not require that a designated test witness be appointed to observe critical tests.
16. Rejection and Retest. The document is either devoid of definitive qualification retesting procedures, or implies retesting in case of quality conformance test failures.

17. Reliability Demonstration. The document does not require a reliability demonstration or implies reliability by quantitative "life" testing.
18. Maintainability Demonstration. The document is devoid of a maintainability demonstration requirement.
19. Quality Assurance Program. The document is devoid of a quality assurance program or existing provisions are stated in ambiguous terms.
20. Component Sampling. The document is either devoid of qualification test sampling, or implies this function by requiring quality conformance sampling.
21. Packing and Shipping. The document is devoid of requirements for packing and shipping.
22. Mandatory Inspection Points. The document is devoid of requirements for in-process inspection points.

GENERIC CLASSIFICATION	DOCUMENT NUMBER, TITLE, REVISION, AMENDMENT, SUPPLEMENT AND DATES	DEFICIENCY	POTENTIAL RELIABILITY/ MAINTAINABILITY IMPACT
Electrical System	<p>MIL-STD-704A Electrical Power, Aircraft, Characteristics and Utilization of Change 2, dated 9 August 1966</p> <p>MIL-B-5087B (ASG) Bonding, Electrical, and Lightning Protection for Aerospace Systems Amendment 2, dated 31 August 1970</p> <p>MIL-W-5088E Wiring, Aircraft, Selection and Installation of Revised 28 March 1972</p>	<p>General: No deficiencies were noted which would have impact on reliability or maintainability.</p> <p>Design Requirements:</p> <ul style="list-style-type: none"> <li>● Workmanship</li> <li>● Human Engineering</li> </ul> <p>Design Requirements</p> <ul style="list-style-type: none"> <li>● Environmental Conditions</li> <li>● Safety</li> <li>● Human Engineering</li> </ul> <p>Testing:</p> <ul style="list-style-type: none"> <li>● Reliability Demonstration</li> <li>● Maintainability Demonstration</li> <li>● Environmental Testing</li> </ul>	<p>Insignificant</p> <p>Significant</p> <p>Significant</p> <p>Significant</p> <p>Significant</p> <p>Significant</p> <p>Significant</p>

Figure 31. Electrical System Document Deficiency Analysis.

GENERIC CLASSIFICATION	DOCUMENT NUMBER, TITLE, REVISION, AMENDMENT, SUPPLEMENT AND DATES	DEFICIENCY	POTENTIAL RELIABILITY/ MAINTAINABILITY IMPACT
	<p>MIL-E-6051D            Electromagnetic Compatibility Requirements, Systems Amendment dated 5 July 1968</p> <p>MIL-E-7016D (ASG)            Electric Load and Power Source Capacity, Aircraft, Analysis of Revised 15 April 1965</p> <p>MIL-E-7080B            Electric Equipment, Aircraft, Selection and Installation of Amendment 3, dated 29 April 1968</p>	<p>General:            No deficiencies were noted which would have impact on reliability or maintainability.</p> <p>General:            No deficiencies were noted which would have impact on reliability or maintainability.</p> <p>Design Requirements:</p> <ul style="list-style-type: none"> <li>● Design and Construction</li> <li>● Environmental Conditions</li> <li>● Standard Components</li> <li>● Safety</li> <li>● Reliability Program</li> <li>● Maintainability Program</li> <li>● Human Engineering</li> <li>● Electromagnetic Interference</li> </ul>	<p>Insignificant</p> <p>Insignificant</p> <p>Significant</p> <p>Significant</p> <p>Significant</p> <p>Significant</p> <p>Significant</p> <p>Significant</p> <p>Significant</p>

Figure 31 - Continued.

GENERIC CLASSIFICATION	DOCUMENT NUMBER, TITLE, REVISION, AMENDMENT, SUPPLEMENT AND DATES	DEFICIENCY	POTENTIAL RELIABILITY/ MAINTAINABILITY IMPACT
	<p>MIL-E-25499C            Electrical Systems,            Aircraft, Design and            Installation of, General            Specification for            Revised 23 March 1970</p>	<p>Testing:</p> <ul style="list-style-type: none"> <li>● Reliability Demonstration</li> <li>● Maintainability Demonstration</li> <li>● Environmental Testing</li> </ul> <p>Design Requirements:</p> <ul style="list-style-type: none"> <li>● Environmental Conditions</li> <li>● Reliability Program</li> <li>● Maintainability Program</li> <li>● Product Identification</li> <li>● Safety</li> <li>● Human Engineering</li> </ul> <p>Testing:</p> <ul style="list-style-type: none"> <li>● Reliability Demonstration</li> <li>● Maintainability Demonstration</li> </ul>	<p>Significant            Significant            Significant</p> <p>Significant            Significant            Significant            Significant            Significant            Significant</p> <p>Significant            Significant</p>

Figure 31 - Continued.

GENERIC CLASSIFICATION	DOCUMENT NUMBER, TITLE, REVISION, AMENDMENT, SUPPLEMENT AND DATES	DEFICIENCY	POTENTIAL RELIABILITY/ MAINTAINABILITY IMPACT
Generator, Brush	<p>MIL-G-6099A (ASG) Generators and Regulators, Air-Cooled, A-C, Aircraft; General Specification for Amendment 1, dated 15 May 1958</p> <p>MIL-G-6340A (USAF) Generator, Alternating Current, Aircraft, Type C-3 Amendment 2, dated 12 July 1957</p>	<p>Design Requirements:</p> <ul style="list-style-type: none"> <li>• Environmental Conditions</li> <li>• Safety</li> <li>• Reliability Program</li> <li>• Maintainability Program</li> <li>• Electromagnetic Interference</li> <li>• Human Engineering</li> </ul> <p>Quality Assurance:</p> <ul style="list-style-type: none"> <li>• Quality Assurance Program</li> <li>• Responsibility for Inspection</li> </ul> <p>Testing:</p> <ul style="list-style-type: none"> <li>• Reliability Demonstration</li> <li>• Maintainability Demonstration</li> <li>• Environmental Testing</li> </ul> <p>Design Requirements:</p> <ul style="list-style-type: none"> <li>• Environmental Conditions</li> <li>• Interchangeability</li> <li>• Workmanship</li> <li>• Production Identification</li> </ul>	<p>Significant</p> <p>Significant</p> <p>Significant</p> <p>Significant</p> <p>Significant</p> <p>Significant</p> <p>Major</p> <p>Major</p> <p>Significant</p> <p>Significant</p> <p>Significant</p> <p>Significant</p> <p>Significant</p> <p>Significant</p> <p>Significant</p> <p>Significant</p>

Figure 32. Alternating Current Circuit Document Deficiency Analysis.



GENERIC CLASSIFICATION	DOCUMENT NUMBER, TITLE, REVISION, AMENDMENT, SUPPLEMENT AND DATES	DEFICIENCY	POTENTIAL RELIABILITY/ MAINTAINABILITY IMPACT
		<ul style="list-style-type: none"> <li>• Safety</li> <li>• Standard Components</li> <li>• Reliability Program</li> <li>• Maintainability Program</li> <li>• Electromagnetic Interference</li> <li>• Human Engineering</li> </ul> <p>Quality Assurance:</p> <ul style="list-style-type: none"> <li>• Quality Assurance Program</li> <li>• Responsibility for Inspection</li> </ul> <p>Testing:</p> <ul style="list-style-type: none"> <li>• Qualification Retest</li> <li>• Reliability Demonstration</li> <li>• Maintainability Demonstration</li> <li>• Environmental Testing</li> <li>• Qualification Sampling</li> </ul>	<p>Significant</p> <p>Significant</p> <p>Significant</p> <p>Significant</p> <p>Significant</p> <p>Significant</p> <p>Major</p> <p>Major</p> <p>Significant</p> <p>Significant</p> <p>Significant</p> <p>Significant</p> <p>Significant</p>

Figure 32 - Continued.

GENERIC CLASSIFICATION	DOCUMENT NUMBER, TITLE, REVISION, AMENDMENT, SUPPLEMENT AND DATES	DEFICIENCY	POTENTIAL RELIABILITY/ MAINTAINABILITY IMPACT
	MIL-G-21075 (AER) Generating System, Single Generator, Constant Frequency, Alternating Current, Aircraft, General Specification for Amendment 1, dated 12 March 1958	Design Requirements: <ul style="list-style-type: none"> <li>● Environmental Conditions</li> <li>● Interchangeability</li> <li>● Product Identification</li> <li>● Workmanship</li> <li>● Safety</li> <li>● Reliability Program</li> <li>● Maintainability Program</li> <li>● Electromagnetic Interference</li> <li>● Human Engineering</li> </ul> Quality Assurance: <ul style="list-style-type: none"> <li>● Quality Assurance Program</li> <li>● Responsibility for Inspection</li> </ul> Testing: <ul style="list-style-type: none"> <li>● Reliability Demonstration</li> <li>● Maintainability Demonstration</li> <li>● Environmental Testing</li> </ul>	Significant Significant Insignificant Significant Significant Significant Significant Significant Significant Significant Major Major Significant Significant Significant

Figure 32 - Continued.

GENERIC CLASSIFICATION	DOCUMENT NUMBER, TITLE, REVISION, AMENDMENT, SUPPLEMENT AND DATES	DEFICIENCY	POTENTIAL RELIABILITY/ MAINTAINABILITY IMPACT
	MIL-G-25704A (USAF) Generator System, Alternating Current, Aircraft, General Specification for Revised 13 June 1963	Design Requirements: <ul style="list-style-type: none"> <li>● Environmental Conditions</li> <li>● Safety</li> <li>● Reliability Program</li> <li>● Maintainability Program</li> <li>● Electromagnetic Interference</li> <li>● Human Engineering</li> </ul> Testing: <ul style="list-style-type: none"> <li>● Qualification Retest</li> <li>● Reliability Demonstration</li> <li>● Maintainability Demonstration</li> <li>● Environmental Testing</li> </ul> Quality Assurance: <ul style="list-style-type: none"> <li>● Responsibility for Inspection</li> </ul>	Significant Significant Significant Significant Significant Significant  Significant Significant Significant Significant  Major

Figure 32 - Continued.

GENERIC CLASSIFICATION	DOCUMENT NUMBER, TITLE, REVISION, AMENDMENT, SUPPLEMENT AND DATES	DEFICIENCY	POTENTIAL RELIABILITY/ MAINTAINABILITY IMPACT
Generator, Brushless	<p>MIL-G-21480A (AS)  Generator System,  400 Hertz Alternating  Current, Aircraft,  General Specification for  Revised 30 September  1970</p>	<p>Design Requirements:</p> <ul style="list-style-type: none"> <li>● Environmental Conditions</li> <li>● Safety</li> <li>● Reliability Program</li> <li>● Maintainability Program</li> <li>● Human Engineering</li> </ul> <p>Quality Assurance:</p> <ul style="list-style-type: none"> <li>● Quality Assurance Program</li> <li>● Responsibility for Inspection</li> </ul> <p>Testing:</p> <ul style="list-style-type: none"> <li>● Reliability Demonstration</li> <li>● Maintainability Demonstration</li> <li>● Environmental Testing</li> </ul>	<p>Significant  Significant  Significant  Significant  Significant</p> <p>Major  Major</p> <p>Significant  Significant  Significant</p>
	<p>MIL-E-23001A (AS)  Electric Generating  System, Variable Speed,  Constant Frequency,  Aircraft, General  Specification for  Revised 1 July 1968</p>	<p>Design Requirements:</p> <ul style="list-style-type: none"> <li>● Environmental Conditions</li> <li>● Safety</li> <li>● Interchangeability</li> <li>● Reliability Program</li> <li>● Maintainability Program</li> </ul>	<p>Significant  Significant  Significant  Significant  Significant</p>

Figure 32 - Continued.

GENERIC CLASSIFICATION	DOCUMENT NUMBER, TITLE, REVISION, AMENDMENT, SUPPLEMENT AND DATES	DEFICIENCY	POTENTIAL RELIABILITY/ MAINTAINABILITY IMPACT
<p>Motor - Generator</p>	<p>No applicable Military Specification was found to exist for Motor - Generators for helicopter applications.</p>	<ul style="list-style-type: none"> <li>● Electromagnetic Interference</li> <li>● Human Engineering</li> </ul> <p>Quality Assurance:</p> <ul style="list-style-type: none"> <li>● Quality Assurance Program</li> <li>● Responsibility for Inspection</li> </ul> <p>Testing:</p> <ul style="list-style-type: none"> <li>● Reliability Demonstration</li> <li>● Maintainability Demonstration</li> <li>● Environmental Testing</li> </ul> <p>General:</p> <p>Military specifications imposing reliability, maintainability, quality assurance, qualification testing requirements and provisions are required to ensure that the design is compatible with the intended use.</p>	<p>Significant</p> <p>Significant</p> <p>Major</p> <p>Major</p> <p>Significant</p> <p>Significant</p> <p>Significant</p> <p>Significant</p>

Figure 32 - Continued.

GENERIC CLASSIFICATION	DOCUMENT NUMBER, TITLE, REVISION, AMENDMENT, SUPPLEMENT AND DATES	DEFICIENCY	POTENTIAL RELIABILITY/ MAINTAINABILITY IMPACT
Inverter, Primary	MIL-I-7032F Inverters, Aircraft, General Specification for Supplement 1, dated 14 October 1970	Design Requirements: <ul style="list-style-type: none"> <li>• Environmental Conditions</li> <li>• Safety</li> <li>• Reliability Program</li> <li>• Maintainability Program</li> <li>• Human Engineering</li> </ul> Quality Assurance: <ul style="list-style-type: none"> <li>• Quality Assurance Program</li> <li>• Responsibility for Inspection</li> </ul> Testing: <ul style="list-style-type: none"> <li>• Qualification Retest</li> <li>• Environmental Testing</li> <li>• Reliability Demonstration</li> <li>• Maintainability Demonstration</li> </ul>	Significant Significant Significant Significant Significant  Major Major  Significant Significant Significant Significant
	MIL-I-27273A Inverter, Power, Static, General Specifications for Amendment 3, dated 12 March 1970	Design Requirements: <ul style="list-style-type: none"> <li>• Safety</li> <li>• Reliability Program</li> <li>• Maintainability Program</li> <li>• Human Engineering</li> </ul>	Significant Significant Significant Significant

Figure 32 - Continued.

GENERIC CLASSIFICATION	DOCUMENT NUMBER, TITLE, REVISION, AMENDMENT, SUPPLEMENT AND DATES	DEFICIENCY	POTENTIAL RELIABILITY/ MAINTAINABILITY IMPACT
Inverter Control	MIL-C-6521 (USAF) Control, Inverter, Changeover, Type A-2 Amendment 2, dated 8 September 1959	<p>Quality Assurance:</p> <ul style="list-style-type: none"> <li>● Quality Assurance Program</li> <li>● Responsibility for Inspection</li> </ul> <p>Testing:</p> <ul style="list-style-type: none"> <li>● Reliability Demonstration</li> <li>● Maintainability Demonstration</li> <li>● Environmental Testing</li> <li>● Qualification Retest</li> </ul> <p>Design Requirements:</p> <ul style="list-style-type: none"> <li>● Environmental Conditions</li> <li>● Safety</li> <li>● Reliability Program</li> <li>● Maintainability Program</li> <li>● Human Engineering</li> <li>● Electromagnetic Interference</li> </ul> <p>Quality Assurance:</p> <ul style="list-style-type: none"> <li>● Quality Assurance Program</li> </ul>	<p>Major</p> <p>Major</p> <p>Significant</p> <p>Significant</p> <p>Significant</p> <p>Significant</p> <p>Significant</p> <p>Significant</p> <p>Significant</p> <p>Significant</p> <p>Significant</p> <p>Significant</p> <p>Major</p>

Figure 32 - Continued

GENERIC CLASSIFICATION	DOCUMENT NUMBER, TITLE, REVISION, AMENDMENT, SUPPLEMENT AND DATES	DEFICIENCY	POTENTIAL RELIABILITY/ MAINTAINABILITY IMPACT
Regulator, Supervisory and Regulatory	MIL-R-6339 (USAF) Regulator, Voltage, Type L-4 Amendment 4, dated 4 December 1959	<p>Testing:</p> <ul style="list-style-type: none"> <li>● Qualification Retest</li> <li>● Reliability Demonstration</li> <li>● Maintainability Demonstration</li> <li>● Environmental Testing</li> </ul> <p>Design Requirements:</p> <ul style="list-style-type: none"> <li>● Environmental Conditions</li> <li>● Interchangeability</li> <li>● Standard Components</li> <li>● Workmanship</li> <li>● Safety</li> <li>● Reliability Program</li> <li>● Maintainability Program</li> <li>● Electromagnetic Interference</li> <li>● Human Engineering</li> </ul> <p>Quality Assurance:</p> <ul style="list-style-type: none"> <li>● Quality Assurance Program</li> <li>● Responsibility for Inspection</li> </ul>	<p>Significant</p> <p>Significant</p> <p>Significant</p> <p>Significant</p> <p>Significant</p> <p>Significant</p> <p>Significant</p> <p>Significant</p> <p>Significant</p> <p>Significant</p> <p>Significant</p> <p>Significant</p> <p>Major</p> <p>Major</p>

Figure 32 - Continued.



GENERIC CLASSIFICATION	DOCUMENT NUMBER, TITLE, REVISION, AMENDMENT, SUPPLEMENT AND DATES	DEFICIENCY	POTENTIAL RELIABILITY/ MAINTAINABILITY IMPACT
Relay, Monitoring Bus Contactor	MIL-R-6466B Relay, Armature, Exciter Protection, Type A-1, dated 28 July 1965	<p>Testing:</p> <ul style="list-style-type: none"> <li>● Qualification Retest</li> <li>● Reliability Demonstration</li> <li>● Maintainability Demonstration</li> <li>● Environmental Testing</li> <li>● Qualification Sampling</li> </ul> <p>Design Requirements:</p> <ul style="list-style-type: none"> <li>● Environmental Conditions</li> <li>● Safety</li> <li>● Reliability Program</li> <li>● Maintainability Program</li> <li>● Human Engineering</li> </ul> <p>Quality Assurance:</p> <ul style="list-style-type: none"> <li>● Quality Assurance Program</li> <li>● Responsibility for Inspection</li> </ul>	<p>Significant</p> <p>Significant</p> <p>Significant</p> <p>Significant</p> <p>Significant</p> <p>Significant</p> <p>Significant</p> <p>Significant</p> <p>Significant</p> <p>Significant</p> <p>Major</p> <p>Major</p>

Figure 32 - Continued.

GENERIC CLASSIFICATION	DOCUMENT NUMBER, TITLE, REVISION, AMENDMENT, SUPPLEMENT AND DATES	DEFICIENCY	POTENTIAL RELIABILITY/ MAINTAINABILITY IMPACT
	<p>MIL-R-7611 (USAF) Relay, Armature, Type MA-1 Amendment 1, dated 5 April 1957</p>	<p>Testing:</p> <ul style="list-style-type: none"> <li>● Reliability Demonstration</li> <li>● Maintainability Demonstration</li> <li>● Test Witness</li> <li>● Environmental Testing</li> </ul> <p>Design Requirements:</p> <ul style="list-style-type: none"> <li>● Environmental Conditions</li> <li>● Safety</li> <li>● Reliability Program</li> <li>● Maintainability Program</li> <li>● Electromagnetic Interference</li> <li>● Human Engineering</li> </ul> <p>Quality Assurance:</p> <ul style="list-style-type: none"> <li>● Quality Assurance Program</li> <li>● Responsibility for Inspection</li> </ul> <p>Testing:</p> <ul style="list-style-type: none"> <li>● Qualification Retest</li> </ul>	<p>Significant Significant Significant Significant</p> <p>Significant Significant Significant Significant Significant Significant</p> <p>Major Major</p> <p>Significant</p>

Figure 32 - Continued.

GENERIC CLASSIFICATION	DOCUMENT NUMBER, TITLE, REVISION, AMENDMENT, SUPPLEMENT AND DATES	DEFICIENCY	POTENTIAL RELIABILITY/ MAINTAINABILITY IMPACT
	<p>MIL-R-7649A (ASG)  Relay, Armature, Exciter-Control, 115/200 Volt, 3-Phase, 4-Wire, 400 Cycle, Type H-1  Revised 21 May 1953</p>	<ul style="list-style-type: none"> <li>● Environmental Testing</li> <li>● Reliability Demonstration</li> <li>● Maintainability Demonstration</li> <li>● Test Witness</li> </ul> <p>Design Requirements:</p> <ul style="list-style-type: none"> <li>● Environmental Conditions</li> <li>● Safety</li> <li>● Reliability Program</li> <li>● Maintainability Program</li> <li>● Electromagnetic Interference</li> <li>● Human Engineering</li> </ul> <p>Quality Assurance:</p> <ul style="list-style-type: none"> <li>● Quality Assurance Program</li> <li>● Responsibility for Inspection</li> </ul> <p>Testing:</p> <ul style="list-style-type: none"> <li>● Qualification Retest</li> <li>● Reliability Demonstration</li> <li>● Maintainability Demonstration</li> <li>● Environmental Testing</li> </ul>	<p>Significant  Significant  Significant  Significant</p> <p>Significant  Significant  Significant  Significant  Significant  Significant</p> <p>Major  Major</p> <p>Significant  Significant  Significant  Significant</p>

Figure 32 - Continued.

GENERIC CLASSIFICATION	DOCUMENT NUMBER, TITLE, REVISION, AMENDMENT, SUPPLEMENT AND DATES	DEFICIENCY	POTENTIAL RELIABILITY/ MAINTAINABILITY IMPACT
	MIL-R-8373A (ASG) Relay, Current, Type D-1 (115 Volts, 400-Cycle, Single Pole), dated 8 October 1954	Design Requirements: <ul style="list-style-type: none"> <li>● Environmental Conditions</li> <li>● Safety</li> <li>● Reliability Program</li> <li>● Maintainability Program</li> <li>● Electromagnetic Interference</li> <li>● Human Engineering</li> </ul> Quality Assurance: <ul style="list-style-type: none"> <li>● Quality Assurance Program</li> <li>● Responsibility for Inspection</li> </ul> Testing: <ul style="list-style-type: none"> <li>● Qualification Retest</li> <li>● Reliability Demonstration</li> <li>● Maintainability Demonstration</li> <li>● Environmental Testing</li> </ul>	Significant Significant Significant Significant Significant Significant  Major Major  Significant Significant Significant Significant

Figure 32 - Continued.

GENERIC CLASSIFICATION	DOCUMENT NUMBER, TITLE, REVISION, AMENDMENT, SUPPLEMENT AND DATES	DEFICIENCY	POTENTIAL RELIABILITY/ MAINTAINABILITY IMPACT
	MIL-P-81653 (AS) Power Controller, Solid State, General Specifications for Supplement 1, dated 17 November 1969	Design Requirements: <ul style="list-style-type: none"> <li>● Environmental Conditions</li> <li>● Interchangeability</li> <li>● Safety</li> <li>● Reliability Program</li> <li>● Maintainability Program</li> <li>● Human Engineering</li> </ul> Quality Assurance: <ul style="list-style-type: none"> <li>● Quality Assurance Program</li> </ul> Testing: <ul style="list-style-type: none"> <li>● Reliability Demonstration</li> <li>● Maintainability Demonstration</li> <li>● Environmental Testing</li> <li>● Qualification Retest</li> </ul>	Significant Significant Significant Significant Significant Significant Major Significant Significant Significant Significant

Figure 32 - Continued.

GENERIC CLASSIFICATION	DOCUMENT NUMBER, TITLE, REVISION, AMENDMENT, SUPPLEMENT AND DATES	DEFICIENCY	POTENTIAL RELIABILITY/ MAINTAINABILITY IMPACT
Relay, Phase Sequence Network	No applicable Military Specification was found to exist for Sequence Relays for helicopter applications.	<p>General:</p> <p>Military specifications imposing reliability, maintainability, quality assurance, qualification testing requirements and provisions are required to ensure that the design is compatible with the intended use.</p>	Significant
Transformer, Auto	MIL-T-9219 (USAF) Transformer, Power, Autotransformers, and Step Down, 400-Cycle Amendment 2, dated 4 June 1965	<p>Design Requirements:</p> <ul style="list-style-type: none"> <li>● Environmental Conditions</li> <li>● Safety</li> <li>● Reliability Program</li> <li>● Maintainability Program</li> <li>● Electromagnetic Interference</li> <li>● Human Engineering</li> </ul> <p>Quality Assurance:</p> <ul style="list-style-type: none"> <li>● Quality Assurance Program</li> <li>● Responsibility for Inspection</li> </ul> <p>Testing:</p> <ul style="list-style-type: none"> <li>● Qualification Retest</li> </ul>	<p>Significant</p> <p>Significant</p> <p>Significant</p> <p>Significant</p> <p>Significant</p> <p>Significant</p> <p>Major</p> <p>Major</p> <p>Significant</p>

Figure 32 - Continued.

GENERIC CLASSIFICATION	DOCUMENT NUMBER, TITLE, REVISION, AMENDMENT, SUPPLEMENT AND DATES	DEFICIENCY	POTENTIAL RELIABILITY/ MAINTAINABILITY IMPACT
Transformer, Current	MIL-T-5383 (USAF) Transformer, Current Type D-1 Amendment 1, dated 9 April 1954	<ul style="list-style-type: none"> <li>● Reliability Demonstration</li> <li>● Maintainability Demonstration</li> <li>● Environmental Testing</li> </ul> <p>Design Requirements:</p> <ul style="list-style-type: none"> <li>● Environmental Conditions</li> <li>● Safety</li> <li>● Reliability Program</li> <li>● Maintainability Program</li> <li>● Electromagnetic Interference</li> <li>● Human Engineering</li> </ul> <p>Quality Assurance:</p> <ul style="list-style-type: none"> <li>● Quality Assurance Program</li> <li>● Responsibility for Inspection</li> </ul> <p>Testing:</p> <ul style="list-style-type: none"> <li>● Qualification Retest</li> <li>● Reliability Demonstration</li> </ul>	<p>Significant</p> <p>Significant</p> <p>Significant</p> <p>Significant</p> <p>Significant</p> <p>Significant</p> <p>Significant</p> <p>Significant</p> <p>Significant</p> <p>Major</p> <p>Major</p> <p>Significant</p> <p>Significant</p>

Figure 3 - Continued.

GENERIC CLASSIFICATION	DOCUMENT NUMBER, TITLE, REVISION, AMENDMENT, SUPPLEMENT AND DATES	DEFICIENCY	POTENTIAL RELIABILITY/ MAINTAINABILITY IMPACT
	MIL-T-7210 (USAF) Transformer, Current, Type D-2 Amendment 1, dated 5 May 1958	<ul style="list-style-type: none"> <li>● Maintainability Demonstration</li> <li>● Environmental Testing</li> </ul> Design Requirements: <ul style="list-style-type: none"> <li>● Environmental Conditions</li> <li>● Safety</li> <li>● Reliability Program</li> <li>● Maintainability Program</li> <li>● Electromagnetic Interference</li> <li>● Human Engineering</li> </ul> Quality Assurance: <ul style="list-style-type: none"> <li>● Quality Assurance Program</li> <li>● Responsibility for Inspection</li> </ul> Testing: <ul style="list-style-type: none"> <li>● Qualification Retest</li> <li>● Reliability Demonstration</li> <li>● Maintainability Demonstration</li> <li>● Environmental Testing</li> </ul>	Significant Significant  Significant Significant Significant Significant Significant Significant  Major Major  Significant Significant Significant Significant

Figure 32 - Continued.



GENERIC CLASSIFICATION	DOCUMENT NUMBER, TITLE, REVISION, AMENDMENT, SUPPLEMENT AND DATES	DEFICIENCY	POTENTIAL RELIABILITY/ MAINTAINABILITY IMPACT
Battery	MIL-B-6146 Batteries, Storage, Shielded, General Specification for Revised 15 May 1950	Design Requirements: <ul style="list-style-type: none"> <li>● Interchangeability</li> <li>● Environmental Conditions</li> <li>● Safety</li> <li>● Reliability Program</li> <li>● Maintainability Program</li> <li>● Human Engineering</li> </ul> Quality Assurance: <ul style="list-style-type: none"> <li>● Quality Assurance Program</li> </ul> Testing: <ul style="list-style-type: none"> <li>● Reliability Demonstration</li> <li>● Maintainability Demonstration</li> <li>● Environmental Testing</li> </ul>	Significant Significant Significant Significant Significant Significant Major Significant Significant Significant
	MIL-B-6428A (USAF) Batteries, Lead Storage, Integrally Shielded, Lead-Acid Type, General Specification for Revised 28 October 1969	Design Requirements: <ul style="list-style-type: none"> <li>● Environmental Conditions</li> <li>● Workmanship</li> <li>● Safety</li> <li>● Reliability Program</li> </ul>	Significant Significant Significant Significant

Figure 33. Battery Circuit Document Deficiency Analysis.

GENERIC CLASSIFICATION	DOCUMENT NUMBER, TITLE, REVISION, AMENDMENT, SUPPLEMENT AND DATES	DEFICIENCY	POTENTIAL RELIABILITY/ MAINTAINABILITY IMPACT
		<ul style="list-style-type: none"> <li>● Maintainability Program</li> <li>● Human Engineering</li> </ul> <p>Quality Assurance:</p> <ul style="list-style-type: none"> <li>● Quality Assurance Program</li> </ul> <p>Testing:</p> <ul style="list-style-type: none"> <li>● Reliability Demonstration</li> <li>● Maintainability Demonstration</li> <li>● Environmental Testing</li> </ul>	<p>Significant</p> <p>Significant</p> <p>Major</p> <p>Significant</p> <p>Significant</p> <p>Significant</p>
	<p>MIL-B-8565G (AS)</p> <p>Batteries and Cells, Storage, Aircraft</p> <p>Revised 9 July 1971</p>	<p>Design Requirements:</p> <ul style="list-style-type: none"> <li>● Environmental Conditions</li> <li>● Safety</li> <li>● Workmanship</li> <li>● Reliability Program</li> <li>● Human Engineering</li> </ul> <p>Quality Assurance:</p> <ul style="list-style-type: none"> <li>● Quality Assurance Program</li> </ul>	<p>Significant</p> <p>Significant</p> <p>Significant</p> <p>Significant</p> <p>Significant</p> <p>Major</p>

Figure 33 - Continued.

GENERIC CLASSIFICATION	DOCUMENT NUMBER, TITLE, REVISION, AMENDMENT, SUPPLEMENT AND DATES	DEFICIENCY	POTENTIAL RELIABILITY/ MAINTAINABILITY IMPACT
	<p>MIL-B-26220C (USAF)</p> <p>Batteries, Storage, Aircraft, Nickel-Cadmium, General Specification for</p> <p>Amendment 2, dated 18 January 1971</p>	<p>Testing:</p> <ul style="list-style-type: none"> <li>● Reliability Demonstration</li> <li>● Maintainability Demonstration</li> <li>● Environmental Testing</li> </ul> <p>Design Requirements:</p> <ul style="list-style-type: none"> <li>● Environmental Conditions</li> <li>● Interchangeability</li> <li>● Safety</li> <li>● Reliability Program</li> <li>● Maintainability Program</li> <li>● Human Engineering</li> </ul> <p>Quality Assurance:</p> <ul style="list-style-type: none"> <li>● Quality Assurance Program</li> </ul> <p>Testing:</p> <ul style="list-style-type: none"> <li>● Reliability Demonstration</li> <li>● Maintainability Demonstration</li> <li>● Environmental Testing</li> </ul>	<p>Significant</p> <p>Significant</p> <p>Significant</p> <p>Significant</p> <p>Significant</p> <p>Significant</p> <p>Significant</p> <p>Significant</p> <p>Significant</p> <p>Major</p> <p>Significant</p> <p>Significant</p> <p>Significant</p>

Figure 33 - Continued.

GENERIC CLASSIFICATION	DOCUMENT NUMBER, TITLE, REVISION, AMENDMENT, SUPPLEMENT AND DATES	DEFICIENCY	POTENTIAL RELIABILITY/ MAINTAINABILITY IMPACT
Relay, Time Delay	No applicable Military Specifications was found to exist for Time Delay Relays.	<p>General:</p> <p>Military specifications imposing reliability, maintainability, quality assurance, qualification testing requirements, and provisions are required to ensure that the design is compatible with the intended use.</p>	Significant

Figure 33 - Continued.

GENERIC CLASSIFICATION	DOCUMENT NUMBER, TITLE, REVISION, AMENDMENT, SUPPLEMENT AND DATES	DEFICIENCY	POTENTIAL RELIABILITY/ MAINTAINABILITY IMPACT
Selector Switch Panel	No applicable Military Specification was found to exist for Selector Switch Panels.	<p>General:  Military specifications imposing reliability, maintainability, quality assurance, qualification testing requirements and provisions are required to ensure that the design is compatible with the intended use.</p>	Significant
Generator Control Panel	No applicable Military Specification was found to exist for Generator Control Panels.	<p>General:  Military specifications imposing reliability, maintainability, quality assurance, qualification testing requirements and provisions are required to ensure that the design is compatible with the intended use.</p>	Significant

Figure 34. Electrical Controls Circuit Document Deficiency Analysis.

GENERIC CLASSIFICATION	DOCUMENT NUMBER, TITLE, REVISION, AMENDMENT, SUPPLEMENT AND DATES	DEFICIENCY	POTENTIAL RELIABILITY/MAINTAINABILITY IMPACT
<p>External Power Receptacle</p>	<p>MIL-C-7974A Cable Assemblies, Plugs and Receptacles, External Power Notice 1, dated 15 June 1961</p>	<p>Design Requirements:</p> <ul style="list-style-type: none"> <li>● Design and Construction</li> <li>● Environmental Conditions</li> <li>● Interchangeability</li> <li>● Safety</li> <li>● Reliability Program</li> <li>● Maintainability Program</li> <li>● Human Engineering</li> <li>● Electromagnetic Interference</li> </ul> <p>Testing:</p> <ul style="list-style-type: none"> <li>● Qualification Retest</li> <li>● Reliability Demonstration</li> <li>● Maintainability Demonstration</li> <li>● Environmental Testing</li> </ul> <p>Quality Assurance:</p> <ul style="list-style-type: none"> <li>● Responsibility for Inspection</li> </ul>	<p>Insignificant Significant Significant Significant Significant Significant Significant Significant  Significant Significant Significant Significant  Major</p>

Figure 35. External Power Circuit Document Deficiency Analysis.

GENERIC CLASSIFICATION	DOCUMENT NUMBER, TITLE, REVISION, AMENDMENT, SUPPLEMENT AND DATES	DEFICIENCY	POTENTIAL RELIABILITY/ MAINTAINABILITY IMPACT
Monitor, Bus Contactor Relay	MIL-E-24021C Electric Power Monitors, External, Aircraft Revised 2 April 1965	Design Requirements: <ul style="list-style-type: none"> <li>● Environmental Conditions</li> <li>● Interchangeability</li> <li>● Workmanship</li> <li>● Safety</li> <li>● Reliability Program</li> <li>● Maintainability Program</li> <li>● Electromagnetic Interference</li> <li>● Human Engineering</li> </ul> Quality Assurance: <ul style="list-style-type: none"> <li>● Quality Assurance Program</li> </ul> Testing: <ul style="list-style-type: none"> <li>● Reliability Demonstration</li> <li>● Maintainability Demonstration</li> <li>● Environmental Testing</li> </ul>	Significant Significant Significant Significant Significant Significant Significant Significant Major Significant Significant Significant

Figure 35 - Continued.

GENERIC CLASSIFICATION	DOCUMENT NUMBER, TITLE, REVISION, AMENDMENT, SUPPLEMENT AND DATES	DEFICIENCY	POTENTIAL RELIABILITY/ MAINTAINABILITY IMPACT
	MIL-P-81653 (AS) Power Controller, Solid State, General Specification for Supplement 1, dated 17 November 1969	See Page 175 for Deficiency Analysis.	

Figure 35 - Continued.



GENERIC CLASSIFICATION	DOCUMENT NUMBER, TITLE, REVISION, AMENDMENT, SUPPLEMENT AND DATES	DEFICIENCY	POTENTIAL RELIABILITY/ MAINTAINABILITY IMPACT
Generator - Starter	MIL-G-6162B Generators and Starter-Generators, Electric, Direct Current, Nominal 30 Volts, Aircraft, General Specification for Revised 15 February 1972	Design Requirements: <ul style="list-style-type: none"> <li>● Environmental Conditions</li> <li>● Safety</li> <li>● Electromagnetic Interference</li> <li>● Human Engineering</li> </ul> Quality Assurance: <ul style="list-style-type: none"> <li>● Quality Assurance Program</li> </ul> Testing: <ul style="list-style-type: none"> <li>● Reliability Demonstration</li> <li>● Maintainability Demonstration</li> <li>● Environmental Testing</li> </ul>	Significant Significant Significant Significant Major Significant Significant Significant
Generator, Brush	MIL-G-6162B Generators and Starter-Generators, Electric, Direct Current, Nominal 30 Volts, Aircraft, General Specification for Revised 15 February 1972	See above, this page, for Deficiency Analysis.	

Figure 36. Direct Current Circuit Document Deficiency Analysis.

GENERIC CLASSIFICATION	DOCUMENT NUMBER, TITLE, REVISION, AMENDMENT, SUPPLEMENT AND DATES	DEFICIENCY	POTENTIAL RELIABILITY/ MAINTAINABILITY IMPACT
Converter, Transformer/ Rectifier	MIL-C-7115D Converters, Aircraft, General Specification for Supplement 1, dated 10 March 1970	Design Requirements: <ul style="list-style-type: none"> <li>● Safety</li> <li>● Reliability Program</li> <li>● Maintainability Program</li> <li>● Electromagnetic Interference</li> <li>● Human Engineering</li> </ul> Quality Assurance: <ul style="list-style-type: none"> <li>● Quality Assurance Program</li> </ul> Testing: <ul style="list-style-type: none"> <li>● Reliability Demonstration</li> <li>● Maintainability Demonstration</li> <li>● Environmental Testing</li> </ul>	Significant Significant Significant Significant Significant  Major  Significant Significant Significant
	MIL-P-26517A (USAF) Power Supply, Transformer-Rectifier, Aircraft, General Specification for Amendment 5, dated 13 October 1971	Design Requirements: <ul style="list-style-type: none"> <li>● Workmanship</li> <li>● Safety</li> <li>● Reliability Program</li> <li>● Maintainability Program</li> <li>● Human Engineering</li> </ul>	Significant Significant Significant Significant Significant

Figure 36 - Continued.

GENERIC CLASSIFICATION	DOCUMENT NUMBER, TITLE, REVISION, AMENDMENT, SUPPLEMENT AND DATES	DEFICIENCY	POTENTIAL RELIABILITY/ MAINTAINABILITY IMPACT
Regulator, Voltage	MIL-R-6809 Regulator, Voltage, 30-Volt, Direct Current, Generator, General Specification for Amendment 1, dated 14 December 1965	<p>Quality Assurance:</p> <ul style="list-style-type: none"> <li>● Quality Assurance Program</li> </ul> <p>Testing:</p> <ul style="list-style-type: none"> <li>● Reliability Demonstration</li> <li>● Maintainability Demonstration</li> <li>● Environmental Testing</li> </ul> <p>Design Requirements:</p> <ul style="list-style-type: none"> <li>● Environmental Conditions</li> <li>● Workmanship</li> <li>● Safety</li> <li>● Reliability Program</li> <li>● Maintainability Program</li> <li>● Electromagnetic Interference</li> <li>● Human Engineering</li> </ul> <p>Quality Assurance:</p> <ul style="list-style-type: none"> <li>● Quality Assurance Program</li> <li>● Responsibility for Inspection</li> </ul>	<p>Major</p> <p>Significant</p> <p>Significant</p> <p>Significant</p> <p>Significant</p> <p>Significant</p> <p>Significant</p> <p>Significant</p> <p>Significant</p> <p>Major</p> <p>Major</p>

Figure 36 - Continued.

GENERIC CLASSIFICATION	DOCUMENT NUMBER, TITLE, REVISION, AMENDMENT, SUPPLEMENT AND DATES	DEFICIENCY	POTENTIAL RELIABILITY/ MAINTAINABILITY IMPACT
	<p>MIL-R-23761 (WEP)</p> <p>Regulator, Voltage, Static, 28-Volt, Direct Current, Generator, General Specification for, dated 7 May 1963</p>	<p>Testing:</p> <ul style="list-style-type: none"> <li>● Reliability Demonstration</li> <li>● Maintainability Demonstration</li> <li>● Environmental Testing</li> </ul> <p>Design Requirements:</p> <ul style="list-style-type: none"> <li>● Environmental Conditions</li> <li>● Workmanship</li> <li>● Safety</li> <li>● Reliability Program</li> <li>● Maintainability Program</li> <li>● Electromagnetic Interference</li> <li>● Human Engineering</li> </ul> <p>Quality Assurance:</p> <ul style="list-style-type: none"> <li>● Quality Assurance Program</li> </ul> <p>Testing:</p> <ul style="list-style-type: none"> <li>● Reliability Demonstration</li> <li>● Maintainability Demonstration</li> <li>● Environmental Testing</li> </ul>	<p>Significant</p> <p>Significant</p> <p>Significant</p> <p>Significant</p> <p>Significant</p> <p>Significant</p> <p>Significant</p> <p>Significant</p> <p>Significant</p> <p>Significant</p> <p>Significant</p> <p>Major</p> <p>Significant</p> <p>Significant</p> <p>Significant</p>

Figure 36 - Continued.

GENERIC CLASSIFICATION	DOCUMENT NUMBER, TITLE, REVISION, AMENDMENT, SUPPLEMENT AND DATES	DEFICIENCY	POTENTIAL RELIABILITY/ MAINTAINABILITY IMPACT
Relay, Bus Control	MIL-R-6463A Relay, Generator Equalizer Bus, Type A-1, dated 31 December 1952	Design Requirements: <ul style="list-style-type: none"> <li>● Environmental Conditions</li> <li>● Safety</li> <li>● Reliability Program</li> <li>● Maintainability Program</li> <li>● Electromagnetic Interference</li> <li>● Human Engineering</li> </ul> Quality Assurance: <ul style="list-style-type: none"> <li>● Quality Assurance Program</li> <li>● Responsibility for Inspection</li> </ul> Testing: <ul style="list-style-type: none"> <li>● Qualification Retest</li> <li>● Reliability Demonstration</li> <li>● Maintainability Demonstration</li> <li>● Environmental Testing</li> </ul> General:           Document has not been updated for over 20 years.	Significant Significant Significant Significant Significant Significant Major Major Significant Significant Significant Significant Significant

Figure 36 - Continued.

GENERIC CLASSIFICATION	DOCUMENT NUMBER, TITLE, REVISION, AMENDMENT, SUPPLEMENT AND DATES	DEFICIENCY	POTENTIAL RELIABILITY/ MAINTAINABILITY IMPACT
Relay, Overvoltage	<p>MIL-P-81653 (AS)  Power Controller, Solid State, General Specification for Supplement 1, dated 17 November 1969</p> <p>MIL-C-5026E  Cutout Relay, Engine Generator, dated 18 January 1971</p>	<p>General:  See Page 175 for Deficiency Analysis.</p> <p>Design Requirements:</p> <ul style="list-style-type: none"> <li>● Environmental Conditions</li> <li>● Safety</li> <li>● Reliability Program</li> <li>● Maintainability Program</li> <li>● Electromagnetic Interference</li> <li>● Human Engineering</li> </ul> <p>Quality Assurance:</p> <ul style="list-style-type: none"> <li>● Quality Assurance Program</li> </ul> <p>Testing:</p> <ul style="list-style-type: none"> <li>● Reliability Demonstration</li> <li>● Maintainability Demonstration</li> </ul>	<p>Significant</p> <p>Significant</p> <p>Significant</p> <p>Significant</p> <p>Significant</p> <p>Significant</p> <p>Major</p> <p>Significant</p> <p>Significant</p>

Figure 36 - Continued.

GENERIC CLASSIFICATION	DOCUMENT NUMBER, TITLE, REVISION, AMENDMENT, SUPPLEMENT AND DATES	DEFICIENCY	POTENTIAL RELIABILITY/ MAINTAINABILITY IMPACT
	<p>MIL-F-81653 (AS)            Power Controller, Solid State, General Specification for Supplement 1, dated 17 November 1969</p>	<ul style="list-style-type: none"> <li>● Environmental Testing</li> </ul> <p>General:            See Page 175 for Deficiency Analysis.</p>	<p>Significant</p> <p>Significant</p>
<p>Relay, Reverse Current</p>	<p>MIL-R-9162            Relay, Generator, Reverse Current, 120 Volt DC, 250 Amperes, Type Q-1, dated 29 September 1953</p>	<p>Design Requirements:</p> <ul style="list-style-type: none"> <li>● Environmental Conditions</li> <li>● Safety</li> <li>● Reliability Program</li> <li>● Maintainability Program</li> <li>● Electromagnetic Interference</li> <li>● Human Engineering</li> </ul> <p>Quality Assurance:</p> <ul style="list-style-type: none"> <li>● Quality Assurance Program</li> <li>● Responsibility for Inspection</li> </ul>	<p>Significant</p> <p>Significant</p> <p>Significant</p> <p>Significant</p> <p>Significant</p> <p>Significant</p> <p>Major</p> <p>Major</p>

Figure 36 - Continued.

GENERIC CLASSIFICATION	DOCUMENT NUMBER, TITLE, REVISION, AMENDMENT, SUPPLEMENT AND DATES	DEFICIENCY	POTENTIAL RELIABILITY/ MAINTAINABILITY IMPACT
		Testing: <ul style="list-style-type: none"> <li>● Qualification Retest</li> <li>● Reliability Demonstration</li> <li>● Maintainability Demonstration</li> <li>● Environmental Testing</li> </ul>	Significant Significant Significant Significant

Figure 36 - Continued.



GENERIC CLASSIFICATION	DOCUMENT NUMBER, TITLE, REVISION, AMENDMENT, SUPPLEMENT AND DATES	DEFICIENCY	POTENTIAL RELIABILITY/ MAINTAINABILITY IMPACT
Actuator, Trim	MIL-A-8064B (USAF) Actuators and Actuating Systems, Aircraft, Electromechanical, General Requirements for Revised 22 January 1970	Design Requirements: <ul style="list-style-type: none"> <li>• Environmental Conditions</li> <li>• Safety</li> <li>• Human Engineering</li> </ul> Quality Assurance: <ul style="list-style-type: none"> <li>• Quality Assurance Program</li> </ul> Testing: <ul style="list-style-type: none"> <li>• Qualification Retest</li> <li>• Reliability Demonstration</li> <li>• Maintainability Demonstration</li> <li>• Environmental Testing</li> </ul>	Significant Significant Significant  Major  Significant Significant Significant Significant
	MIL-A-23622 (WEP) Actuator, Aircraft, Electromechanical, Linear, Direct Current, dated 15 April 1963	Design Requirements: <ul style="list-style-type: none"> <li>• Environmental Conditions</li> <li>• Safety</li> <li>• Reliability Program</li> </ul>	Significant Significant Significant

Figure 37. Load Circuit Document Deficiency Analysis.

GENERIC CLASSIFICATION	DOCUMENT NUMBER, TITLE, REVISION, AMENDMENT, SUPPLEMENT AND DATES	DEFICIENCY	POTENTIAL RELIABILITY/ MAINTAINABILITY IMPACT
<p>Motor, Alternating Current</p>	<p>MIL-M-7969C Motors, Alternating Current, 400-Cycle, 115/200 Volt System, Aircraft, General Specification for Revised 25 May 1965</p>	<ul style="list-style-type: none"> <li>● Maintainability Program</li> <li>● Human Engineering</li> </ul> <p>Quality Assurance:</p> <ul style="list-style-type: none"> <li>● Quality Assurance Program</li> </ul> <p>Testing:</p> <ul style="list-style-type: none"> <li>● Qualification Retest</li> <li>● Maintainability Demonstration</li> <li>● Reliability Demonstration</li> <li>● Environmental Testing</li> </ul> <p>Design Requirements:</p> <ul style="list-style-type: none"> <li>● Environmental Conditions</li> <li>● Safety</li> <li>● Reliability Program</li> <li>● Maintainability Program</li> <li>● Human Engineering</li> </ul>	<p>Significant Significant</p> <p>Major</p> <p>Significant Significant Significant Significant</p> <p>Significant Significant Significant Significant</p>

Figure 37 - Continued.

GENERIC CLASSIFICATION	DOCUMENT NUMBER, TITLE, REVISION, AMENDMENT, SUPPLEMENT AND DATES	DEFICIENCY	POTENTIAL RELIABILITY/ MAINTAINABILITY IMPACT
Motor, Direct Current	MIL-M-8609B Motors, Direct Current, 28-Volt System, General Aircraft, General Specification for Revised 26 July 1965	Quality Assurance: <ul style="list-style-type: none"> <li>● Quality Assurance Program</li> </ul> Testing: <ul style="list-style-type: none"> <li>● Qualification Retest</li> <li>● Reliability Demonstration</li> <li>● Maintainability Demonstration</li> <li>● Environmental Testing</li> </ul> Design Requirements: <ul style="list-style-type: none"> <li>● Environmental Conditions</li> <li>● Safety</li> <li>● Reliability Program</li> <li>● Maintainability Program</li> <li>● Human Engineering</li> </ul> Quality Assurance: <ul style="list-style-type: none"> <li>● Quality Assurance Program</li> </ul>	Major  Significant Significant Significant Significant   Significant Significant Significant Significant Significant  Major

Figure 37 - Continued.

GENERIC CLASSIFICATION	DOCUMENT NUMBER, TITLE, REVISION, AMENDMENT, SUPPLEMENT AND DATES	DEFICIENCY	POTENTIAL RELIABILITY/ MAINTAINABILITY IMPACT
		Testing: <ul style="list-style-type: none"> <li>● Qualification Retest</li> <li>● Reliability Demonstration</li> <li>● Maintainability Demonstration</li> <li>● Environmental Testing</li> </ul>	Significant Significant Significant Significant

Figure 37 - Continued.

GENERIC CLASSIFICATION	DOCUMENT NUMBER, TITLE, REVISION, AMENDMENT, SUPPLEMENT AND DATES	DEFICIENCY	POTENTIAL RELIABILITY/ MAINTAINABILITY IMPACT
Cable	<p>MIL-C-5756B Cable and Wire, Power, Electric, Portable Amendment 4, dated 9 June 1972</p> <p>MIL-C-7078C Cable, Electric, Aerospace Vehicle, General Specification for Supplement 1, dated 9 August 1971</p>	<p>Design Requirements:</p> <ul style="list-style-type: none"> <li>● Interchangeability</li> <li>● Safety</li> <li>● Reliability Program</li> <li>● Maintainability Program</li> <li>● Human Engineering</li> </ul> <p>Quality Assurance:</p> <ul style="list-style-type: none"> <li>● Quality Assurance Program</li> <li>● Responsibility for Inspection</li> </ul> <p>Testing</p> <ul style="list-style-type: none"> <li>● Reliability Demonstration</li> <li>● Maintainability Demonstration</li> </ul> <p>Design Requirements:</p> <ul style="list-style-type: none"> <li>● Interchangeability</li> <li>● Safety</li> <li>● Reliability Program</li> <li>● Maintainability Program</li> <li>● Human Engineering</li> </ul>	<p>Significant</p> <p>Significant</p> <p>Significant</p> <p>Significant</p> <p>Significant</p> <p>Major</p> <p>Major</p> <p>Significant</p> <p>Significant</p> <p>Significant</p> <p>Significant</p> <p>Significant</p> <p>Significant</p>

Figure 38. Electrical Component Parts Document Deficiency Analysis.

GENERIC CLASSIFICATION	DOCUMENT NUMBER, TITLE, REVISION, AMENDMENT, SUPPLEMENT AND DATES	DEFICIENCY	POTENTIAL RELIABILITY/ MAINTAINABILITY IMPACT
		<p>Quality Assurance:</p> <ul style="list-style-type: none"> <li>● Quality Assurance Program</li> <li>● Responsibility for Inspection</li> </ul> <p>Testing:</p> <ul style="list-style-type: none"> <li>● Reliability Demonstration</li> <li>● Maintainability Demonstration</li> <li>● Qualification Retest</li> </ul> <p>General:</p> <p>See Page 184 for Deficiency Analysis</p>	<p>Major</p> <p>Major</p> <p>Significant</p> <p>Significant</p> <p>Significant</p>
	<p>MIL-C-7974A</p> <p>Power Controller, Solid-State, General Specification for Supplement 1, dated 17 November 1969</p>	<p>Design Requirements</p> <ul style="list-style-type: none"> <li>● Interchangeability</li> <li>● Safety</li> <li>● Reliability Program</li> <li>● Maintainability Program</li> <li>● Human Engineering</li> </ul>	<p>Significant</p> <p>Significant</p> <p>Significant</p> <p>Significant</p> <p>Significant</p>
	<p>MIL-C-27072A</p> <p>Cable, Special Purpose Electrical, Multiconductor Supplement 1C, dated 7 August 1969</p>		

Figure 38 - Continued.

GENERIC CLASSIFICATION	DOCUMENT NUMBER, TITLE, REVISION, AMENDMENT, SUPPLEMENT AND DATES	DEFICIENCY	POTENTIAL RELIABILITY/ MAINTAINABILITY IMPACT
		Quality Assurance: <ul style="list-style-type: none"> <li>● Quality Assurance Program</li> <li>● Responsibility for Inspection</li> </ul> Testing: <ul style="list-style-type: none"> <li>● Reliability Demonstration</li> <li>● Maintainability Demonstration</li> <li>●</li> </ul> Design Requirements: <ul style="list-style-type: none"> <li>● Interchangeability</li> <li>● Safety</li> <li>● Reliability Program</li> <li>● Maintainability Program</li> <li>● Human Engineering</li> </ul> Quality Assurance: <ul style="list-style-type: none"> <li>● Quality Assurance Program</li> <li>● Responsibility for Inspection</li> </ul> Testing: <ul style="list-style-type: none"> <li>● Reliability Demonstration</li> <li>● Maintainability Demonstration</li> </ul>	Major Major  Significant Significant  Significant Significant Significant Significant Significant  Major Major  Significant Significant
	MIL-C-27500A (USAF) Cable, Electrical, Shielded and Unshielded, Aircraft and Missile Amendment 2, dated 24 February 1971		

Figure 38 - Continued.

GENERIC CLASSIFICATION	DOCUMENT NUMBER, TITLE, REVISION, AMENDMENT, SUPPLEMENT AND DATES	DEFICIENCY	POTENTIAL RELIABILITY/ MAINTAINABILITY IMPACT
Capacitor	MIL-C-55543A Cable, Electrical, Flat Multiconductor, Flexible, Unshielded Supplement 1, dated 6 October 1971	Design Requirements: <ul style="list-style-type: none"> <li>● Interchangeability</li> <li>● Safety</li> <li>● Reliability Program</li> <li>● Maintainability Program</li> <li>● Human Engineering</li> </ul> Quality Assurance: <ul style="list-style-type: none"> <li>● Quality Assurance Program</li> <li>● Responsibility for Inspection</li> </ul> Testing: <ul style="list-style-type: none"> <li>● Qualification Retest</li> <li>● Reliability Demonstration</li> <li>● Maintainability Demonstration</li> </ul> General: No deficiencies were noted which would have impact on reliability or maintainability.	Significant Significant Significant Significant Significant  Major Major  Significant Significant Significant  Insignificant

Figure 38 - Continued.



GENERIC CLASSIFICATION	DOCUMENT NUMBER, TITLE, REVISION, AMENDMENT, SUPPLEMENT AND DATES	DEFICIENCY	POTENTIAL RELIABILITY/ MAINTAINABILITY IMPACT
Circuit Breaker	MIL-C-5809F Circuit Breakers, Trip-Free, Aircraft, General Specification for Supplement 1, dated 27 April 1972	Design Requirements: <ul style="list-style-type: none"> <li>• Safety</li> <li>• Reliability Program</li> <li>• Maintainability Program</li> <li>• Electromagnetic Interference</li> <li>• Human Engineering</li> </ul> Quality Assurance: <ul style="list-style-type: none"> <li>• Quality Assurance Program</li> <li>• Responsibility for Inspection</li> </ul> Testing: <ul style="list-style-type: none"> <li>• Qualification Retest</li> <li>• Reliability Demonstration</li> <li>• Maintainability Demonstration</li> </ul>	Significant Significant Significant Significant Significant  Major Major  Significant Significant Significant
	MIL-C-7079A (USAF) Circuit Breaker, Non-trip-free, General Specification for Amendment 1, dated 23 March 1967	Design Requirements: <ul style="list-style-type: none"> <li>• Safety</li> <li>• Reliability Program</li> <li>• Maintainability Program</li> <li>• Electromagnetic Interference</li> <li>• Human Engineering</li> </ul>	Significant Significant Significant Significant Significant

Figure 38 - Continued.

GENERIC CLASSIFICATION	DOCUMENT NUMBER, TITLE, REVISION, AMENDMENT, SUPPLEMENT AND DATES	DEFICIENCY	POTENTIAL RELIABILITY/ MAINTAINABILITY IMPACT
		Quality Assurance: ● Quality Assurance Program ● Responsibility for Inspection Testing: ● Qualification Retest ● Reliability Demonstration ● Maintainability Demonstration	Major Major Significant Significant Significant
	MIL-C-8379A (ASG) Circuit Breaker, Electrically Operated, 3-Pole, Type A-1 Amendment 4, dated 26 December 1957	Design Requirements: ● Safety ● Reliability Program ● Maintainability Program ● Electromagnetic Interference ● Human Engineering Quality Assurance: ● Quality Assurance Program ● Responsibility for Inspection Testing: ● Qualification Retest	Significant Significant Significant Significant Significant Major Major Significant

Figure 38 - Continued.

GENERIC CLASSIFICATION	DOCUMENT NUMBER, TITLE, REVISION, AMENDMENT, SUPPLEMENT AND DATES	DEFICIENCY	POTENTIAL RELIABILITY/ MAINTAINABILITY IMPACT
Compound	<p>MIL-S-8516C</p> <p>Sealing Compound, Synthetic Rubber, Electric Connectors and Accelerator Required</p> <p>Amendment 2, dated 21 June 1968</p>	<ul style="list-style-type: none"> <li>● Reliability Demonstration</li> <li>● Maintainability Demonstration</li> </ul> <p>Design Requirements:</p> <ul style="list-style-type: none"> <li>● Product Identification</li> <li>● Workmanship</li> <li>● Safety</li> <li>● Reliability Program</li> <li>● Maintainability Program</li> <li>● Human Engineering</li> </ul> <p>Quality Assurance:</p> <ul style="list-style-type: none"> <li>● Quality Assurance Program</li> </ul> <p>Testing:</p> <ul style="list-style-type: none"> <li>● Reliability Demonstration</li> <li>● Maintainability Demonstration</li> <li>● Qualification Retest</li> </ul>	<p>Significant</p> <p>Significant</p> <p>Insignificant</p> <p>Significant</p> <p>Significant</p> <p>Significant</p> <p>Significant</p> <p>Significant</p> <p>Major</p> <p>Significant</p> <p>Significant</p> <p>Significant</p>

Figure 38 - Continued.

GENERIC CLASSIFICATION	DOCUMENT NUMBER, TITLE, REVISION, AMENDMENT, SUPPLEMENT AND DATES	DEFICIENCY	POTENTIAL RELIABILITY/ MAINTAINABILITY IMPACT
	MIL-S-23586C Sealing Compound, Electrical, Silicone Rubber, Accelerator Required Amendment 2, dated 12 June 1972	Design Requirements: <ul style="list-style-type: none"> <li>● Safety</li> <li>● Reliability Program</li> <li>● Maintainability Program</li> <li>● Human Engineering</li> </ul> Quality Assurance: <ul style="list-style-type: none"> <li>● Quality Assurance Program</li> </ul> Testing: <ul style="list-style-type: none"> <li>● Reliability Demonstration</li> <li>● Maintainability Demonstration</li> <li>● Qualification Retest</li> </ul>	Significant Significant Significant Significant Major Significant Significant Significant

Figure 38 - Continued.

GENERIC CLASSIFICATION	DOCUMENT NUMBER, TITLE, REVISION, AMENDMENT, SUPPLEMENT AND DATES	DEFICIENCY	POTENTIAL RELIABILITY/ MAINTAINABILITY IMPACT
	MIL-M-24041 (SHIPS) Molding and Potting Compound, Chemically Cured, Polyurethane (Poly-ether Based) Amendment 3, dated 15 March 1971	Design Requirements: <ul style="list-style-type: none"> <li>● Product Identification</li> <li>● Safety</li> <li>● Reliability Program</li> <li>● Maintainability Program</li> <li>● Human Engineering</li> </ul> Quality Assurance: <ul style="list-style-type: none"> <li>● Quality Assurance Program</li> </ul> Testing: <ul style="list-style-type: none"> <li>● Qualification Retest</li> <li>● Reliability Demonstration</li> <li>● Maintainability Demonstration</li> </ul>	Significant Significant Significant Significant Significant  Major  Significant Significant Significant
Conduit	MIL-C-6136A Conduit, Electrical, Flexible, Shielded, Aluminum Alloy for Aircraft Installations, dated 10 December 1965	Design Requirements: <ul style="list-style-type: none"> <li>● Interchangeability</li> <li>● Safety</li> <li>● Reliability Program</li> <li>● Maintainability Program</li> </ul>	Significant Significant Significant Significant

Figure 38 - Continued.

GENERIC CLASSIFICATION	DOCUMENT NUMBER, TITLE, REVISION, AMENDMENT, SUPPLEMENT AND DATES	DEFICIENCY	POTENTIAL RELIABILITY/ MAINTAINABILITY IMPACT
Connectors	MIL-C-18148C Connector, Plug, Electrical, Quick-disconnect, Battery Amendment 2, dated 21 April 1972	<ul style="list-style-type: none"> <li>● Human Engineering Testing:</li> <li>● Reliability Demonstration</li> <li>● Maintainability Demonstration</li> </ul> Design Requirements: <ul style="list-style-type: none"> <li>● Environmental Conditions</li> <li>● Interchangeability</li> <li>● Workmanship</li> <li>● Safety</li> <li>● Electromagnetic Interference</li> <li>● Reliability Program</li> <li>● Maintainability Program</li> <li>● Human Engineering</li> </ul> Quality Assurance: <ul style="list-style-type: none"> <li>● Quality Assurance Program</li> <li>● Responsibility for Inspection</li> </ul>	Significant  Significant Significant   Significant Significant Significant Significant Significant Significant Significant  Major Major

Figure 38 - Continued.

GENERIC CLASSIFICATION	DOCUMENT NUMBER, TITLE, REVISION, AMENDMENT, SUPPLEMENT AND DATES	DEFICIENCY	POTENTIAL RELIABILITY/ MAINTAINABILITY IMPACT
		<b>Testing:</b> <ul style="list-style-type: none"> <li>● Qualification Retest</li> <li>● Reliability Demonstration</li> <li>● Maintainability Demonstration</li> <li>● Environmental Testing</li> </ul>	Significant Significant Significant Significant
	MIL-C-21097C Connector, Electrical, Printed Wiring Board, General Purpose, General Specification for Amendment 2, dated 30 May 1972	<b>Design Requirements:</b> <ul style="list-style-type: none"> <li>● Interchangeability</li> <li>● Safety</li> <li>● Reliability Program</li> <li>● Maintainability Program</li> <li>● Human Engineering</li> <li>● Electromagnetic Interference</li> </ul> <b>Testing:</b> <ul style="list-style-type: none"> <li>● Qualification Retest</li> <li>● Reliability Demonstration</li> <li>● Maintainability Demonstration</li> </ul> <b>Quality Assurance:</b> <ul style="list-style-type: none"> <li>● Responsibility for Inspection</li> </ul>	Significant Significant Significant Significant Significant Significant Significant Significant Significant Significant Significant Significant Significant Major

Figure 38 - Continued.

GENERIC CLASSIFICATION	DOCUMENT NUMBER, TITLE, REVISION, AMENDMENT, SUPPLEMENT AND DATES	DEFICIENCY	POTENTIAL RELIABILITY/ MAINTAINABILITY IMPACT
	MIL-C-23216C (NAVY) Contact, Electric Connector, General Specification for Supplement 1A, dated 27 March 1972	Design Requirements: <ul style="list-style-type: none"> <li>● Interchangeability</li> <li>● Safety</li> <li>● Reliability Program</li> <li>● Maintainability Program</li> <li>● Human Engineering</li> </ul> Quality Assurance: <ul style="list-style-type: none"> <li>● Quality Assurance Program</li> </ul> Testing: <ul style="list-style-type: none"> <li>● Qualification Retest</li> <li>● Reliability Demonstration</li> <li>● Maintainability Demonstration</li> </ul>	Significant Significant Significant Significant Significant  Major  Significant Significant Significant
	MIL-C-24308A Connector, Electric, Rectangular, Miniature, Polarized Shell, Rack and Panel, General Specification for Amendment 3, dated 15 May 1972	Design Requirements: <ul style="list-style-type: none"> <li>● Safety</li> <li>● Reliability Program</li> <li>● Maintainability Program</li> <li>● Human Engineering</li> </ul>	Significant Significant Significant Significant

Figure 38 - Continued.



GENERIC CLASSIFICATION	DOCUMENT NUMBER, TITLE, REVISION, AMENDMENT, SUPPLEMENT AND DATES	DEFICIENCY	POTENTIAL RELIABILITY/ MAINTAINABILITY IMPACT
	<p>MIL-C-26482E  Connector, Electric, Circular, Miniature, Quick Disconnect, Environment Resisting, dated 29 May 1969</p>	<p>Testing:</p> <ul style="list-style-type: none"> <li>● Qualification Retest</li> <li>● Reliability Demonstration</li> <li>● Maintainability Demonstration</li> </ul> <p>Quality Assurance:</p> <ul style="list-style-type: none"> <li>● Responsibility for Inspection</li> </ul> <p>Design Requirements:</p> <ul style="list-style-type: none"> <li>● Safety</li> <li>● Reliability Program</li> <li>● Maintainability Program</li> <li>● Electromagnetic Interference</li> <li>● Human Engineering</li> </ul> <p>Quality Assurance:</p> <ul style="list-style-type: none"> <li>● Quality Assurance Program</li> <li>● Responsibility for Inspection</li> </ul> <p>Testing:</p> <ul style="list-style-type: none"> <li>● Qualification Retest</li> <li>● Reliability Demonstration</li> </ul>	<p>Significant  Significant  Significant</p> <p>Major</p> <p>Significant  Significant  Significant  Significant  Significant</p> <p>Major  Major</p> <p>Significant  Significant</p>

Figure 38 - Continued.

GENERIC CLASSIFICATION	DOCUMENT NUMBER, TITLE, REVISION, AMENDMENT, SUPPLEMENT AND DATES	DEFICIENCY	POTENTIAL RELIABILITY/ MAINTAINABILITY IMPACT
	<p>MIL-C-26518B (USAF) Connector, Electrical, Miniature, Rack and Panel, Environment Resisting, 200°C Ambient Temperature Amendment 1, dated 23 June 1972</p>	<ul style="list-style-type: none"> <li>● Maintainability Demonstration</li> </ul> <p>Design Requirements:</p> <ul style="list-style-type: none"> <li>● Safety</li> <li>● Reliability Program</li> <li>● Maintainability Program</li> <li>● Human Engineering</li> <li>● Electromagnetic Interference</li> </ul> <p>Quality Assurance:</p> <ul style="list-style-type: none"> <li>● Quality Assurance Program</li> <li>● Responsibility for Inspection</li> </ul> <p>Testing:</p> <ul style="list-style-type: none"> <li>● Reliability Demonstration</li> <li>● Maintainability Demonstration</li> </ul>	<p>Significant</p> <p>Significant</p> <p>Significant</p> <p>Significant</p> <p>Significant</p> <p>Significant</p> <p>Major</p> <p>Major</p> <p>Significant</p> <p>Significant</p>
	<p>MIL-C-26636A (USAF) Contact, Crimp-Type For Electrical Connectors, dated 21 September 1961</p>	<p>Design Requirements:</p> <ul style="list-style-type: none"> <li>● Interchangeability</li> <li>● Safety</li> <li>● Reliability Program</li> </ul>	<p>Significant</p> <p>Significant</p> <p>Significant</p>

Figure 38 - Continued.

GENERIC CLASSIFICATION	DOCUMENT NUMBER, TITLE, REVISION, AMENDMENT, SUPPLEMENT AND DATES	DEFICIENCY	POTENTIAL RELIABILITY/ MAINTAINABILITY IMPACT
		<ul style="list-style-type: none"> <li>● Maintainability Program</li> <li>● Human Engineering</li> </ul> <p>Quality Assurance:</p> <ul style="list-style-type: none"> <li>● Quality Assurance Program</li> <li>● Responsibility for Inspection</li> </ul> <p>Testing:</p> <ul style="list-style-type: none"> <li>● Qualification Retest</li> <li>● Reliability Demonstration</li> <li>● Maintainability Demonstration</li> </ul>	<p>Significant</p> <p>Significant</p> <p>Major</p> <p>Major</p>
	<p>MIL-C-38300A (USAF)</p> <p>Connector, Electrical, Circular, Multicontact, High Density, Quick Disconnect, Environment Resistant, Removable Crimp Contacts</p> <p>Interim Amendment 2, dated 7 April 1972</p>	<p>Design Requirements:</p> <ul style="list-style-type: none"> <li>● Safety</li> <li>● Reliability Program</li> <li>● Maintainability Program</li> <li>● Electromagnetic Interference</li> <li>● Human Engineering</li> </ul> <p>Quality Assurance:</p> <ul style="list-style-type: none"> <li>● Quality Assurance Program</li> <li>● Responsibility for Inspection</li> </ul>	<p>Significant</p> <p>Significant</p> <p>Significant</p> <p>Significant</p> <p>Significant</p> <p>Major</p> <p>Major</p>

Figure 38 - Continued.

GENERIC CLASSIFICATION	DOCUMENT NUMBER, TITLE, REVISION, AMENDMENT, SUPPLEMENT AND DATES	DEFICIENCY	POTENTIAL RELIABILITY/ MAINTAINABILITY IMPACT
	<p>MIL-C-38999C  Connector, Electrical, Circular, Miniature, High Density, Quick Disconnect, Environment Resistant, Removable Crimp Contacts  Interim Amendment 2 dated 7 April 1972</p>	<p>Testing:</p> <ul style="list-style-type: none"> <li>● Qualification Retest</li> <li>● Reliability Demonstration</li> <li>● Maintainability Demonstration</li> <li>● Environmental Testing</li> </ul> <p>Design Requirements:</p> <ul style="list-style-type: none"> <li>● Safety</li> <li>● Reliability Program</li> <li>● Maintainability Program</li> <li>● Electromagnetic Interference</li> <li>● Human Engineering</li> </ul> <p>Quality Assurance:</p> <ul style="list-style-type: none"> <li>● Quality Assurance Program</li> <li>● Responsibility for Inspection</li> </ul> <p>Testing:</p> <ul style="list-style-type: none"> <li>● Qualification Retest</li> </ul>	<p>Significant  Significant  Significant  Significant</p> <p>Significant  Significant  Significant  Significant  Significant</p> <p>Major  Major</p> <p>Significant</p>

Figure 38 - Continued.

GENERIC CLASSIFICATION	DOCUMENT NUMBER, TITLE, REVISION, AMENDMENT, SUPPLEMENT AND DATES	DEFICIENCY	POTENTIAL RELIABILITY/ MAINTAINABILITY IMPACT
	<p>MIL-C-39029  Contact, Electric,  General Specification for  Supplement 1C, dated  16 June 1972</p>	<ul style="list-style-type: none"> <li>● Reliability Demonstration</li> <li>● Maintainability Demonstration</li> </ul> <p>Design Requirements:</p> <ul style="list-style-type: none"> <li>● Interchangeability</li> <li>● Safety</li> <li>● Reliability Program</li> <li>● Maintainability Program</li> <li>● Human Engineering</li> </ul> <p>Quality Assurance:</p> <ul style="list-style-type: none"> <li>● Quality Assurance Program</li> </ul> <p>Testing:</p> <ul style="list-style-type: none"> <li>● Qualification Retest</li> <li>● Reliability Demonstration</li> <li>● Maintainability Demonstration</li> </ul>	<p>Significant</p> <p>Significant</p> <p>Significant</p> <p>Significant</p> <p>Significant</p> <p>Significant</p> <p>Major</p> <p>Significant</p> <p>Significant</p> <p>Significant</p>

Figure 38 - Continued.

GENERIC CLASSIFICATION	DOCUMENT NUMBER, TITLE, REVISION, AMENDMENT, SUPPLEMENT AND DATES	DEFICIENCY	POTENTIAL RELIABILITY/ MAINTAINABILITY IMPACT
	<p>MIL-C-55544A  Connector, Electrical, Environment Resistant, For Use With Flat Conductor Cable and Round Wire, General Specification for Supplement 1, dated 25 June 1971</p>	<p>Design Requirements:</p> <ul style="list-style-type: none"> <li>● Safety</li> <li>● Reliability Program</li> <li>● Maintainability Program</li> <li>● Electromagnetic Interference</li> <li>● Human Engineering</li> </ul> <p>Quality Assurance:</p> <ul style="list-style-type: none"> <li>● Quality Assurance Program</li> <li>● Responsibility for Inspection</li> </ul> <p>Testing:</p> <ul style="list-style-type: none"> <li>● Qualification Retest</li> <li>● Reliability Demonstration</li> <li>● Maintainability Demonstration</li> <li>● Test Witness</li> </ul>	<p>Significant  Significant  Significant  Significant  Significant</p> <p>Major  Major</p> <p>Significant  Significant  Significant  Significant</p> <p>Significant  Significant  Significant  Significant</p>
	<p>MIL-C-83723A (USAF)  Connector, Electrical, Circular, Environment Resisting, General Specification for Amendment 1, dated 30 June 1972</p>	<p>Design Requirements:</p> <ul style="list-style-type: none"> <li>● Safety</li> <li>● Reliability Program</li> <li>● Maintainability Program</li> </ul>	<p>Significant  Significant  Significant</p> <p>Significant  Significant  Significant</p>

Figure 38 - Continued.

GENERIC CLASSIFICATION	DOCUMENT NUMBER, TITLE, REVISION, AMENDMENT, SUPPLEMENT AND DATES	DEFICIENCY	POTENTIAL RELIABILITY/ MAINTAINABILITY IMPACT
		<ul style="list-style-type: none"> <li>● Human Engineering</li> </ul> <p>Quality Assurance:</p> <ul style="list-style-type: none"> <li>● Quality Assurance Program</li> <li>● Responsibility for Inspection</li> </ul> <p>Testing:</p> <ul style="list-style-type: none"> <li>● Qualification Retest</li> <li>● Test Witness</li> <li>● Reliability Demonstration</li> <li>● Maintainability Demonstration</li> </ul>	<p>Significant</p> <p>Major</p> <p>Major</p> <p>Significant</p> <p>Significant</p> <p>Significant</p> <p>Significant</p>
Fuse	<p>MIL-F-5372C (ASG)</p> <p>Fuse, Current Limiter Type, Aircraft Amendment 2, dated 20 April 1965</p>	<p>Design Requirements:</p> <ul style="list-style-type: none"> <li>● Interchangeability</li> <li>● Safety</li> <li>● Reliability Program</li> <li>● Maintainability Program</li> <li>● Human Engineering</li> </ul> <p>Quality Assurance:</p> <ul style="list-style-type: none"> <li>● Quality Assurance Program</li> </ul>	<p>Significant</p> <p>Significant</p> <p>Significant</p> <p>Significant</p> <p>Significant</p> <p>Major</p>

Figure 38 - Continued.

GENERIC CLASSIFICATION	DOCUMENT NUMBER, TITLE, REVISION, AMENDMENT, SUPPLEMENT AND DATES	DEFICIENCY	POTENTIAL RELIABILITY/ MAINTAINABILITY IMPACT
		<ul style="list-style-type: none"> <li>● Responsibility for Inspection</li> </ul>	Major
		Testing: <ul style="list-style-type: none"> <li>● Qualification Retest</li> <li>● Test Witness</li> <li>● Reliability Demonstration</li> <li>● Maintainability Demonstration</li> </ul>	Significant Significant Significant Significant
	MIL-F-5373C (ASG) Fuseholders, Block Type, Aircraft, dated 24 January 1964	Design Requirements: <ul style="list-style-type: none"> <li>● Interchangeability</li> <li>● Safety</li> <li>● Reliability Program</li> <li>● Maintainability Program</li> <li>● Human Engineering</li> </ul> Quality Assurance: <ul style="list-style-type: none"> <li>● Quality Assurance Program</li> <li>● Responsibility for Inspection</li> </ul>	Significant Significant Significant Significant Significant Major Major
		Testing: <ul style="list-style-type: none"> <li>● Qualification Retest</li> <li>● Reliability Demonstration</li> <li>● Maintainability Demonstration</li> </ul>	Significant Significant Significant

Figure 38 - Continued.



GENERIC CLASSIFICATION	DOCUMENT NUMBER, TITLE, REVISION, AMENDMENT, SUPPLEMENT AND DATES	DEFICIENCY	POTENTIAL RELIABILITY/ MAINTAINABILITY IMPACT
Insulation	MIL-I-10B Insulating Compound, Electrical, Ceramic, Class L Amendment 1, dated 10 April 1967	Design Requirements: <ul style="list-style-type: none"> <li>● Safety</li> <li>● Reliability Program</li> <li>● Maintainability Program</li> <li>● Human Engineering</li> </ul> Quality Assurance: <ul style="list-style-type: none"> <li>● Quality Assurance Program</li> <li>● Responsibility for Inspection</li> </ul> Testing: <ul style="list-style-type: none"> <li>● C.ualification Retest</li> <li>● Reliability Demonstration</li> <li>● Maintainability Demonstration</li> </ul>	Significant Significant Significant Significant  Major Major  Significant Significant Significant
	MIL-I-631D Insulation, Electrical, Synthetic-Resin Composition, Nonrigid Amendment 5, dated 20 June 1968	Design Requirements: <ul style="list-style-type: none"> <li>● Product Identification</li> <li>● Safety</li> <li>● Reliability Program</li> <li>● Maintainability Program</li> <li>● Human Engineering</li> </ul>	Insignificant Significant Significant Significant Significant

Figure 38 - Continued.

GENERIC CLASSIFICATION	DOCUMENT NUMBER, TITLE, REVISION, AMENDMENT, SUPPLEMENT AND DATES	DEFICIENCY	POTENTIAL RELIABILITY/ MAINTAINABILITY IMPACT
	<p>MIL-P-997D  Plastic Material, Laminated, Thermo-setting, Electrical Insulation, Sheets, Glass, Cloth, Silicone Resin  Amendment 2, dated 14 June 1968</p>	<p>Quality Assurance:</p> <ul style="list-style-type: none"> <li>● Quality Assurance Program</li> <li>● Responsibility for Inspection</li> </ul> <p>Testing:</p> <ul style="list-style-type: none"> <li>● Reliability Demonstration</li> <li>● Maintainability Demonstration</li> </ul> <p>Design Requirements:</p> <ul style="list-style-type: none"> <li>● Safety</li> <li>● Reliability Program</li> <li>● Maintainability Program</li> </ul> <p>Quality Assurance:</p> <ul style="list-style-type: none"> <li>● Quality Assurance Program</li> </ul> <p>Testing:</p> <ul style="list-style-type: none"> <li>● Qualification Retest</li> <li>● Reliability Demonstration</li> <li>● Maintainability Demonstration</li> <li>● Test Witness</li> </ul>	<p>Major  Major    Significant  Significant    Significant  Significant  Significant    Major    Significant  Significant  Significant  Significant</p>

Figure 38 - Continued.

GENERIC CLASSIFICATION	DOCUMENT NUMBER, TITLE, REVISION, AMENDMENT, SUPPLEMENT AND DATES	DEFICIENCY	POTENTIAL RELIABILITY/ MAINTAINABILITY IMPACT
	MIL-I-3190B Insulation Sleeving, Electrical, Flexible, Treated Amendment 2, dated 2 March 1964	Design Requirements: <ul style="list-style-type: none"> <li>● Product Identification</li> <li>● Workmanship</li> <li>● Safety</li> <li>● Reliability Program</li> <li>● Maintainability Program</li> <li>● Human Engineering</li> </ul> Quality Assurance: <ul style="list-style-type: none"> <li>● Quality Assurance Program</li> <li>● Responsibility for Inspection</li> </ul> Testing: <ul style="list-style-type: none"> <li>● Qualification Retest</li> <li>● Reliability Demonstration</li> <li>● Maintainability Demonstration</li> </ul>	Significant Significant Significant Significant Significant Significant Major Major Significant Significant Significant
	MIL-I-7444C Insulation Sleeving, Electrical, Flexible Amendment 3, dated 22 September 1971	Design Requirements: <ul style="list-style-type: none"> <li>● Safety</li> <li>● Reliability Program</li> <li>● Maintainability Program</li> <li>● Human Engineering</li> </ul>	Significant Significant Significant Significant

Figure 38 - Continued.

GENERIC CLASSIFICATION	DOCUMENT NUMBER, TITLE, REVISION, AMENDMENT, SUPPLEMENT AND DATES	DEFICIENCY	POTENTIAL RELIABILITY/ MAINTAINABILITY IMPACT
		Quality Assurance: <ul style="list-style-type: none"> <li>● Quality Assurance Program</li> <li>● Responsibility for Inspection</li> </ul> Testing: <ul style="list-style-type: none"> <li>● Qualification Retest</li> <li>● Reliability Demonstration</li> <li>● Maintainability Demonstration</li> </ul>	Major Major  Significant Significant Significant
	MIL-I-16923E Insulating Compound, Electrical, Embedding, dated 19 July 1963	Design Requirements: <ul style="list-style-type: none"> <li>● Product Identification</li> <li>● Workmanship</li> <li>● Safety</li> <li>● Human Engineering</li> </ul> Quality Assurance: <ul style="list-style-type: none"> <li>● Quality Assurance Program</li> <li>● Responsibility for Inspection</li> </ul> Testing: <ul style="list-style-type: none"> <li>● Qualification Retest</li> <li>● Reliability Demonstration</li> <li>● Maintainability Demonstration</li> </ul>	Significant Significant Significant Significant  Major Major  Significant Significant Significant

Figure 38 - Continued.

GENERIC CLASSIFICATION	DOCUMENT NUMBER, TITLE, REVISION, AMENDMENT, SUPPLEMENT AND DATES	DEFICIENCY	POTENTIAL RELIABILITY/ MAINTAINABILITY IMPACT
	<p>MIL-I-18057A  Insulation Sleeving, Electrical, Flexible, Glass Fiber, Silicone Rubber Treated  Interim Amendment 2, dated 21 May 1965</p>	<p>Design Requirements:</p> <ul style="list-style-type: none"> <li>● Product Identification</li> <li>● Safety</li> <li>● Reliability Program</li> <li>● Maintainability Program</li> <li>● Human Engineering</li> </ul> <p>Quality Assurance:</p> <ul style="list-style-type: none"> <li>● Quality Assurance Program</li> <li>● Responsibility for Inspection</li> </ul> <p>Testing:</p> <ul style="list-style-type: none"> <li>● Qualification Retest</li> <li>● Reliability Demonstration</li> <li>● Maintainability Demonstration</li> </ul>	<p>Significant  Significant  Significant  Significant  Significant</p> <p>Major  Major</p> <p>Significant  Significant  Significant</p>
	<p>MIL-I-22076B  Insulation Tubing, Electrical, Nonrigid, Vinyl, Very Low Temperature Grade, dated 5 August 1963</p>	<p>Design Requirements:</p> <ul style="list-style-type: none"> <li>● Product Identification</li> <li>● Safety</li> <li>● Reliability Program</li> <li>● Maintainability Program</li> <li>● Human Engineering</li> </ul>	<p>Significant  Significant  Significant  Significant  Significant</p>

Figure 38 - Continued.

GENERIC CLASSIFICATION	DOCUMENT NUMBER, TITLE, REVISION, AMENDMENT, SUPPLEMENT AND DATES	DEFICIENCY	POTENTIAL RELIABILITY/ MAINTAINABILITY IMPACT
		<p>Quality Assurance:</p> <ul style="list-style-type: none"> <li>● Quality Assurance Program</li> <li>● Responsibility for Inspection</li> </ul> <p>Testing:</p> <ul style="list-style-type: none"> <li>● Qualification Retest</li> <li>● Reliability Demonstration</li> <li>● Maintainability Demonstration</li> </ul>	<p>Major</p> <p>Major</p> <p>Significant</p> <p>Significant</p> <p>Significant</p>
	<p>MIL-I-22129C</p> <p>Insulation Tubing, Electrical, Polytetra-flouroethylene Resin, Nonrigid</p> <p>Amendment 1, dated 18 February 1965</p>	<p>Design Requirements:</p> <ul style="list-style-type: none"> <li>● Product Identification</li> <li>● Safety</li> <li>● Reliability Program</li> <li>● Maintainability Program</li> <li>● Human Engineering</li> </ul> <p>Quality Assurance:</p> <ul style="list-style-type: none"> <li>● Quality Assurance Program</li> <li>● Responsibility for Inspection</li> </ul> <p>Testing:</p> <ul style="list-style-type: none"> <li>● Qualification Retest</li> </ul>	<p>Significant</p> <p>Significant</p> <p>Significant</p> <p>Significant</p> <p>Significant</p> <p>Major</p> <p>Major</p> <p>Significant</p>

Figure 38 - Continued.

GENERIC CLASSIFICATION	DOCUMENT NUMBER, TITLE, REVISION, AMENDMENT, SUPPLEMENT AND DATES	DEFICIENCY	POTENTIAL RELIABILITY/ MAINTAINABILITY IMPACT
	<p>MIL-I-23053B</p> <p>Insulation Sleeving, Electrical, Heat Shrinkable, General Specification for Amendment 3, dated 24 March 1970</p>	<ul style="list-style-type: none"> <li>● Reliability Demonstration</li> <li>● Maintainability Demonstration</li> </ul> <p>Design Requirements:</p> <ul style="list-style-type: none"> <li>● Product Identification</li> <li>● Safety</li> <li>● Reliability Program</li> <li>● Maintainability Program</li> <li>● Human Engineering</li> </ul> <p>Quality Assurance:</p> <ul style="list-style-type: none"> <li>● Quality Assurance Program</li> <li>● Responsibility for Inspection</li> </ul> <p>Testing:</p> <ul style="list-style-type: none"> <li>● Qualification Retest</li> <li>● Reliability Demonstration</li> <li>● Maintainability Demonstration</li> </ul>	<p>Significant</p> <p>Significant</p> <p>Significant</p> <p>Significant</p> <p>Significant</p> <p>Significant</p> <p>Major</p> <p>Major</p> <p>Significant</p> <p>Significant</p> <p>Significant</p>

Figure 38 - Continued.

GENERIC CLASSIFICATION	DOCUMENT NUMBER, TITLE, REVISION, AMENDMENT, SUPPLEMENT AND DATES	DEFICIENCY	POTENTIAL RELIABILITY/ MAINTAINABILITY IMPACT
	<p>MIL-I-81550A</p> <p>Insulating Compound, Electrical, Embedding, Reversion Resistant Silicone</p> <p>Interim Amendment 1, dated 9 March 1970</p>	<p>Design Requirements:</p> <ul style="list-style-type: none"> <li>● Safety</li> <li>● Reliability Program</li> <li>● Maintainability Program</li> <li>● Human Engineering</li> </ul> <p>Quality Assurance:</p> <ul style="list-style-type: none"> <li>● Quality Assurance Program</li> <li>● Responsibility for Inspection</li> </ul> <p>Testing:</p> <ul style="list-style-type: none"> <li>● Qualification Retest</li> <li>● Reliability Demonstration</li> <li>● Maintainability Demonstration</li> </ul>	<p>Significant</p> <p>Significant</p> <p>Significant</p> <p>Significant</p> <p>Major</p> <p>Major</p> <p>Significant</p> <p>Significant</p> <p>Significant</p>
Meter	<p>MIL-A-6752A (ASG)</p> <p>Ammeter, Voltmeters and Loadmeters, Direct Current</p> <p>Amendment 3, dated 3 March 1958</p>	<p>Design Requirements:</p> <ul style="list-style-type: none"> <li>● Safety</li> <li>● Reliability Program</li> <li>● Maintainability Program</li> <li>● Electromagnetic Interference</li> <li>● Human Engineering</li> </ul>	<p>Significant</p> <p>Significant</p> <p>Significant</p> <p>Significant</p> <p>Significant</p>

Figure 38 - Continued.



GENERIC CLASSIFICATION	DOCUMENT NUMBER, TITLE, REVISION, AMENDMENT, SUPPLEMENT AND DATES	DEFICIENCY	POTENTIAL RELIABILITY/ MAINTAINABILITY IMPACT
	<p>Quality Assurance:</p> <ul style="list-style-type: none"> <li>● Quality Assurance Program</li> <li>● Responsibility for Inspection</li> </ul> <p>Testing:</p> <ul style="list-style-type: none"> <li>● Reliability Demonstration</li> <li>● Maintainability Demonstration</li> </ul> <p>Design Requirements:</p> <ul style="list-style-type: none"> <li>● Safety</li> <li>● Reliability Program</li> <li>● Maintainability Program</li> <li>● Electromagnetic Interference</li> <li>● Human Engineering</li> </ul> <p>Quality Assurance:</p> <ul style="list-style-type: none"> <li>● Quality Assurance Program</li> <li>● Responsibility for Inspection</li> </ul> <p>Testing:</p> <ul style="list-style-type: none"> <li>● Reliability Demonstration</li> <li>● Maintainability Demonstration</li> </ul>	<p>Major</p> <p>Major</p> <p>Significant</p> <p>Significant</p> <p>Significant</p> <p>Significant</p> <p>Significant</p> <p>Significant</p> <p>Major</p> <p>Major</p> <p>Significant</p> <p>Significant</p>	
	<p>MIL-V-6753A</p> <p>Voltmeters, 0-150 Volt, 330 to 1200 Cycles, Alternating Current</p> <p>Amendment 2, dated 24 November 1958</p>		

Figure 38 - Continued.

GENERIC CLASSIFICATION	DOCUMENT NUMBER, TITLE, REVISION, AMENDMENT, SUPPLEMENT AND DATES	DEFICIENCY	POTENTIAL RELIABILITY/ MAINTAINABILITY IMPACT
Relay	MIL-R-5757F Relays, Electrical (for Electronic and Communication Type Equipment), General Specification for Amendment 3, dated 28 January 1972	Design Requirements: <ul style="list-style-type: none"> <li>● Environmental Conditions</li> <li>● Interchangeability</li> <li>● Safety</li> <li>● Reliability Program</li> <li>● Maintainability Program</li> <li>● Electromagnetic Interference</li> <li>● Human Engineering</li> </ul> Quality Assurance: <ul style="list-style-type: none"> <li>● Quality Assurance Program</li> <li>● Responsibility for Inspection</li> </ul> Testing: <ul style="list-style-type: none"> <li>● Qualification Retest</li> <li>● Reliability Demonstration</li> <li>● Maintainability Demonstration</li> <li>● Environmental Testing</li> </ul>	Significant Significant Significant Significant Significant Significant Significant Major Major Significant Significant Significant Significant

Figure 38 - Continued.

GENERIC CLASSIFICATION	DOCUMENT NUMBER, TITLE, REVISION, AMENDMENT, SUPPLEMENT AND DATES	DEFICIENCY	POTENTIAL RELIABILITY/ MAINTAINABILITY IMPACT
	MIL-R-6106F (ASG) Relays, Electric, General Specification for Amendment 1, dated 27 January 1970	Design Requirements: <ul style="list-style-type: none"> <li>● Safety</li> <li>● While Reliability is specified in quantitative longevity terms, it is not related to end item requirements.</li> <li>● Maintainability Program</li> <li>● Human Engineering</li> </ul> Quality Assurance: <ul style="list-style-type: none"> <li>● Quality Assurance Program</li> <li>● Responsibility for Inspection</li> </ul> Testing: <ul style="list-style-type: none"> <li>● Qualification Retest</li> <li>● Reliability Demonstration</li> <li>● Maintainability Demonstration</li> </ul>	Significant Significant  Significant Significant  Major Major  Significant Significant Significant
Resistor	MIL-R-11F Resistors, Fixed, Composition (Insulated), General Specification for, dated 17 April 1967	Design Requirements: <ul style="list-style-type: none"> <li>● Interchangeability</li> <li>● Safety</li> <li>● Reliability Program</li> </ul>	Significant Significant Significant

Figure 38 - Continued.

GENERIC CLASSIFICATION	DOCUMENT NUMBER, TITLE, REVISION, AMENDMENT, SUPPLEMENT AND DATES	DEFICIENCY	POTENTIAL RELIABILITY/ MAINTAINABILITY IMPACT
	<p>MIL-R-22B Resistors, Variable Wire-Wound (Power Type), General Specification for Amendment 2, dated 10 September 1964</p>	<ul style="list-style-type: none"> <li>● Maintainability Program</li> <li>● Human Engineering</li> </ul> <p>Quality Assurance:</p> <ul style="list-style-type: none"> <li>● Quality Assurance Program</li> <li>● Responsibility for Inspection</li> </ul> <p>Testing:</p> <ul style="list-style-type: none"> <li>● Qualification Retest</li> <li>● Reliability Demonstration</li> <li>● Maintainability Demonstration</li> </ul> <p>Design Requirements:</p> <ul style="list-style-type: none"> <li>● Interchangeability</li> <li>● Safety</li> <li>● Reliability Program</li> <li>● Maintainability Program</li> <li>● Human Engineering</li> </ul> <p>Quality Assurance:</p> <ul style="list-style-type: none"> <li>● Quality Assurance Program</li> </ul>	<p>Significant Significant</p> <p>Major Major</p> <p>Significant Significant Significant</p> <p>Significant Significant Significant Significant</p> <p>Major</p>

Figure 38 - Continued.

GENERIC CLASSIFICATION	DOCUMENT NUMBER, TITLE, REVISION, AMENDMENT, SUPPLEMENT AND DATES	DEFICIENCY	POTENTIAL RELIABILITY/ MAINTAINABILITY IMPACT
	<p>MIL-R-26E Resistors, Fixed, Wire-Wound (Power Type), General Specification for Supplement 1, dated 11 July 1967</p>	<p>Testing:</p> <ul style="list-style-type: none"> <li>• Qualification Retest</li> <li>• Reliability Demonstration</li> <li>• Maintainability Demonstration</li> </ul> <p>Design Requirements:</p> <ul style="list-style-type: none"> <li>• Interchangeability</li> <li>• Safety</li> <li>• Reliability Program</li> <li>• Maintainability Program</li> <li>• Human Engineering</li> </ul> <p>Quality Assurance:</p> <ul style="list-style-type: none"> <li>• Quality Assurance Program</li> <li>• Responsibility for Inspection</li> </ul> <p>Testing:</p> <ul style="list-style-type: none"> <li>• Qualification Retest</li> <li>• Reliability Demonstration</li> <li>• Maintainability Demonstration</li> </ul>	<p>Significant</p> <p>Significant</p> <p>Significant</p> <p>Significant</p> <p>Significant</p> <p>Significant</p> <p>Significant</p> <p>Significant</p> <p>Major</p> <p>Major</p> <p>Significant</p> <p>Significant</p> <p>Significant</p>

Figure 38 - Continued.

GENERIC CLASSIFICATION	DOCUMENT NUMBER, TITLE, REVISION, AMENDMENT, SUPPLEMENT AND DATES	DEFICIENCY	POTENTIAL RELIABILITY/ MAINTAINABILITY IMPACT
	MIL-STD-199A Resistors, Selection and Use of Note 8, dated 16 October 1972	<p>General: Resistors which are known to be utilized in aircraft design as a result of this analysis are listed separately. This document has no deficiencies which impact directly on helicopter reliability and maintainability.</p>	Insignificant
Semiconductor	MIL-S-19500E Semiconductor Devices, General Specification for Amendment 3, dated 23 October 1970	<p>Design Requirements:</p> <ul style="list-style-type: none"> <li>● Interchangeability</li> <li>● Safety</li> <li>● Reliability Program</li> <li>● Maintainability Program</li> <li>● Human Engineering</li> </ul> <p>Quality Assurance:</p> <ul style="list-style-type: none"> <li>● Quality Assurance Program</li> <li>● Responsibility for Inspection</li> </ul> <p>Testing:</p> <ul style="list-style-type: none"> <li>● Qualification Retest</li> </ul>	<p>Significant</p> <p>Significant</p> <p>Significant</p> <p>Significant</p> <p>Significant</p> <p>Major</p> <p>Major</p> <p>Significant</p>

Figure 38 - Continued.

GENERIC CLASSIFICATION	DOCUMENT NUMBER, TITLE, REVISION, AMENDMENT, SUPPLEMENT AND DATES	DEFICIENCY	POTENTIAL RELIABILITY/ MAINTAINABILITY IMPACT
Switch, Push (Snap Action)	MIL-S-8805C Switches and Switch Assemblies, Sensitive, and Push (Snap Action), General Specification for Supplement 1A, dated 22 May 1972	<ul style="list-style-type: none"> <li>● Reliability Demonstration</li> <li>● Maintainability Demonstration</li> </ul> <p>Design Requirements:</p> <ul style="list-style-type: none"> <li>● Interchangeability</li> <li>● Safety</li> <li>● Reliability Program</li> <li>● Maintainability Program</li> <li>● Human Engineering</li> </ul> <p>Quality Assurance:</p> <ul style="list-style-type: none"> <li>● Quality Assurance Program</li> <li>● Responsibility for Inspection</li> </ul> <p>Testing:</p> <ul style="list-style-type: none"> <li>● Qualification Retest</li> <li>● Reliability Demonstration</li> <li>● Maintainability Demonstration</li> </ul>	<p>Significant</p> <p>Significant</p> <p>Significant</p> <p>Significant</p> <p>Significant</p> <p>Significant</p> <p>Major</p> <p>Major</p> <p>Significant</p> <p>Significant</p> <p>Significant</p>

Figure 38 - Continued.

GENERIC CLASSIFICATION	DOCUMENT NUMBER, TITLE, REVISION, AMENDMENT, SUPPLEMENT AND DATES	DEFICIENCY	POTENTIAL RELIABILITY/ MAINTAINABILITY IMPACT
Switch, Rotary	MIL-S-6746B Switch, Rotary, Shielded, Aircraft Ignition Revised 20 June 1963	Design Requirements: <ul style="list-style-type: none"> <li>● Safety</li> <li>● Reliability Program</li> <li>● Maintainability Program</li> <li>● Electromagnetic Interference</li> <li>● Human Engineering</li> </ul> Quality Assurance: <ul style="list-style-type: none"> <li>● Quality Assurance Program</li> <li>● Responsibility for Inspection</li> </ul> Testing: <ul style="list-style-type: none"> <li>● Reliability Demonstration</li> <li>● Maintainability Demonstration</li> <li>● Qualification Retest</li> </ul>	Significant Significant Significant Significant Significant  Major Major  Significant Significant Significant
	MIL-S-6807D Switch, Rotary, Selector Power, General Specification for, dated 25 September 1968	Design Requirements: <ul style="list-style-type: none"> <li>● Interchangeability</li> <li>● Safety</li> <li>● Reliability Program</li> <li>● Maintainability Program</li> <li>● Human Engineering</li> </ul>	Significant Significant Significant Significant Significant

Figure 38 - Continued.



GENERIC CLASSIFICATION	DOCUMENT NUMBER, TITLE, REVISION, AMENDMENT, SUPPLEMENT AND DATES	DEFICIENCY	POTENTIAL RELIABILITY/ MAINTAINABILITY IMPACT
Switch, Thermostatic	MIL-S-24236B Switch, Thermostatic (Metallic and Bimetallic), General Specification for Supplement 1, dated 25 August 1972	<p>Quality Assurance:</p> <ul style="list-style-type: none"> <li>● Quality Assurance Program</li> </ul> <p>Testing:</p> <ul style="list-style-type: none"> <li>● Qualification Retest</li> <li>● Reliability Demonstration</li> <li>● Maintainability Demonstration</li> </ul> <p>Design Requirements:</p> <ul style="list-style-type: none"> <li>● Interchangeability</li> <li>● Safety</li> <li>● Reliability Program</li> <li>● Maintainability Program</li> <li>● Electromagnetic Interference</li> <li>● Human Engineering</li> </ul> <p>Quality Assurance:</p> <ul style="list-style-type: none"> <li>● Quality Assurance Program</li> </ul>	<p>Major</p> <p>Significant</p> <p>Significant</p> <p>Significant</p> <p>Significant</p> <p>Significant</p> <p>Significant</p> <p>Significant</p> <p>Major</p>

Figure 38 - Continued.

GENERIC CLASSIFICATION	DOCUMENT NUMBER, TITLE, REVISION, AMENDMENT, SUPPLEMENT AND DATES	DEFICIENCY	POTENTIAL RELIABILITY/ MAINTAINABILITY IMPACT
Switch, Toggle	MIL-S-3950E Switch, Toggle, Environmentally Sealed, General Specification for Supplement 1A, dated 24 July 1972	<p>Testing:</p> <ul style="list-style-type: none"> <li>● Qualification Retest</li> <li>● Reliability Demonstration</li> <li>● Maintainability Demonstration</li> </ul> <p>Design Requirements:</p> <ul style="list-style-type: none"> <li>● Interchangeability</li> <li>● Safety</li> <li>● Reliability Program</li> <li>● Maintainability Program</li> <li>● Human Engineering</li> </ul> <p>Quality Assurance:</p> <ul style="list-style-type: none"> <li>● Quality Assurance Program</li> <li>● Responsibility for Inspection</li> </ul> <p>Testing:</p> <ul style="list-style-type: none"> <li>● Qualification Retest</li> <li>● Reliability Demonstration</li> </ul>	<p>Significant</p> <p>Significant</p> <p>Significant</p> <p>Significant</p> <p>Significant</p> <p>Significant</p> <p>Significant</p> <p>Significant</p> <p>Major</p> <p>Major</p> <p>Significant</p> <p>Significant</p>

Figure 38 - Continued.

GENERIC CLASSIFICATION	DOCUMENT NUMBER, TITLE, REVISION, AMENDMENT, SUPPLEMENT AND DATES	DEFICIENCY	POTENTIAL RELIABILITY/ MAINTAINABILITY IMPACT
	<p>MIL-S-8834C (ASG)  Switch, Toggle, Positive Break, Aircraft, General Specification for Supplement 1, dated 15 August 1969</p>	<ul style="list-style-type: none"> <li>● Maintainability Demonstration</li>   <li>Design Requirements: <ul style="list-style-type: none"> <li>● Interchangeability</li> <li>● Safety</li> <li>● Reliability Program</li> <li>● Maintainability Program</li> <li>● Human Engineering</li> </ul> </li> <li>Quality Assurance: <ul style="list-style-type: none"> <li>● Quality Assurance Program</li> <li>● Responsibility for Inspection</li> </ul> </li> <li>Testing: <ul style="list-style-type: none"> <li>● Qualification Retest</li> <li>● Reliability Demonstration</li> <li>● Maintainability Demonstration</li> </ul> </li> </ul>	<p>Significant</p> <p>Significant  Significant  Significant  Significant  Significant</p> <p>Major  Major</p> <p>Significant  Significant  Significant</p>

Figure 38 - Continued.

GENERIC CLASSIFICATION	DOCUMENT NUMBER, TITLE, REVISION, AMENDMENT, SUPPLEMENT AND DATES	DEFICIENCY	POTENTIAL RELIABILITY/ MAINTAINABILITY IMPACT
	MIL-S-9419D Switch, Toggle, Momentary, Four-Position ON, Center OFF, Amendment 1, dated 10 August 1972	Design Requirements: <ul style="list-style-type: none"> <li>● Interchangeability</li> <li>● Safety</li> <li>● Reliability Program</li> <li>● Maintainability Program</li> <li>● Human Engineering</li> </ul> Quality Assurance: <ul style="list-style-type: none"> <li>● Quality Assurance Program</li> <li>● Responsibility for Inspection</li> </ul> Testing: <ul style="list-style-type: none"> <li>● Qualification Retest</li> <li>● Reliability Demonstration</li> <li>● Maintainability Demonstration</li> </ul>	Significant Significant Significant Significant Significant  Major Major  Significant Significant Significant

Figure 38 - Continued.

GENERIC CLASSIFICATION	DOCUMENT NUMBER, TITLE, REVISION, AMENDMENT, SUPPLEMENT AND DATES	DEFICIENCY	POTENTIAL RELIABILITY/ MAINTAINABILITY IMPACT
Terminals	MIL-T-7099D Terminals, Lug and Splice, Crimp Style Aluminum, for Aluminum Aircraft Wire Amendment 3, dated 23 August 1971	Design Requirements: <ul style="list-style-type: none"> <li>● Interchangeability</li> <li>● Safety</li> <li>● Reliability Program</li> <li>● Maintainability Program</li> <li>● Human Engineering</li> </ul> Quality Assurance: <ul style="list-style-type: none"> <li>● Quality Assurance Program</li> <li>● Responsibility for Inspection</li> </ul> Testing: <ul style="list-style-type: none"> <li>● Qualification Retest</li> <li>● Reliability Demonstration</li> <li>● Maintainability Demonstration</li> </ul>	Significant Significant Significant Significant Significant  Major Major  Significant Significant Significant
	MIL-T-7928F Terminals, Lug and Splice, Conductor, Crimp Style, Copper, General Specification for Supplement 1A, dated 19 July 1971	Design Requirements: <ul style="list-style-type: none"> <li>● Interchangeability</li> <li>● Safety</li> <li>● Reliability Program</li> <li>● Maintainability Program</li> <li>● Human Engineering</li> </ul>	Significant Significant Significant Significant Significant

Figure 38 - Continued.

GENERIC CLASSIFICATION	DOCUMENT NUMBER, TITLE, REVISION, AMENDMENT, SUPPLEMENT AND DATES	DEFICIENCY	POTENTIAL RELIABILITY/ MAINTAINABILITY IMPACT
Wire	MIL-W-5086B Wire, Electric, Hookup and Interconnecting, Polyvinyl Chloride-Insulated, Copper or Copper Alloy Conductor Interim Amendment 2, dated 16 December 1970	Quality Assurance: <ul style="list-style-type: none"> <li>● Quality Assurance Program</li> <li>● Responsibility for Inspection</li> </ul> Testing: <ul style="list-style-type: none"> <li>● Qualification Retest</li> <li>● Reliability Demonstration</li> <li>● Maintainability Demonstration</li> </ul> Design Requirements: <ul style="list-style-type: none"> <li>● Interchangeability</li> <li>● Safety</li> <li>● Reliability Program</li> <li>● Maintainability Program</li> <li>● Human Engineering</li> </ul> Quality Assurance: <ul style="list-style-type: none"> <li>● Quality Assurance Program</li> <li>● Responsibility for Inspection</li> </ul>	Major Major  Significant Significant Significant  Significant Significant Significant Significant Significant  Major Major

Figure 38 - Continued.

GENERIC CLASSIFICATION	DOCUMENT NUMBER, TITLE, REVISION, AMENDMENT, SUPPLEMENT AND DATES	DEFICIENCY	POTENTIAL RELIABILITY/ MAINTAINABILITY IMPACT
	MIL-W-5846B	<p>Testing:</p> <ul style="list-style-type: none"> <li>● Qualification Retest</li> <li>● Reliability Demonstration</li> <li>● Maintainability Demonstration</li> </ul>	<p>Significant</p> <p>Significant</p> <p>Significant</p>
	Wire, Electrical, Chromel and/or Alumel, Thermocouple	<p>Design Requirements:</p> <ul style="list-style-type: none"> <li>● Interchangeability</li> <li>● Safety</li> <li>● Reliability Program</li> <li>● Maintainability Program</li> <li>● Human Engineering</li> </ul>	<p>Significant</p> <p>Significant</p> <p>Significant</p> <p>Significant</p> <p>Significant</p>
	Interim Amendment 5, dated 26 May 1972	<p>Quality Assurance:</p> <ul style="list-style-type: none"> <li>● Quality Assurance Program</li> </ul> <p>Testing:</p> <ul style="list-style-type: none"> <li>● Qualification Retest</li> <li>● Reliability Demonstration</li> <li>● Maintainability Demonstration</li> </ul>	<p>Major</p> <p>Significant</p> <p>Significant</p> <p>Significant</p>

Figure 38 - Continued.

GENERIC CLASSIFICATION	DOCUMENT NUMBER, TITLE, REVISION, AMENDMENT, SUPPLEMENT AND DATES	DEFICIENCY	POTENTIAL RELIABILITY/ MAINTAINABILITY IMPACT
	MIL-W-7072B (ASG) Wire, Electric, 600-Volt, Aluminum, Aircraft, General Specification for, dated 4 September 1962	Design Requirements: <ul style="list-style-type: none"> <li>● Interchangeability</li> <li>● Safety</li> <li>● Reliability Program</li> <li>● Maintainability Program</li> <li>● Human Engineering</li> </ul> Quality Assurance: <ul style="list-style-type: none"> <li>● Quality Assurance Program</li> <li>● Responsibility for Inspection</li> </ul> Testing: <ul style="list-style-type: none"> <li>● Qualification Retest</li> <li>● Reliability Demonstration</li> <li>● Maintainability Demonstration</li> </ul>	Significant Significant Significant Significant Significant  Major Major  Significant Significant Significant
	MIL-W-8777C (ASG) Wire, Electrical, Silicone-Insulated, Copper, 600-Volt, 200°C, dated 11 April 1968	Design Requirements: <ul style="list-style-type: none"> <li>● Interchangeability</li> <li>● Safety</li> <li>● Reliability Program</li> <li>● Maintainability Program</li> <li>● Human Engineering</li> </ul>	Significant Significant Significant Significant Significant

Figure 38 - Continued.



GENERIC CLASSIFICATION	DOCUMENT NUMBER, TITLE, REVISION, AMENDMENT, SUPPLEMENT AND DATES	DEFICIENCY	POTENTIAL RELIABILITY/ MAINTAINABILITY IMPACT
		Quality Assurance: <ul style="list-style-type: none"> <li>● Quality Assurance Program</li> <li>● Responsibility for Inspection</li> </ul> Testing: <ul style="list-style-type: none"> <li>● Qualification Retest</li> <li>● Reliability Demonstration</li> <li>● Maintainability Demonstration</li> </ul>	Major Major  Significant Significant Significant
	MIL-W-16878D (NAVY) Wire, Electrical, Insulated, High Temperature Amendment 1, dated 15 June 1967	Design Requirements: <ul style="list-style-type: none"> <li>● Interchangeability</li> <li>● Safety</li> <li>● Reliability Program</li> <li>● Maintainability Program</li> <li>● Human Engineering</li> </ul> Quality Assurance: <ul style="list-style-type: none"> <li>● Quality Assurance Program</li> <li>● Component Sampling</li> <li>● Responsibility for Inspection</li> </ul>	Significant Significant Significant Significant Significant  Major Significant Major

Figure 38 - Continued.

GENERIC CLASSIFICATION	DOCUMENT NUMBER, TITLE, REVISION, AMENDMENT, SUPPLEMENT AND DATES	DEFICIENCY	POTENTIAL RELIABILITY/ MAINTAINABILITY IMPACT
	<p>MIL-W-22759C  Wire, Electric,  Flourocarbon-Insulated,  Copper or Copper Alloy  Amendment 1, dated  20 November 1970</p>	<p>Testing:</p> <ul style="list-style-type: none"> <li>• Qualification Retest</li> <li>• Reliability Demonstration</li> <li>• Maintainability Demonstration</li> </ul> <p>Design Requirements:</p> <ul style="list-style-type: none"> <li>• Interchangeability</li> <li>• Safety</li> <li>• Reliability Program</li> <li>• Maintainability Program</li> <li>• Human Engineering</li> </ul> <p>Quality Assurance:</p> <ul style="list-style-type: none"> <li>• Quality Assurance Program</li> <li>• Responsibility for Inspection</li> </ul> <p>Testing:</p> <ul style="list-style-type: none"> <li>• Qualification Retest</li> <li>• Reliability Demonstration</li> <li>• Maintainability Demonstration</li> </ul>	<p>Significant  Significant  Significant</p> <p>Significant  Significant  Significant  Significant  Significant</p> <p>Major  Major</p> <p>Significant  Significant  Significant</p>

Figure 38 - Continued.

GENERIC CLASSIFICATION	DOCUMENT NUMBER, TITLE, REVISION, AMENDMENT, SUPPLEMENT AND DATES	DEFICIENCY	POTENTIAL RELIABILITY/ MAINTAINABILITY IMPACT
	MIL-W-25038D Wire, Electrical, High Temperature and Fire Resistant, Aircraft, dated 10 January 1972	Design Requirements: <ul style="list-style-type: none"> <li>• Interchangeability</li> <li>• Safety</li> <li>• Reliability Program</li> <li>• Maintainability Program</li> <li>• Human Engineering</li> </ul> Quality Assurance: <ul style="list-style-type: none"> <li>• Quality Assurance Program</li> <li>• Responsibility for Inspection</li> </ul> Testing: <ul style="list-style-type: none"> <li>• Qualification Retest</li> <li>• Reliability Demonstration</li> <li>• Maintainability Demonstration</li> </ul>	Significant Significant Significant Significant Significant  Major Major  Significant Significant Significant
	MIL-W-81044A (AS) Wire, Electric, Crosslinked, Poly-alkene Insulated, Copper Amendment 4, dated 30 November 1970	Design Requirements: <ul style="list-style-type: none"> <li>• Interchangeability</li> <li>• Safety</li> <li>• Reliability Program</li> <li>• Maintainability Program</li> <li>• Human Engineering</li> </ul>	Significant Significant Significant Significant Significant

Figure 38 - Continued.

GENERIC CLASSIFICATION	DOCUMENT NUMBER, TITLE, REVISION, AMENDMENT, SUPPLEMENT AND DATES	DEFICIENCY	POTENTIAL RELIABILITY/ MAINTAINABILITY IMPACT
		Quality Assurance: <ul style="list-style-type: none"> <li>● Quality Assurance Program</li> <li>● Responsibility for Inspection</li> </ul> Testing: <ul style="list-style-type: none"> <li>● Qualification Retest</li> <li>● Reliability Demonstration</li> <li>● Maintainability Demonstration</li> </ul>	Major Major
	MIL-W-81381 (AS) Wire, Electric, Polyimide-Insulated Copper and Copper Alloy Amendment 5, dated 12 November 1970	Design Requirements: <ul style="list-style-type: none"> <li>● Interchangeability</li> <li>● Safety</li> <li>● Reliability Program</li> <li>● Maintainability Program</li> <li>● Human Engineering</li> </ul> Quality Assurance: <ul style="list-style-type: none"> <li>● Quality Assurance Program</li> <li>● Responsibility for Inspection</li> </ul>	Significant Significant Significant Significant Significant Significant Major Major

Figure 38 - Continued.

GENERIC CLASSIFICATION	DOCUMENT NUMBER, TITLE, REVISION, AMENDMENT, SUPPLEMENT AND DATES	DEFICIENCY	POTENTIAL RELIABILITY/ MAINTAINABILITY IMPACT
		Testing: <ul style="list-style-type: none"> <li>● Qualification Retest</li> <li>● Reliability Demonstration</li> <li>● Maintainability Demonstration</li> </ul>	Significant Significant Significant

Figure 38 - Continued.