

LWL
TR-74-29
C. 2

TECHNICAL REPORT NO. 74-29

HELICOPTER DROPSIGHT

by

Neal C. Wogsland
Munitions Branch

May 1974

Final Report

COUNTED IN

TECHNICAL LIBRARY
BLDG. 305
ABERDEEN PROVING GROUND, MD.
STEAP-TL

APPROVED FOR PUBLIC RELEASE; DISTRIBUTION UNLIMITED

U. S. ARMY LAND WARFARE LABORATORY

Aberdeen Proving Ground, Maryland 21005

20081003 054

LWL
TR-74-29
C. 2

The findings in this report are not to be construed as an official Department of the Army position unless so designated by other authorized documents.

The contents of this report are not to be used for advertising, publication, or promotional purposes. Citation of trade names does not constitute an official endorsement or approval of the use of such commercial products.

DISPOSITION INSTRUCTIONS

Destroy this report when no longer needed. Do not return it to the originator.

UNCLASSIFIED

SECURITY CLASSIFICATION OF THIS PAGE (When Data Entered)

REPORT DOCUMENTATION PAGE		READ INSTRUCTIONS BEFORE COMPLETING FORM
1. REPORT NUMBER TECHNICAL REPORT NO. 74-29	2. GOVT ACCESSION NO.	3. RECIPIENT'S CATALOG NUMBER
4. TITLE (and Subtitle) HELICOPTER DROPSIGHT	5. TYPE OF REPORT & PERIOD COVERED Final Report	
	6. PERFORMING ORG. REPORT NUMBER	
7. AUTHOR(s) Neal C. Wogsland Munitions Branch	8. CONTRACT OR GRANT NUMBER(s)	
9. PERFORMING ORGANIZATION NAME AND ADDRESS US Army Land Warfare Laboratory Aberdeen Proving Ground, MD 21005	10. PROGRAM ELEMENT, PROJECT, TASK AREA & WORK UNIT NUMBERS LWL Task No. 08-F-71	
11. CONTROLLING OFFICE NAME AND ADDRESS	12. REPORT DATE May 1974	
	13. NUMBER OF PAGES 18	
14. MONITORING AGENCY NAME & ADDRESS (if different from Controlling Office)	15. SECURITY CLASS. (of this report) Unclassified	
	15a. DECLASSIFICATION/DOWNGRADING SCHEDULE	
16. DISTRIBUTION STATEMENT (of this Report) Approved for public release; distribution unlimited		
17. DISTRIBUTION STATEMENT (of the abstract entered in Block 20, if different from Report)		
18. SUPPLEMENTARY NOTES		
<p style="text-align: right;">TECHNICAL LIBRARY BLDG. 305 ABERDEEN PROVING GROUND, MD. STEAP-TL</p>		
19. KEY WORDS (Continue on reverse side if necessary and identify by block number)		
Helicopter Dropsight Sight Sensors	Unattended Ground Sensors Ground Sensors	
20. ABSTRACT (Continue on reverse side if necessary and identify by block number)		
<p>The Helicopter Dropsight was developed for use when hand dropping unattended ground sensors and other hardware from UH-1D/H Helicopters. It consists of a simple cross hair mounted in a ring that projects outside the helicopter on an arm attached to a standard installed in a rear doorway. Sighting consists of aligning the cross hair, a marker on the helicopter skid, and the drop zone. It can be adjusted for various drop conditions, weighs less than 10 pounds, and can be installed within 5 minutes. Dropsights have been</p> <p style="text-align: right;">Continued on Reverse</p>		

UNCLASSIFIED

SECURITY CLASSIFICATION OF THIS PAGE(When Data Entered)

BLOCK 20. ABSTRACT CON'T

evaluated and are being used for training by the US Army Intelligence Center/
School at Fort Huachuca, AZ.

AD-784551

TABLE OF CONTENTS

	Page
REPORT DOCUMENTATION PAGE (DD FORM 1473)	iii
INTRODUCTION	3
DESCRIPTION	5
DEVELOPMENT	7
CONCLUSIONS	13
APPENDIX:	
Military Characteristics for Helicopter Dropsight	A-1
DISTRIBUTION LIST	14

INTRODUCTION

The use of unattended ground sensors has provided commanders at all echelons of command with valuable real time information. In a highly mobile, fluid, and fast-moving tactical situation, maneuver elements, as well as the stationary units, must have a means of emplacing sensors that will provide the flexibility required in that battlefield. Aerial delivery provides the commander a flexible and responsive means of deployment that can be used in a variety of tactical situations, especially when speed of implant is essential or when the area to be seeded is extremely remote or is dominated by enemy forces. The most critical problem facing the delivering unit is accuracy. US Army units do not have a standard sighting system which enables the deployment of unattended ground sensors or other equipment from a helicopter with a high degree of accuracy. Various procedures have evolved, primarily based upon the experience level of the personnel involved, but a suitable, inexpensive sight is required.

In September 1968, the Department of the Army approved an ENSURE for a Multi-purpose Helicopter Dropsight, which had been proposed by the Army Concept Team in Vietnam (ACTIV), to assist in accurately delivering munitions and sensors to the ground from a helicopter in flight. This task was assigned to the US Army Materiel Command (Frankford Arsenal). Twenty-four preliminary sights were delivered to Vietnam in February - April 1969. Sighting was accomplished by the copilot, who viewed the target through a polaroid ring sight mounted near eye level and through a grid installed on the chin bubble of the UH-1D Helicopter. Deficiencies observed during testing resulted in the conclusion that this sight was not suitable for employment in Vietnam and it was recommended that no further development effort be expended on this sight.

During the visit of an LWL briefing team to Headquarters, US Army - Pacific (USARPAC), in February 1970, a need was expressed for a means of accurately dropping a variety of types of packages from Army light aircraft or helicopters to units on the ground from altitudes of 2,000 feet or less. A similar need was expressed in a letter dated July 1970 from Headquarters, US Army Project MASSTER.

The present method for dropping unattended ground sensors, an "eyeballing" technique, involves sighting over the tip of the skid on the right side of the helicopter. The dropper, an Unattended Ground Sensor Specialist (MOS 17M20), sits in the open doorway behind the pilot with the sensor in his hands. He releases the sensor when the target on the ground comes into line with the tip of the skid. With one to two hours of practice, a soldier can become proficient in making drops from one specific altitude at one specific aircraft speed. However, additional practice often is needed prior to a mission in order to regain proficiency.

A suggestion for an Unattended Ground Sensor Air Employment Sight (Suggestion No. 1-3-44) was received from the Incentive Awards Committee, Civilian Personnel Division, Fort Huachuca, AZ, in January 1971. The suggestion was to place a sight, a simple cross hair, on a stand in the doorway of the helicopter so the UGS Specialist would have two points to align with the target or drop zone (Figure 1). The sight would be adjustable vertically to permit

setting for different drop altitudes (or different helicopter speeds) and horizontally (perpendicular to the line of flight) as indicated in Figure 2.

The suggestion was evaluated and specific military needs for a sight to aid in drops of sensors and other items were identified. Since it was apparent that a need still existed, LWL Task 08-F-71 was initiated in June 1971 to fabricate and evaluate a prototype dropsight along the suggested lines to permit evaluation of the suggested concept. A list of Military Characteristics was prepared (Appendix) to provide design and performance goals.

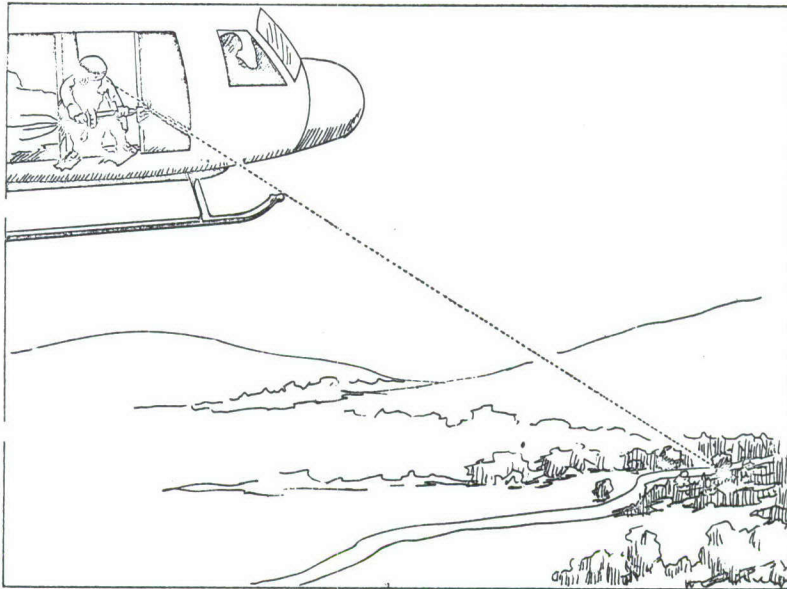

Figure 1. Operational Concept for Helicopter Dropsight

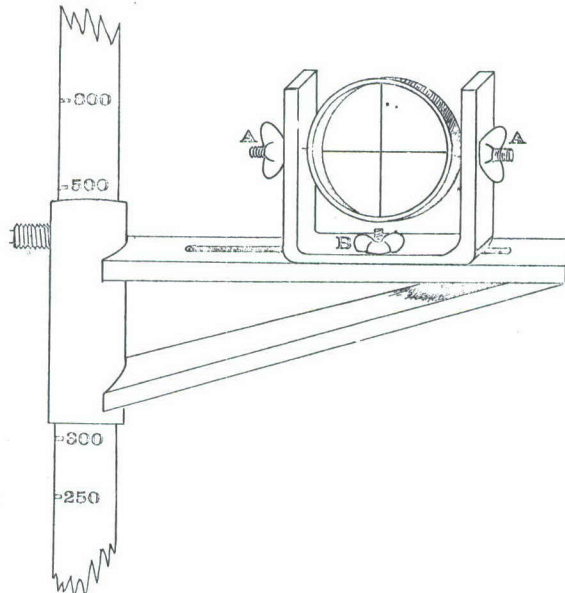

Figure 2. Sight Details for Proposed Helicopter Dropsight

DESCRIPTION

The Helicopter Dropsight consists of a simple cross hair mounted in a ring on an arm that projects outside the helicopter. The arm assembly is attached to a standard installed directly behind the pilot in the rear doorway on the right side of the aircraft (Figures 3 and 4). An auxiliary attachment for the skid provides the front sighting point. The dropsight is designed for use in the UH-1D and UH-1H helicopters. Sighting consists of aligning the cross hair, the marker on the skid, and the target or drop zone. When all points are in line, the sensor or other hardware is hand dropped. The dropsight can be set for various drop conditions including payload, altitude, and flight speed. Ballistic tables for the specific payload being dropped are needed to achieve accuracy. The sight weighs less than 10 pounds and can be installed within five minutes.

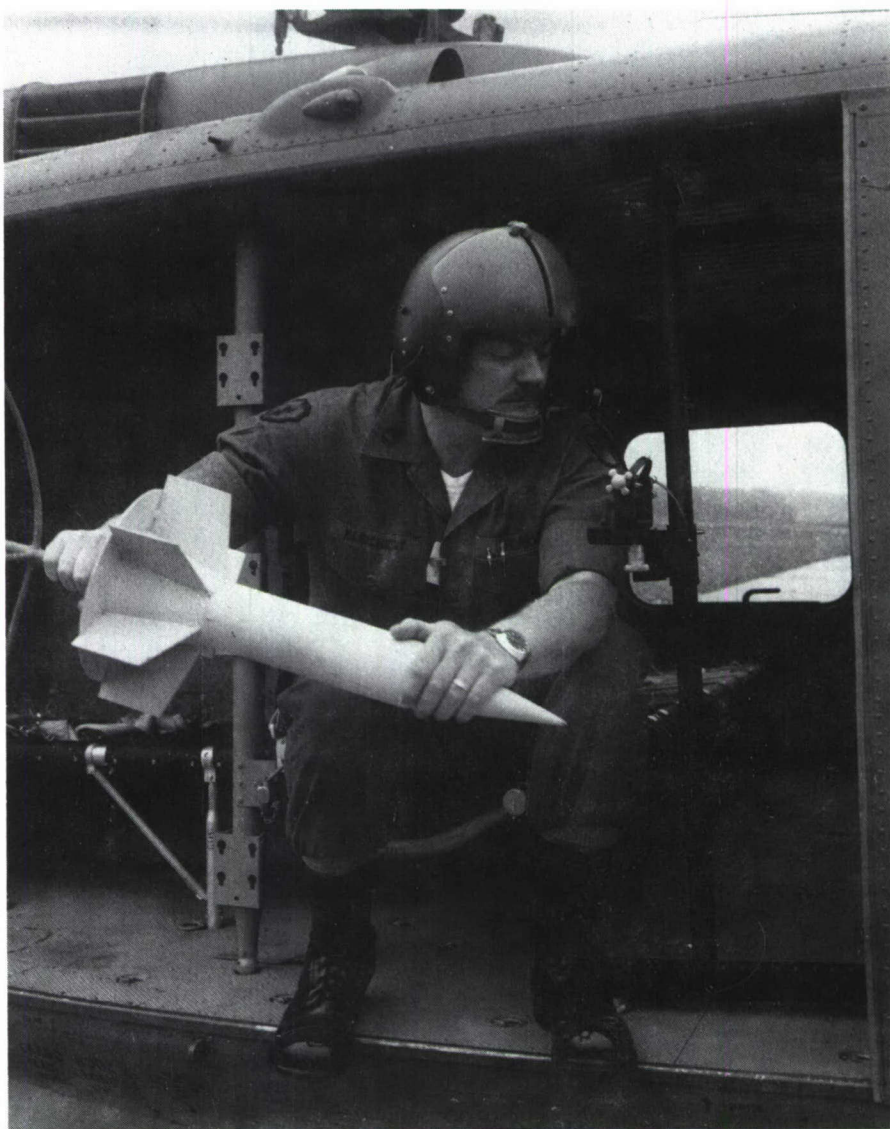

Figure 3. Helicopter Dropsight in UH-1H Helicopter

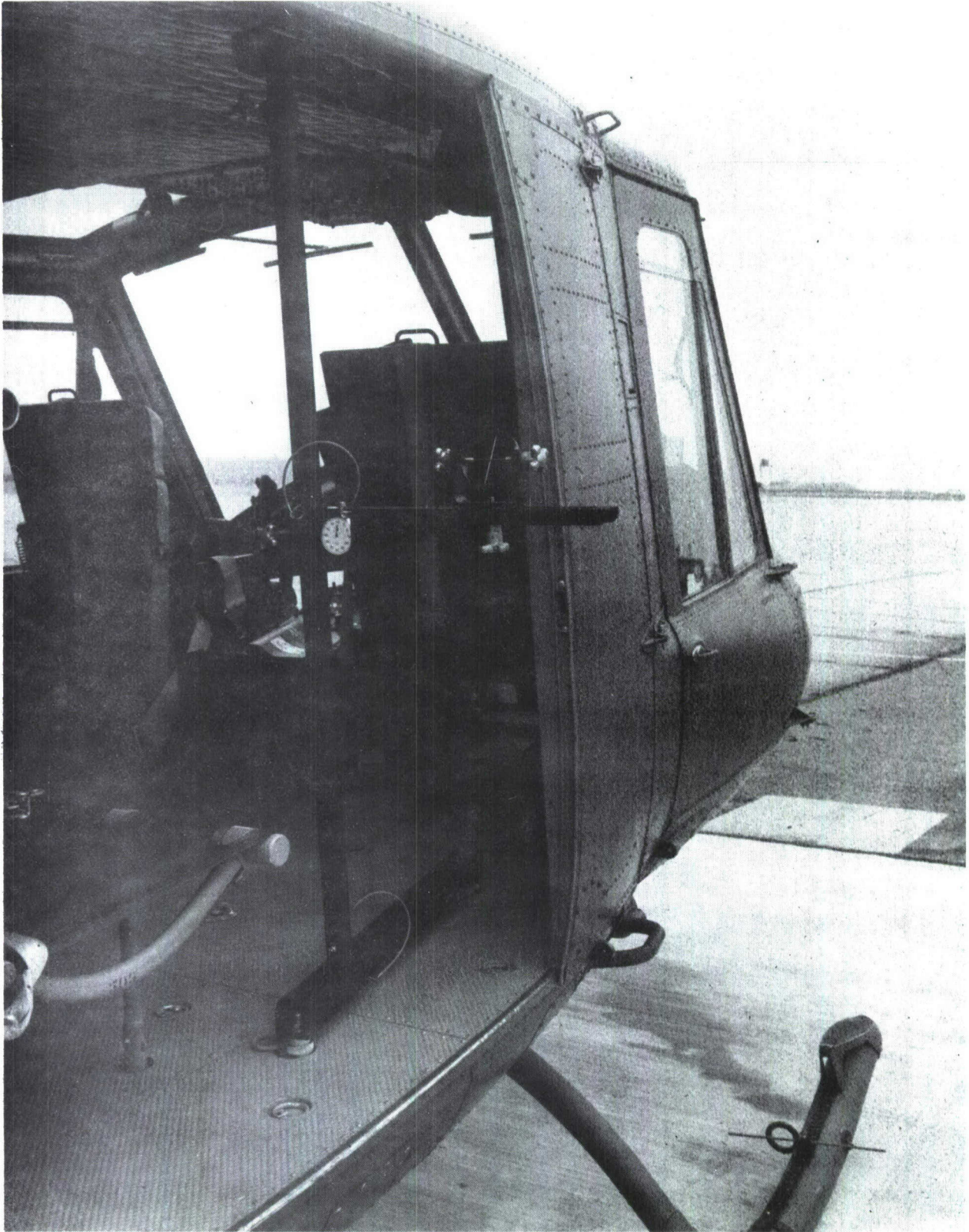

Figure 4. Sight in Operating Position

DEVELOPMENT

A helicopter dropsight was designed in accordance with the military characteristics. The cross hair was made and mounted in a manner similar to the sketch shown in Figure 2. A slot in the top of the crossarm permitted the sight holder to be moved inward or outward as desired by the user. Stanchion mounting points in the floor and the ceiling were utilized to provide a rigidly mounted standard upon which the crossarm could move up or down. To install and use the sight, it was necessary to remove the small door directly behind the pilot, on the right side of the helicopter, and to move the sliding door rearward. The sight standard was located approximately at the center of the small doorway and the operator, secured by an auxiliary safety harness, knelt in the open doorway to the rear of the standard.

After installation of the feasibility model in a UH-1D Helicopter, drop tests were conducted using obsolete ADSID I-S Sensors. The drops were made from an altitude of 1000 feet and an air speed of 80 knots. The sensors fell short on all drops and it was quickly determined that vertical adjustment of the sight on the standard was not sufficient to cover the desired range of altitudes and air speeds.

The mounts for the standards were modified and the sight was installed at a new location, just in front of the rear seat. The operator then sat sideways on the rear seat, using the safety harness provided for that seat (Figure 5). Using this mounting position, additional drops were made from altitudes of 500 and 1000 feet. A few fairly reasonable dispersion patterns were achieved, but sufficient adjustments could not be made to place the sensors close to the target. It was apparent that a greater flexibility would be needed; sighting over the tip of the skid (i.e., using the tip of the skid as the front sight), which is the technique proposed in the original suggestion, is limited to a few special drop conditions. These tests also showed that fairly accurate drops can be achieved by untrained personnel. Also during these drops, the hand-release techniques were improved from rolling the sensor off the finger tips (the method illustrated in Figure 5) to a quick release from an over-the-top grip when holding the sensor in the air stream (see Figure 3).

Additional modifications were then made to improve mounting and versatility. Floor and ceiling channels were built that would permit changing the location of the standard forward or rearward at one-inch increments. Sighting markers were also provided along the skid to supplement the use of the tip of the skid as the front sight.

The initial test results were used to compute preliminary ballistic tables for use in selecting sight settings for future drops. Then a series of drops was made to calibrate the sight. Each set of drops was conducted at a specific sight setting and no range adjustments were made to close in on the target. The calibration results are shown in Table I. The mean deviation along the flight path from the center of impact (CI) is comparable to "mean radius," a familiar term used when evaluating target patterns for small arms.

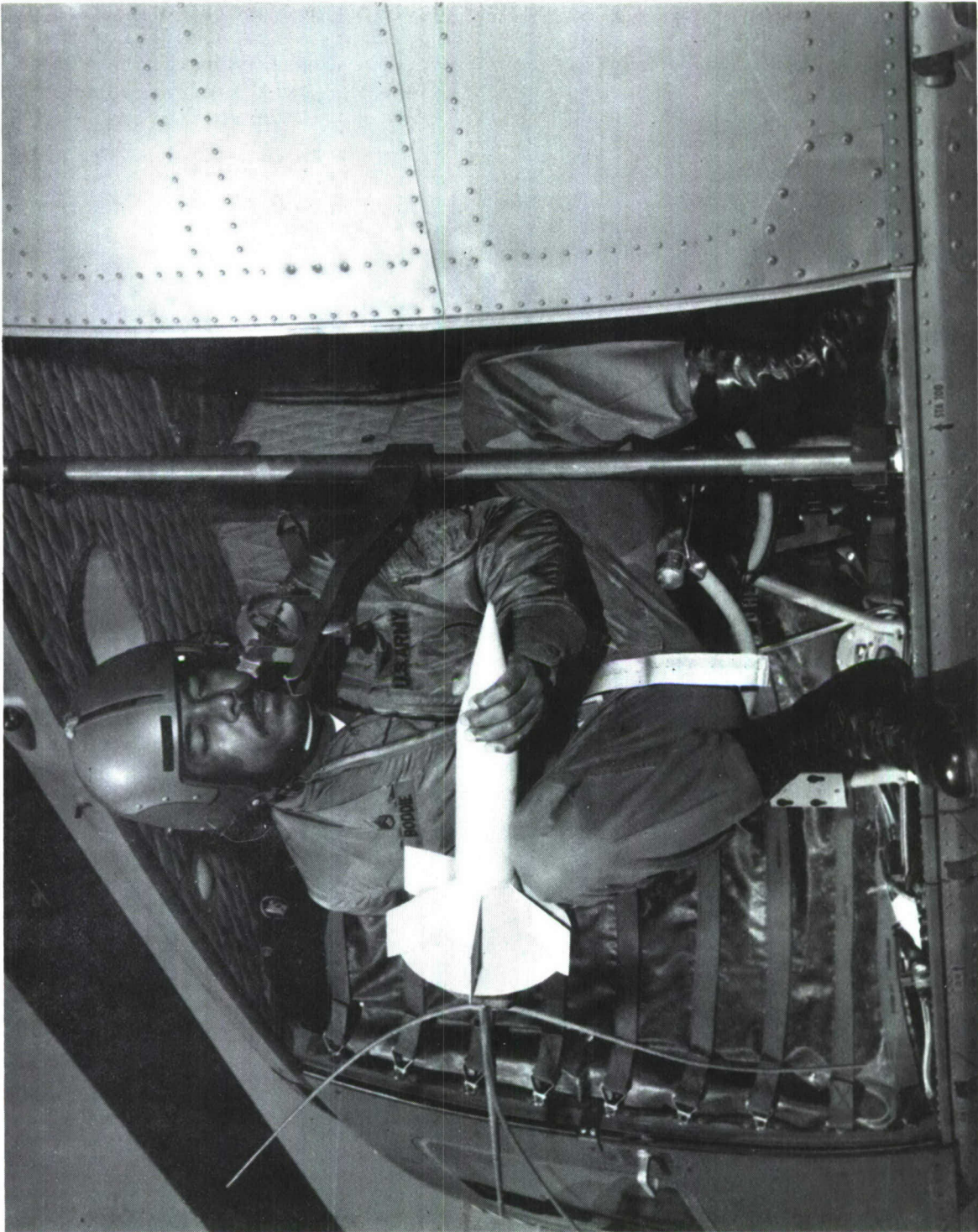

Figure 5. Feasibility Model in UH-1H Helicopter

TABLE I. HELICOPTER DROPSIGHT CALIBRATION TESTS

Altitude (feet)	Air Speed (knots)	Ground Speed (knots)	Sensors Dropped (number)	Spread Along Flight Path		Mean Dev. from CI (meters)
				Extreme (meters)	Best Group	
500	60	55.5	9	39	7 in 18 meters	10.3
500	80	75.5	8	21	5 in 13 meters	7.9
500	80	75.5	9	30	6 in 18 meters	9.9
500	100	95.5	8	31	6 in 12 meters	7.0
1000	60	46.5	9	43	7 in 14 meters	7.9
1000	80	66.5	9	45	6 in 25 meters	13.1
1000	100	86.5	8	31	5 in 8 meters	12.6

With this data in hand, sight positions were selected for two specific drop conditions - 500 feet @ 60 knots and 500 feet @ 80 knots. Markers were placed on the skid to provide front sighting points as shown in Figure 6. The 80 knot marker was located at the heel of the step and the 60 knot marker approximately 12 inches farther rearward. In addition, the standard was marked with a zero setting, the same for both airspeeds (Figure 7), and marks were provided to permit compensation for headwind and tailwind. Alternate markings were provided to adjust the sight based on observed impact points. For example, if the observed impact was short of the target, the sight arm was raised to compensate; a scale (in red) on the standard was marked in 10-meter increments.

An instruction manual was prepared to provide installation and operating instructions. The test results and manual were reviewed by the LWL Safety Committee and a Safety Statement was issued. The US Army Aviation Systems Command was queried relative to a safety of flight release and a reply was received that a safety of flight release would not be required.

The feasibility model was taken to Europe for possible demonstration during training maneuvers during the summer of 1972. It was demonstrated only once and the response was not enthusiastic.

An evaluation plan was prepared and the sight was taken to Fort Huachuca in March 1973 for demonstration and evaluation by personnel of the US Army Combat Surveillance and Electronic Warfare School (USACSEWS), which since has been consolidated into the US Army Intelligence Center and School (USAICS). Here, the sight was well received. It was tested on the range used to train students in the hand-dropping of unattended ground sensors. School personnel testing the sight felt it would improve accuracy, consistency, and the training of personnel. They indicated that a different system of marking the standard would be better for their sensor dropping technique and they recommended a number of modifications. It was requested that one sight be modified accordingly and then sent to Fort Huachuca for additional trials prior to fabrication by LWL of ten additional sights for use in evaluation and training. It was indicated that the standard drop altitude was 500 feet but that an altitude of 800 feet would be preferred. There was no interest in higher altitudes or

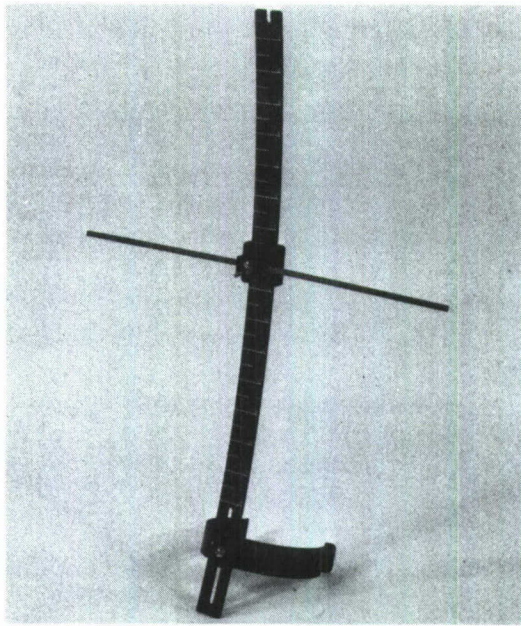

Feasibility Model

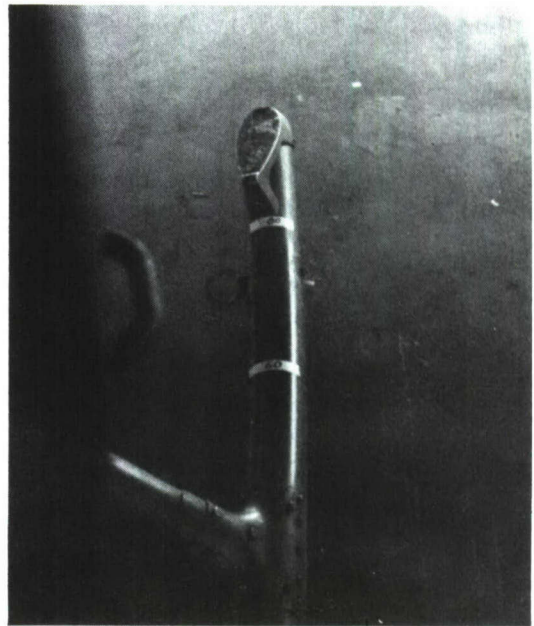

Final Model

Figure 6. Front Sighting Markers

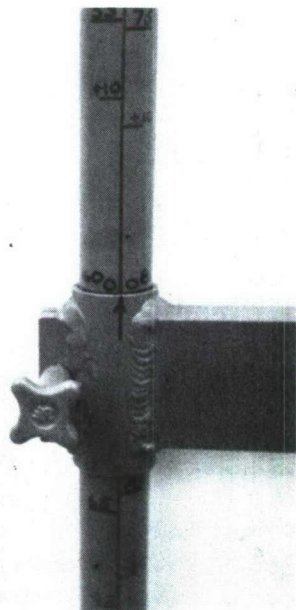

Feasibility Model

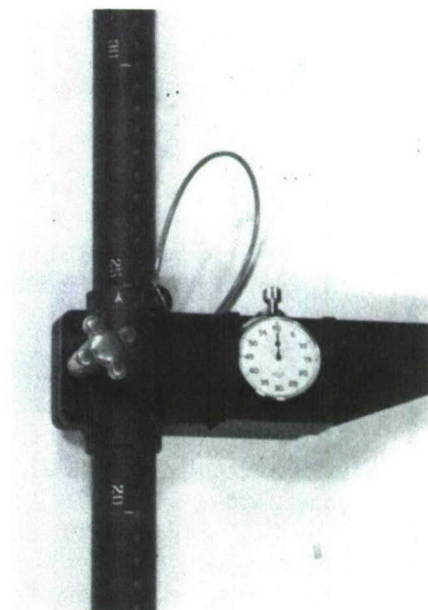

Final Model

Figure 7. Sight Standard and Arm at Zero Setting

in drops from nap-of-the-earth; the angle of entry of the sensor into the ground is sensitive and therefore low release altitudes are ruled out except from a hovering helicopter.

Several modifications were made and then evaluated at Fort Huachuca. New markings were provided on the standard and on the floor and ceiling channels. Positive locking of the crossarm on the standard was achieved by drilling holes through the standard at 1/2-inch intervals and locking with a quick-release pin. An adjustable skid marker was developed to provide a movable front aiming point. A mount on the crossarm was provided for installing a stopwatch that could be used to provide uniform spacing when dropping a string of sensors. Another sight that could be leveled in flight was built and evaluated; but it was rejected as being too complex.

While these modifications were being made, a class of students was used to run an evaluation of the feasibility model. The class was split so that some of the students started using the standard "eyeballing" technique and others started with the sight. All of the students indicated that they preferred to use the sight and had more confidence when using the sight. Each student made five drops and 80% of them had better accuracy when using the sight; 72% of the drops were within 20 meters of the target and 52% within 10 meters.

In April 1973, after the modifications had been completed, two experienced instructors made drops from various altitudes with the following results:

TABLE II. ACCURACY OF SENSOR DROPS USING HELICOPTER DROPSIGHT, 11-12 Apr 73

Altitude (feet)	Sensors Dropped (number)	Average Miss Distance (meters)
500	8	5.0
800	8	3.3
800	4	8.6
1000	5	9.2
1000	10	10.4
1500	6	15.1

As a result of these tests, the helicopter dropsight was immediately phased into the doctrine for unattended ground sensors and incorporated into the training cycle beginning with the class starting 16 Apr 73. The standard drop altitude of 500 feet was retained for a while, but was changed to 800 feet a few months later. Students still were significantly more accurate from 800 feet than previous students had been when "eyeballing" from 500 feet.

Twelve additional sights were fabricated in the final configuration, ten of which are being used for training, etc., at USAICS and in various Army and Marine Corps units. The eleventh sight went to the Ordnance Museum at Aberdeen Proving Ground, MD.

Data on the Helicopter Dropsight and the twelfth sight were forwarded to the US Army Aviation Systems Command (AVSCOM), PO Box 209, St. Louis, MO 63166, which was assigned as the US Army Materiel Command Parent Agency for this task. The point of contact is Mr. Silas G. Garrett, AMSAV-ERR, AV 698-3821.

CONCLUSIONS

1. The Helicopter Dropsight successfully achieved the goal of providing a simple, low-cost sighting system for use in dropping unattended ground sensors and other hardware.
2. Students dropped sensors with significantly greater accuracy from an altitude of 800 feet than previous students had when using the "eyeballing" technique from 500 feet.
3. The Helicopter Dropsight improves accuracy and consistency and should reduce training and periodic proficiency training requirements.
4. The sight is very light in weight and can be installed in approximately five minutes on UH-1D and Uh-1H helicopters.

APPENDIX

MILITARY CHARACTERISTICS FOR HELICOPTER DROPSIGHT

10 JUN 1971
REC'D

19 May 1971

MILITARY CHARACTERISTICS FOR HELICOPTER DROPSIGHT

1. REQUIREMENT:

a. Provide U. S. Army units conducting aerial deployment of unattended ground sensors or aerial delivery of free fall items, the capability of reliably emplacing equipment in the intended target area with a high degree of accuracy.

b. Sources of Requirement:

(1) LWL Briefing Team Report, USARPAC Visit, 2-4 Feb 70.

(2) Ltr, HQ USA Project MASSTER, 2 July 70, subject: ADSID III/S Test Report (U).

(3) DA 2440, HQ Fort Huachuca, 30 Dec 70, subject: Unattended Ground Sensor Air Employment Sight.

2. OPERATIONAL AND ORGANIZATIONAL CONCEPTS:

a. Operational Concept: Aviation units, airmobile companies, and command and control aircraft would utilize this device to accurately deploy sensor devices or other free dropped equipment while airborne from UH-1 helicopters. Device would be operated by a crewman or observer other than the pilot or co-pilot.

b. Organizational Concept: It is envisioned this item would be available to using units through normal supply channels for the class of supply.

3. JUSTIFICATION AND PRIORITY:

a. Reason for the Requirement: A need has been established for a device to enable sensor devices or other equipment to be accurately air delivered from a helicopter at altitude up to 2,000 feet above ground level. The only method presently available is to train an individual to drop the devices by sighting over the landing skid of a UH-1D aircraft. This method requires that the aircraft remain below 800 feet to ensure accuracy. Statistics from South East Asia show that the percentage of sensors deployed by air has increased from 5 percent in 1968 to 40 percent in 1970. Air employment is preferred for the following reasons:

19 May 1971

- (1) Immediate mission response time.
- (2) Requires less manpower - 3 man crew versus hand employment which requires 10 to 15 personnel.
- (3) The possibility of compromise is reduced due to less time spent over the target area.

b. Priority: Priority Group II.

4. CHARACTERISTICS:

a. Performance Characteristics: During the course of the feasibility study, it is felt that the following characteristics should be considered:

- (1) Number of components - To be determined.
- (2) Maximum weight - 10 lbs.
- (3) Cubic measurements - To be determined.
- (4) Assembly/disassembly time - Installation or removal in less than one hour by one man.
- (5) Power requirements - To be determined.
- (6) Transportability - Easily transported by one man, air and vehicle transportable.
- (7) Environmental requirement - Categories 1 thru 8, AR 70-38.
- (8) Compatability - Must be capable of being mounted on UH-1 series helicopters.
- (9) Performance requirements:
 - (a) Range - Accurate for altitudes of 2,000 feet above ground level or less.
 - (b) Accuracy - Accurate enough to ensure sensor emplacement within existing accuracies required for aerial emplacement of sensor devices.

MC'S FOR HELICOPTER DROPSIGHT

19 May 1971

(c) Night operation - Must be capable of being used at night utilizing the aircraft power source.

(10) Storage (Shelf Life) - Indefinite.

b. Maintenance Concept: Require no maintenance other than visual inspection prior to use.

c. Human Engineering Concept: Require a minimum of training and be safe in operation in accordance with AR 602-1, dated 4 Mar 68 and AR 385-16, dated 11 Feb 67.

d. Priority of Characteristics: Reliability, performance.

5. PERSONNEL CONSIDERATIONS: Introduction of this item into the Army inventory will require no additional personnel spaces in TO&E of tactical units.

DATE

19 May 71

APPROVED:

Sgd
F. A. HENNING

LTC, GS

Chief, Military Opns Division

DISTRIBUTION LIST

	<u>Copies</u>
Commander US Army Materiel Command ATTN: AMCDL 5001 Eisenhower Avenue Alexandria, VA 22333	1
Commander US Army Materiel Command ATTN: AMCRD 5001 Eisenhower Avenue Alexandria, VA 22333	3
Commander US Army Materiel Command ATTN: AMCRD-P 5001 Eisenhower Avenue Alexandria, VA 22333	1
Director of Defense, Research & Engineering Department of Defense WASH DC 20301	1
Director Defense Advanced Research Projects Agency WASH DC 20301	3
HQDA (ODCSRDA) WASH DC 20310	2
HQDA (DAMO-PLW) WASH DC 20310	1
Commander US Army Training & Doctrine Command ATTN: ATCD Fort Monroe, VA 23651	1

Commander US Army Combined Arms Combat Developments Activity Fort Leavenworth, KS 66027	1
Commander US Army Logistics Center Fort Lee, VA 23801	1
TRADOC Liaison Office HQS USATECOM Aberdeen Proving Ground, MD 21005	1
Commander US Army Test and Evaluation Command Aberdeen Proving Ground, MD 21005	1
Commander US Army John F. Kennedy Center for Military Assistance Fort Bragg, NC 28307	1
Commander-In-Chief US Army Pacific ATTN: GPOP-FD APO San Francisco 96558	1
Commander Eighth US Army ATTN: EAGO-P APO San Francisco 96301	1
Commander Eighth US Army ATTN: EAGO-FD APO San Francisco 96301	1
Commander-In-Chief US Army Europe ATTN: AEAGC-ND APO New York 09403	4
Commander US Army Alaska ATTN: ARACD APO Seattle 98749	1

Commander 1
MASSTER
ATTN: Combat Service Support & Special Programs Directorate
Fort Hood, TX 76544

Commander 2
US MAC-T & JUSMAG-T
ATTN: MACTRD
APO San Francisco 96346

Senior Standardization Representative 1
US Army Standardization Group, Australia
c/o American Embassy
APO San Francisco 96404

Senior Standardization Representative 1
US Army Standardization Group, UK
Box 65
FPO New York 09510

Senior Standardization Representative 1
US Army Standardization Group, Canada
Canadian Forces Headquarters
Ottawa, Canada K1A0K2

Director 1
Air University Library
ATTN: AUL3T-64-572
Maxwell Air Force Base, AL 36112

Battelle Memorial Institute 1
Tactical Technical Center
Columbus Laboratories
505 King Avenue
Columbus, OH 43201

Defense Documentation Center (ASTIA) 12
Cameron Station
Alexandria, VA 22314

Commander 2
Aberdeen Proving Ground
ATTN: STEAP-TL
Aberdeen Proving Ground, MD 21005

Commander 1
US Army Edgewood Arsenal
ATTN: SMUEA-TS-L
Aberdeen Proving Ground, MD 21010

US Marine Corps Liaison Officer
Aberdeen Proving Ground, MD 21005

1

Director
Night Vision Laboratory
US Army Electronics Command
ATTN: AMSEL-IV-D (Mr. Goldberg)
Fort Belvoir, VA 22060

1

Commander
US Air Force Special Communications Center (USAFSS)
ATTN: SUR
San Antonio, TX 78243

1

Commander
US Army Armament Command
ATTN: AMSAR-ASF
Rock Island, IL 61201

1

Commander
US Army Intelligence Command and School
ATTN: Ground Sensor Department
Unattended Ground Sensor Division
Fort Huachuca, AZ 85613

10

Commander
Fort Huachuca
ATTN: SCCH-PCA-CPM
Fort Huachuca, AZ 85613

1

Commander
101st Airborne Division (Air Mobile)
Fort Campbell, KY 42223

2

Commander
82nd Airborne Division
Fort Bragg, NC 28307

2

Commander
2nd Armored Division
Fort Hood, TX 76545

2

Commander
25th Infantry Division
APO San Francisco 96557

2

Director Marine Corps Development Center ATTN: Intelligence Division Marine Corps Development and Education Command Quantico, VA 22134	2
Commandant Headquarters, US Marine Corps Code RD Washington, DC 20380	1
Commanding General 1st Marine Division Camp Pendleton, CA 92055	2
Commanding General 2nd Marine Division Camp Lejeune, NC 28542	2
Commanding General 3rd Marine Division Camp Smedley D. Butler FPO San Francisco 96602	2
Commanding Officer US Navy Amphibian Group Naval Amphibious Base Norfolk, VA 23521	1
Commander US Army Aviation Systems Command ATTN: AMSAV-ERR (Garrett) PO Box 209 St. Louis, MO 63166	4
Commanding Officer US Navy Amphibian School Naval Amphibious Base San Diego, CA 92155	2