

Ad 773 806

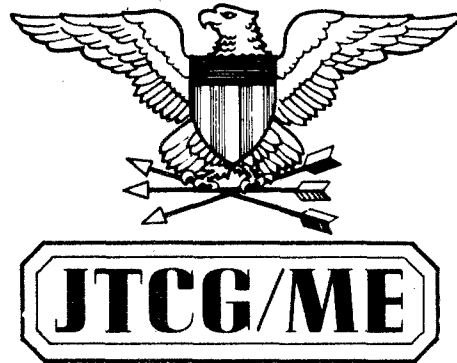

**Joint Technical Coordinating Group**

**for**

**Munitions Effectiveness**

**FLARE EFFECTIVENESS FACTORS:  
A GUIDE TO IMPROVED UTILIZATION  
FOR  
VISUAL TARGET ACQUISITION**

**TARGET ACQUISITION WORKING GROUP REPORT**

20061010144

**Best Available Copy**

**Joint Technical Coordinating Group  
for  
Munitions Effectiveness**

FO 8635-75-C-0004

**FLARE EFFECTIVENESS FACTORS:  
A GUIDE TO IMPROVED  
UTILIZATION FOR VISUAL  
TARGET ACQUISITION**

**TARGET ACQUISITION WORKING GROUP REPORT**

Reproduction for nonmilitary use of the information or illustrations contained in this publication is not permitted without specific approval of the issuing service.

Date shown on the title page (lower right corner) is for identification only. This is not a distribution date. Processing time sometimes causes distribution to only appear to have been delayed.

**INSERT LATEST CHANGED PAGES. DESTROY SUPERSEDED PAGES.**

## LIST OF EFFECTIVE PAGES

Dates of issue for original and changed pages are:

Original . . . 0 . . . November 1973

**TOTAL NUMBER OF PAGES IN THIS PUBLICATION IS 90 CONSISTING OF THE FOLLOWING:**

Page No.	*Change No.
Title . . . . .	0
A . . . . .	0
i - iv . . . . .	0
1 - 84 . . . . .	0

NOTE: On a changed page, the portion of the text affected by the latest change is indicated by a vertical line, or other change symbol, in the outer margin of the page.

\* Zero in this column indicates an original page.

## PREFACE

This technical report documents an "in-house" survey conducted from September 1972 to March 1973 by the Aerospace Medical Research Laboratory. The work is part of a joint Services program on air-to-ground target acquisition. The research was undertaken in response to a request from the Target Acquisition Working Group (TAWG) established by the Joint Tactical Coordinating Group for Munitions Effectiveness under the Joint Munitions Effectiveness Manual/Air-to-Surface. The request was for the publication of information which will become part of the Joint Munitions Effectiveness Manual and which pertains to the effective planning and execution of flare missions for unaided air-to-ground visual target acquisition.

Current TAWG tasks include the definition of problem areas in airborne forward air controller operations, the description and effectiveness estimation of target markers, research on target acquisition by flarelight, summary and synthesis of existing target acquisition field test data, and the description and evaluation of mathematical models of the visual target acquisition process.

The scope of the study was broadly defined by the TAWG steering committee composed of Ronald Erickson, Chairman (Naval Weapons Center), Major Robert Hilgendorf, Co-chairman (Wright-Patterson Air Force Base), Dr. Howland Bailey, Mathematical Model Subgroup Chairman (Rand Corp.), Ronald Bruns (Naval Missile Center), V. Darryl Thornton (Elgin AFB), Lt Col C. E. Waggoner (Brooks AFB), and Paul Amundson (Naval Weapons Center). The work was conducted by the TAWG Flare Research Subgroup. Dr. Shelton Macleod (Aerospace Medical Research Laboratory) was the principle investigator. The study was technically reviewed by other members of this Subgroup.

The aid of the following individuals in the preparation of this report is especially acknowledged: Mr. Carl W. Lohkamp, Research and Development Department, Naval Ammunition Depot, Crane, Indiana, reviewed the manuscript, provided most of the ideas for the introductory Summary of Applied Principles, and rewrote the section on Candle Composition; Mr. Robert B. Davis, Pyrotechnics Division, Picatinny Arsenal, Dover, New Jersey, reviewed the manuscript and provided a useful critique on the inadequacies of current pyrotechnic illumination standards.

## TABLE OF CONTENTS

<i>Section.</i>	<i>Page</i>
I INTRODUCTION	1
Background	1
Summary of Applied Principles for Effective Flare Utilization	1
Military Applications of Illuminating Flares	4
Target Acquisition Responses	4
Description of Flare Dispensing Systems	5
Summary of Factors Controlling Flare Effectiveness	8
II RESEARCH APPROACHES	10
Flare Tunnel	10
Tower Facility	10
Field Test	10
Pyrotechnic Evaluation Range (PER)	10
Observer Opinion Test	13
Observer Performance Test	13
Terrain-Model Studies	13
Math-Model Studies	15
III FLARE EFFECTIVENESS FACTORS	17
Candle Composition	17
Particle Size	19
Amount of Magnesium	19
Altitude Effect	19
Flare Diameter	22
Flare Binder	22
Flare Smoke	22
Flare Deployment Factors	22
Ground Illumination Requirements	23
Flare Altitude	25
Burn-Rate	30
Rate of Descent	30
Flare Orientation	30
Multiple Flare Systems	31
Flare Shielding	33
Wind Drift	36
Atmospheric Effects	39
Target/Background Factors	43
Observer Factors	43
IV CONCLUSIONS	47
<i>Appendixes</i>	
A Aircraft Flare Descriptions	53
B Flare Questionnaire	80
<i>References</i>	48

## LIST OF ILLUSTRATIONS

<i>Figure</i>		<i>Page</i>
1	MK-45 Aircraft Parachute Flare	6
2	MK-45 Illumination and Final Collapse Stages	7
3	Flare Tunnel	11
4	Flare Tower Facility	12
5	Pyrotechnic Evaluation Range	14
6	Terrain Model showing Observer and Simulated Flare-Drop Device	16
7	Wavelength Spectrum of a Typical Magnesium Flare	18
8	Effects of Magnesium Particle Size on Flare Burning Rate and Candlepower	20
9	Luminous Efficiency for Four Flare Diameters as a Function of Percentage of Magnesium	21
10	Ground Area Illuminated to 0.2 Footcandles by Flares at various Heights and Intensities	27
11	Ground Area Illuminated to 0.2 Footcandles at Optimum Heights of Flares with Different Intensities	28
12	Radial Measures of Ground Illumination from the Pyrotechnic Evaluation Range for the M335A1 at Various Elevations	29
13	Machine Plotted Output for a Ground Illumination Contour of 0.5 Footcandles	34
14	A Shielded Flare at the Beginning and End of the Burn Period	35
15	Visibility Plot for Shielded and Unshielded Flares at Different Flare-Observer-Target Angles	37
16	Luminous Intensity versus Degrees from Pattern Center for a 60-degree 45-inch Shield	38
17	Tolerable Wind Drift for Target Acquisition (See text for explanation)	40
18	Paths of Atmospheric Degradation for Target Visibility under Flarelight	41
19	Effect of Atmosphere on Contrast under Flare Illumination	42
20	Illumination Required for Recognition as a Function of Target Illumination Angle	46

<i>Figure</i>		<i>Page</i>
A-1	XM170 Aircraft Parachute Flare	54
A-2	XM-715 Mechanical Time Fuze	55
A-3	XM-127 Aircraft Flare Dispenser	56
A-4	XM-15 Aircraft Dispenser and Flare	57
A-5	XM170 Aircraft Parachute Flare Deployment Sequence	58
A-6	M8A1 Aircraft Parachute Flare	61
A-7	M8A1 Aircraft Parachute Flare Deployment Sequence	62
A-8	LUU-2/B Aircraft Parachute Flare	64
A-9	LUU-2/B Flare Operation Sequence	66
A-10	MK-45 Aircraft Parachute Flare	67
A-11	MK-45 Flare, Aircraft, Parachute Launch and Initial Separation Stages	69
A-12	MK-45 Secondary Separation and Ignition Stages	70
A-13	MK-45 Illumination and Final Collapse Stages	71
A-14	Aircraft Parachute Flare, MK24, Cross-Section	72
A-15	Attack Flare	75
A-16	Attack Flare Deployment Sequence	76
A-17	Briteye Flare Assy B-2	78
A-18	Briteye Flare Assembly B-2	79

## SECTION I INTRODUCTION

### BACKGROUND

This document is responsive to a request from the Target Acquisition Working Group (TAWG) of the Joint Tactical Coordinating Group for Munitions Effectiveness for the publication of information which will become part of the Joint Munitions Effectiveness Manual and which pertains to the effective planning and execution of flare missions for unaided air-to-ground visual target acquisition. The following ground rules have been adopted in interpreting TAWG's request and organizing the contents of this report. The data provided are intended for that community of interest within the Armed Forces which is concerned with research, engineering, planning or operational activities involving the design or deployment of illuminating flares for air-to-ground visual target acquisition.

Ideally this report should be a manual which provides the user with complete information for researching, operating and evaluating current and future illuminating flare systems. However, such a compendium is now virtually impossible to produce, given the existing gaps and limitations of data on flare effectiveness. Sufficient data that are valid, quantitative and applicable to all user needs simply do not exist. Nevertheless, within the past 10 years ground has been broken and a considerable amount of relevant pyrotechnic and visual research has been generated by all three Services. This paper extracts, organizes and evaluates the data of those studies that appear to have immediate or potential user application. Accordingly, a research-centered document has been prepared providing the user with information, guidance and recommendations that are primarily concept oriented rather than hardware oriented. Hopefully, the reader will be able to select, interpret and apply those sections of the report that are relevant to his particular problems.

Certain advantages may be derived from this approach: (a) It systematizes and integrates a wide variety of research efforts, thus increases the degree of impact on current user needs; (b) Rather than limiting the approach to the specific equipments or systems of a particular organization, it permits a broader degree of generality applicable to the needs of many groups within all services; (c) It can result in stronger and more relevant interdependency between researcher and user so that technological needs are better selected, stated and prioritized.

### SUMMARY OF APPLIED PRINCIPLES FOR EFFECTIVE FLARE UTILIZATION

Although this report is primarily research oriented, stressing gaps in knowledge and the need for empirically derived information, it would be a mistake to deny the reader those benefits derived from practical experience which govern effective deployment of illuminating flare systems. Such experience has led to certain "rules-of-thumb" which tend to pay off under a relatively wide range of conditions. Some of these working principles will be included herein for the benefit of those readers who participate directly in the planning or operation of flare missions. These points are by no means exhaustive and are given in no particular order. They represent the kind of advice that a seasoned user would give the planner who is learning to deploy a flare system. Despite the likelihood that this advice will be generally beneficial, the



phrase "other things being equal" should be applied to all helpful hints of this type. Subsequent sections of this document will be more concerned with these "other things."

### Types of Flare Missions

As pointed out by Davis and Tyroler (1972), there are three general categories of missions into which the use of illuminating flares fall, and most applications are one or a combination of these categories:

1. Fixed Position. Here a predesignated target is at a known location and must be illuminated as a basis for subsequent military action (e.g., strike or damage assessment).
2. Specific area. In this situation a specified area must be illuminated to such a level that, if a known target is present, the observer has a high probability of recognizing it. This tactic is commonly deployed in securing an area against infiltration by enemy troops.
3. Search. In this case one is concerned about finding known targets or targets of opportunity in a relatively large suspect area, e.g., searching for tanks or trucks along a road.

Flare deployment tactics will obviously differ for each of these situations. For effective target acquisition, the number of flares, as well as the amount of illumination required per flare will generally increase progressively (possibly by a factor of two) as one proceeds from the Fixed Position to the Specific Area to the Search Situation.

### Multiple Flares

The need for multiple flare deployment (including the selection of number of component units and temporal spacing between them) depends largely upon mission requirements. For the Specific Area and Search Situations, multiple deployment patterns will usually be necessary. Suggested formulae for effective launch cycles under these conditions are given in reports by Blunt and Schmeling (1968 pgs 57-63) and by Starrett (1964). Fixed-Position missions are unlikely to require launching more than two flares the same pass.

### Atmospheric Effects

Because cloud formations greatly reduce the probability of target acquisition by scattering and attenuating flare light, every attempt should be made to launch flares over openings in cloud cover or beneath cloud layers.

Even a moderately restrictive meteorological condition (i.e., a slight ground haze) which reduces the meteorological range by one-half is also likely to reduce the probability of detecting a target by the same amount.

### Glare-Angle

The geometry of deployment should be such as to maintain a glare-angle (i.e., the angle formed at the observers eye from respective lines of regard to the flare and the target) larger

than 7°. For smaller glare angles excessive veiling illumination from the flare will obscure the visual image of the target. In any case the observer should refrain from looking at the flare, since this can significantly impair his night vision for several minutes. During this time his ability to acquire targets will be reduced.

### Flare Ignition Altitude

This should generally be kept as low as possible without sacrificing other requirements to (1) prevent glare, (2) maintain a sufficient burn-period to search for the target, and (3) avoid ground-burning. Flares ignited at low altitudes provide less opportunity for wind-drift and enemy-alert before the target is adequately illuminated. Moreover, a relatively low illuminating source, increases the probability of effectively silhouetting the target.

### Relative position of Observer, Target and Flare.

If mission requirements emphasize the need for visual target acquisition, it is generally best to drop the flare on the far side of the target from the observer (i.e., back-lighting the target). Under these conditions it is most advantageous to *not* have the observer, target and flare in the same vertical plane. A minimum lateral observer-offset of 15 degrees is recommended.

If, on the other hand, a higher priority is placed on the safety of the observational aircraft, the flare should be dropped between it and the target, thus providing an illuminating shield against hostile detection.

### Illuminating Target Background.

Placement of flares should be such as to take full advantage of cues to target detection, i.e., features of the environment (rivers, roads) which are invariably associated with certain types of targets (boats, bridges, vehicles). If, on the other hand, features of the environment constitute clutter (i.e., irrelevant objects such as trees or cattle likely to be confused with targets), the level of flare illumination must be increased to minimize observer-error.

### Slant Range Visibility

The probability of recognition approaches an unacceptable level at observer-to-target distances (slant ranges) where the visual angle subtended by the target is less than one minute of arc. A rapid estimation of this limiting distance is given by the formula  $D = 3500L$  where  $D$  is the observer-to-target distance and  $L$  is the largest dimension of the target projected to the eye. At most practical slant ranges it will be virtually impossible for the aircraft observer to identify discrete personnel. Direct sighting of this small a target (which is able to effectively use ground cover) is generally not feasible.

### Aircraft Speed

There is generally an inverse relationship (beyond some low limiting speed) between aircraft

velocity and probability of target acquisition. Hence observer aircraft speed should be maintained as slow as possible (within equipment or mission constraints).

### Utilization of Wind

Flare light acquisition will generally be unfeasible during periods of exceptionally strong or gusty winds which blow the flarelight off the target. Nevertheless for moderate winds (up to about 20 knots), where altitude profiles of wind velocity are available, flares may be advantageously dropped with wind-drift taken into account so as to drift over the target at the time of most effective illumination or, possibly, to provide effective light while drifting over an extended area.

### Wind-Screen Condition

A surprising amount of degradation in the observer's ability to sight targets may be directly attributable to the condition of the wind screen through which he is looking. Accumulated effects of scratches, dirt and grease on this viewing media can reduce light transmission by as much as 50 percent. The transmissivity of the window material is also important and requires checking.

## MILITARY APPLICATIONS OF ILLUMINATING FLARES

The deployment of visual illuminating flares is part of a broad class of operations known as Military Pyrotechnics. This has been defined by Hart (1955) as a "category of ammunition employed primarily for the production of light, heat, smoke and sound for such typical nondestructive purposes as battlefield illumination, signalling, marking, tracking, tracing, spotting, ignition, simulation and aerial night photography . . . produced as a result of chemical reactions caused by the application of proper stimuli to chemical elements or compounds alone or in intimate mixtures. Military pyrotechnics are major aids and accessories in tactical operations for communications, warning, reconnaissance and the effective application of destructive firepower, in strategic operations for intelligence, in supporting activities such as rescue operations and troop training, in research and development of rocket powders and propellants, and in exploration of the upper atmosphere."

Within the broader range of pyrotechnics this paper is concerned with the illumination flare, a ground illumination system designed to be air-launched at night and to provide sufficient light over designated areas for specific kinds of military operations to occur. Included here are such diverse activities as navigation, rendezvous, reconnaissance, target marking, ground support, search and rescue, disruption of enemy gunners, terminal guidance, and strike illumination. Note that for special applications flares may be designed to emit invisible irradiation. Here the flare emission enhances the use of infrared night vision aids for target acquisition by providing the required type of background illumination.

## TARGET ACQUISITION RESPONSES

Of prime concern in this report is the use of flares for air-to-ground unaided visual target acquisition from observational aircraft. A point worth stressing here is that the required kinds and

levels of target acquisition responses can vary widely depending on the type of military application which the flare-light illumination supports. Thus illuminating a prelocated target places a different visual requirement on the human observer (elicitation of a single preset confirming reaction) than does the illumination of an area under surveillance (which requires search and the possibility of alternative responses). Still another alternative would be the illumination of suspect areas for targets of opportunity, where an observer searches with even less knowledge of what he is looking for. Differing military requirements can also dictate different levels of response specificity. These have been categorized as: (1) Detection—merely locating an unspecified object, (2) Orientation—being able to discern the long and short dimensions of a suspect target, (3) Recognition—sufficient labeling of a target to establish the general class of objects to which it belongs (e.g., tank), (4) Identification—more precise categorization of a target (e.g., an M-15).

In addition to the responses associated with labeling the target, target acquisition may also involve responses for gauging the relative or absolute location or distance of the target with respect to the observer or other points of reference.

Mission requirements for visual target acquisition will also dictate the speeds with which observers must respond and the relative cost of different types of response errors, i.e., errors of location, misidentifications or omissions.

For visual flares (as is the case for all other visual acquisition systems), the effectiveness of the total system, as well as its various components, is based largely on the extent to which system outputs in the form of target acquisition responses satisfy the information acquisition requirements for which the system has been designed. In this case the responding unit is the eye and brain of a human observer.

## DESCRIPTION OF FLARE DISPENSING SYSTEMS

As indicated in the Introduction, the approach to be taken in this paper is to provide guidance to tri-service users on flare effectiveness at a generalizable level as opposed to a more specific equipment-centered approach. However, to satisfy the interests of the more operationally oriented reader descriptions will be given in Appendix A of seven flare systems: XM170, M8A1, LUU-2/B, MK45, MK24, LUU-3/B (ATTACK), and MLU-32/B (Briteye). These have been taken from a recent report of the Joint Technical Coordinating Group for Air Launched Non Nuclear Ordinance (JTCG/ALNNO). They are representative of air launched illumination flares for the three services. Table I gives numerical comparisons among these systems with respect to: candlepower, burn-time, descent rate, weight, diameter, length, status and user. However, here it will suffice to merely provide a functional listing of the major components comprising a typical air-drop illumination flare system along with a description of how these fit into the deployment cycle. For illustrative purposes a cross section of the MK-45 showing major flare components is given in figure 1 and an illustration of its deployment appears in figure 2.

The components of a typical flare are housed in a cylindrical container. One of these is a pre-set, time-delay fuse assembly activated by the pull of a launching lanyard. A fuse-setting controls

END VIEW OF FUZE  
(WITH END CAP REMOVED)

# MK-45 AIRCRAFT PARACHUTE FLARE

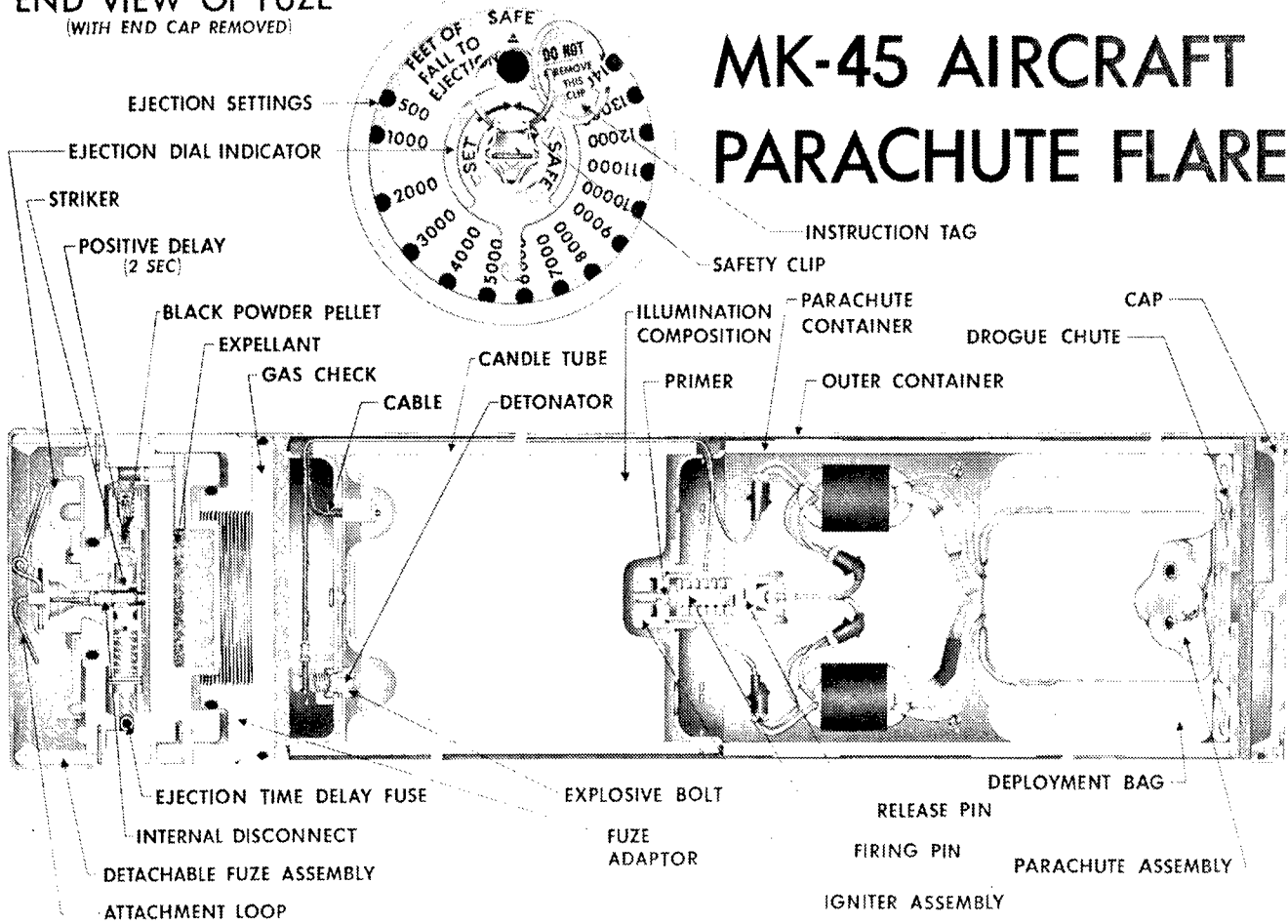

Figure 1. MK-45 Aircraft Parachute Flare

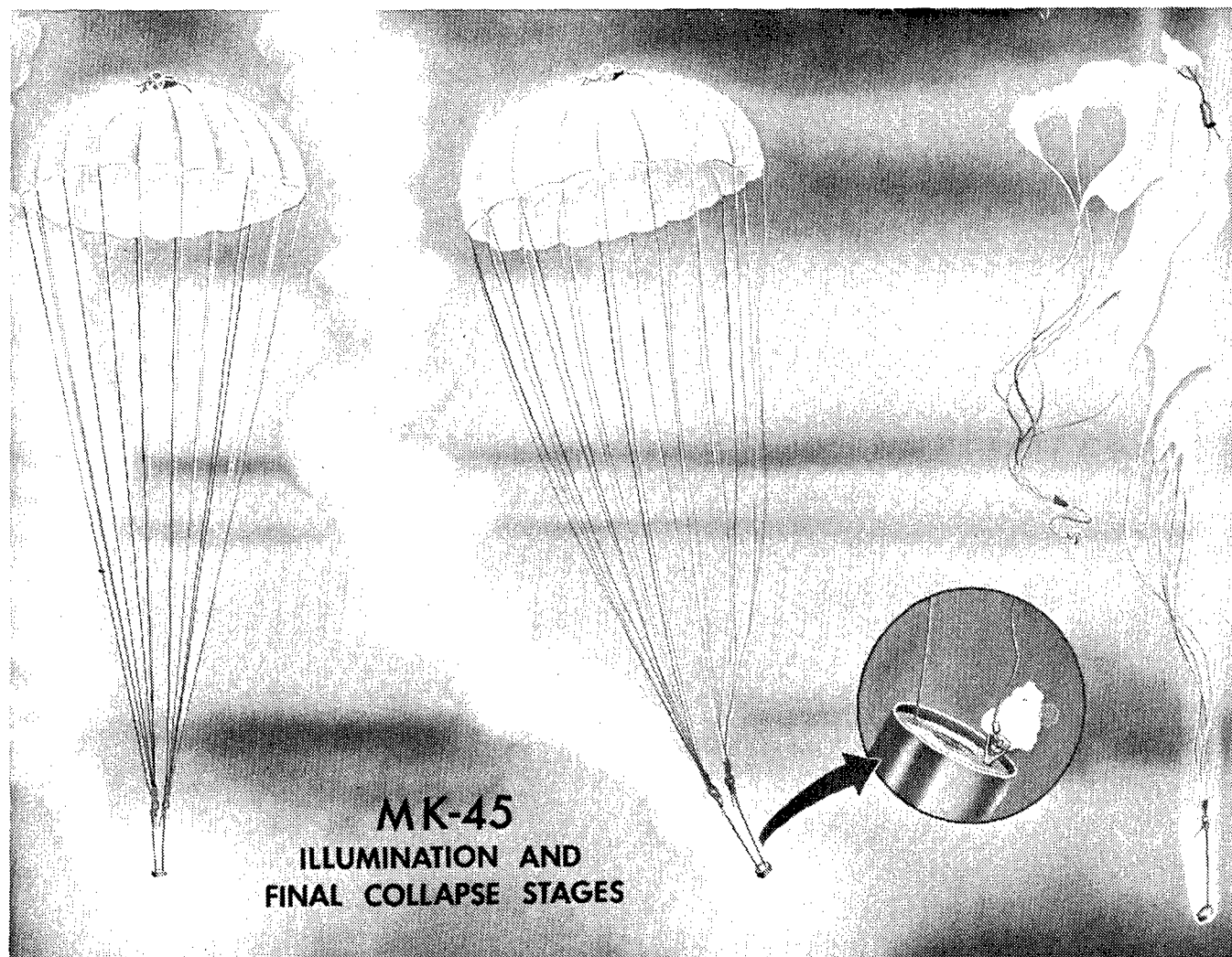

Figure 2. MK-45 Illumination and Final Collapse Stages

footage of fall between launch and the ejection of the candle and parachute assembly (also housed in the container). The pull of the open chute activates an igniter assembly which initiates the burning of a candle (typically 22 inches long by 4.5 inches in diameter). The chute slows and stabilizes the candle's descent thus providing more effective ground illumination. At the end of its burn-time, the candle activates an explosive bolt (which releases the shroud lines and causes the parachute to collapse and plummet to the ground.

## SUMMARY OF FACTORS CONTROLLING FLARE EFFECTIVENESS

Critical factors which determine the usefulness of flare light for target acquisition will be summarized prior to being discussed in greater detail in the main body of the report.

First, there are the following factors associated with the flare itself: Launch Altitude and Fuse Setting. These jointly determine the ignition altitude of the flare; Candle Size and Composition. This determines the spectral distribution, candlepower and burn-time of the flare; Parachute Suspension System. This determines the descent rate of the burning flare.

Within recent years some flares have also been designed with a surrounding conical shield designed to release smoke upward while it facilitates target acquisition by reducing glare and concentrating the circle of light on the ground.

Flares may also be deployed in multiple launch systems to provide either simultaneous or successive exposures from an aggregate of candles. This not only affords a fail-safe technique against possible duds, but also serves as a pre-planned means of increasing the area, amount and the duration of ground illumination. Controlling factors in multiple launch systems include the number of candles as well as the spatial/temporal drop-intervals between them.

Another parameter affecting light dispersion is the orientation of the falling flare which can be suspended to burn in a downward, horizontal or upward position (the latter option is currently not in accepted use).

Two other environmental factors prevail, being external to the design and deployment of the flare but capable of significantly altering its effectiveness. These are: (a) Wind velocity which if high or gusty, will cause undesirable shifts in ground illumination patterns, but if moderate, may even enhance target acquisition; and (b) Atmospheric effects which, under cloudy conditions, reduce the apparent target-to-background contrast through attenuation and scattering of the flare light.

Many relevant factors are inherently associated with the target (including its shadow) and target background. The following parameters should be mentioned: (a) Brightness-contrast, referring to the ratio of the luminous reflectivity of a target to the reflectivity of its immediate surrounds; (b) Color-contrast, dependent upon spectral reflectivities of both the target and its surrounds; (c) Target size, limiting the distance at which it can be visually resolved; (d) Target shape, an important but largely undetermined factor in target recognition; (e) Target motion, again an undetermined factor which may under specified conditions enhance target

acquisition. In addition to affecting contrast, the (f) Target surrounds may degrade target acquisition if it contains clutter which is confused with the target, or it may enhance target acquisition if it provides cues to target recognition.

Of critical importance to visual flare effectiveness are those factors pertaining to the observer himself. He provides the informational output of the system, but imposes additional constraints on its design in terms of his unique perceptual characteristics and the way he is positioned and interfaced with the illumination system. The following topics in visual perception of interest in this connection are: (a) spatial/temporal visual acuity (b) color vision, (c) light and dark adaptation, and (d) space/time/motion perception. Detailed discussion of these subjects is beyond the scope of this paper. A suggested source for the interested reader is Vision and Visual Perception by Graham et al. (1965).

Nevertheless, so that the reader may better appreciate some of the human factors problems which affect flare-light target acquisition, a description of typical conditions which affect the observer's performance in this situation will be given.

The observer will probably be adapted to a relatively low level of illumination extending downward to 0.01FC. He will be moving at a speed of from 100 to 500 knots at distances from a few hundred feet to several miles from relatively small tactical targets. He is likely to be in voice communication with a Forward Air Controller who has deployed the flare from another aircraft and is directing him toward the target. In addition to inadequate illumination, the following factors will probably degrade his acquisition performance under flare light conditions: (a) stress induced by mission hazards, (b) temporal or spatial disorientation, (c) glare effects, (d) flickering ground shadows, (e) lack of depth cues, and (f) inadequate time to search and identify the target.



## SECTION II

### RESEARCH APPROACHES

Before engaging in a more detailed analysis of flare effectiveness factors it will first be necessary to describe the different kinds of research facilities where these factors are being evaluated. These facilities are staffed by scientists who are expert in such diverse areas as chemistry, physics, systems analysis, computer technology and behavioral sciences. The major kinds of facilities and their associated research techniques are categorized below. References describing each approach in more detail are also cited.

#### FLARE TUNNEL

Here the flare is mounted and burned either face-up or face-down in a manner to facilitate smoke removal. Recording photocells are used to measure the candle-power and burn time of alternative candle compositions, sizes, or configurations. An application of this technique is described by Feagans (1967). An illustration of a flare tunnel appears in figure 3.

#### TOWER FACILITY

Here static tests are performed on the flare while it burns in a fixed and suspended face-down position. Again, photocells are used to measure candle-power. In addition to the kinds of tests performed in the flare tunnel, ground illumination can be directly measured here at various multiaspect angles. This method has been described by Stoval (1966) and is illustrated in figure 4.

#### FIELD TEST

In this type of test flares are deployed over test ranges under simulated and relatively controlled operational conditions; i.e., using appropriate launch and/or observational aircraft, tactical maneuvers, drop altitudes, deployment of targets, etc. Within the general category of field tests the following alternative techniques are being used.

##### Pyrotechnic Evaluation Range (PER)

This technique described by Brooks (1970) utilizes a spaced matrix of photo sensors placed on the ground at fixed separations. The sensitivity of each sensor is adjusted so that it can be triggered by a required amount of illumination (usually some fraction of a footcandle). The pattern of response for the entire sensor matrix (covering a ground area of 8100 ft sq) can be observed and recorded by means of a remote real-time electro-optical display. Determination of flare candle-power can also be made by conventional detectors, analogue or by a so-called peripheral technique utilizing the "on" cells at the periphery of the illuminated area [JTCG/ALNO (1971)]. The PER technique has permitted a reliable real-time, photometric intercomparison of ground illumination patterns registered by operational or developmental flares as a function of such factors as altitude, wind-drift, burn-time, or rate of descent. Useful supplementary data are also recorded from observer stations in the form of judgments

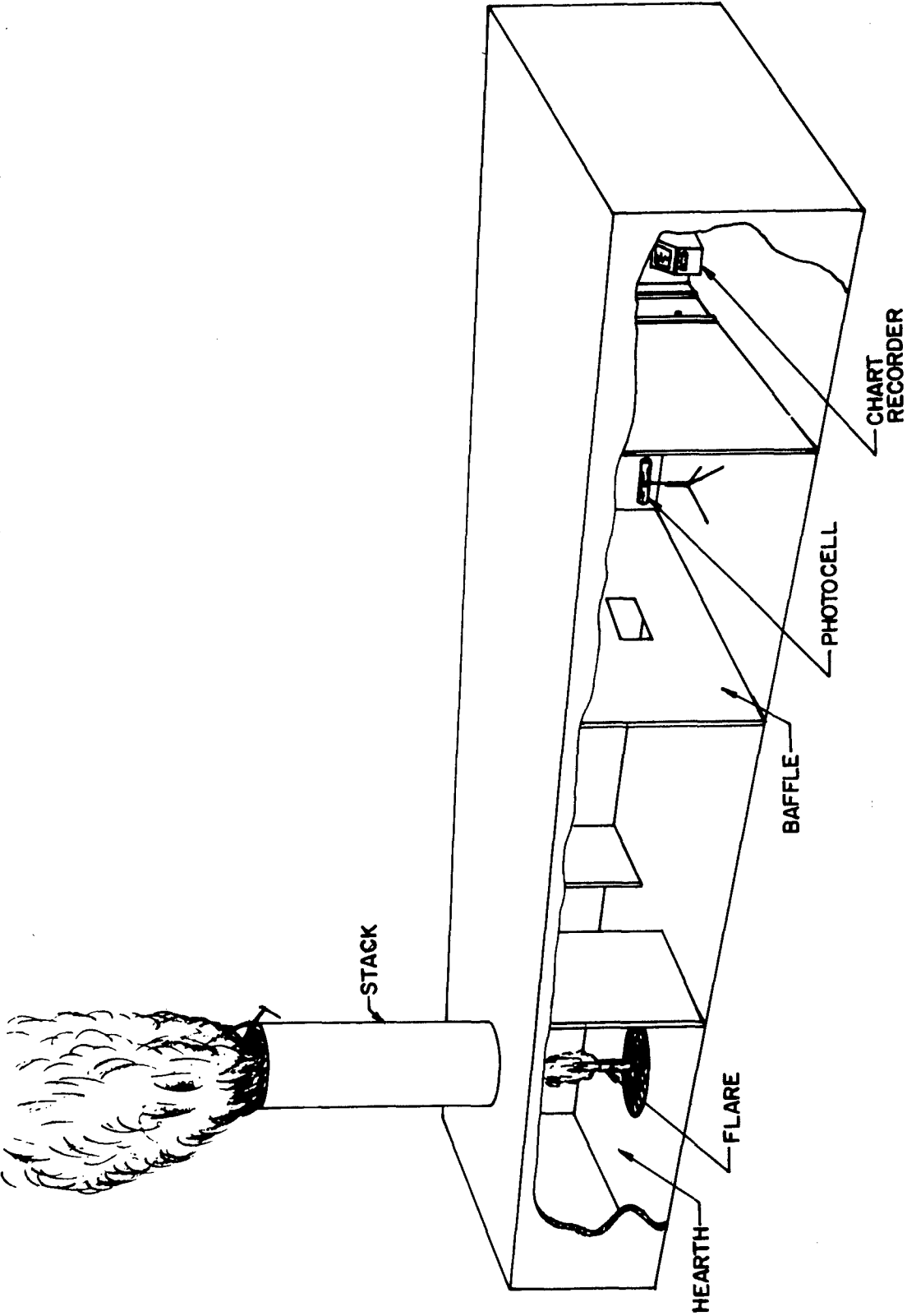

# FLARE TUNNEL

Figure 3. Flare Tunnel

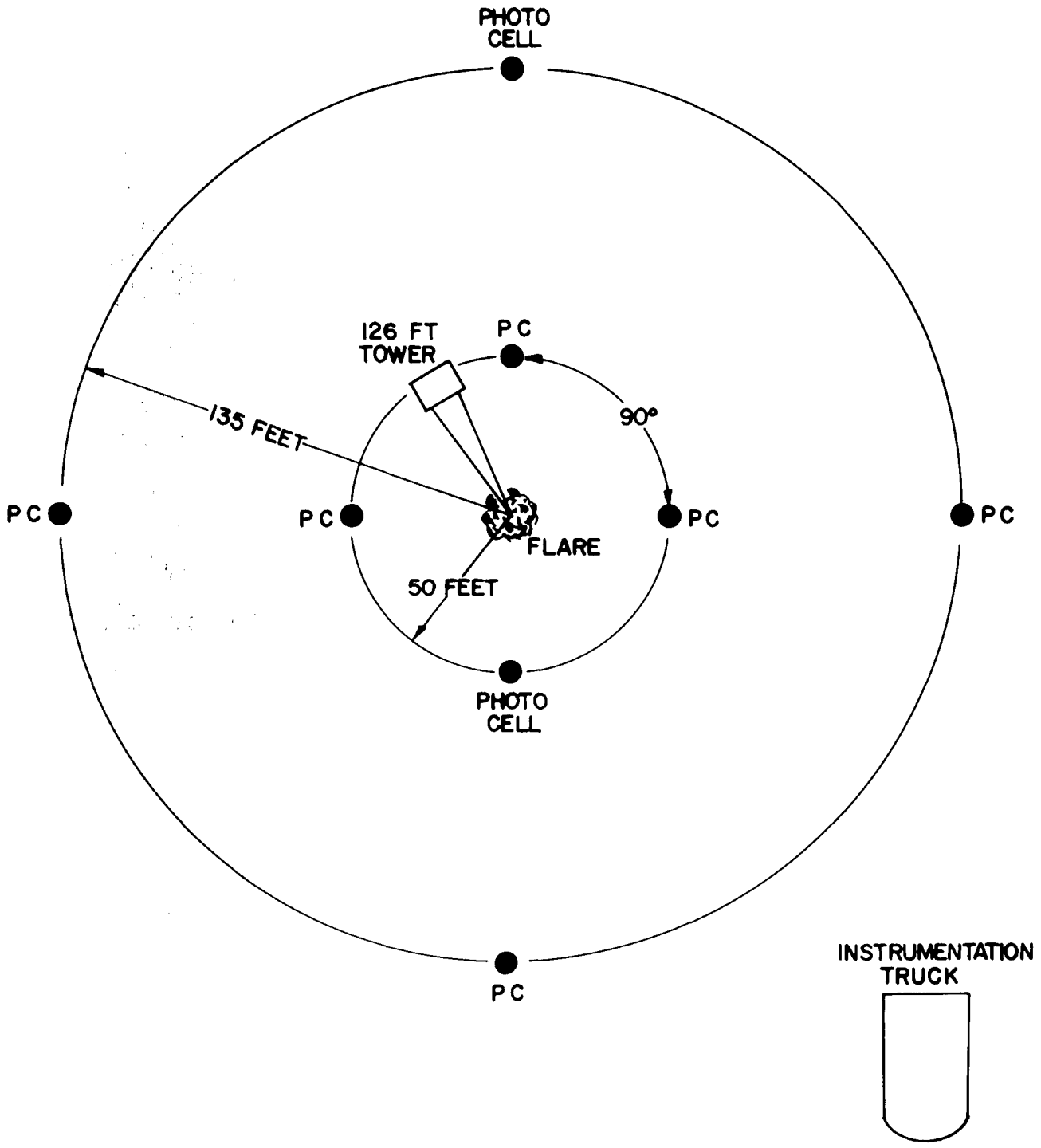

Figure 4. Flare Tower Facility

and time/distance measures. These data apply to such discrete events in the flare cycle as launch, parachute deployment, ignition, descent-rate, burn-time and burn-out. A number of reports on the PER recently installed at Yuma Proving Ground (YPG) have been issued. A good description of the results of YPG tests on six aircraft flares may be found in the report by JTCG/ALNNO (1971). See figure 5 for an illustration of the PER technique.

### Observer Opinion Test

Some of the more subjective aspects of flare effectiveness, dealing with pilot/observer flare handler preferences, can be assessed and evaluated through the use of appropriate questionnaires. An example of such a questionnaire described by Craven (1970) has been used by the TAC Special Operation Force in conjunction with a field test of LUU/2B. This is reproduced, along with tallies of pilot and flare-handler responses, in appendix B.

### Observer Performance Tests

This type of field-test provides a means of validating other techniques since it deals directly with visual target acquisition and provides quantitative indices of its speed or effectiveness. It requires the deployment of known targets in known positions so that both the accuracy and level of target, identification, as well as the precision of subsequent target-related actions taken by the observer, can be objectively scored and evaluated. The value of this technique depends on the degree to which the types of equipments, target/terrains and scenarios of interest to the user can be effectively integrated. In addition to its relative high cost some disadvantages of this method are: (1) that it may be neither safe nor feasible to incorporate some of the factors (e.g., high wind velocity or minimum visibility) of interest to designers or users, (2) that weather or other flight contingencies may result in unacceptable deviations between the actual and the planned test conditions, and (3) that it is virtually impossible to replicate test conditions with a degree of consistency required for experimental analysis. This method has been used in flare evaluation by Weasner (1965) and Strauss and DeTogni (1962).

## TERRAIN-MODEL STUDIES

Although lacking some of the realism offered by field tests, this method provides more research flexibility allowing the investigator (at a small fraction of field-test cost) to simulate, specify, vary, combine and measure a wide variety of alternative flare design or deployment factors with respect to a miniaturized terrain. The terrain is contoured and constructed at a fixed scale which determines its simulated dimensions (as well as those of the targets deployed on it) and the altitudes and viewing distances associated with it. Considerable opportunity for both realism and controlled variation is possible here with respect to: (1) physical and cultural features of terrain; (2) types/deployments of stationary or moving targets; (3) types of flares or flare deployment concepts; (4) position/height/movement of observer viewing stations; (5) wind drift; and (6) ambient illumination conditions. Commensurate with the degree of precise and flexible control over the environmental factors is the capability here for precise measurement of flare intensity, the illumination of targets and their surrounds and observer

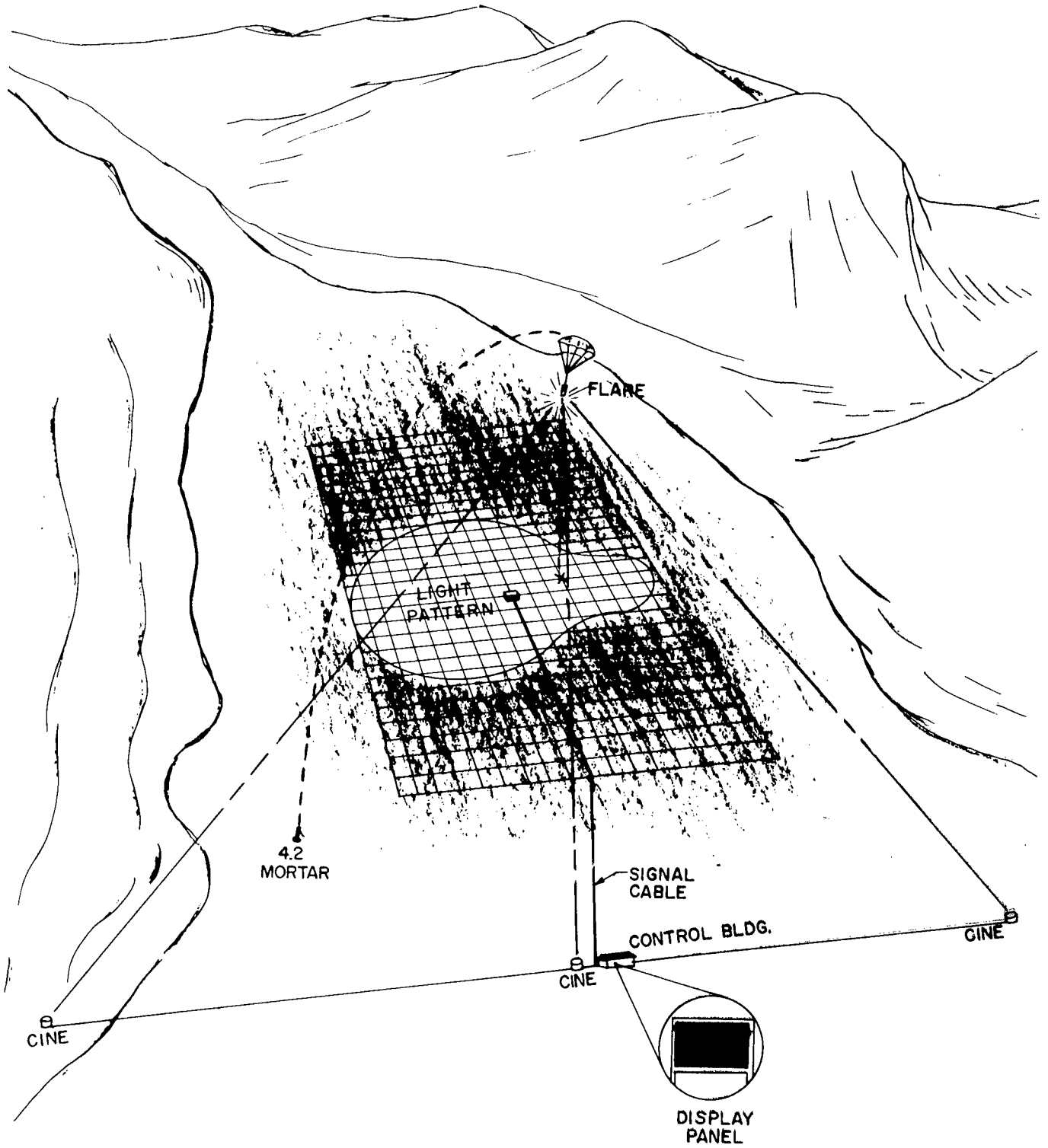

Figure 5. Pyrotechnic Evaluation Range

response. However, a strong possibility exists with this method for over-simplification and artificiality in incorporating real-world factors. Moreover, there are current state-of-the-art limitations in adequately simulating and measuring certain variables, such as smoke, atmospheric aerosols, or observer stress.

Ideally an in-flight check of the type reported by Hucker (1972) is required to establish the validity of the data developed through terrain modeling research. Flare effectiveness data is now being produced for the Armed Forces with terrain models described by Hilgendorf (April 1971) and Tyroler (1971). A photograph of one of these models is shown in figure 6.

## MATH-MODEL STUDIES

One limitation of the previously described techniques lie in their failure to handle economically a sufficient number of critical parameters contributing to the prediction of flare effectiveness. A math modeling approach allows the researcher maximum flexibility in the selection and manipulation of parameters for arriving at predictions on the probability of target acquisition. Here, as has been stated by Kemp (1968), he has the opportunity here to adopt a total systems approach in handling and analyzing (with computer simulation) all relevant factors and assumptions in continuous sets of mathematical operations. Many published predictions on flare effectiveness have come from math modelers. These include a succession of models which have been developed at Crane Naval Ammunition Depot dealing with: Visibility, Bradley (1969); Optimization of the illumination characteristics of the MK45, Laswell (1971); Dynamic evaluation of aircraft parachute flares, Laswell (1972) and Non-isotropic light emissions, Laswell (1972).

Despite the convenience and economy of math models, uncritical acceptance of their predictions is ill-advised. The user of these predictions should remember that they are no more valid than the assumptions and types of data on which they are based. One particular source of weakness in these models is the injudicious use of data drawn from basic research which may be inapplicable to the complexities of target acquisition in the real-world. Another limitation is the inability to account for unique interactions among variables which require empirical determination. In view of these potential drawbacks, math modeling predictions require continuous validation and updating using the most applicable data gathered by the other research techniques.

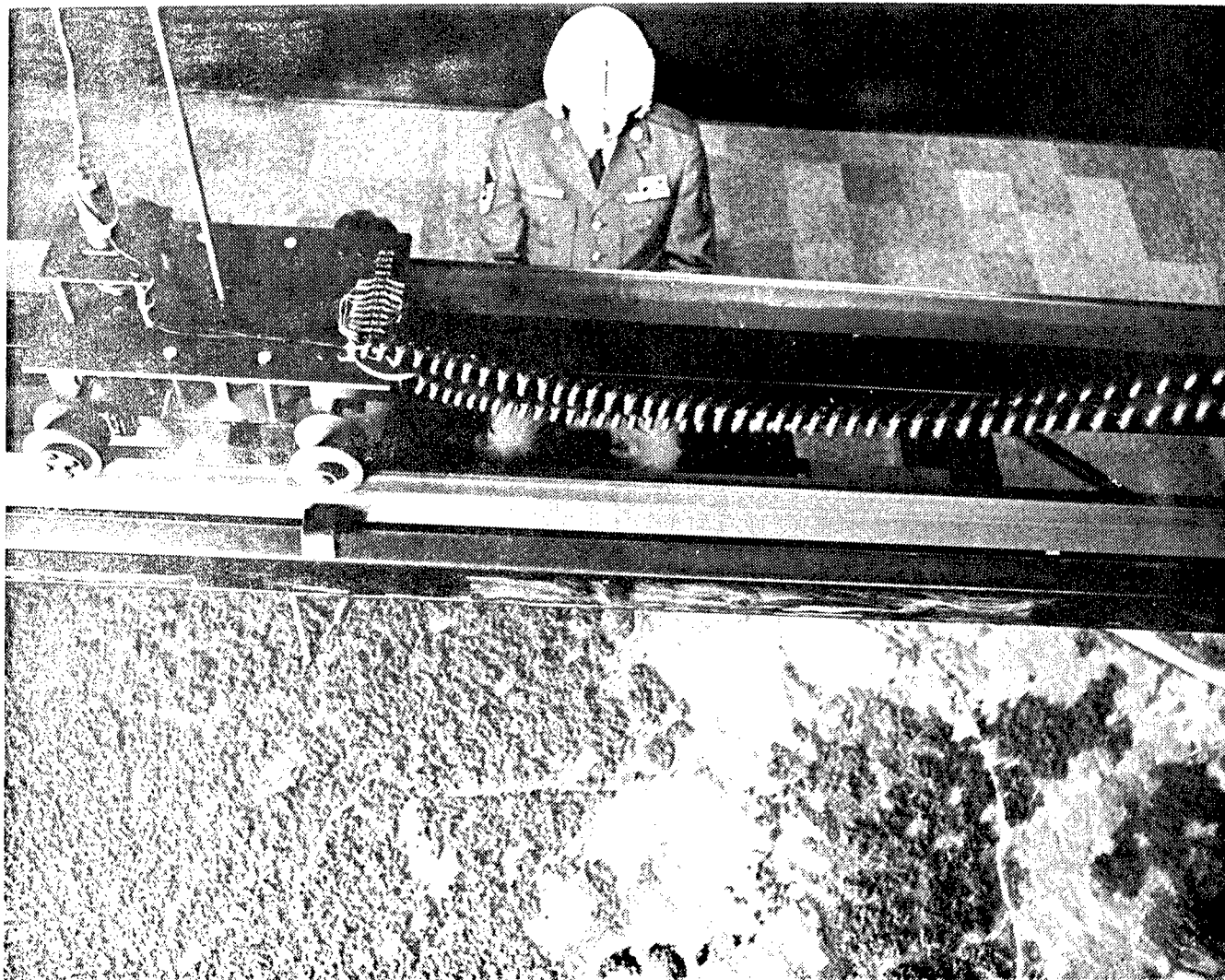

Figure 6. Terrain Model showing Observer and Simulated Flare-Drop Device

## SECTION III

### FLARE EFFECTIVENESS FACTORS

Having provided a background for the types of research methodology on which flare effectiveness is based, relevant data from recent studies will now be reviewed. Results and recommendations will be discussed within the context of factors associated with: (a) Candle Composition; (b) Flare Deployment; (c) Wind drift; (d) Atmosphere; (e) Target/Background characteristics; and (f) Observer Position.

#### CANDLE COMPOSITION

The source of the flare system is the burning candle which, depending on its composition, emits wavelengths of varying intensities from both the visible and invisible regions of the spectrum. Pyrotechnic light sources can be represented in terms of selective radiation by thermally excited molecules superimposed on the radiation of solids and liquids in flame. By appropriately selecting the materials used in compounding the flare candle, it is possible to control the spectral regions at which this emission occurs, thus producing red, yellow, green, blue or white radiation. Ellern (1968) gives typical formulations for each color of flame. For illumination flares, however, an effective spectral distribution is one approximating sunlight. This is presently best obtained from a composition expressed in percentages of magnesium (in powdered form), sodium nitrate and a binder. A flame of high luminosity is provided by selective radiation from the sodium which broadens into a continuum over the visible range from about 500 to 650 nanometers. The visible radiation is due primarily to the broadened sodium D line and a gray body continuum from the condensed species of magnesium oxides. A typical burning flare plume is approximately 10 percent sodium and 50 percent magnesium oxides. A typical spectral flare distribution from the magnesium candle is shown in figure 7. Blunt (1972) gives spectra obtained from different regions of the illuminating flare flame.

From a research point of view, the most efficient pyrotechnic source is one designed to maximize the ratio of selective emission of visible light to the total emission. Data reported by Doua (1968) show that the production of light by the MK24 candle represents about 11 percent of the total energy produced by the flare reaction, which according to Blunt and Schmeling (1968) shows remarkable efficiency.

As indicated by Blunt and Schmeling (1968) colored illumination is generally inadvisable for illuminating flares because of its relatively low luminous efficiency per unit weight or volume of source. Its special applications are for increasing the contrast between a particular target and its background, or as a distinctive ground target marker. Color purity is affected by several variables. Data on color purity as a function of several variables are contained in an article by Doua (1964). Green is normally desaturated by yellow and/or red; and blue, in addition to being contaminated by mixtures of red, is hard to produce at an acceptable intensity level.

For a detailed listing of spectral illumination characteristics and composition codes for hundreds of indexed pyrotechnic compositions of white, yellow, red, green and blue flares, the reader is referred to tables XIV-XXI compiled by Blunt and Schmeling (1968).



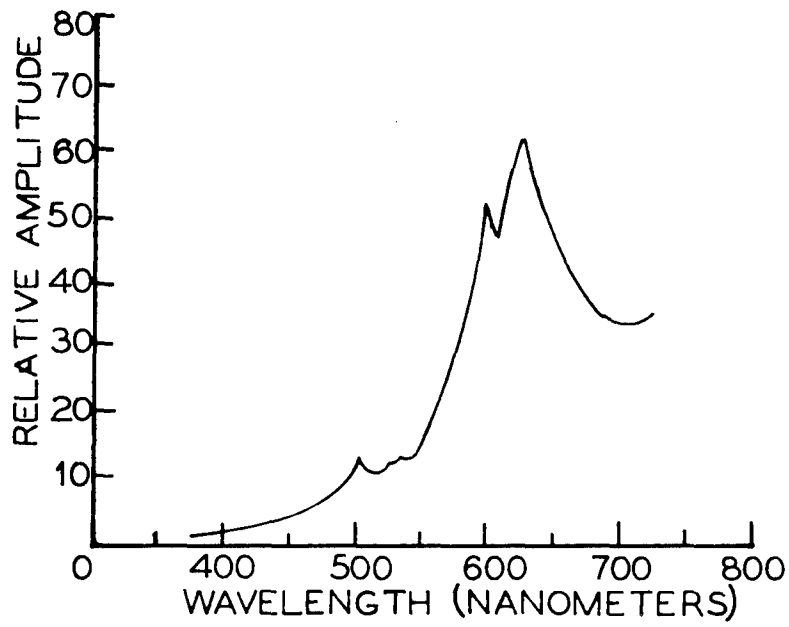

Figure 7. Wavelength Spectrum of a Typical Magnesium Flare

Within recent years a considerable amount of applied pyrotechnic research has been reported which deals with the physical/chemical reactions in the plume of the burning flare. Such studies attempt to demonstrate and explain causal relationships between the variables associated with these reactions and the luminous efficiency of the flare candle.

Some of these studies reported by Hamrick et al. (1968) have been based on math-modeling and empirical approaches utilizing photographic, spectroscopic, x-ray and radiometric analysis. The technology required here includes such specialized areas as fluid mechanics, thermodynamics, combustion, and spectroscopy. Much of this research has relevance to the improved design of flare compositions. In this connection, a summary of findings and recommendations associated with the following variables will be presented: (1) Particle Size, (2) Amount of Magnesium, (3) Altitude Effect, (4) Flare Diameter, (5) Flare Binder, and (6) Flare Smoke.

In the report by Hamrick et al. (1968), evaluations of these kinds of factors are made with respect to an ideal flare which converts all of its heat of reaction into visible light emissions. "Thus all factors that influence a given flare's performance and cause its amount of emitted light to be less than that of the ideal flare contribute to the inefficiency of the flare burning process."

#### Particle Size

The Army Materiel Command (1967) shows, for an illuminating composition, an inverse relationship for both burning rate and candlepower as a function of a particle size. Figure 8 taken from the AMC pamphlet shows these relationships.

#### Amount of Magnesium

Hamrick et al. (1968) report a drop in luminous efficiency for small (1.76 and 2.66 inches diameter) flares when the percentage magnesium is reduced below 62 percent. However, for larger flares (4.25 and 7.35 inches in diameter) there is an increase in luminous efficiency for a similar reduction in magnesium content. Of the four flares tested, the greatest overall luminous efficiency was shown for the one having a diameter of 4.25 inches. These data are shown graphically in figure 9. The efficiency is not only a function of the magnesium-to-sodium nitrate ratio but also a function of the binder type. The optimum magnesium-to-sodium nitrate ratio at one flare diameter may not be optimum at another diameter.

In another study by Hamrick et al. (1968), which used a scanning radiometer to analyze small flares of 1-inch diameter, luminous efficiency was shown to increase from 29,300 to 57,400 candle-seconds per gram as the percentage of magnesium increased from 45 to 68. Under these conditions burn-times were shown to decrease while plume areas increased. Note, however, that this particular effect may not be extrapolated to other diameters.

#### Altitude Effect

Douda in NAD Crane RDTR 205 (1972) and RDTR 206 (1972) demonstrates in detail the effect of altitude (pressure) on the intensity and spectral distribution of flare emission. With

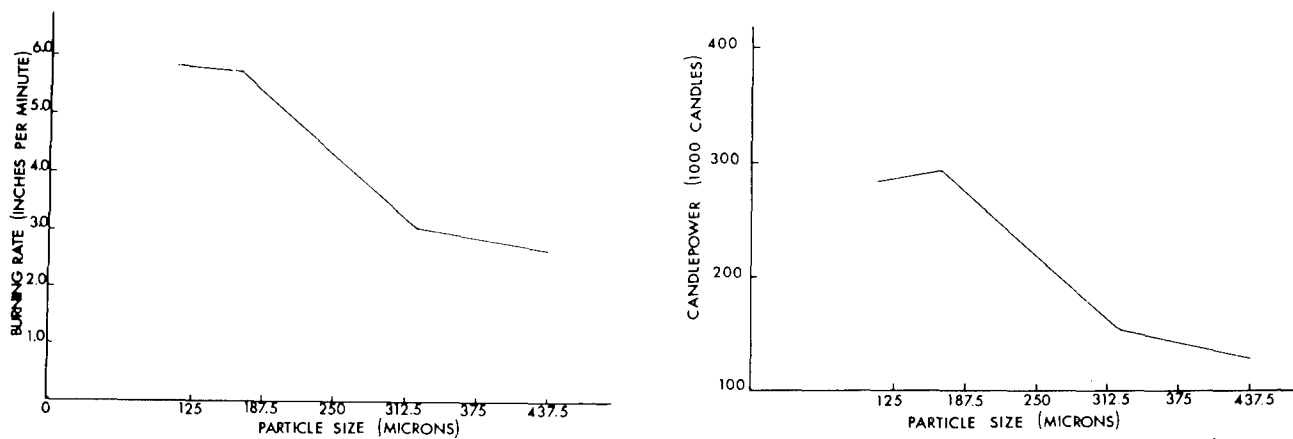

Figure 8. Effects of Magnesium Particle Size on Flare Burning Rate and Candlepower

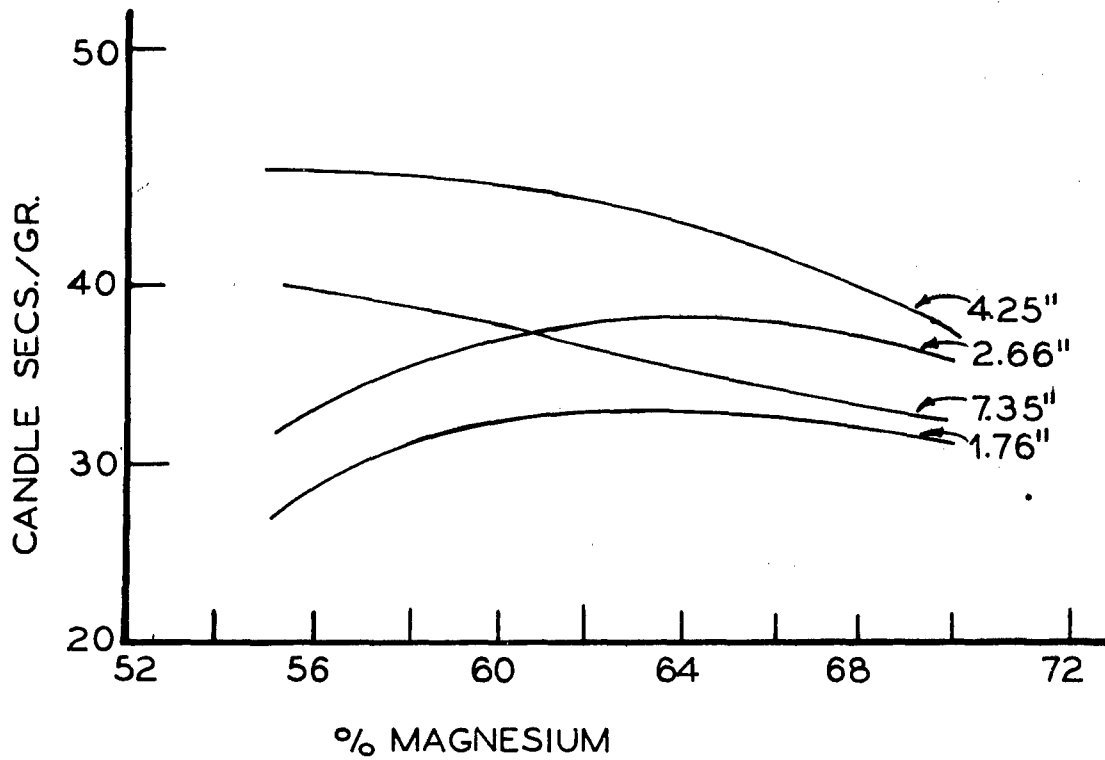

Figure 9. Luminous Efficiency for Four Flare Diameters as a Function of Percentage of Magnesium

increasing altitude, the illuminating flare intensity is greatly reduced by the reduction in its spectral continuum and in the broadening of the sodium D lines.

### Flare Diameter

Douda, (1968) has shown that the efficiency of a 30-percent magnesium pressed flare increases with up to 4.25 inches in flare diameter. Beyond this size, luminous efficiency rapidly decreases. In the case of cast flares, where plume size rather than flare diameter appears to be the critical factor, luminous efficiency levels off above a larger, 15-inch diameter. Binder levels necessary in making these large diameter cast flares introduce another variable into this diameter experiment making diameter efficiency statements very difficult. The Army Materiel Command (1967) discuss relationships of flare diameter and flare efficiency for colored flares.

### Flare Binder

The flare binder used to consolidate the other flare ingredients is described by Hamrick (1968) as a low viscosity liquid which polymerizes upon the addition of chemicals that cross-link the binder molecules. A cast flare requires four times as much binder composition as a pressed flare. Binders containing fluorocarbons may be more effective because they are oxidizers. Since the luminous effectiveness of a flare has been found by Hamrick et al. (1968) to decline rapidly with increases in binder content, an optimum percentage of binder needs to be determined for each flare composition. That is one that will hold the composition without degrading flare performance. Tanner (1972) has investigated the effect of binder oxygen content on adiabatic flame temperature. The most important binder variable found was the relative amount of fuel and oxidizer elements in the binder compound.

### Flare Smoke

According to Johnson (1966), two types of smoke have been identified for the magnesium flare. The first type, known as cenospheric smoke, forms the ash or fallout of a burning particle of magnesium and has no demonstrable effect on luminous efficiency. It is the second type, described as aerosol smoke, that can significantly attenuate the light output. For a downward burning flare of 8 inches diameter with 68 percent magnesium, aerosol smoke is typically buoyant and will rise with minimum interference, while, in the case of 59 percent magnesium composition, the aerosol smoke tends to hover below the flare and obscure its effectiveness. This effect occurs primarily in the last portion of the burn.

## FLARE DEPLOYMENT FACTORS

Given a highly efficient candle for its source, any illuminating flare system must be designed in all of its phases of deployment, (launch, ignition, suspension, descent, and burn-out) so that the circle of light on the ground has the required brightness, area, stability and duration to permit required types and levels of target acquisition to occur.

Therefore, a logical starting point for discussion in this section of the report will be the ground illumination requirements for flares. Relevant data on the following topics will then be re-

viewed: altitude, burn-rate, rate of descent, flicker, candle orientation, multiple launch and flare shielding ,

### Ground Illumination Requirements

a. Intensity. Since the effectiveness of ground luminance is so dependent on the spectral reflective properties of targets and their background, the attenuating effects of atmosphere, observer viewing distance, physiological state of the eye, type of observer task to be performed, etc., it becomes meaningless to specify any single footcandle value that would be recommended for all flares. Much work needs to be done within a systems context to determine specific ground illumination requirements for a complete family of flare target acquisition tasks. Present illumination standards are somewhat arbitrary and are anchored to such ground illumination values as reported by Blunt and Schmeling (1968).

	Footcandles
Full Sunlight	10,000
Twilight	0.3
Full Moonlight	0.1

A criteria value of 0.2 FC has been used as a threshold for the sensors on the Pyrotechnic Evaluation Range at Yuma Proving Grounds.

Current operational parachute flare systems have different source intensities. These have been listed by the Joint Technical Coordinating Group for Air Launched Non-Nuclear Ordnance (JTCG/ALNNO) in the first row of table 1.

Using a terrain model approach, Hilgendorf (1969) has simulated flare drops of two of these systems (MK24 and Briteye) over 1:1000 scale model and shown significant target acquisition advantages (measured in terms of observer accuracy and response speeds) for the brighter MLU-32 system. Despite this apparent advantage, an upper limit of optimal flare intensity may have been exceeded in the Briteye since observers complained of excessive glare from the simulated five million candlepower source.

b. Color. No studies on this factor have been reported for illumination flare systems. As previously indicated, candles producing color are less efficient than standard illumination flares. Nevertheless, in certain cases, advantages may accrue to the deployment of colored flares which have spectra-zonal illuminating characteristics designed to enhance visible contrast for particular target/background combinations.

c. Area. Increasing the area of effective light on the ground may be dictated either by military requirements for wider combat zone coverage or by the observer's need for contextual cues to support his identifications. Research aimed at both these requirements is needed which shows relationships between extents of lighted areas and target acquisition measures.

d. Stability. Flares, not only produce noticeable flicker as they burn, but also cast moving shadows on the ground as they oscillate and drift with the wind. Again, we have little data to indicate the degree to which target acquisition is affected by these kinds of temporal/

**TABLE I**  
**PRINCIPAL FLARE CHARACTERISTICS**

Characteristics	XM170	M8A1	LUU-2/B	MK45	MK24	ATTACK <sup>(1)</sup>	MLU-32	XM170E-1*
Candlepower (10 <sup>6</sup> ) <sup>(2)</sup>	1.27	0.47	97	1.65	1.49	4.10	4.70	1.80
Burning Time (sec) <sup>(2)</sup>	137	236	286	202	187	303	324	1.35
Descent Rate (fps) <sup>(2)</sup>	7.61	8.37	7.72	7.47	6.45	9.03	6.41 <sup>(3)</sup>	8.50
Complete Round Weight (lbs)	12.0	17.6	29.5	28.0	26.5	103.6	155.0	15.0
Size-Diameter (in)	2.75	4.25	5.0	5.0	5.0	8.0	8.0	2.75
Size-Length (in)	36.0	25.0	36.0	36.0	36.0	61.5	63.0	44.0
Shipping Weight (lbs)	14.7	29.3	31.7	29.7	29.1	170.0	233.0	15.3
Shipping Volume (ft <sup>3</sup> )	0.66	0.60	1.38	1.38	1.38	7.62	7.62	.825
Composition Weight (lbs)	8.0	10.0	20.5	16.9	15.6	61.7	90.1	10.0
User Service	Army	AF/Army	AF	Army/Navy	AF/Army/Navy	AF	AF/Navy	Army
Status	Development	Production	Production	Production	Production	Adv. Delop.	Devel.	Devel.

(1) Unverified, supplied by AF from AFATL-TR-70-71 & ADTC-TR-71-91.

(2) Based upon YPG PER Site data as received from Dec 70 test. Also, applies to a 0.2 ft-cdl illuminated level, flare burn thru optimum altitude and no wind condition.

(3) Unverified, supplied by AF from APGC-TR-68-81.

\* XM170E-1 is the current replacement for the XM170.

spatial changes in light patterns. Until such determinations are made, one can hardly justify the cost of redesigning flares to eliminate flicker and drift.

One study soon to be published by Tyroler and Davis employs the terrain model (scaled at 160:1) located at Picatinny Arsenal. Here they have examined the effect of flicker on target recognition. This work measures target recognition illumination requirements at selected frequencies from 1 to 25 Hz and also non-flicker conditions. Initial results of this experiment indicate that the lower frequencies approximately 3-10 Hz require more illumination for target recognition than do the higher frequencies of approximately 12-25 Hz. The higher frequencies differ little from the no flicker conditions in the illumination required for target recognition.

e. Duration. Like area, time is a factor in flare illumination, and is, in turn, dependent on both operational and observer requirements. Over-extended exposure may be tactically disadvantageous (unnecessarily warning the enemy or revealing friendly forces on the ground), while too brief an interval of light may not afford the observer enough search-time to carry out his assigned task. This problem of exposure duration arises in connection with the design, suggested by Tyroler (1971), of rapid burning flares which emit brighter light for shorter periods of time. Research is needed to determine best intensity/time tradeoffs for flare-light to enable an observer to perform effectively in tactical situations.

#### Flare Altitude

A basic point of departure in planning a flare launch cycle is consideration of the altitude range over which the flare is effective. In particular a single altitude exists (and can be determined) for any flare where a maximum area can be illuminated to a predetermined level. This so-called "optimal height" of a burning flare can be derived from basic illumination theory and, in the simplest case, is based on the following assumptions:

- a. That the flare represents a point source of illumination having known candlepower (I) and altitude (h).
- b. That the ground is essentially a plane surface, either normal to the path of light from the flare, or at some known angular inclination from it.
- c. That the wind velocity is zero and light transmission through the atmosphere is 100 percent.

Given the above assumptions, along with specific values representing flare intensity and ground illumination requirements, Cohen and Kottler (1954) have applied the inverse square law of light ( $E = \frac{I}{D^2}$ ) to calculate:

(1) The optimum height (h opt) of the flare for a desired radius (Ro) to be illuminated at a specified level of footcandles (E):

$$h \text{ opt} = 0.71 R_o$$

If an average ground inclination of 45 degrees is assumed, the equation becomes:

$$h \text{ opt} = 0.28 R_o$$



(2) The required minimum flare candlepower (I) for a desired radius (Ro) with the desired footcandles (E) at the periphery.

$$I = 2.58 E R_o^2$$

For an average ground inclination of 45 degrees the equation becomes:

$$I = 1.24 E R_o^2$$

(3) The optimum height of a flare (h opt) which will provide a specified illumination (E) in FC on the ground with a specified candlepower (I):

$$h \text{ opt} = 0.438 I/E$$

To better portray the concept of "optimum height," Laswell (1963) has developed a family of curves (shown in figure 10) in which flare intensities are varied from  $.5 \times 10^6$  candlepower to  $3.5 \times 10^6$  candlepower and the threshold illumination values are held constant at 0.20 FC (a value which has been arbitrarily selected based on its usage for protective lighting of large areas). Figure 11 shows the optimum flare heights required to obtain maximum area at this illumination value for different flare intensities. For maximum areas pertaining to any other required illumination value, different sets of "optimum altitudes could be similarly derived.

As previously indicated, the Pyrotechnic Evaluation Range (PER) at Yuma Proving Grounds offers a sophisticated technique for continuously recording ground illumination patterns under the falling flare. It will be recalled that the PER technique uses an array of sensors covering a field 8,100 ft square. In tests reported by Brooks (1970) of illumination cartridges (M335A1) fired to function at a 700-meter height, the sensors were set to respond to 0.05 FC of illumination. The curve shown in figure 12 is derived from the PER measuring technique and shows how the effectively illuminated ground area (derived from a continuous record of number of sensors lit) actually varies with height throughout the functional period of the flare. A phenomenon referred to as the "search light effect" was observed in these tests. This phenomenon is attributed to the fact that light from some flares approximates a directed beam whose axis is oblique to the surface. The resulting elliptical pattern rotates about one of its foci resulting in several areas being intermittently illuminated. This effect is noticeable and could prove troublesome to the observer in target acquisition.

Using his 1000:1 scale terrain model, Hilgendorf (Aug 1971) measured target acquisition responses at three simulated ignition altitudes (2000, 2500, and 3000 ft) for a simulated MK24 system. The greatest number of targets were acquired at the lowest (2000 ft) ignition altitude.

Considerable use has been made of the equations listed above for "optimum heights" of flares to provide a maximum area lit to a selected level of illumination. However, the use of such data for target acquisition disregards many critical factors which need consideration and/or empirical determination. These include the spatial relationships between flare, observer, and target, visual task to be performed, mission requirements, etc. Note also that when "optimum height" determinations are made, the first one-third to one-half of the burn period occurring above the "optimum height" may not provide adequate illumination for target acquisition, yet give advance warning to hostile forces. This inadequacy has been pointed out in the Army Field Manual FM 20-60 (Jan 1970).

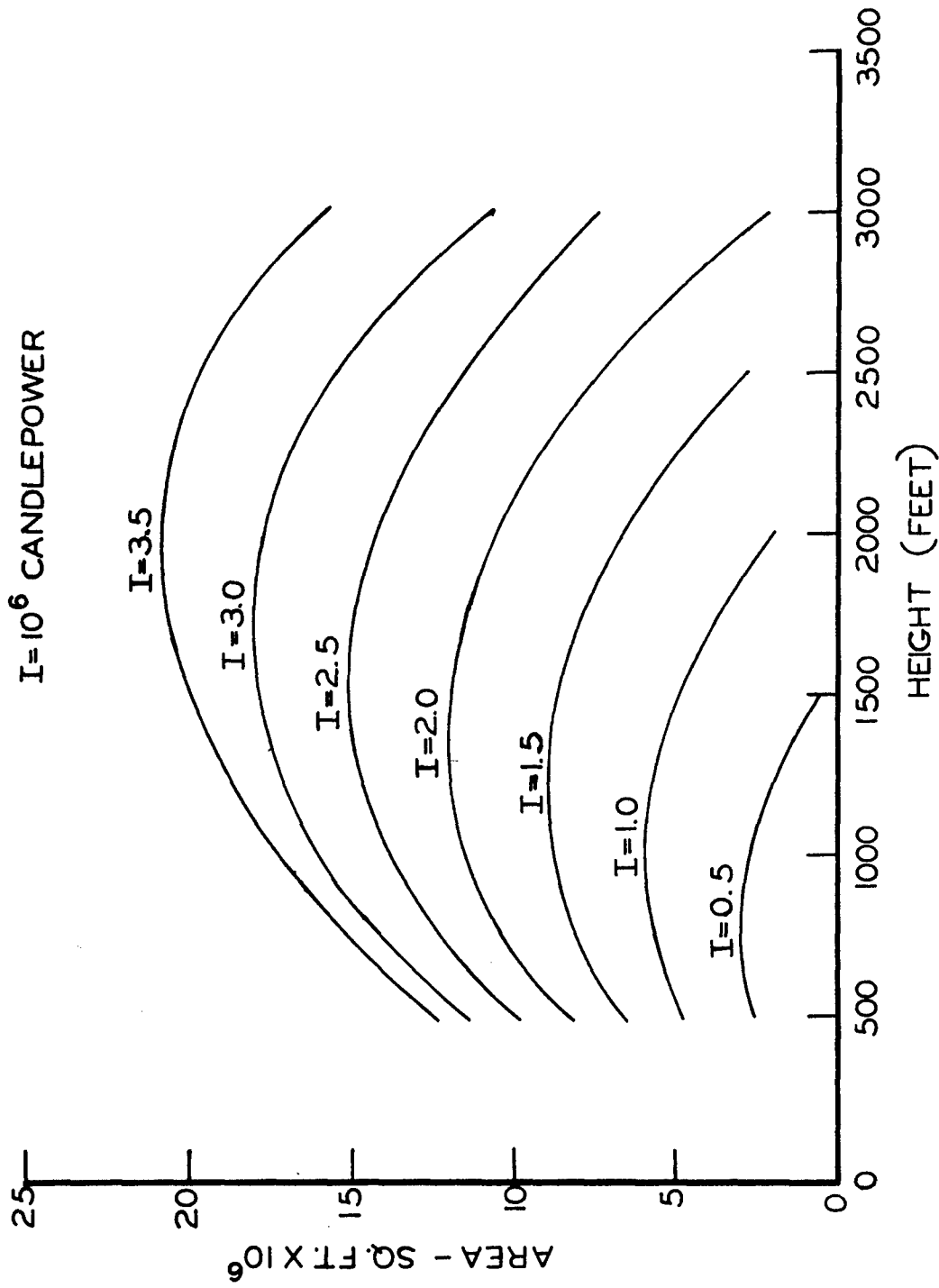

Figure 10. Ground Area Illuminated to 0.2 Footcandles by Flares at Various Heights and Intensities

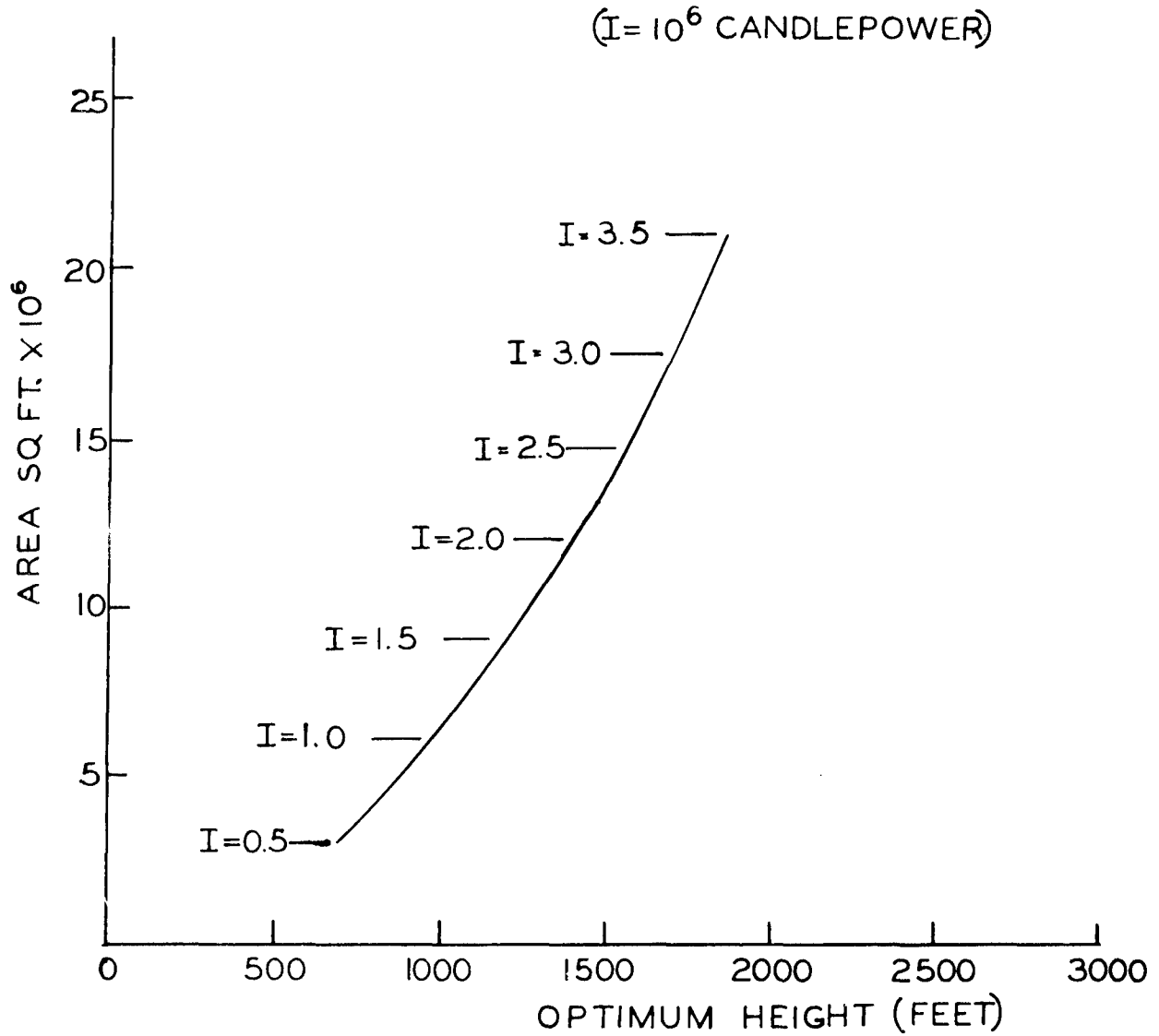

Figure 11. Ground Area Illuminated to 0.2 Footcandles at Optimum Heights of Flares with Different Intensities

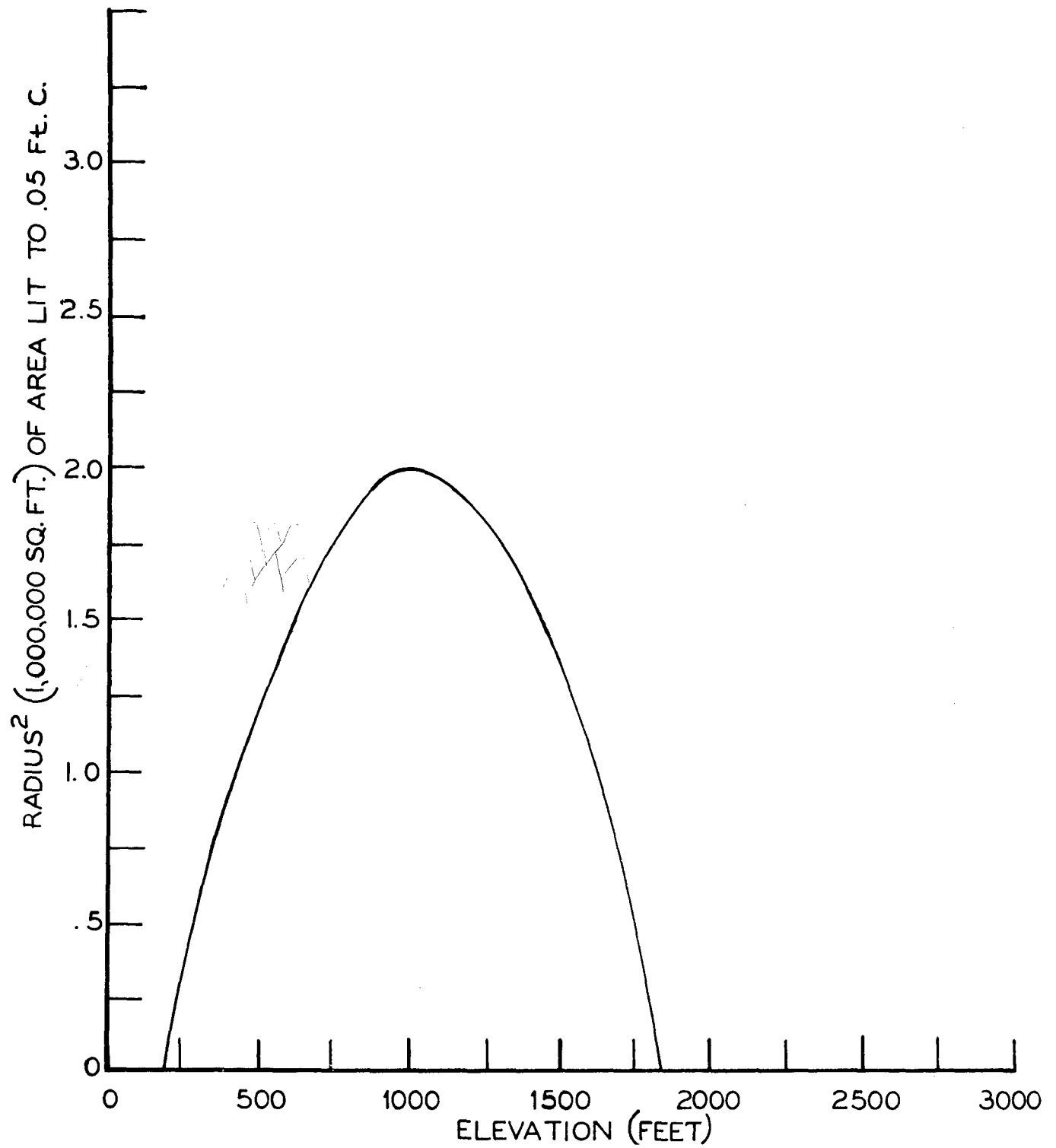

Figure 12. Radial Measures of Ground Illumination from the Pyrotechnic Evaluation Range for the M335AI at Various Elevations

## Burn-Rate

Associated with the composition of the flare is the rate at which it burns. Moreover, there is a reciprocal relationship between burn-time and intensity, i.e., halving the burn-time approximately doubles the intensity of a flare. Tyroler, in an unpublished article (1971), is concerned with four contingencies related to burn-time which are clearly important in any estimate of flare system effectiveness:

- a. The amount of area adequately illuminated.
- b. The total time during which the area is so illuminated.
- c. The alerting of enemy personnel in the target area prior to adequate illumination.
- d. The probability of the illuminated area remaining in the desired location.

Given all these considerations Tyroler suggests that the design of a new flare of equal size but faster burn-time, might increase effectiveness; moreover, he feels that such a design might best be achieved by the incorporation of successive stages of decreasing burn-time (incremental concept). Such a modification could provide a larger ground area of adequate illumination and maintain this illumination during the early period of flare ignition. The likelihood of prematurely warning an enemy would also be diminished and the probability of prevailing winds blowing the flare off-target prior to the establishment of adequate illumination would be decreased.

## Rate of Descent

Another factor controlling the effectiveness of a flare is its rate of descent. Other things being equal, the most effective use of a flare would be to hold it stationary at the optimum altitude over the target during the entire burn-period. Barring the feasibility of this condition, the next best recommendation is to slow the flare's descent-rate. However, this requires enlarging the size of the parachute, thus increasing both cost and weight of the total flare package. In fact, Laswell (1963) states that the cost of cutting the descent rate by one-half raises the total cost of flare deployment six times. In any case, an appreciable drop-rate of at least two to three feet per second (FPS) is required to remove light-attenuating smoke from the flare. Also, too slow a descent will increase susceptibility to wind drift. Average drop-rates for current operational systems evaluated by JTCG/ALNNO (1971) vary from 6.4 FPS for the MK24 to 8.5 FPS for the M8A. One should also note that these rates are not constant throughout the descent period but decrease as the burning flare loses mass and generates heat.

## Flare Orientation

Flare illumination can also be affected by the orientation of the burning candle, i.e., whether it is suspended in its typical face-down position, or whether its orientation is altered so that it descends in either a horizontal or a face-up position. In a tunnel test Feagans (1967) compared the intensities of multiple flares burned side-by-side either in a perpendicular or parallel align-

ment with the plane of the detector. The first arrangement represented "burning across a front" and resulted in a four-fold increase in candle power for four flares oriented in this position. The second arrangement represents "burning in depth" and resulted in no appreciable increase in intensity with increments up to four flares. In an expansion of this kind of research, Wildridge (1966) checked out various single or multiple flare systems capable of producing five million candle power for a 5-minute burn-time. Both static tests from tower facilities and flight tests were run. Two basic orientations were studied; multiple candles burning face downward and multiple candles burning horizontally. The horizontal method of suspension was found in general to provide illumination equivalent to the vertical system and had the following specific advantages: (1) the possibility of cleaner smoke removal, (2) more uniform illumination patterns, and (3) elimination of heat arising around the candle (which could burn parachute suspension cables). The main disadvantage here was the increased cost and pay-load requirement for a spreader mechanism to suspend the flares in a horizontal position.

### Multiple Flare Systems

Conventional single flare systems are so limited with respect to the intensity, area, and duration of the ground illumination they can provide that many military applications require the use of multiple flare systems. One type of multiple deployment would be to release several flares simultaneously, these either being suspended from a single parachute system or from individual chutes. Aside from payload cost, two or more flares dropping from a single chute can cause problems such as over-rapid rates of descent or excessive oscillation. If the heat and smoke of a heavy flare system could be effectively utilized, the rates of descent might, however, be decreased to tolerable limits.

With simultaneous multiple-chute deployment Wildridge (1966) states that mutual interference is likely to occur. The smoke of faster-falling flares may attenuate the light of a slower one, or the candle of one flare may burn the shroud lines of another. Wildridge also refers to another malfunction of multi-chute systems known as "squidding" whereby the system reaches a velocity below the opening velocity of one of the parachutes causing it to dump.

An alternative kind of multiple-flare drop involves successive discrete deployments with appreciable intervals between drops. Although this sequential launching avoids the payload and interference problems of simultaneous launch, it does introduce spatial separation of light patterns which would have been mutually reinforcing had they come from a single source. However, according to Blunt and Schmeling (1968) loss of ground illumination due to this separation will not be too severe if the distance between units in a train of flares and the center of their mass does not exceed ten percent of the source height. This provision can be met even at low altitudes and high speeds with the SUU-12 system which can maintain launch intervals down to 0.10 seconds.

If the main concern, however, is lighting up an extensive area rather than approximating a single source, then much larger inter-flare distances can be used. If the area is to be a long narrow path, Blunt and Schmeling (1968) offer a formula for computing the ground illumination in foot candles of a point beneath a numbered string of flares of known height, candle

power, and separation. Using their mode of analysis the illuminance of a point ( $E_p$ ) in the center of a seven-flare string is shown to be  $4.12 I/h^2$  (where  $I$  = candle power and  $h$  = altitude). This formula reveals a principle of diminishing returns whereby increasing the flare number by 30 percent (from 7 to 9) would only increase the brightness coefficient by 7.5 percent (from 4.12 to 4.42).

Another formula is given by Blunt and Schmeling (1968) for the case of a circular launch-path around which flares are being deployed at regular intervals. Here, the illumination at a point on the ground ( $E_p$ ) below the center of the circular path will depend on the number ( $n$ ) intensity ( $I$ ) and altitude ( $h$ ) of the sources as well as the circumference of the flight circle with radius ( $a$ ). The formula reads:

$$E_p = \frac{n I H}{(h^2 + a^2)^{3/2}}$$

Laswell (1963) has developed a formula stating that the maximum area ( $A_{max}$ ) illuminated to a specified level with a given intensity flare will be directly proportional to the product of the flare intensity and its optimum illuminating height.

$$A_{max} = K I h_{opt}$$

Based on this expression he states that two flares with half the intensity of one large flare would illuminate somewhat more than twice its area if they were positioned in such a manner that overlapping reinforcement in the respective illumination patterns is obtained. However, this type of gain is relatively small (about five percent of the maximum area) and may not be cost-effective.

Starrett (1964) provides a series of analytical and numerical formulae for determining the Ground Illumination Contour (GIC) which results from linear deployment of an arbitrary number of flares (with equal separation and at the same height and intensity). Geometric coordinates ( $X, Y$ ) for a GIC at any specified value of illumination is calculable from the following equations derived by Starrett:

$$E = hI \sum_{j=1}^N (h^2 + R_{jP}^2)^{-3/2}$$

where  $R_{jP}^2 = [X + (N - 2j + 1) d/2]^2 + Y^2$ .

for  $j = 1, 2 \dots N$

$E$  = Illumination required on the ground in footcandles

$h$  = Flare height

$I$  = Flare intensity in candles

$R_{jP}$  = Distance (feet) from the ground point directly below flare  $j$  to the ground point  $P$  in feet.

$N$  = Number of flares

$d$  = Distance between flares (feet)

$X, Y$  = Respective coordinates of the GIC

A value of Y is sought which will satisfy the above equations when X is fixed and N, d, E, I and h are given.

Starrett also provides a machine program (GRILCO) written in FORTRAN for the IBM 709 for generating GIC graphs, printed listings of their coordinates or other information necessary to produce them. A machine-plotted output for a ground illumination contour of 0.5 foot candles resulting from a string of five flares is shown in Figure 13.

Hilgendorf (Aug 1971), using his 1:1000 scale terrain model and simulated launch trains of MK24 flares, tested four separation patterns at simulated altitudes of 2.0 and 2.5 thousand feet. These were: (1) six flares, 0.25 miles apart; (2) six flares, 0.50 miles apart; (3) four flares, 0.75 miles apart; and (4) two flares, 1.0 miles apart. In each case an observer was required to locate two types of targets. The results showed no improvement in target acquisition with increases in numbers of flares or with decreases in their separations. This rather unexpected finding was at least partially accounted for by the increased glare effects of the longer more-continuous flare train which caused a sufficient number of targets to be missed on the far side of the flare to offset the benefits of higher terrain illumination.

### Flare Shielding

A recent innovation in flare technology reported by Carlson and Jewsbury (1968) (1969) has been the addition of a thin, conical metallic shield. This is illustrated in Figure 14 and has been designed to provide the following advantages:

- a. Concentration of light below the flare where it is needed.
- b. Reduction of light above the flare where it could expose friendly aircraft or provide a disturbing glare source to a pilot or observer.
- c. Allowing light-occluding smoke to escape through the top (chimney) of the shield, thus further improving the ground illumination while providing an overhead screen for friendly aircraft.

One of the problems posed by Carlson and Jewsbury in designing an effective shield was how to prevent oscillation of both candle and shield during descent. This would not only cause a disturbing flicker but might also induce the illusion that stationary ground targets were moving. Shields having 60-degree included angles and varying in length from 36-54 inches were found to have sufficient stability to effectively control oscillation in the MK24 shielded system.

Maximum smoke evaluation was also established for this system by means of a 54-inch vertical shield height and a 2.4 sq ft top exit area. In comparison with the naked flare this shield was shown to reduce glare and smoke above the candle while increasing ground illumination below. Descent of the heavier payload was slowed down to the required rate by using a larger (28-ft diameter) parachute.

The above described system was evaluated by Bradley (1969) using a visibility model which



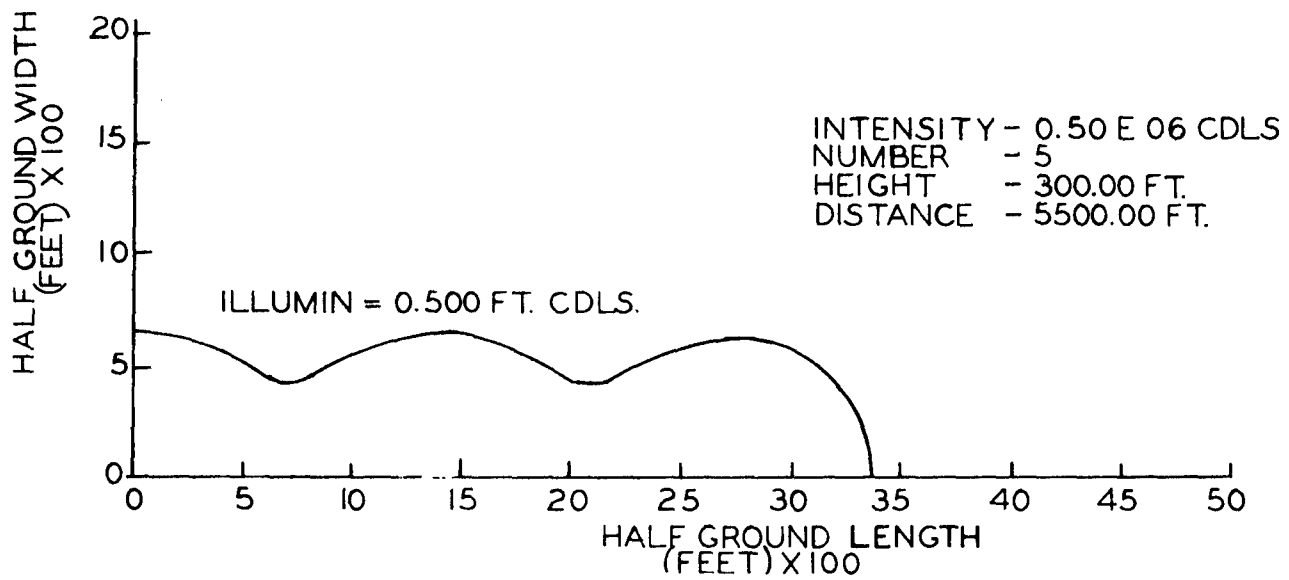

Figure 13. Machine Plotted Output for a Ground Illumination Contour of 0.5 Footcandles

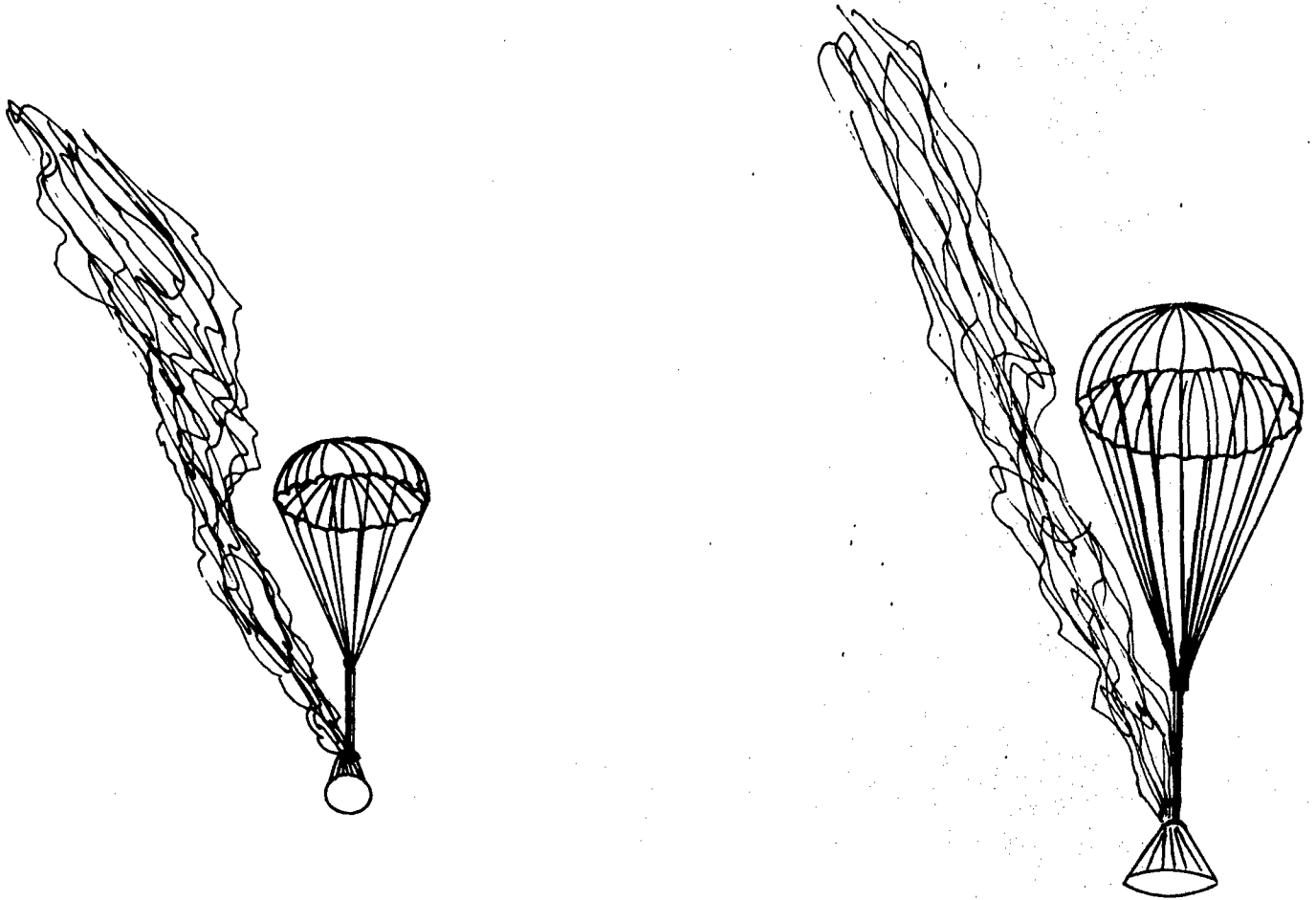

Figure 14. A Shielded Flare at the Beginning and End of the Burn Period

incorporated the following variables: (1) Target/background reflectivity; (2) Attenuation of light from the flare to the target, and from the target to the observer; (3) visual angular subtense of the target; (4) Path luminance to the observer; and (5) flare glare. Series of computer runs were programmed for shielded and unshielded flares at altitudes of 2600 and 1500 ft. As shown in figure 15, the results indicate that glare effects (and the advantage of shielding) increase when the angle formed between the flare, observer and target is small.

Jewsbury (1968) has measured the luminous intensity of both shielded and unshielded flares in terms of the number of degrees from the center of their respective illumination patterns. These data are graphically portrayed in Figure 16. It can be seen that, for angles of less than 40 degrees, shielded flares provide greater brightness. However, for angles greater than this value (i.e., further out from the center of illumination), unshielded flares give stronger light.

Hilgendorf (Apr 1971), again using his terrain model and simulation facility, compared the performance of observers searching for tactical targets under conditions of both shielded and unshielded flare light. Shields were effectively simulated by modified flashlight reflectors coated with opaque white paint. Terrain illumination for each type of flare approximated the patterns shown in Figure 16. The results, however, did not support the efficacy of flare shielding for target acquisition since no significant advantages for this condition could be demonstrated with respect to number of targets found, number of errors, or observer response time. It was pointed out that the results could have been affected by the nature of the acquisition task (wide area search for targets of opportunity) and that other potential advantages of shielding (e.g., providing obscuration of overhead aircraft) were not evaluated by this test. Nevertheless, recent field testing by the Armament Development and Test Center (Ernst, 1972) has validated Hilgendorf's finding in showing no improvement in target acquisition using the shielded flare.

## WIND DRIFT

Most of the previous discussion has been based on the assumption that a flare drops perpendicularly from its launch point to the earth's surface. Mission planning for target acquisition under flare light would be greatly simplified if this were the case. However, winds of 5 to 20 miles per hour are usually prevalent in the flare's environment and can easily cause the pattern of light to drift away from the intended target area. For a typical 3-minute flare one might expect movements of more than a mile. Tyroler (1971) points out that because winds are usually gusty the flight pattern of a flare may well become unpredictable even if the average wind velocity is known, and that "the longer a flare burns the less likely it will be usefully placed for its entire burning time."

Nevertheless, a mathematical approach for achieving effective flare utilization with nominal wind velocities by computing two circles of adequate ground illuminations (based on the inverse square principle and assumed to be 0.2 FC) has been proposed. A smaller circle represents the situation for the higher ignition altitude and a larger circle for the lower, burn-out altitude. With no wind drift a continuous succession of concentric circles can be constructed to represent adequate ground illumination during the burn-time of the flare and any target visible within the small circle at ignition would obviously remain visible until burn-out. Wind,

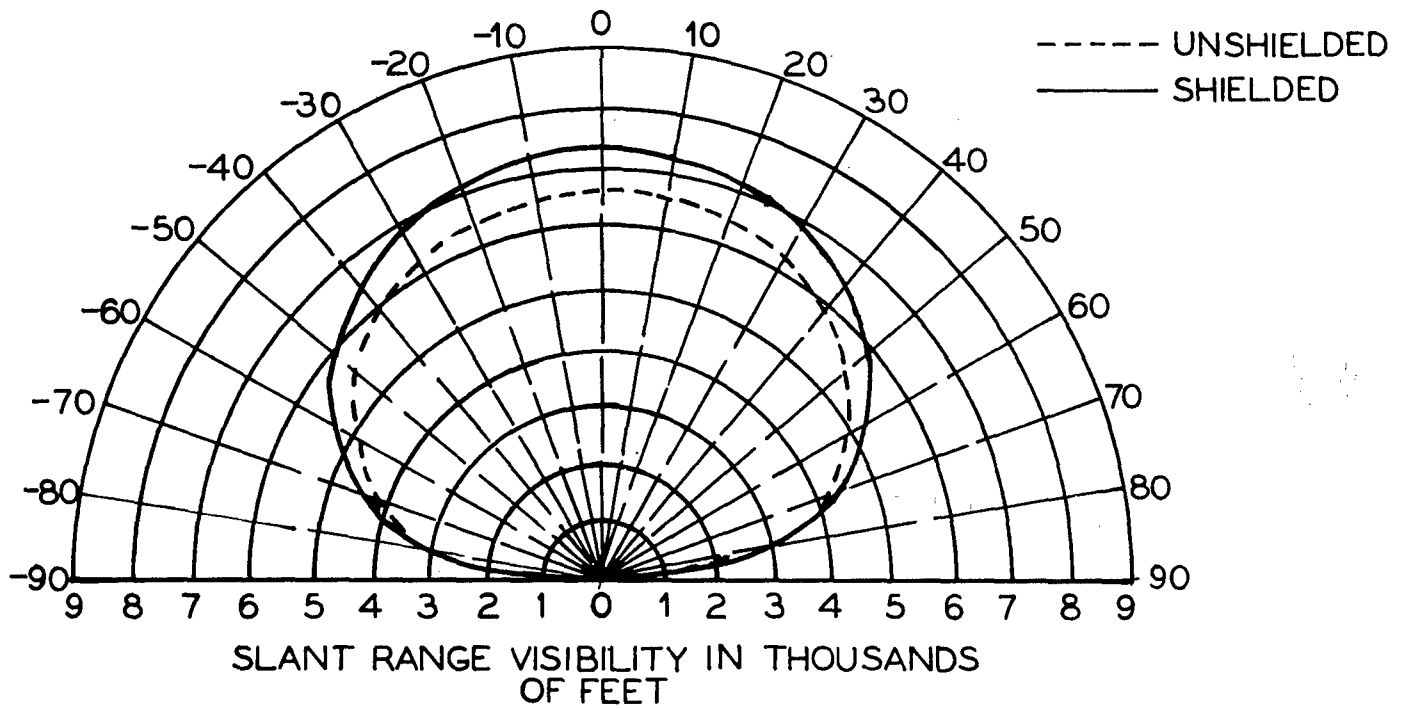

Figure 15. Visibility Plot for Shielded and Unshielded Flares at Different Flare-Observer-Target Angles

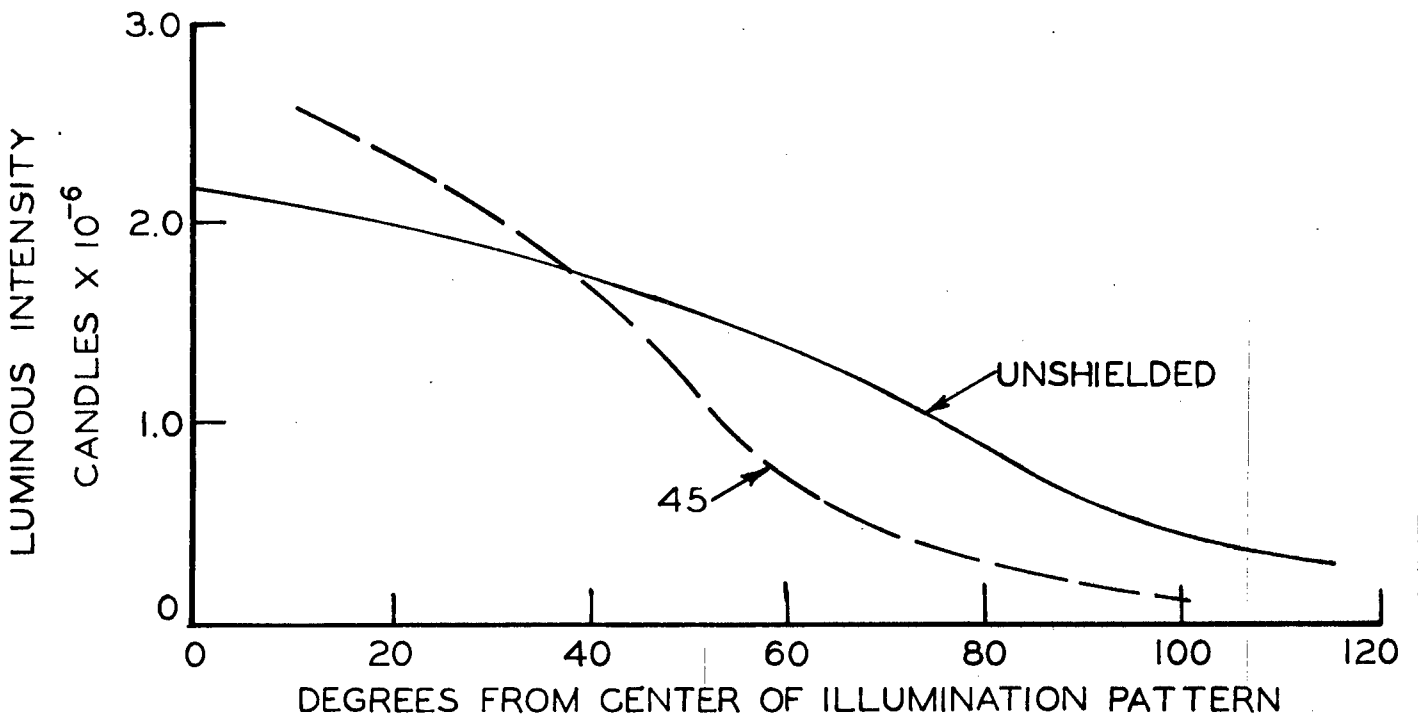

Figure 16. Luminous Intensity versus Degrees from Pattern Center for a 60-degree 45-inch Shield

however, causes the circles to drift apart in the direction of its movement, and, given sufficient velocity, can render initially perceived targets invisible. The planning principle here is to so select the type of flare (based on its ignition/burn-out altitudes, burn-time and candlepower) for a given wind velocity that: (1) there will be spatial overlap between the respective circles of visible light at ignition and burn-out; and (2) the target will remain in this overlapping area.

In accomplishing this set of circumstances, the planners goal would be to achieve ignition at an ideal altitude with the flare drifting directly over the target and burning out at an ideal altitude. Figure 17 provides a graphic portrayed of the tolerable wind drift distance for acquiring a target under one set of conditions.

## ATMOSPHERIC EFFECTS

Just as there is almost always wind to complicate the planning of flare missions so there is an atmospheric medium which scatters and absorbs the light being transmitted from the flare to the ground, from the ground to the observer, and from the flare to the observer. Irradiation of light, as would be predicted by the inverse square law is thus reduced by a so-called extinction coefficient which is less than unity and depends upon such factors as wavelength, atmospheric gases, temperature, pressure, as well as amounts of rain, fog, snow, dust and other aerosols. Visibility or meteorological range refers to the horizontal distance at which atmospheric attenuation (extinction) reduces the apparent contrast of a target to two percent of its intrinsic contrast.

On cloudy nights under flare light conditions target visibility is subject to two kinds of atmospheric degradation. One of these involves light reflected from the target and attenuated according to the extinction coefficient. The other, referred to as path luminance, involves light which is scattered by the atmosphere and added to the attenuated path of light entering the observer's eye. The net effect of this combined attenuation and scattering is to further veil the visibility of the target against the background. These two atmospheric effects along the observer's line of sight are depicted in figure 18. Another visual path shown in the figure which represents still further degradation comes directly to the eye from the flare which acts as a glare source.

Lohkamp (1970) has constructed a mathematical model which predicts the probability of target detection under various conditions of atmospheric clarity, flare location and intensity, as well as pertinent characteristics of the target background. According to the author, this model utilizes the best available psychophysical and engineering data and is intended to accept improved data as this becomes available. Once its validity is checked and all necessary improvements are made, it can provide the designers, planners, and evaluators of flare systems with a sophisticated tool for predicting target acquisition, taking into account the effects of source, medium, target, background, detection and geometry as a function of time. More recently, Bradley and Lohkamp (1973) have analyzed the effect of atmosphere on target-background contrast under flare illumination. Their analysis of the reduction of target-to-background contrast attributable to atmospheric effects is described in figure 19. Figure 19 contains four curves, each of which represents a particular geometric flare-target-observer relationship. The specific relationships studied are given in the Bradley and Lohkamp report.

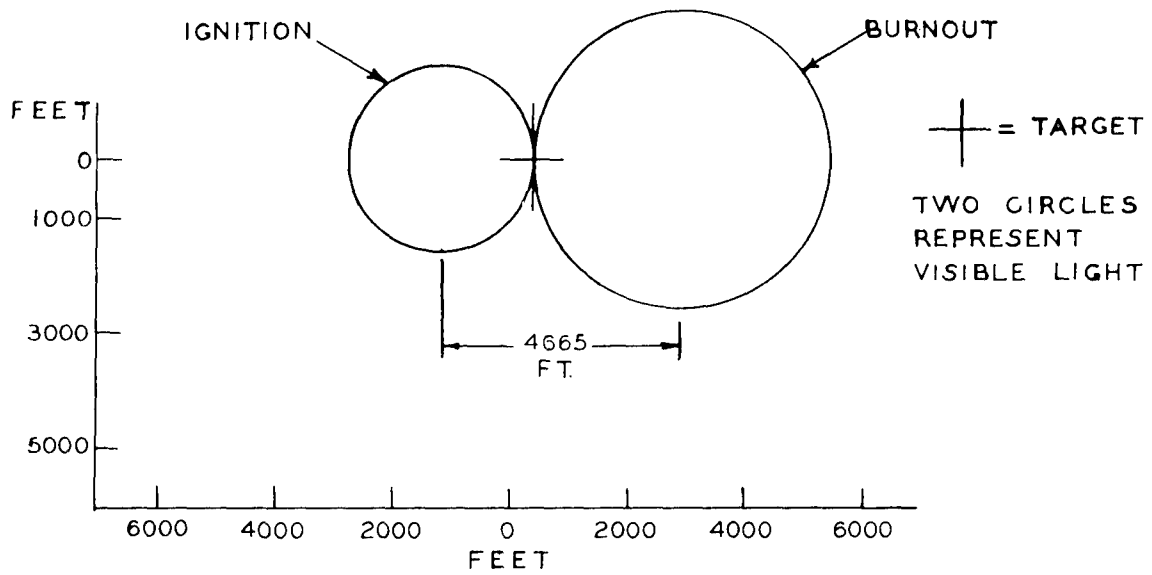

Figure 17. Tolerable Wind Drift for Target Acquisition  
(See text for explanation)

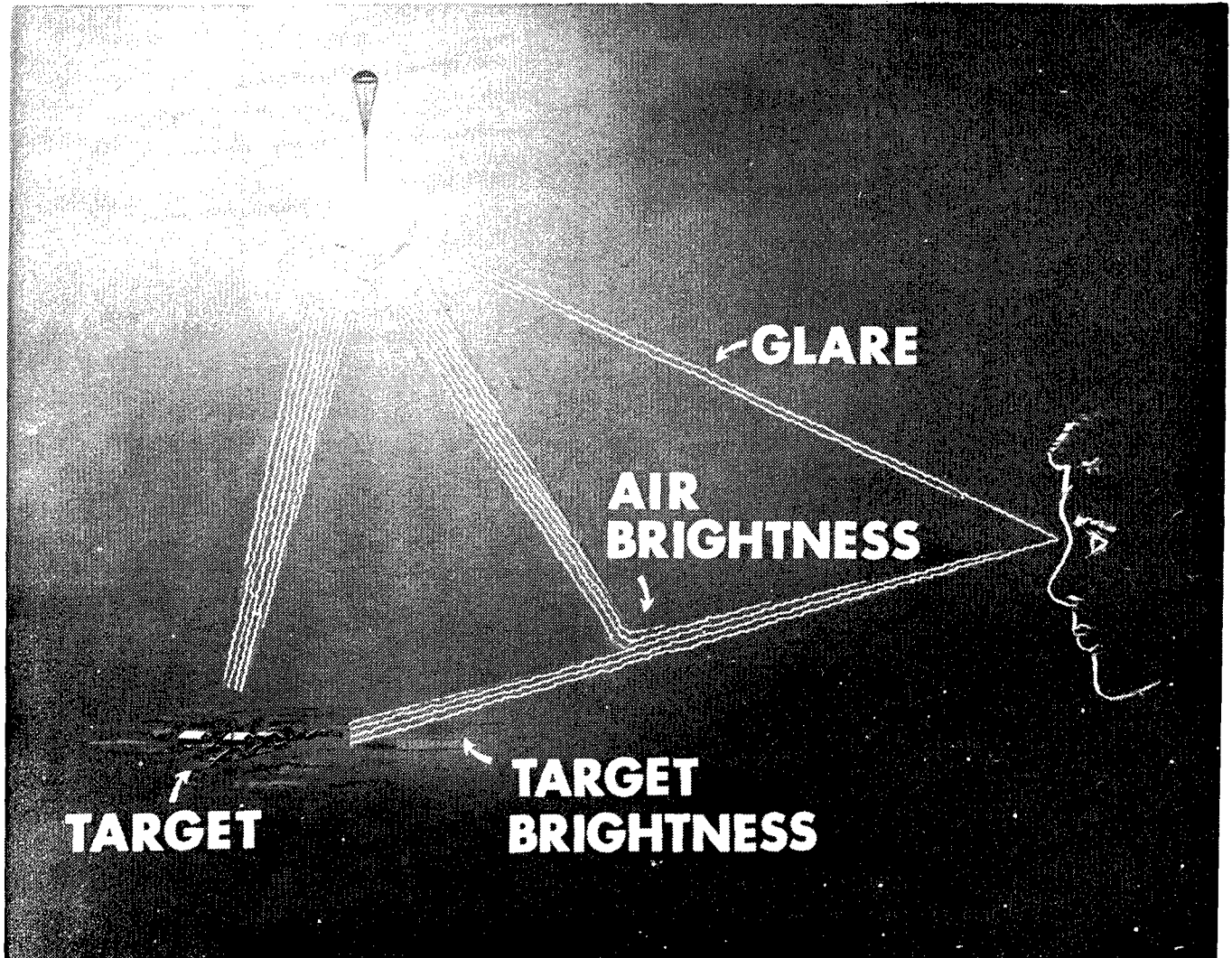

Figure 18. Paths of Atmospheric Degradation for Target Visibility under Flarelight



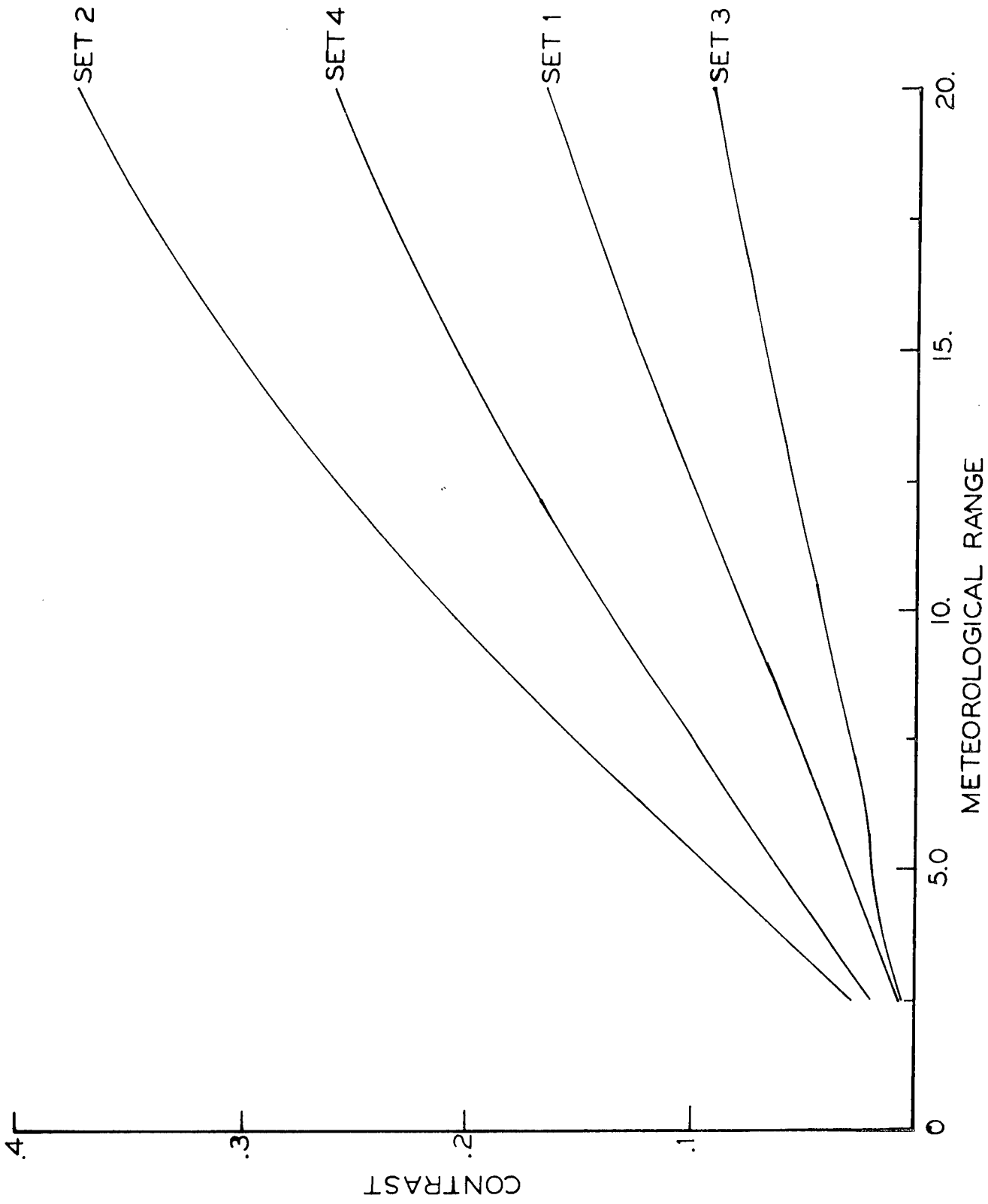

Figure 19. Effect of Atmosphere on Contrast under Flare Illumination

Katz et al. (1970) has designed an environmental chamber for the study of visual acuity with simulated flare light under cloud conditions. An experimental generator was constructed to produce aerosol particles of stearic acid (having a diameter of 0.68 microns). These were dispersed into the room at one of two levels of density ( $25 \times 10^5$  or  $5.0 \times 10^6$  particles/ml). Other experimental factors were two simulated flare light intensities ( $2 \times 10^6$  and  $5 \times 10^6$  cp) and the use of yellow (haze cutting) eye filters. To measure visual acuity, subjects were required to select the smallest discernible break in a diminishing series of Landolt C's. Results indicated: (1) no advantage for the yellow filters, (2) loss of visual acuity at the lower flare intensity, (3) a linear decrease in visual acuity with increasing fog level. This study represents a beginning step in the simulation of a real-world environment (hitherto only studied in field tests) as a measurable experimental factor. Using the guidelines suggested by this study, the Aerospace Medical Research Laboratory has installed an experimental chamber with an associated aerosol generator and nephelometer for future visibility research.

### TARGET/BACKGROUND FACTORS

There are obviously many measurable parameters associated with both the target to be acquired and its background which can affect the planning and outcome of a flare mission. For the target these include size, shape, color, brightness, and contrast. Additional background factors include brightness, color, texture, clutter elevation, etc. The impact of these variables on flare light acquisition will not be reviewed in this paper; however, readers are referred to Blunt and Schmeling (1968) and Clisham (1969) who have covered this subject matter. Blunt and Schmeling's paper provides a multi-step planner's guide for selecting an appropriate flare from known physical characteristics of the target being sought. These steps involve calculation of: (1) target reflection, (2) inherent target contrast, (3) target area, (4) observer-to-target viewing distance, (5) visual angular subtense of the target, (6) threshold of apparent contrast at the selected viewing range, (7) intensity of the required flare, and (8) range at which required ground illumination level may be produced from available flares.

Despite the inclusiveness and rigor of this computational model (which is based on a variety of available visibility data), the result of computations for the particular example used (an OD painted tank viewed against dry sand) do not appear credible. A 115-million candlepower flare is presumed in this analysis to be required which could hardly be cost-effective even if it were available. Far smaller flares than this have been successfully deployed for similar types of target acquisition. This disparity is due primarily to the unavailability of more appropriate data which forced Blunt to solve the problem at an over-conservative suprathreshold level where a lower level would have sufficed.

### OBSERVER FACTORS

The last and possibly the most critical group of factors pertaining to the effectiveness of a target acquisition under flare light are those inherent in the visual and decision-making processes of the observer himself. Again, this subject matter has been reviewed in some detail by Blunt and Schmeling (1968) and Clisham (1969), and will not be covered extensively in this paper. Discussion here will be restricted to the geometric position of the observer's eye with respect to the target and/or the flare. Specifically, the points to be covered will be:

observer distance from the target, observer altitude, observer movement, and relative positions of the observer, target and flare.

### Observer Distance from Target

This is the slant range from the observer at which the target is sighted and determines the visual angle of the object being viewed. The following formula may be used for computing this angle ( $\theta$ ) in minutes of arc.

$$\theta = 2 \text{ ARCTAN} \frac{D}{2SL}$$

where D = Linear Dimension of target in feet  
and SL = Slant range in ft.

Given a sufficiently long viewing range,  $\theta$  will diminish to a value below resolution threshold. This occurs typically during daylight when the maximum dimension of the target projected to the eye subtends a visual angle of about one minute of arc.

However, under simulated MK24 flare light illumination with a simulated mist concentration of 3.0 particles/ml, Katz, et al. (1970) found the minimum visual angle for resolving a target to be about 1.5 minutes. Additional factors such as decreased illumination, flicker, target/observer motion might still further degrade target resolution and decrease minimal visibility ranges under typical flare mission conditions. More applied research needs to be done to clarify these matters. One such study has been reported by Davis (1971) where the illumination required to detect a target under simulated flarelight on a 1:160 scale terrain model was found to vary directly with the square of the slant range.

### Observer Altitude

Part of the problem associated with slant range is the aircraft altitudes at which the observer views the target. If there are broad elevated features (e.g., mountains, towers) between the eye and the target, then sufficient altitude is obviously required to provide an unobscured view. Determination of this altitude would depend on knowledge of the terrain features and their dimensions. Another factor, which probably requires more research, is the effect on recognizability for particular target shapes as these are viewed in different air-to-ground perspectives at higher altitudes.

Hilgendorf (1971) has studied the effect of variations in observer altitude for resolving targets under simulated Naval MK24 flare-light. Subjects were required to resolve separations in Landolt rings and acuity gratings at eight simulated altitudes (from 500 to 4000 ft). Performance was measured as the response time from flare ignition to a correct acuity response. An intermediate altitude ranging from 2000 to 3000 feet was found to be optimal in this study. These results were confirmed by Hucker (1972) in a flight test at Eglin AFB.

### Observer Movement

This is a critical factor (related to dynamic visual acuity) which requires systematic study.

Some data on the effect of aircraft speed on target acquisition have been provided by Clisham (1969) showing in general that increasing speed leads to decreases in detection range and detection probabilities. These data, however, were based on daylight acquisition and need to be rerun under flarelight conditions.

### Relative Position of Observer, Target and Flare

An obvious planning factor is the relative position of the observer and the flare with respect to the target being viewed. The position of the flare as a glare source is one thing to be considered. This effect can be gauged both in terms of the intensity of the flare and its glare angle, i.e., the angle between the flare's line of projection to the eye and the observer's line of regard to the target. A glare source will produce a veiling luminance at the retina which is more deleterious to target acquisition the closer it is to the target image. Hence, the flare should be positioned with respect to the observer and the target so as to provide a relatively large glare angle. The smallest tolerable angle (which is usually greater than 7°) will increase with increasing flare brightness. This angle should be always smaller than the glare angle which exists at the burn-out altitude. The Illuminating Engineering Society (Kaufman (1972)) has defined the amount of veiling luminance  $L_v$  attributable to glare as follows:

$$L_v = \frac{K E}{\theta^{(3/2)}}$$

where K refers to a constant (depending on the units being used) E to flare luminance and  $\theta$  to the glare angle.

Davis (1971), using the 1:160 scale terrain model and flare-simulating facility at Picatinny Arsenal, provides systematic data on the amount of ground illumination required for the recognition of vehicular and personnel-sized targets as a function of the target illumination angle, range, terrain background and angle of observation. Observers were positioned at a fixed distance and elevation for each test. The simulated flare was placed in a particular orientation with respect to both observer and target. The observer then increased the flare's intensity up to the point of target recognition. Typical results appear in figure 20 showing that a progressively smaller amount of flare light is needed to recognize the target as the flare moves from a position between the target and the observer at a target illumination angle of 30 degrees, through an overhead position at 90 degrees, to a position well-behind and above the target at 150 degrees. Similar tests were made with variations in observer elevation, target/background contrast, type of target (personnel vs vehicle) and slant range. Results of these tests are graphically portrayed in 17 figures appearing in Davis' report.

One way of expressing the advantage of deploying the flare behind the target is that the flare silhouettes the target rather than illuminating it. Strauss and DeTogni (1962) in an observational field test of a small flare (50,000 cp) noted that silhouetted targets (situated in front of the flare) are more frequently detected than illuminated targets (in back of the flare) at equal distances from the flare. It would seem likely that the acquisition of targets with pronounced vertical features (e.g., towers) would benefit most from the silhouetting mode of flare deployment.

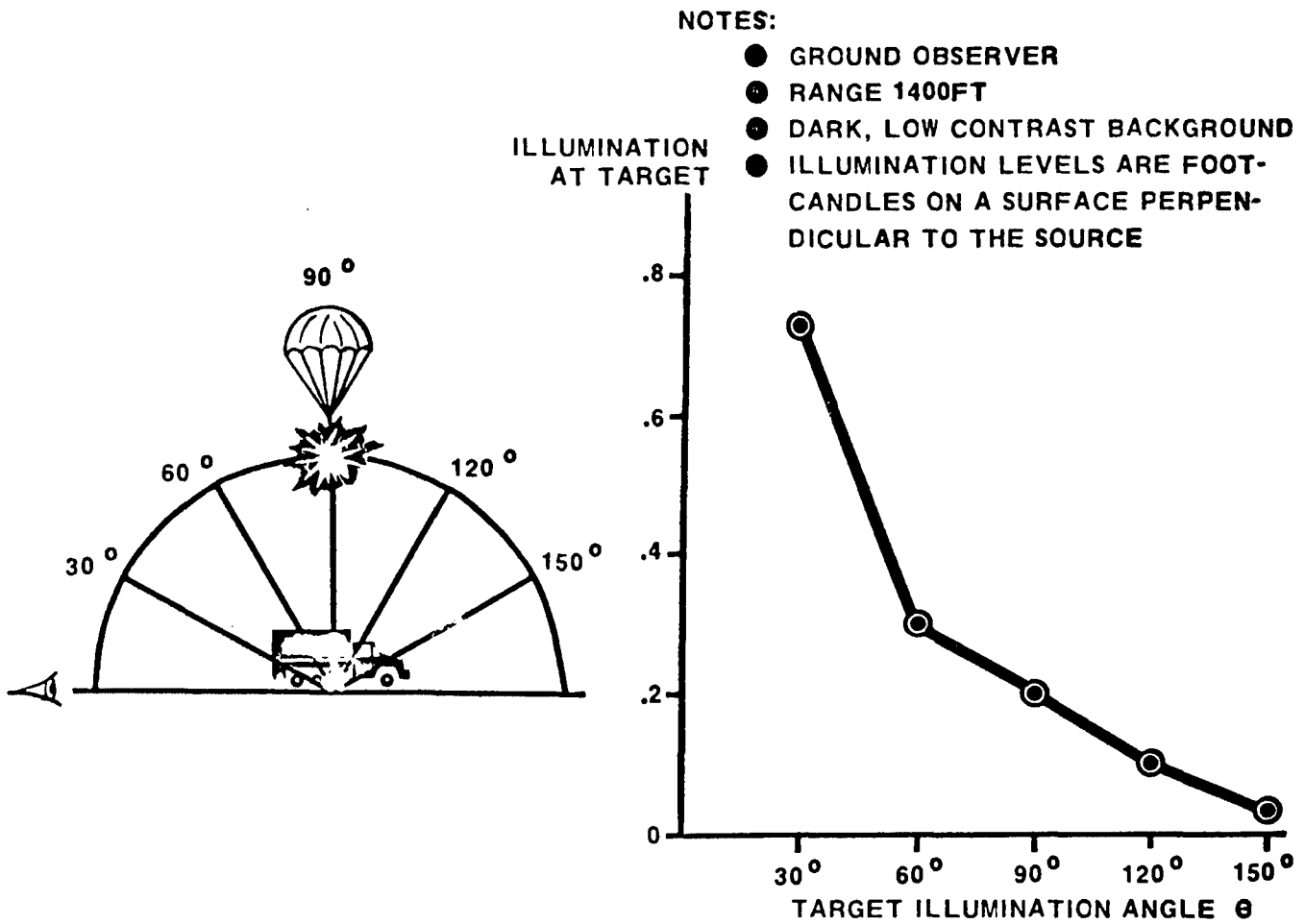

Figure 20. Illumination Required for Recognition as a Function of Target Illumination Angle

## SECTION IV

### CONCLUSIONS

In this paper an attempt has been made to extract, integrate and evaluate data from current research which pertains to the more effective design and utilization of illuminating flares. The principal criterion of effectiveness is the improved capability for air-to-ground visual acquisition of targets. Various research techniques for gathering data on flare effectiveness have been considered and relevant factors have been reviewed under the major headings of candle composition, deployment, wind drift, atmosphere, target and observer.

The information contained in this report is addressed to those Armed Forces personnel who study, design and use systems involving illuminating flares for target acquisition. In addition to providing them guidance on flare effectiveness, an effort has been made to review current research programs and to suggest areas requiring further investigation.

A disproportionate amount of pyrotechnic research apparently has been expended in areas related to composition development and parachute deployment with too little concern for the amount or type of illumination actually needed to acquire a target. On the other hand, relatively little effort has been expended, within the context of mission requirements, which relates flare effectiveness factors to the responses of human observers. Without knowledge of such relationships, one cannot confidently evaluate the relative merits of alternative flare systems or of proposed innovations.

## REFERENCES

- Army, Hq., *Field Manual—Battlefield, Illumination, FM 20-60, Hq, Dept of the Army, Jan 1970.*
- Army Materiel Command. *Engineering Design Handbook, Military Pyrotechnics Series, Part One, Theory and Application, AMC Pamphlet No. 706-185, Army Materiel Command, Washington, D.C., April 1967.*
- Blunt, R. M., & Schmeling. *Study of Psychophysical Factors of Vision and Pyrotechnic Light Sources.* Technical Report AFATL-TR-68-17, Air Force Armament Laboratory, Eglin AFB, FL., Feb 1968.
- Blunt, R. M. *Spectral Distribution of Different Regions of Illuminating Flare Flames.* RDTR No. 220, Naval Ammo Depot, Crane, Ind., Dec 1972.
- Bradley, G. *Visibility Model.* RDTR No. 151, Naval Ammo Depot, Crane, Ind., Nov 1969.
- Bradley, G. S., & Lohkamp, C. E. *An Analysis to Determine the Effect of the Atmosphere on the Contrast Produced by Flare Illumination.* RDTN No. 229, Naval Ammo Depot, Crane, Ind., Jan 1973.
- Brooks, W. *Methodology Study of Illuminating Pyrotechnic Test and Evaluation.* First Partial Report. Y.P.G. Project No. 6002, Yuma Proving Ground, Yuma, Ariz., Jan 1970.
- Brooks, W. *Methodology Study of Illuminating Pyrotechnic Test and Evaluation.* Second and Final Partial Report. Y.P.G. Report 0052, Yuma Proving Ground, Yuma, Ariz. Oct 1970.
- Carlson, B. & Jewsbury, W. *Advanced Development of the Packaging and Deployment of a Shielded Flare.* Technical Report AFATL-TR-69-124, Air Force Armament Laboratory, Eglin AFB, FL., Sept 1969.
- Carlson, B. & Jewsbury, W. *Flight Feasibility Testing of an Improved Target Illuminating Flare.* Technical Report AFATL-TR-68-118, Air Force Armament Laboratory, Eglin AFB, FL., Oct 1968.
- Clisham, W. F. Jr. *Advanced Concept Studies of Aircraft Flares and Dispensing Systems—Part II: Operational Analysis and Human Factors Affecting Second Generation Flare Illumination Studies.* Report R-1935, Frankford Arsenal, Philadelphia, PA, Oct 1969.
- Cohen, H. N. & Kottler, G. F. *The Optimum Height of a Burning Flare.* Tech Report 2091, Picatinny Arsenal, Dover, N.J., Oct 1954.
- Craven, T. D. *Operational Test and Evaluation of the LUU-2/B Airborne Flare.* TAC TR 69-55A, USAF Special Operations Force, TAC, USAF, Eglin AFB, FL., July 1970.

Davidson, C. I. *The Effects of Flare Tunnel Geometry and Reflectivity on Light Measurements*. Pyrotechnics Laboratory Information Report, Picatinny Arsenal, April 1970.

Davis, R. B. *Results of Air Illumination Requirement Study using a Pyrotechnic Terrain Model*. Technical Report 4184, Picatinny Arsenal, Dover, N.J., Nov 1971.

Davis, S. G. *Illumination Meter for Low Level Light Measurements*. Pyrotechnics Laboratory Information Report, Picatinny Arsenal, Dover, N.J. April 1970.

Davis, R. B. and Tyroler, J. F. *An Investigation of the Effect of Change in Flare Intensity on the Recognition of Vehicular Size Targets*, Pyrotechnic Division Information Report IR 5-72, Picatinny Arsenal, Dover, N.J., Dec 1972.

Douda, B. E. *Relationships Observed in Colored Flames*. RDTR No. 45, Naval Ammo Depot, Crane, Ind., 1964.

Douda, B. E. *Emission Studies of Selected Pyrotechnic Flames*. Journal of Optical Society of America, 55(7), 1965.

Douda, B. E. *Twenty Five Million Candle Cast Flares, Diameter and Binder Study*. RDTR No. 105, Naval Ammo Depot, Crane, Ind., Jan 1968.

Douda, B. E. *Determination of the Amount of Energy Radiated in the Visible by an Illuminating Flare Flame*. RDTN No. 135, Naval Ammo Depot, Crane, Ind., July 1968.

Douda, B. E. *Pyrotechnic Flare Spectroscopy*. RDTR No. 206, Naval Ammo Depot, Crane, Ind., June 1972.

Douda, B. E. *Atlas of Radiant Power Spectra of Four Flare Formulas at Eight Levels of Ambient Pressure*. RDTR No. 205, Naval Ammo Depot, Crane, Ind., June 1972.

Douda, B. E. and Bair E. *Visible Radiation from Illuminating—Flare Flames: Strong Emission Features*. Journal of Optical Society of America, 55(7), 1965.

Ellern, H. *Military and Civilian Pyrotechnics*. Chemical Publishing Company, New York, 1968.

Ernst, B. G. *Functional and Effectiveness Test of the Improved Target Illumination Flare (Shielded Flare)*. Technical Report ADTC-TR-72-130, Armament Development and Test Center, Eglin AFB, FL., Dec 1972.

Feagans, J. W. *An Evaluation of Flame Intensity by Comparison of Flares*. RDTR No. 98-23. Naval Ammo Depot, Crane, Ind., May 1967.

Graham, C. H. et al. *Vision and Visual Perception*. John Wiley and Sons, New York 1965.

Hamrick, J. T. *Proceedings of First Pyrotechnic Seminar. Areas for further Exploratory Development*. RDTR No. 131, Denver Research Inst., Denver, Col., Oct 1968



Hamrick, J. T., Blackshear, P. L. Jr., and Stanitz, J. D. *Exploratory Development of Illumination Flares*. Aerospace Research Corp., Roanoke, VA., Aug 1968.

Hart, D. *Research and Development Progress in Military Pyrotechnics*. R&D Lect. #24, Picatinny Arsenal, Dover, N.J., Feb 1955.

Hilgendorf, R. L. *Visual Search and Detection under Simulated Flarelight*. AMRL-TR-68-112(II). Aerospace Medical Research Laboratory, W-PAFB, OH., Jan 1969.

Hilgendorf, R. L. *Visual Performance with Simulated Flarelight: Effects of Flare-Ignition Altitude*. Human Factors, Aug 1971, 13(4).

Hilgendorf, R. L. "Visual Acuity" under Simulated Flarelight: Effects of Observer Altitude. Aerospace Medical Association, 1971 Annual Scientific Meeting.

Hilgendorf, R. L. *Current Research in Simulated Battlefield Illumination: Effects of Flare Shielding*, Proceedings, Psychology in the Air Force, 2nd Annual Symposium, USAF Academy, April 1971.

Hilgendorf, R. L. *Air-To-Ground Target Acquisition with Flare Illumination*. Agard Conference Preprint No. 100. On Air-to-Ground Target Acquisition, NATO Advisory Group for Aerospace Research and Development, June 1972.

Hucker, J. A. *Testing for Flare Simulation Study Validation*. ADTC-TR-72-3, Armament Development and Test Center, Eglin AFB, FL., Jan 1972.

Jewsbury, W. *Study, Analysis and Experimentation of an Improved Target Illuminating Flare*. Technical Report AFATL-TR-68-2, Air Force Armament Laboratory, Eglin AFB, FL., Jan 1968.

Johnson, D. M. *Proposed Kinetics and Mechanics of Illuminant Flares: Maximizing Efficiency*. RDTR No. 32, Naval Ammo Depot, Crane, Ind., Jan 13, 1966.

JTCCG/ALNNO. *Results of YPG PER Site Test on Six Aircraft Flares*. Working Party for Pyrotechnics, Joint Technical Coordinating Group for Air Launched Non-Nuclear Ordnance. Sept 1971.

Katz, S., Ase, P. K., Raisen, E., and Hilgendorf, R. L. *Visual Performance with Simulated Flarelight in Artificial Clouds*. AMRL-TR-69-121, Aerospace Medical Research Laboratory, W-PAFB, OH., Jan 1970.

Kaufman, J. E. *Illuminating Engineering Society Lighting Handbook*. Fifth Ed., Published by Illum Eng Soc, 1972.

Kemp, J. L. *Proceedings of First Pyrotechnic Seminar. Math Simulation Models*. RDTR No. 131. Denver Research Inst., Denver, Col., Oct 1968.

Laswell, J. E. *Study of the Optimum Suspension of a High Intensity Parachute Flare*. RDTN No. 30, Naval Ammo Depot, Crane, Ind., May 1963.

Laswell, J. E. *An Investigation to Optimize Illumination Characteristics of a Parachute Flare (MK 45 Type)*. RDTN No. 202. Naval Ammo Depot, Crane, Ind., Nov 1971.

Laswell, J. E. *A Method to Simulate the Dynamical Evaluation of Aircraft Parachute Flares*. RDTN No. 206, Naval Ammo Depot, Crane, Ind., Feb 1972.

Laswell, J. E. *A Mathematical Model which Simulates Non-Isotropic Light Emission at Yuma Grounds PER Site*. RDTN No. 210, Naval Ammo Depot, Crane, Ind., July 20, 1972.

Lazarus, M. *Measurements at an Outdoor Flare Test Facility and a Relation To Ground Illumination*. Pyrotechnics Laboratory Information Report. Picatinny Arsenal, Dover, N.J., May 1969.

Lazarus, M. *Picatinny Flare Tower Objective and Comparison to a Flare Tunnel*. Pyrotechnics Laboratory Information Report. Picatinny Arsenal, Dover, N.J., 1971.

Lohkamp, C. W. *Visibility under Pyrotechnic Flare Illumination and of Pyrotechnic Signals*. Naval Ammo Depot, Crane, Ind., 1970.

Lohkamp, C. W. *Fleet Use of 5"/54 Illuminating Projectile*. RDTN No. 228. Naval Ammo Depot, Crane, Ind., Dec 1972.

Lohkamp, C. W. *Validation Flight Test*. RDTN No. 231. Naval Ammo Depot, Crane, Ind., Jan 1973.

Middlebrooks, D. E. & Kaye, S. M. *The Effects of Processing on Pyrotechnic Compositions. Part II: Statistical Analysis of Effects of Particle Size on Burning Rate and Illuminance for Consolidated Pyrotechnic Items*. Technical Report No. 3253, Picatinny Arsenal, Dover, N.J., Jan 1966.

Naval Ammo Depot, Crane, Ind. *Predictions of Shielded Flares Capability*. Letter to Naval Air Systems Command, Naval Ammo Depot, Crane, Ind., Nov 1970.

Smith, C., Lazarus, M., and Davidson, C. *True Effects of Air Drop Velocity on Flare Output*. Pyrotechnic Laboratory Information Report. Picatinny Arsenal, Dover, N.J., Nov 1972.

Starrett, C. M. *A Computer Program for the Analysis of Illumination Patterns Resulting from N Separated Flares*. Tech Memo 1458, Picatinny Arsenal, Dover, N.J., Dec 1964.

Starrett, C. M. *A Collection of the Illuminating Patterns Resulting from N Separated Flares*. Tech Memo 1620, Picatinny Arsenal, Dover, N.J., June 1965.

Stoval, R. J. *General Description of MAPI Data Acquisition Systems*. RDTR No. 38. Naval Ammo Depot, Crane, Ind., 1966.

Strauss, P. S. & DeTogni, G. R. *Personnel Target Acquisition under Flare Illumination*. Technical Report 3012, Picatinny Arsenal, Dover, N.J., July 1962.

Tanner, J. *Effect of Binder Oxygen Content on Adiabatic Flame Temperature of Pyrotechnic Flares*. RDTR No. 181, Naval Ammo Depot, Crane, Ind., August 1972.

Tyroler, J. F. *Illuminating Flare Performance and Illuminating Requirements*. Unpublished Report, Picatinny Arsenal, Dover, N.J., 1971.

Tyroler, J. F. *The Pyrotechnic Terrain Model, A New Dimension in Pyrotechnic Design Description and Initial Results*. Tech Report 4075. Picatinny Arsenal, Dover, N.J., 1971.

Weasner, M. H. *Detection of Ground Targets under Flare Illumination*. Tech Report 3266, Picatinny Arsenal, Dover, N.J., 1965.

Wildridge, J. E. *Design and Tests of Experimental High Intensity Flare Systems*. RDTR No. 75, Naval Ammo Depot, Crane, Ind., Aug 1966.

## APPENDIX A

### AIRCRAFT FLARE DESCRIPTIONS

#### 1. XM170 AIRCRAFT PARACHUTE FLARE:

a. Description. The XM170 Aircraft Parachute Flare (Fig A-1) is 35 inches long, 2.75 inches in diameter and weighs 12.5 pounds. It consists of five major sub-assemblies, the XM715 MT Fuze, two separate candles, a parachute housing assembly and a quickmatch initiation transfer system. The sub-assemblies are structurally attached to each other by the rubber-die crimp method with the exception that the fuze has a threaded interface connection. The flare is designed in such a manner as to make the use of an outer case unnecessary.

The XM715 MT Fuze (Fig A-2) consists of a zinc die cast housing which contains an interlock, a cover retainer detent system, a mechanical timer, a fuze functioning pilot parachute, an explosive firing train and a cover for time setting adjustments. Six safety interlock systems are incorporated into the fuze assembly.

The Candle and Parachute Assembly consists of illuminating candles attached to a parachute housing and a closure plug for one end and a fuze adapter on the other end. The illuminating candles, two per flare, utilize aluminum cases for an outer case, contain a magnesium based illuminating composition, and have a first fire composition pressed into the candle's face. One candle has an aluminum fuze adapter crimped to the aluminum case, and the other candle's face is sealed with an aluminum closure plug crimped to its case.

The parachute Housing Assembly is an aluminum container with a blow-off-door and a parachute in a rubber bag which protects it from the hot ejection gases. The blow-off-door is held in place by aluminum bands that break when the ejection charge is activated. The main parachute is attached to the candle assembly by two bolts, one of which contains an explosive charge that when initiated by candle burnout, releases half of the parachute suspension lines, thus causing the residual hardware to descend rapidly to the ground.

The XM127 Aircraft Flare Dispenser (Fig A-3) consists of a SUU-7 strongback which has mounting provisions for the standard 14-inch aircraft suspension lugs, 19 SUU-14 type tubes and heavy skin which forms the main reinforcing member. The dispenser will be assembled using a liquid foam to hold all parts in their proper positions.

The weight of the empty and the fully loaded XM127 Dispenser is 105 and 333 pounds, respectively.

The XM18 SUU-14/A) Dispenser (Fig A-4), either in a single (XM18) configuration or in a double (XM15) configuration as shown, may also be used to deliver the XM170, by loading two rounds per tube (these are simultaneously ejected on activation).

#### b. Functioning (Fig A-5)

(1) Dispenser Functioning. Prior to leaving on a mission, two XM127 Aircraft Dispensers,

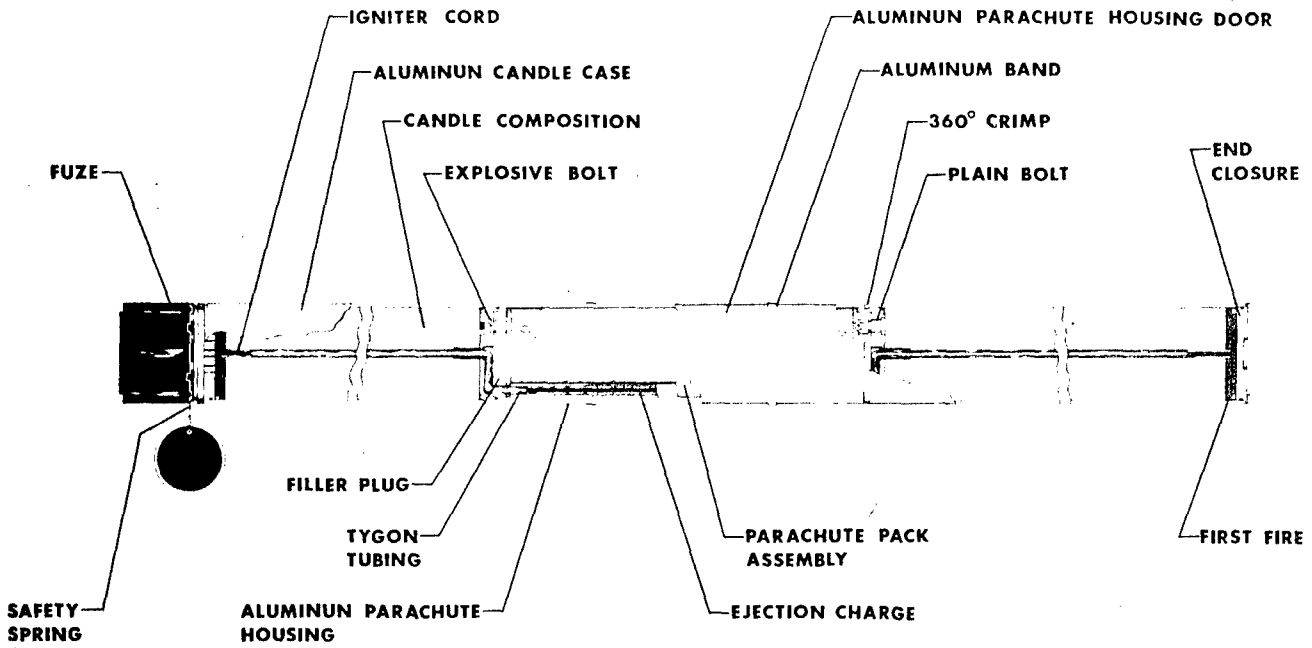

# **XM170 AIRCRAFT PARACHUTE FLARE**

FIG A-1

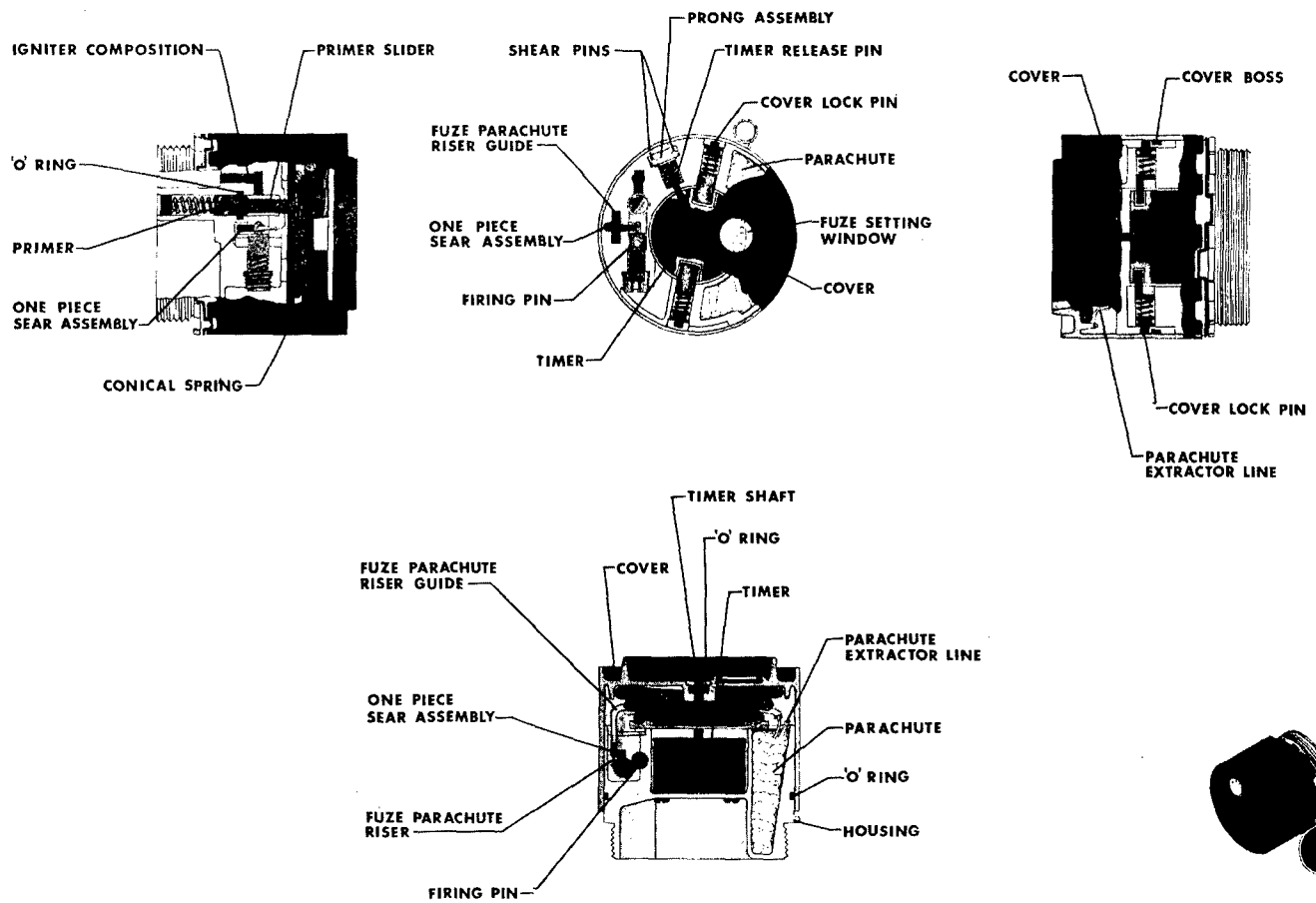

# **XM-715 MECHANICAL TIME FUZE**

FIG A-2

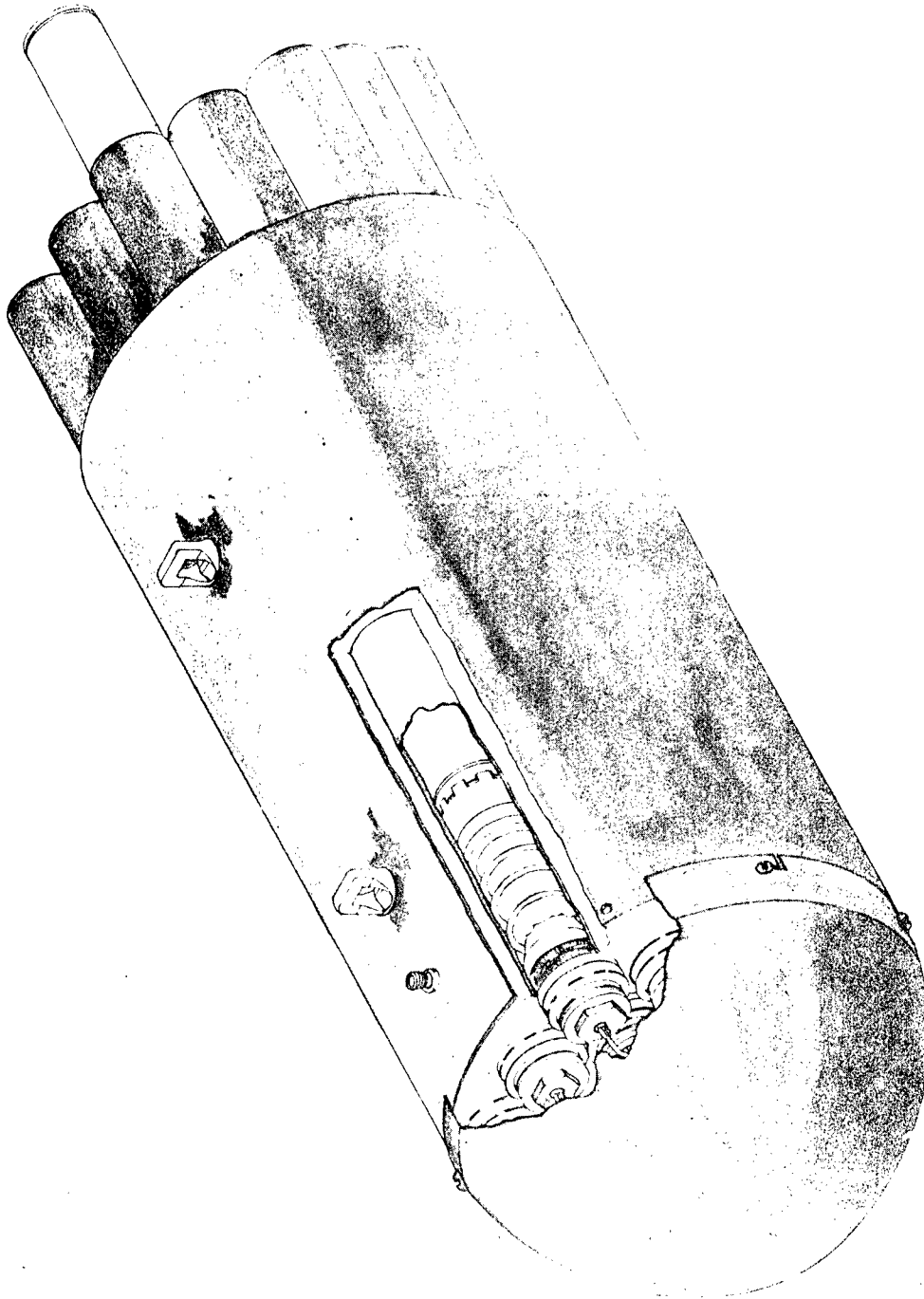
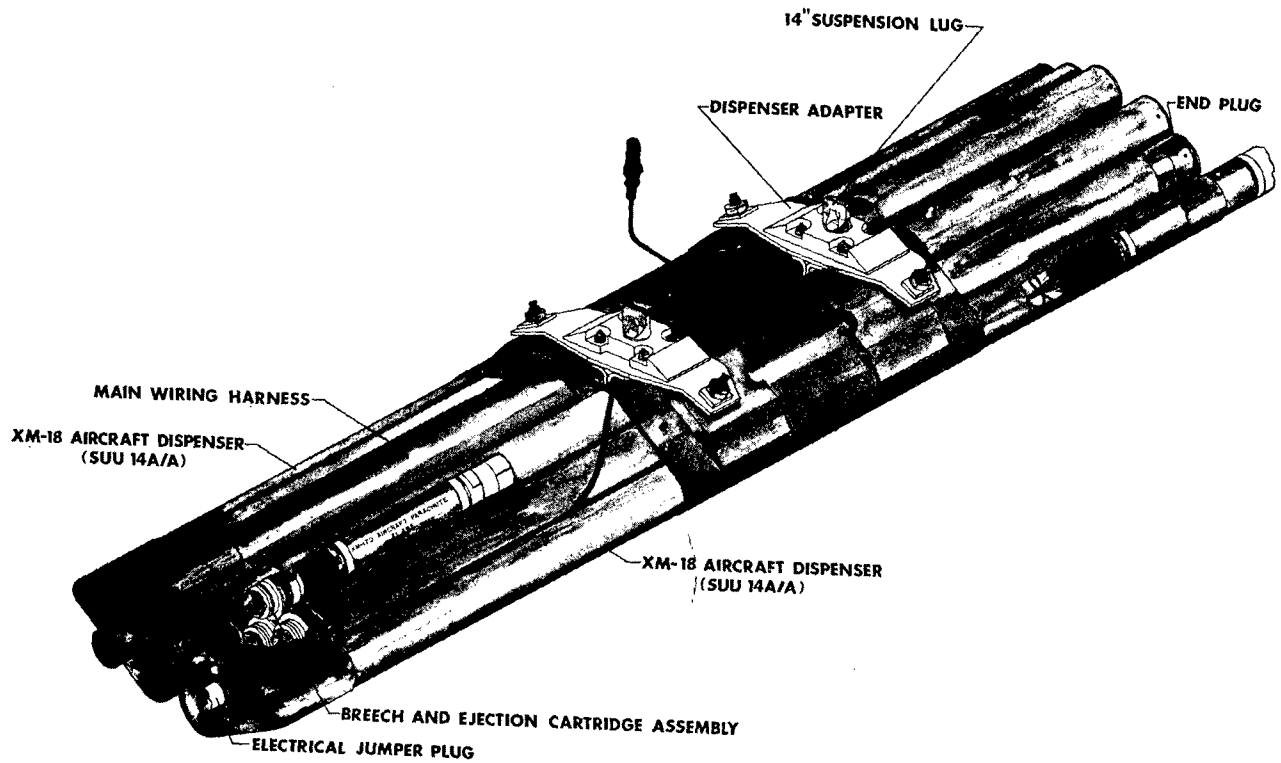

FIG A-3



## XM-15 AIRCRAFT DISPENSER AND FLARE

FIG A-4



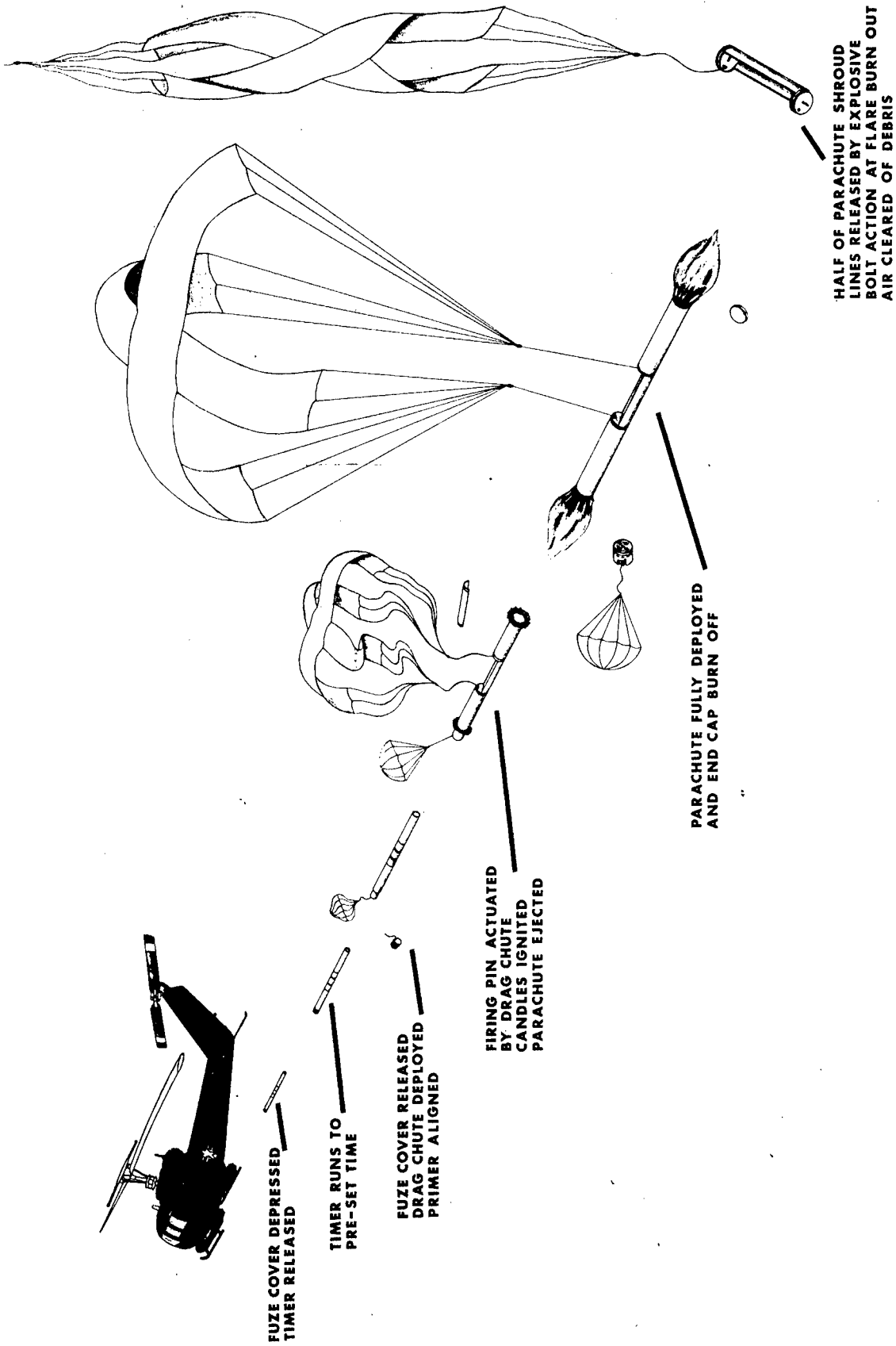

# XM170 AIRCRAFT PARACHUTE FLARE DEPLOYMENT SEQUENCE

FIG A-5

fully loaded with XM170 Aircraft Parachute Flares, are mounted on the Aircraft's external suspension system and connected electrically to the appropriate fire control circuit. The aircraft's fire control circuit has two switches, exclusive of the firing button, an arming switch, which shorts out the firing circuit until placed in the armed position, and a selector switch which allows the choice of a single flare from either left, right or both dispensers. These switches can be set, reset or changed anytime during the mission.

In operation, the pilot triggers his firing button on the control panel which closes a circuit from a power supply to the externally mounted dispensers. The firing command pulse passes through a RADHAZ filter and the arming switch (in the armed position) to the selector switch which is always set for single tube fire of either the left, right or both dispensers. The firing pulse then goes through the rotary selector switch and activates one of the ejection cartridges. The ejection cartridge builds up a high pressure behind the obturation piston and spring assembly and after providing enough force to shear the end plug rivets, ejects in order, the end plug, one XM170 Aircraft Parachute Flare and the piston and spring assembly.

(2) Fuze Functioning. When the dispenser tube is activated, the ejection charge gas pressure against the fuze cover is sufficient to completely compress the conical spring by moving the fuze cover forward; this will move the interlock assembly to the released position, releasing a pin in the timer's gear train and thus allowing the timer to function. The conical spring at this point has moved the fuze cover forward against the two cover retaining pins. When the previously set time is reached by the mechanical timer, a cam within the timer releases the two cover retaining pins. These pins are spring-loaded and move radially inward when released by the cam, freeing the fuze cover. As the cover is pushed off by the conical spring, two separate parallel actions transpire, the out-of-line primer moves into alignment with the firing pin, and a parachute extractor attached to the fuze cover pulls the fuze parachute out of its cavity and aids in its opening. The resultant opening shock force of parachute deployment, shears a pin and rotates a sear mechanism away from the spring-loaded firing pin. The firing pin, thus released, impinges upon the now aligned percussion primer, which propagates to a two second delay (allowing the fuze parachute to stabilize and retard the round). The delay transfers to an ignition composition containing granules of boron-potassium nitrate. The resulting total output of the propagating ignition composition is directed toward the aft end of the fuze housing.

(3) Flare Functioning. When the fuze functions, the output of particles and gases simultaneously ignites both the first fire of the nearest candle (which blows off the fuze adapter) and the quickmatch transfer line. The transfer line instantly ignites both the black powder parachute ejection charge and the second candle's first fire (which blows off the end closure). As the ejection charge burns, it forces the parachute against the blow-off-door, finally shearing the aluminum bands. As the door is ejected, it pulls out the parachute and aids in its deployment through the use of a deployment ribbon attached to the door and folded into the parachute assembly. The parachute now suspends the flare system in a horizontal mode leaving the candles to provide useful illumination. As the candles burnout, one candle ignites an explosive element in one of the parachute attachment bolts, freeing half the parachute shroud lines. Freeing half of the parachute shroud lines allows the parachute to spill its air, collapse and utilize the weight of the aluminum center section to aid in its descent to the ground, thus removing the hazard that expanded parachute flares normally present to operational aircraft.

## 2. M8A1 AIRCRAFT PARACHUTE FLARE

a. Description. The M8A1 Aircraft Parachute Flare (Fig A-6) is 25.42 inches long by 4.25 inches in diameter and weighs 17.6 pounds. The flare consists of a candle, parachute assembly and two friction igniters. This item does not contain a delay type time fuze.

The illuminant charge weighs 10 pounds and is contained in a paper tube encased in a zinc sheathing. The illuminant composition consists of barium nitrate, magnesium, aluminum, sodium oxalate, and small percentages of linseed and castor oils. A quickmatch passes through the length of the center tube of the illuminant assembly and provides the means of relaying the flame from the igniters to the priming composition and thence, in turn, to the first-fire composition and illuminant charge. A top seal of fire clay separates the igniters from the illuminant charge.

The aluminum base block fits immediately over the top seal. This base block holds screws which fasten the parachute case to the illuminant case. The base block also is an anchorage for the suspension cable and contains the two friction igniters which consist of a friction composition and a friction wire coated with red phosphorus. One end of the friction wire is attached to the suspension cable above the shock absorber. So that an appreciable pull will be required to operate the igniters, the friction wires are secured against the base block by an aluminum safety strip secured, in turn, by a brass retainer. The shock absorber consists of the flexible steel suspension cable encased in a hand-drawn copper tube, the whole formed into a closely wound helix. A paper safety disk closes the cup housing the shock absorber assembly. The disk must be removed by a jerk on the suspension cable before the friction igniters will fire.

The parachute is made of silk or synthetic fabric and is 15 feet in diameter. The shroud lines are braided cotton cord, having a 100-pound breaking strength. The shroud lines are 14 feet in length and are attached to the suspension cable by means of the suspension cable spool. Two pilot disks, through which the parachute pullout cord passes, are assembled underneath the hangwire cover.

The parachute case is closed by the hangwire cover which is in the position of a cup opening outward. The hangwire with swivel loop is not permanently attached to the cover, but is assembled to the hangwire plug passing through a central hole in the cover and held by a release spring on the underside of the cover. One end of the release spring is held in a clip soldered or welded to the underside of the hangwire container. The other end passes through the central hole in the release plug. The release spring is held in this position by the parachute case. As soon as the hangwire cover is free of the case, the spring releases the hangwire plug, then the hangwire and its plug separate from the cover.

A shipping cover, held by a tear strip, protects the parachute case end of the flare. A closing cover is press fitted over the open end of the illuminant portion of the flare and is loose enough to be blown off when the composition begins to burn.

b. Functioning (Fig A-7)

When the flare is released from the aircraft, the hangwire cover is removed by the resulting

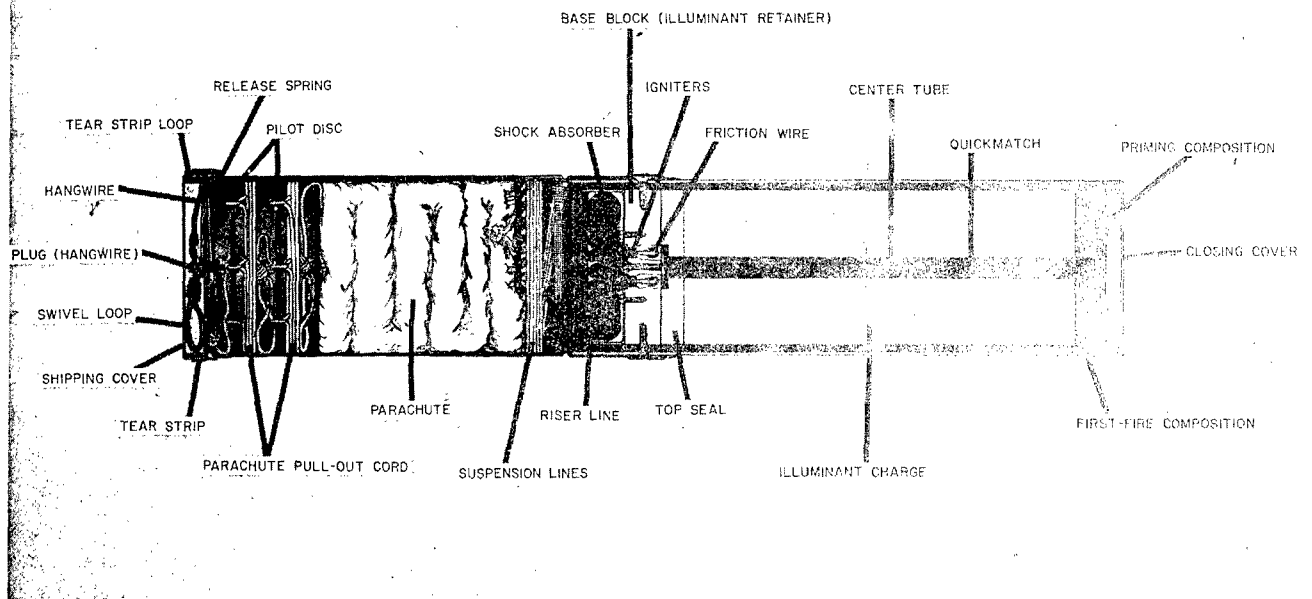

# M8A1 AIRCRAFT PARACHUTE FLARE

FIG A-6

MSAI AIRCRAFT PARACHUTE FLARE  
DEPLOYMENT SEQUENCE

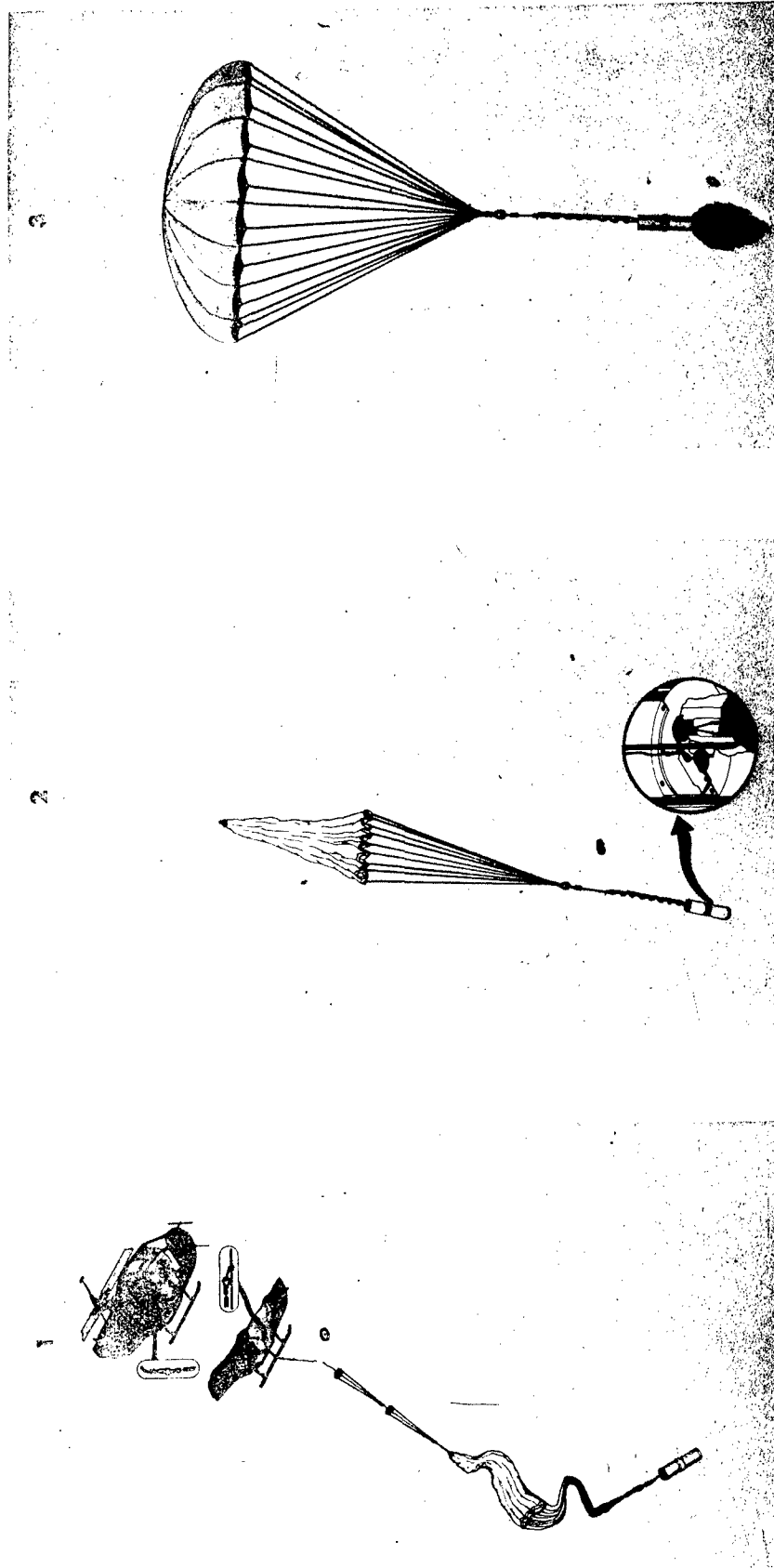

FIG A-7

jerk of the lanyard on the hangwire. The flare is now free of the aircraft. The pilots disks and parachute pull-out cord withdraw the parachute from its case and the parachute deploys. As soon as the hangwire cover leaves the case, the release spring pulls away from the hangwire plug and the cover is free to fall away from the hangwire.

The sudden pull of the deployed parachute causes the suspension cable, shock absorber assembly and safety disk to pull out of the case, and simultaneously cause the friction wire to pull through the friction composition.

The resultant flame is transmitted by the quickmatch to the priming composition and, in turn, to the first-fire composition and the illuminant charge. The pressure produced by the burning composition blows off the closing cover on the illuminant end of the flare, resulting in proper candle operation.

### 3. LUU-2/B AIRCRAFT PARACHUTE FLARE

a. Description. The LUU-2/B Aircraft Parachute Flare (Fig A-8) is 36 inches long, 4.87 inches in diameter and weighs approximately 29½ pounds. The flare consists of four major sub-assemblies, the timer-end cap assembly, the parachute suspension system, the ignition system and the case assembly with the tamped candle. The flare is designed so that the outer aluminum case is partially consumed during candle burning.

The timer-end cap assembly consists of a timer and related hardware enclosed in a lexan plastic housing. The setting dial knob and calibrated markings (from 500 to 10,500 feet of fall) are coated with a luminous paint which has an after glow from 8 to 10 hours after being exposed to light. The timer consists of a simple clock mechanism in which the main spring is wound tighter, if more than a 500 foot free fall is desired, as the timer dial knob is set to the desired drop distance. The timer is kept at a 500 foot setting during storage. A small drogue bag is packed in a compartment located in the timer cover. The plastic cover over the drogue bag compartment is removed when the timer dial knob is pulled. The purpose of the drogue bag is to prevent the flare from developing an excessively high rate of tumbling; thus, should tumbling reach 100 to 200 revolutions per minute, the drogue bag is deployed.

The parachute suspension system utilizes an 18 foot diameter cruciform shaped canopy, for good stability. Two riser cables connect the parachute to a bulkhead separating the parachute compartment from the remainder of the flare assembly. One cable is attached to an explosive bolt for parachute dump at candle burn out.

The ignition system utilizes a lanyard, which is attached to one of the parachute riser cables. This lanyard is led through the bulkhead and past the candle in an internal raceway along the side of the aluminum case leading to the ignition assembly in the ignitor housing near the candle's face. The lanyard is attached to a triggering mechanism consisting of a bell crank, firing pin housing, firing pin spring, shear pin, pivot pin and primer. The firing train sequence of propagation is primer-ignition pellets-ignition wafer-candle composition.

The illumination candle is a tamp cast sodium nitrate-magnesium pyrotechnic composition

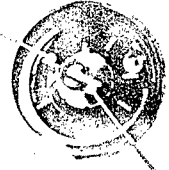
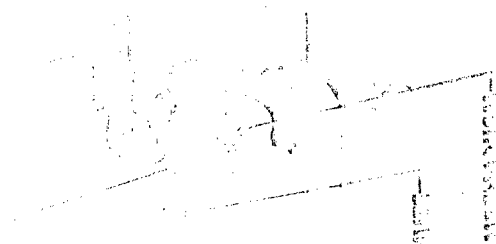
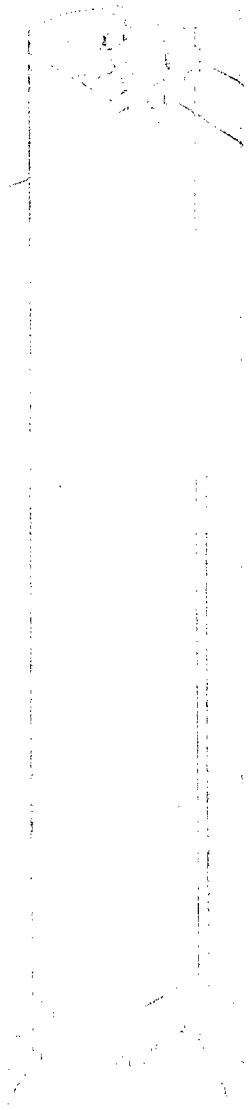

PARACHUTE

TIMER AND RELEASE MECHANISM

TIMER KNOB

TIMER KNOB

**L11-2/B AIRCRAFT PARACHUTE FLARE**

FIG A-8

which is loaded directly into the flare's lined out aluminum container. The candle grain is approximately 22 inches long.

b. Functioning (Fig A-9). During dispenser up-loading, a lanyard is attached to the dial knob on the flare timer. At launch; the timer dial knob is pulled out of the timer (approximately 35 pounds force), starting the clock mechanism. After the preset time (drop distance) has elapsed, the three locking pawls in the timer assembly, which are maintained in place by a rotary cam, are released.

The three pawls retract releasing the timer-end cap assembly. The spring, located between the timer assembly and packed parachute, expels the timer assembly which is attached to the top of the parachute by a cord having sufficient strength to initiate removal of the parachute from the flare case and subsequently breaking to separate the timer assembly from the parachute.

As the parachute system deploys and its main cables are pulled taut, the ignition lanyard, having insufficient slack to accommodate the cable movement, is pulled to activate the ignition system. The ignition lanyard must exert a force of 50 pounds to break the shear pin. Then, the ignition lanyard rotates a bell crank which cocks and releases the firing pin against the primer. The primer ignites a small charge of pelletized boron-potassium nitrate, which in turn ignites a propellant wafer, which produces sufficient heat for candle ignition.

Pressure build-up during candle ignition blows out two pressure relief plugs in the ignitor housing. Most of the ignitor housing is consumed by the burning flare; however, the last small pieces of the aluminum ignitor housing fall free. Just before candle burn out, the explosive bolt functions to release one of the suspension cables causing the parachute to dump.

#### 4. MK45 AIRCRAFT PARACHUTE FLARE

a. Description. The MK45 Aircraft Parachute Flare (Fig A-10) is 36 inches long, 4.87 inches in diameter and weighs 28 pounds. The flare consists of a fuze assembly, an outer container, the candle assembly, a suspension ignition assembly and a parachute assembly.

The fuze assembly is used to control the ejection altitude in relation to the launch altitude. it does not directly control candle ignition. The fuze consists of an internal disconnect, a striker and plunger assembly, a 1.5 second minimum fixed delay element, a time delay fuze cord and an expelling charge. Fuze setting is accomplished with a single yellow dial indicator which can be set at 15 different positions (500 to 14,000 feet of fall). Raised projections at SAFE and at each setting point facilitate setting the fuze in total darkness. A spring loaded detent holds the dial indicator at the selected setting.

The outer container is an aluminum tube sealed at one end by an O-ring and the fuze assembly, and at the other end by another O-ring and an aluminum cap.

The candle assembly, consisting of the illuminating composition, candle case and explosive bolt assembly, is located directly behind the fuze assembly in the forward half of the outer container. The candle's ignition surface is faced away from the fuze end of the outer container



# LUU-2/B FLARE OPERATION SEQUENCE

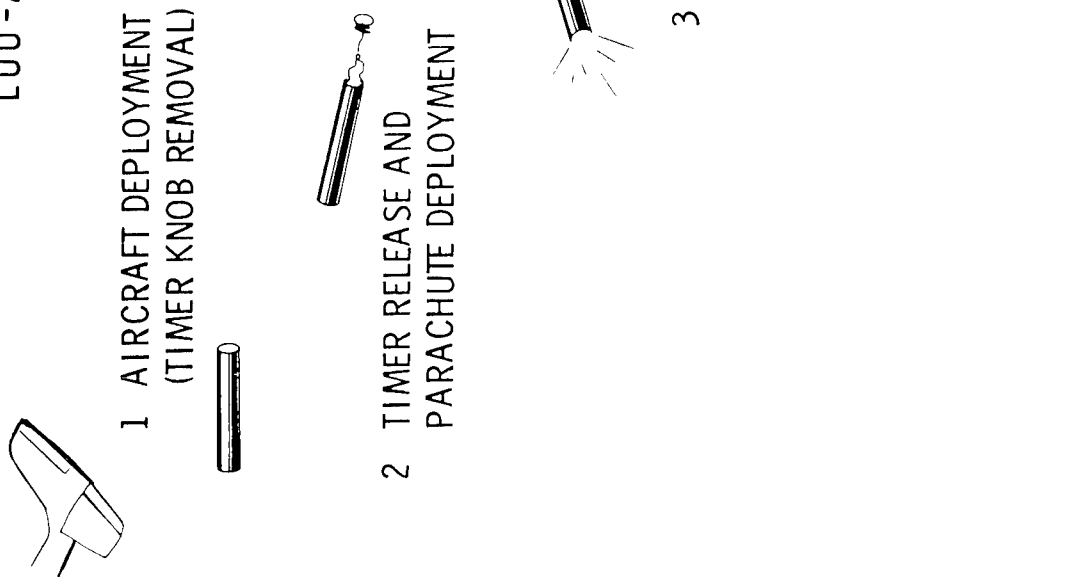

FIG A-9

**END VIEW OF FUZE**  
(WITH END CAP REMOVED)

# MK-45 AIRCRAFT PARACHUTE FLARE

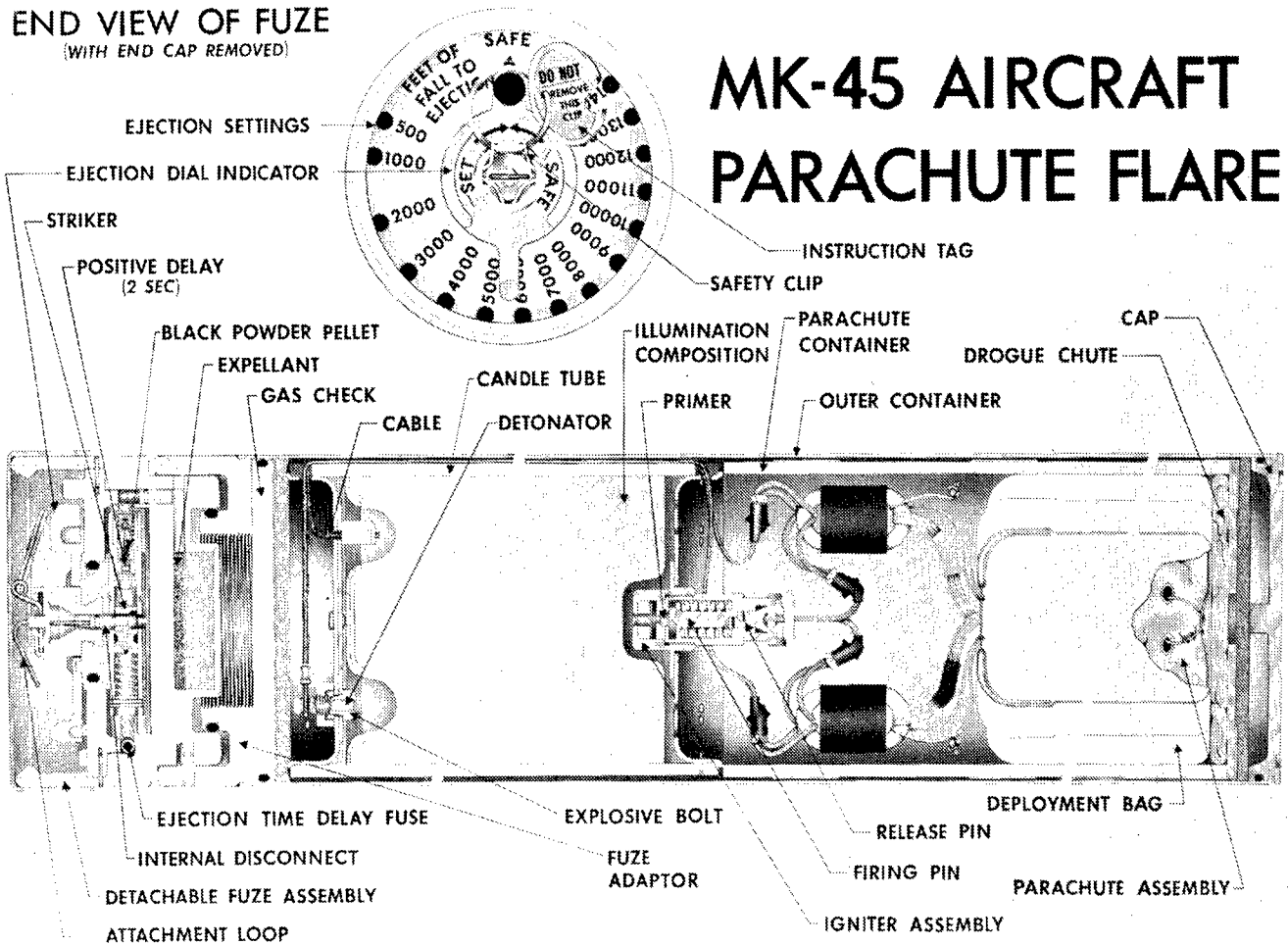

FIG A-10

and a gas check is used to insure that ejection charge gases do not prematurely ignite the candle.

The suspension and ignition assembly consists of a release pin, a firing pin, a primer and a suspension cable. The first three items are located in a housing on the candles ignition face and the suspension line attaches them to the parachute assembly.

The parachute assembly consists of a drogue chute, a main parachute, a deployment bag and a split case; all located in the back half of the outer container.

b. Functioning (Fig A-11, A-12, A-13). When the flare is launched, the lanyard snaps the safety clip from its position over the toggle and exerts sufficient force (more than 30 pounds) on the attachment loop to release the internal disconnect from the fuze mechanism. Releasing the disconnect frees a spring loaded striker to function a primer in the base of the plunger. The primer ignites the 1.5 second fixed delay element and drives the plunger into the time delay fuze cord. When the delay element burns through, it propogates to a black powder charge (still in the plunger) and then to the fuze cord. After the fuze cord burns for the desired time (drop distance) setting it ignites the expelling charge, which in turn develops sufficient pressure against a gas check to blow off the end cap and expel the parachute, suspension/ignition and candle assemblies.

The drogue chute deploys, separating the main parachute from its deployment bag. As the main parachute is deployed, it exerts a force on the suspension/ignition system cable. The cable pulls the release pin from the igniter assembly, that cocks and releases the firing pin so that it strikes the primer. The primer initiates an ignition pellet which ignites the candle. The candle assembly then inverts itself to hang in a face down position directly below the parachute.

Near the end of its burning time, the candle activates an explosive bolt that releases 10 of the 18 parachute shroud lines, thus collapsing the parachute.

## 5. MK24 AIRCRAFT PARACHUTE FLARE

a. Description. The MK24 Aircraft Parachute Flare (Fig A-14) is 36 inches long, 4.87 inches in diameter and weighs approximately 27 pounds. It consists of eleven major and minor sub-assemblies as follows; an outer case, a weather cap, a desiccant bag, a lanyard assembly, an ejection fuze, an ignition fuze, a candle assembly, a parachute assembly, a cable assembly, a compression pad and an end cap.

The outer case is a one-piece aluminum tube which houses the complete flare and fuze assemblies. An "O"-Ring seal is provided between the ejection fuze assembly and the outer case in an attempt to assure the internal integrity of the round.

Held in place by a moisture proof tape is the weather cap which is a vacuum formed plastic piece that is used to protect the fuze end of the round during shipment and storage.

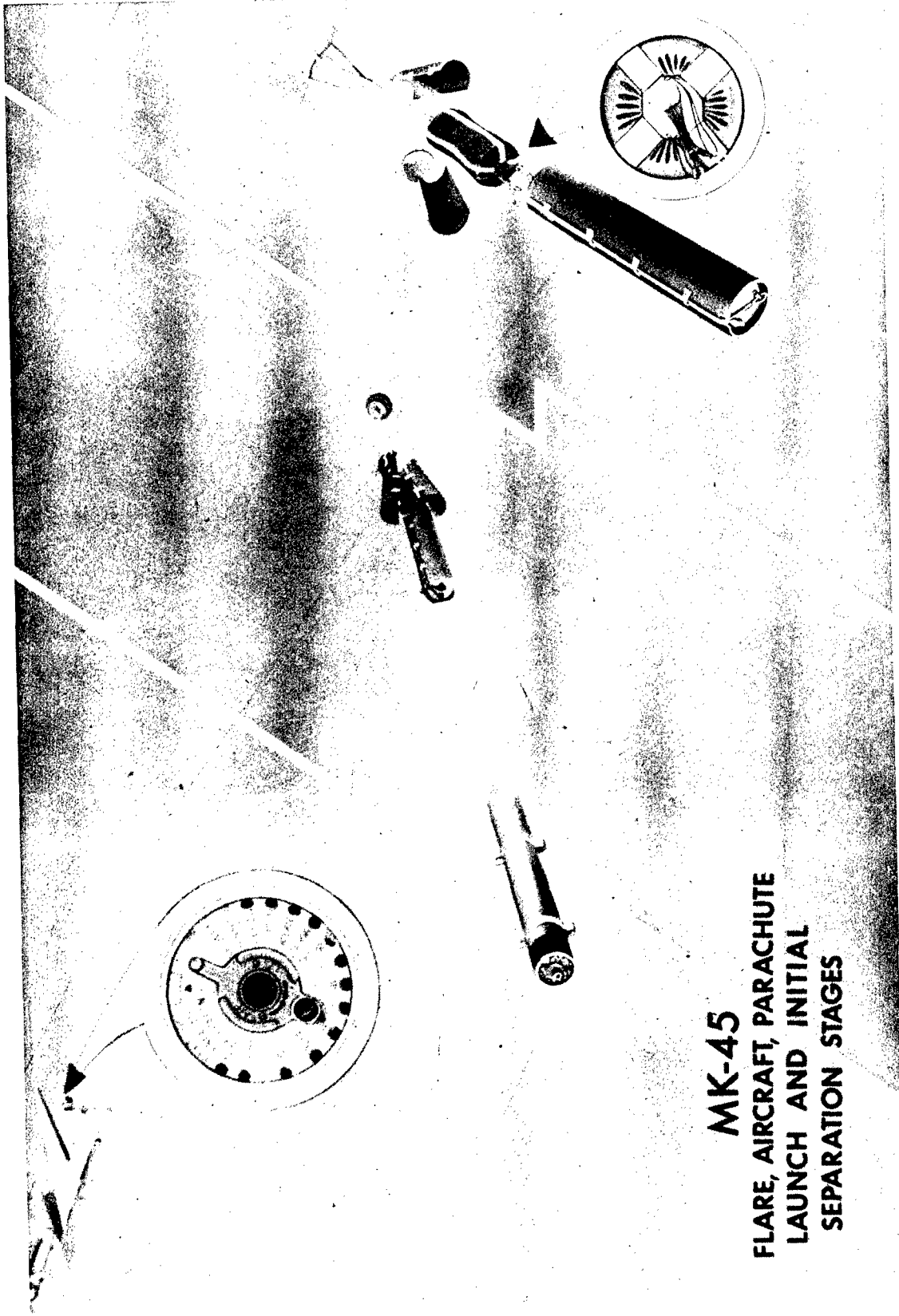

**MK-45**  
**FLARE, AIRCRAFT, PARACHUTE**  
**LAUNCH AND INITIAL**  
**SEPARATION STAGES**

FIG A-11

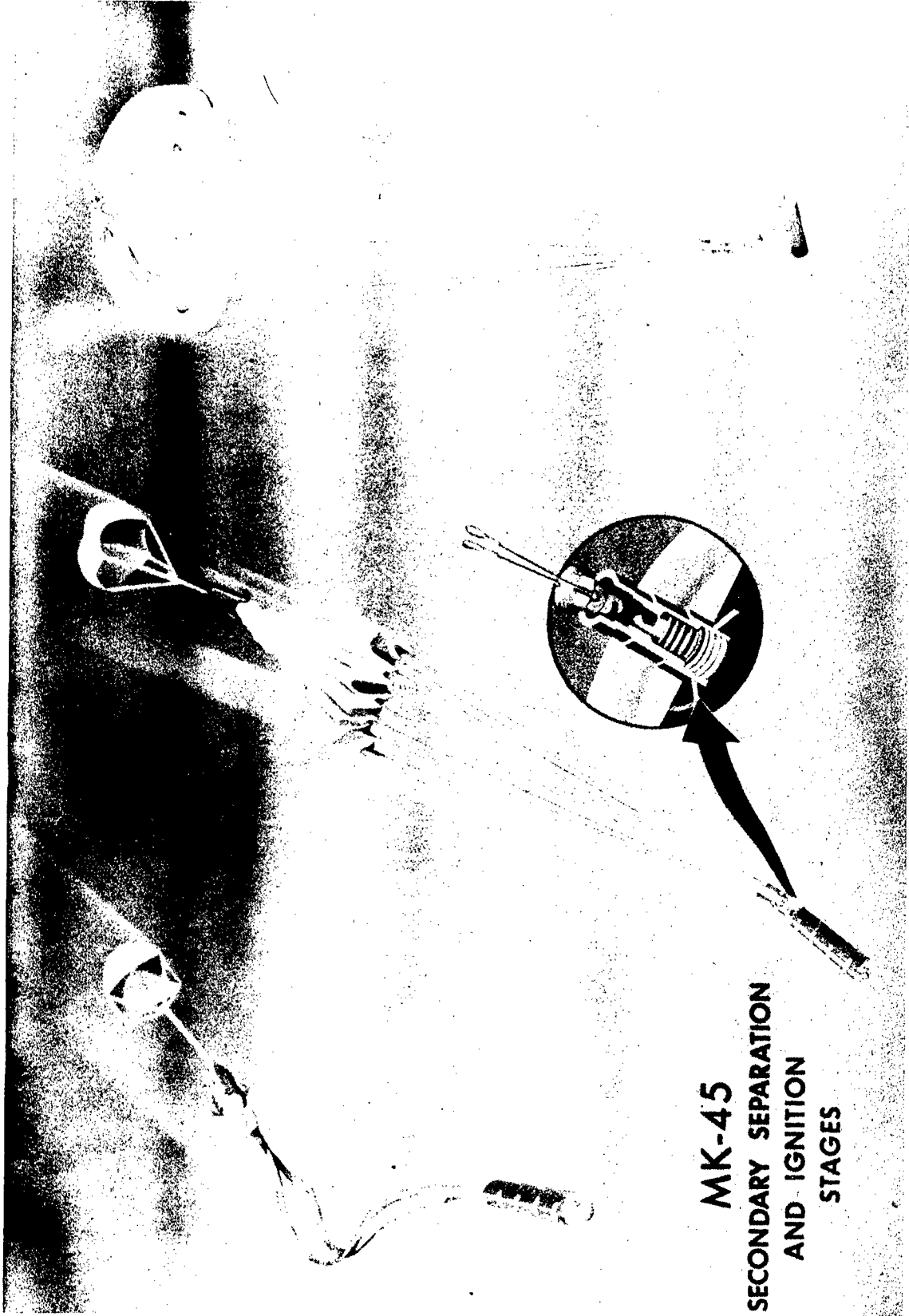

FIG A-12

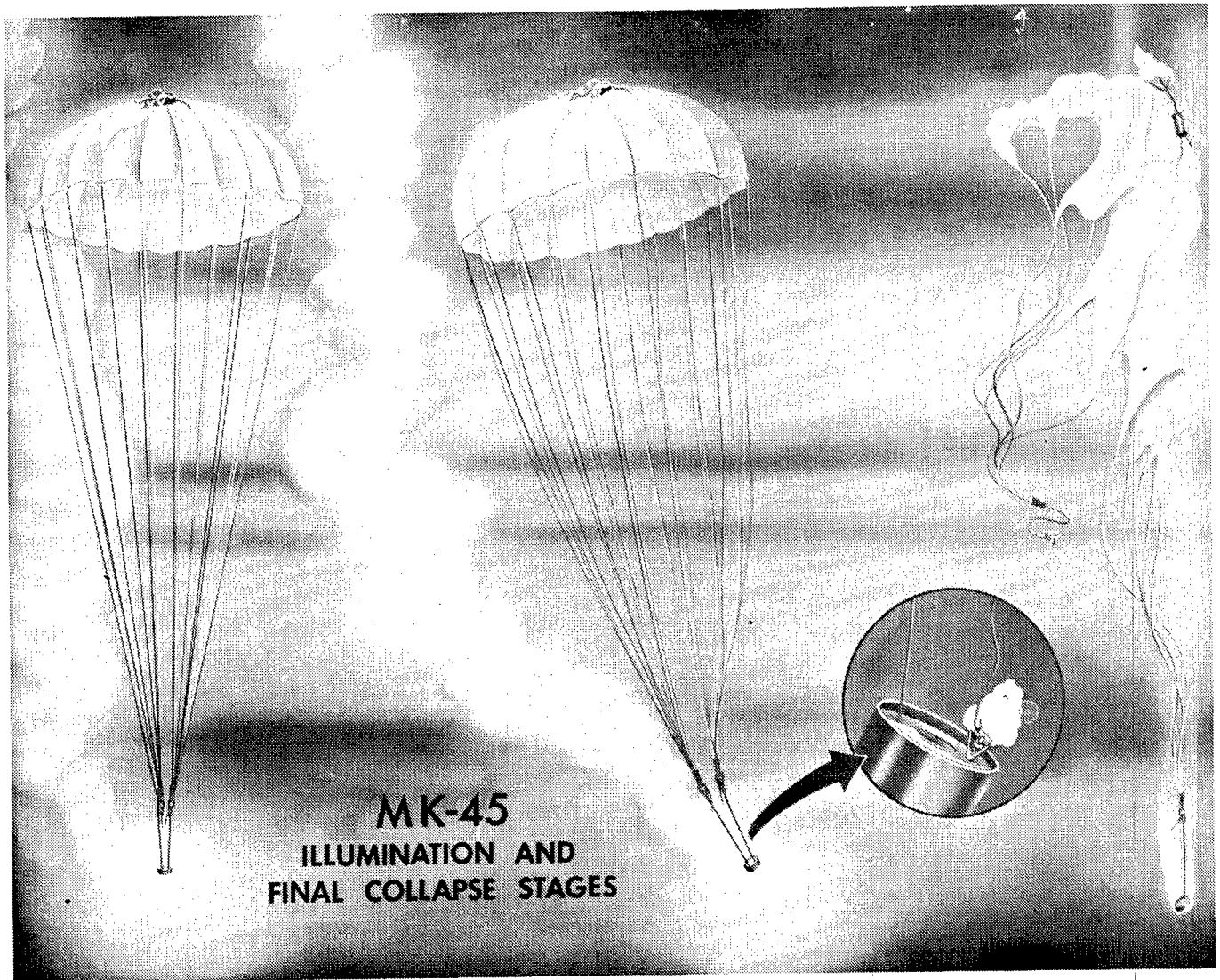
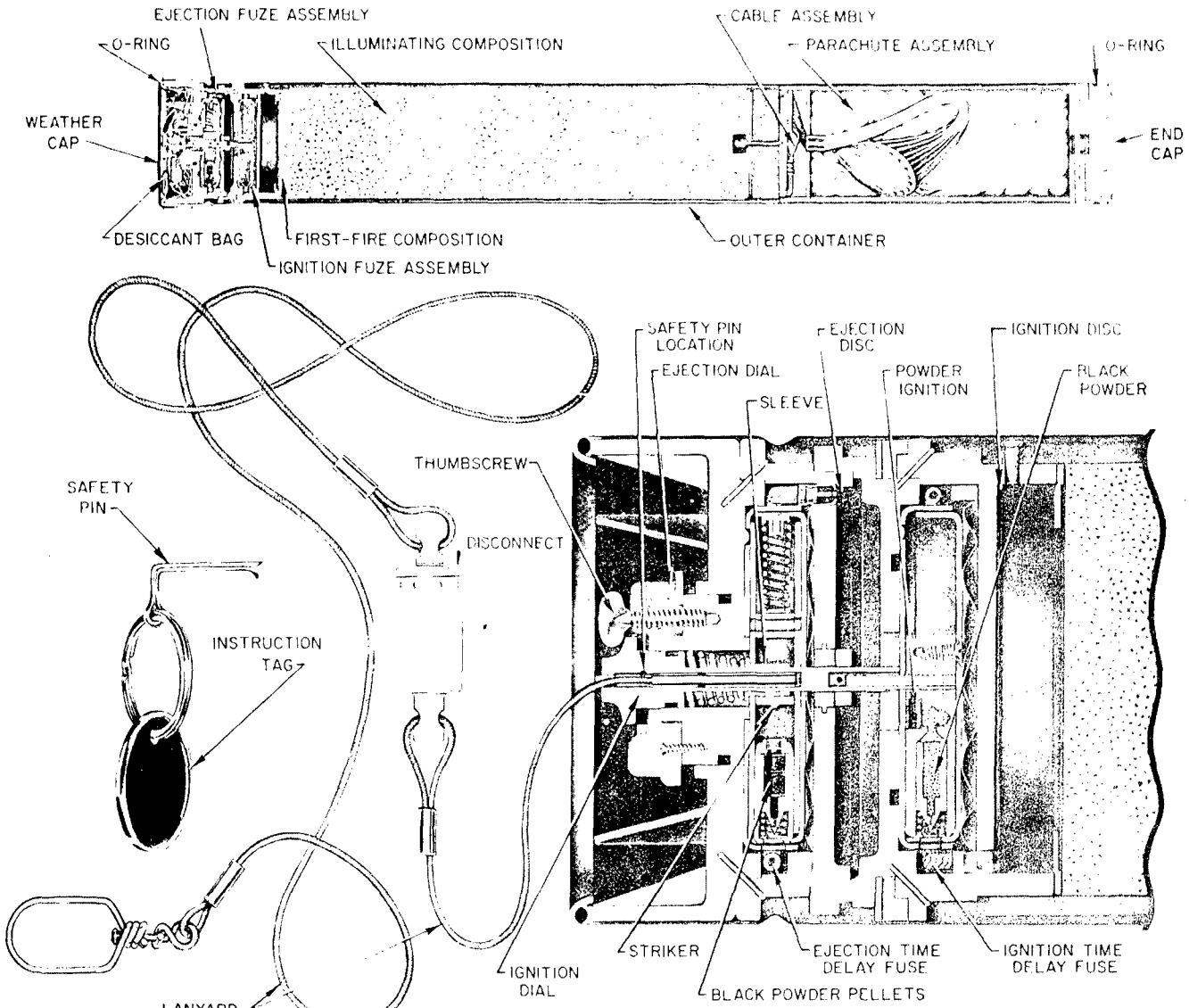

FIG A-13



ENLARGED CROSS SECTION VIEW OF EJECTION AND IGNITION FUZE

AIRCRAFT PARACHUTE FLARE, MK 24, CROSS-SECTION

FIG A-14

The desiccant bag is utilized to protect the fuze assemblies from moisture during shipment and storage. It is located between the weather cap and the ejection fuze.

Also located between the weather cap and the ejection fuze is the lanyard assembly, which consists of two flexible, stainless steel cables (7 and 27 inches long, respectively) joined by a disconnect which releases between 55 and 75 pounds force.

Located at the forward end of the round, directly below the fuze dials, is the ejection fuze assembly. Consisting of an ejection plunger and housing assembly, a delay fuze line and an ejection charge assembly. It controls the candle and parachute ejection from the outer case. The ejection fuze dial is yellow with a black arrow which points to the outer ring of black figures on the fuze dial. It contains a thumbscrew, for dial locking, which passes through the yellow ejection fuze setting dial. The ejection fuze has a range from 5 to 30 seconds in five second intervals.

Controlling candle ignition is the ignition fuze assembly, which is located directly below the ejection fuze assembly. It consists of an ignition plunger and housing assembly, a delay fuze line, and an ignition composition assembly. The ignition fuze setting dial is painted black with a white arrow which points to an inner ring of white figures on a black background on the fuze dial. A spring steel safety pin is inserted through the bottom of the dial. The ignition fuze has a range from 10 to 30 seconds in five second intervals.

The candle assembly, located directly behind the ignition fuze, consists of a kraft paper tube filled with an illuminant composition of magnesium, sodium nitrate and epoxy binder. There is 16.2 pounds of composition contained in every candle. A wooden block is stapled inside the aft section of the candle tube for suspension system attachment.

The parachute assembly consists of a 16 foot diameter flat circular parachute in a split cardboard container. It is located directly to the rear of the candle assembly.

The cable assembly connects the parachute assembly with the wooden block in the candle assembly.

The compression pad, located between the parachute and the end cap, assures that all component manufacturing tolerances are taken up and all assemblies are held firmly in place.

Crimped to the aft end of the outer container is the aluminum end cap which, by means of an "O"-Ring seals the aft end of the round.

b. Functioning. When the flare is launched from the aircraft, it falls free for a distance equal to the length of the lanyard. When the pull of the flare on the lanyard reaches 12 pounds, the lanyard raises a sleeve in the ejection fuze. This permits a spring-loaded striker to hit the percussion primer, which initiates the fuze cord according to the ejection fuze time setting. During this time the force on the lanyard becomes large enough (55 to 75 pounds) to disconnect the flare from its static line. At the end of the preset delay, the ejection delay fuze ignites the ejection charge disc. Gases from the burning ejection charge disc forcibly eject (in order) the end cap, the compression pad, the parachute assembly with split cardboard con-



tainer, the candle assembly and the ignition fuze assembly. The ejection charge also propagates to an ignition charge on the ignition fuze assembly.

Upon ejection, the parachute opens and suspends the candle with the ignition fuze assembly attached. The ignition fuze burns for the time preset on the dial and ignites a gasless ignition powder. This powder in turn ignites the candle which then burns off the ignition fuze assembly and continues to burn for the appropriate burning time.

## 6. ATTACK AIRCRAFT PARACHUTE FLARE

a. Description. The Attack Aircraft Parachute Flare (Fig A-15) is 61.4 inches long, 8.00 inches in diameter and weighs 103.6 pounds. The flare consists of nine major sub-assemblies or components; a thin aluminum case, an illuminant tamp-cast into and bonded to the case, an ignition system, a main support parachute, a decelerator drogue parachute (with support line and five-second delay pyrotechnic reefing line center), a mechanical drogue release time assembly, an aerodynamic nose cone, a cast aluminum hardback and a set of four aerodynamically stabilizing fins.

The forward end of the flare utilizes the ogive nose cone to reduce aerodynamic drag during aircraft carry. The nose cone is hollow and contains two pressure relief ports. Attached to the aft end are four fins which provide aerodynamic stability during aircraft separation and free fall. The illuminant candle, ignition system, main parachute, drogue parachute and reefing line cutter are all contained within the eight inch diameter cylindrical aluminum case. The cast aluminum hardback is attached to the flare case by two band type coupler clamps, one at the ignition housing and one at the bulkhead between the candle and parachute compartments.

The main parachute support cables and the drogue parachute support line are attached to the case bulkhead. The aft end of the flare case is closed by a plastic cover which houses, and is released by, the mechanical timer and related fuze mechanisms. The flare candle compartment is lined with an asbestos insulation material and a mastic liner, prior to tamp casting the illuminant composition (magnesium, sodium nitrate and polyester binder). The candle end of the case is sealed by an O-ring in the igniter housing and the parachute compartment is sealed by an O-ring in the timer housing.

b. Functioning (Fig A-16). As the Attack Flare is released from the aircraft, the arming wire is pulled and the preset timer is initiated. When the flare has fallen the desired distance (500 to 9,000 feet), the timer and cover are released and ejected (by spring) from the aft end of the flare case. The ejecting timer pulls out the drogue parachute which is attached to the flare bulkhead.

The drogue parachute opening shock initiates a five second delay, which when burned through activates the reefing line cutter, releasing the drogue parachute from the bulkhead. The drogue parachute then pulls out the main parachute. The shock of the main parachute deployment causes flare ignition. The nose cone and igniter assembly are consumed during the initial period of candle burning. An explosive bolt is initiated 20 seconds prior to candle burnout and dumps the main parachute.

# ATTACK FLARE

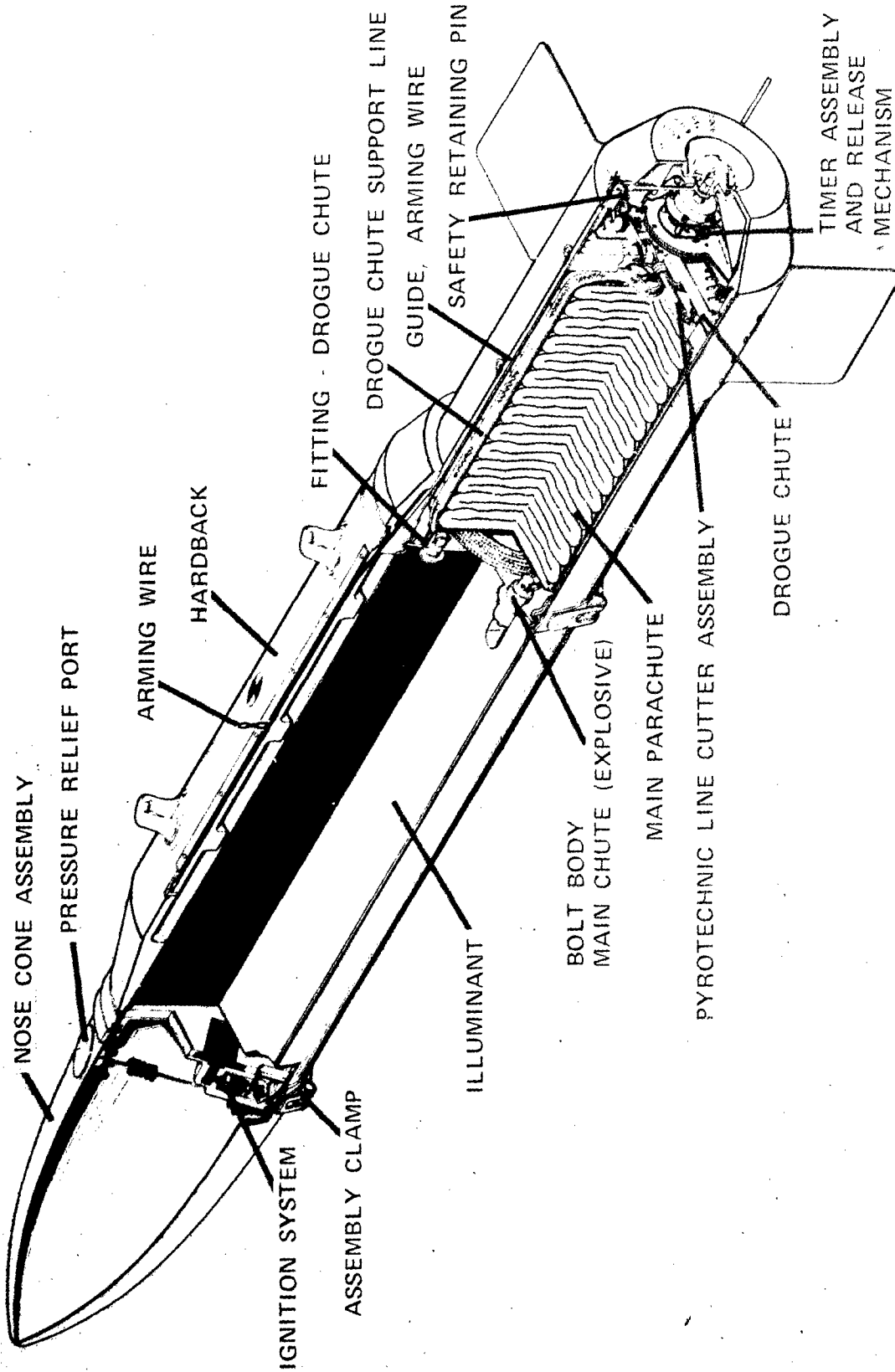
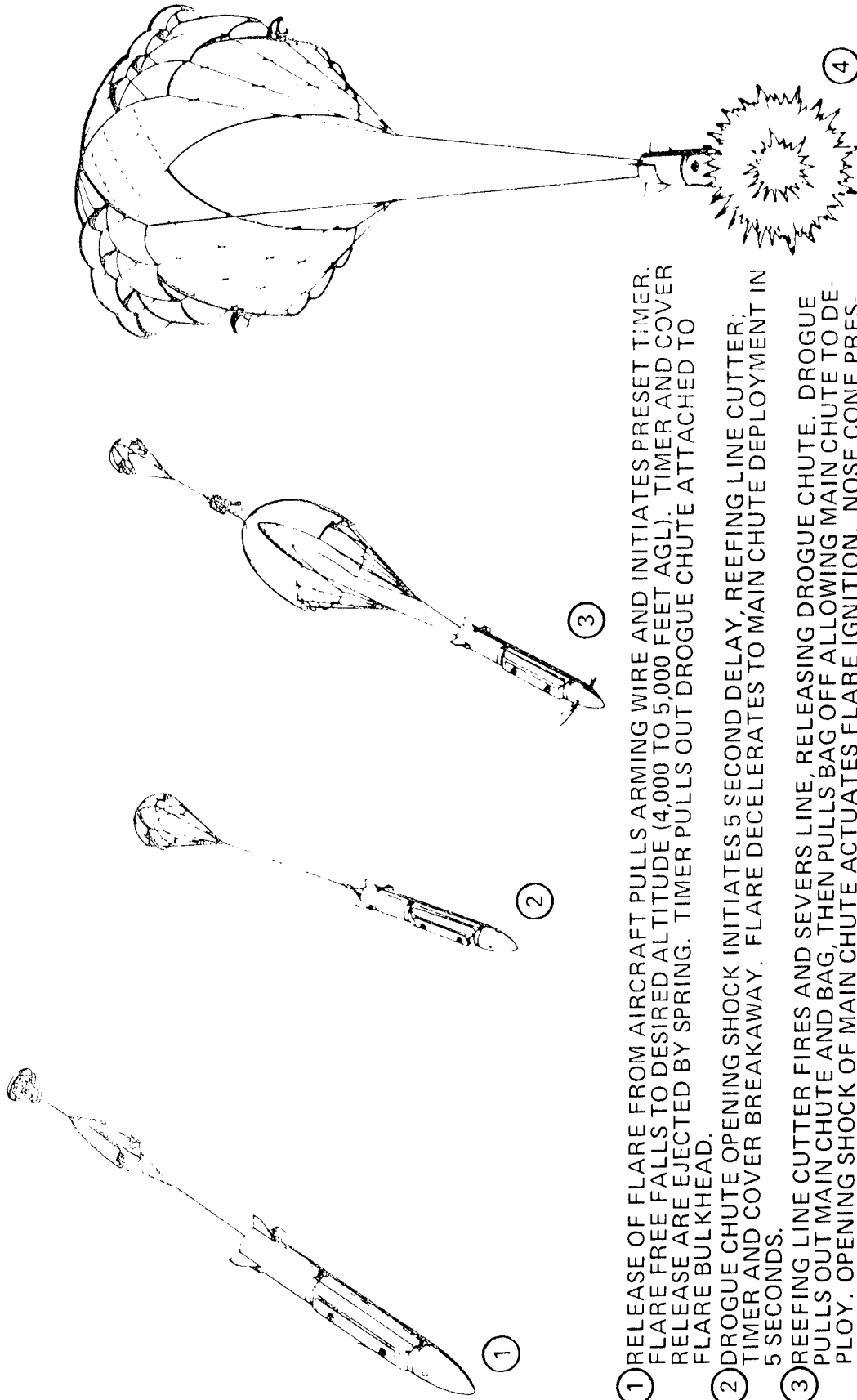

FIG A-15

ATTACK FLARE DEPLOYMENT SEQUENCE



- ① RELEASE OF FLARE FROM AIRCRAFT PULLS ARMING WIRE AND INITIATES PRESET TIMER. FLARE FREE FALLS TO DESIRED ALTITUDE (4,000 TO 5,000 FEET AGL). TIMER AND COVER RELEASE ARE EJECTED BY SPRING. TIMER PULLS OUT DROGUE CHUTE ATTACHED TO FLARE BULKHEAD.
- ② DROGUE CHUTE OPENING SHOCK INITIATES 5 SECOND DELAY, REEFING LINE CUTTER; TIMER AND COVER BREAKAWAY. FLARE DECELERATES TO MAIN CHUTE DEPLOYMENT IN 5 SECONDS.
- ③ REEFING LINE CUTTER FIRES AND SEVERS LINE, RELEASING DROGUE CHUTE. DROGUE PULLS OUT MAIN CHUTE AND BAG, THEN PULLS BAG OFF ALLOWING MAIN CHUTE TO DEPLOY. OPENING SHOCK OF MAIN CHUTE ACTUATES FLARE IGNITION. NOSE CONE PRESURIZES AND OPENS RELIEF PORTS.
- ④ BURNING CANDLE CONSUMES NOSE CONE AND FLARE CASE. STRONGBACK REMAINS ATTACHED TO FLARE. EXPLOSIVE BOLT IS INITIATED 20 SECONDS BEFORE CANDLE BURN-OUT AND MAIN CHUTE DUMPS. DEBRIS FALLS RAPIDLY TO EARTH.

FIG A-16

## 7. MLU-32A/B99 AIRCRAFT FLARE

a. Description. The MLU-32A Aircraft Flare (Fig A-17) is 63 inches long, 8.38 inches in diameter and weighs 147 pounds. The flare consists of an outer case and hardback assembly, a timer assembly, a balloon, a heat generator and the flare's candle. The outer case and hardback assembly consists of a cylindrical container and a tapered nose section, both made of 0.07 inch aluminum. A strongback is bonded with epoxy to the container and further secured to it by two steel straps. Two fixed suspension lugs, spaced 14 inches apart, are installed in the strongback. This item is only capable of being launched from standard 14 inch aircraft bomb racks mounted externally. There are no internal or external aircraft dispensers that will hold the MLU-32A Aircraft Flare.

Located at the forward end of the strongback, the timer assembly can be set at 2 seconds, 5 seconds and then at 5 second intervals up to 25 seconds. The timer's arming wire is routed through a retainer guide, which is attached to the strongback, and then inserted in the timer. A streamer assembly, which is a safety device that is removed before flight, is installed in both the timer and the nose cone's clamp. Internally, the timer assembly consists of a mechanical timer, a striker assembly, a stab primer and an initiation charge.

The balloon assembly consists of the balloon itself, a drag parachute, a cloth deployment bag and a "Y"-bridle. The balloon assembly and its heat generator constitute the suspension system for this flare.

Contained within the cylindrical container is the candle assembly. Its composition is of the magnesium, sodium nitrate and binder type. The candle also provides for 30 seconds of emitting a red light at the termination of candle burning. There is a descent system which deflates the balloon at candle burnout.

b. Functioning (Fig A-18). Ejection of the flare pulls the arming wire from the timer, which will then function after the preset delay has run out. The timer initiates a shaped charge that severs the nose cone clamp. The nose cone is then spring-ejected, releasing the drogue parachute. Upon opening, the drogue parachute, actuates the line cutter and initiates the pyrotechnic delay train of the vent and self destruct system. After approximately 3 seconds, a cloth deployment bag is stripped off of the balloon. The balloon deploys and is filled with ram air through its perimeter inflation ports. The "Y"-bridle is pulled taut by the balloon expansion and mechanically actuates the candle igniter. The candle ignition system simultaneously ignites the heat generator and the candle. The candle quickly burns through the fuzeable joint, tips over, and falls downward until it is suspended approximately 20 feet below the balloon by the energy-absorbing cable. The hot gases from the heat generator quickly arrest the balloons descent. After the candle burns for approximately 4 minutes, the vent functions to control the descent rate. This is necessary to release the buildup of hot gasses in the balloon, which would otherwise cause the flare to rise. Thirty seconds prior to burnout, the candle light turns red. The emitted red light acts as a burnout warning to those utilizing the flare. At this point, the self-destruct system cuts the balloon top, which completely deflates the balloon and allows the flare remnants to descend rapidly to the ground.

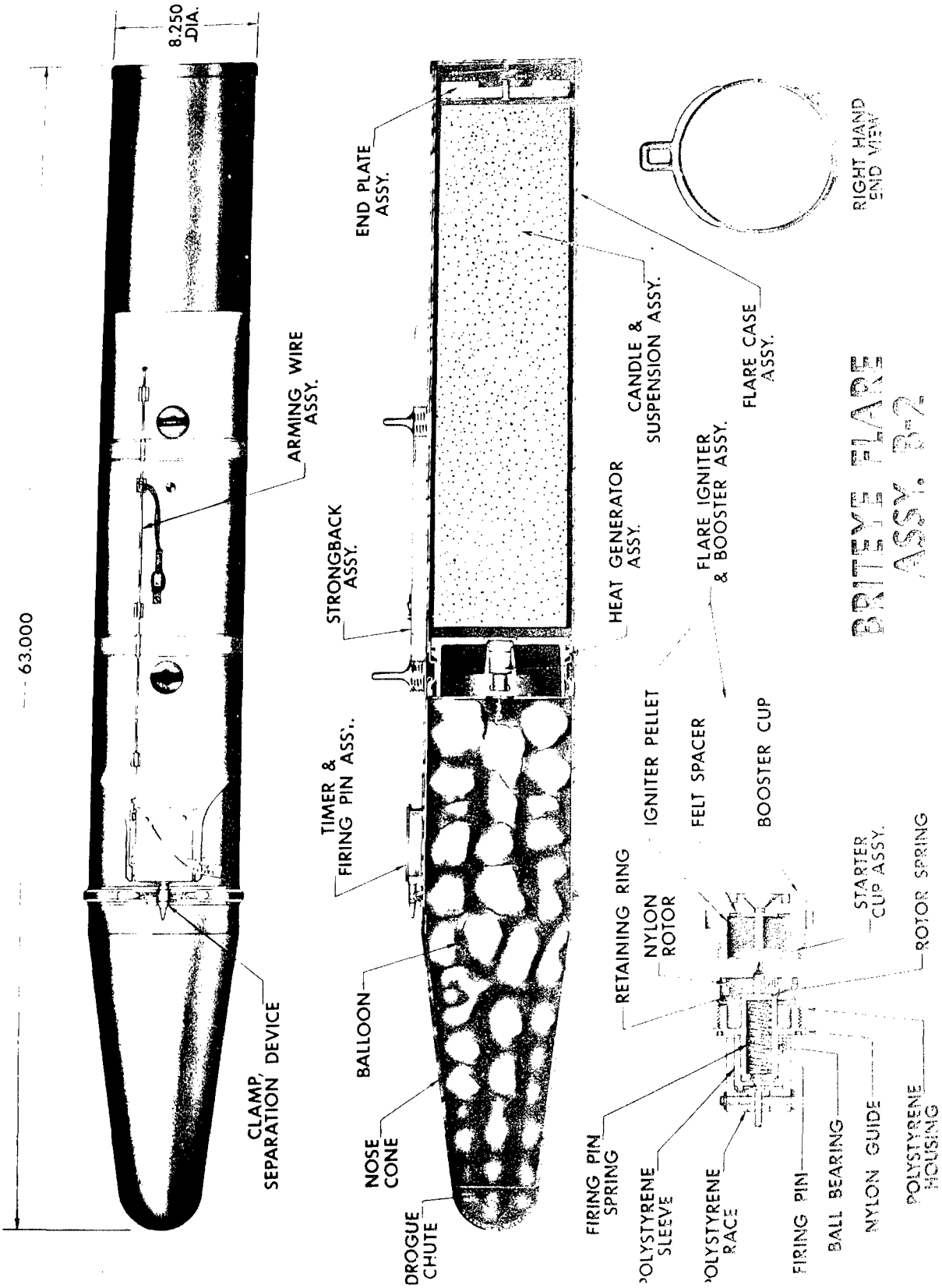

FIG A-17



**BRITEYE FLARE  
ASSEMBLY B-2**

FIG A-18

**APPENDIX B****FLARE QUESTIONNAIRE**

A. Pilots Questionnaire: All pilots did not answer every question; therefore, the total number of responses to some questions may appear incorrect. Eighteen strike pilots completed this questionnaire.

**LUU-2/B FLARE QUESTIONNAIRE**

The purpose of this questionnaire is to determine which flare (MK-24 or LUU-2/B) is most effective for night strike operations. Your answers may have a direct impact on which flare will be bought for Fiscal Year 71, so please consider each question carefully. The timer mechanisms in the flares are different; however, an attempt will be made to ignite the flares over the target with the same burnout altitudes so that your comparison will be more valid.

(Circle the Appropriate Answer)

1. (Q) Which flare best enabled you to locate and attack the target on the first pass?

LUU-2/B—3

MK-24—9

No Difference—6

2. (Q) Did you observe any glare from either the LUU-2/B or MK-24?

Yes—11

No—7

If yes, which flare?

MK-24—6

LUU-2/B—0

Both—5

If yes, did the glare affect your ability to locate and attack the target?

Yes—2

No—9

3. (Q) If weather conditions such as haze, smoke, fog, or light rain (Circle those applicable) were present,

Haze—3

Smoke—4

Both—5

None—6

which flare provided the best illumination?

MK-24—5

LUU-2/B—4

No Difference—3

4. (Q) Did you observe flickering of the light from either the LUU-2/B or MK-24 flare?  
 Yes—8  
 No—10

If yes, which flare?

MK-24—5

LUU-2/B—2

Both—1

If yes, did the flickering affect your ability to locate and attack the target?

Major effect—0

Minor effect—1

No effect—7

5. (Q) The LUU-2/B flare burns approximately two minutes longer than the MK-24 flare. Did this additional burn time improve your ability to conduct a greater number of effective passes against the target?

Yes—14

No—4

6. (Q) How do you rate the LUU-2/B burn duration?

Adequate—12

Inadequate—0

More than adequate—6

If inadequate, indicate the recommended burn time which you believe would improve the attack mission. \_\_\_\_\_ minutes.

Not applicable

7. At the end of full flare burning time, the LUU-2/B flare parachute is dumped, causing the burned-out flare to fall to the ground. (Q) Compared to the MK-24 flare which does not spill its parachute, how do you rate the dump feature of the LUU-2/B flare?



- Desirable—13
- Undesirable—2
- Not observed—3

If undesirable, explain what effect this feature would have on the mission. \_\_\_\_\_

Two pilots felt that they could not work under a flare if they didn't know when it would dump. It is not standard practice, however, for strike aircraft to fly under flares, because of the danger of presenting a good target to ground fire.

8. (Q) Which flare do you consider most effective for night strike operations?

- MK-24—4
- LUU-2/B—4
- Both are equally effective—9
- Not enough observed—1

9. Additional comments: (Be specific in your remarks about the LUU-2/B flare, as to recommended operational improvements or existing deficiencies of those flares which you observed).

a. A common comment was that the LUU-2/B "seems to flatten out the terrain features. Vertical development is not as noticeable as with the MK-24."

b. Several pilots said that the wind carried the LUU-2/B away from the target before burn-out, wasting the longer burn.

c. Several pilots found that they liked the LUU-2/B flare better as they gained experience with it.

10. Type Aircraft Crew Position SEA Tour Flare Operations Experience

The pilots responding flew A-1, OV-10, T-28, and A-37 aircraft. Fourteen of these pilots and copilots had SEA experience. Four had completed two tours. Thirteen had flare operations experience.

B. Flare Handlers Questionnaire:

### LUU-2/B FLARE QUESTIONNAIRE

The purpose of this questionnaire is to examine the flare loading and handling, timer setting, and launch characteristics of the LUU-2/B flare. Your answers will have a direct effect on which flare will be bought for Fiscal Year 71, so please consider each question carefully.

## Flare Description:

LUU-2/B. The LUU-2/B flare requires no mechanical safety devices. A 12 lb. pull on the lanyard removes the timer knob, permitting the timer to run down and to actuate the spring-loaded release mechanism. The released timer assembly serves as a drogue to pull the main parachute from its container. The opening shock of the parachute exerts  $50 \pm 10$  lb. of pull on the igniter lanyard which activates the firing pin. This pin starts the flare candle ignition. If the flare time mechanism is actuated during in-flight (flaeship) operations, it will not directly initiate the candle. The parachute lines may be tied or taped to the candle to prevent pulling of the igniter lanyard. The flare can then be safely jettisoned.

MK-24 Mod ¾. The MK-24 has a weather cap to protect the fuzes, a thumb screw to lock the fuze dials, and a safety cotter pin through the ignition dial to prevent accidental lanyard pull. The ejection fuze will dud if fired with the dial on SAFE. The ignition fuze will dud if both ejection and ignition dials are on SAFE. With the safety devices removed and neither fuze on SAFE, a 12 lb. lanyard pull will actuate the ejection fuze. This fuze fires an explosive charge to expel the ignition fuze, flare candle and parachute from the outer container.

(Circle the Appropriate Answer)

1. (Q) Do you consider the safety aspects of the LUU-2/B flare adequate for loading, handling, timer setting, and launch?

Yes—7

No—1

If no, indicate reason. Safety pin should be added.

How do you rate the overall safety of the LUU-2/B compared to the MK-24 flare?

Same—0

Better—8

Worse—0

2. (Q) Were the LUU-2/B timer markings easily read for accurate setting?\*

Yes—8

No—0

How did the LUU-2/B timer markings compare to the MK-24 markings?

Same—0

Better—8

Worse—0

3. (Q) Do you consider the addition of a lanyard cotter pin necessary to prevent inadvertent timer actuation during the LUU-2/B handling and loading?

Yes—2

No—6

4. Please make specific, detailed comments on deficiencies noted and your recommendations for improvement.

One flare handler commented that the drogue strip made recovery of the lanyard a little difficult after manual launch from the "Raingutter."

\*The white paint for the timer dial markings was missing from several flares, but the markings could still be read with the use of a flashlight. The use of a flashlight is standard when setting MK-24 flares, but is made easier with the LUU-2/B because the settings are much easier to make. The white paint is desirable, however.