

AD-772 535

HUMAN ENGINEERING GUIDE TO SHIP SYSTEM  
DEVELOPMENT (RESPONSIBILITIES, PROCEDURES,  
AND METHODS FOR CARRYING OUT HUMAN  
ENGINEERING PROGRAMS)

R. Coburn

Naval Electronics Laboratory Center  
San Diego, California

3 October 1973

DISTRIBUTED BY:

**NTIS**

National Technical Information Service  
U. S. DEPARTMENT OF COMMERCE  
5285 Port Royal Road, Springfield Va. 22151

**Best  
Available  
Copy**

NELC/TD 278

Technical Document 278

NELC/TD 278

AD772535

**HUMAN ENGINEERING GUIDE  
TO  
SHIP SYSTEM DEVELOPMENT**

**Responsibilities, Procedures, and Methods  
for Carrying Out Human Engineering Programs**

**R. Coburn**

**Human Factors Technology Division**

**NAVAL ELECTRONICS LABORATORY CENTER**

San Diego, California 92152

3 October 1973

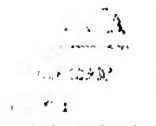
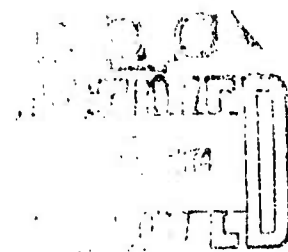

Approved for public release; distribution unlimited

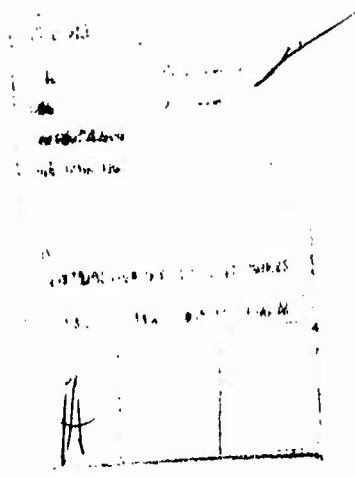

UNCLASSIFIED  
Security Classification

DOCUMENT CONTROL DATA - R & D		
<i>(Security classification of title, body of abstract and indexing annotation must be entered when the overall report is classified)</i>		
1. ORIGINATING ACTIVITY (Corporate author)  Naval Electronics Laboratory Center San Diego, California 92152		2a. REPORT SECURITY CLASSIFICATION  UNCLASSIFIED
		2b. GROUP
3. REPORT TITLE  HUMAN ENGINEERING GUIDE TO SHIP SYSTEM DEVELOPMENT		
4. DESCRIPTIVE NOTES (Type of report and inclusive dates)		
5. AUTHOR(S) (First name, middle initial, last name)  R. Coburn		
6. REPORT DATE  3 October 1973	7a. TOTAL NO. OF PAGES  171	7b. NO. OF REFS  135
8a. CONTRACT OR GRANT NO.	9a. ORIGINATOR'S REPORT NUMBER(S)  NELC Technical Document 278	
b. PROJECT NO. SF39.511.001, Task 15222 (NELC NS14)	9b. OTHER REPORT NO(S) (Any other numbers that may be assigned this report)	
c.		
d.		
10. DISTRIBUTION STATEMENT  Approved for public release; distribution unlimited		
11. SUPPLEMENTARY NOTES		12. SPONSORING MILITARY ACTIVITY  Naval Ship Systems Command
13. ABSTRACT  Responsibilities, procedures, and methods for carrying out human engineering programs are summarized in this document, which is intended to provide positive management control of the human engineering effort regardless of system size. The Guide answers such questions as: What is Human Engineering? Why must Human Engineering be integrated during the design effort to be cost-effective? How should Human Engineering be invoked in contracts and planning documentation? How should Human Engineering be accomplished in the context of real-world constraints? How should contractors' products be evaluated? The Human Engineering Guide is not a compendium of detailed data applicable to system development. It directs the reader to this information, however, via an extensive bibliography.		

UNCLASSIFIED

Security Classification

14 P. 1. 1. 1. 1.	LINK A		LINK B		LINK C	
	ROLE	WT	ROLE	WT	ROLE	WT
Human engineering						
Human factors						
Human factors engineering						
Biotechnology						
Ergonomics						
Man-machine relations						
Man-machine systems						
Personnel subsystems						
Ship systems design						
Engineering psychology						

## ACKNOWLEDGMENTS

This document is the successor to an unpublished guide called Human Engineering Manual (HEMAN). The present version differs considerably from HEMAN in content and format, although the purpose to provide guidance to the practicing human factors and project management personnel remains the same.

The early contributors to HEMAN included Mel Freitag, Betty Bean, Jerry Miller, and the staff of Man Factors, Inc. Their contributions are gratefully acknowledged. A general-purpose human engineering checklist, largely the work of Bosco Welch, was included in HEMAN and appears in this Guide, substantially intact, as appendix D. Recognition is also accorded the many reviewers of HEMAN who gave generously of their time and energy in critique and constructive suggestions.

Special thanks go to George Graine, the NAVSHIPS Human Factors Coordinator and sponsor of HEMAN and this Guide for his guidance and support of this effort.

## PREFACE

The Human Engineering Guide to Ship System Development (hereafter called HE Guide for brevity) has been prepared to assist Navy and contractor personnel in planning, managing, and carrying out human engineering programs to support the development of ship systems. It is thus intended to provide positive management control of the human engineering effort regardless of system size.

HE Guide attempts to answer the questions of what human engineering is; why it must be integrated during design effort in a cost-effective manner; how to invoke human engineering in contracts and planning documentation; how to accomplish human engineering in context of real-world constraints; and how to evaluate contractors' products.

The guide is concerned with human engineering in all aspects of system development. From requirements determination to fleet operation, the development sequence is discussed in terms of human engineering requirements, methods, and products; personnel resources; and costs.

HE Guide is not a compendium of detailed human engineering data applicable to system development. This information can be found elsewhere in selected references listed in this guide.



## CONTENTS

	Page
1.0 INTRODUCTION	9
1.1 Human Engineering: The Design-Oriented Aspect of Human Factors	9
1.2 Benefits From Systematic Human Engineering	10
1.3 Requirement for Human Engineering	10
1.3.1 Instructions, Specifications, and Standards	10
1.3.2 Requirements Generated by System Complexity	11
1.4 HE Guide	11
1.4.1 Objectives	11
1.4.2 Scope	12
2.0 ROLE OF HUMAN ENGINEERING IN SYSTEM DEVELOPMENT	15
2.1 Overview of Human Engineering	15
2.1.1 Why Human Engineering?	15
2.1.2 Basis for Human Engineering	15
2.1.3 When to Do Human Engineering	16
2.1.4 Who Does Human Engineering?	16
2.1.5 What Do Human Engineers Do?	17
2.2 Important Human Engineering Reference Documents	17
2.2.1 Instructions and Guides	17
2.2.2 Specifications	17
2.2.3 Standards	18
2.2.4 Authorized Data List and Data Item Descriptions	18
2.2.5 Reports, Manuals, and Books	19
2.3 Human Engineering Within the Project Organization	19
2.3.1 Administrative Position	19
2.3.2 Human Factors Program Manager	19
2.4 Interface Requirements	20
2.4.1 Intradiscipline Interaction	20
2.4.1.1 Navy	20
2.4.1.2 Contractor	21
2.4.1.3 Navy Contractor	21
2.4.2 Interdiscipline Interaction	22
2.4.2.1 Design Engineering	22
2.4.2.2 Other	22

## CONTENTS (Continued)

	Page
3.0 SEQUENCE OF HUMAN ENGINEERING ACTIVITY	23
3.1 Requirements Analysis	23
3.1.1 Overview	23
3.1.2 General Operational Requirement (GOR)	23
3.1.2.1 Objective	23
3.1.2.2 Human Factors Responsibilities	25
3.1.3 Tentative Specific Operational Requirement (TSOR)	25
3.1.3.1 Objective	25
3.1.3.2 Human Engineering Responsibilities	25
3.2 Man-Machine Concept Development and Analysis	26
3.2.1 Overview	26
3.2.2 General Human Engineering Responsibilities	27
3.2.3 Methods Appropriate for Concept Development and Analysis	27
3.2.3.1 Functional Block Diagramming	27
3.2.3.2 Information Flow Charts	28
3.2.3.3 Man-Machine Allocation Trade-Off Studies	32
3.2.3.4 Preliminary Man-Machine Analysis	35
3.2.3.5 Preliminary Hazards Analysis	36
3.2.3.6 Preliminary Operability/Maintainability Analysis	36
3.2.3.7 Man-Machine Flow Charting	38
3.2.3.8 Input-Output Charting	38
3.2.3.9 Operational Sequence Diagrams (OSDs)	38
3.2.3.10 Operator Functional Requirements Worksheet	41
3.2.3.11 Time-Line Analysis	41
3.2.3.12 Link Analysis	43
3.3 Man-Machine Design	45
3.3.1 Overview	45
3.3.2 Prerequisites to Detail Design	45
3.3.2.1 Control-Display Definition	46
3.3.3 Scope of Detail Design Effort	46
3.3.4 The System Human Engineering Specification	47
3.3.5 Task-Equipment Analysis	49
3.3.6 Mock-Ups	51
3.3.7 Documentation	53

## CONTENTS (Continued)

	Page
3.4 Design Verification	54
3.4.1 Overview	54
3.4.2 Navy Responsibilities	54
3.4.2.1 Development Test and Evaluation	55
3.4.2.2 Operational Test and Evaluation	55
3.4.3 Test Planning	56
3.4.4 Methods Appropriate for Test and Evaluation	57
3.4.4.1 Iterative Use of Analytic Tools	57
3.4.4.2 Questionnaire and Interview Techniques	57
3.4.4.3 Direct Observation	58
3.4.4.4 Data Recording	58
3.4.4.5 Work Study	59
3.4.4.6 Mock-Ups	59
4.0 CONTRACTED WORK	61
4.1 Overview	61
4.2 Human Engineering Services and End Products	61
4.2.1 Categories	61
4.2.1.1 Program Planning	61
4.2.1.2 Requirements Analysis	61
4.2.1.3 Man-Machine Concept Development	62
4.2.1.4 Man-Machine Concept Analysis	62
4.2.1.5 Man-Machine System Design	65
4.2.1.6 Design Verification	67
4.2.1.7 Applied Research	69
4.2.2 Specification of Services and End Products	69
4.2.3 Labor Costs for Human Engineering Services	69
4.2.4 Proportion of Project Costs for Human Engineering	74
4.3 Preparation of the Request for Proposal (RFP)	75
4.4 Proposal Evaluation	80
4.4.1 Advance Planning for Proposal Evaluation	80
4.4.2 Proposal Evaluation Criteria	81
4.4.2.1 Criteria Related to Technical Aspects	81
4.4.2.2 Criteria Related to Managerial Aspects	82
4.5 Human Factors Program Plan	82
4.6 Tests by the Contractor	83
4.7 Contract Monitoring	86
4.7.1 Guidance Meeting	86
4.7.2 Visits to the Contractor's Plant	86
4.7.3 Drawing Review	87
4.7.4 Formal Design Review	88

## CONTENTS (Continued)

	Page
5.0 BIBLIOGRAPHY	91
5.1 Instructions and Notices	91
5.2 Specifications	92
5.3 Standards	93
5.4 Manuals and Guides	93
5.5 General Human Engineering Publications	94
5.6 Bibliographies	96
5.7 Journals and Periodicals Relevant to Human Engineering	97
5.8 Miscellaneous	98
APPENDIX A: Comparison of Human and Machine Capabilities for Performing Various Tasks	99
APPENDIX B: Time-Line Analysis	103
APPENDIX C: Lin' Analysis Procedure	105
APPENDIX D: Sample Human Engineering Checklist	109
APPENDIX E: Human Engineering Data Item Descriptions (DIDs)	129
APPENDIX F: MIL-H-46855A Human Engineering Requirements for Military Systems, Equipment and Facilities	147

## ILLUSTRATIONS

Figure 3.1 Levels of functional block diagramming	29
Figure 3.2 Abbreviated block diagram, hypothetical combat information system	30
Figure 3.3 Gross information flow chart for detection and tracking (no man-machine function allocation assumed)	33
Figure 3.4 Information flow chart (hypothetical -- fragment of flow for tracking function)	34
Figure 3.5 Man-machine flow chart	39
Figure 3.6 Sample input-output chart	40
Figure 3.7 Sample operational sequence diagram: two-station intercom, with station 1 acting as originator	42
Figure 3.8 Typical time-line chart (relative effort vs time)	44
Figure 3.9 USS BELKNAP (DLG 26) CIC (1/12 scale)	51
Figure 3.10 Electronic warfare console mock-up	53

## EXHIBITS

	Page
Exhibit 3.1 Preliminary operator functional requirements worksheet	43
Exhibit 3.2 Summary checklist	48
Exhibit 3.3 Sample task analysis worksheet	50
Exhibit 4.1 Human engineering services and products	70

THE MAJOR ORIENTATIONS OF HUMAN FACTORS

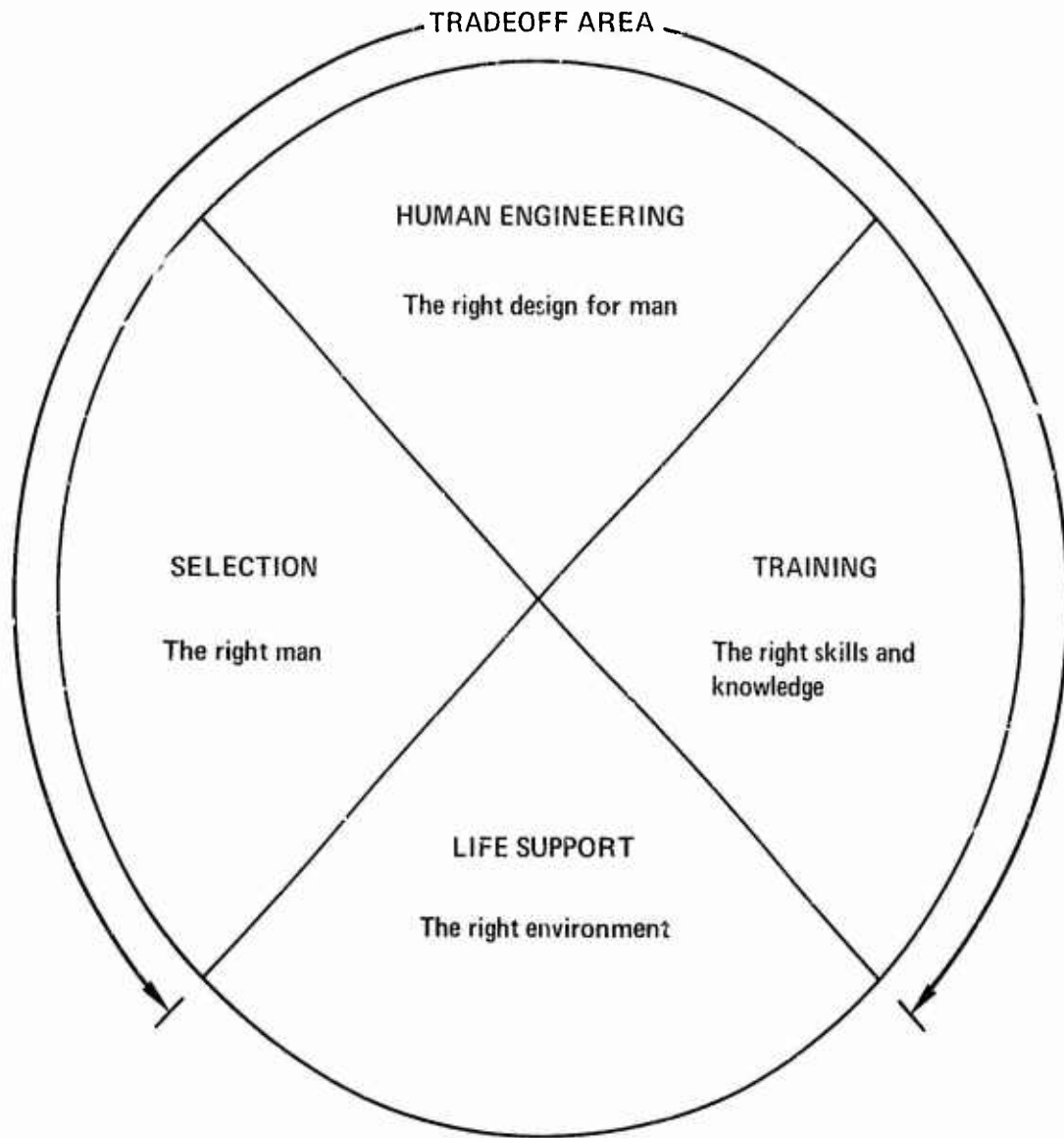

Frontispiece

2.2

SECTION 4	SECTION 3	SECTION 2	SECTION 1
APPENDIX C	APPENDIX B	APPENDIX A	SECTION 5
	APPENDIX F	APPENDIX E	APPENDIX D

## 1.0 INTRODUCTION

### 1.1 HUMAN ENGINEERING: THE DESIGN-ORIENTED ASPECT OF HUMAN FACTORS

Human engineering, life support, and personnel selection and training together constitute the field of human factors. Human engineering consists of those aspects of the human factors field which are design-oriented; primary emphasis is on the design of system equipment for effective interfacing with human operators, maintainers, and users. Human engineering involves determining man's capabilities and limitations as they relate to the operation, maintenance, and use of Navy equipment and then applying this knowledge to the planning, design, and testing of each system to ensure efficient, reliable, and safe operation by the human operator.\* The aim of human engineering is to ensure the level of man-machine system performance needed for mission success.

Naval Material Command policy requires that the human element of Navy systems shall undergo the same development, test, and evaluation steps that equipment elements of the same system undergo. Human factors, then, is an essential part of all Navy system development and acquisition effort. In carrying out this policy, the assistance of two bureaus outside the Naval Material Command and the SYSCOMs is enlisted. BUPERS provides support in personnel selection and training, and BUMED in life support.

To some degree human engineering, selection, and training can be traded off with one another. That is, in order to attain a given level of performance from a man-machine system, a deficiency in any one of these three areas may be at least partially compensated for by the other two. For example, if there simply are not enough good men to go around and selection standards must be relaxed, then human engineering can simplify system operation as much as possible, and more attention can be devoted to training to develop the needed skills. With respect to these trade-offs, the position taken in HE Guide is that human engineering should never be neglected, with the expectation of salvation through compensatory trades. The reason is that human engineering is done once by a small corps of personnel and the total dollar figure is small. Selection and training, however, apply to much larger populations with a continuing cost impact throughout the operational life of the system. Therefore, compensating for inadequate human engineering by using either higher selection standards or more comprehensive training programs ends up as the costly way to go. The point, then, is that planning and implementation of sound human engineering programs not only directly benefit individual man-machine systems, but also help the Navy make better use of its overall resources.

---

\*Although the term "human engineering" is fairly standard in Navy use, other terms somewhat similar in meaning are sometimes used. Thus, such terms as biotechnology, human factors, personnel subsystems, ergonomics, and man-machine relations are often used to describe activities which in this guide are considered to be human engineering.



Although all three human factors fields are involved in ship system development, HE Guide directly addresses only the role of human engineering. The interfacing relationships with life support and personnel selection and training are, however, indicated at appropriate points to encourage effective interaction among all human factors personnel.

## 1.2 BENEFITS FROM SYSTEMATIC HUMAN ENGINEERING

The payoff in conducting a systematic human engineering program is realized in improved system performance, reduced training cost, improved manpower utilization, fewer errors and accidents, reduced maintenance costs, higher probability of mission success, and improved user acceptance. Without applying a systematic human engineering program, attainment of an effective ship system is fortuitous and improbable.

Failure to apply systematic human engineering can be costly. Research indicates that typically up to 40% of all ship system malfunctions are attributable to human error.\* Even increasing automation of ship systems does not eliminate the application of human engineering programs, since man is still involved as a user and maintainer.

To maximize the payoffs previously cited, human engineering must be applied throughout the ship system life cycle. It starts with inputs to planning documents and continues throughout concept formulation, contract definition, engineering development and production, test and evaluation, and finally fleet operations.

## 1.3 REQUIREMENT FOR HUMAN ENGINEERING

The requirement to involve human engineering in all ship system development programs and projects is rooted in instructions, specifications, standards, etc., as well as in the technical nature of modern naval man-machine systems.

### 1.3.1 INSTRUCTIONS, SPECIFICATIONS, AND STANDARDS

There are several official instructions originating from such sources as DoD and CNO (see 5.0 BIBLIOGRAPHY) which specifically describe the role of human engineering in Navy programs. The key instruction applicable to Navy projects is NAVMATINST 3900.9 of 29 September 1970, "Human Factors."

In addition to these instructions, there are military specifications and standards devoted exclusively to defining human engineering requirements and providing human engineering design criteria. These specifications and standards are applied to all Navy system development and procurement efforts, regardless of whether they are performed in-house or contracted for from outside sources. (See MIL-H-46855A in appendix F.)

---

\*Pickrel, E.W., and McDonald, T.A., "Quantification of Human Performance in Large, Complex Systems," *Human Factors*, 1964, 6, 647-662

Finally, there exists a series of human engineering design guides, manuals, and standards that are frequently included as controlling documents in development programs.

### 1.3.2 REQUIREMENTS GENERATED BY SYSTEM COMPLEXITY

Those involved in ship system projects clearly recognize the trend toward more complex, sophisticated, and increasingly capable ship systems. Any new naval system, regardless of its technical superiority, is useless unless it can be operated, maintained, and supported by existing manpower. Thus, as system complexity increases, more and more emphasis must be placed on designing systems around the human operator/maintainer, keeping in mind those functions he performs well and those he does not. Even though a new system may have excellent hardware reliability, it will not have satisfactory overall reliability unless human reliability is also assured.

This increasing realization of the critical role of man as a part of the naval weapon or support system is reflected in the new emphasis being given within the Navy to the use of human engineering in all phases of new system development. Thus, in addition to formal, written requirements dictating the use of human engineering, the technical requirements of new ship systems are continually placing new importance on engineering the systems with man as an integral part—not an addition to them at some postdesign period.

## 1.4 HE GUIDE

### 1.4.1 OBJECTIVES

HE Guide has been prepared for use by the System Commands within NAVMAT, their supporting laboratories and shipyards, and their contractors as a guide for incorporating and managing human engineering efforts in development of ship systems. HE Guide is concerned primarily with methodology, documentation, program requirements, available resources, and organizational approaches to ensure proper and adequate application of human engineering in ship system development projects. Thus, HE Guide is intended for use by Navy and contractor personnel, at all levels, who are responsible for procuring, funding, monitoring, or evaluating human engineering efforts during development of ship systems.

Current NAVMAT policy requires that human engineering be applied in all systems under development in due measure with the degree of involvement of human functions in operation, maintenance, and utilization of the system. Management responsibility for ensuring that human engineering is properly accomplished in a development program ultimately rests with the program manager. For this reason, the program manager needs to know what human engineering is, where it fits in the development cycle, how to plan and arrange for human engineering support, what it costs, what it contributes, and, finally, how to evaluate a human engineer's product. Therefore, a basic objective of this guide is to provide program and project managers with essential information on the use, management, and methodological aspects of human engineering. In addition to this general objective, HE Guide has the following specific objectives:

- a. Standardize procedures. Extensive experience with human engineering technology and methods has been accumulated by the Navy over the

past years. Experience has shown that to ensure application of human engineering at the appropriate times in a ship system development cycle, a need exists for formalizing and standardizing human engineering participation. By referring to this guide, each project manager, regardless of project size or nature, can clearly identify where human engineering should be included in this project.

b. Optimize use of resources. Because of limited sources of money, manpower, and facilities, there is always considerable competition for resources among ship system development projects. Utilizing HE Guide, the project manager can now more accurately establish his human engineering requirements in terms of when human engineering should be used, who should do the job, and what it will cost him.

c. Orient new personnel. Although not intended as a textbook, HE Guide can provide valuable orientation for new engineering personnel or for engineers who are given human engineering responsibility as a collateral assignment.

d. Assist in preparing contract specifications. The triservice human engineering specification, MIL-H-46855, "Human Engineering Requirements for Military Systems, Equipment and Facilities," was published in February 1968 and revised in May 1972.\* Until that time, each service had its own human engineering specification. The triservice specification makes human engineering mandatory in development of military equipment, systems, and facilities. HE Guide supplements MIL-H-46855 and aids program and project management personnel in determining the scope and depth of human engineering support programs which should be written into contract specifications.

e. Improve system effectiveness. Human engineering is aimed at enhancing system effectiveness, and HE Guide is a tool to this end. Consistent use of HE Guide along with the triservice specification and appropriate standards should result in improved man-machine systems in terms of performance and cost effectiveness.

#### 1.4.2 SCOPE

HE Guide covers system development from requirements determination to fleet operation, identifying for each phase the factors which are important in successfully implementing human engineering in ship systems. HE Guide does not contain specific human engineering design criteria, since this information is provided in MIL-STD-1472 and elsewhere. Neither does HE Guide cover the research aspect of human engineering. In recognition of the fact that personnel both with and without human engineering experience will be involved in human engineering matters, HE Guide has been prepared for use by individuals with responsibility in this area irrespective of their professional backgrounds.

---

\*References to all specifications and standards in this guide are with respect to the original issue; users should be sure to utilize the latest issue in effect.

HE Guide does not specifically address human engineering in ship acquisition programs. A separate human engineering document, a part of the Ship Life Cycle Management (SLCM) support manual series, will cover unique human engineering requirements in ship acquisition programs.

In order to provide universal application, HE Guide has been prepared to cover large-scale system developments (those systems costing over \$50 million for R&D programs, \$200 million for production projects). A project engineer overseeing the smaller project can selectively eliminate those sections of the HE Guide applicable only to large-scale developments.

## 2.0 ROLE OF HUMAN ENGINEERING IN SYSTEM DEVELOPMENT

### 2.1 OVERVIEW OF HUMAN ENGINEERING

#### 2.1.1 WHY HUMAN ENGINEERING?

The need for human engineering in the Navy is based on the fact that the science of man and his capabilities must keep pace with, and be included in, the hardware design technology if system effectiveness is to be maximized. Machines never fight alone; they need men to operate and maintain them. The task, then, of human engineering is to elicit the best performance from man and his equipment by combining them in such a way as to optimize the man/machine/environment system. The key concept in human engineering is that man is an integral part of any Navy system—not an adjunct to it—and, therefore, engineering for human functions is just as important as engineering for mechanical or electrical functions.

#### 2.1.2 BASIS FOR HUMAN ENGINEERING

In the past, engineers responsible for design of new systems have sometimes failed to use human engineers, citing three major reasons. First, the design engineer is a human being and thus can reasonably know what a man can and cannot do. Secondly, with or without human engineering, the operator/maintainer of the system will adapt to it eventually regardless of its design. Finally, human engineering costs money which can be better spent on hardware acquisition. None of these are legitimate reasons for omitting human engineering from a development project.

As noted in a later section, ultimate responsibility for ensuring that human engineering gets into the system design does, in fact, rest with the design engineer. But simply being human does not qualify him as a human engineering expert. Human engineering over the years has become a separate, distinct profession complete with methods, research data, and criteria. The design engineer should be aware of what human engineering is, and where it should be used in his particular project. He should solicit help from the human engineer when such input is required. He should not attempt to do the human engineering himself.

Because man is so adaptable, many previous Navy systems which had little or no human engineering included in their design have operated successfully. However, the costs in terms of personnel selection, training, system errors, downtime, etc., over the total system life cycle prohibit this approach in the future. Selecting, training, and maintaining personnel often comprise the largest single expense (usually over 50% of the life cycle cost) in operating and maintaining a Navy weapon or support system. If the system can be designed to lower the training requirements or make available a larger inventory of available operators/maintainers, then system manpower costs can be reduced.

Human engineering proceeds on the basis that the capacities and limitations of man are established within certain natural limits. If system design requires human capabilities beyond these limits, maximum system

**Preceding page blank**

efficiency is not achieved, even though the system manages to operate at some lesser level of performance. The expeditious use of human engineering during design can assure systems which are adapted to man's natural limits and thereby reduce training requirements, increase potential operator/maintainer populations, and minimize overall system costs.

### 2.1.3 WHEN TO DO HUMAN ENGINEERING

To be maximally effective, human engineering must be included in the system development cycle from requirements determination through fleet operation. It is imperative that man be considered during the entire development phase. System performance must not be compromised by designs which impose limitations on human operator/maintainer efficiency simply because the human was considered adaptable enough to fit whatever hardware was built. Man is a system component and as such deserves systematic, specialized attention. System development program managers, because of lack of familiarity with or interest in human engineering, have sometimes been responsible for relegating human engineering to a "non-essential" status, only to find they are faced with costly redesign at a later date. Such redesign and retrofiting may be needed because of personnel hazards, man-machine performance limitations, or excessive manpower costs. Human engineering application early in system development would have precluded the need for these added costs and, in many cases, delays in making the system available to the fleet.

### 2.1.4 WHO DOES HUMAN ENGINEERING?

Human engineers do not represent any one professional discipline; human engineering is interdisciplinary. The original academic discipline of the human engineer might have been electrical or mechanical engineering, psychology, physiology, anthropology, industrial design, medicine, or industrial engineering. In Navy laboratories the human engineer is most typically an engineering psychologist with a broad background familiarizing him with military operations and engineering practices.

Unfortunately, there are not enough qualified human engineering specialists to do all the potential human engineering work in development projects. For this reason priorities must be established so that the human engineering attention goes where the needs are most critical. It is important, therefore, that program managers recognize the need to use their human engineering talent effectively. The engineers and designers must be made aware of the role of the human engineering specialists and know when to call upon them to assist in design concept development. It is particularly important to be very clear about the scope and depth of human engineering services specified in contractual documents.

### 2.1.5 WHAT DO HUMAN ENGINEERS DO?

Human engineers conduct research, establish design criteria, and assist in developing system hardware, software, and support facilities all properly engineered for effective human use. In collaboration with hardware engineers, human engineers seek to develop new and improved man-equipment interface that will simplify operator/maintainer tasks and increase probability of mission success. They seek to achieve displays that will most effectively present information to the human senses, to obtain the most efficient controls for human operation, and to create an optimum work environment. Because the successful design of a system requires consideration of man's basic characteristics, human engineers study man's sensory capacities, muscular strength and coordination, body dimensions, perception and judgment, basic skills, work capacity, and requirements for comfort, safety, and freedom from environmental stress. Such studies include both basic and applied experimental research, utilizing scientific methodology to collect quantifiable data. These studies attempt to control conditions and manipulate variables in such a way that cause-and-effect information directly applicable to human performance within an operational environment is obtained. Thus, the human engineer knows and studies man in a systems context just as the design engineer knows and studies equipment. Together they use this knowledge to create a man-machine system which combines the best of both.

## 2.2 IMPORTANT HUMAN ENGINEERING REFERENCE DOCUMENTS

### 2.2.1 INSTRUCTIONS AND GUIDES

Over the past years, several instructions and general guides have been issued covering the use and need for human engineering in Navy development and procurement programs. (See 5.0 BIBLIOGRAPHY.) NAVMATINST 3900.9 is particularly significant for human engineering in Navy development, T&E, and production programs and projects. This instruction presents official NAVMAT policy on human factors.

The official policy requires that the human element of Navy systems shall undergo the same development, test, and evaluation steps as equipment elements of the same system. This requires, in turn, integration of appropriate human factors information into design and the use of such information in all major management and/or technical decisions and documents. As a minimum, this will involve human factors inputs to project documentation, proposal evaluations, contractual statements of work, engineering change proposals, and T&E plans.

### 2.2.2 SPECIFICATIONS

Until 1968 each branch of the military utilized its own independent human engineering specification, which served as contractual requirements. In February 1968 MIL-H-46855 was issued, superseding all other independent

human engineering specifications and providing, therefore, a single triservice human engineering specification.

This specification establishes and defines the general requirements for applying human engineering principles and criteria to the development of military systems, equipment, and facilities. It is to be used as a contractually binding and controlling document on all ship system development programs. It may be unnecessary to call out all sections of MIL-H-46855 on every project; however, it is the responsibility of each project manager, through his human engineering staff, to select those parts of the specification which should be invoked as contractually binding requirements.

Information requirements to support personnel aspects of new ship and system programs are contained in MIL-P-28700 (NAVY), Personnel Planning Data for Naval Systems. Human engineering programs will ordinarily generate much of the information called for in this specification.

### 2.2.3 STANDARDS

The one standard most widely used in ship system development programs is MIL-STD-1472, "Human Engineering Design Criteria For Military Systems, Equipment and Facilities." As the name implies, this standard provides specific human engineering design criteria for such things as visual and auditory displays, controls, labeling, anthropometry (body dimensions), operating environment, workspace, and control panel layouts. MIL-STD-1472 is a contractually binding document.

Although MIL-STD-1472 is the prime human engineering design standard, others are commonly referenced for ship development programs. These include NAVWEPS OD-18413A, "Human Factors Design Standards for the Fleet Ballistic Missile Weapon System," and MIL-STD-470, "Maintainability Program Requirements for Systems and Equipments." The decision to use standards supplementary to MIL-STD-1472 should be left to the Navy's human engineering staff for each particular project.

### 2.2.4 AUTHORIZED DATA LIST AND DATA ITEM DESCRIPTIONS

The Navy Authorized Data List (NADL) is a listing of significant data submittal items approved for contractual application during system acquisition. An NADL committee under the chairmanship of NAVORD reviews, evaluates, and approves items for the NADL. Data Item Descriptions (DIDs) describe the data item to be furnished in terms of content, instructions for preparation, format, and intended use. Specific DIDs are called out in contracts requiring data submittals as end products. NADL DIDs pertinent to human engineering are included as appendix E.



## 2.2.5 REPORTS, MANUALS, AND BOOKS

Besides the previously listed instructions, specifications, and standards, there are a number of reports, manuals, and books which contain human engineering design criteria. Frequently one or more of these items are referenced in an RFP. This is particularly true of two books: "Human Engineering Guide to Equipment Design" and "Human Engineering Guide for Equipment Designers." Also, a popular design handbook is NAVSHIPS 94324, "Maintainability Design Criteria Handbook for Designers of Shipboard Electronic Equipment."

## 2.3 HUMAN ENGINEERING WITHIN THE PROJECT ORGANIZATION

### 2.3.1 ADMINISTRATIVE POSITION

To adequately meet the intent of the various human engineering instructions and responsibilities, a responsible focal point for human engineering within both the Navy's and contractor's project office is required. It is desirable that this focal point be an individual who reports directly to the project manager. Both the Navy and the contractor(s) should provide a human factors program manager who is a member of the project manager's immediate management staff. This places the human factors function at a sufficiently high level administratively so that its recommendations can be made on the basis of the total system as viewed by top management. This is necessary if human engineering is to have an impact on design decisions and to assure compatibility between operational performance objectives and man-machine system design results. Further, human factors at this level can serve across organizational or functional design groups within the system development project with a minimum loss in communication or delay in resolving system interface problems.

To facilitate the exchange of human factors contacts between the Navy and its contractor(s), it is highly recommended that group titles, responsibilities, and positions within both Navy project manager and contractor project structures be parallel. With this arrangement, there is no doubt within either group as to who is responsible for the human factors effort.

### 2.3.2 HUMAN FACTORS PROGRAM MANAGER

The term "human factors" has been used intentionally since it is extremely desirable that all the subgroups within the human factors discipline (human engineering, personnel and training, and life support) be represented by a single manager or branch (depending on size of project office) within the project manager's office. Because of the complex interrelationships between subgroups, a human factors branch or manager can better integrate these subgroups, eliminate duplication, and ensure positive participation for the roles of each in the systems development process.

In certain large project offices such as a SHAPM (Ship Acquisition Program Manager) where there is a need for accomplishment of a significant amount of human engineering during system development, the project office should be able to justify permanent human engineer(s) within the staff office acting as the human factors program manager(s). These human factors managers should also have responsibility for personnel/training and life support (and they may even be required to represent other disciplines such as safety and habitability, depending on specific organization and personnel limitations).

For smaller project offices, where there will be a need for a limited amount of human engineering during system development, it is still desirable that a qualified human engineer be part of the permanent in-house staff. It is recognized, however, that this may not be possible or economically feasible with present manpower limitations and limited personnel ceilings. If this be the case, the general engineer (or manager or specialist in Integrated Logistic Support (ILS)) representing certain related disciplines should also be designated with responsibility for human engineering. He should then seek proper training in human engineering so that he will know what it is, why it is required, and when and how to invoke proper requirements in a cost-effective manner. He should also seek advice of human engineers (in-house or laboratories) or task them to assist him as necessary at any phase of system development, especially for requirements determination.

In the case in which the project office is organized so that human engineering responsibility is in one branch but personnel selection/training and manning in another (for example, grouped under ILS), the responsibilities and tasks remain the same and should be accomplished as defined here in, but the coordination among the different subgroups will be much more difficult.

The human factors program manager will also have interrelationships with ILS personnel. There are many potential overlaps and complex interfaces between human engineering and the various ILS functions. A concerted effort must be made to utilize inputs or data submissions from the related disciplines so as to cut costs and efficiently complete analysis and documentation tasks.

## 2.4 INTERFACE REQUIREMENTS

### 2.4.1 INTRADISCIPLINE INTERACTION

2.4.1.1 NAVY. As noted earlier, although the human engineer is primarily concerned with equipment design, he often is involved in life support and personnel functions. And, typically, the products generated by a personnel-oriented group are often used by the human engineering group. Thus, early manpower predictions, educational information for potential operator/maintainers, and data covering trainability of crew members are all used by the human engineer in establishing man-machine trade-offs. On the other hand, results of the human engineer's mission and task analyses, work space arrangements, and panel layouts are used by personnel and training specialists in establishing training requirements and by publications specialists in preparation of technical manuals.

For a detailed identification of information requirements for personnel and training, see MIL-P-28700 (NAVY), Personnel Planning Data for Naval Systems. This specification establishes the requirements for Personnel Planning Data (PPD) development during the analysis, design, development, test, and evaluation of military weapon and support systems (less Aviation and Medical). The decision as to the applicability of this specification to individual system development projects is the responsibility of the project manager in consultation with NAVSHIPS 047C, the Personnel and Training Analysis Office.\*

Normally, environmental factors of concern in new ship system development projects include such things as humidity, temperature, ventilation, noise, and vibration control. The human engineer is generally well qualified to assist design engineers in these areas without direct BUMED participation. In cases in which the life support requirements are new or exotic (for example, a new submarine environmental system) or in which the human engineer's work load prohibits his participation in this area, then the project manager should request BUMED support. In such cases, the human engineer/life support interface activity is measurably increased.

2.4.1.2 CONTRACTOR. Industrial firms which possess an in-house human factors capability are organized in various ways. Generally, they will have institutional human factors engineering or life science organizations. They will then have independent training and publication groups. When such firms take on a new project, they normally take personnel from these groups and assign them to the new project. The typical approach is to assign these specialists as follows: (a) the human factors personnel are assigned to a design group within the project (crew station design, electronic systems, reliability, etc.), and (b) the training and publications personnel are assigned to a product support group. In addition, they may assign life support personnel (for example, aeromedical specialists) to a thermodynamics group and other human engineering personnel to a systems analysis group. With this separation of the various human factors functions, special attention must be given to central coordination of all elements of the total human factors program. It is therefore important that the Navy emphasize to its contractor the importance of organizing his project so that human factors personnel are integrated under a single manager, preferably a person with human engineering training and experience.

2.4.1.3 NAVY-CONTRACTOR. The need for direct interface requirements between Navy and contractor(s) human factors staffs would seem to be evident. Yet, frequently one or both organizations bury their groups within an organizational structure which prohibits such interaction or reduces its effectiveness. Even so, if the guideline described in the previous section concerning placement of human factors in the project organization is followed, efficient interaction between the two human factors groups can occur.

---

\*Until recently, the responsibility for determination of qualitative and quantitative military personnel and training requirements to operate and maintain ships and equipment was assigned to BUPERS. Effective 1 July 1973, this responsibility was transferred to the Naval Ship Systems Command.

## 2.4.2 INTERDISCIPLINE INTERACTION

2.4.2.1 DESIGN ENGINEERING. Of the three subgroups comprising the human factors discipline, human engineering requires the greatest amount of direct interaction with the system design engineers. Past experience indicates that almost daily face-to-face contact between the two functions is required if the human engineer is to be effective in assisting system hardware design. Thus, both Navy and contractor project management must consider this in establishing human engineering manpower and cost requirements as well as selecting the actual physical location of the human engineering staff.

2.4.2.2 OTHER. In almost all system development projects separate groups are assigned the responsibility for incorporating reliability, maintainability, safety, etc., into the finished product. Although the human engineer is not directly responsible for these functions, he does contribute to them, often on a continuous basis. Therefore, access to these groups and familiarity with their programs are required.

### 3.0 SEQUENCE OF HUMAN ENGINEERING ACTIVITY

The formal terminology and phasing of the system life cycle have undergone changes in the past and are sure to do so in the future. However, regardless of how the life cycle may be formally structured, there is a logical progression of human engineering activity beginning with requirements analysis then moving on to man-machine concept development and analysis, detail design, and design verification. This section of HE Guide is organized along the lines of this logical progression rather than in terms of formal life cycle phases since the latter are subject to change at any time.

#### 3.1 REQUIREMENTS ANALYSIS

##### 3.1.1 OVERVIEW

As a prerequisite to all other human engineering activity, the requirements for and constraints upon the proposed system must be clearly identified. The mission of the proposed system and the operational setting in which it is conducted are examined, with particular emphasis on those factors involving man-machine performance. All relevant constraints (for example, number and level of personnel, R&D and production cost of operator consoles) and man-machine performance requirements (for example, number of targets which must be processed per minute) are identified and analyzed with respect to their impact on man-machine design, personnel development, facilities requirements, and life support.

The justification for developing any new Navy system is not to produce hardware but rather to achieve some specific operational capability. Further, no new capability is sought unless a well established requirement exists for such a capability. Most properly, then, it is requirements which are, and should be, the foundation for the development of any new Navy system.

##### 3.1.2 GENERAL OPERATIONAL REQUIREMENT (GOR)

3.1.2.1 OBJECTIVE. The objective of the GOR is to state the capabilities the Navy needs within a particular functional warfare or support area. There are four broad classes of GORs: Strike Warfare, ASW, Command Support, and Operational Support. Needless to say, each of these classes deals with requirements which ultimately require human factors participation. One GOR in the Operational Support Category deserves special mention here. This is GOR 43, "Personnel Logistics." Human engineering is discussed in two places in this GOR. These are excerpted below.

- a. From an outline of functional areas within personnel logistics:

Human Factors Engineering. This area is primarily concerned with the implementation of human operator considerations in the development, operations, and maintenance

of new and current organizations, weapons, and support systems. The human operator is defined in the broadest context, to include system managers, assigned leaders, operators, maintainers, and support personnel. The requirement for successful integration of people insists that qualitative and quantitative elements of normally functioning human capabilities, within the constraints of people resource availability, be the focal points around which organizations, weapons, and support systems are designed.

Objectives in this area depend upon the establishment of a theoretical and scientific basis for understanding human performance with respect to sensory, perceptual, motor, and cognitive processes, in the context of operational naval systems. The attainment of these objectives requires the development of methodologies and techniques for translating human factors criteria into systems design specifications, and for assuring their implementation during systems development.

b. From a discussion of capability goals:

Human Factors Engineering. Human factors engineering is essential to the design, procurement, and operational utilization of equipment and systems in order that systems management, operation, and maintenance can be effectively and efficiently accomplished by available naval personnel. Required capability goals are as follows.

1. Theoretical and scientific bases for understanding human performance and determining meaningful relationships among human performance, equipment characteristics, and environmental conditions.
2. Techniques to quantify and extrapolate meaningful relationships among natural and induced environmental factors, personnel performance, and equipment system characteristics.
3. Optimum man-machine standards, specifications, and trade-off analysis methodologies for application in systems planning, development, and procurement.
4. Techniques for greater extension and application of human capabilities to anticipated demands of future weapons systems.

The GOR 43 provisions on human engineering are, of course, aimed at the development of the human engineering field itself and its successful integration with other development disciplines. Other GORs which explicitly or implicitly refer to human engineering do so in the sense of applying human engineering at the current state of its development. For a more detailed discussion on GORs, reference should be made to OPNAVINST 3910.9b.

3.1.2.2 HUMAN FACTORS RESPONSIBILITIES. There are no direct human factors (life support, personnel, or human engineering) responsibilities associated with GOR preparation. Being general statements of anticipated needs and operational requirements, the GORs are written in operational terms by the user Navy. The requirements invariably have human factors implications; therefore, those persons responsible for human factors in the Navy must be aware of the GORs as they are prepared since they may eventually be the basis for work assignments.

### 3.1.3 TENTATIVE SPECIFIC OPERATIONAL REQUIREMENT (TSOR)

The TSOR is a document prepared by the office of the Chief of Naval Operations (OPNAV) and addressed to the Chief of Naval Material (CNM). Promulgation of a TSOR by CNO does not establish a firm Navy commitment nor does it authorize the commencement of a full development program. It simply is the first step toward arriving at a more detailed definition of a needed capability identified initially in the GOR.

3.1.3.1 OBJECTIVE. The objective of the TSOR is to tentatively state, in increased amplification and detail, a needed capability which was stated in general terms in the GOR. In addition, the TSOR identifies the anticipated or existing military threat to which the added capability would be directed, defines those performance and operational criteria which can be specified at the time, indicates the time period in which the new capability is needed, and, in as specific terms as possible, establishes procurement, operating, and maintenance cost limitations. It should be emphasized that in meeting these objectives those responsible for preparing the TSOR should state only the operational requirements and not attempt to make design judgments as to how these requirements should be met. The basic guidance document for TSOR preparation is OPNAVINST 3910.6B.

3.1.3.2 HUMAN ENGINEERING RESPONSIBILITIES. Within OPNAV (RDT&E), human factors personnel are responsible for making an input to TSORs. Their responsibilities include:

- a. Ensuring that stated requirements are not prematurely assigned to either hardware or human implementation.
- b. Identifying those operational requirements which are likely to pose serious human factors problems.

The first responsibility serves to keep later design options open (if system development continues). In particular, decisions regarding allocation of system functions to men and machines are not appropriate at this stage. The second responsibility involves the anticipation and identification of potential human engineering problems which are likely to appear during system development.

Unlike the later phases of development in which specific human engineering methods and techniques are available, no such "cookbook" approach is appropriate at this point. Other than information available on

the human engineering shortcomings of similar systems already in the fleet, there appears to be no substitute for on-the-job human engineering experience in accomplishing the responsibilities listed above.

Human engineering inputs to the TSOR should appear in the "Human Compatibility" section. Included in this section, at a minimum, should be the following:

- a. A description of specific human engineering problems associated with other systems fulfilling capabilities similar to those specified in the new TSOR.
- b. Identification of particular human engineering problems which should receive special attention in the next development phase document (Proposed Technical Approach (PTA)).
- c. A discussion of the probable human engineering involvement in R&D aimed at satisfying the requirements of the TSOR.

### 3.2 MAN-MACHINE CONCEPT DEVELOPMENT AND ANALYSIS

#### 3.2.1 OVERVIEW

Before any decisions can be made regarding design of a system, regardless of its size or complexity, it is necessary to establish a well-defined concept of what the system is to do and how. This is certainly true of the human role in the proposed system. Thus, the human engineer or project manager defines such factors as: who is going to use the system, under what environmental operating conditions the system will be used, and what the performance limits of the operator/maintainer are expected to be. Alternative man-machine concepts potentially capable of satisfying the known requirements are identified and formulated. The alternatives may differ with respect to number and types of personnel required, the degree of automation employed, the type of work station to be utilized, etc.

Some man-machine analysis is required on every project. For larger systems this might include the full list included in MIL-H-46855, while for smaller projects only one or two of the analytic techniques might be involved. But detailed human engineering design cannot successfully take place without some man-machine analysis as the supporting base. Each candidate concept (including the manning concept) must be analyzed for feasibility, cost effectiveness, and all significant trade-off factors. This analysis always includes some means of "exercising the system," such as tracing through the sequence of events involved at the man-machine stations for each system mission. The aim is to anticipate the level of performance which might be attained under operational conditions and to recognize potential problems such as information queuing, commission of serious errors, and catastrophic failures. The analysis identifies the best candidate(s) for design implementation and provides justification for the choice(s).

Development and analysis are treated in the same section because they are interactive processes and make use of the same tools -- if in somewhat different ways. In development the tools are used to evolve realizable solutions to known sets of requirements. In analysis the same tools may be



used to examine the proposed solutions from many standpoints to see if they really meet all requirements. Thus, the human engineer must be prepared to use the tools described in this section in both ways, in an iterative fashion.

### 3.2.2 GENERAL HUMAN ENGINEERING RESPONSIBILITIES

Formulation of man-machine concepts must be concurrent with formulation of system concepts. During this formative period of system development the human engineer has a number of important responsibilities including:

- a. Ensuring that human engineering inputs are incorporated in system documentation.
- b. Participation in allocation of system functions to man and machine.
- c. Development of design concepts for each operator/maintainer work station to the point that it is reasonably assured such a work station arrangement is feasible.
- d. Ensuring that each candidate system is feasible in all respects from a human engineering point of view.
- e. Identification of potential human engineering problem areas which may require attention.
- f. Conduct and documentation of preliminary trade-off analyses pertaining to human engineering considerations.
- g. Preparation of inputs to Requests for Proposals (RFPs) for contracted work.

### 3.2.3 METHODS APPROPRIATE FOR CONCEPT DEVELOPMENT AND ANALYSIS

Over the years human engineers have developed a number of powerful tools and methods to aid in applied human engineering work.

Methods which are appropriate for use in concept development and analysis are discussed below. Also included are sample formats which are suitable for use in project documentation.

**3.2.3.1 FUNCTIONAL BLOCK DIAGRAMMING.** Block diagramming is perhaps the most familiar means of showing basic system organization and function. It should be noted, though, that much of what purports to be "functional" block diagramming is really equipment block diagramming, as is readily evidenced by the appearance of blocks labeled "display console," "data entry panel," "tape recorder," "drum storage," etc. Functional blocks are concerned with what is done rather than the specific realization of a means to do it. Functional block diagrams should not be allowed to evolve into equipment block diagrams prematurely. As an example, "detection" is functional terminology; "detector's console" is not, and already assumes an allocation of function to man and machine. Since

allocation of functions should always follow development of the initial system concept, it is essential to avoid equipment representation and its implication that function allocation has already been completed. A premature man/machine allocation may overlook the possibility that a man may perform a given task with greater cost effectiveness than a machine. However, as the various trade-offs are considered, the original block diagrams may be refined for each of the alternatives under consideration. The succeeding block diagrams will make tentative assignments of hardware, software and personnel. This is proper but only after some initial analysis of man and machine capabilities.

Some of the essential features of functional block diagramming are illustrated in figure 3.1. Note that:

- a. An expanding series of diagrams gives successively more detailed information on each functional block. This detail may be carried to as many levels as appropriate.
- b. Functions are numbered in a manner which preserves continuity of function and logical breakout from function origin.
- c. The top-level diagram should show the system development process itself as well as the operational function of the system being developed. In other words, the system being developed is within a larger system which is the system for accomplishing the development.
- d. Branching can and should be shown as indicated in the top-level diagram. Once the particular system in the example goes operational, it is either in combat information service or in a maintenance state, both of which need additional breakout with finer-level diagrams. The introduction of branching in functional block diagramming provides great flexibility and facilitates the transition to information flow charting.
- e. The diagram should be organized so that one can easily find the input and follow the flow through the function blocks to the resulting output.
- f. It is good practice to limit the physical size of diagrams which will be included in manuals and similar documentation. One double fold-out (about 11 x 25 inches) is the maximum for convenience in handling. By means of nesting and splitting techniques, complex diagrams can usually be handled in sheets of this size.

Figure 3.2 is a more detailed (but incomplete) block diagram of function block 5.0 from figure 3.1 for a hypothetical combat information system. Note that this diagram, as may sometimes be desired, is of mixed levels (second and third). Note also that except for the associated systems there is not yet any implication of man-machine function allocation.

**3.2.3.2 INFORMATION FLOW CHARTS.** Information flow charting is a technique used to show the flow of information, in terms of operations and decisions, required to accomplish the functions identified in the block diagram. Like block diagramming, information flow charting may be used at various levels of detail. The initial information flow charts should be concerned with gross functions without regard to whether functions are

performed by machine or by man. Information flow charts prepared subsequently to tentative man-machine function allocation will reflect this allocation in the decisions, operations, and branching which are represented. At the PTA stage, however, these charts would ordinarily be prepared at a detailed level only for the more critical man-machine functions.

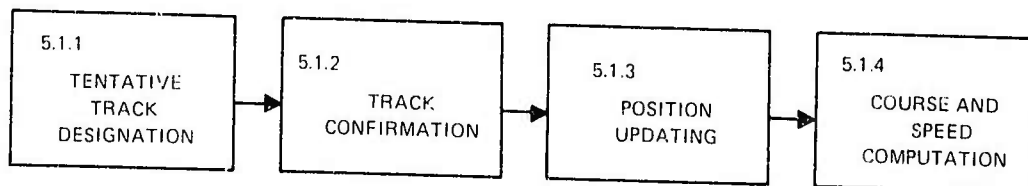
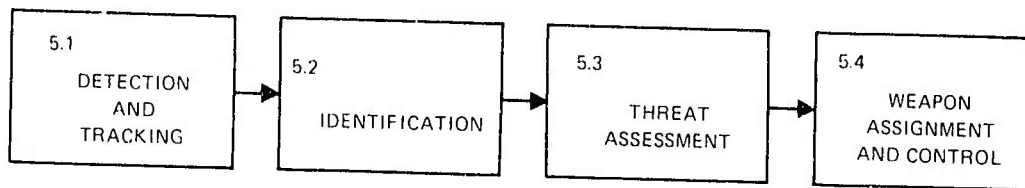
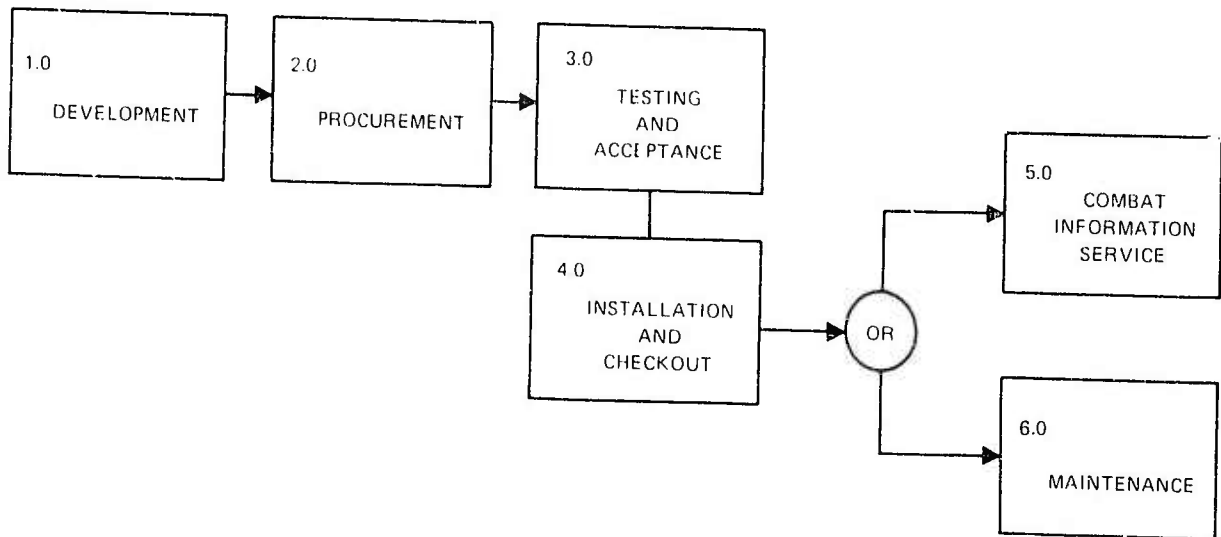
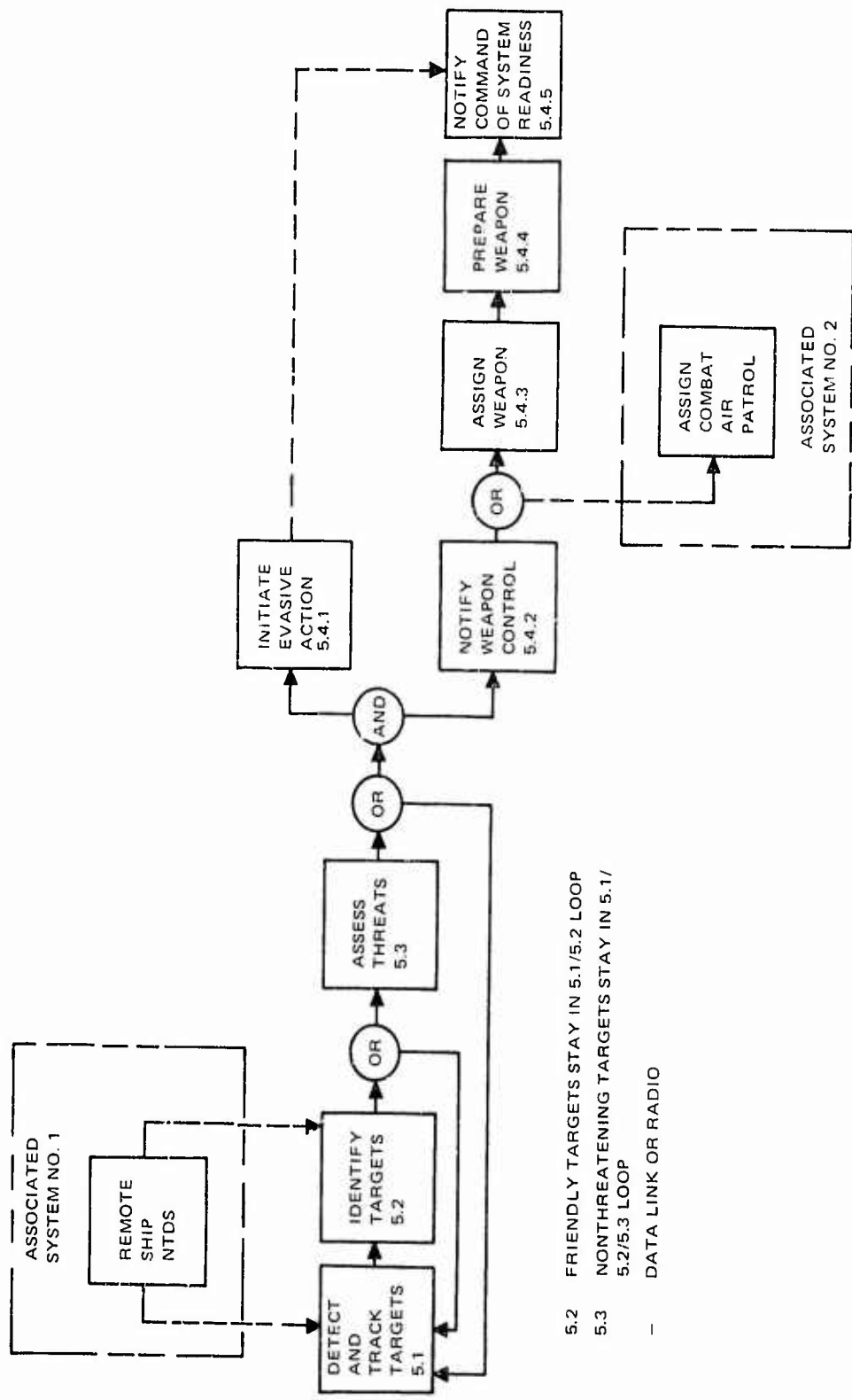

Figure 3.1. Levels of functional block diagramming.



5.2 FRIENDLY TARGETS STAY IN 5.1/5.2 LOOP  
 5.3 NONTHREATENING TARGETS STAY IN 5.1/  
 5.2/5.3 LOOP  
 - DATA LINK OR RADIO

Figure 3.2. Abbreviated block diagram, hypothetical combat information system.

In that it records the sequence of operations and decisions which must be performed to satisfy a definite system function, the information flow chart is similar to the flow chart used by computer programmers. Both charts are based on binary choice decisions and intervening operations. That most decisions can be reduced to a binary situation is evidenced by the vast array of problems which can be computerized via simple binary logic. There are two important reasons for using binary decision logic as standard in all information flow charting:

- a. To expedite communication through use of simple yet universally applicable conventions.
- b. To provide for easy translation of information flow charts into logic flow charts for computerized sections of the system.

Like block diagramming, information flow charting can be used at various levels of specificity. A decision at a general level may split into several decisions at a more detailed level, for example:

- |                      |   |
|----------------------|---|
| General level:       | Any targets need identification processing?   |
| More specific level: | <ul style="list-style-type: none"><li>● Any newly entered targets need ID processing?</li><li>● Any target tracks need confirmation of tentative ID?</li><li>● Any confirmed IDs need rechecking?</li></ul> |

Each of these more detailed decisions may have associated with it one or more detailed operations.

Similarly, an operation at a general level may break down into more detailed decisions and operations. In the following example, human functions are represented by a single symbol and machine functions by two concentric symbols:

- |                       |                              |
|-----------------------|------------------------------|
| General level:        | ○ Call up track              |
| More specific levels: | ○ Enter track digits         |
|                       | ○ Press TN call-up button    |
|                       | ◎ Load track data in buffers |
|                       | ◎ Display track data         |
|                       | ◇ TN readout correct?        |
|                       | ○ Proceed with operation     |

It is not necessary that the flow chart be prepared to a uniform level of specificity. For many situations it may be entirely appropriate to treat certain parts of a process in only a general sense and focus in on other more critical aspects by going into greater detail. The analyst must keep his purposes in mind and peg the level of detail accordingly. Usually those parts of a flow chart which initially are presented in only general terms are broken down into greater detail as the development progresses.

Figure 3.3 is an information flow chart for gross-level detection and tracking functions. Note that at this level the chart is applicable to virtually any detection and tracking system — the decisions and operations are common to all such systems. Even here, however, the power of the flow chart is apparent because it makes one begin to think of implementation alternatives, such as:

- a. By what means can any given signal set be compared with known targets in the system?
- b. How can probable targets be marked so their reappearance can be readily recognized?

The information flow chart shown in figure 3.4 diagrams the tracking function at a finer level of detail (for a hypothetical system). In this figure each machine decision or operation is represented by two concentric symbols to differentiate it from a human function.

Note that the recommended format for these charts utilizes a narrow column at the left of the page for the chart proper consisting only of symbols and connecting lines and a wide column for textual statements keyed line-by-line with the respective flow chart symbols. (As previously noted a double foldout (11" x 25") is suggested as maximum physical size of individual sheets to be included in documents.)

Note also that flow paths are complete: every path either recirculates or eventually terminates in a valid exit, and no ends are left dangling. This fact is extremely important and is what makes the information flow chart such a powerful tool. The flow chart technique imposes a discipline upon the analyst, requiring him to consider alternatives which might easily be overlooked. This results in a thoroughness and logical closure which could never be attained by conventional block diagramming techniques or by narrative descriptions. The information flow chart may be the first tool to reveal serious shortcomings in system thinking or to indicate that information flow is much more complex than originally believed. For these reasons it is considered an indispensable tool to the system designer and the human engineer.

### 3.2.3.3 MAN-MACHINE ALLOCATION TRADE-OFF STUDIES.

With the completion of the block and gross information flow diagrams, it is appropriate to perform preliminary studies of man-machine allocations for each of the alternate designs being considered.

Working in conjunction with the project's system engineers and using the block and information flow diagrams, plus their past experience with similar systems, the human engineers should make a preliminary allocation of the actions, decisions, and/or functions shown in the charts to men and/or machines. Thus, the block diagrams and information flow charts (especially the latter) become very important. The assignment of the functions, actions, and/or decisions to man and/or machine must be based upon: (a) the known capabilities and limitations of the human being (see appendix A), (b) the state of the art of hardware and software, and (c) estimated performance to be required in terms of speed, accuracy, and load. The need for a cooperative effort between the system and human engineers at

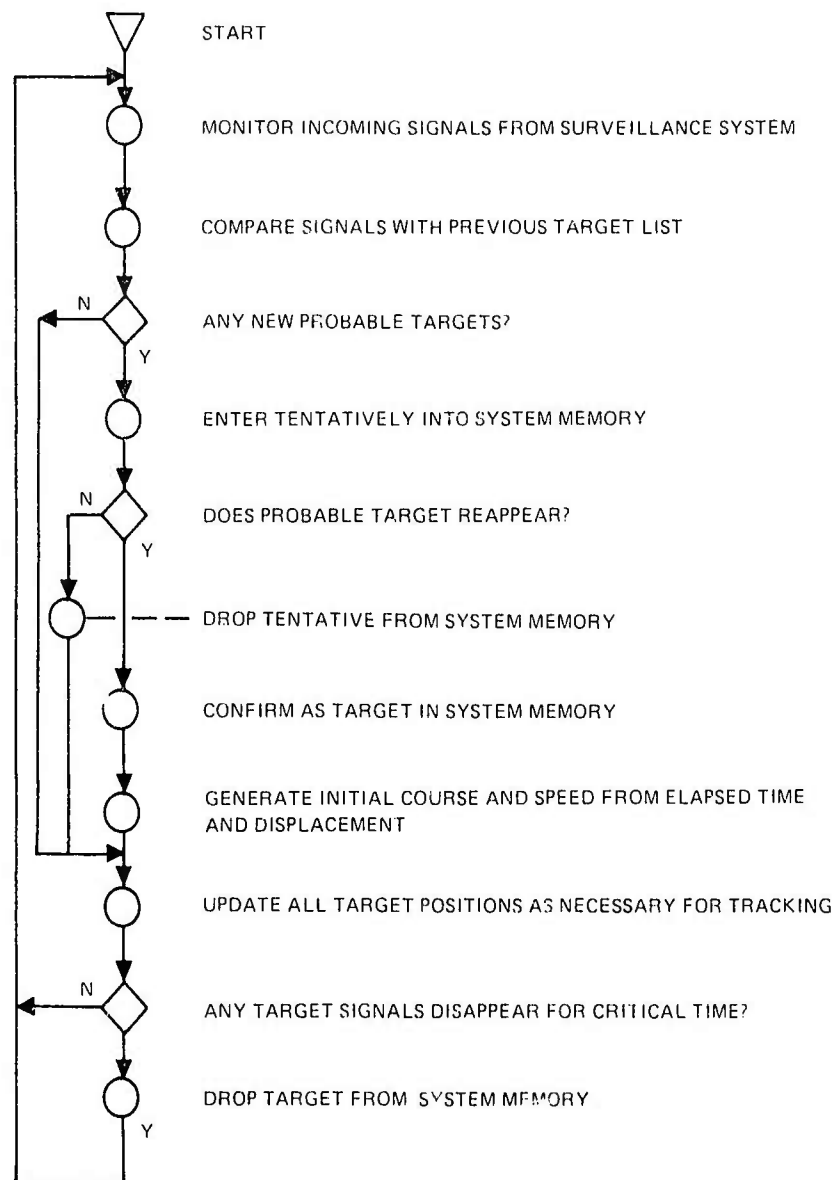

Figure 3.3. Gross information flow chart for detection and tracking (no man-machine function allocation assumed).

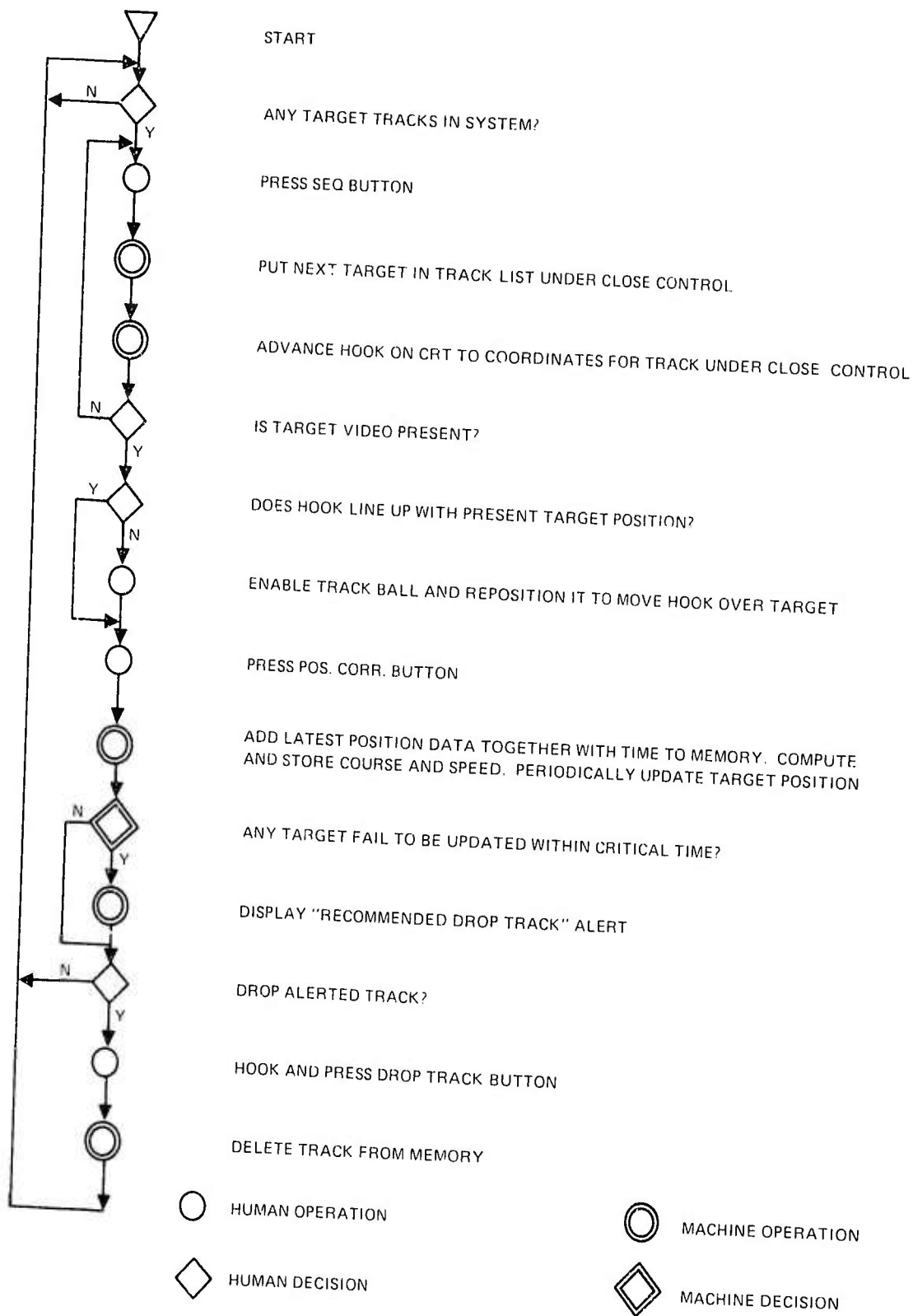

Figure 3.4. Information flow chart (hypothetical fragment of flow for tracking function).



this point cannot be overemphasized, for each must contribute to make the allocations meaningful.

At the conclusion of this preliminary effort, a tentative assignment to man and/or machine for each function, action, or decision on the block and information flow charts should be made. Thus, it is at this point in the system development cycle that consideration is first given to identifying specific equipment, software, and personnel contributions required to make the system work. Man-machine allocation trade-off studies must be performed for each alternative being considered. Like the flow charts, the man-machine allocation studies will be continually reworked and updated as the system continues through the development cycle. Thus, the allocation studies should be retained for future use.

When alternative concepts may involve different manning levels, life cycle personnel costs should be considered in trade-off studies. Appropriate figures to use in estimating personnel costs may be obtained from BUPERS in references such as NAVPERS 15163, "Navy Military Manpower Billet Cost Data for Life Cycle Planning Purposes," and NAVPERS 18660, "Annual Training Time and Costs for Navy Ratings and NEC's."

Before system concepts are finalized, iterations of the man-machine allocation studies should have: (a) identified plausible candidates for implementation (human pattern recognition, computer algorithm, or hardware function); (b) identified criteria for allocation (response time, error rate or probability, cost); (c) analyzed data related to these criteria; (d) prepared a comparison matrix which exhibits all candidates vs the selected criteria (entries in the matrix are the estimated absolute performance or rank for each candidate on each of the criterion measures); (e) selected and justified the allocation.

**3.2.3.4 PRELIMINARY MAN-MACHINE ANALYSIS.** In simplified terms, man-machine analysis refers to critical examination of the man-machine interfaces involved in operating, maintaining, and using system equipment under conditions approximating those of operational employment in order to identify all potential man-machine problems. Obviously, such analyses could not be completed for every man-machine combination existing in a particular system, especially if the system is large (for example, a ship). But a preliminary analysis of selected man-machine interactions is appropriate in order to identify which problems should receive greater attention as system development progresses. As an example, these analyses might uncover a human operator performing a complex mental task during combat, an equipment function which required critical, but infrequent, human operation, or a decision requiring a large volume of input data in various forms. Since the charts and allocation studies are at a gross level, the man-machine analysis must also be performed at a gross level. But this is the time to begin pinpointing potential man-machine interaction problems.

Results of these man-machine analyses should be included in the project documentation. Each analysis should be covered by a short write-up describing why the particular man-machine combination may pose design problems and offering suggested solutions if available. Sketches, pictures, references, or any other aid which would help to support the design concern should be included.

3.2.3.5 PRELIMINARY HAZARDS ANALYSIS. For each of the design alternatives, a gross hazards analysis should be performed and the results included in project documentation. If the project team contains a specific safety engineering slot, then the human engineer should act in an assistant capacity. Usually, however, this is not the case, so the human engineer is responsible for identifying potential safety hazards at this early stage.

The requirements for system safety programs are spelled out in MIL-STD-882, "Requirements for System Safety Program for Systems and Associated Subsystems and Equipments." Other important references include NAVSHIPSINST 5200.17, "Promulgation of Shipborne System/Equipment Acquisition Manual," Appendix 26, "Safety"; AFSC DI11-6, "System Safety Handbook"; NBS H30, "National Electrical Safety Code"; and DoD Directive 1000.3, "Accident Prevention and Safety Policy for the Department of Defense."

In performing a hazards analysis the human engineer reviews his own material developed to this point (block diagrams, flow charts, allocations, etc.) and talks with system engineers about proposed design concepts. Then, keeping in mind the general areas of safety hazards and the experience of safety problems in other systems, he identifies potential safety hazards associated with the design alternatives being considered. The primary hazard considerations which should be documented include the following:

- a. Noise
- b. Shock and vibration
- c. Extreme temperature
- d. Atmospheric contamination
- e. Toxic substances
- f. Electrical shock
- g. Mechanical hazards (moving parts, etc.)
- h. Electromagnetic and nuclear radiation
- i. Explosion/fire
- j. Pressure and/or decompression

3.2.3.6 PRELIMINARY OPERABILITY/MAINTAINABILITY ANALYSIS. The objective of preliminary operability/maintainability analysis is to make an initial assessment of the impact of human performance on the operation of the overall system for each design alternative being considered. Specifically, the human engineering analyst should address the following:

- a. To what extent is system performance a function of the human operator/maintainer?
- b. Which human functions are particularly critical to meeting the mission requirements?

- c. What is the acceptable range of performance for these functions?
- d. What areas should be called out for future study effort to ensure acceptable performance?

The analysis must include both system operation and maintenance functions.

It is very important to assess the human contribution to system performance since, for most shipboard systems, machine executions are performed very rapidly with very low error rates and little variability. Thus, the bulk of system response time, error, and variability will reside in human functions. The necessity to establish realistic human operability goals follows immediately from these considerations.

a. Operability. We recommend approach to making preliminary operability assessment of a proposed operator station is as follows:

(1) Define the design goal in terms of quantity and quality of information throughput for that station under design load. (Typically, this is done for the SOR or later requirement formulations.) For example:

- "The detection operator must have a detection probability of at least 0.85 against a beam target at 10 000 yards; detection time must be less than 75 seconds with false-alarm probability not to exceed 0.10."

- "Operator at station X must process incoming messages at an average rate of 15 per hour ( $\pm 3$ ) with error rate not to exceed 0.05."

(2) Make a rough prediction of the quantity and quality of information flow (throughput) which might be expected of the typical operator under design load.

(3) Compare the predicted throughput with the performance goal. If the predicted quantity and quality of throughput both are equal to or better than the goal, operability may be considered to be satisfactory; if either quantity or quality is deficient, operability is unsatisfactory, and the design concept should be altered as necessary to attain the operability goal.

b. Maintainability. The recommended approach to preliminary maintainability parallels that for operability.

(1) Define the design goal. Maintainability goals are established by analysis of the system maintainability concepts and gross man-machine allocations. The current trend in electronic system design is toward increased automation of the maintenance functions of fault detection, diagnosis, isolation, and repair so that on the surface it might appear that human engineering would play a lesser role in the design of these systems in comparison to conventional (predominantly manual) maintenance systems. However, this is not necessarily and perhaps not generally the case. Decisions relative to automating maintenance functions will require more rather than less consideration of man and equipment capabilities/limitations, since it is a basic shift of maintainer responsibility, not an elimination of responsibility. Also, "automatic" systems are usually in fact semiautomatic; that is, some form of human participation is required. For example, programs must be loaded into the machine, controls operated, and displays monitored, read,

and interpreted. Finally, some maintenance functions cannot be automated economically; for example, removal, replacement, and repair of faulty modules.

(2) Make a rough prediction of the tasks and performance times for probable kinds of system malfunctions. Maintenance information flow charts are useful points of departure. Where operations and decisions have been assigned to machine execution, estimates for these processes must be supplied by the hardware/software specialists. These estimates are then subtracted from the stated system requirements for mean-time-to-repair to yield repair-time goals for the human maintainers.

(3) Compare the predicted performance with the goal. If predicted performance falls short of the goal, maintainability features of the design concept should be improved as necessary to attain goal performance.

**3.2.3.7 MAN-MACHINE FLOW CHARTING.** The purpose of man-machine flow charting is to aid in developing and evaluating concepts for each operator station.

The man-machine flow chart is concerned basically with the man-machine subsystem or operator station. It is similar in concept to the information flow chart (see fig. 3.3), but the decisions and operations with which it deals are confined to the man and the hardware and equipment closely associated with him rather than being representative of the system as a whole.

A separate man-machine flow chart is required for each manned station, as determined by the function allocation process. Figure 3.5 shows a sample man-machine flow chart for a hypothetical operation station—in this case, a tracker operating a computer-aided tracking console.

In preparing such a chart the human engineer should ensure that: all logical possibilities are included, all loops are completed or terminated in a valid exit, and all operations are performable by the operator. He must then develop answers to questions of the following kind: (a) how will each operator decision be made? (b) what are the criteria to be used for decision making? (c) what information requirements must be met to provide a basis for decision making? Answers to such questions provide the working material for the next step, preparation of the operator station input-output chart, which further defines and refines the operator station concept.

**3.2.3.8 INPUT-OUTPUT CHARTING.** The input-output chart (fig. 3.6) begins simply as the man-machine flow chart stripped of all symbol-connecting lines. Then inputs and outputs are added. Note that every operation has associated with it at least one output (or else why perform the operation in the first place?). Every decision has at least one new input (or else why is a decision necessary?). All inputs and outputs are indicated by arrows on the chart and are summarized in a tabular listing. If the input-output flow chart has been properly done, it will summarize all significant information categories which must be processed at the operator station.

**3.2.3.9 OPERATIONAL SEQUENCE DIAGRAMS (OSDs).** The OSD is a comprehensive means of showing major system functions and their interactions in sequential time. Together with the information flow

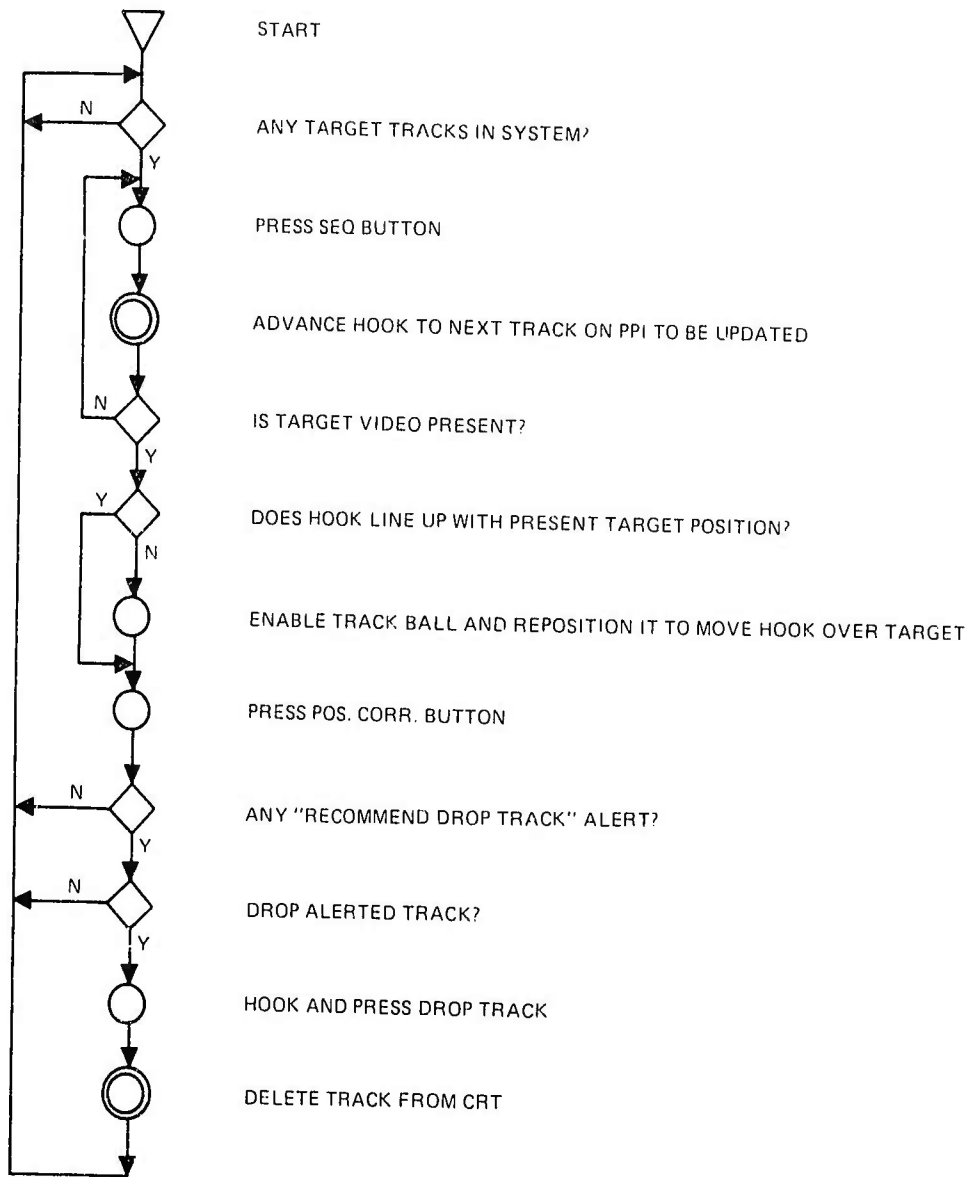
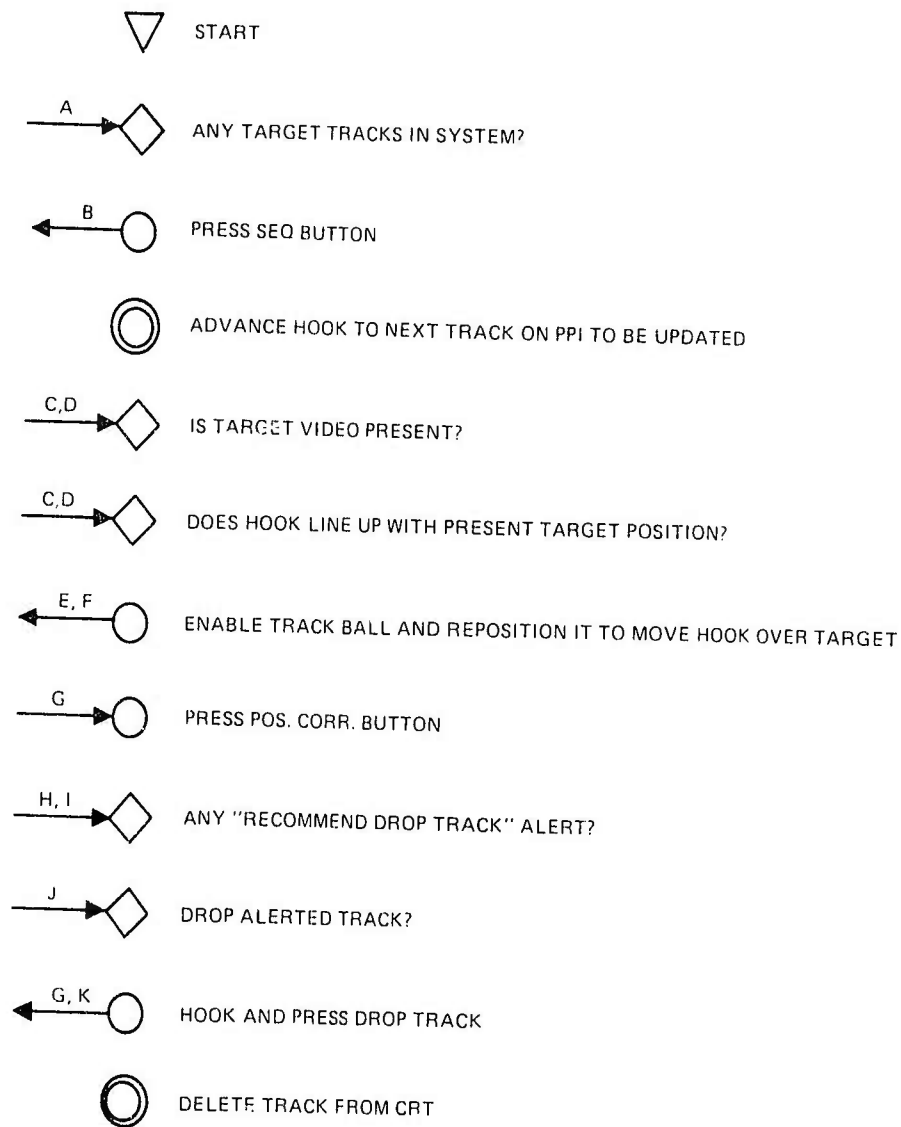

Figure 3.5. Man-machine flow chart.



INPUTS/OUTPUTS

- A. MARKERS ON CRT
- B. ORDER TO COMPUTER TO ADVANCE 1 STEP IN TRACK LIST
- C. VIDEO DISPLAY
- D. HOOK
- E. TRACK BALL ENABLE SIGNAL
- F. X AND Y FOR HOOK
- G. TARGET XY
- H. AUDITORY ALERT
- I. SPECIAL MARKER ON CRT TRACK
- J. IDENTIFY, THREAT, ENGAGEMENT STATUS
- K. DROP TRACK ORDER

Figure 3.6. Sample input-output chart.

charts and man-machine and input-output flow charts developed previously, it effectively completes the base upon which detailed human engineering requirements for information, control, and display will be evolved.

The OSD (fig. 3.7) uses a separate column for each operator, equipment station, or equipment unit to be analyzed. Each column shows the operations, decisions, delays, transmissions, and receipts pertinent to that particular system element. Because the OSD cannot conveniently accommodate extensive branching, separate OSDs must usually be prepared for each mode of operation, type of threat, level of manning, casualty condition, etc., which may be of interest.

One of the main virtues of the OSD is that all major information flow between system elements, as well as within system elements, is represented. This view of the system concept may expose difficulties, omissions, or incompatibilities which would not otherwise be detected. Revision of the man-machine concept is then in order. In any case, when selectively applied, the OSD is a powerful tool for identifying and solving interface problems and for laying the groundwork for developing human engineering design details.

It should be noted that the OSD and the information flow chart are two quite different kinds of system representation. The OSD emphasizes the main activities associated with each major station and the interfaces between stations. The information flow chart, on the other hand, emphasizes the network of decisions and operations pretty much irrespective of where they occur. The OSD is particularly valuable for detecting conditions of overload and underload as well as interface problems, whereas the information flow chart checks on the logical consistency of the system concept. Together they provide a firm base for evolving detailed human engineering requirements.

**3.2.3.10 OPERATOR FUNCTIONAL REQUIREMENTS WORKSHEET.** To help define functional requirements at operator/maintainer positions before progressing to detail design, the contractor may also prepare a functional requirements worksheet for each major task. This is particularly needed when the function involves a potentially heavy workload, unusual environmental stress protection, and/or unusual physical or cognitive demands (accurate manipulations, lifting heavy loads, making critical decisions, etc.). An example of such a worksheet is shown in exhibit 3.1.

**3.2.3.11 TIME-LINE ANALYSIS.** As part of the expansion of the man-machine analysis, the contractor will also ordinarily prepare a time-line analysis, at least for critical operator/maintainer positions. Time-line analysis is a descriptive chart which provides a graphic picture of an individual's workload by plotting his task involvement against a time-line base (see figure 3.8). Although the time-line analysis depicts individual activity, its greatest effectiveness is realized when several operator/maintainer positions are plotted together on the same graph (as shown in figure 3.8). This way unbalanced workload distributions among the listed individuals are readily apparent. As noted in the example, Operator A appears to bear the brunt of the task loading, therefore requiring some relief, either through automation

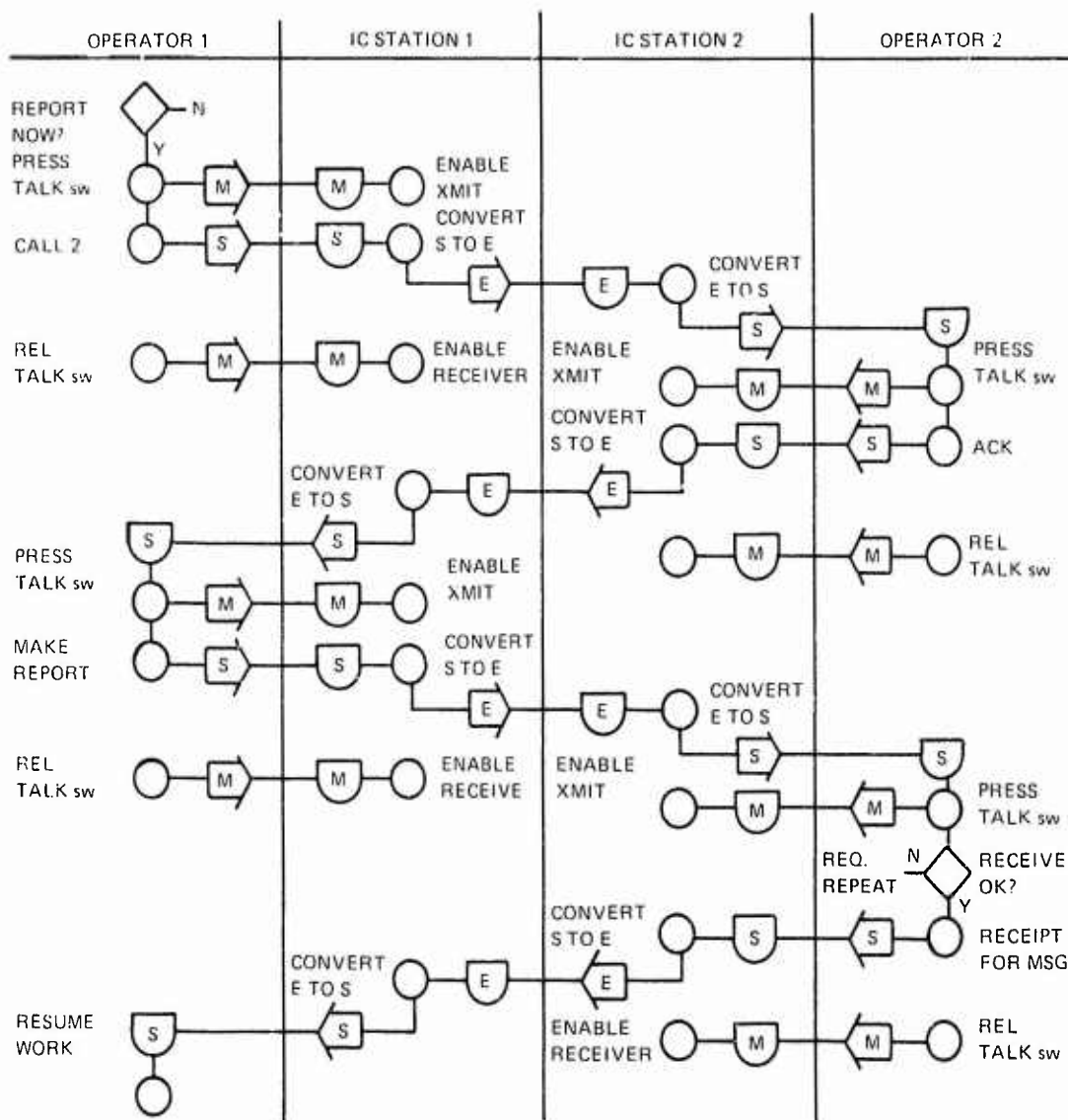

NOTES ON OPERATIONAL SEQUENCE DIAGRAM  
LINKS

SYMBOLS

- |   |                  |      |                      |
|---|------------------|------|----------------------|
| ◇ | DECISION         | M    | MECHANICAL OR MANUAL |
| ○ | OPERATION        | E    | ELECTRICAL           |
| ◀ | TRANSMISSION     | V    | VISUAL               |
| ◐ | RECEIPT          | S    | SOUND                |
| ◑ | DELAY            | ETC. |                      |
| ◒ | INSPECT. MONITOR |      |                      |
| ◓ | STORE            |      |                      |

STATIONS OR SUBSYSTEMS ARE SHOWN BY COLUMNS  
SEQUENTIAL TIME PROGRESSES DOWN THE PAGE

Figure 3.7. Sample operational sequence diagram: two-station intercom, with station 1 acting as originator.



EXHIBIT 3.1. PRELIMINARY OPERATOR FUNCTIONAL REQUIREMENTS WORKSHEET.

Function 4.1.2 Load xx projectile in x-1 breech block	PRELIMINARY OPERATOR FUNCTIONAL REQUIREMENTS WORKSHEET
SYSTEM/OP CONSTRAINTS: LOADING RATE = 2/MIN., SEA STATE 4	
<p>TASK DESCRIPTION: Monitor ammunition shaft delivery signal, open door, position projectile carriage, transfer projectile to carriage, move loaded carriage to loading position, open gun breech, transfer projectile to breech, check position, adjust fuse, close breech, notify fire control officer "ready."</p> <p>PHYSIOLOGICAL CONSIDERATIONS: Maximum lift capability for one man is 60 pounds; higher weights require special sling or method for direct roll-transfer of projectile.</p> <p>PSYCHOLOGICAL CONSIDERATIONS: Visual codes for identification and special calibration markings must be legible as well as visible under battle (red) lighting environment.</p> <p>SAFETY CONSIDERATIONS: Automatic door closure on ammunition delivery system and possible effects of ship roll require special indoctrination and drill to prevent accidents (e.g., closure of door on personnel) or loss of control of projectile.</p>	

or reallocation of tasks to the other operators. To perform a time-line analysis, the human engineer may need to enlist the help of persons familiar with similar functions in order to obtain a consensus of the time it takes to perform each given function. A more complete discussion of the time-line chart is presented in appendix B.

3.2.3.12 LINK ANALYSIS. This analytic tool is often used as a first step in developing an optimized panel, work station, or work area layout. Its purpose is to make a first estimate of the frequency with which various interactions occur between men and equipment and/or between man and man. The analyst first starts with the man and equipment interactions (links) established during the functional analysis, OSDs, and initial list of control-display interfaces. To this is added the man-man links which take the form of direct (voice) or indirect (radio, telephone, etc.) verbal conversations, walking from one place to another, etc. If the link analysis is being performed on a particular panel layout, there may be little of the man-man links involved. If the link analysis is performed on a CIC room, however, the man-man interactions will be extensive.

Beginning with a particular design (panel layout, room arrangement, etc.) all the interactions (links) required to perform a particular task are examined carefully in terms of the frequency with which they occur and the importance they hold in completing the task. The importance and frequency factors are assigned some value (usually on a scale of 3) primarily based on the analyst's previous experience or talks with similar system operators. When the frequency value is multiplied by the importance value, a "load" or "link" value is obtained. The panel, work area, etc., along with the links (with their load values) are drawn out on paper permitting a visual picture of all the interactions taking place with the system under investigation. The system design is then altered and the process repeated. In this way the design containing the fewest interactions, lowest link loads, and smallest operator work loads can be tentatively established. A brief description and accompanying example of the link analysis procedure is provided in appendix C.

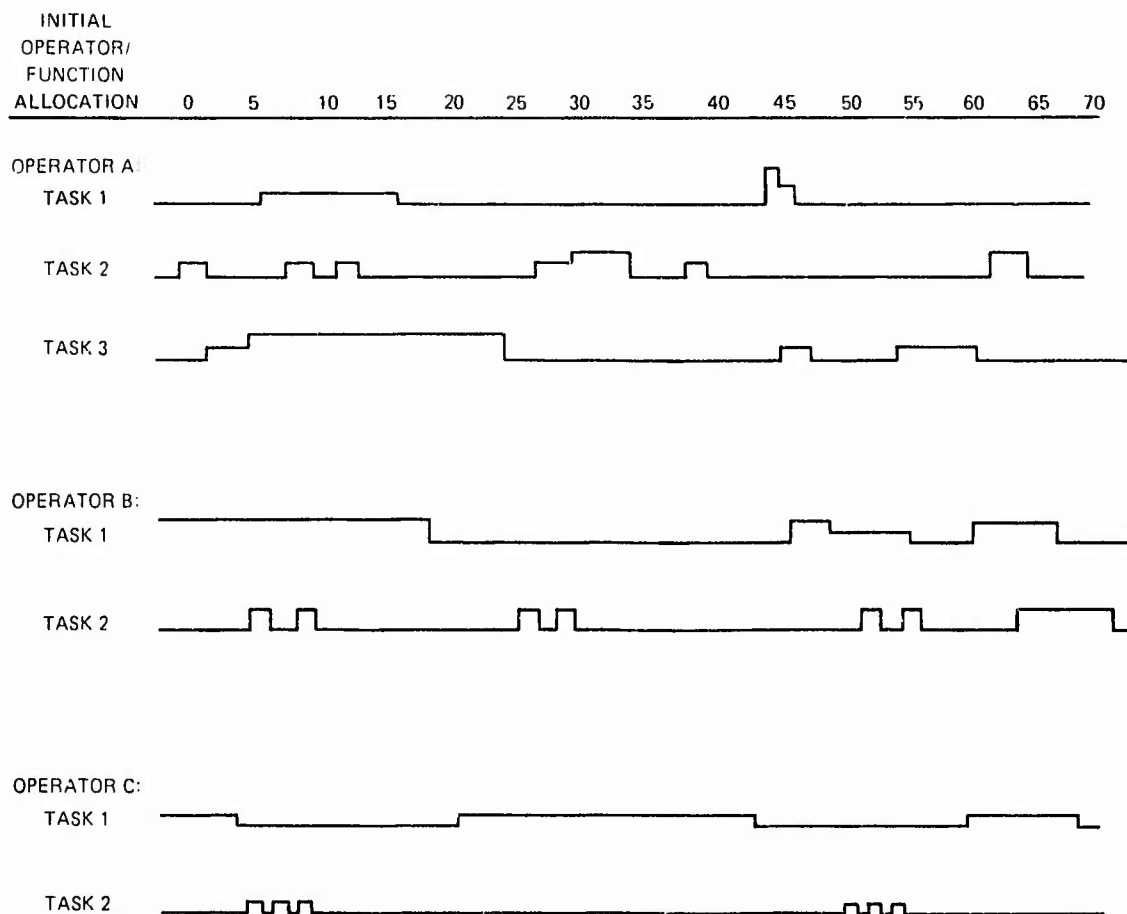

Figure 3.8. Typical time-line chart (relative effort vs time).

### 3.3 MAN-MACHINE DESIGN

#### 3.3.1 OVERVIEW

The human engineer makes his most direct impact on system development through recommendations on detail design. He provides specific design guidance in a timely fashion to engineering groups concerned with software, hardware, and environmental design as these interface with the operator/maintainer. The design guidance generally includes such things as recommended panel layout and arrangement, console form factor, and workspace arrangement and environmental controls. Equipment operating procedures, operational sequence diagrams, task analyses, etc. are provided the activity responsible for manpower development.

Usually, human engineering detail design is carried out by the development contractor. Navy human engineering personnel may be involved to the extent of monitoring the contractor's effort and ensuring compliance with applicable specifications and standards. In some situations, particularly one-of-a-kind developments, Navy human engineering personnel may have the responsibility for providing detail design guidance on human engineering aspects of the development. This section does not attempt to differentiate between functions performed by Navy in-house personnel and those performed by contractors; however, specific guidance with respect to contract monitoring is provided in section 4.

As pointed out earlier, to be effective human engineering must be introduced early in the system development cycle and carried through test and evaluation phases. The time when engineering designs are being finalized is particularly critical, however, because all the prior human engineering studies and analyses are wasted if the final drawings include major human engineering deficiencies. Unfortunately, it is sometimes left up to the equipment designer to decide when human engineering assistance is needed. The result can be that deficiencies are not caught until it is too late to do anything about them. Human engineers must begin working with the designers before they begin to make drawings. The human engineer and designer should come to an understanding about the design before the designer becomes ego-involved in his creation. It is extremely crucial at this point for the human engineer to establish the impression that he is there to help rather than hinder. It is also important to clarify the level to which human engineering drawing review is carried. It is generally safe to say that all top-level drawings should be reviewed and approved by the human engineering group. On the other hand, it is extremely wasteful to ask human engineers to review and approve every component drawing (small brackets, bolt and screw descriptions, etc.).

#### 3.3.2 PREREQUISITES TO DETAIL DESIGN

It is essential before proceeding with human engineering detail design that prior activities be properly performed and documented, although this need not be performed by the same group. Specifically, man-machine requirements must have been analyzed, and man-machine concepts developed.

Efforts on detail design should begin with a review of prior human engineering work. Earlier man-machine analyses should be expanded as necessary to provide a solid basis for proceeding with detail design.

3.3.2.1 CONTROL-DISPLAY DEFINITION. Human engineers should take a primary role in defining control-display requirements. Operator/maintainer functions should be examined and preliminary estimates made as to the numbers of displays required, including their types (shape, qualitative vs quantitative, etc.) and the basic display performance requirements (phosphor brightness, persistence, etc.). Normally a preliminary list of required displays is created jointly by human engineers and equipment engineers. To aid the equipment designer, human engineers should determine whether information should be displayed aurally, visually, or tactually and should specify certain critical features such as the format of visual signals and coding techniques. Criteria for these decisions may be found in several of the standard human engineering guides. The amounts and types of information to be displayed and controlled must be determined for the entire range of operational situations in which the system is to be used. The human engineer should then refine the control-display concepts as necessary to be sure the proposed man-machine configuration can handle the required information within the applicable time and accuracy constraints. It is essential at this point that the human engineer be in close contact with the responsible design engineers and that they cooperatively work out design details which are satisfactory from both the technical and human engineering standpoint.

### 3.3.3 SCOPE OF DETAIL DESIGN EFFORT

The following areas typically are covered in development of human engineering detail design:

- a. Selection and/or design of individual controls, displays, tools and operator aids.
- b. Configuration and layout of consoles, equipment racks, and control panels. (Link analysis techniques as described in appendix C may be helpful in working out the details of panel and workspace arrangements.)
- c. Maintenance accessibility, including openings and doors or covers, arrangement of components, selection of fasteners and connector hardware, and test point locations and identification.
- d. Arrangement of equipment and personnel within compartments.
- e. Illumination of display-control panels and compartment areas.
- f. Packaging of portable equipment in terms of compatibility with human limitations for handling and carrying.
- g. Workspace habitability and safety, including specification of temperature, humidity, ventilation, illumination, and noise limits for the work area.
- h. Life support requirements and implications for special protective garments and their effect on equipment interface design.

i. Special auxiliary support requirements including seats, test equipment, tools, cranes, forklifts, and elevators.

j. Special surface finishes (workspace and consoles), color selection, treatment of optical surfaces, etc.

k. Design and location of hatches, windows, stairs, ladders, etc., especially with reference to emergency egress.

Different types of systems will demand more emphasis on certain of the above human engineering considerations than others. Within the time and budget constraints of a particular program, priorities may have to be established for the contractor. The project manager should depend upon his human factors program manager to help establish these priorities so that the study results provide maximum design decision information in the areas which are most critical. The key human factors criteria for defining such priorities in order of importance are: (1) personnel safety, (2) operator/maintainer performance efficiency, and (3) personnel comfort.

#### 3.3.4 THE SYSTEM HUMAN ENGINEERING SPECIFICATION

Early in the prototype development program (usually during pre-design) a project-specific specification document of human engineering design criteria should be prepared. Comprised of pertinent data extracted from various human engineering specifications, standards, and other material, this document will eliminate the need for equipment designers to pore over unrelated specifications themselves to find the data they need. The specification should be tailored to the design effort; that is, it should be organized according to major design problems or end items. For example, if consoles are to be designed, the document should be organized so that all the information necessary to complete the console design is included under that heading. It is a common fault of many such documents that they are organized under headings familiar to the psychologist—for example, visual problems, anthropometric considerations, and environmental requirements and are thus of limited use to equipment designers.

The human engineering specification should include a summary checklist which can be used as a prompter for the equipment designer and for the human engineer when checking the designer's final product design. The summary checklist should be given to each equipment designer at the start of the prototype program, since it is very important that the designer know ahead of time what the human engineer will be looking for when he reviews final drawings. A typical summary checklist is shown in exhibit 3.2. In the sample checklist all that is requested of the evaluator is a checkmark to indicate that the design appears to be satisfactory (S) for the item in question, the design is controversial (C) and requires additional investigation before approval will be given, or the design is considered to be unsatisfactory (U) and must be changed before approval can be given. In the case of a (C) or (U) the human engineer should go directly to the responsible designer and discuss the problem as he sees it. Hopefully, a

### EXHIBIT 3.2. SUMMARY CHECKLIST

<p><b>A. EQUIPMENT OPERATION</b></p> <p><b>1. CONSOLE SHAPE/SIZE</b></p> <ul style="list-style-type: none"> <li>a. Desk height, area</li> <li>b. Control reach</li> <li>c. Display view</li> <li>d. Body, limb clearance</li> </ul>	<table border="1" style="width: 100%; height: 100%; border-collapse: collapse;"> <thead> <tr> <th style="width: 33%;">S</th> <th style="width: 33%;">C</th> <th style="width: 33%;">U</th> </tr> </thead> <tbody> <tr><td> </td><td> </td><td> </td></tr> <tr><td> </td><td> </td><td> </td></tr> <tr><td> </td><td> </td><td> </td></tr> <tr><td> </td><td> </td><td> </td></tr> </tbody> </table>	S	C	U													<p><b>3. CHASSIS LAYOUT, PACKAGING</b></p> <ul style="list-style-type: none"> <li>a. Ease of handling</li> <li>b. Access to components for test (component) replacement</li> <li>c. Identification</li> <li>d. Hazard/damage protection</li> </ul>	<table border="1" style="width: 100%; height: 100%; border-collapse: collapse;"> <thead> <tr> <th style="width: 33%;">S</th> <th style="width: 33%;">C</th> <th style="width: 33%;">U</th> </tr> </thead> <tbody> <tr><td> </td><td> </td><td> </td></tr> <tr><td> </td><td> </td><td> </td></tr> <tr><td> </td><td> </td><td> </td></tr> <tr><td> </td><td> </td><td> </td></tr> <tr><td> </td><td> </td><td> </td></tr> </tbody> </table>	S	C	U																		
S	C	U																																					
S	C	U																																					
<p><b>2. PANEL LOCATION</b></p> <ul style="list-style-type: none"> <li>a. Frequency of use</li> <li>b. Sequence of use</li> <li>c. Emergency response</li> <li>d. Multioperator use</li> </ul>	<table border="1" style="width: 100%; height: 100%; border-collapse: collapse;"> <tbody> <tr><td> </td><td> </td><td> </td></tr> <tr><td> </td><td> </td><td> </td></tr> <tr><td> </td><td> </td><td> </td></tr> <tr><td> </td><td> </td><td> </td></tr> </tbody> </table>													<p><b>4. CABLES/LINES/CONNECTIONS</b></p> <ul style="list-style-type: none"> <li>a. Ease and security of assembly-disassembly</li> <li>b. Connection error</li> <li>c. Identification</li> <li>d. Access, test, trouble-shooting, replacement</li> </ul>	<table border="1" style="width: 100%; height: 100%; border-collapse: collapse;"> <tbody> <tr><td> </td><td> </td><td> </td></tr> <tr><td> </td><td> </td><td> </td></tr> <tr><td> </td><td> </td><td> </td></tr> <tr><td> </td><td> </td><td> </td></tr> <tr><td> </td><td> </td><td> </td></tr> </tbody> </table>																								
<p><b>3. PANEL LAYOUT</b></p> <ul style="list-style-type: none"> <li>a. Functional grouping</li> <li>b. Sequential organization</li> <li>c. Identification</li> <li>d. Spacing for clearance</li> </ul>	<table border="1" style="width: 100%; height: 100%; border-collapse: collapse;"> <tbody> <tr><td> </td><td> </td><td> </td></tr> <tr><td> </td><td> </td><td> </td></tr> <tr><td> </td><td> </td><td> </td></tr> <tr><td> </td><td> </td><td> </td></tr> </tbody> </table>													<p><b>C. SYSTEM SAFETY</b></p> <p><b>1. PERSONNEL HAZARDS</b></p> <ul style="list-style-type: none"> <li>a. Shock</li> <li>b. Burns: direct, chemical</li> <li>c. Hearing damage</li> <li>d. Tripping/falling</li> <li>e. Pinching</li> <li>f. Cutting</li> <li>g. Bumping</li> </ul>	<table border="1" style="width: 100%; height: 100%; border-collapse: collapse;"> <tbody> <tr><td> </td><td> </td><td> </td></tr> <tr><td> </td><td> </td><td> </td></tr> <tr><td> </td><td> </td><td> </td></tr> <tr><td> </td><td> </td><td> </td></tr> <tr><td> </td><td> </td><td> </td></tr> </tbody> </table>																								
<p><b>4. DISPLAYS</b></p> <ul style="list-style-type: none"> <li>a. Functional compatibility for intended purposes</li> <li>b. Intelligibility of information content</li> <li>c. Control interaction</li> <li>d. Legibility: figures, pointers, scales</li> <li>e. Visibility: illumination, parallax</li> <li>f. Location</li> <li>g. Identification</li> </ul>	<table border="1" style="width: 100%; height: 100%; border-collapse: collapse;"> <tbody> <tr><td> </td><td> </td><td> </td></tr> <tr><td> </td><td> </td><td> </td></tr> <tr><td> </td><td> </td><td> </td></tr> <tr><td> </td><td> </td><td> </td></tr> <tr><td> </td><td> </td><td> </td></tr> <tr><td> </td><td> </td><td> </td></tr> <tr><td> </td><td> </td><td> </td></tr> <tr><td> </td><td> </td><td> </td></tr> </tbody> </table>																									<p><b>2. EQUIPMENT DAMAGE</b></p> <ul style="list-style-type: none"> <li>a. Electrical overload, short, ground</li> <li>b. Mechanical overload, strip, bend, rupture, break</li> <li>c. Explosion/fire</li> </ul>	<table border="1" style="width: 100%; height: 100%; border-collapse: collapse;"> <tbody> <tr><td> </td><td> </td><td> </td></tr> <tr><td> </td><td> </td><td> </td></tr> <tr><td> </td><td> </td><td> </td></tr> <tr><td> </td><td> </td><td> </td></tr> </tbody> </table>												
<p><b>5. CONTROLS</b></p> <ul style="list-style-type: none"> <li>a. Functional compatibility for intended purpose</li> <li>b. Location, motion, excursion, and force</li> <li>c. Display interaction</li> <li>d. Spacing, clearance, size</li> <li>e. Identification</li> </ul>	<table border="1" style="width: 100%; height: 100%; border-collapse: collapse;"> <tbody> <tr><td> </td><td> </td><td> </td></tr> <tr><td> </td><td> </td><td> </td></tr> <tr><td> </td><td> </td><td> </td></tr> <tr><td> </td><td> </td><td> </td></tr> <tr><td> </td><td> </td><td> </td></tr> <tr><td> </td><td> </td><td> </td></tr> </tbody> </table>																			<p><b>D. GENERAL</b></p> <p><b>1. LABELS/MARKING</b></p> <ul style="list-style-type: none"> <li>a. Intelligibility</li> <li>b. Legibility</li> <li>c. Location, spacing</li> <li>d. Permanence</li> </ul>	<table border="1" style="width: 100%; height: 100%; border-collapse: collapse;"> <tbody> <tr><td> </td><td> </td><td> </td></tr> <tr><td> </td><td> </td><td> </td></tr> <tr><td> </td><td> </td><td> </td></tr> <tr><td> </td><td> </td><td> </td></tr> </tbody> </table>																		
<p><b>B. ASSEMBLY SERVICES MAINTENANCE</b></p> <p><b>1. INSTALLATION, SERVICE, &amp; MAINT ACCESSIBILITY</b></p> <ul style="list-style-type: none"> <li>a. Location, size of openings</li> <li>b. Covers, fastening/removal</li> <li>c. Identification</li> </ul>	<table border="1" style="width: 100%; height: 100%; border-collapse: collapse;"> <tbody> <tr><td> </td><td> </td><td> </td></tr> <tr><td> </td><td> </td><td> </td></tr> <tr><td> </td><td> </td><td> </td></tr> </tbody> </table>										<p><b>2. EQUIPMENT FINISH</b></p> <ul style="list-style-type: none"> <li>a. Color</li> <li>b. Texture</li> <li>c. Reflectivity</li> </ul>	<table border="1" style="width: 100%; height: 100%; border-collapse: collapse;"> <tbody> <tr><td> </td><td> </td><td> </td></tr> <tr><td> </td><td> </td><td> </td></tr> <tr><td> </td><td> </td><td> </td></tr> </tbody> </table>																											
<p><b>2. EQUIPMENT HANDLING/TRANSPORT</b></p> <ul style="list-style-type: none"> <li>a. Size/shape/weight/balance</li> <li>b. Handling clearance</li> <li>c. Handling aids</li> <li>d. Instructions/labels/warnings</li> </ul>	<table border="1" style="width: 100%; height: 100%; border-collapse: collapse;"> <tbody> <tr><td> </td><td> </td><td> </td></tr> <tr><td> </td><td> </td><td> </td></tr> <tr><td> </td><td> </td><td> </td></tr> <tr><td> </td><td> </td><td> </td></tr> </tbody> </table>													<p><b>3. STORAGE</b></p> <ul style="list-style-type: none"> <li>a. Location</li> <li>b. Volume</li> <li>c. Material accessibility, security</li> </ul>	<table border="1" style="width: 100%; height: 100%; border-collapse: collapse;"> <tbody> <tr><td> </td><td> </td><td> </td></tr> <tr><td> </td><td> </td><td> </td></tr> <tr><td> </td><td> </td><td> </td></tr> <tr><td> </td><td> </td><td> </td></tr> </tbody> </table>																								
		<p><b>4. WORK AREA ILLUMINATION</b></p> <ul style="list-style-type: none"> <li>a. Light level: range, control</li> <li>b. Distribution, contrast</li> <li>c. Color</li> </ul>	<table border="1" style="width: 100%; height: 100%; border-collapse: collapse;"> <tbody> <tr><td> </td><td> </td><td> </td></tr> <tr><td> </td><td> </td><td> </td></tr> <tr><td> </td><td> </td><td> </td></tr> </tbody> </table>																																				

S = Satisfactory  
 C = Controversial  
 U = Unsatisfactory

solution can be worked out directly with the designer. In some cases the designer may have a constraint (lack of space, structural problem, etc.) which prevents any alternative solution. In such cases the human engineer may then give approval, but will record this information in his personnel-equipment file for future reference and progress reporting. In isolated cases in which an agreement cannot be reached, the question may have to be resolved by higher authority. The human engineer should prepare a brief summary of the facts in defense of his position both to help higher authority to make the final decision and also to record the fact that he did not agree with the design and the reason he did not agree with it. This is extremely important if he expects a probable operational problem later on and must show cause why the design was not properly human engineered. Critical deficiencies should be brought to the attention of the Navy human factors program manager as soon as possible.

### 3.3.5 TASK-EQUIPMENT ANALYSIS

As each of the proposed hardware end item designs becomes sufficiently well defined, the human engineer should examine the apparent operator/maintainer tasks implied by the design and begin to create narrative task descriptions. This effort has two purposes. The first is that such an analysis may uncover problems of task procedure which suggest modification of the design; the second is that a task description is required to identify manning, training, and training equipment requirements. The human engineer normally requires for each design, the drawings which describe the internal electromechanical processes and input-output interfaces, a copy of the operator control panel drawing, and other basic operational descriptive materials such as the OSDs. He will then visualize the operating procedure and describe it in detail from the time the equipment is prepared for operation or maintenance to the time it is shut down. Once a preliminary description of the operating task is completed, it should be reviewed with the original designer to elicit comments. In many cases, it may occur that the human engineer's interpretation of how the equipment will be operated differs from what the designer intended. Such differences must be resolved. In some cases, this may require discussion with more than one engineer, since responsibility for the electrical and mechanical aspects of a given system may lie with different designers. There have been occasions on which the design of an electro-mechanical system resulted in incompatibilities brought about by lack of communication between the electrical and mechanical engineers. The human engineer's attempt to describe the operator procedure immediately exposes such incompatibilities.

Use of a worksheet such as shown in exhibit 3.3 is recommended for recording the data from the task-equipment analysis.

EXHIBIT 3.3. SAMPLE TASK ANALYSIS WORKSHEET.

1. Job Operation Prepare Swimmer Delivery Vehicle (SDV) for Launch		2. Task Title Replenish Breathing Gas Supply		3. Location of Task Performance on Dock or in Water		4. Source Reference SDV Spec.		5. Operational Site Worldwide	
EQUIPMENT DATA					PERSONNEL DATA				
6. Equipment Required Breathing Gas Supply Pump and Containers Pressure Gauge		CSE Required Breathing Gas Supply Containers		7. Source Reference None	8. Number of Personnel 2	9. Recommended Position Title Vehicle Maintenance Man		10. Applicable Rating BM	
TASK PERFORMANCE DATA									
11. Time Required Hours <u>0</u> Minutes <u>25</u>		12. Frequency Day   Week   Month Unknown		13. Probable Error Low on Land Mod. in Water		14. Speed <input type="checkbox"/> 1. Not Critical <input checked="" type="checkbox"/> 2. Moderately Critical <input type="checkbox"/> 3. Highly Critical		15. Positioning & Handling Equipment/Special Care Required <input type="checkbox"/> 1. Little <input type="checkbox"/> 3. Considerable <input checked="" type="checkbox"/> 2. Moderate	
16. Manipulating Controls <input type="checkbox"/> None <input type="checkbox"/> Pushbuttons <input checked="" type="checkbox"/> Hand Valves <input type="checkbox"/> Cont. Auditory Feedback <input type="checkbox"/> Toggle Switches <input type="checkbox"/> Cont. Visual Feedback <input type="checkbox"/> Selector Switches					17. Source of Special Dangers <input type="checkbox"/> None <input checked="" type="checkbox"/> Explosive* <input type="checkbox"/> Toxic Substances <input type="checkbox"/> Mechanical <input type="checkbox"/> Temperature <input type="checkbox"/> Electrical <input type="checkbox"/> Volatile Fuels <input type="checkbox"/> Other <small>*Poss. of over-pressurization or filling system with wrong breathing gas.</small>				
TRAINING DATA									
18. Nature of Procedure <input type="checkbox"/> Fixed <input checked="" type="checkbox"/> Motor Skill <input type="checkbox"/> Circuit Analysis <input checked="" type="checkbox"/> Variable <input type="checkbox"/> System Analysis				19. Technical Manual Function <input type="checkbox"/> Primary <input checked="" type="checkbox"/> Secondary		20. Training Difficulty <input type="checkbox"/> Easy <input type="checkbox"/> Hard <input checked="" type="checkbox"/> Moderate		21. Train. Eq. Catg. <input type="checkbox"/> Complex <input checked="" type="checkbox"/> Simple <input type="checkbox"/> None	
22. Technical Manual Title Life Support System. Maintenance and Replenishment of SDV-TR-013				23. Training Course Title Life Support System Repair and Replenishment of SDV					
24. Task Performance Date <input type="checkbox"/> Estimated <input checked="" type="checkbox"/> Tried (Mock-up) <input type="checkbox"/> Tried (Hardware)		25. Equipment Development Status <input type="checkbox"/> Design Plan <input type="checkbox"/> Preliminary Design <input type="checkbox"/> Mock-up <input checked="" type="checkbox"/> Prototype <input type="checkbox"/> Production Design <input type="checkbox"/> Production Equipment			26. Narrative Task Information. Remove skin cover plate over life support quick-connect fitting. Attach gas supply nozzle to boat, open supply valve, and monitor flow rate. Shut off valve when pressure reaches 2800 psi. Disconnect supply and check for leaks at nozzle. Replace skin cover.				



### 3.3.6 MOCK-UPS

Some type of mock-up study is generally required for most system developments. Although most people are familiar with the very elaborate and complete full-scale soft mock-ups (total aircraft fuselage, complete interior layout of a CIC, etc.), they often are not aware of the value of studying other types of mock-ups.

The following is a listing of possible mock-ups which might be utilized during prototype equipment development:

a. Small-scale mock-ups are useful to show a three-dimensional overview of system elements. Because of the small scale, large or complex systems of prime and/or supporting equipments can be arranged and viewed in several configurations to study design alternatives and possible problem areas which cannot be examined with full-scale models. Due to the small size of such mock-ups, they can be transported to local or distant conferences. Such models can also be photographed in several arrangements to provide a record of trade-off analyses or used as a means of simplifying communication of ideas between persons isolated from the contractor's facilities. A typical 1/12-scale mock-up of a working space is shown in figure 3.9.

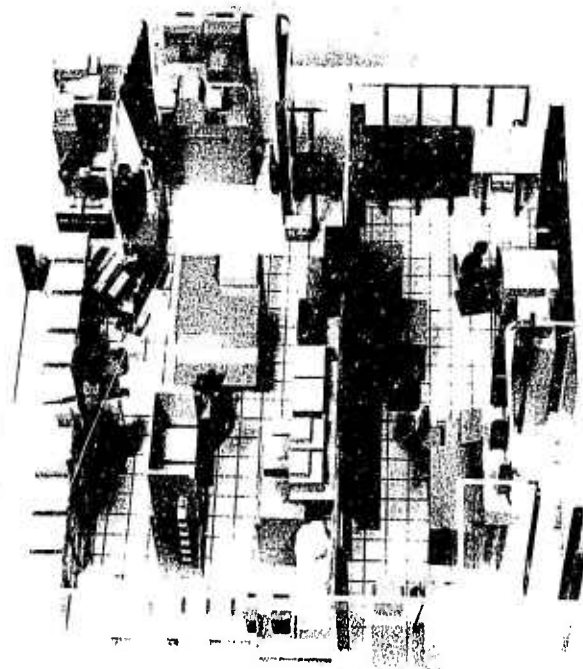

Figure 3.9. USS BELKNAP (DLG 26) CIC (1/12 scale).

b. Full-scale soft mock-ups are used to demonstrate actual size, shape, and location characteristics relative to typical operator/maintainer operations. Such mock-ups may be made of wood, cardboard, and/or a combination of these materials plus certain hardware components. Because some project managers view the full-scale soft mock-up as a sales tool more than a design evaluation tool, the mock-ups are often constructed in a way that negates easy changes. From a human factors design point of view this creates an untenable constraint on the utility of the mock-up as a technique for study purposes, and fabrication costs are increased appreciably.

Design evaluation mock-ups should be designed and constructed for ease in changing major features. For example, controller positions, panel layouts, seating, work space arrangements, and other features should be capable of quick and simple alterations without extensive assistance from shop personnel. A full-scale mock-up of this type using movable magnetically-attached panel hardware is shown in figure 3.10.

It is not always necessary to create mock-ups of a complete system for human factors study purposes. It may be advantageous to consider several partial system mock-ups; such as mock-ups of only a part of a work station, an entryway and hatch, and a single maintenance bay. In addition, it is not necessary for a mock-up to be attractive, as long as it contains the critical features necessary for evaluation. Since time is usually of the essence during prototype development, mock-up studies are of little value unless they can be completed in time to contribute to design decisions. If the prototype contractor prepared a full-scale mock-up during a contract definition study, he should be encouraged to utilize it (with appropriate modifications) wherever feasible rather than incur the expense of preparing a completely new one.

c. Hard mock-ups are used to check component installation features and to provide a model for production work. Generally constructed of materials similar to those of the final prototype equipment, these mock-ups are of value to the human engineer primarily in the area of evaluating ease of maintenance (for example, accessibility for inspection, removal, and replacement of components). Usually such mock-ups are located in the contractor's factory near the fabrication line. This allows production workers to check installation plans directly against a finalized model.

Human engineering uses of any or all of the above mock-up types include the following:

a. To check out anthropometric relationships (body size and limits) at operator/maintainer and equipment locations, including visual envelopes, arm reach requirements, clearance features, seating, and ingress and egress.

b. To check out lighting conditions, both ambient and proposed internal systems, glare, reflection, color, quality, and levels.

c. To check out interface characteristics between special operator protective garments and life support equipment with system connector hardware, seats and restraints, and general mobility of the operator.

d. To check out arrangement of work space in terms of convenience, ease of identification, and functional efficiency.

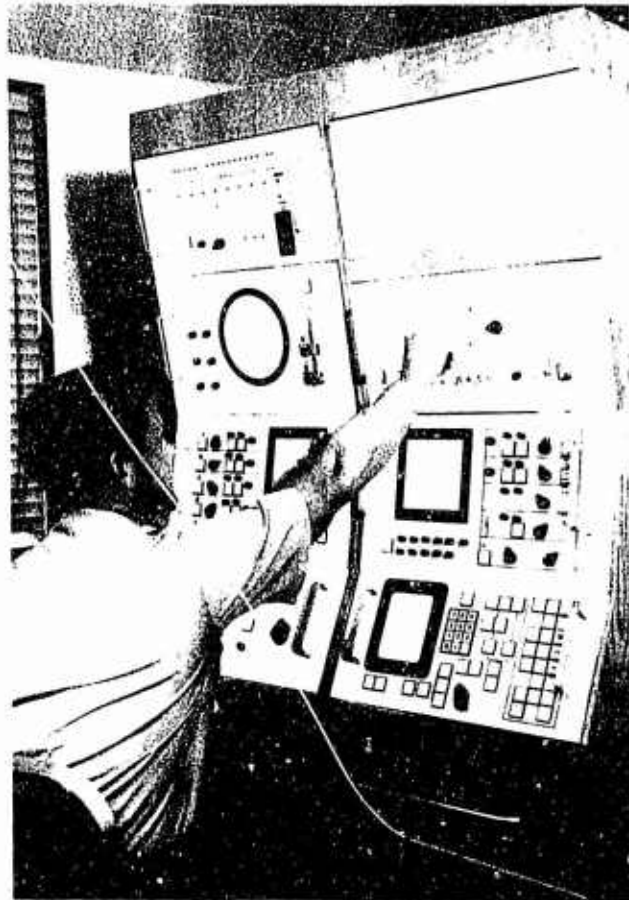

Figure 3-10. Electronic warfare console mock-up.

- e. To check out ease of manipulation and transport of equipment within work and maintenance areas.
- f. To evaluate general traffic-flow and equipment arrangement efficiency, considering routing of hard power and communication lines (electrical, pneumatic, and hydraulic lines; telephone cables; etc.).
- g. To evaluate suitability of labels and nomenclature.
- h. To perform time and motion studies.
- i. To obtain operator reaction.

### 3.3.7 DOCUMENTATION

Documentation of human engineering detail design work takes various forms including:

- a. Sketches of proposed panel layouts, console designs, workspace arrangements, etc., for use by engineering personnel.
- b. Photographs of mock-ups.

- c. Reports of analyses and studies pertinent to detail design.
- d. Memoranda of recommendations to project management and engineering personnel.
- e. Interim and final human engineering and project reports.

### 3.4 DESIGN VERIFICATION

#### 3.4.1 OVERVIEW

Ideally, if proper system development practices are followed and human engineering attention is provided on a continuous basis, the completed man-machine system will work according to expectation. In this ideal sense design verification is incorporated at each stage of the development as it progresses, thereby rendering final test programs superfluous. It is well to strive for this ideal, but in a practical sense it cannot be attained, at least not entirely. What does make sense is to do the bulk of design verification as early as possible in the development when costs for changes are minimal. Even when this is done, however, human engineering tests must be included in final technical and operational evaluations to confirm satisfactory man-machine performance.

The objectives of human engineering design verification, whether done early or as part of final test programs, include the following:

- a. To verify the maximum human performance effectiveness has been achieved.
- b. To establish that task requirements and crew skill levels are compatible.
- c. To verify that work space arrangements are compatible with human anthropometrics.
- d. To evaluate the crew work loads and verify that they are compatible with the operating environment and job requirements.
- e. To verify that operating procedures are optimized.
- f. To establish that job aids are adequate and effective.
- g. To evaluate crew training programs to assure that human capability matches that of the equipment.
- h. To verify crew safety on all aspects of system design and operation.

#### 3.4.2 NAVY RESPONSIBILITIES

During early phases of development done by the Navy in-house, the Navy human engineering team performs design verification functions as work progresses. When development is contracted out, the Navy human engineering team must assess the adequacy of the contractor's test program and monitor its progress. (See section 4.) The Navy is again actively involved with human engineering design verification when prototype equipments and systems are delivered to the Navy for operational evaluation.

Three major categories of test and evaluation are defined in OPNAV-INST 3960.8 of 22 January 1973. These are: developmental test and evaluation (DT&E), operational test and evaluation (OT&E), and acceptance trials. Each is discussed briefly below.

3.4.2.1 DEVELOPMENT TEST AND EVALUATION. These tests are conducted by the developing agency or its contractors. Their purpose is to facilitate the evolution of a system, with the end objective that production versions will meet the requirements stated in the Development Concept Paper or comparable acquisition document. All critical human engineering features affecting operability and maintainability should be included in the development tests.

Such tests are typically conducted within a Navy laboratory or at a contractor's plant.

One of the virtues of the development test is that performance can be measured under carefully controlled and defined conditions. This is unlike the operational evaluation, which tends to be realistic, but, for this reason, not to provide strict control and manipulations of all variables.

3.4.2.2 OPERATIONAL TEST AND EVALUATION. In the Navy "operational testing and evaluation" is handled by an independent testing agency, the Operational Test and Evaluation Force (OPTEVFOR), based on the East Coast at Norfolk and on the West Coast at San Diego.

As described in Chapter 3, Volume II, of COMOPTEVFORINST 3930.1, COMOPTEVFOR is required to verify the suitability, from a human factors standpoint, of Navy systems proposed for fleet service. Principally, human engineering efforts during OPEVAL are limited to verifying that the system meets the requirements of MIL-H-46855 and MIL-STD-1472. This objective is met by an assessment of at least the following aspects of system design:

- a. Maintainability
- b. Workspace design
- c. Special tool requirements
- d. Communications
- e. Environmental conditions
- f. Hazards and safety
- g. Work cycles
- h. Adherence to design specifications for such things as control-display relationships, visual and auditory displays, controls, labeling, and anthropometric (body measurement) factors

As each system is submitted to OPTEVFOR for evaluation, an OPEVAL test plan is prepared. If the system is small and uncomplicated, or if work loads are severe, the human engineering tests may be left to the overall OPEVAL test project manager. If the system is large and complex, or if the OPEVAL project manager requests direct support, then the human engineering test program may be handled by human engineering personnel brought in from Navy laboratories.

Assessment of system human engineering status is obtained via a series of tests conducted during OPFVAL. One such test is the H-1A, "Master Check List for Human Engineering." Used extensively, but especially in those cases in which the evaluation is being directed only by the project officer, this checklist is basically MIL-STD-1472 adapted to COMOPTEVFOR use. The H-1A test is used on almost every OPTEVFOR evaluation program, and additional human engineering tests involving direct observation and recording may be used if either the project officer or human engineer deems it advisable. When appropriate, noise and illumination levels are also sampled as part of the human engineering tests. On occasion, human engineering variables are included with other test variables in the Operational Acceptability Tests (O-Tests).

At the conclusion of the OPTEVFOR tests a report is prepared describing system deficiencies. This report should contain a human engineering section complete with photographs illustrating human engineering problems.

In general, operational testing may be in any one of the three following categories.

a. Initial operational test and evaluation (IOT&E). This includes the testing accomplished by or under the supervision of OPTEVFOR prior to the first major production decision. Such tests are often conducted by operational personnel on production prototypes to determine reliability, operability, compatibility, maintainability, and supportability prior to going into production.

b. "Follow-on operational test and evaluation (FOT&E)" is the continuing test and evaluation conducted under fleet conditions by operational personnel under OPTEVFOR direction. The purposes of FOT&E include: (1) verification of system performance under operational conditions, (2) validation of the corrections made for previously identified deficiencies, (3) refinement of tactical employment doctrine, and (4) validation of the requirements for personnel and training. FOT&E may be initiated either with production prototype or initial production systems.

c. Acceptance Trials. The Board of Inspection and Survey is responsible to the Chief of Naval Operations for conducting acceptance trials of new ships and aircraft models prior to Navy acceptance from the contractor. The Board inspects the material condition of ships and aircraft and requires demonstrations of equipment and systems to ensure that performance meets contract specifications and satisfies Navy requirements.

### 3.4.3 TEST PLANNING

Careful attention must be given to test planning in order to get the desired results at reasonable cost. So as to save time and cost, human engineering tests should be combined with other tests whenever this can advantageously be done.

The test plan should include the test objectives, descriptions of the test system, criteria to be used, procedures, instrumentation, test

personnel, simulation requirements, and testing sequences. It is also important that it include a specific treatment of how the data will be reduced and analyzed. This is essential to ensure that the provisions for data gathering are sound and reasonable.

The question of the degree of realism to be incorporated in the test must be carefully considered. It should also be recognized that there is a trade-off between realism and degree of control. That is, if a test is to be conducted under carefully controlled conditions akin to those in a psychology laboratory, operational realism must be sacrificed. Conversely, if a test is conducted under highly realistic operational conditions, many factors are completely out of the experimenter's control. What is usually done is to test specific man-machine relationships under highly controllable laboratory-type conditions, but to test the entire system under more nearly representative operational conditions. For example, if performance on a new keyset is to be tested, it can be done under rigidly-controlled experimental conditions including precisely-generated and repeatable simulated inputs. On the other hand, testing of a new intercept control system cannot use a "canned" repeatable simulation, because operator actions influence the behavior of the interceptor and the target. A similar situation holds in all complex man-machine systems in that there is operator-to-operator and operator-to-environment interaction which precludes use of a rigid simulation. The best that can be done in these situations is to make the runs qualitatively similar (where this is desired) by presenting the same initial test situation and making similar perturbations during the course of the test run.

Test planners should be familiar with experimental design procedures and good test practice insofar as validity and reliability of the tests are concerned. There are many standard reference works covering these topics.

#### 3.4.4 METHODS APPROPRIATE FOR TEST AND EVALUATION

3.4.4.1 ITERATIVE USE OF ANALYTIC TOOLS. During the development process, the human engineer uses a number of analytic tools as described in sections 3.2 and 3.3. Selected use of these tools in an iterative fashion is appropriate to verify that the system as realized really operates in the way in which it was assumed to operate during development. It should be noted that the same tool — operational sequence diagramming — may be used, but it is used to record what actually takes place rather than to analyze what should take place. Using these tools to record, the human engineer can spot overloading, interface problems, etc., with respect to the actual flow of information.

3.4.4.2 QUESTIONNAIRE AND INTERVIEW TECHNIQUES. The questionnaire and interview are useful to get information which cannot be obtained by direct observation. By going directly to operators, maintainers, and users with properly structured questionnaires or interviews, the following kinds of information can be derived:

- a. Unusual problems in operation and maintenance of the same or similar systems

- b. Ideas for improved procedures and practical equipment modifications
- c. Estimates of processing times and error rates under various conditions
- d. User acceptability
- e. Interfacing problems with other systems

Questionnaires and interviews must be planned and used judiciously so as to be able to elicit the needed information, but not impose excessive burden on operational personnel.

3.4.4.3 DIRECT OBSERVATION. A great deal of evaluative-type information can be obtained by direct observation, especially when done in accordance with a carefully prepared checklist. Some observations are best made under static conditions, as for instance inspecting console panels for human engineering suitability of scale design, legends, illumination, etc. Other observations can be made only under actual operating conditions, including, for instance, the time required to complete operation or maintenance functions. A sample checklist designed to apply to both operability and maintainability factors is included in appendix D.

3.4.4.4 DATA RECORDING. As used here, data recording means collection of quantitative data or reproducible sequences by means of instrumentation such as counters, event recorders, XY plotters, and audio and video tapes. These may be an integral part of the test system, but more often than not must be interfaced with it. The matter of the interface is often extremely important because, in many situations, the recording equipment must not intrude electrically, mechanically, or psychologically with the man-machine system under test. An example of a non-intrusive recording system is OPREDS, recently developed by NELC's Human Factors Technology Division. OPREDS is designed to record operator actions at up to 15 NTDS consoles. It interfaces with NTDS at the buffer amplifier, but in no way interferes with the NTDS hardware or software functioning.

Data recording must be used judiciously, not only to avoid interfering with the operational system, but also because recording and analysis of unnecessary data can seriously inflate the cost of the test and evaluation program. Particularly during OPEVALS, there are so many variables that can affect performance that the candidates for recording must be selected with care. Also, it should be noted that many variables are slow-changing with respect to the duration of a particular operation. Weather conditions, sea state, propagation anomalies, crew training and morale, equipment readiness state, etc., may be dealt with simply by noting the prevailing conditions at the time of the test. It is, however, important that all major performance-shaping variables be dealt with in some way — by controlling them, continuously recording them, noting their presence, etc. — so that the main-stream performance data which are obtained will be interpreted in the proper context.



3.4.4.5 WORK STUDY. Included in work study are a number of formalized techniques for critical examination and work measurement. Critical examination involves systematic questioning of design features pertaining to the who, what, where, when, why, and how of operation and maintenance. Work measurement includes a number of techniques adapted from industrial engineering, such as motion and time study. A description of work study techniques may be found in the Ship System Command publication N.S. 0900-005-1010, Technical Manual for Design Work Study, and standard reference on industrial engineering covers work measurement techniques.

3.4.4.6 MOCK-UPS. Man-equipment relationships in three dimensions can be evaluated by means of mock-up techniques. Refer to section 3.3.6 on mock-ups.

## 4.0 CONTRACTED WORK

### 4.1 OVERVIEW

There is considerable variability with respect to the timing and scope of contractor involvement in Navy development efforts. In some developments, contractors are brought in early and have a major responsibility for development of system concepts. In other cases system concepts are fully developed by the Navy, and the contractors are requested to respond to highly specific and detailed specifications for hardware and software. Generally, human engineering services and products are included as part of a larger contract for hardware and/or software development. The material in this section is applicable in either situation; however, when human engineering is part of a larger contract, RFP preparation, proposal evaluation, and contract monitoring are coordinated with corresponding effort on other parts of the contract.

### 4.2 HUMAN ENGINEERING SERVICES AND END PRODUCTS

#### 4.2.1 CATEGORIES

A contract for human engineering may be explicitly for the purchase of services, end products, or both. When the contract is for end products, performance of associated services is implicit. Services may be purchased from a contractor either because they will have a beneficial effect on other aspects of a contractor's program (hardware development, computer programs, training manuals, etc.) or because they are necessary steps in evolving specific end products which are to be delivered to the government. Specific end products are desired by the government to verify the quality of the human engineering effort and for use in other aspects of the program. For example, the government may want a fine task analysis to use as a basis for developing a training curriculum. Human engineering deliverable end products, then, are items of intrinsic value delivered to the government for its use. Of course, every end product has associated with it, and is the result of, performance of one or more services.

The major categories of human engineering services are identified in the following subsections, together with associated deliverable end products.

4.2.1.1 PROGRAM PLANNING. The program planning service category includes preparation of the original human factors plan, as discussed in section 4.5, and necessary updating of that plan during the life of the contract. The associated end product is a human factors plan.

4.2.1.2 REQUIREMENTS ANALYSIS. This human engineering service category addresses the pattern of requirements associated with the proposed development and is basic to consideration of all further human factors work. Two approaches to requirements analysis are recognized:

a. Documentation Review. In this approach the contractor reviews and interprets relevant documentation dealing with such material as

**Preceding page blank**

deficiencies of predecessor or related systems; field observations, exercises, and evaluations; formal requirements documents; and program constraints in time, money, material, and personnel. The associated end product is a requirements report.

b. **Field Studies.** In this approach the contractor makes direct observations in the field to develop a systematic understanding of requirements. These observations are directed to personnel, environments, operational settings, systems, and facilities which are as closely related to the proposed development as practicable. The associated end product is a requirements report.

**4.2.1.3 MAN-MACHINE CONCEPT DEVELOPMENT.** This service category includes preparation of concepts or contribution to concept formulation in several areas. The associated end product in each case is a concept development report.

a. **Systems Concepts.** The contractor prepares concepts of man-machine systems potentially capable of satisfying operational requirements and compatible with all existing constraints.

b. **Equipment Concepts.** The contractor prepares concepts of specific manned equipments compatible with overall system concepts.

c. **Facilities Concepts.** The contractor prepares concepts of facilities needed for housing of personnel, storage of material, overhaul and repair functions, etc.

**4.2.1.4 MAN-MACHINE CONCEPT ANALYSIS.** This category includes analyses and trade-offs of candidate and selected design concepts.

a. **Information Flow.** Analyses are performed to determine basic information flow and processing required to accomplish the system objective. They include decisions and operations without reference to any specific machine implementation or level of human involvement. The associated end product is an information flow chart, together with such supporting documentation as may be necessary (see section 3.2.3.2).

b. **Time Line.** A detailed time line analysis of system behavior as related to the mission may be prepared for normal and degraded system operation. The time line analysis provides a graphic representation of each individual's workload by plotting his task involvement against a time line base. When the performance of several individuals is closely interrelated, their profiles should be plotted together on the same graph so as to highlight the workload balance. The associated end product is a time line chart (fig. 3.8), together with supporting documentation.

c. **Performance Prediction.** This service includes those analytic functions aimed at predicting man-related aspects of system performance for candidate or selected system configurations. Estimates of processing capability in terms of load, accuracy, rate, and time delay may be prepared for each potential operator/maintainer information processing function. These estimates are used initially in determining allocation of functions and are later

refined at appropriate times for use in definition of operator/maintainer information, control-display, and communication requirements. In addition, estimates are made of the effects on these capabilities likely to result from implementation or nonimplementation of detail design recommendations. Where total system response time and accuracy are primarily determined by human performance, predictions of total system response in terms of speed and accuracy should be included. For maintenance functions, performance prediction should include mean fault isolation and restoration times. The associated end products are operability and maintainability performance prediction reports.

d. Gross Task. This analysis presents in brief narrative form a complete procedural description of the operator/maintainer's action in performing the given task. Other relevant information is included, such as type and location of equipments used, rough estimate of time required, frequency of performance, critical performance factors, and type of personnel and training required. The associated end product is a set of gross task analysis sheets.

e. Fine Task. Fine task analysis identifies: (1) information required by man, including cues for task initiation; (2) information available to man; (3) his evaluation process; (4) the decision reached after evaluation; (5) the action taken; (6) body movements required by the action taken; (7) workspace envelope for man required by the action taken; (8) workspace available to man; (9) location and condition of the work environment; (10) frequency and tolerance of action; (11) the time base; (12) feedback informing man of the adequacy of his actions; (13) tools and equipment used; (14) number of personnel required, their specialty, and experience; (15) job aids or references required; (16) communications required, including type of communication; (17) special hazards; and (18) operator interaction, where more than one crew member is involved. The analysis may be performed for all missions and phases, including degraded modes of operation. The associated end product is a set of fine task analysis sheets.

f. Operational Sequence and Interface. This analysis identifies the sequence of operations, delays, transmissions, and receipts within and between stations of interest. Separate analyses are prepared for each situation of interest, such as each mode of operation, type of threat, level of manning, and casualty condition. Conditions of overloading and underloading and interfacing problems are identified. The analysis is performed at various levels of detail, as discussed below. The operational sequence diagram is the associated end product for this analysis. The OSD records operating sequences for, and interfacing relationships between, a number of stations of interest. The recommended format and symbology is shown in figure 3.7. Four levels of OSDs are identified below; selected levels may be mixed in a single OSD as appropriate. Contractual documents and human engineering plans should specify the level of OSD required.

(1) The first- or top-level OSD utilizes composite stations (two or more functionally related operators or man-machine stations treated as a single station) for column headings and shows information transfer between stations at a functional level only. For example, column headings might be

“bridge,” “engine room,” and “CIC.” Information transferred might include “rudder orders,” “engine speed orders,” “new target detections,” “CPAs,” and “recommended course changes.”

(2) The second-level OSD also utilizes information transfer at the functional level, but uses individual man-machine stations as column headings. For example, column headings might be “tracking station,” “identification station,” and “intercept control station.”

(3) The third-level OSD also utilizes the individual man-machine stations as column headings, but shows information transfer in specific modes such as electrical, voice, and visual.

(4) The fourth-level OSD also shows information transfer in specific modes, but deals with information at the discrete action level (button-pushing operations, voice commands, etc.). At this level each operator is represented with a separate column, and system equipments are represented in the remaining columns.

g. Man-Machine Station. This analysis is performed for each man-machine station. It is similar to the information flow analysis (section 3.2.3.2) except that the decisions and operations with which it deals are confined to man and his close-coupled equipment rather than being representative of the system as a whole. The analysis is completed by summarizing all significant information categories which must be processed at the operator station. The associated end products are man-machine flow charts (fig. 3.5), input-output charts (fig. 3.6), and supporting documentation.

h. Hazards. In this analysis all potential hazards in operation and maintenance of system equipment are systematically identified. Hazards typically considered include electrical shock, cuts and bruises from bumping into protruding hardware, burns, fingers or clothing caught in hardware, excessive radiation, tube implosions, explosions, toxic fumes and substances, damaging noise levels, inadequate illumination levels, and sudden pressure changes. The analysis identifies the hazard, why it exists, and what can be done to minimize it. The associated end product is a hazards analysis report.

i. Habitability. This is an analysis of all significant factors affecting the livability of working, messing, berthing, sanitary, and recreational spaces. Factors taken into account are lighting, air circulation and purity, temperature, humidity, color environment, comfort of chairs and bunks, suitability of lockers, adequacy of sanitary facilities, noise levels, housekeeping factors, esthetic considerations, etc. The analysis assesses habitability in terms of prevailing standards and identifies means of correcting specific problems or making general improvement. The associated end product is a habitability analysis report.

j. Trade-off Studies. Human factors trade-off studies analyze various design options relating to human participation in systems in terms of their impact on performance and cost. Most such studies are normally accomplished in the pursuit of selected human factors analyses such as allocation studies. Any additional trade-off studies involving a significant commitment of manpower shall be carried out as specially negotiated with the contracting agency. The associated end product is a set of trade-off analyses reports.

k. Allocation Studies. From projected operator/maintainer performance data, cost data, and known constraints, the contractor shall conduct analyses and trade-off studies to determine which system functions should be machine-implemented and which should be reserved for the human operator/maintainer. The associated end product is a function allocation table, together with justification.

l. Information Requirements. Completion of information flow analysis, gross task analysis, and man-machine analysis is prerequisite to this service, which defines the characteristics of the information to be displayed and controlled at an operator or maintainer station. The information requirements analysis must include type and amount of information, together with characteristics such as granularity, formatting, updating period, and persistence. The associated end product is an information requirements table.

m. Control/Display/Communication Requirements. This analysis extends the information requirements analysis. It specifically derives what must be displayed, controlled, and communicated, and how this may be accomplished. The service is prerequisite to proceeding with specifications for detail design. The associated end product is a control/display/communications requirements table.

4.2.1.5 MAN-MACHINE SYSTEM DESIGN. Human engineering services in this category contribute directly to design of system hardware, software, and support equipment; development of personnel subsystem elements such as selection and training programs; and development of trainers, life support equipment, and other facilities. These services and their associated end products are listed below.

a. Performance Specifications. Performance specifications set the bounds on man-machine system performance and define what the system must do in operational terms. The associated end product is a performance specification.

b. Hardware Specifications. This service defines hardware and component characteristics needed for man-machine interfaces and operator station designs. The associated end product is a hardware specification.

c. Software Specifications. This service defines computer programming requirements for man-machine interfacing and information processing. The associated end product is a software specification.

d. Mock-up Preparation. The following listing includes types of mock-ups which may be utilized during design and development. The associated end product in each case is a mock-up and supporting documentation.

(1) Reduced-scale mock-ups for three-dimensional representation of consoles, workspaces, and manned facilities.

(2) Full-scale "soft" mock-ups of wood, paperboard, or similar materials plus panel hardware components for human engineering study of panel layouts, seating, workspace arrangements, illumination, and related factors. These mock-ups are constructed for critical manned equipments at the earliest practical point in the development program. The mock-ups

should be kept up-to-date to reflect design progress and changes. The workmanship should be no more elaborate than is essential for human engineering purposes; the least expensive practical materials should be used for fabrication.

(3) Full-scale "hard" mock-ups to check component installation features, to evaluate ease of maintenance (accessibility for inspection, removal, and replacement of components), and to provide a model for production work.

(4) Functional, full-scale mock-ups to check the operation of critical controls and displays in the prototype configuration.

e. Dynamic Simulation. Dynamic simulation techniques may be utilized as a human engineering design tool when necessary for the detail design of equipment requiring critical human performance. The associated end product is a dynamic simulation report.

f. Consultation. Human engineering consultation service is provided to contractor design groups during design and development. Familiarity with the progress of development is required; day-to-day guidance is rendered on an on-the-spot basis. There is no associated end product (administrative summary only).

g. Design Guidance. This human engineering service differs from consultation in that it is a more formalized approach and requires timely documentation of design guidance material. The initial effort is an overall human engineering design guide. This is later supplemented by specific design recommendations to contractor design groups. Timeliness is essential; such recommendations shall be provided at the inception of the particular design effort. The associated end product is a design guidance package including initial guides and periodic supplements.

h. Design Review. Human engineering design review is a continuing service rendered during design efforts. With regard to all human engineering features it provides for (1) close scrutiny of design progress through informal contact, (2) review and approval sign-off on drawings, and (3) participation in all design review meetings. An essential aspect of this service is the resolution of design problems which could adversely affect human engineering features. When satisfactory internal resolution is not attainable, the situation must be called immediately to the attention of the contract monitor. There is no associated end product (administrative summary only).

i. Control/Display Hardware Selection. This service provides for: (1) review of available control/display hardware with regard to general human engineering suitability and specific control/display/communication requirements; (2) procurement recommendations for specific hardware items; (3) review of these recommendations with cognizant engineering groups; and (4) compilation of final hardware lists which are acceptable from both engineering and human engineering standpoints. Any irreconcilable differences should immediately be called to the attention of the contract monitor. There is no associated end product (administrative summary only).

j. Panel Layout and Arrangement. This service provides human engineering panel layouts and arrangements for guidance of detail design. The service includes review of the recommended panel layouts with cognizant

engineering groups and preparation of final layouts acceptable from both engineering and human engineering standpoints. The associated end product is a set of panel layout drawings, together with supporting documentation.

k. Work Space Arrangement. This service is comparable to service j above except that it treats an entire workspace for operation or maintenance. The associated end product is a set of workspace layout drawings, together with supporting documentation.

l. Equipment Procedures. This service provides for the development of a detailed set of equipment operating procedures compatible with good human factors practice. The associated end product is an equipment operating procedures manual.

m. Human Engineering Detail. This service calls for the development of human engineering design for all relevant aspects of the contracted effort. It specifically covers detail design of hardware items to be fabricated instead of purchased. All designs shall be compatible with the provisions of MIL-STD-1472. The service includes review of all recommended detail design with cognizant engineering groups and agreement on the acceptability of final design detail from both engineering and human engineering standpoints. The associated end product is a set of detail design drawings and supporting documentation.

n. Training Programs. This service develops training programs for user, operator, maintenance, and support personnel associated with the system under development. The training program should primarily meet the requirements of the initial personnel team assigned to the test program but should also provide a solid foundation for establishing training programs in service schools. The associated end product is a training program package consisting of curriculum, text materials, audio visual aids, and technical aids.

o. Operator Manuals. This service provides for preparation of operator manuals to be used in training programs and in the field. The associated end product is an operator manual.

p. Maintenance Manuals. This service provides for human engineering support in the preparation of maintenance manuals and shall include: (1) specific discussion of man-machine interfaces for maintenance actions and the maintainer's decision-making functions; and (2) guidance on formatting, layout, and packaging of maintenance instructional materials for ready use by maintenance personnel. The associated end products are appropriate sections of maintenance manuals.

4.2.1.6 DESIGN VERIFICATION. This service category provides for systematic review, test, and evaluation of all human engineering elements of the contracted effort.

a. Checklist Preparation. This service calls for preparation of special-purpose human engineering checklists customized for the system under development. The associated end product is a set of checklists.

b. Appraisal Through Checklist. This service calls for appraisals of human engineering elements of the system under development by use of



either special-purpose or standard checklists as appropriate. These appraisals are made as early as feasible in the development process and as often as necessary to ensure timeliness with design changes. The associated end product is a design verification report.

c. Test Planning. This service includes all planning necessary to ensure proper consideration of human engineering in all in-house test programs. Human engineering tests are integrated or coordinated with other aspects of the test program. The objective of human engineering participation is to verify compliance with system requirements and particularly the human engineering requirements which are contractually imposed. Human engineering test planning shall include but not be limited to:

- (1) Simulation (or actual conduct if possible) of the mission or work cycle.
  - (2) Tests in which human participation is critical with respect to speed, accuracy, reliability, or cost.
  - (3) A representative sample of noncritical scheduled and unscheduled maintenance tasks.
  - (4) Proposed job aids.
  - (5) Utilization of personnel who are representative of the range of the intended military user population.
  - (6) Collection of task performance data.
  - (7) Identification of discrepancies between required and obtained task performance.
  - (8) Criteria for the acceptable performance of the above tests.
- The associated end product is a human factors test plan.

d. Test and Evaluation. This service provides for the carrying out of tests planned under service c above, the evaluation of test results, the initiation of appropriate corrective action as needed, and the preparation of test reports. The associated end product is a set of human engineering test reports.

e. Test Support. This service provides continuing test support during tests conducted by the government in its laboratories, at test facilities, in the field, or in the fleet. This support includes test planning, participation in testing programs, interpretation and evaluation of results, and reporting on the test program as members of a government-industry test team. There is no end product associated with this service.

f. Environmental Measures. This service is for measurement of features of the physical environment affecting on-the-job performance and habitability. This includes illumination, noise, vibration, temperature, humidity, air circulation, and air quality. The end product is a set of tables covering the spaces sampled and the measures used.

g. Follow-up Studies. This service is to conduct systematic follow-up studies of a new system after it has been accepted for service use. The service involves direct observation of the system in simulated or actual use, interview of selected operator/maintainer personnel, and collection of broader-based data through questionnaires administered to a representative operator/maintainer population. The associated end product is a follow-up report.

4.2.1.7 APPLIED RESEARCH. Applied research may be required at any stage of development as determined by the contracting agency. The associated end product is a research report.

#### 4.2.2 SPECIFICATION OF SERVICES AND END PRODUCTS

This section suggests a mechanism for specifying services and end products using a matrix of the type shown in exhibit 4.1. This matrix may be used by a prospective contractor to summarize the pattern of human factors services and end products which he proposes to supply for each block of work. The same type of matrix may be used by the contracting agency to summarize the human engineering services and end products which are being included in an RFP or contract.

One way to use such a matrix would be to enter in each cell: (a) a designation for service only, or service plus delivered product; and (b) the number of man-days to be scheduled. Cell encoding could also designate the level of end product desired whenever options have been defined. Whether the service/product is oriented to subsystem use, subsystem maintenance, or both could also be encoded. In all cases in which a service is called out but the associated end product is not, the contractor should be required to maintain working papers in his files which demonstrate that the service was actually performed.

In a total ship program the subsystem columns might be labeled bridge, CIC, radio central, engine room, galley, berthing spaces, etc., thereby allowing for the differential treatment which should be applied to these various spaces. In very small systems only the total labor column would be needed.

#### 4.2.3 LABOR COSTS FOR HUMAN ENGINEERING SERVICES

a. Laboratories. Labor cost for human engineering personnel in Navy laboratories is a composite of the individual labor rate and the various overhead expenses which may be applied. Total applied overhead will typically be from 60 to 110% of the salary. As an example, for the 1974 fiscal year the average man-year cost for human engineering services at the Naval Electronics Laboratory Center is \$35k. Projected costs for future years should be calculated on the basis of a 5% annual increase.

b. Contractor. Costs for contractor human engineering personnel vary more than for Navy in-house laboratory support, principally due to industry's tendency to expand the pay scale to more strongly differentiate between levels of experience and education. As a result, current costs range

EXHIBIT 4.1  
HUMAN ENGINEERING SERVICES AND PRODUCTS

This table identifies the human engineering services and products which may be needed on system development projects. The table is laid out so that it can be used for estimating human engineering labor in each service category in each of several subsystems (A-H).

Service Category	End Product	Labor (Man Days) by Subsystem								Man Days Total
		A	B	C	D	E	F	G	H	
A. <u>Program Planning</u> . Preparation of original HE plan and updating as required.	Program Plan									
B. <u>Requirements Analysis</u>  1. Documentation review - prior systems, fleet observations, evaluations, requirements, documents, etc.  2. Field studies. Direct observation of personnel, environments, operational settings, systems, facilities, etc., of related systems.	Report and bibliography  Report									
C. <u>Man-Machine Concept Development</u> .  1. Man-machine systems potentially meeting requirements.  2. Specific manned equipments compatible with overall system concepts.  3. Facilities needed for housing of personnel, materials storage, repair, etc.	Report  Report  Report									
D. <u>Man-Machine Concept Analysis</u> .  1. Information flow, operations, and decisions required to accomplish system objective.  2. Time line. Graphic representation of each operator's workload against time line base.	Info flow chart  Time line									

Service Category	End Product	Labor (Man-Days) by Subsystem								Man-Days Total
		A	B	C	D	E	F	G	H	
3. Performance prediction of accuracy, rate, and time delay for each operator/maintainer.	Report									
4. Gross task analysis - narrative description of operator's action in performing the given task.	Gross T. A.									
5. Fine task analysis. Identifies information requirements, decision and motor actions, workspace, tools, personnel qualifications, etc.	Fine T. A.									
6. Operational sequence. Sequence of operations, delays, transmissions, and receipts within and between man-machine stations.	OSD levels 1-4									
7. Man-machine station. Thorough information flow analysis for each operator station	MM flow charts Input-Output charts									
8. Hazards. Systematic identification of potential hazards in operation and maintenance, and possible solutions.	Report									
9. Habitability. Livability of working, messing, berthing, sanitary, and recreational spaces.	Report									
10. Trade studies. Analysis of design options relating to human involvement in systems in terms of impact on cost and performance.	Report									
11. Allocation of functions to man or machine.	Allocation table									
12. Information requirements. Type, amount, format, and time characteristics of information to be displayed.	Info requirements table									

Service Category	End Product	Labor (Man-Days) by Subsystem								Man-Days Total
		A	B	C	D	E	F	G	H	
13. Control/display/communication requirements. Extends information analysis to specifically derive what, how, where, and when information will be displayed and controlled.	C/D/C tables									
<u>E. Man-Machine System Design.</u>										
1. Performance specifications. Human engineering contribution to equipment and system performance specifications.	Spec input									
2. Hardware specifications. Human engineering contribution to equipment and system hardware specifications.	Spec input									
3. Software specifications. Computer programming requirements for man-machine interfacing and information processing.	Spec input									
4. Mock-ups, (a) reduced scale, (b) full-scale "soft," (c) full-scale hard, (d) functional.	Mock-up a-d									
5. Dynamic simulation. Computer simulation of critical man-machine tasks.	Report									
6. Consultation.	As appropriate									
7. Design guidance. General and specific recommendations to design groups.	Design guides									
8. Design review. Participation in and critiquing of design reviews.	As appropriate									
9. Hardware selection. Review and recommendations for selection of off-the-shelf hardware for controls, displays, workspace, etc.	Hardware list									

Service Category	End Product	Labor (Man-Days) by Subsystem								Man-Days Total
		A	B	C	D	E	F	G	H	
10. Panel layout. Human engineered panel layouts for guidance of detail design.	Drawings & supp documentation									
11. Work space arrangement. Human engineered arrangements for an entire work-space.	Drawings & supp documentation									
12. Equipment procedures. Detailed operating procedures concerning mechanics of operation.	Equipment proc									
13. Human engineering detail. Recommended detail design covering items to be made rather than bought.	Drawings and documentation									
14. Training programs. Development of initial training programs for test and support personnel for use during development and testing.	Training pkg									
15. Operator manuals. Differs from (12) in that it provides operationally-oriented as well as equipment-oriented procedural inputs.	Inputs to opn manual									
16. Maintenance manuals. Man-machine interfaces for maintenance; maintenance decisions; guidance on formatting, pkg maintenance instruction materials.	Input to maint manual									
<b>F. Design Verification.</b>										
1. Checklist preparation. Customized checklists for the system under development.	Checklist									
2. Appraisal through checklist. Check proposed or implemented design features against checklist provisions.	Design verif									

Service Category	End Product	Labor (Man-Days) by Subsystem								Man-Days Total
		A	B	C	D	E	F	G	H	
3. Test planning. All planning necessary to ensure proper consideration of human reliability and man-machine performance in system tests.	HE test plan									
4. Test and evaluation. Provides for carrying out planned tests, evaluation of results, and test reporting.	HE test report									
5. Environmental measures. Quantitative measurement of the physical environment under normal and/or extreme conditions.	Tables									
6. Follow-up studies. Provides for systematic follow-up studies of a new system after acceptance for service use.	Report									
G. <u>Applied Research.</u> 1. System-specific human engineering studies related to man-machine system design options.	Report									

from approximately \$25k to \$50k per man-year, depending upon the human engineer's qualifications and job requirements.

#### 4.2.4 PROPORTION OF PROJECT COSTS FOR HUMAN ENGINEERING

The limited experience with human engineering as a contract requirement on ship's system programs has not permitted indisputable determination of the cost for human engineering support on a new system, piece of equipment, or ship type. Available evidence on recent development programs indicates that human engineering costs have varied from slightly less than 1% to 5% of the total acquisition costs. Based on experience, it appears that these figures actually represent the minimum and maximum normally spent on ship system programs. Although minimal human engineering can be accomplished with the less than 1% figure, it is recommended that a value of 1% to 2% be budgeted for most development programs. The program manager

must realize that for some new systems which are extremely complex and may present a new exotic operating environment, or in which perhaps extensive crew interactions are required, human engineering costs may reach 6% or 7% of the acquisition costs.

### 4.3 PREPARATION OF THE REQUEST FOR PROPOSAL (RFP)

Most RFPs will include a requirement for total personnel subsystem analysis and development of outputs relating to human engineering, system manning requirements, training, and training equipment. To adequately oversee all these areas, the Navy project staff should include a human factors program manager with appropriate assistants representing the several personnel subsystem specialty areas.

This subsection deals only with the human engineering aspects of the total program as it relates to assisting in the preparation of an RFP. The major tasks, discussed in detail below, are: (a) review and expansion of function analysis, (b) definition of scope, (c) estimation of human engineering effort, (d) selection of criteria for assessing personnel qualifications, (e) selection of references and guides, (f) identification of end products, (g) definition of criteria for evaluating proposals, and (h) preparation of inputs to the RFP.

a. Review and Expansion of Function Analysis. The human factors program manager and staff should participate in the review of documentation and assist in development of top- and first-level function flow diagrams. The human factors manager should refer to the several available guides to assist in this analysis activity: "Human Engineering Guide to Equipment Design" (Morgan, ed.), "Human Engineering Guide for Equipment Designers" (Woodson and Conover), and "Human Factors Evaluation in System Development" (Meister and Rabideau).

In the event the function analysis indicates to the human factors program manager that unique environmental hazards may be involved in the new system—hazards beyond the usual requirements for conventional control of noise, vibration, and acceleration hazards—he should seek assistance from BUMED (NM&S 713) in defining the seriousness of the problem and determining whether special studies may be required before certain operational or design concepts are finalized. This may have considerable influence on what the RFP requires of the contractor in terms of special studies and/or personnel.

The final product of this function analysis task should be the following items, to be placed directly in the RFP or included as exhibits to it: (1) top- and first-level function flow diagrams, (2) a set of operator/maintainer task descriptions, (3) gross description of major man-machine interface elements (control-display positions, etc.), and (4) a list of the major human factors problem areas which appear to require further definition and resolution. The inclusion of these items in the RFP accomplishes two major functions: (1) reduces the contractor's overall workload, thus permitting his personnel to spend more time on detail design effort, and (2) provides an indication to the contractor concerning the Navy's thoughts regarding man-machine allocations.



b. Definition of Scope. MIL-H-8855, "Human Engineering Requirements for Military Systems, Equipment and Facilities," should be used as a basic guide to define the scope of the human engineering effort. This specification establishes and defines the general requirements for applying human engineering principles and criteria to military systems development, including work to be accomplished by contractors. In general this specification requires human engineering effort in the following key areas: (1) system engineering, (2) design and development, and (3) test and evaluation.

In the case of system engineering, the RFP should state to what extent the contractor should further define functional requirements, man-machine allocations, operator/maintainer task descriptions, and man-machine interface requirements. The RFP should define the extent to which human engineering inputs will be applied to predesign and detail design efforts during Phase B and to what extent this effort will be documented or demonstrated by means of drawings or mock-ups. Finally, the RFP should specify such special human engineering studies as appear to be required because of some unique environmental problem, new control-display concept, or suspected operator workload stress which may affect final design decisions and what type of information should be developed to support other personnel subsystem design decisions. It should be noted in this latter case that most contractors will develop manning estimates and training requirements as part of their ILS function. Although these functions should be closely allied to the human engineering effort, it may in fact not occur unless the RFP makes a point of it. The RFP must make it clear that man-machine function allocations, hardware design, task descriptions, manning estimates, and training plans must be developed as an integrated package with sufficient documentation to confirm that this has been accomplished.

The Navy human factors program manager should request (in the RFP) that a human engineering program plan be submitted as a distinct requirement in each contractor's proposal. This plan should include at least the following:

(1) A detailed description of the proposed human engineering effort, including a set of specific work statements covering systems analysis, literature review, design trade-off studies, mock-up studies, design assist and monitoring, maintenance concept development, safety analysis, and program planning for the prototype development phase. (See also section 4.5.)

(2) A schedule of the proposed human engineering effort showing start and end dates for each task and points for progress reporting and/or review, and an estimate of the manloading across the schedule, including a percent of the total effort assigned to each task.

(3) A description of the end products to be provided as a result of the human engineering effort, including analysis worksheet summaries, design trade-off study results, literature survey reports, and results of laboratory, mock-up, or other study efforts.

Section 4.2 provides additional guidance in defining the scope of the human engineering effort.

c. Estimation of Human Engineering Effort. It is important for the human factors program manager to know how much to budget for human engineering. Since budgets are always subject to scrutiny by higher authority, all study tasks must be able to pass the acid test of "Is it really vital?" There are no hard-and-fast rules by which the human factors manager can assess this requirement—only experience and common sense. This is why it is very important to select an experienced manager, one who has "lived through" several programs.

As a general rule, the human factors program manager should examine each task he has identified in b above. He should compare these with similar tasks which contractors have done on other programs, when such information is available to him. Otherwise, he must refer to his own experience. A block of hours should be estimated for each task. Each task should then be rated in order of priority. This is done so that if budget cuts require reduction in desired manpower he can decide whether a task should be omitted or modified. In many cases reduction in effort makes the task useless and, therefore, better to be dropped than modified.

It should be pointed out, however, that the human factors program manager is responsible for seeing that essential human engineering tasks are not arbitrarily omitted. A good example is the case in which a project manager feels that designers can apply human engineering principles without the assistance of human engineering specialists. Experience has demonstrated quite clearly that such a decision generally results in operator/maintainer failures in the field.

The level of effort to be required should be based upon an evaluation by the human factors program manager of the magnitude of specific tasks. For example, if the system design involves development of a great number of new subsystems, more human engineering effort is required both for evaluating design concepts and for new task descriptions. Similarly, if the system involves new operator-control interfaces wherein special laboratory studies may be involved, an obvious increase in human engineering effort is required. In these special cases it will be necessary for the Navy human factors program manager to prepare a preliminary outline of the task and roughly estimate the hours required for designing the experiment, setting up the test apparatus, running the test, and analyzing the results.

For detailed guidance on estimating human engineering effort, see section 4.2.

d. Selection of Criteria for Assessing Personnel Qualifications. In conjunction with the estimation of human engineering manpower requirements, the Navy human factors program manager should establish criteria for judging the qualifications of the key personnel proposed by the contractor. Once again, there are no hard-and-fast rules for doing this. On the other hand, there are a number of considerations to keep in mind, such as the following: the contractor's human factors program manager should be a person with several years' experience on several programs similar to the one in question; he should have managed at least one of these programs; and he should be a human engineering specialist, not an engineer who is assigned human engineering responsibility as a collateral duty. A minimum of 5 years' experience is recommended.

In the event the study requires research in a specialty area such as vision, audition, or control-display simulation, the contractor should provide a specialist for these special programs. Each specialist should have recent experience in performing similar studies which demonstrates that he is up with the current state of the art in his area.

Similarly, the contractor should provide applications-oriented human engineers to follow design work. An academically- or research-oriented human factors scientist seldom does an adequate job in assisting and monitoring designers. These applications human engineers should have recent experience on military (and preferably Navy) hardware programs.

e. Selection of References and Guides. Two primary references should be included in all RFPs MIL-H-46855 and MIL-STD-1472. The first reference provides general guidance for defining the requirements of a human engineering program, the second provides a set of human engineering design criteria and principles which should be considered in the design of hardware. Special references related to the systems under development should be included as appropriate. A few general references such as the following should also be cited:

- "Human Engineering Guide to Equipment Design," (rev. ed) Van Cott and Kinkade (ed), 1972
- "Human Engineering Guide for Equipment Designers." Woodson and Conover, 1966
- "Maintainability Design Criteria Handbook for Designers of Shipboard Electronic Equipment." NAVSHIPS 94324, 1965
- "Psychological Principles in System Development." Gagne (ed), 1962
- "Human Factors Evaluation in System Development." Meister and Rabideau, 1965
- "Human Factors: Theory and Practice," Meister, 1971

f. Specific human engineering services and end products to be required of the contractor should be identified, as categorized in section 4.2. Also refer to MIL-H-46855 for basic requirements pertaining to services and end products.

g. Criteria for evaluating proposals should be established for the human engineering area and stated in the RFP. These criteria should be stated as specifically as possible and given weightings in terms of importance. For example, the following evaluation criteria should be considered as basic:

- (1) Understanding the problem -- how well the contractor has interpreted the operational requirement, defined the study objectives, and specified the tasks he expects to perform to meet those objectives.
- (2) Scope of proposed effort -- whether the contractor's proposed study displays adequate coverage of all considerations with appropriate emphasis on those aspects considered by the Navy to be most critical.

(3) Technical approach – whether the contractor's approach to problem analysis and solution is technically sound and sufficiently supported by previous experience or backup material to indicate probability of success.

(4) Technical personnel qualification – whether the contractor's proposed staff for the contracted work is qualified technically, whether specific individuals are assigned sufficient man-hours to be effective, and whether the proposed organization provides for effective use of personnel and interaction among personnel and their technical outputs.

See also the criteria in section 4.4.2.

h. Preparation of Inputs to the RFP. A separate section should be set aside in the RFP for human engineering. This section should cover at least the following topics:

- (1) Scope (prime system, support equipment, facilities, life support, etc.).
- (2) Desired Approach (methods, techniques, etc.).
- (3) Special Studies (literature reviews, analyses and trade-offs, simulation and laboratory experiments, mock-up evaluations, etc.).
- (4) Interface Requirements (interaction internally, with the Navy, and with other government agencies).
- (5) Reference Documents (specifications, standards, guides, technical reports).
- (6) Organization and Personnel Qualifications.
- (7) Reporting Requirements and Procedures.
- (8) Level of Effort and Proposal Evaluation Criteria and Priority.
- (9) Applicable Data Item Descriptions.
- (10) Summary of Required Human Engineering Submittals.

Other parts of the RFP should be reviewed as they are being developed. It will be apparent that human engineering statements and/or references should be made in or to other sections of the RFP. It is particularly important that human engineering requirements be written into engineering sections. These requirements may include operator/maintainer function allocation, control-display design, seating, lighting, noise, vibration, acceleration, shock, environmental protection, habitability, space arrangement, equipment packaging for portability and ease of access for maintenance, etc. In addition, strong emphasis should be made in introductory and management sections of the RFP regarding the role of human engineering and the necessity for its being integral rather than an adjunctive part of the requested study program.

It is extremely important that no contradictions or confusing requirements exist between the Human Engineering Section and other sections of the RFP. The Navy human factors program manager should detect and resolve the following types of situations:

- (1) Conflicting descriptions of operator/maintainer functions and procedures.
- (2) Conflicts between reference documents (i.e., a hardware specification may conflict with MIL-STD-1472 human engineering in certain cases).

(3) Conflicts in terminology (i.e., human engineering terminology for a certain type of analysis may be different from that used by the system engineer although both are referring to the same technique).

(4) Redundant tasks which have the same ultimate purpose.

(5) Conflicts between analytic descriptions (i.e., a function block diagram may be at variance with other analysis charts or tables).

The above types of discrepancies occur because different people may prepare the various parts of the RFP without sufficient time and opportunity to communicate with each other. Although a final editor will correct many of the inconsistencies in the final draft of the RFP, only the technical people really know whether the inconsistencies have been properly eliminated.

Conflict (2) above is perhaps the most confusing to the potential study contractor and should, therefore, receive special attention. It is unfortunate but true that the updating of military specifications and standards is always behind the need. Moreover, no one knows all the specifications and standards thoroughly, and often new ones are prepared in lieu of overhauling ones already in existence.

It has been typical to list a group of specifications and standards without really knowing what they contain. This should be avoided. Since human engineering specifications and standards overlap with a great many other non-human engineering references, there are bound to be conflicting statements. It is very important, therefore, that the Navy human factors program manager examine all the engineering specifications and standards referenced by his engineering colleagues and identify specific points which appear to conflict with human engineering reference documents. These conflicts should be resolved by deletion of one or the other (i.e., deletion of a particular paragraph) or by supplying a statement of policy regarding priority. Above all, do not accept the general policy that an engineering specification always has priority over a human engineering specification (a common practice).

#### 4.4 PROPOSAL EVALUATION

Human engineering is but one factor of many which must be considered by the Navy in selecting a contractor for a large system task. It therefore does not follow that the proposal which is rated best for human engineering will be selected; other factors may outweigh this one. (Of course, no proposal which is unsatisfactory from a human engineering standpoint should be accepted without modification even though it might rank best with respect to other factors.) It is, however, important that the human engineering factor be properly assessed so it can be given proper weight in the overall evaluation. This subsection provides guidance which should be useful in evaluating human engineering aspects of proposals.

##### 4.4.1 ADVANCE PLANNING FOR PROPOSAL EVALUATION

On large systems a proposal evaluation team is selected and an evaluation plan is prepared well in advance of the delivery of the contractor's

proposal. There should always be one or more human factors specialists on the team. This may include a BUPERS representative when new selection or training requirements are involved and a BUMED representative when there are unique life support considerations.

Because of the magnitude of the evaluation task, contractor submittals will generally be broken out into distinct technical and management categories, and team members will be given those subsections which pertain to their particular specialty; that is, human factors materials will be assigned to the human factors specialists for review and evaluation. In addition, there generally are many sections of the contractor's submittals which include human-factors-related information which fall under a different categorical title; that is, work station layouts may appear only in design sections, all test plans in a general testing program section, etc. The evaluation plan must be designed so that human factors representatives have access to these materials and, therefore, can participate both as principal reviewer for specific human factors sections and as advisory reviewer for other related sections.

#### 4.4.2 PROPOSAL EVALUATION CRITERIA

The specific factors to look for in the proposal may vary considerably depending upon type of system and phase of the development cycle. Of course any evaluation criteria which were included in the RFP should be utilized with their specified weightings. Other criteria which may be useful are listed below.

##### 4.4.2.1 CRITERIA RELATED TO TECHNICAL ASPECTS.

- a. Completeness of the basic human engineering analysis package (function, task, information flow, OSD, time line, link, and other analyses) provided to support the proposed baseline system(s).
- b. Quality and completeness of engineering trade-off information pertaining to man-machine interface definition, environmental effects analysis, and environmental and life support engineering concepts.
- c. Quality and effectiveness of special human engineering research study efforts and validity of the conclusions. These studies should be judged on the basis of their relevance, technical approach, expected value of the results, schedule compatibility, and cost, and on whether the contractor has readily available facilities where required.
- d. Effectiveness of proposed display-control configurations and other man-machine interface designs and completeness, quality, and effectiveness of supporting rationale and data.
- e. Adequacy of proposed concepts for design of operator and maintainer work station configurations and for support equipment to be used in maintenance and training.
- f. Adequacy of the personnel system manning and training analysis and training concept.

#### 4.4.2.2 CRITERIA RELATED TO MANAGERIAL ASPECTS.

a. Suitability of proposed human factors program staffing and scheduling for the next phases of development.

The contractor's organization should indicate (1) the priority placed on human engineering by the level at which his human factors program manager appears, and (2) the probable effectiveness of his human engineering program by how his human engineering staff is integrated throughout the various engineering groups. For example, if a contractor shows the entire human engineering staff concentrated at a low organizational level, under the control of a single engineering subsection (ILS, Reliability, Mechanical or Electronic Design, etc.), it can be assumed the contractor does not expect much human engineering interaction with the total system.

b. Related experience whether the contractor has sufficient experience with similar systems and proved capability in all the technical areas required (hardware development, production, test, personnel subsystem development, program management, etc.) and an acceptable record of cost and schedule control.

c. Availability of facilities which may be needed for research, simulation, development, production, test, etc., in carrying out the contract.

d. Completeness of statement of work. Each proposed work task should be clear and concise and reflect an understanding of the operational requirement and study objectives stated in the RFP. Proposed work tasks which are in addition to those requested in the RFP should be judged on their own merits on the basis of (1) whether or not they appear to contribute useful information which can further support substantiation of the prerequisites for system acquisition, (2) whether or not the tasks will add an unnecessary burden in terms of costs, and (3) whether or not they will dilute or interfere with the basic tasks defined in the RFP.

e. Suitability of Schedule, Manpower, and Cost. The scheduled completion of individual human engineering tasks should indicate timely input to other aspects of the program. Human engineering inputs to system design are of little value if the designs are completed before the inputs arrive.

#### 4.5 HUMAN FACTORS PROGRAM PLAN

The content and scope of the human factors program plan will vary depending upon the development effort being contracted. As an example the typical plan for prototype development should include at least the following:

a. A description of the system design analysis to be performed during predesign. This should be minimal, involving only those refinements of previous analysis necessary to define man-machine interface component drawing requirements.

b. A description of expected design trade-off analysis to be conducted during detailed design. This also should be minimal, involving possible recommended changes as a result of Navy evaluations.

c. An outline of the human engineering design criteria to be used during detailed design, including references from which the basic criteria will be drawn. This is a human engineering reference specification tailored to the design problems of the specific system to be developed.

d. A description of the mock-ups to be fabricated and the studies to be performed on these mock-ups.

e. A description of any special human engineering research required in support of design. This will include any additional operator performance validation studies.

f. A description of activities required to complete development of final task and job description, skill and knowledge information requirements, manning estimate refinement, training concepts and plans, development of training objectives, course materials, and training equipment requirements.

g. A description of major training simulator end items proposed, training facility modifications, and design and production cost and schedule development for training equipment.

h. A description of the proposed human engineering test and evaluation plan, including tentative methods, techniques, and criteria for operator/maintainer performance assessment, safety evaluation, etc.

i. A work/task schedule based on the overall program milestones and significant end product items.

j. A description of the proposed organization, staffing, and management of the human factors program.

Although the program plan carries the title Human Factors, in most ship system projects human engineering responsibilities constitute the greatest part of the plan. In the above list, only items f and g are not prepared by the contractor's human engineering staff. They are usually the responsibility of the contractor's training specialist.

One additional consideration which is generally not required during a contract definition study is a plan for monitoring the human engineering effort of subcontractors and vendors. The contractor should include in his human factors program plan a special section dealing with this problem. This is particularly important if subcontractors and vendors do not have their own human engineering capability.

#### **4.6 TESTS BY THE CONTRACTOR**

The primary responsibility of the system development contractor in the test and evaluation area is to perform all those tests and evaluations necessary to ensure delivery of a reliable, operable, and maintainable hardware system which meets the functional requirements prescribed by the general system specification.



In addition to the contract test program, the contractor generally assumes certain responsibilities in support of the Navy OPEVAL program once the system is delivered for OPTEVFOR test (see section 3.4.2.2). For example, the contractor typically provides technical personnel to help with any technical problems which might occur during the tests.

Test planning and conduct of tests should be accomplished by the contractor's professional human engineering staff wherever possible. Normally a human engineering test plan will have been submitted as part of the human engineering program plan (reference MIL-H-46855). Prior to commencing testing each proposed test identified in that original plan should be elaborated upon to the following level of detail:

a. Purpose of Test

(1) General objectives (for example, to verify that system personnel can perform required tasks).

(2) Specific objectives (for example, to collect data on human errors in task performance on the XYZ sonar).

b. Description of System Being Evaluated

(1) Equipments on which data are to be secured.

(2) Equipment tests during which data will be gathered.

(3) Operation/maintenance tasks for which data will be gathered.

(4) Applicable operating/maintenance procedures.

c. Data Collection Parameters or Categories of Data Recorded (length of work cycle, size of crew to perform checkout, etc.).

d. Test Criteria and Measures

(1) Criteria of test accomplishment (for example, two replications of each task, weapon successfully fired, etc.).

(2) Measures to be taken (for example, start/stop time, errors, discrepancies between operator actions and prescribed TO procedures).

e. Data Collection Methods

(1) Number of data collectors and where assigned.

(2) Training of data collectors (if required).

(3) Data collection schedule.

(4) Detailed data collection procedures.

(5) Data collection tools to be used (for example, questionnaires, interview forms, observations, and how they are to be used).

(6) Instrumentation required and how used (tape recorders, cameras, etc.).

f. Subjects

(1) Number.

(2) Type (characteristics, background, rating, etc.).

g. Data Analysis

(1) Relationships which are to be tested statistically (for example, number of test points as related to speed of troubleshooting).

(2) Statistical analysis methods to be employed (Chi-square, regression analysis, etc.).

h. Corrective Action and Reporting Procedures

Several types of test and evaluations may be conducted by the contractor's human engineers. These include: (a) mock-up time and motion tests; (b) operator/maintainer procedure error performance tests; (c) work load studies; (d) environmental stress tests; (e) job aid evaluation; and (f) control, display, and habitability interface evaluations. In addition, the contractor's human engineers should participate in other engineering tests wherein human engineering implications are present. For example, they should participate in equipment tests which provide an opportunity to measure equipment vibration and noise levels, examine moving machinery hazards, and observe assembly and disassembly procedures.

Special test facilities unique to human factors test and evaluation should ordinarily not be required. When a contractor does have such facilities already available, they should be utilized effectively; that is, the contractor's human factors program manager should recognize his own facility capabilities and design his test program to utilize these effectively. When it appears that a human engineering test is required and the contractor does not have such a facility within his own plant, he should identify these needs and potential availability of such facilities elsewhere in his original proposal. The Navy human factors manager should also assist in locating useful facilities and be prepared to suggest these early enough in the program planning to make them available. This may be an area in which Navy laboratories can provide assistance.

The more important facilities to consider in conjunction with human engineering tests are the following:

- a. Darkroom for lighting and visibility tests.
- b. Dynamic visual field simulator for generating a picture of the outside visual environment as it changes with the motion of the operator/system.
- c. Dynamic motion simulator to simulate operator/system kinesthetic motion effects.
- d. Deep diving (water) tanks to simulate underwater environment.
- e. Environmental pressure chambers (man-rated).

Human engineering test and evaluation reports should be prepared and submitted to the Navy human factors program manager on a timely basis, either as a part of periodic progress reports or as a separate report following a significant test event.

## 4.7 CONTRACT MONITORING

All contracted work involving human engineering services and end products requires monitoring by qualified Navy representatives to ensure compliance with contractual provisions and applicable specifications and standards.

### 4.7.1 GUIDANCE MEETING

Normally on large contracts a guidance meeting is called by the Navy project manager with participation by key representatives of both the Navy project office and the contractor. Both Navy and contractor human factors representatives should take part. If no overall guidance meeting is held, then the Navy human factors representatives should set up such a meeting on human factors matters within a few weeks of award of contract. The purpose of this meeting is to review the contractor's human factors program, particularly the human engineering effort, and to agree upon the final scope of work. At this time, modification to the program based upon deficiencies noted by the Navy evaluations will be presented, changes in level of effort required by negotiated budget considerations will be discussed, and new task recommendations or modifications in approach will be considered. The primary constraint in these deliberations will be the budget allotment. Any changes in the contractor's final plan must be compatible with the negotiated contract budget.

The final outcome of this meeting must be an exact definition of agreed-upon contractor tasks, including the mandatory end product submittal requirements. If the contractual provisions are sufficiently explicit, there should be no major questions about scope and depth of effort at this time. However, to be sure there is common understanding, the Navy representative should carefully review the human engineering services and end products as defined in section 4.2 above and as called out in the contract.

### 4.7.2 VISITS TO THE CONTRACTOR'S PLANT

The frequency of visits to the contractor's plant should be determined in general by the magnitude of the human factors effort and the pace of the schedule. In addition there are special times when the Navy representative should be present, such as at formal design reviews and mock-up demonstrations and during test programs, which are discussed in separate subsections. In routine visits the Navy representative typically will be involved with doing the following:

- a. Reviewing progress on contracted services and end products as measured against schedule and cost criteria.
- b. Checking for compliance with good human engineering practice as called out in applicable specifications and standards.
- c. Checking on thoroughness and effectiveness of the human engineering review on drawings.

d. Reviewing the human engineering file for quality of work and potential problems.

e. Participating in informal design reviews.

In all his dealings with the contractor, the Navy representative must make certain that he offers no statements, instructions, guidance or remarks of any kind which can be interpreted by the contractor as a change in the scope of the contract. If it should become apparent to the Navy representative that a change potentially affecting scope is needed, he must report this back through the Navy project office, which will handle all such negotiations with the contractor.

The Navy representative should provide the Navy project office with a trip report on each visit to the contractor's plant. The report should cover a status review, all problems encountered, and particularly any changes needed which may change scope of contract.

#### 4.7.3 DRAWING REVIEW

It is mandatory that human engineering be included in the contractor's drawing review and sign-off cycle. (This is a MIL-H-46855 requirement.) Many design engineers tend to resist this review (they insist such a step will delay their drawing release schedule), yet it has been found that poor human engineering design is likely to occur when it is not included. Human engineering review of drawings need not cause delay if proper review protocol is established. One effective method is for all drawings to have the date stamped on them when they must pass on to the next review group.

The contractor's human engineers should not try to review every drawing. Only those drawings which imply a critical human interface should be checked. To determine which drawings should be reviewed, the contractor's human factors program manager should obtain a copy of the drawing release schedule, go over it in detail, and identify those drawings which appear important. If he is in doubt about a particular drawing title, he should contact the responsible engineer or designer and discuss with him what will be included on the drawing by the time it is released. When it can be determined that a drawing has nothing to do with operator/maintainer activity, it should be excluded from routing through the human engineering groups.

For the drawing review to be effective, the contractor's human engineer should have all pertinent functional information at his finger tips (functional descriptions, OSDs, task descriptions, etc.). By means of something like the human engineering design category list prepared earlier, each drawing should be checked for compliance with recognized human engineering design principles. Noted deficiencies and recommendations for change should be placed directly on the review copy drawing and sent through the rest of the review cycle. The human engineer may have to consult the originating designer before finishing the review to determine whether there were mitigating circumstances which caused abandonment of certain human engineering principles. For example, it may have been necessary to lay out a panel in a certain manner because of lack of "behind the panel" space.

Care must be taken in establishing the drawing review protocol so that recycling includes the human engineering function. Too often a signature is obtained on the first go-around, and later changes are made without letting human engineers review them.

One further note concerning the contractor's drawing review involves the method used to cover outside vendor or subcontractor design. The contractor can accomplish this in one of two ways: (1) vendor drawings can be submitted to the prime contractor for human engineering review, or (2) the vendor or subcontractor can complete his own human engineering drawing review and provide the prime contractor with documentation of the results. In either case, it is extremely important that all relevant subcontractor and prime contractor drawings be reviewed by a qualified human engineering representative before they are released for fabrication.

With respect to drawing review, the Navy representative's responsibilities are, of course, simply to make certain that drawing review is properly carried out. He can do this best by sampling drawings during his plant visits.

#### 4.7.4 FORMAL DESIGN REVIEW

Although human engineering personnel will be involved in frequent in-house informal design review sessions, this section is devoted to those key, specific, contractually required review meetings held at specified times between the Navy and the development contractor. Two formal customer/contractor reviews are normally included as contractual obligations for all prototype model developments: Preliminary Design Review (PDR) and Critical Design Review (CDR). These are designated as key milestones on the negotiated development schedule.

The titles of the formal reviews are generally self-explanatory. The PDR is a decision point at which the contractor's pre-design is examined in detail to decide whether all parties are satisfied that detailed design work should proceed. The CDR is a decision point at which detail design is accepted by the Navy and the contractor is permitted to proceed with fabrication. Beyond this point no major design changes should be introduced. Although the CDR is ostensibly the final formal review prior to design freeze, it is possible that another similar review may be necessary. This would occur if changes resulting from the initial CDR made it necessary to perform additional trade-off studies and new design activity requiring another approval prior to initiation of fabrication.

For these reviews to be effective, both parties (Navy and contractor project staffs) must have completed their "homework" so they are prepared to discuss the design intelligently. Although the contractor should be ready due to his day-to-day design activity, the Navy has received only bits and pieces of information through informal contracts, progress reports, etc. It is the contractor's responsibility (and also to his advantage) to supply the Navy project manager with as much backup material as possible in addition to the

design descriptions and drawings to be presented in the review. The contractor's human factors program manager should provide a prereview package including at least the following:

- a. The latest versions of the functional descriptions of system hardware.
- b. The latest versions of the operator/maintainer task analysis, OSDs, equipment lists, manning charts, training plans, and other end product submission items pertinent to the particular stage of development.
- c. Results of critical engineering and human factors trade-off studies, mock-up, and simulation studies or other supporting studies performed prior to the review.
- d. Copies of any plans (preliminary or otherwise) needed to be considered during the review.
- e. Pertinent drawings, photographs, or sketches useful in providing the Navy's human factors program representatives a clearer picture of the state of the program.

This human factors prereview package should be made available to the Navy human factors program manager no less than 2 weeks prior to the review to allow adequate time for assimilation of the information.

In most cases PDRs and CDRs will include a mock-up demonstration at the contractor's facility. It is suggested that a demonstration plan, including an objective checklist for mock-up evaluation, be developed and distributed as part of the agenda. In this way the Navy project manager and his staff will have an opportunity to suggest additional items for the demonstration.

Although the contractor has responsibility for review planning and preparation, the actual review is generally conducted by the Navy project manager (he is the chairman). The contractor should coordinate his proposed review plans with the Navy project manager as early as possible to make sure they meet with his approval.

During the reviews the contractor's human factors program manager should be prepared to assist in every way possible, including: (a) oral presentation of those sections of the design effort which are the prime responsibilities of human factors engineering, (b) preparation of mock-ups, slides, or other visual aids, and (c) provision for demonstration subjects appropriately supported by typical garments and life support or other gear and equipment which are necessary to create a realistic demonstration of the operability and maintainability features of the mock-ups.

## 5.0 BIBLIOGRAPHY\*

### 5.1 INSTRUCTIONS AND NOTICES

COMOPTEVFORINST 3930.1, Volumes I and II, Revision of Project Instructions (Volume II, Chapter 3, Annex D, E, F)

DOD DIR 1000.3, Accident Prevention and Safety Policy for the Department of Defense

DOD DIR 4100.35, Integrated Logistics Support Planning Guide for DOD Systems and Equipment

DOD DIR 5000.1, Acquisition of Major Defense Systems

NAVMATINST 3900.9, Human Factors

NAVMATINST 3910.5, Procedures for Preparation, Submission and Distribution of Technical Development Plans (TDP's) and Research and Development Planning Summaries (DD Form 1634)

NAVMATINST 4000.20, Integrated Logistic Support Planning Policy

NAVMATINST 5300.8, Development and Review of Enlisted Manpower Requirements in Naval Ships

NAVSHIPSINST 4000.17, Promulgation of Integrated Logistic Support Planning Policy

NAVSHIPSINST 5432.1, Naval Ship Systems Command (NAVSHIPS) Organization Manual

NAVSHIPSINST 9020.30, Utilization, Inspection, and Approval of Full Scale Mock-ups of Machinery Spaces in Non-nuclear Surface Ships

NAVSHIPSINST 9020.35, Policies and Procedures for Standards in Shipboard Command and Control Spaces

NAVSHIPS NOTICE 5430, 10 September 1969, Guidance for NAVSHIPS Financial Support of BUPERS Personnel Research

OPNAVINST 1500.8, Preparation and Implementation of Navy Training Plans for New Developments

OPNAVINST 1500.20, Personnel and Training Policy Related to New Systems

OPNAVINST 3910.4, Technical Development Plan (TDP)

OPNAVINST 3910.6, Instructions for Preparation, Coordination and Review of Specific Operational Requirements (SOR)

---

\*Last issue in effect; therefore, letters and dates are not usually included.

**Preceding page blank**

- OPNAVINST 3910.7, Procedure for Preparation of Advanced Development Objective (ADO)
- OPNAVINST 3910.8, Proposed Technical Approaches (PTA)
- OPNAVINST 3910.9, General Operational Requirements (GOR) for Navy Research and Development
- OPNAVINST 4100.3, Department of the Navy Integrated Logistic Support (ILS) System
- OPNAVINST 4700.16, Standard Navy Maintenance and Material Management System (3-M System)
- OPNAVINST 5300.3, Development and Review of Enlisted Manpower Requirements in Naval Ships
- OPNAVINST 9330.5, Environmental Control Standards
- SECNAVINST 3900.7, Research, Development, Test and Evaluation Policies
- SECNAVINST 3900.36, Policy for Reliability and Maintainability (R&M) of Naval Material
- SECNAVINST 4000.29, Development of Integrated Logistic Support for Systems and Equipment
- SECNAVINST 5000.1, System Acquisition in the Department of the Navy
- SECNAVINST 5430.67, Assignment of Responsibilities for Research, Development, Test and Evaluation

## 5.2 SPECIFICATIONS

- MIL-E-16400 (NAVY) Electronic Equipment, Naval Ship and Shore, General Specification
- MIL-F-18870, Fire Control Equipment, Naval Ship and Shore, General Specification
- MIL-H-46855, Human Engineering Requirements for Military Systems, Equipment and Facilities
- MIL-I-983, Basic Design Requirements for Interior Communication Equipment, Naval Shipboard
- MIL-M-17779, Mock-ups for Shipboard Command, Control, Combat Direction, and Communications Stations and Spaces
- MIL-M-23530, Mock-up of Main and Auxiliary Shipboard Machinery Spaces
- MIL-M-24100, Manuals, Orders and Other Technical Instructions for Equipment and Systems



MIL-P-28700 (NAVY), Personnel Planning Data for Naval Systems

MIL-T-23991, General Specification for Training Devices, Military

### 5.3 STANDARDS

MIL-STD-470, Maintainability Program Requirements (for Systems and Equipments)

MIL-STD-471, Maintainability Demonstration

MIL-STD-721, Definitions of Effectiveness Terms for Reliability, Maintainability, Human Factors, and Safety

MIL-STD-756, Reliability Prediction

MIL-STD-785, Reliability Program for Systems and Equipment Development and Production

MIL-STD-882, Requirements for System Safety Program for Systems and Associated Subsystems and Equipments

MIL-STD-1472, Human Engineering Design Criteria for Military Systems, Equipment and Facilities

### 5.4 MANUALS AND GUIDES

AFSC DH 1-6, System Safety Handbook

NAVEXOS P-643, Handbook of Human Engineering Data for Design Engineers

NAVMAT P3910A, February 1966, Guide for the Preparation of Proposed Technical Approaches (section 8)

NAVMAT P3941-A, 1 July 1968, Navy Systems Performance Effectiveness Manual (page 24, appendix A)

NAVPERS 15163, Navy Military Manpower Billet Cost Data for Life Cycle Planning Purposes

NAVPERS 18660, Annual Training Time and Costs for Navy Ratings and NEC's

NAVSHIPS 94324, Maintainability Design Criteria Handbook for Designers of Shipboard Electronic Equipment

NAVSHIPS 0900-002-3000, Reliability and Maintainability Training Handbook

NAVSHIPSINST 5200.17, Promulgation of Shipborne System/Equipment Acquisition Manual (SS/EAM), Design Work Study/Human Engineering and Shipboard Manning, appendix 6: Safety, appendix 26

NAVSO P-2457 (rev 7-69), Department of the Navy RDT&E Management Guide

NAVWEPS OD 18413, Human Factors Design Standards for the Fleet Ballistic Missile Weapon System (Volume 1 Design of Systems, Volume 2 Design of Equipment)

NBS H30, National Electrical Safety Code

## 5.5 GENERAL HUMAN ENGINEERING PUBLICATIONS

Chapanis, A., "Research Techniques in Human Engineering," Baltimore, Maryland, Johns Hopkins Press, 1959

Condon, C. F. M., and Hannaman, D. L., "Personnel and Training Research in Support of Advanced Ship Programs," Volume I: Overview and Conclusions and Volume II: Procedural Guide, URS Data Sciences, Report No. PTB 71-2, Bureau of Naval Personnel, March 1971

Damon, A., et al., "The Human Body in Equipment Design," Cambridge, Massachusetts, Harvard University Press, 1966

DeGreene, K. B., "Systems Psychology," New York, New York, McGraw-Hill, 1970

Dreyfuss, H., "Designing for People Paragraphic Books," New York, New York, Grossman Publishers, 1967

Fitts, P. M. and Posner, M. I., "Human Performance Basic Concepts in Psychology Series," Belmont, California, Brooks/Cole, 1968

Fogel, L. J., "Biotechnology: Concepts and Applications," Englewood Cliffs, New Jersey, Prentice Hall, 1963

Folley, J. D., (ed), "Human Factors Methods for System Design," The American Institute for Research, Contract Nonr-2700(00), Office of Naval Research, 1960

Gagne, R. M. (ed), "Psychological Principles in System Development," New York, New York, Holt, Rinehart & Winston, 1962

Gerathwohl, S. J., "Principles of Bioastronautics," Englewood Cliffs, New Jersey, Prentice Hall, 1963

Goldman, A. S., and Slattery, T. B., "Maintainability," New York, New York, John Wiley & Sons, 1967

Harris, D. H., and Chaney, F. B., "Human Factors in Quality Assurance," New York, New York, John Wiley & Sons, 1969

Howell, W. C., and Goldstein, I. L., "Engineering Psychology: Current Perspectives in Research," New York, New York, Appleton-Century-Crofts, 1971

I.E.S. "Lighting Handbook" (3rd ed), New York, New York, Illuminating Engineering Society, 1959

Kelley, C. R., "Manual and Automatic Control," New York, New York, John Wiley & Sons, 1968

- Kraft, J. A., "Human Factors and Biotechnology - A Status Survey for 1968-69 (Volume I and II)," Lockheed Missiles & Space Company, Contract N00014-68-C-0378, Work Unit 196-079, Report LMSC-687154, Office of Naval Research, April 1969
- Kubokawa, C. (ed), "Databook for Human Factors Engineers, Volume I: Human Engineering Data," Man Factors, Inc., Contract NAS2-5298, Report CR114271, National Aeronautical and Space Administration Ames Research Center, November 1969
- Kubokawa, C. (ed), "Databook for Human Factors Engineers, Volume II: Common Formulas, Metrics, Definitions," Man Factors, Inc., Contract NAS2-5298, Report CR114272, National Aeronautical and Space Administration Ames Research Center, November 1969
- McCormick, E. J., "Human Factors Engineering (3rd ed)," New York, New York, McGraw-Hill, 1970
- Meister, D., "Human Factors: Theory and Practice," New York, New York, Wiley-Interscience, 1971
- Meister, D., and Rabideau, G. F., "Human Factors Evaluation in System Development," New York, New York, John Wiley & Sons, 1965
- Meister, D., and Sullivan, D. J., "Guide to Human Engineering Design for Visual Displays," Bunker-Ramo Corp., Contract N00014-68-C-0278, Work Unit NR 196-080, Office of Naval Research, 30 August 1969
- Morgan, C. T. (ed), "Human Engineering Guide to Equipment Design," New York, New York, McGraw-Hill, 1963
- Murrell, K. F. H., "Human Performance in Industry," New York, New York, Reinhold Publishing, 1965
- Parsons, H. M., "Man-Machine System Experiments," Baltimore, Maryland, Johns Hopkins University Press, 1972
- Poulton, E. C., "Environment and Human Efficiency," Springfield, Illinois, Charles C. Thomas, 1970
- Roth, E. M. (ed), "Compendium of Human Responses to the Aerospace Environment" (volume I, sections 1-6; volume II, sections 7-9; volume III: A Descriptive Model for Determining Optimal Human Performance in Systems), NASA CR-1205(I), Clearinghouse for Federal Scientific and Technical Information, Springfield, Va.
- Singleton, W. T. (ed), "The Human Operator in Complex Systems," London, England, Taylor & Francis, 1967
- Woodson, W. E., and Conover, D. W., "Human Engineering Guide for Equipment Designers (2nd ed)," Berkeley, California, University of California Press, 1966
- Wulfeck, J. W., et al, "Vision in Military Aviation," Technical Report 58-399, Aerospace Systems Division, WPAFB, Ohio, 1958

## 5.6 BIBLIOGRAPHIES

- Bender, E. K., and Collins, A. M., "Effects of Vibration on Human Performance: A Literature Review." Bolt, Beranek and Newman, Inc., Contract N00014-69-C-0095, Subproject S46-06, Report 1767, Naval Ship Research and Development Center, 15 February 1969
- Caswell, J., et al, "A Bibliography of Human Factors in Airborne Weapon Systems." Naval Air Development Center, Report NADC-MR-6808, 16 September 1968
- Knowles, W. B. (ed), "Cumulative Index to Human Factors Volumes I-10, 1958-1968." Human Factors Society, Santa Monica, California, 1969
- Kurtz, A. K., and Smith, M. C., "Annotated Bibliography of Human Factors Laboratory Reports (1945-1968)." Naval Training Device Center, Technical Report III-158, February 1969
- Man Factors, Inc., "Regulatory and Advisory Documents Applicable to Human Factors, Personnel, and Training Requirements (3rd ed)." Man Factors, Inc., San Diego, California, Report MFI 69-1, March 1969
- Naval Electronics Laboratory Center, "Bibliography of Human Factors Reports" (covers work conducted 1949-1970), March 1971
- Reilly, R. E., "Annotated Bibliography: Human Performance in the Undersea Environment." Biotechnology, Inc., ONR Contract N00014-70-C-0052, Naval Research Laboratory, January 1970
- Ronco, P. G., et al, "Human Factors Engineering Bibliographic Series, Volume 1, 1940-1959 Literature." Institute for Psychological Research, Tufts University, HEL BIB VOL 1, U.S. Army Human Engineering Laboratories, May 1966
- Ronco, P. G., et al, "Human Factors Engineering Bibliographic Series, Volume 2, 1960-1964 Literature." Institute for Psychological Research, Tufts University, HEL BIB VOL 2, U.S. Army Human Engineering Laboratories, October 1966
- Ronco, P. G., et al, "Human Factors Engineering Bibliographic Series, Volume 3, 1965 Literature." Institute for Psychological Research, Tufts University, HEL BIB VOL 3, U.S. Army Human Engineering Laboratories, May 1967
- Ronco, P. G., et al, "Human Factors Engineering Bibliographic Series, Volume 4, 1966 Literature." Institute for Psychological Research, Tufts University, HEL BIB VOL 4, U.S. Army Human Engineering Laboratories, December 1967

NOTE: The Human Factors Society, P. O. Box 1369, Santa Monica, California 90406, published a "Table of Equivalents Between HEIAS (Human Engineering Information and Analysis Service) Accession Numbers and Defense Documentation Center Numbers." by Stanley Lippert, Paul Ronco, and the HEIAS Staff. This document includes DDC numbers for the above four volumes published under U.S. Army Human Engineering Laboratories' sponsorship.

Stevenson, S. A., and Johnson, R. A., 1966 supplement to "A Bibliography of Reports...(see following item)," April 1967

Stevenson, S. A., and Trygg, L. E., "A Bibliography of Reports Issued by the Behavioral Sciences Laboratory: Engineering Psychology, Training Psychology, Environmental Stress, Simulation Techniques, and Physical Anthropology, April 1946 - December 1965," Aerospace Medical Research Laboratories, June 1966

## 5.7 JOURNALS AND PERIODICALS RELEVANT TO HUMAN ENGINEERING

Aerospace Medicine  
Applied Ergonomics  
Audiology  
Aviation Week  
Behavioral Science  
Biomedical Engineering  
Biometrika  
Biophysics  
Ecology  
Engineering Cybernetics  
Environmental Quarterly  
Human Factors  
IEEE Transactions. Man-Machine System  
IEEE Transactions. Systems, Man, and Cybernetics  
Illuminative Engineering  
Industrial Engineering  
Information Display  
Journal of Air Traffic Control  
Journal of Engineering Psychology  
Journal of Experimental Psychology  
Journal of Speech and Hearing Research  
Journal of Verbal Learning and Verbal Behavior  
Language and Speech  
Light and Lighting  
Noise Control  
Operations Research  
Pattern Recognition  
Perception and Psychophysics

Psychological Abstracts  
Psychological Review  
Simulation  
Vision Research

#### 5.8 MISCELLANEOUS

CNM Memorandum for the Deputy CNO (D), 30 April 1964, Subject:  
Statement of Human Factors Responsibilities of CNM

General Operational Requirement 43 (Rev 10/71), Personnel Logistics

Letter CNO to CNM, OP-701E2/amm Ser 612P70, 27 May 1968, Subject:  
Implementation of Military Specification MIL-H-46855, and Military  
Standard 1472

## APPENDIX A

### COMPARISON OF HUMAN AND MACHINE CAPABILITIES FOR PERFORMING VARIOUS TASKS

#### SENSING AND MONITORING

Man	Machine
Men are poor monitors of infrequent events or of events which occur frequently over a long period of time.	Machines can be constructed to detect reliably infrequent events and events which occur frequently over a long period of time.
Man can interpret an input signal even when subject to distraction, high noise, or message gap.	Machines perform well only in a generally clean, noise-free environment.
Man is a selecting mechanism and can adjust to sense specific inputs.	Machines are fixed sensing mechanisms, operating only on that which has been programmed for them.
Man has very low absolute thresholds for sensing (e.g., vision, audition, tactition).	Machines, to have the same capability, become extremely expensive.
Expectation or cognitive set may lead an operator to "see what he expects or wants to see."	Machines do not exercise these processes.

#### INFORMATION PROCESSING

Man	Machine
Man complements the machine by aiding in sensing, extrapolating, decision making, goal setting, monitoring, and evaluating.	Machines have no capacity for performance different from that originally designed.
Man can acquire and report information incidental to the primary mission.	Machines cannot do this.
Man can perform time contingency analyses and predict events in unusual situations.	Corresponding machines do very poorly.
Man generally requires a review or rehearsal period before making decisions based on items in memory.	Machines go directly to stored information for decision.

Man	Machine
Man has a built-in response latency of about 200 milliseconds in a go/no-go situation.	Machines need to have virtually no response latency.
Man is not well adapted to a high-speed, accurate search of a large volume of information.	Computers are designed to do just this.
Man does not always follow an optimum strategy.	Machines will always follow the strategy designed into them.
Man has an extremely limited short-term memory for factual material.	Machines may have as much short-term (buffer) memory as can be afforded.
Man is not well suited to data coding, amplification, or transformation tasks.	Machines are well suited to these kinds of tasks.
Human performance is degraded by fatigue and boredom.	Machine performance is degraded only by wearing out or by lack of calibration.
Man saturates quickly in terms of the number of things he can do and the duration of his effort.	Machines can do one thing at a time so fast that they seem to do many things at once for a long period of time.
The human has a limited channel capacity.	Machines may have as much channel capacity as can be afforded.
Men are subject to anxiety which may affect their performance efficiency.	Machines are not subject to this factor.
Man is dependent upon his social environment, both present and remembered.	Machines have no social environment.
Man can recognize and use information redundancy (pattern) in the real world to simplify complex situations.	Machines have limited perceptual constancy and are very expensive.
Man has high tolerance for ambiguity, uncertainty, and vagueness.	Machines are highly limited by ambiguity and uncertainty in input.
Man has excellent long-term memory for related events.	Machines, to have the same capability, become extremely expensive.



Man	Machine
Man can become highly flexible in terms of task performance.	Machines are relatively inflexible.
Man can improvise and exercise judgment based on long-term memory and recall.	Machines cannot exercise judgment; they are best at routine, repetitive functions.
Man can perform under transient overload; his performance degrades gracefully.	Machines stop under overload; generally fail all at once.
Man can make inductive decisions in novel situations; can generalize.	Machines have little or no capability for induction or generalization.
Man can modify his performance as a function of experience; he can learn "to learn."	Trial and error behavior is not characteristic of machines.
Man can override his own actions should the need arise.	Machines can do only what they are built to do.
Man complements the machine in the sense that he can use it in spite of design failures, for a different task, or use it more efficiently than it was designed for.	Machines have no such capability.

### CONTROL

Man	Machine
Man can generate only relatively small forces, and cannot exert large forces for very long or very smoothly.	Machines can generate and exert forces as needed.
When performing a tracking task, man requires frequent reprogramming; he does best when changes are under 3 radians/second.	Machines do not have such limitations.
Much of human mobility is predicated and based on gravity relationships.	Machines may be built which perform independently of gravity.
Human control functions are adversely affected by high g-forces.	Machine control functions may be designed to be largely unaffected by g-force.

Man	Machine
Humans are subject to coriolis effects, motion sickness, disorientation, etc.	Machines are not subject to these effects.
Unselected individuals differ greatly among themselves.	Individual differences among machines are small.
Human performance is degraded by long duty periods, repetitive tasks, and cramped or unchanged positions.	Machines are less affected by long duty periods, perform repetitive tasks well; some may be restricted by position.

## APPENDIX 3

### TIME-LINE ANALYSIS

Time-line analysis is a technique used to help derive human performance requirements by showing (diagrammatically) the functional and temporal relationships among tasks as well as the task loadings for any combination of tasks.

The time-line analysis is displayed by means of a chart or series of charts. Although numerous formats have been developed and used by various analyses, the most useful type is illustrated in figure 3.10 of this guide. In this format it can be seen that tasks are grouped by operator and displayed as a two-dimensional graph that indicates the estimated amount of the operator's time which is occupied at various intervals along a common time scale.

With this type of graphic the analyst can easily spot those intervals during a mission in which a given operator may be overloaded. It is obvious that an operator cannot accomplish two tasks simultaneously if both occupy a single perceptual-motor channel or decision-making response 100% of the time. The time-line chart exposes such conditions if it is properly developed. When such conditions are spotted, it is apparent that one of two things must be done — either a task will have to be given to another operator or the operator must be provided some type of machine assist (e.g., an operation becomes automatic rather than manual).

The task load estimates come from several sources. For example, the task may be the same as or similar to a task required in another system which is in actual operation. Task time information from previous systems is generally the most reliable, since it has been verified in practice. When such information is not documented, the next best source of information is from operators who perform or have performed similar tasks. It is desirable to get estimates from several operators, since there is frequent variation in their estimates. The human engineer generally has to probe the task question with the operator in fairly good detail to provide the operator with a basis upon which to make an estimate. It is important, for instance, to clarify the fact that in some cases two tasks can occupy almost 100% of the operator's time if one task involves a different perceptual-motor channel than the other. For example, an operator can usually monitor an aural channel almost full time and still monitor a visual display almost full time. When experienced operators are not available, the human engineer along with knowledgeable equipment engineers may have to make an "expert guess" about the task. The human engineer will have to break the task down into its simplest elements and extrapolate from what he knows about division of attention on the basis of human performance studies.

The time line may be made up of a single, continuous chart from beginning to end of a mission, or there may be several charts, each of which expands a particularly critical segment of the mission. The time scale should be commensurate with task complexity; i.e., 5-minute intervals may be all that is necessary for simple tasks while 5-second intervals may be required for more complex tasks. Whatever interval is used, however, should be common for the total group of tasks and operators when they interact.

## APPENDIX C

### LINK ANALYSIS PROCEDURE

Link analysis is a technique for developing a best arrangement of components on a control panel, functional elements within a work station, elements and traffic flow within a work area, or men and machines in a system. This technique is used only after decisions have been made regarding what items are to be on the panel, what equipment will be used in the system, how many men will be used, etc. Thus, link analysis is used to place the system components, be they items on a panel or men and machine in a work room, in the "best arrangement" on the basis of criteria (such as minimum distance between men or fewest movements between men and equipment) important for the system under evaluation.

The term "link" as used here refers to any connection between a man and a machine or between one man and another. If one man must talk or physically contact another (for example, hand him a message), this is represented by a link. If a man must see a display or reach a control on a machine, he has a link to that machine. Ordinarily, any links between machines can be neglected unless the link possesses some quality which might cause the system to operate inefficiently (for example, excessive length of a hardwire connection between two machines might result in high line loss in power). In these cases, links between machines are also included in the link analysis.

A typical example of a link analysis for a system involving four operators and four pieces of equipment is shown below.

Step 1. Draw a circle for every man in the system and label it with a code number.



Draw a square for every item of equipment and label it with a code letter:



Step 2. Determine the type of link between each of the equipments and operators, equipments and equipments, and operators and operators. The different link types should be coded, such as:

- — — control links
- visual links
- . . . . . talk links

The three codes are fairly standard for link analysis use. Other codes required can be made up by the individual doing the analysis.

Step 3. Establish the "link value" for each link. The link value is based on two factors: (1) the importance of the link in accomplishing the mission assigned to the system under evaluation, and (2) the number of times

**Preceding page blank**

(frequency) the link is used in completing the mission. A number between 1 and 3 is assigned for both frequency and importance, with the highest number representing maximum importance and frequency. As an example, if a particular control movement on the panel is very critical in fulfilling the equipment use (3) and frequently activated during equipment use (3), the link value for that particular control link will be 9 (3X3). If, on the other hand, a link is infrequently used (1) but critical when needed (3), its link value will be 3 (1X3). Thus, the link value is found by multiplying the frequency rating by the importance rating.

Selection of the frequency and importance ratings is usually based on past experience, either by the individual doing the analysis or someone familiar with similar systems already in use. In addition, the engineer responsible for the equipment design should be of assistance.

Step 4. Prepare an analysis chart (fig. C-1) of the link values established for the system under evaluation. For each operator, show all the links (with each link value) associated with him. Do the same for each piece of equipment. For each operator and equipment item, add up the total of the link values and write this number to the right side. This provides an idea of the priority of equipment use and the operators most active in the system operation.

Step 5. Prepare a schematic diagram (or series of diagrams) of possible arrangements. It is preferable to make this schematic to scale by cutting components out of paper and laying them on a scaled drawing of the space available (panel face, work space floor plan, etc.). Starting with the operator or machine with the highest total link value, place the remaining components around it, moving them as necessary to minimize link crossing and shorten links, especially those with high link values. If conflicts occur between links, it may be necessary to reassess the original link values. The evaluation and rearrangement continues until the "best fit" solution is obtained. Figure C-2 shows the final layout of the sample system. It should be emphasized that additional changes may be required in system layout once full-scale mock-ups or early hardware make actual system layout and evaluation possible.

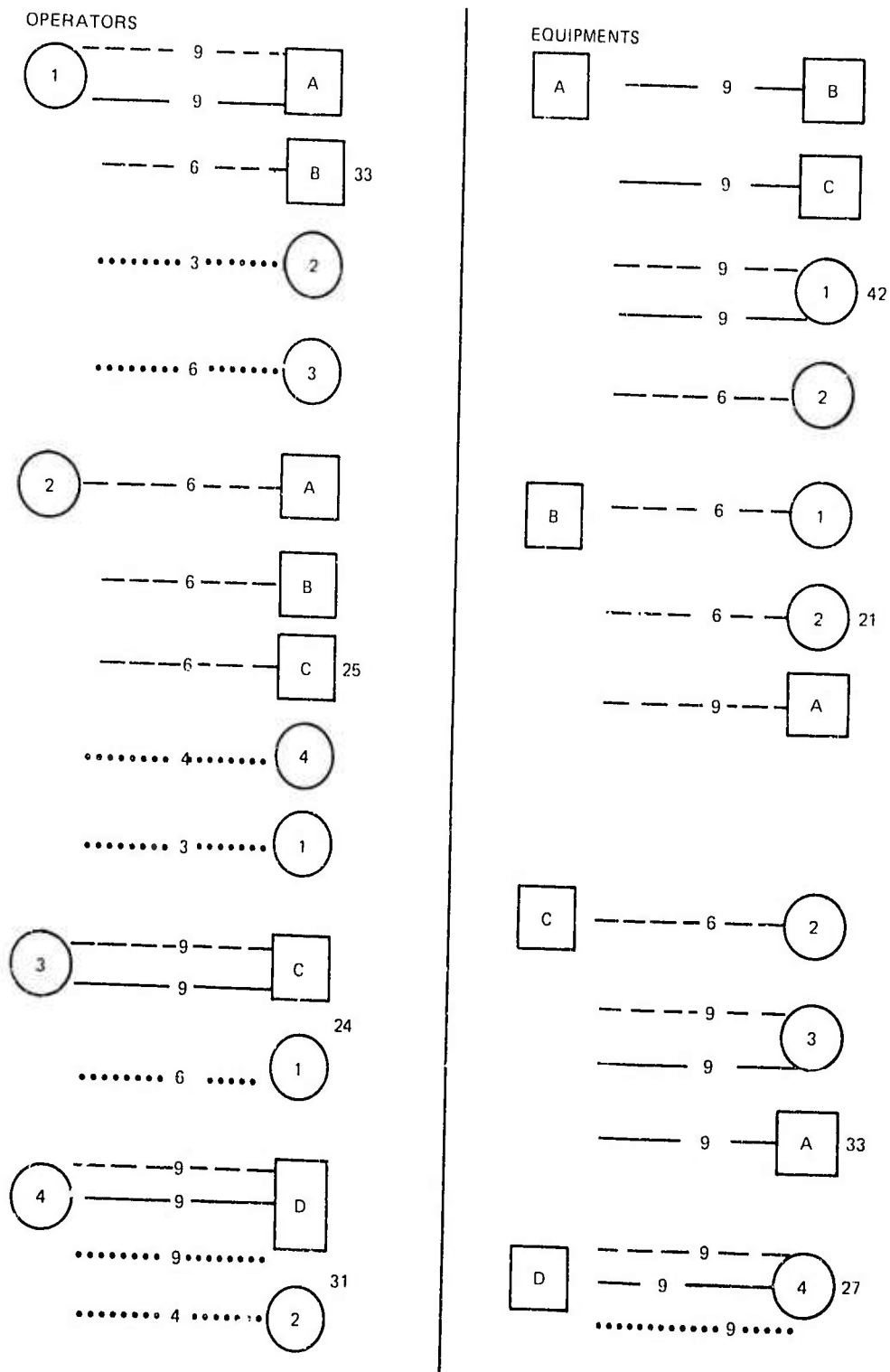

Figure C-1. Sample analysis chart for link values.

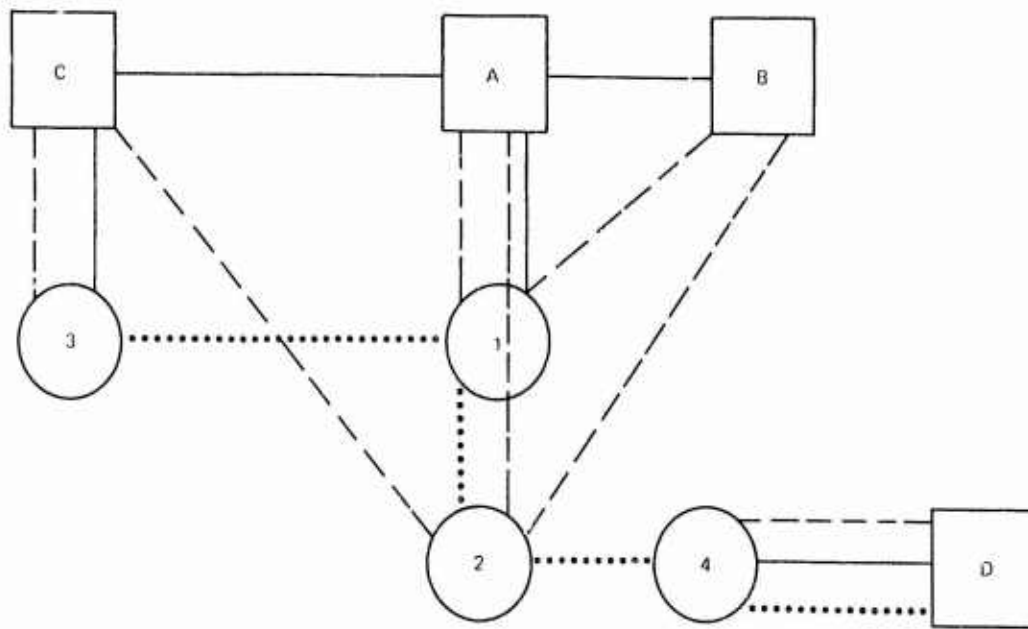

Figure C-2. Schematic of final system layout.

APPENDIX D

SAMPLE HUMAN ENGINEERING CHECKLIST

VISUAL DISPLAYS

DISPLAY TYPE, FORMAT, AND CONTENT

	SAT	UNSAT
How appropriate to the purpose are display type, format, and content?	_____	_____
Only needed information displayed	_____	_____
Minimum conversion and interpolation	_____	_____
Digital indicators if use is quantitative readout only	_____	_____
Moving-pointer fixed-scale vice moving-scale fixed-pointer	_____	_____
GO/NO-GO for either/or states	_____	_____
Suitability for both maintenance and operation	_____	_____
Scalar displays for qualitative information	_____	_____
Is redundant information displayed	_____	_____

LOCATION OF DISPLAYS

	SAT	UNSAT
Does placement and grouping of displays satisfy the following?	_____	_____
Can be checked from one position	_____	_____
Single, simple access when located behind panels	_____	_____
No removal of parts required for use	_____	_____
Prime visual area reserved for frequently used displays	_____	_____
Related instruments grouped together	_____	_____
Easy identification of separate groups	_____	_____
Arranged for sequential operation if appropriate	_____	_____
Acceptable parallax and shadow effects	_____	_____

INDICATOR LIGHTS

	SAT	UNSAT
Indicator light use should conform to the following:	_____	_____
Single function for each light	_____	_____
Clear and unambiguous labeling	_____	_____
Lights for maintenance covered during normal operation	_____	_____
Needed labels visible at appropriate time	_____	_____
Positive indication of power failure	_____	_____
Easy check for operation of all lights	_____	_____
Dimming control if ambient illumination changes	_____	_____



	SAT	UNSAT
When necessary, legends readable when not illuminated	_____	_____
Flashing lights (2-6 Hz) for critical alerts	_____	_____
Consistent color coding	_____	_____
Front replaceable bulbs	_____	_____
Apparent brightness of different colors balanced	_____	_____
Critical or emergency lights brighter than others	_____	_____
Lights visible under brightest ambient illumination expected	_____	_____
Lamp types standardized	_____	_____

### SCALAR DISPLAYS

Scalar displays should be considered when:	SAT	UNSAT
Information shows direction and/or rate of change	_____	_____
Information quantitative over continuous range of values	_____	_____
Scalar displays should provide for:		
In/out-of tolerance coding	_____	_____
Graduations fine enough for reading without interpolation	_____	_____
Quick, easy, and accurate reading	_____	_____
Immediate display of changes	_____	_____
Critical limits not at either end of scale	_____	_____
Clear break between ends of scale for single-revolution indicators	_____	_____
Numerals placed outside of graduation marks	_____	_____
Numerals should increase from left to right or bottom to top	_____	_____
No upside down or horizontal reading of numerals required	_____	_____

### COLOR CODING

Color coding should use unambiguous colors which have some universally accepted meaning

Color coding should indicate:	SAT	UNSAT
RED equipment inoperative	_____	_____
FLASHING RED immediate corrective action required	_____	_____
AMBER marginal, unsatisfactory, or impending emergency condition	_____	_____
GREEN in-tolerance or satisfactory operation	_____	_____
WHITE nothing other than displayed by its label	_____	_____
Operating and danger areas of indicators should be appropriately coded	_____	_____

LEGENDS AND LABELS

Legends and labels should conform to the following:	SAT	UNSAT
Capital letters a minimum of 1/8 inch high	_____	_____
Brief. Abbreviations where used are meaningful	_____	_____
Location of display in block diagram of equipment is indicated	_____	_____
Functional quantity vice just electrical characteristics identified	_____	_____
Single legend displays readable when not lighted	_____	_____
Etched or embossed vice stamped or printed	_____	_____

CATHODE RAY TUBES

CRTs should have:	SAT	UNSAT
Uniform brightness over scope face	_____	_____
Scope face perpendicular to operator's normal line-of-sight	_____	_____
Maximum 25% screen brightness from diffuse reflection and/or phosphor excitation by ambient illumination	_____	_____
Adequate shielding for use in high ambient illumination	_____	_____
Adjacent surfaces finished in dull matte	_____	_____
No specular reflections projected into observer's eyes	_____	_____

COUNTERS

Use of counters should consider:	SAT	UNSAT
Horizontal vice vertical mounting	_____	_____
Change slow enough to be read	_____	_____
Manual reset which increases display with clockwise rotation	_____	_____
Significant digits displayed not greater than inputs received	_____	_____

FLAGS, GO/NO-GO, AND CENTER-NUL INDICATORS

These two-state type indicators consider:	SAT	UNSAT
High contrast between indicator and background	_____	_____
State change with snap action	_____	_____
Will not indicate in-tolerance if power fails	_____	_____

## CONTROLS

### LOCATION

Controls should conform to the following:	SAT	UNSAT
Within easy reach of operator	_____	_____
Spaced for easy manipulation	_____	_____
Spaced to prevent accidental activation	_____	_____
Placed in order of normal use	_____	_____
Separated from high voltages and hot components	_____	_____
Adjustment controls on a single panel	_____	_____
No disassembly/removal of equipment for viewing/operation	_____	_____
Work load distributed between right and left hand	_____	_____
Front panel maintenance controls covered when not in use	_____	_____

### CHARACTERISTICS OF CONTROLS

Controls should have the following characteristics:	SAT	UNSAT
Operate according to expectation (right to increase, up for on)	_____	_____
Size appropriate for torque or force required for operation	_____	_____
Precision control knobs about 2 inches in diameter	_____	_____
Two-position toggle switches only	_____	_____
Toggle switch displacement great enough to indicate position	_____	_____
Scales compatible with setting accuracy required	_____	_____
Audible or tactual feedback to indicate pushbutton activation	_____	_____
Pushbuttons large enough that finger or thumb will not slip off	_____	_____
Pushbutton actuation pressure not excessive or inconvenient	_____	_____
Smooth, even resistance except for detents on selector switches	_____	_____
Multiposition selector switches cannot be left between detents	_____	_____
Mechanical guards or electrical interlocks on critical controls	_____	_____
Sharp edges or points avoided on controls	_____	_____
Indexes or pointers clearly visible on rotary switches	_____	_____
Tool-operated controls operable by medium-size screwdriver or tool	_____	_____

### LABELING

Labeling should conform to the following:	SAT	UNSAT
Positions for rotary switches clearly labeled	_____	_____
Descriptive rather than coded	_____	_____
Indicates control function	_____	_____

SAT UNSAT

Numbered in sequence where fixed sequence used

\_\_\_\_\_

Controls readily identified under expected operating conditions

\_\_\_\_\_

### CONTROL DISPLAY RELATIONSHIPS

The following control display relationships should be maintained:

SAT UNSAT

Related displays and/or controls on same face of unit

\_\_\_\_\_

Logical relationship in location and movement

\_\_\_\_\_

Arrangement reflects sequence and/or frequency of use

\_\_\_\_\_

Display easily and accurately read when control is operated

\_\_\_\_\_

Displays not obscured by control operation

\_\_\_\_\_

Functional groups clearly delineated

\_\_\_\_\_

Control display relationship is unambiguous

\_\_\_\_\_

Directional correspondence between controls and displays

\_\_\_\_\_

Ratio of control to display movement appropriate for task

\_\_\_\_\_

Adjustment or alignment possible with only one control

\_\_\_\_\_

## MAINTAINABILITY

### COMPONENT LOCATION

Location of components should conform to the following:

SAT UNSAT

Stacking of components is avoided

\_\_\_\_\_

Access possible without hazard to personnel

\_\_\_\_\_

Tools and test equipment can be used without difficulty

\_\_\_\_\_

Internal controls avoid heat or dangerous voltages

\_\_\_\_\_

Replaceable units removable through single access panel

\_\_\_\_\_

Contamination by dirt, water, etc., is avoided

\_\_\_\_\_

Minimum place-to-place movement required during checkout

\_\_\_\_\_

Installation behind stress members, pipes, etc., avoided

\_\_\_\_\_

Removal of one unit does not require removal of other units

\_\_\_\_\_

No components blocked by large or difficult-to-remove components

\_\_\_\_\_

Frequency of access considered when locating units

\_\_\_\_\_

Higher skilled help not required to aid in gaining access to units

\_\_\_\_\_

Delicate components protected from damage

\_\_\_\_\_

Blind replacement or adjustments not required

\_\_\_\_\_

Heat or electrical charge not a hazard to personnel during access

\_\_\_\_\_

	SAT	UNSAT
No interference with access for tube replacement	_____	_____
Miniature tube sockets have same physical orientation	_____	_____
Sensitive adjustments protected from accidental disturbance	_____	_____
Frequently removed components mounted on roll-out racks, slides, etc.	_____	_____

### COMPONENT CHARACTERISTICS

Components should conform to the following. SAT    UNSAT

Where structurally or functionally feasible rapid and easy removal of malfunctions accomplished by one man	_____	_____
Easy removal and replacement where isolation of a malfunction is in normal operating position is possible	_____	_____
Parts mounted on one side of a surface with associated wiring (including printed or soldered circuits) on the other side	_____	_____
Maximum standardization and interchangeability within and between equipments	_____	_____
Functionally similar components interchangeable between different applications	_____	_____
Components can be checked and adjusted separately and connected together with minimum adjustment	_____	_____
Packaging designed with complete circuits in a single module	_____	_____
Replaceable component types minimized	_____	_____
Number of inputs and outputs for each replaceable unit minimized	_____	_____
If carried or moved short distances by one man, the following limits are not exceeded:		

Height lifted from ground (ft)	Maximum allowable weight (lb)
1	85
2	80
3	65
4	50
5	35

### RESTS AND STANDS

Are rests and/or stands provided:	SAT	UNSAT
For components while they are being removed or installed	_____	_____
For any test equipment, tools, and manuals which might be used	_____	_____
On which units can be set to prevent damage to delicate parts	_____	_____
As part of the basic chassis	_____	_____

COVERS, CASES, AND ACCESS DOORS

Covers, cases, and access doors should meet the following:	SAT	UNSAT
If hinged, captive quick-opening fasteners used consistent with security and stress requirements	_____	_____
Adequate swing space where hinges are used	_____	_____
Attached covers for plugs to keep out dirt and/or moisture	_____	_____
Self-supporting in the open position when not completely removable	_____	_____
Hinged at bottom or provided with mechanical lock in open position	_____	_____
Access shaped as necessary to permit passage of components and tools	_____	_____
Instructions lettered on hinged doors properly oriented with door open	_____	_____
Minimum number of large screws used where quick-opening fasteners do not meet stress, pressurization, shielding, or safety requirements	_____	_____
Cover plate with captive quick-opening fasteners where space is inadequate for hinged opening	_____	_____
No interference with opening or removal by structural members, bulkheads, or other components	_____	_____
Covers can be removed, carried, and installed by one man with common handtools	_____	_____
Covers provided with recessed handles	_____	_____
Adequate storage space in lids or covers of test equipment for leads, adapters, etc.	_____	_____
Rounded corners and edges with minimum radius of curvature 1/8 inch	_____	_____
Method of opening obvious from construction of cover or instructions attached to the outside	_____	_____
Secured condition obvious when the cover is in place	_____	_____
Screw holes large enough for passage of a screw without perfect alignment when screws must pass through covers or shields for attachment	_____	_____
Improper replacement of covers impossible	_____	_____
Ventilation holes small enough to prevent inadvertent insertion of test probes or other conductors	_____	_____
Cases can be lifted off units vice units lifted out of cases	_____	_____
Transparent window or quick-opening metal cover used for visual inspection	_____	_____
Cases larger than units covered so damage to wires and components minimized when put on and taken off	_____	_____

	SAT	UNSAT
Edges of accesses provided with internal fillets — rubber, fiber or plastic — to protect technician's hands or arms	_____	_____
Proper orientation of components within case obvious through design or appropriate labels	_____	_____
Portable test equipment cases rectangular for easier storage	_____	_____
Covers and cases have stock numbers to aid in replacement	_____	_____
No more than four screws in screw-fastened access plates	_____	_____
Maximum of six fasteners to secure a case	_____	_____
Same size fasteners for all covers and cases on a given equipment	_____	_____
Safety interlocks on accesses to equipment with high voltages	_____	_____
Shields or covers to prevent accidental contact with voltages in excess of 40 volts, including potentials on charged capacitors	_____	_____

HANDLES

Units weighing more than 10 pounds or which are difficult to grasp, remove or hold should be provided with handles meeting the following:	SAT	UNSAT
Located over center of gravity to minimize tipping when lifted/ carried	_____	_____
Positioned for comfort	_____	_____
Provided on covers to facilitate holding or carrying a unit	_____	_____
Positioned to minimize catching on other units, wiring, or structures	_____	_____
Recessed near the back of heavy units to facilitate handling	_____	_____
Recessed rather than extended to conserve space and preclude injuries	_____	_____
Hoist and lift points clearly marked when handles not provided	_____	_____
Minimum dimensions for use by the ungloved hand:		
Handle diameter    ¼-½ inch under 25 pounds, ½-3/4 if over 25	_____	_____
Finger clearance    2 inches	_____	_____
Handle width        4½ inches	_____	_____

LUBRICATION

Moving mechanical components:	SAT	UNSAT
Can be lubricated without disassembly or lubrication not required	_____	_____
Have lubricant type and frequency of lubrication on label at or near lubrication points	_____	_____

COMPONENT MOUNTING

Mounting of components for easy access or removal should conform to the following:

	SAT	UNSAT
Protection for easily damaged components	_____	_____
Coding to indicate the correct unit and its orientation for replacement	_____	_____
Physically similar but electrically noninterchangeable components keyed to prevent wrong use	_____	_____
Guide pins or equivalent for alignment	_____	_____
Limit stops (with override) on roll-out racks and drawers	_____	_____
Frequently moved units mounted on roll-out racks, slides, or hinges	_____	_____
Drawers and slide-out racks can be pulled out without breaking electrical connections	_____	_____
Removal possible along a straight or slightly curved line rather than through an angle	_____	_____
Guides, tracks, and stops provided to prevent cocking and possible damage when removed or replaced	_____	_____
Field removable components replaceable with common hand tools	_____	_____
Opening or removal of a minimum number of covers or panels for removal or replacement	_____	_____
Maximum of four screws/bolts for mounting a major component	_____	_____
Field replaceable units mounted to housing rather than attached to each other	_____	_____
Replaceable components are plug-in rather than solder connected	_____	_____
Only interconnecting wiring and structural members permanently attached to the unit chassis	_____	_____
Easily damaged conductors such as waveguides, high-frequency cables, or insulated high-voltage cables protected from damage	_____	_____
Components of same or similar form mounted with standard orientation yet are readily identifiable, distinguishable, and not physically interchangeable	_____	_____
Electrical components mounted on plug-in subassemblies	_____	_____
Fold-out construction or other special techniques used when necessary	_____	_____
Where fold-out construction is used, parts and wiring positioned to prevent damage when opening and closing assembly	_____	_____
Brace or other provision to hold hinged assemblies in 'out' position during maintenance	_____	_____
Lights, indicators, or displays/controls for maintenance or routine adjustments concealed during normal operations	_____	_____



SAT    UNSAT

Shafts or screws mounted vertical or guides provided where blind screwdriver adjustments must be made

\_\_\_\_\_

EXTERNAL ACCESSIBILITY

Location of accesses for maintenance should consider how the equipment will be installed. To ease the maintenance burden, the following should be satisfied:

SAT    UNSAT

Visual and manual accesses for direct access for maintenance

\_\_\_\_\_

Access with enough room for technician's hands or arms and an adequate view of what he is doing

\_\_\_\_\_

Easy removal of irregular extensions such as bolts, tables, wave-guides and hoses

\_\_\_\_\_

Labels on accesses for clear identification in job instruction

\_\_\_\_\_

Nomenclature of auxiliary equipment to be used at or items accessible through each access identified by label

\_\_\_\_\_

Indication of recommended period for maintenance operations in calendar or operating time

\_\_\_\_\_

Sliding, rotating, or hinged units to which rear access is required free to open full distance and remain so without hand support

\_\_\_\_\_

For visual access only the following should be used consistent with possible performance degradation:

Opening with no cover

\_\_\_\_\_

Plastic window (if dirt, moisture, or foreign materials a problem)

\_\_\_\_\_

Break-resistant glass (if physical wear or contact with solvent will cause optical deterioration)

\_\_\_\_\_

Quick-opening metal cover (if glass does not meet stress or other requirements)

\_\_\_\_\_

When access for tools, test heads, and service equipment is required, the following practices, in order of preference, should be followed:

SAT    UNSAT

Opening with no cover

\_\_\_\_\_

Sliding or hinged cap (if dirt, moisture, or other foreign materials are a problem)

\_\_\_\_\_

Quick-opening cover plate if a cap will not meet stress requirements

\_\_\_\_\_

INTERNAL ACCESSIBILITY

To improve access for maintenance inside equipment, the following must be considered:

	SAT	UNSAT
Structural members do not prevent access	_____	_____
Sufficient space to use test probes and tools without difficulty	_____	_____
Removal of an assembly from a major component not necessary to troubleshoot the assembly	_____	_____
Replaceable modules used	_____	_____
Throw-away assemblies or parts accessible without removal of other components	_____	_____
Connectors and associated labels positioned for full view	_____	_____
Components not self-checking can be checked in operating condition without use of special rigs and harnesses	_____	_____
Check and adjustment points, cable-end connectors, and labels are accessible and if possible face the operator	_____	_____
Technicians not required to retrace movements during checking due to layout	_____	_____
Rear of plug connectors accessible for test and service, except where potted, sealed, etc.	_____	_____
Possible to replace tubes without removing units from installation	_____	_____
External indication of position for pin-insertion for tubes inserted through small accesses (e.g., matching stripes or dots)	_____	_____
Special guide tools provided when adjustments would be difficult or dangerous to locate	_____	_____
Guide pins provided for alignment during mounting	_____	_____
Screwdriver-operated controls adjustable with the handle clear of obstructions or hazards	_____	_____
Units of more than 25 pounds installed within normal reach	_____	_____

**CONDUCTORS**

BINDING AND SECURING

	SAT	UNSAT
Conductors bound into cables and held by lacing twine or other acceptable means	_____	_____
Long internal conductors or cables secured to chassis by easily operated cable clamps	_____	_____

LENGTH

The length of cables should be:

SAT    UNSAT

Long enough so that drawers or slide-out racks can be opened without breaking electrical connections

\_\_\_\_\_

Adequate for checking functioning units in a convenient place or extension cables provided

\_\_\_\_\_

Long enough to permit jockeying or movement of components when it is difficult to connect or disconnect cables

\_\_\_\_\_

Units can be moved to a more convenient position if connecting and disconnecting cables difficult when mounted

\_\_\_\_\_

Lead lengths appropriate to maintenance tasks and conditions

\_\_\_\_\_

PROTECTION

SAT    UNSAT

Cables and wires routed through holes in metal partitions protected from mechanical damage by grommets or other acceptable means

\_\_\_\_\_

Electrical cables not routed below fluid lines

\_\_\_\_\_

ROUTING

Routing of cables should conform to the following:

SAT    UNSAT

Routing to prevent being walked on or used for hand holds

\_\_\_\_\_

Easily accessible for inspection and repair

\_\_\_\_\_

No need to be bent and unbent sharply when connected or disconnected

\_\_\_\_\_

Cannot be pinched by doors, lids, etc.

\_\_\_\_\_

Not under floor boards or behind difficult-to-remove panels

\_\_\_\_\_

Easy passage of cables and attached connectors through walls, bulkheads, etc.

\_\_\_\_\_

Test cables not terminating on control/display panels have receptacles located so that they do not interfere with controls or displays

\_\_\_\_\_

CODING

SAT    UNSAT

Single or multiconductor lines and cables should be standardized, coded, labeled, and easily identifiable throughout their length

\_\_\_\_\_

FABRICATION

SAT    UNSAT

Cable harnesses can be fabricated and installed as a unit

\_\_\_\_\_

Preformed cables with spare leads are used when possible

\_\_\_\_\_

Wires, harnesses, and cables minimized in number by simple and logical routing and layout

\_\_\_\_\_

## CONNECTORS

To prevent maintenance errors, mismatching, and cross-connection, simplify maintenance tasks, and safeguard equipment and personnel, the selection and use of connectors should meet the following:

	SAT	UNSAT
Located and mounted for easy access during replacement or repair	_____	_____
No tools or standard hand tools required to connect auxiliary equipment	_____	_____
Auxiliary or test equipment connectors operate in a fraction of a turn or with a quick snap action	_____	_____
Designed to prevent excessive tightening	_____	_____
Self-locking plugs with safety catch vice plugs requiring safety wire	_____	_____
Quick and easily disconnected plugs used	_____	_____
Adequate separation for firm grasp when connecting and disconnecting	_____	_____
Terminals for solder connections long enough and far enough apart to prevent damage to neighboring terminals, insulation, surrounding material, or other parts	_____	_____
About 1/16 in pigtail on soldered leads to simplify removal	_____	_____
Damage to lugs prevented when wires are unsoldered and removed	_____	_____
Stripes, arrows, or other coding of proper insertion position for keys or aligning pins	_____	_____
Unkeyed symmetrical arrangements of aligning pins avoided	_____	_____
Aligning pins on plugs project beyond the electrical pins	_____	_____
Female (socket type) receptacles are 'hot' male (pin type) plugs are 'cold' when disconnected	_____	_____
Contact and shorting by external objects prevented	_____	_____
Plugs and receptacles of removable equipment will disconnect before the cabling breaks	_____	_____
Plugs/receptacles vice pigtailing	_____	_____
Rapid removal lugs used for screw terminals vice ring type	_____	_____
Pins on plugs clearly identified	_____	_____
No more than three wires on any one terminal	_____	_____
Adequate spare connector contacts provided	_____	_____

## FASTENERS

Hand-operated fasteners are preferred, those requiring standard hand tools are acceptable, and those requiring nonstandard tools should not be used

### COVER FASTENERS

SAT    UNSAT

- |  |       |       |
|--|-------|-------|
| Maximum use of tongue-and-slot catches   | _____ | _____ |
| Fasteners standardized with minimum numbers, types, sizes, torques, and tools required | _____ | _____ |

### MOUNTING BOLTS AND FASTENERS

Selection and use of bolts and fasteners should consider the following: SAT    UNSAT

- |   |       |       |
|---|-------|-------|
| Heads unobstructed by components or structural members  | _____ | _____ |
| Combination bolts with internal slot and hexagonal heads used                                   | _____ | _____ |
| Screws with different threads are different sizes to prevent stripping when used in wrong holes | _____ | _____ |
| Fasten or unfasten in less than one complete turn if stress and load permits                    | _____ | _____ |
| Number of turns to tighten or loosen bolts minimized (less than 10)                             | _____ | _____ |
| External hexagonal head bolts for high-torque use   | _____ | _____ |
| Semipermanent captive bolts used (e.g., with snap-on collars)                                   | _____ | _____ |

## TEST POINTS

Test points should be supplied at the input and output for each major unit, stage, assembly, circuit, or throw-away component. Test points should conform to the following:

SAT    UNSAT

- |   |       |       |
|---|-------|-------|
| Standardized  | _____ | _____ |
| Readily accessible  | _____ | _____ |
| Located away from hazards   | _____ | _____ |
| Protected from damage   | _____ | _____ |
| Sufficient strength to prevent bending  | _____ | _____ |
| Ammeter phone jacks are of make-before-break type                             | _____ | _____ |
| Covers used when mounted on external surfaces to keep out moisture and dirt   | _____ | _____ |
| Measurements are with respect to ground, except ammeter phone jacks           | _____ | _____ |
| Adjustments associated with only one control                                  | _____ | _____ |
| Testing of essential waveforms possible when terminals not readily accessible | _____ | _____ |

LOCATION AND MOUNTING

Do location and mounting conform to the following:	SAT	UNSAT
Internal test points clustered on the most accessible portion of the unit	_____	_____
Centrally located and grouped when possible	_____	_____
Access not impeded by other parts of the equipment	_____	_____
Located on the front panel if test equipment uses displays on the front panel	_____	_____
Connectors for signal inputs	_____	_____
Located on outer case when external test equipment required	_____	_____
Quick-disconnects to prevent unheld probes from falling out	_____	_____
Barriers between terminals used as test points to prevent shorting or contact with high voltages	_____	_____
Located close to the associated controls and displays	_____	_____
Primary points grouped in line or matrix reflecting sequence of tests	_____	_____
Secondary (maintenance) test points distinguishable from primary	_____	_____
Removal of one component not required to troubleshoot another	_____	_____

LABELING AND CODING

Test points should be appropriately labeled by symbol, name, or color, which conforms to the following:	SAT	UNSAT
Outstanding color for easy location	_____	_____
In-tolerance or tolerance limits indicated	_____	_____
Job instructions coded to test points when full or detailed information not provided at the test point	_____	_____
Unit designation marked at outputs	_____	_____

**TEST EQUIPMENT**

Selection, use, and provisions for test equipment should consider:	SAT	UNSAT
Easily portable test equipment can be used where built-in test equipment is not provided	_____	_____
Standardized to minimize requirements for specialized test equipment	_____	_____
Required inputs for alignment available in one standard signal generator	_____	_____
Performance characteristics clearly specified (accuracy, calibration, etc.)	_____	_____

	SAT	UNSAT
Warning signals or safety devices provided	_____	_____
Adequate space available for use (consoles should be equipped with trays for holding test equipment)	_____	_____
Space for storing spare test cables, adapters, and tools	_____	_____
Easily attached adapters provided	_____	_____
Checking of accuracy and calibration is simple	_____	_____
Unless attachment is permanent, only a fraction of a turn required for attachment	_____	_____

INDICATORS

	SAT	UNSAT
Readouts in directly usable form	_____	_____
Luminescent markings for use in low illumination	_____	_____

CONTROLS

Controls on test equipment should conform to the following:	SAT	UNSAT
Built-in test equipment and selector switches for monitoring outputs if separate displays are not provided	_____	_____
Controls susceptible to vibration or shock have positive locking devices to retain settings	_____	_____
Alignment/adjustment controls neither so fine that a number of turns required to obtain peak value nor so coarse that peak position quickly passed	_____	_____
Alignment controls permit observation of associated display during adjustment	_____	_____

**TEST PROCEDURES**

Test procedures should meet with the following requirements:	SAT	UNSAT
Unambiguous signal at each point when associated control is moved	_____	_____
Alignment procedure straightforward; i.e., readjustment of earlier stage not necessary after adjusting a later stage	_____	_____
Signals and changes can be read while operating adjustments controls	_____	_____
Simple, complete, and readable instructions in view during operation	_____	_____
Units activated by a triggering pulse have a self-triggering capability	_____	_____

## FUSES AND CIRCUIT BREAKERS

Selection and location of fuses and circuit breakers should permit:	SAT	UNSAT
Easy viewing, replacement, and reactivation	_____	_____
Resetting/replacement unhampered by other components	_____	_____
Replacing/resetting without the use of tools	_____	_____
Determining signal source and fuse ratings through use of labels	_____	_____

## TOOLS

When considering the use of tools for maintenance, the following should be considered:	SAT	UNSAT
Variety of tools held to a minimum	_____	_____
Special tools avoided as much as possible	_____	_____
Tools for use near high voltages adequately insulated	_____	_____
Metal handles avoided on tools for use in extreme heat or cold	_____	_____
Tools have a dull finish to avoid glare in strong light	_____	_____
Nonsparking tools selected for use in explosive atmospheres	_____	_____
Magnetic tools avoided for use near delicate circuits	_____	_____
Speed, ratchet-type, and/or offset tools provided when necessary	_____	_____

## LABELS AND CODING

Labels and coding should conform to the following:	SAT	UNSAT
Full identifying information for all units and parts	_____	_____
Not hidden by units and parts	_____	_____
Readable from operator's position	_____	_____
Located so operators are unlikely to use wrong control or indicator	_____	_____
Labels etched or embossed vice painted or stamped on surface	_____	_____
Decals or stamped labels vice stencils	_____	_____
Meaning of colors consistent throughout the equipment	_____	_____
Meaning of colors explicit in job instructions and/or on a panel of the equipment having color coding	_____	_____
Color coding resistant to chipping and located away from points of physical wear	_____	_____
Unique designations for wires when required for tracing	_____	_____



	SAT	UNSAT
Terminals labeled with the same code as the wire to be attached	_____	_____
Outside coverings of parts such as resistors, condensers, and tubes marked with information concerning electrical characteristics	_____	_____
Transformers, chokes, and other potted networks have circuit diagrams with current, voltage, and impedance ratings on the outside	_____	_____
Coil contacts on relays clearly marked	_____	_____
Controls and displays labeled as to function or use	_____	_____

### SAFETY

General safety considerations in equipment design are:	SAT	UNSAT
Appropriate safeguards against injury to personnel and/or damage to equipment	_____	_____
Fail-safe design	_____	_____
Overload indicators on major components even if it is sometimes desirable to keep overloaded circuits in operation	_____	_____
Adequate illumination for the tasks to be performed	_____	_____

### MATERIALS

	SAT	UNSAT
Materials should not be used which, when exposed to extreme service conditions, liberate gases or liquids that combine with the atmosphere to become corrosive, toxic, or combustible mixtures	_____	_____

### FIRE AND EXPLOSION PROTECTION

To minimize fire and explosion, the following should be complied with:	SAT	UNSAT
Flame arrestors on exhausts of equipment used where flammable or explosive vapors or fumes might collect	_____	_____
No flammable vapors emitted during storage or operation	_____	_____
Fire extinguishers available where fire hazards exist	_____	_____
Equipment for use in vicinity of flammable gases or vapors is of an approved explosion-proof type	_____	_____

### PROTECTION FROM MECHANICAL HAZARDS

	SAT	UNSAT
Protection provided from imploding cathode-ray tubes	_____	_____
Rounded corners on doors, covers, and cases	_____	_____
Protrusions avoided, padded, or conspicuously marked	_____	_____
Access to moving parts is guarded	_____	_____

ELECTRICAL SAFETY

Protection of personnel from electrical shock hazards requires:

Cheater switches that automatically reset when access is closed if access for maintenance required while equipment is energized

SAT    UNSAT

\_\_\_\_\_

Means are provided to prevent accidental contact with voltages in excess of 70 volts, including potentials on charged capacitors

\_\_\_\_\_

Warning indicators where interlocks can be bypassed for maintenance

\_\_\_\_\_

External metal parts, control shafts, etc., are at ground potential

\_\_\_\_\_

Guards, covers, or warning plates where potentials in excess of 350 volts rms are possible

\_\_\_\_\_

Insulating paint used on exposed noncurrent-carrying parts to prevent them from becoming potential electrodes

\_\_\_\_\_

Rounded vice sharp terminals to reduce hazard of electrical shock

\_\_\_\_\_

Potentials in excess of 150 volts with respect to ground removed by interlocks on all accesses

\_\_\_\_\_

APPENDIX E  
HUMAN ENGINEERING DATA ITEM DESCRIPTIONS (DIDs)

**Preceding page blank**

DATA ITEM DESCRIPTION	2 IDENTIFICATION NO(S)	
	AGENCY	NUMBER
1 TITLE  PLAN, HUMAN ENGINEERING PROC RAM	NAVY	DI-H-2104
3 DESCRIPTION PURPOSE  This plan provides a description of how the contractor will incorporate his human engineering effort into the system development and acquisition. This plan includes definition of human engineering tasks, task schedule, level of effort, documentation and reporting requirements, personnel qualification and assignment, and human engineering deliverable end items. The plan provides the procuring activity with assurance of positive management control of the contractor effort.	4 APPROVAL DATE 1973 July 20	
	5 OFFICE OF PRIMARY RESPONSIBILITY (& USERS) NM (AS EC OS SH)	
	6 DIDC REQUIRED NA	
	8 APPROVAL LIMITATION NA	
7 APPLICATION INTERRELATIONSHIP  7.1 This data item describes data required by MIL-H-46855, para 3.1.2, 3.2.2.3, 3.2.2.4, 3.3, 3.4 and 3.5.  7.2 This plan constitutes the implementing document for contractual compliance of human engineering efforts. The plan identifies human engineering tasks to be performed by the contractor and delineates contractor furnished human engineering data. The plan will be used as a basis for monitoring contractor progress and will also indicate any need for assistance and/or guidance from the procuring activity.	9 REFERENCES (Mandatory as cited in block 10)  MIL-H-46855 MIL-STD-1472	
	MCSI NUMBER(S)  10781	
10 PREPARATION INSTRUCTIONS  10.1 Unless otherwise indicated herein, the documents cited in this block, of the issue in effect on date of invitation for bids or request for proposals, form a part of this DID to the extent specified herein.  10.2 The Human Engineering Program Plan shall be prepared in contractor format and in accordance with the requirements of MIL-H-46855, para. 3.1.2. The plan shall consist of the following sections: <ul style="list-style-type: none"> <li>a. <u>General</u>. Description of the means by which the contractor will meet the requirements in MIL-H-46855 and the human engineering requirements in the procurement documentation.</li> <li>b. <u>Human engineering implementation schedule</u>. In milestone chart form show start and end dates for each task, points for progress reporting and/or review, and an estimate of the man-loading across the schedule including a percent of the total effort assigned to each task.</li> <li>c. <u>Human engineering data</u>. Description of human engineering data to be made available to the procuring activity as specified by the Contract Data Requirements List (DD Form 1423) and MIL-H-46855, para. 3.2.2.4, 3.3, 3.4, and 3.5.</li> <li>d. <u>Human engineering effort in systems analysis</u>.</li> <li>e. <u>Human engineering in equipment detail design</u>.</li> <li>f. <u>Work environment and facilities design</u>.</li> <li>g. <u>Human engineering in system performance, safety, design, and acceptance test specifications</u>, in accordance with MIL-H-46855, para. 3.2.2.3 and 3.2.2.4.</li> <li>h. <u>Studies, mock-ups, and simulation</u>.</li> <li>i. <u>Operability/maintainability analyses</u>.</li> </ul>		

Preparation Instructions (Continued)

j. Human engineering verification, test and evaluation.

k. Human engineering program personnel qualifications. This section will contain resumes of personnel responsible for and participating in the human engineering program, including a complete description of their individual qualifications and responsibilities.

l. Organizational structure and management relationships. Description of organizational structure and management relationships for accomplishing human engineering including provision for control and approval (e.g., participation in design reviews). This structure shall delineate the relations between the contractor and subcontractor(s). In addition, the relationships between human engineering activities and associated activities shall be defined. This shall include integrated logistic support, logistic support analysis, design engineering, design work study manning, training, reaction time analysis, habitability, safety, test and evaluation, and technical manuals.

10.3 The plan shall reflect how the contractor system design review meetings/exercises will be used to evaluate human engineering in design.

10.4 The plan shall reflect functions and equipments to be evaluated and procedures/techniques/checklists to be used.

10.5 The plan shall reflect how the equipment will be evaluated to determine whether human engineering design requirements specified in MIL-STD-1472 have been met.

1. DATA ITEM DESCRIPTION	2. IDENTIFICATION NO(S)	
	AGENCY	NUMBER
3. TITLE PLAN, HUMAN ENGINEERING TEST	NAVY	DI-H-2105
4. DESCRIPTION/PURPOSE This plan describes in detail the contractor's proposed test and demonstration plan which will verify the man-equipment interface requirements for the operation and maintenance of the system, as specified by the contract.	5. APPROVAL DATE 1973 July 20	
	6. OFFICE OF PRIMARY RESPONSIBILITY (USI-RS) NM (AS OS SH)	
	7. DDIC REQUIRED NA	
	8. APPROVAL LIMITATION NA	
9. APPLICATION, INTERNAL ATTENTION 7.1 This data item describes the contractor's proposed plan for complying with requirements of MIL-H-46855, para. 3.2.2.4, 3.2.4, 3.2.4.3, and 6.2.1. 7.2 The human engineering test plan delineates a detailed test program to be followed by the contractor and it is used by the procuring activity to assure completeness of contractor's test program and conformance to contractual requirements. Upon approval by the procuring activity, the Human Engineering Test Plan will supersede test and evaluation portions of the Human Engineering Program Plan (DI-H-2104) when specified in the Contract Data Requirements List. 7.3 This data item is related to DI-H-2111, Human Engineering Test Report, and DI-H-2112, Human Engineering Final Report.	10. REFERENCES (Mandatory as cited in block 10) MIL-H-46855	
	11. MSC NUMBER(S) 10781	
12. REFERENCE LIST (Optional) 10.1 Unless otherwise indicated herein, the documents cited in this block, of the issue in effect on date of invitation for bids or request for proposals, form a part of this DID to the extent specified herein.  10.2 Human Engineering Test Plan shall be prepared in compliance with MIL-H-46855, para. 3.2.4, in contractor format for systematic and comprehensive testing necessary to verify that the system can be safely operated, maintained, and supported by user personnel in accordance with contract requirements. The Human Engineering Test Plan shall describe the approach(es) for obtaining data and shall establish and explain all standards, tests, associated analyses, and other means that will constitute adequate proof upon completion of the development phase that acceptable levels of human performance, time, accuracy, and safety factors can be achieved in operational use under specified manning levels.  10.3 The Human Engineering Test Plan shall consist of the following sections: a. <u>General.</u> The detailed objectives, concepts, and requirements for the Human Engineering Test Plan shall be in accordance with MIL-H-46855, para 3.2.2.4, and shall be described with consideration being given to: (1) Updating of human engineering data, task performance requirements, and operating and maintenance task procedures. (2) Verification that all human engineering requirements, as specified by the contract, have been implemented. (3) Identification of potential training problems and validation of the functional adequacy of the training equipment, where applicable.		

Preparation Instructions (Continued)

b. List of all systems, subsystems, or equipment to be tested whose operation and/or maintenance requires critical human performance as defined by MIL-H-46855, para 6.2.1.

c. Description of specific human engineering tests to be performed. This description shall also include a list of other tests of interest to human engineering (e.g., maintainability demonstrations, ILS reviews). Tests to be included in the testing program shall be briefly described. The types of tests to be described include:

- (1) Drawing and equipment inspections.
- (2) Human performance experimental tests.
- (3) Man-machine simulation tests.
- (4) Operator and maintainer mock-up evaluations/demonstrations.
- (5) Human engineering of technical manuals.
- (6) Selected system tests (e.g., operational field tests, lighting level tests, noise and speech intelligibility tests, environmental control system tests).
- (7) Training equipment, simulator and job aid tests/evaluations.
- (8) Operator and maintainer safety.

d. Complete schedule of testing. If firm dates are not known, this shall be stated or estimates given. The schedule shall be prepared in milestone chart form or other form as approved by the procuring activity. The schedule shall include:

- (1) Date of contract award.
- (2) Implementation and reporting dates for each human engineering test conducted or monitored including CDRL item identification.
- (3) Equipment delivery dates (feasibility, prototype, preproduction, or first article delivery).
- (4) Technical manual delivery dates/validation dates.
- (5) Maintainability demonstration dates.
- (6) ILS review dates.
- (7) Date of each system test conducted or monitored.
- (8) Date of each special laboratory or simulation facility delivery.
- (9) Date of each trainer, training simulator, or special job aid delivery.
- (10) Test location(s).

e. Test procedures. Description of proposed human engineering test procedures, methodology, and data analysis shall include:

- (1) Test purpose.
- (2) Detailed objectives.

Preparation Instructions (Continued)

- (3) Methodological approach, experimental, or test design.
- (4) Apparatus, instrumentation, facilities required.
- (5) Data acquisition techniques, methods, conditions under which data are taken, data recording techniques, and parameters measured.
- (6) Test criteria (e.g., design performance).
- (7) Test subject selection, number, type, selection criteria.
- (8) Test conductor, support engineer, and technician task responsibilities.
- (9) Description of test reporting, anticipated results, failures, data usage.

f. Identification of task for testing/analysis. The Human Engineering Test Plan shall express the requirements for testing the performance of tasks or functions. Determining and testing critical tasks shall be given first priority for obtaining task performance data for analysis and evaluation. Particular attention shall be given to the consequences of critical task failure in terms of:

- (1) Loss or degradation of system reliability or effectiveness.
- (2) Decreased confidence in quality of system performance.
- (3) Prediction of human-initiated equipment malfunctions during the operational phase.

g. Data usage. Data usage concepts, objectives, requirements, and plans shall be described with consideration being given to:

(1) Evaluation of human performance reliability. A description of a systematic method to be used for identifying and recording human-initiated malfunctions shall be provided, showing how the data to be obtained may be (a) correlated with equipment performance data to determine interaction of equipment failure and human performance and (b) converted to a reliability index which can be related to system functions for use in predicting system performance.

(2) Human performance quantification and evaluation. Plans shall be described to determine (a) the extent to which each critical task contributes to system performance and (b) the minimal level of human performance required to meet system operating requirements.

(3) Probability statement. The plan shall show how human performance within the system will be characterized by a probability statement whereby human-initiated system error and acceptable system error are compared by statistical techniques.

(4) Failure analysis. Plans for incorporation of human performance evaluation in failure analysis (MIL-H-46855, para. 3.2.4.3) efforts shall describe the basis for: (a) the limits of satisfactory human performance;



Preparation Instructions (Continued)

(b) how these limits will be used to influence system updating and modification; (c) how design deficiencies will be analyzed (MIL-H-46855, para 3.2.4.3) in terms of their effects on human performance.

(5) Maintenance engineering analysis. The plan shall describe utilization of logistic support analysis data.

h. Test reporting. The test plan shall describe contractor test reporting procedures and techniques (DI-H-2111, Human Engineering Test Report).

i. Final test report. The final test report shall summarize results of the individual tests. When a Human Engineering Final Report is required (DI-H-2112, Human Engineering Final Report), the final test report will be included in the verification, test and evaluation section.

j. Human Engineering program personnel qualifications. Resumes of personnel responsible for and participating in, conduct of human engineering test planning, design, conduct, and reporting shall be provided, including complete descriptions of their individual qualifications and responsibilities.

k. Organizational responsibility. Description of the contractor's organizational structure relative to human engineering testing program responsibility shall be provided. This shall include a block diagram illustrating lines of authority, communication, and liaison.

l. Coordination. The test plan shall be compatible with the overall contractor test program. The plan shall describe how the human engineering test program shall be coordinated with reliability, maintainability, training, and integrated logistic support efforts noting, where applicable, any segment of the human engineering program which will be conducted as a portion of these related programs.

DATA ITEM DESCRIPTION	2 IDENTIFICATION NO(S)	
	AGENCY	NUMBER
1 TITLE  REPORT, PERSONNEL PLANNING INFORMATION	NAVY	DI-H-2106
3 DESCRIPTION PURPOSE  This report will be used by system engineers, human factors engineers, ILS managers, and others for planning purposes in order to develop needed manpower data so that total system manning and training estimates can be made.	4 APPROVAL DATE 1973 July 20	
	5 OFFICE OF PRIMARY RESPONSIBILITY (& USERS) NM (AS SH)	
	6 DDC REQUIRED NA	
	8 APPROVAL LIMITATION NA	
7 APPLICATION INTERRELATIONSHIP  7.1 This data item describes data documenting a portion of the contractor's effort required by MIL-H-46855, para. 3.2.1 and 3.2.3.  7.2 Personnel planning information will form the basis of the design approach for systems, equipment, and facilities. The definition of this personnel planning information is one of several system engineering techniques used to describe the system and major subsystems. The report will also be used by the Bureau of Naval Personnel in arriving at estimates of manpower requirements for the new acquisition. It will be related to design work study inputs and will be coordinated with reliability and maintainability inputs and used by the ILS Manager for the total Integrated Logistic System Program Plan.	9 REFERENCES (Mandatory as cited in block 10) MIL-H-46855 NAVPERS 15105 NAVPERS 15839 NAVPERS 18068 NAVPERS 18455 NAVPERS 18564	
	MCSI NUMBER(S) 10781	
10 PREPARATION INSTRUCTIONS  10.1 Unless otherwise indicated herein, the documents cited in this block, of the issue in effect on date of invitation for bids or request for proposals, form a part of this DID to the extent specified herein.  10.2 The Personnel Planning Information Report shall be prepared in compliance with MIL-H-46855, para. 3.2.1 and 3.2.3, in contractor format which shall provide:  a. Brief summary of the system, subsystems, and equipment.  b. Preliminary summary of the minimum quantitative and qualitative manning and training requirements to operate, maintain, and support the system acquisition.  c. Identification of special skills, knowledges, and selection requirements related to critical human involvement.  d. Description of new equipment items for which special skills may be required and new training requirements foreseen.  e. Identification of special training support items; e.g., simulators, part-task trainers, visual aids, training manuals, etc.  10.3 In defining manning considerations, the Personnel Planning Information Report shall be consistent with the manual of Navy Officer Classifications (NAVPERS 15839), Manual of Qualifications for Limited Duty Officers USN (NAVPERS 18564), Manual of Qualifications for Warrant Officers (NAVPERS 18455), Manual of Qualifications for Advancement (NAVPERS 18068), and Manual of Navy Enlisted Classifications (NAVPERS 15105).  10.4 The content of this report shall not duplicate any effort being performed by the procuring activity and/or other contractor agencies.		

DD FORM 1664

5/N-0102-019-4000

PLATE NO. 19448

PAGE 1 OF 1 PAGES

D-6617

DATA ITEM DESCRIPTION		2 IDENTIFICATION NO(S)	
1 TITLE		AGENCY	NUMBER
DESIGN DOCUMENT, HUMAN ENGINEERING		NAVY	DI-H-2107
3 DESCRIPTION PURPOSE  This document describes the arrangement/layout and detail design of the crew station, crew station equipment, and all other equipment having an interface with the human operator(s)/maintainer(s). It is used by the procuring activity to: (a) determine a technical approach to layout/arrangement/detail design of the crew station(s) and all equipment, (b) evaluate layout/arrangement/detail design of crew station(s) and all equipment, (c) evaluate crew station ingress/egress if applicable.		4 APPROVAL DATE 1973 July 20	
		5 OFFICE OF PRIMARY RESPONSIBILITY (& USI-RS) NM (AS EC SH)	
		6 DOC REQUIRED NA	
		8 APPROVAL LIMITATION  NA	
7 APPLICATION INTERRELATIONSHIPS  7.1 This data item describes data documenting a portion of the contractor's effort required by MIL-H-46855, para. 3.2.1.4, 3.2.2, 3.2.2.3, and 3.5, and MIL-STD-1472.  7.2 This data item is related to DI-H-2109, Task Analysis/Task Description Report.		9 REFERENCES (Mandatory as cited in block 10)  MIL-H-46855 MIL-STD-1472	
		MCSI NUMBER(S)  10781	
10 PREPARATION INSTRUCTIONS  10.1 Unless otherwise indicated herein, the documents cited in this block, of the issue in effect on date of invitation for bids or request for proposals, form a part of this DID to the extent specified herein.  10.2 The Human Engineering Design Document shall be prepared, in contractor format, which describes the contractor human engineering effort regarding crew station layout/arrangement (MIL-H-46855, para 3.2.1.4, 3.2.2.3, and 3.5) and detail design of equipment having an operator/maintainer interface (MIL-H-46855, para. 3.2.2 and 3.5). This report shall describe the extent to which the requirements of MIL-STD-1472 and other applicable human engineering/design documents specified by the contract have been incorporated into the arrangement, layout, and detail design of the crew station and all equipment having an operator/maintainer interface.  10.3 The Human Engineering Design Document shall consist of the following:  a. A list of panels (e.g., instrument panel, console panel, overhead panel), racks, controls, displays, and indicators existing at the time of document submission which have received human engineering approval.  b. Rationale of the human engineering layout/arrangement/detail design of the crew station(s) and any equipment having an operator/maintainer interface. Considerations for system mission, operator task requirements, maintenance requirements, equipment operation, and limitations imposed by the contractor or state of the art shall be presented. Adequate narrative shall be presented on each item to familiarize the reader with the considerations used to reach specific design decisions (i.e., MIL-STD-1472 requirements, results of analyses, other contract requirements, mock-up tests or mock-up board decisions, simulation, and			

#### Preparation Instructions (Continued)

others as applicable). Where appropriate analyses are available (DI-H-2109, Task Analysis/Task Description Report), their recommendations shall be incorporated, in part or whole, depending upon the criticality of the equipment.

c. Narrative which notes and explains any requirement to deviate from human engineering or design requirements appropriate to the man-machine interface.

d. Sketches, drawings, or photographs of required or anticipated panel and rack arrangements/rearrangements or new designs/design modifications.

e. A drawing or photograph of each crew station design (as it exists at the time of document submission) which shows the location of all crew station panels in relation to the seat/operator position.

f. Schedule of major design reviews, demonstrations, or mock-ups encompassing human engineering for the crew station(s) or any equipment having an interface with operator/maintainer.

DATA ITEM DESCRIPTION		2 IDENTIFICATION NO(S)	
		AGENCY	NUMBER
1 TITLE	REPORT, HUMAN ENGINEERING MAINTENANCE/ ACCESSIBILITY DESIGN	NAVY	DI-H-2108
3 DESCRIPTION PURPOSE	This report describes accessibility to equipment for purpose of replacement, inspection, servicing, adjustment, and calibration during preventive and corrective maintenance at the organizational level and especially in the maintenance of aircraft, during the intermediate and depot levels.	4 APPROVAL DATE 1973 July 20	
		5 OFFICE OF PRIMARY RESPONSIBILITY (& USERS) NM (AS FC OS SH)	
		6 DDC REQUIRED NA	
7 APPLICATION INTERRELATIONSHIP	7.1 This data item describes data documenting a portion of the contractor's effort required by MIL-H-46855, para. 3.2.2 and MIL-STD-1472, para. 5.9.  7.2 This data item is related to DI-H-2104, Human Engineering Program Plan, and DI-H-2107, Human Engineering Design Document. This report is used in the design phase by the procuring activity to ensure adequate accessibility to equipment.	8 APPROVAL LIMITATION NA	
		9 REFERENCES (Mandatory as cited in block 10) MIL-H-46855 MIL-STD-1472	
		MCSL NUMBER(S) 10781	
10 PREPARATION INSTRUCTIONS			
10.1 Unless otherwise indicated herein, the documents cited in this block, of the issue in effect on date of invitation for bids or request for proposals, form a part of this DID to the extent specified herein.			
10.2 The Human Engineering Maintenance/Accessibility Design Report shall be prepared in contractor format and describe the human engineering effort applied to ensuring the accessibility of equipment (especially for organizational level) required by MIL-H-46855, para. 3.2.2, and MIL-STD-1472, para. 5.9, and shall consist of the following:			
a. Preliminary drawings, sketches, or photographs showing each equipment and its location in relation to surrounding equipment, passageways, and structure. The drawings, sketches, or photographs shall clearly depict the equipment (as viewed by the maintainer while performing required maintenance) from top, side, and front views showing door and panel opening clearance of the equipment. Connectors, electrical leads, cables, ducts, piping, etc., shall also be shown.			
b. Rationale of the human engineering design of each item of equipment requiring maintenance. Adequate narrative shall be presented to familiarize the reader with such considerations used to reach specific decisions such as MIL-STD-1472 requirements, results of studies, simulations, mock-ups, demonstrations, and others as applicable. Where maintenance task analyses are available, they shall be incorporated in part or whole, depending upon the criticality of rapid maintenance times and other constraints specified by the procuring activity.			
c. Narrative describing the following:			
(1) Physical size, weight, and purpose of portable support and test equipment required for performing maintenance on the equipment.			

Preparation Instructions (Continued)

- (2) Procedures involved in maintenance of each unit of equipment.
  - (3) The relation between accessibility of each unit equipment and its component failure rate, servicing frequency, calibration frequency, and requirements for rapid maintenance for mission essential operation.
  - (4) Methods used to determine accessibility for maintenance.
- d. Identification of equipment accessibility and maintenance problem areas that may be anticipated.

10.3 This report shall be updated, as required, to indicate changes to design affecting the accessibility of equipment or compliance with applicable requirements for equipment design specified by the contract.

DATA ITEM DESCRIPTION	2 IDENTIFICATION NO(S)	
	AGENCY	NUMBER
1 TITLE REPORT, TASK ANALYSIS/TASK DESCRIPTION	NAVY	DI-H-2109
3 DESCRIPTION PURPOSE  This report describes the results of task analyses performed by the contractor and presents task descriptions. The purpose of the report is to summarize the work that the operator/maintainer performs and to provide a basis for the design of the system, equipment, or facilities.	4 APPROVAL DATE 1973 July 20	
	5 OFFICE OF PRIMARY RESPONSIBILITY (& USERS) NM (AS FC SH)	
	6 DOC REQUIRED NA	
	8 APPROVAL LIMITATION NA	
7 APPLICATION INTEREST AND NOTES  7.1 This data item describes data documenting a portion of the contractor's effort required by MIL-H-46855, para. 3.2.1.3, 3.2.1.3.1, and 3.2.1.3.2.  7.2 Task Analysis/Task Description Reports will be used to evaluate the contractor's analyses of men in the system.  7.3 This data item is related to DI-H-2104, Human Engineering Program Plan, and DI-H-2107, Human Engineering Design Document	9 REFERENCE (Mandatory as cited in bloc 10) MIL-H-46855	
	10 USE NUMBER(S) 10781	
<p>11 PREPARATION INSTRUCTIONS</p> <p>10.1 Unless otherwise indicated herein, the documents cited in this block, of the issue in effect on date of invitation for bids or request for proposals, form a part of the DID to the extent specified herein.</p> <p>10.2 The Task Analysis/Task Description Report shall be prepared in contractor selected format of flow diagrams, tabular presentations, and narrative. The report shall describe the results of the task analyses required by MIL-H-46855, para 3.2.1.3, and shall consist of the following:</p> <ul style="list-style-type: none"> <li>a. Summary of gross tasks identified during analyses performed in response to MIL-H-46855, para. 3.2.1.3.1.</li> <li>b. Identification of critical task characteristics as required by MIL-H-46855, para. 3.2.1.3.2, if applicable. Supporting evidence shall be supplied if applicable. <u>Example:</u> The method by which an operator's reaction time is estimated should be included.</li> <li>c. The results of the operator/maintainer workload analysis. If there is more than one crew member involved in the system operation, the interaction workload of the crew members shall also be identified.</li> <li>d. Discussion of related factors such as system or equipment performance, cost, and delivery schedule when these factors are affected by one or more of the critical tasks.</li> <li>e. Discussions of task-related data shall be extracted from the task analyses and compiled in preliminary operator/maintainer procedurally-oriented task descriptions for use in developing procedures documents, personnel planning, and system testing.</li> </ul>		

DATA ITEM DESCRIPTION		IDENTIFICATION NO(S)	
		AGENCY	NUMBER
1 TITLE	REPORT, HUMAN ENGINEERING PROGRESS	NAVY	DI-H-2110
3 DESCRIPTION PURPOSE	<p>This report describes status of the contractor's human engineering program. Each report is used to transmit human engineering progress, problems, and plans for each succeeding reporting period. These reports provide evidence that human engineering considerations are reflected in system design and development and indicate compliance with contractual requirements for human engineering.</p>	4 APPROVAL DATE	1973 July 20
		5 OFFICE OF PRIMARY RESPONSIBILITY (& USFRS)	NM (AS EC OS SH)
		6 DDC REQUIRED	NA
		8 APPROVAL LIMITATION	
7 APPLICATION INTERRELATIONSHIP	<p>7.1 This data item describes data required by MIL-H-46855, para. 3.1.2.3, 3.2.1.3.1, and 3.2.1.3.2.</p> <p>7.2 The reports inform the procuring activity of the contractor's status on the human engineering program defined by the contract and by the Human Engineering Program Plan (DI-H-2104) previously submitted by the contractor and approved by the procuring activity.</p>	NA	
		9 REFERENCES (Mandatory, as cited in block 10)	MIL-H-46855
		MCSL NUMBER(S)	10781
9 PREPARATION INSTRUCTIONS			
<p>10.1 Unless otherwise indicated herein, the documents cited in this block, of the issue in effect on date of invitation for bids or request for proposals, form a part of this DID to the extent specified herein.</p> <p>10.2 <u>REPORT CONTENT</u>: Human Engineering Progress Reports shall summarize the human engineering work performed during the reporting period. Each report will be concise and will not repeat previously reported material except for reasons of clarity. Each report shall be in sufficient detail for the procuring activity to ascertain whether human engineering considerations are reflected in system design and development, verification, and test and evaluation. The Human Engineering Progress Reports shall include:</p> <p>a. List of equipment requiring human engineering effort. The initial report shall list in priority order the equipments/functional spaces requiring human engineering in detailed design. The list and modifications thereto shall be determined in compliance with MIL-H-46855, para. 3.2.1.3.1 and 3.2.1.3.2.</p> <p>b. Description of human engineering support of design engineering shall include:</p> <p>(1) An annotated listing of all drawings having an impact on the man-machine interface that have been approved by the contractor's human engineering group.</p> <p>(2) Summary and status of all human engineering design recommendations.</p> <p>(3) Summary of human engineering participation in design reviews.</p> <p>c. A summary of detailed task analyses with emphasis on their impact on design, training, procedures, layouts, critical situations, etc. Other human engineering activities relating to design of equipment which utilizes man as a central element shall be reported in sufficient detail to demonstrate effective integration of the human component into the system. Results of trade-off studies during systems analysis to determine the man-equipment combination required.</p>			



Preparation Instructions (Continued)

d. A summary of the operator/maintainer performance measures, verification procedures, and test criteria that will be utilized for human engineering test and evaluation.

e. Status reports and final reports on human engineering special studies such as mock-ups, static and dynamic simulations, and other controlled experiments.

f. Deviation from the Human Engineering Program Plan (DE-H-2104) not requiring additional funds or change in conceptual scope.

g. Summary of human engineering verification, test and evaluation results.

h. Additions to or changes in human engineering data bank.

10.3 REPORT FORMAT: Human Engineering Progress Reports shall be prepared in the contractor format and shall cover the following sections:

a. Work accomplishment this reporting period. Tasks begun or completed; significant results or completed tasks; end item products completed and available for review; unusual conclusions that may portend modification of future activities.

b. Work planned for next reporting period. Tasks that will be completed and/or commenced.

c. Significant problems. Identification of specific problems that have occurred during the reporting period; indication of their effect on other tasks, schedules, or costs; satisfactory solutions reached.

d. Actions required of the procuring activity. Identification of special requirements or problems wherein procuring activity assistance is or may be required.

e. Budget and schedule information. Summary of the human engineering man-hours expended and program schedule in terms of the original and predicted estimates.

10.4 These reports shall include additional information, sketches, drawings, lists, etc., as required, and provided as attachments to the basic report.

DATA ITEM DESCRIPTION	2 IDENTIFICATION NO(S)	
3 TITLE	AGENCY	NUMBER
<p>REPORT, HUMAN ENGINEERING TEST</p> <p>DESCRIPTION PURPOSE</p> <p>This report will be prepared following each major test, evaluation, or demonstration and shall be submitted to the procuring activity to provide evidence that the man-equipment interface requirements for the operation and maintenance of the system, as specified in the contract, have been met</p>	4 APPROVAL DATE	1973 July 20
<p>APPLICABLE INTELLIGENCE ACTIVITY</p> <p>7.1 This data item describes data documenting a portion of the contractor's effort required by MIL-H-46855, para. 3.2.2.4, and 3.2.4, and 3.2.4.3.</p> <p>7.2 The Human Engineering Test Report describes in detail the results of the contractor's demonstration of the item(s) under test, and it is used by the procuring activity to assure that the man-equipment interface requirements for the operation and maintenance of the system conform to the contractual requirements.</p> <p>7.3 This data item is related to DI-H-2105, Human Engineering Test Plan.</p>	5 OFFICE OF PRIMARY RESPONSIBILITY (& USERS)	NM (AS EC OS SH)
	6 LDC REQUIRED	NA
	8 APPROVAL LIMITATION	NA
	7 REFERENCES (Mandatory in format of block 10)	
	MCSL NUMBER(S)	
	10781	
<p>11 FREE AVAILATION INSTRUCTIONS</p> <p>10.1 Unless otherwise indicated herein, the documents cited in this block, of the issue in effect on date of invitation for bids or request for proposals, form a part of this DID to the extent specified herein.</p> <p>10.2 The Human Engineering Test Report shall be prepared in compliance with the provisions of MIL-H-46855, para. 3.2.2.4, and 3.2.4 and where applicable MIL-STD-831 for each major test, evaluation, or demonstration.</p> <p>a. Test title and identifying number.</p> <p>b. Type of test (see DI-H-2105, Human Engineering Test Plan, para. 10.3.c).</p> <p>c. Description of test purpose, identification of test objectives, identification of equipment being tested, if applicable.</p> <p>d. Description of test methods and procedures, measurement methods, criteria, apparatus, instrumentation, facilities, personnel.</p> <p>e. Description of findings, including any deficiencies noted, failures, problem areas. Reporting of deficiencies and failures, required by MIL-H-46855, para. 3.2.4.3, shall include:</p> <ol style="list-style-type: none"> <li>(1) Enumeration of each deficiency/failure.</li> <li>(2) Description of any contract requirement affected by the deficiency/failure.</li> <li>(3) Complete discussion of effects of the deficiency/failure. For deficiencies, the rationale for not making design changes will be included if no changes are recommended.</li> <li>(4) Recommendations including estimate of cost and schedule.</li> </ol>		

Preparation Instructions (Continued)

- f. Implications of significant test findings for the system/equipment.
- g. Limitations of test results and suggestions for further testing.
- h. Conclusions reached from the findings.
- i. Specific recommendations derived from the conclusions, with indication of government or contractor organizations responsible for implementing recommended actions.

## APPENDIX F

### MIL-H-46855A HUMAN ENGINEERING REQUIREMENTS FOR MILITARY SYSTEMS, EQUIPMENT AND FACILITIES

MIL-H-46855A

2 May 1972

Superseding

MIL-H-46855, 16 Feb 1968

### MILITARY SPECIFICATION

#### HUMAN ENGINEERING REQUIREMENTS FOR MILITARY SYSTEMS, EQUIPMENT AND FACILITIES

This specification is mandatory for use by all Departments and Agencies of the Department of Defense.

#### 1. SCOPE

1.1 This specification establishes and defines the general requirements for applying the principles and criteria of human engineering to the development and acquisition of military systems, equipment and facilities. These requirements include the work to be accomplished or subcontracted by the contractor in effecting an integrated human engineering effort. Compliance with these requirements form the basis for including human engineering during proposal preparation and data reporting by the contractor (e. g. , such items as flow charts, functional allocation tables, operational sequence diagrams, link analyses, and task descriptions) where specified by the contract. (See 6.1 for intended use.)

#### 2. APPLICABLE DOCUMENTS

2.1 The following documents of the issue in effect on the date of invitation for bids or request for proposal form a part of this specification to the extent specified herein:

##### STANDARDS

MIL-STD-1472 - Human Engineering Design Criteria for  
Military Systems, Equipment and Facilities

(Copies of specifications, standards, drawings, and publications required by suppliers in connection with specific procurement functions should be obtained from the procuring activity or as directed by the Contracting Officer.)

#### 3. REQUIREMENTS

3.1 General Requirements      **Preceding page blank**

3.1.1 Scope and Nature of Work. - The principles and criteria of human engineering shall be applied during development and acquisition of military systems, equipment and facilities to achieve the effective integration of man into the design of the system. Within the parameters established by system, equipment and facilities requirements, a human engineering effort shall be provided to improve the man-machine interface and to achieve required effectiveness of personnel performance during system operation/maintenance/control and to make economical demands upon manpower resources, skills, training and costs. The human engineering effort shall include, but not necessarily be limited to, active participation in the following three major interrelated areas of system development:

a. Analysis to identify and define system, equipment and facilities operations, maintenance, training and control functions; to allocate these functions to man, equipment, or man and equipment; to analyze tasks derived from these functions; to develop human engineering design criteria, operation and maintenance procedures, and other requirements in the proper format and language for performance and design specifications and other documentation. Human engineering participation in analysis begins with initial system planning and remains a significant element of the overall analysis effort. Where system engineering is specified by contract, the analysis requirements herein shall be incorporated as an integral element of the system engineering effort. Analytical parameters shall be quantified where possible and in a form permitting cost effectiveness studies of the man-machine interfaces and personnel participation in total system operation. The identification of human engineering high risk areas shall be initiated as part of the analysis.

b. Design and development of equipment, procedures, work environments and facilities associated with the system functions requiring human performance. This includes human engineering inputs to formulation of design concepts, system definition and detail design of system equipment and software.

c. Test and evaluation to verify that design of equipment, software, facilities and environment meets human engineering and life support criteria and is compatible with the overall system requirements.

### 3.1.2 Human Engineering Program Plan and Other Data

3.1.2.1 Human Engineering Program Plan. - The proposed Human Engineering Program Plan, in accordance with the requirements of this

specification and the equipment specification, shall be submitted as an identifiable and complete entity within the total system or equipment project proposal. The Plan shall include a description of the tasks to be performed, human engineering milestones, methods to be used, design concepts to be utilized, test and evaluation program and other data in accordance with 3.3. The Human Engineering Program Plan, as approved by the procuring activity and incorporated into the contract, will be the basis for contractual compliance. The Plan shall describe an integrated effort within the total project; it shall provide specific information to show what tasks the contractor will do to meet specified human engineering requirements and when he will do these tasks.

3.1.2.2 Changes to the Human Engineering Program Plan. - The Human Engineering Program Plan shall be changed only with procuring activity approval. The request for change shall state what the change is, why it is required, and its effect on system operation and maintenance, equipment, facilities, cost and human performance.

3.1.2.3 Other Data. - Other technical and administrative data pertinent to the Human Engineering Program, including progress, milestone and failure reports furnished by the contractor as prescribed by the contract, shall reflect consideration of the requirements herein.

3.1.3 Nonduplication. - The efforts performed to fulfill the human engineering requirements specified herein shall be coordinated with, but not duplicate efforts performed in accordance with other contractual requirements. Necessary extensions or transformations of the results of other efforts for use in the human engineering program will not be considered duplication. Instances of duplication or conflict shall be brought to the attention of the Contracting Officer.

3.2 Detail Requirements. - The contractor shall perform the following:

3.2.1 Analysis. - Analysis shall include application of human engineering techniques as follows:

3.2.1.1 Defining and Allocating System Functions. - The functions that must be performed by the system in achieving its objective shall be analyzed. Human engineering principles and criteria shall be applied to specify man-equipment performance requirements for system operation, maintenance and control functions and to allocate system functions to (1) automatic operation/maintenance, (2) manual operation/maintenance, or (3) some combination thereof.

MIL-H-46855A

3.2.1.1.1 Information Flow and Processing Analysis. - Analyses shall be performed to determine basic information flow and processing required to accomplish the system objective and include decisions and operations without reference to any specific machine implementation or level of human involvement.

3.2.1.1.2 Estimates of Potential Operator/Maintainer Processing Capabilities. - Plausible human roles (e.g., operator, maintainer, programmer, decision maker, communicator, monitor) in the system shall be identified. Estimates of processing capability in terms of load, accuracy, rate and time delay shall be prepared for each potential operator/maintainer information processing function. These estimates shall be used initially in determining allocation of functions and shall later be refined at appropriate times for use in definition of operator/maintainer information requirements and control, display and communication requirements. In addition, estimates shall be made of the effects on these capabilities likely to result from implementation or non-implementation of human engineering design recommendations. Results from studies in accordance with 3.2.2.1 may be used as supportive inputs for these estimates.

3.2.1.1.3 Allocation of Functions. - From projected operator/maintainer performance data, cost data, and known constraints, the contractor shall conduct analyses and tradeoff studies to determine which system functions should be machine-implemented and which should be reserved for the human operator/maintainer.

3.2.1.2 Equipment identification. - Human engineering principles and criteria shall be applied along with all other design requirements to identify and select the equipment to be operated/maintained/controlled by man. The selected design configuration shall reflect human engineering inputs, expressed in quantified or "best estimate" quantified terms, to satisfy the functional and technical design requirements and to insure that the equipment will meet the applicable criteria contained in MIL-STD-1472, as well as other human engineering criteria specified by the contract.

3.2.1.3 Analysis of Tasks. - Human engineering principles and criteria shall be applied to analyses of tasks.

3.2.1.3.1 Gross Analysis of Tasks. - The analyses shall provide one of the bases for making design decisions; e.g., determining, to the extent practicable, before hardware fabrication, whether system performance requirements can be met by combinations of anticipated equipment and personnel, and assuring that human performance requirements do not exceed human capabilities. These analyses shall also be used as basic

information for developing preliminary manning levels, equipment procedures, and skill, training and communication requirements. Those gross tasks identified during human engineering analysis which are related to end items of equipment to be operated or maintained by man and which require critical (see 6.2.1) human performance, reflect possible unsafe practices or are subject to promising improvements in operating efficiency shall be further analyzed, with the approval of the procuring activity.

3.2.1.3.2 Analysis of Critical Tasks. - Further analysis of critical tasks shall identify the : (1) information required by man, including cues for task initiation; (2) information available to man; (3) evaluation process; (4) decision reached after evaluation; (5) action taken; (6) body movements required by action taken; (7) workspace envelope for man required by action taken; (8) workspace available to man; (9) location and condition of the work environment; (10) frequency and tolerances of action; (11) time base; (12) feedback informing man of the adequacy of his actions; (13) tools and equipment required; (14) number of personnel required, their specialty and experience; (15) job aids or references required; (17) special hazards involved; (18) operator interaction where more than one crew member is involved; (19) operational limits of man (performance); and (20) operational limits of machine (state of the art). The analysis shall be performed for all affected missions and phases including degraded modes of operation.

3.2.1.3.3 Loading Analysis. - Individual and crew workload analysis shall be performed and compared with performance criteria.

3.2.1.3.4 Concurrency and Availability. - Analyses of tasks, modified as required to remain current with the design effort, shall be available to the procuring activity.

3.2.1.4 Preliminary System and Subsystem Design. - Human engineering principles and criteria shall be applied to system and subsystem designs represented by design criteria documents, performance specifications, drawings and data, such as functional flow diagrams, system and subsystem schematic block diagrams, interface control drawings, overall layout drawings and related applicable drawings provided in compliance with contract data requirements. The approval of those documents by the contractor shall signify that the system and subsystem configuration and arrangement satisfy man-equipment performance requirements and comply with applicable criteria specified in MIL-STD-1472 as well as other human engineering criteria specified by the contract.



**3.2.2 Human Engineering in Equipment Detail Design.** - During detail design of equipment, the human engineering inputs, made in complying with the analysis requirements of paragraph 3.2.1 herein, as well as other appropriate human engineering inputs, shall be converted into detail equipment design features. Design of the equipment shall meet the applicable criteria of MIL-STD-1472 and other human engineering criteria specified by the contract. Human engineering provisions in the equipment shall be evaluated for adequacy during design reviews. Personnel assigned human engineering responsibilities by the contractor shall participate in design reviews and engineering change proposal reviews of equipment end items to be operated or maintained by man. Human engineering requirements during equipment detail design are specified in paragraphs 3.2.2.1, 3.2.2.2, 3.2.2.3 and 3.2.2.4 herein.

**3.2.2.1 Studies, Experiments and Laboratory Tests.** - The contractor shall conduct experiments, laboratory tests (including dynamic simulation per paragraph 3.2.2.1.2), and studies required to resolve human engineering and life support problems specific to the system. Human engineering and life support problem areas shall be brought to the attention of the procuring activity, and shall include the estimated effect on the system if the problem is not studied and resolved. These experiments, laboratory tests, and studies shall be accomplished in a timely manner, i. e., such that the results may be incorporated in equipment design. The performance of any major study effort shall require approval by the procuring activity.

**3.2.2.1.1 Mockups and Models.** - At the earliest practical point in the development program and well before fabrication of system prototypes, full-scale three-dimensional mockups of equipment involving critical human performance (such as an aircrew compartment, maintenance work shelter, or a command control console) shall be constructed. The proposed Human Engineering Program Plan shall specify mockups requiring procuring activity approval and modification to reflect changes. The workmanship shall be no more elaborate than is essential to determine the adequacy of size, shape, arrangement, and panel content of the equipment for use by man. The most inexpensive materials practical shall be used for fabrication. These mockups and models shall provide a basis for resolving access, workspace and related human engineering problems, and incorporating these solutions into system design. In those design areas where equipment involves critical human performance and where human performance measurements are necessary, functional mockups shall be provided, subject to prior approval by the procuring activity. The mockups shall be available for inspection as determined by the procuring activity. Upon approval by

the procuring activity, scale models may be substituted for mockups. Disposition of mockups and models, after they have served the purposes of the contract, shall be as directed by the procuring activity.

3.2.2.1.2 Dynamic Simulation. - Dynamic simulation techniques shall be utilized as a human engineering design tool when necessary for the detail design of equipment requiring critical human performance. Consideration shall be given to use of various models for the human operator, as well as man-in-the-loop simulation. While the simulation equipment is intended for use as a design tool, its potential relationship to, or use as, training equipment shall be considered in any plan for dynamic simulation.

3.2.2.2 Equipment Detail Design Drawings. - Human engineering principles and criteria shall be applied to equipment drawings during detail design to assure that the equipment can be efficiently, reliably and safely operated and maintained. The following drawings are included: panel layout drawings, communication system drawings, overall layout drawings, control drawings and other drawings depicting equipment important to system operation and maintenance by human operators. The approval of these drawings by the contractor shall signify that human engineering requirements are incorporated thereon and that the design complies with applicable criteria of MIL-STD-1472 and other human engineering criteria specified by the contract.

3.2.2.3 Work Environment, Crew Stations and Facilities Design. - Human engineering principles and criteria shall be applied to detail design of work environments, crew stations and facilities to be used by man in the system. The approval of drawings, specifications and other documentation of work environment, crew stations and facilities by the contractor shall signify that human engineering requirements are incorporated thereon and that the design complies with applicable criteria of MIL-STD-1472 and other human engineering criteria specified by the contract. Design of work environment, crew stations and facilities which affect human performance, under normal, unusual and emergency conditions, shall consider at least the following where applicable:

- a. Atmospheric conditions, such as composition, volume, pressure and control for decompression, temperature, humidity and air flow.
- b. Weather and climate aspects, such as hail, snow, mud, arctic, desert and tropic conditions.
- c. Range of accelerative forces, positive and negative, including linear, angular and radial.

MIL-H-46855A

- d. Acoustic noise (steady state and impulse), vibration, and impact forces.
- e. Provision for human performance during weightlessness.
- f. Provision for minimizing disorientation.
- g. Adequate space for man, his movement, and his equipment.
- h. Adequate physical, visual, and auditory links between men and men, and men and their equipment, including eye position in relation to display surfaces, control and external visual areas.
- i. Safe and efficient walkways, stairways, platforms and inclines.
- j. Provisions for minimizing psychophysiological stresses.
- k. Provisions to minimize physical or emotional fatigue, or fatigue due to work-rest cycles.
- l. Effects of clothing and personal equipment, such as full and partial pressure suits, fuel handler suits, body armor, polar clothing, and temperature regulated clothing.
- m. Equipment handling provisions, including remote handling provisions and tools when material and environment require them.
- n. Protection from chemical, biological, toxicological, radiological, electrical and electromagnetic hazards.
- o. Optimum illumination commensurate with anticipated visual tasks.
- p. Sustenance and storage requirements (i. e. , oxygen, water and food), and provision for refuse mangement.
- q. Crew safety protective restraints (shoulder, lap and leg restraint systems, inertia reels and similar items) in relation to mission phase and control and display utilization.

3.2.2.4 Human Engineering in Performance and Design Specifications. - The provisions of performance and design specifications, prepared by the contractor, shall conform to applicable human engineering criteria

of MIL-STD-1472 and other human engineering criteria specified by the contract.

3.2.3 Equipment Procedure Development. - Based upon the human performance functions and tasks identified by human engineering analyses (3.2.1 herein), the contractor shall apply human engineering principles and criteria to the development of procedures for operating, maintaining or otherwise using the system equipment. This effort shall be accomplished to assure that the human functions and tasks identified through human engineering analysis are organized and sequenced for efficiency, safety and reliability and to assure that the results of this effort shall be reflected in the development of training and technical publications. The approval of these publications by the contractor shall signify that the human engineering requirements are incorporated therein.

3.2.4 Human Engineering in Test and Evaluation. - The contractor shall establish and conduct a test and evaluation program to: (1) assure fulfillment of applicable requirements herein; (2) demonstrate conformance of system, equipment and facility design to human engineering design criteria; (3) confirm compliance with performance requirements where man is a performance determinant; (4) secure quantitative measures of system performance which are a function of man-machine interaction; and (5) determine whether undesirable design or procedural features have been introduced. (The fact that these functions may occur at various stages in system or equipment development shall not preclude final human engineering verification of the complete system. Both operator and maintenance tasks shall be performed as described in approved test plans during the final system test.)

3.2.4.1 Planning. - Human engineering testing shall be incorporated into the test and evaluation program and shall be integrated into engineering design tests, contractor demonstrations, R&D acceptance tests and other major development tests. Compliance with human engineering requirements shall be tested as early as possible. Human engineering findings from early testing shall be used in planning and conducting later tests.

3.2.4.2 Implementation. - The human engineering test and evaluation program, contained in approved test plans, shall be implemented by the contractor. Test documentation (e.g., checklists, data sheets, questionnaires, schedules, operating procedures, test procedures) shall be available at the test site. Human engineering portions of all tests

MIL-H-46855A

shall include, where applicable, the following:

- a. A simulation (or actual conduct where possible) of mission or work cycle.
- b. Tests in which human participation is critical with respect to speed, accuracy, reliability or cost.
- c. A representative sample of non-critical scheduled and unscheduled maintenance tasks.
- d. Proposed job aids.
- e. Utilization of personnel who are representative of the range of the intended military user population in terms of skills, size and strength and wearing suitable military garments and equipment which are appropriate to the tasks, and approved by the procuring activity.
- f. Collection of task performance data.
- g. Identification of discrepancies between required and obtained task performance.
- h. Criteria for the acceptable performance of the test.

3.2.4.3 Failure Analysis. - All failures occurring during, or as a result of, test and evaluation shall be subjected to a human engineering review to differentiate between failures due to equipment alone, man-equipment incompatibilities and those due to human error. The procuring activity shall be notified of design deficiencies which contribute to human error.

3.2.5 Cognizance and Coordination. - The human engineering program shall be coordinated with maintainability, system safety, reliability, personnel, training and other related programs, and shall be integrated into the total system program. The human engineering portion of any analysis, design or test and evaluation program shall be conducted under the direct cognizance of personnel assigned human engineering responsibility by the contractor.

3.3 Data Requirements. - All human engineering data requirements shall be as specified by the contract (DD Form 1423).

3.4 Data Availability. - All data, such as analyses, design review results, sketches, drawings, checklists, design and test notes, and other supporting and background documents reflecting human engineering actions and decision rationale, shall be available to the procuring activity.

3.5 Drawing Approval. - Personnel assigned human engineering responsibility by the contractor shall approve all drawings having an impact on the man-machine interface.

#### 4. QUALITY ASSURANCE

Compliance with the requirements of this specification and other human engineering requirements specified by the contract will ultimately be demonstrated by the system's ability to meet its mission and operational objectives. During the development program, compliance with the human engineering requirements, as they pertain to system design and effectiveness, will be demonstrated at the scheduled design and configuration reviews and inspections.

#### 5. PREPARATION FOR DELIVERY

This section is not applicable to this specification.

#### 6. NOTES

6.1 Intended Use. - This specification may be invoked in its entirety or selectively as prescribed by the procuring activity. Although intended primarily for exploratory, advanced and engineering development, this specification may also be applied selectively to other efforts where applicable. The primary use of this specification for procurement does not necessarily preclude its utilization for in-house efforts, where desired. Compliance with this specification will provide the procuring activity with assurance of positive management control of the human engineering effort required in the development and acquisition of military systems, equipment and facilities. Specifically, it is intended to assure that:

a. System requirements are achieved by appropriate use of the human component.

b. Through proper design of equipment and environment, the man-equipment combination performs within system tolerance limits.

c. Design features will not constitute a hazard to personnel.

MIL-H-46855A

d. Trade-off points between automated vs manual operation have been chosen for peak system efficiency within appropriate cost limits.

e. Human engineering applications are technically adequate.

f. The equipment is designed to facilitate required maintenance.

g. Procedures for operating and maintaining equipment are efficient, reliable and safe.

h. Potential error-inducing equipment design features are minimized.

i. The layout of the facility and the arrangement of equipment affords efficient communication and use.

j. The contractors provide the necessary manpower and technical capability to accomplish the above objectives.

6.2 Explanation of Terms. - For purposes of this specification, the following definitions are applicable:

6.2.1 Critical. - That human performance which, if not accomplished in accordance with system requirements, will most likely have adverse effects on cost, system reliability, efficiency, effectiveness, or safety. Critical performance is usually part of a "single" line of flow in the operation or maintenance cycle of the system. An example of a "single" flow involving human performance is the transmission of a message which must be passed for operations or maintenance cycles to commence or to continue, such as an order to prepare a missile for launching. If this order is not passed, or if it is garbled, the entire missile operation cycle may cease to function as required. Human performance shall also be considered critical whenever equipment design characteristics demand performance which exceeds human capabilities or approaches limitations (e. g. , human performance functions and tasks are too demanding, information presented to man is inadequate to meet his performance requirements, appropriate information displayed is not perceived, or controls provided cannot be efficiently operated) and thereby significantly contributes to the occurrence of one or more of the following conditions but not necessarily limited thereto:

a. Jeopardized performance of an authorized mission.

b. Degradation of the circular error probability (CEP) to an unacceptable level.

c. Delay of a mission beyond acceptable time limits; e. g. , human time to react will not meet required system reaction time.

d. Improper operation resulting in a system "no-go," inadvertent weapons firing, or failure to achieve operational readiness alert.

e. The exceeding of predicted times for maintenance personnel and maintenance ground equipment (MGE) to complete maintenance tasks. As a rule, performance times will be considered critical if the total maintenance response time significantly exceeds maintenance analysis estimates, and affects MGE quantitative requirements.

f. Degradation of system equipment below reliability requirements; i. e. , mean time between failures (MTBF) is reduced.

g. The damaging of system equipment, resulting either in a return to a maintenance facility for major repair, or in unacceptable costs, spare requirements, or system downtime.

h. A serious compromise of weapon system security.

i. Injury to personnel.

6.2.2 Overall Layout Drawings. - System design drawings which include but are not limited to: (1) the configuration and arrangement of major items of equipment for manned stations, such as a pilot's or astronaut's station, or launch control officer's station, or shipboard command station; (2) the configuration and arrangement of items of equipment, such as modular rack or maintenance ground equipment, which may not be a part of a manned station for operation, but require man-equipment access for maintenance; (3) the arrangement of interior lighting for operating or maintaining the equipment; and (4) labels identifying general panel content (e. g. , flight mission panel, countdown status panel, communications panel, or malfunction status panel).

6.2.3 Panel Layout Drawings. - Equipment detail drawings which include, but are not necessarily limited to : (1) a scale layout of the controls and displays on each panel or an item of equipment, such as an astronaut's, pilot's or launch control officer's console, or shipboard command console; (2) a description of all symbols used; (3) identification of the color coding used for displays and controls; (4) the labeling used on each control or display; and (5) the identification of control type (e. g. , alternate action or momentary) and a clear differentiation between controls and indicators.



6.2.4 System Engineering. - A basic tool for systematically defining the equipment, personnel, facilities and procedural data required to meet system objectives. It is an iterative process, requiring updating, and having feedback loops to insure that each component developed contributes to the system in meeting mission objectives. A system engineering analysis may include, but is not necessarily limited to, the following:

- a. Preparation of functional flow block diagrams for the system.
- b. Functional analysis of each flow block.
- c. Preparation of system and subsystem schematic block diagrams.
- d. Study of detailed functions, environment and technical design requirements to allocate assignment of tasks to personnel, equipment, or some combination thereof.
- e. Preparation of timeline analyses (operation/maintenance/control) to determine system reaction time.
- f. Preparation and analysis of maintenance loading charts to determine equipment quantities, personnel loads and system down-time for scheduled and unscheduled maintenance.
- g. Training implications.

6.2.5 Task Analysis. - A time-oriented description of man-equipment interactions brought about by an operator in accomplishing a unit of work with an item of equipment. It shows the sequential and simultaneous manual and intellectual activities of man operating, maintaining or controlling equipment, rather than a sequential operation of the equipment. (It is a part of system engineering analysis where system engineering is required.)

MIL-H-46855A

Custodians

Army - MI  
Navy - AS  
Air Force - 11

Review Activities

Army - MI - EL - GL - MD - MR - MU - WC - AT - AV - ME -  
TM - HEL  
Navy - AS - MS - OS - PE - SH - TD - YD  
Air Force - 11 - 14 - 19 - 26

User Activities

Army -  
Navy -  
Air Force -

Preparing Activity

Army - MI

Civilian Agencies

NASA - MSFC  
DOT - RDS  
GSA - FSS

Project Number:  
MISC - 0727

SPECIFICATION ANALYSIS SHEET		Form Approved Budget Bureau No. 22-R256
<p><b>INSTRUCTIONS:</b> This sheet is to be filled out by personnel, either Government or contractor, involved in the use of the specification in procurement of products for ultimate use by the Department of Defense. This sheet is provided for obtaining information on the use of this specification which will insure that suitable products can be procured with a minimum amount of delay and at the least cost. Comments and the return of this form will be appreciated. Fold on lines on reverse side, staple in corner, and send to preparing activity. Comments and suggestions submitted on this form do not constitute or imply authorization to waive any portion of the referenced document(s) or serve to amend contractual requirements.</p>		
SPECIFICATION		
ORGANIZATION		
CITY AND STATE		CONTRACT NUMBER
MATERIAL PROCURED UNDER A <input type="checkbox"/> DIRECT GOVERNMENT CONTRACT <input type="checkbox"/> SUBCONTRACT		
1. HAS ANY PART OF THE SPECIFICATION CREATED PROBLEMS OR REQUIRED INTERPRETATION IN PROCUREMENT USE?  A. GIVE PARAGRAPH NUMBER AND WORDING.   B. RECOMMENDATIONS FOR CORRECTING THE DEFICIENCIES		
2. COMMENTS ON ANY SPECIFICATION REQUIREMENT CONSIDERED TOO RIGID		
3. IS THE SPECIFICATION RESTRICTIVE?  <input type="checkbox"/> YES <input type="checkbox"/> NO (If "yes", in what way?)		
4. REMARKS (Attach any pertinent data which may be of use in improving this specification. If there are additional papers, attach to form and place both in an envelope addressed to preparing activity)		
SUBMITTED BY (Printed or typed name and activity - Optional)		DATE

DD FORM 1426  
1 JAN 66

REPLACES EDITION OF 1 OCT 64 WHICH MAY BE USED

DATA ITEM DESCRIPTION		2 IDENTIFICATION NO(S)	
		AGENCY	NUMBER
1 TITLE  PLAN, HUMAN ENGINEERING PROGRAM		NAVY	DI-II-2104
3 DESCRIPTION PURPOSE  This plan provides a description of how the contractor will incorporate his human engineering effort into the system development and acquisition. This plan includes definition of human engineering tasks, task schedule, level of effort, documentation and reporting requirements, personnel qualification and assignment, and human engineering deliverable end items. The plan provides the procuring activity with assurance of positive management control of the contractor effort.		4 APPROVAL DATE 1973 July 20	
		5 OFFICE OF PRIMARY RESPONSIBILITY & USERS NM (AS FC OS SH)	
		6 DDC REQUIRED NA	
		8 APPROVAL LIMITATION NA	
7 APPLICATION INTERRELATIONSHIP  7.1 This data item describes data required by MIL-II-46855, para 3.1.2, 3.2.2.3, 3.2.2.4, 3.3, 3.4 and 3.5.  7.2 This plan constitutes the - implementing document for contractual compliance of human engineering efforts. The plan identifies human engineering tasks to be performed by the contractor and delineates contractor furnished human engineering data. The plan will be used as a basis for monitoring contractor progress and will also indicate any need for assistance and/or guidance from the procuring activity.		9 REFERENCES (Mandatory as cited in block 10)  MIL-II-46855 MIL-STD-1472	
		MC SL NUMBER(S)  10781	
1 PREPARATION INSTRUCTIONS  10.1 Unless otherwise indicated herein, the documents cited in this block, of the issue in effect on date of invitation for bids or request for proposals, form a part of this DID to the extent specified herein.  10.2 The Human Engineering Program Plan shall be prepared in contractor format and in accordance with the requirements of MIL-II-46855, para. 3.1.2. The plan shall consist of the following sections:  a. General. Description of the means by which the contractor will meet the requirements in MIL-II-46855 and the human engineering requirements in the procurement documentation.  b. Human engineering implementation schedule. In milestone chart form show start and end dates for each task, points for progress reporting and/or review, and an estimate of the man-loading across the schedule including a percent of the total effort assigned to each task.  c. Human engineering data. Description of human engineering data to be made available to the procuring activity as specified by the Contract Data Requirements List (DD Form 1423) and MIL-II-46855, para. 3.2.2.4, 3.3, 3.4, and 3.5.  d. Human engineering effort in systems analysis.  e. Human engineering in equipment detail design.  f. Work environment and facilities design.  g. Human engineering in system performance, safety, design, and acceptance test specifications, in accordance with MIL-II-46855, para. 3.2.2.3 and 3.2.2.4.  h. Studies, mock-ups, and simulation.  i. Operability/maintainability analyses.			

DATA ITEM DESCRIPTION	7 IDENTIFICATION NO(S)	
	AGENCY	NUMBER
1 TITLE  PLAN, HUMAN ENGINEERING TEST	NAVY	DI-H-2105
3 DESCRIPTION/PURPOSE  This plan describes in detail the contractor's proposed test and demonstration plan which will verify the man-equipment interface requirements for the operation and maintenance of the system, as specified by the contract.	4 APPROVAL DATE 1973 July 20	
	5 OFFICE OF PRIMARY RESPONSIBILITY (USER'S) NM (AS OS SH)	
	6 DDIC REQUIRED NA	
	8 APPROVAL LIMITATION NA	
7 APPLICATION INTERRELATIONSHIP  7.1 This data item describes the contractor's proposed plan for complying with requirements of MIL-H-46855, para. 3.2.2.4, 3.2.4, 3.2.4.3, and 6.2.1. 7.2 The human engineering test plan delineates a detailed test program to be followed by the contractor and it is used by the procuring activity to assure completeness of contractor's test program and conformance to contractual requirements. Upon approval by the procuring activity, the Human Engineering Test Plan will supersede test and evaluation portions of the Human Engineering Program Plan (DI-H-2104) when specified in the Contract Data Requirements List. 7.3 This data item is related to DI-H-2111, Human Engineering Test Report, and DI-H-2112, Human Engineering Final Report.	9 REFERENCES (Mandatory as cited in block 10)  MIL-H-46855	
	MCSL NUMBER(S) 10781	
10 VERIFICATION/TESTING/TIMING  10.1 Unless otherwise indicated herein, the documents cited in this block, of the issue in effect on date of invitation for bids or request for proposals, form a part of this DID to the extent specified herein.  10.2 Human Engineering Test Plan shall be prepared in compliance with MIL-H-46855, para. 3.2.4, in contractor format for systematic and comprehensive testing necessary to verify that the system can be safely operated, maintained, and supported by user personnel in accordance with contract requirements. The Human Engineering Test Plan shall describe the approach(es) for obtaining data and shall establish and explain all standards, tests, associated analyses, and other means that will constitute adequate proof upon completion of the development phase that acceptable levels of human performance, time, accuracy, and safety factors can be achieved in operational use under specified manning levels.  10.3 The Human Engineering Test Plan shall consist of the following sections: a. General. The detailed objectives, concepts, and requirements for the Human Engineering Test Plan shall be in accordance with MIL-H-46855, para 3.2.2.4, and shall be described with consideration being given to: (1) Updating of human engineering data, task performance requirements, and operating and maintenance task procedures. (2) Verification that all human engineering requirements, as specified by the contract, have been implemented. (3) Identification of potential training problems and validation of the functional adequacy of the training equipment, where applicable.		

DATA ITEM DESCRIPTION		2 IDENTIFICATION NO(S)	
1 TITLE		AGENCY	NUMBER
3 DESCRIPTION PURPOSE		NAVY	DI-II-2106
<p>This report will be used by system engineers, human factors engineers, ILS managers, and others for planning purposes in order to develop needed manpower data so that total system manning and training estimates can be made.</p> <p>7.1 This data item describes data documenting a portion of the contractor's effort required by MIL-II-46855, para. 3.2.1 and 3.2.3.</p> <p>7.2 Personnel planning information will form the basis of the design approach for systems, equipment, and facilities. The definition of this personnel planning information is one of several system engineering techniques used to describe the system and major subsystems. The report will also be used by the Bureau of Naval Personnel in arriving at estimates of manpower requirements for the new acquisition. It will be related to design work study inputs and will be coordinated with reliability and maintainability inputs and used by the ILS Manager for the total Integrated Logistic System Program Plan.</p>		4 APPROVAL DATE 1973 July 20	
		5 OFFICE OF PRIMARY RESPONSIBILITY (& USERS) NM (AS SH)	
		6 DDC REQUIRED NA	
		8 APPROVAL LIMITATION NA	
7 APPLICATION INTERRELATIONSHIP		9 REFERENCES (Mandatory as cited in Block 10) MIL-II-46855 NAVPEERS 15105 NAVPEERS 15839 NAVPEERS 18068 NAVPEERS 18455 NAVPEERS 18564	
		10 MCSL NUMBER(S) 10781	
11 PREPARATION INSTRUCTIONS			
10.1 Unless otherwise indicated herein, the documents cited in this block, of the issue in effect on date of invitation for bids or request for proposals, form a part of this DID to the extent specified herein.			
10.2 The Personnel Planning Information Report shall be prepared in compliance with MIL-II-46855, para. 3.2.1 and 3.2.3, in contractor format which shall provide:			
a. Brief summary of the system, subsystems, and equipment.			
b. Preliminary summary of the minimum quantitative and qualitative manning and training requirements to operate, maintain, and support the system acquisition.			
c. Identification of special skills, knowledges, and selection requirements related to critical human involvement.			
d. Description of new equipment items for which special skills may be required and new training requirements foreseen.			
e. Identification of special training support items; e.g., simulators, part-task trainers, visual aids, training manuals, etc.			
10.3 In defining manning considerations, the Personnel Planning Information Report shall be consistent with the manual of Navy Officer Classifications (NAVPEERS 15839), Manual of Qualifications for Limited Duty Officers USN (NAVPEERS 18564), Manual of Qualifications for Warrant Officers (NAVPEERS 18455), Manual of Qualifications for Advancement (NAVPEERS 18068), and Manual of Navy Enlisted Classifications (NAVPEERS 15105).			
10.4 The content of this report shall not duplicate any effort being performed by the procuring activity and/or other contractor agencies.			

DATA ITEM DESCRIPTION		2 IDENTIFICATION NO(S)		
		AGENCY	NUMBER	
1 TITLE	NAVY                      DI-H-2107			
3 DESCRIPTION PURPOSE  This document describes the arrangement/layout and detail design of the crew station, crew station equipment, and all other equipment having an interface with the human operator(s)/maintainer(s). It is used by the procuring activity to: (a) determine a technical approach to layout/arrangement/detail design of the crew station(s) and all equipment, (b) evaluate layout/arrangement/detail design of crew station(s) and all equipment, (c) evaluate crew station ingress/egress if applicable.	4 APPROVAL DATE 1973 July 20	5 OFFICE OF PRIMARY RESPONSIBILITY (& USERS) NM (AS EC SH)		
		6 DDC REQUIRED NA		
		8 APPROVAL LIMITATION  NA		
7 APPLICATION INTERRELATIONSHIP  7.1 This data item describes data documenting a portion of the contractor's effort required by MIL-H-46855, para. 3.2.1.4, 3.2.2, 3.2.2.3, and 3.5, and MIL-STD-1472.  7.2 This data item is related to DI-H-2109, Task Analysis/Task Description Report.	9 REFERENCES (Mandatory as cited in block 10)  MIL-H-46855 MIL-STD-1472			
		MCSL NUMBER(S)  10781		
11 PREPARATION INSTRUCTIONS  10.1 Unless otherwise indicated herein, the documents cited in this block, of the issue in effect on date of invitation for bids or request for proposals, form a part of this DID to the extent specified herein.  10.2 The Human Engineering Design Document shall be prepared, in contractor format, which describes the contractor human engineering effort regarding crew station layout/arrangement (MIL-H-46855, para 3.2.1.4, 3.2.2.3, and 3.5) and detail design of equipment having an operator/maintainer interface (MIL-H-46855, para. 3.2.2 and 3.5). This report shall describe the extent to which the requirements of MIL-STD-1472 and other applicable human engineering/design documents specified by the contract have been incorporated into the arrangement, layout, and detail design of the crew station and all equipment having an operator/maintainer interface.  10.3 The Human Engineering Design Document shall consist of the following: a. A list of panels (e.g., instrument panel, console panel, overhead panel), racks, controls, displays, and indicators existing at the time of document submission which have received human engineering approval. b. Rationale of the human engineering layout/arrangement/detail design of the crew station(s) and any equipment having an operator/maintainer interface. Considerations for system mission, operator task requirements, maintenance requirements, equipment operation, and limitations imposed by the contractor or state of the art shall be presented. Adequate narrative shall be presented on each item to familiarize the reader with the considerations used to reach specific design decisions (i.e., MIL-STD-1472 requirements, results of analyses, other contract requirements, mock-up tests or mock-up board decisions, simulation, and				

DATA ITEM DESCRIPTION	2 IDENTIFICATION NO(S)	
	AGENCY	NUMBER
1 TITLE REPORT, HUMAN ENGINEERING MAINTENANCE/ ACCESSIBILITY DESIGN	NAVY	DI-H-2108
3 DESCRIPTION PURPOSE This report describes accessibility to equipment for purpose of replacement, inspection, servicing, adjustment, and calibration during preventive and corrective maintenance at the organizational level and especially in the maintenance of aircraft, during the intermediate and depot levels.	4 APPROVAL DATE 1973 July 20	
	5 OFFICE OF PRIMARY RESPONSIBILITY (& USERS) NM (AS EC OS SH)	
	6 DDC REQUIRED NA	
	8 APPROVAL LIMITATION NA	
7 APPLICATION INTERRELATIONSHIP  7.1 This data item describes data documenting a portion of the contractor's effort required by MIL-H-46855, para. 3.2.2 and MIL-STD-1472, para. 5.9.  7.2 This data item is related to DI-H-2104, Human Engineering Program Plan, and DI-H-2107, Human Engineering Design Document. This report is used in the design phase by the procuring activity to ensure adequate accessibility to equipment.	9 REFERENCES (Mandatory as cited in block 10)  MIL-H-46855 MIL-STD-1472	
	MCSL NUMBER(S)  10781	
10 PREPARATION INSTRUCTIONS  10.1 Unless otherwise indicated herein, the documents cited in this block, of the issue in effect on date of invitation for bids or request for proposals, form a part of this DID to the extent specified herein.  10.2 The Human Engineering Maintenance/Accessibility Design Report shall be prepared in contractor format and describe the human engineering effort applied to ensuring the accessibility of equipment (especially for organizational level) required by MIL-H-46855, para. 3.2.2, and MIL-STD-1472, para. 5.9, and shall consist of the following:  a. Preliminary drawings, sketches, or photographs showing each equipment and its location in relation to surrounding equipment, passageways, and structure. The drawings, sketches, or photographs shall clearly depict the equipment (as viewed by the maintainer while performing required maintenance) from top, side, and front views showing door and panel opening clearance of the equipment. Connectors, electrical leads, cables, ducts, piping, etc., shall also be shown.  b. Rationale of the human engineering design of each item of equipment requiring maintenance. Adequate narrative shall be presented to familiarize the reader with such considerations used to reach specific decisions such as MIL-STD-1472 requirements, results of studies, simulations, mock-ups, demonstrations, and others as applicable. Where maintenance task analyses are available, they shall be incorporated in part or whole, depending upon the criticality of rapid maintenance times and other constraints specified by the procuring activity.  c. Narrative describing the following:  (1) Physical size, weight, and purpose of portable support and test equipment required for performing maintenance on the equipment.		



DATA ITEM DESCRIPTION		2 IDENTIFICATION NO(S)	
		AGENCY	NUMBER
1 TITLE REPORT, TASK ANALYSIS/TASK DESCRIPTION		NAVY	DI-H-2109
3 DESCRIPTION PURPOSE <p>This report describes the results of task analyses performed by the contractor and presents task descriptions. The purpose of the report is to summarize the work that the operator/maintainer performs and to provide a basis for the design of the system, equipment, or facilities.</p>		4 APPROVAL DATE 1973 July 20	
		5 OFFICE OF PRIMARY RESPONSIBILITY (& USERS) NM (AS EC SH)	
		6 DDC REQUIRED NA	
7 APPLICATION INTERRELATIONSHIP <p>7.1 This data item describes data documenting a portion of the contractor's effort required by MIL-H-46855, para. 3.2.1.3, 3.2.1.3.1, and 3.2.1.3.2.</p> <p>7.2 Task Analysis/Task Description Reports will be used to evaluate the contractor's analyses of men in the system.</p> <p>7.3 This data item is related to DI-H-2104, Human Engineering Program Plan, and DI-H-2107, Human Engineering Design Document.</p>		8 APPROVAL LIMITATION NA	
		9 REFERENCES (Mandatory as cited in block 10) MIL-H-46855	
		MCSI NUMBER(S) 10781	
10 PREPARATION INSTRUCTIONS <p>10.1 Unless otherwise indicated herein, the documents cited in this block, of the issue in effect on date of invitation for bids or request for proposals, form a part of the DID to the extent specified herein.</p> <p>10.2 The Task Analysis/Task Description Report shall be prepared in contractor selected format of flow diagrams, tabular presentations, and narrative. The report shall describe the results of the task analyses required by MIL-H-46855, para 3.2.1.3, and shall consist of the following:</p> <ul style="list-style-type: none"> <li>a. Summary of gross tasks identified during analyses performed in response to MIL-H-46855, para. 3.2.1.3.1.</li> <li>b. Identification of critical task characteristics as required by MIL-H-46855, para. 3.2.1.3.2, if applicable. Supporting evidence shall be supplied if applicable. Example: The method by which an operator's reaction time is estimated should be included.</li> <li>c. The results of the operator/maintainer workload analysis. If there is more than one crew member involved in the system operation, the interaction workload of the crew members shall also be identified.</li> <li>d. Discussion of related factors such as system or equipment performance, cost, and delivery schedule when these factors are affected by one or more of the critical tasks.</li> <li>e. Discussions of task-related data shall be extracted from the task analyses and compiled in preliminary operator/maintainer procedurally-oriented task descriptions for use in developing procedures documents, personnel planning, and system testing.</li> </ul>			

DATA ITEM DESCRIPTION	2 IDENTIFICATION NO(S)	
	AGENCY	NUMBER
1 TITLE REPORT, HUMAN ENGINEERING PROGRESS	NAVY	DI-H-2110
3 DESCRIPTION PURPOSE  This report describes status of the contractor's human engineering program. Each report is used to transmit human engineering progress, problems, and plans for each succeeding reporting period. These reports provide evidence that human engineering considerations are reflected in system design and development and indicate compliance with contractual requirements for human engineering.	4 APPROVAL DATE 1973 July 20	
	5 OFFICE OF PRIMARY RESPONSIBILITY (& USERS) NM (AS EC OS SH)	
	6 DDC REQUIRED NA	
	8 APPROVAL LIMITATION NA	
7 APPLICATION INTERRELATIONSHIP  7.1 This data item describes data required by MIL-H-46855, para. 3.1.2.3, 3.2.1.3.1, and 3.2.1.3.2.  7.2 The reports inform the procuring activity of the contractor's status on the human engineering program defined by the contract and by the Human Engineering Program Plan (DI-H-2104) previously submitted by the contractor and approved by the procuring activity.	9 REFERENCES (Mandatory as cited in block 10)  MIL-H-46855	
	10 USE NUMBERS 10781	
11 PREPARATION INSTRUCTIONS  10.1 Unless otherwise indicated herein, the documents cited in this block, of the issue in effect on date of invitation for bids or request for proposals, form a part of this DID to the extent specified herein.  10.2 <u>REPORT CONTENT</u> : Human Engineering Progress Reports shall summarize the human engineering work performed during the reporting period. Each report will be concise and will not repeat previously reported material except for reasons of clarity. Each report shall be in sufficient detail for the procuring activity to ascertain whether human engineering considerations are reflected in system design and development, verification, and test and evaluation. The Human Engineering Progress Reports shall include:  a. List of equipment requiring human engineering effort. The initial report shall list in priority order the equipments/functional spaces requiring human engineering in detailed design. The list and modifications thereto shall be determined in compliance with MIL-H-46855, para. 3.2.1.3.1 and 3.2.1.3.2.  b. Description of human engineering support of design engineering shall include:  (1) An annotated listing of all drawings having an impact on the man-machine interface that have been approved by the contractor's human engineering group.  (2) Summary and status of all human engineering design recommendations.  (3) Summary of human engineering participation in design reviews.  c. A summary of detailed task analyses with emphasis on their impact on design, training, procedures, layouts, critical situations, etc. Other human engineering activities relating to design of equipment which utilizes man as a central element shall be reported in sufficient detail to demonstrate effective integration of the human component into the system. Results of trade-off studies during systems analysis to determine the man-equipment combination required.		

DATA ITEM DESCRIPTION	2 IDENTIFICATION NO(S)		
	AGENCY	NUMBER	
1 TITLE REPORT, HUMAN ENGINEERING TEST	NAVY	DI-H-2111	
3 DESCRIPTION PURPOSE <p>This report will be prepared following each major test, evaluation, or demonstration and shall be submitted to the procuring activity to provide evidence that the man-equipment interface requirements for the operation and maintenance of the system, as specified in the contract, have been met.</p>	4 APPROVAL DATE 1972 July 20	5 OFFICE OF PRIMARY RESPONSIBILITY (& USI-RS) NM (AS EC OS SH)	
	6 DEC REQUIRED NA	8 APPROVAL LIMITATION NA	
	7 APPLICATION INTENT, APPROVAL 7.1 This data item describes data documenting a portion of the contractor's effort required by MIL-H-46855, para. 3.2.2.4, and 3.2.4, and 3.2.4.3. 7.2 The Human Engineering Test Report describes in detail the results of the contractor's demonstration of the item(s) under test, and it is used by the procuring activity to assure that the man-equipment interface requirements for the operation and maintenance of the system conform to the contractual requirements. 7.3 This data item is related to DI-H-2105, Human Engineering Test Plan.	9 REFERENCES (Mandatory as cited in block 10) MIL-H-46855 MIL-STD-831	10 MCSL NUMBER(S) 10781
	11 PREPARATION INSTRUCTIONS 10.1 Unless otherwise indicated herein, the documents cited in this block, of the issue in effect on date of invitation for bids or request for proposals, form a part of this DID to the extent specified herein. 10.2 The Human Engineering Test Report shall be prepared in compliance with the provisions of MIL-H-46855, para. 3.2.2.4, and 3.2.4 and where applicable MIL-STD-831 for each major test, evaluation, or demonstration. a. Test title and identifying number. b. Type of test (see DI-H-2105, Human Engineering Test Plan, Para. 10.3.e). c. Description of test purpose, identification of test objectives, identification of equipment being tested, if applicable. d. Description of test methods and procedures, measurement methods, criteria, apparatus, instrumentation, facilities, personnel. e. Description of findings, including any deficiencies noted, failures, problem areas. Reporting of deficiencies and failures, required by MIL-H-46855, para. 3.2.4.3, shall include: (1) Enumeration of each deficiency/failure. (2) Description of any contract requirement affected by the deficiency/failure. (3) Complete discussion of effects of the deficiency/failure. For deficiencies, the rationale for not making design changes will be included if no changes are recommended. (4) Recommendations including estimate of cost and schedule.		

1. TITLE	2. IDENTIFICATION NO(S)	
	AGENCY	NUMBER
REPORT, HUMAN ENGINEERING FINAL	NAVY	DI-H-2112
3. DESCRIPTION/PURPOSE  This report summarizes contractor's human engineering efforts during design, development, verification, test and evaluation of the system, equipment, or facility. This report also documents decisions and trade-offs influencing design configuration. It identifies remaining human engineering problems, if any, and recommends remedial action.	4. APPROVAL DATE 1973 July 20	
	5. OFFICE OF PRIMARY RESPONSIBILITY (& USERS) NM (AS EC OS SH)	
	6. DDC REQUIRED NA	
	8. APPROVAL LIMITATION NA	
7. APPLICATION, INTEREST, AND SCOPE  7.1 This data item summarizes the contractor's human engineering efforts performed under MIL-H-46855, para 3.1.2.3.  7.2 The report will be used by the procuring activity to evaluate the contractor's human engineering efforts and to serve as a baseline for application to subsequent system improvements and future procurements.  7.3 This data item is related to DI-H-2104, Human Engineering Program Plan.	7. REFERENCES (Mandatory as cited in block 10) MIL-H-46855	
	9. MCSI NUMBER(S) 10781	
10. PREPARATION INSTRUCTIONS  10.1 Unless otherwise indicated herein, the documents cited in this block, of the issue in effect on date of invitation for bids or request for proposals, form a part of this DID to the extent specified herein.  10.2 The Human Engineering Final Report shall be prepared in compliance with MIL-H-46855, para 3.1.2.3 in contractor format which shall  a. Describe the system, by major item, and outline the activities performed and results achieved in accordance with the contract and the Human Engineering Program Plan (DI-H-2104).  b. Summarize human engineering input to the following areas  (1) Equipment detail design. (2) Work environment, facilities design and safety. (3) Contractor prepared system performance and design specifications, and acceptance test specifications. (4) Reports of subcontractors human engineering activities. (5) Studies. (6) Design review. (7) Verification, test and evaluation.  c. Describe remaining human engineering problems, if any, and recommended remedial action.  d. Provide human engineering recommendations for system improvements and/or future procurements.		