

AFRRI TN73-10
AUGUST 1973

AFRRI
TECHNICAL
NOTE

**REAL-TIME DISPLAY OF
RADIATION FIELD INTENSITY DISTRIBUTION**

P. A. Berardo
J. A. Willis

ARMED FORCES RADIOBIOLOGY RESEARCH INSTITUTE
Defense Nuclear Agency
Bethesda, Maryland

Approved for public release; distribution unlimited

AFRRI 18/3-10

REAL-TIME DISPLAY OF RADIATION FIELD INTENSITY DISTRIBUTION

P. A. BERARDO
J. A. WILLIS

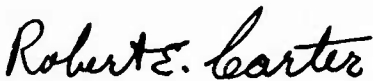

R. E. CARTER
Chairman
Physical Sciences Department



MYRON I. VARON
Captain MC USN
Director

ARMED FORCES RADIOBIOLOGY RESEARCH INSTITUTE
Defense Nuclear Agency
Bethesda, Maryland

ACKNOWLEDGMENT

The authors are grateful to D. M. Verrelli for project guidance, to J. L. Rouch for technical assistance, and to the AFRRRI staff for many areas of support.

TABLE OF CONTENTS

	Page
Abstract	iii
I. Introduction	1
II. Design and Operation	2
General method	2
CRT display and strobe signal generation.	3
Multiplexer	7
III. Performance	8
Results with simulated detector grid	8
Results with radiation detectors	11
System costs	11
IV. Discussion	11
References	14

LIST OF FIGURES

	Page
Figure 1. Elements of field monitor display system	3
Figure 2. Elements of background and strobe generator and connections to multiplexer and CRT.	5
Figure 3. Multiplexer block diagram showing shift register and detail of multiplex and reset switches for channel 1	7
Figure 4. Three-dimensional 6 x 6 grid before detector signals are added.	9
Figure 5. Three-dimensional 6 x 6 grid with 32 signals from a uniform radiation field	9
Figure 6. Three-dimensional 6 x 6 grid with 32 signals from a Gaussian intensity distribution	10
Figure 7. Two-dimensional sequence of profiles with 32 signals from a Gaussian intensity distribution	10

TABLE

Table I. Typical Wave-Form Parameters for an 8 x 8 Grid	6
-------------------------------------------------------------------	---

ABSTRACT

A real-time display system has been designed and tested for use with a radiation field monitor. The system uses only pulse and wave-form generators, a multiplexer and an oscilloscope. The display consists of either a three-dimensional representation of the field intensity distribution or a series of simultaneous profiles.

I. INTRODUCTION

The electron linear accelerator (LINAC) at the Armed Forces Radiobiology Research Institute (AFRRI) is used to provide pulsed radiation fields up to 40 cm in diameter for biological research. Large radiation fields cannot always be completely characterized by the intensity at the center of the field. Some measure of the spatial intensity distribution is required in many cases. It is also usually desirable that this information be immediately available to make necessary changes in the field parameters.

Real-time monitoring of the AFRRI LINAC radiation field usually is done with a single detector remotely controlled to scan the field along lines perpendicular to the beam. The primary disadvantage of this method is that considerable time is required for a complete area scan. Another approach, developed by Hornstra and Simanton¹⁻³ at Argonne National Laboratory, uses wire planes operating as current collectors. The main limitations of this approach are that only fixed resolution profiles are obtained and the planes are insensitive to certain distributions, such as occur with elliptical fields.

A monitor providing an immediate and quantitative indication of the intensity at many points in a radiation field would have considerable advantages. This could be achieved with individual detectors interfaced through analog to digital converters (ADC's) to a computer which then drives a cathode-ray tube (CRT) oscilloscope display of the radiation intensity distribution. However, hardware and personnel costs for programming and implementation can be prohibitive.

To circumvent the problems and expense of a computer-based monitor, a system has been designed and tested which essentially couples the detectors directly to a CRT display. This system provides (1) continuous, real-time operation without a computer, (2) discrete detector inputs, (3) independence of field size, (4) independence of number or type of detectors, (5) CRT display of a three-dimensional representation of the field spatial intensity distribution, (6) CRT display of a series of simultaneous intensity profiles, and (7) quantitative measure of each detector response.

II. DESIGN AND OPERATION

General method. To determine the radiation intensity at a number of points, individual detectors are used. The radiation detectors can be ion chambers, diodes or any device from which radiation-induced charge can be collected in a capacitive circuit. When the voltage across the capacitor is measured for each detector, a grid of such detectors provides information on the spatial intensity distribution. The basic feature of the design is that the individual detector output voltages are gated in sequence and superimposed on a CRT base-line display of horizontal rows of the detector grid. The number, spacing and size of the detectors ultimately determine the spatial resolution.

The basic elements of the system are shown schematically in Figure 1. For each pulse of radiation, a LINAC trigger is used to reset the multiplexer and to start the strobe and CRT base-line generator. The strobes and base lines are synchronous signals, so each strobe into the multiplexer always superimposes the zero point of each detector signal in a fixed location on the base lines. All detectors are sampled and a complete display is generated for each LINAC trigger. The LINAC trigger can be obtained from the LINAC electronics or from a detector in the radiation field.

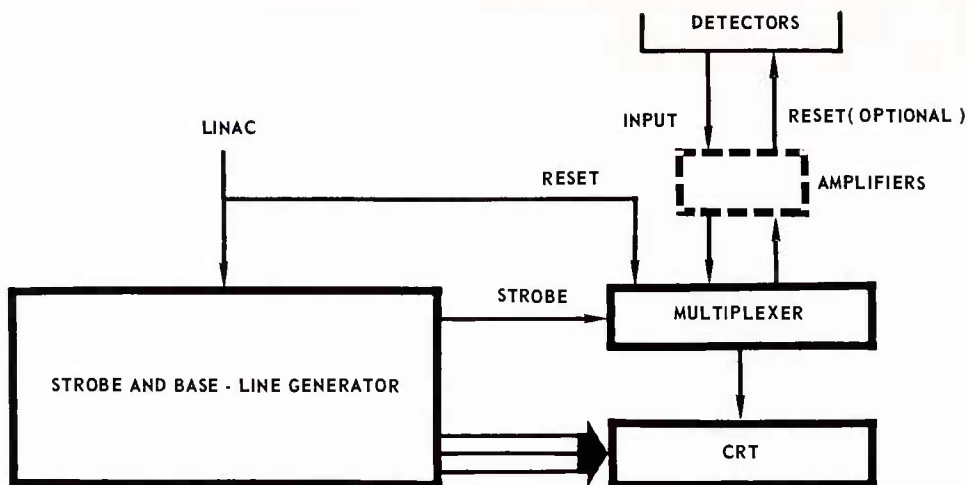

Figure 1. Elements of field monitor display system

The reset from the multiplexer is used to discharge the detector charge holding circuits. If the reset is disabled, then each detector circuit accumulates a charge until irradiation is stopped and holds the charge until it is manually reset. Thus one may operate the system for a predetermined irradiation time or number of radiation pulses and measure the integrated response of each detector. In this mode the LINAC trigger may be replaced by any convenient pulse generator and the display will be maintained after the irradiation stops.

When the reset is enabled, the resets are synchronized with the LINAC trigger, so that detector voltages will not be reset during a pulse or while they are being displayed on the CRT. In the present system, the multiplexer initiates the reset after the last detector strobe.

CRT display and strobe signal generation. To generate the CRT base-line display and synchronous strobe pulses, three identical stages of pulse and wave-form generators are used. The Tektronix 160 series was used for two reasons: first, it

has wide flexibility in triggering modes, delay, pulse widths and repetition rates; second, it is inexpensive. Because it internally adds two signals on both the horizontal and vertical inputs, a Tektronix RM503 oscilloscope was used for the CRT. The three stages and CRT are operated as shown in Figure 2.

In the first stage, labeled Y in Figure 2, a LINAC pulse triggers a ramp generator, R1, the output of which is used to trigger a pulse generator, G1. The output width of G1 is variable. Independently variable is the time at which G1 pulses relative to the LINAC trigger. This is important because the strobe pulses cannot start until the detectors respond to the radiation field. When the detector reset is not enabled, R1 may be internally triggered at 60 Hz. One element of the base-line display is obtained when the output of the ramp generator R1 is used as a vertical input on the CRT to obtain a single vertical sweep.

The second stage, labeled X in Figure 2, is identical to the first stage except that, instead of acting as a trigger, the G1 pulse is used to gate on the second ramp generator R2. While G1 is present, a preset number of R2 ramps are obtained. The number of R2 ramps is variable (by varying the width of G1) and is set to the number of horizontal rows in the detector grid. For illustration, only two ramps are shown. When the output of the second ramp generator R2 is used for both horizontal and vertical input on the CRT, a 45° sweep is obtained. The vertical sweep from the first ramp generator R1 causes the 45° sweeps to be separated, one above the other, since the first ramp continues for a longer time than all of the R2 ramps.

The third stage, labeled STROBE in Figure 2, performs different functions but operates in exactly the same way as the second stage. The G3 pulses strobe the

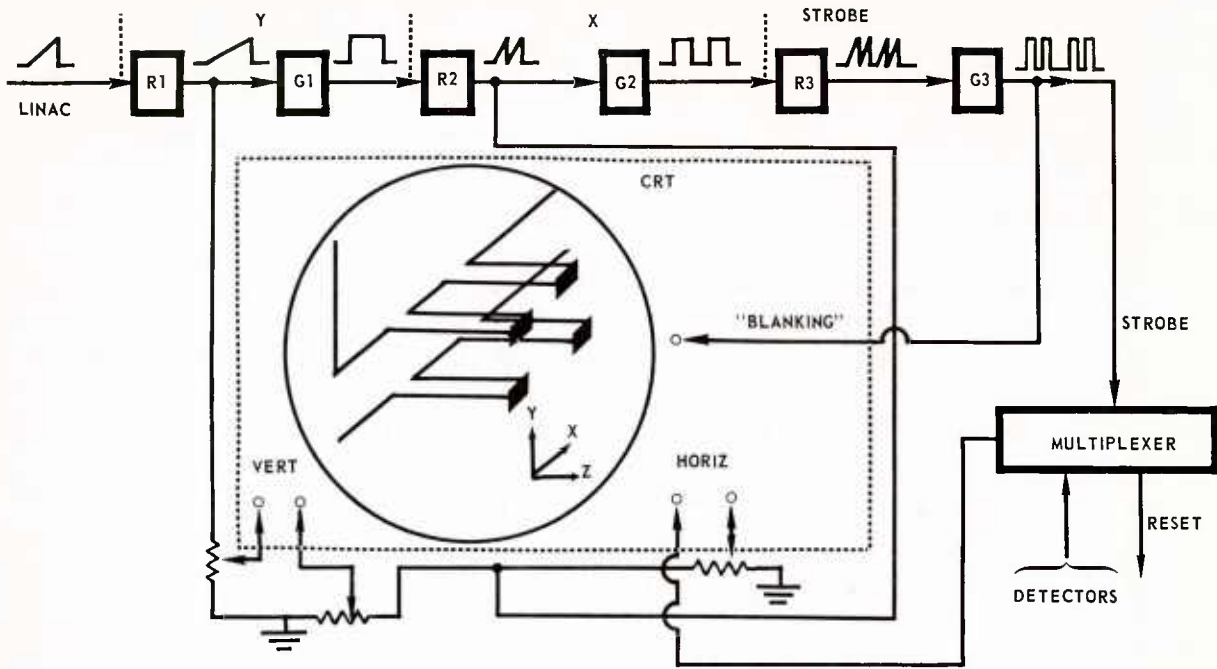

Figure 2. Elements of background and strobe generator and connections to multiplexer and CRT

multiplexer, which gates the detector voltages through in sequence. When the detector voltages are added to the CRT horizontal input, each detector causes a horizontal displacement from its base line proportional to the voltage level it generates. The G3 pulses can also increase the CRT intensity simultaneously with the detector signals. This is labeled "BLANKING" in Figure 2 and enhances the contrast between the detector signals and the base-line display. The amplitude of the G3 pulses and the CRT intensity control give both differential and threshold control for the CRT image. The width of the G3 strobe pulses can be narrow, so that the detector signals appear as points; or wide, so that nearly a histogram effect is achieved.

Also shown in Figure 2 are variable resistors on the CRT ramp inputs. These resistors, together with the normal CRT scale controls, provide any orientation of the

background image as seen from one octant. In the example shown, the view is from the negative X and positive Y and Z octant. By rearranging the CRT inputs, any octant view can be obtained. If the CRT horizontal scale is not changed, then the detector signals maintain a constant displacement from their base lines, and quantitative values can be obtained independently of the orientation.

Note that in three-dimensional CRT displays of sharply peaked distributions, the points in the rear tend to be masked by points in the front. In addition to changing the orientation of the display, this can be avoided by having different spacings between rows and columns in the display. This can be accomplished by independently varying the repetition rates of the R2 and R3 ramps or by use of the perspective and horizontal and vertical scale controls. Table I lists typical wave-form widths and repetition rates which will generate an 8 x 8 display grid at up to 60 Hz. Since the minimum R3 ramp width is about 0.1 msec with the Tektronix 160 series, higher display repetition rates effectively require the number of columns in the display grid to be reduced. The number of rows and columns can be independently controlled by varying the widths of G1 and G2, respectively.

Wave form	Width (msec)	Rate (Hz)	Mode
Ramp R1	16.7	60	Internal or external trigger
Gate G1	11	60	Triggered by R1
Ramp R2	1.6	480*	Gated by G1
Gate G2	1.1	480	Triggered by R2
Ramp R3	0.16	3840*	Gated by G2
Strobe G3	Variable	3840	Triggered by R3

Table I.
Typical Wave-Form Parameters
for an 8 x 8 Grid

* Approximately eight times preceding ramp repetition rate

Multiplexer. The multiplexer is composed of a shift register and pairs of MOSFET switches, as shown in Figure 3. The LINAC trigger resets the multiplexer by setting a "one" in the first position of the previously all zero shift register. Each G3 strobe pulse causes the "one" to move to the next position, leaving a "zero" behind. When a position has a "one", it turns on a MOSFET switch which gates through an individual detector voltage to the CRT while the strobe pulse is present. This allows variable width output, with constant strobe repetition rate, by varying the width of the

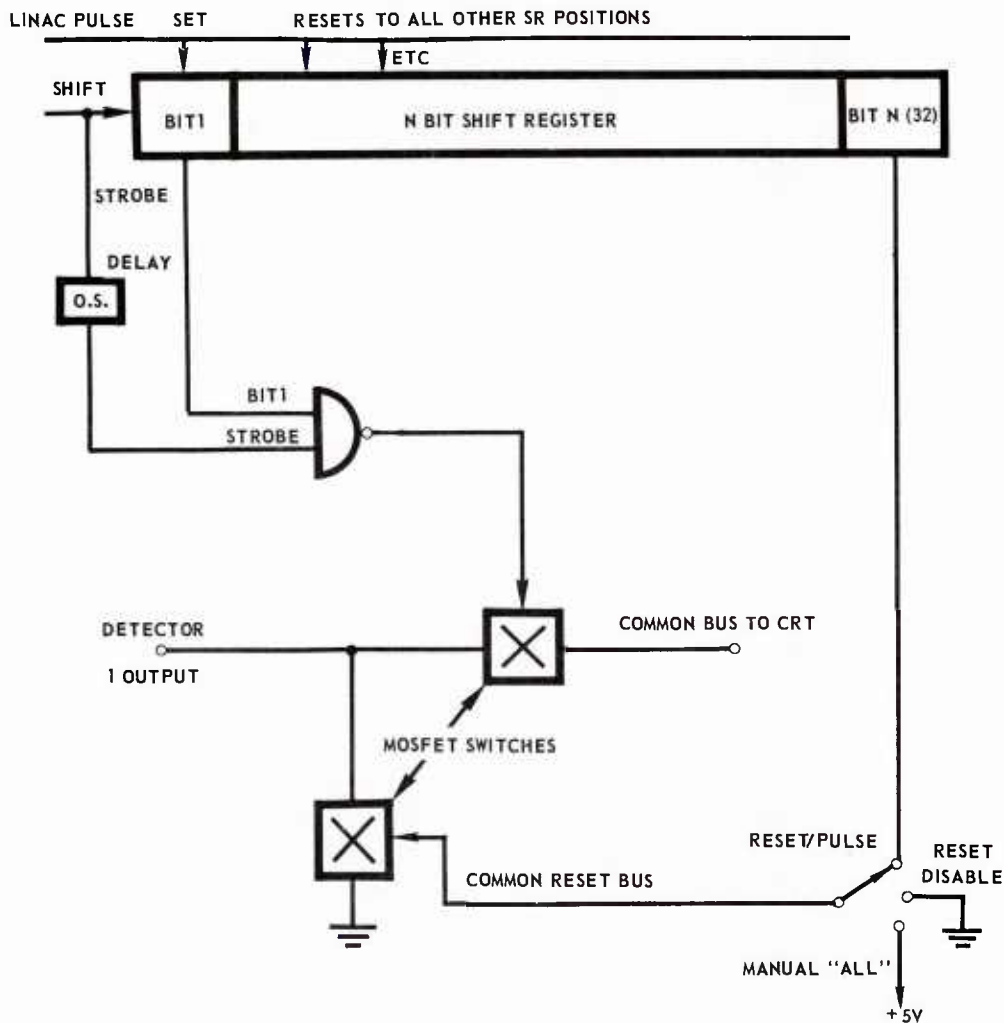

Figure 3. Multiplexer block diagram showing shift register and detail of multiplex and reset switches for channel 1

G3 strobe pulse. The output of the last position in the shift register is also used to trigger a reset circuit which sets the shift register back to zero and provides a logic level to reset the detectors. Each detector is reset by a second MOSFET switch which zeroes the collecting circuit. At present the reset is obtained from either the 32nd or 64th position of the shift register. More flexibility in grid design can be obtained by having the reset switch capable of selection from any position in the shift register.

III. PERFORMANCE

Results with simulated detector grid. To simulate a grid of detector signals, a 6 V battery was connected to a chain of variable resistors. Each detector input channel of the multiplexer was then connected to a certain position in the resistance chain to simulate a Gaussian intensity distribution at the grid. The last resistor before ground determined the width of the distribution.

In the prototype multiplexer there are 32 detector input channels, which can handle all but four detectors in a 6 x 6 grid. Figure 4, which is a Polaroid picture of the CRT, shows the 6 x 6 grid in three dimensions before the detector voltages are added. For a uniform field, as shown in Figure 5, all detector voltages are equally displaced to the right from their base lines. Note that the four detectors with no input channels remain in the base line. Figure 6 shows how a Gaussian distribution may be represented by the detector grid. The Gaussian distribution is evident along each row and along each column, with the horizontal displacement a quantitative measure of each detector response. Note also that the spacing between rows is about twice that between columns, which allows each detector voltage to be readily identified.

By routing the first ramp R1 to the horizontal input and the detector voltages to the vertical input, a sequence of profiles is obtained, as shown in Figure 7. As before,

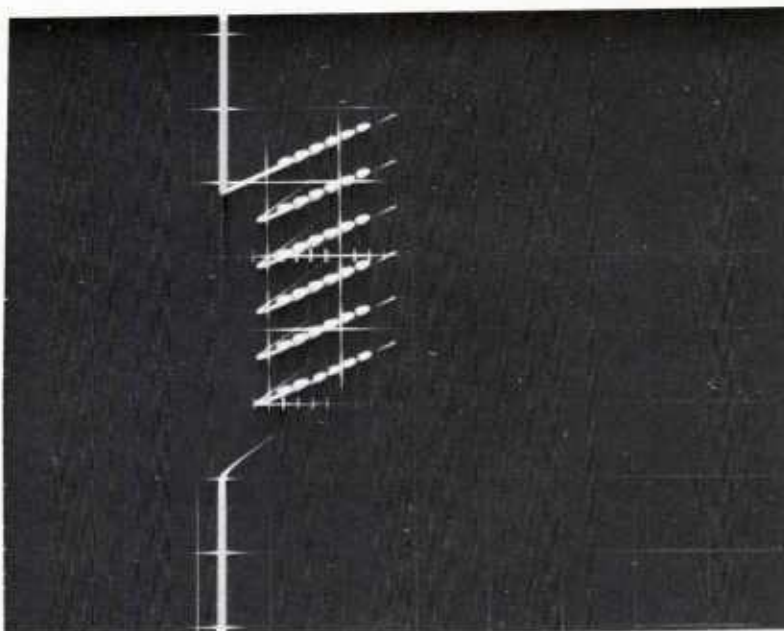

Figure 4. Three-dimensional 6 x 6 grid before detector signals are added. Display orientation is the same as in Figure 2.

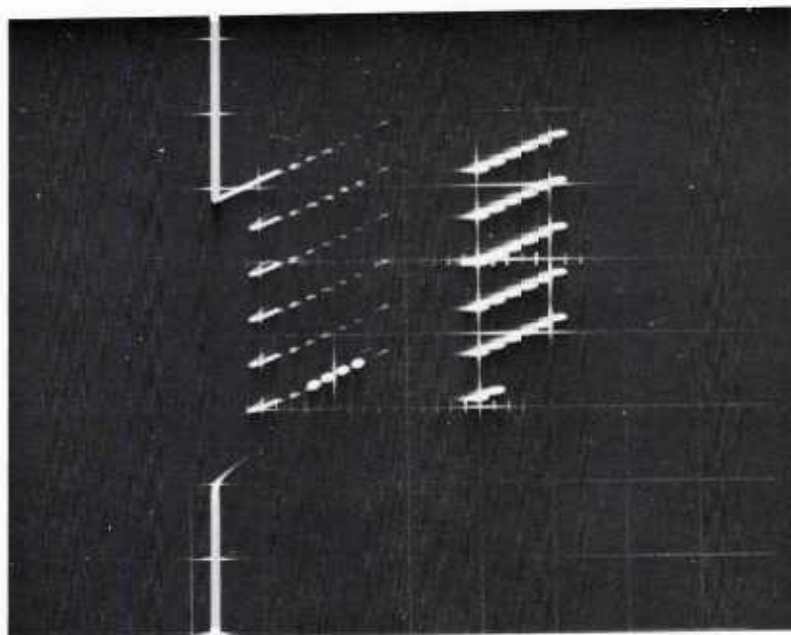

Figure 5. Three-dimensional 6 x 6 grid with 52 signals from a uniform radiation field. Display orientation is the same as in Figure 2.

a complete display is obtained for each LINAC trigger and the detector voltages are quantitatively preserved.

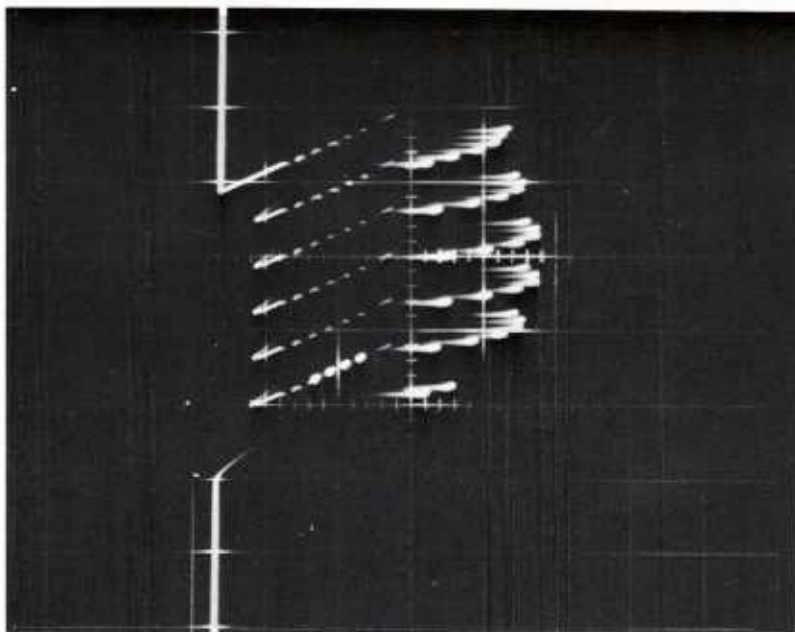

Figure 6. Three-dimensional 6 x 6 grid with 32 signals from a Gaussian intensity distribution. Display orientation is the same as in Figure 2.

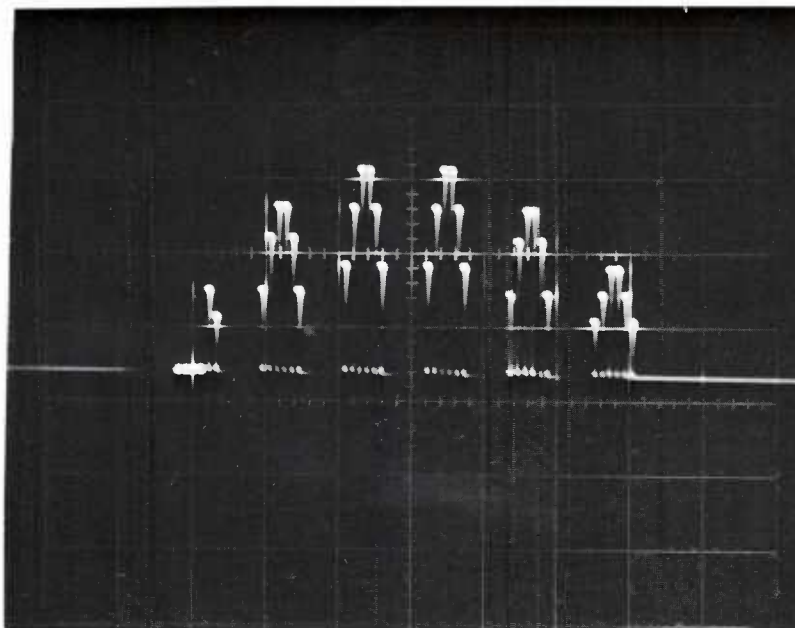

Figure 7. Two-dimensional sequence of profiles with 32 signals from a Gaussian intensity distribution

Results with radiation detectors. Unbiased diodes and ionization chambers were interfaced with the multiplexer and were tested as possible elements of a detector grid. Small capacitors were connected in parallel with each detector to collect radiation-induced charge. The detectors were irradiated at the AFRRI LINAC in an electron field of about 35 rads per 4- μ sec pulse at up to 60 pulses per second. Switching transients, due to capacitive coupling in the MOSFET switches, were large at the normal CRT input impedance. When this impedance was reduced, the transients were eliminated but the signal was also attenuated. A marginally acceptable displacement of the signal levels from their base lines was obtained by expanding the CRT vertical and horizontal scales and attenuating the ramp signals to the CRT (using the variable resistors shown in Figure 2). However, it was concluded that for low-level signals amplifiers are required between the detectors and the multiplexer. Amplifiers have been designed and preliminary tests have demonstrated their feasibility.

System costs. One of the main design objectives was to keep the cost of this display system low relative to methods using computers or memory devices. The power supplies, wave-form and pulse generators can be purchased new for about \$1800 and the CRT for about \$700.⁴ The 32-channel prototype multiplexer costs about \$500 for parts, with about \$250 required for each additional 32-input channel. Thus it is believed that this system provides the basis for a relatively inexpensive, versatile, real-time monitor for radiation fields.

IV. DISCUSSION

Ultimately, the choice of detector depends upon the application. Signal amplitudes, detector reliability and saturation characteristics, and field intensities must be

considered. It would be desirable for each detector to have its radiation sensitivity adjustable to a known value without being in a radiation field. This would allow the multiplexer to be near the detector grid and would avoid running separate cables for each detector from the exposure area to the readout area. The system could then be basically composed of two portable elements, i. e. , the detector grid-multiplexer unit and the strobe and base-line generator-CRT unit, with only three cables required to couple them (Figure 1).

Frequently it is desired to duplicate, up to a normalization factor, a previous radiation field. For uniform fields this is achieved when all the detector responses are the same; that is, when all detector voltages lie on a plane. If other fields are used, then a photograph of the CRT image can be taken when the detector voltage distribution is satisfactory. This provides a permanent quantitative record of the field, and later a negative of the photograph can be fastened over the CRT. The tuning objective is then to simply have the CRT image masked by the negative. Note that, even if the horizontal and vertical scale factors or the maximum field intensity are changed (i. e. , normalization), the relative distribution will be the same.

One feature of the system is that there can be fewer detectors than elements in the display grid. Elements with no detector input appear as detectors with zero voltages. So a few detectors can be positioned in the radiation field in a certain configuration and can be connected to the corresponding multiplexer inputs of a rectangular grid. By independently varying the number of rows and columns in the display grid, almost any configuration of detectors can be represented on the CRT. A new

configuration requires only that different detector channels be connected and that the number of rows and columns be adjusted.

An interesting application is that two-dimensional depth-dose distributions could be taken in real time. This requires only that the detectors be positioned so that rows correspond to displacements from the field center line and the columns correspond to depths. Of course, rows and columns can be interchanged. Since the number of rows and columns are independently variable, by varying the widths of G1 and G2 pulses, many different field shapes and depth-dose distributions could be monitored in this way.

REFERENCES

1. Hornstra, F., Jr. and Simanton, J. R. A simple, nondestructive profile monitor for external proton beams. Nucl. Instr. and Meth. 68:138-140, 1969.
2. Hornstra, F., Jr. and Simanton, J. R. A multichannel integrator and scanner for wire plane beam profile displays. Nucl. Instr. and Meth. 77:303-305, 1970.
3. Simanton, J. R., Marquardt, R. F. and Hornstra, F., Jr. A fast, wire-plane profile monitor for extracted proton beams. Nucl. Instr. and Meth. 68:209-212, 1969.
4. Tektronix, Inc. Catalog. Beaverton, Oregon, 1971.

UNCLASSIFIED

Security Classification

DOCUMENT CONTROL DATA - R & D

(Security classification of title, body of abstract and indexing annotation must be entered when the overall report is classified)

1. ORIGINATING ACTIVITY (Corporate author) Armed Forces Radiobiology Research Institute Defense Nuclear Agency Bethesda, Maryland 20014		2a. REPORT SECURITY CLASSIFICATION UNCLASSIFIED	
		2b. GROUP N/A	
3. REPORT TITLE REAL-TIME DISPLAY OF RADIATION FIELD INTENSITY DISTRIBUTION			
4. DESCRIPTIVE NOTES (Type of report and inclusive dates)			
5. AUTHOR(S) (First name, middle initial, last name) P. A. Berardo and J. A. Willis			
6. REPORT DATE August 1973		7a. TOTAL NO. OF PAGES 18	7b. NO. OF REFS 4
8a. CONTRACT OR GRANT NO.		9a. ORIGINATOR'S REPORT NUMBER(S) AFRRI TN73-10	
b. PROJECT NO. NWED QAXM		9b. OTHER REPORT NO(S) (Any other numbers that may be assigned this report)	
c. Task and Subtask C 908			
d. Work Unit 05			
10. DISTRIBUTION STATEMENT Approved for public release; distribution unlimited			
11. SUPPLEMENTARY NOTES		12. SPONSORING MILITARY ACTIVITY Director Defense Nuclear Agency Washington, D. C. 20305	
13. ABSTRACT A real-time display system has been designed and tested for use with a radiation field monitor. The system uses only pulse and wave-form generators, a multiplexer and an oscilloscope. The display consists of either a three-dimensional representation of the field intensity distribution or a series of simultaneous profiles.			