

AD-768 729

PROCEEDINGS OF SYMPOSIUM ON FLEXIBLE PACKAGING FOR  
HEAT-PROCESSED FOODS, HELD IN HOLIDAY INN, HILLSIDE, ILL.,  
ON NOVEMBER 9-10, 1972

ARMY NATICK LABS.

SEPTEMBER 1973

DISTRIBUTED BY:

**NTIS**

National Technical Information Service  
U. S. DEPARTMENT OF COMMERCE

Proceedings

SYMPOSIUM ON FLEXIBLE PACKAGING FOR HEAT-PROCESSED FOODS

November 9-10, 1972

Holiday Inn  
4400 Frontage Road  
Hillside, Illinois

*Sponsored by*

U.S. Army Natick Laboratories  
Natick, Massachusetts

Committee on Container Development  
Advisory Board on Military Personnel Supplies  
National Research Council  
National Academy of Sciences  
Washington, D.C.

September 1973

Reproduced by  
NATIONAL TECHNICAL  
INFORMATION SERVICE  
U S Department of Commerce  
Springfield VA 22151

NATIONAL ACADEMY OF SCIENCES - NATIONAL RESEARCH COUNCIL

Advisory Board on Military Personnel Supplies

*Chairman:*

William O. Baker, President  
Bell Telephone Laboratories, Inc.  
600 Mountain Avenue  
Murray Hill, New Jersey 07974

*Executive Director:*

Frank R. Fisher

Committee on Container Development

*Chairman:*

Hubert O. Ranger, President  
Consultants International, Ltd.  
1535 E. Goodrich Lane  
Milwaukee, Wisconsin 53217

Nelson Allen, Consultant  
509 St. George Drive  
Georgian Terrace  
Wilmington, Delaware 19809

W. Page Andrews  
General Director,  
Packaging Research  
Reynolds Metals Company  
10th and Byrd Streets  
Richmond, Virginia 23219

Frank C. Campins, Consultant  
36 Storer Avenue  
Pelham, New York 10803

R. Bruce Holmgren, Editor  
PACKAGE ENGINEERING  
5 South Wabash Avenue  
Chicago, Illinois 60603

R. Vernon Jones, President  
Phillips Scientific Corporation  
Sales Service Laboratory-PRC  
Bartlesville, Oklahoma 74004

## FOREWORD

As anyone who has served in combat knows, the present C ration has severe drawbacks -- the tin containers are unduly heavy, bulky, and awkward for an infantryman to carry; under adverse conditions, they are often difficult to open.

A flexible package has now been developed that promises to alleviate these difficulties and improve the combat soldier's fare as well. This symposium was arranged to discuss the development of that package in detail.

From the military viewpoint, flexible packages have several advantages over the old tin can. They are easier to carry in your pocket, lighter weight, and simple to open. But their attractiveness should not be evaluated only by military requirements; the packages also have civilian commercial potential because they maintain foodstuffs in high quality, enhance convenience in preparation, and provide good shelf life.

This symposium presents the current status and future prospects of a system for thermoprocessing foods in flexible packages. Pioneering this concept has meant establishing a total technology -- from testing of potential packaging films and specific food formulations to the final transition from concept to production line, demonstrating that reliable production is possible. Supporting technology, such as test procedures, in-process control systems, and quality-assurance techniques are included. Although all relevant aspects of this development will be discussed, emphasis in this symposium is on the determination of reliability under production conditions.

It was recognized at Natick Laboratories that the most propitious overall approach to a reliability program was establishment of the capability of a complete prototype production system. The requirements for establishing a reliability program were subsequently defined and the program was implemented through a contract to a consortium of five leading food, equipment, and packaging-film manufacturers. In this symposium, representatives of the individual firms will explain their roles and efforts in the program.

The Natick-industry team approach to solving flexible-packaging problems has been mutually beneficial. But it is important to add that the exchange of technology and cooperation among the multiple interests have also resulted



in a net effect greater than the sum of the participants' efforts: packaging technology, *per se*, has been significantly advanced.

We wish to thank the participants and their back-up performing personnel for their contributions, enthusiasm, and cooperation in making this symposium a complete, important, and successful event. We gratefully acknowledge the sponsorship and participation of the Advisory Board on Military Personnel Supplies, National Research Council.

Brig. Gen. John C. McWhorter, Jr.  
Commanding General  
U.S. Army Natick Laboratories

## C O N T E N T S

SESSION I: Background*Chairman:* Dale H. Sieling

Military Need . . . . .	1
Robert B. Dillaway	
Technical Effort . . . . .	5
Frank J. Rubinate	
Establishment of Reliability Program . . . . .	9
Rauno A. Lampi	

SESSION II: Reliability Program*Chairman:* Edward A. Nebesky

Organization of Contract Effort and Foods Development by Swift & Company . . . . .	15
Dean D. Duxbury	
Bakery Items in Flexible Packages . . . . .	29
Powell F. Sams	
Reliability of Packaging Materials and Closure . . . . .	39
Allan O. Corning	
Reliability of Package Forming and Filling . . . . .	49
William N. Miller	
Feasibility of Retorting Foods in Flexible Packages . . . . .	57
James H. Gee	
Test Procedures and Performance Values Required to Assure Reliability . . . . .	71
Gerald L. Schulz	
Summary of Reliability Contract Results . . . . .	83
Dean D. Duxbury	

APPENDIX (Attendance List) . . . . .	89
--------------------------------------	----

SESSION I

BACKGROUND

*Chairman,*

Dale H. Sieling  
Technical Director  
U.S. Army Natick Laboratories

## MILITARY NEED

Robert B. Dillaway  
Deputy for Laboratories  
U.S. Army Materiel Command

The modern military has provided our combat troops with highly sophisticated fighting equipment -- devices that can see the enemy in the dark, or hear the movement of troops, or pinpoint targets for missile fire.

But in one way, and a very important way to the combat soldier, our infantryman is no better off today than he was in World War II. His field ration -- called Meal, Combat, Individual -- does not differ substantially from the old C ration. Meat and other major components of his meal are still packaged in that 19th-Century container, the tin can. He deserves better.

The military's need for flexible packaging of thermoprocessed foods is the subject of this symposium. Flexible packaging is a part, but only a part, of the Army Materiel Command's concern for feeding combat soldiers. The U.S. Department of Defense Food Research, Development, Test, and Engineering Program at the Natick Laboratories has a comprehensive program to respond to military needs in all feeding situations -- from inflight and shipboard, to base and field dining halls, to foxholes. All aspects of feeding are covered: nutrition, acceptability, microbiology, chemistry, packaging, and preparation. Each military Service has a full-time representative at Natick Laboratories. A Joint Formulation Board, with each Service having voting power, establishes the need and priorities for specific tasks.

The point I emphasize is that we are serious about, have a mandate for, and are taking tangible steps toward improvement in the food and feeding of the combat soldier. As for the Army, two independent organizations are involved in this project. The Combat Development Command (CDC) has the responsibility of representing the combat soldier and, as such, establishes specific materiel requirements. In a manner of speaking, the CDC is the consumer. Army Materiel Command Laboratories -- specifically, the Packaging Division of Natick Laboratories -- have responsibility as the suppliers to respond innovatively to the CDC requirements and to do so using the latest technology.

In this instance, there were several potentially applicable, advanced technologies that could be brought to bear. They include: heat-sealable laminated packaging materials that are resistant to sterilization temperatures, heat-sealing techniques, testing and evaluation methodologies, and knowledge of the relationship between food quality and processing conditions. On this basis, the CDC established requirements that reflected the latest achievable technology.

#### DEFINING THE NEED

Once the basic requirements had been established, they were converted into specific guidelines for the developers. These guidelines translate the generalities into documents of detailed descriptions that governed the development of the package. The initial need for a new package for the Meal, Ready-to-Eat, Individual included the following: compatibility with clothing pockets, light weight, compactness, durability, flexibility, easy opening with the food acceptable hot or cold (and therefore requiring no preparation), and stable.

Collectively, the requirements pointed to replacing the metal can with a flexible, flatter package that would fit into field-clothing pockets. Although not always appropriate, the new package would be compared to the metal can in several aspects and criteria -- product quality and stability, package durability, and item compactness would have to be at least as good; weight, compatibility with clothing, and ease of opening would have to be better. The ready-to-eat requirement indicated the use of high-moisture foods and, in turn, demanded a revolutionary approach to thermoprocessed foods.

#### RESPONSE TO THE NEED

The response to these requirements is the subject of this symposium -- the flexible package for thermoprocessed foods. Figure 1 shows both the new Flex-Pack and the can it will replace. Engineering tests, performed early in the development cycle, established the acceptability of the flexible-package concept in both the functional and the organoleptic aspects. Beyond meeting the functional requirements, we found that product quality could be higher and the products could be in forms familiar to the consumer, such as full-size frankfurters and flat one-piece beefsteaks. Another factor was that there existed in industry the capability of producing packaging films, preparation equipment, flexible-packaged food items. It was recognized, however, that public health considerations dictated that care had to be taken in converting from laboratory to production-plant environment and that the conversion would be of significant magnitude. Nevertheless, establishing the production criteria for the Flex-Pack would not involve completely new or untested concepts; the conversion could be accomplished within the existing state of the art.

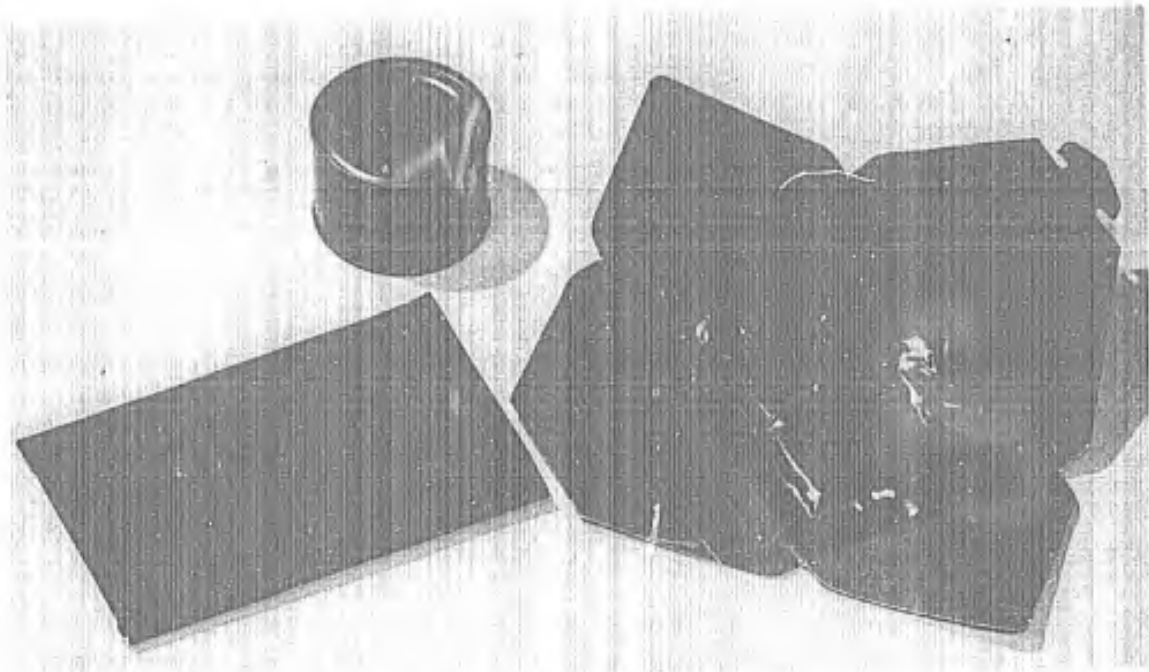

FIGURE 1 Flexible Package and Metal Can for Thermoprocessed Foods

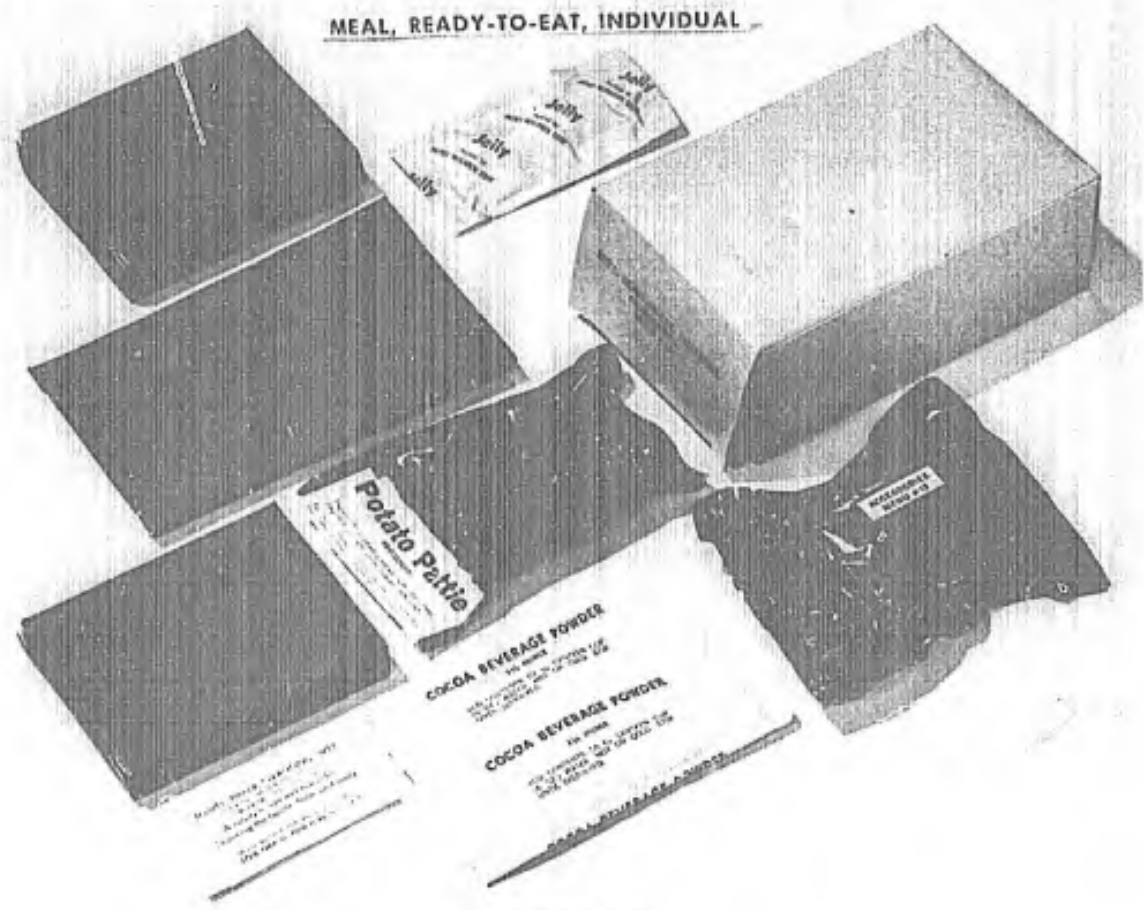

FIGURE 2

Repeatedly, the Joint Formulation Board governing this program has given the Flex-Pack development program a high priority, indicating recognition of its importance and high success potential beyond immediate Army interest. Further, the Panel has given highest priority to the development of second-generation flexible packages and products during the fiscal year 1974.

Figure 2 shows the flexibly packaged components of the new Meal, Ready-to-Eat, Individual. As a unit, these will become the standard operational ration. The military testing programs, which are required to substantiate the applicability and performance of Flex-Packs, have been carried out with several menu variations of this ration.

The properties and capabilities of the Flex-Pack include the following:

Military advantage. The package is light, compact, easy to carry, easy to open, and acceptable to troops in the field. The 4 1/2 inches x 7 inches in size fits into field jacket pockets. The softness of the package precludes any harm to the soldier on falling or crawling. (One unanticipated advantage is that the empty container does not become instant shrapnel should enemy shells hit disposal areas.)

Stability. The products are stable for at least 2 years at 72°F or 6 months at 100°F. Flavor evaluations are now being made after 8 years storage because the hedonic ratings have remained high.

Durability. The package is durable. Extensive transportation, field use, and laboratory abuse tests, some in direct comparison to cans, have proven the ruggedness of the item. Military performance requirements for durability are generally acknowledged to be more stringent than commercial standards.

Quality. The flat shape permits shorter thermoprocess times and, therefore, better product quality. Not only will the soldier in the field receive high-quality foods, but their use in dining halls when stocks are rotated should be more acceptable.

The intent of listing the above characteristics is not to detract from the following papers but to let you know that the Army knows the capabilities and advantages of the Flex-Pack and has definite plans to use it for our field rations. The soldier wants it; we want it.

To support this demand, however, we need a procurement base. This is where the food industry can help. It is our hope that this symposium will help to convince the industry to do so.



## TECHNICAL EFFORT

Frank J. Rubinate  
Chief, Packaging Division  
General Equipment & Packaging Laboratory  
U.S. Army Natick Laboratories

Dr. Dillaway has explained why the military has such a keen interest in flexible packaging. I will summarize the technical effort expended by Natick Laboratories up to the determination of the need for the contract effort that is the subject of this symposium.

When flexible packaging was first considered, it was felt that neither the packaging materials nor the laminating techniques available were adequate to meet the need. Therefore, initiation of the project was delayed until our review of the state of the art indicated a sufficiently high success potential.

Very early in our consideration of the new system a decision was made to use conventional steam- or water-cook retorts. Aseptic packaging was considered, but at that time very little heat-exchange equipment was available for anything other than liquids and semiliquids. Equipment and techniques were non-existent for sterilizing and subsequently handling film materials. (The Flash-18 process came along later.) Realizing that there were problems associated with packaging equipment, we chose not to add the additional problems associated with aseptic packaging. Steam- and water-cook retorts were the standard that was generally available in the plants of food processors.

## TECHNICAL REQUIREMENTS

In our study of the problems, we identified eight major technical requirements that the flexible package must meet. They are as follows:

- (1) It must be able to withstand exposure to 250°F in water or steam for approximately 30 minutes.
- (2) Its seals and bonding agents must be adequate to withstand fluctuations in pressure in the retort at 250°F.
- (3) The materials must meet or surpass U.S. Food and Drug Administration regulations.



(4) The sealed package must be resistant to bacterial penetration.

(5) The package, after retort processing, must preserve its contents at an acceptable level of quality for at least 6 months at 100°F and 2 years at 70°F.

(6) The package must fit into the pockets of the field clothing.

(7) It must be easy to open.

(8) It must withstand the hazards of shipment and handling in the military supply system without loss of integrity.

The first 2 years of the program were devoted to evaluating materials submitted by industry before a material suitable for processing at 250°F was found. The suitable material was a lamination of 3.0 mils vinyl, 0.35 mil aluminum foil, and 0.5 mil polyester with the vinyl surface in contact with the food. Later, the vinyl was replaced by a modified polyolefin or high-density polyethylene. More than 200 materials have now been evaluated for the program.

The earliest overall package design consisted of the pouch with a fiberboard backing on one side and the four seals protected by a fiberboard picture-frame arrangement on the other side. When we realized that the pouch required complete protection against mechanical damage, the present fiberboard folder package was designed. In evaluating its performance, it was found that bonding the pouch to the folder provided four times better performance than just placing the pouch in the folder.

#### EARLY TESTS

Having selected materials and a design that would perform in the retort and also provide mechanical strength, it was essential to determine whether the structure was resistant to penetration by bacteria. Studies were made under contract to determine the resistance to bacterial penetration of each component film as well as the complete lamination. They showed that each of the components (polyolefin, aluminum foil, and polyester) might be penetrated through pinholes inherent in the materials, but that the three films laminated together effectively overcame this weakness. No penetration of the composite structure was experienced except when deliberate mechanical damage caused a complete break through the three layers.

Further studies were conducted to determine type and amount of extractable substances that might migrate from the packaging material into the food during thermoprocessing. These tests showed that the materials were well within the safety limits established by the Food and Drug Administration.

Packages containing fruits, meats, and vegetables were stored for periods up to 1 year at 100°F and up to 2 years at 70°F. Examination of these indicated that both package and contents were acceptable over this period.

To determine the performance under simulated field conditions, packages were subjected to durability tests at Fort Lee, Virginia. The tests consisted of placing a number of packages in the pockets of troops who traversed an obstacle course as many as five times. The results of these tests indicated that the packages were satisfactory for field use.

An engineer-service test of the packages indicated a failure rate of 0.3 percent among 50,000 examined packages. Failures were primarily due to poor seals and punctures, which were production deficiencies caused by the lack of adequate equipment to form, fill, and seal the packages.

The results of this test required that concentrated effort be directed toward problems of sealing, leak detection, testing of seals, and determination of package reliability under production conditions.

Seal failures were caused primarily by food, oil, grease, and moisture being entrapped in the seal area and by wrinkles. Sealing through oil, grease, and moisture was solved at Natick Laboratories by use of a curved-jaw sealing bar and a silicone-rubber anvil system. A system to detect defects in the seals was developed. It consists of a scanning device that measures changes in infrared radiation along the seal produced by changes in the seal structure. Single pineapple fibers, a single sugar crystal, and voids in the seal, for example, are easily detected by infrared. A prototype scanner with an automatic rejection system for on-line examination of closure seals is available.

The remaining problem was to determine the reliability of the flexible package under production conditions. This symposium is devoted to our efforts to solve this problem.

## ESTABLISHMENT OF RELIABILITY PROGRAM

Rauno A. Lampi  
Chief, Systems Development Branch  
Packaging Division  
General Equipment & Packaging Laboratory  
U.S. Army Natick Laboratories

After the engineer-service test, a single problem remained. The flexible packages containing the developmental ration had failed at a rate of 0.3 percent at the point of issue. This finding was based on an inspection of more than 53,000 packages. The fail rate included, as a safety precaution, many packages only superficially suspect; the rate was judged to be too high even though, in itself, it was low. Analysis of the defects revealed that inadequate filling and sealing techniques and poor in-plant handling were the causes. Seals were contaminated, irregular, and wrinkled. Pouch body cuts were found beneath unmarked areas of the overwrap folder. None of the defects or package failures, however, could be definitely attributed to lack of inherent package durability.

We decided that rather than attack the filling, sealing, and handling problems individually, the most propitious overall approach would be to establish a prototype production system that could reliably manufacture the heat-processed foods in flexible packages. This approach, in essence, recognized that the many production-line functions were interrelated and interdependent. Beyond the immediate objective, establishment and use of such a line would yield much valuable data on which to base firm yet realistic procurement documents. This symposium will describe the program and its current status and results.

## OBJECTIVES AND GUIDELINES

The program was established with the following objectives and guidelines:

Reliability. The reliability goal was the first and most difficult requirement to establish. The metal can was used as the criterion and it is a good one. The problem, however, was in assigning to any point in production, warehousing, or distribution, numbers that would reflect the tremendous safety record the metal can has at the consumer level. A. M. Weinberg, Director of Oak Ridge National Laboratory, has

**Preceding page blank**

coined the term "trans-science" for such problems. It applies to problems between science and politics where questions can be stated in scientific terms but that are, in principle, beyond the proficiency of science to answer. While Weinberg's example related to the biological effect on humans of very low-level radiation never being unequivocally ascertained because of the huge number of animals required, it also applies to the thermoprocessed-food chain. True definition and simulation of the chain is impossible because of the numbers required. Therefore, tempering scientific knowledge with experience and judgment, a reliability goal of no more than .01 percent (1 in 10,000) defective packages was set. Reliability was defined as the ability of the production line to yield defect-free packages (prior to warehousing) when established process-control and quality-assurance procedures were followed. It is important to note that the .01 percent is a goal and not an absolute requirement.

Equipment. Selection, innovation, and modification of equipment and components would be necessary to achieve the desired reliability. Emphasis would be on filling, sealing, and handling and could encompass totally new developments.

Diverse foods. To meet military ration requirements, the system had to be proven for 17 diverse foods ranging from cake to beef stew. It was assumed that all 17 could constitute separate filling problems.

Pilot production. In view of the low-failure-rate goal, significant numbers of packages would have to be produced for evaluation. Fifty thousand packages of each item would be required; they would be 100 percent inspected for defects.

Production rate. A minimum production rate of 30 packages per minute was specified; higher rates would be acceptable only if there was no increase in rate of package failures.

Inspection. Although not essential at the developmental stage, it was preferred that the production line be suitable for operation in a U.S. Department of Agriculture sanctioned and inspected processing plant.

Retorting. Standard commercial retorting processes were to be used because the prime objective did not include innovative retort design or development other than modifications to assure uniform and adequate sterility.

## CONSORTIUM

The complex program was implemented by a contract to a consortium of food processing engineering companies headed by Swift & Company and including Pillsbury, Continental Can,

Rexham (Bartelt), and FMC. Although there may be a precedent, this team is rare in that a packer, package supplier, and equipment manufacturer had to work closely together throughout the entire project. This requirement has revealed subtle and some not-so-subtle relationships among food, package, and machinery and has contributed significantly to the technology. In addition to the hardware development, the program involved establishing test procedures, sampling plans, and quality assurance techniques.

The technical effort was divided into two phases. Phase I encompassed paper, laboratory, and bench-model evaluations and analyses to determine whether the actual engineering, fabrication, and use of a production line would be feasible and, if so, to establish the technical and conceptual basis for the second phase. Phase I was completed in mid-1970 with the recommendation to proceed to Phase II.

Beyond the simple conclusion that production-line reliability was feasible, Phase I also established that four fillers and four nozzles, in various combinations, could handle all 17 food items under investigation. This permitted a reduction in the scope of Phase II without any adverse effect on attainment of the objective. Six products were selected for the production runs. They were chosen to represent various particle size and rheological property classes and to test the specified filler-nozzle combinations. All other equipment and performance requirements were specified.

The presentations to follow by the contract participants will cover the organization of the work, details of development effort, and the results to date.

S E S S I O N I I

RELIABILITY PROGRAM

*Chairman,*

Edward A. Nebesky

Director

General Equipment & Packaging Laboratory  
U.S. Army Natick Laboratories

ORGANIZATION OF CONTRACT EFFORT  
AND  
FOODS DEVELOPMENT BY SWIFT & COMPANY

Dean D. Duxbury  
Manager, Grocery Products Research  
Research and Development Center  
Swift & Company

Now that the extensive background of this contract has been outlined for you, let me attempt to detail the organization required with so many participating companies and the role that Swift & Company played. Although as overall Program Manager I cannot take credit for originating or planning some of the details of this project, I have the privilege of representing all five companies in the implementation and administration of the program. Therefore, when I speak now of the duties and activities, I emphasize the success of a team effort that has been prevalent throughout the contract effort.

ORGANIZATION OF EFFORT

As already indicated, the team consisted of a multicompany organization that was assembled to conduct the final program approved by U.S. Army Natick Laboratories. Figure 1 shows the organization chart of participants.

At the top of the chart, Swift & Company has responsibility as the prime contractor. This responsibility included overall coordination and legal responsibility of total accomplishment. The Pillsbury Company and Continental Can Company have first-tier sub-contractor status under Swift. Further, Continental Can coordinates the activities of second-tier sub-contractors, Rexham Corporation and FMC.

The organization of such a multicompany, varied commercial-interest group -- with each participant having his own company organization and protocol requirements -- was accomplished through a teamwork effort of Project Leaders and their technical teams or task leaders. The organization chart also represents a "chain of command" for protocol, legal requirements, and assignment of responsibility. All verbal and written reports, accounting records, contract and patent matters, and inventory-control records were handled through coordination of the Project Leaders and then submitted to U.S.

**Preceding page blank**

ORGANIZATION CHART

U.S. Army Natick Laboratories Contract No. DAAG 17-69-C-0160  
"Reliability of Flexible Packaging for Thermoprocessed Foods under Production Conditions—Phase I:  
Feasibility & Phase II"

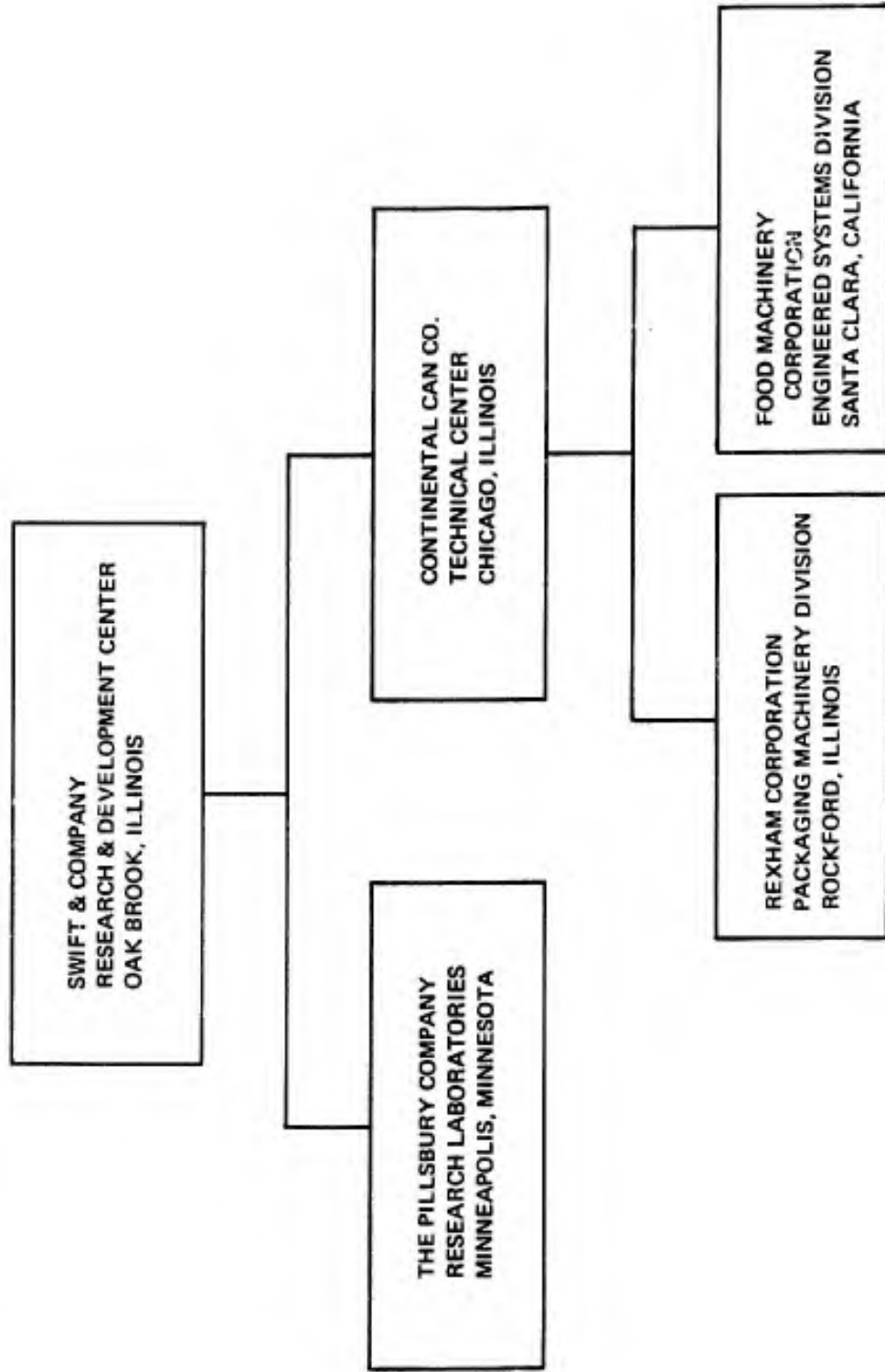

FIGURE I



Army Natick Laboratories either through the Program Manager to the Technical Project Officer or through the Swift Contract Coordinator to the Natick Contract Officer. Written technical status reports were submitted after each six-month period and a final report for publication was, or will be, prepared at the end of each phase. These reports included all test data, comments, conclusions, blueprints, and photographs of all equipment and production processing operations.

Figure 2 indicates that besides coordination of the overall program, Swift was also responsible for formulating non-bakery (primarily meat-containing) food items, and for coordination and conduct of the Phase II volume production of packaged foods. Selection of Swift & Company for this position provided a research pilot plant with available U.S. Department of Agriculture (Animal and Plant Health Inspection Service) meat-inspection supervision.

The food-development facilities, staff, and experience of both Swift and The Pillsbury Company, in their respective product assignments, were considered necessary for providing high-quality foods in the new container and for applying the potential commercially feasible packaging techniques. Figure 3 shows that Pillsbury had responsibility for development and product supervision of the bakery items.

In Figure 4, Continental Can Company's participation is shown. The extensive Technical Center facilities and staff of Continental Can Company had the capability of providing packaging materials, equipment design, and expertise in quality control, statistical programming, and thermoprocessing. Continental also coordinated design, construction, and testing activities for equipment developed by their sub-contractors, Rexham Corporation and FMC. More specifically, Continental had responsibility for supplying and assuring quality of the packaging laminate and for development and evaluation of all equipment; including the pouch transfer mechanism, the vacuum-top sealer, pouch carriers, racks, retort cars, and package dryer. Continental's responsibility also included design and conduct of pre-production-acceptance testing, data evaluation of the total equipment line and food-production process, the in-process evaluation, and in-line quality-control procedures. Determining package reliability remains their priority assignment.

As shown in Figure 5, Rexham had not only to design, build, and qualify a form-fill unit for foods in flexible packages, but also had to determine how to fill packages with 17 different foods without seal contamination. They determined that this could be done with four fillers and four different filler nozzles.

Swift and Company  
Research and Development Center  
Oak Brook, Illinois

Program Manager: Dean D. Duxbury

Project Leader: Donald L. Davies

Collaborators

Robert L. Pavey  
James N. Knapp

Stanley D. Gershenson  
Patrick E. Mone

PHASE I:

TASK A: Food Preparation and Processing Concepts -- Products 1-12 (non-bakery)

PHASE II:

TASK A: Food Preparation and Processing Concepts -- Products 3, 4, 8, 9, and 12  
(non-bakery)

Food Preparation and Processing Concepts Finalization  
Preparation for Installation of Packaging and Processing System

TASK I: Food Processing and Manufacture Meat Products

FIGURE 2 Organization and Responsibility

The Pillsbury Company  
Research Laboratories  
Minneapolis, Minnesota

Project Leader: Powell F. Sams

Collaborators: Donald A. Beadell  
Morris H. Katz  
Duane M. Riley

PHASE I:

TASK B: Food Preparation and Processing Concepts -- Products 13-17 (bakery)

PHASE II:

TASK B: Food Preparation and Processing Concepts  
Food Preparation and Processing Concepts Finalization  
Design (Cake) Process System  
Control System Liaison

TASK J: Food Processing and Manufacture Bakery Products

FIGURE 3 Organization and Responsibility

Continental Can Company  
 Technical Center  
 Chicago, Illinois

Project Leader: John L. Maloney

Task Leaders: Florren E. Long (C) Allan O. Corning (H)  
 John L. Maloney (D,E,F,G) Robert E. Henry (K)

Collaborators: Eugene Dewey  
 Rudy Stefaniak

<u>PHASE</u>	<u>TASK</u>
I&II	C
I	D
I	E
II	F
II	G
I&II	H
I&II	K

Total Packaging and Processing System Specifications and Performance  
 Technical Feasibility of Packaging System  
 Technical Feasibility of Processing System  
 Engineering and Building Packaging System  
 Engineering and Building Processing System  
 System Component and Installation Acceptance Testing  
 Packaging, Processing, and Food Quality Assurance

FIGURE 4 Organization and Responsibility

Rexham Corporation  
Packaging Machinery Division  
Rockford, Illinois

Project Leader: William N. Miller  
Collaborators: Allen B. Canfield      Larry Ferraro  
                  Donald R. Dobbelaire     Leroy Krum

PHASE I:

TASK DD: Technical Feasibility of Filling and Package Forming System

PHASE II:

TASK FF: Product Filling and Package Forming  
          Package Forming  
          Pumpable Product Filler -- Placeable Product Filler  
          Extrudable Product Filler -- Bakery Product Filler  
          Integration of Filling and Package Forming  
          Installation of Filling and Package Forming  
          Acceptance Testing  
          Production Packaging

FIGURE 5 Organization and Responsibility

Food Machinery Corporation  
Engineered Systems Division  
Santa Clara, California

Project Leader: James H. Gee

PHASE I:

TASK EE: Technical Feasibility of Retorting

PHASE II:

TASK GG: Engineering and Building Retort and Auxilliary Equipment  
Purchase and Install Retort and Auxilliary Equipment  
Acceptance Testing

FIGURE 6 Organization and Responsibility

The FMC, as shown in Figure 6, was required to provide production-size automated retorts with programmed controls that could handle all products regardless of the specific cooking necessary.

The effectiveness of the coordinated team effort resulted from regular status or progress meetings of all project leaders and their key subordinates. The meetings were particularly necessary in the Phase I feasibility study and early in Phase II during equipment construction, assembly, and pre-testing at the individual participants' manufacturing locations which were scattered throughout the United States. Detailed verbal reports reviewed all progress and many current and future problems were resolved in the meetings.

In Phase II, coordination continued with project technical personnel and field servicemen during assembly, testing, and operation at Swift & Company's Research and Development Center in Oak Brook, Illinois.

An extensive installation effort was required to set up the production line at Swift's facility and Swift's technical and utility personnel assisted sub-contractors in installation and "start-up." Installation of the several large pieces of equipment required professional movers, enlargement of doors, relocation of normal research pilot-plant equipment, and the usual utility hook-ups.

Extensive pre-production testing with flexible packaging materials, equipment, and food-handling concepts was conducted at the Swift facility. Also, the availability of necessary participating equipment servicemen from outside Swift and daily scheduling of manpower from Swift (not to mention ingredients) for the production line on a flexible and part-time basis required considerable organization.

#### FOODS DEVELOPMENT BY SWIFT

Let us now review the specific technical problems encountered in Swift's assignments. Although I shall try to confine my comments to the specific assignments to Swift, and let you hear from other speakers regarding other companies, there may be some overlap.

Of the original 17 food items, 12 are non-bakery foods and their development was the responsibility of Swift & Company. They included two non-meat items, crushed pineapple in syrup, and beans in tomato sauce. The others contain meat; they are beef loaf, beefsteak, beef stew, sliced beef in barbeque sauce, chicken a la king, chicken loaf, frankfurters, ham and chicken loaf, ground beef with pickle-flavored sauce (or "Sloppy Joe"), and pork sausage.

These 12 items, plus the five bakery items assigned to Pillsbury, were selected primarily because they were considered representative of all the different classes or types of food items in the field-ration menu. But not only were they in the menu, they also represented food types that most challenged food-handling and packaging systems.

The bakery doughs and meat loaves were proposed to be handled as extruded items; the beef steaks, frankfurters, and pork sausage were pre-formed and pre-cooked solid items proposed for manual placement in the pouch; the pineapple, Sloppy Joe, and chicken a la king were proposed to be pumped into the pouches, and the beef stew and beef slices with barbeque sauce were proposed as combination items requiring both a solid fill and a pump fill. This range of foods was not only a formulation challenge but also a handling and equipment problem, since all operations had to be handled on a single food-processed line and placed in a single-size package. Swift formulation planning had to consider the potential equipment that would be supplied later.

There were other criteria also requiring attention in initial product-formulation tests. The government initially provided tentative bench-model formulas and product specifications for each food item, and these served as the basis for our formulation and acceptance tests. Product samples of each item were prepared as suggested and modified where required. These formulas and samples were then reviewed by a staff of food technologists with experience in canned-food formulation, handling, and processing. They considered government ingredient approval, usage levels, and labeling; economics of the formulation; application of canned-food processing arts; substitution of ingredients so that commercially proven thickeners and flavorings that are more available or yield improved results could be used; and ingredients and handling techniques that could be used in the pilot-plant equipment as well as in commercial production facilities. All new formulations had to meet the original criteria; including government approval, package size, quality acceptance by Natick Laboratories, and satisfactory processing by the equipment without contaminating package seals.

Quality acceptance was based on constant sample evaluation by the Packaging Division at Natick and followed by testing by sensory-evaluation panels conducted at Swift. The sensory technique used 10 male panel participants judging for overall acceptance on a 1 to 9 hedonic scale; a rating of 1 was considered unacceptable and a rating of 9 most acceptable. In all cases, it was established that 6 out of 10 panelists must score a formulation 6.0 or better for the formulation to be acceptable. In almost all food items tested, the average score was approximately 7.5. These scores, regardless of their



actual numerical rating, were established only on samples that had received Natick acceptance; they then became the goal for further sensory evaluations conducted during the production phase. Later, when 50,000 packages of each of the six selected food items were manufactured in Phase II, similar tests by taste panels were, and are, conducted at Swift using randomly selected samples from each lot. The panel tests are held the day after the production day for each lot as a quality check on consistency in production. Panelists not only score on general acceptance, but also indicate specific comments relating to flavor, texture, and appearance. (A briefing was required to train consumer-oriented panelists to evaluate certain foods for military rations. Reasonable and honest acceptance scores were only possible if the consumer-oriented panelist was aware that these were shelf-stable packaged field rations for soldiers.)

Another serious consideration in product formulation was microbiological safety. Heat-Processing studies were required to determine a safe "commercially sterile" cook process and to evaluate any product-quality problem related to the retort-cooking process. For the latter, the advantages of reduced-heat processes, required for the relatively thin flexible package, made this problem minor as compared to problems encountered with cans of the same capacity. Preliminary heat-penetration studies were made in pilot-plant retorts at Swift during Phase I to determine equipment needs and product quality, next on small numbers of samples in the FMC production-line retorts installed during Phase II, and finally, on the first full-retort production lot. Consultation between thermoprocessing technologists from Natick Laboratories, Continental Can Company Technical Center, and Swift R&D Center agreed on a sterility value (or  $F_0$ ) of 8.0 for all meat products. The pineapple product required only pasteurization to achieve shelf stability due to a pH of less than 4.5 in the finished product. End-product microbiological safety was also ensured through the 100 percent product incubation for 14 days at  $100^{\circ} \pm 2^{\circ}F$ , followed by 100 percent visual inspection for package integrity and bacteriological analysis of representative packages from each retorted lot. It was desirable to determine the reliability of the package because future commercial production will require only representative sampling and incubation or analysis from each lot.

Our program also required Swift to prepare large quantities of the developmental food products for shipment to Rexham Corporation in Phase I and early Phase II for filler-equipment testing. Similarly, some quantities of food samples were supplied to Continental Can Company for handling, pouch vacuumization, and top-sealing tests. These evaluations were important also in determining the final food formulas and handling specifications. For example, the optimum product temperature at time of fill was found to be ambient temperature (approximately

70°F) for all items except beef steaks and frankfurters, which were restricted to a "tempered from frozen" temperature (approximately 40°F).

#### PRODUCT FORMULATION CHANGES

In beans in tomato sauce, the emulsifier specified was deleted since it was found unnecessary. Black pepper was added to improve flavor. Presoaking the beans was increased from 80 to 100 percent water pickup to improve texture of the beans and consistency of the sauce.

In the beef loaf, the amount of beef used was reduced from 80 to 74.2 percent, beef juices were added at 10 percent, and cracker meal was reduced from 10 to 5 percent to improve texture. The addition of beef juices as well as of .5 percent salt, .2 percent hydrolyzed vegetable protein, and .1 percent white pepper improved the flavor.

Frankfurters were reduced in diameter to permit four franks per pouch; they were also increased in density by application of leaner meat formulas.

For pineapple in syrup, crushed pineapple canned in heavy syrup was used rather than the specified fresh-frozen pineapple due to an objectionable flavor in the finished product when frozen pineapple was used. Initially, the juice from the canned pineapple was used in preparation of the specified 70° Brix syrup for this project, but subsequently, it was found possible to purchase the raw material directly with the desired 30° Brix. This resulted in handling and cost savings.

In the beef steaks, beef slices (for the beef slices in barbeque sauce), and the ground beef with pickle-flavored sauce, "Economy" grade beef was substituted for the "Good" grade specified, based on better acceptance of lesser grades with a retort process.

From the considerations, tests, and formula changes just discussed, final "Commercial Production Guidelines" were prepared and accepted for the Phase II production of 50,000 samples of each of six food items, including four meat items -- beef steaks, beef stew, frankfurters, and ham and chicken loaf -- and for the crushed pineapple. These guidelines covered food formulas, handling, fill weight, and cooking process.

#### USDA APPROVAL

Once the final food formulations were accepted, we sought U.S. Department of Agriculture meat-inspection approval for

actual numerical rating, were established only on samples that had received Natick acceptance; they then became the goal for further sensory evaluations conducted during the production phase. Later, when 50,000 packages of each of the six selected food items were manufactured in Phase II, similar tests by taste panels were, and are, conducted at Swift using randomly selected samples from each lot. The panel tests are held the day after the production day for each lot as a quality check on consistency in production. Panelists not only score on general acceptance, but also indicate specific comments relating to flavor, texture, and appearance. (A briefing was required to train consumer-oriented panelists to evaluate certain foods for military rations. Reasonable and honest acceptance scores were only possible if the consumer-oriented panelist was aware that these were shelf-stable packaged field rations for soldiers.)

Another serious consideration in product formulation was microbiological safety. Heat-Processing studies were required to determine a safe "commercially sterile" cook process and to evaluate any product-quality problem related to the retort-cooking process. For the latter, the advantages of reduced-heat processes, required for the relatively thin flexible package, made this problem minor as compared to problems encountered with cans of the same capacity. Preliminary heat-penetration studies were made in pilot-plant retorts at Swift during Phase I to determine equipment needs and product quality, next on small numbers of samples in the FMC production-line retorts installed during Phase II, and finally, on the first full-retort production lot. Consultation between thermoprocessing technologists from Natick Laboratories, Continental Can Company Technical Center, and Swift R&D Center agreed on a sterility value (or  $F_0$ ) of 8.0 for all meat products. The pineapple product required only pasteurization to achieve shelf stability due to a pH of less than 4.5 in the finished product. End-product microbiological safety was also ensured through the 100 percent product incubation for 14 days at  $100^{\circ}\pm 2^{\circ}\text{F}$ , followed by 100 percent visual inspection for package integrity and bacteriological analysis of representative packages from each retorted lot. It was desirable to determine the reliability of the package because future commercial production will require only representative sampling and incubation or analysis from each lot.

Our program also required Swift to prepare large quantities of the developmental food products for shipment to Rexham Corporation in Phase I and early Phase II for filler-equipment testing. Similarly, some quantities of food samples were supplied to Continental Can Company for handling, pouch vacuumization, and top-sealing tests. These evaluations were important also in determining the final food formulas and handling specifications. For example, the optimum product temperature at time of fill was found to be ambient temperature (approximately

our equipment and for packing test lots at Swift's facility. Although the program was a military research contract and no food was produced for distribution in commercial channels, either for test or sale, the project intended to conduct all meat-product handling under government supervision.

Four different branches of the Animal and Plant Health Inspection Service of the U.S. Department of Agriculture were consulted. The Bartelt pouch former-filler units and the Continental vacuum top-seal unit were all designed and constructed to comply with standards of construction as reviewed by the Equipment Division. This included submission of a written operational description. Swift applied for a meat food-plant installation and usage approval for the equipment through the Field Operations Division. The previous approvals of the packaging materials granted by FDA were reviewed by the Laboratory Services Division. And lastly, properly identified labels, including product name, ingredient phrases, manufacturer identity, weight marking, and government meat-inspection identity seal were submitted for approval before shipping the products to Natick Laboratories for subsequent usage test. All these approvals have been granted on a temporary basis for military research only, but it is hoped that the mutual assistance and information relating to future commercial application will be beneficial to the U.S. Department of Agriculture, the military, and commercial interests.

## CONCLUSION

The current activity by Swift involves the coordination and conduct of the Phase II production program. We are presently in the middle of manufacturing 50,000 packages of the third food item. I have already mentioned the problems of coordinating production schedules, but further effort is required to schedule a daily specialized work force on a semi-automated simulated production line under research conditions. Our staff is divided into product preparation, process line, retort operation, finished-product inspection and handling, quality control, and administrative personnel. People are assigned according to qualification, ability, and availability, and have been trained for several different duties.

Figure 7 shows the overall schematic production layout.

I am sure you have many questions remaining, but I trust they will be answered either in the next presentations, later today in our question-and-answer panel discussion, or tomorrow when you visit the Swift facilities and see the equipment.



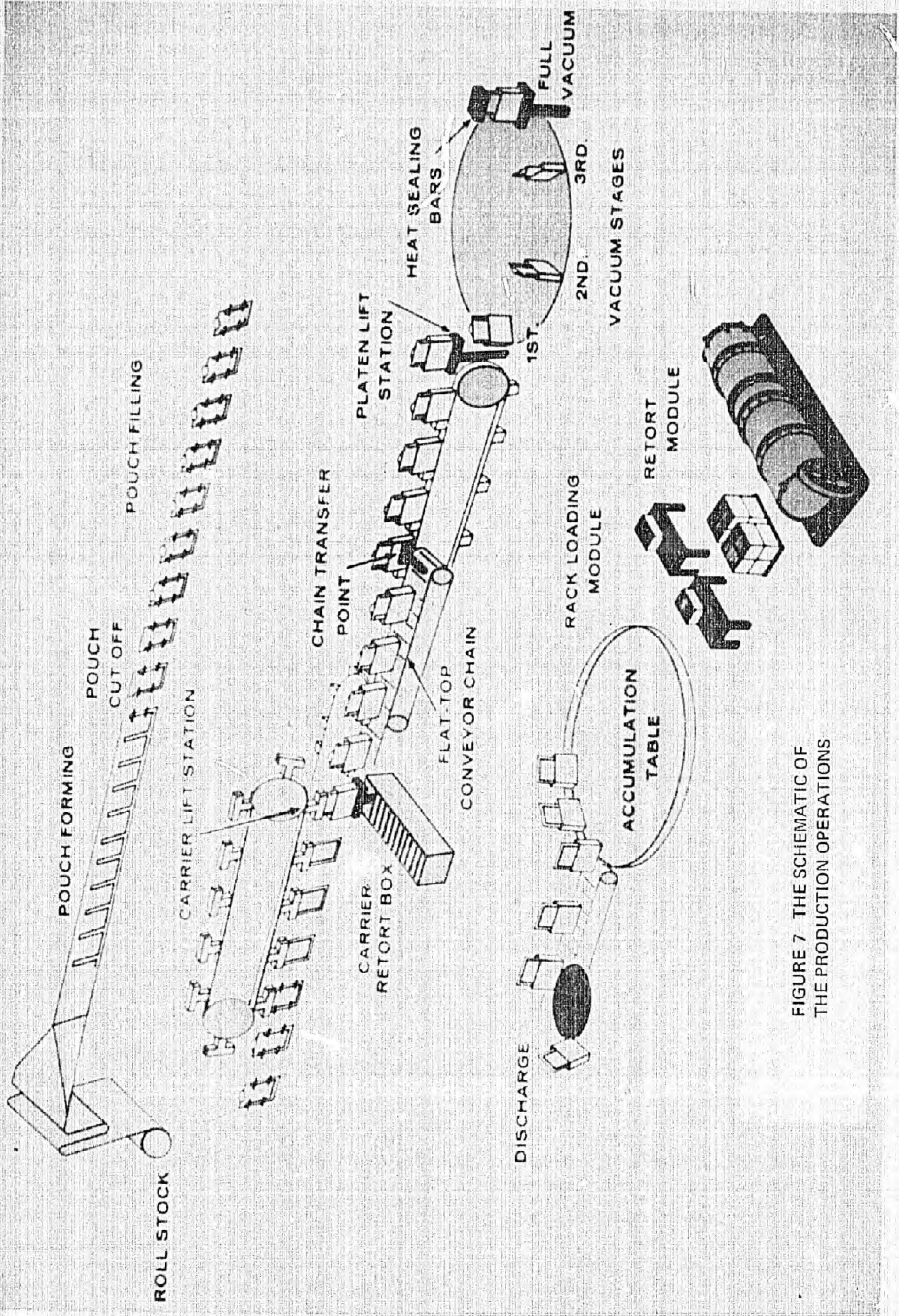

FIGURE 7 THE SCHEMATIC OF THE PRODUCTION OPERATIONS

## BAKERY ITEMS IN FLEXIBLE PACKAGES

Powell F. Sams  
Manager, Advanced Foods and Support Systems  
Research Laboratories  
The Pillsbury Company

Potential processors of bakery products should be interested in knowing why these products are marketable and in the problems encountered in manufacturing them. Rather than give you a chronology of the research and development of the formulas and processing criteria for bakery products, I will try to answer the questions of marketability and manufacturing problems.

## MARKETABILITY

The question here is: Why put bakery products in flexible pouches? In answering this question, I propose that the military reasons are closely related to those of manufacturers who supply the consumer market and that there is a consumer market for products like these that are safe, nutritious, and high in quality. To begin with, I make three assumptions that represent what food manufacturers want for their consumers and discuss each briefly.

Food safety. It is reasonable to assume that food manufacturers want to market only those products that are safe. Current consumer awareness makes this the dominant issue that will face food processors during the next decade. Food safety is directly affected by the reliability of the product, the package, the processing equipment, and the thermal process. For bakery products, the safety issue is different than for other foods in the program. It differs because the water activity of these products after thermal processing is .75 or lower and, at this level, pathogenic bacteria will not grow. If the package becomes punctured after thermal processing, however, the consumer will reject it because the product will become hard and dry in about 2 weeks. Food safety is certainly achievable and is a market-related reason to pack bakery products in flexible packages.

Product quality. It is safe to assume that food processors want to attain product-quality levels as high as possible within the parameters of food safety. From a quality standpoint, one can readily see the advantages of this technology as it pertains to



entree items, but these advantages are not so apparent for bakery items. We have demonstrated that we can match the quality of frozen bakery items for a longer period of storage time. For the four cake items we produced during Phase I of this contract, we had an initial average hedonic score of 6.9. This score did not change after storage at 100°F for one year. From a marketing standpoint, the quality issue is a dominant one; it makes little sense to manufacture products that the consumer does not want or will not accept. Product quality, then, as achieved by this technology, is certainly a reason for packing bakery products in flexible pouches.

Shelf life. Food processors, like the military, are concerned with shelf life and storage conditions. This is an important issue, and our goal was to achieve shelf life the same as that attainable in a metal can. We have kept bakery products under many storage conditions for several years and have found them to be still quite acceptable. We know we can achieve shelf life of long duration if the package maintains its original integrity. The shelf life of bakery products is certainly another reason for putting bakery products in flexible packages.

Convenience and portability are two more qualities whose advantages are obvious and which constitute another reason for bakery products in flexible packages.

For most products, the objective of thermal processing is microbiologic safety. Thermoprocessing for bakery items has a second function -- simply to bake the cakes. This function is normally accomplished in an air oven at atmospheric pressure. While I don't want to dismiss safety, most of what I have to say deals with baking and thermal process conditions that are most favorable for producing highly acceptable quality products.

What we needed was a way to bake an individual slice of cake so that when the consumer viewed it, an image of the entire cake would be conveyed to his mind. We found it is possible to design a product with the same quality attributes as conventionally baked foods and that physically resemble a slice of cake. We have shown that we could do this for both pound cake and fruitcake, the two extremes of production difficulties in bakery items.

Before going to the second question, however, let me add a few more thoughts. The concept of commercially sterile consumer foods in flexible packages is not new. In fact, as you have already heard, the concept and technology have been studied, researched, engineered, and developed at considerable expense over the last decade. In spite of this, flexible packaging is new technology. The reason, of course, is that until now package reliability has been questionable. As a result of this project, we believe this issue has now been favorably resolved.

## MANUFACTURING PROBLEMS

Here the question is: What problems are connected with manufacturing bakery products in flexible packages and how are they resolved? At the outset, the problems are many and complicated because of the number of different operations the production machinery was required to perform. For instance, we decided early to build a water retort because water retorts were considered to be most suitable for the variety and types of products to be produced. This choice complicated the problem of developing a cake structure, particularly a leavened cake structure, under pressure. By way of explaining and describing this problem, we began by asking, "How do you bake a cake in a pressure cooker?" and then expanded on that by asking, "How do you bake a cake under water in a pressure cooker?" Underwater pressures are different due to the added head pressure. Now, the problem became one of product-quality constancy throughout the retort, and the question we asked was, "Can cake products be designed to compensate for overriding retort pressure and the additional waterhead pressure?" As you will see, the answer to this question is "Yes," providing certain conditions are met. The final question we asked was, "Can the retort pressure be controlled in such a way so that the pressure outside the package is nearly the same as that being developed by the cake inside the package?"

The tasks, then, were to design a product capable of overcoming external pressures and develop a retort pressure-control system in which the pressure differences between the inside of the package and the retort could be maintained at a set level.

While developing formulas and processes for the products, we discovered that prior art was somewhat limited because the majority of the successful work had been done with steam retorts.

Bakery-formula criteria. Pound cake is a basic cake with a known texture and flavor. It was selected as a research model. Most of the results from pound cake development are applicable to other bakery items and duplicate formula research is not required. As a result of the formula work and succeeding process studies, we have developed formulas and process criteria for each of the five bakery items. Formulation work was directed toward producing a conventional baked cake structure and texture. Experimental design variables in the formula trials were primarily related to the leavening system and its ability to overcome waterhead and temperature-related pressures in the retort. The development of a leavened crumb structure is not possible unless compensation is made for external pressures.

To properly heat process for safety and stability, retort temperatures of 250°F must be reached. At this temperature, an external pressure of approximately 15 psig is applied to



the packages being processed. During water cooks, additional pressure is applied to the outside of the packages by water-head pressure. This latter varies according to the package position in the retort. Because we don't wish to operate at minimum retort pressures for control reasons, it is necessary that the products be designed to more than compensate for these basic pressure levels and variations.

Leavening, steam, and air contribute to pressures inside the package. The only independent variable with which we could work was leavening, and the leavening system was designed to compensate for the variable external pressures. Time interval is an important factor in the control of the overriding pressure in the retort. The time limits between blending and heat processing have been established for each of the products. The heavier cakes, such as fruitcake, are the most stable with respect to batter density changes over time and require less control of this variable. Vacuum packaging is neither necessary nor desirable in packaging bakery items. It is desirable, however, to remove residual air from the pouch before sealing so that each package has approximately the same amount of residual gas and achieves approximately the same internal pressure during heat processing. To achieve the desired size, shape, density, structure, texture, color, and flavor, it was necessary to create a process condition that would produce a product in the retort that resembled a product baked in a conventional air oven. If the cakes being processed were subjected to excess external pressure, they would not develop the leavened crumb structure.

Cake shaping. We discovered that restricting the package as the batter expanded would force the cakes into the shape of a natural-appearing slice. To determine the best thickness for the pouches, we calculated the potential volume for the packages at thicknesses ranging from 3/8 inch to 1.8 inch, the maximum thickness where the pouch takes the shape of a sphere. Figure 1 shows the potential pouch volume at its maximum.

Figure 2 is a cross section of the pouch when it is fully expanded between two platens. We assumed that the pouch would take a regular geometric shape similar to a parallelepiped. The calculations allowed us to select reasonable experiment variables to determine both the optimum amount of leavening and the amount of dough per package to obtain a regular, slice-like, product shape.

The carrier designed by Continental Can satisfied the dimensional restriction requirements and little more needs to be said about that here, except that the configuration chosen helped considerably in the development of the shape we wanted.

Processing criteria. Creating the processing conditions we wanted was not achieved quite as easily. Figure 3 graphs

EXPANDED POUCH VOLUMES  
4" x 6" Pouches

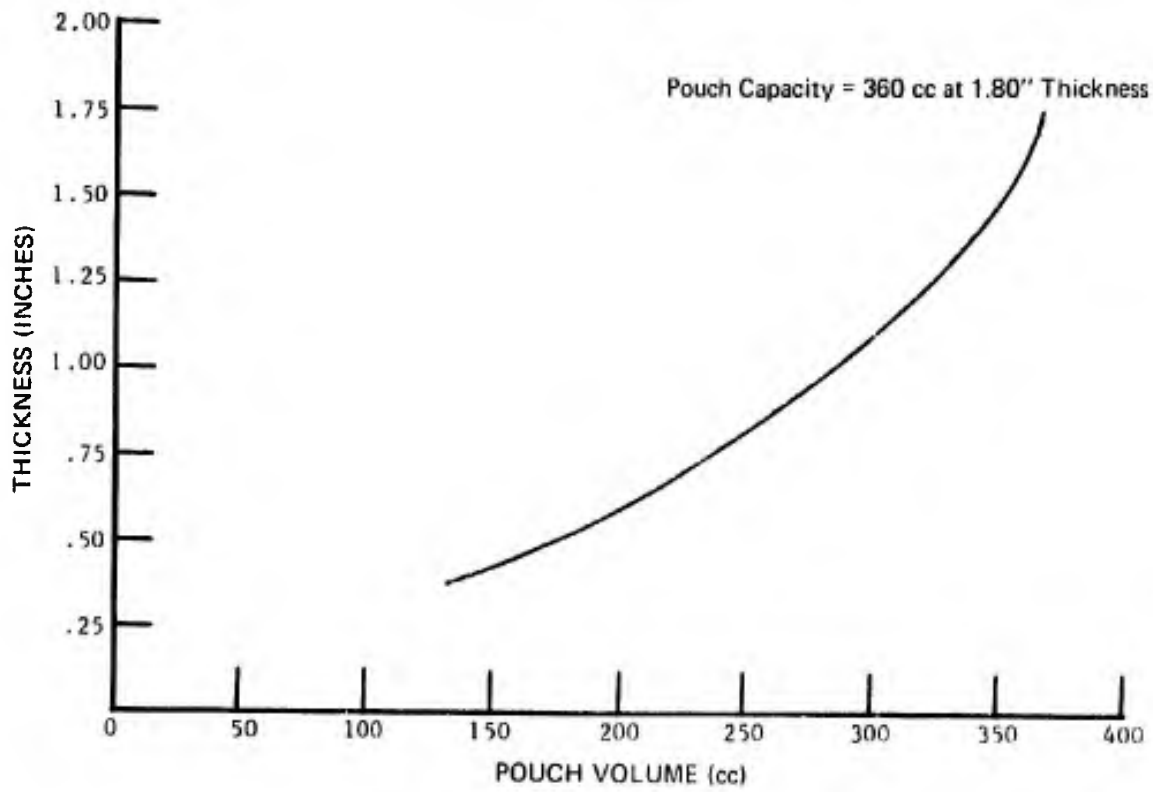
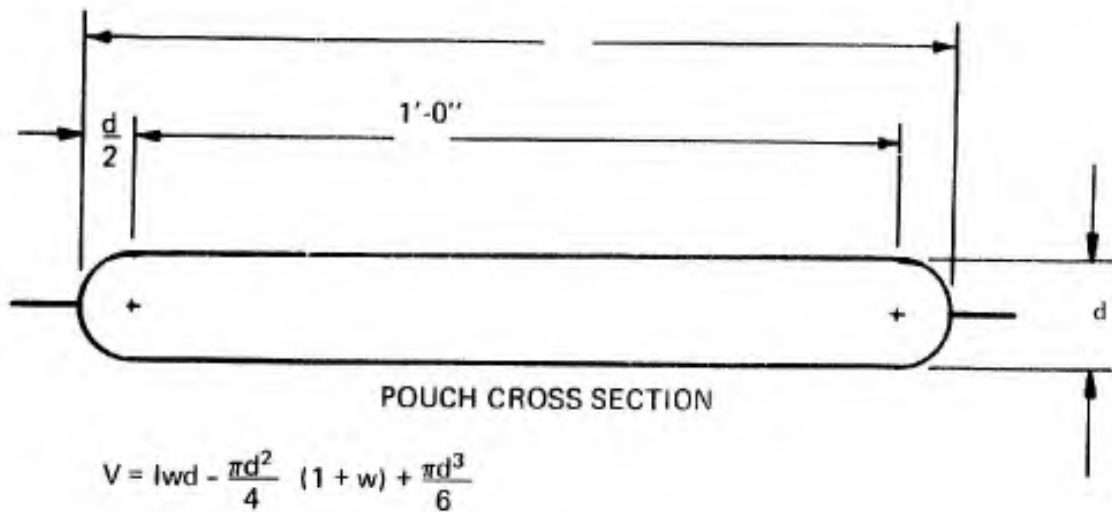

FIGURE 1



w = width

POUCH VOLUME CALCULATION

FIGURE 2

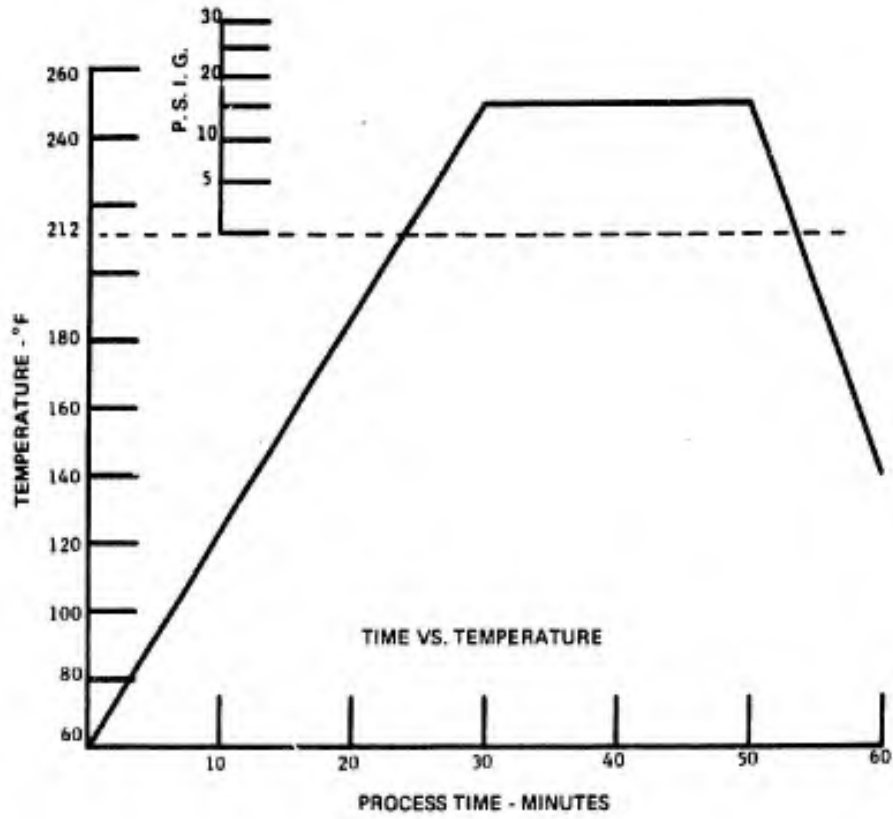

FIGURE 3

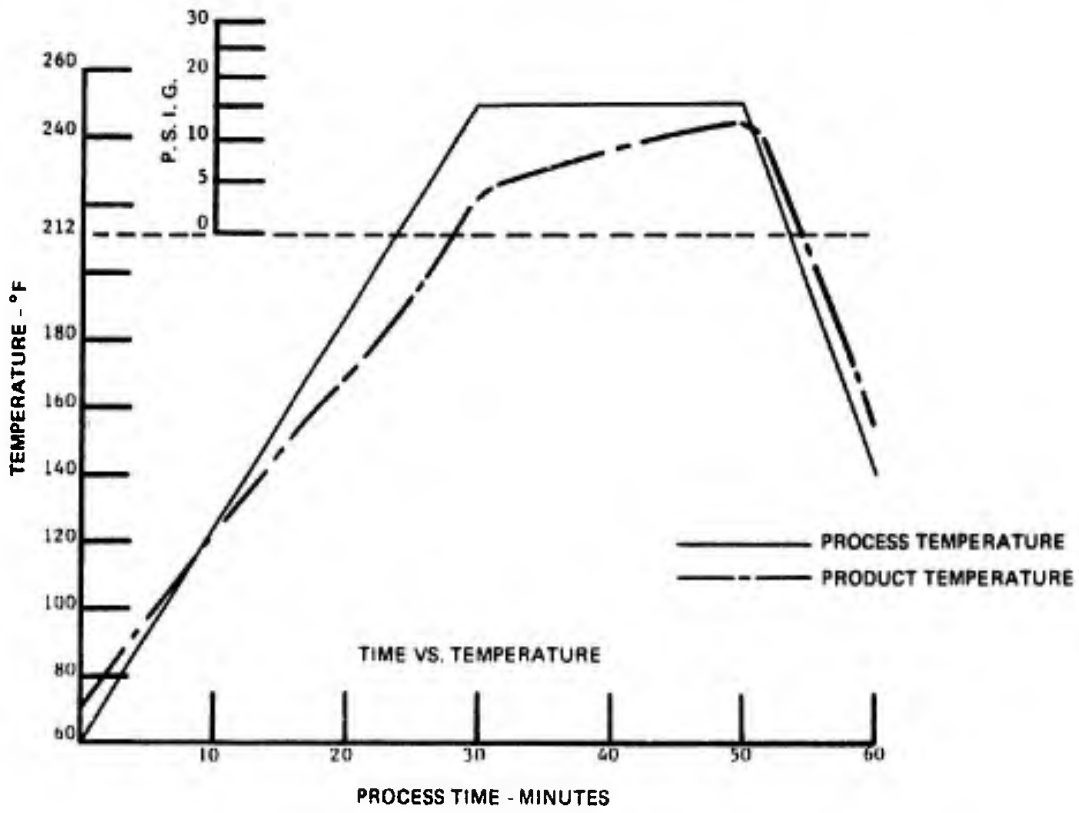

FIGURE 4

the thermal process we developed for fruitcake; plotted on the ordinate are temperatures ranging from 60°F to 260°F. Plotted along the abscissa is the process time in minutes. The thermal process is simply a time-versus-temperature relationship. It is important to observe that the curve above 212°F also describes the gauge pressure necessary to prevent the retort water from boiling, remembering that the objective is to create a condition in which no excess pressure is applied to the cakes during processing.

Figure 4 is a graph of the product temperature through the preceding process. Note particularly the curve above 212°F. Here, the parallel ordinate for the curve also shows the contribution of steam to internal package pressure when the package is restricted. In other words, for every degree in temperature above 212°F, there is a resulting pressure contribution from steam in the package. Because we did not require vacuum packaging, we had air trapped in the dough and the package headspace. This air also contributed to the internal package pressure.

The graph in Figure 5 shows the additive pressure effect of the air above the product temperature and pressure curve. With this condition, the internal pressure and the external pressure equalize after the internal temperature reaches approximately 240°F. This assumes that the retort pressure is being controlled at the minimum pressure. Note also that the internal pressure is higher than the retort pressure at the end of the process holding period.

It is not desirable to have minimum pressures in the retort nor to have excess pressure applied to the package. The leavening, then, must be such that it will supply internal pressures high enough to stay above the process temperature and pressure curve. Two of the principal characteristics of a leavening system are reaction rate and reaction temperature.

Figure 6 shows the additive effect of our leavening on the internal pressure in a restricted package. Note that with this leavening, the generation of CO<sub>2</sub> occurs when the dough reaches temperatures between 130°F and 145°F. This curve also shows the cumulative pressure from the expansion of water, air, and leavening gas as the product is heated. This demonstrates that cakes can be formulated in such a way that the overriding retort pressure can be controlled at the same pressure level as the packages. It is also possible to maintain retort pressures slightly higher or slightly lower than that in the package.

Pressure control. What kinds of pressure controls were available and how is package pressure measured? Can these pressures be accurately calculated and predicted? These are two of the questions we needed to answer. We tried the

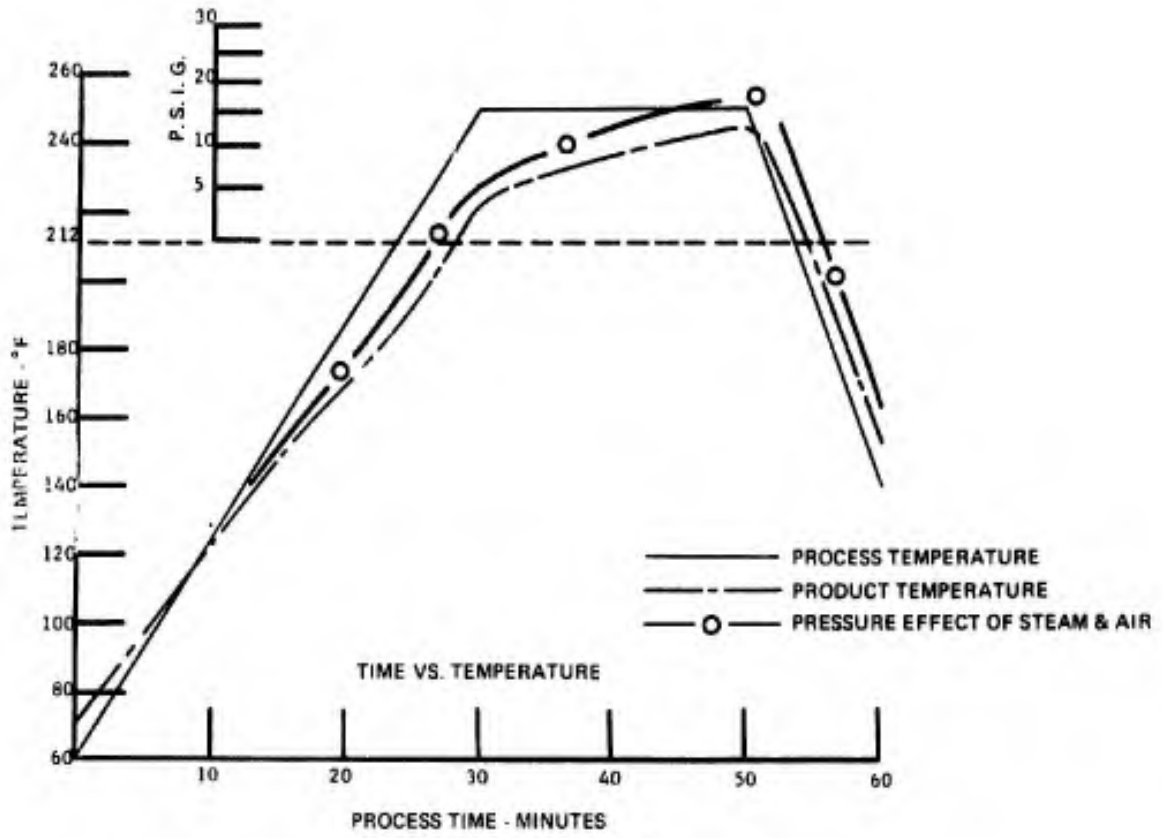

FIGURE 5

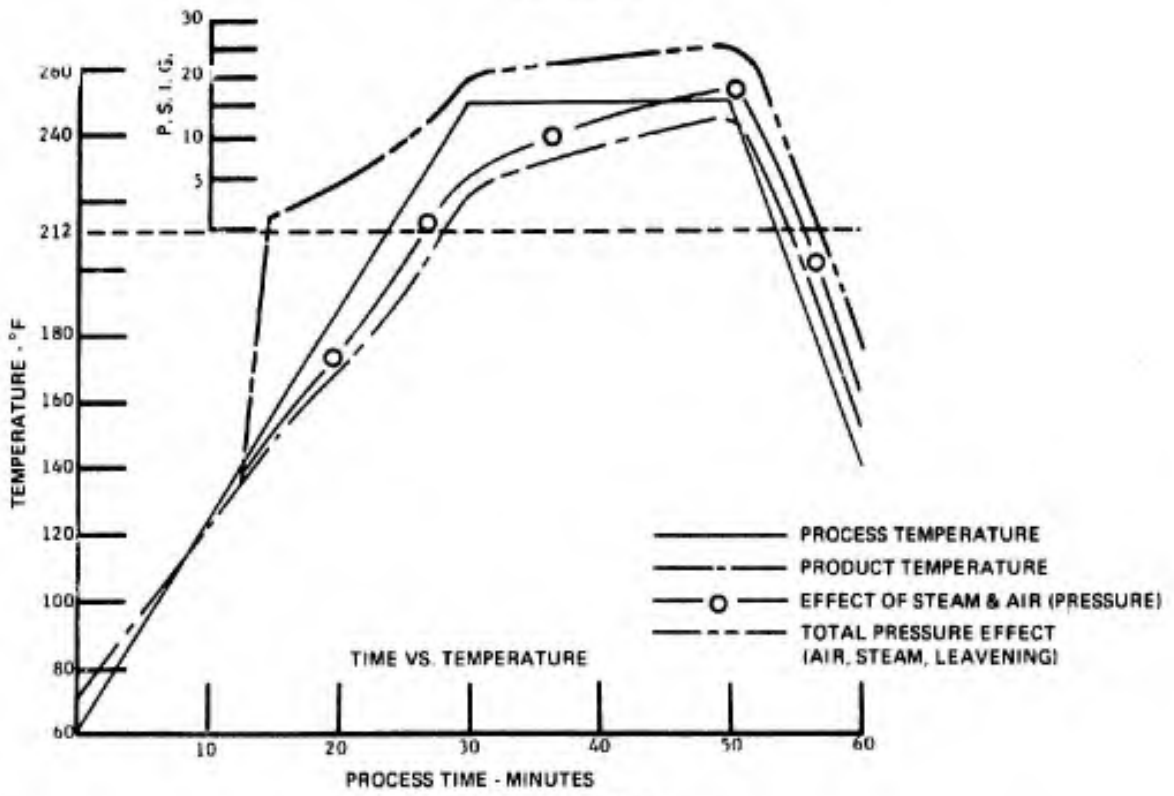

FIGURE 6

programmed cycle route, but found that normal process variations caused the conditions to always be different and that cutting a process cam was not a workable possibility. What was needed was a way to directly measure the actual package pressure. What evolved was a sensing can shown in Figure 7. Its size, shape, and heat-transfer characteristics were similar to the packages being processed. This sensor is a rigid container in the shape of a package at its full restricted dimension. For every retort load, this can is filled with an identical amount of cake batter from the same batch as that being filled in the packages.

Figure 8 is a flow diagram of the control strategy. During the process, the can pressure measured at No. 1 is transmitted through a capillary tube to one side of a differential-pressure cell at No. 3. On the other side of the differential-pressure cell, retort pressures are measured at No. 2 and transmitted to a differential-pressure controller at No. 4. With this device, we can limit the overriding air pressure in the retort to within  $\pm 1$  psig through the critical stages of processing. This is especially important when the temperature rises and the cake is forming its cellular structure. By keeping the retort approximately 2 psig under the pressure in the package, even those packages subjected to greater head pressures will be expanded. By doing this, the structural quality of the cake can be maintained, regardless of the package location in the retort. The pressure controller automatically opens or closes an air-inlet valve or air-exhaust valve such as the ones shown here as Nos. 5 and 6 to maintain the overriding air pressure. This solution of the pressure-control problem resulted in a process that produces cakes of a quality comparable to hot-air oven-baked goods.

Reliability. The objective of the 50,000-pouch production run was package reliability and our goal was to have no more than one seal failure in every 10,000 pouches, or a .01 percent fail rate. We have completed the 50,000-pouch run of fruitcake and found only two packages with any kind of seal failure. All packages from the run were inspected; suspected leakers were subjected to a vacuum test. Two seal failures in 50,000 pouches is a fail rate of .004 percent -- considerably better than our original target.

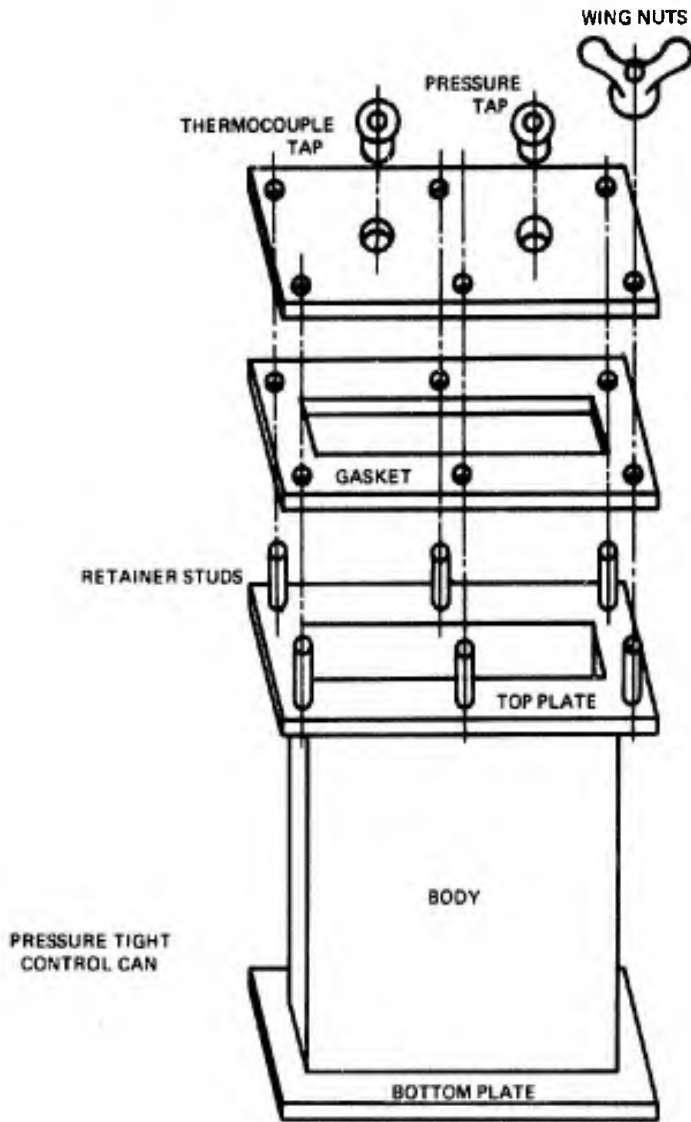

FIGURE 7

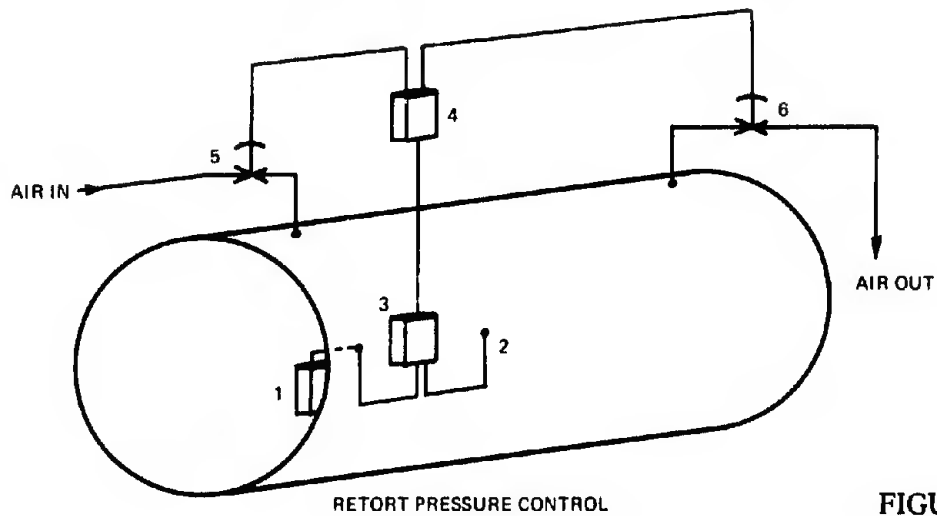

FIGURE 8

## RELIABILITY OF PACKAGING MATERIALS AND CLOSURE

Allan O. Corning  
Manager, Customer Research  
Flexible Packaging Technical Center  
Continental Can Company, Inc.

I will cover briefly the responsibilities and efforts of Continental Can Company in completing the contract. They include:

- (1) Establishment of systems-specification guidelines.
- (2) Establishment of criteria for equipment and line acceptance testing.
- (3) Performance of equipment-engineering tasks and management of all engineering.
- (4) Quality-assurance program.

## SPECIFICATION GUIDELINES

The interrelationships between flexible-packaging material and form-fill seal machines are a growing concern in the food industry. A laminate that is ideal for forming on one machine may not have the characteristics required for forming on another machine. In this project -- and in general application -- this relationship is critically important. We, therefore, gave first consideration in the specification guidelines to packaging material.

The guidelines were prepared at the inception of the project. They challenged the design engineers with specific performance requirements for each station, or module, in the system. For example, seal bars were restricted to a maximum temperature variation of  $\pm 10^{\circ}\text{F}$  in an operating range of  $400^{\circ}\text{F}$  to  $500^{\circ}\text{F}$ ; and an allowable pressure variation of  $\pm 10$  lbs at seal pressures up to 200 lbs per inch of width. At the same time, the guidelines specified that no heat-seal creep would be allowed. Heat-seal creep reduces seal quality. It is a jagged seal along the inner edge of the pouch; when it is present, any compressive force on the pouch exerts a concentrated stress on the narrow places in the seal, often separating and further weakening the seal.

Each station in the system was similarly defined. The performance and design-acceptance criteria were also established to optimize the system's performance. Most importantly, the



guidelines stressed avoidance of negative effects on the quality and integrity of the finished package. The criteria for the finished package were based on pouch developments during the past decade.

The system has 16 stations. They are designated as pouch material, pouch fabrication, transfer to pouch conveyor, pouch opening, pouch filling, pouch shaping, partial seal\*, transfer to carrier and conveyor, pouch evacuation and sealing, pouch transfer to racking station, pouch placement in retort rack, retorts, pouch drying, pouch inspection, pouch jacket packing, and case packing.

Because the packaging material, which was specified in the project contract, has its own characteristics, it had to be our first consideration. The material is three-ply. When formed in a pouch, the outer layer is 50-gauge polyester; the middle layer is 35-gauge foil; and the inner layer, which is the layer that seals and is in touch with the food, is 300-gauge (3-mil) polyolefin. Curing type adhesives are used for the lamination.

The material meets the 14 requirements listed by Long in "Flexible Packages Now Withstand Heat Processing Temperature of Foods" (*PACKAGE ENGINEERING*, March 1962). The requirements include low gas and moisture permeability; resistance to thermoprocessing temperatures of 250°F and variable storage temperatures; low hydrophilic properties; economy; heat sealability; FDA approval; resistance to penetration by fats, oils, and other food components; dimensional stability and chemical inertness; resistance to tearing, pin holing on impact, and abrasion; consumer or esthetic appeal; adaptability for use on automatic fabricating and filling equipment; long shelf life; and receptivity of printing inks that withstand thermoprocessing.

For this contract, the polyester film was reverse, or trap, printed with military olive drab before it was laminated to the foil. The printing could be done as easily in other colors or designs for commercial products.

Pouch material specifications cover yield, odor, carbon count, bond, seal strength, heat resistance, color, visual appearance, retortability, and roll-dimension tolerances -- all relatively typical requirements in contemporary roll-stock specifications. All stock was subjected to a quality analysis using accepted sampling techniques for roll-form production operations.

The guidelines, in addition, require the stock to meet an air-burst value. Air burst is a test unique to retortable

---

\* This station was not used in the final machine design.

pouch development. It was developed a number of years ago to comparatively evaluate the structure and quality of formed material under retort conditions. In the test, a sample pouch is inserted in the testing machine shown in Figure 1. The open end of the pouch is clamped with rubber-faced jaws against an open air port in an air line. Regulated air pressure can then be forced into the pouch for a specified number of seconds, such as 35 psig for 30 seconds. Considerable past experience confirms that set air-burst levels are necessary criteria for pouches to be retorted. They also provide quick and meaningful quality-control data once production has begun.

Each station in the system was assigned tentative specifications based on anticipated design requirements. From the time the project began through Phases I and II, the specifications and associated values were altered as necessary, with the overriding consideration always the absolutely unique performance goal of the project.

#### ACCEPTANCE TESTING

Throughout Phases I and II, the performance of each station was tested individually and in conjunction with the stations associated with it. The tests were repetitive. The testing plan required that three lots be taken at each station. Each lot consisted of 30 consecutive pouches under simulated full-scale production. One or more failures resulting from defects in the 90 pouches was cause for rejecting the particular station's operation. Statistically, a single failure implied that the minimum reliability goal of 1 defective pouch in 2,000 could not be met and that the ultimate goal of 1 (or less) defective pouch per 10,000 could not be met under full-scale production. Conversely, meeting the 90 defect-free pouch requirement provides 95 percent assurance that the production-reliability goal will be met.

#### EQUIPMENT ENGINEERING

In addition to supplying the laminated material, preparing specification guidelines, and testing the acceptability of all modules, Continental Can Company was responsible for engineering and constructing certain pieces of equipment.

The problem of transferring the unsealed pouch from the filling module to the evacuating and closing module was resolved with the development of a carrier unit. The carrier unit underwent several stages of design; the final design is shown in Figure 2.

The carrier is a unique approach to flexible pouch handling; it was also a key factor in designing related equipment for

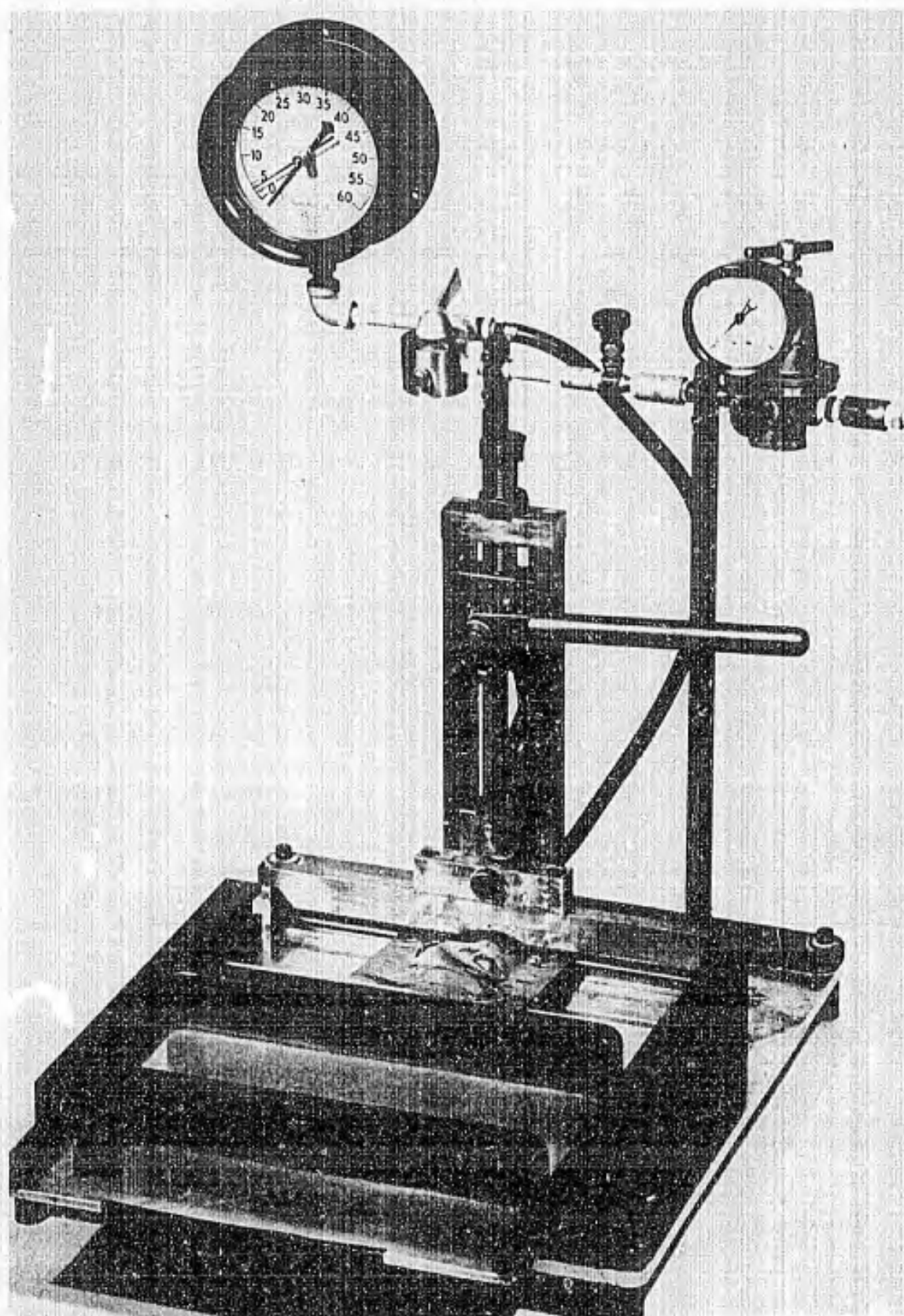

FIGURE 1 Pouch Burst Tester

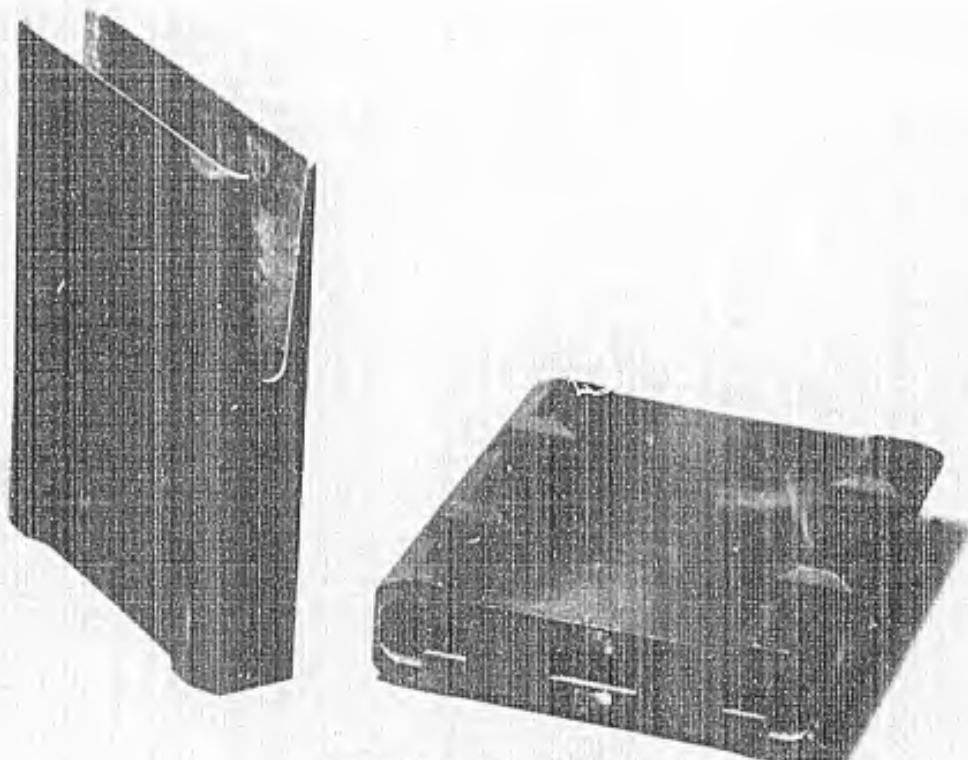

FIGURE 2 Pouch Carrier

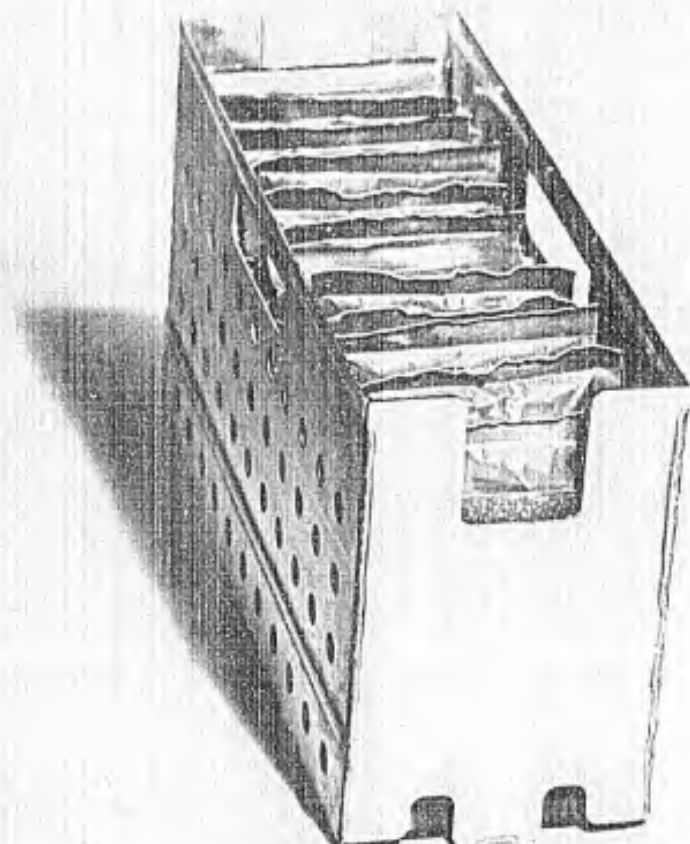

FIGURE 3 Loaded Retort Rack

handling the filled unsealed pouches. The carrier serves a number of functions including protecting the pouch from physical abuse, positive feeding and positioning in the closing machine, automatic-racking capability, and maintaining a constant pouch cross section during retorting. The last two functions are important -- particularly for bakery items -- because they make possible establishment of optimum processing times and prevention of undue pouch swelling from high inside pressures during processing.

The carrier is die-cast aluminum with the inside bottom shaped to receive the tapered pouch. Cut-outs in the bottom allow water to flow through the carrier and protuberances on the outside allow water to flow between carriers -- assuring that each pouch in the retort will be exposed to uniform processing temperatures. The top third of the carrier side walls are cut out to allow for the flattening action of the evacuation and sealing station.

A stainless steel rack, shown in Figure 3, was designed to hold 12 carriers. The rack was also designed so that in the future the carriers could be loaded or, once emptied, fed back into the production line automatically.

As with the carriers, the racks are designed to allow maximum water flow. They have perforated side walls, two narrow ribs for a bottom, and an open top.

The problem of transferring the filled pouches from the Bartelt intermittent-motion machine to the carrier was resolved with the development of a transfer module -- a chain-mounted system. The system also shapes the pouches before they are placed in the carrier. Top grippers pick up the filled unsealed pouches from the Bartelt edge grippers. As shown in Figure 4, when it is necessary to shape the pouches so they will fit in the carriers, shaping paddles (or plates) close on each pouch, molding it to a cross-section dimension that will fit.

Natick Laboratories data had previously confirmed that the pouch closure seal was the most critical production aspect in assuring quality and reliability of the finished package. Absence of foodstuff from the sealing surfaces, achievement of high tensile strength, and uniform wrinkle-free seals were considered mandatory requirements. There was also need to evacuate air from the pouch to a specified level immediately before sealing.

Initially, impulse-type seals were considered because of their proven advantage of cooling under bar pressure immediately after the heating portion of the sealing cycle. Earlier work with impulse sealing, using seal-bar pressures up to 100 lbs per inch, had demonstrated it was possible to



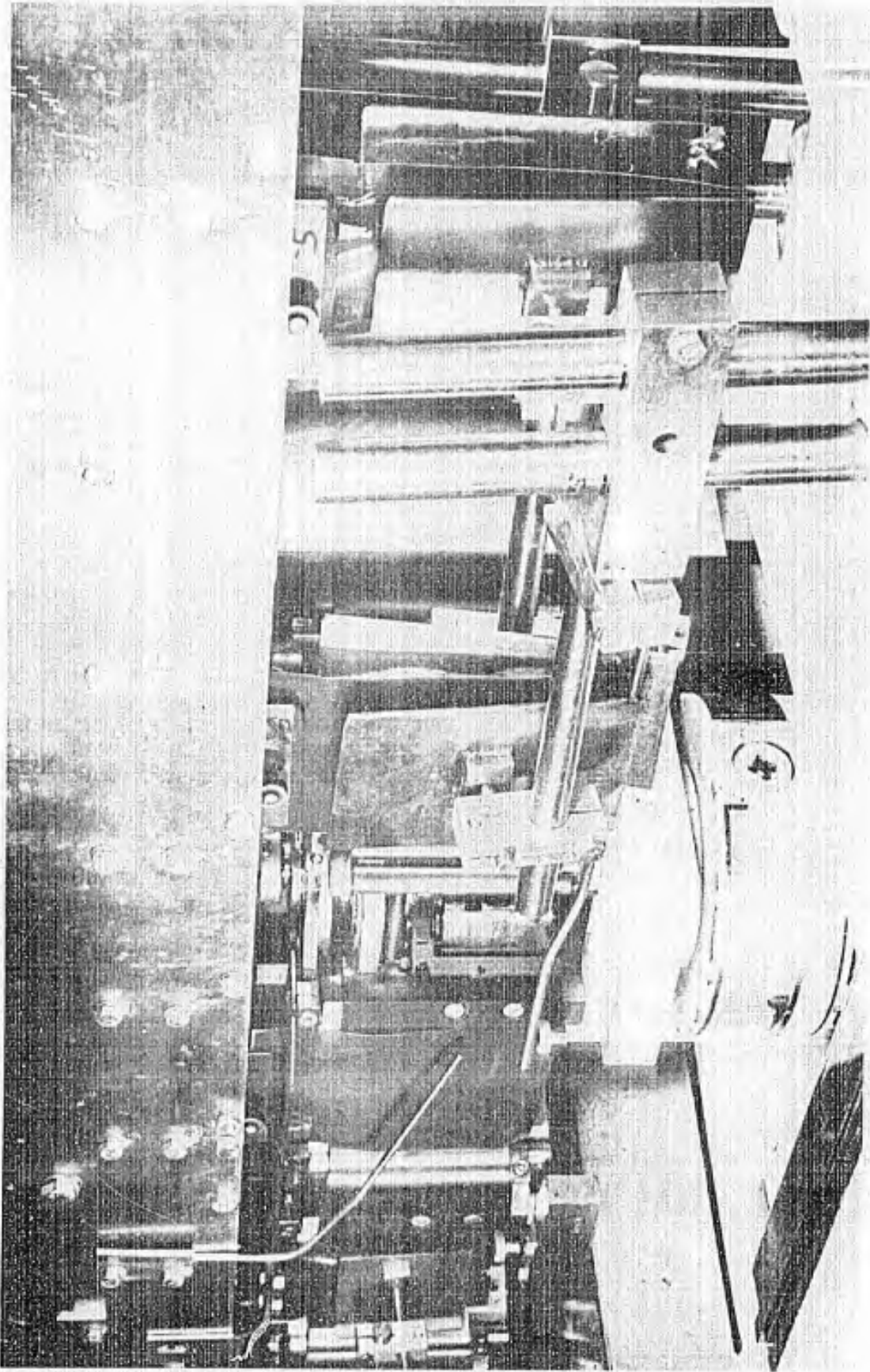

FIGURE 4 Pouch Flattener Stations on Bartelt Packaging Machine

achieve closing-seal strengths of up to 22 lbs per inch of width and optimum seal uniformity.

Of known available equipment, the Continental Can Company's Model 216 (normally used for evacuating and closing ham cans) was selected because potentially it required only minimum modification. The modified unit is now known as Model 661.

The rigid carriers for the filled pouches allowed the use of conventional transport mechanisms to and through the vacuum-closing module. At the same time, the carriers protected the pouches from damage in transport and during positioning and handling in the rotating turret of the Model 661.

An analysis of sealing-cycle time versus the productivity goal quickly confirmed the need to consider the advantages and disadvantages of resistance-type sealing. The seal strengths attainable with resistance sealing equaled the seal strengths obtained from impulse sealing. From available technology in resistance, or bar, seals the Model 661 evacuation and closing unit, shown in Figure 5, was developed for Phase II production. This figure shows the conveyor feeding carriers into the rotating turret of the unit. The turret carries the carrier through three progressively higher vacuum stages to the final chamber, where the closing seal is made on the package. The seal bars are closed with a pneumatic cylinder-mechanical clamp-linkage action, and can exert up to 200 lbs per inch width pressure. As on the Bartelt pouch former, uniform and positive seal-bar pressures are assured by a metal-faced bar pressing against a Teflon and glass-cloth-covered rubber-faced bar.

The no-seal-wrinkles requirement resulted in the use of a positive gripper system for flattening the seal area when the pouches contained meat products. Various grippers were evaluated and metal-to-metal grippers were selected. The grippers are located above spring-loaded fold-over bars and their opening and closing can be carefully timed. The fold-over bars also help prevent seal wrinkles.

The grippers and fold-over bars close on the pouch just before the seal bars close. The jaws of the grippers move in opposite directions, an action that flattens the seal area.

The time required to position the carrier, grip the pouch edges, close the seal bars, seal the pouch, and release the pouch indicated that this size sealing unit could process 35 to 40 packages per minute. A unit with a turret of larger diameter and multi-head sealing unit would have increased productivity.

In a later design stage, the Model 661 turret-movement index of the pouches was halved to  $22\ 1/2^\circ$  to allow more time

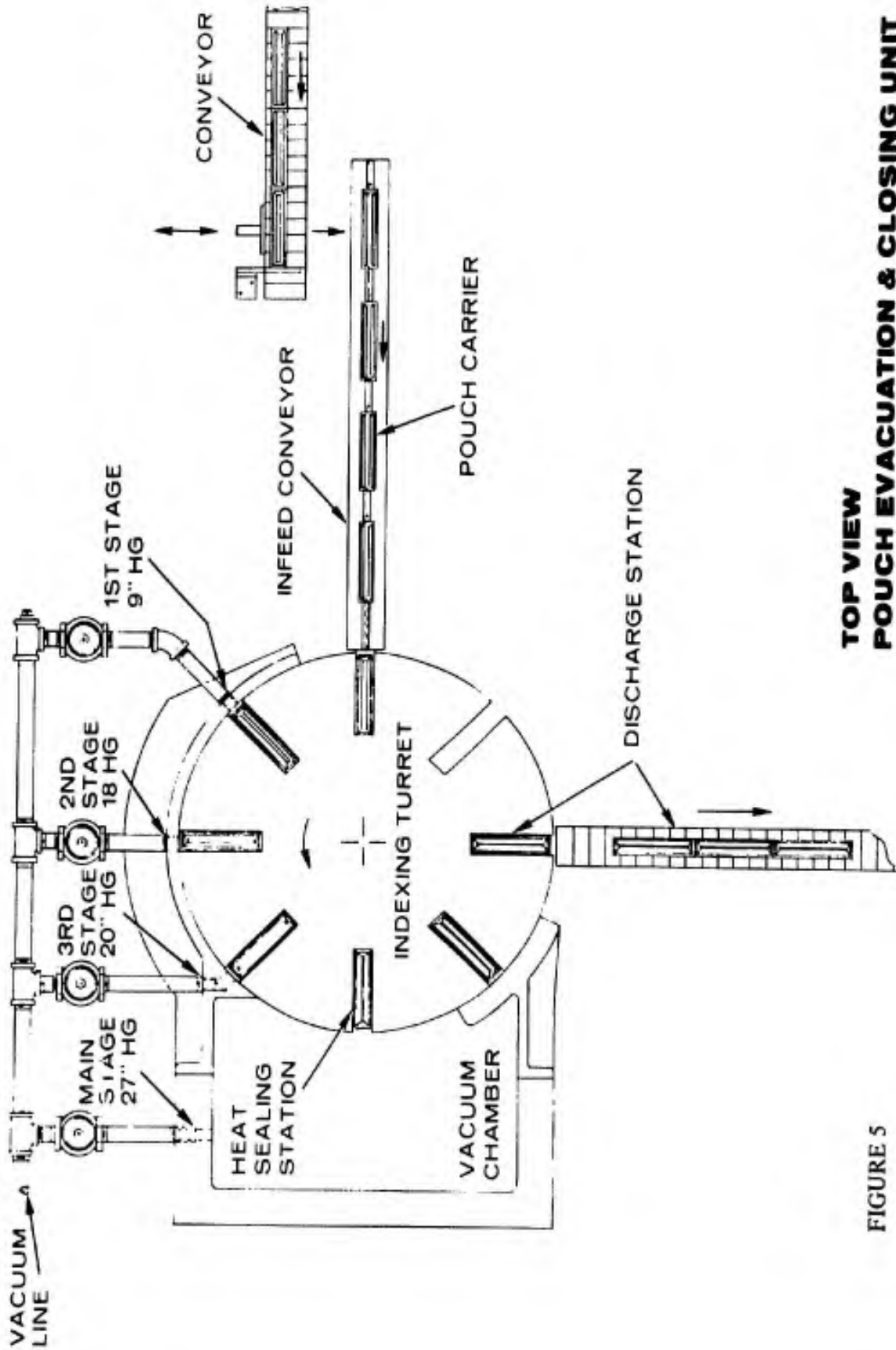

**TOP VIEW  
POUCH EVACUATION & CLOSING UNIT**

**FIGURE 5**



for the seal to cool before it was exposed to atmospheric pressure. This overcame a stress on the nascent seal that caused wrinkles to form.

The staged vacuum approach of the Model 661 avoids boiling or splashing the air-filled foodstuffs and contamination of the closure-seal area. The four vacuum stages proved satisfactory.

In the next module, the racks of pouches in carriers are loaded on carts. The carts are designed to optimize space use in the retorts. The size of the retorts was based on the productivity goal and the time restrictions on holding the uncooked foodstuffs. Filled meat pouches have especially restrictive maximum holding times of 120 minutes before retorting. A basket-weave aluminum grid is locked over the top of the rack-loaded cart, making it a self-contained unit when placed in the retort.

For fruitcake, which is not evacuated before sealing, a hold-down bar keeps the pouches from floating out of the carriers in the retort. The hold-down bar is perforated aluminum and V-shaped.

#### SYSTEM QUALITY ASSURANCE

There are three categories of quality assessment and prediction systems for producing thermoprocessed shelf-stable foods in flexible packages. They are incoming packaging material, equipment reliability, and production. Of these, sound statistical assessment of equipment reliability before production began was considered the most important. To assess the equipment, 14 inspection stations were established to evaluate the complete packaging system. Tests for critical defects were made at each inspection station and at selected strategic points in the production line so as to assess the capability of combined production modules to produce defect-free packages. While this method of acceptance testing is rigorous, it is the optimal means of generating sufficient statistical data for making precise probability predictions. The key to the approach is the system's ability to produce small lots of defect-free pouches successively. In addition, the system will be assessed from the running record of pouches that swell or leak after two weeks of incubation.

## RELIABILITY OF PACKAGE FORMING AND FILLING

William N. Miller  
Chief Engineer  
Packaging Machinery Division  
Rexham Corporation

To meet the reliability goal of this research contract, Rexham Corporation was faced with the most restrictive and demanding performance requirements in the history of flexible-packaging forming, filling, and sealing machinery.

During Phase I, our program, which led to the conclusion that the reliability goal could be achieved, included:

- (1) Testing the machineability of the laminate.
- (2) Development and testing of the package-forming and package-filling modules.
- (3) Determining the filling methods for 17 food products.

## MACHINEABILITY

The packaging material was first subjected to a pouch-forming test to determine whether any material damage occurred during this operation. Heat seals and the easy-opening notch were omitted so that the material could be unfolded and inspected. The results of this test were acceptable. Only six foil breaks and no material failures over a 6-foot length of material resulted from the machine folding and forming operations.

## PACKAGE-FORMING AND PACKAGE-FILLING MODULES

A prime function of the basic packaging machine is sealing and the heat-sealing specifications for this material required maintaining a temperature uniformity on the sealing surface of each seal bar with variations of no more than  $\pm 10^{\circ}\text{F}$  during machine operation. Standard components could not meet this requirement.

The six separate side heat-sealing bar configurations shown in Figure 1 were evaluated during development of reliable seal bars. Configuration 1 is a standard heat-sealing bar used on a Bartelt form, fill, seal machine. Configurations 2 through 6 are modifications to this basic design. They position additional seal-bar material adjacent to the sealing surface.

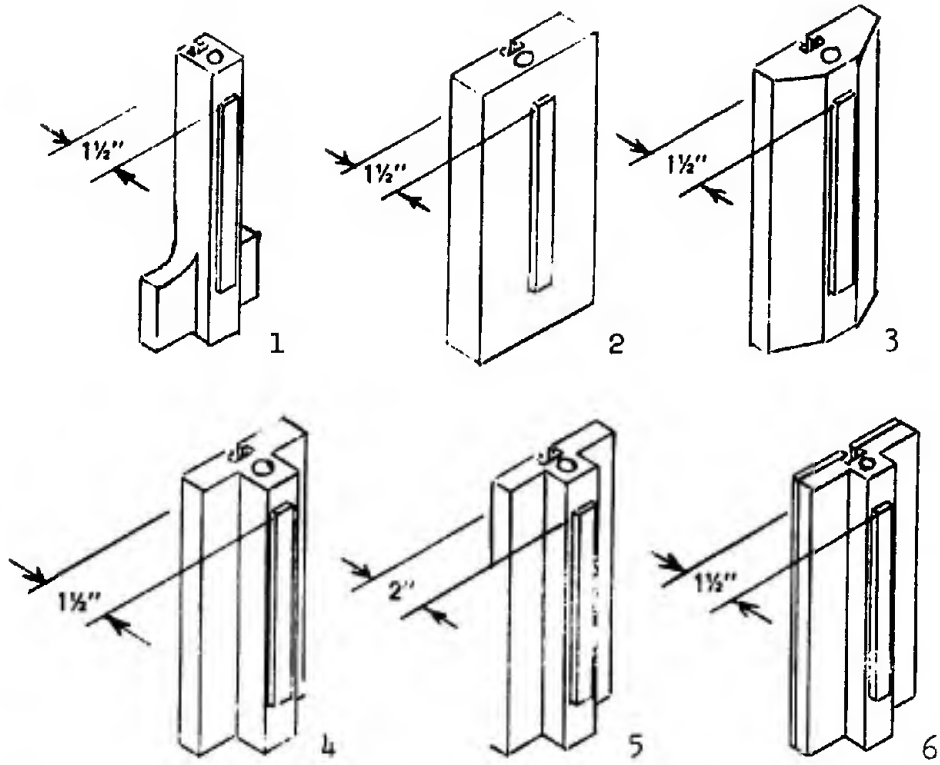

FIGURE 1 Side Heat Sealing Bar Configurations

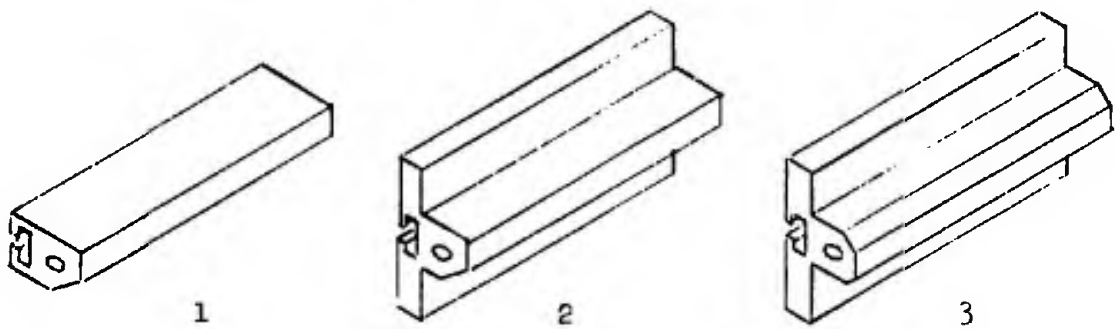

FIGURE 2 Bottom Heat Sealing Bar Configurations

More than 195 separate temperature tests were conducted during this development. Four different seal-bar materials and four brands of cartridge heaters were also evaluated. The size of the cartridge heater hole and the location of the cartridge heater and thermocouple probe were optimized with respect to the sealing surface. Configuration 6, incorporating the optimum of the preceding features, was successful in meeting the static temperature uniformity requirements. Figure 2 shows several configurations of the bottom heat-sealing bar.

Three types of temperature controllers were tested. These included variable-voltage transformer, on-off time proportioning, and voltage proportioning controllers. The latter provided the most accurate temperature control. Conductive-heat losses from the seal bars into the supporting mechanisms were also evaluated. They were reduced by machining a deep circumferential groove into the support plug.

Tests indicated a significant seal-bar temperature drop on machine start-up and an overshoot beyond the allowable temperature limits after shut-down. A unique anticipatory control system was developed to eliminate this condition. It involved supplying full voltage for a short predetermined time prior to start-up to each cartridge heater, by-passing the temperature controller, thus anticipating the initial heat requirements. After each run, the machine is prevented from cycling by a time delay until the temperature has returned to set point.

Pouches were produced on a modified Bartelt horizontal packager in the sequence shown in Figure 3. The operations include bottom heat sealing, bottom seal cooling, side heat sealing, side seal cooling, easy-opening notch, photoelectric registration, and pouch cut-off. The completed pouch is shown in Figure 4.

Pouches were then transferred to the 11-station conveyor of the packaging machine. Station 0 is pouch pickup; Station 1 is air-jet opening; Station 2 is pouch-forming; Stations 3 and 7 are product-filling; Station 8 is reserved for top-pre-sealing, which is not required; Stations 9 and 10 are open; and Station 11 is pouch-removal.

The most difficult requirement in maintaining package reliability is dispensing and positioning the product in the pouch without contaminating the top seal area.

Our first consideration on the Bartelt machine was to provide a reliable pouch-conveying clamp to positively control and position the pouch for opening and filling operations. This new clamp, attached to an endless chain, consisted of a fixed leading jaw and a movable trailing jaw. The pouch was then formed into an oval configuration by a mechanical forming mechanism.

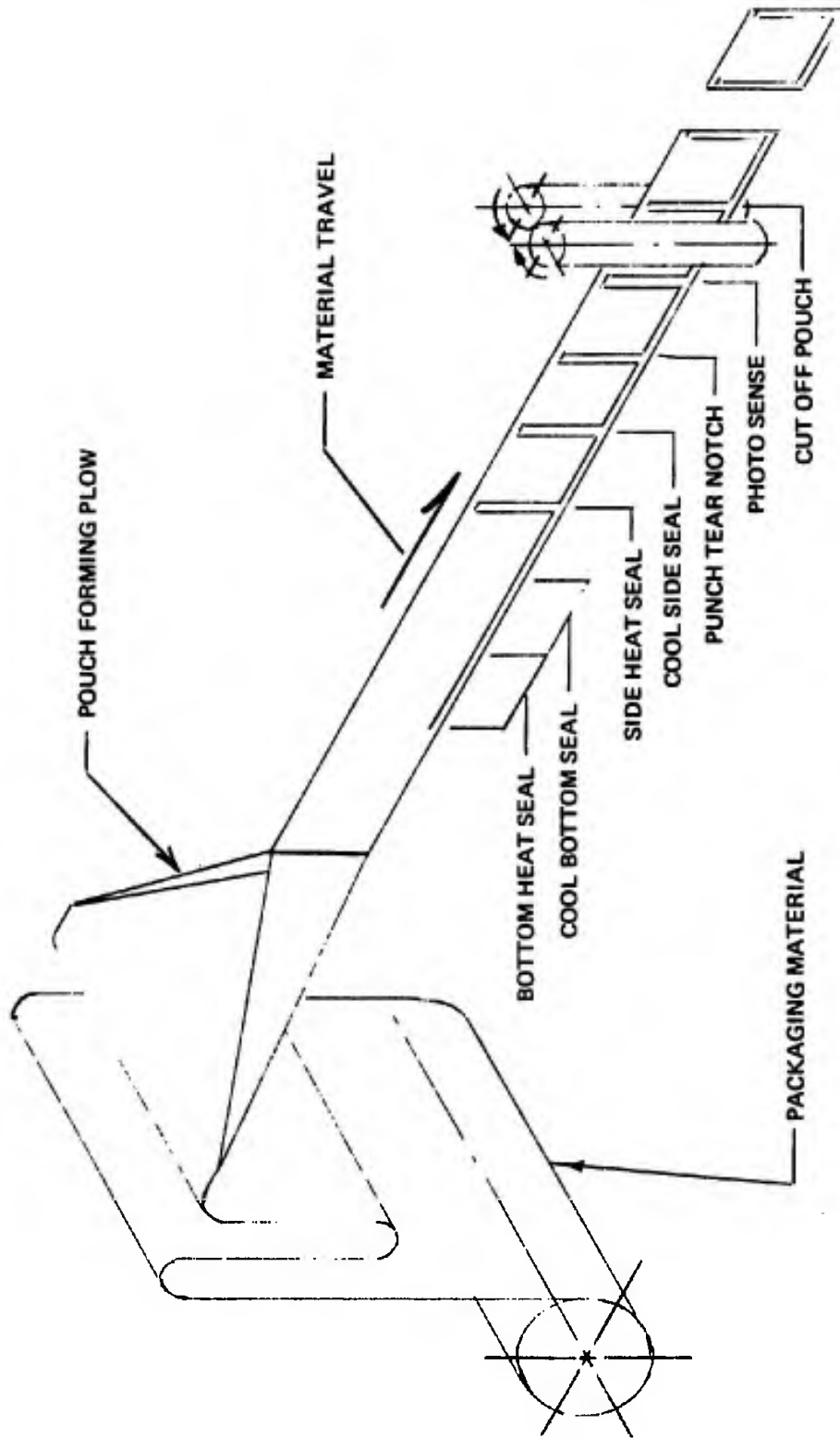

FIGURE 3 Schematic Drawing of Pouch Making

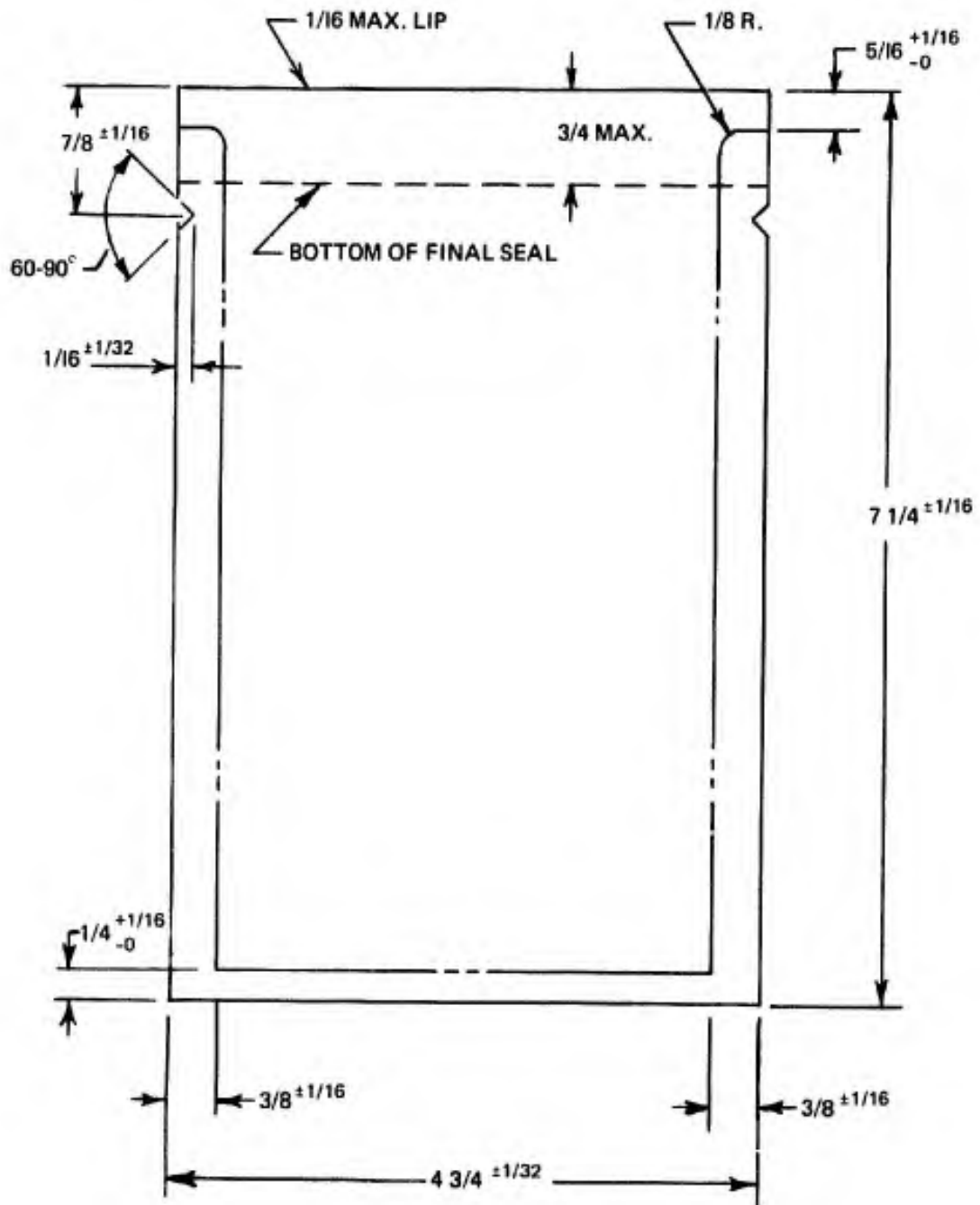

FIGURE 4 Flexible Pouch Dimensions

## FILLING METHODS

The 17 menu foods were arranged in three classifications for detailed filling-method study. These were "pumpable," "extrudable," and "placeable."

Standard fillers with successful histories were first surveyed and tested. Eight filling units were evaluated for pumpable products, three for extrudable, and two for placeable. In all, 221 separate, thorough, comparative filling tests were conducted to obtain the correct filler for each category of product. Modifications were necessary to improve each performance. Each filler was evaluated for filling speed, accuracy, and absence of product damage. Dispensing temperatures were optimized for each product.

Two separate fillers are required to dispense the pumpable products. A horizontal piston filler is used for barbeque sauce, beans in tomato sauce, beef stew, chicken a la king, ground beef in pickle-flavored sauce, and pineapple in syrup. A rotary pump filler is used for the five bakery products. A Bartelt auger filler is required to dispense the extrudable beef, chicken, and ham and chicken loaf products. A mechanical depositing device was developed to load the beef slices, beef steak, diced meat for beef stew, frankfurters, and pork sausages.

Selection of the proper filler device solved only half of the filling problem. Locating each product in the pouch without contaminating the top 1 1/2 inches of the pouch became the real challenge.

Product-dispensing nozzles, connected to the pumpable and extrudable fillers, were developed to preclude top-seal contamination. The first nozzle designed was for the products using the piston filler. It consists of a round vertical chamber with a product-entry port near the center and an exit port at the bottom. A piston rod, located inside the chamber, is raised or lowered to open and positively close the exit port in time with the filler. The piston rod is hollow and both a vacuum source and compressed-air blow-off can be valved through the piston to prevent product build-up on the end of the nozzle. A stationary external vacuum ring, immediately below and around the nozzle tip, eliminates any product contamination on the outside end of the nozzle. A unique constant water-flush ring between the internal moving parts of the nozzle reduces the possibility of internal product build-up. Movable shields are provided to protect the top seal area of the pouch as the nozzle enters.

Bottom-up filling techniques were used to position all pumpable and extrudable products in the pouch. This technique involves placing a filling nozzle inside and near the bottom

of the pouch before dispensing the product and slowly raising the nozzle as the pouch is filled to prevent contamination of the lower tip of the nozzle. The flow of product is stopped before the nozzle reaches the top of the pouch. The vacuum suck-back or air blow-off is applied immediately after the exit port closes and before the nozzle is removed from the pouch.

A rotary spool valve nozzle was developed for the bakery products. It has a vertical product chamber with the rotary valve at the bottom. A vacuum suck-back is provided. Movable shields protect the top seal area of the pouch.

A sliding tube nozzle was designed for dispensing the extrudable loaf items. It consists of a product-entry chamber connected to the Bartelt auger filler. A round sliding tube with a matching entry port is located inside this chamber. A movable piston is positioned inside the sliding tube. Product flows into the tube and is cut off into a round slug as the tube and piston descend together into the pouch. The piston is then moved down, relative to the tube, to strip the product and position it in the bottom of the pouch. A vacuum suck-back, protector shields, and water-flush ring eliminate top-seal-area contamination.

In Phase II, our objective was to design and build a package-forming and package-filling module using the technical guidelines established in Phase I.

A special Bartelt 11-station horizontal intermittent-motion packaging machine was designed and manufactured to form the package automatically from a minimum of 30 to a maximum of 60 machine cycles per minute. Only one operator is required for this machine.

All equipment was designed following the guidelines of the Meat and Poultry Inspection Program of Animal and Plant Health Inspection Services. I want to emphasize that this machine was not a standard catalog item. A detailed description of the equipment includes:

- (1) A powered web-roll arbor to unwind the roll of packaging material in time with the machine.
- (2) Automatic web-centering control to continuously position the top lip overlap of the pouch.
- (3) A printer assembly to code an identification control number on each pouch.
- (4) Web-forming assembly.
- (5) Temperature-control system that includes a separate temperature controller and chart recorder for each seal bar. High- and low-temperature warning lights and alarm are also provided for each heat-sealing bar.
- (6) Bottom heat-sealing and cooling bars. Teflon-coated glass cloth is positioned between the laminate material and



each seal bar to keep the material from sticking to the bars. Silicon rubber, reinforced with fiberglass, is used on one seal bar to distribute the sealing pressure uniformly over the laminate material.

(7) Side heat-sealing and cooling bars.

(8) A strain link has been attached to both the bottom and side heat-sealing assemblies to accurately measure heat-sealing pressures. The output signal from the link is connected to an amplifier and continuous indicating meter. A chart recorder is provided to obtain a permanent record.

(9) Easy-opening notch and photoelectric registration assemblies.

(10) Web-feed and pouch cut-off assembly.

(11) Clamp assembly to position and convey each pouch.

(12) An automatic pouch-diverter assembly that deflects certain pouches away from the bag clamps where they can be collected for process-control inspection.

(13) Air-jet splitter blade assembly to pre-open each pouch.

(14) Pouch-former assembly to provide the controlled pouch opening.

(15) The horizontal piston filler for barbeque sauce, beans in tomato sauce, beef stew, chicken a la king, ground beef in pickle-flavored sauce, and pineapple in syrup. The filler is positioned behind and above the machine and is connected to the dispensing nozzle through a reinforced flexible plastic hose.

(16) The nozzle for these products with the external vacuum ring.

(17) The rotary-pump filler for the five bakery products.

(18) The nozzle for dispensing these.

(19) The Bartelt auger filler and sliding tube nozzle for dispensing extrudable beef, chicken, and ham and chicken loaf products.

(20) The rotary-drum placeable filler for beef slices, beef steak, diced meat for beef stew, frankfurters, and pork sausages. These products are manually positioned in the rotary drum for this contract; however, this function can be mechanized.

(21) Pouch-flattening paddles to shape the pouch for entry into the pouch carrier for subsequent operations.

Safety interlocks are provided to stop the packaging machine automatically at the end of each roll of laminate material and to interrupt the filling of product (but not stop the machine) if one or more pouches are missing from the bag-clamp conveyor. This no-pouch/no-fill feature also reduces product contamination on the bag clamps.

## FEASIBILITY OF RETORTING FOODS IN FLEXIBLE PACKAGES

James H. Gee  
Staff Project Engineer  
Engineered Systems Division  
Food Machinery Corporation

In the overall program of packaging and thermoprocessing food in flexible pouches, FMC's Engineered Systems Division, had responsibility for retorting the food items after the pouches have been filled and sealed.

Preliminary studies of the flexible pouch material, pouch construction, and the foods to be processed indicated that the retorting operation could be similar to that now being used for cooking food in glass containers; this system is a water-cook with overriding air pressure. The glass containers are loaded into the retort, which is then filled with water to completely cover the containers; steam is introduced into the water through steam inlet spreaders and the water is usually agitated either by air or mechanical means, or it is recirculated by a pumping system. By this method the product is uniformly heated up to the cooking temperature and held there for a predetermined length of time. The product is then cooled at a controlled rate and unloaded from the retort. If the product is to be cooked at more than 212°F, air pressure must be applied over the water to prevent boiling and container damage due to excessive pressure differences between the inside of the container and the retort.

Six products -- frankfurters, beef stew, ham and cheese loaf, beef steak, pineapple, and fruitcake -- were to be processed. For retorting, these products are divided into three categories: meat, fruit, and bakery. The different cooking temperatures and times shown in Figure 1 were established by Pillsbury and Swift in their pilot plants.

The three diagrams show the theoretical process curves for each type of food item. Process time is shown on the horizontal axis with temperature on the vertical axis. Preliminary process times are as follows:

Fruit. Ten minutes to fill the retort, 18 minutes to heat to 195°F, 5 minutes to cook, 12 minutes to cool the retort, and 5 minutes to drain it -- for a total time of 50 minutes.

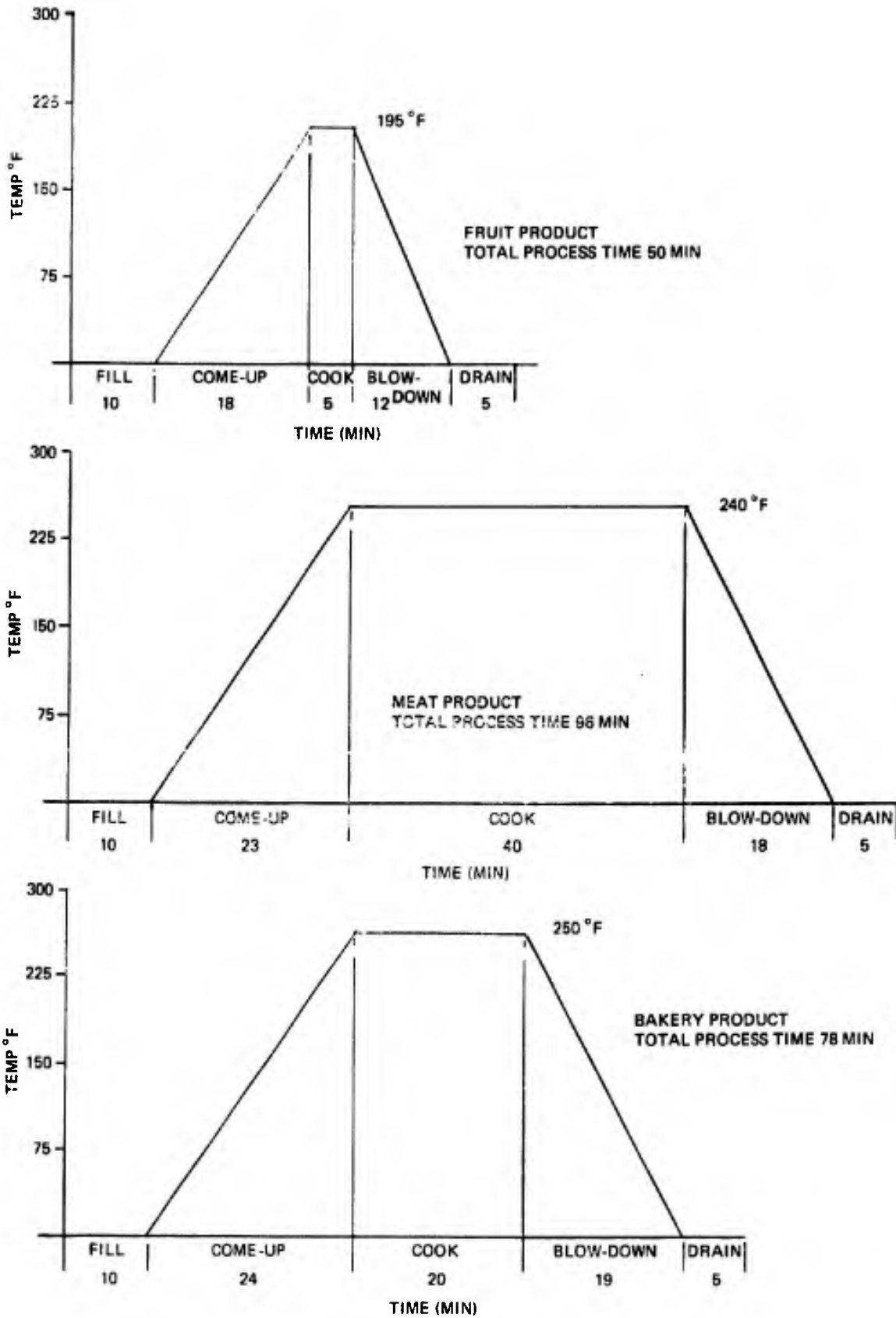

FIGURE 1 Graph Showing Theoretical Process Functions

Mea . Ten minutes to fill the retort, 23 minutes to heat to  $240^{\circ}\text{F}$ , 40 minutes to cook, 18 minutes to cool the retort, and 5 minutes to drain it -- for a total time of 90 minutes.

Bakery. Ten minutes to fill the retort, 24 minutes to heat to  $250^{\circ}\text{F}$ , 20 minutes to cook, 19 minutes to cool the retort, and 5 minutes to drain it -- for a total time of 78 minutes.

The tentative design requirements in Figure 2 were established for the water-cook, overriding-air process. These requirements were to be used as goals in developing the retort equipment. At the outset of the program, the major foreseen problem was achieving even distribution of the heat throughout the retort during the complete processing cycle (see Figure 3). Previous studies have shown that heat distribution can be controlled accurately if the retort is relatively short in length (a maximum of 4 feet) and all the water is recirculated through the retort every 4 to 5 minutes. These facts helped to establish the design approach. The 14-foot retort was considered as 4 short retorts, although no physical separation existed between the sections.

The diagram shows a cross section of the retort. Each section has recirculation water headers, recirculation water collectors, and a steam spreader. The steam spreader also serves as the feed water inlet. All the spreaders and headers run the full length of the retort. A single 25-hp pump recirculates the water through all sections. Manual control valves are located in the supply lines for each retort section. The flow of water and steam to each section can be accurately controlled by these valves. Because of the extreme temperature-control requirements, agitating air is also used to help provide uniform temperature throughout the retort.

Steam is fed into the water at the bottom of the retort. This area is used as a steam-and-water mixing chamber. The heated water is immediately pulled from the retort through the two recirculation water collectors by the pump and fed back into the retort by the three recirculating water headers located below the water level at the top of the retort. This recirculation creates a downward flow of heat through the packages. In order to provide a clear path for the recirculating water, the aluminum carriers used to transport the pouches through the filling and sealing machines are used. These carriers are designed to space and support the pouches for optimum water flow during the retorting operation.

Figure 4 shows 12 carriers positioned in a rack, the path for the heating or cooling water around the carrier is indicated by cross hatch marks. Three holes in the bottom of carriers allow additional water to be circulated between the pouches and the inner carrier wall. The racks with the carriers are loaded onto retort cars as shown in Figure 5.

- 1) Two stationary horizontal retorts to be used, each retort to be 5'-0" in diameter and 14'-0" in length and to be equipped with a quick-opening door.
- 2) The production rate of the line established the capacity of the retorts. Each retort must accommodate 2,688 pouches when processing meat and fruit products and 2,016 pouches when processing bakery products. The reason for the difference will be explained later.
- 3) Process must be an underwater process with superimposed air pressure.
- 4) Air pressure must provide a minimum of 35 psi in the retort.
- 5) Retort must provide optimum flow of water, steam, and air during the process to ensure uniform heat distribution throughout the retort.
- 6) Temperature throughout the retort must be maintained within  $\pm 2^{\circ}\text{F}$ .
- 7) Overriding air pressure must not fluctuate more than 2 psi during the complete process.
- 8) For heat penetration tests, access for a minimum of 12 thermocouple leads must be provided.
- 9) All products have an optimum heating rate of  $8^{\circ}\text{F}/\text{minute}$ .
- 10) Retort controls must be capable of operating at three temperatures:  $195^{\circ}$ ,  $240^{\circ}$ , and  $250^{\circ}\text{F}$ .
- 11) Retort must have a minimum ASME rating of 45 psi.
- 12) During the retorting, the pouches must remain in the aluminum carriers used in the filling and sealing machines.

FIGURE 2 Tentative Design Requirements  
of Flexible Pouch Retorts

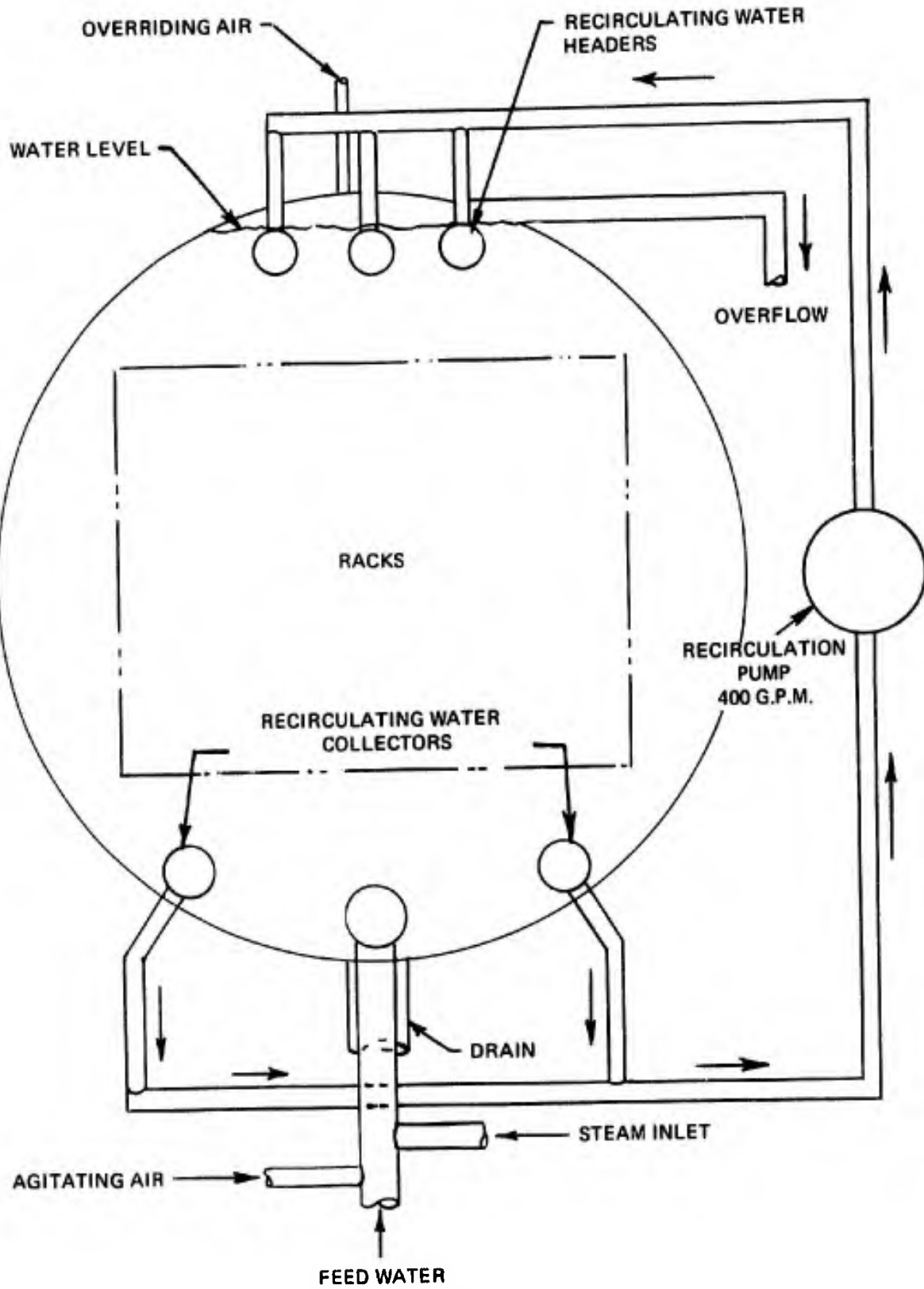

FIGURE 3 Retort Cross Section Showing Piping

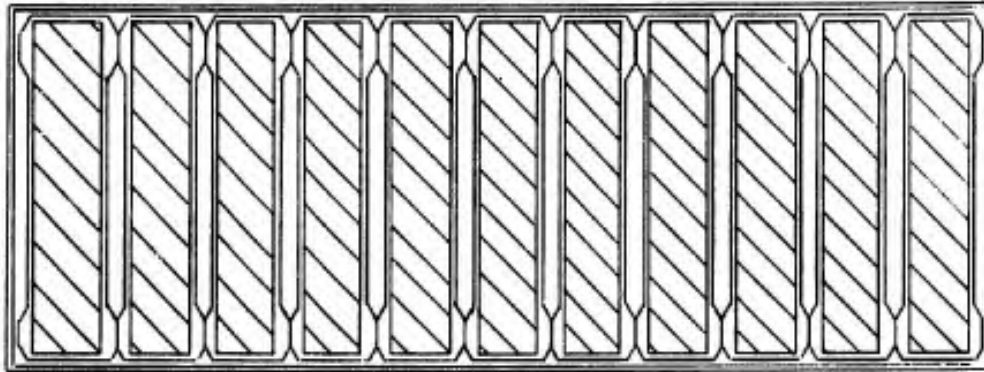

FIGURE 4 Carriers Positioned in Rack

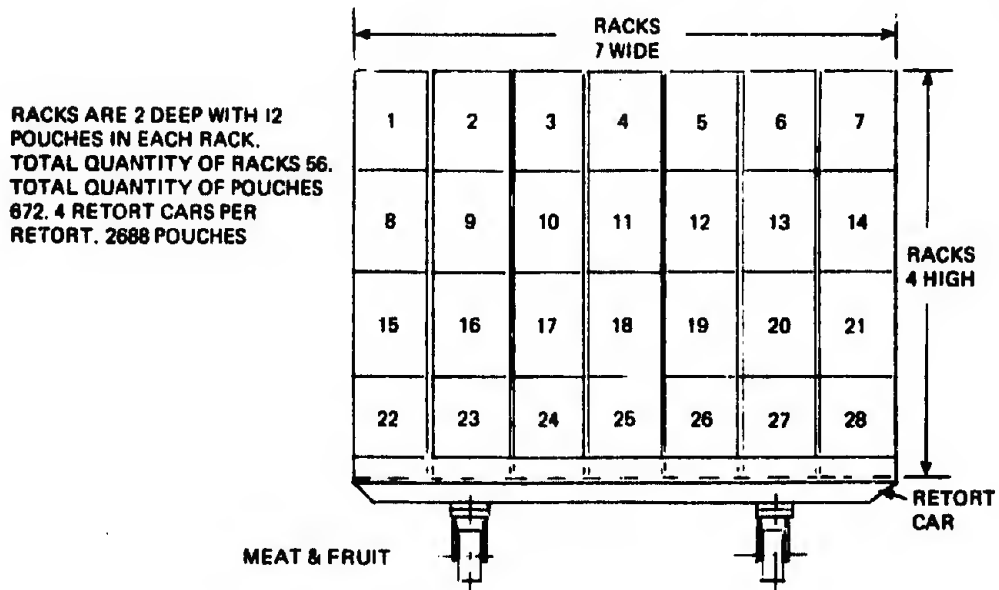
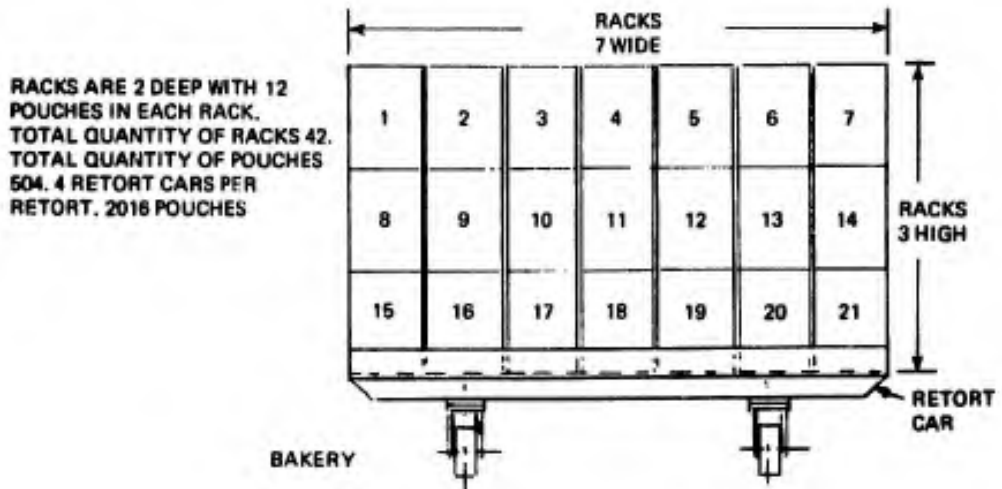

FIGURE 5 Retort Car Patterns



The reason for only three layers of racks when handling bakery products is that it was thought that the pressure difference due to the head of water felt by the pouches in the top and bottom layers would be sufficient to affect the quality and uniformity of the product.

To control the overall retort operation, a combination of Taylor instruments was selected. These instruments are housed in a vertical control panel beside each retort. Figure 6 shows the front of the control panel. A digital-set programmer, which is the process-control memory, is used to determine which function and when each function of the process is to be performed. The temperature controller controls the temperature at which the product is processed and is reset for each category of food being cooked. The center instrument is the steam-and-water flow controller. The quantity of steam controls the rate at which the retort is heated, whereas the amount of water determines the cooling rate. The third controller, the differential-pressure controller, is used for bakery products. It is also used, however, for the retort-pressure control when cooking meat and fruit. When retorting bakery items, a close pressure differential must be maintained between the internal pouch pressure and the retort pressure; this controller does that. Charts of the temperature, steam-and-water flow, and differential pressure are plotted by the Taylor recording controllers. These charts are kept as permanent records for each batch in each retort run.

To go into a little more detail on the controls, Figure 7 schematically illustrates the temperature-control system. The temperature controller is connected to a temperature sensor that is located inside the retort, halfway between the center of the retort and the top of the water. A control line from the low-pressure selector is connected to the pressure switch. The pressure switch is actuated when the cooking temperature, as set on the temperature controller, is reached. The temperature is maintained for the cooking time by the temperature controller, which opens and closes the steam-flow control valve. The solenoid-activated air valve is operated by the digital-set programmer at the start of the heating phase of the process and maintained until the end of the cooling phase. This valve controls the flow of agitating air into the bottom of the retort.

The steam-and-water flow-control system is shown in Figure 8. The optimum heating and cooling rate of the food items is 8°F per minute. It was determined that with a constant heat load, a constant flow of steam and cooling water would produce the desired heating or cooling effect. The steam-and-water flow controller, which is activated by the programmer during the heating and cooling phases, is a dual control unit connected to flow transmitters in the supply lines, which monitor and adjust the flow of steam or cooling water into

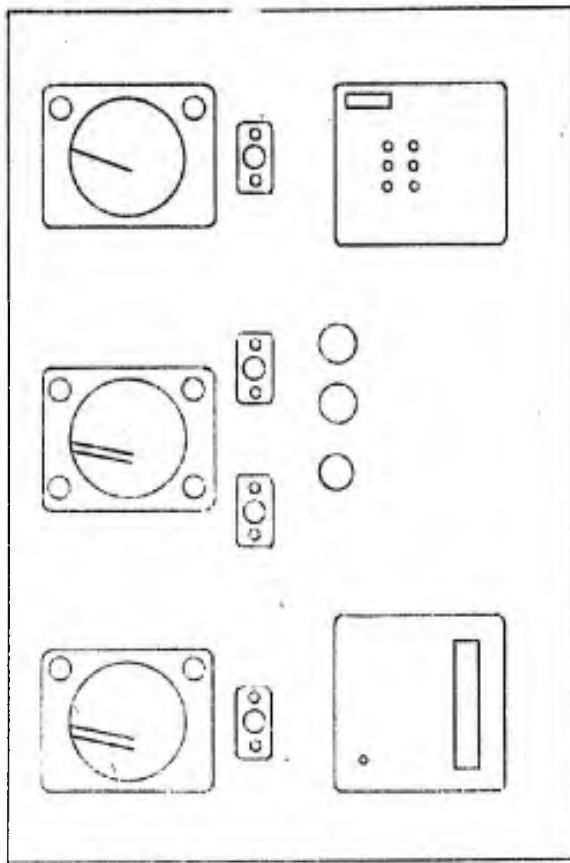

FIGURE 6 Control Panel Block Diagram

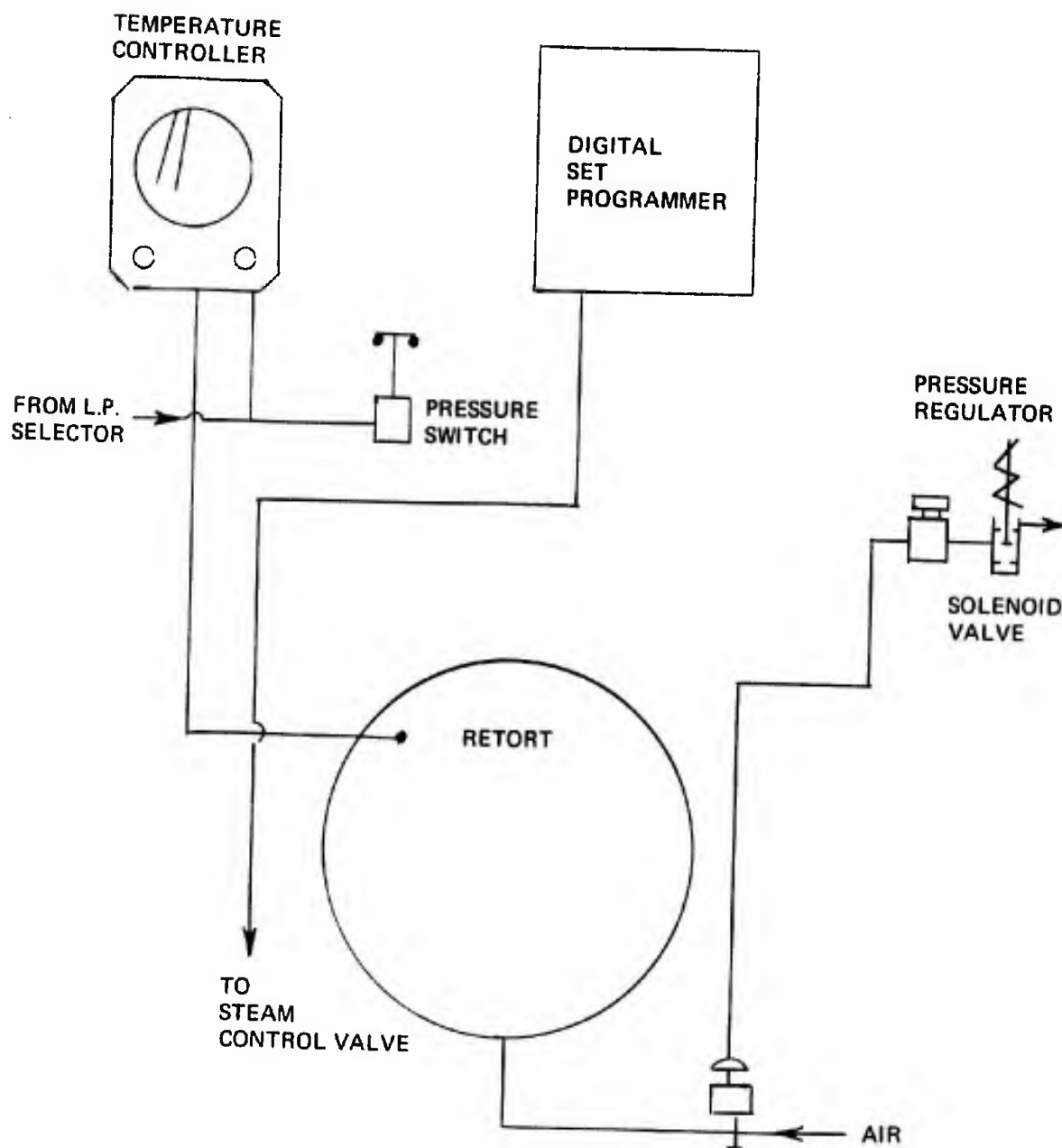

FIGURE 7 Schematic Showing Temperature Control

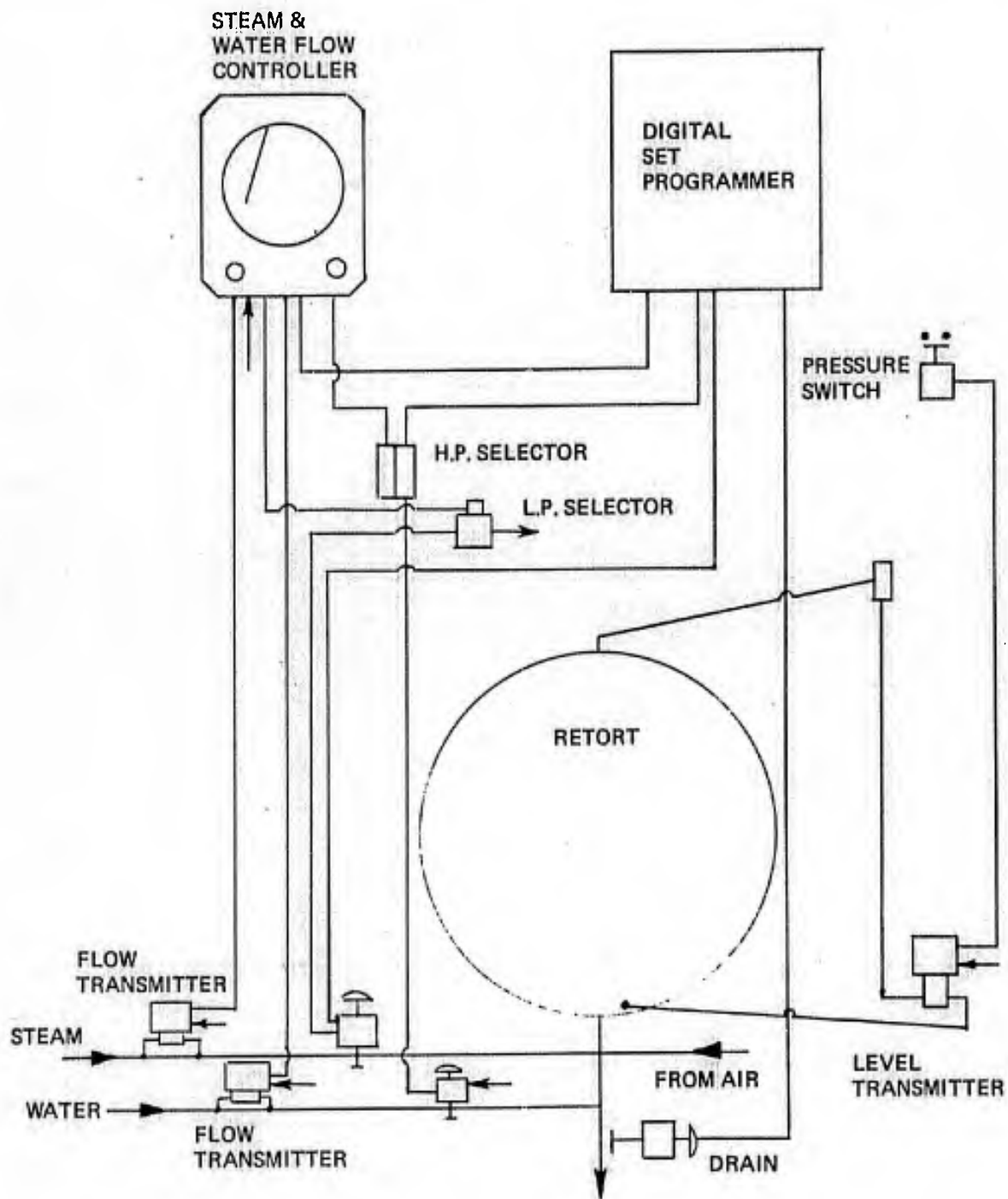

FIGURE 8 Schematic Showing Steam and Water Flow Control

the retort. The high-pressure selector also shown in Figure 8, allows the retort to be filled by the same cooling-water supply line. The control valve is held wide open as the retort is being filled. To control the level of water in the retort during the fill cycle, a level transmitter is used in conjunction with a pressure switch. As the retort is filled, the pressure due to the waterhead on this side of the transmitter increases until the differential pressure is great enough to activate the pressure switch, which in turn closes the fill water-inlet valve.

When processing bakery products, it is essential to maintain a positive pressure inside the pouch at all times. The control system shown in Figure 9 performs this function. It consists of a pressure can, which simulates the pressure in the pouch, differential pressure transmitter, differential pressure controller, and inlet and exhaust air valves. The differential pressure controller is set at the difference in pressure to be maintained between the inside of the pressure can and the inside of the retort. A predetermined weight of bakery product from the same batch that is being processed is loaded into the pressure can and the can is sealed. The retort door is closed and the cooking is started. As the product is heated it expands. The pressure inside the can and the pressure in the retort are sensed by the differential-pressure transmitter and controlled by the differential-pressure controller by opening or closing the air inlet and exhaust valves. In processing non-bakery products, the pressure control is not so critical; then, a fixed air pressure is introduced into the pressure can. The system then controls the pressure in the retort to within 2 psi of the can pressure. The digital-set programmer activates the control system at the start of the heating phase and maintains it during the complete cooking process.

In summary, the operation of the retort is as follows:

- (1) At the retort, open all main hand valves in the supply lines to ensure that all automatic valves are in control when operations commence.
- (2) Load racks on retort cars and load cars into retort. Close and secure door.
- (3) Set desired operational mode and set product selector to appropriate product -- meat, bakery, or fruit.
- (4) Set desired temperature and cooking time for the appropriate product.
- (5) Start digital-set programmer. The subsequent steps in the process are fully automatic.
- (6) The feed-water valve is opened and the retort is filled to a predetermined level. The level is detected by the level transmitter and the feed-water valve is closed when the pressure switch is closed.
- (7) Overriding air-pressure valves are opened by the digital-set programmer.

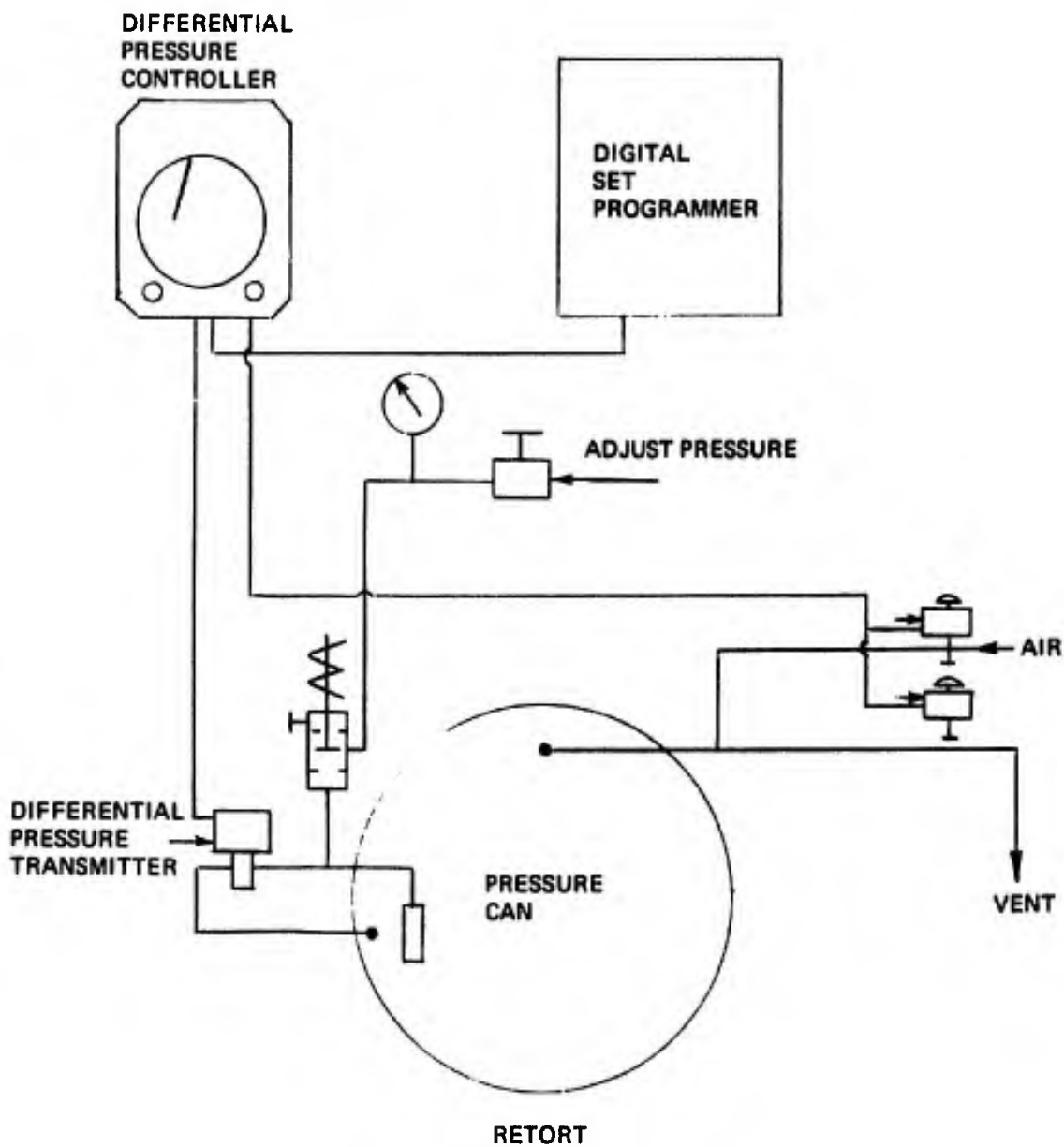

FIGURE 9 Schematic Showing Differential Pressure Control

(8) Steam-flow and agitating air valves are opened and the heating phase is started. Recirculation pump is started.

(9) When cooking temperature is reached, the steam valve is throttled down and the timer in the digital-set programmer is activated. Temperature is then maintained at this level by the temperature controller.

(10) When cooking time ends, the steam valve is closed and the cooling water valve opened.

(11) The flow of cooling water is controlled by the flow transmitter and the control valve to maintain the desired cooling rate.

(12) When the retort is cooled to approximately 100°F, the pressure control and the cooling water stop, the drain valve is opened, and the retort is drained.

(13) The process is now complete; the product is removed from the retort.

In order to verify the uniformity of temperature distribution and pressure and the retort-control system; an extensive test program was carried out at FMC's plant in California and the Swift plant at Oak Brook. All the design requirements for an automatic retort for processing foods in flexible pouches were satisfied.



TEST PROCEDURES AND PERFORMANCE VALUES  
REQUIRED TO ASSURE RELIABILITY

Gerald L. Schulz  
Packaging Technologist  
Systems Development Branch  
Packaging Division  
General Equipment & Packaging Laboratory  
U.S. Army Natick Laboratories

We are rapidly approaching the time when flexible packages of heat-processed foods will be used as components of operational rations. Therefore, it is necessary to consider the documentation necessary for large-scale procurement under the military system. The effort at U.S. Army Natick Laboratories has been directed toward adapting established test methods or developing new tests to measure performance characteristics of flexible packages of heat-processed foods, and toward establishing test levels to assure that the packages will meet the performance levels required.

MATERIAL REQUIREMENTS

A number of obvious requirements must be met by packaging materials before they can be considered for this application. Included are such items as:

- (1) Extractive levels must meet U.S. Food and Drug Administration regulations.
- (2) Basic strength of the material must be sufficient to withstand handling during processing.
- (3) Barrier properties must be sufficient to prevent product deterioration during storage. We have accepted, at least for the present time, that a layer of aluminum foil is necessary to provide the barrier to oxygen and water vapor needed to meet military storage requirements.
- (4) Material structure must be capable of withstanding thermal processing under commercial conditions without adverse effect on the package or the contents.

Although meeting these basic material requirements is essential, the fact that a material has met them does not assure that long-term storage life and handling durability of the fabricated pouch will be adequate for military applications. Therefore, in addition to basic material requirements, our procurement documents must be more detailed, at least until an

**Preceding page blank**

industrial base is established and more experience with this packaging system is obtained. Because many of our studies on test procedures and performance levels are still in progress, I cannot give you a set of minimum values for specific performance characteristics that will assure that a material will meet all military requirements. I will, however, present some of the findings of our studies on flexible package performance and discuss some test procedures that, at this point, appear to be feasible.

### FLEXIBLE PACKAGES VERSUS METAL CANS

Because the Flex-Pack is being developed as a replacement for metal cans in operational rations, we conducted a series of tests on both types of containers to compare the relative resistance to damage from rough handling. For these tests, two commercially available flexible materials were compared with metal cans under identical rough handling conditions. The flexible packages were 11.4 cm x 17.8 cm pouches and the metal cans were standard 300 x 200 three-piece sanitary cans.

For all tests, the flexible packages were glued to a paperboard folder, shown in Figure 1. Two foodstuffs -- chicken a la king and beefsteak -- were used; one is pumpable and the other semisolid. Shipping containers for both package types were style RSC, fabricated from 200 lb test corrugated fiberboard. The test consisted of one hour of vibration at 1 "G", followed by 10 drops from 45.7 cm. The drop test was in accordance with ASTM\* test D-775-68, Objective B. Table I shows the aggregate percentage of failures of 3600 flexible packages and 2160 metal cans. In all instances, the failure rate of the flexible packages was equal to or lower than that of the metal can, but a difference in failure rate was found between the two test products. The failure rate was higher when both the flexible packages and the metal cans were filled with a pumpable product, that is, chicken a la king, than when filled with beefsteak. Table II shows the failure rates from tests with packages filled with pumpable product. Both flexible packages have a lower failure rate than the metal cans; however, for this product, flexible material No. 2 was found to be significantly better than flexible material No. 1. As shown in Table III, the flexible packages performed as well or better than the metal cans when both were filled with a semisolid product. It is interesting to note that the flexible material, which showed the lower failure rate with the pumpable product, showed a 50 percent higher failure rate than the other flexible material when filled with the semisolid product. Failure criteria were either product leakage or swelling after biotesting and incubation.

---

\* American Society for Testing and Materials

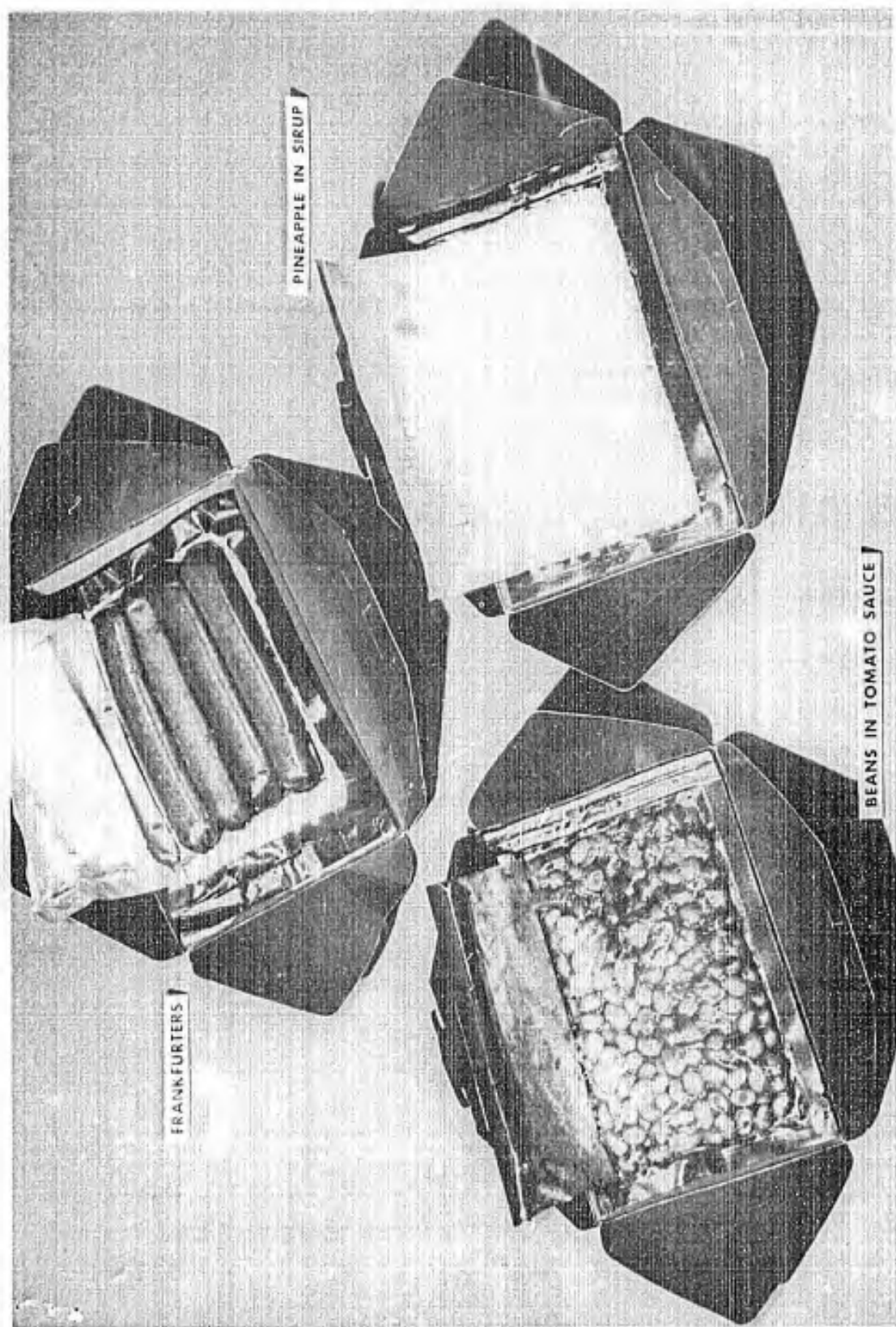

FRANKFURTERS

PINEAPPLE IN SIRUP

BEANS IN TOMATO SAUCE

FIGURE 1 Thermoprocessed Foods in Flexible Packages

**FAILURES %  
CAN + FLEX-PACK ROUGH HANDLING TESTS**

	<b>PUMPABLE PRODUCT</b>	<b>SEMISOLID PRODUCT</b>	<b>TOTAL</b>
<b>METAL CANS</b>	2.22	0.56	1.66
<b>FLEXIBLE PACKAGES</b>	1.62	0.41	1.14

**TABLE I** Comparative Failure Rates of Cans and Flexible Packages under Identical Rough Handling Tests

**PUMPABLE PRODUCT  
ROUGH HANDLING TESTS**

	<b>TESTED</b>	<b>FAILED</b>	<b>% FAILURE</b>
<b>CANS</b>	1440	32	2.22
<b>FLEX. MTL. NO. 1</b>	1440	30	2.08
<b>FLEX. MTL. NO. 2</b>	720	5	0.7

**TABLE II** Comparative Failure Rates of Cans and Flexible Packages when Filled with a Pumpable Product

**SEMISOLID PRODUCT  
ROUGH HANDLING TESTS**

	<b>TESTED</b>	<b>FAILED</b>	<b>% FAILURE</b>
<b>CANS</b>	720	4	0.56
<b>FLEX. MTL. NO. 1</b>	720	2	0.28
<b>FLEX. MTL. NO. 2</b>	720	4	0.56

**TABLE III** Comparative Failure Rates of Cans and Flexible Packages when Filled with a Semisolid Product

It should be pointed out that this was a comparative test intended to cause failure. These data should not be interpreted as an indication of lack of durability of the metal can.

In all instances, the flexible packages were found to perform as well or better than the metal cans. At the 90 percent confidence level, flexible material No. 2 was found to be significantly better than material No. 1 or the metal can when used for the pumpable product. No other significant differences were found.

#### PACKAGE STRENGTH

A number of tests are available to measure the strength of a package. These include such tests as seal tensile strength, bond strength between the inner layer and the aluminum foil, static load, and internal pressure burst. Limitations exist, however, with many of the standard tests; these include:

Seal tensile test. This test does not necessarily measure the strength of the weakest part of the package. It is adequate as a spot-check on sealing conditions and equipment operation, but does not provide a true measure of the overall package strength.

Bond strength. Bond of the inner ply plays a direct role in package performance, but it has been found that a comparatively low bond in the body areas alone may have only a minor effect on the package performance during rough-handling tests. Reliance on bond strength alone as a measure of package strength could therefore lead to overrestrictive requirements.

Static load. A static-load test has the primary advantage of being non-destructive and it can be conducted on finished, filled, and processed packages. This test is limited to liquid-type products, and is therefore applicable only to selected items.

Internal-pressure burst tests. Studies conducted at Natick Laboratories indicate that an internal-pressure burst test provides a good overall measure of the ability of a package to withstand transportation and handling. Our tests have shown a correlation between internal-pressure burst and bond strength at the seal area, tensile strength of seals, and rough-handling endurance. This test offers the advantage of measuring the weakest part of the package and, with experience, an operator can identify irregularities in sealing bars, excessive heat creep, and non-fusion seals by visual examination of packages after pressure testing.

## CLOSURE SEALS

Another area to which we have devoted attention is the closure seal. Our aim is to define closure-seal requirements without being overrestrictive. Because occasional contamination of the seal surfaces can be expected, at least during initial procurements, a study was conducted to determine the effect of items entrapped in the closure seal on package performance.

Our studies included 0.32 cm- and 0.64 cm-wide seals with and without defects. The defect used was an 0.16 cm x 0.16 cm x 0.08 cm piece of rubber. The results of internal-pressure burst tests on the two seal widths without defects before and after retorting are shown in Figure 2. The 0.64 cm-wide seal showed greater strength prior to retorting, but after retorting, there was no significant difference between the two seal widths. Figure 3 shows the results of internal-pressure burst tests of packages containing defects. Again, there was no significant difference after retorting between the 0.32 cm- and 0.64 cm-seals. The effect of a defect, although not evident in the above data, proved significant in the number of failures during retorting (8.3 percent) and in the failure rate during rough handling of the narrower seals (11 percent).

Although these tests are still in progress to determine the changes over time and under storage conditions, it appears that a contamination-free closure seal is a valid requirement, especially with narrower seals as normally made with thermal impulse sealing.

Because a relatively small entrapped particle results in a comparatively large unsealed area in the seal, visual inspection can detect many packages that have contaminated closure seals. An automated infrared method has been developed by Natick Laboratories for detecting closure-seal defects. Shown in Figure 4 is a prototype infrared scanner that is currently in operation at Natick Laboratories. This machine is capable of scanning seals at a rate of 15.24 cm per second and will automatically reject packages with entrapped particles or voids in the seal, or completely unsealed packages.

## LONG-TERM STORAGE

Figure 5 shows a flexible package that was filled, sealed, and retorted approximately 8 years ago. The package is still intact and no signs of deterioration are visible. Shown in Figure 6 is a package that was opened after 3 months' storage. Nearly complete delamination has taken place. The two packages were made from different materials, and both were intact immediately after retorting. I have chosen examples at both extremes to point out the need for a rapid, simple test to

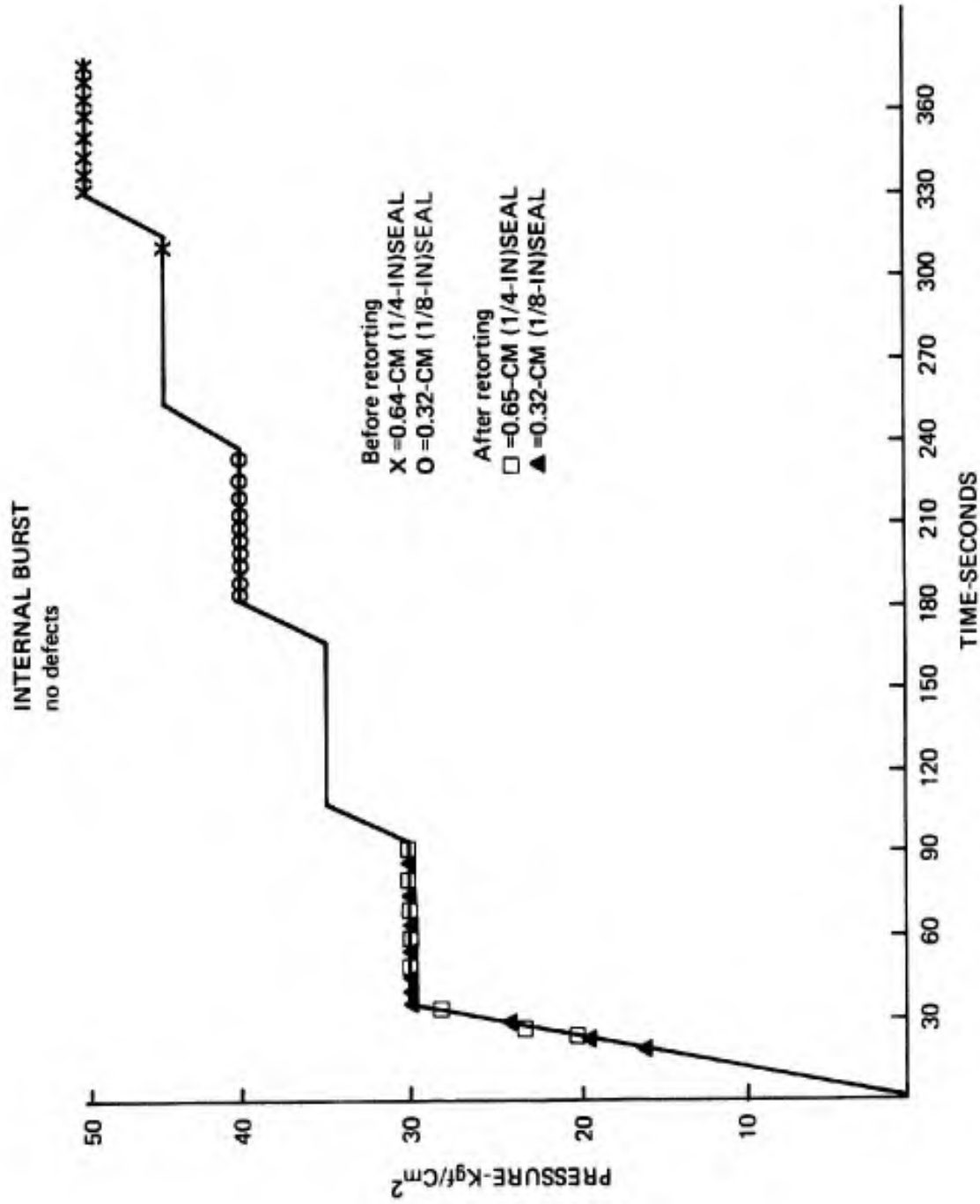

FIGURE 2 Internal Pressure Burst Test Results - Closure Seals without Defects



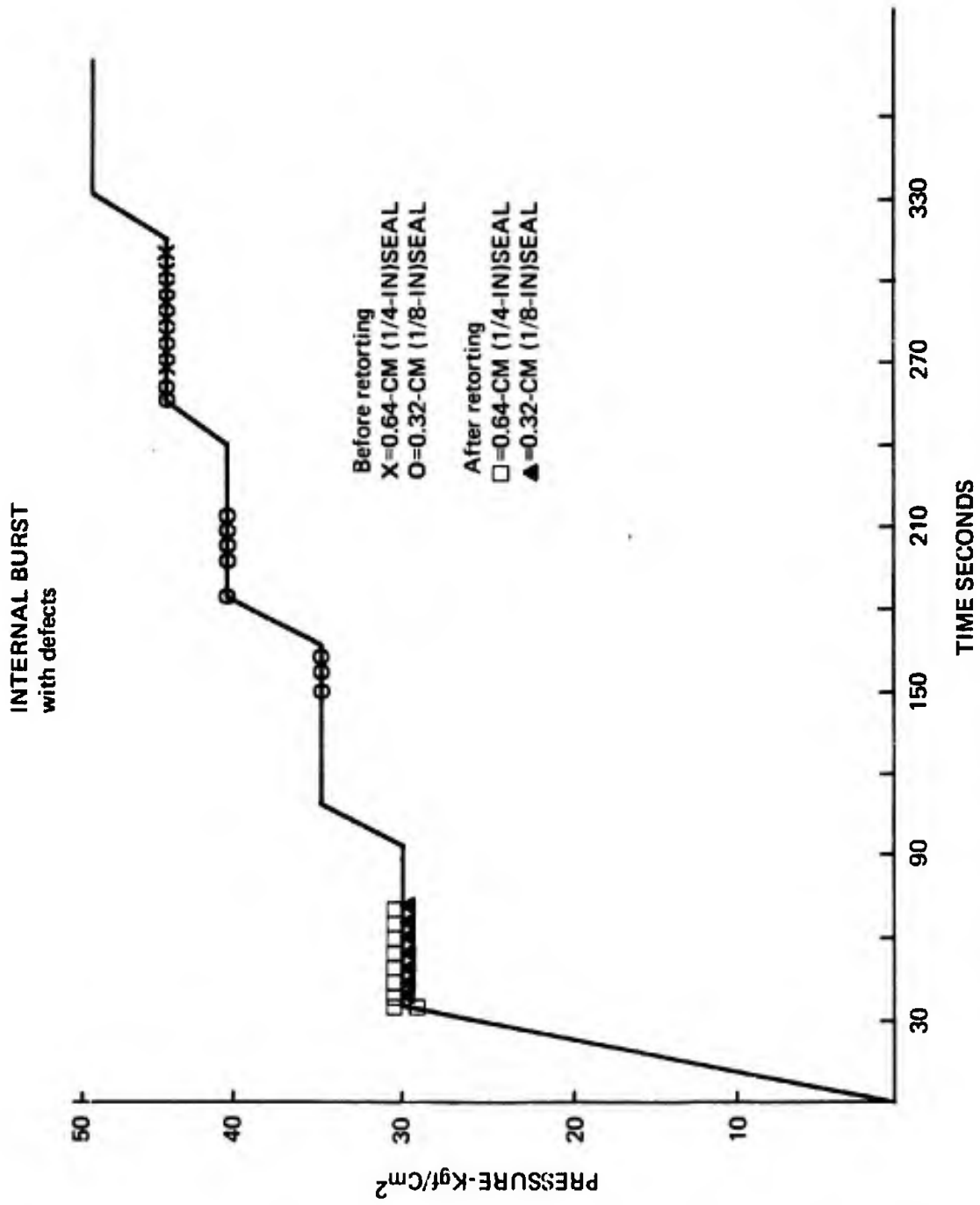

FIGURE 3 Internal Pressure Burst Test Results - Closure Seals with Defects

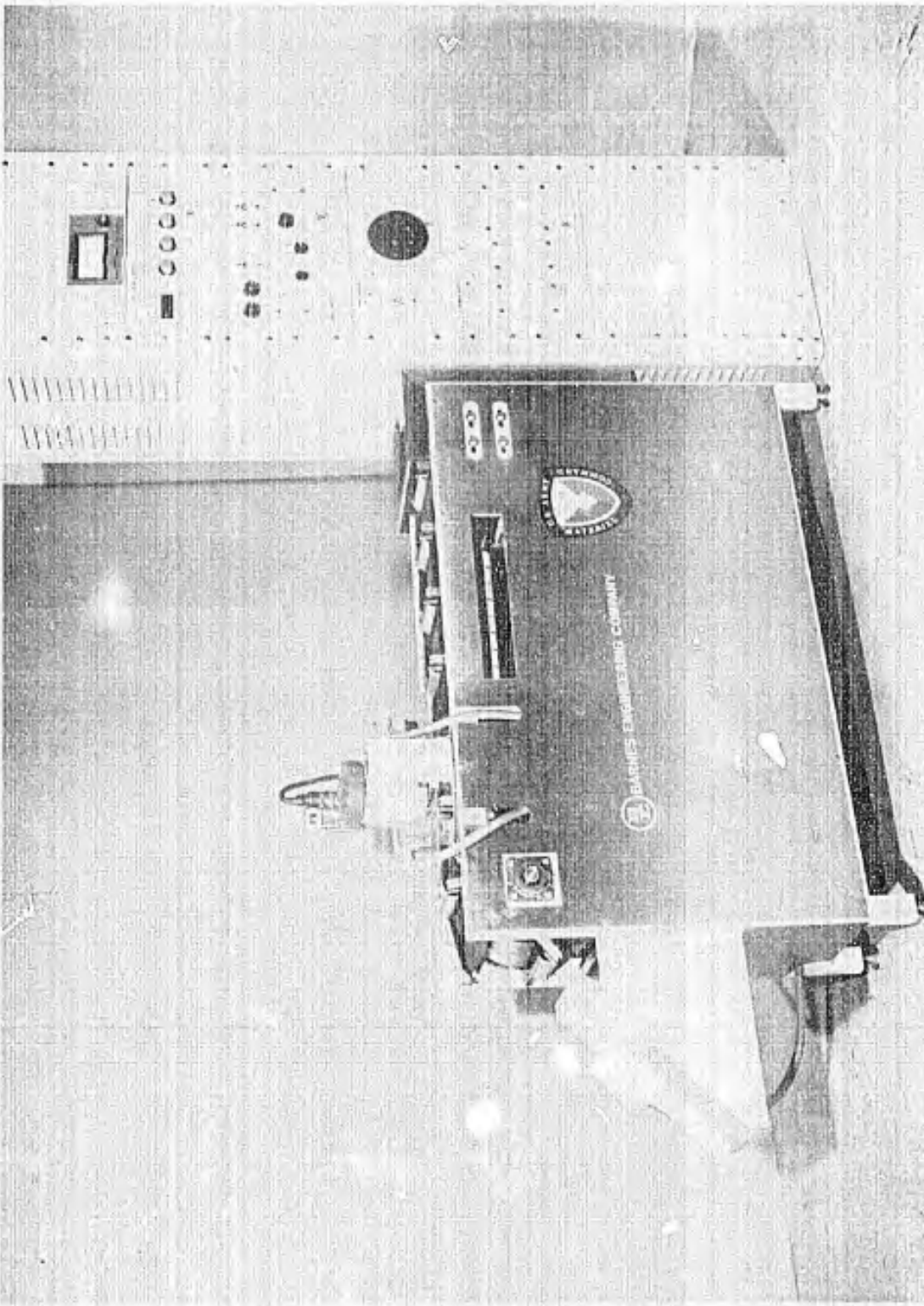

FIGURE 4 Infrared Scanner for Flexible Package Seal Defects

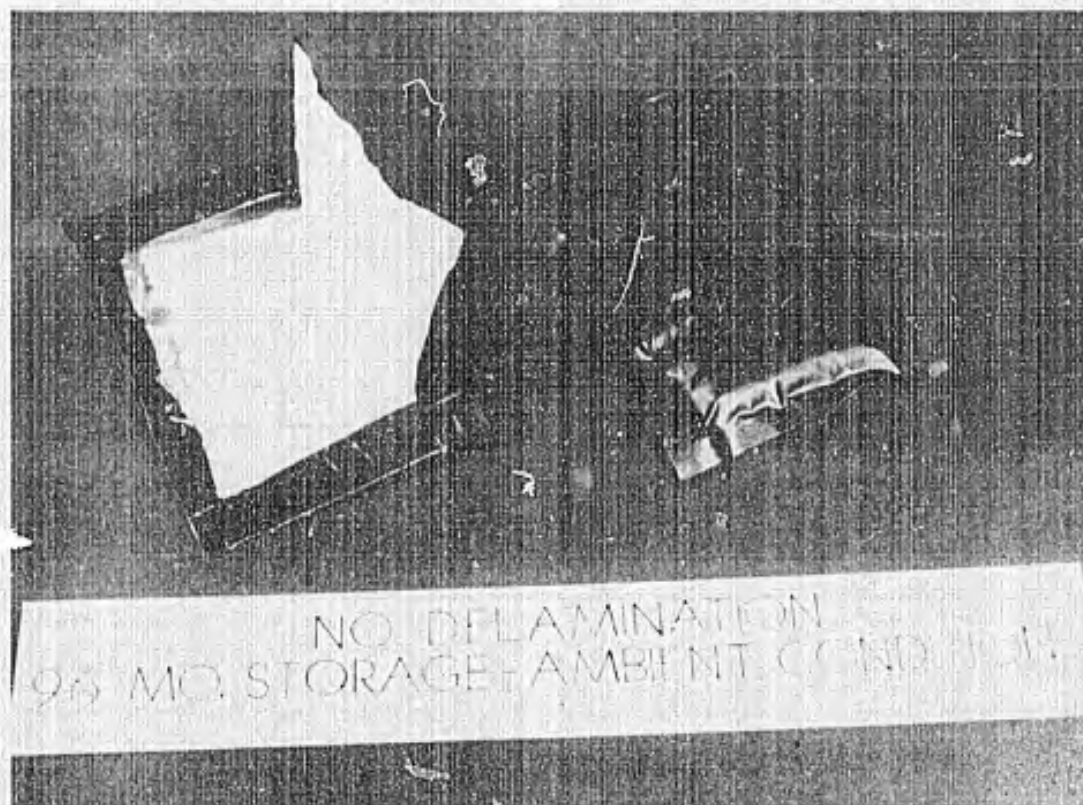

FIGURE 5 Flexible Package after Approximately 8 Years Storage



FIGURE 6 Flexible Package after Approximately 3 Months Storage

screen out materials that are likely to deteriorate rapidly as a result of product exposure during storage. A test of this type would be of value to material manufacturers, packers, and the government.

Under our exploratory development program, we are investigating methods of accelerating package delamination, with the ultimate goal of developing a test that can be used to screen materials without the necessity of retorting and storage for extended periods of time. This work is in the early stages and the data are based on a limited number of tests.

To accelerate the effect of product reaction on the package, we are experimenting with model products which contain components of selected food items. A typical model product contains oil, acetic acid, and a terpene in a starch-water matrix. Changes in bond strength of the inner layer of film to the aluminum foil are measured after the model product is stored at an elevated temperature for various periods of time in a pouch made of the test packaging material. Figure 7 shows the changes on bond strength at 24-hour intervals of a material exposed to the model product and the changes after storage of a food item in packages made from the same material. I want to emphasize that this is one material, one test-product formulation, and one set of tests. We are currently testing several materials with different product models, and conducting long-term storage of a variety of food items in pouches made of various materials. Our objective is to devise a go-no-go type test, that is, if a material will survive exposure to a test product for a specified period of time without delamination, we will be reasonably sure that long-term storage properties are adequate. We are currently using the most-difficult-to-package food items as our standard. In the future, it may be possible to use less stringent requirements for foods that are less damaging, such as low-fat food items.

I have reviewed some of the work currently being done in our program at Natick Laboratories and have summarized the results of some rather extensive testing that we have recently completed.

After many years of work in flexible packaging for heat-processed foods, we have accumulated a considerable amount of information. Our next step is to translate this information into realistic procurement documents that will assure performance without being overrestrictive. Based on past work, the contract effort discussed at this symposium, and the encouraging results from our preliminary tests, we do not envision any major obstacles in preparing the procurement documents.

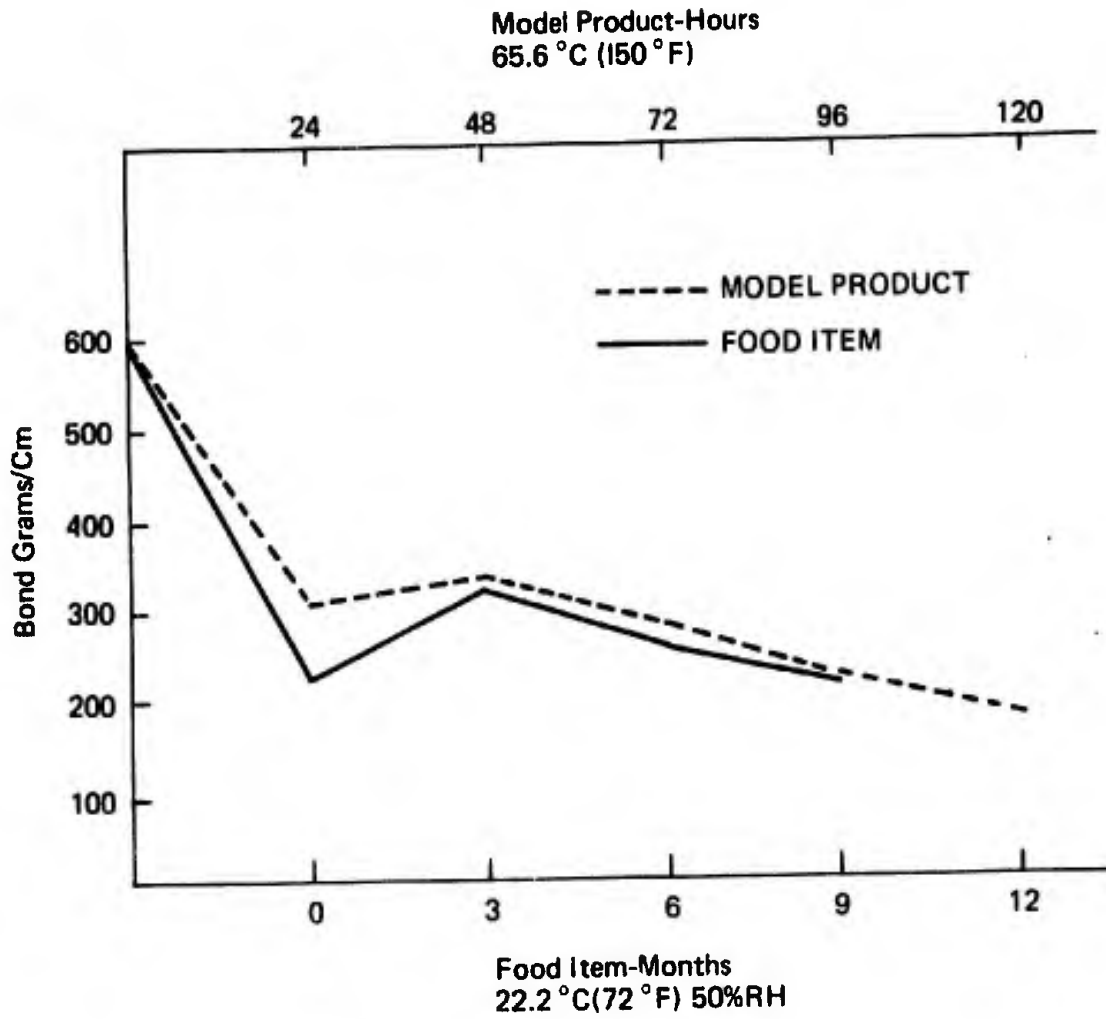

**FIGURE 7** Changes in Bond Strength -- Model Product and Food Item



## SUMMARY OF RELIABILITY CONTRACT RESULTS

Dean D. Duxbury  
Manager, Grocery Products Research  
Research and Development Center  
Swift & Company

The results of the reliability contract discussed today illustrate two types of accomplishment, both of which were based on predetermined goals, whether specified or assumed. Let me briefly summarize the latter more intangible accomplishments first.

First, a government-industry team was established to plan, coordinate, and complete a complex research and development program. Second, to implement the effort, a five-company working team of various -- sometimes competitive -- industries was developed. The give and take resulted in an appreciation of each other's capabilities and limits. Each, therefore, had to undertake burdens to assure performance. There was no room to blame factors outside one's own responsibility -- such as film or equipment or food product characteristics -- for non-performance. The team was successful. Third, improvements in design and construction found in our prototype processing line are applicable to operation and sanitation of all types of food equipment. They were developed by the equipment manufacturers during this contract. These improvements include the seal-bar design to achieve a burst-test level of more than 30 psi; minimizing closure-seal wrinkles in the vacuum closing machine; a pouch carrier to control the position of the pouch through the equipment line, provide maximum water and heat circulation during retorting, and control the shape of the product; the capability of the single basic processing line to package 17 or more different food items (although we will test only 6 now); and the adaptability of the equipment for handling minor film variations. In this regard, there have been a total of 12 patent disclosures so far in this project.

Improvements designed for microbiological protection included use of stainless hex-head bolts instead of slotted screws, use of a crack-sealing compound approved for food use, and use of rectangular-tubing frame construction instead of angle iron to prevent bacterial build-up.

Advancements have also been made in packaging knowledge and food-safety assurance as it relates to the flexible-container concept for shelf-stable thermoprocessed foods.

Much information has been gained for military research and procurement agencies, government regulatory agencies, the equipment development industry, and for the food processing industry. The experience in handling technology and product formulation for the variety of foods should also benefit the food industry. Of necessity, for clarity in the coordination of the efforts of the participants, a glossary of common terminology has been established.

The specific primary results in this interim report are based on fully analyzed data regarding fruitcake, the first food item produced. Although we completed the manufacture of the ham and chicken loaf before this symposium, the incubation period is still in process for part of the samples and, therefore, the data are only partially available.

First, let me review the preliminary and necessarily limited data on ham and chicken loaf. Only 9 of 396 fell below the fill-weight specification of  $142 \pm 14$  gms. These 9 included 7 that were underweight by .5 gm, 1 underweight by 1.5 gms, and 1 underweight by 2.5 gms. An additional 260 samples -- 18 from each of 20 loss -- weighed after retorting yielded only 4 underweight by .5 gm. Based on this, we have the ability to control the net weight.

In each lot, two sealed uncooked pouches and two retorted pouches were analyzed for residual gas. None recorded more than 7.0 cc of gas. The maximum allowable in the guidelines was 10.0 cc.

Organoleptic testing by a 10-member sensory panel was conducted each working day on the previous working day's production lot. The panel provided general acceptance scores and specific comments on flavor, texture, and appearance. The panel acceptance-score goal was 7.0. Of 20 lots evaluated, 15 were rated 7.0 or above, and all were above 6.6. This indicates there were no off-flavor problems in any lot.

Outgoing product-quality evaluation of ham and chicken loaf to date is based on more than 45,400 pouches retorted, incubated, and 100 percent visually inspected. This has shown a total of 13 top-seal leakers confirmed by the Meade vacuum leak test. There have also been 11 top-seal-wrinkle rejects after incubation, although none were leakers.

Results from the fruitcake processing are based on 26 lots of 2,016 pouches each. Our first in-process evaluation during production focused on package integrity as related to sealing-equipment performance. Formed pouches both before filling and after filling and sealing were subjected to an air-burst test. Specifications for this test were established at 35 psi for 30 seconds with a 30-second come-up. Six consecutive packages were sampled every 30 minutes for side



and bottom seals after forming and for top seals after filling and vacuum closure. This allowed a continual auditing of the production line and an occasional corrective action was taken to control the process and permit consistent quality and assurance of integrity of the pouch seals during forming, filling, and sealing operations. After retorting each lot, an additional 13 randomly selected samples were evaluated for seal integrity against an air-burst specification of 15 psi for 10 seconds with a 15-second come-up. Six of these samples were checked for the side and bottom seals and 7 for integrity of the top seals. There were no air-burst test failures on any sample seals after retorting -- again illustrating the consistent reliability of the package-sealing operations.

Another in-process sampling of 6 consecutive pouches every 30 minutes was made after the filling operation to determine production compliance with the net fill-weight specification of  $135 \pm 10$  gms for fruit cake. Statistical evaluation of data indicated that the capability of the filling process is  $\pm 8.9$  gms as compared with the specification spread of  $\pm 10$  gms. Out of 456 samples checked, only 1 package fell below the minimum 125 gm fill-weight limit (it contained 121 gms). Additional fill-weight data were collected on 13 randomly selected pouches per lot -- or 338 packages in all -- after retorting. All these samples fell within the specification.

A requirement for "uniform and identifiable" ingredient distribution was specified to ensure a uniform product. Six filled pouches of raw dough were sampled and evaluated every 30 minutes. In addition, 13 samples were randomly selected from each retorted batch. All samples indicated excellent uniform distribution of all ingredients both in the raw dough and in the finished cake slice.

As an additional check on the quality of dough mix, handling, processing, and organoleptic acceptance, two samples per retorted lot were subjected to a moisture analysis. Specifications called for 13 to 18 percent moisture; all samples analyzed fell within a range of 15.7 to 17.1 percent.

Organoleptic testing by the sensory panel resulted in general acceptance scores and specific comments on flavor, texture, and appearance. These scores were compared against the "no off-flavors or off-odors detected" requirement. An average panel score of 7.5 (or a minimum of 6 out of 10 panelists scoring 6.5 or more on a 1-to-9 hedonic scale) was the goal. Results indicated no objectionable off-flavors reported in any lot. Also, although only 9 out of 26 average panel scores were 7.5 or higher, all batches scored an average of 6.2 or higher (in descriptive panel terminology, a 6.2 score is equivalent to "like slightly" or better). The lower scores were apparently due to a nebulous response of the panelists regarding a dryness in texture.

Microbiological analyses were conducted for aerobic bacterial, yeasts, and mold counts. These tests were made for reference and reassurance of finished product safety on packages being shipped for further military testing. Six representative random samples per retorted lot were selected after 14 days in 100°F incubation for analysis. All samples indicated microbial counts of less than 10 per gm to provide what is commonly considered a "commercially sterile" product.

In summary of the assessment of outgoing product quality from our prototype line, we have drawn the following conclusions. Of approximately 50,000 pouches of fruit cake that were manufactured, retorted, incubated, and 100 percent visually inspected, no top-seal wrinkles were found. Seven hundred sixteen packages were removed because of various imperfections, and these were all subjected to the Meade vacuum-leak test to isolate any leakers. Twenty-two packages were found to leak -- 17 for reasons not related to the performance of the packaging line. Five leakers could be related to the packaging line, but the causes were considered to be random and, therefore, a direct indication of the ability of this prototype line to provide reliable shelf-stable thermoprocessed packages. The ratio of 5 out of approximately 50,000 packages demonstrated that we are approaching the goal of the contract of one detectable defective pouch in 10,000.

The 694 non-leakers contained imperfections such as minor film delaminations, body creases, uneven seals, and imperfect tear notches. None of these defects affect package performance.

## APPENDIX

Attendance List

Lawrence I. Abrams  
John Sexton and Company  
222 S. Riverside Plaza  
Chicago, Illinois 60606

Ralph Adesso  
Thomas J. Lipton, Inc.  
800 Sylvan Avenue  
Englewood Cliffs, New Jersey  
07632

William J. Aichele  
Nabisco, Inc.  
Route 208  
Fair Lawn, New Jersey 07410

Edward E. Anderson  
U.S. Army Natick Laboratories  
Natick, Massachusetts 01760

Cal Andres  
FOOD PROCESSING  
111 East Delaware Place  
Chicago, Illinois 60611

Gerald B. Anthes  
Thomas J. Lipton, Inc.  
800 Sylvan Avenue  
Englewood Cliffs, New Jersey  
07632

N. E. Asher  
American Home Foods Corporation  
Milton, Pennsylvania 17847

D. W. Aud  
Swift Processed Meats Company  
115 West Jackson Boulevard  
Chicago, Illinois 60604

Jackie Bailey  
Federal State Reports, Inc.  
Box 986  
Court House Station  
Arlington, Virginia 22216

M. P. Baldauf  
Quaker Oats Research  
Laboratories  
617 West Main Street  
Barrington, Illinois 60010

Maj. Charles D. Barbe  
U.S. Army Natick Laboratories  
Natick, Massachusetts 01760

John C. Bard  
Oscar Mayer and Company  
P. O. Box 1409  
Madison, Wisconsin 53701

Wayne E. Batterman  
Geo. A. Hormel and Company  
P. O. Box 800  
Austin, Minnesota 55912

Donald S. Becker  
Trenton Foods  
A Division of Carnation  
Company  
Trenton, Missouri 64683

Frank L. Bender, Jr.  
Raymond Eisenhardt and  
Son, Inc.  
Oakland, New Jersey 07070

Robert B. Bennett  
National Academy of Sciences  
2101 Constitution Avenue  
Washington, D.C. 20418

Harry F. Bernholdt  
Swift and Company, R&D Center  
1919 Swift Drive  
Oak Brook, Illinois 60521

M. E. Bilskie  
Swift Processed Meats Company  
115 West Jackson Boulevard  
Chicago, Illinois 60604

Leo J. Blankfield  
Rexham Corporation  
1665 Elmwood Road  
Rockford, Illinois 61101

Charles Bratz  
Uncle Ben's, Inc.  
P. O. Box 1752  
Houston, Texas 77001

C. H. Bridges  
Kellogg Company  
235 Porter Street  
Battle Creek, Michigan 49016

Paul R. Broten  
Cornell University  
Ithaca, New York 14850

J. Lorne Cameron  
E. S. & A. Robinson (Canada), Ltd.  
69 Laird Drive  
Toronto 17, Ontario, Canada

L. S. Campbell  
Continental Can Company  
Toronto, Canada

Frank C. Campins  
36 Storer Avenue  
Pelham, New York 10803

Allen B. Canfield  
Rexham Corporation  
1665 Elmwood Road  
Rockford, Illinois 61101

Norman W. Carey  
Rexham Corporation  
1665 Elmwood Road  
Rockford, Illinois 61101

Walter L. Clark  
Quaker Oats Company  
617 West Main Street  
Barrington, Illinois 60010

O. A. Clemens  
Swift and Company  
1919 Swift Drive  
Oak Brook, Illinois 60521

George H. Coleman  
E. I. du Pont de Nemours  
and Company, Inc.  
Wilmington, Delaware 19898

Weld Conley  
Votator Division  
Chematron Corporation  
P. O. Box 43  
Louisville, Kentucky 40201

Allan O. Corning  
Continental Can Company  
1200 West 76th Street  
Chicago, Illinois 60620

Richard C. Covington  
National Pet Food Corporation  
2801 W. 47th Street  
Chicago, Illinois 60632

Wayne H. Dahlgren  
Rexham Corporation  
1665 Elmwood Road  
Rockford, Illinois 61101

Donald L. Davies  
Swift and Company, R&D Center  
1919 Swift Drive  
Oak Brook, Illinois 60521

Rees B. Davis  
Continental Can Company, Inc.  
1200 West 76th Street  
Chicago, Illinois 60620

M. J. De Bella  
Swift Processed Meats Company  
115 West Jackson Boulevard  
Chicago, Illinois 60604

Robert F. De Long  
American Can Company  
Neenah, Wisconsin 54956

Hans-Günther Dermitzel  
Schmalbach-Lubeca-Werke AG  
Braunschweig, Germany

Eugene E. Dewey  
Continental Can Company  
1200 West 76th Street  
Chicago, Illinois 60620

Victoria Dibbern  
U.S. Army Foreign Science  
and Technology Center  
220-7th Street, N.E.  
Charlottesville, Virginia 22901

Robert B. Dillaway  
U.S. Army Materiel Command  
Attn: AMCDL  
Washington, D.C. 20315

Robert P. Dudley  
Geo. A. Hormel and Company  
P. O. Box 800  
Austin, Minnesota 55912

Dean D. Duxbury  
Swift and Company, R&D Center  
1919 Swift Drive  
Oak Brook, Illinois 60521

Paula J. Ebbert  
National Academy of Sciences  
2101 Constitution Avenue  
Washington, D.C. 20418

D. W. Edwards  
Banquet Foods Corporation  
515 Olive Street  
St. Louis, Missouri 63101

Ward F. Eldred  
Continental Can Company  
5745 East River Road  
Chicago, Illinois 60631

Robert L. Esse  
General Mills, Inc.  
James Ford Bell  
Technical Center  
9000 Plymouth Avenue North  
Minneapolis, Minnesota  
55427

Daniel F. Farkas  
U.S. Department of  
Agriculture  
800 Buchanan Street  
Berkeley, California 94710

A. Feberwee  
Unilever Research  
Laboratorium  
Vlaardingen/Duiven  
Zevenaar, Holland

Frank R. Fisher  
National Academy of Sciences  
2101 Constitution Avenue  
Washington, D.C. 20418

Gerald Flint  
Alberto Culver Company  
2525 Armitage  
Melrose Park, Illinois  
60160

Claus M. Foltys  
Rexham Corporation  
1665 Elmwood Road  
Rockford, Illinois 61101

Nugmes Francesco  
STAR  
Agrhreb, Italy

John M. Fultz  
Kraftco Corporation  
Glenview, Illinois 60025

James H. Gee  
Engineered Systems Division  
Food Machinery Corporation  
328 Brokaw Road  
Santa Clara, California  
95052

Roger Genske  
Friday Canning Corporation  
New Richmond, Wisconsin 54017

Peter Gfeller  
Hero Conserven Lenzburg  
Lenzburg, Switzerland 5600

Lawrence E. Giuliani  
Rexham Corporation  
1665 Elmwood Road  
Rockford, Illinois 61101

P. L. Goldfarb  
Reynolds Metals Company  
10th and Byrd Streets  
Richmond, Virginia 23219

Charles V. Goldsworthy  
Cranberry Products  
Eagle River, Wisconsin 54521

G. A. Gordon  
PIRA  
Research Association for  
Paper Board Building and  
Packaging  
Randalls Road  
Leatherhead, Surrey, England

W. H. Gray  
RHM (Research), Ltd.  
The Lord Rank Research Centre  
Lincoln Road  
High Wycombe, Bucks., England

Richard A. Greenberg  
Swift and Company, R&D Center  
1919 Swift Drive  
Oak Brook, Illinois 60521

Herman O. Gregg  
Continental "NU" Process, Inc.  
Box 23  
Crookston, Minnesota 56716

Harry J. Cribnitz  
Quaker Oats Company  
617 West Main Street  
Barrington, Illinois 60010

Philip A. Guarino  
McCormick and Company, Inc.  
Hunt Valley, Maryland 21204

James Guenther  
Milprint, Inc.  
Milwaukee, Wisconsin 53201

Arthur W. Harckham  
Thomas J. Lipton, Inc.  
800 Sylvan Avenue  
Englewood Cliffs, New Jersey  
07632

Carol D. Hardin  
Rexham Corporation  
P. O. Box 4068  
Charlotte, North Carolina  
28204

Jerry Hartz  
Reynolds Metals Company  
410 N. Michigan  
Chicago, Illinois 60611

Pieter Hemmes  
Thomassen & Drijver-Verblifa NV.  
Deventer, Netherland

Robert E. Henry  
Continental Can Company, Inc.  
1200 West 76th Street  
Chicago, Illinois 60620

John Hetrick  
University of Illinois  
Urbana, Illinois 61801

Dwight L. Hill  
Rexham Corporation  
1665 Elmwood Road  
Rockford, Illinois 61101

Arthur Hirsch  
Standard Packaging  
Corporation  
1 Lisbon Street  
Clifton, New Jersey 07013

Edward Hirschberg  
E. Hirschberg Freeze Drying, Inc.  
179 Starlite Street  
South San Francisco, California  
94080

Gary A. Hohner  
Quaker Oats Company  
617 West Main Street  
Barrington, Illinois 60010

Herbert A. Hollender  
U.S. Army Natick Laboratories  
Natick, Massachusetts 01760

R. Bruce Holmgren  
PACKAGE ENGINEERING  
5 South Wabash Avenue  
Chicago, Illinois 60603

J. E. Houston  
Continental Can Company  
5745 N. East River Road  
Chicago, Illinois 60631

Milton A. Howe, Jr.  
W. R. Grace  
Duncan, South Carolina 29334

Gerald H. Ingraham  
The Pillsbury Company  
311 Second Street S. E.  
Minneapolis, Minnesota 55414

Henry J. Izzo  
Armour-Dial, Inc.  
801 W. 22nd Street  
Oak Brook, Illinois 60521

John M. Jackson  
Green Giant Company  
1100 North 4th  
LeSueur, Minnesota 56058

Orlan V. Jennings  
William Underwood Company  
One Red Devil Lane  
Watertown, Massachusetts 02172

Kenneth R. Johnson  
Rexham Corporation  
1665 Elmwood Road  
Rockford, Illinois 61101

Ralph W. Johnston  
U.S. Department of Agriculture  
Meat and Poultry Inspection  
Program  
Washington, D.C. 20250

R. Vernon Jones  
Phillips Scientific Corporation  
Bartlesville, Oklahoma 74004

R. M. Jorgensen  
Del Monte Corporation  
P. O. Box 89  
Rochelle, Illinois 61068

Robert R. Jule  
American Can Company  
433 N. Northwest Highway  
Barrington, Illinois 60010

E. H. Kane  
Reynolds Metals Company  
10th and Byrd Streets  
Richmond, Virginia 23219

Morris H. Katz  
The Pillsbury Company  
311 S.E. 2nd Street  
Minneapolis, Minnesota 55414

Philip Keane  
Continental Can Company  
5745 N. East River Road  
Chicago, Illinois 60631

Robert G. Keller  
Best Foods Research Center  
Division CPC International  
Union, New Jersey 07083

Ronald W. Koper  
Thomas J. Lipton, Inc.  
800 Sylvan Avenue  
Englewood Cliffs, New Jersey  
07632

Arnold A. Kopetz  
American Can Company  
American Lane  
Greenwich, Connecticut 06830

Thomas J. Krainik  
Campbell Soup Company  
Campbell Place  
Camden, New Jersey 08101

Gordon J. Krueger  
American Can Company  
433 N. Northwest Highway  
Barrington, Illinois 60010

Jack K. Krum  
R. T. French Company  
One Mustard Street  
Rochester, New York 14609

William G. Kurtz  
Defense Supply Agency  
Cameron Station  
Alexandria, Virginia 22314

Rauno A. Lampi  
U.S. Army Natick Laboratories  
Natick, Massachusetts 01760

P. R. Latimer  
Rexham Corporation  
Box 111  
Flemington, New Jersey 08822

Morton Levine  
Celanese Plastic Company  
Box 828  
Greer, South Carolina 29651

Joseph Lindwarm  
Office, Deputy for Laboratories  
U.S. Army Materiel Command  
Washington, D.C. 20315

Wilbur G. Ludwig  
Rexham Corporation  
1665 Elmwood Road  
Rockford, Illinois 61101

B. R. Lundquist  
Armour Food Company  
Oak Brook, Illinois 60521

Charles W. Luxford  
U.S. Department of Agriculture  
Room 0721  
South Building  
Washington, D.C. 20250

Russell H. Maas  
Oscar Mayer and Company  
P. O. Box 1409  
Madison, Wisconsin 53701

J. L. Maloney  
Continental Can Company, Inc.  
1350 West 76th Street  
Chicago, Illinois 60620

Charles S. Mangleburg, Jr.  
Poss Manufacturing Company, Inc.  
P. O. Box 5339  
Athens, Georgia 30604

Mrs. Charles S. Mangleburg, Jr.  
Poss' Famous Foods, Inc.  
P. O. Box 5339  
Athens, Georgia 30604

R. M. Martin  
Reynolds Metals Company  
Packaging Division  
Richmond, Virginia 23234

Frank B. May, III  
USACDC Supply Agency  
Ft. Lee, Virginia 23801

George R. McCain  
Kraftco Corporation  
R&D Division  
Glenview, Illinois 60025

Shirley McCarthy  
U.S. Army Troop Support Agency  
Ft. Lee, Virginia 23801

John McClelland  
Votator Division  
Chemetron Corporation  
P. O. Box 43  
Louisville, Kentucky 40201

R. McFedries  
Dow Chemical U.S.A.  
P. O. Box 6717  
Cleveland, Ohio 44130

Richard L. McKee  
CANNER PACKER  
301 East Main Street  
Barrington, Illinois 60010



Bernard J. McKernan  
Central States Can Company  
1801 Harsh Avenue S.E.  
Massillon, Ohio 44646

Patrick L. McRoberts  
Borden, Inc.  
New Products Division  
50 E. Broad Street  
Columbus, Ohio 43215

J. A. McWhorter  
American Beef Packers  
Omaha, Nebraska 68124

Brig. Gen. John C. McWhorter, Jr.  
U.S. Army Natick Laboratories  
Natick, Massachusetts 01760

Ferdinand P. Mehrlich  
U.S. Army Natick Laboratories  
Natick, Massachusetts 01760

William N. Miller  
Rexham Corporation  
1665 Elmwood Road  
Rockford, Illinois 61108

Lionel Mills  
Castleberry's Food Company  
P. O. Box 1010  
Augusta, Georgia 30903

J. David Mitchell  
John Labatt, Ltd.  
451 Ridout Street North  
London, Ontario, Canada

Jens L. Moller  
Continental Can Company, Inc.  
1350 West 76th Street  
Chicago, Illinois 60620

Thomas Mulvaney  
Food and Drug Administration  
Washington, D.C. 20204

H. Nagel  
E. I. du Pont de Nemours  
and Company, Inc.  
Wilmington, Delaware 19898

Edward A. Nebesky  
U.S. Army Natick Laboratories  
Natick, Massachusetts 01760

Reginald J. Ohlson  
Mars, Inc.  
1651 Old Meadow Road  
McLean, Virginia 22101

George B. Ordway  
Barnes Engineering Company  
30 Commerce Road  
Stamford, Connecticut 06904

Richard D. Pankey  
Quaker Oats Company  
617 West Main Street  
Barrington, Illinois 60010

George O. Payne  
Continental Can Company, Inc.  
5745 East River Road  
Chicago, Illinois 60631

Dominic J. Peters  
Suter's Foods  
258 May Street  
Sycamore, Illinois 60178

George Peterson  
Continental Can Company  
1200 West 76th Street  
Chicago, Illinois 60620

Peter J. Pezzella, Jr.  
Thomas J. Lipton, Inc.  
800 Sylvan Avenue  
Englewood Cliffs, New Jersey  
07632

Irving J. Pflug  
University of Minnesota  
545 Space Science Center  
Minneapolis, Minnesota 55455

Larry Piet  
Alberto-Culver Company  
2525 W. Armitage Avenue  
Melrose Park, Illinois 60160

Capt. J. L. Pinsent  
National Defence Headquarters  
Directorate of Clothing and  
General Engineering  
Ottawa, Ontario, Canada

Mykola Plawiuk  
Essex Packers, Ltd.  
Brant and Hillyard Streets  
Hamilton, Ontario, Canada

Dennis Quinlan  
Swift and Company  
1919 Swift Drive  
Oak Brook, Illinois 60521

Hubert O. Ranger  
Consultants International, Ltd.  
1535 E. Goodrich Lane  
Milwaukee, Wisconsin 53217

Enzo Ravetta  
Goglio Luigi Milano S.p.A.  
Via Solari, 10  
Milano, Italy

R. B. Reed, Jr.  
Food and Drug Administration  
200 C Street, S.W.  
Washington, D.C. 20204

Richard C. Rheinhardt  
Quaker Oats Company  
617 West Main Street  
Barrington, Illinois 60010

Donald W. Riester  
American Can Company  
Barrington, Illinois 60010

Duane Riley  
The Pillsbury Company  
211 2nd Street S.E.  
Minneapolis, Minnesota 55414

Thomas E. Riley, Jr.  
Riley and Geehr, Inc.  
2749 N. Lincoln Avenue  
Chicago, Illinois 60614

William F. Robertson, Jr.  
Continental Can Company, Inc.  
1350 West 76th Street  
Chicago, Illinois 60620

George Robinson  
R.J.R. Foods, Ltd.  
750 Laurentian Boulevard  
Montreal, Quebec, Canada

Frank J. Rubinate  
U.S. Army Natick Laboratories  
Natick, Massachusetts 01760

Powell F. Sams  
The Pillsbury Company  
311 2nd Street S.E.  
Minneapolis, Minnesota 55414

Charles A. Sanna  
Beatrice Foods Company  
P. O. Box 1587  
Madison, Wisconsin 53701

F. Leon Sanna  
Beatrice Foods Company  
P. O. Box 1587  
Madison, Wisconsin 53701

Robert M. Schaffner  
Food and Drug Administration  
Washington, D.C. 20204

C. C. Schmiede  
Continental Can Company  
1200 West 76th Street  
Chicago, Illinois 60620

William F. Schroeder  
Carnation Company  
8015 Van Nuys Boulevard  
Van Nuys, California 91412

Gerald L. Schulz  
U.S. Army Natick Laboratories  
Natick, Massachusetts 01760

C. G. Schuytema  
Swift Processed Meats Company  
115 West Jackson Boulevard  
Chicago, Illinois 60604

M. E. Seehafer  
U.S. Steel Corporation  
600 Grant Street  
Pittsburgh, Pennsylvania 15230

Fred B. Shaw  
Continental Can Company, Inc.  
1200 West 76th Street  
Chicago, Illinois 60620

R. S. Shock  
Swift Processed Meats Company  
115 West Jackson Boulevard  
Chicago, Illinois 60604

Edward S. Shorkey  
Continental Can Company, Inc.  
633 Third Avenue  
New York, New York 10017

Dale H. Sieling  
U.S. Army Natick Laboratories  
Natick, Massachusetts 01760

Hal D. Sieling  
Borden, Inc.  
50 West Broad  
Columbus, Ohio 43215

Carl C. Simmons  
3M Company  
St. Paul, Minnesota 55101

John W. Sloan  
Meat and Poultry Inspection  
Program  
U.S. Department of Agriculture  
Washington, D.C. 20250

William Sofge  
Castleberry's Food Company  
P. O. Box 1010  
Augusta, Georgia 30903

R. W. Somerville  
E. I. du Pont de Nemours  
and Company, Inc.  
Wilmington, Delaware 19898

Ed A. Stafford  
Beatrice Foods Company  
P. O. Box 1587  
Madison, Wisconsin 53701

Wayne Staniec  
Perk Foods, Inc.  
Chicago, Illinois 60632

R. W. Stephenson  
Cherry-Burrell Corporation  
2400 Sixth Street S.W.  
Cedar Rapids, Iowa 52406

Victor Studer  
Thomas J. Lipton, Inc.  
800 Sylvan Avenue  
Englewood Cliffs, New Jersey  
07632

Frank J. Sylvester  
Thomas J. Lipton, Inc.  
800 Sylvan Avenue  
Englewood Cliffs, New Jersey  
07632

Joseph W. Szczeblowski  
U.S. Army Natick Laboratories  
Natick, Massachusetts 01760

F. Warren Tauber  
Union Carbide  
Films-Packaging Division  
6733 W. 65th Street  
Chicago, Illinois 60638

Frank H. Terwilliger  
Campbell Soup Company  
Campbell Place  
Camden, New Jersey 08101

R. H. Thorpe  
The Campden Food Preservation  
Research Association  
Chipping Campden  
Glos. GL55 6LD, United Kingdom

James Tingey  
Wyler Foods  
2301 Shermer Road  
Northbrook, Illinois 60062

Edward G. Tonn  
Crown Zellerback Corporation  
2101 Williams Street  
San Leandro, California 94577

Robert Tramontana  
 Armour-Dial, Inc.  
 801 W. 22nd Street  
 Oak Brook, Illinois 60521

Frank Troutman, Jr.  
 Castleberry's Food Company  
 P. O. Box 1010  
 Augusta, Georgia 30903

Earl W. Turner  
 ITT Continental Baking Company  
 Rye, New York 10580

Tom Turner  
 U.S. Services  
 853 Kipling Avenue  
 Toronto, Ontario, Canada

Wendell P. Turner, Jr.  
 Headquarters  
 U.S. Army Materiel Command  
 Attn: AMCRD-JI  
 Washington, D.C. 20315

John G. Valek, Jr.  
 Emblem Tool and Engineering  
 Company, Inc.  
 3213 S. Lombard Avenue  
 Cicero, Illinois 60650

T. A. Valvoda  
 Libby, McNeill and Libby  
 1800 W. 119th Street  
 Chicago, Illinois 60643

Eugene V. Waterfall  
 Rexham Corporation  
 1665 Elmwood Road  
 Rockford, Illinois 61101

David S. Watson  
 Rexham Corporation  
 1201 Greenwood Cliff  
 Charlotte, North Carolina 28204

Richard A. Waugh  
 Borden, Inc.  
 50 West Broad Street  
 Columbus, Ohio 43215

Frank E. Weber  
 R. T. French Company  
 One Mustard Street  
 Rochester, New York 14609

K. G. Weckel  
 University of Wisconsin  
 Madison, Wisconsin 53706

Robert L. Wedrall  
 Votator Division  
 Chemetron Corporation  
 P. O. Box 43  
 Louisville, Kentucky 40201

Samuel M. Weisberg  
 League for International  
 Food Education  
 1155 Sixteenth Street, N.W.  
 Room 705  
 Washington, D.C. 20036

Clarence Weisman  
 John Sexton and Company  
 1099 Pratt Boulevard  
 Park Grove Village, Illinois  
 60007

Robert M. Weiss  
 The Pillsbury Company  
 311 2nd Street S.E.  
 Minneapolis, Minnesota 55414

George R. Wilkens  
 RJR Archer, Inc.  
 Bowman Gray Development  
 33rd Street  
 Winston-Salem, North Carolina  
 27102

Wayne C. Williams  
 Aluminum Company of America  
 Pittsburgh, Pennsylvania  
 15219

R. B. Wilson  
 Mobil Chemical  
 Pittsburgh, Pennsylvania  
 15233

James V. Winkler  
 The Dow Chemical Company  
 1825 K Street N.W.  
 Washington, D.C. 20006

Gerald J. Winter  
Nabisco Research Center  
2111 Route 208  
Fair Lawn, New Jersey 07410

Kenneth J. Wohlpart  
Aluminum Company of America  
Alcoa Technical Center  
P. O. Box 2970  
Pittsburgh, Pennsylvania 15230

Carl Wolfe  
Quaker Oats Company  
617 West Main Street  
Barrington, Illinois 60010

William R. Wollum  
Cranberry Products, Inc.  
Eagle River, Wisconsin 54521

R. K. F. Yeates  
U.S. Services  
Toronto, Ontario, Canada

B. J. Young  
Swift Processed Meats Company  
115 West Jackson Boulevard  
Chicago, Illinois 60604

William E. Young  
William E. Young and Company  
280 Midland Avenue  
Saddle Brook, New Jersey 07662

John V. Ziemba  
FOOD ENGINEERING  
100 South Wacker Drive  
Chicago, Illinois 60606

The *National Academy of Sciences* is a private, honorary organization of more than 700 scientists and engineers elected on the basis of outstanding contributions to knowledge. Established by a Congressional Act of Incorporation signed by Abraham Lincoln on March 3, 1863, and supported by private and public funds, the Academy works to further science and its use for the general welfare by bringing together the most qualified individuals to deal with scientific and technological problems of broad significance.

Under the terms of its Congressional charter, the Academy is also called upon to act as an official -- yet independent -- adviser to the Federal Government in any matter of science and technology. This provision accounts for the close ties that have always existed between the Academy and the Government, although the Academy is not a governmental agency and its activities are not limited to those on behalf of the Government.

The *National Academy of Engineering* was established on December 5, 1964. On that date the Council of the National Academy of Sciences, under the authority of its Act of Incorporation, adopted Articles of Organization bringing the National Academy of Engineering into being, independent and autonomous in its organization and the election of its members, and closely coordinated with the National Academy of Sciences in its advisory activities. The two Academies join in the furtherance of science and engineering and share the responsibility of advising the Federal Government, upon request, on any subject of science or technology.

The *National Research Council* was organized as an agency of the National Academy of Sciences in 1916, at the request of President Wilson, to enable the broad community of U.S. scientists and engineers to associate their efforts with the limited membership of the Academy in service to science and the nation. Its members, who receive their appointments from the President of the National Academy of Sciences, are drawn from academic, industrial, and government organizations throughout the country. The National Research Council serves both Academies in the discharge of their responsibilities.

Supported by private and public contributions, grants, and contracts, and voluntary contributions of time and effort by several thousand of the nation's leading scientists and engineers, the Academies and their Research Council thus work to serve the national interest, to foster the sound development of science and engineering, and to promote their effective application for the benefit of society.

The *Division of Engineering* is one of the eight major Divisions into which the National Research Council is organized for the conduct of its work. Its membership includes representatives of the nation's leading technical societies as well as a number of members-at-large. Its Chairman is appointed by the Council of the Academy of Sciences upon nomination by the Council of the Academy of Engineering.

The *Advisory Board on Military Personnel Supplies* undertakes activities serving research concerned with feeding, clothing, protecting, and supplying military personnel in any environment, when such activities are accepted by the Academy as a part of its functions.