

AD-767 726

HIGH PERFORMANCE STEEL AND TITANIUM CASTINGS

NATIONAL MATERIALS ADVISORY BOARD (NAS-NAE)

PREPARED FOR
DEPARTMENT OF DEFENSE (ODDR/E)

FEBRUARY 1973

DISTRIBUTED BY:

NTIS

National Technical Information Service
U. S. DEPARTMENT OF COMMERCE

DISCLAIMER NOTICE

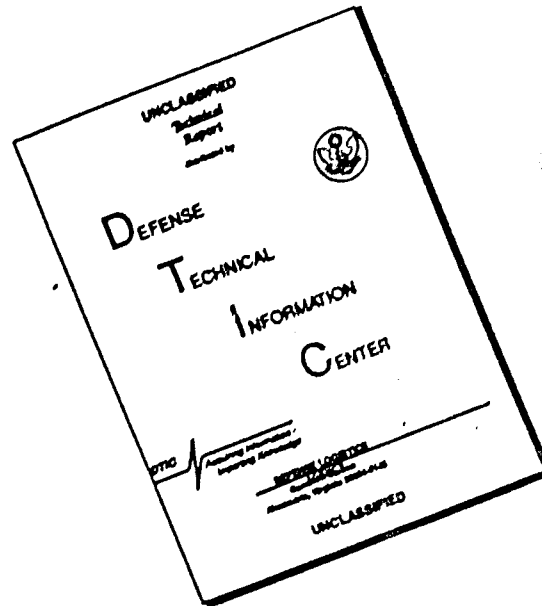

THIS DOCUMENT IS BEST QUALITY AVAILABLE. THE COPY FURNISHED TO DTIC CONTAINED A SIGNIFICANT NUMBER OF PAGES WHICH DO NOT REPRODUCE LEGIBLY.

UNCLASSIFIED

AD 767-724

Security Classification

DOCUMENT CONTROL DATA - R & D		
<i>(Security classification of title, body, abstract and indexing annotation must be entered when the overall report is classified)</i>		
1. ORIGINATING ACTIVITY (Corporate author)		20. REPORT SECURITY CLASSIFICATION
National Materials Advisory Board Ad Hoc Committee on High Performance Steel and Titanium Castings		Unclassified
3. REPORT TITLE		21. GROUP
HIGH PERFORMANCE STEEL AND TITANIUM CASTINGS		
4. DESCRIPTIVE NOTES (Type of report and inclusive dates)		
Final Report of the Committee		
5. AUTHOR(S) (First name, middle initial, last name)		
NMAB Ad Hoc Committee on High Performance Steel and Titanium Castings		
6. REPORT DATE	7A. TOTAL NO OF PAGES	7B. NO OF REFS
February 1973	232	95
8A. CONTRACT OR GRANT NO.	8B. ORIGINATOR'S REPORT NUMBER(S)	
DA49-083-OSA-3131	NMAB-296	
9. PROJECT NO.	9B. OTHER REPORT NO(S) (Any other numbers that may be assigned this report)	
	None	
10. DISTRIBUTION STATEMENT		
This document has been approved for public release and sale; its distribution is unlimited.		
11. SUPPLEMENTARY NOTES		12. SPONSORING MILITARY ACTIVITY
		Department of Defense (ODDR&E)
13. ABSTRACT		
<p>The present state of foundry technology pertinent to the production of high performance HY-130 and HY-180 steel and titanium alloy castings is assessed. Problems encountered in current production and those anticipated in future production of large castings up to 20,000 pounds (finished weight) are discussed. Programs and approaches to resolve these problems are recommended. Factors considered were: specific melting processes and furnaces for preparing and refining molten alloys, casting design, mold and pouring practice, influence of chemical composition, impurity elements, heat treatment and other processing variables on mechanical properties of casting, present and anticipated foundry problems with specific alloys, weld repair and structural joining, scrap reclamation, and appropriate procurement specification requirements to assure attainment of desired properties and qualities in castings of all sizes. While minimal problems will be encountered in the production of large HY-130 steel castings using present foundry facilities and practices, in HY-180 steel castings, considerable development work involving facilities and foundry practice is required. Current production of titanium alloy castings is limited to a maximum casting weight of approximately 2,000 lbs.</p>		

DD FORM 1473
1 NOV 66

Reproduced by
NATIONAL TECHNICAL
INFORMATION SERVICE
US Department of Commerce
Springfield, VA. 22151

UNCLASSIFIED
Security Classification

14 KEY WORDS	LINE A		LINE B		LINE C	
	NOLE	WT	NOLE	WT	NOLE	WT
HY-130 and HY-180 steel and titanium alloy castings Melting processes and furnaces Arc Furnace Melting Practices for HY-130 and HY-180 steels Argon Purging Argon-Oxygen Decarburization (AOD) Process Electroslag welding and remelting Casting design Mold and pouring practice Influence of chemical composition Impurity elements Heat treatment Weld repair and structural joining Scrap reclamation Antiflaking treatments						

AD 767 726

HIGH PERFORMANCE STEEL AND TITANIUM CASTINGS

Report of
The ad hoc Committee on High Performance
Steel and Titanium Castings
National Materials Advisory Board
Division of Engineering — National Research Council

DISTRIBUTION STATEMENT A
Approved for public release;
Distribution Unlimited

Report NMAB-296
National Academy of Sciences — National Academy of Engineering
Washington, D. C.

1-3

July 1973

NOTICE

The project which is the subject of this report was approved by the Governing Board of the National Research Council, acting in behalf of the National Academy of Sciences. Such approval reflects the Board's judgment that the project is of national importance and appropriate with respect to both the purposes and resources of the National Research Council.

The members of the committee selected to undertake this project and prepare this report were chosen for recognized scholarly competence and with due consideration for the balance of disciplines appropriate to the project. Responsibility for the detailed aspects of this report rests with that committee.

Each report issuing from a study committee of the National Research Council is reviewed by an independent group of qualified individuals according to procedures established and monitored by the Report Review Committee of the National Academy of Sciences. Distribution of the report is approved, by the President of the Academy, upon satisfactory completion of the review process.

This study by the National Materials Advisory Board was conducted under Contract No. DA-49-083-OSA-3131 with the Department of Defense.

Members of the National Materials Advisory Board study groups serve as individuals contributing their personal knowledge and judgments and not as representatives of any organization in which they are employed or with which they may be associated.

The quantitative data published in this report are intended only to illustrate the scope and substance of information considered in the study, and should not be used for any other purpose, such as in specifications or in design, unless so stated.

Requests for permission to reproduce this report in whole or in part should be addressed to the National Materials Advisory Board.

For sale by the National Technical Information Service, Springfield, Virginia 22151.

NATIONAL MATERIALS ADVISORY BOARD
AD HOC COMMITTEE ON HIGH PERFORMANCE STEEL AND TITANIUM CASTINGS

Chairman: Mr. A. Hurlich, Manager, Materials Technology, Department 643-0,
Convair Aerospace Division/General Dynamics Corporation,
P. O. Box 80847, San Diego, California 92138.

Members: Mr. A. James Kiesler, Manager, Metals Processing Operations,
Metals & Ceramics Labs, General Electric Research Center,
P. O. Box 8, Schenectady, New York 12301.

Dr. Thomas S. Piwonka, Materials Technology Laboratory, TRW Inc.,
23555 Euclid Avenue, Euclid, Ohio 44117.

Dr. Lew F. Porter, Section Supervisor Research Laboratory, United
States Steel Corporation, Monroeville, Pennsylvania 15146.

Mr. Laurence J. Venne, Chief Metallurgist, ESCO Corporation,
2141 N. W. 25th Avenue, Portland, Oregon 97110.

Dr. John F. Wallace, Professor of Metallurgy, Division of Metallurgy
and Material Science, Case-Western Reserve University, Cleveland,
Ohio 44106.

Mr. Thomas Watmough, Assistant Director, Metals Research, IIT
Research Institute, 10 West 35th Street, Chicago, Illinois 60616.

Mr. Ralph Zusman, Vice President, Research and Engineering,
Precision Castparts Corporation, 4600 S. E. Harney Drive, Portland,
Oregon 97206.

Liaison Representatives:

Dr. Paul J. Ahearn, Army Materials and Mechanics Research Center,
Watertown, Massachusetts 02171.

Mr. Robert A. Beall, Research Supervisor, Metals Processing Projects,
United States Department of the Interior, Bureau of Mines, Albany,
Oregon 97321.

Mr. W. Theodore Hignberger, Naval Air Systems Command, Department
of the Navy, Washington, D. C. 20360.

Mr. Bernard B. Rosenbaum, Naval Ship Systems Command, Department
of the Navy, Washington, D. C. 20360.

Mr. Jerome Persh, Staff Specialist for Materials and Structures
(Engineering Technology), ODDR&E, Department of Defense, The Pentagon,
Washington, D. C. 20301.

NMAB Staff:

Mr. Ben A. Kornhauser, Technical Staff Secretary, ad hoc Committee on
High Performance Steel and Titanium Castings, National Materials Advisory
Board, NAS-NAE-NRC, 2101 Constitution Avenue, Washington, D. C. 20418.

FOREWORD

This report outlines the requirements for both facilities and processes to enable the production of very large castings (up to 20,000 pounds in weight) of special alloy steels and titanium. Present capabilities for producing such castings are assessed and a number of evolutionary development programs are suggested to attain the desired goals.

In view of the significant differences in steel and titanium casting technologies, two separate Panels were established, as noted below, to prepare individual reports for consideration by the main committee and to expedite the preparation of the final report.

Steel Castings Panel

Mr. Laurence J. Venne, Chairman

Dr. Paul J. Ahearn

Mr. A. James Kiesler

Dr. Lew F. Porter

Mr. Bernard B. Rosenbaum

Dr. John F. Wallace

Titanium Castings Panel

Dr. Thomas S. Piwonka, Chairman

Mr. Robert A. Beall

Mr. W. Theodore Highberger

Mr. Thomas Watmough

Mr. Ralph Zusman

The Committee extends its appreciation to the Bureau of Mines, Albany, Oregon, for hosting a meeting of the Titanium Castings Panel and to the

following companies that graciously provided tours through their facilities to the members of the Titanium Castings Panel:

ESCO Corporation, Portland, Oregon

Oregon Metallurgical Corporation, Albany, Oregon

Precision Castparts Corporation, Portland, Oregon

TILine, Inc., Albany, Oregon

Use was also made of information on steel and titanium castings technology contained in National Materials Advisory Board report NMAB-291, High Performance Castings, March 1972.

	<u>Page</u>
G. Effect of Impurities on Properties	20
H. Minimum and Maximum Section Size	21
I. Weld Repair and Structural Joining	21
J. Scrap Reclamation	22
K. Specifications for HY-130 and HY-180 Steel Castings	22
L. Conclusions and Recommendations: HY-130 and HY-180 Steel Castings	24
1. Conclusions	24
2. Recommendations	25
 IV TITANIUM CASTINGS	 27
A. Introduction	27
B. Methods, Facilities and Melting Capacity	27
1. Consumable Electrode Skull Melting and Casting	27
2. Nonconsumable Electrode Melting	31
3. Electron Beam Melting	31
4. Induction Melting	32
5. Incremental Melting	32
6. Conclusion	32
C. Pour Temperature Monitoring and Control	33
1. Temperature Measurement	33
2. Superheat Control	34
3. Pour Temperature Control	35
D. Mold Materials and Systems	35
1. Oxide Molds with Oxide Binders	36
2. Carbon Coated Oxide Molds or Oxide Binder Impregnated Molds	37
3. Carbon and Graphite Molds	38
4. Tungsten Interfaced Investment Molds	41
5. Influence of Mold Materials on Casting Quality	42
E. Casting Design, Gating and Feeding	43
F. Alloy Systems for Castings	44

CONTENTS

	<u>Page</u>
ABSTRACT	xii
I SUMMARY OF CONCLUSIONS AND RECOMMENDATIONS	1
A. Conclusions	1
B. Recommendations	3
II INTRODUCTION	5
III STEEL CASTINGS, HY-100, -130 AND -180	7
A. Introduction	7
B. Steelmaking Methods	10
1. Arc-Furnace Practice	10
2. Vacuum Degassing	11
3. Vacuum Melting	11
4. Argon Purging	11
5. Argon/Oxygen Decarburization (AOD)	11
6. Electroslag Remelting	12
C. Foundry Production Facilities	12
1. Production of HY-130 Castings	13
2. Production of HY-180 Castings	14
D. Molding Practices for HY-130 and HY-180 Castings	14
E. Foundry Problems	14
1. Hydrogen Flakes and Antiflaking Treatments	15
2. Aluminum Nitride Embrittlement	16
3. Craze Cracking	16
4. Feeding and Microshrinkage	17
5. Deoxidation Practice	17
F. Heat Treatment	18
1. HY-130 Steel Castings	18
2. HY-180 Steel Castings	19

	<u>Page</u>
G. Porosity in Titanium Castings	47
1. Morphology	47
2. Effect on Properties	47
3. Prevention of Porosity	48
H. Effect of Impurities on Properties	48
1. Interstitial Pickup Due to Mold Reaction	49
2. Interstitials in the Charge Metal	49
I. Processing of Titanium Castings	50
1. Knockout	50
2. Cutoff	51
3. Sandblasting	51
4. Machining	51
5. Grinding	52
6. Chemical Milling	52
J. Heat Treatment and Mechanical Properties	53
K. Minimum and Maximum Section Sizes	55
1. Minimum Sections	55
2. Maximum Sections	59
L. Weld Repair and Structural Joining	59
M. Reclamation of Titanium Scrap	61
1. Tack-Welding Scrap for Consumable Melting	61
2. Durarc (Westinghouse) and Schlienger Rotating Electrode Processes	62
3. Electron-Beam Process	62
4. Split Crucible Induction Slag-Melting Process	63
5. Skull Casting Over Loose Scrap	63
N. Specifications for Titanium Castings	63
O. Conclusions and Recommendations: Titanium Castings	64
1. Conclusions	64
2. Recommendations	65
V. REFERENCES	67
A. Steel Castings	67
B. Titanium Castings	68

	<u>Page</u>
VI. APPENDIXES	
Appendix A — Specification MIL-S-23008B (SHIPS) of September 29, 1964: Steel Castings, Alloy, High Yield Strength (HY-80 and HY-100)	73
Appendix B — Military Specification MIL-T-81915: Titanium and Titanium-Alloy Castings, Investment	85
Appendix C — Suggested Arc Furnace Melting Practices for HY-130 and HY-180 Steels	99
Appendix D — Argon Purging of HY-80, HY-130 and HY-180 Steels	109
Appendix E — Production of HY-130 and HY-180 Steel by the Argon-Oxygen Decarburization (AOD) Process	123
Appendix F — Use of Electroslag Welding and Remelting to Produce HY-130 and HY-180 Steel Castings	129
Appendix G — Molding Practices for HY-130 and HY-180 Steel Castings	131
Appendix H — Antiflaking Treatments for HY-130 and HY-180 Steel Castings	135
Appendix I — Notch Toughness Required for "Extreme Service" Applications	141

TABLES

	<u>Page</u>
Table 1 -- Specified Compositions of HY-Steels and the Most Promising Candidate for the HY-180 Grade	8
Table 2 -- U. S. Commercial Sources of Titanium Castings	29
Table 3 -- Properties of Cast vs. Wrought Titanium	46
Table 4 -- Mechanical Properties of Cast Titanium	54
Table 5 -- Effect of Mold Preheat Temperature on Mold Fill for Ti-6Al-4V and Ti-6Al-2Sn-4Zr-2Mo	58
Table 6 -- Weldability of Titanium Alloys	60
Table 7 -- Antiflaking Procedures	138

FIGURES

	<u>Page</u>
Figure 1 -- Typical Skull-Casting Furnace	28
Figure 2 -- Argon Requirement for Hydrogen and Nitrogen Removal at 2912° F.	120
Figure 3 -- Ratio Analysis Diagram Definition of the Influence of Tempering Heat Treatment on the Fracture Characteristics and Yield Strength of 10 Ni Steel	143

ABSTRACT

The present state of the foundry technology pertinent to the production of high performance HY-130 and HY-180 steel and titanium alloy castings is assessed. Problems are discussed that are encountered in their current production as well as those anticipated in the future production of large castings up to 20,000 pounds in finished weight. Programs and approaches are recommended to resolve these problems.

The factors considered were the specific melting processes and furnaces for preparing and refining the molten alloys, casting design, mold and pouring practice, the influence of chemical composition, impurity elements, heat treatment and other processing variables upon the mechanical properties of casting, present and anticipated foundry problems with the specific alloys, weld repair and structural joining, scrap reclamation, and appropriate procurement specification requirements to assure the attainment of the desired properties and qualities in castings of all sizes.

While minimal problems probably will be encountered in the production of large HY-130 steel castings using present foundry facilities and practices, in the case of HY-180 steel castings, considerable development work involving both facilities and foundry practice is required. Current production of titanium alloy castings is limited to a maximum casting weight of approximately 2,000 pounds. Extensive development work is necessary to extrapolate titanium melting furnace capacities by an order of magnitude. Thick-section titanium castings also require development of reliable mechanical property data, possibly new alloy systems, and solution of mold and other foundry problems inherent in process scale-ups.

I. SUMMARY OF CONCLUSIONS AND RECOMMENDATIONS

The conclusions and recommendations, summarized below, are detailed at the conclusion of each section of the report dealing with HY steels and titanium alloy castings.

A. Conclusions

1. HY Steel Castings

- a. The chemical composition of a castable HY-130 grade steel and the necessary techniques for its melting, pouring and casting have been developed.
- b. While the HY-130 grade has not been cast in 6-inch thick sections or in large castings weighing up to 20,000 pounds, this alloy can be produced successfully in these sizes with existing foundry equipment.
- c. HY-130 steel has been made satisfactorily by arc-melting, followed by vacuum-degassing. Probably, this steel could be made by vacuum melting and by the argon/oxygen degassing (AOD) process also.
- d. Mechanical property data on 6-inch thick HY-130 steel castings are not available currently nor has a procurement specification for HY-130 castings been prepared. The same is true for the HY-180 grade of steel castings.
- e. In HY-180 steel castings, the final chemical composition still must be standardized. However, a 10Ni-8Co-2Cr-1Mo analysis appears promising and has been cast experimentally in 4-inch thick sections. Its hardenability appears adequate for 6-inch thick sections.
- f. Air melting, followed by vacuum degassing, appears inadequate for producing HY-180 steel. Probably, this alloy must be vacuum melted, although the AOD process may be satisfactory. An acceptable melting process still must be demonstrated.

g. The steel-foundry industry has very few large vacuum-melting furnaces and no foundry presently is equipped with AOD facilities.

h. Foundry problems with HY-180 steel have not been resolved yet. Some of these problems involve solidification and risering, scrap reclamation, and possible craze-cracking of the surfaces of castings.

i. Weld repair and structural joining of HY-180 castings require further development.

2. Titanium Alloy Castings

a. The titanium casting industry in the United States currently is limited to producing a casting weighing no more than 1500 pounds. Of the available melting processes, the vacuum-arc remelting furnace appears the most feasible for scaling up to produce a finished 20,000 pound casting.

b. Completely nonreactive mold systems have not been developed yet for the casting of titanium. Rammed-graphite molds may be satisfactory for the production of large titanium castings, but the possibility of exothermic reactions in heavy section castings exists. To date, only rammed-graphite molds have proved practicable for the largest titanium castings that have been made.

c. Current titanium casting-alloy compositions have limited hardenability. New alloy compositions must be developed for the attainment of desired mechanical properties in thick sections. Considerable development effort will be necessary to resolve foundry problems associated with porosity, alloy segregation, hot-tearing, shrinkage, metal-mold reactions, grain-size control, and gating and risering of large castings.

d. Virtually no data exist on the mechanical properties of thick-section titanium-alloy castings, and no procurement specification for large titanium castings is currently available.

B. Recommendations

The recommendations below are based upon the afore-mentioned conclusions.

1. HY — Steel Castings

a. Develop reliable mechanical property data (including fracture toughness) of HY-130 and HY-180 steels on section thicknesses up to and including 6 inches.

b. Cast relatively large laboratory heats of optimum composition(s) of HY-180 steel (determined from smaller heats of candidate compositions produced by varying deoxidation practices) for evaluating their mechanical properties in sections up to 6 inches thick.

c. Determine the feasibility of the argon/oxygen degassing (AOD) process for melting both HY-130 and HY-180 grades of steel.

d. Study the solidification characteristics of HY-180 steel to establish required gating and risering procedures to produce high-quality castings.

e. Investigate the factors responsible for craze-cracking of the surfaces of HY-130 and HY-180 steel castings.

f. Study the weld repairing and structural welding of HY-180 steel castings to evaluate strength and fracture toughness properties of the various heat-affected zones in weldments.

g. Prepare procurement specification for HY-130 and HY-180 steel castings that cover items such as the desired compositions, section thicknesses, and mechanical properties, and that are based upon the development programs recommended above.

2. Titanium Alloy Castings

a. Increase (by incremental steps to resolve scale-up problems) the capacity of titanium melting furnaces to permit pouring of 20,000-pound finished weight castings. The consumable arc-melting process is considered the most feasible for scale-up, with electroslag melting as the next best alternative.

b. Develop titanium alloys with suitable casting properties and characteristics in sections up to 6 inches thick. Alloy development studies should include characteristics such as solidification, shrinkage, hot-tearing, fluidity, porosity, weldability, and hardenability. The mechanical properties, including fracture toughness, should be determined on alloys in the annealed and heat-treated conditions.

c. Study the effect of carbon content and interstitial elements upon the mechanical properties of titanium casting alloys, particularly since rammed-graphite molds are the most feasible for larger titanium castings and result in some carbon pickup.

d. Develop a practical method for reclaiming and reusing titanium alloy foundry scrap so that the cost of titanium castings may be reduced.

e. Develop necessary mechanical property data and quality requirements, including nondestructive test requirements and standards, to prepare meaningful specifications for larger titanium alloy castings.

II. INTRODUCTION

Immediately preceding the current study, the National Materials Advisory Board had completed an investigation whose objective was to delineate the problem areas that impeded the more widespread acceptance and use of high performance castings. Report NMAB-291, "High Performance Castings," March 1972, presented the results of that investigation. The report made specific recommendations and proposed an integrated plan for improving the quality, reliability, and uniformity of, in addition to developing greater user confidence in, high-performance castings made from a variety of metallic alloy systems.

For the purpose of the earlier study, high-performance castings were defined as efficient load-carrying structures that are designed to withstand service stresses, which represent a significantly high proportion of their ultimate strengths and whose service failures could have catastrophic or other serious safety and/or economic consequences.

The previous investigation considered broadly the field of castings technology from the viewpoints of design, manufacture, quality control, information dissemination, and education. The present study focuses closer attention upon two classes of castings that are of increasing interest, the HI-100, -130 and -180 alloy steel castings and the titanium castings, in weights ranging up to 20,000 pounds for each type. The above definition of high-performance castings will apply in most cases to the end use of steel- and titanium-alloy castings in naval vessels.

The ad hoc Committee on High Performance Steel and Titanium Castings was established at the request of the Department of Defense. The Committee was charged with determining the required equipment and procedures, such as vacuum-melting and deoxidation, for a facility to produce high-performance

castings of steel (HY-100, HY-130 and HY-180) and titanium and outlining a method to obtain satisfactory castings of those materials up to 20,000 pounds in finished weight.

The report is based on information collected as of September, 1972.

III. STEEL CASTINGS, HY-100, -130 AND -180

A. Introduction

The HY (High-Yield strength) series of low-carbon quenched and tempered alloy steels is characterized by excellent combinations of strengths and toughness along with good weldability and high resistance to brittle fracture in both base metal and weld joints. These steels were developed by the United States Steel Corporation, with much of the work being conducted under U. S. Navy-funded programs. The numbers following the dash, such as HY-100, represent the minimum yield strength of each alloy class in thousands of pounds per square inch (lbs/in²).

The first steel of the HY- series was HY-80, which has been used widely for submarine pressure hulls, armor plating to resist bomb and explosive shell impact, and other critical applications in naval and merchant marine vessels and in land based structural applications requiring high toughness steels. As a result of higher performance requirements, increasingly higher strength steels, such as HY-100, -130, -150 and -180, were developed. Although these steels contained progressively higher alloy contents, they continued to possess excellent combinations of strength toughness, and weldability. The chemical composition ranges of some of these steels are listed in Table 1.

Specific chemical compositions and heat treatments have been developed for all but the HY-180 steel. The latter steel, having a minimum yield strength of 180,000 psi, still is considered developmental with no precise composition or heat treatment yet standardized.

Almost invariably, high-performance steels that possess high-yield strength, combined with good ductility and toughness, have appreciable nickel, low carbon to enhance weldability, and other alloying elements, such as chromium and molybdenum, in sufficient amounts to provide the hardenability required, particularly for thick section sizes. When the nickel content of these

Table 1
Specified Compositions of HY - Steels and the
Most Promising Candidate for the HY-180 Grade
(in percent)

<u>Grade</u>	<u>C</u>	<u>Mn</u>	<u>P</u>	<u>S</u>	<u>Si</u>	<u>Ni</u>	<u>Cr</u>	<u>Mo</u>	<u>V</u>	<u>C</u>	<u>Ti</u>	<u>Cu</u>	<u>Other</u>
HY-80 *	0.20 max.	0.55 0.75	0.020 max.	0.015 max.	0.50 max.	2.50 3.25	1.35 1.65	0.30 0.60	0.03 max.	--	0.02 max.	0.25 max.	--
HY-100*	0.22 max.	0.55 0.75	0.020 max.	0.015 max.	0.50 max.	2.75 3.50	1.35 1.85	0.30 0.60	0.03 max.	--	0.02 max.	0.25 max.	--
HY-130	0.12 max.	0.60 0.90	0.010 max.	0.010 max.	0.30 0.45	5.00 5.50	0.40 0.70	0.30 0.65	0.05 0.10	--	0.02 max.	0.25 max.	--
HY-180	0.09 0.13	0.05 0.25	0.010 max.	0.008 max.	0.15 max.	9.5 10.5	1.80 2.20	0.90 1.10	--	7.5 8.5	0.02 max.	--	**

* From Military Specification MIL-S-23008B, September 29, 1964.

** Al-0.025 max., N-0.0075 max., O-0.0025 max.

steels increases from the 3 percent for HY-80 and -100 steels to 5 percent for HY-130 steel and to 10 percent or greater for HY-180 steel, their manufacturing practices become more complex. In addition, to obtain the required toughness at high-strength levels, the gas (oxygen, nitrogen, and hydrogen) and impurity (phosphorus and sulfur) contents must be lowered progressively as the yield strength increases. Generally, the foundry industry lacks the vacuum-melting and degassing equipment that is required to produce 20,000- to 25,000-pound castings with 6-inch thick sections and very low gas and residual element contents (except for elements such as copper). Accordingly, possible melting and casting procedures that might provide the required steel quality should be considered to determine their practical and economic adaptability to the production of such large castings.

The steels of the high-yield series were developed initially as wrought steels for application as rolled plate or forgings. Because of their strength, toughness, weldability and resistance to stress corrosion and general corrosion in sea water, the high-yield steels, at least in lower and moderate strength alloys, have been accepted widely for use in marine environments.

The HY-80 alloy has been produced extensively in cast form and sufficient sizes to meet past and projected requirements. The very modest increase in alloy content and strength of the HY-100 steel as compared to HY-80 poses no foundry problems, and current foundry equipment and practices are expected to be fully suitable for the production of large castings from the HY-100 composition. Consequently, no further attention will be given to HY-100 castings.

Recently, high-strength steels with carbon contents of about 0.40 percent have been developed. However, these higher carbon steels are unsatisfactory for

many applications because of their relatively poor weldability and the necessity for post-weld heat treatments. Other steels, such as the precipitation-hardening and the maraging steels, were considered but were unsatisfactory because of their low fracture toughness, particularly in thick sections, or low resistance to corrosion or stress-corrosion cracking in either the base or weld metal. For these reasons, the current study has considered only steel castings of the high-yield compositions.

B. Steelmaking Methods

The combinations of high strength and toughness obtainable in high-yield steels can be achieved only when solid and gaseous impurity contents are very low. This requirement becomes more severe with increasing strength levels and is extreme in the HY-180 grade. Special melting methods and the use of equipment, not generally available in the great majority of steel foundries, become necessities in the manufacture of the higher strength high-yield steels. Casting practices that might be used for these chemistries and particularly heavy sections (with a brief explanation of the particular practice) are listed below.

1. Arc-Furnace Practice

A conventional basic arc-furnace, double-slag melting practice is used with special additives and special metal handling to lower the sulfur and hydrogen. Sometimes normal basic arc-furnace practice is reversed by removing the sulfur at the beginning of the heat (Kiesler, 1963). Suggested arc-furnace melting practices for HY-130 and HY-180 steel are presented in Appendix C. Reports describing melting practices for HY-130 steel castings, produced as a part of Naval Ships Systems Command Contract No. bs88540, are referenced in the final reports on the HY-130 development (Giudici and Waite, 1966; Davis and Black, 1966; Porter et al., 1966).

2. Vacuum Degassing

Several methods of degassing steel in a vacuum are in use in producing wrought steel. In some procedures, the molten metal in the ladle is kept in a vacuum; in others, the molten metal in the ladle is poured through a vacuum into another ladle. By these methods, hydrogen can be reduced to very low levels. These procedures have not been used in the casting industry because of excessive temperature losses in relatively small heats. However, vacuum degassing might be very beneficial in producing heavy castings of HY-130 steel.

3. Vacuum Melting

Vacuum melting of high-quality wrought steel is a conventional production practice in which the steel is melted under vacuum and, in some cases, poured under vacuum. Generally, the vacuum-melting furnaces in the foundry industry are of limited size and number.

4. Argon Purging

A relatively inexpensive way to remove some hydrogen is by argon flushing where argon is injected into the side or base of a ladle through a special porous plug. Argon purging has been used in the production of HY-80 castings. Appendix D presents a general discussion of argon purging and describes its use in the production of HY-80, HY-130 and HY-180 steel castings.

5. Argon/Oxygen Decarburization (AOD)

The Linde Division of the Union Carbide Corporation has patented a system of liquid steel processing that is known as argon/oxygen decarburization and is used world-wide. To date, a preponderance of the tonnage produced with this unit has been stainless steel because of the economies in alloy savings. Essentially, the steel charge is dead-melted in an arc furnace, transferred to the AOD, and decarburized by a variable mixture of argon and oxygen. The process reduces hydrogen to lower levels than are obtained normally by the arc furnace. In addition, nitrogen is reduced significantly and desulfurization to very low levels can be performed easily. The advantages and disadvantages of AOD are presented

in Appendix E and in the last paragraph of the discussion on argon-purging of HY-130 steel in Appendix D.

6. Electroslag Remelting

Electroslag remelting, like vacuum-arc remelting, is a secondary process for metals. It uses a cast or wrought electrode of scrap or primary metal for raw material. A slag bath, contained in a water-cooled mold, is resistance heated by an electric current that flows between the consumable electrode and a water-cooled base plate. As the temperature of the slag bath exceeds the melting point of the metal electrode, droplets melt from the tip of the electrode, fall through the slag, and collect in a pool on the base plate. Refining occurs when the metal reacts with the slag either as the droplet, detached from the electrode tip, falls through the slag or after the molten metal collects in a pool at the top of the ingot. Shapes can be produced by the electroslag process. A casting could be made by first producing a number of shapes and then joining them by electroslag welding to make a one-piece casting. The use of electroslag welding and remelting to produce HY-130 and HY-180 discussed in Appendix F.

C. Foundry Facilities

Today, the steel foundry industry is very limited in vacuum-degassing and vacuum-melting equipment for producing finished-weight castings of 25,000 pounds. The Erie Steel Division of National Forge has vacuum-degassing equipment and has produced castings of HY-130 steel. General Electric has a 25-ton vacuum-melting furnace that might be suited for HY-180 production also. Currently, no foundries have argon/oxygen decarburization equipment, but, in the foreseeable future, foundries producing heavy, stainless steel castings might acquire this equipment. ESCO Corporation has indicated an interest in doing experimental work in this area.

Steel foundries have very limited electroslag equipment. However, shapes have been cast by this method. Because of the relative simplicity of the equipment,

conceivably castings of high integrity could be produced. ESCO Corporation has worked experimentally with electro-slag remelting and is believed to be the only foundry with this equipment at the present time.

Generally, the foundries mentioned above now have electric furnaces that produce large castings and, possibly, in the future, might install the necessary equipment to produce either HY-130 or HY-180. Other foundries are capable of melting and pouring large castings, but, so far as is known, they are open-hearth shops that would not be in a position to produce these particular analyses. Foundries that are equipped with relatively large electric-melting furnaces, generally are geared to a high production of relatively small castings.

1. Production of HY-130 Castings

Apparently, HY-130 can be cast successfully in heavy sections; however, special treatment probably will be required to reduce hydrogen levels to acceptable values. Of the above melting and processing methods, the most promising ones are:

- a) vacuum degassing,
- b) argon/oxygen decarburization, and
- c) vacuum melting.

Since vacuum degassing apparently was used successfully in casting HY-130 steel, this steel might be specified as a vacuum-degassed or specially treated product, particularly when heavy sections are ordered.

No casting work has been done with an argon/oxygen degassing unit, but, presumably, AOD could produce satisfactory HY-130 steels. Accordingly, in the future, foundries might procure this equipment in sizes capable of producing a 25,000-pound finished casting.

Undoubtedly, vacuum melting would be satisfactory. However, at present, such a foundry installation is not economical for the limited production of HY-130 or HY-180 castings.

2. Production of HY-180 Castings

To date, very minimal work has been done to determine the castability of HY-180 steel. However, this work indicates that vacuum melting with air pouring is the best combination for obtaining relatively good mechanical properties. Apparently, a casting can be produced with a satisfactory solidity, but the determining factor is the required melting process to produce the low residuals that are needed to obtain the desired mechanical properties. Since vacuum degassing alone appears insufficient to produce satisfactory HY-180 castings, particularly in heavy sections, the other possible melting practices (AOD, vacuum-melting, and electroslag remelting) should be considered. Since little work has been done on the production of HY-180 steel castings, additional research is necessary to define the potential of various melting procedures for making this steel.

D. Molding Practices for HY-130 and HY-180 Castings

The molding practices required for HY-130 and HY-180 castings are similar to those utilized for castings of other quality steels. The sands are mixed in conventional sand mullers of either the horizontal or vertical-wheel types. Only new or reclaimed sand should be used for facing or molds. Western bentonite must be the high-liquid limit type. The mixing order is sand, water, western bentonite, and cereal. Adequate mulling time is required to attain the proper bond distribution, see Appendix G. Gating procedures also follow accepted practices. Nonpressurized gating is preferred; tile sprues, runners, and gates are desirable for the larger castings. Although sound castings were produced, a number of casting problems were encountered.

E. Foundry Problems

Several production heats of HY-130 steel castings have been made and limited laboratory studies have been conducted on HY-180 steel castings.

In addition to the usual casting problems of shrinkage, hot tears, laps, and large nonmetallic surface inclusions, HY-130 and HY-180 steels are subject to

specialized difficulties in the occurrence of flaking, aluminum-nitride embrittlement, and surface-craze cracking. These problems arise because of the influence of the high nickel content of HY-130 and of the high-nickel and cobalt content of HY-180 on gas solubility, liquidus-solidus temperature, and hardenability range. Each condition is discussed in a separate paragraph below.

1. Hydrogen Flakes and Antiflaking Treatments

Hydrogen flakes exist particularly in heavier sections. The prevention of this defect requires minimal hydrogen content in the molten steel during its solidification and especially controlled cooling and/or soaking cycles for hydrogen release by diffusion.

Vacuum melting and degassing are preferred for minimization of hydrogen content. However, these foundry facilities are very limited. Flakes are minimized with conventional melting and handling equipment by:

- a) reducing hydrogen in the melting furnace with a long active boil,
- b) minimizing the block, or dead period of holding, in the furnace, and
- c) handling the metal during transfer and pouring to avoid contact with water and to minimize turbulence.

Even with these precautions to keep hydrogen at a low level, extensive hydrogen-removal heat treatments do not preclude flaking.

Because of the limitations of the possible melting and degassing processes to remove hydrogen, the castings also may require a special heat treatment to reduce the hydrogen content to a level that prevents flaking or loss of ductility in the steel. These antiflaking treatments are involved and lengthy. Some recommended treatments would require long times (64 hours) at high temperatures (1750°F) and the castings probably must be heat-treated in furnaces in an inert atmosphere or vacuum to prevent excessive oxidation. A discussion of antiflaking treatments is presented in Appendix H.

The presence of hydrogen also contributes to lower ductility in the steel. If flakes have been avoided, this embrittlement can be reduced by 400 to 600 F soaking treatments for 4 to 72 hours, depending on the section thickness. To avoid flakes, the steel should be melted under vacuum or degassed before pouring, and proper precautions should be taken against hydrogen pickup during metal transfer and mold filling.

The General Steel Foundries and Birdsboro Corporation have produced HY-130 steel castings successfully using a conventional double-slag electric-furnace melting practice. These castings contained hydrogen flakes in sections that were below the risers and were over 4-inches thick. The castings were salvaged by excavating the flakes with an oxygen lance and by welding repair.

2. Aluminum-Nitride Embrittlement

The frequency of aluminum-nitride embrittlement or "rock-candy" conchoidal fracture of HY-130 and HY-180 steel castings increases with higher nitrogen and aluminum contents and heavy sections. The heavy sections promote this embrittlement because of the slower solidification rate and the accompanying increased segregation. Prevention of aluminum-nitride embrittlement requires low nitrogen and aluminum contents and the most rapid solidification possible. Nitrogen is reduced by steel melting and molten-steel handling methods, described above for low-hydrogen contents. Aluminum contents are reduced by using deoxidizers containing only small additions of aluminum, appreciable calcium, and nitrogen combiners, such as zirconium and titanium. Use of excess titanium may produce other ductility problems. Increasing the rates of solidification requires extensive chilling of the heavier sections.

3. Craze Cracking

Craze cracking, also called alligator cracking, appears as a network of shallow, fine cracks that may persist through several weld-repair and reheat-treating cycles. The problem is more severe in heavier, more slowly

solidified sections. This problem appears to be a characteristic of high nickel steels and is attributed variously to hydrogen, solidification phenomena, mold/metal reactions, and even embrittling elements, such as phosphorus and sulfur. The exact nature and cause of craze cracking are not established clearly and should be investigated further because of the high cost of its removal. Preventive measures range from the use of special mold washes to the very costly, and somewhat self-defeating, process of machining the entire casting surface. Also, standard methods of obtaining low hydrogen contents and rapid solidification rates of steel with a minimum of embrittling elements may help to minimize the problem.

4. Feeding and Microshrinkage

Specific solidification and feeding characteristics must be determined for HY-130 and HY-180 steel. This information is obtained from directional solidification studies that yield information on segregation, microporosity, and inclusions vs. grain structure. These characteristics influence mechanical properties such as tensile strength, ductility, toughness, and fatigue. Thus, it becomes possible to prescribe solidification conditions for given mechanical properties. Practically, controlled solidification is obtained by methods such as proper placement of risers and chills, employing tapers on the casting, and use of insulation and hot-topping. Indications are that the foundry engineering for HY-130 and HY-180 will be more sensitive to the mass effect on section size. These problems will be solved by foundry engineering studies on riser placement and riser feeding distance, on the use of various chills, etc.

5. Deoxidation Practice

While appropriate deoxidation practices have been developed for HY-130 castings, this is not the case for HY-180 castings. Deoxidation appears to be a key to successful production of HY-180 castings, and the following deoxidants require investigation:

- a) calcium metal or alloys,
- b) rare earths,

- c) aluminum* (as a dilute alloy), and
- d) variations of the above with possible additions of titanium or zirconium to combine with nitrogen.

F. Heat Treatment

Heat-treating procedures have been established for heavy plates of HY-130 and HY-180 steel. These procedures should be satisfactory for their castings unless the chemical compositions are changed markedly to improve their hardenability or casting characteristics. The isothermal transformation diagram of these steels and their tempering characteristics provide a basis for understanding the recommended heat treatments and the possible effects of variations in heat treatments.

1. HY-130 Steel Castings

The chemical composition of HY-130 castings has been adjusted to a somewhat higher silicon content than the wrought steel to improve castability (0.30 to 0.45 percent silicon for casting versus 0.20 to 0.35 percent for plate), and to a somewhat higher nickel content to provide additional hardenability (5.0 to 5.5 percent nickel for castings versus 4.75 to 5.25 percent for plate). With these changes, a yield strength of 130 ksi minimum should be attained in sections of 6-inch thickness. Removal of risers and rough machining should be accomplished prior to final heat treatment to provide the lightest sections possible and the most uniform section thickness for heat treating. Normalizing and tempering of the castings are advisable prior to riser removal to avoid any cracking tendency from burning.

The standard heat treatment of HY-130 castings is as follows:

- a) Austenitize at $1700^{\circ} \pm 25^{\circ}$ F for 1 hour per inch of section (3 hours maximum), water quench.

* Preliminary work has indicated that aluminum additions as low as 0.025 percent have resulted in rock-candy fracture; however, the nitrogen content may be a controlling factor.

- b) Re-austenitize at $1500^{\circ} \pm 25^{\circ}$ F for 1 hour per inch of section (3 hours maximum), water quench.
- c) Temper at not less than $1075^{\circ} \pm 15^{\circ}$ for 1 hour per inch of section, water quench.

The normal tempering temperature for different sections is as follows:

Through 2 inches	1150°F
Over 2 through 4 inches	1120°F
Over 4 through 6 inches	1075°F

A well-agitated water quench is desirable. The highest tempering temperature that will achieve the desired yield strength is preferred because the toughness of steel improves as the tempering temperature is raised. The maximum tempering temperature is limited by the A_1 temperature of the steel (1210°F). Tempering temperatures below 1075°F are not recommended because of the onset of temper embrittlement in the range 850° to 1050°F. Slow cooling should be avoided through the temper-embrittlement range after tempering. When the hardenability of the steel is marginal and when difficulty is experienced in attaining the minimum yield strength in a heavy section tempered at 1075°F, the necessary hardenability may be achieved by raising the final austenitizing temperature to 1650°F. The higher austenitizing temperature increases the prior austenitic grain size and also puts more vanadium into solution. However, loss in toughness may result from this treatment.

2. HY-180 Steel Castings

Unless a marked change in steel composition is necessary in the production of HY-180 castings, the heat treatment of the casting should be the same as that of the wrought steel. The proposed heat treatment for HY-180 castings is as follows:

- a) Austenitize at 1700°F for 1 hour per inch of section (3 hours maximum), water quench.

- b) Re-austenitize at 1500°F for 1 hour per inch of section (3 hours maximum), water quench.
- c) Temper at 950°F for 5 hours for sections through 1-inch thickness and for 10 hours for sections over 1-inch thickness, water quench.

Sections over 2 inches thick are expected to exhibit a lower yield strength (175 ksi minimum yield strength) than lighter sections (180 ksi minimum yield strength). The steel in 6-inch and much thicker sections has sufficient hardenability that its yield strength should not be reduced below 175 ksi.

G. Effect of Impurities on Properties

The notch toughness of steels with strengths of 100 to 250 ksi is very sensitive to the amount of impurity elements, especially elements that produce nonmetallic or intermetallic particles. To maintain high toughness at 180 ksi yield strength, oxides, sulfides, nitrides, and carbides must be reduced to the lowest possible levels. Accordingly, although air melting is satisfactory for HY-100 and HY-130 steel, HY-180 steel with satisfactory toughness has been produced only by special melting practices, such as vacuum-induction melting and vacuum-arc remelting.

Based on its deleterious effect on notched impact properties of HY-180 wrought materials, silicon should be kept at the lowest level (probably a maximum of 0.2 percent) commensurate with the ability to fill a given mold. Manganese levels in castings probably should be higher than the 0.05 to 0.15 percent in wrought product to neutralize sulfur as manganese sulfide and to improve castability. One of the keys to successful production of HY-180, particularly if a vacuum-melted material is required, may be the ability to secure satisfactory charge material.*

In addition to low levels of the "dirt"-forming element, other impurities, such as phosphorus, antimony, arsenic, and tin, can produce grain-boundary embrittlement in quenched-and-tempered high yield-strength steels. Considerable information on the effect of variations in the level of impurities on the properties of HY-130 and HY-180 steel was obtained as a part of their development studies.

* If double vacuum-melted material is indicated, a source of vacuum induction melted material for melting stock is necessary.

H. Minimum and Maximum Section Size

If these alloys (HY-130 and HY-180) can be cast, the minimum section would be limited only by the ability to "run" castings. A typical minimum section might be a half-inch, depending upon the geometry of the part. Maximum section size, however, might be a different story. As section size increases, the segregation of impurities may become the factor that governs the maximum section thickness and may be reduced by using high purity melting practices. For example, HY-80 steel can be produced in 4-inch sections with little or no difficulty. However, in 9-inch sections, the castings become more difficult to produce. Probably, the same section effect would occur in HY-130 and HY-180 steel although the relative section sizes may be different.

Nickel-bearing martensitic steels tend to have a wide solidification range and, hence, are prone to segregation. Because of this segregation, small quantities of nitrogen form aluminum nitride at very low aluminum contents and produce a "rock-candy" fracture in heavy sections.

Hydrogen in nickel-bearing steels also can be very significant and cause field failures at very low stress levels, if a critical hydrogen level is exceeded.

With proper melting equipment and consideration of their hardenability limits, castings of both HY-130 and HY-180 steel should be producible in 6-inch sections.

I. Weld Repair and Structural Joining

Low hydrogen weld-metal compositions and welding procedures have been developed for weld repair and structural joining of HY-130 and HY-180 steel either after final heat treatment or, in the case of HY-130 steel, using special heat-treatable welding-electrode compositions prior to final heat treatment. Generally, the weld metals, developed for use in the as-deposited condition, exhibit strength and toughness superior to those of the base metal. The superior properties result from grain-structure refinement and tempering effects of low heat-input multipass welding. Low heat input during welding is so important in

attaining high-strength HY-180 steel welds that the only satisfactory welding process for HY-180 steel, at present, is low deposition-rate GTA welding.

Additional work is now in progress under Government contract to develop higher deposition-rate welding processes for HY-180 steel. With the exception of a small over-tempered region of slightly lower strength than the base metal, the heat-affected zone of the welds is equivalent or superior in strength to the base metal and exhibits excellent notch toughness.

A specification would be useful to provide procedures for fabrication of casting weldments and for repair of castings. A similar specification would be required for the fabrication of HY-180 weldments.

J. Scrap Reclamation

Apparently, HY-130 steel does not create a problem in scrap reclamation. The high nickel content is desirable as charge material for many low-alloy steels and, in fact, could be used for its significant nickel content in stainless steels.

HY-180 steel is a different situation. Its high cobalt content makes the scrap undesirable except for special steels, such as HY-180. However, any melting process that finally is adopted for this alloy should be capable of using "revert" scrap, such as gates and risers of the same composition, up to approximately 50 percent of the total poured weight.

K. Specifications for HY-130 and HY-180 Steel Castings

Specifications for HY-130 and HY-180 steel castings would be based on MIL-S-23008B (SHIPS) (Military Specification, 1964), see Appendix A. Certain modifications seem advisable on the basis of present information, and additional modifications may become apparent in the future. A justification for the notch-toughness requirements of the specifications is given in Appendix I.

Using specification MIL-S-23008B (SHIPS) as the base, the modifications proposed by this Committee suggest that the following items be considered in any proposed specifications:

HY-130 Steel Castings

1. Section 3.2. The specification should state that the castings shall be free of hydrogen flakes.
2. Section 3.8. The specification should permit weld repairing or joining if the heat-treatable filler metals are used and the casting or weldment are heat-treated after welding.

HY-180 Steel Castings

1. Section 3.2 — Material. The castings shall be produced from steel made by vacuum-melting or other qualified melting processes.
2. Section 3.3 — Chemical Composition. The chemical composition shall conform to the following:

Chemical Composition

(Ladle Analysis)

<u>Element</u>	<u>Percent Maximum Unless a Range Is Shown</u>
Carbon	0.09 - 0.13
Manganese	0.05 - 0.25
Phosphorus	0.010 max.
Sulfur	0.006 max.
Silicon	0.15 max.
Nickel	9.5 - 10.5
Chromium	1.8 - 2.2
Molybdenum	0.90 - 1.10
Cobalt	7.5 - 8.5
Aluminum	0.040 max.

L. Conclusions and Recommendations: HY-130 and HY-180 Steel Castings

1. Conclusions

- a) A satisfactory HY-130 steel composition has been developed for wrought products and is expected to be suitable for castings.
- b) Satisfactory results have been obtained with HY-130 steel by arc melting followed by vacuum degassing. Probably, HY-130 steel could be produced also by vacuum-melting and by the argon/oxygen-degassing (AOD) process.
- c) An acceptable HY-180 steel composition has not been established. Accordingly, HY-180 steel is not approaching a production alloy like the HY-130 steel composition.
- d) A composition of 10Ni-8Co-2Cr-1Mo is the most promising candidate for HY-180 steel castings produced to date and has proven suitable in wrought products. Although castings of 4-inch thickness have been made only experimentally, hardenability considerations indicate that thicknesses in excess of 6 inches are feasible.
- e) HY-180 steel probably could be produced by vacuum melting and air-pouring and by the AOD process. It is doubtful that arc-melting, followed by vacuum degassing, would be satisfactory.
- f) The solidification characteristics and risering of HY-180 are not understood completely, although the solidification appears similar to other alloy steels.
- g) Craze cracking, or alligatoring, that appears on some castings of the HY steel series, may be a problem in HY-130 and HY-180 steels and needs further study.

- h) HY-130 and HY-180 steel castings that weigh up to 25,000 pounds and have 6-inch sections probably can be produced with existing foundry equipment. However, the proper combination of equipment is not available today in any foundry to make large production castings of either steel.**

2. Recommendations

It is recommended that the following work be performed to evaluate HY-130 and HY-180 steel as cast materials for heavy-section castings:

- a) Produce and test additional vacuum-degassed HY-130 steel castings in sections 6 inches thick.**
- b) Produce and test heats of vacuum-melted HY-180 steel of 10Ni-8Co-2Cr-1Mo composition in sections up to 6 inches thick and with variations in deoxidation practice.**
- c) Study the mechanical properties of various candidate HY-180 steel compositions by using small (200#) vacuum-melted heats.**
- d) Determine the feasibility of the AOD process for melting HY-180 and HY-130 steel for casting in sections up to 6 inches thick.**
- e) Study the fundamental of solidification of HY-180 steel to establish the necessary gating and risering. Directional solidification studies should be conducted to determine the influence of solidification structures on tensile, toughness, and fatigue properties.**
- f) Determine the basic cause of craze cracking in these alloys.**
- g) Determine the mechanical properties, including fracture toughness (K_{1c} values), of heat-treated HY-130 and HY-180 steel castings in heavy sections and establish the minimum toughness required for extreme service applications.**

IV. TITANIUM CASTINGS

A. Introduction

For many years, titanium and its alloys appeared to be attractive for structural use because of their high strength-to-weight ratio and excellent corrosion resistance. However, titanium castings were used far below their potential because titanium-casting production presented formidable engineering challenges, arising from the reactivity of molten titanium and its ability to dissolve all known substances at a rapid rate. Thus, foundry research and development in titanium alloys concentrated on finding a melting method that did not consume the crucible and a molding material that permitted the casting to solidify without contamination. Now, since these problems have been solved, titanium castings are available commercially. However, recent developments indicate a need for castings that are larger than those made currently and that weigh around 20,000 pounds. The purpose of this review is to discuss the current status of titanium-casting technology, indicate areas where knowledge is needed to realize the full potential of titanium castings, and describe the type of facility that is required to produce large titanium castings.

B. Methods, Facilities, and Melting Capacity

1. Consumable Electrode Skull Melting and Casting

Presently the "Skull-Casting Process" is the accepted method for casting titanium. This process, developed by the U. S. Bureau of Mines in the mid-1950's, is a modification of the consumable-electrode vacuum-arc melting process for ingots and frequently is called the cold-mold process. An early Bureau of Mines' research project disclosed a surprising pool depth during conventional consumable-electrode arc melting. This discovery led logically to a tilting, water-cooled crucible that permitted the mass of molten metal to be transferred to a mold. The general plan, shown in Figure 1, consists of an enclosure for atmospheric control, a consumable electrode, a tilting crucible, and a mold (Beall et al., 1968).

In operation, the crucible is charged with titanium machine chips or solid scrap in an amount up to 40 percent of the expected casting weight. After the

Figure 1

Typical Skull-Casting Furnace

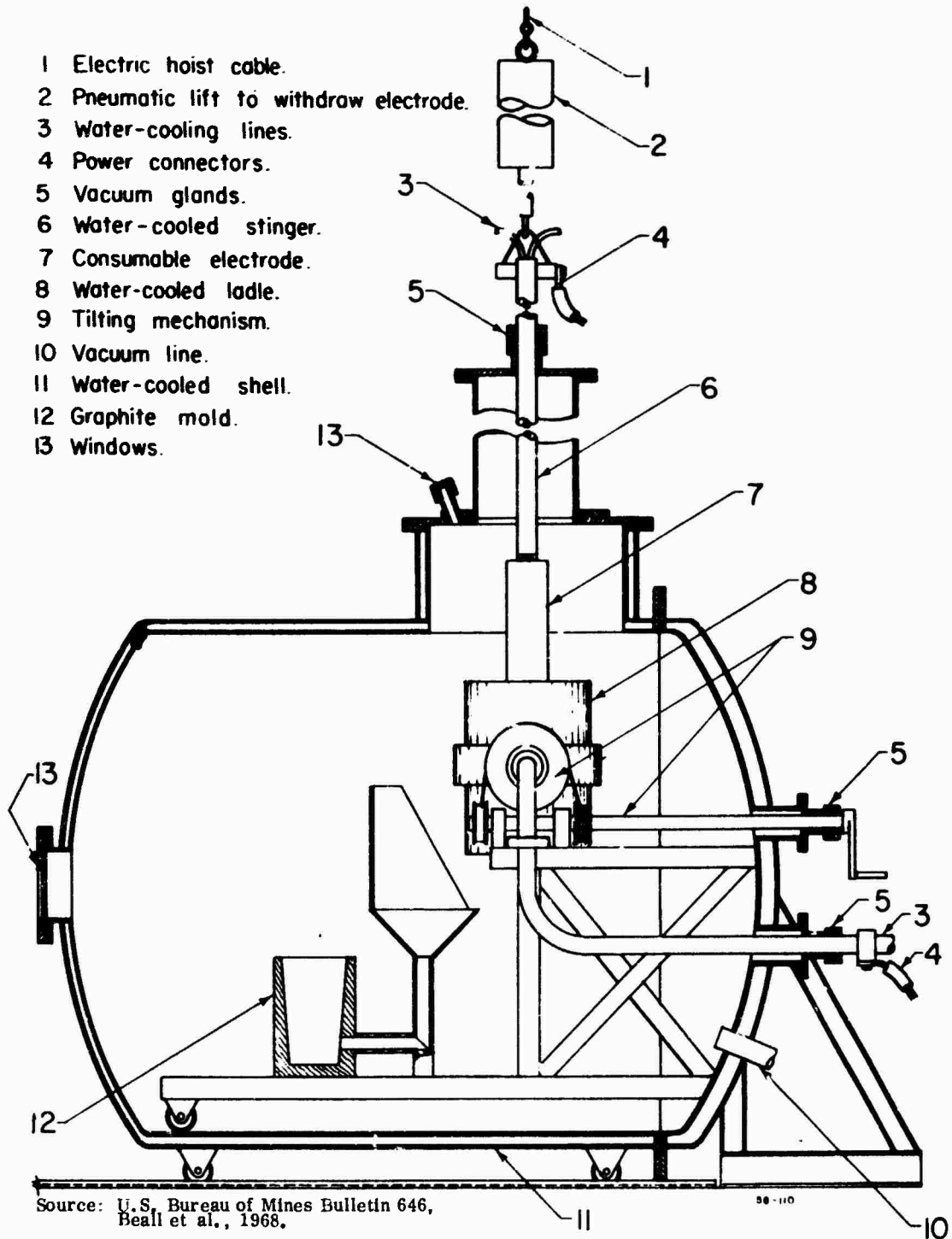

gas is evacuated from the vessel and a direct current arc is struck, the initial scrap charge becomes molten and the titanium electrode begins to be consumed. Empirically, the arc current in amperes is 700 to 1000 times the crucible diameter in inches. The arc potential may vary from 24 to 40 volts. When the pool is of sufficient size, the following events occur in a few seconds: the arc is extinguished; the electrode is withdrawn; and the crucible is emptied. A thin lining of titanium remains in the copper crucible; the process received its name from this "skull" or shell. The skull may be reused repeatedly if the pouring lip is trimmed occasionally.

Many engineering improvements have been made to the process since the beginning of its commercial exploitation. Recently, some major technique changes that may be worthy of industrial application have been investigated.

Molding material is a major area of industrial development. The requirements for a mold are discussed below. Each commercial titanium casting facility, listed in Table 2, has developed a mold process which generally has proprietary aspects.

Table 2

U. S. Commercial Sources of Titanium Castings

<u>Company</u>	<u>Pour Capacity Pounds</u>
Howmet Corporation, Whitehall, Michigan	200
Oregon Metallurgical Corporation, Albany, Oregon	300
Precision Castparts, Inc., Portland, Oregon	500
REM Corporation, Albany, Oregon	125
Titanium Technology Corporation, Pomona, California	800
Ti-Line, Inc., Albany, Oregon	2,000

Details of the above listed firms are given below:

Oregon Metallurgical Corporation pioneered the commercial exploitation of the skull-casting process for titanium. It has a modest, but consistent,

business now making titanium castings mostly for corrosion-resisting applications, and for aircraft use. It operates two skull-casting units with an approximate capacity of 300 pounds. The Oregon Metallurgical Corporation mold is a rammed-and-sintered graphite powder that uses organic binders. The casting furnaces are equipped with spinning tables, and most of the castings are centrifuged.

Ti-Line of Albany, Oregon, as the name indicates, originally was organized to produce titanium-lined valves, fittings, etc. Iron, brass, or aluminum was poured around these formed and welded titanium inserts. Recently, Ti-Line has gone heavily into skull casting massive titanium parts, primarily for corrosion-resisting applications. The outstanding size of the Ti-Line furnace (~ 10'-diameter) permits pouring titanium castings over 2,000 pounds. A larger crucible is being prepared to produce larger castings. Now, Ti-Line is a division of Whittaker Corporation.

The Titanium Technology Corporation of Pomona, California, is a new company in the casting field. The basic equipment of the firm consists of two arc furnaces, one for ingots and one for castings. The casting furnace has a pouring capacity of nearly 800 pounds of titanium and is equipped with a rotating mold table for centrifugal castings. Both furnaces have provision for a water-cooler copper nonconsumable electrode.

Three other foundries produce precision castings primarily for aircraft use. The Reactive Metals Products Division of Howmet Corporation of Whitehall, Michigan has a unique furnace coolant, a sodium-potassium eutectic (NaK), instead of water for the copper crucible. The liquid metal coolant provides a safety feature in that no steam or water explosion can occur in the event of a crucible burn-through. The massiveness of the copper crucible permits the process to operate with no coolant for a short time.

Precision Castparts, Inc. of Portland, Oregon, is well known for precision iron and nickel-base castings. For titanium casting, it uses a lost-wax shell mold of a proprietary composition and vacuum consumable arc melting.

REM Metals Corporation of Albany, Oregon, also uses a lost wax shell mold process.

New possibilities are being considered for melting the charge besides the conventional consumable-electrode arc-heated furnace now used in most commercial operations.

2. Nonconsumable Electrode Melting

Now two commercially manufactured nonconsumable electrodes are available as a replacement for the consumable electrode. Their chief virtue is melting scrap into ingots in a conventional cold mold furnace. However, both of these electrodes may be used in casting applications. As noted in the early Bureau of Mines reports, a major heat source to the molten pool (when cold mold arc-melting) is the molten metal dripping from the consuming electrode. Hence, molten pools are much shallower for comparable power when the non-consumable (water-cooled) copper electrode is used.

3. Electron Beam Melting

Electron-beam heating of the skull furnace also produces shallow molten pools, that is, power requirements are higher for comparable pool volumes than those for consumable electrode-arc melting. Electron-beam heating may purify the charge somewhat because of the high vacuum present. However, this advantage may be offset by difficulties in holding alloy compositions.

The Ulvac Corporation of Japan has published (Takei and Ishigami, 1971) preliminary information on hollow-cathode discharge melting of titanium and niobium alloys. This firm has constructed a large-scale plasma unit incorporating six hollow cathode discharge heads, with a possible total power output of three megawatts. Available test results indicate that ingots of either round or rectangular cross-section can be poured. The application of this heating principle to shape castings presents interesting possibilities.

4. Induction Melting

Induction heating for titanium casting, the Inducto-slag Process, is being studied as a source of casting at the Bureau of Mines, Albany, Oregon. The process utilizes a split water-cooled crucible surrounded by an induction coil. A skull of solid slag (CaF_2) is formed during melting that effectively prevents the charge from leaking through the vertical splits of the crucible. Although the process has been demonstrated successfully as a means of preparing ingots from scrap on a continuous basis, the tilt-pour modification has not yet reached an equal state of development.

At TRW-Cleveland, researchers investigated the utilization of induction-heating titanium in a graphite crucible for casting. A semi-levitation technique is used. Approximately 0.10 percent of carbon is picked up during melting. Efforts to make this technique commercially feasible have not proven successful, and work on the process has been discontinued.

5. Incremental Melting

The possibility of preparing shaped castings by an incremental melting process was demonstrated at a recent meeting in Kiev, U.S.S.R., by a method of electroslag-melting in shaped crucibles (Paton et al., 1972). Presumably, the process was developed for ferrous-base alloys. However, titanium also can be electro-slag melted.

6. Conclusion

Despite efforts to develop melting techniques other than vacuum-arc remelt (skull-casting), no commercial success has been achieved with other methods. For large sections, the Soviet concept of joining, or in situ solidification, by electroslag remelting appears promising and should be investigated further. At the same time, as melt sizes increase, more information on arc-melting parameters is required to improve the reproducibility of this process.

At present no existing facility in the United States is capable of producing cast shapes in excess of 2,000 pounds. If castings of the order of

20,000 pounds are envisioned, a step-wise progression in increments of 10,000 pounds should be undertaken to increase furnace capacity to 40,000 pounds. Technical difficulties are expected at all levels, particularly in the mold reaction (see below) and solidification behavior of heavy casting sections.

C. Four Temperature Monitoring and Control

Conventional casting processes, using crucible melting, depend heavily on control of the pouring temperature to assure casting quality. Foundrymen usually pour at the lowest temperature that will fill the mold without producing cold shuts to (1) minimize shrinkage, metal mold reaction, and volatilization of alloy constituents, and (2) refine the dendrite-arm spacing. However, titanium presents unique problems to the implementation of this approach, both in measurement and control of pouring temperature.

1. Temperature Measurement

Because of the high melting point of titanium alloys (around 3,000°F), few bimetallic thermocouple systems are candidates for immersion pyrometers. Of these, tungsten-tungsten/rhenium couples have been used successfully for measuring the cooling of castings in the mold (Tsareff and Hellman, 1969; Grala, 1970). These couples were sheathed in tantalum or molybdenum to protect them for the short time that the alloy was molten. Even these refractory metal protection tubes were dissolved by the molten titanium, particularly when the couples were placed in heavy sections, pouring basins, and sprue wells. This experience discouraged the use of refractory metal sheaths to protect thermocouples immersed in molten metal baths. Oxide refractory protection tubes cannot be used because either those oxides that possess adequate thermal shock resistance are attacked by the molten metal or the oxides that resist attack by molten titanium lack thermal shock resistance.

Therefore, optical methods are used to monitor melt temperatures. Two-color pyrometers, such as the Pyro-Eye or Milletron, have been tried. Difficulties arose with them (Piwonka et al., 1972) due to the variation in the

emissivity of metals with temperature (Unvala and Goel, 1970) that affects the temperature readings. Furthermore, response instability was found in these instruments at titanium-melting temperatures. Therefore, infrared pyrometry was recommended since the emissivity variance in the infrared region of the spectrum is less than in the optical region.

2. Superheat Control

Crucible melting is the only method of producing a bath at a controllable, essentially uniform superheat that remains constant during pour. Since crucibles for melting titanium alloys tend to contaminate the melt, semi-levitation techniques were tried (Piwonka et al, 1972; Zotos et al., 1958). Levitation melting decreases the crucible contamination and provides metal at a uniform, constant temperature because the molten metal comes to a steady state temperature and shape that does not vary as the power input is increased (Peifer, 1965). However, levitation melting does not permit control of metal superheat and, hence, has attracted little interest in the industry.

Cold wall-crucible techniques suffer because the molten metal exists over temperatures ranging from the solidus at the skull interface to a very high temperature at the source of heat input. Thus, it is difficult to assign a temperature to the bath. Experiments that correlated pour temperature with power input were performed (Magnitskiy, 1970) by measuring the temperature on the a) surface of the pool prior to pouring, b) surface of the system during pouring, and c) skull after pouring. The Naval Research Laboratory also investigated the problem (Huber et al., 1959). Indirect methods also have been used in which casting quality was correlated with melting variables. Although the ideal method of superheat control is not currently available, present methods are adequate to produce acceptable castings. No agreement exists on the melting method (cold-wall, consumable, nonconsumable, or electron beam) that is most amenable to superheating.

3. Pour Temperature Control

Present methods are acceptable since, apparently, pour temperature does not have a strong influence on castability, structure, or properties. Fluidity is affected little by pour temperature (Magnitskiy, 1970). Because of the difficulty in establishing thermal gradients in the casting to encourage soundness (Grala, final -- March, 1970; Magnitskiy, 1970), pour-temperature control is of little use in regulating porosity.

The control of pour temperature to govern cast-grain size also appears to be ineffective (Magnitskiy, 1970). Generally, titanium alloys are insensitive to normal grain-refinement techniques, such as vibration and use of alloy grain refiners, although certain rare-earth additions (notably 0.5 percent La, and 0.5 percent Ce) do have an effect. Presumably, changes in cast-grain size have little effect on cast properties (Magnitskiy, 1970). However, this conclusion is contrary to findings in other metal systems and should be investigated further.

In the manufacture of thick section castings, the dendrite substructure (dendrite arm spacing) may require controlling to govern microsegregation and improve hardenability in heavy sections. Microsegregation in cast-titanium alloys depends upon both the cooling rate and the composition (alloy content) (Nurminen and Brody, 1972). In some systems (Ti-10 percent Mo, Ti-10 percent Al, Ti-10 percent V), segregation ratios decreased as the cooling rate decreased. In many systems, significant solid diffusion apparently occurs during and after solidification.

In general, control of pouring temperature is significantly less important in the production of acceptable titanium castings than in other metal systems, such as steel and aluminum, and the present state-of-the-art of cold wall techniques is no barrier to the procurement of high-quality parts.

D. Mold Materials and Systems

The major problem with mold materials and systems used in casting titanium is the reactivity of titanium in the molten and solid states. In the molten

state, this reactivity is extreme and no known oxide-type refractory material can be considered inert. The molten titanium and solidifying titanium casting rapidly dissolve oxygen and nitrogen, if present, and these titanium compounds (even if present in small amounts) embrittle the metal.

To inhibit this reaction between mold materials and molten titanium, a variety of approaches have been taken such as (a) the use of machined metal and graphite molds, (b) rammed-graphite molds with suitable binders, (c) graphite-shell molds, (d) ceramic molds impregnated or coated with pyrolytic graphite or other "nonreactive" carbonaceous material, and (e) ceramic molds incorporating a large percentage of powdered tungsten in the first slurry coat. Information on each producer's mold formulation and manufacturing method is proprietary.

Therefore, the mold problem in titanium requires some compromise. Preferably, a mold should have sufficient heat capacity and conductivity to reduce the solidification time of the titanium liquid and to minimize mold reaction. However, the mold must not have such a high "chill" capacity that misruns, cold-shuts, etc., are produced. The general types of mold materials and systems, discussed below, have been used since the first casting of titanium was attempted.

1. Oxide Molds with Oxide Binders

Investment molds that were made from a fugitive pattern in which the molding materials consisted of refractory-oxide grains (such as silica, zirconium silicate, alumina, magnesia, etc.), and binders (such as ethyl silicate, colloidal silica, etc.) have been evaluated for titanium casting. Other ceramic-molding processes, where the pattern is not fugitive, have been used in this application also.

When conventional oxide refractory grains and binders are used, the following general disadvantages have been experienced:

- a. oxygen contamination, particularly at the surface of the casting (typically, the depth of contamination may range from 0.020-inch

- in 1/8-inch sections to 0.030 to 0.040 inch in 1-inch sections);
- b. embrittlement or increased hardness of the cast metal;
 - c. development of oxide folds in the surface of the casting;
 - d. embedded nonmetallic inclusions in the surface of the casting; and
 - e. danger of cracks and tears in the casting due to metal-mold reaction and brittleness.

One producing foundry uses a lost-wax shell-mold of a proprietary oxide composition and claims to produce castings with a minimum of surface contamination, particularly after mechanical and chemical cleaning.

2. Carbon Coated Oxide Molds or Oxide Binder Impregnated Molds

Since the reaction between molten titanium and carbon is considerably less than the reaction between titanium and ceramic oxides, various methods have been investigated for incorporating carbon into molds produced from refractory oxides with oxide binders. One process conventionally produces an investment shell mold from zircon-refractory grain, bonded with a suitable silicate binder (U. S. Patent, 3,284,862, 1966). The mold, after conventional processing, i. e., dewaxing, firing, etc., is coated with pyrolytic graphite in a reaction chamber or furnace. During the coating sequence, parameters such as hydrocarbon gas composition, gas flow rates, pressures, and mold temperatures, are varied to suit the size and shape of the mold. The specific details are considered proprietary. The coating thickness, about 0.002 inches, is claimed to be minimal and to have little effect on finished part dimensions.

The molds can be preheated to 2200°F in vacuum, prior to pouring. From the data, the strength of the mold is adequate (Grala, March, 1970). Reactivity of this mold system with titanium has been documented, and the reaction occurs at the casting surface when molds are preheated above 1500°F in sections thicker than 1/4 inch. The titanium carbide that formed extended to a depth of 0.0015 inch. The surface of castings produced by this method is good when the mold is cooled after casting to at least 800°F in either vacuum or argon.

Ceramic cores can be incorporated into the mold before the pyrolytic graphite-casting cycle and coated along with the rest of the mold. With this type of mold, a danger of hot-tearing and cracking exists because of the increased mold rigidity that is produced by the pyrolytic graphite and due possibly to the impregnation of the mold pores with carbon.

Another investigator (Dunlop and Child, 1967) has taken a similar approach whereby an investment mold or a solid ceramic mold produced from a nonfugitive pattern, is impregnated with carbon by heating the mold in an atmosphere containing hydrocarbons. The temperature and specific gas mixtures are not given because of the proprietary nature of the process. However, controlled impregnation or carbonization of the mold has been achieved. The depth of surface contamination in a 5/8 inch section of a titanium casting was 0.015 inch, as measured by hardness testing, when the carbon pickup in the ceramic mold by carbonization was 10 percent by weight.

The advantages of these approaches are that the basic molds or cores can be produced by conventional precision ceramic-molding techniques. Therefore, molds can be produced having a high degree of detail for castings of intricate design and close tolerances. While surface contamination is considerably reduced when compared to straight refractory oxide mold systems, still it occurs in heavier sections particularly where a high degree of mold preheat is required.

3. Carbon and Graphite Molds

As previously indicated, the degree of reactivity or surface contamination between carbon or graphite molds is much less than that experienced with conventional refractory-oxide mold materials. Consequently, a number of molding systems utilizing graphite or carbon as the basic material have been developed.

a. Machined Graphite Molds

One of the first mold materials used successfully to produce titanium castings was machined graphite, and such molds appear to have some applications today in casting processes. Machined graphite is used extensively for

specific mold parts such as risers, runners and funnels. The chief disadvantages of molds that are machined from graphite are:

- 1) They are expensive to make.
- 2) They have relatively short life. Even for simple shapes, a mold life of 30 to 40 castings is typical.
- 3) They are apt to produce laps or rippled finish on castings.
- 4) The attainable mold cavities are restricted somewhat in variety.
- 5) When the mold is heated to offset the chilling tendency of graphite and to allow the production of relatively thin-section castings, surface contamination of the casting by carbon occurs invariably.

b. Rammed-Graphite Molds

Rammed-graphite molds, incorporating binder materials, including starch, sodium silicate, proprietary halide fluxes, pitch, "carbonaceous cement," synthetic resins, etc., have been used by various producers for casting titanium.

Typical rammed-graphite mold systems that employed carbonaceous materials as binders and were used by earlier workers in the field, have been reported (Feild, 1956; Feild and Edelman, 1957; Antes et al., 1958). Mixtures of up to 70 percent fine graphite powder (AFS-GFN85), 10 percent pitch, 10 percent "carbonaceous cement," starch, water, and surface activating agents were mulled together to make a mold material that could be rammed in place around a conventional pattern and have a high green strength to allow the pattern to be stripped from the rammed mold. The green molds were air dried, oven dried, and then baked at temperatures up to 1800°F under powdered graphite to prevent oxidation.

More recent work (Pulkonik et al., 1967; Pulkonik et al., 1966) on producing unreactive rammed graphite molds developed mold material mixtures typified by the following:

Graphite Powder (AFS grain fineness 45-55)	100 parts by weight
Flux	20 parts by weight
Starch or Sodium Silicate	2 to 5 parts by weight
Water	10 percent

The flux binder, that is proprietary under the name MITRON, is composed of a combination of halides which are claimed to be nonreactive with titanium. This mixture, after mulling, can be rammed around a pattern. After the pattern is stripped, the graphite mold is processed by simply baking at 250°F for four to eight hours (depending upon mold size) and then followed by brief torch-heating of the mold cavities to insure complete absence of volatiles near the mold surface. This type of mold system, when compared to graphite molds bonded with carbonaceous binders, supposedly allows the production of castings of improved quality at lower cost because of reduced mold-processing times and temperatures, reduced mold-metal reaction, water solubility of the molds, and negligible mold shrinkage during processing.

Castings of a reasonable degree of complexity and weighing up to 400 pounds can be made by this process. Some carbon contamination of the casting surface is reported as typical to about 0.010-inch depth in a casting section thickness of 4 inches. This contamination is claimed to be lower than that produced by rammed carbonaceous-bonded graphite molds.

Other producers are utilizing rammed and sintered graphite molds incorporating organic binders. Using these molding techniques, one producer has made a 500-pound titanium casting successfully, while another producer has made castings weighing up to 1,560 pounds.

c. Graphitic Shell Molds

In an attempt to provide, at reasonable cost, titanium castings with an acceptably low degree of surface contamination and with a surface finish as smooth as possible, mold materials were investigated that were based on the use of high purity graphite powders and contained up to 40 percent phenolic resin (Westwood, 1960). This molding mixture, along with suitable solvents, is invested on a conventional shell-mold pattern and heated between 400° and 550°F to produce a shell between 1 and 2 mm thick. These shell molds subsequently are baked at 1,650°F for about 2 hours in an inert atmosphere to remove completely all volatile mold materials from the mold.

Titanium castings produced by this process are claimed to exhibit little contamination and have a superior surface quality than similar castings produced in machined graphite molds (Westwood, 1960). However, no data were quoted for these two factors; it is not known whether this technique is being used in production.

d. Graphitic Investment Molds

The Mono-Graf process is based on the production of an investment mold where the mold material or stucco is graphitic and the binder decomposes on curing or firing to a carbonaceous product. The claimed benefits are close tolerance, good replication, and casting integrity comparable to normal investment casting processes. Casting surface finishes ranging from 90 to 125 rms, with dimensional tolerances of ± 0.005 inch/inch can be secured. The degree of surface contamination has not been reported. However, castings are processed by sand blasting and chemical cleaning as a normal part of the production sequence. Castings weighing up to 50 pounds can be produced by this process.

4. Tungsten Interfaced Investment Molds

Recent developments (Lee, 1970; Brown et al., 1970) that centered on the need to obtain nonreactive mold and binder materials for the investment casting of titanium and its alloys, are the use of a tungsten-refractory metal as the first

coat on the wax or plastic pattern, followed by outer layers of inorganic or mixed oxides. The pattern material is removed and the laminated shell mold is fired to remove volatiles and to produce a strong, nonreactive, permeable mold that is claimed to be heatable to temperatures in excess of 2,000°F at the time of casting. The precise combinations of mold materials, binders, and casting techniques are considered proprietary (U. S. Patent No. 3,442,880; U. S. Patent No. 3,537,949). The user of this process claims that no surface contamination occurs in the casting and that large thin sectioned, complicated precision castings are produced weighing up to 75 pounds.

5. Influence of Mold Materials on Casting Quality

In selecting a mold system for casting titanium, the prevention or reduction of any reaction of the mold with the molten titanium must be given primary consideration. Defects in titanium castings that can be attributed to mold materials are as follows:

- a. gross carbonization of the casting surface;
- b. gross oxygen, hydrogen, or nitrogen contamination in the casting;
- c. formation of intermetallic inclusions or layers in the casting;
- d. formation of gas pits, holes, and porosity in the casting;
- e. embedded nonmetallic and metallic inclusions or layers in the casting;
- f. formation of severe cold laps and misruns on the casting surface;
- g. no-fill in the casting;
- h. formation of cracks and tears in the casting;
- i. formation of a rough (> 125 rms) casting surface;
- j. embrittlement or increased hardness of the cast metal;
- k. penetration; and
- l. oxide folds.

As previously indicated, the degree to which these defects are found is a function of the type of mold material employed, degree of mold preheat, casting section thickness, casting temperature, casting complexity, gating system, etc.

E. Casting Design, Gating, and Feeding

Titanium castings should be designed in accordance with the recommendations for steel, cobalt, and nickel superalloy castings given by the American Society for Metals' Casting Design Handbook (1962) and the Investment Casting Institute Investment Casting Handbook (1968). Since titanium shrinks slightly more volumetrically from liquidus to solidus than steel or superalloys, this shrinkage may be reflected in the radiographic quality of thin walls. Generally, walls should be tapered to promote directional solidification, and intersections of thick and thin sections should have generous radii to minimize hot spot formation and to facilitate filling and feeding. Although sections less than 0.050 inch have been produced, normal practice adheres to a minimum wall thickness of 0.060 inch to 0.100 inch, with 0.080 inch preferred. Dimensional tolerances of ± 0.005 inch/inch can be made successfully with the investment casting process, while much larger tolerances must be allowed for processes that are rammed graphite-block molds.

Almost any configuration now being produced in the investment casting of steel and superalloys can be achieved with titanium castings, except for intricately cored configurations. The state-of-the-art is improving but limitations do exist. Molds produced from machined or rammed graphite have greater design limitations than the investment casting process. This is especially true where designs have re-entry angles and resulting tolerances across mold parting lines are in excess of 0.005 inches per inch.

Titanium requires more extensive gating and risering systems than other metals. In-gates and down-sprues must be larger and more contact points are necessary on thin wall sections, when statically cast. to compensate for the feeding qualities of titanium. The result of this additional material is a much

higher gate-to-part ratio than that for steel or superalloys, causes higher prices for similar configurations and increases the need for recycling of foundry scrap.

The specific gating that can be employed depends upon the casting configuration, molding system, mold material, and mold preheat. For example, machined- or rammed-graphite molds, which are not heated to high temperatures and not centrifuged, require excessive in-gates to supply adequate molten metal to various parts of the mold cavity to offset the chilling tendency of the graphite in order to avoid such casting defects as cold shut and no-fill. Conversely, investment molds can be preheated to high temperatures; therefore, both the size and number of in-gates can be reduced; and the defects, mentioned above, can be minimized.

As with other cast metals, wherever possible, the gating system should be arranged to create a minimum of turbulence during the pouring operation. This arrangement can result in less gas formation that is caused by mold-metal interaction and in less cold lapping in the casting. Although not directly applicable in all of its techniques, light metal gating has elements of nonturbulent gating (bottom filling) that are directly applicable. Tapering and padding sections may be desirable to eliminate macro- and micro-shrinkage, and the placement of gates to achieve directional solidification is essential to eliminate both macro- and micro-shrinkage. When designs lend themselves to centrifugal casting, the resulting castings have reduced shrinkage and gas porosity, and a higher utilization of metal.

Casting utilization and, consequently, design are restricted by alloy choice. At present, the most commonly cast compositions are commercially pure Ti, Ti-6Al-4, and Ti-5Al-2.5Sn. When designing titanium castings, designers should consider the properties of titanium alloys.

F. Alloy Systems for Castings

The program in existing alloy casting has two aspects: (1) their properties in the as-cast condition and (2) improving the properties of as-cast material.

Some information is available on the first item for which the Air Force programs contributed most of the available data (Carter, 1960; McClaren et al., 1967).

Generally, titanium castings and forgings are comparable in those structural uses where tensile properties are most important (Miska, 1971). Castings are outperformed by forgings in smooth fatigue tests. Tensile properties are shown in Table 3. Many conventional titanium alloys can be cast successfully. If they are heat-treatable, they can be heat-treated in the as-cast state. Castings whose strengths are improved by heat-treating suffer a loss in ductility and impact strength.

To date, titanium-alloy castings are made of compositions that were developed for wrought material. A need exists for a casting-alloy composition that has a lower melting temperature, is more tolerant of interstitial elements (such as carbon and nitrogen), is less reactive with the mold, and has higher mechanical properties than present alloys. A search for this alloy investigated over 112 alloys and achieved little improvement in castability (Carter, 1960).

A U.S.S.R. document on titanium alloys concludes that casting fluidity is a function of the alloy, the mold, and the melting conditions, and it is improved by increasing the alloy's heat of fusion, preheating the mold, increasing the arc current density, and casting centrifugally (Magnitskiy, 1970). Al, Cu, Fe and Mn additions decrease alloy viscosity, while Sn, Co, and V do not affect it. Small additions of Zr, Ni, Nb (Cb), Mo, and Si decrease viscosity initially, but the viscosity increases as the additions are increased.

Early conclusions from work in progress at the U. S. Bureau of Mines are as follows:

1. Si, Fe, Cu, Mo, etc., broaden the freezing range of Ti alloys and result in decreased flowability.
2. Al tends to raise the heat of fusion; consequently, increasing Al content improves flowability.

Table 3

Properties of Cast vs. Wrought Titanium

<u>Alloy</u>	<u>Casting</u>		<u>Forging</u>		<u>Extrusion</u>		
	<u>Ten.Str.</u> <u>(ksi)</u>	<u>Yld.Str.</u> <u>(ksi)</u>	<u>Ten.Str.</u> <u>(ksi)</u>	<u>Yld.Str.</u> <u>(ksi)</u>	<u>Ten.Str.</u> <u>(ksi)</u>	<u>Yld.Str.</u> <u>(ksi)</u>	<u>Elong.</u> <u>(%)</u>
Ti6Al-4V*	135	122	140	130	146	130	15
Ti6Al-4V**	163	153	180-160	175-150	-	-	-
Ti5Al-2.5Sn	126	108	130	120	-	-	-

* Data is for 70°F and does not necessarily represent optimum or highest heat treatment for specific application.

** Annealed. Fully heat treated. (Solution, heat treated, and aged).

Source: Materials Engineering, Miska, K., August 1971, pp 20-23.

3. Mn and probably all volatile alloying elements tend to lower metal temperature and, therefore, decrease the fluidity of the cast metal.

G. Porosity in Titanium Castings

Porosity is a major concern in the manufacture of titanium castings.

1. Morphology

The source of the porosity is difficult to identify because the porosity is usually present as a smooth walled cavity within an ingot or casting. Generally, when the cavity is large and nonspherical, as in a titanium ingot melted with a deep pool, foundries consider the defect a result of solidification shrinkage; whereas when it occurs as dispersed spheres, it is considered to be due to gas (Poole, 1965). Actually, the pores probably are caused by shrinkage and gas, acting in combination as expected from theoretical treatments of porosity (Piwonka and Fleming, 1966; Coble et al., 1971).

In these analyses, pouring in a vacuum has been found to magnify the effect of gas, particularly in lighter alloys whose densities are insufficient to establish a high metallostatic head. Gas is rejected from the solid at the liquid-solid interface. If the gas bubble is large enough to rise at an appreciable rate and if there is a continuous path of liquid to the atmosphere, the bubble will float out. However, if the surface of the casting freezes quickly, as in titanium alloys with their high melting point, the bubble will be trapped in the liquid, located in the last section of the casting to solidify, and combine with the solidification shrinkage that occurs there also. The resultant cavities can be rather large (Piwonka et al., 1972).

2. Effect on Properties

Although pores are present in titanium castings, apparently small spherical pores are not detrimental to tensile properties. In the annealed condition, strength levels comparable to forgings were reported in castings where porosity was present (Piwonka et al., 1972; Humphrey, 1972; McClaren et al, 1969). The casting strength is not impaired as long as the porosity is not

visible on the surface of the casting. Comparing cast test-bars with large pores (up to 10 percent of the gage-length cross section) with those with smaller pores reveals that the larger pore size decreases only the reduction-in-area values (Piwonka et al., 1972; Humphrey, 1972).

However, porosity (presumably interdendritic porosity) does affect creep, fracture toughness, and fatigue properties. Titanium castings are competitive with forgings under static loads and at room temperatures (Bass, 1969; Bass and Harmsworth, 1969). Porosity reduces dynamic properties, especially when present at, or near, the casting surface (Soffa, 1967).

3. Prevention of Porosity

Directional or progressive solidification techniques, normally successful in cast alloys, have not been effective in preventing porosity in titanium. The low thermal conductivity and density of the alloys slow heat transfer and limit the effect of externally imposed thermal gradients. Massive copper chills have shown no effect (Magnitskiy, 1970; Grala, 1970). Tapers must be increased to 8-10° to have any effect (Kukkonen et al., 1965).

Gas porosity can be minimized by using degassed charge material, bottom pouring (Poole, 1965; Kukkonen et al., 1965), and vacuum degassing the molds prior to pouring (Magnitskiy, 1970). Molds should be degassed in the chamber in which they are to be poured to avoid readsorption of gas on their surfaces.

Centrifugal casting (Poole, 1965; Magnitskiy, 1965; Magnitskiy, 1970) is the only completely effective method for the elimination of gas pores without the use of very large risers and is being used in American foundries to make titanium castings. Its effectiveness in casting 1,000- to 2,000-pound parts is unknown.

H. Effect of Impurities on Properties

Generally, interstitial elements (C, O, N, and H) affect the mechanical properties of titanium alloys, usually strengthening them at the expense of their

ductility. Because these elements decrease ductility, toughness, and weldability of alloys, their concentration levels have been limited, although the need for such limits for casting alloys has not been demonstrated.

1. Interstitial Pickup Due to Mold Reaction

The reaction of titanium with various mold materials is a major problem in titanium casting. In many cases, a compound, such as TiO_2 or TiC , is formed. (The fact that titanium burns in nitrogen has discouraged the use of materials, such as silicon nitride or boron nitride, for molds.) However, interstitials dissolve readily in liquid titanium even in the absence of a reaction. Therefore, oxide systems, such as MgO and ZrO_2 , that are thermodynamically stable relative to TiO_2 , are infrequently used as molds. The resultant "case" that forms at the mold-metal interface is a material discontinuity that must be removed. Some foundries have opted to use oxide or carbon mold systems and remove the surface case. The thickness of this layer increases with the time that the mold-metal interface remains at a high temperature and limits to thin sections the use of high preheat temperatures. Also, because the layer is thicker in heavy sections than in thin sections, the removal of this case is complicated on complex castings with varying section size. The possibility of exothermic metal-mold reactions increases with section thickness and may be significant in 6-inch sections.

For marine applications, knowledge is needed on the effect of interstitials on mechanical properties of cast titanium in sea water environments. A recent study (Morton, 1972) showed that the presence of oxygen affected greatly the high cycle-fatigue strength and stress-corrosion cracking susceptibility of Ti-6Al-4V and that the performance of the material decreased with increasing oxygen content. A preliminary study (Piwonka and Cook, 1972) is underway to determine whether carbon has a similar effect.

2. Interstitials in the Charge Metal

Of the interstitial elements present in the charge, hydrogen is found in the casting as gas pores. Carbon has been limited arbitrarily to the same

concentrations in castings as in forgings, notwithstanding studies that show carbon to be an excellent strengthener of titanium alloys (Shamblen, 1969; Child and Dalton, 1966). Alloys with carbon content of 0.18 to 0.25 percent had higher tensile and creep strengths and only slightly lower ductilities than base alloys containing lower carbon levels of 0.025 to 0.004 percent. Induction-melted titanium alloys, prepared in a graphite crucible and containing 0.14 percent C, had tensile properties similar to those of carbon-free alloys, except that beta-alloys were embrittled by the formation of a carbide phase (Piwonka et al., 1972). A separate study (Grala, 1970) of another alloy (Ti-6Al-2Cb-1Ta-0.8Mo), prepared this way and containing 0.12 percent C, had Charpy-impact values of 13.5 ft/lb at 32°F and 9.5 ft/lb at -80°F in the as-cast condition. However, no evaluation has been published on the effect of carbon content on notch-specimen properties, fatigue, or "sensitized," (i.e., after long-time exposure at elevated temperature) properties. In view of the widespread use of carbon as a mold material, this information should be obtained.

I. Processing of Titanium Castings

After metal has been melted and poured into the mold system (commercial and/or investment casting), the resultant castings are processed further through a series of operations referred to in the industry as "clean-up." These operations include mold knockout, gate cutoff, sandblast, machining, grinding, and chemical milling. Much of the information related in the following paragraphs is compared with the processing techniques for 17-4PH stainless steel. Because of its high corrosion resistance and greater strength-per-weight ratio, titanium has been replacing alloys, such as 17-4PH, 410, and 316, in many aircraft and chemical applications.

1. Knockout

This operation consists of removing castings, gates, risers, etc., from the mold system. Almost any method where vibration is employed can be used. The use of high pressure water streams can be very effective but is not in common usage.

Castings that contain deep and intricate cores require a chemical processing for shell removal; the particular chemical reagent depends upon mold composition. Reagents such as hydrofluoric acid, molten caustic, aqueous caustic, and sodium hydride baths, have been used. If the mold material is not susceptible to leaching, then shell removal can be accomplished only by sandblasting.

2. Cutoff

Gates and riser systems have been removed successfully by cutting with alumina abrasive discs. The time required for cutting titanium by such a disc is roughly twice that required for an equivalent thickness of 17-4PH steel. Generally, large gate systems, found on commercial castings, can be removed effectively by electric-arc methods. Extreme care must be exercised in using either of the cutoff methods to ensure that the casting proper is not heated excessively and, consequently, oxidized adjacent to the cutoff section, creating a hard alpha case.

3. Sandblasting

Most ordinary commercial systems (rotoblast, etc.), which use beach and alumina sand of various grit sizes, will effectively clean up the cast surface. Excessive grit velocity will cause erosion of the metal beyond dimensional tolerances, especially in investment castings.

4. Machining

Generally, tools used to machine titanium are the same as those used for 17-4PH stainless steel. A comparison of these two materials indicates that:

- a. the tool speed for titanium is one-half that of 17-4PH;
- b. feed rates are identical in most cases;
- c. to prevent surface contamination, cutting fluid, if used, must not contain any halogens or sulfur;

- d. carbide tools may be used for both titanium and 17-4PH; and
- e. tool wear in machining titanium is about twice that of 17-4PH.

The overall result of these factors is that the machining time for titanium is about twice that of 17-4PH and tools must be replaced more frequently. In addition, the usually more extensive gating system requires more machining time for removal.

5. Grinding

Both dry- and wet-grinding of titanium is very successful. However, for the same configuration, grinding titanium takes about five times longer than grinding 17-4PH. Aluminum oxide grits 50 and 60 are acceptable. Belt wear on titanium grinding is about four times that on 17-4PH. Wet-grinding reduces the fire hazard potential of titanium dust. However, during the grinding operation, titanium dust usually ignites immediately and, consequently, does not build up in volume.

6. Chemical Milling

Proprietary chemical milling operations for forgings, sheet stock, etc., have the same effect on cast titanium. Normally, these solutions are based on a specific ratio of nitric to hydrofluoric acid. Careful attention to the operation will ensure uniform mill rates. Generally, fixtures that can be rotated in a chemical milling bath are used to assure equal metal removal from all sections of the casting. Chemical milling is used to remove hardened cases resulting from metal-mold reactions, hot-forging operations, and exposed heat treatments.

The above operations do not cause the manufacturer of castings any severe, technical problems. Labor and materials costs for each operation are usually higher than those for performing the same task on the common stainless steel alloys.

J. Heat Treatment and Mechanical Properties

Tensile data obtained from skull-cast, arc-melted, and wrought Ti alloys, shown in Table 4, indicate that the properties of skull-casting materials approach those of wrought alloys prior to heat treatment. While wrought alloys are generally more responsive to heat treatment, cast material is more heat treatable than as-cast, arc-melted ingots. An exception to this is the Beta III alloy; the arc-melted materials appear to be more susceptible to heat treatment than the skull-cast.

Today, most titanium castings are shipped in the as-cast condition; some castings are given a solution treatment; and only a very few are given a solution treatment followed by an aging treatment. With the increasing use of titanium castings, different aging treatments may be developed. Further, conventional heat treatments (i. e., those developed for forgings) may be applied to castings, since the response of cast alloys to heat treatments appears satisfactory, as shown in Table 4 prepared for low carbon alloys.

Thus, limitations on the extent of deep hardenability that apply to current wrought alloys also apply to current cast alloys. For heavy section castings, alloys with specific hardenability may be required and development of such alloys is currently underway.

In general, satisfactory heat-treatment response has been found in alpha-beta alloys such as Ti-6Al-4V and Ti-6Al-2Sn-4Zr-6Mo in section sizes of 1 to 2 inches. However, heavier sections required the development of beta alloys, such as Beta III (Ti-11.5-6Mo-6Zr-4.5Sn) (Broadwell and Coyne, 1969). The successful development of Beta III spurred efforts to find other alloys that could be fully hardened in section sizes up to 6 inches (Heitman, 1969). Alpha-beta alloy, Ti-6Al-6V-4Mo-4Zr, develops properties of 160-170 ksi yield strength in 3-1/2 inch sections. This alloy appears to be comparable to the alpha-beta alloy, Ti-6Al-2Sn-4Zr-6Mo, and better than Ti-6Al-6V-4Sn, and IMI 680, but below the

Table 4
Mechanical Properties of Cast Titanium Alloys

Alloy	Heat-Treat	Ult Ten	Yld Str	Elong	Red of Area	Charpy	Typical Notch Rupture Str	
		(ksi)	(ksi)	%	%	ft-lb	Stress (ksi)	Time (hr)
Ti-6Al-4V	As cast	128	122	11	29	20	170	5
	1300/2/Argon cool + 950 F/1/turn cool to 600/AC	142	128	11.5	18.5	19	170	5
	1675/1/WQ + 1100F/4/AC	155	140	7	15	17	185	5
	1900/1/WQ + 900/4/AC	174	162	3	7	14	196	5
Ti-6Al-4V-3Co	As cast	163	153	3	9	—	—	—
	1500/1/WQ + 1000/2/AC	183	180	2	3	—	—	—
Ti-6Al-6V-2Sn	1100/1/AC	154	141	6	18	13	200	5
	1600/1/WQ + 1200/4/AC	167	158	4	9.5	13	200	5
Ti-3Al-13V-11Cr	As cast	118	112	5	11	—	—	—
	1425/0.5/AC + 1050/16/AC	152	140	4	8	—	—	—
Ti-6Al-2Sn-4Zr-2Mo	As cast	145.5	123.5	9.5	17	22	170	5
	1100/8/AC	141	127	10	18	22.5	170	5
	1650/1/AC + 1100/8/AC	141	127	12	20	29	180	5
	1900/1/OQ + 1650/1/AC + 1100/4/AC	156	143	8.5	17	13	200	5
Beta III	1350/0.25/WQ + 920/8/AC	197	180	6	8	—	—	—
	1450/0.25/WQ + 950/8/AC	182	164	7	15	—	—	—
	1275/0.25/WQ + 800/8/AC + 950/3.5 AC	174	163	7	18	14	220	5
	1375/0.25/WQ + 950/3.5/AC	173	160	7	17	15	210	5
Ti-5Al-6Sn-2Zr-1Mo-0.25Si	As cast	137	120	11	22	—	—	—
	1800/1/WQ + 1100/2/AC	173	155	3.5	6	—	—	—
	1800/1/OQ + 1100/2/AC	156	137	7	13	—	—	—
Beta C ^b	As cast	147	128.5	8	17.5	—	—	—
	1500/0.25/WQ + 1100/6/AC	164	156	4	7	6	180	5
	1600/0.25/WQ + 1100/6/AC	162	156	3	9	5	180	5

^a All temp in degrees F. Data interpreted as follows: e.g. Heat treat to 1300 F for 2 hours, followed by cooling in argon atmosphere and then reheat to 950 F for 1 hr and let furnace cool to 600 F, followed by final air cooling. ^b Beta III is Ti-3Al-8V-6Cr-4Mo-4Zr.

Source: REM Metals Corporation

beta alloys Ti-13V-11Cr-3Al, and Ti-8Mo-8V-2Fe-3Al (Broadwell and Coyne, 1969). To obtain comparable data, these tests were performed on the same type of forging. The alloy Ti-8Mo-8V-2Fe-3Al is reported to be hardenable to 160 ksi yield strengths in sections up to 8 inches thick (Bohanek, 1972). Silicon also is being used to achieve deep hardenability. One recently developed alloy using silicon, Ti-6Al-2Sn-2Zr-2Mo-2Cr-0.25Si, (Hall et al., 1972) is capable of developing moderately good strength (150 ksi yield) in sections up to 4 inches thick. There is a need to extend the hardenability studies to heavy-section cast-structures (up to 6 inches).

Recently, the Air Force initiated a program to develop a high-strength alloy with good toughness that can be hardened in section sizes greater than present alloys (Froes et al., 1972). Those alloying elements (Mo, Fe, and Cr) that appear to confer deep hardenability also decrease weldability, as discussed later in Section L. This program is screening current alloys and attempting to discover relationships that will facilitate design of other alloys. The work will not be concluded until 1974.

Presently, there are no published data on fracture toughness or crack growth characteristics for titanium castings in either ambient or hostile environments.

K. Minimum and Maximum Section Sizes

1. Minimum Sections

Thin sections save weight and thus contribute to a more favorable strength-to-weight ratio in a finished casting. By requiring a smaller volume of metal, thin walls (within practical limits) also may lower casting costs, particularly when an expensive alloy is being poured. Realization of the advantages of thin walls in a casting depends largely on the casting process, the characteristics of the mold system, and certain physical limitations of the metal. The major physical limitation is the molten metal fluidity, which affects mold filling. The casting process factors are the degree of superheat that can be obtained in the melting equipment, speed of pouring the metal, and ability to apply external forces to the

metal during casting, as in centrifugal casting. The influential characteristics of the mold system are: the thermal diffusivity of the mold; the ability to preheat the mold to an optimum temperature; and the reactions between the mold material and the molten metal. Gating practice and casting design obviously will influence the casting of thin sections also.

Previously, the inability of the consumable-electrode vacuum-melting process (skull-melting) to superheat molten metal appreciably was discussed, and this is a deterrent to obtaining thin-section castings. In titanium casting operations, the speed of pouring is usually high because the metal is cast directly from the melting "crucible" or furnace into the mold cavity. Centrifugal casting is used by some producers also.

Mold materials, such as graphite or carbon, have a high-chilling potential or high-thermal diffusivity. However, if investment casting practice is followed to obtain thin sections and good mold filling, the molds usually are preheated to a high temperature to offset the chilling potential of carbon mold materials. In titanium casting practice, the reaction between mold material and molten metal can be severe, particularly in thick sections of preheated molds. However, in thin sections, solidification is rapid and the reaction between mold and metal is estimated to be of secondary importance to other factors that influence the ability to obtain thin sections.

The gating practice and general techniques used to produce thin sections in other metals are applicable here. These include methods such as gating the hottest metal possible into, or close to, the thin section, having metal flow through the section, and not having two streams of metal meet in a thin section. Casting-design factors include the use of heavy sections at the termination of light sections, the incorporation of ribs into thin plate-like sections, etc.

In current commercial production, many statements are made regarding minimum castable section thicknesses; sections between 0.050 and 0.080 inches are claimed to have been produced by utilizing vacuum consumable-electrode melting and graphite-base investment-molding practices. Another source indicates that the following typical wall thicknesses and tolerances can be obtained by using vacuum consumable-electrode melting practice and rammed-graphite molds with reaction inhibiting fluxes.

Flat area running distance:

0.120-inch wall — 5-inch maximum

0.180-inch wall — 10-inch maximum

0.250-inch wall — 15-inch maximum

This company indicates that the thickness tolerances across the parting line is ± 0.020 -inch up to 1-inch thick section. They also state that as-cast wall thicknesses less than 0.100 inch can be obtained over short-running distances, or in tapered sections that possess suitable metal-feeding geometries.

The influence of mold preheat-temperature was investigated by examining the ability to fill 1 x 4-inch plan-area sections of different thickness and cast in two alloys, Ti-6Al-4V and Ti-6Al-2Sn-4Zr-2Mo (Grala, 1970); the results are summarized in Table 5. Vacuum-induction melting practice was followed and pyrolytic graphite-coated ceramic-investment molds were used. The 1 x 4-inch test coupons were appendages of a tensile-bar cluster and, as such, no metal flowed through the section. These data show that by utilizing this particular melting, casting, and molding practice, sections of 0.090 inch and greater can be secured, if the mold is preheated in the range of 1,000 to 2,000°F. Generally, sections less than 0.090 inch could be obtained only when the mold is preheated to 2,000°F.

In summary, the minimum section that can be cast in titanium in an investment mold is considered to be 0.060 inches, provided a high degree of mold preheat and maximum permissible superheat of the molten metal were used.

Table 5

**Effect of Mold Preheat Temperature on Mold Fill
for Ti-6Al-4V and Ti-6Al-2Sn-4Zr-2Mo**

Mold Temp. (°F)	Percent Mold Fill*							
	Bottom Gated Section Thickness (inch)				Top and Bottom Gated Section Thickness (inch)			
	<u>0.250</u>	<u>0.090</u>	<u>0.060</u>	<u>0.030</u>	<u>0.250</u>	<u>0.090</u>	<u>0.060</u>	<u>0.030</u>
	<u>Ti-6Al-4V</u>							
1000	100	100	33.1	19.7	100	100	87.4	32.0
1200	100	100	36.9	28.8	100	100	76.2	32.0
1500	100	100	64.2	40.8	100	100	78.3	10.1
1500	100	100	61.2	39.1	100	98.5	94.0	28.5
2000	100	100	100	25.2	100	100	76.8	6.4
2000	100	100	100	71.3	100	100	91.2	11.4
	<u>Ti-6Al-2Sn-4Zr-2Mo</u>							
1000	100	100	20.7	22.4	100	100	100	9.0
1200	100	100	50.7	18.6	100	100	96.0	43.2
1500	100	100	58.4	41.5	100	100	76.2	22.8
1500	100	100	70.3	32.4	100	100	100	22.8
2000	100	100	100	14.5	100	100	100	20.4
2000	100	100	67.1	23.4	100	100	100	18.2

* Determined as a percent of the total surface section, 1 x 4 inch.

Source: TRW INC., Report IR-164-0(11), "Manufacturing Methods for Precision Casting Titanium Alloy Aircraft Components," Grala, E.M., 1970.

Apparently, with a rammed-graphite molding system, the minimum section thickness is 0.100 inch. A practical limit on section thickness of 1/16 inch per inch in length and width has been reported for machined graphite molds.

2. Maximum Sections

No limits on maximum castable section thicknesses are given by the various producing foundries. Some problems have been experienced in the maintenance of specified mechanical properties in cast heavy sections in other metal systems due to contamination and segregation. Probably titanium alloys will behave similarly. Further, the potential problem of reaction between titanium and mold materials will be magnified in heavy, slowly solidifying sections. While large, heavy-section titanium castings for the chemical industry have been produced in rammed-graphite molds, data on the mechanical properties in heavy sections of titanium-alloy castings should be obtained, particularly in highly stressed areas.

L. Weld Repair and Structural Joining

In general, the titanium alloys currently used in castings have good weldability, particularly the alpha and alpha-beta alloys (Magnitskiy, 1970; McLaren et al., 1969; Poole, 1965; Humphrey, 1972; Piwonka and Cook, 1972). Obviously, the effectiveness of welding, either for repair or for structural joining, depends greatly on the degree to which good weld practice is followed and on the effectiveness of nondestructive evaluation techniques in finding discontinuities in the weld structure. Similar to other alloys, large titanium castings are more difficult to weld than small ones, because of the difficulty of heat-treating large sections and problems with residual stresses, including stresses resulting from the casting process (Glasunov and Yassinsky, 1972).

A rating of the weldability of titanium alloys is shown in Table 6 (Welding Handbook, 1966). Generally, welding is not recommended for alloys containing Mn, Fe, Cr, or Mo. No data have been published on the performance of welded castings, weld properties of castings in sea-water environments, or weldments of heavy cast sections.

Table 6

Weldability of Titanium Alloys

<u>Nominal Composition Percentage (balance Ti)</u>	<u>Rating*</u>
Commercially pure (all)	A
0.15 Pd	A
5Al-2.5Sn (standard interstitial)	B
5Al-2.5Sn (low interstitial)	A
5Al-2Sn-5Zr	A
7Al-12Zr	B
7Al-2Cb-1Ta	A
8Al-1Mo-1V	A
8Mn	C
2Fe-2Cr-2Mo	D
2.5Al-16V	C
4Al-4Mn	D
4Al-3Mo-1V	C
5Al-1.25Fe-2.75Cr	C
5Al-1.5Fe-1.4Cr-1.2Mo	D
6Al-4V (standard interstitial)	B
6Al-4V (low interstitial)	A
6Al-6V-2Sn-1(Fe, Cu)	C
7Al-4Mo	C
1Al-8V-5Fe	D
3Al-13V-11Cr	B

- * A = Excellent
- B = Fair to Good
- C = Limited, for special applications or welded with special treatment
- D = Welding not recommended

Source: Welding Handbook, 1966 Edition, Vol. 4, p. 73.8.

The use of electroslag welding (discussed in Section A) in the structural joining to obtain large sections remains a possible method of achieving large structural shapes in the absence of production casting facilities.

M. Reclamation of Titanium Scrap

One major manufacturing cost in the production of titanium castings is the inability of the industry to recycle scrap economically. Double-melted electrode stock, used in consumable arc-melting furnaces, ranges in price from \$2.00 to \$3.50 a pound, while scrap is marketed at less than \$0.25 per pound. The high cost of raw material, combined with the high gating ratio required to feed titanium castings, are factors in making titanium casting unattractive to the aircraft industry.

At present, there are basically five techniques used to reclaim scrap.

They are:

1. tack-welding scrap together to form a consumable electrode;
2. remelting pieces of scrap fed into a crucible, using a nonconsumable electrode, such as the Durarc (Alurs et al., 1969) or the Schlienger rotating electrode (Schlienger, 1970);
3. electron-beam techniques (Scriver, 1972);
4. split crucible inductive slag-melting process; and
5. skull casting over loose scrap.

1. Tack-Welding Scrap for Consumable Melting

The most common method today consists of tack-welding pieces of scrap either around a forged electrode or to form an electrode shape. Alloy additions can be made by welding strips of elements along the electrode. Major producers of titanium ingot have used this technique for more than ten years. The low packing density of the resulting shape and the high cost of welding labor have not resulted in a recycling process that is significantly more economical than the standard techniques used to make virgin electrode stock (compacted sponge).

2. Durarc (Westinghouse) and Schlienger Rotating Electrode Processes

Both processes involve a nonconsumable copper electrode whose arc rotates very rapidly around the circumference of the electrode. The Durarc process uses an electromagnetic coil to achieve this effect, while the Schlienger process uses mechanical means of rotating the copper electrode. The process is similar to consumable-electrode melting, except that the scrap to be melted is charged into the crucible at frequent intervals rather than melting the electrode. The high speed rotating arc and water-cooling of the electrode reduce erosion of the copper electrode significantly. Both processes are capable of efficient scrap reprocessing. Alloy additions can be made by feeding pure elements along with the scrap. Several major companies have installed both these systems and are using them for scrap reclamation.

3. Electron-Beam Process

This method uses a stream of energetically charged particles flowing from a tungsten cathode emitter and accelerated by high voltage, direct-current power supply. The kinetic energy of this stream of charged particles becomes heat energy when the electrons strike a metal surface. The system requires very high vacuums, generally more than the consumable-electrode melting systems. Scrap is placed in a water-cooled copper crucible and the electron beam is scanned over the surface of the scrap to be melted. Due to the large, shallow surface area to be scanned, only 30 to 50 percent of the melted metal can be poured, while the remainder is retained as a skull. The electron-beam technique is capable of superheating and permits adding of alloying elements, but it requires an expensive power supply, a long melting cycle, and much better vacuum equipment.

Reactive Metals, Inc. and Leybold-Heraeus jointly have an Air Force-sponsored program that uses electron-beam melting to reclaim titanium-scrap turnings, stampings, etc. Much that is learned from this program could be applied to the reclamation of chopped scrap created by casting processes.

4. Split-Crucible Induction Slag-Melting Process

This process developed at the Albany Metallurgy Research Center of the U. S. Bureau of Mines joins the split water-cooled induction-melting process (Schippereit) with the electroslag process. Schippereits' (Battelle) process failed on scaling-up because of electrical shorting between the cooled sections (the splits) by liquid metal. The problem was solved through the use of a nonreactive slag (Clites and Beall, 1972). When the CaF_2 slag enters the splits, it freezes and becomes an electrical insulator. In practice, melting takes place in a sleeve section; as the ingot is formed, it is withdrawn. Scrap chunks or light scrap are fed continuously. The resultant ingot may be forged directly or used as a consumable electrode for remelting. The Bureau of Mines has produced ingots up to 5 inches in diameter by 40 inches long. The continuing program is now aimed toward tilt pouring from an Industoslag crucible.

5. Skull Casting over Loose Scrap

At least one producer consolidates scrap in a casting process. Loose scrap is placed in an open box mold with the cross sectional area of an electrode-briquette and titanium metal is skull cast over the scrap, effectively freezing it together. Then, the resulting block can be included in a fabricated consumable electrode for subsequent remelting.

N. Specifications for Titanium Castings

At present, no specifications for titanium castings have wide acceptance. A number of aerospace companies have prepared their own specifications covering titanium alloy castings. The specification in Appendix N covering titanium alloy investment castings was issued recently by the Navy. Also, ASTM Committee E07.0211B is drawing up specifications. Generally, casting specifications have been written using the chemistry of comparable wrought materials and the casting quality of aluminum-casting specifications. In view of published data (discussed in Sections IV. G and I) for titanium castings, apparently this practice is without merit. Indeed, the use of wrought compositions that limit carbon content to below 0.08 percent carry an economic penalty, if carbon molds (such as rammed

graphite) are used, since this effectively prohibits remelting and reclamation of gates, risers, sprues, and scrap castings. More data on the performance of titanium castings, particularly large thick-section castings, are needed before meaningful specifications can be issued.

The military specification on investment titanium-alloy castings in Appendix N was developed for relatively thin sections and should be reevaluated for thick sections.

O. Conclusions and Recommendations

1. Conclusions

- a. The current state-of-the-art in the titanium casting industry permits cast shapes to be manufactured readily in sizes up to 1500 pounds in weight. However, the industry has no experience in the manufacture of larger castings.
- b. Limitations exist on the ability of present manufacturing methods to produce castings comparable to steel castings in some configurations within this 1500-pound weight limit.
- c. Each titanium foundry uses its own specific mold material. To date, only rammed-graphite molds have been adequate for the production of large castings (up to 1500 pounds).
- d. Insufficient data exist today on the effect of:
 - 1) alloying elements on cast properties;
 - 2) carbon on cast properties;
 - 3) heat treatments on cast properties, and hardenability of of thick sections of castings;
 - 4) section size on cast properties;
 - 5) the weldability of cast heavy sections;
 - 6) heavy sections on casting problems, such as mold reaction and alloy segregation; and
 - 7) cast grain size on properties.

- e. The open literature has meager information today on:
 - 1) mold systems for use with titanium alloys,
 - 2) gating and risering of titanium castings, and
 - 3) the effect of defect level on cast properties.
- f. The only proven commercial melting system is the vacuum-arc remelt (skull-casting) system that uses a cold crucible and a consumable or nonconsumable electrode.
- g. Titanium castings are particularly susceptible to porosity. Porosity may be overcome by the use of centrifugal casting, large metallostatic head, or generous padding.
- h. No industry-wide specifications have been developed for titanium castings using titanium castings for evaluation.
- i. Further experimental work is required to bring titanium-casting technology and user acceptance to a mutually satisfactory level.

2. Recommendations

- a. Determine the effect of defects on properties and performance of titanium castings in conjunction with the development of meaningful NDE standards for the industry.
- b. Determine the effect of carbon level on casting properties and performance in view of the widespread use of carbonaceous mold materials in the industry.
- c. Develop alloys specifically for casting applications. These alloys should have lower melting temperatures, improved fluidity, reduced mold reaction, and a higher tolerance for interstitials (especially O₂ and C) than existing alloys.

- d. Characterize the material in thick sections of castings with regard to mechanical properties, hardenability, weldability, foundry problems (shrink mold reaction, etc.), and metallurgical features. Solidification phenomena, such as grain formation and segregation, need to be evaluated also for their effect on casting performance.
- e. Develop casting technology in areas of anticipated use by placing orders for prototype castings of the desired size and complexity. Evaluation of these castings (by independent sources) should answer the need expressed in item (d) above.
- f. Investigate electroslag melting as a method of casting large heavy shapes.
- g. Study the consumable-arc melting process further to improve its reproducibility.
- h. Develop a method of titanium-scrap regeneration capable of reducing the price of titanium alloy castings to \$0.50 to \$0.75 a pound.
- i. Adopt or develop inexpensive methods of gas analysis for foundry use to permit identification of gas porosity to eliminate gas as a source of defects.
- j. Increase furnace capacity in 10,000-pound increments until a 40,000-pound furnace capacity is reached, permitting the pouring of a 20,000-pound casting.

V. REFERENCES

A. Steel Castings

- Choulet, R. J., R. L. W. Holmes and L. R. Chrzan, "Argon Degassing Practice and Results," Journal of Metals, January 1966, pp 72-78.
- Dabkowski, D. S., T. W. Olesnevich and L. F. Porter, "Properties of Bars, Tubes, and Extruded Shapes Produced from 10Ni-Cr-Mo-Co Steel," U. S. Steel and Applied Research Laboratory Reprint No. 39.018-007 (46), July 30, 1971.
- Davis, W. E. and E. V. Black, "Production and Evaluation of HY-130(T) Steel Castings," General Steel Industries, July 1, 1966.
- Fletcher, E. E., and A. R. Elsea, "Hydrogen Movement in Steel — Entry, Diffusion, and Elimination," Defense Metals Information Center Report 219, Battelle Memorial Institute, Columbus, Ohio, June 30, 1965.
- Giudici, H. and R. G. Waite, "Production and Evaluation of HY-130 (T) Steel Castings; Birdsboro Corporation, July 1, 1966.
- Hamburg, E. G., and L. F. Porter, "Embrittlement of 10Ni-2Cr-1Mo-8Co Steel by Antimony, Arsenic, Tin, and Phosphorus," Applied Research Laboratory Report No. 39.018-007 (32), May 15, 1969.
- Hobson, J. D., "The Removal of Hydrogen by Diffusion from Large Masses of Steel," Journal of the Iron and Steel Institute, April 1959, pp 342-352.
- Kiesler, A. J., "Method for Making Low Sulfur Steel." General Electric Company Patent No. 3099552, July 30, 1963.
- Military Specification, Steel Castings, High Yield Strength (HY-80 and HY-100), MIL-S-23008B(SHIPS), September 29, 1964.
- Military Specification, Steel Plate, Alloy, Structural, High Yield Strength (HY-130), MIL-S-24371(SHIPS), December 19, 1968.
- Novak, S. R., "Effect of Prior Uniform Plastic Strain on the K_{Isc} of High-Strength Steels in Sea Water," Presented at the Symposium on Fracture and Fatigue, George Washington University, May 3-5, 1972 (to be published in the Journal of Engineering Fracture Mechanics).
- Pellini, W. S., "Evolution of Engineering Principles for Fracture-Safe Design of Steel Structures," Naval Research Laboratory Report 6957, September 23, 1969.

Porter, L. F., A. M. Rathbone, S. T. Rolfe, K. E. Dorschu, W. L. Wilcox, R. W. Waite, C. B. Jenni, R. T. Telford, and W. T. DeLong, "The Development of an HY-130 (T) Steel Weldment," Applied Research Laboratory Report No. 39.018-001(64), July 1, 1966.

Porter, L. F., G. C. Carter, and S.J. Manganello, "A Study of Temper Embrittlement During Stress Relieving of 5Ni-Cr-Mo-V Steels," Temper Embrittlement of Steel, ASTM STP-407, American Society for Testing and Materials, 1968, pp 20-45.

Porter, L. F., P. J. Konkol, D. S. Dabkowski, L. P. Connor, J. M. Barsom, A. K. Shoemaker, S. R. Novak, and J. H. Smith, "Final Report — Preliminary Development of an HY-180 Weldment System," Applied Research Laboratory Report No. 39.018-007 (52), August 16, 1971.

Procurement Specification, Steel Plate, Alloy, Structural, High Yield Strength (HY-130), MI-30-P/4, December 1971.

Puzak, P. P., and E. A. Lange, "Fracture Toughness Characteristics of the New Weldable Steels of 180 to 210 Ksi Yield Strengths," Naval Research Laboratory Report 6951, September 18, 1969.

Rolfe, S. T., and S. R. Novak, "Slow-Bend K_{Ic} Testing of Medium-Strength High-Toughness Steels," Review of Developments in Plane Strain Fracture Toughness Testing, ASTM STP-463, American Society for Testing and Materials, 1970, pp 124-159.

B. Titanium Castings

Alurs, R. R., N. Griffing, and R. C. Buell, "Development of a Water-Cooled Nonconsumable Electrode for Vacuum Melting," AVS Vacuum Metallurgy Conference, June 16-19, 1969, Pittsburgh, Pennsylvania.

Antes, H. W., J. T. Norton, and R. E. Edelman, "Foundry Characteristics of a Rammed Graphitic Mold Material for Casting Titanium," Modern Castings, Vol. 32, p. 135, April 1958.

Bass, C. D., and C. L. Harmsworth, "Fatigue Behavior of Titanium Castings," ASME paper 69-GT-22, March 1969.

Bass, C. D., "Evaluation of Titanium Castings," Technical Report AFML-TR-69-116, AFML, WPAFB Ohio, September 1969.

Beall, R. A. and others, "Cold-Mold Arc Melting and Casting," U. S. Bureau of Mines Bulletin 646, 1968, 151 pp.

- Bohanck, E., "Deep Hardenable Titanium Alloys for Large Airframe Elements," presented at the Second International Conference on Titanium, Boston, May 1972.
- Broadwell, R. G., and J. E. Coyne, "The Fracture Toughness-Tensile Property Relationships of Several Deep Hardenable Titanium Alloys," presented at Winter Meeting TMS-AIME, Las Vegas, February 1969.
- Brown, R. A., and J. Richard Humphrey, "Manufacturing Methods for Producing Large, Close Tolerance, Thin Wall Titanium Shapes for Aircraft Structural Applications, Air Force Materials Laboratory, Contract F33615-70-C-1410, Report No. IR-162-0 (I), June 1970.
- Carter, R. V., "Development of Titanium Alloy Casting Method," AMC Technical Report 60-7-656, September 1960. AMC Aeronautical Systems Center, U. S. Air Force, Wright-Patterson Air Force Base, Ohio.
- Casting Design Handbook, ASM, Metals Park, Ohio, 1962.
- Child, H. W., and A. L. Dalton, "Titanium-Base Alloys Strengthened by Carbon," British Patent 1,049,624, 1966.
- Clites, P. G., and R. A. Beall, "Inductoslag Melting of Titanium Scrap and Sponge," Light Metals 1972, ed. by W. C. Rotsell, pp 325-351, AIME, 1972.
- Coble, R. L., and M. C. Flemings, "On the Removal of Pores from Castings by Sintering," Met. Trans. 1971, vol. 2, p. 409.
- Dunlop, A., and H. C. Child, "The Production and Evaluation of the Properties of Titanium Alloy Castings," UK Ministry of Aviation, Contract KS/1/0157/CB 43(a)2, S and T Memo 2/67, March 1967.
- Feild, A. L., Metal Progress, vol. 70, p. 92. October 1956.
- Feild, A. L., and R. E. Edelman, Modern Castings, vol. 31, p. 64, 1957.
- Froes, F. H., V. C. Peterson, and R. F. Malone, "Research on Deep Hardening Titanium Alloy for Large Airframe Structural Member," AFML Contract F33615-71-C-1525, Interim Report #2, March 1972.
- Glasunov, S. G., and K. K. Yassinsky, "Investigation of Residual Stresses in Cast Titanium Alloys," presented at the Second International Conference on Titanium, Boston, May 1972.

- Grala, E. M., "Castability of Ti-6Al-2Cb-1Ta-0.8Mo Alloy," Naval Applied Science Laboratory, Contract NOO140-69-C-240, Final Report, March 1970.
- Grala, E. M., "Manufacturing Methods for Precision Casting of Titanium Alloy Aircraft Components," Air Force Materials Laboratory, Contract F33615-70-C-1409 with TRW Inc., Cleveland, Ohio, March 1970.
- Hall, G. S., S. R. Seagle, and H. B. Bomberger, "Development of a Deep-Hardenable Alloy for Intermediate Temperature Applications," presented at the Second International Conference on Titanium, Boston, May 1972.
- Heitman, G. H., "Development of a New High Strength Deep Hardenable Titanium Alloy," Conference on Titanium, New York University, 1969.
- Huber, R. W., E. J. Chapin, and I. R. Lane, "Vacuum Arc Melting and Casting of Titanium," Foundry, v. 87, no. 7, pp 86-70, July 1959.
- Humphrey, J. R., "Manufacturing Methods for Producing Large, Close Tolerance, Thin-Walled Titanium Shapes for Aircraft Structural Applications," presented at Third Air Force Metalworking Conference, WESTEC, March 1972.
- Investment Casting Handbook, ICI, Chicago, Illinois, 1968.
- Kukkonen, E. Ya., G. A. Faplunovskii, A. A. Demidova, O. N. Magnitskiy, and B. B. Gulyaev, "Effect of Gases on the Quality of Titanium Alloy Castings," in Gases in Cast Metals, Translated by Consultants Bureau, New York, 1965.
- Lee, R. G., "Precision Titanium and Columbium Castings," Presentation to NMAB Ad Hoc Committee, October 1970.
- Magnitskiy, O. N., "Conditions of Formation of Gas Pores in Titanium Castings," Gases in Cast Metals, 1965.
- Magnitskiy, O. N., "Casting Properties of Titanium Alloys," Translation by Foreign Technology Division, WPAFB, Ohio, Translation No. FTD-HT-386-69, Nat. Technical Information Service No. AD706642, April 1970.
- McClaren, S. W., O. H. Cook, and D. C. LaGrone, "Processing, Evaluation, and Standardization of Titanium Alloy Castings," 1: -9-169 (LLL) June to November, 1967. Air Force Materials Laboratory, Wright-Patterson Air Force Base, Ohio.
- McClaren, S. W., O. H. Cook, and G. Pascador, "Processing, Evaluation, and Standardization of Titanium Alloy Castings," Technical Report AFML-TR-68-264, AFML, WAPFB, Ohio, April 1969.

- Miska, K., "Titanium Castings Combine Lightweight Corrosion Resistance," Materials Engineering, August 1971, pp. 20-23.
- Morton, A. B. S., "Titanium Castings for Marine Applications," presented at the Second International Conference on Titanium, Boston, May, 1972.
- Nurminen, J. I., and H. D. Brody, "Dendrite Morphology and Microsegregation in Titanium Base Alloys," presented at the Second International Conference on Titanium, Boston, Massachusetts, May 1972.
- Paton, B. E., B. I. McDovar, G. A. Bojko, I. I. Koomish, and V. F. Karpov, "New Potentialities of Electroslag Shaped Casting, Published in Part 1, Report of the International Symposium on Special Electro-Metallurgy, Kiev, U. S. S. R., June 1972.
- Peifer, W. A., "Levitation Melting," Journal of Metals, May 1965, p. 487.
- Petersen, V. A., F. H. Froes, and R. F. Malone, "Metallurgical Characteristics and Mechanical Properties of Beta III, a Heat-Treatable Beta Titanium Alloy," presented at the Second International Conference on Titanium, Boston, May 1972.
- Piwonka, T. S. and M. C. Flemings, "Pore Formation in Solidification," TMS-AIME, 1966, vol. 236, p. 1157.
- Piwonka, T. S., and C. R. Cook, "Manufacturing Methods for Precision Casting Titanium Alloy Aircraft Components," Interim Engineering Progress Report, IR-164-0(VIII), Contract F33615-70-C-1409, AFML, WPAFB, March 1972.
- Piwonka, T. S., and C. R. Cook, "Manufacturing Methods for Precision Casting Titanium Alloy Aircraft Components," Contract F33615-70-C-1409, AFML, WPAFB, Final Report, 1972.
- Piwonka, T. S., E. M. Grala, and C. R. Cook, "Induction Melting and Casting of Titanium Alloys," presented at Third Air Force Metalworking Conference. WESTEC, March 1972.
- Poole, H. G., "Fundamentals of Casting Titanium," Titanium Metallurgy Course, New York University, September 13-15, 1965.
- Pulkonik, K. J., R. D. Regan, W. E. Lee, and R. A. Rosenberg, "Manufacturing Process for Premium Quality Titanium Castings," Air Force Materials Laboratory, Report No. AFML-TR-66-184, June 1966.
- Pulkonik, K. J., W. E. Lee, and R. A. Rosenberg, "New Developments in Titanium Castings," Trans. AFS, p. 38, 1967.

- Shipperit, G. H., A. F. Leatherman, and D. Evers, "Cold-Crucible Induction Melting of Reactive Metals," J. of Metals, February 1961, pp 140-143.
- Schlienger, M., "Strike Your Arc on a Spinning Wheel, " 33, p. 79, November 1970.
- Scriven, R. M., "Ti Alloy Scrap Reclamation Process," Contract No. F33615-69-C-1898, AFML, WPAFB, Ohio, 1972.
- Shamblen, C. E., "Carbon Concentration Optimization for an Alpha Stabilized Titanium Alloy," presented ASM Titanium Conference, 1969.
- Soffa, L. L., "Titanium Castings for Airframe Structural Applications," ASM Technical Report No. C7-14.1, October 1967.
- Takei, H., and Y. Ishigami, "Hollow-Cathode Discharge Melting of Ti-6Al-4V and Nb-56Ti-3.3 Zr Alloys," Journal of Vacuum Science and Technology, v. 8, No. 6, November/December 1971, pp 33-37.
- Tsareff, T. C., and U. L. Hellmann, "Development of Titanium Alloys for Cast Gas Turbine Engine Components," Six Month Technical Management Report, 15 June - 31 December, 1969, Contract F33615-69-C-1608, AFML, WPAFB, Ohio.
- U. S. Patent No. 3,284,832, November 15, 1966.
- U. S. Patent No. 3,442,880, May 6, 1969.
- U. S. Patent No. 3,537,949, November 3, 1970.
- Unvala, B. A., and T. C. Goel, "Thermal Conductivity, Electrical Resistivity, and Total Emittance of Titanium at High Temperatures," Rev. Int. Hautes Temper. et Refract., 1970 vol. 7, p. 341.
- Welding Handbook, 1966 edition, vol. 4, p. 73.8.
- Westwood, A. R. C., "New Breakthrough on Casting Titanium," Modern Castings, p. 36, March 1960.
- Zotos, J., P. J. Ahearn, and H. M. Green, Trans. AFS, v. 66, 1958, p. 225.

APPENDIX A

SPECIFICATION MIL-S-23008B (SHIPS)
OF SEPTEMBER 29, 1964

STEEL CASTINGS, ALLOY, HIGH YIELD STRENGTH
(HY-80 AND HY-100)

Preceding page blank

MIL-S-23008E(SHIPS)
→ 29 September 1964 ←
SUPERSEDING
MIL-S-23008A(SHIPS)
12 August 1963
(See 6.3)

MILITARY SPECIFICATION

STEEL CASTINGS, ALLOY, HIGH YIELD STRENGTH

(HY-80 AND HY-100)

1. SCOPE

1.1 This specification covers HY-80 and HY-100 alloy steel castings for use in applications where good weldability and notch toughness are required.

2. APPLICABLE DOCUMENTS

2.1 The following documents, of the issue in effect on date of invitation for bids or request for proposal, form a part of the specification to the extent specified herein.

STANDARDS

FEDERAL

FED-STD-151 - Metals; Test Methods.

MILITARY

MIL-STD-23 - Nondestructive Testing Symbols.

PUBLICATIONS

NAVSHIPS - 250-634-3 - Method for Conducting Drop-Weight Test to Determine Niductility Transition Temperatures of Ferritic Steels.

NAVSHIPS - 250-692-13 - Radiographic Standards for Steel Castings.

NAVSHIPS - 250-637-3 - Fabrication, Welding Inspection of HY-80 Submarine Hulls.

(Copies of specifications, standards, drawings, and publications required by suppliers in connection with specific procurement functions should be obtained from the procuring activity or as directed by the contracting officer.)

2.2 Other publications.- The following documents form a part of this specification to the extent specified herein. Unless otherwise indicated, the issue in effect on date of invitation for bids or request for proposal shall apply.

OFFICIAL CLASSIFICATION COMMITTEE

Uniform Freight Classification Rules.

(Application for copies should be addressed to the Official Classification Committee, 1 Park Avenue at 33rd Street, New York 16, New York.)

AMERICAN SOCIETY FOR TESTING MATERIALS

E 71-52 - Industrial Radiographic Standards for Steel Castings.

(Application for copies should be addressed to the American Society for Testing Materials, 1916 Race Street, Philadelphia 3, Pennsylvania.)

(Technical society and technical association specifications and standards are generally available for reference from libraries. They are also distributed among technical groups and using Federal agencies.)

FSC MECA

MIL-S-23008B(SHIPS)

3. Requirements.

3.1 Preproduction test.- Prior to delivering of castings conforming to this specification, prospective producers shall submit their material to the preproduction tests required by the Bureau or Agency concerned. For Bureau of Ships procurement, the preproduction testing shall be carried out in accordance with 4.2.

3.2 Material.- The castings shall be produced from electric furnace or open hearth quality steel. The steel shall be fully killed.

3.3 Chemical composition.- The chemical composition shall conform to table I.

Table I - Chemical composition.

Element	Percent, Maximum unless a range is shown	
	HY-80	HY-100
Carbon	0.20	0.22
Manganese	0.55/0.75	0.55/0.75
Phosphorous	0.020	0.020
Sulphur	0.015	0.015
Silicon	0.50	0.50
Nickel	2.50/3.25	2.75/3.50
Chromium	1.35/1.65	1.35/1.85
Molybdenum	0.30/0.60	0.30/0.60
Residual Element	Maximum Percent Permitted	
	HY-80	HY-100
Titanium	0.02	0.02
Vanadium	0.03	0.03
Copper	0.20	0.20

3.3.1 Check analysis variations.- On check analysis, the percentages of the elements shall not be over the upper limits or under the lower limits shown in table I by more than the following amounts. Where no check analysis variation is shown, the limits for check analysis and ladle analysis are the same.

Element	Variations	
	Over the Upper Limit	Under the Lower Limit
Manganese	0.05	0.05
Phosphorus	.005	----
Sulphur	.005	----
Silicon	.03	----
Nickel	.07	.07
Chromium	.06	.06
Molybdenum	.03	.03

3.4 Tensile properties.- The tensile properties shall be within the limits of table II.

Table II - Tensile properties.

	HY-80	HY-100
Yield strength, p.s.i., at 0.2 percent offset	80,000/95,000	100,000/120,000
Tensile strength, p.s.i.	1/	1/
Elongation, percent minimum in two inches	20.0	18.0
Reduction of area, percent minimum.	35.0	30.0

1/To be recorded for information only.

3.5 Impact properties and nilductility transition temperature. The material shall meet the requirements of 3.5.1 or 3.5.2. Both properties need not be determined.

3.5.1 Impact properties.- The castings shall show a Charpy V-notch impact value of thirty foot-pounds minimum, on the average of three tests, at a temperature of $-100^{\circ}\text{F} \pm 3^{\circ}\text{F}$. No individual test result shall be more than five foot-pounds below the specified minimum of thirty foot-pounds.

3.5.2 Nilductility transition temperature.- The material shall have a nilductility transition temperature below $-100^{\circ} \pm 5^{\circ}\text{F}$ as shown by the drop-weight test. In the event of conflict with the results of 3.5.1, this test shall govern. Either or both tests may be performed, the selection shall be the choice of the supplier.

3.6 Heat treatment.- The castings shall be furnished in the quenched and tempered condition. The quenching and temper shall be preceded by an homogenization, normalize or anneal treatment.

3.6.1 Austenitizing.- A suitable austenitizing temperature shall be selected not exceeding 1750°F .

3.6.2 Tempering.- The tempering treatment shall be carried out at a minimum temperature of 1100°F and a temperature below the lower critical temperature of the involved steel. Quenching from the tempering temperature is mandatory. When necessary, double tempering is permitted. Those restrictions specified for single tempering apply to double tempering.

3.6.3 Weld repaired castings may be stress relieved in accordance with the requirements specified in Nominal Repairs of Section 16 of NAVSHIPS 250-637-3.

3.6.4 Heat treatment equipment.- Continuous or automatic heat treating equipment may be employed provided such equipment is capable of producing heat treated castings to meet the requirements of this specification.

3.6.5 Pyrometric control.- Adequate recording pyrometric equipment shall be employed to indicate the temperature of the casting during the heating and cooling cycles of the heat treatment. A heat-treatment record shall be available to show that the heat-treatment requirements have been carried out.

3.7 Cleaning.- Castings shall have heads and gates removed, shall be thoroughly cleaned and all sand, scale, fins, excessive rough spots shall be removed by mechanical means before final inspection. Padding added by the foundry to provide directional solidification shall be removed unless provisions are made in the procurement document to permit such padding to remain for removal by subsequent machining operations. When heads, gates, and padding are removed by gas cutting or scarfing, the removal shall be performed before the final heat treatment and in such a manner as not to impair the casting. Gas cutting or scarfing shall be followed by cutting, chipping, or grinding operations as necessary to provide the specified contour. Flame or arc cutting and beveling of edges will be permitted. The flame or arc cut surfaces to be welded shall not contain gouges or other irregularities. The flame or arc cut surfaces shall be magnetic particle inspected for cracks (see 4.4.4) as requested by cognizant Naval authority.

3.8 Repair of defects.- Unless otherwise specified, welding may be used to repair defects. This is contingent upon the producer complying with the requirements of section 16 of NAVSHIPS 250-637-3. Defects not requiring welding may be ground or chipped out provided defective area is well flared into the surrounding area and the design thickness is not violated.

MIL-S-23008B(SHIPS)

3.9 Soundness.- Castings shall be of uniform quality and condition, free of harmful defects such as injurious tears, cracks, porosity, sand inclusions, blow-holes, shrinkage-cavities, cold shuts, and unfused chaplets or internal chills as determined by visual examination and applicable nondestructive tests, including radiographic examination, ultrasonic testing, and magnetic particle inspection. The acceptability of discontinuities in the castings shall be determined by comparison with the standards set forth in this specification.

3.9.1 Radiographic examination.- Unless otherwise specified (see 6.1), the castings shall be radiographed in accordance with 4.4.2 and shall meet the requirements of class 2 castings of NAVSHIPS 250-602-13 or class 2 castings of ASTM E 71-52.

3.9.2 Ultrasonic examination in lieu of radiography. When approved by the Bureau, ultrasonic testing may be substituted for radiography to the extent specified in the ordering data. The ultrasonic testing shall be carried out in accordance with 4.4.3. Any discontinuities whose reflections do not exceed a height equal to 20 percent of the normal back reflection, or do not reduce the height of the back reflection by more than 30 percent during movement of the transducer two inches in any direction, shall be considered acceptable. When true back reflection cannot be obtained due to non-parallel sides, the reflectoscope shall be adjusted for testing the thickness involved by use of a sound test block of the same material and nominal thickness. The surface shall be reprepared for proper crystal contact. Any discontinuity whose reflections exceed a height of 20 percent of the back reflection, as given by the test block, during movement of the transducer two inches in any direction shall be subjected to further examination or be cause for rejection. Sections of the castings which exceed the limits set forth above shall be repaired in accordance with 3.8 unless proven acceptable by the radiography of 3.9.1.

3.9.3 Each casting shall be magnetic particle tested in accordance with 4.4.4. The castings shall be in the completed condition, ready for shipment, that is, either in the rough or the machined condition as specified (see 6.1). All indications of linear discontinuities 1/8 inch or longer shall be investigated to insure they are not defects unacceptable to the requirements of 3.9. When defects are discovered by this method they shall be repaired in accordance with 3.8.

3.10 Straightness.- The responsibility for furnishing heat treated castings that can be machined to the finished dimensions within the tolerances given and without further straightening shall rest with the contractor. Layout points, when required, shall be shown as such on the applicable drawings and shall be suitably incorporated in the castings. Castings of excessive oversize or overweight with regard to the dimensions shown on the drawings shall not be furnished.

3.11 Marking.- The castings shall be identified with the manufacturer's name or trademark and a serial number which will positively identify the casting to pattern and part number, melt from which they were poured and the lot with which they were heat treated. Markings shall be placed in a location such that they are not machined off in finishing and in an area that is stressed least in service.

3.12 Workmanship.- Workmanship shall be first class in every respect. Each casting shall be free from harmful defects and shall meet all the requirements of this specification.

4. QUALITY ASSURANCE PROVISIONS

4.1 Responsibility for inspection.- Unless otherwise specified in the contract or purchase order, the supplier is responsible for the performance of all inspection requirements as specified herein. Except as otherwise specified, the supplier may utilize his own facilities or any commercial laboratory acceptable to the Government. The Government reserves the right to perform any of the inspections set forth in the specification where such inspections are deemed necessary to assure supplies and services conform to prescribed requirements.

4.1.1 Quality control system.- The supplier shall provide and maintain a quality control system acceptable to the Government.

4.2 Preproduction testing.- Prior to award of a contract or order, prospective bidders who have not previously produced castings under this specification shall demonstrate to the Bureau that their facilities are capable of producing quality products. The number and size of sample castings to be produced for preproduction tests shall be a result of negotiation between the Bureau of Ships and prospective producer. Sufficient material will be required to obtain the variability in the notch toughness, mechanical properties, and weldability. Ordinarily, the prospective producer will be required to furnish cast plate weldments in accordance

with NAVSHIPS 250-637-6, Standard Evaluation Procedures for Explosion Bulge Testing (Weldments) Including Preproduction Tests of HY-80 Steel.

4.3 Sampling for inspection and test.-

4.3.1 Lot size.- For purposes of inspections and tests, lot sizes are defined as follows:

- (a) Chemical or spectrographic analysis.- Each melt of steel is a lot; also, a ladle of a number of smaller melts is a lot.
- (b) Mechanical tests.- All castings produced from one heat or melt, heat treated under similar conditions in the same heat treating charge shall constitute a lot.
- (c) Examination and inspection.- Each casting shall constitute a lot.

4.3.2 Sampling for chemical or spectrographic analysis.- Two samples shall be taken at random from each lot. Samples may be poured from the ladle in the form of a test block or drilled from the casting proper, provided it is drilled in such a manner as not to impair the castings usefulness. Where one casting represents the product of a heat, one chemical sample will suffice.

4.3.3 Sampling for mechanical tests.- A sufficient number of test blocks shall be separately cast with the heat to fulfill the mechanical test requirements of this specification. Adequate measures shall be taken to insure test block soundness. The use of chills or chill molds is prohibited. The size of the test block shall be in proportion to the thickness (T) of the casting, where (T) is the diameter of the largest circle that can be inscribed in any cross section of the casting. Two test blocks shall be heat treated with each lot. One shall represent the maximum T of the largest casting in a lot and one shall represent the maximum T of the smallest casting in a lot. The terms large and small castings are defined by the respective (T) of each. Where castings representing a lot are identical, one test block will suffice.

4.3.3.1 The recommended dimensions of the nonchilled, test coupons are exhibited in table III. The dimensions shown are minimum dimensions. Dimensions in excess of those in table III are permitted, providing sound test blocks are secured.

Table III

Test block sizes	
(T) Test block thickness ^{1/}	Test block dimension ^{2/}
Under - 1 inch	1 x 7 x 7
1 inch - 2 inches excluded	T x 4.5T x 4.5T
2 inches - 4 inches excluded	T x 3T x 3T
4 inches and over	T x T x 6√T

^{1/}T shall be defined as the diameter of the largest circle that can be inscribed in any cross section of the as heat treated casting unless defined otherwise in advance by the bureau or agency concerned.

^{2/}Dimensions specified are minimum. Should need arise, length and width may be increased in order to secure a practical test block for cutting tests.

4.3.3.2 Heat treating test blocks.- Test blocks shall accompany the product through all the heat treatment cycles except the stress relief. Sufficient precautions shall be taken to insure the test block receives the same thermal treatment as the parent casting.

4.3.3.3 Charpy V-notch and drop weight tests.- Three Charpy V-notch tests or two drop weight tests shall be taken from each test block representing a lot. The test shall be taken at least 1 inch below the test block surface when the thickness permits. In the case of Charpy V-notch tests, the length of the notch shall be perpendicular to the as cast surface.

MIL 8-23008B(SHIPS)

4.3.3.4 Tension test.- One tension test shall be taken from each test block representing a lot. The test specimens shall be taken at T/4¹/ or 1 inch whichever is less the surface of the as quenched test block.

4.4 Examination and inspection.-

4.4.1 Visual and dimensional examination.- Each casting shall be examined for conformance to the specified dimensions and shall be visually examined to determine whether the requirements of this specification are met.

4.4.2 Radiography.- The radiographic testing of castings shall be carried out in accordance with this section of this specification.

4.4.2.1 Qualification of procedure.- Prior to performing the necessary radiography of these castings, the manufacturer shall provide, to the local inspector, adequate information on their radiographic procedure to adjudge its suitability for the intended inspection. The procedure shall be qualified in accordance with the applicable paragraphs of section 4 in NAVSHIPS 250-637-3.

4.4.2.2 Qualification of radiographic personnel.- Prior to performing the necessary radiography of these castings the manufacturer shall insure all personnel engaged in any phase of radiography are adequately qualified in accordance with the provisions of the applicable paragraphs in section 4 of NAVSHIPS 250-637-3.

4.4.2.3 Radiographic technique.- The radiographic technique for inspection of castings shall be in accordance with the Radiographic Inspection requirements of section 15 of NAVSHIPS 250-637-3 except for the following:

- (a) Where the word "weld" or "joint" appears, delete and substitute "casting".
- (b) The requirement for Shims is not applicable.
- (c) The requirement for placing the long axis of the penetrometer within 1/8 to 1/4 inch from the edge and parallel to the weld is not applicable.
- (d) The four penetrometers required for Single Exposure of Continuous Welds Which are Essentially Circular, is not applicable.
- (e) Under Identification of Radiographs, the casting serial number and manufacturers name or trade mark shall be required in lieu of the Hull number.
- (f) Delete surface preparation and substitute the following:

"Surface preparation.- The casting surface shall be suitable for radiographic inspection such that any surface irregularities shall not mask or be confused with any internal defect."

4.4.3 Ultrasonic testing in lieu of radiography.- The ultrasonic testing of castings shall be carried out in accordance with the terms of this specification.

4.4.3.1 Approval to perform ultrasonic testing.- Prior to performing ultrasonic testing of castings, a procedure shall be submitted to the bureau or agency concerned for approval.

4.4.3.2 Qualification of personnel.- Personnel performing ultrasonic testing shall have demonstrated their ability to calibrate and operate the ultrasonic equipment. Additionally, they shall be thoroughly familiar with inspection requirements and acceptance standards outlined in this specification.

4.4.3.3 Ultrasonic procedure.- At minimum, the requirements for approval of an ultrasonic procedure are outlined below.

- (a) Equipment: The inspection equipment shall be capable of producing, receiving and displaying high frequency pulses at the required frequencies and energy levels.
- (b) Instrument: The instrument shall be of the pulse echo type, capable of operating at frequencies of 2.25-5 megacycles.
- (c) Transducers: The type transducer shall be compatible with the testing instrument. The minimum frequency for performing ultrasonic testing of castings shall be 2.25 megacycles. The maximum transducer (crystal) size shall be 1-1/8 inches in diameter or 1 square inch in contact surface.

¹/T is used here as defined in footnote 1 of table III.

- (d) Couplant: The couplant used shall give the best results for the equipment and prevailing surface conditions. The surface shall be free of loose scale and dirt.
- (e) Calibration: Transducer shall be placed on experimentally determined defect-free area. The instrument shall be adjusted to display a minimum gain setting equivalent to produce a 90 percent of the screen height back reflection. When back reflection cannot be obtained due to non-parallel sides, the reflectoscope shall be adjusted for testing the thickness involved by use of a sound test block of the same material and nominal thickness.
- (f) Scanning procedure: Area to be ultrasonic tested in lieu of radiography shall be 100 percent scanned with each pass overlapping the previous pass by 10 percent of the crystal contact area.
- (g) Acceptance rejection standards: Areas exhibiting defects in excess of those described in 3.9.2 shall be rejected unless the defects are proven to meet the radiography requirements of 3.9.1.

4.4.4 Magnetic particle inspection.- Magnetic particle inspection shall be carried out in accordance with the requirements in this section.

4.4.4.1 Magnetic particle procedure and equipment qualification requirements.- Procedure and equipment qualification shall be carried out in accordance with section 4 of NAVSHIPS 250-637-3 with the following exception:

- (a) Where the word "weld" appears insert the word "casting".

4.4.4.2 Operator qualification requirements.- Operator qualification shall be carried out in accordance with section 4 of NAVSHIPS 250-637-3.

4.4.4.3 Magnetic particle inspection.- Final magnetic particle inspection shall be carried out in accordance with the applicable paragraphs under section 15 of NAVSHIPS 250-637-3 with the following exceptions:

- (a) Where the word "weld" appears delete and substitute "casting".
- (b) Under Magnetizing Direction, delete the requirement for placing the prod across the weld at an angle of 30-45 degrees with the long axis of the weld.
- (c) Under "Magnetizing Method" delete and substitute:

"Method.- The direct magnetization circular field high amperage prod system shall be used for final inspection of castings. Unless approval is received from the Bureau or agency concerned. No other method is permitted."

- (d) The Sequence of Operations requirement is not applicable.

4.5 Tests.-

4.5.1 Chemical or spectrographic analysis.- Chemical or spectrographic analysis shall be performed in accordance with methods 111.1 or 112.1 of FED-STD-151.

4.5.2 Tension test.- Type R-1 tensile specimens shall be tested in accordance with method 211.1 of FED-STD-151.

4.5.3 Charpy V-notch test.- Charpy V-notch specimens shall be tested in accordance with method 221.1 of FED-STD-151. The specimen dimensions shall comply with figure 3 of method 221.1 of FED-STD-151. The specimen shall be tested at $-100^{\circ}\text{F} \pm 3^{\circ}\text{F}$.

4.5.4 Drop-weight test.- The drop-weight specimens, selected in accordance with 4.3.3, shall be tested by the drop weight method in accordance with NAVSHIPS 250-634-3. The test shall be made at $-100^{\circ}\text{F} \pm 5^{\circ}\text{F}$. All specimens in each group of three shall pass the test, as illustrated in figure 14 of NAVSHIPS 250-634-3.

4.6 Rejection.- Individual castings not meeting the requirements of this specification shall be cause for rejection. If a casting representative of a lot fails to meet the chemical or mechanical property requirements of this specification, the lot shall be subject to rejection. Retests shall be made in accordance with the provisions of FED-STD-151.

4.6.1 Retreatment.- Upon failure to meet mechanical or impact properties, castings may be requenched and tempered or retempered. All tests shall be performed after reheat treatment and shall meet the requirements of this specification.

MIL-8-23008B(SFIPS)

5. PREPARATION FOR DELIVERY

5.1 Domestic shipment and early material use.

5.1.1 Castings.

5.1.1.1 Packaging.- Packaging shall be sufficient to afford adequate protection against damage during shipment from the supply source to the using activity and until early installation.

5.1.1.2 Packing.- Packing shall be accomplished in a manner which will insure acceptance by common carrier and will afford protection against physical or mechanical damage during direct shipment from the supply source to the using activity for early installation. The shipping containers or method of packing shall conform to the Uniform Freight Classification Rules and Regulations or other carrier regulations as applicable to the mode of transportation.

5.1.1.3 Marking.- Shipment marking information shall be provided on interior packages and exterior shipping containers in accordance with the contractor's commercial practice. The information shall include nomenclature, Federal stock number, contract or order number, contractor's name, and destination.

5.2 Domestic shipment and storage or overseas shipment.- The requirements and levels of packaging and marking for shipment shall be specified by the procuring activity (see 6.1).

(5.2.1 The following provides various levels of protection during domestic shipment and storage or overseas shipment, which may be required when procurement is made (see 6.1).

5.2.1.1 Preservation and packaging.- Not applicable.

5.2.1.2 Packing.- Shipping containers shall be of similar construction, uniform size, and shall contain the same number of castings of one size, melt or lot number. Containers shall be designed to fit the contents in a compact manner.

5.2.1.2.1 Levels A and B.- Castings having projections which may be damaged in handling or shipment shall be packed individually, or in multiple units with adequate blocking, bracing, and cushioning in unsheathed crates conforming to MIL-C-132 and the appendix thereto. Castings shall be securely bolted, blocked, braced, or strapped to prevent shifting and damage within the crates. The gross weight of the crates shall not exceed 500 pounds unless individual castings exceed this weight.

5.2.1.2.1.1 Castings weighing more than 200 pounds each and not subject to damage in shipment may be shipped unpacked.

5.2.1.3 Marking.- In addition to any special marking required by the contractor or order, shipment shall be marked in accordance with MIL-STD-129.)

6. NOTES

6.1 Ordering data.- Procurement documents should specify the following:

- (a) Title, number, and date of this specification.
- (b) Whether patterns are to be furnished by the Government or are to be supplied by the contractor.
- (c) That all patterns furnished by the Government shall be properly cared for by the contractor and when being returned to the Government shall be suitably boxed or crated by the contractor to prevent damage or breakage in transit. Before shipment from the foundry, patterns should be inspected by the Government inspector and a report should be made by him if the patterns are found to be in an unsatisfactory condition.
- (d) When ultrasonic testing may be substituted for radiographic examination, under what circumstances, and to what extent it may be substituted.
- (e) The numbers of the applicable drawings.
- (f) The extent of radiographic inspection.
- (g) Level of preparation for shipment (see Section 5).
- (h) Number of castings required and estimated weight per piece.

6.2 Preproduction.-

6.2.1 Invitations for bids should provide that the Government reserves the right to waive the requirement for preproduction samples as to those bidders offering a product which has been previously procured or tested by the Government, and that bidders offering such products, who wish to rely on such production or test, must furnish evidence with the bid that prior Government approval is presently appropriate for the pending procurement.

6.3 CHANGES FROM PREVIOUS ISSUE.- THE EXTENT OF CHANGES (DELETIONS, ADDITIONS, ETC.) PRECLUDE THE ANNOTATION OF THE INDIVIDUAL CHANGES FROM THE PREVIOUS ISSUE OF THIS DOCUMENT.

Preparing activity:
Navy - SK
(Project MECA-N001Sh)

MIL-S-23008B(SHIPS)
→ AMENDMENT - 1
→ 6 July 1965

MILITARY SPECIFICATION
STEEL CASTINGS, ALLOY, HIGH YIELD STRENGTH
(HY-80 AND HY-100)

This amendment forms a part of Military Specification MIL-S-23008B(SHIPS), dated 29 September 1964.

Page 3, paragraph 3.6.3: Add: "Castings that are stress relieved shall be subjected to Charpy impact or drop weight tests after final stress relief treatment. This may be accomplished by submitting the test block specified in 4.3.3 to the thermal treatment along with the casting proper. The impact tests shall meet the requirements of either 3.5.1 or 3.5.2, whichever is applicable."

Preparing activity:
Navy - SH
(Project MECA-NO07Sh)

FSC - MECA

APPENDIX B

MILITARY SPECIFICATION MIL-T-81915
TITANIUM AND TITANIUM-ALLOY CASTINGS, INVESTMENT

MILITARY SPECIFICATION

TITANIUM AND TITANIUM-ALLOY CASTINGS, INVESTMENT

This specification is approved for use by all Departments and Agencies of the Department of Defense.

1. SCOPE

1.1 Scope. This specification prescribes the requirements for Titanium and Titanium-alloy castings produced by the investment casting process.

1.2 Classification. The titanium and titanium-alloy castings furnished under this specification shall be of the following types, compositions and grades (see 6.2).

1.2.1 Types and composition.

Type I - Commercially pure titanium
Composition A (see 3.2)

Type II - Alpha-titanium alloy
Composition A - Ti-5Al-2.5Sn

Type III - Alpha-beta titanium alloy
Composition A - Ti-6Al-4V
Composition B - Ti-6Al-2Sn-4Zr-2Mo

1.2.2 Grades. Castings shall be of Grades A, B and C as shown in Tables II and III, and shall be in accordance with the radiographic reference specified in the tables.

FSC MECA

MIL-T-81915

2. APPLICABLE DOCUMENTS

2.1 The following documents of the issue in effect on date of invitation for bids or request for proposal, form a part of this specification to the extent specified herein.

SPECIFICATIONS

Military

MIL-H-81200	Heat Treatment of Titanium and Titanium Alloys
MIL-C-6021	Castings; Classification and Inspection of

STANDARDS

Federal

Fed. Test Method Std. No. 151	Metals; Test Methods
FED-STD-184	Identification Marking of Aluminum, Magnesium and Titanium

Military

MIL-STD-105	Sampling Procedures and Tables for Inspection by Attributes
MIL-STD-129	Marking for Shipment and Storage
MIL-STD-453	Inspection, Radiographic
MIL-STD-649	Aluminum and Magnesium Products, Preparation for Shipment and Storage

(Copies of specifications, standards, drawings and publications required by suppliers in connection with specific procurement functions should be obtained from the procuring activity, or as directed by the contracting officer.)

2.2 Other publications. The following documents form a part of this specification to the extent specified herein. Unless otherwise indicated, the issue in effect on date of invitation for bids or request for proposal shall apply.

MIL-T-81915

American Society for Testing and Materials

ASTM E 155 Reference Radiographs for Inspection of
Aluminum and Magnesium Castings (Series II)

ASTM E 8 Tension Testing of Metallic Materials

(Application for copies should be addressed to the American Society for Testing and Materials, 1916 Race Street, Philadelphia, Pennsylvania 19103.)

3. REQUIREMENTS

3.1 Melting Processes. The material shall be produced by multiple melting under vacuum or inert atmosphere. Melting processes shall include either singly or in combination, electro-consumable arc, electron beam or other vacuum melting processes suitable for the production of materials meeting the requirements of this specification.

3.2 First Article. Unless otherwise specified in the contract or order, two castings shall be submitted in advance of production as directed by the procuring activity for examination and written approval. One casting shall be identified as the "dimensional sample," and shall be for dimensional approval. The other casting shall be identified as the "foundry control sample," and shall be for radiography and destructive tests as necessary for approval (see 6.2).

3.2.1 The submitted castings shall be fully representative of the foundry practice that will be used in production. If temporary gating was used to develop suitable foundry practice, the submitted casting shall be made after the permanent gating has been installed. All critical melting and pouring parameters shall be recorded.

3.2.2 Molds. The mold materials should be essentially nonreactive, as shall the atmospheres in the molds at the time of pouring.

3.2.3 Surface contamination. The surfaces of castings shall be free from surface contamination by oxygen, nitrogen or carbon. Pickling or chemical milling may be used to remove contaminated zones from as-cast surfaces. The surface roughness shall not exceed RHR 80 when the casting is submitted to the purchaser.

3.3 Material. The material shall be such as to produce investment castings in full compliance with the requirements specified herein.

3.4 Chemical composition. The chemical analysis of castings shall comply with the limits specified in Table I.

TABLE I
CHEMICAL COMPOSITION, PERCENT BY WEIGHT 1/

COMPOSITION	ELEMENTS											Total Other Elements
	Al	Sn	Mo	V	Zr	Fe	C	N	H <u>2/</u>	O	Ti	
TYPE I - COMMERCIAL PURE TITANIUM												
A	-	-	-	-	-	0.20	0.08	0.05	0.015	0.20	Bal	0.60
TYPE II - ALPHA TITANIUM ALLOY												
A (5Al-2.5Sn)	4.50- 5.75	2.0- 3.0	-	-	-	0.50	0.08	0.05	0.020	0.20	Bal	0.40
TYPE III - ALPHA-BETA TITANIUM ALLOY												
A (6Al-4V)	5.5- 6.75	-	-	3.5- 4.5	-	0.30	0.08	0.05	0.015	0.20	Bal	0.40
B (6Al-2Sn-4Zr -2Mo)	5.5 6.5	1.5 2.5	1.5 2.5	-	3.6 4.4	0.35	0.08	0.05	0.015	0.12	Bal	0.40

1/ Percent maximum, except where indicated as a range.

2/ Hydrogen shall be determined on each lot of the product as shipped.

MIL-T-81915

3.5 Foundry control. Castings shall be produced under foundry control approved by the procuring activity. Foundry control shall consist of examination of castings by radiographic methods for determining internal defects until the gating and other foundry practices have been established to produce castings meeting the quality standards furnished by the procuring activity or agreed upon by the procuring activity and contractor. When foundry practices have been so established, the production method shall not be changed until the procuring activity is satisfied that the change does not adversely affect the quality of the castings.

3.6 Soundness. When specified (see 6.2), the soundness of castings shall conform to standards furnished or approved by the procuring activity. The extent of porosity and other defects in the castings shall not exceed those shown by the standard, and such defects shall be absent in designated areas. The standards supplied or approved by the procuring activity for determining conformance with soundness requirements may consist of sectioned castings or photographs thereof or radiographs of at least the important sections of the castings. When specified (see 6.1), the minimum weight of each casting shall be controlled.

3.7 Identification marking. Each casting shall be identified with the part number by the use of raised numerals in a location indicated on the drawing. When no location is shown on the drawing, the number shall be located so as not to be machined off in finishing to the required dimensions. Castings on which it is impracticable to provide raised numerals shall be so marked as to be properly identified at the point of delivery.

3.8 Surface imperfections. The casting surface shall not contain cracks, laps, cold shuts or inclusions (see 4.4.2.3).

3.9 Radiographic requirements. After the foundry control methods of 3.5 have been established, the castings shall be radiographically inspected as specified in 4.5.2.

3.10 Mechanical properties. The mechanical properties shall conform to the requirements of Table IV. The strength requirements of the casting, tested in full size, shall be as specified on the drawing for the part concerned or in other purchase information (see 6.2).

3.11 Heat-treatment. Heat-treatment shall be performed on a whole casting and never on a portion only. Heat treatment shall be conducted as detailed in MIL-H-81200.

MIL-T-81915

3.12 Dimensions. The dimensions of the castings shall be within the dimensions and tolerances specified on the applicable drawings.

3.13 Workmanship. Castings shall be uniform in quality and condition, sound, clean, and substantially free from foreign materials.

3.13.1 Castings shall not be repaired by plugging, welding, or other methods without written permission from the procuring activity. Castings shall not be mechanically straightened after heat-treatment without written permission from the procuring activity.

4. QUALITY ASSURANCE PROVISIONS

4.1 Responsibility for inspection. Unless otherwise specified in the contract or purchase order, the supplier is responsible for the performance of all inspection requirements as specified herein. Except as otherwise specified in the contract or order, the supplier may use his own or any other facilities suitable for the performance of the inspection requirements specified herein, unless disapproved by the Government. The Government reserves the right to perform any of the inspections set forth in the specification where such inspections are deemed necessary to ensure that supplies and services conform to prescribed requirements.

4.1.1 Foundry control approval. Production of a given casting shall not begin until the foundry is approved, unless such approval be waived in writing by the procuring activity. Foundry control samples shall be submitted as directed by the procuring activity. The manufacturer shall use the same foundry practices and the same heat-treating procedures for production castings as for approved sample castings. If necessary to make any change, the foundry shall notify the procuring activity before the first shipment of castings incorporating such a change, and shall submit sample castings produced by the changed procedure for approval in accordance with 3.5.

4.1.1.1 Radiographic acceptance procedure. Acceptance shall be made by comparison with a standard set of radiographs contained in ASTM E 155. Radiographic indications shall be identified in terms of the defects listed in Table II. Acceptance shall be made in accordance with one of three grades specified in the engineering drawing (see 6.3). When no grade is specified, Grade C shall apply.

4.2 Classification of tests. The inspection and testing of castings shall be classified as follows:

- a. First Article inspection (see 4.3)
- b. Quality conformance inspection (see 4.4)

MIL-T-81915

TABLE II

MINIMUM SOUNDNESS FOR TITANIUM-ALLOY CASTINGS SUBMITTED FOR FOUNDRY CONTROL APPROVAL (MAXIMUM PERMISSIBLE RADIOGRAPH IN ACCORDANCE WITH ASTM E 155)

Imperfection (ASTM E 155)	Radiograph Reference	Grade A	Grade B	Grade C
Porosity (round)	1.21	None	None	1
Porosity (elongated)	1.22	None	None	2
Shrinkage cavity	2.1	None	1	1
Foreign material (less dense)	3.11	None	None	1
Foreign material (more dense)	3.12	None	1	1
Cracks	-	None	None	None
Cold shuts	-	None	None	None
Laps	-	None	None	None

4.3 First Article.

4.3.1 First Article inspection. First article inspection of the titanium-alloy castings shall consist of all tests described under Test Methods for all the requirements specified in Section 3 (see 4.5).

MIL-T-81915

4.3.2 First article sample. The first two castings produced under each contract or order shall be the first article test samples (see 3.1). The samples shall be forwarded to a testing activity designated by the procuring activity. The manufacturer shall supply a certified statement of composition and prior tests which show that the castings comply with the requirements of this specification (see 3.5). Samples shall be identified as required by the procuring activity for acceptance procedure.

4.4 Quality conformance inspection. Quality conformance inspection shall consist of all tests as described under 4.5.

4.4.1 Lot. Unless otherwise specified in the contract or order, a lot shall consist of not more than 2000 pounds of casting of the same part number produced in a pouring period not exceeding eight hours with metal from a single heat which is heat-treated in one furnace load.

4.4.2 Sampling for quality conformance inspection. Unless otherwise specified on the drawing or other purchase information and where applicable, sampling plans and procedures in the determination of the acceptability of products submitted by a supplier shall be in accordance with MIL-STD-105.

4.4.2.1 Sampling for visual and dimension examination. A random sample shall be selected from each lot in accordance with MIL-STD-105, Inspection Level II, Acceptable Quality Level (AQL) 2.5 percent defective for the test of 4.5.5.

4.4.2.2 Sampling for chemical composition. A random sample shall be selected from each lot in accordance with MIL-STD-105, Inspection Level S-1, acceptance number of zero for the test of 4.5.1. Preparation of sample specimens for the chemical analysis shall be in accordance with Methods 111.1 or 112.1 of Federal Test Method Standard No. 151.

4.4.2.3 Sampling for radiographic and penetrant inspection. The frequency of sampling of each lot for radiographic and penetrant inspection for the tests of 4.5.2 and 4.5.3 shall be in accordance with MIL-C-6021 and MIL-H-6866.

4.4.2.4 Sampling for mechanical properties. Castings shall be selected at random from each lot in accordance with MIL-STD-105, Inspection Level S-2, acceptance number zero for test of 4.5.4.

4.4.2.4.1 Unless otherwise specified in the contract or drawing, tension test specimens shall be cut from locations shown on the drawing according to the sampling specified in 4.4.2 or on the drawing. If no location is shown, three specimens shall be taken from a thick, medium, and thin section of each casting selected at random, as close as practicable to cover thickness variations.

4.5 Test methods.

MIL-T-81915

4.5.1 Chemical analysis. Analysis shall be spectrographic or chemical; Methods 111.1 or 112.1 of Fed. Test Method Std. No. 151. In case of dispute, the chemical analysis by wet chemical methods shall be the basis for acceptance.

4.5.2 Radiographic inspection. This examination shall be conducted in accordance with MIL-STD-453. Unless otherwise noted, the limits of X-ray indications shall be as specified in Table III. Additional radiographic inspection may be specified by the procuring activity.

TABLE III

MAXIMUM ACCEPTANCE DEFECTS IN TITANIUM-ALLOY
CASTINGS (MAXIMUM PERMISSIBLE RADIOGRAPH IN
ACCORDANCE WITH ASTM E 155) 1/, 2/, 3/, 4/

Defects (ASTM E 155)	Radiograph Reference	Grade A		Grade B		Grade C	
		Thickness (inch)		Thickness (inch)		Thickness (inch)	
		1/4	3/4	1/4	3/4	1/4	3/4
Porosity (round)	1.21	None		1	1	3	3
Porosity (elongated)	1.22	None		1	2	3	4
Shrinkage cavity	2.1	None		1	NA	2	NA
Foreign material (less dense)	3.11	None		1	1	2	2
Foreign material (more dense)	3.12	None		1	1	2	1
Cracks	-	None		None		None	
Cold shuts	-	None		None		None	
Laps	-	None		None		None	

1/ When two or more types of defects are present to an extent equal to or not significantly better than the acceptance standards for respective defects, the parts shall be rejected.

MIL-T-81915

- 2/ When two or more types of defects are present and the predominating defect is not significantly better than the acceptance standard, the part shall be considered borderline.
- 3/ Borderline castings shall be reviewed for acceptance or rejection by competent engineering personnel and Government quality assurance representative(s).
- 4/ Porosity and inclusions allowed by this table shall be cause for rejection when closer than twice their maximum dimension to an edge or extremity of a casting.

4.5.3 Penetrant inspection. Casting selected from each lot shall be penetrant-inspected in accordance with MIL-C-6021; both Classes 1 and 2 castings of MIL-C-6021 shall receive 100-percent inspection.

4.5.4 Mechanical properties. The mechanical properties of test specimens, taken as specified in ASTM E 8, Figures 6 and 8, shall conform to the requirements of Table IV. When the size or shape of the casting restricts the use of the above test specimens, or when otherwise determined, the full-size casting may be tested (see 6.2). When a complete-casting test is required, the strength requirement and the direction or method of loading of the full-size casting shall be specified on the drawing for the part concerned.

TABLE IV
MECHANICAL PROPERTIES OF SPECIMENS
CUT FROM ANNEALED CASTING (SEE 4.5.4)

Alloy	Tensile Strength (min) PSI	Yield Strength 0.2 Percent Offset (min) PSI	Elongation in 2 in. or 4D Percent (min)	Reduction in Area, Percent (min)
Unalloyed Ti	35,000	25,000	24	-
Ti-5Al-2.5Sn	110,000	105,000	10	20
Ti-6Al-4V	125,000	115,000	8	16
Ti-6Al-2Sn- 4Zr-2Mo	125,000	115,000	8	20

MIL-T-81915

4.5.5 Visual and dimensional examination. Castings shall be examined for identification of product, surface imperfections, dimensions, and workmanship requirements of 3.7, 3.8, 3.12, and 3.13, respectively.

4.5.6 Microscopic inspection. Evidence of unacceptable surface contamination shall be determined by microscopic inspection of a section through an outer surface of a casting. The microstructure shall not show evidence of an oxygen diffused layer.

4.5.7 Preservation, packing, and marking. Preservation, packing, and marking shall be examined for conformance with Section 5 of this specification.

4.6 Rejection and retest. Rejected lots may be retested in accordance with Fed. Test Method Std. No. 151.

5. PREPARATION FOR DELIVERY

5.1 Preservation and packing. All castings shall be preserved and packaged in accordance with the requirements of MIL-STD-649. The procuring activity will specify the levels required (see 6.2).

5.2 Marking of shipments. Each shipping container shall be marked in accordance with MIL-STD-129.

5.2.1 Identification of product. The castings shall be marked in accordance with FED-STD-184.

6. NOTES

6.1 Intended use. The high-strength titanium-alloy castings covered by this specification are intended for use in airframe, missile, and other applications where sound lightweight castings are required.

6.2 Ordering data. Procurement documents should specify the following:

- a. Title, number and date of this specification.
- b. Alloy number, type, composition and grade of castings (see 1.2).
- c. The applicable drawings (area and size of defect allowed to be identified).
- d. Level of packing desired (see 5.1).

MIL-T-81915

- e. Requirement for testing full-size casting (see 3.10).
- f. Address to which the first article samples should be sent, the activity responsible for testing, and instructions concerning submittal of the test reports (see 3.1).

6.3 Radiographic inspection quality grades.

Grade A - Highest grade of casting with no discernible defect on the radiograph or specified area of a casting.

Grade B - A premium grade of casting for critical applications, or specified area of a casting with low margins of safety.

Grade C - A high-quality grade of casting for general applications, or specified area of a casting with average margin of safety.

Custodians:

Army - MR
Navy - AS
Air Force - 11

Preparing activity:

Navy - AS
(Project No. MECA-0066)

Review activities:

Army - AV, GL, ME
Air Force - 84

User activities:

Army - MV, WC

Preceding page blank

APPENDIX C

**SUGGESTED ARC FURNACE MELTING PRACTICES FOR
HY-130 AND HY-180 STEELS**

1. The International Nickel Company, Inc., letter of May 8, 1972.
2. Air Melting and Desulfurization of HY-130 and HY-180 Steel.

THE INTERNATIONAL NICKEL COMPANY, INC.

ONE NEW YORK PLAZA - NEW YORK, N. Y. 10004

LOS ANGELES DISTRICT OFFICE

W. E. HOPKINS, District Manager

WELLS FARGO BANK BUILDING SUITE 224
21535 HAWTHORNE BOULEVARD
TORRANCE, CALIFORNIA 90503
(213) 542-1626

May 8, 1972

Mr. L. J. Venne
Manager, Metallurgy
ESCO Corporation
2141 N.W. 25th Avenue
Portland, Oregon 97210

Dear Larry:

Enclosed are charge calculations and a steelmaking procedure for HY-180 in a five-ton basic arc furnace. These are from Larry Diran who comments further as follows:

"Since the nominal HY-180 composition furnished you by Larry Venne of Esco indicates residual manganese, phosphorous, sulphur and silicon must be extremely low, only those charge materials have been used that make certain these residuals will be sufficiently low in the finished heat. Less costly materials could have been used if more information were available. It has also been suggested that, in the interest of "purity" the furnace bottom and sidewalls be clean and free of undesirable subversive contaminants.

"The procedure outlined herein is in essence one generally practiced in specialty steel ingot shops that has been modified to meet steel foundry requirements. This procedure has been used a number of times. In each instance the results obtained have exceeded expectations, particularly in producing cast alloys low in manganese, silicon, phosphorous and sulphur."

Larry also told me in a phone conversation last week that hydrogen may be a problem no matter what form of nickel is used. It apparently enters the bath from the arc and is purged by the oxygen blow.

If you want to discuss this practice further you can call Larry or D. F. MacDonald in New York, (212) 742-4126.

Best regards to you and Lee.

Sincerely yours,

Bill Hopkins

W. E. Hopkins, Manager
Los Angeles District Office

HY-180

10,000# VIRGIN HEAT

The raw materials and melting procedure have been arbitrarily chosen to produce a low residual heat in the basic electric arc furnace. The condition of the furnace bottom and side walls is equally important. Serious consideration must be given to make certain furnace bottom and sidewall refractories are low in phosphorous, silica and sulphur. Using spall-resistant high alumina roofs is also particularly effective in holding the silicon residual below the desired .10% maximum. Since the acceptable composition range for wrought HY-180 has not been adequately defined, the acceptable melt shop range of the cast version of the steel has been deliberately held to the minimum range that can be consistently attained under ideal melt shop conditions.

Melt Shop

	<u>Specification</u>	<u>Aim</u>
C	.10/.14	.12
Mn	-./.15	.15 max.
P	-./.010	.005 max.
S	-./.010	.005 max.
Si	-./.15	.10 max.
Ni	9.50/10.50	10.00
Co	7.50/8.50	8.00
Cr	1.75/2.25	2.00
Mo	.90/1.10	1.00

Special Additions

.2% Al
.05% Ca

Assumptions

1. 95% Ni, Co and Fe recoveries.
2. 90% Cr recovery
3. 95% Mo recovery from clean and pure Mo metal scrap.
4. 50% C recovery Lo-C petroleum coke; melt down C aim = .65%
5. Raw material variability .1%

Material	C	Ni	Co	Cr	Mo	Fe
Elec. Fe						100
Elec. Ni		100				
Lo-S petroleum coke	90					
Elec. Co			100			
L.C.FeCr(.30% max. Si)	.05			70.90		27.10
Mo metal scrap					100	
Al cylinders		100% Al				
Ca metal		100% Ca				
O ₂ input = 200 cfm						

	Aim	C	Ni	Co	Fe	Cr	Mo
Required 10,000#		.12	10.00	8.00	Bal.	2.00	1.00
Materials		12#	1000#	800#	-	200#	100#
1053# Elec. Ni	1000		1000				
90# Lo-S coke	12	12					
842# Elec. Co	800			800			
105# Mo scrap	100						100
8218# Elec. Fe	7807				7807		
25# Al cylinders							
313# L.C.FeCr	281				81	200	
5# Ca metal							
TOTAL	10,000#	12#	1000#	800#	7888#	200#	100#

Carbon

C required:

$$10,000 \times .0065 = 65\#$$

Lo-S petroleum coke required:

$$\frac{65}{.80 \times .90} = 90\#$$

Nickel

Ni required:

$$10,000 \times .1000 = 1000\#$$

Elec. Ni required:

$$\frac{1000}{.95} = 1053\#$$

Cobalt

Co required:

$$10,000 \times .0800 = 800\#$$

Co shot required:

$$\frac{800}{.95} = 842\#$$

Chromium

Cr required:

$$10,000 \times .0200 = 200\#$$

L.C.FeCr required:

$$\frac{200}{.90 \times .7090} = 313\#$$

Aluminum

Al added to block bath:

$$10,000 \times .0025 = 25\#$$

Calcium

Ca metal added to bath prior to tap:

$$10,000 \times .0005 = 5\#$$

Iron

Fe required:

$$10,000 - (12 + 1000 + 800 + 200 + 100) = 10,000 - 2112 = 7888\#$$

Fe from L.C.FeCr:

$$313 \times .2710 \times .95 = 81\#$$

Fe from Elec. Fe:

$$\frac{7807}{.95} = 8218\#$$

Melt down slag

Slag volume = 1.50%; slag mix = 4 CaO/2 spar/1 SiO₂

Slag weight:

$$10,000 \times .0150 = 150\#$$

$$\text{CaO} = \frac{4}{7} \times 150 = 86\#$$

$$\text{Spar} = \frac{2}{7} \times 150 = 43\#$$

$$\text{Sand} = \frac{1}{7} \times 150 = 20\#$$

Refining slag mix

Slag volume = 2.00%; slag mix = 6 CaO/3 spar/1 Al

Slag weight:

$$10,000 \times .0200 = 200\#$$

$$\text{CaO} = 200 \times .60 = 120\#$$

$$\text{Spar} = 200 \times .30 = 60\#$$

$$\text{Al} = 200 \times .10 = 20\#$$

Melting sequence

1. Charge in order:
 - a. 85# Elec. Ni
 - b. 100# Lo-S petroleum coke
 - c. 200# Elec. Ni + 105# bare Mg metal scrap
 - d. 842# Co shot
 - e. 8218# Elec. Fe.
2. Melt down as rapidly as possible, occasionally adjusting power input to avoid bridging charge and breaking electrodes.
3. As soon as charge begins to melt, add about one-half melt down slag mix consisting of 86# lime, 43# spar and 21# clean white sand on sides of charge. Add the balance when charge 60-70% melted.
4. When bath reaches 2800°F (ITC), mix heat and take test for carbon. Recarburize bath to .65% by dipping graphite electrodes if carbon less than .60%.
5. With carbon at .65% and bath at 2900°F (ITC), lance bath with oxygen supplied at 200 cfm using a refractory-coated 1/2" iron pipe to .12% carbon. (Theoretical blowing time = 10.6 minutes)

Decarburizing calculation:

C in bath at start of O₂ blow = 65#
 C retained in finished heat:
 10,000 x .0012 = 12#
 C removed during O₂ blow:
 65-12 = 53#
 O₂ required:
 1# C requires 1.3333# O₂
 53 x 1.3333 = 71#
 Fe oxidized during O₂ blow:
 8218 x .05 = 411#
 O₂ required:
 1# Fe requires .2865# O₂
 411 x .2865 = 118#
 Total O₂ required:
 71 + 118 = 189#
 Volume of O₂ required:
 $\frac{189}{32} \times 359 = 2120$ cu.ft.
 Theoretical blowing time:
 With O₂ supplied at 200 cfm
 $\frac{2120}{200} = 10.6$ minutes

6. Take test for carbon. Reblow heat if carbon more than .13%.
7. With carbon in range, tilt furnace back slightly and deslag bath clean as possible in a minimum length of time; then plunge .25% (25#) virgin aluminum cylinder firmly fixed on steel bar and hold beneath surface of bare bath until completely melted. Immediately thereafter, add reducing slag mix consisting of 120# lime, 60# spar and 20# grained aluminum.
8. After shaping up slag with minimum use of power, add 313# L.C. FeCr. Turn on power to assure rapid melting of ferrochrome. Check slag condition. If slag not reducing (white in color), dust slag with one or two small additions of grained aluminum (10-20#).
9. Tap the completely melted heat through strongly desulphurizing slag into clean and hot lip pour ladle coated with Al_2O_3 wash to avoid silicon pickup from firebrick lining.
10. Remove furnace roof and pour heat through desulphurizing slag upon 80# lime.
11. Take sample for C, Mn, P, S, Si, Ni, Co, Cr and Mo.
12. On obtaining bath composition, adjust bath composition to specified aim.
13. Rabble heat well and measure bath temperature. If necessary, readjust bath temperature at 2875°F.
14. With clean and hot teeming ladle in position, plunge 5# dry calcium bars firmly fixed on steel bar. Hold below surface of bath until calcium reaction completed (about 30 seconds).
15. Tap finished heat at 2875°F through desulphurizing slag into hot and clean teeming ladle washed with aluminum oxide cement to avoid silicon pick up from firebrick lining.
16. Pour HY-180 castings at 2780-2820°F (ITC).

2. The Air Melting and Desulfurization of HY-130 and HY-180 Steels

This summary is concerned only with methods for eliminating sulfur in air melting vessels. The Argon/Oxygen Degassing process, vacuum treatments, etc. will be covered in other reports. The chemical reactions that occur during the sulfur removal period will not be covered as these reactions have been detailed classically by Chipman and others.

If HY-130 and/or HY-180 steel is made by an air melting practice, it will probably be melted in basic arc or induction melting furnaces that are most suited for foundry melting.

Over the past decade, very few new practices have been published on sulfur removal. Most of the research using basic arc furnaces has been on the direct injection of desulfurizing agents into the bath. Some of the materials added were:

- a. CaO + Al-Mg alloy
- b. Ca-Mg
- c. Ca-cyanamide
- d. Ca-carbide
- e. Ca-silicide
- f. Ca-silico-Mg
- g. Ca-silico-Mn
- h. CaO-Al₂O₃
- i. Rare earths

In all reported cases, injection techniques improved sulfur removal. Apparently, the mixture of burnt lime and magnesium powder was most effective. The deoxidation and desulfurizing reactions depend on slag-metal contact for their effectiveness, and the injection method meets this criterion better than the normal solid-slagging techniques.

In Russia, data indicated that the rate of sulfur removal by electro-chemical means increased in the presence of an electric-arc when anode oxidation and vaporization occurred (Esin et al., 1960). Both direct and alternating currents of the main frequency were used in this work. Continuing research indicated that immersion of electrodes and the use of alternating current enhanced sulfur removal (Dobryden et al., 1963). No further work has been published.

Research on sulfur removal in basic induction furnaces and using a normal solid slagging technique primarily has been done by inoculation with some of the materials mentioned above (Ca-Mn-Si, etc.) combined with high basicity slags.

The only new technique used in the past ten years is the "reversed slag process." This process takes advantage of the well known increase in desulfurizing ability that occurs with a high lime slag in the presence of high carbon, silicon, and low iron oxide in the liquid steel bath. The sulfur, dissolved in liquid iron, has over five times the escaping tendency of sulfur dissolved in low carbon steel.

In this process, the metal to be purified is melted with the conventional slagging components used for the effective removal of phosphorus. When the phosphorus has been reduced to its predetermined level, this oxidizing slag is removed. At this point, the heat is deoxidized with aluminum, and a new slag is added by using the powder injection technique. When the sulfur is at the desired level, this slag is removed. Then, the heat is blown with oxygen to remove carbon, manganese, silicon, aluminum, etc. The vigorous action of the oxygen blow also acts as a flushing operation for removal of hydrogen and nitrogen. Finally, metal, that is treated as required with manganese, silicon, etc., is tapped and cast according to conventional practice. An essential element of this process is a magnesite hearth to minimize sulfur reversion.

In summary, the low sulfur heats that are made by normal practice and injection techniques may not produce steels with low hydrogen or nitrogen content. The combining of the injection technique with the "reverse slag" process appears

to be the best method for sulfur removal and low gas content. Undoubtedly, the cost of making steel by this process would be high.

3. References

Dobryden, A. A., O. A. Esin, and J. K. Chuchmarev, Invest. Vuz Chern. Met. (3) 20-25, 1963 (in Russian).

Esin, O. A., A. I. Pastukhov, S. I. Popel, and Dzemyan, "Desulphurization of Steel and Slag by the Electric Current in the Arc Furnace," Invest. Vuz Chern. Met. (11), 20-261, 1960 (in Russian).

APPENDIX D

ARGON PURGING OF HY-80, HY-130, AND
HY-180 STEELS

1. Argon Degassing HY-80
2. Argon Purging of HY-130 and HY-180 Steel

1. ARGON DEGASSING HY-80*

by

Paul E. Eubanks**

In the production of HY-80 castings the gamut was run, taking all the usual precautions of eliminating or reducing moisture from all materials — with the hope being that it would thereby produce a lower hydrogen content in the melts. These precautions were such things as pre-drying all furnace additions, exerting extreme care in having a completely dry pouring spout, never using a green ladle, and testing all molds for moisture content prior to pouring. These precautions did not in every case produce castings free of hydrogen-flaking.

The next logical step was the consideration of applying some other corrective procedure. The corrective procedure that was chosen was argon degassing, taking into account that time and capital expenditure were the dominant factors to be considered.

The first degassing test was made within 6 weeks of the initial discussions of the effects of argon degassing. This paper presents experience, results, and relative costs of treating HY-80 heats, ranging in size from 6,000 to 13,000 pounds. The results of this practice were:

1. Since the institution of argon degassing on HY-80, not one casting has been lost because of hydrogen-flaking.
2. The treated metal was consistently poured at a temperature 50° to 60°F below those normally used.
3. The capital expenditure was less than \$25,000.
4. The treatment increased the cost of metal at the spout by 1.68 cents per pound.

* Steel Foundry Facts, February, 1971, pp 7-9.

** Plant Metallurgist, Lebanon Steel Foundry, Lebanon, Pennsylvania.

Dissolved gas removal by argon is a practical application of the principle expressed in Sievert's Law. This law states that a bimolecular gas, such as hydrogen, will dissolve in molten metal to a concentration proportional to the square root of the absolute pressure of that gas in contact with the metal at equilibrium. Further, the absolute pressure may be any value and practically be a partial pressure with any other gas making up the total pressure on the system. This Sievert's Law is written

$$C_{H_2} \% = K \sqrt{P_{H_2}}$$

where: C_{H_2} is hydrogen content; P_{H_2} is hydrogen partial pressure in absolute atmospheres; and K is a constant. This constant is the concentration of hydrogen at 1 atmosphere pressure and at a selected temperature. At 1 atmosphere hydrogen pressure and at 2912°F (1600°C) K has the value of 0.0027 percent in pure iron. This value is affected slightly by alloying elements, but for practical purposes, it is adequate.

The above is readily visualized for hydrogen pick-up. Conversely, hydrogen can be removed from molten metal by presentation of gases which have less than equilibrium partial pressures of hydrogen. The relatively high mobility of hydrogen atoms in liquid metals permits the practical removal of this gas by introducing argon which does not have a hydrogen partial pressure.

Argon injected at or near the bottom of a steel bath will remove dissolved hydrogen. The theoretical equation derived from the above law assuming complete equilibration is:

$$V = 3870 K \left(\frac{1}{H_2} - \frac{1}{H_1} \right)$$

Where:

V = amount of argon (plus hydrogen) (cubic feet per ton)

K = equilibrium constant for H_2 gas -- 2 H

H_2 = final hydrogen content (%)

H_1 = start hydrogen content (%)

Figure 1 shows the above relationship of hydrogen content and argon consumption. (Note that the two curves shown for hydrogen represent starting points of 10 parts per million and 5 parts per million. Obviously, other curves may be drawn representing other starting values of hydrogen.) The injected argon then prompts the removal of hydrogen in satisfying three very important situations. First, argon remains as a bubble. This bubble forms a gas-liquid surface for the escape of hydrogen from the molten metal. Second, the rising or moving argon bubble stirs the metal, so that bubble surface is continually exposed to a new surface metal. Third, the argon bubble has a low partial pressure of hydrogen.

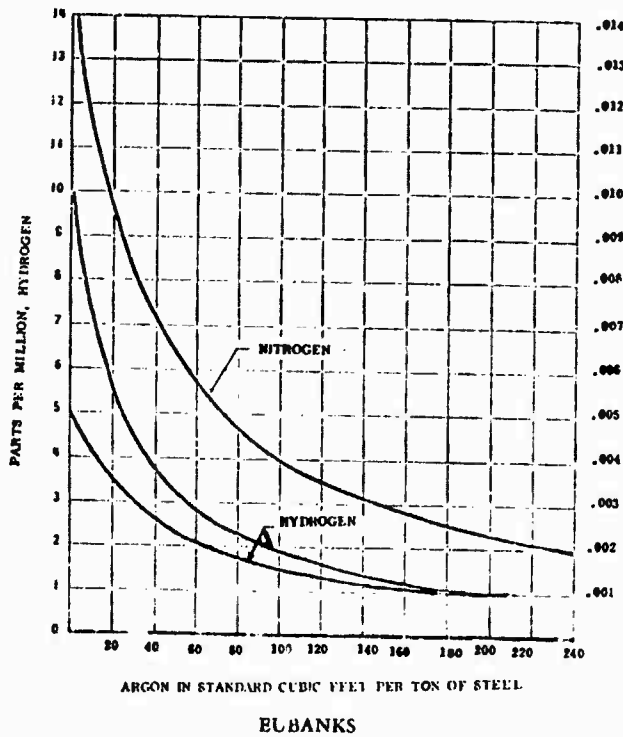

ELBANKS
Figure 1—Volume of argon required for removal of hydrogen and nitrogen from iron at 2912 F

To be practical, the argon degassing process must be completed rapidly to minimize metal temperature loss, and the metal must be protected from the atmosphere while the degassing argon passes through the molten metal. From the

theoretical, 40 - 50 cubic feet of argon per ton of steel must pass through the molten metal to attain final hydrogen content between 2.5 and 3.5 parts per million.

Argon degassing is done by rapidly injecting the gas at or near the bottom of a covered teeming ladle during, and for a short period after tapping the heat. Argon is injected through a refractory protected tuyere located near the bottom of the ladle.

Figure 2 shows a cross-section of a tuyere and a description of the individual parts. Basically, the tuyere is a heavy-wall tube with standard stopper sleeve protection. A special refractory head similar to a normal stopper head covers the end of the tuyere. The tuyere is assembled and dried prior to installing in the ladle.

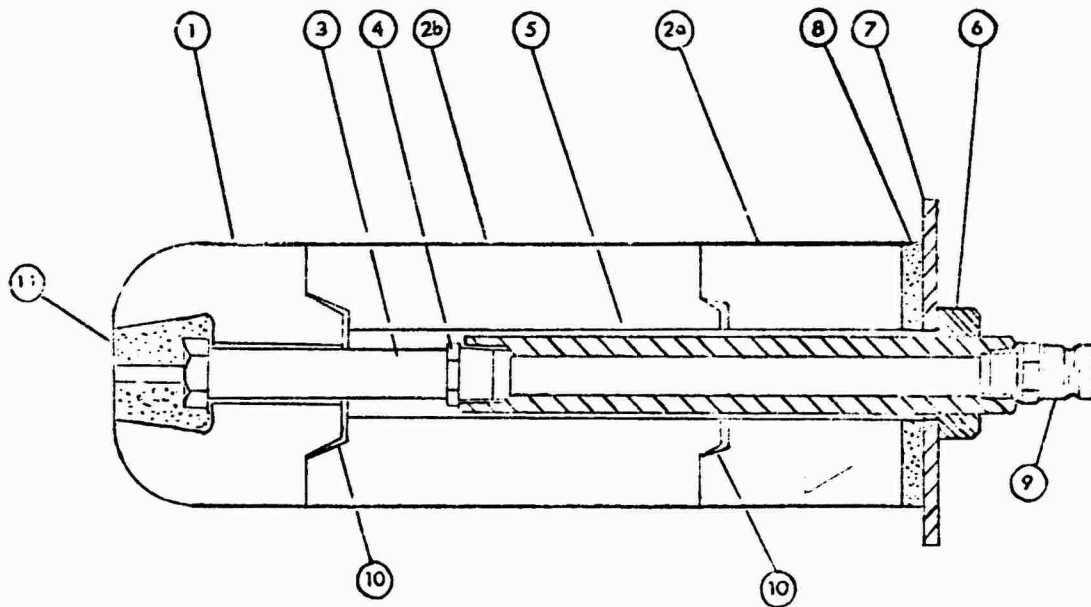

EUBANKS

Figure 2—Tuyere assembly

- | | |
|---|---|
| 1. Clay stopper head swaik S-15483 | 6. Stopper rod nut 1 3/4 NC thread |
| 2a. 6 in. clay tile H&W style 621A | 7. Tuyere plate (Linde part no. 649069) |
| 2b. 6 in. clay tile H&W style 621B | 8. Expansion washer (Linde part no. 649071) |
| 3. Nozzle assembly (Linde part no. 6837B38) | 9. Kamlock quick coupler brass 3/4 in. 633F |
| 4. Pipe reducer bushing 3/4 x 1 NPT steel | 10. Super 3000 bonding refractory |
| 5. Tuyere tube (Linde part no. 6489B34) | 11. H&W Korundel ramming refractory |

The tuyere is inserted through the ladle shell and held in place by an adapter. A tapered access hole in the normal ladle lining is made by ramming plastic refractory around a tapered form. The adapter is welded to the ladle shell to give a little clearance between the tuyere refractory and the ladle bottom.

When the ladle is not being used for degassing, a plug replaces the tuyere to fill the tuyere access hole. This plug is made from a half of a stopper sleeve with plastic refractory filling the central hole in the sleeve. The sleeve is cemented to a plate and stud simulating the rear end of a normal tuyere.

A refractory lined cover is placed on the ladle top to minimize heat loss due to radiation and to maintain an argon atmosphere above the molten metal. The cover actually aids in ladle preheat, allowing higher preheat temperature with minimum fuel consumption and heating time.

The cover has an access hole for the ladle stopper rod and another for permitting entrance of furnace spout into the ladle. Pins are used to locate the cover on the ladle so as to align the stopper rod identically on every use.

Since the injected argon flow during degassing is not adequate to maintain an inert atmosphere in the ladle headspace, argon is added to eliminate air infiltration. A piping system to distribute this headspace argon is imbedded in the cover refractory.

The ladle stopper rod is longer than normal to compensate for clearance above the ladle cover. A 10-inch extension of the rod would have been adequate. However, to accommodate an extension of the slide mechanism a rod about 15 inches longer than normal was used.

Since the injection of argon agitates the metal and slag, larger than normal stopper sleeves are used to compensate for added wear at the slag line. The sleeve diameter was increased 2 inches. This was the next larger diameter readily available.

In preparation for degassing a heat, the ladle nozzle is set. An assembled tuyere is installed and sealed in the ladle lining. The cover is seated on the ladle and the joint sealed. An assembled stopper rod is set, aligned, and sand checked for sealing. Then, this rod is removed and set aside for installation just prior to tap. An air-gas or oil burner is used to preheat the ladle to a lining temperature that gives a surface lining temperature of 1600° to 1800°F and a shell temperature of 300° to 400°F.

A concern for temperature loss has been expressed repeatedly. There is an inherent acceleration of temperature losses brought about by the injection of argon into a molten metal bath. This increased temperature loss is due to metal agitation which obliterates temperature gradients normally present in quiescent liquids. This impresses on the refractory walls the bulk metal temperature which may be as much as 200° to 300°F higher than normal. Further, the agitation maintains a bright radiating surface on the top of the metal. Heating of the argon accounts for only 0.2°F per cubic foot of argon per ton of metal.

Initially, tap temperature was increased by about 150°F to compensate for expected temperature loss. However, due to increased metal flowability, it was found that the pouring temperature could be reduced. Finally, a slightly higher than normal tap temperature was used negating the need for excessive metal superheat in preparation for degassing.

The normal melting procedure was followed with minor modification. Melt composition aims were met in the furnace, however, deoxidants, including most of the silicon were held until degassing was complete. Bath silicon content was aimed at 0.10 to 0.15 percent.

When a heat is ready for tap, at temperature and aim composition, the preheated ladle is positioned under the tapping spout, the argon hoses attached to the ladle cover and tuyere. Then with argon flowing to the tuyere and cover the heat is rapidly tapped into the ladle. Cover argon flow is 4000 cfh and tuyere argon flow is 1300 to 1600 cfh. The treating period is dependent upon metal

temperature determined by immersion thermocouple at about 2-minute intervals and upon the amount of argon required to be injected. At temperatures from 2840° to 2860°F, tuyere argon flow is reduced to 500 cfh. Final deoxidizer additions are stirred in by the low flow argon for about a half minute; then argon flows are terminated. The metal is sampled. Hoses are disconnected and the heat is poured. After casting is completed, slag is run from the ladle through the nozzle.

The ultimate practice was to inject 35 cubic feet of argon per ton of melt. The total argon consumption was approximately 125 cubic feet of argon per ton of melt.

The gage of a process is always a comparison of theoretical results with the actual results plotted as shown in Figure 3.

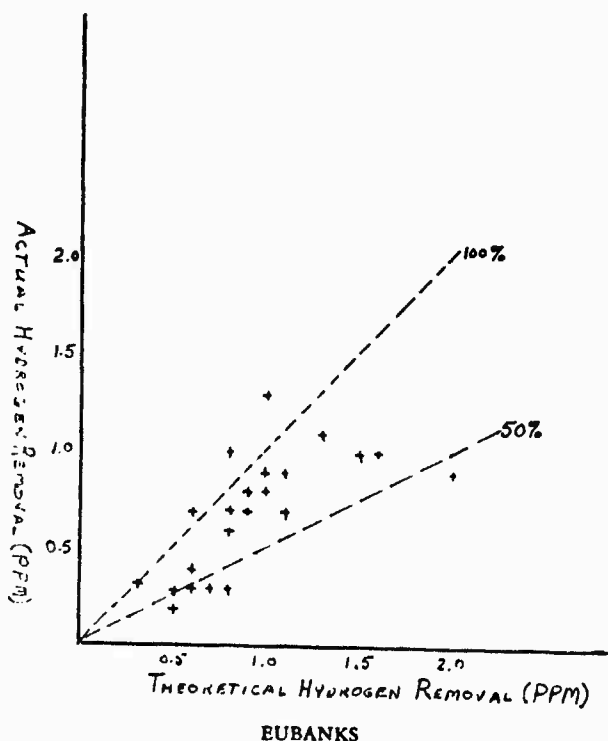

Figure 3—Actual vs theoretical hydrogen removal

There has been some question over the accuracy of the hydrogen determinations. The POROTEC ST instrument which was developed and designed by British Steel Castings Research Association, was the one used for these determinations.

The basic operation is one of hot vacuum extraction. Duplicate samples were produced from many heats and hydrogen analyses were made by two outside laboratories. All three labs (including Lebanon) reported completely different values of hydrogen, but all three agreed on a relative basis. For example, Lebanon might report 7 parts per million on sample A, and 3 parts per million on sample B. One of the labs might report 4 and 2 on the duplicate samples, and the other lab might report 10 and 5. The points plotted in Figure 3 were the values reported by the outside laboratory which consistently reported the lowest values. As a matter of information, all the samples were rapidly quenched and stored in liquid nitrogen.

At this point, it is important to state that since installing the degassing equipment, 121 heats of HY-80 have been treated and not one hydrogen flake has been found.

No statistical comparison has been made between degassed and non-degassed castings with respect to non-metallic inclusions on casting surfaces due to exigencies in meeting commitments on these castings. Some experienced observers are of the opinion that the surfaces of the degassed castings were better than the others. Other experienced observers hold opposite opinions.

Finally, argon degassing was done by readily modifying existing equipment. As stated earlier, six weeks elapsed from the time the decision was made to try argon degassing until the first trial was made. Both pressure pour and bottom pour ladles were modified and used in the trials. Only minor adjustments were made in melting and metal handling practices to accommodate the argon degassing process. No expensive equipment, electrical power or steam generating capacities were needed. The addition of unproductive space was not necessary. The preparation for and control of the process was handled by manpower and labor skills existing in the melt shop.

In conclusion, the help of Union Carbide Company, particularly Mr. M. F. Hoffman, in putting this practice into operation, and in preparation of this paper is acknowledged.

2. Argon Purging of HY-130 and HY-180 Steel

a. General

Argon purging practices for deoxidation and hydrogen removal have been developed by The Union Carbide Corporation Linde Division (Choulet et al., 1966). The removal of hydrogen from steel by argon results from (1) nucleation of dissolved gasses at sites provided by argon-gas bubbles, (2) increased reaction caused by stirring and agitation, and (3) the driving force provided by argon bubbles low in hydrogen content. Because the equipment for argon purging might be considerably simpler and less costly than vacuum-melting or degassing equipment, argon purging may be the most economical method of removing hydrogen from electric furnace steel and, thus, preventing flaking in HY-130 and HY-180 steel castings. A reduction in the hydrogen content of the castings from a level of about 6 parts per million, currently encountered in HY-130 steel, to about 2 parts per million could eliminate, or greatly reduce, antifracking heat treatments.

b. HY-130 Steel

According to Figure 2 (Choulet et al., 1966), approximately 75 to 100 cubic feet of argon per ton of liquid steel would be used in purging the steel to lower the hydrogen level from 6 parts per million to less than 2 parts per million. An estimated cost for the argon is \$1.80 per 100 cubic feet if less than 25,000 cubic feet are used per month. This figure may drop to \$0.75 per 100 cubic feet if usage is 25,000 to 50,000 cubic feet a month.

Possible methods of purging are use of: (1) a covered argon-degassing ladle with a side tuyere, (2) a porous plug in the bottom of the ladle, (3) a hollow stopper rod inserted into the ladle from the top, and (4) special refractory-coated rods plunged into the electric-furnace bath before tapping. Any of these methods should provide the necessary agitation and bubble formation to remove hydrogen. The method chosen would be the one that is easiest to handle in the existing melt shop; however, temperature loss as a result of degassing and refractory erosion is a problem that may influence the selection of the purging method.

Figure 2

Argon Requirement for Hydrogen and Nitrogen Removal at 2912°F.

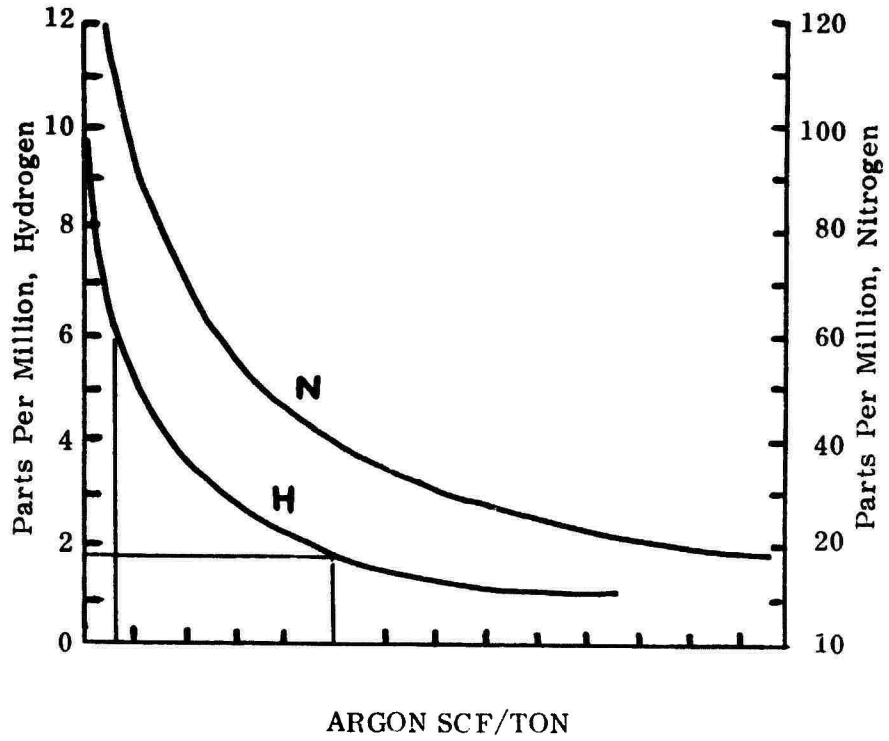

Source: Choulet et al., 1966

Any method in which argon purging occurs in the ladle will result in a relatively high temperature loss. For example, steel tapped into a covered and preheated ladle is expected to lose 150° to 200°F during a 12-minute purging cycle (purging of a 30-ton heat at a rate of 200 to 300 cubic feet per minute). Ladle-refractory wear is increased by the agitation of the bath. To reduce refractory losses, the use of 85 percent alumina brick is recommended at the vessel slag line and conventional firebrick in the remainder of the ladle (Choulet et al., 1966).

If degassing is accomplished by argon purging in the furnace as the final step before tapping, temperature loss may be lower and no change in ladle refractories would be required. However, the degassing may be less effective because the shallow bath may not permit sufficient time or agitation for the gas bubbles to pick up hydrogen.

Foundries, having existing AOD equipment, may develop a practice whereby degassing and carbon removal could take place in the AOD vessel, with the CO reaction furnishing enough heat to prevent cooling while the purging removes hydrogen. However, the cost of this equipment is expected to be of the same order as vacuum-degassing equipment, and the AOD process may be much less effective in removal of hydrogen than vacuum degassing. Thus, unless a foundry has other uses than hydrogen degassing for the AOD equipment, it would not be likely to favor this method of degassing.

c. HY-180 Steel

HY-180 steel probably will be produced by melting processes that incorporate vacuum melting or vacuum treatment and, as a result, low hydrogen levels will be achieved as a normal part of the melting procedure. If a special degassing treatment is required, probably the treatment used for HY-130 steel also would be effective for the hydrogen removal in HY-180 steel.

3. References

Choulet, R. J., R. L. W. Holmes, and L. R. Chrzan, "Chrzan, "Argon Degassing Practice and Results," Journal of Metals, January 1966, pp 72-78.

APPENDIX E

PRODUCTION OF HY-130 AND HY-180 STEEL
BY THE ARGON-OXYGEN DECARBURIZATION
(AOD) PROCESS

Union Carbide Corporation, Linde Division, Letter
of June 5, 1972.



UNION CARBIDE CORPORATION

LINDE DIVISION

SAN MELL RIVER ROAD, ROUTE 100C, TARRYTOWN, N. Y. 10591

MARKET
DEVELOPMENT

June 5, 1972

Mr. L. Venne
Manager Metallurgy
Esco Corporation
2141 N.W. 25th Ave.
Portland, Oregon 97210

Dear Mr. Venne:

With reference to our telephone conversation about the proposed use of the AOD process on alloy steels, particularly those with nickel content in the range 5-10%, I feel there are several potential advantages for this process over conventional degassing whether argon or vacuum.

As you pointed out, argon degassing is being used or evaluated in some foundries for these steels. The results obtained by one company, Lebanon Steel Foundries, have already been published (1). In general, it has been determined that argon degassing is valuable in the production of quality castings principally by lowering the hydrogen and possibly the oxygen content of the steel. However, the results that can be expected by this process are in some respects limited. The volume of flushing gas needed to remove gaseous impurities (hydrogen, nitrogen, and oxygen (as carbon monoxide)) can be theoretically calculated (1), (2). Within the physical and thermal limitations of any given plant (heat size, tapping temperature requirements, alloy composition, etc.), it can be predicted that some significant quantities of the impurities can be removed. However, the practical results which have been achieved have never shown the flushing efficiency to be consistently 100% (1), (2). This results in a higher argon or other flushing gas requirement than theoretical. In any steel casting operation, there is only a limited time available, because of heat losses, between the time the melting furnace is tapped and time the heat must be cast. This serves to limit the amount of flushing gas which can be injected and hence limits the degassing results which can be obtained.

With respect to hydrogen removal, argon degassing is limited by the above factors and it has been found that it is not practically possible to reach residual hydrogen contents below about 2.5 ppm. Usually final hydrogen contents are above this level. This has resulted in the necessity of employing one of the several vacuum

Mr. L. Venne
Esco Corporation

June 5, 1972

degassing processes when low hydrogen levels are required. Examples of this would be for large rotor forgings and die steels where levels about 1 ppm are generally specified.

Primarily because of kinetic factors, significant nitrogen removal is not consistently achieved by any known degassing process, either argon or vacuum. Although some plants report a somewhat lower product nitrogen content after initiating degassing procedures, this is usually associated with the fact that there is less chance of nitrogen absorption during final refining in a plant using a degassing system (and possibly argon casting protection). However, these lower product levels are not sufficiently different from non-degassed product to alone justify degassing.

In the AOD process, much larger volumes of gas, both argon and oxygen, are injected. Because heat is generated during refining, there is no time limitation because of temperature losses which would limit the amount of flushing gases injected. Therefore, it is believed that there is technically no limit as to the reduction in nitrogen and hydrogen contents which can be achieved. In addition, because AOD is a total refining process, improved control over the final deoxidation practices can be achieved and results in improved product cleanliness. Several references to these factors have been reported in the literature (3), (4), (5).

Based on the extensive production experience using AOD on high alloy materials (stainless steels and nickel base alloys predominantly), we predict the following characteristics for AOD process steels of interest to you.

1. Lower Gas Content

In stainless steel, hydrogen contents equivalent to the best vacuum degassed material have been reported (3). We expect for other materials a more consistent and greater hydrogen reduction than is possible with argon degassing.

Even though removal of nitrogen in stainless steel is very difficult because of kinetic factors, as well as its high solubility, an efficient flushing removal is observed in AOD refining. Anticipating similar efficiencies in other alloys (eg. 5-10% nickel steels), we would predict that removal of nitrogen, for example, from levels of 0.008% to 0.002% is feasible.

Because of the greater control of slag chemistry and excellent mixing in AOD, we expect an improvement (reduction) in oxygen content of the steels and hence would anticipate a higher quality product could be produced.

2. Lower Sulphur

- 126 -

Appendix E

The ability to completely mix the alloy with a slag results in fast effective desulphurization. Some operating AOD plants are regularly producing nickel base and high alloy steels to sulphur specifications of .002 to .003% maximums. Desulphurization to these levels takes only 5 to 10 minutes.

Because of the best desulphurization of any low cost steel refining process, AOD operators are able to select and use a broad range of lower cost alloys in the basic furnace charge which were heretofore unacceptable.

3. Temperature Control

Precise control of tapping temperature is easy because of the complete mixing in the vessel. Coupled with this is the ability to add heat via oxygen blowing, or subtract heat via metallic coolants or simply stirring with argon.

4. Productivity

Because all of the principal refining operations are carried on outside the melting furnace, the productivity of the melting furnace can be significantly increased. In stainless operations, this results in as much as a doubling of production from a single furnace.

5. Low Residuals

In addition to the low gas and sulphur contents obtained, it has been observed the lead is always removed to less than 10 ppm.

6. Nitrogen Control as an Alloying Element

Although in most applications nitrogen is desired to be as low as possible in the product, in specific alloys it is used as an alloying element. It has been found that it is possible to use nitrogen gas as one component of the refining gases in the AOD process and reach closely controlled levels up to the saturation content in equilibrium with one atmosphere of nitrogen gas.

In summary, we feel that the AOD process offers the opportunity for performing all of the refining functions necessary to produce superior quality steel. As compared to degassing processes, the AOD process potentially affords far greater opportunities to consistently and economically produce castings for high performance applications.

Very truly yours,

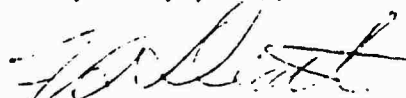

F. S. Death
Marketing Manager - AOD

FSD/gb

cc: -G.O. Williams, Portland, Ore.

REFERENCES

1. Argon Degassing at Lebanon Steel Foundry, P. Eubanks, 1970 Technical and Operating Conference, Steel Founders Society of America.
2. Argon Degassing Practice and Results, R. J. Choulet et al., 1965 Electric Furnace Conference.
3. Recent Developments in Argon-Oxygen Reactor Stainless Making at Joslyn, J. D. Ellis et al, 1969 Electric Furnace Conference.
4. Argon-Oxygen Decarburization Process for Stainless Steel Production at Ilssa Viola S. Fabbri, 1969 Electric Furnace Conference.
5. Argon-Oxygen Brings New Life to Stainless, November 11, 1971, Iron Age.

Preceding page blank

- 129 -

Appendix F

APPENDIX F

**USE OF ELECTROSLAG WELDING
AND REMELTING TO PRODUCE
HY-130 AND HY-190 STEEL CASTINGS**

USE OF ELECTROSLAG WELDING AND REMELTING TO PRODUCE HY-130 AND HY-180 STEEL CASTINGS

1. Electroslag Welding of Castings

Apparently, if low hydrogen electrodes and dry flux are used, satisfactory welds could be made in HY-130 steel by electroslag welding. Due to the slow cooling of the weld metal and the heat-affected zone, as-deposited welds would have insufficient strength and poor toughness. Thus, the weld should be made with a heat-treatable weld metal, and the weldment should be heat-treated after welding. The welds should be made on quenched and tempered or normalized and tempered castings, rather than green castings.

If a satisfactory casting alloy is developed, satisfactory electro-slag welds of HY-180 steel should be possible, assuming that hydrogen is maintained at low levels. As with HY-130 steel, the castings would require a preliminary heat treatment and reheat treatment after welding.

2. Forming Castings by Electroslag Remelting (ESR)

The forming of castings by electroslag remelting should result in a high quality casting with a fine as-cast structure. However, the electroslag remelting of anything but a simple ingot (rectangular, round, or hollow) appears to be a formidable task. The water-cooled copper molds would be costly, and the problems of providing electrodes of unusual shape and with proper fill ratios appear to make this casting method uneconomical except for simple mass-produced shapes.

The HY-180 steel used for wrought products should be modified by the addition of appropriate deoxidizers to permit electroslag remelting without the formation of blow holes and porosity. Rectangular ingots of 10Ni-Cr-Mo-Co steel have been produced by ESR but were unsatisfactory because of excessive porosity.

The mechanical properties of conventionally cast steel can be improved by electroslag remelting. The improved properties result from reducing the sulfur content of the steel to one-half the level in the electrode, reducing the oxygen content somewhat, and producing a fine cast-grain structure. These advantages make ESR worth considering as a casting method for HY-130 and HY-180 steel.

APPENDIX G

MOLDING PRACTICES FOR HY-130 AND
HY-180 STEEL CASTINGS

MOLDING PRACTICES FOR HY-130 AND HY-180 STEEL CASTINGS

The types of sands, listed below, include regular silica-base green sand that is employed for smaller sized castings. Green zircon- and chromite-base sands are employed for the special purposes indicated. Dry sand is employed for the larger sized molds. Where oven facilities are available, dry-sand molds should be dried for 12 hours at 300° - 350°F. Molds dried in situ should be dried with air that is heated with oil- or gas-fired burners and is blown through the mold. The products of combustion should not be blown through the mold cavity. Mold drying in situ should be conducted for 36 to 48 hours. Silica-sand is usually adequate for dry-sand molds, but zircon- and chromite-sands, based on the green-sand types with adjusted ratios of bond and water, can be employed when chilling or reduction of penetration is required. The base sands are similar to those listed for green sand, and the molds are dried in a similar manner:

a. Green Sands for Regular Use

- 91 percent relatively high-purity silica sand 50-70 AFS* fineness
- 5 percent western bentonite
- 3 percent water
- 1 percent cereal

b. Green Zircon Sand for Chill or Prevention of Penetration

- 96.5 percent zircon - 100 AFS fineness
- 1.8 percent western bentonite
- 0.1 percent cereal
- 1.6 percent H₂O

c. Green Chromite Sand for Chill or Prevention of Penetration

- 95.0 percent chromite - 50-70 AFS fineness
- 2.5 percent western bentonite

* American Foundrymen Society

0.5 percent cereal

2.0 percent water

d. Dry Sand

78.5 percent relatively high purity silica sand 50-70 AFS fineness

10.0 percent western bentonite

10.0 percent water

1.5 percent cereal

Molds should be rammed by conventional procedures that include hand ramming and low- and high-pressure molding machines of the jolt, jolt-squeeze, and hydraulic-squeeze types. The higher pressure ramming improves the dimensional stability of the mold and the dimensional control of the sand.

Core practice follows conventional quality steel casting practice. Cores of the phenolic shell type, sodium silicate bonded sand cores, and conventional oven baked cores, are employed widely in the mixes listed below. These mixes illustrate the core ingredients for alkyd resin bonds. Furan bonds also may be used with precautions to avoid pick-up of tramp elements from the strong mineral acid catalyst that is employed in heavier sections. Low nitrogen or nitrogen-free core binders are recommended:

Oil Base (Alkyd Resin)

a. Silica Sand

96.0 percent silica sand

2.1 percent iron oxide

1.6 percent binder (oil)

20 percent of binder wt — catalyst

4.8 percent of binder wt — activator

b. Chromite Sand

99.0 percent chromite sand

0.75 percent binder (oil)

20 percent of binder wt — catalyst

4 percent of binder wt — activator

Core sands should be mixed in conventional core mixers and can be blown or rammed using conventional equipment. Ribbon blenders that mix the sand and convey it directly to the core box are employed widely for no-bake core-sand mixtures. These latter mixes require little ramming.

Several mold and core washes of the "white" or refractory type are utilized for steel molds and cores. Proprietary washes are available from several suppliers. Mold washes may be employed to prevent penetration, improve surface finish, or provide a metal/mold barrier. A typical mixed zircon base mold and core wash is listed below. This wash is mixed with water to 65° Baume. It should be mixed and kept agitated in a drum that has a vertical axis, rounded bottom, baffles, and propeller. The wash may be applied by spraying, painting, or immersion of the core. The wash should be dried on both the mold and core after its application.

A Typical Mixed Zircon Base Mold and Core Wash

89.5 percent zircon flour

3.8 percent dextrine

3.8 percent western bentonite

2.88 percent core oil

0.02 percent sodium benzoate

APPENDIX H

**ANTIFLAKING TREATMENTS FOR HY-130
AND HY-180 STEEL CASTINGS**

ANTIFLAKING TREATMENTS

1. General

The preferred method of removing hydrogen by antifraking heat treatments is to transform the steel to a ferritic microstructure before attempting to diffuse the hydrogen from the steel (Hobson, 1959; Fletcher and Elsea, 1965). This microstructure is preferred because the diffusion coefficient of hydrogen in ferrite is much higher (2.1×10^{-4} at 1200°F) than the diffusion coefficient of hydrogen in austenite (2.3×10^{-5} at 1200°F). Generally, the steel is transformed isothermally at an elevated temperature and then held for long times just below the lower transformation temperature to remove hydrogen.

HY-130 and HY-180 (10Ni-Cr-Mo-Co) steels have very high pearlite hardenability and transform to mixtures of low temperature bainite and martensite even on very slow cooling. For HY-130 steel, transformation on cooling begins below 950°F and is completed by about 500°F; for HY-180 steel, transformation on cooling begins below 700°F and is completed by about 400°F. Accordingly, transformation of these steels to a ferritic structure before removing hydrogen may not be possible without flaking during the transformation.

2. HY-130 Castings

Large HY-130 castings have been produced by Birdsboro Corporation and General Steel Industries. The hydrogen content of these castings was 4.8 to 6.7 parts per million on ladle analysis of the steel when poured. Hydrogen flakes were found beneath the risers in sections about 4 inches thick in every casting produced. Two different antifraking heat-treatments (Procedures I and II of Table 7) were used, but neither of the procedures were satisfactory. Procedure II (Hobson, 1959), should have reduced hydrogen from 6 parts per million to 2 parts per million in a cylindrical section, 12 inches in diameter.

The antifraking treatments may have failed because the flaking occurred before the outgassing heat treatment was performed. Another proposed treatment to remove hydrogen from castings is based on preventing the austenite from

transforming to bainite or martensite and by lengthy holding at an elevated temperature in the austenite region. This treatment, Procedure III of Table 7, would be more effective if the furnace atmosphere were dry. Also, an electrically heated muffle-furnace purged with dry air or inert atmosphere should be used. Under these conditions, the hydrogen in a 6-inch diameter section is calculated to drop from 6 parts per million to less than 2 parts per million after holding the casting for 64 hours at 1750°F.

The time for outgassing increases as the square of the radius of the casting section. Thus, for sections thicker than 6 inches in diameter, the time required to reduce hydrogen to less than 2 parts per million becomes excessive. Increasing the holding temperature is helpful in reducing time, and as a result, some consideration could be given to outgassing at very high temperatures. For instance, heating to 2200°F would reduce the time to remove hydrogen from a 6-inch diameter section to 24 hours, and a 10-inch diameter section could be outgassed from 6 parts per million to less than 2 parts per million in 72 hours. Use of very high temperatures requires outgassing in a large vacuum furnace and is likely to be uneconomical.

3. HY-180 Castings

The HY-180 steel must be made by special melting practices that will produce very high levels of cleanliness to achieve castings with a level of notch toughness compatible with wrought steel plate. These practices may permit vacuum-melting processes only to attain hydrogen levels sufficiently low that anti-flaking heat treatments will be unnecessary. If an antifracking heat treatment is required, the principles for removing hydrogen from the 10Ni-Cr-Mo-Co HY-180 steel are the same as for the HY-130 steel, and the antifracking treatment (Procedure III of Table 7) could be used for the HY-180 steel.

Table 7

Antiflaking Procedures

Procedure I

1. Mold-cool (4 days) to approximately 300°F surface temperature.
2. Shake out and heat to 1600°F, hold 6 hours.
3. Furnace-cool to 1100°F, hold 6 hours.
4. Furnace-cool to below 600°F.
5. Air-cool from 600°F.

Procedure II

1. Mold-cool to between 400° and 500°F.
2. Shake out and transfer hot to a furnace at 500°F. Heat to 1165°F at 100°F per hour. Hold at 1165°F for 48 hours. (Do not exceed 1200°F at any time.)
3. Heat from 1165° to 1650°F and hold 3 hours at 1650°F.
4. Furnace-cool to 450°F and equalize at 450°F.
5. Reheat to 1165°F at 100°F per hour and hold at 1165°F for 48 hours. (Do not exceed 1200°F at any time.)
6. Furnace-cool to 450°F, equalize at 450°F, and air-cool.

Procedure III

1. Mold-cool to 1000°F.
2. Shake out and transfer hot to an electrically heated muffle furnace at 1000°F. Purge furnace with dry air or inert atmosphere.
3. Heat from 1000°F to 1750°F and hold at 1750°F for 64 hours.
4. Furnace cool to 450°F, equalize at 450°F, and air-cool.

4. References

Fletcher, E. E., and A. R. Elsea, "Hydrogen Movement in Steel — Entry, Diffusion, and Elimination," DMIC Report 219, Battelle Memorial Institute, Columbus, Ohio, June 30, 1965.

Hobson, J. D., "The Removal of Hydrogen by Diffusion from Large Masses of Steel," Journal of the Iron and Steel Institute, April 1959, pp 342-352.

APPENDIX I

**NOTCH TOUGHNESS REQUIRED FOR
"EXTREME SERVICE" APPLICATIONS**

NOTCH TOUGHNESS REQUIRED FOR "EXTREME SERVICE" APPLICATIONS

1. General

The philosophy for extreme service design is to prevent the development of fast running cracks by using structural materials with sufficient toughness. Under these conditions, although fatigue cracks may grow large enough to extend through the thickness of the hull, the cracks will cause leaks rather than produce a long-running brittle failure. The toughness requirements of this fracture-safe design concept (Pellini, 1969) at various strength levels and material thicknesses may be established with the aid of a "Ratio Analysis Diagram" (RAD, shown in Figure 3.

To determine the minimum notch toughness that would be acceptable under the fracture-safe design concept, the section thickness involved must be established. Some casting sections may be as much as 6 inches thick; however, to establish the lowest possible toughness that might be satisfactory, the analysis is based on a 3-inch-thick section. Experts on fracture mechanics are not in agreement on the proper criterion for fracture-safe design. However, the level of toughness should be high enough that plain-strain conditions cannot develop in the section under consideration. Under this criterion, a K_{Ic}/σ_{ys} ratio of over 1.0 would be required for a 3-inch thick section. Thus, for HY-130 at an average yield strength of 140 ksi, the K_{Ic} value should be a minimum of 140 ksi $\sqrt{\text{inch}}$. For HY-180 steel with an average yield strength of 185 ksi, the minimum allowable K_{Ic} would be 185 ksi $\sqrt{\text{inch}}$. A relation between K_{Ic} and Charpy V-notch energy has been found to be quite accurate in the yield-strength range from 130 to 200 ksi (Rolfe and Novak, 1970). This relationship, illustrated in Figure 24, shows that a K_{Ic}/σ_{ys} ratio of 1 corresponds to a CVN/ σ_{ys} ratio of 1/4. Thus, for a 3-inch-thick section, the minimum Charpy V-notch energy should be 35 ft-lb for HY-130 steel and 46 ft-lb for HY-180 steel.

Figure 3

Ratio Analysis Diagram Definition of the influence of Tempering Heat Treatment on the Fracture Characteristics and Yield Strength of 16Ni Steel

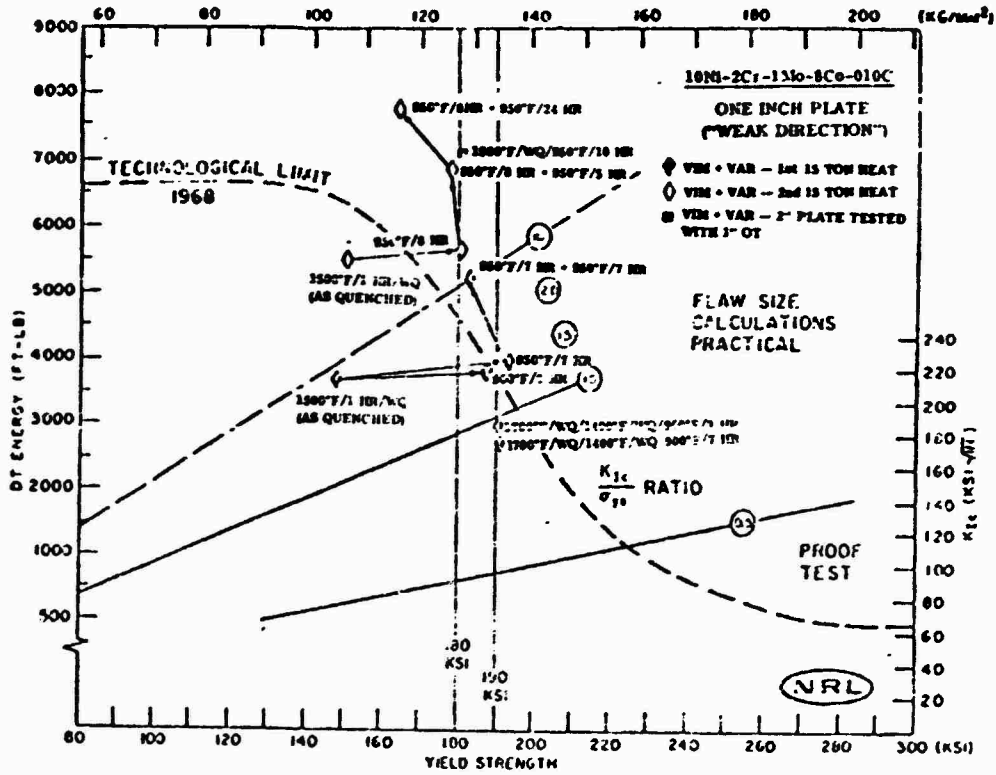

Source: Naval Research Laboratory

2. References

Pellini, W. S., "Evolution of Engineering Principles for Fracture-Safe Design of Steel Structures," Naval Research Laboratory Report 6957, September 23, 1969.