

AD-764 079

PLASMA CATHODE FOR E-BEAM LASERS

John R. Bayless

Hughes Research Laboratories

Prepared for:

Office of Naval Research
Advanced Research Projects Agency

July 1973

DISTRIBUTED BY:

NTIS

National Technical Information Service
U. S. DEPARTMENT OF COMMERCE
5285 Port Royal Road, Springfield Va. 22151

AD 7648079

Reproduced by
NATIONAL TECHNICAL
INFORMATION SERVICE
U.S. Department of Commerce
Springfield, VA 22151

DDC
RECEIVED
AUG 6 1973
R
B

SEMIANNUAL TECHNICAL REPORT
CONTRACT N00014-72-C-0486

HUGHES
HUGHES AIRCRAFT COMPANY

PLASMA CATHODE FOR E-BEAM LASERS

1 DECEMBER 1972 THROUGH 31 MAY 1973

HUGHES RESEARCH LABORATORIES • MALIBU

Sponsored by
ADVANCED RESEARCH PROJECTS AGENCY
ARPA ORDER 1807

DISTRIBUTION STATEMENT A
Approved for public release
Distribution unlimited

HUGHES RESEARCH LABORATORIES
Malibu, California

a division of hughes aircraft company

PLASMA CATHODE FOR E-BEAM LASERS

Semiannual Technical Report
Contract No. N00014-72-C-0496
Reporting Period: 1 December 1972
through 31 May 1973

ARPA Order No. 1807
Program Code No. 3E90

Effective Date of Contract: 1 May 1972
Contract Expiration Date: 31 December 1973

Amount of Contract: \$228,571.00
Principal Investigator: J.R. Bayless
(213) 456-6411

Senior Scientist: R.C. Knechtli

Scientific Officer: Director Physics Programs
Physical Sciences Division
Office of Naval Research
Department of the Navy
800 North Quincy Street
Arlington, Virginia 22217

This research was supported by the Advanced Research Projects Agency of the Department of Defense and was monitored by ONR under Contract N00014-72-C-0496.

Reproduction in whole or in part is permitted for any purpose of the United States Government.

Distribution of this document is unlimited.

DOCUMENT CONTROL DATA - R&D		
<i>(Security classification of title, body of abstract and indexing annotation must be entered when the overall report is classified)</i>		
1. ORIGINATING ACTIVITY (Corporate author) Hughes Research Laboratories 3011 Malibu Canyon Road Malibu, CA 90265		2a. REPORT SECURITY CLASSIFICATION Unclassified
		2b. GROUP N/A
3. REPORT TITLE PLASMA CATHODE FOR E-BEAM LASERS		
4. DESCRIPTIVE NOTES (Type of report and inclusive dates) Semiannual Technical Report, 1 December 1972 through 31 May 1973		
5. AUTHOR(S) (First name, middle initial, last name) John R. Bayless		
6. REPORT DATE July 1973	7a. TOTAL NO. OF PAGES 55	7b. NO. OF REFS 9
8a. CONTRACT OR GRANT NO. N00014-72-C-0496	9a. ORIGINATOR'S REPORT NUMBER(S)	
b. PROJECT, TASK, WORK UNIT NO. ARPA Order No. 1807		
c. DOD ELEMENT	9b. OTHER REPORT NO(S) (Any other numbers that may be assigned this report)	
d. DOD SUBELEMENT		
10. DISTRIBUTION STATEMENT Distribution of this document is unlimited.		
11. SUPPLEMENTARY NOTES Details of illustrations in this document may be better studied on microfiche.	12. SPONSORING MILITARY ACTIVITY Advanced Research Projects Agency Arlington, VA 22209	
13. ABSTRACT <p>The objective of this program is to develop a new type of plasma cathode electron gun and demonstrate that it has properties suitable for operation with E-beam lasers. This device employs a plasma generated within a low-voltage hollow cathode discharge rather than a thermionic emitter as the source of electrons. Electrons extracted from the plasma pass through a triode-type control grid structure and are accelerated to high energies in a plasma-free region prior to emerging from the gun through a thin foil window. The device is characterized by ruggedness, low cost, low power consumption, and fast response in comparison to thermionic cathode E-guns.</p> <p>A plasma cathode device producing a beam of up to 30 cm² in area has been experimentally evaluated (see Section III) at beam energies up to 140 keV, at 100 μsec pulsed beam current densities up to 1 A/cm², and at cw, power-supply-limited current densities of greater than 0.7 mA/cm². Good beam current uniformity has been demonstrated and the beam has been measured to be monoenergetic to better than 3% upstream of the foil window. The major life limiting factors have been shown to be minimal.</p> <p>Devices capable of producing E-beams with areas of up to 160 cm² are presently under construction (see Section IV) and will soon undergo testing. Successful completion of these tests will serve as a final verification of the efficacy of the plasma cathode concept for the production of high energy E-beams of arbitrarily large areas.</p>		

UNCLASSIFIED

Security Classification

14. KEY WORDS	LINK A		LINK B		LINK C	
	ROLE	WT	ROLE	WT	ROLE	WT
Plasma cathode						
Electron gun						
High energy laser						

UNCLASSIFIED

Security Classification

TABLE OF CONTENTS

	LIST OF ILLUSTRATIONS	vii
I	INTRODUCTION	1
II	TECHNICAL APPROACH	7
III	PLASMA CATHODE EVALUATION PROGRAM	17
	A. Experimental Apparatus	17
	B. Discharge Characteristics	22
	C. Paschen Breakdown Studies	24
	D. Beam Extraction Characteristics	27
	E. Beam Current-Density Distribution	29
	F. Electron Energy-Distribution and Foil Transmission Measurements	31
	G. Preliminary Life Tests	34
IV	LARGE EXPERIMENTAL DEVICE DEVELOPMENT	37
	A. 10 x 15 cm High Voltage Device	38
	B. 4 x 40 cm Low-Voltage Cylindrical Device	44
	C. Conceptual Design of 20 x 200 cm Plasma Cathode E-Gun	50
V	CONCLUSIONS AND FUTURE PLANS	53
	REFERENCES	55

LIST OF ILLUSTRATIONS

Fig. 1.	Plasma cathode program schedule	4
Fig. 2.	Schematic of the plasma cathode electron gun	7
Fig. 3.	Hollow cathode low pressure glow discharge	9
Fig. 4.	Low pressure breakdown voltage in the plasma cathode accelerating region	15
Fig. 5.	Experimental apparatus used to evaluate small plasma cathode E-gun devices	18
Fig. 6.	Re-entrant electrodes containing the plasma cathode and beam collector	19
Fig. 7.	Exploded view of the discharge chamber and grid assembly	19
Fig. 8.	Experimental apparatus and energy analyzer shown with half of the lead shield removed	20
Fig. 9.	Hollow cathode discharge characteristics for an anode grid area	23
Fig. 10.	Assembly for studying Paschen breakdown in the presence of an E-beam	25
Fig. 11.	Electron beam control characteristics	29
Fig. 12.	Electron beam current density distribution for a 3 x 10 cm, 60 keV beam	30
Fig. 13.	Electron beam energy analyzer	32
Fig. 14.	Electron beam energy distribution	33
Fig. 15.	Possible approaches for combining several individual plasma cathode modules	39
Fig. 16.	End view of 3-module high voltage configuration	40
Fig. 17.	Partially completed re-entrant electrode containing the plasma cathode discharge region	41

Fig. 18.	Partially completed re-entrant beam collector electrode showing the arrangement of the current density probe system	42
Fig. 19.	High voltage ceramic which will support the electrodes shown in Figs. 17 and 18 . . .	43
Fig. 20.	Schematic cross-section of a cylindrical high voltage gun design	45
Fig. 21.	Schematic diagram of 4 x 40 cm low voltage cylindrical device	46
Fig. 22.	Plasma cathode assembly	47
Fig. 23.	Plasma cathode collector electrode showing the current density probe	48
Fig. 24.	Completed low-voltage plasma cathode device mounted in vacuum staticn	49
Fig. 25.	Schematic cross section of the conceptual 20 x 200 cm high voltage gun design	51

SUMMARY

The objective of this program is to develop a new type of plasma cathode electron gun and demonstrate that it has properties suitable for operation with E-beam lasers. This device employs a plasma generated within a low-voltage hollow cathode discharge rather than a thermionic emitter as the source of electrons. Electrons extracted from the plasma pass through a triode-type control grid structure and are accelerated to high energies in a plasma-free region prior to emerging from the gun through a thin foil window. The device is characterized by ruggedness, low cost, low power consumption, and fast response in comparison to thermionic cathode E-guns.

A plasma cathode device producing a beam of up to 30 cm^2 in area has been experimentally evaluated (see Section III) at beam energies up to 140 keV, at 100 μsec pulsed beam current densities up to 1 A/cm^2 , and at cw power supply limited, current densities of greater than 0.7 mA/cm^2 . Good beam current uniformity has been demonstrated and the beam has been measured to be monoenergetic to better than 3% upstream of the foil window. The major life limiting factors have been shown to be minimal.

Devices capable of producing E-beams with areas of up to 160 cm^2 are presently under construction (see Section IV) and will soon undergo testing. Successful completion of these tests will serve as a final verification of the efficacy of the plasma cathode concept for the production of high energy E-beams of arbitrarily large areas.

I. INTRODUCTION

The objective of the plasma cathode program is to develop a new type of electron gun suitable for electron beam plasma conditioning of large volume electric discharge lasers. This gun employs a plasma which is generated within a low voltage, hollow cathode discharge as the source of electrons rather than a thermionic cathode as in conventional electron guns. The beam current extracted from the discharge is controlled by means of a grid system in a manner very similar to that employed in standard vacuum triodes. This permits the generation of any desired pulse shape. After extraction from the discharge plasma the electron beam is accelerated to energies in the range 100 to 200 keV prior to passing through a thin metal foil window and into the active laser region.

The plasma cathode electron gun is characterized by its simplicity and has advantages over conventional thermionic devices which include:

- Rugged construction — No inherently delicate heater elements are required and, since operation is obtained at near ambient temperatures, thermal stress problems are minimized.
- Insensitivity to contamination — Since high temperature, low work function surfaces are not required, cathode poisoning is not possible; if the foil window ruptures the plasma cathode will not be damaged.
- Suitability for large area beam production — Scaling to any desired size is achieved by simply enlarging the device dimensions without the constraints imposed by heater element design.
- Instantaneous startup — No warm-up time is required since beam extraction can be obtained immediately after discharge ignition which occurs in about a microsecond.
- Low power consumption for pulsed operation — Power is only consumed during the beam on-time and, therefore, the average power consumption can be lower than an equivalent thermionic device which requires a continuous supply of power.

- Low cost — The inherent structural simplicity of the plasma cathode is indicative of substantial cost savings in relation to thermionic devices.

Several plasma E-guns of various types are described in the literature some of which have been used on lasers.¹ These employ either a high-voltage glow discharge or a low pressure incipient vacuum arc. The plasma cathode gun is unlike either of these types and is expected to have advantages which include:

- Good foil penetration for plasma conditioning — Good foil penetration is achieved due to the highly monoenergetic property of the beam generated by the plasma cathode gun. Other gas discharge devices, in which a plasma sheath exists in the region between the accelerating electrodes, produce a broader energy distribution with substantial amounts of electrons at lower energy; this results in reduced foil penetration ability.
- Long pulse and cw capability — The incipient vacuum-arc devices, which have the best foil penetration characteristics, are inherently limited to short pulse ($\approx 5 \mu\text{sec}$) operation. The device described here also has good foil penetration characteristics and can be operated to produce pulsed beams of any pulse length, up to dc.
- Long life — Since the plasma cathode incorporates a relatively low voltage (500 to 800 V) discharge, sputtering is greatly reduced in comparison to high voltage glow discharge devices in which ions with energies comparable to the E-beam energy strike the cathode.
- Improved control — The triode type grid control utilized with the plasma cathode gun is expected to be simpler and more versatile than that of diode type high voltage discharge devices. The high acceleration voltage can be dc in the present device and rectangular-pulsed beam operation is achieved by pulsing the hollow cathode discharge or the control grid. Operation with other pulse shapes can be obtained by proper temporal biasing of the control grid.

Under the present contract the plasma cathode concept is being developed to the point of demonstrating suitable operation of a device which produces an electron beam having the following properties:

- Beam dimensions $\geq 10 \text{ cm} \times 15 \text{ cm}$
- Beam current density = 100 mA/cm^2
- Beam energy = 150 keV
- Pulse length = 100 μsec .

In order to accomplish the technical objectives of this contract, the program is divided into five principle tasks as described below.* The work performed during the last six month period is outlined for each task while the technical details of this program are given in later sections. The related program schedule is shown in Fig. 1.

Task 1: Discharge Development and Optimization

Under this task the hollow cathode discharge is being developed and optimized for production of a uniform electron beam. During the past six month period the discharge chamber design has been brought to a high level of development in small devices, producing beams with cross sectional areas of up to 30 cm^2 . A new discharge ignition scheme has been invented and developed for the plasma cathode which eliminates any need for the presence of high ignition voltages, close dimensional tolerances, or a magnetic field. Furthermore, the single-module beam extraction area has been increased to a value which permits integration of a number of discharge chamber modules into a device capable of producing a uniform, large-area electron beam. Measurements of the discharge characteristics (current, voltage, and pressure dependences) have been performed and documented. Plasma probe measurements of the discharge properties have demonstrated that the discharge can be well understood on the basis of the hollow cathode model outlined in Section II.

*The plasma cathode program tasks have been expanded and the contract extended for an additional period of 12 months. These tasks described above are based on work performed under the original contract goals which were reported in the previous semiannual report.²

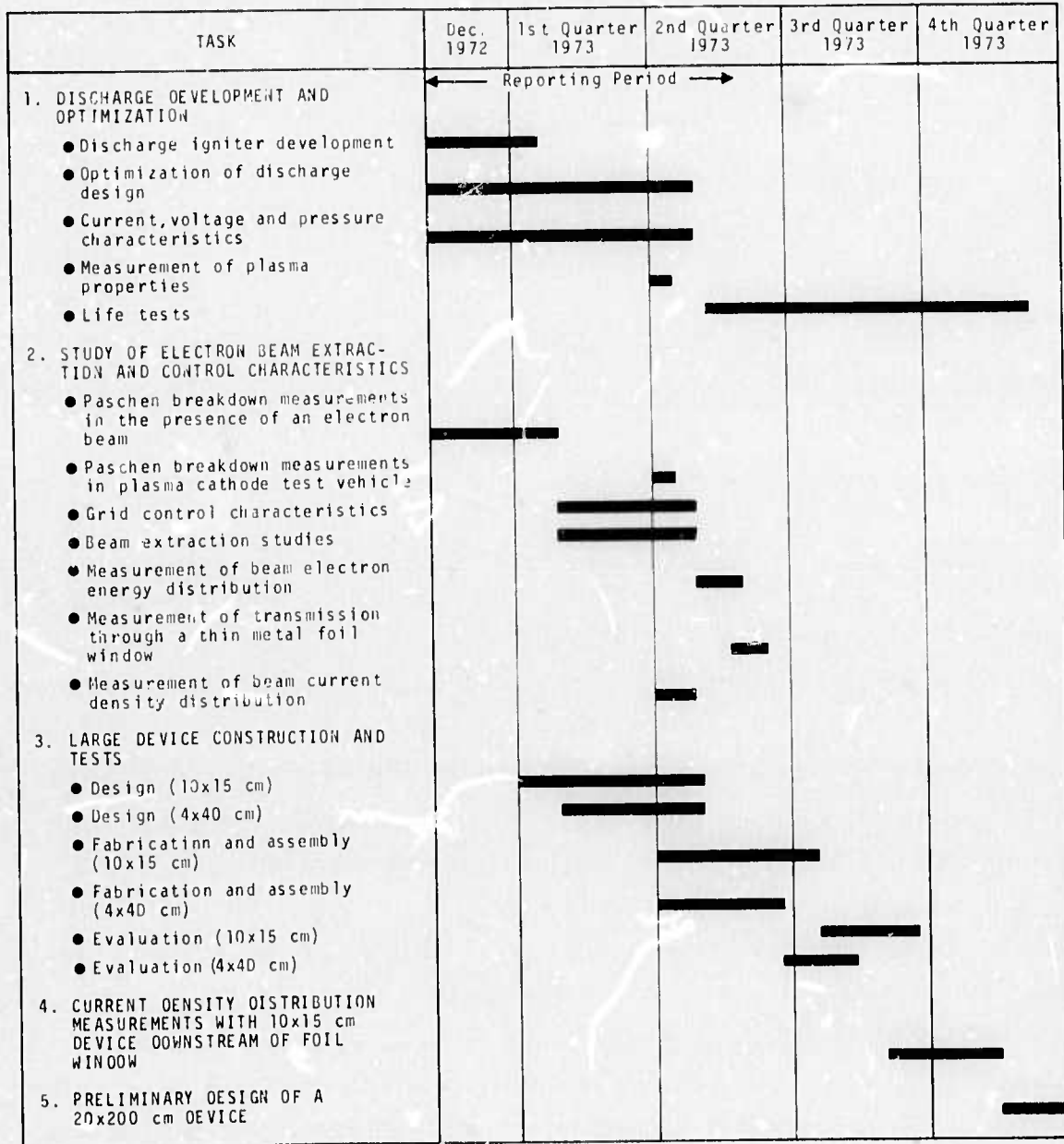

Fig. 1. Plasma cathode program schedule.

Measurements of the life characteristics of the plasma cathode electron gun, which are expected to be determined primarily by the discharge properties, have begun. Preliminary data indicates the capability for hundreds of hours of operation.

Task 2: Study of Electron Beam Extraction and Control Characteristics

The goal of this task is to perform a systematic study of the electron extraction characteristics of the plasma cathode, and to establish design requirements for extracted current control, and for the configuration of the beam accelerating geometry. The experimental evaluations performed under this task have been undertaken with the same small devices as used in Task 1. Measurements made in the presence of a thermionically generated high energy electron beam in a geometry similar to that used in a plasma cathode device have demonstrated that the Paschen characteristics are not influenced by the beam. Similar measurements, performed without a beam in the plasma cathode test vehicle, have confirmed that the extraction grid structure does not significantly reduce the breakdown capabilities of the device. Measurements of the beam control and extraction characteristics have been completed. Beam current densities of up to 1 A/cm^2 in pulsed operation and 0.7 mA/cm^2 in cw, power-supply-limited operation, have been measured. Although cw operation was not originally intended under the present contract, measurements under typical conditions have been documented as a natural extension of the contractual effort. These studies indicate that the device properties are well understood and can be related directly to the properties of simple vacuum triodes as desired. In particular, the electron beam energy distribution has been measured to be monoenergetic to better than 3%. Measurements of the transmission of the electron beam through a thin metal foil window are consistent with this energy distribution result. Measurements of the electron beam current density distribution have been completed in devices having areas of up to 30 cm^2 . These measurements have demonstrated the capability for generation of highly uniform electron beams in large area devices.

Task 3: Large Device Construction and Tests

The goal of Task 3 is to design, construct, and test a grid-controlled high-voltage plasma-cathode electron gun consisting of three integrated modules (each module is similar to the smaller devices evaluated in Tasks 1 and 2) having a beam cross-section of at least 10 x 15 cm (150 cm²) and capable of operating at a beam voltage of 150 kV, an average beam current density of 100 mA/cm², and a pulse duration of 100 μsec. At the present time the fabrication of this device is near completion. In addition, a second device which will produce a 4 cm x 40 cm beam (160 cm²) is also being built and is near completion. This latter device is based on a simplified cylindrical design which can be easily scaled to any desired dimensions. It will, however, operate only at low voltage (≲25 kV) in order to permit studies of extraction characteristics, beam stability, and uniformity without the complexities of high voltage operation. Experimental evaluation of both of these devices will be completed during the next six months. The results of investigations performed with these two devices will provide accurate information applicable to the design of arbitrarily large, high-voltage plasma-cathode electron guns.

Task 4: Beam Current Density Distribution Measurements with 10 x 15 cm Device

The objective of this task is to measure the electron beam current density distribution in the 10 x 15 cm device after transmission through a suitable foil window. This work will begin following the completion of Task 3.

Task 5: Preliminary Design of a 20 x 200 cm Device

Under this task a plasma cathode electron gun having beam dimensions of 20 x 200 cm will undergo preliminary design. Based on presently existing data, a conceptual design of this device has been established. This design will be subject to modification based on the data to be obtained under Tasks 3 and 4.

II. TECHNICAL APPROACH

A diagram of the plasma cathode electron gun is shown in Fig. 2. The device consists of three major regions: (1) the plasma generation region in which the beam electrons originate, (2) the extraction and control region where electrons are removed from the plasma and transported in a controlled manner into the acceleration region, and (3) the high voltage acceleration region where the electrons are accelerated, without making collisions, to high energies prior to passing through a thin metal foil window and into the laser medium. These regions are comparable to the thermionic cathode, control grid and the grid-to-anode space of a conventional vacuum triode.

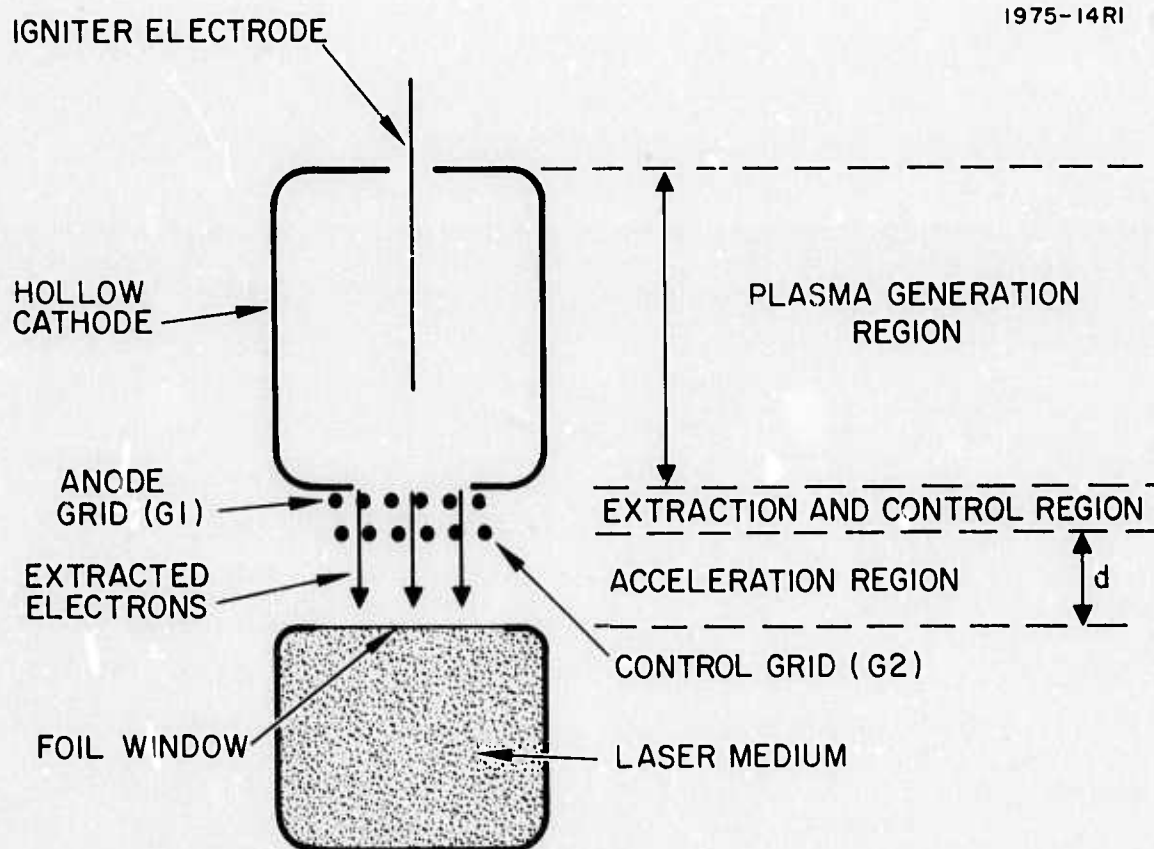

Fig. 2. Schematic of the plasma cathode electron gun.

The plasma generation region in the present device consists of a hollow-cathode discharge struck between the hollow cathode surfaces and the anode grid G1. After preliminary investigation of alternate types of discharges this type was chosen due to its stability, reliability, simplicity, and ability to operate at the low gas pressures required to preclude gas breakdown in the acceleration region.² In the present application, the discharge operates at a voltage of typically 500 to 800 V with helium at pressures typically in the range 15 to 30 mTorr. Helium is used because He^+ ions have relatively low sputtering yields and because it has desirable high voltage breakdown characteristics.

A qualitative understanding of the operation of this hollow cathode discharge can be gained by considering the anode grid G1 in Fig. 2 to be effectively the anode of the hollow cathode discharge; this leads to the equivalent discharge configuration shown in Fig. 3. (The ignition electrode, whose function will be discussed later, is omitted from Fig. 3). A key feature of this discharge is that most of the plasma volume is surrounded by the cathode surface. The discharge is operated in a regime where the rate of ion generation by ionization in the discharge volume is sufficient to maintain the plasma potential at or slightly above anode potential. Under these conditions, the discharge is a cold cathode glow discharge sustained by secondary electron emission due to ion bombardment of the cathode surface. To first order, the applied discharge voltage V appears entirely across the cathode sheath. This results in two effects: (1) ions from the plasma are accelerated by the full discharge voltage through the cathode sheath, thus gaining the energy required for secondary electron emission, and (2) the secondary electrons emitted at the cathode are accelerated through the cathode sheath to the full discharge voltage, thus acquiring an energy at which the ionization cross section for gas atoms is near maximum.

2510-2

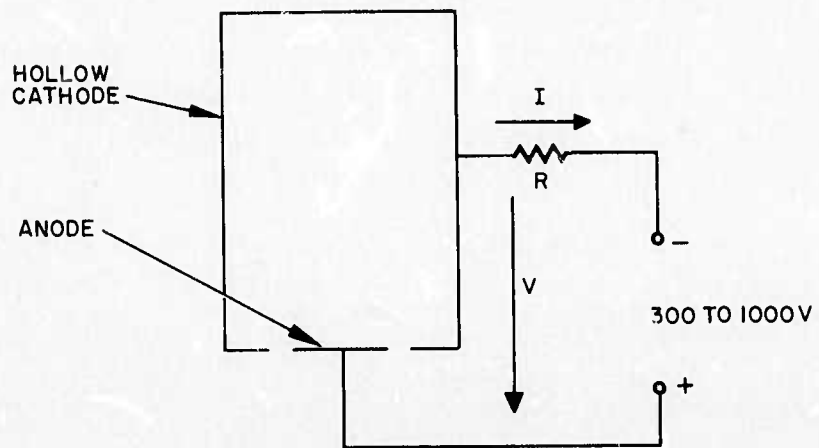

Fig. 3. Hollow cathode low pressure glow discharge.

Maintenance of a large cathode area-to-anode area ratio in a configuration in which the cathode surface surrounds most of the discharge plasma leads to the known results that: (1) most ions (generated by the secondary electrons) are accelerated through the cathode sheath, intercepted by the surrounding cathode surfaces, and utilized with maximum efficiency for secondary electron emission, thus minimizing the rate of ion generation required per emitted electron; (2) when the gas pressure is reduced to a point where the electron ionization mean-free path exceeds the dimensions of the discharge chamber, the secondary electrons accelerated through the cathode sheath are not lost after their first transit through the discharge chamber; most of them are repeatedly reflected from opposing cathode surfaces and have a high probability of making ionizing collisions before reaching the anode in spite of the low gas pressure.³ The discharge can thus be sustained at low pressures, where the electron ionization mean-free path exceeds the dimensions of the hollow cathode discharge region.

These features of the hollow cathode discharge had been recognized to various degrees for some time.* They are systematically exploited in the present design to lead to the lowest gas pressure at which this mode of discharge will still be stable. To this effect, the anode is made flush with the cathode so that it interferes as little as possible with the oscillating ionizing electrons, while it is close enough to the active plasma to provide good coupling and, thereby, a low discharge voltage. Furthermore, the anode area is kept relatively small, so as to present as small an intercepting area as possible for the oscillating electrons before they have dissipated their energy through inelastic (ionizing) collisions. Finally, care is taken that as much of the plasma volume as possible be surrounded by the cathode area so as to minimize the areas through which ions can escape from the plasma without producing secondary electrons.

*An up to date list of references going back to Paschen (1916) can be found in reference 3.

The existence of a minimum pressure, below which this mode of discharge cannot be sustained, is believed to be due to the following circumstances: as the gas pressure is reduced, the number of oscillations which a secondary electron must perform before making an ionizing collision increases. As the number of oscillations increases, the probability for an oscillating electron to fall on the anode before making an ionizing collision increases; its probability of being captured rather than reflected by a cathode surface also increases.³ Both effects result in a reduction of the percentage of oscillating electrons which are effectively utilized in making ionizing collisions. As the utilization efficiency of the oscillating electrons decreases with decreasing gas pressure, the energy which must be imparted to them increases to maintain the required rate of ion generation; this leads to the experimentally observed increase of discharge voltage with decreasing gas pressure. As the discharge voltage increases with decreasing gas pressure, the ionization collision cross-section for the oscillating electrons decreases and eventually the rate of ion generation per emitted secondary electron becomes smaller than the corresponding rate of ion loss. The gas pressure at which this happens is the minimum below which the discharge cannot be sustained in this mode.

The flush anode configuration of Fig. 3 is directly suitable for electron extraction and acceleration. There is no difference to the discharge if some of the electrons available at the anode surface are accelerated through a mesh (G1 in Fig. 2) instead of being collected by an anode at the same location. In the limit, it is expected that all electrons available at the accelerating mesh G1 can be extracted.

The hollow cathode discharge mechanism discussed above is predicated upon the existence of a plasma region at a potential close to anode potential, and a relatively thin cathode sheath through which electrons and ions are respectively accelerated to energies corresponding to the full discharge voltage. Such a plasma will not be formed by simply applying a positive potential to a flush anode as shown in Figs. 2 and 3. In the absence of plasma, the vacuum field configuration is

such that any initial electron present in the hollow cathode volume will be captured by the anode before having had an appreciable probability of making an ionizing collision. Some method of discharge ignition is, therefore, required. To this effect, a thin wire (shown as the igniter electrode in Fig. 2) is provided within the hollow cathode volume. This wire is pulsed positive to a voltage comparable to the steady-state hollow cathode discharge voltage. This initiates a glow discharge in which the electrons are trapped for a relatively long time in orbital trajectories around the thin wire, as described by McClure.⁴ The space potential, corresponding to this discharge, is close enough to that of the fully developed hollow cathode discharge, so that the discharge readily transfers from the igniter wire to the anode of the hollow cathode discharge. After such transfer, which can take place in a time of the order of a microsecond, the ignition wire serves no further purpose and its potential can be left floating.

Electrons are extracted from the discharge plasma through grid G1 and pass through the control grid G2 into the acceleration region. Voltages of typically 0 to -100 V relative to G1 are applied to G2 in order to control the beam intensity from 1 A/cm² to near cut-off. Grid G2 also serves to provide isolation between the low voltage glow discharge region and the high voltage acceleration region. Alternately, control of the beam current is possible through variation of the hollow cathode discharge current through the potential of G1.

The width d , of the acceleration region is crucial to the successful operation of the plasma cathode electron gun since the entire electron acceleration voltage is applied across this gas-filled gap. In order to produce a high-energy electron beam with a narrow energy distribution, the number of inelastic collisions which the electrons make with gas molecules in this region must be kept to a minimum. Three reasons for this requirement are: (1) every inelastic collision experienced by a high-energy electron reduces its energy and populates the low-energy region of the beam's electron energy distribution, (2) the secondary electrons produced by ionizing collisions in the acceleration region also become part of the electron beam and since

they are not formed at cathode potential their energy on reaching the foil window is much less than the acceleration voltage, and (3) collisions produce ions which are accelerated back towards the cathode region through many kilovolts and impinge on the cathode surface where they produce substantial sputtering because of their high energy. This can result in the formation of a deposit on the foil window, and a reduction in the transmission of high energy electrons.

Minimization of inelastic collisions in the accelerating and high voltage region of the plasma cathode electron gun is achieved by operating at low gas pressures, maintaining a small acceleration region width, and thus avoiding the formation of a gas discharge in this region. This width, l , is determined primarily by the principles of vacuum breakdown. Previous experience has shown that parallel-plate electrodes will conservatively withstand applied fields of 70 kV/cm without breakdown in vacuum.⁵ This result is not changed if gas at sufficiently low pressures is present in the interelectrode space. The vacuum breakdown voltage, V , is plotted as a function of d in Fig. 4.*

As the gas pressure is increased, the probability of gas or Paschen breakdown is increased. The present device operates to the left of the Paschen minimum,* as shown in Fig. 3, for a helium pressure of 50 mTorr. As is well known, the Paschen breakdown voltage depends only on the product pd and, thus, a reduction in pressure results in a proportional increase in width d for which breakdown occurs at a given voltage.⁶ It has been experimentally demonstrated that, as expected, the Paschen breakdown characteristic is unaffected by the presence of an electron beam in the acceleration region. This will be discussed further in Section III.

As seen from Fig. 4, there is a region between the two breakdown characteristics where high voltage operation is possible without incurring breakdown. In the present device width d is chosen for a

*There exists a wide scatter in data for vacuum breakdown as well as for Paschen breakdown in helium. The curves shown in Fig. 4 represent a conservative interpretation of this data, supplemented by our own measurements.

given maximum operating voltage (150 kV for this example) so that the operating point will lie nearer to vacuum breakdown characteristic. This is desirable since this characteristic is expected to be more stable in time than the Paschen curve which is sensitive to the presence of outgassing products. As can be seen from Fig. 4, this design is conservative and accelerating voltages up to 250 kV may be possible with a helium pressure of 50 mTorr; even higher voltages may be possible at lower pressures.

Operation of the plasma cathode electron gun in either high current pulsed or cw modes is possible. However, cw operation results in much greater heating of the cathode surfaces due to ion bombardment than is encountered for pulsed operation at similar discharge current levels and low duty cycles. It is, therefore, necessary to operate at lower discharge currents and correspondingly reduced beam currents in the cw case. This requirement is also imposed by the inability of thin metal foil windows to withstand high average energy deposition rates resulting from high-energy electron scattering within the foil.

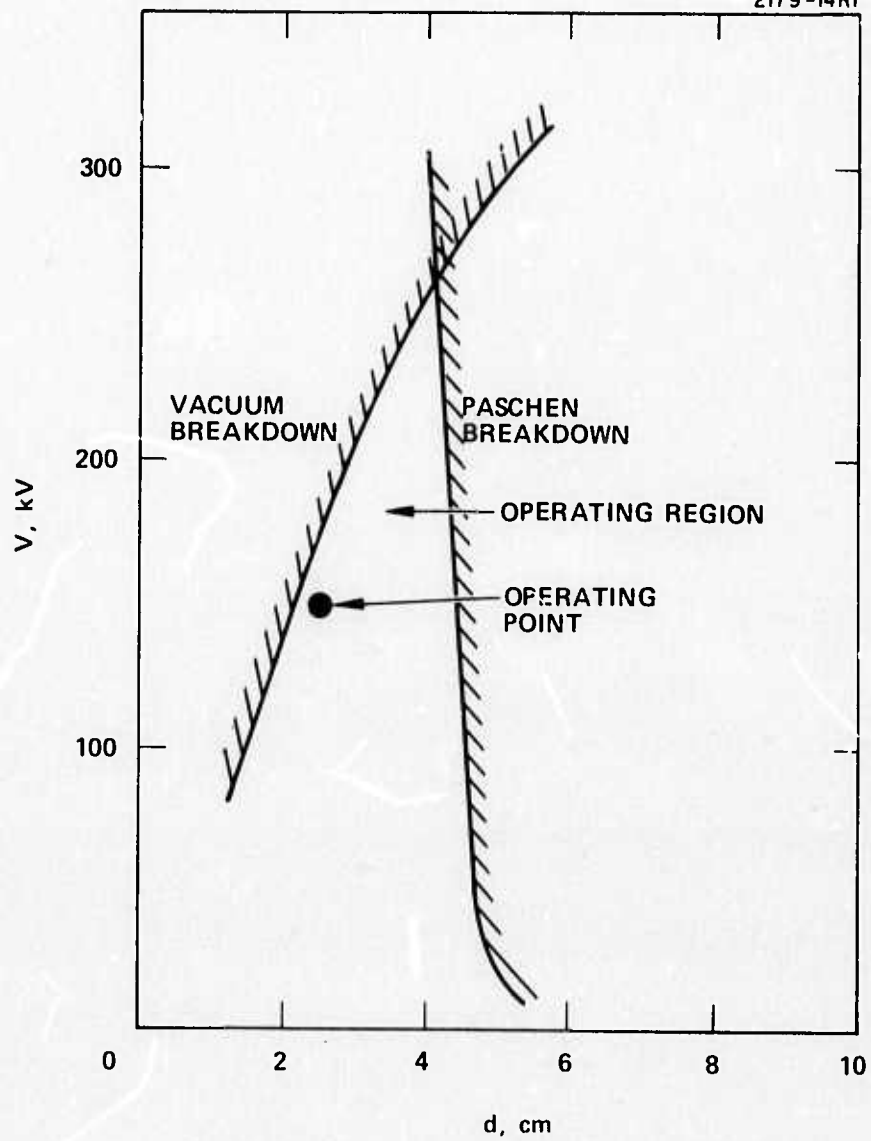

Fig. 4. Low pressure breakdown voltage in the plasma cathode accelerating region as a function of the gap width, d .

III. PLASMA CATHODE EVALUATION PROGRAM

This section discusses the details of the program undertaken to experimentally evaluate the plasma cathode electron gun. The experimental results discussed below have been obtained with small devices which produce beams with cross-sectional areas of 11 and 30 cm². Since it is expected that the plasma cathode electron gun can be scaled to any desired dimensions without incurrent significant alterations in the operating characteristics, the results discussed in this section are expected to be applicable to devices of any size. The development of large devices to verify this expectation will be discussed in Section IV.

This section is divided into subsections which discuss the following areas:

- Experimental Apparatus
- Discharge Characteristics
- Paschen Breakdown Studies
- Beam Extraction Characteristics
- Beam Current-Density Distribution
- Electron Energy-Distribution and Foil Transmission Measurements
- Preliminary Life Tests

Studies of small devices in all areas except the last have been completed during the past six months and further experiments (excluding life testing) will be performed with the devices discussed in the next section.

A. Experimental Apparatus

The device which has been used to evaluate the plasma cathode E-gun concept is shown schematically in Fig. 5. Figure 6 shows the two re-entrant electrodes; one contains the plasma cathode discharge chamber and grid assembly, and the other forms the beam collector. Figure 7 shows an exploded view of the discharge chamber and grid assembly and Fig. 8 shows the assembled experimental apparatus. The

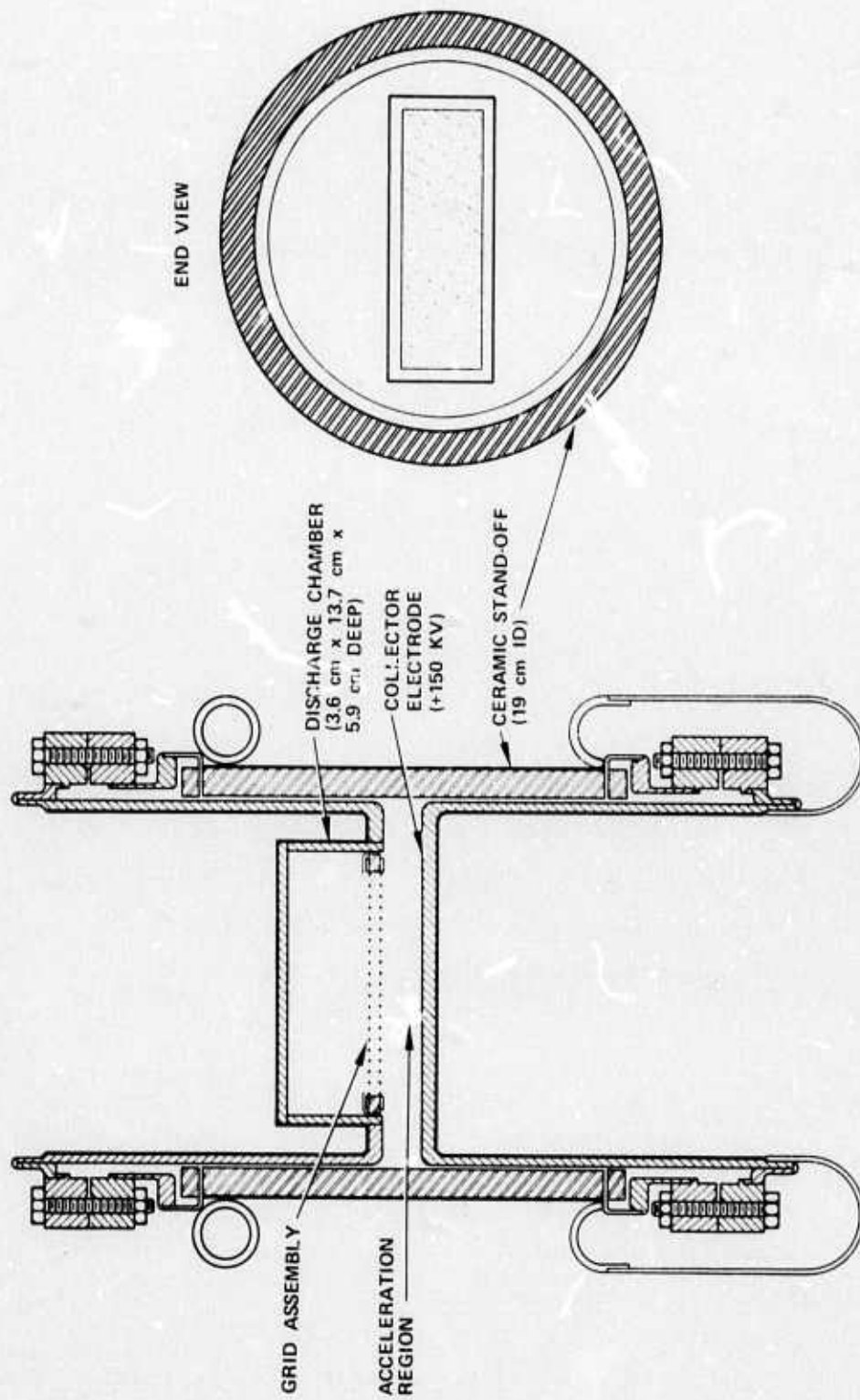

Fig. 5. Experimental apparatus used to evaluate small plasma cathode E-gun devices.

M9205

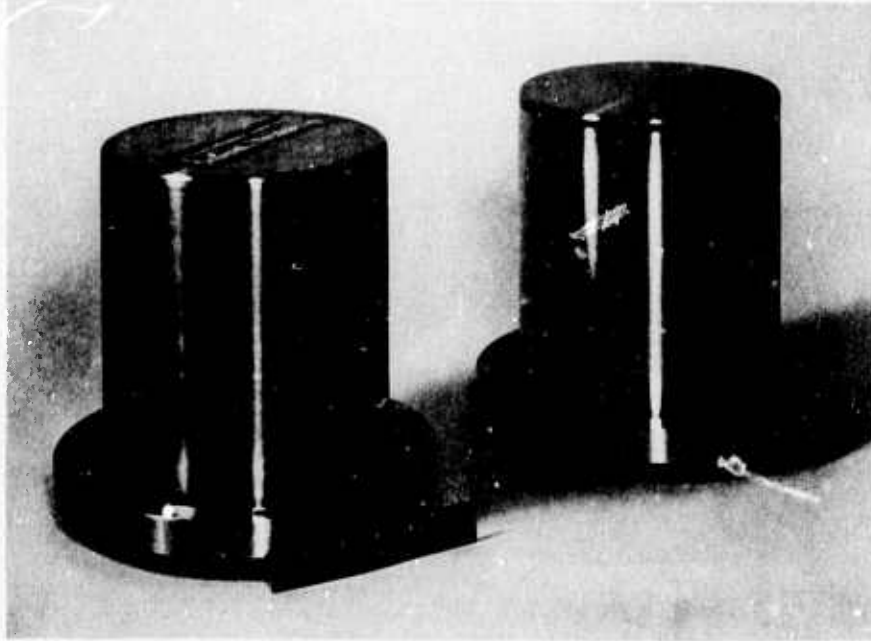

Fig. 6. Re-entrant electrodes containing the plasma cathode and beam collector.

M9206

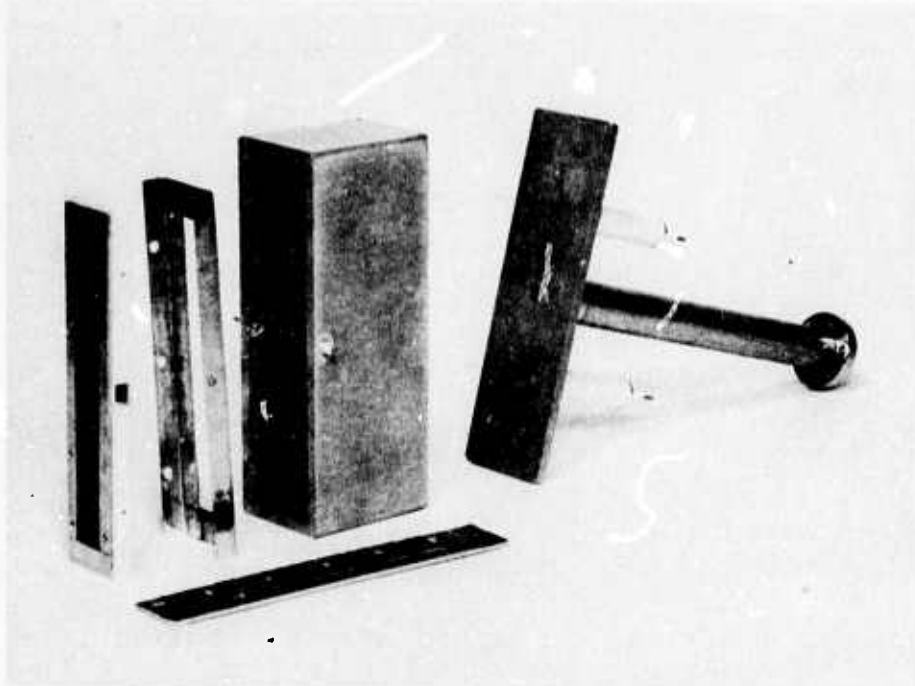

Fig. 7. Exploded view of the discharge chamber and grid assembly.

M9687

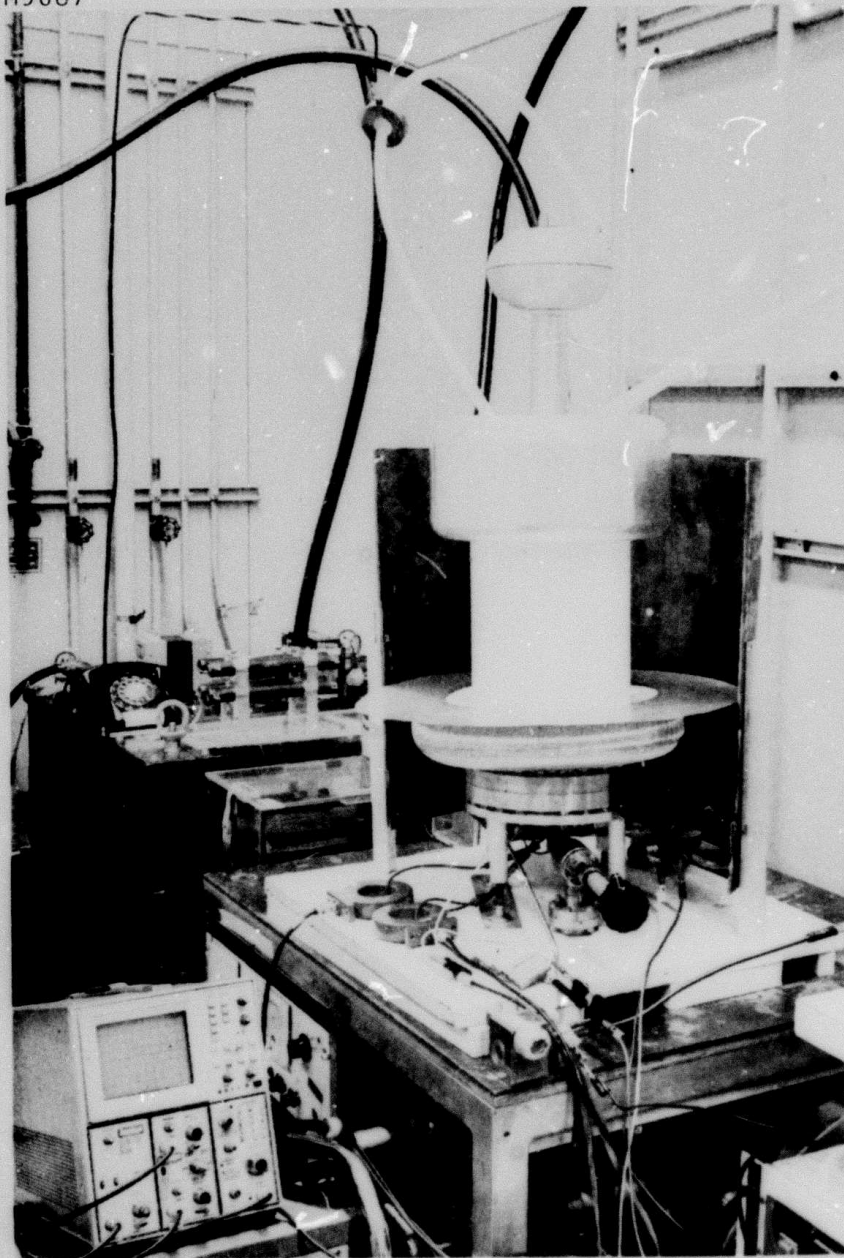

Fig. 8. Experimental apparatus and energy analyzer shown with half of the lead shield removed. The collector electrode is located at the top of the device.

hollow cathode is formed from stainless steel and has inside dimensions of 3.6 cm x 13.7 cm x 5.9 cm deep. The grid structure (G1 and G2) consists of two identical, 44% transparent, stainless steel meshes spaced 0.8 cm apart. Experiments were performed with two grid assemblies; one which provided a 1 x 11 cm (11 cm^2) extraction area, and one which had an area of 3 x 10 cm (30 cm^2). The extraction area is equal to the area of the anode grid that is exposed to the discharge plasma. The hollow cathode and grid assembly are mounted in the end of a re-entrant electrode which protrudes into the cylindrical ceramic stand-off. This stand-off also serves as part of the vacuum enclosure. The collector electrode is re-entrant from the opposite end of the ceramic cylinder and is spaced 2.5 cm from the opposing electrode. In actual usage the solid collector would be replaced by a thin foil window. With this device the characteristics of beam extraction and acceleration are studied without involving the unrelated complicating factors of foil transmission. In the experimental studies the cathode was grounded and the collector was biased up to 150 kV. Suitable corona shields were fitted to the exterior of the device and the assembly was mounted on a LN_2 trapped oil diffusion pump station. The tube was valved off whenever the LN_2 trap was not operating in order to inhibit backstreaming of diffusion pump oil. The system was first evacuated, then filled with helium and finally gettered in order to remove outgassing products. During the experimental program various probes (described under specific experimental areas) were mounted as part of the collector to permit measurements of the beam current density distribution, energy distribution, and foil transmission characteristics of the beam.

A major advance in the design of this device during the last six months has been the incorporation of two igniter electrodes (shown in Figs. 5 and 7) which protrude approximately 4 cm into the discharge region from the upstream cathode surface. The igniter electrodes are formed from 0.025-cm diameter tungsten wire supported by ceramic stand-offs. Their operation was described in Section II. The discharge

is ignited by supplying a capacitor discharge pulse of typically 500 V at 0.5 A for a duration of about 10 μ sec. This pulse also triggers the main discharge pulse supply so that voltage is applied to the anode grid immediately after the igniter discharge is initiated. Provided the igniter discharge has sufficient amplitude to trigger the main discharge, its amplitude has no effect on the main discharge characteristics.

B. Discharge Characteristics

Figure 9 illustrates typical hollow cathode discharge characteristics measured in 100 μ sec pulsed operation and in the absence of beam extraction. These results are independent of pulse length provided no significant heating occurs. Figure 9 shows the dependence of the voltage of the anode grid V_{G1} on the grid current I_{G1} for helium pressures of 17 and 20-mTorr. It is seen that, for higher currents, the voltage tends to saturate. The dependence of V_{G1} on helium pressure is shown in Fig. 9(b) for a constant discharge current. As the pressure decreases the discharge voltage increases until ignition becomes unreliable, which is consistent with the theoretical model of Section II. For long life operation it is desirable to have minimal sputtering which means that the discharge voltage should be minimized. This suggests that larger pressures are desirable. However, in order to insure that Paschen breakdown does not occur in the acceleration region of the device, which operates at the same pressure as the discharge, it is desirable to minimize the helium pressure as previously discussed. In consideration of these competing factors an operating pressure in the range of 15 to 30 mTorr is used in the present experimental studies.

Plasma probe measurements, performed using one of the two igniter electrodes as a Langmuir probe, indicate that the electron temperature is in the range 4 to 10 eV and that the plasma potential is slightly more positive than the potential applied to grid G1. These results are consistent with the model of the hollow cathode glow discharge discussed in Section II.

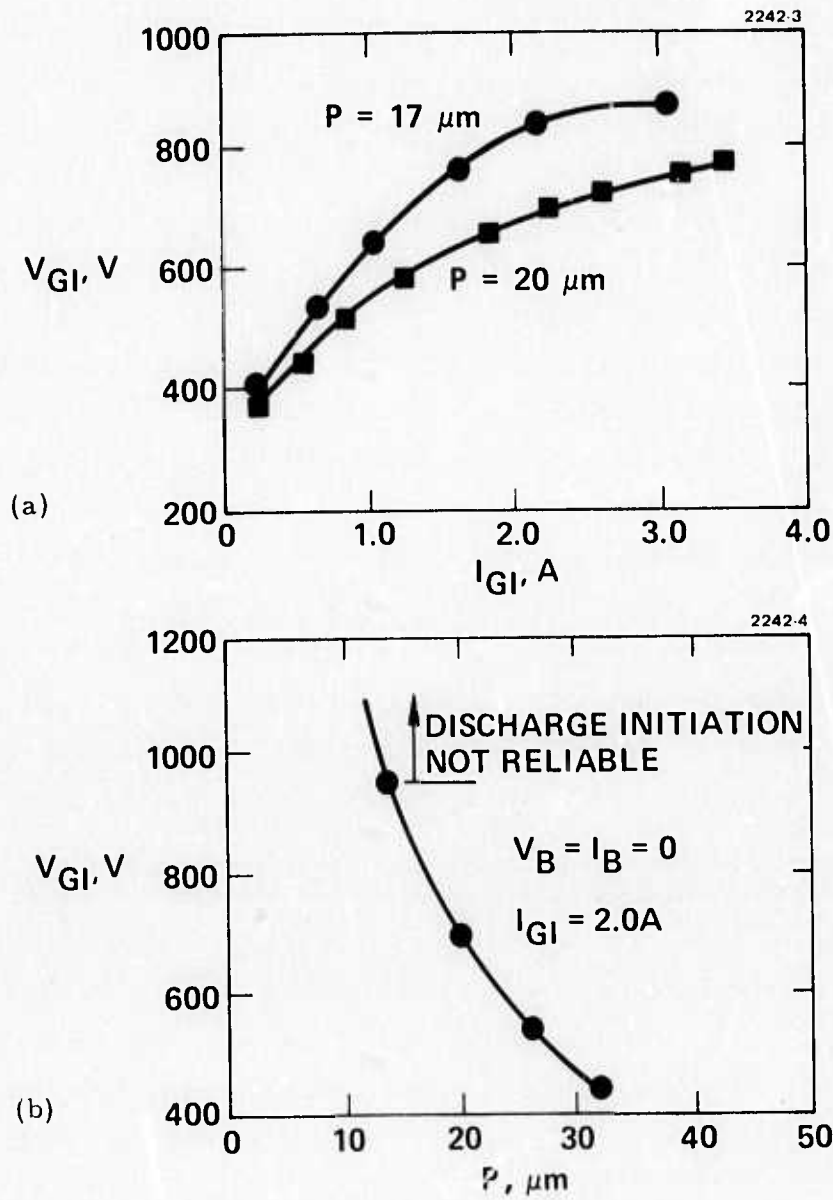

Fig. 9. Hollow cathode discharge characteristics for an anode grid area of 11 cm^2 with $I_{G2} = I_{\text{collector}} \approx 0$ and $V_{G2} = V_{\text{cathode}} = V_{G1}$.

C. Paschen Breakdown Studies

As discussed in Section II, the Paschen breakdown characteristics in the acceleration region of a plasma cathode E-gun are critical to the proper design and operation of the device. Studies of Paschen breakdown at low pressures by other investigators have all been performed in the absence of an electron beam and have demonstrated considerable disagreement.⁶ Therefore, measurements have been undertaken under the present program to: (1) determine the effects due to the presence of an E-beam, and (2) determine the Paschen breakdown characteristics in the present experimental plasma cathode devices.

In the plasma cathode E-gun, electrons of low energy (~ 10 eV) enter the acceleration region and are accelerated toward the collector electrode. The same acceleration process will also occur for stochastically generated electrons which, for sufficiently high pressures and electrode spacings, can cause an avalanche and, thereby, Paschen breakdown. Since the same process applies in both cases, it is expected that the presence of an electron beam in the acceleration region will have little effect on the Paschen breakdown characteristics.

To verify this reasoning experiments have been performed in a modified version of the device shown in Fig. 5. The test device, shown schematically in Fig. 10, contains a small thermionic cathode located within the re-entrant electrode which would normally contain the plasma cathode. Electrons emitted from this cathode pass through a 0.1-cm diameter beam aperture in the re-entrant electrode and are accelerated across a $d = 8.5$ cm-wide gap to the collector electrode. This electrode could be biased at up to 150 kV relative to the opposite, grounded surface. Since the beam aperture diameter was much smaller than the gap width, it perturbed the electric field in the acceleration region by an insignificant amount. The electron beam was turned on and off by simply varying the dc bias of the cathode relative to the containing electrode; thus, the effects of the beam on the breakdown characteristics were easily determined. The device

2104-4 R2

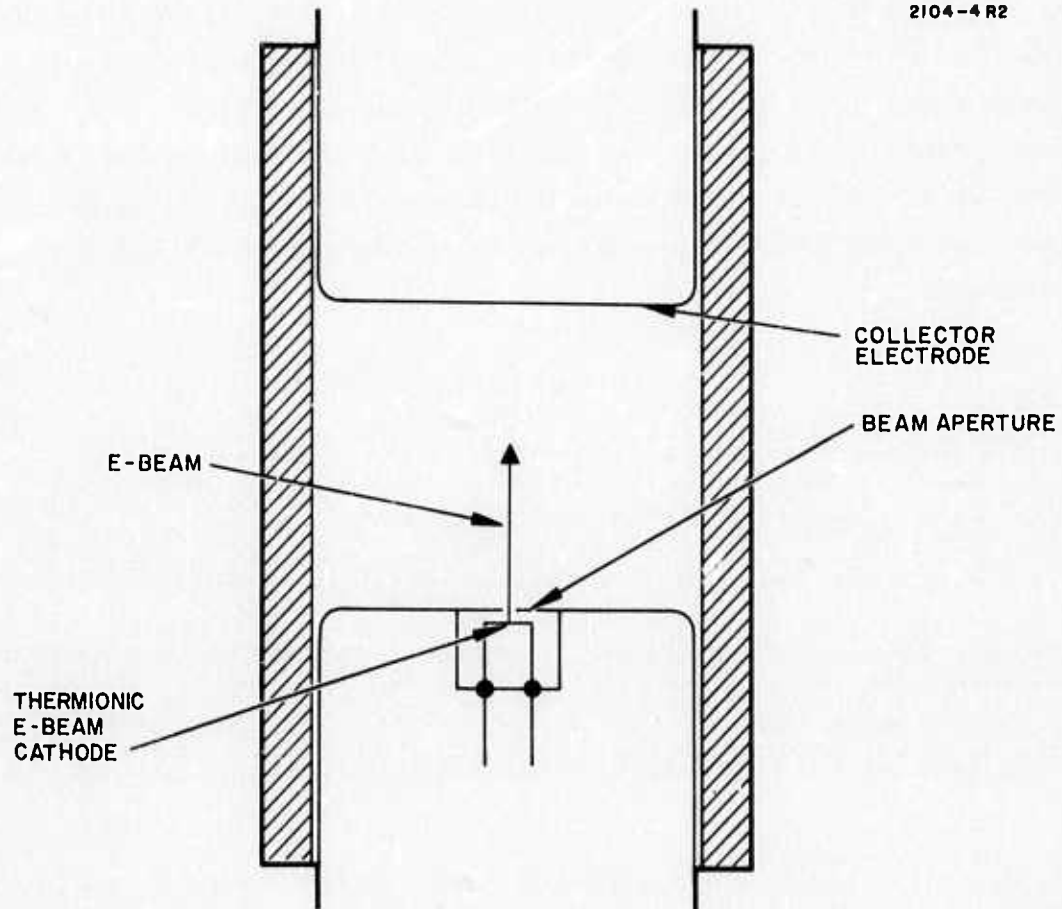

Fig. 10. Assembly for study of Paschen breakdown in the presence of E-beam.

was evacuated and refilled with helium after each breakdown in order to ensure that the results were not influenced by the presence of contaminants released from the interior surfaces.

The results, summarized in Table I, indicate that a beam of 110 mA/cm^2 reduces the pressure at which Paschen breakdown occurs by less than 20%. This is consistent with the basic expectations and indicates that the Paschen breakdown properties of a given geometry can be determined (within 20%) without an electron beam. The result that breakdown occurs at lower pressures, in the presence of an electron beam, may be due to the evolution of contaminants from the beam collector although precautions were taken to avoid this possibility.

TABLE I
Paschen Breakdown in Helium at 100 kV

Condition	Helium Pressure, P (mTorr)	Pd (Torr-cm)
Electron Beam Off	57	0.48
Electron Beam On (110 mA/cm^2)	47	0.40

T961

Measurements of the Paschen breakdown voltage for the plasma cathode test device shown in Fig. 5 were performed in the absence of an E-beam in order to assess the influence of the surface irregularities, associated with the grid structure, on the breakdown characteristics. For applied voltages greater than about 100 kV the value of Pd for which breakdown occurred had a constant value of 0.25 Torr-cm. Therefore, with this geometry, a value of 0.20 Torr-cm is applicable for design purposes. Thus, for the given gap width of 2.5 cm it is necessary to operate at pressures below 80 mTorr. This is easily achieved based on the discharge characteristics already discussed.

D. Beam Extraction Characteristics

Under the present program, experimental plasma cathode devices have been operated over a wide range of parameter values. Table II summarizes several characteristic data points as well as indicating the expected maximum operating levels determined on the basis of existing experimental data. The data given in the table were obtained without any attempt to simultaneously maximize all of the beam parameters (beam current, beam energy, etc.). For the first set of data it should be noted that the control grid current is much greater than that collected by the anode grid due to the presence of 400Ω in series with the anode grid. If, instead, this resistance were placed in series with the control grid, then the 5 A current would flow to the anode grid. For this data set, the beam current is six times greater than the current flowing in the grid circuits, thus demonstrating highly efficient discharge current utilization.

The expected maximum operating levels do not take into account the presence of a foil window. Substantial window cooling will be required for the indicated maximum levels under cw and medium repetition rate (100 cps) pulsed operation.

Figure 11 illustrates the electron beam control characteristics which are equivalent to the control characteristics of a standard vacuum triode. In this figure the voltage across the acceleration region (between collector and cathode) is plotted as a function of the potential between the grids, $(V_{G2} - V_{G1})$, for a fixed beam current $I_B = 1.0$ A and fixed anode grid voltage V_{G1} . These data are for a 11 cm^2 beam area. It is seen that, as the beam voltage increases, the potential of the control grid must be made increasingly negative in order to maintain a constant beam current. The shape of the curve at low beam voltages is strongly dependent on interception and focusing of the beam in passing through the control grid. The slope of the linear portion of the curve gives the triode equivalent amplification factor μ which is measured to be 6×10^3 . An approximate theoretical calculation gives a value of 7.5×10^3 (Ref. 7). This agreement indicates that, as desired, no plasma exists within the acceleration region, and that the control and acceleration characteristics are well understood.

TABLE II
Device Operating Parameters

Beam ^a Current Density, mA/cm ²	Beam Energy, keV	Pulse Length, μsec	Beam Dimensions, cm	Helium Gas Pressure, mTorr	Anode Grid Current, A	Control Grid Potential Relative to Grid G1, V	Control Grid Current, A
Typical Experimental Data							
1000	45	100	3 x 10	17	0	~0	5.0
91	140	100	1 x 11	17	2.5	-30	0
0.7	40 ^b	cw	1 x 11	17	0.013	-100	0
Expected Maximum Operating Levels							
> 1000	> 150	> 100	> 3 x 10	17	~1/10 I _B	~0	0
> 10	> 150	cw	> 1 x 11	17	~I _B	-100	0
^a Measured upstream of foil window location. ^b Energy was limited by the high voltage power supply.							

T962

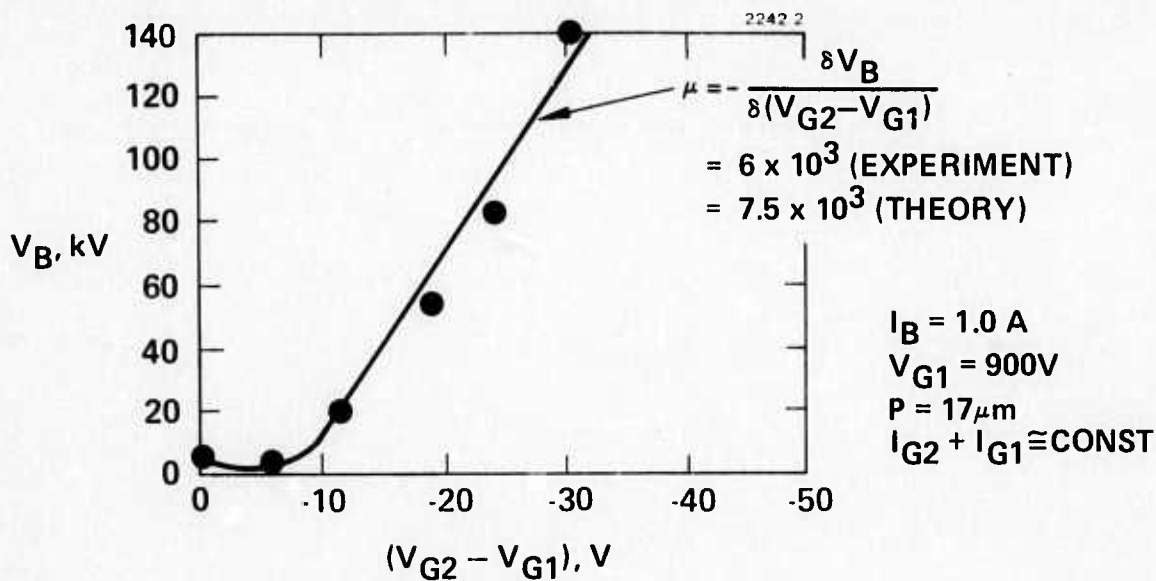

Fig. 11. Electron beam control characteristics.

E. Beam Current-Density Distribution

Figure 12 shows the electron beam current density distribution for a 3×10 cm beam accelerated to an energy of 60 keV. The measurements were obtained using seven fixed current probes recessed into the collector. Plots are shown from the axes to the edges of the cathode emission area in both the long and short dimensions. The dashed portions of the curves indicate extrapolations which are based on similar results measured with a 1×11 cm beam. It is seen that the beam is quite uniform in the long dimension. In the short dimension the beam intensity falls by about 15% at one-half the dimension. It is expected that the indicated nonuniformity is an edge effect, possibly due to plasma inhomogeneity, which can be expected to decrease in significance as the beam area is increased. Improved beam uniformity in the short dimension, if necessary, can be achieved by: (1) tailoring the transparency of the control grid, (2) masking of the beam edges, and (3) improving the plasma density distribution through changes in the discharge chamber geometry.

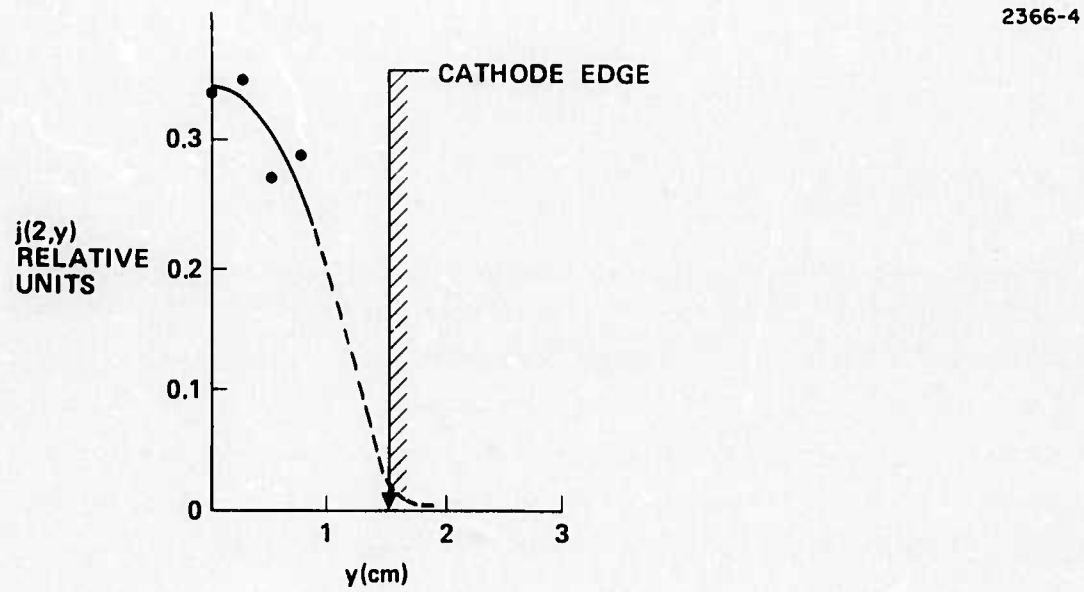
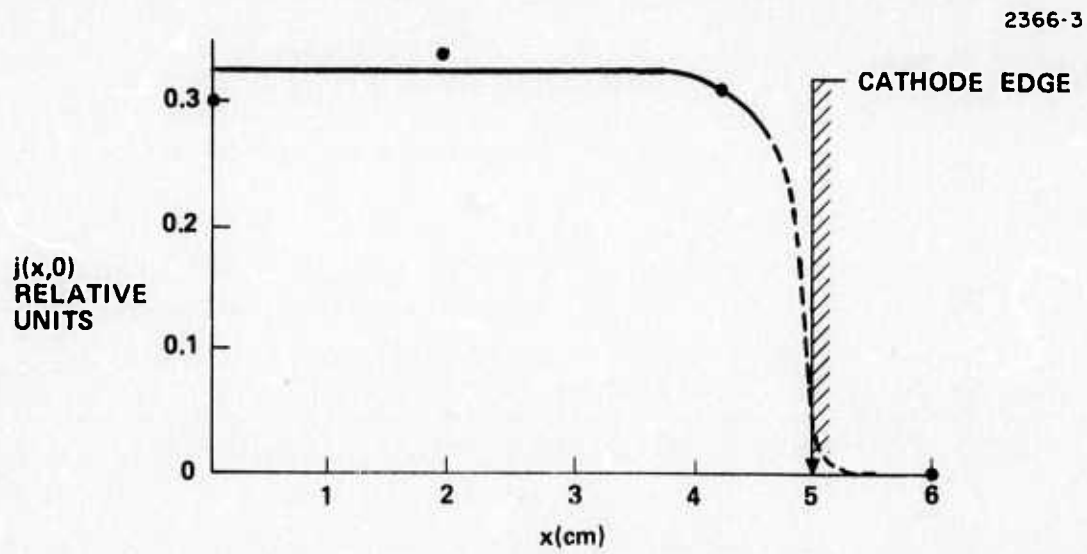

Fig. 12. Electron beam current density distribution for a 3 x 10 cm, 60 keV beam.

F. Electron Energy-Distribution and Foil Transmission Measurements

In order to measure the energy distribution of electrons incident on the beam collector, the probe assembly shown in Fig. 13 was installed in place of the collector electrode shown in Figs. 5 and 6. This assembly forms a deep-cup, retarding Faraday probe. A small portion of the electron beam, as defined by the 0.1 cm diameter probe aperture, is sampled by this probe. The Faraday collector portion of the probe is supported by the glass stand-off so that it can be biased at any potential between that of the beam collector and cathode potential.

Figure 14 illustrates the electron beam energy distribution measured at the center of a 30 cm^2 beam. The beam energy was 50 keV and the current density was 146 mA/cm^2 . The dashed portion of the curve is estimated so that the integrated current is consistent with the beam current density. Most of the beam (90%) fell in the major peak having a full-width-half-maximum of 1.4 keV which is less than 3% of the total energy. It is expected, furthermore, that most of the measured width is associated with the measuring apparatus rather than the beam properties. The small peak at low energies is attributed to instrument effects resulting from generation of electron-ion pairs within the relatively large volume of the Faraday probe. The measurements demonstrate the formation of a highly monoenergetic beam in these devices.

To further demonstrate the monoenergetic characteristics of the electron beam, a 0.0014 cm (0.00055 in.) thick titanium foil was placed over the probe aperture and the electron transmission was measured. At a beam energy of 100 keV the transmission was measured to be $(50 \pm 6) \%$. The theoretical value is 54%, well within the experimental error.⁸

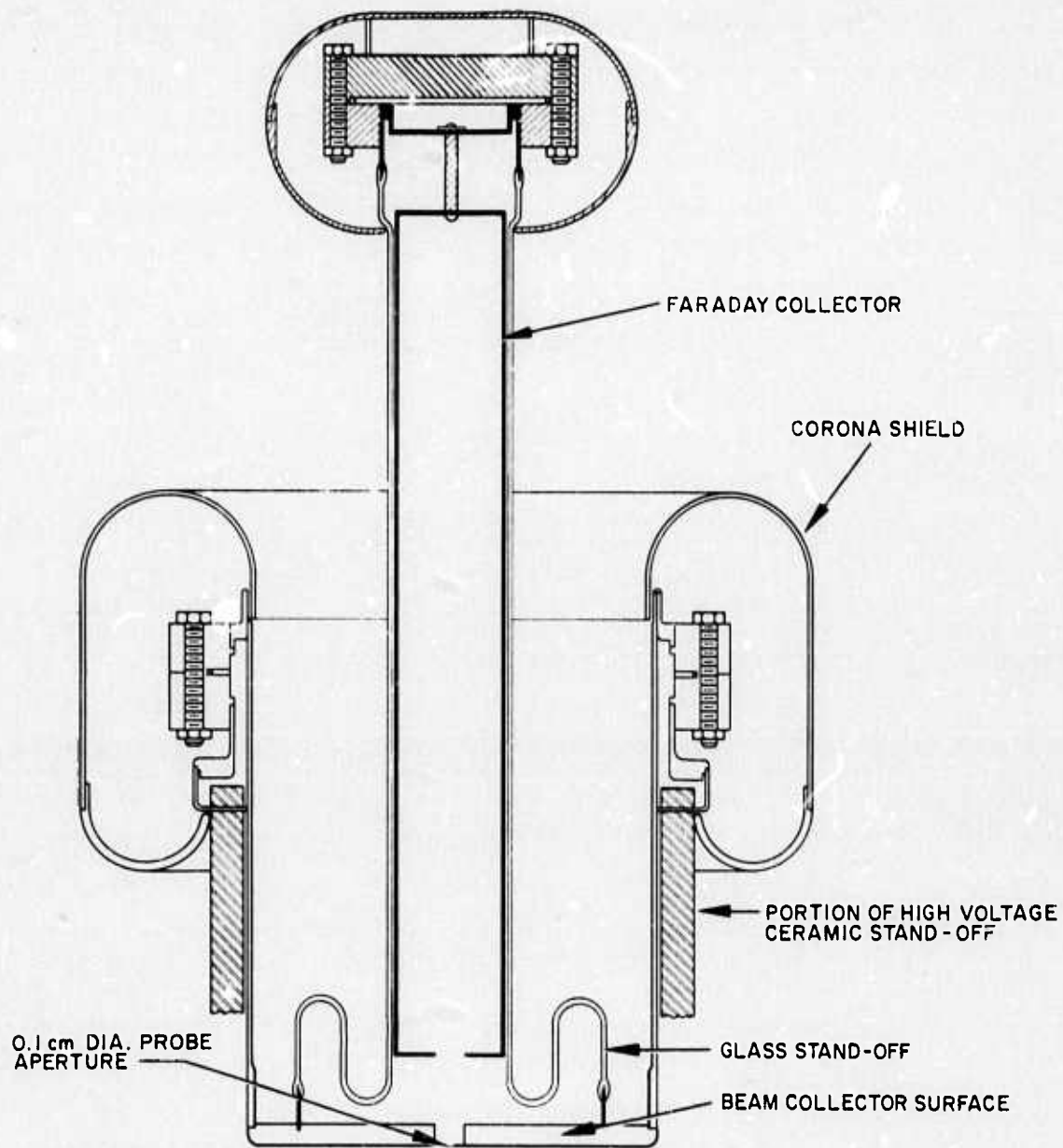

Fig. 13. Electron beam energy distribution.

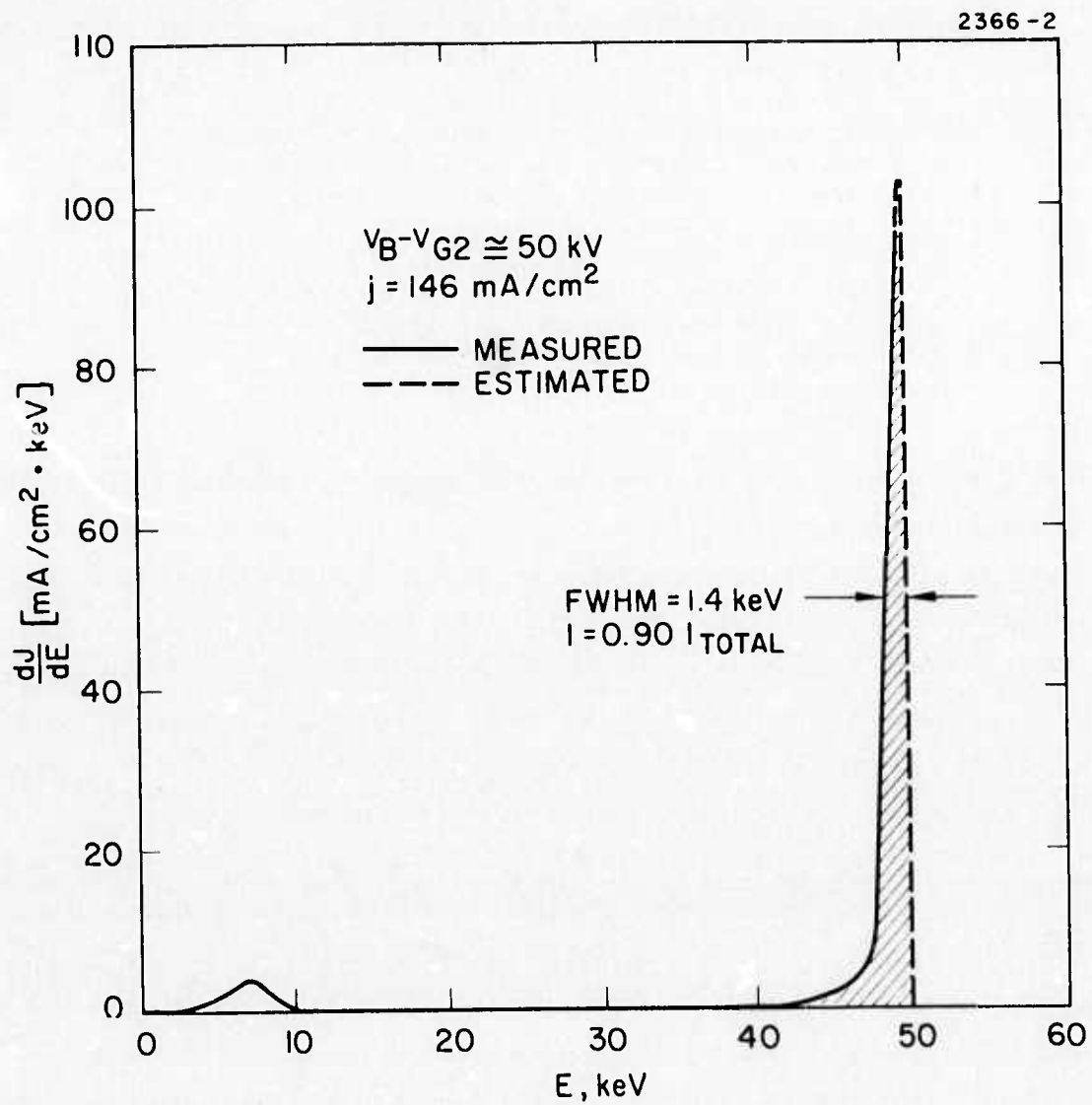

Fig. 14. Electron beam energy distribution.

G. Preliminary Life Tests

It is expected that the operating life of a plasma cathode E-gun will be limited by the following two factors:

1. A reduction in the transparency of the thin metal foil window due to the deposition of material sputtered from the interior surfaces of the hollow cathode.
2. A reduction in the helium gas pressure below that necessary to maintain the hollow cathode discharge due to ion burial and sputtering within the plasma generation region.

It is also possible that the deposition of sputtered material on the grid structure may lead to a loss of grid transparency and/or electrical shorting between the grids. However, since the typical dimensions in this case (≥ 0.025 cm) are much greater than those associated with a significant decrease in the foil window transmission (the transmission of a 0.00125-cm thick titanium window will be reduced by about 10% at 100 keV for a change in thickness of 0.00025 cm),⁸ it is doubtful that this process will be a dominant life limiting factor.

Preliminary measurements have been made to determine the lifetime of the plasma cathode E-gun. The tests were performed with the same experimental arrangement as described in the previous subsection for the measurement of the beam transmission through a foil window. This was accomplished by operating the plasma cathode (30 cm^2 beam area) for an accumulated 6 hours at 20 cps and a pulse duration of 100 μsec under the nominal conditions listed in Table III. For these tests measurements of foil transmission and gas pressure were recorded about every hour. The electron transmission through the foil window was measured at 100 keV.

For the duration of this test the following changes were measured:

- Decrease in foil transmission = $0 \pm 2\%$ for a measured value of 50%
- Decrease in helium pressure = 5 mTorr

The test is equivalent to about one hour of operation at a beam current of 3.0 A (100 mA/cm^2), a pulse length of 100 μsec , and a repetition rate of 100 cps. On the basis of the foil transmission results, one may expect lifetimes of at least tens to hundreds of hours with the present device which is formed from stainless steel. Incorporation of refractory metal cathode surfaces which provide an order of magnitude lower sputtering yield can be expected to increase this by a factor of ten.

TABLE III

Nominal Life Test Operating Conditions

Initial Helium Pressure	18 mTorr
Anode Grid Voltage	600 V
Anode Grid Current	2 A
Control Grid Voltage (relative to the anode grid)	-23 V
Control Grid Current	0
Electron Beam Current	1.5 A
Electron Beam Energy ^a	60 keV

^aThe long duration tests were performed at a beam energy of 60 keV in order to prevent automatic shut-down of the high voltage power supply if an arc were to occur.

T963

The reduction of operating helium pressure imposes a more severe life limiting constraint for sealed-off gun designs. However, a simple gas pressure control system of existing design which adds gas as required, can be employed, thereby eliminating this constraint.

Measurements of the gas pumping rate with only the hollow cathode discharge operating (no electron beam extraction) have given results similar within a factor of two to those given above. Since both foil transmission and pressure changes are caused by the same phenomenon, it can be expected that life tests performed without beam extraction will provide useful life data. Of course, beam extraction at high voltage will be required in order to measure the foil transmission as a function of operating time; however, such measurements need be performed only occasionally during the test.

Further experiments are being performed to more fully assess the lifetime characteristics of the plasma cathode E-gun.

IV. LARGE EXPERIMENTAL DEVICE DEVELOPMENT

During the past six month reporting period, data has been obtained exclusively with small plasma cathode devices which produce beams with cross sections no greater than 30 cm^2 . This data has demonstrated that the plasma cathode has properties which make it quite suitable for use with E-beam lasers. Furthermore, the models which describe the device operation have been well verified by these experiments. Although it is fully expected that larger devices will operate in the same predictable manner, it is also necessary to confirm this expectation experimentally. In particular, it will be important to measure the electron beam current density distribution and, if necessary, devise ways to improve its uniformity. In addition, it will be important to measure the current density profile after transport of the beam through a thin foil window as would be used in laser applications. Finally, full assessment of the overall operating characteristics of large devices is necessary in order to provide data useful for future system development.

In order to answer the above questions, two devices are presently being assembled. One has a parallelepiped geometry which essentially consists of three small modules combined in order to achieve a beam cross-section of $10 \times 15 \text{ cm}$ (150 cm^2). This device will be capable of operating at beam energies up to at least 150 keV and beam current density measurements downstream of a foil window will be performed with it.

The second device will serve as a test vehicle to demonstrate the efficacy of a simplified cylindrical design which can be easily scaled to large beam areas and conveniently integrated into practical laser systems. This device will produce a beam having a cross-section of $4 \times 40 \text{ cm}$. In order to avoid the complexity and cost associated with operation at high beam energies, this device will be operated only up to about 25 keV. This energy is sufficiently high to permit accurate measurements of beam current density uniformity and of most operating characteristics.

In addition to the two large experimental devices, a conceptual design has been established for a 20 x 200 cm device. On the basis of the experimental work to be done during the next six months, this conceptual design will be developed into a preliminary design under Task V.

The details of the design of each of these three devices is described below.

A. 10 x 15 cm High Voltage Device

The purpose of this device is to provide a simple test vehicle based on proven technology with which to evaluate the usefulness of the plasma cathode for the generation of large area E-beams. One approach to obtaining a large area device is to combine a number of modules such as described in Section III. In the present device three such modules are combined in order to simulate an arbitrarily large gun geometry. Several methods for combining these modules is illustrated in Fig. 15. The method shown in Fig. 15(a) is undesirable due to the resultant beam nonuniformity. This situation is improved in Fig. 15(b) by expanding the beam in the region between the cathode and the foil window. This method, however, is quite complicated. The final approach is conceptually the simplest and, based on the experimental results discussed for the 3 x 10 cm device in Section III, this design should operate stably at low pressures. The approach shown in Fig. 15(c) will be employed with the 10 x 15 cm apparatus. An end-view of this device is shown schematically in Fig. 16. The same high voltage design as used with the experiments of Section III is used here, thereby minimizing the development of new designs, while providing a completely adequate test vehicle.

At the present time the design and fabrication of the device is complete and the assembly is about 80% finished. The major device components are shown in Figs. 17, 18, and 19. The hollow cathode discharge chamber is shown in Fig. 17 without the partitions between the individual modules and without the grid assembly. Figure 18 shows

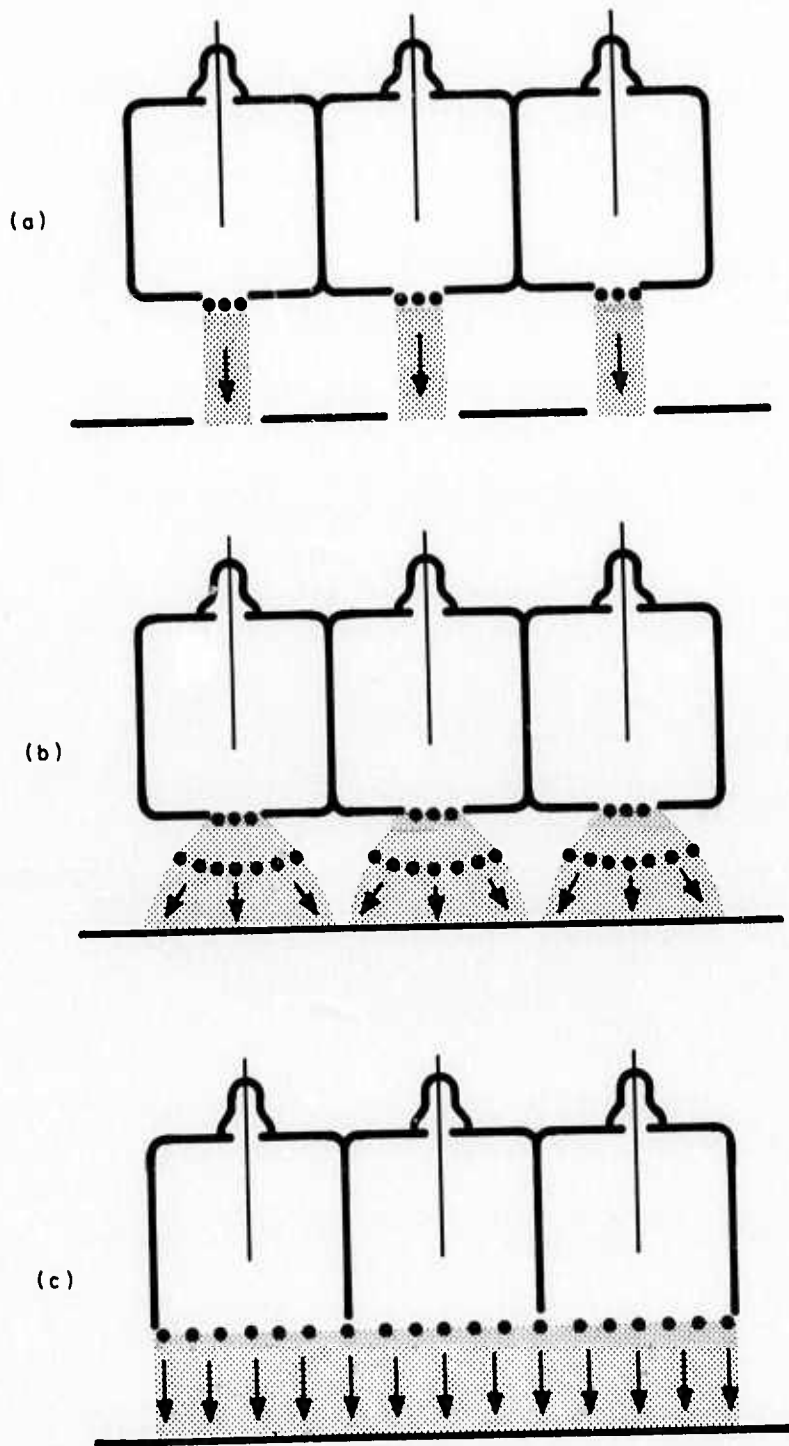

Fig. 15. Possible approaches for combining several individual plasma cathode modules to form a large area beam.

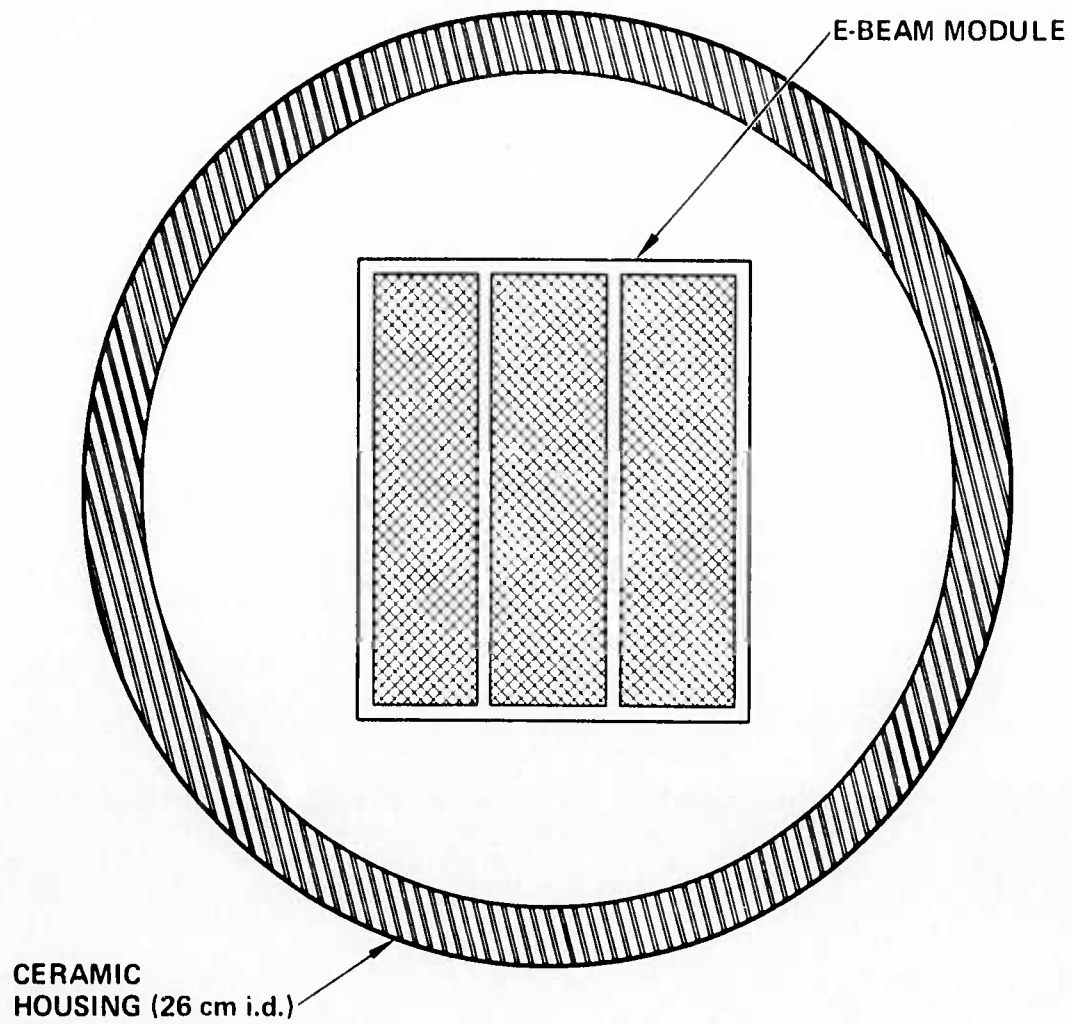

Fig. 16. End view of 3-module high voltage configuration.

M9692

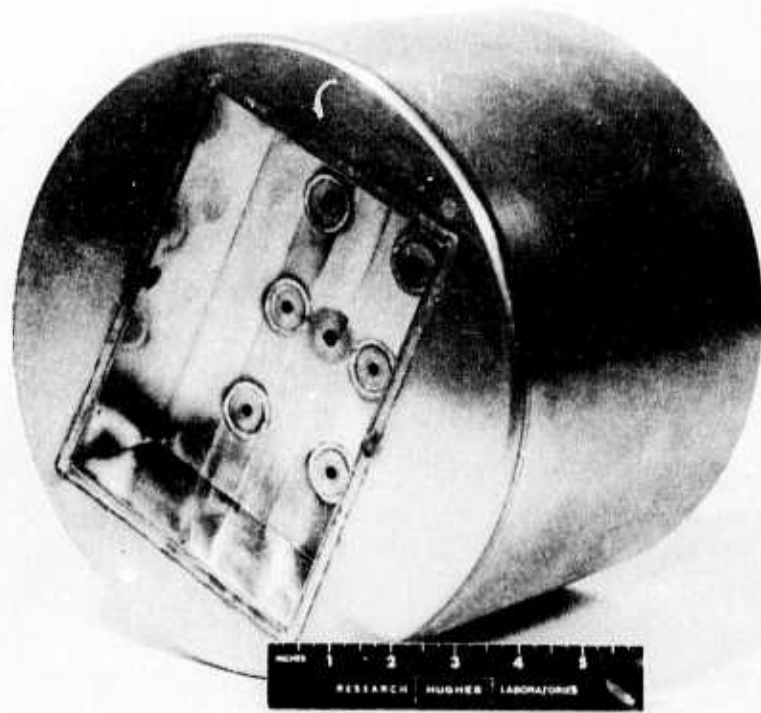

Fig. 17. Partially completed re-entrant electrode containing the plasma cathode discharge region.

M9691

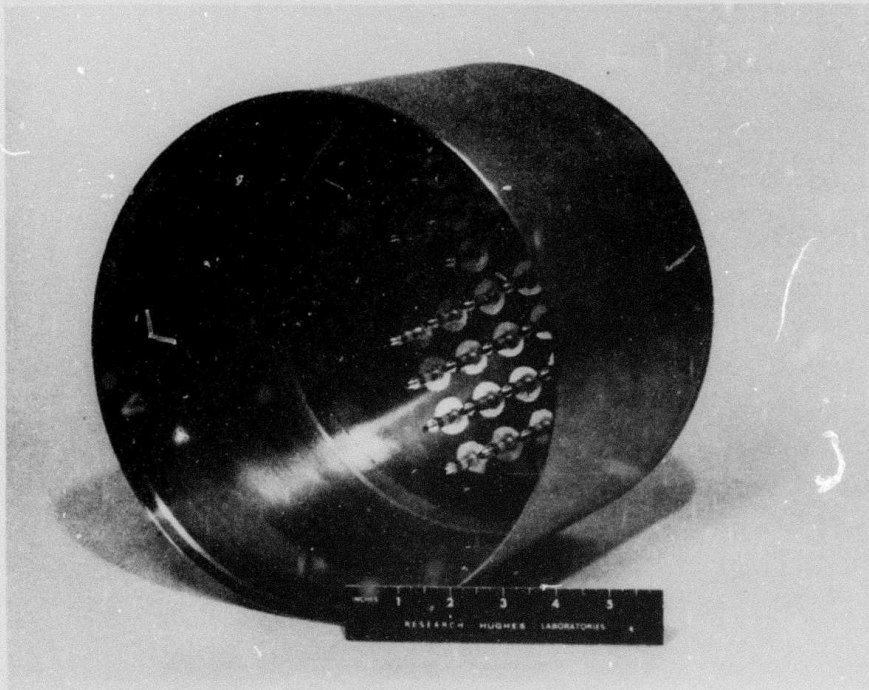

Fig. 18. Partially completed re-entrant beam collector electrode showing the arrangement of the current density probe system.

M9688

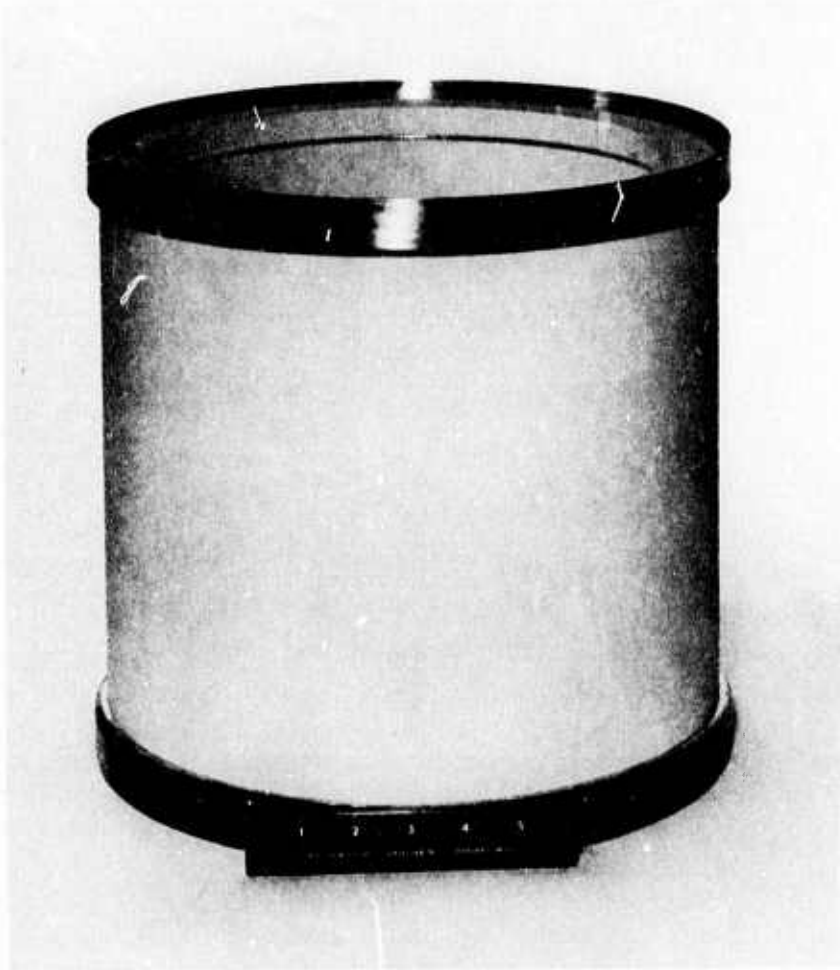

Fig. 19. High voltage ceramic which will support the electrodes shown in Figs. 17 and 18.

the backside of the collector electrode and the 25 probes which are used to measure the spatial current density distribution. Each probe collects the current which passes through a 0.3-cm diameter aperture in the beam collector. The high voltage ceramic shown in Fig. 19 will support the two re-entrant electrodes as done in the single module device shown in Fig. 4.

B. 4 x 40 cm Low-Voltage Cylindrical Device

Although the 10 x 15 cm device will permit verification of the applicability of the plasma cathode to large area beam production, its design is awkward to extend to very large area devices due to its parallelepiped geometry. It is clear that a cylindrical design such as shown in Fig. 20 will more easily fulfill the simultaneous requirements for a uniform high voltage electrode spacing to prevent Paschen and vacuum breakdown, simplicity of construction, lightweight vacuum envelope, and ease of integrating with a practical laser. In this design, the beam length is simply increased by increasing the length of the coaxial cylinders. Increasing the width requires a proportional increase in the diameter of the device. A modified version of the high voltage design described in Section III would be used to support the inner cylinder relative to the outer one.

Under the present program a low voltage (≤ 25 kV) cylindrical device capable of producing a beam having dimensions of 4 x 40 cm has been built. The purpose of this work is to evaluate and optimize the beam current density distribution both in time and space. Operation at beam energies up to 25 keV will facilitate this without involving the complexities and expense of operation at higher voltages. This device has the same cross-sectional design as shown in Fig. 20 but it does not have a foil window. A schematic side view of the device is shown in Fig. 21. Figures 22 and 23 shows the inner and outer cylinders, respectively. Figure 24 shows the final system assembled for testing on a diffusion pump station. Testing will begin early in July, 1973.

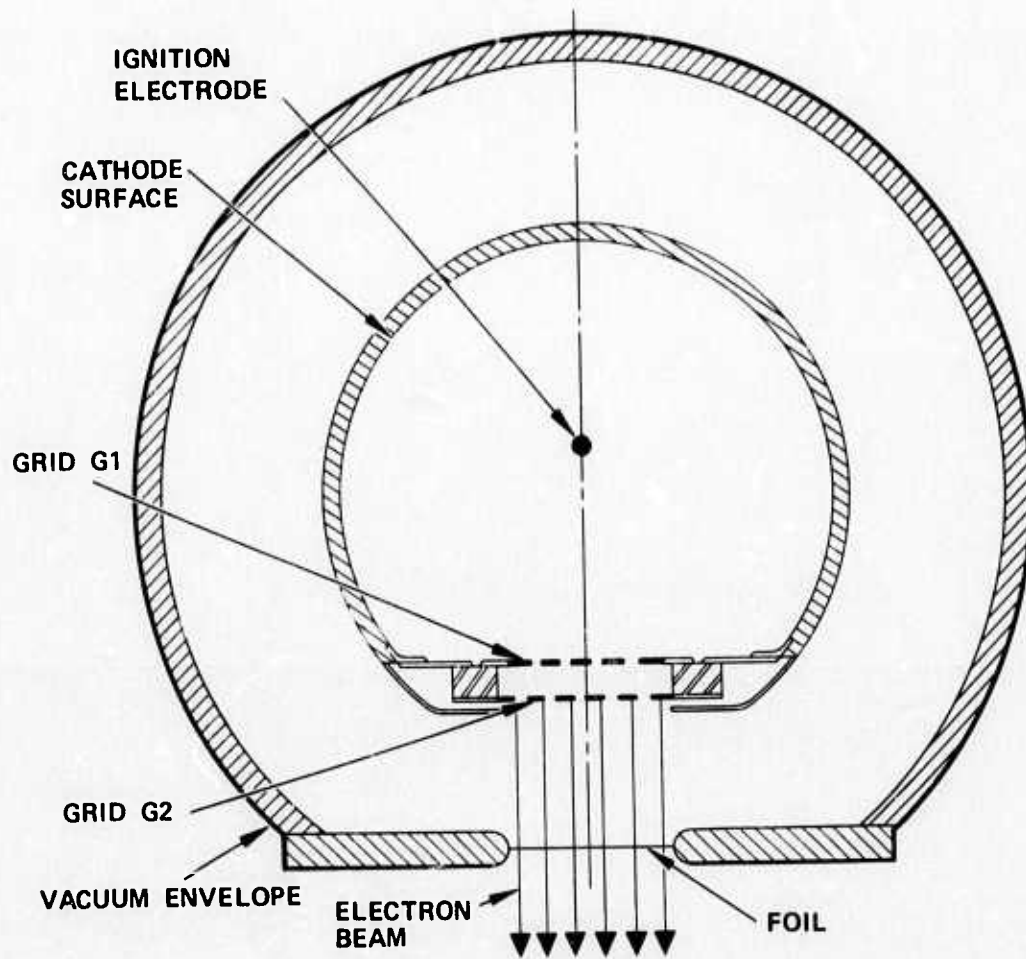

Fig. 20. Schematic cross-section of a cylindrical high voltage gun design.

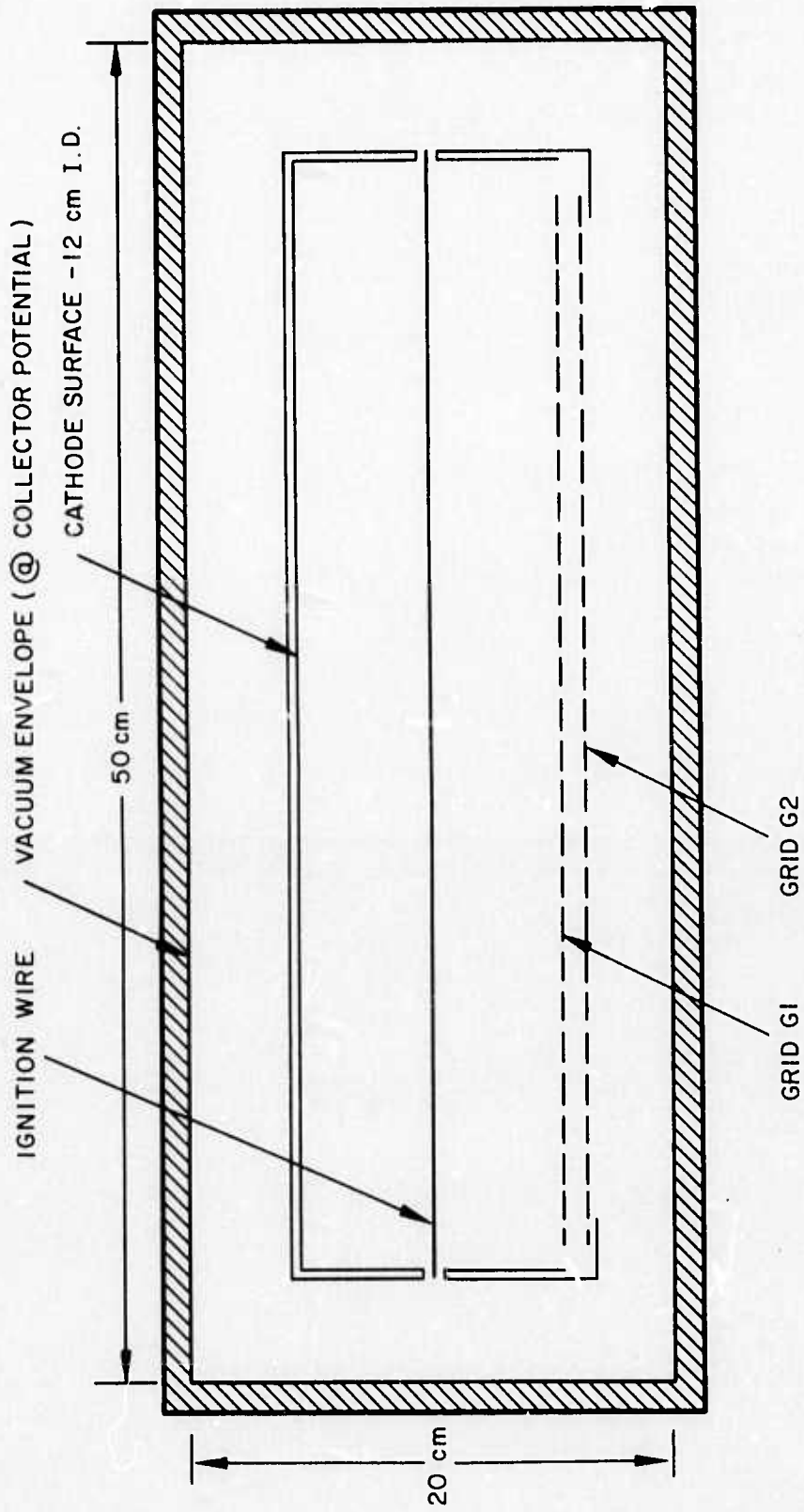

Fig. 21. Schematic diagram of 4 x 40 c m low-voltage cylindrical device.

M9689



Fig. 22. Plasma cathode assembly.

M9690

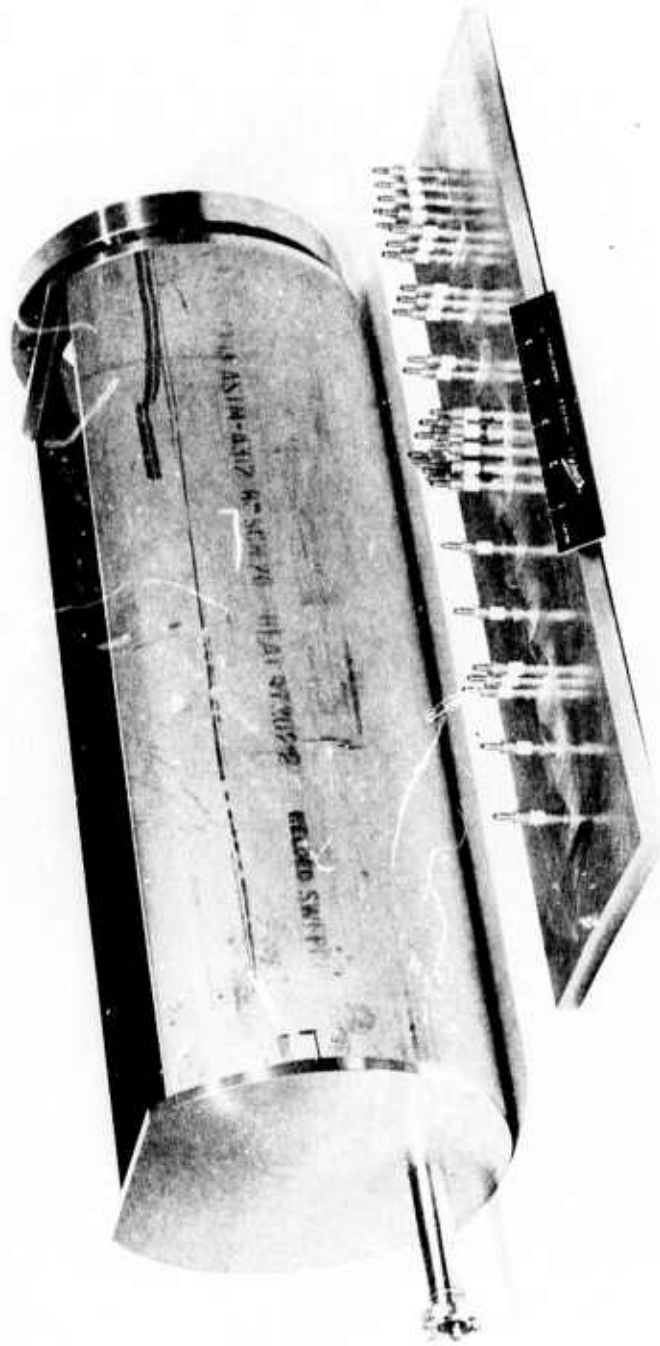

Fig. 23. Plasma cathode collector electrode showing the current density probe assembly prior to welding.

Reproduced from
best available copy.



M9750

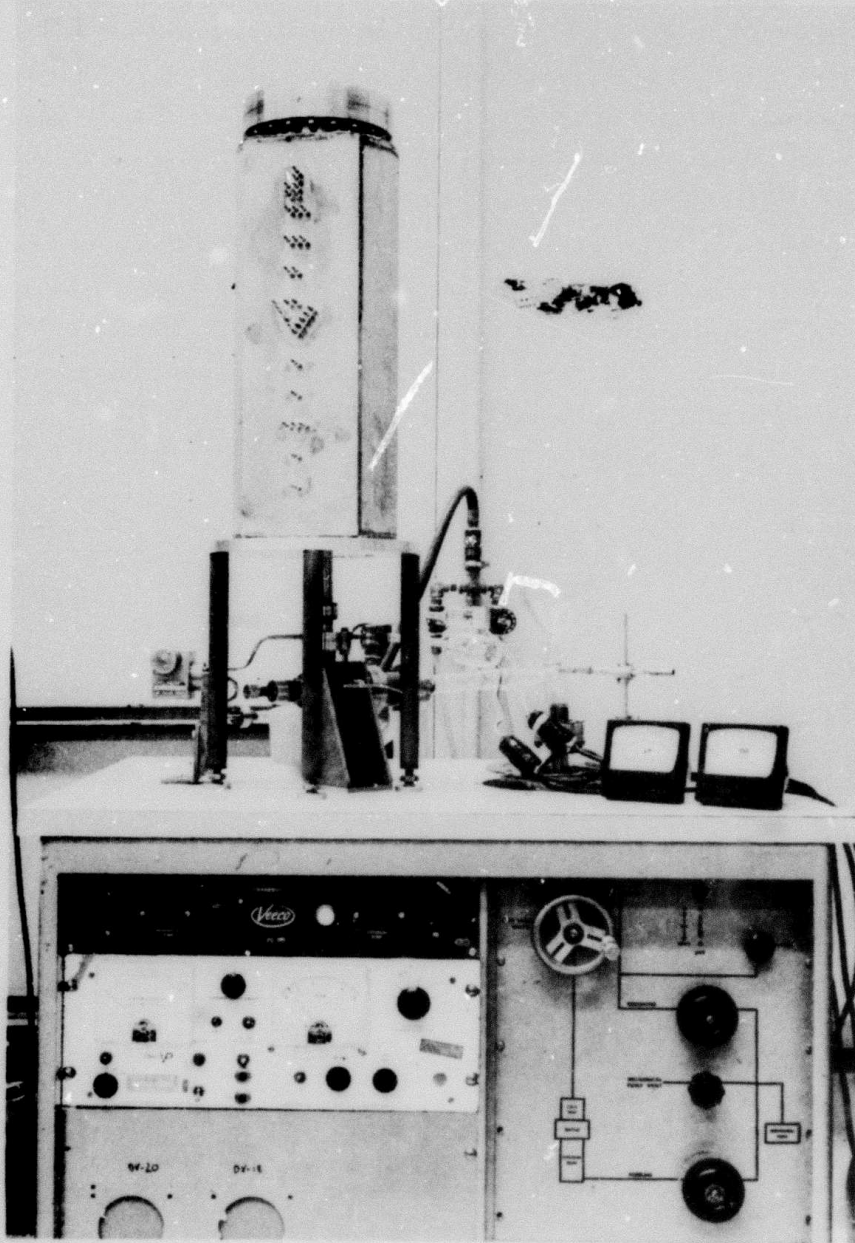

Fig. 24. Completed low-voltage plasma cathode device mounted on vacuum stations.

C. Conceptual Design of 20 x 200 cm Plasma Cathode E-Gun

Assuming the achievement of successful operation of the cylindrical plasma cathode design, it is evident that a cylindrical construction is best suited for large scale E-guns. This leads to the conceptual cross sectional design shown in Fig. 25 for a 20 x 200 cm device. Both cylinders have increased diameters in order to maintain approximately the same anode-to-cathode area ratio as used with the low voltage test vehicle. This may eventually prove to be more conservative than required, in which case the cylinder diameters could be reduced. A 4 cm spacing between the cylinders is based on the requirement of Paschen and vacuum breakdown.

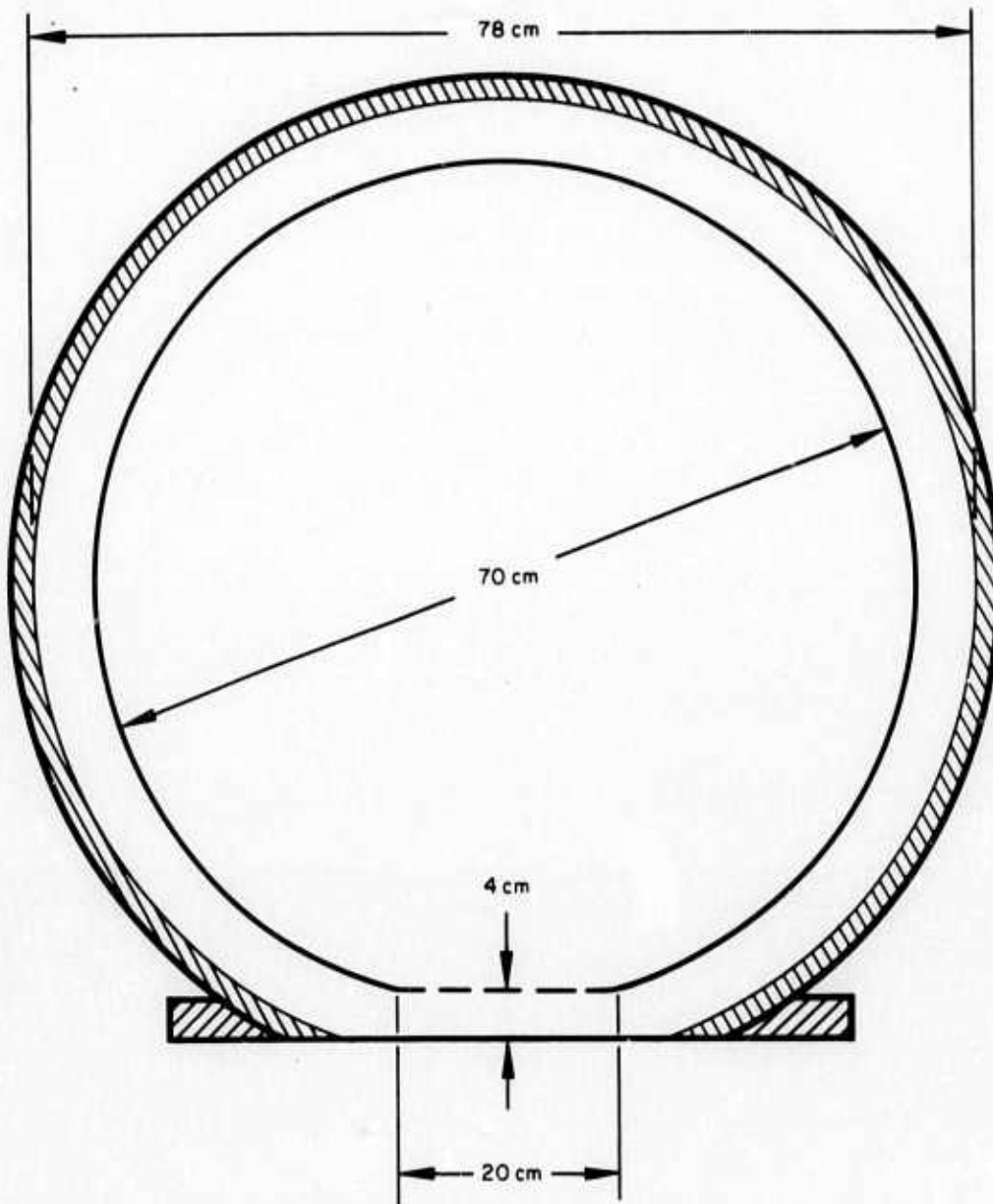

Fig. 25. Schematic cross section of the conceptual 20 x 200 cm high voltage gun design.

V. CONCLUSIONS AND FUTURE PLANS

The plasma cathode electron gun has been evaluated at beam energies and current densities suitable for both pulsed and cw operation with E-beam lasers. It has been verified that the control characteristics are essentially the same as obtained with standard vacuum triodes. The emitted beam has been found to be highly monoenergetic and to offer good current density uniformity. Preliminary life tests have indicated long-life capabilities for this device. Assembly of devices capable of producing beams of up to 160 cm^2 in cross-sectional area is near completion and these devices will soon undergo testing. The tests will provide the final verification of the efficacy of the plasma cathode concept for the production of large area, high energy E-beams. Combination of proven performance with a number of advantages over other types of high energy E-guns indicates that the plasma cathode electron gun is a very desirable device for use with high power lasers.

During the remaining six months of this program work will be completed in the following areas:

- Life testing of a small parallelepiped device
- Assembly of the 10 x 15 cm high voltage plasma cathode device
- Operation and evaluation of the 10 x 15 cm device
- Measurement of the current density distribution downstream of a foil window in the 10 x 15 cm E-gun
- Evaluation of the 4 x 40 cm cylindrical test vehicle, particularly with regard to the operating characteristics and current density distribution
- Preliminary design of 20 x 200 cm plasma cathode E-gun.

REFERENCES

1. R.K. Garnsworthy, L.E.S. Mathias, and C.H.H. Carmichael, "Atmospheric-Pressure Pulsed CO₂ Laser Utilizing Preionization by High-Energy Electrons," *Appl. Phys. Lett.* 19, 506-508 (December 15, 1971); A. Crocker, H. Foster, H.M. Lamberton, and J.H. Holiday, "A Pulsed Atmospheric-Pressure CO₂ Laser Initiated by a Cold-Cathode Glow-Discharge Electron Gun," *SERL Technical Journal* 23, 2.1 - 2.3 (February 1973); H.G. Sullivan, W. Beggs, J. Benze, and G.H. Canavan, "Cold-Cathode Electron-Beam-Sustained CO₂ and CO Lasers," *IEEE/OSA Conference on Laser Engineering and Applications*, paper No. 11.3 (May-June 1973); J.G. Trump, "Low Dose Rate High Output Electron Beam Tube," U.S. Patent No. 3,588,565 (June 28, 1971).
2. R.C. Knechtli and G.N. Mercer, "Plasma Cathode for E-Beam Lasers," *Semiannual Technical Report, Contract No. N00014-72-C-0496*, Hughes Research Laboratories, Malibu, CA (1973).
3. H. Helm, "Experimenteller Nachweis des Pendel-Effektes in einer Zylindrischen Niederdruck-Hohlkathoden-Entladung in Argon," *Zeitschrift für Naturforschung* 27a, 1812-1820 (1972).
4. G.W. McClure, "Low-Pressure Glow Discharge," *Appl. Phys. Lett.* 2, 233-234 (1963).
5. W.H. Kohl, Handbook of Materials and Techniques for Vacuum Devices, Reinhold Publishing Corp., New York, 588-596 (1967).
6. L.G. Guseva, *Zh. Tekh. Riz. Sov. Phys.-Tech. Phys.* 15, 1760 (1971); D.D. Aleksandrov, N.F. Olendzkaia, and S.V. Ptitsyn, *Zh. Tekh. Fiz. Sov. Phys.-Tech. Phys.* 3, 836 (1958); R. Quinn, *Phys. Rev.* 55, 482 (1937).
7. K.R. Spangenberg, Vacuum Tubes, McGraw-Hill, New York, 125-161 (1948).
8. P.R. Smith and R.H. Stahl, "Electron Beams for IEMP Simulation, (U)" *Final Report (Secret), Contract No. DNA001-72-C-0238*, by Gulf Radiation Technology, San Diego, CA (February 1973).