

AD-763 152

TEMPERATURE DISTRIBUTION IN IMPACTED
PLATES

Paul F. Gordon

Frankford Arsenal
Philadelphia, Pennsylvania

March 1973

DISTRIBUTED BY:

NTIS

National Technical Information Service
U. S. DEPARTMENT OF COMMERCE
5285 Port Royal Road, Springfield Va. 22151

AD 763152

MEMORANDUM REPORT M73-6-1

AD

TEMPERATURE DISTRIBUTION
IN
IMPACTED PLATES

by

PAUL F. GORDON

March 1973

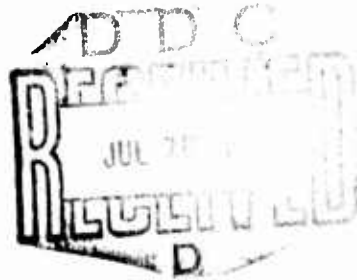

Approved for public release; distribution unlimited.

Reproduced by
NATIONAL TECHNICAL
INFORMATION SERVICE
U.S. Department of Commerce
Springfield VA 22151



DEPARTMENT OF THE ARMY
FRANKFORD ARSENAL
Philadelphia, Pa. 19137

27

DISPOSITION INSTRUCTIONS

Destroy this report when it is no longer required. Do not return it to the originator.

ACCESSION INFO	
NTIS	White Section <input checked="" type="checkbox"/>
ERIC	Buff Section <input type="checkbox"/>
UNANNOUNCED	<input type="checkbox"/>
JUSTIFICATION IN	
BY	
DISTRIBUTION AVAILABILITY CODES	
Dist.	PRIV. AND W/ SPECIAL
A	

The findings in this report are not to be construed as an official Department of the Army position unless so designated by other authorized documents.

MEMORANDUM REPORT M73-6-1

TEMPERATURE DISTRIBUTION
IN
IMPACTED PLATES

by

PAUL F. GORDON

AMCMS Code: 662604.11.232

Approved for public release; distribution unlimited.

Pitman-Dunn Laboratory
FRANKFORD ARSENAL
Philadelphia, PA 19137

March 1973

;

ABSTRACT

A simplified model is presented for the heat transfer and subsequent temperature distribution in a thin metal target being impacted by a cylindrical projectile. The mechanism for the temperature generated is based on the linear Fourier law or diffusion assumption. An example of the transient temperatures in an aluminum target impacted by a steel projectile is given. The calculated temperature profiles are not in agreement with practical experience.

It is concluded, based on this example, that this model is not appropriate for impact problems. A more refined model is suggested.

UNCLASSIFIED

Security Classification

DOCUMENT CONTROL DATA - R & D

(Security classification of title, body of abstract and indexing annotation must be entered when the overall report is classified)

1. ORIGINATING ACTIVITY (Corporate author) FRANKFORD ARSENAL Philadelphia, PA 19137		2a. REPORT SECURITY CLASSIFICATION Unclassified	
		2b. GROUP N/A	
3. REPORT TITLE TEMPERATURE DISTRIBUTION IN IMPACTED PLATES			
4. DESCRIPTIVE NOTES (Type of report and inclusive dates) Technical research memorandum			
5. AUTHOR(S) (First name, middle initial, last name) Paul F. Gordon			
6. REPORT DATE March 1973	7a. TOTAL NO. OF PAGES 2627	7b. NO. OF REFS 9	
8a. CONTRACT OR GRANT NO. AMCMS Code: 662604.11.232		8b. ORIGINATOR'S REPORT NUMBER(S) F. A. Memorandum Report M73-6-1	
8c. 		8d. OTHER REPORT NO(S) (Any other numbers that may be assigned this report)	
8d.			
10. DISTRIBUTION STATEMENT Approved for public release; distribution unlimited.			
11. SUPPLEMENTARY NOTES		12. SPONSORING MILITARY ACTIVITY USA SASA	
13. ABSTRACT <p>A simplified model is presented for the heat transfer and subsequent temperature distribution in a thin metal target being impacted by a cylindrical projectile. The mechanism for the temperature generated is based on the linear Fourier law or diffusion assumption. An example of the transient temperatures in an aluminum target impacted by a steel projectile is given. The calculated temperature profiles are not in agreement with practical experience.</p> <p>It is concluded, based on this example, that this model is not appropriate for impact problems. A more refined model is suggested.</p>			

DD Form 1473

REPLACES DD FORM 1473, 1 JAN 64, WHICH IS OBSOLETE FOR ARMY USE.

///

UNCLASSIFIED

Security Classification

UNCLASSIFIED

Security Classification

14 KEY WORDS	LINK A		LINK B		LINK C	
	ROLE	WT	ROLE	WT	ROLE	WT
Penetration Impact Energy Deposition Heat Transfer						

UNCLASSIFIED

Security Classification

TABLE OF CONTENTS

	<u>Page</u>
INTRODUCTION	1
THEORY	2
Nomenclature	2
The Ballistic Model	4
The Heat Transfer Solution	8
EXAMPLE PROBLEM	13
CONCLUSIONS AND RECOMMENDATIONS	17
REFERENCES	19
APPENDIX - Coefficients in the Asymptotic Expansion	20
DISTRIBUTION	22

List of Illustrations

Figure

1.	Projectile-Target Impact; Coordinate System	5
2.	Assumed Variation of Heat Flux with Time	8
3.	Temperature Rise as a Function of Time at the Interface: r = 0.6 in.	15
4.	Temperature Rise as a Function of Time at Two Radial Locations	16

INTRODUCTION

The objective of the Small Arms Ammunition Technology Project 1J562604A010 is the improvement of the performance of small arms munitions. Task 01 of this project deals with the ballistic effects of projectiles and part of the work performed under that task is described in this report.

This study was undertaken to investigate the resulting temperature effects when an impacting projectile transfers its kinetic energy to a target plate by the formation of a plug. The method used was to employ a simplified analytical model which would yield a one-dimensional temperature distribution in the plate. The linear Fourier Law was chosen as the tool for this problem in order to investigate whether it would yield results in reasonable agreement with experiment.

The mechanisms occurring during the impact of a projectile on a target constitute a complex phenomena. Both target and projectile are deformed, become highly stressed and, possibly, fractured. Efforts to analytically explain these phenomena occurring between striker and target rely upon obtaining accurate physical models for the observed behavior of both components during the impact process. Certainly one anticipates any reasonable model to account for the exchange of momentum, mass, and energy between the target and projectile. It is the concept of energy exchange which is of prime consideration in this report.

During the impact of a projectile on a target, it is a well-known experimental result that both the target and projectile will show a transient increase in temperature. Many factors (such as materials, impact velocity, obliquity, and failure mode) will strongly influence the temperature rise in the target and projectile. If plate failure occurs, several failure mechanisms may be interacting: spallation, shattering, petalling, or plugging. This analysis assumes that only plugging occurs.

A knowledge of the temperature distribution in the target is important for several reasons. Very localized melting and, possibly, vaporization may occur in the immediate vicinity of the impact point. For all metals of practical interest, the yield strength is reduced by

temperatures approaching the melting point.¹ Phase changes near the impact point would seem to be dependent in part on the temperature, its gradient and duration. The stress and deformation fields will also be strongly influenced by the temperature gradient. This latter factor will, of course, be important when considering failure at other than the impact point. This study of the temperature distribution in impacted plates was undertaken because of the effect of increase in temperature on ballistics performance.

An exact formulation of the problem would, in general, involve the integration of highly difficult equations describing the coupling of the stress, deformation, and energy fields in the target and projectile. The present treatment establishes an approximate solution of the linear heat transfer problem by classical techniques. An already existing simplified ballistic model is used to provide input parameters such as materials, properties, impact velocities, and geometries, into a classical heat transfer model. The final result is the transient temperature at any position in the target during and after penetration.

THEORY

Nomenclature

- a constant (Equation 7)
- A constant (Equation 23)
- b constant (Equation 7)
- c constant (Equation 7)
- C_o (approximate) hydrodynamic wave speed in target (Equation 23)
- \bar{C}_o (approximate) hydrodynamic wave speed in projectile (Equation 23)

¹L. J. Hageman et al, HELP (Vol 1), BRL CR39 (AD 726459), 1971, pg 24.

h $2\bar{\rho}_o \bar{C}_o / (\rho_o C_o + \bar{\rho}_o \bar{C}_o)$, constant (Equation 4)
J Joules' constant (778 ft-lb_f/Btu)
K thermal conductivity (Btu/hr-ft-°F)
K₀(η) modified Bessel function of second kind, order zero (Equation 15)
K₁(η) modified Bessel function of second kind, order one (Equation 15)
L length of projectile
n constant (Equation 23)
p transform parameter
P_o hydrodynamic component of pressure in target
q² p/α (Equation 15)
Q heat flux (Btu per unit area per unit time)
Q_o constant (Equation 14)
r radial coordinate
R radius of projectile
t time (measured from impact)
t_f time necessary for projectile face to traverse target thickness
T thickness of target plate
v projectile velocity
v_o initial projectile velocity or impact velocity
V(r, t) difference between actual and ambient temperature (°F)
W work (ft-lb_f)
Y_o yield strength of plate
Z axial location of projectile-target interface
Z_r $ThV_o / (C_o + hV_o/2)$
α thermal diffusivity (ft²/hr)
ρ_o mass density of plate (lb_f-sec²/ft⁴)
 $\bar{\rho}_o$ mass density of projectile (lb_f-sec²/ft⁴)
~ denotes the Laplace transform of a variable

The Ballistic Model

During the normal impact of a cylindrical projectile on a flat thin plate, one possible mode of target failure is the shearing out of a plug. During this process, the initial kinetic energy of the projectile is partially absorbed by the target in the form of deformation, increased internal energy, and heat. Heyda² has presented an approximate model for the residual velocity and minimum perforation velocity of cylindrical flat nosed projectiles impacting relatively thin plates. Previous more approximate models³ do not present specific expressions for the forces acting on the target during deformation; the Heyda model presents these required expressions. It is the purpose of this analysis to present a mathematical model relating the mechanical work done by certain of those forces and the heating in the target.

Following Figure 1 and the notation of reference 2, one has a projectile of constant length L , radius R , density $\bar{\rho}_0$, impacting a plate of thickness T , density ρ_0 , and yield strength Y_0 . In Heyda's model it is assumed that two components of pressure resist the motion of the projectile through the plate.

The first component, of very high intensity, is of magnitude P_0 . Because of the fact that this pressure may create a thin fluid zone at the projectile nose target interface, this component is calculated according to the hydrodynamic theory of impact. This calculation implies that material strength properties (i. e., yield strength, hardness, etc), as well as elastic or plastic flow, are ignored.

The second component of pressure is the resistance of the plug at its periphery to shear. It is only this component, one assumes here, that performs mechanical work which may be converted to heat energy.

The shear stress at the plug plate periphery is assumed to be constant and to obey the Tresca criterion, thus being of magnitude $Y_0/2$ at all times during penetration. Therefore, the total resisting shear force has a value, according to Heyda,² of

²J. F. Heyda, "Ballistic Impact into Metal Plates," General Electric Co. (SSL) Technical Memorandum Report TM 70-002, pp 1-10, February 1970.

³R. F. Recht and T. W. Ipson, "Ballistic Perforation Dynamics," J Appl Mech, Trans of ASME, pp 384-389, September 1963.

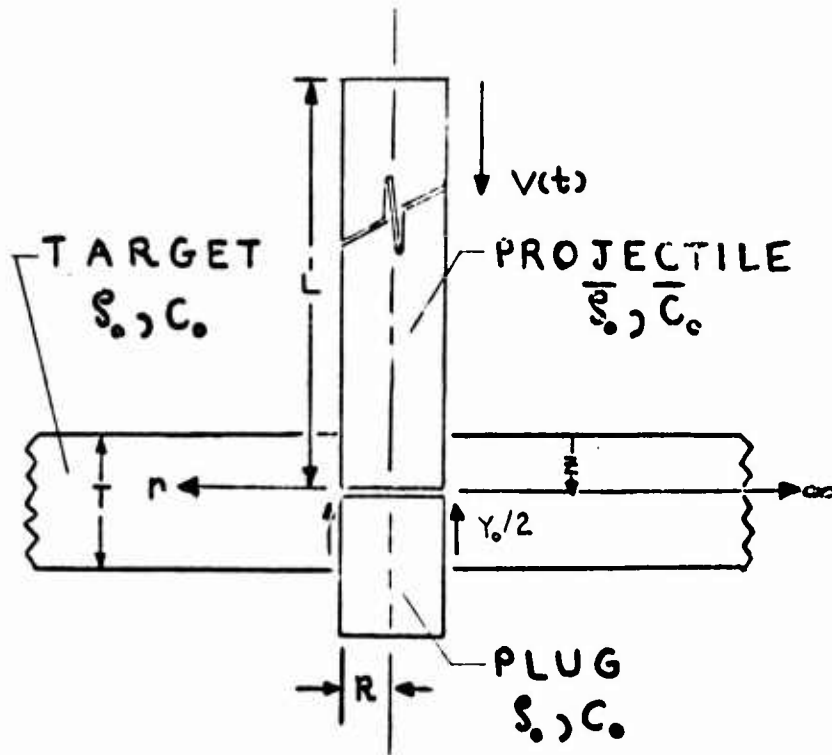

Figure 1. Projectile-Target Impact; Coordinate System

$$\left(\frac{Y_0}{2}\right) (2\pi R) (T - Z) \quad (1)$$

where Z is the projectile target interface location or, equivalently, the approximate length of the plug forward of the target;

T is the target thickness; and

Y_0 is the yield strength in tension.

The total approximate mechanical shear work done as the projectile moves from $Z = 0$ to $Z = T$ is

$$W = \int_0^T Y_0 \pi R (T - Z) dZ = \frac{Y_0 \pi R T^2}{2} \quad (2)$$

In what follows it will be assumed that heat is transferred only in the radial direction (the heat transferred through the thickness being negligible) and that the velocity of the plug is approximately that of

the projectile target interface. Thus, if one divides the right hand side of Equation 2 by the product of the area available for heat transfer, $(2\pi RT)$, the time interval, t_f , required for the interface to transverse the target thickness, and Joules' constant, one has

$$Q = \frac{Y_0 T}{4Jt_f} \quad (3)$$

which is an approximate expression for the heat per unit area per unit time, or heat flux, delivered to the target at the location $r = R$.

A value for t_f may be found as follows. If the projectile at any time t is treated as a rigid body then, from Newton's law, a force balance and integration leads to an expression for the projectile velocity $V(t)$. Since V is a function of t , and the location of the interface Z is also a function of t , then the chain rule of calculus provides a functional relation between Z and t . In accordance with Heyda,² this relation is

$$\frac{dZ}{dt} = \frac{h}{2} V(Z) \quad (4)$$

where $h/2$ is the (approximate) constant ratio between the initial interface speed and the impact velocity, V_0 .

Integrating Equation 4, one easily shows that

$$t_f = \int_0^{t_f} dt = \frac{2}{h} \int_0^T \frac{dZ}{v(Z)} \quad (5)$$

In performing the integration in Equation 5, utilization is made of the following expressions for the velocity $V(Z)$

²J. F. Heyda, "Ballistic Impact into Metal Plates," General Electric Co. (SSL) Technical Memorandum Report TM 70-002, pp 1-10, February 1970.

$$v_o^2 = \left(\frac{4 P_o}{\bar{\rho}_o Lh} + \frac{4 Y_o T}{\bar{\rho}_o R Lh} \right) Z + \frac{2 Y_o}{\bar{\rho}_o R Lh} Z^2, \quad 0 \leq Z < Z_r$$

$$v_o^2 = \frac{4 P_o Z_r}{\bar{\rho}_o Lh} - \left(\frac{4 Y_o T}{\bar{\rho}_o R Lh} \right) Z + \frac{2 Y_o}{\bar{\rho}_o R Lh} Z^2, \quad Z_r \leq Z \leq T$$

which follow easily from reference 2 (pp 6 and 7). Here P_o is the (approximate) amplitude of the hydrodynamic shock wave which is assumed to vanish for $t > t_r$. The quantities Z_r and t_r are, respectively, the location and time at which the initial hydrodynamic component of pressure P_o is attenuated (to zero) by a rarefaction wave returning from the free plate surface. Carrying out the integration of Equation 5, with $V(Z)$ being given by Equation 6, leads to

$$t_f = \frac{2}{hc^{1/2}} \left\{ \ln \left[-b + c Z_r + c^{1/2} (a - 2b Z_r + c Z_r^2)^{1/2} \right] + \right. \\ \left. - \ln \left[-b + (ca)^{1/2} \right] + \ln \left[-b' + c T + c^{1/2} (a' - 2b' T + c T^2)^{1/2} \right] + \right. \\ \left. - \ln \left[-b' + c Z_r + c^{1/2} (a' - 2b' Z_r + c Z_r^2)^{1/2} \right] \right\} \quad (7. a)$$

where

$$a = v_o^2$$

$$a' = a - 4 P_o Z_r / \bar{\rho}_o Lh$$

$$b = 2 [P_o + Y_o T / R] / \bar{\rho}_o Lh$$

$$b' = 2 Y_o T / \bar{\rho}_o Lh R$$

$$c = b' / T$$

(7. b)

are introduced for convenience.

²J. F. Heyda, "Ballistic Impact into Metal Plates," General Electric Co. (SSL) Technical Memorandum Report TM 70-002, pp 1-10, February 1970.

The calculation of t_f above allows the heat flux given by Equation 3 to be determined. It will be assumed that the total heat per unit area is deposited at $r = R$ in the time interval t_f . Thus, Q will be assumed to have the simple form depicted in Figure 2. Other estimates for the time required for plate failure, based on arguments other than those presented here, are given in reference 2, pp 13-14.

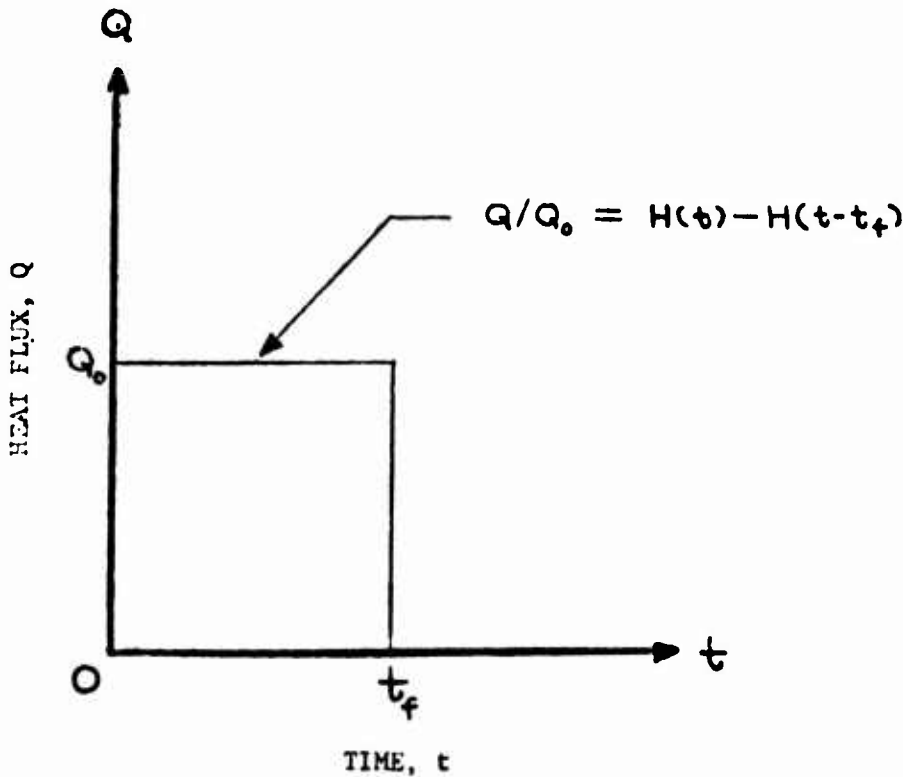

Figure 2. Assumed Variation of Heat Flux with Time

The Heat Transfer Solution

Assuming the heat generated varies only with the radial coordinate and time, and the linear Fourier law of conduction as valid, one has the equation of heat transfer in the polar cylindrical coordinate system of Figure 1 for a target of inner radius R and infinite radial extent as

²J. F. Heyda, "Ballistic Impact into Metal Plates," General Electric Co. (SSL) Technical Memorandum Report TM 70-002, pp 1-10, February 1970.

$$\frac{\partial^2 V}{\partial r^2} + \frac{1}{r} \frac{\partial V}{\partial r} - \frac{1}{\alpha} \frac{\partial V}{\partial t} = 0 \quad (8)$$

$$V = V(r, t); \quad r > R, \quad t > 0$$

subject to the initial condition of constant ambient temperature

$$V(r, 0) = 0 \quad (9)$$

and the boundary conditions

$$\lim_{r \rightarrow \infty} V(r, t) = 0; \quad t > 0 \quad (10)$$

$$\frac{\partial V}{\partial r} (R, t) = \frac{1}{K} Q(t); \quad t > 0 \quad (11)$$

Here V is the temperature above ambient, α is the thermal diffusivity, and K is the thermal conductivity.

The initial condition, Equation 9, specifies the initial temperature throughout the plate to be ambient. The boundary condition, Equation 10, requires the temperature to approach ambient as the radius approaches infinity for all values of time. The condition, Equation 11, is a specification that the heat flux, Q , is applied at the sheared surface, $r = R$.

The method of solution closely parallels that of Carslaw and Jaeger,⁴ who, using the Laplace transform technique with $Q(t)$ given by

$$Q(t) = Q_0 H(t) \quad (12)$$

⁴H. Carslaw and J. Jaeger, Conduction of Heat in Solids, 2d ed, pp 338-340; Oxford, England: Oxford University Press; 1959.

where

$$H(t) = \begin{cases} 0 & t < 0 \\ 1 & t \geq 0 \end{cases} \quad (13)$$

obtained a two-term asymptotic solution valid for small time for the system Equation 8 through Equation 11. Omitting the intermediate details, one takes the transform of the above system with the $Q(t)$ of Equation 13 replaced by that of Figure 2, i. e.,

$$Q(t) = Q_0 \left[H(t) - H(t - t_f) \right] \quad (14)$$

to obtain the solution for the transformed temperature, $\tilde{V}(r, p)$

$$\tilde{V}(r, p) = \frac{Q_0}{K} \frac{(1 - e^{-pt_f}) K_0(q, r)}{pqK_1(q, R)} \quad (15)$$

where p is the transform parameter, $q^2 = p/d$; $K_0(\eta)$ and $K_1(\eta)$ are modified Bessel functions of the second kind of zeroth and first order, respectively. (One notes that Equation 15 is identical to Equation 16 (p 338 of reference 4) if t_f is allowed to approach infinity.)

It is necessary to invert Equation 15 to obtain $V(r, t)$. The formal integral solution, as presented in reference 4, does not lend itself easily to simple numerical evaluation. Instead, an asymptotic expansion solution is presented. From the general theory of reference 4 we expand the Bessel functions of Equation 15 in asymptotic series of the form

$$K_n(\eta) = \left(\frac{\eta}{2\eta} \right)^{1/2} e^{-\eta} \left[1 + \frac{4n^2 - 1}{1! 8\eta} + \frac{(4n^2 - 1)(4n^2 - 3^2)}{2! (8\eta)^2} + \dots \right] ;$$

$$n = 0, 1, 2, \dots \quad (16)$$

⁴H. Carslaw and J. Jaeger, Conduction of Heat in Solids, 2d ed, pp 338-340; Oxford, England: Oxford University Press; 1959.

Carrying the expansions in general form, retaining five terms, and inverting, the final result,

$$V(r, t) = V_1(r, t) + V_2(r, t) \quad (17)$$

where

$$V_1(r, t) \cong \frac{2Q_0}{K} \left(\frac{\alpha R t}{r} \right)^{1/2} \sum_{j=0}^4 (2)^j (\alpha t)^{j/2} C_j \times \left[i^{(j+1)} \operatorname{erfc} \left(\frac{r - R}{2(\alpha t)^{1/2}} \right) \right] \quad (18)$$

$$V_2(r, t) \cong - \frac{2Q_0}{K} H(t-t_f) \left(\frac{\alpha R [t-t_f]}{r} \right)^{1/2} \sum_{j=0}^4 (2)^j (\alpha [t-t_f])^{j/2} \times C_j \left[i^{(j+1)} \operatorname{erfc} \left(\frac{r - R}{2 \langle \alpha (t-t_f) \rangle^{1/2}} \right) \right] \quad (19)$$

In Equations 18 and 19, the C_j are given in the Appendix and the n^{th} order repeated error function is defined as

$$i^{(n)} \operatorname{erfc} \eta \equiv \int_{\eta}^{\infty} i^{(n-1)} \operatorname{erfc} \xi \, d\xi; \quad n = 1, 2, \dots \quad (20)$$

and

$$\operatorname{erfc} \eta \equiv 1 - \frac{2}{\sqrt{\pi}} \int_{\eta}^{\infty} e^{-\xi^2} \, d\xi \quad (21)$$

The expansion given above is somewhat more accurate than that given in reference 4. One notes that five terms appear in the present expansions as opposed to two in reference 4. One also sees that the first two terms in Equation 18 are exactly those of reference 4, lending credence to the present procedures.

In evaluating the error functions appearing in Equations 18 and 19, provision is made to ensure the highest possible numerical accuracy. By numerical experimentation it was found that the standard use of the recursion formula⁵

$$i^{(n)} \operatorname{erfc} \eta = -\frac{\eta}{n} i^{(n-1)} \operatorname{erfc} \eta + \frac{1}{2n} i^{(n-2)} \operatorname{erfc} \eta \quad (22)$$

in computing the n^{th} order error function in terms of the $(n-1)$ and $(n-2)$ order functions may be inaccurate if the argument, η , is small. It was concluded that for $\eta \geq 0.4$, $0 \leq \eta \leq 4$; this inaccuracy is small and the application of Equation 22 is acceptable. However, when $\eta < 0.4$, a technique due to Gautschi⁶ is employed. In this technique a certain class of difference equations whose solutions are the repeated error functions, are numerically solved. Although extremely accurate, the amount of computation is large and, hence, usage is restricted to $\eta < 0.4$. All computations are performed to 15 significant figures.

The use of asymptotic expansions is generally acceptable for small values of time. In a related problem, Carslaw and Jaeger⁴ recommend that $\alpha t/R^2$ be less than 0.02 and r/R be not small. One finds, however, that for $r = R$, the present expansion for Equation 18 introduces negligible error for times up to about $\alpha t/R^2 = 0.7$. Asymptotic expansions depart from the exact solution in an unpredictable manner after their range of validity is exceeded. In practice, this range is found by erratic or unexpected behavior in the solution. In the present study this was estimated to be about $\alpha t/R^2 = 0.7$. For times beyond this value, the solution is disregarded.

⁴H. Carslaw and J. Jaeger, Conduction of Heat in Solids, 2d ed, pp 338-340; Oxford, England: Oxford University Press; 1959.

⁵R. Abramowitz (ed), Handbook of Mathematical Functions, U. S. Dept of Commerce, Bureau of Standards, pp 299, June 1964.

⁶W. Gautschi, "Recursive Computation of the Repeated Integrals of the Error Function," Mathematics and Computation (M. T. A. C), Vol 15, pp 227-232, 1961.

The heat conduction equation (Equation 8) has been postulated on the basis of no heat transfer in the Z or target thickness direction. This is not completely realistic since, in practice, the target surfaces ($Z = 0$ and $Z = T$) are not insulated and may conduct heat to the surrounding environment. The amount of error incurred by this assumption is thought to be small. Ingersoll et al⁷ and Boley and Weiner⁸ present laborious theories which might allow the error to be estimated.

EXAMPLE PROBLEM

As a numerical example, the impact at 4000 fps of a steel projectile on an aluminum target was investigated. The target was assumed to be 1/4 inch thick, have a yield strength of 75×10^3 psi, with a density of $5.39 \text{ sec}^2\text{-lb}_f/\text{ft}^4$. The projectile has a length of 3 inches, a radius of 0.6 inch, and a density of $15.29 \text{ sec}^2\text{-lb}_f/\text{ft}^4$. In order to estimate the hydrodynamic sound speeds in the target and projectile, it was assumed that the increase in density in both target and projectile, due to shock compression, is small. Then the approximate expressions of Huang and Davids⁹ are applicable. These are

$$C_o^2 = \frac{nA}{\rho_o} ; \quad \bar{C}^2 = \frac{nA}{\bar{\rho}_o} \quad (23)$$

where $n = 3.55$, $A = 232 \times 10^3$ bar for aluminum and $n = 3.53$, $A = 480 \times 10^3$ bar for steel.

(The assumptions concerning the approximations embodied in Equation 23 are presented in Huang and Davids (pp 39-50).⁹ In the case of steel, whose shock wave structure varies with the pressure,

⁷L. R. Ingersoll et al, "Theory of Earth Heat Exchanges for the Heat Pump," Heating, Piping and Air Conditioning Journal, pp 115-118, May 1950.

⁸B. Boley and J. H. Weiner, Theory of Thermal Stresses, pp 160-163; New York: John Wiley; 1960.

⁹Y. Huang and N. Davids, "Shock Dynamics of Hypervelocity Impact of Metals," J Franklin Inst, pp 39-50, 1963.

n and A are not truly constant but depend upon the pressure, P_0 . However, the error incurred in calculating \bar{T}_0 by using the values given above will not exceed 14 percent.)

In addition, the diffusivity, α , for aluminum was assumed to be $2.4 \text{ ft}^2/\text{hr}$, and the conductivity to be $80 \text{ Btu/hr-ft-}^\circ\text{F}$; these values are taken as representative of aluminum alloys. The pressure, P_0 , is calculated as shown in Reference 2 (Equation 5, p 4); the calculation of other constants in the ballistic model follows Heyda.²

The temperature distributions above ambient as a function of time at several locations are shown in Figures 3 and 4. The curve of Figure 3, which corresponds to the location $r = R$ (0.6 in.) or the projectile periphery, indicates a temperature rise of about $34 \times 10^3 \text{ }^\circ\text{F}$ within $7.6 \text{ } \mu\text{sec}$ after impact. This decreases rapidly until at about one second it is sensibly back to 33° F above ambient.

Figure 4, which corresponds to the locations of $r = 0.058 \text{ ft}$ (0.70 in.) and 0.067 ft (0.80 in.) indicates maximum temperatures of 110° and 50° F above ambient at about 0.05 and 0.2 second, respectively. As in the case of the interface location, at one second both these temperature profiles are tending to ambient, about 30° F above.

(Actually, in the course of computation, none of these temperature profiles reaches ambient. As the point in time in which the asymptotic expansions are no longer valid, at 2.5 second for the radii calculated, the temperatures have decreased to between 18° and 21° F above.) At a radial location of 1.2 inches, the temperature rise is negligible at the end of 0.1 second. The heat flux, Q_0 , has a numerical value of $4.75 \times 10^8 \text{ Btu/ft}^2\text{-sec}$, and t_f is $7.6 \text{ } \mu\text{sec}$.

²J. F. Heyda, "Ballistic Impact into Metal Plates," General Electric Co. (SSL) Technical Memorandum Report TM 70-002, pp 1-10, February 1970.

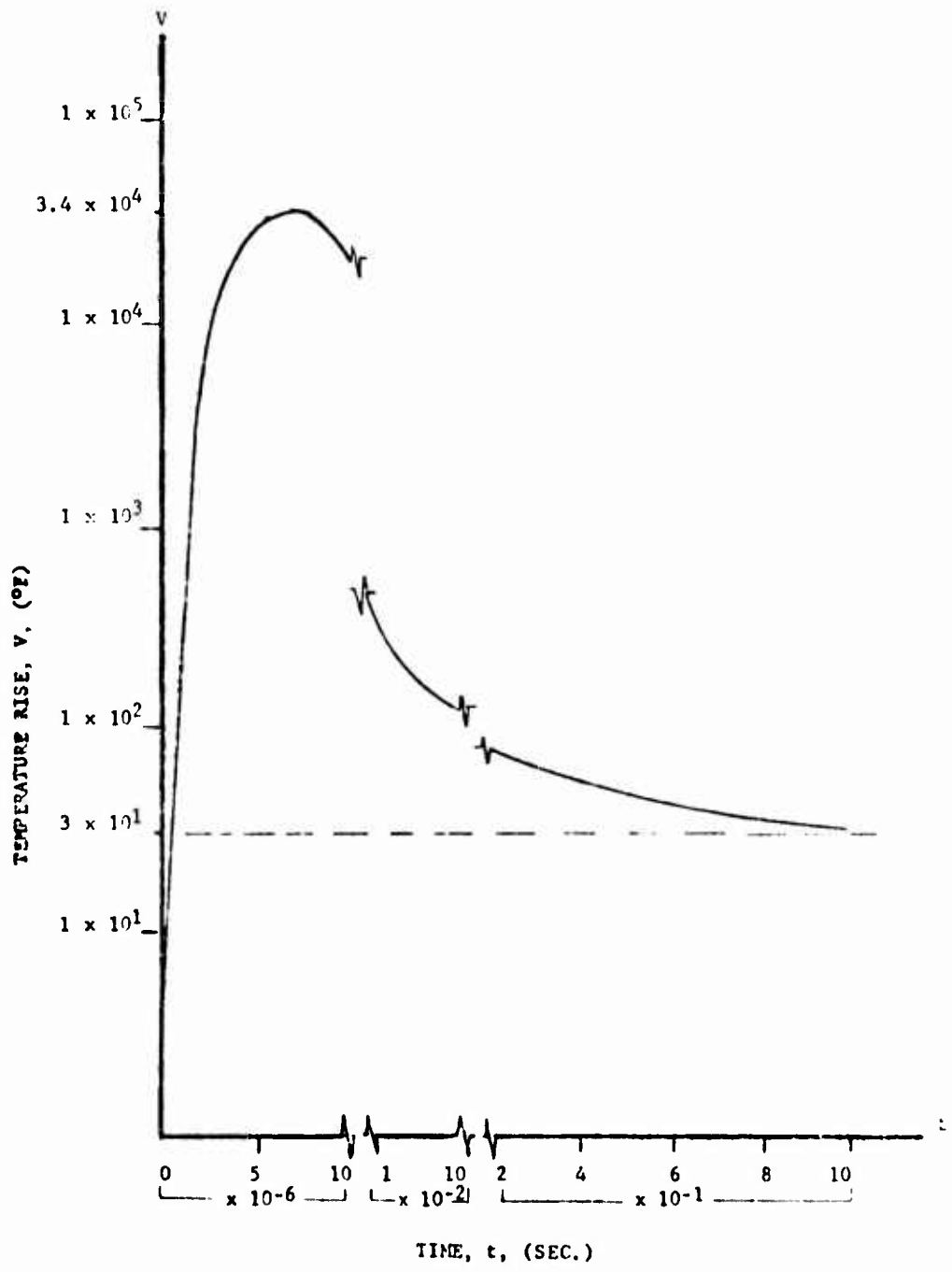

Figure 3. Temperature Rise as a Function of Time at the Interface: $r = 0.6$ in.

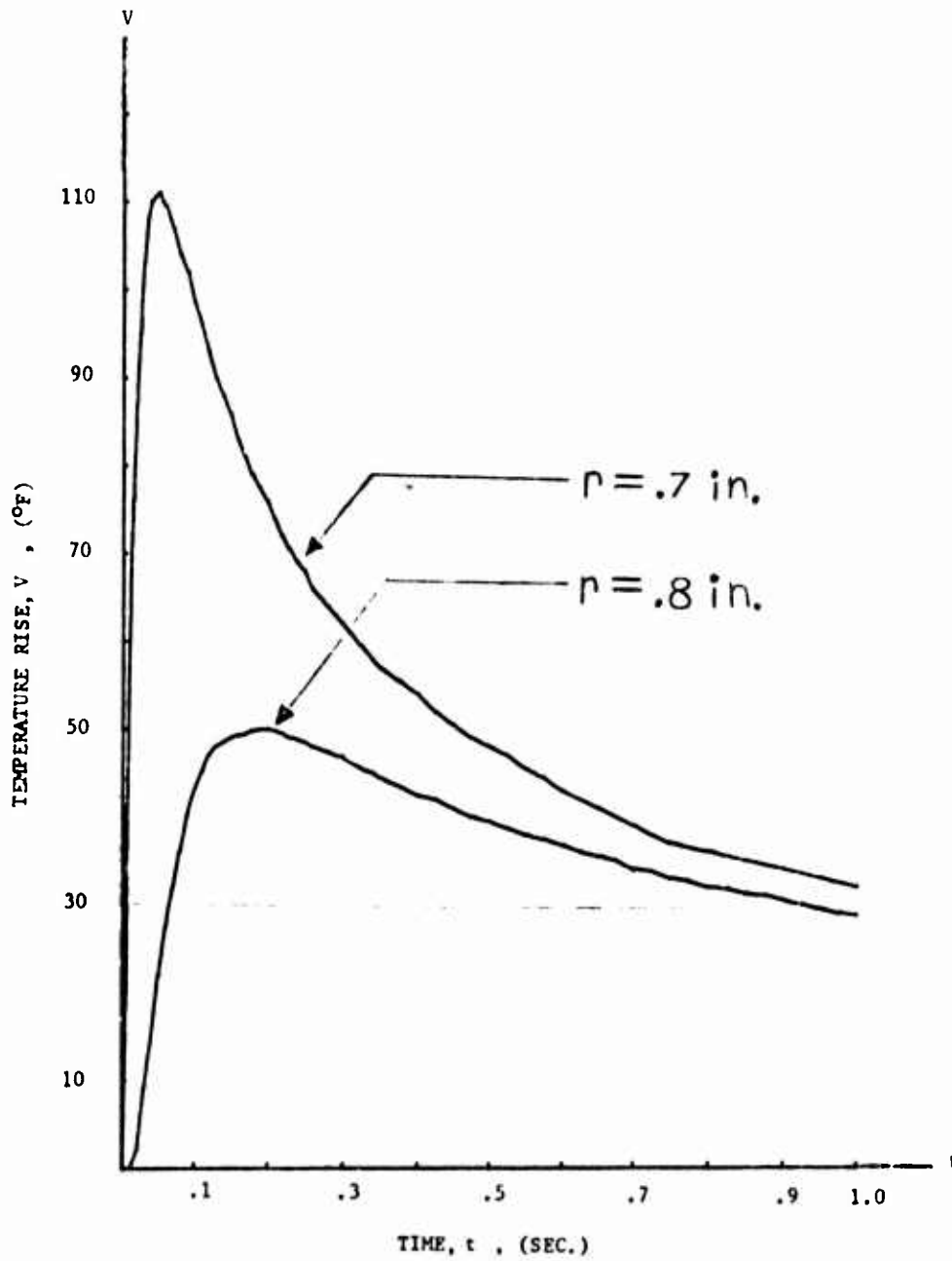

Figure 4. Temperature Rise as a Function of Time at Two Radial Locations

CONCLUSIONS AND RECOMMENDATIONS

The preceding numerical example presents four points:

1. The maximum temperature at the interface is far in excess of the melting point of aluminum;
2. The maximum temperature rises at 0.1 and 0.2 inch from the interface are lower than is thought to be true from practical experience;
3. The time required for the temperature to approach ambient (several seconds) seems too short; and
4. Essentially no temperature rise occurs within 0.1 second at a location 0.6 inch from the interface.

It is concluded that, based on this example, the mechanism of energy transfer postulated is not valid for the current problem.

The explanation for the lack of agreement with practical experience is found by noting that the present model assumes that: all available shearing work done is converted to thermal energy in the target; no account is made for the energy required for either target or projectile deformation; and the classical Fourier heat transfer mechanism is applicable.

It is seen (viz, Equations 18 and 19) that the magnitude of the temperature is in direct proportion to the value of Q_0 as determined by the present ballistic model. Q_0 , in turn, decreases with an increased value of t_f . If a more refined ballistic model were to substantially increase the value of t_f , the maximum interface temperature would tend to decline and the time required to approach ambient would tend to increase. (The aforementioned values of "time-of-plate-failure" of reference 2 might provide some guidance in this respect.)

It is suggested that a new model, incorporating these latter features (neglected in the present work), be constructed. The equations of motion, or equilibrium equations, together with the continuity or mass conservation relation, could be coupled with the conservation of energy equation and solved simultaneously. This formulation is very attractive from the points of view that

²J. F. Heyda, "Ballistic Impact into Metal Plates," General Electric Co. (SSL) Technical Memorandum Report TM 70-002, pp 1-10, February 1970.

1. The energy to deform the target is considered;
2. The increase in internal energy is accounted for; and
3. The temperature will tend to propagate outward from the impact point along with the transverse and radial waves of deformation.

REFERENCES

1. L. J. Hageman et al, HELP (Vol 1), BRL CR39 (AD 726459), 1971, pg 24.
2. J. F. Heyda, "Ballistic Impact into Metal Plates," General Electric Co. (SSL) Technical Memorandum Report TM 70-002, pp 1-10, Feb 1970.
3. R. F. Recht and T. W. Ipson, "Ballistic Perforation Dynamics," J Appl Mech, Trans of ASME, pp 384-389, September 1963.
4. H. Carslaw and J. Jaeger, Conduction of Heat in Solids, 2d ed, pp 338-340; Oxford, England: Oxford University Press; 1959.
5. R. Abromowitz (ed), Handbook of Mathematical Functions, U.S. Dept of Commerce, Bureau of Standards, pp 299, June 1964.
6. W. Gautschi, "Recursive Computation of the Repeated Integrals of the Error Function," Mathematics and Computation (M. T. A. C.), Vol 15, pp 227-232, 1961.
7. L. R. Ingersoll et al, "Theory of Earth Heat Exchanges for the Heat Pump," Heating, Piping and Air Conditioning Journal, pp 115-118, May 1950.
8. B. Boley and J. H. Weiner, Theory of Thermal Stresses, pp 160-163; New York: John Wiley; 1960.
9. Y. Huang and N. Davids, "Shock Dynamics of Hypervelocity Impact of Metals," J. Franklin Inst, pp 39-50, 1963.

APPENDIX

Coefficients in the Asymptotic Expansion

Using the expansion (Equation 16), Equation 15 may be written as

$$\tilde{V}(r, p) = \frac{Q_0 (1 - e^{-pt_f})}{Kpq} \left(\frac{R}{r} \right) e^{-q(r-R)} \frac{\left[1 + \sum_{i=1}^{\infty} d_i / (q)^i \right]}{\left[1 + \sum_{i=1}^{\infty} b_i / (q)^i \right]} \quad (A1)$$

where the d_i and b_i are deduced from Equation 16. By representing the division of the two series of Equation A1 by

$$\frac{1 + \sum_{i=1}^{\infty} d_i / (q)^i}{1 + \sum_{i=1}^{\infty} b_i / (q)^i} = 1 + \sum_{i=1}^{\infty} C_i / (q)^i \quad (A2)$$

where the C_i are to be determined, it follows by induction that

$$\begin{aligned} C_0 &= 1 \\ C_n &= d_n - b_n - \sum_{j=1}^{n-1} C_j b_{n-j}; \quad n = 1, 2, 3, \dots \end{aligned} \quad (A3)$$

The first five terms of the series in Equation A3 are

$$\begin{aligned} C_0 &= 1 \\ C_1 &= - \frac{3}{(8)^1} \left[\frac{1}{3r} + \frac{1}{R} \right] \end{aligned}$$

$$C_2 = + \frac{3}{(8)^2} \left[\frac{3}{2r^2} + \frac{1}{Rr} + \frac{11}{2R^2} \right]$$

$$C_3 = - \frac{3}{(8)^3} \left[\frac{25}{2r^3} + \frac{(8)^3}{2R^3} + \frac{11}{2R^2r} + \frac{9}{2Rr^2} \right]$$

$$C_4 = + \frac{3}{(8)^4} \left[\frac{1225}{8r^4} + \frac{3321}{8R^4} + \frac{(8)^3}{2R^3r} + \frac{75}{2Rr^3} + \frac{99}{4R^2r^2} \right]$$

Substitution of Equation A2 into Equation A1 and the use of standard inversion tables yields Equations 17 through 19.