

AD-755 456

PRODUCTION OF ADVANCED X-RAY SOURCES USING
INTENSE RELATIVISTIC BEAMS. VOLUME 2.
SNARK UPGRADE PROGRAM

P. Champney, et al

Physics International Company

Prepared for:

Defense Nuclear Agency

November 1972

DISTRIBUTED BY:

NTIS

National Technical Information Service
U. S. DEPARTMENT OF COMMERCE
5285 Port Royal Road, Springfield Va. 22151

AD 755456

DNA 2979F-2
November 1972
PIFR-296

PRODUCTION OF ADVANCED X-RAY SOURCES
USING INTENSE RELATIVISTIC BEAMS (U)

VOLUME 2

SNARK UPGRADE PROGRAM

Final Report

P. Champney, G. Hatch, and I. Smith

Headquarters

Defense Nuclear Agency
Washington, D. C. 20305

DDC
RECEIVED
FEB 15 1973
C

Approved for public release;
distribution unlimited

PHYSICS INTERNATIONAL COMPANY
2700 MERCED STREET • SAN LEANDRO, CALIF. 94577 • PHONE 357-4610 (415) • TWX 891-9669 (415)



Reproduced by
NATIONAL TECHNICAL
INFORMATION SERVICE
U.S. Department of Commerce
701 23 20151

ACCESSION for		
NTIS	Write Section	<input checked="" type="checkbox"/>
DIC	Ref Section	<input type="checkbox"/>
UNAN ORDERED		<input type="checkbox"/>
JUSTIFICATION.....		
BY		
DISTRIBUTION/AVAILABILITY CODES		
Dis.	AVAIL. and/or SPECIAL	
A		

Destroy this report when it is no longer needed. Do not return to sender.

DOCUMENT CONTROL DATA - R&D

(Security classification of title, body of abstract and indexing annotation must be entered when the overall report is classified)

1 ORIGINATING ACTIVITY (Corporate author) Physics International Company 2700 Merced Street San Leandro, California 94577		2a. REPORT SECURITY CLASSIFICATION Unclassified	
		2b GROUP NA	
3 REPORT TITLE PRODUCTION OF ADVANCED X-RAY SOURCES USING INTENSE RELATIVISTIC BEAMS; VOLUME 2, SNARK UPGRADE PROGRAM			
4 DESCRIPTIVE NOTES (Type of report and inclusive dates) Final covering period from January 1970 through June 1971			
5 AUTHOR(S) (Last name, first name, initial) Champney, P., Hatch, G., and Smith, I.			
6 REPORT DATE November 1972		7a. TOTAL NO. OF PAGES 6069	7b. NO OF REFS 0
8a. CONTRACT OR GRANT NO. DASA01-71-C-0052		8a. ORIGINATOR'S REPORT NUMBER(S) PIFR-296, Volume 2	
b PROJECT NO. NWER Code L		8b. OTHER REPORT NO(S) (Any other numbers that may be assigned this report) DNA 2979F-2	
c Task & Subtask Code A013			
d Work Unit Code 17			
10 AVAILABILITY/LIMITATION NOTICES Approved for public release; distribution unlimited			
11. SUPPLEMENTARY NOTES		12. SPONSORING MILITARY ACTIVITY Director Defense Nuclear Agency Washington, D. C. 20305	
13 ABSTRACT <p>This report describes a program to upgrade the SNARK machine built under DASA contract 01-70-C-0063. In the SNARK program, a machine was built capable of delivering a 50-kJ electron beam to an X-ray target in 50 nsec. Triggered high pressure gas switches were developed to switch the Mylar striplines. The machine delivers the energy to an accelerating tube from two replaceable modules (each containing stacked Mylar stripline Blumleins). With this machine, the concept of modular Mylar energy sources is demonstrated.</p>			

14 KEY WORDS	LINK A		LINK B		LINK C	
	ROLE	WT	ROLE	WT	ROLE	WT
SNARK Stacked Mylar stripline Blumleins Triggered gas switches Mylar energy sources						

INSTRUCTIONS

1. **ORIGINATING ACTIVITY:** Enter the name and address of the contractor, subcontractor, grantee, Department of Defense activity or other organization (*corporate author*) issuing the report.

2a. **REPORT SECURITY CLASSIFICATION:** Enter the overall security classification of the report. Indicate whether "Restricted Data" is included. Marking is to be in accordance with appropriate security regulations.

2b. **GROUP:** Automatic downgrading is specified in DoD Directive S200.10 and Armed Forces Industrial Manual. Enter the group number. Also, when applicable, show that optional markings have been used for Group 3 and Group 4 as authorized.

3. **REPORT TITLE:** Enter the complete report title in all capital letters. Titles in all cases should be unclassified. If a meaningful title cannot be selected without classification, show title classification in all capitals in parenthesis immediately following the title.

4. **DESCRIPTIVE NOTES:** If appropriate, enter the type of report, e.g., interim, progress, summary, annual, or final. Give the inclusive dates when a specific reporting period is covered.

5. **AUTHOR(S):** Enter the name(s) of author(s) as shown on or in the report. Enter last name, first name, middle initial. If military, show rank and branch of service. The name of the principal author is an absolute minimum requirement.

6. **REPORT DATE:** Enter the date of the report as day, month, year; or month, year. If more than one date appears on the report, use date of publication.

7a. **TOTAL NUMBER OF PAGES:** The total page count should follow normal pagination procedures, i.e., enter the number of pages containing information.

7b. **NUMBER OF REFERENCES:** Enter the total number of references cited in the report.

8a. **CONTRACT OR GRANT NUMBER:** If appropriate, enter the applicable number of the contract or grant under which the report was written.

8b, 8c, & 8d. **PROJECT NUMBER:** Enter the appropriate military department identification, such as project number, subproject number, system numbers, task number, etc.

9a. **ORIGINATOR'S REPORT NUMBER(S):** Enter the official report number by which the document will be identified and controlled by the originating activity. This number must be unique to this report.

9b. **OTHER REPORT NUMBER(S):** If the report has been assigned any other report numbers (*either by the originator or by the sponsor*), also enter this number(s).

10. **AVAILABILITY/LIMITATION NOTICES:** Enter any limitations on further dissemination of the report, other than those

imposed by security classification, using standard statements such as:

- (1) "Qualified requesters may obtain copies of this report from DDC."
- (2) "Foreign announcement and dissemination of this report by DDC is not authorized."
- (3) "U. S. Government agencies may obtain copies of this report directly from DDC. Other qualified DDC users shall request through _____."
- (4) "U. S. military agencies may obtain copies of this report directly from DDC. Other qualified users shall request through _____."
- (5) "All distribution of this report is controlled. Qualified DDC users shall request through _____."

If the report has been furnished to the Office of Technical Services, Department of Commerce, for sale to the public, indicate this fact and enter the price, if known.

11. **SUPPLEMENTARY NOTES:** Use for additional explanatory notes.

12. **SPONSORING MILITARY ACTIVITY:** Enter the name of the departmental project office or laboratory sponsoring (*paying for*) the research and development. Include address.

13. **ABSTRACT:** Enter an abstract giving a brief and factual summary of the document indicative of the report, even though it may also appear elsewhere in the body of the technical report. If additional space is required, a continuation sheet shall be attached.

It is highly desirable that the abstract of classified reports be unclassified. Each paragraph of the abstract shall end with an indication of the military security classification of the information in the paragraph, represented as (TS) (S) (C) or (U)

There is no limitation on the length of the abstract. However, the suggested length is from 150 to 225 words.

14. **KEY WORDS:** Key words are technically meaningful terms or short phrases that characterize a report and may be used as index entries for cataloging the report. Key words must be selected so that no security classification is required. Identifiers, such as equipment model designation, trade name, military project code name, geographic location, may be used as key words but will be followed by an indication of technical context. The assignment of links, roles, and weights is optional.

DNA 2979F-2
November 1972
PIFR-296

PRODUCTION OF ADVANCED X-RAY SOURCES
USING INTENSE RELATIVISTIC BEAMS (U)

VOLUME 2

SNARK UPGRADE PROGRAM

Final Report

This effort was supported by Defense Nuclear Agency
under: NWER Subtask LA013-17

P. Champney, G. Hatch, and I. Smith

Headquarters

Defense Nuclear Agency
Washington, D. C. 20305

Physics International Company
2700 Merced Street
San Leandro, California 94577
Contract DASA01-71-C-0052

Approved for public release;
distribution unlimited

CONTENTS

	<u>Page</u>
SECTION 1 INTRODUCTION	1
SECTION 2 SNARK GAS SWITCH DEVELOPMENT	3
2.1 Introduction	3
2.2 Design Approach	4
2.3 Gas Switch Test	7
2.4 Installation of Gas Switches in SNARK Modules	25
SECTION 3 MACHINE ITERATION AND PULSER OPERATION	33
3.1 Introduction	33
3.2 Improved Solid Dielectric Switch Modules	34
3.3 Gas-Switch Modules	36
3.4 Machine Operation With Gas-Switched Modules	39

ILLUSTRATIONS

<u>Figure</u>		<u>Page</u>
1	History of Mylar Line Triggered Gas Switch Development	5
2	SNARK Gas Switch Disassembled	8
3	SNARK Gas Switch Assembled	9
4	Plot of Gas Switch Self-Breakdown Voltage Versus SF ₆ Gas Pressure	10
5	Gas Switch With Lucite Blocking and Trigger Feed	12
6	Blumlein-Test Assembly	13
7	448-kV, 815-kA SF ₆ Rail Switch	15
8	Plot of Number of Channels Per Switch Versus Line Voltage	16
9	Test Assembly Trigger Waveforms	17
10	Plot of Switch Breakdown Time Versus Percentage of Self-Breakdown	20
11	Plot of Standard Deviation of Jitter Versus Percentage of Self-Breakdown	21
12	Blumlein Switch Current Waveforms for Various Resistive Terminations	23
13	SNARK Gas-Switched Module	26
14	SNARK Gas-Switched Module	27
15	SNARK Switching Photographs	29

ILLUSTRATIONS (cont.)

<u>Figure</u>		<u>Page</u>
16	Gas-Switched SNARK, Voltage and Current Waveforms, Shot 436	31
17	Gas-Switched SNARK, Voltage and Current Waveforms, Shot 452	32
18	Comparison of Normal Shot and Pre-Fire With Precursor (All 50 nsec/cm)	41
19a	SNARK Daily Shot Record	43
19b	SNARK Daily Shot Record	45
20	Comparison of Line-Charge Voltage as Modules are Improved	47
21	Summary of SNARK Daily Shot Record	49

SECTION 1

INTRODUCTION

This report describes the work performed to upgrade the SNARK machine built under DASA contract 01-70-C-0063. The objective of the SNARK program was to build a machine capable of delivering a 50-kJ electron beam in 50 nsec. The machine was to deliver the energy to an accelerating tube from two replaceable modules (each containing stacked Mylar stripline Blumleins), thus illustrating the concept of modular Mylar energy sources which could ultimately be combined to yield much higher outputs.

The SNARK was developed and built and high outputs were attained with the machine. However, electrical breakdown in the modules thwarted attempts to reach the machine's design specifications. Lack of sufficient time hampered efforts to correct the problems. Two specific difficulties were isolated: voltage grading problems at the edges of the striplines and breakdown near the solid-dielectric line switches.

During the latter stages of the SNARK construction an internally funded program made progress in developing a gas switch which could replace the solid-dielectric switch. Also, it was clear at the end of the machine testing that improvements could be made to eliminate the voltage-grading problems in the striplines.

The results of the SNARK construction effort under DASA Contract 01-70-C-0063 have been reported in PIFR-226 (Draft Final, July 1971).

A follow-on program was proposed to upgrade the SNARK machine. This report describes that effort. The upgrading program was primarily concerned with:

1. The development of a gas switch for installation in the SNARK machine.
2. The raising of the machine output by building modules to include improved voltage grading and gas switches; test the machine.

In this report the gas switch development is described in Section 2, and the machine iteration and pulser operation are discussed in Section 3.

SECTION 2

SNARK GAS SWITCH DEVELOPMENT

2.1 INTRODUCTION

The SNARK pulser generates at the switches a rate of change of current approaching 10^{15} amperes per second. This rate of change of current has been made possible by using eight solid-dielectric switches, each producing many parallel spark channels (see PIFR-226).

An internal research and development (IR&D) program at PI demonstrated that Mylar lines could be gas switched, thus simplifying the operation of a facility machine. A multiple-channel triggered spark gap was developed with an effective inductance of approximately 5.5 nH. The spark gap was used to switch a 2.5-ohm line impedance Blumlein (the PI Mylar Line, PIML) at voltages up to 350 kV with resultant output risetimes of less than 15 nsec (10 to 90 percent). The switch operated repeatedly with only occasional maintenance and was variable over a large voltage range by adjusting the pressure.

The goal of the SNARK gas switching program was to develop the triggered gas switch to take the place of the replaceable solid-dielectric switches originally used. Although the data from the IR&D experiments formed a good basis for this program, switches were now required to handle currents five times higher, for twice the pulse duration, and at a 30 percent higher voltage.

Also, the initial IR&D test assembly had fired into a passive matching load; on SNARK, under dynamic loading conditions where the diode may cause a near-open or short-circuit termination of the generator, the switch was required to have a high total coulomb rating because of reflected pulses. Finally, the use of eight switches in a routinely operating generator required high reliability.

The most appropriate final switch design was sought in an intensive 3-month period of study and experimentation, followed by a month of switch and module fabrication, and finally a month of complete-system testing (Figure 1).

The following presents the rationale used to determine the design approach and the basis for experimentation. The discussion also deals with the experimental procedure, the interaction of the PI gas-switched Mylar line, and the testing of the SNARK gas-switched prototype.

2.2 DESIGN APPROACH

For a triggered gas switch to take the place of each solid-dielectric switch on SNARK, the switch must operate reliably over a 150- to 450-kV range and have an inductance of no greater than 7 nH. Thus, when feeding a 0.55-ohm line impedance, the switch can generate an e-folding risetime of better than 15 nsec. The switch must also be capable of handling currents of up to 900 kA and have a triggering jitter over the whole voltage range that does not exceed about 4 nsec (1σ).

The self-breakdown-versus-pressure curve for the PI-developed gas switch virtually flattens out at the 200-psi SF₆ level, corresponding to a voltage of 400 kV and a mean field of about

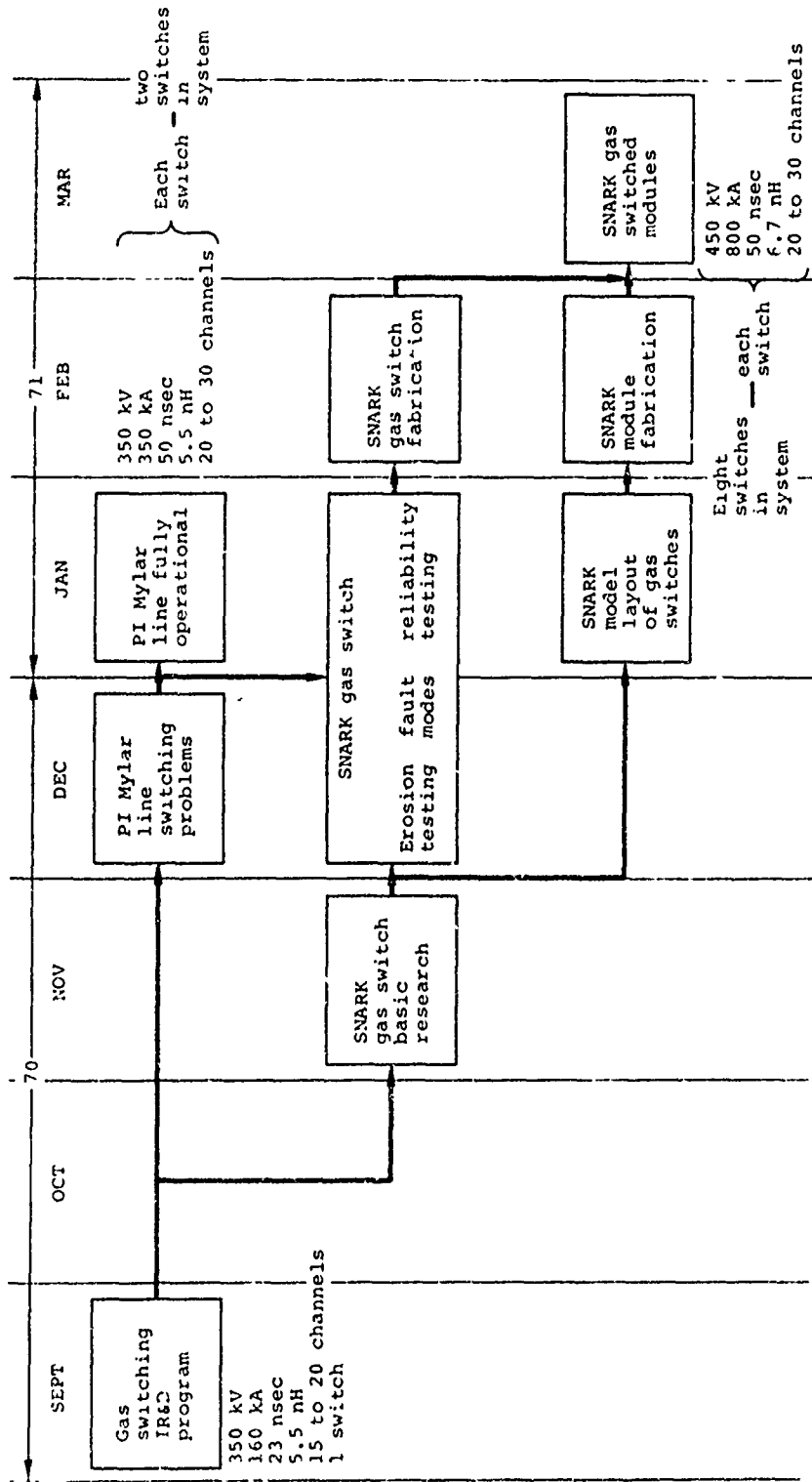

Figure 1 History of Mylar line triggered gas switch development.

650 kV/cm. The SNAPK prototype was required to operate at levels up to 450 kV (i.e., at self-breakdown voltages of up to approximately 600 kV). Thus, a main-electrode spacing roughly 50 percent greater was required. To maintain both a low field-enhancement factor and an adequately long tracking path along the gas envelope interface, a scaled-up version of the switch was fabricated.

The outer cross section of the envelope was increased from 2 inches to 2-1/2 inches square, and the main-electrode diameter was increased from 0.5 inch to 0.75 inch. The main-electrode spacing increased from 0.25 inch to 0.37 inch.

The risetime resulting from such a switch is essentially inductance limited and, therefore, the required width of the switch may be calculated. The overall inductance, L , of the switch is given approximately by

$$L = 4\pi \frac{s^2}{2w}$$

where s is the external envelope dimension in centimeters and w is the width of the main electrodes in centimeters. Thus

$$L = \frac{4\pi \times 6.3^2}{2w}$$

$$L = \frac{254}{w}$$

The switch feeds a line impedance of 0.55 ohm; therefore, for an e-fold risetime of, say, 12 nsec, the switch inductance must be 6.7 nH. Thence, $w = 38$ cm (15 inches).

Thus the main-switch electrodes were made 15 inches long. The prototype SNARK switch was fabricated in a similar manner to the PIML switch. The face of the envelope adjacent to the Mylar dielectric was fluted to provide resistive grading between the main electrodes. The knife-edge trigger electrode was positioned so the gap spacing was within the ratio 60:40, which is intended to produce simultaneous-mode triggering. The advantage of the simultaneous mode of operation is that the time to breakdown and the jitter are minimized (Figures 2 and 3).

2.3 GAS SWITCH TEST

The prototype switch was used to plot a self-breakdown-versus-pressure curve. At 200 psig SF₆, the self-breakdown voltage was still too low. (This pressure was regarded as the maximum safe operating value; failure was predicted in the nylon bolts at 750 psi and in the Lucite due to hoop stress at 900 psi. In a static overtest, a switch failed at 800 psi.)

The main-electrode spacing was increased by another 1/8 inch by removing electrode material on the side adjacent to the envelope. By this means the self-breakdown voltage was raised to greater than 600 kV at 200 psi SF₆ (Figure 4). The self-breakdown curve has essentially flattened out at 200 psig, which corresponds to a mean field of about 470 kV/cm.

A test Mylar Blumlein was then designed and fabricated to accept the prototype gas switch. To conserve space, the electrical length of the Blumlein was reduced to produce a 25-nsec-wide pulse. The output of the Blumlein was loaded with a liquid resistor contained in a Lucite pipe the full width of the Blumlein. The switch was triggered by feeding the trigger pulse down a high-

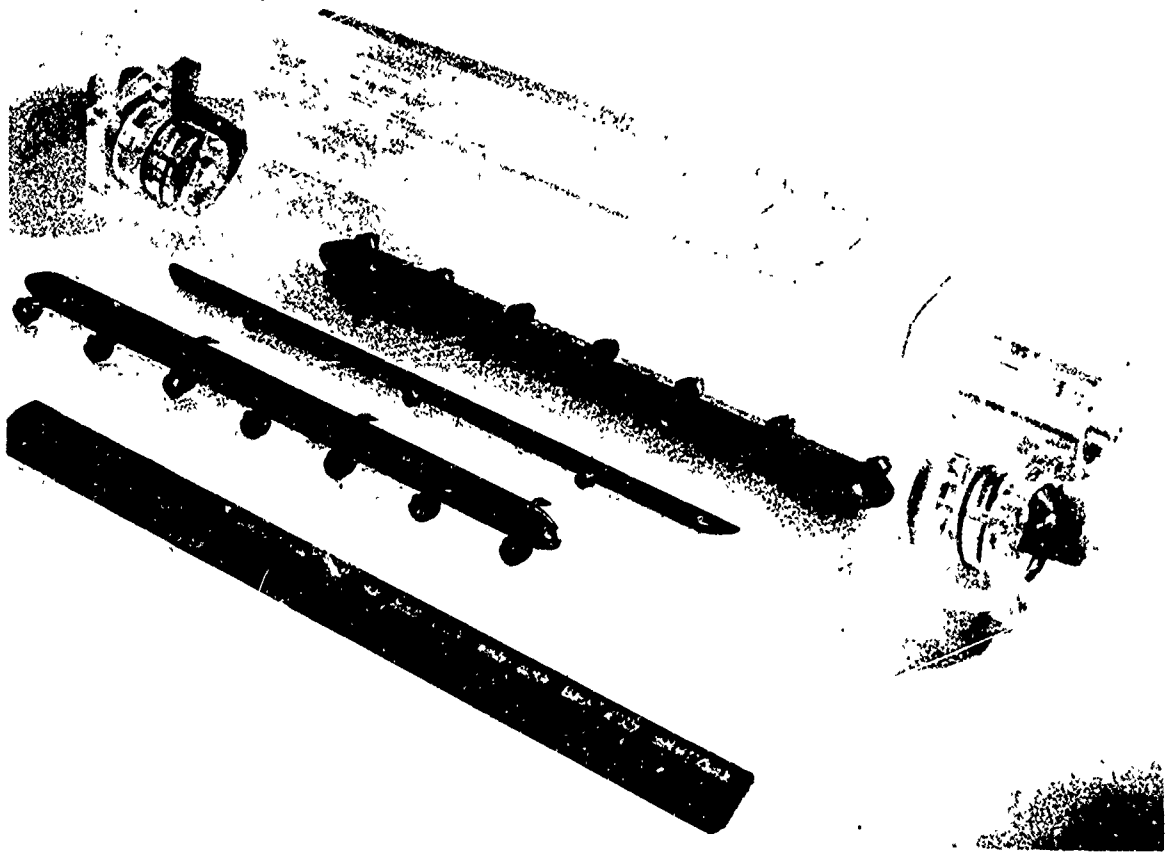

Figure 2 SNARK gas switch disassembled.

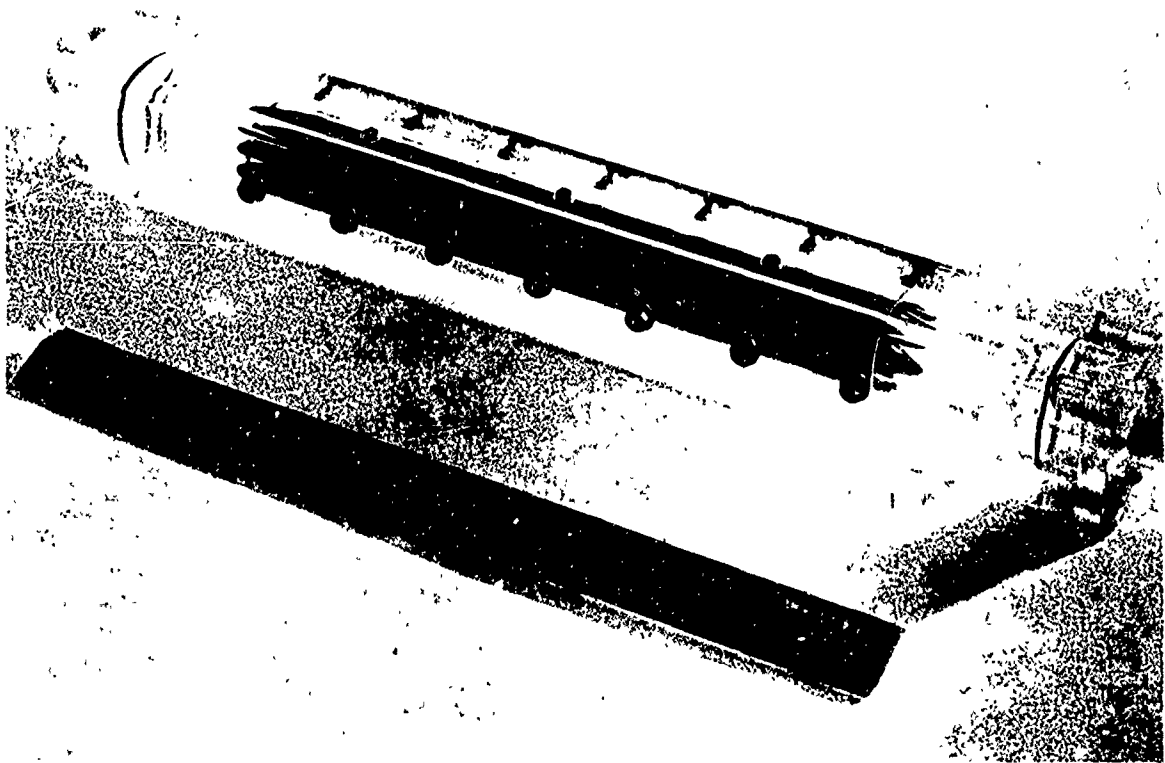

Figure 3 SNARK gas switch assembled.

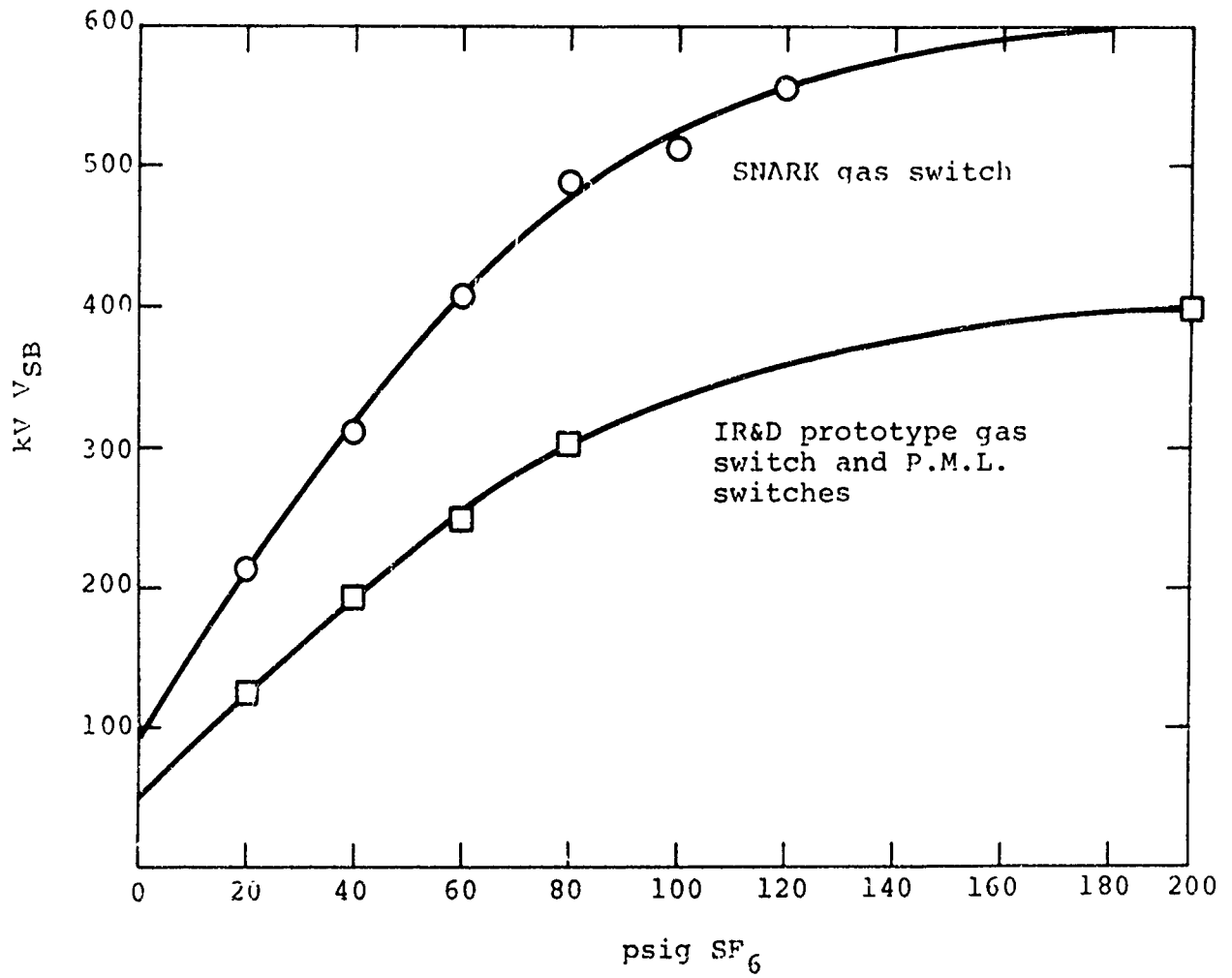

Figure 4 Plot of gas switch self-breakdown voltage versus SF₆ gas pressure.

voltage coaxial cable connected to the trigger electrode by a series terminating resistor, which reduces the amplitude of transients fed back down the cable when the switch fires. Copper-sulphate solution was used to form this series resistor, and was contained in a block of Lucite. The Lucite substantially reduces the capacitive and resistive coupling that would otherwise exist through the water. This is important not only in holding the trigger electrode at the correct potential during the charging phase, but also in reducing the loading imposed upon the triggering pulse (Figure 5).

The general arrangement of the test Blumlein assembly is shown in Figure 6a. The equivalent circuit is given in Figure 6b. A Marx generator, C_0 , with inductance L_0 , pulse charges the test Blumlein. Series inductance, L , is added to slow the charging waveform to a half point greater than that of the SNARK pulser. Thus, potential problems in the vicinity of the switch due to pulse charge time would be accentuated. For SNARK t_{eff} is $0.8 \mu\text{sec} \pm 10$ percent, while t_{eff} for the test Blumlein was $1.05 \mu\text{sec} \pm 10$ percent.

A sample of the charging voltage existing on the Blumlein is applied to a variable-geometry copper-sulphate resistor (V/n resistor). By means of a tap-off section in the V/n resistor, a fraction of the charging voltage is applied to a master switch. This switch is connected, through the trigger cable and series resistor, to the trigger electrode of the rail switch. The trigger electrode is held at the correct potential (0.4 V) by monitoring the V and V/n waveforms and tuning the V/n resistor accordingly. The master switch, S_1 , consists of a solid-dielectric pre-stabbed polyethylene card which is arranged to fire at approximately 85 percent of the peak of the charging waveform.

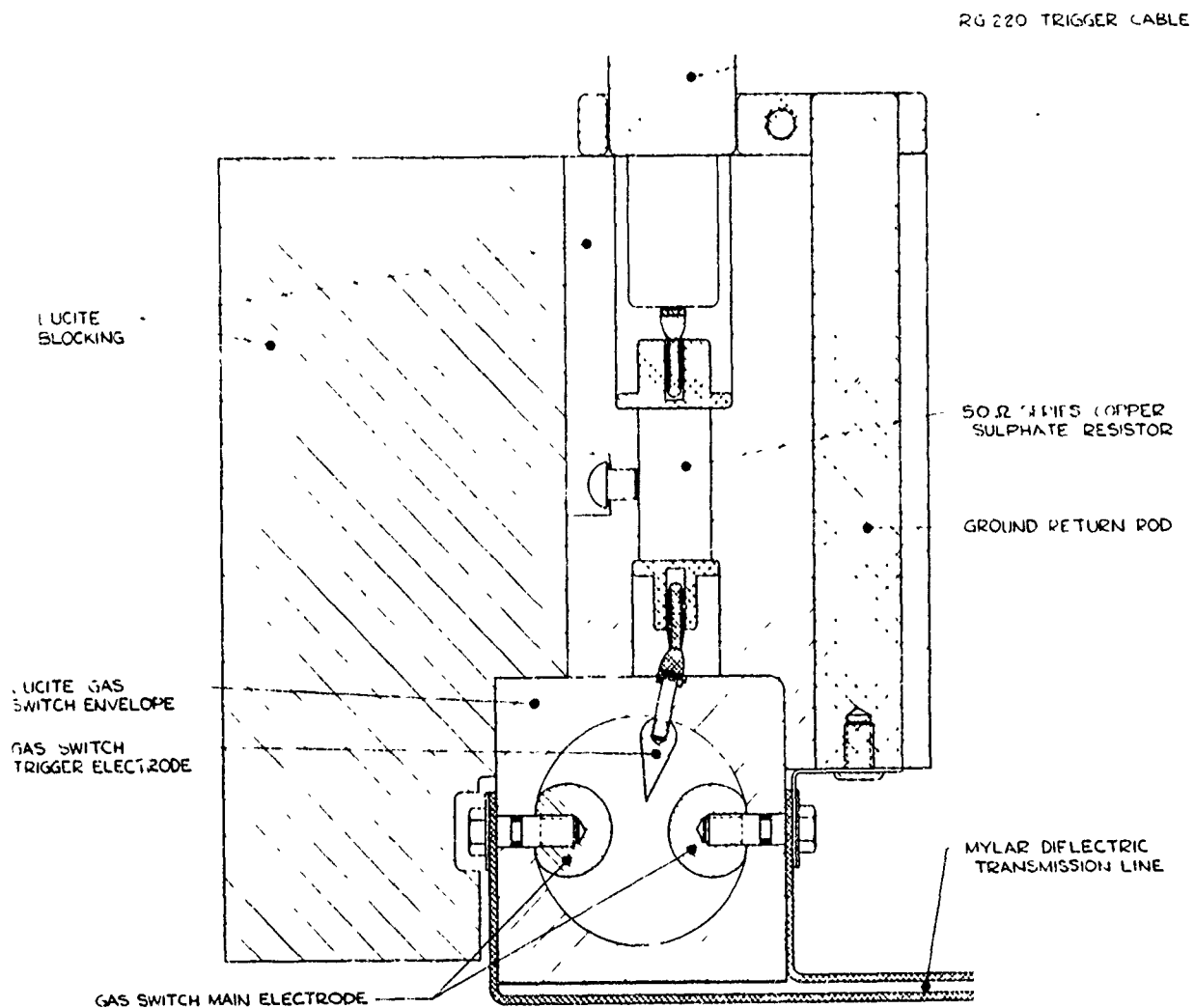
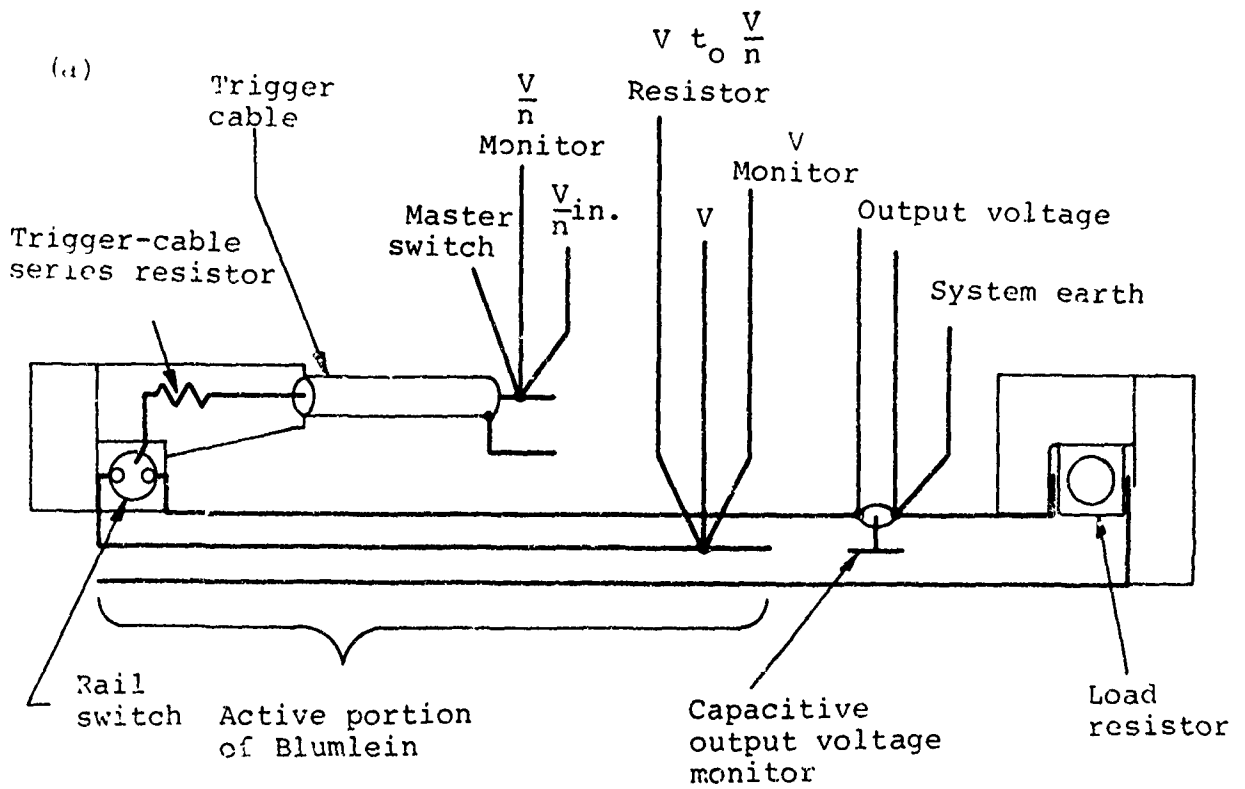
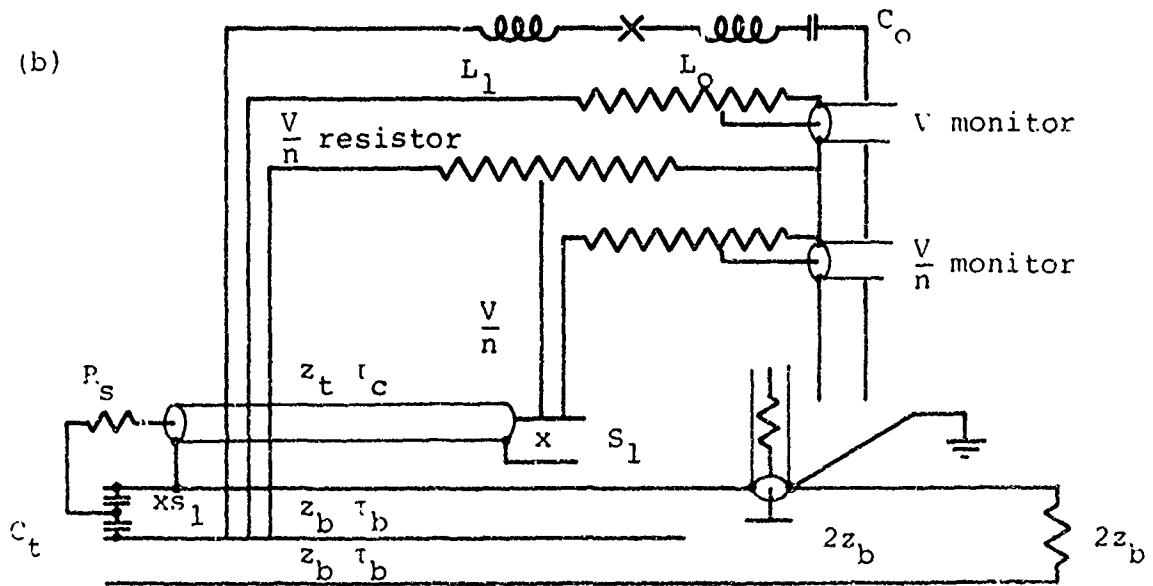

Figure 5 Gas switch with Lucite blocking and trigger feed.



a. General arrangement



b. Equivalent circuit.

Figure 6 Blumlein-test assembly.

A capacitive divider on the trigger cable near the rail switch was used to monitor the trigger waveform and to time-reference the rail-switch closure. A parallel-plate capacitive monitor was used to record the Blumlein output waveform. Initially, the Blumlein load resistor was arranged to be an approximate termination. The rail switch was triggered at successively higher voltages, while recordings were made of charging voltage, trigger voltage, trigger pulse, number of channels in the rail switch, and the Blumlein output pulse. Figure 7 shows a typical multichannel breakdown of the rail switch at about 450 kV, together with the corresponding Blumlein output pulse. Figure 8 is a plot of the average number of breakdown channels per switch versus line voltage.

During these tests, problems were experienced with tracking between the ends of the main electrodes inside the Lucite envelope. The tracking involved the Lucite end plugs. Changes were made in the grading around the outside and at the ends of the envelope and also in the internal shape of the envelope end plugs. These changes prevented further internal tracking when testing was continued.

Trigger waveforms were taken with the aid of the coaxial capacitive monitor, to determine the time to breakdown for both the large and small spacings of the rail switch. Figure 9 shows a number of these waveforms taken with a variety of envelope pressures. The rail switch is shown triggered at various percentages of self break. The step in the trigger waveform is caused by the capacitive trigger monitor being positioned a little down the cable from the rail switch. The switch appears to be operating in the cascade mode; as the switch is triggered at lower percentages of self breakdown (SB), the time taken for the first

A

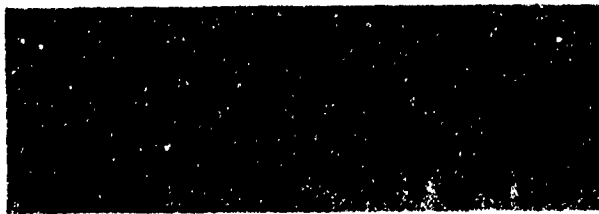

Photograph of multichannels in rail switch

B



Output pulse, 10 nsec/division

Figure 7 448-kV, 815-kA SF₆ rail switch.

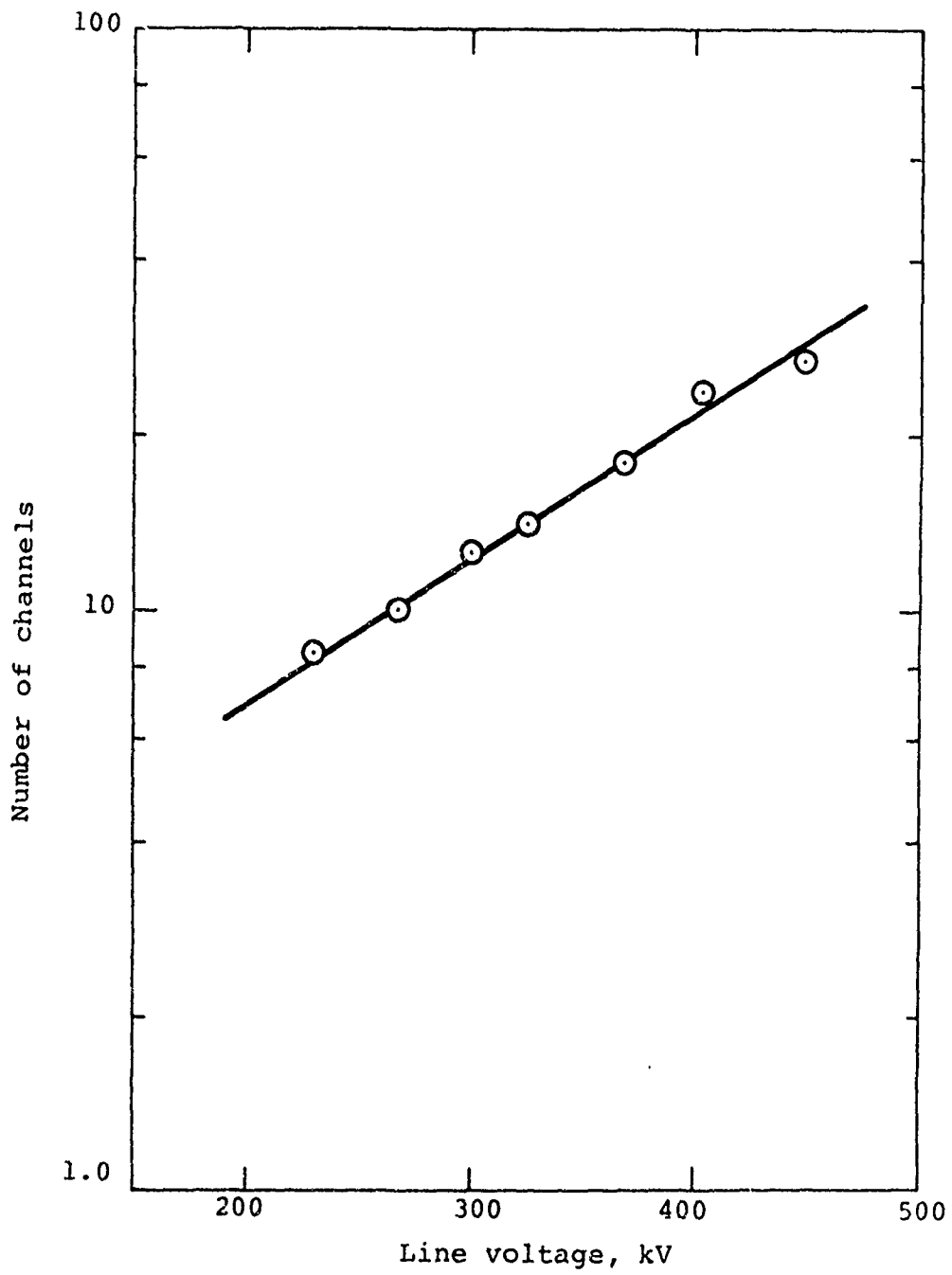

Figure 8 Plot of number of channels per switch versus line voltage.

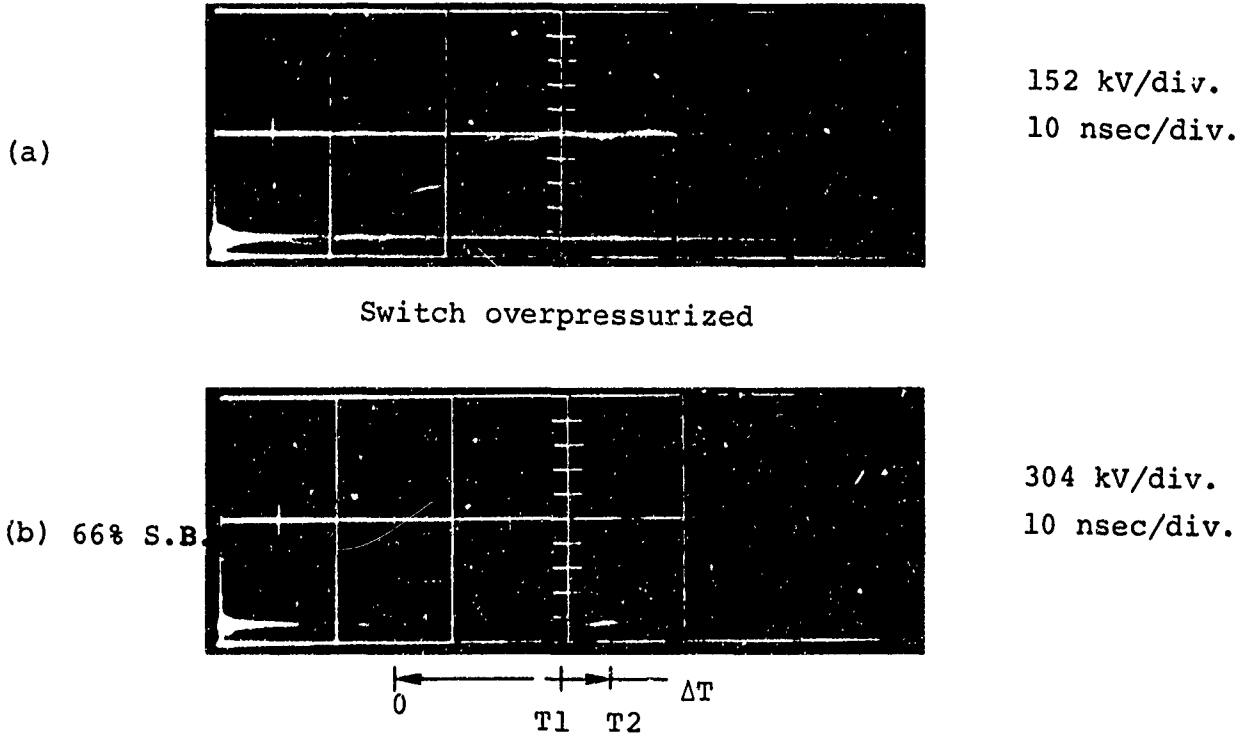
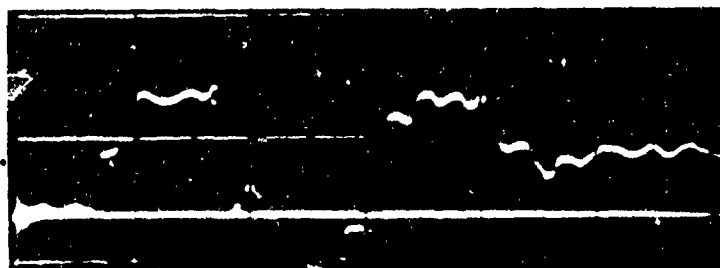

Figure 9 Test assembly trigger waveforms.
 T1 = Time interval between arrival of trigger pulse and breakdown of large gap spacing.
 T2 = Time interval between breakdown of small gap spacing and large gap spacing.
 ΔT = Total time interval between arrival of trigger pulse and breakdown of switch.

(c) 45% S.B.



152 kV/div.
20 nsec/div.

0 T1 T2 ΔT

(d) 39% S.B.



152 kV/div.
20 nsec/div.

0 T1 T2 ΔT

Figure 9 (continued) Test assembly trigger waveforms.
T1 = Time interval between arrival of trigger pulse and breakdown of large gap spacing.
T2 = Time interval between breakdown of small gap spacing and large gap spacing.
 ΔT = Total time interval between arrival of trigger pulse and breakdown of switch.

(larger) gap to break (T1) varies very little but the second (smaller) gap takes progressively longer to break (T2). This implies that a switch with a ratio of, say, 70:30 might perform even better. However, the ratio of 60:40 has certainly provided an adequate switch in this application.

Figure 10 shows a plot of the total switch breakdown time versus the percentage of self breakdown. Figure 11 plots the jitter (Δt) of switch closure versus the percentage of self breakdown. For SNARK, with a pulse width of 55 nsec and with eight switches, each having an approximate e-fold rise of 12 nsec, an individual switch jitter (Δt) of 4 nsec may be tolerated without significant distortion to the output pulse shape. Thus, Figure 11 indicates that this design of rail switch may be operated down to about 50 percent of self break without causing significant degradation to the output pulse. This is important in terms of the reliability of much larger systems where more conservative percentages of self breakdown are required than the traditional 75-to 80-percent self break. It is also important to note that the number of breakdown channels remains roughly constant for a given voltage as the pressure is raised and, hence, the percentage of self break is lowered. Thus, there appears to be no penalty for operating at a conservative value of self breakdown.

The second phase of the prototype switch tested consisted of checking out various fault modes that could occur on the Snark pulser, together with general reliability testing.

While erosion of the switch electrodes due to normal operation is expected to be small (i.e., currents of up to about 800 kA distributed through approximately 20 to 30 channels, resulting in about 40 kA per channel), there is the possibility of a single-

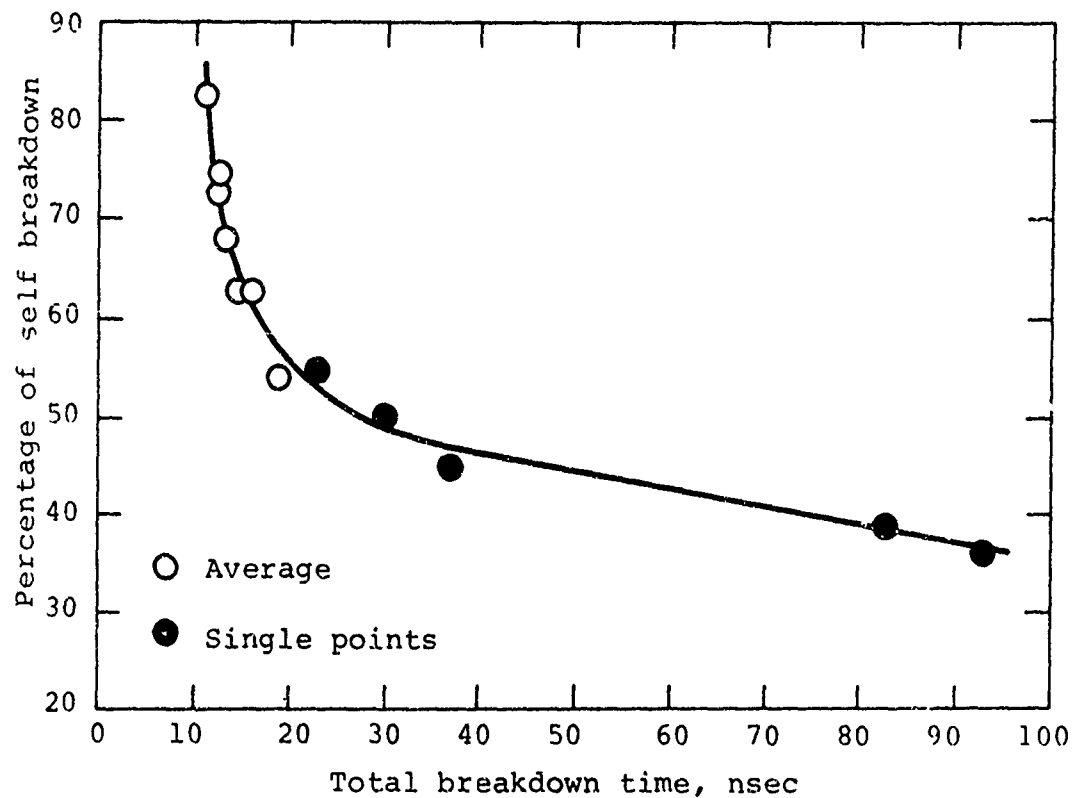

Figure 10 Plot of switch breakdown time versus percentage of self breakdown.

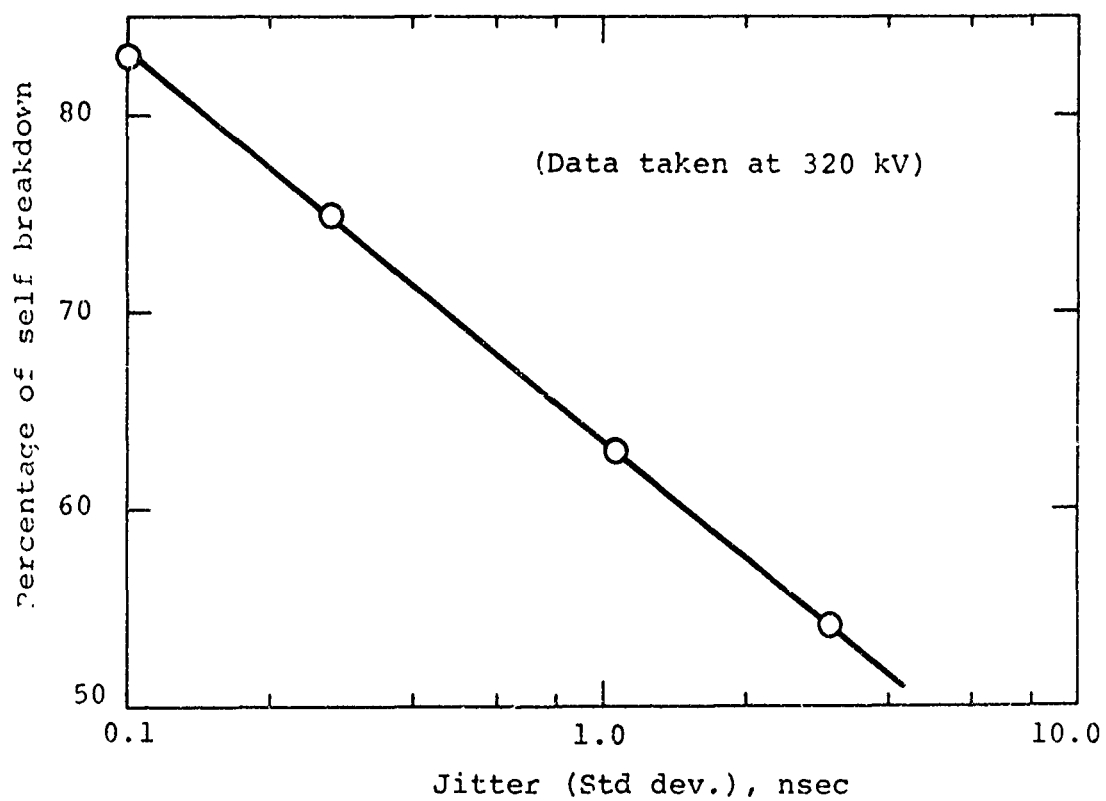

Figure 11 Plot of standard deviation of jitter versus percentage of self breakdown.

channel self breakdown of the switch, which would result in up to 800 kA flowing in one channel. The prototype switch had been fabricated using brass electrodes; additional electrodes made of various tungsten alloys were also fabricated as replacements in case the erosion in the brass proved excessive. The brass-electrode prototype switch was allowed to self break at voltages up to 500 kV, which corresponds to peak single-channel currents of 900 kA. On subsequent shots, after each self break, the switch was successfully triggered, resulting in conventional multi-channel operation. Thus, as far as switch self breakdowns were concerned, the brass electrodes were quite adequate.

There were two additional fault modes that required consideration and testing:

1. If the diode that the pulser is driving results in a near-open or short-circuit condition, especially early in the pulse, the charge that each Blumlein switch must carry rises enormously. Figure 12 shows Blumlein switch current waveforms for various resistive terminations, where n is the number of times the load impedance is greater than the impedance the switch is driving. For example, for a load impedance one-half or twice the matched impedance, twice the total charge flows through each switch than in a normal matched case. Similarly, for a load impedance one-quarter or four times the matched impedance, four times the charge flows. Under normal operating conditions there are various damping elements in the circuit that tend to reduce the magnitude of these numbers; however, a near-open or short-circuit load still causes a large increase in the charge that the individual switches carry.

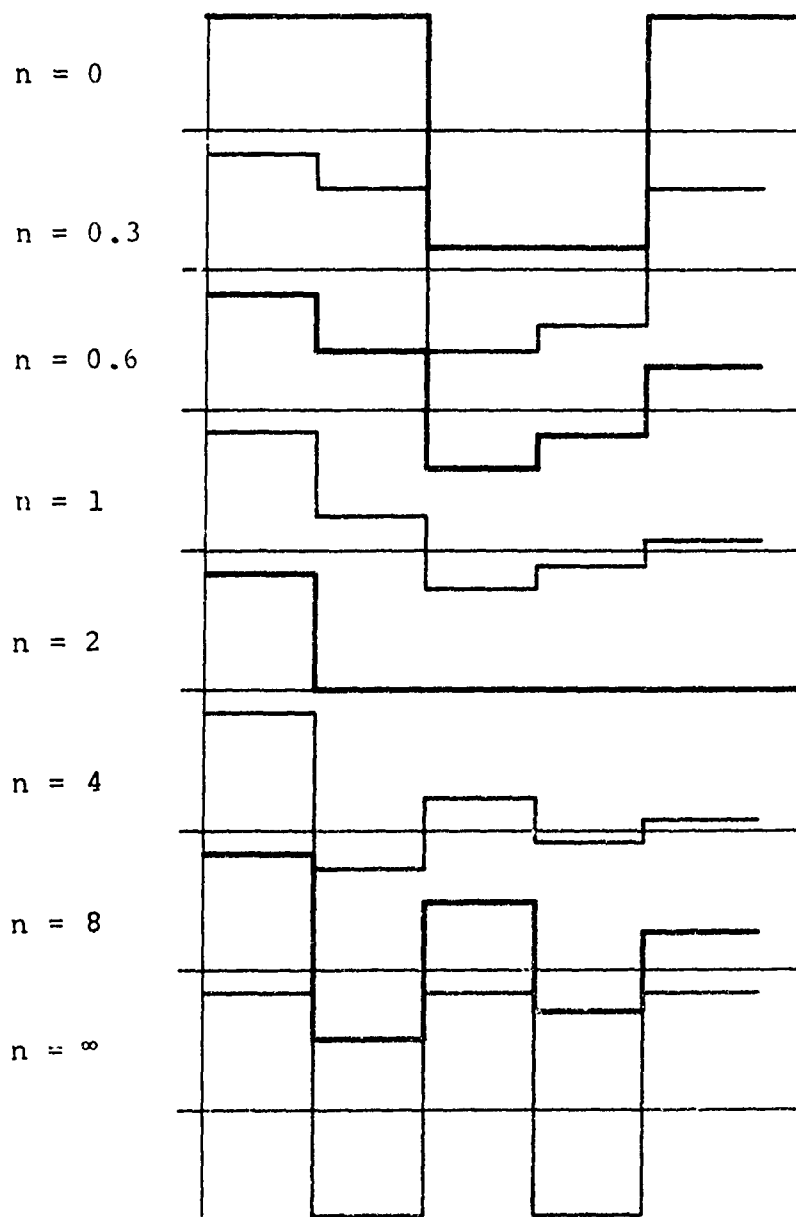

Figure 12 Blumlein switch current waveforms for various resistive terminations.

2. The SNARK pulser is triggered by means of a self-closing master switch firing at approximately 85 percent of the peak charging waveform. Thus, 30 percent of the original energy in the Marx is available to ring around the circuit formed by the Marx, the charging leads, and the Blumlein switches. Unless series resistive damping is provided, this energy will continue to ring through the Blumlein switches for tens of microseconds, causing an excessive number of coulombs to flow in the switches, resulting in serious electrode erosion.

For these reasons it was planned to vary the load resistance of the prototype Blumlein to progressively mismatch the Blumlein while operating it at or near peak voltage, to investigate any degradation in switch performance. During the beginning of these tests, results from the operation of the PI Mylar line at voltages and currents somewhat less than those required by SNARK showed that this type of switch using brass electrodes was capable of handling short-circuit load conditions without degradation. Therefore, erosion testing on the prototype SNARK switch was discontinued.

Reliability testing under normal load conditions was continued, however, to investigate possible internal-flashover problems due to byproduct contamination of the insulating envelope. Repeated testing at or near full voltage showed that this contamination was not a problem, providing that at full voltage the SF₆ gas was purged every 10 or 12 shots. At the end of January 1971, prototype testing was discontinued and in early February 1971, fabrication of the Snark gas switches and the associated Lucite blocking was begun.

During prototype gas-switch-reliability testing, a full-scale model was made of the switch end of a SNARK module. This model enabled optimization of the modifications that were required to install switches in a module. The full-scale model also enabled the copper-sulphate grading around the whole switch end of the module to be carefully checked. An additional modification built into the model was increased insulation at the end of the dummy line of each Blumlein. The thickness of the insulation in this region was doubled in a graded manner. This extra insulation prevents breakdown caused by large transients originating from short-circuit-load conditions.

2.4 INSTALLATION OF GAS SWITCHES IN SNARK MODULES

In early February 1971, fabrication of the gas-switched SNARK modules was begun. In early March 1971, testing of the gas-switched SNARK pulser was started. These tests were carried out using a resistive load so that the resultant rapid firing rate would minimize the pulser testing phase.

Figure 13 shows a photograph of the switch end of one of the SNARK modules. Four switches can be seen, each feeding one Blumlein, and triggered through the vertical coaxial-trigger leads from a common solid-dielectric master switch.

Figure 14 shows how these four trigger leads are brought back to the centrally positioned master switch. Two of these trigger leads rise to the full output potential, while the other two rise to half the output potential. Although the far end of the leads are grounded, enough inductive isolation is provided to prevent significant loading of the output pulse. The leads are suspended on nylon cords to prevent breakdown to each other

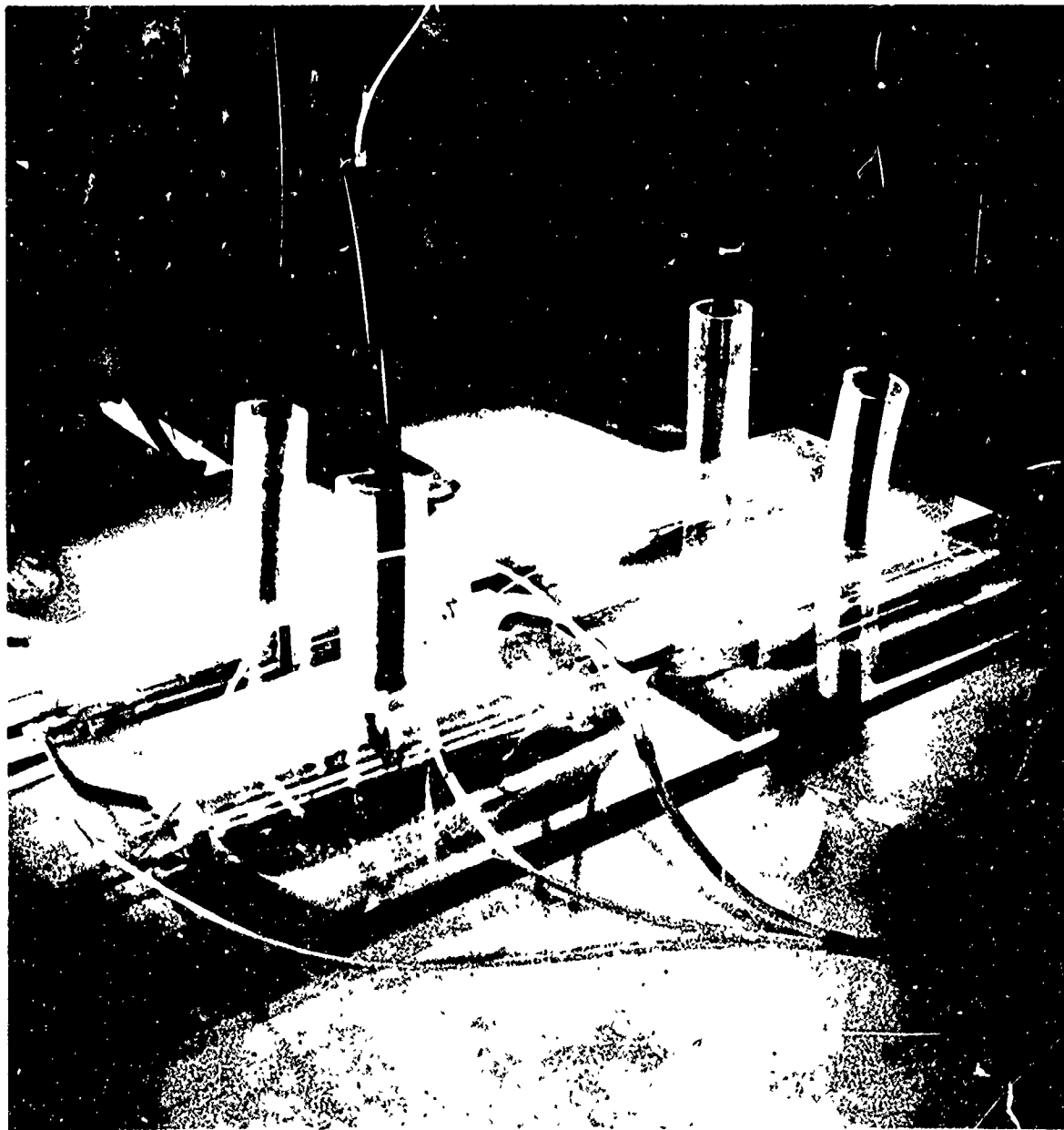

Figure 13 SNARK gas-switched module.

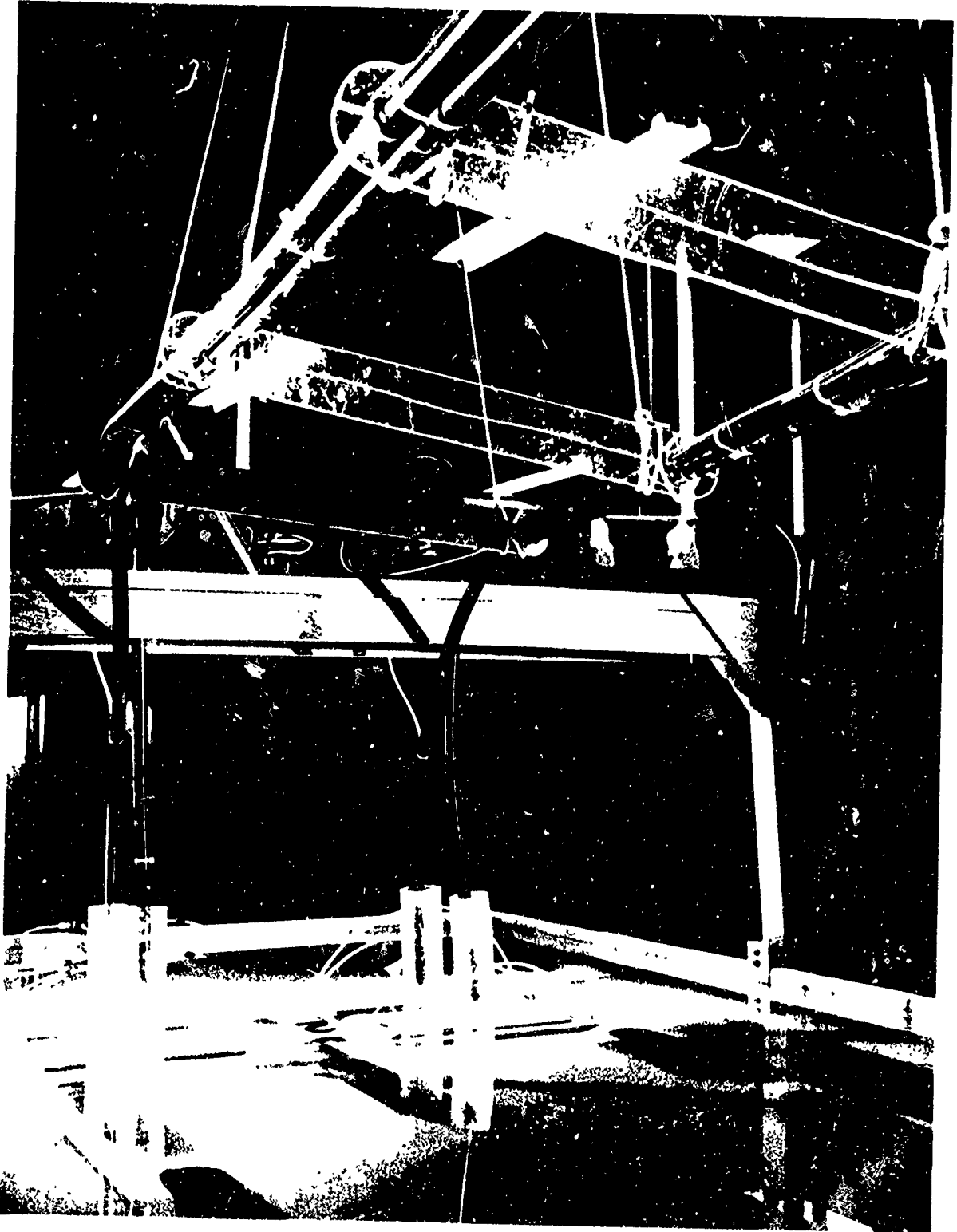

Figure 14 SNARK gas-switched module.

or to ground. Figure 15 shows typical open-camera-switching photographs of the two modules.

During the initial pulser testing, switch failure occurred because the switches did not seat correctly in the transmission line. It was necessary to provide vertical loading on the switch bodies to ensure good contact, correct resistive grading between the Lucite envelope and the main Mylar dielectric, and to exclude CuSO_4 from between the Mylar sheets. Vertical compression pipes may be seen on the switching photograph, two pipes to each switch.

Initial tests on the PI Mylar line in December 1970 had shown that except when the trigger electrodes were new, the switches were prone to self breaking during pulse charge. The breakdown occurred because the trigger potential was lagging behind the main charging waveform. This lag was corrected by reducing the impedance of the V/n resistor and the resistor in series with the voltage monitor. Thus, the capacity of the trigger cables is charged through a lower resistance, thereby reducing the trigger-waveform lag.

These points were considered when testing the gas-switched SNARK modules, and the appropriate changes were made. However, self breaking of the SNARK switches still occurred, when they were in theory operating at 60 to 70 percent of self break. It was determined that the resistance of the V/n resistor had been reduced too much. The V/n circuit has a finite associated inductance that results in an $L \, di/dt$ voltage drop, which in turn results in a trigger voltage error. A compromise resistance value was found that resulted in each of these errors being limited to a few percent..



Module
I

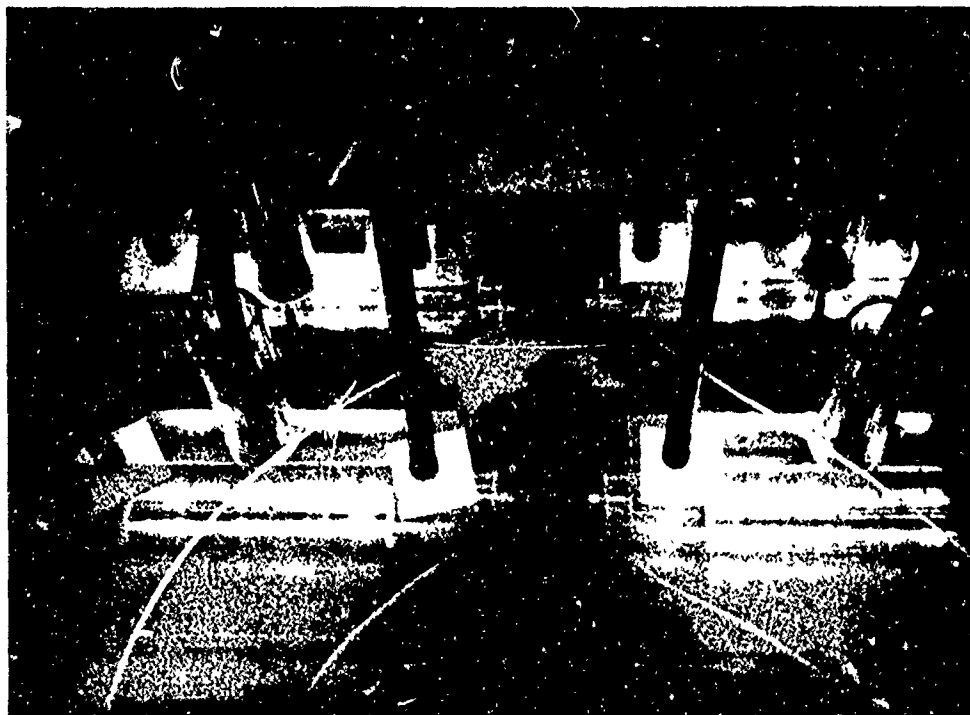

Module
II

Figure 15 SNARK switching photographs.

As a result of these changes the switches operate at 60 to 65 percent of self break, reliably without self breakdowns occurring. Figures 16 and 17 show typical gas-switched SNARK waveforms of the pulser feeding a diode load.

A more detailed analysis of switch performance in the SNARK pulser is included in Section 3.

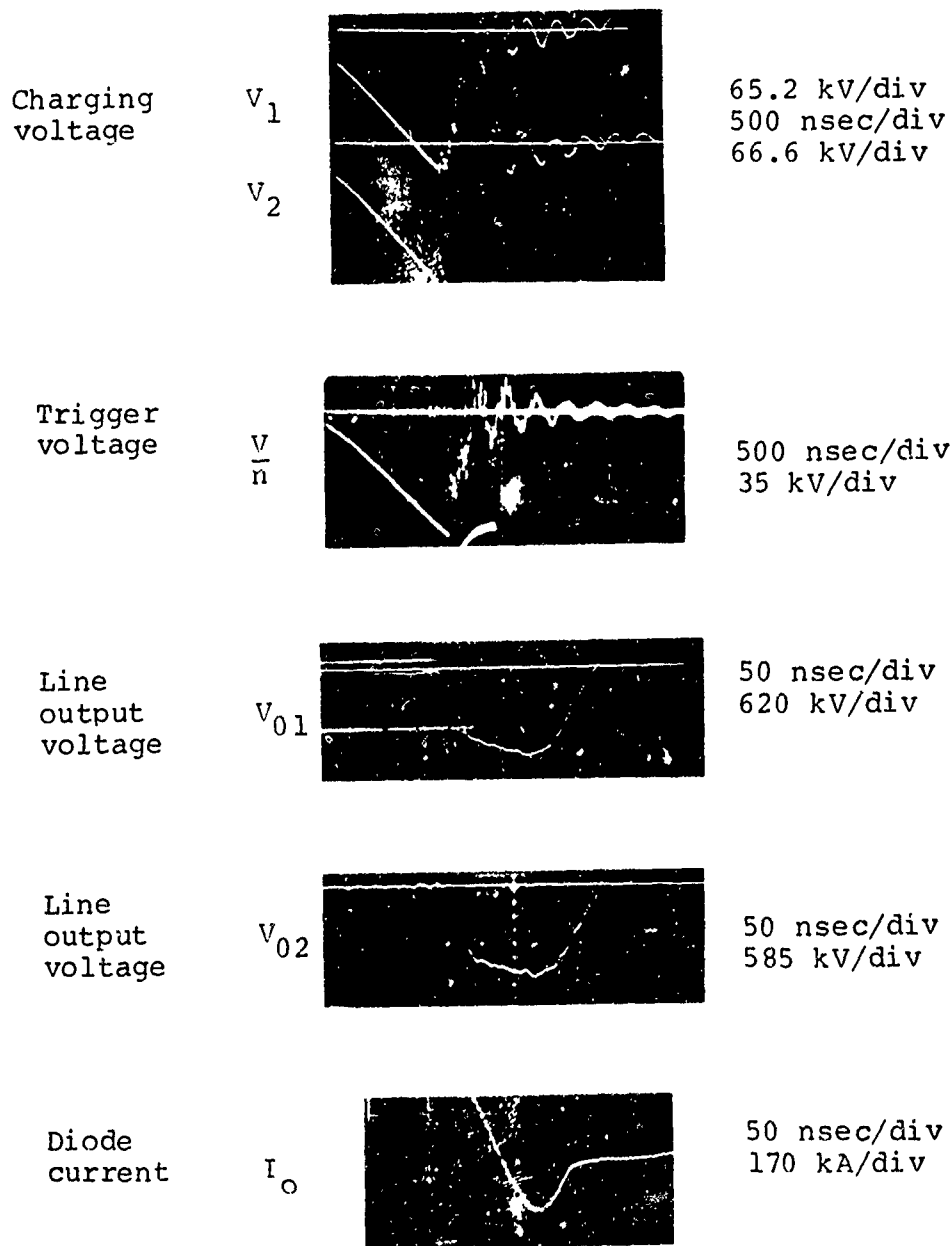

Figure 16 Gas-switched SNARK, voltage and current waveforms, Shot 436.

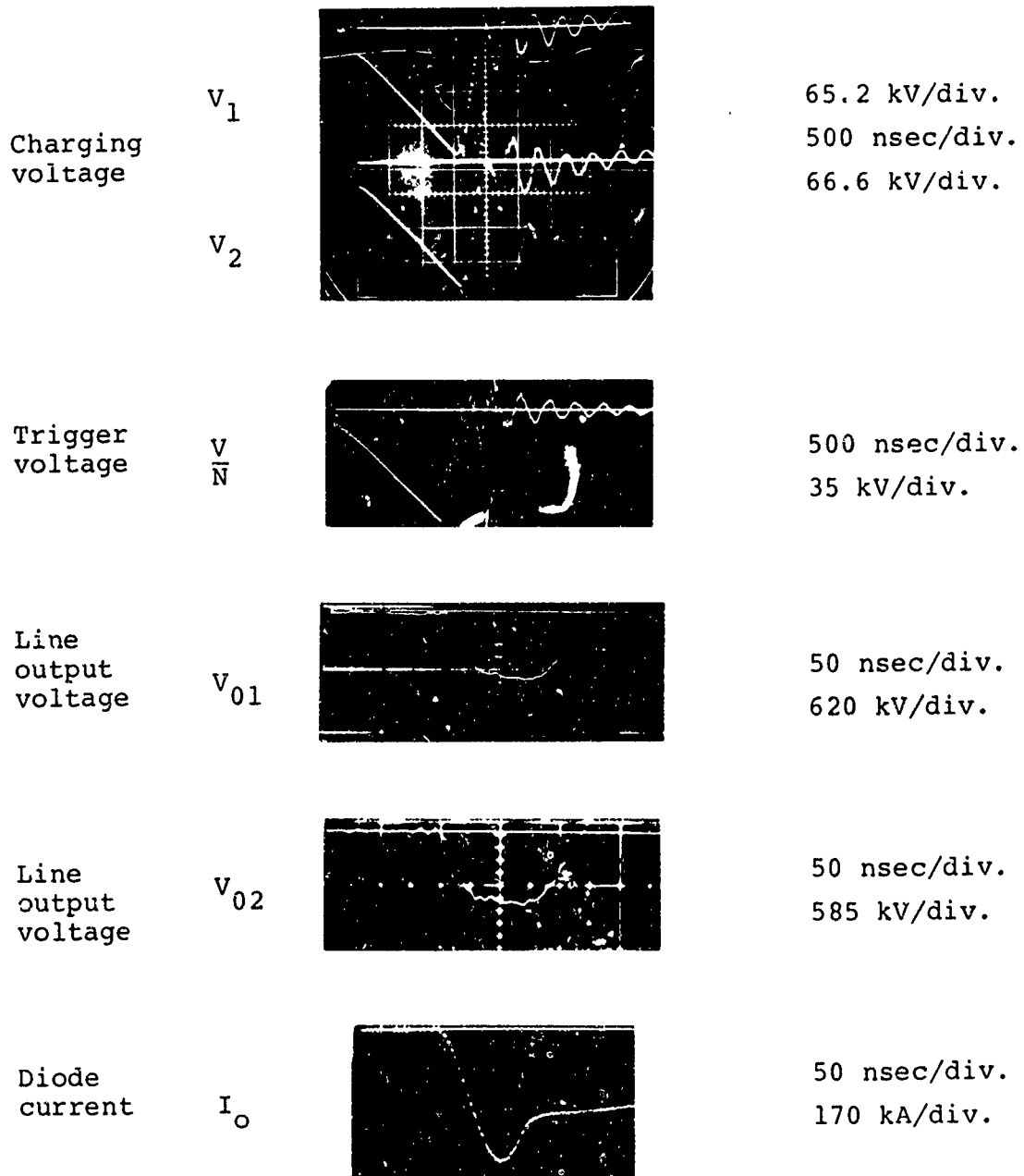

Figure 17 Gas-switched SNARK, voltage and current waveforms, Shot 452.

SECTION 3

MACHINE ITERATION AND PULSER OPERATION

3.1 INTRODUCTION

This section describes the effort made to raise the output of the SNARK to 50 kJ and discusses the pulser operation for beam studies. In the previous program, the machine output was limited by module failures. Those that occurred most frequently in the previous program and were most likely, when corrected, to raise the machine output were tracks through the water and Mylar at the edge of the copper electrodes, and tracks in the water occurring around the solid-dielectric switches. In this program larger edging was used to combat the problem, and gas switches were developed and installed. Both changes led to higher reliable output for SNARK.

The program plan required operating the machine to perform electron beam and diode studies throughout the entire program. However, the gas switches had to be developed and manufactured during the early part of the program. During this time, improved solid switch modules were built and used to operate the machine until the gas switch modules were ready. Thus a stepwise improvement of the modules was made, with the installation of the gas switches as the last task.

3.2 IMPROVED SOLID DIELECTRIC SWITCH MODULES

It was realized at the end of the last program that complete development of a fully reliable pulser module would require the incorporation of gas switching and the experience of more operating tests. At the outset of this program it was judged necessary to replace the two modules in use at the end of the preceding contract; these had undergone extensive repairs. The new modules of necessity had solid dielectric switches at this stage. They were also made with larger diameter copper wire soldered to the edges of the copper electrodes to improve the grading. The electrical breaks at the edge of the electrodes in the previous program had been attributed to poor nesting of the layers of Mylar around the wire edge, which cut off the grading of the voltage away from the electrode edge. Larger wire eliminated this problem.

At the same time a technique of crimping a wire to the edge of the copper electrode without solder was being developed for use on future modules. By the new method, corrosion is eliminated and wire is permanently held in place. In addition, trouble from bubbles and other byproducts of the interaction of the copper-sulphate solution with the solder is eliminated. Using this method also decreases the time required for fabrication of a module.

A second modification to the modules was to add extra insulation at the switch end of the lines. In the previous program edge breaks had occurred near the open ends of the unswitched lines. Large transient voltages caused by diode impedance collapse were believed to have been the cause, and these were expected to recur occasionally.

The new solid-switch modules were completed, and checkout of the pulser made so that pulsing of SNARK for beam experiments was started in early January. It was decided not to fabricate a spare module because of the limited period of use expected with solid switches, and because of the cost involved. The operating level was therefore conservative.

During the following two-month period the machine was operated at 250-kV charge with resulting peak line voltages of 650 kV and peak currents of 600 kA for an electron-beam energy of about 20 kJ maximum. The machine operated reliably at these voltages.

Carrying out pinch experiments on SNARK required low machine jitter in order to synchronize the pinch current with the electron beam current. The Marx had been designed with three of its spark gaps triggered. In order to meet the timing requirements of the pinch experiments, all gaps in the Marx were converted to trigger gaps. All the Marx gaps were then driven by a triggered master gap with excellent overall results.

The machine jitter was reduced to under ± 100 nsec which was wholly acceptable for the pinch beam studies. Further reduction could be made by triggering the master switch that triggers the pulse line slaves but this was not needed.

Turn-around time for the machine depended on the apparatus being used in the beam studies but ranged from less than 30 minutes to 60 minutes. Generally, the decision making between shots (so necessary in new study areas) was responsible for shot rate being low; however it was shown on many occasions that 7 to 8 shots per eight-hour shift was an attainable rate.

During February the gas-switch modules were being constructed as shooting continued on SNARK with the solid-switch modules. Operation of SNARK continued with pulse-charge voltages up to 300 kV. Near the end of February poor switch reliability began to hamper machine operation as the voltage was increased to 300 kV. Since the gas-switch modules were nearly completed, it was decided to convert to gas-switched modules, and the pulser was disassembled for this purpose at the end of February.

During the total period of January 1 to February 26 about 110 shots were taken on SNARK at charge voltages up to 300 kV. Operation became more routine as the personnel became more familiar with the machine. The improvements on the electrode edging and the extra line insulation appeared to help machine reliability and were incorporated in the gas-switch modules.

The Marx was operating very reliably with low jitter after its alterations. Near the end of this period the Marx was fitted with a mechanical output switch so that the modules could be decoupled from the Marx during Marx charging. This switch is closed just before firing the machine. In this way only the full Marx voltage is applied to the modules, ensuring that the master switch fires. If the Marx erects before reaching full charge prematurely it does not discharge into the modules. If it did, the master might not fire and the line charging voltage would ring on, almost tracking the lines if the charging voltage is high.

3.3 GAS-SWITCH MODULES

The gas-switch modules were assembled in the machine in early March. Figure 14 in Section 2 shows the gas-switch module

with trigger leads. With the introduction of the new gas-switch modules several changes were made in the machine operation. First, though there was still a single solid master switch changed after each shot, the remaining eight line slave switches were not changed. Preliminary tests on PIML with a gas master had shown the need for development and the return to the solid master was prudent. Second, to make a low-voltage ringing test shot to check the modules now merely required raising the gas pressure in the line switches and inserting a blank master. Third, to change the line-charging voltage the gas-switch pressure was changed accordingly while the appropriate master switch was used. Fourth, to monitor the number of channels in the gas switches, inexpensive Polaroid pictures were taken during each shot and entered in the shot log book for reference. The number of channels is easily read off these prints and, most important, single channels make it easy to identify switches that have pre-fired.

A change that had an effect on the line-charge voltage monitoring system employed in SNARK was a reduction in the module voltage dividing resistors used to establish the V/N voltage for the slave-switch triggers. Experience using the gas switches on PIML had shown that these resistors had to be smaller than those originally used with solid switches. A phase difference between the line-charging voltage applied to the electrodes of switch and the V/N voltage applied to the switch-trigger electrode was not critical in the solid switches, but the gas switches are more sensitive because of the field-enhanced trigger electrode.

The reduction of the V/N resistors leads to an Ldi/dt voltage drop between the site at which the line-charge voltage is sampled and the site at which the sample is measured. This

requires a small correction to the line-charge voltages at the switching point as recorded by an oscilloscope trace. An additional correction must be made because switch noise causes the line-charge-voltage oscilloscope trace to vanish shortly before the actual switching time. The corrections could be separately identified and measured; this amounted to a total correction of 11 to 12 percent. A 10 percent increase has been included in quoting line-charge voltages.

To test the SNARK gas-switch modules, the tube was again converted to a CuSO_4 resistive load. In this way checkout could be completed more easily with a stable tube impedance (0.5 ohm) and without the need for taking the tube apart after each shot as is the case in the electron beam mode. The gas-switched modules coupled to the CuSO_4 load permitted a very high firing rate; 40 shots were easily completed in one eight-hour shift.

The gas switches functioned quite well after the proper trigger conditions were established. With a single switch the charge voltage can run as high as 80 percent of self-fire with only rare self-fires. However, with as many as eight switches operating simultaneously there seems to be an aggregate effect probably due in part to variations in the actual geometry of switch interior (electrodes and their location), requiring operation nearer to 60 percent of self-fire. The switch jitter increases as the percentage of self-break is decreased, but on Snark the jitter is about 1 nsec, which is completely negligible.

The line-charging voltage was gradually increased to test the high-voltage properties of the new lines. Some tracking occurred under the switch bodies, leading to broken Lucite switch envelopes. The condition was eliminated by weighting the individual switches. No internal tracking has occurred on the Lucite envelopes during over 400 shots on eight switches, i.e., over 3000 tests.

A gradual stepwise increase of the charging voltage was made to determine the maximum useful output of the machine. Many shots were taken near 330 kV with the machine operating very reliably. However, above this charging voltage various problems hampered the machine performance. At 415 kV charging voltage, nearly 60 kJ was delivered to the 0.5-ohm CuSO_4 load; some time after the pulse, a line break probably occurred near the tube. On the next shot this breakdown recurred, and the damage required repairs to lines, switches, and the epoxy tube insulator. A spare epoxy insulator was manufactured at this time.

As a result of the machine performance during this period, it was considered prudent to limit the charging voltage to 330 kV, at which level about 30 kJ can be delivered to a 0.5- to 1-ohm diode.

The CuSO_4 resistive load was then disassembled in order to revert to the normal diode operation to continue the electron beam studies at the levels specified above.

3.4 MACHINE OPERATION WITH GAS-SWITCHED MODULES

The testing phase for the gas-switched modules was carried out during March; about 160 shots were fired. Both risetime and shape of the output pulse were seen to have been improved over those obtained with the solid dielectric-switched modules. Examples are shown in Figures 16 and 17, Section 2. No evidence of the need for switch maintenance was observed and, with the number of spark channels per switch at least 10, there has been little electrode erosion. With the gas switches and the copper-sulphate resistive load the number of shots per eight-hour shift was as high as 50, i.e., a shot every 9.5 minutes. The turn-around time of the machine when in the electron beam mode is

30 to 40 minutes. This shows that tube removal, cleaning, replacement, and experiment setup time are the major determinants of turn-around time. At the end of this testing phase the machine emerged as a 30-kJ pulser of high expected reliability.

Starting in early April the machine was operated for electron beam studies. A standard 280-kV pulse charge operating level was established by mid-April. The number of shots per shift ran about 7 to 8 with a high of 13 per shift on one occasion. The peak line voltage ran from 600 to 850 kV and peak current was 300 to 600 kA, determined by the tube impedance, which varied from 1 to 2 ohms, depending on the cathode being used in the beam experiments.

The operation was occasionally hampered by line gas switches self firing. Most of the time this led to a very short (50 nsec) precursor pulse of about 15 percent of the line voltage peak and occurred immediately before the main pulse (Figure 18). The current pulse showed very little change. This type of self fire was normally acceptable to the experimenter. Presumably, one switch prefired and sent to the master switch a pulse of sufficient amplitude to fire it, thus triggering the remaining seven switches simultaneously after a time interval almost entirely composed of the transit-times of the trigger cables. However, in some cases the output was unacceptable because the remaining switches fired out of synchronism.

Several remedies were tried to eliminate the self fires, which appeared to be an effect of the large number of switches being used. Tests of an individual switch in the gas-switch development program had shown that frequent gas purging was not necessary and that the switches would behave well at levels of

Shot 570
Prefire with precursor

Shot 571
Normal

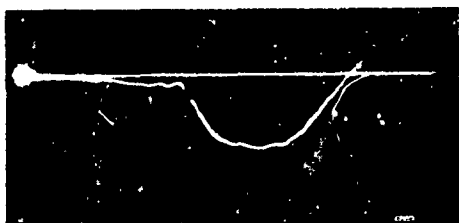

L₁

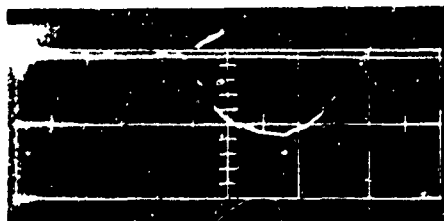

L₂

Module 1

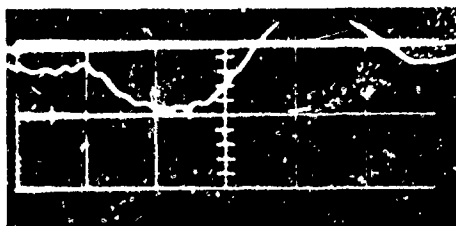

L₁

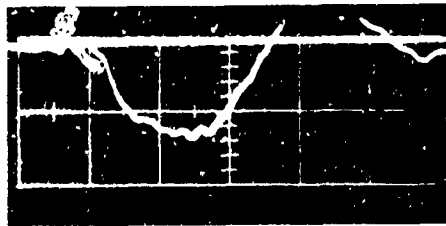

L₂

Module 2

Line voltage

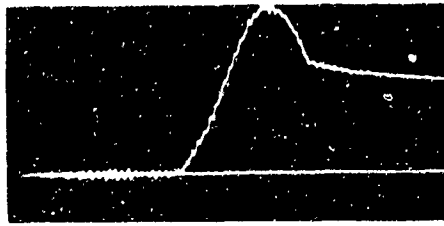
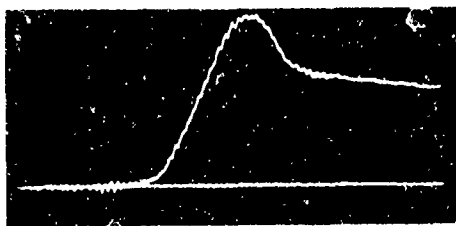

Diode current

Figure 18 Comparison of normal shot and pre-fire with precursor (all 50 nsec/cm).

80 percent of self fire. However, experience with SNARK showed that gas purging was advisable after each shot. (Since the total volume of the switch bodies is small, this does not constitute a large use of SF₆.) Secondly, reliable switch operation was entirely realized when the switches were operated near 60 percent of self fire.

The machine operation continually improved with these additional procedures and by late May the average number of shots per day was six, still determined primarily by the experiment setup.

That the precaution of gas purging is necessary was confirmed by further experience. At one point it was also found that a nearly empty SF₆ bottle was responsible for faulty switch behavior and a fresh bottle restored reliable switching.

In Figure 19 the shots per day are shown for the period from January 6 to July 1. There are several interesting features:

- a. The average line-charging voltage increased by 20 kV over that of April when the switches were functioning unreliably (Figure 20).
- b. Very few self-fires occurred and half occurred on the first shot on Monday when the operator failed to purge the gas switches.
- c. Two breaks occurred in two of the high-voltage feed cables. The shots on those days were about average for that period of shooting, the repairs being made in a very short time (one to two hours).
- d. The machine operated successfully on 29 consecutive working days (see Figure 21). A total of 163 shots were taken and of these 99 percent gave a useful output.

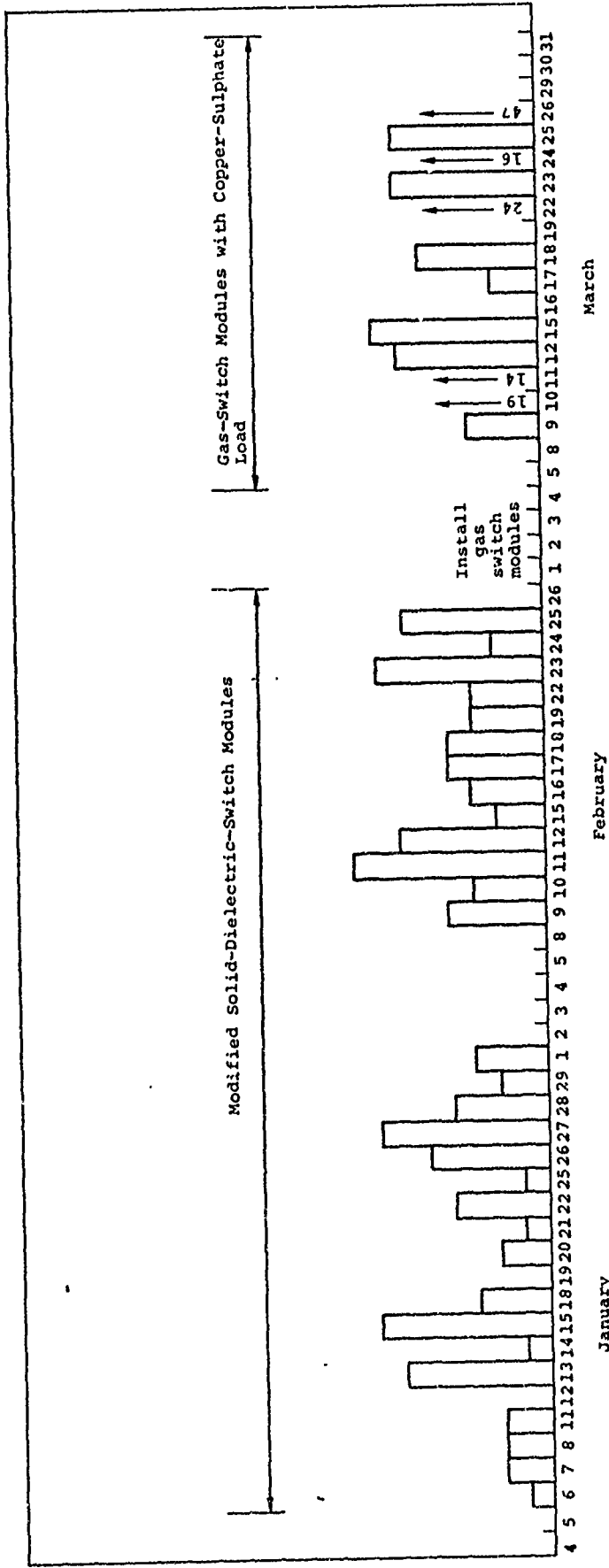

Figure 19a SNARK daily shot record.

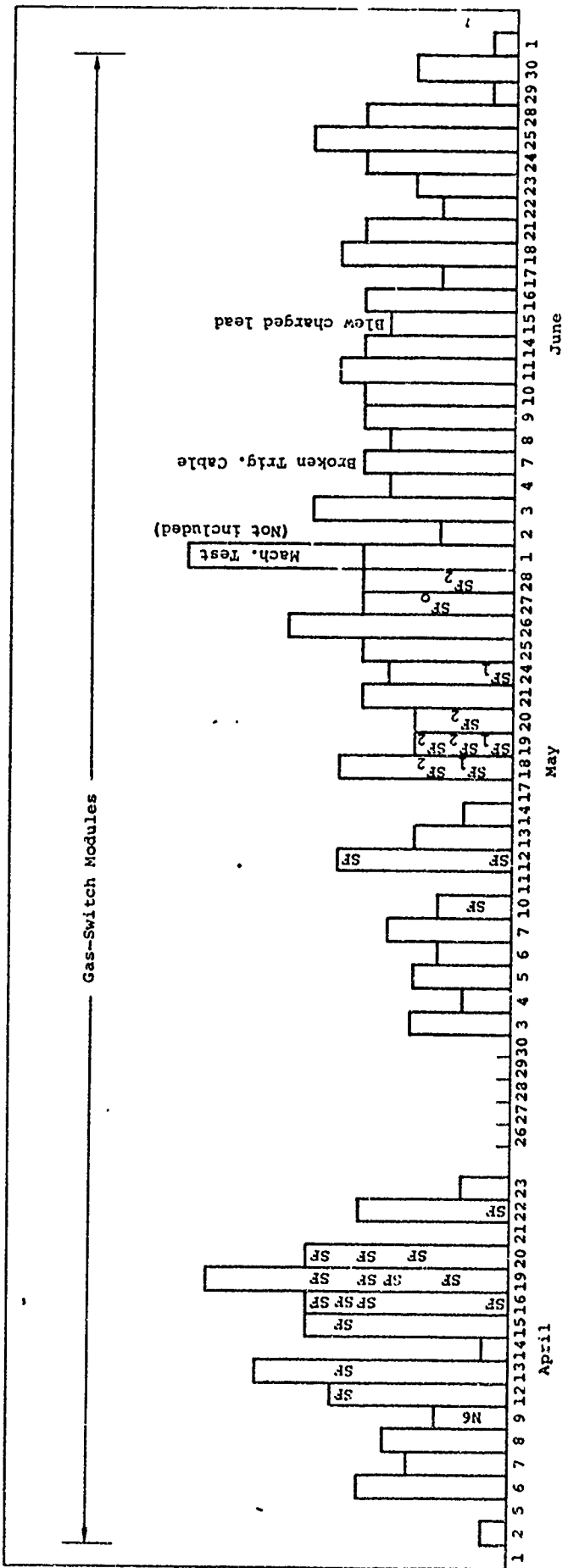

Figure 19b SNARK daily shot record.

Preceding page blank

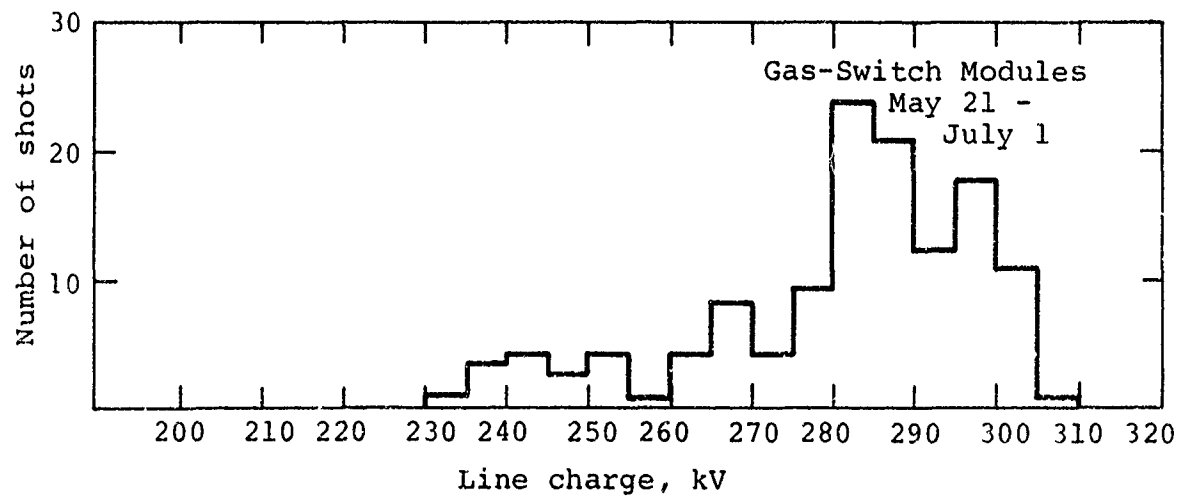
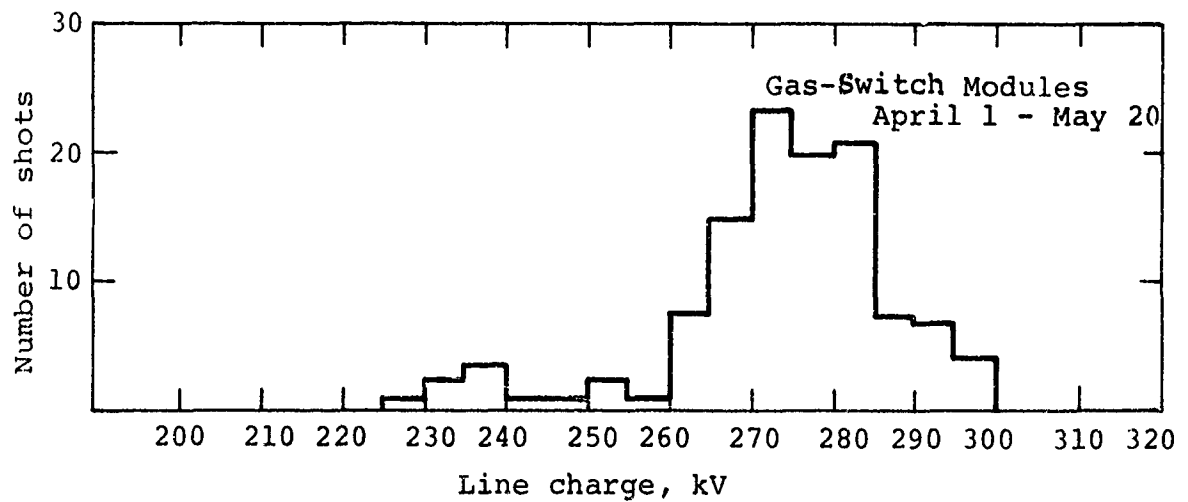
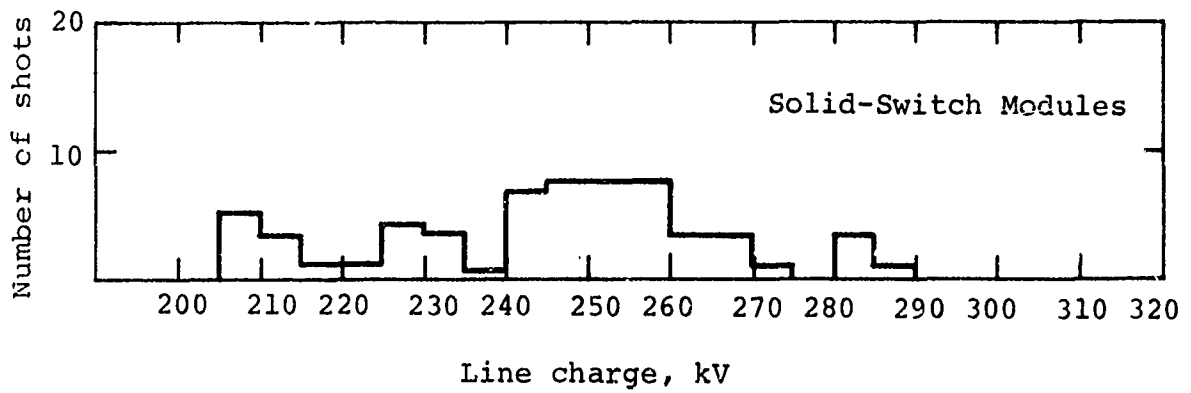

Figure 20 Comparison of line-charge voltage as modules are improved.

In describing the machine output the terms used are:

- a. Machine performed correctly--the machine was command-fired and the switches behaved normally, i.e., the output pulse was normal in shape.
- b. Desired output--a line switch prefired but the output was almost the same as if the switches had performed as in (a). As far as electron beam use is concerned, the output is not distinguishable from (a).
- c. Acceptable output--a prefire has occurred and the experiment did not require synchronization so that the output was useful.

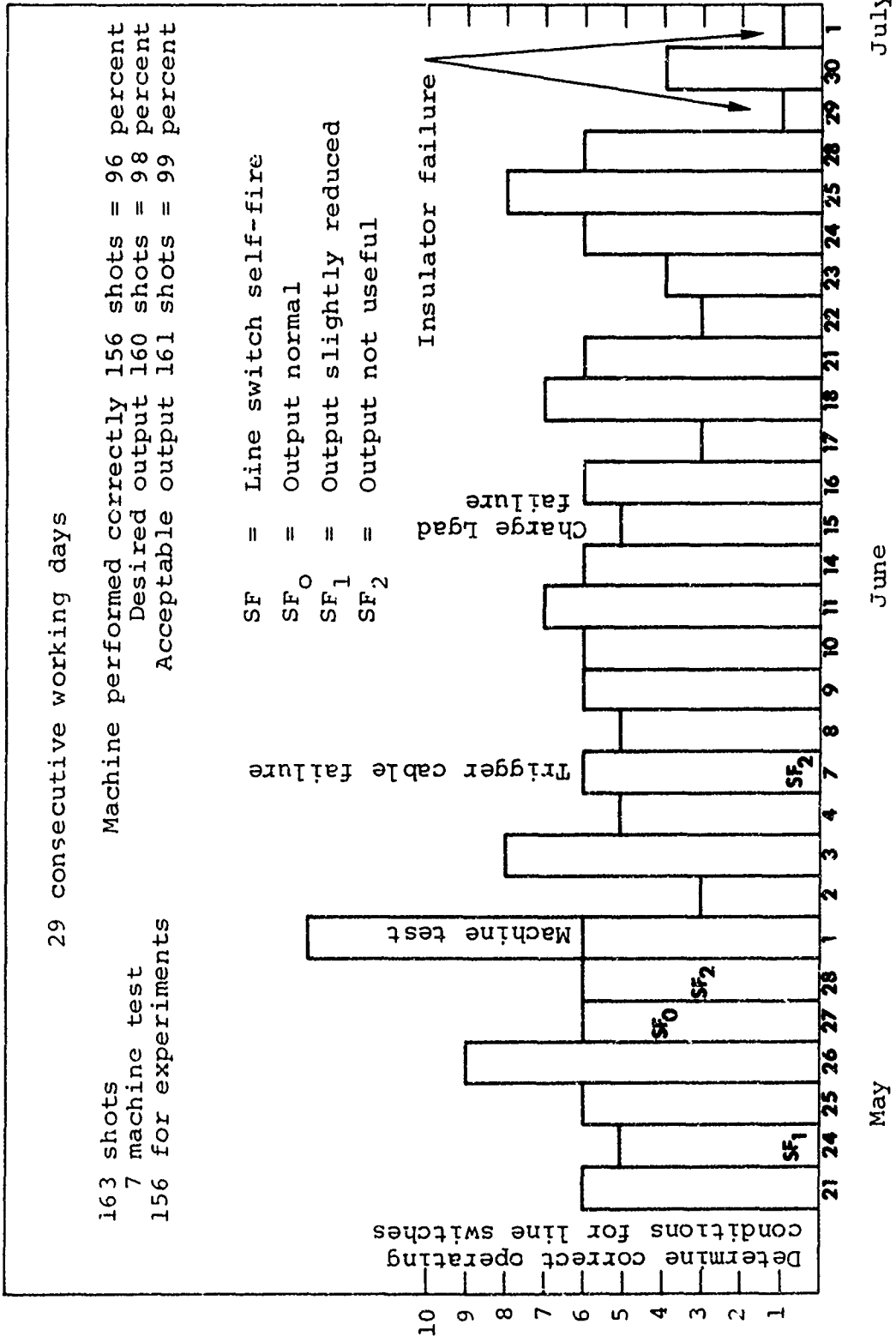

Figure 21 Summary of SNARK daily shot record.