

AD-752 804

**DYNAMIC AND STATIC TESTS OF PLAIN CONCRETE  
SPECIMENS. REPORT II. PHASE II: FLEXURE  
AND TRIAXIAL COMPRESSION**

**R. L. Lundeen**

**Army Engineer Waterways Experiment Station  
Vicksburg, Mississippi**

**November 1964**

**DISTRIBUTED BY:**

**NTIS**

**National Technical Information Service  
U. S. DEPARTMENT OF COMMERCE  
5285 Port Royal Road, Springfield Va. 22151**

US GPO

Property of the United States Government

604  
t.2

MISCELLANEOUS PAPER NO. 6-609

179

# DYNAMIC AND STATIC TESTS OF PLAIN CONCRETE SPECIMENS

Report 2

## PHASE II: FLEXURE AND TRIAXIAL COMPRESSION

by

R. L. Lundeen

AD 752804



November 1964

Sponsored by

**U. S. ARMY MATERIEL COMMAND**

Conducted by

**U. S. Army Engineer Waterways Experiment Station  
CORPS OF ENGINEERS**

Vicksburg, Mississippi

RESEARCH CENTER LIBRARY  
US ARMY ENGINEER WATERWAYS EXPERIMENT STATION  
VICKSBURG, MISSISSIPPI

MISCELLANEOUS PAPER NO. 6-609

# DYNAMIC AND STATIC TESTS OF PLAIN CONCRETE SPECIMENS

Report 2

PHASE II: FLEXURE AND TRIAXIAL COMPRESSION

by

R. L. Lundeen



November 1964

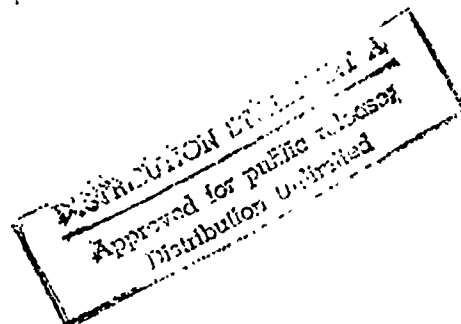

Sponsored by

U. S. ARMY MATERIEL COMMAND  
DA Project No. 1-A-0-13001-A-03909

Conducted by

U. S. Army Engineer Waterways Experiment Station  
CORPS OF ENGINEERS  
Vicksburg, Mississippi

ARMY-MRC VICKSBURG, MISS.

T111  
W 24  
no. 6-1 ?  
1964

FOREWORD

The funds for this investigation were provided by the U. S. Army Materiel Command for an in-house research and development project to be selected by the Director, U. S. Army Engineer Waterways Experiment Station (WES), Vicksburg, Miss. The authorization for the project is contained in a memorandum to Chief, Concrete Division, from the Director, WES, dated 5 November 1963, subject, "New R and D Work - FY 1964."

This work was conducted by personnel of the Concrete Division, WES, under the supervision of Mr. T. B. Kennedy, Chief. Staff members actively concerned with the investigation included Messrs. James M. Polarty, W. O. Tynes, K. L. Saucier, and SP-4 R. L. Lundeen. The investigation was under the direct supervision of SP-4 Lundeen who also prepared this report.

Director of the WES during the conduct of this investigation and preparation and publication of this report was Col. Alex G. Sutton, Jr., CE. Technical Director was Mr. J. B. Tiffany.

## CONTENTS

	<u>Page</u>
FOREWORD . . . . .	iii
SUMMARY . . . . .	vii
PART I: INTRODUCTION . . . . .	1
Background . . . . .	1
Purpose and Scope of Investigation . . . . .	2
PART II: MATERIALS, MIXTURES, AND TEST SPECIMENS . . . . .	3
Materials . . . . .	3
Mixtures . . . . .	3
Test Specimens . . . . .	3
Strain Gages . . . . .	4
PART III: TEST METHODS, APPARATUS, AND PROCEDURES . . . . .	5
Static Tests . . . . .	5
Dynamic Tests . . . . .	6
PART IV: RESULTS . . . . .	11
Triaxial Compression Tests . . . . .	11
Flexure Tests . . . . .	12
Test Methods . . . . .	13
PART V: SUMMARY OF RESULTS . . . . .	14
LITERATURE CITED . . . . .	15
TABLES 1-6	
PLATES 1-9	
APPENDIX A: METHOD OF TEST FOR BEHAVIOR OF CYLINDRICAL CONCRETE SPECIMENS SUBJECTED TO TRIAXIAL COMPRESSION BY IMPACT . . . . .	A1
APPENDIX B: METHOD OF TEST FOR FLEXURAL STRENGTH OF CONCRETE BY IMPACT (USING SIMPLE BEAM WITH CENTER-POINT LOADING) . . . . .	B1

## SUMMARY

The effect of the rate of application of load on the triaxial compressive and flexural strengths of specimens from two concrete mixtures having static compressive strengths of approximately 2000 and 4000 psi, respectively, was investigated. The test specimens were cast as 1-1/2- by 3-in. cylinders and 6- by 6- by 20-in. beams, which were tested in triaxial compression and flexure, respectively. Triaxial specimens were tested under three lateral pressures (0, 250, and 500 psi) in order to establish the relation between shear strength and principal stresses. Dynamic loading of the specimens was accomplished with the rapid-loading, MIT-WES, gas-operated impact machine. Resistance-wire strain gages were bonded to the concrete specimens used in the triaxial compression tests to obtain stress-strain relations. Static tests were made on a hydraulic testing machine.

The triaxial compressive and flexural strengths of the concrete were higher under the dynamic loading than under static loading. For both strength levels, the ratios of dynamic to static strength were approximately 1.37 and 2.46 for triaxial compressive and flexural strengths, respectively. The ratios of dynamic to static modulus of elasticity obtained in triaxial compression tests varied, but generally approximated 1:1. Results of triaxial compression tests were plotted as Mohr circles.

Test methods and procedures giving reproducible results were developed for determining triaxial compressive and flexural strengths of concrete. These methods are included as Appendixes A and B.

## DYNAMIC AND STATIC TESTS OF PLAIN CONCRETE SPECIMENS

### PHASE II: FLEXURE AND TRIAXIAL COMPRESSION

#### PART I: INTRODUCTION

##### Background

1. In Phase I<sup>1\*</sup> of this investigation, the effect of the rate of application of load on the compressive, diametral compressive (tensile-splitting), and flexural strengths of specimens, made from three different concrete mixtures, having static compressive strengths of approximately 2000, 3000, and 4000 psi, respectively, was investigated. The test specimens were cast as 1-1/2- by 3-in. cylinders, 3- by 6-in. cylinders, and 6- by 6- by 20-in. beams, which were tested in compression, diametral compression, and flexure, respectively. Dynamic loading of the specimens was accomplished with the rapid-loading, MIT-WES,\*\* gas-operated impact machine. Resistance-wire strain gages were bonded to the concrete specimens used in the compression and diametral compression tests to obtain stress-strain relations. For comparison, a hydraulic testing machine was used to load the specimens statically.

2. The compressive, diametral compressive, and flexural strengths of the concrete specimens were higher under the high rate of loading than under static loading. For all three strength levels, the ratios of dynamic to static strength were approximately 1.36, 1.74, and 4.37 for compressive, diametral compressive, and flexural strengths, respectively. The ratios of dynamic to static modulus of elasticity obtained in the diametral compression and compression tests varied, but generally approximated 1:1.

3. Reproducible test methods and procedures were developed for determining the dynamic compressive and diametral compressive strengths of concrete. Results of flexure tests showed the need for additional

---

\* Raised numbers refer to similarly numbered items in the Literature Cited at end of text.

\*\* A loading apparatus developed by the Massachusetts Institute of Technology and subsequently modified by the Waterways Experiment Station.

improvement of the test apparatus to eliminate apparently erroneous dynamic strength readings probably caused by a sizable absorption of strain energy in the test apparatus or inertial effects of the specimens, or both.

#### Purpose and Scope of Investigation

4. The purpose of the investigation reported herein was to develop reproducible methods and procedures for testing concrete specimens of different strength levels at high rates of loading in flexure and triaxial compression.

5. The investigation consisted of laboratory tests in which (a) the WES-modified MIT rapid-loading apparatus was used to determine the triaxial compressive and flexural strengths of concrete specimens under dynamic loading, and (b) a hydraulic testing machine was used to determine such strengths under static loading. Stress-strain relations and shear strength envelopes were obtained in the triaxial compression tests.



mic  
gy

PART II: MATERIALS, MIXTURES, AND TEST SPECIMENS

Materials

6. The materials used in the concrete test specimens consisted of type II portland cement manufactured in Alabama, and crushed-limestone fine and coarse aggregates obtained from Tennessee. The air-entraining admixture used was laboratory-stock, neutralized vinsol resin solution.

Mixtures

7. Two concrete mixtures, designed to produce a low- and a high-strength concrete (static compressive strengths of approximately 2000 and 4000 psi, respectively), were proportioned to have a slump of 1-1/2 in. (+1/2 in.) and an air content of 5.0 percent (+0.5 percent). The maximum-size aggregate used was 3/8 in. The mixture proportions are given in table 1. The concrete was mixed in a turbine mixer of 13.5-cu-ft capacity. Coarse aggregate, water and cement, and fine aggregate were placed in that order in the mixer. The concrete was mixed for 2 min, allowed to rest for 3 min, and remixed for 1 min.

Test Specimens

8. Three rounds of each of the two mixtures (low-strength and high-strength) were made. From each round the following types and numbers of specimens were cast:

- a. Twenty 1-1/2- by 3-in. cylinders for triaxial compression tests (18 were used for testing purposes).
- b. Twelve 6- by 6- by 20-in. beams for flexural strength tests (9 were used for testing purposes).

The small size of the triaxial test specimens was dictated by the limited capacity of the dynamic testing machine.

9. The specimens were consolidated in the molds. The 1-1/2- by 3-in. cylinders were consolidated for 10 sec using a vibration table (external vibration) with a frequency of 3600 vibrations per min. The

6- by 6- by 20-in. beams were vibrated internally for 25 sec with a portable, 1-1/2-in.-diameter, flexible-shaft vibrator with a frequency of 6000 vibrations per min.

10. The concrete specimens were moist-cured for 21 days. On the twenty-second day, the 1-1/2- by 3-in. cylinders were capped with hydrostone, a high-strength gypsum plaster, on the cast end to obtain a plain surface. The specimens were then air-dried until tested at 28 days age. In preparation for attachment of the strain gages, the surfaces of the concrete cylinders were lightly roughened with fine sandpaper and cleaned with acetone. Voids on the surface of the concrete cylinders were filled with hydrostone to prevent the confining pressure in the triaxial chamber from puncturing the neoprene rubber membrane placed over the specimen.

#### Strain Gages

11. Two SR-4 strain gages were mounted diametrically opposite each other on each triaxial specimen. The strain gages had thin paper backs; were mounted on the specimens with a nitrocellulose glue; and were wired in series. Each gage was 1 1/2 in. long. The gages had a resistance of 120 ohms (240 ohms when wired in series), and a gage factor of 2.05.

PART III: TEST METHODS, APPARATUS,  
AND PROCEDURES

Static Tests

Triaxial compression

12. From each round, three 1-1/2- by 3-in. cylinders for each of three confining pressures (0, 250, and 500 psi) were tested statically. The triaxial test apparatus is shown in fig. 1. The electrical-resistance

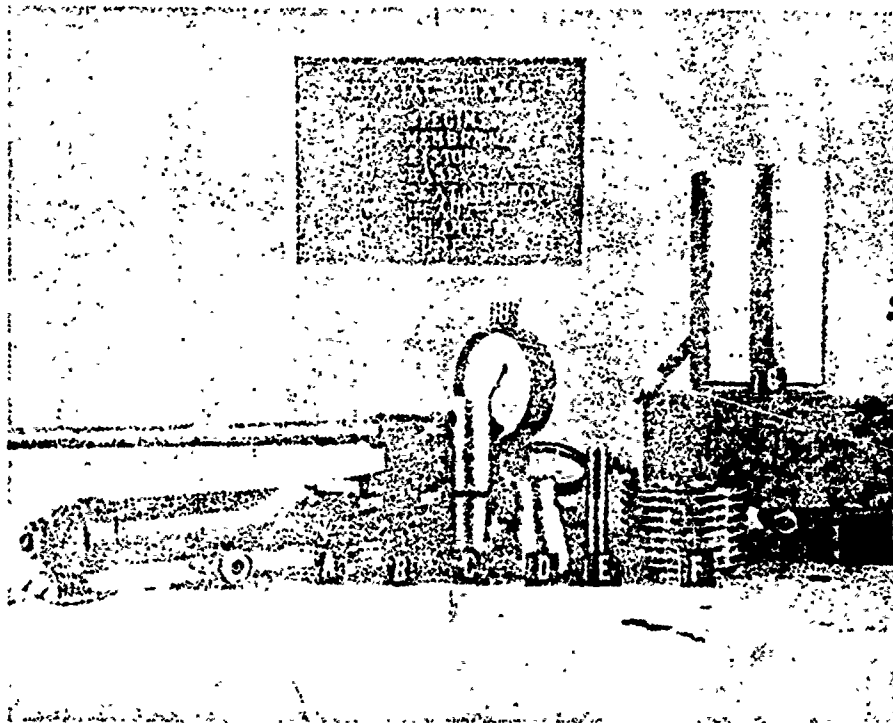

Fig. 1. Triaxial test apparatus

strain gages described in paragraph 11 were used in all static triaxial compression tests to provide an indication of the stress-strain relation. An X-Y recorder was used to record stress-strain measurements using temperature-compensating gages wired into a two-arm bridge. The specimens were tested in accordance with Test Method CRD-C 93-64<sup>2</sup> using a 440,000-lb-capacity Universal testing machine. The rate of loading was

approximately 35 psi, or 3720 lb per min. The test setup is shown in fig. 2.

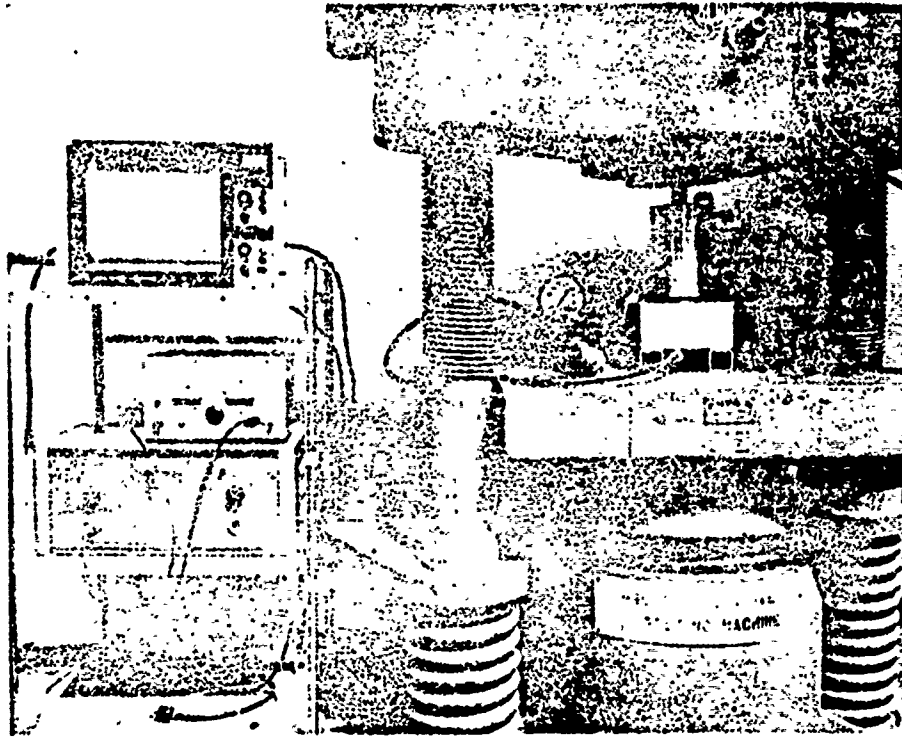

Fig. 2. Static triaxial compression test setup

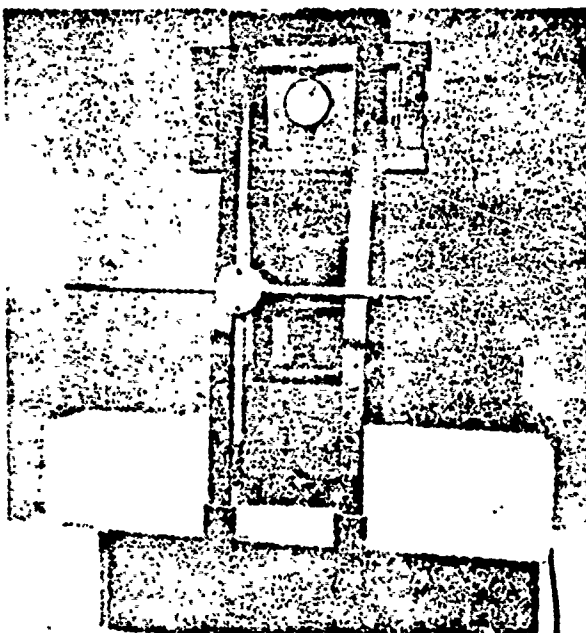

Fig. 3. Static flexural test setup

#### Flexure

13. Three 6- by 6- by 20-in. beams (from each round) were tested according to Test Method CRD-C 17-63<sup>2</sup> (center-point loading). The rate of loading was 150 psi, or 1200 lb per min. The static flexural test setup is shown in fig. 3.

#### Dynamic Tests

14. In the field of dynamic testing of concrete specimens,

7

a limited amount of work has been done using slow-loading equipment. In investigations to date of the effect of rate of loading on the strength and elastic properties of concrete,<sup>3,4,5,6,7</sup> either a weight dropped onto the specimen or a hydraulic testing machine run at full speed has been used to apply load. Wätstein<sup>6,7</sup> attained a maximum stressing rate of 1 psi per  $10^{-7}$  sec using a dropped weight as compared to a rate of 2 psi per  $10^{-7}$  sec attained in compression at the U. S. Army Engineer Waterways Experiment Station using the MIT-WES impact loader.

#### MIT-WES impact loader

15. Only a brief description of the rapid-loading machine used for producing dynamic loads in this study is given in this report. For a more detailed description the reader is referred to the thesis by Dr. R. J. Hansen.<sup>8</sup>

16. The impact load is produced by a high-pressure, gas-operated, cylinder-piston arrangement. The use of this type of system limits the machine to the production of a single concentrated load (25,000 lb). The stroke of the piston rod in all tests was limited to 1/2 in.

17. The piston, piston rod, and load-initiation system were designed so that nitrogen at 1000 psi would drive the piston to the capacity of the machine. Bottled nitrogen was used to provide the required gas pressure as it is a fairly light gas and produces a constant-slope loading pulse which peaked in approximately 1 msec for the compression tests. A mechanical, trip-lever system was used that restrained the piston rod from applying the load to the specimen until it was tripped. The actual tripping operation is initiated by a plunger which pushes the trip lever at the desired moment by release of a gas-operated solenoid. The load was released by evacuating the gas from the accumulator cylinder above the piston by the use of another solenoid. The total volume of the accumulator cylinder was 982 cu in.

18. The base of the supporting system for the machine was made heavy and massive to minimize vertical support vibration during testing (see fig. 4).

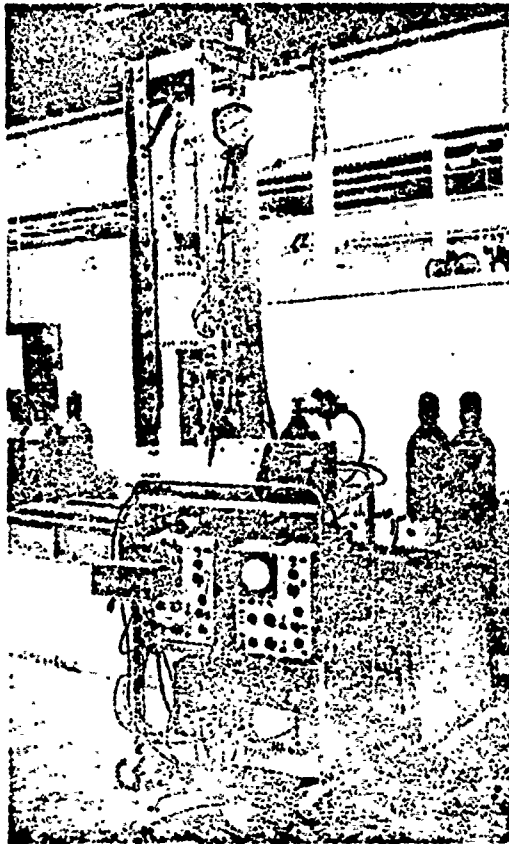

Fig. 4. Impact machine and instrumentation

#### Instrumentation

19. The instrumentation, also shown in fig. 4, consisted essentially of a 30,000-lb-capacity load cell attached to the piston rod, and an oscilloscope modified to provide only one trigger sweep or to be used with a d-c amplifier as an X-Y recorder. The stress-strain relations were recorded on a dual-trace oscilloscope equipped with a camera.

20. The load cell was calibrated statically periodically by loading it with a hydraulic testing machine and relating the corresponding changes in load to the position change of the beam on the oscilloscope. For strain calibration, a known resistance was switched into the strain circuit and the resulting change noted. By use of the gage factor relation, the known

resistance was equated to a definite value of strain.

21. Initially, a pressure transducer was mounted through the wall of the triaxial chamber to record increases in the pressure of the confining fluid occurring before failure of the specimen.

#### Test procedures

22. Three 1-1/2- by 3-in. cylinders from each round were tested dynamically in compression at each of the confining pressures used in the static tests (0, 250, and 500 psi). Nine 6- by 6- by 20-in. beams from each round were tested dynamically in flexure.

23. These test specimens were equipped with the same type of strain gages, mounted and wired in the same way, as the specimens used in the static tests. The testing cap attached to the load cell consisted of a beveled male surface which fitted into the complementary female surfaces of the different testing heads to provide a rotating ball joint. The

different heads are shown in fig. 5 along with the center-point-loading flexure apparatus. A rocking bar was employed on one end of the flexure

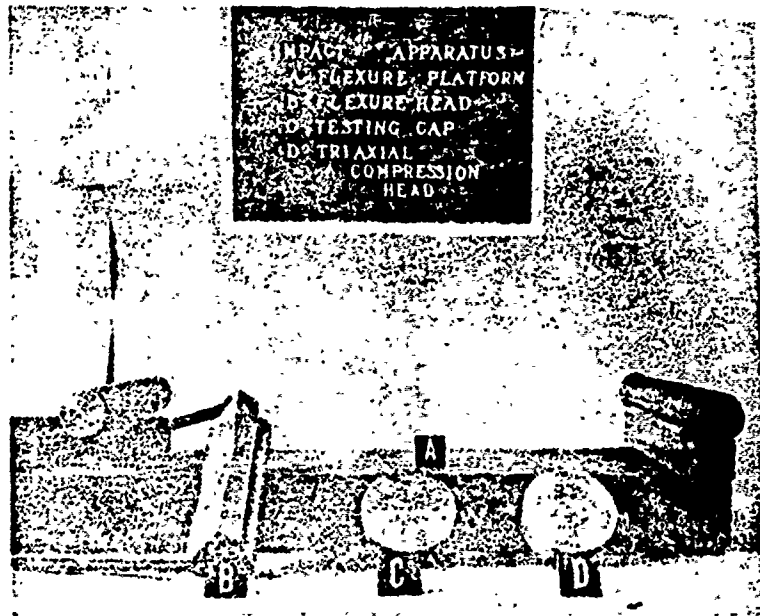

Fig. 5. Testing heads and flexure apparatus

apparatus to compensate for any casting irregularities in the specimens. Dynamic test setups for triaxial compression and flexure are shown in figs. 6 and 7, respectively.

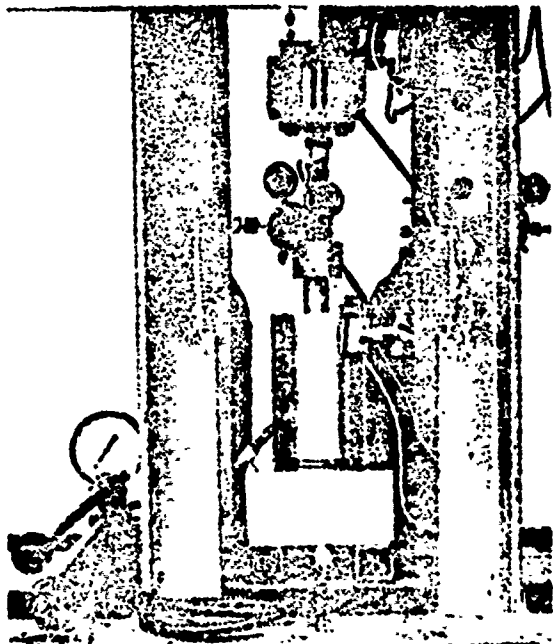

Fig. 6. Dynamic triaxial compression test setup

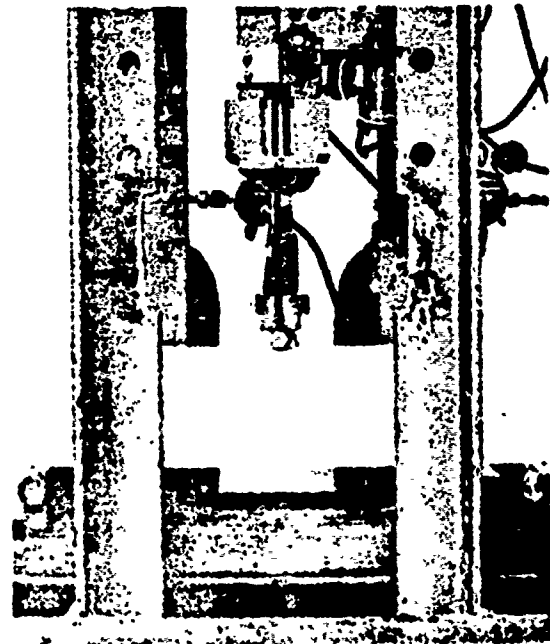

Fig. 7. Dynamic flexure test setup

24. For each test, the trigger of the impact machine was set with a preload of 200 psi. The test specimen was placed in the impact machine, and the testing head was brought to bear on the specimen by turning the testing cap until it was tight. Next the accumulator pressure was increased to the desired amount. The impact machine was then triggered by the operator, which automatically triggered the oscilloscope. The camera was tripped by the operator at the same instant at which the impact loader was triggered.

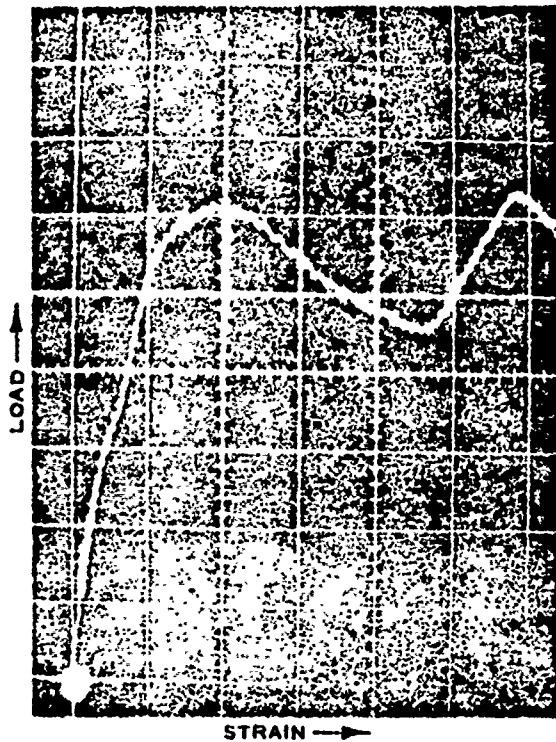

Fig. 8. Typical dynamic triaxial compression test trace

Fig. 9 illustrates the recorded load obtained on a flexure specimen. The strain trace is produced by the two strain gages wired in series, and represents the average strain in the specimen.

26. The load-strain curve obtained from the photographs was converted to a stress-strain curve which was enlarged using an opaque projector.

#### Recording and reduction of data

25. The records of the test were photographed on the screen of the cathode-ray oscilloscope with a 75mm still camera. A typical record of the load and strains observed in a triaxial test is shown in fig. 8.

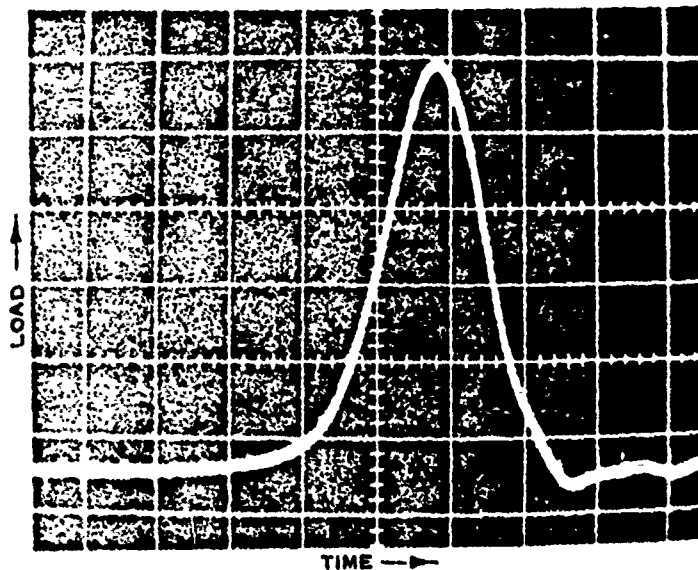

Fig. 9. Dynamic flexure test load trace



PART IV: RESULTS

Triaxial Compression Tests

27. The results of the triaxial compression tests on specimens of the two strength levels of concrete under static and dynamic loading are given in table 2. Each test value in this table represents the average of three specimens in each of three rounds. The average static major principal ultimate strengths for confining pressures of 0, 250, and 500 psi were 1890, 3240, and 3920 psi, respectively, for the low-strength mixtures and 3630, 5280, and 6190 psi, respectively, for the high-strength mixtures. The ratios of dynamic to static strengths for the same confining pressures were 1.34, 1.37, and 1.37 and 1.37, 1.36, and 1.36 for the low- and high-strength mixtures, respectively.

28. Composite stress-strain curves, both static and dynamic, for each round and confining pressure for each of the two concretes are shown in plates 1 through 3 and 5 through 7. The modulus of the concrete is given as the slope of the secant drawn from the origin to a point on the curve corresponding to a strain value of 0.001 in./in. Use of the secant modulus of elasticity eliminated the error in human judgment that is possible in determining the modulus of elasticity by the initial tangent method. The ratios of dynamic to static moduli for confining pressures of 0, 250, and 500 psi were 1.18, 1.02, and 1.08, respectively, for the low-strength mixtures and 1.07, 1.18, and 1.03, respectively, for the high-strength mixtures.

29. Triaxial test data for the individual test specimens for the low- and high-strength mixtures are given in tables 3 and 4, respectively. Mohr circles for each round are shown in plates 4 and 8 for low- and high-strength mixtures, respectively. The shear strength parameters, i.e. the angle of internal friction  $\phi$  and the value of cohesion  $c$ , are not reported because the pronounced curvature of the envelope of failure indicated that they were not constant.

30. Results obtained from the pressure transducer employed to record variances in confining pressure before failure of the specimen indicated increases of approximately 60 and 110 psi for lateral

pressures of 250 and 500 psi, respectively.

31. There was no significant difference in the manner of failure of the triaxial compression test cylinders in the dynamic and static tests. All specimens failed in the characteristic manner of brittle material in a compression test by developing cones at the ends which served to split the cylinder.

#### Flexure Tests

32. Table 5 gives the results of tests on the individual flexural specimens by strength levels. The average static flexural strengths, shown in table 6, were 300 and 455 psi for the low- and high-strength mixtures, respectively, as computed by the following relation:

$$R = \frac{3 Pl}{2 bd^2}$$

where

R = modulus of rupture, psi

P = maximum applied load, lb

l = span length, in.

b = width of specimen, in.

d = depth of specimen, in.

33. Plate 9 shows the relation by round of the ultimate static to ultimate dynamic modulus of rupture. As shown in table 5, the impact factor (ratio of dynamic stress to static stress) is approximately 2.5 compared to a value of approximately 4 reported in Phase I of this investigation.<sup>1</sup> The decrease in the impact factor is the result of a revised test apparatus that utilizes a rigid base and a load cell mounted on the piston rod. This resulted in obtaining the following conditions which are considered necessary for determining a valid impact factor for a suddenly applied load:<sup>9</sup> (a) the proportional limit of the test specimen material is not exceeded, and (b) all the energy supplied by the impacting body is absorbed in stressing the beam. Also, with the revised apparatus the load reaction recorded on the load cell was not affected by the inertial effects of the specimen and the energy supplied by the machine was

not affected by the test apparatus before the load reaction was recorded.

#### Test Methods

34. Variance in individual dynamic test results compare reasonably well with those of their static counterpart, as illustrated in tables 3, 4, and 5. Based on this and results obtained in Phase I, test methods and procedures for determining dynamically the triaxial compressive and flexural strengths of concrete that give reproducible results were developed and are included as Appendixes A and B.

## PART V: SUMMARY OF RESULTS

35. The following results were derived from the tests conducted in this investigation:

- a. Triaxial compressive strength of specimens of each strength level was higher under the dynamic loading than under the static loading. For the two strength levels and the three confining pressures, an average ratio of dynamic to static strength of 1.37 was obtained.
- b. For both strength levels, the modulus of rupture of the flexure specimens was greater under dynamic loading than under static loading; average ratio of dynamic to static strength was 2.46.
- c. The ratio of dynamic secant modulus of elasticity to static for triaxial compression specimens ranged from 0.99 to 1.19 for the low-strength mixture and 0.95 to 1.22 for the high-strength mixture.
- d. Dynamic envelopes of failure derived from a plot of Mohr circles were higher than their static counterpart.
- e. Reproducible test methods for determining the triaxial compressive and flexural strengths of concrete dynamically were developed.

## LITERATURE CITED

1. U. S. Army Engineer Waterways Experiment Station, CE, Dynamic and Static Tests of Plain Concrete Specimens, by R. L. Lundeen. Miscellaneous Paper No. 6-609, Vicksburg, Miss., November 1963.
2. \_\_\_\_\_, Handbook for Concrete and Cement, with quarterly supplements. Vicksburg, Miss., August 1949.
3. Abrams, D. A., "The effect of rate of application of load on the compressive strength of concrete." Proceedings, American Society for Testing Materials, Part II, vol XVII (1917), pp 364-374.
4. Jones, P. G., and Richart, F. E., "The effect of testing speed on strength and elastic properties of concrete." Proceedings, American Society for Testing Materials, Part II, vol 36 (1936), pp 380-391.
5. McHenry, Douglas, and Shideler, J. J., "Review of data on effect of speed in mechanical testing of concrete." Symposium on Speed of Testing of Non-Metallic Materials, ASTM Special Technical Publication No. 185 (29 June 1955), p 72.
6. Watstein, D., "Effect of straining rate on the compressive strength and elastic properties of concrete." Journal of the American Concrete Institute, vol 24, No. 8 (April 1953), pp 729-744.
7. \_\_\_\_\_, "Properties of concrete at high rates of loading." Symposium on Impact Testing, ASTM Special Technical Publication No. 176 (27 June 1955), pp 156-169.
8. Hansen, R. J., Development of Experimental Technique for Controlled Impulsive Loading of Simple Beams. ScD thesis, Massachusetts Institute of Technology, Cambridge, Mass., January 1948.
9. Seely, F. B., and Smith, J. O., "Dynamic loads," in Resistance of Materials, 4th ed. John Wiley and Sons, Inc., New York, N. Y., 1956, Chap. X.

Table 1

Mixture Proportions for Test Concretes

<u>Specimen</u>	<u>Actual Slump in.</u>	<u>Fine Aggregate: Total Aggregate % by vol</u>	<u>Air Content %</u>	<u>Cement Factor bags/cu yd</u>		<u>Water:Cement Ratio by Weight</u>
				<u>Theoretical</u>	<u>Actual</u>	
<u>Low-Strength Concrete</u>						
DL-1	1-1/2	51	5.5	3.50	3.30	0.95
DL-2	1-1/2	51	5.3	3.50	3.31	0.95
DL-3	1-1/2	51	4.5	3.50	3.34	0.95
<u>High-Strength Concrete</u>						
DH-1	1-1/2	49	5.4	4.50	4.26	0.70
DH-2	1-1/4	49	5.5	4.50	4.25	0.70
DH-3	1-1/4	49	5.4	4.50	4.26	0.70

Table 2

Summary of Triaxial Test Results

<u>Test</u>	<u>Low Strength</u>	<u>High Strength</u>
<u><math>\sigma_3 = 0</math> psi</u>		
Major principal stress, psi		
Dynamic ( $f'_{cd}$ )	2540	4970
Static ( $f'_c$ )	1890	3630
$f'_{cd}/f'_c$	1.34	1.37
Modulus of elasticity, $10^6$ psi		
Dynamic ( $E_{cd}$ )	1.95	3.00
Static ( $E_{cs}$ )	1.65	2.81
$E_{cd}/E_{cs}$	1.18	1.07
<u><math>\sigma_3 = 250</math> psi</u>		
Major principal stress, psi		
Dynamic ( $f'_{cd}$ )	4450	7180
Static ( $f'_c$ )	3240	5280
$f'_{cd}/f'_c$	1.37	1.36
Modulus of elasticity, $10^6$ psi		
Dynamic ( $E_{cd}$ )	2.12	3.59
Static ( $E_{cs}$ )	2.08	3.03
$E_{cd}/E_{cs}$	1.02	1.18
<u><math>\sigma_3 = 500</math> psi</u>		
Major principal stress, psi		
Dynamic ( $f'_{cd}$ )	5360	8390
Static ( $f'_c$ )	3920	6190
$f'_{cd}/f'_c$	1.37	1.36
Modulus of elasticity, $10^6$ psi		
Dynamic ( $E_{cd}$ )	2.56	3.43
Static ( $E_{cs}$ )	2.37	3.33
$E_{cd}/E_{cs}$	1.08	1.03

Table 3

High  
Strength

970

630

1.37

3.00

2.81

1.07

180

280

1.36

3.59

3.03

1.18

390

190

1.36

3.43

3.33

1.03

Table 3

Triaxial Strength Test Data, Low-Strength Concrete

Round No.	Static Principal Major Stress				Dynamic Principal Major Stress				$f'_{cd}/f'_c$				$E_{cd}/E_{cs}$					
	$\sigma_3 = 0$ psi		$\sigma_3 = 250$ psi		$\sigma_3 = 500$ psi		$\sigma_3 = 0$ psi		$\sigma_3 = 250$ psi		$\sigma_3 = 500$ psi		$\sigma_3 = 0$ psi		$\sigma_3 = 250$ psi		$\sigma_3 = 500$ psi	
	$f'_c$	$E_{cs}$	$f'_c$	$E_{cs}$	$f'_c$	$E_{cs}$	$f'_{cd}$	$E_{cd}$	$f'_{cd}$	$E_{cd}$	$f'_{cd}$	$E_{cd}$	$f'_{cd}$	$E_{cd}$	$f'_{cd}$	$E_{cd}$	$f'_{cd}$	$E_{cd}$
DL-1	1790	1.55	3000	2.00	4030	2.28	2600	1.90	4420	2.32	5530	2.15	0	250	500	0	250	500
	1780	1.60	3240	1.98	3800	2.30	2530	1.86	4300	2.15	5260	2.40						
	1860	1.75	3310	2.05	3860	2.35	2640	2.04	4330	1.96	5210	2.32						
Avg	1820	1.65	3180	2.01	3900	2.31	2590	1.93	4350	2.14	5330	2.29	1.42	1.37	1.37	1.17	1.06	0.99
DL-2	1970	1.65	3560	2.20	4220	2.35	3000	2.00	4940	2.10	5800	3.07						
	2000	1.67	3380	2.40	4110	2.50	2680	1.93	4760	2.10	5540	2.70						
	2050	1.73	3400	2.10	4290	2.70	2420	2.04	4400	2.42	5830	3.21						
Avg	2010	1.68	3450	2.23	4210	2.52	2700	1.99	4700	2.21	5720	2.99	1.34	1.36	1.36	1.18	0.99	1.19
DL-3	1860	1.65	3110	1.98	3570	2.20	2000	1.84	4300	2.15	5080	2.40						
	1770	1.58	2990	2.03	3640	2.35	2510	1.96	4560	1.93	5030	2.45						
	1850	1.65	3190	2.00	3700	2.28	2520	1.96	4070	1.98	5020	2.37						
Avg	1830	1.63	3100	2.00	3640	2.28	2340	1.92	4310	2.02	5040	2.41	1.28	1.39	1.38	1.18	1.01	1.06

Note:  $f'_{cd}$  and  $f'_c$  expressed in psi;  $E_{cd}$  and  $E_{cs}$  expressed in  $10^6$  psi.



Table 4

## Triaxial Strength Test Data, High-Strength Concrete

Round No.	Static Principal Major Stress						Dynamic Principal Major Stress						$f'_{cd}/f'_c$		$E_{cd}/E_{cs}$	
	$\sigma_3 = 0$ psi		$\sigma_3 = 250$ psi		$\sigma_3 = 500$ psi		$\sigma_3 = 0$ psi		$\sigma_3 = 250$ psi		$\sigma_3 = 500$ psi		$f'_c$	$\sigma_3$	$f'_c$	$\sigma_3$
	$f'_c$	$E_{cs}$	$f'_c$	$E_{cs}$	$f'_c$	$E_{cs}$	$f'_c$	$E_{cd}$	$f'_c$	$E_{cd}$	$f'_c$	$E_{cd}$	psi	psi	psi	psi
DH-1	3930	2.90	5690	3.40	6370	3.55	5280	2.98	7590	3.70	8590	3.13	0	250	500	500
	3490	2.65	5310	2.75	6010	3.15	5610	2.90	7500	3.90	8900	3.53	0	250	500	500
	4100	2.75	5550	3.08	6320	3.50	5660	2.97	7570	3.67	8780	3.07	0	250	500	500
AVG	3840	2.77	5520	3.08	6230	3.40	5520	2.95	7550	3.76	8760	3.24	1.44	1.37	1.41	1.06
DH-2	3770	2.83	5460	2.95	6280	3.25	4570	2.55	7470	3.75	8350	3.30	0	250	500	500
	3390	2.65	5150	3.03	6580	3.38	4660	3.12	7350	3.80	8340	3.89	0	250	500	500
	3680	2.98	5990	3.25	6290	3.80	4820	2.92	7500	3.79	8340	3.26	0	250	500	500
AVG	3680	2.82	5530	3.08	6380	3.48	4680	2.86	7440	3.78	8340	3.48	1.27	1.35	1.31	1.01
DH-3	3330	2.73	4990	2.93	5770	3.08	4930	3.04	6520	2.84	8090	3.49	0	250	500	500
	3370	2.90	4470	2.90	5930	2.98	5130	3.11	6390	3.28	8100	3.61	0	250	500	500
	3370	2.93	4900	3.00	6160	3.25	4040	3.46	6700	3.56	8060	3.60	0	250	500	500
AVG	3360	2.85	4790	2.94	5950	3.10	4700	3.20	6540	3.23	8080	3.57	1.39	1.37	1.36	1.12

Note:  $f'_{cd}$  and  $f'_c$  expressed in psi;  $E_{cd}$  and  $E_{cs}$  expressed in  $10^6$  psi.

Note:  $f'_c$  and  $f'_d$  expressed in psi;  $E_{cd}$  and  $E_{cs}$  expressed in  $10^6$  psi.

Table 5  
Flexural Strength Test Data

Round No.	Static			Dynamic			R <sub>d</sub> /R <sub>s</sub>
	Strength (R <sub>s</sub> ) psi	Range* psi	Strength (R <sub>d</sub> ) psi	Range* psi	Strength (R <sub>d</sub> ) psi	Range* psi	
<u>Low-Strength Specimens</u>							
DL-1	285		570		1085		
	320		635		1160		
	265		745		1250		
			690		1440		
			660		1230		
			645		1345		
AVG	290	55	660	175	1250	355	2.60
<u>High-Strength Specimens</u>							
DL-2	340		845		1190		
	305		830		1085		
	300		835		1135		
			825		1095		
			865		1090		
			810		1200		
AVG	315	40	835	55	1135	115	2.36
DL-3	310		600		1060		
	285		670		1115		
	290		680		1060		
			635		925		
			770		980		
			790		930		
AVG	295	25	690	190	1010	190	2.46

\* Range is the difference between the highest and lowest values recorded.

Table 6

Summary of Flexure Test Results

<u>Test</u>	<u>Low Strength</u>	<u>High Strength</u>
Modulus of rupture in flexure, psi		
Dynamic ( $R_d$ )	730	1130
Static ( $R_s$ )	300	455
$R_d/R_s$	2.43	2.48

# DYNAMIC AND STATIC TRIAXIAL TEST RESULTS $\sigma_3 = 0$ PSI LOW-STRENGTH CONCRETE

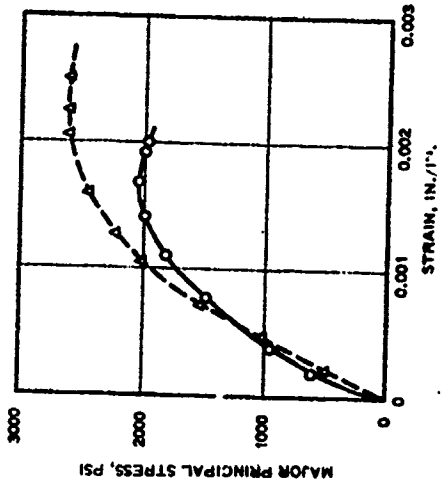

LEGEND  
○ ——— ○ STATIC  
△ ——— △ DYNAMIC

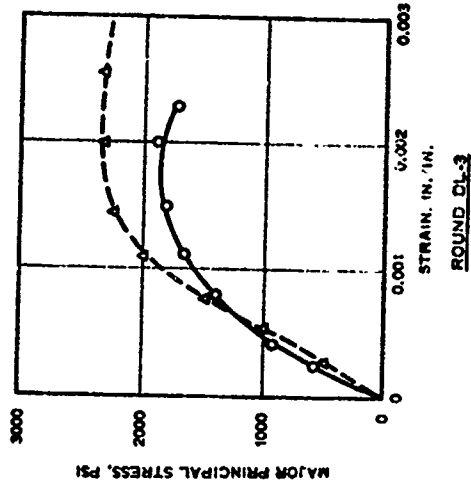
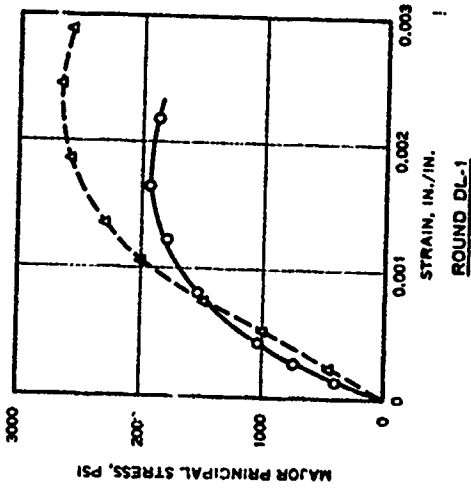

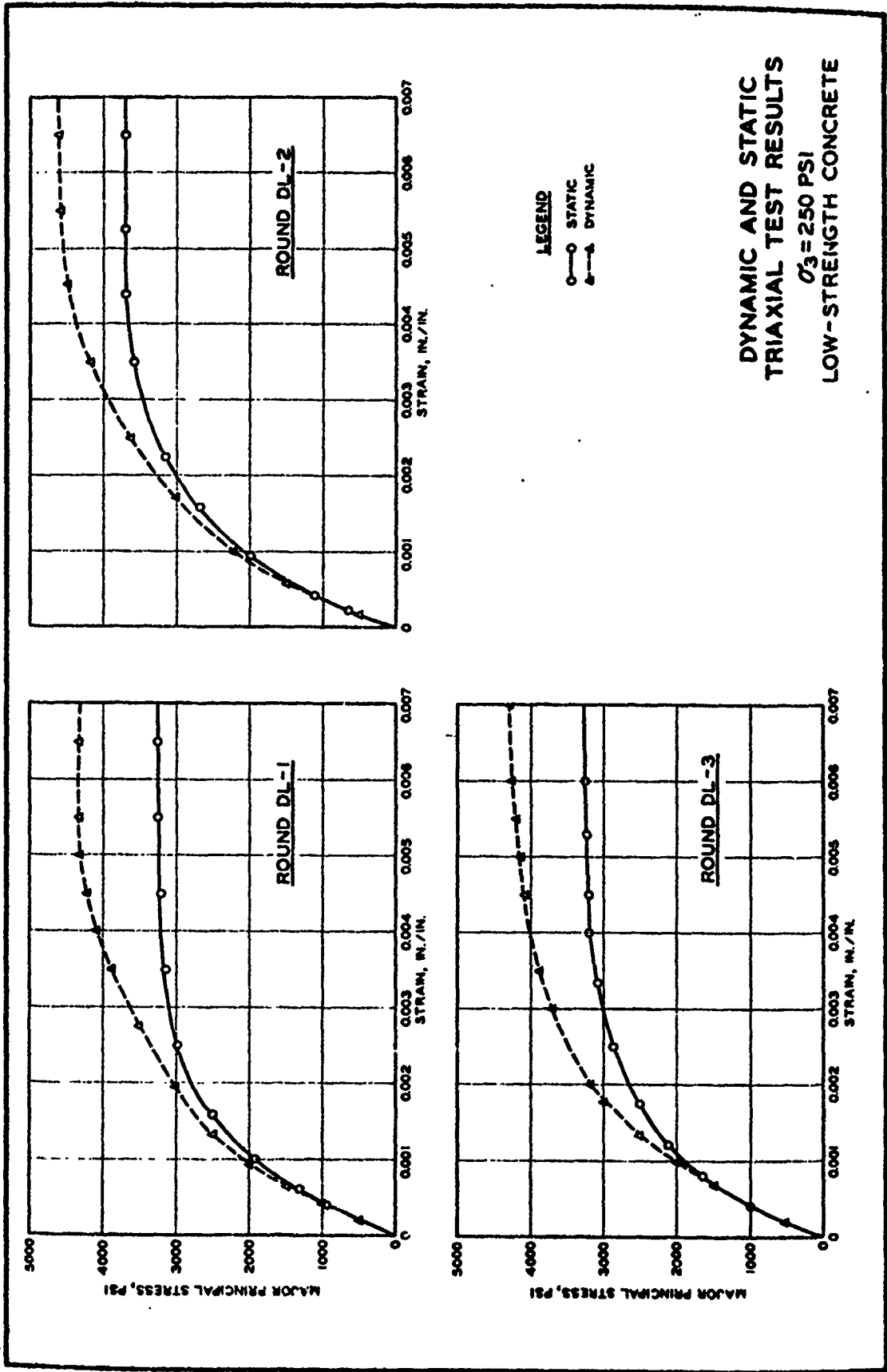
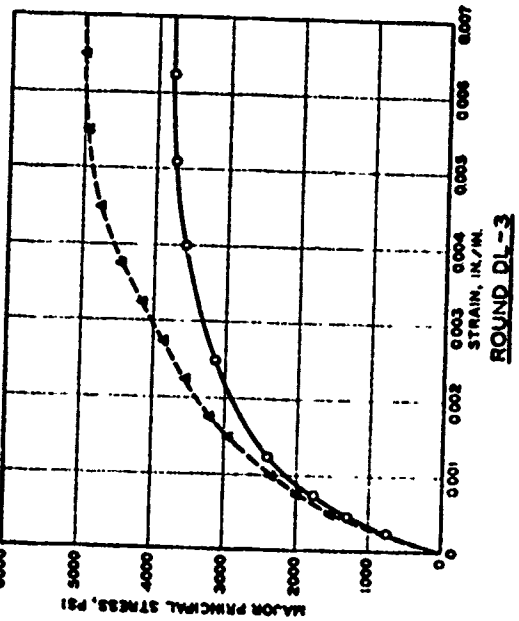
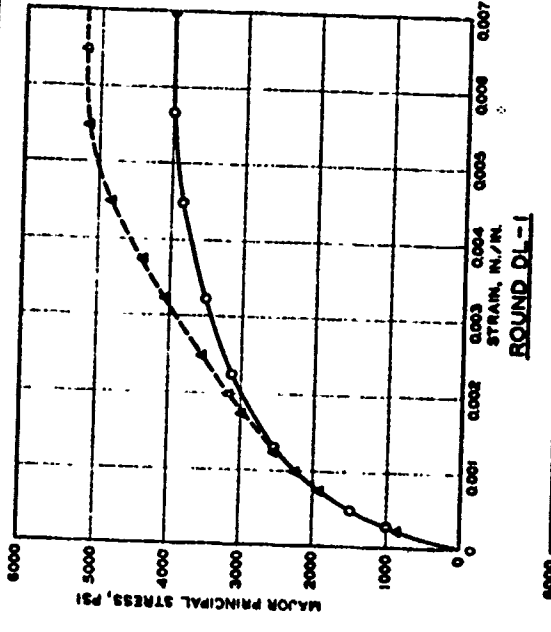
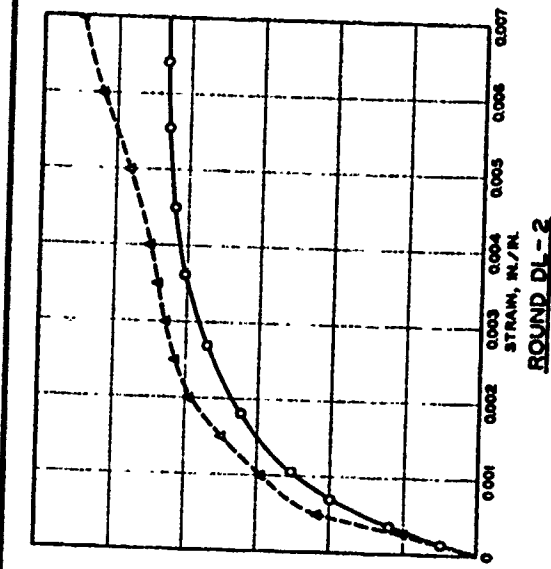

PLATE 2

**DYNAMIC AND STATIC TRIAXIAL TEST RESULTS**  
 $\sigma_3 = 500 \text{ PSI}$   
**LOW-STRENGTH CONCRETE**

**LEGEND**  
 ○—○ STATIC  
 ▲—▲ DYNAMIC



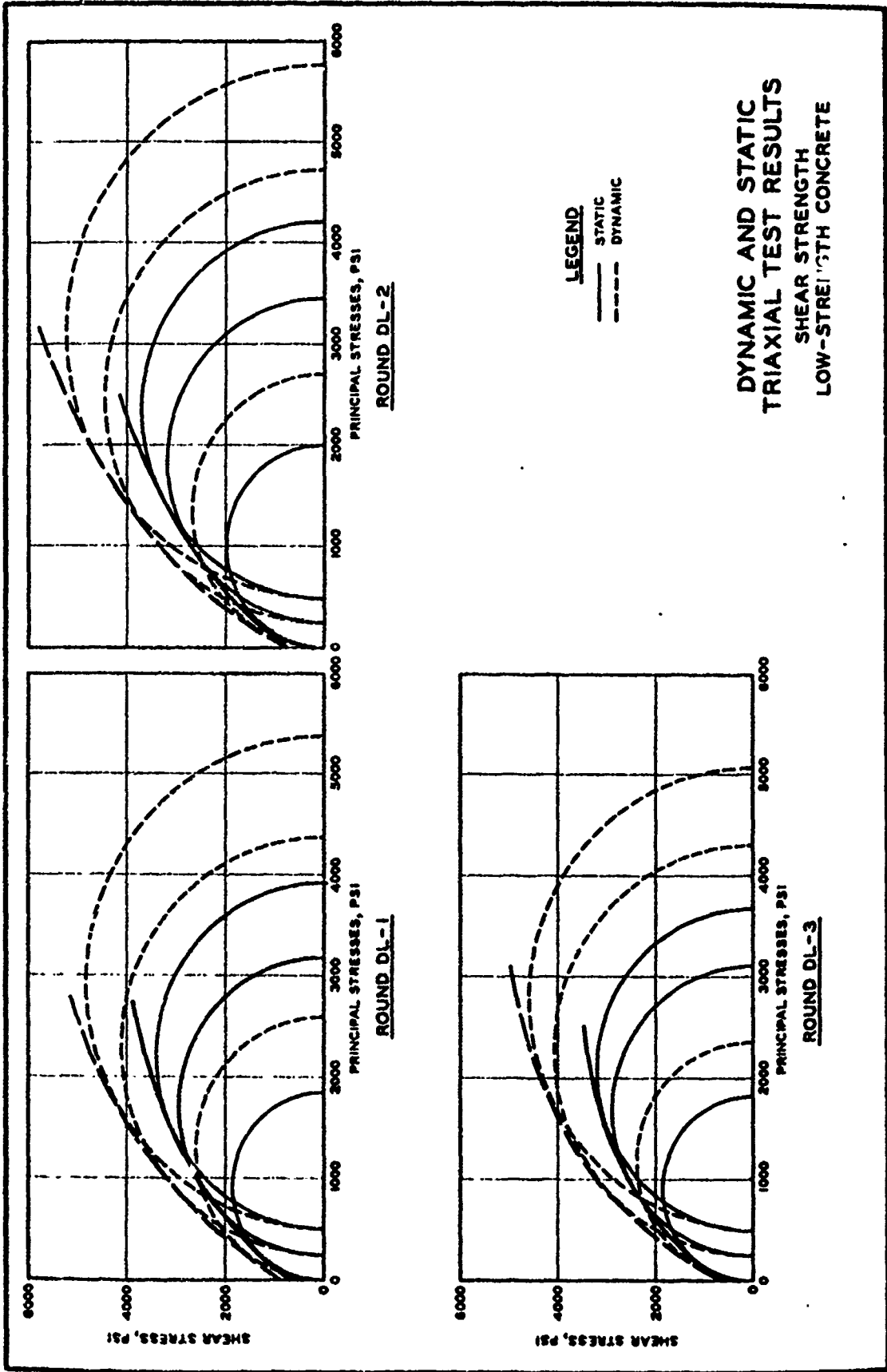
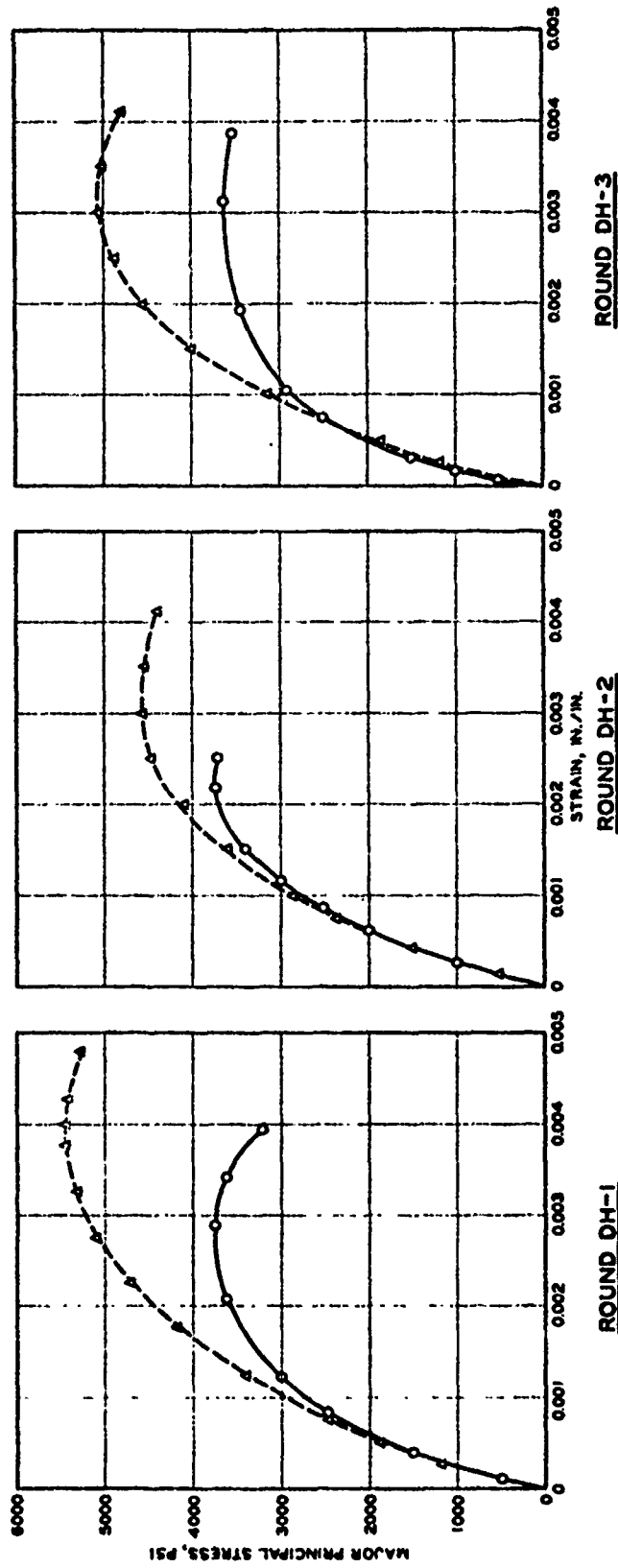

PLATE 4

DYNAMIC AND STATIC  
 TRIAXIAL TEST RESULTS  
 $\sigma_3 = 0$  PSI  
 HIGH-STRENGTH CONCRETE



ROUND DH-3

ROUND DH-2

ROUND DH-1

LEGEND  
 ○ ——— ○ STATIC  
 △ ——— △ DYNAMIC



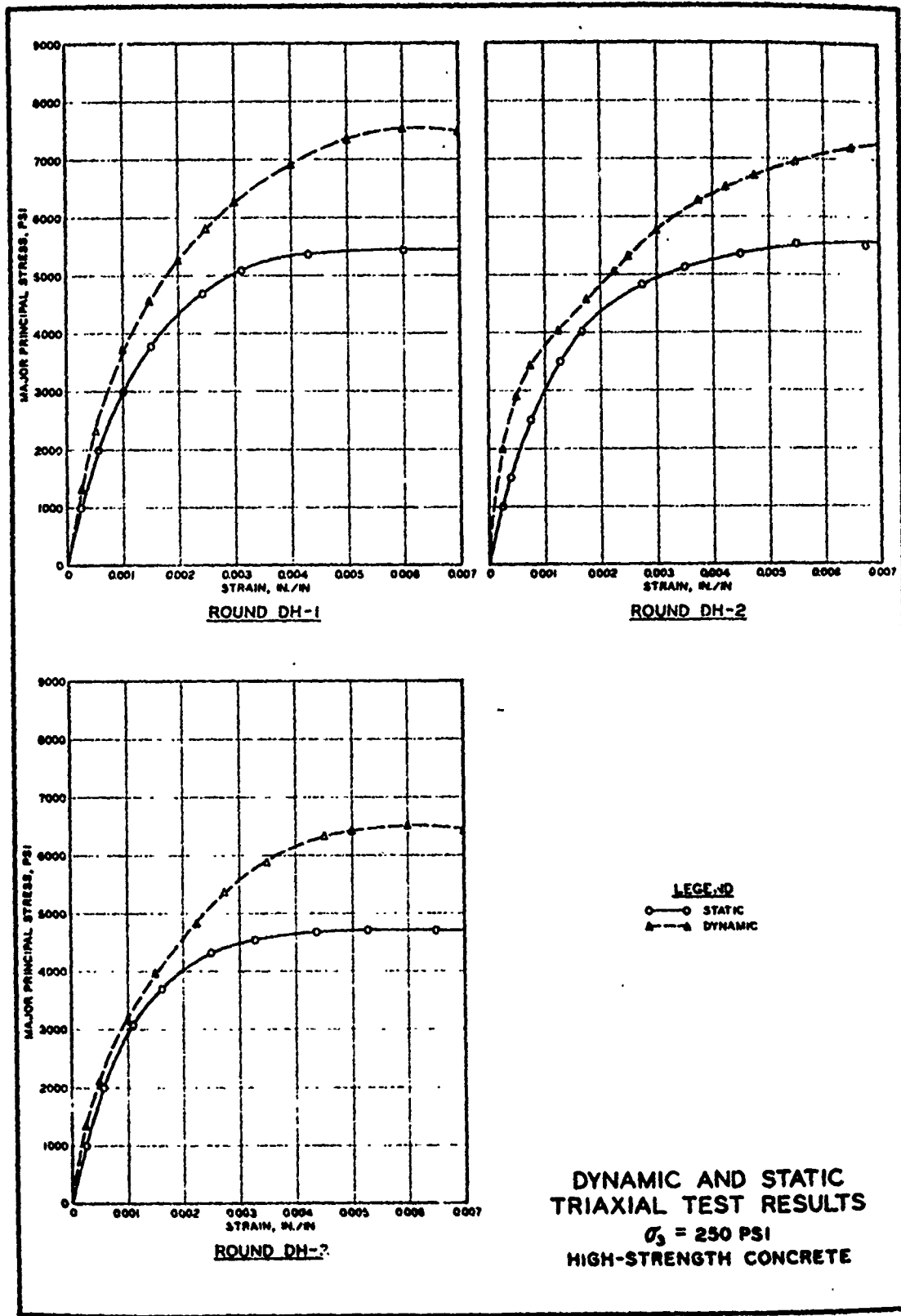

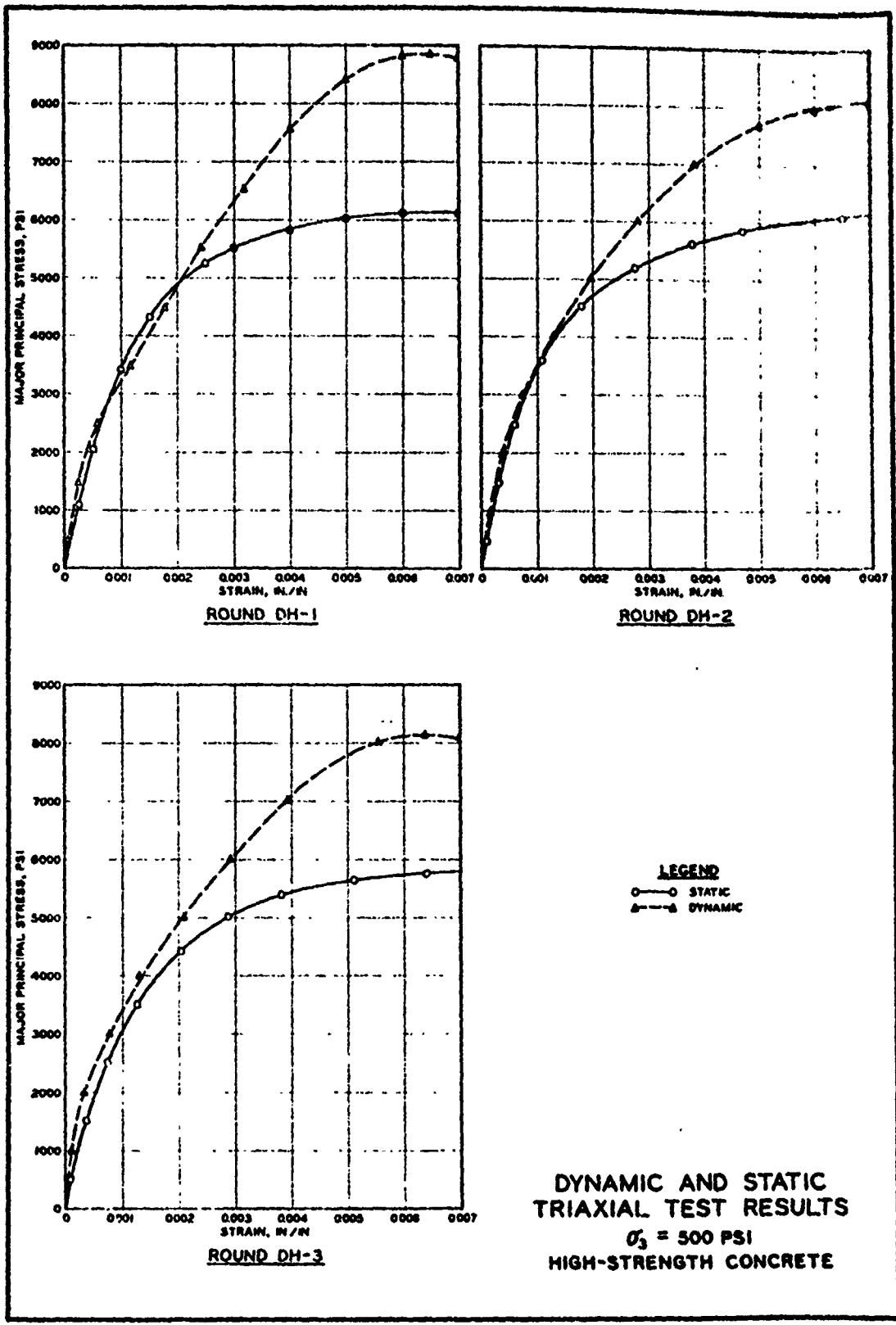

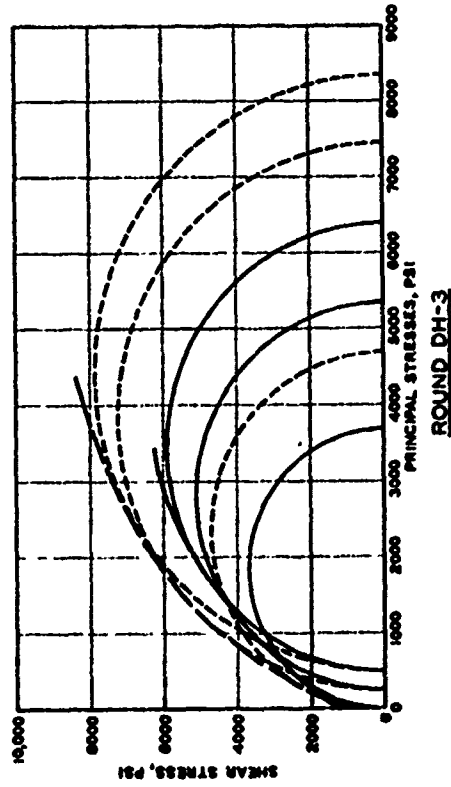
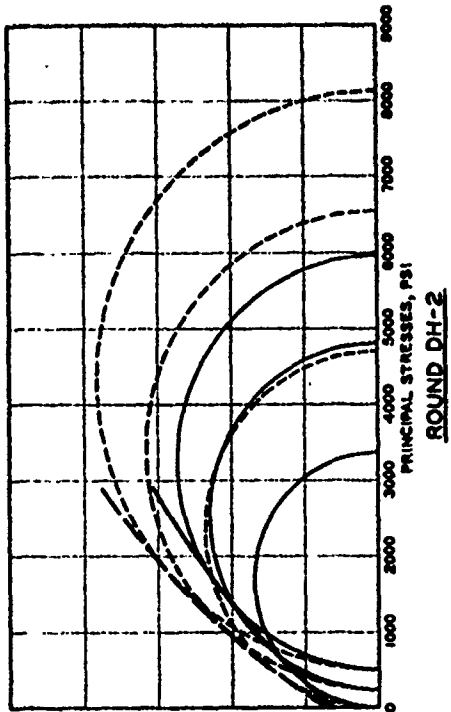
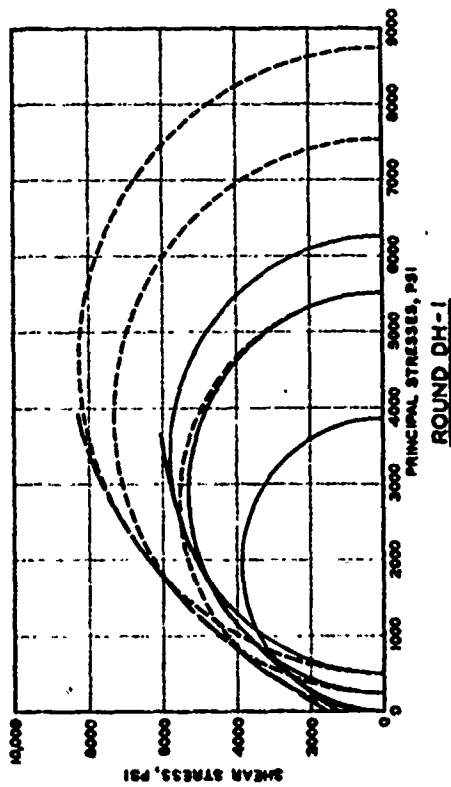

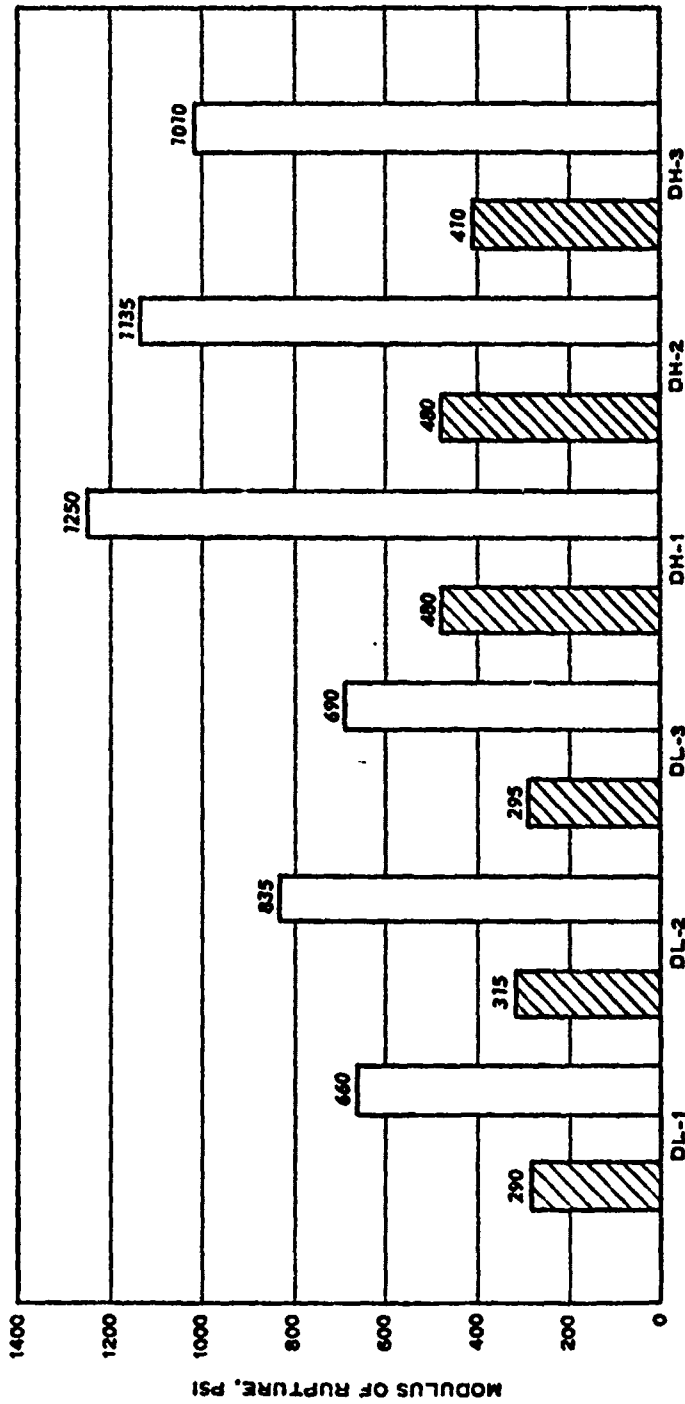

**LEGEND**  
— STATIC  
- - - DYNAMIC

**DYNAMIC AND STATIC  
TRIAXIAL TEST RESULTS  
SHEAR STRENGTH  
HIGH-STRENGTH CONCRETE**



ROUND NUMBER OF TWO STRENGTH LEVELS

**LEGEND**

-  STATIC
-  DYNAMIC

**COMPARISON OF MODULUS OF RUPTURE IN FLEXURE  
STATIC VS DYNAMIC TEST RESULTS**

APPENDIX A: METHOD OF TEST FOR BEHAVIOR OF CYLINDRICAL  
CONCRETE SPECIMENS SUBJECTED TO TRIAXIAL  
COMPRESSION BY IMPACT

Scope

1. This test method covers a procedure for determining the stress parameters and stress-strain relations of cylindrical concrete specimens subjected to triaxial compression by impact.

Principle

2. A cylindrical specimen encased in a flexible membrane is placed in a triaxial compression chamber, subjected to a constant lateral fluid pressure, and then loaded axially to failure. The degree of saturation of the test specimen is not permitted to change during the test. At least three identical specimens, each under a different lateral pressure, are tested to failure to establish the relation between shear strength and normal stress. Initially, the three principal stresses are equal to the lateral pressure on the specimen. During the application of load, the major principal stress ( $\sigma_1$ ) is equal to the applied axial stress ( $\sigma = P/A$ ) plus the lateral pressure ( $\sigma_3$ ) (see fig. A1). The applied axial stress  $\sigma$  is termed the "deviator stress." The intermediate principal stress  $\sigma_2$  and the minor principal stress  $\sigma_3$  are identical and are equal to the lateral pressure used in the test.

$P$  = applied load, lb  
 $A$  = cross-sectional area of specimen, sq in.  
 $\sigma_1$  = major principal stress, psi  
 $\sigma_3$  = lateral stress, psi

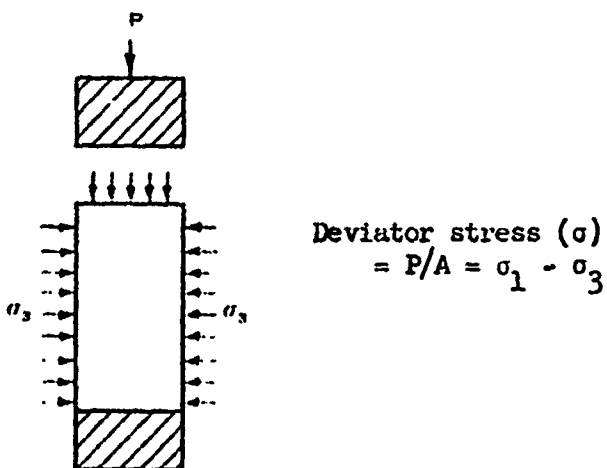

Fig. A1. Diagram of stresses during triaxial test

Apparatus

3. (a) Testing Machine. - The testing machine shall be of the

WES-MIT, rapid-loading impact machine type. The machine is equipped with a 30,000-lb-capacity load cell attached to the piston rod, and a testing

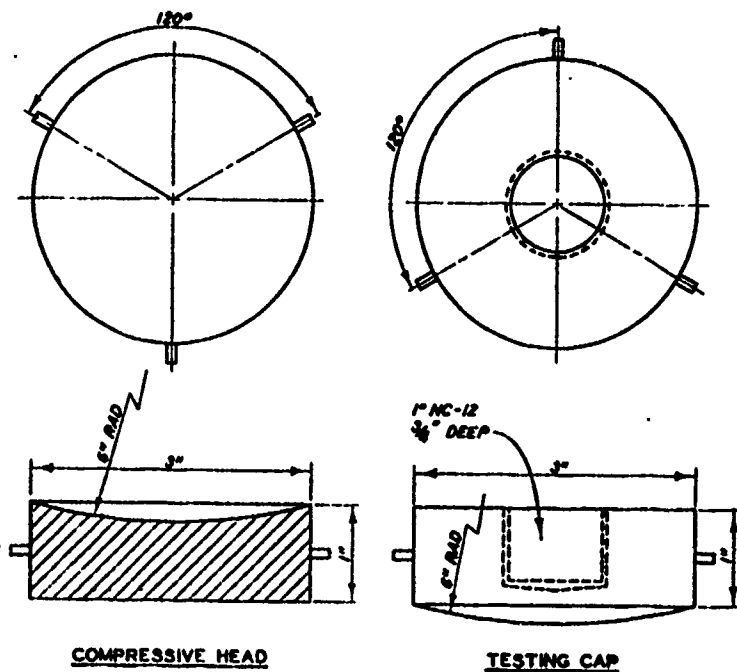

Fig. A2. Sketch of triaxial compression head and testing cap

lateral pressure  $\sigma_3$  shall be provided. Castor oil shall be used as the confining fluid.

(c) Triaxial

Chamber.- A test chamber with accessories, baseplate, seating bolt, piston, and head shall be provided. The triaxial chamber and testing machine are shown in fig. A3.

(d) Recording Equip-

ment.- Recording equipment shall consist of a dual-beam oscilloscope employed as an X-Y recorder on which is mounted a 75mm still camera.

cap attached to the load cell consisting of a beveled male surface which is fitted into the complementary female surface of the different testing heads to provide a rotating ball joint. The testing cap and triaxial compression head are shown in fig. A2.

(b) Hydraulic Pump.- A hydraulic pump, either manually or automatically operated, of sufficient capacity to maintain the specified

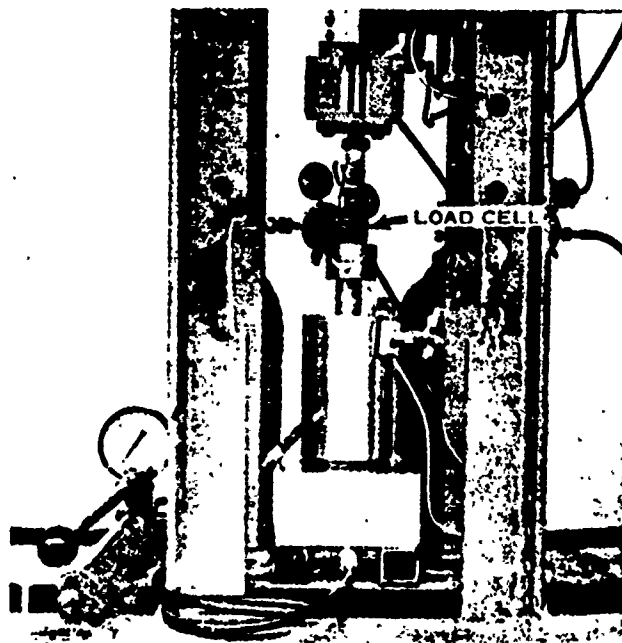

Fig. A3. Triaxial compression specimen undergoing dynamic testing

(e) Flexible Membrane.- Flexible membrane material in the form of cylindrical sections which when slightly stretched have an inside diameter equal to that of the specimen, base, and piston shall be used. Neoprene tubing having a nominal wall thickness of 1/8 in. is suitable.

#### Test Specimen

4. The test specimen shall be cylindrical. Due to the limited capacity of the dynamic testing machine, the size of the specimen is limited to 1-1/2 in. in diameter by 3 in. in height. Molded cylinders shall be made and stored in accordance with the applicable provisions of CRD-C 10, and drilled core specimens shall be taken and moisture-conditioned in accordance with applicable provisions of CRD-C 27. The diameter of the test specimen shall be determined to the nearest 0.01 in. by averaging two diameters measured at right angles to each other at about midheight of the specimen. This average diameter shall be used for calculating the cross-sectional area. The length of the specimen, including caps, shall be measured to the nearest 0.1 in.

#### Strain Gages

5. Two SR-4 strain gages of type A-3-S6 (nominal length of 1 in.) or equivalent shall be mounted diametrically opposite one another midway between the ends of each triaxial compression specimen as illustrated in fig. A4. The gages shall be wired in series to obtain the average strain. Lead wires from the gages should be insulated from the specimen with friction tape.

#### Procedure

6. (a) Preparing the Specimen.- Prepare the specimen for testing as follows:

(1) Place the specimen on the base pedestal, and place the piston on the specimen.

(2) Place a neoprene rubber membrane over the specimen, pedestal, and bottom of the piston. Fasten the membrane to pedestal and piston with a hose clamp secured hand-tight with a screwdriver. Bring the strain gage wires from under the membrane and out of the chamber. For lateral pressures over 1000 psi, 3/4-in. strips of 0.009-in.-thick steel shim

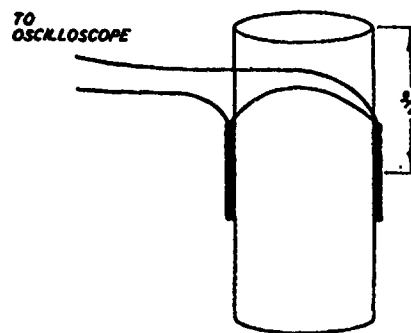

Fig. A4. Position of SR-4 strain gages

stock should be placed over the points between the specimen and the plates under the membrane to prevent lateral pressure from puncturing the membrane.

(3) Center the specimen with attached base pedestal and piston in the chamber, and tighten the seating bolt.

(4) Fill the chamber with confining fluid, and place the head on the chamber.

(5) Position the chamber in the impact testing machine, and attach the hydraulic pump.

(6) Open the bleed valve, and pump fluid into the chamber until a few drops escape. Close the bleed valve.

(b) Application of Load.- (1) Set the trigger on the impact machine; apply a preload of approximately 200 psi to seat the trigger mechanism. Bring the triaxial compression head to bear on the chamber piston by turning the testing cap until it is tight. Adjust the triaxial compression head while turning the testing cap so that uniform seating is obtained.

(2) Slowly apply the lateral pressure until a predetermined pressure has been obtained.

(3) Increase the accumulator-tank pressure to the required amount to produce failure of the specimen. Then trigger the impact machine, which automatically triggers the oscilloscope. The camera is tripped at the same instant at which the impact loader is triggered.

(c) Release of Load.- After completion of the test, release the accumulator-tank pressure and reset the trigger mechanism; then release the lateral pressure, open the bleed valve, dismantle the triaxial chamber, and remove the specimen.

(d) Repetition of Test.- Repeat the test on the two remaining specimens at different lateral pressures. All tests, the results of which are to be compared, should be conducted using the same accumulator-tank pressure.

#### Calculations

7. Plot major principal stress  $\sigma_1$  versus the axial strain from the load-strain curve obtained on the photographs of the X-Y record for each of the specimens. The ultimate principal major stress is taken as point of failure. Construct Mohr stress circles on an arithmetic plot with shear stresses as ordinates and principal stresses as abscissas. As shown in



fig. A5, the applied principal stresses  $\sigma_1$  and  $\sigma_3$  are plotted on the abscissa, and Mohr circles are constructed with radii of one-half the maximum deviator stresses

$$\left( \frac{\sigma_1 - \sigma_3}{2} \right) \text{ and with}$$

their centers at values equal to one-half the sum of the major and minor principal stresses

$$\left( \frac{\sigma_1 + \sigma_3}{2} \right).$$

Plot a Mohr circle, or a sufficient segment thereof, for each

specimen as shown in fig. A5. Draw a smooth curve tangent to the Mohr stress circles to define the shear strength envelope; if the curve is a straight line, indicate the angle of internal friction  $\phi$  and cohesion  $c$ .

#### Report

8. The report shall include the following:

- (1) Specimen identification number
- (2) Diameter of specimen, in.
- (3) Cross-sectional area of specimen, sq in.
- (4) Accumulator-tank pressure, psi
- (5) Load cell scale recorded by oscilloscope, lb per cm
- (6) Strain scale recorded by oscilloscope, in./in. per cm
- (7) The lateral pressure  $\sigma_3$ , the maximum deviator stress  $\sigma$ , and the major principal stress  $\sigma_1$  for each specimen
- (8) Stress(major principal)-strain curves for each specimen
- (9) A plot of Mohr circles, including the envelope of failure, the angle of internal friction  $\phi$ , and the value of cohesion  $c^*$
- (10) Age of specimen
- (11) Defects in specimen

\* When the curvature of the envelope is pronounced, the shear strength parameters ( $\phi$  and  $c$ ) are not constants and need not be reported.

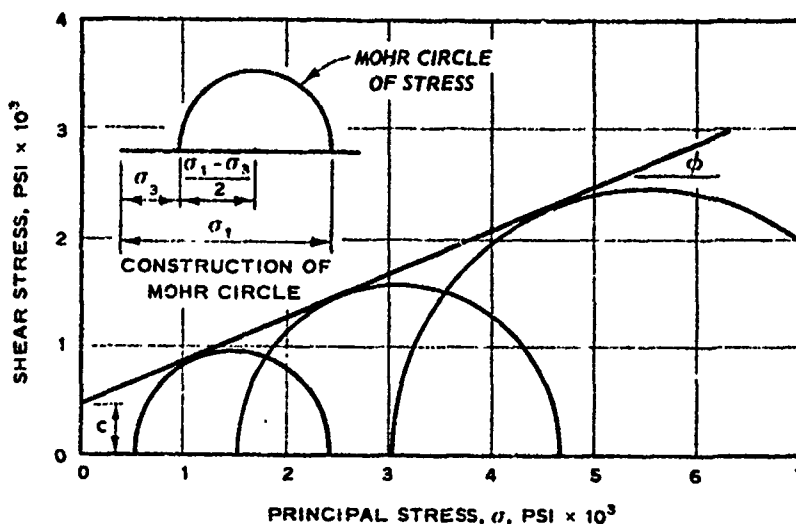

Fig. A5. Determination of shear strength parameters

**APPENDIX B: METHOD OF TEST FOR FLEXURAL STRENGTH OF CONCRETE  
BY IMPACT (USING SIMPLE BEAM WITH CENTER-POINT LOADING)**

Scope

1. This method of test covers the procedure for determining the flexural strength of concrete by impact using a simple beam with center-point loading.

Apparatus

2. (a) Testing Machine.- The testing machine shall be of the WESMIT, rapid-loading impact machine type. The machine is equipped with a 30,000-lb-capacity load cell attached to the piston rod, and a testing cap attached to the load cell consisting of a beveled male surface which is fitted into the complementary female surface of the different testing heads to provide a rotating ball joint. The testing cap and flexural test head are shown in fig. B1.

(b) Method of Loading.- The center-point loading method shall be used in making flexure tests of concrete, employing bearing blocks that will ensure that forces applied to the beam will be vertical only and applied without eccentricity. The load shall be applied at the center point of the span normal to the loaded surface. A flexure specimen undergoing dynamic testing

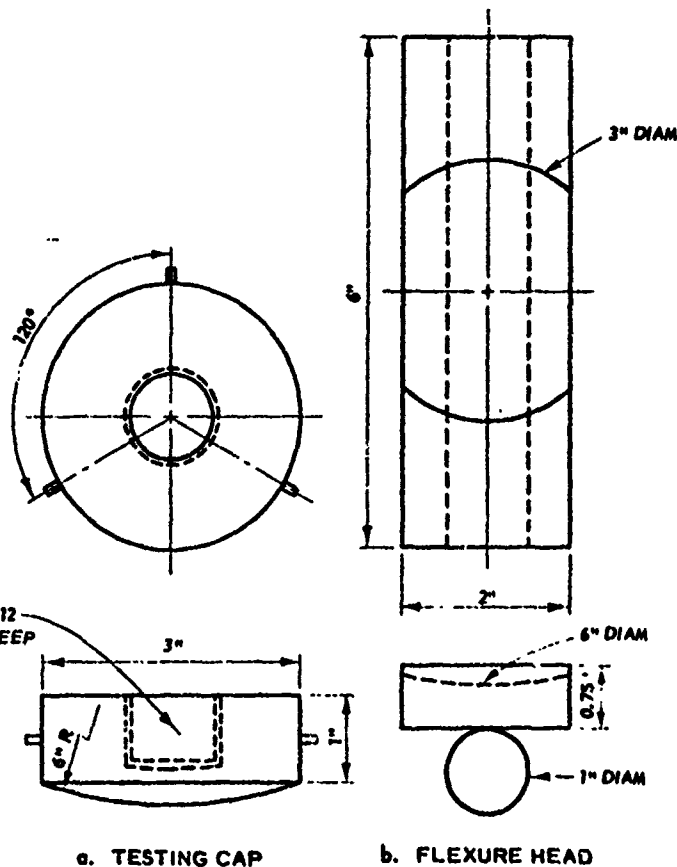

Fig. B1. Sketch of flexure head and testing cap

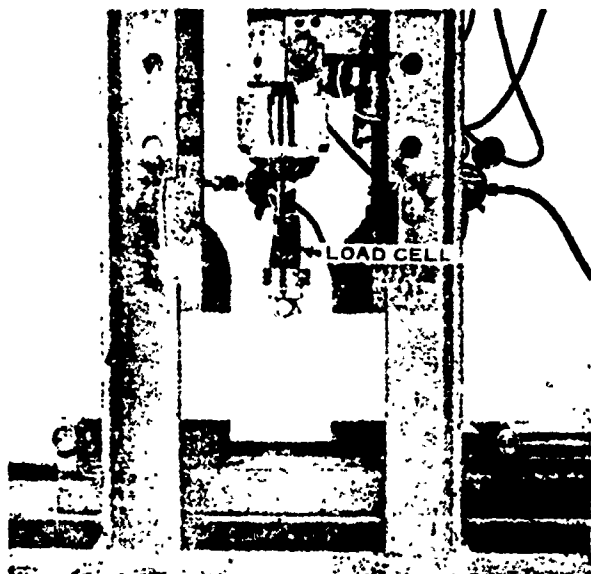

Fig. B2. Dynamic testing of flexure specimen

cal specimens are to be tested to failure.

#### Procedure

4. (a) Positioning the Specimen.- Center the test specimen on the supporting cylindrical bearing blocks with the top surface as molded in a vertical position. Bring the load-applying flexure head in contact with the upper surface at the center line between the supports. If full contact is not obtained between the specimen and the load-applying flexure head or the supports due to the surfaces of the specimen being out of plane, the surfaces of the specimen, where they are in contact with the head or the supports, shall be capped according to applicable provisions of CRD-C 29 so that full contact is obtained.

(b) Application and Release of Load.- First set the trigger on the impact machine; apply a preload of approximately 200 psi to seat the trigger mechanism. Bring the flexure head to bear on the specimen by turning the testing cap until it is tight; adjust the flexure head while turning the testing cap so that uniform seating is obtained. Increase the accumulator-tank pressure to the required amount to produce failure of the specimen. Then trigger the impact machine, which automatically triggers the single-sweep oscilloscope. The camera is tripped at the same instant at which the impact loader is triggered. After completion of the test,

is shown in fig. B2.

(c) Recording Equipment.- Recording equipment shall consist of a dual-beam oscilloscope that has been modified to provide a single trigger sweep and on which is mounted a 75mm still camera.

#### Test specimen

3. The test specimen shall be made and cured according to applicable provisions of CRD-C 10, and have a span as nearly as practicable three times its depth as tested. At least six identi-

release the accumulator-tank pressure and reset the trigger mechanism. All tests, the results of which are to be compared, should be conducted using the same accumulator-tank pressure.

#### Calculations

5. The modulus of rupture shall be calculated as follows:

$$R = \frac{3 Pl}{2 bd^2}$$

where

R = modulus of rupture, psi

P = maximum applied load indicated by the oscilloscope trace, lb

l = span length, in.

b = average width of specimen, in.

d = average depth of specimen, in.

The results shall be expressed to the nearest 5 psi.

#### Report

6. The report shall include the following:
- (1) Specimen identification number
  - (2) Average width of specimen, in.
  - (3) Average depth of specimen, in.
  - (4) Span length, in.
  - (5) Accumulator-tank pressure, psi
  - (6) Load cell scale recorded by oscilloscope, lb per cm
  - (7) Time scale recorded by oscilloscope, msec per cm
  - (8) Defects in specimen
  - (9) Type of fracture
  - (10) Age of specimen