

AD-750 910

AN EXAMINATION OF THE CURRENT UNITED STATES
AIR FORCE AIRCRAFT ENGINE STATUS REPORTING
SYSTEM

James F. Brady, et al

Air Force Institute of Technology
Wright-Patterson Air Force Base, Ohio

September 1972

DISTRIBUTED BY:

NTIS

National Technical Information Service
U. S. DEPARTMENT OF COMMERCE
5285 Port Royal Road, Springfield Va. 22151

AD750910

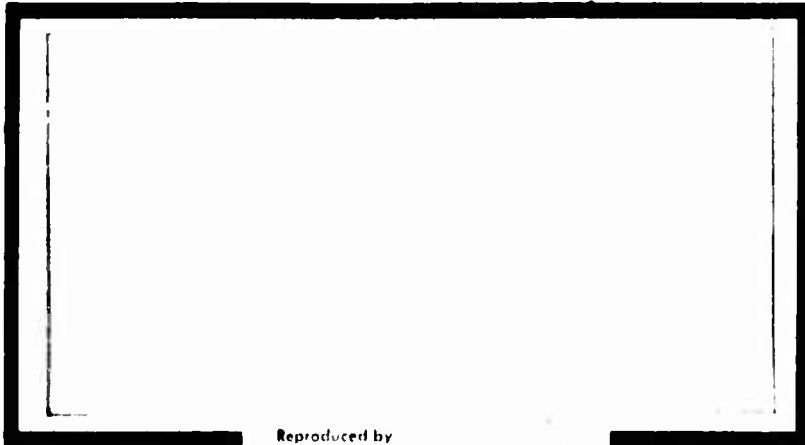

Reproduced by
NATIONAL TECHNICAL
INFORMATION SERVICE
U.S. Department of Commerce
Springfield VA 22151

D D C
RECEIVED
NOV 13 1972
D

UNITED STATES AIR FORCE
AIR UNIVERSITY
AIR FORCE INSTITUTE OF TECHNOLOGY
Wright-Patterson Air Force Base, Ohio

This document has been approved
for public release and sale; its
distribution is unlimited.
90 R

DOCUMENT CONTROL DATA - R & D

(Security classification of title, body of abstract and indexing annotation must be entered when the overall report is classified)

| | | | |
|--|---|--|--|
| 1. ORIGINATING ACTIVITY (Corporate author) Air Force Institute of Technology School of Systems and Logistics | | 2a. REPORT SECURITY CLASSIFICATION | |
| | | 2b. GROUP | |
| 3. REPORT TITLE An Examination of the Current United States Air Force Engine Status Reporting System | | | |
| 4. DESCRIPTIVE NOTES (Type of report and inclusive dates) Thesis | | | |
| 5. AUTHOR(S) (First name, middle initial, last name) J. F. Brady (Capt, USAF) and M.J. Scritchfield (Capt, USAF) | | | |
| 6. REPORT DATE September 1972 | 7a. TOTAL NO. OF PAGES 81 | 7b. NO. OF REFS | |
| 8a. CONTRACT OR GRANT NO. | 8b. ORIGINATOR'S REPORT NUMBER(S) SLSR-9-72 | | |
| b. PROJECT NO. | | | |
| c. | 9b. OTHER REPORT NO(S) (Any other numbers that may be assigned this report) | | |
| d. | | | |
| 10. DISTRIBUTION STATEMENT Publish and distribute under Provisions of Statement A, unlimited distribution. (DDC, AFR 80-45) | | | |
| 11. SUPPLEMENTARY NOTES Cleared for public release IAW AFR 190-17 | | 12. SPONSORING MILITARY ACTIVITY <i>Jerry C. Hix</i> JERRY C. HIX, Capt, USAF Director of Information | |
| 13. ABSTRACT By 1972, the United States Air Force had had an aircraft engine status reporting system for over twenty-two years. It was felt that due to new advances in engine design that could possibly overburden the system, the system was in need of a cross examination. The decision making environment of the Engine Item Manager was evaluated along with the information he was provided by the current reporting system. In addition, Maintenance, Supply, and Transportation Information Systems were examined to see what parallel engine data they presented. As a result of this research, a new system was proposed that would eliminate the Engine Status Reporting System at a substantial savings to the Air Force. | | | |
| KEY WORDS: Aircraft Engines Engine Status Reporting | | | |
| <i>It</i> | | | |

**AN EXAMINATION OF THE CURRENT
UNITED STATES AIR FORCE AIRCRAFT
ENGINE STATUS REPORTING SYSTEM**

**James F. Brady, Captain, USAF
Michael J. Scritchfield, Captain, USAF**

SLSR-9-72

NOV 1972

NOV 1972

IA

This thesis, written by

Captain James F. Brady

and

Captain Michael J. Scritchfield

and approved in an oral examination, has been accepted by the undersigned on behalf of the faculty of the School of Systems and Logistics in partial fulfillment of the requirements for the degree of

MASTER OF SCIENCE IN LOGISTICS MANAGEMENT

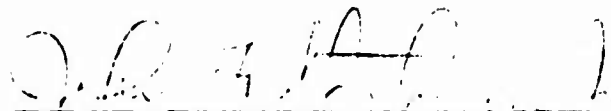

Committee Chairman



Committee Member

IC

SLSR-9-72

AN EXAMINATION OF THE CURRENT
UNITED STATES AIR FORCE AIRCRAFT
ENGINE STATUS REPORTING SYSTEM

A Thesis

Presented to the Faculty of the School of Systems and Logistics
of the Air Force Institute of Technology

Air University

In Partial Fulfillment of the Requirements for the
Degree of Master of Science in Logistics Management

By

James F. Brady
Captain, USAF

Michael J. Scritchfield
Captain, USAF

September 1972

Approved for public release;
distribution unlimited

Id

TABLE OF CONTENTS

| Chapter | Page |
|---|------|
| I. INTRODUCTION | 1 |
| Problem Statement | |
| Background | |
| Statement of Objectives | |
| Scope | |
| Hypotheses | |
| Methodology | |
| II. DECISION MAKING ENVIRONMENT | 12 |
| Responsibilities | |
| D024 Engine Status Reporting | |
| Aerospace Engine Life Committee (AELC) | |
| Jet Engine Technical Service Branch | |
| Requirements and Distribution Branch | |
| III. DATA COLLECTION | 25 |
| Base Level Engine Manager | |
| Data Source | |
| IV. ALTERNATE DATA COLLECTION SYSTEMS | 36 |
| Transportation | |
| Maintenance | |
| AFTO Form 349 | |
| AFTO Form 350 | |
| Data Collection | |
| Product Performance System (D056) | |
| LOG-K261 and LOG-K262 Series Reports | |
| Supply | |
| Not Operationally Ready Supply (ENORS) Report | |
| V. AN ALTERNATIVE PROPOSAL | 52 |
| Arrival At An Operating Base | |
| Maintenance Activity | |
| Departure From The Base | |
| ENORS | |
| Aircraft Transfers | |
| Loss Information | |
| VI. SUMMARY | 61 |
| Research Findings | |
| Conclusion | |

| APPENDICES | Page |
|---|------|
| A. STRUCTURED INTERVIEW GUIDE | 66 |
| B. INFORMATION PROVIDED BY AF FORM 1534 | 69 |
| C. ENGINE OWNERSHIP ACCOUNT | 73 |
| D. ENGINE TYPE REPORT | 75 |
| E. ENGINE REMOVAL REASON | 77 |
| BIBLIOGRAPHY | 79 |

LIST OF FIGURES

| Figure | | Page |
|--------|--|------|
| 2-1 | D024 ENGINE STATUS REPORTING SYSTEM | 17 |
| 2-2 | ORGANIZATIONAL CHART OF THE JET ENGINE ITEM MANAGEMENT DIVISION | 20 |
| 3-1 | ENGINE STATUS REPORT | 29 |
| 4-1 | MAINTENANCE DATA COLLECTION RECORD | 41 |
| 4-2 | REPARABLE ITEM PROCESSING TAG | 42 |
| 4-3 | DATA FLOW | 45 |
| 5-1 | PROPOSED SYSTEM | 53 |

LIST OF TABLES

| Table | Page |
|--|------|
| 1. ACTIVITIES REPORTING ENGINE STATUS CHANGE | 16 |

CHAPTER I

INTRODUCTION

The United States Air Force has a wide variety of weapons systems and support equipment which require one or more engines. Engines are needed to propel aircraft from the O-1 to the C-5, missiles from the SCAD to the Titan III; as well as to power the ground support equipment necessary to maintain these weapons. Management and control of these engines is one of the most complex problems that face Air Force Logistics managers today.

In 1971, the Air Force possessed 65,931 engines representing a capital investment of over seven billion dollars.¹ To manage this massive investment, the Air Force Logistics Command (AFLC) established the Engine Management System. Responsible individuals, assigned at each operating base, provide up-to-date information on the engines located at their station. Submitted daily, to the Item Manager at the controlling depot, these reports reflect such factors as: quantity; readiness condition; parts requirements; and engine life--in effect the information a manager needs to

¹Alan A. Fielding and Thomas R. Harruff, "A Proposed Simulation to Forecast Jet Engine Maintenance Removals" (Unpublished Master's thesis, School of Systems and Logistics, 1971), p. 24.

control these important assets. The data from these reports is used by the Item Manager to determine allocation of funds for the purchase of new engines and spare parts, to compute overhaul requirements for existing engines, to redistribute engines between bases--preventing over stock conditions, and finally to select engines to be removed from inventory for salvage.

Problem Statement

The engine status reporting procedure under the Engine Management System will soon meet a severe test of its capabilities. Engines for the Air Force's new air superiority fighter, the F-15, are of an advanced modular design that will harshly tax the existing status reporting system. This new engine is to be made of five functional modules that can be easily removed and replaced upon failure. Under the present status reporting procedure, each of these modules will have to be reported separately in order to maintain the needed control. Currently the system operates manually, and each additional report will have to be filled out by hand. The new modular concept may require as much as a five-fold increase in paperwork. If the engines for the F-15 are an indication of the next generation of aircraft engines, the additional time required to fill out forms and to have them transmitted could cause the engine status reporting system to become overburdened and unresponsive as a management tool.

Before this and other advances overtake the present engine status reporting system, the system should be given a thorough examination. Is it still the best way to acquire raw engine data or is there perhaps a better method? This is the basic question to be addressed by the thesis.

Background

Management of spare engines in the Air Force has not always been the orderly procedure that it is today. During World War II engines were purchased and managed on an arbitrary percentage basis.

The percentages agreed upon for buying spare engines to satisfy the war requirements of the various services . . . were: cargo aircraft, 50%; tactical aircraft, 40%; trainer aircraft, 25%. During 1943, 1944, and 1945, as experience was gained, these percentages were revised upward and downward. Combat aircraft, as an example, were lost in great enough numbers that the original spare engines percentage proved to be too high; on the other hand, percentages of spare engines for transport and trainer aircraft whose loss or attrition rate¹ was relatively low, consistently had to be increased.

By the end of the War it was recognized that the old system of management was no longer workable and a Joint Services Aeronautical Board was established to provide a more realistic set of percentage guidelines. To aid their forecasting, the Board called for the collection of basic information covering important events in an engine's life. This was the

¹Air Force Spares Study Group, Report Number 8 (Wright-Patterson Air Force Base, Ohio: Headquarters Air Material Command, 1958), p. III-13.

. . .first major effort to collect statistics on the frequency and causes of failures, operating hours accrued on removed engines, actual hours flown by the entire fleet, how long it took to move engines through the various segments of the transportation and repair pipeline, and engine inventories by individual type, model and series and by base location. . . .¹

Although crude in comparison to the current system of gathering information, this marked the real beginning of modern data collection for the management of engines. Unfortunately these new management tools were not used in the most efficient manner; in fact during fiscal years 1950 and 1951, the Air Force purchased an average of five spare engines for every four engines that were installed in an aircraft.² With spare engines consuming the largest portion of the aircraft support dollar, the Air Force began to attack the problem of management. An Air Force Engine Study Group was organized under the chairmanship of a prominent consultant, Dr. Edmund Learned of Harvard University, and manned by specialists from within the Air Force. The Group had the task of making a detailed analysis of aircraft engine requirements, and broad powers to initiate corrective actions. Using data which they had collected over a period of time, the Group pioneered techniques of analysis that are still in use today. Dr. Learned's Group decided that pipeline

¹Air Force Spares Study Group, Report Number 8 (Wright-Patterson Air Force Base, Ohio: Headquarters Air Material Command, 1958), p. III-14.

²H. O. King, "Aircraft Spares" (Memorandum for the Under Secretary of the Air Force, August 15, 1952), p. 2.

time and programming considerations offered the greatest opportunity for reducing spares quantities. Through the use of the new data to pinpoint delays, the six month pipeline time considered standard for operations in the continental United States was reduced to four and one-half months and the overseas pipeline was reduced from eight to seven months.¹ Programming reforms resulted in equally important savings. Data was compiled on flying hour utilization rates, attrition rates, deployment, and other subjects that greatly aided the forecasting of spares requirements. The studies made by the Group resulted in a sizeable reduction of authorized stock levels and of the time allowed to cycle engines through transportation and repair cycles.

At the same time, a group studying aircraft spares in general, was making similar, far reaching recommendations. The Chairman, Mr. H. O. King, spoke in favor of separate control for high dollar value spares.

Such study and review of air frame spares and engine spare parts as has already been made by our group points rather clearly to the need for a separate system to control high dollar items. Today we treat our "diamonds" and "popcorn" in a similar manner beginning with their selection at the provisioning conference, to their entrance in our supply system and their use in support of our operations.²

The result of this study was to focus even more management attention on the problems of engines as a class. No longer

¹Air Force Spares Study Group, Report Number 8 (Wright-Patterson Air Force Base, Ohio: Headquarters Air Material Command, 1958), p. III-16.

²H. O. King, "Aircraft Spares" (memorandum for the Under Secretary of the Air Force, August 15, 1952), p. 2.

would they be treated in the same way as less costly supply items.

A final development in improved engine management, during the early 1950's, came when the Air Force adopted actuarial principles for computing engine failure rates and expected engine life. This new technique was patterned after the one used by life insurance companies to project human mortality rates and life expectancies. Taking advantage of the improved data base, this method became a powerful device for predicting spares requirements and stock levels.

The important point to be made is that these insights came from improved use of the information collected in the field. Decisions on resource allocation were not being made on an arbitrary percentage basis, but as the result of systematic mathematical and statistical analysis. The methods used in the current Engine Management System have evolved a great deal since these early beginnings, but they still require the same type of accurate comprehensive information. This information is provided through the engine status reporting system.

Statement of Objectives

When this thesis began, the United States Air Force had had an engine status reporting system for almost twenty-two years. The objective of the research was to impartially examine this system to see whether it had stood the test of time. Was it still the best method the Air Force had for

the collection of raw engine data, or had other information systems grown up that were better?

Three major areas were examined:

1. The decision-making environment of the AFLC Engine Item Manager (EIM).
2. The engine status reporting system that provides the AFLC Engine Manager Item Manager with the information needed to make decisions.
3. Alternatives to the existing engine status reporting system.

Scope

The range of operation suggested by these objectives is such a broad one that two severe constraints had to be imposed to make them viable. Although the Engine Management System controls engines from Aerospace Ground Equipment (AGE), missiles, and drones as well as from aircraft; this thesis only investigated the latter. There were two reasons for this decision. First, aircraft engines comprised the largest percentage of the Air Force inventory of engines. As such, they provided an ideal sample group that was representative of the way the total population of engines was managed. Secondly, by limiting the scope to aircraft engines, the authors were able to apply their eighteen years of experience in aircraft maintenance to a familiar topic.

A further constraint imposed on this study dealt with the origins of the data for the engine status reporting

system. Only reports and procedures used by base level engine managers to input data into the status reporting system were investigated. It was felt that this level would be the most fruitful for examination and one that would yield the greatest benefits if a more efficient method of reporting could be found. Depot and contract maintenance inputs were not a specific item of investigation in this study as they were considered too specialized a topic to treat on an initial examination of a complex subject.

Hypotheses

The thesis tested the following hypotheses:

1. The AFLC Engine Item Manager routinely uses all the information he receives from the engine status reporting system to accomplish his mission.
2. There is a better way to gather the needed information that will improve the status reporting of the current generation of engines.

Methodology

Research for this thesis began with an intensive review of the available literature on the Air Force Engine Management System. From this preparation the authors were able to divide their investigation into three major areas. It was felt that a three part structure would aid the examination of this complex subject. Although these areas have been outlined in the Statement of Objectives, this

section will expand on them and explain some of the research involved in each.

The first area that was examined was the decision-making environment of the AFLC Engine Item Manager. Each series of engines in the Air Force inventory has an Engine Item Manager, located at the controlling Air Material Area (AMA), who is responsible for world-wide logistics management of that series engine. This is the individual vitally concerned with the information provided by the engine status reporting system. Before attempting to find a possible alternative to the existing system, the authors had to discover what information the individual required. A series of structured interviews were conducted with Engine Item Managers at Tinker Air Force Base, Oklahoma City, Oklahoma, using the interview guide attached in Appendix A. This guide was constructed to answer these basic questions: (1) What decisions does an Engine Item Manager have to make; (2) What data does he use to make these decisions; and (3) How rapidly do these decisions have to be made? Answers to these questions helped define the environment in which the Engine Item Manager worked and indicated the kinds of facts he needed from his information reporting system.

In addition, the same interview guide was used to interview recognized experts from the Headquarters, Air Force Logistics Command, Engine Program Manager's office. Interviews with these individuals, charged with the policy making and guidance for Engine Item Managers, confirmed the impres-

sions gained from the Oklahoma interviews. These interviews also provided insight into the type of data which managers at Headquarter's level require to supervise and to engage in long range planning.

The second area that was examined was the reporting system that provided the Engine Item Manager with the information he needed. The present engine status reporting system was evaluated from two ends. Base level inputs into the system were identified as to origin and purpose. Engine Managers assigned to each operating base are responsible for collecting and transmitting the data, but it was essential that all the sources for the data and the time constraints under which it was collected be understood. On the other end, the output was examined to see how well it provided the facts the Engine Item Managers had said they needed. Did it perhaps contain too much information that was not used or did it lack some information essential for management decisions?

Research for this area made more use of the interviews already conducted as well as the outline of the engine status reporting system as contained in Air Force Manual 400-1, Selective Management of Propulsion Units. The essence was a review of input forms, automatic data transmission, and computerized output products.

The final area that was investigated dealt with alternative methods of collecting the required information at base level in such a way that the old system would be

improved. Maintenance, Supply, and Transportation data collection systems were examined to see if they gathered the same information required by the Engine Item Manager. Where an overlap was found, the new source was evaluated and a recommendation was made.

Dividing the research effort into three areas allowed the authors to concentrate on one topic at a time, gather information, and thus be firmly grounded when they moved on to the next topic. This method has worked so well that it will become the outline for the succeeding chapters. Chapter Two will deal with the Engine Item Manager's decision-making environment, Chapter Three with the engine status reporting system, and Chapter Four will deal with alternate data collection systems. Once these topics have been covered, Chapter Five will present a proposal for an improved engine status reporting system and Chapter Six will set forth the authors' conclusions.

CHAPTER II

DECISION MAKING ENVIRONMENT

The objectives of the D024, Propulsion Unit Logistics System, are to specify how to manage engines and to reflect how well those engines are managed. Data collected are intended to provide management with the information needed to determine allocation of funds, procurement, computation of overhaul requirements, engine inventory and distribution, spare engine requirements and disposal, and to prepare the budget estimate. The intermediate objectives are to maintain an accurate and timely engine inventory, to reduce pipeline times to speed transportation, to reduce overhaul time, to extend field maintenance capabilities and in general, to streamline engine management techniques.¹

Responsibilities

Headquarters USAF is responsible for the general surveillance of the engine reporting system, providing overall policy guidance, and making the final determination of engines to be reported. They review data products pertaining to the

¹U.S., Department of the Air Force, Selective Management of Propulsion Units, AFM 40C-1, Volume I, (Washington, D.C.: Government Printing Office, January 5, 1970), pp. 1-1, 1-2.

total Air Force inventory position in order to determine areas requiring future management review, and issue field directives for major changes involving all Air Force commands.

Air Force Logistics Command has been delegated the direct responsibility for monitoring the engine reporting system. Headquarters AFLC develops specifications, or approves specifications developed by the respective Air Material Areas for changes to the reporting system, then coordinates changes to Part II, AFM 400-1 and incorporates such changes into official amendments as soon as practical. The Headquarters is also responsible for insuring that all contracts contain provisions for engine status reporting when applicable, and that the contractors report the engines in accordance with established directives. Additionally, the Command acts as the central control point for policing the timeliness, accuracy, and responsiveness of the engine status reporting system and performs periodic surveys and analyses to insure the management effectiveness of the system used to collect, process and distribute engine data. They initiate corrective measures and advise concerned activities and Headquarters USAF about actions required to improve the system.¹

The Accounting Division (ACD) Comptroller, Oklahoma City Air Material Area (OCAMA) has the primary responsibility

¹U.S., Department of the Air Force, Selective Management of Propulsion Units, AFM 400-1, Volume I, (Washington, D.C.: Government Printing Office, January 5, 1970), pp. 2-1, 2-2.

for the gathering, compiling and distribution of the data received from the reporting activities.

OCAMA, Data Automation Division, is the world-wide engine data processing AMA. It is responsible for developing, integrating and implementing the system as approved by Headquarters AFLC. OCAMA monitors, processes and maintains the data gathered by the engine reporting system; operates and maintains surveillance over the centralized USAF inventory control system for all engines covered by the engine status reporting system; develops recommendations for changes to system; prepares and distributes output products; and establishes, maintains and publishes a listing of engine management products.¹

The data file maintained by the Data Automation Division, OCAMA, gives the Air Force Engine Manager a historical record of all transactions that have taken place on the engine, by serial number, from the time it was brought into the Air Force inventory until its subsequent removal (salvage through reclamation, transfer to another service, or loss by crash). The primary objective of having one AMA responsible for the engine status reporting system is to provide management with a central contact point for information relating to all reportable aspects of an Air Force

¹U.S., Department of the Air Force, Selective Management of Propulsion Units, AFM 400-1, Volume I, (Washington, D.C.: Government Printing Office, January 5, 1970), p. 5-1.

engine. Additionally, the system is designed to provide a centralized accounting capability with decentralized management. The D024 System is a base line file facilitating selective management through serialized control of AF property.¹

D024 Engine Status Reporting

Air Force Manual 400-1, Selective Management of Propulsion Units, has established stringent policies and procedures for engine management because of the high investment cost and numbers of engines reported. The term selective management as used by Engine Item Managers, refers to the serial number control of high value or critical items. This concept pervades all of engine logistics management which includes the maintenance, procurement, supply and transportation functions. The success of this management technique is directly dependent upon coordinated action on the part of these separate functional areas at all levels of command. To emphasize the need for the management attention given to USAF engines one should consider the number of status change transactions reported to OCAMA. As of June, 1972, the Air Force averaged some 4000 individual transactions a day.²

¹Tinker Air Force Base, Oklahoma, personal interview with Mr. Olin Roberts, Data Automation Division, Comptrollers Office, Headquarters Oklahoma Air Material Area, Air Force Logistics Command, June 22, 1972.

²Ibid,

TABLE 1

ACTIVITIES REPORTING ENGINE STATUS CHANGES¹

| <u>Activity</u> | <u>Number</u> |
|--|---------------|
| AF Bases | 266 |
| Contractors. | 126 |
| Logistics Activities | 8 |
| Navy Special Repair Activities | 6 |
| Army Special Repair Activities | 1 |

NUMBER OF ENGINES REPORTED

| <u>Status</u> | <u>Number</u> |
|----------------------------|---------------|
| Installed Engines. | 4300 |
| Serviceable. | 9000 |
| Repair Cycle | 12000 |

All transactions concerning engines that are physically possessed by AMAs, Air Force Depots, Air Force Bases, and other Air Force organizations are reported by serial number on an AF Form 1534, "Engine Status Report". The focal point for this input of data, OCAMA/ACDP, edits the data for content and arranges it in sequence. The data is matched with previous transactions to insure reporting continuity and is then assembled in the prescribed format and disseminated to the using activities. Distribution of this information is depicted in Figure 2-1.

¹Tinker Air Force Base, Oklahoma, Personal interview with Mr. Olin Roberts, Data Automation Division, Comptrollers Office, Headquarters Oklahoma Air Material Area, Air Force Logistics Command, June 23, 1972.

**DO24 ENGINE STATUS
REPORTING SYSTEM¹**

ENGINE SERIAL #
LOCATION
CONDITION
TRANSACTION

AF FORM
1534

17

BASE
ENGINE
MANAGER

AUTO-
DIN

OCAMA

DO-24A
DATA INPUT
COLLECTING
EDITING
STORAGE

OUTPUT

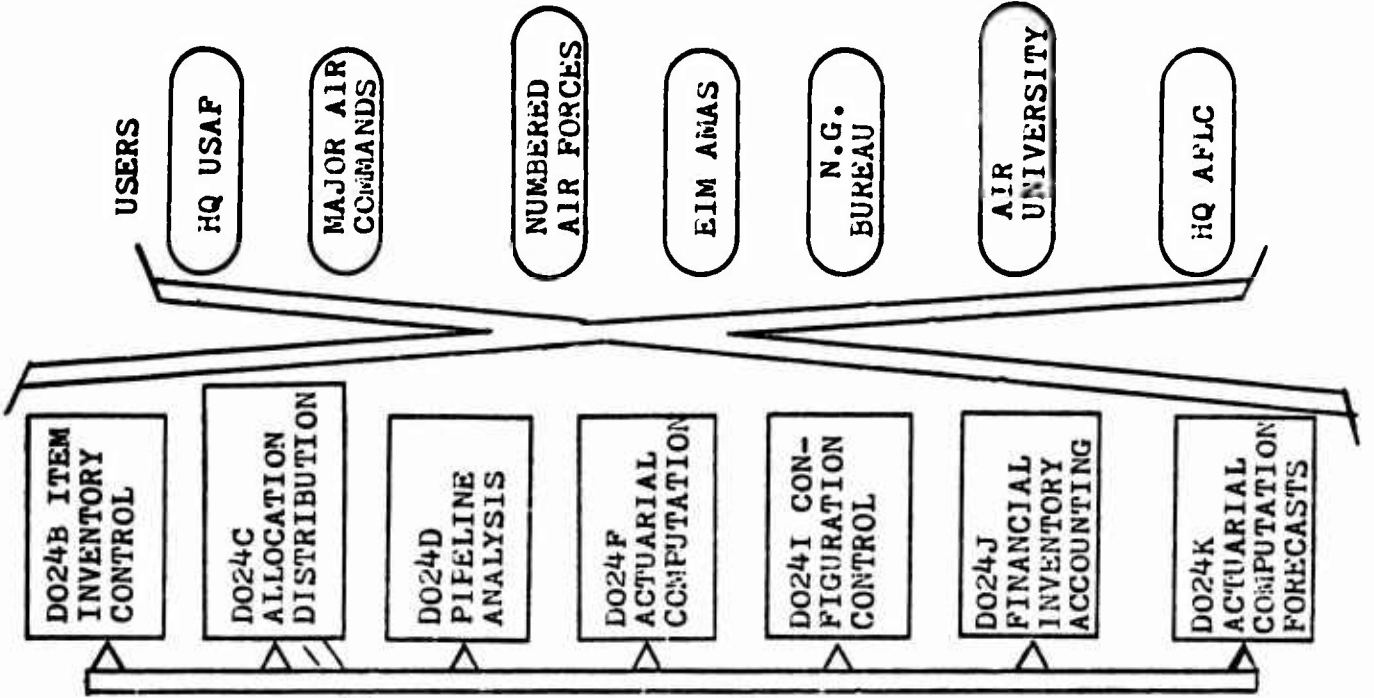

Figure 2-1

¹Wright-Patterson Air Force Base, Ohio, Briefing Chart, Requirements and Distribution Division, Headquarters Air Force Logistics Command, May 8, 1971.

Standard automatic data processing equipment and sophisticated electronic communications networks have been utilized to initiate, process, transmit, and digest the tremendous amount of data reported by the engine status reporting system. Headquarters AFLC presently has established standards for the time required to receive status changes from the time of submission until it is received by the Engine Item Manager. The standard for the Automatic Digital Network (AUTODIN) is set at two and one-half days or five days if submitted by mail. That standard, as a rule, has been met and in most cases reports are submitted in less than standard time.¹ Those submissions which were delinquent (approximately 15%) were due primarily to edit faults-- receipt of AF Form 1534s out of sequence, missing reports, improper logic. They were not due to late submission by the reporting activity.²

Within the engine management environment there are several groups which utilize the information reported by the AF Form 1534, "Engine Status Report", to assist the Engine Item Manager in developing improved engine maintenance procedures. These groups are the Aerospace Engine Life

¹Wright-Patterson Air Force Base, Ohio, Personal interview with Mr. Ralph H. McGary, Monitor D024 Report, Headquarters Air Force Logistics Command, May 8, 1972.

²Tinker Air Force Base, Oklahoma, Personal interview with Mr. James Sweet, Chief Engine Control Section, Requirements and Distribution Branch, Director Material Management, Headquarters Oklahoma City Air Material Area, Air Force Logistics Command, June 22, 1972.

Committee, the Technical Service Branch, and the Requirements and Distribution Branch. A typical organizational relationship is depicted in Figure 2-2. Although in this case a jet engine division is used, reciprocating engine management is organized in much the same way.

Aerospace Engine Life Committee (AELC)

The AELC, established by AFM 400-1, is a high level engine management group. It is chaired by the Director of Propulsion Systems, Headquarters AFLC and consists of representatives from the AFLC Actuarial Office; the Headquarters AFLC Accessories, Equipment and Propulsion Branch; the Headquarters AFLC Directorate of Supply; Air Force Systems Command, Aeronautical Systems Division Directorate of Systems Support; AFSC Deputy for Engineering; each AMA EIM; Deputy for Material of each USAF Major Air Command except the Air University; the Air Force Academy; the USAF Southern Command; the Directorate of Maintenance Engineering, Headquarters USAF; and the Directorate of Production and Programming, Headquarters USAF. The committee normally meets twice each year to conduct business and to make decisions which have an impact upon engine logistics.

The primary responsibility of the AELC is to review and approve methods, procedures, and policies as related to engine life. Much of the information and data used in decision making stems from the appropriate AMA Technical Service Branch.

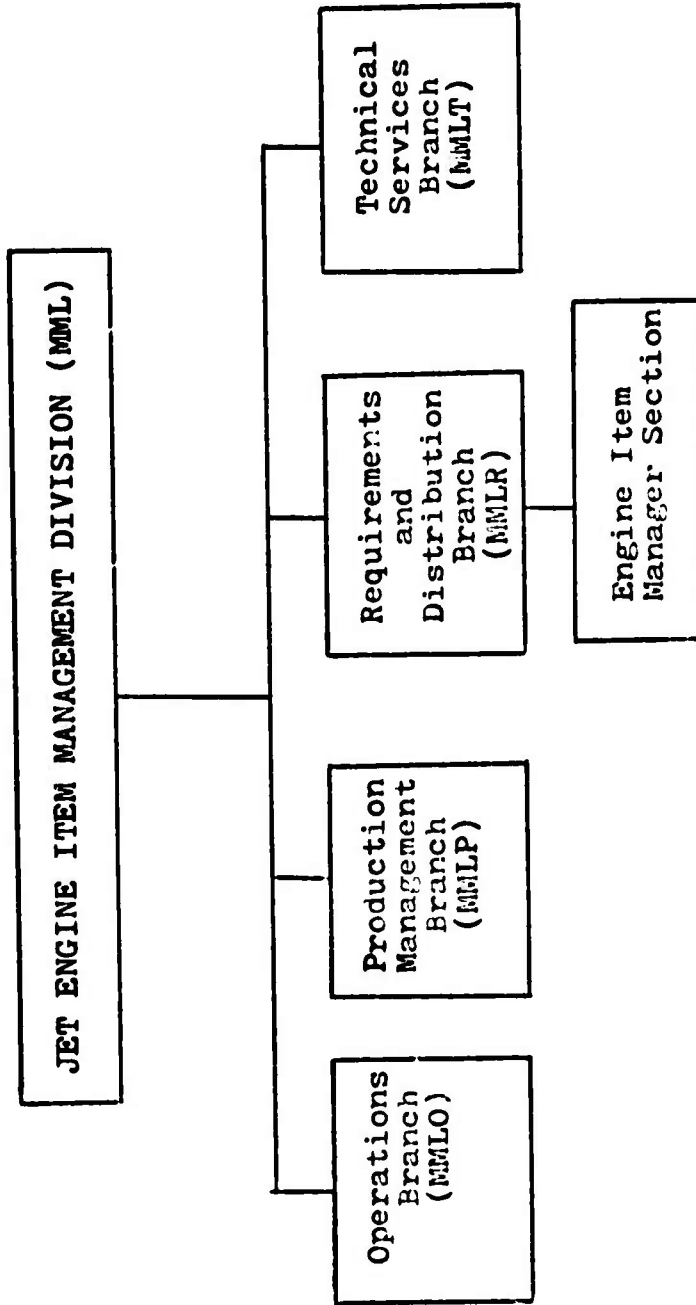

Figure 2-2
Organizational Chart for Jet Engine Item Management Division

Jet Engine Technical Service Branch

The Jet Engine Item Manager Division within the Air Material Areas Directorate of Material Management (DMM) is the focal point for the control of jet engines within the Air Force inventory. This division is typical of the AMA organization for the control of aircraft engines and as such serves as a good example.

The Technical Service Branch strives to improve engine performance and to extend engine life. The personnel within this branch closely monitor the reasons for engine removal so that deficiencies can be identified and corrected. They can also direct an analytical teardown of an engine that is experiencing a high failure rate, as reported by AF Form 1534s, "Engine Status Report", to determine possible causes. The branch also provides the technical direction for accomplishing engine maintenance, including specific limitations for base maintenance repair. The results of Technical Services Branch activity are reported to the AELC and form a failure basis for the committee's decision. The coordinated activity of both the AELC and the Technical Services Branch have a direct bearing on the success of the selective management concept applied by the Engine Item Manager.¹

¹Tinker Air Force Base, Oklahoma, Personal interview with Mr. Wilburn Hagood, Deputy Chief, Engine Control Section, Requirements and Distribution Branch, Director Material Management, Headquarters Oklahoma City Air Material Area, Air Force Logistics Command, June 22, 1972

Requirements and Distribution Branch

The Requirements and Distribution Branch of the Jet Engine Item Manager Division has the responsibility of determining the number of engines required to support Air Force aircraft and their missions. Part of this responsibility includes determining the number of engines that will require overhaul based on the USAF Program Aerospace Vehicles and Flying Hours (PA) and the overhaul removal interval (OHRI). The PA is a document published by Headquarters USAF showing the planned flying hours for all USAF aircraft. The OHRI is an Actuarial Removal Interval sub-factor developed by actuarial analysis that is used to predict engine removals for major overhaul. The overhaul requirements are then passed to the Production Management Branch, still within the Jet Engine Item Manager Division. The removals and shipments are then monitored through the Engine Status reporting system. This allows the Requirements Branch to continually compare actual removals for overhaul against those projected, and to notify production management whenever the difference becomes significant.

One of the major time consumers for the Engine Item Managers is the surveillance of engines returned to depot to insure; (1) that the engines returned did, in fact, require depot level maintenance and (2) that the bases returning engines were meeting their obligations to turn-around or

repair an agreed upon percentage of engines at the field level.¹

The Engine Item Manager is also directly responsible for the distribution and stock level requirements of those engines under his control. Here the EIM must insure that the using activities have the correct stockage levels on hand. If the stock level is below the authorized stockage level, and there are no replacement engines enroute, he must determine from the D024, Propulsion Unit Logistics System, report the location and status of available engines at other activities. The Engine Item Manager then contacts the using activity, usually by telephone, to insure that the need for an engine still exists and that the engine is available at the activity as reflected by the engine status reporting system. He then coordinates the transfer of the engine between the two activities.²

In summary then, the Engine Item Manager is primarily concerned with decisions involving two areas; (1) the status of engines at each using activity, and (2) the location of the engines throughout the world.

To enable him to make decisions concerning these areas the following data is essential: status changes of

¹Tinker Air Force Base, Oklahoma, Personal interview with Mr. James Sweet, Chief of Engine Control Section, Requirements and Distribution Branch, Director of Material Management, Headquarters Oklahoma City Air Material Area, Air Force Logistics Command, June 22, 1972.

²Ibid.

assigned engines, location of engine by serial number, nature of engine failure, number of engines returned to depot for overhaul, reason for return to depot, status of engine levels, and, finally, pipeline times.¹ It was determined that the EIM did seem to require the information he received from the engine status reporting system. However, it was noted that his dependence upon double checking a situation prior to any decision made it appear that he did not need the information reported as rapidly as he received it.

This chapter has examined the environment of jet engine management as being typical of aircraft engine management, to provide a foundation for answering the questions; What decisions does an Engine Item Manager have to make and how does he set about gathering the necessary information to support his decision? This examination has considered engine management responsibilities, the management groups responsible for engine life consideration, and the utilization of such knowledge having a significant impact on all aspects of engine logistics management.

In the following chapter the authors will describe the AF Form 1534, "Engine Status Report", and explain the data gathered by that form. It centers on current methods and techniques used in documenting engine status by the technician and the Base Engine Manager.

¹Tinker Air Force Base, Oklahoma, Personal interview with Mr. John Dillam, Engine Item Manager, Requirements and Distribution Branch, Director of Material Management, Headquarters Oklahoma City Air Material Area, Air Force Logistics Command, June 22, 1972.

CHAPTER III

DATA COLLECTION

The use of the D024, Propulsion Unit Logistics System, has been demonstrated in the previous chapter. As a management tool, it has certainly become an important source of information for AFLC Engine Managers. This chapter will continue the analysis of the system by identifying the individual responsible for the collection of the raw data and describing the environment in which he works. It will then identify the source document for this raw data and outline the type of data collected.

Base Level Engine Manager

The individual charged with inputting the required data is the base level engine manager. According to AFM 400-1, the engine manager must be a supply inventory management specialist/supervisor, hold a 7-skill level, and be at least a Technical Sergeant. An equally well qualified civilian may also hold this position. After he has had six consecutive months of experience as an Engine Manager, the Base Personnel Office is directed to assign him a Special Experience Identifier Code acknowledging this fact.

It should be realized from the start that this

individual works in a unique environment. Engines differ from most items handled by base supply in that they do not normally arrive at a base ready for use. Basic engines are often used on two or three different aerospace vehicles and will generally require different accessories for each one. These accessories may range from simple plumbing on a piece of ground equipment to complete hydraulic, electric, and pneumatic systems on a jet fighter. Even if the engine is particular to one type of vehicle, an aircraft for example, simply changing it from the left side to the right side of the fuselage may require an entirely new engine configuration. Therefore, when an engine arrives at a base, it is delivered to a maintenance unit to be "built up" for installation. For aircraft engines, a Quick Engine Change (QEC) kit is added to the basic engine to prepare it for the exact job it will do on the aircraft. Once these engines are built up, they are not returned to a supply warehouse, but for convenience sake, are kept in the maintenance facility ready to be installed.

This is the first major problem area that confronts the base level engine manager. The manager must rely entirely on maintenance to inform him of any change in reportable status. These changes take place many times a day on the various engines in any active engine shop and it becomes essential for the engine manager to maintain close coordination with the mechanics doing the work. A missed item in the logical sequence of events leading up to the installation of

an engine will cause an error message to be sent directly from Oklahoma City demanding immediate correction. The engine manager must also be aware of the engines that are out of commission for parts and what action is being taken on them. It is a comment on the closeness of the interaction that must take place between maintenance and supply at this level that more often than not, the engine manager's desk is to be found in the engine shop office.

The second problem area that faces the engine manager is that he is not given the authority to carry out his duties as outlined by AFM 400-1. These duties are indicated by the following quotation:

The base engine manager will exercise management control over all engines possessed by base and tenant activities, including engines received on base, built up, repaired, installed, removed for reason and shipped off base. . . .¹

The passage then goes on to list twenty specific duties that do require a great deal of management control. This is the fallacy of the system because the base level engine manager is not a manager. Management implies control or power over the item being managed. When an engine arrives at a base, it first becomes the responsibility of the engine shop and later of the organization that owns the aerospace vehicle.

¹U.S., Department of the Air Force, Selective Management of Propulsion Units, AFM 400-1, Volume I (Washington D.C.: Government Printing Office, August 31, 1971), p. 3-6.

The engine manager never signs for an engine and is never held responsible for one.

With no real power in the system, the engine manager's life is sometimes very difficult. As an example, he is charged with insuring that build up pipeline times are within the standards set by the Engine Item Manager. These pipeline times are of a critical nature because they are used to compute the minimum number of spare engines that are needed by the system. If maintenance is falling behind, the only recourse the engine manager has is to report the situation to his superior, the Chief of Supply, who then reports to the Deputy Commander for Logistics (DCL). The DCL moves down the maintenance chain of command to the Chief of Maintenance who corrects the problem in the engine shop. This route is many times too circuitous to be effective except in the most extraordinary circumstances. Realistically the engine manager's duties consist of reporting engine status and little more. The next section of this chapter will deal with this reporting in more detail.

Data Source

The source document for the D024, Propulsion Unit Logistic System, is the Air Force Form 1534, "Engine Status Report." This is a comprehensive form designed to follow a particular engine, by serial number, from procurement through salvage. It will be necessary to describe this form in some detail in order to properly test the hypothesis that there

is an alternate method of gathering this data. For a pictorial summary, refer to the chart listed as Appendix B. All the information contained in this section is taken from AFM 400-1, Volume II, Chapter 4.

| Form Approved Budget Bureau No. 21-R0120 | | | | | | | | | | | | | | | | |
|--|----------|-----------------------|--------|----------------------|-----|-----------------|------------|---------------------------------|--------------------------------------|-----------------------------|---------------------------------------|-----------------------|------------|---------|--|-----------------|
| ENGINE STATUS REPORT | | | | | | | | | | | RCS | | | | | |
| 1. ENGINE DESIGNATION | | | | 2. ENGINE SERIAL NO. | | | 3. C/D NO. | | 4. ORG. | | 5. STATION NO. | 6. ACCT. | 7. RE-PORT | 8. DATE | | 9. SEQUENCE NO. |
| TYPE LTR. | TYPE NO. | MODEL | MODIF. | TR. NO. | NO. | MAJ. | SUB. | | | | | | YR. | DAY | | |
| 10. TRANSACTION | | | | 11. CONDITION | | | | 12. TO OR FROM | | 13. CON. TAINER TYPE | 14. TRANSPORTATION CONTROL NO. | | | | | |
| GAIN | | EVORS | | E SERVICEABLE | | C/D STATION NO. | | | 15. REPARABLE ENG. SERIAL NO. | | | | | | | |
| NEW PRODUCTION | | A WORK COMPLETED | | F RAW | | R | | | | | | | | | | |
| REIMBURSABLE | | B TEST CELL REJECT | | G BUILT-UP | | B | | | | | | | | | | |
| NON-REIMBURSABLE | | C WORK STOPPED | | H | | | | | 16. DOCUMENT NUMBER | | | 17. MAP NUMBER | | | | |
| EXCHANGE | | D WORK STARTED | | J REPARABLE | | | | | | | | | | | | |
| LOSS | | REMOVED TRANSIENT | | K WITH GEC | | F | | 18. REMOVAL REASON | 19. ENGINE TIME | 20. | | 21. | | | | |
| ATTRITION | | W REMOVED OTHER | | L WITHOUT GEC | | G | | | | 22. | | 23. | | | | |
| FOR PARTS | | X CHANGE IN MAINT. | | M MAJOR | | L | | | | | | | | | | |
| SALVAGE/R-M | | Y AWAIT DISPOSITION | | N MINOR | | K | | | | | | | | | | |
| OTHER | | Z | | CONDEYND | | C | | | | | | | | | | |
| NON-GAIN/LOSS | | | | | | | | | | | | | | | | |
| RECEIVED | | R | | INSTALLED | | | | 28. END ITEM DESIGNATION | 29. END ITEM SERIAL NO. | 30. POSITION NO. | | | | | | |
| SHIPPED | | S INSTALLED TRANSIENT | | U ACTIVE | | A | | | | | | | | | | |
| TRANSFERRED | | T INSTALLED OTHER | | V INACTIVE | | Z | | | | | | | | | | |

AF FORM 1534, JUL 68 PREVIOUS EDITIONS OF THIS FORM ARE OBSOLETE.

Reproduced from best available copy.

ENGINE STATUS REPORT

Figure 3-1

As was previously stated, the information system depends on the accurate identification of an individual engine. The first six blocks of the AF Form 1534 are devoted to this purpose. Block 1 indicates the engine designation by type and model as shown on the engine data plate. Block 2 of the form pins the specific engine down even more by

identifying its serial number. The next four blocks record location data and begin to collect status on engine condition. Codes identifying major command and sub-command are entered in Block 3 and the station number of the activity preparing the report is placed in Block 5. Additionally engine ownership account information is entered in Block 6. This account information indicates those engines that are Air Force assets and those in other programs such as Military Assistance, Air National Guard, or Ground Training. A complete list of engine ownership accounts is found in Appendix C. Explanation of Block 4 was delayed intentionally because of its confusing function. Although it is labeled "Organization Code," it records engine status information. Engines that do not require Time Compliance Technical Orders (TCTO's) are coded with an "X" in this block and those set aside as War Readiness Material (WRM) assets are coded with a "Y". If these conditions do not exist, the block is authorized for local use.

Block 7 is entitled "Engine Type Report" and entries there help differentiate between routine reports (Code R) and reports requiring special action. For example, transfers between Air Force and other than Air Force accounts are flagged with Code K to set them apart. For a full listing of the various reports see Appendix D. The "as of" date of the report goes in Block 8, and Block 9 records what is known as the report sequence number. A sequence number is assigned to each engine status report by the base engine manager

before it is submitted to OCAMA and provides an efficient way to cross-index a particular action.

. . . , if ten status reports are submitted to OCAMA on 1 January the sequence control number would be A0001 A for January, A0002, A0003, etc. through A0010. If then on . . . the following day, eight reports were submitted, the sequence control would begin with A0011 and continue through A0018.¹

In this way, the base engine manager maintains a complete numerical listing of every report he transmits.

All transactions involving Air Force engines are entered in Block 10 of AF Form 1534. It is important to note that changes between transaction codes are the basic reason for the initiation of an AF Form 1534. For coding purposes, these transactions have been further divided into three major categories. The first of these categories includes all engines to be added to the Air Force inventory. Uninstalled engines entering the inventory from new procurement will be listed as "New Production Gains". "Reimbursable Gains" are engines from any source other than a new production contract and involving monetary reimbursement. Conversely, "Non-Reimbursable" engines do not involve such payment. Lastly, engines gained by the inventory through a negotiated exchange agreement where a reparable engine is exchanged for a serviceable engine or vice versa, and a repair cost is involved, are to be coded as "Exchange".

¹U.S., Department of the Air Force, Selective Management of Propulsion Units, AFM 400-1, Volume II (Washington, D.C.: Government Printing Office, August 31, 1971), p. 5-1.

The second major category involves all engines lost from the inventory. Reasons for loss can be specified as "Attrition," used "For Parts," or "Salvage/R-M". Conditions not covered by these may be noted under the catch-all designation of "Other"--although there is no way of explaining what this might be on the form.

Third, and the final category, is titled "Non-Gain/Loss" and represents the bulk of the transactions reported to the system. Here the engines are already on hand and data is being collected on them as they move from one pipeline segment to the next. Such segments dealing with transportation can be represented on the AF Form 1534 as "Received," "Shipped," "Transferred," or "Await Disposition." Maintenance actions are more inclusive and include "Work Started," "Work Stopped," "Work Completed," "Change in Maintenance," and "Test Cell Reject." Three more actions also fall under the classification of maintenance, but deal with remove or replace work on in-commission engines. These actions are "Installed Other," "Installed Transient," and "Removed Transient." The final code is a supply classification used to report those engines requiring parts. This is the standard designation of Engine Not Operationally Ready--Supply or "ENORS." It should be noted that there is no place designated on the form for indicating the parts that are required to end this situation.

Connected very closely to the information presented in Block 10 is that provided in Block 11, "Condition." For ease of coding this section is also divided into three

categories, "Serviceable," "Reparable," and "Installed." Serviceable engines are recorded as "Raw" if they are not in a condition to act as a power pack and "Built-up" if they are in a power pack configuration, ready to be installed.

Reparable engines, on the other hand, require some form of maintenance before they are ready for use. It is here that the close interconnection between data provided by Block 10 and that in Block 11 is most evident. Reparable engines are coded "Major" if they are located at a depot or contractor overhaul site that require or are undergoing major overhaul and "Minor" if the overhaul is minor. Reparable "With QEC" includes engines that are in a power pack configuration and undergoing base level maintenance. Those engines "Without QEC" are undergoing similar maintenance, but are not fully configured for use. Interestingly, a final coding possibility under reparable is "Condemned." This is basically for engines that are condemned or are otherwise held in an inactive status pending determination of disposal or rehabilitation action.

The last category in Block 11 is Installed. "Active" engines are installed in any active aerospace vehicle from aircraft to missiles to ground equipment. "Inactive" installed engines are those in extended storage.

Blocks 12 through 17 are reasonably straight forward. If the engine has moved, the shipped to or received from command and four positions of the station number are entered in Block 12 to help trace transportation problems. Block 13

records the type of transportation container used for engine shipment and Block 14 is for the transportation control number covering the shipment.

In the event that an engine is being replaced by a serviceable shipment from a depot overhaul storage site, the serial number of the engine being replaced will be entered in Block 15. Document numbers covering gain and loss transactions are recovered in Block 16, and Block 17 holds the Military Assistance Program identification number if the engine is under one of the many programs.

Block 18 is more complicated in that it can record a wealth of information. The title of the Block is "Removal Reason" and there are 56 reasons listed in the code manual AFM 300-4, Volume III. A full list of these reasons can be found in Appendix D. Ranging from "flame out" to "Foreign Object Damage (FOD)", the list is extensive and requires intuitive judgement by the technician completing the form.

Engine time since the last major overhaul or since manufacture goes in Block 19. At the present time Blocks 20 through 27 are unused by the system. The last two blocks record information on the end item in which the engine is installed. Block 29 holds the year and serial number of the end item and Block 30 holds the position number the aircraft engine held or will hold.

This concludes a rather tedious block by block explanation of the AF Form 1534. It was considered necessary, by the authors, however, so that the reader might have a better

understanding of the depth and breadth of the data provided by that system. In the next chapter the Transportation, Maintenance, and Supply Data Collection Systems will be described and the role they play in reporting the status of an engine will be presented.

CHAPTER IV

ALTERNATE DATA COLLECTION SYSTEMS

Over time Air Force maintenance, supply, and transportation managers have found it necessary to establish information systems to provide the raw material they need to make intelligent decisions. Often these systems parallel each other and provide much the same information to more than one functional area. This chapter will examine several of these information systems in order to identify common data elements between these systems and the L024, Propulsion Unit Logistics System. An additional purpose is to highlight other data elements that might be useful to the Engine Item Manager.

Transportation

A great deal of the engine movement information provided by AF Form 1534, "Engine Status Report", is also available in a reporting system used by transportation personnel to evaluate engine pipeline times. This particular system, the LOG-J74, "Supplemental Engine Transit Time Report", was established under the Military Supply and Transportation Evaluation Procedures (MILSTEP) program to give managers a better idea of what was happening while engines were in

transit. It had been found, through experience, that transportation times as reported by the engine status reporting system were so inaccurate and vague as to be almost useless for any type of systematic evaluation.¹ The first problem, discovered by AFLC Transportation Specialists, was that the D024 pipeline report only recorded initial departure and final arrival times for engines. Under such a restriction, there was no way for a transportation specialist to analyze and correct possible delays enroute. Base level engine managers often compounded the problem by reporting an engine as "Shipped" when it had merely been delivered to the packing section for preparation.² To gain the visibility they needed, Air Force Transportation managers devised an accurate reporting system that depended on standard MILSTEP procedures, but that isolated engine data for special action. The most significant of these reports is the LOG-J74, "Supplemental Engine Transit Time Report".³

The LOG-J74 Report is driven by DD Form 1384-1, "Intransit Data Cards" (IDC) which trace an engine's progress from the shipper through transshipment points to its ultimate destination. Within an Air Force system, such as LOGAIR,

¹Wright-Patterson Air Force Base, Ohio, Personal interview with Mr. Harvey W. Laughrey, Traffic Management Specialist, Headquarters Air Force Logistics Command, August 10, 1971.

²Ibid.

³U.S., Department of the Air Force, Transportation of Materiel, AFM 75-1 (Washington, D.C.: Government Printing Office, November 30, 1970), p. 58-18.

very accurate records can be kept. Movement from the base transportation dock requires that one IDC be electrically transmitted to the Control Data Collection Point (CDCP) at McClellan AFB, California, and arrival at the LOGAIR Terminal requires yet another. Every stop along the way produces another IDC and another link in the data train. All intransit data cards that pass an edit procedure at the CDCP are consolidated by Transportation Control Number (TCN) for use in preparation for a variety of transit reports.

Engines shipped under a Government Bill of Lading do not generate as much data as outlined above, but the dates and times provided are consistent with standard transportation evaluation procedures. Essentially an IDC is begun by the shipping activity and mailed to the using activity. When the property is received, all the information is electrically transmitted to the CDCP at McClellan AFB. Although this alternative does take a bit longer, it still provides all the information needed to establish and maintain an effective transportation network.

Specifically, the LOG-J74 report presents transportation managers with the location and station number of both the shipping and the receiving activities. It shows the shipped date, received date, mode, priority, and then indicates the total days in transit. At this time the report is only able to display the type of engine and its series, but currently plans are being considered which would expand the data base to include engine serial numbers. The proposal is to

make use of several unused spaces within the present transportation control number.¹

Actually, the only bit of transportation data provided by AF Form 1534 that is not reproduced by the LOG-J74 Report is the type of container that holds the engine during shipment. While this data may be important when tests are being conducted on specific types of containers, it would not seem to be of significance in the routine management of engines and should therefore be considered of doubtful value to the overall D024 system. In the event that a new type of container was being tested, a modification to the system could be incorporated to provide that data. For example, the type of container is always listed on the Transportation Control and Movement Document (TCMD) accompanying every shipment.

Maintenance

Another source of information that runs parallel to that provided by the AF Form 1534 is the Maintenance Data Collection (MDC) System. The details of this system are outlined in T. O. 00-20-2 and AFM 66-1. Air Force Technical Order (AFTO) Form 349, "Maintenance Data Collection Record", (Figure 4-1) and AFTO Form 350, "Reparable Item Processing Tag", (Figure 4-2) comprise the basic documents for this system and were both designed with sufficient flexibility to be used to record maintenance actions on various types of

¹Wright-Patterson Air Force Base, Ohio, Personal interview with Mr. Harvey W. Laughrey, Traffic Management Specialist, Headquarters Air Force Logistics Command, August 10, 1972.

equipment. These two forms are the ones applicable to aircraft engines.

AFTO Form 349

The AFTO Form 349 is a multi-purpose form used to record maintenance actions on Air Force equipment that is under the MDC system. Information of this sort is used by work center supervisors, chief of maintenance staff functions such as Maintenance Analysis and Quality Control, and Headquarters AFLC to carry out their management responsibilities.¹

A significant feature of this form is that it makes use of an identification (ID) number which causes the processing computer conversion routine to record complete end item identification information on the various reports it produces. The six character ID number, centered in block three of the AFTO Form 349, permits positive identification of data applicable to a given aircraft or uninstalled engine by serial number.

AFTO Form 350

An AFTO Form 350 is a two part, perforated tag that is attached to components that are removed from an end item. This term end item can briefly be described as the next higher assembly that is supported by a component. For example, an

¹U.S., Department of the Air Force, Objectives and Concepts of the MDC System, T.O. 00-20-2 (Washington, D.C.: Government Printing Office, January 1, 1970), p. 1-1.

| | | | | | | | | | | | | | | | | | | | | | |
|---|--|---|--|-------------------------|--|---------------------|--|-------------------------|--|-------------------|--|--|--|------------------------|--|-----------------------|--|----------------|--|-----------------|--|
| 1. JOB CONTROL NO. | | 2. WORK CENTER | | 3. I. O. NO./SERIAL NO. | | 4. NOS | | 5. EG/CL | | 6. TIME | | 7. PRI | | 8. SORTIE NO. | | 9. LOCATION | | | | | |
| 10. ENG. TIME | | 11. ENGINE I.D. | | 12. INST. ENG. TIME | | 13. INST. ENG. I.D. | | 14. | | 15. | | 16. | | 17. TIME SPEC. REQ | | 18. JOB STD. | | | | | |
| 19. FSC | | 20. PART NUMBER | | 21. SER. NO./OPEN. TIME | | 22. TAG NO. | | 23. INST. ITEM PART NO. | | 24. SERIAL NUMBER | | 25. OPER. TIME | | | | | | | | | |
| A CARD AND ITEM NO | | B TYPE MAINT | | C WORK UNIT CODE | | D ACTION TAKEN | | E WH-EM DISC | | F HOW MAL | | G LIMITS | | H START DAY HOUR | | I STOP DAY HOUR | | J CREW SIZE | | K MAN NUMBER | |
| 1 | | | | | | | | | | | | | | | | | | | | | |
| 2 | | | | | | | | | | | | | | | | | | | | | |
| 3 | | | | | | | | | | | | | | | | | | | | | |
| 4 | | | | | | | | | | | | | | | | | | | | | |
| 5 | | | | | | | | | | | | | | | | | | | | | |
| 26. DISCREPANCY | | | | | | | | | | | | | | | | | | | | | |
| Reproduced from best available copy. | | | | | | | | | | | | | | | | | | | | | |
| 27. CORRECTIVE ACTION | | | | | | | | | | | | | | | | | | | | | |
| 28. RECORDS ACTION | | | | | | | | | | | | | | | | | | | | | |
| AFM FORM 349 NOV 69 | | MAINTENANCE DATA COLLECTION RECORD | | | | | | | | | | AF-MAW, Inc., New Carlisle, Ohio 12-69 12/AM | | | | | | | | | |
| PREVIOUS EDITION WILL BE USED | | | | | | | | | | | | | | | | | | | | | |

MAINTENANCE DATA COLLECTION RECORD

Figure 4-1

AFTO FORM 310 MAY 70
PREVIOUS EDITIONS ARE OBSOLETE

BUDGET BUREAU
NO. 81-80287

REPARABLE ITEM PROCESSING TAG

| | | | | |
|----------------------------|---------------------|-------------------|-----------|--------------------|
| 5. JOB CONTROL NO. | 2. ID. / SERIAL NO. | 3. TM | 3A. EQ/CL | 4. WHOM DISC |
| 5. HOW MAL | 6. MDS | 7. WORK UNIT CODE | | 8. ITEM OPER. TIME |
| 9. QTY. | | 10. PSC | | |
| 11. PART NUMBER | | 12. SERIAL NUMBER | | |
| 13. SUPPLY DOCUMENT NUMBER | | 14. DISCREPANCY | | |
| 15. SHOP USE ONLY | | | | |
| TAG NO. 170270 | | AFTO 330 PT. I | | |

| | | | | |
|----------------------------|----------|-------------------|--|--|
| 16. SUPPLY DOCUMENT NUMBER | | | | |
| 17. NOMENCLATURE | | | | |
| 18. PART NUMBER | | | | |
| 19. FSN | | | | |
| 20. ACTION TAKEN | 21. QTY. | 22. A/C. USE ONLY | | |
| TAG NO. 170270 | | AFTO 330 PT. II | | |

U. S. GOVERNMENT PRINTING OFFICE 1971 799 138

WARNING
Unauthorized copying, removing, defacing, or destroying this tag for labels may be subject to a fine of not more than \$1,000 or imprisonment for not more than one year or both. (18 USC 1361)

REPAIR CYCLE DATA

| | | | |
|-----------------------------------|--|-----------------|--|
| 23. FSN | | 24. SRAN CODE | |
| 25. TRANSPORTATION CONTROL NUMBER | | 26. RES CON CEN | |

| DATE / CODES | STATUS CHANGED TO |
|------------------------------------|-------------------|
| 27. REMOVED (MO / DAY / YR.) | 39. SERVICABLE |
| 28. AWP DAYS BASE FROM BLOCK 42 | |
| 29. REC'D IN BASE SUPPLY (YR. DAY) | |
| 30. TO TMO (YR. DAY) | |
| 31. REC'D AT SRA NO. 1 (YR. DAY) | |
| 32. SRA NO. 1 CODE (SRAN) | |
| 33. REC'D AT SRA NO. 2 (YR. DAY) | |
| 34. REC'D IN MAINT. SHOP (YR. DAY) | |
| 35. TO AWP (SRA) (YR. DAY) | |
| 36. TO WORK (SRA) (YR. DAY) | |
| 37. MADE SERVICABLE (YR. DAY) | 40. CONDEMNED |
| 38. MAINTENANCE ACTION CODE (SRA) | |

41. SUPPLY INSPECTOR'S STAMP

| 42. BASE REPAIR CYCLE DATA | | MO. | DAY | YR. | TIME |
|----------------------------|--------------|-----|-----|-----|------|
| DATE REMOVED | REC'D BY RPC | | | | AWM |
| TO: | | | | | |
| TO: | | | | | AWP |
| TO: | | | | | |
| TO: | | | | | |
| TO: | | | | | |
| TO: | | | | | |
| DATE COMPLETED | | | | | |

REPARABLE ITEM PROCESSING TAG

Figure 4-2

engine is the end item for a generator and the aircraft is the end item for an installed engine. The form is a basic source for in-shop documentation of the AFTO Form 349 for maintenance shop repair action. What this means is that data is extracted from the AFTO Form 350 and then reentered in the appropriate blocks of the AFTO Form 349 for eventual key punching. This makes the AFTO Form 349 the primary document in the MDC system and as such it is the one that will be treated in this discussion of aircraft engine reporting.

Data Collection

Each work center participating in a job on an engine will record their actions on an AFTO Form 349, "Maintenance Data Collection Record", and forward these completed forms to the base data collection agency. All actions on an engine, both installed and uninstalled, are tied together by a job control number in block one of the form, thereby providing an overview of all maintenance performed.¹

The data collected by the AFTO Form 349, "Maintenance Data Collection Record", like the AF Form 1534, "Engine Status Report", does not provide information on work done on engines installed in an aircraft by engine serial number. Instead, all maintenance coding is made to the aircraft itself. The AFTO Form 349, however, does provide the Engine Item Manager

¹U.S., Department of the Air Force, Off-Equipment Maintenance Documentation, T.O. 00-20-2-10, (Washington, D.C.: April 15, 1970), p. 1-1.

with the same data as the AF Form 1534 for uninstalled engines. Further, the AFTO Form 349 contains information not presently provided the EIM, but that is considered important enough for future incorporation. The Air Force is presently field testing the expanded use of the AF Form 1534 to include component failure data. This testing, conducted at Randolph AFB, Texas, is studying the effectiveness of entering component failure data in the presently unused blocks (20-27) of the form.¹

Product Performance System (D056)

Data collected on maintenance actions completed on engines is reported on AFTO Form 349, "Maintenance Data Collection Record".² These actions include minor maintenance, accomplishment of scheduled inspections, removal and replacement of whole engines or their components. A series of reports are generated by AFLC compiling the data provided by the AFTO Form 349 from bases throughout the Air Force. The LOG-K261 and LOG-K262 are two such series of reports that assist the item manager in identifying potentially critical trends or items requiring product improvement. Figure 4-3 represents the data routine from the point of collection until it is received by using managers. The 3-LOG-K261,

¹Tinker Air Force Base, Oklahoma, Personal interview with Mr. Bill E. Lawrance, Engine Logistics Planner Board Member, Oklahoma City Air Material Area, Headquarters Air Force Logistics Command, June 23, 1972.

²U.S., Department of the Air Force, Air Force Logistics Command Product Performance, AFLCM 66-15 (Wright-Patterson Air Force Base, Ohio, February 11, 1970), p. 5-7.

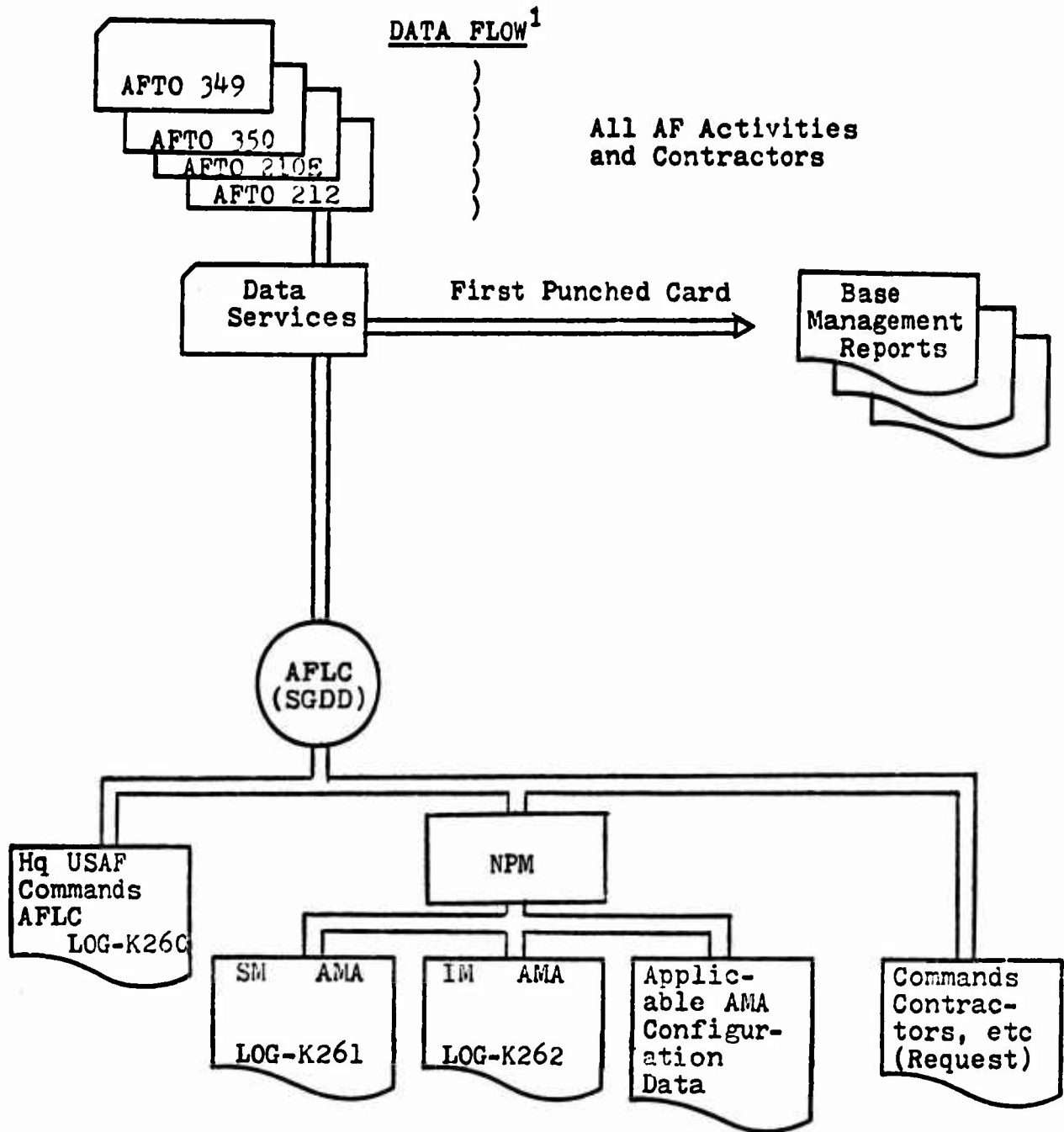

Figure 4-3

¹U.S., Department of the Air Force, Use of Maintenance Data for Logistics Management, AFLCP 50-3 (Wright-Patterson Air Force Base, Ohio, October 4, 1968), p. 1-3.

for example, is a report generated upon demand which reflects maintenance data by how malfunction code, action taken code, base, and serial number for a specific item.

LOG-K261 and LOG-K262 Series Reports

In the Maintenance Data Collection program, as in all computer oriented programs, it is necessary to assign certain codes to specific elements of data input to the system. Which item or equipment required maintenance, why/how did it malfunction, what was done to make it serviceable, and when was the discrepancy discovered, are all identified by specific codes. The following list of data and their codes is the information provided by the LOG-K261/262 Reports:

- (a) Work Unit Code (WUC): the work unit code identifies the hardware on which work was accomplished and the relationship of that piece of hardware within a functional system.
- (b) How Malfunctioned Code (HOW MAL): a three digit numeric code which describes how an item failed to perform its function.
- (c) When Discovered Codes (When Disc): a single digit alphabetic character indicating when the malfunction was discovered, i.e., inflight, before flight, or during inspection.
- (d) Action Taken Code (Action): a single digit code, (alpha or numeric) indicating the specific type of maintenance performed on the item identified by the WUC.
- (e) Base Code - Each AF activity including DOD contractors are assigned a permanent installation code.
- (f) Command Code - Each Major Command has a single digit alpha code for use in the reporting system.

- (g) Aircraft Serial Number - The specific serial number assigned to each aircraft owned by the Air Force.
- (h) Equipment Classification Code - A code assigned to each type of equipment to assist in system identification.
- (i) Where Work Performed - Describes the location of the maintenance action (Code A: engine installed on the aircraft, Code X: engine removed from aircraft.)
- (j) Type of maintenance - The type of maintenance performed on item, (i.e., special inspection, overhaul).
- (k) Parts Replaced - Would only be reflected on a removed engine. This data used to reflect parts replaced on a WUC during repair cycle.
- (l) AMA Responsible For Article - The AMA which has item responsibility for the WUC reported.
- (m) Engine Serial Number - Reported when the engine is the end item (off-equipment).¹

Uninstalled engine maintenance information is much the same as that provided for installed engine maintenance with one exception. This exception is that all actions on the engine are recorded by engine serial number. The off-equipment, "Removed", LOG-262 series reflects such information as failures, man hours required to correct the discrepancy, parts usage, and action taken to repair the component. These reports are prepared by Federal Supply Class (FSC) and Part Number (P/N) and oriented particularly to Item Managers.

¹U.S., Department of the Air Force, Air Force Logistics Command Product Performance, AFLCM 66-15 (Wright-Patterson Air Force Base, Ohio, February 11, 1970), p. 5-7.

Managers, however, must be equally familiar with each of the reports provided. In many cases, both series of reports require review for the complete maintenance history.

Supply

A final functional area that was examined for Management Systems containing engine related information was that of supply. Unfortunately, with one major exception, base level supply organizations do not concern themselves with engines. It is true that the Base Engine Manager is assigned to Base Supply, but all of his reports by-pass the local systems. To emphasize the point, engines are not even listed on the Standard Base Supply System 1050-II computer.

Not Operationally Ready Supply (ENORS) Report

The exception to engines not being a part of the Standard Base Supply System is when an engine becomes Not Operationally Ready Supply (ENORS). This happens when a mechanic is forced to stop working on an engine because the local base supply cannot support his request for a replacement part. As was mentioned in the previous chapter, the Base Engine Manager is charged with reporting this condition on an AF Form 1534, "Engine Status Report", but has no continuing reporting obligation. The only information reported by the D024, Propulsion Unit Logistics System, is ENORS start and stop time. There is no way for the Engine Item Manager to identify engine parts problems using his information

system. Base supply on the other hand does provide higher level managers with extensive ENORS data. A sub-activity of base supply known as NORS Control is charged with monitoring the status of all parts requisitions that are keeping an engine out of commission, from the time they are ordered until receipt.

An aid to managers in this important area is the HAF-S52, "Not Operationally Ready Supply (NORS) Report".¹ Fed by inputs to the 1050-II computer and electrical transmissions to the appropriate AMA, this system provides positive control of all NORS parts on order. Each item manager is made aware of the worldwide demands on his resources. Reports identify the end item, such as an engine in this case, by type and serial number. In addition, they provide information on part nomenclature, stock number, quantity required, and even the Maintenance Work Unit Code. Items will remain on the various products of this system until the demand is satisfied. This system provides the same ENORS start and stop times that are recorded on the AF Form 1534, but goes on to present additional information that cannot be found in the D024, Propulsion Unit Logistics System.

This chapter has demonstrated that some transportation, maintenance, and supply data collection systems do parallel the D024, Propulsion Unit Logistics System. These reports,

¹U.S., Department of the Air Force, United States Air Force Supply Manual, AFM 67-1, Volume I, Part One (Washington, D.C.: Government Printing Office, May 1, 1972), p. 2-3.

although prepared for a specific use within a functional area of logistics management, reflect much of the same information as that presently provided to the Engine Item Manager.

The transportation reporting system, LOG-J74, "Supplemental Engine Transit Time Report", provides the means of pinpointing location and improving engine pipeline times. With minor modification of the system, control by engine serial number could be available.

Maintenance Data Collection, primarily through the use of the AFTO Form 349, "Maintenance Data Collection Record", provides information for a series of comprehensive reports. These reports document actions taken both on installed and uninstalled engines. Installed engine maintenance is primarily displayed in the LOG-K261 series reports which are specifically designed to be used by the AFLC System Manager (SM). Uninstalled engine maintenance, as indicated, is that maintenance accomplished in base maintenance shops, depots, and contractor plants. This category of maintenance data is displayed in the LOG-K262 series reports. Prepared by Federal Supply Class (FSC) and Part Number (PN), these reports are addressed particularly to AFLC Engine Item Managers. The Maintenance Data Collection System provides much of the same information on engines as does the D024, Propulsion Unit Logistics System, but it surpasses it by additionally providing information on components especially when work is done on an uninstalled engine.

The supply system also generates a report that contains engine related information. This is the HAF-S52, "Not Operationally Ready Supply (NORS) Report". Whenever work is stopped on an engine for lack of a part, the part and the engine serial number are reported by this system. Although the D024 System does display the start and stop times of an ENORS condition, the Engine Item Manager has no way of identifying a particular parts problem as he would with the use of the HAF-S52 report.

The next chapter will offer a proposal for the expanded utilization of these reports which will accomplish everything currently being done by the D024 System as well as providing more accurate failure analysis and pipeline trend identification.

CHAPTER V

AN ALTERNATIVE PROPOSAL

The previous two chapters of this thesis have outlined the sources of engine status information within the existing Air Force Maintenance, Supply, and Transportation Information Systems. Together they provide much of the raw data reported on the AF Form 1534, "Engine Status Report". This chapter will describe how the information from these three functional areas can be integrated into a single thread reporting system eliminating the need for AF Form 1534 reporting at base level. It will further be demonstrated that the proposed system will not sacrifice any of the accuracy or completeness required by Engine Item Managers.

For ease of explanation, the proposed system will be divided into four different segments; Engine Entry into the System, Arrival at an Operating Base, Maintenance Activities, and Departure from the Base. This sequence will represent the path taken by the majority of aircraft engines. After treating these topics, the chapter will go on to describe several of the problems that must be solved by the proposed system. A pictorial representation to aid the understanding of this system can be found in Figure 5-1.

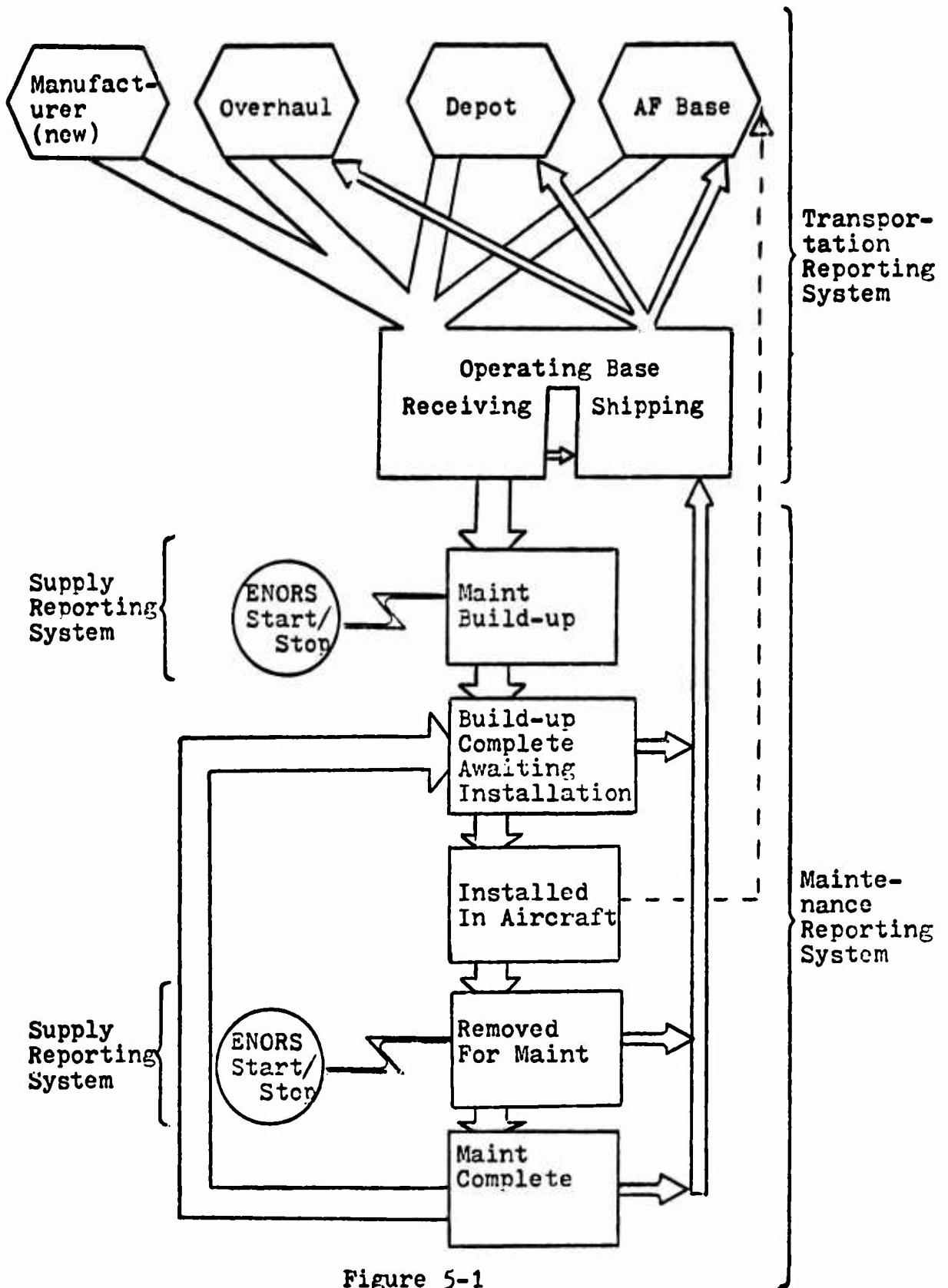

Figure 5-1

Entry into the System

An engine can enter an operating base's reporting system from four basic sources: a manufacturer, a depot, a repair activity, or another Air Force Base. Upon shipment from one of these locations, an Intransit Data Card (IDC) would be initiated and transmitted to the Central Data Collection Point (CDCP) at McClellan AFB, California. From here the information would be forwarded, on a daily basis, to the appropriate Engine Item Manager. In the case of shipment through Air Force channels, the EIM would have the basic "shipped to/from" location data he has now, plus pipeline data on all transshipment points. At worst, if the engine is shipped under a Government Bill of Lading from a manufacturer or contractor, the EIM will still receive the same shipped to/from data that is now gathered by the AF Form 1534, "Engine Status Report".

Implementation of this portion of the proposed system will require three modifications to the existing LOG-J74, "Supplemental Engine Transit Time Report". Two of these modifications are already under consideration.¹ The first change would be to record the engine serial number on the Intransit Data Card. This would continue the serialized control of engine location, which is the first category of

¹Wright-Patterson Air Force Base, Ohio, Personal interview with Mr. Harvey W. Laughrey, Traffic Management Specialist, Headquarters Air Force Logistics Command, August 10, 1972.

considered necessary by the Engine Item Managers. The second change, also under consideration, would be to require Government contractors to conform to MILSTEP and submit Intransit Data Cards. At the present time compliance is optional. With these modifications, all four sources of engines would be firmly tied into the system. The final change would have IDL data transmitted to Engine Item Managers on a daily basis. Currently it is being compiled for long term trend analysis. These three modifications would transform the LOG-J74, "Supplemental Engine Transit Time Report", into an effective engine location management system.

Arrival at an Operating Base

Under the present system, when an engine arrives at an operating base, an Intransit Data Card is generated and transmitted to the data center at McClellan AFB, California. As recommended in the previous section, this information would then be forwarded, on a daily basis, to the EIM to update his location file. The next step under the present system is to move the engine directly to the base engine shop to prepare it for installation. There would be no change here under the new system, except that the Maintenance Data Collection System would assume the reporting responsibility. The pipeline time that elapsed between the arrival of an engine on station and the start of maintenance work could be easily calculated, if necessary, by a compiling computer. Subtracting the start maintenance time, entered on an AFTO

Form 349, "Maintenance Data Collection Record", from the arrival time logged on the IDC, would result in an accurate indication of possible base level pipeline delay. This is information that is not readily available under the present system.

This particular section would require no change to data collection procedures at the local level. The only addition would be of a computer routine at the Engine Item Manager's level to calculate the pipeline time segment from the expanded data to be provided.

Maintenance Activity

Once the engine has entered the maintenance facility, AFTO Form 349s, "Maintenance Data Collection Record", would be used to reflect any change in engine condition. With a few minor changes that will be described later, this would be the source of the second category of information demanded by Engine Item Managers, that of engine status. Every maintenance transaction normally entered in Block 10 of AF Form 1534, "Engine Status Report", is also recorded on AFTO Form 349s. In addition, maintenance actions are recorded on AFTO Form 349s that are desired, but currently not found in the Engine Status Reporting System. Through access to this data, Base Engine Item Managers will have a wealth of information for trend analysis and requirements forecasting that they have never had before. This would all be available without the problem of redesigning, field

testing, and finally using a brand new AF Form 1534 simply to collect maintenance data.

Engine operationally ready status would be easy for a central computer site to establish. Any engine not needing maintenance or parts would be considered operationally ready by the system. Installation of the final part of a Quick Engine Change Kit (QEC) would cause an AFTO Form 349 to be completed indicating to the EIM that the engine was ready to be put on an aircraft. In this way he would still have worldwide visibility of his assets for control or possible reallocation without the need of AF Form 1534 reporting.

The Maintenance Data Collection System will also need minor modifications before it could assume its portion of AF Form 1534 reporting. First of all an AFTO Form 349, "Maintenance Data Collection Record," would have to be filled out at the start of any maintenance work on an uninstalled engine, as well as at the finish as is currently required. This new AFTO Form 349 would allow the maintenance "Start Time" to be fed into the system in the proper sequence instead of after the work is done. With this minor change, managers would have a complete record of engine pipelines as well as a listing of maintenance accomplished.

Another minor change that would have to take place would be the addition of a code to identify engines on War Readiness Material (WRM) Status. Perhaps an additional "How Malfunction" would serve this function. This addition would involve a small change to the code listing and would close the gap between the two systems.

Departure from the Base

Normal departure of an engine from an operating base would necessitate the same modification to the transportation system as an arrival. In this way positive control could be maintained over the movement and location of these important assets. There are several distinct problems that will have to be faced in the implementation of this new system. These will be treated in the following sections.

ENORS

The first problem that will have to be handled by the proposed system, that is outside of the normal sequence of transactions, is ENORS. To deal with this eventuality, inputs from the HAF-S52, "Not Operationally Ready Supply Report", will have to be included along with the maintenance and transportation data. This would be an advance over the current AF Form 1534 reporting in that parts requirement data would be available to the Engine Item Manager from his own system. No longer would he be constrained by the simple ENORS start and stop data he now receives.

Aircraft Transfers

The system, as outlined so far, provides Engine Item Managers with location data only on engines that are not installed in an aircraft. To remedy this problem it will be necessary to involve the base level aircraft records section.

This Chief of Maintenance Staff Agency is responsible for all official records when an aircraft is transferred from base to base. These records include extensive detail on engine maintenance by serial number. It would be a simple task for this organization to inform the proper EIM upon loss or gain of a new aircraft. The transmission of engine serial numbers would be a "one time" act as the proposed system would be able to handle all further routine location data. This method may seem a bit awkward, but it is no different from having a base level Engine Manager transmit the same data. It even eliminates a step that currently exists, for the Aircraft Records Section is the basic source of the Local Engine Managers information on transferred aircraft.

Loss Information

A final problem that will face the proposed system will be how to account for engine loss through salvage, crash damage, or the removal of an excessive number of parts. When these situations occur under the present system, the Base Level Engine Manager indicates the category of loss on an AF Form 1534, "Engine Status Report", and transmits it to the Data Processing Center at Oklahoma City. In addition, he also forwards a certified copy of an AF Form 695-7, covering uninstalled engine transfers to Redistribution and Marketing Activities, together with the original copies of DD Forms 1348-1, 250, 200, and SF 361, covering uninstalled gains and losses to

the Air Force, to the AMA at Oklahoma City, Oklahoma.¹

As these latter documents, and not the AF Form 1534, provide the basis for supporting loss transactions, the new proposal recommends that they take its place. A phone call or message from the Aircraft Records Section could give the EIM preliminary warning of a loss to the system and the required paperwork would back it up. There are various alternatives for providing initial notification, but nothing can take the place of the final notification provided by the forms that must be sent and kept on file.

By reference back to Figure 5-1, it can be seen that the Maintenance, Supply, and Transportation Information Systems do provide all of the data the Engine Item Manager states that he requires, as well as some he would like to have. Combining these three systems at a central site would totally eliminate the need for the current AF Form 1534, "Engine Status Report", reporting system. At present there are 355 base level engine managers throughout the Air Force. Incorporation of the changes recommended in this study should eliminate the need for this manpower. The value of the manpower spaces saved would more than pay for the establishment and maintenance of this proposed system.

¹U.S., Department of the Air Force, Selective Management of Propulsion Units, AFM 400-1, Volume I (Washington, D.C.: Government Printing Office, January 5, 1970), p. 5-3.

²Wright-Patterson Air Force Base, Ohio, Personal interview with Mr. Ralph H. McGary, Monitor D024 Report, Headquarters Air Force Logistics Command, May 8, 1972.

CHAPTER VI

SUMMARY

When this thesis effort began, the United States Air Force had had an Engine Status Reporting System for almost twenty-two years. The objective of the research was to impartially examine this system to see whether it had stood the test of time or had other management information systems grown up that perhaps were better.

This study has concerned itself basically with the information needed by the Engine Item Manager, both in scope and timeliness, and his source for obtaining that information. The study also evaluated other information reporting systems reporting the same data which might be incorporated into the engine management system. Limitations imposed by the authors required that only systems reporting aircraft engines be examined.

To determine the answer to the first hypothesis posed by this thesis: "The AFLC Engine Item Manager routinely uses all the information he receives from the Engine Status Reporting System to accomplish his mission" it was necessary to examine the environment of the Engine Item Manager. Here the authors wanted to determine the significance of the data reported to

the EIM and his need, if any, for this data to be reported to him within twenty-four hours. Additionally, the authors wanted to learn which of the data bits the Engine Item Manager depended upon in his decision making process and which were not essential or "nice to know".

Through the use of the structured interview guide Engine Item Managers were questioned to determine: (1) What decisions does an EIM have to make; (2) What data does he use to make these decisions; and (3) How rapidly do these decisions have to be made?

The first question was evaluated by having the EIM's discuss the decisions that they frequently were involved with and the rank order of most important to the least important. It was found that the decisions concerning the status of engines at each using activity and the location of their respective engines throughout the world were considered to be the most essential.

Based upon these criteria, the data that was reported to the EIM was then examined to determine the information he uses to make his decisions. The data required is:

1. Status changes of assigned engines.
2. Location of engine by serial number.
3. Nature of engine failure.
4. Number of engines returned to depot for overhaul.
5. Reason for return to depot.
6. Status of engine level.
7. Pipeline times.

Decisions concerning allocation and location of engines, it was determined, required quick action to insure mission accomplishment and proper utilization of resources. However, it was also determined that the EIM seldom made any decision upon these matters based solely upon the data reported by the AF Form 1534, "Engine Status Report". Instead, upon noting an unsatisfactory condition reflected by this reporting system, he would contact the activity by telephone or message to confirm the condition. Only after validation would the Engine Item Manager take corrective action. Although the EIM does use the reported data to monitor the system, vital decisions are based upon person to person contact via telephone or message.

It was concluded that the first hypothesis was valid in that the Engine Item Manager did seem to be using the information he received from the Engine Status Reporting System, the D024, Propulsion Unit Logistics System. The one discrepancy though, was that he did not seem to need the information as rapidly as he received it. In fact he had time to double-check on his reports before actually making a decision.

The authors next tested the second hypothesis of the thesis, that "There was a better way to gather the needed information that would improve the status reporting of the current generation of engines." To do this they made an in depth study of the D024, Propulsion Unit Logistics System,

both at the base level and at the Air Material Area. The purpose of this study was to learn the interaction of the system at these two levels and to determine the method of gathering the reported data. Once they had traced the data from the source to its final destination and determined the responsibilities of each activity involved with engine status reporting the authors then made a comparative study of other reporting systems in existence which reported the same data as that provided by the AF Form 1534, "Engine Status Report".

The authors were able to identify reports, with some modification, within the Maintenance, Supply and Transportation Data Collection Systems, which paralleled the D024, Propulsion Unit Logistics System and could supply the EIM with that data which he considered necessary. The second hypothesis that there is a better way to gather the needed information was found to be valid. There does exist within the Maintenance, Supply, and Transportation Management Information Systems, the same data elements that are currently reported by the D024 System.

Research Findings

In the present environment, it appears that some duplication could be eliminated. The AF Form 1534, "Engine Status Report", requires a considerable amount of time and expense on the part of technicians, base engine managers and electrical transmission personnel. This same data provided by the Maintenance, Supply and Transportation Data Collection

System could not be consolidated and given to the EIM in the format he needed thus eliminating the need for the submission of AF Form 1534, "Engine Status Reports".

Conclusion

The engine reporting system should be revised to incorporate the Maintenance, Supply, and Transportation Data Collection Systems thus providing the Engine Item Manager with the information he requires. This change would then make it possible to eliminate some 355 base engine manager positions and free AUTODIN lines and personnel for other transmissions. This conversion would also provide the EIM with that data which he considers necessary as well as other data bits which could be of importance to engine management that are not presently available.

APPENDIX A

STRUCTURED INTERVIEW GUIDE

In order to insure standardization of response from those interviewed by the authors, the following check list was used.

Check List

1. Interviewer introduces himself, his organization and the purpose of his visit:

I am Captain Michael Scritchfield/James Brady from the Air Force Institute of Technology, School of Systems and Logistics. I am presently working on a Masters Thesis whose topic is The Air Force Engine Management System. I would like to ask you some questions that I have drawn up which I think will help me to learn more about this subject.

2. Interviewer explains the nature of questions:

These questions which I have are on those areas which I feel are closely related to my subject, however, if you know of any information which may help me to learn more about this, please feel free to make any suggestions.

3. Interviewer thanks the individual for his assistance upon departure.

Structured Interview Guide

1. How long have you been associated with engine management?

2. Do you personally become involved with Engine Status Reports on a routine basis? If yes--3; if no--4.
3. What information do you screen these reports for?
4. Who routinely screens incoming reports?
5. How current are these reports in respect to when they were initiated?
6. How reliably do you think these reports reflect the true status of a given engine?
7. How often do you find it necessary to make telephone calls or wire for supplemental or more current data?
8. From what data source do you obtain the information to make decisions on:
 - a. Trend analysis
 - b. Maintenance difficulty
9. How often do you refer to historical data?
10. What historical data do you usually refer to?
11. For what reason do you refer to historical data?
12. Of the information contained in the daily reports, how much of this do you use on a daily basis, aside from normal updating of status charts, etc?
13. What information in the AF Form 1534 and D024 Report do you consider the most important? Why?
14. What information in the 1534 and D024 Report do you consider least important? Why?
15. Is there any information you think should be contained in one of these reports that is not? What?
16. Do you think any of the information could be deleted without detracting from the system? What?
17. Do you refer to 66-1 Maintenance Data Collection Report? For what information?

18. What decisions do you routinely make? Which do you consider the most important?
19. What data base do you rely on for most of your decisions?
20. What problems do you expect to experience with the modular engine concept?

APPENDIX B

INFORMATION PROVIDED BY AF FORM 1534

Engine Designation Type
 Model
 Modification

Engine Serial Number

Command Major

Organization (TCTO or WRM)

Station Number

Engine Ownership Account

Engine Type Report

As of Data

Sequence Control Number

Gain New Production (A)

Gain Reimbursable (B)

Gain Non-reimbursable (C)

Gain Exchange (D)

Loss Attrition (W)

Loss For Parts (X)

Loss Salvage/R-M (Y)

Loss Other (Z)

Now Gain/Loss Received (R)

Now Gain/Loss Shipped (S)

Now Gain/Loss Transferred (T)

| | |
|--------------------------------------|-----|
| Now Gain/Loss ENORS | (E) |
| Now Gain/Loss Test Cell Reject | (G) |
| Now Gain/Loss Work Stopped | (H) |
| Now Gain/Loss Work Started | (J) |
| Now Gain/Loss Removed Transient | (K) |
| Now Gain/Loss Removed Other | (L) |
| Now Gain/Loss Change in Maint | (M) |
| Now Gain/Loss Await Disposition | (N) |
| Now Gain/Loss Installed Transient | (U) |
| Now Gain/Loss Installed Other | (V) |
| Now Gain/Loss Work Completed | (F) |
| Serviceable Raw | (R) |
| Servicable Built-up | (B) |
| Reparable with QEC | (F) |
| Reparable without QEC | (G) |
| Reparable Major | (L) |
| Reparable Minor | (K) |
| Reparable Condemned | (L) |
| Installed Active | (Z) |
| Installed Inactive | (Z) |
| Command Station Number To or From | |
| Type of Container | |
| Transportation Control Number | |
| Reparable Engine Serial Number | |
| Document Number | |
| Map | |
| Reason for Removal | |

Engine Time

End Item Destination

End Item Serial Number

Position Number

APPENDIX C

ENGINE OWNERSHIP ACCOUNT

AFM 300-4, Vol III

1 Oct. 70

1. Title: Engine Ownership Account, ADE EN-273,
Chg Eff: 1 Jul 68 (Continued)

5. Data Items and Explanations

Data Codes

MILITARY ASSISTANCE PROGRAM (MAP)

J

Engine owned by MAP that is assigned to and possessed by the AF. This includes MAP owned engines on an AF contract and installed engines wherein the end item is assigned to and possessed by the AF.

GOVERNMENT FURNISHED AIRCRAFT EQUIPMENT (GFAE)

K

Engine owned by the AF that is possessed by a contractor for installation (including those installed) in new production aircraft.

AIR NATIONAL GUARD (ANG)

N

Engine possessed by the AFG.

AIR FORCE RESERVE (AFR)

R

Engine possessed by the AFR.

GROUND TRAINING

S

Engine owned and possessed by the AF being used for ground training.

DEPARTMENT OF THE NAVY

T

Engine owned by the Navy that is assigned to and possessed by the AF. This includes Navy owned engines on an AF contract and installed engines wherein the end item is assigned to and possessed by the AF.

OTHER NON-AIR FORCE ACTIVITIES

W

Engine owned by an AF auxiliary unit, NASA, school, other government agency or commercial activity that is assigned to and possessed by the AF. This includes non-AF activity engines on AF contract and installed engines wherein the end item is assigned to and possessed by the AF.

AERO CLUB

Engine owned by the AF that is possessed by an Aero Club at an AF reporting activity.

X

AIRCRAFT STORAGE SITE

Engine installed in an aircraft that was transferred to R&M on AF Form 695-7. This code restricted for use by the Davis-Monthan aircraft storage site.

Z

APPENDIX D

ENGINE REPORT TYPE

AFM 300-4, VOL III(C1)

1 February 1971

1. Title: Engine Report Type, ADE EN-281, Chg
Eff: 1 Jul 68
2. Data Name: ENG-RPRT-TYPE
3. Definition/Explanation: The purpose for which
the engine status report was prepared
4. Data Use Identifier and Explanation: 4a. Data Name
4b. Code Size and Class

Engine Report Type-See 3 above ENG-RPRT-TYPE IAN

5. Data Items and Explanations Data Codes

- | | |
|--|---|
| END OF MONTH | A |
| A report submitted by each reporting activity to denote that no more reports will be submitted for reporting month. Report is submitted on the first day of the month showing total reports submitted during the preceding reporting period. | |
| CORRECTION | C |
| A report submitted by affected reporting activity to correct information previously submitted in error when so advised by the ADP AMA on the D024AAN2-01 and D024AAN-02 products. | |
| DELETION | D |
| A report submitted by affected reporting activity to delete data previously submitted in error when so advised by the ADP AMA on the D024AAN2-01 or D024AAN2-02 products. | |
| ACCOUNT TRANSFER | K |
| A report submitted to effect an engine transfer between AF and other than AF accounts. | |
| ROUTINE | R |
| A report submitted on all transactions other than those specifically identified. | |

INSTALLED ENGINE OPERATING TIME

T

A report submitted by affected reporting activity to update installed engine operating time as of the last day of each quarter.

VERIFICATION

V

A report to verify previously submitted data that appears as questionable on the D024AAN2-01 or D024AAN2-02 products.

RECORD ADJUSTMENT

4

A report to correct a previously reported error when such data will not appear on the D024AAN2-01 or D024AAN2-02; and change possession without previous possessor reporting.

APPENDIX E

ENGINE REMOVAL REASON

AFM 300-4, VOL III(C1)

1 February 1971

1. Title: Engine Removal Reason, ADE EN-278, Chg Eff: 1 Jan 71
2. Data Name: ENG-REMOVAL-REASON
3. Definition Explanation: The cause for which an engine is removed from an installed position.
4. Data Use Identifier and Explanation: 4a. Data Name
4b. Code Size and Class 2AN

Engine Removal Reason--See 3 above ENG-REMOVAL-REASON

5. Data Items and Explanations Data Codes

OBSERVED OR RECORDED OPERATIONAL CONDITIONS:

| | |
|---|----|
| Hot starts or overtemperature | 5A |
| Flameout | 5B |
| Overspeed | 5C |
| Low Power or Thrust | 5D |
| Inability to start, adjust to limits, or accelerate | 5E |
| Excessive vibration or rough operation | 5F |
| Excessive fuel consumption | 5G |
| Fuel leakage | 5H |
| Contaminated Fuel | 5J |
| Excessive oil consumption | 5K |
| Oil leakage | 5L |
| Contaminated Oil | 5M |
| Smoke or fumes in cockpit | 5N |
| Corroded internal surfaces | 5P |
| Low compression, blowby or detonation (recip engine only) | 5Q |
| Manifold pressure beyond limit, overboost (recip engine only) | 5R |
| Low manifold pressure (recip engine only) | 5S |
| Oil in induction system (recip engine only) | 5T |
| Sudden stoppage or reduction (recip engine only) | 5U |
| Excessive oil from breathers | 5V |
| Spectrometric oil analysis | 5W |
| Low oil pressure | 5X |
| Metal in sump or screen | 5Y |
| Servicing with Improper Grade or Type of Fuel | 5Z |

IDENTIFIED COMPONENTS:

| | |
|--|----|
| Compressor rotor change (other than FOD) | 6A |
| Turbine wheel change | 6B |
| Accessory drive gear (box) failure | 6C |
| Integrated reduction gear failure | 6D |
| Compressor case failure or excessive air leakage | 6E |
| Structural or mount failure | 6F |
| Engine or afterburner fire damage | 6G |
| Impeller or inducer damage (recip engine only) | 6H |
| Turbo supercharger failure (induction system contaminated with metal from turbo) (recip engine only) | 6J |
| Cracked cases | 6K |
| Removal to perform scheduled inspection | 6L |
| Compressor Damage due to material failure | 6M |
| Cracked Inlet Guide Vanes | 6N |
| Cracked Diffuser Cases | 6P |
| Thrown Buckets | 6Q |
| Slipped Blower Clutch (Recip) | 6R |

CHANCE OCCURRENCE/OPERATIONAL HAZARD:

| | |
|---|----|
| Damage by solid foreign objects (metal, stone) | 7A |
| Damage by semi-solid foreign objects (birds) | 7B |
| Damage by semi-solid foreign object (ice) | 7C |
| Damage from actual or simulated combat | 7D |
| Damage by aircraft accident or incident | 7E |
| Damage by semi-solid foreign objects (rugs, plastic, rubber, etc.) | 7F |

MANAGERIAL DECISION:

| | |
|---|----|
| Expiration of Maximum Time (T.O. 2-1-18) | 8A |
| Transfer time limit (T.O. 2-4-18) | 8B |
| Time change of an item (failure) other than a basic engine component | 8C |
| Modification, including TOC | 8D |
| Removal for maintenance experiment | 8E |
| Removal for research or test purpose | 8F |
| Removal to facilitate other aircraft maintenance | 8H |
| Removal during aircraft IRAN or PARC | 8J |
| Shipping, handling or storage damage or deter- ioration | 8K |
| Removal for reuse (T.O. 00-25-226) | 8L |

BIBLIOGRAPHY

1. Air Force Spares Study Group. Report Number 8.
Wright-Patterson Air Force Base, Ohio;
Air Material Command, 1958.
2. Fielding, Alan A. and Harruff, Thomas R. "A
Proposed Simulation to Forecast Jet Engine
Maintenance Removals." Unpublished Master's
thesis, School of Systems and Logistics, 1971.
3. King, H. O. "Aircraft Spares". Memorandum for the
Under Secretary of the Air Force, August 15,
1952.
4. U.S., Department of the Air Force. Maintenance
Management. AFM 66-1. Washington, D.C.:
Government Printing Office, February 10,
1970.
5. U.S. Department of the Air Force. United States Air
Force Supply Manual. AFM 67-1, Volume I,
Part One. Washington, D.C.: Government
Printing Office, May 1, 1972.
6. U.S., Department of the Air Force. Transportation
of Material, AFM 75-1. Washington, D.C.:
Government Printing Office, November 30,
1970.
7. U.S., Department of the Air Force. Selective Manage-
ment of Propulsion Units. AFM 400-1, Volume I.
Washington, D.C.: Government Printing Office,
January 5, 1970.
8. U.S., Department of the Air Force. Selective Manage-
ment of Propulsion Units. Washington, D.C.:
Government Printing Office, August 31, 1971.
9. U.S., Department of the Air Force. Air Force Logistics
Command Product Performance, AFLCM 66-15.
Wright-Patterson Air Force Base, Ohio,
February 11, 1970.

10. U.S., Department of the Air Force. Propulsion Unit Data Collection Status Reporting System. AFLCM 171-237. Wright-Patterson Air Force Base, Ohio; Government Printing Office, March 31, 1972.
11. U.S., Department of the Air Force. Use of Maintenance Data For Logistics Management. AFLCP 50-3. Wright-Patterson Air Force Base, Ohio; Government Printing Office, October 4, 1968.
12. U.S., Department of the Air Force. Objectives and Concepts of the MDC System, T. O. 00-20-2. Washington, D.C.; Government Printing Office, January 1, 1970.
13. U.S., Department of the Air Force. Common Recording Requirements and General Recording Procedures. T.O. 00-20-2-1. Washington, D.C.; Government Printing Office, September 15, 1969.
14. U.S., Department of the Air Force. "In-Shop" Engine Maintenance Documentation. T.O. 00-20-2-4. Washington, D.C.; Government Printing Office, July 30, 1970.
15. U.S., Department of the Air Force. Off-Equipment Maintenance Documentation, T.O. 00-20-2-10. Washington, D.C.; Government Printing Office, April 15, 1970.
16. U.S., Department of the Air Force. "On-Equipment" Maintenance Documentation for Aircraft, Air Launched Missiles, Ground Launched Missile, Drones, their AFS's and Class II Training Equipment not managed under the AGLS System. T.O. 00-20-2-7. Washington, D.C.; Government Printing Office, July 30, 1970.
17. U.S., Department of the Air Force. AFM 66-1 Error Detail Listing RCS No. 4-LOG-K260. T.O. 00-20-2-11. Washington, D.C.; Government Printing Office, February 10, 1971.
18. U.S., Department of the Air Force. Maintenance Processing of Reparable Property and Repair Cycle Asset Control System. T.O. 00-20-3. Washington, D.C.; Government Printing Office, June 15, 1972.
19. Tinker Air Force Base, Oklahoma. Personal interview with Mr. Paul Davis, Engine Item Manager, Requirements and Distribution Branch, Director of Material Management, Headquarters Oklahoma Air Material Area, Air Force Logistics Command, June 23, 1972.

20. Tinker Air Force Base, Oklahoma. Personal interview with Mr. John Dillam, Engine Item Manager, Requirements and Distribution Branch, Director of Material Management, Headquarters Oklahoma Air Material Area, Air Force Logistics Command, June 22, 1972.
21. Tinker Air Force Base, Oklahoma. Personal interview with Mr. Wilburn Hagood, Deputy Chief, Engine Control Section, Requirements and Distribution Branch, Director of Material Management, Headquarters Oklahoma City Air Material Area, Air Force Logistics Command, June 22, 1972.
22. Tinker Air Force Base, Oklahoma. Personal interview with Mr. Bill E. Lawerance, Engine Logistics Planning Board Member, Oklahoma Air Material Area, Headquarters Air Force Logistics Command, June 23, 1972.
23. Tinker Air Force Base, Oklahoma. Personal interview with Mr. Olin Roberts, Data Automation Division, Comptrollers Office, Headquarters Oklahoma Air Material Area, Air Force Logistics Command, June 22, 1972.
24. Tinker Air Force Base, Oklahoma. Personal interview with Mr. James Sweet, Chief Engine Control Section, Requirements and Distribution Branch, Director Material Management, Headquarters Oklahoma City Air Material Area, Air Force Logistics Command, June 22, 1972.
25. Wright-Patterson Air Force Base, Ohio. Personal interview with Mr. Harvey W. Laughrey, Traffic Management Specialist, Headquarters Air Force Logistics Command, August 10, 1972.
26. Wright-Patterson Air Force Base, Ohio. Personal interview with Mr. Robert L. Lough, Data Collection and Use Branch, Headquarters, Air Force Logistics Command, July 7, 1972.
27. Wright-Patterson Air Force Base, Ohio. Personal interview with Mr. Ralph H. McGary, Monitor D024 Report, Headquarters Air Force Logistics Command, May 8, 1972.

BIOGRAPHICAL SKETCHES OF THE AUTHORS

Captain James F. Brady was born in Jamaica, New York, and received a Bachelor of Arts degree in history from the University of the South, Sewanee, Tennessee in June, 1967. He received his commission through OTS and reported for active duty as a student in the Aircraft Maintenance Officer course at Chanute AFB, Illinois. His first operational assignment was at RAF Alconbury, England, where he served as OIC of the Field Maintenance Aerospace Systems Branch, Wing Job Control Officer, and Squadron Maintenance Officer. This tour preceded his entry to the Graduate Logistics Management course. Captain Brady's next assignment is to the 23rd Tactical Air Support Squadron, Nakhon Phanom, Thailand.

Captain Michael J. Scritchfield is a native of West Virginia. He entered the Air Force in August, 1958 and received his commission in September, 1968 through the Airman Education and Commissioning Program. He received his Bachelor of Business Administration Degree from the University of Oklahoma. Before attending the Graduate Logistics Management School, Captain Scritchfield served as a Squadron Aircraft Maintenance Officer at Howard Air Force Base, Canal Zone. His next assignment is to Headquarters, Air Force Logistics Command, Wright-Patterson Air Force Base, Ohio, as an inspector for the Inspector General's Office.