



RADC-TR-72-195
Technical Report
July 1972



AD 748487

LASER ABSORPTION IN THE 5 MICRON BAND
(3271-3)

The Ohio State University
ElectroScience Laboratory

Department of Electrical Engineering
Columbus, Ohio 43212

SEE AD 745585

Sponsored by
Defense Advanced Research Projects Agency
ARPA Order No. 1279

Approved for public release;
distribution unlimited.

D D C
RECEIVED
SEP 21 1972
RECEIVED

A

The views and conclusions contained in this document are those of the authors and should not be interpreted as necessarily representing the official policies, either expressed or implied, of the Defense Advanced Research Projects Agency or the U. S. Government.

Reproduced by
NATIONAL TECHNICAL
INFORMATION SERVICE
U S Department of Commerce
Springfield, VA 221

Rome Air Development Center
Air Force Systems Command
Griffiss Air Force Base, New York

32

DOCUMENT CONTROL DATA - R&D

(Security classification of title, body of abstract and indexing annotation must be entered when the overall report is classified)

1. ORIGINATING ACTIVITY (Corporate author) ElectroScience Laboratory Department of Electrical Engineering, The Ohio State University, Columbus, Ohio 43212	2a. REPORT SECURITY CLASSIFICATION Unclassified
	2b. GROUP

3. REPORT TITLE

LASER ABSORPTION IN THE 5 MICRON BAND

4. DESCRIPTIVE NOTES (Type of report and inclusive dates)

Quarterly Report December 23, 1971 - March 23, 1972

5. AUTHOR(S) (Last name, first name, initial)

Ford, D.L., Mills, F.S., and Long, R.K.

6. REPORT DATE

July 1972

7a. TOTAL NO. OF PAGES

24

7b. NO. OF REFS

11

8a. CONTRACT OR GRANT NO.

F30602-72-C-0016

b. PROJECT NO.

c. TASK

d.

9a. ORIGINATOR'S REPORT NUMBER(S)

ElectroScience Laboratory 3271-3

9b. OTHER REPORT NO(S) (Any other numbers that may be assigned this report)

RADC-TR-72-195

10. AVAILABILITY/LIMITATION NOTICES

Approved for public release; distribution unlimited.

11. SUPPLEMENTARY NOTES

Monitored by
James W. Cusack, RADC/OCSE
Griffiss AFB NY 13440

12. SPONSORING MILITARY ACTIVITY

Advanced Research Projects Agency
1400 Wilson Blvd
Arlington VA 22209

13. ABSTRACT

This report describes the progress on the experimental study of atmospheric water vapor absorption at CO, HF, and DF laser frequencies using a one km White absorption cell and laser sources.

Experimental data at 8 CO laser frequencies is reported which has an overall accuracy of $\pm 5\%$.

The design and construction of a small pulsed electric discharge HF-DF laser is described.

14 KEY WORDS	LINK A		LINK B		LINK C	
	ROLE	WT	ROLE	WT	ROLE	WT
CO laser						
HF laser						
DF laser						
Water vapor absorption						
Laser propagation						

INSTRUCTIONS

1. **ORIGINATING ACTIVITY:** Enter the name and address of the contractor, subcontractor, grantee, Department of Defense activity or other organization (*corporate author*) issuing the report.

2a. **REPORT SECURITY CLASSIFICATION:** Enter the overall security classification of the report. Indicate whether "Restricted Data" is included. Marking is to be in accordance with appropriate security regulations.

2b. **GROUP:** Automatic downgrading is specified in DoD Directive 5200.10 and Armed Forces Industrial Manual. Enter the group number. Also, when applicable, show that optional markings have been used for Group 3 and Group 4 as authorized.

3. **REPORT TITLE:** Enter the complete report title in all capital letters. Titles in all cases should be unclassified. If a meaningful title cannot be selected without classification, show title classification in all capitals in parenthesis immediately following the title.

4. **DESCRIPTIVE NOTES:** If appropriate, enter the type of report, e.g., interim, progress, summary, annual, or final. Give the inclusive dates when a specific reporting period is covered.

5. **AUTHOR(S):** Enter the name(s) of author(s) as shown on or in the report. Enter last name, first name, middle initial. If military, show rank and branch of service. The name of the principal author is an absolute minimum requirement.

6. **REPORT DATE:** Enter the date of the report as day, month, year, or month, year. If more than one date appears on the report, use date of publication.

7a. **TOTAL NUMBER OF PAGES:** The total page count should follow normal pagination procedures, i.e., enter the number of pages containing information.

7b. **NUMBER OF REFERENCES:** Enter the total number of references cited in the report.

8a. **CONTRACT OR GRANT NUMBER:** If appropriate, enter the applicable number of the contract or grant under which the report was written.

8b, 8c, & 8d. **PROJECT NUMBER:** Enter the appropriate military department identification, such as project number, subproject number, system numbers, task number, etc.

9a. **ORIGINATOR'S REPORT NUMBER(S):** Enter the official report number by which the document will be identified and controlled by the originating activity. This number must be unique to this report.

9b. **OTHER REPORT NUMBER(S):** If the report has been assigned any other report numbers (*either by the originator or by the sponsor*), also enter this number(s).

10. **AVAILABILITY/LIMITATION NOTICES:** Enter any limitations on further dissemination of the report, other than those imposed by security classification, using standard statements such as:

- (1) "Qualified requesters may obtain copies of this report from DDC."
- (2) "Foreign announcement and dissemination of this report by DDC is not authorized."
- (3) "U. S. Government agencies may obtain copies of this report directly from DDC. Other qualified DDC users shall request through _____."
- (4) "U. S. military agencies may obtain copies of this report directly from DDC. Other qualified users shall request through _____."
- (5) "All distribution of this report is controlled. Qualified DDC users shall request through _____."

If the report has been furnished to the Office of Technical Services, Department of Commerce, for sale to the public, indicate this fact and enter the price, if known.

11. **SUPPLEMENTARY NOTES:** Use for additional explanatory notes.

12. **SPONSORING MILITARY ACTIVITY:** Enter the name of the departmental project office or laboratory sponsoring (*paying for*) the research and development. Include address.

13. **ABSTRACT:** Enter an abstract giving a brief and factual summary of the document indicative of the report, even though it may also appear elsewhere in the body of the technical report. If additional space is required, a continuation sheet shall be attached.

It is highly desirable that the abstract of classified reports be unclassified. Each paragraph of the abstract shall end with an indication of the military security classification of the information in the paragraph, represented as (TS), (S), (C), or (U).

There is no limitation on the length of the abstract. However, the suggested length is from 150 to 225 words.

14. **KEY WORDS:** Key words are technically meaningful terms or short phrases that characterize a report and may be used as index entries for cataloging the report. Key words must be selected so that no security classification is required. Identifiers, such as equipment model designation, trade name, military project code name, geographic location, may be used as key words but will be followed by an indication of technical context. The assignment of links, rules, and weights is optional.

18

LASER ABSORPTION IN THE 5 MICRON BAND
(3271-3)

D. L. Ford
F. S. Mills
R. K. Long

Contractor: The Ohio State University
Contract Number: F30602-72-C-0016
Effective Date of Contract: 23 June 1971
Contract Expiration Date: 31 March 1973
Amount of Contract: \$65,000.00
Program Code Number: OE20

Principal Investigator: Dr. Ronald K. Long
Phone: 614 422-6077

Assistant Supervisor: Dr. Dale L. Ford
Phone: 614 422-6726

Contract Engineer: James W. Cusack
Phone: 315 330-3443

Approved for public release;
distribution unlimited.

This research was supported by the
Defense Advanced Research Projects
Agency of the Department of Defense
and was monitored by James W. Cusack
FADC (OCSE), GAFB, NY 13440 under
Contract F30602-72-C-0016.

FOREWORD

This report, Ohio State University Research Foundation Report Number 3271-3 (Third Quarterly Report), was prepared by The Ohio State University ElectroScience Laboratory, Department of Electrical Engineering at Columbus, Ohio. Research was conducted under Contract F30602-72-C-0016. Mr. James W. Cusack, RADC(OCSE), of Rome Air Development Center, Griffiss Air Force Base, New York, is the Project Engineer.

PUBLICATION REVIEW

This technical report has been reviewed and is approved.

RADC Project Engineer

RADC Contract Engineer

ABSTRACT

This report describes the progress on the experimental study of atmospheric water vapor absorption at CO, HF, and DF laser frequencies using a one km White absorption cell and laser sources.

Experimental data at 8 CO laser frequencies is reported which has an overall accuracy of $\pm 5\%$.

The design and construction of a small pulsed electric discharge HF-DF laser is described.

CONTENTS

	Page
I. INTRODUCTION	1
II. NEED FOR HIGH ACCURACY EXPERIMENTAL MEASUREMENTS	1
III. EXPERIMENTAL PROGRESS	4
IV. HF-DF LASER	14
A. <u>Description of Laser</u>	14
B. <u>Laser Performance</u>	16
REFERENCES	19
Appendix	
A EQUATIONS AND UNITS FOR CALCULATION OF ATMOSPHERIC TRANSMITTANCE USING LORENTZ LINE SHAPE AND CALFEE-BENEDICT LINE DATA	20

I. INTRODUCTION

This is the third quarterly report on Contract Number F30602-72-C-0016 entitled "Laser Absorption in the 5 Micron Band" for the period December 23, 1971 through March 23, 1972. The objectives of this contract are to perform laboratory measurements and theoretical computations in order to determine values of atmospheric transmittance at CO laser, HF laser, and DF laser wavelengths. The technical accomplishments during this period are described in this report.

The CO laser was received at the beginning of this quarter and during the quarter the primary effort was directed towards putting this laser into operation in our laboratory and making high accuracy water vapor absorption measurements with it. No particular difficulties were encountered in putting the laser into operation although the available observing time was limited to a disturbing degree by troubles with the mechanical refrigeration system used to cool the laser. On the other hand it was necessary to expend a great deal of effort before the goal of 5% overall accuracy in the measured transmittance could be achieved. Finally the construction and testing of a small pulsed HF-DF laser was undertaken during this work period.

II. NEED FOR HIGH ACCURACY EXPERIMENTAL MEASUREMENTS

The following analysis discusses the accuracy required of laboratory measurements made at path lengths of up to one km when the results may be used to compute transmittance on much longer path lengths. It is shown that the extrapolated transmittance is strongly dependent on the accuracy of the laboratory measurement.

The transmittance $T(\nu)$ at wavenumber ν is given by

$$(1) \quad T(\nu) = e^{-k(\nu) \cdot \ell}$$

where $k(\nu)$ is the extinction coefficient in km^{-1} and ℓ is the path length in km. To extrapolate to longer path lengths under identical conditions of pressure, temperature and absorber concentration, only ℓ is changed. We assume that the uncertainty in the transmittance is ΔT , $\Delta T \ll T$, and no uncertainty exists in ℓ . Taking the logarithm of Eq. (1) and then differentiating the resulting equation one has

$$(2) \quad \frac{dT}{T} = -dk \cdot \ell$$

or

$$(3) \quad \frac{\Delta T}{T} \doteq - \Delta k \cdot \ell .$$

The uncertainty Δk is a constant for different path lengths, so that the fractional error transmittance $\frac{\Delta T^*}{T^*}$ over another path ℓ^* is related to the original fractional error transmittance by the following:

$$(4) \quad \frac{\Delta T^*}{T^*} = \frac{\Delta T}{T} \left(\frac{\ell^*}{\ell} \right).$$

Equation (4) shows that the fractional error of the transmittance for a different path length is the same as the fractional error for the original path times the ratio of the two path lengths. Thus, if the transmittance over a 20 km path is estimated from transmittance measurements made over a 1 km path the relative error of the transmittance over the longer path is 20 times that of the transmittance over the shorter path. For this reason the accuracy of laboratory measurements over limited path lengths should be as high as realistically possible. An even more serious difficulty occurs with respect to the absorption coefficient.

While the accuracy of extrapolated transmittance predictions does not depend upon the value of the transmittance, as seen by Eq. (4), the same is not true for the accuracy of the absorption coefficient. In fact the accuracy of the absorption coefficient becomes very low when relatively high transmittances are measured. Using Eqs. (1) and (3) the following expression for the fractional error in the absorption coefficient is obtained:

$$(5) \quad \frac{\Delta k}{k} \doteq \frac{\Delta T}{T \ln T} .$$

For $T \approx 1$, $\ln T \doteq - (1-T)$ so that

$$(6) \quad \frac{\Delta k}{k} = - \frac{\Delta T}{T(1-T)} .$$

Thus, for example, if the transmittance over a 1 km path is .95 with an uncertainty of .01 the absorption coefficient is .0513 with a fractional uncertainty $\Delta k/k$ of .205. In Fig. 1 the fractional error of the absorption coefficient is plotted vs the fractional error of the transmittance for various values of the transmittance. From this figure, it is apparent that the best comparison of laboratory determined and calculated absorption coefficients should occur for small values of transmittance. These facts should be used in the selection of path length

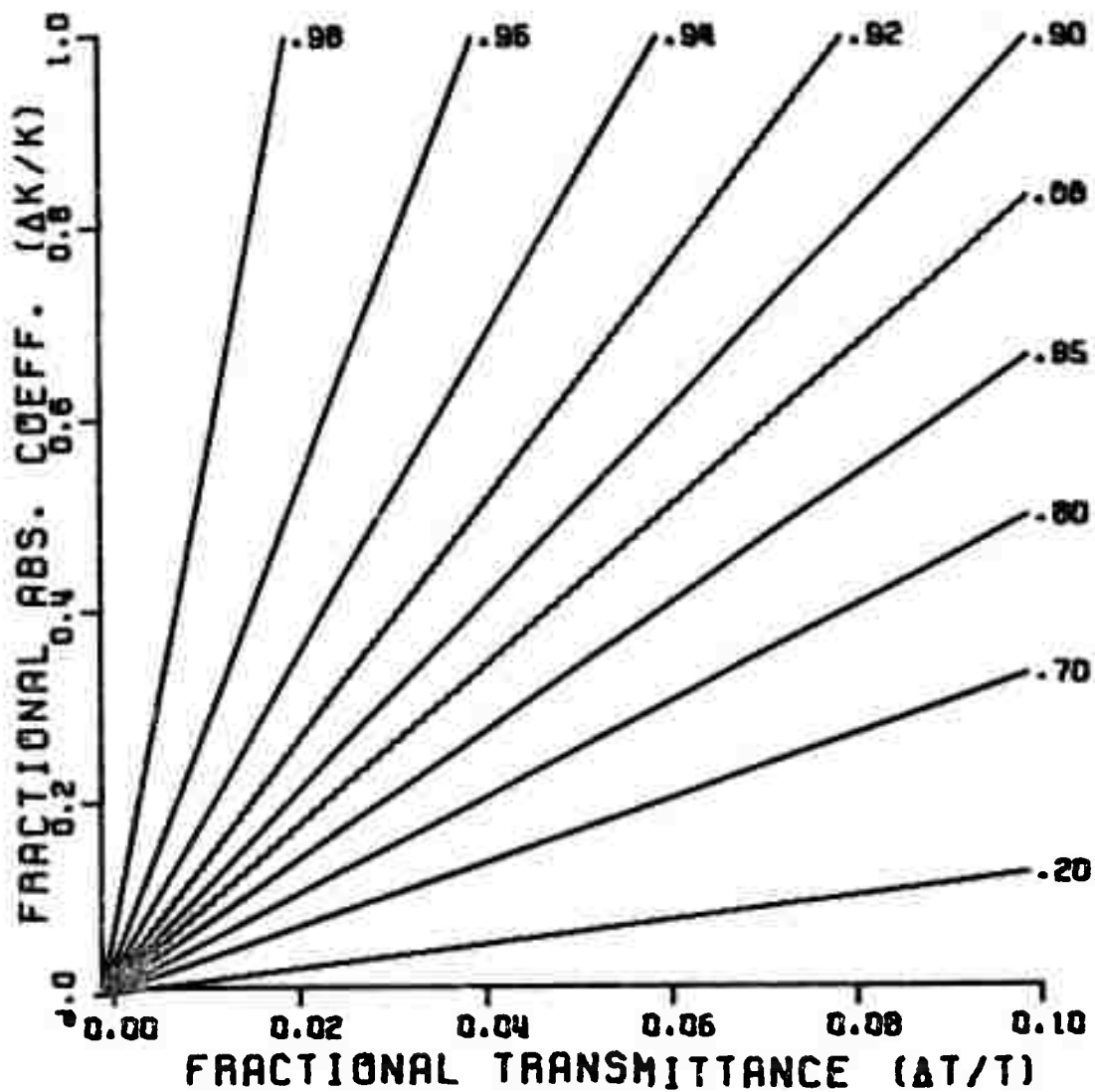

Fig. 1. The fractional absorption coefficient error vs the fractional transmittance error for various values of transmittance.

in the absorption cell. However, if the transmittance is still high at the maximum obtainable path length a reduced accuracy in the absorption coefficient will have to be accepted.

III. EXPERIMENTAL PROGRESS

The initial design of the experiment is shown in Fig. 2. A NaCl window located before the absorption cell was used as a beam splitter. The reflected beam was directed onto a thermocouple, while the transmitted beam was focussed by a 1 m focal length mirror to a spot adjacent to the front surface of the first mirror in the White type absorption cell. After up to 64 traversals through the cell the radiation was focussed onto another thermocouple detector. A removable salt window beam splitter was used to introduce a He-Ne laser beam into the system for alignment purposes. A 13 cycle chopper, located before the beam splitter, modulated the radiation. The modulated voltage of each of the thermocouples was amplified by an IR Industries tunable microvoltmeter, model 601. The DC output of each of these microvoltmeters was then amplified to a maximum of 10 volts. These signals were converted to digital form with a Datrac II, Model 1400, 14 bit analog to digital converter for further analysis with an XDS 920 computer. The problems encountered with this first experimental arrangement can be classed into 3 main groups: problems associated with the laser, problems associated with the external optics and detection system, and problems associated with the absorption cell.

Laser

There were no major difficulties encountered with the operation of the laser itself. The first gas fill lasted six weeks before it was necessary to refill the laser. Since then the laser fill has been changed about once a month. The short-term stability of the laser is very good and since a detector is used to monitor the output of the laser concurrently with the measurement of radiation through the absorption cell, long term stability is not required. Two problems inherent in the design of the laser result from the use of the grating for line selection. A given laser line will oscillate for a range of settings of the micrometer drive attached to the grating. Within this range the intensity of radiation changes but more importantly, the direction of the laser beam also changes. Thus, proportional amounts of energy may not be focussed upon the two detectors for all settings of the grating drive mechanism. If the transmittance of only one line is being measured for a given set of parameters, this effect would not be important, since a fixed grating position could be used. However, when the transmittance of several lines is being determined, this effect degrades the reproducibility of the measurements, and the accuracy of the transmittances as two independent measurements at each grating position are required; one with the gas sample in the cell, and one with the cell evacuated. The effect of this problem was reduced by changing the size of the detectors and the focusing mirrors and is discussed in more detail in the next section.

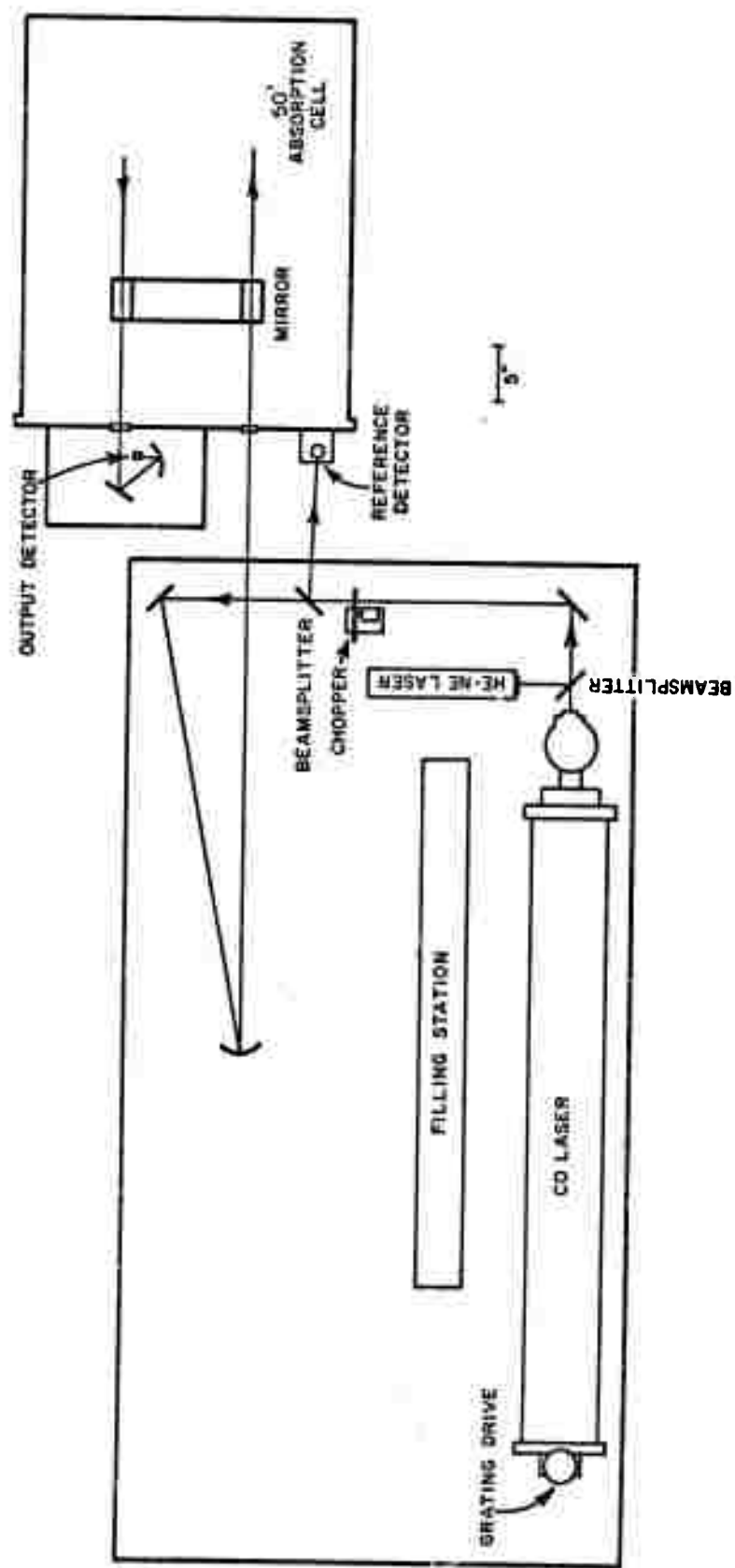

Fig. 2. Early version of the experimental arrangement to measure transmittance values.

The second problem arises from the fact that with this laser two or more lines less than 2 wavenumbers apart may lase at the same setting of the grating. For the preliminary measurements only lines that are unblended were investigated.

Finally severe delays in the experimental program were caused by the unreliable operation of the Harris Engineering two stage refrigerator used to cool the laser.

External Optics

Since the active area of the thermocouple detectors is only 1/4 mm by 3 mm, small changes in the direction of the laser beam through the absorption cell can drastically change the energy reaching the detector.

Finally both thermocouple detectors were replaced with Eppley thermopiles having a diameter of 10 mm. With these detectors it is possible to focus all of the radiation onto the detector over a much wider range of grating positions and the variation with grating setting was much less than that observed with the thermocouple detectors.

An example of how the output of each thermopile detector varied as a function of grating position is shown for two CO laser lines in Figs. 3 and 4. In each figure the relative voltage output of the reference and output detectors and the ratio of these values as a function of grating position is plotted. Both figures were obtained with the same position of all mirrors. In Fig. 3, the best line, the peak readings of the reference and output detectors occur at nearly the same position of the grating and the ratio is nearly constant for all positions of the grating ($\pm 1/2\%$). For the other line the maximums of the reference and output signals occur at different positions of the grating and the ratio is not constant. However, the ratio of the output and the reference signals is reproducible and nearly constant between settings 7.730 to 7.734. Since the grating drive micrometer can be positioned to ± 0.0005 mm reproducible results are obtained. The latter line showed the most variation for this experimental setup.

The NaCl beam splitter shown in Fig. 2 was also replaced at this time as it was suspected that heating of the beam splitter was affecting the output of the reference detector. The polished aluminum chopper blade of a one hertz chopper was positioned such that the reflected laser radiation of each 1/2 revolution was focussed onto the Eppley reference detector. The output of the reference detector was now much more stable than that of the earlier combination of the beam splitter and the thermocouple detector.

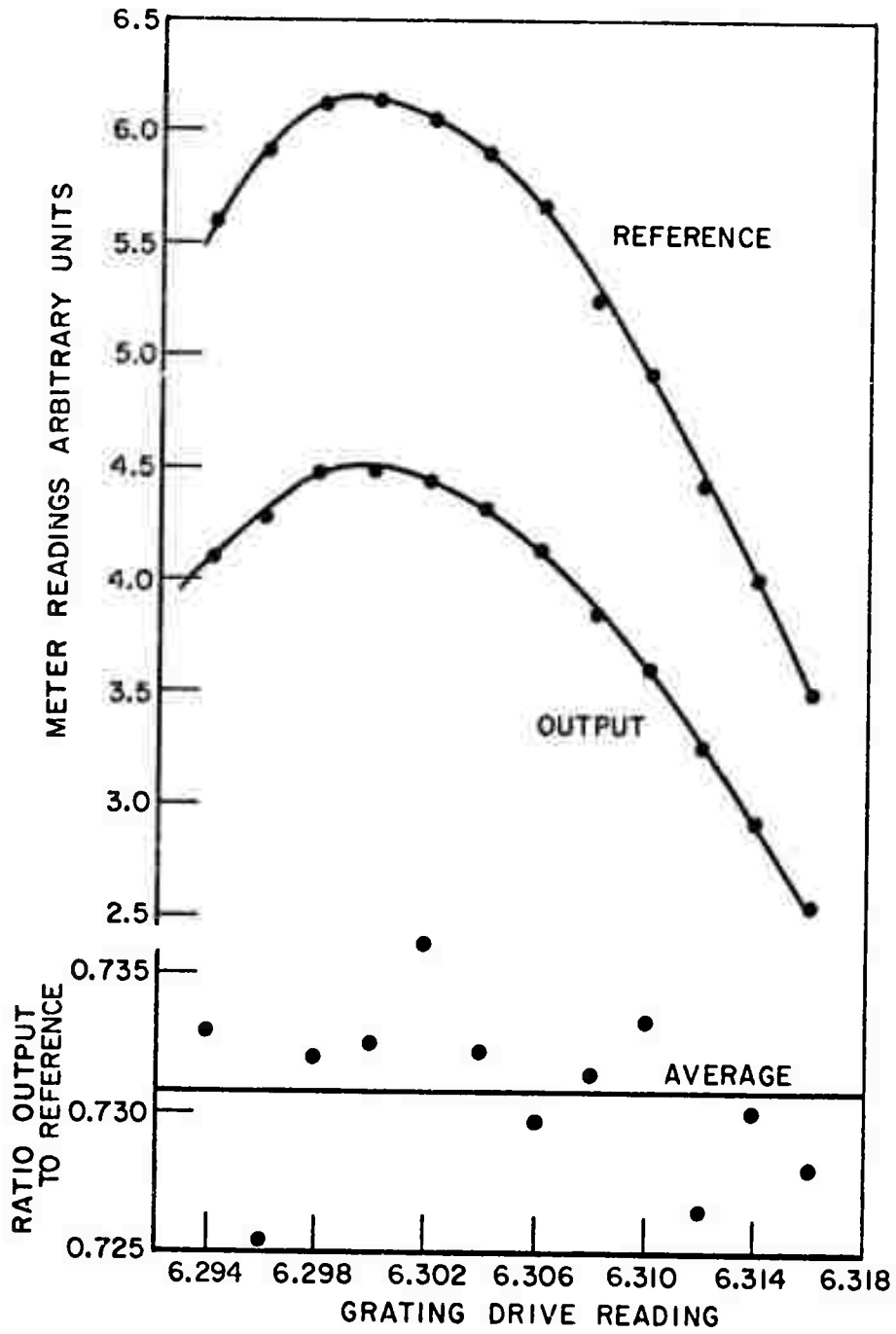

Fig. 3. Output and reference signals from the thermopile detectors and their ratio vs the position of the grating drive mechanism for the CO laser line at 1957.070 cm^{-1} .

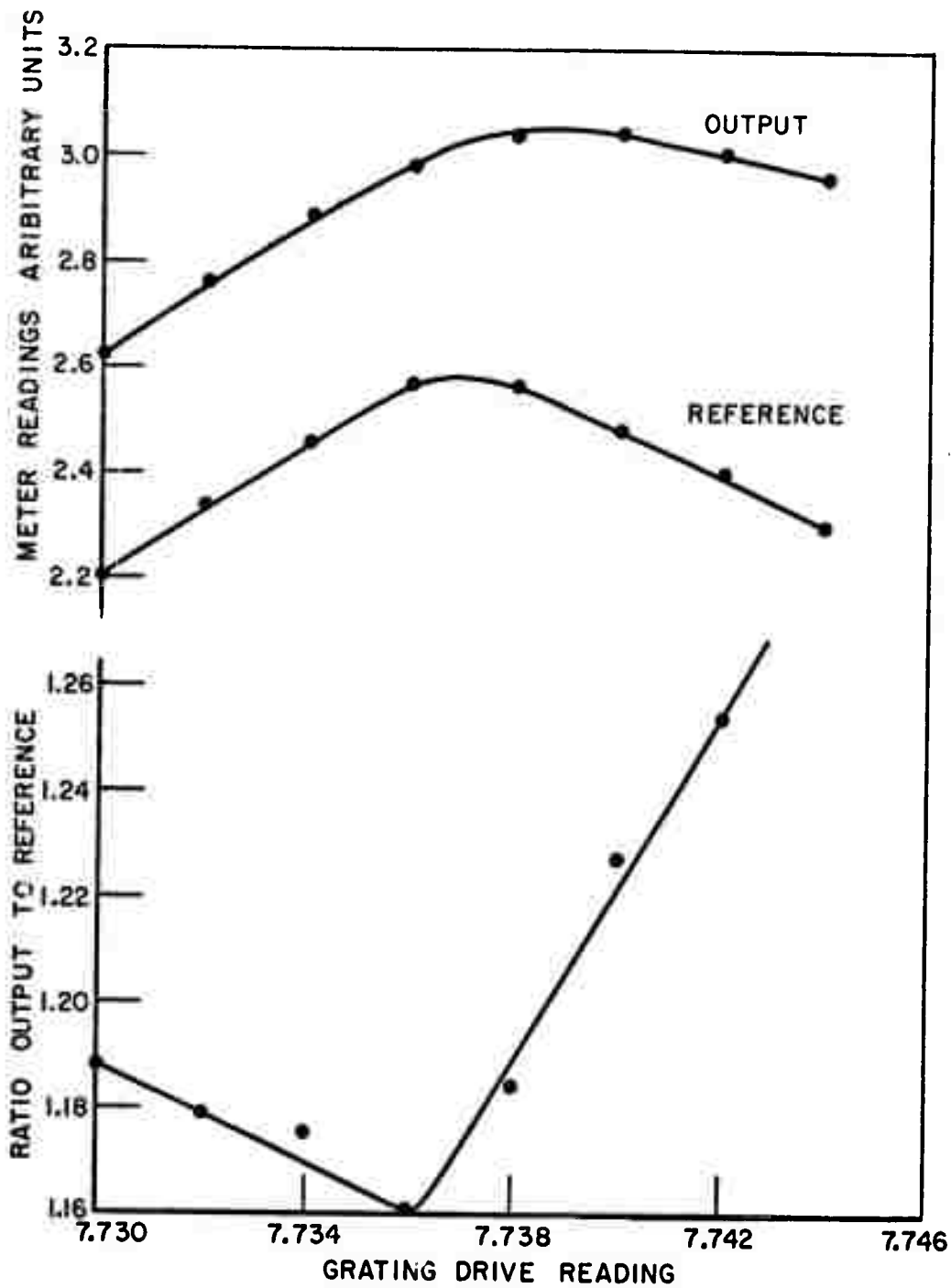

Fig. 4. Output and reference signals from the thermopile detectors and their ratio vs the position of the grating drive mechanism for the CO laser line at 1854.927 cm^{-1} .

A lower chopping frequency was now necessary because of the one second time constant of the Eppley thermopiles. One hertz is the lowest frequency that can be amplified by the microvoltmeters, which determined the lowest chopping frequency that could be used. In addition, at the lower frequency, a longer sampling time is necessary to achieve data with the same RMS error as that previously obtained using the 13 hertz chopper. Because of the poor performance of the IR Industries microvoltmeters at this low frequency (they are also quite old instruments), they were replaced for final transmittance measurements with HP425A dc microvoltmeters, although some data is reported which was obtained with the tunable microvoltmeters.

The voltage on the laser piezoelectric transducer changes the length of the laser cavity and therefore, the power output. Before the thermocouple detectors were replaced the ratio of the output and reference voltages was a function of the piezoelectric voltage. With the Eppley detectors and their larger areas this ratio is nearly independent of the voltage on the piezoelectric transducers.

The most recent experimental setup on is shown in Fig. 5.

Absorption Cell

Several problems were encountered when using the absorption cell. At higher pressures the number of traversals of the laser radiation would change, i.e., 48 traversals at 10 torr became 52 traversals at 620 torr. Also at pressures near one atmosphere turbulence within the cell resulted in beam wander. It is difficult to distinguish between beam wander due to inhomogenities in the gas mixture and beam wander due to thermal effects. In most instances no difference in transmittance was noted after 6 to 8 hours of mixing. The use of the Eppley detector after the cell reduced the effect of beam wander as all energy traversing the cell was focussed onto this detector. Additional insulation on parts of the cell that were previously uninsulated had an insignificant effect on the beam wander. A slight improvement was noted by making measurements during evening hours. An attempt was made to keep the diameter of the laser beam traversing the absorption cell small thereby reducing the effect of thermal turbulence. This technique leads to an increased size of the images formed on the twelve inch mirror of the absorption cell and reduces the number of possible traversals. Best results were obtained when the laser beam was about five inches diameter at the far end of the cell, i.e., the spot about one half filled one of the 20" mirror halves.

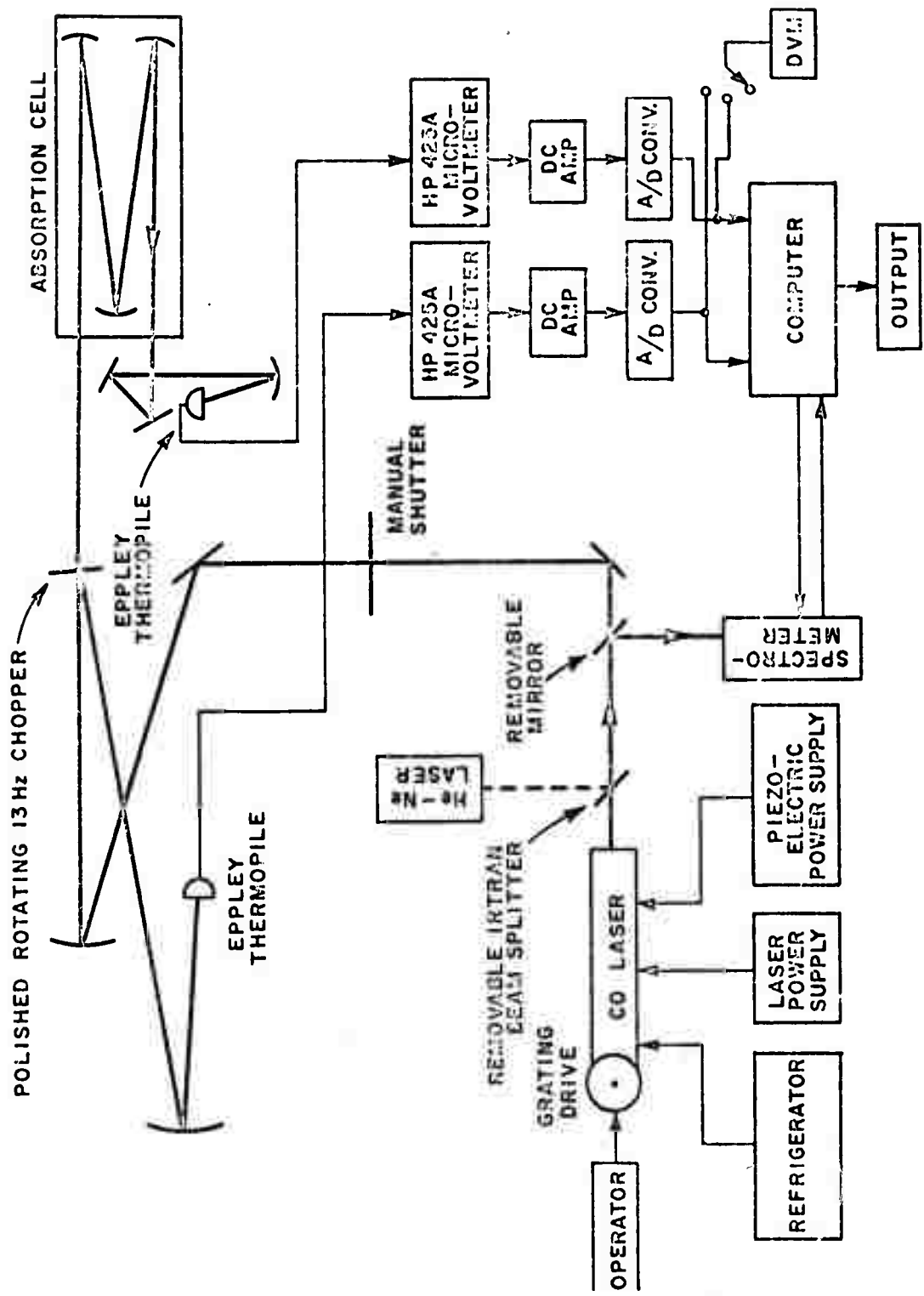

Fig. 5. The most recent experimental arrangement.

Results

While optimizing the experimental arrangement, data was obtained under various conditions of partial pressure of water vapor, total pressure, and path length. For most cases the estimated accuracy of transmittance was 10% or above; however, by the end of this work period the data being obtained was reproducible to 3%.

One set of data will be described in this report. This data was obtained while the above described modifications to the experimental apparatus were underway. The results serve to illustrate the reproducibility of the measurements for a given sample under independent experimental conditions. A more complete analysis of this set of data will be included with the later data to be reported in the next quarterly report.

Listed in Table I are the transmittances of 8 CO laser lines for four different total pressures of H₂O and N₂. The path length was .7317 km and the partial pressure of water vapor was 8.89 torr. The calculated transmittances used all water lines within 150 cm⁻¹ of each CO laser line whose strength was greater than 0.01 cm⁻¹/(gm-cm⁻²). More recent calculations have used a BOUND of 25 cm⁻¹, after McClatchey, in recognition of the limited knowledge of the line shape. Calculated transmittances would be a little higher than those reported in Table I. Not all CO lines were measured under all conditions. This fact arose because difficulties were encountered in keeping the temperature of the laser sufficiently low that the desired lines would always lase.

The two measurements at the pressure of 346 torr were taken 20 hours apart. The first set of measurements were made using the one hertz chopper and the tuned microvoltmeters. The second set of measurements were made using the one hertz chopper, but eliminating the AC microvoltmeters and using HP-425 DC microvoltmeters in their place. This change required different backgrounds to be used for each set of measurements. Between measurements the external optics were adjusted to peak the signals again. The average of the absolute value of the percentage difference of comparable measurements is 4.2% which is well within the estimated accuracy of ±5% for each measurement. These data also indicate that adsorption onto or off of the walls of the absorption cell of water vapor was small during this time.

The two sets of measurements at a pressure of 620 torr were taken the same day. After the first set of measurements was taken it was found that instead of 48 traversals through the cell, the laser beam actually made 52 traversals. The absorption cell was realigned for 48 traversals, the external optics readjusted, and the set of measurements repeated. The data for the 52 traversals were reduced to an equivalent 48 traversals through the cell by correcting for the absorption in the longer path length and the losses from the extra mirror reflections. Neglecting the line at 1854.927 cm⁻¹ which changed 20%, the average of the absolute value of the percentage difference is 4.5%. This average is expected to be greater at higher pressures due to greater wander of

TABLE I
 TRANSMITTANCE OF SELECTED CO LASER LINES
 PARTIAL PRESSURE OF WATER VAPOR 8.89 TORR; OPTICAL PATH LENGTH .732 km

Rank*	CO Laser Wavenumber cm^{-1}	126		346		620		767	
		Obs	Calc	Obs	Calc	Obs	Calc	Obs	Calc
16	1854.927	0.775	0.772	0.385	0.543	0.237	0.190	0.126	0.278
15	1880.330	0.852	0.800	0.520	0.591	0.333	0.320	0.236	0.333
10	1927.282	0.859	0.845	0.501	0.672	0.359	0.363	0.283	0.433
14	1948.730	0.894	0.826	0.614	0.636	0.451	0.463	0.328	0.388
6	1952.888	0.925	0.926	0.704	0.835	0.649	0.608	0.538	0.684
11	1970.159	0.925	0.810	-	0.624	0.495	0.443	0.373	0.427
2	1974.357	0.964	0.965	-	0.919	0.819	0.795	0.698	0.837
1	1978.609	-	0.974	-	0.940	-	0.856	0.751	0.878

*See text.

the laser beam than would be the case at the lower pressures, but is still within the estimated $\pm 5\%$ accuracy of each measurement.

The measured transmittance of six of the CO lines is plotted as a function of pressure in Fig. 6. The measured transmittance

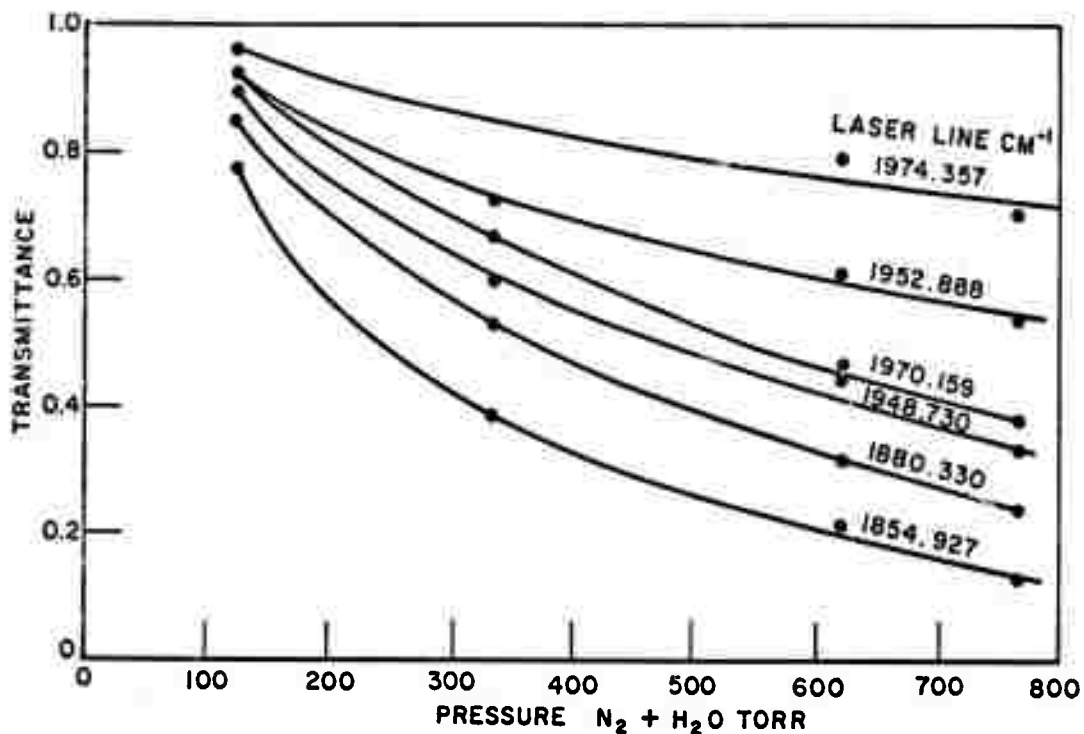

Fig. 6. Measured transmittance of 6 CO laser lines vs total pressure for a partial pressure of water vapor of 8.89 torr. The path length is .732 km and the temperature is 76° F.

is nearly always lower than the calculated values, see Table I. At 126 torr the agreement between the calculated transmittance and measured transmittance is within experimental error. However there is some reason to believe that the 126 torr results may not be as accurate as the other results. Further measurements are required to clarify this point.

The eight lines used in this experiment were selected as follows: A calculation was made using the Calfee-Benedict tables[4] and an atmospheric model called the 0km, 30°N July model. The H₂O pressure used in this model is 22.6 torr. Transmittances were noted at each CO line included in the work of Mantz et. al[11], plus a few additional transitions which had been reported by other workers. From this the 25 best lines

were tabulated (see Appendix B of Report 3271-2). This table was then compared with the unblended lines available in the output of our laser. The group of lines in Table I resulted. The first column gives the rank of that line in the group of 25 selected as described above.

The agreement between calculated and observed values, see Table I, varies from excellent to fair. At 7.67 torr the difference between calculated and observed transmittance varies from 5 to 15% with 5 of the eight lines differing by 15%. A more complete comparison of calculated and observed results should take into account the nature of the H₂O spectrum in the vicinity of each CO line. Further analysis will be delayed until next quarter when a larger amount of measured data is available. It should be noted that corrections for the non-linearities of the detectors were made in the data analysis and that the non-linearities of the HP425A dc microvoltmeters was observed to be less than 1/2%.

IV. HF-DF LASER

The final activity of the quarter was the design and construction of a pulsed HF-DF electric discharge laser which will be used in 2.8 and 3.8 μ absorption measurements.

A. Description of Laser

1. Gases

Gases used in the laser are helium, sulfur hexafluoride (SF₆), oxygen, and either hydrogen or deuterium for either HF or DF operation. The active elements are sulfur hexafluoride and hydrogen or deuterium which react in a pulsed electric discharge to form either HF or DF which are the active lasing media for the HF and DF lasers respectively. Helium is added to serve as a heat sink and it probably also promotes discharge stability. A small amount of oxygen is added to keep the walls of the discharge tube clean.

A conventional 15 CFM mechanical vacuum pump maintains a pressure of from 3 to 12 torr in the discharge tube and a flow rate sufficient to change the gas mixture in the discharge tube between pulses. The optimum pressure in the discharge tube varies somewhat according to the particular line which is oscillating. In the HF laser, the laser output is very sensitive to the amount of SF₆ and H₂ in the discharge, and somewhat less sensitive to the amount of helium.

Estimated mass flow rates for operation at 6 torr are: helium, 21 gm/hour; SF₆, .49 gm/hour; hydrogen, .7 gm/hour; deuterium, 1.4 gm/hour. Estimated operating cost is \$.95/hour for the HF laser, and \$4.00/hour for the DF laser.

2. Laser tube geometry

The laser tube is shown schematically in Fig. 7. The tube is

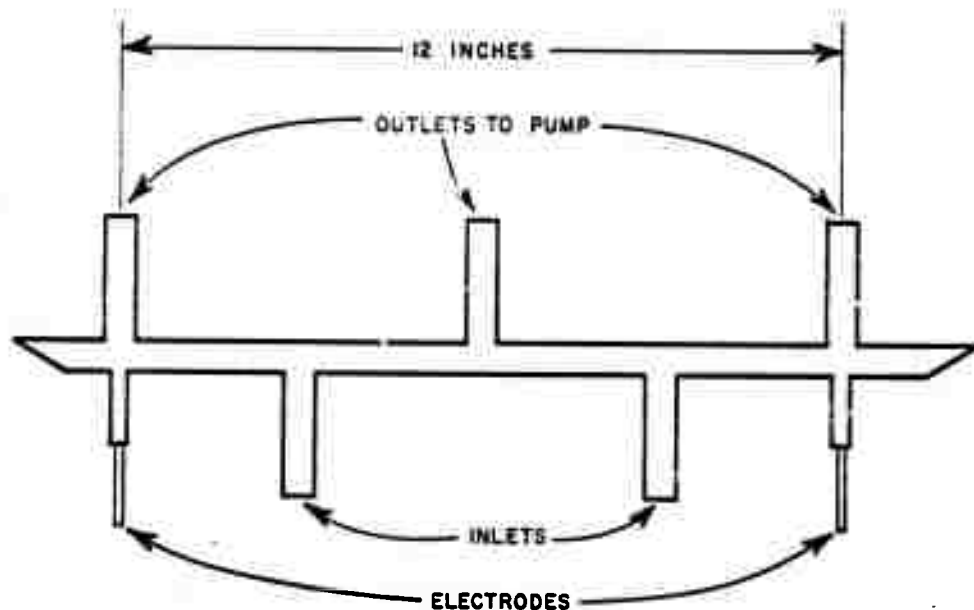

Fig. 7. HF-DF laser tube.

constructed of 10 mm I.D. pyrex tubing with two inlet ports and three outlet ports. The electrodes are Kovar glass to metal seals. Swagelok fittings are used to make connections at the inlet and outlet ports.

The windows are calcium fluoride with the Brewster angle in the proper orientation for operation with a grating.

3. Optical cavity

The optical cavity consists of a 300 line/mm grating blazed at $3\mu\text{m}$ and 20 m radius of curvature Germanium mirror coated for greater than 80% reflectivity between $3\mu\text{m}$ and $4\mu\text{m}$. The grating and the mirror are separated by 121 cm.

The grating mount was designed so that the grating can be easily aligned, and so that the grating can be easily and reproducibly tuned to a specific laser line.

The mirror is mounted in a piezoelectric drive and the drive is mounted in a commercial gimbal mount, which in turn, is mounted on a horizontal translation stage. Thus the mirror can be moved to adjust the longitudinal cavity mode for optimum power from a single line.

The grating mount, laser tube and mirror mount are all attached directly to a limestone slab, five feet long, one foot wide and three inches thick. This arrangement has proved to be quite stable and no realignment is necessary.

4. Power supply

The laser discharge is excited by discharging a .02 μ fd capacitor through a thyratron. The capacitor is charged to about 12 kv using a commercial high voltage power supply. The pulser was supplied by Aerospace Corporation and is capable of single pulse operation or repetitive pulsing up to about 100 pulses per second.

It was necessary to redesign the high voltage portion of the Aerospace pulser to reduce ground loop problems and to add shielding to reduce radiation of signals to the detectors.

B. Laser Performance

Initial measurements have been made with the HF laser operating at 20 pulses per second. A 1-meter Interactive Technology Model CT-103 spectrometer was used to identify the laser lines and an Eppley thermopile was used to measure the average power. The results of these measurements are shown in Table II.

The frequencies listed were calculated from the Dunham potential constants of HF given by Webb and Rao[1]. It is possible that the lines which could not be separated by the laser grating may be separable by varying the gas mixture or the cavity length. This possibility will be examined. The relationship between average power and pulse repetition rate will also be examined.

The DF laser has also been operated at 20 pulses per second. Twenty five lines have been observed in the range from 3.6 to 4.1 microns. The lines have been tentatively identified from the laser drum calibration. A summary of this data is given in Table III.

TABLE II
OBSERVED HF LASER LINES

Identification Band	Transition	Frequency (cm ⁻¹)(a)	Wavelength (Vacuum) _μ	Average Power (mw)(g)		
1-0	P(4)	3788.21	2.6398	1.5		
	P(5)	3741.43	2.6728	0.44		
	P(6)	3693.36	2.7076	2.6		
	P(7)	3644.08	2.7442	4.8		
	P(8)	3593.62	2.7827	5.3		
	P(9)	3542.06	2.8232	6.4		
	P(10)	3489.44	2.8658	6.9	(b)	
	P(11)	3435.84	2.9105	7.7	(c)	
	P(12)	3381.30	2.9574	3.2	(d)	
	P(13)	3325.89	3.0067	1.7		
	P(14)	3269.67	3.0584	0.53		
	P(15)	3212.67	3.1128	0.16		
	2-1	R(2)	3898.96	2.5649	0.17	
		R(1)	3863.95	2.5880	0.48	
		R(0)	3827.45	2.6127	0.23	
P(2)		3708.81	2.6963	1.3		
P(3)		3666.38	2.7275	2.8		
P(4)		3622.61	2.7604	2.6		
P(5)		3577.53	2.7952	4.6		
P(6)		3531.20	2.8319	5.0	(e)	
P(7)		3483.68	2.8705	5.9	(f)	
P(8)		3435.03	2.9112	7.7	(c)	
P(9)		3385.29	2.9540	3.2	(d)	
P(10)		3334.53	2.9989	1.2		
P(11)		3282.79	3.0462	1.1		
P(12)		3230.15	3.0958	1.3		
P(13)		3176.64	3.1480	0.13		

- (a) Estimated accuracy $\pm 0.12 \text{ cm}^{-1}$, calculated (see text).
 (b) Some blending with 2-1 P(7) line.
 (c) Laser cannot resolve 1-0 P(11) and 2-1 P(8) lines.
 (d) Laser cannot resolve 1-0 P(11) and 2-1 P(9) lines.
 (e) Some blending with 1-0 P(9) line.
 (f) Some blending with 1-0 P(10) line.
 (g) 20 pulses per second.

TABLE III
OBSERVED DF LASER LINES

Identification Band	Transition	Frequency (cm ⁻¹)	Wavelength (vacuum) _μ	Average Power (mw)		
1-0	P(6)	2770	3.61	0.037	(a)	
	P(8)	2717	3.680	0.29	(b)	
	P(9)	2691	3.716	0.53	(b)	
	P(10)	2665	3.752	0.67	(b)	
	P(11)	2639	3.790	0.91	(b)	
	P(12)	2611.20	3.8298	0.45	(c)	
2-1	P(3)	2750.20	3.6363	0.25	(c)	
	P(4)	2727.41	3.6665	0.53	(c)	
	P(5)	2704.09	3.6983	0.70	(c)	
	P(6)	2680.27	3.7310	0.75	(c)	
	P(7)	2655.94	3.7651	0.76	(c)	
	P(8)	2631.14	3.8007	0.69	(c)	
	P(9)	2605.88	3.8375	0.59	(c)	
	P(10)	2580.16	3.8757	0.56	(c)	
	P(11)	2554.01	3.9155	1.0	(c)	
	P(12)	2527.44	3.9565	0.53	(c)	
	P(13)	2500.47	3.9995	0.30	(c)	
	3-2	P(5)	2617.44	3.8206	0.19	(c)
		P(6)	2594.25	3.8547	0.20	(c)
P(7)		2570.57	3.8903	0.25	(c)	
P(8)		2546.42	3.9272	0.20	(c)	
P(9)		2521.81	3.9654	0.15	(c)	
P(10)		2496.77	4.0054	0.11	(c)	
P(11)		2461.29	4.0464	0.19	(c)	
P(12)		2445.41	4.0895	0.17	(c)	

- (a) Wavelength estimated from laser calibration.
 (b) See Reference [2]
 (c) See Reference [3]

REFERENCES

1. Webb, D.U. and Rao, K.N., J. Mol. Spectry., 28, 1968, pp. 121-124.
2. Spectroscopy of HF and DF Continuous Lasers, SAMSO-TR-20-226, Aerospace.
3. Deutsch, T.F., Applied Physics Letters, 10, 1967, p. 234.
4. Benedict, W.S. and Calfee, Robert F. (1967), Line Parameters for the 1.9 and 6.3 Micron Water-Vapor Bands, ESSA Professional Paper No. 2.
5. Calfee, Robert F. and Benedict, William S. (1966), Carbon Dioxide Spectral Line Positions and Intensities Calculated for the 2.05 and 2.7 Micron Regions, NBS Technical Note 332.
6. Gates, David M., Calfee, Robert F., Hansen, David, W., and Benedict, W.S., (1964), Line Parameters and Computed Spectra for Water Vapor Bands at 2.7 μ , NBS Monograph, 71.
7. McClatchey, R.A., Private Communication.
8. Burch et. al., Applied Optics, Vol. 1, (1962), p. 359.
9. Bradford, W.R., "Predicting the Molecular Absorption of Infra-Red Radiation over Atmospheric Paths," Report DMP1422, EMI Electronics Ltd., February 1963.
10. Calfee, R.F., "A Note on Terminologies Used in Gaseous Absorption Processes," NOAA Tech. Report ERL211-WPL 15, August 1971.
11. Mantz, A.W., Nichols, E.R., Alpert, B.D., and Rao, K.N., J. Mol. Spectroscopy, 35, 2, 1970.

APPENDIX A
EQUATIONS AND UNITS FOR CALCULATION OF ATMOSPHERIC
TRANSMITTANCE USING LORENTZ LINE SHAPE
AND CALFEE-BENEDICT LINE DATA

A. Introduction

The material of this appendix is available in several references but never all in one place or in the desired form. For that reason it is presented here.

Since 1964 three publications by Calfee and Benedict[4,5,6] have presented tabulations of infrared absorption lines of CO₂ and H₂O. Tabulated data includes line positions, strengths, half-widths and lower energy state. Additionally R.A. McClatchey at AFCRL has been engaged in a project to update the previously published material and to add new tabulations which expand the frequency range and the number of gases covered[7]. It is promised that a "master computer tape" of this data will be available in early 1973.

B. Basic Equation for Lorentz Line

$$(1) \quad \ln T = -ku$$

where T = transmittance
 u = absorber concentration
 k = extinction coefficient

and

$$(2) \quad k_{\nu} = \sum_i \frac{S_i \alpha_i}{\pi [(\nu - \nu_i)^2 + \alpha_i^2]}$$

where S_i = line strength
 ν = wavenumber
 ν_i = line center wavenumber
 α_i = half-width at half intensity.

C. Units for Half-Width

The half-width at reference temperature and pressure is given in $\text{cm}^{-1}/\text{atm}$. Additionally an effective pressure is defined as follows[8,9]:

$$(3) \quad p_e = Bp_a + Fp_f$$

where p_a = partial pressure of absorbing gas, torr.
 p_f = partial pressure of broadening gas, torr.
 $P = p_a + p_f$ = total pressure, torr.
 B = self broadening coefficient
 F = foreign broadening coefficient.

For laboratory measurements using nitrogen as the broadening gas, F is defined to be unity. Thus

$$(4) \quad p_e = \frac{Bp_a + p_f}{760} = \frac{P + (B-1)p_a}{760} \text{ atm.}$$

Typically B is assumed to be

5 for H_2O and

1.3 for CO_2

so that

$$p_e = \frac{P + 4 p_{\text{H}_2\text{O}}}{760} \text{ atm.}$$

and

$$(6) \quad p_e = \frac{P + 0.3 p_{\text{CO}_2}}{760} \text{ atm.}$$

The temperature and pressure dependence of the half-width is given by

$$(7) \quad \alpha = \alpha_0 \left(\frac{P_e}{P_0} \right) \left(\frac{T_0}{T} \right)^{CX} \text{ cm}^{-1}$$

where α_0 = reference half-width at temperature T_0 and pressure $P_0 = 1$ atm. (units $\text{cm}^{-1}/\text{atm}$).

Typically it is assumed that

$$CX = 0.62 \text{ for } \text{H}_2\text{O}$$

$$\text{and } CX = 0.58 \text{ for } \text{CO}_2.$$

D. Temperature Dependence of Line Strength

$$(8) \quad S = S_0 \left(\frac{T_0}{T} \right)^{BX} \exp \left(\frac{-E''}{k} \cdot \frac{T_0 - T}{T_0 T} \right)$$

where E'' = lower energy state in cm^{-1}

k = Boltzman constant = $0.6951 \text{ cm}^{-1}/^\circ\text{K}$

and typically

$$BX = 1.5 \text{ for } \text{H}_2\text{O}$$

$$\text{and } BX = 2.0 \text{ for } \text{CO}_2.$$

E. Units of S and u

1. It is now necessary to specify the units of S and u so that the product ku is dimensionless.

It has been common to use different units for CO_2 and other gases and for water vapor. Recently, however, Calfee and others have begun to use similar units for all gases. All of these units will be discussed.

2. Units of S

H₂O: S is in cm⁻¹/gm cm⁻²
(pr-cm and gm cm⁻² are the same)

CO₂: S is in cm⁻¹/atm-cm.

H₂O and CO₂ (uniform system): S is in cm⁻¹/molecules cm⁻².

3. Units of Absorber Concentration, u.

H₂O: gm cm⁻² or pr-cm

$$(9) \quad u_{\text{H}_2\text{O}} = \rho \ell = \frac{288.34 \times 10^{-4} p_{\text{H}_2\text{O, torr}} \ell_{\text{mtr}}}{T_{\text{OK}}} \quad \text{pr-cm}$$

for reference

$$(10) \quad \rho_{\text{H}_2\text{O}} = \frac{1.05821 \times 10^{-6} p_{\text{H}_2\text{O, torr}}}{1 + .00367 T_{\text{OC}}} \quad \text{gm/cm}^3$$

CO₂: atm-cm T_{OK}

$$u_{\text{CO}_2} = p_{\text{CO}_2} \times \ell.$$

It is necessary to specify the temperature since pressure depends on temperature through the gas law $p = NkT$, i.e., p_{CO_2} is CO₂ pressure in atm. at T₀.

ℓ = path length in cm.

H₂O and CO₂ (uniform system): molecules/cm²

4. Conversion factors between separate and uniform system[10].

$$u[\text{atm-cm}_{\text{STP}}] \times 2.689 \times 10^{19} = u[\text{molecules/cm}^2]$$

$$u[\text{pr cm}_{\text{H}_2\text{O}}] \times 3.34 \times 10^{22} = u[\text{molecules/cm}^2]$$

$$S_0[\text{cm}^{-1}/\text{atm-cm}_{\text{STP}}] \times 3.72 \times 10^{-20} = S_0[\text{cm}^{-1}/\text{molecules cm}^{-2}]$$

$$S_0[\text{cm}^{-1}/\text{pr cm}] \times 2.991 \times 10^{-23} = S_0[\text{cm}^{-1}/\text{molecules cm}^{-2}].$$

It is most convenient to have one computer program for all gases. Thus, the uniform system is to be recommended. Older data sets from references 1, 2, and 3 can be easily updated once they are in computer readable form.

F. Combined Equation

$$(11) \quad \ln T = - \frac{S_0 \left(\frac{T_0}{T}\right)^{BX} \exp\left(\frac{-E''}{k} \cdot \frac{T_0 - T}{T_0 T}\right) \cdot \alpha_0 P_e \left(\frac{T_0}{T}\right)^{CX} \cdot u}{\left[(v - v_0)^2 + \alpha_0^2 P_e^2 \left(\frac{T_0}{T}\right)^{2(CX)}\right]}$$

P_e is in atm.

α_0 in $\text{cm}^{-1}/\text{atm}$

E'' in cm^{-1}

k in $\text{cm}^{-1}/\text{deg K} = 0.6951$

T & T_0 in deg K

v & v_0 in cm^{-1}

S_0 & u in consistent units as described above.