

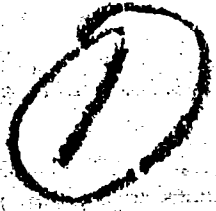

DEFENSE COMMUNICATIONS AGENCY

SATELLITE COMMUNICATIONS
REFERENCE DATA
HANDBOOK



AD 746165

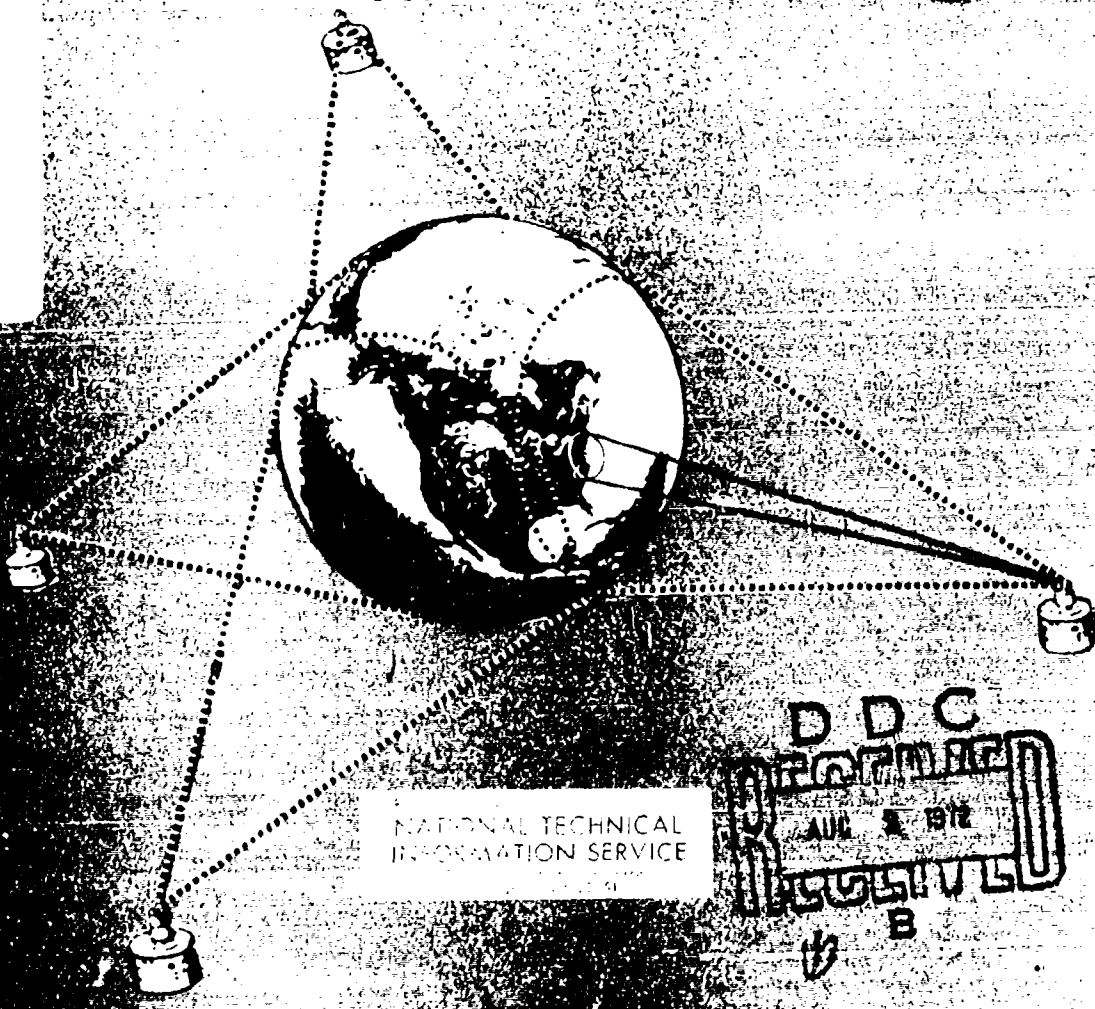

NATIONAL TECHNICAL
INFORMATION SERVICE

D D C
RECEIVED
AUG 2 1972
REGISTRY
B



JULY 1972

279

UNCLASSIFIED

Security Classification

DOCUMENT CONTROL DATA - F & D

(Security classification of title, body of abstract and indexing annotation must be entered when the overall report is classified)

1. ORIGINATING ACTIVITY (Corporate author) Prepared for the Defense Communications Agency, Washington, D. C. 20305 by Computer Sciences Corp., Falls Church, Va. 22046		2a. REPORT SECURITY CLASSIFICATION UNCLASSIFIED	
		2b. GROUP NA	
3. REPORT TITLE Satellite Communications Reference Data Handbook			
4. DESCRIPTIVE NOTES (Type of report and inclusive dates) Reference Handbook			
5. AUTHOR(S) (First name, middle initial, last name) Computer Sciences Corp. staff members including Frederick J. Altman, John L. Burgess, Clarence R. Driscoll, Neil F. McAllister, George O. Selz, Brian Tunstall, Herbert M. Young.			
6. REPORT DATE July 1972	7a. TOTAL NO. OF PAGES 278	7b. NO. OF REFS 0	
8a. CONTRACT OR GRANT NO. DCA 100-72-C-0002	8b. PROJECT NO. Task 7		
c.	9a. ORIGINATOR'S REPORT NUMBER(S) NA		
d.	9b. OTHER REPORT NO(S) (Any other numbers that may be assigned this report) NA		
10. DISTRIBUTION STATEMENT Distribution of this document is unlimited.			
11. SUPPLEMENTARY NOTES NA		12. SPONSORING MILITARY ACTIVITY Defense Communications Agency, Code 480 Washington, D. C. 20305 (COR) WU HEAD OK 2-271	
13. ABSTRACT This document provides a general survey of the background and present status of the satellite communications field in general and of Defense Satellite Communications System (DSCS) in particular. The main body of the report provides general and technical data on the major sub-systems of a satellite communications network. The orbital characteristics of the spacecraft and the performance characteristics of the satellite transponder are explained. The characteristics of earth terminal receivers and transmitters are also covered. An explanation of the basic principles of multiplex, modulation, coding, and multiple access techniques is provided and applied to satellite communications. The basic parameters and essential formulas for understanding the analysis and engineering of satellite links and systems follows. A series of appendices provides reference data directly relating to the DSCS. This includes descriptions of DSCS Phase I and II satellites, of various DSCS earth terminals (on hand and under development) and a description of the past, present and proposed phases of the DSCS. Also provided is data on future trends in the satellite communications field and numerous nomographs and tables that are helpful in analyzing satellite communications engineering problems.			
Details of illustrations in this document may be better studied on microfiche			

14. KEY WORDS	LINK A		LINK B		LINK C	
	ROLE	WT	ROLE	WT	ROLE	WT
Communications Engineering						
Defense Satellite Communications System (DSCS)						
Earth Terminals						
Handbook						
Initial Defense Communications Satellite Program (IDCSP)						
Reference Data Book						
Satellite						
Satellite Communications						
Satellite Engineering						

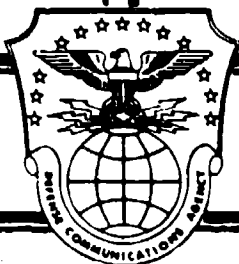

DEFENSE COMMUNICATIONS AGENCY

**SATELLITE COMMUNICATIONS
REFERENCE DATA
HANDBOOK**

**DDC
RECEIVED
AUG 2 1972
B**

DISTRIBUTION STATEMENT A
Approved for public release;
Distribution Unlimited

JULY 1972

TABLE OF CONTENTS

<u>Section 1 - Introduction</u>		1-1
1.1	Purpose	1-1
1.2	Scope	1-1
1.3	Satellite Communications Systems	1-2
1.3.1	General	1-2
1.3.2	Brief History of Satellite Communications	1-5
1.3.3	Defense Satellite Communications System.	1-10
<u>Section 2 - Space Subsystem</u>		2-1
2.1	General	2-1
2.2	Orbital Characteristics	2-1
2.2.1	Orbital Considerations	2-1
2.2.2	Orbital Control	2-10
2.3	Satellite Transponder	2-17
2.3.1	Transponder Transfer Characteristics.	2-17
2.3.2	Beacon	2-20
2.3.3	Power Subsystem	2-20
2.3.4	Antenna Subsystem	2-21
<u>Section 3 - Earth Terminal Subsystems</u>		3-1
3.1	General	3-1
3.2	SHF Earth Terminals	3-2
3.2.1	Antenna Subsystem	3-2
3.2.2	Transmitter Subsystem	3-8
3.2.3	Receiver Subsystem	3-9
3.2.4	Tracking Subsystem	3-12
3.2.5	Intermodulation Problems	3-16
3.2.6	Terminal Availability	3-17
3.3	UHF Earth Terminals	3-17
3.3.1	Comparison of UHF and SHF	3-17
3.3.2	Antenna Subsystem	3-18
3.3.3	Transmitter Subsystem	3-18
3.3.4	Receiver Subsystem	3-18
3.4	Earth Terminal Siting	3-18
3.4.1	Land and Terrain Considerations	3-22

TABLE OF CONTENTS (Cont'd)

<u>Section 4 - Multiplexing, Modulation and Coding</u>		4-1
4.1	General	4-1
4.2	Multiplexing Techniques	4-1
4.2.1	Frequency Division Multiplex	4-1
4.2.2	Time-Division Multiplex	4-4
4.3	Modulation Techniques (RF)	4-8
4.3.1	Analog Modulation Techniques	4-13
4.3.2	Digital Modulation	4-18
4.4	Coding Techniques	4-26
<u>Section 5 - Satellite Link Engineering</u>		5-1
5.1	General	5-1
5.2	Transmission Requirements	5-1
5.2.1	Analog Requirements and Standards	5-1
5.2.2	Digital Requirements and Standards	5-2
5.2.3	Antijamming Requirements	5-3
5.3	Bandwidth Considerations	5-4
5.3.1	Analog Bandwidth Requirements	5-4
5.3.2	Digital Bandwidth Requirements	5-5
5.3.3	Satellite/ET Bandwidth Capabilities	5-6
5.4	Frequency Considerations	5-7
5.4.1	Frequency Bands and Characteristics	5-7
5.4.2	Transponder Capabilities	5-10
5.4.3	Intermodulation	5-10
5.5	Satellite Link Parameters	5-14
5.6	Use of Basic Link Equation	5-17
5.6.1	Downlink Considerations and Examples	5-17
5.6.2	Uplink Consideration and Examples	5-20
5.6.3	Analysis of Digital Requirements	5-20
5.6.4	Analysis of Analog Requirements	5-22
<u>Section 6 - System Considerations</u>		6-1
6.1	General	6-1
6.2	Multiple-Access Techniques	6-2
6.2.1	General	6-2
6.2.2	FDMA	6-2
6.2.3	SSMA	6-4
6.2.4	TDMA	6-5
6.3	System Design	6-6

TABLE OF CONTENTS (Cont'd)

Section 6 - Cont'd

6.3.1	Power Sharing	6-6
6.3.2	Bandwidth Sharing	6-8
6.3.3	Frequency Sharing	6-9
6.4	System Engineering Tradeoffs	6-10
6.5	Reliability/Availability	6-10
6.5.1	Equipment Reliability	6-10
6.5.2	Parameters and Relationships	6-11
6.5.3	Satellite Availability	6-13
6.5.4	Link Availability	6-15
6.6	Interference and Jamming	6-18
6.6.1	Types of Interference	6-18
6.6.2	Jamming	6-20
6.6.3	Frequency Coordination	6-23

Section 7 - Control

7.1	General	7-1
7.2	Satellite Control	7-2
7.3	Satellite Communications Control	7-3
7.4	Circuit Control	7-5

Appendix A - Satellites

A-1

Appendix B - Earth Terminals

B-1

Appendix C - Phase I

C-1

Appendix D - Phase II

D-1

Appendix E - Future Trends

E-1

Appendix F - Reference Data

F-1

Appendix G - Glossary

G-1

LIST OF ILLUSTRATIONS (Cont'd)

<u>Figure</u>		
5-1	Theoretical Rainfall Attenuation for Various Frequencies .	5-9
5-2	Frequency Versus Noise Temperature	5-11
5-3	Receiver Noise Figure Versus Frequency	5-12
5-4	Transmitter Efficiency Versus Frequency	5-13
5-5	Typical Single Access Link	5-19
5-6	Number of Voice Channels Versus C/kT	5-26
6-1	Example of Satellite Reliability	6-12
6-2	Example of Availability of One Satellite System With Launch of Spare Satellite at 0.7 Reliability of Initial Satellite . . .	6-16
A-1	DSCS Phase I Transponder Block Diagram	A-4
A-2	DSCS Phase II Transponder Block Diagram	A-9
A-3	DSCS Phase II Satellite Frequency Transition Plan	A-10
A-4	TACSAT Transponder Repeater Block Diagram	A-18
A-5	Skynet Communications Transponder Block Diagram	A-24
A-6	Intelsat IV Transponder Block Diagram	A-32
B-1	20 kW Fixed-Station Terminal, 60-Foot Antenna	B-4
B-2	AN/FSC-9 - Simplified Functional Diagram	B-5
B-3	The AN/MSC-46 Earth Terminal With No Radome But With Updated Dielectric Antenna Feed	B-8
B-4	AN/MSC-46 Simplified Functional Diagram	B-10
B-5	The AN/TSC-54, Highly Transportable Terminal, With Cloverleaf Antenna Which Is Equivalent to an 18-Foot Diameter Reflector	B-11
B-6	AN/MSC-60 (HT)	B-13
B-7	Field Layout of AN/MSC-61 (MT)	B-16
B-8	The SCT-21 Transportable Terminal	B-17
B-9	Shelter Terminal (AN/TSC-80)	B-20
B-10	Block Diagram of TACSAT SHF Ground Terminal (AN/ TSC-80)	B-21
B-11a	AN/TSC-80 RF Channel Frequency Plan	B-22
B-11b	AN/TSC-80 Typical Frequency Allocation Chart	B-22
B-12	TACSAT Vehicular Terminal (AN/MSC-57)	B-24
B-13	DTS Terminal	B-26
B-14	Block Diagram of DTS Terminal	B-27
C-1	Basic Block Diagram of Typical User Link	C-3
C-2	DSCS Phase I Satellite Visibility	C-7
C-3	Computer-to-Computer Satellite Communication Link	C-10
C-4	IDCSP Typical Satellite Link Configuration	C-2
D-1	A Typical System Configuration for Stage 1a	D-1

LIST OF ILLUSTRATIONS (Cont'd)

Figure

D-2	Stage 1b Phase II DSCS Typical Satellite Link Configuration	D-16
D-3	Typical Stage 1c Digital Traffic Configuration	D-20
F-1	Free Space Attenuation Between Isotropic Antennas	F-5
F-2	Voice Traffic, ERP Required Versus Receive Station G/T (Earth Coverage)	F-9
F-3	Data Traffic, ERP Required Versus Receive Station G/T (Earth Coverage)	F-10
F-4	Voice Traffic, ERP Required Versus Receive Station G/T (Narrow Beam)	F-11
F-5	Data Traffic, ERP Required Versus Receive Station G/T (Narrow Beam)	F-12
F-6	Relative Noise Scales	F-14
F-7	Error Correcting PSK Code Performance	F-17
F-8	Uniform Monthly Cost for DSCS Earth Coverage Operations	F-18
F-9	Uniform Monthly Cost for Narrow Beam Coverage Oper- ations	F-19

LIST OF TABLES

Table

1-1	Major Parameters of Intelsat Satellites	1-11
2-1	Percentage of Earth's Surface Visible From a Satellite. . .	2-8
2-2	Summary of Launch Vehicle Capabilities	2-11
2-3	Achievable Gain for Earth Coverage Antenna Configuration	2-22
3-1	Effective Noise Temperature of SHF Low-Noise Devices. . .	3-11
4-1	Sequential Decoding Procedure.	4-36
4-2	E_b/N_o Coding Gain for Several Coded Systems	4-40
5-1	Atmospheric Attenuation and Antenna Noise Temperature Versus Elevation Angle and Weather Conditions at 8 GHZ	5-8
5-2	Summary of Means and Variances for a 6-Foot Terminal at 60° Latitude	5-18
5-3	Required Satellite Power Versus Data Rate.	5-22
5-4	Required C/kT Versus Number of Voice Channels	5-25
6-1	Summary of Multiple-Access Techniques	6-3
6-2	Percent of Satellite Power Required for FDMA	6-7
6-3	Percentage of Satellite Power Required for TDMA.	6-7
6-4	Bandwidth Requirements of FDMA.	6-8
A-1	DSCS Phase I Satellite Data	A-2
A-2	DSCS Phase I Satellite Characteristics.	A-5
A-3	DSCS Phase I Duplex Channel Capacity and Performance. . .	A-6
A-4	DSCS Phase I Access Frequencies.	A-7
A-5	DSCS Phase II Satellite Characteristics	A-12
A-6	TACSAT Satellite Data	A-13
A-7	TACSAT Frequencies (MHz).	A-14
A-8	Signal Processing for TACSAT UHF Modes.	A-15
A-9	Signal Processing for TACSAT SHF Modes.	A-16
A-10	TACSAT Characteristics	A-17
A-12	Skynet Frequencies.	A-20
A-11	Skynet Satellites.	A-21
A-13	Skynet I Satellite Characteristics	A-23
A-14	NATO Satellite Characteristics.	A-27
A-15	Intelsat IV Characteristics.	A-29
A-16	Intelsat Frequency Assignments	A-31
B-1	Summary of Earth Terminal Characteristics.	B-2
C-1	DCSP Objectives	C-1
D-1	Summary of Modifications and New Equipment for DSCS Phase II.	D-1

LIST OF TABLES (Cont'd)

Table

F-1	Decibel Conversion.	F-2
F-2	Decibel Conversion in Powers of Ten.	F-3
F-3	Antenna Fact Sheet.	F-4
F-4	Percent of Satellite Power Required to Provide DSCS Voice Service.	F-6
F-5	Percentage of Stage 1b Satellite Power Required to Provide DSCS Data Service.	F-7
F-6	Antenna Size and G/T of Terminals Using DSCS Phase II Satellites.	F-8
F-7	DSCS Phase II, Stage 1a Exclusive Band Carrier Frequencies.	F-13
F-8	Monthly Space Subsystem Cost Allocation for One Analog Voice Channel DCS Quality.	F-15
F-9	Monthly Space Subsystem Cost Allocation for One Analog Voice Channel Tactical Quality.	F-15
F-10	Digital Data, 1 kbps (\$ Thousand).	F-16
F-11	Digital Data, 2.4 kbps (\$ Thousand).	F-16
F-12	Monthly Space Subsystem Cost Allocation Digital Data Channel, 1 kbps.	F-20
F-13	Monthly Space Subsystem Cost Allocation Digital Data Channel, 2.4 kbps.	F-20

FOREWORD

This is the first edition of DCA's Satellite Communications Reference Data Handbook. It is recognized that the users of the Handbook will have varied assignments and variations in their need for detailed data on the topics discussed herein. In order to make the Handbook more useful to you, the user, your suggestions for improvement, comments and corrections would be greatly appreciated. Kindly forward any such items to: Defense Communications Agency, Attention Code 483, Washington, D. C., 20305. Either brief handwritten notes or detailed coverage is welcome.

SECTION 1 - INTRODUCTION

1.1 PURPOSE

It is the purpose of this reference book to provide, in one source, sufficient information on satellite communications in general and on the Defense Satellite Communications System (DSCS) in particular to familiarize the reader with this special field of communications. The intent is to present data so that one familiar with communications, but not necessarily an engineer, can readily grasp the fundamental characteristics, capabilities and limitations of satellite communications as well as the background and present status of the DSCS. A glossary of terms and abbreviations is given in a table at the end of the book.

1.2 SCOPE

Sections 2 through 8 of this reference book provide a survey of basic technical data related to satellite communications systems in general. This includes:

Section 2 - Data on space subsystems such as orbital characteristics and satellite transponders

Section 3 - Data on earth terminals including transmit, receive and antenna subsystems

Section 4 - Data on typical multiplex, modulation and multiple-access techniques that are suitable for satellite communications systems. This section also covers pertinent data on the use of error-correcting coding techniques to conserve satellite power and/or improve performance of digital transmission.

Section 5 - Basic parameters and formulas essential to an understanding of the problems involved in engineering a satellite communications link

Section 6 - Data relative to the integration of satellite communications systems into a global terrestrial communication network

Section 7 - Development of a system engineering approach to the sharing of the limited power and bandwidth capacity of a satellite

Section 8 - Data on both nonreal-time and real-time control systems that are appropriate for use with multiple-access satellite systems.

The remainder of the book consists of seven appendices addressing specific areas closely related to the DSCS. These are:

Appendix A - Descriptive summary of the characteristics of presently available or planned satellites of interest to military communicators

Appendix B - Descriptive summary of presently available or proposed earth terminals of interest to military communicators

Appendix C - Detailed description of Phase I of the DSCS

Appendix D - Detailed description of Phase II of the DSCS

Appendix E - Brief coverage of future trends in communications that may have an influence on the DSCS

Appendix F - Compilation of technical reference data useful in analyzing satellite planning and engineering problems.

Appendix G - Glossary

1.3 SATELLITE COMMUNICATIONS SYSTEMS

1.3.1 General

A communications satellite serves as a relay station for a long-distance communications system. Such a system has the advantage of being able to cover a large portion of the earth's surface with the satellite antenna. Thus it needs only a single antenna to connect remote sites.

In most ways a satellite communications link is similar to a line-of-sight (LOS) microwave system, with the satellite transponder serving as the replacement for the numerous intermediate repeaters that would be necessary on a long-distance system. A problem in common with terrestrial microwave systems is a need for wide frequency bands and low internal and external noise. Since both satellite and terrestrial services are allocated frequencies from shared frequency bands, it requires careful coordination prior to frequency assignment to avoid interference between using systems.

Although many of the basic principles are the same as in terrestrial systems, satellite communication systems do have differences that will be emphasized throughout this book. As will be seen, satellite communications are particularly suited for long-distance wide-band communications, providing the capacity for transoceanic high data rate circuits that are not practical by undersea cable or terrestrial radio. Figure 1-1 is a block diagram of a satellite system showing the space, earth and control subsystems and the three types of control--satellite, earth terminal, and circuit.

Satellites used in communication systems may be classified into general categories by electromagnetic and orbital characteristics. Electromagnetically, there are two general types of satellites: passive and active. A passive satellite merely acts as a reflector of radio waves. For example, the moon was used as part of the first passive satellite communication system (as discussed in Paragraph 1.3.2.1). One serious disadvantage of this type of system is that the reflected signal received at the earth terminal is extremely weak. Thus, passive satellites are not considered for major communications systems and are of historical interest only. An active satellite carries a transponder (receiver-amplifier-transmitter) system analogous to a terrestrial or undersea repeater. This results in stronger signals at the earth terminal, but at the expense of greater complexity and cost. Because a satellite is visible over a wide area, it is available for use by others, and ordinary transmissions may be easily interfered with or readily jammed.

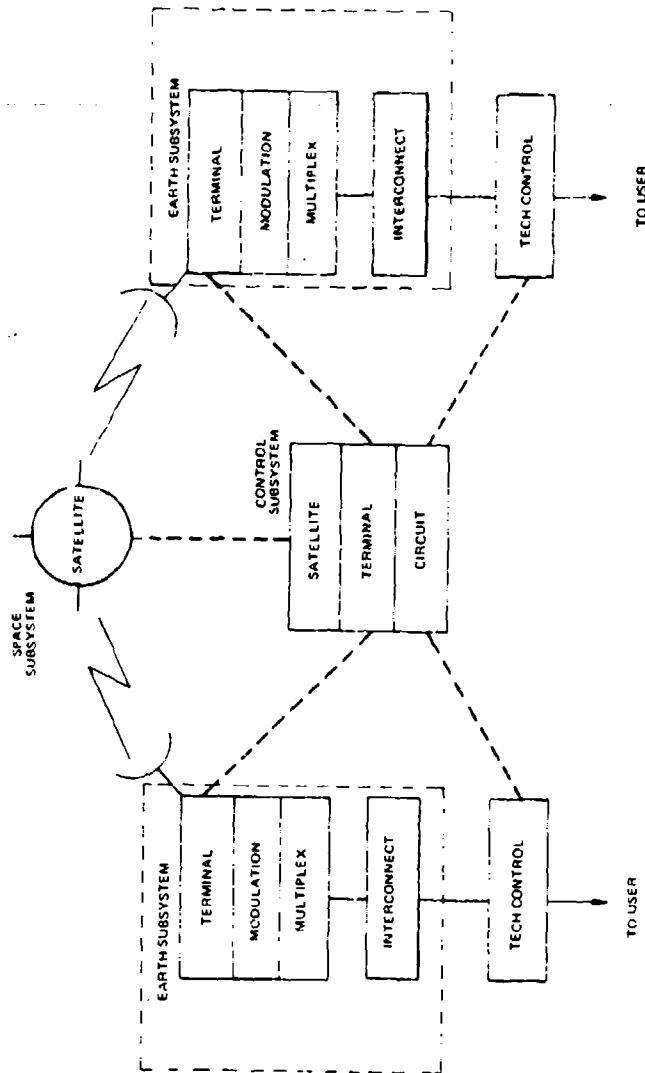

Figure 1-1. Active Satellite System Block Diagram

A major difference from terrestrial systems is the requirement for remote multiple access, often changing with time and space. In FM systems, this leads to problems of intermodulation among the transmitted signals, and requires signal power control for the several kinds of signals. These problems are largely avoided by using time-division or spread-spectrum multiple access techniques.

According to their orbital characteristics, communication satellites may be divided into two general types: synchronous and nonsynchronous. Synchronous satellites have an orbital altitude of 22,300 statute miles and will rotate with the same angular velocity as the earth. A synchronous satellite in an equatorial orbit will thus remain stationary with respect to a point on the earth's surface. A nonsynchronous satellite has an altitude other than 22,300 statute miles and circles the earth at a rate dependent on its altitude. It will be visible from a given point on the earth during only a portion of its orbit. The duration and frequency of the visibility depends on the orbital parameters and earth terminal locations. There may be no visibility from some terminals; from others the satellite may be visible only on some orbits. Thus, many nonsynchronous satellites are needed for continuous service; and these systems may involve complex acquisition, tracking and handover problems.

1.3.2 Brief History of Satellite Communications

The following paragraphs give a brief review of some of the major events in the development of today's operational satellite communication systems.

1.3.2.1 Passive Satellites

1. Moon

The first voice message to be transmitted via a space relay used the moon as a passive reflector. In 1954, the Naval Research Laboratory (NRL) transmitted over an earth-moon-earth link successfully, and in 1955 established the first transcontinental transmission via the

moon. By 1959 a duplex link between Washington, D.C. and Hawaii became operational on frequencies of 400 and 450 MHz.

2. Project Echo

The Echo-I sphere, an artificial echo-producing body, was placed in an orbit of 1000-mile altitude following launch by NASA in August 1960. It was a mylar-aluminum balloon, 100 feet in diameter weighing 175 pounds. Echo-II, launched in January 1964, was larger and more rigid. It weighed 500 pounds and was placed in a 600- to 800-mile, near-polar orbit. Both were used in an intensive program of tests by the United States and other countries. They were still in orbit as of January 1972.

3. Project West Ford

Project West Ford, sponsored by the U.S. Air Force, was an investigation into the feasibility of using an orbital belt of dipoles as passive reflectors. On 10 May 1963 a launch was made and the dipoles were successfully dispersed in a polar orbit of about 3700-km altitude. The dipoles were designed for operation at a frequency of about 8000 MHz. Ground stations in Massachusetts and California were used to measure the dipole belt characteristics and usefulness in point-to-point communications. Speech was transmitted in digitized form and received intelligibly, and the results agreed with theoretical predictions. The individual dipole orbits decayed with time and after 5 years the belt virtually ceased to exist.

1.3.2.2 Active Satellites

1. Project Score

In December 1958, an Atlas 10-B vehicle put into an elliptical orbit (perigee of 110 miles, apogee of 920 miles) a 150-pound package

capable of both delayed and real-time transmission of voice and teletype. The system operated successfully for 12 days, with an output power of 8 watts at 150 MHz.

2. Project Courier

In October 1960, a Thor-Able Star vehicle put Courier 1-B, a DOD satellite, into a 600- to 700-mile orbit. It operated for 17 days, with an output power of 3 watts at 2 GHz. It could receive and store 360,000 teletype words during each overhead passage, and retransmit them to each of four ground stations. Tests of delayed and real-time voice, teletype and facsimile were conducted between Fort Monmouth, New Jersey and Puerto Rico.

3. Project Telstar

Telstar I was launched on 10 June 1962 by a Delta vehicle, and placed in an elliptical 593- to 3503-nautical-mile orbit as a joint AT&T-NASA project. The satellite weighed 170 pounds and was operable on a communication duty cycle of 10 percent. Another satellite, Telstar II, was launched in May 1963. The Telstars provided tests for telephone, television, facsimile and data among the United States, Great Britain, France, Italy and Japan until March 1965. The output power was 3 watts with 6-GHz uplink and 4-GHz downlink frequencies.

4. Project Relay

In December 1962, Relay I, weighing 172 pounds, was launched by NASA into an elliptical 819- to 4612-nautical-mile orbit. In January 1964 Relay II was placed in a similar orbit. The output powers were 10 watts with 1700-MHz uplink and 4200-MHz downlink frequencies. Relay I operated successfully until February 1965, supporting more than 2000 communication tests among the United States, Europe and South America. Relay II was used by U. S. earth stations until September 1965.

5. Project Syncom

This NASA Project included three satellites. Syncom I failed to achieve a proper orbit. Syncom II was placed in an inclined synchronous orbit in July 1963 and was used for testing. Syncom III was placed in a synchronous equatorial orbit near the international date line in August 1964, and was used for TV transmission of the Tokyo Olympic Games to the U.S. in the fall of 1964. In April 1965, after its program of tests was completed, NASA transferred operation of both satellites to DOD. Neither is currently operational.

6. DOD Tactical Satellite Communication Activities

In 1965 the three services initiated studies on tactical/mobile satellite communications. On 1 July 1967, LES-5 (Lincoln Laboratory Experimental Satellite), a UHF satellite repeater weighing 225 pounds, was placed in a high orbit by a multiple payload Titan III-C developmental launch. The UHF system was tested by SAC aircraft as well as by Army and Navy mobile terminals. This launch also deployed a gravity-gradient experiment (DODGE) and an electronically despun array test satellite (DATS) with 3 IDCSP satellites. Later, in September 1968, LES-6 was launched in further support of the tactical communications study program. This was followed in February 1969 with the launch of TACSAT I, a high-powered experimental tactical communication satellite for use by all military services to assess the role of satellites in tactical situations. The TACSATCOM program includes LES-6 and TACSAT I, which are both geostationary satellites. LES-6 is a small, single-band UHF satellite, whereas TACSAT I was the largest and most powerful communication satellite launched up to that time, having high capacity and operating in both UHF and SHF bands. These two equatorial satellites were aligned with the central

with earth coverage capacities of 6000 telephone circuits and 12 video channels or equivalent combinations, is now available. The first Intelsat IV was successfully placed in orbit in January 1971 and became operational in March over the Atlantic region. An innovation on the Intelsat IV series is the provision of two spot beams in addition to the earth coverage antenna to focus more power over high-traffic regions. Its design life is 7 years. A summary of the principal characteristics of the Intelsat satellites appears in Table 1-1.

1.3.3 Defense Satellite Communications System

The Defense Satellite Communications System (DSCS) is an integral portion of the global Defense Communications System designed to provide vital communications service to the United States and Allied Forces throughout the world by means of satellites. The system is being implemented in phases. Phase I has been providing a limited operational capability since 1967. The Phase I space subsystem at maximum consisted of 26 low-power satellites drifting slowly in near-synchronous, near-equatorial orbits. As of May 1972 there were only 17 Phase I satellites operational. This number will decrease as the satellites approach their 6-year automatic cutoff design life. Each satellite supports only one duplex communication link (connecting two earth terminals). Depending on earth terminal sizes involved, each link has a capacity of one to five voice channels.

The Phase II satellites are to be positioned in geostationary orbits and thus will be continuously available for use by earth terminals located within about 5000 nautical miles of their subsatellite points. The Phase II satellites are larger and transmit more power than the Phase I satellite. In addition to the earth coverage antennas they have two steerable narrow-beam antennas for greater communication capability between selected earth locations. They have two separate transponders with four separate frequency bands.

Table 1-1. Major Parameters of Intelsat Satellites

Characteristics	Intelsat I	Intelsat II	Intelsat III	Intelsat IV
Diameter (inches)	28.4	56	56	93.7
Height (inches)	23.25	26.5	41	208
Weight (pounds)	85	190	334	1587
dc Power (watts)	33	75	125	500-600
Repeaters	2	1	1	12
Bandwidth per repeater (MHz)	25	130	225	36
Antenna Beam	11° x 360° centered at +7°	12° x 360° centered at equator	20° x 20°	One each 20° x 20° Two each 4.5° x 4.5°
Effective radiated power per repeater (watts)	10	35	150	200 with 20° beam 4000 with 4.5° beam
Total effective radiated power (all repeaters) (watts)	20	35	300	2400 (all 20° beam) 25,200 (6 each 20° beam + 6 each 4.5° beam)
Total two-way telephone circuits*	240	240	1200	3000 to 9000 depending on type of modulation, number of carriers per repeater and antenna beamwidths used

*When used with standard earth stations having 85- to 97-ft diameter antennas

The Phase II DSCS will have several stages. Stage 1a will consist of a number of point-to-point links similar to those of Phase I. In Stage 1b certain of the earth terminals will have nodal capabilities (communicating simultaneously with several other terminals). The Stage 1c system will be all digital (digitized voice and digital data) to increase system capability. Stage 2 will employ TDMA. More detailed descriptions of the system and its components are covered in Appendices A through D.

SECTION 2 - SPACE SUBSYSTEM

2.1 GENERAL

This section provides basic data on the satellite subsystem, including launching and orbital considerations and characteristics. The section also covers typical satellite transponder characteristics with emphasis on the constraints peculiar to operating from a satellite platform. These constraints include size, weight, power, antenna pointing and coverage area of the antenna.

2.2 ORBITAL CHARACTERISTICS

2.2.1 Orbital Considerations

For the following presentation of the basic relationships between the orbit characteristics of terrestrial satellites, a spherical earth with a spherically symmetric gravitational field is assumed. This assumption neglects the earth's oblateness and inhomogeneous mass distribution as well as the effects of the sun and the moon on the resultant gravitational force applied to the satellite body. Under this assumption, the trajectory of a satellite is planar and elliptical with the earth's center of gravity as one of the foci of the elliptic orbit. The communication satellites used by the United States have all had essentially circular orbits, which are special cases of elliptical orbits.

Figure 2-1 shows the different possible types of circular orbits, from the equatorial type to the polar type, obtained by varying the angle between the orbital plane and the equator (inclination angle), i , from 0° to 90° .

The period of a satellite in circular orbit in hours is given by:

$$T = 2\pi \sqrt{\frac{(R_o + h)^3}{GM}} = 0.0000564 (3958 + h)^{3/2} \quad (2-1)$$

where h is height of the satellite above the earth in statute miles.

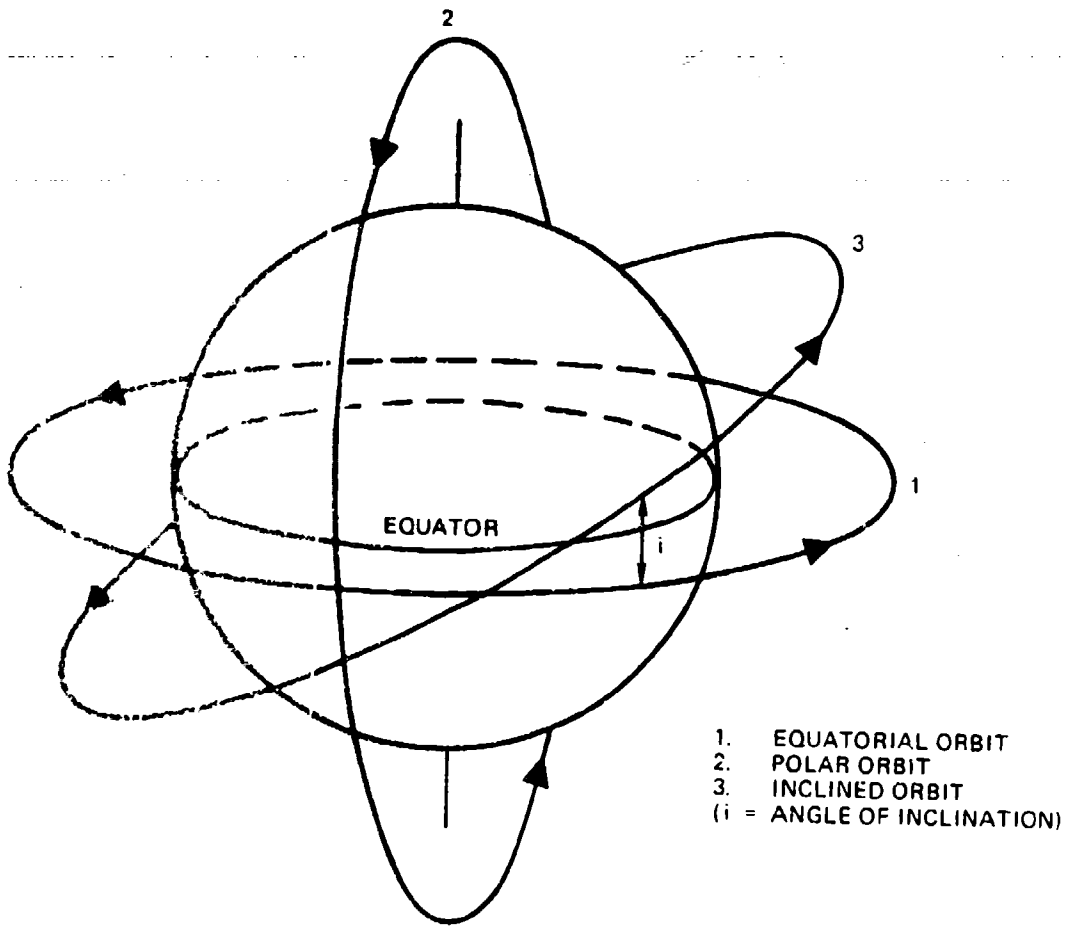

Figure 2-1. Possible Types of Circular Orbits

Figure 2-2 shows the satellite period for various altitudes. A satellite at a height of 22,300 miles and in the equatorial plane (zero inclination angle) will appear stationary with respect to the earth and is called synchronous. At this height and at an inclination angle other than zero, the satellite as viewed from the earth will appear to describe a figure eight.

An elliptical orbit, shown in Figure 2-3, is described in terms of the apogee, or maximum height above the earth's surface, and the perigee, or height of the satellite at its minimum distance from the earth. The satellite average velocity is equal to that of a satellite in a circular orbit whose diameter is equal to the major axis of the ellipse. The instantaneous velocity of the satellite is dependent on its position in its orbit; minimum at apogee and maximum at perigee. Its period may be found by using the average of apogee and perigee heights in Figure 2-2.

The total area of the earth seen by the satellite at any instant, or reciprocally the area from which the satellite is visible from the surface of the earth, is bounded by a circle the radius of which is a function of satellite altitude h and minimum allowable earth antenna elevation angle, α . The coverage geometry is illustrated by Figure 2-4. In the case of a geostationary satellite the earth coverage area is fixed. For a nonsynchronous circular orbit satellite, the coverage circle is fixed in size and moving continuously over the earth's surface.

The coverage or spherical area of the earth's surface within the visibility cone of angle 2θ is given by:

$$A_s = 2\pi R_e^2 (1 - \cos\theta) \quad (2-2)$$

where

$$\theta = \left[\cos^{-1} \left(\frac{R_e \cos\alpha}{R_e + h} \right) \right] - \alpha \quad (2-3)$$

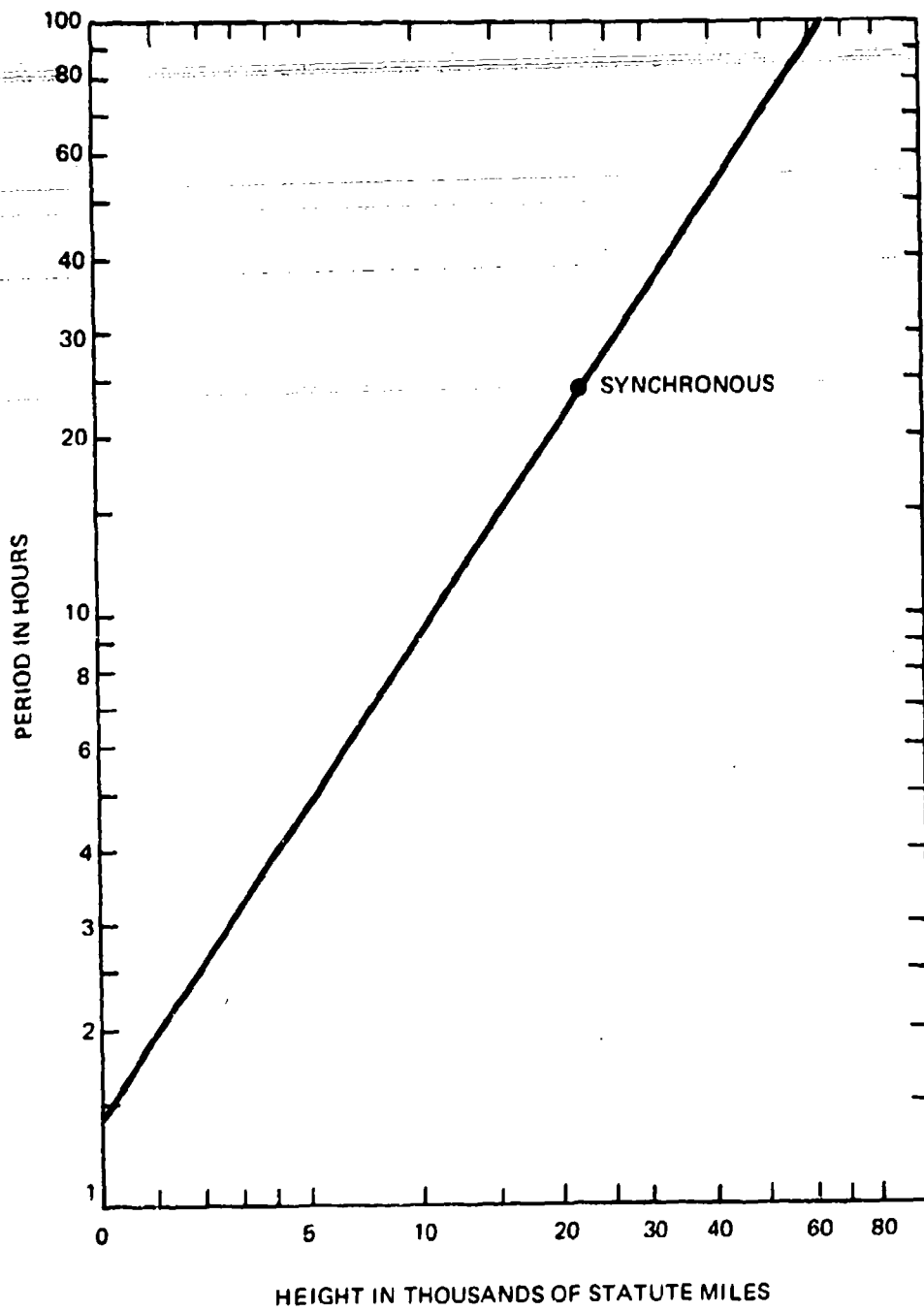

Figure 2-2. Satellite Period for Various Altitudes

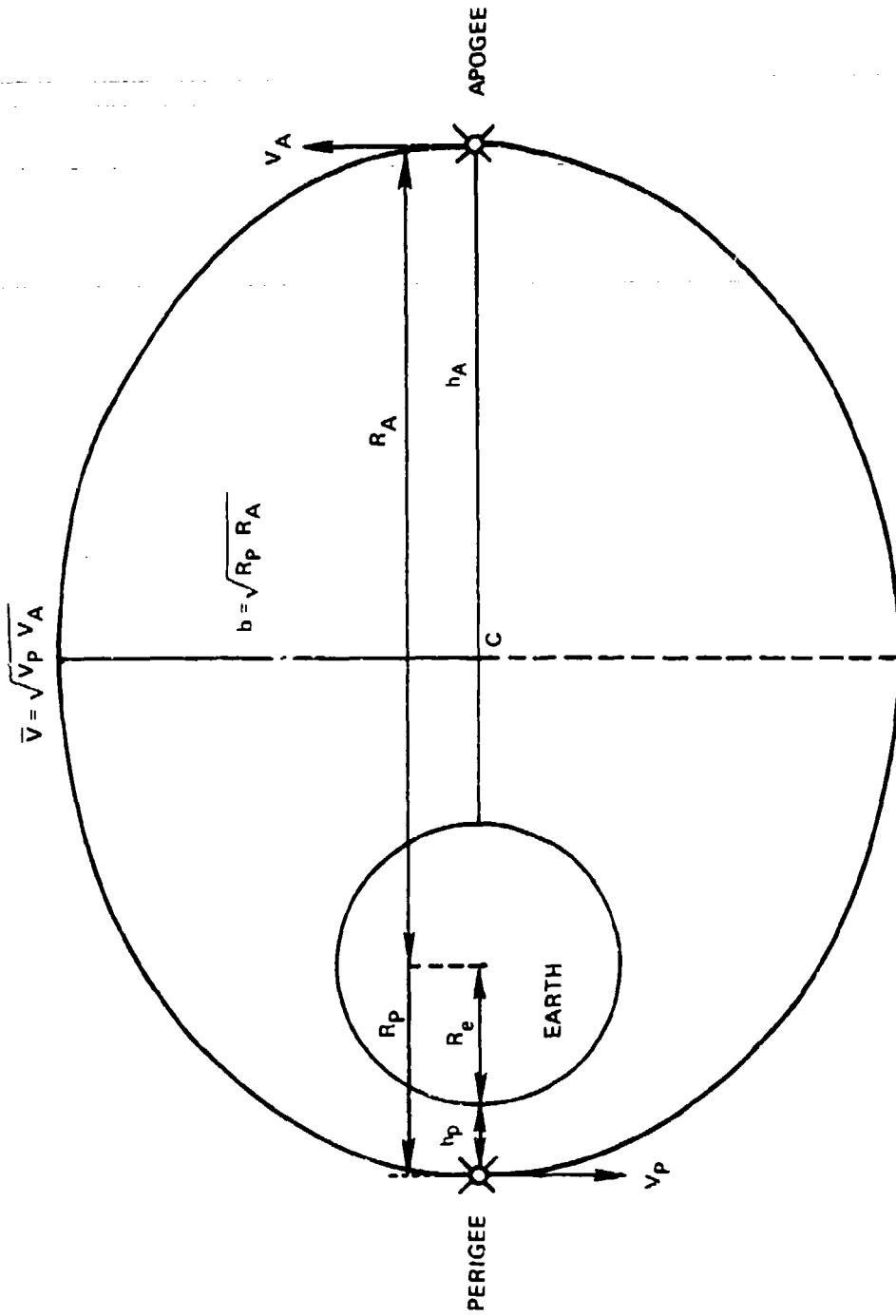
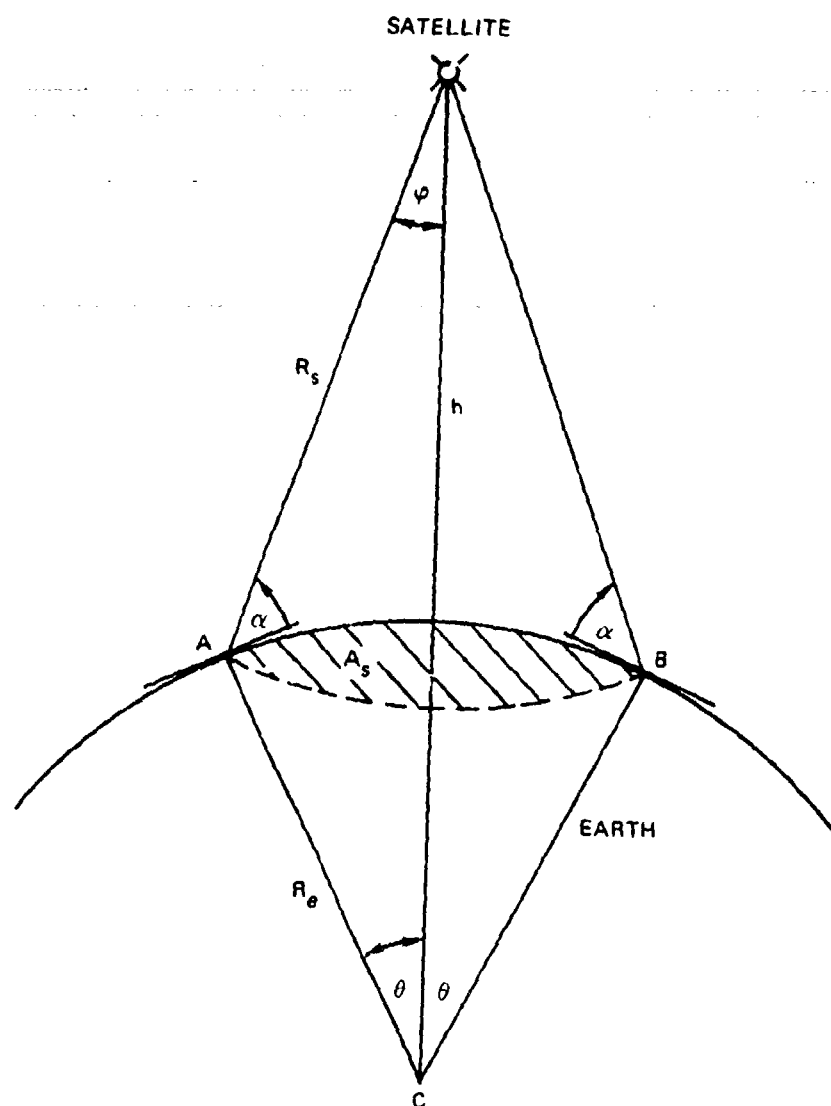

Figure 2-3. Elliptical Orbit Geometry



- ϕ = $90^\circ (\alpha + \theta)$
- h = HEIGHT OF SATELLITE ABOVE THE EARTH
- R_s = SLANT RANGE, TERMINAL-TO-SATELLITE
- R_e = RADIUS OF EARTH
- α = ELEVATION ANGLE AT TERMINAL
- θ = ANGULAR RADIUS OF VISIBILITY
- C = CENTER OF THE EARTH
- A_s = COVERAGE AREA

Figure 2-4. Coverage Geometry

The percentage of the earth's surface in view from a satellite at any altitude is shown in Table 2-1 for several values of α . For $\alpha = 0^\circ$ the spherical area becomes:

$$A_s = 2\pi R_e^2 \left(\frac{h}{R_e + h} \right) \quad (2-4)$$

A typical coverage area for a stationary synchronous satellite located on the equator at 30° W longitude is shown in Figure 2-5.

For a satellite at nonsynchronous altitude the duration of visibility at an earth terminal is an important quality. The duration of visibility increases with the orbital altitude and also as the satellite orbital plane moves closer to the earth terminal. At any altitude a direct overhead pass results in the longest duration of visibility. When using a communication satellite without storage capability, two earth terminals must have simultaneous view of the satellite to establish a link. Therefore the design of a nonsynchronous system is more complex than that of a synchronous system.

A parameter of interest is the maximum rate of tracking required for the ground antenna. This maximum corresponds to an overhead passage of the satellite, expressed by the rate of change of angle η in Figure 2-6. The angle η varies because of the motion of the satellite and the rotation of the earth. For a circular satellite orbit the maximum rate of change occurs for a terminal located on the equator and a satellite in retrograde equatorial orbit (opposite to the rotation of the earth). Also the maximum tracking rate decreases as the satellite altitude increases.

The capabilities of available launch vehicles is an important consideration in overall satellite design. The launch vehicle is a support subsystem whose cost typically amounts to about one-half of the total space system cost. The launch vehicle has to furnish the satellite with electrical power prior to separation, structural and dynamic support, and provision for dispensing. The

Table 2-1. Percentage of Earth's Surface Visible From a Satellite

Height		Percentage of Area Visible		
Kilometers	Statute Miles	$\alpha = 0^\circ$ %	$\alpha = 7.5^\circ$ %	$\alpha = 10^\circ$ %
1850	1150	11.15	7.7	6.70
3700	2300	18.4	13.6	12.5
7400	4600	26.9	21.3	19.80
11,100	6900	31.8	25.9	24.25
14,800	9200	34.9	28.8	27.15
18,500	11,500	37.2	31.1	29.20
22,200	13,200	38.8	32.5	30.7
25,900	16,100	40.1	33.8	31.9
29,600	18,400	41.1	34.8	32.85
33,300	20,700	41.9	35.6	33.65
35,900	22,300 (synchronous)	42.4	36.1	34.0
37,600	23,400	42.5	36.2	34.1

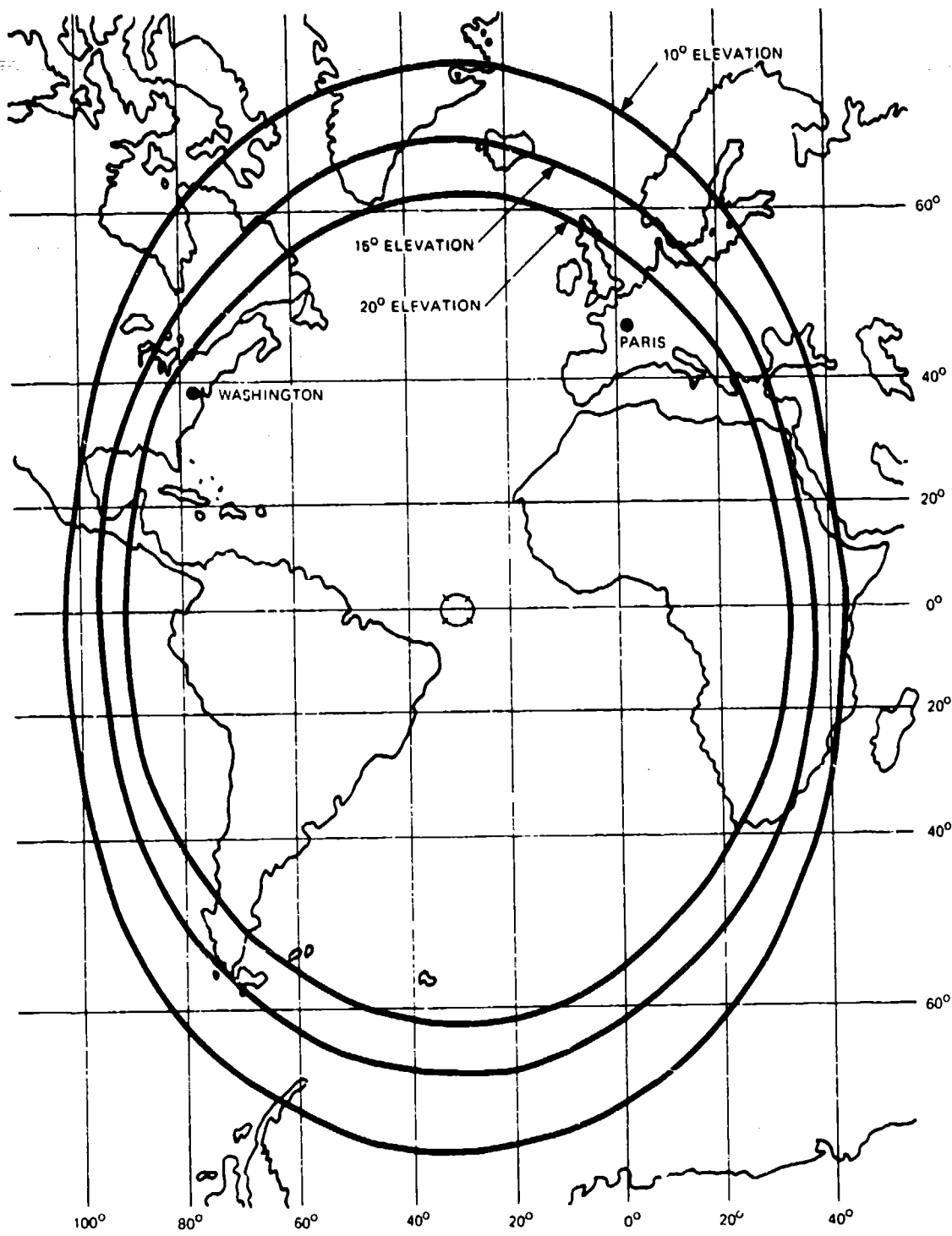

Figure 2-5. Coverage Contours for a Synchronous Satellite

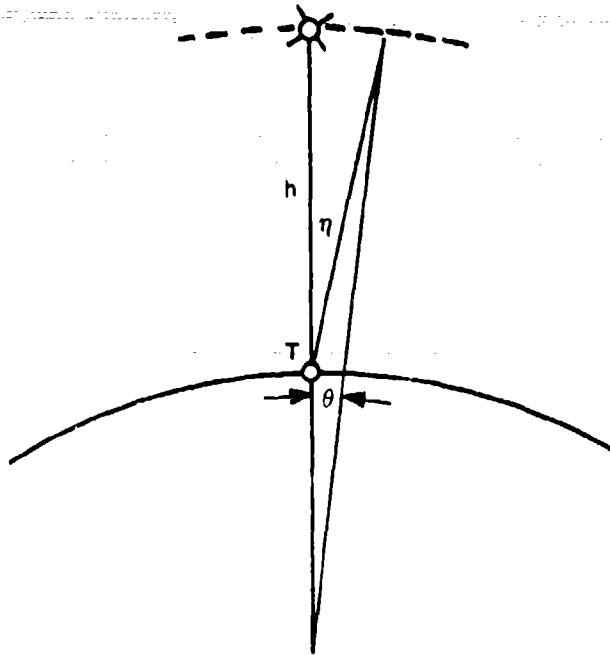

Figure 2-6. Maximum Tracking Rate

allowable satellite weight per launch is constrained by the number of launch vehicle stages and their thrusts, launch site location, and the desired spacecraft orbital altitude and inclination. In addition, there are volumetric and shape constraints imposed on the satellite since a shroud at the nose of the launch vehicle must enclose satellites during their passage through the earth's atmosphere. Table 2-2 presents pertinent data on launch vehicles available either now or in the near future.

2.2.2 Orbital Control

The two types of orbital control that may be used on satellites are attitude control and stationkeeping. Attitude control, which is used on practically all satellites, can be implemented about one axis, two axes or all three axes. The attitude control system implemented has a great effect on the

design of directionally sensitive satellite subsystems such as antennas for communication and solar cells for prime power generation. Station keeping refers to the maintenance of a fixed satellite position relative to the earth (in the case of a synchronous satellite) or to another satellite (in the case of several satellites spaced along the same nonsynchronous orbit). Station keeping control is not used in the case of one satellite in a nonsynchronous orbit but it normally is used in synchronous satellite systems.

2.2.2.1 Attitude Control

Required pointing accuracy, system lifetime, reliability, weight and cost are some of the factors involved in attitude control system design. The early satellites, which were designed for long-term operation, were spin stabilized. The more stringent requirements of the present space missions have demanded more precise control.

The types of attitude control systems used are listed below with comments on each system:

1. Spin Stabilization

- a. Advantages. (1) Fixed inertial orientation with limited accuracy can be achieved with a completely passive system; and (2) most disturbances including torques from velocity correction jet misalignments have only a small effect on the accuracy of a spin-stabilized body.
- b. Disadvantages. (1) Only one axis can be controlled; (2) after obtaining orbit, a system is required to initially point the spin axis; (3) spin speed control may be required on systems where disturbance torques may cause large changes in the spin momentum of the system; and (4) unless provisions are made to despun the communications antenna, most of the transmitter power is lost (radiated into space).

2. Gravity Gradient

An advantageous feature of gravity-gradient stabilization is that the communications antenna orientation is maintained in the correct position to direct the transmitted power toward the earth. The limitations of the usefulness of gravity-gradient torque for stabilizing a satellite with respect to local vertical and the orbit plane are:

- a. Gravity-gradient torques decrease with altitude, whereas some disturbance torques (notably solar radiation pressure torques) are invariant with altitude, thus it is difficult to design high-altitude satellites to operate primarily with gravity-gradient stabilization.
- b. Orbit eccentricity introduces disturbances in the gravity-gradient control which preclude the use of this type of control for highly eccentric orbits.
- c. At low altitudes aerodynamic torques are encountered which greatly complicate the design of a gravity-gradient controlled satellite.
- d. Satellite requirements such as solar arrays to collect solar energy, communication antenna placement, booms for experiments, and restrictions on configuration for compatibility with the boost vehicle may so constrain the satellite configuration that gravity-gradient stabilization cannot be achieved.
- e. Highly accurate orientation is difficult to achieve since attitude errors must be developed to provide gravity-gradient torques to counter disturbance torques.

3. Momentum Storage

Continuously rotating devices are used to store momentum and thus absorb the effect of disturbing torques, and to perform special control maneuvers.

The effectiveness of reaction wheels for momentum storage is based on the law that the time rate of change of wheel momentum is equal to the torque. The attitude error signal is used with filtering to control the wheel speed, meaning that for nonzero constant momentum storage there must be an angular pointing error. A control signal including the integral of this error can be used to alleviate this problem in the steady state.

The momentum storage system adds complexity to the system. If the problem of coupling between axes is significant, careful design will be required. Methods proposed for obtaining momentum storage include rotating inertia (a motor-driven inertial flywheel, gyro stabilizer gimballed gyroscopes) and the control of the motion of a fluid moving in an enclosed circuit.

4. Mass Expulsion

Attitude control can be accomplished by means of the torque derived from the expulsion of mass. Torques can be achieved by the release under pressure of stored gas, by small rockets, by ion propulsion, or by plasma engines.

Cold gas systems are the most attractive mass expulsion method for smaller satellites since they appear to offer the highest reliability. The low specific impulse (typically a nitrogen-gas system will exert about 60 pound-seconds of impulse per pound of gas) does not prevent their use since usually a small total torque impulse is desired. The thrust level desired from the

gas jet nozzles is fixed by the inertia of the satellite and the nozzle mounting arrangement.

When these jets are to be used alone for attitude control, they will operate on a limit cycle which can be calculated from the desired precision of orientation, control system parameters, disturbance torques anticipated, and torque-to-inertia ratio of the system.

For larger satellites low thrust hot gas engines may be used for attitude control at some expense in reliability. The many required rocket firings in such a system favors monopropellant systems.

However, either a monopropellant or bipropellant engine is feasible, and several versions of each type have been developed.

5. Mixed Systems

A mixture of more than one method of attitude control appears to offer significant advantages in performance and efficiency over reliance on only one source of torque. There is a trade between the added complexity of a second system and the increased reliability from the redundancy of the second system. Gravity gradient and reaction wheels, magnetic torques and reaction wheels or gas jets and reaction wheels are useful combinations.

In combination with a mass expulsion system, a reaction wheel eliminates the need for releasing gas during cycle torque variations and provides for removing zero-centered time-varying disturbance torques, while the gas jets remove bias torques. Without a mass expulsion system, the size of an inertial flywheel and the motor drive needed to handle torques for long operation would be very large. From the types of orbits and the constraints placed on the satellite by the communication system it appears that a combination of inertial storage elements and some form of absolute torque generator is desirable.

2.2.2.2 Stationkeeping

Stationkeeping is the procedure of keeping a satellite in a desired position in orbit within acceptable limits. For example a synchronous satellite is given occasional commands that adjust its position so that it will remain in a fixed position within a few degrees relative to the earth.

Stationkeeping is necessary to offset the effect of perturbing forces on the satellite orbit. These forces include solar radiation, atmospheric drag, gravity perturbations from the sun and moon, and gravity perturbations due to the oblateness of the earth. The advantages of station keeping include the simplification of acquisition and tracking the satellite with narrow-beam earth antennas and the provision of a satellite that permits continuous or predictable links between selected earth terminals.

For synchronous satellites, the strongest forces are those of the sun and moon, which act in a north-south direction to incline the orbit about 1° per year. This would require a velocity increment of 176 feet/second/year for cancellation, but the current modest life requirements permit the simple alternative of injection into a preset inclination so that after 5 years the final inclination of about 2.5° is acceptable. In synchronous orbit an uncontrolled satellite will oscillate due to the earth's oblateness about one of the two stable points (located at $70^\circ E$ and $101^\circ W$ longitude) with a period several hundred days. Unfortunately, these stable locations do not satisfy the requirements of most communications systems. Fortunately, a velocity increment of only 7 feet per second per year is required for cancellation.

A mass expulsion system is used for station keeping and can be integrated with the attitude control system. Certain combinations of gas jets are fired simultaneously for attitude control and other combinations are fired simultaneously for stationkeeping. The satellite is allowed to drift slowly between limits imposed by system requirements. The stationkeeping function is performed infrequently; every few weeks or months.

2.3 SATELLITE TRANSPONDER

2.3.1 Transponder Transfer Characteristics

The purpose of a satellite transponder is to receive, amplify and transmit input signals. If a repeater is operated on the same frequency band for both input and output signals, sufficient isolation must be achieved by employing different frequency bands for uplink and downlink operation. Two methods of frequency conversion are commonly employed to achieve this result: single-conversion and double-conversion. These are shown in the simplified block diagram, Figure 2-7. The choice of one method over the other is a function of the input-to-output power gain required and the channel bandwidth desired. Where the input and output operating frequencies are high (for example X-Band) and a narrow bandwidth is required, a double-conversion transponder may be necessary. Where the bandwidth is larger a single conversion may be permissible.

In some cases the transponder design may include signal processing. Here, the input RF signal is demodulated and then the baseband signal is modulated onto the output RF carrier. Processing transponders can improve the protection against jamming in a military system. Figure 2-7 also shows a processing transponder.

The satellite transponder has some special constraints inherent to its being on board a satellite. These constraints include inaccessibility after launch, leading to a design emphasizing reliability, long life, stability, and absence of maintenance, and weight, leading to emphasis on an efficient, lightweight prime power supply, circuit efficiency, and optimization of antenna design. In addition many communication satellites, especially stationary satellites, are required to provide simultaneous links among many ground stations. This feature also imposes special requirements on the transponder design. The multiple-access feature will be discussed in Section 7.

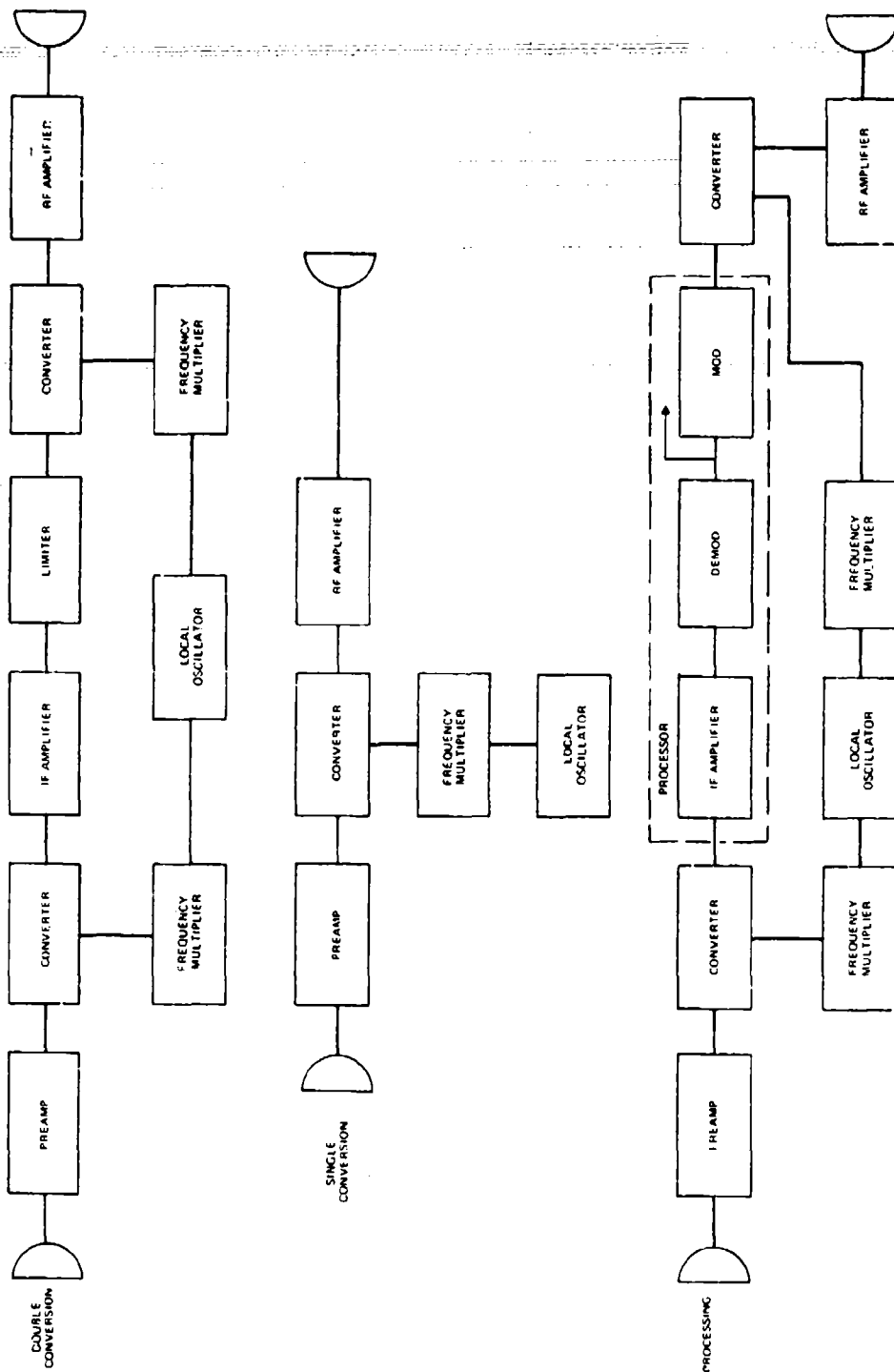

Figure 2-7. Three Fundamental Satellite Transponder Block Diagrams

The satellite communication subsystem may consist of one or more RF channels, with each channel required to receive from one signal to several simultaneous signals depending on the communication system design. Band-pass filters are installed to channelize the subsystem to prevent intermodulation.

The allowable noise temperature of the receiver must be specified in the system design. Because of the inaccessibility and weight and power limitations, low-noise travelling-wave tube (TWT) or parametric amplifiers are not used as preamplifiers. The RF preamplifier is either a transistor at lower UHF frequencies, or a tunnel diode at higher frequencies. This leads to typical system noise temperatures of 2000°K at X-Band.

The transponder output device normally is a transistor for frequencies up to several hundred megahertz. Above that frequency a TWT is used. Power outputs up to several hundred watts have been obtained by paralleling a number of transistors. However, the highest power from a single transistor is about 40 watts. Space-qualified TWT power output capability currently ranges up to about 35 watts at X-Band.

A communication transponder has a saturating nonlinear input-output characteristic. Only amplitude modulation, which is rarely used, requires highly linear amplitude characteristics. For frequency or phase modulation, which is often used, only approximate linearity is required in the multisignal output amplifier. A hard limiter is sometimes used at the amplifier input so that the weakest expected earth terminal signal will result in saturated output from the transponder so interference is minimized. When several signals at different frequencies enter the transponder simultaneously, this causes intermodulation distortion which may be held to acceptable levels by proper frequency spacing of the entering signals. However, in many cases of multiple simultaneous signals, the TWT is operated at a backoff point several decibels below saturation. This reduces the satellite effective isotropic radiated power (EIRP) (system capacity), but more important it keeps intermodulation at an acceptable level.

2.3.2 Beacon

A beacon signal is normally transmitted from the satellite to aid acquisition and tracking by the earth terminal antenna. The beacon signal may either be generated within the satellite or generated by frequency converting a signal transmitted by the earth terminal. Very often the beacon and telemetry functions are combined by modulating the telemetry information onto the beacon signal. In addition, the beacon signal can be transmitted by the same power tube as the communication signals.

2.3.3 Power Subsystem

The requirements of a satellite power supply are reliability, long life, high efficiency as measured in watts per pound and possibly operation during eclipse. The three major sources of energy that have been investigated experimentally are chemical, nuclear and solar, and prototype systems were built. At present, the solar cell is the only device available in production quantities to provide satellite power for long durations at good efficiency. The only apparent limit to the power available from this source is the physical size of the array. If very high power satellites (5 kW or more) are required in the future, nuclear power sources probably will be used.

Solar cells are mounted in arrays whose power output is a function of the angle between the sun and a perpendicular to the plane of the array. The most efficient method of mounting the array is on a flat panel with a drive mechanism to keep the array continuously oriented to the sun. A second method is to mount the solar cells on both sides of fixed flat paddles. No orienting control is necessary but the power output fluctuates as the angle between the normal and the sun varies. The array size must be larger than that of the oriented array. The solar array also may be mounted directly on the satellite skin. This leads to fluctuations in power output with time and, in addition, involves problems with the temperature-control system that is necessary for the satellite

interior. However, where this configuration can be used it leads to a significant reduction in weight. Spin-stabilized satellites covered with solar cells have been used in a number of programs.

Storage batteries are usually used in conjunction with solar cells. These batteries, which are charged by the solar cells, allow operation during eclipse periods when the satellite is not in view of the sun and help supply the load either when the array orientation is poor or during brief periods of particularly high power demand.

2.3.4 Antenna Subsystem

The satellite antenna is characterized by its frequency, bandwidth, polarization, gain and beamwidth. The gain and beamwidth are related; the gain increases with the size of the antenna and the beamwidth decreases at the same rate. The prime parameter used in the design of an antenna is its coverage. Two types of antennas are used: earth coverage and narrow beam (sometimes called spot beam). Operational requirements determine the type to be used in any application. The aperture of an antenna covering the earth disk from horizon to horizon is dependent on the altitude of the satellite, and corresponds to a beamwidth of about 18° for synchronous altitude. This angle corresponds to a gain of 15 to 18 dB. A narrow-beam antenna, if properly pointed, will concentrate its power in a limited area determined by the beamwidth, and will correspondingly have a higher gain. To provide the desired coverage, the narrow-beam antenna must be pointed accurately and stabilized.

Antenna design and gain are affected by the type of satellite stabilization used. For each satellite stabilization method there are one or more antenna configurations that may be used. For the spin stabilization method, toroidal, despun, and switched beam configuration are employed. For gravity-gradient and active three-axis stabilization, earth or area coverage pencil beam configurations are used. Table 2-3 contains a summary of the achievable gains for

Table 2-3. Achievable Gain for Earth Coverage Antenna Configurations

Orbital Altitude (statute miles)	Antenna Gain (dB)				Spin Stabilization, Switched Beam.
	Spin Stabilization, Toroidal Pattern Antenna	Spin Stabilization Despun Antenna*	Gravity Gradient**	Spin Stabilization, Switched Beam.	
6,440 (6 hrs)	2.5	11.5	10.0	6	
12,500 (12 hrs)	4.5	15.5	13.5	10	
22,300 (24 hrs)	6.5	19.5	16.0	14	

*Assumes a controlled spin-axis satellite and earth coverage antenna; circuit losses inherent in an electronically despun antenna are not included (usually 2 dB).

**Earth coverage antenna, $\pm 5^\circ$ pointing accuracy.

earth coverage antenna configurations at different altitudes and with various types of stabilization and antenna patterns. Antenna system losses, which vary with the particular design approach used, are not included.

Spin stabilization is a widely used method of providing passive orientation. The combination of spin stabilization and an antenna which has a toroidal pattern was used on the majority of early communication satellites, for example, Telstar, Relay and Syncom. Such an antenna provides focused radiation in only one plane and therefore has low antenna gain.

An improvement in antenna gain can be obtained by electronically or mechanically despinning the antenna to provide earth coverage in a direction normal to the spin axis. Table 2-3 illustrates the large improvement in gain for such a system over the toroidal pattern antenna. An electronically despun antenna is implemented by mounting a number of pencil beam radiating elements on the satellite. As the satellite spins, the receiver-transmitter is continuously switched to the element whose beam covers the earth. A mechanically despun antenna is implemented by rotating a bearing-mounted platform counter to the satellite spin. Thus, an antenna on the platform can be pointed continuously toward the earth. A three-axis stabilized satellite can provide the same antenna gains as a despun antenna. Two-axis stabilization by gravity-gradient torques can be achieved by proper design. Consequently, an antenna can be used with this stabilization technique to provide earth coverage. Once deployed and properly captured, the gravity-gradient stabilization mechanism requires no active control or additional energy; however, there is an oscillation (libration) inherent in this system. The antenna gains available with this stabilization technique are listed in Table 2-3.

An experimental communication satellite developed by Lincoln Laboratories spins about one axis but has no preferred orientation. Such a system uses horizon sensors to locate the earth and control a switching subsystem which selects an antenna pointing toward the earth. The antenna gains obtainable with the switched-beam antenna concept are also listed in Table 2-3.

SECTION 3 - EARTH TERMINAL SUBSYSTEMS

3.1 GENERAL

Another major subsystem of a satellite communications system to be discussed is the earth subsystem. In general this is very similar to a terrestrial microwave terminal facility. The earth subsystem consists of the basic earth terminal and the related multiplex, coding and modulation equipment. This section will describe the basic earth terminal, its functions and components. The related signal processing equipments are discussed in Section 4.

Like a terrestrial microwave terminal, the satellite communications earth terminal has a transmitter, receiver, and antenna subsystem. The satellite earth terminals normally operate in the ultrahigh frequency (UHF) or super high frequency (SHF) band.

The most notable differences between a satellite communications earth terminal and a conventional microwave terminal are that the earth terminal has a high-gain antenna subsystem capable of tracking a moving satellite, a transmitter that is frequently of much higher power to provide a suitable level signal at the satellite, and a receiver that has a very low noise front end to compensate for the very weak signals received from the power-limited satellite thousands of miles away.

The earth terminal accomplishes the following basic functions:

1. Receives signals at an intermediate frequency from one or more modulators, translates them to radio frequency, and transmits them to a satellite
2. Receives radio frequency signals from the satellite, translates them to an intermediate frequency, and feeds them to one or more demodulators.

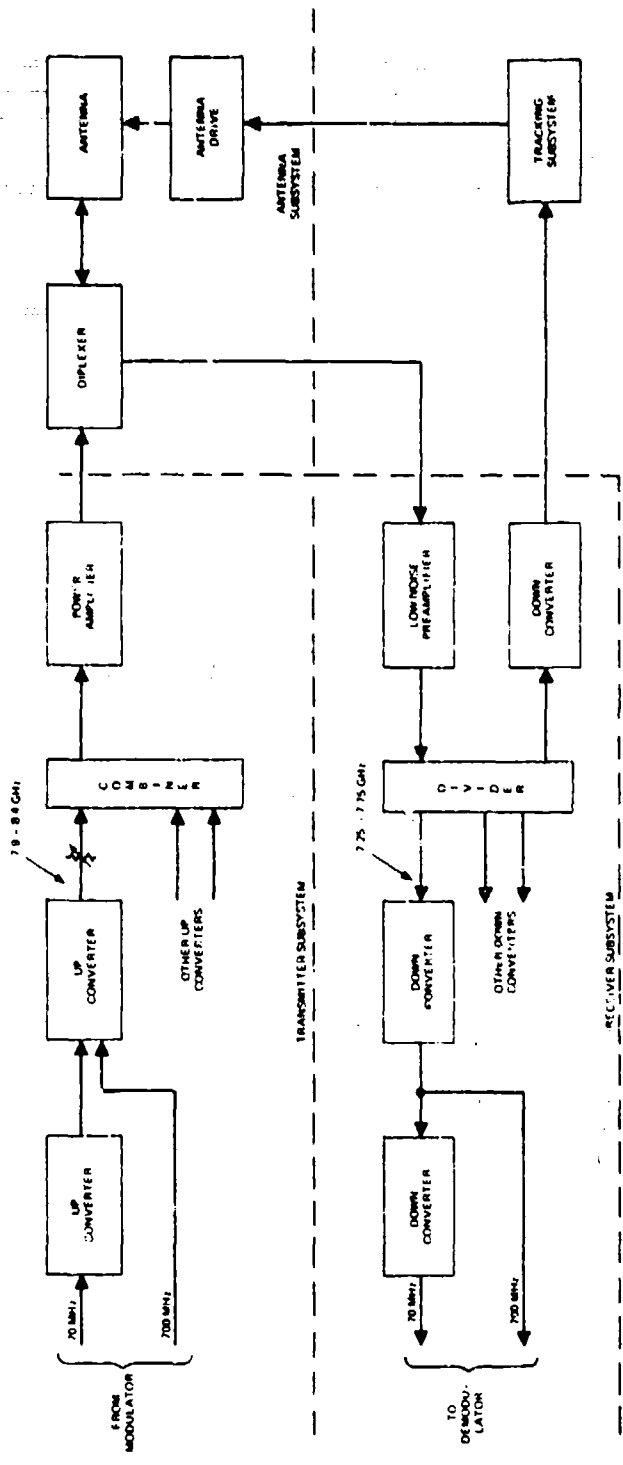

Figure 3-1. Typical Block Diagram of an SHF Earth Terminal

Equation (3-2) is plotted in Figure 3-2 for frequencies of 8150 and 7500 MHz, which are the midpoints of the uplink and downlink frequency bands used by DSCS Phase II.

The antenna can be mounted on a pedestal which permits steering 360° in azimuth and 180° in elevation. However, some fixed terminals are designed for use with geostationary satellites only and therefore have a limited pointing range. Shipboard terminals often have a three-axis mount, which includes a roll axis to permit correction for ship's roll.

The antenna diameter may be limited by the particular application planned for the earth terminal. The following list shows various existing and planned communication earth terminal applications and their respective maximum antenna diameters:

<u>Application</u>	<u>Maximum Antenna Diameter</u>
Fixed	120 feet
Air Transportable (one aircraft)	18 feet
Vehicular	8 feet
Shipboard	8 feet
Airborne	6 feet

The selection of the antenna diameter for a particular application is largely determined by the transmit and receive capability required. Since satellite transmitter power is limited compared to terminal transmitter power, the receive considerations are usually dominant. However, there are cases when the transmit capability is the principal factor. An example of this situation is a terminal which is to transmit at a very high data rate and receive at a low data rate.

The receiving performance of an earth terminal depends on the equivalent input receiver noise power as well as on antenna gain because the gain is effective only if the signal power is greater than the noise power. The equivalent input receiver noise power is usually expressed as a noise temperature T

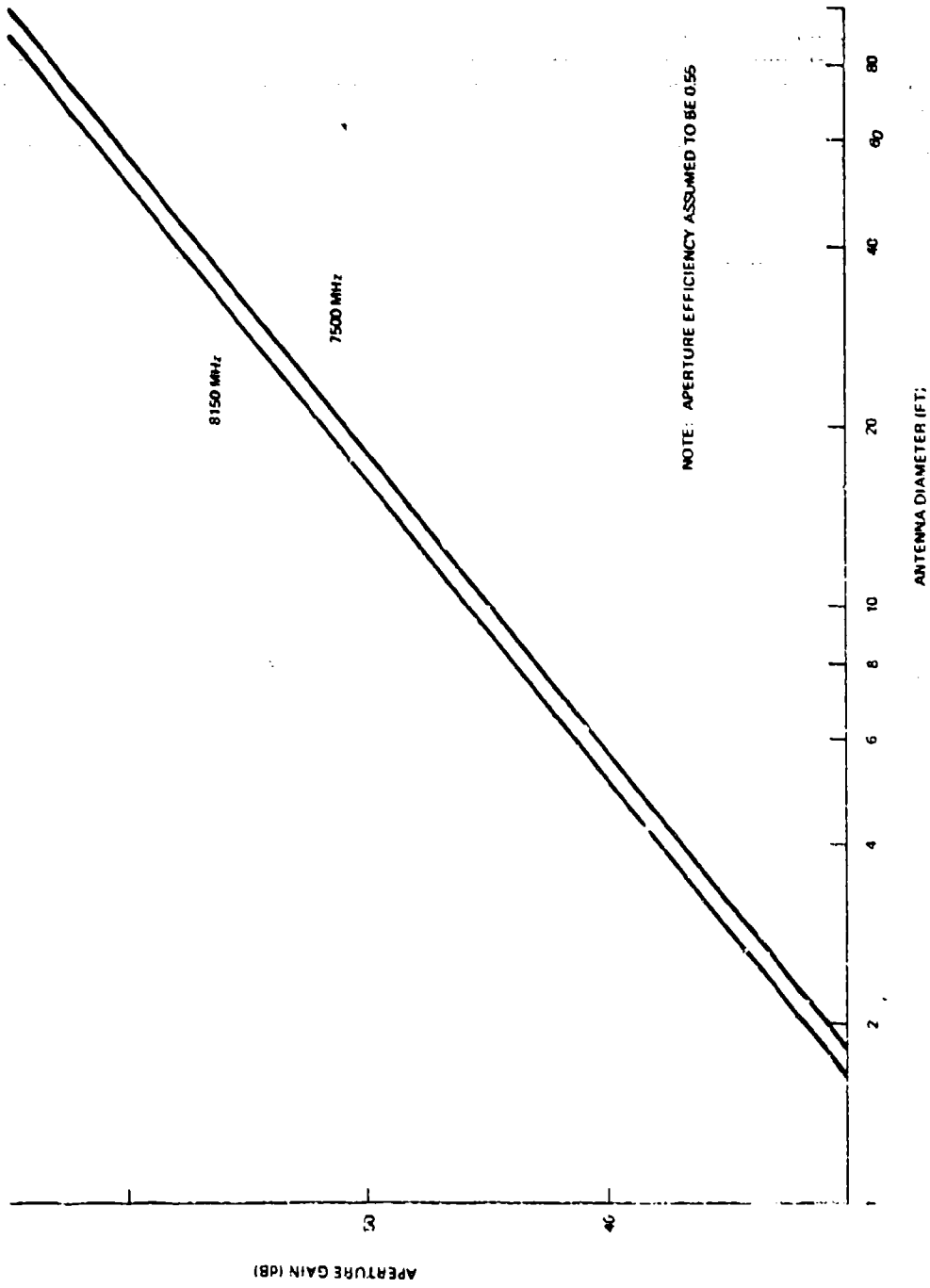

Figure 3-2. Aperture Gain of Paraboloid Dish

in degrees on the Kelvin scale, with absolute zero at -273°C or -460°F . Thus a perfect receiver would have $T = 0^{\circ}\text{K}$, a fair one $T = 293^{\circ}\text{K}$ (room temperature), and a poor one $T = 2930^{\circ}\text{K}$ (noise figure = 10). The antenna must provide not only signal gain but also low noise input from side lobes and transmission lines. It therefore often uses a Cassegrain feed which consists of a feed horn mounted at the vertex of the paraboloidal reflector and a hyperboloidal subreflector located at the focus of the dish (Figure 3-3). The Cassegrain feed has the following advantages relative to one with the feed horn at the focus of the dish:

- The low-noise preamplifier can be mounted behind the dish and close to the feed horn. This minimizes the transmission line loss and noise.
- Spillover radiation from the feed horn is directed toward space which has a very low noise temperature. With a front feed, spillover radiation is directed toward the relatively warm earth. Therefore, the antenna noise temperature with a Cassegrain feed is lower.

A radio wave may be linearly polarized either horizontally or vertically according to the direction in which the electric field changes are greatest. In a circularly-polarized wave this direction (the E vector) may rotate in one of two senses as seen from the source, either right-handed (clockwise) or left-handed (counterclockwise).

In the DSCS, right-hand circular polarization is used in the uplink and left-hand circular polarization in the downlink. If linear polarization were used, the polarization of the signal received at the terminal would range from vertical to horizontal depending on the location and elevation angle of the terminal. The use of different senses of circular polarization for the uplinks and down links simplifies the design of the polarizer and the diplexer, which separates the transmitted and received waves, traveling in opposite directions on the same transmission line.

CASSEGRAIN ANTENNA

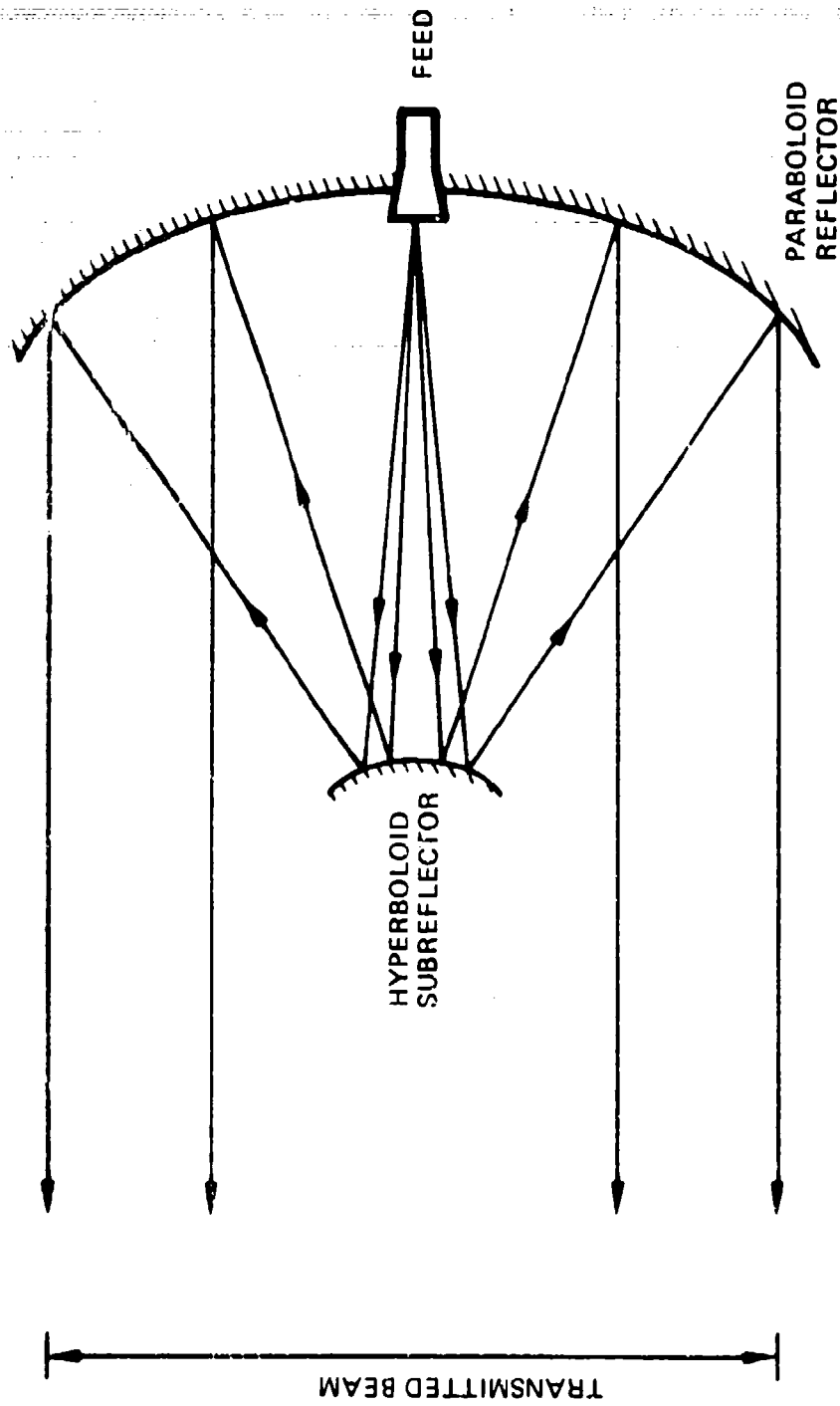

Figure 3-3. Geometric Relationship Between Antenna Feed, Subreflector, and Main Reflector in a Conventional Cassegrain Design

3.2.2 Transmitter Subsystem

The SHF transmitter subsystem shown in Figure 3-1 can accept signals from modulators with center frequencies of 70 MHz or 700 MHz. The former is used for signals with a maximum bandwidth of 40 MHz, the latter with signals with a maximum bandwidth of 125 MHz. When the 70-MHz modulator is used, its output is frequency-translated to 700 MHz. The 700-MHz signal (either the upconverted 70-MHz signal or the output of the 700-MHz modulator) is then frequency-translated to the 7.9- to 8.4-GHz band. The level of the signal is then adjusted to the desired value and combined with the signals from other up converters. The power amplifier amplifies the combined output of the up converters to the desired level.

Not all earth terminals have a 700-MHz interface, but a 70-MHz interface is almost invariably provided. If only a 70-MHz interface is provided, up conversion to SHF is usually accomplished in two stages; however, the higher intermediate frequency may not be 700 MHz.

The frequency of translation may be fixed or variable from a frequency synthesizer. In either case, the spectrum of the oscillator must be extremely pure because frequency (or phase) modulation added to the transmitted signal will degrade the performance. If more than one carrier is required, a separate up converter is provided for each.

Currently, traveling-wave tubes and klystrons are used for power amplifiers. The traveling-wave tube can have a bandwidth sufficient for the entire band (500 MHz), but its output power is limited to about 5 kW at X-Band. Output powers in excess of 10 kW can be attained with a klystron, but its instantaneous bandwidth is limited to 170 MHz. If more than one signal is being transmitted, the power amplifier is operated below saturation to avoid the generation of intermodulation products. The RF bandwidth of some earth terminals covers the entire 7.9- to 8.4-GHz band used by DSCS Phase II. Others can operate in only a small part of this band.

A characteristic commonly used for the earth terminal transmitter is its effective isotropic radiated power (EIRP). This value is dependent on the antenna gain at the transmit frequency and the power output of the final transmit amplifier. (This is covered in detail in Section 5.) Figure 3-4 shows typical values of EIRP as a function of antenna diameter and transmitter power.

3.2.3 Receiver Subsystem

Referring to Figure 3-1, signals received by the antenna are fed to the low-noise preamplifier. Although functionally part of the receiver subsystem, this unit is almost always mounted on the antenna to minimize the transmission line loss and resultant noise increase. The output of the low-noise preamplifier is fed to a divider and then to a number of down converters. The first down converter frequency translates a signal in the 7.25- to 7.75-GHz band to 700 MHz. The second down converter frequency translates the 700-MHz signal to 70 MHz.

The discussions of the translation frequencies and of bandwidth given in Paragraph 3.2.2 apply to the receiver subsystem. However, in many earth terminals receiving several signals, a common down converter is used for several signals. This is feasible if the frequency spacing and the levels of the signals are such that the intermodulation products generated in the down converter are insignificant.

A number of devices can be used for the low-noise preamplifier. The effective noise temperatures of state-of-the-art devices operating at a frequency of about 7500 MHz are given in Table 3-1.

The common figure of merit used with the earth terminal receiver is its G/T ratio. This is the ratio of the receiving antenna gain to the receiver system noise temperature.

$$G/T = 10 \log (\eta/T) (\pi D/\lambda)^2 \quad (3-3)$$

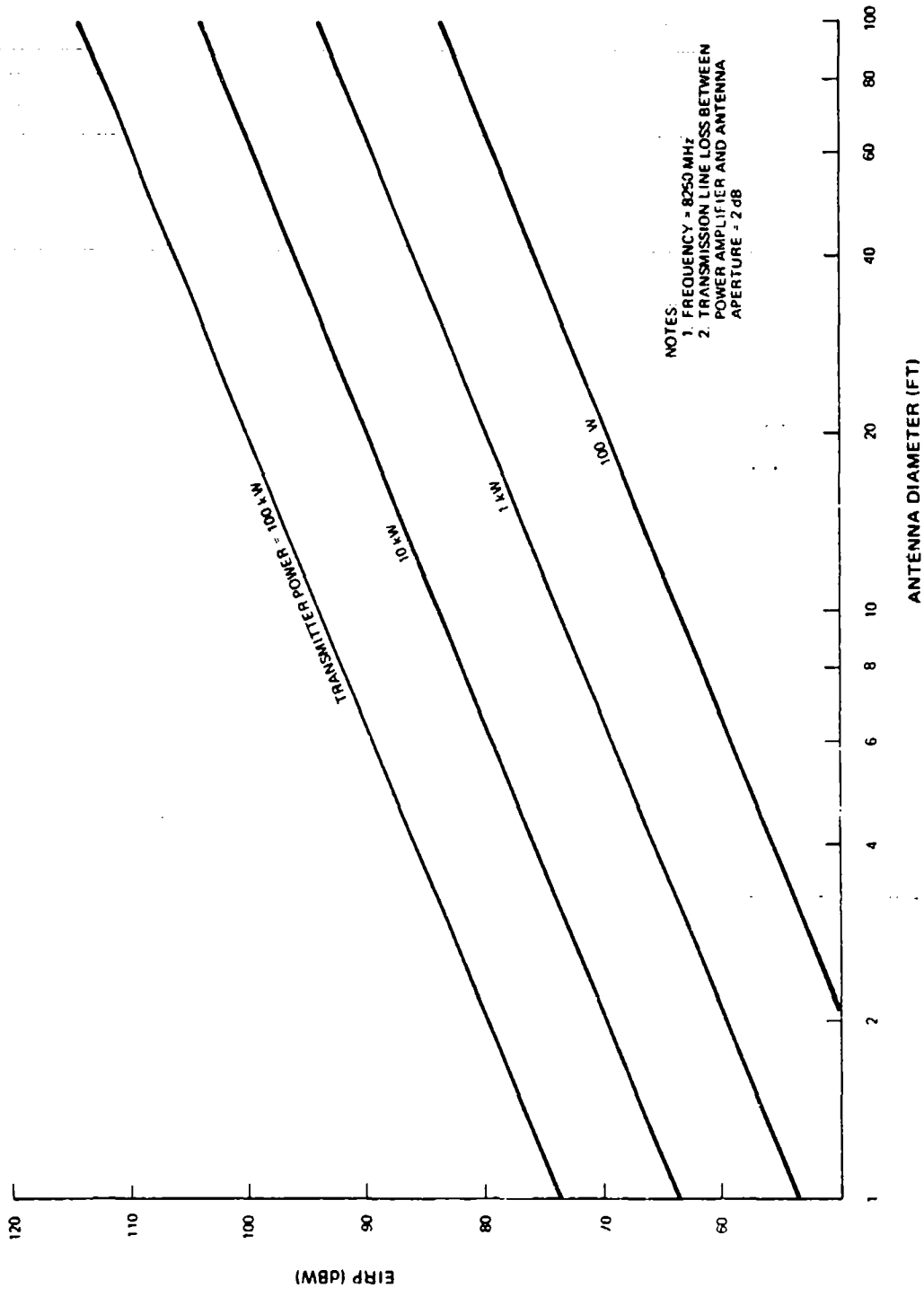

Figure 3-4. Effective Isotropic Radiated Power

Table 3-1. Effective Noise Temperature of SHF Low-Noise Devices

Device	Effective Noise Temperature
Maser (cooled to 4.2°K)	10°K
Parametric Amplifier (cooled at 25°K)	35°K
Uncooled Parametric Amplifier	120°K
Inexpensive Parametric Amplifier	300°K
Tunnel Diode Amplifier	530°K
Schottky Mixer	1000°K

This figure indicates the relative capability of the receive subsystem to receive a signal. For example a terminal with a G/T of 36 dB requires twice as large a received signal level for proper reception as does a terminal with a G/T of 39 dB.

Figure 3-5 shows typical values of G/T as a function of antenna diameter for each of the devices listed in Table 3-1.

3.2.4 Tracking Subsystem

The tracking subsystem permits the antenna to be manually positioned or to automatically track the satellite. The three techniques used for automatic tracking in earth terminals are monopulse, step track and program track.

3.2.4.1 Monopulse

In a monopulse tracking subsystem, a four-horn antenna feed and a comparator network are used to obtain the necessary antenna beams from a single aperture. Referring to Figure 3-6, feeds 1 and 3 are summed in hybrid 1, and feeds 2 and 4 are summed in hybrid 2. The two sums are then summed in hybrid 3 to give a radiation pattern maximized in the boresight direction (sum pattern). The difference port of hybrid 3 gives the difference of the sums of feeds 1 and 3 and feeds 2 and 4, and thus gives a control signal which is zero in the boresight direction, with maximums of opposite phases occurring on either side of boresight in the azimuth plane (azimuth difference pattern).

The two difference ports of hybrids 1 and 2 when summed in hybrid 4 give the difference of the sums of feeds 1 and 3 and feeds 2 and 4, and thus a control signal is obtained which is zero in the boresight direction, with maximums of opposite phases occurring on either side of boresight in the elevation plane (elevation difference pattern). The difference port of hybrid 4 gives the difference of the sums of the diagonal feeds, which is redundant information, so it is usually terminated in a load. Comparisons of the sum and difference patterns are then used to generate error voltages which are used to keep the antenna pointed in the direction of the target.

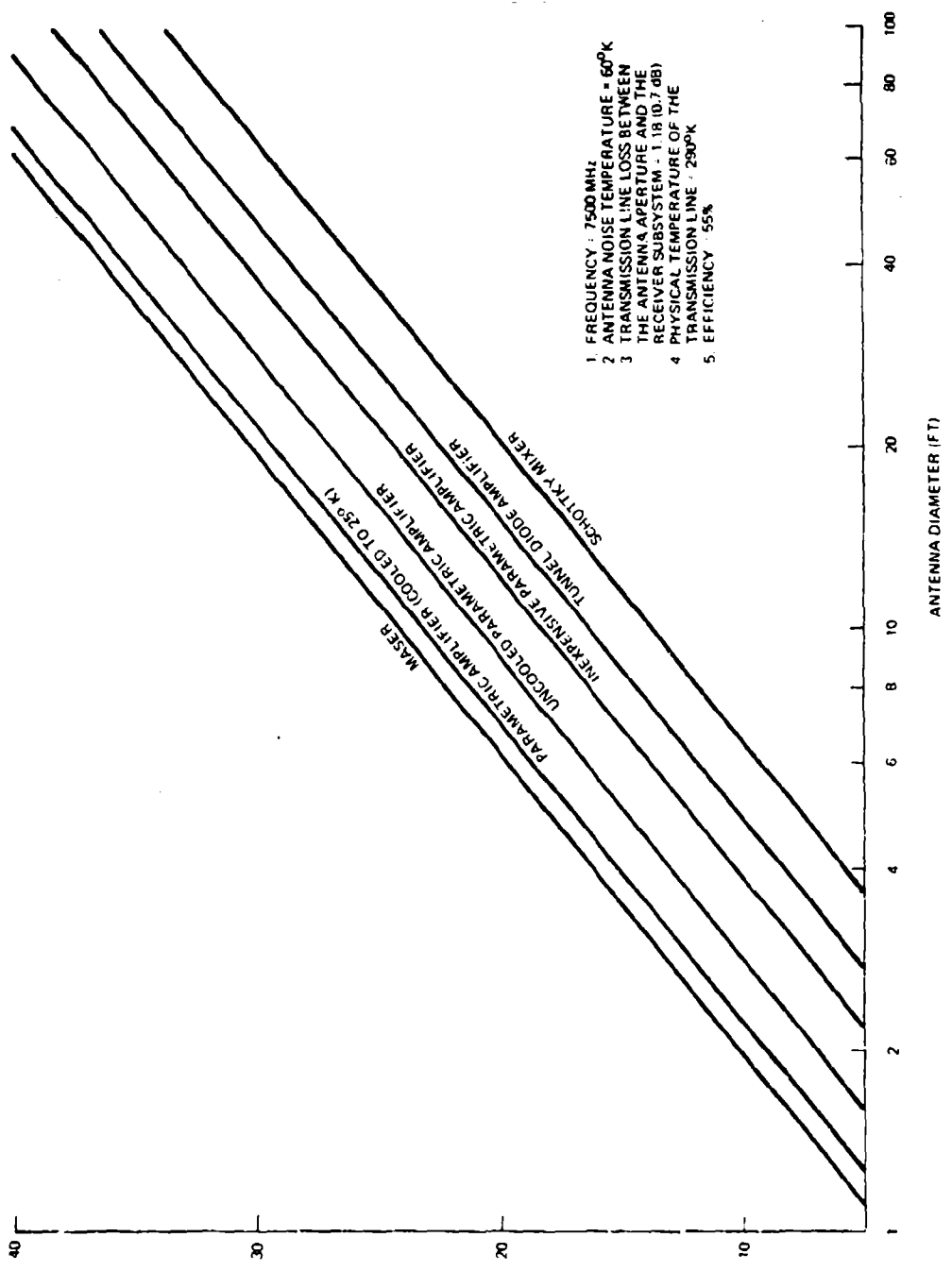

Figure 3-5. Gain-to-Noise Temperature Ratio

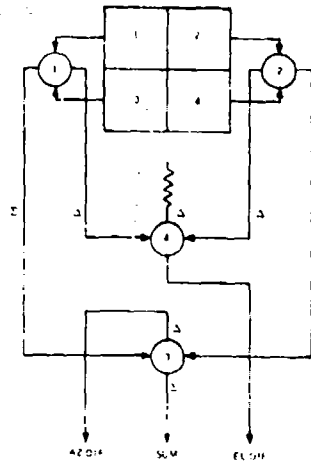

Figure 3-6. Four-Horn Antenna Feed and Comparator

Figure 3-7 is a block diagram of typical tracking subsystem. The azimuth and elevation difference signals are commutated by ferrite switches controlled by a digital scan generator. The sequence of the switched output might be: azimuth difference, azimuth difference shifted in phase by 180° , elevation difference, elevation difference shifted in phase by 180° .

The commutated output of the ferrite switches is added to the sum signal by a directional coupler. Since the difference and sum signals are phase coherent, this has the effect of amplitude modulating the sum signal.

The resultant signals are amplified by the same low-noise preamplifier that is used for the communication signals, down converted and demodulated. The signals are next decommutated and phase detected to obtain error voltages which are used to drive the antenna so that the azimuth and elevation difference signals are minimized.

3.2.4.2 Step Track

The step track antenna feed is a single horn, and amplitude of the received signal is used instead of its phase to maximize the received signal level.

The antenna beam is moved by preset increments alternately in azimuth and elevation. If the signal level increases during the first azimuth movement, the antenna is moved in the same direction during the next azimuth movement. If the signal level decreases, the antenna is moved in the opposite direction the next time. The elevation movement is similar.

In comparison with monopulse tracking, step tracking has the advantage of being simpler and less expensive. However, there is a signal loss with step track because the antenna does not always point directly at the satellite.

3.2.4.3 Program Track

In program track, the orbital data relative to the satellite path are stored in a digital computer which continuously computes the antenna pointing angles and commands the antenna to point at these angles.

Program track has the advantage of not requiring a signal from the satellite. However, the cost of this technique has limited its use except for acquisition.

3.2.5 Intermodulation Problems

Problems arise when a nonlinear process causes transmitted signals to create intermodulation products within a receiver pass-band. Three cases are of importance in earth terminals. The first occurs in any FM microwave relay terminal when antenna or transmission line impedance mismatches cause large delayed reflections. The second occurs in any amplifier carrying two or more signals if the signals are large enough so that the amplifier characteristic is nonlinear, and if the signal frequencies are poorly chosen or too numerous for ease of control. The third case occurs with the same awkward frequency selection if the transmitted signals are present in the same transmission line with amplitudes strong enough to generate a product within a receiver pass-band, usually at some slightly rectifying waveguide joint.

3.2.6 Terminal Availability

The availability of a terminal is the fraction of time that it is available for use. Outages are caused by failures and maintenance requirements. If redundant standby units are not included in the terminal, the availability is about 0.95, which is too low for DCS traffic. To obtain an availability of about 0.999, at least one standby unit of each type is required except for the antenna, diplexer and antenna drive.

3.3 UHF EARTH TERMINALS

The part of the UHF band used in military satellite communications systems is 240- to 328.6-MHz and 335.4- to 339.9-MHz.

3.3.1 Comparison of UHF and SHF

The downlink free space loss at UHF is 26 to 29 dB less than at SHF and rain attenuation is not important. Therefore, the gain of the UHF terminal antenna can be much less than at SHF. Even when the physical sizes of the SHF and UHF antennas are about the same, the reduction in antenna gain results in a wider beamwidth and therefore eases the tracking problem. However, reduced data rates usually required for mobile UHF circuits permit further reduction in size and cost as well as enhanced mobility. UHF has the additional advantages of lower equipment costs and higher transmitter efficiencies. The latter is of particular importance in the satellite, where prime power is limited.

The basic disadvantage of UHF is that the band is heavily used by air-ground and air-air communications. Because of this, very little spectrum is available for satellite communications. Therefore, the use of UHF is limited to signals with low information bandwidths. The available spectrum can best be used by having a number of terminals share a common frequency channel using push-to-talk or broadcast operation. Therefore, UHF is used primarily for tactical satellite communications from vehicular, shipboard and airborne terminals.

3.3.2 Antenna Subsystem

Large parabolic dishes are not normally used for UHF earth terminals. Typical antennas are shown in Figures 3-8 through 3-10. The vehicular terminal has a short backfire antenna with a gain of 13 dB and a beamwidth of 40°. A tracking subsystem is not required since the antenna is positioned mechanically.

The large shipboard antenna is an array of four crossed-dipoles with a gain of 13 dB. The small shipboard antenna is a single crossed-dipole with a gain of 8 dB. Both are manually positioned by the operator.

Both the airborne antennas of Figure 3-10 are fixed antennas with typical gains of 0 dB. The crossed-dipoles are used at high elevation angles, the blade at low angles.

3.3.3 Transmitter Subsystem

A UHF terminal has only a 70-MHz interface with the modulator. The modulator output is up converted in a single stage to the transmitted frequency. Because of the low information rate transmitted, the transmitter power rarely exceeds 1 kW even in an airborne terminal.

3.3.4 Receiver Subsystem

The antenna noise temperature at UHF typically is 250° to 450°K. Since this is so high, extremely low-noise devices such as maser and parametric amplifiers are not used. Typically a tunnel diode amplifier is used and yields a system noise temperature of about 1000°K.

3.4 EARTH TERMINAL SITING

The following paragraphs provide criteria pertinent to the selection of sites for an earth terminal and related facilities for the Defense Satellite Communications System, and provide guidance for collection of engineering design and field survey data. More detailed coverage is provided in Supplement 8 to DCA Circular 370-160-3, "Site Survey Data Book for Communications

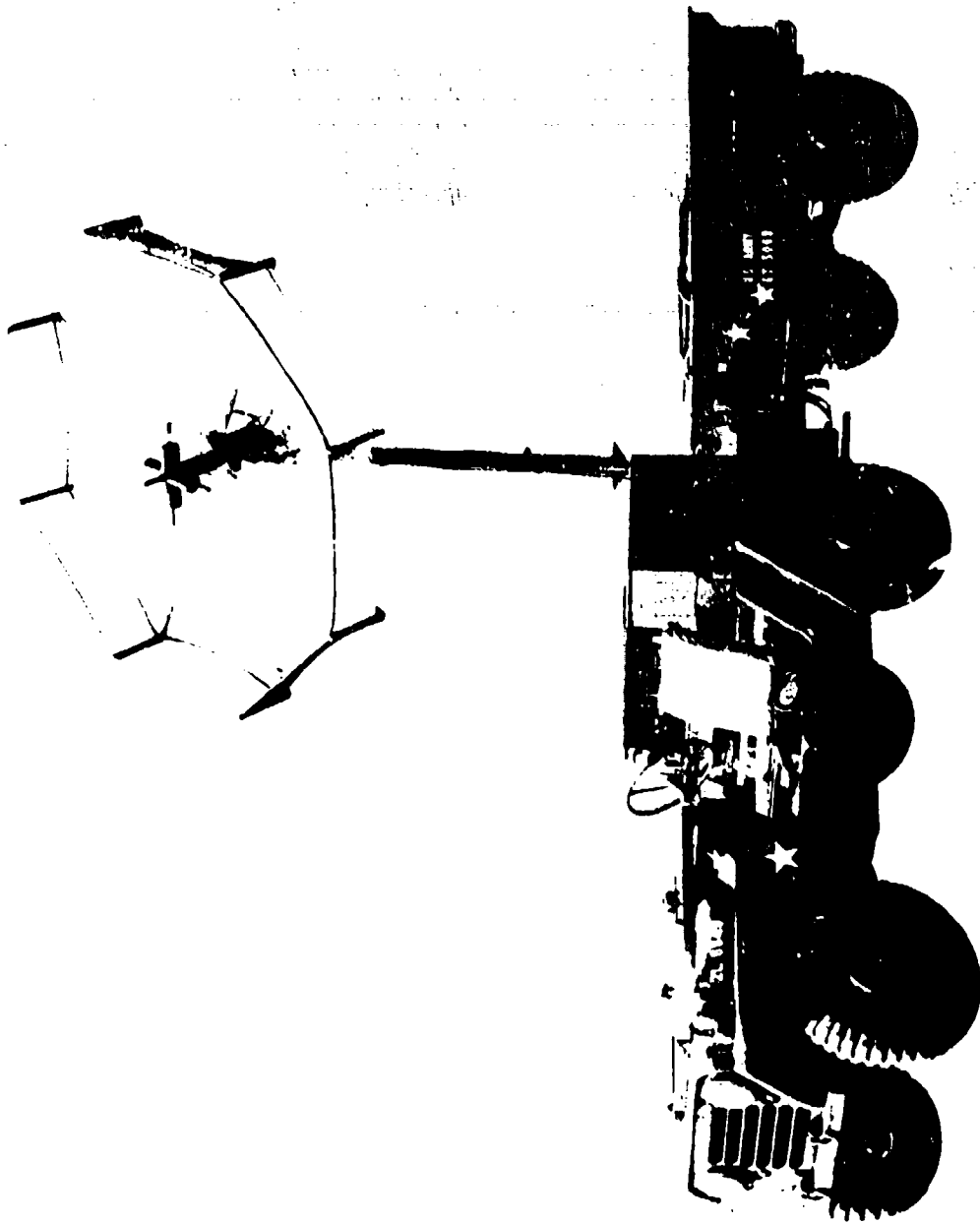

Figure 3-8. UHF Vehicular Terminal

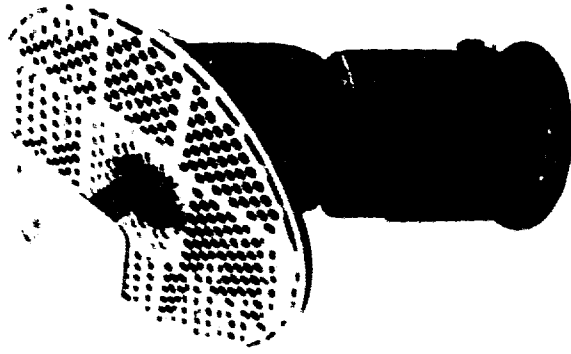

Figure 3-9. UHF Shipboard Antennas

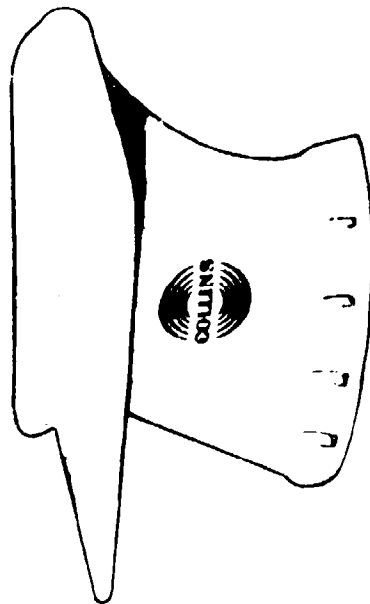
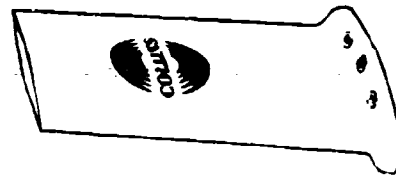

Figure 3-10. UHF Airborne Antennas

Facilities," which furnishes criteria and establishes procedural guidance for conducting site surveys and serves as a standard reference guide for those who have been assigned the responsibilities for conducting site surveys.

Possible earth terminal locations are tentatively selected prior to a detailed site survey. Site survey teams are concerned with determining how well the facilities can be adapted to the proposed sites. When several alternate sites are surveyed for a specific facility, the most suitable and appropriate site that meets the facility criteria will be recommended for selection.

The following is a presentation of the site selection criteria which have been used for technical guidance during site surveys, site selection, and subsequent facility design.

3.4.1 Land and Terrain Considerations

Siting requirements for an earth terminal station location should include:

1. For a multiterminal site, a minimum separation between terminals for protection against mutual radio frequency interference (RFI). When one antenna may look over another antenna, the separation between the two must be large enough to permit the beam path of the former to have a clearance of at least 5-degree elevation above the latter antenna. Survivability considerations may also make an intervening ridge desirable.
2. Remoteness from heavily populated areas. This is desirable because:
 - a. Electromagnetic interference (EMI) from local sources may cause disturbances in earth terminal antennas.
 - b. Earth terminal transmissions may cause intermodulation in local TV and broadcast receivers.

3. Ideally, location in a relatively large, basin-shaped area with a uniform horizon mask of about 2.5° . This would provide maximum access to satellites in all orbital configurations combined with protection from RFI, assuming that no RFI sources lie within the horizon of the terminal in the line-of-sight of the antenna. In most cases, however, a perfect basin-shaped site area clear of obstruction will not be found. It is, therefore, necessary to survey the site to determine if there are obstructions that will mask the satellite at any particular azimuth, and to use natural screening from interference where possible.
4. Earth terminals should have an uninterrupted source of power supply. Primary power supplies must have adequate auxiliary power sources available which can provide emergency (backup) power during critical and noncritical periods.

SECTION 4 - MULTIPLEXING, MODULATION AND CODING

4.1 GENERAL

In addition to the satellite and the basic earth terminal, there are three components that can play major roles in establishing satellite communications circuits. They are the multiplexing, modulation and coding (bit error control) equipment. As shown in Figure 4-1a the multiplexer combines various signals into a common baseband and passes the signal to the RF modulator, which in turn modulates the information on the earth terminal transmit carrier. At the distant end the earth terminal receivers shift and amplify the signal. It is then demodulated and passed to the demultiplexer, which breaks the common group baseband into the individual signals that were sent. This is shown in Figure 4-1b.

The encoder and decoder (shown dotted) may be added to improve bit error performance in digital systems. The following paragraphs discuss the operation and capability of each of these three types of equipment.

4.2 MULTIPLEXING TECHNIQUES

Multiplexing is a method for simultaneously transmitting several messages over one transmission path. There are two general methods for accomplishing this: (1) the division of the available frequency spectrum into discrete bands each of which carries one of the messages, and (2) the division of the available time into discrete intervals which are assigned successively to the several messages. The first method is called frequency division multiplex (FDM) and the second time division multiplex (TDM).

4.2.1 Frequency Division Multiplex

The most common form of multiplexing presently used is FDM. It is used in most terrestrial networks as well as with satellite communications, and the same principles apply to both media.

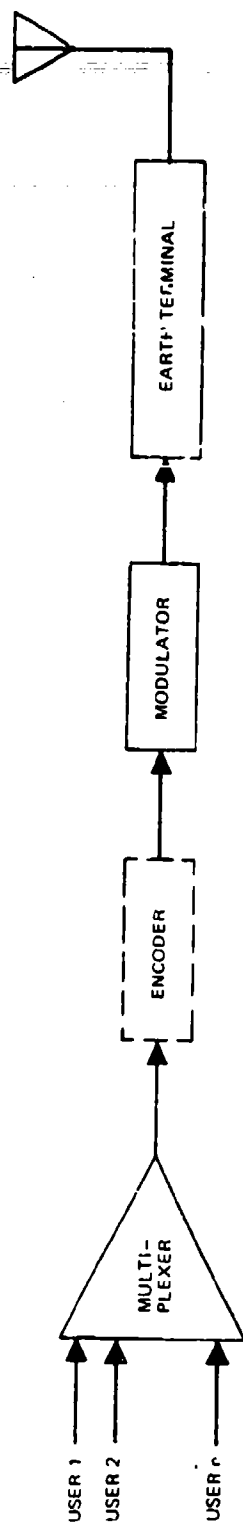

Figure 4-1a. Transmitter Signal Processing

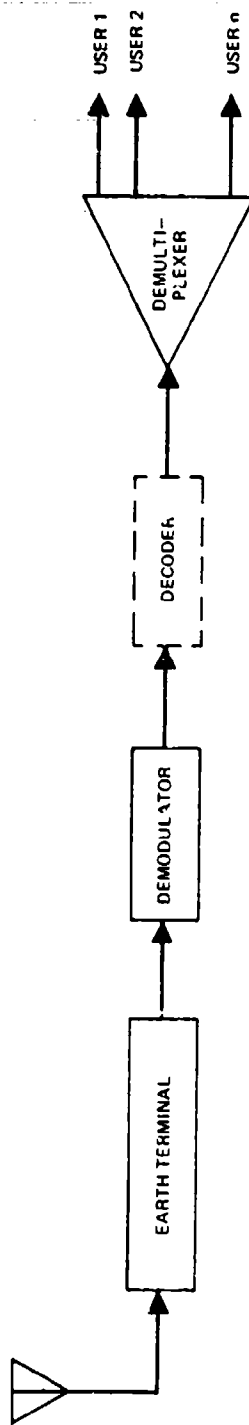

Figure 4-1b. Receiver Signal Processing

In an FDM system the available bandwidth is divided into several subbands and the various independent information signals (messages) to be transmitted are shifted into assigned subbands. The combined signal is then used to modulate the final carrier for transmission.

For example, consider a telephone channel requiring a total bandwidth of about 4 kHz and capable of transmitting one high-quality voice circuit. If 12 channels are brought together, the first one will occupy the band from 12 to 16 kHz, the second will occupy the band from 16 to 20 kHz, the third occupies 20 to 24 kHz, etc., up to the 12th channel, which would be modulated on a 44-kHz carrier and occupy the band 56 to 60 kHz. This entire band of frequencies, 12 to 60 kHz, carrying 12 independent telephone channels may then be placed on a wire line, modulated onto a UHF or microwave transmission frequency, or used as a group that in combination with other groups formed in the same way and with successive groups frequency-translated to higher bands, may form a "supergroup." And if the transmission bandpass is sufficiently wide, a number of supergroups are combined for final modulation of the carrier frequency. A group normally consists of 12 telephone channels; a supergroup consists of five groups. Usually, the first group occupies a band of frequencies from 12 to 60 kHz, leaving the space from 0 to 12 kHz available for orderwire, signaling, etc.

By this method, several hundred telephone channels will be carried on one transmission circuit, the total number possible being limited only by the power and bandwidth of the transmission path and the availability of frequency translating equipment, etc.

At the receiving site, the channels are recovered from the detected carrier by the use of precision filter networks that separate the supergroups into groups, and the groups into single channels. After combining the channels and throughout the transmission system until channel separation, system

linearity is of vital importance. Nonlinear elements or factors result in unwanted intermodulation, which causes distortion and crosstalk between the channels.

Each telephone channel may itself be subdivided into several teleprinter, data or other digital channels by time or frequency division. Frequency-division of a single telephone channel is normally accomplished on a tone-keying basis. Two tones 85 Hz apart are allocated to each telegraph channel, one for mark and one for space. At the receiver after the telephone channels have been separated, those carrying telegraph channels are sent through additional filter systems to recover the keyed tones corresponding to the telegraph channels. It will be seen that the keying of mark and space tones is the same as frequency-shift keying of a carrier.

4.2.2 Time-Division Multiplex

Digital coding systems by their very nature offer an attractive means of multiplexing. In a typical pulse code modulation (PCM) system for voice, the functions performed by the PCM modulator are sampling, quantizing, encoding, and modulating. Encoding here refers to the digital representation of an analog quantity. This is different from encoding for error correction purposes, which was referred to in Paragraph 4.1 and will be discussed in detail in Paragraph 4.4. Voice waveforms are usually sampled at 8000 Hz, or once every 125 microseconds. This is often enough for excellent reproduction of the received signal, since the upper cutoff frequency of ordinary speech channels is below 4000 Hz. If the quantization levels are correctly chosen, 128 different levels can convey the speech message with a high degree of fidelity. The levels are usually nonuniformly spaced so that small signal amplitudes are more finely quantized than are the large signal amplitudes. Each of the 128 (2^7) levels can be represented by a distinct seven-digit binary code word; for example, if the levels are labeled 0 to 127, then the i th level

can be represented by the binary representation of i . The pulse code is then seven equispaced pulses per sample, with values of 0 or 1 according to the digits of the code word.

Finally the sequence of bits or encoded quantized voice samples, is modulated in an appropriate manner for the transmission medium. If the bandwidth and signal-to-noise ratio of the transmission channel are greater than necessary for the single PCM signal, TDM may be used to multiplex additional messages and send them all over the same channel. An example of how this may be done is shown in Figure 4-2.

In Figure 4-2, the multiplexing occurs at the earliest possible point: between sampling and quantizing. Multiplexing could take place at a later point, for example between encoding and modulation, but this would require separate quantizers and encoders for each baseband. At the receiver the order of the processing is reversed and each baseband is low-pass filtered to recover the original speech waveform as shown in Figure 4-3.

In addition to the bits representing message information, TDM/PCM systems usually transmit bits for supervisory signaling and frame synchronization. One frame is the group of information and supervisory bits produced during one revolution of the multiplexer commutator. A typical frame format is illustrated in Figure 4-4.

In Figure 4-4, 3 bits have been allocated to supervisory information, such as message identity and length, and to frame synchronization. Seven bits have been allocated to each of the three voice channels. Assuming the original sampling rate of 8000 Hz per voice, the transmitted bits will be spaced $125/24 = 5.2$ microseconds apart.

Any mode of digital coding lends itself to time-division multiplexing by interleaving channels. The only requirement is that the receiving equipment be able to separate the several channels so that the sample pulses may be

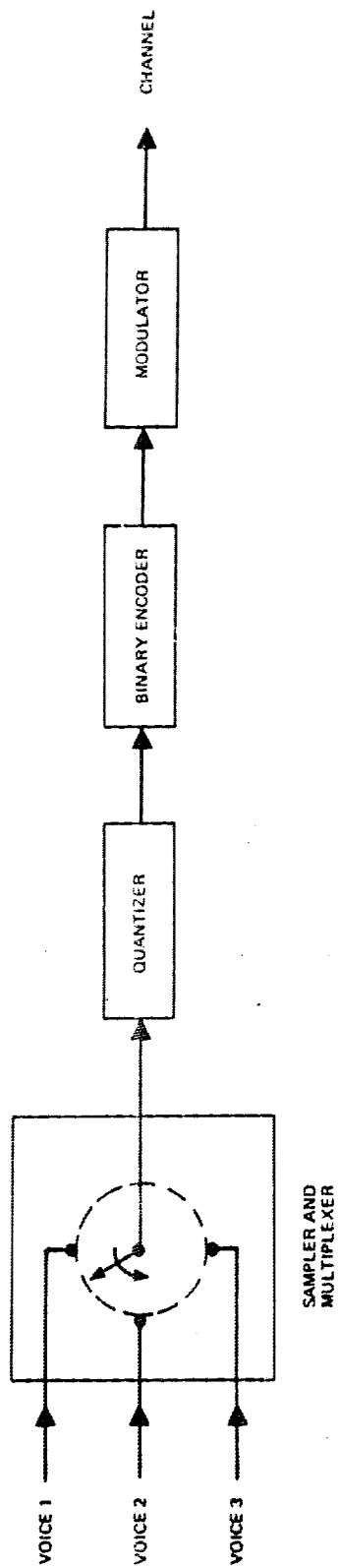

Figure 4-2. TDM/PCM Modulator

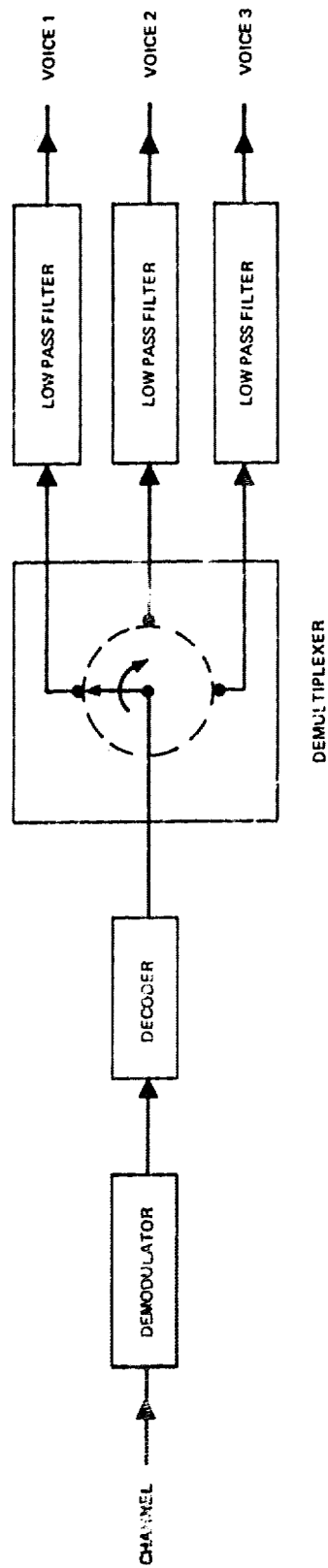

Figure 4-3. TDM/PCM Demodulator

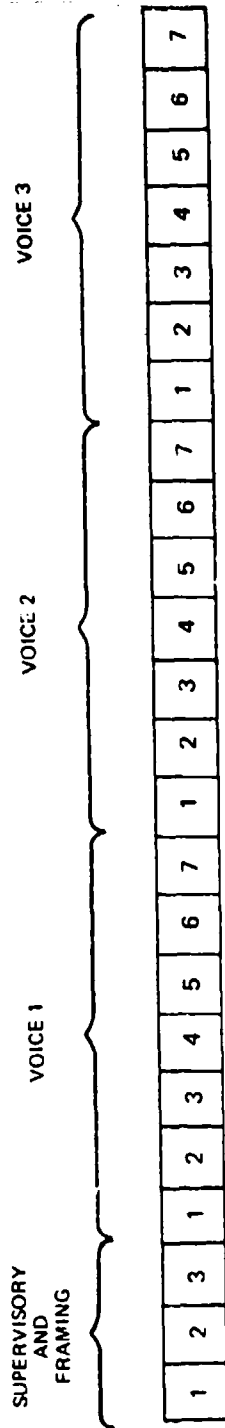

Figure 4-4. Typical Frame Format

used to reconstruct the original modulating signal with distortion within acceptable limits.

4.3 MODULATION TECHNIQUES (RF)

The process by which information is impressed on a suitably chosen RF carrier frequency for transmission is referred to as modulation. The two forms of modulation that are normally used to convey information are analog and digital modulation processes. Analog modulation methods encompass those techniques which vary the amplitude, phase or frequency of the carrier over a continuous range of values in response to source information. Digital modulation methods encompass those techniques that cause discrete changes in the amplitude, phase or frequency of the carrier after the source information has been digitized into a stream of marks (ones) and spaces (zeros) prior to the carrier modulation process. Both analog and digital modulation methods attempt to convey the source information using the minimum amount of available average power and bandwidth while maintaining the system performance goal or quality of the transmission.

The performance measures applied to analog modulation systems do not coincide precisely with those applied to digital modulation systems. For an analog modulation system the performance is usually measured in terms of receiver output signal-to-noise ratio (S/N) for a given receiver input S/N ratio where the bandwidth of the measurement is equal to the intelligence bandwidth of the source (e.g., the highest frequency component of the source if the bandwidth of interest starts at zero frequency). Digital modulation system performance, on the other hand, is usually measured by the probability of error in making a decision at the receiver as to which information bit (1 or 0) was sent (probability of bit error or bit error rate). Despite the differences in performance measures there are many unifying features between these two modulation schemes that can form a basis for comparison. The principal

comparison standards usually used concern the efficiency of both techniques in their use of average power and bandwidth when compared to a theoretically ideal system standard. For either technique, performance is a function of the bandwidth expansion factor, m , of the modulation process. The bandwidth expansion factor is defined as the ratio of RF spectrum required to the total intelligence bandwidth which is transmitted by the information source. For analog modulation techniques, the spectrum occupancy is strongly influenced by the highest frequency, f_m , which is contained in the modulating signal; for digital systems the spectrum occupancy is strongly dependent on the transmitted data rate, R , in bits per second. In both systems the RF spectrum or bandwidth occupancy of the modulated signal will be designated as B Hz and this bandwidth must be less than or equal to the total available channel bandwidth, W (i. e., $B \leq W$ Hz). Consequently, m is defined as:

$$m = \begin{cases} B/f_m; & \text{for analog modulation} \\ B/R; & \text{for digital modulation} \end{cases} \quad (4-1)$$

The classic work of C. E. Shannon is used to demonstrate the power/bandwidth tradeoff inherent in modulation systems. Shannon's equation gives the maximum rate, called the channel capacity, which can be transmitted theoretically over a channel. The equation is written:

$$C = W \log_2 [1 + (P/N)] \quad (4-2)$$

where C is the highest possible data rate in bits per second that can be reliably transmitted over a bandwidth W , when the receiver has available an average signal power of P watts and an average thermal noise of N watts. Starting with Equation (4-2), relationships between power and bandwidth for analog and digital modulation have been derived.

For analog modulation Shannon's equation can be rewritten as:

$$\left(\frac{S}{N_o}\right) \leq \left[1 + \left(\frac{S_i}{N_o f_m}\right) \frac{1}{m}\right]^m - 1 \quad (4-3)$$

where $\left(\frac{S}{N_o}\right)$ = detector output signal-to-noise ratio,

and $\frac{S_i}{N_o f_m}$ = receiver input signal-to-noise ratio in the intelligence bandwidth.

Thus, the right side of Equation (4-3) is the upper boundary on the value of $\left(\frac{S}{N_o}\right)$. Figure 4-5 is a plot of Equation (4-3) for various values of m , including $m = \infty$. It indicates the reduction in required power input with the increase in bandwidth for analog modulation systems.

For digital modulation Shannon's equation can be rewritten as:

$$E_b/N_o \geq m (2^{1/m} - 1) \quad (4-4)$$

where E_b = energy per bit of information

and N_o = noise power density (watts per Hz).

The term E_b/N_o is a commonly used factor in defining power required for transmitting digital information.

The factor E_b/N_o is plotted in Figure 4-6 and represents a lower boundary on the required value for high-quality reception. The bit error probability is a function of E_b/N_o in any digital modulation system. Digital modulation can operate with values of m less than or greater than 1. Using m less than 1 corresponds to each symbol containing several bits of information. This is termed multilevel digital modulation. As expected from Figure 4-6, the bandwidth reduction is accompanied by an increase in the power required for a given bit error rate. However, using several transmitted symbols to convey one bit of information increases the bandwidth but allows a reduction in the required signal power.

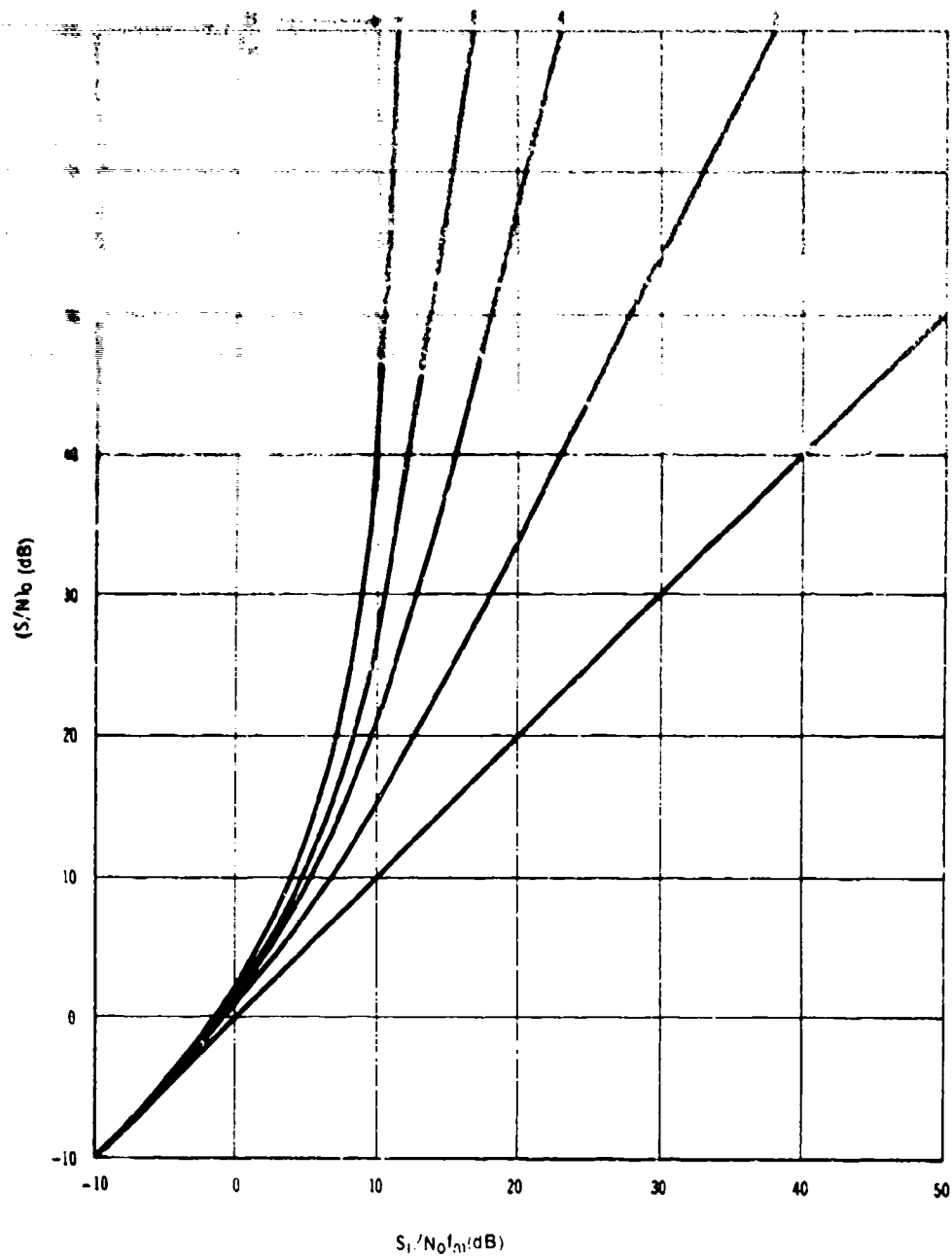

Figure 4-5. Upper Performance Bounds for Analog Modulation

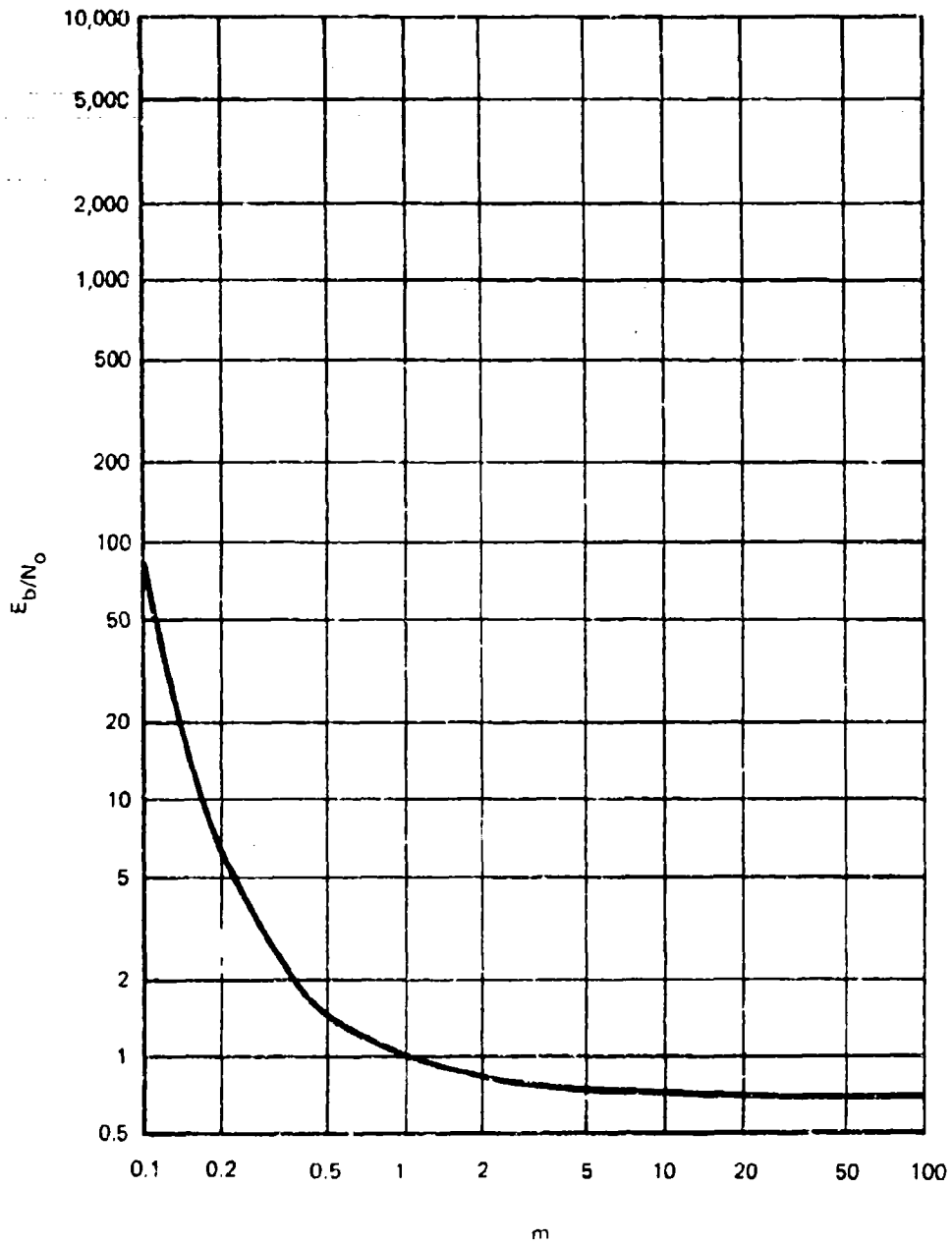

Figure 4-6. Upper Performance Boundary for Digital Modulation

4.3.1 Analog Modulation Techniques

4.3.1.1 Amplitude Modulation

In this paragraph the most commonly used analog modulation systems, amplitude modulation (AM), and frequency modulation (FM) will be introduced. Their performance will be investigated and compared to a theoretically ideal system's performance.

The basic equation for an amplitude modulated carrier is:

$$y(t) = A_o [1 + \gamma f(t)] \cos 2\pi f_c t \quad (4-5)$$

where $y(t)$ = modulated carrier

A_o = amplitude of unmodulated carrier

γ = modulation index, $0 \leq \gamma < 1$

$f(t)$ = modulating signal, $|f(t)| \leq 1$

f_c = frequency of carrier

The spectrum of $y(t)$ will contain the original carrier, as well as components above and below the carrier frequency, as a result of the modulating waveform, $f(t)$. The relationship between the spectrum of $f(t)$ and that of $y(t)$ is shown in Figure 4-7.

In Figure 4-7:

$F(j2\pi f)$ = Fourier transform of $f(t)$

$Y(2\pi f)_m$ = Fourier transform of $y(t)$

f_m = highest angular frequency in the modulating waveform, $f(t)$.

Three commonly used amplitude modulation techniques modify the modulated carrier spectrum in different ways. Double sideband AM (DSB-AM) uses the carrier and both sidebands, as shown in Figure 4-7. In double sideband suppressed carrier AM (DSB-SC-AM) the carrier is eliminated.

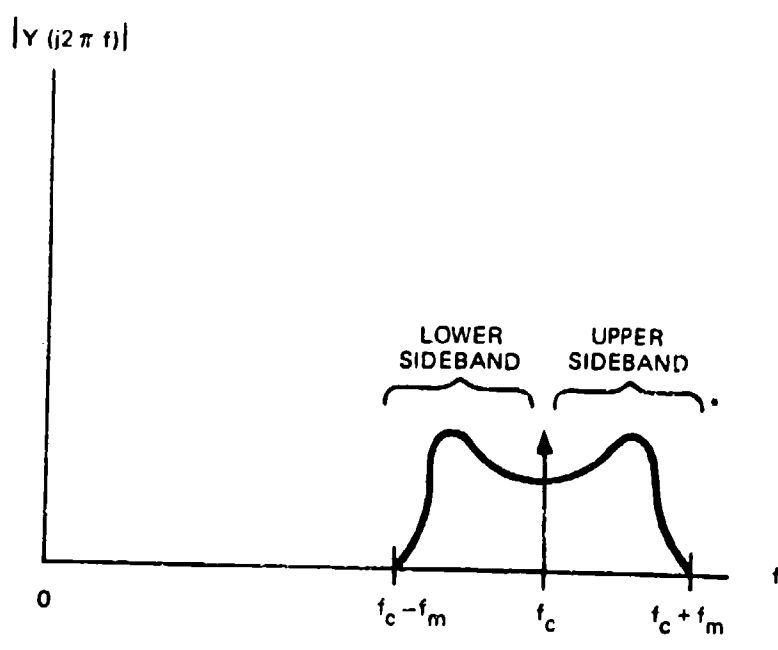
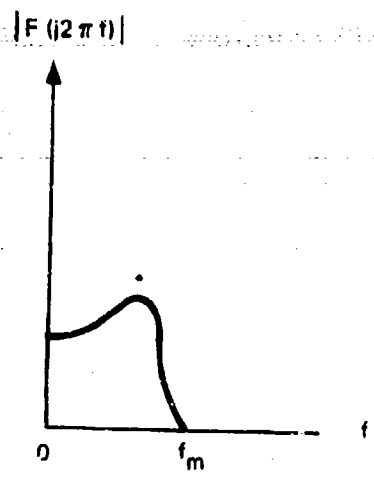

Figure 4-7. Spectrum of Amplitude Modulated Carrier

In single sideband modulation (SSB-AM), the carrier and one sideband are eliminated.

The performance of these forms of AM is illustrated in Figure 4-8

where (S/N_o) = receiver output signal-to-noise ratio

$(S_i/N_o f_m)$ = receiver input signal-to-noise ratio measured within the intelligence bandwidth, $0 - f_m$.

For comparison the curves representing theoretical upper performance boundaries of analog modulation systems are repeated in Figure 4-8.

Note the following observations:

1. The most efficient form of DSB-AM (that with modulation index $\gamma = 1$) is about 5 dB poorer in performance than DSB-SC-AM or SSB-AM.
2. The modulation index γ , which relates the amounts of power in the carrier and the sidebands, does not appear as a parameter in the performance curves for DSB-SC-AM and SSB-AM since these forms of modulation do not transmit a carrier component.
3. The performance of SSB-AM equals the ideal system performance for $m = 1$.
4. DSB-SC-AM performs as well as SSB-AM on a signal power basis but requires twice the bandwidth.

4.2.1.2 Frequency Modulation

An FM signal may be expressed in the form:

$$S(t) = A \cos 2\pi [f_o t + f_d \int S_m(t) dt] \quad (4-6)$$

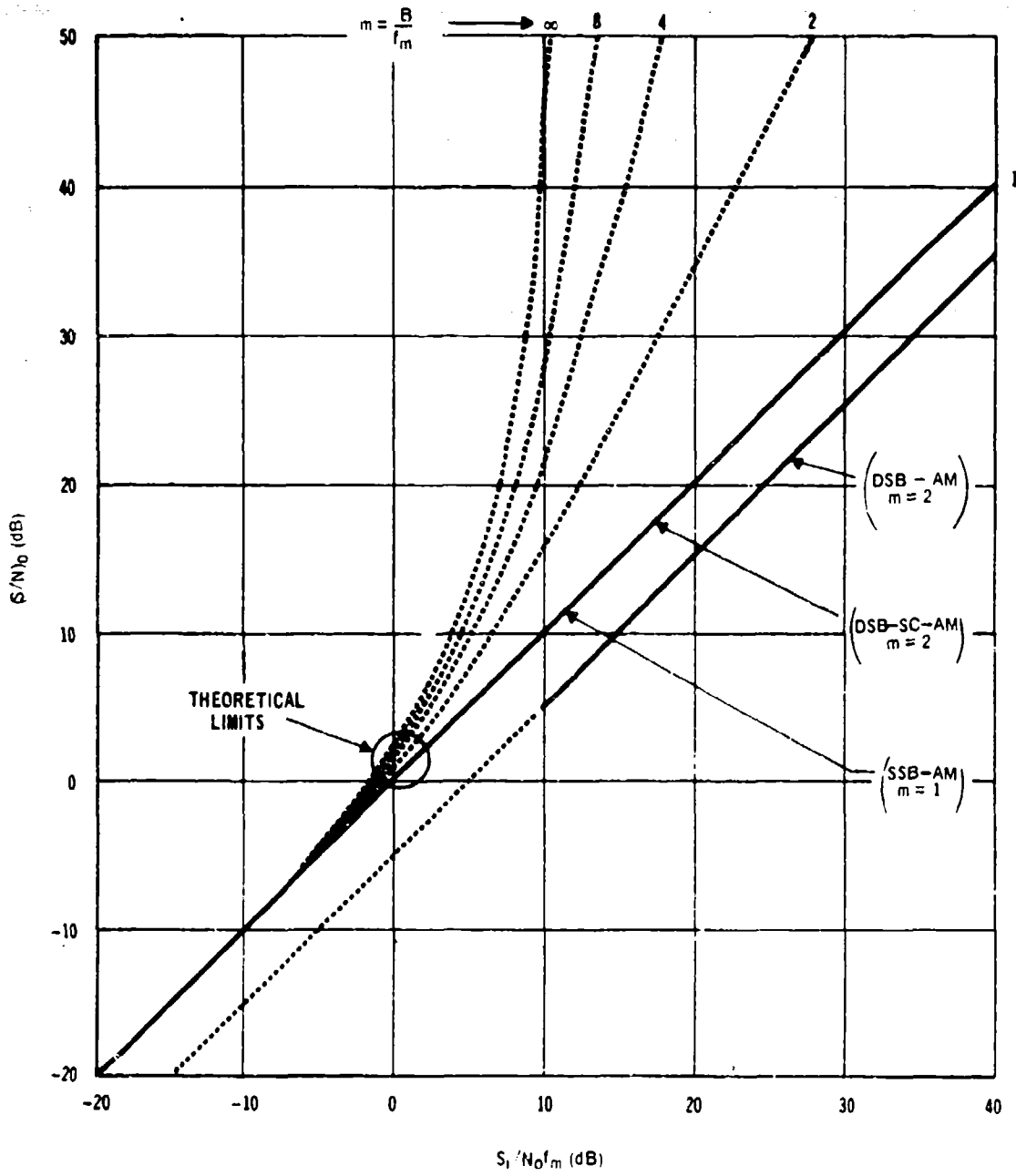

Figure 4-8. Analog AM Performance

where $S_m(t)$ = the modulating process; $|S_m(t)| \leq 1$ for all t ; e.g.,
 $\cos 2\pi f_m t$
 f_d = the maximum instantaneous-frequency deviation
 γ = the modulation index = f_d/f_m .

Frequency modulation derives its name from the fact that the instantaneous frequency, denoted f_i , depends linearly on $S_m(t)$; that is:

$$f_i = \frac{d}{dt} \left[f_o t + f_d \int S_m(t) dt \right] = f_o + f_d S_m(t) \quad (4-7)$$

The RF spectral occupancy of an FM signal is normally taken as:

$$B = \begin{cases} 2f_m (\gamma + 1); & \gamma \geq 1 \\ 2f_m; & \gamma < 1 \end{cases} \quad (4-8)$$

B is often called the Carson's Rule bandwidth for an FM modulation system. Under certain conditions the performance equation for FM has the following form:

$$(S/N)_o = (3/2) \gamma^2 \left(\frac{S_i}{N_o f_m} \right) \quad (4-9)$$

The conditions which must be satisfied for Equation (4-9) to be valid are that the FM demodulator is operating above threshold, the $S_m(t)$ function is varying slowly (quasi-static assumption), and $\gamma \gg 1$. Equation (4-9) can also be expressed in terms of the bandwidth expansion factor as follows:

$$(S/N)_o = 3/2 \left(\frac{m}{2} - 1 \right)^2 \frac{S_i}{N_o f_m}; m \geq 4 \quad (4-10)$$

This relationship describes the performance of an FM system provided the FM demodulator is operating above threshold. The threshold region is qualitatively defined as that value of input S/N below which the demodulator performance exhibits anomalous behavior (e.g., phase flips and cycle skipping). To avoid this type of behavior the input S/N , measured in bandwidth B (Equation 4-8), must satisfy the following constraints:

$$\frac{S_i}{N_o f_m} \geq 10 \log_{10} \frac{B}{f_m} + T(\text{dB}) \quad (4-11)$$

where the threshold level is T.

Whereas conventional demodulator thresholds are 12 dB, values as low as 3 dB may be realizable with more advanced demodulator designs such as phase-lock loops or feedback receiver implementations. When the demodulator is operating above threshold, the performance bandwidth trade-off given in Equation (4-10) is obtained. Results for some typical values of bandwidth expansion factor are shown in Figure 4-9, with the theoretical performance boundary from Equation (4-3). Note that increasing $(S/N)_o$ for a fixed $(S_i/N_o f_m)$ requires less efficient spectrum use (i. e., large γ implies $B/f_m \gg 1$) and that the theoretical performance curves can only be approached if the demodulator threshold is reduced. Practical design problems prohibit continued reduction of the threshold and hence prohibit achievement of theoretically ideal performance. Figure 4-10 illustrates the use of preemphasis to compensate for the nonlinear rising spectrum of noise from the demodulator.

4.3.2 Digital Modulation

A good digital modulation system is one which communicates the maximum amount of data reliably. The performance of a digital system is bounded theoretically by Shannon's classical results, which state that given sufficient processing, data at rate R in bits per second can be communicated with arbitrarily small error through a channel of capacity C, provided $R < C$. More specifically if a channel is linear, restricted to bandwidth B, has average power S_i , and is perturbed by additive white Gaussian noise (with single-sided noise power density N_o), then:

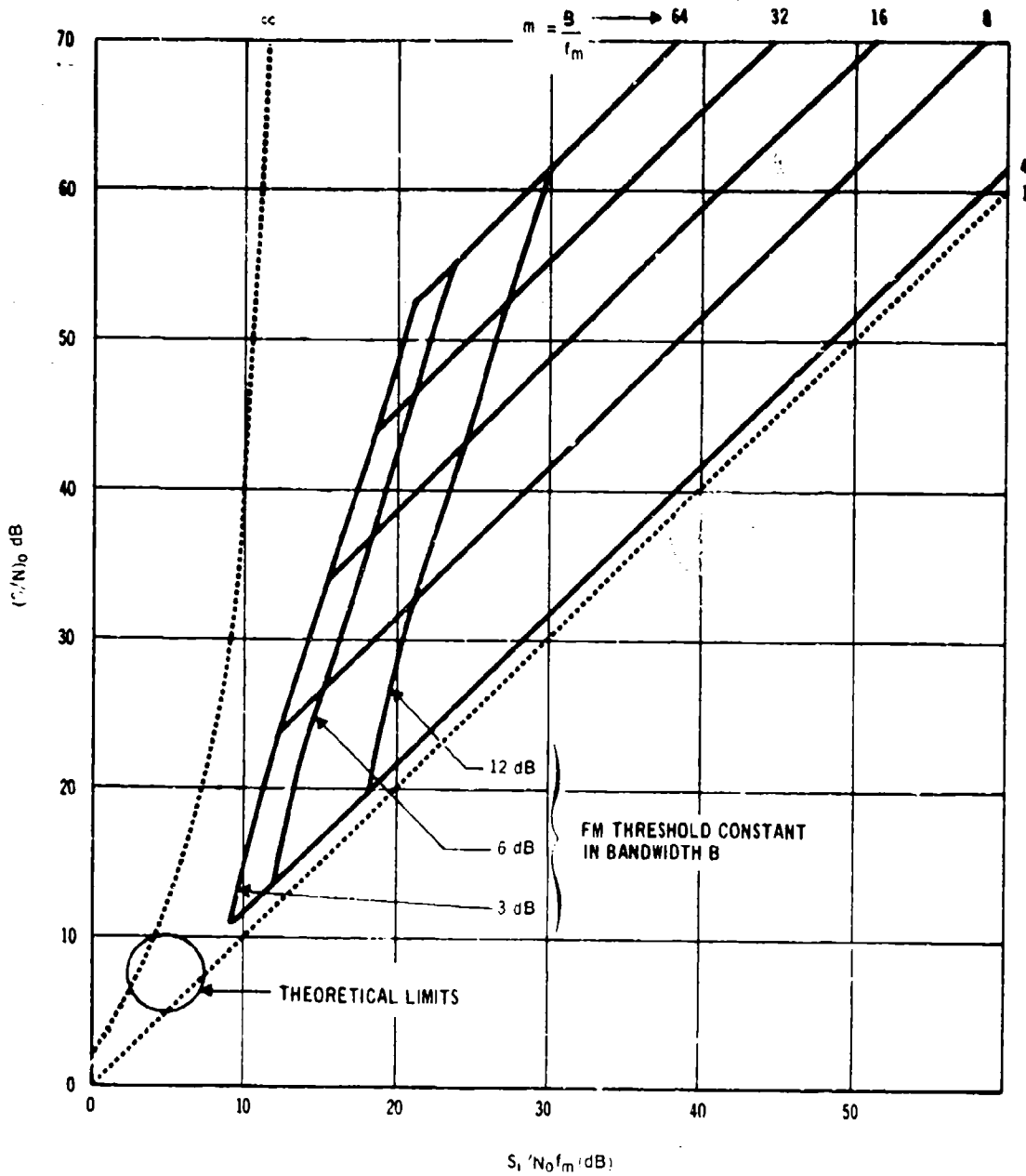

Figure 1-9. Analog FM Performance

$$R \leq C = B \log_2 \left(1 + \frac{S_1}{N_0 B} \right) \quad (4-12)$$

This equation can be rewritten in terms of the system bandwidth expansion factor ($m = B/R$) and the available energy per bit-to-noise density ratio, $E_b/N_0 = S_1/N_0 R$, as follows:

$$R/B \leq \log_2 \left(1 + \frac{E_b R}{N_0 B} \right) \quad (4-13)$$

This leads to Equation (4-1) which gives the minimum possible energy per bit-to-noise density ratio that is required to reliably communicate with bandwidth expansion factor m .

In a binary digital communication system (higher-order or M-ary systems are possible but will not be discussed), the transmitter selects and sends one of two basic waveforms depending on whether a binary zero or one is delivered by the digitized (i. e., sampled and quantized) information source. For example, if the N th term of the binary digital sequence is a zero, the system transmits, during interval $NT < t \leq (N + 1) T$, the signal waveform $S_0(t)$; if it is a one, the system transmits $S_1(t)$. Since T seconds are required to transmit one symbol of the sequence, the transmission rate is $1/T$ symbols per second. If the binary data source selects the bits of the sequence with equal probability and independently, then each symbol conveys one bit of information and hence the information rate is $1/T$ bits per second. Because of the addition of noise (e. g., the receiver will always have a finite temperature and thus will add a finite noise power density to the received signal), there will be a nonzero probability that the receiver will make an error when attempting to decide whether $S_0(t)$ or $S_1(t)$ was transmitted. The performance of the digital system therefore is measured in terms of the probability that the receiver will err in making this and subsequent decisions. To calculate the performance of a particular digital modulation technique requires knowledge

of the form of the waveforms selected for transmission, the transmission channel characteristics and the exact structure and decision rule employed at the receiver. The signal waveform characteristics of interest are the energy per signal, the spectral occupancy and a measure of the basic difference in the signal structures used to represent transmitted zeros and ones (this latter characteristic is referred to as the signal's normalized inner product and is denoted as ρ). The channel characteristics of interest pertain to its linearity, phase response and noise properties. The receiver structure details pertain to the a priori knowledge assumed to exist regarding which signal was sent, knowledge of the signal structure (i. e., the signal's epoch, amplitude, phase and frequency), and the decision rule employed. For example, if information is conveyed by shifting the carrier phase 180° to represent a one and by 0° to represent a zero (space) and all other aspects of the waveforms are identical, the system usually is referred to as binary antipodal modulation, or simply binary phase-shift keying (PSK). For an additive white Gaussian noise channel that permits retention of carrier phase information, the optimum receiver can be shown to be a coherent matched filter receiver with one filter matched to each of the phase states sent at the transmitter. Exact knowledge of received signal time, phase and frequency is required to implement this ideal detector, and the decision rule is simply to look at the outputs of the matched filter every T seconds and decide in favor of the filter with the largest output (this assumes ones and zeros are equally likely to have been transmitted and that ties are resolved by simply flipping a coin). For this binary PSK system with a coherent ideal PSK detector, the performance is given by:

$$P_E = Q\left(\sqrt{\frac{2E_b}{N_0}}\right); \text{ (coherent, antipodal PSK signals) } \quad (4-14)$$

where
$$Q(X) = \frac{1}{\sqrt{2\pi}} \int_{-\infty}^{-X} \exp(-y^2/2) dy$$

$$E^* = \text{signal energy} \int_0^T S_1^2(t) dt = \int_0^T S_0^2(t) dt$$

and the normalized inner product a measure of the correlation of the binary signals, is:

$$\rho = \int_0^T \frac{S_0(t) S_1(t) dt}{E_b} = -1 ; \text{ (antipodal PSK signaling)}$$

In the event that the channel does not permit a coherent detector to be built; i. e., the received signal's phase is a random variable, $-\pi \leq \phi \leq \pi$, an optimum noncoherent receiver may be built. In this case decisions can be based on the magnitude of the envelope of the received signal (since the phase information has been destroyed by the channel).

The transmitter can elect to send one of two frequencies (frequency-shift keying, FSK), to represent the binary source data. Such a selection causes the normalized inner product, ρ , of the signals to be zero (referred to as orthogonal signaling) and the performance is given by

$$P_E = \frac{1}{2} \exp\left(-\frac{E_b}{2N_0}\right); \text{ (noncoherent, orthogonal FSK signals) (4-15)}$$

For coherently detected orthogonal signal sets, such as coherently detected frequency shift-keyed (FSK) signals, the performance becomes

$$P_E = Q\left(\sqrt{\frac{E_b}{N_0}}\right); \text{ (coherent, orthogonal FSK signals) (4-16)}$$

For all but high P_E cases the E_b/N_0 required to achieve a given P_E with non-coherent reception is about twice that required with coherent reception.

* E_b energy per bit = E for these systems, since there is one bit per symbol.

An intermediate case, referred to as "differentially coherent PSK," is also of interest with binary digital systems. Unlike the preceding systems, in differentially coherent PSK (Δ PSK), a binary one dictates a change in phase in the transmitted signal and a zero dictates no change in phase. The receiver requires two sets of detectors with overlapping operation; while one operates on the received signal during even intervals forming decisions on even-numbered data symbols, the other operates during the odd intervals forming decisions on the odd-numbered data symbols. In effect the phase of the preceding symbol serves as a reference for the present symbol. The performance of Δ PSK is given by

$$P_E = \frac{1}{2} \exp\left(\frac{-E}{N_0}\right); (\Delta \text{ PSK}) \quad (4-17)$$

It should be noted that for a given P_E exactly one half the energy is required in a Δ PSK system relative to the noncoherent orthogonal signal case (non-coherent, FSK).

Performance curves for each of the binary digital systems discussed above are shown in Figure 4-11. Finally, the bandwidth expansion factor for these signaling schemes can be shown to be:

$$m = \frac{B}{R} = \begin{cases} 2; & \text{orthogonal (FSK)} \\ 1; & \text{antipodal (PSK and } \Delta \text{ PSK)} \end{cases} \quad (4-18)$$

Generalizations of these basic concepts to higher-order alphabet systems (M -ary) are conceptually easy. Digital communication systems of this type use K consecutive symbols of the data sequence to select and transmit one of $M = 2^K$ stored signals ($K = 1$ for binary systems). The performance obtained requires less E_b/N_0 than for the binary case but requires an exponential increase in bandwidth and receiver complexity relative to the binary signaling schemes.

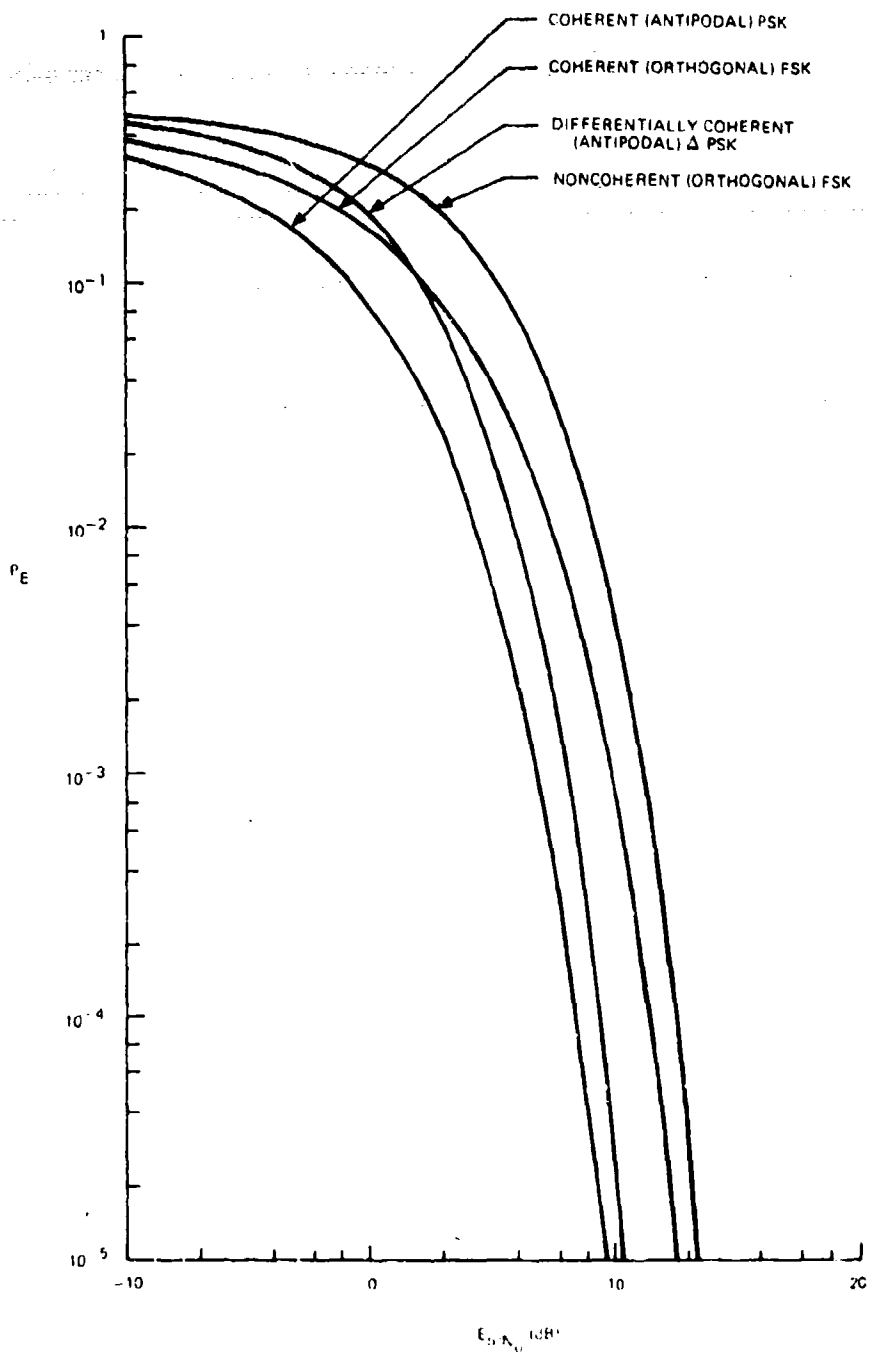

Figure 4-11. Error Probability Versus E_b/N_0 for Coherent, Noncoherent and Differentially Coherent Reception

4.4 CODING TECHNIQUES

In the preceding discussions on the performance of digital modulation/demodulation (modem) techniques, the probability of bit error (P_E) for a given energy per bit-to-noise-density (E_b/N_o) ratio was used as a measure of how well the modem could operate. A modulation technique that satisfied the system probability of bit error (P_E) specification without requiring an excessive E_b/N_o ratio (E_b = ratio of average received carrier power to data rate, PR_b) or bandwidth allocation was deemed an acceptable choice. Furthermore, since the performance of an ideal digital system could be calculated under certain conditions, it was possible to assess how any particular choice of modem deviated from the ideal and to quantitatively measure how much loss was incurred relative to the ideal system. To specify the ideal system's performance it was necessary that the channel, or modem-transmission medium combination be linear, restricted to bandwidth B , average power P and be perturbed only by additive white Gaussian noise (AWGN), with single-sided noise power density N_o (watts/Hertz). These considerations are of more than academic interest since many satellite communication systems can be modeled as an AWGN channel. It is precisely for this reason that forward acting error correcting (FEC) coding techniques can and should be applied to satellite communication system designs. These FEC techniques allow a system design that better approximates the ideal system's performance. In general, the coding technique changes each information bit--input from the source-- into a sequence of binary digits or symbols before transmission over the satellite channel. The coded sequence or representation of the information bit has a structure that permits the complementary decoding technique at the receiver to properly identify the transmitted information bit despite errors that occur in the coded sequence because of the channel noise conditions. The set of rules used to represent an information bit by a sequence of symbols at the transmitter is referred to as an encoding technique and the corresponding set of rules used to unscramble the received sequence to an information bit is

referred to as a decoding technique or algorithm. When the encoding-decoding technique does not rely on retransmission strategies to decode an information bit it is referred to as an FEC coding strategy or technique. These FEC techniques are distinctly different from automatic repeat request (ARQ) techniques that rely on detecting the presence of an error in the received sequence (only detecting not correcting) and automatically requesting a retransmission of any bit or sequence that has been detected to contain errors. In satellite communication system applications, ARQ techniques are of only limited utility since the long propagation delays (1/4 second) and occasionally high error rates due to rain severely limit the throughput of ARQ systems. Consequently only FEC techniques will be treated in the remainder of this discussion.

The placement of an FEC encoder-decoder in a typical communication system configuration is indicated in Figure 4-12. Thus, from the FEC coder's standpoint, the channel includes the items shown between the dotted lines of Figure 4-12. There are two broad classes of error-correcting codes; namely, block codes and convolutional codes. With block coding techniques each group of K consecutive information bits is encoded into a group of N symbols for transmission over the channel. Normally, the K information bits are located at the beginning of the N symbol block code and the last N-K symbols correspond to parity (check) bits formed by taking the modulo 2* sum of certain sets of the K information bits. Block codes exhibiting this property are referred to as systematic block codes. The term block code stems from the fact that each block of N symbols corresponds to a particular group of K information bits. The encoded symbols for the K + 1st bit and beyond are completely independent of the symbols generated for the first K information bits, and hence cannot be used to help decode the first group of K

*Modulo 2 binary arithmetic is normal except that $1 \oplus 1 = 0$ where the input information stream is assumed to be in binary form; that is, 1 = mark and 0 = space. For example, $0011 + 1010 = 1001$.

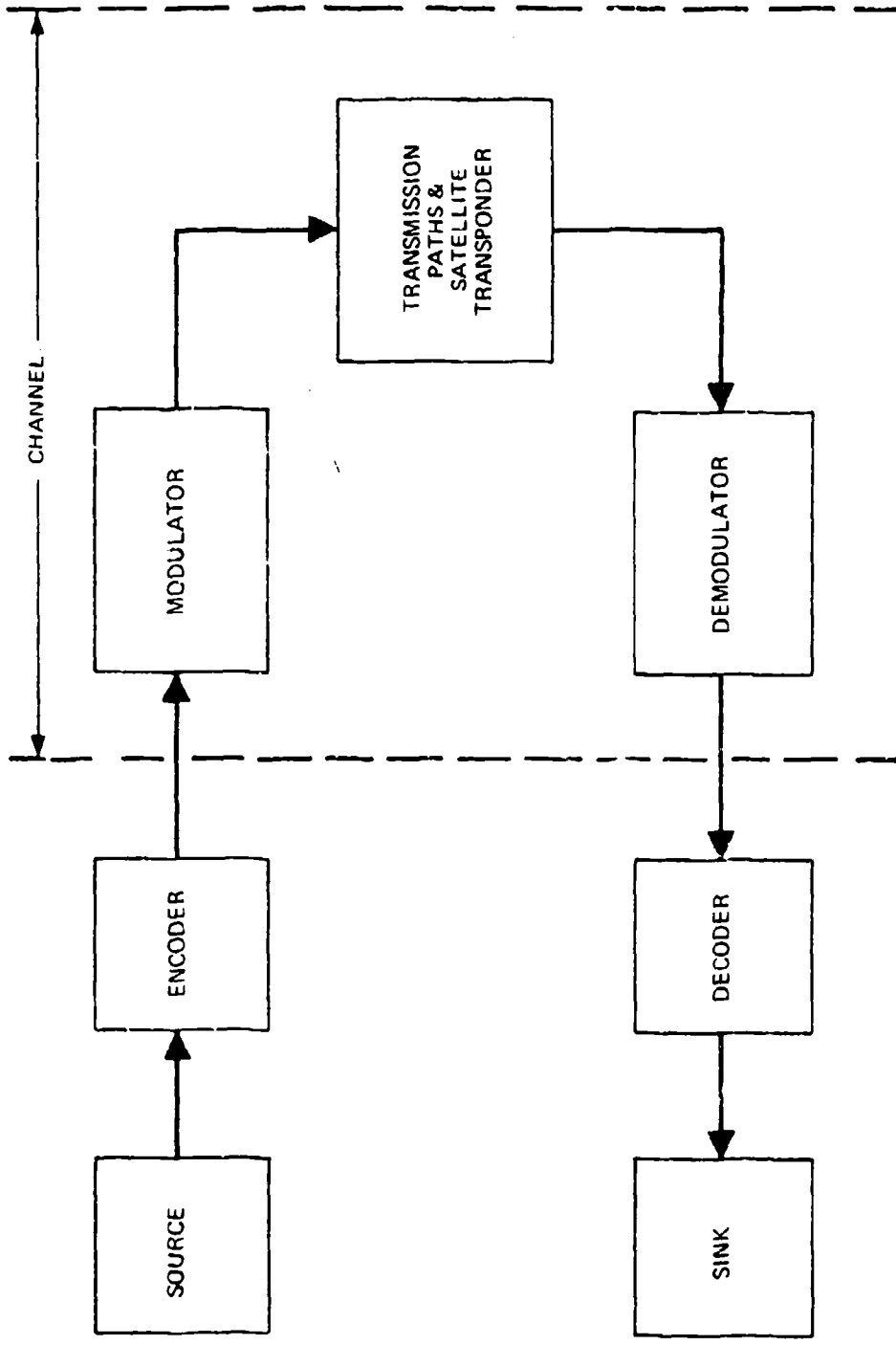

Figure 4-12. Typical Communication System

information bits at the receiver. Because N symbols are used to represent K information bits, the (code) rate (R) of such a block code is K/N bits per symbol ($R = K/N$). The encoder structure for the ($N=7$, $K=4$) binary code is shown in Figure 4-13. The information bits are stored in the $K=4$ storage devices, and then the device is made to shift $N-7$ times. The first K symbols that come out will be the information symbols, and the last $N-K$ symbols will be a set of check symbols that form the whole N symbol word. A block code is often denoted with the symbols (N, K, t) ; N corresponds to the block length, K to the number of information symbols in the word and t to the number of errors in a block of N symbols that the code is guaranteed to correct. The code of Figure 4-13 is a $(7, 4, 1)$ code in this notation.

Figure 4-14 is a block diagram of a convolutional encoder. Information bits are shifted to the right through the L stage shift register as new information bits enter from the left. Bits out of the last stage of the shift register are discarded. The bits are shifted one position each T seconds, where $1/T$ is the information rate in bits per second. The modulo-2 adders are used to form the parity check bits, each of which is a binary function of a particular subset of the information bits in the shift register. The parity check bits are seen to depend on a sequence of L information bits, so that the constraint length of the code is L .

Once each T seconds, the terminals labeled $1, 2, \dots, r$ are sampled in succession. Thus for each information bit fed into the encoder, there are r parity check bits at the output. These output parity check bits are referred to as symbols. Since each symbol carries an average of $1/r$ information bits, the code is said to have rate $1/r$.

When the first modulo-2 adder is replaced by a direct connection to the first stage of the shift register, the first symbol becomes a replica of the information bit. Such an encoder is termed a systematic convolutional encoder.

The code can be thought of as forming a tree structure. At each node the information bit determines which direction will be taken; up for a 1 and

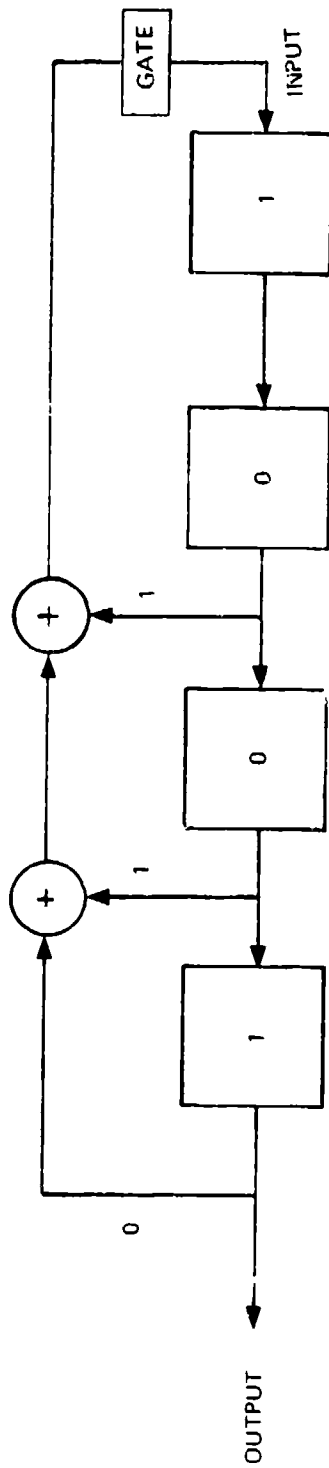

Figure 4-13. Shift Register for Encoding the (7, 4) Code

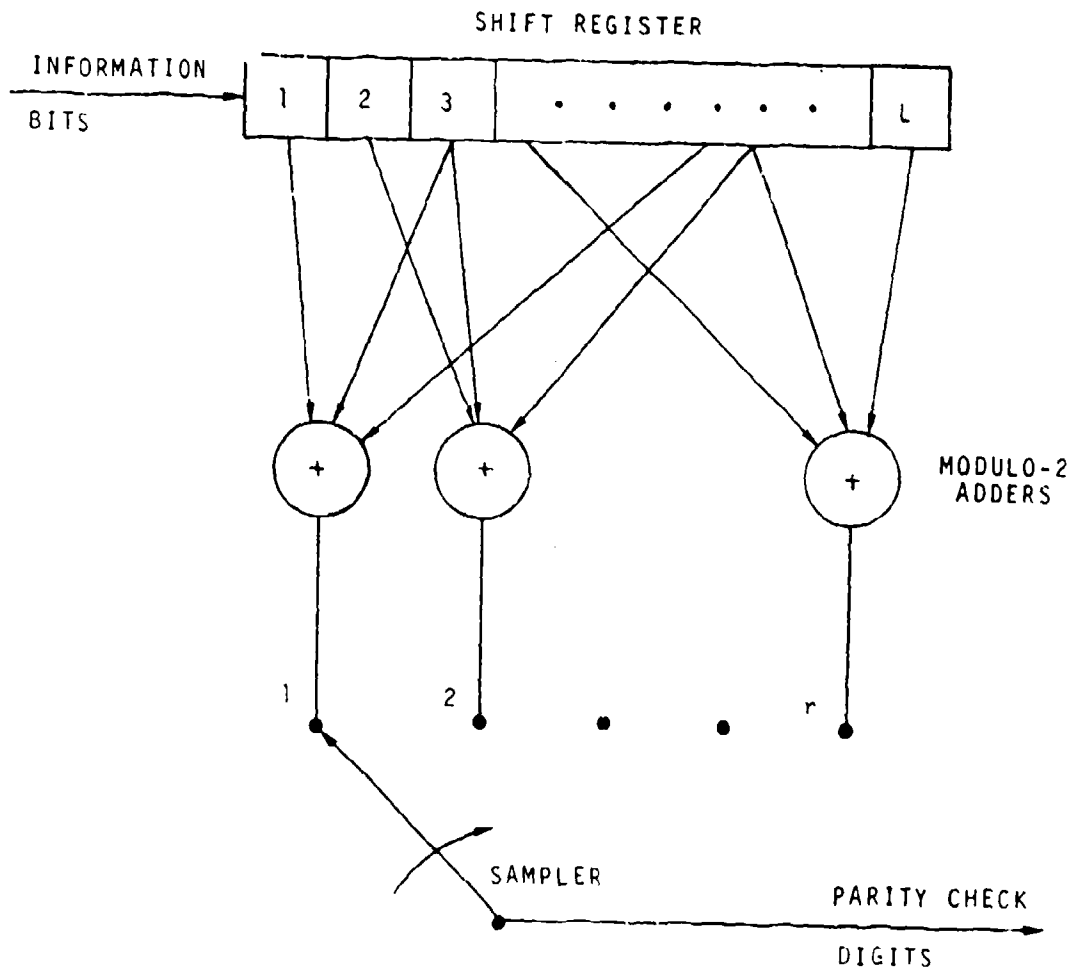

Figure 4-14. Convolutional Encoder

down for a 0. The r digits occurring on the branch selected correspond to the output symbols. A particular sequence of information bits then describes a particular path through the code tree. This will be illustrated by the following example.

Consider the rate $1/2$ encoder of Figure 4-15 and let the shift register contain all zeros initially. Now assume that the input sequence of information bits is 1100, The path defined by this sequence is illustrated as the heavy line in the code tree of Figure 4-16. Since the code generated by this encoder is a systematic code, the first digit of the output at each branch is the information bit, as shown in Figure 4-15. The second digit is the output of the modulo-2 adder in Figure 4-15. After the first information bit is fed into the shift register, the contents are 1000000, ..., so that the output of the adder is a 1 and is shown as the second digit on the first branch of the code tree. After the second input to the shift register, the contents are 1100000, ..., and the adder output is a 0; this is easily seen since the modulo-2 sum of an even number of 1s is a 0. Continuing in this fashion, the remaining portion of the tree can be constructed. It should be noted that unlike block codes, convolutional codes have no formal block structure in the generated code words. That is, past information bits do have an influence on the symbols used to represent a present information bit. The code can be constructed by taking the convolution of the shift register tap connection set (code generating polynomial) with the information bit pattern; hence the name convolutional codes.

Decoding algorithms for block and convolutional codes are usually quite different. The formal structure of the block encoded words permits decoding by taking advantage of the the known structural properties of the words or the algebraic nature of the constraints among the symbols used to represent an information sequence. Examples of decoding algorithms for block codes are the algebraic decoding techniques of Peterson, Chien and Berlekamp for the Bose-Chaudhuri (BCH) codes. Decoding of convolutional codes, on the other

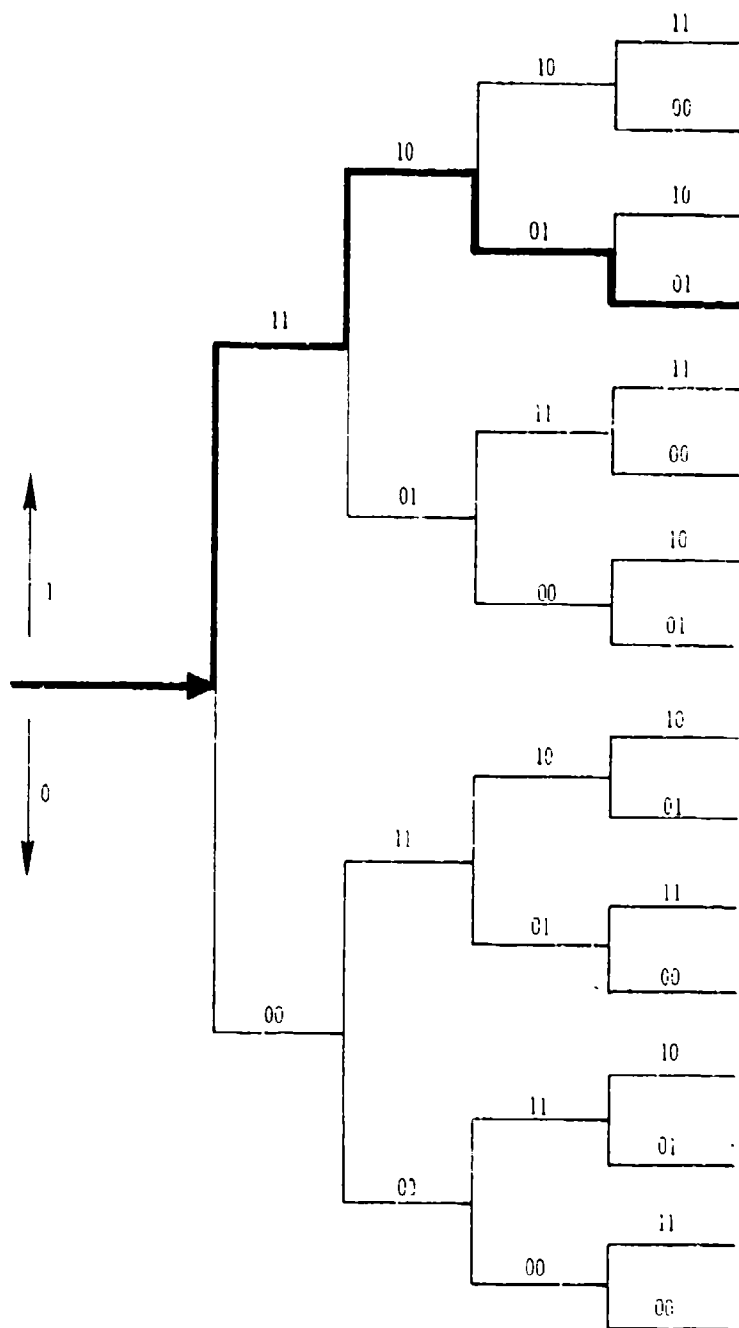

Figure 4-16. A Code Tree

hand, is often done using the probabilistic techniques of Wozencraft (sequential decoding) or Viterbi (Viterbi decoding). These latter techniques rely not on the algebraic structure of the code words but on the ability to home in on the correct sequence by designing efficient search procedures that discard unlikely sequences very quickly. As an example, consider a sequential decoding algorithm for convolutional codes. The symbols presented to the decoder are the symbols generated as described in Figure 4-14 after they have been corrupted by noise. In a communication system the output of the demodulator would constitute the decoder input. Assume that the symbols presented to the decoder are 1s and 0s, each symbol being in error with probability p (i. e., assume a binary symmetric channel).

The decoder contains a duplicate of the encoder, whose shift register contains the received information bits. By comparing the input-code-plus-noise symbols at the input to the decoder with the symbols found at branch points of the tree as in Table 4-1 the decoder attempts to find the most probable path through the code tree.

The sequential decoder differs from most other types of decoders in that, when it finds itself on a wrong path in the tree, it has the ability to search back and forth, changing previously decoded information bits, until it finds the correct path. The frequency with which the decoder has to search back, and the depth of these backward searches, is dependent on the value of the channel error probability (p).

One of the most important properties of a sequential decoder is that, if the chosen constraint length is large enough, the probability that the decoder will make an error becomes negligible (e. g., less than 10^{-9}). The type of error that becomes significant is the occurrence of an overflow, which is defined as being a situation in which the decoder is unable to perform the necessary number of computations in the performance of the tree search. To be more precise, a computation is defined as having occurred when the decoder

Table 4-1. Sequential Decoding Procedure

Message	1	1	0	0	Notes
Code	11	10	01	01	Fig. 4-16
Noise	00	10	00	00	Assumed
Input	11	00	01	01	Code + Noise
<u>Decision</u>				<u>Total</u>	
1 Go To	11				
	00			0	determinate
2 Try	11	10			
	00	10		1	
Try	11	01			
	00	01		1	same as above
3 Try	11	10	10		
	00	10	11	3	
Try	11	10	01		
	00	10	00	1	lowest possible
Try	11	01	11		
	00	01	10	2	check
Try	11	01	00		
	00	01	01	2	check
4 Go To	11	10	01	01	
	00	10	00	00	1
Try	11	10	01	10	
	00	10	00	11	3
					check

NOTE: Total is sum of digits in sum modulo 2 of Input and line above Total

⊕ = modulo 2 addition; e. g., 1 ⊕ 1 = 0

examines a path through the decoding tree. Since the decoder is able to search back and forth through the tree, and does so according to how the errors arrive at the decoder input, the number of computations the decoder must make to decode one information bit is a random variable. An important parameter in the system then becomes the average number of computations per decoded information bit. As long as the channel error probability (p) is not too high, the probability of decoder overflow will be acceptably low and thus satisfactory performance results.

The performance of block decoding algorithms, however, is determined by the number of errors that the code is guaranteed to correct (t) in a block of N received symbols. If the channel error probability (p) is too high then the probability of obtaining $t + 1$ or more errors in a block of N symbols becomes significant and hence the decoder will fail in its attempt to identify the transmitted code word.

Up to this point it has been assumed that the demodulator supplies only hard decisions (that is, the demod output has been hard-limited) to the decoder. If instead the demodulator output is quantized into 4 or 8 levels (2- or 3-bit quantization, respectively), certain decoding algorithms can use this additional information to obtain a lower probability of output bit error than if supplied only with hard decisions. Both the sequential and Viterbi decoding algorithms can effectively use this soft-decision demodulator information, giving these algorithms a distinct advantage over algebraic decoding techniques that cannot easily account for this added information in making a final decoder decision.

To gain some insight into the performance of error-correcting codes on random error channels, Figure 4-17 is plotted. Five codes of moderate complexity are shown. These are: BCH (15, 7), Golay (24, 12), Viterbi ($K=4$), diffuse threshold ($K=4$) and sequential decoding.

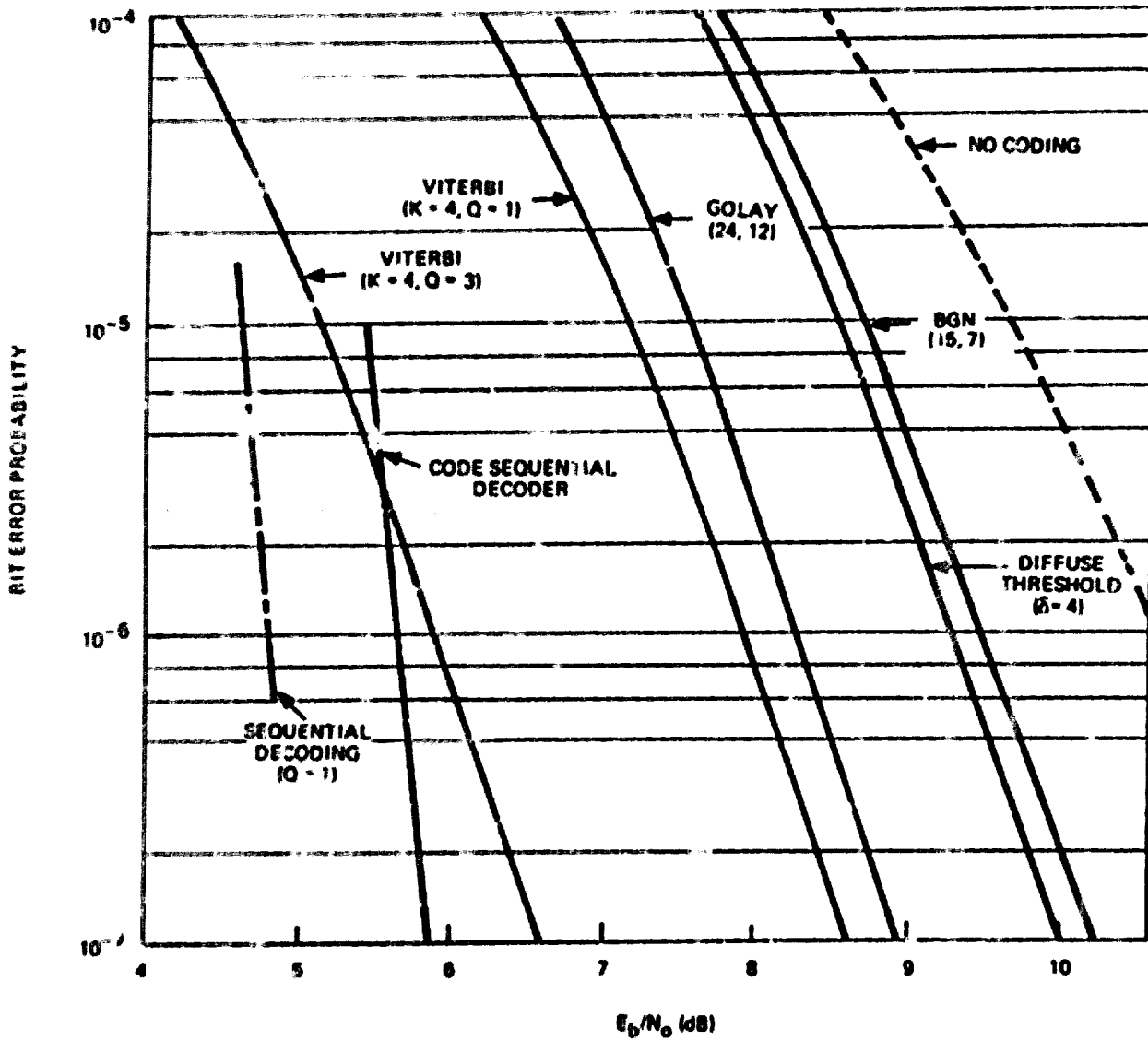

Figure 4-17. Error Correcting PSK Code Performance

The curve for the sequential decoder is based on a rate 1/2 code operating on a hard-decision binary symmetric channel (BSC). The curve is shown as a nearly vertical line to emphasize the relative insensitivity to undetected errors. One of the curves for a Viterbi decoder is for 3-bit quantization ($Q=3$) and the other is for the hard-decision case ($Q=1$). The remaining curves are based on calculations. Several observations from Figure 4-17 are worthy of note.

For the parameters shown, the Viterbi decoder with $Q=1$ provides performance exceeding that of the block codes and the threshold decoder. The advantage of the Viterbi decoder is even more apparent when quantization is considered. Using a quantized version of the demodulator output, in lieu of hard decisions, improves performance on the order of 2 dB. This improvement may not be directly realized with block codes.

Another pertinent observation from Figure 4-17 is the increased slope of the sequential decoder curve. This may be particularly important in regard to performance requirements on the order of $P_E \leq 10^{-10}$.

As an example of how effective FEC techniques can be in a satellite communication system, consider the performance of the coded systems in Figure 4-17 relative to the no-coding (ideal PSK demodulation) system also shown in this figure. For a 10^{-5} output bit error specification, the improvement in required E_b/N_o for these systems is shown in Table 4-2. As shown, the largest coding gain is supplied by the sequential decoder, 5 dB. This means that for a fixed received average power to thermal noise density ratio (P_r/N_o), the sequential decoder system can support a 5-dB higher data rate (3.2 times more data) than the uncoded system, or correspondingly, the same data rate as the uncoded system with 5 dB less average power. Furthermore, if even lower output probability of bit error rates are required than 10^{-5} , the gain of the coded systems (particularly sequential decoding) relative to the uncoded system is even more impressive. Finally, it should be emphasized

Table 4-2. E_b/N_o Coding Gain for Several Coded Systems

System	Required E_b/N_o at 10^{-5} (dB)	Gain (E_b/N_o Uncoded - E_b/N_o Coding) dB
No Coding	9.6	-
(15, 7) BCH	8.65	1
Threshold	8.5	1.1
Golay (24, 12)	7.5	2.1
Viterbi (Q=1)	7.1	2.5
Viterbi (Q=3)	5.1	4.5
Sequential (Q=1)	4.6	5

that this sizable coding gain comes at the expense of only a 2 to 1 increase in channel bandwidth. All the coded designs shown operate at a code rate of 1/2 (bits/symbol) and hence the bandwidth required, for a fixed modulation method, is twice that of the uncoded system design. That is, the symbol rate is 2 times the data rate with a rate 1/2, bit per symbol code. This is a very moderate price to pay for the dramatic savings in satellite power obtained with sequential or Viterbi decoding.

SECTION 5 - SATELLITE LINK ENGINEERING

5.1 GENERAL

The design of a satellite communications link involves many interrelated factors. This section describes the general design considerations applicable to many types of satellite communication links. The key parameters are described and typical values are given. The section describes the characteristics of traffic carried by the link, the considerations involved in the choice of a frequency for the link, and the bandwidth requirements of the traffic and bandwidth capabilities of the important link elements. The important parameters and the performance of satellite uplinks and downlinks are defined and examples given. Finally, link performance requirements are related to the kind and amount of traffic that may be carried. This results in development of tables relating traffic requirements to satellite transponder power, which is a crucial element in the overall satellite communication system design.

5.2 TRANSMISSION REQUIREMENTS

5.2.1 Analog Requirements and Standards

Two types of analog signals that are transmitted are voice and television. An analog voice channel is allocated a 4-kHz bandwidth. As described in Section 4, voice channels can be stacked by the FDM technique into groups of 12 channels and into supergroups of 60 channels (5 groups) for modulation of a carrier. The important parameters to be controlled for end-to-end voice transmission on a global-quality channel are:

- Gain variation versus frequency: -3 dB to +6 dB referenced to 1000 Hz over: 200 Hz to 3400 Hz
- Circuit Noise: Median value of 10,000 picowatts psophometric at a point of 0 dB transmission level (pWp0) per satellite hop plus 131 pWp0 for multiplex operations. This is equivalent to a weighted test tone-to-noise ratio at the receiver of 50 dB

- Echo magnitude: 30 dB or more round-trip echo loss.

The values given are military specifications for a global-quality voice channel, applying to DSCS Phase II Stage 2. For Stage 1, 25,000 pWp0 are permitted.

The commercial recommendation for a television channel is a video bandwidth for 5 MHz and a ratio of signal to weighted noise at the receiver of at least 55 dB for 99 percent of the time.

Voice is the normal analog communication signal currently used in military communications. In designing an analog voice communications system account must be taken of the characteristics of speech signals and the statistics of telephone talkers. In general, the amplitude of a single speech signal can vary as much as 30 dB. For transmission, it is important to keep the average power as high as possible without clipping the speech too much in peak-power-limited systems. It has been experimentally determined that the average power can be maintained about 2 dB below the clipping level without causing the peaks to be clipped more than 0.01 percent of the time when the number of channels is very large.

When a number of analog voice channels are multiplexed for transmission, the average total signal power is much less than the simple addition of individual channel powers. The speech load factor is not constant and it has been determined from statistical analysis of telephone traffic that the average power, P , in dB due to N channels, relative to the test-tone power of 1 milliwatt is:

$$P = -15 + 10 \log N \quad N > 240$$

$$P = -1 + 4 \log N \quad 12 \leq N \leq 240 \quad (5-1)$$

5.2.2 Digital Requirements and Standards

The information to be transmitted digitally, initially, may be either analog or digital. If it is initially analog, then an analog-to-digital converter is required at the receiving transmission end and a digital-to-analog converter

may be required at the receiving end. Analog voice, for example, is usually digitized to 64 kilobits per second (kbps). This rate is based on an 8-kHz sampling rate and a 128-level (7-bit) amplitude quantization as discussed in Paragraph 4.2.2. An eighth bit is added for parity. Imagery is also digitized, resulting in high digital data rates.

The lowest digital data rate normally transmitted in a communications transponder is 75 baud (bps) teletype (TTY). If analog voice is also being transmitted, four or more TTY signals may be placed in one voice channel. The highest presently anticipated digital data rate traffic is about 10 megabits per second.

Digital data may be transmitted with or without coding. Coding increases the bandwidth but decreases the transmitted power required from the transponder. The criterion of system operation is the allowable bit error rate. In the DSCS this is specified as a maximum allowable error rate of one error in 10^5 bit for at least 99 percent of the time.

An important parameter in digital transmission is the required channel bandwidth. If it is not large enough, intersymbol interference will cause the bit error rate to increase above the prediction based on noise alone. It has been determined that if channel filters limit the RF spectrum to 1.25 times the bit rate, then intersymbol interference will be within acceptable values.

5.2.3 Antijamming Requirements

There is a requirement for certain links to be maintained in the presence of electronic interference (jamming). Jamming resistance is achieved by coding the information with a pseudorandom sequence to spread the spectrum of the transmitted signal to a bandwidth much greater than the information bandwidth. Two techniques for achieving this are frequency hopping the carrier in a pseudorandom fashion and superimposing modulation by a high bit rate, pseudorandom code, on the data modulation. The latter technique is called pseudorandom noise (PN). Digitized voice or data is used with these antijamming techniques.

The important characteristic of PN transmission is the wide bandwidth it requires since its effect is to spread the spectrum of the carrier. The digital data spectrum (data rate) must be small compared to the PN spectrum for the antijamming characteristic to be effective. Typically, the protection is proportional to the ratio of the carrier spread-spectrum bandwidth to the data bandwidth. The spectra of PN transmission and regular data transmission can overlap as long as the data rate carried by the PN transmission is relatively low.

5.3 BANDWIDTH CONSIDERATIONS

5.3.1 Analog Bandwidth Requirements

For FM transmission of a baseband signal, the RF bandwidth required is usually specified as the Carson's Rule bandwidth. For a baseband consisting of a single sine wave of frequency f_m , or a spectrum of highest frequency f_m , the Carson's Rule bandwidth, B , required is:

$$B = 2 f_m (\gamma + 1) = 2 (f_m + f_d) \quad (5-2)$$

where f_m = highest baseband frequency
 γ = modulation index
 f_d = highest deviation frequency

A voice signal is assumed to occupy a band from 300 to 3400 Hz. However, when multiplexing voice channels, 4000 Hz per channel is used to allow spacing between voice spectra. In addition, the lowest channel frequency used for voice may be higher than 0 to 4000 Hz, typically 12,000 Hz to 16,000 Hz. Thus for N multiplexed channels f_m is taken as $12,000 + 4000 N$ Hz. To determine the required bandwidth the modulation index, γ , must be found. Two simultaneous equations must be solved to determine γ and the bandwidth. One equation relates the carrier power-to-noise density ratio at the earth terminal receiver to γ and f_m . The other equation relates the received carrier-to-noise density ratio to the required demodulated voice signal-to-noise ratio, to γ and f_m , and to several fixed factors.

Based on the previous signal power-bandwidth discussion there is a trade-off of power and bandwidth to assure satisfactory operation of a link. Therefore, the bandwidth required depends on the margin designed into the system. The higher the margin, the smaller the bandwidth. Examples of required bandwidths are given in Paragraph 7.3.2.

5.3.2 Digital Bandwidth Requirements

PCM requires sampling an analog signal at twice the rate of the highest frequency in the spectrum. The amplitude of each sample is then quantized at a number of levels and a binary code is generated to indicate the level of each sample. This leads to a pulse repetition rate considerably higher than the highest analog frequency present. As discussed previously, an analog voice signal whose highest frequency is 3400 Hz is encoded into 64,000 bits per second.

The bandwidth of a digital modulation system is related to the bit rate. For binary digital modulation the required bandwidth is 1.25 times the bit rate for PM and twice the bit rate for FM. One of the important aspects of digital modulation is that it provides the opportunity of bandwidth compression. This is denoted as L-level digital modulation and is accomplished by modulating the carrier's amplitude, frequency or phase so that a number of amplitudes, frequencies or phases can be represented by one symbol. If $L = 2$ then we have binary modulation. In practically all cases more power is required to maintain the same bit error rate as L increases. The one exception is quadriphase ($L=4$) for PM where the required power is the same as with $L=2$ for a given bit error rate.

Another possibility with digital modulation is increasing the bandwidth to reduce the power requirements for a given bit error rate. This is accomplished by the so-called M-ary digital modulation techniques. In these techniques n consecutive symbols of the data sequence are used to select and transmit one of $m = 2^n$ stored signals. The m stored signals are chosen to bear specific relationships to each other that result in lower required signal power.

5.4 FREQUENCY CONSIDERATIONS

5.4.1 Frequency Bands and Characteristics

In considering frequencies suitable for communication satellites, propagation and environmental conditions must be taken into account. The frequency should be above 100 MHz to avoid ionospheric reflection and to permit reasonable bandwidths. The ionosphere above 100 MHz changes the polarization of the transmitted signal (Faraday rotation effect). Above 1 GHz Faraday rotation is not generally considered a problem. However, between 500 MHz and 5 GHz there may be a greater or lesser effect as a function of latitude, season and time of day. Above 1 GHz the propagational effect of importance is frequency-dependent attenuation of the signal due to the atmosphere. The principal absorbing elements in frequency bands currently being considered are rain, water vapor absorption and oxygen absorption. The attenuation produced by ice particles in the atmosphere occurring as hail, snow, or ice-crystal clouds is much less than that caused by rain at an equivalent precipitation rate. The attenuation due to rain is considered negligible at L- and S-Band but at X-band it can be appreciable. Table 5-1, based on theoretical analysis, shows typical attenuation versus ground antenna elevation angle at 8 GHz in an earth terminal-satellite link. Figure 5-1 presents theoretical values of attenuation in a number of frequencies versus rainfall rate. Attenuation due to water vapor absorption peaks in narrow bands around 60 GHz and 120 GHz.

The environmental effect of importance in frequency consideration is the radio noise seen by the earth terminal and satellite antennas. This noise arises from sky sources (galaxy), our own sun, the atmosphere, and the earth radiating as a black body at 200°K. In addition, rain will present a noise background associated with its attenuation. Table 5-1 presents some typical rain-induced noise temperatures at 8 GHz.

Table 5-1. Atmospheric Attenuation and Antenna Noise Temperature Versus Elevation Angle and Weather Conditions at 8 GHz

Weather Conditions	Atmospheric Attenuation at Various Angles (dB)					Antenna Noise Temp. at Various Angles (°K)				
	5°	10°	24°	27°	35°	5°	10°	24°	27°	35°
Clear	0.45	0.25	-	-	-	22	14	-	-	-
Heavy clouds: 0.4 gm/m ³ (0.4 in./hr) at 3.5 km	0.75	0.47	-	-	-	46	27	-	-	-
Rain: 5 mm/hr (0.2 in./hr)	2.1	1.1	0.45	0.41	0.33	95	58	27	24	20
Rain: 10 mm/hr (0.4 in./hr)	4.5	2.4	1.1	0.95	0.75	160	120	57	53	44

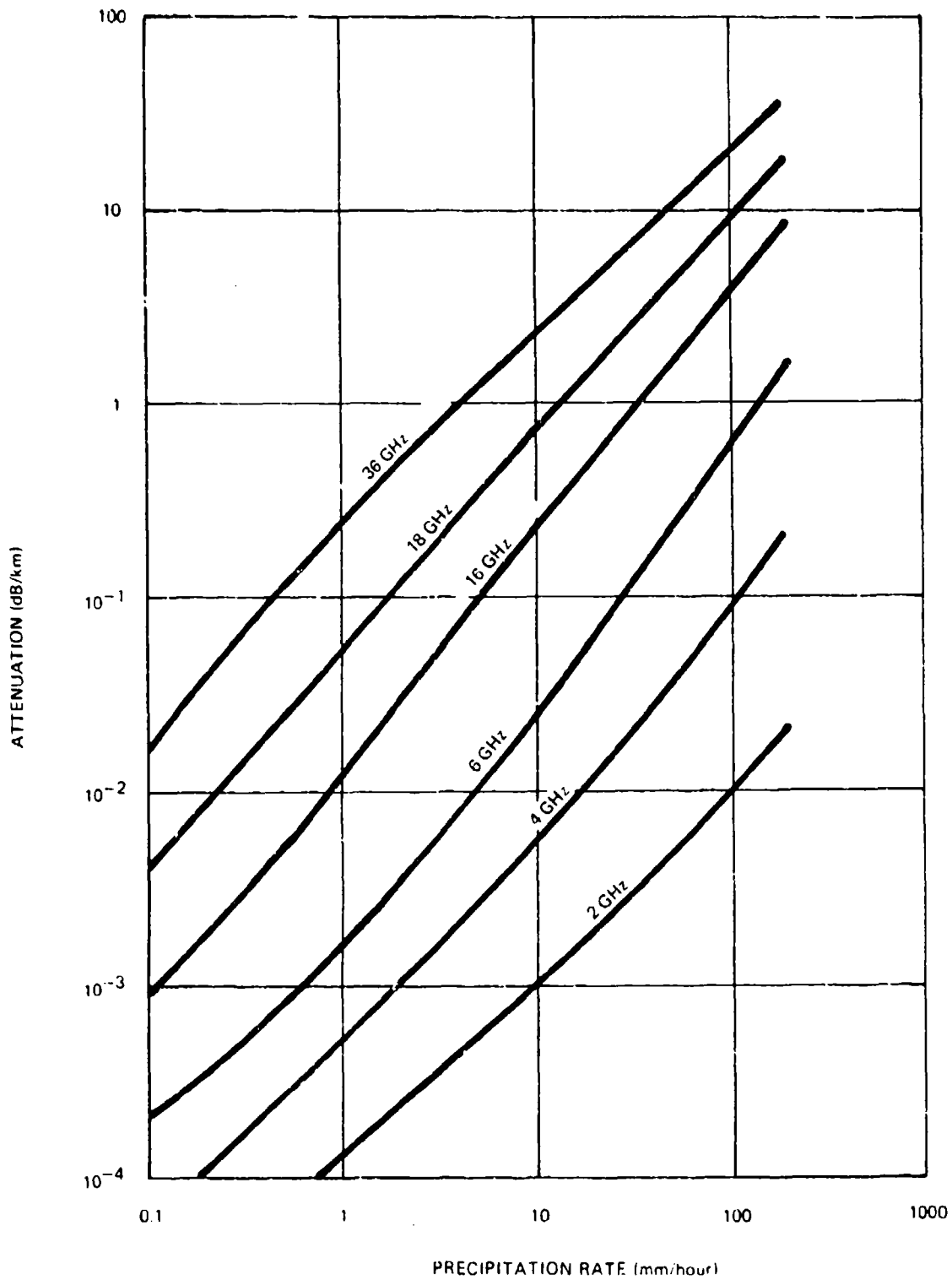

Figure 5-1. Theoretical Rainfall Attenuation for Various Frequencies

Galactic noise decreases with frequency, whereas atmospheric noise increases with frequency. A curve of the thermal noise background as seen by an earth terminal antenna has been derived (Figure 5-2) which takes account of all factors except rain. Figure 5-2 shows the almost flat characteristic that prevails above 1 GHz. Comparison of values in Figure 5-2 with those in Table 5-1 illustrates the importance of rain in determining both background noise temperature and signal attenuation.

5.4.2 Transponder Capabilities

At present, reliable transponder components are available through X-Band. The bandwidth capability increases with frequency, thus making the higher microwave frequencies more attractive for large bandwidth systems. For any given beamwidth the antenna size decreases with frequency. Antenna size and weight do not present limitations for earth coverage antennas, but for narrow beamwidths higher frequencies allow more reasonable antenna sizes.

Receiver noise figure is another important parameter. Figure 5-3 shows how this varies with frequency for various devices.

At present, power outputs of up to 40 watts have been achieved up to X-Band by paralleling two or more output devices. The transmitter efficiency decreases with frequency, as shown in Figure 5-4.

5.4.3 Intermodulation

1. General - When two or more carrier frequencies are simultaneously present in a nonlinear device, the output contains sum and difference frequencies (in addition to the original signals) of all multiples of the original signals. The additional frequencies generated produce two effects: if they fall within the passband of the transponder they take a share of the transmitter power and thus reduce the useful transmitter power; if their spectra overlap the spectrum of a desired signal, they interfere with the desired signal.

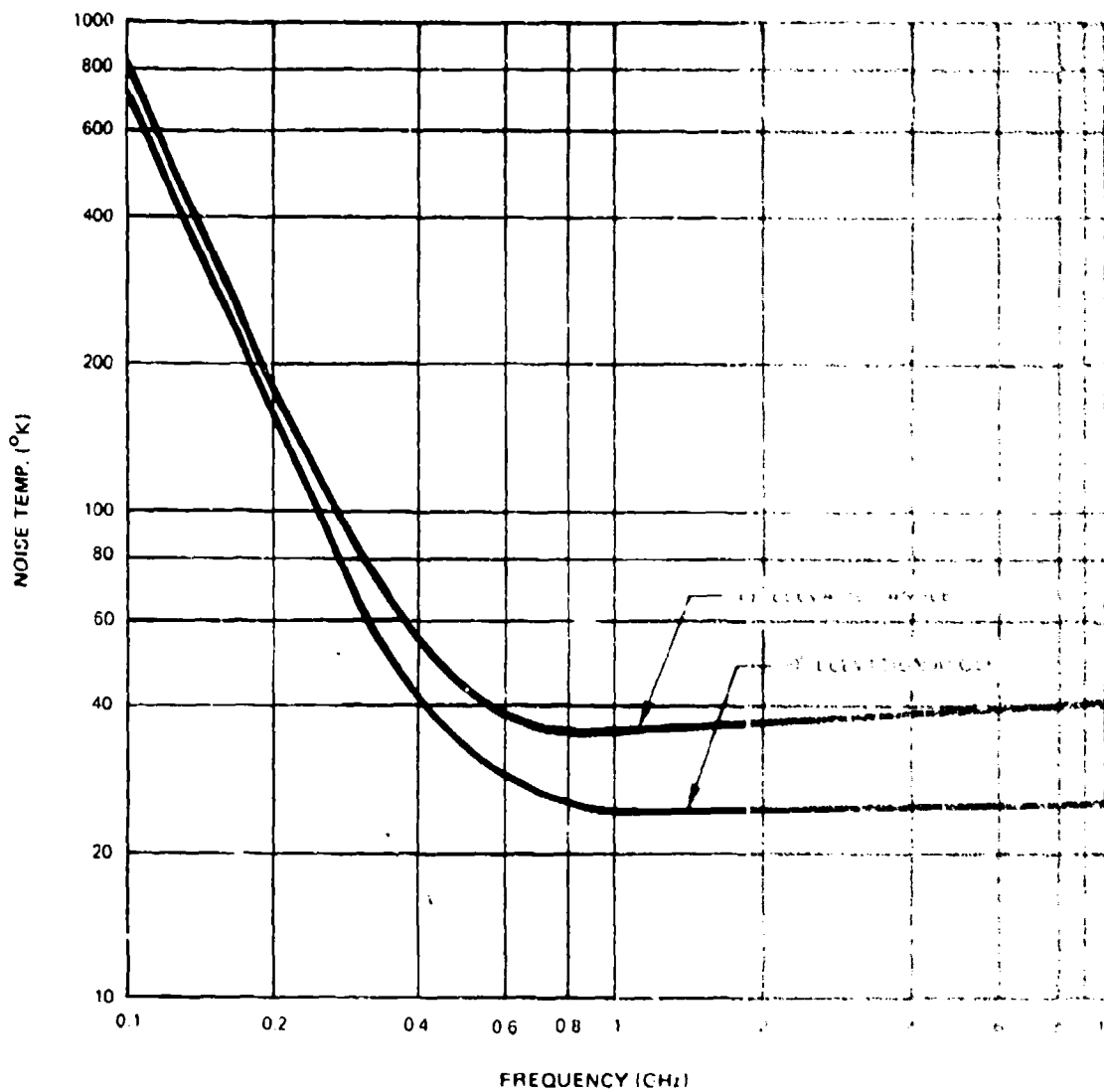

Figure 5-2. Frequency Versus Noise Temperature.

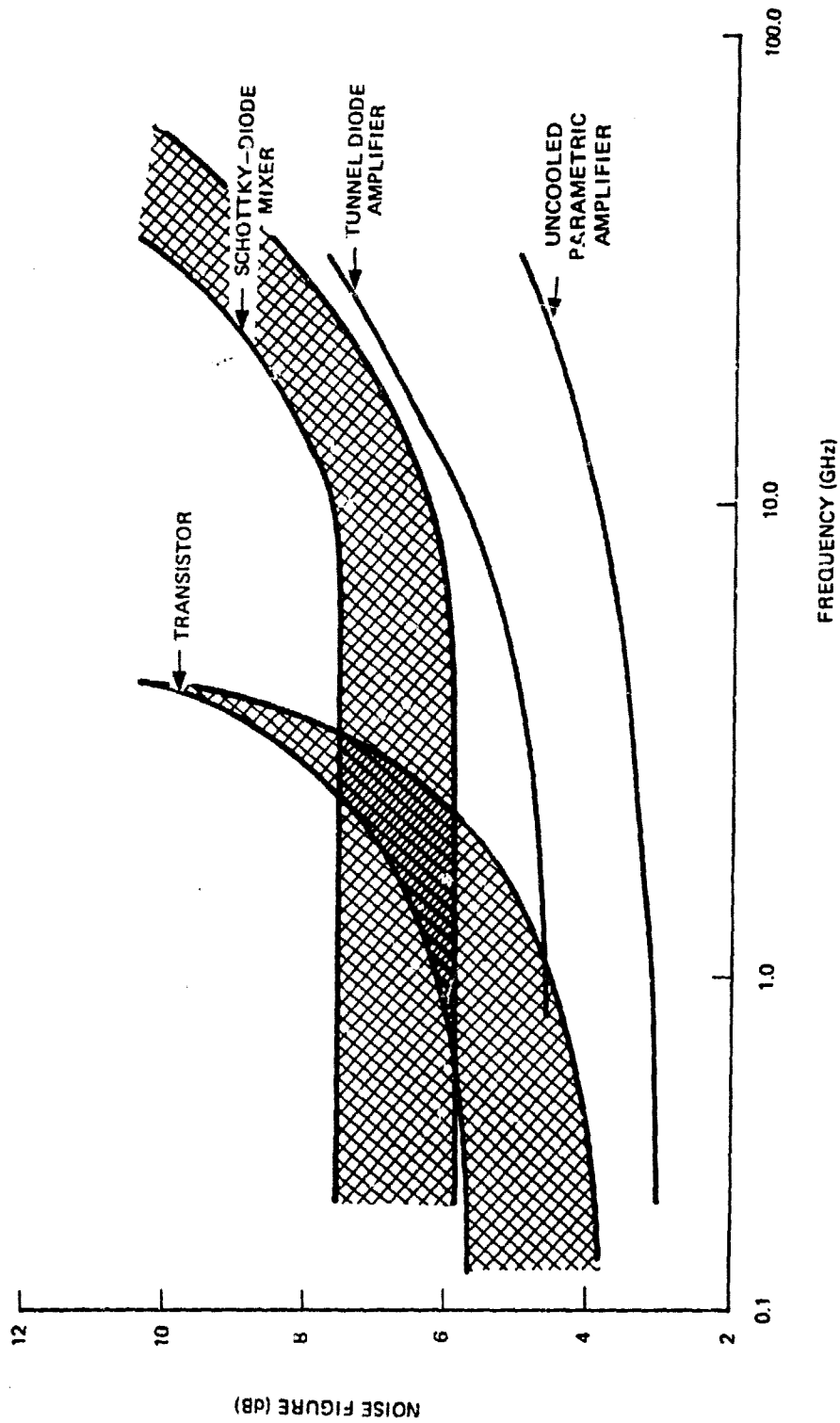

Figure 5-3. receiver Noise Figure Versus Frequency

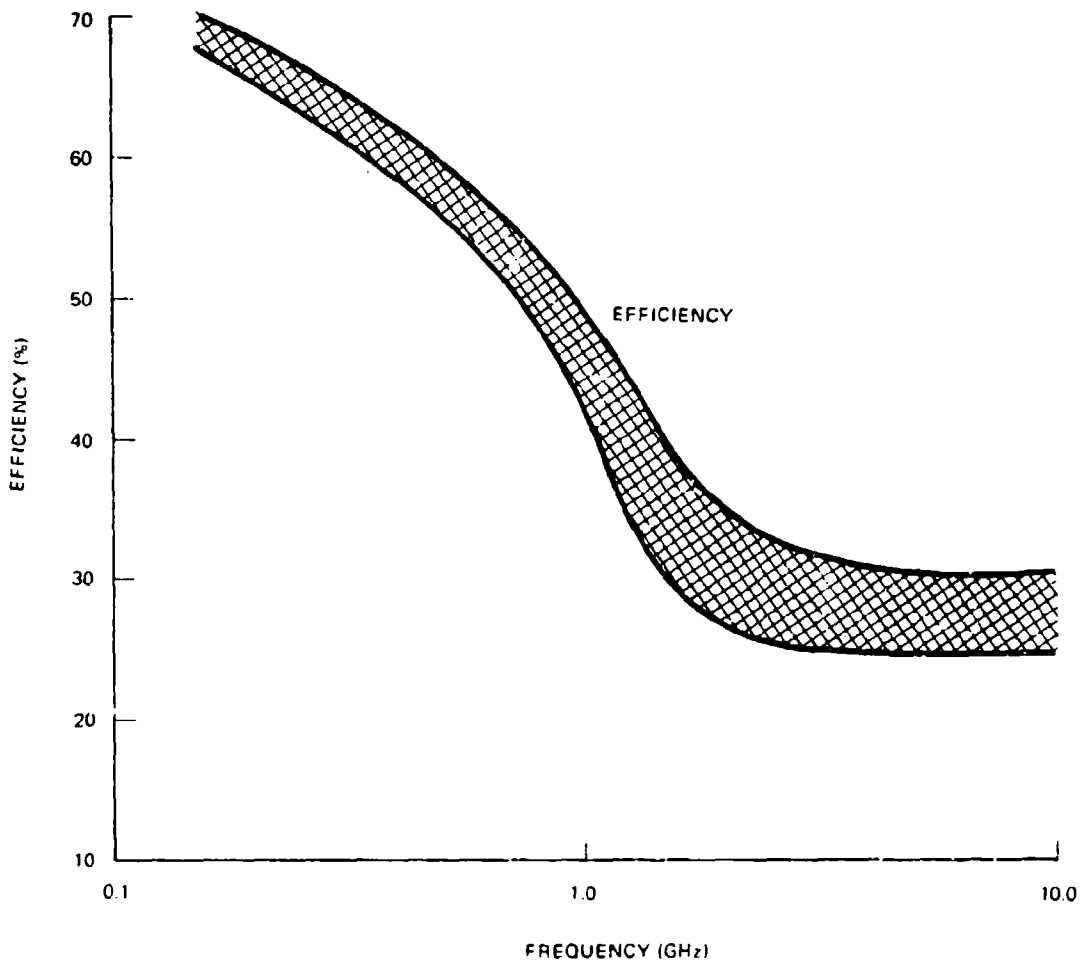

Figure 5-4. Transmitter Efficiency Versus Frequency

2. Uplink - Uplink interference due to intermodulation is normally much less than downlink.
3. Downlink - Downlink interference due to intermodulation is caused by limiting (saturation) in the output power device. At microwave frequencies this device is a traveling wave tube amplifier (TWTA). It is usually desirable to obtain as much power as possible from the output device since the transponder is power-limited. Studies have shown that with equally spaced input frequencies, the TWTA power output should be backed off 3 dB from its saturation power to reduce intermodulation to a tolerable level. Unequally spaced carriers allow higher output powers but at the cost of an increase in the required bandwidth or a smaller number of carriers within a fixed bandwidth.

5.5 SATELLITE LINK PARAMETERS

Basic Link Parameters

1. **Basic Link Equation** - The communication capacity that can be achieved over a satellite link is a function of communication system parameters. The relationship of the communication capacity and the parameters affecting it can be written in various ways. A form of the relationship that illustrates the important equipment, geometric, and system factors is given here and the various factors are discussed briefly. The equation presented holds strictly for one path of a repeater system; for example, ground transmitter-to-satellite receiver. The effect of the overall two-path link is also discussed.

The form of the equation with all terms expressed in decibels is

$$\left(\frac{C}{kT}\right) = (\text{EIRP}) - (L_{FS}) + \left(\frac{G}{T}\right)_R - (k) - L_o \quad (5-5)$$

where $k = -228.6$ dB. The other factors are discussed below.

2. Carrier-to-Noise Density (C/kT) - In the carrier-to-noise density expression (C/kT), C refers to the RF carrier power into the receiving system, k is Boltzmann's constant, and T is the receiving system noise temperature in °K. Note that kT is the noise power in a bandwidth of 1 Hz; hence the equivalent term, noise density. The significance of this expression comes from this factor's being basic to determining the channel capacity of a satellite communication link. Once the arbitrary factors such as desired channel S/N and modulation index have been determined, then channel capacity can be determined from C/kT .
3. Effective Isotropic Radiated Power (EIRP) - Effective isotropic radiated power (EIRP), a term that has been found convenient for use in describing the power radiated from a terminal, is the product of the transmitter power output and the antenna gain, or in decibels, $EIRP = P_s + G_s$. For instance, a satellite transponder with a 20-watt final amplifier and an antenna with a gain of 10 dB would have an EIRP of 200 watts or 23 dBW.
4. Free Space Loss (L_{FS}) - Free space loss is the loss in signal level experienced by an electromagnetic wave of frequency f , traveling a distance d , between two isotropic (omnidirectional) antennas. It is related to the product $f^2 d^2$ by a constant whose value is dependent on the units of d and other fixed factors. (See Figure F-1 in Appendix F.)
5. Receiving System Figure of Merit G/T - The parameter G is the gain of the receiving antenna. The receiving system noise temperature T is described by

$$T = T_A + (L - 1) T_L + LT_R \quad (5-6)$$

where: T_A = antenna noise temperature

L = transmission line loss between the antenna and the low-noise amplifier

T_L = ambient temperature of the transmission line loss

T_R = amplifier noise temperature

For high-quality receiving systems, the ratio of G/T describes how well the antenna and receiver front end combination acts to achieve a high C/kT at the receiver. As indicated by Equation (5-6), antenna design affects not only G but T , through the contribution of T_A .

6. Transmission Losses (L_0) - Transmission losses include such items as polarization mismatch between satellite and ground antennas, tracking loss due to misalignment of high-gain ground antenna power, losses in satellite in coupling of transmitter to antenna, and rain attenuation, if applicable at the frequency being used.
7. Two-Path Link - The two-path earth terminal-repeater-earth terminal link results in the C/kT at the earth terminal being to some extent affected by the C/kT at the satellite. The extent is a strong function of the transmitted EIRP and the type of transponder--linear or hard-limited. For a linear transponder, as the Phase II satellite will be in Stages 1a, 1b and 1c, the C/kT at the receiver, $(C/kT)_R$, is

$$\left(\frac{C}{kT}\right)_R = \frac{1}{\left(\frac{1}{C}\right)_{UL} + \left(\frac{1}{kT}\right)_{DL}} \quad (5-7)$$

where $(C/kT)_{UL}$ = uplink C/kT at satellite receiving antenna

$(C/kT)_{DL}$ = downlink C/kT at earth terminal antenna

5.6 USE OF BASIC LINK EQUATION

5.6.1 Downlink Considerations and Examples

To predict the C/kT at the earth terminal the values of the contributing parameters have to be known. As these parameters will have a statistical distribution assumed to be rectangular, the mean and variance of each parameter has to be determined. Then a margin (excess transmitted power) has to be available so that minimum allowable C/kT is achieved for a given percentage of the time.

Table 5-2 presents a summary of a statistical power budget for an X-Band military communications satellite at slightly subsynchronous altitude. The tabulated values apply to two-input operation where the satellite power is shared. Thus item 2, carrier level below power output, refers to sharing of satellite power by the two inputs. The example uses a two-input situation to illustrate that the power sharing also has a statistical variation.

The right side (downlink) of Figure 5-5 presents typical values of the important parameters for a simplex AN/TSC-54 to AN/TSC-54 link through one of the channels of the Phase II military communications satellite operating at X-Band. The G/T of the ground terminal is typical for medium-sized terminals that are currently being implemented or designed. The satellite beam-edge EIRP of 28 dBW is based on the end-of-life output power of the TWT. With several simultaneous accesses there would have to be a backoff of power to reduce intermodulation.

The effect of rain has been neglected in the above discussion. A margin based on statistical distribution of rain has to be included in a system design.

Table 5-2. Summary of Means and Variances for
a 6-Foot Terminal at 60° Latitude

Parameter	Two Signals	
	Mean (dB)	Variance (dB) ²
1. Repeater transmitter power output (dBm)	48.9	0.70
2. Carrier level below power output (dB)	-3.5	0.08
3. Satellite transmitting antenna system gain (dB)	4.4	0.21
4. Free space attenuation (dB)	-201.35	
5. Atmospheric absorption (dB)	-0.25	0.37
6. Tracking error loss	-0.15	0.01
7. Receiving antenna gain (dB)	39.7	0.07
8. Polarization loss (dB)	-0.25	0.01
9. Power control error (dB)	-0.1	0.33
10. Net carrier (dBm)	-112.6	1.78
11. Ground terminal noise power density (dB/Hz)	-173.0	
12. Net C/kT	60.4	1.78

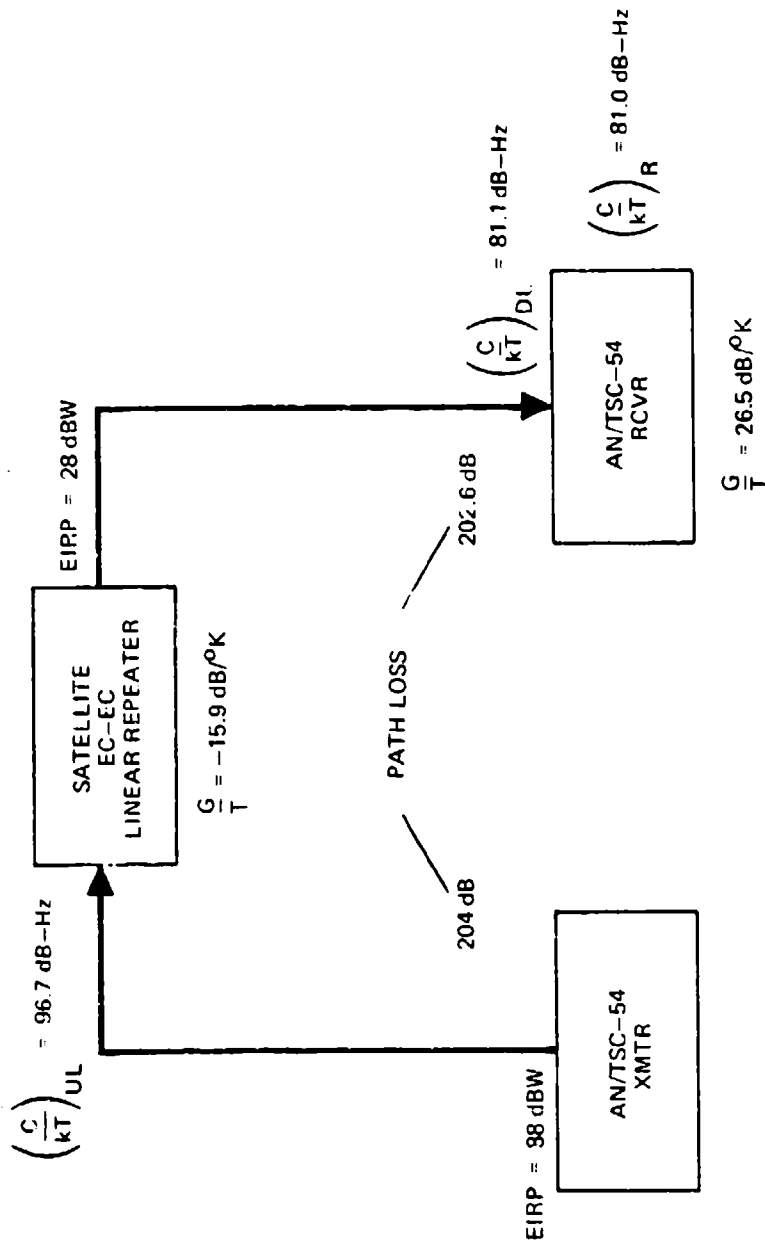

Figure 5-5. Typical Single Access Link

2. Coding Considerations - The best-known codes allow the required value of $\frac{E_b}{N_0}$ to be reduced by 3 to 5 dB for a given type of modulation and value of P_E . The use of rate 1/2 convolutional encoding-maximum likelihood decoding results in an improvement factor of 4 dB. Rate 1/2 means that the transmitted symbol rate is twice the information bit rate, thus doubling the bandwidth required. This type of code is becoming widely used because the increase in equipment complexity is less than with other codes for the same improvement in performance.
3. Relationship of Data Rates to Satellite Power (EIRP) - Using Equation (5-8) the relationship between C/kT and data rate R can be written in dB as

$$C/kT = (E_b/N_0) + R + M \quad (5-9)$$

where M is the desired margin.

By substituting in Equation (5-5), the equation for the satellite EIRP required for receiving a given data rate at any size (G/T) terminal can be obtained.

$$EIRP = E_b/N_0 + R + M - G/T + L + k \quad (5-10)$$

Table 5-3 shows the satellite EIRP required for various data rates and earth terminal figures of merit. The table values are based on Equation (5-10) and the following assumptions:

$$E_b/N_0 = 10 \text{ dB uncoded; } 6 \text{ dB coded}$$

$$M = 6 \text{ dB}$$

$$L(\text{Free Space + Miscellaneous Losses}) = 203.6 \text{ dB}$$

$$k = -228.6 \text{ dB (Boltzmann constant)}$$

Table 5-3. Required Satellite Power Versus Data Rate

G/T (dB)	1 Mbps (dBW)	1.53 Mbps (dBW) Uncoded	3.07 Mbps (dBW)	6.14 Mbps (dBW)
20	31	32.9	35.9	38.9
25	26	27.9	30.9	33.9
30	21	22.9	25.9	28.9
35	16	17.9	20.9	23.9
39	12	13.9	16.9	19.9
		Coded		
20	27	28.9	31.9	34.9
25	22	23.9	26.9	29.9
30	17	18.9	21.9	24.9
35	12	13.9	16.9	19.9
39	8	9.9	12.9	15.9

5.6.4 Analysis of Analog Requirements

1. FM Equations - The carrier-to-noise density at the receive earth terminal required to support a given access is determined by solving two simultaneous equations. The first equation (Equation 5-11) shows the test-tone-to-noise ratio, TTNR, as a function of carrier-to-noise density, C/kT , highest frequency in the baseband, f_m , and the peak deviation, f_d . The second equation (Equation 5-12) gives the relation between C/kT , f_m , f_d , and the carrier-to-noise ratio at the modem threshold, CNR_{Th} plus the required margin, M . Solving these two equations simultaneously enables one to compute the C/kT and corresponding peak deviation that yields the desired quality and margin for the given value of f_m and the number of voice channels.

$$\text{TTNR} = 5 \frac{C}{kT} \cdot \frac{f_d^2}{\left[f_m^3 - (f_m - 3.1 \times 10^3)^3 \right]} \cdot \frac{\text{PDI}}{P_f L_f} \quad (5-11)$$

$$\frac{C}{kT} \cdot \frac{1}{2(W_i + f_m)} \cdot \text{CNRTh} \cdot M \quad (5-12)$$

Equations (5-10) and (5-11) may be rewritten in terms of dB, as follows:

$$\begin{aligned} \text{TTNR} = \frac{C}{kT} + 10 \log 3 + 20 \log f_d + \text{PDI} - L_f - P_f \\ - 10 \log \left[(f_m)^3 - (f_m - 3.1 \times 10^3)^3 \right] \end{aligned}$$

$$\left(\frac{C}{kT} \right) = \text{CNRTh} + M + 10 \log \left[2(f_d + f_m) \right]$$

where: C/kT = carrier-to-noise density at receiving earth terminal, in dB

f_d = peak composite deviation, in Hz

f_m = highest frequency in baseband, in Hz

PDI = pre-emphasis improvement factor, in dB

P_f = peak factor = 12 dB

L_f = multichannel load factor, in dB = $-1 + 4 \log N$

N = number of voice channels

M = desired margin, in dB

CNRTh = carrier-to-noise ratio at modem threshold

To illustrate how Equations (5-11) and (5-12) are used, the solution to a particular situation is demonstrated below. Consider the following case:

$$\text{TTNR} = 44.2 \text{ dB (i. e., channel noise - 24,000 pwp)}$$

$$M = 6 \text{ dB}$$

$$\text{CNRTh} = 6 \text{ dB}$$

$$N = 12 \text{ channels}$$

$$f_m = 60 \text{ kHz}$$

$$\text{PDI} = 3.8 \text{ dB}$$

Substituting these values in the two equations written in terms of dB we obtain

$$\text{TTNR} = 44.2 = \frac{C}{kT} + 20 \log f_d - 142.1$$

$$\frac{C}{kT} = 6 + 6 + 10 \log [2 f_d + 1.2 \times 10^5]$$

Solving these two relationships simultaneously will yield the value of C/kT required to support the 12-voice channel example. A graphical solution of these equations is very often performed. For the 12-channel case, the required C/kT is found to be 72.3 dB/Hz, and $f_d = 0.5$ MHz.

2. Relationship of Analog Quantity/Quality Requirements to Satellite Power - With the method discussed above, the C/kT corresponding to any set of conditions can be calculated. The following relationships allow easy interpolation for variations in several parameters.

- For every dB increase (or decrease) in the desired quality (TTNR), the required C/kT increases (or decreases) by 1/3 of a dB.
- For every dB increase (or decrease) in the desired margin, the required C/kT increases (or decreases) by 2/3 of a dB.

Table 5-4 shows the C/kT required versus number of voice channels for a TTNR of 44.2 dB, the DSCS voice standard. These are plotted in Figure 5-6.

Table 5-4. Required C/kT Versus Number of Voice Channels

Number of Channels	C/kT
1	68.0
2	69.1
3	69.9
6	71.3
12	72.3
36	75.8

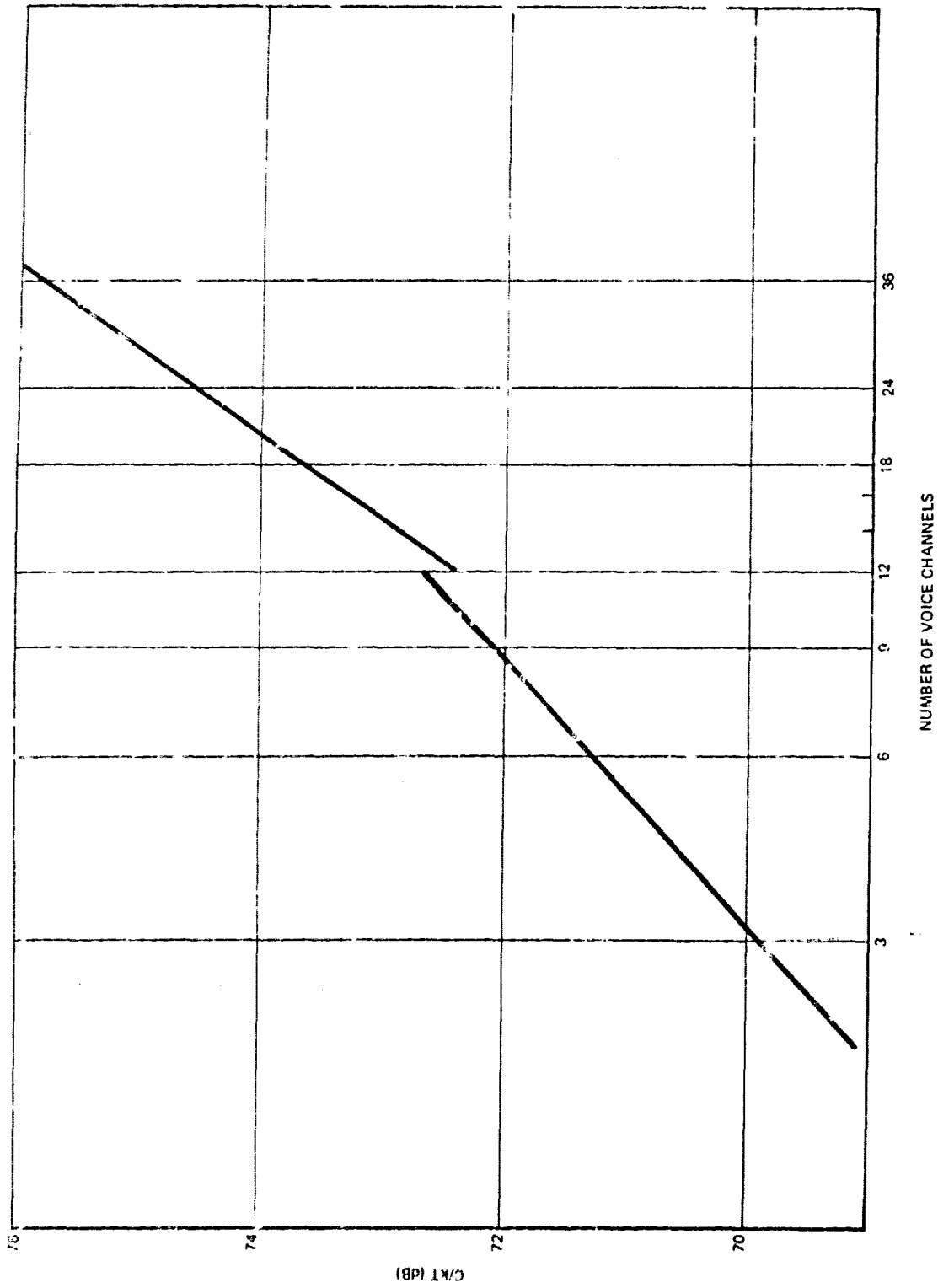

Note: Lines are not continuous due to preemphasis and load factor variations.

Figure 5-6. Number of Voice Channels Versus C/kT

SECTION 6 - SYSTEM CONSIDERATIONS

6.1 GENERAL

The preceding sections have described the space and earth subsystems and their components and relationships, including link engineering. This section describes the parameters that affect the operation of several links through one satellite as well as other factors influencing system operation.

In satellite system engineering, it is the satellite transponder that is the central limiting factor. The satellite deployed in space has a limited amount of power (EIRP) and bandwidth to share among the various earth terminals that access it. Thus a system can become either power or bandwidth limited if all of either resource is fully committed and additional communication requirements must be met through the satellite.

To date the requirements to be met by the DSCS Phase II satellite have been of such a nature that they used the EC-EC mode and power loading (EIRP) was the limiting factor on meeting additional requirements. As more data requirements, particularly wideband special-user requirements are considered, it is possible for the satellite to become bandwidth limited, particularly in the NB modes of operation.

There are parameters that can be controlled to meet increased requirements. These include earth subsystem considerations such as the multiple-access technique used, the earth terminal G/T, coding, and system margin. Additionally the geographic pattern of the earth terminals, the position of the satellite and the placement of the narrow beams all can play a major role in systems design. Also, this section discusses other system considerations, including satellite and earth terminal availability, jamming and regulatory controls relative to interference, and frequency usage.

6.2 MULTIPLE-ACCESS TECHNIQUES

6.2.1 General

Since a communication satellite is often in view of many earth terminals, it is desirable to permit any terminal to be in contact with one or more other terminals at will. This should be performed in such a way that there is as little interference as possible with other users of the transponder. The primary multiple-access (MA) techniques that are used to accomplish the above purposes in communication satellites are:

- Frequency division multiple access (FDMA)
- Spread spectrum multiple access (SSMA)
- Time division multiple access (TDMA)

Table 6-1 summarizes the characteristics, advantages and disadvantages of these MA techniques.

6.2.2 FDMA

In FDMA each earth terminal is assigned a carrier frequency within the transponder bandwidth. The carrier frequencies must have a minimum spacing large enough so that the modulated spectra do not overlap. An earth terminal receiver is tuned to the downlink frequency corresponding to the uplink frequency of the desired transmitter. The transponder power is shared by all the links simultaneously transmitted. Two important considerations in the use of FDMA are efficient use of the available transponder power and avoidance of interference among the simultaneous users. If a linear transponder is used, then the carrier frequencies can be spaced at the minimum spacing referred to previously. However, individual earth terminal power and/or maximum number of users must be controlled to avoid driving the output power device into saturation. If this happens, nonlinearity in the power output device will cause intermodulation products of the signals to rise to an unacceptable level.

Table 6-1. Summary of Multiple-Access Techniques

Technique	Characteristics	Advantages	Disadvantages
FDMA	Constant envelope signals	Uses existing hardware	Intermodulation in repeater
	Signals confined to non overlapping frequency bands MA demultiplexing by filtering Message information by angle modulation	No network timing	Requires uplink power control
TDMA	Signals from different links never present simultaneously in satellite MA demultiplexing by time gating	High efficiency in using satellite power Does not require uplink power control Peak power transmitter	Network timing required Analog to digital conversion required
	Message information by angle modulation within carrier burst		
SSMA	Constant envelope carriers	No network timing required	Link synchronization required
	Transmitted spectrum is spread over satellite bandwidth MA demultiplexing by correlation with local replica of code Message information by angle modulation	Can use fixed-address assignments Minimizes suppression in hard limiter	Uplink power control required

If a hard-limiting transponder is used, intermodulation products will be formed in the limiter. The carrier frequencies may be spaced so that the intermodulation products do not fall on any of the carriers. It has been shown that for equally spaced carriers and a limiting transponder the signal-to-intermodulation noise power ratio (measured in the bandwidth of the signal) will vary from 9 to 11 dB depending on the spacing of the carriers. In either case the number of accesses possible in the transponder bandwidth is reduced. In addition, the intermodulation products use some output power of the transponder, reducing the useful output power. Finally, the small signal suppression effect of a limiter makes power control of the earth transmitters necessary.

6.2.3 SSMA

In SSMA, each multiple-access carrier signal usually occupies all or a large part of the transponder bandwidth. In this technique a carrier is modulated with two different signals. The bandspreading modulation can be either analog or digital. When the bandspreading is accomplished by phase-shift keying it is often referred to as pseudonoise and when frequency-shift keying is employed the term frequency hopping is used. To date the greatest consideration has been given to digital techniques. The bandspreading modulation results in a noise-like carrier with over 90 percent of its power in a bandwidth twice the modulation rate. The information modulation, at a rate typically one-tenth or less than that of the bandspreading modulation, is impressed as an additional phase or frequency variation.

The pattern of the bandspreading modulation is called its code. At the intended receiver a code identical to the transmitted code is generated. This is synchronized with the received code and allows detection of the information. By proper choice of codes other SSMA transmission simultaneously present at the receiver will cause relatively small interference. The codes are then said to exhibit low cross-correlation.

This technique requires uplink power control as in FDMA; otherwise one or more signals will use too much of the transponder power output. However, neither use of a limiter nor a saturated output device will result in interference from intermodulation products. That the receiver must use an exactly matching replica of the transmitted code presents the problem of synchronizing the receiver before message transmission can begin. This requires an initial synchronization searching procedure by the receiver and is one of the critical aspects of SSMA.

6.2.4 TDMA

In TDMA multiple access is accomplished, like the multiplexing discussed in Paragraph 4.2.2, as a time-gating function which correctly locates each earth terminal transmission burst relative to those of the other terminals. Thus each earth terminal is assigned exclusive use of the transponder during specified time slots and the transmissions do not overlap. An access channel in TDMA designates a particular sequence of time slots. The simplest sequence would allow the time slot of a channel to occur periodically at a definite repetition frequency, called the frame repetition rate of the system. All other channels would have the same frame rate but different times of occurrence, and possibly different slot durations.

TDMA offers higher performance and more flexibility than FDMA or SSMA. Since only one carrier is present in the transponder, there is no power loss or interference due to intermodulation. The power output device can be run at saturation, providing higher output power (typically 3 dB) and efficiency. There is no need for earth terminal power control.

TDMA places stringent requirements on system timing. System timing accuracy affects required guard times between adjacent transmission bursts from earth terminals. Guard time is one of the components of overhead time in a TDMA system. The other components of guard time are in the preamble of each burst, carrier synchronization time, bit synchronization time, carrier

phase ambiguity resolution time, and word synchronization time. In the DSCS Phase II TDMA system, the goal for time utilization efficiency is 95 percent, where the efficiency is the ratio of time during which message information is transmitted to total frame time. TDMA rates are limited by transponder bandwidth, burst acquisition times, and practical data storage capabilities.

6.3 SYSTEM DESIGN

6.3.1 Power Sharing

1. FDMA - The use of FDMA necessitates sharing the satellite EIRP among all the simultaneous users. In addition, a backoff of about 3 dB from maximum transponder power is used to keep inter-modulation products at an acceptable level. Each FDMA access consists of a carrier FM modulated with a number of voice and data circuits. The transponder EIRP required per access depends on the number of equivalent voice circuits, circuit quality desired and the figure of merit (G/T) of the receiving station. An example will be given using the Phase II satellite. The earth coverage mode has a maximum EIRP of 28 dBW which is backed off to 25 dBW for FDMA operation, allowing 1 dB for power-control losses, $10 \log \frac{C}{kT} = C/kT - G/T - 30$. Table 6-2 shows the C/kT and the percent of power required for various receiving situations. The system design must be such that an uplink signal will result in the required downlink power. Uplink power control must be used whether the transponder input is linear or hard limiting to assure that the uplink signal uses the correct share of the transponder output power.
2. TDMA - In TDMA the maximum transponder power can be used since there are no intermodulation products present. Table 6-3

Table 6-2. Percent of Satellite Power Required for FDMA

No. of Voice Channels	C/kT Required	Percent of Satellite Power		
		AN/TSC-54 (G/T = 26.5)	AN/MS-46 (G/T = 34)	AN/FSC-9 (G/T = 38)
3	69.9	21.8	3.9	1.5
6	71.3	30.2	5.4	2.1
9	72.1	36.3	6.5	2.5
12	72.3	38.0	6.8	2.6
24	74.5	63.0	11.2	4.4
36	75.8	87.1	15.5	6.2

Table 6-3. Percentage of Satellite Power Required for TDMA

Data Rate	C/kT Required	Percent of Satellite Power		
		AN/TSC-54 (G/T = 26.5)	MS-46 (G/T = 34)	AN/FSC-9 (G/T = 38)
1.0 Mbps	72.0	17.7	3.15	1.26
1.53 Mbps	73.9	27.5	4.9	1.95
3.07 Mbps	76.9	54.8	9.75	3.9
6.14 Mbps	79.9	----	19.45	7.7
12.28 Mbps	82.9	----	38.9	15.5
24.56 Mbps	85.9	----	77.8	30.9
55.0 Mbps	89.0	----	----	62.8

The bandwidth required by a PSK modulated carrier is approximately 1.25 times the data rate. Thus a maximum data rate of 100 Mbps could be carried by the 125-MHz channel. This corresponds, for example, to 100 accesses of data rate 1 Mbps. The burst rate of each access is 100 Mbps. The requirement for guard times to prevent overlap and the state-of-the-art of logic equipment limits the burst rate to approximately 50 Mbps at this time.

3. SSMA Bandwidth Constraints - In a SSMA system all accesses can be present simultaneously in the channel and each can cover the complete channel bandwidth. The individual accesses share the transponder power and also act as noise to each other in the earth terminal receiver. These two factors, rather than the bandwidth, limit the number of simultaneous accesses.

6.3.3 Frequency Sharing

1. FDMA - FDMA imposes the requirement of nonoverlapping spectra sharing a common channel. In addition intermodulation effects impose requirements on spacing and number of accesses sharing the channel. Frequency plans involving nonuniform frequency spacing can be devised which reduce intermodulation effects in the transponder.
2. TDMA - This multiple-access technique allows all accessing links to use a common frequency.
3. SSMA - This multiple-access technique allows all accessing links to use a common frequency.
4. Mixed Multiple-Access Techniques - SSMA can share a common bandwidth with TDMA or FDMA as long as the SSMA signal level is sufficiently below that of the TDMA or FDMA signal. SSMA is kept at about 10 percent of the available power in the DSCS for

nonjamming operations. FDMA and TDMA signals must be separated in frequency as in a straight FDMA system.

6.4 SYSTEM ENGINEERING TRADEOFFS

Power and bandwidth in the transponder are two constraining parameters of system design. In any system one of these constraints will be reached first. Using concepts developed previously it is then possible to increase system capacity by a tradeoff of system bandwidth and power. In most present-day systems the satellite becomes power limited before it becomes bandwidth limited.

With digital traffic, coding can be used to increase the traffic capability. Thus, the use of rate 1/2 convolutional encoding-maximum likelihood decoding will allow a 4 dB (0.4) reduction in E_b/N_0 (and therefore transponder output power) while doubling the required bandwidth. Each of the percentages in Table 6-3 will be reduced to 0.4 of the value given there.

6.5 RELIABILITY/AVAILABILITY

6.5.1 Equipment Reliability

Reliability of a component having a constant failure rate, i. e. ; subject to random failure, is expressed by the exponential form

$$R(t) = \exp(-Bt) \quad (6-1)$$

where $R(t)$ = reliability at time t , and B = failure rate.

Items that exhibit wearout phenomena have a fairly well-defined end-of-life as well as being subject to random failures. For example, solar cells can fail randomly, and in addition, their output decreases with life in orbit as a result of solar radiation. Therefore, the solar array should be designed so that its output after some specified time in orbit is sufficient for satellite operation. Wearout causes the reliability to decrease at a greater rate as the wearout lifetime is approached, and the reliability function is usually

truncated at the wearout time. This has the effect of lowering the expected life of the item because the area under the reliability curve has decreased.

Several methods for improving reliability are available to the designer, and a combination of these methods is generally applied. One method entails careful design of components, selection of parts, and thorough testing prior to use. Other methods, which are discussed in subsequent paragraphs, involve application of redundancy and careful design of components which exhibit wear-out phenomena so that wearout occurs after some specified time.

Reliability of a series circuit; i. e., one in which all parts must operate for the circuit to operate, is the product of the reliabilities of each part. This is equivalent to replacing the part failure rate in the equation by the sum of the part failure rates; therefore, the reliability function is still exponential. An example of a reliability function for a satellite in which all parts must operate, or conversely a satellite having no redundant circuitry or paths leading to success, is shown in Figure 6-1. For the exponential case the expected life or MTBF occurs at a reliability $R(t) = 0.37$.

If redundancy is applied to the satellite design so that failure of a particular component does not render the satellite inoperable, the reliability function is no longer exponential but tends toward the shape of a normal function. An example of such a reliability curve is also shown in Figure 6-1. The shape of the curve depends on the amount and type (active or standby) of redundancy applied, which in turn depend on such factors as allowable weight and volume, power requirements and availability.

6.5.2 Parameters and Relationships

The probability that equipment will be operating at any time is equal to the uptime ratio for that equipment. The formula for this parameter is

$$UTR = \frac{MTBF}{MTBF + MTTR} \quad (6-2)$$

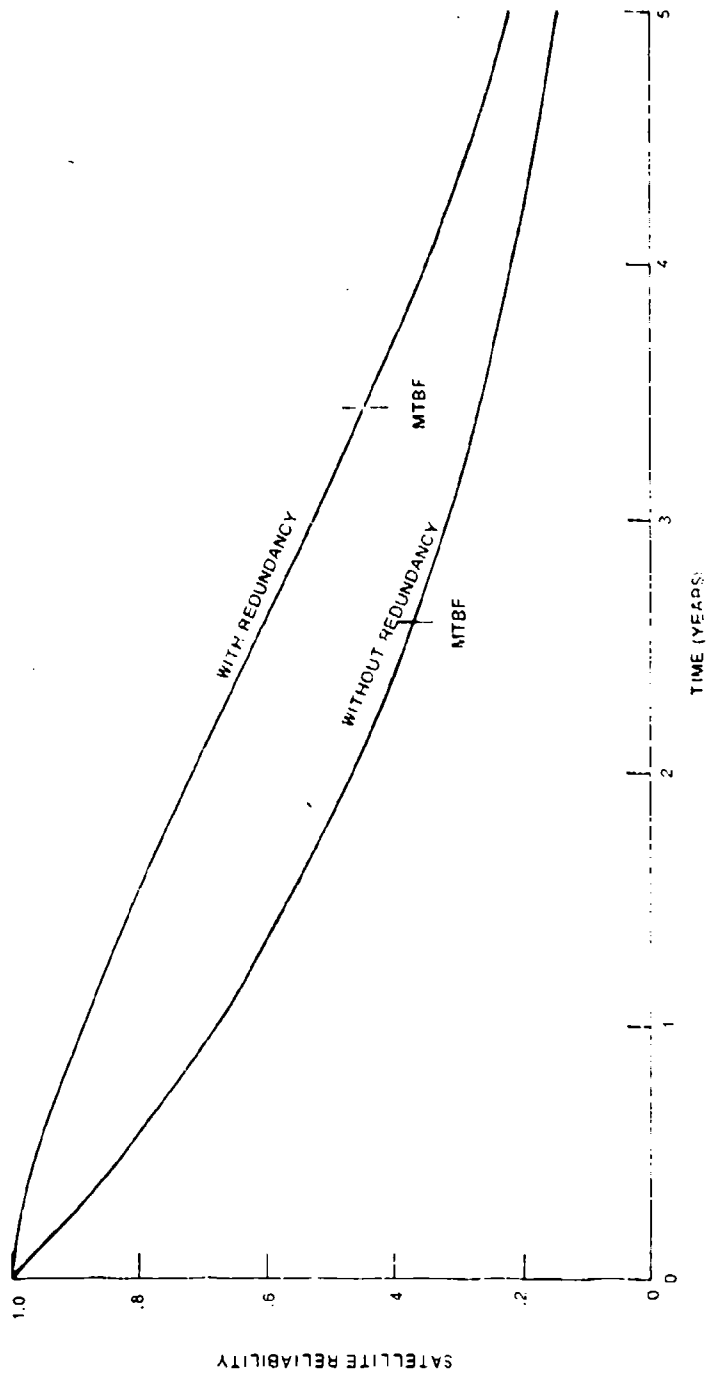

Figure 6-1. Example of Satellite Reliability

where UTR = uptime ratio

MTBF = mean time between failures

MTTR = mean time to repair.

The MTBF is a function of the reliability, where reliability is the probability that the equipment will operate satisfactorily for a given time. In general, the MTBF is the integral of the reliability or the area under the reliability curve; therefore, MTBF will be increased if reliability is improved. The MTTR is a function of the equipment design and complexity.

6.5.3 Satellite Availability

Satellite availability is the probability that a particular satellite in a satellite communications system will be available for use at a given point in time. Since satellites are not repaired the availability is a combination of satellite reliability and satellite replenishment strategy. Satellite reliability has been discussed.

Assuming that the desired useful communication system lifetime will be long compared to expected individual satellite lifetime, it will be necessary to provide replacement satellites for those which fail in orbit, to maintain acceptable levels of performance. The manner in which replacement would occur must be given careful analysis since it may have substantial effects on operating costs. If the individual orbits are established by a booster with multisatellite dispenser, the use of the same booster for single satellite replenishment would likely be prohibitively expensive. One alternative solution would be to delay replenishment until a sufficient number of satellites had failed, so that replenishment of a complete dispenser load could be justified. A second alternative would be to establish the initial orbits with multisatellite dispensers and to use a smaller launch vehicle to orbit individual replenishment satellites. Any scheme for satellite replenishment will be dependent on the type of orbits selected for the system.

Some of the significant variables whose values must be estimated in predicting the replenishment cost of the satellite are:

- Number of satellites in orbit (average, minimum, and peak values)
- Mean time to failure
- Cost of each satellite
- Number of satellites per launch
- Launch success probability
- Launch costs
- Launch pad turn-around time (in some cases this is of minor significance)
- Number of reserve boosters and satellites which must be ordered to provide for contingencies.

For systems employing satellites which maintain a fixed spacing relative to each other, it is important that the following items be considered:

- Positioning of spare satellites
- Maximum orbital velocities for spares
- Frequency of repositioning satellite
- Optimum number of spares
- Time required to replace a failed satellite
- Circumstances that will trigger a decision to attempt a replenishment launch
- Probability of further deterioration of the space system during the replenishment attempt, and its effect on coverage.

A replenishment strategy for a system involving numerous satellites can be evolved from system reliability or system mean-time-before-failure considerations. In the case of only one operating satellite in orbit and possibly only one spare satellite, a satisfactory approach might be to launch the spare when a failure seems to be imminent. Although the operating satellite is expected to fail at its mean-time-before-failure, it may fail much earlier or much later. With greater telemetry capability designed into the satellite, the probability of detecting most types of impending failures tends to increase. Impending failure should be apparent early enough to prepare and launch the spare.

In Figure 6-2 a replenishment strategy is shown for a one-satellite system. If a probability of 0.7 of maintaining the satellite system for 5 years is desired, a second launch must be provided for. To extend the satellite system beyond 5 years with the same probability of success will require the launch of an additional satellite.

6.5.4 Link Availability

Link availability is the probability that a link of specified capacity and quality connecting system users is operating satisfactorily at any time. In considering the availability, each of the following factors must be specified:

- Satellite availability
- Earth terminal availability
- Satellite visibility
- Satellite conjunction
- Signal level variations

Satellite availability has been discussed. Each earth terminal in the link will have an associated availability, which is the same as the uptime ratio discussed previously.

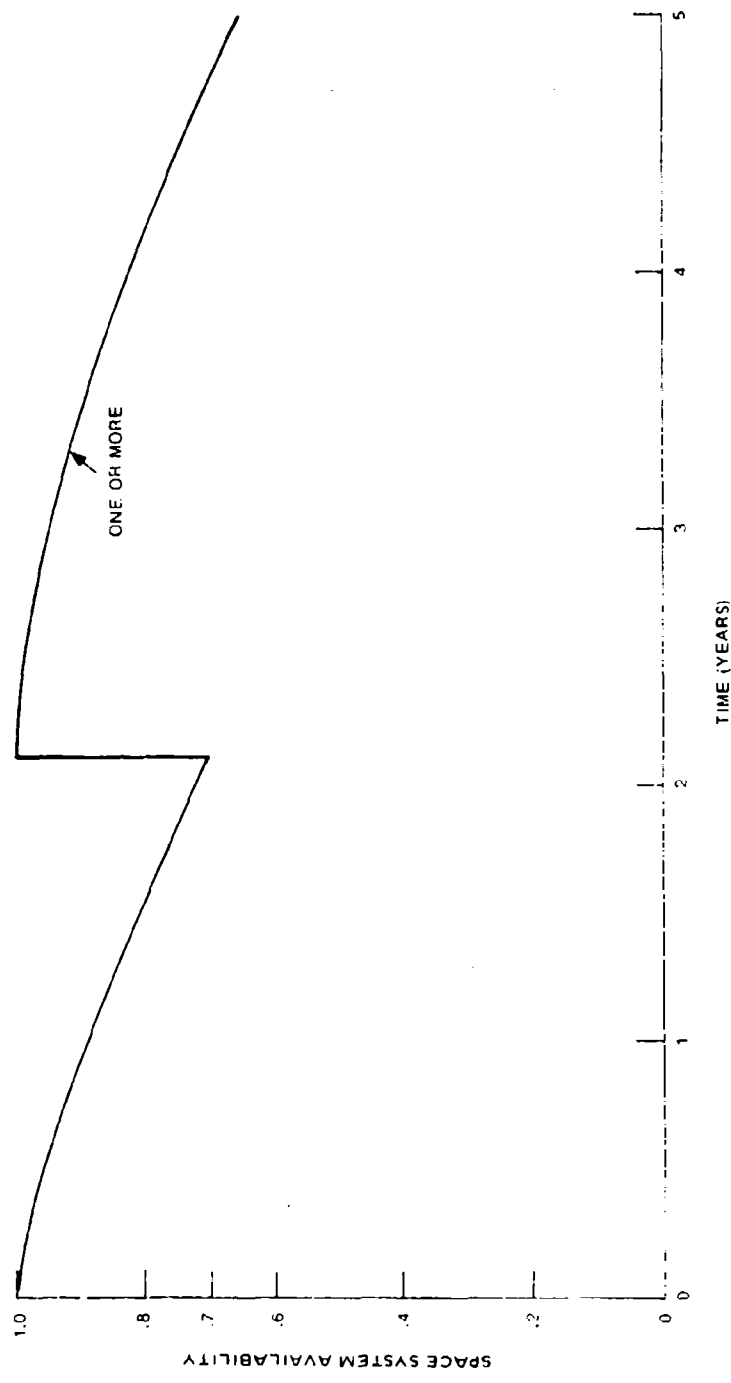

Figure 6-2. Example of Availability of One Satellite System With Launch of Spare Satellite at 0.7 Reliability of Initial Satellite

For a communications link to be established, a satellite has to be simultaneously visible to both earth terminals. In a synchronous satellite system, the satellite is essentially motionless (stationkeeping limits motion) and its area of visibility on the earth is fixed.

For subsynchronous satellite systems, a number of satellites are used and three basic satellite positioning schemes may be used:

1. Phased orbits in which a stationkeeping capability is used to maintain fixed orbital relationships
2. Random orbits in which no orbital control is exercised
3. Precision orbits in which satellites have no stationkeeping capability but are precisely placed in orbit

Of importance in some satellite systems are the factors of conjunctions of satellites with each other, conjunctions of satellites with the sun, and outages of solar-powered satellites passing through the earth's shadow. Each of these factors reduces the availability of satellites and, therefore, requires an increase in the number of orbiting satellites to achieve a given performance objective. Conjunctions between satellites are not generally significant in a system in which satellites maintain a fixed spacing from each other. If power storage devices such as batteries are not used, earth-shadow effects may be significant. Earth-shadow effects become less significant as orbital altitude increases, and produce less than a 1 percent reduction in satellite availability at synchronous altitude.

Although signal level variations of satellite links are much less than those of high frequency, microwave relay, or tropospheric scatter links, they must be considered because the margins of the former are usually low to avoid wasting satellite power. Major variations of signal level in a moving satellite system result from changes in range and satellite aspect angle.

Severe fading in any satellite system can occur as a result of attenuation caused by rain. It is not possible to make precise statements because rainfall distribution varies widely throughout the world and, frequently, even within confined geographical areas. As a general rule, a margin for atmospheric and rainfall attenuations of 2.2 dB in the temperate zones and 3.8 dB in the tropics will be adequate for a 7.3-GHz system 99.9 percent of the time.

6.6 INTERFERENCE AND JAMMING

6.6.1 Types of Interference

In designing a satellite communication system, the possibility of mutual interference with other communication systems and other services must be considered. Interference considerations can affect communication link frequency and antenna design. Mutual interference can occur between space and terrestrial communication systems and among two or more space systems. In addition other electronic systems such as radar can cause interference to space communication systems.

There are four possible modes of interference between satellite communication systems and terrestrial systems. These modes are:

1. Satellite radiating power into terrestrial receivers
2. Earth terminal transmitters radiating power into terrestrial receivers
3. Terrestrial transmitters radiating power into earth terminal receivers
4. Terrestrial transmitters radiating power into satellite receivers.

By international agreement the radiation from transmitters has limitations placed on it to reduce interference with other users at the same frequency. For example, for frequency bands in the range of 3400 to 7750 MHz which are shared between communication satellite systems and terrestrial radio relay systems,

the maximum power flux density produced at the surface of the earth by radiation from a satellite should not exceed

$$\begin{array}{ll} -152 & 0 < \alpha < 5^\circ \\ -152 + \frac{\alpha - 5}{2} & 5 < \alpha < 25 \\ -142 & 25^\circ < \alpha < 90^\circ \end{array} \quad (6-3)$$

decibels relative to 1 watt per square meter per 4-kHz band, where α is the angle of arrival of the radiation (degrees above the horizontal). In a similar way, the radiation from the satellite communication system earth terminal and the radiation from terrestrial communication systems have limitations placed on them.

Any proposed communication system must compete with existing users of the congested radio spectrum or present a strong enough case to warrant any readjustment of existing spectrum users. This is because the demands placed upon the radio frequency spectrum continuously exceed the space available within propagational or technological limits, and create the need for national regulation that considers priorities, validation of requirements, and technical conditions of frequency sharing. Because communication extends beyond national areas, these regulatory measures have international impact that are the subject of treaty arrangements. Although each nation retains the right to regulate its own telecommunications, the mutual advantages of avoiding international radio interference encourage agreements among all users of the radio spectrum. The regulatory agreements made among nations thereby place general restraints on frequency usage and require national efforts to respect international frequency allocations while satisfying national needs. Radio regulatory actions involve consideration of national security, public welfare, economic and technical factors.

The relatively recent application of satellite techniques has complicated frequency provision because there is no suitable unused spectrum in which to

place the new service, and the satellite's line-of-sight range transcends the areas controlled by any one nation. The recent World Administrative Radio Conference for Space Telecommunications (WARC-ST) held in Geneva in June 1971 devoted much of its proceedings to satellite communication systems, in terms of gain and allowable side lobe level and other factors. As more communication satellites (especially geostationary satellites) are put into orbit, interference will become a constraining factor in system design.

6.6.2 Jamming

With reference to communications systems, jamming is defined as action taken against the communications system to prevent it from accomplishing its function. Antijamming is defined as action taken to minimize or cancel the effects of the jamming. Jamming can be accomplished by subjecting the system to electromagnetic radiation to cause interference with, or loss of, communications.

6.6.2.1 Jamming Techniques

A satellite communications system could be jammed on either the downlink (satellite-to-earth receiving station) or in the uplink (earth transmitting station-to-satellite).

In considering jamming of the downlink, however, it becomes obvious that the highly directional antenna of the earth receiving station will reject virtually all signals except those coming from the immediate direction of the satellite. Nevertheless, jamming of the downlink could still be accomplished by a satellite-based jammer placed in orbit so that it would appear (to the earth receiving station) to have tracking coordinates near those of the communications satellite. However, the time required to place such a jammer satellite in orbit would be too great to allow it to be of any tactical advantage, and the cost of such a project would be nearly prohibitive.

Shortly after a communications satellite is placed in operation, a potential enemy with any degree of sophistication in electronic warfare will have compiled data on the satellite. This data would probably include the following: ephemeris data indicating the satellite's orbit characteristics, and information relative to frequency, bandwidth, and modulation of the satellite. On the basis of this information, a jamming technique would be selected. Jamming operates on the premise that if enough jamming power is radiated into a receiver, the legitimate signal will be indistinguishable from the unwanted signal. Various jamming techniques are summarized below:

1. Spot Jamming - Spot jamming consists of concentrating all of the jamming transmitter energy in a narrow band in order to achieve a high noise density in that band. For purposes of considering noise density in relation to jamming, noise density power is discussed in terms of watts per MHz. Therefore, a spot jammer concentrating a 1000-watt noise signal in a 1-MHz bandwidth is said to have a noise density of 1000 watts per MHz.
2. Broadband Jamming - Spot jamming is ineffective against a wide-band signal or a signal that shifts in frequency faster than the spot jammer can follow it. Under these circumstances broadband jamming is used. Broadband jamming spreads energy out over a broad band of frequencies rather than on a spot frequency. However, this broadbanding results in a lower noise density at any one particular frequency. Therefore, a spot jamming signal of 1000 watts per MHz, when spread over a 100-MHz bandwidth, will have only a 10-watt per MHz noise density.
3. Swept-Spot Jamming - Swept-spot jamming combines the high noise density of spot jamming with the wide bandwidth of broadband jamming. This is accomplished by sweeping the spot jammer at a very high sweep rate across the spectrum to be jammed.

3. Satellite Directional Antennas - Directional antennas on communication satellites provide an anti-jam capability, depending on the orientation of the satellite directional antenna. Jammer power received at the satellite receiver is represented by:

$$Pr_j = \frac{P_j \cdot G_j \cdot G_{sj} \cdot \lambda^2}{(4\pi R_o)^2} \quad (6-4)$$

where P_j = jammer power

G_j = jammer antenna gain

G_{sj} = satellite antenna gain for the jammer signal

R_o = distance between the satellite and jammer.

It can be seen from Equation (7-4) that a low value of G_{sj} will have a large effect on the jammer power received at the satellite receiver. A 20-dB or 30-dB attenuation of the jammer signal due to off-axis loss will degrade the jammer signal to the extent that it will have small effect.

6.6.3 Frequency Coordination

The frequency regulatory process uses as common managerial tools the terms allocation, assignment, services and classes of services, and channelization. Channelization may also be identified as a frequency assignment plan. Allocation is a planning process of dividing the spectrum among compatible emissions or similar types of operations based on total requirements and characteristics. Assignments are made to specific stations or used in consonance with the allocation table. The assignment process includes technical considerations of frequency sharing to control interference between assignments. Assignment may be guided by a frequency plan to maintain interference control as stations are activated, or it may be based on channelization which guides the equipment manufacturer, the frequency manager and the operational planner.

The various types of users of spectrum space are identified as services and classes of services (e. g. , broadcasting, maritime mobile, and land mobile, etc.). There are about 380 services and classes using the radio spectrum in the U. S.

Within the allocation framework, additional subdivisions are made in the U. S. between government and nongovernment or in shared frequency space. No allocations to services are further subdivided to government or nongovernment unless both have operations involved. For example, there is no government subdivision of the broadcast bands or nongovernment subdivisions of radar bands for missile weapon systems. Of the total frequency space, about 30 percent is currently used by the government.

SECTION 7 - CONTROL

7.1 GENERAL

Control systems are highly important for the efficient operation of a terrestrial communications network. They play an even more important role in satellite communications networks, particularly those networks using TDMA and/or demand assignment techniques, since the capacity of the satellite transponder is shared by many users on a real-time basis.

There are three major categories of control required when using satellites in a communications network. They are:

1. Satellite Control - This involves actions necessary to position, track, monitor and command the satellite during the course of its operational lifetime. This type of control has been discussed in Section 2, Space Subsystems.
2. Satellite Communications Control - This type of control involves supervising and monitoring the establishment, reconfiguration and control of each required RF link through the satellite transponder in accordance with desired parameters.
3. Circuit Control - This control involves actions necessary to assure that the required circuits between all authorized users are established, maintained and restored satisfactorily. This function is regularly performed by Technical Control Facilities personnel. It applies to circuits using any transmission media such as cable, LOS, tropo or satellite.

These three categories are general in nature and the specifics will vary depending on the type of satellite orbit, the modulation and multiple-access techniques used and the circuit requirements and usage.

7.2 SATELLITE CONTROL

This function has no direct counterpart in terrestrial systems but is critical to successful satellite communications operations. The degree and type of satellite control required is in large part dependent on whether the satellite orbit is synchronous or nonsynchronous and on the user requirements of the satellite.

Tracking requirements exist for a synchronous or near-synchronous satellite, but they are less severe than those for a nonsynchronous satellite. The synchronous satellite must be monitored and kept on station by periodic positioning actions. In the DSCS the Phase II satellites will be maintained within 3° of their assigned longitude. A periodic activation of the gas propulsion system is planned to accomplish this.

In a nonsynchronous system, repositioning may also be used on a periodic basis to keep the satellites drifting in the desired orbit or, as in the case of the Phase I satellites, they may drift on a random basis. If the random basis is used, more satellites are required to assure higher availability of a correctly positioned satellite to meet users' needs. In addition closer monitoring of satellite movement is required for nonsynchronous satellites to provide the necessary data to prepare schedules for transferring use of a satellite to different earth terminals as the satellite orbits the earth.

Additional satellite control operations can include repositioning of satellites, monitoring satellite performance by receiving regular or periodic telemetry messages from the satellites, and sending commands to the satellite to perform such actions as switching to redundant units, changing amplification levels within the satellite transponder and antenna control functions, etc.

The Air Force Satellite Control Facility (AFSCF) with its Satellite Test Center located at Sunnyvale, California performs this mission for DCA. The AFSCF has numerous remote tracking stations around the globe to assist in this mission.

7.3 SATELLITE COMMUNICATIONS CONTROL

In terrestrial systems, network engineering and control is needed to establish and revise the various links and their capacities to meet the changing user requirements. Additionally, frequencies and power limitations are assigned to minimize interference or intermodulation within the network or with external activities. The same requirements exist for a satellite network. However, the need for prior planning and control is increased in the satellite operation because of several factors, including the wide-area coverage of satellite antennas, the low receive signal strengths involved, and the use of common amplifiers in the satellite transponder by more than one carrier (multiple access).

The use of multiple-access techniques is highly efficient, but it gives ample opportunity for intermodulation to develop. Thus systems must be closely controlled in time, power or frequency to ensure that intermodulation is reduced to an acceptable level.

With proper prior planning and engineering, the available capacity of the transponder can be allotted on a preassigned basis to meet user needs. For FDMA operations such as predominate in Phase I of the DSCS, the frequencies, bandwidth and power required to provide a desired receive signal level, with adequate margin, and without serious intermodulation can be preplanned.

The frequency and bandwidth problems are similar to but more critical than those normally found in terrestrial networks. This is because many carriers go through the same components in the satellite transponder and the

satellite earth coverage antenna, if used, covers all of the earth terminals in that satellite network. The problem of staying on frequency and within the prescribed bandwidth, however, is basically the same for any radio network, and monitoring and readjustment is not a unique problem.

Of more concern is the maintenance of proper signal level at the input to the satellite, since the power of the satellite is shared by several carriers. If the total summed signal level gets too high, the system will be operating in a nonlinear mode, causing intermodulation. Further, if one or more signals are larger than planned, these signals would get more than their share of the limited transponder power, and thus would deprive other users of their allotted share. Therefore, the monitoring of frequency and power levels is essential for an efficiently operated network. Although automated real-time control of that transmitter frequency, bandwidth and ERP would be desirable for such a network, it is not essential. Satisfactory control can be achieved by monitoring the various downlink carriers and notifying offenders of any transmission violations via a voice or teletype orderwire system.

With a TDMA network the problem becomes one of real-time coordination after the allotment of transponder capacity. The extremely accurate synchronization required to permit sharing the satellite power on a time block basis demands real-time control of all of the earth terminals in the network. Synchronization and control systems have been developed and successfully tested.

The basic plan for the system to be used with TDMA in Phase II of the DSCS consists of a master station providing time and frequency correction to all other terminals in the network. This coordination is a regular part of the network operation. Orderwire control is provided to each station on a common SSMA channel.

7.4 CIRCUIT CONTROL

This control is essentially the same for any segment (transmission media) of the system. In the DCS the circuits using satellite transmission links would normally be monitored and controlled by the same DCA activities controlling microwave or cable circuits. Only with a particular problem caused by or affecting a satellite link would special action by satellite communicators be required. Initially, exceptions to this may be frequent because of satellites carrying special wideband circuits that may bypass normal TCF's and go directly to users. In such cases, the satellite earth terminal operators would be more directly involved with circuit control monitoring and restoration.

APPENDIX A - SATELLITES

A.1 GENERAL

This appendix provides a descriptive summary of the characteristics of presently available or planned satellites that are of particular interest to the military communicator. The satellites that are included are: DSCS Phase I (IDCSP), DSCS Phase II, TACSAT, Skynet, NATO, and Intelsat I to IV. Intelsat I to IV are included to provide data on a commercial communications satellite for information purposes.

A.2 INITIAL DEFENSE COMMUNICATIONS SATELLITE PROGRAM (IDCSP) - DSCS PHASE I

A.2.1 Space Subsystem, General

The overall Phase I or IDCSP system is covered in detail in Appendix C. The space subsystem, consisting of 26 near-synchronous, random-spaced equatorial satellites, was placed into orbit in four separate launches, with the first launch of seven satellites on 16 June 1966. Table A-1 summarizes data relating to the launches. As of May 1972, 17 of the satellites were still operational.

The satellites are in a near-synchronous orbit at an altitude of approximately 21,000 statute miles. Relative to the earth, they drift west to east at about 30° per day, thus a single satellite stays within view of a particular ground station for 4-1/2 days. The satellites were released into orbit with slightly different initial velocities, causing a relatively random distribution.

The satellites are spin stabilized at approximately 150 rpm (by two nitrogen nozzles) to maintain the spin axis within 5° of normal to the earth's equatorial plane. Each satellite weighs approximately 100 pounds. It is solar powered and has no batteries. The original designed mean time to failure (MTTF) was 1-1/2 years, with a goal of 3 years. This goal has been greatly exceeded and an MTTF in excess of 5 years has been achieved to date.

Table A-1. DSCS Phase I Satellite Data

Satellite	DSCS Phase I				
Manufacturer and Sponsor	Philco-Ford, DOD/DCA/SAMSO				
Launch Vehicle	Titan III C				
Launch Date	16 June 1966	26 August 1966	18 January 1967	1 July 1967	13 June 1968
Number Launched	7	8	8	3	8
Initial Orbit Data		Launch			
Period (minutes)	1334.2-1344.0	Failed	1330-1343	1309.8-1319	1269-1350.6
Perigee (statute miles)	20,913-20,949		20,835-20,935	20,509-20,692	19,121-20,976
Apogee (statute miles)	21,051-21,250		21,031-21,275	20,846-20,894	21,027-21,401
Inclination (degrees)	0.0-0.2		0.0-0.1	7.2	0.1
Operational Status as of May 1972	5		7	2	3

A.2.2 Satellite Transponder

The transponder of the DSCS Phase I satellite is a double frequency conversion, hard-limiting repeater operating in the 7- to 8-GHz range. The EIRP has a design minimum of 7 dBW. Each satellite in a launch payload has a beacon signature at its own unique telemetry frequency, in the 400-MHz area, for identification purposes.

The repeater, shown in simplified block diagram form in Figure A-1, is primarily solid state. Amplification and limiting of the signal take place at intermediate frequencies. The mixing frequencies are derived from a basic oscillator and multiplier chains. The output of the IF amplifier/limiter is then summed with the beacon signal, up converted, and fed through the traveling wave tube amplifier and out to the transmitting antenna. A redundant TWT amplifier can be switched on in case the first TWTA fails. The switch-over is done automatically and can occur only once. There is also included an automatic power shutoff circuit which activates between 6 and 6-1/2 years after launch. The automatic cutoff period for the five operational satellites from the first launch is June 72 to December 72 and the minimum number of satellites required for acceptable service has been estimated to be 15. Thus the DSCS Phase I will have limited capability beyond mid-1973.

The transmitting and receiving antennas are separate biconical horns with toroidal patterns, omnidirectional in azimuth and earth-coverage (28°) in the other plane. Characteristics of the satellites are summarized in Table A-2.

Table A-3 indicates the voice channel capacity on particular duplex links as a function of terminal type on each end of the link. These figures are for duplex (dual) accesses, the maximum satellite loading used in DSCS Phase I. The link margins were not found to be great enough to support more than two simultaneous accesses. The satellite frequency plan, optimized to yield minimum intermodulation interference, is indicated in Table A-4.

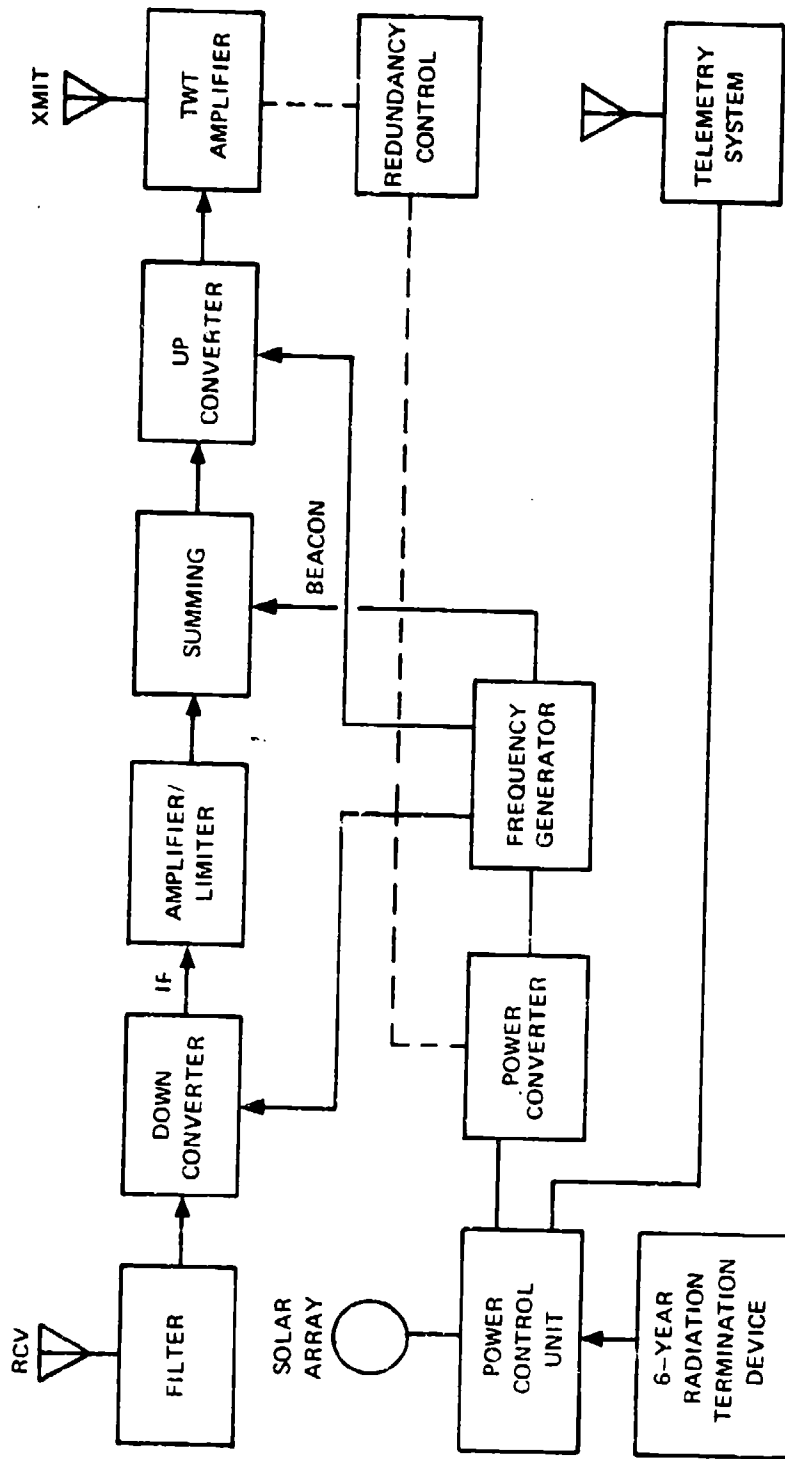

Figure A-1. DSCS Phase I Transponder Block Diagram

Table A-2. DSCS Phase I Satellite Characteristics

Antenna	Type	Biconical - toroidal pattern	
	Number	Two - RHCP receive, LHCP transmit	
	Beamwidth	Earth coverage, $360^{\circ} \times 28^{\circ}$	
	Gain	5 dB in plane normal to the spin axis, 3 dB minimum in all directions within $\pm 14^{\circ}$ of the plane	
Repeaters	Frequency Band	SHF - 7.3 GHz transmit, 8.0 GHz receive	
	Type	Hard-limiting, double frequency conversion	
	3 dB Bandwidth	26 MHz	
	Number	One	
	Receiver	Type Front End	Down conversion mixer
		System Noise Figure	10 dB
Transmitter	Type	Redundant TWT	
	Power Out	3 watt	
EIRP		7 dBW minimum	
General Features	Stabilization	Type	Spin at approximately 150 rpm
		Capability	$\pm 5^{\circ}$ spin axis attitude
	Power Source	Primary	4000 n-on-p solar cells provide 40 watts at launch
		Supplemental	None
	Comm. Power Needs	22 watts	
	Size	36-inch diameter, 32 inches high	
	Weight	102 lb. or less	
Telemetry	Frequency	≈ 400 MHz	
	EIRP	-12 dBW minimum in all directions within $\pm 45^{\circ}$ of a plane normal to the spin axis	
Beacon	Frequency	≈ 7.3 GHz	
	EIRP	-5.5 dBW minimum	

Table A-4. DSCS Phase I Access Frequencies

Satellite RF Access Channel	Frequency (MHz)	
	Uplink (Receive)	Downlink (Transmit)
1	7,267.0250	7,985.7450
2	7,271.7125	7,990.4325
3	7,277.9625	7,966.6825
4	7,285.7550	8,004.4950

A.3 DSCS PHASE II SATELLITE

A.3.1 Space Subsystem, General

Phase II of the DSCS is planned to provide greatly increased capability over that of the Phase I. A detailed description of Phase II is provided in Appendix D. Contrasted with the DSCS Phase I, the space subsystem for Phase II will provide satellites with greater EIRP and in synchronous orbit. This will result in increased system capacity and higher satellite availability. The satellites will be maintained within $\pm 3^\circ$ of their designated orbital positions. The satellites may be repositioned at least once during their operational life to any other equatorial point at a rate of 15° per day.

A.3.2 Satellite Transponder

The Phase II satellite transponder consists of a multichannel repeater with the channels cross-linked, a receive and a transmit EC antenna, and two steerable NB antennas, each capable of receiving and transmitting simultaneously.

This arrangement will provide four different modes of operation:

1. Earth coverage to earth coverage (EC-EC)
2. Earth coverage to narrow beam (EC-NB)
3. Narrow beam to earth coverage (NB-EC)
4. Narrow beam to narrow beam (NB-NB)

The basic interconnection for these four modes is shown in the block diagram, Figure A-2.

The uplink frequency transmitted by a Phase II earth terminal determines which of the four modes will be used. (This assumes that an earth terminal planning to use either the NB-NB or NB-EC channels is within the geographical area covered by one of the NB antenna patterns.) The received signal is amplified and retransmitted in the 7275- to 7750-MHz band. A simplified frequency diagram presented in Figure A-3 relates the various channel modes, together with their related frequency translations and satellite antennas. Both the EC-EC

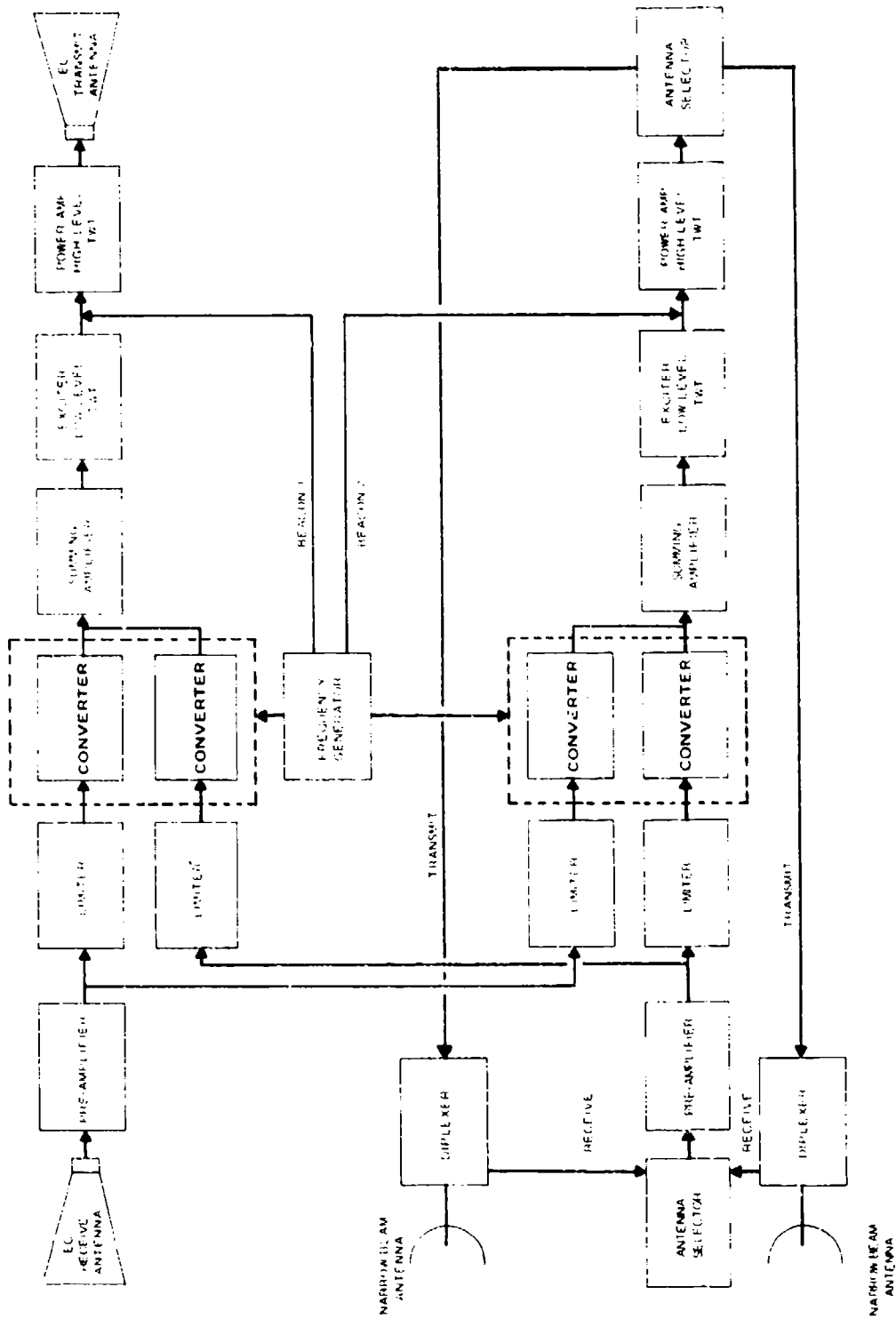

Figure A-2. DSCS Phase II Transponder Block Diagram

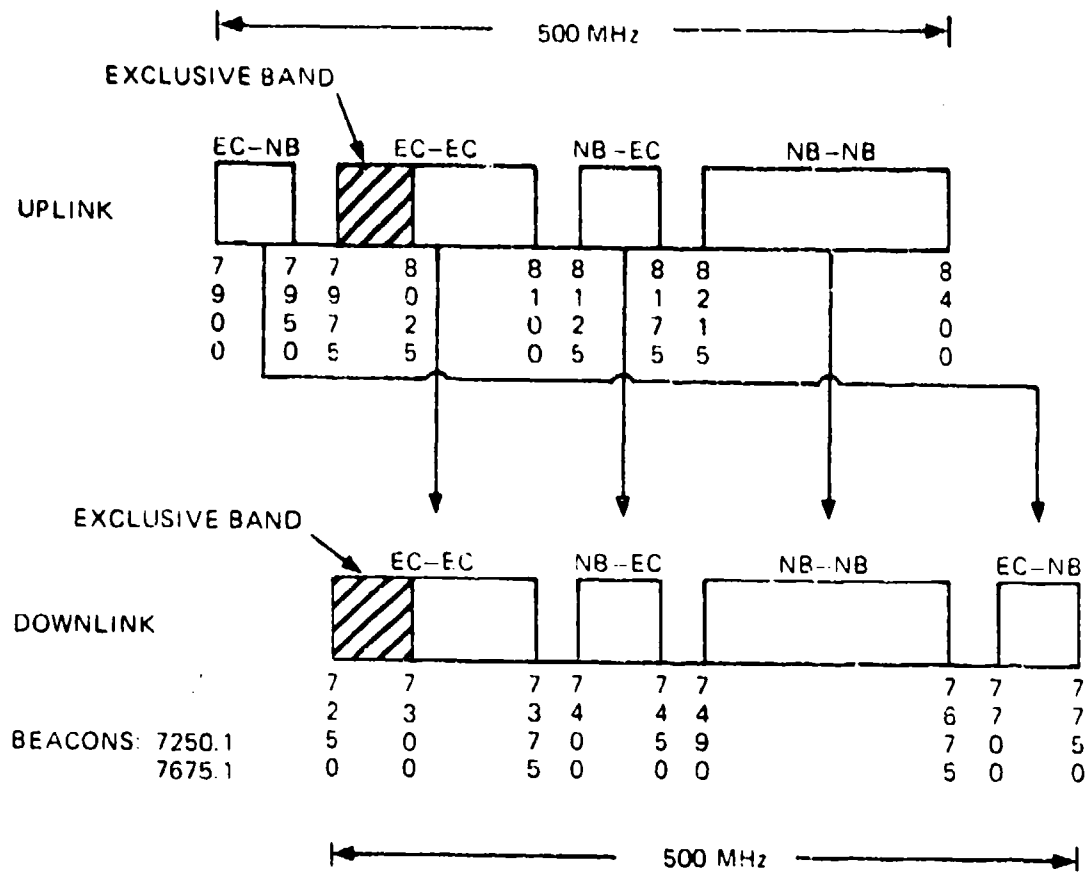

Figure A-3. DSCS Phase II Satellite Frequency Translation Plan

and NB-EC channels share the output power of a 20-watt TWT amplifier, using the earth coverage antenna. Likewise, the NB-NB and EC-NB channels are combined and transmitted via a second 20-watt TWT, using either one or both of the narrow coverage antennas. The bandwidth of each channel is presented in Figure A-3 and represents 410 MHz of usable bandwidth. The satellite EIRP is 28 dBW for the EC mode and 43 dBW for a NB antenna (or 40 dBW each if two are used). This allows a marked increase in capacity and flexibility compared with the 7 dBW of the Phase I satellite. Table A-5 provides a summary of the major characteristics of the Phase II satellite.

All active components within the transponder are redundant. The selection of the active components and narrow beam antenna switching and steering is done by ground command. To achieve maximum in-orbit usage of the Phase II satellite, all onboard systems have been sized to provide a minimum 5-year operational lifetime. Each channel within the satellite can be commanded to operate in a linear, quasi-linear or hard-limiting mode.

All transmitting antennas will be left-hand circularly polarized, whereas the receiving antennas will be right-hand circularly polarized. The two narrow-beam antennas will be capable of being independently steered $\pm 10^\circ$ from each of two orthogonal directions, and the half-power beamwidth will cover an area approximately 750 miles in diameter near the subsatellite point. The earth coverage antennas (transmit and receive horns) will provide coverage to approximately one-third of the earth's surface.

A.4 TACSAT

A.4.1 Space Subsystem, General

The TACSAT program was designed to provide satellite communications between mobile tactical terminals. In January 1967, after a series of successful experiments, a contract was for the development of the Tactical Communications Satellite (TACSAT). On 9 February 1969, the satellite was launched into synchronous orbit and positioned over the U. S. The satellite has been very

Table A-5. DSCS Phase II Satellite Characteristics

TYPE		X-BAND MECHANICALLY DESPUN HORN	X-BAND MECHANICALLY DESPUN PARABOLOID REFLECTOR	S-BAND BICONICAL HORN FOR T&C	
ANTENNAS	Number	1	1	1	
	Beamwidth	Earth Coverage Beam - 18°	Narrow Beam - nominal 2.5°	Toroidal 32' wide	
	Gain	Xmit. - 16.8 dB (Edge)	Xmit. - 33 dB (Edge)	3 dB (Peak)	
REPEATERS	Type	Single conversion with each of 4 channels operating in a linear, quasi-linear, or hard-limiting mode as selected by ground commands			
	Configuration	EC-EC*	EC-NB*	NB-NB*	NB-EC*
	Bandwidth (1 dB)	125 MHz	50 MHz	185 MHz	50 MHz
	Number	One	One	One	One
	Receiver	Tunnel Diode common to EC-EC & EC-NB channels		Tunnel Diode common to NB-NB & NB-EC channels	
	Type Front End	No Data		No Data	
	Front End Gain	8.3 dB		12.8 dB	
	System Noise Figure				
	Transmitter	TWT common to EC-EC & NB-EC channels		TWT common to EC-NB & NB-NB channels	
	Type	20 Watts		20 Watts	
Power Out			This channel shares a transmitter with EC-EC channel.		
EIRP	28 dBW	40 dBW (Each of 2 antennas) 43.1 dBW (1 antenna)**			
GENERAL FEATURES	Stabilization	Spin stabilized - nominal 60 RPM with hydrazine thrusters for stationkeeping and attitude correction.			
	Type				
	Capability	Pointing accuracy of despun platform *0.14". That of NB antenna ±0.2" East-West stationkeeping to within 1° of designated subsatellite point for 5 years.			
	Power Source	Right cylindrical array of solar cells, capable of providing 520 watts at launch and 1357 watts after 5 years.			
	Primary	Three nickel-cadmium batteries			
	Supplement	235 watts			
Communication Power Needs	9-foot diameter 13-foot height				
Size	1120 lb				
Weight					

*Denotes uplink and downlink antennas that channel interconnects.

**With 2 NB antennas employed, TWT output power is split. With 1 antenna, full power goes to that antenna.

successful in its testing and development role, and it was used in support of Apollo recovery operations. Table A-6 summarizes data relative to the spacecraft.

Table A-6. TACSAT Satellite Data

Satellite	TACSAT	
Manufacturer & Sponsor	Hughes Aircraft & AF Space and Missile Systems Organization	
Launch Date	February 9, 1969	
Launch Vehicle	Titan IIC	
Orbital Data	Apogee (mi.)	22,397
	Perigee (mi.)	22,331
	Inclination	0.6°
	Period	24 hours
Status	Active	

A. 4.2 TACSAT Transponder

The TACSAT communications subsystem consists of both an SHF (7 to 8 GHz) frequency translating repeater and a UHF (240 to 340 MHz) frequency translating repeater, each capable of operating with selectable bandwidths from 50 kHz to 16 MHz. In addition there are two crossover modes of operation (from UHF to SHF and from SHF to UHF).

The modes are under control of commands transmitted by the satellite control earth terminal. In keeping with the concept of mobile terminal simplicity, the satellite performs system frequency control by transmitting UHF and SHF beacon signals which are used for antenna pointing and as references for all transmit and receive function frequencies generated at the terminals.

Table A-7 shows the operating frequency bands at UHF and SHF. The UHF band uses three operational modes. These are (1) narrow-band voice; (2) a frequency hopping system, known as tactical transmission system (TATS), designed for military communications environments; and (3) broadcast alert. Table A-8 shows the signal processing techniques used in each UHF mode.

Table A-7. TACSAT Frequencies (MHz)

Purpose	Uplink	Downlink
SHF Communications	7977.5 to 7987.5	7252.5 to 7262.5
SHF Beacon	---	7298.5
UHF Communications	302.5 to 312.5	249.3875 to 249.8125
UHF Beacon	---	254.1

The SHF band uses four modes of operations. They are (1) FM, (2) TATS, (3) broadcast alert and (4) DPSK. Table A-9 shows the signal processing used in the SHF modes.

Characteristics of the communications-related subsystems of TACSAT are described in Table A-10. A block diagram of the communications repeater is shown in Figure A-4. There are eight ground-commandable modes corresponding to the four filter bandwidths at each frequency band. Two of the modes represent cross-coupled operation between the UHF and SHF repeaters.

TACSAT was the first U. S. spacecraft stabilized with gyrostat technology. This means that the satellite does not have to be spun about its maximum moment of inertia and thus frees the designer of on-board equipment from the moment of inertia design constraints.

The spacecraft consists of a large spinning cylinder within which is mounted a cone-shaped structure. A bearing assembly attached to the cone structure supports, on its housing, a despun platform containing antennas and communications and telemetry equipment. The spinning section contains solar cells; batteries; auxiliary telemetry, tracking, and command equipment; design control electronics; the hydrogen peroxide propulsion system; and the nitrogen spinup system. A pendulum liquid damper is used for nutation damping.

The intent of the program was to provide experimental hardware for testing tactical satellite communications and, therefore, to be conservative in the spacecraft development approach. Space-proven technology was used

Table A-8. Signal Processing for TACSAT UHF Modes

Mode	Narrow-band FM Voice	TATS	Broadcast Alert
Multiple Access	FDMA - 11 channels available	Random Access	Only one warning transmission at any one time.
RF Modulation	FM	MFSK and frequency hopping	FSK
Ground Demodulator Performance	Threshold estimated at 10-dB C/N based upon employing conventional discriminators	Threshold is 8 db for $P_E = 1 \times 10^{-3}$	Threshold estimated at 10-dB C/N based upon employing conventional disc.
Ground Terminal* Receive Carrier-to-Noise	29.3 dB** 16.7 dB	24.1 dB*** 11.5 dB	21.7 dB**
Ground Receive Margin*	19.3 dB 6.7 dB	16.1 dB 3.5 dB	11.7 dB

*Higher value is for strongest UHF terminal pair and lower value is for weakest UHF terminal pair. All results for single access.

**Based on 15-kHz IF bandwidth.

***Based on 50-kHz detection bandwidth for high data rate TATS mode.

Table A-9. Signal Processing for TACSAT SHF Modes

Mode	FM	TATS	DPSK (288 kbps)	Broadcast Alert Warning
Multiple access	FDMA	SSMA	FDMA	Only one warning transmission at any one time
RF modulation	FM	MFSK plus fre- quency hopping	DPSK	FSK
Ground demodulator performance	Threshold estimated at 6 dB C/N based upon employing phase-lock demodulator	Threshold is 8 dB for $P_E = 1 \times 10^{-3}$	Threshold is estimated at 6 dB C/N based upon em- ploying phase-lock de- modulator	No data
Ground terminal ⁽¹⁾ receive carrier-to- noise	26.7 dB ⁽²⁾ 11.4 dB	21.5 dB 6.2 dB	12.1 dB ⁽⁵⁾	No data
Ground receive margin	20.7 dB 5.4 dB	13.5 dB -1.8 dB ⁽⁴⁾	6.1 dB	No data

NOTES: (1) Higher value is for strongest SHF terminal pair and lower value is for weakest SHF terminal pair.

All results for single access.

(2) Based on 15-kHz IF bandwidth.

(3) Based on 50-kHz detection bandwidth for high data rate TATs mode.

(4) TATs modem is not used by teampack (weakest link) at present.

(5) Based on 432-kHz IF bandwidth. Shelter terminal is only station equipped with DPSK modem.

Table A-10. TACSAT Characteristics

Antennas	Type	UHF- Five element Helical array for transmit and receive	SHF- Separate fin loaded horns for transmit and receive	T & C- Biconical Horn	
	Number	One	One	One	
	Bearwidth	Earth coverage (190). Receive and transmit patterns not identical and not symmetrical.	Earth coverage (190). Receive and transmit patterns not identical and not symmetrical.	Approximately 300	
	Gain	Receive peak 17.58dB minimum over coverage area 12.79dB Transmit peak 17.12dB minimum over coverage area 14.67dB	Receive peak 19.3dB minimum over coverage area 15.2dB Transmit peak 18.4dB minimum over coverage area 15.2dB	No data	
Repeaters	Frequency Band	UHF	SHF (X-BAND)		
	Type	Hard limiting IF translation. Adjustable bandwidth and crossover to SHF repeater by command.	Hard limiting IF translation. Adjustable bandwidth and crossover to UHF repeater by command.		
	3dB Bandwidth	Straight through modes- 50kHz, 100kHz and 425kHz;crossover modes 425kHz and 10MHz	Straight through modes 50kHz, 1MHz and 10MHz;crossover mode 425kHz		
	Number	One with some redundancy	One with some redundancy		
	RECEIVER	Type Front End	Transistor preamplifier into down conversion mixer	Tunnel diode amplifier into down conversion mixer	
		System Noise Figure	3.7dB	6.9dB	
	TRANSMITTER	Type	16 parallel transistor amplifiers with summing of any number possible	3 TWTs - Any 2 summed in an output TWT switch.	
		Power Out	Carrier power (16 power amplifiers) 23.6dBW Beacon power (16 power amplifiers) 8.0dBW	Carrier power (2 TWTs) 14.6dBW Beacon power (2 TWTs) 0.2dBW	
	EIRP	Carrier 40.7dBW Beacon 25.1dBW	Carrier 33.0dBW Beacon 18.6dBW		
	General Features	STABILIZATION	Type	Gyrostab - consists of spinning cylinder containing solar cells and a despun platform containing communications equipment. Bearings and slip rings used between the 2 sections. Nitrogen spinup system, hydrogen peroxide reaction jets and nutation damper are used.	
Capability			Overall pointing capability is approximately 0.1 degree rms. However, intermittent nutation of about 1 degree occurs. Has been investigated and confirmed theoretically and can be corrected on future spacecraft.		
POWER SOURCE		Primary	Solar array with 980 watts output		
		Supplement	Battery capacity-over 20 ampere-hours		
SIZE		Cylinder 25 feet long and 9 feet in diameter			
WEIGHT		About 1600 lb in orbit			

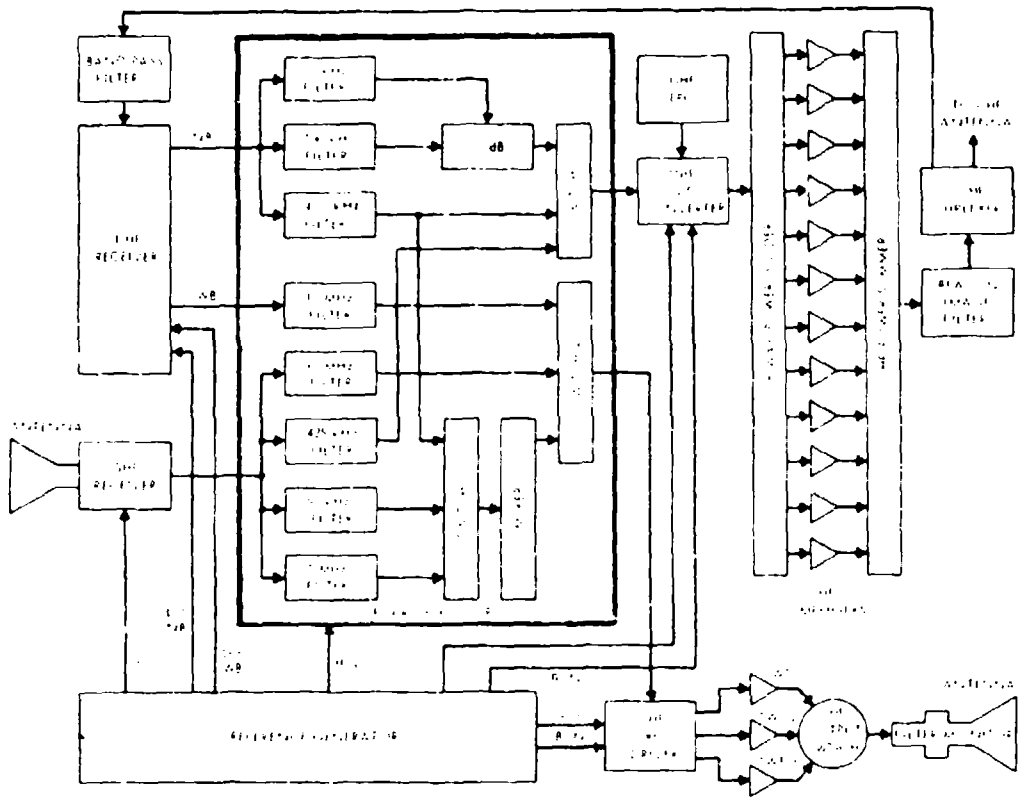

Figure A-4. TACSAT Transponder Repeater Block Diagram

of the United States' DSCS Phase I. The U.K. built five earth terminals (three with 40-foot antennas), one shipborne terminal and one mobile land terminal. All were completed and participated in testing during 1966.

The U. S. , in accordance with a memorandum of understanding with the U. K. , built and launched two satellites required by the Skynet program.

Two satellites were to be launched in 1969-70, with one satellite acting as a backup for the other to provide a 5-year system capability. Skynet IA was successfully launched into synchronous orbit in November 1969. Skynet IB was launched in August 1970 and was a total loss when it failed to make synchronous orbit. It was generally believed that the apogee kick motor used to circularize the orbit exploded. Table A-11 summarizes information on the Skynet satellites.

The United Kingdom has initiated procurement of additional higher-powered satellites from Marconi, a U. K. firm working under license to Philco-Ford of the U. S. The U. K. anticipates launching the first of the Skynet II series in the summer or fall of 1972. Skynett II will be similar in design to Skynet I but will have considerably higher EIRP (20-watt TWT versus 3-watt TWT).

Based on Skynet communications requirements for long distance strategic point to point digital communications and selected tactical communications with mobiles, it was decided that two independent satellite bands would be required (20 and 2 MHz wide). Table A-12 gives the frequencies of the two bands.

Table A-12. Skynet Frequencies

	2-MHz Channel (MHz)	20-MHz Channel (MHz)	Beacon (MHz)
Uplink	7976.02 to 7978.02	7985.12 to 8005.12	--
Downlink	7257.3 to 7259.3	7266.4 to 7286.4	7299.5

The satellite with two independent bands allowed the tailoring of the modulation and multiple access to satisfy all system requirements. Other specified features of the system include providing reliability of communications under

Table A-11. Skynet Satellites

Satellite	Skynet IA	Skynet IB	Skynet II
Manufacturer	Philco-Ford (USA)	Philco-Ford (USA)	Marconi (UK) under license to Philco-Ford (US)
Sponsors	United Kingdom Ministry of Technology United Kingdom Ministry of Defense		
Launch date	21 November 1969	19 August 1970	Estimated summer/fall 1972
Launch vehicle	Augmented Thrust-Thor-Delta		
Orbital Data	Apogee (mi) Perigee (mi) Inclination Period (hrs) Position (°E)	21,559.5 22,791.7 less than 3° 24 39 ± 3	No orbit achieved In procurement
Status		Spacecraft lost because of Apogee kick motor failure	In procurement

various conditions of weather, loading and interference, and flexibility as to interconnections and traffic carried.

The requirements of Skynet communications led to a choice of terminals of varying capacities. In addition, the satellite antenna beam was made as broad as possible to provide coverage from the U.K. in the West to Hong Kong in the Far East. The U.K.'s other areas of interest fall between these two extremes.

Traffic requirements were in the form of telegraphy, speech, and medium-speed data circuits. It was decided that the strategic system would be designed specifically for digital signals at medium-speed rates of 75×2^{11} bits per second using the 20-MHz channel.

For this channel, SSMA was chosen over FDMA since critical power balance and frequency planning could be eliminated by using SSMA. In addition, SSMA transmissions can be superimposed without complete degradation when the nominal capacity is exceeded, and SSMA signals are virtually immune to intermodulation effects except for the small loss of useful power (about 1 dB).

In the more difficult mobile terminal case it was decided to use FDMA with FM as the basic modulation in the 2-MHz satellite band. In addition the 2-MHz channel is used to provide engineering teletype orderwire facilities between fixed stations.

A. 5. 2 Skynet Satellite Transponder

Characteristics of the Skynet satellites are shown in Table A-13. A simplified block diagram showing the transponder of the satellite is shown in Figure A-5.

The communications subsystem (as shown in Figure A-5) receives, frequency translates, amplifies, and retransmits X-Band signals. Two channels, 20- and 2-MHz bandwidth (1 dB), are provided. The total output power is divided equally between the two channels. Figure A-5 indicates only the single thread path. The complete equipment redundancy and cross-strapping which is employed

Table A-13. Skynet I Satellite Characteristics

Antennas	Type	X-Band mechanically despun	UHF array for TT&C with redundant UHF transponders and command/telemetry processing equipment	
	Number	One	Two	
	Beamwidth	19	Essentially omnidirectional	
	Gain	18.5 dB	-0.7 dB	
Repeaters	Frequency Band	X-Band		
	Type	Hard-limiting dual channel		
	1 dB Bandwidth	20 MHz and 2 MHz channels		
	Receiver	Type Front End	Down conversion mixer into linear amplifier	
		Noise Figure	10.2 dB	
	Transmitter	Type	Redundant TWT	
Power Output		1-1.4 watts		
EIRP		19.5 dBW		
General Features	Stabilization	Type	Spin 90 rpm - 5 years	
		Capability (station keeping)	± 3 for 5 years	
	Power	Primary	Cylindrical array of silicon solar cells, capable of providing 97 watts of prime power, throughout 5 years of orbit life	
		Supplemental	Two redundant 16-cell nickel-cadmium batteries for operation during eclipse (6 AH per cell)	
	Size	54-inch diameter, 60 inches high		
Weight	Launch 325 lb, on orbit 280 lb			

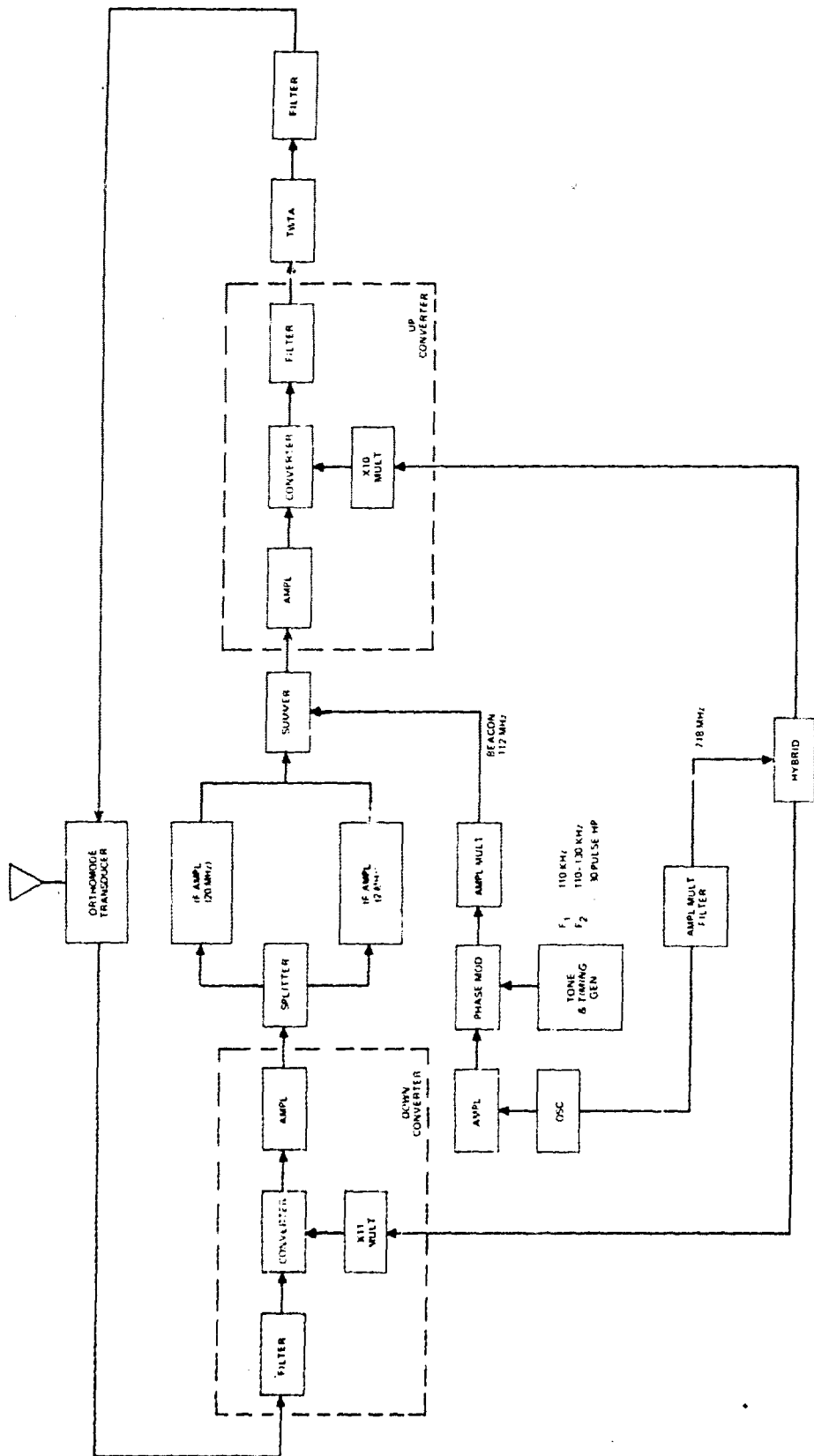

Figure A-5. Skynet Communications Transponder Block Diagram

to achieve reliability is not shown. Selection of either set of communications equipment, operating with either traveling wave tube amplifier, is done by ground command.

The communications antenna consists of the RF assembly and the motor drive assembly (MDA). RF energy is circularly polarized, collimated into a plane wave front and focused on the flat plate reflector. The beam axis, reflected through a 90° angle, is continually directed toward the subsatellite point by the despun motion of the radiating aperture. A rotary choke joint at the lower end of the MDA housing permits efficient transfer of energy between the spacecraft's fixed and despun waveguide sections. A hydrazine reaction control subsystem provides for attitude control and station keeping, and in addition will allow the future relocation of the Skynet satellite if system requirements change.

Three redundant antenna-pointing control systems--earth horizon sensors, sun angle sensors and a backup earth-to-satellite command link--are provided. A UHF subsystem, also redundant, is provided for telemetry tracking and command services (TT&C).

Electrical power is supplied to the satellite from solar arrays, with batteries provided for eclipse operation. Redundant power control units are used to provide regulation, battery charging and load control.

A.6 NATO

A.6.1 General

In 1967 a Memorandum of Understanding between the United States and NATO was signed whereby the U.S. would build and launch two Skynet-type satellites. The U.S. Air Force's Space and Missile System Organization (SAMSO), with technical support from the Aerospace Corporation, was to act as the procurement agent for NATO.

System studies indicated that two minor changes in the Skynet satellite would provide a better system for NATO. The first modification was to change

the equal power division between the 20- and 2-MHz channels of the transponder to a 6:1 ratio, respectively. The second change was to shift the antenna-aiming point from the subsatellite point on the earth to between 40- and 45°N latitude since all NATO earth terminals were to be located north of the Equator. This yielded a better power spread for NATO coverage over the Northern Hemisphere.

In addition, NATO decided to participate in the DSCS Phase I test program. They initially leased and finally purchased two 15-foot diameter MASCOT satellite ground terminals built by Philco-Ford. These terminals were used to train personnel for the advanced system (NATO SATCOM Phase II). The early part of the program involving operations with the DSCS Phase I was called NATO SATCOM Phase I.

The NATO SATCOM Phase II included launching the two modified Skynet-type satellites and building a satellite ground system. The two satellites were to be launched in 1969-70 with one satellite acting as a backup to provide a 5-year system capability. NATO I was successfully launched into synchronous orbit in March 1970. The launch of NATO II was delayed until 1971 because of the apogee motor failure that occurred during the launch of Skynet IB. NATO II was successfully launched into synchronous orbit in February 1971.

The operational requirements dictated the use of 12 fixed earth terminals. The 12 stations are located near the capital cities of the following 12 countries: Belgium, Germany, United States, United Kingdom, Norway, Turkey, Italy, Canada, the Netherlands, Denmark, Greece, and Portugal.

The terminals are all equipped with 42-foot diameter antennas; however, the (L) terminals will be equipped to handle 24 voice channels and the (M) terminals only three voice channels.

A.6.2 NATO Transponder

Table A-14 provides the NATO satellite characteristics. The simplified block diagram of the NATO satellite is the same as that shown in Figure A-5 for Skynet.

Table A-14. NATO Satellite Characteristics

ANTENNAS	Type	X-Band (point-to-point) system with lens to aim center of beam at 42° - 45° N.	UHF array for TT&C with standard UHF transmitters and command telemetry processing equipment.
	Number	One	Two
	Beamwidth	No data available	Essentially omnidirectional
	Gain	17.5 dB	0.7 dB
REPEATERS	Frequency Band	X-Band	
	Type	Hard frequency channel	
	1-dB Bandwidth	20 x 12-MHz channels	
	<u>Receiver</u>		
	Type/Front End	Down conversion mixer into pre-amplifier	
	Noise Figure	10.2 dB	
	<u>Transmitter</u>		
Type	Excimerant TWT		
Power Output	3.0 dBW (20 MHz) 5.5 dBW (2-MHz channel)		
EIRP (peak of beam)		20.5 dBW (20-MHz channel) 17 dBW (2-MHz channel)	
GENERAL FEATURES	<u>Stabilization</u>		
	Type	Spin 90 rpm - 5 years	
	Capacity (satellite keep-out)	10° for 5 years	
	<u>Power Source</u>		
	Primary	Cylindrical array of silicon solar cells, capable of providing 97 watts of prime power throughout 5 years of orbit life.	
	Supplement	Two redundant 16-cell nickel-cadmium batteries for operation during eclipse (6 AH per cell).	
	Size	54-inch diameter	60 inches high
Weight	Launch 5.35 lb	on orbit 260 lb	

Table A-15. Intelsat IV Characteristics

Antenna	Type	Global, receive, global transmit: conical horn with flat plate reflection. Spot Beam: 50-inch parabolic reflector. Omnidirectional command receive antenna and omnidirectional telemetry transmit.
	Number Transmitter Beamwidth (global/spot beam) Transmitter Gain (global/spot) Polarization	2 of each of the above communications antennas 17/4.5° 20.5/31.7 dB Circular
Repeater	Frequency Band Type Bandwidth 1 dB Number	C-band Linear or limiting* single RF conversion repeater 36 MHz 12
	Receiver Type Front End Front End GaLl System Noise Figure	Tunnel Diode Amplifier 13.8 dB 8.2 dB
	Transmitter Type Power Out	TWTA 8 dBW per transponder
	EIRP** (global/spot beam)	22.5/34.2 dBW per transponder at beam edge
General Features	Stabilization Type	Spin with hydrazine jet attitude and orbital** control.
	Power Supply Primary Supplement	42,240 solar cells - 750 watts at launch Nickel-cadmium batteries
	Size Weight (at liftoff) (in orbit)	Cylindrical: 7'9" diameter, 17'4" height overall, 9'3" solar drum alone 3094 lbs 1544 lbs

Notes: *Selectable by ground command.

**Both north/south and east/west stationkeeping provided.

paraboloidal dish, are mounted on the despun control mast. The aiming of the spot beams is controlled from the ground. These antennas have a 4.5° beam-width and can provide high-gain coverage in selected areas. Figure A-6 is the block diagram of Intelsat IV. The satellite, using the EC antenna, will be capable of relaying 6000 half duplex channels or 12 color television programs, or equivalent combinations of such transmissions.

Operating frequencies for the four types of Intelsat spacecraft are shown in Table A-16. The bands of usage indicated show that the Intelsat I, II, and III spacecraft contained two, one and two independent repeaters, respectively. In Intelsat IV, the bandwidth shown spans the total operating frequency range of 12 independent repeaters. Downlink center frequencies for the 12 repeaters are: 3725, 3765, 3805, 3845, 3885, 3925, 3975, 4015, 4055, 4095, 4135, and 4175 MHz, respectively. Uplink frequencies for each repeater are 2225 MHz above the indicated downlink frequencies. The frequencies employed were selected to be compatible with the shared frequency bands allocated to commercial satellite communications by the International Telecommunications Union in 1963.

Table A-16. Intelsat Frequency Assignments

Spacecraft	Communications		TT&C		
	Uplink	Downlink	Command	Telemetry	Beacon
Intelsat I (Early Bird)	6288-6314 MHz	4068-4004 MHz	6289 MHz	4104 MHz	136, 4104 MHz
	6377-6403 MHz	4118-4174 MHz	6402 MHz	4138 MHz	137, 4138 MHz
Intelsat II	6282-6408 MHz	4057-4133 MHz	No Data	136 MHz	136 MHz
Intelsat III	5930-6155 MHz	3705-3930 MHz	6175 MHz	3933-3967*	3933-3967
	6195-6420 MHz	3970-4195 MHz			
Intelsat IV	5930-6420 MHz**	3705-4195 MHz**	6175 MHz	3950 MHz	3950 MHz

*Telemetry used to phase-modulate the beacon.

**Divided into 12 channels, each 36 MHz wide.

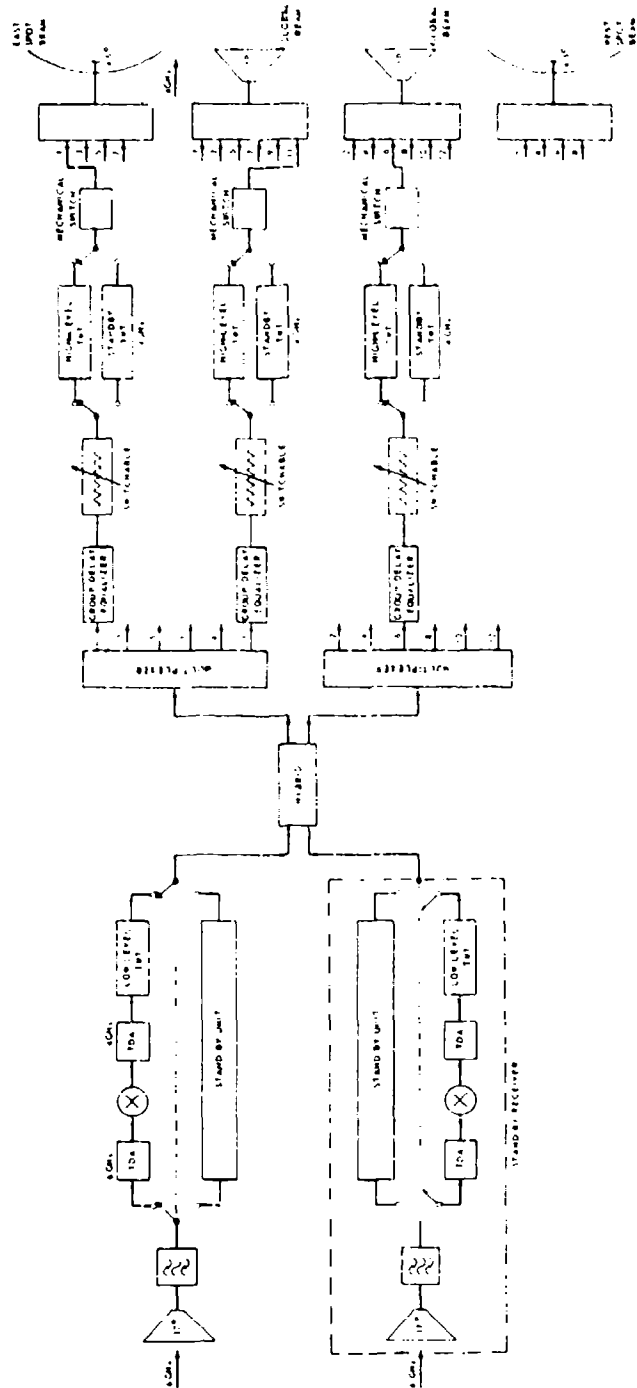

Figure A-6. Intelsat IV Transponder Block Diagram

APPENDIX B - EARTH TERMINALS

B.1 GENERAL

This appendix presents a summary of the characteristics of currently available and proposed earth terminals of interest to military communicators. Major design characteristics of the earth terminals covered in this section are provided in Table B-1.

B.2 AN/FSC-9

This terminal type was originally developed for an R&D program and was converted to meet the requirements of DSCS Phase I and other experimental programs. Figure B-1 is a photograph of the AN/FSC-9 antenna and Figure B-2 is a simplified block diagram of the original earth terminal. There are two existing terminals of this type; one at Fort Dix, New Jersey and the other at Camp Roberts, California.

The antenna is a 60-foot diameter paraboloid reflector with an automatic tracking feed system. The reflector for the antenna includes a superstructure that acts as a counterweight and provides housing for electronic equipment. The weight of the antenna is approximately 190 tons. The antenna was designed to operate with low-altitude satellites, hence the axes have rotational rates of about 10° per second. Also the antenna was originally designed to operate at a lower frequency than that used by DSCS Phase I and the gain at 7 and 8 GHz was lower than desired. Improvements during 1971 partially rectified this problem. Automatic tracking is provided by a pseudomonopulse technique.

The AN/FSC-9 terminal is equipped with both FM and spread spectrum (pseudonoise) modulation equipment. The FM modulator accepts the 0.3- to 52-kHz baseband from the AN/FCC-55 multiplexer and modulates it to one of four frequencies in the 70-MHz IF. The demodulator takes the 70-MHz signal from the microwave receiver and demodulates it to the 0.3- to 52-kHz baseband.

Table B-1. Summary of Earth Terminal Characteristics

Terminal Features	AN ESC-9	AN MSC-6	AN TSC-51	AN MSC-60B/C	AN MSC-61 (ATO)
Antenna Type Aperture Diameter (feet)	Cassegrain 60	Cassegrain 40	1 Cassegrain Dish Area 18 (Effective)	Cassegrain 60	4 Cassegrain Dish Areas 18 (Effective)
Receive System Type Type Bandwidth (MHz) Frequency Range (GHz)	Cooled Paramp 30 dB point 7.25 to 7.75	Cooled Paramp 30 dB point 7.25 to 7.75	Cooled Paramp 30 dB point 7.25 to 7.75	Uncooled 500	Cryogenically cooled 500
Transmit System Type Type Bandwidth (MHz) Amp Power, Out Frequency Range (GHz)	Klystron 50 dB point 10 W to 20 kW 7.9 to 8.1	Klystron 30 dB point 100 W to 10 kW 7.9 to 8.4	Klystron 10 dB point 5 kW maximum 7.9 to 8.1	1 Klystron (HPA) 2 TWT (LPA) LPA - 500 HPA - 170 LPA - 3 kW HPA - 4 kW	1 Klystron (HPA) 1 TWT (LPA) LPA - 500 HPA - 170 LPA - 3 kW HPA - 4 kW
Tracking Type	Autotrack	Autotrack	Autotrack	Autotrack	Autotrack
Total Performance G, dB ERP, dBm	38 133	33.0 127	26.0 118	39 127	27 117
Polarization	circular	circular	circular	circular	circular
Power Voltage Frequency Watts (Max)	100 V, 3ø 60 Hz 200 kW	Local commercial power 3 diesel gen. at 200 kW each 120 200 V, 1ø 50 or 60 Hz, 3ø 175 kW, 1 wire	Lightweight diesel Generator set 120 200 V, 2ø 400 Hz, 2ø 45 kW, 1 wire	120 V 50 or 60 Hz 300 kW	208/120 V 50/60 Hz 160 kW
Installation Radome Facility	Some Large Fixed Terminal	Double wall inflatable radome Moveable by 3 vans or C-124 C-130E, C-133 aircraft.	Rigid radomes used at some loc. Highly transportable by truck, helicopter or aircraft.	None Semi-fixed local. in 3 vans and antenna Land, sea or air transportable	None Transportable by 3 vans or C-133 aircraft.
Weight	150 tons - Ant. weight	Approx. 114,000 lbs. total wts. Antenna - radome - 5000 lbs	17,500 lbs. - total system 65,000 lbs. in transportation configuration	400,000 lbs. including maintenance and service vans and power units	Approx. 50,000 lbs. 100,000 including maint. and service vans and power units

Table B-1. Summary of Earth Terminal Characteristics (Continued)

Terminal Features	AN/USC-57	AN/USC-50	SSC-5 (MASS)	SCF-21	PIS	AN/USC-56 (L)
Antenna Type Aperture Diameter (ft)	Parabolic 3	Parabolic 4	Cassegrain 6	Cassegrain 21	Cassegrain 15 (side terminal)	4
Receive System Type Pre-amplifier Bandwidth (MHz) Frequency Range (GHz)	Uncooled paramp foll. by tuned disk amp. 10 7.25 to 7.75	Uncooled paramp foll. by tuned disk amp. 10 7.25 to 7.75	Uncooled paramp. 500 7.25 to 7.75	Cooled paramp 20 7.25 to 7.75	Paramp 50 7.25 to 7.75	Paramp 500 7.25 to 7.75
Transmit System Type Amplifier Bandwidth (MHz) Amp Power Out Frequency Range (GHz)	Traveling-wave tube 10 50 to 150 W max. ---	Klystron 10 1.5 W to 430 or 500 W ---	Klystron 125 12.5 kW 7.96	Flywheel 40 5.1 W 7.3 to 7.4	---	Klystron 10 (1 db point) 1 kW 7.25 to 7.4
Tracking Type	None	None	Autotrack	Autotrack	Autotrack	Autotrack
Total Performance G/T (dB/K) ERP (dlim)	Approx. 9.4 81.5 to 83.5 dlim (1)	12.9 to 11.5 Adjust. from 69.3 to 94.5 dlim (1)	14 110	31 120	26 104	14 103
Polarization	circular	circular	circular	circular	circular	circular
Power Voltage Frequency Watts (Max)	110 Vac, 10 60 Hz ---	208 Vac, 30 60 Hz ---	---	1.0, 208 V, 30, 30, 60 Hz, 15, 15, 15 15 kW, 1 watt	115 V, single phase 50 to 60 Hz 1 kW	220 V, 30 50 to 60 Hz 10 kW
Installation Radome Facility Weight	None Transp. by small vehicle & accessory trailer for prime power supply 534 lbs including Ant. 2273 Vehicle 10531 Trailer	None Transportable by truck or aircraft 1600 lbs including Ant. 5000 Vehicle 2531 Trailer	None Fixed shipboard	None Transportable, non- militarized, commercial	None Transportable	None Transportable 2700 lbs less antenna 5000 lbs



Figure B-1. 20 kW Fixed-Station Terminal, 60-Foot Antenna

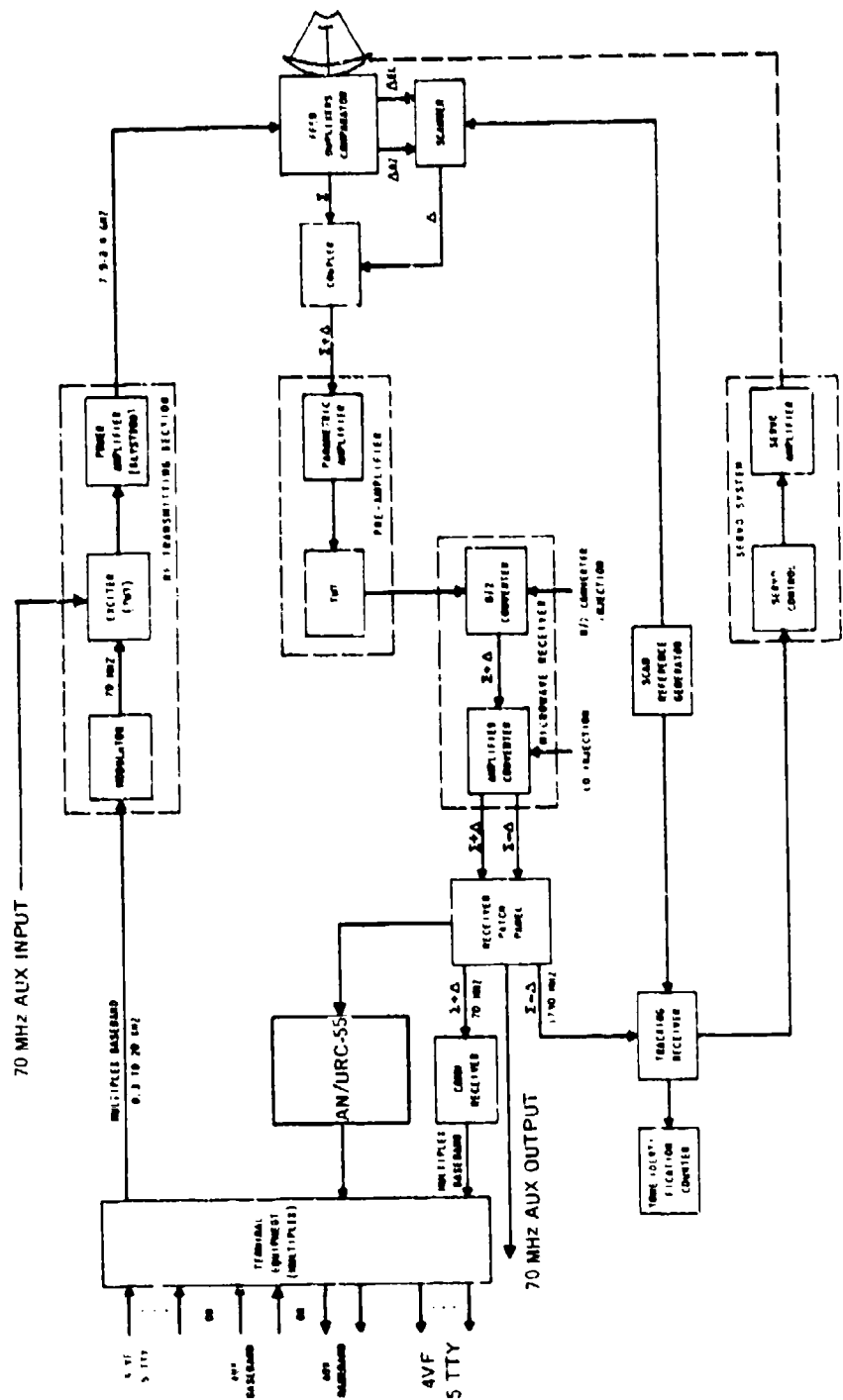

Figure B-2. AN/FSC-9 - Simplified Functional Diagram

The spread spectrum (pseudonoise) equipment, AN/URC-55, processes the baseband of up to four voice channels with deviation factors of 2, 4 and 8. The digital modes of operation can process one digital channel at rates of from 75 to 4800 bps in multiples of 75 times 2^N . The IF is at 70 MHz.

The AN/FCC-55 multiplexer/demultiplexer performs the following functions:

1. Multiplexes a total of 12 incoming user voice channels, a 0- to 4-kHz orderwire, and the out-of-band teletypewriters (TTYs) into a 300-Hz to 52-kHz baseband package. One TTY channel serves as a terminal orderwire; the second TTY channel may serve as a TCF-to-TCF orderwire. The 4-kHz channel normally is used as a voice communications channel for the 5-channel mode.
2. Demultiplexes the received 52-kHz baseband package into the individual circuits as enumerated above.

The prime power for the AN/FSC-9 earth terminals is supplied by commercial sources. The requirements for terminal operation are 400-volt, 3-phase, 60-Hz, 700-kW voltage. The AN/FSC-9 terminals have been rehabilitated and upgraded in performance, including modifications to incorporate some redundancy and increase the availability of the terminals.

B.3 AN/MSC-46

The AN/MSC-46 is a mobilize satellite communication terminal that operates with synchronous or near-synchronous satellites. There are 13 AN/MSC-46 terminals now deployed for operational use in the system. One additional AN/MSC-46 is located at Fort Monmouth, New Jersey for testing and training. The AN/MSC-46 provides an output power of 10 kW in the frequency range from 7.9 to 8.4 GHz. The receive frequency is in the range from 7.25 to 7.75 GHz. The system contains multiplex equipment with an installed capacity of 12 duplex voice channels and five duplex TTY channels

in a baseband of 4 to 52 kHz. Auxiliary wideband baseband inputs of 0.3 to 500 kHz or 0.3 to 252 kHz (up to 60 voice channels) can be accommodated. To facilitate operations, an additional TTY channel is used as an orderwire. Figure B-3 is a photograph of the AN/MSC-46.

The AN/MSC-46 terminal is housed in a cargo van, a maintenance van, an operations control van (OCV) and an inflatable radome. Power is furnished by three diesel generators of 100 kW each, or local commercial power, if available. The complete terminal, including the disassembled antenna and radome, can be transported in C-124, C-130E, or C-133 aircraft. The total weight is approximately 114,000 pounds. After arrival on site, a crew of eight trained men is required to erect the terminal.

The AN/MSC-46 terminal uses a 40-foot diameter Cassegrain type antenna system with an automatic tracking feed system capable of tracking synchronous and near-synchronous communication satellites. The reflector is mounted on a transportable pedestal which uses a tripod ground support. The RF room, containing the receiver and high-power amplifier, is located directly behind the main reflector. The antenna feed is a four-horn (modified) monopulse, circularly polarized feed that is used both for transmitting and receiving. The feed provides sum, elevation error, and azimuth error signals to the RF receiver for communication signal processing and antenna tracking. The metallic subreflector originally used a tripod mount. The AN/MSC-46 antennas have been modified by replacing the subreflector assembly with a single Dielectric (dielectric cone) feed.

The AN/MSC-46 terminal is equipped with FM and spread spectrum (pseudonoise) modulation and multiplex equipment similar to that described for the AN/FSC-9 except that the IF frequencies are different.

The AN/MSC-46 terminals also have the AN/TCC-3, a five-channel tactical quality multiplex unit. The baseband configuration of the top four channels is inverted; that is, the carriers and lower sidebands are suppressed.

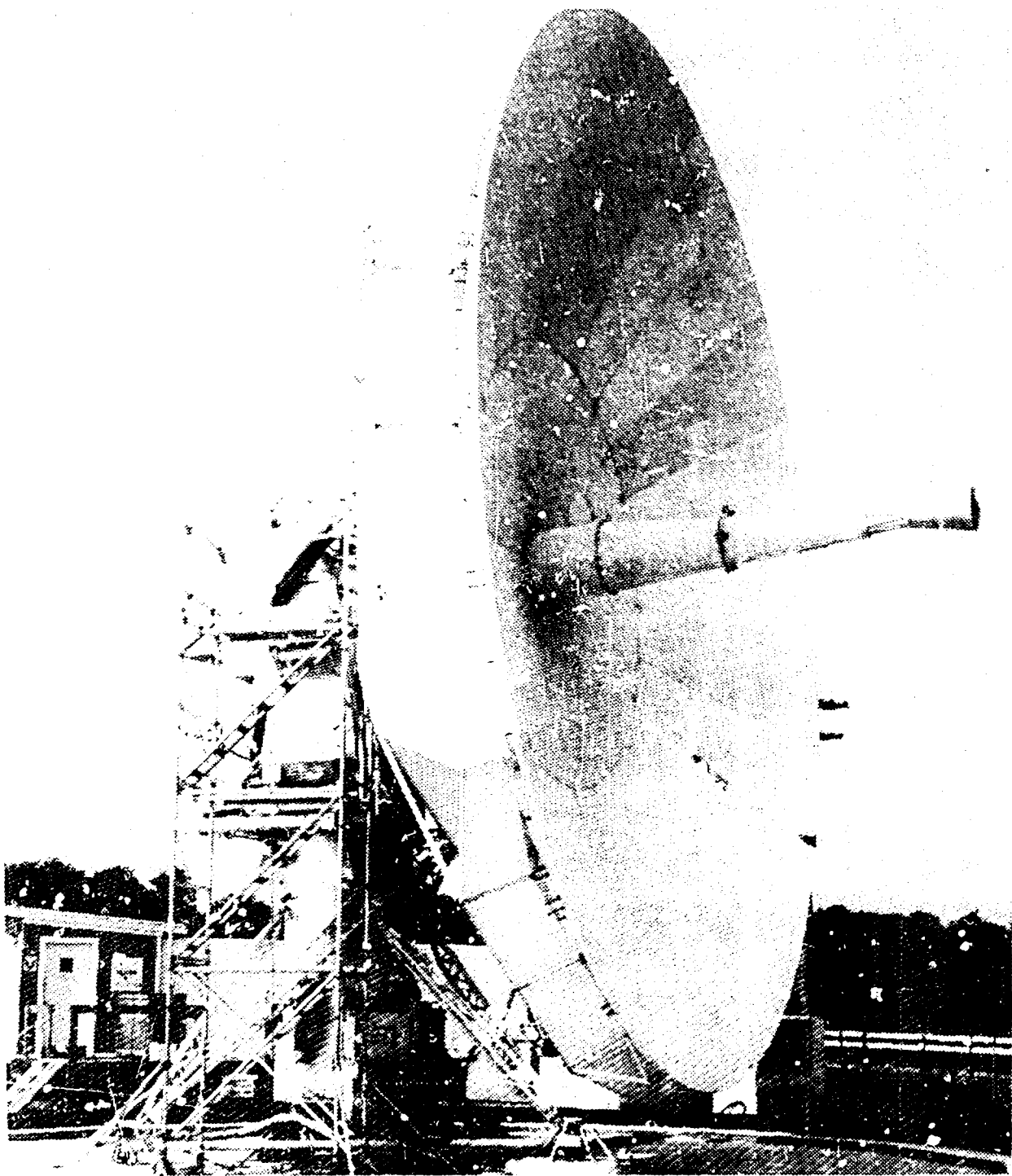

Figure B-3. The AN/MSC-46 Earth Terminal With No Radome
But With Updated Dieguide Antenna Feed

The baseband configuration of the AN/FCC-55 multiplex is upright; i. e., the carriers and upper sidebands are suppressed. Thus, the AN/TCC-3 baseband is incompatible with the AN/FCC-55 baseband. Figure B-4 is a simplified block diagram of the AN/MS-46.

B.4 AN/TSC-54

The AN/TSC-54 is a transportable satellite communication earth terminal. It provides the capability for tracking a communication satellite and for transmitting 7.9 to 8.4 GHz and receiving 7.25- to 7.75-GHz signals. A six-man crew can erect or dismantle the terminal in 2 hours. Figure B-5 is a photograph of the AN/TSC-54. The primary elements of the terminal are a modified S-141/G equipment shelter and the antenna assembly. To complete the terminal a primary power source and suitable mobilizing equipment are supplied.

The equipment is configured to be transported overland with attachment of suitable wheel assemblies. Detachable ground mobilizers (GOAT mobilizer - goes over all terrain) are supplied that allow towing of the terminal over unimproved terrain. The equipment can also be airlifted by helicopter. The entire system weighs less than 17,500 pounds without fuel; no single package weighs more than 6000 pounds. Also the maximum dimensions and overall weight are compatible with the loading capability of cargo aircraft such as the C-130E.

The AN/TSC-54 terminal uses an array of four 10-foot diameter parabolic dishes, each of which has a Dieguide feed for Cassegrain illumination, providing an 18-foot effective diameter. The antenna is supported and stabilized in the operational configuration by tripod outriggers. The klystron power amplifier, exciter, and power supplies are mounted in the antenna pedestal base. The parametric amplifier and frequency translators are located directly behind the antenna reflectors. The signal frequencies of the antenna-mounted electronics are at 400 MHz.

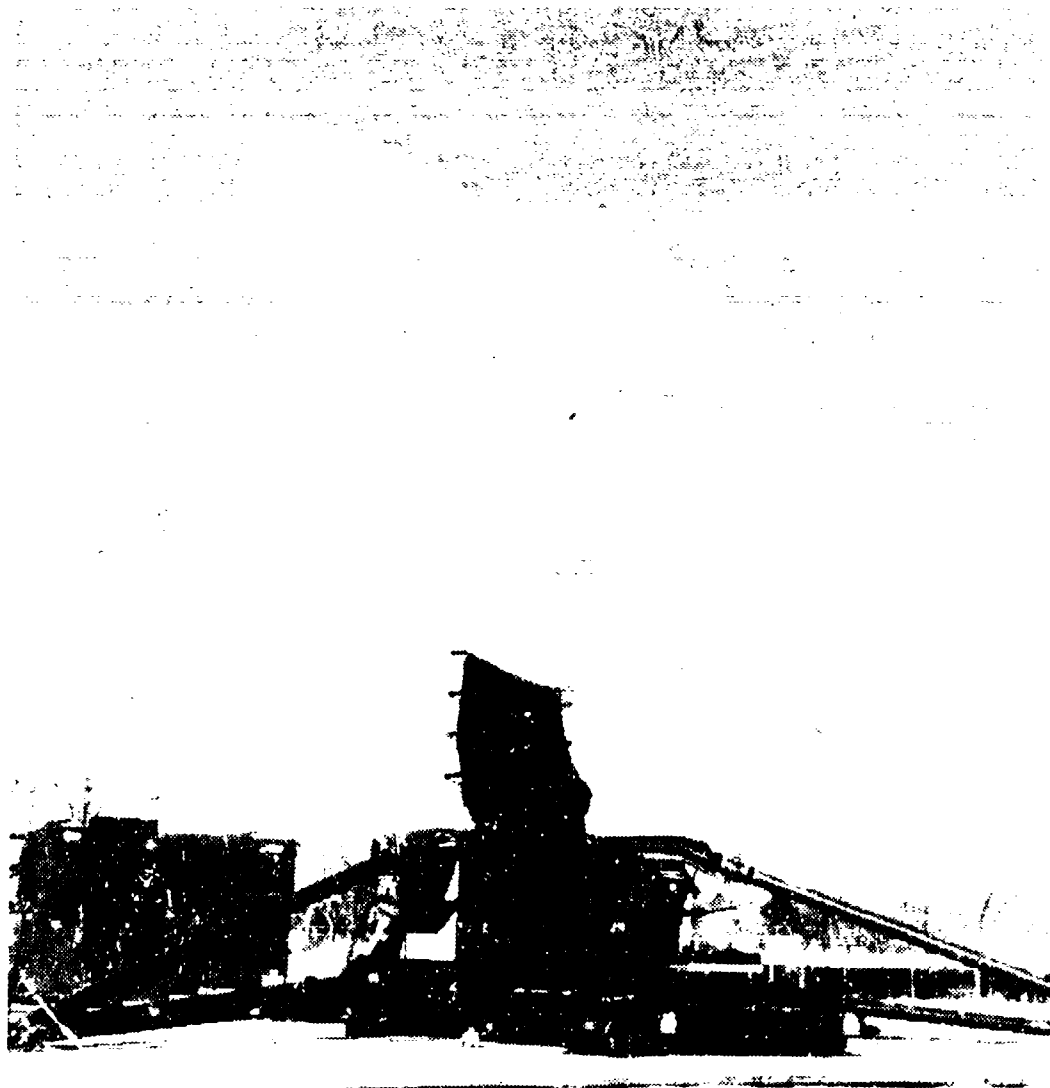

Figure B-5. The AN/TSC-54, Highly Transportable Terminal,
With Cloverleaf Antenna Which Is Equivalent to an 18-Foot Diameter Reflector

The AN/TSC-54 is equipped with FM and pseudonoise (PN) modulation equipment. The Navy AN/TSC-54 terminals are also equipped with differential phase-shift keying (DPSK) modulation equipment. The FM receiver is a phase-lock demodulator with selectable bandwidths (by switch) and additional bandwidths are selectable by module change.

The FM modulator provides for the following modes of operation:

1. One voice plus one duplex out-of-band user TTY and one out-of-band orderwire TTY
2. One in-band TTY (last ditch operation)
3. One, four, eight or 16 multiplex TTY
4. One truncated voice channel.

The DPSK modulation/demodulation equipment is capable of supporting up to 16 time division-multiplexed teletype channels. The PN equipment, AN/URC-61, processes one voice channel plus one FSK-TTY orderwire or FDM of 16 VFTG TTY channels. The digital modes of operation can process one digital channel at rates of from 75 to 4800 bps. Prime electrical power is supplied by a light-weight 45-kW 400-Hz diesel generator set. The electrical specifications for prime power are 120/208 volts \pm 5 percent, 400 Hz \pm 2 percent, 3-phase, 4-wire.

This terminal will be modified and equipped to fulfill either of two missions in Phase II. It will be used for DCS trunking in the earth coverage mode providing from three to six voice channels. It will also be capable of being rapidly deployed as a contingency terminal utilizing the satellite narrow-beam antenna.

B.5 AN/MSC-60, HEAVY TRANSPORTABLE (HT)

Table B-1 presents the design characteristics of the AN/MSC-60. The AN/MSC-60 earth terminal shown in Figure B-6 is a transportable terminal

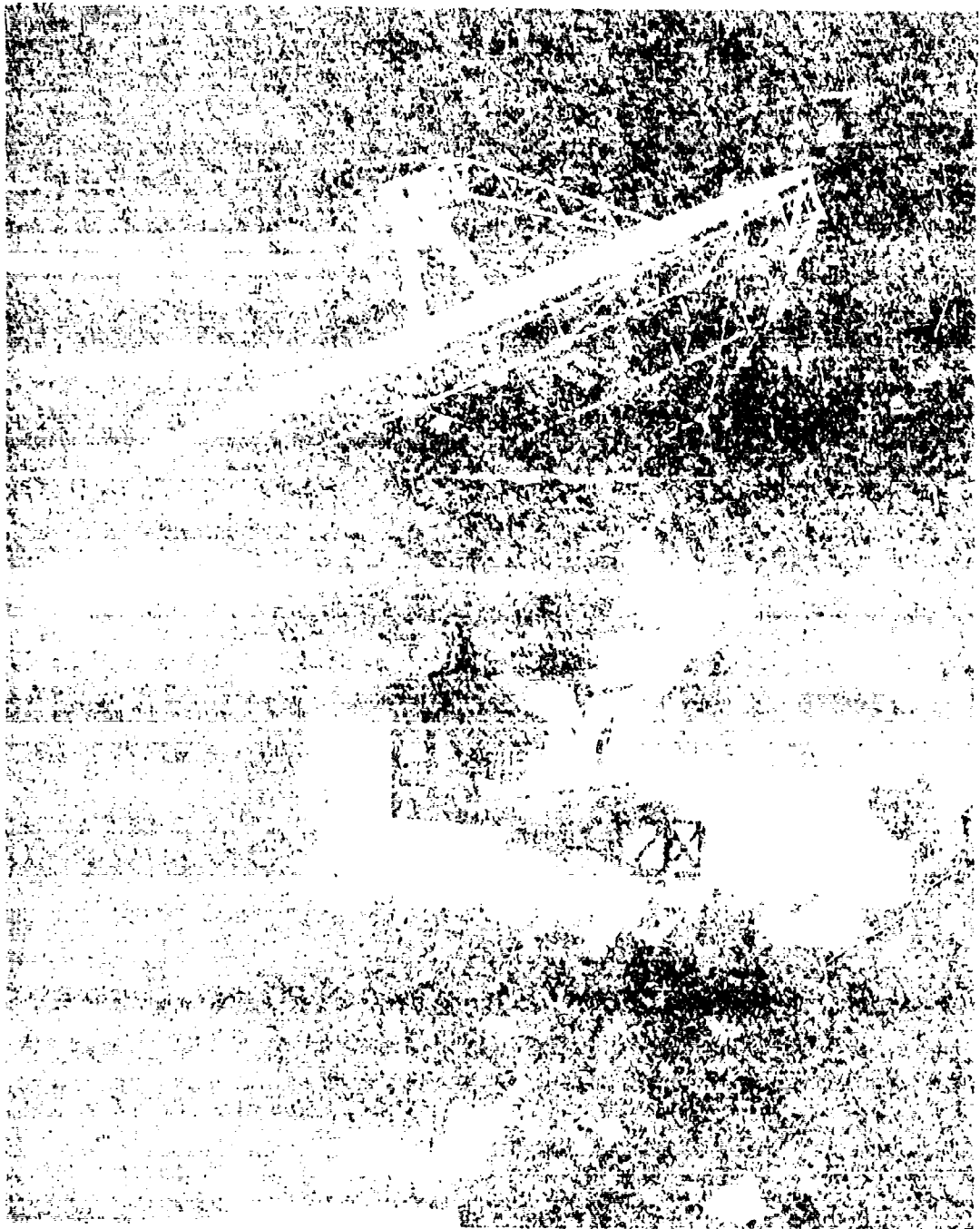

designed as a semifixed installation, but having recovery (disassembly/reassembly) capability. It requires a prepared site and about 45 days to install. A prototype model has recently been developed by the Army SATCOM Agency under a contract to Philco-Ford Corporation. The terminal is expected to be delivered during 1972 and deployed operationally as a nodal terminal in Phase II.

The antenna reflector system consists of a solid-surface, 60-foot diameter, high-efficiency main reflector and a subreflector. The HT terminal G/T and EIRP capabilities are 39 dB/K and 127 dB, respectively, and the terminal provides a multiple transmit and receive carrier capability.

The AN/MSC-60 terminal interfaces with a communications subsystem at IF frequencies of 70 to 700 MHz for both transmit and receive carriers. Tuning of transmit and receive carriers in increments of 1 kHz over the full 500-MHz uplink and downlink satellite frequency bands is provided. An automatic carrier balance capability is used that provides automatic leveling of each transmitted carrier with an accuracy of ± 0.2 dB. The AN/MSC-60 terminal has been designed with extensive and sophisticated automatic fault location, monitors and alarms. An interface has been provided which is suitable for remoting the analog and digital signals relating to the many parameters which are monitored.

The terminal will include three vans in addition to the antenna and pedestal subsystem. One van is used for housing the transmitters and heat exchangers, another van houses the RF operations equipment including the control console and a third van is used for maintenance purposes. The total weight of the AN/MSC-60 is 400,000 pounds, including the maintenance and service vans and the prime power units.

The AN/MSC-60 can be equipped with up to nine transmit and 12 receive (FDMA) carriers. However, the initial models procured will be equipped with five transmit and nine receive carriers. These terminals are designed to be deployed to nodal locations, replacing selected AN/MSC-46 terminals. The

higher inherent availability of these terminals, together with their performance capability, will increase the overall performance of Phase II.

B.6 AN/MSC-61, MEDIUM TRANSPORTABLE (MT)

The AN/MSC-61 is the medium-weight counterpart of the AN/MSC-60 heavy terminal. Both terminals are basically similar in electronic design and have the same interfaces, redundancy and availability. A primary difference is that the AN/MSC-61 is equipped with an 18-foot, aluminum, cloverleaf antenna that is used with the AN/TSC-54. This increases the mobility of the terminal but decreases the G/T from 39 to 27 dB/°K.

The overall weight of this terminal will be approximately 100,000 pounds, including the maintenance and service vans and the prime power units. The AN/MSC-61 and AN/MSC-60 vans have been designed with sufficient commonality to be interchangeable. The van equipment, as normally outfitted for the AN/MSC-61 terminal, will not include the redundant 5-kW TWT power amplifier, and will have only three up converters and four down converters as opposed to five and nine, respectively for the AN/MSC-60. Figure B-7 is a picture of the AN/MSC-61.

B.7 SCT-21

Figure B-8 shows the SCT-21, a transportable earth terminal designed by Philco-Ford and intended for nonmilitarized use.

The 21-foot satellite communications terminal is a link terminal capable of providing microwave communications between earth-based stations via active satellite repeater systems operating in the military satellite communication frequency bands. The system consists basically of the following:

1. 21-foot high efficiency antenna
2. Communications transmitter
3. Communications receiver, including cryogenic paramp

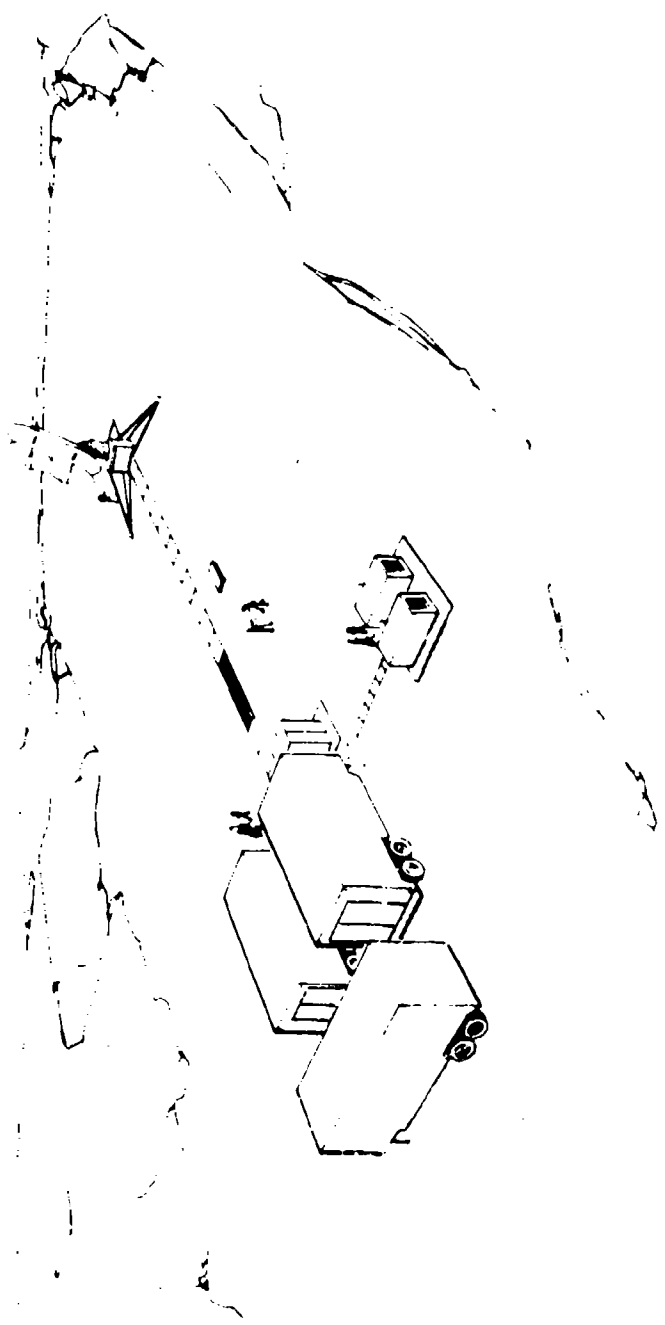

Figure B-7. Field Layout of AN/MS-61 (MT)

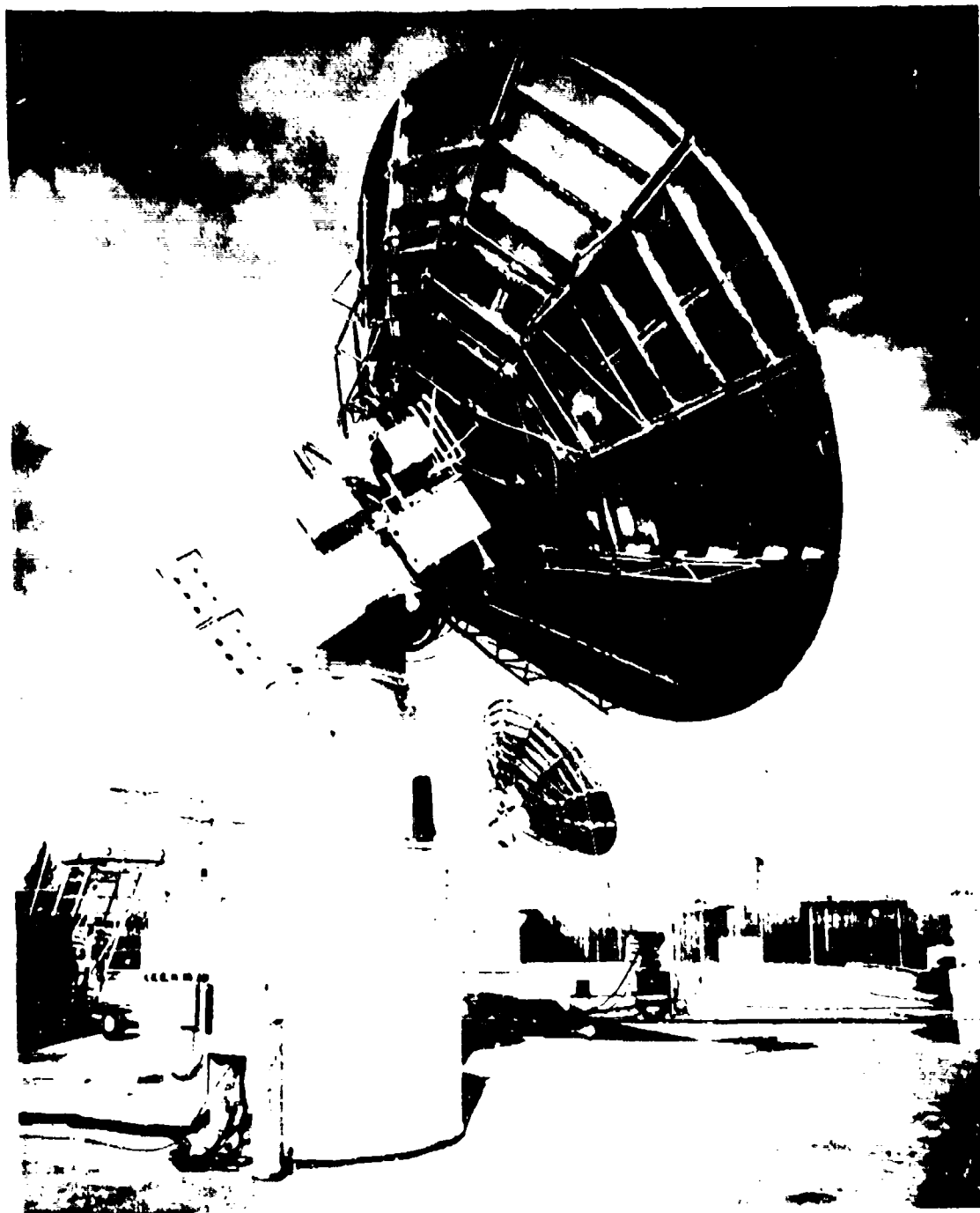

Figure B-8. The SCT-21 Transportable Terminal

4. Beacon tracking receiver
5. Alarm and status equipment
6. Communications terminal equipment
7. High-efficiency digital modem.

The terminal is a modular design to facilitate changing operational capabilities and to provide a high degree of maintainability with a low mean time to repair.

The terminal is capable of accepting nominal 4-kHz analog voice channels, 2400-bps data channels modulated onto a 4-kHz channel wire line and TTY channels from up to 20 user lines and provides a minimum capability to relay up to four of the 4-kHz channels including two TTY channels or up to 50 kbps of digital data on a single carrier frequency. Multiplex equipment and transmit/receive equipment provided for near optimum communications of the following two communications modes.

1. Analog - The terminal is capable of providing up to four full duplex voice or 2400 bps data links or any combination thereof and 2 full duplex out of band 60/100 wpm teletype circuits. One teletype is a dedicated terminal-to-terminal orderwire.
2. Digital - The terminal is capable of providing one full duplex 50.0 kbps channel and one full duplex 60/100 wpm teletype circuit.

The modular design concept readily permits simple addition or deletion of capabilities. The terminal has a 21-foot diameter, high-efficiency antenna and a 5-kW power amplifier. The primary frequency bands are 7.975- to 8.025-GHz transmit and 7.25- to 7.30-GHz receive. A low noise parametric pre-amplifier amplifies incoming communication and beacon signals. The tracking beacon frequency is assumed to lie within the 50-MHz band containing the communication signal. The data and tracking receivers use phased lock loop techniques. Automatic tracking is provided by the wideband monopulse-type feed.

System noise temperature is 125°K maximum resulting in a G/T ratio of 31 dB/°K minimum. The availability for this terminal is not less than 0.998. The terminal system is capable of being operated by a single man, although normally two men per shift would be used. The equipment operates and maintains a specified performance from power sources having the characteristics outlined in Table B-1.

B.8 AN/TSC-80

The AN/TSC-80 (shelter terminal) is an SHF tactical satellite communications ground terminal. Table B-1 presents the major characteristics of the shelter terminal. The AN/TSC-80 shelter terminal shown in Figure B-9 incorporates all of the transmit and receive functions outlined in Figure B-10 and generates frequencies necessary for operation on all the carriers designated in Figure B-11. All of the electronics equipment is housed in an S-318()/G shelter transportable by a 1-1/4 ton M-715 vehicle, helicopter, or aircraft. An accessory trailer carries dual 5-kW gasoline generators, and provides stowage for the 4-foot antenna reflector, feed system, antenna supports, and fuel. The antenna system, including the SHF receiving amplifier containing both parametric and tunnel diode sections, mounts on the corner of the shelter using quick-release pin hardware.

The transmitter output signal is applied to the antenna feed through a section of twistable waveguide to allow elevation and azimuth adjustment. A crank-driven worm drive provides azimuth adjustment, and a chain drive mechanism provides elevation adjustment. Hand transits are provided for initial setup and a remote beacon strength indicating meter allows the operator to make precise manual adjustments. Consistent setting accuracies of under $\pm 0.5^\circ$ have been experienced. Acquiring the satellite has proved to be easy and straightforward on all terminals. Setup times with a two-man crew have run under 20 minutes.



Figure B-9. Shelter Terminal (AN/TSC-50)

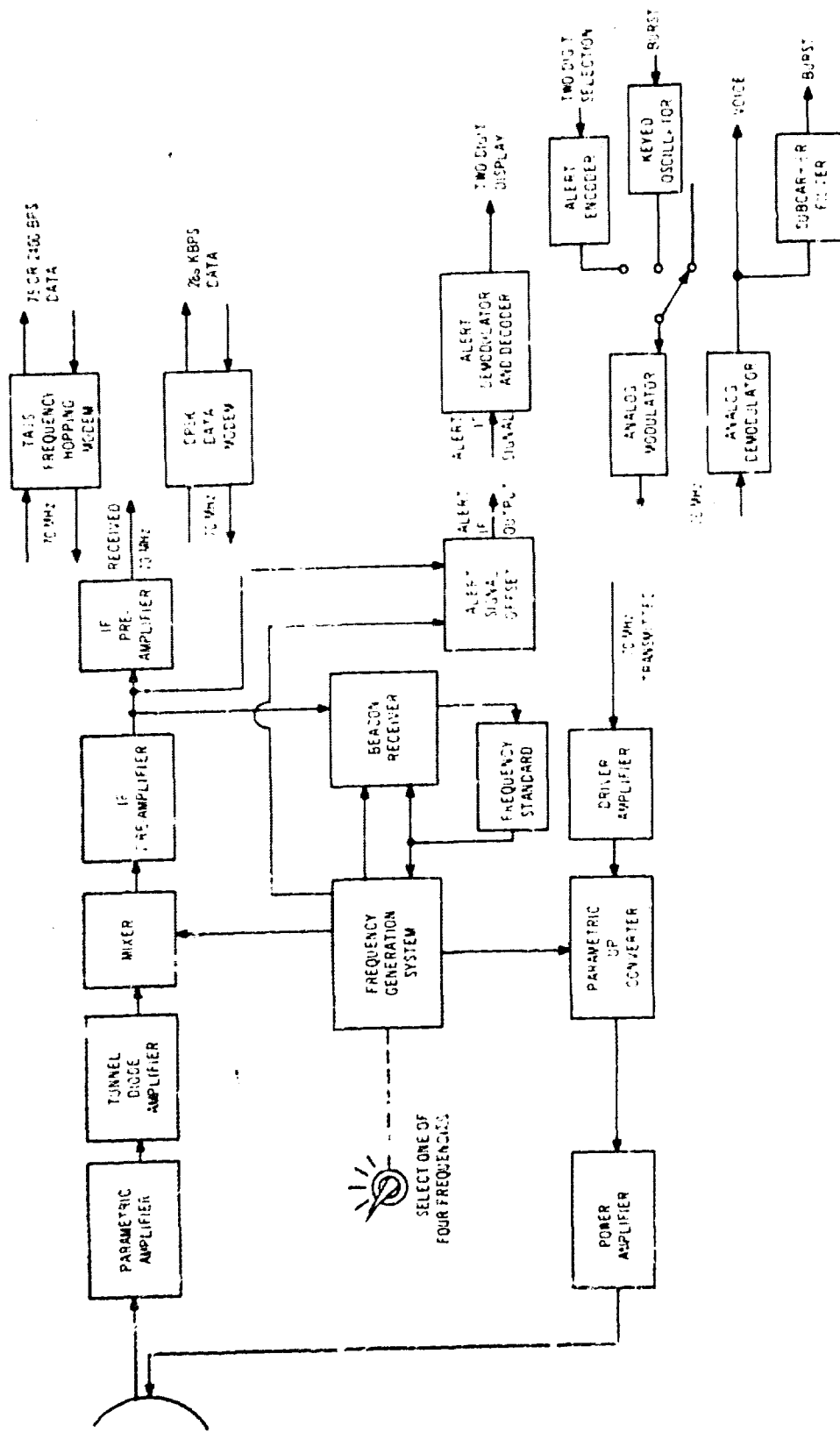

Figure B-10. Block Diagram of TACSAT SHF Ground Terminal (AN/TSC-80)

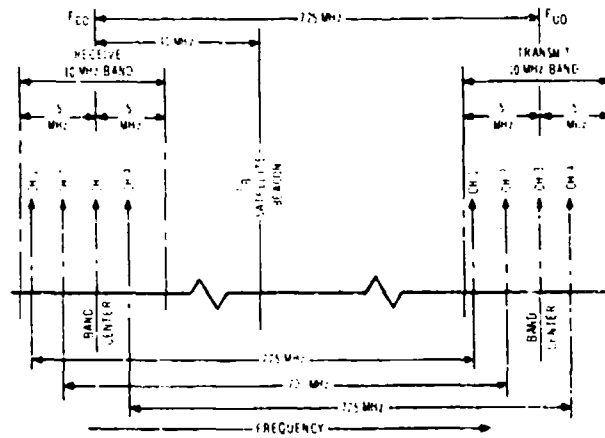

Figure B-11a. AN/TSC-80 RF Channel Frequency Plan

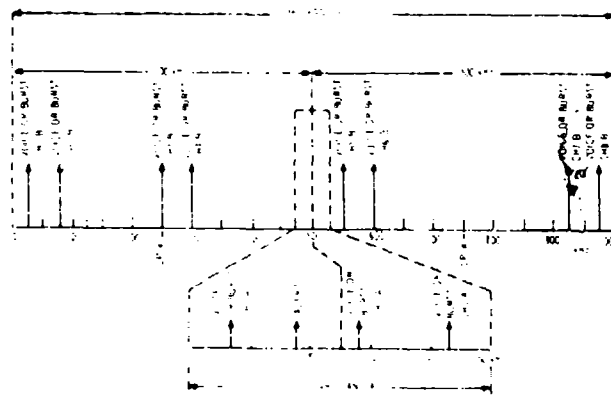

Figure B-11b. AN/TSC-80 Typical Frequency Allocation Chart



Figure B-12. TACSAT Vehicular Terminal (AN/MS-57)

B.10 DIPLOMATIC TELECOMMUNICATIONS SERVICE (DTS)

The DTS terminal, shown in Figure B-13, is intended to provide relatively inexpensive dedicated or special-purpose user service. The equipment is designed for unattended operation and features a relocatable configuration. Table B-1 presents the design characteristics of one DTS terminal (designated SC-1B) intended for nodal service. This terminal will have the capability of receiving and transmitting two carriers.

The equipment design is modular so that many variations are possible as desired by the user. Figure B-14 is a functional block diagram of the terminal. Individual carrier power is adjustable over a 40-dB range. The modem uses convolutional encoding and Viterbi algorithm decoding, which achieves a bit error rate of 10^{-5} with an $\frac{E_b}{N_o} = 6$ dB.

Two service test models of the terminal have been procured. The SC-1B will have the capability of handling 2400 bps PSK on one carrier and either 150 or 300 bps PSK on the other carrier. Provision will be made to incorporate a spread spectrum modem with an RF bandwidth of 20 MHz. The second terminal, designated SC-1A, will have a 6-foot antenna with a $\frac{G}{T} = 17.5$ dB/°K and an EIRP = 94 dBm. The SC-1A will have the same capabilities as the SC-1B.

The DTS is planning to procure a third terminal (designated SC-2) to be used as an entry station. The antenna diameter will be about 30 feet, the $\frac{G}{T} = 31$ dB/°K, and the EIRP = 118 dBm. This terminal will have the capability of transmitting and receiving 25 PSK or spread spectrum carriers.

Additional optional configurations include antenna diameters up to 60 feet, transmitter powers up to 2.5 kW, and FM analog of QPSK modems.

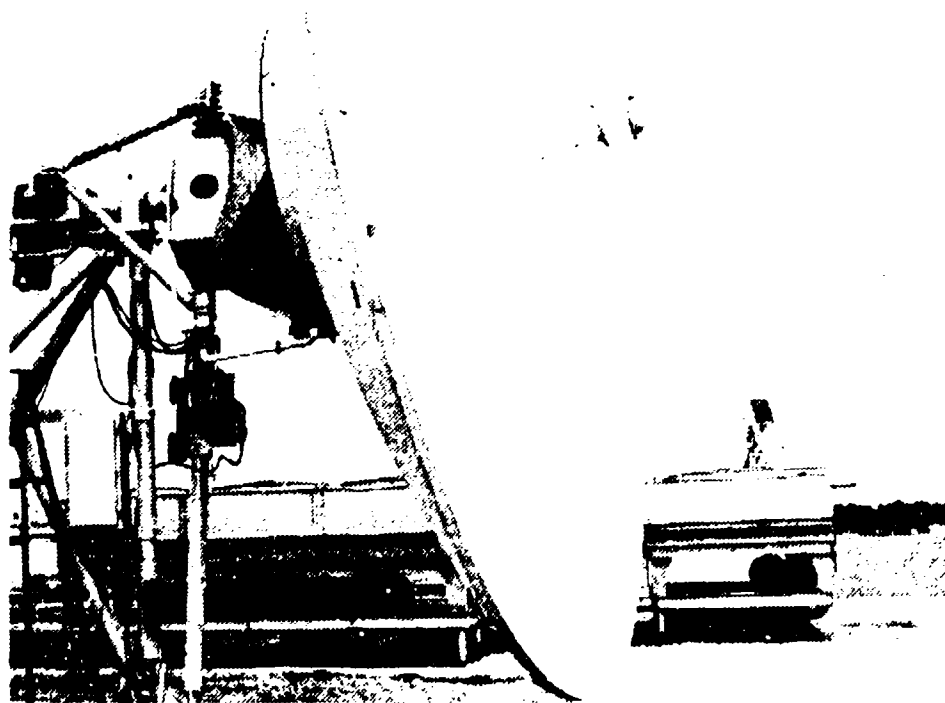

Figure B-13. DTS Terminal

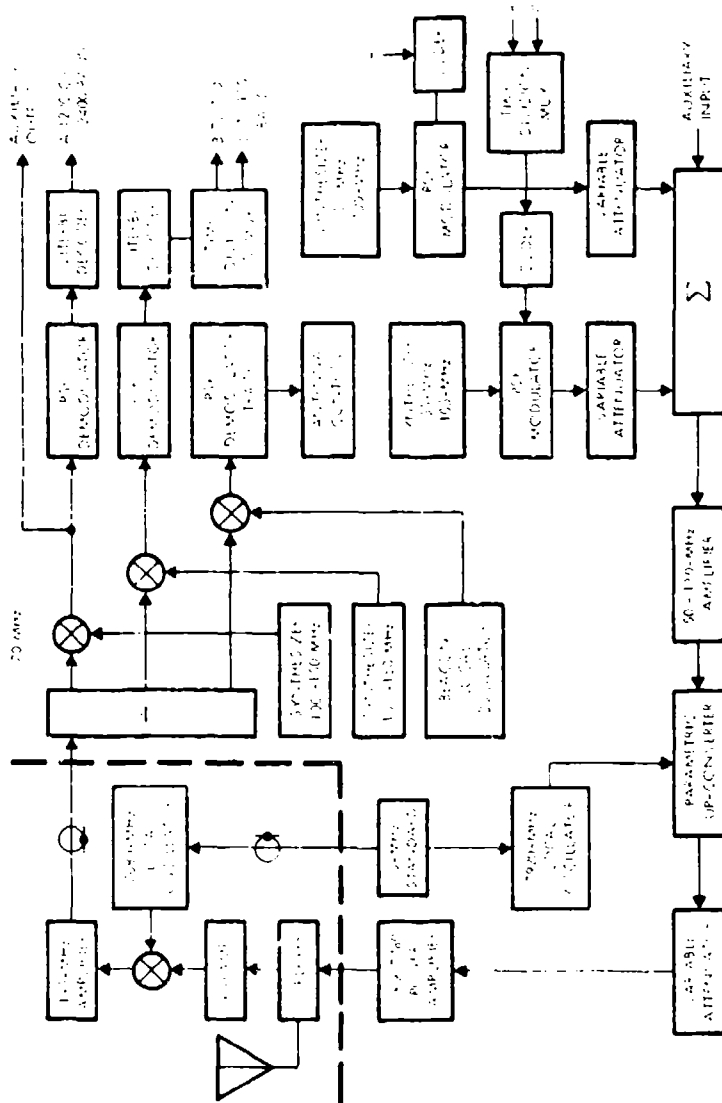

Figure B-14. Block Diagram of DTS Terminal

B.11 MAJOR SHIP SATELLITE TERMINAL (MASST)

The Navy is currently procuring four AN/SSC-6 terminals for use on fleet flagships. Each terminal will have a 6-foot antenna and will have a dual transmit and receive carrier capability. The terminal design characteristics are shown in Table B-1. IF interfaces are provided at 700 MHz and at 70 MHz. As presently configured, the terminals will have a DPSK modem and an AN/URC-61 pseudonoise modem. The terminals will provide voice and teletype communications between the flagships and shore stations.

B.12 AN/TSC-86(LT)

This earth terminal family has not yet been completely defined; however, two development models will be procured when a contractor is selected. The terminals are to be capable of truck transportation for rapid deployment. Table B-1 presents typical parameters for one of the LT terminals, which will have a capability of one transmit and one receive carrier. The terminals are intended for special user service, such as contingency, Presidential support, DCS extension, and intra-area trucking. The terminals for the most part are intended for FDMA operation while the DSCS uses FDMA. When TDMA is introduced into the DSCS, either a channelized satellite repeater will have to be used or a special low-cost TDMA modem will have to be developed for the small user.

APPENDIX C - PHASE I

C.1 BACKGROUND AND CONCEPT

In 1962 the Secretary of Defense established the Defense Communication Satellite Program (DCSP) to develop a satellite communication system that would provide long-haul links between fixed, transportable, or shipboard terminals. Overall responsibility for DCSP was assigned to the Defense Communications Agency (DCA).

The initial objectives of the program are shown in Table C-1.

Table C-1. DCSP Objectives

Number	Objectives
1	Conduct system research, development, testing and evaluation to determine operational compatibility and utility of the Initial Defense Communication Satellite System (IDCSS) to meet user requirements.
2	Establish a research and development communications satellite system, designed for the most part to be directly convertible and expandable to an operational system through integration and compatibility with the DCS and, thereby, also capable of providing service to specified users of the National Communications System.
3	Provide an emergency capability for supplementing the Defense Communications System (DCS) and improving its assurance of provision of the minimal essential survival communications for the National Military Command and Control purposes.

Phase I of this program was given the title Initial Defense Communications Satellite Program (IDCSP).

The development concept of the IDCSP satellite included the requirement that the operational satellite be independent of ground command and that

simplicity be stressed in the design of the communication subsystem. Thus, there was no active control of position or orientation of the satellite either during deployment or during the life of the system.

The period immediately after the first launch on 16 June 1966 was used for system testing between deployed terminals. In particular a two-channel duplex link capability between two AN/MSC-46 terminals was demonstrated. In December 1966 emergency operational links were established between Hawaii-RVN and Philippines-RVN. In July 1967 the entire Pacific network was placed in initial operational status, and integration of IDCSP into the DCS was begun. Thus, designed as an R&D system, the IDCSP quickly became an operational system, though some R&D was continued in other portions of the system.

C.2 SYSTEM DESCRIPTION

The Defense Satellite Communications System (DSCS) is one part of the total Defense Communications System (DCS), which is a worldwide complex of long-haul, point-to-point communications facilities. These facilities include transmission via conventional VLF through HF radio, land and submarine cable, microwave, and tropospheric scatter. The IDCSP augmented and, where physically or technically advantageous, replaced conventional communication methods. The IDCSP provides near-synchronous communication satellites to relay voice and digital communications between fixed and mobile users. It consists of four subsystems: earth station, launch and deployment, space, and control.

Figure C-1 shows one half of a typical DSCS user-to-user link; the exact configuration of the earth station/user interface varies depending on the situation. For example, it is possible for the user (especially tactical or contingency users) to be connected directly to the link terminal. However, in normal DCS use the user interfaces with the Technical Control Facility (TCF), as shown in

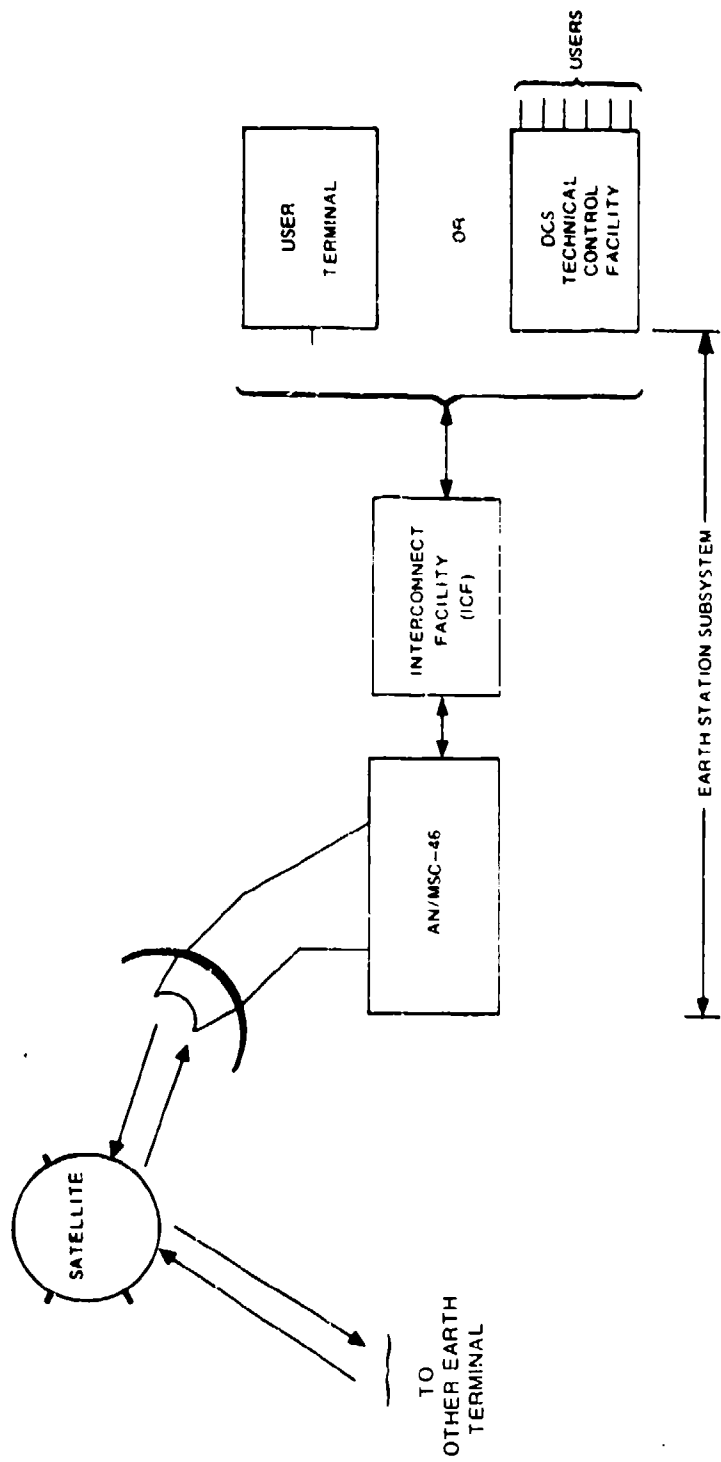

C-3

Figure C-i. Basic Block Diagram of Typical User Link

in Figure C-1. Each satellite has one transponder which is used for one duplex link.

The earth station subsystem includes all the elements necessary to establish satellite communication channels which serve DCS stations or the directly connected users.

There are several types of terminals used in the IDCSP. Two AN/FSC-9 terminals are used, one at Camp Roberts, California and the other at Fort Dix, New Jersey. They are fixed installations, each equipped with a 60-foot-diameter antenna. The AN/MSC-46 earth terminals developed for IDCSP are deployed at nodes. They are transportable units with 40-foot-diameter antennas. They are intended for use primarily as DCS trunk terminals. The highly transportable AN/TSC-54 terminals are used for extension of the DCS into contingency areas, for tributary-type links to outlying activities, and as Navy shore stations. Local conditions dictate the type of transmission facility used as an interconnect link. A descriptive summary of these and other earth terminals is presented in Appendix B (Table B-1).

The launch and deployment subsystem includes: the Titan IIC launch vehicles, satellite dispensers, and facilities to implement and support the launch operations, satellite injection into orbit, the ensuing telemetry readout, and tracking and ephemeris determinations. Launch phase technical support was provided by the Air Force Satellite Control Facility (SCF). Since the completion of the launches, the SCF has provided orbital tracking data and telemetry monitoring to determine satellite condition. This information is forwarded to the Satellite Communication Control Facility (SCCF) at DCA Headquarters to be used in system control.

For the space subsystem 26 satellites were launched into near equatorial orbits at a near synchronous altitude of approximately 20,600 miles in the four launches. Table A-1 in Appendix A summarizes data relating to launches.

Fifteen of these satellites were still operational as of December 1971. The satellites, viewed from the earth, drift from west to east at about 30° of longitude per day. A single satellite stays within view of a particular earth terminal about 4-1/2 days. A varying distribution of satellites encircling the earth exists, since each satellite was released from the dispenser at a slightly different orbital velocity. The differential velocities are chosen in such a way as to provide a quasirandom distribution of the satellites. Originally designed for a mean time to failure (MTTF) of 1.5 years (with a goal of 3 years), the satellites have exceeded the goal and have an MTTF now of over 5 years. The satellite transmitters are scheduled to turn off automatically about 6 years from date of launch.

The purpose of the control subsystem is to achieve an orderly allocation of system assets among various users in accordance with validated user requirements. The basic elements of the control subsystem are the Satellite Communications Control Facility (SCCF), the Area Communications Control Function (ACCF), and the Earth Station Control Function (ESCF). The SCCF is the focal point of the control subsystem, collocated with the DCA Operations Center (DCAOC) in Arlington, Virginia. The primary mission of the SCCF is preparation and distribution of long-term (for 60 days, prepared every 30 days), short-term (up to 30-day duration), and emergency satellite/terminal schedules in accordance with validated user requirements.

To a large extent the circuits provided by the IDCSP appear similar to conventional trunks. Careful engineering of the earth station and DCS station interface make it possible to replace a standard common user channel with a satellite link involving a minimum of special consideration and realignment of equipment on the part of the user or operator. However, certain system characteristics of the satellite channel can introduce peculiar problems. These are propagation delay, handover, and Doppler shift. One way propagation

delay ranges from about 200 to 260 milliseconds. Experience has shown that this amount of delay is not bothersome on typical voice circuits and has little effect on the quality of data transmission. The occurrence of outage because of handovers (the transfer from one satellite to another) is normally predictable in advance, and with proper scheduling and coordination its effects can be minimized. The handover time design objective is 2 minutes. The maximum Doppler shift, 0.21 ppm, occurs when the satellite is rising or setting with respect to a given earth terminal. In general, these shifts are small enough that they have no noticeable effects on data transmitted via IDCSP.

To establish communications between two terminals it is necessary for a satellite to be mutually visible to the terminals. SCCF is able to provide satellite scheduling data for all links for a 60-day interval. Satellite visibility prediction based on probabilistic analysis for various links is shown in Figure C-2 as a function of the total number of orbiting satellites. For Hawaii and the Republic of Vietnam (RVN) the satellite visibility prediction is shown for at least one link and at least two simultaneous links. Two satellites and four earth terminals would be required when the channel requirements exceed the capability of one satellite. Thus, with a system composed of 15 satellites, the probability of at least one satellite's being visible for the Hawaii-RVN link is 89 percent and a second satellite for a second simultaneous link is 64 percent. Since there is no orbital control to permit repositioning of the satellites, random gaps can occur for the orbital plane. In addition, satellites may become temporarily unusable because of conjunction with other satellites (resulting in multipath) or with the sun or moon (resulting in an increase in system noise temperature). Also, since the satellites have no batteries, they do not operate during eclipse (while in the earth's shadow).

C.3 MODULATION CHARACTERISTICS

Four forms of modulation are used in Phase I, including frequency division multiplex-frequency modulation (FDM-FM), spread spectrum (SS), differential

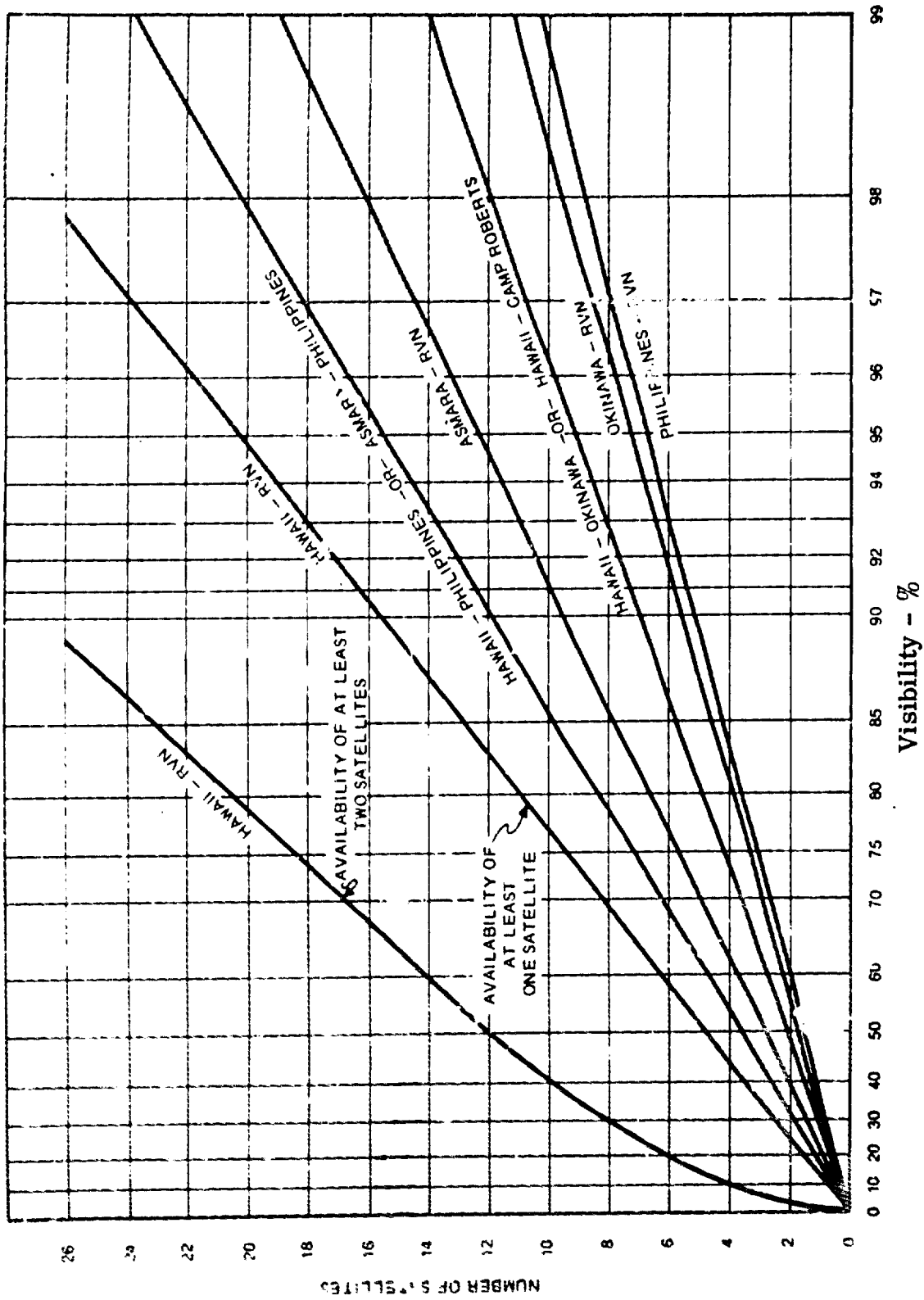

Figure C-2. DSCS Phase I Satellite Visibility

phase shift keying (DPSK), and multiple frequency shift keying (MFSK). All earth terminals use FDM-FM and SS. The AN/TSC-54 terminals also use DPSK and the four AN/MS-46 terminals are capable of operating with MFSK. Spread spectrum modulation can provide anti-jam protection for the system.

The FDM baseband consists of nominal 4-kHz channels, or frequency-shift-keyed (FSK) telegraph channels, or a combination of both. The AN/FSC-9 and AN/MS-46 terminals were modified to accommodate up to 12 voice channels. The earth terminal equipment is also capable of accepting up to five individual TTY channels and frequency shift-keying them into one of the voice channels. This latter capability is not used for normal DCS service. It is usually more efficient to multiplex the TTY channels at a DCS facility. The capability could be used, however, for direct access . . . user to the satellite link terminal if necessary.

The baseband configuration of the AN/TSC-54 terminal is compatible with the baseband of the larger terminals; thus, interoperability in the FDM-FM mode is assured. The AN/TSC-54 has no voice frequency multiplex equipment, but is equipped with voice frequency telegraph keyers and converters and can provide one voice frequency channel and two out-of-band TTY channels.

Certain AN/TSC-54 link terminals are capable of differentially biphase modulating the carrier with serial binary data streams up to 2400 bps with a design objective of 50 kbps. A teletype time division multiplex (TDM) unit accepts up to sixteen 75-bps teletype inputs and converts them into a binary stream suitable for DPSK modulation.

C.4 SPACECRAFT

The IDCSP satellites are spin-stabilized to maintain the spin axis within $\pm 5^\circ$ of normal to the earth's equatorial plane. The repeaters are double-frequency conversion, hard-limiter repeaters. They are not equipped with batteries and have a transmitted EIRP of 7 dBW minimum. The repeater is discussed in detail in Appendix A.

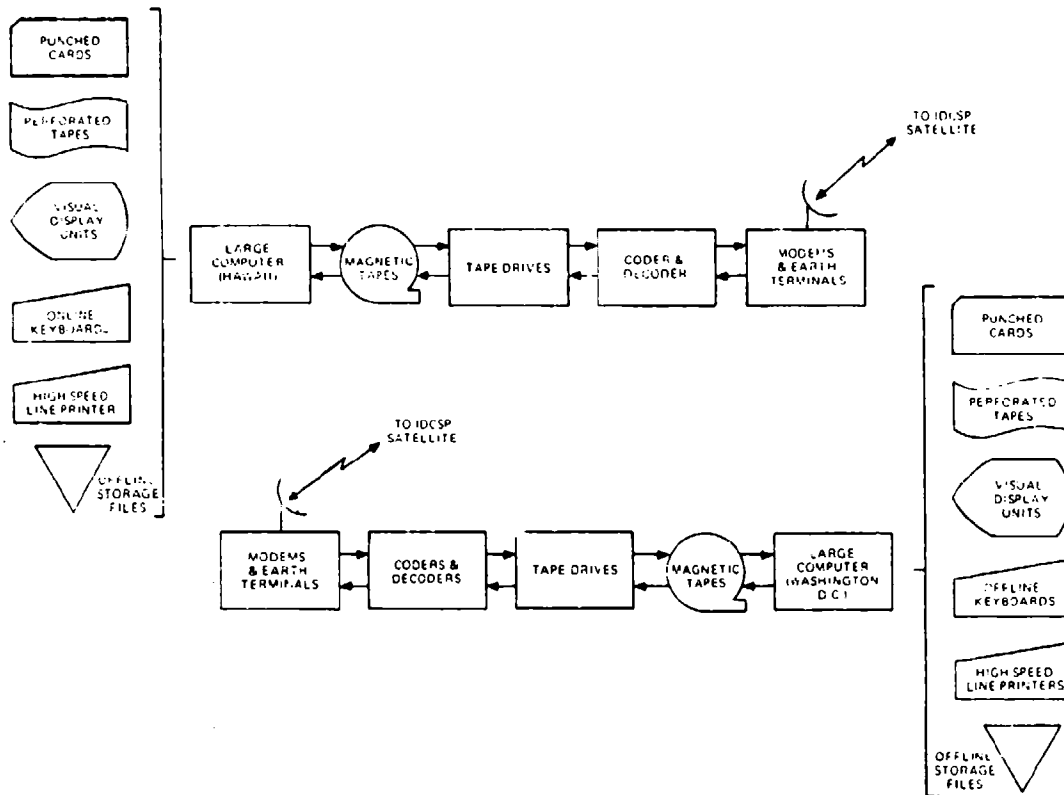

Figure C-3. Computer-to-Computer Satellite Communication Link

5. Compatible with MSC-46 earth terminals and IDCSP satellites
6. Provision for adaptive error control with full duplex operation.

For the purpose of the computer test a triple error correcting (four-error detecting) code was used to correct errors over the satellite link. This did not, however, provide for error correction over the ICF. To accommodate the typical format of computer tapes, which consists of randomly positioned data with gaps to separate the data and variations in tape speed, several features had to be incorporated into the equipment. These features consisted of buffer storage, gap recognition and generation circuitry, and generation of filler data to maintain synchronization when gaps occur in the tape format.

C.6 DCS INTERFACE

The satellite communication terminals are connected to DCS through an Interconnect Facility (ICF) and a Technical Control Facility (TCF).

The interconnect facility consists of two groups of terminating equipment and an interconnect link. The transmission medium may be LOS microwave, tropospheric scatter, cable, or other, as appropriate. Local conditions dictate what type will be used as an interconnect link.

Most ICF links are paired cables as only voice circuits are necessary.

C.7 LINK CONFIGURATION

The terminals of the IDCSP are arranged to provide a point-to-point communications circuit. Typical link and terminal types are shown in Figure C-4.

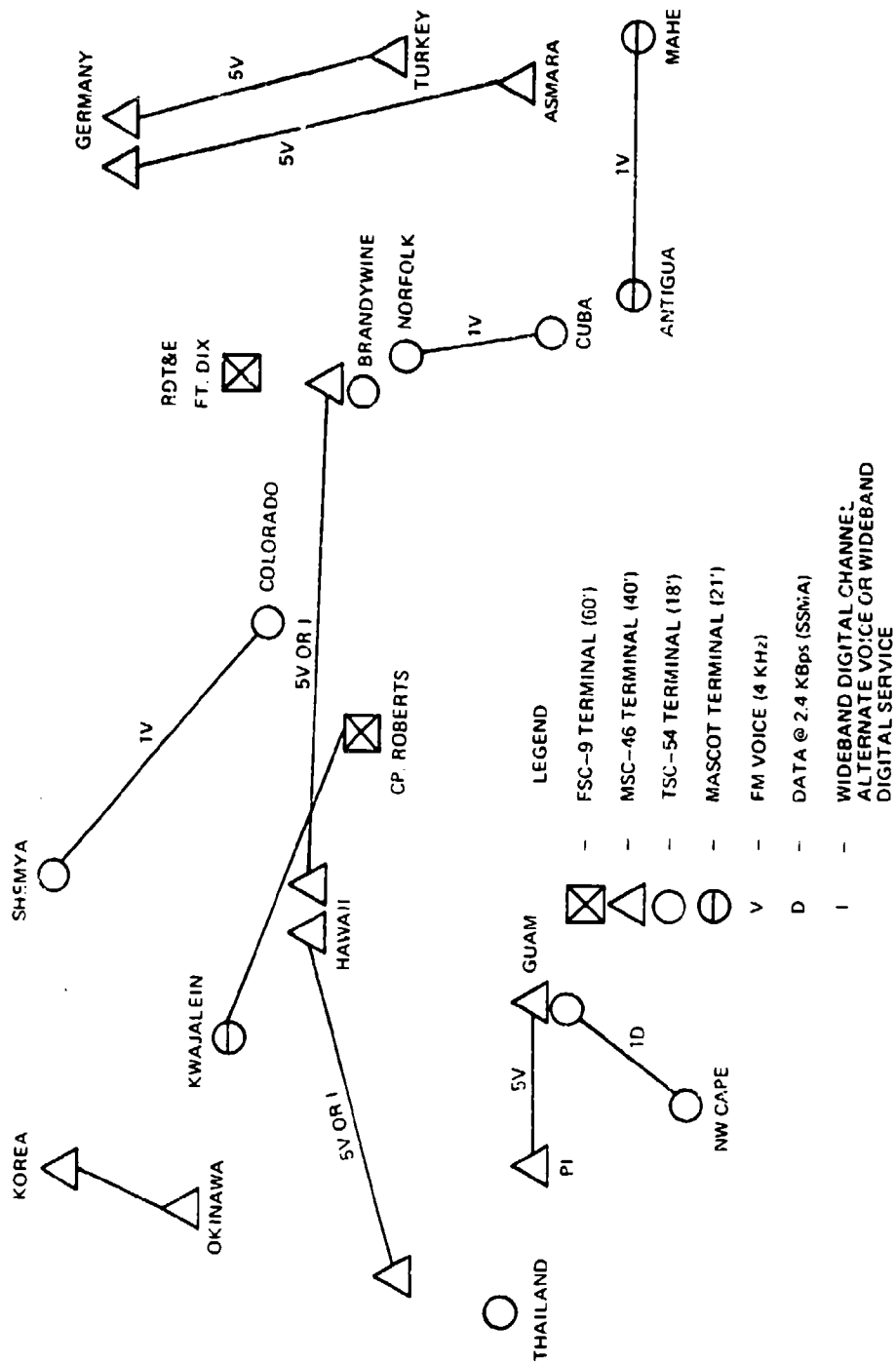

Figure C-4. IDCSP Typical Satellite Link Configuration

APPENDIX D - PHASE II

D.1 PROGRAM DESCRIPTION

In June 1968, the Department of Defense announced its decision to acquire six new satellites and additional earth terminals as the second phase of the Defense Satellite Communications System (DSCS). The first phase (IDCSP) had successfully completed its research and development objectives and since late 1967 had been providing a limited operational capability.

The objective of Phase II of DSCS is to establish an operational military satellite communications system which will provide substantial increases in capacity and performance, together with a wider variety of services for users. The Phase II DSCS will be a part of the Defense Communications System (DCS) and will function both as a long-haul strategic trunking system and as a system capable of supporting military contingency operations. In addition, the system will be capable of supporting service to small tactical users, if needed.

The Titan III-C booster is the vehicle intended for launching the satellites into synchronous orbit. Phase II will be operational starting in CY 1972. Additional launches will be made on an as-required basis for replenishment and to establish additional in-orbit operational satellites. A detailed presentation of Phase II spacecraft characteristics is presented in Appendix A.

The earth terminals currently being used with Phase I (see Appendix B) will be modified and upgraded for operational use with the Phase II DSCS. In addition, a limited quantity of new terminals will be procured and deployed to fulfill the operational requirements.

The system will be implemented in three distinct periods, each providing different communications capabilities. In the first period Stage 1a, Phase II systems will operate in the frequency division multiple access (FDMA) and

spread-spectrum multiple-access (SSMA) modes and will provide a point-to-point operational capability after completing essential on-orbit satellite tests on the satellites launched in November 1971. However, unlike Phase I operations, many links will be handled simultaneously by each Phase II satellite. In Stage 1b the Phase II system will operate in the FDMA mode to provide a multipoint network satellite communications capability and the SSMA mode to provide point-to-point protected (i. e. , jam resistant) communications for vital traffic. New FM and PSK modems and FDM multiplexers will be purchased to provide the capacity required to fulfill the Stage 1b requirement. The PSK modems will replace MFSK modems for wide-band data and secure voice services. A number of earth terminals will provide a multiple carrier transmission/reception capability. These terminals will be deployed to locations (defined as nodal locations) to satisfy specific DSCS requirements.

stage 1c will begin when new developmental digital equipment (PCM, TDM, PSK and later, coding equipment) is introduced into the system and the conversion from an analog to a digital system begins, still using FDMA to the satellite. The introduction of digital operation will result in increased system capacity through a more efficient combination of different types of traffic (voice, TTY, secure voice, data, and wide-band data) than is possible in an analog system, and through the use of coding which allows more efficient use of satellite effective isotropically radiated power (EIRP). As the time division multiplex (TDM) and pulse code modulation (PCM) equipment becomes available, the system will phase from an almost all-analog system to a hybrid (part analog, part digital), and finally into an all-digital system. During this state the new HT and/or MT terminals may become available and will be integrated into the system.

It should also be noted that this stage will provide digital experience which will be very useful when TDMA is introduced into the DSCS. Protected traffic will continue to be provided using spread-spectrum equipment.

However, the SSMA modems employed will be of an advanced model specifically designed to meet the Phase II system requirements. A full complement of modified Phase I and newly procured terminals will be available for use during this stage.

D.2 EQUIPMENT ASPECTS

The earth terminals to be employed in the Phase II DSCS include modified Phase I DCS² terminals and new terminals presently under development. The characteristics of the Phase I earth terminals were presented in Appendix B. Modifications and additions being made to these terminals are presented in Table D-1 and are discussed in the following paragraphs.

D.2.1 Requirements for Stage 1a

D.2.1.1 Earth Terminals

The initial modification of all Phase I earth terminals will consist of providing the capability for transmission and reception of both FM and SS carriers on new frequency assignments compatible with the Phase II frequency plan. The Phase II frequency capability was obtained by procuring new crystals chosen in accordance with the frequency plan.

To provide a system multiple-access capability in which the carriers do not interfere with each other, it is necessary for each terminal to be able to monitor and control its own transmit signal power level. A transmit carrier power monitor will be provided for each of the Phase I earth terminals to perform the monitoring function. In addition to this modification, all of the AN/ MSC-46 tracking receivers will be modified to track the biphasic modulated beacon signal. Four AN/ MSC-46 terminals will be modified to demodulate and provide alphanumeric readout of the beacon data (telemetry) for satellite control. Two of the four terminals will be instrumented with manual and automatic spectrum analyzers capable of monitoring the satellite downlink frequencies at a monitoring/nodal earth terminal.

Table D-1. Summary of Modifications and New Equipment for DSCS Phase II

Modifications	Stage			Comments
	1a	1b	1c	
Earth Terminal				
Frequency	X	X		Phase I terminals - new crystals to allow operation with the Stage 1a frequency plan All terminals - new frequency synthesizers to allow operation with the Stage 1b frequency plan
Params	X			Four AN/MSC-46 terminals - interim uncooled 500 MHz paramps
	X			AN/TSC-54 terminals - uncooled 500 MHz paramps
Multiple Carriers	X	X		AN/MSC-46 terminals - cooled 500 MHz paramps AN/TSC-54 terminals - provide two independently tunable carriers
Control	X	X		AN/MSC-46 and 1 AN/FSC-9 terminals - FDMA - up to 3 transmit and 7 receive carriers; SSMA - up to 7 transmit and receive signals on a single RF carrier
Modulation AN/URC-55 and 61		X		All Phase I terminals - provide own power output monitoring capability, all AN/MSC-46 terminals to provide satellite beacon tracking capability, four AN/MSC-46 terminals to demodulate beacon provide readout of satellite data (telemetry) for satellite control; two AN/MSC-46 terminals and SEN to have spectrum analyzers for measuring relative satellite carrier powers and frequencies. Standardization to ensure compatibility.

Ft. Monmouth ETM, Ft. Monmouth, training, Germany Landstuhl, and Hawaii (Helemano).

Table D-1. Summary of Modifications and New Equipment for DSCS Phase II (Continued)

Modifications	Stage			Comments
	1a	1b	1c	
Interconnection				
TCF	X	X	X	Modifications will be made on an as-required site-by-site basis
ICF	X	X	X	A determination has been made of the operational capability of the ICFs on a site-by-site basis. Appropriate modifications will be made where required and will be initiated during Stage 1a.
Communication Subsystem				Equipment vans to house the modulation, multiplex, and conditioning equipment
Analog				
Modem		X		All nodal and AN/TSC-54 terminals - FM modems capable of operating with 3 to 72 voice channels.
Multiplex		X		All terminals - new FDM equipment to provide a wider range of capabilities
Digital				
Modems		X		Terminals providing imagery - PSK modems will replace MFSK modems
			X	All DCS terminals - new developmental PSK modems to provide a wide variety of data rates
			X	All terminals - new developmental AN/TSC-28 spread spectrum equipment
Multiplex			X	All DCS terminals - new developmental flexible TDM equipment and PCM equipment to convert 4-kHz analog voice to 64-kbps digital voice
New Terminals			X	New developmental AN/MSC-60 and AN/MSC-61 terminals
Coding			X	New developmental convolutional encoding/maximum likelihood decoding equipment

The Phase I AN/TSC-54 terminals are equipped with only one voice channel. Equipping two of these terminals with additional FM modems and FDM multiplex to provide a limited contingency capability during Stage 1a began prior to the first satellite launch. These modified terminals will be self-contained in that they will be provided with FM modems, FDM multiplex, and ancillary equipment to handle up to 12 voice channels. However, the FM modems will be capable of modulating an RF carrier with up to 72 voice channels of which 60 must be delivered to the terminal in a baseband form from a technical control facility (TCF). This additional 60-channel capability can be used to provide high-priority DCS restoration. The remaining 11 AN/TSC-54s will be modified for this contingency capability as soon as possible and can be completed early in Stage 1b.

All of the AN/TSC-54 terminals will be equipped with new uncooled paramps capable of receiving within a 500-MHz bandwidth. These paramps will be modified versions of the paramps used in the AN/TSC-54 terminals in Phase I. As an interim modification until cooled 500-MHz paramps are developed, four AN/MS-46 terminals, including one for control purposes for each satellite, will be equipped with the same type of uncooled wide-band (500 MHz) paramp as the AN/TSC-54s.

D.2.1.2 Interconnect Facility Modifications

Except for new sites and AN/TSC-54 contingency terminal locations, most of the existing Phase I interconnect facilities will be adequate for Stage 1a operation. This is because the Phase I interconnect facilities (ICFs) are generally 100-pair cables or AN/FRC-109 LOS radio equipment. Locations where existing ICFs will have to be augmented to support new or special user requirements will be treated on a case-by-case basis. New or modified ICFs required for new wide-band digital requirements will be designed and engineered on an as-needed basis.

All new ICFs (ICFs not existing at Phase II satellite launch) will require complete evaluation of the interconnection requirements. This evaluation will consider the feasibility of providing an ICF capable of operating in all stages of Phase II.

D.2.1.3 Technical Control Facility Modifications

Since Stage 1a will be an analog transmission facility providing a relatively small number of voice channels, only minor equipment additions will be required in the technical control facilities. These additions will consist of channel and multiplex equipment at the TCFs and channel and multiplex equipment as terminals that have not been upgraded to 12 channels.

D.2.2 Requirements for Stage 1b

D.2.2.1 Earth Terminals

Seven of the AN/MSC-46 and both of the AN/FSC-9 terminals will receive additional up and down converters to provide a multiple carrier capability for operation in Stage 1b as nodal terminals. Both the up converter and the down converters will interface with the modulation equipment at 70 MHz. This modification will allow the terminals to handle the following number of signals:

Transmit

FM/FDMA - Up to three uplink RF carriers

SSMA - Up to seven SS carriers using a common RF frequency

Receive

FM/FDMA - Up to seven downlink RF carriers

SSMA - Up to seven SS carriers using a common RF frequency

Beacon - One signal on its own RF carrier frequency

Each nodal terminal will be equipped according to the number of carriers required at its location. These nodal terminals will also be modified with cooled paramps which will provide a receive capability over the full 500-MHz receive frequency band.

The remaining Phase I terminals not slated for nodal service and which were not modified in Stage 1a will be modified to provide a paramp instantaneous bandwidth of 150 MHz, spectrum analyzers and CNR meters. These modifications are required to provide the monitoring capability discussed previously.

New FM modems will be provided for all Stage 1b nodal terminals and all AN/TSC-54 terminals. These modems will be capable of providing 3, 6, or 9 4-kHz analog circuits at a lower quality (e. g., TTNR = 33 dB) or 3, 6, 9, 12, 24, 36, 48, 60, or 72 DCS quality (e. g., TTNR = 44 dB) 4-kHz analog circuits. Up to three modulators and up to seven demodulators will be installed at nodal terminals to provide service for the number of transmit and receive carriers required. A single modem will be installed in non-nodal terminals.

During Stage 1b, PSK modems will be used to provide the wide-band data service and the secure voice transmissions. These modems will be capable of operating at a number of data rates from 19.2 kbps to 1.8 Mbps.

To provide flexibility in the choice of transmit and receiver carrier frequencies, a new frequency selection subsystem will be provided in all seven modified nodal Phase I terminals. The local oscillator signals for up and down converters will be derived from frequency synthesizers which will use an atomic standard as a reference frequency source. These synthesizers will provide the proper frequency increments to change transmit and receive frequencies in 1-kHz steps over the entire satellite transmit and receive bands.

D.2.2.2 Interconnect Facility Modifications

It is anticipated that no modifications of the non-nodal terminal ICFs will be required for Stage 1b. In the case of new terminal locations where ICFs will be required, an evaluation of the interconnect requirements will be made and consideration will be given to providing ICFs capable of operating in the digital Stage 1c as well as in Stage 1b. Modifications to ICFs to be used with nodal terminals will be made prior to Stage 1b to ensure meeting the operational requirements at these earth terminal locations.

D.2.2.3 Technical Control Facility Modifications

The TCFs serving nodal locations in Stage 1b will require additional equipment to process up to 60 analog channels. The impact on other non-nodal TCFs will depend on the satellite's traffic requirements to these locations in Stage 1b.

D.2.2.4 New Terminal Developments

A contract was awarded in June 1970 for the design, development and testing of one prototype AN/MSC-60 (HT) and one prototype AN/MSC-61 (MT) terminal. Final acceptance testing of the two prototype terminals should be completed by mid-1973 (Stage 1b). Major characteristics of the terminals are given in Appendix B.

D.2.3 Requirements for Stage 1c

D.2.3.1 Earth Terminals

Stage 1c will require no modifications to the earth terminals beyond those made in Stages 1a and 1b. However, new digital communication subsystems housing all new digital equipment will be defined and specified prior to Stage 1c.

D.2.3.2 Interconnect Facility Modifications

Depending on the traffic requirements in Stage 1c, the existing LOS ICFs may be capable of satisfying requirements for Stage 1c. However, 100-pair cable ICFs may have to be replaced by either wide-band cable or a LOS ICF. Where the ICF must be replaced, the new ICF will be designed to provide a growth capability to meet expanding traffic requirements in later stages.

D.2.3.3 Technical Control Facility Modifications

With the introduction of an all-digital service in Stage 1c, PCM equipment that will convert the 4-kHz analog voice signals to 64-kbps digital voice signals will have to be installed in the TCFs, and the FDM equipment replaced with TDM equipment.

D.3 DESCRIPTION OF PHASE II STAGES

D.3.1 Stage 1a

The beginning of Stage 1a will occur when the first Phase II satellite is made available for operations (mid-1972). Phase I terminals are modified as defined previously, thus allowing them to operate through the Phase II satellites.

In Stage 1a the terminals will operate on a "point-to-point" link arrangement as they presently do in the Phase I, however, several links will be handled simultaneously in one satellite. A typical link configuration is shown in Figure D-1. The traffic on these links will range from one analog voice channel and a link orderwire on an AN/TSC-54 to AN/TSC-54 link, to 12 analog voice channels and a link orderwire on an AN/MSC-46 to AN/MSC-46 link. Wide-band digital traffic will be carried. These digital links will be time-shared with FM voice circuits. The equipment (i.e., FM modems, multiplex, etc.) presently in use in Phase I will be used to provide this capability. In order to satisfy some special user requirements, selected terminals may have special modifications performed to provide them with a multiple-link operational capability.

Normal unprotected (against an electronic jammer) analog DCS/DSCS traffic will be carried using frequency division multiplex, frequency modulation and frequency division multiple access (e.g., FDM/FM/FDMA). This traffic will consist of basic 4-kHz circuits which can be used to support either voice, teletype or narrow-band digital traffic (such as 2400-bps data and secure voice), or appropriate combinations of each. Using MFSK and FDMA, a limited amount of wide-band data and wide-band secure voice will be provided between selected locations in Stage 1a.

Protected traffic (i.e., antijam) will be provided during this stage on a terminal-to-terminal basis using existing AN/URC-55 and AN/URC-61 spread-spectrum equipment. This equipment will operate using pseudonoise phase shift-keyed modulation and spread spectrum multiple access (e.g., PN/PSK/SSMA). These links will be dedicated between selected users and will pass essential core traffic only. The protected traffic on these lines will be commensurate with the capabilities of the present AN/URC-55 and AN/URC-61 equipments.

Control of the system during Stage 1a will be on a nonreal-time basis with system coordination and discipline maintained using the TCFs. The satellite will be operated in a linear mode, sufficient margin will be provided, and the capacities will be conservative so that a more extensive FDMA control system will not be required.

The AN/TSC-54 terminals will be capable of supporting a gateway (or interarea) type contingency with the existing equipment and modifications previously defined. This same terminal could support a limited connectivity intra-area contingency, but will not have the FM modem or the multiple carrier equipment to transmit more than 60 channels in support of a full intra-area type contingency. Operation of contingency terminals during Stage 1a will be via the satellite's narrow beam to narrow beam satellite communications channel.

D.3.1.1 System Control

Satellite control includes those functions involved with the tracking and acquiring telemetry from the satellite, analyzing satellite condition, and sending commands to the satellite to effect the desired control. These functions will be implemented through the Air Force Satellite Control Facility (SCF), as required and directed by the NCS/DCAOC to support operational requirements.

A dedicated terrestrial teletype orderwire will be provided between the DCAOC and the SCF. The primary purpose of the orderwire is to provide a means of coordination between the SCF and DCAOC and to relay decisions made by the DCAOC related to satellite command and control. This circuit will also be used between the SCF and each of the SATCOM controllers (via the DCAOC) to pass information regarding the condition of the satellites and to coordinate operational plans regarding reconfiguration of the satellites' operational modes (i. e., transponder gain setting, etc.).

The purpose of satellite communications (SATCOM) control is to assure proper power sharing of the satellite transponder among all the earth terminals using it. This control function will be the responsibility of the SA Operations Control Center (DOCC).

In Stage 1a, the SATCOM controller will do the following:

- Monitor the transmissions from the satellite transponder to determine the status of the satellite and the earth terminals accessing it
- Assemble and maintain an up-to-date overview of the total operation through the satellite
- Analyze anomalies which may arise to determine their source (satellite, earth terminal, jammer or unauthorized user, or environmental conditions)

- Decide what corrective actions are required to correct anomalies
- Direct and/or coordinate the earth terminals as necessary to achieve desired results
- Report system status, problems encountered, and actions taken to other levels of authority within the DOCC.

All of these functions except monitoring will be assigned to a SATCOM controller (one for each satellite) who will be located at an area communication operations center (ACOC). The monitoring function will be assigned to specific earth terminals, one terminal for each satellite.

In addition to the functions identified above, each earth terminal accessing the satellite will monitor its own performance (uplink carrier frequency and power level) and will report this information to the SATCOM controller using terrestrial orderwires established within DOCC. System discipline will be maintained by standard operating procedures that are being developed.

Link orderwires will be established via the satellite to allow problems occurring on a link to be identified without involving the SATCOM controller. However, all adjustments to link parameters must require SATCOM controller authorization since variations on a single link influence all links accessing a particular satellite. These link orderwires will be injected into the low end of the FM baseband.

D.3.2 Stage 1b

Stage 1b will begin with the implementation of a multiple carrier capability in the modified AN/MS-46 and AN/FSC-9 earth terminals. These nodal terminals will transmit up to three separate carrier frequencies. Each of these transmitted carriers will contain varying amounts of traffic, ranging from a baseband multiplexed group (12 channels) to four baseband multiplexed

groups (48 channels). Non-nodal earth terminals receiving one of the nodal transmissions will then demodulate the carrier and demultiplex the traffic destined for its location, usually as a 12-channel group. Transmissions from non-nodal to nodal earth terminals will complete the duplex circuits. Present earth terminal deployment plans indicate that nodal terminals may be required to receive from up to seven different non-nodal earth terminals.

The multipoint network (Figure D-2) operation in Stage 1b will result in an overall increase in operational capability. Both the quantity and quality of voice channels will increase during this time, since the satellite link connectivity will increase and most equipment modifications will be completed and new baseband equipments will have been procured. Traffic on each of these multiple links will range from 12 voice channels plus a link orderwire on the AN/MSC-46 to AN/MSC-46 links to three voice channels and a link orderwire on the AN/MSC-46 to AN/TSC-54 links. In addition, selected links will be used to provide digital traffic in support of wide-band data and secure voice requirements. When the wide-band traffic is not being transmitted over these links, provision will be made to carry analog traffic instead.

All unprotected analog traffic will continue to be transmitted in Stage 1b as in Stage 1a, that is FDM/FM/FDMA. However, new FM modems will be in use during this period, allowing the quality of the analog circuits to be improved.

Protected traffic will be provided on a terminal-to-terminal basis using existing AN/URC-55 and AN/URC-61 spread-spectrum equipment. As in Stage 1a, dedicated links will be provided between selected users and will pass low data rate hard-core traffic only. It will be necessary to locate multiple spread-spectrum equipment at a node if more than one protected link is to be established between the node and other terminals. The capacity on these links will be commensurate with the capabilities of the present AN/URC-55 and AN/URC-61 equipment and the allocated satellite power split with the analog traffic.

New PSK modulation equipment will be used in Stage 1b to support the wide-band digital and imagery traffic requirements in a PSK/FDMA mode of operation. This new PSK modulation equipment will allow a more efficient use of the satellite's RF bandwidth than do the present MFSK modems.

Because of the dependence of multiple links on a single nodal terminal, it is essential that the nodal terminals have a higher degree of reliability than presently exists. Therefore, reliability modifications will be made to all Phase I terminals to increase their reliability for operation in Stage 1b. Consideration has also been given to deploying redundant terminals at nodal locations to improve the overall terminal availability at these locations.

During 1972 prototype models of the AN/MSC-60 (HT) and AN/MSC-61 (MT) will be delivered. Test results taken from these terminals will form the basis for decisions on the procurement of additional terminals that would be available for Stage 1c.

D.3.2.1 System Control

Control of the DSCS in Stage 1b will still be on a self-discipline basis. The satellite will operate in a linear mode, sufficient margin will be provided and the capacities will be conservative so that a more extensive control system will not be required. A limited multipoint network control will be possible during this period since a major nodal terminal in each satellite is in communication with and has a link orderwire with almost all other terminals accessing the satellite. In this situation the FM baseband orderwire, which will be established below 12 kHz in the baseband, will be used for traffic to be transmitted to and from the major nodal terminal to each of the nodal terminals in the multipoint network (i.e., for example the Kwajalein - CONUS West link). These terminals would have to be controlled in a manner similar to that used in Stage 1a.

D.3.3 Stage 1c

Stage 1c begins with the introduction of the PCM, TDM and PSK modulation equipment on the first Phase II satellite communication link. Since this new digital equipment will be phased into the Phase II DSCS over an extended period of time, the initial period of Stage 1c will be a hybrid operation; i. e., a mixture of analog and digital operation on separate RF carriers. The extent of this period will depend on the availability of the equipment and the necessary procurement funds.

Stage 1c operation may also see the introduction of production AN/MSC-60 and AN/MSC-61 earth terminals. A number of these earth terminals may be procured and deployed to nodal terminal locations on a priority basis. The higher inherent availability of these earth terminals, together with their higher performance capability (e. g., larger G/T) will be reflected in an increase in the overall performance of the Phase II DSCS. The displaced nodal AN/MSC-46 terminals could be relocated to new nodal locations based on the current DCS/DSCS requirements.

To improve the efficiency of the digital transmissions in Stage 1c, error correction coding equipment will be procured. This coding equipment will allow the transmission of digital data using smaller amounts of satellite power, thus allowing larger amounts of digital communications to be processed through the Phase II satellites.

Unprotected traffic will be transmitted in Stage 1c using either analog FM or digital PSK transmissions, depending on the nature of the requirements and the availability of the digital equipment. As more digital equipment is procured and deployed in the DSCS, Stage 1c will evolve over a period of time

into an all-digital communications system (Stage 2) satisfying all DCS/DSCS traffic requirements using PCM and TDM/PSK

To decrease the cost and complexity of the TDM baseband configurations, traffic to be transmitted to specific terminals will be multiplexed separately at baseband and transmitted on separate RF carriers. The receiving terminals to which these RF carriers are transmitted will receive, demodulate and demultiplex all of the traffic on their specified carrier for their own use. Thus multiple duplex satellite communication links will be established between earth terminals in Stage 1c. The majority of these duplex links will originate and terminate at nodal terminal locations as in Stage 1b. In addition to this type of satellite link operation, some satellite links will continue with a multiplexed baseband RF broadcast type of operation. This type of operation is more cost-effective for small amounts of user traffic. A final determination of the satellite communication link configuration in each satellite will have to be made on a link-by-link basis when the traffic/user requirements for this period have been validated. Figure D-3 illustrates a typical baseband to RF carrier functional operation which will occur at multiple carrier earth terminals.

This type of operation will require more RF carriers to access each of Phase II satellites than were required in Stage 1b. For this reason, it is anticipated that the full 125-MHz earth coverage to earth coverage frequency band will be used during Stage 1c.

Protected traffic will be provided in the early period of Stage 1c as it was in Stage 1b by using the AN/URC-55 and 61 spread-spectrum equipment. However, later in Stage 1c the new AN/USC-28 spread-spectrum equipment should be available and will be deployed in all DCS/DSCS earth terminal locations. In addition to increased anti-jam protection, the AN/USC-28 will provide the operational capability to establish a protected network orderwire. This network

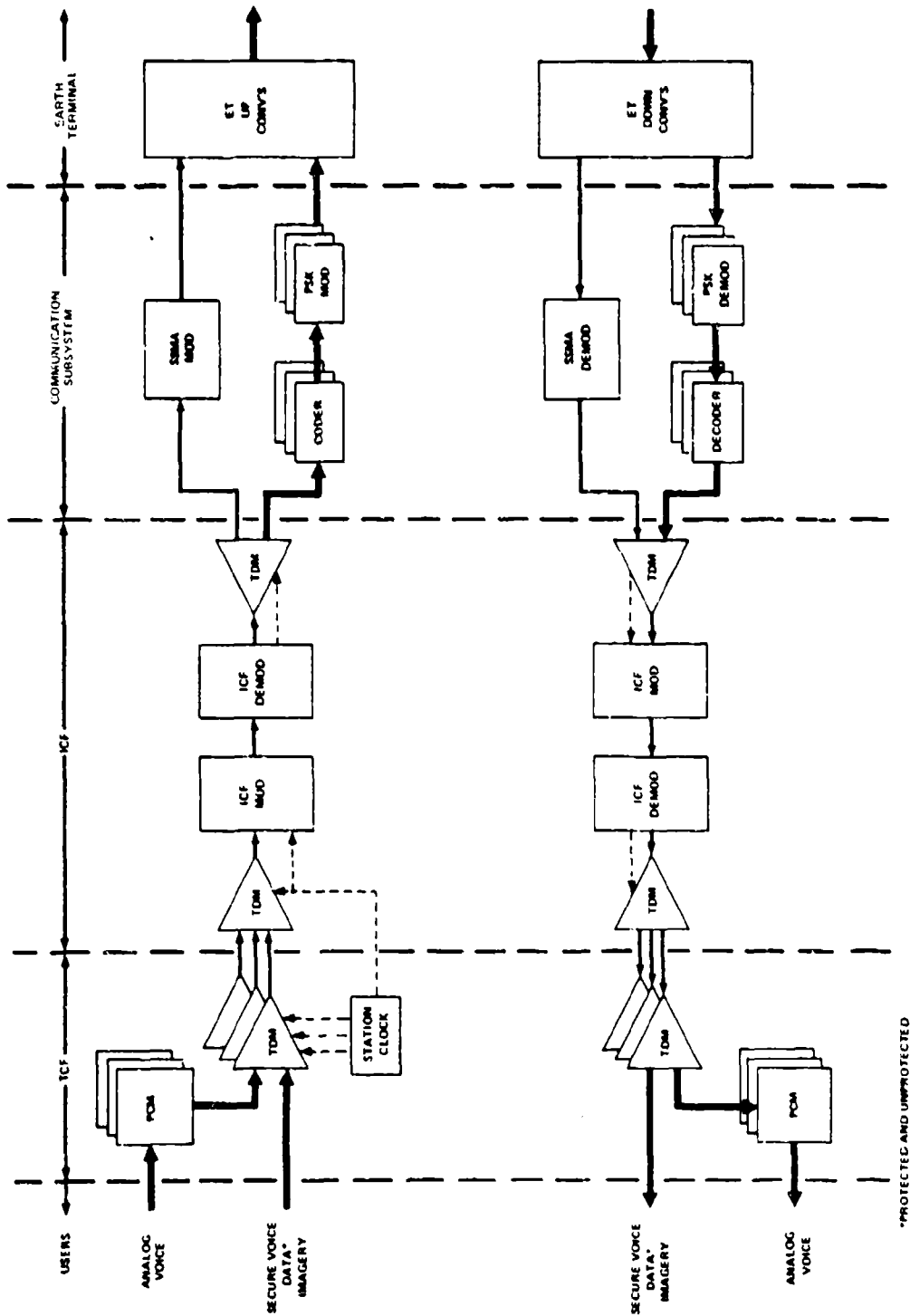

Figure D-3. Typical Stage 1c Digital Traffic Configuration

orderwire will not only provide the capability of a real-time SATCOM control, but will provide a systemwide timing capability imperative to a TDMA operation, which is presently planned as a follow-on to Stage 1c.

Contingency operations will continue to be handled in Stage 1c as they were in Stage 1b by using the AN/TSC-54 terminals and operating via the satellite's narrow beam to narrow beam or cross-strap channels.

APPENDIX E - FUTURE TRENDS

E. 1 INTRODUCTION

This appendix gives an overview of future trends in space and earth subsystems that will affect development and progress in the satellite communications field.

E. 2 SPACE SUBSYSTEM TRENDS

E. 2. 1 General

In the relatively short time that satellite communications have been available in either an R&D or operational status, great progress has been made.

As discussed in the basic report and in Appendix A, there has been an evolution from a simple passive reflector of 1960 to the DSCS Phase II and Intelsat IV with their wide-band multimode active repeaters of today. Progress will not halt at this point. There are continually expanding requirements for more and more high-speed wide-band global circuits. This means relaying more traffic through satellites with increased capability and reliability. Thus more powerful and versatile satellites are desired, which may require increased loads for the launch vehicle and greater demands on the finite orbit and usable frequency spectrum.

E. 2. 2 Satellite Position

The developments to date have shown the advantages of using geostationary orbits for communications satellites. However, the present satellites are not completely stationary with respect to the earth. The DSCS satellite makes a figure eight pattern, going as far as 3° north and south of the equator. Hence many of the earth terminals using the satellite are equipped with costly automatic tracking devices. This requirement can be eliminated by stationkeeping that maintains the satellite within limits so that tracking will not be required once the

antenna is properly oriented. Maintaining a geostationary position will probably require more fuel for executing stationkeeping commands.

E. 2. 3 Higher Frequency Bands

Today's commercial communications satellites use the 4- to 6-GHz band and the military uses the 7- to 8-GHz band for global communications. These bands, like the lower frequency UHF band, are becoming crowded from both a satellite and terrestrial viewpoint. The trend for satellites as well as for other means of communications will be toward higher frequencies. Action is already underway in the 11- to 15-GHz and 30- to 35-GHz regions. These higher frequencies open new areas and provide greater bandwidths for high data rate links, but they also introduce problems. The 1- to 10-GHz region is favored because of its low propagation loss as a result of rain and water absorption. These two losses become very serious above 10 GHz. Additionally, the capability to generate adequate power at the higher frequencies requires new development. These frequencies do permit smaller and more directional antennas with a resultant increase in antenna gain. This is partially counteracted by the accompanying increase in free space loss.

E. 2. 4 RF Amplifiers

The movement to higher frequencies is always limited by the state-of-the-art in the manufacturing of RF power amplifiers. To produce the required output power in the GHz-range transistors, klystrons and traveling-wave tubes (TWTs) are used. The transistors are normally considered more reliable than a tube. However, above 2 GHz the transistors tend to become inefficient and the TWT or klystron takes over. At present an output of 20 watts with an efficiency of 40 percent is practical at the 7- to 8-GHz region using a TWT. R&D effort will be required to provide this capability above 10 GHz. Such effort is in the initial stages at this time.

E. 2. 5 Prime Power

The increased demand for satellite circuits can be met by a larger transponder capability. A prime factor in providing this is having adequate, reliable power on board. Progress has been made in this area by improvements in the solar arrays to meet the increasing loads and by better batteries to store energy and provide it to the system when the sun is not providing the required energy to the solar arrays, such as during eclipses. The silicon solar cell appears to be a source that will be used for direct conversion, although nuclear power supplies have been under development. Present satellite dc power supplies can produce about 2 kW, which should increase to about 5 kW within the next decade.

E. 2. 6 Antennas

Today's satellites have reached the stage of having both earth coverage antennas for global communications and narrow-beam or spot antennas to serve requirements concentrated in regional areas. The efficiency of such antennas obviously depends upon a well-positioned satellite providing a stable platform. Today's technical ability can provide such a setting for the satellite antennas. Among the most promising improvements expected in the antenna field is the development of multibeam antennas with RF switching arrangements that will permit rapid reconfiguring of the network by control from the earth in accordance with varying traffic loads.

E. 2. 7 Satellite-to-Satellite Links

To have a truly global capability it would be desirable to have links available directly from satellite to satellite for interconnecting points that do not have one common satellite for a relay. Such studies have been under way and experiments are planned using optical frequency devices. It is realistic to expect that such a capability will exist and be operational within the next 10 years.

E. 2. 8 Improved Capacity

To meet the challenge of the growing requirements, satellites have increased in power and bandwidth. Additionally, the recent models such as Intelsat IV have taken advantage of the design feature of using separate transponders to meet the varied requirements, such as TV, voice circuits, demand assignment networks, etc. This channelization separates the different modes of operation, thus greatly reducing intermodulations. Future satellites will undoubtedly be configured to continue this trend.

The gain in transmission capacity of satellites and their associated ground systems is evidenced by the increase in traffic carrying capability from 240 half duplex circuits for Intelsat I in 1965 to 6000 for Intelsat IV in 1971.

E. 3 EARTH SUBSYSTEM TRENDS

E. 3. 1 General

Like the space subsystem, the earth subsystem has experienced improvements during these initial years of operational space communications as larger more reliable terminals have been developed. These improvements will continue, with emphasis on the areas discussed below.

E. 3. 2 Receive System G/T

The capability of the receive system to perform can be measured by its figure of merit (G/T), the ratio of the receive antenna gain to the system noise temperature. This figure of merit depends on several parameters in areas subject to further research and development.

1. Antenna - The design for large fixed-plant antennas is not expected to change radically. The size is limited by cost, with pointing accuracy and smoothness of the antenna surface being major factors for large antennas. Limited progress is being made in increasing the nominal 54 percent efficiency of large parabolic antennas.

However, for other DOD uses such as aboard aircraft there should be notable improvement. Blade and phased-array antennas are research areas that should improve the gain of the airborne antenna.

2. **Low-Noise Receivers** - The currently available DSCS terminals have a receive noise temperature in the 200 to 300 K° range. This figure undoubtedly will be reduced to about the 50°K range by 1980 for the 1- to 10-GHz band. However, the primary areas of concern will be obtaining equally low receive system temperatures at the frequencies above 10-GHz.

An additional area that will see improvement is the obtaining of simpler, quieter, low-noise amplifiers for mobile or tactical users.

3. **RF Modulation and Multiple-Access Techniques** - The majority of traffic today, as in the past, is analog. However, with the advent of data processing, the computer, and other digital devices-- including encoders for secure voice circuits and wide-band data units--the volume of digital traffic is growing at a far faster rate than analog requirements. As indicated earlier, the DSCS will be evolving from an analog system to a hybrid analog-digital system and finally to an all-digital system. Much work and development effort has already gone into developing baseband pulse code modulation/time division multiplexing (PCM/TDM) equipment and DOD is presently procuring such units. The PCM equipment will sample and quantize analog signals and feed them to a TDM unit to be multiplexed into a composite serial stream for transmission. The TDM output can be sent via satellite using either FDMA or TDMA. This trend toward digital communications will accelerate and result in the majority of DCS trunking being handled on a digital basis.

For the signals transmitted via satellite to remain digital, the present DSCS RF modem (which is FM) will be replaced with a phase-shift keying (PSK) modem. Such units are under development for the DSCS. During the coming decade it is reasonable to assume that such units will gain in reliability, simplicity and in the capability to handle more and higher data rates. PSK offers the advantage of permitting power, bandwidth and error rate tradeoffs, thus adding to the flexibility in circuit and system design.

Although either FDMA or TDMA can be used to transmit the PSK signal, the future will see a trend toward TDMA. Such satellite systems have already been tested and proven practical. Although at this time TDMA is not a common mode operationally in either the commercial world or DCS, its advantages are recognized and plans and programs have been established to use TDMA when the PCM, TDM and PSK units are operational and the TDMA synchronizing and control systems are in production. This trend will result in PSK/TDMA largely replacing FM/FDMA by 1980 for satellite transmission of nontactical traffic.

Other modulation/multiple access techniques of particular interest to the military communicator are SSMA and high peak power/TDMA. The SSMA field is just reaching the practical operational stages, thus growth and improvements in data rate, jamming-to-signal ratio, and bit error rate performance are to be expected.

The basic idea behind the high peak power amplifier is to provide a very high level signal on the uplink to overpower jamming signals. Peak power levels of 1 MW with average power of 1 to 10 kW are under consideration.

4. Demand Assignment Multiple Access - Just as switches concentrate traffic and increase the utilization of interswitch trunks, demand

assignment techniques can improve the efficiency of the utilization of the satellite traffic-carrying capability. This is particularly true for low-duty cycle users. Demand assignment is simply a system whereby a user requests use of satellite power, bandwidth and frequencies when required and releases them for others to use immediately upon completion of his call. Comsat has developed, tested and begun installing such a system under the code name Spade. Nine terminals should be operating in the network by the end of 1972. This is a single carrier per circuit FDMA system. Additionally, Comsat and several other organizations are developing and testing demand assignment systems using TDMA. This very flexible and efficient system should grow and be a normal part of satellite communication networks within the next 5 to 10 years.

5. Coding - Another new and exciting technical development of the past 10 years has been the theoretical analysis of error correcting techniques and codes. This new field is moving from the theoretical to the practical era and is providing a new tool for the system engineer. Coding permits tradeoffs among power, bandwidth, bit error rate and information transmission rate. Analytical results have shown the potential of various coding techniques. The practical hardware is now entering the field to use the benefits of coding. Further research and hardware development will result in improved performance in this emerging field.

APPENDIX F - REFERENCE DATA

F.1 INTRODUCTION

This appendix provides convenient reference charts and tables that are of particular interest to the communications satellite engineer. Particular attention should be paid to footnotes to ensure that this simplified information is used in consonance with the parameters to which it applies, rather than being applied in all cases. For example, Table F-4 shows the percentage of power from the DSCS Phase II satellite earth coverage transponder required to pass a particular data rate. The computed percentages were based on specific parameters, including a satellite EIRP of 25 dBW, a required E_b/N_0 of 6 dB, and a downlink margin of 6 dB. If the given percentages were applied to the Phase II satellite narrow-beam transponder, a correction of -12 dB would be necessary because of the higher narrow-beam EIRP (37 dBW).

Table F-1. Decibel Conversion

dB	Power Ratio
0	1.00
0.1	1.02
0.2	1.04
0.3	1.07
0.4	1.09
0.5	1.12
0.6	1.14
0.7	1.17
0.8	1.20
0.9	1.23
1.0	1.26
2.0	1.6
3.0	2.0
4.0	2.5
5.0	3.2
6.0	4.0
7.0	5.0
8.0	6.3
9.0	8.0
10.0	10.0
20.0	100.00
30.0	1,000.00
40.0	10,000.00
50.0	100,000.00

Table F-2. Decibel Conversion in Powers of Ten

POWER RATIO	dB	POWER RATIO
10^{-1}	10	10
10^{-2}	20	10^2
10^{-3}	30	10^3
10^{-4}	40	10^4
10^{-5}	50	10^5
10^{-6}	60	10^6
10^{-7}	70	10^7
10^{-8}	80	10^8
10^{-9}	90	10^9
10^{-10}	100	10^{10}

Table F-3. Antenna Fact Sheet

Type Antenna -- Parabolic reflector with 54 percent efficiency (η)

Receive Frequency -- 7.25 GHz

Transmit Frequency -- 7.9 GHz

$$G = \frac{4\pi A}{\lambda^2} \eta$$

$$G_{\text{REC}} = 20 \log f + 20 \log D - 52.6 = 24.6 + 20 \log D$$

$$G_{\text{TRANS}} = 25.3 + 20 \log D$$

Diameter-Ft.	20 log D	G_{TRANS}	G_{REC}	G/T (T = 316°K = 25 dB)
1	0	25.3	24.6	-0.4
2	6.0	31.3	30.6	5.6
3	9.5	34.8	34.1	9.1
4	12.0	37.3	36.6	11.6
5	14.0	39.3	38.6	13.6
6	15.6	40.9	40.2	15.2
7	16.9	42.2	41.5	16.5
8	18.0	43.3	42.6	17.6
9	19.1	44.4	43.7	18.7
10	20.0	45.3	44.6	19.6
11	20.8	46.1	45.4	20.4
12	21.6	46.9	46.2	21.2
15	23.5	48.8	48.1	23.1
16	24.1	49.4	48.7	23.7
17	24.6	49.9	49.2	24.2
20	26.0	51.3	50.6	25.6
30	29.5	54.8	54.1	29.1
40	32.0	57.3	56.6	31.6
60	35.6	60.9	60.2	35.2
80				
100				

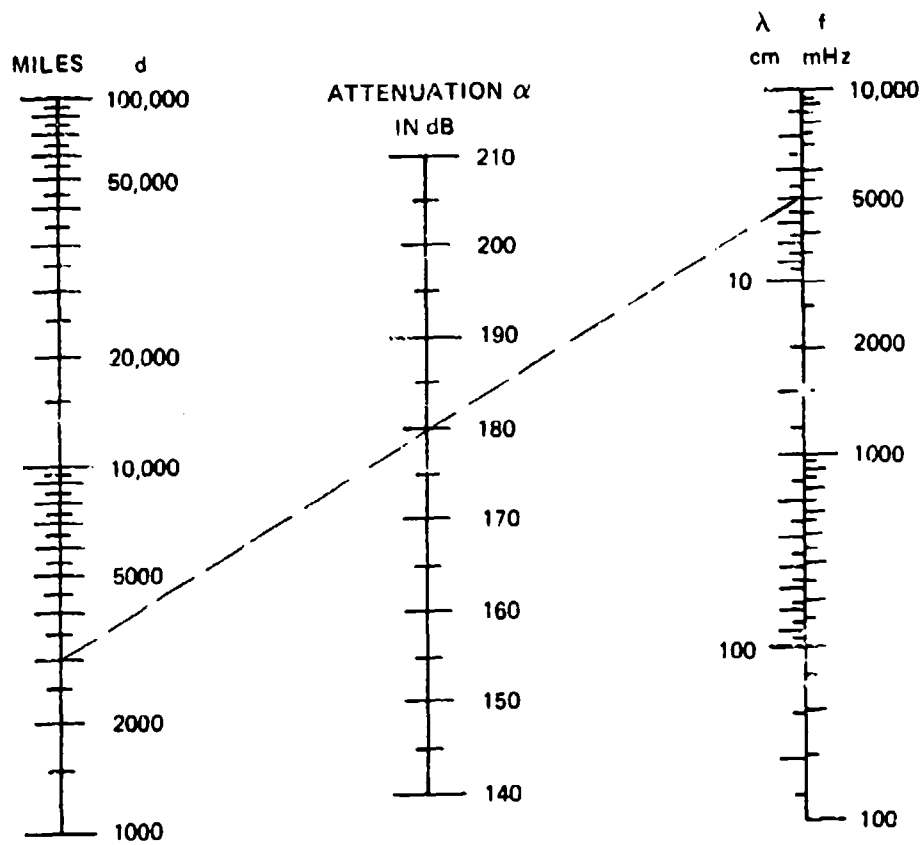

$$\alpha = 37 + 20 \text{ LGG } f + 20 \text{ LOG } d$$

Figure F-1. Free Space Attenuation Between Isotropic Antennas

Table F-4. Percent of Satellite Power Required to Provide DSCS Voice Service*

No. of Voice Channels	C/T Required	Percent of Satellite Power				
		G/T = 26.5 (AN/TSC-54)	G/T = 27 (MT)	G/T = 31 (SCC-21)	G/T = 34 (AN/MSC-46)	G/T = 39 (HT)
1	68.0	14.2	12.7	5.0	2.5	0.8
2	69.1	17.8	16.3	6.4	3.2	1.0
3	69.9	21.8	19.7	7.8	3.9	1.2
4	70.3	24.0	21.1	8.5	4.3	1.4
5	70.8	27.5	24.0	9.5	4.8	1.5
6	71.3	30.2	26.7	10.7	5.4	1.7
9	72.1	36.3	32.1	12.8	6.5	2.0
12	72.3	38.0	34.1	13.5	6.8	2.1
18	73.6	51.2	45.9	18.2	9.0	2.9
24	74.5	63.0	56.5	22.4	11.2	3.5
36	75.2	87.1	77.7	30.9	15.5	4.9

*Based on 25 dBw = EIRP and lowest baseband channel frequency = 12,000 Hz, TTNR = 44.2 (FLAT)

Assumes negligible intermodulation

Table F-5. Percentage of Stage 1b Satellite Power Required to Provide DSCS Data Service*

Data Rate	C/kT Required	Percent of Satellite Power				
		G/T = 17	G/T = 27 (MT)	G/T = 31 (SCT-21)	G/T = 34 (MSC-46)	G/T = 39 (HT)
150 bps	33.8	0.05	0.005	0.002	0.001	0.0003
300 bps	36.8	0.10	0.010	0.004	0.002	0.0005
600 bps	39.8	0.19	0.019	0.008	0.004	0.0010
1.2 kbps	42.8	0.38	0.038	0.015	0.008	0.0030
2.4 kbps	45.8	0.75	0.075	0.030	0.015	0.0050
4.8 kbps	48.8	1.50	0.150	0.060	0.030	0.0100
9.6 kbps	51.8	3.00	0.300	0.120	0.060	0.0200
19.2 kbps	54.8	6.00	0.600	0.240	0.120	0.0380
50.0 kbps	59.0	16.00	1.600	0.630	0.320	0.1000
112.5 kbps	62.5	35.00	3.500	1.400	0.700	0.2200
384.0 kbps	67.8	---	12.000	4.800	2.400	0.7600
900.0 kbps	71.5	---	28.400	11.300	5.600	1.7700
1.0 Mbps	72.0	---	31.600	12.600	6.300	2.0000
1.53 Mbps	73.9	---	49.000	19.500	9.800	3.1000
3.07 Mbps	76.9	---	97.800	38.900	19.500	6.2000
6.14 Mbps	79.9	---	---	77.800	38.900	12.3000
12.28 Mbps	82.9	---	---	---	77.800	24.6000
24.56 Mbps	85.9	---	---	---	---	49.2000
50.1 Mbps	89.0	---	---	---	---	100.0000

*Margin = 6 dB
 $F_b N_0 = 6$ dB
 ERP = 25 dBW

$$C/M = R + M + F_b N_0$$

Miscellaneous Losses = 0
 Implementation Losses = 0

Table F-6. Antenna Size and G/T of Terminals Using DSCS
Phase II Satellites

Terminal	Antenna Diameter (feet)	G/T (dB)
Intelsat Typical (3rd Generation)	97	43*
AN/MSC-60 (HT)	60	39
AN/FSC-9	60	38
AN/MSC-46	40	34
AN/MSC-61 (MT)	18	27
AN/MSC-61 (proposed)	35	33
SCT-21	21	31
AN/TSC-54	18	265
SC-1a	6	17.5
SC-1b	18	26
SC-2	30	31
NATO	42	34.8
SKYNET (UK) (1)	42	32
SKYNET (UK) (2)	40	32.4
SKYNET (UK) (3)	21	31.4
SKYNET (UK) S1	6	15.7
Army Tactical Terminals		
AN/MSC-59 (1/4-ton)	8	18
AN/TSC-84 (1-1/2-ton)	8	18
AN/TSC-86 (2-1/2-ton) (LT)	8	18
Navy Shipborne		
AN/WSC-2 (1)	8	15
AN/WSC-2 (2)	4	12
SSC-6 (MASST)	6	14
Airborne	3	5

*Gain computed at 4 GHz, all others at 7.2 GHz.

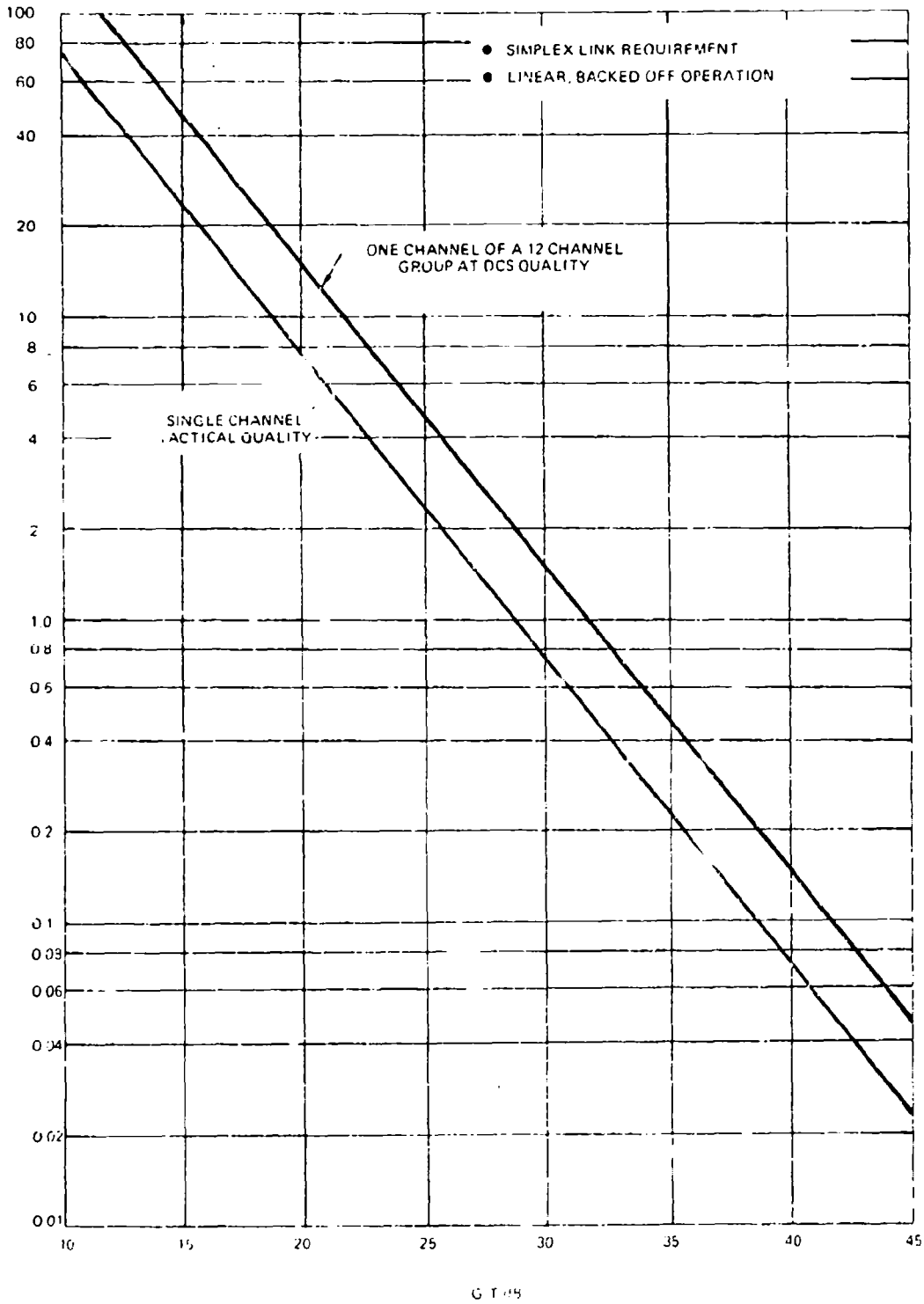

Figure F-2. Voice Traffic, ERP Required Versus Receive Station G/T (Earth Coverage)

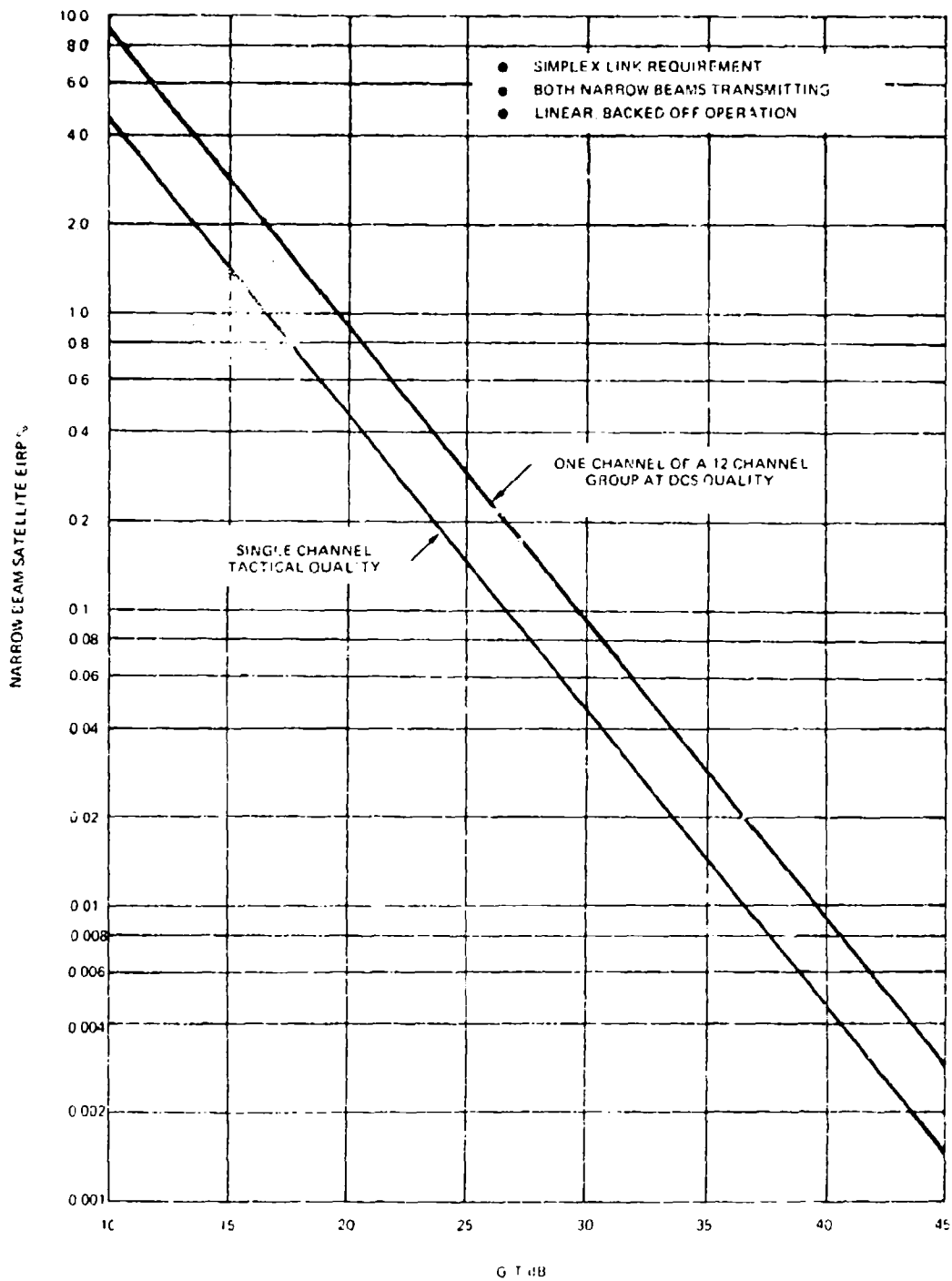

Figure F-4. Voice Traffic, ERP Required Versus Receive Station G/T (Narrow Beam)

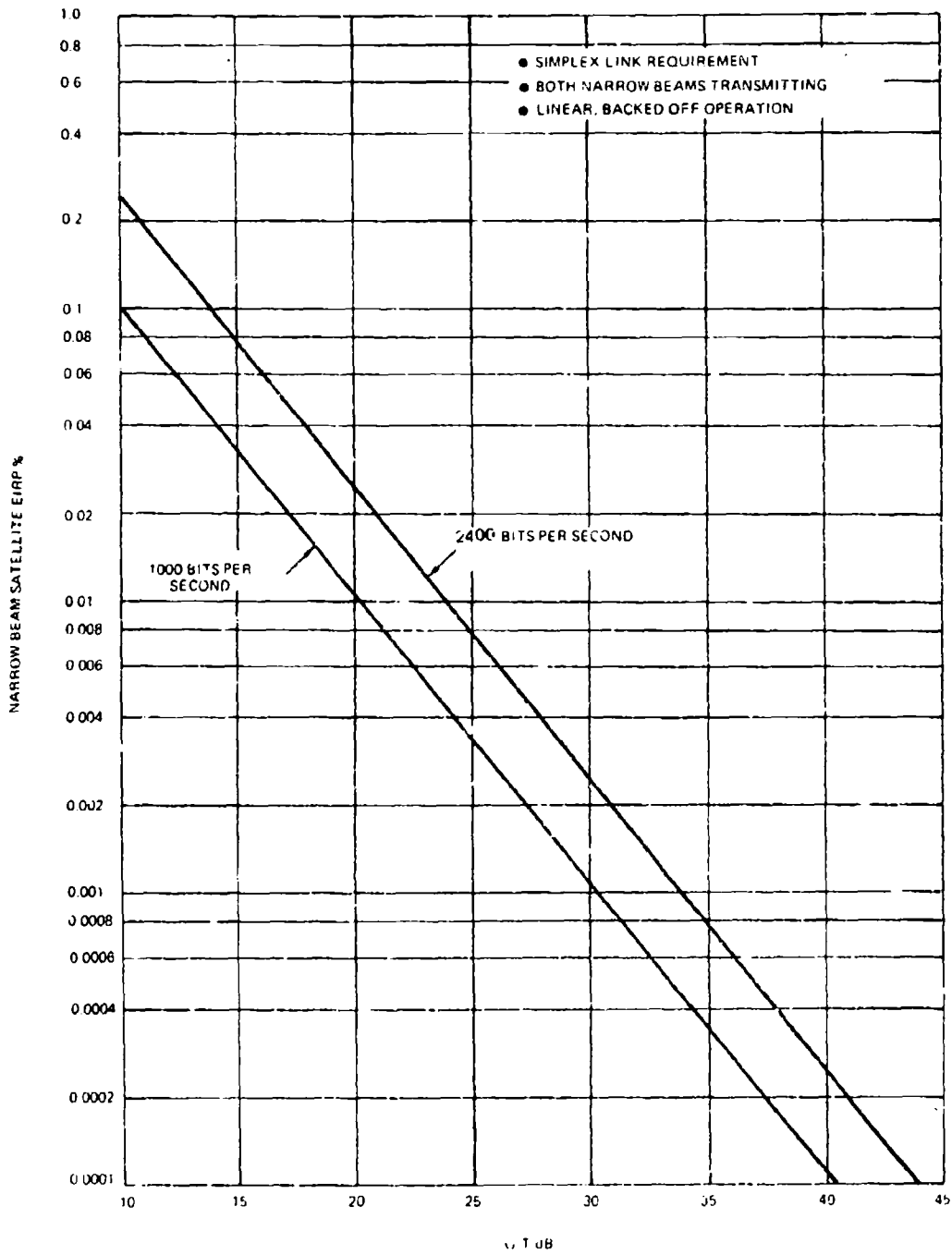

Figure F-5. Data Traffic, ERP Required Versus Receive Station G/T (Narrow Beam)

Table F-7. DSCS Phase II, Stage 1a Exclusive Band Carrier Frequencies

	Downlink (MHz)	Uplink (MHz)	Emission
1. *	7251.3700	7976.3700	1800 F9
2. *	7252.9325	7977.9325	1800 F9
3. *	7256.0575	7981.0575	1800 F9
4. *	7260.7450	7985.7450	3500 F9
5. *	7265.4325	7990.4325	3500 F9
6. *	7270.1200	7995.1200	20,000 F9
7. *	7271.6825	7996.6825	3500 F9 & 8000 F9
8. *	7277.9325	8002.9325	3500 F9
9. *	7279.4950	8004.4950	3500 F9
10.	7282.6200	8007.6200	3500 F9
11. *	7284.1825	8009.1825	3500 F9
12. *	7287.3075	8012.3075	3500 F9
13. *	7290.4325	8015.4325	3500 F9
14.	7293.5575	8018.5575	1800 F9
15.	7296.6825	8021.6825	1800 F9
16.	7298.2450	8023.2450	1800 F9
17.	Beacon-7250.1**		5 F9

*DSCS Recommended Frequency Plan.

**Earth Coverage Beacon.

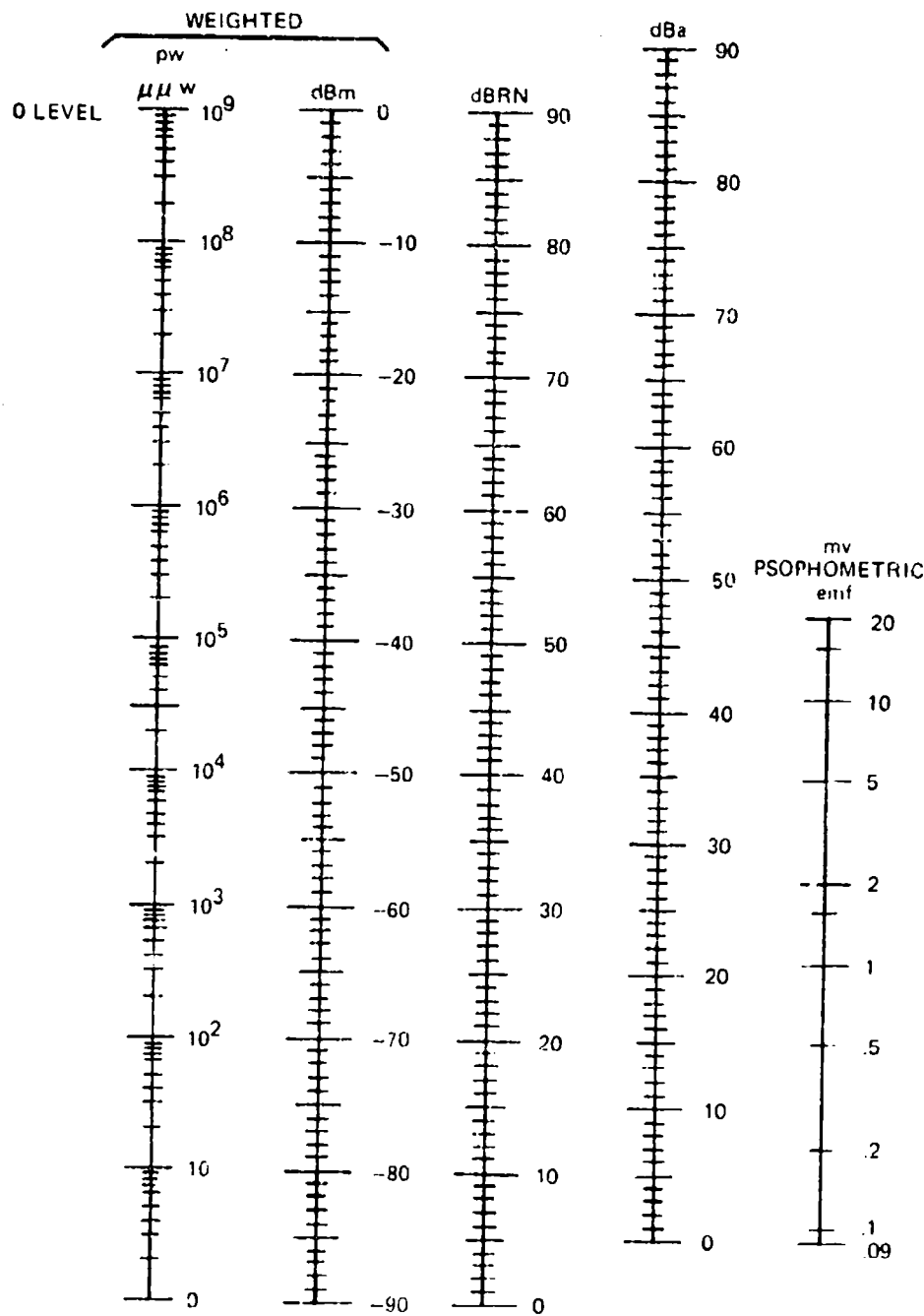

Figure F-6. Relative Noise Scales

Table F-8. Monthly Space Subsystem Cost Allocation for One Analog Voice Channel DCS Quality*†

Terminal Type	G/T (dB)	\$ Thousand	
		EC	NB
HT	39	1.405	0.086
MT	34	4.449	0.281
MSC-46	34	4.449	0.281
TSC-54	26.5	24.979	1.531
WSC-2 (8')	18	-	10.928
LT	18	-	10.928
SSC-6	14	-	27.321

*Based on Phase II development, procurement launch and O&M costs averaged over 10-year life cycle.

†Based on one channel of a 12-channel group.

Table F-9. Monthly Space Subsystem Cost Allocation for One Analog Voice Channel Tactical Quality*

Terminal Type	G/T (dB)	\$ Thousand	
		EC	NB
HT	39	0.703	0.045
MT	34	2.186	0.141
MSC-46	34	2.186	0.141
TSC-54	26.5	12.489	0.781
WSC-2 (8')	18	85.866	5.542
LT	18	85.866	5.542
SSC-6	14	218.568	14.051
WSC-2 (4')	12	354.392	22.637
TSC-80	12	354.392	22.637
MSC-57	8	-	56.584
Airborne	5	-	109.282

*Based on Phase II development, procurement launch and O&M costs averaged over 10-year life cycle.

MONTHLY SPACE SUBSYSTEM COST ALLOCATION

Table F-10. Digital Data, 1 kbps (\$ Thousand)

Terminal Type	G/T	EC	NB
HT	39	.016	.001
MT	34	.050	.003
MSC-46	34	.050	.003
TSC-54	26.5	.273	.018
WSC-2 (8')	18	1.952	.133
LT	18	1.952	.133
SSC-6	14	4.996	.320
WSC-2 (4')	12	7.806	.515
TSC-80	12	7.806	.515
MSC-57	8	20.296	1.249
Airborne	5	39.029	2.498
Submarine	3	63.960	4.134

Table F-11. Digital Data, 2.4 kbps (\$ Thousand)

Terminal Type	G/T	EC	NB
HT	39	.037	.002
MT	34	.120	.008
MSC-46	34	.120	.008
TSC-54	26.5	.656	.043
WSC-2 (8')	18	4.684	.312
LT	18	4.684	.312
SSC-6	14	11.990	.768
WSC-2 (4')	12	19.515	1.249
TSC-80	12	19.515	1.249
MSC-57	8	48.397	3.044
Airborne	5	93.670	5.995
Submarine	3	152.100	9.750

G/T - Figure of Merit

EC - Earth Coverage

NB - Narrow Beam

Based on Phase II development, procurement launch and O&M costs averaged over 10-year life cycle.

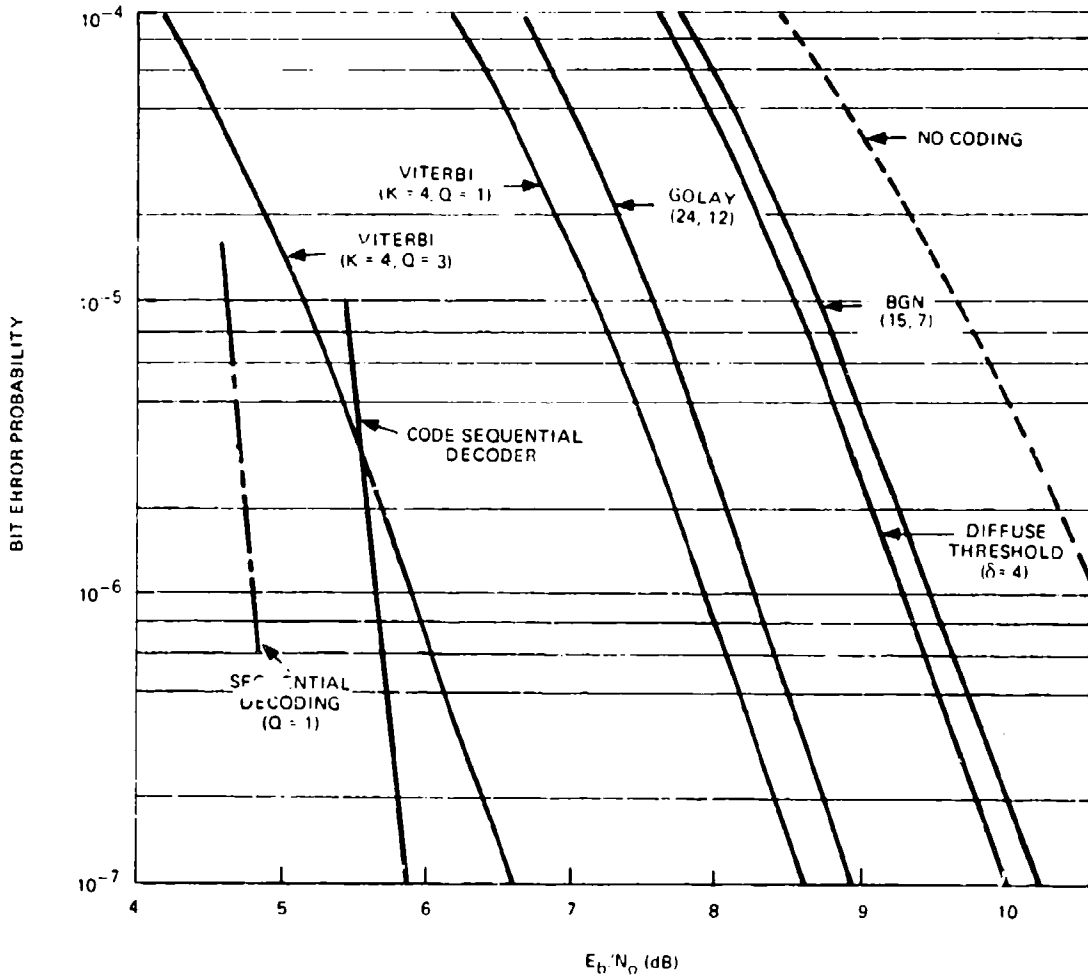
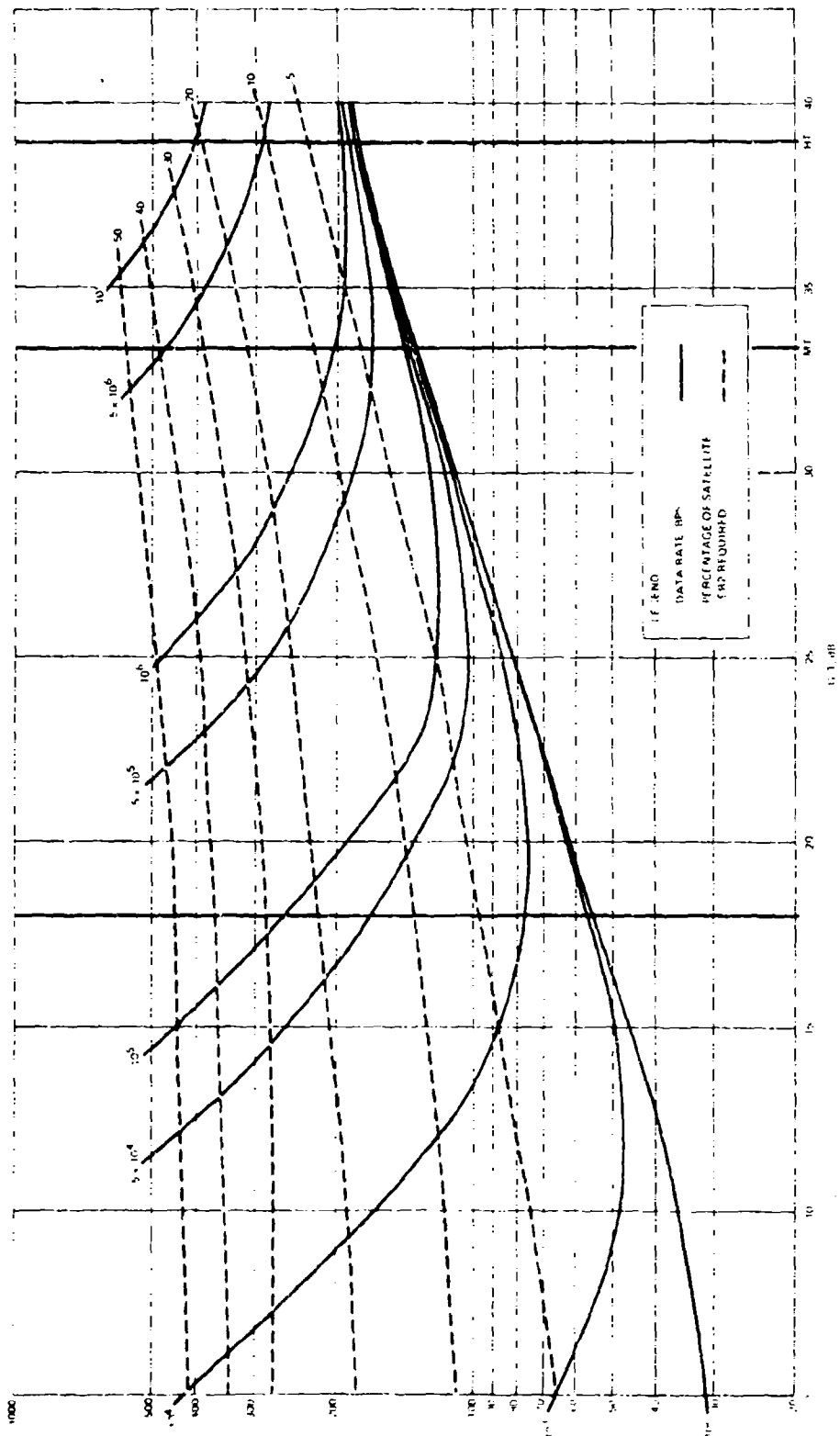
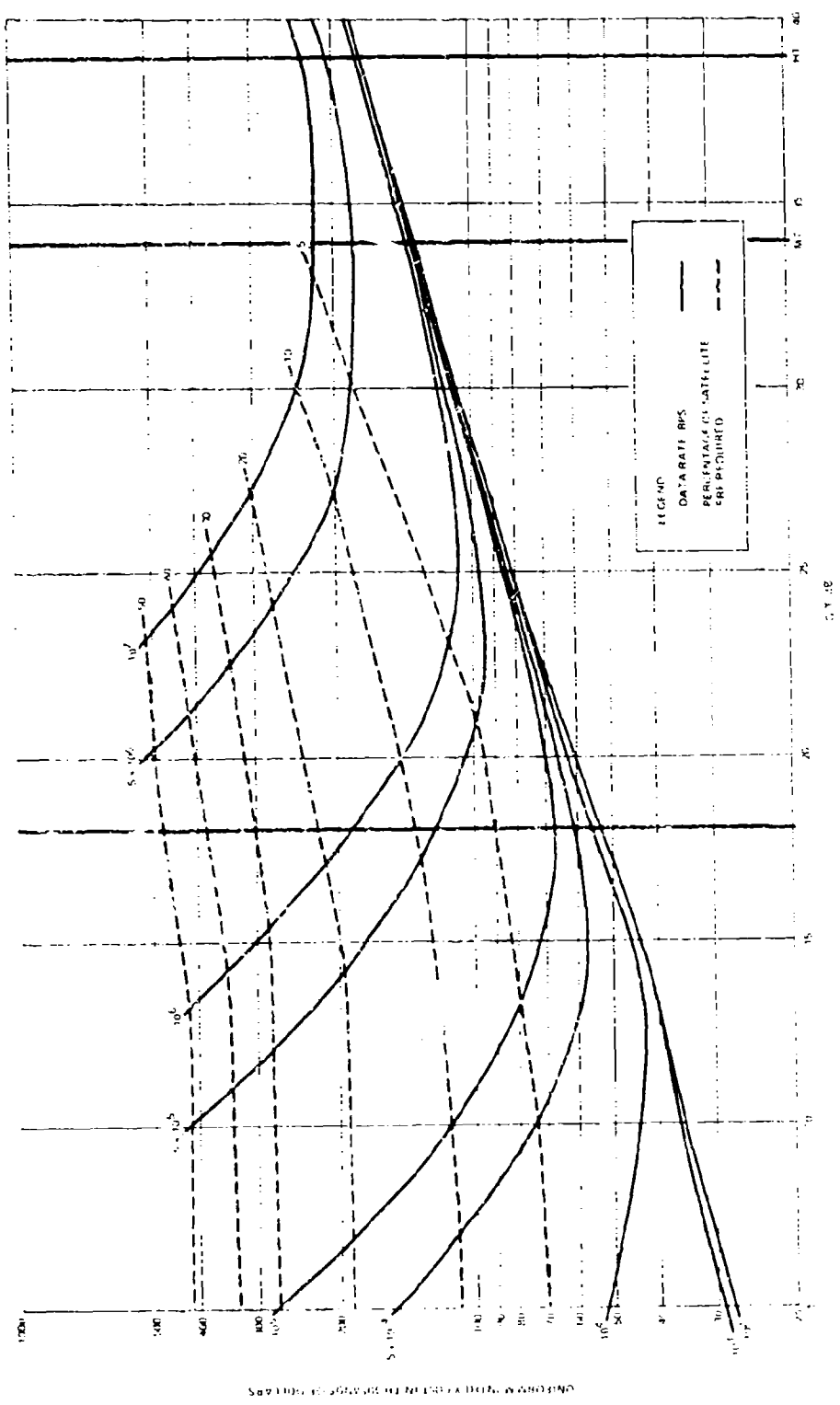

Figure F-7. Error Correcting PSK Code Performance



NOTE: BASED ON PHASE II SATELLITE DEVELOPMENT, PROCUREMENT LAUNCH AND O&M COSTS AVERAGED OVER 10 YEARS, PLUS TYPICAL DEVELOPMENT PROCUREMENT AND O&M COSTS AVERAGED OVER 10 YEARS FOR MILITARY TERMINAL PROVIDING SELECTED G/T.

Figure F-8. Uniform Monthly Cost for DSCS Earth Coverage Operations



NOTE: BASED ON PHASE II SATELLITE DEVELOPMENT, PROCUREMENT LAUNCH AND O&M COSTS AVERAGED OVER 10 YEARS; PLUS TYPICAL DEVELOPMENT PROCUREMENT AND O&M COSTS AVERAGED OVER 10 YEARS FOR MILITARY TERMINAL PROVIDING SELECTED G/T.

Figure F-9. Uniform Monthly Cost for Narrow Beam Coverage Operations

Table F-12. Monthly Space Subsystem Cost Allocation Digital Data Channel, 1 kbps

Terminal Type	G/T (dB)	\$ Thousand	
		EC	NB
HT	39	0.016	0.001
MT	34	0.050	0.003
MSC-46	34	0.050	0.003
TSC-54	26.5	0.273	0.018
WSC-2 (8')	18	1.952	0.133
LT	18	1.952	0.133
SSC-6	14	4.896	0.320
WSC-2 (4')	12	7.806	0.515
TSC-80	12	7.806	0.515
MSC-57	8	20.296	1.249
Airborne	5	39.029	2.498
Submarine	3	63.960	4.134

*Based on Phase II development, procurement launch and O&M costs averaged over 10-year life cycle.

Table F-13. Monthly Space Subsystem Cost Allocation Digital Data Channel, 2.4 kbps*

Terminal Type	G/T (dB)	\$ Thousand	
		EC	NB
HT	39	0.037	0.002
MT	34	0.120	0.008
MSC-46	34	0.120	0.008
TSC-54	26.5	0.656	0.043
WSC-2 (8')	18	4.684	0.312
LT	18	4.684	0.312
SSC-6	14	11.990	0.768
WSC-2 (4')	12	19.515	1.249
TSC-80	12	19.515	1.249
MSC-57	8	48.397	3.044
Airborne	5	93.670	5.995
Submarine	3	152.100	9.750

*Based on Phase II development, procurement launch and O&M costs averaged over 10-year life cycle.

APPENDIX G - GLOSSARY

Ae	Effective area of antenna
A _o	Amplitude of unmodulated carrier
ACOC	Area communication operations center
A/D	Analog-to-digital converter
AGC	Automatic gain control
AKM	Apogee kick motor
AM	Amplitude modulation
AWGN	Additive white Gaussian noise
B	Bandwidth occupied by a modulated signal
BER	Bit error rate
bps	Bits per second
BSC	Binary symmetric channel
Bw	Bandwidth
C	Channel capacity in bits per second
C/kT	Received carrier power to noise power density ratio
CNRTH	Carrier-to-noise ratio at modem threshold
D/A	Digital-to-analog converter
dB	Decibel
dBm	Decibels referred to one milliwatt of power
DSB-AM	Double sideband - amplitude modulation
DSB-SC-AM	Double sideband suppressed carrier - amplitude modulation
DSCS	Defense Satellite Communications System
E	Signal energy
E _b	Energy per bit
EC	Earth coverage (applied to satellite antenna)
EIRP	Effective isotropic radiated power
EMI	Electromagnetic interference
ET	Earth terminal

ETC	Earth terminal complex
ETR	Eastern Test Range
f_d	Maximum instantaneous-frequency deviation
$f(t)$	Modulating signal
f_i	Instantaneous frequency
f_m	Highest frequency in a signal
FDM	Frequency division multiplex
FDMA	Frequency division multiple access
FEC	Forward acting error correcting
FM	Frequency modulation
FSK	Frequency-shift keying
G	Antenna gain
g	Acceleration
GHz	Gigahertz
G/T	Antenna receiving figure of merit
h	Height of satellite above earth
HPA	High-power amplifier
HT	Heavy transportable terminal
ICF	Interconnect facility
IDCSP	Initial Defense Communications Satellite Program
IF	Intermediate frequency
J/S	Jammer-power-to-signal-power ratio
°K	Degrees in Kelvin scale
kbps	Thousands of bits per second
km	Kilometers
kW	Kilowatt
L	Transmission line loss between antenna and low-noise amplifiers
L_f	Multichannel load factor

L_{FS}	Free space loss
L_o	Transmission losses in system
LOS	Line of sight
LPA	Low-power amplifier
M	Margin
m	Bandwidth expansion factor
Mbps	Millions of bits per second
MDA	Motor drive assembly
MFSK	Multiple frequency shift keying
MHz	Megahertz
Modem	Modulation-demodulation combination
MUX	Multiplex
MT	Medium transportable terminal
MTBF	Mean time between failures
MTTR	Mean time to repair
N	Average thermal noise power
N_o	Noise power density
NB	Narrow beam (applied to satellite antenna)
NPR	Noise power ratio
NRZ	Nonreturn to zero
P	Average signal power
p	Channel error probability
P_E	Probability of bit error
PCM	Pulse code modulation
PDI	Pre-emphasis improvement factor
PM	Phase modulation
PN	Pseudorandom noise
PSK	Phase-shift keying
Δ PSK	Differentially-coherent phase-shift keying
pWp	Picowatts (10^{-12} watts) psophometrically-weighted

R	Data rate
r	Number of parity check bits at encoder output
R(t)	Reliability at time t
R_e	Earth radius
R_s	Slant angle, earth terminal-to-satellite
RF	Radio frequency
RFI	Radio frequency interference
SAMSO	Space and Missile System Organization
SCF	Satellite control facility
SEN	System Evaluation Network
SHF	Super high frequency
S_i	Average power
S/N	Signal-to-noise ratio
$(S/N)_o$	Detector output signal-to-noise ratio
SS	Spread spectrum
SSB-AM	Single sideband-amplitude modulation
SSF	System simulation facility
SSMA	Spread spectrum multiple access
T	Time duration of one bit of data
T_A	Antenna noise temperature
TACSAT	Tactical Communications Satellite
TATS	Tactical Transmission System
T_L	Ambient temperature of the transmission line loss
T_R	Low-noise amplifier noise temperature
TCF	Technical control facility
TDM	Time division multiplex
TDMA	Time division multiple access
TT&C	Telemetry tracking and command
TTNR	Test-tone-to-noise ratio
TTY	Teletype

TWT	Traveling-wave tube
TWTA	Traveling-wave tube amplifier
UHF	Ultra high frequency
UTR	Uptime ratio
W	Channel bandwidth
W_c	Angular frequency of carrier
WTR	Western Test Range
z	Angle of arrival of incident radiation
α	Angle of elevation at terminal
i	Angle of inclination of orbit
θ	Angular radius of visibility
η	Aperture efficiency
λ	Wavelength
γ	Modulation index
ρ	Normalized inner product of a signal
φ	Phase of received signal
β	Failure rate