

AD 745753

MONTANA LARGE APERTURE SEISMIC ARRAY
SECOND QUARTERLY TECHNICAL REPORT, PROJECT VT 2708

CONTRACT F33657-72-C-0390

1 MARCH 1972 - 31 MAY 1972

15 June 1972

SPONSORED BY

ADVANCED RESEARCH PROJECTS AGENCY
NUCLEAR MONITORING RESEARCH OFFICE

ARPA ORDER NO. 1620

NOTICE

Approved for Public Release.
Distribution Unlimited

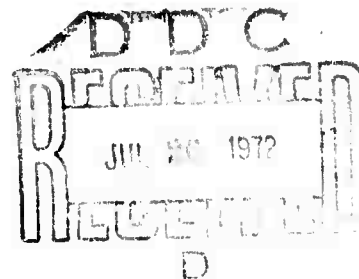

Reproduced by
NATIONAL TECHNICAL
INFORMATION SERVICE
U S Department of Commerce
Springfield VA 22151

by

PHILCO-FORD
COMMUNICATIONS & TECHNICAL SERVICES
DEFENSE SYSTEM SUPPORT ACTIVITY
214 North 30th Street
Billings, Montana

DOCUMENT CONTROL DATA - R & D

(Security classification of title, body of abstract and indexing annotation must be entered when the overall report is classified)

1. ORIGINATING ACTIVITY (Corporate author)

Philco-Ford Corporation
 Communications and Technical Services Div.
 214 North 30th, Billings, Montana 59101

2a. REPORT SECURITY CLASSIFICATION

UNCLASSIFIED

2b. GROUP

N/A

3. REPORT TITLE

SECOND QUARTERLY TECHNICAL REPORT
 MONTANA LARGE APERTURE SEISMIC ARRAY

4. DESCRIPTIVE NOTES (Type of report and inclusive dates)

Technical, 1 March 1972 - 31 May 1972

5. AUTHOR(S) (First name, middle initial, last name)

Robert E. Matkins

6. REPORT DATE

15 June 1972

7a. TOTAL NO. OF PAGES

86

7b. NO. OF REFS

10

8a. CONTRACT OR GRANT NO.

F33657-72-C-0390 ✓

8b. PROJECT NO.

VELA T/2708

8c. ARPA Order No. 1620

8d. ARPA Program Code No. 2F10

9a. ORIGINATOR'S REPORT NUMBER(S)

2056-72-21

9b. OTHER REPORT NO(S) (Any other numbers that may be assigned this report)

10. DISTRIBUTION STATEMENT

Approved for Public Release. Distribution unlimited.

11. SUPPLEMENTARY NOTES

12. SPONSORING MILITARY ACTIVITY

Advanced Research Projects Agency
 Nuclear Monitoring Research Office
 Arlington, Va.

13. ABSTRACT

The technical activity associated with the operation, maintenance, and improvement of the Montana Large Aperture Seismic Array (LASA) during the period 1 March - 31 May 1972 is related in this report. The short-period (SP) and long-period (LP) seismograph sensitivity performance statistics are indicated. Performance data on the SP seismometer and the SP and LP seismic amplifiers are presented. A new method of seismograph calibration using pseudo-random binary sequences (PRBS) and the development of a PDP-7 program to provide an LP PRBS input to the LP seismograph are described. Removal dates for the array's microbarograph sensors are given. Statistics relating to the operation and maintenance of the array and data center equipment and land facilities support are provided.

ie

14. KEY WORDS	LINK A		LINK B		LINK C	
	ROLE	WT	ROLE	WT	ROLE	WT
LASA - Large Aperture Seismic Array Seismic Array Seismic Observatory Operation Seismic Measurement Channel Performance Seismometers Seismic Amplifiers Pseudo-random binary sequences						

il

017

MONTANA LARGE APERTURE SEISMIC ARRAY
SECOND QUARTERLY TECHNICAL REPORT

15 June 1972

IDENTIFICATION

AFTAC Project No.: VELA T/2708
Project Title: Montana Large Aperture Seismic Array
ARPA Order No.: 1620
ARPA Program Code No.: 2F10
Philco-Ford Corporation
Contract No.: F33657-72-C-0390
Effective Date: 1 December 1971
Amount of Contract: \$1,200,627.00
Contract Expiration Date: 30 June 1973
Project Manager: B. G. Herrin, Phone No. (406)245-6332

NOTICE

Approved for Public Release. Distribution Unlimited

AVAILABILITY

Qualified users may request copies of this document from:
Defense Documentation Center, Cameron Station, Alexandria, Va.
22314

ACKNOWLEDGEMENT

This research was supported by the Advanced Research Projects Agency, Nuclear Monitoring Research Office, under Project VELA-UNIFORM, and accomplished under the technical direction of the Air Force Technical Applications Center under Contract No. F33657-72-C-0390.

Neither the Advanced Research Projects Agency nor the Air Force Technical Applications Center will be responsible for information contained herein which has been supplied by other organizations or contractors, and this document is subject to later revision as may be necessary. The views and conclusions presented are those of the authors and should not be interpreted as necessarily representing the official policies, either expressed or implied, of the Advanced Research Projects Agency, the Air Force Technical Applications Center, or the US Government.

Preceding page blank

ABSTRACT

The technical activity associated with the operation, maintenance, and improvement of the Montana Large Aperture Seismic Array (LASA) during the period 1 March - 31 May 1972 is related in this report. The short-period (SP) and long-period (LP) seismograph sensitivity performance statistics are indicated. Performance data on the SP seismometer and the SP and LP seismic amplifiers are presented. A new method of seismograph calibration using pseudo-random binary sequences (PRBS) and the development of a PDP-7 program to provide an LP PRBS input to the LP seismograph are described. Removal dates for the array's microbarograph sensors are given. Statistics relating to the operation and maintenance of the array and data center equipment and land facilities support are provided.

Preceding page blank

TABLE OF CONTENTS

<u>SECTION</u>	<u>TITLE</u>	<u>PAGE</u>
I	<u>INTRODUCTION</u>	1
	1.1 History	1
	1.2 Description	3
II	<u>SUMMARY</u>	9
III	<u>OPERATION</u>	11
	3.1 General	11
	3.2 Data Center	11
	3.2.1 SAAC/LDC Systems	11
	3.2.2 IBM/360 Model 44 Computer	13
	3.2.3 DEC PDP-7 Computer	13
	3.2.4 Analog System	13
	3.2.5 Tape/Film Library	13
	3.3 Array	16
	3.3.1 Monitoring	16
	3.3.2 Calibrations	16
	3.3.3 Communications	20
	3.4 Logistics	31
IV	<u>ARRAY PERFORMANCE</u>	
	4.1 Systems	33
	4.1.1 SP Seismograph	33
	4.1.2 LP Seismograph	37
	4.2 Equipment	40
	4.2.1 SP Seismometer, HS-10-1A	40
	4.2.2 SP Seismic Amplifier, RA-5	50
	4.2.3 LP Seismic Amplifier, Type II	50
	4.2.4 Develocorder	59
	4.3 Failure Report	60
	4.4 Array Aging Study	66
V	<u>IMPROVEMENTS AND MODIFICATIONS</u>	67
	5.1 General	67
	5.2 System	67

Preceding page blank

LIST OF FIGURES

<u>NUMBER</u>	<u>TITLE</u>	<u>PAGE</u>
1.1	Montana LASA	2
1.2	LASA Subarray Configurations	4
1.3	LASA Seismographs Response Curves	7
4.1	Percentage Distribution of SP Sensors in $\pm 15\%$ Sensitivity Tolerance	35
4.2	LASA SP Sensor Period vs Sensitivity Response Curves	36
4.3	Percentage Distribution of LP Sensors within $\pm 50 \text{ mV}/\mu\text{m}$ Sensitivity Tolerance	42
4.4	SP Seismometer Natural Frequency Distribution 1970 - 1972	47
4.5	SP Seismometer Damping Ratio Distribution 1972	48
4.6	Seismometer Natural Frequency Status of Array	49
5.1	Spectrum of PRBS Output	69
5.2	Modified Calibration Signal Flow	72
5.3	RA-5 Detector Response Curve	75

LIST OF TABLES

<u>NUMBER</u>	<u>TITLE</u>	<u>PAGE</u>
I	LASA Seismograph Operating Parameters and Tolerances	5
II	LASA Seismograph Channel Identification	6
III	SAAC/LDC System Operating Times	12
IV	System/360 Model 44 Computer Utilization	14
V	PDP-7 Computer Utilization	15
VI	Subarray Data Interruption Outages	17
VII	LASA Seismograph Calibration Response Tolerances	21
VIII	Incidence of Defective Subarray Channels	22
IX	SP Array Sinusoidal Calibrations	23
X	LP Array Sinusoidal Calibrations	26
XI	Extended Array Data Interruptions Due to Communications Outages	32
XII	SP Array Performance Testing Sensitivity Statistics	34
XIII	SP Seismograph Frequency Response Measurement Data	38
XIV	A Distribution of the Standard Deviations of 86 LASA SP Channels	39
XV	LP Array Performance Testing Sensitivity Statistics	41
XVI	LP Channel Sensitivity Statistics, Nov '71 thru May '72	43
XVII	SP Seismometer Natural Frequency Measurements March - May '72	45
XVIII	SP Seismometer Output from Electromagnetic Calibration, Subarrays B1 and F3	51
XIX	RA-5 Amplifier Gain Statistics, Subarrays B1 and F3	53

Preceding page blank

LIST OF TABLES (CONCLUDED)

<u>NUMBER</u>	<u>TITLE</u>	<u>PAGE</u>
XX	SP Channel 1-hertz Sensitivity Statistics, Dec. '70 - May '72	55
XXI	LP Type II Amplifier Gain Statistics, Dec '70 - May '72	57
XXII	LASA System Failure Detections and Corrections	61
XXIII	Equipment Failures	62
XXIV	Microbarograph Array Sensor Removal Dates	73
XXV	Work Order Summary March - May 1972	78
XXVI	SP Channel Status, 31 May 1972	81

ACRONYMS

ACC	Auxiliary Conditioning and Control
ADC	Analog to Digital Converter
AFSC	Air Force Systems Command
ARPA	Advanced Research Projects Agency
CTH	Central Terminal Housing
D/A	Digital to Analog
DCASD	Defense Contract Administration Services District
EDP	Electronic Data Processing
IRSPS	Integrated Seismic Research Signal Processing System
IPE	Industrial Plant Equipment
LASA	Large Aperture Seismic Array
LASAPS	LASA Processing Subsystem
LDC	LASA Data Center
LMC	LASA Maintenance Center
LP	Long-Period
MDC	Maintenance Display Console
MET	Meteorological Equipment
MINS	Manual Input System
MIT	Massachusetts Institute of Technology
MOIS	Multiple On-line Processing System
OPE	Other Plant Equipment
PC	Printed Circuit
PDC	Power Distribution and Control
PLINS	Phone Line Input Systems
PMEL	Precision Measurement and Equipment Laboratory

ACRONYMS (CONCLUDED)

PRBS	Pseudo-Random Binary Sequences
SAAC	Seismic Array Analysis Center
SDL	Seismic Data Laboratory
SEM	Subarray Electronics Module
SOU	Serial Output Unit
SP	Short-Period
STE	Special Test Equipment
TC	Telemetry Command
TELCO	Telephone Company
TFSO	Tonto Forest Seismological Observatory
VLR	Very Low Rate
VSC	VELA Seismological Center
WHV	Well Head Vault

SECTION I

INTRODUCTION

This report presents the accomplishments and administration of Contract Number F33657-72-C-0390. This contract between the Philco-Ford Corporation and AFSC Aeronautical Systems Division is for continued operation, research, and development of the Montana Large Aperture Seismic Array (LASA).

The LASA is part of the Vela Uniform Program which is sponsored by the Advanced Research Projects Agency (ARPA) of the Department of Defense. LASA is an experimental system consisting of many seismometers installed near Miles City, Montana, (Figure 1.1) used for the development of appropriate methods for the detection and identification of seismic events. Initially, the detection, location, and identification of seismic data were performed at the LASA Data Center (LDC) located at Billings, Montana. However, subsequent to implementation of the Integrated Seismic Research Signal Processing System (IRSPS), the array data is now transmitted to the Seismic Array Analysis Center (SAAC) in Alexandria, Va., for processing and analysis.

1.1 History

The LASA, installed in Eastern Montana during 1964 and 1965, is used for experiments in advanced seismological detection and discrimination. The initial installation, composed of 21 subarrays geometrically placed at a diameter of 200 kilometers with 525 short-period and 63 long-period seismometers, has evolved into the present array with the original 21 subarrays reduced to 347 short-period seismometers and 51 long-period seismometers.

Philco-Ford's participation in the Montana LASA began in 1964 by providing MIT Lincoln Laboratory with field engineering assistance. In June 1966, Philco-Ford assumed operational and maintenance responsibilities for MIT Lincoln Laboratory. On 1 May 1968, the project direction was transferred to the Electronics Systems Division, AFSC, with prime contracts to Philco-Ford through 30 November 1970.

On 1 December 1970, technical direction of the Montana LASA was assigned to the Vela Seismological Center (VSC). Under Projects V/T 1708 and V/T 2708 Philco-Ford continues the work of previous Montana LASA projects. This work basically involves the continued operation and maintenance of the array and data center systems, logistics and administrative support, data provision, and hardware evaluation and installation.

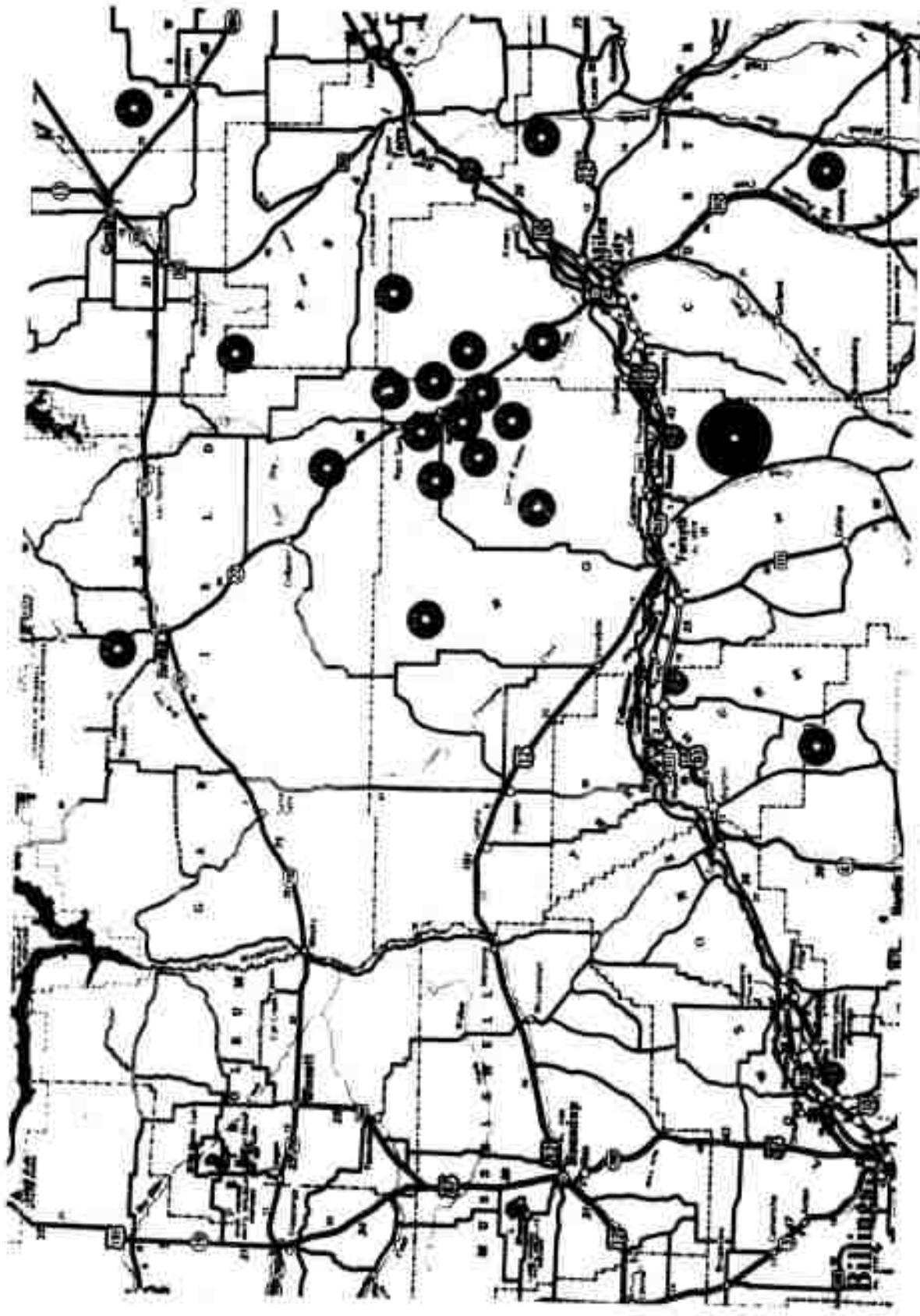

Figure 1.1 Montana LASA

1.2 Description

The LASA with an overall diameter of 200 kilometers (124 miles) is composed of 21 subarrays arranged as shown in Figure 1.1. With the exception of subarray E3 which is 19 km in diameter, all subarrays are 7 km in diameter. Subarray E3 is configured with 25 short-period seismometers while others now have 16. All subarrays originally were designed with 25 seismometers each, however, programmed sensor removal has now lowered this number to 16 except E3. The short-period seismometers are located along six radial cables which terminate in a central under-ground vault containing the Subarray Electronics Module (SEM). The subarrays also contain three-component long-period sensors, and weather sensors. Figure 1.2 shows the present configuration of each subarray.

The LDC controls the array operation by sending a command signal to each SEM at a rate of twenty times each second to cause sampling of the subarray signals. This command signal is suitably delayed at the LDC prior to transmission so that data from all SEM's will arrive at the LDC within predetermined time intervals.

The SEM responds to LDC timing system control signals with signal sampling, conversion, and transmission of all data to the LDC. Flexibility exists within the array in that the SEM can accommodate as many as 30 signal inputs; currently, signals from 21 SEM's are transmitted to microwave junction points by open wire lines at a 19.2 kilobaud rate; from these points they are sent to the LDC by microwave radio facilities. At the LDC the data are processed and reformatted for transmission over a 50 kilobaud channel to SAAC. The LDC also contains the array timing and maintenance monitoring equipment. By means of telemetry commands, signal sources at the subarray are controlled to provide equipment calibrations and verify equipment performance.

The different LASA seismographs operating parameters and tolerances are identified in Tables I and II. Figure 1.3 shows the five different seismograph responses available.

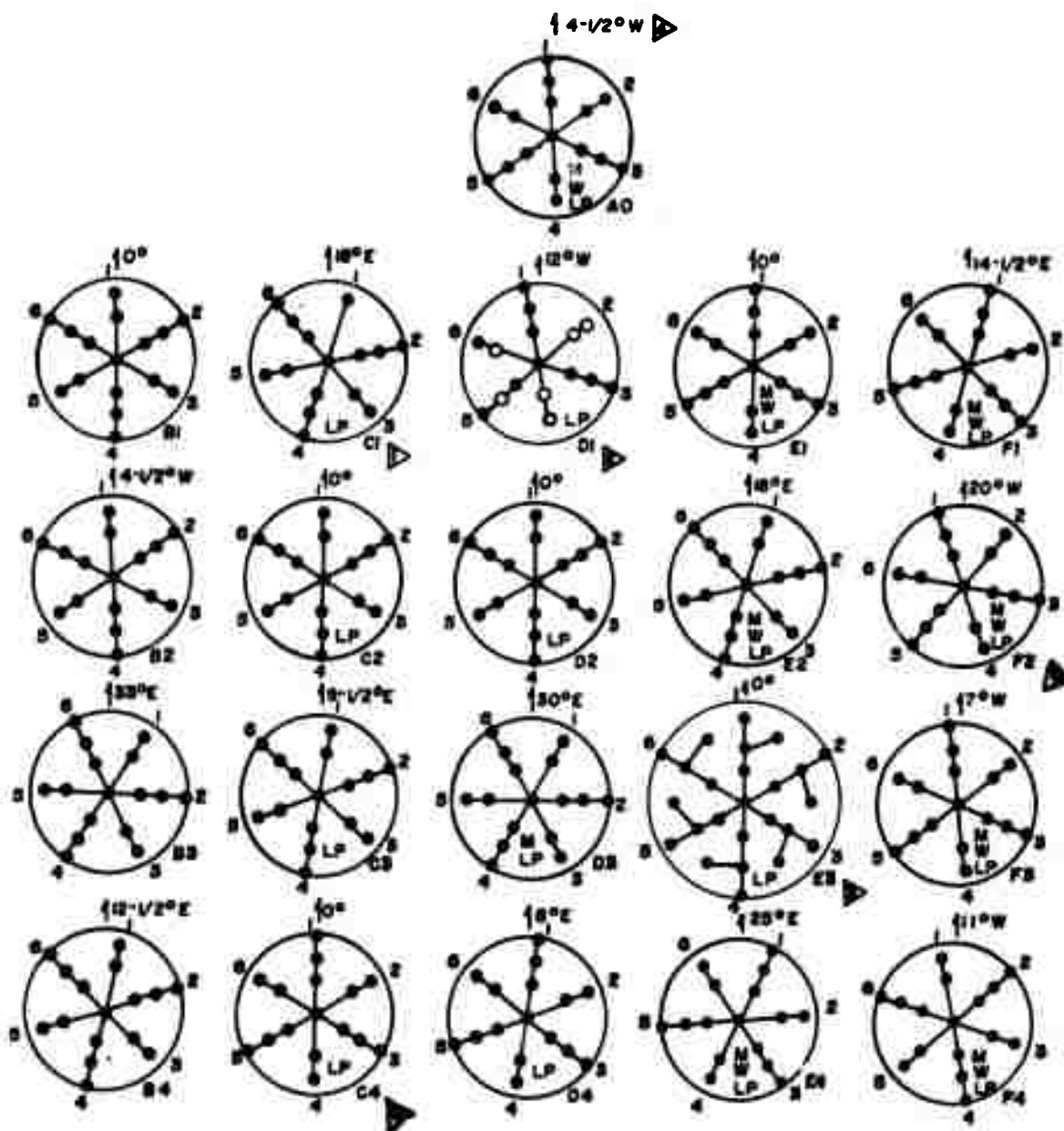

▶ Notes

1. SP Sensors removed from leg 1 because of access difficulties
2. 0 denotes near surface SP sensors
3. Expanded subarray, 18 km diameter
4. SP sensor inoperative and lost in cased hole

All degrees shown are orientations with respect to true north. The letters LP, M, and W denote long period seismic, microbarograph, and weather sensors installed at the center of the subarray. Microbarograph data was not available for transmission to SAAC after March 24, 1972.

Figure 1.2 LASA Subarray Configurations

TABLE I
LASA SEISMOGRAPH OPERATING PARAMETERS AND TOLERANCES

CHANNEL IDENT.	OPERATING PARAMETERS AND TOLERANCES				
	T _s	λ _s	(MP _s)	S _{chan}	Full Scale Within
SPZ	1.0	0.7±0.1		20±3mV/nm@1.0s	609-823nm@1.0s
SPIZ	"	"		"	"
SPTZ	1.15	0.7		"	"
SPTN	1.06	"		"	"
SPTZ	1.03	"		"	"
SPAZ	1.0	0.7±0.1		636±95mV/μm@1.0s	19.2-25.9μm@1.0s
LPZ	20.0±5%	0.77	0±1.5mm	350±50mV/μm@25s	35.0-46.7μm@25s
LPH	"	"	"	"	"
LPAZ	"	"	"	11±1.7mV/μm@25s	1102-1505μm@25s
LPAH	"	"	"	"	"
LPWZ	"	"	"	55±8.3mV/μm@25s	221-300μm@25s
LPWH	"	"	"	"	"
LEGEND:	T _s = Seismometer Free Period (Sec); λ _s = Seismometer Damping (MP _s) = Seismometer Mass Position from Center S _{chan} = Channel Sensitivity				

TABLE II
LASA SEISMOGRAPH CHANNEL IDENTIFICATION

CHANNEL	MANUFACTURER/MODEL	SEISMIC AMPLIFIER MFGR/MODEL	FILTER MFGR/MODEL/TYPE
SPZ	GeoSpace/HS-10-1A	Texas Inst./RA-5	4 pole 1/2 dB ripple Chebyshev low pass, $f_c=5.0$ hertz, @10 hertz, -30dB.
SPAZ	GeoSpace/HS-10-1A	Texas Inst./RA-5	
SPIZ	GeoSpace/HS-10-1B	Ithaco/6072-65	
SPTZ	Teledyne/TD-201D	Texas Inst./RA-5	
SPTN	Teledyne/TD-201D	Texas Inst./RA-5	
SPT E	Teledyne/TD-201D	Texas Inst./RA-5	
LPZ	Geotech/7505A	Texas Inst./Type II	
LPH	Geotech/8700C	Texas Inst./Type II	
LP AZ	Geotech/7505A	Texas Inst./Type II	
LPAH	Geotech/8700C	Texas Inst./Type II	
LPWZ	Geotech/7507A	Texas Inst./Type II	Texas Inst./Type II/Response A. 24 dB/oct high-cut, centered at 65 sec.
LPWH	Geotech/8700C	Texas Inst./Type II	

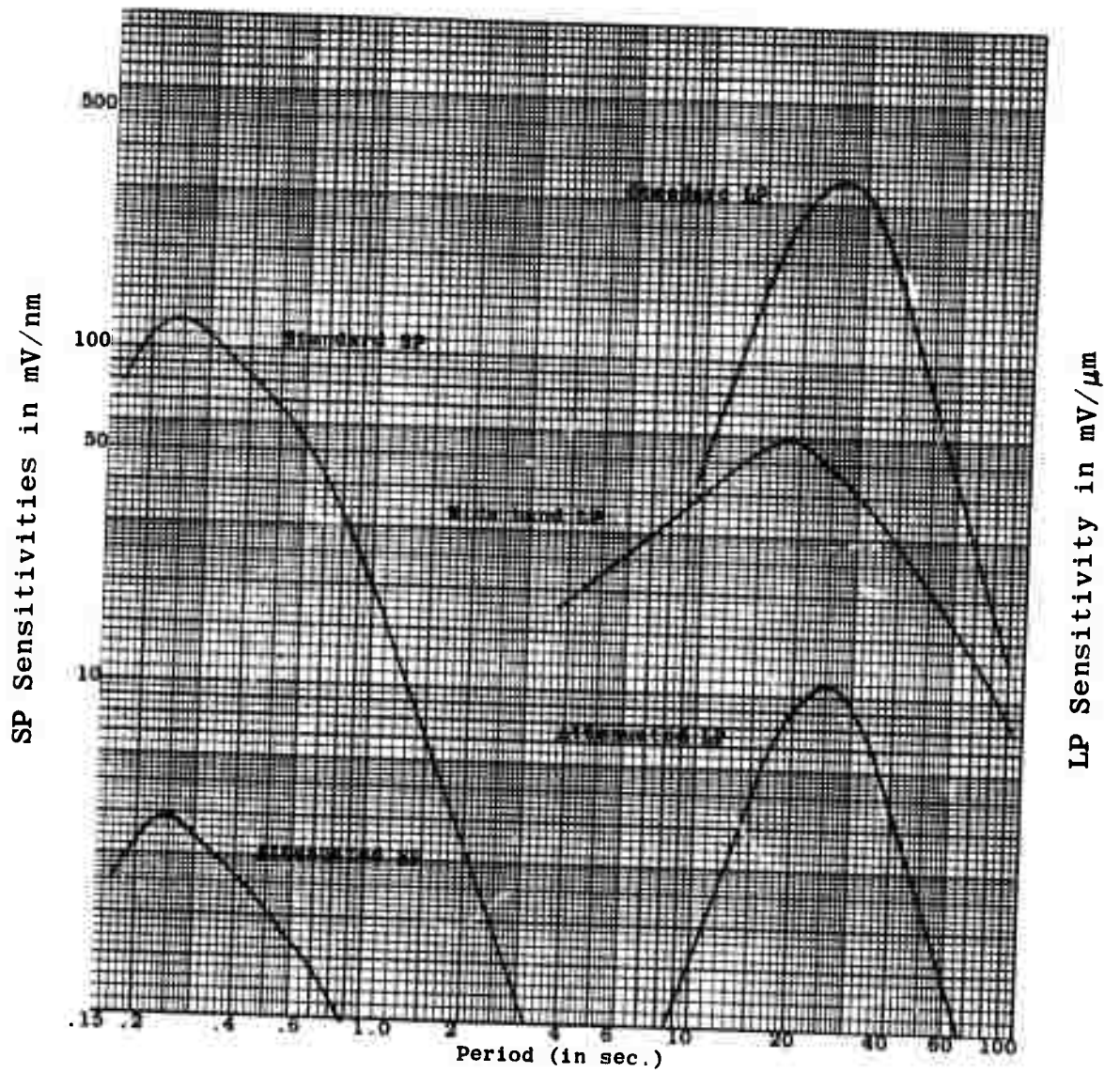

Figure 1.3 LASA Seismographs Response Curves

SECTION II

SUMMARY

The array operation, maintenance, and system improvement activities at the Montana LASA continue to reflect increased effort directed towards achieving efficient seismic array operation. The array operation support provided to SAAC via the LDC computers which totaled 94.4% for on-line data transmission and 5.6% for back-up recording is detailed.

The results of the array monitoring and remote calibrations performed are indicated. The array seismograph channel sensitivities averaged over the 92 day period were 20.5 mV/nm at 1s and 358.4 mV/ μ m at 25s for the short and long-period channels respectively. The sensitivity variation from channel to channel continues to show improvement over the previous spring period for both seismograph systems. Investigation of the performance of individual LP seismograph channels has been added to the SP seismograph study initiated last quarter. Amplitude stability of a large majority of the channels show performance within ± 2 mV/nm at 1s for the SP channels and within ± 35 mV/ μ m at 25s for the LP channels. Performance data on the SP seismometers (natural frequency, damping, and output) and the SP and LP seismic amplifiers (gain and gain stability) are presented.

A new technique using pseudo-random binary sequences (PRBS) to provide a broad band seismograph calibration is described together with a new PDP-7 program (LPRPG) and a SEM control drawer modification to permit application of an LP PRBS input to the LP seismometers.

The microbarograph sensors and instrumentation have all been removed from the array; the removal dates are given.

Maintenance activity and equipment failure statistics are presented. The array equipment aging study has shown that the replacements and repairs necessary to offset the effects of equipment aging on the array can be readily handled with very little cost by the on-going array maintenance programs.

Preceding page blank

SECTION III

OPERATION

3.1 General

Array operation is performed to provide data continuously from the array sensing and data acquisition systems to the LDC, to provide data on-line from the LDC to the SAAC, and to provide data recording in the event data transmission to SAAC is interrupted.

3.2 Data Center

The LASA Data Center (LDC) contains the equipment necessary to process the seismic array data either for transmission to SAAC or for recording locally. The activities in support of the LASAPS and other data center systems include: (1) IBM 360/44 computer operation on-line to SAAC, (2) PDP-7 computer operation to record array data in back-up of the 360 computer and to perform array monitoring, automatic calibrations, and off-line processing of array performance information, (3) maintenance display console operation for test and diagnosis of array equipment performance, (4) tape and film library operation for storage, handling, and shipment of array data recordings, (5) Develocorder operation for continuous recording of selected sensor channels for the Seismic Data Laboratory (SDL) and array quality control testing and analysis, and (6) telemetry link operation for continuous on-line data transmission of selected seismograph channels to MIT for data analysis.

3.2.1 SAAC/LDC Systems

Operation of the real-time data link between the SAAC and LDC so that a maximum amount of useful seismic data from the Montana array reaches SAAC for analysis is one of the main goals of our data center's operation. Monitoring of the SAAC/LDC operation during this quarterly period produced the operational statistics in Table III. Three operational modes which cause the outages shown are: (1) the SAAC computers are not available for LASAPS data acquisition, (2) the LDC Model 44 computer is not available for processing LASAPS data, and (3) the wideband communications channel between the LDC and SAAC is not in operation. These outage times are covered with digital recordings of the LASA data by the PDP-7 computer; however, no real time data is available at SAAC. Periods in which LASAPS data was not used in the IRSAPS operation at SAAC totaled 125.4 hours so that for 94.37% of this reporting period the SAAC/LDC systems operated together. The wideband data link between the two centers was inoperative 24.0 hours or 1.09% of the period.

Preceding page blank

TABLE III
SAAC/LDC SYSTEM OPERATING TIMES

March 72 - May 72

	MARCH	APRIL	MAY	TOTAL
SAAC & LDC 360 On-Line	706.9	674.5	701.2	2082.6
SAAC Off-Line, LDC 360 Running				
PDP-7 Recording	34.0	28.7	30.5	93.2
360 Training	0.6	0.4	0.0	1.0
SAAC Up, LDC 360 Down, PDP-7 Recording				
Scheduled	0.7	2.1	3.8	6.6
Unscheduled	0.2	0.4	0.0	0.6
SAAC Up, Other Equipment Down, PDP-7 Recording				
Scheduled	0.0	0.0	0.0	0.0
Unscheduled	1.6	13.9	8.5	24.0
Totals (in hours)	744.0	720.0	744.0	2208.0

3.2.2 IBM/360 Model 44 Computer

The IBM/360 computer, the LASAPS data processor, was fully operational at the LDC for 99.62% of this quarter. The complete computer utilization statistics are given in Table IV. On-line processing time equalled 94.30% of the period. Maintenance activities used 6.6 hours or 00.30% of the available time.

3.2.3 DEC PDP-7 Computer

The DEC PDP-7 computer was fully operational for data center processing 98.39% of this quarter of which on-line processing accounted for 81.21% off-line 17.18%. The complete summary of computer utilization statistics are shown in Table V. The back-up operating mode of high-rate recording (Ref. 1) was required on 112 occasions covering an accumulated time period of 131.5 hours. During this operation 999 magnetic tapes were recorded by the computer on 57 of the 92 days of this reporting period. Low rate recordings totaling 1046.8 hours were also made. Both low rate and high rate recordings are retained at the LDC for at least 30 days of recycle time prior to reuse.

3.2.4 Analog System

Two Geotech Model 4000 Develocorders are operated at the LDC. One is used to support data analysis work at SDL and the other to support array maintenance by providing a means to display various sensor outputs during different intervals of time. The SDL Develocorder is operated 24 hours a day and each film record is scanned in the film viewer to determine the quality of the film record and provide a log of occurrences which affect the quality and usability of the film record.

3.2.5 Tape/Film Library

The data center's library is used to store the PDP-7 computer magnetic tape recordings, the 360 computer disc recordings, and the Develocorder film recordings (prior to distribution) for reuse or reference. As of May 31, PDP-7 high-rate back-up recordings dating back to 7 April 1972 were in the library awaiting request or recycling. The library of back-up recordings presently contains 553 tapes. During this period there were no tapes returned from SAAC and 70 faulty tapes were disposed of.

The library use statistics for this quarter are:

- 999 PDP-7 high rate format tapes retained for recycling.
- 428 PDP-7 high-rate format tapes distributed to SAAC.
- 3 PDP-7 high-rate format tapes distributed to Lincoln Laboratory

TABLE IV
 SYSTEM/360 MODEL 44 COMPUTER UTILIZATION
 March 72 - May 72

OPERATION	ACCUMULATED TIME, HOURS			
	MARCH	APRIL	MAY	TOTAL
On-line processing including:				
Fully operational with SAAC	706.9	674.5	701.2	2082.6
Running at LASA only	34.0	28.7	30.5	93.2
Down-time operating including:				
Scheduled maintenance	0.7	2.1	3.8	6.6
Corrective maintenance	0.0	0.0	0.0	0.0
Training	0.6	0.4	0.0	1.0
Shut down - 360 equipment	0.0	0.0	0.0	0.0
Shut down - other equipment	1.6	13.9	8.5	24.0
Program halt or loop	0.2	0.4	0.0	0.6
Idle time	0.0	0.0	0.0	0.0
Totals	744.0	720.0	744.0	2208.0

TABLE V
PDP-7 COMPUTER UTILIZATION
March 72 - May 72

OPERATION	ACCUMULATED TIME, HOURS			
	MARCH	APRIL	MAY	TOTAL
On-line program operation including:				
Monitor & Weather Processing only	58.5	214.4	216.7	489.6
VLR Recording only	154.7	7.5	0.0	162.2
High Rate Recording only	9.8	30.9	25.9	66.6
Low Rate Recording only	83.0	299.6	349.3	731.9
VLR & High Rate Recording	28.1	0.0	0.0	28.1
VLR & Low Rate Recording	268.6	0.0	9.2	277.8
VLR & High & Low Rate Recording	0.0	0.0	0.3	0.3
High & Low Rate Recording	1.0	16.9	18.6	36.5
Off-line program operation including:				
Tape Duplication & Verification	6.4	0.0	0.0	6.4
Data Analysis	0.0	0.8	0.0	0.8
Utility Operation	24.5	8.2	13.4	46.1
Program Development	102.1	113.6	105.1	320.8
Diagnostic Programs & Testing	0.0	0.5	4.8	5.3
Training	0.0	0.0	0.0	0.0
Down-time operation including:				
Scheduled Maintenance	0.0	2.0	0.0	2.0
Corrective Maintenance	0.0	9.3	0.0	9.3
Shut down PDP-7 Inoperative	0.0	16.3	0.0	16.3
Shut down - Other Equipment	0.1	0.0	0.6	0.7
Program Halts	2.9	0.0	0.1	3.0
Idle	4.3	0.0	0.0	4.3
Totals	744.0	720.0	744.0	2208.0

- 828 PDP-7 low-rate format tapes retained for recycling
- 20 PDP-7 very low-rate tapes distributed to the Dallas Seismological Observatory
- 92 Develocorder film distributed to SAAC

3.3 Array

Array operations functions performed include (1) monitoring of all array systems to detect equipment and data degradation, (2) testing of all array systems to measure equipment performance characteristics, (3) interfacing with telephone company personnel to determine communications equipment performance, and (4) processing of array maintenance and operation data to obtain statistics and information for efficient array management. These tasks are performed utilizing the PDP-7 computer, the maintenance display console, and the Develocorders. The overall system quality control efforts are applied through these activities.

3.3.1 Monitoring

Array monitoring refers to the sensing of performance of the operational equipment through the measurement of equipment characteristics on an essentially continuous basis. At the LDC continuous monitoring of the array systems is accomplished using the built-in data monitors, viz. (1) the MDC alarm monitor panel, (2) the PDP-7 monitor program and (3) the 360 computer's on-line system. The MDC alarm monitor panel provides instantly both a visual and audible indication at the occurrence of either a data link failure between the LDC and a subarray or an alarm signal of subarray power and vault failures transmitted on telemetry word 31. The PDP-7 monitor program outputs each telemetry word 31 data change from any subarray and also prints out the duration of subarray data interruptions. The 360 computers on-line system program periodically generates a variety of monitoring messages.

Operation and maintenance of the array equipment requires that the data be interrupted at various periods, during which time normal or reliable data may not be available to the LASA data user. The reasons established for data interruptions are: maintenance, either being performed or initiated; subarray equipment failure in which no maintenance has been initiated; telephone company(s) performing tests on the communication link not functioning; power outage at the subarray; or special data center testing. In the event any of these situations occur, a notation is made in the data interruption log relating to the data affected and the time period. For the case of short-period and long-period interruptions, SAAC is alerted via the System 360 typewriter. The total duration of data interruption reported for each subarray is broken down by month in Table VI.

TABLE VI
SUBARRAY DATA INTERRUPTION OUTAGES

SUB ARRAY	DATA	TOTAL TIME DURATION OF DATA INTERRUPTIONS (HOURS:MINUTES)			
		MAR.	APR.	MAY	TOTALS
A0	SP	0:0	2:10	9:58	12:08
	LP	0:0	2:10	9:58	12:08
	Meteor	0:0	2:10	9:58	12:08
	Telco	0:0	0:0	3:37	3:37
B1	SP	0:0	3:52	5:42	9:34
	Telco	0:0	0:0	2:35	2:35
B2	SP	0:0	3:52	0:0	3:52
	Telco	0:0	0:03	0:59	1:02
B3	SP	1:51	0:0	0:0	1:51
	Telco	0:0	0:0	1:12	1:12
B4	SP	0:0	0:0	0:0	0:0
	Telco	1:00	0:16	0:35	1:51
C1	SP	0:0	0:21	0:10	0:31
	LP	0:0	0:21	0:10	0:31
	Telco	0:0	0:0	0:35	0:35
C2	SP	3:14	0:10	0:0	3:24
	LP	3:14	0:10	0:0	3:24
	Telco	0:0	0:0	2:33	2:33
C3	SP	4:42	3:10	0:0	7:52
	LP	0:40	0:10	0:0	0:50
	Telco	0:0	0:21	3:23	3:44

TABLE VI

SUBARRAY DATA INTERRUPTION OUTAGES (CONTINUED)

SUB ARRAY	DATA	TOTAL TIME DURATION OF DATA INTERRUPTIONS (HOURS:MINUTES)			
		MAR.	APR.	MAY	TOTALS
C4	SP	0:0	17:19	0:0	17:19
	LP	0:0	17:19	0:0	17:19
	Telco	0:0	0:0	5:05	5:05
D1	SP	0:0	1:38	20:13	21:51
	LP	0:0	2:43	20:13	22:56
	Telco	0:0	0:0	0:45	0:45
D2	SP	5:21	1:09	0:22	6:52
	LP	5:21	1:09	0:22	6:52
	Telco	0:0	0:0	1:30	1:30
D3	SP	0:0	0:0	3:27	3:27
	LP	0:0	0:0	3:27	3:27
	Telco	0:0	0:0	0:29	0:29
D4	SP	0:0	0:49	0:0	0:49
	LP	0:0	0:49	0:0	0:49
	Telco	0:0	1:28	1:15	2:43
E1	SP	0:0	4:42	10:48	15:30
	LP	0:0	4:42	10:48	15:30
	Meteor	0:0	4:42	10:48	15:30
	Telco	0:50	17:38	17:24	35:52
E2	SP	0:0	0:50	8:58	9:48
	LP	0:0	0:50	8:58	9:48
	Meteor	0:0	0:50	8:58	9:48
	Telco	0:0	0:58	1:30	2:28

TABLE VI
SUBARRAY DATA INTERRUPTION OUTAGES (CONCLUDED)

SUB ARRAY	DATA	TOTAL TIME DURATION OF DATA INTERRUPTIONS (HOURS:MINUTES)			
		MAR.	APR.	MAY	TOTALS
E3	SP	0:0	3:26	0:0	3:26
	LP	0:0	3:26	0:0	3:26
	Telco	0:0	9:27	2:04	11:31
E4	SP	0:0	11:45	0:0	11:45
	LP	0:0	11:45	0:0	11:45
	Meteor	0:0	11:45	0:0	11:45
	Telco	0:0	2:46	15:30	18:16
F1	SP	0:0	1:42	0:0	1:42
	LP	0:0	1:42	0:0	1:42
	Meteor	0:0	1:42	0:0	1:42
	Telco	0:0	0:0	2:20	2:20
F2	SP	0:0	0:0	15:47	15:47
	LP	0:0	0:0	15:47	15:47
	Meteor	0:0	0:0	15:47	15:47
	Telco	0:0	0:0	1:00	1:00
F3	SP	2:16	0:0	3:46	6:02
	LP	2:16	0:0	3:46	6:02
	Meteor	2:16	0:0	3:46	6:02
	Telco	0:0	0:0	1:31	1:31
F4	SP	0:0	0:0	0:0	0:0
	LP	0:0	0:0	0:0	0:0
	Meteor	0:0	0:0	0:0	0:0
	Telco	1:00	4:38	1:14	6:52

3.3.2 Calibrations

Array calibrations refer to the performance sensing of the operational equipment through the periodic measurement of one or more equipment characteristics. Calibrations are performed daily for the short-period seismographs and weekly for the long-period seismographs from the LDC. The communications links between the LDC and each subarray provide the connection necessary for the set of telemetry command (TC) controls from which the condition of the various equipment may be determined remotely. Calibration of a complete seismograph channel is provided by TC-06 for the short-period system and TC-20 for the long-period system. Normal channel responses to these sinusoidal calibrations are shown in Table VII, where A (volts) is the analog value, A (digital) is the digital value in decimal, and Y is the corresponding equivalent earth motion.

When the measured responses exceed the tolerances established for a particular channel, an equipment failure is reported. The report, the Defective Signal Channel Status is distributed each week to authorized agencies. Table VIII indicates the incidence of defective channels detected during the three-month period for the three types of array channels.

The precise times in which array calibrations occur are readily available from the PDP-7 computer's MOPS on-line monitor program output. A report of these times for this quarterly period is shown in Table IX and X for the SP and LP sensors respectively. For the short-period calibrations only one calibration time is shown in Table IX for each week; the daily times are available at the LDC. The equivalent earth motion of the calibration input signals to the seismometers are also shown in the two tables. Equivalent earth motion is determined from SEM channel 30 measurements during the calibration times. SEM channel 30 monitors the output of the sinusoidal oscillators which generate the signals applied to the seismometer.

Another calibration is the remote measurement/adjustment of the long-period seismometer positioning performed by the PDP-7 computer. Using the appropriate telemetry commands, the PDP-7 computer controls on a weekly basis both the measurement and adjustment of each LP seismometer position. Program MASPOS maintains each seismometer mass to within ± 1.4 mm from its center position. Similarly, the seismometer natural frequencies are maintained to within 20 ± 1 sec/cycle by program FREECK. The number of these remote adjustments performed for each subarray is shown in Table VIII where the quantities in parenthesis indicate the out-of-tolerance measurements of seismometer mass position (118) and free-period (24) which were corrected remotely by telemetry. In one instance, the E/W seismometer at subarray C2 could not be adjusted remotely from the LDC and required on-site maintenance action to recenter.

TABLE VII
LASA SEISMOGRAPH CALIBRATION RESPONSE TOLERANCES

CHANNEL IDENT.	TC	Peak-to-Peak Sinusoidal Amplitudes									
		Anom Volts	Amax Volts	Amin Volts	Anom Digital	Amax Digital	Amin Digital	Y _{nom}	Y _{max}	Y _{min}	
SPZ	06 ¹	7.91	9.09	6.72	9257	10638	7864	395nm	455nm	336nm	
SPAZ	06 ¹	.25	.289	.214	293	407	236	395nm	455nm	336nm	
SPIZ	06 ¹	7.91	9.09	6.72	9257	10638	7864	395nm	455nm	336nm	
SPTZ	06 ¹	7.91	9.09	6.72	9257	10638	7864	395nm	455nm	336nm	
SPTN	06 ¹	7.91	9.09	6.72	9257	10638	7864	395nm	455nm	336nm	
SPTN	06 ¹	7.91	9.09	6.72	9257	10638	7864	395nm	455nm	336nm	
SPTN	06 ¹	7.91	9.09	6.72	9257	10638	7864	395nm	455nm	336nm	
SPTN	06 ¹	7.91	9.09	6.72	9257	10638	7864	395nm	455nm	336nm	
LPZ	20 ²	6.98	7.98	5.99	8168	9339	7010	20.0μm	22.8μm	17.1μm	
LPH	20 ²	6.98	7.98	5.99	8168	9339	7010	20.0μm	22.8μm	17.1μm	
LPZ	20 ³	2.77	3.19	2.34	3242	3733	2738	252μm	290μm	213μm	
LPAH	20 ³	2.77	3.19	2.34	3242	3733	2738	252μm	290μm	213μm	
LPWZ	20 ²	1.10	1.26	0.93	1287	1475	1088	20.0μm	22.9μm	16.9μm	
LPWH	20 ²	1.10	1.26	0.93	1287	1475	1088	20.0μm	22.9μm	16.9μm	

Note 1. Amplitude measurements corrected for response to 400nm, 1s calibration signal.
 2. Amplitude measurements corrected for response to 20μm, 25s calibration signal.
 3. Amplitude measurements corrected for response to 222μm, 25s calibration signal.

TABLE VIII
INCIDENCE OF DEFECTIVE SUBARRAY CHANNELS
 March 1972 - May 1972

SUBARRAY	CHANNELS		
	SP	LP	METEOR
A0	3	1 (8)	0
B1	4	-	-
B2	3	-	-
B3	2	-	-
B4	1	-	-
C1	1	5 (9)	-
C2	3	0 (13)	-
C3	3	0 (11)	-
C4	2	0 (3)	-
D1	5	0 (9)	-
D2	3	0 (9)	-
D3	1	0 (6)	-
D4	3	0 (10)	-
E1	1	0 (7)	1
E2	2	2 (7)	0
E3	3	0 (7)	-
E4	6	0 (11)	0
F1	3	1 (10)	0
F2	4	0 (11)	0
F3	6	0 (6)	0
F4	1	0 (5)	0
TOTALS	60	9 (142)	1

TABLE IX

SP ARRAY SINUSOIDAL CALIBRATIONS

S U B A R R A Y	Short-Period Array Sinusoidal Calibration Signal Start Times and Amplitudes				S U B A R R A Y					
	Day 066 6 Mar. 72	Day 073 13 Mar. 72	Day 080 20 Mar. 72	Day 087 27 Mar. 72		Day 094 3 Apr. 72				
	Start Time (GMT)	P-P Ampl. nm	Start Time (GMT)	P-P Ampl. nm	Start Time (GMT)	P-P Ampl. nm				
AO	1914:04	445	1607:08	446	1522:17	444	1621:09	443	1545:40	443
B1	1914:34	405	1607:38	404	1522:47	404	1621:39	405	1546:10	405
B2	1915:04	406	1608:08	414	1523:17	410	1622:09	412	1546:40	417
B3	1915:34	421	1608:38	421	1523:47	418	1622:39	422	1547:10	422
B4	1916:04	403	1609:08	404	1524:17	401	1623:09	405	1547:40	405
C1	1916:34	400	1609:38	400	1524:47	400	1623:39	393	1548:10	400
C2	1917:04	414	1610:08	413	1525:17	410	1624:09	410	1548:40	405
C3	1917:34	404	1610:38	404	1525:47	403	1624:39	404	1549:10	404
C4	1918:04	395	1611:08	394	1526:17	396	1625:09	396	1549:40	395
D1	1918:34	408	1611:38	408	1526:47	407	1625:39	405	1550:10	407
D2	1919:04	386	1612:08	386	1527:17	387	1626:09	387	1550:40	382
D3	1919:34	388	1612:38	388	1527:47	391	1626:39	388	1551:10	387
D4	1920:04	414	1613:08	413	1528:17	410	1627:09	411	1551:40	412
E1	1920:34	416	1613:38	413	1528:47	413	1627:39	413	1552:10	415
E2	1921:04	423	1614:08	422	1529:17	422	1628:09	422	1552:40	422
E3	1921:34	400	1614:38	404	1529:47	404	1628:39	400	1553:10	404
E4	1922:04	417	1615:08	417	1530:17	417	1629:09	416	1553:40	418
F1	1922:34	407	1615:38	405	1530:47	404	1629:39	403	1554:10	398
F2	1923:04	408	1616:08	410	1531:17	410	1630:09	410	1554:40	410
F3	1923:34	418	1616:38	418	1531:47	417	1630:39	417	1555:10	417
F4	1924:04	406	1617:08	415	1532:17	415	1631:09	416	1555:40	415

TABLE IX
 SP ARRAY SINUSOIDAL CALIBRATIONS (CONTINUED)

S U B A R R A Y	Short-Period Array Sinusoidal Calibration Signal Start Times and Amplitudes				S U B A R R A Y					
	Day 101 10 Apr. 72	Day 108 17 Apr. 72	Day 115 24 Apr. 72	Day 122 1 May 72		Day 129 8 May 72				
	Start Time (GMT)	P-P Ampl. nm	Start Time (GMT)	P-P Ampl. nm	Start Time (GMT)	P-P Ampl. nm	Start Time (GMT)	P-P Ampl. nm		
AO	1501:55	440	1518:49	441	1303:40	440	1513:50	442	1502:04	440
B1	1502:25	405	1519:19	405	1304:10	404	1514:20	405	1502:34	405
B2	1502:55	411	1519:49	410	1304:40	413	1514:50	410	1503:04	414
B3	1503:25	420	1520:19	420	1305:10	416	1515:20	417	1503:34	414
B4	1503:55	404	1520:49	405	1305:40	407	1515:50	406	1504:04	404
C1	1504:25	400	1521:19	400	1306:10	401	1516:20	401	1504:34	401
C2	1504:55	407	1521:49	406	1306:40	406	1516:50	406	1505:04	405
C3	1505:25	404	1522:19	404	1307:10	404	1517:20	404	1505:34	404
C4	1505:55	396	1522:49	397	1307:40	396	1517:50	396	1506:04	398
D1	1506:25	408	1523:19	407	1308:10	408	1518:20	408	1506:34	408
D2	1506:55	387	1523:49	388	1308:40	388	1518:50	388	1507:04	388
D3	1507:25	391	1524:19	393	1309:10	393	1519:20	393	1507:34	393
D4	1507:55	407	1524:49	407	1309:40	407	1519:50	407	1508:04	406
E1	1508:25	413	1525:19	413	1310:10	410	1520:20	412	1508:34	414
E2	1508:55	422	1525:49	422	1310:40	422	1520:50	422	1509:04	422
E3	1509:25	405	1526:19	405	1311:10	405	1521:20	405	1509:34	406
E4	1509:55	416	1526:49	417	1311:40	417	1521:50	417	1510:04	414
F1	1510:25	405	1527:19	405	1312:10	402	1522:20	404	1510:34	403
F2	1510:55	410	1527:49	410	1312:40	410	1522:50	408	1511:04	410
F3	1511:25	417	1528:19	416	1313:10	417	1523:20	417	1511:34	416
F4	1511:55	416	1528:49	417	1313:40	416	1523:50	416	1512:04	417

TABLE IX
SP ARRAY SINUSOIDAL CALIBRATIONS (CONCLUDED)

S U B A R R A Y	Short-Period Array Sinusoidal Calibration Signal Start Times and Amplitudes			S U B A R R A Y		
	Day 136 15 May 72	Day 143 22 May 72	Day 150 29 May 72			
	Start Time (GMT)	P-P Ampl. nm	Start Time (GMT)	P-P Ampl. nm	Start Time (GMT)	P-P Ampl. nm
AO	1449:50	438	1527:22	400	1303:27	398
B1	1450:20	404	1527:52	405	1303:57	405
B2	1450:50	411	1528:22	410	1304:27	415
B3	1451:20	413	1528:52	410	1304:57	412
B4	1451:50	408	1529:22	408	1305:27	408
C1	1452:20	401	1529:52	401	1305:57	401
C2	1452:50	404	1530:22	402	1306:27	402
C3	1453:20	404	1530:52	404	1306:57	404
C4	1453:50	395	1531:22	398	1307:27	386
D1	1454:20	408	1531:52	407	1307:57	407
D2	1454:50	388	1532:22	390	1308:27	390
D3	1455:20	395	1532:52	397	1308:57	397
D4	1455:50	403	1533:22	400	1309:27	400
E1	1456:20	413	1533:52	411	1309:57	406
E2	1456:50	422	1534:22	421	1310:27	422
E3	1457:20	405	1534:52	407	1310:57	407
E4	1457:50	414	1535:22	415	1311:27	414
F1	1458:20	402	1535:52	401	1311:57	401
F2	1458:50	410	1536:22	410	1312:27	410
F3	1459:20	415	1536:52	414	1312:57	414
F4	1459:50	418	1537:12	418	1313:27	418

TABLE X

LP ARRAY SINUSOIDAL CALIBRATIONS

S U B A R R A Y	Long-Period Array Sinusoidal Calibration Signal Times and Input Amplitude						S U B A R R A Y			
	Day 066: 6 Mar. 72		Day 073: 13 Mar. 72		Day 080: 20 Mar. 72					
	Start Time (GMT)	Stop Time (GMT)	Input Ampl. μ m P-P	Start Time (GMT)	Stop Time (GMT)	Input Ampl. μ m P-P				
AO	1951:55	1954:55	20.2	1632:22	1635:22	20.4	1824:00	1827:00	20.3	AO
C1	"	"	19.9	"	"	21.2	"	"	20.4	C1
C2	1959:56	2002:56	268	1640:22	1643:22	263	1640:22	1643:22	270	C2
C3	"	"	20.2	"	"	20.2	"	"	20.2	C3
C4	2007:56	2010:56	20.8	1648:22	1651:22	21.1	1648:22	1843:00	20.5	C4
D1	"	"	20.7	"	"	20.5	"	"	20.3	D1
D2	2015:56	2018:56	20.5	1656:23	1659:23	20.5	1656:23	1851:01	20.6	D2
D3	"	"	20.7	"	"	21.0	"	"	21.1	D3
D4	2023:56	2026:56	21.0	1704:23	1707:23	21.0	1704:23	1859:01	21.0	D4
E1	"	"	19.9	"	"	19.8	"	"	19.9	E1
E2	2031:56	2034:56	20.6	1712:23	1715:23	20.5	1712:23	1907:01	20.6	E2
E3	"	"	20.4	"	"	20.3	"	"	20.0	E3
E4	2039:56	2042:56	19.9	1720:23	1723:23	20.4	1720:23	1915:01	19.7	E4
F1	"	"	20.4	"	"	20.5	"	"	20.5	F1
F2	2047:56	2050:56	21.0	1728:23	1731:23	21.0	1728:23	1923:01	21.1	F2
F3	"	"	19.8	"	"	20.4	"	"	20.5	F3
F4	2055:57	2058:57	19.4	1736:23	1739:23	19.5	1736:23	1931:01	20.2	F4

TABLE X
LP ARRAY SINUSOIDAL CALIBRATIONS (CONTINUED)

S U B A R R A Y	Long-Period Array Sinusoidal Calibration Signal Times and Input Amplitude						S U B A R R A Y		
	Day 087: 27 Mar. 72		Day 094: 3 Apr. 72		Day 101: 10 Apr. 72				
	Start Time (GMT)	Stop Time (GMT)	Input Ampl. μ m P-P	Start Time (GMT)	Stop Time (GMT)	Input Ampl. μ m P-P			
AO	1715:27	1728:27	20.3	1623:30	1626:31	20.3	1636:50	1639:50	20.1
C1	"	"	20.0	"	"	20.0	"	"	20.8
C2	1723:27	1726:27	270	1631:31	1634:31	266	1644:50	1647:50	269
C3	"	"	20.1	"	"	20.2	"	"	20.2
C4	1731:27	1734:27	20.9	1639:31	1642:31	21.1	1652:50	1655:50	20.8
D1	"	"	20.3	"	"	21.0	"	"	20.8
D2	1739:27	1742:27	20.6	1647:31	1650:31	20.5	1700:50	1703:50	20.5
D3	"	"	20.7	"	"	21.0	"	"	20.9
D4	1747:28	1750:28	21.2	1655:31	1658:31	21.0	1708:50	1711:50	21.0
E1	"	"	19.8	"	"	19.9	"	"	19.9
E2	1755:28	1758:28	20.7	1703:31	1706:31	20.8	1716:50	1719:50	20.7
E3	"	"	20.2	"	"	20.1	"	"	20.8
E4	1803:28	1806:28	20.3	1711:31	1714:31	19.9	1724:50	1727:50	20.5
F1	"	"	20.6	"	"	20.4	"	"	20.5
F2	1811:28	1814:28	21.1	1719:32	1722:32	21.1	1732:51	1735:51	21.1
F3	"	"	20.5	"	"	19.8	"	"	20.5
F4	1819:28	1822:28	20.1	1727:32	1730:32	20.2	1740:51	1743:51	19.5

TABLE X

LP ARRAY SINUSOIDAL CALIBRATIONS (CONTINUED)

S U B A R R A Y	Long-Period Array Sinusoidal Calibration Signal Times and Input Amplitude						S U B A R R A Y			
	Day 108: 17 Apr. 72		Day 115: 24 Apr. 72		Day 122: 1 May 72					
	Start Time (GMT)	Stop Time (GMT)	Input Ampl. μ m P-P	Start Time (GMT)	Stop Time (GMT)	Input Ampl. μ m P-P				
AO	1540:33	1543:33	20.3	1653:08	1656:08	20.4	1526:01	1529:01	20.4	AO
C1	"	"	21.3	"	"	21.1	"	"	20.7	C1
C2	1548:33	1551:33	261	1701:08	1704:08	262	"	"	266	C2
C3	"	"	20.2	"	"	20.2	"	"	"	C3
C4	1556:33	1559:33	21.3	1709:09	1712:09	20.7	"	"	20.2	C4
D1	"	"	20.4	"	"	20.3	"	"	20.5	D1
D2	1604:33	1607:33	20.6	1717:09	1720:09	20.5	"	"	20.3	D2
D3	"	"	21.0	"	"	20.5	"	"	20.5	D3
D4	1612:34	1615:34	21.0	1725:09	1728:09	20.9	"	"	20.5	D4
E1	"	"	19.9	"	"	19.9	"	"	19.9	E1
E2	1620:34	1623:34	20.8	1733:09	1736:09	20.4	"	"	20.6	E2
E3	"	"	20.6	"	"	20.1	"	"	20.6	E3
E4	1628:34	1631:34	20.0	1741:09	1744:09	20.3	"	"	20.6	E4
F1	"	"	20.4	"	"	20.5	"	"	20.2	F1
F2	1636:34	1639:34	21.0	1749:09	1752:09	21.1	"	"	20.4	F2
F3	"	"	19.9	"	"	20.3	"	"	21.0	F3
F4	1644:34	1647:34	20.2	1757:10	1800:10	19.5	"	"	20.1	F4
									20.2	

TABLE X
LP ARRAY SINUSOIDAL CALIBRATIONS (CONTINUED)

S U B A R R A Y	Long-Period Array Sinusoidal Calibration Signal Times and Input Amplitude			S U B A R R A Y		
	Day 129: 8 May 72		Day 136: 1. May 72			
	Start Time (GMT)	Stop Time (GMT)	Input Ampl. μ m P-P	Start Time (GMT)	Stop Time (GMT)	Input Ampl. μ m P-P
AO	1515:22	1518:22	20.2	1502:42	1505:42	20.4
C1	"	"	20.5	"	"	20.8
C2	1523:22	1526:22	270	1510:42	1513:42	271
C3	"	"	20.2	"	"	20.2
C4	1531:23	1534:23	21.1	1518:42	1521:43	20.8
D1	"	"	20.4	"	"	20.9
D2	1539:23	1542:23	20.6	1526:43	1529:43	20.6
D3	"	"	21.2	"	"	20.9
D4	1547:23	1550:23	21.1	1534:43	1537:43	20.9
E1	"	"	20.0	"	"	19.9
E2	1555:23	1558:23	19.9	1542:42	1545:43	20.7
E3	"	"	20.1	"	"	20.3
E4	1603:23	1606:23	20.0	1550:43	1553:43	20.3
F1	"	"	20.4	"	"	20.3
F2	1611:23	1614:23	21.0	1558:43	1601:43	21.1
F3	"	"	20.5	"	"	20.4
F4	1619:23	1622:23	20.2	1606:43	1609:43	19.5

TABLE X

LP ARRAY SINUSOIDAL CALIBRATIONS (CONCLUDED)

S U B A R R A Y	Long-Period Array Sinusoidal Calibration Signal Times and Input Amplitude				S U B A R R A Y	
	Day 143: 22 May 72		Day 150: 29 May 72			
	Start Time (GMT)	Stop Time (GMT)	Input Ampl. μ m P-P	Start Time (GMT)	Stop Time (GMT)	Input Ampl. μ m P-P
AO	1541:01	1544:01	20.4	1528:10	1531:11	20.2
C1	"	"	20.2	"	"	20.7
C2	1549:01	1552:01	265	1536:11	1539:11	267
C3	"	"	20.3	"	"	20.2
C4	1557:01	1600:02	20.8	1544:11	1547:11	21.1
D1	"	"	20.6	"	"	20.5
D2	1605:02	1608:02	20.6	1552:11	1555:11	20.6
D3	"	"	21.2	"	"	21.1
D4	1613:02	1616:02	21.1	1600:11	1603:11	21.2
E1	"	"	19.9	"	"	20.2
E2	1621:02	1624:02	20.0	1608:11	1611:11	20.3
E3	"	"	20.4	"	"	20.6
E4	1629:02	1632:02	19.7	1616:11	1619:11	19.7
F1	"	"	20.5	"	"	20.4
F2	1637:02	1640:02	21.0	1624:12	1627:12	21.1
F3	"	"	19.9	"	"	20.4
F4	1645:02	1648:02	20.2	1632:12	1635:12	19.5

3.3.3 Communications

The interface between array and data center provided by the communications systems plays an important part in the success of the array operation. Determination of data interruptions due to telephone circuit outages is one responsibility of the LDC operations activity. All outages reported by data center personnel are assigned a ticket number to aid in accounting for and identifying of the data interruption. Weekly meetings are held with the telephone company, viz., Mountain Bell and Mid-Rivers, personnel to review and describe all outages.

For the period between March and May 1972, the communications outages which exceeded a two-hour duration and the reasons attributed to the outages are listed in Table XI. Wind and rain storms in the array were the chief source of circuit outages.

Of interest are the outages shown for subarrays E1 and F4 which are still under investigation. In addition to the times listed, several short duration outages have occurred at these subarrays. Due to the intermittent nature of the outages, maintenance diagnosis has been difficult both on the part of the LASA and the telephone companies crews. The trouble has been observed most frequently at subarray E1. Here, the SEM output multiplexer, and MODEM assemblies have been replaced and installed in other subarrays to help locate the trouble source. Filters and other telco equipment have also been exchanged. To date, however, no success has been achieved in eliminating this intermittent trouble. This trouble indicates the problems involved in isolating intermittent troubles which occur in the communications circuits between the subarrays and the data center.

3.4 Logistics

The logistics activity of the Montana array supports the operation and is divided into purchasing, property, and material. All operations were supported with a minimum of equipment down time. Thirty-two purchase orders were released to effect continuous array operation. The inventory presently contains 354 line items of property (IPE, STE, OPE). This reflects a decrease of 42 line items due to the incorporation of assembly items into end items on the EDP record system. Approximately 1700 line items of material are maintained.

TABLE XI
EXTENDED ARRAY DATA INTERRUPTIONS
DUE TO COMMUNICATIONS OUTAGES

DATE	DURATION	SITE	REASON FOR OUTAGE
04/10/72	4:38	F4	Open wire trouble near subarray
04/19/72	9:27	E3	Open wire lines crosses near subarray
05/05/72	2:20	F1	Open wire trouble near subarray
05/09/72	2:59	A0	Release for Telco maintenance
05/17/72	2:05	E1	Storm in array
05/17/72	2:05	E4	Storm in array
05/19/72	3:05	E1	Storm in array
05/19/72	3:05	E4	Storm in array
05/19/72	3:35	C4	Storm in array
05/20/72	2:00	E4	No trouble found; under investigation
05/20/72	2:00	E1	No trouble found; under investigation
05/25/72	2:06	E4	No trouble found; under investigation
05/25/72	2:06	E1	No trouble found; under investigation

SECTION IV

ARRAY PERFORMANCE

4.1 Systems

The overall performance measure applied to each of the array's sensor systems is the array data availability. The percentage of time the array systems are on-line providing quality data determine the value of this measure. Data availabilities are calculated by combining the total subarray data interruption times shown in Table VI with the total sensor outage times reported on the Defective Signal Channel Status reports. The data availabilities compared with those of previous periods are as follows:

	<u>2nd Quarter</u>	<u>Previous 2nd Quarter</u>	<u>Previous Contract</u>
SP	95.38	96.3	96.7
LP	97.43	98.9	98.6
Met	98.91	98.9	99.2

Telephone circuit and power outages which affect all subarray systems are not included in the percentages. During this quarterly period the listed data availabilities were further reduced by 0.23% by the telco outages.

4.1.1 SP Seismograph

The performance monitoring from the sinusoidal calibrations of the 345 short-period seismograph channels during this three month period has indicated an average channel sensitivity of 20.54 mV/nm at 1 second periods and an average standard deviation of 1.33. A summary of the test results obtained each week is shown in Table XII where the statistics are compared with those of the previous contract and those of the previous March - May period. The SP array maintenance programs continue to reflect increases in the amplitude stability of the SP seismographs. This is further illustrated by the distribution of SP sensors within the $\pm 15\%$ sensitivity tolerance plotted in Figure 4.1. This figure shows the weekly percentages of sensors within the tolerance since 30 March 1970. The cyclic variation that occurs with the seasonal temperature changes is increasingly more apparent.

Measurement of the SP channel frequency response by subarray continued with the collection of response data from 79 sensors at five subarrays this quarter. Shown in Figure 4.2 are the plots of the mean, the minimum, and the maximum responses of the SP sensors of the array as measured during the period May 19, 1970 through May 22, 1972. These curves are calculated using equation 4-1 of reference 7. Values of A, i, and T were

TABLE XII
SP ARRAY PERFORMANCE TESTING SENSITIVITY STATISTICS

DATE	NO. SENSORS	SENS. MEAN mV/nm	SENS. σ mV/nm	SENS. MAX. mV/nm	SENS. MIN. mV/nm	SENS. DEV. mV/nm
3/6	342	20.32	1.53	25.34	12.68	12.66
3/13	344	20.45	1.48	24.10	13.88	10.22
3/20	341	20.64	1.38	25.08	12.95	12.13
3/27	325	20.40	1.47	24.46	11.17	13.29
4/3	339	20.42	1.46	23.76	11.22	12.54
4/10	342	20.63	1.34	23.37	13.10	10.27
4/17	342	20.61	1.30	25.16	10.47	14.69
4/24	341	20.65	1.26	24.86	10.91	13.95
5/1	341	20.70	1.25	25.19	11.25	13.94
5/8	342	20.66	1.23	24.96	11.27	13.69
5/15	342	20.54	1.21	25.88	16.22	9.66
5/22	344	20.47	1.19	25.89	10.00	15.89
5/29	343	20.56	1.21	25.13	16.45	8.68
AVERAGE	325.23	20.54	1.33	24.86	12.43	12.43
PREVIOUS 2ND QTR. AVERAGE	338.4	20.7	1.82	26.9	9.9	17.0
CONTRACT AVERAGE	334.23	20.38	1.46	24.17	13.44	10.73
PREVIOUS CONTRACT AVERAGE	343.9	20.36	1.69	26.5	12.7	13.8

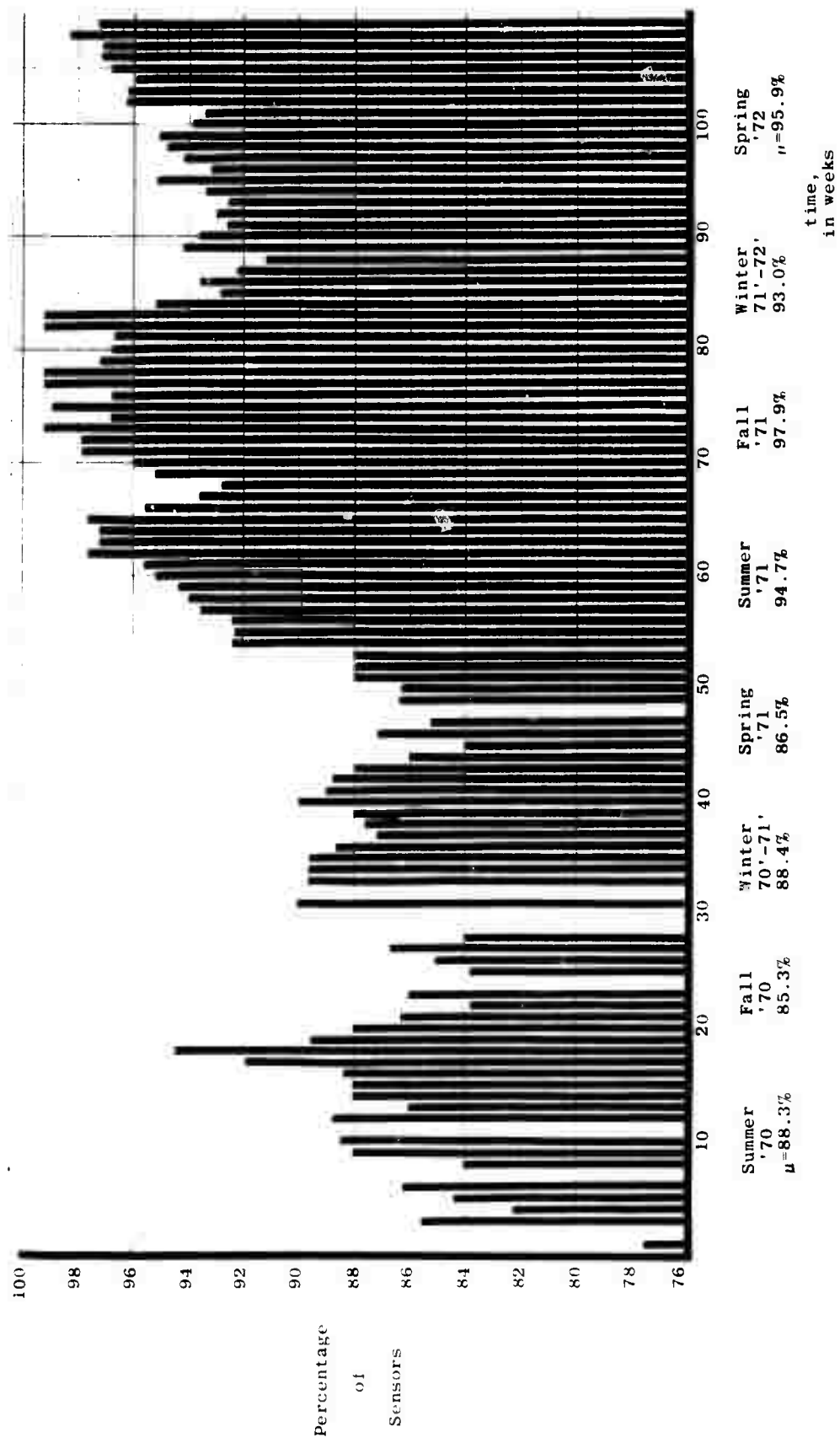

4.1 Percentage Distribution of SP Sensors in $\pm 15\%$ Sensitivity Tolerance

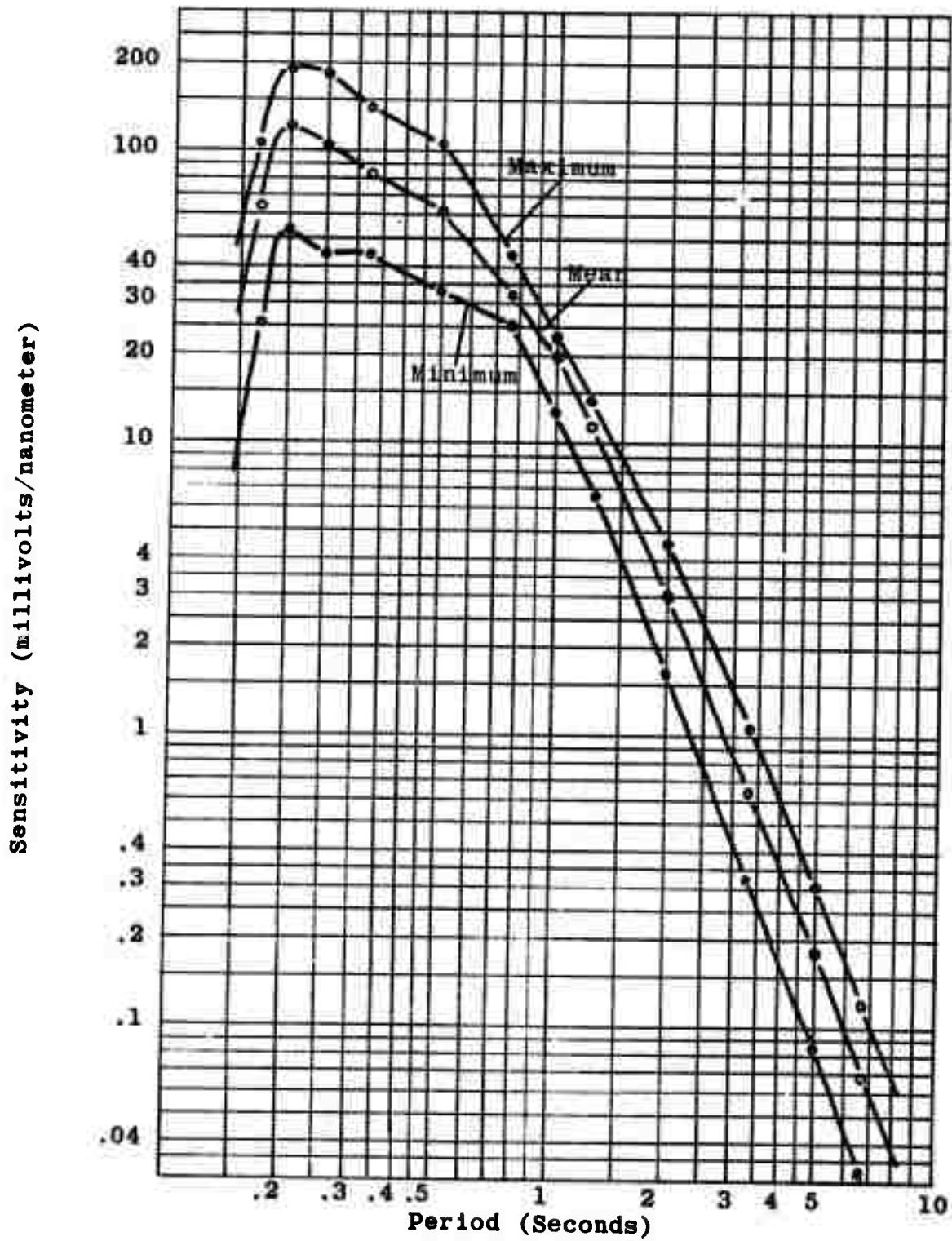

Figure 4.2 LASA SP Sensor Period vs Sensitivity Response Curves

measured while G_c and M assumed nominal values. Table XIII shows the average channel sensitivities for each of the 16 frequencies used in the frequency response measurement. Individual plots are prepared to display the frequency response of each SP seismograph channel and to assist maintenance quality control in determining channel malfunctions (see Table XXVI).

To determine the individual channel stability of the SP seismograph, 86 sensors were selected to receive special study (Ref. 2). Six of the sensors were picked at random from subarray E3 and four were randomly sampled from each of the other 20 subarrays. The sensitivities of each of these 86 channels since 1 November 1971 have been obtained from the daily printout of program TESP. At the end of each month a standard deviation of the sensitivity is calculated for each channel. Table XIII summarizes this information.

Assuming the distribution of the sensitivity of an individual channel is normal or at least can be approximated by a normal distribution, Table XIV shows that in the large majority of cases the measured sensitivity of a channel will be within 1 mV/nm of the mean sensitivity. The variation in the percentage is attributed to two factors, viz. temperature variation and incidence of amplifier failures over the array during the month. This has not been verified yet; however, such analysis is a planned part of this study.

The total number of SP seismograph channel outputs from the array has been reduced by one to 366. The operation of one SP sensor was discontinued on April 18. During maintenance at location C4-63 the seismometer was found to be lodged in the cased bore and could not be removed. Installation of another seismometer on top of the defective one, as in the case of F1-45, could not be done because of the seismometer cable broken about 10-15 feet below the surface does not allow sufficient space in the $5\frac{1}{2}$ inch hole.

The 366 SP seismograph channels originate from 346 individual seismometers, twenty channels are attenuated outputs of twenty of the 346 seismometer locations. Twelve of the 346 seismometers vary somewhat from the configuration of the initial LASA installation. These are at subarray D2 where three channels are derived from a TD-202 Tri-Axial seismometer in hole 10, and three channels are from high level combination seismometer-amplifier sensors at holes 62, 23 and 46 and at subarray D1 where six channels originate in near-surface seismometers at holes 52, 72, 54, 74, 65, and 56.

4.1.2 LP Seismograph

The performance monitoring of the 45 standard LASA LP long-period sensors continued during the quarterly period following the procedures of the previous contract. A channel sensitivity average of 358.39 mV/ μ m at 25s and a standard deviation of 14.77

TABLE XIII

SP SEISMOGRAPH FREQUENCY RESPONSE MEASUREMENT DATA

FREQUENCY HERTZ	SENSITIVITY mV/nm
0.15	0.0708
0.20	0.183
0.30	0.651
0.50	3.10
0.70	8.04
0.80	11.5
0.90	15.9
1.00	20.0
1.10	24.5
1.20	29.1
1.30	33.5
2.0	60.5
3.0	83.8
4.0	105.6
5.0	121.2
6.0	63.4
Number channels - 346	

TABLE XIV
 A DISTRIBUTION OF THE STANDARD DEVIATIONS OF 86 LASA SP CHANNELS

	MEAN S In mV/nm	MAXIMUM S In mV/nm	MINIMUM S In mV/nm	% <.3333 mV/nm
Nov. 71	0.1831	1.072	0.0570	95.3
Dec. 71	0.2236	1.945	0.0277	86.0
Jan. 72	0.2902	1.306	0.0807	73.3
Feb. 72	0.2559	1.690	0.0630	80.2
Mar. 72	0.3075	2.050	0.0849	70.6
Apr. 72	0.2030	3.007	0.0415	93.0

is reported from these seismographs for the three month period. The weekly test results obtained are shown in Table XV where this quarter's statistics are summarized and compared with those of the previous contract and those of the previous December - February period.

Plotted in Figure 4.3 is the percentage distribution of the LP sensors within the 350 ± 50 mV/ μ m sensitivity tolerance throughout the 18 month period starting 8 December 1970 through 31 May 1972.

To determine the channel stability of the LP seismograph the 45 channels of the 15 standard LASA-LP sensors are being studied individually. Shown in Table XVI are the sensitivity statistics of the data collected each week of the 31-week period from 1 November 1971 through 31 May 1972. The standard deviation of the channel sensitivity is used to measure the week-to-week variation or stability of the channel output to electromagnetic calibration. The average of the 45 standard deviations calculated for the period is 11.53 mV/ μ m or 11.5% of the ± 50 mV/ μ m tolerance. The best performance was obtained from the vertical channel of the C3 LP seismograph with a 4.59 mV/ μ m standard deviation. The vertical channel at subarray F1 had a sensitivity standard deviation of 34.04 mV/ μ m for the poorest performance.

4.2 Equipment

The equipment within the array systems are being evaluated on a continuing basis to identify their individual performance characteristics and to improve methods of detecting equipment malfunctions. Progress of these evaluation efforts is reported in this section as information is collected and made available for further analysis.

4.2.1 SP Seismometer, HS-10-1A

With the start of the spring season and access to the WHV locations, the SP array maintenance has begun. In conjunction with the maintenance visits to the WHV locations, seismometer natural frequency and damping measurements are made. Measurements were made at 39 sensor locations in four subarrays during this quarter. The natural frequency data collected is tabulated in Table XVII where the measured value may be compared with the previous frequency measurement. These data have been combined with others collected from this measurement program to produce the frequency distribution shown in Figure 4.4. The distribution of damping measurements is shown in Figure 4.5.

Since seismometer natural frequency measurements are now being made routinely in conjunction with the SP array maintenance program, the status of this parameter throughout the array is becoming better known. The tolerance allowed is $\pm 10\%$ so that all seismometers measuring 1.0 ± 0.1 hertz are considered to be operating satisfactory. Figure 4.6 indicates the natural frequency status of the array.

TABLE XV

LP ARRAY PERFORMANCE TESTING SENSITIVITY STATISTICS

DATE	NO. SENSORS	SENS. MEAN mV/ μ m	SENS. σ mV/ μ m	SENS. MAX. mV/ μ m	SENS. MIN. mV/ μ m	SENS. DEV. mV/ μ m
3/6	45	368.16	16.00	416.89	327.98	88.91
3/13	44	368.20	14.52	407.42	338.38	69.04
3/20	44	360.69	18.17	403.98	292.89	110.09
3/27	44	361.91	13.62	389.14	330.51	58.63
4/3	45	360.75	14.28	387.44	330.62	56.82
4/10	45	358.77	14.00	393.35	330.10	63.25
4/17	45	358.24	14.22	385.65	324.85	60.80
4/24	45	356.82	14.81	389.35	328.97	60.38
5/1	45	354.68	11.90	375.94	326.94	49.00
5/8	45	355.57	13.37	382.80	323.82	58.98
5/15	45	353.58	14.86	398.19	318.79	79.40
5/22	45	350.88	15.76	393.01	311.30	81.71
5/29	45	350.76	16.03	408.70	316.49	92.21
AVERAGE	44.76	358.39	14.77	394.76	323.20	71.56
PREVIOUS 2ND QTR. AVERAGE	44.3	364.3	17.3	408	325	83
CONTRACT AVERAGE	44.81	362.98	16.28	406.61	326.99	79.63
PREVIOUS CONTRACT AVERAGE	44.6	356.1	18.8	403	312	90

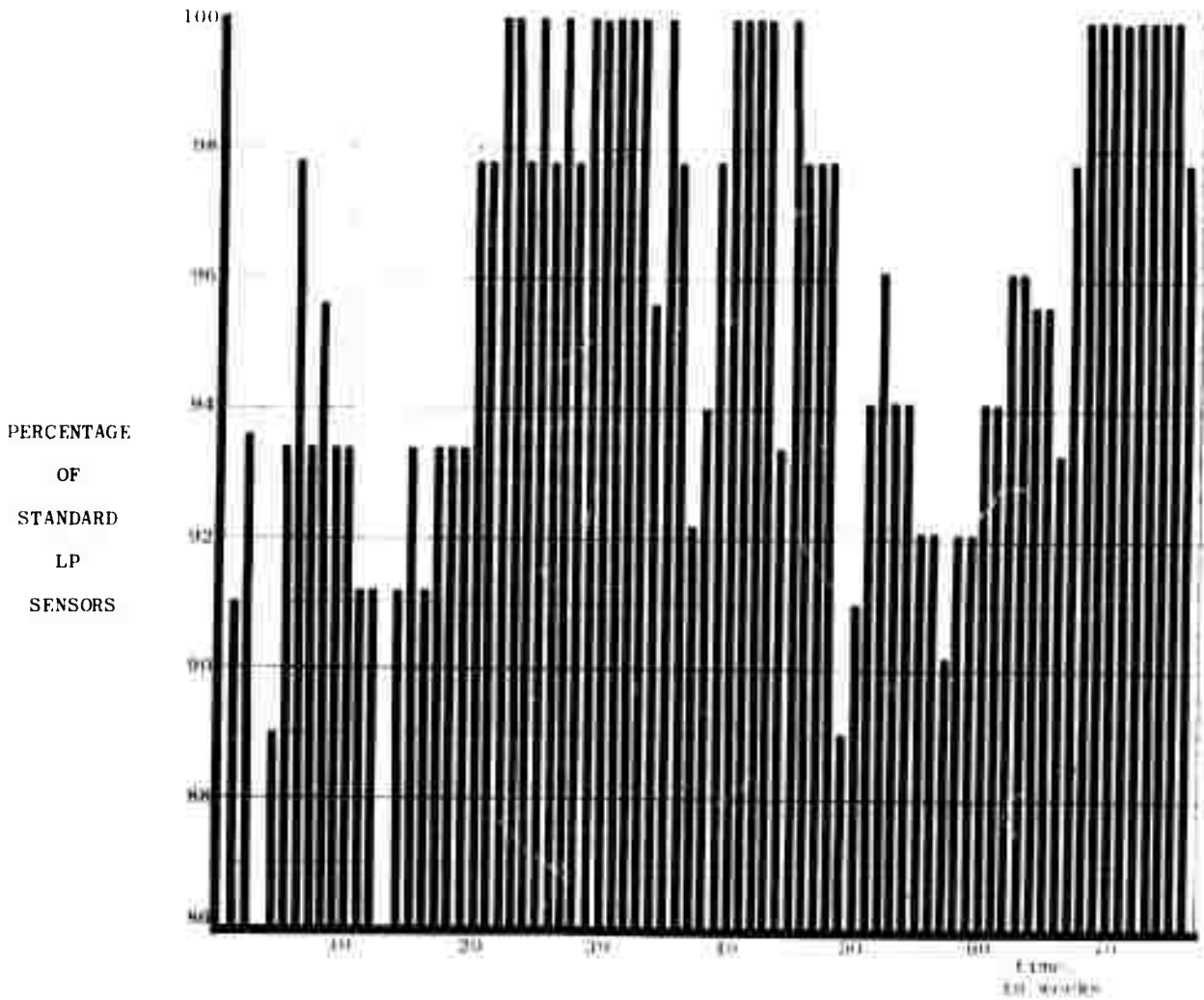

Figure 4.3 Percentage Distribution of LP Sensors within $\pm 50 \text{ mV}/\mu\text{m}$ Sensitivity Tolerance

TABLE XVI

LP CHANNEL SENSITIVITY STATISTICS, NOV '71 THRU MAY '72

(All channels except C1 and C2)

LP CHANNEL	CHANNEL SENSITIVITY IN mv/ μ m AT 25 SECOND PERIODS				
	MEAN	STD DEV	MAXIMUM	MINIMUM	MAXIMUM DEV
AO-V	366.71	21.28	428.82	333.01	95.91
AO-N/S	376.89	13.83	407.42	354.69	52.73
AO-E/W	352.48	10.26	369.42	330.56	38.86
C3-V	364.26	4.59	373.58	355.32	18.26
C3-N/S	384.53	12.08	424.68	368.21	56.47
C3-E/W	366.67	10.52	382.07	342.36	39.71
C4-V	348.53	6.26	356.42	334.74	21.68
C4-N/S	352.15	12.47	411.02	335.81	75.21
C4-E/W	338.51	12.18	396.47	326.74	69.73
D1-V	363.58	6.84	380.24	348.83	31.41
D1-N/S	356.90	9.42	376.15	327.38	48.77
D1-E/W	363.52	8.87	377.10	334.99	42.11
D2-V	353.39	18.09	378.53	325.79	52.74
D2-N/S	354.68	16.48	400.04	335.28	64.76
D2-E/W	338.35	13.31	370.06	311.30	58.76
D3-V	357.27	6.38	369.00	345.48	23.52
D3-N/S	360.25	9.98	375.07	331.85	43.22
D3-E/W	365.31	5.89	380.79	353.45	27.34
D4-V	365.89	6.15	373.46	352.19	21.27
D4-N/S	378.15	9.38	392.69	355.23	37.46
D4-E/W	370.38	8.29	393.20	353.51	39.69
E1-V	377.28	13.18	405.01	328.80	76.21
E1-N/S	353.07	6.37	365.37	341.78	23.59

TABLE XVI

LP CHANNEL SENSITIVITY STATISTICS, NOV '71 THRU MAY '72
(CONCLUDED)

(All channels except C1 and C2)

LP CHANNEL	CHANNEL SENSITIVITY IN $mv/\mu m$ AT 25 SECOND PERIODS				
	MEAN	STD DEV	MAXIMUM	MINIMUM	MAXIMUM DEV
E1-E/W	358.31	9.72	374.65	338.30	36.35
E2-V	349.09	6.42	356.61	335.58	21.03
E2-N/S	369.47	5.53	378.71	350.72	27.99
E2-E/W	382.69	14.96	408.70	344.32	64.38
E3-V	375.81	8.02	388.11	354.06	34.05
E3-N/S	381.68	6.88	391.55	367.01	24.54
E3-E/W	395.54	23.81	420.61	346.83	73.78
E4-V	340.46	4.89	350.41	331.05	19.36
E4-N/S	354.35	6.65	365.17	342.10	23.07
E4-E/W	359.07	6.74	370.56	345.28	25.28
F1-V	370.65	34.04	423.08	292.89	130.19
F1-N/S	359.46	11.21	391.50	329.83	61.67
F1-E/W	380.65	28.50	411.70	341.28	70.42
F2-V	362.00	12.17	373.24	306.41	66.83
F2-N/S	366.40	10.00	378.95	347.66	31.29
F2-E/W	364.52	16.98	380.43	288.52	91.91
F3-V	359.09	4.69	373.29	353.28	20.01
F3-N/S	349.95	7.58	364.31	327.98	36.33
F3-E/W	370.27	17.76	379.86	280.44	99.42
F4-V	337.11	22.46	352.47	231.63	120.84
F4-N/S	351.77	7.72	364.80	329.01	35.79
F4-E/W	358.32	9.84	372.77	341.47	31.30

TABLE XVII
 SP SEISMOMETER NATURAL FREQUENCY MEASUREMENTS
 MARCH - MAY 1972

SUBARRAY SENSOR	CURRENT f_n HERTZ	CURRENT DAMPING RATIO TO CRITICAL	PREVIOUS f_n HERTZ	CHANGE f_n HERTZ
A0-10	0.985 (5/72)	0.670	0.89 (9/70)	+.10 (20)
-61	1.055 (5/72)	0.677	0.99 (1965)	+.07 (83)
-72	0.97 (5/72)	0.677	0.88 (9/70)	+.09 (20)
-43	1.10 (5/72)	0.684	1.13 (9/70)	-.03 (20)
-54	0.90 (5/72)	0.701	New Seis.	
-65	1.10 (5/72)	0.677	1.11 (9/70)	-.01 (20)
-85	0.98 (5/72)	0.706	New Seis.	
-56	1.0 (5/72)	-	1.12 (1965)	-.12 (83)
-76	1.055 (5/72)	0.653	1.12 (9/70)	-.07 (20)
C4-10	1.09 (4/72)	-	1.20 (1965)	-.11 (82)
-41	1.10 (4/72)	0.662	1.14 (1965)	-.04 (82)
-61	1.07 (4/72)	0.667	1.09 (3/71)	-.02 (13)
-43	1.06 (4/72)	0.653	0.98 (1965)	+.08 (82)
-83	1.10 (4/72)	0.653	0.96 (1965)	+.14 (82)
-54	0.92 (4/72)	0.662	0.98 (1965)	-.06 (82)
-74	1.08 (4/72)	0.662	1.09 (1965)	-.01 (82)
-65	0.96 (4/72)	0.653	1.12 (3/71)	-.16 (13)
-85	1.07 (4/72)	0.662	1.07 (3/71)	.0 (13)
-56	1.03 (4/72)	0.653	1.03 (3/71)	.0 (13)

TABLE XVII
 SP SEISMOMETER NATURAL FREQUENCY MEASUREMENTS (CONCLUDED)

MARCH - MAY 1972

SUBARRAY SENSOR	CURRENT f_n HERTZ	CURRENT DAMPING RATIO TO CRITICAL	PREVIOUS f_n HERTZ	CHANGE f_n HERTZ
E4-10	0.97 (4/72)	-	1.44 (1965)	-.47 (82)
-41	1.03 (4/72)	0.662	1.12 (4/71)	-.09 (12)
-61	0.99 (4/72)	0.677	1.18 (4/71)	-.19 (12)
-43	1.05 (4/72)	0.662	1.16 (4/71)	-.11 (12)
-63	0.97 (4/72)	0.653	1.16 (1965)	-.19 (82)
-83	1.10 (4/72)	0.653	1.05 (4/71)	.0 (12)
-54	1.10 (4/72)	0.670	1.07 (1965)	+.03 (82)
-45	1.04 (4/72)	0.653	1.02 (4/71)	+.02 (12)
-65	1.01 (4/72)	0.677	1.10 (1965)	-.09 (82)
F2-41	0.964 (5/72)	0.662	0.96 (1965)	.0 (83)
-52	1.027 (5/72)	0.690	1.04 (1965)	-.01 (83)
-72	1.10 (5/72)	0.677	0.97 (1965)	+.13 (83)
-63	1.04 (5/72)	0.662	1.06 (1965)	-.02 (83)
-83	1.03 (5/72)	0.662	New Seis.	
-54	0.932 (5/72)	0.653	New Seis.	
-74	0.96 (5/72)	0.662	0.86 (6/71)	+.10 (11)
-45	1.10 (5/72)	0.653	New Seis.	
-65	1.085 (5/72)	0.653	1.15 (1965)	-.06 (83)
-85	0.962 (5/72)	0.670	0.97 (1965)	-.01 (83)
-56	0.963 (5/72)	0.690	0.88 (6/71)	+.08 (11)

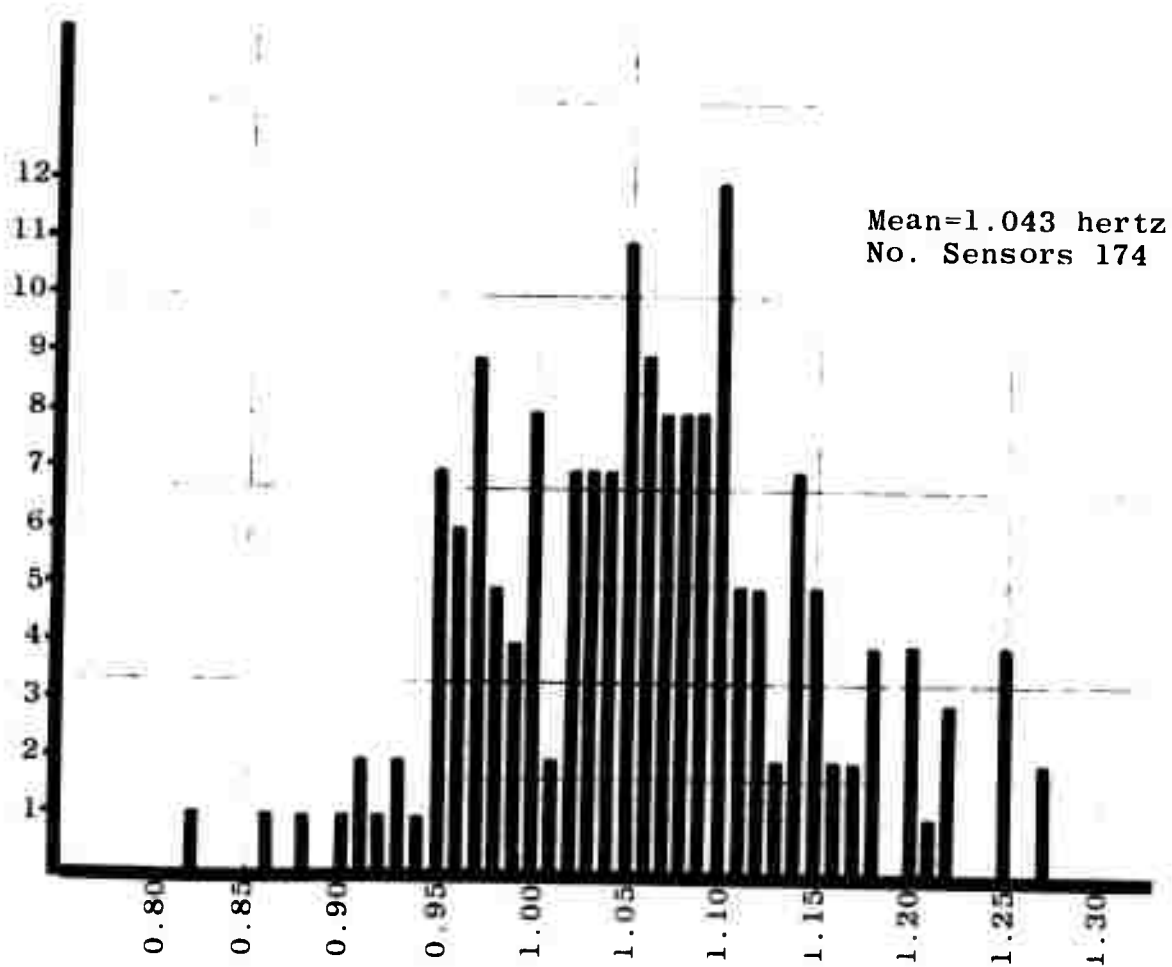

Seismometer Natural Frequency (hertz)

Figure 4.4 SP Seismometer Natural Frequency Distribution, 1970-1972

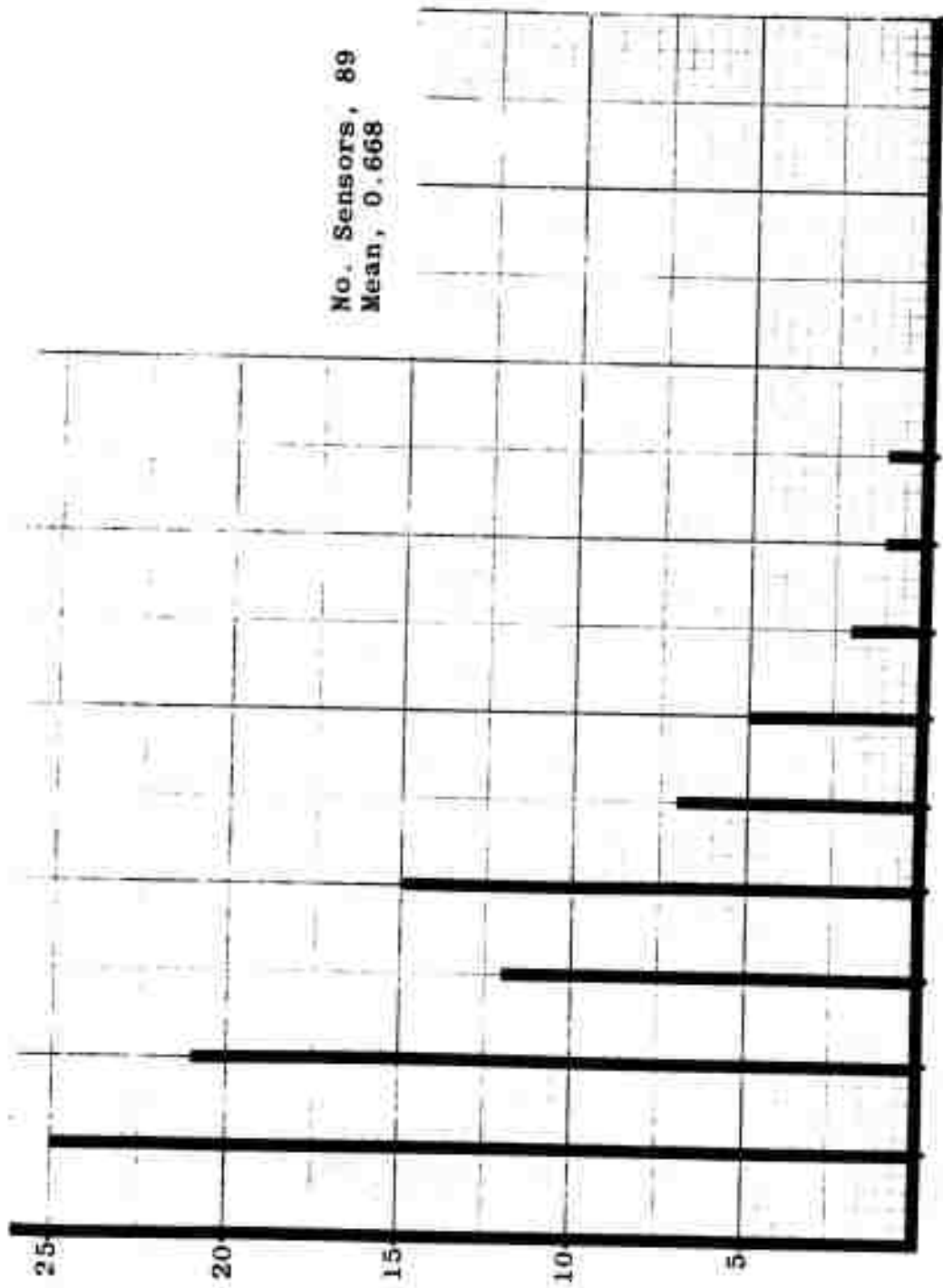

No. Sensors, 89
 Mean, 0.668

15/1 16/1 17/1 18/1 19/1 20/1 21/1 22/1 23/1 OVERSHOOT RATIO
 .653 .662 .670 .677 .684 .690 .696 .701 .706 DAMPING RATIO TO CRITICAL

Figure 4.5 SP Seismometer Damping Ratio Distribution, 1972

Figure 4.6

Seismometer Natural Frequency Status of Array

Data Channel Number	Subarrays																					
	A0	B1	B2	B3	B4	C1	C2	C3	C4	D1	D2	D3	D4	E1	E2	E3	E4	F1	F2	F3	F4	
1	0	X		0		0	X	X	0	0								0		0	0	0
2	W	E	E	E	E	E	E	E	E	E		E	E	W	W		W	W	W	W	W	W
3	0	E	E	E	E	E	E	E	0	X			0	0			0		0	X	E	
4	0	0		0	X	E	X	0	0					0	0							X
5							0	0				X										0
6	W	E	E	E	E	E	E	E	E	E	E	E	E	W	W		W	W	W	W	W	W
7	E	0	0	X	X	X	0		E	E	0		E	X								
8				0		X	X	X	0					0			0		0			
9	X	X			0		0	0						0					0		0	0
10	W	E	E	E	E	E	E	E	E	E		E	E	W	W		W	W	W	W	W	W
11	X	E	E	E	E	E	E	E	0	X		E		E		0	X	0		E		
12		X	X		X	X	0		E				0	X			0		0		0	0
13			X		X		0	0	0	0	0	0	0	X			0		X	X	X	X
14	E	E	E	E	E	E	E	E	E	E	E	E	E	E	E	E		E	E	E	E	E
15	W		X	0		0	X	0	E	E	0		E	E			E	E	E	E	X	X
16	X		0		0		0		0			X	0	X			0	0	X			
17			0	0			0	0	0			0					0	0	X	X	0	0
18	E	E	E	E	E	E	E	E	E	E	E	E	E	E	E	E		E	E	E	E	E
19	0	E	E	E	E	E	E	E		0	E	E		X	E		0	0	0	0	E	E
20	X				X		0		0	X			X	0			0		0	0		
21	X			0	0		0	0	0	X	0	0		0	0		0	0	0			
22	0	X		0		0	X	X		0							0		0	0	0	0
23	E	0		0	X			X	E	E			E	E			E	E	E	W		
24	0	X		X			0	X	0	0	0		0						X		X	X
25	X	X	X		0		0	0			0		0	0				0	E		X	X

- Legend: 0 - Natural frequency within $1 \pm .1$ hertz
 X - Natural frequency exceeds $1 \pm .1$ hertz
 E - Empty data channel, no sensor connected
 W - Weather Instrumentation Data Channel
 Blank - Natural frequency measurement data not current

A capability for the measurement of the SP seismometer p-p output during sinusoidal calibration was added with the preparation of program TASP (Ref. 3). The output data collected from the 32 seismometers at subarrays B1 and F3 for the past two months, April and May are presented in Table XVIII. The table shows the mean, standard deviation, and the ratio of the standard deviation to the mean for each seismometer. We plan to observe this ratio and use it to compare the amount of deviation of the seismometers output from each channel.

From this initial set of data the output does appear to vary among the 32 seismometers from about 704 to 1366 μv p-p; however, the difference between the monthly mean values of particular seismometers is relatively small. As more data is collected a more detailed analysis of the seismometers output to electromagnetic calibration will be performed.

4.2.2 SP Seismic Amplifier, RA-5

A remote measurement of the SP seismic amplifier gain was added by PDP-7 program TASP (Ref. 3). This measurement was developed to assist in locating the sources which affect the stability of the SP seismograph. Previously, we have stated that the environmental stresses on the RA-5 amplifier were the cause of week-to-week variations in the calibration responses from the SP sensors. Using amplifier gain data collected on line from subarrays B1 and F3 we hope to find correlation between the RA-5 gain variations and the variation in measured SP channel sensitivities. Table XIX shows the amplifier gain statistics collected from 34 amplifiers for the past two months, April and May. The table gives the mean, standard deviation and the ratio of the standard deviation to the mean for each amplifier gain. Table XX presents the same statistics for the SP channel sensitivities.

Future analysis will compare the (σ/μ) ratios of the RA-5 amplifier gains and the SP channel sensitivities.

4.2.3 LP Seismic Amplifier, Type II

The LP seismic amplifier gain is measured remotely each week from the LDC under control of PDP-7 program TELP (Ref. 4). The gain stability of 45 of the array's Type II amplifiers is being determined from the gain measurement data collected since December 1970. The individual amplifier gains measured during this 78-week period are summarized in Table XXI, where the mean, standard deviation, maximum, minimum, and maximum deviation of the gains are indicated.

A standard seismograph channel sensitivity is provided across the array's LP sensors. Since the seismometer data coil generator constants vary, the channel amplification must vary to provide the standardization. The mean gains of the 45 amplifiers vary from 8,770 to 15,890.

TABLE XVIII
 SP SEISMOMETER OUTPUT FROM ELECTROMAGNETIC
 CALIBRATION, SUBARRAYS B1 and F3

SENSOR	OUTPUT STATISTICS APRIL 1972			OUTPUT STATISTICS MAY 1972		
	MEAN (μ) $\mu\text{v p-p}$	STD DEV (σ) $\mu\text{v p-p}$	σ/μ	MEAN (μ) $\mu\text{v p-p}$	STD DEV (σ) $\mu\text{v p-p}$	σ/μ
B1-10	1338.52	17.73	0.013	1366.87	17.78	0.013
B1-51	1224.67	13.38	0.011	1221.90	12.97	0.011
B1-71	704.41	5.98	0.008	706.03	3.72	0.005
B1-42	1086.22	11.84	0.011	1087.97	11.42	0.010
B1-62	991.07	11.74	0.012	990.16	11.68	0.012
B1-82	1175.41	12.13	0.010	1162.87	14.80	0.013
B1-53	971.11	8.93	0.009	968.00	12.13	0.013
B1-73	963.44	11.34	0.012	959.74	19.69	0.021
B1-44	1117.04	13.72	0.012	1090.48	21.68	0.020
B1-64	907.52	9.00	0.010	912.58	10.67	0.012
B1-84	790.89	52.53	0.066	777.06	50.16	0.065
B1-55	1144.07	13.59	0.012	1139.00	12.57	0.010
B1-75	810.30	9.76	0.012	809.35	8.89	0.011
B1-46	1098.70	13.27	0.012	1088.83	10.67	0.010
B1-66	952.41	11.38	0.012	947.23	10.96	0.012
B1-86	862.16	20.02	0.023	867.29	9.85	0.011

TABLE XVIII
 SP SEISMOMETER OUTPUT FROM ELECTROMAGNETIC
 CALIBRATION, SUBARRAYS B1 and F3
 (CONCLUDED)

SENSOR	OUTPUT STATISTICS APRIL 1972			OUTPUT STATISTICS MAY 1972		
	MEAN (μ) $\mu\text{v p-p}$	STD DEV (σ) $\mu\text{v p-p}$	σ/μ	MEAN (μ) $\mu\text{v p-p}$	STD DEV (σ) $\mu\text{v p-p}$	σ/μ
F3-10	1114.86	16.30	0.015	1116.06	16.07	0.014
F3-41	1143.29	13.79	0.012	1141.35	14.43	0.013
F3-61	1379.46	17.49	0.013	1386.22	16.88	0.012
F3-81	1201.89	16.03	0.013	1233.74	22.55	0.018
F3-52	839.96	10.93	0.013	845.23	12.89	0.015
F3-72	1333.68	16.80	0.013	1334.94	14.77	0.011
F3-43	1337.96	14.11	0.011	1338.19	16.04	0.012
F3-63	800.79	12.00	0.015	800.87	11.71	0.015
F3-83	1040.36	10.72	0.010	1039.35	13.67	0.013
F3-54	1258.68	18.41	0.015	1276.97	18.07	0.014
F3-74	972.00	11.73	0.012	971.81	10.88	0.011
F3-45	1042.96	14.01	0.013	1038.77	11.84	0.011
F3-65	1272.36	17.52	0.014	2368.26	15.70	0.012
F3-85	1312.21	18.14	0.014	1313.39	16.20	0.012
F3-56	1453.50	21.50	0.015	1454.03	18.22	0.013
F3-76	1021.77	28.37	0.028	1041.03	12.88	0.012

TABLE XIX
RA-5 AMPLIFIER GAIN STATISTICS
SUBARRAYS B1 and F3

AMP. LOC.	GAIN STATISTICS APRIL 1972			GAIN STATISTICS MAY 1972		
	MEAN (μ)	STD DEV (σ)	σ/μ	MEAN (μ)	STD DEV (σ)	σ/μ
B1-10	4568.56	60.27	0.013	4465.71	79.03	0.018
B1-51	6020.78	80.00	0.013	5869.71	124.33	0.021
B1-71	9812.26	112.29	0.011	9659.87	151.61	0.016
B1-42	6999.19	81.74	0.012	6862.94	129.38	0.019
B1-62	7049.56	87.90	0.012	6903.26	164.05	0.024
B1-82	5849.04	88.35	0.015	5881.06	73.04	0.012
B1-53	6516.52	72.74	0.011	6527.90	75.44	0.012
B1-73	7886.96	92.68	0.012	7848.71	107.12	0.014
B1-44	5976.33	67.78	0.011	5885.32	97.87	0.017
B1-64	7419.18	106.18	0.014	7195.61	166.68	0.023
B1-84	85.52	5.65	0.066	79.38	6.77	0.085
B1-55	6132.63	146.71	0.024	6370.10	144.66	0.023
B1-75	8410.26	103.91	0.012	8440.40	167.21	0.020
B1-10A	157.48	2.99	0.019	152.77	3.21	0.021
B1-46	6781.11	75.90	0.011	6769.23	67.48	0.010
B1-66	7169.52	87.02	0.012	6962.32	169.30	0.024
B1-86	8199.07	309.22	0.038	7939.87	127.19	0.016

TABLE XIX
 RA-5 AMPLIFIER GAIN STATISTICS
 SUBARRAYS B1 AND F3 (CONCLUDED)

AMP. LOC.	GAIN STATISTICS APRIL 1972			GAIN STATISTICS MAY 1972		
	MEAN (μ)	STD DEV (σ)	σ/μ	MEAN (μ)	STD DEV (σ)	σ/μ
F3-10	5608.50	73.65	0.013	5514.13	94.64	0.017
F3-41	6006.43	78.18	0.013	5869.58	101.43	0.017
F3-61	5241.21	69.53	0.013	5192.94	86.45	0.017
F3-81	5950.18	175.14	0.029	5922.23	93.18	0.016
F3-52	8092.75	138.99	0.017	7987.68	331.03	0.041
F3-72	4681.11	62.75	0.013	4548.48	102.54	0.023
F3-43	5258.71	77.98	0.015	5206.13	77.56	0.015
F3-63	8715.32	119.39	0.014	8508.39	171.12	0.020
F3-83	5738.64	139.61	0.024	5525.55	219.39	0.040
F3-54	5533.71	75.32	0.014	5486.16	84.21	0.015
F3-74	7003.46	93.00	0.013	6909.55	92.21	0.013
F3-45	6032.50	72.51	0.012	5936.45	78.66	0.013
F3-65	5817.57	137.35	0.024	5808.71	82.18	0.014
F3-85	5153.57	72.30	0.014	5002.74	107.23	0.021
F3-10A	170.82	2.66	0.016	166.97	3.03	0.018
F3-56	5141.39	96.04	0.019	5106.96	80.64	0.016
F3-76	6990.18	165.04	0.024	6959.74	102.20	0.015

TABLE XX
 SP CHANNEL 1 HERTZ SENSITIVITY STATISTICS
 SUBARRAYS B1 and F3

CHANNEL SENSOR	SENSITIVITY STATISTICS APRIL 1972			SENSITIVITY STATISTICS MAY 1972		
	MEAN (μ) mv/nm	STD DEV (σ) mv/nm	σ/μ	MEAN (μ) mv/nm	STD DEV (σ) mv/nm	σ/μ
B1-10	18.28	0.0702	0.0038	18.21	0.1345	0.0074
B1-51	22.22	0.2014	0.0090	21.64	0.4594	0.0212
B1-71	20.52	0.0905	0.0044	20.26	0.2208	0.0109
B1-42	22.99	0.1108	0.0048	22.61	0.3685	0.0163
B1-62	21.19	0.2120	0.0100	20.78	0.4564	0.0220
B1-82	20.50	0.2251	0.0109	20.37	0.2272	0.0112
B1-53	18.83	0.2189	0.0116	18.71	0.1114	0.0060
B1-73	22.99	0.1736	0.0075	22.92	0.2253	0.0098
B1-44	20.07	0.1524	0.0075	19.38	0.5239	0.0270
B1-64	20.22	0.1146	0.0056	19.70	0.3830	0.0194
B1-84	0.20	0.0103	0.0515	0.03	0.0165	0.5500
B1-55	20.62	0.3789	0.0183	21.27	0.3776	0.0178
B1-75	20.44	0.1610	0.0078	20.57	0.4328	0.0210
B1-10A	0.68	0.0066	0.0097	0.66	0.0131	0.0198
B1-46	22.44	0.1399	0.0062	22.32	0.3384	0.0152
B1-66	20.48	0.1820	0.0088	19.78	0.5338	0.0270
B1-86	21.16	0.2171	0.0102	20.71	0.3258	0.0157

TABLE XX
 SP CHANNEL 1 HERTZ SENSITIVITY STATISTICS
 SUBARRAYS B1 and F3 (CONCLUDED)

CHANNEL SENSOR	SENSITIVITY STATISTICS APRIL 1972			SENSITIVITY STATISTICS MAY 1972		
	MEAN (μ) mv/nm	STD DEV (σ) mv/nm	σ/μ	MEAN (μ) mv/nm	STD DEV (σ) mv/nm	σ/μ
F3-10	18.81	0.1562	0.0083	18.58	0.1471	0.0079
F3-41	20.81	0.1252	0.0060	20.28	0.2629	0.0130
F3-61	21.97	0.1166	0.0053	21.89	0.1974	0.0090
F3-81	21.13	0.1302	0.0061	21.44	0.1674	0.0078
F3-52	20.62	0.2757	0.0133	20.48	0.8282	0.0404
F3-72	18.90	0.1064	0.0051	18.39	0.3420	0.0186
F3-43	21.12	0.2135	0.0101	20.95	0.1615	0.0077
F3-63	21.26	0.0955	0.0044	20.86	0.2727	0.0131
F3-83	18.25	0.4186	0.0229	17.55	0.6563	0.0374
F3-54	20.82	0.1792	0.0086	21.03	0.0844	0.0040
F3-74	20.24	0.1173	0.0057	20.02	0.1779	0.0089
F3-45	18.96	0.1229	0.0060	18.64	0.1381	0.0074
F3-65	22.37	0.1246	0.0055	22.26	0.1253	0.0056
F3-85	20.09	0.2098	0.0104	19.58	0.3319	0.0170
F3-10A	0.59	0.0071	0.0120	0.58	0.0235	0.0405
F3-56	22.40	0.2514	0.0112	22.36	0.2090	0.0093
F3-76	21.27	0.2261	0.0106	21.61	0.2581	0.0119

TABLE XXI

LP TYPE II AMPLIFIER GAIN STATISTICS - DEC 70 THRU MAY 72

TYPE II AMPLIFIER CHANNEL	MEAN GAIN $\times 10^3$	GAIN STD. DEV $\times 10^3$	MAX. GAIN $\times 10^3$	MIN. GAIN $\times 10^3$	MAX. Δ GAIN $\times 10^3$
AO-V	15.89	0.7463	17.38	13.94	3.44
AO-N/S	12.21	0.5075	13.24	11.05	2.19
AO-E/W	12.67	0.5379	13.57	11.18	2.39
C3-V	13.10	0.5533	14.49	11.27	3.22
C3-N/S	13.52	0.4120	14.52	12.59	1.93
C3-E/W	12.65	0.4824	14.27	11.54	2.73
C4-V	12.70	0.4644	13.76	11.41	2.35
C4-N/S	11.79	0.5095	13.43	10.51	2.92
C4-E/W	11.68	0.3741	12.44	10.57	1.87
D1-V	9.48	0.3901	10.34	7.75	2.59
D1-N/S	8.86	0.3901	9.65	7.37	2.28
D1-E/W	8.77	0.4318	9.46	6.77	2.69
D2-V	13.56	0.7665	14.89	12.21	2.68
D2-N/S	12.70	0.7865	14.05	11.56	2.49
D2-E/W	9.52	0.6352	10.73	7.13	3.60
D3-V	15.60	0.6442	16.67	13.95	2.72
D3-N/S	14.91	0.7203	16.20	12.12	4.08
D3-E/W	14.35	0.6294	15.32	12.17	3.15
D4-V	13.52	0.5758	14.68	12.03	2.65
D4-N/S	11.68	0.3694	12.53	10.62	1.91
D4-E/W	11.62	0.5406	14.70	10.51	4.19
E1-V	11.31	0.7891	15.49	9.82	5.67

TABLE XXI

LP TYPE II AMPLIFIER GAIN STATISTICS - DEC 70 THRU MAY 72
(CONCLUDED)

TYPE II AMPLIFIER CHANNEL	MEAN GAIN $\times 10^3$	GAIN STD. DEV $\times 10^3$	MAX. GAIN $\times 10^3$	MIN. GAIN $\times 10^3$	MAX. Δ GAIN $\times 10^3$
E1-N/S	10.80	0.3694	11.62	9.89	1.73
E1-E/W	14.54	0.5026	15.95	13.17	2.78
E2-V	13.40	0.4027	14.52	12.19	2.33
E2-N/S	11.50	0.2660	12.13	10.81	1.32
E2-E/W	12.01	0.4551	13.20	11.07	2.13
E3-V	11.93	0.4550	12.98	10.83	2.15
E3-N/S	11.50	0.3490	12.40	10.70	1.70
E3-E/W	12.05	0.4185	12.85	10.90	1.95
E4-V	12.99	0.6570	14.27	11.01	3.26
E4-N/S	12.55	0.4655	13.43	11.29	2.14
E4-E/W	12.10	0.5364	14.54	11.01	3.53
F1-V	13.15	0.9036	14.33	10.81	3.53
F1-N/S	12.13	0.4291	13.11	11.39	1.72
F1-E/W	14.92	0.9634	18.71	12.25	6.46
F2-V	15.52	0.6937	16.71	12.00	4.71
F2-N/S	10.83	0.3871	11.42	9.63	1.79
F2-E/W	12.60	0.1412	13.90	11.67	2.23
F3-V	11.37	0.3510	12.38	10.47	1.91
F3-N/S	11.19	0.3146	12.04	10.42	1.62
F3-E/W	13.24	0.6199	14.12	9.87	4.25
F4-V	11.97	0.5711	14.92	10.57	4.35
F4-N/S	10.59	0.3225	11.34	9.63	1.71
F4-E/W	13.05	0.5185	14.49	11.52	2.97

The standard deviation of the gain is the measure we are looking at to determine the expected stability performance of the Type II amplifier in the present LASA CTH environment. The average standard deviation of the gain obtained from the Table XXI data is 519. The best stability was obtained from the E/W channel amplifier at subarray F2 where the average was 141. Compared with the similar statistics provided for the 52-week period from December 1970 through November 1971 (Ref. 9), the average has improved from 578. Thirty-eight (84%) of amplifier channels showed an improved gain stability from the previous report.

4.2.4 Develocorder

The chemical pumps have been removed (1967) from the LDC Develocorders and their function replaced with a gravity-flow regulated system connected to each Develocorder from a central source of chemicals located at the top of the Develocorder rack. The chemical sources are plastic reservoirs; one for each of the two chemicals, viz. developer and fixer. These chemicals flow through separate flexible, plastic pipe minifolds to each Develocorder rack position where two transfusion type medical drip regulators or "drippers" are connected to meter and control the fluids into a Develocorder.

During this reporting period, a new model dripper was received from TFSO for evaluation in the LDC system. This micro-dripper, from Cutter Laboratories (Berkeley, California) is the 860-05 (60 drips/ml) Saftiset Sixty Intravenous Injection Set. Operation using these drippers appears to be very satisfactory. The addition of the steel ball in the drip rate measurement chamber as an aid in visually checking and adjusting the drip rate increases the accuracy and reduces the time for this adjustment.

Two of the 860-05 (60 drips/ml) type drippers have been tested at the LDC for about three months. Operation during this period has not been continuous; however, use separated by periods of non-operation provides a better test. As the chemical developer in the lines becomes old, the sediment build-up increases and the possibility of the micro-size drip clogging is greater. The smaller opening into the measurement chamber of the 60 drips/ml dripper compared with the 20 drop/ml dripper increases the possibility of chemical flow stoppage from sediment blockage. Further, since the opening is made of metal it is unknown at this time if continued use over a prolonged time will result in any reactions with the chemicals which might influence the flow.

Experience here has shown that the type of film and chemicals cannot be underestimated if dependable Develocorder operation is to be achieved. Satisfactory results have been obtained from the following:

- (1) film - Kodak Recordak Fine Grain 7457 (Product No. 01323) 16 mm, 160 ft.

(2) developer - Kodak Liquid X-Ray Developer and Replenisher, Solution A.

(3) fixer - General Electric Super Mix Fixer (Speed type for X-Ray Film) Catalog Number 4058A.

4.3 Failure Report

The array system and equipment failures which occurred this quarter are discussed in this section. All the failures are classified according to the type of failure and include these five classifications:

- (1) System failure - A failure resulting in zero or no system output which prevents the system or equipment assembly from performing its primary function and identified as a Type 1 failure.
- (2) Mode failure - A failure resulting in a zero or no system output only during one of several different modes of operation; a Type 2 failure.
- (3) Limited failure - A failure resulting in a system output which is outside the allowable tolerance limits but permits degraded performance; a Type 3 failure.
- (4) Latent failure - A failure which changes a system output either by an amount less than the allowable tolerance or from the nominal output when no tolerance limits have been established; a Type 4 failure.
- (5) Temporary failure - A failure produced by an operating or environmental stress which results in no permanent physical damage; a Type 5 failure.

Table XXII indicates the number of failures detected and corrected in each of the ten array systems. All microbarograph equipment was removed from the array during this quarter and will be eliminated from this failure report. In decreasing order the three systems with the largest number of failures were the SP sensor, PDP-7 computer, and the LDC Test and Support. The 360 Computer system operated during this quarter without any failures and the Meteorological system had only one failure of an intermittent nature. The distribution of the equipment failures within each system is shown in Table XXIII.

TABLE XXII
 LASA SYSTEM FAILURE DETECTIONS AND CORRECTIONS
 MARCH 1972 - MAY 1972

	STARTING BACKLOG	DETECTED	CORRECTED	ENDING BACKLOG
SP SENSOR	17	54	49	22
LP SENSOR	1	3	4	0
METEOROLOGICAL SYSTEM	0	1	1	0
SEM	1	7	8	0
POWER SYSTEM	0	2	2	0
360 COMPUTER	0	0	0	0
PDP-7 COMPUTER	7	29	33	3
LDC DIGITAL	1	6	7	0
LDC ANALOG	0	10	10	0
LDC TEST AND SUPPORT	0	21	20	1
TOTALS	27	133	134	26

TABLE XXIII
EQUIPMENT FAILURES

ARRAY SYSTEM/EQUIPMENT	NUMBER OF FAILURES					TOTAL
	TYPE OF FAILURE					
	1	2	3	4	5	
Short-Period System						
Seismometer	0	0	0	10	0	10
WHV Panel W/RA-5	2	0	8	23	4	37
RA 5 Power Supply	2	0	0	0	0	2
WHV Junction Box	0	0	0	0	0	0
WHV/Cables	0	0	0	0	0	0
CTH Junction Box (SP)	0	0	0	0	0	0
Total	4	0	8	33	4	49
Long-Period System						
Vertical Seismometer/Tank	0	0	0	0	0	0
Horizontal Seismometer/Tank	0	0	0	0	0	0
LP Vault/Cabling	0	0	0	0	0	0
LP Junction Assembly	0	0	0	0	0	0
Motor Assembly	0	0	1	0	0	1
Seismic Amplifier, Type II	0	0	1	1	0	2
Amplifier Power Supply	0	0	0	0	0	0
CTH Junction Box (LP)	0	0	1	0	0	1
Total	0	0	3	1	0	4
Meteorological System						
Aerovane, Wind Direction	0	0	0	0	0	0
Aerovane, Wind Speed	0	0	0	0	0	0
Pole Assembly	0	0	0	0	0	0
Pole Junction Box/Cabling	0	0	0	0	0	0
Temperature Probe	0	0	0	0	1	1
Electrobarometer/Baffle	0	0	0	0	0	0
Rain Gauge	0	0	0	0	0	0
Rain Gauge Electronics Panel	0	0	0	0	0	0
Total	0	0	0	0	1	1

TABLE XXIII
EQUIPMENT FAILURES (CONTINUED)

ARRAY SYSTEM/EQUIPMENT	NUMBER OF FAILURES					TOTAL
	TYPE OF FAILURE					
	1	2	3	4	5	
Subarray Electronics Modules						
Input Drawer #1	0	0	0	0	0	0
Input Drawer #2	1	0	1	0	0	2
Multiplexer/ADC	1	0	0	0	0	1
Output Drawer	0	0	0	0	1	1
PDC Drawer	0	0	3	1	0	4
ACC Cabinet	0	0	0	0	0	0
SEM Cabinet/Cabling	0	0	0	0	0	0
Alarms	0	0	0	0	0	0
Total	2	0	4	1	1	8
Power System						
Contral Drawer	0	0	1	0	0	1
Inverter	1	0	0	0	0	1
Charger	0	0	0	0	0	0
Battery	0	0	0	0	0	0
SOLA Transformer	0	0	0	0	0	0
Rack Cabling	0	0	0	0	0	0
Isolation Transformer	0	0	0	0	0	0
Breaker Panel	0	0	0	0	0	0
Vault/Wiring/Breakers/Outlets	0	0	0	0	0	0
Total	1	0	1	0	0	2

TABLE XXIII
EQUIPMENT FAILURES (CONTINUED)

ARRAY SYSTEM/EQUIPMENT	NUMBER OF FAILURES					TOTAL
	TYPE OF FAILURE					
	1	2	3	4	5	
360 System						
CPU 2044	0	0	0	0	0	0
Disc Drive 2315	0	0	0	0	0	0
Typewriter 1052	0	0	0	0	0	0
Card Reader 2501	0	0	0	0	0	0
Data Control 1826	0	0	0	0	0	0
Data Adapter 1827	0	0	0	0	0	0
Data Adapter 2701	0	0	0	0	0	0
Total	0	0	0	0	0	0
PDP-7 System						
Computer	1	0	2	0	0	3
Teletypewriter KSR-35	0	0	1	0	0	1
Card Reader	0	0	0	0	1	1
SOU	0	0	0	0	0	0
Interface	0	0	0	0	0	0
Tape Unit #19	1	0	5	0	1	7
Tape Unit #32	0	0	6	0	2	8
Tape Unit #33	0	0	3	0	0	3
Tape Unit #22	2	0	7	0	0	9
Incremental Recorder	0	0	0	0	1	1
Total	4	0	24	0	5	33
Digital System						
Timing System #1	2	0	3	0	0	5
Timing System #2	1	0	0	0	0	1
Digital Data Simulator	0	0	0	0	0	0
Power System	0	0	0	0	0	0
PLINS	1	0	0	0	0	1
MINS	0	0	0	0	0	0
Total	4	0	3	0	0	7

TABLE XXIII
EQUIPMENT FAILURES (CONCLUDED)

ARRAY SYSTEM/EQUIPMENT	NUMBER OF FAILURES					TOTAL
	TYPE OF FAILURE					
	1	2	3	4	5	
Analog System						
D/A Patch Panel Cabinet	0	0	0	0	0	0
D/A Converter #1	0	0	0	0	0	0
D/A Converter #2	0	0	0	0	0	0
D/A Converter #3	0	0	0	0	0	0
D/A Converter #4	0	0	0	0	0	0
FM System	0	0	0	0	0	0
16 Channel Chart Recorder	0	0	1	0	0	1
WWV Receiver	0	0	0	0	0	0
Analog Calibration System	0	0	0	0	0	0
Analog Timing System	0	0	3	0	0	3
SP Develocorder	1	1	1	0	0	3
LP Develocorder	2	1	0	0	0	3
Total	3	2	5	0	0	10
LDC Test and Support System						
MDC-1	1	0	16	0	0	17
MDC-2	0	0	3	0	0	3
Clocks	0	0	0	0	0	0
Film Viewer	0	0	0	0	0	0
Film Duplicator	0	0	0	0	0	0
Copier	0	0	0	0	0	0
Emergency Lights	0	0	0	0	0	0
Compressor, Blower	0	0	0	0	0	0
Digital Clocks	0	0	0	0	0	0
Air Conditioners	0	0	0	0	0	0
Humidifier	0	0	0	0	0	0
Tape Cleaner	0	0	0	0	0	0
Electrostatic Filters	0	0	0	0	0	0
Total	1	0	19	0	0	20

The HS-10-1A seismometer and RA-5 amplifier in the short-period system accounted for 47 of the 49 failures in that system. All 10 of the seismometer failures were identified for repair, because of out-of-tolerance natural frequency, during the current SP rehabilitation program. Of the 37 RA-5 failures only 2 failed completely, 8 were out-of-tolerance, 4 were intermittent, and the remaining 23 were latent failures identified for repair during the SP rehabilitation program.

The tape units in the PDP-7 system accounted for 27 of the 33 failures, the Develocorders for 6 of the 10 failures in the analog system, and the MDC 1 and 2 for all 20 failures in the LDC Test and Support System. These type of failures have been previously reported and are expected due to constant use of this equipment. These failures are usually mechanical for the tape units and Develocorders and battery replacement in the zero suppression amplifiers of the Maintenance Display Console.

All other failures were isolated in nature and do not indicate trends or maintenance programs.

Descriptions of pertinent equipment repairs can be found in Section VI.

4.4 Equipment Aging Study

A report relating the effects of aging on the arrays systems has been prepared (Ref. 10). In addition to identifying aging effects, an indication of possible corrective measures that can be taken and an estimation of the material cost involved were included for all of the arrays systems.

For the most part the study has shown that the replacements and repairs necessary to offset the effects of equipment aging on the array can be accommodated by the on-going array maintenance programs. For example, the sensor amplifier (RA-5) aging effects are being handled with the amplifier rehabilitation program begun in March 1970 and known as phase 1 of the SP sensor maintenance program. This program is scheduled to continue with less and less effort as more and more amplifiers are rehabilitated. The array's SP seismometers are scheduled for maintenance as phase 2 of this program. New programs incorporated with the routine maintenance will be prepared as required to accommodate new maintenance situations.

SECTION V

IMPROVEMENTS AND MODIFICATIONS

5.1 General

Important to the operation of the Montana LASA is the continuing incorporation of improvements and modifications into the various equipments. These improvements permit increased efficiency in the utilization, operation and maintenance of the seismic observatory's systems. The improvements are categorized into these three areas, PDP-7 programming, array equipment and data center equipment. Improvements in the PDP-7 programming result in more efficient operation and increase the data collection capability of the array performance measurement activity. Modifications to the array and data center equipment are made to reduce the need for maintenance (i.e. improve reliability), to improve data quality, or to extend the operating capability.

5.2 System

The usefulness of the array's two seismic systems (SP and LP) can be improved through better identification of the systems performance characteristics both collectively and individually. The present method of routine calibrations (performed daily or weekly) limits characterization of the system to the response to the single sinusoidal frequency used in the calibration test and omits the remainder of the systems useful bandwidth. During subarray level testing (performed much less frequently) calibrations in which a set of sinusoids covering the seismograph channel bandwidth are sequenced into the system input are performed. However, timely diagnosis of seismograph channel malfunctions and adequate results, when the interfering seismic noise level is somewhat higher than usual, are not achieved by this manual calibration method performed at the subarray CTH by the field maintenance technicians.

Techniques for more comprehensive calibrations are being sought and investigated. Techniques for automatic calibration control and analysis performed so that array operation is not interfered with or degraded are the type needed. One such technique is discussed in paragraph 5.2.1.

5.2.1 PRBS Calibrations

One way of providing a signal input for calibration of the seismograph channels which covers the bandwidth of the system is the use of broadband noise.

One method of providing a signal input to the seismograph channel which covers the bandwidth of the system is the use of pseudo-random binary sequences (PRBS) to develop a

broadband noise signal. Pseudo-random signals are periodic signals that appear to be random. The PRBS waveforms are completely defined 1 and 0 bit patterns of selectable lengths, repeated over and over. A pseudo-random binary sequence has a line power spectrum with an envelope shaped by a $(\sin x/x)^2$ curve. Figure 5.1 illustrates this spectrum. The first lobe contains most of the available power. Nulls between other lobes occur at intervals of the clock frequency. The line spacing is determined by the sequence length and the clock frequency. Spectrum lines occur at $\frac{f_c}{N}$ or $\frac{1}{N\Delta T}$ where N is the number of bits in the sequence and ΔT is the clock period. Increasing the length of the sequence brings the lines closer together. The upper 3dB or half-power frequency is at $0.45f_c$.

Since the binary waveform always switches between the same two amplitude levels, the rms value does not change. Consequently, the total power is not changed by a change in bandwidth. The power at each line varies inversely with the sequence length. If the sequence length is doubled, the power at any particular line is halved. But, since line density is also doubled, the total signal power remains constant and, therefore, independent of bandwidth.

5.3 PDP-7 Programming

Three programming efforts are reported for this period. One, a new patch program, overlays a portion of the PDP-7 memory during MOPS operation to provide a broadband input for remote controlled calibration of the LP system. The others are program modifications. Program TESP has been changed to improve the measurement of the distortion of the sinusoidal responses to remote SP calibrations. New features have been added to the standard deviation program.

5.3.1 LPRPG

Program LPRPG was prepared to provide a long-period pseudo-random bit sequence generator for use in broad band calibrations of the long-period system. This patch program which overlaps a portion of the PDP-7 memory during MOPS operation, controls the application of telemetry command TC-21 to any subarray.

During application of command TC-21 a 15-volt dc level is applied to each long-period seismometer calibration line. Program LPRPG offers two alternatives for telemetry command control, (1) for a fixed duration and (2) according to a pseudo-random sequence stored in memory. The duration of the fixed pulse in number of frames (50 msec/frame) is determined by the present octal value of the accumulator switches.

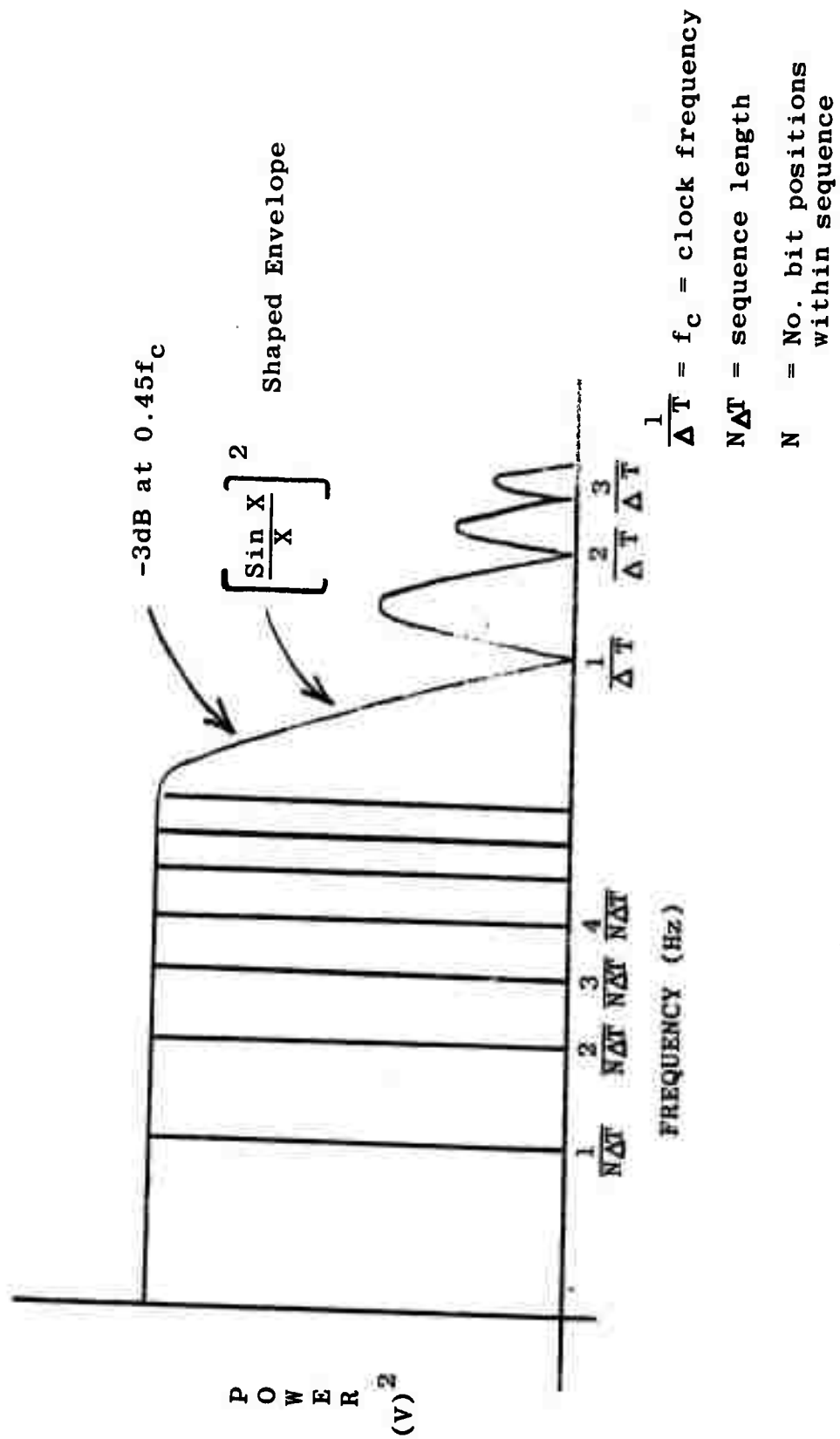

Figure 5.1 Spectrum of PRBS Output

The pseudo-random sequence stored in the memory consists of the following 127 bit pattern:

```
00010010011011010110111101100011
01001011101110011001010101111111
00000010000011000010100011110010
0010110011101010011111010000111
```

Each bit is transmitted for one second so that 127 seconds are required for each sequence; sequences continue until the operator cancels program operation. To identify the start of each sequence, telemetry command TC-63 is sent for one bit time period (20 frames). Response from this battery measure command appears on channels 30 and 31 at the beginning of the sequence of voltage pulses which input long-period seismograph channels 26, 27, and 28.

5.3.2 TESP

Program TESP, which provides automatic measurement and channel parameter calculations of the short-period seismograph sinusoidal calibrations, is important to the daily array operation. Consequently, development of the program has continued through new versions and improvements. In addition to the features previously described (Ref. 5), some changes have been incorporated. First, to provide a better indication of the distortion in the sinusoidal calibration responses, the ratio R is now calculated to four places. R is the ratio of the peak positive half-cycle sinusoid value to the peak negative half-cycle value. The program now offers the capability to select subarrays individually for SP sinusoidal calibration as well as the previous method of automatically sequencing through the array. Further, a listing of all defective sensors whose amplitude responses are outside the $\pm 15\%$ tolerance is printed out at the end of the computer output report.

5.3.3 Standard Deviation

Use of statistics plays an important part in our system performance measurement and equipment evaluations. The parameter standard deviation is used to measure system stabilities. Previously, all calculations were made using the data for all the arrays sensors or the total population. Now, frequently only a selected sample is used to support a study effort. Consequently, some minor changes in the program have been made to the standard deviation calculations; one for use when an entire population is being considered and another when only a sample of the population is taken.

Further, print out of the maximum and minimum values have been added to the output listing which includes: number of samples, sample total, mean, variance and standard deviation.

5.4 Array Equipment

5.4.1 LP Step Function Input Connections

In order to provide a remote telemetry controlled step input to the long-period seismograph system to support the PRBS calibrations, a minor modification to the SEM control drawer has been prepared. This simple modification, the installation of two short jumper wires on PC board connector A6, increases the capability of SEM calibration function. Figure 5.2 is the SEM calibration signal flow diagram updated to reflect this modification.

5.4.2 Microbarograph Removal

During this quarter the microbarograph array was eliminated by the removal of all the sensors and instrumentation. The LTV-6 microbarographs installed at eight subarrays in the E and F rings and AO were removed. The schedule of the sensor removals and the data disconnections is shown in Table XXIV. Recording of the microbarograph data at the LDC in the very-low-rate recording format was discontinued at 1939 GMT on March 24, 1972.

5.4.3 Measurement of Distortion

An indication of the SP seismograph channel distortion is obtained from the computer program TESP (see paragraph 5.2.1). The ratio of the positive half-cycle amplitude to the negative half-cycle amplitude of the TC-06 sinusoidal calibration responses provides this distortion check.

Let A be the peak-to-peak sinusoidal amplitude response

p the positive amplitude,

n the negative amplitude, and

R the ratio $\frac{p}{n}$

Then $p+n=A$ and $p=A-n$,

$$\text{so that } R = \frac{A-n}{n} \quad (5-1)$$

The relationships between the half-cycle amplitudes and A and R are,

$$n = \frac{A}{R+1} \quad (5-2)$$

$$p = \frac{AR}{R+1} \quad (5-3)$$

A tolerance limit of $R = 1 \pm 0.1$ has been established for this measurement. Whenever this value is exceeded a channel trouble is indicated; probably in the RA-5 amplifier.

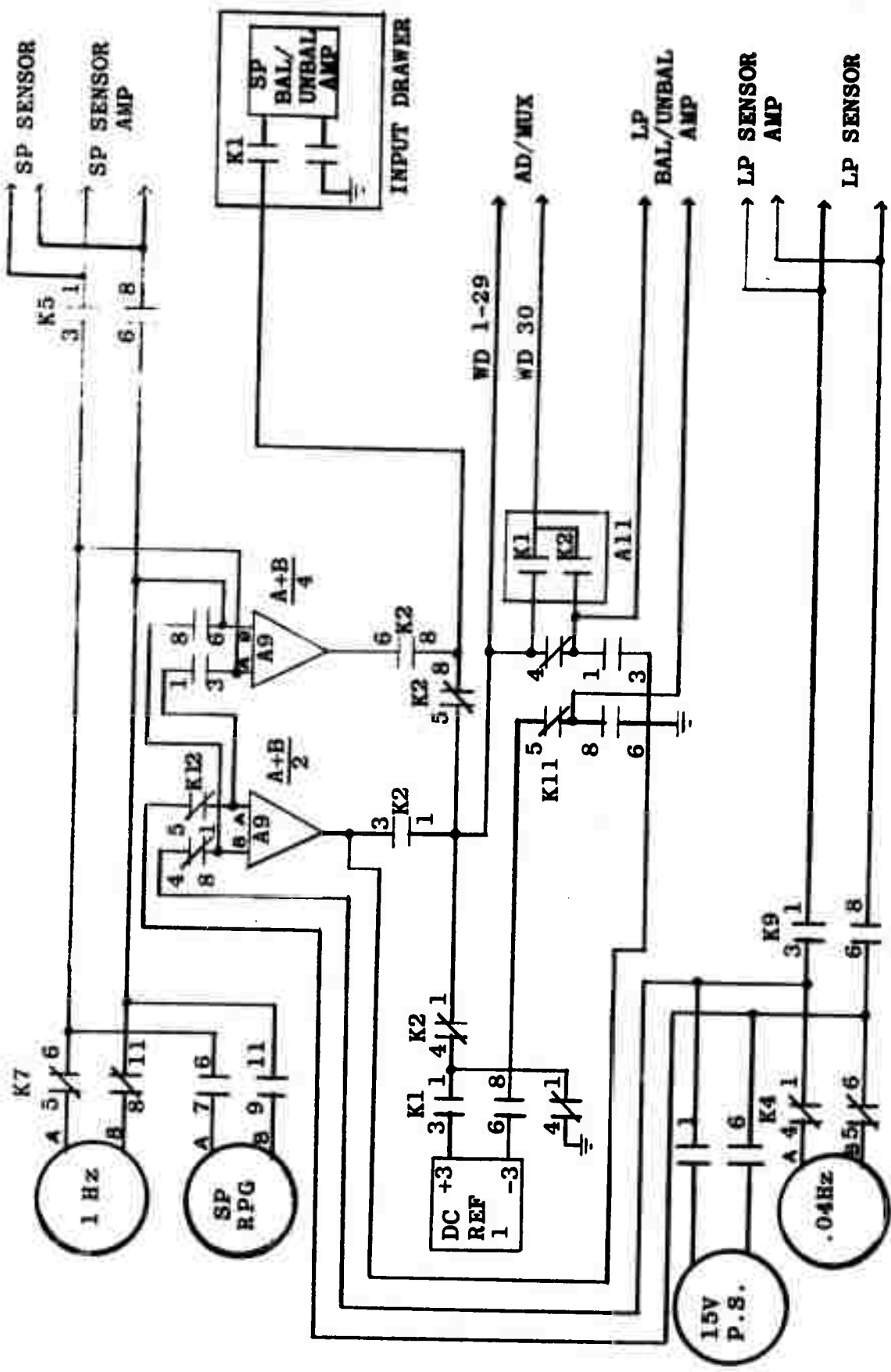

Figure 5.2 Modified Calibration Signal Flow

TABLE XXIV
MICROBAROGRAPH ARRAY SENSOR REMOVAL DATES

Site	Equipment	Serial Number	Affected Data Word	Data Equipment Removed and/or Data Disconnected
A0	LTV-6	110	07	April 12, 1972
A0	LTV-6	103	14	April 12, 1972
A0	ESYS	11	18	February 16, 1972
B1	ESYS	5	18	February 8, 1972
B2	ESYS	10	18	February 15, 1972
B3	ESYS	6	18	February 17, 1972
B4	ESYS	12	18	February 16, 1972
C1	ESYS	4	18	February 11, 1972
C2	ESYS	3	18	February 11, 1972
C3	ESYS	9	18	February 7, 1972
C4	ESYS	8	18	February 17, 1972
D1	ESYS	2	18	February 11, 1972
D2	ESYS	1	18	February 15, 1972
D3	ESYS	13	18	March 20, 1972
D4	ESYS	7	18	February 16, 1972
E1	LTV-6	107	14	April 26, 1972
E2	LTV-6	104	14	April 25, 1972
E4	LTV-6	101	14	April 26, 1972
F1	LTV-6	106	14	April 28, 1972
F2	LTV-6	105	14	April 25, 1972
F3	LTV-6	109	14	April 26, 1972
F4	LTV-6	111	14	April 20, 1972

Input signals to the RA-5 amplifier vary around the detector voltage level, normally 5.0 volts. In the case of the TC-06 calibration signal, the normal detector waveform is as shown in Figure 5.3. The full range of the signal is passed undistorted. However, if the signal voltage exceeds 10 volts or goes below 0 volts, the excess signal is limited and a distorted signal results. Consequently, maintaining the 5.0 volt detector voltage level is important to the satisfactory operation of the SP seismograph channel.

Important too, is the effect on the accuracy of the channel sensitivity calculation caused by variations in the ratio R. Consider the case where the sensitivity, S, is calculated to be 20 mV/nm at 1 hertz and R is 0.90. Here

$$A = \frac{20}{2.53} = 7.91 \text{ volts}$$

$$n = \frac{7.91}{.9+1} = 4.16 \text{ volts}$$

$$p = \frac{7.91 (0.9)}{.9+1} = 3.75 \text{ volts}$$

$$A = n+p = 4.16 + 3.75 = 7.91 \text{ volts}$$

Assume that the difference between n and p is caused by an improper RA-5 amplifier detector level so that 4.16-3.75 or 0.41 of the positive half-cycle is "chopped off". The actual response of the channel without distortion would be n=p=4.16 volts or A=8.32 volts. At 1 hertz, the calculated sensitivity is now 21 mV/nm or a 5% error in the original 20 mV/nm measurement.

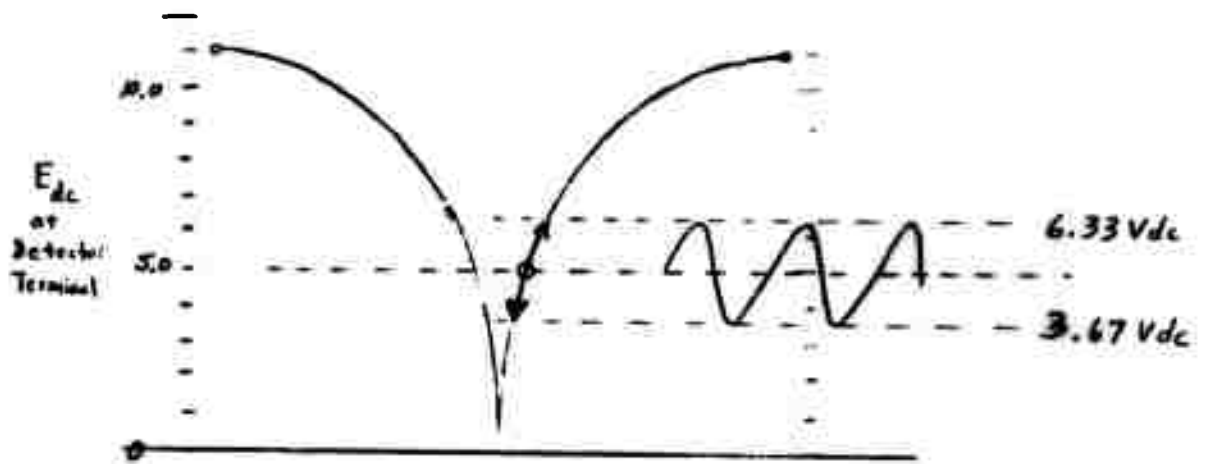

$$\begin{aligned}
 e_{\text{out RA-5}} \Big|_{\text{TC-06}} &= G_{\text{IF AMP}} \times G_{\text{LINE DRIVER}} \times e_{\text{DET}} \Big|_{\text{TC-06}} \\
 &= 0.75 \times 4.0 \times e_{\text{DET}} \Big|_{\text{TC-06}} \\
 &= 3.0 \times e_{\text{DET}} \Big|_{\text{TC-06}}
 \end{aligned}$$

Since $e_{\text{out RA-5}} \Big|_{\text{TC-06}}$ nominally equals 8.0 V p-p,

$$e_{\text{DET}} \Big|_{\text{TC-06}} = 2.67 \text{ V p-p}$$

Figure 5.3 RA-5 Detector Response Curve

SECTION VI

MAINTENANCE

6.1 General

Maintenance activity at LASA includes correction of failures, preventive maintenance, modifications, special tests required for evaluations or quality control activities, facility and access maintenance and improvements, and vehicle maintenance. LASA maintenance activity is divided into three different categories: Data Center (LDC), Maintenance Center (LMC), and Facilities Support. The LDC in Billings covers these six systems: the IBM 360/44 computer, the DEC PDP-7 computer, LDC Digital, LDC Analog, and LDC Test and Support. The LMC located in Miles City maintains all array equipment systems which are comprised of SP Sensor, LP Sensor, Meteorological, SEM, and Power. Facilities Support provides maintenance of buildings, vehicles, land leases, and array facilities such as cable trenches, access trails, fences, WHV sites, and CTH sites.

6.1.1 Philosophy

During the March - May period the weather conditions improve in the array to permit unrestricted travel. Consequently, the array maintenance at the subarray level starts (usually in April) and continues until October (sometimes November). During these months the SP rehabilitation program receives the prime attention of the array maintenance section, both in the field and at the LMC to prepare RA-5 amplifiers and HS-10-1/A seismometers for sensor replacements. Other LMC work, such as printed circuit card repairs, are deferred until inclement weather makes array travel difficult.

6.1.2 Summary

A full schedule of array maintenance, including the SP rehabilitation at four subarrays, removal of all microbarograph array sensing and instrumentation equipment, and array preventive maintenance, was completed. At the data center, maintenance actions were concentrated on the PDP-7 tape units, air conditioning, preventive maintenance, and preparation for the DCASD facility inspection.

Table XXV summarizes the number of all equipment (LASA) and facility (Utility) work orders completed this quarter. The 376 completed work orders represented 506 separate maintenance actions by technical personnel. The number and type of operational equipment failures corrected are discussed in paragraph 4.3. Work orders are used to document all LASA maintenance activity. The actual time or complexity required for a task is not indicated, but the summary does indicate the type of work performed and the

TABLE XXV
 WORK ORDER SUMMARY
 MARCH 1972 - MAY 1972

WORK ORDER TYPE	BACKLOG START OF QTR	INITIATED	COMPLETED	BACKLOG END OF QTR
LASA:				
System - A	51	221	229	43
Subassembly - B	33	46	36	43
Component - C	16	21	14	23
Total	100	288	279	109
Utility:				
Cable trench & trail inspection	0	17	14	3
Cable trench backfill	1	0	1	0
WHV sites landscaped	0	35	35	0
Marker posts &/or WHV covers replaced	0	19	19	0
CTH maintenance	5	10	14	1
Vehicle mainte- nance and in- spection	1	9	10	0
Fence inspections	3	4	4	3
Trail repairs	2	0	0	2
Total	12	94	97	9
WORK ORDER TOTALS	112	382	376	118

size of the work load. During this quarter 90% of 110 array routines and 53 data center routines scheduled were completed. Such considerations as weather, work load, and man hours available affect the number of routines completed each month.

6.2 Data Center

6.2.1 System 360

The IBM 360/44 system operated this quarter without any failures. All of the scheduled preventive maintenance procedures were completed and no problems were encountered.

6.2.2 System PDP-7

The three on-line TD-570 tape units were repaired to meet all specifications utilizing parts from the five salvaged units received from MIT. All deteriorated appearance items (e.g., door glass, panels, switches, etc.) were also replaced. One of the salvaged units was placed on a limited operational basis to be used for checking out major salvaged parts, such as power supplies, printed circuit cards, compressors, etc.

A failure occurred in the PDP-7 memory system. The memory read/write power supply failed due to an open filter capacitor which prevented operation of the system. A substitute capacitor was used to restore operation of the system until a new component was obtained and installed.

6.2.3 Other LDC Equipment

Develocorder #174 operated full time during the quarter with only two failures requiring replacement of a projection lamp and a film storage tube. Unit #190 was used intermittantly for monitoring and maintenance purposes. Two metered intravenous infusion sets received from Tonto-Forest Seismological Observatory were installed on unit #190 to operate with the gravity flow system.

The 15-ton, rooftop air conditioner required repair due to a refrigerant leak and a fan belt problem. Following this repair, a study determined an efficient set-up for the computer room's environmental system. An SOP covering the operation of the system to maintain full-flow, double filtered air at 72°F with approximately 40% humidity in the computer room was prepared. Improvement has already been noted by the cleanliness of the equipment.

6.3 Maintenance Center

The LMC maintenance efforts are divided into two activities: array and shop.

6.3.1 Array Activities

Improvement in the weather and road conditions allowed an increase in field maintenance. The number of field trips almost doubled from 63 last quarter to 112 trips covering 17,657 miles for this period plus three trips were made to the PMEL at Great Falls to pick up and deliver test equipment for calibration.

The SP rehabilitation program began with four of the sixteen subarrays planned for this summer season completed. Replacements and/or adjustments of 13 HS-10-1/A seismometers and 29 RA-5 amplifiers were made at subarrays AO, C4, E4, and F2. All repairs are being performed to maintain the SP seismographs year around within $\pm 15\%$ of the nominal channel sensitivity and $\pm 10\%$ of the 1.0 hertz natural frequency.

The 13 microbarographs installed in the B, C, and D ring and AO subarrays have been eliminated from the array. Removal was performed in two steps: (1) the electronics assemblies were disconnected and returned to the LMC during the period February 8 - March 20 and (2) the microbarograph sensor cans were dug up from the approximately 20-inch hole in which they were buried, during the period March 20 - 22.

The eight LTV-6 microbarographs installed at the E and F ring and AO subarrays were removed from the array during April 12 - 28. All microbarograph sensors have now been removed from the array, packed, and shipped as per instructions. The pipe arrays associated with the microbarographs will be left at the subarrays.

Table XXVI reflects the SP channel status as of May 31. The information in this table summarizes the outstanding conditions in the SP array requiring maintenance attention. This information is based on the five test criteria shown in the column headings. A total of 107 unsatisfactory tests results are indicated; a decrease of 50% from the 215 reported last quarter.

6.3.2 Shop Activities

Repair of RA-5 amplifiers and HS-10-1/A seismometers in support of the SP rehabilitation work and testing of the LP Type II amplifier were the main shop activities this quarter. Twenty RA-5 amplifiers and 12 seismometers were repaired and tested to the LASA standards.

Type II amplifier tests were performed in conjunction with studies of spurious noise sources in the LASA LP system.

6.4 Facilities Support

Since travel in the array was difficult in March, subarray surficial inspections began in April with fourteen completed. No

TABLE XXVI
 SP CHANNEL STATUS, 31 MAY 1972

SUBARRAY	CALIBRATION RESPONSE		NATURAL FREQUENCY		SENSITIVITY RESPONSE		SEISMIC EVENT POLARITY		SEISMIC EVENT AMPLITUDE	
	SAT.	UNSAT.	SAT.	UNSAT.	SAT.	UNSAT.	SAT.	UNSAT.	SAT.	UNSAT.
A0	17	0	16	0	16	0	17	0	17	0
B1	11	6	11	5	16	0	17	0	17	0
B2	12	5	12	4	16	0	17	0	17	0
B3	12	5	14	2	15	1	17	0	17	0
B4	14	3	10	6	16	0	17	0	17	0
C1	11	5	12	3	15	0	16	0	16	0
C2	11	6	12	4	15	1	17	0	17	0
C3	15	2	12	4	15	1	17	0	17	0
C4	16	0	15	0	15	1	16	0	16	0
D1	15	2	13	3	15	1	17	0	17	0
D2	19	2	19	1	20	0	21	0	21	0
D3	13	4	14	2	16	0	17	0	17	0
D4	17	0	16	0	16	0	17	0	17	0
E1	16	1	12	4	16	0	17	0	17	0
E2	12	5	14	2	15	1	17	0	17	0
E3	25	0	25	0	25	0	25	0	25	0
E4	17	0	16	0	16	0	17	0	17	0
F1	16	1	16	0	16	0	17	0	17	0
F2	16	0	15	0	14	1	16	0	16	0
F3	14	3	13	3	16	0	17	0	17	0
F4	16	1	11	5	15	1	17	0	17	0
TOTAL	315	51	298	48	339	8	366	0	366	0

major damage was detected and the minor repairs to trails and cable trenches will begin following inspection of the remaining seven subarrays. Eighteen marker posts were replaced and one new "coolie hat" was installed.

The CTH at subarray E1, which had experienced water leakage during the spring runoff, was treated with a heavy surface application of bentonite worked into the soil above and surrounding the vault. Bentonite is a special, pure form of clay, a volcanic ash, mined in Wyoming. The bentonite swells and seals when it comes in contact with water, consequently, it is used to seal dams and irrigation ditches. None of the vaults that have been given the bentonite treatment leaked this spring.

Oil exploration drilling occurred at one location seven miles from WNV 85 at subarray F2. Drilled to a 4700-ft depth in Custer County, section 24, 1 north and 49E, this hole was plugged and abandoned. The one location reported last quarter near F1-83 has been plugged and abandoned also.

SECTION VII

ASSISTANCE PROVIDED TO OTHER AGENCIES

7.1 Seismic Data Laboratory

Develocorder film recordings of selected SP sensor data are made for SDL. Each film covers a period of approximately 24 hours; film change is made at about 2200 GMT. Ninety-two films with the format described in reference 8 were recorded during this period.

7.2 MIT Lincoln Laboratory

Tests were performed for the Seismic Discrimination Group to provide digital data recordings of step responses from the LP seismometers at subarray D1. Tests were run using two different step amplitudes, viz. 15 and 24 VDC. These tests used the step calibration capability of PDP-7 program LPRPG described in paragraph 5.3.1.

SECTION VIII

DOCUMENTATION PROVIDED UNDER VT2708

8.1 Technical Reports

The following reports were distributed during this period:

- 1) Montana LASA First Quarterly Technical Report, Project VT/2708. T/R 2056-72-16, March 15, 1972.
- 2) "LASA Equipment and Facilities Aging Report" Report No. 2056-72-17, March 31, 1972.
- 3) "Operation and Maintenance of LASA, Monthly Progress Report" Report No. 2056-72-18, April 7, 1972.
- 4) "Seismograph Calibrations Using Pseudo-Random Binary Sequences", Report No. 2056-72-19.
- 5) "Operation and Maintenance of LASA, Monthly Progress Report" Report No. 2056-72-20, May 5, 1972.

8.2 Operations Data

Thirteen weekly issues of the Defective Signal Channel Status and Data Interruption Log Reports and Develocorder operations logs were distributed to approved using agencies. Two issues of the Array Status Report (AS-66, 21 March and AS-67, 1 May) were prepared and distributed.

8.3 Alternate Management Summary Reports

Three Alternate Management Summary Reports (AMSR) were prepared and distributed from Philco-Ford C&TS Division Headquarters; one for each of the months March, April and May 1972.

Preceding page blank

REFERENCES

1. Philco-Ford Corp. Montana LASA Second Quarterly Technical Report AD846155, Billings, Mt., Nov. 68, Appendix A.
2. Philco-Ford Corp. Montana LASA First Quarterly Technical Report, Project VT2708, TR 2056-72-17, Billings, Mt., 15 Mar. 72, p. 36.
3. ibid., pp 53-55
4. Philco-Ford Corp. Montana LASA Final Technical Report, VT1708 TR 2039-71-13 (AD738003) Billings, Mt., 22 Dec. 71, pp 129-131
5. ibid., pp 127-128
6. ibid., p 121
7. ibid., p 60
8. ibid., p 121
9. Philco-Ford Corp. Montana LASA Second Quarterly Technical Report VT1708, TR 2039-71-07 (AD885649) Billings, Mt., 15 June 71, pp 47-53.
10. R. E. Matkins, and S. T. Smith LASA Equipment and Facilities Aging Report, TR2056-72-17, Billings, Mt., 31 Mar. 72.