



DEPARTMENT OF THE ARMY
U.S. ARMY FOREIGN SCIENCE AND TECHNOLOGY CENTER
 220 SEVENTH STREET NE.
 CHARLOTTESVILLE, VIRGINIA 22901

AD 745365

In Reply Refer to:
 FSTC-HT-23- 1060-72
 DIA Task No. T70-23-01

Date: 13 June 1972

TRANSLATION

ENGLISH TITLE: The Influences of Shock Compression Pressure on
 Critical Shear Stress in Metals

FOREIGN TITLE: O Vliyaniy Davleniya Udarnogo Szhatiya na Velichiny
 Kriticheskikh Napryazheniy Sdviga v Metallakh

AUTHOR:	S. A. Novikov and L. M. Sinityna	LANGUAGE:	Russian
SOURCE:	Zhurnal Prikladnoy Mekhaniki i Tekhnich- eskoy Fiziki, No. 6, 1970, pp 107-110.	TRANSLATOR:	Albert L. Peabody Leo Kanner Associates
		REQUESTOR:	Frankford Arsenal

Explosive experiments have been performed to study the critical shear stress σ_* beyond the leading edge of shockwaves in aluminum at pressures of 300 and 650 kbar, copper in pressures of 240 and 550 kbar and lead at pressures of 460 kbar. Estimates of this quantity were performed by comparison of experimental data characterizing the decrease in pressure at the leading edge of the shockwave due to unloading with the results of calculation.

1. It was experimentally demonstrated in [1, 2] that the critical shear stress σ_* in metals increases significantly with increasing hydrostatic pressure. With shock compression, the value of critical shear stress determines the amplitude of the elastic unloading wave in the material preliminarily compressed by the shockwave. A diagram of the change in stress state upon impact compression with subsequent expansion of an infinite medium is shown on Figure 1, where ABC is the shock compression curve (im-

Approved for public release. Distribution unlimited.

Reproduced by
**NATIONAL TECHNICAL
 INFORMATION SERVICE**
 U S Department of Commerce
 Springfield VA 22151

D D C
 REPRODUCED
 JUL 26 1972
 REPRODUCED
 B

fact adiabatic curve); CDE is the expansion curve; CD is the elastic sector, expansion is performed in the elastic unloading wave; DE is the sector of plastic unloading; AF is the hydrostatic compression curve.

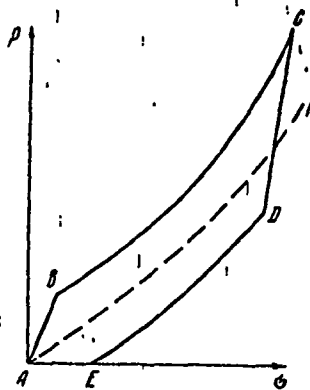

Figure 1.

The value of critical shear stress σ_* which, when reached, results in return transition from elasticity to plasticity in the process of expansion of a shock compressed material is related to the amplitude of the pressure in the elastic unloading wave P_* by the relationship

$$\sigma_* = \frac{P_*}{2} \frac{1-2\mu}{1-\mu} \quad (1)$$

where μ is Poisson's coefficient of the material at the given shock compression pressure.

In calculations of the compression of metal by strong shockwaves, the strength properties are frequently ignored, looking upon the metal as a fluid (hydrodynamic theory). Consideration of the strength, i.e. the elastic sector on the expansion curve, significantly changes the flow picture during shock compression [3].

It was first experimentally shown in [4] that with a shock compression pressure of 100 kbar, the role of strength in aluminum is quite significant -- the critical shear stress is 28.5 kbar. In [5], this result was confirmed in experiments with aluminum alloys: with shock compression pressures of 110 and 345 kbar, the critical shear stresses were 8.6 and 22 kbar respectively¹. In [6], results are presented from numerical calculations which consider the influence of elastic unloading on the propagation and attenuation of shockwaves in solids.

Estimation of the value of σ_* in this work, as in works [4, 5], was performed by comparison of calculated and experimental dependences characterizing the decrease in pressure at the leading edge of the shockwave in these metals, occurring due to the elastic unloading wave which catches up.

¹ The values of critical stresses presented were produced from the values of pressures P_* determined in [5] where $\mu = 0.31$.

2. In order to determine the critical shear stress behind the leading edge of the shockwave, the attenuation of pressure at the leading edge of the shockwave caused by the impact of a plate on a specimen made of the same material as the plate was studied. To describe the method, let us study a diagram of the successive change in pressure at the leading edge of the shockwave due to its interaction with the elastic unloading wave in coordinate x , t (travel-time) as shown on Figure 2, where A is the impacting plate; B is a semi-infinite specimen.

When the plate strikes the specimen, two shockwaves 1 and 2 are formed. The unloading wave which catches up with the leading edge of the shock compression wave 3 is formed when the shockwave 1 is reflected in the plate from its free surface. The metal is unloaded first in the elastic unloading wave 3, then to zero in the plastic unloading wave 4 (curves CD and DE on Figure 1). The velocity of the elastic unloading wave is higher than the velocity of the plastic unloading wave. When the elastic unloading wave interacts with the shockwave, the pressure at the leading edge of the wave drops by a quantity determined by the amplitude of the elastic unloading wave, i.e., by the critical shear stress. A weak elastic compression wave 5 propagates to the left through the specimen. Then this wave interacts with the plastic unloading wave, elastic unloading wave 6 propagates to the right once more, catching up to the leading edge of the shockwave, etc. The process is repeated until the pressure at the leading edge of the shockwave drops to zero.

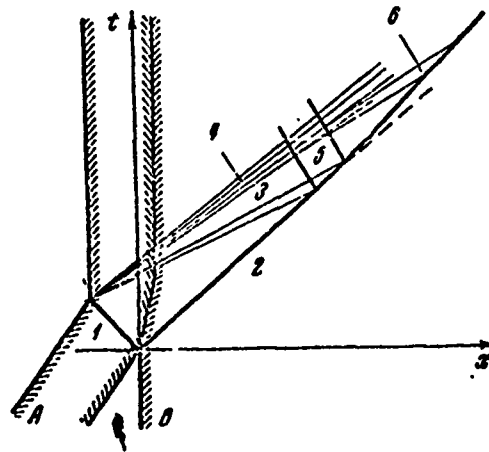

Figure 2.

ACCESSION FOR		
CFSTI	WHITE SECTION	<input checked="" type="checkbox"/>
DDC	DIFF SECTION	<input type="checkbox"/>
UNANNOUNCED		<input type="checkbox"/>
JUSTIFICATION		
BY		
DISTRIBUTION/AVAILABILITY CODES		
DET.	AVAIL.	SPECIAL
A		

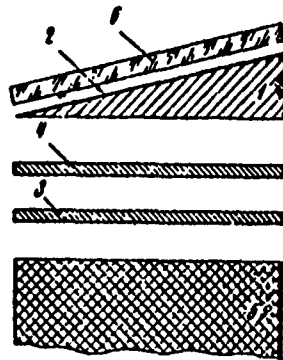

Figure 3.

Thus the pressure at the leading edge of the shockwave decreases in jumps as it propagates through the specimen. The velocity of the material (mass velocity) u behind the leading edge of the wave and the velocity of the free surface of specimen w change correspondingly as the shockwave reaches the free surface.

3. Experiments were used to study specimens of aluminum alloy D1, copper M1 and lead as delivered (without additional heat treatment). The quantity measured in the experiments was the velocity of the free surface of the specimen being studied w .

The experimental diagram as shown on Figure 3, where 1 is the specimen; 2 is foil; 3 and 4 are plates of the material being studied; 5 is an explosive charge with a planar detonation wave; 6 is a block of organic glass, recording the approach of the foil by the photochronographic method. The function $w = w(x)$ was determined in experiments with specimens made in the shape of wedges. The use of specimens of this shape allows us to produce the function $w = w(x)$ for $0 < x < h$ in each experiment (where h is the maximum thickness of the specimen). The shockwave in the specimen was excited by the impact of plate 4 of the same material, 2 mm thick. To eliminate the influence of pressure of the explosion products on propagation of the shockwave in the specimen, a second plate 3 was placed between the striking plate and the charge; the explosive accelerated plate 3.

When the plates collided, plate 4 was given a velocity equal to the velocity of plate 3, while plate 3 moved significantly more slowly. An air gap of 5 mm was set up between the explosive and plate 3 to avoid splitting of the plate. The approach velocity of plate 4 to the specimen was measured in special experiments. The velocity was changed by using explosives of various compositions. The photochronographic and electrical contact methods, described in the [7], were used to measure the velocity of the free surface. The time intervals between the moment of contact of the free surface by the shockwave and the moments when the free surface approached contacts located at 3 to 4 mm from the surface of the specimen (or the block of organic glass 6 when the photochronographic method was used) were recorded. In order to eliminate the influence of separation on the velocity measured in the experiments, aluminum foil 2, 0.2 mm thick, was tightly glued to the surface of the aluminum specimens. The correction for the drop in free surface velocity due to separation in experiments with copper specimens was based on experimental data [8].

4. Calculation of the flow behind the leading edge of the shockwave considering its interaction with the elastic unloading waves which catch up was performed on the basis of known equations of the state of these metals, presented in [9]. The experimental and calculated dependences $w = w(x)$ for aluminum with $P = 680$ kbar and lead with $P = 460$ kbar are presented on Figure 4a and 4b respectively. Shaded areas 2 are determined by the spread of experimental data in each series of identical experiments. Dotted curves 1 are the calculation dependences for $\sigma_* = 0$ (hydrodynamic theory), solid lines 3 and 4 (Figure 4a) are the calculated dependences for $P = 70$ kbar and $P = 100$ kbar. During performance of the calculations, as in [4], the change in Poissons coefficient with pressure was ignored; the values of μ were taken equal to 0.31, 0.34 and 0.44 respectively for aluminum, copper and lead¹.

We note that none of the experimental curves show a sudden change in free surface velocity. This apparently can be explained by the fact that the transition from elasticity to plasticity during expansion of shock compressed metals occurs according to a smooth curve, not according to a broken curve (CDE on Figure 1). This behavior of metals upon transition from elasticity to plasticity must be expected from the results of [10].

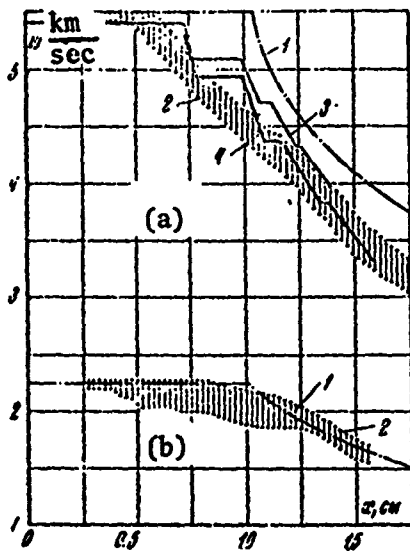

Figure 4.

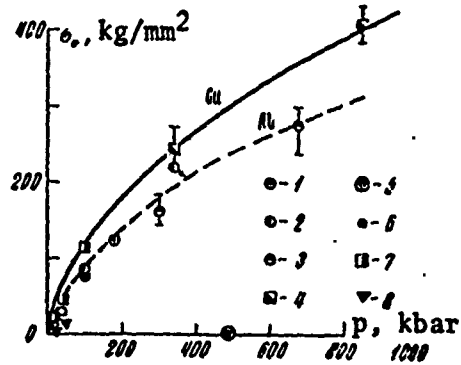

Figure 5.

¹ Consideration of the dependence of Poissons coefficient on pressure in the shockwave can change the value of σ_* slightly.

Three or four identical experiments were performed for each material with identical flight velocity of the impact plate.

As the value of critical shear stress corresponding to a given pressure behind the leading edge of the shockwave, we used the value of σ_* , the calculation dependence $w = w(x)$ for which best described the experimental data.

As the value of error in determination of σ_* , based on comparison of experimental and calculated data, we use the interval between values of σ_* , the calculation curves $w = w(x)$ for which touched the upper and lower boundaries of the shaded area.

As we can see from Figure 4b, the experimental dependence $w = w(x)$ for lead is well described by the calculated curve produced using the hydrodynamic theory ($\sigma_* = 0$).

Let us present the estimates of σ_* produced in this manner and the corresponding amplitudes of pressure in the elastic unloading wave P_* in kbar with shock compression pressure P in kbar for the metals studied

	P	σ_*	P_*
Al	300-680	17-29	60-100
Cu	340-860	25-41	90-150
Pb	460	0	0

5. Comparison of the calculated and experimental data shows that the role of strength is significant for aluminum and copper in the shock compression pressure area studied (up to 680 kbar for aluminum and 860 kbar for copper).

The values of σ_* produced in this work for the material studied as a function of pressure behind the leading edge of the shockwave are presented on Figure 5: points 3, 4 and 5 correspond to aluminum, copper and lead. Here also we show the results of similar investigations for aluminum (points 1 and 2) from [4] and [5] respectively. This Figure also shows data on the influence of hydrostatic pressure on the value of σ_* in aluminum, copper and lead: points 6 and 8 from [1] for aluminum and lead, points 7 from [2] for copper. The data on aluminum are quite satisfactorily described by the general curve.

As the shock compression pressure increases, the temperature behind the leading edge of the shockwave increases. The effect of these factors, pressure and temperature, on the critical shear stress, is directly opposite. Obviously, at the shock compression pressure where melting of the metal occurs, the value of σ_* is practically equal to zero. Thus, the function $\sigma_* = \sigma_*(P)$ has a maximum with shock compression.

According to the results of theoretical and experimental studies [11, 12], the melting of aluminum behind the leading edge of a shockwave occurs in the area of 1,050-2,020 kbar, copper -- at 2,050-2,550 kbar, lead -- at 410-1,240 kbar.

The fact that the results of the experiments performed indicate that the value of σ_* for lead is practically equal to zero at 460 kbar confirms the fact of melting of the lead behind the leading edge of the shockwave at this pressure.

BIBLIOGRAPHY

1. Bridzhmen, P. V., *Issledovaniye Bol'shikh Plasticheskikh Deformatsiy i Razryva* [Study of Five Plastic Deformations and Rupture], Moscow, Foreign Literature Press, 1955.
2. Voronov, F. F., Vereshchagin, L. F., "Influence of Hydrostatic Pressure on Elastic Properties of Metals, I. Experimental Data," *Fizika Metallov i Metallovedeniye*, Vol 11, No 3, 1961.
3. Morland, L. W., "The Propagation of Plane Irrotational Waves Through an Elastoplastic Medium," *Philos. Trans. Roy. Soc., London, Ser. A.*, Vol 251, No 997, 1959.
4. Curran, D. R., "Nonhydrodynamic Attenuation of Shockwaves in Aluminum," *J. Appl. Phys.*, Vol 34, No 9, 1963.
5. Erkman, J. O., Christensen, A. B., "Attenuation of Shockwaves in Aluminum," *J. Appl. Phys.*, Vol 38, No 13, 1967.
6. Che-Hung Mok, "Effects of Solid Strength on the Propagation and Attenuation of Spherical and Plane Shockwaves," *J. Appl. Phys.*, Vol 39, No 4, 1968.
7. Al'tshuler, L. V., "Use of Shockwaves in High Pressure Physics," *Usp. Fiz.*, Vol 85, No 2, 1965.
8. Novikov, S. A., Divnov, I. I., Ivanov, A. G., "Study of Rupture of Steel, Aluminum and Copper Under Explosive Loading," *Fizika metallov i Metallovedeniye*, Vol 21, No 4, 1966.
9. Al'tshuler, L. V., Kormer, S. B., Brazhnik, M. I., Vladimirov, L. A., Speranskaya, M. P., Funtikov, A. I., "Isentropic Compressibility of Aluminum, Copper, Lead and Iron at High Pressures," *ZhETF*, Vol 38, No 4, 1960.
10. Novikov, S. A., Sinitsyn, V. A., Ivanov, A. G., Vasil'yev, L. V., "Elastic-Plastic Properties of a Number of Metals Under Explosive Loading," *Fizika Metallov i Metallovedeniye*, Vol 21, No 3, 1966.
11. Mineyev, V. N., Savinov, Ye. V., "Ductility and Melting Point of Aluminum, Lead and Sodium Chloride Under Impact Compression," *ZhETF*, Vol 52, No 3, 1967.
12. Urlin, V. D., "Melting at Super High Pressures Produced in a Shockwave," *ZhETF*, Vol 49, No 2, 1965.