

AD 744679

①

A Preprint
from the

OWENS VALLEY RADIO OBSERVATORY

California Institute of Technology
Pasadena, California

1972

A. APERTURE SYNTHESIS STUDY OF NEUTRAL HYDROGEN IN THE GALAXIES NGC 6946 AND IC 342

by

D. H. Rogstad, G. S. Shostak and A. H. Rots

DDC
REGISTERED
JUL 8 1972
C

AR

Reproduced by
NATIONAL TECHNICAL
INFORMATION SERVICE
U.S. Department of Commerce
Springfield, VA 22161

REGISTERED
JUL 9 1972
C

32-

DISTRIBUTION STATEMENT A
Approved for public release;
Distribution Unlimited

DOCUMENT CONTROL DATA - R & D

(Security classification of title, body of abstract and indexing annotation must be entered when the overall report is classified)

1. ORIGINATING ACTIVITY (Corporate author) California Institute of Technology Owens Valley Radio Observatory Pasadena, California 91109	2a. REPORT SECURITY CLASSIFICATION UNCLASSIFIED
	2b. GROUP

3. REPORT TITLE
APERTURE SYNTHESIS STUDY OF NEUTRAL HYDROGEN IN THE GALAXIES NGC 6946 AND IC 342.

4. DESCRIPTIVE NOTES (Type of report and inclusive dates)

5. AUTHOR(S) (First name, middle initial, last name)
D. H. Rogstad, G. S. Shostak and A. H. Rots

6. REPORT DATE

4, 1972

7a. TOTAL NO. OF PAGES

32

7b. NO. OF REFS

21

8a. CONTRACT OR GRANT NO

Nonr N00014-67-A-0094-0019

A. PROJECT NO.

c.

d.

8b. ORIGINATOR'S REPORT NUMBER(S)

#4, 1972

8c. OTHER REPORT NO(S) (Any other numbers that may be assigned this report)

10. DISTRIBUTION STATEMENT

This document has been approved for public release and sale; its distribution is unlimited.

11. SUPPLEMENTARY NOTES

12. SPONSORING MILITARY ACTIVITY

Office of Naval Research

13. ABSTRACT

Synthesis observations of neutral hydrogen emission in the two spiral galaxies NGC 6946 and IC 342 are presented. The velocity resolution is 21 km/s and the angular resolution is 2 and 4 min of arc for NGC 6946 and IC 342 respectively. Results are presented in the form of contour maps of the integral and mean velocity of the HI profile at each position in the galaxy, as well as a line profile for each galaxy as a whole. Both galaxies evidence a central depression in their HI distributions. The rotation curves have steep central gradients with rather constant velocities once the maximal velocity is reached. The HI mass for NGC 6946 is $21 \times 10^9 M_{\odot}$ and for IC 342 is $15 \times 10^9 M_{\odot}$, assuming distances of 10.1 and 4.5 Mpc respectively. Other properties are summarized in the table.

I

ABSTRACT

Synthesis observations of neutral hydrogen emission in the two spiral galaxies NGC 6946 and IC 342 are presented. The velocity resolution is 21 km/s and the angular resolution is 2 and 4 min. of arc for NGC 6946 and IC 342 respectively. Results are presented in the form of contour maps of the integral and mean velocity of the HI profile at each position in the galaxy, as well as a line profile for each galaxy as a whole. Both galaxies evidence a central depression in their HI distributions. The rotation curves have steep central gradients with rather constant velocities once the maximal velocity is reached. The HI mass for NGC 6946 is $21 \times 10^9 M_{\odot}$ and for IC 342 is $15 \times 10^9 M_{\odot}$, assuming distances of 10.1 and 4.5 Mpc respectively. Other properties are summarized in the table.

Address of authors: Drs. D. H. Rogstad and G. S. Shostak
Owens Valley Radio Observatory
California Institute of Technology
1201 East California Blvd.
Pasadena, CA. 91109, U.S.A.

Dr. A. F. Rots
Kapteyn Laboratory
Groningen, Netherlands

Key Words: Galaxies - Hydrogen

I. INTRODUCTION

NGC 6946 and IC 342 are two Scd galaxies of luminosity class ScI (or possibly ScII in the case of NGC 6946, van den Bergh, 1960). Both galaxies are located near the galactic plane ($b \sim 11^\circ$) and, consequently, are significantly affected by Galactic extinction. For this reason both of these systems were included in the recent photometric studies of Ables (1971). He estimates the Galactic extinction in blue light to be 1.75 mag for NGC 6946 and 2.2 mag for IC 342. Using these numbers and Ables' photometric results, we estimate the optical diameters of these galaxies, to the same surface brightness limit used by Holmberg (1958), to be 19 min. of arc and 40 min. of arc respectively. The most recent distance estimates are provided by Tammann and Sandage (Tammann, 1971, private communication). They give 10.1 Mpc for NGC 6946, and an uncertain value of 4.5 Mpc for IC 342.

Early HI observations of IC 342 were made by Dieter (1962) using the 60 ft (18.3m) telescope of the Harvard Observatory. NGC 6946 was observed with the same instrument by Epstein (1964). Recent observations of NGC 6946 with the NRAO 300' (91.5m) telescope were made by Gordon, Remage and Roberts (1968). A serious difficulty encountered by these observers was that the low Galactic latitude and nearly zero systemic velocity of both objects resulted in confusion of their line profiles by intense Galactic HI emission. This confusion is largely avoided with interferometric observations since the interferometer is relatively insensitive to the smooth spatial character of the Galactic HI emission.

For this reason we were able to include these two galaxies in the HI synthesis program at the Owens Valley Radio Observatory.

The results of this study are summarized in the last section of this paper. An extensive comparison of the present results with similar observations of three other Scd galaxies (M33, NGC 2403 and M101) is contained in Rogstad and Shostak (1972).

II. OBSERVATIONS

The 90' (27.4m) twin-element interferometer of the Owens Valley Radio Observatory was used to synthesize maps in the hydrogen line for NGC 6946 and IC 342 to resolutions of 2 and 4 min. of arc respectively. The spectral resolution was 100 kHz (21 km/s.). The instrument and observing technique have been described by Rogstad and Shostak (1971). An exception to that description is that no frequency shift was used for the present observations. Therefore the interval between adjacent filters was 100 kHz instead of 50 kHz. Figure 1 shows the coverage obtained in the U-V plane. The total observing time on NGC 6946 was about 120 hours, and for IC 342 about 40 hours.

Using the reduction methods described by Rogstad and Shostak (1971), the data were Fourier-inverted. The results are presented in Figures 2 through 5 as the distribution of integrated brightness temperature, \bar{T}_{int} , and the weighted mean velocity field, \bar{V} , for each galaxy. The bar on these quantities indicates that

they have been smoothed by the synthesized beam. As mentioned above, Galactic HI emission confuses the radiation from both NGC 6946 and IC 342. Because of the smooth spatial character of Galactic hydrogen at this latitude, it does not appear in these observations as emission. Instead, it absorbs the extragalactic radiation primarily in one channel for NGC 6946 and in two channels for IC 342. The amount of absorption was estimated from the brightness temperature of the Galactic emission assuming a spin temperature of 100°K . Correction for this absorption (a factor no greater than 1.5) resulted in continuity of the peak brightness temperatures in adjacent channel maps, as well as a symmetric integrated line profile for each galaxy. Therefore it is believed that any remaining effects are no greater than the noise in the maps.

First order corrections were determined for distortions in the velocity maps due to weighting by the hydrogen distribution. They were found to be less than the observational uncertainties and consequently were not applied. The velocity fields given in Figures 3 and 5 are believed to represent the true mean velocity at each position in the galaxies to within the errors and resolution quoted.

The individual two-dimensional channel maps were integrated spatially to obtain the global line profiles shown in Figure 6. These are useful for comparison with the results from other observers because they are, to a large degree, independent of the observing instrument.

A map of the continuum emission at 21 cm for each galaxy was obtained from an average of the narrowband channels which contained no line radiation. These are shown in Figures 7 and 8. The integral under each map yields a continuum flux density of 1.6 ± 0.1 f.u. for NGC 6946 and 1.6 ± 0.2 f.u. for IC 342. The value for NGC 6946 is in good agreement with that measured by Heeschen and Wade (1964), where measurements at two other frequencies indicate that most of the continuum radiation must be non-thermal with a spectral index of about -1. The slightly lower value measured by Lequeux (1971) may be due to differences in our estimates of the flux contained in broad components. De Jong (1965, 1967) has observed IC 342 at 40, 21 and 11 cm and obtains a flux density at 21 cm of twice our value. This is probably due to his inclusion of emission from the two components on either side of the main central source which lies at the center of the galaxy. De la Beaujardière et al. (1968) have also observed IC 342 and give a central component flux density of 2.2 ± 0.3 f.u., and an E-W diameter in good agreement with our results. Their flux density is slightly higher than the present value. This may be due to very broad components which have been partially resolved by our instrument. The spectral index obtained by de Jong (1967) is similar to that for NGC 6946, about -1.

III. DISCUSSION

Photographs of NGC 6946 and IC 342, reproduced from the Palomar Sky Atlas, are presented in Figures 9 and 10. The faint

outer regions in NGC 6946 have been taken from a deeper plate given in the Catalogue of Peculiar Galaxies of Arp (1968) and superposed on the Sky survey image. The orientation of the photographs here and in the following figures is such that the major axis of the galaxy, as determined from the velocity field, coincides with the horizontal axis of the figure. The scale is indicated by the bar in the corner. It is evident that there is considerable obscuration in both images.

(a) HI distribution

Contour maps of the HI surface density distributions have been superposed on the photographs of the galaxies and reproduced in Figures 11 and 12. A notable feature in both of these maps is the deep central depression found in an area of the galaxy where the light distributions peak. Similar depressions have been found in a number of other spirals by Roberts (1967). Rogstad (1971) has suggested that ionization may be the cause of the central depression found in the galaxy M1C1, but since ionization is not always found in galaxies for which a lack of HI is noted (e.g. M31, see Monnet, 1971) it is unlikely that this serves as a general explanation.

Pikethner (1968) has suggested a more satisfactory explanation for this phenomenon. He notes that the combination of a radially increasing HI layer thickness together with an upper limit to the HI volume density will produce a central decrease in the hydrogen surface density. Unfortunately these ideas have

not been developed sufficiently to allow detailed comparisons with observations, except that, as Pikel'ner points out, the evidence for constant HI volume density and increasing HI scale height with radius found in the Galaxy supports this explanation.

With the exception of the central regions, comparison of the HI and light distributions indicates a general similarity, with the most intense HI peaks and ridges tending to fall on corresponding optical features. More detailed comparisons are not warranted because of the relatively low resolutions in the HI maps and obscuration in the photographs. The diameters of the overall hydrogen distributions are close to the optical sizes estimated above: approximately 80% of the observable hydrogen lies within the optical diameter. The slight asymmetry about the center of the HI map of NGC 6946, as well as the anomalous major to minor axis ratio found for IC 342, tend to be reflected in the low level photometric results of Ables (1971) for these objects.

Assuming low optical depths and the distances given above the HI maps have been integrated to yield hydrogen masses of $(21 \pm 1) \times 10^9 M_{\odot}$ and $(15 \pm 1) \times 10^9 M_{\odot}$ for NGC 6946 and IC 342 respectively. A previous estimate for NGC 6946 by Gordon, et al. (1968) is close to the present value, but Dieter's (1967) result for IC 342 is low by a factor of 2 due to confusion with Galactic hydrogen.

(b) Velocity field

In Figures 13 and 14 the velocity fields are superposed on the optical image of the corresponding galaxy. Both objects show the expected circular rotation. This component of the velocity can be represented quite well in each galaxy by a Brandt model rotation curve (see Brandt and Scherer 1965) with the same value for n , but scaled appropriately by turnover radius and maximal velocity. The most notable features of these rotation curves is their steep central gradient, and flatness once the maximum velocity has been reached. This latter result implies that any extrapolation of the total mass estimate to infinite radius is very uncertain.

Both velocity fields show significant deviations from circular rotation, frequently appearing as extended ridges in the contour maps. Because of the poorer coverage in the U-V plane for IC 342 relative to that required by its size (see Figure 1), the cause of the ridges in this galaxy is somewhat uncertain. However, deviations in NGC 6946, often on the order of 10 kms^{-1} , are believed to be real and are consistent with the type of velocity streaming predicted by the density wave theory of spiral structure (Lin, Yuan and Shu, 1969). A model velocity field showing the effects of density wave streaming is given in Rogstad (1971). The observations suggest that the pattern speed is slower than the rotation velocity, placing the co-rotation point outside the visible spiral arms. These results are very qualitative. Higher spatial resolution and better sensitivity are needed before more quantitative results can be obtained.

Dynamical parameters such as position angle and systemic velocity have been estimated by fitting simple models to the velocity fields. These results are summarized in the table.

(c) Continuum emission

Both galaxies exhibit continuum emission consisting of an unresolved source coincident with the nucleus and containing in each case less than 10% of the total emission, together with a diffuse background source that appears to arise in the disk of the galaxy (Figures 7 and 8). The source in NGC 6946 also shows a second peak west of the center, again containing less than 10% of the total emission. Comparison with the optical image and with the distribution of HII regions obtained by Hodge (1967) suggests that this peak may be thermal emission associated with a group of HII regions. Four supernova have been detected in NGC 6946 since 1885 (Kowal and Sargent, 1971), but no feature in the continuum map seems to be associated with them.

IV. SUMMARY

Moderate angular resolution synthesis observations of NGC 6946 and IC 342 have provided the first HI results for these galaxies that are relatively free of the confusion caused by Galactic HI emission.

A summary of the galaxy properties used or derived in this study are given in the table. We conclude that there is a general agreement between the HI surface density, and the optical light distribution as seen in blue sensitive photographs,

although there may be differences in detail which will require higher spatial resolution to be properly understood. As in the case of M101, NGC 6946 evidences non-circular velocities in its velocity field which may be explained as density wave streaming.

We wish to express our appreciation to G. J. Stanley, Director of the Owens Valley Radio Observatory, for his continued interest in this project, as well as to the observatory staff for their invaluable assistance. We also wish to thank the staffs of the Kapteyn Laboratory and the University of Groningen computing center, where much of the analysis for these observations took place. We gratefully acknowledge G. Tammann's kind assistance in providing distance estimates for both galaxies. The program of research at the Owens Valley Radio Observatory is supported by the National Science Foundation under grant GP30400-X and by the Office of Naval Research, contract N00014-67-A-0094-0019.

REFERENCES

- Ables, H. D. 1971, Pub. of U.S. Naval Obs., Second Series,
Vol. II, Part 4, Washington, D.C.
- Arp, H. 1966, Cat. of Peculiar Galaxies (Pasadena: California
Inst. of Tech.) No. 29.
- Brandt, J. C., and Scheer, L. S. 1965, A. J., 70, 471.
- De Jong, M. L. 1965, Ap. J., 142, 1333.
- De Jong, M. L. 1967, Ap. J., 150, 1.
- De la Beaujardière, O., Kazès, I., Le Squeren, A. M., and
Nguyen Quang Rieu 1968, Ann. Astrophys. 31, 387.
- de Vaucouleurs, G., and de Vaucouleurs, A. 1964, Ref. Cat. of
Bright Galaxies (Austin: Univ. of Texas Press.)
- Dieter, N. H. 1962, A. J., 67, 313.
- Epstein, E. E. 1964, A. J., 69, 490.
- Gordon, K. J., Remage, N. H., and Roberts, M. S. 1968, Ap. J.
154, 845.
- Heeschen, D. S., and Wide, C. M. 1964, A. J., 69, 277.
- Hodge, P. W. 1967, An Atlas and Catalog of HII Regions in
Galaxies (Seattle: Univ. of Wash. Astr. Dept.).
- Holmberg, E. 1958, Lund Medd., Ser. II, No. 136.
- Kowal, C. T., and Sargent, W. L. W. 1971, A. J. 76, 756.
- Lin, C. C., Yuan, D., and Shu, F. H. 1969, Ap. J. 155, 721.
- Monnet, G. 1971, Astr. & Astrophys., 12, 379.
- Pikel'ner, S. B. 1968, Ann. Rev. Astr. and Astrophys., 6, 165.
- Roberts, M. S. 1967, I.A.U. Symp. No. 31, ed. H. van Woerden
- Rogstad, D. H. 1971, Astr. & Astrophys., 13, 108.

Rogstad, D. H., and Shostak, G. S. 1971, Astr. & Astrophys.,
13, 99.

Rogstad, D. H., and Shostak, G. S. 1972, Ap. J. (in press).

SUMMARY OF PROPERTIES

	<u>NGC 6946</u>	<u>IC 342</u>
TYPE (de Vaucouleurs, 1964)	SAB(rs)cd	SAB(rs)cd
CLASS (Van den Bergh, 1960)	ScI(or II)	ScI
DISTANCE (Mpc)	10.1	4.5
POSITION (1950.0)	($\alpha = 20\ 33\ 48.6$ ($\delta = +59\ 58\ 47$	($\alpha = 03\ 41\ 56.6$ ($\delta = +67\ 56\ 33$
RADIUS R(kpc) (in Holmberg 1958 system)	28	26
MAJOR AXIS P.A.	$62^\circ \pm 3$	$40^\circ \pm 3$
INCLINATION	$30^\circ \pm 5$	$25^\circ \pm 5$
SYSTEMIC VELOCITY (kms^{-1}) (relative to Sun)	$+40 \pm 5$	$+25 \pm 5$
DYNAMICAL PARAMETERS		
n	1.0 ± 0.2	1.0 ± 0.2
R_{to} (kpc)	16.5 ± 2	15.2 ± 2
V_{max} (kms^{-1})	208 ± 5	192 ± 5
$M_T(R)$ ($\times 10^{10} M_\odot$)	18.0	14.1
HYDROGEN MASS		
M_{HI} ($\times 10^9 M_\odot$)	21 ± 1	15 ± 1
CONTINUUM FLUX ($\times 10^{-26} \text{W m}^{-2} \text{Hz}^{-1}$)	1.6 ± 0.1	1.6 ± 0.2

FIGURE CAPTIONS

Fig. 1: Portion of the U-V plane covered by the present observations. Points were obtained along the curves shown. The data were sufficient to synthesize a 2 min. of arc beam for NGC 6946 and a 4 min. of arc beam for IC 342.

Fig. 2: Distribution of integrated brightness temperature, \bar{T}_{int} , for NGC 6946. The contour interval is $100^\circ\text{K} \times \text{km s}^{-1}$. The r.m.s. noise level is about $30^\circ\text{K} \times \text{km s}^{-1}$.

Fig. 3: Mean velocity field, \bar{V} , for the HI in NGC 6946. The contour interval is 15 km s^{-1} , and the r.m.s. noise level is $2-4 \text{ km s}^{-1}$.

Fig. 4: Distribution of integrated brightness temperature, \bar{T}_{int} , for IC 342. The contour interval is $100^\circ\text{K} \times \text{km s}^{-1}$. The r.m.s. noise level is about $50^\circ\text{K} \times \text{km s}^{-1}$.

Fig. 5: Mean velocity field, \bar{V} , for the HI in IC 342. The contour interval is 15 km s^{-1} , and the r.m.s. noise level is $3-6 \text{ km s}^{-1}$.

Fig. 6: Integrated line profiles for NGC 6946 and IC 342. The r.m.s. noise in each point is about 0.5 f.u. Velocities are relative to the Sun.

Fig. 7: Distribution of the 21 cm continuum emission in NGC 6946. The contours are beam smoothed brightness temperature in intervals of 1.5 K, with the lowest contour at 1.5 K. The r.m.s. noise level is 0.5 K.

Fig. 8: Distribution of the 21 cm continuum emission in IC 342. The contours are beam smoothed brightness temperature in intervals of 0.5 K, with the lowest contour at 0.5 K. The r.m.s. noise level is 0.3 K.

Fig. 9: Photo of NGC 6946 enlarged from blue Palomar Sky Survey print. The faint outer regions are superposed from a deep photo found in the Catalogue of Peculiar Galaxies (Arp, 1966).

Fig. 10: Photo of IC 342 enlarged from blue Palomar Sky Survey print.

Fig. 11: Contour map of HI surface density for NGC 6946 superposed on optical picture. One contour interval represents 1.83×10^{20} atoms cm^{-2} .

Fig. 12: Contour map of HI surface density for IC 342 superposed on optical picture. One contour interval represents 1.83×10^{20} atoms cm^{-2} .

Fig. 13: Observed mean-velocity field of the HI in NGC 6946 superposed on photograph.

Fig. 14: Observed mean-velocity field of the HI in IC 342 superposed on photograph.

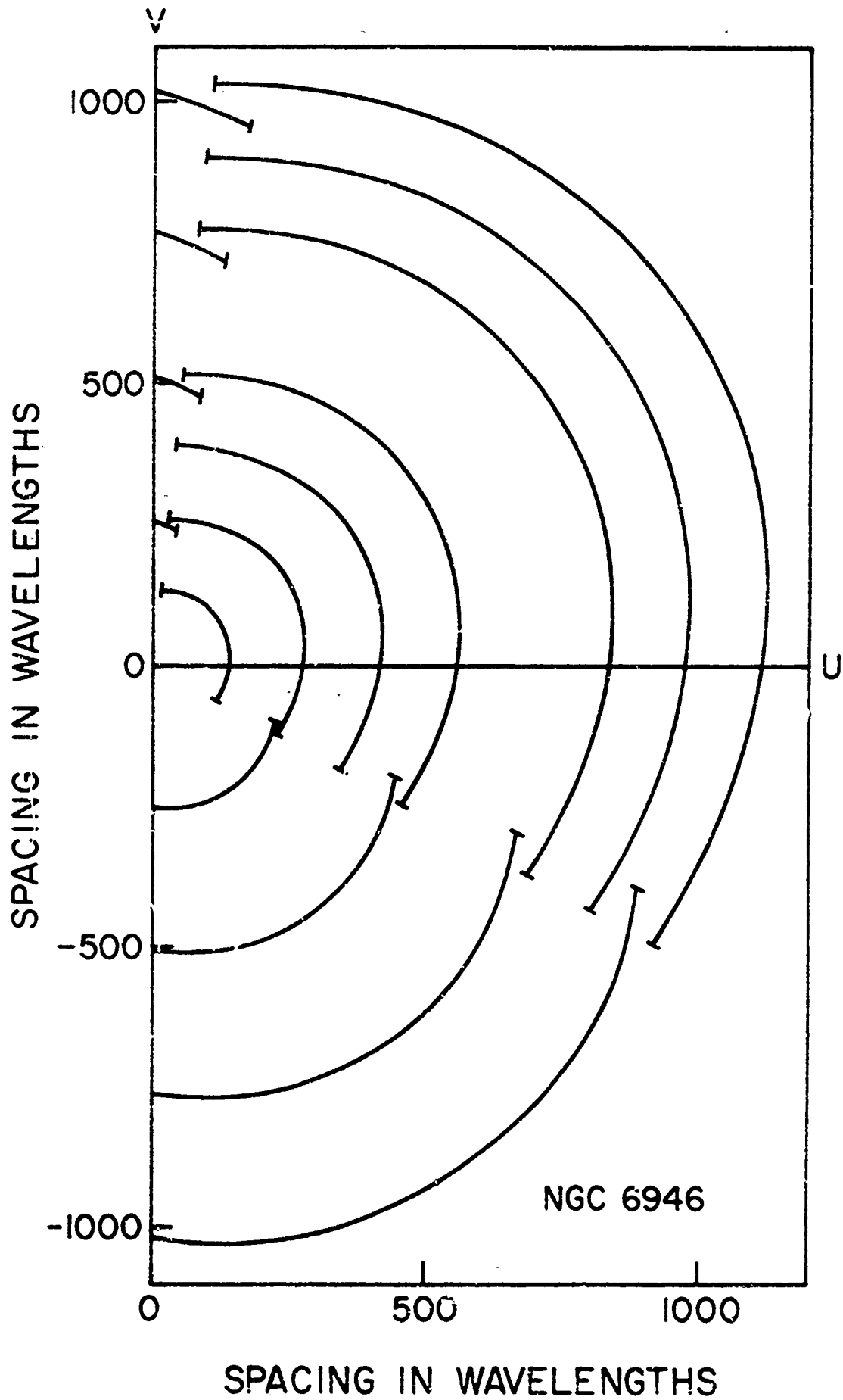

SPACING IN WAVELENGTHS

Figure 1a -16-

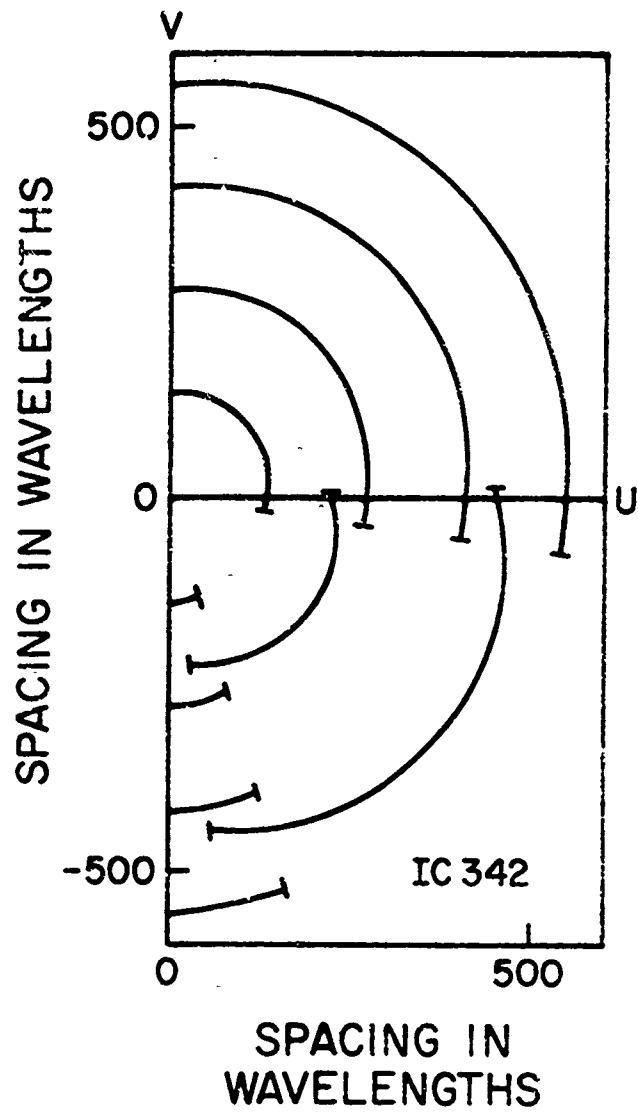

Figure 1b

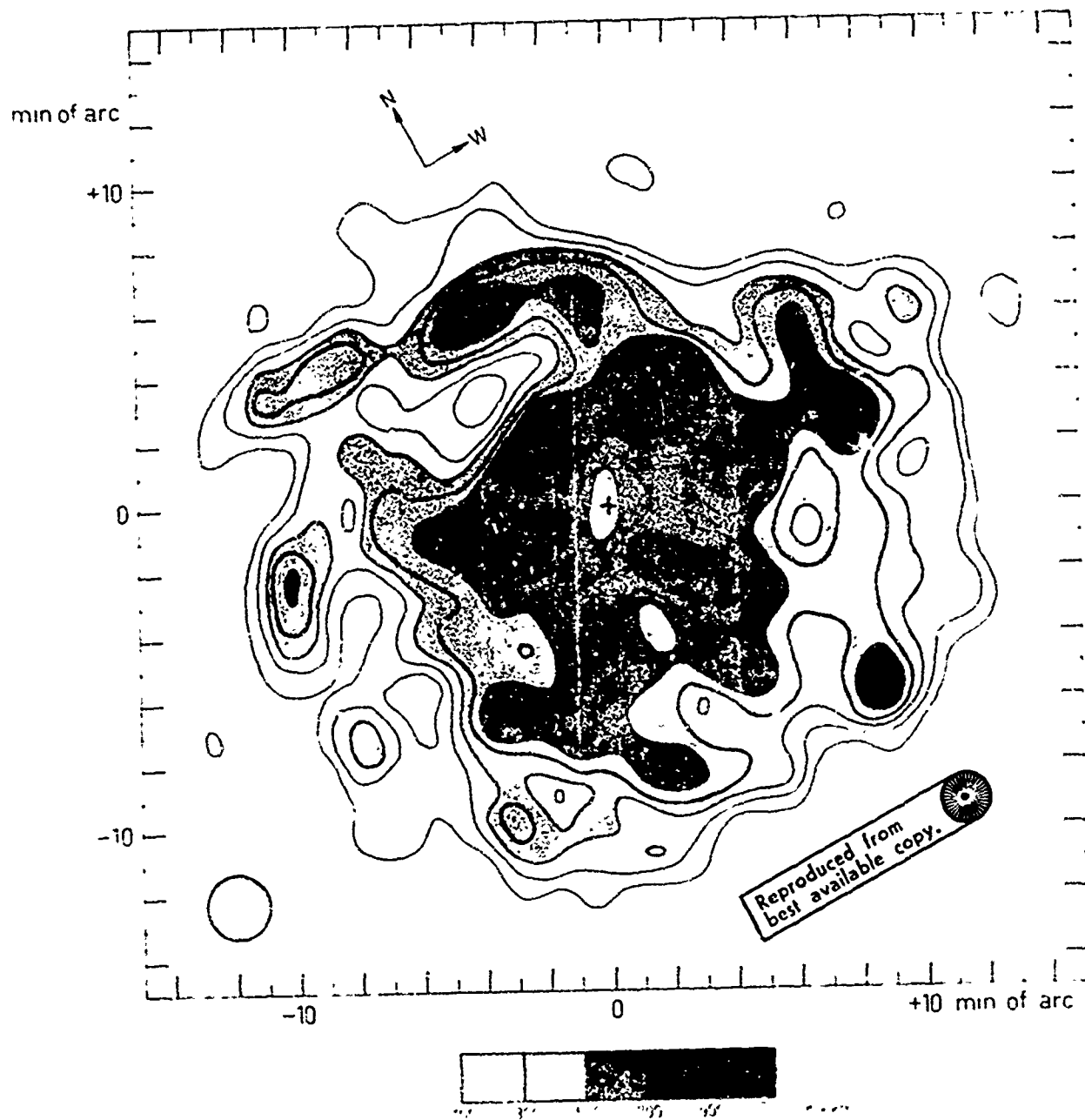

Figure 2

- 18 -

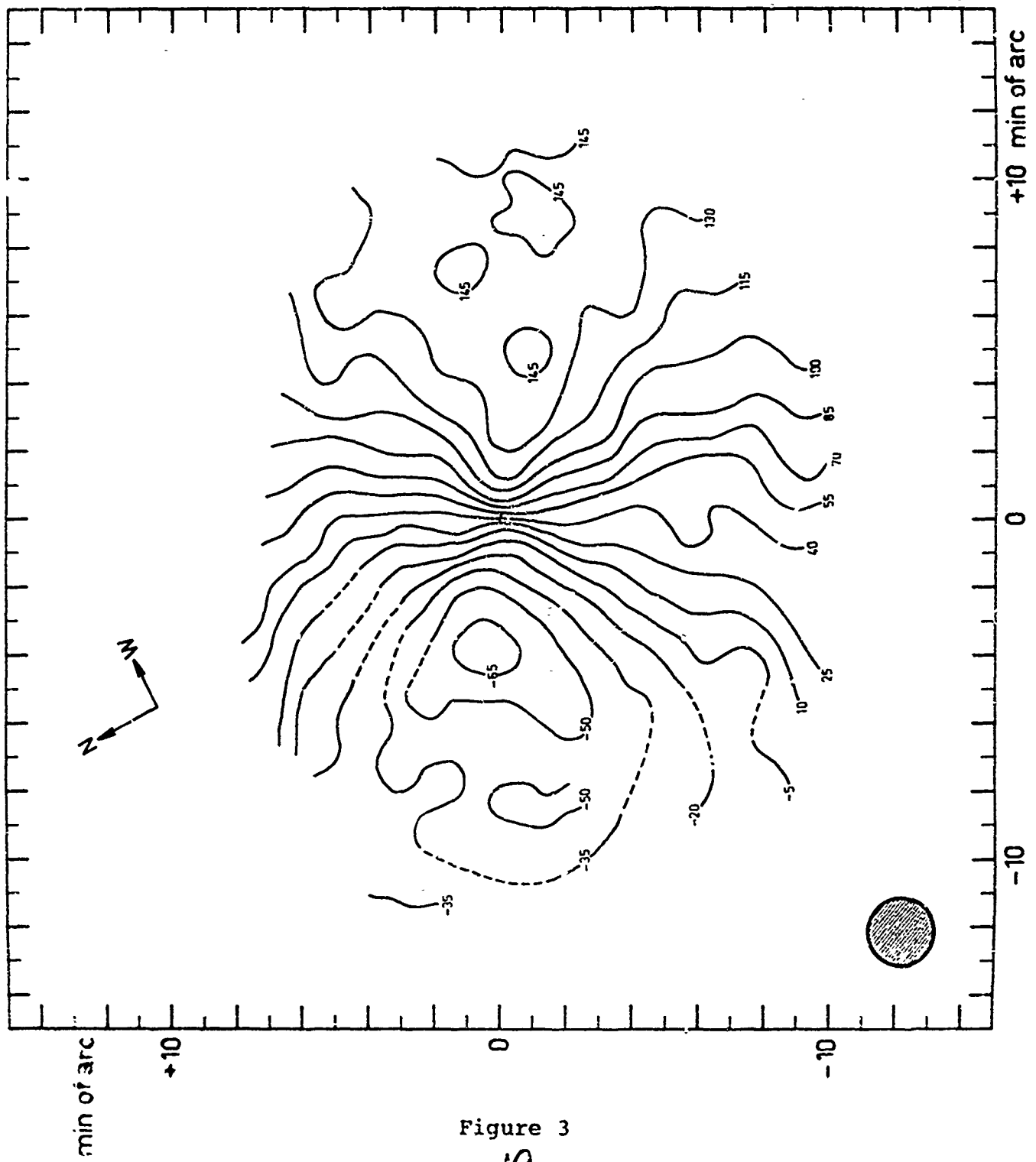
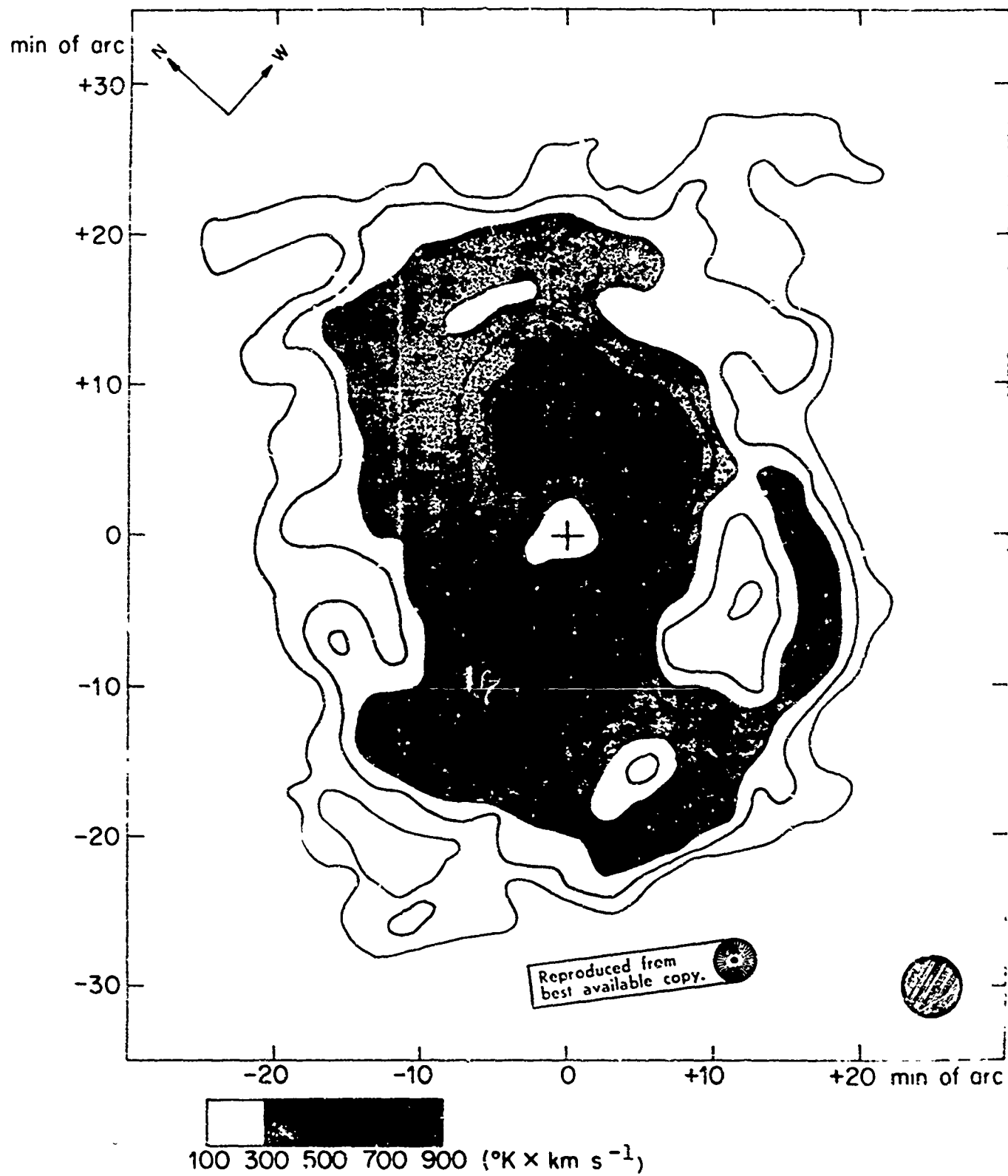

Figure 3



-20-

Figure 4

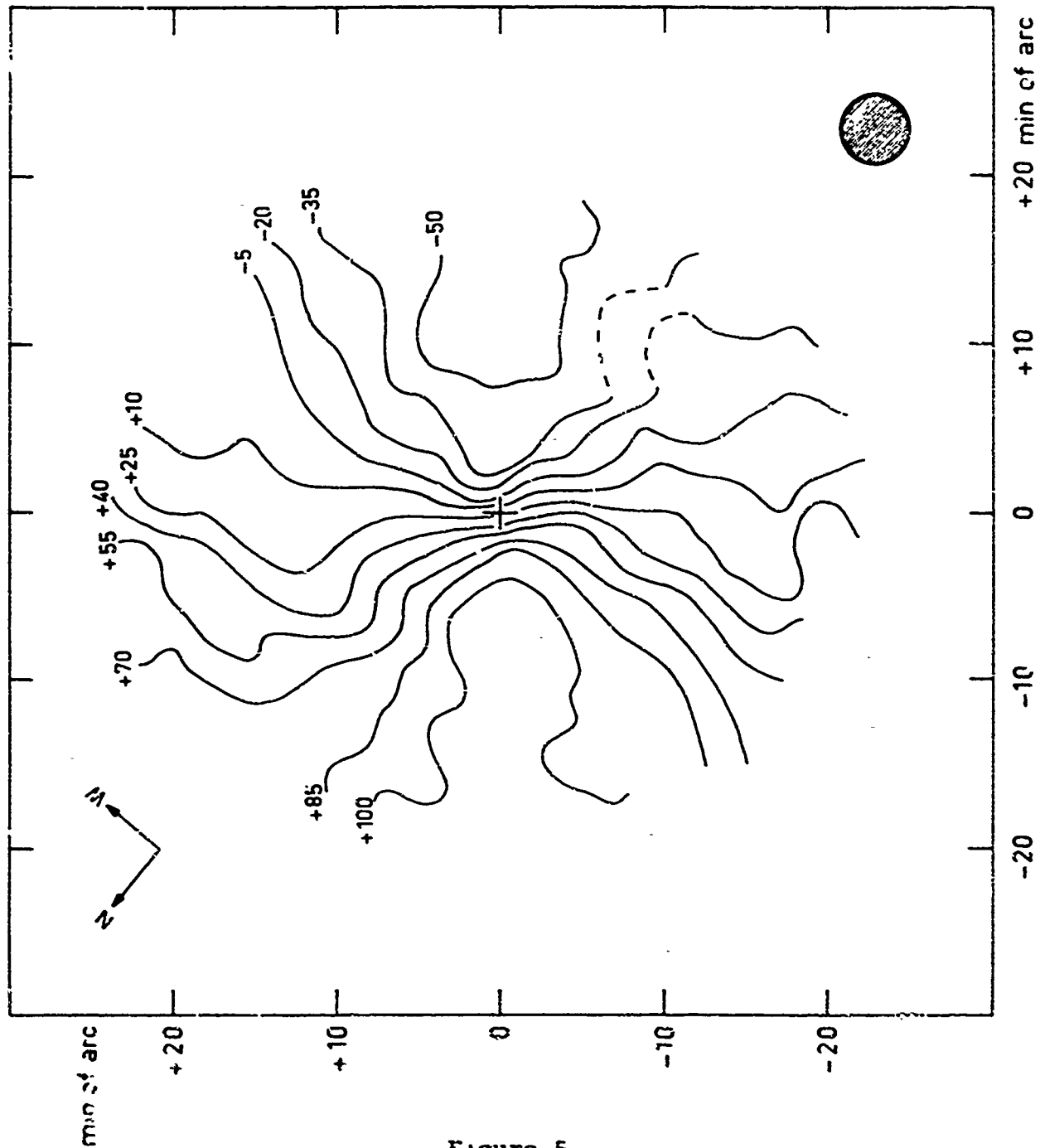

Figure 5

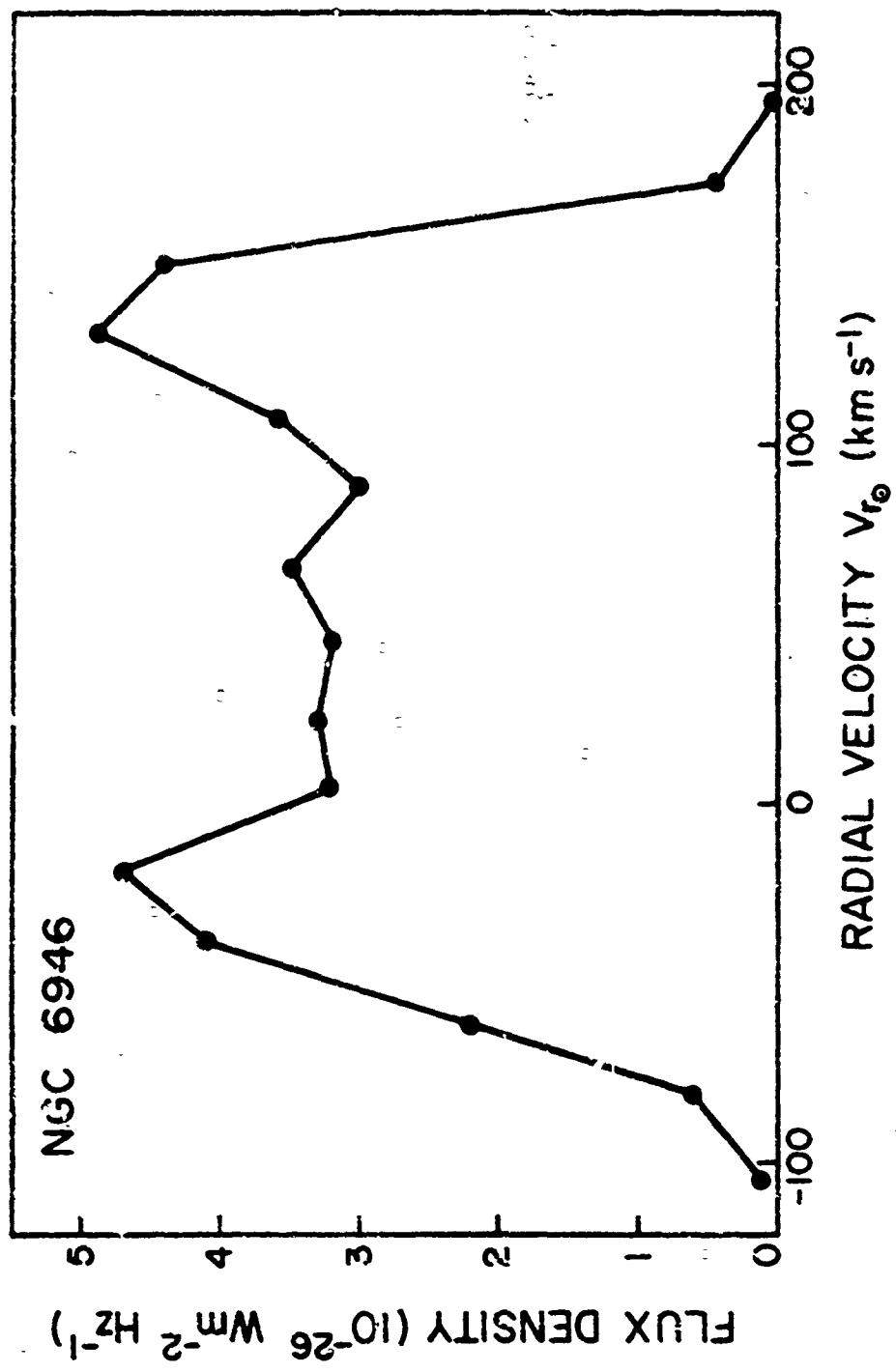
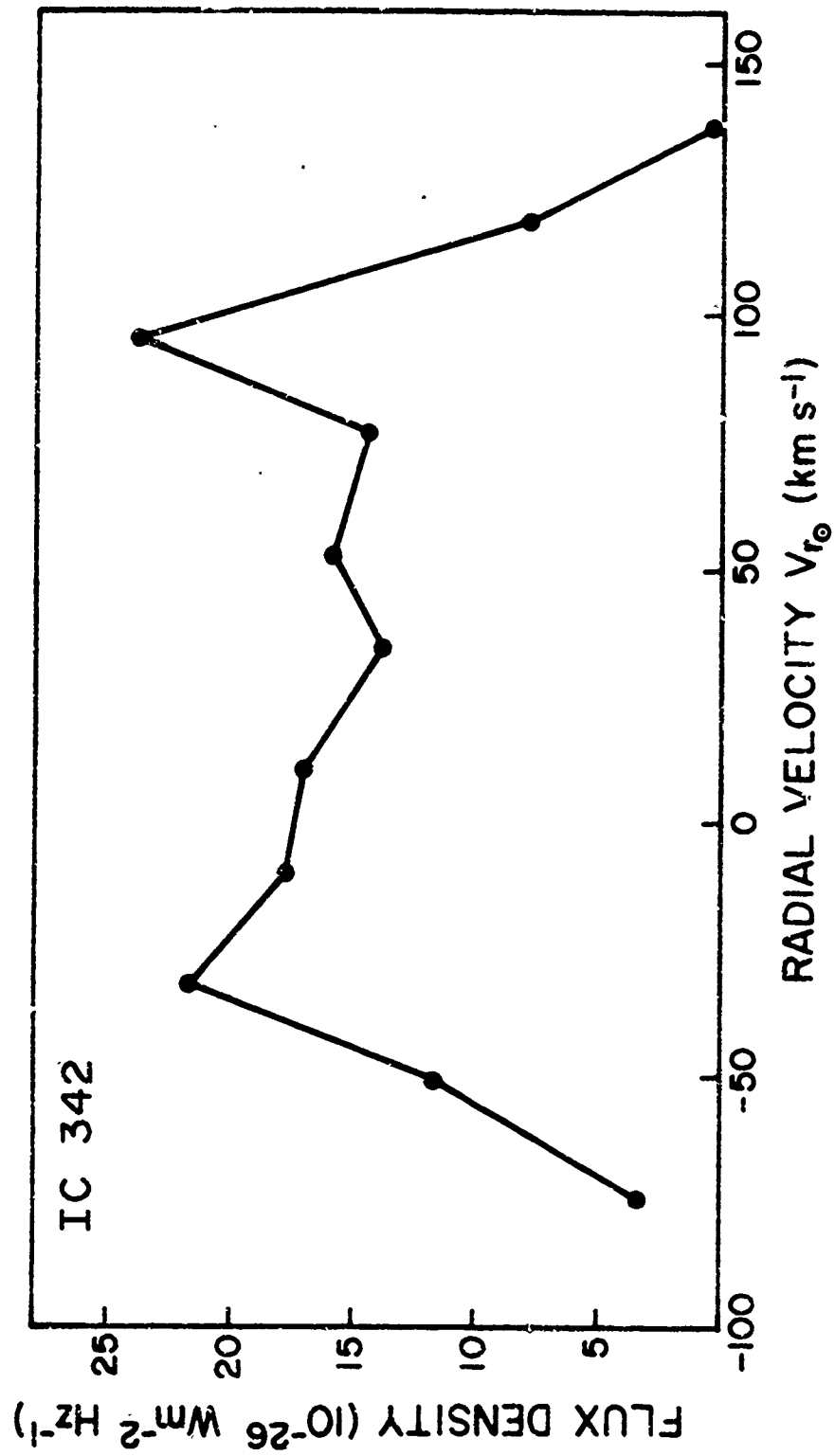

Figure 6a



-23-

Figure 6b

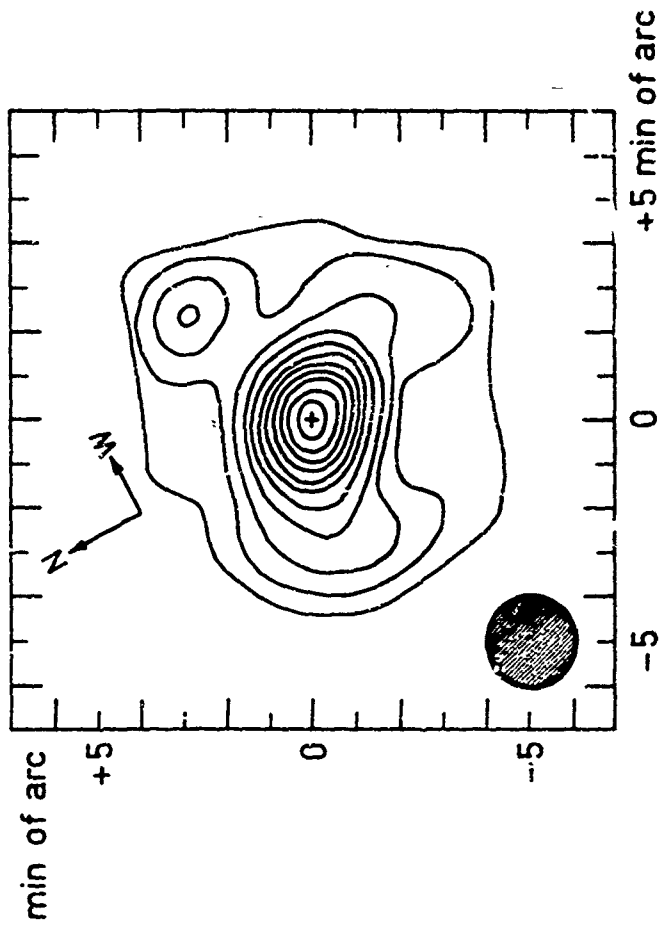

Figure 7

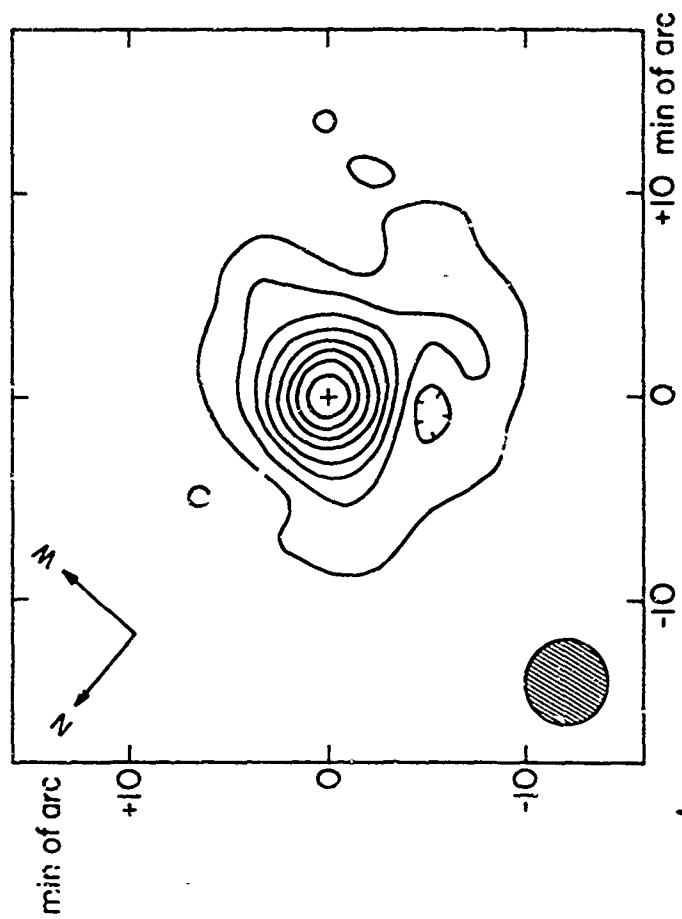
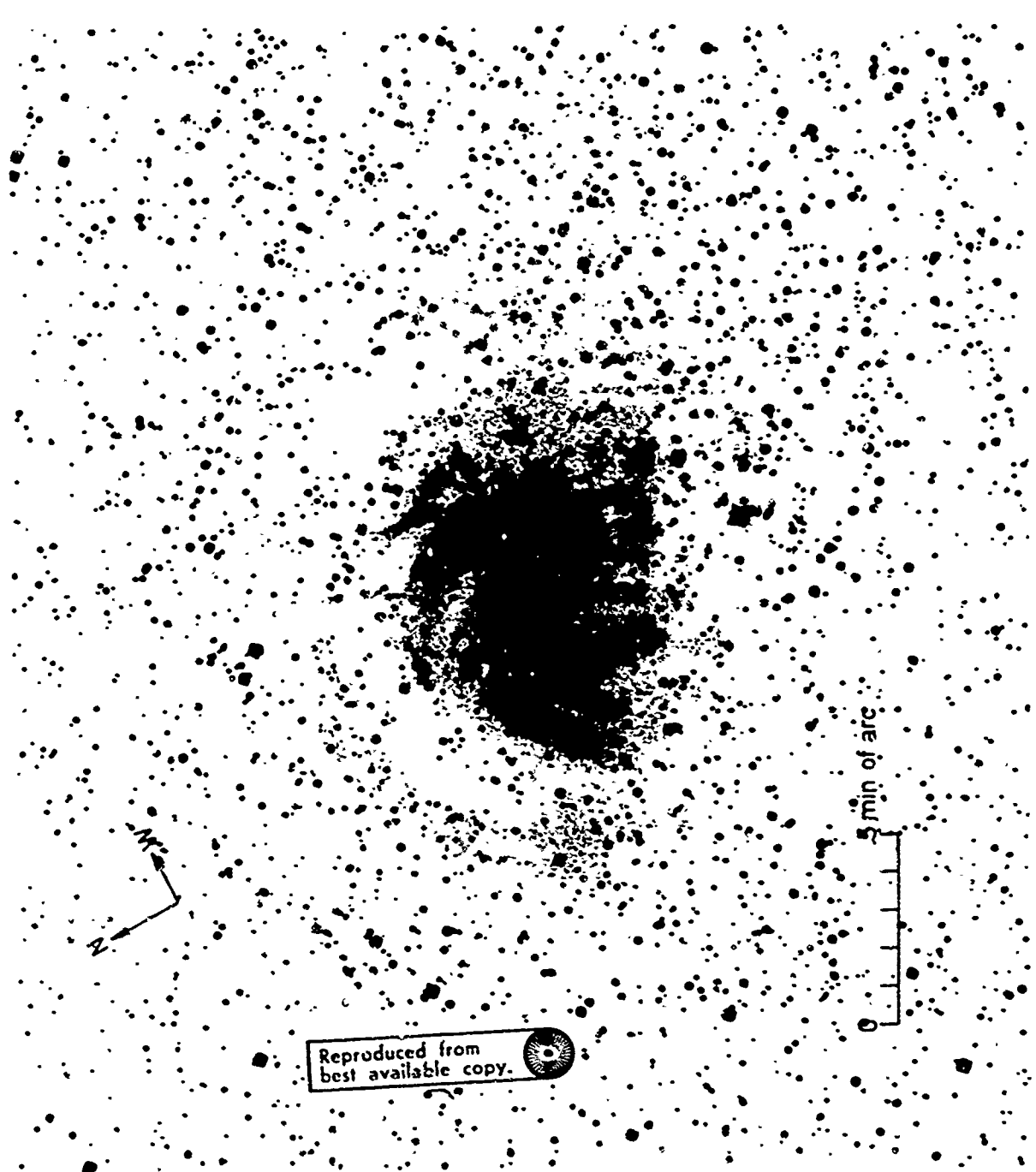
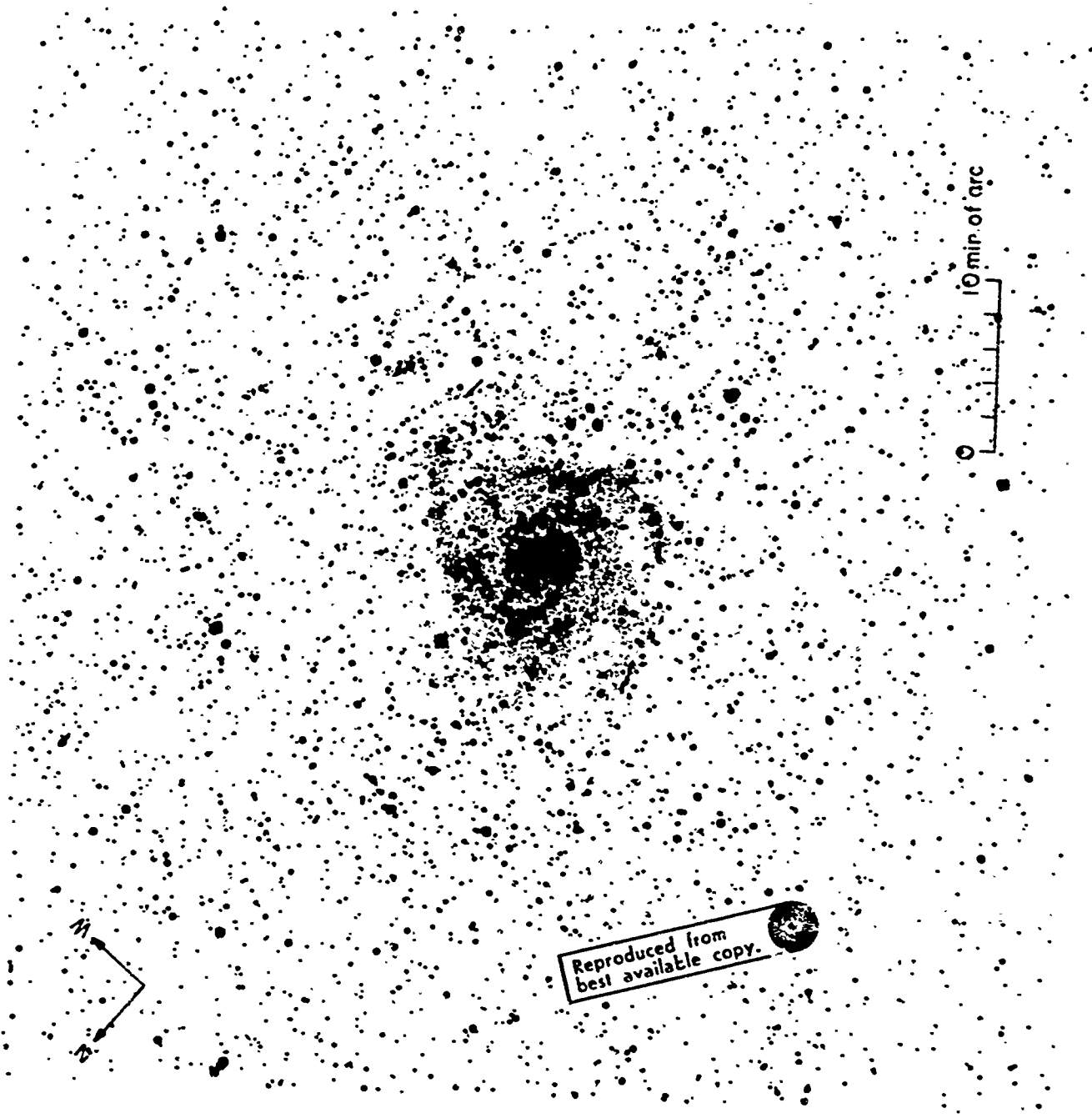

Figure 8



Reproduced from
best available copy.

-26-
Figure 9



10 min. of arc

Reproduced from
best available copy.



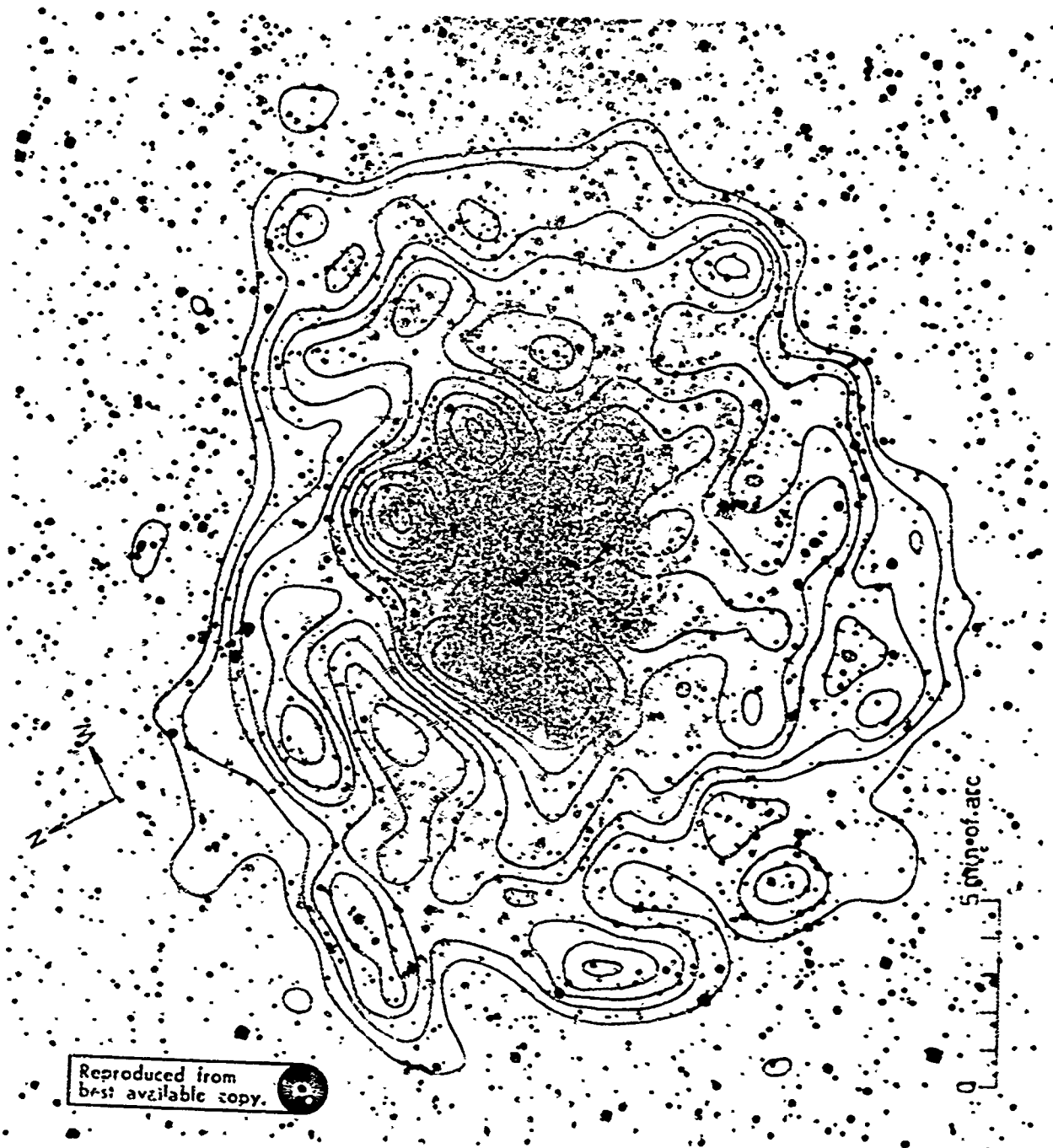

-27-
Figure 10

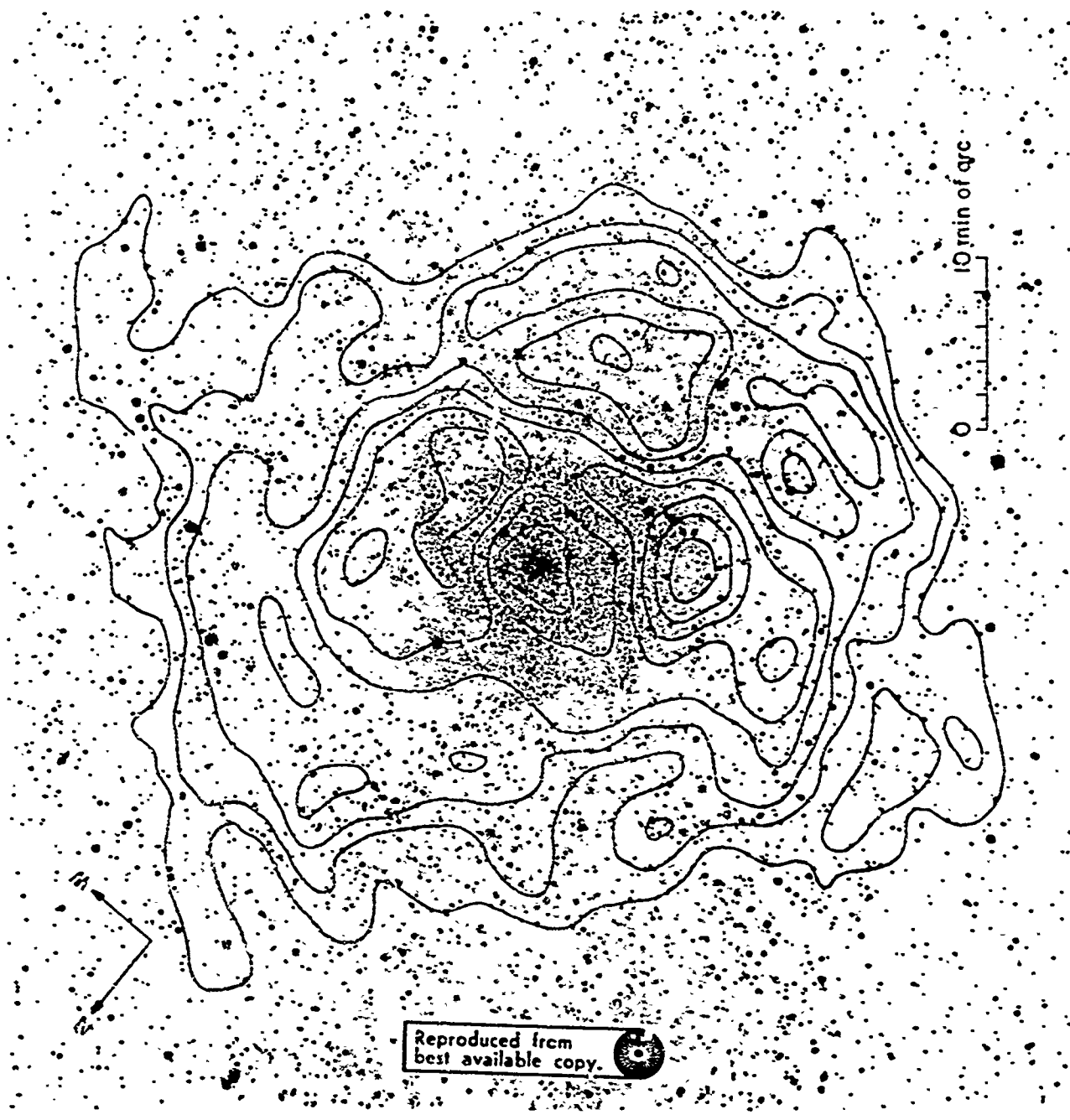

-28-

Figure 11



Reproduced from
best available copy. 

-249-
Figure 12

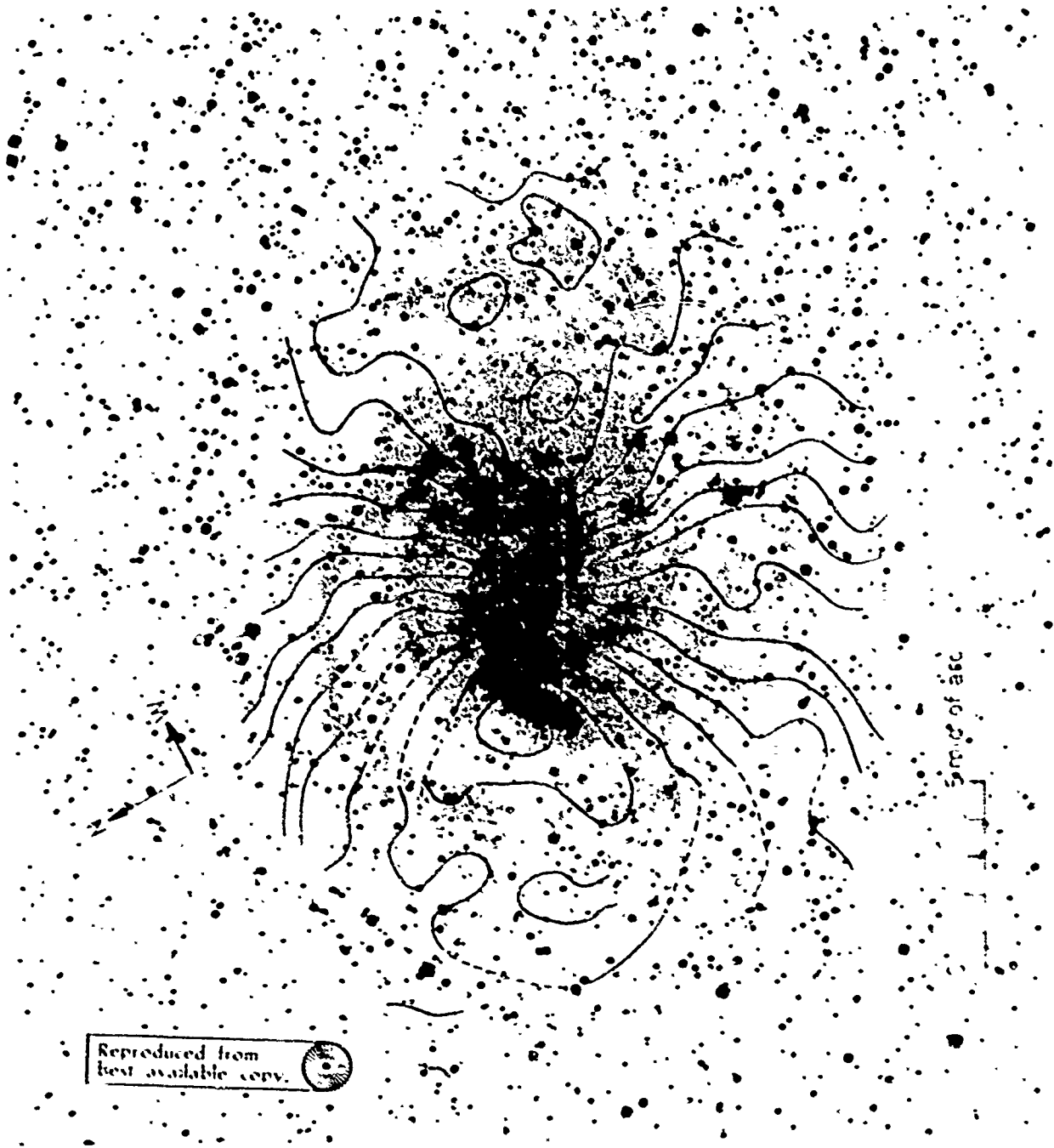

Reproduced from
best available copy.



30
Figure 11

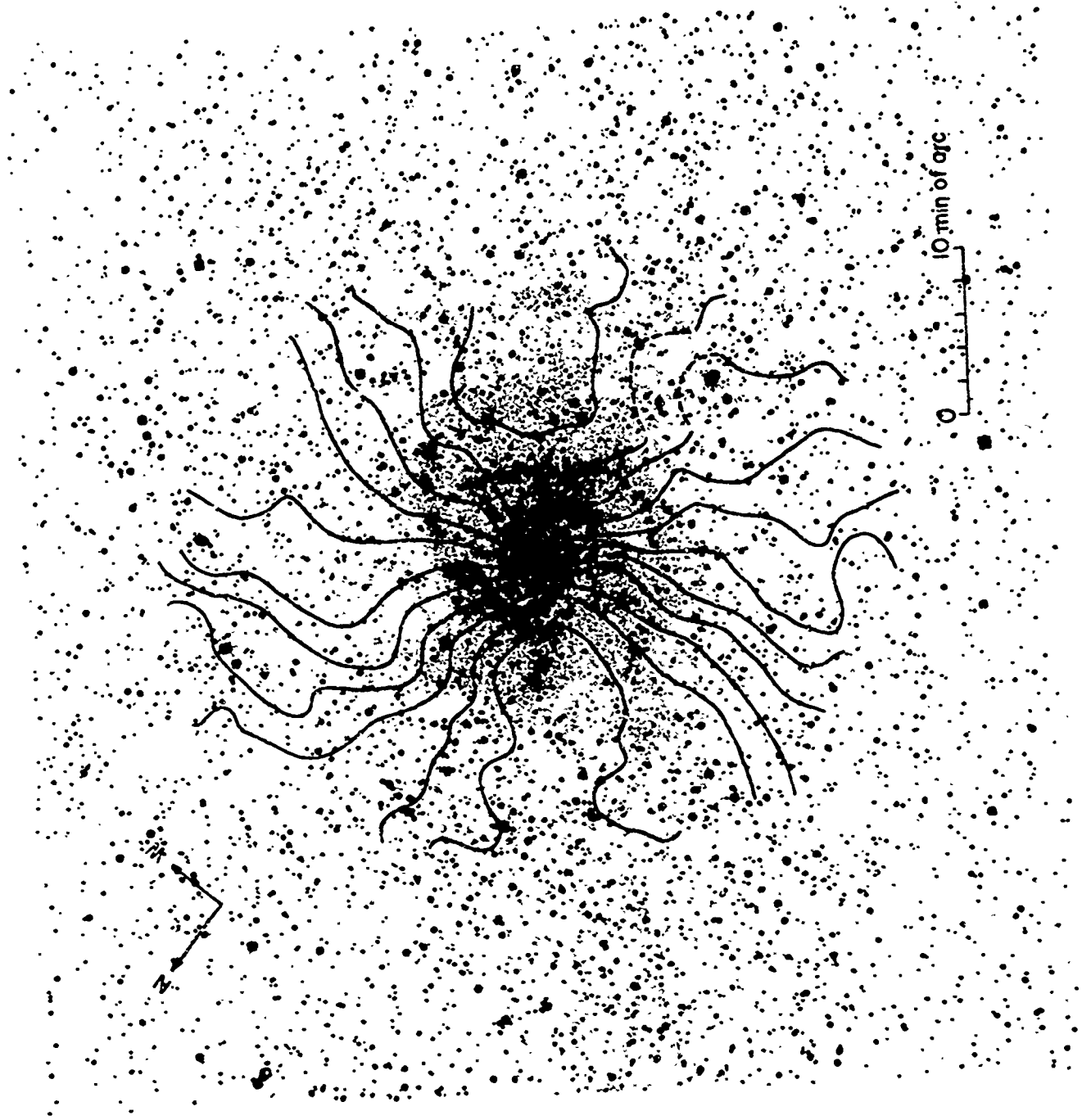

Figure 14