

TECHNICAL REPORT

72-51-CE

01

3898AN

AD 0743465

THE BODY SIZE OF SOLDIERS
U.S. Army Anthropometry-1966

by

Robert M. White

U.S. Army Natick Laboratories

Natick, Mass.

and

Edmund Churchill

Anthropology Research Project

Yellow Springs, Ohio

December 1971

Approved for public release;
distribution unlimited.

UNITED STATES ARMY
NATICK LABORATORIES
 Natick, Massachusetts 01760



20030110160

Clothing & Personal Life Support
Equipment Laboratory
C&PLSEL-94

Approved for public release;
distribution unlimited.

AD

TECHNICAL REPORT
72-51-CE

THE BODY SIZE OF SOLDIERS
U. S. Army Anthropometry - 1966

by

Robert M. White
U. S. Army Natick Laboratories

and

Edmund Churchill
Anthropology Research Project
Yellow Springs, Ohio

Project Reference:
1K024701A122-02

Series: C&PLSEL-94

December 1971

Clothing and Personal Life Support Equipment Laboratory
U. S. ARMY NATICK LABORATORIES
Natick, Massachusetts

20030110 160

FOREWORD

In the research and development of military materiel, man and his equipment must be considered as an integrated system. A basic requirement in this concept, however, is that adequate information on human body size be provided for use in the design and sizing of equipment and materiel. Data on the variability of body size in the user population must be available to develop a suitable range of sizes in clothing or to provide adequate design and adjustability in equipment. Only in this way can the man and his equipment be successfully integrated to increase compatibility and improve performance.

The fact that large numbers of men are available for measurement presents a unique opportunity for anthropometric research in the "population laboratory" represented by the U. S. Armed Forces. Anthropometric data on U. S. Army and Air Force personnel have been available and in use for over 25 years. New anthropometric surveys of the U. S. Armed Forces, carried out in 1966, make possible an up-dating of these data, and for the first time, provide standard anthropometric data for all of the services. The body size characteristics of the present generation of U. S. Army men are presented in this report.

CONTENTS

	Page
LIST OF TABLES	vi
LIST OF FIGURES	ix
ABSTRACT	x
1. INTRODUCTION	1
a. Military Anthropometry	1
b. Historical Summary	2
c. The U. S. Armed Forces Anthropometric Surveys	4
d. Summary of Report	6
2. THE U. S. ARMY ANTHROPOMETRIC SURVEY – 1966	7
a. Planning and Organization	7
b. Methodology and Techniques	8
c. Locations and Chronology of Measuring	10
d. U. S. Army Basic Trainees	12
3. DATA PROCESSING	13
a. Data Reduction	13
b. Editing Programs	13
c. Computation of Statistics	16
4. THE SAMPLE OF U. S. ARMY MEN MEASURED	21
a. Military Information	21
(1) Military Rank and Pay Grade	21
(2) Army Service Category	24

CONTENTS (Continued)

	Page
(3) Army Branch of Service	25
(4) Length of Military Service	28
b. Personal Information	28
(1) Age	28
(2) Birthplace and Residence	33
(3) National Extraction	33
(4) Education	37
(5) Marital Status	37
(6) Eyeglasses and Handedness	37
(7) Size of Combat Boots	39
5. THE STATISTICAL MEASURES	41
a. The Arithmetic Mean	41
b. The Median	42
c. The Standard Deviation	42
d. The Coefficient of Variation	42
e. The Percentiles	43
f. The Standard Errors	43
g. Beta I -- a Measure of Symmetry	45
h. Beta II -- a Measure of Kurtosis	45
i. The Frequency Tables	46
6. THE ANTHROPOMETRIC DATA	47
a. Index of Body Measurements	47

CONTENTS (Continued)

	Page
b. Visual Index	61
c. The Anthropometric Data	69
7. SUMMARY TABLES OF ANTHROPOMETRIC DATA	210
a. Tables of Percentile Values	210
b. Tables of Statistical Values	226
c. Selected Bivariate Tables	242
8. ANALYSES AND DISCUSSION OF THE ANTHROPOMETRIC DATA	256
a. U. S. Army Standards for Height and Weight	256
b. Estimated and Measured Weight and Stature	260
c. Comparisons of Army Subseries	270
d. Comparisons with Other Services	276
e. Changes in Body Size, 1946 to 1966	304
9. SUMMARY AND CONCLUSIONS	321
10. ACKNOWLEDGEMENTS	322
11. REFERENCES	323
APPENDIX — The Data Sheet	328

LIST OF TABLES

Table		Page
I	Locations and Chronology of Measuring	11
II	A List of Selected Editing Combinations	15
III	Classifications of Rank	22
IV	Rank and Pay Grade	23
V	Army Service Category	25
VI	Army Branch of Service	26
VII	Length of Service	29
VIII	Age of Total Army Series	30
IX	Distributions of Age	32
X	Geographical Distribution of Total Series	34
XI	Geographical Distribution of Subseries	35
XII	National Extraction	36
XIII	Education	38
XIV	Marital Status	38
XV	Combat Boot Size	40
XVI	Percentile Values for Total Army Series	211
XVII	Percentile Values for Basic Trainees	214
XVIII	Percentile Values for Infantry	217
XIX	Percentile Values for Armored Crewmen	220
XX	Percentile Values for Aviators	223
XXI	Statistical Values for Total Army Series	227

LIST OF TABLES (Continued)

Table		Page
XXII	Statistical Values for Basic Trainees	230
XXIII	Statistical Values for Infantry	233
XXIV	Statistical Values for Armored Crewmen	236
XXV	Statistical Values for Aviators	239
XXVI	Coefficients of Correlation	243
XXVII	Bivariate Table of Stature and Weight (Frequencies)	246
XXVIII	Bivariate Table of Stature and Weight (Percentages)	247
XXIX	Bivariate Table of Chest Circumference and Weight	248
XXX	Bivariate Table of Chest Circumference and Stature	249
XXXI	Bivariate Table of Crotch Height and Waist Circumference	250
XXXII	Bivariate Table of Sitting Height and Functional Reach	251
XXXIII	Bivariate Table of Sitting Height and Shoulder Breadth	252
XXXIV	Bivariate Table of Sitting Height and Hip Breadth, Sitting	253
XXXV	Bivariate Table of Stature and Weight (1946 Data)	254
XXXVI	Bivariate Table of Stature and Chest Circumference (1946 Data)	255
XXXVII	Army Standards for Height and Weight	258
XXXVIII	Army Aviation Standards for Height and Weight	259
XXXIX	Estimated Weight for Total Army Series	262
XL	Estimated Stature for Total Army Series	264
XLI	Statistical Values for Weight and Stature	266

LIST OF TABLES (Continued)

Table		Page
XLII	Percentile Values for Weight	268
XLIII	Percentile Values for Stature	269
XLIV	Statistical Values for Selected Measurements	272
XLV	Percentile Values for Selected Measurements	274
XLVI	Anthropometric Series	278
XLVII	Statistical Values for Weight	283
XLVIII	Statistical Values for Stature	284
XLIX	Statistical Values for Sitting Height	285
L	Statistical Values for Shoulder Breadth	286
LI	Statistical Values for Hip Breadth, Sitting	287
LII	Statistical Values for Chest Circumference	288
LIII	Statistical Values for Waist Circumference	289
LIV	Percentile Values for Weight	290
LV	Percentile Values for Stature	292
LVI	Percentile Values for Sitting Height	294
LVII	Percentile Values for Shoulder Breadth	296
LVIII	Percentile Values for Hip Breadth, Sitting	298
LIX	Percentile Values for Chest Circumference	300
LX	Percentile Values for Waist Circumference	302
LXI	Statistical Values for 1966 and 1946 Army Series	307
LXII	Percentile Values for 1966 and 1946 Army Series	314

LIST OF FIGURES

Figure		Page
1	Standing Measurements	62
2	Sitting Measurements	63
3	Breadth Measurements	64
4	Circumferences	65
5	Surface Measurements	66
6	Head and Face Measurements	67
7	Hand and Foot Measurements	68

ABSTRACT

As a part of the U. S. Armed Forces anthropometric surveys of 1966, a sample of 6682 Army men was measured, including basic trainees, infantrymen, armored crewmen, and aviation personnel. Seventy body measurements were taken on each man. The anthropometric data from this survey are presented and discussed. These new data represent the first major up-dating of body size information on U. S. Army personnel since the Army anthropometric survey of 1946. Changes in the body size of Army men between 1946 and 1966 are discussed and the Army data are compared with anthropometric data from other services.

THE BODY SIZE OF SOLDIERS

U. S. Army Anthropometry – 1966

1. INTRODUCTION

a. Military Anthropometry

A fundamental concept in the area of military research and development is represented by the so-called systems approach. According to this concept, the man or the individual soldier together with his equipment, whether it be personal equipment he is wearing or using or a machine he is operating, is considered to be a man/equipment system. A basic requirement for the efficient use and operation of such a system is that the man and the equipment be compatible.

Effective human engineering plays an important role in achieving such compatibility. Since anthropometric data constitute a basic requisite for defining the elements of body size in the human engineering of man/equipment systems, anthropometry provides an essential input in the development of such systems.

Anthropometry is the measurement of the human body. Since effective human engineering requires the use of body size data on the specific population for which the equipment is intended, military anthropometry is one important source of the information necessary for the design and sizing of equipment and materiel to be used by the Armed Forces.

Anthropometric data are collected by measuring large, representative samples of the military population. Through the compilation, processing, analysis, and synthesis of such data, it is possible to provide a metric description of the military population. This information is then available for general use in the design and human engineering of military equipment and materiel, as well as for specific application in the design, sizing, and tariffing of clothing and individual equipment.

New anthropometric surveys have been conducted recently on all of the United States Armed Forces. To provide wide availability for such information, the anthropometric data obtained during these surveys will be published in a series of technical reports. It is the purpose of the present report to present new anthropometric data on men of the United States Army.

b. Historical Summary

Military anthropometry in the United States is not a new development, since anthropometric data on military personnel have been in use for at least 100 years or more. Some data on the body size of soldiers in the Civil War are available. Large quantities of anthropometric data were collected during and at the end of World War I, and an extensive anthropometric survey was conducted by the U. S. Army in 1946 at the conclusion of World War II. A brief review of military anthropometry in the United States will indicate the primary sources of anthropometric data prior to the new surveys of 1966.

Information on the body size of Civil War soldiers was reported by Gould in 1869 and by Baxter in 1875. Although these data include only a few body measurements, they do provide some indication of the body size of soldiers some 100 years ago.

A large volume of anthropometric data and statistics on World War I soldiers was published by the Medical Department of the U. S. Army in 1921. In this monumental work, Davenport and Love analyzed data on some 2,000,000 draft recruits of 1917-1918, and on 100,000 troops demobilized in 1919. While a large part of the material in this volume consists of medical or clinical information, it is significant that extensive analyses were made of the correlations between body size and clothing size. In fact, many of the procedures utilized today in applied military anthropometry may be traced to the work of Davenport and Love in 1921.

Interest in the utilization and application of anthropometric data was renewed early in World War II with the establishment of the Anthropology Branch at the Aero Medical Laboratory, Wright-Patterson Air Force Base, Ohio, where anthropologists conducted anthropometric surveys and carried out human engineering work on aircraft cockpits, gun turrets, oxygen masks, and flight clothing throughout the war. A summary of this work in applied anthropometry by Randall, Damon, Benton and Patt was published in 1946.

Following his active duty in the Army Air Forces, Francis E. Randall transferred to the Army Quartermaster Corps, where he planned and carried out the Army anthropometric survey of 1946. This was the first extensive survey to be conducted primarily to provide body size data for military clothing sizing and tariffing; it included the measurement of both men and women. In this survey, 105,062 Army men were measured at six separation centers; of the total series, 96,381 men were separatees, and 8,681 men were new inductees. Sixty-six body measurements were obtained on all individuals, while body build photographs were taken of 49,500 men. In the series of 8,859 Army women measured, 5,116 were Women's Army Corps (WAC) personnel, while 3,742 were Army nurses. The data from these Army surveys were published in a series of some twelve technical reports between 1947 and 1952. The basic data on women were reported by Randall and Munro in 1949, and the data on men were reported by Newman and White in 1951.

As an outgrowth of the Army's work in anthropometry and clothing, a similar effort was initiated in the United States Marine Corps in 1948. This resulted in a survey of some 2,000 Marine Corps personnel, carried out by William J. Beer, a Marine Corps officer. The anthropometric data collected were used extensively in the development and sizing of Marine Corps clothing and equipment, but unfortunately the data were never published in report form.

Another anthropometric survey was carried out by the Army Quartermaster Corps in 1949, primarily to obtain additional data on Army men in the younger age groups. In this survey, 7,272 men were measured, including 1,938 draftees, 3,921 enlistees, and 1,413 re-enlistees. Although these data have been utilized in research, they have not been published.

With the establishment of the United States Air Force as a separate service, anthropometric surveys of Air Force personnel were carried out in 1950-1952. A series of 4,063 USAF flying personnel was measured at fourteen air bases in 1950; 132 body measurements were taken. This series consisted of 61 percent officers, 15 percent cadets, and 24 percent enlisted men. In 1952, a survey of 3,332 Air Force basic trainees was conducted, in which 60 measurements were taken. Also in 1952, 63 measurements were taken on a series of 852 Women's Air Force (WAF) personnel. The anthropometric data from these three surveys have been published in a large number of reports. The basic report on USAF flying personnel by Hertzberg, Daniels, and Churchill was published in 1954, and has been widely used as a standard reference for anthropometric data. The series of USAF basic trainees was reported by Daniels, Meyers, and Churchill in 1953, while the WAF data on women were reported by Daniels, Mayers, and Worrall, also in 1953.

To meet in increasing need for specific data on personnel in Army aviation, an anthropometric survey of Army aviators was carried out in 1959. The data, consisting of 41 measurements on 500 Army pilots, were published by White in 1961.

Data on 1190 U. S. Navy pilots were collected in 1957-1958, based upon 25 measurements. Subsequently, a more extensive survey of 1,549 Navy (and Marine Corps) aviators was carried out in 1964, in which 96 measurements were taken. The earlier work was reported by Gifford in 1960, while a report on the 1964 survey by Gifford, Provost, and Lazo was published in 1965.

As indicated in the preceding summary, data from some ten major anthropometric surveys of military personnel in the United States were accumulated during the 20 years following World War II. By contrast, there have been only a very few anthropometric surveys of the civilian population of the United States. A survey of some 14,698 women

was conducted in 1939-1940 by the Bureau of Home Economics, U. S. Department of Agriculture. The resulting data on 59 body measurements were reported by O'Brien and Shelton in 1941, and were used extensively for sizing and pattern development in women's clothing. During the National Health Survey of 1960-1962, carried out by the Public Health Service, U. S. Department of Health, Education, and Welfare, 18 body measurements were taken on a carefully selected sample of 3,091 men and 3,581 women from the civilian population. Two reports by Stoudt, Damon, McFarland and Roberts were published in 1965 and 1970, respectively. An anthropometric survey of 684 Air Traffic Control trainees was carried out by the Civil Aeronautical Research Institute, Federal Aviation Agency in 1960-1961, in which 64 measurements were taken. The report by Snow and Snyder was published in 1965.

It may be noted here that the emphasis on military anthropometry in the United States in recent years has been accompanied by an expanding interest in the anthropometry of foreign military populations. This has resulted in the availability of anthropometric data from an increasing number of foreign countries. Anthropometric surveys were conducted in 1960-1961 on military personnel in Turkey, Greece, and Italy, under the auspices of NATO's Advisory Group for Aeronautical Research and Development (AGARD). The report on these surveys by Hertzberg and his team of co-workers was published in book form in 1963. The results of an anthropometric survey of Republic of Korea Air Force pilots were reported by Colonel W. C. Kay in 1961, while a survey of Japanese Air Self-Defense Force pilots was reported by Oshima *et al* in 1962. An anthropometric survey of the Royal Thai Armed Forces was conducted by White in 1962, and a similar survey was carried out by White in the Republic of Vietnam in 1963. The Thailand and Vietnam reports both were published in 1964. Republic of Korea Armed Forces were surveyed in 1965, and the report by Hart, Rowland, and Malina was published in 1967. Further anthropometric work is being continued by the Korean Army. A survey to collect anthropometric data on Central and South American military personnel was initiated in 1965 at the U. S. Army Tropic Test Center in the Canal Zone, and has now been completed. An interim report was published by Dobbins and Kindick in 1967, and a final report is in preparation. An anthropometric survey of the Imperial Iranian Armed Forces was carried out by the Iranian Army in 1968 with technical assistance from the United States, and a report on the data was published in 1970. Only a few references to published results of foreign anthropometric surveys have been mentioned here; there are undoubtedly many others which have been completed or are in progress.

c. The U. S. Armed Forces Anthropometric Surveys

New anthropometric surveys of the U. S. Armed Forces were first proposed in April, 1964. The surveys were requested and sponsored by the Defense Supply Agency,

with the ultimate objective of achieving improvements in the sizing, fit, tariffing, distribution and issue of military clothing and personal equipment.

The purpose of the new surveys was two-fold. Initially there existed a requirement for the up-dating of anthropometric data on the U. S. military population. Since the basic Army data were some 20 years old and Air Force data were about 15 years old, new body size information was required on the present generation of men in the Armed Forces. Secondly, it was recognized that data should be obtained from all of the Armed Forces, so that the surveys were planned to include samples from the major groups comprising the U. S. military population.

In planning the anthropometric surveys, it was agreed that surveys of Army, Marine Corps, and Navy personnel would be conducted by U. S. Army anthropologists, while those of Air Force personnel would be carried out by Air Force anthropologists. Following a year of planning, preparation and coordination, the surveys were initiated in August, 1965, when the Air Force obtained 158 measurements on a series of 2,632 USAF basic trainees. Seventy body measurements were taken in the Army, Marine Corps, and Navy surveys, which were carried out between November, 1965 and April, 1966. The total Army series of 6,682 men included 2,639 basic trainees, 3,429 infantry personnel, 489 armored crewmen, and 125 Army aviation personnel. The Marine Corps sample consisted of 2,008 men, while the Navy series comprised 4,095 recruits. The field work of the surveys was completed in 1967, when the Air Force obtained 187 measurements on a series of 2,420 USAF flying personnel between January and March, 1967.

Subsequent to the Armed Forces surveys, two anthropometric surveys of U. S. Army aviation personnel have been carried out. In the first, nine body measurements were made on a series of 1,640 Army warrant officer candidate flight trainees in 1968, and the report by Schane, Littell, and Moultrie was published in 1969. In the second study, a series of 1,482 Army aviators was measured in 1970; 85 measurements were taken, and a report on the data by Churchill, McConville, Laubach, and White was published in 1971. Also, a new anthropometric survey of U. S. Air Force women was conducted in 1968, in which 137 measurements were made on a sample of 1,905 women, including officers and enlisted women. The report by Clauser and co-authors was published in 1971.

The anthropometric surveys of the U. S. Armed Forces, carried out between 1965 and 1967, represented a new approach in that for the first time standard body measurements were taken in coordinated surveys on personnel of all the military services within the same time frame. The new data provide a basis for describing the body size of today's military population and make possible direct comparisons of body size among the Armed Forces. Furthermore, since questions regarding the changes or increases in body size of military personnel from World War I to the present are frequently asked, the new data will be useful in investigations of such changes. Since anthropometric data on military personnel are now available for a time span of some 50 years, it may be possible to analyze trends in body size as a basis for postulating the body size of future military populations.

d. Summary of Report

Following this introduction, the results of the Army anthropometric survey are presented in eleven sections in this report.

In Section 2, the Army survey is discussed in terms of the planning and organization of the survey, the methodology and techniques used, and the locations and chronology of the measuring during the survey.

The methods of data processing, including data reduction, editing, and the computation of statistics are presented in Section 3.

The sample of U. S. Army men measured in the survey is discussed in Section 4. The background information obtained during the survey serves to describe characteristics of the sample of men in terms of military information, such as rank and length of service, and personal information, such as age, birthplace, and education.

The statistics used in the presentation of the anthropometric data are discussed and explained in Section 5.

In Section 6, the detailed anthropometric data obtained during the survey are given, together with an index of terms and a visual index of the body measurements.

Summary tables of percentile and statistical values for the anthropometric data are shown in Section 7, as well as selected examples of bivariate tables.

An analysis and discussion of the Army anthropometric data are given in Section 8. Comparisons of the Army subseries, comparisons of the Army with other services, and a discussion of changes in body size are included here.

Section 9 contains a summary and conclusions, while acknowledgements are given in Section 10. A list of references may be found in Section 11. The data sheet used in the survey is reproduced in the Appendix.

2. THE U. S. ARMY ANTHROPOMETRIC SURVEY -- 1966

a. Planning and Organization

A request for the conduct of a new anthropometric survey of the U. S. Army was initiated by the Defense Supply Agency in April, 1964. It was planned that the Army survey would be carried out in conjunction with similar surveys of personnel in the other services of the Armed Forces.

Responsibility for planning and organizing the Army survey was assigned to the U. S. Army Natick Laboratories, Natick, Massachusetts, by the U. S. Army Materiel Command. Since the Natick Laboratories did not have either the civilian or military personnel to carry out a large-scale anthropometric survey in the field, assistance was requested from the U. S. Army General Equipment Test Activity, an element of the U. S. Army Test and Evaluation Command, located at Fort Lee, Virginia. This activity provided the military personnel, as well as the administrative and logistic support for the collection of the anthropometric data during the survey. Twenty enlisted men were requested from Fort Meade, Maryland; these men were members of the 11th Armored Cavalry Regiment and were assigned to USAGETA, Fort Lee for temporary duty to serve on the measuring teams for the duration of the survey.

Technical direction and monitorship of the scientific aspects of the survey were the responsibilities of Natick Laboratories anthropologists. Administrative planning and supervision, scheduling and travel arrangements, and logistic support were performed by the General Equipment Test Activity under the direction of an officer who served as Project Director, assisted by a sergeant, who served as Administrative Coordinator.

In the field, the survey team was directed and supervised by a Survey Officer, assisted by a non-commissioned officer in charge (NCOIC). The measuring team personnel were organized into three teams, each with a team leader and six measurers. At each installation where measuring was carried out, additional enlisted men were requested on a temporary basis to serve as data recorders.

The Project Director was authorized to establish direct coordination with the various Army installations which would be visited by the measuring team. In planning the schedule for the survey, the Project Director contracted a designated project officer at each installation to be visited and provided information on the plan of operations, as well as on the number of men required to be measured, the space and equipment required, and the efficient scheduling of personnel. A liaison officer visited each installation prior to the team's scheduled arrival in order to carry out the final coordination of plans and to provide guidance to the installation project officer.

The installation project officers were designated by the respective participating Army installations. It was the responsibility of the installation project officer to assist the Project Director and the Survey Officer in liaison functions and installation administrative procedures, including the provision of facilities and equipment required and the scheduling of participants for a smooth flow of men through the measuring lines. He was also responsible for providing the additional personnel required, as well as the quarters and messing facilities for the measuring team personnel.

b. Methodology and Techniques

The first step in the technical planning for the Army anthropometric survey consisted of the selection of body measurements to be taken. Primary consideration was given to the problem of selecting a large enough number of measurements to be useful for a variety of requirements, while at the same time keeping the number of measurements to a manageable minimum suitable for a large-scale survey. A total of seventy body measurements was selected. These included weight, standing measurements, sitting measurements, breadth measurements, circumferences and body surface measurements, as well as measurements of the head and face, the hands, and the feet. It was felt that this selection of dimensions, while not as extensive or inclusive as it might be, still would provide most of the data and body size information required for the efficient design and sizing of military clothing and personal equipment, as well as for basic human engineering information necessary in the design of military vehicles, aircraft, and other weapons systems.

Following the selection of the body measurements to be taken, a data sheet was drawn up which would be used for the recording of the anthropometric data in the field. The format of the data sheet was arranged to facilitate transcription of the data to punch cards; column numbers for the punch cards were indicated on the data sheet. Five punch cards were required for each man measured; the first card contained the background data on each individual, while the remaining four cards contained the anthropometric data. The background data were coded to simplify punching and subsequent data processing. The body measurements were measured and recorded in millimeters, while weight was measured and recorded to the nearest whole pound. The data sheet is reproduced in the Appendix of this report. The skinfold thicknesses shown at the end of the data sheet were not measured.

Standard techniques of measurement and standard anthropometric measuring instruments were used throughout the survey. The anthropometer (Siber Hegner 101) consists of four tubes which fit together to form a rigid rod; it is calibrated in millimeters, with the scale running from zero at the base up to 2000 mm at the top. The anthropometer has one fixed arm at the top and a second arm on a sliding sleeve which can be moved up and down on the rod. The full anthropometer was used to measure stature and other

major body heights or lengths. The lower half of the anthropometer was used for lesser heights, such as crotch height, kneecap height, or calf height. The top half of the anthropometer was used as a large sliding caliper for taking body breadths and also measurements of the arms and legs, such as elbow-fingertip length and buttock-knee length. A millimeter scale on the reverse side of the instrument was used when taking this type of measurement.

Small sliding calipers (Siber Hegner 104), with straight arms, were used for various measurements of the face and hands. Spreading calipers (Siber Hegner 106), with curved arms, were used for other measurements of the head and face. A two-meter steel tape (K & E Tip Top Wyteface), graduated in millimeters, was used for all circumference and body surface measurements.

In addition to the standard instruments, several other items of equipment were used in the survey. Foot measurements (i.e., foot length, instep length, and foot breadth) were taken with a foot board, which consists of a metal tray fitted with a sheet of millimeter graph paper covered with transparent plastic. In taking the foot measurements, a wooden block was held against the toe or the ball of the foot and the value of the dimension was read on the scale. In positioning the knees for taking leg measurements on a seated individual, a box was used as a foot-rest; squares of plywood were added to elevate the feet when necessary in order to have the thighs level and the knees at right angles.

In planning the measuring process in detail, an attempt was made to develop a system which would permit accurate and rapid measurement of men, but which also would insure a relatively smooth and efficient progression of men through the processing line. To this end, a sequence of six measuring stations was planned. The seventy body measurements to be taken were divided up into groups or blocks of measurements; each of these blocks of measurements was taken at one of the measuring stations. The selection of the measurement groupings was based partly upon the measuring instrument (or instruments) to be used at that station and partly upon the position or posture required of the man to be measured at that station. This was done primarily to reduce time and motion to minimum.

The actual measurement procedure may be outlined as follows. After a brief orientation concerning the purpose of the anthropometric survey, the men to be measured were requested to strip to their undershorts. Each man then reported to Station #1, where his name, rank, service number, and the rest of the background data were entered on his data sheet. He also was asked to estimate his weight and height, and then his weight was measured to the nearest pound on platform scales. The subject then moved on to Station #2 for a group of height measurements, taken with the anthropometer, and to Station #3 for a group of breadth and length measurements, taken with the large calipers. At Station #4, spreading and sliding calipers, and the foot board were used

for a group of head, face, hand, and foot measurements. Circumferences and body surface measurements (such as sleeve length and waist back length) were taken with a steel tape at the last two locations, Stations #5 and #6. Specific descriptions of the individual body measurements, including the position of the subject, how the measurement was taken, and the instrument used, may be found in Section 6 with the data on each measurement.

A measurer worked at each station and took the specific group of measurements assigned to that station. The measurer was assisted by a data recorder at each station.

In order to process and measure large numbers of men rapidly and efficiently, it was planned to operate three measuring lines simultaneously. Therefore, in a typical measuring operation, there were three sets of six stations, manned by three measuring teams, each of six men. With all stations in operation, 18 men were being measured at once, and normally three to five men would be waiting their turn at each station.

Before initiation of the measuring and data collection in the survey, training sessions for the measuring teams were held at Fort Lee, Virginia. Initially, the measuring personnel were briefed on the survey and on anthropometric techniques. Visual training aids were used to illustrate the measurements and the sequence of stations. The measurers were then shown the anthropometric instruments and assigned to their respective measuring stations. Thus, the measurers could specialize in the use of one type of instrument and learn to take a specific group or block of body measurements. Training in the use of the instruments was carried on by having the measurers practice on each other and then measure a small group of subjects in trial runs. The training and practice were continued until a satisfactory level of accuracy and consistency was attained.

c. Locations and Chronology of Measuring

Although the U. S. Army survey was a part of the Armed Forces anthropometric surveys of 1966, the collection of data in the Army survey was actually initiated in November, 1965 and completed in April 1966. During the survey, Army men were measured at a total of twelve Army posts throughout the United States. Six installations were sampled in November and December, 1965, while measuring was carried out at an additional six posts between January and April, 1966. The total Army sample of 6682 men was measured in approximately 37 working days; on the average, 180 men were processed per day. The locations and dates of measuring are shown in Table I.

TABLE I -- LOCATIONS AND CHRONOLOGY OF MEASURING

No.	Location	Dates	No. of Men Measured	Percent
1	Ft. Lee, Va.	Nov. 8-10, 1965	368	5.5
2	Ft. Knox, Ky.	Nov. 15-18, 1965	601	9.0
3	Ft. Leonard Wood, Mo.	Nov. 22-26, 1965	601	9.0
4	Ft. Polk, La.	Nov. 29 - Dec. 2, 1965	593	8.9
5	Ft. Jackson, S.C.	Dec. 6-9, 1965	608	9.1
6	Ft. Dix, N.J.	Dec. 13-16, 1965	613	9.2
7	Ft. Bragg, N.C.	Jan. 17-19, 1966	605	9.0
8	Ft. Benning, Ga.	Jan. 21-25, 1966	611	9.1
9	Ft. Hood, Texas	Feb. 3-4, 1966	442	6.6
10	Ft. Ord, Calif.	Apr. 5-6, 1966	603	9.0
11	Ft. Lewis, Wash.	Apr. 8-11, 1966	585	8.8
12	Ft. Devens, Mass.	Apr. 25-26, 1966	<u>452</u>	<u>6.8</u>
		Total	6682	100.0

As indicated in Table I, approximately nine percent of the total Army series was measured at each of nine Army posts, while a smaller number of men was processed at the remaining three installations (Ft. Lee, Ft. Hood, and Ft. Devens). The subseries of 2639 Army basic trainees was measured at six Army training posts: Ft. Knox, Ft. Leonard Wood, Ft. Polk, Ft. Jackson, Ft. Dix, and Ft. Ord. On the average about 440 trainees (or 17 percent of the trainees) were measured at each of the six basic training centers. Army infantry personnel were measured at all of the installations during the survey. Of the subseries of 489 armored personnel, about 85 percent were measured at Ft. Hood, about 12 percent at Ft. Benning, and the remaining six percent at Ft. Knox. The small sample of Army aviators was measured at Ft. Benning and Ft. Hood.

During the large Army anthropometric survey of 1946, a total of 105,062 men was measured at six separation centers between May and November, 1946. The six separation centers utilized and the number of men measured at each were: Ft. Dix, N. J. (21,021); Ft. Meade, Md. (15,328); Ft. Bragg, N. C. (17,447); Ft. Sheridan, Ill. (20,951); Ft. Lewis, Wash. (11,719); and Camp Beale, Calif. (18,596). Of the 105,062 men measured, 96,381 were being separated from the Army or were re-enlisting, while 8,681 men were just entering the Army, and were without previous military service.

d. U. S. Army Basic Trainees

A separate study of Army basic trainees was conducted concurrently with the U. S. Army anthropometric survey to investigate the changes in body size which take place during the first six months of Army service. Of the 2639 basic trainees measured initially, 1069 (or 40 percent) were re-measured after the completion of four months of basic training. This second measurement of trainees was carried out during March, 1966 at six basic training centers and at seven additional Army posts. A group of 290 men (11 percent) was measured a third time at the end of six months of Army service. The final measurement of trainees was carried out during May, 1966 at eleven Army installations. The results of this study will be published in a separate technical report.

3. DATA PROCESSING

a. Data Reduction

Data processing in this survey began with the recording of the data in the field by the several recorders on special survey blanks (see Appendix). Weight was recorded in pounds and the linear measurements in millimeters. Following completion of the field work, the data were transferred to standard punch-cards. Each recorded digit was punched into a corresponding column in one of five cards used for each subject. The punching was verified using a conventional card verifier.

The punched cards were then delivered to the Anthropology Research Project. All major steps in the data processing from this point on were done by this group using the facilities of the Digital Computational Division, Aeronautical Systems Division at Wright-Patterson Air Force Base, Ohio. Computations were done on an IBM 7094-7044 direct coupled system. All programs were written in Fortran and computations were done in single precision arithmetic.

The punch-cards were read into the computer and transferred to magnetic tape. Certain minor adjustments were made to the data at this point, e.g., 10 mm was added to each crotch height value to compensate for the fact that the recorded values had been read at the lower edge of the anthropometer arm, although the measurement was actually to the top of the arm.

b. Editing Programs

The first steps in the processing of the data tapes consisted of checking the data for errors which might have taken place at any point in the data gathering-recording-transcribing process. Two computer programs which had been developed specifically for this purpose were used.

The first of these programs, designated as XVAL (= extreme value), was used to isolate values which seemed to be inconsistent with the other data for that variable. This program performs the following functions:

1. It provides, for each variable, a list of the ten smallest and the ten largest values and the record numbers of the subjects with these values.
2. It calculates, for each variable, the mean, standard deviation, and the measures of symmetry and kurtosis (β_1 and β_2).
3. It estimates, for each variable, the values of the mean and the standard deviation on the basis of all the data with the exception of the ten largest and ten smallest values.

Data values out of line with respect to other values for the same variable were usually identified from this program's listings. Outliers were often signaled by several items in the program output. The size of the smallest or largest value itself was usually a clear indicator of a major error, as was a substantial difference between the standard deviation computed from all the data and the value estimated from the central N-20 values.

The measure of kurtosis, β_2 , described in the section on statistical measures, was effective particularly in signalling the presence of even one or two values lying well outside the "normal" range. For a normal (i.e., gaussian) distribution, the theoretical value of β_2 is 3.0, and the final values for this statistic were fairly close to 3 for most of the data covered by this report, being somewhat larger for variables with skewed distributions. On the other hand, the presence of a single highly extraneous value in a set of data may result in a value of β_2 almost as large numerically as the sample size.

All values signaled by the XVAL program as questionable were investigated and obvious errors corrected. The data were then examined by use of the editing program. This program was designed to evaluate each recorded datum in terms of related data for the same individual. Each subject's stature, for example, was compared by means of multiple regression equations with other height measurements. Similarly, each subject's chest circumference measurement was weighed as reasonable or unreasonable in terms of the combination of his chest breadth and chest depth values.

Some fifty-six three-variable combinations were specified to the program for analysis. Twenty-one more-or-less typical combinations are listed in Table II.

The primary criterion for the selection of the variables which are grouped together was that one or more members of a combination could be estimated with reasonable accuracy from the other members of the combination. Each variable was included in at least one combination and all but a few were included in at least two.

The computer calculated regression equations for each variable in a combination in terms of the other two. Once the equations (and the associated standard errors) had been computed, the equations were used to estimate the values of the variables in each combination. These estimates were compared with the recorded values. Whenever an estimate and the recorded value differed by more than five times the appropriate standard error of estimate, an error message was printed out. This message contained, in addition to the estimate and recorded value, a considerable amount of other data about the subject in question which was deemed to be of value in evaluating the questioned datum. For example, where a stature measurement was in question, this message included the subject's other height measurements, expressed both in millimeters and in standard score form.

TABLE II – A LIST OF SELECTED EDITING COMBINATIONS

Stature	Cervicale Height	Shoulder Height
Shoulder Height	Waist Height	Crotch Height
Sitting Height	Eye Height, Sitting	Mid-Shoulder Height, Sitting
Stature	Crotch Height	Sitting Height
Weight	Neck Circumference	Shoulder Circumference
Shoulder Circumference	Chest Circumference	Waist Circumference
Hip Circumference	Upper Thigh Circumference	Lower Thigh Circumference
Lower Thigh Circumference	Calf Circumference	Ankle Circumference
Chest Circumference	Interscye Breadth	Interscye, Maximum
Chest Depth	Chest Breadth	Chest Circumference
Hip Breadth	Hip Breadth, Sitting	Hip Circumference
Shoulder Breadth	Maximum Forearm- Forearm Breadth	Shoulder Circumference
Biceps Circumference, Relaxed	Biceps Circumference, Flexed	Forearm Circumference, Flexed
Occiput-External Canthus	Occiput-Nasal Root	Occiput-Pronasale
Face Breadth	Bitragion Breadth	Head Breadth
Head Length	Head Breadth	Head Circumference
Hand Length	Palm Length	Thumb Crotch Length
Hand Breadth	Wrist Circumference	Hand Circumference
Crotch Height	Buttock-Knee Length	Buttock-Popliteal Length
Heel Breadth	Ball of Foot Breadth	Ball of Foot Circumference
Functional Reach	Sleeve Length	Sleeve Inseam Length

Each questioned value was thoroughly examined. Errors in punching were, of course, rectified. Often, when the value recorded for one variable for a particular subject appeared to be most unlikely, other data for this subject would indicate a value for this variable which a simple observational or recording error could have turned into the recorded value. Thus, for example, a subject might have values for stature, shoulder height, waist height, and crotch height all approximately equal to the mean values of these measurements, plus a cervicale height value of 1409 mm, a value about one and a half standard deviations below the mean for cervicale height. In such a case, it seemed quite reasonable to believe that this man's cervicale height had actually been 1490 mm — approximately average — and that the third and fourth digits had been reversed in the recording; a corresponding change was made in the data. In general, when the data indicated quite clearly both that a value was in error and what, approximately, the correct value almost certainly was, the appropriate change was made.

The large number of measurements made on each man and the generally high level of intercorrelations among the variables made it possible to estimate almost any one of the variables with high accuracy from a knowledge of the others. It was, therefore, possible to do a fairly thorough editing job on most of the variables.

c. Computation of Statistics

Computation of the summary statistics and frequency tables were carried out on the computer, working from the magnetic tape record of the edited data. Four constants were stored in the computer for each variable before the calculations began.

- a) $A_{i,1}$ — the lower limit of the first interval in the frequency table for the i -th variable;
- b) $A_{i,2}$ — the maximum value attained by the i -th variable;
- c) $A_{i,3}$ — an integer value approximately equal to the average value of the i -th variable, and
- d) WID_i — the width of the intervals for the i -th variable.

The first of these constants, $A_{i,1}$, was, of necessity, either equal to or slightly less than the minimum value of the i -th variable. Thus, the first two constants defined a range of values into which every value for the i -th variable should fall. Each datum was tested as it was read into the computer to insure that it did, in fact, lie within the appropriate range.

The third of these constants, $A_{i,3}$, was subtracted from each value for the i -th variable and all summations required for the statistical computations were based on the resulting differences. This procedure markedly reduced the size of the summations, minimizing truncation errors in these computations, and ensuring adequate results from simple precision calculations.

The first and last of the stored constants were used in establishing the frequency tables. These constants were chosen to provide tables with no more than fifty intervals.

As each data record was read into the computer:

a) each value was checked to guarantee it was in range. Had any non-zero value been out of range, all data for that subject would have been rejected. On the final run, no values, as should have been expected, were out of range.

b) each non-zero value, x_i , was converted to its difference value:

$$Y = X_i - A_{i,3}$$

c) the first four powers of Y were accumulated:

$$S_{i,1} = S_{i,1} + Y$$

$$S_{i,2} = S_{i,2} + Y^2$$

$$S_{i,3} = S_{i,3} + Y^3$$

$$S_{i,4} = S_{i,4} + Y^4$$

d) The count of the number of non-zero values for the i -th variable was accumulated:

$$N_i = N_i + 1$$

e) the interval of the frequency table for the i -th variable to which x_i belongs was determined:

J = the smallest whole number less than or equal to

$$(X_i - A_{i,1})/WID_i + 1.0$$

and unity was then added to the previous count for this interval:

$$F_{i,j} = F_{i,j} + 1$$

When all of the data had been processed, the summary statistics were computed using these formulas:

$$a) \quad W = S_{i,1} / N_i$$

$$Z = S_{i,2} / N_i$$

$$U = S_{i,3} / N_i$$

$$V = S_{i,4} / N_i$$

followed by:

$$b) \quad M = \text{arithmetic mean} = W + A_{i,3}$$

$$SD = \text{standard deviation} = \sqrt{Z - W^2}$$

$$\beta_1 = \text{symmetry} = (U - 3ZW + 2W^3) / (SD)^3$$

$$\beta_2 = \text{kurtosis} = (V - 4W + 6ZW^2 - 3W^4) / (SD)^4$$

$$V = \text{coefficient of variation} = 100 \cdot SD/M$$

$$SE(M) = \text{standard error of the mean} = SD / \sqrt{N_1}$$

$$SE(SD) = \text{standard error of the standard deviation} = SE(M) 0.7071$$

The computation of the percentiles was carried out using a procedure developed by Churchill to achieve the speed and reproducibility of computer calculations while simulating the procedure of plotting cumulative frequencies on normal-probability graph paper and reading percentiles from these graphs.

The first step in these computations consisted of calculating rough values for each percentile by direct interpolation in the frequency table. To compute the K-th percentile, the first interval for which the cumulative percent frequency, CPF(U), exceeded K% was located. If L represents the cumulative percent frequency up to but not including this interval; then the K-th rough percentile was computed as

$$L + \text{WID} \left(\frac{K - \text{CPF}(L)}{\text{CPF}(U) - \text{CPF}(L)} \right)$$

To illustrate this formula, we may calculate the rough 1st percentile for stature, using the data shown on page 72. We observe that the eighth interval (158.75 – 159.74 centimeters) is the first interval for which the cumulative frequency count exceeds 1%. Hence,

L = the lower limit of this interval = 158.75

WID = the width of the interval = 1.0

CPF(L) = the cumulative percent frequency for the first seven intervals = 0.94

CPF(U) = the cumulative percent frequency for the first eight intervals = 1.27, and

the K-th percentile =

$$158.75 + 1.0 \left(\frac{1.00 - 0.94}{1.27 - 0.94} \right) = 158.75 + 1.0 \cdot 0.18 =$$

$$158.75 + 0.18 = 158.93 \text{ cm.}$$

We note that the smoothed value of 158.87 cm. also given on page 73, differs from the result of these calculations by less than one millimeter. This computation was done for each of the 25 percentiles listed for each measured variable.

In the second step of these computations, the 25 computed percentiles were then smoothed by a process designed to simulate plotting on normal probability graph paper and drawing a smooth line through the set of points. What is actually done is to assign an 'X-value' to each raw percentile equal to the corresponding deviate of the normal distribution, fit a fourth degree polynomial to these points, and read the smoothed values from this polynomial. By using orthogonal polynomials, the computational procedure is fairly simple.

The statistics (except for β_1 , β_2 , and V , which are dimensionless) were, in most instances, then multiplied by 0.1 to convert from millimeters to centimeters. The centimeter values were then multiplied by 0.3937 to provide inch values, and weights were converted to kilograms by using 0.45359 as the multiplier.

To provide a maximum of flexibility in listing the statistics and frequency tables for photographic reproduction in this report, the results were entered on punched cards and tables prepared by listing these cards on the IBM 407 tabulator.

4. THE SAMPLE OF U. S. ARMY MEN MEASURED

A total sample of 6682 U. S. Army men was processed and measured during the Army anthropometric survey. During the analyses of the data the Army sample was sorted into four groups. The first group included 2639 basic trainees, who were young men just entering the Army and beginning their period of basic training. The second group of 3429 men actually consisted of Army men who were not basic trainees, armored personnel, or aviation personnel. Although predominantly infantrymen, this group also included personnel of other Army branches, and may be regarded as a general Army sample. It has been arbitrarily designated as "infantry", with the provision that it is not exclusively infantry. A third group consisted of 489 armored personnel who had served as tankers or other armored vehicle crewmen. Finally, the fourth group consisted of a small sample of 125 Army aviation personnel, including both pilots and aircrewmen. In the discussions of both the background information and the anthropometric data to follow, reference will be made to the total Army series, and to the four subseries of basic trainees, infantry, armored, and aviation personnel.

While the primary objective of the Army anthropometric survey was to obtain body measurement data, additional information was necessary as a supplement to the anthropometric data. Therefore, two general types of background data on the men were recorded at the time they were processed and measured. In the category of military information, such items as rank, pay grade, service number and prefix, branch of service, and length of service were recorded and subsequently analyzed. An attempt also was made to record primary and duty military occupational specialty (MOS), additional military specialty, and present job assignment, but the recording of these items was unsatisfactory and the results are not reported. In the category of personal information, such items as age, birthplace, birthplace of father and mother, location of longest residence, national extraction, education, and marital status were recorded. Notations also were made on whether the individual wore glasses, his handedness, and his combat boot size. These items of background information will serve to describe and characterize the sample of Army men measured in the survey.

a. Military Information

(1) **Military Rank and Pay Grade.** The total series of Army men measured during the 1966 anthropometric survey consisted primarily of enlisted men. Over 91 percent of the total series were enlisted men, less than seven percent were non-commissioned officers, and less than two percent were warrant and commissioned officers. A summary of this classification is given in Table III. Classifications within the four Army subseries also are shown in this table. The subseries of basic trainees, of course, was composed entirely of enlisted men. The infantry subseries was composed of 92 percent enlisted men, eight percent NCO's, and a few officers. A much higher proportion of

TABLE III - CLASSIFICATIONS OF RANK

Classification	Total Series		Basic Trainees		Infantry		Armored		Aviators	
	No.	%	No.	%	No.	%	No.	%	No.	%
Enlisted Men	6110	91.4	2639	100.0	3143	91.7	303	62.0	25	20.0
NCO's	456	6.8			276	8.0	177	36.2	3	2.4
Warrant Officers	30	0.5			1	0.1			29	23.2
Comm. Officers	85	1.3			8	0.2	9	1.8	68	54.4
Total	6681	100.0	2639	100.0	3428	100.0	489	100.0	125	100.0

TABLE IV - RANK AND PAY GRADE

Pay Grade	Rank	Enlisted Men (E-1 to E-8)		NCO'S (E-4 to E-9)		Warrant Officers (W-1 to W-4)		Comm. Officers (O-1 to O-6)		
		No.	%	Rank	No.	Rank	No.	Rank	No.	%
1	PV1	2851	46.7			W01	23	2LT	11	12.9
2	PV2	1700	27.8			CW2	6	1LT	25	29.4
3	PFC	626	10.3			CW3	1	CPT	26	30.6
4	SP4	662	10.8	CPL	23	CW4	—	MAJ	22	25.9
5	SP5	261	4.3	SGT	200			LTC	1	1.2
6	SP6	7	0.1	SSG	192			COL	—	—
7	SP7	1	—	SFC	37					
8	SP8	2	—	1SG	4					
9				SGM	—					
Total		6110	100.0		456		30		85	100.0

noncommissioned officers was found in the subseries of armored personnel; 62 percent of this group were enlisted men, 36 percent were NCO's, and less than two percent were officers. The small sample of Army aviators included aircrewmembers and crew chiefs (22 percent), warrant officers (23 percent), and commissioned officers (55 percent).

A further breakdown of this classification for the total Army series is given in Table IV, which shows both rank and pay grade for the various categories. On the basis of pay grade, there were 5177 enlisted men (77.5 percent) who were privates or privates, first class in the first three pay grades. There were 1389 enlisted men and noncommissioned officers (20.7 percent) in pay grades 4 to 8. The 30 warrant officers (0.5 percent) and 85 commissioned officers (1.3 percent) made up the remainder of the total Army series.

By contrast the sample of 24,540 separatees measured in the 1946 Army survey consisted of 9184 (37.4 percent) privates and privates, first class; 14,319 (58.4 percent) non-commissioned officers; and 1037 (4.2 percent) commissioned officers. In terms of the Army organization in effect in 1946, this sample was composed of 15.2 Army Air Force personnel, 50.5 percent Army Ground Force personnel, and 34.3 percent Army Service Force personnel.

(2) **Army Service Category.** Service numbers were recorded for all men measured. Since the letter prefix to each man's service number indicates the category of service of that individual, an attempt was made to determine the number of men serving in the various service categories. Through a coding error, however, most of the officer data and some of the enlisted data were not useable, so that service category information for the aviator subseries and for the total series is not available. The remaining data on enlisted men from the basic trainee, infantry and armored personnel subseries are summarized in Table V. Four general categories are shown. The group consisting of all Regular Army enlistees includes those who have Reserve commissions (Prefix RO), those who have Reserve warrants (RW), those who were retired from previous enlistment, but who have been recalled (RP), and those enlistees without any of the above (RA). The Inductee category consists of typical Army draftees, including those volunteering for the draft (US), and inductees holding Reserve commissions or warrants (UR). The Enlisted Reservist category is composed of those men whose current enlistment was in the Army Reserve but who are presently on active duty, either undergoing training or who have extended their terms of active service (ER). The National Guardsman category is identical with the Enlisted Reservist category except that the individual's current enlistment was in the National Guard (NG).

TABLE V - ARMY SERVICE CATEGORY

	Service Number Prefixes	Basic Trainees		Infantry		Armored	
		No.	%	No.	%	No.	%
Enlisted Regular Army	RA, RO, RW, RP	1108	42.0	1980	57.9	353	73.6
Inductees	US, UR	1314	49.8	1295	37.9	113	23.5
Enlisted Reservists	ER	45	1.7	60	1.7	9	1.9
National Guardsmen	NG	135	5.1	76	2.2	5	1.0
Not properly recorded		37	1.4	9	0.3		
Total		<u>2639</u>	<u>100.0</u>	<u>3420</u>	<u>100.0</u>	<u>480</u>	<u>100.0</u>

About one-half of the basic trainees were inductees (draftees), while 42 percent were Regular Army enlistees. In contrast, the infantry subseries was predominantly Regular Army (58 percent), with 42 percent in other categories. The armored subseries was even more strongly Regular Army (74 percent), with only 26 percent in other categories.

(3) **Army Branch of Service.** Consideration of the Army branch of service assignment of the men measured provides a means of assessing the proportions of combat troops and technical service personnel in the Army sample. Table VI shows the distribution of branch of service for the total Army series and the four subseries. The total series included a large proportion of men from the Infantry Branch (62.35 percent). This was due in part to the large number of basic trainees in Infantry basic training units. The other four combat arms (Armor, Artillery, Corps of Engineers, and Signal Corps) together accounted for 15.87 percent of the total series, while the technical services comprised 20.11 percent. Branch of service was not recorded for 1.66 percent of the total series. All but four of the technical services were represented in the total sample; no personnel were measured from the Army Nurse Corps, Army Medical Specialist Corps (both composed solely of commissioned officers), Veterinary Corps, or Chaplains Corps.

TABLE VI - ARMY BRANCH OF SERVICE

Branch	Total Series		Basic Trainees		Infantry		Armored		Aviators	
	No.	%	No.	%	No.	%	No.	%	No.	%
Adjutant General Corps	271	4.06	1	0.04	269	7.84	1	0.20		
Armor	444	6.64	7	0.26	131	3.82	298	60.94	8	6.40
Army Intelligence & Security	183	2.74			183	5.34				
Artillery	232	3.47			186	5.42	28	5.73	18	14.40
Chemical Corps	40	0.60			39	1.14			1	0.80
Corps of Engineers	287	4.30			270	7.87	15	3.07	2	1.60
Dental Corps	1	0.01			1	0.03				
Finance Corps	44	0.66	1	0.04	42	1.22	1	0.20		
Infantry	4166	62.35	2628	99.58	1397	40.74	110	22.50	31	24.80
Judge Advocate General Corps	3	0.04			3	0.09				
Medical Corps	34	0.51			30	0.88	1	0.20	3	2.40
Medical Service Corps	3	0.04			3	0.09				
Military Police	36	0.54			34	0.99			2	1.60
Ordnance Corps	142	2.12			132	3.85	7	1.43	2	1.60
Quartermaster Corps	362	5.42	1	0.04	348	10.15	10	2.05	4	3.20
Signal Corps	98	1.47			93	2.71	2	0.41	3	2.40
Staff Specialist Corps	2	0.03			2	0.06				
Transportation Corps	223	3.34			197	5.75	12	2.45	14	11.20
Not recorded	111	1.66	1	0.04	69	2.01	4	0.82	37	29.60
Total	6682	100.00	2639	100.00	3429	100.00	489	100.00	125	100.00

More than 99 percent of the basic trainee subseries were Infantry trainees, not yet qualified for service in other branches. The ten individuals who indicated a branch other than Infantry either had enlisted for a particular specialty or had received orders for further training at a branch service school and thus knew of their future assignments.

The Infantry subseries was so termed because of a predominance of personnel assigned to the Infantry branch. In addition to the 40.74 percent from the Infantry, this group had 19.82 percent from the other four combat arms, 37.41 percent from the technical services, and 2.01 percent whose branch of service was not recorded. The Infantry subseries, then, cannot be considered as necessarily representative or typical of Army combat forces, primarily because the ratio of combat arms troops to technical service troops varies greatly among Army ground combat units. Also, during the tabulation of the Infantry subseries, all personnel with experience in armored vehicles were excluded. However, the approximate ratio of 60 percent combat arms to 40 percent technical services personnel appears to be an acceptable "mix" of personnel for design purposes, excluding armored vehicles or aircraft. Although combat arms troops do predominate, the Infantry subseries is not overly unbalanced in this direction.

The armored crewmen subseries was tabulated by selecting those individuals who had actually served in armored combat vehicles (tanks, self-propelled artillery, armored personnel carriers) at some time in their military careers. This series was composed of 92.63 percent from the combat arms, with 60.94 percent serving in the Armored branch. Only 6.52 percent were from the technical services, with 2.45 percent from the Transportation Corps, whose members operate armored personnel carriers.

The aviator subseries consisted of commissioned or warrant officer pilots and enlisted crewmen (crew chiefs, mechanics, door gunners, and medical personnel) who had been assigned as members of operational aircrews. Army pilots can be trained from any branch of service with requirements for pilots, since there is no specific branch designation exclusively for Army aviators. Combat arms and Transportation Corps units have the greatest number of aircraft; this is reflected in the predominance of these branches in the aviator subseries. Enlisted men serving as crew chiefs, mechanics, or door gunners usually are considered to be of the same branch as is the unit in which they are serving. There are no particular branch requirements for these crew positions, but aviation or air-evacuation medical personnel are members of the Medical Corps, regardless of their unit assignment.

(4) Length of Military Service. In general, the length of service recorded for men measured in the survey indicated a relatively short duration for their military duty in the Army. The distribution of length of service is shown in Table VII.

The total Army series included a large proportion (39.5 percent) of basic trainees, all of who had less than one month of service. As a result, 39.8 percent of the total series had less than one month of military service, while 68.5 percent had less than one year of service, 76.5 percent less than two years, 84.4 percent less than three years, and 88.6 percent less than five years of service. Only 11.4 percent of the total Army series had five years or more of military service.

The infantry subseries reflects the large numbers of draftees and first-term enlistees in the Army. Of this group, 55.7 percent had served less than one year, 69.2 percent less than two years, and 80.5 percent less than three years. In contrast, the armored and aviator personnel subseries consisted of men with longer periods of service; 85.7 percent of the armored personnel and 79.2 percent of the aviator personnel had two or more years of service, which is reflected in their higher ranks. These two groups, therefore, may be considered to include primarily professional soldiers, rather than drafted men with military obligations.

b. Personal Information

(1) Age. The ages of men measured in the Army anthropometric survey were recorded as of their last birthday. The mean age of the total Army series was 22.17 years. The standard deviation was 4.64 years, giving a coefficient of variation of 20.92 percent. The range of age in the total Army series was from 17 to 55 years; however, approximately 58 percent of the men in this series were between 19 and 21 years of age. The distribution and statistical values of age for the total Army series are given in Table VIII.

As might be expected, considerable variation in age was found in the Army subseries. The basic trainees, of course, represented the youngest age group, with a mean age of 20.18 years, and a standard deviation of 1.48 years. Over 68 percent of the basic trainees were in the 19 and 20-year-old age bracket. The infantry subseries showed a wide range of variation in age, with a mean of 22.79 years and a standard deviation of 5.05 years. Approximately 62 percent of the infantry sample were between 19 and 22 years of age. The subseries of armored and aviation personnel were older. The armored subseries showed a mean age of 27.02 years, with a standard deviation of 6.14 years, while the aviator subseries had a mean age of 28.11 years, and a standard deviation of 6.04 years. The frequency distributions of age for the four Army subseries, as well as for the total Army series, are shown in Table IX.

TABLE VII - LENGTH OF SERVICE

Length of Service	Total Series		Basic Trainees		Infantry		Armored		Aviators	
	No.	%	No.	%	No.	%	No.	%	No.	%
Less than 1 month	2659	39.8	2639	100.0	20	0.6	-	-	-	-
1 to 6 months	151	2.3	-	-	146	4.2	5	1.0	-	-
6 months to 1 year	1768	26.4	-	-	1746	50.9	17	3.5	5	4.0
1 to 2 years	532	8.0	-	-	463	13.5	48	9.8	21	16.8
2 to 3 years	526	7.9	-	-	387	11.3	120	24.5	19	15.2
3 to 5 years	280	4.2	-	-	208	6.1	63	12.9	9	7.2
5 to 10 years	326	4.9	-	-	195	5.7	105	21.5	26	20.8
10 to 15 years	183	2.7	-	-	96	2.8	59	12.1	28	22.4
15 years and over	257	3.8	-	-	168	4.9	72	14.7	17	13.6
Total	6682	100.0	2639	100.0	3249	100.0	489	100.0	125	100.0

TABLE VIII - AGE OF TOTAL ARMY SERIES

INTERVALS	FREQUENCIES			
	YEARS	ACTUAL FREQ	CUMULA TIVE-F	PERCENT FREQ
55.00 - 55.99	3	6682	0.04	100.00
54.00 - 54.99	1	6679	0.02	99.96
53.00 - 53.99	4	6678	0.06	99.94
52.00 - 52.99	2	6674	0.03	99.88
51.00 - 51.99	5	6672	0.07	99.85
50.00 - 50.99	1	6667	0.02	99.78
49.00 - 49.99	4	6666	0.06	99.76
48.00 - 48.99	3	6662	0.04	99.70
47.00 - 47.99	3	6659	0.04	99.66
46.00 - 46.99	6	6656	0.09	99.62
45.00 - 45.99	7	5650	0.11	99.53
44.00 - 44.99	7	5643	0.11	99.42
43.00 - 43.99	8	6636	0.12	99.31
42.00 - 42.99	12	6628	0.18	99.19
41.00 - 41.99	10	6616	0.15	99.01
40.00 - 40.99	18	6606	0.27	98.86
39.00 - 39.99	14	6588	0.21	98.59
38.00 - 38.99	25	6574	0.38	98.38
37.00 - 37.99	43	6549	0.64	98.00
36.00 - 36.99	37	6506	0.55	96.36
35.00 - 35.99	48	6469	0.72	96.81
34.00 - 34.99	28	6421	0.42	96.09
33.00 - 33.99	40	6393	0.60	95.67
32.00 - 32.99	29	6353	0.44	95.07
31.00 - 31.99	33	6324	0.49	94.63
30.00 - 30.99	42	6291	0.63	94.14
29.00 - 29.99	38	6249	0.57	93.51
28.00 - 28.99	39	6211	0.58	92.94
27.00 - 27.99	56	6172	0.84	92.36
26.00 - 26.99	83	6116	1.24	91.52
25.00 - 25.99	155	6033	2.32	90.28
24.00 - 24.99	320	5878	4.79	87.96
23.00 - 23.99	486	5558	7.27	83.17
22.00 - 22.99	532	5072	7.96	75.90
21.00 - 21.99	916	4540	13.71	67.94
20.00 - 20.99	1533	3624	22.94	54.23
19.00 - 19.99	1414	2091	21.16	31.29
18.00 - 18.99	449	677	6.72	10.13
17.00 - 17.99	228	228	3.41	3.41

TABLE VIII – AGE OF TOTAL ARMY SERIES (Continued)

PERCENTILES

YEARS

42.96	99 TH
37.72	98 TH
34.86	97 TH
31.50	95 TH
27.43	90 TH
25.33	85 TH
23.98	80 TH
23.02	75 TH
22.59	70 TH
21.73	65 TH
21.28	60 TH
20.91	55 TH
20.60	50 TH
20.34	45 TH
20.12	40 TH
19.93	35 TH
19.77	30 TH
19.61	25 TH
19.46	20 TH
19.29	15 TH
19.06	10 TH
18.59	5 TH
18.14	3 RD
17.73	2 ND
17.39	1 ST

THE SUMMARY STATISTICS

YEARS

Arithmetic Mean	=	22.17
Standard Error Of Mean	=	0.06
Standard Deviation	=	4.64
Standard Error Std Dev	=	0.04
Symmetry – Beta I	=	2.99
Kurtosis – Beta II	=	14.15
Coefficient Of Variation	=	20.92
Sample Size	=	6682

TABLE IX - DISTRIBUTIONS OF AGE

Years	Total Series		Basic Trainees		Infantry		Armored		Aviators	
	No.	%	No.	%	No.	%	No.	%	No.	%
55	3	0.04			3	0.09				
54	1	0.02			1	0.03				
53	4	0.06			4	0.12				
52	2	0.03			2	0.06				
51	5	0.07			3	0.09	2	0.41		
50	1	0.02			1	0.03				
49	4	0.06			2	0.06	2	0.41		
48	3	0.04			2	0.06			1	0.80
47	3	0.04			3	0.09				
46	6	0.09			6	0.17				
45	7	0.11			6	0.17	1	0.21		
44	7	0.11			5	0.15	2	0.41		
43	8	0.12			7	0.20	1	0.21		
42	12	0.18			8	0.23	4	0.82		
41	10	0.15			7	0.20	3	0.61		
40	18	0.27			13	0.38	5	1.02		
39	14	0.21			9	0.26	4	0.82	1	0.80
38	25	0.38			13	0.38	5	1.02		
39	14	0.21			9	0.26	4	0.82	1	0.80
37	43	0.64			26	0.76	13	2.66	4	3.20
36	37	0.55			20	0.58	13	2.66	4	3.20
35	48	0.72			27	0.79	16	3.27	5	4.00
34	28	0.42			12	0.35	10	2.05	6	4.80
33	40	0.60			20	0.58	9	1.84	11	8.80
32	29	0.44			16	0.47	11	2.25	2	1.60
31	33	0.49	1	0.04	13	0.38	12	2.45	7	5.60
30	42	0.63			24	0.70	14	2.86	4	3.20
29	38	0.57			23	0.67	11	2.25	4	3.20
28	39	0.58	1	0.04	17	0.50	20	4.09	1	0.80
27	56	0.84	1	0.04	36	1.05	12	2.45	7	5.60
26	83	1.24	2	0.08	50	1.46	25	5.11	6	4.80
25	155	2.32	20	0.76	93	2.71	34	6.95	8	6.40
24	320	4.79	50	1.89	201	5.86	57	11.66	12	9.60
23	486	7.27	79	2.99	317	9.24	81	16.56	9	7.20
22	532	7.96	109	4.13	375	10.94	40	8.18	8	6.40
21	916	13.71	204	7.73	673	19.63	32	6.54	7	5.60
20	1533	22.94	831	31.49	662	19.30	34	6.95	6	4.80
19	1414	21.16	982	37.21	413	12.04	13	2.66	6	4.80
18	449	6.72	219	8.30	226	6.29	2	0.41	2	1.60
17	228	3.41	140	5.30	87	2.54	1	0.21		
Total	6682	100.00	2639	100.00	3429	100.00	489	100.00	125	100.00
Mean Age (years)		22.17		20.18		22.79		27.02		28.11
S.D.		4.64		1.48		5.05		6.14		6.04

(2) Birthplace and Residence. To assess the geographical distribution of the sample of men measured during the Army survey, the men were asked to give their birthplace, as well as the birthplaces of their parents. In addition, they also were asked to state the area of longest residence prior to military service in the Army.

In the compilation of the information on geographical distribution, the individual states of the United States were grouped into the nine geographical divisions used by the Bureau of the Census. The two newest states of Alaska and Hawaii were recorded separately. The Commonwealth of Puerto Rico, the Canal Zone, and the island of Guam also were listed separately. The large number of foreign countries which were reported were arbitrarily grouped for convenience into geographical areas.

The geographical distribution for the total Army series is shown in Table X, with the four categories of subject's birthplace, father's birthplace, mother's birthplace, and subject's longest residence. In Table X, subtotals are indicated for the United States, for territories, and for foreign countries. The geographical distribution for the total Army series and for the four subseries is summarized in Table XI.

In the total Army series, about 95 percent of the men were born in the United States, about two percent were born in the territories, and about three percent were born abroad in foreign countries. Approximately 91 percent of the fathers were born in the United States, two percent were from the territories, and seven percent were foreign born; 92 percent of the mothers were born in the United States, two percent were from the territories, and six percent were foreign born. About 97 percent of the men reported living in the United States prior to military service, while less than four percent had lived in the territories or in foreign countries.

More than one-half of the men in the total Army sample were born in three of the nine U. S. geographical divisions. The East North Central division (Ohio, Indiana, Illinois, Michigan, and Wisconsin) represented an area in which 18.5 percent of the Army series were born. The Middle Atlantic division (New York, New Jersey, and Pennsylvania) included 17.2 percent, while the South Atlantic division (Delaware, Maryland, District of Columbia, Virginia, West Virginia, North Carolina, South Carolina, Georgia, and Florida) accounted for 14.6 percent. Among the foreign-born, the majority were born in Canada, Mexico, the United Kingdom, or countries of central or southern Europe.

(3) National Extraction. During the Army survey, men were requested to give their ethnic derivation or national extraction. A tabulation of this information for the total Army series and for the four subseries is shown in Table XII.

TABLE X – GEOGRAPHICAL DISTRIBUTION OF TOTAL SERIES

Area	Subject's Birthplace		Father's Birthplace		Mother's Birthplace		Subject's Residence	
	No.	%	No.	%	No.	%	No.	%
United States:								
New England	390	5.84	360	5.58	364	5.55	384	5.75
Middle Atlantic	1150	17.21	1002	15.52	1010	15.53	1196	17.91
East North Central	1238	18.53	1047	16.21	1041	15.86	1312	19.65
West North Central	615	9.21	716	11.09	727	11.08	575	8.61
South Atlantic	974	14.58	1024	15.86	1040	15.85	945	14.15
East South Central	520	7.78	644	9.97	671	10.22	429	6.43
West South Central	578	8.65	626	9.69	646	9.84	509	7.62
Mountain	248	3.71	220	3.41	229	3.49	244	3.66
Pacific	592	8.86	195	3.02	241	3.67	811	12.15
Alaska	3	0.04	1	0.02	1	0.02	8	0.12
Hawaii	31	0.46	21	0.33	33	0.50	36	0.54
Total United States	6639	94.87	5856	90.70	6012	91.61	6449	96.59
Territories:								
Puerto Rico	112	1.68	117	1.81	122	1.86	96	1.44
Canal Zone	9	0.13	6	0.09	6	0.09	5	0.08
Guam	8	0.12	9	0.14	8	0.12	8	0.12
Total Territories	129	1.93	132	2.04	136	2.07	109	1.64
Foreign Countries:								
Canada	33	0.49	70	1.08	84	1.28	23	0.35
Mexico	29	0.43	65	1.01	50	0.76	12	0.18
Antilles	8	0.12	14	0.22	15	0.23	7	0.11
Central America	11	0.16	10	0.15	13	0.20	6	0.09
South America	9	0.13	12	0.18	11	0.17	10	0.15
United Kingdom	22	0.33	33	0.51	44	0.67	6	0.09
Ireland	4	0.06	21	0.32	19	0.29	4	0.06
Scandinavia	5	0.07	21	0.32	16	0.24	3	0.04
Western Europe	8	0.12	10	0.15	11	0.17	5	0.08
Central Europe	35	0.52	49	0.76	35	0.53	19	0.29
Eastern Europe	5	0.07	21	0.32	19	0.29	2	0.03
Russia	6	0.09	23	0.36	20	0.30	—	—
Southern Europe	19	0.29	72	1.12	42	0.64	10	0.15
Balkans	5	0.07	17	0.26	11	0.17	3	0.04
Middle East	3	0.04	6	0.09	3	0.05	4	0.06
Northern Africa	1	0.01	1	0.02	1	0.02	—	—
Southern Africa	1	0.01	1	0.02	1	0.02	1	0.01
South Asia	—	—	1	0.02	—	—	—	—
Southeast Asia	2	0.03	1	0.02	3	0.05	1	0.01
Eastern Asia	4	0.06	18	0.28	12	0.18	1	0.01
Australia, New Zealand	1	0.01	1	0.02	2	0.03	1	0.01
Oceania	2	0.03	2	0.03	2	0.03	1	0.01
Total Foreign	213	3.20	469	7.26	414	6.32	119	1.77
Total	6681	100.00	6457	100.00	6562	100.00	6677	100.00

TABLE XI – GEOGRAPHICAL DISTRIBUTION OF SUBSERIES

	Subject's Birthplace		Father's Birthplace		Mother's Birthplace		Subject's Residence	
	No.	%	No.	%	No.	%	No.	%
Total Series:								
United States	6339	94.87	5856	90.70	6012	91.61	6449	96.59
Territories	129	1.93	132	2.04	136	2.07	109	1.64
Foreign Countries	213	3.20	469	7.26	414	6.32	119	1.77
Total	6681	100.00	6457	100.00	6562	100.00	6677	100.00
Basic Trainees:								
United States	2542	96.31	2328	92.12	2389	93.06	2576	97.76
Territories	29	1.10	33	1.31	34	1.33	23	0.87
Foreign Countries	68	2.59	166	6.57	144	5.61	36	1.37
Total	2639	100.00	2517	100.00	2567	100.00	2635	100.00
Infantry:								
United States	3216	93.80	2986	89.79	3077	90.82	3282	95.73
Territories	86	2.52	86	2.59	89	2.63	75	2.19
Foreign Countries	126	3.68	254	7.62	222	6.55	71	2.08
Total	3428	100.00	3326	100.00	3388	100.00	3428	100.00
Armored:								
United States	457	93.46	428	89.17	434	90.04	467	95.50
Territories	14	2.86	13	2.71	13	2.70	11	2.25
Foreign Countries	18	3.68	39	8.12	35	7.26	11	2.25
Total	489	100.00	480	100.00	482	100.00	489	100.00
Aviators:								
United States	124	99.20	114	91.94	112	89.60	124	99.20
Territories	—	—	—	—	—	—	—	—
Foreign Countries	1	0.80	10	8.06	13	10.40	1	0.80
Total	125	100.00	124	100.00	125	100.00	125	100.00

TABLE XII – NATIONAL EXTRACTION

National Extraction	Total Series		Basic Trainees		Infantry		Armored		Aviators	
	No.	%	No.	%	No.	%	No.	%	No.	%
American, White	1955	29.38	874	33.27	860	25.21	150	30.68	71	56.80
Negro	973	14.62	223	8.49	630	18.46	115	23.52	5	4.00
Indian	99	1.49	30	1.14	59	1.73	0	1.54	1	0.80
Armenian	3	0.04	1	0.04	2	0.06				
Austrian	0	0.14	4	0.15	5	0.15				
Belgian	5	0.08	4	0.15	1	0.03				
Canadian	49	0.74	20	0.76	24	0.07	5	1.02		
Chinese	5	0.08	3	0.11	2	0.06				
Cuban	6	0.09	1	0.04	5	0.15				
Czechoslo- vakian	45	0.68	19	0.72	24	0.70	2	0.41		
Danish	28	0.42	14	0.53	13	0.38			1	0.80
Dutch	110	1.65	57	2.17	45	1.32	5	1.02	3	2.40
English	441	6.63	176	6.70	232	6.80	30	6.14	3	2.40
Filipino	11	0.16	4	0.15	4	0.12	2	0.14	1	0.80
Finnish	10	0.15	3	0.11	7	0.21				
French	184	2.77	78	2.97	95	2.78	11	2.25		
German	802	12.05	337	12.83	422	12.37	36	7.36	7	5.60
Greek	4	0.06	3	0.11			1	0.20		
Guamanian	6	0.09	3	0.11	1	0.03	2	0.41		
Hawaiian	6	0.09	3	0.11	2	0.06	1	0.20		
Hungarian	35	0.53	15	0.57	17	0.50	2	0.41	1	0.80
Irish	686	10.31	268	10.20	351	10.29	50	10.23	17	13.60
Italian	274	4.12	129	4.91	129	3.78	12	2.45	4	3.20
Japanese	24	0.36	11	0.42	12	0.35	1	0.20		
Korean	2	0.03	1	0.04	1	0.03				
Lithuanian	22	0.33	11	0.42	11	0.32				
Mexican	106	1.59	29	1.10	70	2.05	7	1.43		
Norwegian	85	1.28	48	1.83	31	0.91	5	1.02	1	0.80
Polish	173	2.60	71	2.70	91	2.67	9	1.84	2	1.60
Portuguese	31	0.47	13	0.50	17	0.50	1	0.20		
Puerto Rican	124	1.86	30	1.14	84	2.46	10	2.05		
Rumanian	2	0.03	2	0.08						
Russian	16	0.24	6	0.23	8	0.23	2	0.41		
Scotch	86	1.29	39	1.48	38	1.11	7	1.43	2	1.60
Spanish	59	0.89	19	0.72	37	1.08	1	0.20	2	1.60
Swedish	86	1.44	47	1.79	44	1.29	2	0.41	3	2.40
Swiss	4	0.06	2	0.08	2	0.06				
Turkish	1	0.02			1	0.03				
Welsh	19	0.29	7	0.27	7	0.21	4	0.82	1	0.80
Yugoslavian	8	0.12	4	0.15	2	0.06	2	0.41		
Other										
European	7	0.10	4	0.15	3	0.09				
Near Eastern	4	0.06	2	0.08	2	0.06				
Asian	4	0.06	1	0.04	2	0.06	1	0.20		
African										
S. American	20	0.30	6	0.23	11	0.32	3	0.61		
Other	14	0.21	5	0.19	8	0.23	1	0.20		
Total	6653	100.01	2627	99.97	3412	100.01	489	99.98	125	100.00

In the listing of national extraction there were three categories in which national extraction was not otherwise specified. The categories of American white (29.4 percent), American Negro (14.6 percent) and American Indian (1.5 percent) together represented about 45 percent of the total Army series. German, Irish, English, and Italian national extractions accounted for 33 percent of the total Army series, while the remaining 22 percent represented some thirty-three other ethnic backgrounds or national extractions, as shown in Table XII.

(4) Education. The educational level of the Army men was recorded on the basis of years of schooling completed. In the total Army series, the range of educational level was from three years of schooling up to 21 years. About 25 percent of the total series had completed eleven years or less, while 57 percent had completed 12 years of education or the equivalent of high school. The remaining 18 percent had received schooling above high school level. A summary of the data on education is given in Table XIII.

By comparison, about 49 percent of the Army series of 1946 had an education level below high school, 46 percent had completed high school, and only five percent had received schooling above high school level.

(5) Marital Status. In the total Army series, about 78 percent of the men were single, less than 21 percent were married, and less than two percent were separated, divorced or were widowers. Of the basic trainees, 89 percent were single and less than ten percent were married, while in the infantry subseries, about 76 percent were single and 23 percent were married. Marital status differed somewhat in the series of armored personnel with 43 percent single and 54 percent married, while among the Army aviators, 28 percent were single and 70 percent were married. A summary of the information on marital status is given in Table XIV.

By contrast, the Army sample of 1946 consisted of 53 percent single men and about 46 percent married men, while about one percent were divorced or were widowers.

(6) Eyeglasses and Handedness. Two additional minor items of personal information were included in the background data obtained during the Army survey. Without specific reference to contact lenses, the men were asked whether or not they wore eyeglasses. In the total Army series, 75 percent stated that they did not wear glasses, while 25 percent replied that they did wear glasses. In the four Army subseries, similar percentages were found in the basic trainee and infantry subseries. Among the armored personnel, 82 percent stated that they did not wear glasses, and 18 percent did, while in the small group of aviation personnel, 88 percent reported they did not wear glasses and 12 percent replied that they did wear glasses.

TABLE XIII - EDUCATION

Educational Level	Total Series		Basic Trainees		Infantry		Armored		Aviators	
	No.	%	No.	%	No.	%	No.	%	No.	%
Below High School	1640	24.5	613	23.2	912	26.6	110	22.5	5	4.0
High School	3816	57.1	1478	56.0	1983	57.8	320	65.4	35	28.0
Above High School	1226	18.4	548	20.8	534	15.6	59	12.1	85	69.0
Total	6682	100.0	2639	100.0	3429	100.0	489	100.0	125	100.0

TABLE XIV - MARITAL STATUS

Marital Status	Total Series		Basic Trainees		Infantry		Armored		Aviators	
	No.	%	No.	%	No.	%	No.	%	No.	%
Single	5186	77.7	2350	89.1	2589	75.6	212	43.4	35	28.0
Married	1376	20.6	250	9.5	777	22.7	262	53.6	87	69.6
Separated	33	0.5	12	0.4	18	0.5	3	0.6		
Divorced	75	1.1	25	1.0	36	1.1	12	2.4	2	1.6
Widower	6	0.1			5	0.1			1	0.8
Total	6676	100.0	2637	100.0	3425	100.0	489	100.0	125	100.0

Army men in the survey also were questioned as to their handedness. In the total Army series, 88 percent replied that they were right-handed, 11 percent were left-handed, and one percent stated that they were ambidexterous. Similar percentages of handedness were found in the Army subseries, with the exception of the aviation personnel, who were 94 percent right-handed, five percent left-handed, and one percent ambidexterous.

(7) **Size of Combat Boots.** While the Army men were being processed prior to measurement, they were asked what size of combat boots they wore. Since many men did not know the width of their boots, the data on boot widths proved to be unsatisfactory; consequently, only the responses on boot size or length were analyzed. Sizes of boots recorded as being worn by men in the total Army series ranged from size 4 to size 15. The modal boot size (worn by the largest number of men) for the total series was size 9, which was worn by about 29 percent of the men, while sized 9 and 10 together were worn by over 54 percent of the men. The information on combat boot sizes is summarized in Table XV.

In taking standard anthropometric measurements of the foot, foot length is measured from the heel to the tip of the longest toe. Information on the relative lengths of the first and second toes is of interest in the design, sizing, and fit of footwear. Consequently, while the foot measurements were being taken during this survey, notations were made on relative toe lengths. The results of these observations indicated that the first or great toe was longer than the second toe on 93 percent of the Army men measured, while the second toe was longer than the first on seven percent of the men.

TABLE XV - COMBAT BOOT SIZE

Boot Size (Length)	Total Series		Basic Trainees		Infantry		Armored		Aviators	
	No.	%	No.	%	No.	%	No.	%	No.	%
4	1	0.0	-	-	1	0.0	-	-	-	-
5	14	0.2	6	0.2	7	0.2	1	0.2	-	-
6	103	1.5	37	1.4	48	1.4	15	3.1	3	2.4
7	477	7.2	192	7.3	242	7.1	38	7.8	5	4.0
8	1209	18.1	515	19.5	595	17.4	77	15.8	22	17.6
9	1929	28.9	733	27.8	1011	29.5	153	31.4	32	25.6
10	1694	25.4	704	26.7	848	24.7	104	21.3	38	30.4
11	894	13.4	331	12.5	477	13.9	71	14.5	15	12.0
12	309	4.6	106	4.0	169	4.9	25	5.1	9	7.2
13	40	0.6	12	0.5	24	0.7	3	0.6	1	0.8
14	7	0.1	3	0.1	3	0.1	1	0.2	-	-
15	3	0.0	-	-	3	0.1	-	-	-	-
Total	6680	100.0	2639	100.0	3428	100.0	488	100.0	125	100.0

5. THE STATISTICAL MEASURES

The usefulness of any anthropometric survey depends in large measure on the extent to which the mass of measurement data generated by the survey is translated by statistical analyses into summaries of value in the solution of design and related problems and which point up the important implications of the data. The statistical summaries presented in this section have been chosen in the belief that they provide the simplest and most generally useful univariate summaries of the more than half a million data collected in the present survey. As valuable as these statistics may prove to be, they contain only a small portion of the useful information embodied in the survey data. Additional information is to be sought in those summaries which involve the simultaneous distribution of two or more sets of these measurement data.

The summary statistics which traditionally have been included in U. S. military anthropometric reports are provided here for each anthropometric variable. Measures of skewness and kurtosis have been added to the list of summary statistics and a frequency distribution of each variable is presented.

The means, standard deviations, standard errors, and the percentiles are listed in both metric and English units. The statistics are given first (to the left of the statistics' name in the tables) in the type of units in which the data were measured and then in the converted units. The intervals in the frequency tables follow the same order.

The traditional statistics reported are as follows:

a. The Arithmetic Mean

The arithmetic mean is the most common of the averages; it is what is usually meant when either "mean" or "average" is used without modification. The arithmetic mean of a number of values is the sum of these values divided by the number of values. For example, since the men measured in this survey weighed a grand total of 1,062,311 pounds, their mean weight was

$$\bar{x} = \frac{\sum X}{N} = \frac{1,062,311}{6677} = 159.10 \text{ pounds}$$

The mean is designated in the statistical literature by several different symbols, the most common being \bar{x} , μ , and M . When more than one set of data are being considered at the same time, the mean values may be denoted variously as: \bar{x} , \bar{y} , \bar{z} , or \bar{x}_1 , \bar{x}_2 , \bar{x}_3 , or M_x , M_y , M_z , or M_1 , M_2 , M_3 , or μ_x , μ_y , μ_z , or μ_1 , μ_2 , μ_3 .

b. The Median

The median, a second average, designates the value of the "man-in-the-middle". If all of the subjects in this survey had been lined up in order from the shortest to the tallest, the height (1744 mm) of the man in the middle of the line would be the median height. The definition of the median is identical with that of the 50th percentile, 50 percent of the data being smaller than it is and 50 percent being larger. The value of the median is to be found at the middle of the percentile tables. The procedure used in computing the percentiles and its relationship to the definition of these statistics is discussed below; that discussion is as relevant to the interpretation of the median as it is to that of the other percentile values.

The median and the arithmetic mean have approximately the same values for most of the data gathered in this survey; for these data the question of whether one or the other is the better average is not important.

c. The Standard Deviation

The standard deviation is the basic measure of variability. If most of a set of data cluster close to their mean value, the standard deviation will be small. If on the other hand, many of the data are either much smaller or much larger than the mean, the standard deviation will be large. By definition, the standard deviation is the square root of the average (i.e., arithmetic mean) of the squared deviations from the mean value. In formula, the standard deviation equals $SD = \sqrt{\Sigma (x - \bar{x})^2 / N}$, where Σ is the summation operator, x represents the individual values, and \bar{x} their arithmetic mean, and N the number of values.

A useful way of conceptualizing the standard deviation is to consider the middle two-thirds of a set of data such as the values of stature. The smallest value in this middle two-thirds will be about one standard deviation below the mean value and the largest value in this set will be roughly equal to the mean value plus one standard deviation. Similarly, the middle 95 percent of the data will have values ranging from approximately two standard deviations below the mean to two standard deviations above it.

The standard deviation is usually designated by SD, S, or σ . Any one of these may be subscripted when several variables are being considered simultaneously. The word "sigma" (σ) is sometimes used verbally to refer to the standard deviation.

d. The Coefficient of Variation

This statistic is a re-statement of the standard deviation as a percent of the mean, and it is usually denoted by the letter V. Thus $V = 100 SD / \bar{x}$. The relationships which were noted for the standard deviation have equivalent forms in terms of V. Thus, about two-thirds of a set of data will lie between (100 - V) percent and (100 + V) percent of the mean, while about 95 percent will lie between (100 - 2V) percent and (100 + 2V) percent of the mean.

For many anthropometric variables, the coefficient of variation varies within a much narrower range than does the standard deviation. The value of V is often associated with the general anatomical nature of the variable involved. Long bone lengths (major heights, arm length, and so forth) tend to have coefficients of variation in the 3.5 to 5 percent range, while fleshy circumferences have coefficients which range from 6 percent to 10 percent.

e. The Percentiles

This group of statistics belongs to a class of measures designated as "measures of order or position". These measures can be thought of as being obtained by arranging the data in order from the smallest value up to the largest one and then observing the value of the datum which lies at a specified position in the array. The smallest value, the next-to-the-largest-value, the middle value, and the like are examples of this type of statistic.

Perhaps the most useful of these statistics are the percentiles. The 99 percentiles - ranging from the 1st up to the 99th - are the values at points which separate consecutive blocks or units of one percent of the data in the ordered array. The first percentile is the value which separates the smallest one percent of the data from the 99 percent of the data with larger values, and the second percentile separates the smallest two percent from the larger 98 percent.

Twenty-five of these percentiles: the 1st, 2nd, 3rd, 97th, 98th, 99th, plus the h -th for all values of h which are multiples of 5, are listed for each anthropometric variable. Several of the listed percentiles have additional names; in particular, the 50th percentile is the median, the 25th, 50th, and 75th are the 1st, 2nd, and 3rd quartiles, and the 10th, 20th, 30th, ..., 90th are the nine deciles.

The percentiles given here are computed by a procedure which follows the spirit rather than the letter of the definition. The reasons for doing this and a description of the computational procedures are given in the section on data processing.

f. The Standard Errors

All statistics computed from a sample of data are subject to the effects of sampling error. When a sample has been selected by a random or other probability sampling process, it is often possible to estimate the magnitude of the sampling error. For many statistics, this estimate takes the form of the standard error of the statistic. The standard error is a standard deviation type statistic and is such that were a large number of samples of data selected in the same way from the same population, about two-thirds of the samples

would have means (or standard deviations or percentiles) with values which lie within one standard error of the corresponding population statistic and 95 percent within two standard errors. Hence, it is conventional to suppose, when dealing with the statistics computed from a single sample, that the population statistics may well be within a standard error - up or down - of the corresponding sample statistics, and that it is rather likely that they are within two standard errors.

Each statistic has its own standard error, the value of which depends on the statistic, on the sample size, and often, on the standard deviation of the data. The standard errors of the most common statistics (except the range) are, for the large samples, inversely proportional in size to the square root of the sample size.

For each variable the standard error of the mean (SD/\sqrt{N}) and that of the standard deviation ($SD/\sqrt{2N}$) are listed. The standard errors of the other statistics used in this report can be computed using the following formulas:

Statistic	Standard Error
30th through 70th Percentiles	1.3 SE of the Mean
20th, 25th, 75th, and 80th Percentiles	1.4 SE of the Mean
15th and 85th Percentiles	1.5 SE of the Mean
10th and 90th Percentiles	1.7 SE of the Mean
5th and 95th Percentiles	2.1 SE of the Mean
3rd and 97th Percentiles	2.5 SE of the Mean
2nd and 98th Percentiles	2.9 SE of the Mean
1st and 99th Percentiles	3.7 SE of the Mean
 Coefficient of Variation	 $V/\sqrt{2N}$
 Beta I	 $\sqrt{6/N}$
 Beta II	 $\sqrt{24/N}$

The standard error is variously designated as SE, SE (ξ) where ξ is the statistic involved, or $\sigma(\xi)$. When a statistic is presented as "164.28 \pm 0.93", the value "0.93" is usually (though not always) the standard error of that statistic.

The standard error is a well-established statistic of wide-spread use, and it is generally expected that the various standard error values and a discussion of them will be included in a report of this type.

Nevertheless, since probability sampling was not used in this survey, it is not clear what relationship exists between these standard errors and the actual sampling errors of the statistics reported here. A similar comment can, of course, be made about the sampling errors for all other large scale, broad anthropometric surveys.

The standard errors of the mean, the standard deviation, and the central percentiles are, in any event, generally rather small, most of them being less than one millimeter, a value of no real significance in evaluating these statistics.

The two statistics not listed in previous U. S. Army anthropometric reports are:

g. Beta I - a Measure of Symmetry

The statistic β_1 is based on the fact that in a symmetric distribution every value equal to a given amount greater than the mean will be matched by a value an equal amount less than the mean, so that the cubes of the deviations from the mean - half negative and half positive - will add up to zero. Although the converse of this fact is by no means true - a zero sum of the cubed deviations in no way implies a symmetric distribution - the size of this sum when properly adjusted is often considered a useful indication of whether a set of data is unsymmetrically distributed and, if so, how badly. Such a use seems reasonable justified for the kind of data reported here.

Beta I is computed from the sum of the cubed deviations by dividing it by the sample size and the cube of the standard deviation, producing a dimensionless statistic :

$$\beta_1 = \frac{\sum (x - \bar{x})^3}{N \cdot SD^3}$$

h. Beta II - a Measure of Kurtosis

The statistic β_2 is similarly computed from the fourth powers of the deviations:

$$\beta_2 = \frac{\sum (x - \bar{x})^4}{N \cdot SD^4}$$

The interpretation of β_2 is not obvious; its major value, along with β_1 , is that its value provides a basis for judging the level of agreement between the normal distribution and the actual distribution of the data.

The normal distribution values for β_1 and β_2 are 0 and 3. In theory, data distributions can deviate from either of these values without deviating from the other. For the data of this study, however, deviant values of either β_1 or β_2 are usually accompanied by deviant values of the other. Most of these deviant values indicate positive skewness ($\beta_1 > 0$) and platykurtosis ($\beta_2 > 3$).

i. The Frequency Tables

The frequency tables group the data for each variable into a table containing up to fifty intervals. Most of the variables, except those with the smallest ranges, were grouped into intervals of 5 or 10 millimeters wide; these intervals always started with values ending in 2.5 mm or 7.5 mm to minimize the effect of any overuse of zero and five as final digits.

The tables list, for each interval, the end points of the intervals in both metric and English units; the number of men whose measurement falls within the interval (ACTUAL FREQ); the cumulative frequency (CUMULATIVE-F), that is the number of men whose measurement did not exceed the upper end point of the interval; and these values expressed as percentages of the total number of men measured (PERCENT-FREQ and CUMUL-PCT-FQ).

6. THE ANTHROPOMETRIC DATA

a. Index of Body Measurements

To facilitate ready reference to any body measurement, an index of terms is provided here. The seventy basic body measurements taken in this survey appear in the index in bold face. Synonymous or alternate terms for body measurements also are included in the index. The listing of body measurements is cross-referenced in order to facilitate the identification of measurements under several different terms. In this way, a particular measurement may be found either by type of measurement or by body region or area.

INDEX OF BODY MEASUREMENTS

	Pages
Acromiale Height - see Shoulder Height	
Ankle - see Heel-Ankle Circumference	
Ankle Circumference	136-137
Arm:	
Arm Reach, Functional - see Functional Reach	
Arm Reach, Upward - see Vertical Arm Reach, Sitting	
Arm Scye Circumference	140-141
Biceps Circumference, Flexed	144-145
Biceps Circumference, Relaxed	142-143
Bideltoid Diameter - see Shoulder Breadth	
Elbow - see Shoulder-Elbow Length	
Elbow-Fingertip Length	98-99
Elbow-to-Elbow Breadth - see Forearm-Forearm Breadth	
Forearm Circumference, Flexed	146-147
Forearm-Forearm Breadth	116-117
Forearm-Hand Length - see Elbow-Fingertip Length	
Functional Reach	86-87
Lower Arm Circumference - see Forearm Circumference, Flexed	
Middle Upper Arm Circumference - see Biceps Circumference, Relaxed	
Scye Circumference - see Arm Scye Circumference	
Shoulder Breadth	114-115
Shoulder-Elbow Length	96-97
Sleeve Inseam Length	158-159

INDEX OF BODY MEASUREMENTS (continued)

	Pages
Sleeve Length	160-161
Upper Arm Circumference - see Biceps Circumference	
Upper Forearm Circumference - see Forearm Circumference, Flexed	
Vertical Arm Reach, Sitting	88-89
Wrist Circumference	148-149
Back:	
Back Waist Length - see Waist Back Length	
Cervicale Height	74-75
Cross Back Width - see Interscye Breadth	
Interscye Breadth	152-153
Interscye, Maximum	154-155
Waist Back Length	156-157
Ball of Foot Breadth	200-201
Ball of Foot Circumference	204-205
Ball of Foot Length - see Instep Length	
Biceps Circumference, Flexed	144-145
Biceps Circumference, Relaxed	142-143
Bideltoid Diameter - see Shoulder Breadth	
Bitragion Breadth	176-177
Bizygomatic Diameter - see Face Breadth	
Breadths (Widths, Diameters):	
Ball of Foot Breadth	200-201
Bideltoid Diameter - see Shoulder Breadth	
Bitragion Breadth	176-177
Bizygomatic Diameter - see Face Breadth	
Chest Breadth	110-111

INDEX OF BODY MEASUREMENTS (continued)

	Pages
Cross Back Width - see Interscye Breadth	
Elbow-to-Elbow Breadth - see Forearm-Forearm Breadth	
Face Breadth	182-183
Foot Breadth - see Ball of Foot Breadth	
Forearm-Forearm Breadth	116-117
Hand Breadth	190-191
Head Breadth	174-175
Heel Breadth	202-203
Hip Breadth, Sitting	118-119
Hip Breadth, Standing	112-113
Interpupillary Breadth	184-185
Interscye Breadth	152-153
Interscye, Maximum	154-155
Seat Breadth - see Hip Breadth, Sitting	
Shoulder Breadth	114-115
Buttock Circumference - see Hip Circumference	
Buttock-Knee Length	104-105
Buttock-Popliteal Length	106-107
Calf Circumference	134-135
Calf Height	84-85
Cervicale Height	74-75
Chest Breadth	110-111
Chest Circumference	124-125
Chest Depth	108-109

INDEX OF BODY MEASUREMENTS (continued)

	Pages
Circumferences (Girths):	
Ankle Circumference	136-137
Arm Scye Circumference	140-141
Ball of Foot Circumference	204-205
Biceps Circumference, Flexed	144-145
Biceps Circumference, Relaxed	142-143
Buttock Circumference - see Hip Circumference	
Calf Circumference	134-135
Chest Circumference	124-125
Crotch Thigh Circumference - see Upper Thigh Circumference	
Foot Circumference - see Ball of Foot Circumference	
Forearm Circumference, Flexed	146-147
Hand Circumference	192-193
Head Circumference	162-163
Heel-Ankle Circumference	208-209
Hip Circumference	128-129
Instep Circumference	206-207
Lower Thigh Circumference	132-133
Neck Circumference	120-121
Shoulder Circumference	122-123
Upper Thigh Circumference	130-131
Vertical Trunk Circumference	138-139
Waist Circumference	126-127
Wrist Circumference	148-149
Cross Back Width - see Interscye Breadth	
Crotch Height	80-81

INDEX OF BODY MEASUREMENTS (continued)

Pages

Crotch Thigh Circumference - see Upper Thigh Circumference

Depths (Thicknesses):

Chest Depth 108-109

Diameters - see Breadths

Elbow - see Shoulder-Elbow Length

Elbow-Fingertip Length 98-99

Elbow-to-Elbow Breadth - see Forearm-Forearm Breadth

External Canthus - see Occiput-External Canthus

Eye Height, Sitting 92-93

Face:

Bizygomatic Diameter - see Face Breadth

External Canthus - see Occiput-External Canthus

Eye Height, Sitting 92-92

Face Breadth 182-183

Face Height - see Face Length

Face Length 180-181

Interpupillary Breadth 184-185

Menton-Nasal Root Length - see Face Length

Nasal Root - see Occiput-Nasal Root

Occiput-External Canthus 168-169

Occiput-Nasal Root 166-167

Occiput-Pronasale 172-173

Pronasale - see Occiput-Pronasale

Fingertip - see Elbow-Fingertip Length

Foot:

Ankle Circumference 136-137

Ball of Foot Breadth 200-201

INDEX OF BODY MEASUREMENTS (continued)

	Pages
Ball of Foot Circumference	204-205
Ball of Foot Length - see Instep Length	
Foot Breadth - see Ball of Foot Breadth	
Foot Circumference - see Ball of Foot Circumference	
Foot Length	196-197
Heel-Ankle Circumference	208-209
Heel Breadth	202-203
Instep Circumference	206-207
Instep Length	198-199
Forearm Circumference, Flexed	146-147
Forearm-Forearm Breadth	116-117
Forearm-Hand Length - see Elbow-Fingertip Length	
Functional Reach	86-87
Girths - see Circumferences	
Hand:	
Elbow-Fingertip Length	98-99
Forearm-Hand Length - see Elbow-Fingertip Length	
Hand Breadth	190-191
Hand Circumference	192-193
Hand Length	186-187
Palm Length	188-189
Thumb Crotch Length	194-195
Vertical Arm Reach, Sitting	88-89
Wrist Circumference	148-149
Head:	
Bitracion Breadth	176-177

INDEX OF BODY MEASUREMENTS (continued)

	Pages
Bizygomatic Diameter - see Face Breadth	
External Canthus - see Occiput-External Canthus	
Face Breadth	182-183
Face Height - see Face Length	
Face Length	180-181
Head Breadth	174-175
Head Circumference	162-163
Head Height	178-179
Head Length	164-164
Interpupillary Breadth	184-185
Menton-Nasal Root Length - see Face Length	
Nasal Root - see Occiput-Nasal Root	
Neck Circumference	120-121
Occiput-External Canthus	168-169
Occiput-Nasal Root	166-167
Occiput-Pronasale	172-173
Occiput-Tragion	170-171
Pronasale - see Occiput-Pronasale	
Tragion - see Bitragion Breadth; Occiput-Tragion	
Tragion-Vertex Height - see Head Height	
Heel-Ankle Circumference	208-209
Heel Breadth	202-203
Height - see Stature	
Heights:	
Acromiale Height - see Shoulder Height	
Calf Height	84-85

INDEX OF BODY MEASUREMENTS (continued)

	Pages
Cervicale Height	74-75
Crotch Height	80-81
Eye Height, Sitting	92-93
Face Height - see Face Length	
Head Height	178-179
Inseam - see Crotch Height	
Knee Height, Sitting	100-101
Kneecap Height	82-83
Mid-Shoulder Height, Sitting	94-95
Outseam - see Waist Height	
Patella Height - see Kneecap Height	
Popliteal Height, Sitting	102-103
Shoulder Height	76-77
Shoulder Height, Sitting - see Mid-Shoulder Height, Sitting	
Sitting Height	90-91
Stature	72-73
Tragion-Vertex Height - see Head Height	
Waist Height	78-79
Hip Breadth, Sitting	118-119
Hip Breadth, Standing	112-113
Hip Circumference	128-129
Iliocristale Height - see Waist Height	
Inseam - see Crotch Height; Sleeve Inseam Length	
Instep Circumference	206-207
Instep Length	198-199
Interpupillary Breadth	184-185

INDEX OF BODY MEASUREMENTS (continued)

	Pages
Interscye Breadth	152-153
Interscye, Maximum	154-155
Knee - see Buttock-Knee Length	
Kneecap Height	82-83
Knee Height, Sitting	100-101
Lengths:	
Back Waist Length - see Waist Back Length	
Ball of Foot Length - see Instep Length	
Buttock-Knee Length	104-105
Buttock-Popliteal Length	106-107
Elbow-Fingertip Length	98-99
Face Length	180-181
Foot Length	196-197
Forearm-Hand Length - see Elbow-Fingertip Length	
Hand Length	186-187
Head Length	164-165
Instep Length	198-199
Menton-Nasal Root Length - see Face Length	
Palm Length	188-189
Shoulder Length	150-151
Shoulder-Elbow Length	96-97
Sleeve Length	160-161
Sleeve Inseam Length	158-159
Thumb Crotch Length	194-195
Waist Back Length	156-157
Lower Arm Circumference - see Forearm Circumference, Flexed	

INDEX OF BODY MEASUREMENTS (continued)

	Pages
Lower Thigh Circumference	132-133
Menton-Nasal Root Length - see Face Length	
Middle Upper Arm Circumference - see Biceps Circumference, Relaxed	
Mid-Shoulder Height, Sitting	94-95
Nasal Root Depression - see Face Length; Occiput-Nasal Root	
Neck Circumference	120-121
Occiput:	
Head Length	164-165
Occiput-External Canthus	168-169
Occiput-Nasal Root	166-167
Occiput-Pronasale	172-173
Occiput-Tragion	170-171
Outseam - see Waist Height	
Palm Length	188-189
Patella Height - see Kneecap Height	
Popliteal - see Buttock-Popliteal Length	
Popliteal Height, Sitting	102-103
Pronasale - see Occiput-Pronasale	
Reaches:	
Arm Reach, Functional - see Functional Reach	
Arm Reach, Upward - see Vertical Arm Reach, Sitting	
Functional Reach	86-87
Vertical Arm Reach, Sitting	88-89
Scye Circumference - see Arm Scye Circumference	
Seat Breadth - see Hip Breadth, Sitting	

INDEX OF BODY MEASUREMENTS (continued)

	Pages
Shoulder:	
Acromiale Height - see Shoulder Height	
Arm Scye Circumference	140-141
Bideltoid Diameter - see Shoulder Breadth	
Mid-Shoulder Height, Sitting	94-95
Shoulder Breadth	141-115
Shoulder Circumference	122-123
Shoulder-Elbow Length	96-97
Shoulder Height	76-77
Shoulder Height, Sitting - see Mid-Shoulder Height, Sitting	
Shoulder Length	150-151
Sitting Height	90-91
Sitting Measurements:	
Bideltoid Diameter - see Shoulder Breadth	
Buttock-Knee Length	104-105
Buttock-Popliteal Length	106-107
Elbow-to-Elbow Breadth - see Forearm-Forearm Breadth	
Eye Height, Sitting	92-93
Forearm-Forearm Breadth	116-117
Hip Breadth, Sitting	118-119
Knee Height, Sitting	100-101
Mid-Shoulder Height, Sitting	94-95
Popliteal Height, Sitting	102-103
Seat Breadth - see Hip Breadth, Sitting	
Shoulder Breadth	114-115
Shoulder Height, Sitting - see Mid-Shoulder Height, Sitting	

INDEX OF BODY MEASUREMENTS (continued)

	Pages
Sitting Height	90-91
Vertical Arm Reach, Sitting	88-89
Sleeve Inseam Length	158-159
Sleeve Length	160-161
Standing Measurements:	
Acromiale Height - see Shoulder Height	
Calf Height	84-85
Cervicale Height	74-75
Chest Breadth	110-111
Chest Depth	108-109
Crotch Height	80-81
Height - see Stature	
Hip Breadth, Standing	112-113
Inseam - see Crotch Height	
Kneecap Height	82-83
Outseam - see Waist Height	
Patella Height - see Kneecap Height	
Shoulder Height	76-77
Stature	72-73
Vertical Trunk Circumference	138-139
Waist Height	78-79
Stature	72-73
Stature, Estimated	266-267
Surface Measurements:	
Back Waist Length - see Waist Back Length	
Cross Back Width - see Interscye Breadth	
Interscye Breadth	152-153
Interscye, Maximum	154-155

INDEX OF BODY MEASUREMENTS (continued)

	Pages
Shoulder Length	150-151
Sleeve Inseam Length	158-159
Sleeve Length	160-161
Waist Back Length	156-157
Thigh:	
Crotch Thigh Circumference - see Upper Thigh Circumference	
Lower Thigh Circumference	132-133
Upper Thigh Circumference	130-131
Thumb Crotch Length	194-195
Tragion - see Occiput-Tragion	
Tragion-Vertex Height - see Head Height	
Trunk - see Vertical Trunk Circumference	
Upper Arm Circumference - see Biceps Circumference	
Upper Forearm Circumference - see Forearm Circumference, Flexed	
Upper Thigh Circumference	130-131
Vertical Arm Reach, Sitting	88-89
Vertical Trunk Circumference	138-139
Waist Back Length	156-157
Waist Circumference	126-127
Waist Height	78-79
Weight	70-71
Weight, Estimated	264-265
Widths - see Breadths	
Wrist Circumference	148-149

b. Visual Index

In order to further assist those who may not be familiar with the terminology of body measurements, a visual index of the measurements is provided here. The visual index summarizes the seventy body measurements by means of illustrative figures showing the location of each measurement on the body. The sketches (Figures 1 and 7) are arranged to show the seven basic groupings of body measurements: Standing Measurements, Sitting Measurements, Breadth Measurements, Circumferences, Surface Measurements, Head and Face Measurements, and Hand and Foot Measurements.

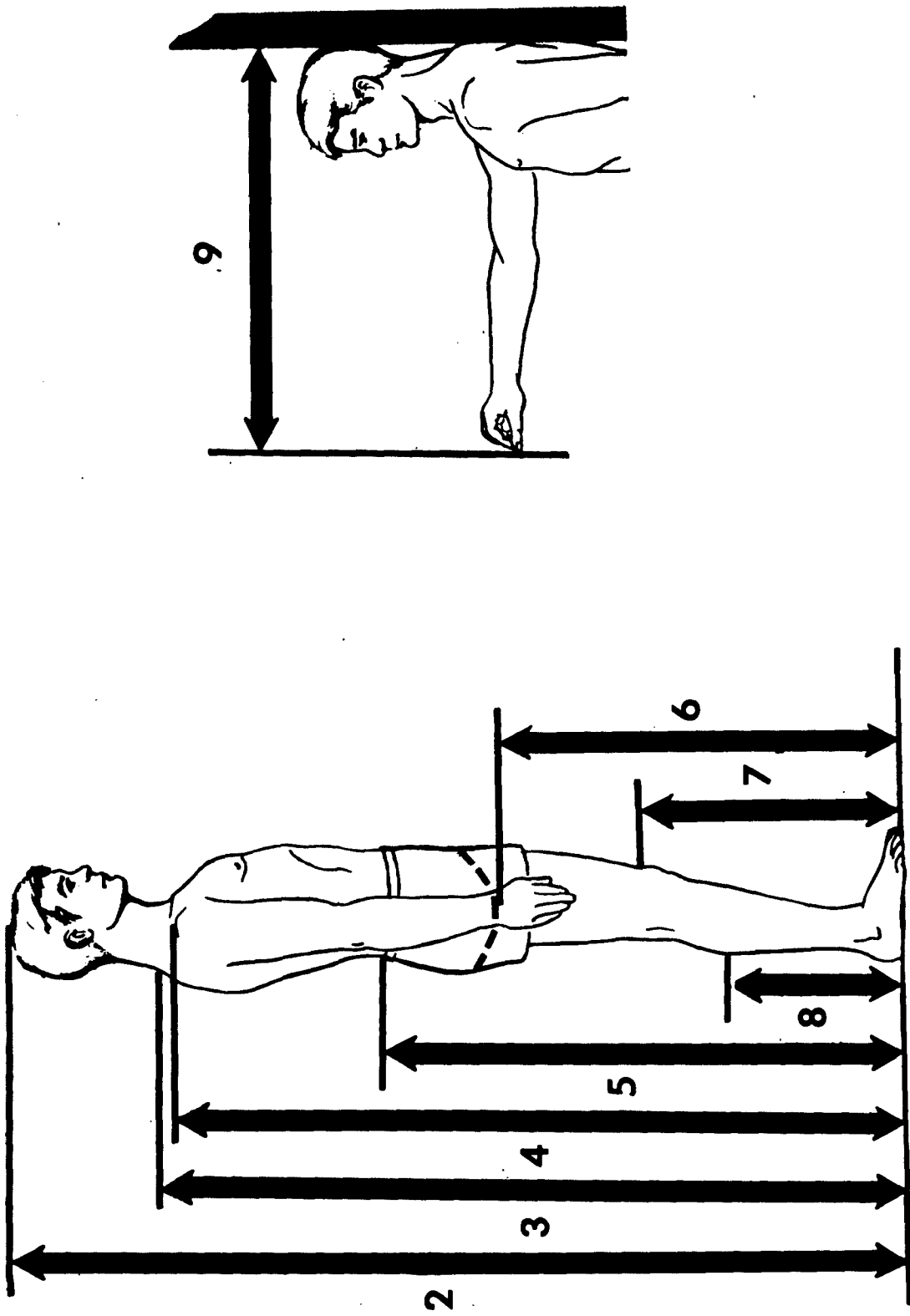

FIGURE 1 - STANDING MEASUREMENTS

- | | | | |
|----|------------------|---|------------------|
| (1 | Weight) | 7 | Kneecap Height |
| 2 | Stature | 8 | Calf Height |
| 3 | Cervicale Height | 9 | Functional Reach |
| 4 | Shoulder Height | | |
| 5 | Waist Height | | |
| 6 | Crotch Height | | |

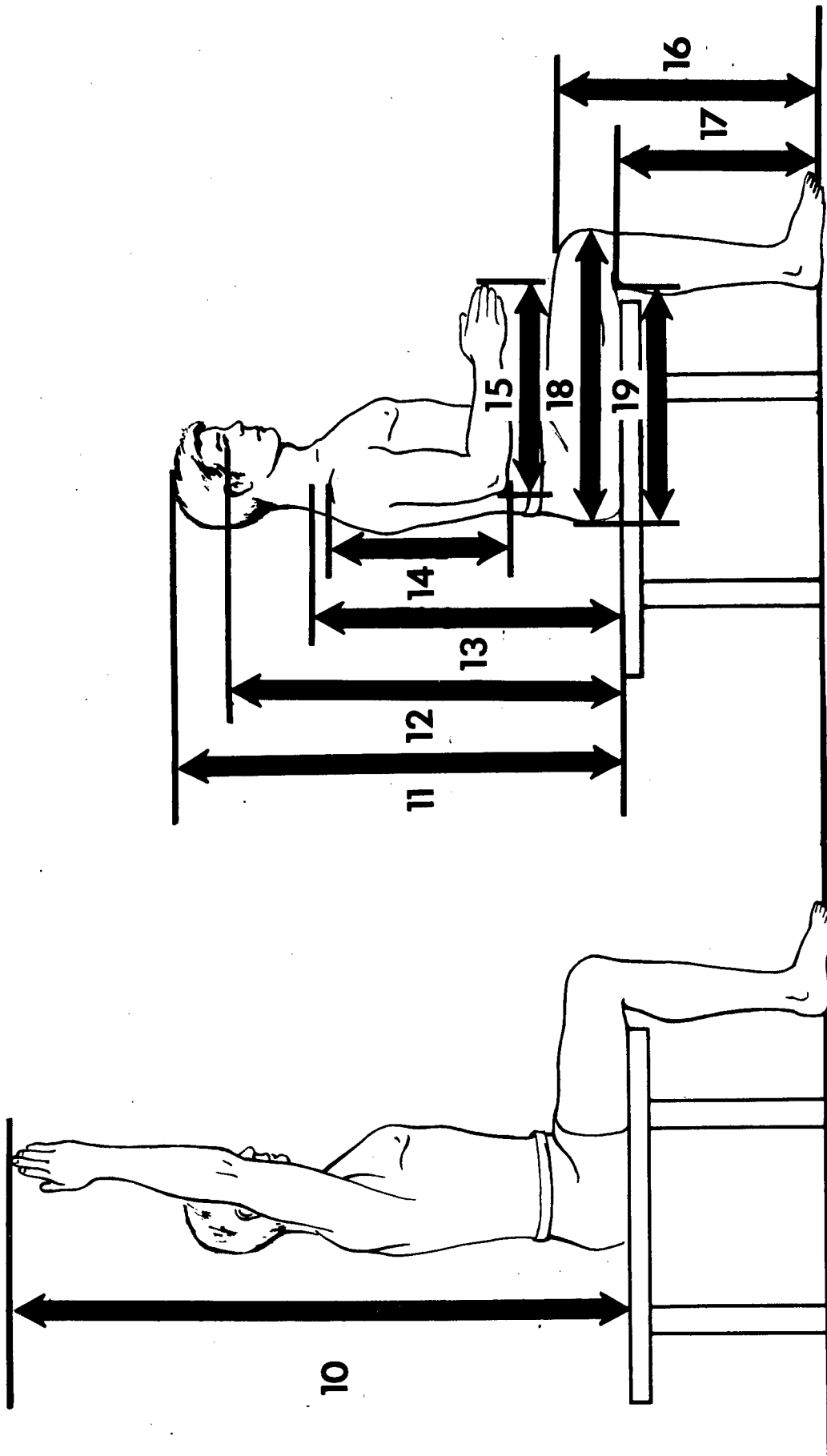

FIGURE 2 - SITTING MEASUREMENTS

- 10 Vertical Arm Reach, Sitting
- 11 Sitting Height
- 12 Eye Height, Sitting
- 13 Mid-Shoulder Height, Sitting
- 14 Shoulder-Elbow Length
- 15 Elbow-Fingertip Length
- 16 Knee Height, Sitting
- 17 Popliteal Height
- 18 Buttock-Knee Length
- 19 Buttock-Popliteal Length

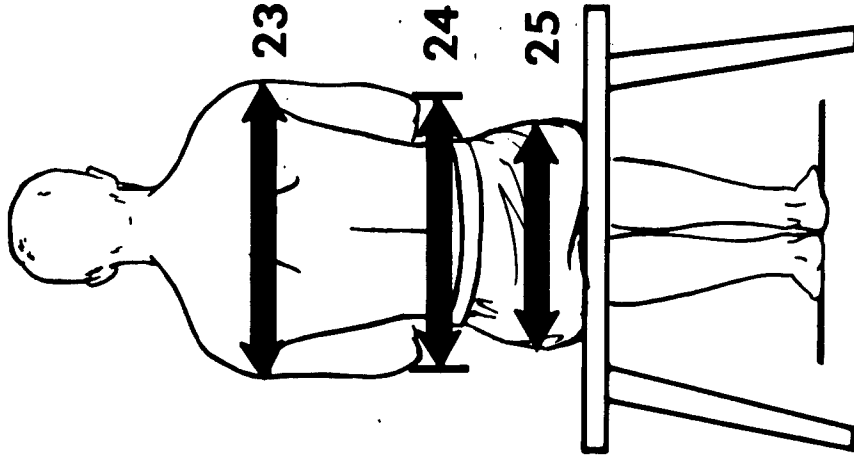
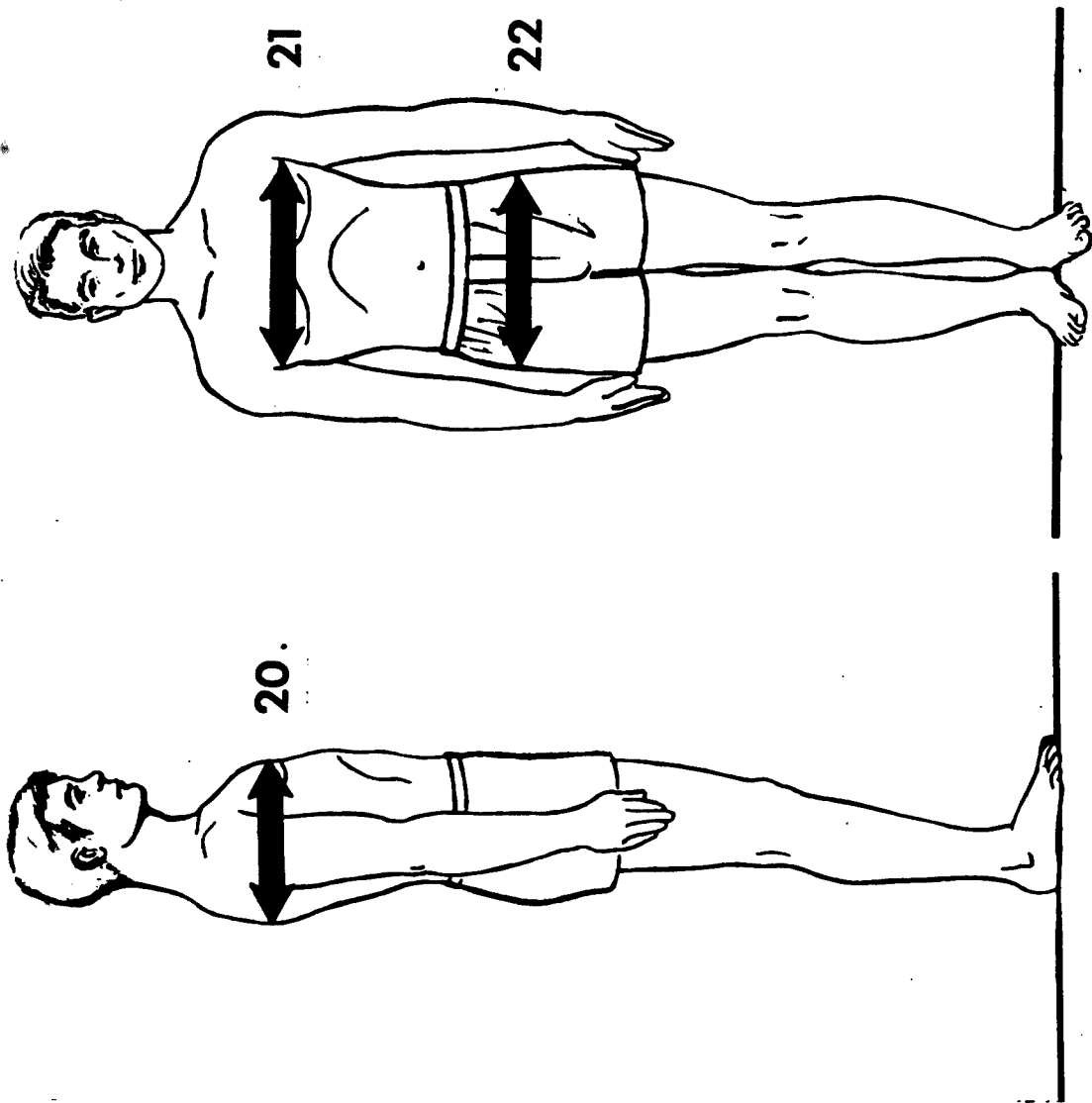

FIGURE 3 — BREADTH MEASUREMENTS

20 Chest Depth
21 Chest Breadth

22 Hip Breadth, Standing
23 Shoulder Breadth

24 Forearm-Forearm Breadth
25 Hip Breadth, Sitting

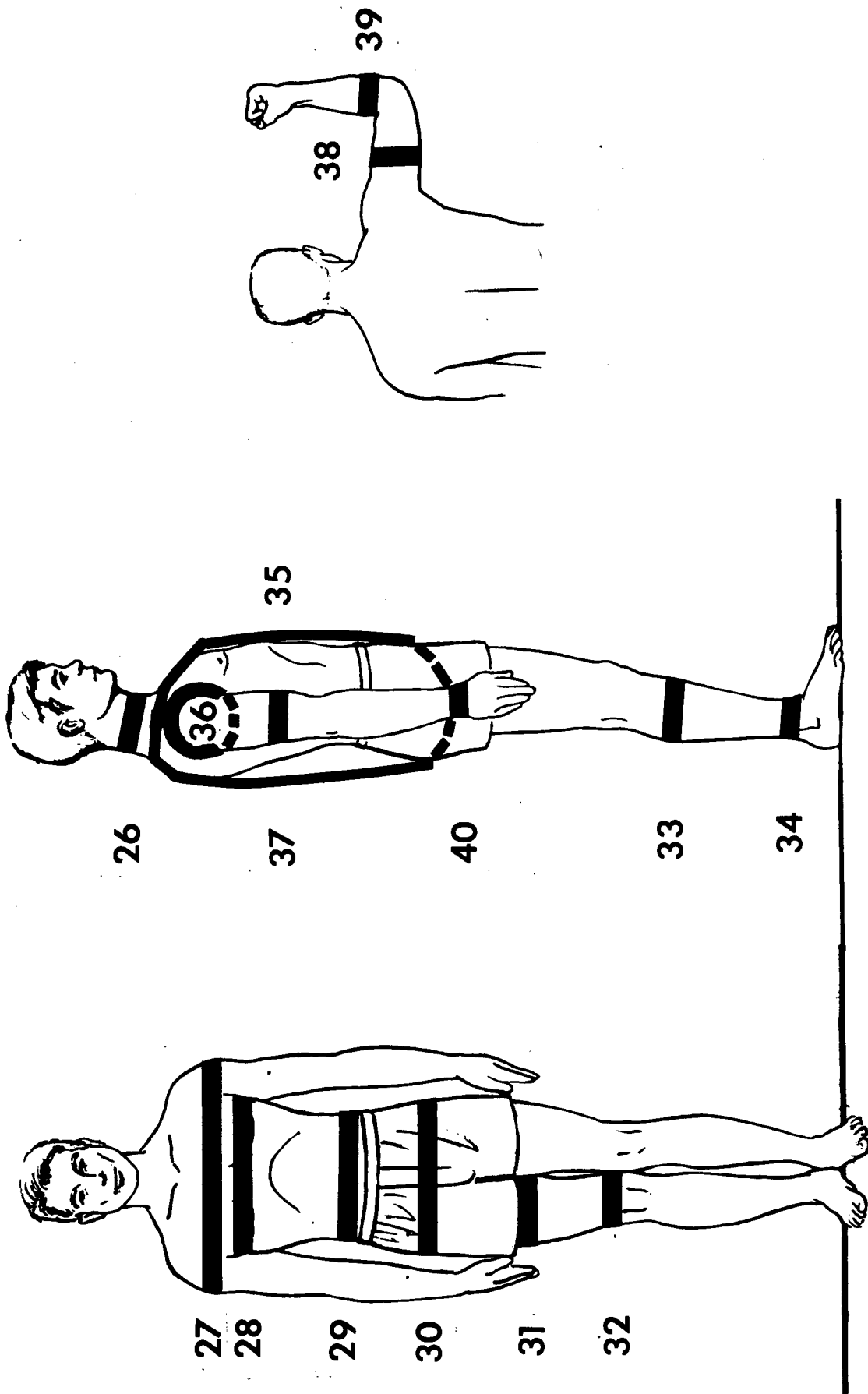

FIGURE 4 - CIRCUMFERENCES

- 26 Neck Circumference
- 27 Shoulder Circumference
- 28 Chest Circumference
- 29 Waist Circumference
- 30 Hip Circumference
- 31 Upper Thigh Circumference
- 32 Lower Thigh Circumference
- 33 Calf Circumference
- 34 Ankle Circumference
- 35 Vertical Trunk Circumference
- 36 Arm Scye Circumference
- 37 Biceps Circum., Relaxed
- 38 Biceps Circum., Flexed
- 39 Forearm Circum., Flexed
- 40 Wrist Circumference

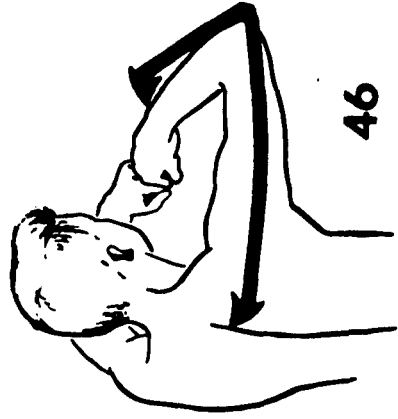
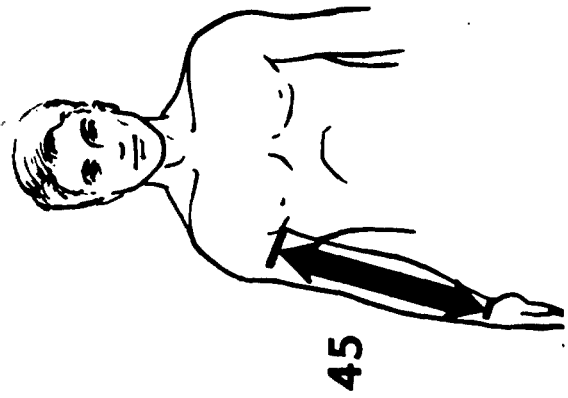
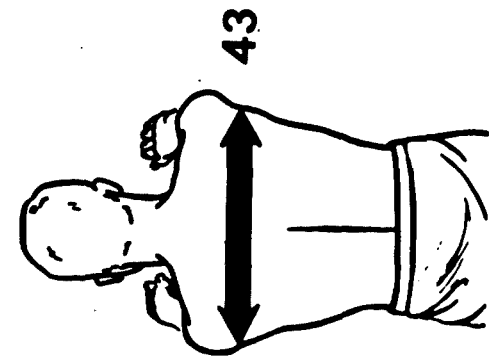
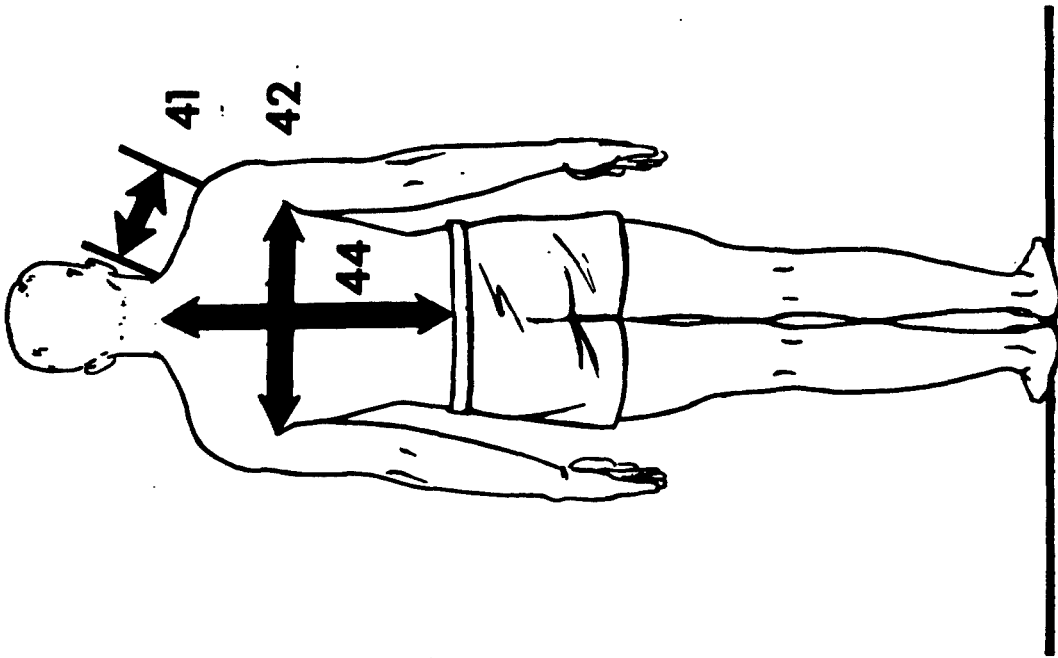

FIGURE 5 - SURFACE MEASUREMENTS

41 Shoulder Length
42 Interscye Breadth

43 Interscye, Maximum
44 Waist Back Length

45 Sleeve Inseam Length
46 Sleeve Length

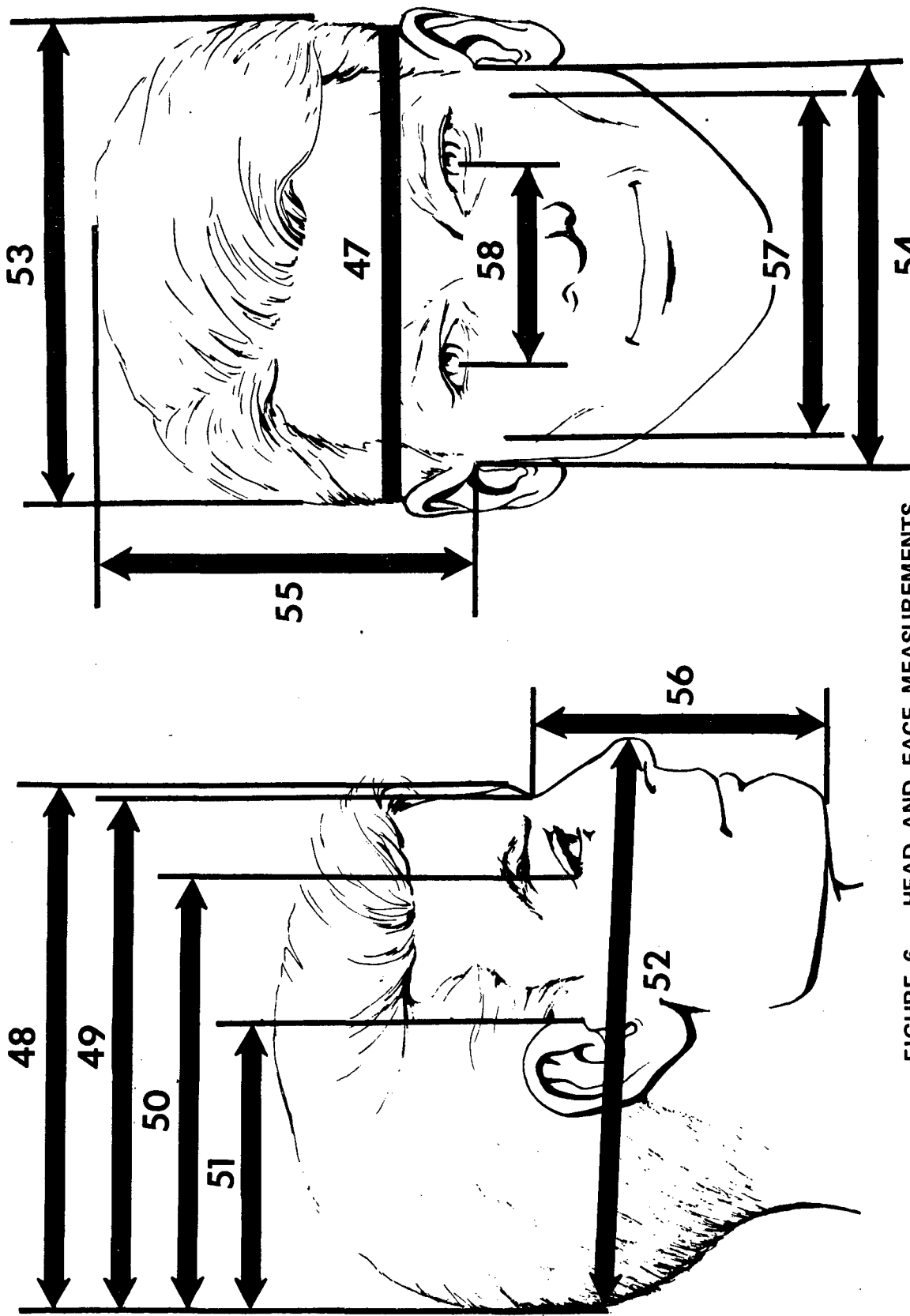

FIGURE 6 -- HEAD AND FACE MEASUREMENTS

- | | |
|-----------------------------|-------------------------|
| 47 Head Circumference | 51 Occiput-Tragion |
| 48 Head Length | 52 Occiput-Pronasale |
| 49 Occiput-Nasal Root | 53 Head Breadth |
| 50 Occiput-External Canthus | 54 Bitracion Breadth |
| 55 Head Height | 56 Face Length |
| 56 Face Length | 57 Face Breadth |
| 57 Face Breadth | 58 Interpillary Breadth |

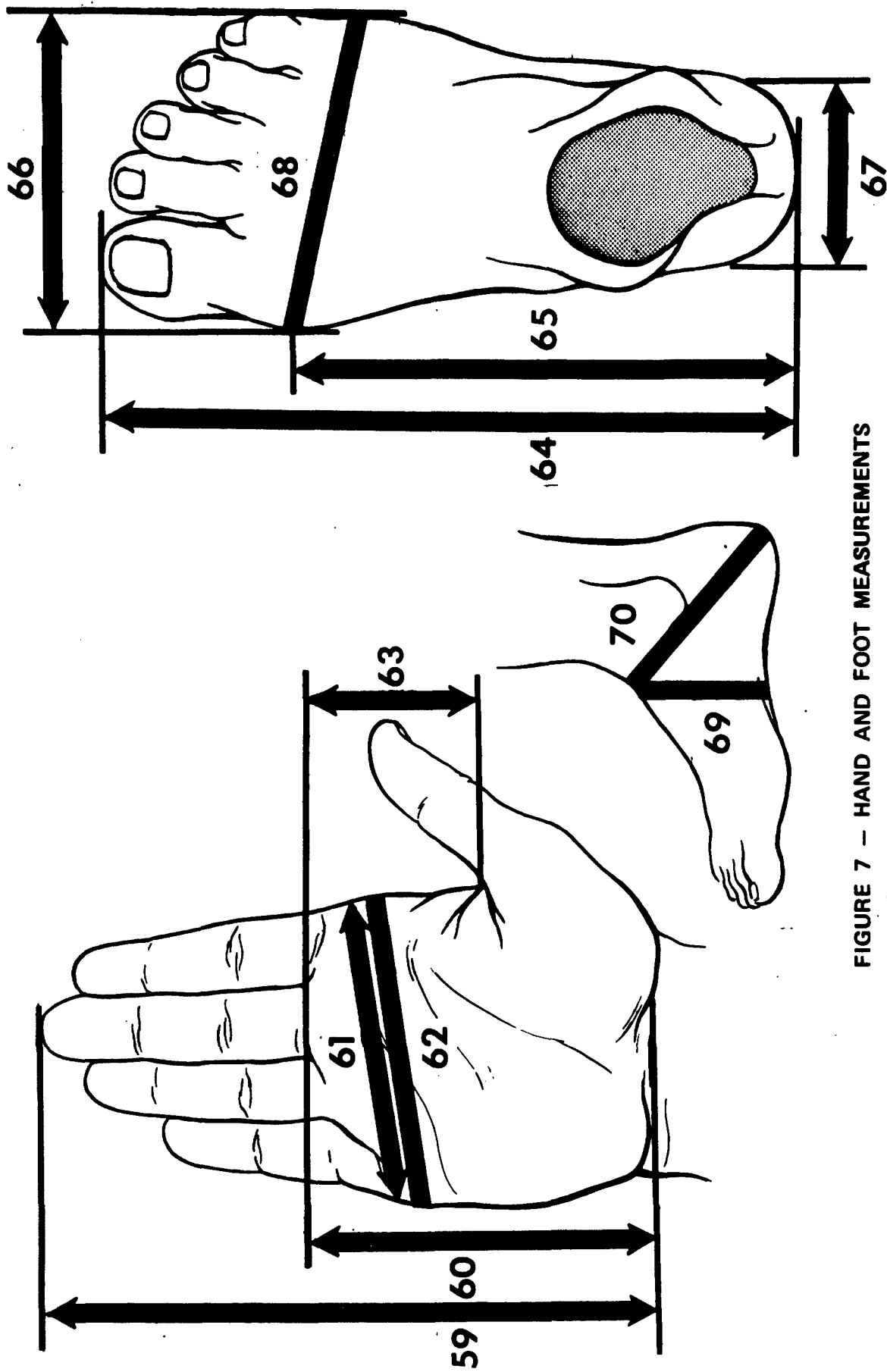

FIGURE 7 - HAND AND FOOT MEASUREMENTS

59 Hand Length
 60 Palm Length
 61 Hand Breadth
 62 Hand Circumference

63 Thumb Crotch Length
 64 Foot Length
 65 Instep Length
 66 Ball of Foot Breadth

67 Heel Breadth
 68 Ball of Foot Circumference
 69 Instep Circumference
 70 Heel-Ankle Circumference

c. The Anthropometric Data

The detailed data on all of the anthropometric measurements taken during the U. S. Army survey are presented in this section. These data are based on the total Army series of 6682 men. The format adopted for the presentation of these data utilizes the direct reproduction of the computer print-outs, thus obviating the possible introduction of errors in transcribing and typing the tabular material. The order of presentation of the 70 body measurements which follow is that indicated in the Visual Index.

The metric system (centimeters and millimeters) was used in the measuring. The resulting data are given in centimeters, together with the equivalent values in inches. (To convert to inches, a value in centimeters is multiplied by 0.3937; to convert to centimeters, a value in inches is multiplied by 2.54). Weight was recorded in pounds; the equivalent values in kilograms also are shown. (To convert to kilograms, a value in pounds is multiplied by 0.4536; to convert to pounds, a value in kilograms is multiplied by 2.205.)

The data for each measurement are presented on two facing pages. On each right-hand page are the percentile values, from the 1st up to the 99th percentile. Below the percentiles are listed the summary statistics, consisting of the mean, the standard error of the mean (SE(M)), the standard deviation (ST DEV), the standard error of the standard deviation (SE(SD)), the Beta I value indicating symmetry, the Beta II value indicating kurtosis, the coefficient of variation, and the sample size or number of men in the series. A sketch indicating where the measurement was taken on the body also is shown on each right-hand page, together with a description of the measurement, the position of the subject, how the measurement was taken, and the instrument used.

Additional data are presented on each left-hand page. The range of variation for each measurement (from the smallest value up to the largest value) is divided into intervals; these intervals are shown on the left of the page in both centimeters and inches. The frequencies (or distribution) of the men measured are shown on the right, opposite the respective intervals. The first column of frequencies (ACTUAL FREQ) gives the actual frequencies or numbers of men whose measurements fell within the indicated intervals. For example, in the case of stature (page 72), 437 men (of the total series of 6682) had statures of between 68.41 and 68.79 inches (or 173.75 and 174.74 centimeters). The second column (CUMULATIVE-F) indicates the cumulative frequencies of the men in the series. Thus, 3509 men in this series had statures of 68.79 inches (174.74 centimeters) or less. The third column (PERCENT-FREQ) represents the actual frequencies expressed as percentages of the total series; in other words, 6.54 percent of the 6682 men measured had statures of between 68.41 and 68.79 inches (or 173.75 and 174.74 centimeters). The fourth column (CUMUL-PCT-FQ) shows the cumulative frequencies expressed as percentages; thus, 52.51 percent of the men in this series were 68.79 inches (174.74 centimeters) or less in stature.

1 Weight

--INTERVALS--			--FREQUENCIES--			
POUNDS	KILOGRAMS	ACTUAL FREQ	CUMULA TIVE-F	PERCEN T-FREQ	CUMUL- PCT-FQ	
279.50- 283.49	126.89-128.70	1	6677	0.01	100.00	
275.50- 279.49	125.08-126.88	0	6676	0.00	99.99	
271.50- 275.49	123.26-125.07	0	6676	0.00	99.99	
267.50- 271.49	121.45-123.25	2	6676	0.03	99.99	
263.50- 267.49	119.63-121.44	1	6674	0.01	99.96	
259.50- 263.49	117.81-119.62	3	6673	0.04	99.94	
255.50- 259.49	116.00-117.80	2	6670	0.03	99.90	
251.50- 255.49	114.18-115.99	1	6668	0.01	99.87	
247.50- 251.49	112.37-114.17	6	6667	0.09	99.85	
243.50- 247.49	110.55-112.36	5	6661	0.07	99.76	
239.50- 243.49	108.73-110.54	7	6656	0.10	99.69	
235.50- 239.49	106.92-108.72	9	6649	0.13	99.58	
231.50- 235.49	105.10-106.91	13	6640	0.19	99.45	
227.50- 231.49	103.29-105.09	16	6627	0.24	99.25	
223.50- 227.49	101.47-103.28	12	6611	0.18	99.01	
219.50- 223.49	99.65-101.46	25	6599	0.37	98.83	
215.50- 219.49	97.84- 99.64	30	6574	0.45	98.46	
211.50- 215.49	96.02- 97.83	52	6544	0.78	98.01	
207.50- 211.49	94.21- 96.01	52	6492	0.78	97.23	
203.50- 207.49	92.39- 94.20	74	6440	1.11	96.45	
199.50- 203.49	90.57- 92.38	102	6366	1.53	95.34	
195.50- 199.49	88.76- 90.56	67	6264	1.00	93.81	
191.50- 195.49	86.94- 88.75	137	6197	2.05	92.81	
187.50- 191.49	85.13- 86.93	156	6060	2.34	90.76	
183.50- 187.49	83.31- 85.12	203	5904	3.04	88.42	
179.50- 183.49	81.49- 83.30	211	5701	3.16	85.38	
175.50- 179.49	79.68- 81.48	212	5490	3.18	82.22	
171.50- 175.49	77.86- 79.67	330	5278	4.94	79.05	
167.50- 171.49	76.05- 77.85	363	4948	5.44	74.11	
163.50- 167.49	74.23- 76.04	441	4585	6.60	68.67	
159.50- 163.49	72.41- 74.22	461	4144	6.90	62.06	
155.50- 159.49	70.60- 72.40	353	3683	5.29	55.16	
151.50- 155.49	68.78- 70.59	586	3330	8.78	49.87	
147.50- 151.49	66.97- 68.77	545	2744	8.16	41.10	
143.50- 147.49	65.15- 66.96	464	2199	6.95	32.93	
139.50- 143.49	63.33- 65.14	468	1735	7.01	25.98	
135.50- 139.49	61.52- 63.32	296	1267	4.43	18.98	
131.50- 135.49	59.70- 61.51	318	971	4.76	14.54	
127.50- 131.49	57.89- 59.69	244	653	3.65	9.78	
123.50- 127.49	56.07- 57.88	193	409	2.89	6.13	
119.50- 123.49	54.25- 56.06	102	216	1.53	3.23	
115.50- 119.49	52.44- 54.24	53	114	0.79	1.71	
111.50- 115.49	50.62- 52.43	20	61	0.30	0.91	
107.50- 111.49	48.81- 50.61	28	41	0.42	0.61	
103.50- 107.49	46.99- 48.80	6	13	0.09	0.19	
99.50- 103.49	45.17- 46.98	7	7	0.10	0.10	

PERCENTILES

POUNDS		KILOGRAMS
226.94	99 TH	103.03
216.46	98 TH	98.27
210.12	97 TH	95.39
201.88	95 TH	91.65
190.07	90 TH	86.29
182.67	85 TH	82.93
177.16	80 TH	80.43
172.60	75 TH	78.36
168.70	70 TH	76.59
165.24	65 TH	75.02
162.07	60 TH	73.58
159.11	55 TH	72.24
156.28	50 TH	70.95
153.55	45 TH	69.71
150.88	40 TH	68.50
148.20	35 TH	67.28
145.49	30 TH	66.05
142.65	25 TH	64.76
139.59	20 TH	63.37
136.20	15 TH	61.83
132.10	10 TH	59.97
126.32	5 TH	57.35
122.70	3 RD	55.71
120.08	2 ND	54.52
115.98	1 ST	52.65

Weight: The subject is weighed on spring scales, while wearing only undershorts. Weight is recorded to the nearest pound.

THE SUMMARY STATISTICS

....

POUNDS		KILOGRAMS
159.10	MEAN	72.23
0.29	SE(M)	0.13
23.35	ST DEV	10.60
0.20	SE(SD)	0.09

....

SYMMETRY--BETA I = 0.74

KURTOSIS--BETA II = 3.96

COEFFICIENT OF VARIATION = 14.68

....

SAMPLE SIZE = 6677

2 Stature

--INTERVALS--		--FREQUENCIES--				
CENTIMETERS	INCHES	ACTUAL FREQ	CUMULA TIVE-F	PERCEN T-FREQ	CUMUL- PCT-FQ	
198.75- 199.74	78.25- 78.63	1	6682	0.01	100.00	
197.75- 198.74	77.85- 78.24	1	6681	0.01	99.99	
196.75- 197.74	77.46- 77.84	2	6680	0.03	99.97	
195.75- 196.74	77.07- 77.45	5	6678	0.07	99.94	
194.75- 195.74	76.67- 77.06	5	6673	0.07	99.87	
193.75- 194.74	76.28- 76.66	3	6668	0.04	99.79	
192.75- 193.74	75.89- 76.27	9	6665	0.13	99.75	
191.75- 192.74	75.49- 75.88	13	6656	0.19	99.61	
190.75- 191.74	75.10- 75.48	19	6643	0.28	99.42	
189.75- 190.74	74.70- 75.09	24	6624	0.36	99.13	
188.75- 189.74	74.31- 74.69	30	6600	0.45	98.77	
187.75- 188.74	73.92- 74.30	46	6570	0.69	98.32	
186.75- 187.74	73.52- 73.91	66	6524	0.99	97.64	
185.75- 186.74	73.13- 73.51	83	6458	1.24	96.65	
184.75- 185.74	72.74- 73.12	113	6375	1.69	95.41	
183.75- 184.74	72.34- 72.73	141	6262	2.11	93.71	
182.75- 183.74	71.95- 72.33	174	6121	2.60	91.60	
181.75- 182.74	71.56- 71.94	207	5947	3.10	89.00	
180.75- 181.74	71.16- 71.55	214	5740	3.20	85.90	
179.75- 180.74	70.77- 71.15	254	5526	3.80	82.70	
178.75- 179.74	70.37- 70.76	307	5272	4.59	78.90	
177.75- 178.74	69.98- 70.36	318	4965	4.76	74.30	
176.75- 177.74	69.59- 69.97	379	4647	5.67	69.55	
175.75- 176.74	69.19- 69.58	374	4268	5.60	63.87	
174.75- 175.74	68.80- 69.18	385	3894	5.76	58.28	
173.75- 174.74	68.41- 68.79	437	3509	6.54	52.51	
172.75- 173.74	68.01- 68.40	405	3072	6.06	45.97	
171.75- 172.74	67.62- 68.00	381	2667	5.70	39.91	
170.75- 171.74	67.22- 67.61	367	2286	5.49	34.21	
169.75- 170.74	66.83- 67.21	352	1919	5.27	28.72	
168.75- 169.74	66.44- 66.82	316	1567	4.73	23.45	
167.75- 168.74	66.04- 66.43	289	1251	4.33	18.72	
166.75- 167.74	65.65- 66.03	209	962	3.13	14.40	
165.75- 166.74	65.26- 65.64	194	753	2.90	11.27	
164.75- 165.74	64.86- 65.25	127	559	1.90	8.37	
163.75- 164.74	64.47- 64.85	115	432	1.72	6.47	
162.75- 163.74	64.07- 64.46	74	317	1.11	4.74	
161.75- 162.74	63.68- 64.06	59	243	0.88	3.64	
160.75- 161.74	63.29- 63.67	56	184	0.84	2.75	
159.75- 160.74	62.89- 63.28	43	128	0.64	1.92	
158.75- 159.74	62.50- 62.88	22	85	0.33	1.27	
157.75- 158.74	62.11- 62.49	11	63	0.16	0.94	
156.75- 157.74	61.71- 62.10	22	52	0.33	0.78	
155.75- 156.74	61.32- 61.70	12	30	0.18	0.45	
154.75- 155.74	60.93- 61.31	8	18	0.12	0.27	
153.75- 154.74	60.53- 60.92	4	10	0.06	0.15	
152.75- 153.74	60.14- 60.52	5	6	0.07	0.09	
151.75- 152.74	59.74- 60.13	1	1	0.01	0.01	

2 Stature

PERCENTILES

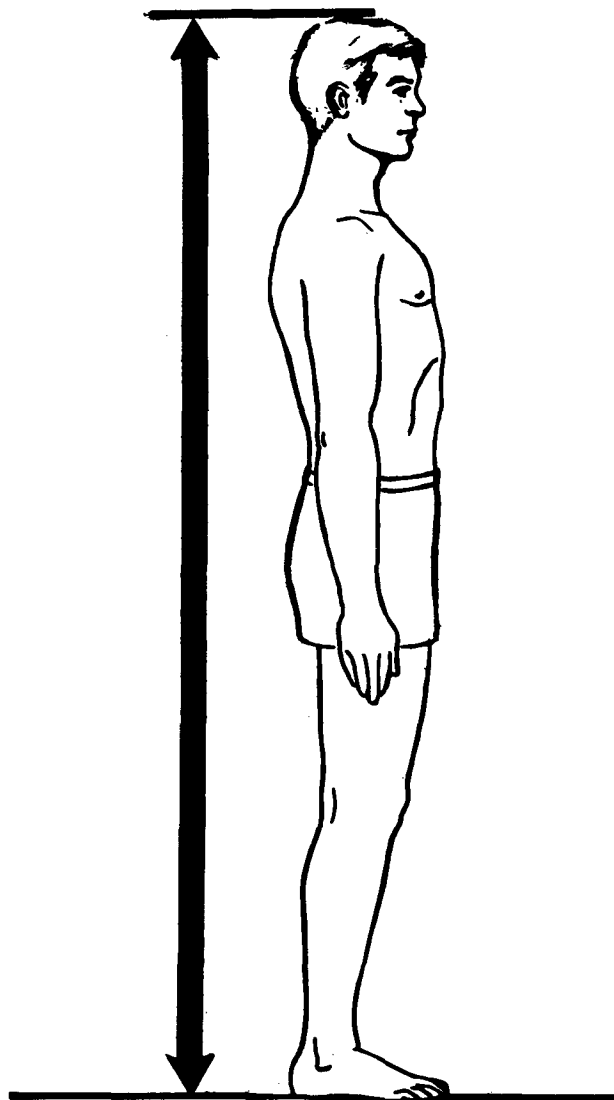

CENTIMETERS		INCHES
190.26	99 TH	74.90
188.40	98 TH	74.17
187.21	97 TH	73.70
185.57	95 TH	73.06
183.04	90 TH	72.06
181.34	85 TH	71.39
180.01	80 TH	70.87
178.87	75 TH	70.42
177.86	70 TH	70.02
176.94	65 TH	69.66
176.06	60 TH	69.32
175.23	55 TH	68.99
174.41	50 TH	68.67
173.59	45 TH	68.34
172.78	40 TH	68.02
171.93	35 TH	67.69
171.05	30 TH	67.34
170.10	25 TH	66.97
169.03	20 TH	66.55
167.79	15 TH	66.06
166.20	10 TH	65.43
163.79	5 TH	64.49
162.17	3 RD	63.84
160.92	2 ND	63.35
158.87	1 ST	62.55

THE SUMMARY STATISTICS

....

CENTIMETERS		INCHES
174.52	MEAN	68.71
0.08	SE(M)	0.03
6.61	ST DEV	2.60
0.06	SE(SD)	0.02

....

SYMMETRY--BETA I = 0.06

KURTOSIS--BETA II = 3.11

COEFFICIENT OF VARIATION = 3.79

....

SAMPLE SIZE = 6682

Stature: Subject stands erect, with heels together and head level. Stature is measured as the vertical distance from the floor to the top of the head (vertex). An anthropometer is used, with the anthropometer arm firmly touching the scalp to compress the hair.

3 Cervical Height

--INTERVALS--		--FREQUENCIES--			
CENTIMETERS	INCHES	ACTUAL FREQ	CUMULA TIVE-F	PERCEN T-FREQ	CUMUL- PCT-FQ
172.75- 173.74	68.01- 68.40	1	6682	0.01	100.00
171.75- 172.74	67.62- 68.00	2	6681	0.03	99.99
170.75- 171.74	67.22- 67.61	3	6679	0.04	99.96
169.75- 170.74	66.83- 67.21	2	6676	0.03	99.91
168.75- 169.74	66.44- 66.82	5	6674	0.07	99.88
167.75- 168.74	66.04- 66.43	7	6669	0.10	99.81
166.75- 167.74	65.65- 66.03	8	6662	0.12	99.70
165.75- 166.74	65.26- 65.64	10	6654	0.15	99.58
164.75- 165.74	64.86- 65.25	17	6644	0.25	99.43
163.75- 164.74	64.47- 64.85	27	6627	0.40	99.18
162.75- 163.74	64.07- 64.46	38	6600	0.57	98.77
161.75- 162.74	63.68- 64.06	60	6562	0.90	98.20
160.75- 161.74	63.29- 63.67	82	6502	1.23	97.31
159.75- 160.74	62.89- 63.28	107	6420	1.60	96.08
158.75- 159.74	62.50- 62.88	130	6313	1.95	94.48
157.75- 158.74	62.11- 62.49	159	6183	2.38	92.53
156.75- 157.74	61.71- 62.10	217	6024	3.25	90.15
155.75- 156.74	61.32- 61.70	251	5807	3.76	86.91
154.75- 155.74	60.93- 61.31	306	5556	4.58	83.15
153.75- 154.74	60.53- 60.92	299	5250	4.47	78.57
152.75- 153.74	60.14- 60.52	341	4951	5.10	74.09
151.75- 152.74	59.74- 60.13	345	4610	5.16	68.99
150.75- 151.74	59.35- 59.73	381	4265	5.70	63.83
149.75- 150.74	58.96- 59.34	420	3884	6.29	58.13
148.75- 149.74	58.56- 58.95	431	3464	6.45	51.84
147.75- 148.74	58.17- 58.55	405	3033	6.06	45.39
146.75- 147.74	57.78- 58.16	395	2628	5.91	39.33
145.75- 146.74	57.38- 57.77	423	2233	6.33	33.42
144.75- 145.74	56.99- 57.37	320	1810	4.79	27.09
143.75- 144.74	56.59- 56.98	307	1490	4.59	22.30
142.75- 143.74	56.20- 56.58	269	1183	4.03	17.70
141.75- 142.74	55.81- 56.19	231	914	3.46	13.68
140.75- 141.74	55.41- 55.80	172	683	2.57	10.22
139.75- 140.74	55.02- 55.40	134	511	2.01	7.65
138.75- 139.74	54.63- 55.01	114	377	1.71	5.64
137.75- 138.74	54.23- 54.62	73	263	1.09	3.94
136.75- 137.74	53.84- 54.22	53	190	0.79	2.84
135.75- 136.74	53.44- 53.83	39	137	0.58	2.05
134.75- 135.74	53.05- 53.43	22	98	0.33	1.47
133.75- 134.74	52.66- 53.04	18	76	0.27	1.14
132.75- 133.74	52.26- 52.65	19	58	0.28	0.87
131.75- 132.74	51.87- 52.25	17	39	0.25	0.58
130.75- 131.74	51.48- 51.86	8	22	0.12	0.33
129.75- 130.74	51.08- 51.47	5	14	0.07	0.21
128.75- 129.74	50.69- 51.07	5	9	0.07	0.13
127.75- 128.74	50.30- 50.68	4	4	0.06	0.06

3 Cervicale Height

PERCENTILES

CENTIMETERS		INCHES
164.14	99 TH	64.62
162.64	98 TH	64.03
161.62	97 TH	63.63
160.16	95 TH	63.05
157.81	90 TH	62.13
156.19	85 TH	61.49
154.91	80 TH	60.99
153.81	75 TH	60.56
152.83	70 TH	60.17
151.93	65 TH	59.82
151.09	60 TH	59.48
150.28	55 TH	59.16
149.48	50 TH	58.85
148.70	45 TH	58.54
147.91	40 TH	58.23
147.10	35 TH	57.91
146.26	30 TH	57.58
145.34	25 TH	57.22
144.33	20 TH	56.82
143.15	15 TH	56.36
141.64	10 TH	55.77
139.33	5 TH	54.85
137.74	3 RD	54.23
136.51	2 ND	53.74
134.43	1 ST	52.93

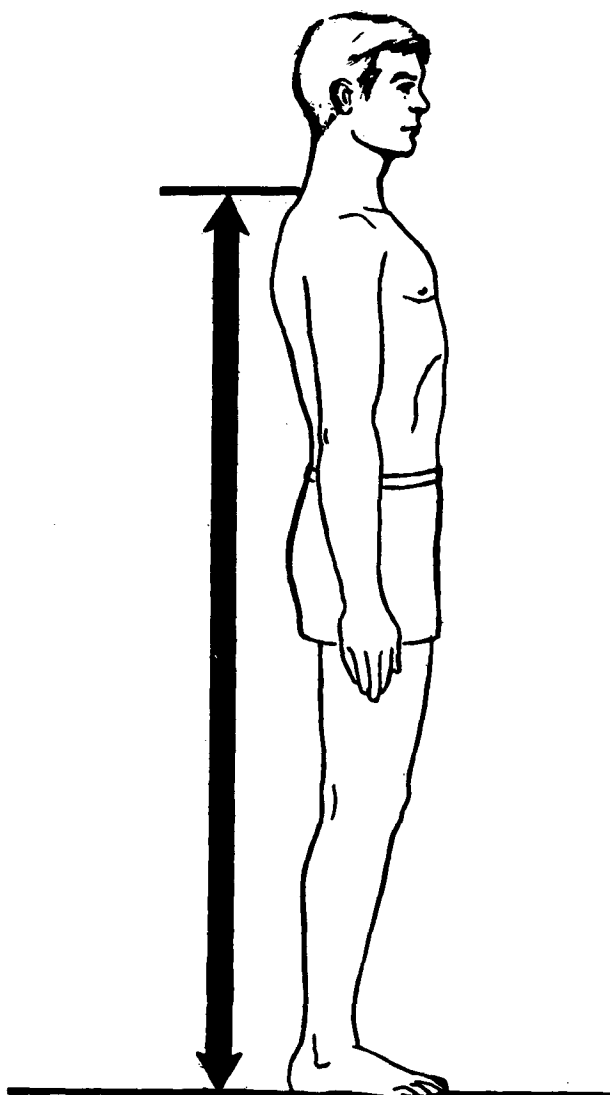

Cervicale Height: Subject stands erect, with heels together and head level. Cervicale height is measured as the vertical distance from the floor to the cervical point (the bony protrusion of the 7th cervical vertebra at the base of the neck). An anthropometer is used.

THE SUMMARY STATISTICS

••••

CENTIMETERS		INCHES
149.56	MEAN	58.88
0.08	SE(M)	0.03
6.34	ST DEV	2.50
0.05	SE(SD)	0.02

••••

SYMMETRY--BETA I =	0.02
KURTOSIS--BETA II =	3.07
COEFFICIENT OF VARIATION =	4.24

••••

SAMPLE SIZE = 6682

4 Shoulder Height

--INTERVALS--		--FREQUENCIES--				
CENTIMETERS	INCHES	ACTUAL FREQ	CUMULA TIVE-F	PERCEN T-FREQ	CUMUL- PCT-FQ	
166.25- 167.24	65.45- 65.84	1	6682	0.01	100.00	
165.25- 166.24	65.06- 65.44	1	6681	0.01	99.99	
164.25- 165.24	64.67- 65.05	2	6680	0.03	99.97	
163.25- 164.24	64.27- 64.66	4	6678	0.06	99.94	
162.25- 163.24	63.88- 64.26	8	6674	0.12	99.88	
161.25- 162.24	63.48- 63.87	8	6666	0.12	99.76	
160.25- 161.24	63.09- 63.47	11	6658	0.16	99.64	
159.25- 160.24	62.70- 63.08	19	6647	0.28	99.48	
158.25- 159.24	62.30- 62.69	22	6628	0.33	99.19	
157.25- 158.24	61.91- 62.29	37	6606	0.55	98.86	
156.25- 157.24	61.52- 61.90	46	6569	0.69	98.31	
155.25- 156.24	61.12- 61.51	60	6523	0.90	97.62	
154.25- 155.24	60.73- 61.11	89	6463	1.33	96.72	
153.25- 154.24	60.33- 60.72	134	6374	2.01	95.39	
152.25- 153.24	59.94- 60.32	146	6240	2.18	93.39	
151.25- 152.24	59.55- 59.93	168	6094	2.51	91.20	
150.25- 151.24	59.15- 59.54	241	5926	3.61	88.69	
149.25- 150.24	58.76- 59.14	273	5685	4.09	85.08	
148.25- 149.24	58.37- 58.75	315	5412	4.71	80.99	
147.25- 148.24	57.97- 58.36	302	5097	4.52	76.28	
146.25- 147.24	57.58- 57.96	357	4795	5.34	71.76	
145.25- 146.24	57.19- 57.57	387	4438	5.79	66.42	
144.25- 145.24	56.79- 57.18	417	4051	6.24	60.63	
143.25- 144.24	56.40- 56.78	414	3634	6.20	54.38	
142.25- 143.24	56.00- 56.39	463	3220	6.93	48.19	
141.25- 142.24	55.61- 55.99	414	2757	6.20	41.26	
140.25- 141.24	55.22- 55.60	410	2343	6.14	35.06	
139.25- 140.24	54.82- 55.21	365	1933	5.46	28.93	
138.25- 139.24	54.43- 54.81	334	1568	5.00	23.47	
137.25- 138.24	54.04- 54.42	258	1234	3.86	18.47	
136.25- 137.24	53.64- 54.03	235	976	3.52	14.61	
135.25- 136.24	53.25- 53.63	193	741	2.89	11.09	
134.25- 135.24	52.85- 53.24	151	548	2.26	8.20	
133.25- 134.24	52.46- 52.84	105	397	1.57	5.94	
132.25- 133.24	52.07- 52.45	85	292	1.27	4.37	
131.25- 132.24	51.67- 52.06	63	207	0.94	3.10	
130.25- 131.24	51.28- 51.66	51	144	0.76	2.16	
129.25- 130.24	50.89- 51.27	28	93	0.42	1.39	
128.25- 129.24	50.49- 50.88	23	65	0.34	0.97	
127.25- 128.24	50.10- 50.48	16	42	0.24	0.63	
126.25- 127.24	49.70- 50.09	7	26	0.10	0.39	
125.25- 126.24	49.31- 49.69	10	19	0.15	0.28	
124.25- 125.24	48.92- 49.30	5	9	0.07	0.13	
123.25- 124.24	48.52- 48.91	4	4	0.06	0.06	

4 Shoulder Height

PERCENTILES

CENTIMETERS		INCHES
158.59	99 TH	62.44
156.81	98 TH	61.74
155.68	97 TH	61.29
154.13	95 TH	60.68
151.76	90 TH	59.75
150.17	85 TH	59.12
148.92	80 TH	58.63
147.85	75 TH	58.21
146.89	70 TH	57.83
146.02	65 TH	57.49
145.20	60 TH	57.16
144.41	55 TH	56.85
143.63	50 TH	56.55
142.85	45 TH	56.24
142.07	40 TH	55.93
141.27	35 TH	55.62
140.42	30 TH	55.29
139.52	25 TH	54.93
138.50	20 TH	54.53
137.33	15 TH	54.07
135.85	10 TH	53.48
133.63	5 TH	52.61
132.16	3 RD	52.03
131.07	2 ND	51.60
129.31	1 ST	50.91

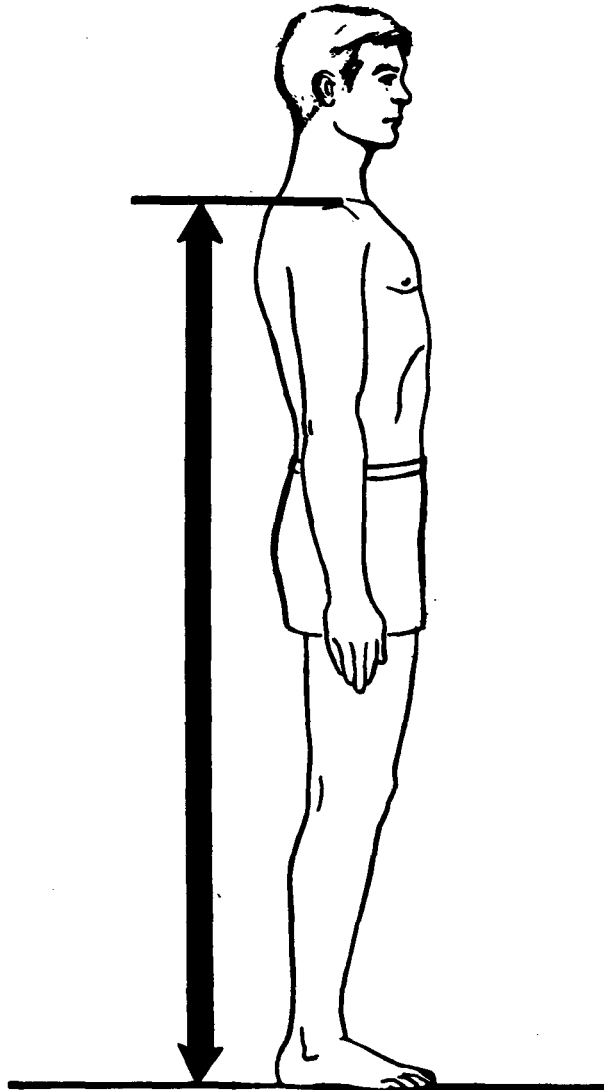

Shoulder Height (Acromiale Height):
 Subject stands erect, with heels together and head level. Shoulder height is measured as the vertical distance from the floor to the outer point (acromion) of the right shoulder. An anthropometer is used.

THE SUMMARY STATISTICS

••••

CENTIMETERS		INCHES
143.72	MEAN	56.58
0.08	SE(M)	0.03
6.22	ST DEV	2.45
0.05	SE(SD)	0.02
	••••	
	SYMMETRY--BETA I =	0.07
	KURTOSIS--BETA II =	3.03
	COEFFICIENT OF VARIATION =	4.33
	••••	
	SAMPLE SIZE =	6682

5 Waist Height

--INTERVALS--		--FREQUENCIES--					
CENTIMETERS		INCHES		ACTUAL FREQ	CUMULA TIVE-F	PERCEN T-FREQ	CUMUL- PCT-FQ
125.25-	126.24	49.31-	49.69	1	6682	0.01	100.00
124.25-	125.24	48.92-	49.30	3	6681	0.04	99.99
123.25-	124.24	48.52-	48.91	5	6678	0.07	99.94
122.25-	123.24	48.13-	48.51	3	6673	0.04	99.87
121.25-	122.24	47.74-	48.12	13	6670	0.19	99.82
120.25-	121.24	47.34-	47.73	22	6657	0.33	99.63
119.25-	120.24	46.95-	47.33	18	6635	0.27	99.30
118.25-	119.24	46.56-	46.94	38	6617	0.57	99.03
117.25-	118.24	46.16-	46.55	44	6579	0.66	98.46
116.25-	117.24	45.77-	46.15	69	6535	1.03	97.80
115.25-	116.24	45.37-	45.76	81	6466	1.21	96.77
114.25-	115.24	44.98-	45.36	144	6385	2.16	95.56
113.25-	114.24	44.59-	44.97	190	6241	2.84	93.40
112.25-	113.24	44.19-	44.58	270	6051	4.04	90.56
111.25-	112.24	43.80-	44.18	301	5781	4.50	86.52
110.25-	111.24	43.41-	43.79	338	5480	5.06	82.01
109.25-	110.24	43.01-	43.40	397	5142	5.94	76.95
108.25-	109.24	42.62-	43.00	447	4745	6.69	71.01
107.25-	108.24	42.22-	42.61	517	4298	7.74	64.32
106.25-	107.24	41.83-	42.21	483	3781	7.23	56.58
105.25-	106.24	41.44-	41.82	560	3298	8.38	49.36
104.25-	105.24	41.04-	41.43	412	2738	6.17	40.98
103.25-	104.24	40.65-	41.03	424	2326	6.35	34.81
102.25-	103.24	40.26-	40.64	381	1902	5.70	28.46
101.25-	102.24	39.86-	40.25	432	1521	6.47	22.76
100.25-	101.24	39.47-	39.85	267	1089	4.00	16.30
99.25-	100.24	39.07-	39.46	231	822	3.46	12.30
98.25-	99.24	38.68-	39.06	162	591	2.42	8.84
97.25-	98.24	38.29-	38.67	108	429	1.62	6.42
96.25-	97.24	37.89-	38.28	120	321	1.80	4.80
95.25-	96.24	37.50-	37.88	64	201	0.96	3.01
94.25-	95.24	37.11-	37.49	44	137	0.66	2.05
93.25-	94.24	36.71-	37.10	34	93	0.51	1.39
92.25-	93.24	36.32-	36.70	19	59	0.28	0.88
91.25-	92.24	35.93-	36.31	12	40	0.18	0.60
90.25-	91.24	35.53-	35.92	16	28	0.24	0.42
89.25-	90.24	35.14-	35.52	5	12	0.07	0.18
88.25-	89.24	34.74-	35.13	3	7	0.04	0.10
87.25-	88.24	34.35-	34.73	3	4	0.04	0.06
86.25-	87.24	33.96-	34.34	1	1	0.01	0.01

5 Waist Height

PERCENTILES

CENTIMETERS		INCHES	
119.16	99 TH	46.91	
117.52	98 TH	46.27	
116.50	97 TH	45.87	
115.16	95 TH	45.34	
113.14	90 TH	44.54	
111.81	85 TH	44.02	
110.78	80 TH	43.61	
109.89	75 TH	43.26	
109.10	70 TH	42.95	
108.37	65 TH	42.67	
107.68	60 TH	42.39	
107.01	55 TH	42.13	
106.35	50 TH	41.87	
105.69	45 TH	41.61	
105.02	40 TH	41.35	
104.32	35 TH	41.07	
103.59	30 TH	40.78	
102.79	25 TH	40.47	
101.89	20 TH	40.11	
100.84	15 TH	39.70	
99.49	10 TH	39.17	
97.46	5 TH	38.37	
96.13	3 RD	37.85	
95.13	2 ND	37.45	
93.55	1 ST	36.83	

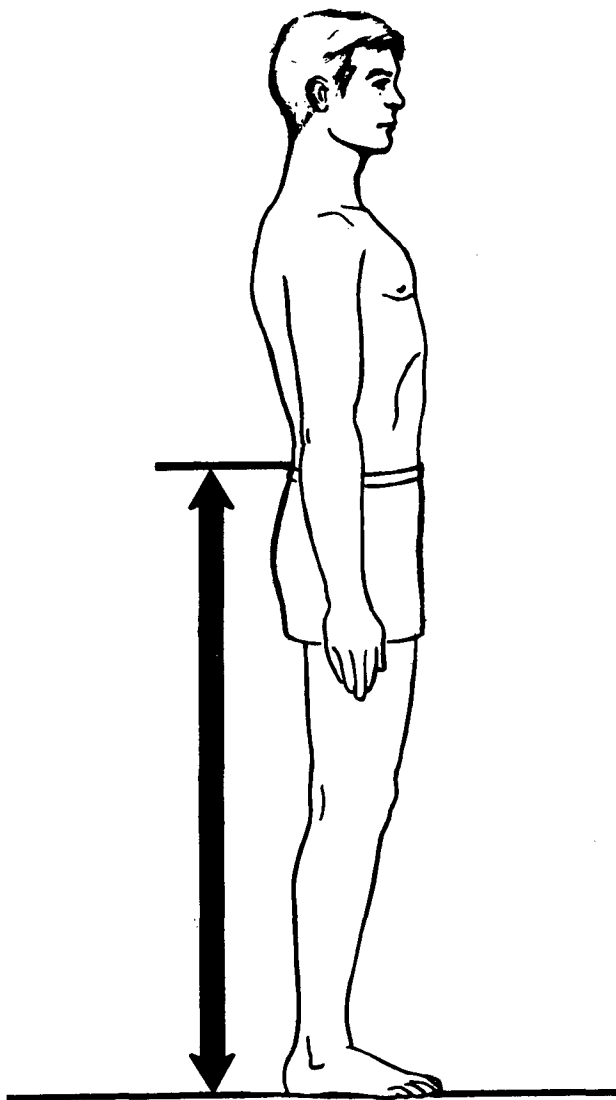

Waist Height (Iliocristale Height):
 Subject stands erect, with heels together. Waist height is measured as the vertical distance from the floor to the upper edge (iliac crest) of the right hip bone. An anthropometer is used.

THE SUMMARY STATISTICS

.....

CENTIMETERS		INCHES	
106.33	MEAN	41.86	
0.07	SE(M)	0.03	
5.37	ST DEV	2.11	
0.05	SE(SD)	0.02	

.....

SYMMETRY--BETA I = -0.01
 KURTOSIS--BETA II = 3.16
 COEFFICIENT OF VARIATION = 5.05

.....

SAMPLE SIZE = 6682

6 Crotch Height

--INTERVALS--		--FREQUENCIES--					
CENTIMETERS	INCHES	ACTUAL FREQ	CUMULA TIVE-F	PERCEN T-FREQ	CUMUL- PCT-FQ		
100.75-	101.74	39.67- 40.05	1	6682	0.01	100.00	
99.75-	100.74	39.27- 39.66	2	6681	0.03	99.99	
98.75-	99.74	38.88- 39.26	5	6679	0.07	99.96	
97.75-	98.74	38.48- 38.87	6	6674	0.09	99.88	
96.75-	97.74	38.09- 38.47	8	6668	0.12	99.79	
95.75-	96.74	37.70- 38.08	29	6660	0.43	99.67	
94.75-	95.74	37.30- 37.69	24	6631	0.36	99.24	
93.75-	94.74	36.91- 37.29	56	6607	0.84	98.88	
92.75-	93.74	36.52- 36.90	80	6551	1.20	98.04	
91.75-	92.74	36.12- 36.51	113	6471	1.69	96.84	
90.75-	91.74	35.73- 36.11	169	6358	2.53	95.15	
89.75-	90.74	35.33- 35.72	232	6189	3.47	92.62	
88.75-	89.74	34.94- 35.32	282	5957	4.22	89.15	
87.75-	88.74	34.55- 34.93	356	5675	5.33	84.93	
86.75-	87.74	34.15- 34.54	440	5319	6.58	79.60	
85.75-	86.74	33.76- 34.14	493	4879	7.38	73.02	
84.75-	85.74	33.37- 33.75	530	4386	7.93	65.64	
83.75-	84.74	32.97- 33.36	618	3856	9.25	57.71	
82.75-	83.74	32.58- 32.96	566	3238	8.47	48.46	
81.75-	82.74	32.19- 32.57	563	2672	8.43	39.99	
80.75-	81.74	31.79- 32.18	514	2109	7.69	31.56	
79.75-	80.74	31.40- 31.78	402	1595	6.02	23.87	
78.75-	79.74	31.00- 31.39	345	1193	5.16	17.85	
77.75-	78.74	30.61- 30.99	237	848	3.55	12.69	
76.75-	77.74	30.22- 30.60	219	611	3.28	9.14	
75.75-	76.74	29.82- 30.21	137	392	2.05	5.87	
74.75-	75.74	29.43- 29.81	88	255	1.32	3.82	
73.75-	74.74	29.04- 29.42	59	167	0.88	2.50	
72.75-	73.74	28.64- 29.03	42	108	0.63	1.62	
71.75-	72.74	28.25- 28.63	33	66	0.49	0.99	
70.75-	71.74	27.85- 28.24	11	33	0.16	0.49	
69.75-	70.74	27.46- 27.84	10	22	0.15	0.33	
68.75-	69.74	27.07- 27.45	6	12	0.09	0.18	
67.75-	68.74	26.67- 27.06	3	6	0.04	0.09	
66.75-	67.74	26.28- 26.66	1	3	0.01	0.04	
65.75-	66.74	25.89- 26.27	1	2	0.01	0.03	
64.75-	65.74	25.49- 25.88	1	1	0.01	0.01	

6 Crotch Height

PERCENTILES

CENTIMETERS		INCHES	
95.08	99 TH	37.43	
93.74	98 TH	36.90	
92.88	97 TH	36.57	
91.72	95 TH	36.11	
89.94	90 TH	35.41	
88.76	85 TH	34.94	
87.83	80 TH	34.58	
87.04	75 TH	34.27	
86.33	70 TH	33.99	
85.69	65 TH	33.73	
85.08	60 TH	33.49	
84.49	55 TH	33.26	
83.91	50 TH	33.04	
83.34	45 TH	32.81	
82.76	40 TH	32.58	
82.16	35 TH	32.35	
81.53	30 TH	32.10	
80.85	25 TH	31.83	
80.08	20 TH	31.53	
79.19	15 TH	31.18	
78.05	10 TH	30.73	
76.30	5 TH	30.04	
75.12	3 RD	29.58	
74.22	2 ND	29.22	
72.75	1 ST	28.64	

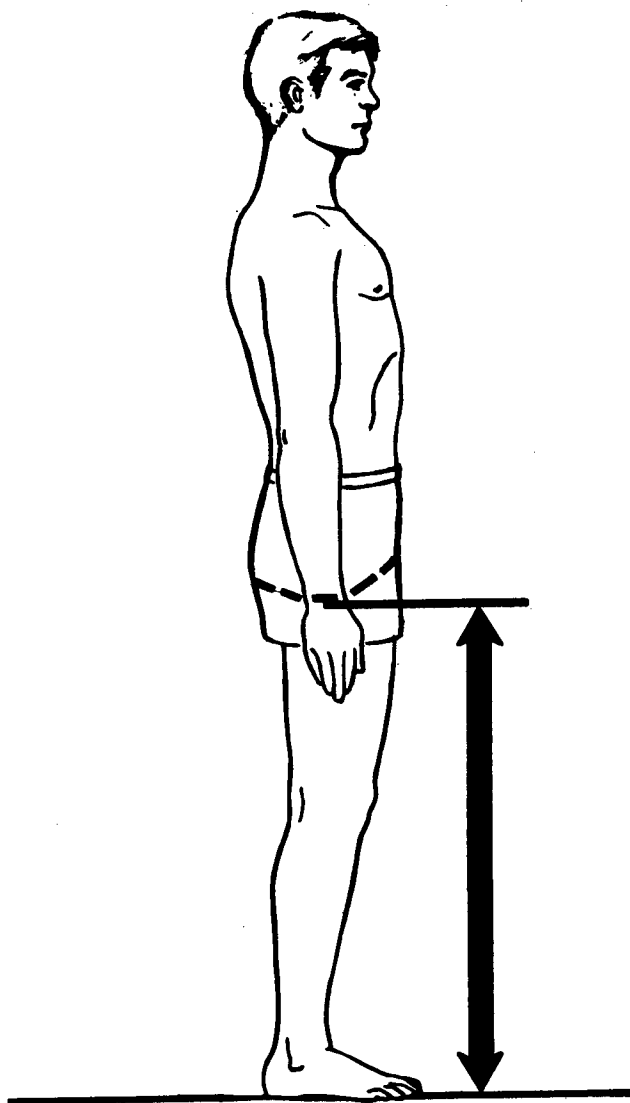

THE SUMMARY STATISTICS

••••

CENTIMETERS		INCHES	
83.94	MEAN	33.05	
0.06	SE(M)	0.02	
4.67	ST DEV	1.84	
0.04	SE(SD)	0.02	

••••

SYMMETRY--BETA I =	0.01
KURTOSIS--BETA II =	3.15
COEFFICIENT OF VARIATION =	5.57

••••

SAMPLE SIZE = 6682

Crotch Height: Subject stands erect, with his feet initially apart and then brought together after the anthropometer is in place. Crotch height is measured as the vertical distance from the floor (or standing surface) to the crotch. An anthropometer is used, with the anthropometer arm firmly in contact with the highest point in the crotch.

7 Kneecap Height

--INTERVALS--				--FREQUENCIES--			
CENTIMETERS		INCHES		ACTUAL FREQ	CUMULA TIVE-F	PERCEN T-FREQ	CUMUL- PCT-FQ
63.75-	64.24	25.10-	25.29	1	6682	0.01	100.00
63.25-	63.74	24.90-	25.09	4	6681	0.06	99.99
62.75-	63.24	24.70-	24.89	3	6677	0.04	99.93
62.25-	62.74	24.51-	24.69	8	6674	0.12	99.88
61.75-	62.24	24.31-	24.50	11	6666	0.16	99.76
61.25-	61.74	24.11-	24.30	21	6655	0.31	99.60
60.75-	61.24	23.92-	24.10	12	6634	0.18	99.28
60.25-	60.74	23.72-	23.91	30	6622	0.45	99.10
59.75-	60.24	23.52-	23.71	44	6592	0.66	98.65
59.25-	59.74	23.33-	23.51	71	6548	1.06	97.99
58.75-	59.24	23.13-	23.32	62	6477	0.93	96.93
58.25-	58.74	22.93-	23.12	84	6415	1.26	96.00
57.75-	58.24	22.74-	22.92	111	6331	1.66	94.75
57.25-	57.74	22.54-	22.73	163	6220	2.44	93.09
56.75-	57.24	22.34-	22.53	177	6057	2.65	90.65
56.25-	56.74	22.15-	22.33	202	5880	3.02	88.00
55.75-	56.24	21.95-	22.14	233	5678	3.49	84.97
55.25-	55.74	21.75-	21.94	319	5445	4.77	81.49
54.75-	55.24	21.56-	21.74	296	5126	4.43	76.71
54.25-	54.74	21.36-	21.55	380	4830	5.69	72.28
53.75-	54.24	21.16-	21.35	371	4450	5.55	66.60
53.25-	53.74	20.96-	21.15	373	4079	5.58	61.04
52.75-	53.24	20.77-	20.95	339	3706	5.07	55.46
52.25-	52.74	20.57-	20.76	467	3367	6.99	50.39
51.75-	52.24	20.37-	20.56	360	2900	5.39	43.40
51.25-	51.74	20.18-	20.36	415	2540	6.21	38.01
50.75-	51.24	19.98-	20.17	363	2125	5.43	31.80
50.25-	50.74	19.78-	19.97	350	1762	5.24	26.37
49.75-	50.24	19.59-	19.77	316	1412	4.73	21.13
49.25-	49.74	19.39-	19.58	235	1096	3.52	16.40
48.75-	49.24	19.19-	19.38	177	861	2.65	12.89
48.25-	48.74	19.00-	19.18	193	684	2.89	10.24
47.75-	48.24	18.80-	18.99	142	491	2.13	7.35
47.25-	47.74	18.60-	18.79	88	349	1.32	5.22
46.75-	47.24	18.41-	18.59	73	261	1.09	3.91
46.25-	46.74	18.21-	18.40	66	188	0.99	2.81
45.75-	46.24	18.01-	18.20	39	122	0.58	1.83
45.25-	45.74	17.82-	18.00	37	83	0.55	1.24
44.75-	45.24	17.62-	17.81	22	46	0.33	0.69
44.25-	44.74	17.42-	17.61	8	24	0.12	0.36
43.75-	44.24	17.22-	17.41	10	16	0.15	0.24
43.25-	43.74	17.03-	17.21	5	6	0.07	0.09
42.75-	43.24	16.83-	17.02	1	1	0.01	0.01

7 Kneecap Height

PERCENTILES

CENTIMETERS		INCHES	
60.66	99 TH	23.88	
59.77	98 TH	23.53	
59.19	97 TH	23.30	
58.39	95 TH	22.99	
57.14	90 TH	22.49	
56.29	85 TH	22.16	
55.62	80 TH	21.90	
55.04	75 TH	21.67	
54.53	70 TH	21.47	
54.06	65 TH	21.28	
53.62	60 TH	21.11	
53.20	55 TH	20.94	
52.78	50 TH	20.78	
52.37	45 TH	20.62	
51.96	40 TH	20.46	
51.53	35 TH	20.29	
51.09	30 TH	20.12	
50.62	25 TH	19.93	
50.09	20 TH	19.72	
49.49	15 TH	19.49	
48.74	10 TH	19.19	
47.62	5 TH	18.75	
46.90	3 RD	18.46	
46.36	2 ND	18.25	
45.50	1 ST	17.91	

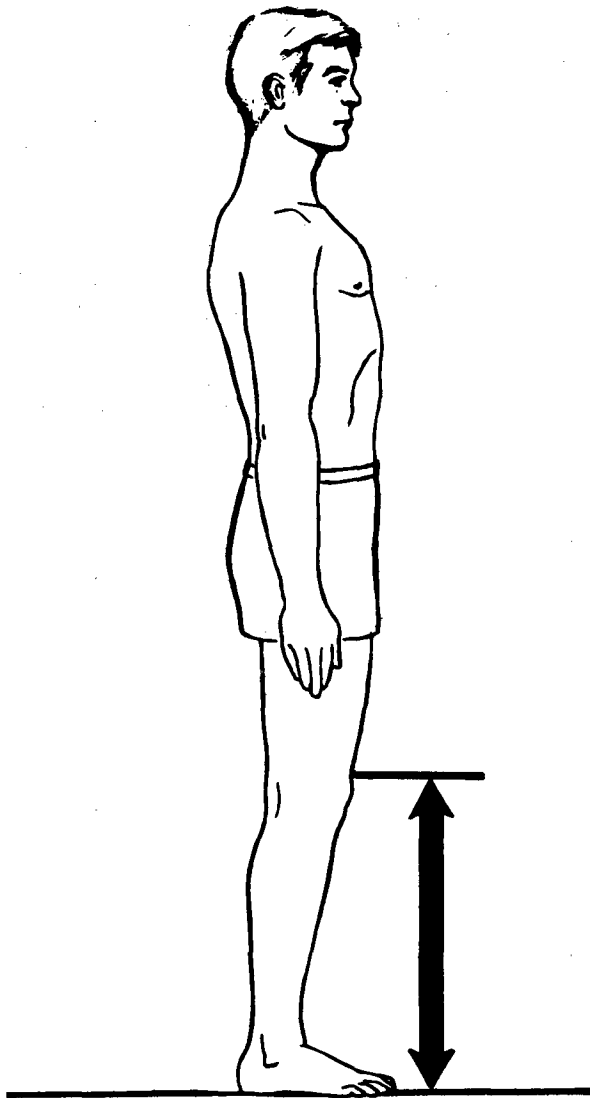

Kneecap Height (Patella Height):
 Subject stands erect, with heels together. Kneecap height is measured as the vertical distance from the floor (or standing surface) to the upper edge of the right kneecap (patella). An anthropometer is used.

THE SUMMARY STATISTICS

....

CENTIMETERS		INCHES	
52.86	MEAN	20.81	
0.04	SE(M)	0.02	
3.25	ST DEV	1.28	
0.03	SE(SD)	0.01	

....

SYMMETRY--BETA I = 0.12

KURTOSIS--BETA II = 2.91

COEFFICIENT OF VARIATION = 6.14

....

SAMPLE SIZE = 6682

8 Calf Height

--INTERVALS--		--FREQUENCIES--					
CENTIMETERS	INCHES	ACTUAL FREQ	CUMULA TIVE-F	PERCEN T-FREQ	CUMUL- PCT-FQ		
47.25-	47.74	18.60-	18.79	1	6682	0.01	100.00
46.75-	47.24	18.41-	18.59	0	6681	0.00	99.99
46.25-	46.74	18.21-	18.40	0	6681	0.00	99.99
45.75-	46.24	18.01-	18.20	0	6681	0.00	99.99
45.25-	45.74	17.82-	18.00	1	6681	0.01	99.99
44.75-	45.24	17.62-	17.81	0	6680	0.00	99.97
44.25-	44.74	17.42-	17.61	3	6680	0.04	99.97
43.75-	44.24	17.22-	17.41	4	6677	0.06	99.93
43.25-	43.74	17.03-	17.21	10	6673	0.15	99.87
42.75-	43.24	16.83-	17.02	16	6663	0.24	99.72
42.25-	42.74	16.63-	16.82	20	6647	0.30	99.48
41.75-	42.24	16.44-	16.62	23	6627	0.34	99.18
41.25-	41.74	16.24-	16.43	37	6604	0.55	98.83
40.75-	41.24	16.04-	16.23	62	6567	0.93	98.28
40.25-	40.74	15.85-	16.03	82	6505	1.23	97.35
39.75-	40.24	15.65-	15.84	121	6423	1.81	96.12
39.25-	39.74	15.45-	15.64	151	6302	2.26	94.31
38.75-	39.24	15.26-	15.44	221	6151	3.31	92.05
38.25-	38.74	15.06-	15.25	279	5930	4.18	88.75
37.75-	38.24	14.86-	15.05	293	5651	4.38	84.57
37.25-	37.74	14.67-	14.85	355	5358	5.31	80.19
36.75-	37.24	14.47-	14.66	382	5003	5.72	74.87
36.25-	36.74	14.27-	14.46	372	4621	5.57	69.16
35.75-	36.24	14.07-	14.26	522	4249	7.81	63.59
35.25-	35.74	13.88-	14.06	479	3727	7.17	55.78
34.75-	35.24	13.68-	13.87	466	3248	6.97	48.61
34.25-	34.74	13.48-	13.67	526	2782	7.87	41.63
33.75-	34.24	13.29-	13.47	443	2256	6.63	33.76
33.25-	33.74	13.09-	13.28	432	1813	6.47	27.13
32.75-	33.24	12.89-	13.08	330	1381	4.94	20.67
32.25-	32.74	12.70-	12.88	275	1051	4.12	15.73
31.75-	32.24	12.50-	12.69	229	776	3.43	11.61
31.25-	31.74	12.30-	12.49	182	547	2.72	8.19
30.75-	31.24	12.11-	12.29	125	365	1.87	5.46
30.25-	30.74	11.91-	12.10	75	240	1.12	3.59
29.75-	30.24	11.71-	11.90	64	165	0.96	2.47
29.25-	29.74	11.52-	11.70	35	101	0.52	1.51
28.75-	29.24	11.32-	11.51	24	66	0.36	0.99
28.25-	28.74	11.12-	11.31	23	42	0.34	0.63
27.75-	28.24	10.93-	11.11	10	19	0.15	0.28
27.25-	27.74	10.73-	10.92	2	9	0.03	0.13
26.75-	27.24	10.53-	10.72	2	7	0.03	0.10
26.25-	26.74	10.33-	10.52	2	5	0.03	0.07
25.75-	26.24	10.14-	10.32	1	3	0.01	0.04
25.25-	25.74	9.94-	10.13	1	2	0.01	0.03
24.75-	25.24	9.74-	9.93	0	1	0.00	0.01
24.25-	24.74	9.55-	9.73	0	1	0.00	0.01
23.75-	24.24	9.35-	9.54	1	1	0.01	0.01

8 Calf Height

PERCENTILES

CENTIMETERS		INCHES
41.92	99 TH	16.51
41.16	98 TH	16.20
40.66	97 TH	16.01
39.98	95 TH	15.74
38.94	90 TH	15.33
38.23	85 TH	15.05
37.68	80 TH	14.84
37.21	75 TH	14.65
36.79	70 TH	14.48
36.41	65 TH	14.33
36.05	60 TH	14.19
35.70	55 TH	14.06
35.36	50 TH	13.92
35.02	45 TH	13.79
34.69	40 TH	13.66
34.34	35 TH	13.52
33.98	30 TH	13.38
33.59	25 TH	13.22
33.15	20 TH	13.05
32.65	15 TH	12.86
32.02	10 TH	12.61
31.09	5 TH	12.24
30.48	3 RD	12.00
30.02	2 ND	11.82
29.28	1 ST	11.53

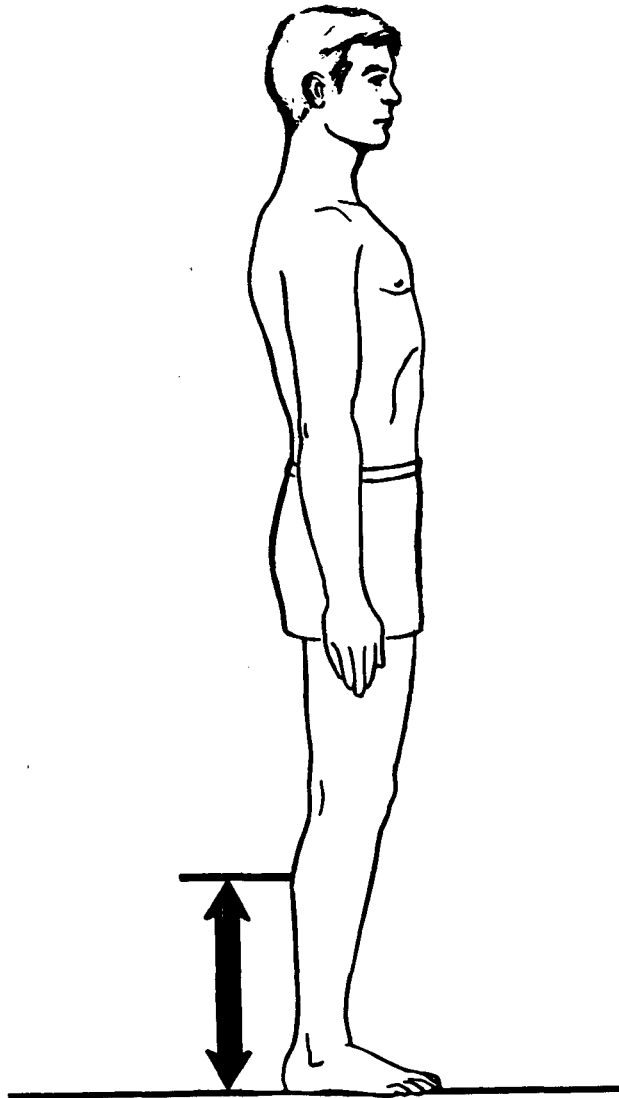

Calf Height: Subject stands erect, with heels together. Calf height is measured as the vertical distance from the floor (or standing surface) to the level of the greatest bulge of the right calf muscle. An anthropometer is used.

THE SUMMARY STATISTICS

.....

CENTIMETERS		INCHES
35.42	MEAN	13.94
0.03	SE(M)	0.01
2.70	ST DEV	1.06
0.02	SE(SD)	0.01

.....

SYMMETRY--BETA I =	0.11
KURTOSIS--BETA II =	3.08
COEFFICIENT OF VARIATION =	7.62

.....

SAMPLE SIZE = 6682

9 Functional Reach

--INTERVALS--		--FREQUENCIES--				
CENTIMETERS	INCHES	ACTUAL FREQ	CUMULA TIVE-F	PERCEN T-FREQ	CUMUL- PCT-FQ	
99.25- 100.24	39.07- 39.46	3	6680	0.04	100.00	
98.25- 99.24	38.68- 39.06	7	6677	0.10	99.96	
97.25- 98.24	38.29- 38.67	7	6670	0.10	99.85	
96.25- 97.24	37.89- 38.28	16	6663	0.24	99.75	
95.25- 96.24	37.50- 37.88	12	6647	0.18	99.51	
94.25- 95.24	37.11- 37.49	32	6635	0.48	99.33	
93.25- 94.24	36.71- 37.10	53	6603	0.79	98.85	
92.25- 93.24	36.32- 36.70	66	6550	0.99	98.05	
91.25- 92.24	35.93- 36.31	100	6484	1.50	97.07	
90.25- 91.24	35.53- 35.92	127	6384	1.90	95.57	
89.25- 90.24	35.14- 35.52	189	6257	2.83	93.67	
88.25- 89.24	34.74- 35.13	228	6068	3.41	90.84	
87.25- 88.24	34.35- 34.73	277	5840	4.15	87.43	
86.25- 87.24	33.96- 34.34	352	5563	5.27	83.28	
85.25- 86.24	33.56- 33.95	420	5211	6.29	78.01	
84.25- 85.24	33.17- 33.55	467	4791	6.99	71.72	
83.25- 84.24	32.78- 33.16	547	4324	8.19	64.73	
82.25- 83.24	32.38- 32.77	572	3777	8.56	56.54	
81.25- 82.24	31.99- 32.37	566	3205	8.47	47.98	
80.25- 81.24	31.59- 31.98	490	2639	7.34	39.51	
79.25- 80.24	31.20- 31.58	499	2149	7.47	32.17	
78.25- 79.24	30.81- 31.19	407	1650	6.09	24.70	
77.25- 78.24	30.41- 30.80	375	1243	5.61	18.61	
76.25- 77.24	30.02- 30.40	262	868	3.92	12.99	
75.25- 76.24	29.63- 30.01	215	606	3.22	9.07	
74.25- 75.24	29.23- 29.62	154	391	2.31	5.85	
73.25- 74.24	28.84- 29.22	93	237	1.39	3.55	
72.25- 73.24	28.45- 28.83	63	144	0.94	2.16	
71.25- 72.24	28.05- 28.44	42	81	0.63	1.21	
70.25- 71.24	27.66- 28.04	20	39	0.30	0.58	
69.25- 70.24	27.26- 27.65	10	19	0.15	0.28	
68.25- 69.24	26.87- 27.25	5	9	0.07	0.13	
67.25- 68.24	26.48- 26.86	0	4	0.00	0.06	
66.25- 67.24	26.08- 26.47	1	4	0.01	0.06	
65.25- 66.24	25.69- 26.07	3	3	0.04	0.04	

9 Functional Reach

PERCENTILES

CENTIMETERS		INCHES
94.62	99 TH	37.25
93.14	98 TH	36.67
92.19	97 TH	36.30
90.92	95 TH	35.79
88.97	90 TH	35.03
87.68	85 TH	34.52
86.67	80 TH	34.12
85.81	75 TH	33.78
85.04	70 TH	33.48
84.35	65 TH	33.21
83.69	60 TH	32.95
83.07	55 TH	32.70
82.45	50 TH	32.46
81.85	45 TH	32.22
81.24	40 TH	31.98
80.61	35 TH	31.74
79.96	30 TH	31.48
79.27	25 TH	31.21
78.50	20 TH	30.90
77.62	15 TH	30.56
76.51	10 TH	30.12
74.90	5 TH	29.49
73.86	3 RD	29.08
73.10	2 ND	28.78
71.89	1 ST	28.30

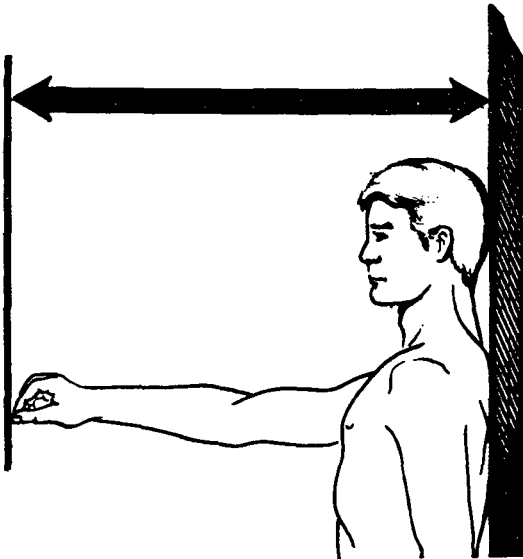

Functional Reach: Subject stands erect against a wall, with his right arm extended forward horizontally, and with the tips of his thumb and index finger pressed together; his shoulders must remain in contact with the wall. Functional reach is measured as the horizontal distance from the wall to the tip of the thumb. An anthropometer is used.

THE SUMMARY STATISTICS

••••

CENTIMETERS		INCHES
82.60	MEAN	32.52
0.06	SE(M)	0.02
4.85	ST DEV	1.91
0.04	SE(SD)	0.02

••••

SYMMETRY--BETA I = 0.19
 KURTOSIS--BETA II = 3.05
 COEFFICIENT OF VARIATION = 5.87

••••

SAMPLE SIZE = 6680

10 Vertical Arm Reach, Sitting

--INTERVALS--		--FREQUENCIES--					
CENTIMETERS	INCHES	ACTUAL FREQ	CUMULA TIVE-F	PERCEN T-FREQ	CUMUL- PCT-FQ		
159.75- 160.74	62.89- 63.28	5	6682	0.07	100.00		
158.75- 159.74	62.50- 62.88	0	6677	0.00	99.93		
157.75- 158.74	62.11- 62.49	3	6677	0.04	99.93		
156.75- 157.74	61.71- 62.10	5	6674	0.07	99.88		
155.75- 156.74	61.32- 61.70	8	6669	0.12	99.81		
154.75- 155.74	60.93- 61.31	21	6661	0.31	99.69		
153.75- 154.74	60.53- 60.92	9	6640	0.13	99.37		
152.75- 153.74	60.14- 60.52	16	6631	0.24	99.24		
151.75- 152.74	59.74- 60.13	18	6615	0.27	99.00		
150.75- 151.74	59.35- 59.73	34	6597	0.51	98.73		
149.75- 150.74	58.96- 59.34	47	6563	0.70	98.22		
148.75- 149.74	58.56- 58.95	65	6516	0.97	97.52		
147.75- 148.74	58.17- 58.55	103	6451	1.54	96.54		
146.75- 147.74	57.78- 58.16	138	6348	2.07	95.00		
145.75- 146.74	57.38- 57.77	156	6210	2.33	92.94		
144.75- 145.74	56.99- 57.37	188	6054	2.81	90.60		
143.75- 144.74	56.59- 56.98	261	5866	3.91	87.79		
142.75- 143.74	56.20- 56.58	324	5605	4.85	83.88		
141.75- 142.74	55.81- 56.19	358	5281	5.36	79.03		
140.75- 141.74	55.41- 55.80	430	4923	6.44	73.68		
139.75- 140.74	55.02- 55.40	479	4493	7.17	67.24		
138.75- 139.74	54.63- 55.01	442	4014	6.61	60.07		
137.75- 138.74	54.23- 54.62	452	3572	6.76	53.46		
136.75- 137.74	53.84- 54.22	477	3120	7.14	46.69		
135.75- 136.74	53.44- 53.83	432	2643	6.47	39.55		
134.75- 135.74	53.05- 53.43	393	2211	5.88	33.09		
133.75- 134.74	52.66- 53.04	352	1818	5.27	27.21		
132.75- 133.74	52.26- 52.65	316	1466	4.73	21.94		
131.75- 132.74	51.87- 52.25	306	1150	4.58	17.21		
130.75- 131.74	51.48- 51.86	221	844	3.31	12.63		
129.75- 130.74	51.08- 51.47	151	623	2.26	9.32		
128.75- 129.74	50.69- 51.07	151	472	2.26	7.06		
127.75- 128.74	50.30- 50.68	102	321	1.53	4.80		
126.75- 127.74	49.90- 50.29	69	219	1.03	3.28		
125.75- 126.74	49.51- 49.89	41	150	0.61	2.24		
124.75- 125.74	49.11- 49.50	35	109	0.52	1.63		
123.75- 124.74	48.72- 49.10	35	74	0.52	1.11		
122.75- 123.74	48.33- 48.71	13	39	0.19	0.58		
121.75- 122.74	47.93- 48.32	10	26	0.15	0.39		
120.75- 121.74	47.54- 47.92	5	16	0.07	0.24		
119.75- 120.74	47.15- 47.53	2	11	0.03	0.16		
118.75- 119.74	46.75- 47.14	4	9	0.06	0.13		
117.75- 118.74	46.36- 46.74	2	5	0.03	0.07		
116.75- 117.74	45.96- 46.35	3	3	0.04	0.04		

10 Vertical Arm Reach, Sitting

PERCENTILES

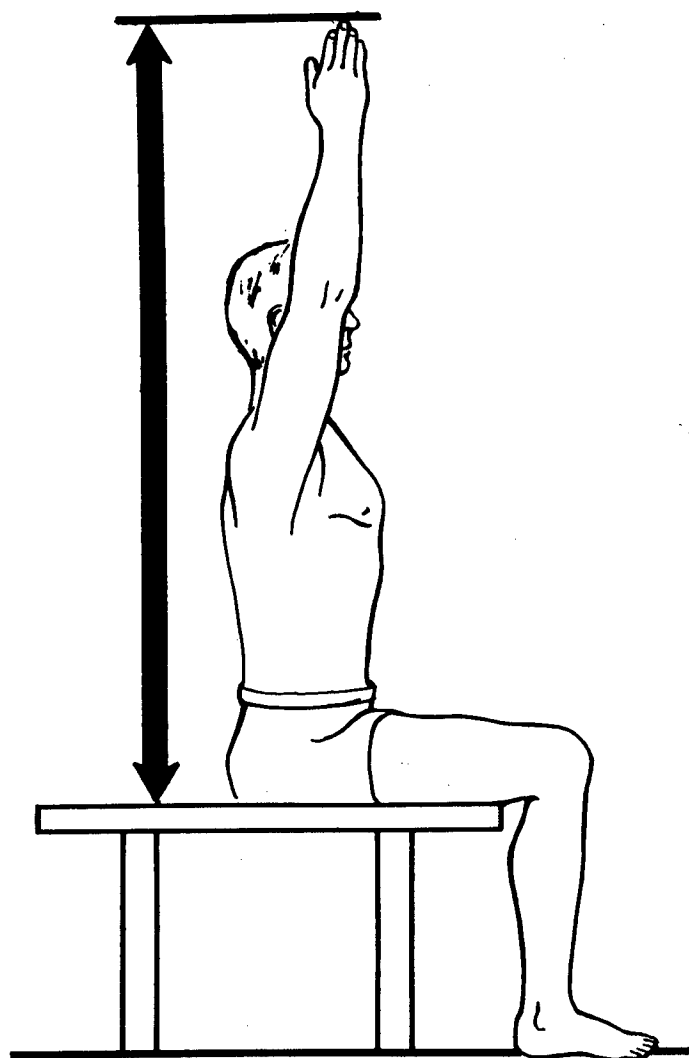

CENTIMETERS		INCHES
152.61	99 TH	60.08
150.56	98 TH	59.28
149.34	97 TH	58.79
147.77	95 TH	58.18
145.50	90 TH	57.28
144.05	85 TH	56.71
142.93	80 TH	56.27
141.98	75 TH	55.90
141.14	70 TH	55.57
140.37	65 TH	55.26
139.64	60 TH	54.97
138.93	55 TH	54.70
138.23	50 TH	54.42
137.53	45 TH	54.15
136.82	40 TH	53.86
136.08	35 TH	53.57
135.29	30 TH	53.26
134.44	25 TH	52.93
133.47	20 TH	52.55
132.34	15 TH	52.10
130.90	10 TH	51.54
128.74	5 TH	50.69
127.33	3 RD	50.13
126.30	2 ND	49.72
124.68	1 ST	49.09

THE SUMMARY STATISTICS

....

CENTIMETERS		INCHES
138.23	MEAN	54.42
0.07	SE(M)	0.03
5.80	ST DEV	2.28
0.05	SE(SD)	0.02

....

SYMMETRY--BETA I =	0.08
KURTOSIS--BETA II =	3.28
COEFFICIENT OF VARIATION =	4.20

....

SAMPLE SIZE = 6682

Vertical Arm Reach, Sitting: Subject sits erect, with his right arm and hand extended vertically above his shoulder. Arm reach is measured as the vertical distance from the sitting surface to the tip of the middle finger of the extended hand. An anthropometer is used.

11 Sitting Height

--INTERVALS--				--FREQUENCIES--			
CENTIMETERS		INCHES		ACTUAL FREQ	CUMULA TIVE-F	PERCEN T-FREQ	CUMUL- PCT-FQ
102.25-	103.24	40.26-	40.64	6	6682	0.09	100.00
101.25-	102.24	39.86-	40.25	8	6676	0.12	99.91
100.25-	101.24	39.47-	39.85	10	6668	0.15	99.79
99.25-	100.24	39.07-	39.46	31	6658	0.46	99.64
98.25-	99.24	38.68-	39.06	75	6627	1.12	99.18
97.25-	98.24	38.29-	38.67	109	6552	1.63	98.05
96.25-	97.24	37.89-	38.28	187	6443	2.80	96.42
95.25-	96.24	37.50-	37.88	277	6256	4.15	93.62
94.25-	95.24	37.11-	37.49	390	5979	5.84	89.48
93.25-	94.24	36.71-	37.10	523	5589	7.83	83.64
92.25-	93.24	36.32-	36.70	637	5066	9.53	75.82
91.25-	92.24	35.93-	36.31	712	4429	10.66	66.28
90.25-	91.24	35.53-	35.92	718	3717	10.75	55.63
89.25-	90.24	35.14-	35.52	752	2999	11.25	44.88
88.25-	89.24	34.74-	35.13	610	2247	9.13	33.63
87.25-	88.24	34.35-	34.73	516	1637	7.72	24.50
86.25-	87.24	33.96-	34.34	368	1121	5.51	16.78
85.25-	86.24	33.56-	33.95	258	753	3.86	11.27
84.25-	85.24	33.17-	33.55	199	495	2.98	7.41
83.25-	84.24	32.78-	33.16	137	296	2.05	4.43
82.25-	83.24	32.38-	32.77	84	159	1.26	2.38
81.25-	82.24	31.99-	32.37	41	75	0.61	1.12
80.25-	81.24	31.59-	31.98	16	34	0.24	0.51
79.25-	80.24	31.20-	31.58	14	18	0.21	0.27
78.25-	79.24	30.81-	31.19	2	4	0.03	0.06
77.25-	78.24	30.41-	30.80	2	2	0.03	0.03

11 Sitting Height

PERCENTILES

CENTIMETERS		INCHES
99.18	99 TH	39.05
98.17	98 TH	38.65
97.54	97 TH	38.40
96.68	95 TH	38.06
95.38	90 TH	37.55
94.50	85 TH	37.21
93.81	80 TH	36.93
93.20	75 TH	36.69
92.66	70 TH	36.48
92.16	65 TH	36.28
91.68	60 TH	36.09
91.22	55 TH	35.91
90.75	50 TH	35.73
90.29	45 TH	35.55
89.82	40 TH	35.36
89.33	35 TH	35.17
88.81	30 TH	34.96
88.24	25 TH	34.74
87.60	20 TH	34.49
86.87	15 TH	34.20
85.93	10 TH	33.83
84.54	5 TH	33.28
83.64	3 RD	32.93
82.98	2 ND	32.67
81.96	1 ST	32.27

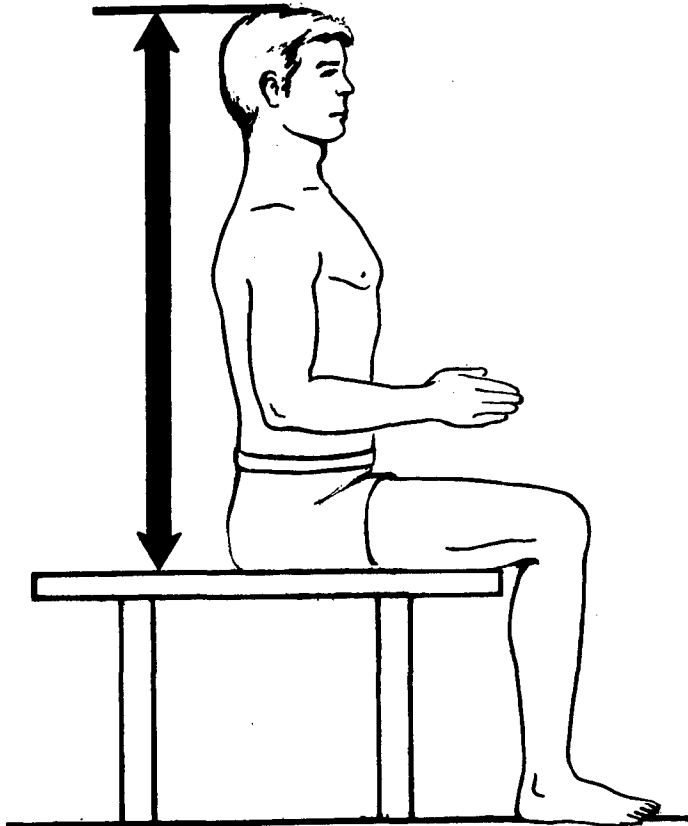

Sitting Height: Subject sits erect, with head level, and with his feet resting on a surface adjusted so that his knees are bent at right angles. Sitting height is measured as the vertical distance from the sitting surface to the top of the head (vertex). An anthropometer is used, with the anthropometer arm firmly touching the scalp to compress the hair.

THE SUMMARY STATISTICS

••••

CENTIMETERS		INCHES
90.69	MEAN	35.70
0.04	SE(M)	0.02
3.66	ST DEV	1.44
0.03	SE(SD)	0.01

••••

SYMMETRY--BETA I = -0.07
 KURTOSIS--BETA II = 3.02
 COEFFICIENT OF VARIATION = 4.04

••••

SAMPLE SIZE = 6682

12 Eye Height, Sitting

--INTERVALS--				--FREQUENCIES--			
CENTIMETERS		INCHES		ACTUAL FREQ	CUMULA TIVE-F	PERCEN T-FREQ	CUMUL- PCT-FQ
91.75-	92.74	36.12-	36.51	2	6682	0.03	100.00
90.75-	91.74	35.73-	36.11	0	6680	0.00	99.97
89.75-	90.74	35.33-	35.72	2	6680	0.03	99.97
88.75-	89.74	34.94-	35.32	8	6678	0.12	99.94
87.75-	88.74	34.55-	34.93	15	6670	0.22	99.82
86.75-	87.74	34.15-	34.54	52	6655	0.78	99.60
85.75-	86.74	33.76-	34.14	90	6603	1.35	98.82
84.75-	85.74	33.37-	33.75	135	6513	2.02	97.47
83.75-	84.74	32.97-	33.36	208	6378	3.11	95.45
82.75-	83.74	32.58-	32.96	338	6170	5.06	92.34
81.75-	82.74	32.19-	32.57	462	5832	6.91	87.28
80.75-	81.74	31.79-	32.18	597	5370	8.93	80.37
79.75-	80.74	31.40-	31.78	690	4773	10.33	71.43
78.75-	79.74	31.00-	31.39	802	4083	12.00	61.10
77.75-	78.74	30.61-	30.99	693	3281	10.37	49.10
76.75-	77.74	30.22-	30.60	673	2588	10.07	38.73
75.75-	76.74	29.82-	30.21	597	1915	8.93	28.66
74.75-	75.74	29.43-	29.81	421	1318	6.30	19.72
73.75-	74.74	29.04-	29.42	346	897	5.18	13.42
72.75-	73.74	28.64-	29.03	222	551	3.32	8.25
71.75-	72.74	28.25-	28.63	153	329	2.29	4.92
70.75-	71.74	27.85-	28.24	78	176	1.17	2.63
69.75-	70.74	27.46-	27.84	47	98	0.70	1.47
68.75-	69.74	27.07-	27.45	19	51	0.28	0.76
67.75-	68.74	26.67-	27.06	22	32	0.33	0.48
66.75-	67.74	26.28-	26.66	9	10	0.13	0.15
65.75-	66.74	25.89-	26.27	1	1	0.01	0.01

12 Eye Height, Sitting

PERCENTILES

CENTIMETERS

INCHES

87.04	99 TH	34.27
86.08	98 TH	33.89
85.46	97 TH	33.64
84.62	95 TH	33.31
83.32	90 TH	32.80
82.45	85 TH	32.46
81.75	80 TH	32.19
81.16	75 TH	31.95
80.62	70 TH	31.74
80.13	65 TH	31.55
79.66	60 TH	31.36
79.21	55 TH	31.19
78.76	50 TH	31.01
78.32	45 TH	30.83
77.86	40 TH	30.65
77.39	35 TH	30.47
76.89	30 TH	30.27
76.35	25 TH	30.06
75.75	20 TH	29.82
75.04	15 TH	29.54
74.14	10 TH	29.19
72.78	5 TH	28.65
71.87	3 RD	28.30
71.19	2 ND	28.03
70.10	1 ST	27.60

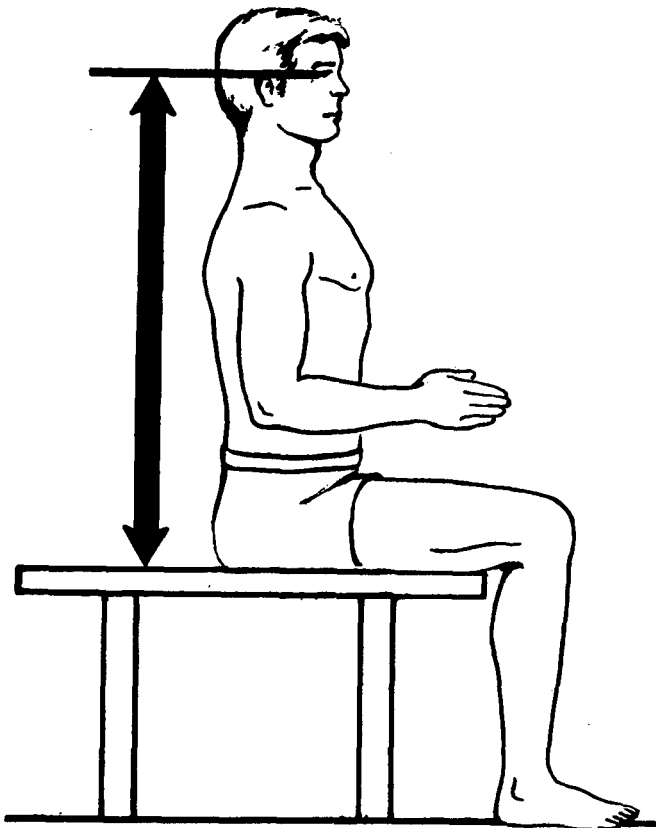

Eye Height, Sitting: Subject sits erect, with head level, and with his feet resting on a surface adjusted so that his knees are bent at right angles. Eye height is measured as the vertical distance from the sitting surface to the inner corner (internal canthus) of the right eye. An anthropometer is used.

THE SUMMARY STATISTICS

••••

CENTIMETERS

INCHES

78.72	MEAN	30.99
0.04	SE(M)	0.02
3.57	ST DEV	1.41
0.03	SE(SD)	0.01

••••

SYMMETRY--BETA I = -0.07

KURTOSIS--BETA II = 3.05

COEFFICIENT OF VARIATION = 4.53

••••

SAMPLE SIZE = 6682

13 Mid-Shoulder Height, Sitting

--INTERVALS--				--FREQUENCIES--			
CENTIMETERS		INCHES	ACTUAL FREQ	CUMULA TIVE-F	PERCEN T-FREQ	CUMUL- PCT-FQ	
72.75-	73.24	28.64-	28.83	2	6682	0.03	100.00
72.25-	72.74	28.45-	28.63	1	6680	0.01	99.97
71.75-	72.24	28.25-	28.44	4	6679	0.06	99.96
71.25-	71.74	28.05-	28.24	7	6675	0.10	99.90
70.75-	71.24	27.85-	28.04	12	6668	0.18	99.79
70.25-	70.74	27.66-	27.84	17	6656	0.25	99.61
69.75-	70.24	27.46-	27.65	17	6639	0.25	99.36
69.25-	69.74	27.26-	27.45	39	6622	0.58	99.10
68.75-	69.24	27.07-	27.25	43	6583	0.64	98.52
68.25-	68.74	26.87-	27.06	78	6540	1.17	97.87
67.75-	68.24	26.67-	26.86	89	6462	1.33	96.71
67.25-	67.74	26.48-	26.66	124	6373	1.86	95.38
66.75-	67.24	26.28-	26.47	125	6249	1.87	93.52
66.25-	66.74	26.08-	26.27	199	6124	2.98	91.65
65.75-	66.24	25.89-	26.07	206	5925	3.08	88.67
65.25-	65.74	25.69-	25.88	277	5719	4.15	85.59
64.75-	65.24	25.49-	25.68	259	5442	3.88	81.44
64.25-	64.74	25.30-	25.48	368	5183	5.51	77.57
63.75-	64.24	25.10-	25.29	356	4815	5.33	72.06
63.25-	63.74	24.90-	25.09	377	4459	5.64	66.73
62.75-	63.24	24.70-	24.89	404	4082	6.05	61.09
62.25-	62.74	24.51-	24.69	462	3678	6.91	55.04
61.75-	62.24	24.31-	24.50	424	3216	6.35	48.13
61.25-	61.74	24.11-	24.30	415	2792	6.21	41.78
60.75-	61.24	23.92-	24.10	353	2377	5.28	35.57
60.25-	60.74	23.72-	23.91	360	2024	5.39	30.29
59.75-	60.24	23.52-	23.71	345	1664	5.16	24.90
59.25-	59.74	23.33-	23.51	280	1319	4.19	19.74
58.75-	59.24	23.13-	23.32	245	1039	3.67	15.55
58.25-	58.74	22.93-	23.12	186	794	2.78	11.88
57.75-	58.24	22.74-	22.92	132	608	1.98	9.10
57.25-	57.74	22.54-	22.73	124	476	1.86	7.12
56.75-	57.24	22.34-	22.53	93	352	1.39	5.27
56.25-	56.74	22.15-	22.33	53	259	0.79	3.88
55.75-	56.24	21.95-	22.14	63	206	0.94	3.08
55.25-	55.74	21.75-	21.94	37	143	0.55	2.14
54.75-	55.24	21.56-	21.74	26	106	0.39	1.59
54.25-	54.74	21.36-	21.55	34	80	0.51	1.20
53.75-	54.24	21.16-	21.35	22	46	0.33	0.69
53.25-	53.74	20.96-	21.15	8	24	0.12	0.36
52.75-	53.24	20.77-	20.95	6	16	0.09	0.24
52.25-	52.74	20.57-	20.76	3	10	0.04	0.15
51.75-	52.24	20.37-	20.56	5	7	0.07	0.10
51.25-	51.74	20.18-	20.36	1	2	0.01	0.03
50.75-	51.24	19.98-	20.17	1	1	0.01	0.01

13 Mid-Shoulder Height, Sitting

PERCENTILES

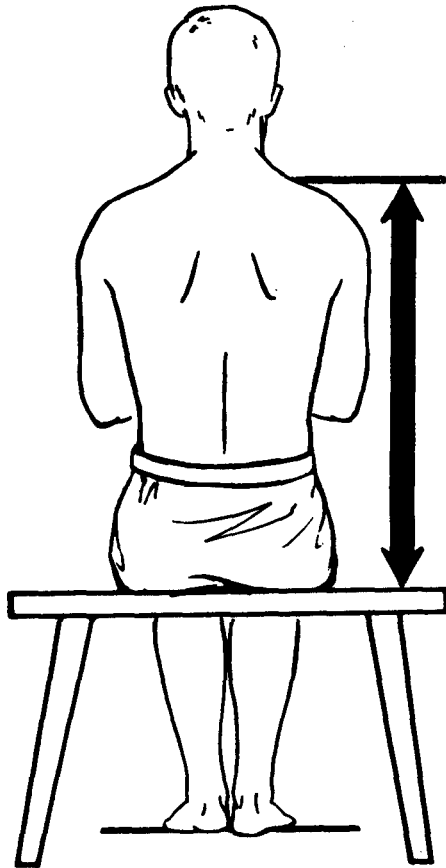

CENTIMETERS		INCHES	
69.66	99 TH	27.42	
68.88	98 TH	27.12	
68.36	97 TH	26.91	
67.63	95 TH	26.63	
66.48	90 TH	26.17	
65.68	85 TH	25.86	
65.06	80 TH	25.61	
64.52	75 TH	25.40	
64.04	70 TH	25.21	
63.60	65 TH	25.04	
63.18	60 TH	24.87	
62.78	55 TH	24.72	
62.38	50 TH	24.56	
61.99	45 TH	24.41	
61.59	40 TH	24.25	
61.19	35 TH	24.09	
60.75	30 TH	23.92	
60.29	25 TH	23.74	
59.76	20 TH	23.53	
59.15	15 TH	23.29	
58.36	10 TH	22.98	
57.13	5 TH	22.49	
56.29	3 RD	22.16	
55.63	2 ND	21.90	
54.53	1 ST	21.47	

Mid-Shoulder Height, Sitting: Subject sits erect, with head level, and with his hands resting on his thighs. Mid-shoulder height is measured as the vertical distance from the sitting surface to the top of the right shoulder, midway between the neck and the outer point (acromion) of the shoulder. An anthropometer is used.

THE SUMMARY STATISTICS

••••

CENTIMETERS		INCHES	
62.38	MEAN	24.56	
0.04	SE(M)	0.02	
3.18	ST DEV	1.25	
0.03	SE(SD)	0.01	

••••

SYMMETRY--BETA I = -0.05

KURTOSIS--BETA. II = 3.04

COEFFICIENT OF VARIATION = 5.09

••••

SAMPLE SIZE = 6682

14 Shoulder-Elbow Length

--INTERVALS--				--FREQUENCIES--			
CENTIMETERS		INCHES		ACTUAL FREQ	CUMULA TIVE-F	PERCEN T-FREQ	CUMUL- PCT-FQ
43.45-	43.74	17.11-	17.21	1	6682	0.01	100.00
43.15-	43.44	16.99-	17.10	2	6681	0.03	99.99
42.85-	43.14	16.87-	16.98	1	6679	0.01	99.96
42.55-	42.84	16.75-	16.86	7	6678	0.10	99.94
42.25-	42.54	16.63-	16.74	6	6671	0.09	99.84
41.95-	42.24	16.52-	16.62	13	6665	0.19	99.75
41.65-	41.94	16.40-	16.51	16	6652	0.24	99.55
41.35-	41.64	16.28-	16.39	19	6636	0.28	99.31
41.05-	41.34	16.16-	16.27	27	6617	0.40	99.03
40.75-	41.04	16.04-	16.15	42	6590	0.63	98.62
40.45-	40.74	15.93-	16.03	67	6548	1.00	97.99
40.15-	40.44	15.81-	15.92	76	6481	1.14	96.99
39.85-	40.14	15.69-	15.80	116	6405	1.74	95.85
39.55-	39.84	15.57-	15.68	124	6289	1.86	94.12
39.25-	39.54	15.45-	15.56	144	6165	2.16	92.26
38.95-	39.24	15.33-	15.44	238	6021	3.56	90.11
38.65-	38.94	15.22-	15.32	254	5783	3.80	86.55
38.35-	38.64	15.10-	15.21	263	5529	3.94	82.74
38.05-	38.34	14.98-	15.09	323	5266	4.83	78.81
37.75-	38.04	14.86-	14.97	344	4943	5.15	73.97
37.45-	37.74	14.74-	14.85	381	4599	5.70	68.83
37.15-	37.44	14.63-	14.73	423	4218	6.33	63.12
36.85-	37.14	14.51-	14.62	452	3795	6.76	56.79
36.55-	36.84	14.39-	14.50	416	3343	6.23	50.03
36.25-	36.54	14.27-	14.38	442	2927	6.61	43.80
35.95-	36.24	14.15-	14.26	414	2485	6.20	37.19
35.65-	35.94	14.04-	14.14	371	2071	5.55	30.99
35.35-	35.64	13.92-	14.03	319	1700	4.77	25.44
35.05-	35.34	13.80-	13.91	303	1381	4.53	20.67
34.75-	35.04	13.68-	13.79	247	1078	3.70	16.13
34.45-	34.74	13.56-	13.67	199	831	2.98	12.44
34.15-	34.44	13.45-	13.55	162	632	2.42	9.46
33.85-	34.14	13.33-	13.44	128	470	1.92	7.03
33.55-	33.84	13.21-	13.32	103	342	1.54	5.12
33.25-	33.54	13.09-	13.20	77	239	1.15	3.58
32.95-	33.24	12.97-	13.08	48	162	0.72	2.42
32.65-	32.94	12.85-	12.96	39	114	0.58	1.71
32.35-	32.64	12.74-	12.84	28	75	0.42	1.12
32.05-	32.34	12.62-	12.73	23	47	0.34	0.70
31.75-	32.04	12.50-	12.61	8	24	0.12	0.36
31.45-	31.74	12.38-	12.49	5	16	0.07	0.24
31.15-	31.44	12.26-	12.37	7	11	0.10	0.16
30.85-	31.14	12.15-	12.25	2	4	0.03	0.06
30.55-	30.84	12.03-	12.14	1	2	0.01	0.03
30.25-	30.54	11.91-	12.02	0	1	0.00	0.01
29.95-	30.24	11.79-	11.90	0	1	0.00	0.01
29.65-	29.94	11.67-	11.78	1	1	0.01	0.01

14 Shoulder-Elbow Length

PERCENTILES

CENTIMETERS		INCHES	
41.32	99 TH	16.27	
40.78	98 TH	16.06	
40.44	97 TH	15.92	
39.98	95 TH	15.74	
39.27	90 TH	15.46	
38.80	85 TH	15.28	
38.43	80 TH	15.13	
38.11	75 TH	15.00	
37.82	70 TH	14.89	
37.56	65 TH	14.79	
37.32	60 TH	14.69	
37.08	55 TH	14.60	
36.85	50 TH	14.51	
36.61	45 TH	14.41	
36.38	40 TH	14.32	
36.14	35 TH	14.23	
35.88	30 TH	14.13	
35.61	25 TH	14.02	
35.31	20 TH	13.90	
34.95	15 TH	13.76	
34.50	10 TH	13.58	
33.84	5 TH	13.32	
33.40	3 RD	13.15	
33.08	2 ND	13.02	
32.56	1 ST	12.82	

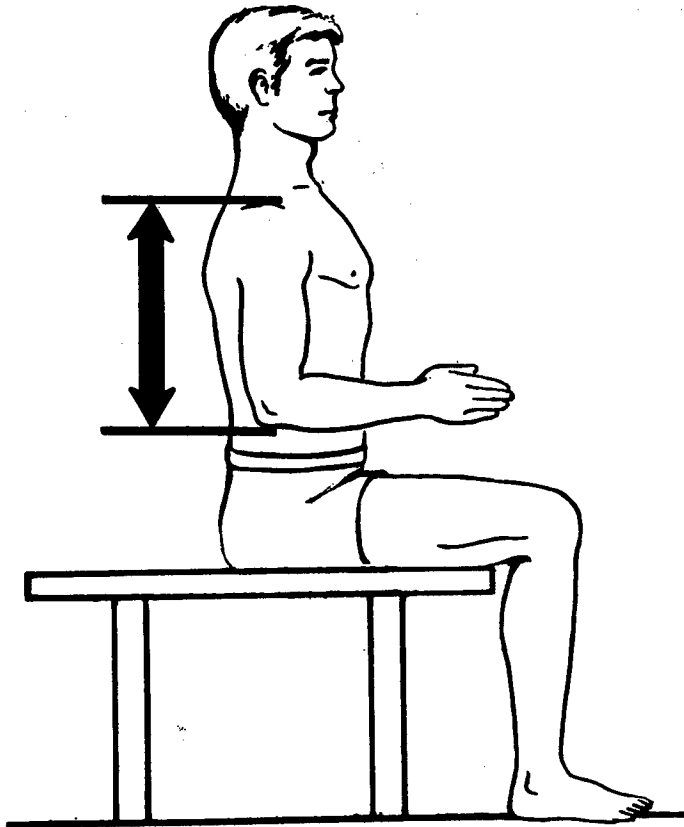

Shoulder-Elbow Length: Subject sits erect, with his arms bent to form right angles at the elbows. Shoulder-elbow length is measured as the vertical distance from the outer point (acromion) of the right shoulder to the bottom of the right elbow. An anthropometer is used.

THE SUMMARY STATISTICS

••••

CENTIMETERS		INCHES	
36.87	MEAN	14.52	
0.02	SE(M)	0.01	
1.86	ST DEV	0.73	
0.02	SE(SD)	0.01	

••••

SYMMETRY--BETA I = 0.06
 KURTOSIS--BETA II = 3.03
 COEFFICIENT OF VARIATION = 5.05

••••

SAMPLE SIZE = 6682

15 Elbow-Fingertip Length

--INTERVALS--		--FREQUENCIES--				
CENTIMETERS	INCHES	ACTUAL FREQ	CUMULA TIVE-F	PERCEN T-FREQ	CUMUL- PCT-FQ	
57.25-	57.64	22.54- 22.69	1	6682	0.01	100.00
56.85-	57.24	22.38- 22.53	1	6681	0.01	99.99
56.45-	56.84	22.22- 22.37	1	6680	0.01	99.97
56.05-	56.44	22.07- 22.21	1	6679	0.01	99.96
55.65-	56.04	21.91- 22.06	3	6678	0.04	99.94
55.25-	55.64	21.75- 21.90	7	6675	0.10	99.90
54.85-	55.24	21.59- 21.74	5	6668	0.07	99.79
54.45-	54.84	21.44- 21.58	14	6663	0.21	99.72
54.05-	54.44	21.28- 21.43	24	6649	0.36	99.51
53.65-	54.04	21.12- 21.27	20	6625	0.30	99.15
53.25-	53.64	20.96- 21.11	40	6605	0.60	98.85
52.85-	53.24	20.81- 20.95	40	6565	0.60	98.25
52.45-	52.84	20.65- 20.80	49	6525	0.73	97.65
52.05-	52.44	20.49- 20.64	87	6476	1.30	96.92
51.65-	52.04	20.33- 20.48	100	6389	1.50	95.62
51.25-	51.64	20.18- 20.32	136	6289	2.04	94.12
50.85-	51.24	20.02- 20.17	177	6153	2.65	92.08
50.45-	50.84	19.86- 20.01	224	5976	3.35	89.43
50.05-	50.44	19.70- 19.85	269	5752	4.03	86.08
49.65-	50.04	19.55- 19.69	319	5483	4.77	82.06
49.25-	49.64	19.39- 19.54	339	5164	5.07	77.28
48.85-	49.24	19.23- 19.38	404	4825	6.05	72.21
48.45-	48.84	19.07- 19.22	380	4421	5.69	66.16
48.05-	48.44	18.92- 19.06	498	4041	7.45	60.48
47.65-	48.04	18.76- 18.91	487	3543	7.29	53.02
47.25-	47.64	18.60- 18.75	486	3056	7.27	45.73
46.85-	47.24	18.45- 18.59	421	2570	6.30	38.46
46.45-	46.84	18.29- 18.44	414	2149	6.20	32.16
46.05-	46.44	18.13- 18.28	394	1735	5.90	25.97
45.65-	46.04	17.97- 18.12	336	1341	5.03	20.07
45.25-	45.64	17.82- 17.96	273	1005	4.09	15.04
44.85-	45.24	17.66- 17.81	189	732	2.83	10.95
44.45-	44.84	17.50- 17.65	177	543	2.65	8.13
44.05-	44.44	17.34- 17.49	112	366	1.68	5.48
43.65-	44.04	17.19- 17.33	75	254	1.12	3.80
43.25-	43.64	17.03- 17.18	65	179	0.97	2.68
42.85-	43.24	16.87- 17.02	33	114	0.49	1.71
42.45-	42.84	16.71- 16.86	28	81	0.42	1.21
42.05-	42.44	16.56- 16.70	25	53	0.37	0.79
41.65-	42.04	16.40- 16.55	7	28	0.10	0.42
41.25-	41.64	16.24- 16.39	12	21	0.18	0.31
40.85-	41.24	16.08- 16.23	4	9	0.06	0.13
40.45-	40.84	15.93- 16.07	4	5	0.06	0.07
40.05-	40.44	15.77- 15.92	0	1	0.00	0.01
39.65-	40.04	15.61- 15.76	0	1	0.00	0.01
39.25-	39.64	15.45- 15.60	1	1	0.01	0.01

15 Elbow-Fingertip Length

PERCENTILES

CENTIMETERS		INCHES
53.83	99 TH	21.19
53.05	98 TH	20.89
52.56	97 TH	20.69
51.91	95 TH	20.44
50.95	90 TH	20.06
50.32	85 TH	19.81
49.84	80 TH	19.62
49.44	75 TH	19.46
49.08	70 TH	19.32
48.76	65 TH	19.20
48.45	60 TH	19.08
48.17	55 TH	18.96
47.88	50 TH	18.85
47.60	45 TH	18.74
47.33	40 TH	18.63
47.04	35 TH	18.52
46.74	30 TH	18.40
46.42	25 TH	18.27
46.06	20 TH	18.13
45.64	15 TH	17.97
45.11	10 TH	17.76
44.30	5 TH	17.44
43.76	3 RD	17.23
43.35	2 ND	17.07
42.67	1 ST	16.80

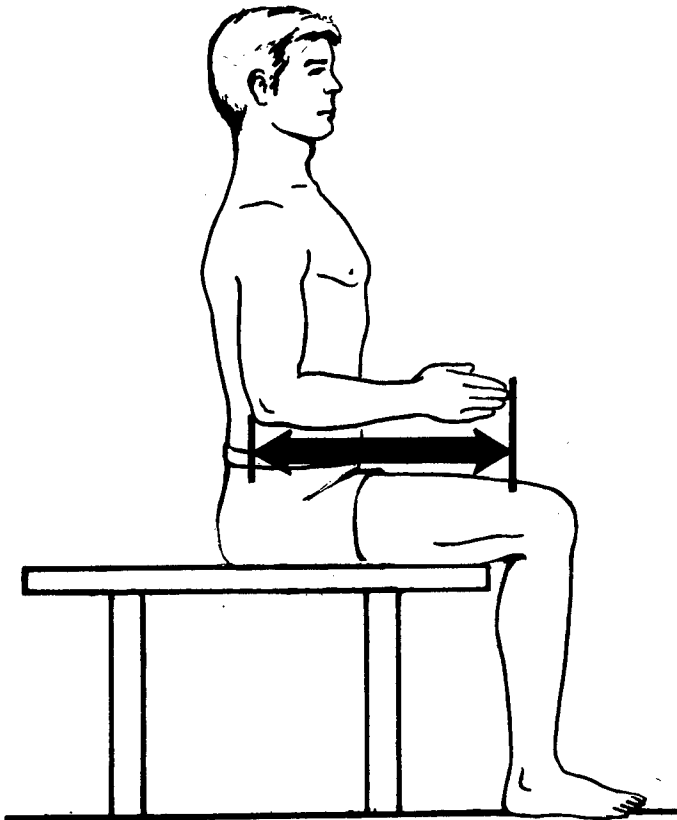

Elbow-Fingertip Length (Forearm-Hand Length): Subject sits erect, with his arms bent to form right angles at the elbows and with his hands extended. Elbow-fingertip length is measured as the horizontal distance from the back of the right elbow to the tip of the middle finger of the extended right hand. An anthropometer is used.

THE SUMMARY STATISTICS

••••

CENTIMETERS		INCHES
47.96	MEAN	18.88
0.03	SE(M)	0.01
2.31	ST DEV	0.91
0.02	SE(SD)	0.01
••••		
SYMMETRY--BETA I =		0.19
KURTOSIS--BETA II =		3.24
COEFFICIENT OF VARIATION =		4.81
••••		
SAMPLE SIZE =		6682

16 Knee Height, Sitting

--INTERVALS--			--FREQUENCIES--			
CENTIMETERS		INCHES	ACTUAL FREQ	CUMULA TIVE-F	PERCEN T-FREQ	CUMUL- PCT-FQ
64.25-	64.74	25.30- 25.48	1	6682	0.01	100.00
63.75-	64.24	25.10- 25.29	3	6681	0.04	99.99
63.25-	63.74	24.90- 25.09	2	6678	0.03	99.94
62.75-	63.24	24.70- 24.89	6	6676	0.09	99.91
62.25-	62.74	24.51- 24.69	4	6670	0.06	99.82
61.75-	62.24	24.31- 24.50	11	6666	0.16	99.76
61.25-	61.74	24.11- 24.30	17	6655	0.25	99.60
60.75-	61.24	23.92- 24.10	16	6638	0.24	99.34
60.25-	60.74	23.72- 23.91	31	6622	0.46	99.10
59.75-	60.24	23.52- 23.71	58	6591	0.87	98.64
59.25-	59.74	23.33- 23.51	77	6533	1.15	97.77
58.75-	59.24	23.13- 23.32	94	6456	1.41	96.62
58.25-	58.74	22.93- 23.12	136	6362	2.04	95.21
57.75-	58.24	22.74- 22.92	158	6226	2.36	93.18
57.25-	57.74	22.54- 22.73	231	6068	3.46	90.81
56.75-	57.24	22.34- 22.53	249	5837	3.73	87.35
56.25-	56.74	22.15- 22.33	301	5588	4.50	83.63
55.75-	56.24	21.95- 22.14	361	5287	5.40	79.12
55.25-	55.74	21.75- 21.94	437	4926	6.54	73.72
54.75-	55.24	21.56- 21.74	393	4489	5.88	67.18
54.25-	54.74	21.36- 21.55	528	4096	7.90	61.30
53.75-	54.24	21.16- 21.35	498	3568	7.45	53.40
53.25-	53.74	20.96- 21.15	443	3070	6.63	45.94
52.75-	53.24	20.77- 20.95	422	2627	6.32	39.31
52.25-	52.74	20.57- 20.76	525	2205	7.86	33.00
51.75-	52.24	20.37- 20.56	378	1680	5.66	25.14
51.25-	51.74	20.18- 20.36	359	1302	5.37	19.49
50.75-	51.24	19.98- 20.17	266	943	3.98	14.11
50.25-	50.74	19.78- 19.97	204	677	3.05	10.13
49.75-	50.24	19.59- 19.77	143	473	2.14	7.08
49.25-	49.74	19.39- 19.58	98	330	1.47	4.94
48.75-	49.24	19.19- 19.38	73	232	1.09	3.47
48.25-	48.74	19.00- 19.18	55	159	0.82	2.38
47.75-	48.24	18.80- 18.99	33	104	0.49	1.56
47.25-	47.74	18.60- 18.79	24	71	0.36	1.06
46.75-	47.24	18.41- 18.59	19	47	0.28	0.70
46.25-	46.74	18.21- 18.40	18	28	0.27	0.42
45.75-	46.24	18.01- 18.20	2	10	0.03	0.15
45.25-	45.74	17.82- 18.00	4	8	0.06	0.12
44.75-	45.24	17.62- 17.81	2	4	0.03	0.06
44.25-	44.74	17.42- 17.61	2	2	0.03	0.03

16 Knee Height, Sitting

PERCENTILES

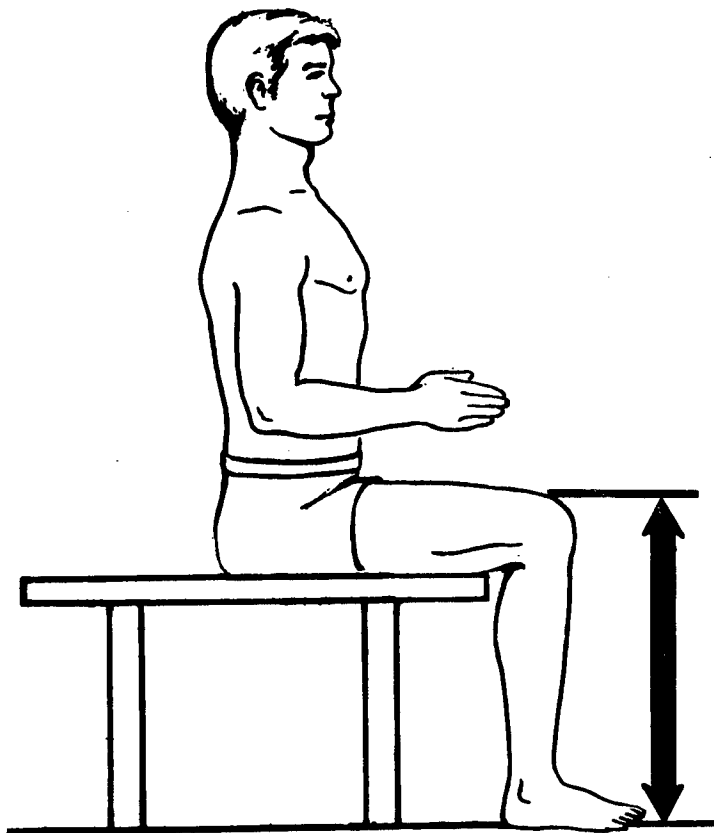

CENTIMETERS		INCHES
60.63	99 TH	23.87
59.90	98 TH	23.58
59.41	97 TH	23.39
58.72	95 TH	23.12
57.65	90 TH	22.70
56.92	85 TH	22.41
56.35	80 TH	22.19
55.87	75 TH	21.99
55.44	70 TH	21.83
55.04	65 TH	21.67
54.68	60 TH	21.53
54.33	55 TH	21.39
53.99	50 TH	21.26
53.65	45 TH	21.12
53.32	40 TH	20.99
52.98	35 TH	20.86
52.62	30 TH	20.72
52.24	25 TH	20.57
51.81	20 TH	20.40
51.32	15 TH	20.20
50.69	10 TH	19.96
49.72	5 TH	19.58
49.06	3 RD	19.31
48.54	2 ND	19.11
47.66	1 ST	18.76

Knee Height, Sitting: Subject sits erect, with his feet resting on a surface adjusted so that his knees are bent at right angles. Knee height is measured as the vertical distance from the footrest surface to the top of the right knee. An anthropometer is used.

THE SUMMARY STATISTICS

••••

CENTIMETERS		INCHES
54.06	MEAN	21.28
0.03	SE(M)	0.01
2.73	ST DEV	1.08
0.02	SE(SD)	0.01

••••

SYMMETRY--BETA I = 0.11
 KURTOSIS--BETA II = 3.14
 COEFFICIENT OF VARIATION = 5.05

••••

SAMPLE SIZE = 6682

17 Popliteal Height, Sitting

CENTIMETERS		INCHES		ACTUAL FREQ	CUMULA TIVE-F	PERCEN T-FREQ	CUMUL- PCT-FQ
54.15-	54.54	21.32-	21.47	1	6682	0.01	100.00
53.75-	54.14	21.16-	21.31	0	6681	0.00	99.99
53.35-	53.74	21.00-	21.15	0	6681	0.00	99.99
52.95-	53.34	20.85-	20.99	3	6681	0.04	99.99
52.55-	52.94	20.69-	20.84	2	6678	0.03	99.94
52.15-	52.54	20.53-	20.68	5	6676	0.07	99.91
51.75-	52.14	20.37-	20.52	11	6671	0.16	99.84
51.35-	51.74	20.22-	20.36	12	6660	0.18	99.67
50.95-	51.34	20.06-	20.21	10	6648	0.15	99.49
50.55-	50.94	19.90-	20.05	11	6638	0.16	99.34
50.15-	50.54	19.74-	19.89	39	6627	0.58	99.18
49.75-	50.14	19.59-	19.73	56	6588	0.84	98.59
49.35-	49.74	19.43-	19.58	72	6532	1.08	97.76
48.95-	49.34	19.27-	19.42	52	6460	0.78	96.68
48.55-	48.94	19.11-	19.26	100	6408	1.50	95.90
48.15-	48.54	18.96-	19.10	154	6308	2.30	94.40
47.75-	48.14	18.80-	18.95	204	6154	3.05	92.10
47.35-	47.74	18.64-	18.79	229	5950	3.43	89.05
46.95-	47.34	18.48-	18.63	181	5721	2.71	85.62
46.55-	46.94	18.33-	18.47	316	5540	4.73	82.91
46.15-	46.54	18.17-	18.32	341	5224	5.10	78.18
45.75-	46.14	18.01-	18.16	327	4883	4.89	73.08
45.35-	45.74	17.85-	18.00	357	4556	5.34	68.18
44.95-	45.34	17.70-	17.84	349	4199	5.22	62.84
44.55-	44.94	17.54-	17.69	474	3850	7.09	57.62
44.15-	44.54	17.38-	17.53	446	3376	6.67	50.52
43.75-	44.14	17.22-	17.37	425	2930	6.36	43.85
43.35-	43.74	17.07-	17.21	428	2505	6.41	37.49
42.95-	43.34	16.91-	17.06	307	2077	4.59	31.08
42.55-	42.94	16.75-	16.90	392	1770	5.87	26.49
42.15-	42.54	16.59-	16.74	322	1378	4.82	20.62
41.75-	42.14	16.44-	16.58	255	1056	3.82	15.80
41.35-	41.74	16.28-	16.43	197	801	2.95	11.99
40.95-	41.34	16.12-	16.27	137	604	2.05	9.04
40.55-	40.94	15.96-	16.11	137	467	2.05	6.99
40.15-	40.54	15.81-	15.95	99	330	1.48	4.94
39.75-	40.14	15.65-	15.80	79	231	1.18	3.46
39.35-	39.74	15.49-	15.64	46	152	0.69	2.27
38.95-	39.34	15.33-	15.48	32	106	0.48	1.59
38.55-	38.94	15.18-	15.32	31	74	0.46	1.11
38.15-	38.54	15.02-	15.17	15	43	0.22	0.64
37.75-	38.14	14.86-	15.01	14	28	0.21	0.42
37.35-	37.74	14.70-	14.85	5	14	0.07	0.21
36.95-	37.34	14.55-	14.69	5	9	0.07	0.13
36.55-	36.94	14.39-	14.54	3	4	0.04	0.06
36.15-	36.54	14.23-	14.38	0	1	0.00	0.01
35.75-	36.14	14.07-	14.22	1	1	0.01	0.01

17 Popliteal Height, Sitting

PERCENTILES

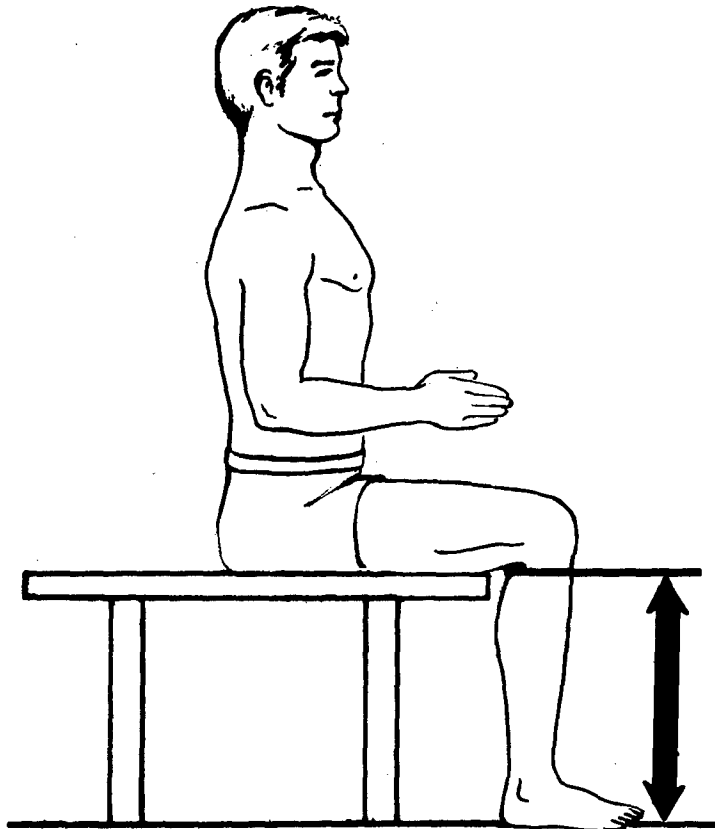

CENTIMETERS		INCHES	
50.45	99 TH	19.86	
49.83	98 TH	19.62	
49.41	97 TH	19.45	
48.82	95 TH	19.22	
47.87	90 TH	18.85	
47.22	85 TH	18.59	
46.71	80 TH	18.39	
46.26	75 TH	18.21	
45.87	70 TH	18.06	
45.51	65 TH	17.92	
45.17	60 TH	17.78	
44.85	55 TH	17.66	
44.53	50 TH	17.53	
44.21	45 TH	17.41	
43.90	40 TH	17.28	
43.58	35 TH	17.16	
43.24	30 TH	17.03	
42.89	25 TH	16.88	
42.49	20 TH	16.73	
42.03	15 TH	16.55	
41.46	10 TH	16.32	
40.59	5 TH	15.98	
40.02	3 RD	15.75	
39.58	2 ND	15.58	
38.85	1 ST	15.30	

Popliteal Height, Sitting: Subject sits erect, with his feet resting on a surface adjusted so that his knees are bent at right angles. Popliteal height is measured as the vertical distance from the footrest surface to the underside of the right knee (popliteal area). An anthropometer is used.

THE SUMMARY STATISTICS

••••

CENTIMETERS		INCHES	
44.61	MEAN	17.56	
0.03	SE(M)	0.01	
2.50	ST DEV	0.98	
0.02	SE(SD)	0.01	

••••

SYMMETRY--BETA I = 0.10
 KURTOSIS--BETA II = 2.99
 COEFFICIENT OF VARIATION = 5.60

••••

SAMPLE SIZE = 6682

18 Buttock-Knee Length

--INTERVALS--				--FREQUENCIES--			
CENTIMETERS		INCHES		ACTUAL FREQ	CUMULA TIVE-F	PERCEN T-FREQ	CUMUL- PCT-FQ
70.75-	71.24	27.85-	28.04	1	6682	0.01	100.00
70.25-	70.74	27.66-	27.84	1	6681	0.01	99.99
69.75-	70.24	27.46-	27.65	3	6680	0.04	99.97
69.25-	69.74	27.26-	27.45	0	6677	0.00	99.93
68.75-	69.24	27.07-	27.25	2	6677	0.03	99.93
68.25-	68.74	26.87-	27.06	5	6675	0.07	99.90
67.75-	68.24	26.67-	26.86	9	6670	0.13	99.82
67.25-	67.74	26.48-	26.66	12	6661	0.18	99.69
66.75-	67.24	26.28-	26.47	15	6649	0.22	99.51
66.25-	66.74	26.08-	26.27	32	6634	0.48	99.28
65.75-	66.24	25.89-	26.07	36	6602	0.54	98.80
65.25-	65.74	25.69-	25.88	60	6566	0.90	98.26
64.75-	65.24	25.49-	25.68	88	6506	1.32	97.37
64.25-	64.74	25.30-	25.48	107	6418	1.60	96.05
63.75-	64.24	25.10-	25.29	116	6311	1.74	94.45
63.25-	63.74	24.90-	25.09	146	6195	2.18	92.71
62.75-	63.24	24.70-	24.89	187	6049	2.80	90.53
62.25-	62.74	24.51-	24.69	235	5862	3.52	87.73
61.75-	62.24	24.31-	24.50	263	5627	3.94	84.21
61.25-	61.74	24.11-	24.30	370	5364	5.54	80.28
60.75-	61.24	23.92-	24.10	394	4994	5.90	74.74
60.25-	60.74	23.72-	23.91	490	4600	7.33	68.84
59.75-	60.24	23.52-	23.71	448	4110	6.70	61.51
59.25-	59.74	23.33-	23.51	473	3662	7.08	54.80
58.75-	59.24	23.13-	23.32	470	3189	7.03	47.73
58.25-	58.74	22.93-	23.12	474	2719	7.09	40.69
57.75-	58.24	22.74-	22.92	410	2245	6.14	33.60
57.25-	57.74	22.54-	22.73	412	1835	6.17	27.46
56.75-	57.24	22.34-	22.53	321	1423	4.80	21.30
56.25-	56.74	22.15-	22.33	263	1102	3.94	16.49
55.75-	56.24	21.95-	22.14	207	839	3.10	12.56
55.25-	55.74	21.75-	21.94	209	632	3.13	9.46
54.75-	55.24	21.56-	21.74	127	423	1.90	6.33
54.25-	54.74	21.36-	21.55	93	296	1.39	4.43
53.75-	54.24	21.16-	21.35	60	203	0.90	3.04
53.25-	53.74	20.96-	21.15	55	143	0.82	2.14
52.75-	53.24	20.77-	20.95	31	88	0.46	1.32
52.25-	52.74	20.57-	20.76	25	57	0.37	0.85
51.75-	52.24	20.37-	20.56	13	32	0.19	0.48
51.25-	51.74	20.18-	20.36	12	19	0.18	0.28
50.75-	51.24	19.98-	20.17	2	7	0.03	0.10
50.25-	50.74	19.78-	19.97	4	5	0.06	0.07
49.75-	50.24	19.59-	19.77	1	1	0.01	0.01

18 Buttock-Knee Length

PERCENTILES

CENTIMETERS		INCHES
66.50	99 TH	26.18
65.62	98 TH	25.83
65.06	97 TH	25.61
64.31	95 TH	25.32
63.16	90 TH	24.87
62.41	85 TH	24.57
61.82	80 TH	24.34
61.32	75 TH	24.14
60.88	70 TH	23.97
60.48	65 TH	23.81
60.10	60 TH	23.66
59.74	55 TH	23.52
59.39	50 TH	23.38
59.04	45 TH	23.24
58.69	40 TH	23.10
58.33	35 TH	22.96
57.95	30 TH	22.81
57.54	25 TH	22.65
57.09	20 TH	22.48
56.57	15 TH	22.27
55.90	10 TH	22.01
54.89	5 TH	21.61
54.22	3 RD	21.35
53.71	2 ND	21.15
52.87	1 ST	20.82

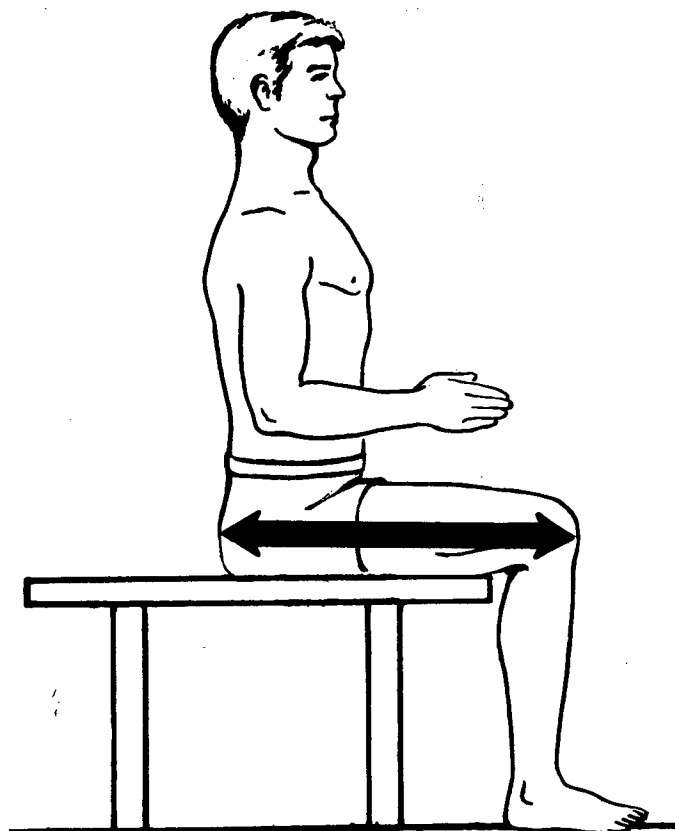

Buttock-Knee Length: Subject sits erect, with his feet resting on a surface adjusted so that his knees are bent at right angles. Buttock-knee length is measured as the horizontal distance from the back of the right buttock to the front of the right knee. An anthropometer is used.

THE SUMMARY STATISTICS

••••

CENTIMETERS		INCHES
59.47	MEAN	23.41
0.03	SE(M)	0.01
2.85	ST DEV	1.12
0.02	SE(SD)	0.01

••••

SYMMETRY--BETA I = 0.15
 KURTOSIS--BETA II = 3.14
 COEFFICIENT OF VARIATION = 4.80

••••

SAMPLE SIZE = 6682

19 Buttock-Popliteal Length

--INTERVALS--				--FREQUENCIES--			
CENTIMETERS		INCHES		ACTUAL FREQ	CUMULA TIVE-F	PERCEN T-FREQ	CUMUL- PCT-FQ
58.35-	58.74	22.97-	23.12	2	6682	0.03	100.00
57.95-	58.34	22.82-	22.96	3	6680	0.04	99.97
57.55-	57.94	22.66-	22.81	4	6677	0.06	99.93
57.15-	57.54	22.50-	22.65	7	6673	0.10	99.87
56.75-	57.14	22.34-	22.49	10	6666	0.15	99.76
56.35-	56.74	22.19-	22.33	9	6656	0.13	99.61
55.95-	56.34	22.03-	22.18	19	6647	0.28	99.48
55.55-	55.94	21.87-	22.02	28	6628	0.42	99.19
55.15-	55.54	21.71-	21.86	45	6600	0.67	98.77
54.75-	55.14	21.56-	21.70	51	6555	0.76	98.10
54.35-	54.74	21.40-	21.55	85	6504	1.27	97.34
53.95-	54.34	21.24-	21.39	89	6419	1.33	96.06
53.55-	53.94	21.08-	21.23	121	6330	1.81	94.73
53.15-	53.54	20.93-	21.07	142	6209	2.13	92.92
52.75-	53.14	20.77-	20.92	190	6067	2.84	90.80
52.35-	52.74	20.61-	20.76	238	5877	3.56	87.95
51.95-	52.34	20.45-	20.60	255	5639	3.82	84.39
51.55-	51.94	20.30-	20.44	308	5384	4.61	80.57
51.15-	51.54	20.14-	20.29	391	5076	5.85	75.97
50.75-	51.14	19.98-	20.13	363	4685	5.43	70.11
50.35-	50.74	19.82-	19.97	423	4322	6.33	64.68
49.95-	50.34	19.67-	19.81	399	3899	5.97	58.35
49.55-	49.94	19.51-	19.66	388	3500	5.81	52.38
49.15-	49.54	19.35-	19.50	435	3112	6.51	46.57
48.75-	49.14	19.19-	19.34	406	2677	6.08	40.06
48.35-	48.74	19.04-	19.18	371	2271	5.55	33.99
47.95-	48.34	18.88-	19.03	371	1900	5.55	28.43
47.55-	47.94	18.72-	18.87	335	1529	5.01	22.88
47.15-	47.54	18.56-	18.71	275	1194	4.12	17.87
46.75-	47.14	18.41-	18.55	213	919	3.19	13.75
46.35-	46.74	18.25-	18.40	175	706	2.62	10.57
45.95-	46.34	18.09-	18.24	143	531	2.14	7.95
45.55-	45.94	17.93-	18.08	120	388	1.80	5.81
45.15-	45.54	17.78-	17.92	73	268	1.09	4.01
44.75-	45.14	17.62-	17.77	52	195	0.78	2.92
44.35-	44.74	17.46-	17.61	45	143	0.67	2.14
43.95-	44.34	17.30-	17.45	35	98	0.52	1.47
43.55-	43.94	17.15-	17.29	27	63	0.40	0.94
43.15-	43.54	16.99-	17.14	17	36	0.25	0.54
42.75-	43.14	16.83-	16.98	8	19	0.12	0.28
42.35-	42.74	16.67-	16.82	7	11	0.10	0.16
41.95-	42.34	16.52-	16.66	2	4	0.03	0.06
41.55-	41.94	16.36-	16.51	1	2	0.01	0.03
41.15-	41.54	16.20-	16.35	1	1	0.01	0.01

19 Buttock-Popliteal Length

PERCENTILES

CENTIMETERS

INCHES

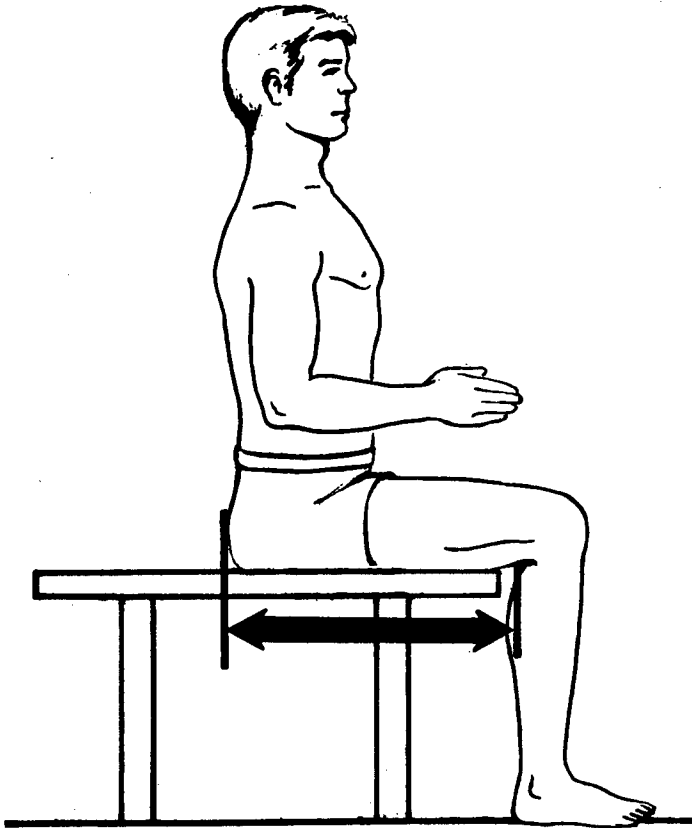

55.78	99 TH	21.96
55.08	98 TH	21.69
54.64	97 TH	21.51
54.02	95 TH	21.27
53.07	90 TH	20.89
52.43	85 TH	20.64
51.92	80 TH	20.44
51.49	75 TH	20.27
51.11	70 TH	20.12
50.75	65 TH	19.98
50.42	60 TH	19.85
50.10	55 TH	19.72
49.78	50 TH	19.60
49.47	45 TH	19.48
49.16	40 TH	19.35
48.83	35 TH	19.23
48.49	30 TH	19.09
48.13	25 TH	18.95
47.72	20 TH	18.79
47.25	15 TH	18.60
46.65	10 TH	18.37
45.75	5 TH	18.01
45.16	3 RD	17.78
44.71	2 ND	17.60
43.98	1 ST	17.32

Buttock-Popliteal Length: Subject sits erect, with his feet resting on a surface adjusted so that his knees are bent at right angles. Buttock-popliteal length is measured as the horizontal distance from the back of the right buttock to the back of the right knee (popliteal area). An anthropometer is used.

THE SUMMARY STATISTICS

.....

CENTIMETERS

INCHES

49.82	MEAN	19.62
0.03	SE(M)	0.01
2.50	ST DEV	0.99
0.02	SE(SD)	0.01

.....

SYMMETRY--BETA I =	0.07
KURTOSIS--BETA II =	3.00
COEFFICIENT OF VARIATION =	5.02

.....

SAMPLE SIZE = 6682

20 Chest Depth

		--INTERVALS--		--FREQUENCIES--			
CENTIMETERS		INCHES		ACTUAL FREQ	CUMULA TIVE-F	PERCEN T-FREQ	CUMUL- PCT-FQ
33.65-	34.04	13.25-	13.40	1	6682	0.01	100.00
33.25-	33.64	13.09-	13.24	1	6681	0.01	99.99
32.85-	33.24	12.93-	13.08	1	6680	0.01	99.97
32.45-	32.84	12.78-	12.92	2	6679	0.03	99.96
32.05-	32.44	12.62-	12.77	1	6677	0.01	99.93
31.65-	32.04	12.46-	12.61	1	6676	0.01	99.91
31.25-	31.64	12.30-	12.45	1	6675	0.01	99.90
30.85-	31.24	12.15-	12.29	4	6674	0.06	99.88
30.45-	30.84	11.99-	12.14	5	6670	0.07	99.82
30.05-	30.44	11.83-	11.98	1	6665	0.01	99.75
29.65-	30.04	11.67-	11.82	10	6664	0.15	99.73
29.25-	29.64	11.52-	11.66	20	6654	0.30	99.58
28.85-	29.24	11.36-	11.51	17	6634	0.25	99.28
28.45-	28.84	11.20-	11.35	20	6617	0.30	99.03
28.05-	28.44	11.04-	11.19	34	6597	0.51	98.73
27.65-	28.04	10.89-	11.03	50	6563	0.75	98.22
27.25-	27.64	10.73-	10.88	50	6513	0.75	97.47
26.85-	27.24	10.57-	10.72	80	6463	1.20	96.72
26.45-	26.84	10.41-	10.56	94	6383	1.41	95.53
26.05-	26.44	10.26-	10.40	142	6289	2.13	94.12
25.65-	26.04	10.10-	10.25	180	6147	2.69	91.99
25.25-	25.64	9.94-	10.09	234	5967	3.50	89.30
24.85-	25.24	9.78-	9.93	268	5733	4.01	85.80
24.45-	24.84	9.63-	9.77	321	5465	4.80	81.79
24.05-	24.44	9.47-	9.62	461	5144	6.90	76.98
23.65-	24.04	9.31-	9.46	477	4683	7.14	70.08
23.25-	23.64	9.15-	9.30	519	4206	7.77	62.95
22.85-	23.24	9.00-	9.14	605	3687	9.05	55.18
22.45-	22.84	8.84-	8.99	561	3082	8.40	46.12
22.05-	22.44	8.68-	8.83	552	2521	8.26	37.73
21.65-	22.04	8.52-	8.67	468	1969	7.00	29.47
21.25-	21.64	8.37-	8.51	442	1501	6.61	22.46
20.85-	21.24	8.21-	8.36	324	1059	4.85	15.85
20.45-	20.84	8.05-	8.20	280	735	4.19	11.00
20.05-	20.44	7.89-	8.04	188	455	2.81	6.81
19.65-	20.04	7.74-	7.88	119	267	1.78	4.00
19.25-	19.64	7.58-	7.73	75	148	1.12	2.21
18.85-	19.24	7.42-	7.57	43	73	0.64	1.09
18.45-	18.84	7.26-	7.41	13	30	0.19	0.45
18.05-	18.44	7.11-	7.25	9	17	0.13	0.25
17.65-	18.04	6.95-	7.10	4	8	0.06	0.12
17.25-	17.64	6.79-	6.94	2	4	0.03	0.06
16.85-	17.24	6.63-	6.78	1	2	0.01	0.03
16.45-	16.84	6.48-	6.62	1	1	0.01	0.01

20 Chest Depth

PERCENTILES

CENTIMETERS		INCHES
28.83	99 TH	11.35
27.92	98 TH	10.99
27.38	97 TH	10.78
26.70	95 TH	10.51
25.75	90 TH	10.14
25.16	85 TH	9.91
24.72	80 TH	9.73
24.36	75 TH	9.59
24.05	70 TH	9.47
23.76	65 TH	9.36
23.50	60 TH	9.25
23.25	55 TH	9.16
23.02	50 TH	9.06
22.78	45 TH	8.97
22.55	40 TH	8.88
22.31	35 TH	8.78
22.06	30 TH	8.69
21.80	25 TH	8.58
21.51	20 TH	8.47
21.18	15 TH	8.34
20.77	10 TH	8.18
20.19	5 TH	7.95
19.83	3 RD	7.81
19.57	2 ND	7.71
19.19	1 ST	7.55

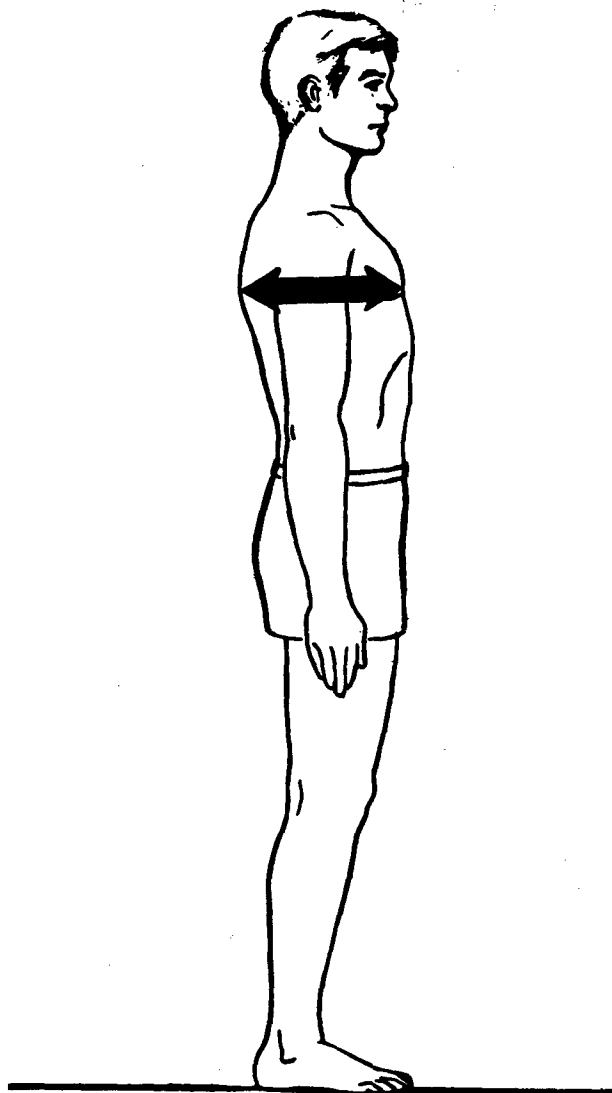

Chest Depth: Subject stands erect, with his arms initially raised and then lowered after the anthropometer is in place under the right arm. The depth of the chest is measured at the level of the nipples during normal breathing. An anthropometer is used, and is held horizontally.

THE SUMMARY STATISTICS

....

CENTIMETERS		INCHES
-------------	--	--------

23.18	MEAN	9.12
0.02	SE(M)	0.01
1.99	ST DEV	0.79
0.02	SE(SD)	0.01
....		
SYMMETRY--BETA I	=	0.58
KURTOSIS--BETA II	=	3.92
COEFFICIENT OF VARIATION	=	8.61
....		
SAMPLE SIZE	=	6682

21 Chest Breadth

--INTERVALS--				--FREQUENCIES--			
CENTIMETERS		INCHES		ACTUAL FREQ	CUMULA TIVE-F	PERCEN T-FREQ	CUMUL- PCT-FQ
41.25-	41.64	16.24-	16.39	1	6682	0.01	100.00
40.85-	41.24	16.08-	16.23	0	6681	0.00	99.99
40.45-	40.84	15.93-	16.07	1	6681	0.01	99.99
40.05-	40.44	15.77-	15.92	0	6680	0.00	99.97
39.65-	40.04	15.61-	15.76	3	6680	0.04	99.97
39.25-	39.64	15.45-	15.60	1	6677	0.01	99.93
38.85-	39.24	15.30-	15.44	3	6676	0.04	99.91
38.45-	38.84	15.14-	15.29	4	6673	0.06	99.87
38.05-	38.44	14.98-	15.13	6	6669	0.09	99.81
37.65-	38.04	14.82-	14.97	3	6663	0.04	99.72
37.25-	37.64	14.67-	14.81	11	6660	0.16	99.67
36.85-	37.24	14.51-	14.66	10	6649	0.15	99.51
36.45-	36.84	14.35-	14.50	15	6639	0.22	99.36
36.05-	36.44	14.19-	14.34	34	6624	0.51	99.13
35.65-	36.04	14.04-	14.18	35	6590	0.52	98.62
35.25-	35.64	13.88-	14.03	45	6555	0.67	98.10
34.85-	35.24	13.72-	13.87	56	6510	0.84	97.43
34.45-	34.84	13.56-	13.71	94	6454	1.41	96.59
34.05-	34.44	13.41-	13.55	80	6360	1.20	95.18
33.65-	34.04	13.25-	13.40	131	6280	1.96	93.98
33.25-	33.64	13.09-	13.24	183	6149	2.74	92.02
32.85-	33.24	12.93-	13.08	200	5966	2.99	89.28
32.45-	32.84	12.78-	12.92	285	5766	4.27	86.29
32.05-	32.44	12.62-	12.77	298	5481	4.46	82.03
31.65-	32.04	12.46-	12.61	391	5183	5.85	77.57
31.25-	31.64	12.30-	12.45	410	4792	6.14	71.72
30.85-	31.24	12.15-	12.29	464	4382	6.94	65.58
30.45-	30.84	11.99-	12.14	570	3918	8.53	58.64
30.05-	30.44	11.83-	11.98	532	3348	7.96	50.10
29.65-	30.04	11.67-	11.82	531	2816	7.95	42.14
29.25-	29.64	11.52-	11.66	460	2285	6.88	34.20
28.85-	29.24	11.36-	11.51	412	1825	6.17	27.31
28.45-	28.84	11.20-	11.35	378	1413	5.66	21.15
28.05-	28.44	11.04-	11.19	290	1035	4.34	15.49
27.65-	28.04	10.89-	11.03	251	745	3.76	11.15
27.25-	27.64	10.73-	10.88	196	494	2.93	7.39
26.85-	27.24	10.57-	10.72	112	298	1.68	4.46
26.45-	26.84	10.41-	10.56	82	186	1.23	2.78
26.05-	26.44	10.26-	10.40	48	104	0.72	1.56
25.65-	26.04	10.10-	10.25	29	56	0.43	0.84
25.25-	25.64	9.94-	10.09	15	27	0.22	0.40
24.85-	25.24	9.78-	9.93	10	12	0.15	0.18
24.45-	24.84	9.63-	9.77	2	2	0.03	0.03

21 Chest Breadth

PERCENTILES

CENTIMETERS		INCHES
36.40	99 TH	14.33
35.54	98 TH	13.99
35.02	97 TH	13.79
34.35	95 TH	13.52
33.37	90 TH	13.14
32.75	85 TH	12.90
32.28	80 TH	12.71
31.89	75 TH	12.56
31.55	70 TH	12.42
31.24	65 TH	12.30
30.96	60 TH	12.19
30.69	55 TH	12.08
30.42	50 TH	11.98
30.17	45 TH	11.88
29.91	40 TH	11.78
29.65	35 TH	11.67
29.38	30 TH	11.57
29.09	25 TH	11.45
28.78	20 TH	11.33
28.42	15 TH	11.19
27.97	10 TH	11.01
27.32	5 TH	10.76
26.91	3 RD	10.59
26.60	2 ND	10.47
26.13	1 ST	10.29

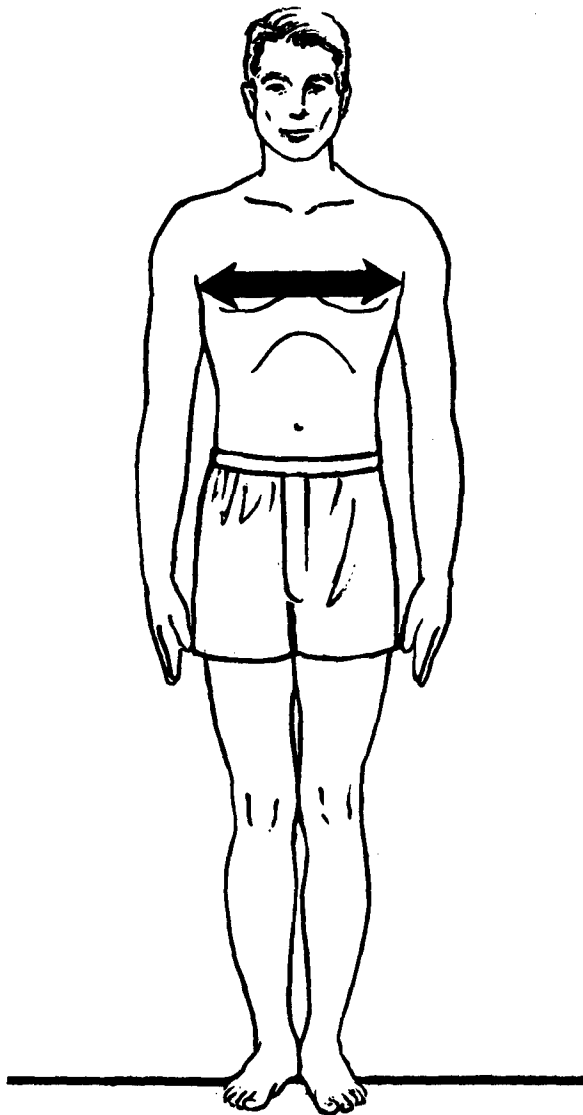

Chest Breadth: Subject stands erect, with his arms initially raised and then lowered after the anthropometer is in place. The breadth of the chest is measured at the level of the nipples during normal breathing. An anthropometer is used, and is held horizontally.

THE SUMMARY STATISTICS

••••

CENTIMETERS		INCHES
30.57	MEAN	12.04
0.03	SE(M)	0.01
2.15	ST DEV	0.84
0.02	SE(SD)	0.01

••••

SYMMETRY--BETA I = 0.48
 KURTOSIS--BETA II = 3.62
 COEFFICIENT OF VARIATION = 7.02

••••

SAMPLE SIZE = 6682

22 Hip Breadth, Standing

--INTERVALS--				--FREQUENCIES--			
CENTIMETERS		INCHES		ACTUAL FREQ	CUMULA TIVE-F	PERCEN T-FREQ	CUMUL- PCT-FQ
44.55-	44.94	17.54-	17.69	1	6682	0.01	100.00
44.15-	44.54	17.38-	17.53	0	6681	0.00	99.99
43.75-	44.14	17.22-	17.37	1	6681	0.01	99.99
43.35-	43.74	17.07-	17.21	0	6680	0.00	99.97
42.95-	43.34	16.91-	17.06	2	6680	0.03	99.97
42.55-	42.94	16.75-	16.90	0	6678	0.00	99.94
42.15-	42.54	16.59-	16.74	0	6678	0.00	99.94
41.75-	42.14	16.44-	16.58	2	6678	0.03	99.94
41.35-	41.74	16.28-	16.43	1	6676	0.01	99.91
40.95-	41.34	16.12-	16.27	2	6675	0.03	99.90
40.55-	40.94	15.96-	16.11	6	6673	0.09	99.87
40.15-	40.54	15.81-	15.95	2	6667	0.03	99.78
39.75-	40.14	15.65-	15.80	7	6665	0.10	99.75
39.35-	39.74	15.49-	15.64	15	6658	0.22	99.64
38.95-	39.34	15.33-	15.48	10	6643	0.15	99.42
38.55-	38.94	15.18-	15.32	23	6633	0.34	99.27
38.15-	38.54	15.02-	15.17	26	6610	0.39	98.92
37.75-	38.14	14.86-	15.01	41	6584	0.61	98.53
37.35-	37.74	14.70-	14.85	69	6543	1.03	97.92
36.95-	37.34	14.55-	14.69	76	6474	1.14	96.89
36.55-	36.94	14.39-	14.54	85	6398	1.27	95.75
36.15-	36.54	14.23-	14.38	148	6313	2.21	94.48
35.75-	36.14	14.07-	14.22	181	6165	2.71	92.26
35.35-	35.74	13.92-	14.06	252	5984	3.77	89.55
34.95-	35.34	13.76-	13.91	249	5732	3.73	85.78
34.55-	34.94	13.60-	13.75	348	5483	5.21	82.06
34.15-	34.54	13.45-	13.59	372	5135	5.57	76.85
33.75-	34.14	13.29-	13.44	467	4763	6.99	71.28
33.35-	33.74	13.13-	13.28	543	4296	8.13	64.29
32.95-	33.34	12.97-	13.12	514	3753	7.69	56.17
32.55-	32.94	12.82-	12.96	599	3239	8.96	48.47
32.15-	32.54	12.66-	12.81	562	2640	8.41	39.51
31.75-	32.14	12.50-	12.65	501	2078	7.50	31.10
31.35-	31.74	12.34-	12.49	451	1577	6.75	23.60
30.95-	31.34	12.19-	12.33	325	1126	4.86	16.85
30.55-	30.94	12.03-	12.18	275	801	4.12	11.99
30.15-	30.54	11.87-	12.02	190	526	2.84	7.87
29.75-	30.14	11.71-	11.86	138	336	2.07	5.03
29.35-	29.74	11.56-	11.70	98	198	1.47	2.96
28.95-	29.34	11.40-	11.55	50	100	0.75	1.50
28.55-	28.94	11.24-	11.39	22	50	0.33	0.75
28.15-	28.54	11.08-	11.23	14	28	0.21	0.42
27.75-	28.14	10.93-	11.07	9	14	0.13	0.21
27.35-	27.74	10.77-	10.92	3	5	0.04	0.07
26.95-	27.34	10.61-	10.76	2	2	0.03	0.03

22 Hip Breadth, Standing

PERCENTILES

CENTIMETERS		INCHES	
38.64	99 TH	15.21	
37.84	98 TH	14.90	
37.35	97 TH	14.71	
36.72	95 TH	14.46	
35.81	90 TH	14.10	
35.23	85 TH	13.87	
34.79	80 TH	13.70	
34.42	75 TH	13.55	
34.10	70 TH	13.43	
33.81	65 TH	13.31	
33.55	60 TH	13.21	
33.29	55 TH	13.11	
33.05	50 TH	13.01	
32.81	45 TH	12.92	
32.57	40 TH	12.82	
32.33	35 TH	12.73	
32.07	30 TH	12.63	
31.81	25 TH	12.52	
31.51	20 TH	12.41	
31.18	15 TH	12.28	
30.76	10 TH	12.11	
30.16	5 TH	11.88	
29.78	3 RD	11.72	
29.50	2 ND	11.61	
29.06	1 ST	11.44	

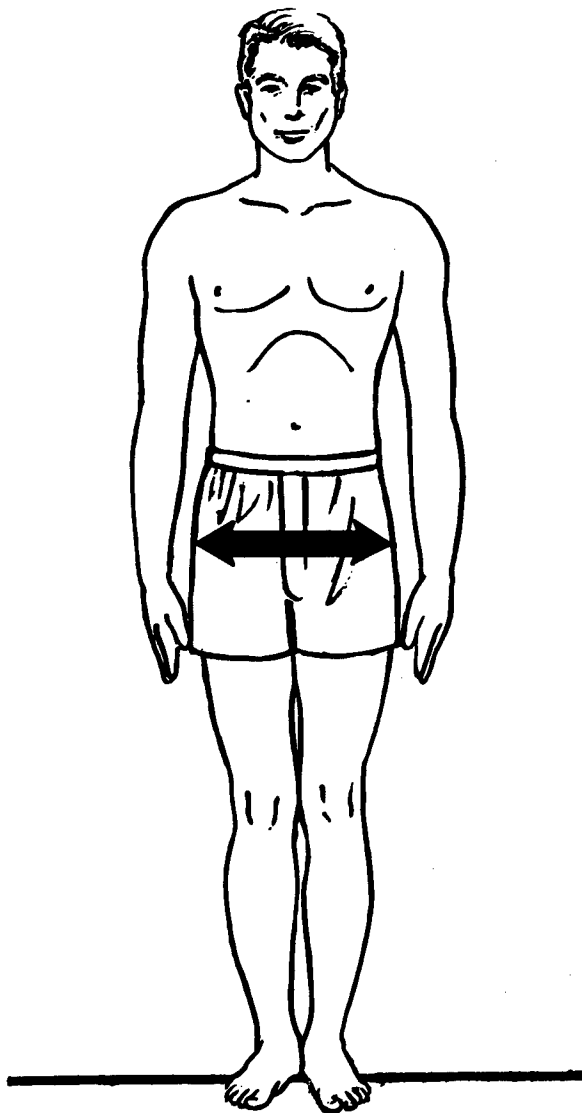

Hip Breadth, Standing: Subject stands erect, with heels together. The maximum breadth across the hips is measured. An anthropometer is used, and is held horizontally.

THE SUMMARY STATISTICS

••••

CENTIMETERS		INCHES	
33.20	MEAN	13.07	
0.02	SE(M)	0.01	
2.01	ST DEV	0.79	
0.02	SE(SD)	0.01	

••••

SYMMETRY--BETA I = 0.51
 KURTOSIS--BETA II = 3.79
 COEFFICIENT OF VARIATION = 6.05

••••

SAMPLE SIZE = 6682

23 Shoulder Breadth

--INTERVALS--				--FREQUENCIES--			
CENTIMETERS		INCHES		ACTUAL FREQ	CUMULA TIVE-F	PERCEN T-FREQ	CUMUL- PCT-FQ
58.25-	58.74	22.93-	23.12	1	6682	0.01	100.00
57.75-	58.24	22.74-	22.92	0	6681	0.00	99.99
57.25-	57.74	22.54-	22.73	0	6681	0.00	99.99
56.75-	57.24	22.34-	22.53	0	6681	0.00	99.99
56.25-	56.74	22.15-	22.33	0	6681	0.00	99.99
55.75-	56.24	21.95-	22.14	3	6681	0.04	99.99
55.25-	55.74	21.75-	21.94	2	6678	0.03	99.94
54.75-	55.24	21.56-	21.74	4	6676	0.06	99.91
54.25-	54.74	21.36-	21.55	4	6672	0.06	99.85
53.75-	54.24	21.16-	21.35	5	6668	0.07	99.79
53.25-	53.74	20.96-	21.15	8	6663	0.12	99.72
52.75-	53.24	20.77-	20.95	13	6655	0.19	99.60
52.25-	52.74	20.57-	20.76	17	6642	0.25	99.40
51.75-	52.24	20.37-	20.56	28	6625	0.42	99.15
51.25-	51.74	20.18-	20.36	35	6597	0.52	98.73
50.75-	51.24	19.98-	20.17	52	6562	0.78	98.20
50.25-	50.74	19.78-	19.97	73	6510	1.09	97.43
49.75-	50.24	19.59-	19.77	91	6437	1.36	96.33
49.25-	49.74	19.39-	19.58	110	6346	1.65	94.97
48.75-	49.24	19.19-	19.38	179	6236	2.68	93.33
48.25-	48.74	19.00-	19.18	214	6057	3.20	90.65
47.75-	48.24	18.80-	18.99	250	5843	3.74	87.44
47.25-	47.74	18.60-	18.79	372	5593	5.57	83.70
46.75-	47.24	18.41-	18.59	376	5221	5.63	78.14
46.25-	46.74	18.21-	18.40	435	4845	6.51	72.51
45.75-	46.24	18.01-	18.20	481	4410	7.20	66.00
45.25-	45.74	17.82-	18.00	545	3929	8.16	58.80
44.75-	45.24	17.62-	17.81	598	3384	8.95	50.64
44.25-	44.74	17.42-	17.61	532	2786	7.96	41.69
43.75-	44.24	17.22-	17.41	464	2254	6.94	33.73
43.25-	43.74	17.03-	17.21	466	1790	6.97	26.79
42.75-	43.24	16.83-	17.02	362	1324	5.42	19.81
42.25-	42.74	16.63-	16.82	303	962	4.53	14.40
41.75-	42.24	16.44-	16.62	216	659	3.23	9.86
41.25-	41.74	16.24-	16.43	172	443	2.57	6.63
40.75-	41.24	16.04-	16.23	111	271	1.66	4.06
40.25-	40.74	15.85-	16.03	75	160	1.12	2.39
39.75-	40.24	15.65-	15.84	33	85	0.49	1.27
39.25-	39.74	15.45-	15.64	24	52	0.36	0.78
38.75-	39.24	15.26-	15.44	12	28	0.18	0.42
38.25-	38.74	15.06-	15.25	6	16	0.09	0.24
37.75-	38.24	14.86-	15.05	6	10	0.09	0.15
37.25-	37.74	14.67-	14.85	3	4	0.04	0.06
36.75-	37.24	14.47-	14.66	0	1	0.00	0.01
36.25-	36.74	14.27-	14.46	1	1	0.01	0.01

23 Shoulder Breadth

PERCENTILES

CENTIMETERS		INCHES
52.09	99 TH	20.51
51.12	98 TH	20.12
50.53	97 TH	19.89
49.77	95 TH	19.59
48.65	90 TH	19.16
47.94	85 TH	18.88
47.40	80 TH	18.66
46.95	75 TH	18.48
46.55	70 TH	18.33
46.19	65 TH	18.19
45.86	60 TH	18.05
45.54	55 TH	17.93
45.23	50 TH	17.81
44.92	45 TH	17.69
44.62	40 TH	17.57
44.31	35 TH	17.44
43.98	30 TH	17.32
43.63	25 TH	17.18
43.25	20 TH	17.03
42.81	15 TH	16.85
42.26	10 TH	16.64
41.46	5 TH	16.32
40.94	3 RD	16.12
40.56	2 ND	15.97
39.97	1 ST	15.74

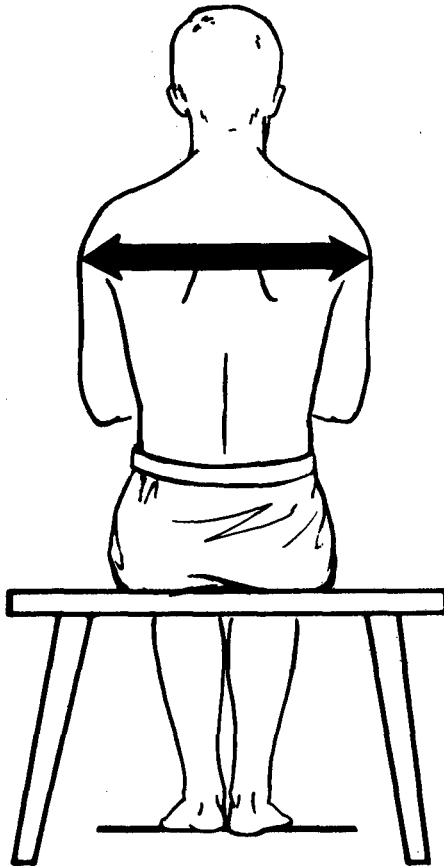

Shoulder Breadth (Bideloid Breadth):
 Subject sits erect, with his arms bent to form right angles at the elbows and with his elbows held against the body. The maximum breadth across the shoulders is measured at the level of the bulges of the deltoid muscles in the upper arms. An anthropometer is used, and is held horizontally.

THE SUMMARY STATISTICS

••••

CENTIMETERS		INCHES
45.37	MEAN	17.86
0.03	SE(M)	0.01
2.54	ST DEV	1.00
0.02	SE(SD)	0.01
••••		
SYMMETRY--BETA I =		0.36
KURTOSIS--BETA II =		3.49
COEFFICIENT OF VARIATION =		5.59
••••		
SAMPLE SIZE =		6682

24 Forearm-Forearm Breadth

--INTERVALS--				--FREQUENCIES--			
CENTIMETERS		INCHES		ACTUAL FREQ	CUMULA TIVE-F	PERCEN T-FREQ	CUMUL- PCT-FQ
65.25-	66.24	25.69-	26.07	2	6682	0.03	100.00
64.25-	65.24	25.30-	25.68	1	6680	0.01	99.97
63.25-	64.24	24.90-	25.29	2	6679	0.03	99.96
62.25-	63.24	24.51-	24.89	0	6677	0.00	99.93
61.25-	62.24	24.11-	24.50	5	6677	0.07	99.93
60.25-	61.24	23.72-	24.10	9	6672	0.13	99.85
59.25-	60.24	23.33-	23.71	12	6663	0.18	99.72
58.25-	59.24	22.93-	23.32	17	6651	0.25	99.54
57.25-	58.24	22.54-	22.92	26	6634	0.39	99.28
56.25-	57.24	22.15-	22.53	40	6608	0.60	98.89
55.25-	56.24	21.75-	22.14	65	6568	0.97	98.29
54.25-	55.24	21.36-	21.74	84	6503	1.26	97.32
53.25-	54.24	20.96-	21.35	129	6419	1.93	96.06
52.25-	53.24	20.57-	20.95	154	6290	2.30	94.13
51.25-	52.24	20.18-	20.56	175	6136	2.62	91.83
50.25-	51.24	19.78-	20.17	289	5961	4.33	89.21
49.25-	50.24	19.39-	19.77	354	5672	5.30	84.88
48.25-	49.24	19.00-	19.38	444	5318	6.64	79.59
47.25-	48.24	18.60-	18.99	525	4874	7.86	72.94
46.25-	47.24	18.21-	18.59	593	4349	8.87	65.09
45.25-	46.24	17.82-	18.20	648	3756	9.70	56.21
44.25-	45.24	17.42-	17.81	668	3108	10.00	46.51
43.25-	44.24	17.03-	17.41	639	2440	9.56	36.52
42.25-	43.24	16.63-	17.02	564	1801	8.44	26.95
41.25-	42.24	16.24-	16.62	429	1237	6.42	18.51
40.25-	41.24	15.85-	16.23	346	808	5.18	12.09
39.25-	40.24	15.45-	15.84	232	462	3.47	6.91
38.25-	39.24	15.06-	15.44	150	230	2.24	3.44
37.25-	38.24	14.67-	15.05	39	80	0.58	1.20
36.25-	37.24	14.27-	14.66	26	41	0.39	0.61
35.25-	36.24	13.88-	14.26	7	15	0.10	0.22
34.25-	35.24	13.48-	13.87	6	8	0.09	0.12
33.25-	34.24	13.09-	13.47	2	2	0.03	0.03

24 Forearm-Forearm Breadth

PERCENTILES

CENTIMETERS		INCHES	
57.60	99 TH	22.68	
55.94	98 TH	22.02	
54.91	97 TH	21.62	
53.57	95 TH	21.09	
51.61	90 TH	20.32	
50.34	85 TH	19.82	
49.39	80 TH	19.44	
48.58	75 TH	19.13	
47.89	70 TH	18.85	
47.26	65 TH	18.61	
46.68	60 TH	18.38	
46.13	55 TH	18.16	
45.60	50 TH	17.95	
45.09	45 TH	17.75	
44.58	40 TH	17.55	
44.06	35 TH	17.35	
43.53	30 TH	17.14	
42.98	25 TH	16.92	
42.38	20 TH	16.68	
41.71	15 TH	16.42	
40.89	10 TH	16.10	
39.77	5 TH	15.66	
39.08	3 RD	15.39	
38.60	2 ND	15.20	
37.88	1 ST	14.91	

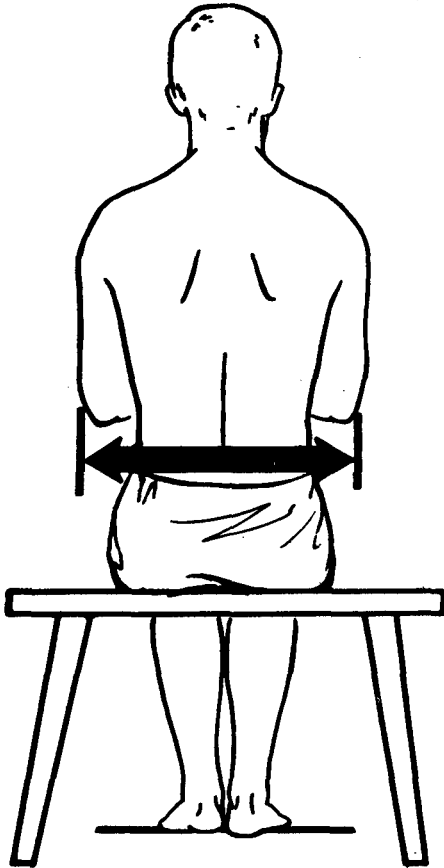

Forearm-Forearm Breadth (Elbow-To-Elbow Breadth): Subject sits erect, with his arms bent to form right angles at the elbows and with his elbows held against the body. The maximum breadth across the body is measured, including the arms at the level of the forearm muscles. An anthropometer is used, and is held horizontally.

THE SUMMARY STATISTICS

••••

CENTIMETERS		INCHES	
45.98	MEAN	18.10	
0.05	SE(M)	0.02	
4.22	ST DEV	1.66	
0.04	SE(SD)	0.01	

••••

SYMMETRY--BETA I	=	0.55
KURTOSIS--BETA II	=	3.49
COEFFICIENT OF VARIATION	=	9.17

••••

SAMPLE SIZE = 6682

25 Hip Breadth, Sitting

--INTERVALS--				--FREQUENCIES--			
CENTIMETERS		INCHES		ACTUAL FREQ	CUMULA TIVE-F	PERCEN T-FREQ	CUMUL- PCT-FQ
49.75-	50.24	19.59-	19.77	1	6682	0.01	100.00
49.25-	49.74	19.39-	19.58	0	6681	0.00	99.99
48.75-	49.24	19.19-	19.38	0	6681	0.00	99.99
48.25-	48.74	19.00-	19.18	0	6681	0.00	99.99
47.75-	48.24	18.80-	18.99	0	6681	0.00	99.99
47.25-	47.74	18.60-	18.79	1	6681	0.01	99.99
46.75-	47.24	18.41-	18.59	1	6680	0.01	99.97
46.25-	46.74	18.21-	18.40	0	6679	0.00	99.96
45.75-	46.24	18.01-	18.20	0	6679	0.00	99.96
45.25-	45.74	17.82-	18.00	0	6679	0.00	99.96
44.75-	45.24	17.62-	17.81	1	6679	0.01	99.96
44.25-	44.74	17.42-	17.61	1	6678	0.01	99.94
43.75-	44.24	17.22-	17.41	4	6677	0.06	99.93
43.25-	43.74	17.03-	17.21	5	6673	0.07	99.87
42.75-	43.24	16.83-	17.02	4	6668	0.06	99.79
42.25-	42.74	16.63-	16.82	5	6664	0.07	99.73
41.75-	42.24	16.44-	16.62	13	6659	0.19	99.66
41.25-	41.74	16.24-	16.43	11	6646	0.16	99.46
40.75-	41.24	16.04-	16.23	19	6635	0.28	99.30
40.25-	40.74	15.85-	16.03	25	6616	0.37	99.01
39.75-	40.24	15.65-	15.84	38	6591	0.57	98.64
39.25-	39.74	15.45-	15.64	52	6553	0.78	98.07
38.75-	39.24	15.26-	15.44	98	6501	1.47	97.29
38.25-	38.74	15.06-	15.25	99	6403	1.48	95.82
37.75-	38.24	14.86-	15.05	134	6304	2.01	94.34
37.25-	37.74	14.67-	14.85	180	6170	2.69	92.34
36.75-	37.24	14.47-	14.66	199	5990	2.98	89.64
36.25-	36.74	14.27-	14.46	295	5791	4.41	86.67
35.75-	36.24	14.07-	14.26	366	5496	5.48	82.25
35.25-	35.74	13.88-	14.06	414	5130	6.20	76.77
34.75-	35.24	13.68-	13.87	464	4716	6.94	70.58
34.25-	34.74	13.48-	13.67	542	4252	8.11	63.63
33.75-	34.24	13.29-	13.47	581	3710	8.70	55.52
33.25-	33.74	13.09-	13.28	604	3129	9.04	46.83
32.75-	33.24	12.89-	13.08	549	2525	8.22	37.79
32.25-	32.74	12.70-	12.88	583	1976	8.72	29.57
31.75-	32.24	12.50-	12.69	444	1393	6.64	20.85
31.25-	31.74	12.30-	12.49	357	949	5.34	14.20
30.75-	31.24	12.11-	12.29	242	592	3.62	8.86
30.25-	30.74	11.91-	12.10	158	350	2.36	5.24
29.75-	30.24	11.71-	11.90	94	192	1.41	2.87
29.25-	29.74	11.52-	11.70	57	98	0.85	1.47
28.75-	29.24	11.32-	11.51	20	41	0.30	0.61
28.25-	28.74	11.12-	11.31	17	21	0.25	0.31
27.75-	28.24	10.93-	11.11	2	4	0.03	0.06
27.25-	27.74	10.73-	10.92	1	2	0.01	0.03
26.75-	27.24	10.53-	10.72	0	1	0.00	0.01
26.25-	26.74	10.33-	10.52	1	1	0.01	0.01

25 Hip Breadth, Sitting

PERCENTILES

CENTIMETERS		INCHES
40.70	99 TH	16.02
39.76	98 TH	15.65
39.18	97 TH	15.43
38.42	95 TH	15.13
37.30	90 TH	14.68
36.58	85 TH	14.40
36.04	80 TH	14.19
35.59	75 TH	14.01
35.20	70 TH	13.86
34.85	65 TH	13.72
34.53	60 TH	13.59
34.22	55 TH	13.47
33.93	50 TH	13.36
33.65	45 TH	13.25
33.37	40 TH	13.14
33.09	35 TH	13.03
32.80	30 TH	12.91
32.50	25 TH	12.79
32.17	20 TH	12.67
31.80	15 TH	12.52
31.35	10 TH	12.34
30.69	5 TH	12.08
30.27	3 RD	11.92
29.96	2 ND	11.80
29.47	1 ST	11.60

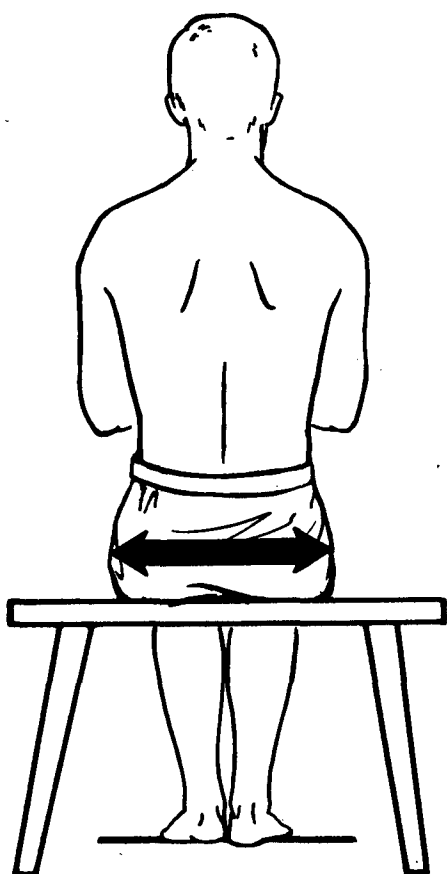

Hip Breadth, Sitting: Subject sits erect, with knees together. The maximum breadth across the hips is measured. An anthropometer is used, and is held horizontally.

THE SUMMARY STATISTICS

••••

CENTIMETERS		INCHES
34.16	MEAN	13.45
0.03	SE(M)	0.01
2.38	ST DEV	0.94
0.02	SE(SD)	0.01

••••

SYMMETRY--BETA I = 0.64
 KURTOSIS--BETA II = 4.03
 COEFFICIENT OF VARIATION = 6.97

••••

SAMPLE SIZE = 6682

26 Neck Circumference

		--INTERVALS--		--FREQUENCIES--			
CENTIMETERS		INCHES		ACTUAL FREQ	CUMULA TIVE-F	PERCEN T-FREQ	CUMUL- PCT-FQ
48.25-	48.64	19.00-	19.14	2	6681	0.03	100.00
47.85-	48.24	18.84-	18.99	0	6679	0.00	99.97
47.45-	47.84	18.68-	18.83	0	6679	0.00	99.97
47.05-	47.44	18.52-	18.67	0	6679	0.00	99.97
46.65-	47.04	18.37-	18.51	1	6679	0.01	99.97
46.25-	46.64	18.21-	18.36	1	6678	0.01	99.96
45.85-	46.24	18.05-	18.20	1	6677	0.01	99.94
45.45-	45.84	17.89-	18.04	1	6676	0.01	99.93
45.05-	45.44	17.74-	17.88	2	6675	0.03	99.91
44.65-	45.04	17.58-	17.73	3	6673	0.04	99.88
44.25-	44.64	17.42-	17.57	4	6670	0.06	99.84
43.85-	44.24	17.26-	17.41	4	6666	0.06	99.78
43.45-	43.84	17.11-	17.25	9	6662	0.13	99.72
43.05-	43.44	16.95-	17.10	12	6653	0.18	99.58
42.65-	43.04	16.79-	16.94	22	6641	0.33	99.40
42.25-	42.64	16.63-	16.78	37	6619	0.55	99.07
41.85-	42.24	16.48-	16.62	48	6582	0.72	98.52
41.45-	41.84	16.32-	16.47	66	6534	0.99	97.80
41.05-	41.44	16.16-	16.31	94	6468	1.41	96.81
40.65-	41.04	16.00-	16.15	122	6374	1.83	95.40
40.25-	40.64	15.85-	15.99	147	6252	2.20	93.58
39.85-	40.24	15.69-	15.84	234	6105	3.50	91.38
39.45-	39.84	15.53-	15.68	256	5871	3.83	87.88
39.05-	39.44	15.37-	15.52	336	5615	5.03	84.04
38.65-	39.04	15.22-	15.36	356	5279	5.33	79.02
38.25-	38.64	15.06-	15.21	370	4923	5.54	73.69
37.85-	38.24	14.90-	15.05	454	4553	6.80	68.15
37.45-	37.84	14.74-	14.89	469	4099	7.02	61.35
37.05-	37.44	14.59-	14.73	603	3630	9.03	54.33
36.65-	37.04	14.43-	14.58	519	3027	7.77	45.31
36.25-	36.64	14.27-	14.42	458	2508	6.86	37.54
35.85-	36.24	14.11-	14.26	470	2050	7.03	30.68
35.45-	35.84	13.96-	14.10	413	1580	6.18	23.65
35.05-	35.44	13.80-	13.95	397	1167	5.94	17.47
34.65-	35.04	13.64-	13.79	251	770	3.76	11.53
34.25-	34.64	13.48-	13.63	166	519	2.48	7.77
33.85-	34.24	13.33-	13.47	133	353	1.99	5.28
33.45-	33.84	13.17-	13.32	88	220	1.32	3.29
33.05-	33.44	13.01-	13.16	67	132	1.00	1.98
32.65-	33.04	12.85-	13.00	26	65	0.39	0.97
32.25-	32.64	12.70-	12.84	14	39	0.21	0.58
31.85-	32.24	12.54-	12.69	16	25	0.24	0.37
31.45-	31.84	12.38-	12.53	3	9	0.04	0.13
31.05-	31.44	12.22-	12.37	2	6	0.03	0.09
30.65-	31.04	12.07-	12.21	2	4	0.03	0.06
30.25-	30.64	11.91-	12.06	2	2	0.03	0.03

26 Neck Circumference

PERCENTILES

CENTIMETERS		INCHES	
42.60	99 TH	16.77	
41.95	98 TH	16.52	
41.53	97 TH	16.35	
40.97	95 TH	16.13	
40.11	90 TH	15.79	
39.54	85 TH	15.57	
39.09	80 TH	15.39	
38.72	75 TH	15.24	
38.38	70 TH	15.11	
38.08	65 TH	14.99	
37.80	60 TH	14.88	
37.53	55 TH	14.78	
37.27	50 TH	14.67	
37.01	45 TH	14.57	
36.76	40 TH	14.47	
36.50	35 TH	14.37	
36.23	30 TH	14.26	
35.94	25 TH	14.15	
35.62	20 TH	14.03	
35.27	15 TH	13.89	
34.83	10 TH	13.71	
34.20	5 TH	13.46	
33.79	3 RD	13.30	
33.50	2 ND	13.19	
33.03	1 ST	13.00	

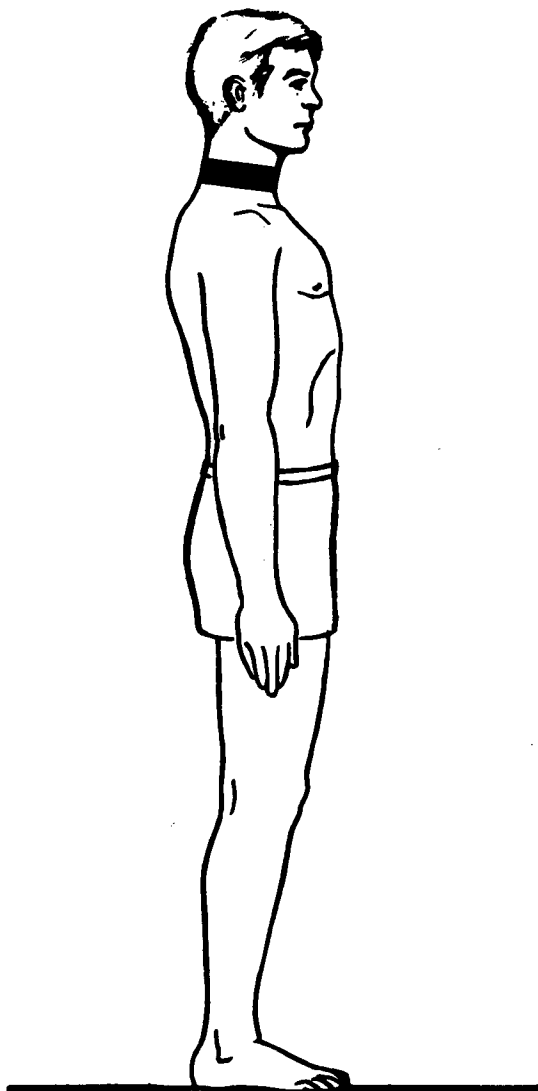

Neck Circumference: Subject stands erect, with head level. The maximum circumference of the neck is measured. A steel tape is used, with the tape passing just below the "Adam's Apple" (thyroid cartilage).

THE SUMMARY STATISTICS

••••

CENTIMETERS		INCHES	
37.39	MEAN	14.72	
0.03	SE(M)	0.01	
2.07	ST DEV	0.81	
0.02	SE(SD)	0.01	

••••

SYMMETRY--BETA I =	0.33
KURTOSIS--BETA II =	3.39
COEFFICIENT OF VARIATION =	5.53

••••

SAMPLE SIZE = 6681

27 Shoulder Circumference

--INTERVALS--		--FREQUENCIES--			
CENTIMETERS	INCHES	ACTUAL FREQ	CUMULA TIVE-F	PERCEN T-FREQ	CUMUL- PCT-FQ
143.75- 145.24	56.59- 57.18	1	6682	0.01	100.00
142.25- 143.74	56.00- 56.58	2	6681	0.03	99.99
140.75- 142.24	55.41- 55.99	0	6679	0.00	99.96
139.25- 140.74	54.82- 55.40	2	6679	0.03	99.96
137.75- 139.24	54.23- 54.81	6	6677	0.09	99.93
136.25- 137.74	53.64- 54.22	3	6671	0.04	99.84
134.75- 136.24	53.05- 53.63	5	6668	0.07	99.79
133.25- 134.74	52.46- 53.04	8	6663	0.12	99.72
131.75- 133.24	51.87- 52.45	12	6655	0.18	99.60
130.25- 131.74	51.28- 51.86	25	6643	0.37	99.42
128.75- 130.24	50.69- 51.27	41	6618	0.61	99.04
127.25- 128.74	50.10- 50.68	50	6577	0.75	98.43
125.75- 127.24	49.51- 50.09	65	6527	0.97	97.68
124.25- 125.74	48.92- 49.50	105	6462	1.57	96.71
122.75- 124.24	48.33- 48.91	170	6357	2.54	95.14
121.25- 122.74	47.74- 48.32	186	6187	2.78	92.59
119.75- 121.24	47.15- 47.73	313	6001	4.68	89.81
118.25- 119.74	46.56- 47.14	334	5688	5.00	85.12
116.75- 118.24	45.96- 46.55	450	5354	6.73	80.13
115.25- 116.74	45.37- 45.95	519	4904	7.77	73.39
113.75- 115.24	44.78- 45.36	613	4385	9.17	65.62
112.25- 113.74	44.19- 44.77	667	3772	9.98	56.45
110.75- 112.24	43.60- 44.18	695	3105	10.40	46.47
109.25- 110.74	43.01- 43.59	576	2410	8.62	36.07
107.75- 109.24	42.42- 43.00	491	1834	7.35	27.45
106.25- 107.74	41.83- 42.41	447	1343	6.69	20.10
104.75- 106.24	41.24- 41.82	353	896	5.28	13.41
103.25- 104.74	40.65- 41.23	234	543	3.50	8.13
101.75- 103.24	40.06- 40.64	140	309	2.10	4.62
100.25- 101.74	39.47- 40.05	90	169	1.35	2.53
98.75- 100.24	38.88- 39.46	39	79	0.58	1.18
97.25- 98.74	38.29- 38.87	30	40	0.45	0.60
95.75- 97.24	37.70- 38.28	3	10	0.04	0.15
94.25- 95.74	37.11- 37.69	4	7	0.06	0.10
92.75- 94.24	36.52- 37.10	3	3	0.04	0.04

27 Shoulder Circumference

PERCENTILES

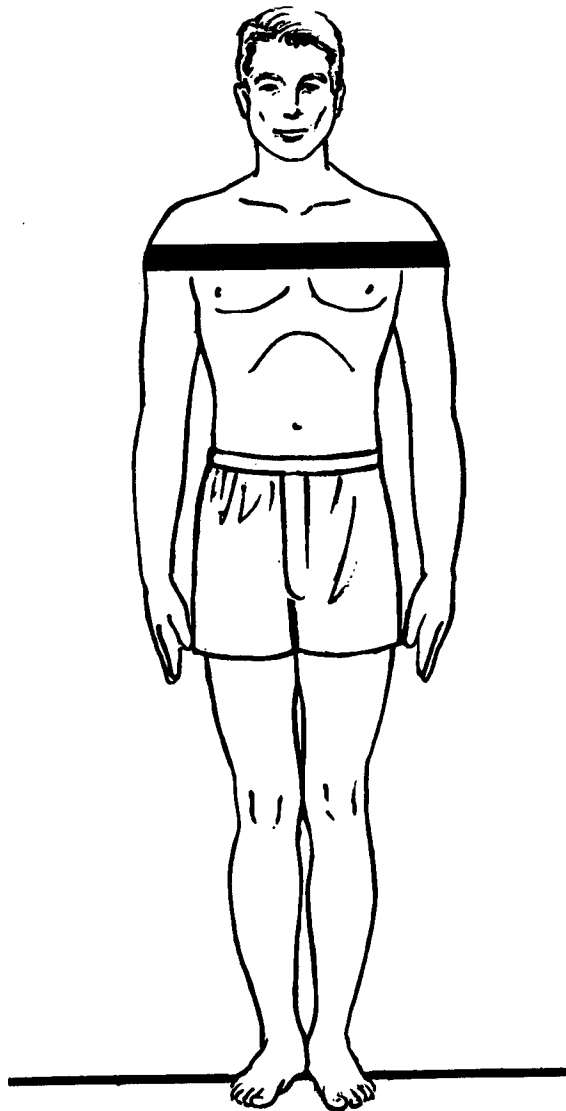

CENTIMETERS		INCHES
130.23	99 TH	51.27
127.72	98 TH	50.28
126.20	97 TH	49.69
124.24	95 TH	48.91
121.41	90 TH	47.80
119.62	85 TH	47.09
118.25	80 TH	46.56
117.11	75 TH	46.11
116.11	70 TH	45.71
115.21	65 TH	45.36
114.36	60 TH	45.03
113.56	55 TH	44.71
112.78	50 TH	44.40
112.01	45 TH	44.10
111.24	40 TH	43.80
110.46	35 TH	43.49
109.64	30 TH	43.16
108.76	25 TH	42.82
107.80	20 TH	42.44
106.70	15 TH	42.01
105.32	10 TH	41.47
103.34	5 TH	40.68
102.08	3 RD	40.19
101.17	2 ND	39.83
99.78	1 ST	39.28

THE SUMMARY STATISTICS

••••

CENTIMETERS		INCHES
113.16	MEAN	44.55
0.08	SE(M)	0.03
6.39	ST DEV	2.51
0.06	SE(SD)	0.02
••••		
SYMMETRY--BETA I =		0.42
KURTOSIS--BETA II =		3.55
COEFFICIENT OF VARIATION =		5.64
••••		
SAMPLE SIZE =		6682

Shoulder Circumference: Subject stands erect, with his arms hanging at his sides. The maximum horizontal circumference of the shoulders is measured at the level of the bulges of the deltoid muscles in the upper arms. A steel tape is used.

28 Chest Circumference

--INTERVALS--		--FREQUENCIES--					
CENTIMETERS	INCHES	ACTUAL FREQ	CUMULA TIVE-F	PERCEN T-FREQ	CUMUL- PCT-FQ		
122.75- 124.24	48.33- 48.91	3	6682	0.04	100.00		
121.25- 122.74	47.74- 48.32	4	6679	0.06	99.96		
119.75- 121.24	47.15- 47.73	10	6675	0.15	99.90		
118.25- 119.74	46.56- 47.14	6	6665	0.09	99.75		
116.75- 118.24	45.96- 46.55	5	6659	0.07	99.66		
115.25- 116.74	45.37- 45.95	15	6654	0.22	99.58		
113.75- 115.24	44.78- 45.36	12	6639	0.18	99.36		
112.25- 113.74	44.19- 44.77	17	6627	0.25	99.18		
110.75- 112.24	43.60- 44.18	48	6610	0.72	98.92		
109.25- 110.74	43.01- 43.59	33	6562	0.49	98.20		
107.75- 109.24	42.42- 43.00	65	6529	0.97	97.71		
106.25- 107.74	41.83- 42.41	79	6464	1.18	96.74		
104.75- 106.24	41.24- 41.82	119	6385	1.78	95.56		
103.25- 104.74	40.65- 41.23	154	6266	2.30	93.77		
101.75- 103.24	40.06- 40.64	214	6112	3.20	91.47		
100.25- 101.74	39.47- 40.05	260	5898	3.89	88.27		
98.75- 100.24	38.88- 39.46	336	5638	5.03	84.38		
97.25- 98.74	38.29- 38.87	413	5302	6.18	79.35		
95.75- 97.24	37.70- 38.28	508	4889	7.60	73.17		
94.25- 95.74	37.11- 37.69	524	4381	7.84	65.56		
92.75- 94.24	36.52- 37.10	634	3857	9.49	57.72		
91.25- 92.74	35.93- 36.51	641	3223	9.59	48.23		
89.75- 91.24	35.33- 35.92	662	2582	9.91	38.64		
88.25- 89.74	34.74- 35.32	567	1920	8.49	28.73		
86.75- 88.24	34.15- 34.73	486	1353	7.27	20.25		
85.25- 86.74	33.56- 34.14	327	867	4.89	12.98		
83.75- 85.24	32.97- 33.55	252	540	3.77	8.08		
82.25- 83.74	32.38- 32.96	154	288	2.30	4.31		
80.75- 82.24	31.79- 32.37	75	134	1.12	2.01		
79.25- 80.74	31.20- 31.78	36	59	0.54	0.88		
77.75- 79.24	30.61- 31.19	18	23	0.27	0.34		
76.25- 77.74	30.02- 30.60	3	5	0.04	0.07		
74.75- 76.24	29.43- 30.01	1	2	0.01	0.03		
73.25- 74.74	28.84- 29.42	0	1	0.00	0.01		
71.75- 73.24	28.25- 28.83	1	1	0.01	0.01		

28 Chest Circumference

PERCENTILES

CENTIMETERS		INCHES
112.83	99 TH	44.42
109.91	98 TH	43.27
108.15	97 TH	42.58
105.86	95 TH	41.68
102.58	90 TH	40.38
100.51	85 TH	39.57
98.97	80 TH	38.96
97.69	75 TH	38.46
96.59	70 TH	38.03
95.61	65 TH	37.64
94.71	60 TH	37.29
93.86	55 TH	36.95
93.05	50 TH	36.63
92.26	45 TH	36.32
91.48	40 TH	36.02
90.70	35 TH	35.71
89.90	30 TH	35.39
89.06	25 TH	35.06
88.14	20 TH	34.70
87.12	15 TH	34.30
85.87	10 TH	33.81
84.10	5 TH	33.11
82.98	3 RD	32.67
82.16	2 ND	32.35
80.90	1 ST	31.85

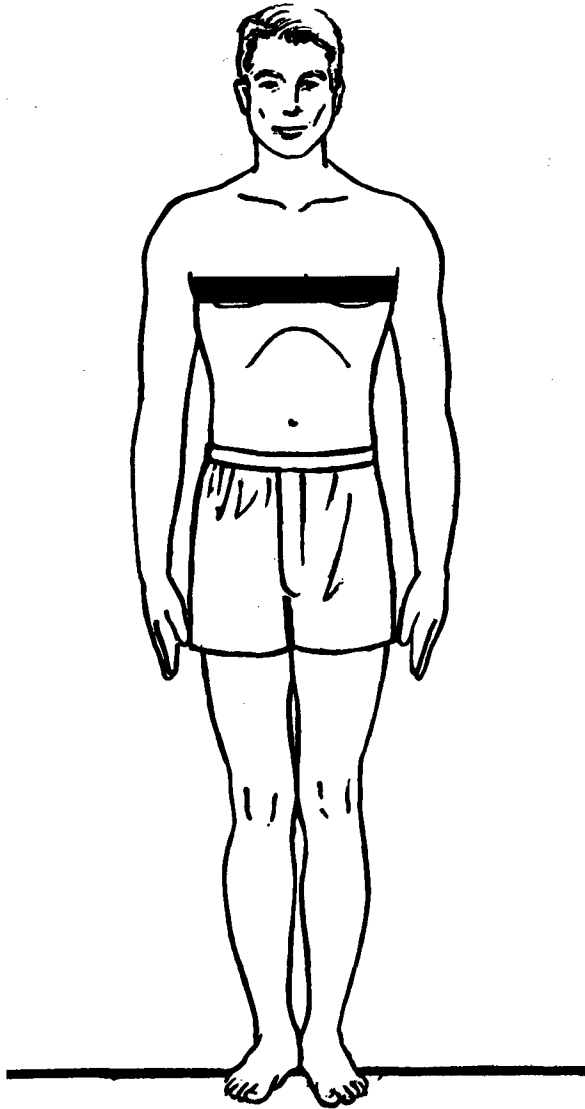

Chest Circumference: Subject stands erect, with his arms initially raised and then lowered after the tape is in place. The maximum horizontal circumference of the chest is measured at the level of the nipples during normal breathing. A steel tape is used.

THE SUMMARY STATISTICS

....

CENTIMETERS		INCHES
93.77	MEAN	36.92
0.08	SE(M)	0.03
6.69	ST DEV	2.63
0.06	SE(SD)	0.02
	SYMMETRY--BETA I =	0.67
	KURTOSIS--BETA II =	3.85
	COEFFICIENT OF VARIATION =	7.13
	SAMPLE SIZE =	6682

....

29 Waist Circumference

--INTERVALS--		--FREQUENCIES--			
CENTIMETERS	INCHES	ACTUAL FREQ	CUMULA TIVE-F	PERCEN T-FREQ	CUMUL- PCT-FQ
126.25- 127.74	49.70- 50.29	1	6681	0.01	100.00
124.75- 126.24	49.11- 49.69	0	6680	0.00	99.99
123.25- 124.74	48.52- 49.10	0	6680	0.00	99.99
121.75- 123.24	47.93- 48.51	0	6680	0.00	99.99
120.25- 121.74	47.34- 47.92	2	6680	0.03	99.99
118.75- 120.24	46.75- 47.33	0	6678	0.00	99.96
117.25- 118.74	46.16- 46.74	2	6678	0.03	99.96
115.75- 117.24	45.57- 46.15	1	6676	0.01	99.93
114.25- 115.74	44.98- 45.56	2	6675	0.03	99.91
112.75- 114.24	44.39- 44.97	4	6673	0.06	99.88
111.25- 112.74	43.80- 44.38	7	6669	0.10	99.82
109.75- 111.24	43.21- 43.79	9	6662	0.13	99.72
108.25- 109.74	42.62- 43.20	12	6653	0.18	99.58
106.75- 108.24	42.03- 42.61	11	6641	0.16	99.40
105.25- 106.74	41.44- 42.02	18	6630	0.27	99.24
103.75- 105.24	40.85- 41.43	21	6612	0.31	98.97
102.25- 103.74	40.26- 40.84	29	6591	0.43	98.65
100.75- 102.24	39.67- 40.25	38	6562	0.57	98.22
99.25- 100.74	39.07- 39.66	51	6524	0.76	97.65
97.75- 99.24	38.48- 39.06	53	6473	0.79	96.89
96.25- 97.74	37.89- 38.47	51	6420	0.76	96.09
94.75- 96.24	37.30- 37.88	86	6369	1.29	95.33
93.25- 94.74	36.71- 37.29	113	6283	1.69	94.04
91.75- 93.24	36.12- 36.70	130	6170	1.95	92.35
90.25- 91.74	35.53- 36.11	136	6040	2.04	90.41
88.75- 90.24	34.94- 35.52	182	5904	2.72	88.37
87.25- 88.74	34.35- 34.93	231	5722	3.46	85.65
85.75- 87.24	33.76- 34.34	256	5491	3.83	82.19
84.25- 85.74	33.17- 33.75	283	5235	4.24	78.36
82.75- 84.24	32.58- 33.16	365	4952	5.46	74.12
81.25- 82.74	31.99- 32.57	414	4587	6.20	68.66
79.75- 81.24	31.40- 31.98	504	4173	7.54	62.46
78.25- 79.74	30.81- 31.39	594	3669	8.89	54.92
76.75- 78.24	30.22- 30.80	559	3075	8.37	46.03
75.25- 76.74	29.63- 30.21	602	2516	9.01	37.66
73.75- 75.24	29.04- 29.62	550	1914	8.23	28.65
72.25- 73.74	28.45- 29.03	425	1364	6.36	20.42
70.75- 72.24	27.85- 28.44	393	939	5.88	14.05
69.25- 70.74	27.26- 27.84	264	546	3.95	8.17
67.75- 69.24	26.67- 27.25	150	282	2.25	4.22
66.25- 67.74	26.08- 26.66	75	132	1.12	1.98
64.75- 66.24	25.49- 26.07	36	57	0.54	0.85
63.25- 64.74	24.90- 25.48	13	21	0.19	0.31
61.75- 63.24	24.31- 24.89	5	8	0.07	0.12
60.25- 61.74	23.72- 24.30	2	3	0.03	0.04
58.75- 60.24	23.13- 23.71	1	1	0.01	0.01

29 Waist Circumference

PERCENTILES

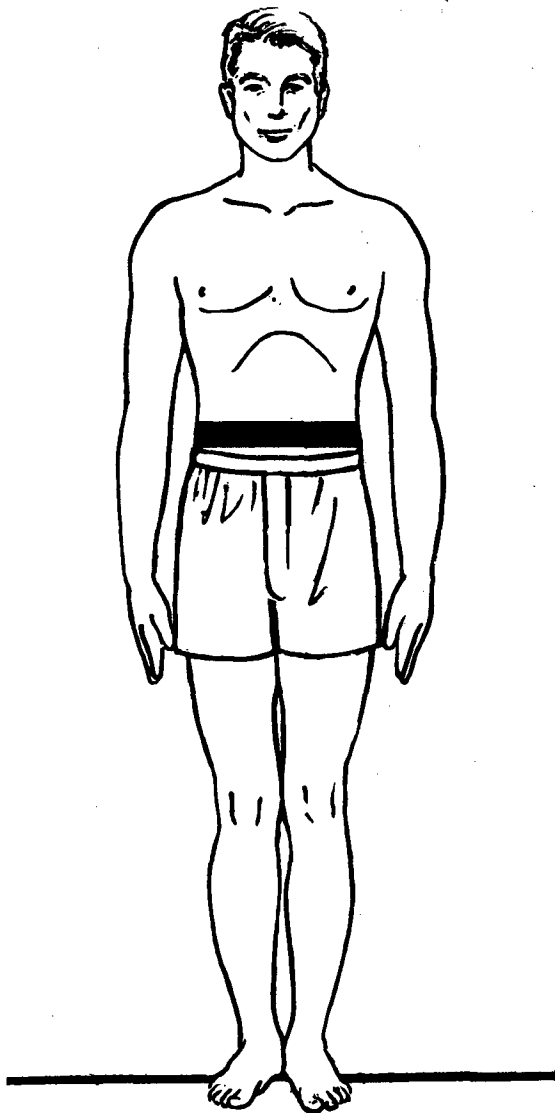

CENTIMETERS		INCHES	
105.63	99 TH	41.59	
101.61	98 TH	40.00	
99.15	97 TH	39.03	
95.94	95 TH	37.77	
91.35	90 TH	35.96	
88.50	85 TH	34.84	
86.41	80 TH	34.02	
84.70	75 TH	33.35	
83.27	70 TH	32.78	
82.01	65 TH	32.29	
80.88	60 TH	31.84	
79.84	55 TH	31.43	
78.87	50 TH	31.05	
77.95	45 TH	30.69	
77.06	40 TH	30.34	
76.20	35 TH	30.00	
75.34	30 TH	29.66	
74.46	25 TH	29.31	
73.54	20 TH	28.95	
72.53	15 TH	28.56	
71.34	10 TH	28.09	
69.66	5 TH	27.43	
68.57	3 RD	27.00	
67.74	2 ND	26.67	
66.33	1 ST	26.12	

THE SUMMARY STATISTICS

....

CENTIMETERS		INCHES	
80.29	MEAN	31.61	
0.10	SE(M)	0.04	
8.18	ST DEV	3.22	
0.07	SE(SD)	0.03	

....

SYMMETRY--BETA I = 1.00
 KURTOSIS--BETA II = 4.42
 COEFFICIENT OF VARIATION = 10.19

....

SAMPLE SIZE = 6681

Waist Circumference: Subject stands erect, with abdomen relaxed. The maximum horizontal circumference of the waist is measured at the level of the navel (omphalion). A steel tape is used.

30 Hip Circumference

--INTERVALS--		--FREQUENCIES--					
CENTIMETERS	INCHES	ACTUAL FREQ	CUMULA TIVE-F	PERCEN T-FREQ	CUMUL- PCT-FQ		
132.75- 134.24	52.26- 52.84	1	6682	0.01	100.00		
131.25- 132.74	51.67- 52.25	0	6681	0.00	99.99		
129.75- 131.24	51.08- 51.66	0	6681	0.00	99.99		
128.25- 129.74	50.49- 51.07	0	6681	0.00	99.99		
126.75- 128.24	49.90- 50.48	0	6681	0.00	99.99		
125.25- 126.74	49.31- 49.89	0	6681	0.00	99.99		
123.75- 125.24	48.72- 49.30	3	6681	0.04	99.99		
122.25- 123.74	48.13- 48.71	0	6678	0.00	99.94		
120.75- 122.24	47.54- 48.12	1	6678	0.01	99.94		
119.25- 120.74	46.95- 47.53	4	6677	0.06	99.93		
117.75- 119.24	46.36- 46.94	4	6673	0.06	99.87		
116.25- 117.74	45.77- 46.35	6	6669	0.09	99.81		
114.75- 116.24	45.18- 45.76	6	6663	0.09	99.72		
113.25- 114.74	44.59- 45.17	18	6657	0.27	99.63		
111.75- 113.24	44.00- 44.58	27	6639	0.40	99.36		
110.25- 111.74	43.41- 43.99	30	6612	0.45	98.95		
108.75- 110.24	42.82- 43.40	53	6582	0.79	98.50		
107.25- 108.74	42.22- 42.81	70	6529	1.05	97.71		
105.75- 107.24	41.63- 42.21	91	6459	1.36	96.66		
104.25- 105.74	41.04- 41.62	127	6368	1.90	95.30		
102.75- 104.24	40.45- 41.03	171	6241	2.56	93.40		
101.25- 102.74	39.86- 40.44	236	6070	3.53	90.84		
99.75- 101.24	39.27- 39.85	352	5834	5.27	87.31		
98.25- 99.74	38.68- 39.26	346	5482	5.18	82.04		
96.75- 98.24	38.09- 38.67	521	5136	7.80	76.86		
95.25- 96.74	37.50- 38.08	542	4615	8.11	69.07		
93.75- 95.24	36.91- 37.49	659	4073	9.86	60.95		
92.25- 93.74	36.32- 36.90	677	3414	10.13	51.09		
90.75- 92.24	35.73- 36.31	673	2737	10.07	40.96		
89.25- 90.74	35.14- 35.72	650	2064	9.73	30.89		
87.75- 89.24	34.55- 35.13	494	1414	7.39	21.16		
86.25- 87.74	33.96- 34.54	388	920	5.81	13.77		
84.75- 86.24	33.37- 33.95	257	532	3.85	7.96		
83.25- 84.74	32.78- 33.36	150	275	2.24	4.12		
81.75- 83.24	32.19- 32.77	70	125	1.05	1.87		
80.25- 81.74	31.59- 32.18	35	55	0.52	0.82		
78.75- 80.24	31.00- 31.58	16	20	0.24	0.30		
77.25- 78.74	30.41- 30.99	4	4	0.06	0.06		

30 Hip Circumference

PERCENTILES

CENTIMETERS		INCHES	
111.96	99 TH	44.08	
109.28	98 TH	43.02	
107.65	97 TH	42.38	
105.53	95 TH	41.55	
102.49	90 TH	40.35	
100.57	85 TH	39.59	
99.13	80 TH	39.03	
97.93	75 TH	38.56	
96.90	70 TH	38.15	
95.98	65 TH	37.79	
95.14	60 TH	37.46	
94.34	55 TH	37.14	
93.58	50 TH	36.84	
92.84	45 TH	36.55	
92.11	40 TH	36.26	
91.37	35 TH	35.97	
90.62	30 TH	35.68	
89.83	25 TH	35.37	
88.97	20 TH	35.03	
88.00	15 TH	34.65	
86.81	10 TH	34.18	
85.12	5 TH	33.51	
84.04	3 RD	33.09	
83.26	2 ND	32.78	
82.02	1 ST	32.29	

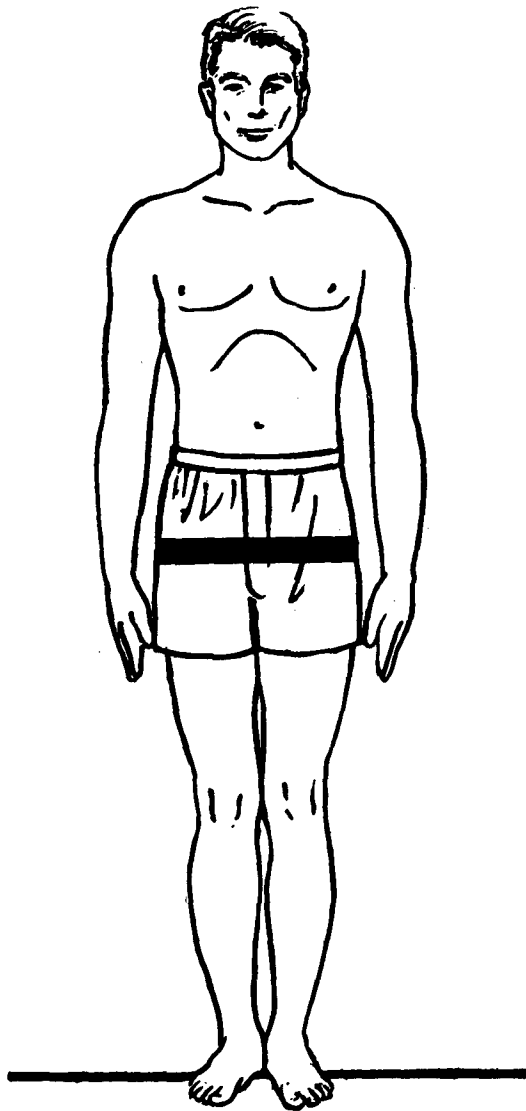

Hip Circumference: Subject stands erect, with heels together. The maximum horizontal circumference of the hips is measured at the level of the greatest protrusion of the buttock muscles. A steel tape is used.

THE SUMMARY STATISTICS

••••

CENTIMETERS		INCHES	
94.21	MEAN	37.09	
0.08	SE(M)	0.03	
6.25	ST DEV	2.46	
0.05	SE(SD)	0.02	
••••			
SYMMETRY--BETA I		=	0.66
KURTOSIS--BETA II		=	3.92
COEFFICIENT OF VARIATION		=	6.63
••••			
SAMPLE SIZE		=	6682

31 Upper Thigh Circumference

--INTERVALS--		--FREQUENCIES--				
CENTIMETERS	INCHES	ACTUAL FREQ	CUMULA TIVE-F	PERCEN T-FREQ	CUMUL- PCT-FQ	
76.75- 77.74	30.22- 30.60	1	6682	0.01	100.00	
75.75- 76.74	29.82- 30.21	0	6681	0.00	99.99	
74.75- 75.74	29.43- 29.81	1	6681	0.01	99.99	
73.75- 74.74	29.04- 29.42	3	6680	0.04	99.97	
72.75- 73.74	28.64- 29.03	2	6677	0.03	99.93	
71.75- 72.74	28.25- 28.63	7	6675	0.10	99.90	
70.75- 71.74	27.85- 28.24	4	6668	0.06	99.79	
69.75- 70.74	27.46- 27.84	9	6664	0.13	99.73	
68.75- 69.74	27.07- 27.45	13	6655	0.19	99.60	
67.75- 68.74	26.67- 27.06	20	6642	0.30	99.40	
66.75- 67.74	26.28- 26.66	39	6622	0.58	99.10	
65.75- 66.74	25.89- 26.27	62	6583	0.93	98.52	
64.75- 65.74	25.49- 25.88	80	6521	1.20	97.59	
63.75- 64.74	25.10- 25.48	103	6441	1.54	96.39	
62.75- 63.74	24.70- 25.09	139	6338	2.08	94.85	
61.75- 62.74	24.31- 24.69	184	6199	2.75	92.77	
60.75- 61.74	23.92- 24.30	253	6015	3.79	90.02	
59.75- 60.74	23.52- 23.91	300	5762	4.49	86.23	
58.75- 59.74	23.13- 23.51	339	5462	5.07	81.74	
57.75- 58.74	22.74- 23.12	444	5123	6.64	76.67	
56.75- 57.74	22.34- 22.73	484	4679	7.24	70.02	
55.75- 56.74	21.95- 22.33	495	4195	7.41	62.78	
54.75- 55.74	21.56- 21.94	518	3700	7.75	55.37	
53.75- 54.74	21.16- 21.55	582	3182	8.71	47.62	
52.75- 53.74	20.77- 21.15	555	2600	8.31	38.91	
51.75- 52.74	20.37- 20.76	507	2045	7.59	30.60	
50.75- 51.74	19.98- 20.36	435	1538	6.51	23.02	
49.75- 50.74	19.59- 19.97	393	1103	5.88	16.51	
48.75- 49.74	19.19- 19.58	247	710	3.70	10.63	
47.75- 48.74	18.80- 19.18	180	463	2.69	6.93	
46.75- 47.74	18.41- 18.79	126	283	1.89	4.24	
45.75- 46.74	18.01- 18.40	85	157	1.27	2.35	
44.75- 45.74	17.62- 18.00	34	72	0.51	1.08	
43.75- 44.74	17.22- 17.61	21	38	0.31	0.57	
42.75- 43.74	16.83- 17.21	8	17	0.12	0.25	
41.75- 42.74	16.44- 16.82	6	9	0.09	0.13	
40.75- 41.74	16.04- 16.43	2	3	0.03	0.04	
39.75- 40.74	15.65- 16.03	0	1	0.00	0.01	
38.75- 39.74	15.26- 15.64	1	1	0.01	0.01	

31 Upper Thigh Circumference

PERCENTILES

CENTIMETERS		INCHES	
67.64	99 TH	26.63	
66.14	98 TH	26.04	
65.18	97 TH	25.66	
63.86	95 TH	25.14	
61.82	90 TH	24.34	
60.47	85 TH	23.81	
59.41	80 TH	23.39	
58.52	75 TH	23.04	
57.73	70 TH	22.73	
57.01	65 TH	22.45	
56.35	60 TH	22.18	
55.71	55 TH	21.93	
55.10	50 TH	21.69	
54.49	45 TH	21.45	
53.89	40 TH	21.22	
53.29	35 TH	20.98	
52.66	30 TH	20.73	
52.00	25 TH	20.47	
51.28	20 TH	20.19	
50.47	15 TH	19.87	
49.48	10 TH	19.48	
48.07	5 TH	18.92	
47.18	3 RD	18.57	
46.53	2 ND	18.32	
45.52	1 ST	17.92	

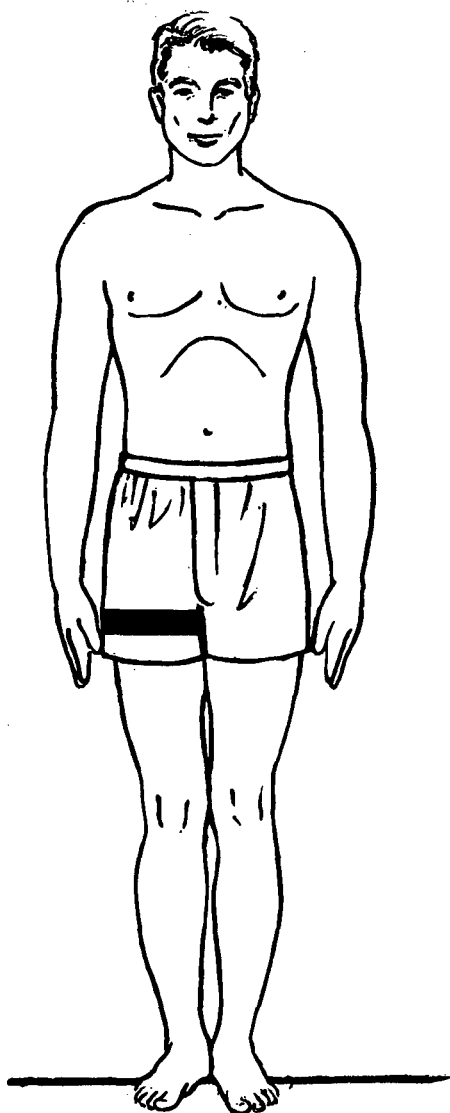

Upper Thigh Circumference: Subject stands erect, with his feet slightly apart. The horizontal circumference of the right upper thigh is measured. A steel tape is used, with the tape passing just below the gluteal furrow.

THE SUMMARY STATISTICS

CENTIMETERS		INCHES	
55.42	MEAN	21.82	
0.06	SE(M)	0.02	
4.80	ST DEV	1.89	
0.04	SE(SD)	0.02	
.....			
SYMMETRY--BETA I		=	0.36
KURTOSIS--BETA II		=	3.18
COEFFICIENT OF VARIATION		=	8.66
.....			
SAMPLE SIZE		=	6682

32 Lower Thigh Circumference

--INTERVALS--				--FREQUENCIES--			
CENTIMETERS		INCHES		ACTUAL FREQ	CUMULA TIVE-F	PERCEN T-FREQ	CUMUL- PCT-FQ
55.75-	56.74	21.95-	22.33	1	6682	0.01	100.00
54.75-	55.74	21.56-	21.94	1	6681	0.01	99.99
53.75-	54.74	21.16-	21.55	1	6680	0.01	99.97
52.75-	53.74	20.77-	21.15	2	6679	0.03	99.96
51.75-	52.74	20.37-	20.76	9	6677	0.13	99.93
50.75-	51.74	19.98-	20.36	15	6668	0.22	99.79
49.75-	50.74	19.59-	19.97	42	6653	0.63	99.57
48.75-	49.74	19.19-	19.58	70	6611	1.05	98.94
47.75-	48.74	18.80-	19.18	110	6541	1.65	97.89
46.75-	47.74	18.41-	18.79	152	6431	2.27	96.24
45.75-	46.74	18.01-	18.40	239	6279	3.58	93.97
44.75-	45.74	17.62-	18.00	288	6040	4.31	90.39
43.75-	44.74	17.22-	17.61	362	5752	5.42	86.08
42.75-	43.74	16.83-	17.21	455	5390	6.81	80.66
41.75-	42.74	16.44-	16.82	541	4935	8.10	73.86
40.75-	41.74	16.04-	16.43	609	4394	9.11	65.76
39.75-	40.74	15.65-	16.03	708	3785	10.60	56.64
38.75-	39.74	15.26-	15.64	659	3077	9.86	46.05
37.75-	38.74	14.86-	15.25	624	2418	9.34	36.19
36.75-	37.74	14.47-	14.85	555	1794	8.31	26.85
35.75-	36.74	14.07-	14.46	485	1239	7.26	18.54
34.75-	35.74	13.68-	14.06	337	754	5.04	11.28
33.75-	34.74	13.29-	13.67	240	417	3.59	6.24
32.75-	33.74	12.89-	13.28	106	177	1.59	2.65
31.75-	32.74	12.50-	12.88	45	71	0.67	1.06
30.75-	31.74	12.11-	12.49	16	26	0.24	0.39
29.75-	30.74	11.71-	12.10	8	10	0.12	0.15
28.75-	29.74	11.32-	11.70	2	2	0.03	0.03

32 Lower Thigh Circumference

PERCENTILES

CENTIMETERS		INCHES
49.87	99 TH	19.63
48.86	98 TH	19.24
48.17	97 TH	18.97
47.20	95 TH	18.58
45.63	90 TH	17.96
44.54	85 TH	17.54
43.69	80 TH	17.20
42.95	75 TH	16.91
42.30	70 TH	16.65
41.70	65 TH	16.42
41.14	60 TH	16.20
40.61	55 TH	15.99
40.10	50 TH	15.79
39.59	45 TH	15.59
39.09	40 TH	15.39
38.59	35 TH	15.19
38.07	30 TH	14.99
37.53	25 TH	14.77
36.94	20 TH	14.54
36.29	15 TH	14.29
35.51	10 TH	13.98
34.44	5 TH	13.56
33.80	3 RD	13.31
33.35	2 ND	13.13
32.66	1 ST	12.86

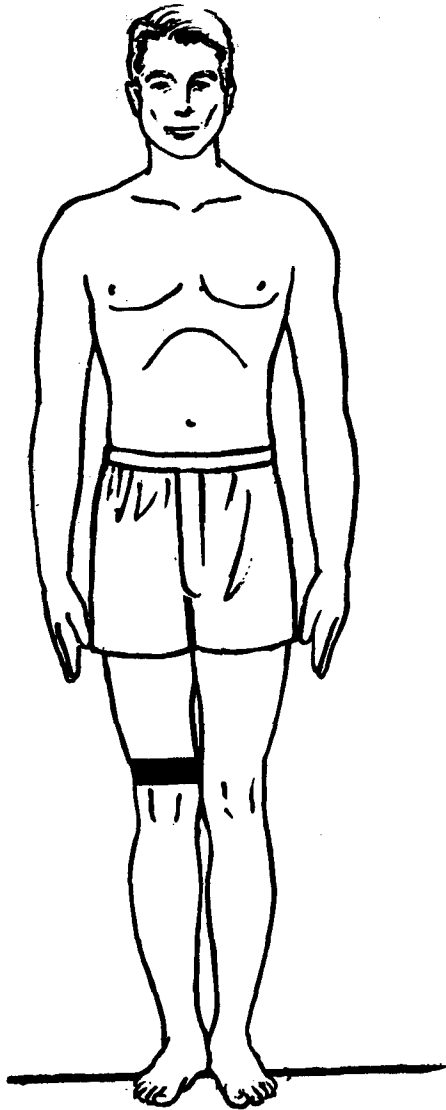

Lower Thigh Circumference: Subject stands erect, with his feet slightly apart. The horizontal circumference of the right lower thigh is measured. A steel tape is used, with the tape passing above the upper edge of the kneecap (patella).

THE SUMMARY STATISTICS

....

CENTIMETERS		INCHES
40.36	MEAN	15.89
0.05	SE(M)	0.02
3.87	ST DEV	1.52
0.03	SE(SD)	0.01

....

SYMMETRY--BETA I = 0.31
 KURTOSIS--BETA II = 2.82
 COEFFICIENT OF VARIATION = 9.58

....

SAMPLE SIZE = 6682

33 Calf Circumference.

--INTERVALS--		--FREQUENCIES--				
CENTIMETERS	INCHES	ACTUAL FREQ	CUMULA TIVE-F	PERCEN T-FREQ	CUMUL- PCT-FQ	
50.25- 50.74	19.78- 19.97	1	6682	0.01	100.00	
49.75- 50.24	19.59- 19.77	0	6681	0.00	99.99	
49.25- 49.74	19.39- 19.58	0	6681	0.00	99.99	
48.75- 49.24	19.19- 19.38	0	6681	0.00	99.99	
48.25- 48.74	19.00- 19.18	0	6681	0.00	99.99	
47.75- 48.24	18.80- 18.99	0	6681	0.00	99.99	
47.25- 47.74	18.60- 18.79	0	6681	0.00	99.99	
46.75- 47.24	18.41- 18.59	1	6681	0.01	99.99	
46.25- 46.74	18.21- 18.40	1	6680	0.01	99.97	
45.75- 46.24	18.01- 18.20	1	6679	0.01	99.96	
45.25- 45.74	17.82- 18.00	6	6678	0.09	99.94	
44.75- 45.24	17.62- 17.81	6	6672	0.09	99.85	
44.25- 44.74	17.42- 17.61	15	6666	0.22	99.76	
43.75- 44.24	17.22- 17.41	15	6651	0.22	99.54	
43.25- 43.74	17.03- 17.21	30	6636	0.45	99.31	
42.75- 43.24	16.83- 17.02	34	6606	0.51	98.86	
42.25- 42.74	16.63- 16.82	41	6572	0.61	98.35	
41.75- 42.24	16.44- 16.62	78	6531	1.17	97.74	
41.25- 41.74	16.24- 16.43	85	6453	1.27	96.57	
40.75- 41.24	16.04- 16.23	120	6368	1.80	95.30	
40.25- 40.74	15.85- 16.03	160	6248	2.39	93.50	
39.75- 40.24	15.65- 15.84	223	6088	3.34	91.11	
39.25- 39.74	15.45- 15.64	213	5865	3.19	87.77	
38.75- 39.24	15.26- 15.44	307	5652	4.59	84.59	
38.25- 38.74	15.06- 15.25	371	5345	5.55	79.99	
37.75- 38.24	14.86- 15.05	431	4974	6.45	74.44	
37.25- 37.74	14.67- 14.85	398	4543	5.96	67.99	
36.75- 37.24	14.47- 14.66	563	4145	8.43	62.03	
36.25- 36.74	14.27- 14.46	460	3582	6.88	53.61	
35.75- 36.24	14.07- 14.26	509	3122	7.62	46.72	
35.25- 35.74	13.88- 14.06	481	2613	7.20	39.11	
34.75- 35.24	13.68- 13.87	474	2132	7.09	31.91	
34.25- 34.74	13.48- 13.67	367	1658	5.49	24.81	
33.75- 34.24	13.29- 13.47	381	1291	5.70	19.32	
33.25- 33.74	13.09- 13.28	229	910	3.43	13.62	
32.75- 33.24	12.89- 13.08	195	681	2.92	10.19	
32.25- 32.74	12.70- 12.88	178	486	2.66	7.27	
31.75- 32.24	12.50- 12.69	135	308	2.02	4.61	
31.25- 31.74	12.30- 12.49	69	173	1.03	2.59	
30.75- 31.24	12.11- 12.29	46	104	0.69	1.56	
30.25- 30.74	11.91- 12.10	26	58	0.39	0.87	
29.75- 30.24	11.71- 11.90	17	32	0.25	0.48	
29.25- 29.74	11.52- 11.70	10	15	0.15	0.22	
28.75- 29.24	11.32- 11.51	4	5	0.06	0.07	
28.25- 28.74	11.12- 11.31	1	1	0.01	0.01	

33 Calf Circumference

PERCENTILES

CENTIMETERS		INCHES
43.40	99 TH	17.09
42.48	98 TH	16.72
41.91	97 TH	16.50
41.16	95 TH	16.21
40.06	90 TH	15.77
39.33	85 TH	15.49
38.78	80 TH	15.27
38.30	75 TH	15.08
37.89	70 TH	14.92
37.51	65 TH	14.77
37.15	60 TH	14.63
36.81	55 TH	14.49
36.48	50 TH	14.36
36.14	45 TH	14.23
35.81	40 TH	14.10
35.47	35 TH	13.97
35.12	30 TH	13.83
34.74	25 TH	13.68
34.32	20 TH	13.51
33.84	15 TH	13.32
33.24	10 TH	13.09
32.38	5 TH	12.75
31.83	3 RD	12.53
31.44	2 ND	12.38
30.85	1 ST	12.15

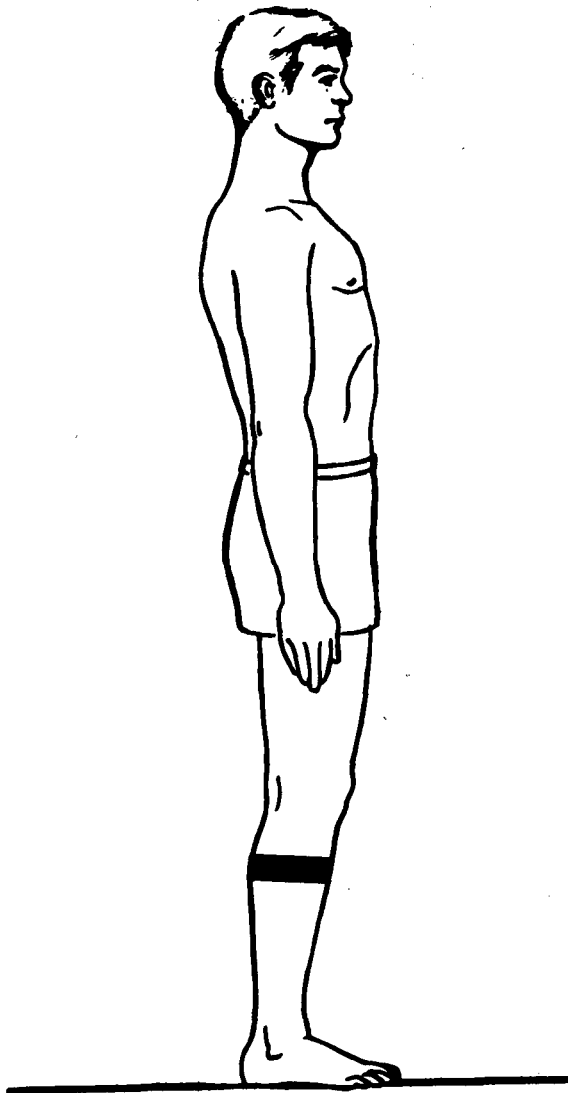

Calf Circumference: Subject stands erect, with his feet slightly apart. The horizontal circumference of the right lower leg is measured at the level of the greatest bulge of the calf muscle. A steel tape is used.

THE SUMMARY STATISTICS

.....

CENTIMETERS		INCHES
36.60	MEAN	14.41
0.03	SE(M)	0.01
2.67	ST DEV	1.05
0.02	SE(SD)	0.01

.....

SYMMETRY--BETA I	=	0.25
KURTOSIS--BETA II	=	3.14
COEFFICIENT OF VARIATION	=	7.29

.....

SAMPLE SIZE = 6682

34 Ankle Circumference

--INTERVALS--		--FREQUENCIES--				
CENTIMETERS	INCHES	ACTUAL FREQ	CUMULA TIVE-F	PERCEN T-FREQ	CUMUL- PCT-FQ	
30.35-	30.64	11.95- 12.06	1	6682	0.01	100.00
30.05-	30.34	11.83- 11.94	1	6681	0.01	99.99
29.75-	30.04	11.71- 11.82	0	6680	0.00	99.97
29.45-	29.74	11.59- 11.70	0	6680	0.00	99.97
29.15-	29.44	11.48- 11.58	0	6680	0.00	99.97
28.85-	29.14	11.36- 11.47	0	6680	0.00	99.97
28.55-	28.84	11.24- 11.35	0	6680	0.00	99.97
28.25-	28.54	11.12- 11.23	0	6680	0.00	99.97
27.95-	28.24	11.00- 11.11	0	6680	0.00	99.97
27.65-	27.94	10.89- 10.99	7	6680	0.10	99.97
27.35-	27.64	10.77- 10.88	4	6673	0.06	99.87
27.05-	27.34	10.65- 10.76	10	6669	0.15	99.81
26.75-	27.04	10.53- 10.64	14	6659	0.21	99.66
26.45-	26.74	10.41- 10.52	20	6645	0.30	99.45
26.15-	26.44	10.30- 10.40	32	6625	0.48	99.15
25.85-	26.14	10.18- 10.29	62	6593	0.93	98.67
25.55-	25.84	10.06- 10.17	84	6531	1.26	97.74
25.25-	25.54	9.94- 10.05	91	6447	1.36	96.48
24.95-	25.24	9.82- 9.93	125	6356	1.87	95.12
24.65-	24.94	9.70- 9.81	167	6231	2.50	93.25
24.35-	24.64	9.59- 9.69	224	6064	3.35	90.75
24.05-	24.34	9.47- 9.58	294	5840	4.40	87.40
23.75-	24.04	9.35- 9.46	329	5546	4.92	83.00
23.45-	23.74	9.23- 9.34	438	5217	6.55	78.08
23.15-	23.44	9.11- 9.22	465	4779	6.96	71.52
22.85-	23.14	9.00- 9.10	519	4314	7.77	64.56
22.55-	22.84	8.88- 8.99	548	3795	8.20	56.79
22.25-	22.54	8.76- 8.87	589	3247	8.81	48.59
21.95-	22.24	8.64- 8.75	577	2658	8.64	39.78
21.65-	21.94	8.52- 8.63	486	2081	7.27	31.14
21.35-	21.64	8.41- 8.51	454	1595	6.79	23.87
21.05-	21.34	8.29- 8.40	295	1141	4.41	17.08
20.75-	21.04	8.17- 8.28	310	846	4.64	12.66
20.45-	20.74	8.05- 8.16	218	536	3.26	8.02
20.15-	20.44	7.93- 8.04	138	318	2.07	4.76
19.85-	20.14	7.82- 7.92	87	180	1.30	2.69
19.55-	19.84	7.70- 7.81	50	93	0.75	1.39
19.25-	19.54	7.58- 7.69	23	43	0.34	0.64
18.95-	19.24	7.46- 7.57	10	20	0.15	0.30
18.65-	18.94	7.34- 7.45	6	10	0.09	0.15
18.35-	18.64	7.22- 7.33	1	4	0.01	0.06
18.05-	18.34	7.11- 7.21	3	3	0.04	0.04

34 Ankle Circumference

PERCENTILES

CENTIMETERS		INCHES	
26.39	99 TH	10.39	
25.92	98 TH	10.21	
25.62	97 TH	10.09	
25.22	95 TH	9.93	
24.60	90 TH	9.69	
24.20	85 TH	9.53	
23.89	80 TH	9.40	
23.62	75 TH	9.30	
23.39	70 TH	9.21	
23.17	65 TH	9.12	
22.98	60 TH	9.05	
22.79	55 TH	8.97	
22.61	50 TH	8.90	
22.43	45 TH	8.83	
22.25	40 TH	8.76	
22.07	35 TH	8.69	
21.88	30 TH	8.61	
21.68	25 TH	8.54	
21.46	20 TH	8.45	
21.22	15 TH	8.35	
20.91	10 TH	8.23	
20.48	5 TH	8.06	
20.20	3 RD	7.95	
20.00	2 ND	7.87	
19.68	1 ST	7.75	

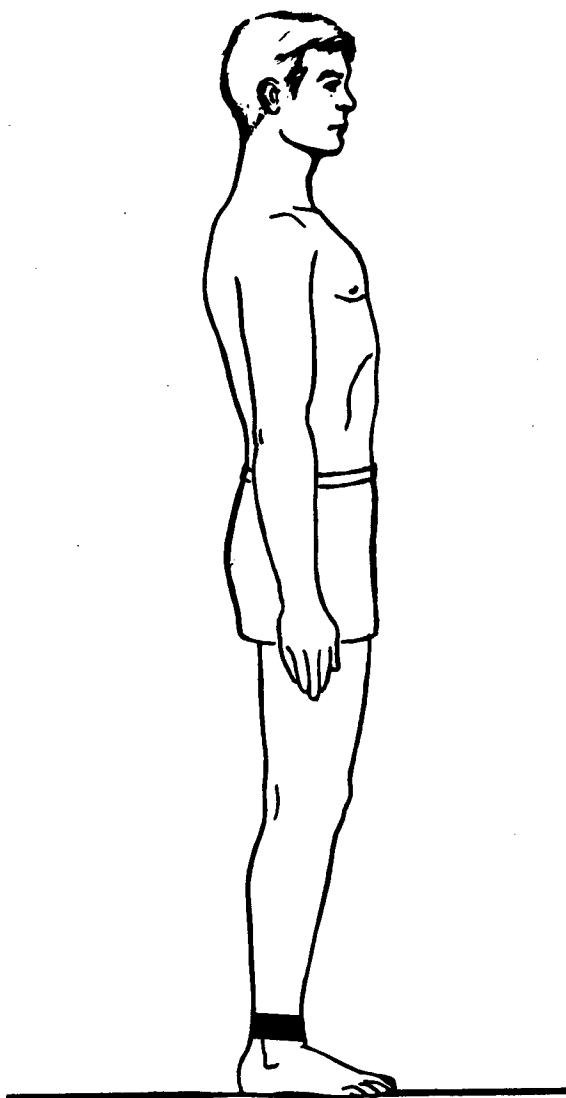

Ankle Circumference: Subject stands erect, with his feet slightly apart. The minimum horizontal circumference of the right ankle is measured. A steel tape is used, with the tape passing above the projections of the ankle bones (malleoli).

THE SUMMARY STATISTICS

.....

CENTIMETERS		INCHES	
22.69	MEAN	8.93	
0.02	SE(M)	0.01	
1.44	ST DEV	0.57	
0.01	SE(SD)	0.00	
.....			
SYMMETRY--BETA I		=	0.35
KURTOSIS--BETA II		=	3.26
COEFFICIENT OF VARIATION		=	6.34
.....			
SAMPLE SIZE		=	6682

36 Vertical Trunk Circumference, Standing

--INTERVALS--		--FREQUENCIES--					
CENTIMETERS	INCHES	ACTUAL FREQ	CUMULA TIVE-F	PERCEN T-FREQ	CUMUL- PCT-FQ		
198.25- 199.74	78.05- 78.63	1	6682	0.01	100.00		
196.75- 198.24	77.46- 78.04	0	6681	0.00	99.99		
195.25- 196.74	76.87- 77.45	2	6681	0.03	99.99		
193.75- 195.24	76.28- 76.86	3	6679	0.04	99.96		
192.25- 193.74	75.69- 76.27	6	6676	0.09	99.91		
190.75- 192.24	75.10- 75.68	4	6670	0.06	99.82		
189.25- 190.74	74.51- 75.09	11	6666	0.16	99.76		
187.75- 189.24	73.92- 74.50	14	6655	0.21	99.60		
186.25- 187.74	73.33- 73.91	23	6641	0.34	99.39		
184.75- 186.24	72.74- 73.32	22	6618	0.33	99.04		
183.25- 184.74	72.15- 72.73	36	6596	0.54	98.71		
181.75- 183.24	71.56- 72.14	44	6560	0.66	98.17		
180.25- 181.74	70.96- 71.55	58	6516	0.87	97.52		
178.75- 180.24	70.37- 70.95	94	6458	1.41	96.65		
177.25- 178.74	69.78- 70.36	128	6364	1.92	95.24		
175.75- 177.24	69.19- 69.77	150	6236	2.24	93.33		
174.25- 175.74	68.60- 69.18	175	6086	2.62	91.08		
172.75- 174.24	68.01- 68.59	247	5911	3.70	88.46		
171.25- 172.74	67.42- 68.00	264	5664	3.95	84.77		
169.75- 171.24	66.83- 67.41	328	5400	4.91	80.81		
168.25- 169.74	66.24- 66.82	391	5072	5.85	75.91		
166.75- 168.24	65.65- 66.23	423	4681	6.33	70.05		
165.25- 166.74	65.06- 65.64	462	4258	6.91	63.72		
163.75- 165.24	64.47- 65.05	444	3796	6.64	56.81		
162.25- 163.74	63.88- 64.46	493	3352	7.38	50.16		
160.75- 162.24	63.29- 63.87	472	2859	7.06	42.79		
159.25- 160.74	62.70- 63.28	442	2387	6.61	35.72		
157.75- 159.24	62.11- 62.69	409	1945	6.12	29.11		
156.25- 157.74	61.52- 62.10	353	1536	5.28	22.99		
154.75- 156.24	60.93- 61.51	315	1183	4.71	17.70		
153.25- 154.74	60.33- 60.92	259	868	3.88	12.99		
151.75- 153.24	59.74- 60.32	186	609	2.78	9.11		
150.25- 151.74	59.15- 59.73	123	423	1.84	6.33		
148.75- 150.24	58.56- 59.14	108	300	1.62	4.49		
147.25- 148.74	57.97- 58.55	70	192	1.05	2.87		
145.75- 147.24	57.38- 57.96	45	122	0.67	1.83		
144.25- 145.74	56.79- 57.37	35	77	0.52	1.15		
142.75- 144.24	56.20- 56.78	18	42	0.27	0.63		
141.25- 142.74	55.61- 56.19	8	24	0.12	0.36		
139.75- 141.24	55.02- 55.60	6	16	0.09	0.24		
138.25- 139.74	54.43- 55.01	4	10	0.06	0.15		
136.75- 138.24	53.84- 54.42	4	6	0.06	0.09		
135.25- 136.74	53.25- 53.83	2	2	0.03	0.03		

35 Vertical Trunk Circumference, Standing

PERCENTILES

CENTIMETERS		INCHES	
185.94	99 TH	73.20	
182.89	98 TH	72.01	
181.04	97 TH	71.28	
178.61	95 TH	70.32	
175.06	90 TH	68.92	
172.76	85 TH	68.02	
171.00	80 TH	67.32	
169.51	75 TH	66.74	
168.20	70 TH	66.22	
167.01	65 TH	65.75	
165.89	60 TH	65.31	
164.82	55 TH	64.89	
163.77	50 TH	64.48	
162.73	45 TH	64.07	
161.69	40 TH	63.66	
160.62	35 TH	63.24	
159.50	30 TH	62.79	
158.30	25 TH	62.32	
156.96	20 TH	61.79	
155.42	15 TH	61.19	
153.48	10 TH	60.43	
150.64	5 TH	59.31	
148.81	3 RD	58.59	
147.47	2 ND	58.06	
145.38	1 ST	57.24	



THE SUMMARY STATISTICS

••••

CENTIMETERS		INCHES	
164.11	MEAN	64.61	
0.10	SE(M)	0.04	
8.49	ST DEV	3.34	
0.07	SE(SD)	0.03	
••••			
SYMMETRY--BETA I		=	0.23
KURTOSIS--BETA II		=	3.20
COEFFICIENT OF VARIATION		=	5.17
••••			
SAMPLE SIZE		=	6682

Vertical Trunk Circumference, Standing: Subject stands erect, with his feet slightly apart. The vertical circumference of the trunk is measured. A steel tape is used, with the tape passing through the crotch and over the midpoints of the right buttock and right shoulder.

36 Arm Scye Circumference

--INTERVALS--				--FREQUENCIES--			
CENTIMETERS		INCHES		ACTUAL FREQ	CUMULA TIVE-F	PERCEN T-FREQ	CUMUL- PCT-FQ
59.25-	60.24	23.33-	23.71	1	6682	0.01	100.00
58.25-	59.24	22.93-	23.32	1	6681	0.01	99.99
57.25-	58.24	22.54-	22.92	1	6680	0.01	99.97
56.25-	57.24	22.15-	22.53	13	6679	0.19	99.96
55.25-	56.24	21.75-	22.14	16	6666	0.24	99.76
54.25-	55.24	21.36-	21.74	19	6650	0.28	99.52
53.25-	54.24	20.96-	21.35	41	6631	0.61	99.24
52.25-	53.24	20.57-	20.95	45	6590	0.67	98.62
51.25-	52.24	20.18-	20.56	65	6545	0.97	97.95
50.25-	51.24	19.78-	20.17	121	6480	1.81	96.98
49.25-	50.24	19.39-	19.77	225	6359	3.37	95.17
48.25-	49.24	19.00-	19.38	279	6134	4.18	91.80
47.25-	48.24	18.60-	18.99	394	5855	5.90	87.62
46.25-	47.24	18.21-	18.59	589	5461	8.81	81.73
45.25-	46.24	17.82-	18.20	748	4872	11.19	72.91
44.25-	45.24	17.42-	17.81	831	4124	12.44	61.72
43.25-	44.24	17.03-	17.41	850	3293	12.72	49.28
42.25-	43.24	16.63-	17.02	845	2443	12.65	36.56
41.25-	42.24	16.24-	16.62	625	1598	9.35	23.91
40.25-	41.24	15.85-	16.23	480	973	7.18	14.56
39.25-	40.24	15.45-	15.84	258	493	3.86	7.38
38.25-	39.24	15.06-	15.44	133	235	1.99	3.52
37.25-	38.24	14.67-	15.05	53	102	0.79	1.53
36.25-	37.24	14.27-	14.66	27	49	0.40	0.73
35.25-	36.24	13.88-	14.26	13	22	0.19	0.33
34.25-	35.24	13.48-	13.87	4	9	0.06	0.13
33.25-	34.24	13.09-	13.47	4	5	0.06	0.07
32.25-	33.24	12.70-	13.08	1	1	0.01	0.01

36 Arm Scye Circumference

PERCENTILES

CENTIMETERS		INCHES	
53.80	99 TH	21.18	
52.29	98 TH	20.59	
51.41	97 TH	20.24	
50.29	95 TH	19.80	
48.73	90 TH	19.18	
47.77	85 TH	18.81	
47.06	80 TH	18.53	
46.47	75 TH	18.29	
45.96	70 TH	18.10	
45.51	65 TH	17.92	
45.09	60 TH	17.75	
44.69	55 TH	17.60	
44.31	50 TH	17.44	
43.93	45 TH	17.29	
43.55	40 TH	17.15	
43.17	35 TH	17.00	
42.77	30 TH	16.84	
42.34	25 TH	16.67	
41.86	20 TH	16.48	
41.31	15 TH	16.27	
40.62	10 TH	15.99	
39.60	5 TH	15.59	
38.93	3 RD	15.33	
38.44	2 ND	15.13	
37.66	1 ST	14.83	

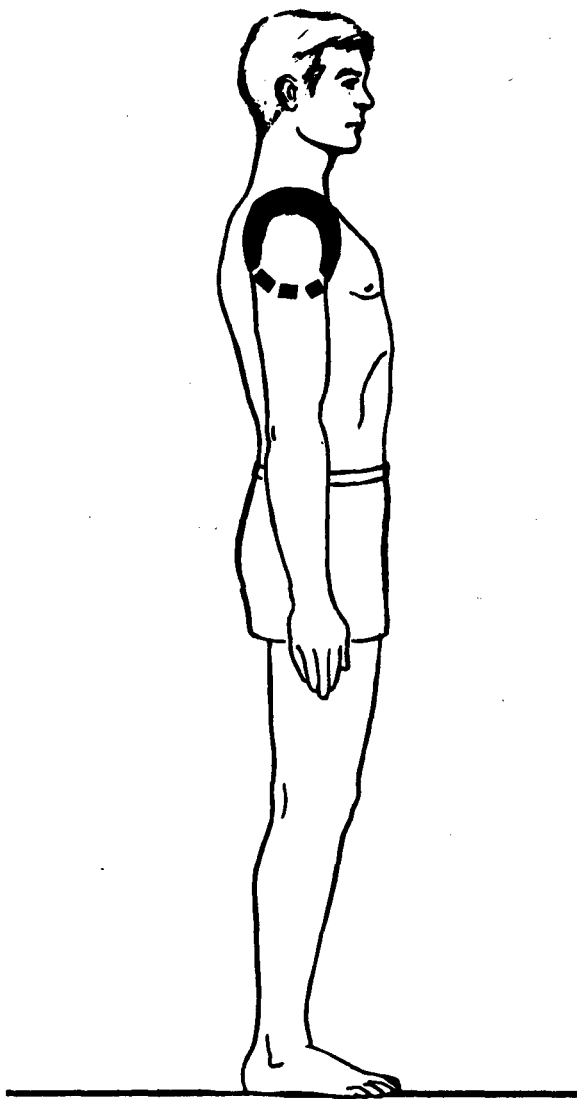

THE SUMMARY STATISTICS

••••

CENTIMETERS		INCHES	
44.56	MEAN	17.54	
0.04	SE(M)	0.02	
3.26	ST DEV	1.28	
0.03	SE(SD)	0.01	

••••

SYMMETRY--BETA I =	0.48
KURTOSIS--BETA II =	3.72
COEFFICIENT OF VARIATION =	7.32

••••

SAMPLE SIZE = 6682

Arm Scye Circumference: Subject stands erect, with his right arm initially raised and then lowered after the tape is in place. The vertical circumference of the scye (sleeve armhole area) is measured. A steel tape is used, with the tape passing under the right armpit and over the outer point (acromion) of the right shoulder.

37 Biceps Circumference, Relaxed

--INTERVALS--				--FREQUENCIES--			
CENTIMETERS		INCHES		ACTUAL FREQ	CUMULA TIVE-F	PERCEN T-FREQ	CUMUL- PCT-FQ
43.75-	44.24	17.22-	17.41	1	6682	0.01	100.00
43.25-	43.74	17.03-	17.21	0	6681	0.00	99.99
42.75-	43.24	16.83-	17.02	0	6681	0.00	99.99
42.25-	42.74	16.63-	16.82	1	6681	0.01	99.99
41.75-	42.24	16.44-	16.62	0	6680	0.00	99.97
41.25-	41.74	16.24-	16.43	1	6680	0.01	99.97
40.75-	41.24	16.04-	16.23	0	6679	0.00	99.96
40.25-	40.74	15.85-	16.03	1	6679	0.01	99.96
39.75-	40.24	15.65-	15.84	1	6678	0.01	99.94
39.25-	39.74	15.45-	15.64	3	6677	0.04	99.93
38.75-	39.24	15.26-	15.44	3	6674	0.04	99.88
38.25-	38.74	15.06-	15.25	5	6671	0.07	99.84
37.75-	38.24	14.86-	15.05	10	6666	0.15	99.76
37.25-	37.74	14.67-	14.85	16	6656	0.24	99.61
36.75-	37.24	14.47-	14.66	15	6640	0.22	99.37
36.25-	36.74	14.27-	14.46	25	6625	0.37	99.15
35.75-	36.24	14.07-	14.26	46	6600	0.69	98.77
35.25-	35.74	13.88-	14.06	41	6554	0.61	98.08
34.75-	35.24	13.68-	13.87	62	6513	0.93	97.47
34.25-	34.74	13.48-	13.67	105	6451	1.57	96.54
33.75-	34.24	13.29-	13.47	130	6346	1.95	94.97
33.25-	33.74	13.09-	13.28	137	6216	2.05	93.03
32.75-	33.24	12.89-	13.08	198	6079	2.96	90.98
32.25-	32.74	12.70-	12.88	185	5881	2.77	88.01
31.75-	32.24	12.50-	12.69	300	5696	4.49	85.24
31.25-	31.74	12.30-	12.49	323	5396	4.83	80.75
30.75-	31.24	12.11-	12.29	372	5073	5.57	75.92
30.25-	30.74	11.91-	12.10	390	4701	5.84	70.35
29.75-	30.24	11.71-	11.90	488	4311	7.30	64.52
29.25-	29.74	11.52-	11.70	479	3823	7.17	57.21
28.75-	29.24	11.32-	11.51	480	3344	7.18	50.04
28.25-	28.74	11.12-	11.31	498	2864	7.45	42.86
27.75-	28.24	10.93-	11.11	477	2366	7.14	35.41
27.25-	27.74	10.73-	10.92	421	1889	6.30	28.27
26.75-	27.24	10.53-	10.72	420	1468	6.29	21.97
26.25-	26.74	10.33-	10.52	279	1048	4.18	15.68
25.75-	26.24	10.14-	10.32	263	769	3.94	11.51
25.25-	25.74	9.94-	10.13	197	506	2.95	7.57
24.75-	25.24	9.74-	9.93	129	309	1.93	4.62
24.25-	24.74	9.55-	9.73	71	180	1.06	2.69
23.75-	24.24	9.35-	9.54	56	109	0.84	1.63
23.25-	23.74	9.15-	9.34	25	53	0.37	0.79
22.75-	23.24	8.96-	9.14	18	28	0.27	0.42
22.25-	22.74	8.76-	8.95	6	10	0.09	0.15
21.75-	22.24	8.56-	8.75	0	4	0.00	0.06
21.25-	21.74	8.37-	8.55	3	4	0.04	0.06
20.75-	21.24	8.17-	8.36	1	1	0.01	0.01

37 Biceps Circumference, Relaxed

PERCENTILES

CENTIMETERS		INCHES	
36.57	99 TH	14.40	
35.63	98 TH	14.03	
35.04	97 TH	13.80	
34.25	95 TH	13.48	
33.06	90 TH	13.01	
32.27	85 TH	12.71	
31.67	80 TH	12.47	
31.16	75 TH	12.27	
30.71	70 TH	12.09	
30.31	65 TH	11.93	
29.93	60 TH	11.79	
29.58	55 TH	11.65	
29.23	50 TH	11.51	
28.90	45 TH	11.38	
28.56	40 TH	11.24	
28.22	35 TH	11.11	
27.87	30 TH	10.97	
27.50	25 TH	10.83	
27.10	20 TH	10.67	
26.65	15 TH	10.49	
26.09	10 TH	10.27	
25.30	5 TH	9.96	
24.80	3 RD	9.76	
24.44	2 ND	9.62	
23.88	1 ST	9.40	

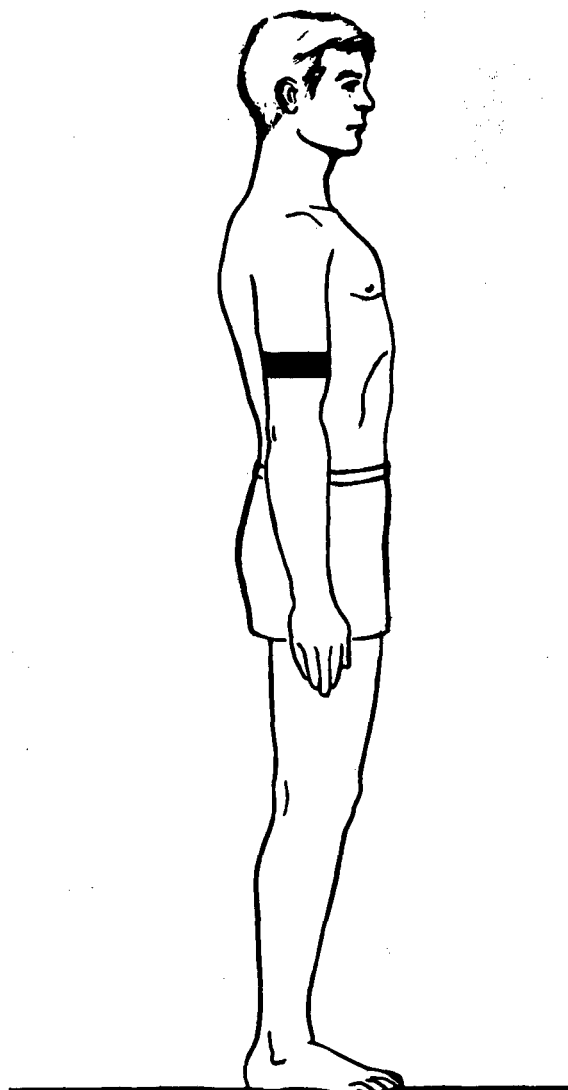

Biceps Circumference, Relaxed: Subject stands erect, with his right arm held slightly away from the body. The circumference of the right upper arm is measured at the level of the biceps muscle, midway between the shoulder and the elbow. A steel tape is used.

THE SUMMARY STATISTICS

....

CENTIMETERS		INCHES	
29.44	MEAN	11.59	
0.03	SE(M)	0.01	
2.74	ST DEV	1.08	
0.02	SE(SD)	0.01	
....			
SYMMETRY--BETA I		=	0.42
KURTOSIS--BETA II		=	3.32
COEFFICIENT OF VARIATION		=	9.29
....			
SAMPLE SIZE		=	6682

38 Biceps Circumference, Flexed

--INTERVALS--				--FREQUENCIES--			
CENTIMETERS		INCHES		ACTUAL FREQ	CUMULA TIVE-F	PERCEN T-FREQ	CUMUL- PCT-FQ
44.75-	45.24	17.62-	17.81	1	6682	0.01	100.00
44.25-	44.74	17.42-	17.61	1	6681	0.01	99.99
43.75-	44.24	17.22-	17.41	0	6680	0.00	99.97
43.25-	43.74	17.03-	17.21	1	6680	0.01	99.97
42.75-	43.24	16.83-	17.02	1	6679	0.01	99.96
42.25-	42.74	16.63-	16.82	5	6678	0.07	99.94
41.75-	42.24	16.44-	16.62	2	6673	0.03	99.87
41.25-	41.74	16.24-	16.43	5	6671	0.07	99.84
40.75-	41.24	16.04-	16.23	6	6666	0.09	99.76
40.25-	40.74	15.85-	16.03	15	6660	0.22	99.67
39.75-	40.24	15.65-	15.84	17	6645	0.25	99.45
39.25-	39.74	15.45-	15.64	18	6628	0.27	99.19
38.75-	39.24	15.26-	15.44	35	6610	0.52	98.92
38.25-	38.74	15.06-	15.25	41	6575	0.61	98.40
37.75-	38.24	14.86-	15.05	62	6534	0.93	97.79
37.25-	37.74	14.67-	14.85	77	6472	1.15	96.86
36.75-	37.24	14.47-	14.66	117	6395	1.75	95.70
36.25-	36.74	14.27-	14.46	114	6278	1.71	93.95
35.75-	36.24	14.07-	14.26	200	6164	2.99	92.25
35.25-	35.74	13.88-	14.06	197	5964	2.95	89.25
34.75-	35.24	13.68-	13.87	260	5767	3.89	86.31
34.25-	34.74	13.48-	13.67	306	5507	4.58	82.42
33.75-	34.24	13.29-	13.47	394	5201	5.90	77.84
33.25-	33.74	13.09-	13.28	414	4807	6.20	71.94
32.75-	33.24	12.89-	13.08	488	4393	7.30	65.74
32.25-	32.74	12.70-	12.88	431	3905	6.45	58.44
31.75-	32.24	12.50-	12.69	518	3474	7.75	51.99
31.25-	31.74	12.30-	12.49	425	2956	6.36	44.24
30.75-	31.24	12.11-	12.29	497	2531	7.44	37.88
30.25-	30.74	11.91-	12.10	402	2034	6.02	30.44
29.75-	30.24	11.71-	11.90	468	1632	7.00	24.42
29.25-	29.74	11.52-	11.70	301	1164	4.50	17.42
28.75-	29.24	11.32-	11.51	252	863	3.77	12.92
28.25-	28.74	11.12-	11.31	228	611	3.41	9.14
27.75-	28.24	10.93-	11.11	147	383	2.20	5.73
27.25-	27.74	10.73-	10.92	75	236	1.12	3.53
26.75-	27.24	10.53-	10.72	70	161	1.05	2.41
26.25-	26.74	10.33-	10.52	41	91	0.61	1.36
25.75-	26.24	10.14-	10.32	25	50	0.37	0.75
25.25-	25.74	9.94-	10.13	9	25	0.13	0.37
24.75-	25.24	9.74-	9.93	9	16	0.13	0.24
24.25-	24.74	9.55-	9.73	2	7	0.03	0.10
23.75-	24.24	9.35-	9.54	2	5	0.03	0.07
23.25-	23.74	9.15-	9.34	1	3	0.01	0.04
22.75-	23.24	8.96-	9.14	2	2	0.03	0.03

38 Biceps Circumference, Flexed

PERCENTILES

CENTIMETERS		INCHES	
39.38	99 TH	15.50	
38.43	98 TH	15.13	
37.84	97 TH	14.90	
37.05	95 TH	14.59	
35.87	90 TH	14.12	
35.10	85 TH	13.82	
34.51	80 TH	13.59	
34.01	75 TH	13.39	
33.58	70 TH	13.22	
33.18	65 TH	13.06	
32.81	60 TH	12.92	
32.46	55 TH	12.78	
32.11	50 TH	12.64	
31.77	45 TH	12.51	
31.44	40 TH	12.38	
31.09	35 TH	12.24	
30.74	30 TH	12.10	
30.36	25 TH	11.95	
29.94	20 TH	11.79	
29.47	15 TH	11.60	
28.88	10 TH	11.37	
28.03	5 TH	11.03	
27.48	3 RD	10.82	
27.09	2 ND	10.66	
26.47	1 ST	10.42	

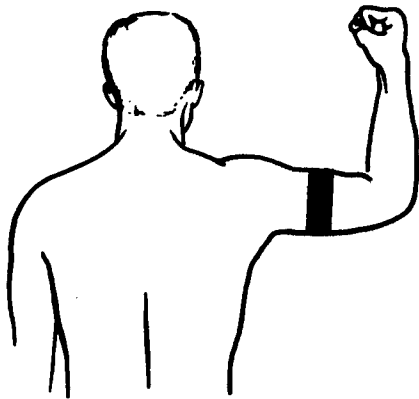

Biceps Circumference, Flexed: Subject stands erect, with his right arm bent, fist clenched, and biceps muscle flexed. The maximum circumference of the right upper arm is measured at the greatest bulge of the flexed biceps muscle. A steel tape is used.

THE SUMMARY STATISTICS

.....

CENTIMETERS		INCHES	
32.27	MEAN	12.70	
0.03	SE(M)	0.01	
2.75	ST DEV	1.08	
0.02	SE(SD)	0.01	

.....

SYMMETRY--BETA I = 0.34
 KURTOSIS--BETA II = 3.29
 COEFFICIENT OF VARIATION = 8.52

.....

SAMPLE SIZE = 6682

39 Forearm Circumference, Flexed

--INTERVALS--				--FREQUENCIES--			
CENTIMETERS		INCHES		ACTUAL FREQ	CUMULA TIVE-F	PERCEN T-FREQ	CUMUL- PCT-FQ
41.05-	41.44	16.16-	16.31	1	6682	0.01	100.00
40.65-	41.04	16.00-	16.15	0	6681	0.00	99.99
40.25-	40.64	15.85-	15.99	0	6681	0.00	99.99
39.85-	40.24	15.69-	15.84	1	6681	0.01	99.99
39.45-	39.84	15.53-	15.68	0	6680	0.00	99.97
39.05-	39.44	15.37-	15.52	1	6680	0.01	99.97
38.65-	39.04	15.22-	15.36	1	6679	0.01	99.96
38.25-	38.64	15.06-	15.21	0	6678	0.00	99.94
37.85-	38.24	14.90-	15.05	0	6678	0.00	99.94
37.45-	37.84	14.74-	14.89	0	6678	0.00	99.94
37.05-	37.44	14.59-	14.73	2	6678	0.03	99.94
36.65-	37.04	14.43-	14.58	9	6676	0.13	99.91
36.25-	36.64	14.27-	14.42	4	6667	0.06	99.78
35.85-	36.24	14.11-	14.26	11	6663	0.16	99.72
35.45-	35.84	13.96-	14.10	20	6652	0.30	99.55
35.05-	35.44	13.80-	13.95	22	6632	0.33	99.25
34.65-	35.04	13.64-	13.79	25	6610	0.37	98.92
34.25-	34.64	13.48-	13.63	32	6585	0.48	98.55
33.85-	34.24	13.33-	13.47	55	6553	0.82	98.07
33.45-	33.84	13.17-	13.32	60	6498	0.90	97.25
33.05-	33.44	13.01-	13.16	105	6438	1.57	96.35
32.65-	33.04	12.85-	13.00	119	6333	1.78	94.78
32.25-	32.64	12.70-	12.84	144	6214	2.16	93.00
31.85-	32.24	12.54-	12.69	237	6070	3.55	90.84
31.45-	31.84	12.38-	12.53	293	5833	4.38	87.29
31.05-	31.44	12.22-	12.37	311	5540	4.65	82.91
30.65-	31.04	12.07-	12.21	347	5229	5.19	78.26
30.25-	30.64	11.91-	12.06	425	4882	6.36	73.06
29.85-	30.24	11.75-	11.90	512	4457	7.66	66.70
29.45-	29.84	11.59-	11.74	431	3945	6.45	59.04
29.05-	29.44	11.44-	11.58	550	3514	8.23	52.59
28.65-	29.04	11.28-	11.43	435	2964	6.51	44.36
28.25-	28.64	11.12-	11.27	494	2529	7.39	37.85
27.85-	28.24	10.96-	11.11	447	2035	6.69	30.45
27.45-	27.84	10.81-	10.95	376	1588	5.63	23.77
27.05-	27.44	10.65-	10.80	390	1212	5.84	18.14
26.65-	27.04	10.49-	10.64	244	822	3.65	12.30
26.25-	26.64	10.33-	10.48	185	578	2.77	8.65
25.85-	26.24	10.18-	10.32	147	393	2.20	5.88
25.45-	25.84	10.02-	10.17	97	246	1.45	3.68
25.05-	25.44	9.86-	10.01	65	149	0.97	2.23
24.65-	25.04	9.70-	9.85	27	84	0.40	1.26
24.25-	24.64	9.55-	9.69	27	57	0.40	0.85
23.85-	24.24	9.39-	9.54	17	30	0.25	0.45
23.45-	23.84	9.23-	9.38	4	13	0.06	0.19
23.05-	23.44	9.07-	9.22	7	9	0.10	0.13
22.65-	23.04	8.92-	9.06	2	2	0.03	0.03

39 Forearm Circumference, Flexed

PERCENTILES

CENTIMETERS		INCHES	
35.09	99 TH	13.81	
34.26	98 TH	13.49	
33.77	97 TH	13.29	
33.13	95 TH	13.04	
32.20	90 TH	12.68	
31.61	85 TH	12.44	
31.16	80 TH	12.27	
30.78	75 TH	12.12	
30.45	70 TH	11.99	
30.14	65 TH	11.87	
29.86	60 TH	11.76	
29.59	55 TH	11.65	
29.33	50 TH	11.55	
29.07	45 TH	11.44	
28.80	40 TH	11.34	
28.54	35 TH	11.23	
28.26	30 TH	11.12	
27.95	25 TH	11.01	
27.62	20 TH	10.87	
27.24	15 TH	10.72	
26.76	10 TH	10.54	
26.07	5 TH	10.26	
25.63	3 RD	10.09	
25.32	2 ND	9.97	
24.84	1 ST	9.78	

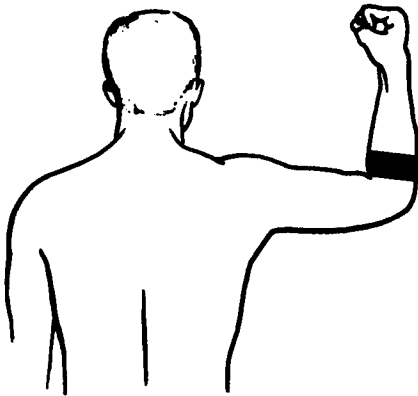

Forearm Circumference, Flexed: Subject stands erect, with his right arm bent, fist clenched, and arm muscles flexed. The maximum circumference of the right forearm is measured at the greatest bulge of the flexed forearm muscles. A steel tape is used.

THE SUMMARY STATISTICS

••••

CENTIMETERS		INCHES	
29.43	MEAN	11.59	
0.03	SE(M)	0.01	
2.15	ST DEV	0.85	
0.02	SE(SD)	0.01	

••••

SYMMETRY--BETA I = 0.34
 KURTOSIS--BETA II = 3.43
 COEFFICIENT OF VARIATION = 7.31

••••

SAMPLE SIZE = 6682

40 Wrist Circumference

--INTERVALS--				--FREQUENCIES--			
CENTIMETERS		INCHES		ACTUAL FREQ	CUMULA TIVE-F	PERCEN T-FREQ	CUMUL- PCT-FQ
21.45-	21.64	8.45-	8.51	1	6682	0.01	100.00
21.25-	21.44	8.37-	8.44	0	6681	0.00	99.99
21.05-	21.24	8.29-	8.36	0	6681	0.00	99.99
20.85-	21.04	8.21-	8.28	1	6681	0.01	99.99
20.65-	20.84	8.13-	8.20	0	6680	0.00	99.97
20.45-	20.64	8.05-	8.12	1	6680	0.01	99.97
20.25-	20.44	7.97-	8.04	2	6679	0.03	99.96
20.05-	20.24	7.89-	7.96	1	6677	0.01	99.93
19.85-	20.04	7.82-	7.88	10	6676	0.15	99.91
19.65-	19.84	7.74-	7.81	9	6666	0.13	99.76
19.45-	19.64	7.66-	7.73	22	6657	0.33	99.63
19.25-	19.44	7.58-	7.65	35	6635	0.52	99.30
19.05-	19.24	7.50-	7.57	42	6600	0.63	98.77
18.85-	19.04	7.42-	7.49	59	6558	0.88	98.14
18.65-	18.84	7.34-	7.41	87	6499	1.30	97.26
18.45-	18.64	7.26-	7.33	119	6412	1.78	95.96
18.25-	18.44	7.19-	7.25	229	6293	3.43	94.18
18.05-	18.24	7.11-	7.18	232	6064	3.47	90.75
17.85-	18.04	7.03-	7.10	267	5832	4.00	87.28
17.65-	17.84	6.95-	7.02	446	5565	6.67	83.28
17.45-	17.64	6.87-	6.94	482	5119	7.21	76.61
17.25-	17.44	6.79-	6.86	634	4637	9.49	69.40
17.05-	17.24	6.71-	6.78	622	4003	9.31	59.91
16.85-	17.04	6.63-	6.70	549	3381	8.22	50.60
16.65-	16.84	6.56-	6.62	666	2832	9.97	42.38
16.45-	16.64	6.48-	6.55	501	2166	7.50	32.42
16.25-	16.44	6.40-	6.47	544	1665	8.14	24.92
16.05-	16.24	6.32-	6.39	350	1121	5.24	16.78
15.85-	16.04	6.24-	6.31	260	771	3.89	11.54
15.65-	15.84	6.16-	6.23	211	511	3.16	7.65
15.45-	15.64	6.08-	6.15	101	300	1.51	4.49
15.25-	15.44	6.00-	6.07	94	199	1.41	2.98
15.05-	15.24	5.93-	5.99	55	105	0.82	1.57
14.85-	15.04	5.85-	5.92	25	50	0.37	0.75
14.65-	14.84	5.77-	5.84	17	25	0.25	0.37
14.45-	14.64	5.69-	5.76	5	8	0.07	0.12
14.25-	14.44	5.61-	5.68	0	3	0.00	0.04
14.05-	14.24	5.53-	5.60	0	3	0.00	0.04
13.85-	14.04	5.45-	5.52	0	3	0.00	0.04
13.65-	13.84	5.37-	5.44	3	3	0.04	0.04

40 Wrist Circumference

PERCENTILES

CENTIMETERS		INCHES	
19.34	99 TH	7.61	
19.01	98 TH	7.48	
18.81	97 TH	7.41	
18.55	95 TH	7.30	
18.18	90 TH	7.16	
17.94	85 TH	7.06	
17.76	80 TH	6.99	
17.61	75 TH	6.93	
17.48	70 TH	6.88	
17.35	65 TH	6.83	
17.24	60 TH	6.79	
17.13	55 TH	6.74	
17.03	50 TH	6.70	
16.92	45 TH	6.66	
16.81	40 TH	6.62	
16.70	35 TH	6.58	
16.59	30 TH	6.53	
16.47	25 TH	6.48	
16.33	20 TH	6.43	
16.17	15 TH	6.37	
15.97	10 TH	6.29	
15.67	5 TH	6.17	
15.47	3 RD	6.09	
15.33	2 ND	6.03	
15.10	1 ST	5.94	

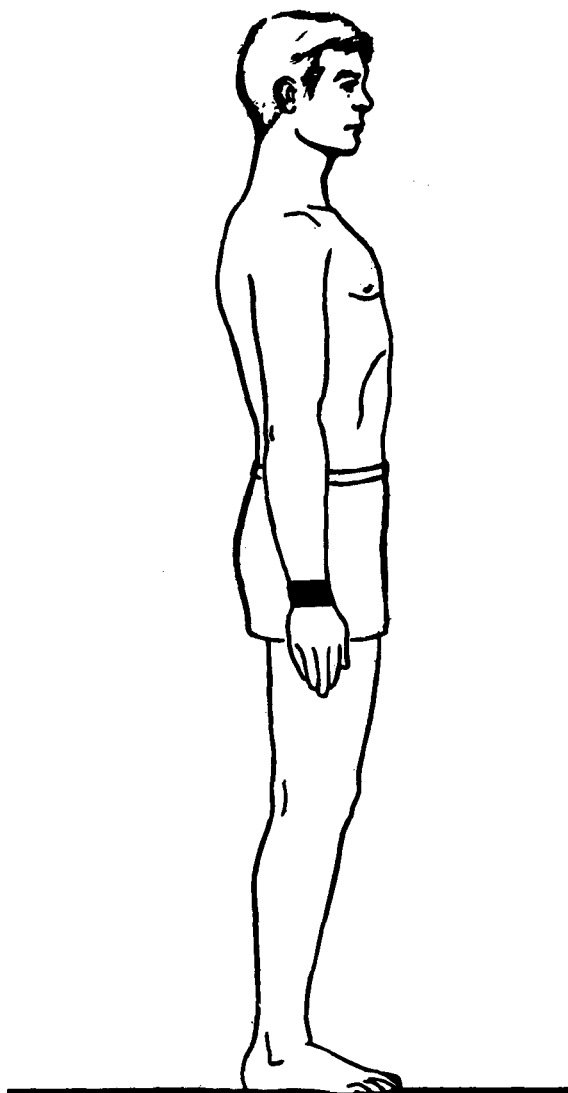

Wrist Circumference: Subject stands erect, with his right arm held slightly away from the body. The minimum circumference of the right wrist is measured. A steel tape is used.

THE SUMMARY STATISTICS

....

CENTIMETERS		INCHES	
17.06	MEAN	6.72	
0.01	SE(M)	0.00	
0.88	ST DEV	0.34	
0.01	SE(SD)	0.00	
....			
SYMMETRY--BETA I =		0.25	
KURTOSIS--BETA II =		3.37	
COEFFICIENT OF VARIATION =		5.13	
....			
SAMPLE SIZE =		6682	

41 Shoulder Length

--INTERVALS--				--FREQUENCIES--			
CENTIMETERS		INCHES		ACTUAL FREQ	CUMULA TIVE-F	PERCEN T-FREQ	CUMUL- PCT-FQ
23.95-	24.34	9.43-	9.58	1	6682	0.01	100.00
23.55-	23.94.	9.27-	9.42	2	6681	0.03	99.99
23.15-	23.54	9.11-	9.26	3	6679	0.04	99.96
22.75-	23.14	8.96-	9.10	1	6676	0.01	99.91
22.35-	22.74	8.80-	8.95	4	6675	0.06	99.90
21.95-	22.34	8.64-	8.79	1	6671	0.01	99.84
21.55-	21.94	8.48-	8.63	6	6670	0.09	99.82
21.15-	21.54	8.33-	8.47	14	6664	0.21	99.73
20.75-	21.14	8.17-	8.32	7	6650	0.10	99.52
20.35-	20.74	8.01-	8.16	16	6643	0.24	99.42
19.95-	20.34	7.85-	8.00	101	6627	1.51	99.18
19.55-	19.94	7.70-	7.84	97	6526	1.45	97.67
19.15-	19.54	7.54-	7.69	231	6429	3.46	96.21
18.75-	19.14	7.38-	7.53	111	6198	1.66	92.76
18.35-	18.74	7.22-	7.37	201	6087	3.01	91.10
17.95-	18.34	7.07-	7.21	386	5886	5.78	88.09
17.55-	17.94	6.91-	7.06	346	5500	5.18	82.31
17.15-	17.54	6.75-	6.90	654	5154	9.79	77.13
16.75-	17.14	6.59-	6.74	503	4500	7.53	67.35
16.35-	16.74	6.44-	6.58	528	3997	7.90	59.82
15.95-	16.34	6.28-	6.43	786	3469	11.76	51.92
15.55-	15.94	6.12-	6.27	446	2683	6.67	40.15
15.15-	15.54	5.96-	6.11	528	2237	7.90	33.48
14.75-	15.14	5.81-	5.95	311	1709	4.65	25.58
14.35-	14.74	5.65-	5.80	268	1398	4.01	20.92
13.95-	14.34	5.49-	5.64	220	1130	3.29	16.91
13.55-	13.94	5.33-	5.48	191	910	2.86	13.62
13.15-	13.54	5.18-	5.32	187	719	2.80	10.76
12.75-	13.14	5.02-	5.17	110	532	1.65	7.96
12.35-	12.74	4.86-	5.01	151	422	2.26	6.32
11.95-	12.34	4.70-	4.85	98	271	1.47	4.06
11.55-	11.94	4.55-	4.69	80	173	1.20	2.59
11.15-	11.54	4.39-	4.54	44	93	0.66	1.39
10.75-	11.14	4.23-	4.38	27	49	0.40	0.73
10.35-	10.74	4.07-	4.22	8	22	0.12	0.33
9.95-	10.34	3.92-	4.06	8	14	0.12	0.21
9.55-	9.94	3.76-	3.91	3	6	0.04	0.09
9.15-	9.54	3.60-	3.75	1	3	0.01	0.04
8.75-	9.14	3.45-	3.59	2	2	0.03	0.03

41 Shoulder Length

PERCENTILES

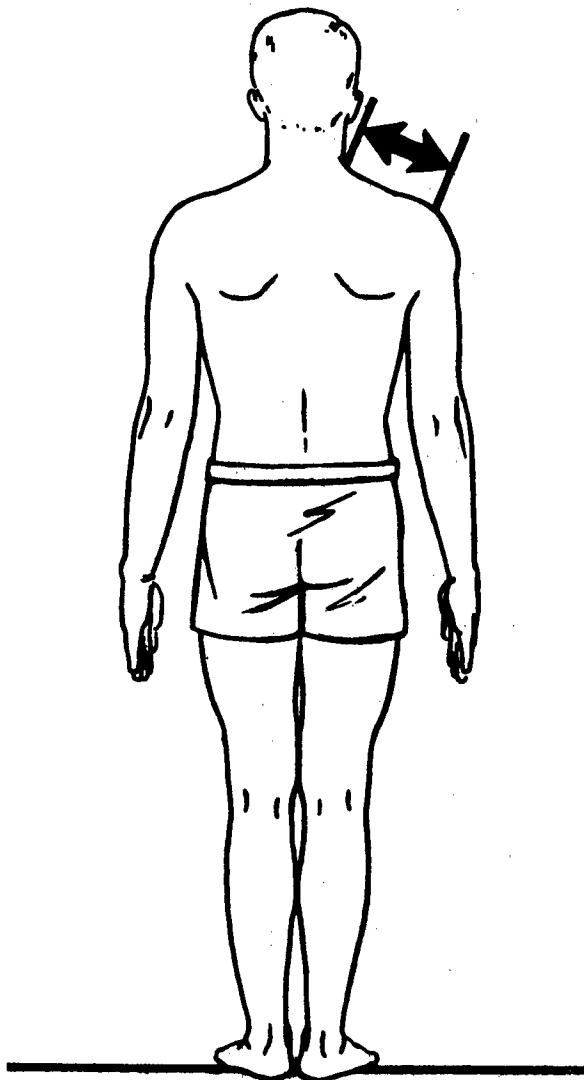

CENTIMETERS		INCHES	
20.49	99 TH	8.06	
19.95	98 TH	7.85	
19.63	97 TH	7.73	
19.22	95 TH	7.57	
18.61	90 TH	7.33	
18.20	85 TH	7.17	
17.87	80 TH	7.04	
17.58	75 TH	6.92	
17.32	70 TH	6.82	
17.07	65 TH	6.72	
16.82	60 TH	6.62	
16.58	55 TH	6.53	
16.34	50 TH	6.43	
16.09	45 TH	6.33	
15.83	40 TH	6.23	
15.55	35 TH	6.12	
15.26	30 TH	6.01	
14.93	25 TH	5.88	
14.56	20 TH	5.73	
14.11	15 TH	5.56	
13.54	10 TH	5.33	
12.70	5 TH	5.00	
12.15	3 RD	4.79	
11.77	2 ND	4.63	
11.18	1 ST	4.40	

THE SUMMARY STATISTICS

••••

CENTIMETERS		INCHES	
16.20	MEAN	6.38	
0.02	SE(M)	0.01	
1.98	ST DEV	0.78	
0.02	SE(SD)	0.01	

••••

SYMMETRY--BETA I = -0.25

KURTOSIS--BETA II = 3.23

COEFFICIENT OF VARIATION = 12.25

••••

SAMPLE SIZE = 6682

Shoulder Length: Subject stands erect, with head level. Shoulder length is measured as the distance along the upper surface of the right shoulder, from the base of the neck to the outer point (acromion) of the shoulder. A steel tape is used.

42 Interscye Breadth

		--INTERVALS--		--FREQUENCIES--			
CENTIMETERS		INCHES		ACTUAL FREQ	CUMULA TIVE-F	PERCEN T-FREQ	CUMUL- PCT-FQ
51.25-	51.74	20.18-	20.36	1	6682	0.01	100.00
50.75-	51.24	19.98-	20.17	2	6681	0.03	99.99
50.25-	50.74	19.78-	19.97	5	6679	0.07	99.96
49.75-	50.24	19.59-	19.77	3	6674	0.04	99.88
49.25-	49.74	19.39-	19.58	3	6671	0.04	99.84
48.75-	49.24	19.19-	19.38	8	6668	0.12	99.79
48.25-	48.74	19.00-	19.18	4	6660	0.06	99.67
47.75-	48.24	18.80-	18.99	12	6656	0.18	99.61
47.25-	47.74	18.60-	18.79	11	6644	0.16	99.43
46.75-	47.24	18.41-	18.59	15	6633	0.22	99.27
46.25-	46.74	18.21-	18.40	25	6618	0.37	99.04
45.75-	46.24	18.01-	18.20	40	6593	0.60	98.67
45.25-	45.74	17.82-	18.00	44	6553	0.66	98.07
44.75-	45.24	17.62-	17.81	73	6509	1.09	97.41
44.25-	44.74	17.42-	17.61	75	6436	1.12	96.32
43.75-	44.24	17.22-	17.41	152	6361	2.27	95.20
43.25-	43.74	17.03-	17.21	129	6209	1.93	92.92
42.75-	43.24	16.83-	17.02	202	6080	3.02	90.99
42.25-	42.74	16.63-	16.82	198	5878	2.96	87.97
41.75-	42.24	16.44-	16.62	285	5680	4.27	85.00
41.25-	41.74	16.24-	16.43	297	5395	4.44	80.74
40.75-	41.24	16.04-	16.23	373	5098	5.58	76.29
40.25-	40.74	15.85-	16.03	363	4725	5.43	70.71
39.75-	40.24	15.65-	15.84	444	4362	6.64	65.28
39.25-	39.74	15.45-	15.64	391	3918	5.85	58.64
38.75-	39.24	15.26-	15.44	493	3527	7.38	52.78
38.25-	38.74	15.06-	15.25	402	3034	6.02	45.41
37.75-	38.24	14.86-	15.05	424	2632	6.35	39.39
37.25-	37.74	14.67-	14.85	318	2208	4.76	33.04
36.75-	37.24	14.47-	14.66	384	1890	5.75	28.28
36.25-	36.74	14.27-	14.46	260	1506	3.89	22.54
35.75-	36.24	14.07-	14.26	301	1246	4.50	18.65
35.25-	35.74	13.88-	14.06	210	945	3.14	14.14
34.75-	35.24	13.68-	13.87	169	735	2.53	11.00
34.25-	34.74	13.48-	13.67	133	566	1.99	8.47
33.75-	34.24	13.29-	13.47	129	433	1.93	6.48
33.25-	33.74	13.09-	13.28	106	304	1.59	4.55
32.75-	33.24	12.89-	13.08	70	198	1.05	2.96
32.25-	32.74	12.70-	12.88	35	128	0.52	1.92
31.75-	32.24	12.50-	12.69	37	93	0.55	1.39
31.25-	31.74	12.30-	12.49	13	56	0.19	0.84
30.75-	31.24	12.11-	12.29	14	43	0.21	0.64
30.25-	30.74	11.91-	12.10	11	29	0.16	0.43
29.75-	30.24	11.71-	11.90	9	18	0.13	0.27
29.25-	29.74	11.52-	11.70	2	9	0.03	0.13
28.75-	29.24	11.32-	11.51	2	7	0.03	0.10
28.25-	28.74	11.12-	11.31	1	5	0.01	0.07
27.75-	28.24	10.93-	11.11	2	4	0.03	0.06
27.25-	27.74	10.73-	10.92	2	2	0.03	0.03

42 Interscye Breadth

PERCENTILES

CENTIMETERS		INCHES
46.70	99 TH	18.39
45.68	98 TH	17.98
45.05	97 TH	17.74
44.24	95 TH	17.42
43.05	90 TH	16.95
42.27	85 TH	16.64
41.66	80 TH	16.40
41.14	75 TH	16.20
40.68	70 TH	16.02
40.25	65 TH	15.85
39.85	60 TH	15.69
39.46	55 TH	15.53
39.07	50 TH	15.38
38.68	45 TH	15.23
38.28	40 TH	15.07
37.87	35 TH	14.91
37.44	30 TH	14.74
36.97	25 TH	14.56
36.44	20 TH	14.35
35.83	15 TH	14.11
35.07	10 TH	13.81
33.94	5 TH	13.36
33.23	3 RD	13.08
32.71	2 ND	12.88
31.94	1 ST	12.57

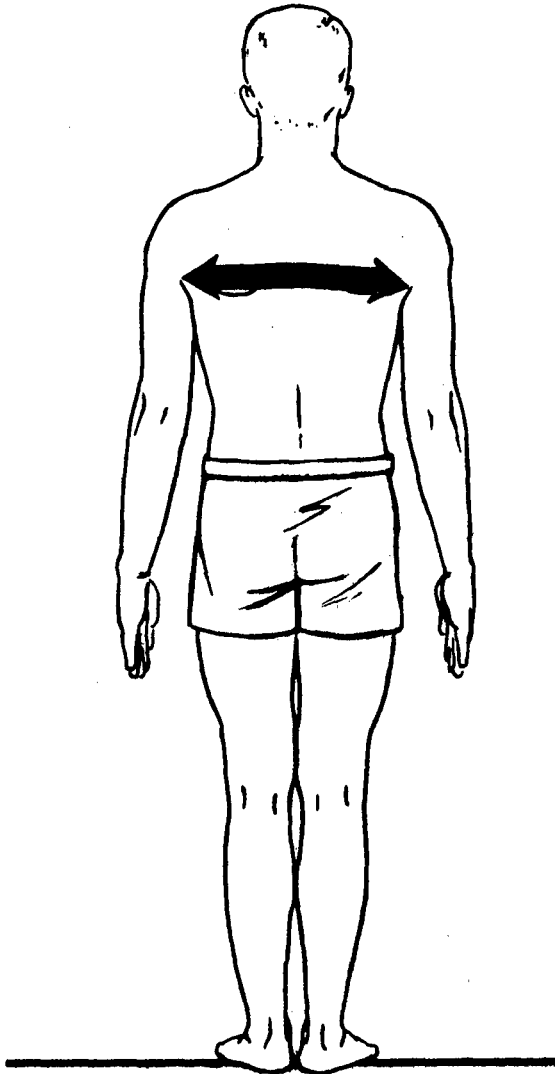

Interscye Breadth: Subject stands erect, with his arms at his sides. Interscye breadth is measured as the horizontal distance across the surface of the back between the upper ends of the armpit creases (scye points). A steel tape is used.

THE SUMMARY STATISTICS

••••

CENTIMETERS		INCHES
39.10	MEAN	15.39
0.04	SE(M)	0.02
3.16	ST DEV	1.24
0.03	SE(SD)	0.01

••••

SYMMETRY--BETA I =	0.08
KURTOSIS--BETA II =	3.24
COEFFICIENT OF VARIATION =	8.07

••••

SAMPLE SIZE = 6682

43 Interscye, Maximum

--INTERVALS--				--FREQUENCIES--			
CENTIMETERS		INCHES		ACTUAL FREQ	CUMULA TIVE-F	PERCEN T-FREQ	CUMUL- PCT-FQ
66.25-	67.24	26.08-	26.47	1	6682	0.01	100.00
65.25-	66.24	25.69-	26.07	2	6681	0.03	99.99
64.25-	65.24	25.30-	25.68	3	6679	0.04	99.96
63.25-	64.24	24.90-	25.29	12	6676	0.18	99.91
62.25-	63.24	24.51-	24.89	21	6664	0.31	99.73
61.25-	62.24	24.11-	24.50	44	6643	0.66	99.42
60.25-	61.24	23.72-	24.10	53	6599	0.79	98.76
59.25-	60.24	23.33-	23.71	133	6546	1.99	97.96
58.25-	59.24	22.93-	23.32	178	6413	2.66	95.97
57.25-	58.24	22.54-	22.92	207	6235	3.10	93.31
56.25-	57.24	22.15-	22.53	421	6028	6.30	90.21
55.25-	56.24	21.75-	22.14	462	5607	6.91	83.91
54.25-	55.24	21.36-	21.74	607	5145	9.08	77.00
53.25-	54.24	20.96-	21.35	688	4538	10.30	67.91
52.25-	53.24	20.57-	20.95	727	3850	10.88	57.62
51.25-	52.24	20.18-	20.56	774	3123	11.58	46.74
50.25-	51.24	19.78-	20.17	632	2349	9.46	35.15
49.25-	50.24	19.39-	19.77	575	1717	8.61	25.70
48.25-	49.24	19.00-	19.38	384	1142	5.75	17.09
47.25-	48.24	18.60-	18.99	263	758	3.94	11.34
46.25-	47.24	18.21-	18.59	182	495	2.72	7.41
45.25-	46.24	17.82-	18.20	135	313	2.02	4.68
44.25-	45.24	17.42-	17.81	91	178	1.36	2.66
43.25-	44.24	17.03-	17.41	45	87	0.67	1.30
42.25-	43.24	16.63-	17.02	24	42	0.36	0.63
41.25-	42.24	16.24-	16.62	13	18	0.19	0.27
40.25-	41.24	15.85-	16.23	5	5	0.07	0.07

43 Interscye, Maximum

PERCENTILES

CENTIMETERS		INCHES	
61.61	99 TH	24.26	
60.42	98 TH	23.79	
59.69	97 TH	23.50	
58.74	95 TH	23.12	
57.31	90 TH	22.56	
56.38	85 TH	22.20	
55.66	80 TH	21.91	
55.04	75 TH	21.67	
54.49	70 TH	21.45	
53.99	65 TH	21.26	
53.51	60 TH	21.07	
53.05	55 TH	20.89	
52.60	50 TH	20.71	
52.14	45 TH	20.53	
51.68	40 TH	20.35	
51.20	35 TH	20.16	
50.69	30 TH	19.96	
50.14	25 TH	19.74	
49.52	20 TH	19.50	
48.79	15 TH	19.21	
47.86	10 TH	18.84	
46.45	5 TH	18.29	
45.52	3 RD	17.92	
44.82	2 ND	17.65	
43.70	1 ST	17.21	

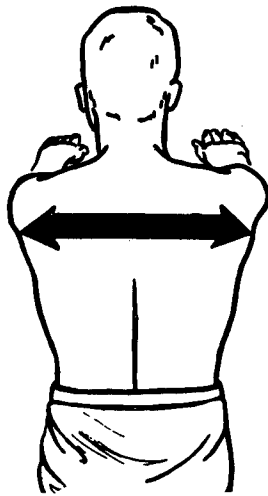

Interscye, Maximum: Subject stands erect, with his arms extended forward horizontally. Interscye, maximum is measured as the horizontal distance across the surface of the back between the rear borders of the right and left armpits (scye points). A steel tape is used.

THE SUMMARY STATISTICS

.....

CENTIMETERS		INCHES	
52.64	MEAN	20.72	
0.05	SE(M)	0.02	
3.70	ST DEV	1.46	
0.03	SE(SD)	0.01	

.....

SYMMETRY--BETA I = 0.04
 KURTOSIS--BETA II = 3.12
 COEFFICIENT OF VARIATION = 7.03

.....

SAMPLE SIZE = 6682

44 Waist Back Length

--INTERVALS--		--FREQUENCIES--			
CENTIMETERS	INCHES	ACTUAL FREQ	CUMULA TIVE-F	PERCEN T-FREQ	CUMUL- PCT-FQ
57.75- 58.24	22.74- 22.92	1	6682	0.01	100.00
57.25- 57.74	22.54- 22.73	0	6681	0.00	99.99
56.75- 57.24	22.34- 22.53	5	6681	0.07	99.99
56.25- 56.74	22.15- 22.33	2	6676	0.03	99.91
55.75- 56.24	21.95- 22.14	3	6674	0.04	99.88
55.25- 55.74	21.75- 21.94	5	6671	0.07	99.84
54.75- 55.24	21.56- 21.74	4	6666	0.06	99.76
54.25- 54.74	21.36- 21.55	8	6662	0.12	99.70
53.75- 54.24	21.16- 21.35	18	6654	0.27	99.58
53.25- 53.74	20.96- 21.15	10	6636	0.15	99.31
52.75- 53.24	20.77- 20.95	33	6626	0.49	99.16
52.25- 52.74	20.57- 20.76	23	6593	0.34	98.67
51.75- 52.24	20.37- 20.56	71	6570	1.06	98.32
51.25- 51.74	20.18- 20.36	59	6499	0.88	97.26
50.75- 51.24	19.98- 20.17	90	6440	1.35	96.38
50.25- 50.74	19.78- 19.97	86	6350	1.29	95.03
49.75- 50.24	19.59- 19.77	176	6264	2.63	93.74
49.25- 49.74	19.39- 19.58	163	6088	2.44	91.11
48.75- 49.24	19.19- 19.38	240	5925	3.59	88.67
48.25- 48.74	19.00- 19.18	188	5685	2.81	85.08
47.75- 48.24	18.80- 18.99	291	5497	4.35	82.27
47.25- 47.74	18.60- 18.79	231	5206	3.46	77.91
46.75- 47.24	18.41- 18.59	386	4975	5.78	74.45
46.25- 46.74	18.21- 18.40	291	4589	4.35	68.68
45.75- 46.24	18.01- 18.20	390	4298	5.84	64.32
45.25- 45.74	17.82- 18.00	322	3908	4.82	58.49
44.75- 45.24	17.62- 17.81	381	3586	5.70	53.67
44.25- 44.74	17.42- 17.61	306	3205	4.58	47.96
43.75- 44.24	17.22- 17.41	407	2899	6.09	43.39
43.25- 43.74	17.03- 17.21	308	2492	4.61	37.29
42.75- 43.24	16.83- 17.02	343	2184	5.13	32.68
42.25- 42.74	16.63- 16.82	336	1841	5.03	27.55
41.75- 42.24	16.44- 16.62	323	1505	4.83	22.52
41.25- 41.74	16.24- 16.43	272	1182	4.07	17.69
40.75- 41.24	16.04- 16.23	229	910	3.43	13.62
40.25- 40.74	15.85- 16.03	186	681	2.78	10.19
39.75- 40.24	15.65- 15.84	124	495	1.86	7.41
39.25- 39.74	15.45- 15.64	106	371	1.59	5.55
38.75- 39.24	15.26- 15.44	78	265	1.17	3.97
38.25- 38.74	15.06- 15.25	66	187	0.99	2.80
37.75- 38.24	14.86- 15.05	39	121	0.58	1.81
37.25- 37.74	14.67- 14.85	27	82	0.40	1.23
36.75- 37.24	14.47- 14.66	23	55	0.34	0.82
36.25- 36.74	14.27- 14.46	15	32	0.22	0.48
35.75- 36.24	14.07- 14.26	6	17	0.09	0.25
35.25- 35.74	13.88- 14.06	7	11	0.10	0.16
34.75- 35.24	13.68- 13.87	3	4	0.04	0.06
34.25- 34.74	13.48- 13.67	1	1	0.01	0.01

44 Waist Back Length

PERCENTILES

CENTIMETERS		INCHES
52.99	99 TH	20.86
52.18	98 TH	20.54
51.62	97 TH	20.32
50.83	95 TH	20.01
49.55	90 TH	19.51
48.66	85 TH	19.16
47.96	80 TH	18.88
47.34	75 TH	18.64
46.79	70 TH	18.42
46.29	65 TH	18.22
45.81	60 TH	18.04
45.35	55 TH	17.86
44.90	50 TH	17.68
44.46	45 TH	17.50
44.01	40 TH	17.33
43.56	35 TH	17.15
43.09	30 TH	16.96
42.58	25 TH	16.76
42.03	20 TH	16.55
41.40	15 TH	16.30
40.63	10 TH	15.99
39.52	5 TH	15.56
38.82	3 RD	15.28
38.32	2 ND	15.08
37.53	1 ST	14.78

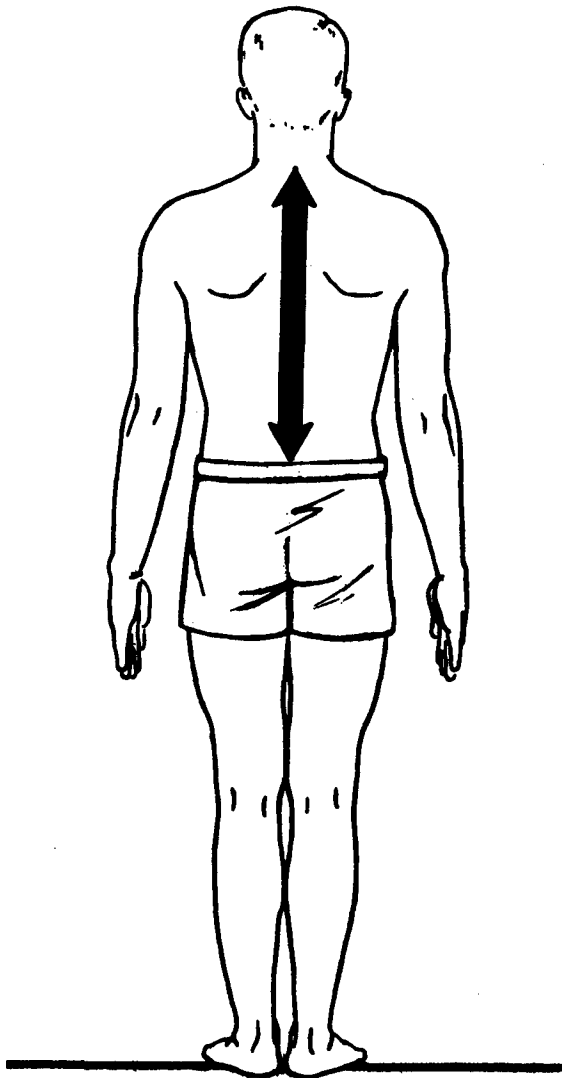

Waist Back Length: Subject stands erect, with head level. Waist back length is measured as the vertical distance along the surface of the back from the cervical point (the bony protrusion of the 7th cervical vertebra at the base of the neck) to the level of the waist. A steel tape is used.

THE SUMMARY STATISTICS

....

CENTIMETERS		INCHES
45.03	MEAN	17.73
0.04	SE(M)	0.02
3.44	ST DEV	1.35
0.03	SE(SD)	0.01
....		
	SYMMETRY--BETA I =	0.15
	KURTOSIS--BETA II =	2.83
	COEFFICIENT OF VARIATION =	7.64
....		
	SAMPLE SIZE =	6682

45 Sleeve Inseam Length

--INTERVALS--		--FREQUENCIES--				
CENTIMETERS	INCHES	ACTUAL FREQ	CUMULA TIVE-F	PERCEN T-FREQ	CUMUL- PCT-FQ	
59.25- 59.74	23.33- 23.51	2	6682	0.03	100.00	
58.75- 59.24	23.13- 23.32	1	6680	0.01	99.97	
58.25- 58.74	22.93- 23.12	0	6679	0.00	99.96	
57.75- 58.24	22.74- 22.92	2	6679	0.03	99.96	
57.25- 57.74	22.54- 22.73	5	6677	0.07	99.93	
56.75- 57.24	22.34- 22.53	4	6672	0.06	99.85	
56.25- 56.74	22.15- 22.33	8	6668	0.12	99.79	
55.75- 56.24	21.95- 22.14	17	6660	0.25	99.67	
55.25- 55.74	21.75- 21.94	21	6643	0.31	99.42	
54.75- 55.24	21.56- 21.74	25	6622	0.37	99.10	
54.25- 54.74	21.36- 21.55	50	6597	0.75	98.73	
53.75- 54.24	21.16- 21.35	58	6547	0.87	97.98	
53.25- 53.74	20.96- 21.15	85	6489	1.27	97.11	
52.75- 53.24	20.77- 20.95	117	6404	1.75	95.84	
52.25- 52.74	20.57- 20.76	155	6287	2.32	94.09	
51.75- 52.24	20.37- 20.56	200	6132	2.99	91.77	
51.25- 51.74	20.18- 20.36	289	5932	4.33	88.78	
50.75- 51.24	19.98- 20.17	299	5643	4.47	84.45	
50.25- 50.74	19.78- 19.97	360	5344	5.39	79.98	
49.75- 50.24	19.59- 19.77	502	4984	7.51	74.59	
49.25- 49.74	19.39- 19.58	462	4482	6.91	67.08	
48.75- 49.24	19.19- 19.38	484	4020	7.24	60.16	
48.25- 48.74	19.00- 19.18	482	3536	7.21	52.92	
47.75- 48.24	18.80- 18.99	521	3054	7.80	45.70	
47.25- 47.74	18.60- 18.79	455	2533	6.81	37.91	
46.75- 47.24	18.41- 18.59	440	2078	6.58	31.10	
46.25- 46.74	18.21- 18.40	355	1638	5.31	24.51	
45.75- 46.24	18.01- 18.20	327	1283	4.89	19.20	
45.25- 45.74	17.82- 18.00	255	956	3.82	14.31	
44.75- 45.24	17.62- 17.81	216	701	3.23	10.49	
44.25- 44.74	17.42- 17.61	132	485	1.98	7.26	
43.75- 44.24	17.22- 17.41	107	353	1.60	5.28	
43.25- 43.74	17.03- 17.21	85	246	1.27	3.68	
42.75- 43.24	16.83- 17.02	65	161	0.97	2.41	
42.25- 42.74	16.63- 16.82	35	96	0.52	1.44	
41.75- 42.24	16.44- 16.62	26	61	0.39	0.91	
41.25- 41.74	16.24- 16.43	14	35	0.21	0.52	
40.75- 41.24	16.04- 16.23	5	21	0.07	0.31	
40.25- 40.74	15.85- 16.03	7	16	0.10	0.24	
39.75- 40.24	15.65- 15.84	8	9	0.12	0.13	
39.25- 39.74	15.45- 15.64	1	1	0.01	0.01	

45 Sleeve Inseam Length

PERCENTILES

CENTIMETERS		INCHES	
55.13	99 TH	21.70	
54.24	98 TH	21.36	
53.71	97 TH	21.14	
53.00	95 TH	20.87	
51.97	90 TH	20.46	
51.30	85 TH	20.20	
50.77	80 TH	19.99	
50.33	75 TH	19.81	
49.93	70 TH	19.66	
49.57	65 TH	19.51	
49.22	60 TH	19.38	
48.89	55 TH	19.25	
48.56	50 TH	19.12	
48.23	45 TH	18.99	
47.89	40 TH	18.85	
47.54	35 TH	18.72	
47.18	30 TH	18.57	
46.78	25 TH	18.42	
46.33	20 TH	18.24	
45.81	15 TH	18.03	
45.15	10 TH	17.77	
44.16	5 TH	17.39	
43.52	3 RD	17.13	
43.05	2 ND	16.95	
42.32	1 ST	16.66	

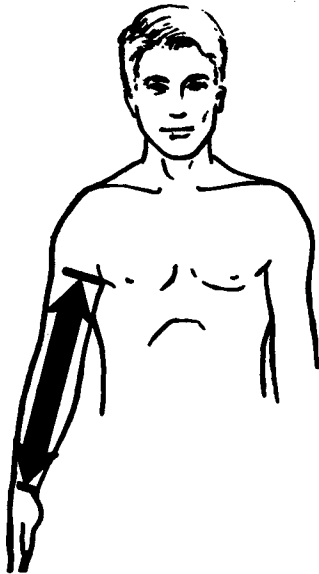

Sleeve Inseam Length: Subject stands erect, with his right arm extended and held slightly away from the body. Sleeve inseam length is measured as the distance along the inner surface of the right arm, from the front edge of the armpit to the wrist. A steel tape is used.

THE SUMMARY STATISTICS

.....

CENTIMETERS		INCHES	
48.59	MEAN	19.13	
0.03	SE(M)	0.01	
2.68	ST DEV	1.05	
0.02	SE(SD)	0.01	

.....

SYMMETRY--BETA I = 0.07
 KURTOSIS--BETA II = 3.20
 COEFFICIENT OF VARIATION = 5.51

.....

SAMPLE SIZE = 6682

46 Sleeve Length

--INTERVALS--

--FREQUENCIES--

CENTIMETERS		INCHES		ACTUAL FREQ	CUMULA TIVE-F	PERCEN T-FREQ	CUMUL- PCT-FQ
99.25-	100.24	39.07-	39.46	5	6682	0.07	100.00
98.25-	99.24	38.68-	39.06	5	6677	0.07	99.93
97.25-	98.24	38.29-	38.67	14	6672	0.21	99.85
96.25-	97.24	37.89-	38.28	13	6658	0.19	99.64
95.25-	96.24	37.50-	37.88	31	6645	0.46	99.45
94.25-	95.24	37.11-	37.49	56	6614	0.84	98.98
93.25-	94.24	36.71-	37.10	105	6558	1.57	98.14
92.25-	93.24	36.32-	36.70	147	6453	2.20	96.57
91.25-	92.24	35.93-	36.31	185	6306	2.77	94.37
90.25-	91.24	35.53-	35.92	288	6121	4.31	91.60
89.25-	90.24	35.14-	35.52	388	5833	5.81	87.29
88.25-	89.24	34.74-	35.13	510	5445	7.63	81.49
87.25-	88.24	34.35-	34.73	580	4935	8.68	73.86
86.25-	87.24	33.96-	34.34	673	4355	10.07	65.18
85.25-	86.24	33.56-	33.95	695	3682	10.40	55.10
84.25-	85.24	33.17-	33.55	649	2987	9.71	44.70
83.25-	84.24	32.78-	33.16	630	2338	9.43	34.99
82.25-	83.24	32.38-	32.77	515	1708	7.71	25.56
81.25-	82.24	31.99-	32.37	425	1193	6.36	17.85
80.25-	81.24	31.59-	31.98	245	768	3.67	11.49
79.25-	80.24	31.20-	31.58	209	523	3.13	7.83
78.25-	79.24	30.81-	31.19	136	314	2.04	4.70
77.25-	78.24	30.41-	30.80	86	178	1.29	2.66
76.25-	77.24	30.02-	30.40	42	92	0.63	1.38
75.25-	76.24	29.63-	30.01	22	50	0.33	0.75
74.25-	75.24	29.23-	29.62	10	28	0.15	0.42
73.25-	74.24	28.84-	29.22	5	18	0.07	0.27
72.25-	73.24	28.45-	28.83	8	13	0.12	0.19
71.25-	72.24	28.05-	28.44	3	5	0.04	0.07
70.25-	71.24	27.66-	28.04	2	2	0.03	0.03

46 Sleeve Length

PERCENTILES

CENTIMETERS		INCHES	
95.33	99 TH	37.53	
94.18	98 TH	37.08	
93.44	97 TH	36.79	
92.44	95 TH	36.40	
90.92	90 TH	35.79	
89.90	85 TH	35.39	
89.10	80 TH	35.08	
88.42	75 TH	34.81	
87.81	70 TH	34.57	
87.26	65 TH	34.35	
86.74	60 TH	34.15	
86.24	55 TH	33.95	
85.74	50 TH	33.76	
85.25	45 TH	33.56	
84.76	40 TH	33.37	
84.25	35 TH	33.17	
83.72	30 TH	32.96	
83.15	25 TH	32.74	
82.51	20 TH	32.48	
81.77	15 TH	32.19	
80.82	10 TH	31.82	
79.41	5 TH	31.26	
78.46	3 RD	30.89	
77.75	2 ND	30.61	
76.60	1 ST	30.16	

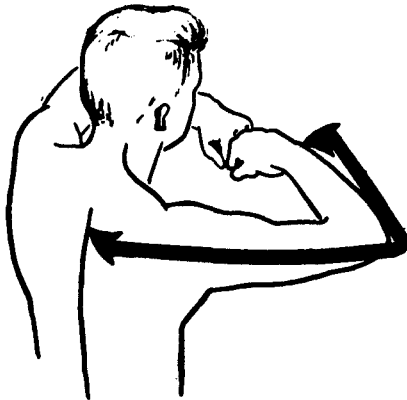

Sleeve Length: Subject stands erect, with his arms bent at the elbows, fists pressed together in front of him, and with his arms held horizontally. Sleeve length is measured as the horizontal distance along the outer surface of the right arm, from the middle of the back, over the elbow, to the center of the bony prominence at the outer edge of the wrist (styloid process of the ulna). A steel tape is used.

THE SUMMARY STATISTICS

••••

CENTIMETERS		INCHES	
85.84	MEAN	33.80	
0.05	SE(M)	0.02	
3.96	ST DEV	1.56	
0.03	SE(SD)	0.01	

••••

SYMMETRY--BETA I = 0.05
 KURTOSIS--BETA II = 3.22
 COEFFICIENT OF VARIATION = 4.61

••••

SAMPLE SIZE = 6682

47 Head Circumference

--INTERVALS--		--FREQUENCIES--				
CENTIMETERS	INCHES	ACTUAL FREQ	CUMULA TIVE-F	PERCEN T-FREQ	CUMUL- PCT-FQ	
63.55- 63.84	25.02- 25.13	1	6682	0.01	100.00	
63.25- 63.54	24.90- 25.01	0	6681	0.00	99.99	
62.95- 63.24	24.78- 24.89	0	6681	0.00	99.99	
62.65- 62.94	24.67- 24.77	0	6681	0.00	99.99	
62.35- 62.64	24.55- 24.66	1	6681	0.01	99.99	
62.05- 62.34	24.43- 24.54	1	6680	0.01	99.97	
61.75- 62.04	24.31- 24.42	2	6679	0.03	99.96	
61.45- 61.74	24.19- 24.30	4	6677	0.06	99.93	
61.15- 61.44	24.07- 24.18	3	6673	0.04	99.87	
60.85- 61.14	23.96- 24.06	9	6670	0.13	99.82	
60.55- 60.84	23.84- 23.95	5	6661	0.07	99.69	
60.25- 60.54	23.72- 23.83	13	6656	0.19	99.61	
59.95- 60.24	23.60- 23.71	33	6643	0.49	99.42	
59.65- 59.94	23.48- 23.59	34	6610	0.51	98.92	
59.35- 59.64	23.37- 23.47	56	6576	0.84	98.41	
59.05- 59.34	23.25- 23.36	83	6520	1.24	97.58	
58.75- 59.04	23.13- 23.24	103	6437	1.54	96.33	
58.45- 58.74	23.01- 23.12	163	6334	2.44	94.79	
58.15- 58.44	22.89- 23.00	211	6171	3.16	92.35	
57.85- 58.14	22.78- 22.88	205	5960	3.07	89.19	
57.55- 57.84	22.66- 22.77	303	5755	4.53	86.13	
57.25- 57.54	22.54- 22.65	322	5452	4.82	81.59	
56.95- 57.24	22.42- 22.53	480	5130	7.18	76.77	
56.65- 56.94	22.30- 22.41	400	4650	5.99	69.59	
56.35- 56.64	22.19- 22.29	407	4250	6.09	63.60	
56.05- 56.34	22.07- 22.18	542	3843	8.11	57.51	
55.75- 56.04	21.95- 22.06	472	3301	7.06	49.40	
55.45- 55.74	21.83- 21.94	532	2829	7.96	42.34	
55.15- 55.44	21.71- 21.82	475	2297	7.11	34.38	
54.85- 55.14	21.59- 21.70	364	1822	5.45	27.27	
54.55- 54.84	21.48- 21.58	382	1458	5.72	21.82	
54.25- 54.54	21.36- 21.47	309	1076	4.62	16.10	
53.95- 54.24	21.24- 21.35	211	767	3.16	11.48	
53.65- 53.94	21.12- 21.23	162	556	2.42	8.32	
53.35- 53.64	21.00- 21.11	128	394	1.92	5.90	
53.05- 53.34	20.89- 20.99	94	266	1.41	3.98	
52.75- 53.04	20.77- 20.88	67	172	1.00	2.57	
52.45- 52.74	20.65- 20.76	29	105	0.43	1.57	
52.15- 52.44	20.53- 20.64	36	76	0.54	1.14	
51.85- 52.14	20.41- 20.52	21	40	0.31	0.60	
51.55- 51.84	20.30- 20.40	8	19	0.12	0.28	
51.25- 51.54	20.18- 20.29	6	11	0.09	0.16	
50.95- 51.24	20.06- 20.17	5	5	0.07	0.07	

47 Head Circumference

PERCENTILES

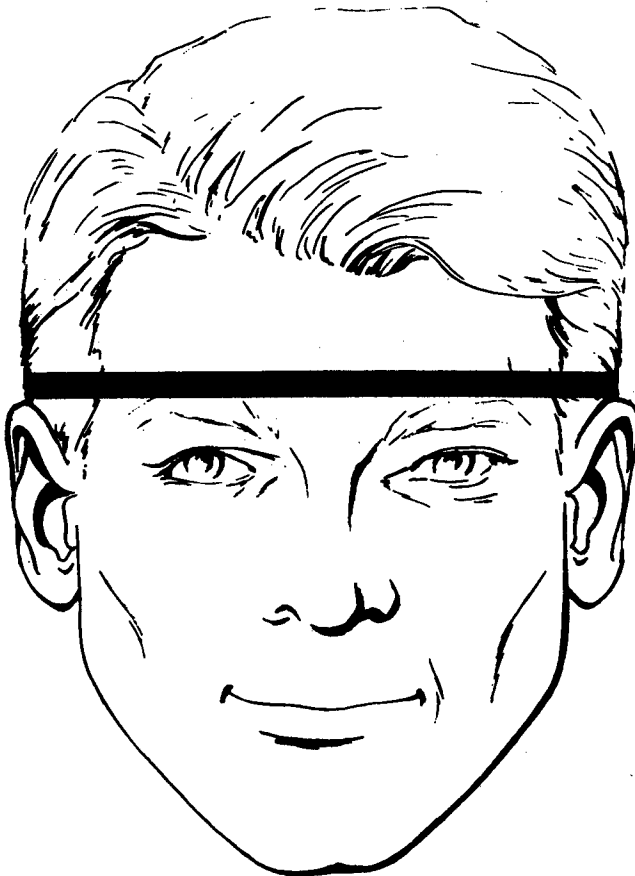

CENTIMETERS		INCHES
59.98	99 TH	23.61
59.52	98 TH	23.43
59.22	97 TH	23.32
58.82	95 TH	23.16
58.20	90 TH	22.91
57.78	85 TH	22.75
57.45	80 TH	22.62
57.17	75 TH	22.51
56.92	70 TH	22.41
56.70	65 TH	22.32
56.48	60 TH	22.24
56.28	55 TH	22.16
56.08	50 TH	22.08
55.88	45 TH	22.00
55.68	40 TH	21.92
55.47	35 TH	21.84
55.26	30 TH	21.76
55.03	25 TH	21.66
54.77	20 TH	21.56
54.47	15 TH	21.44
54.09	10 TH	21.30
53.52	5 TH	21.07
53.14	3 RD	20.92
52.86	2 ND	20.81
52.39	1 ST	20.63

THE SUMMARY STATISTICS

••••

Head Circumference: Subject sits erect, with head level. The maximum circumference of the head is measured. A steel tape is used, with the tape passing just above the bony brow ridges of the forehead and above both ears.

CENTIMETERS		INCHES
56.11	MEAN	22.09
0.02	SE(M)	0.01
1.61	ST DEV	0.63
0.01	SE(SD)	0.01

••••

SYMMETRY--BETA I = 0.11
 KURTOSIS--BETA II = 3.11
 COEFFICIENT OF VARIATION = 2.86

••••

SAMPLE SIZE = 6682

48 Head Length

--INTERVALS--				--FREQUENCIES--			
CENTIMETERS		INCHES		ACTUAL FREQ	CUMULA TIVE-F	PERCEN T-FREQ	CUMUL- PCT-FQ
22.25-	22.44	8.76-	8.83	1	6682	0.01	100.00
22.05-	22.24	8.68-	8.75	2	6681	0.03	99.99
21.85-	22.04	8.60-	8.67	2	6679	0.03	99.96
21.65-	21.84	8.52-	8.59	6	6677	0.09	99.93
21.45-	21.64	8.45-	8.51	14	6671	0.21	99.84
21.25-	21.44	8.37-	8.44	23	6657	0.34	99.63
21.05-	21.24	8.29-	8.36	50	6634	0.75	99.28
20.85-	21.04	8.21-	8.28	96	6584	1.44	98.53
20.65-	20.84	8.13-	8.20	154	6488	2.30	97.10
20.45-	20.64	8.05-	8.12	235	6334	3.52	94.79
20.25-	20.44	7.97-	8.04	365	6099	5.46	91.28
20.05-	20.24	7.89-	7.96	523	5734	7.83	85.81
19.85-	20.04	7.82-	7.88	520	5211	7.78	77.99
19.65-	19.84	7.74-	7.81	744	4691	11.13	70.20
19.45-	19.64	7.66-	7.73	610	3947	9.13	59.07
19.25-	19.44	7.58-	7.65	759	3337	11.36	49.94
19.05-	19.24	7.50-	7.57	747	2578	11.18	38.58
18.85-	19.04	7.42-	7.49	497	1831	7.44	27.40
18.65-	18.84	7.34-	7.41	442	1334	6.61	19.96
18.45-	18.64	7.26-	7.33	335	892	5.01	13.35
18.25-	18.44	7.19-	7.25	221	557	3.31	8.34
18.05-	18.24	7.11-	7.18	162	336	2.42	5.03
17.85-	18.04	7.03-	7.10	84	174	1.26	2.60
17.65-	17.84	6.95-	7.02	46	90	0.69	1.35
17.45-	17.64	6.87-	6.94	23	44	0.34	0.66
17.25-	17.44	6.79-	6.86	15	21	0.22	0.31
17.05-	17.24	6.71-	6.78	4	6	0.06	0.09
16.85-	17.04	6.63-	6.70	0	2	0.00	0.03
16.65-	16.84	6.56-	6.62	2	2	0.03	0.03

48 Head Length

PERCENTILES

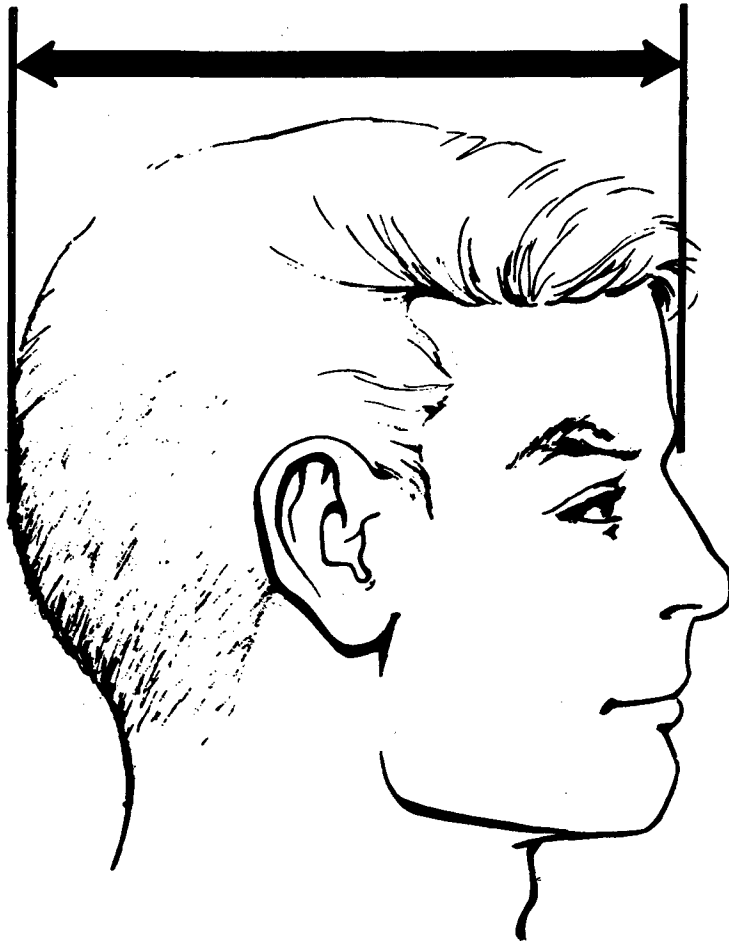

CENTIMETERS		INCHES
21.17	99 TH	8.34
20.97	98 TH	8.26
20.85	97 TH	8.21
20.67	95 TH	8.14
20.41	90 TH	8.03
20.23	85 TH	7.96
20.09	80 TH	7.91
19.96	75 TH	7.86
19.85	70 TH	7.82
19.75	65 TH	7.78
19.66	60 TH	7.74
19.56	55 TH	7.70
19.47	50 TH	7.67
19.38	45 TH	7.63
19.28	40 TH	7.59
19.19	35 TH	7.55
19.08	30 TH	7.51
18.97	25 TH	7.47
18.85	20 TH	7.42
18.70	15 TH	7.36
18.52	10 TH	7.29
18.25	5 TH	7.19
18.08	3 RD	7.12
17.95	2 ND	7.07
17.75	1 ST	6.99

THE SUMMARY STATISTICS

....

Head Length: Subject sits erect, with head level. The maximum length of the head is measured from the back of the head (occiput) to the forehead (glabella). Spreading calipers are used.

CENTIMETERS		INCHES
19.47	MEAN	7.66
0.01	SE(M)	0.00
0.73	ST DEV	0.29
0.01	SE(SD)	0.00

....

SYMMETRY--BETA I = -0.00
 KURTOSIS--BETA II = 3.01
 COEFFICIENT OF VARIATION = 3.77

....

SAMPLE SIZE = 6682

49 Occiput-Nasal Root

--INTERVALS--				--FREQUENCIES--			
CENTIMETERS		INCHES		ACTUAL FREQ	CUMULA TIVE-F	PERCEN T-FREQ	CUMUL- PCT-FQ
21.85-	22.04	8.60-	8.67	1	6682	0.01	100.00
21.65-	21.84	8.52-	8.59	0	6681	0.00	99.99
21.45-	21.64	8.45-	8.51	2	6681	0.03	99.99
21.25-	21.44	8.37-	8.44	6	6679	0.09	99.96
21.05-	21.24	8.29-	8.36	12	6673	0.18	99.87
20.85-	21.04	8.21-	8.28	25	6661	0.37	99.69
20.65-	20.84	8.13-	8.20	47	6636	0.70	99.31
20.45-	20.64	8.05-	8.12	89	6589	1.33	98.61
20.25-	20.44	7.97-	8.04	162	6500	2.42	97.28
20.05-	20.24	7.89-	7.96	282	6338	4.22	94.85
19.85-	20.04	7.82-	7.88	366	6056	5.48	90.63
19.65-	19.84	7.74-	7.81	530	5690	7.93	85.15
19.45-	19.64	7.66-	7.73	614	5160	9.19	77.22
19.25-	19.44	7.58-	7.65	696	4546	10.42	68.03
19.05-	19.24	7.50-	7.57	720	3850	10.78	57.62
18.85-	19.04	7.42-	7.49	733	3130	10.97	46.84
18.65-	18.84	7.34-	7.41	650	2397	9.73	35.87
18.45-	18.64	7.26-	7.33	523	1747	7.83	26.14
18.25-	18.44	7.19-	7.25	413	1224	6.18	18.32
18.05-	18.24	7.11-	7.18	335	811	5.01	12.14
17.85-	18.04	7.03-	7.10	202	476	3.02	7.12
17.65-	17.84	6.95-	7.02	114	274	1.71	4.10
17.45-	17.64	6.87-	6.94	76	160	1.14	2.39
17.25-	17.44	6.79-	6.86	47	84	0.70	1.26
17.05-	17.24	6.71-	6.78	19	37	0.28	0.55
16.85-	17.04	6.63-	6.70	11	18	0.16	0.27
16.65-	16.84	6.56-	6.62	6	7	0.09	0.10
16.45-	16.64	6.48-	6.55	1	1	0.01	0.01

49 Occiput-Nasal Root

PERCENTILES

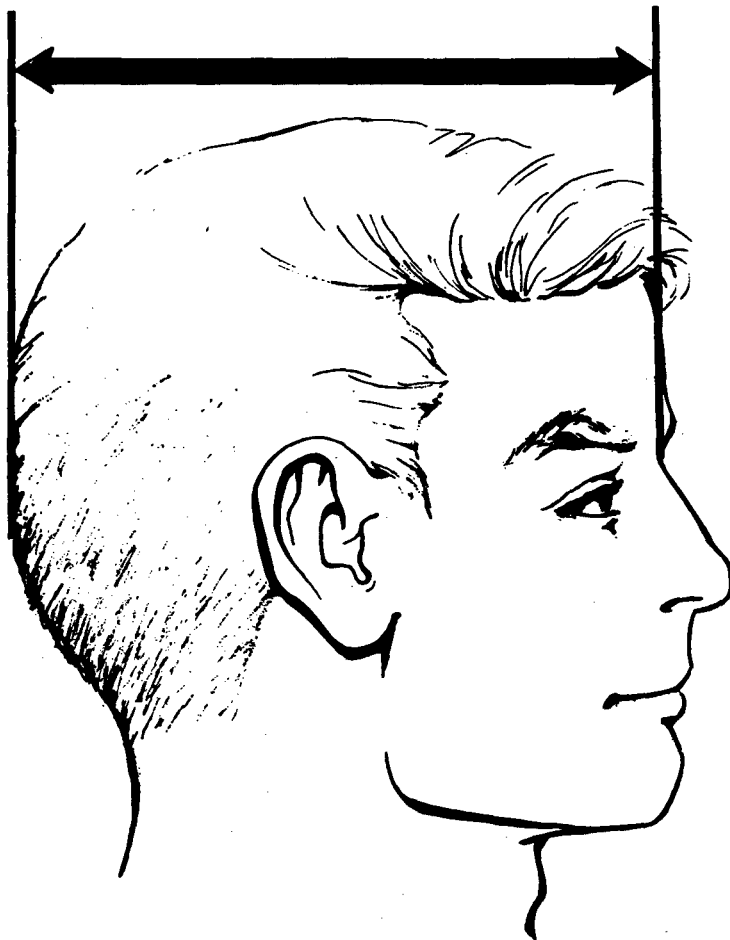

CENTIMETERS		INCHES	
20.75	99 TH	8.17	
20.56	98 TH	8.09	
20.44	97 TH	8.05	
20.27	95 TH	7.98	
20.02	90 TH	7.88	
19.85	85 TH	7.81	
19.71	80 TH	7.76	
19.59	75 TH	7.71	
19.49	70 TH	7.67	
19.39	65 TH	7.63	
19.29	60 TH	7.60	
19.20	55 TH	7.56	
19.11	50 TH	7.52	
19.02	45 TH	7.49	
18.93	40 TH	7.45	
18.83	35 TH	7.41	
18.73	30 TH	7.37	
18.62	25 TH	7.33	
18.50	20 TH	7.28	
18.35	15 TH	7.22	
18.17	10 TH	7.15	
17.89	5 TH	7.04	
17.72	3 RD	6.97	
17.59	2 ND	6.92	
17.38	1 ST	6.84	

THE SUMMARY STATISTICS

....

Occiput-Nasal Root: Subject sits erect, with head level. The distance from the back of the head (occiput) to the nasal root depression between the eyes is measured. Spreading calipers are used.

CENTIMETERS		INCHES	
19.10	MEAN	7.52	
0.01	SE(M)	0.00	
0.72	ST DEV	0.28	
0.01	SE(SD)	0.00	

....

SYMMETRY--BETA I = -0.05

KURTOSIS--BETA II = 2.98

COEFFICIENT OF VARIATION = 3.77

....

SAMPLE SIZE = 6682

50 Occiput-External Canthus

--INTERVALS--				--FREQUENCIES--			
CENTIMETERS		INCHES		ACTUAL FREQ	CUMULA TIVE-F	PERCEN T-FREQ	CUMUL- PCT-FQ
20.65-	20.84	8.13-	8.20	1	6682	0.01	100.00
20.45-	20.64	8.05-	8.12	0	6681	0.00	99.99
20.25-	20.44	7.97-	8.04	0	6681	0.00	99.99
20.05-	20.24	7.89-	7.96	10	6681	0.15	99.99
19.85-	20.04	7.82-	7.88	6	6671	0.09	99.84
19.65-	19.84	7.74-	7.81	18	6665	0.27	99.75
19.45-	19.64	7.66-	7.73	33	6647	0.49	99.48
19.25-	19.44	7.58-	7.65	61	6614	0.91	98.98
19.05-	19.24	7.50-	7.57	104	6553	1.56	98.07
18.85-	19.04	7.42-	7.49	151	6449	2.26	96.51
18.65-	18.84	7.34-	7.41	153	6298	2.29	94.25
18.45-	18.64	7.26-	7.33	254	6145	3.80	91.96
18.25-	18.44	7.19-	7.25	295	5891	4.41	88.16
18.05-	18.24	7.11-	7.18	366	5596	5.48	83.75
17.85-	18.04	7.03-	7.10	327	5230	4.89	78.27
17.65-	17.84	6.95-	7.02	447	4903	6.69	73.38
17.45-	17.64	6.87-	6.94	461	4456	6.90	66.69
17.25-	17.44	6.79-	6.86	556	3995	8.32	59.79
17.05-	17.24	6.71-	6.78	552	3439	8.26	51.47
16.85-	17.04	6.63-	6.70	498	2887	7.45	43.21
16.65-	16.84	6.56-	6.62	513	2389	7.68	35.75
16.45-	16.64	6.48-	6.55	417	1876	6.24	28.08
16.25-	16.44	6.40-	6.47	428	1459	6.41	21.83
16.05-	16.24	6.32-	6.39	320	1031	4.79	15.43
15.85-	16.04	6.24-	6.31	218	711	3.26	10.64
15.65-	15.84	6.16-	6.23	184	493	2.75	7.38
15.45-	15.64	6.08-	6.15	127	309	1.90	4.62
15.25-	15.44	6.00-	6.07	79	182	1.18	2.72
15.05-	15.24	5.93-	5.99	41	103	0.61	1.54
14.85-	15.04	5.85-	5.92	25	62	0.37	0.93
14.65-	14.84	5.77-	5.84	21	37	0.31	0.55
14.45-	14.64	5.69-	5.76	11	16	0.16	0.24
14.25-	14.44	5.61-	5.68	4	5	0.06	0.07
14.05-	14.24	5.53-	5.60	0	1	0.00	0.01
13.85-	14.04	5.45-	5.52	1	1	0.01	0.01

50 Occiput-External Canthus

PERCENTILES

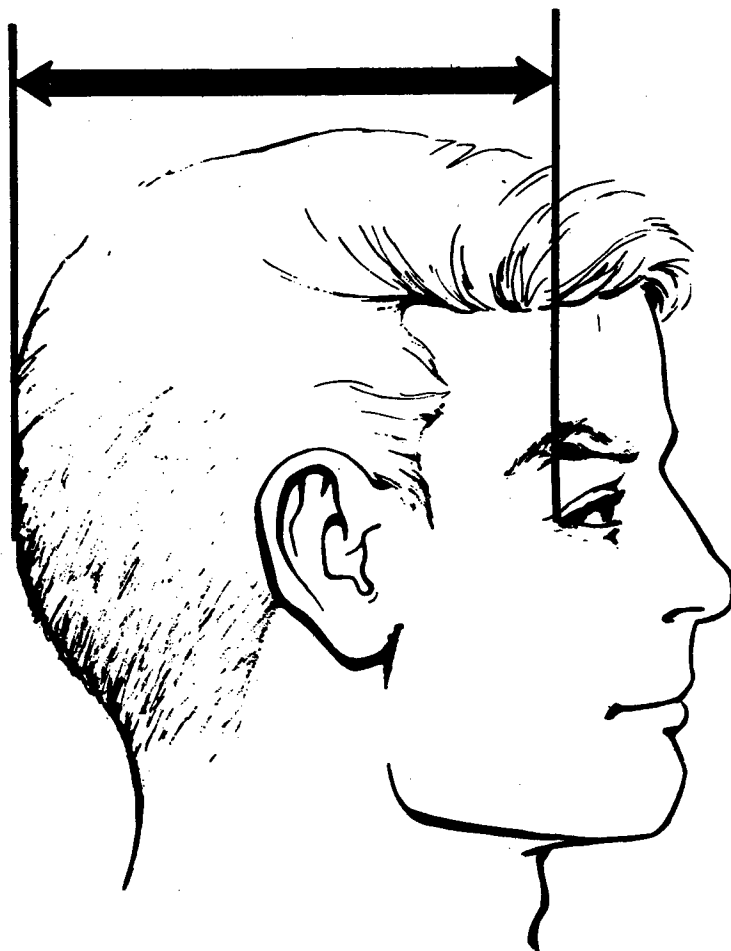

CENTIMETERS

INCHES

19.45	99 TH	7.66
19.26	98 TH	7.58
19.12	97 TH	7.53
18.91	95 TH	7.44
18.55	90 TH	7.30
18.30	85 TH	7.20
18.09	80 TH	7.12
17.92	75 TH	7.05
17.76	70 TH	6.99
17.61	65 TH	6.93
17.47	60 TH	6.88
17.34	55 TH	6.83
17.21	50 TH	6.78
17.09	45 TH	6.73
16.96	40 TH	6.68
16.83	35 TH	6.63
16.70	30 TH	6.57
16.55	25 TH	6.52
16.40	20 TH	6.46
16.22	15 TH	6.39
16.01	10 TH	6.30
15.69	5 TH	6.18
15.48	3 RD	6.09
15.33	2 ND	6.03
15.07	1 ST	5.93

THE SUMMARY STATISTICS

....

Occiput-External Canthus: Subject sits erect, with head level. The distance from the back of the head (occiput) to the outer corner (external canthus) of the right eye is measured. An anthropometer is used.

CENTIMETERS

INCHES

17.24	MEAN	6.79
0.01	SE(M)	0.00
0.98	ST DEV	0.38
0.01	SE(SD)	0.00

....

SYMMETRY--BETA I =	0.09
KURTOSIS--BETA II =	2.75
COEFFICIENT OF VARIATION =	5.67

....

SAMPLE SIZE = 6682

51 Occiput-Trasion

--INTERVALS--

--FREQUENCIES--

CENTIMETERS		INCHES		ACTUAL FREQ	CUMULA TIVE-F	PERCEN T-FREQ	CUMUL- PCT-FQ
14.45-	14.64	5.69-	5.76	1	6682	0.01	100.00
14.25-	14.44	5.61-	5.68	0	6681	0.00	99.99
14.05-	14.24	5.53-	5.60	0	6681	0.00	99.99
13.85-	14.04	5.45-	5.52	0	6681	0.00	99.99
13.65-	13.84	5.37-	5.44	2	6681	0.03	99.99
13.45-	13.64	5.30-	5.36	9	6679	0.13	99.96
13.25-	13.44	5.22-	5.29	11	6670	0.16	99.82
13.05-	13.24	5.14-	5.21	18	6659	0.27	99.66
12.85-	13.04	5.06-	5.13	37	6641	0.55	99.39
12.65-	12.84	4.98-	5.05	71	6604	1.06	98.83
12.45-	12.64	4.90-	4.97	100	6533	1.50	97.77
12.25-	12.44	4.82-	4.89	144	6433	2.16	96.27
12.05-	12.24	4.74-	4.81	180	6289	2.69	94.12
11.85-	12.04	4.67-	4.73	188	6109	2.81	91.42
11.65-	11.84	4.59-	4.66	230	5921	3.44	88.61
11.45-	11.64	4.51-	4.58	287	5691	4.30	85.17
11.25-	11.44	4.43-	4.50	290	5404	4.34	80.87
11.05-	11.24	4.35-	4.42	289	5114	4.33	76.53
10.85-	11.04	4.27-	4.34	273	4825	4.09	72.21
10.65-	10.84	4.19-	4.26	288	4552	4.31	68.12
10.45-	10.64	4.11-	4.18	346	4264	5.18	63.81
10.25-	10.44	4.04-	4.10	372	3918	5.57	58.64
10.05-	10.24	3.96-	4.03	378	3546	5.66	53.07
9.85-	10.04	3.88-	3.95	449	3168	6.72	47.41
9.65-	9.84	3.80-	3.87	457	2719	6.84	40.69
9.45-	9.64	3.72-	3.79	483	2262	7.23	33.85
9.25-	9.44	3.64-	3.71	409	1779	6.12	26.62
9.05-	9.24	3.56-	3.63	381	1370	5.70	20.50
8.85-	9.04	3.48-	3.55	291	989	4.35	14.80
8.65-	8.84	3.41-	3.47	216	698	3.23	10.45
8.45-	8.64	3.33-	3.40	166	482	2.48	7.21
8.25-	8.44	3.25-	3.32	113	316	1.69	4.73
8.05-	8.24	3.17-	3.24	96	203	1.44	3.04
7.85-	8.04	3.09-	3.16	51	107	0.76	1.60
7.65-	7.84	3.01-	3.08	30	56	0.45	0.84
7.45-	7.64	2.93-	3.00	8	26	0.12	0.39
7.25-	7.44	2.85-	2.92	9	18	0.13	0.27
7.05-	7.24	2.78-	2.84	7	9	0.10	0.13
6.85-	7.04	2.70-	2.77	2	2	0.03	0.03

51 Occiput-Tragion

PERCENTILES

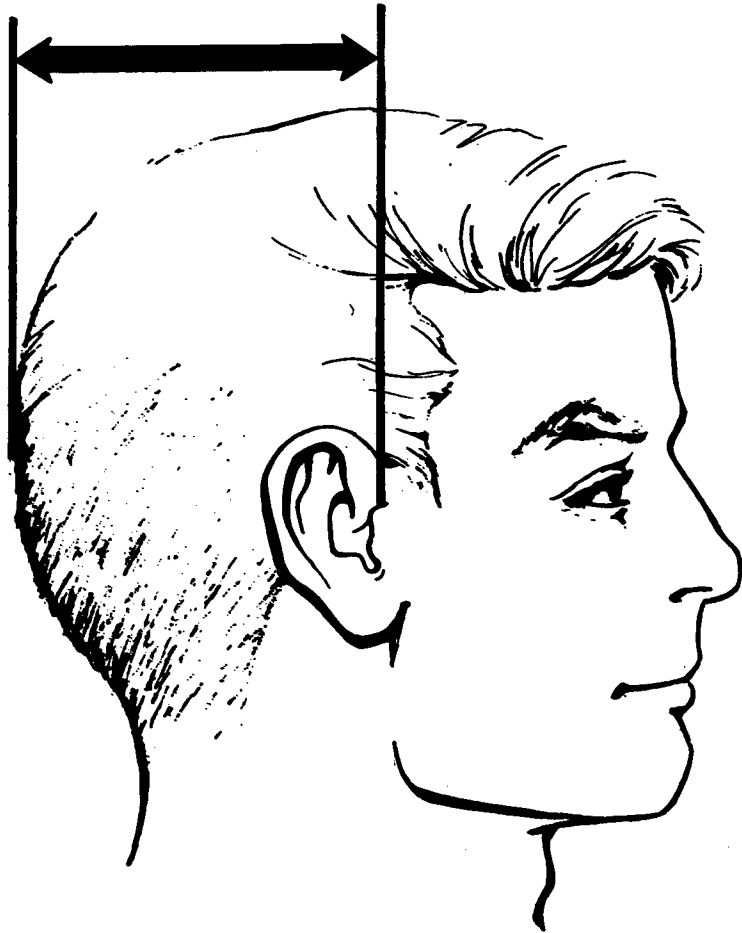

CENTIMETERS		INCHES	
12.86	99 TH	5.06	
12.73	98 TH	5.01	
12.60	97 TH	4.96	
12.37	95 TH	4.87	
11.94	90 TH	4.70	
11.62	85 TH	4.57	
11.35	80 TH	4.47	
11.11	75 TH	4.37	
10.90	70 TH	4.29	
10.71	65 TH	4.22	
10.53	60 TH	4.14	
10.35	55 TH	4.08	
10.19	50 TH	4.01	
10.03	45 TH	3.95	
9.87	40 TH	3.88	
9.71	35 TH	3.82	
9.55	30 TH	3.76	
9.38	25 TH	3.69	
9.21	20 TH	3.62	
9.01	15 TH	3.55	
8.79	10 TH	3.46	
8.47	5 TH	3.33	
8.27	3 RD	3.26	
8.12	2 ND	3.20	
7.88	1 ST	3.10	

THE SUMMARY STATISTICS

....

Occiput-Tragion: Subject sits erect, with head level. The distance from the back of the head (occiput) to the cartilaginous notch (tragion) at the front of the right ear is measured. An anthropometer is used.

CENTIMETERS		INCHES	
10.28	MEAN	4.05	
0.01	SE(M)	0.01	
1.19	ST DEV	0.47	
0.01	SE(SD)	0.00	

....

SYMMETRY--BETA I = 0.23
 KURTOSIS--BETA II = 2.45
 COEFFICIENT OF VARIATION = 11.58

....

SAMPLE SIZE = 6682

52 Occiput-Pronasale

--INTERVALS--

--FREQUENCIES--

CENTIMETERS		INCHES		ACTUAL FREQ	CUMULA TIVE-F	PERCEN T-FREQ	CUMUL- PCT-FQ
25.25-	25.44	9.94-	10.01	1	6682	0.01	100.00
25.05-	25.24	9.86-	9.93	2	6681	0.03	99.99
24.85-	25.04	9.78-	9.85	1	6679	0.01	99.96
24.65-	24.84	9.70-	9.77	7	6678	0.10	99.94
24.45-	24.64	9.63-	9.69	4	6671	0.06	99.84
24.25-	24.44	9.55-	9.62	24	6667	0.36	99.78
24.05-	24.24	9.47-	9.54	38	6643	0.57	99.42
23.85-	24.04	9.39-	9.46	54	6605	0.81	98.85
23.65-	23.84	9.31-	9.38	102	6551	1.53	98.04
23.45-	23.64	9.23-	9.30	180	6449	2.69	96.51
23.25-	23.44	9.15-	9.22	261	6269	3.91	93.82
23.05-	23.24	9.07-	9.14	377	6008	5.64	89.91
22.85-	23.04	9.00-	9.06	351	5631	5.25	84.27
22.65-	22.84	8.92-	8.99	564	5280	8.44	79.02
22.45-	22.64	8.84-	8.91	545	4716	8.16	70.58
22.25-	22.44	8.76-	8.83	641	4171	9.59	62.42
22.05-	22.24	8.68-	8.75	672	3530	10.06	52.83
21.85-	22.04	8.60-	8.67	562	2858	8.41	42.77
21.65-	21.84	8.52-	8.59	599	2296	8.96	34.36
21.45-	21.64	8.45-	8.51	430	1697	6.44	25.40
21.25-	21.44	8.37-	8.44	409	1267	6.12	18.96
21.05-	21.24	8.29-	8.36	294	858	4.40	12.84
20.85-	21.04	8.21-	8.28	185	564	2.77	8.44
20.65-	20.84	8.13-	8.20	145	379	2.17	5.67
20.45-	20.64	8.05-	8.12	91	234	1.36	3.50
20.25-	20.44	7.97-	8.04	58	143	0.87	2.14
20.05-	20.24	7.89-	7.96	43	85	0.64	1.27
19.85-	20.04	7.82-	7.88	21	42	0.31	0.63
19.65-	19.84	7.74-	7.81	11	21	0.16	0.31
19.45-	19.64	7.66-	7.73	8	10	0.12	0.15
19.25-	19.44	7.58-	7.65	1	2	0.01	0.03
19.05-	19.24	7.50-	7.57	0	1	0.00	0.01
18.85-	19.04	7.42-	7.49	1	1	0.01	0.01

52 Occiput-Pronasale

PERCENTILES

CENTIMETERS		INCHES	
24.08	99 TH	9.48	
23.87	98 TH	9.40	
23.73	97 TH	9.34	
23.54	95 TH	9.27	
23.25	90 TH	9.15	
23.05	85 TH	9.07	
22.89	80 TH	9.01	
22.75	75 TH	8.96	
22.63	70 TH	8.91	
22.52	65 TH	8.86	
22.41	60 TH	8.82	
22.30	55 TH	8.78	
22.20	50 TH	8.74	
22.09	45 TH	8.70	
21.99	40 TH	8.66	
21.87	35 TH	8.61	
21.76	30 TH	8.57	
21.63	25 TH	8.52	
21.49	20 TH	8.46	
21.32	15 TH	8.39	
21.11	10 TH	8.31	
20.79	5 TH	8.18	
20.58	3 RD	8.10	
20.42	2 ND	8.04	
20.17	1 ST	7.94	

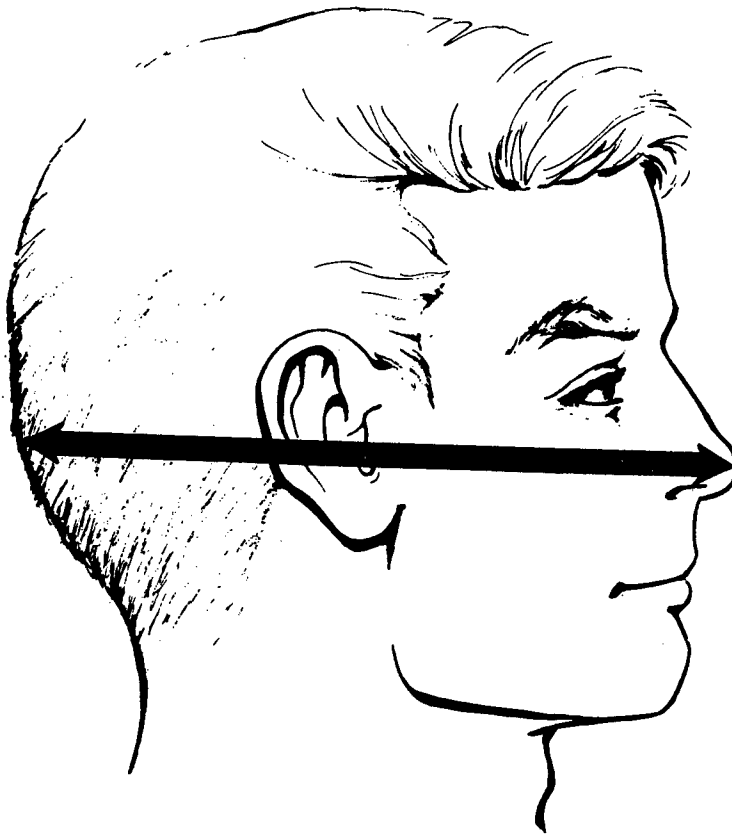

Occiput-Pronasale: Subject sits erect, with head level. The distance from the back of the head (occiput) to the tip of the nose (pronasale) is measured. Spreading calipers are used.

THE SUMMARY STATISTICS

.....

CENTIMETERS		INCHES	
22.19	MEAN	8.74	
0.01	SE(M)	0.00	
0.83	ST DEV	0.33	
0.01	SE(SD)	0.00	

.....

SYMMETRY--BETA I = -0.06
 KURTOSIS--BETA II = 3.02
 COEFFICIENT OF VARIATION = 3.75

.....

SAMPLE SIZE = 6682

53 Head Breadth

--INTERVALS--		--FREQUENCIES--					
CENTIMETERS		INCHES		ACTUAL	CUMULA	PERCEN	CUMUL-
				FREQ	TIVE-F	T-FREQ	PCT-FQ
17.35-	17.44	6.83-	6.86	1	6682	0.01	100.00
17.25-	17.34	6.79-	6.82	3	6681	0.04	99.99
17.15-	17.24	6.75-	6.78	3	6678	0.04	99.94
17.05-	17.14	6.71-	6.74	1	6675	0.01	99.90
16.95-	17.04	6.67-	6.70	6	6674	0.09	99.88
16.85-	16.94	6.63-	6.66	13	6668	0.19	99.79
16.75-	16.84	6.59-	6.62	26	6655	0.39	99.60
16.65-	16.74	6.56-	6.58	42	6629	0.63	99.21
16.55-	16.64	6.52-	6.55	30	6587	0.45	98.58
16.45-	16.54	6.48-	6.51	31	6557	0.46	98.13
16.35-	16.44	6.44-	6.47	85	6526	1.27	97.67
16.25-	16.34	6.40-	6.43	114	6441	1.71	96.39
16.15-	16.24	6.36-	6.39	136	6327	2.04	94.69
16.05-	16.14	6.32-	6.35	158	6191	2.36	92.65
15.95-	16.04	6.28-	6.31	127	6033	1.90	90.29
15.85-	15.94	6.24-	6.27	231	5906	3.46	88.39
15.75-	15.84	6.20-	6.23	332	5675	4.97	84.93
15.65-	15.74	6.16-	6.19	350	5343	5.24	79.96
15.55-	15.64	6.12-	6.15	382	4993	5.72	74.72
15.45-	15.54	6.08-	6.11	215	4611	3.22	69.01
15.35-	15.44	6.04-	6.07	529	4396	7.92	65.79
15.25-	15.34	6.00-	6.03	638	3867	9.55	57.87
15.15-	15.24	5.96-	5.99	484	3229	7.24	48.32
15.05-	15.14	5.93-	5.95	413	2745	6.18	41.08
14.95-	15.04	5.89-	5.92	282	2332	4.22	34.90
14.85-	14.94	5.85-	5.88	408	2050	6.11	30.68
14.75-	14.84	5.81-	5.84	395	1642	5.91	24.57
14.65-	14.74	5.77-	5.80	321	1247	4.80	18.66
14.55-	14.64	5.73-	5.76	254	926	3.80	13.86
14.45-	14.54	5.69-	5.72	124	672	1.86	10.06
14.35-	14.44	5.65-	5.68	186	548	2.78	8.20
14.25-	14.34	5.61-	5.64	136	362	2.04	5.42
14.15-	14.24	5.57-	5.60	79	226	1.18	3.38
14.05-	14.14	5.53-	5.56	42	147	0.63	2.20
13.95-	14.04	5.49-	5.52	29	105	0.43	1.57
13.85-	13.94	5.45-	5.48	17	76	0.25	1.14
13.75-	13.84	5.41-	5.44	24	59	0.36	0.88
13.65-	13.74	5.37-	5.40	13	35	0.19	0.52
13.55-	13.64	5.33-	5.36	8	22	0.12	0.33
13.45-	13.54	5.30-	5.32	7	14	0.10	0.21
13.35-	13.44	5.26-	5.29	4	7	0.06	0.10
13.25-	13.34	5.22-	5.25	1	3	0.01	0.04
13.15-	13.24	5.18-	5.21	0	2	0.00	0.03
13.05-	13.14	5.14-	5.17	1	2	0.01	0.03
12.95-	13.04	5.10-	5.13	0	1	0.00	0.01
12.85-	12.94	5.06-	5.09	1	1	0.01	0.01

53 Head Breadth

PERCENTILES

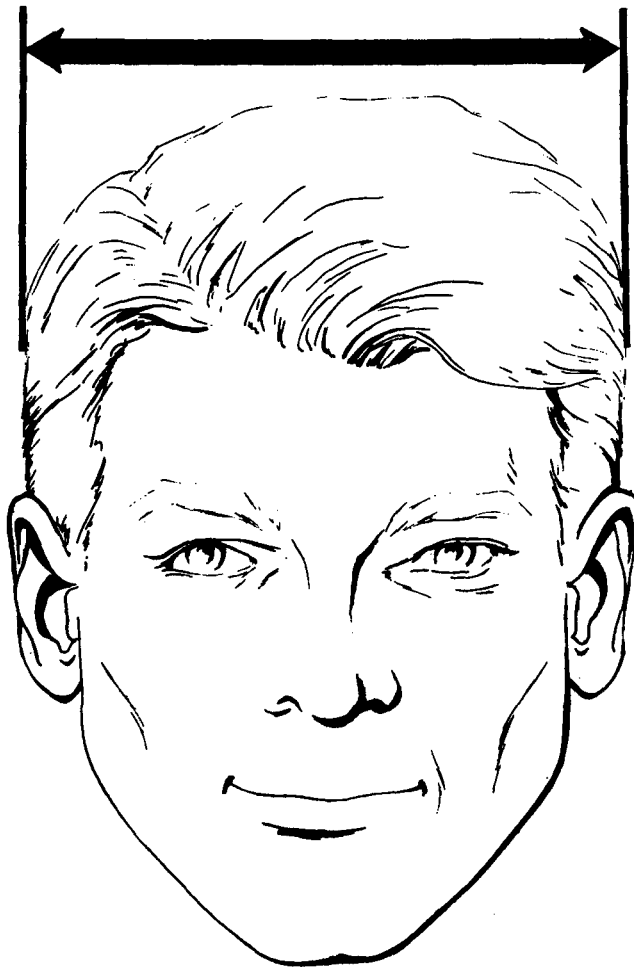

CENTIMETERS.		INCHES
16.71	99 TH	6.58
16.53	98 TH	6.51
16.41	97 TH	6.46
16.26	95 TH	6.40
16.02	90 TH	6.31
15.87	85 TH	6.25
15.75	80 TH	6.20
15.64	75 TH	6.16
15.55	70 TH	6.12
15.47	65 TH	6.09
15.40	60 TH	6.06
15.32	55 TH	6.03
15.25	50 TH	6.00
15.18	45 TH	5.98
15.11	40 TH	5.95
15.04	35 TH	5.92
14.96	30 TH	5.89
14.88	25 TH	5.86
14.79	20 TH	5.82
14.68	15 TH	5.78
14.55	10 TH	5.73
14.34	5 TH	5.65
14.20	3 RD	5.59
14.09	2 ND	5.55
13.92	1 ST	5.48

THE SUMMARY STATISTICS

••••

Head Breadth: Subject sits erect, with head level. The maximum horizontal breadth of the head is measured above and behind the ears. Spreading calipers are used.

CENTIMETERS		INCHES
15.27	MEAN	6.01
0.01	SE(M)	0.00
0.59	ST DEV	0.23
0.01	SE(SD)	0.00

••••

SYMMETRY--BETA I = 0.10
KURTOSIS--BETA II = 3.13

COEFFICIENT OF VARIATION = 3.83

••••

SAMPLE SIZE = 6682

54 Bitragon Breadth

--INTERVALS--				--FREQUENCIES--			
CENTIMETERS		INCHES		ACTUAL FREQ	CUMULA TIVE-F	PERCEN T-FREQ	CUMUL- PCT-FQ
15.55-	15.64	6.12-	6.15	1	6682	0.01	100.00
15.45-	15.54	6.08-	6.11	2	6681	0.03	99.99
15.35-	15.44	6.04-	6.07	2	6679	0.03	99.96
15.25-	15.34	6.00-	6.03	6	6677	0.09	99.93
15.15-	15.24	5.96-	5.99	7	6671	0.10	99.84
15.05-	15.14	5.93-	5.95	9	6664	0.13	99.73
14.95-	15.04	5.89-	5.92	9	6655	0.13	99.60
14.85-	14.94	5.85-	5.88	32	6646	0.48	99.46
14.75-	14.84	5.81-	5.84	29	6614	0.43	98.98
14.65-	14.74	5.77-	5.80	53	6585	0.79	98.55
14.55-	14.64	5.73-	5.76	92	6532	1.38	97.76
14.45-	14.54	5.69-	5.72	74	6440	1.11	96.38
14.35-	14.44	5.65-	5.68	154	6366	2.30	95.27
14.25-	14.34	5.61-	5.64	150	6212	2.24	92.97
14.15-	14.24	5.57-	5.60	193	6062	2.89	90.72
14.05-	14.14	5.53-	5.56	260	5869	3.89	87.83
13.95-	14.04	5.49-	5.52	287	5609	4.30	83.94
13.85-	13.94	5.45-	5.48	367	5322	5.49	79.65
13.75-	13.84	5.41-	5.44	401	4955	6.00	74.15
13.65-	13.74	5.37-	5.40	490	4554	7.33	68.15
13.55-	13.64	5.33-	5.36	466	4064	6.97	60.82
13.45-	13.54	5.30-	5.32	392	3598	5.87	53.85
13.35-	13.44	5.26-	5.29	521	3206	7.80	47.98
13.25-	13.34	5.22-	5.25	439	2685	6.57	40.18
13.15-	13.24	5.18-	5.21	442	2246	6.61	33.61
13.05-	13.14	5.14-	5.17	376	1804	5.63	27.00
12.95-	13.04	5.10-	5.13	327	1428	4.89	21.37
12.85-	12.94	5.06-	5.09	282	1101	4.22	16.48
12.75-	12.84	5.02-	5.05	214	819	3.20	12.26
12.65-	12.74	4.98-	5.01	192	605	2.87	9.05
12.55-	12.64	4.94-	4.97	125	413	1.87	6.18
12.45-	12.54	4.90-	4.93	74	288	1.11	4.31
12.35-	12.44	4.86-	4.89	81	214	1.21	3.20
12.25-	12.34	4.82-	4.85	42	133	0.63	1.99
12.15-	12.24	4.78-	4.81	43	91	0.64	1.36
12.05-	12.14	4.74-	4.77	16	48	0.24	0.72
11.95-	12.04	4.70-	4.73	16	32	0.24	0.48
11.85-	11.94	4.67-	4.69	8	16	0.12	0.24
11.75-	11.84	4.63-	4.66	3	8	0.04	0.12
11.65-	11.74	4.59-	4.62	2	5	0.03	0.07
11.55-	11.64	4.55-	4.58	1	3	0.01	0.04
11.45-	11.54	4.51-	4.54	1	2	0.01	0.03
11.35-	11.44	4.47-	4.50	1	1	0.01	0.01

54 Bitracion Breadth

PERCENTILES

CENTIMETERS		INCHES	
14.85	99 TH	5.85	
14.69	98 TH	5.78	
14.58	97 TH	5.74	
14.44	95 TH	5.69	
14.22	90 TH	5.60	
14.08	85 TH	5.54	
13.97	80 TH	5.50	
13.87	75 TH	5.46	
13.78	70 TH	5.43	
13.70	65 TH	5.40	
13.63	60 TH	5.37	
13.56	55 TH	5.34	
13.49	50 TH	5.31	
13.42	45 TH	5.28	
13.35	40 TH	5.25	
13.27	35 TH	5.23	
13.20	30 TH	5.20	
13.11	25 TH	5.16	
13.02	20 TH	5.13	
12.91	15 TH	5.08	
12.78	10 TH	5.03	
12.58	5 TH	4.95	
12.45	3 RD	4.90	
12.35	2 ND	4.86	
12.19	1 ST	4.80	

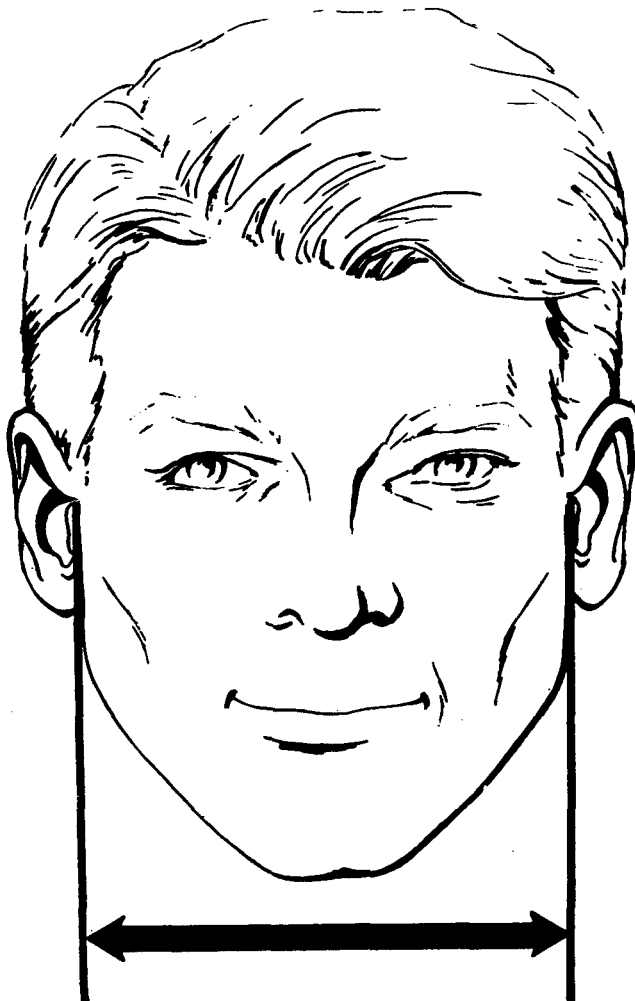

THE SUMMARY STATISTICS

.....

Bitracion Breadth: Subject sits erect, with head level. The horizontal breadth of the head is measured from the right tracion (the cartilaginous notch at the front of the right ear) to the corresponding tracion of the left ear. Spreading calipers are used.

CENTIMETERS		INCHES	
13.50	MEAN	5.31	
0.01	SE(M)	0.00	
0.56	ST DEV	0.22	
0.00	SE(SD)	0.00	
.....			
SYMMETRY--BETA I =		0.08	
KURTOSIS--BETA II =		3.06	
COEFFICIENT OF VARIATION =		4.18	
.....			
SAMPLE SIZE =		6682	

55 Head Height

--INTERVALS--				--FREQUENCIES--			
CENTIMETERS		INCHES		ACTUAL FREQ	CUMULA TIVE-F	PERCEN T-FREQ	CUMUL- PCT-FQ
15.85-	16.04	6.24-	6.31	1	6682	0.01	100.00
15.65-	15.84	6.16-	6.23	4	6681	0.06	99.99
15.45-	15.64	6.08-	6.15	5	6677	0.07	99.93
15.25-	15.44	6.00-	6.07	19	6672	0.28	99.85
15.05-	15.24	5.93-	5.99	29	6653	0.43	99.57
14.85-	15.04	5.85-	5.92	55	6624	0.82	99.13
14.65-	14.84	5.77-	5.84	94	6569	1.41	98.31
14.45-	14.64	5.69-	5.76	187	6475	2.80	96.90
14.25-	14.44	5.61-	5.68	279	6288	4.18	94.10
14.05-	14.24	5.53-	5.60	375	6009	5.61	89.93
13.85-	14.04	5.45-	5.52	441	5634	6.60	84.32
13.65-	13.84	5.37-	5.44	505	5193	7.56	77.72
13.45-	13.64	5.30-	5.36	579	4688	8.67	70.16
13.25-	13.44	5.22-	5.29	676	4109	10.12	61.49
13.05-	13.24	5.14-	5.21	709	3433	10.61	51.38
12.85-	13.04	5.06-	5.13	591	2724	8.84	40.77
12.65-	12.84	4.98-	5.05	577	2133	8.64	31.92
12.45-	12.64	4.90-	4.97	455	1556	6.81	23.29
12.25-	12.44	4.82-	4.89	380	1101	5.69	16.48
12.05-	12.24	4.74-	4.81	278	721	4.16	10.79
11.85-	12.04	4.67-	4.73	172	443	2.57	6.63
11.65-	11.84	4.59-	4.66	115	271	1.72	4.06
11.45-	11.64	4.51-	4.58	63	156	0.94	2.33
11.25-	11.44	4.43-	4.50	39	93	0.58	1.39
11.05-	11.24	4.35-	4.42	25	54	0.37	0.81
10.85-	11.04	4.27-	4.34	13	29	0.19	0.43
10.65-	10.84	4.19-	4.26	9	16	0.13	0.24
10.45-	10.64	4.11-	4.18	2	7	0.03	0.10
10.25-	10.44	4.04-	4.10	4	5	0.06	0.07
10.05-	10.24	3.96-	4.03	1	1	0.01	0.01

55 Head Height

PERCENTILES

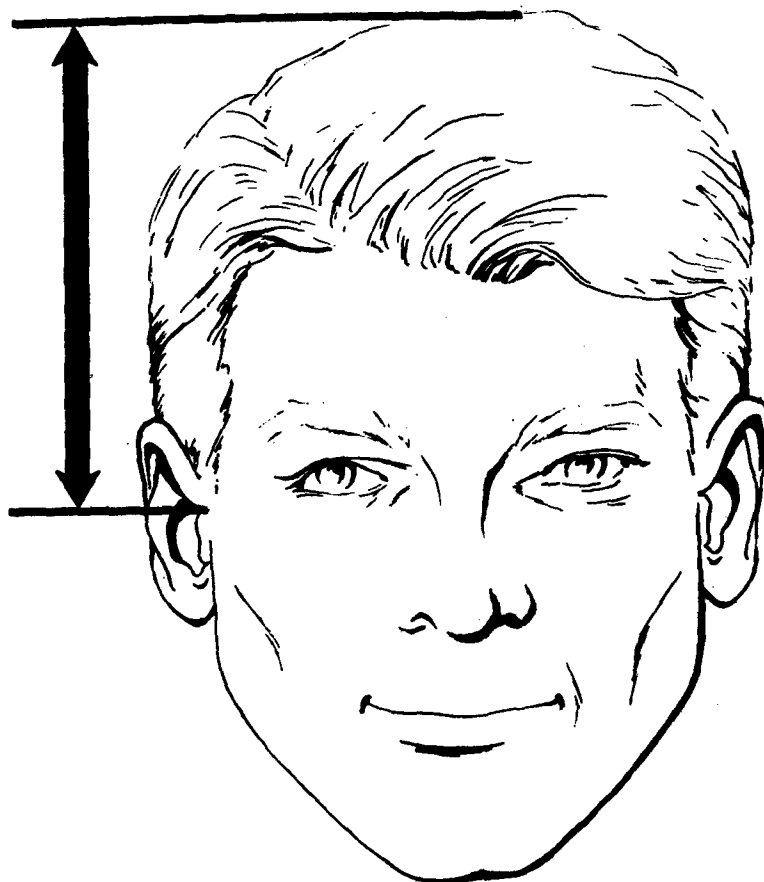

CENTIMETERS		INCHES	
15.00	99 TH	5.90	
14.82	98 TH	5.83	
14.70	97 TH	5.79	
14.52	95 TH	5.72	
14.25	90 TH	5.61	
14.05	85 TH	5.53	
13.90	80 TH	5.47	
13.77	75 TH	5.42	
13.65	70 TH	5.37	
13.54	65 TH	5.33	
13.43	60 TH	5.29	
13.33	55 TH	5.25	
13.23	50 TH	5.21	
13.13	45 TH	5.17	
13.03	40 TH	5.13	
12.92	35 TH	5.09	
12.81	30 TH	5.04	
12.69	25 TH	5.00	
12.56	20 TH	4.94	
12.41	15 TH	4.88	
12.21	10 TH	4.81	
11.91	5 TH	4.69	
11.72	3 RD	4.61	
11.57	2 ND	4.56	
11.33	1 ST	4.46	

THE SUMMARY STATISTICS

Head Height (Tragion-Vertex Height):
 Subject sits erect, with head level.
 Head height is measured as the vertical distance from the cartilaginous notch (tragion) at the front of the right ear to the top of the head (vertex). An anthropometer is used.

CENTIMETERS		INCHES	
13.23	MEAN	5.21	
0.01	SE(M)	0.00	
0.79	ST DEV	0.31	
0.01	SE(SD)	0.00	

.....
 SYMMETRY--BETA I = -0.07
 KURTOSIS--BETA II = 2.99
 COEFFICIENT OF VARIATION = 5.99

 SAMPLE SIZE = 6682

56 Face Length

		--INTERVALS--		--FREQUENCIES--			
CENTIMETERS		INCHES		ACTUAL FREQ	CUMULA TIVE-F	PERCEN T-FREQ	CUMUL- PCT-FQ
14.55-	14.64	5.73-	5.76	1	6681	0.01	100.00
14.45-	14.54	5.69-	5.72	0	6680	0.00	99.99
14.35-	14.44	5.65-	5.68	1	6680	0.01	99.99
14.25-	14.34	5.61-	5.64	3	6679	0.04	99.97
14.15-	14.24	5.57-	5.60	6	6676	0.09	99.93
14.05-	14.14	5.53-	5.56	7	6670	0.10	99.84
13.95-	14.04	5.49-	5.52	3	6663	0.04	99.73
13.85-	13.94	5.45-	5.48	8	6660	0.12	99.69
13.75-	13.84	5.41-	5.44	13	6652	0.19	99.57
13.65-	13.74	5.37-	5.40	19	6639	0.28	99.37
13.55-	13.64	5.33-	5.36	33	6620	0.49	99.09
13.45-	13.54	5.30-	5.32	30	6587	0.45	98.59
13.35-	13.44	5.26-	5.29	47	6557	0.70	98.14
13.25-	13.34	5.22-	5.25	68	6510	1.02	97.44
13.15-	13.24	5.18-	5.21	88	6442	1.32	96.42
13.05-	13.14	5.14-	5.17	89	6354	1.33	95.11
12.95-	13.04	5.10-	5.13	109	6265	1.63	93.77
12.85-	12.94	5.06-	5.09	165	6156	2.47	92.14
12.75-	12.84	5.02-	5.05	202	5991	3.02	89.67
12.65-	12.74	4.98-	5.01	260	5789	3.89	86.65
12.55-	12.64	4.94-	4.97	252	5529	3.77	82.76
12.45-	12.54	4.90-	4.93	245	5277	3.67	78.99
12.35-	12.44	4.86-	4.89	423	5032	6.33	75.32
12.25-	12.34	4.82-	4.85	375	4609	5.61	68.99
12.15-	12.24	4.78-	4.81	406	4234	6.08	63.37
12.05-	12.14	4.74-	4.77	411	3828	6.15	57.30
11.95-	12.04	4.70-	4.73	306	3417	4.58	51.15
11.85-	11.94	4.67-	4.69	462	3111	6.92	46.56
11.75-	11.84	4.63-	4.66	382	2649	5.72	39.65
11.65-	11.74	4.59-	4.62	376	2267	5.63	33.93
11.55-	11.64	4.55-	4.58	312	1891	4.67	28.30
11.45-	11.54	4.51-	4.54	266	1579	3.98	23.63
11.35-	11.44	4.47-	4.50	291	1313	4.36	19.65
11.25-	11.34	4.43-	4.46	241	1022	3.61	15.30
11.15-	11.24	4.39-	4.42	202	781	3.02	11.69
11.05-	11.14	4.35-	4.38	130	579	1.95	8.67
10.95-	11.04	4.31-	4.34	110	449	1.65	6.72
10.85-	10.94	4.27-	4.30	116	339	1.74	5.07
10.75-	10.84	4.23-	4.26	71	223	1.06	3.34
10.65-	10.74	4.19-	4.22	47	152	0.70	2.28
10.55-	10.64	4.15-	4.18	29	105	0.43	1.57
10.45-	10.54	4.11-	4.14	21	76	0.31	1.14
10.35-	10.44	4.07-	4.10	19	55	0.28	0.82
10.25-	10.34	4.04-	4.06	13	36	0.19	0.54
10.15-	10.24	4.00-	4.03	10	23	0.15	0.34
10.05-	10.14	3.96-	3.99	9	13	0.13	0.19
9.95-	10.04	3.92-	3.95	1	4	0.01	0.06
9.85-	9.94	3.88-	3.91	0	3	0.00	0.04
9.75-	9.84	3.84-	3.87	0	3	0.00	0.04
9.65-	9.74	3.80-	3.83	3	3	0.04	0.04

PERCENTILES

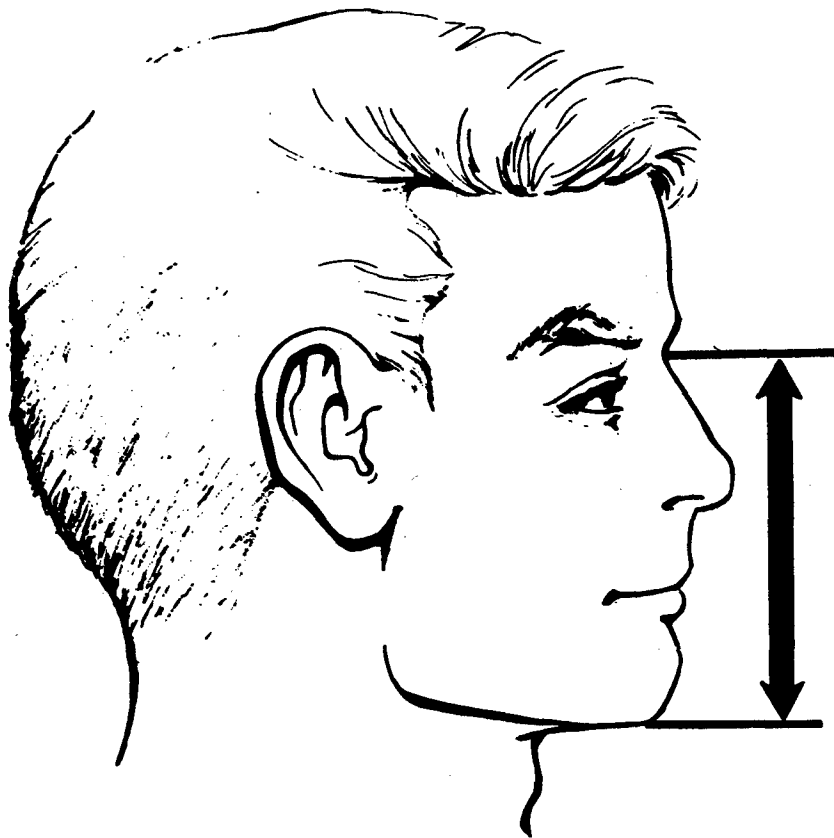

CENTIMETERS		INCHES
13.63	99 TH	5.37
13.43	98 TH	5.29
13.30	97 TH	5.24
13.13	95 TH	5.17
12.88	90 TH	5.07
12.71	85 TH	5.00
12.58	80 TH	4.95
12.46	75 TH	4.91
12.36	70 TH	4.87
12.27	65 TH	4.83
12.18	60 TH	4.80
12.10	55 TH	4.76
12.02	50 TH	4.73
11.94	45 TH	4.70
11.85	40 TH	4.67
11.77	35 TH	4.63
11.68	30 TH	4.60
11.58	25 TH	4.56
11.47	20 TH	4.52
11.35	15 TH	4.47
11.19	10 TH	4.41
10.96	5 TH	4.31
10.81	3 RD	4.25
10.69	2 ND	4.21
10.52	1 ST	4.14

Face Length (Menton-Nasal Root Length): Subject sits erect, with head level. Face Length is measured as the vertical distance from the tip of the chin (menton) to the nasal root depression between the eyes. Sliding calipers are used.

THE SUMMARY STATISTICS

.....

CENTIMETERS		INCHES
12.03	MEAN	4.74
0.01	SE(M)	0.00
0.66	ST DEV	0.26
0.01	SE(SD)	0.00
.....		
SYMMETRY--BETA I =		0.09
KURTOSIS--BETA II =		3.10
COEFFICIENT OF VARIATION =		5.50
.....		
SAMPLE SIZE =		6681

57 Face Breadth

		--INTERVALS--		--FREQUENCIES--			
CENTIMETERS		INCHES		ACTUAL FREQ	CUMULA TIVE-F	PERCEN T-FREQ	CUMUL- PCT-FQ
16.25-	16.34	6.40-	6.43	1	6681	0.01	100.00
16.15-	16.24	6.36-	6.39	0	6680	0.00	99.99
16.05-	16.14	6.32-	6.35	0	6680	0.00	99.99
15.95-	16.04	6.28-	6.31	1	6680	0.01	99.99
15.85-	15.94	6.24-	6.27	2	6679	0.03	99.97
15.75-	15.84	6.20-	6.23	5	6677	0.07	99.94
15.65-	15.74	6.16-	6.19	11	6672	0.16	99.87
15.55-	15.64	6.12-	6.15	16	6661	0.24	99.70
15.45-	15.54	6.08-	6.11	5	6645	0.07	99.46
15.35-	15.44	6.04-	6.07	29	6640	0.43	99.39
15.25-	15.34	6.00-	6.03	34	6611	0.51	98.95
15.15-	15.24	5.96-	5.99	62	6577	0.93	98.44
15.05-	15.14	5.93-	5.95	63	6515	0.94	97.52
14.95-	15.04	5.89-	5.92	62	6452	0.93	96.57
14.85-	14.94	5.85-	5.88	113	6390	1.69	95.64
14.75-	14.84	5.81-	5.84	174	6277	2.60	93.95
14.65-	14.74	5.77-	5.80	257	6103	3.85	91.35
14.55-	14.64	5.73-	5.76	254	5846	3.80	87.50
14.45-	14.54	5.69-	5.72	191	5592	2.86	83.70
14.35-	14.44	5.65-	5.68	434	5401	6.50	80.84
14.25-	14.34	5.61-	5.64	407	4967	6.09	74.35
14.15-	14.24	5.57-	5.60	573	4560	8.58	68.25
14.05-	14.14	5.53-	5.56	445	3987	6.66	59.68
13.95-	14.04	5.49-	5.52	317	3542	4.74	53.02
13.85-	13.94	5.45-	5.48	481	3225	7.20	48.27
13.75-	13.84	5.41-	5.44	447	2744	6.69	41.07
13.65-	13.74	5.37-	5.40	506	2297	7.57	34.38
13.55-	13.64	5.33-	5.36	386	1791	5.78	26.81
13.45-	13.54	5.30-	5.32	231	1405	3.46	21.03
13.35-	13.44	5.26-	5.29	371	1174	5.55	17.57
13.25-	13.34	5.22-	5.25	211	803	3.16	12.02
13.15-	13.24	5.18-	5.21	203	592	3.04	8.86
13.05-	13.14	5.14-	5.17	124	389	1.86	5.82
12.95-	13.04	5.10-	5.13	70	265	1.05	3.97
12.85-	12.94	5.06-	5.09	80	195	1.20	2.92
12.75-	12.84	5.02-	5.05	37	115	0.55	1.72
12.65-	12.74	4.98-	5.01	36	78	0.54	1.17
12.55-	12.64	4.94-	4.97	19	42	0.28	0.63
12.45-	12.54	4.90-	4.93	6	23	0.09	0.34
12.35-	12.44	4.86-	4.89	7	17	0.10	0.25
12.25-	12.34	4.82-	4.85	4	10	0.06	0.15
12.15-	12.24	4.78-	4.81	4	6	0.06	0.09
12.05-	12.14	4.74-	4.77	1	2	0.01	0.03
11.95-	12.04	4.70-	4.73	1	1	0.01	0.01

57 Face Breadth

PERCENTILES

CENTIMETERS		INCHES
15.37	99 TH	6.05
15.19	98 TH	5.98
15.08	97 TH	5.94
14.94	95 TH	5.88
14.72	90 TH	5.79
14.57	85 TH	5.74
14.46	80 TH	5.69
14.36	75 TH	5.66
14.28	70 TH	5.62
14.20	65 TH	5.59
14.13	60 TH	5.56
14.06	55 TH	5.53
13.99	50 TH	5.51
13.92	45 TH	5.48
13.85	40 TH	5.45
13.77	35 TH	5.42
13.70	30 TH	5.39
13.61	25 TH	5.36
13.52	20 TH	5.32
13.42	15 TH	5.28
13.28	10 TH	5.23
13.09	5 TH	5.15
12.96	3 RD	5.10
12.87	2 ND	5.07
12.73	1 ST	5.01

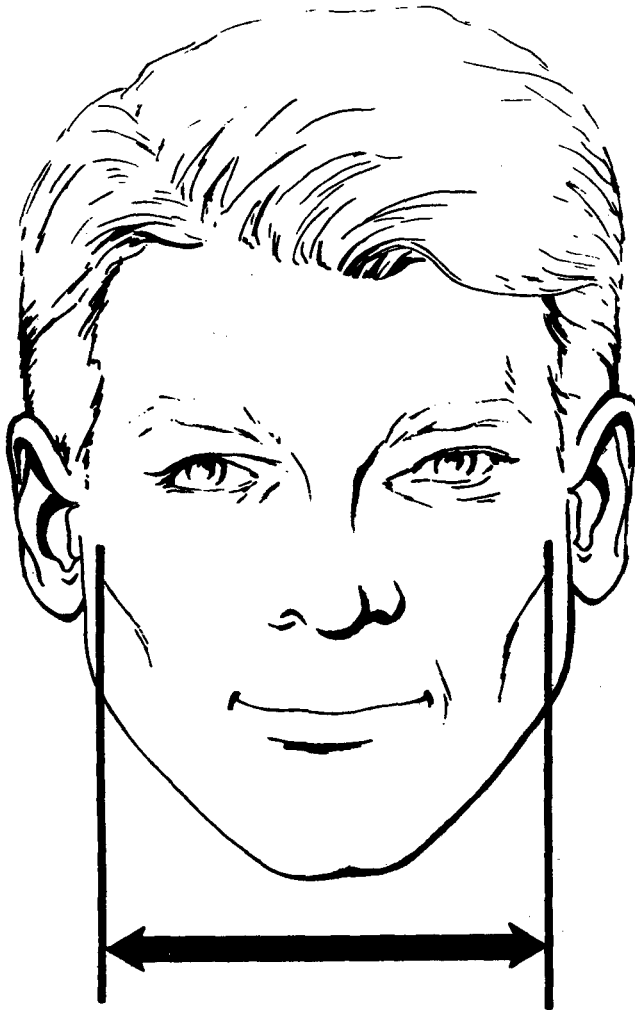

THE SUMMARY STATISTICS

••••

Face Breadth (Bizygomatic Breadth):
 Subject sits erect, with head level.
 The maximum horizontal breadth of
 the face is measured between the
 lateral projections of the cheek bones
 (zygomatic arches). Spreading
 calipers are used.

CENTIMETERS		INCHES
13.99	MEAN	5.51
0.01	SE(M)	0.00
0.56	ST DEV	0.22
0.00	SE(SD)	0.00

••••

SYMMETRY--BETA I = 0.11
 KURTOSIS--BETA II = 3.07
 COEFFICIENT OF VARIATION = 4.00

••••

SAMPLE SIZE = 6681

58 Interpupillary Breadth

--INTERVALS--				--FREQUENCIES--			
CENTIMETERS		INCHES		ACTUAL FREQ	CUMULA TIVE-F	PERCEN T-FREQ	CUMUL- PCT-FQ
7.85-	7.94	3.09-	3.12	2	6680	0.03	100.00
7.75-	7.84	3.05-	3.08	0	6678	0.00	99.97
7.65-	7.74	3.01-	3.04	1	6678	0.01	99.97
7.55-	7.64	2.97-	3.00	2	6677	0.03	99.96
7.45-	7.54	2.93-	2.96	1	6675	0.01	99.93
7.35-	7.44	2.89-	2.92	4	6674	0.06	99.91
7.25-	7.34	2.85-	2.88	14	6670	0.21	99.85
7.15-	7.24	2.82-	2.84	29	6656	0.43	99.64
7.05-	7.14	2.78-	2.81	42	6627	0.63	99.21
6.95-	7.04	2.74-	2.77	48	6585	0.72	98.58
6.85-	6.94	2.70-	2.73	78	6537	1.17	97.86
6.75-	6.84	2.66-	2.69	164	6459	2.46	96.69
6.65-	6.74	2.62-	2.65	251	6295	3.76	94.24
6.55-	6.64	2.58-	2.61	303	6044	4.54	90.48
6.45-	6.54	2.54-	2.57	371	5741	5.55	85.94
6.35-	6.44	2.50-	2.53	598	5370	8.95	80.39
6.25-	6.34	2.46-	2.49	655	4772	9.81	71.44
6.15-	6.24	2.42-	2.45	687	4117	10.28	61.63
6.05-	6.14	2.38-	2.41	677	3430	10.13	51.35
5.95-	6.04	2.34-	2.37	544	2753	8.14	41.21
5.85-	5.94	2.30-	2.33	554	2209	8.29	33.07
5.75-	5.84	2.26-	2.29	495	1655	7.41	24.78
5.65-	5.74	2.22-	2.25	374	1160	5.60	17.37
5.55-	5.64	2.19-	2.21	276	786	4.13	11.77
5.45-	5.54	2.15-	2.18	216	510	3.23	7.63
5.35-	5.44	2.11-	2.14	141	294	2.11	4.40
5.25-	5.34	2.07-	2.10	82	153	1.23	2.29
5.15-	5.24	2.03-	2.06	41	71	0.61	1.06
5.05-	5.14	1.99-	2.02	17	30	0.25	0.45
4.95-	5.04	1.95-	1.98	8	13	0.12	0.19
4.85-	4.94	1.91-	1.94	3	5	0.04	0.07
4.75-	4.84	1.87-	1.90	2	2	0.03	0.03

58 Interpupillary Breadth

PERCENTILES

CENTIMETERS		INCHES
7.11	99 TH	2.80
6.97	98 TH	2.74
6.89	97 TH	2.71
6.78	95 TH	2.67
6.63	90 TH	2.61
6.53	85 TH	2.57
6.46	80 TH	2.54
6.39	75 TH	2.52
6.34	70 TH	2.49
6.28	65 TH	2.47
6.23	60 TH	2.45
6.18	55 TH	2.43
6.13	50 TH	2.41
6.08	45 TH	2.39
6.03	40 TH	2.37
5.98	35 TH	2.35
5.92	30 TH	2.33
5.86	25 TH	2.31
5.79	20 TH	2.28
5.71	15 TH	2.25
5.61	10 TH	2.21
5.47	5 TH	2.15
5.38	3 RD	2.12
5.32	2 ND	2.10
5.24	1 ST	2.06

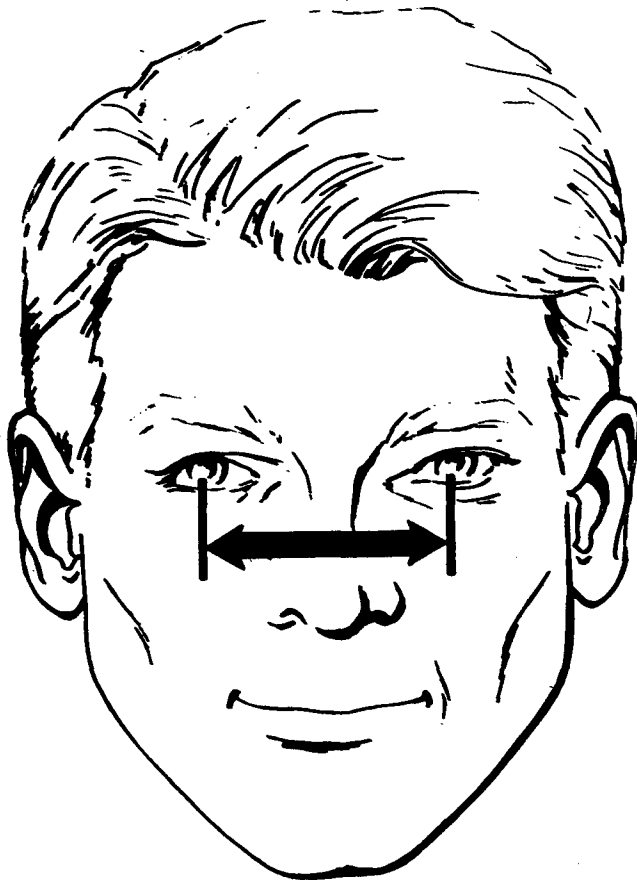

THE SUMMARY STATISTICS

••••

Interpupillary Breadth: Subject sits erect, with head level. The distance between the centers of the pupils of the eyes is measured. Sliding calipers are used.

CENTIMETERS		INCHES
6.13	MEAN	2.41
0.00	SE(M)	0.00
0.40	ST DEV	0.16
0.00	SE(SD)	0.00

••••

SYMMETRY--BETA I = 0.08
 KURTOSIS--BETA II = 3.08
 COEFFICIENT OF VARIATION = 6.51

••••

SAMPLE SIZE = 6680

59 Hand Length

--INTERVALS--

--FREQUENCIES--

CENTIMETERS		INCHES		ACTUAL FREQ	CUMULA TIVE-F	PERCEN T-FREQ	CUMUL- PCT-FW
23.45-	23.64	9.23-	9.30	1	6682	0.01	100.00
23.25-	23.44	9.15-	9.22	3	6681	0.04	99.99
23.05-	23.24	9.07-	9.14	1	6678	0.01	99.94
22.85-	23.04	9.00-	9.06	2	6677	0.03	99.93
22.65-	22.84	8.92-	8.99	1	6675	0.01	99.90
22.45-	22.64	8.84-	8.91	2	6674	0.03	99.88
22.25-	22.44	8.76-	8.83	5	6672	0.07	99.85
22.05-	22.24	8.68-	8.75	11	6667	0.16	99.78
21.85-	22.04	8.60-	8.67	8	6656	0.12	99.61
21.65-	21.84	8.52-	8.59	15	6648	0.22	99.49
21.45-	21.64	8.45-	8.51	16	6633	0.24	99.27
21.25-	21.44	8.37-	8.44	28	6617	0.42	99.03
21.05-	21.24	8.29-	8.36	54	6589	0.81	98.61
20.85-	21.04	8.21-	8.28	84	6535	1.26	97.80
20.65-	20.84	8.13-	8.20	124	6451	1.86	96.54
20.45-	20.64	8.05-	8.12	130	6327	1.95	94.69
20.25-	20.44	7.97-	8.04	196	6197	2.93	92.74
20.05-	20.24	7.89-	7.96	265	6001	3.97	89.81
19.85-	20.04	7.82-	7.88	327	5736	4.89	85.84
19.65-	19.84	7.74-	7.81	411	5409	6.15	80.95
19.45-	19.64	7.66-	7.73	367	4998	5.49	74.80
19.25-	19.44	7.58-	7.65	618	4631	9.25	69.31
19.05-	19.24	7.50-	7.57	524	4013	7.84	60.06
18.85-	19.04	7.42-	7.49	555	3489	8.31	52.21
18.65-	18.84	7.34-	7.41	566	2934	8.47	43.91
18.45-	18.64	7.26-	7.33	475	2368	7.11	35.44
18.25-	18.44	7.19-	7.25	521	1893	7.80	28.33
18.05-	18.24	7.11-	7.18	424	1372	6.35	20.53
17.85-	18.04	7.03-	7.10	281	948	4.21	14.19
17.65-	17.84	6.95-	7.02	216	667	3.23	9.98
17.45-	17.64	6.87-	6.94	151	451	2.26	6.75
17.25-	17.44	6.79-	6.86	130	300	1.95	4.49
17.05-	17.24	6.71-	6.78	73	170	1.09	2.54
16.85-	17.04	6.63-	6.70	44	97	0.66	1.45
16.65-	16.84	6.56-	6.62	21	53	0.31	0.79
16.45-	16.64	6.48-	6.55	12	32	0.18	0.48
16.25-	16.44	6.40-	6.47	13	20	0.19	0.30
16.05-	16.24	6.32-	6.39	1	7	0.01	0.10
15.85-	16.04	6.24-	6.31	5	6	0.07	0.09
15.65-	15.84	6.16-	6.23	0	1	0.00	0.01
15.45-	15.64	6.08-	6.15	1	1	0.01	0.01

PERCENTILES

CENTIMETERS		INCHES	
21.43	99 TH	8.44	
21.12	98 TH	8.31	
20.92	97 TH	8.24	
20.66	95 TH	8.13	
20.27	90 TH	7.98	
20.01	85 TH	7.88	
19.82	80 TH	7.80	
19.65	75 TH	7.74	
19.50	70 TH	7.68	
19.36	65 TH	7.62	
19.24	60 TH	7.57	
19.11	55 TH	7.53	
19.00	50 TH	7.48	
18.88	45 TH	7.43	
18.76	40 TH	7.39	
18.64	35 TH	7.34	
18.51	30 TH	7.29	
18.38	25 TH	7.23	
18.23	20 TH	7.18	
18.05	15 TH	7.11	
17.84	10 TH	7.02	
17.51	5 TH	6.90	
17.31	3 RD	6.81	
17.15	2 ND	6.75	
16.91	1 ST	6.66	

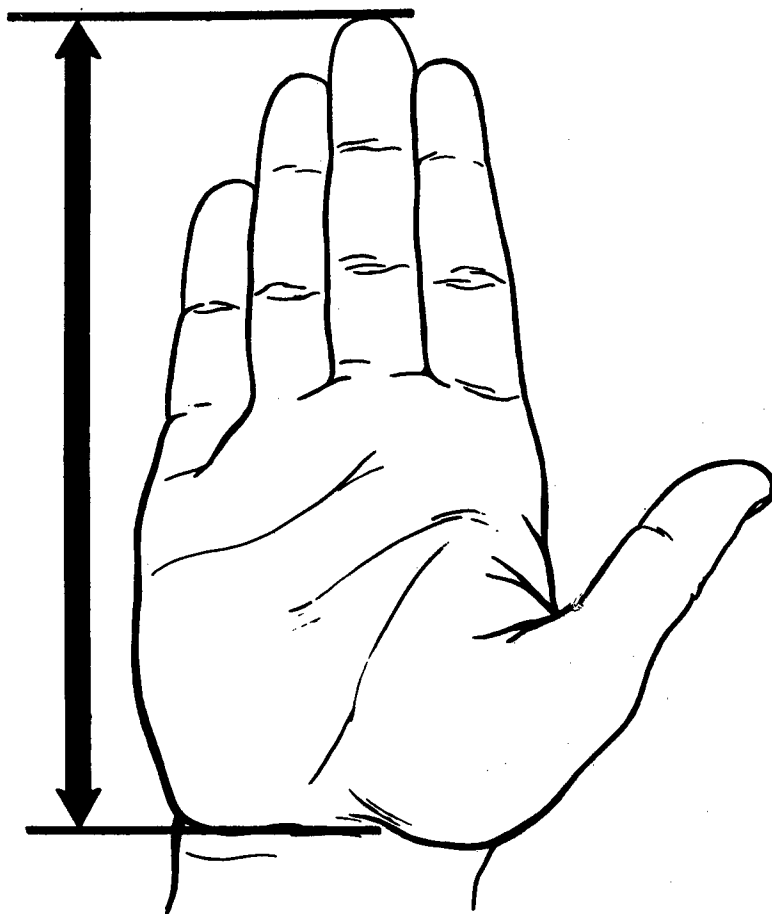

Hand Length: Subject sits, with his right hand and fingers extended, palm up. The length of the right hand is measured from the wrist crease to the tip of the middle finger. Sliding calipers are used.

THE SUMMARY STATISTICS

.....

CENTIMETERS		INCHES	
19.03	MEAN	7.49	
0.01	SE(M)	0.00	
0.96	ST DEV	0.38	
0.01	SE(SD)	0.00	
.....			
SYMMETRY--BETA I =		0.26	
KURTOSIS--BETA II =		3.44	
COEFFICIENT OF VARIATION =		5.06	
.....			

SAMPLE SIZE = 6682

60 Palm Length

--INTERVALS--

--FREQUENCIES--

CENTIMETERS		INCHES		ACTUAL FREQ	CUMULA TIVE-F	PERCEN T-FREQ	CUMUL- PCT-FQ
13.25-	13.44	5.22-	5.29	1	6682	0.01	100.00
13.05-	13.24	5.14-	5.21	1	6681	0.01	99.99
12.85-	13.04	5.06-	5.13	5	6680	0.07	99.97
12.65-	12.84	4.98-	5.05	5	6675	0.07	99.90
12.45-	12.64	4.90-	4.97	13	6670	0.19	99.82
12.25-	12.44	4.82-	4.89	26	6657	0.39	99.63
12.05-	12.24	4.74-	4.81	43	6631	0.64	99.24
11.85-	12.04	4.67-	4.73	104	6588	1.56	98.59
11.65-	11.84	4.59-	4.66	147	6484	2.20	97.04
11.45-	11.64	4.51-	4.58	236	6337	3.53	94.84
11.25-	11.44	4.43-	4.50	424	6101	6.35	91.30
11.05-	11.24	4.35-	4.42	529	5677	7.92	84.96
10.85-	11.04	4.27-	4.34	638	5148	9.55	77.04
10.65-	10.84	4.19-	4.26	831	4510	12.44	67.49
10.45-	10.64	4.11-	4.18	771	3679	11.54	55.06
10.25-	10.44	4.04-	4.10	955	2908	14.29	43.52
10.05-	10.24	3.96-	4.03	758	1953	11.34	29.23
9.85-	10.04	3.88-	3.95	450	1195	6.73	17.88
9.65-	9.84	3.80-	3.87	350	745	5.24	11.15
9.45-	9.64	3.72-	3.79	175	395	2.62	5.91
9.25-	9.44	3.64-	3.71	137	220	2.05	3.29
9.05-	9.24	3.56-	3.63	50	83	0.75	1.24
8.85-	9.04	3.48-	3.55	17	33	0.25	0.49
8.65-	8.84	3.41-	3.47	8	16	0.12	0.24
8.45-	8.64	3.33-	3.40	6	8	0.09	0.12
8.25-	8.44	3.25-	3.32	1	2	0.01	0.03
8.05-	8.24	3.17-	3.24	1	1	0.01	0.01

60 Palm Length

PERCENTILES

CENTIMETERS		INCHES
12.18	99 TH	4.79
11.97	98 TH	4.71
11.84	97 TH	4.66
11.67	95 TH	4.59
11.41	90 TH	4.49
11.24	85 TH	4.43
11.11	80 TH	4.38
11.00	75 TH	4.33
10.90	70 TH	4.29
10.81	65 TH	4.26
10.73	60 TH	4.22
10.65	55 TH	4.19
10.57	50 TH	4.16
10.49	45 TH	4.13
10.42	40 TH	4.10
10.34	35 TH	4.07
10.25	30 TH	4.04
10.16	25 TH	4.00
10.06	20 TH	3.96
9.95	15 TH	3.92
9.80	10 TH	3.86
9.59	5 TH	3.77
9.44	3 RD	3.72
9.34	2 ND	3.68
9.17	1 ST	3.61

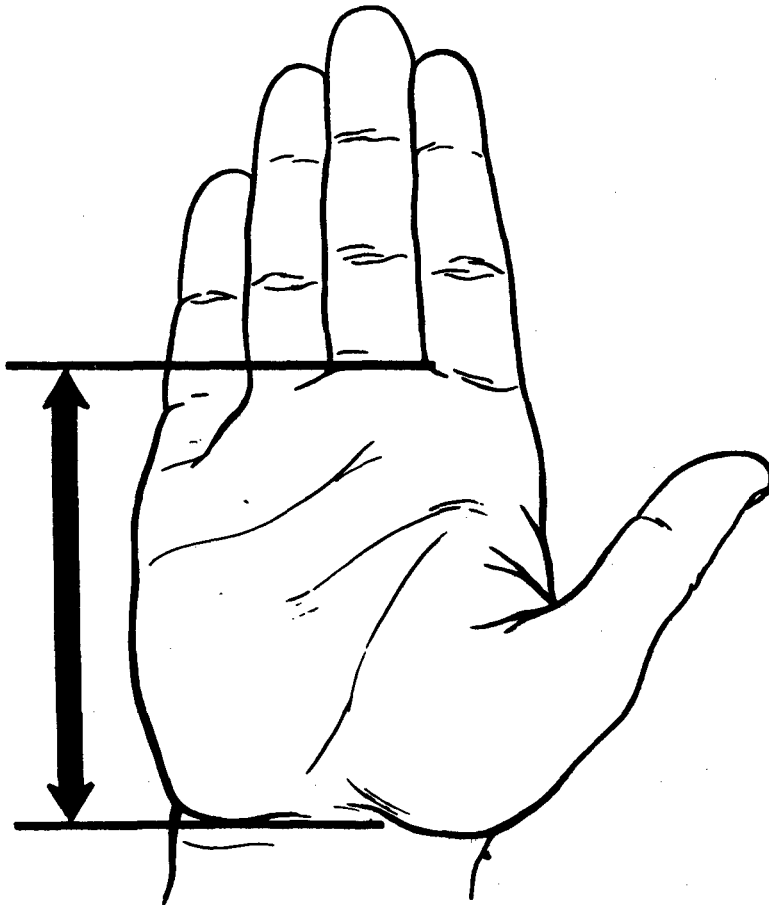

Palm Length: Subject sits, with his right hand and fingers extended, palm up. The length of the palm of the right hand is measured from the wrist crease to the crease at the base of the middle finger. Sliding calipers are used.

THE SUMMARY STATISTICS

.....

CENTIMETERS		INCHES
10.59	MEAN	4.17
0.01	SE(M)	0.00
0.63	ST DEV	0.25
0.01	SE(SD)	0.00
.....		
SYMMETRY--BETA I =		0.19
KURTOSIS--BETA II =		3.27
COEFFICIENT OF VARIATION =		5.93
.....		
SAMPLE SIZE =		6682

61 Hand Breadth

--INTERVALS--

--FREQUENCIES--

CENTIMETERS		INCHES		ACTUAL FREQ	CUMULA TIVE-F	PERCEN T-FREQ	CUMUL- PCT-FQ
10.65-	10.74	4.19-	4.22	2	6681	0.03	100.00
10.55-	10.64	4.15-	4.18	4	6679	0.06	99.97
10.45-	10.54	4.11-	4.14	7	6675	0.10	99.91
10.35-	10.44	4.07-	4.10	7	6668	0.10	99.81
10.25-	10.34	4.04-	4.06	19	6661	0.28	99.70
10.15-	10.24	4.00-	4.03	26	6642	0.39	99.42
10.05-	10.14	3.96-	3.99	31	6616	0.46	99.03
9.95-	10.04	3.92-	3.95	44	6585	0.66	98.56
9.85-	9.94	3.88-	3.91	77	6541	1.15	97.90
9.75-	9.84	3.84-	3.87	95	6464	1.42	96.75
9.65-	9.74	3.80-	3.83	131	6369	1.96	95.33
9.55-	9.64	3.76-	3.79	189	6238	2.83	93.37
9.45-	9.54	3.72-	3.75	221	6049	3.31	90.54
9.35-	9.44	3.68-	3.71	313	5828	4.68	87.23
9.25-	9.34	3.64-	3.67	388	5515	5.81	82.55
9.15-	9.24	3.60-	3.63	454	5127	6.80	76.74
9.05-	9.14	3.56-	3.59	490	4673	7.33	69.94
8.95-	9.04	3.52-	3.55	447	4183	6.69	62.61
8.85-	8.94	3.48-	3.51	566	3736	8.47	55.92
8.75-	8.84	3.45-	3.47	522	3170	7.81	47.45
8.65-	8.74	3.41-	3.44	584	2648	8.74	39.63
8.55-	8.64	3.37-	3.40	473	2064	7.08	30.89
8.45-	8.54	3.33-	3.36	381	1591	5.70	23.81
8.35-	8.44	3.29-	3.32	374	1210	5.60	18.11
8.25-	8.34	3.25-	3.28	271	836	4.06	12.51
8.15-	8.24	3.21-	3.24	221	565	3.31	8.46
8.05-	8.14	3.17-	3.20	122	344	1.83	5.15
7.95-	8.04	3.13-	3.16	76	222	1.14	3.32
7.85-	7.94	3.09-	3.12	61	146	0.91	2.19
7.75-	7.84	3.05-	3.08	39	85	0.58	1.27
7.65-	7.74	3.01-	3.04	20	46	0.30	0.69
7.55-	7.64	2.97-	3.00	8	26	0.12	0.39
7.45-	7.54	2.93-	2.96	7	18	0.10	0.27
7.35-	7.44	2.89-	2.92	3	11	0.04	0.16
7.25-	7.34	2.85-	2.88	5	8	0.07	0.12
7.15-	7.24	2.82-	2.84	1	3	0.01	0.04
7.05-	7.14	2.78-	2.81	2	2	0.03	0.03

PERCENTILES

CENTIMETERS

INCHES

10.14	99 TH	3.99
9.97	98 TH	3.93
9.87	97 TH	3.89
9.74	95 TH	3.83
9.54	90 TH	3.75
9.41	85 TH	3.70
9.30	80 TH	3.66
9.22	75 TH	3.63
9.14	70 TH	3.60
9.07	65 TH	3.57
9.01	60 TH	3.55
8.94	55 TH	3.52
8.88	50 TH	3.50
8.82	45 TH	3.47
8.76	40 TH	3.45
8.70	35 TH	3.43
8.64	30 TH	3.40
8.57	25 TH	3.37
8.49	20 TH	3.34
8.40	15 TH	3.31
8.29	10 TH	3.26
8.12	5 TH	3.20
8.02	3 RD	3.16
7.94	2 ND	3.12
7.81	1 ST	3.07

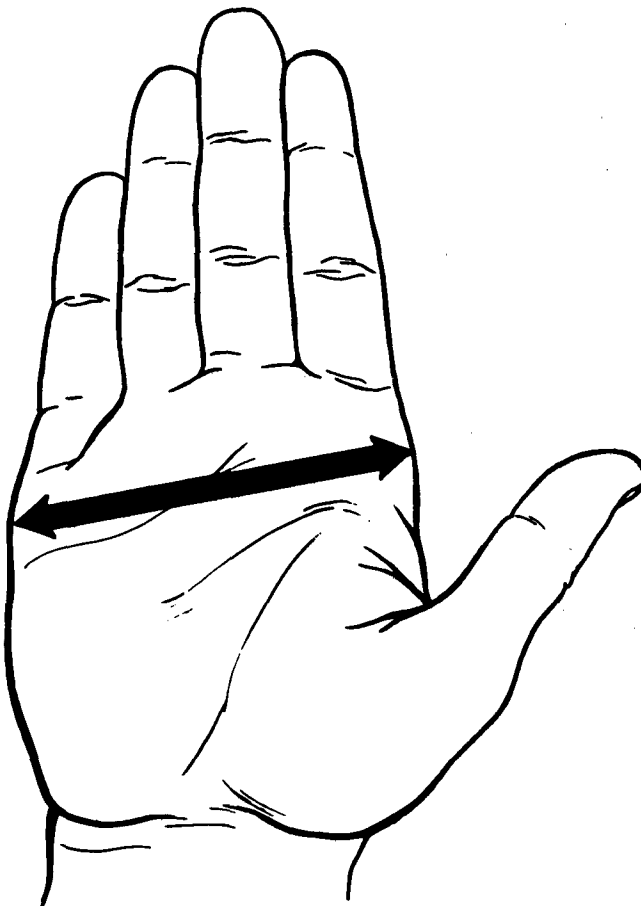

Hand Breadth: Subject sits, with his right hand and fingers extended, palm up. The breadth of the hand is measured at the level of the knuckles (distal ends of the metacarpal bones). Sliding calipers are used.

THE SUMMARY STATISTICS

••••

CENTIMETERS

INCHES

8.90	MEAN	3.50
0.01	SE(M)	0.00
0.49	ST DEV	0.19
0.00	SE(SD)	0.00

••••

SYMMETRY--BETA I =	0.17
KURTOSIS--BETA II =	3.16
COEFFICIENT OF VARIATION =	5.52

••••

SAMPLE SIZE = 6681

62 Hand Circumference

--INTERVALS--		--FREQUENCIES--					
CENTIMETERS		INCHES	ACTUAL FREQ	CUMULA TIVE-F	PERCEN T-FREQ	CUMUL- PCT-FQ	
26.15-	26.34	10.30-	10.36	1	6682	0.01	100.00
25.95-	26.14	10.22-	10.29	5	6681	0.07	99.99
25.75-	25.94	10.14-	10.21	1	6676	0.01	99.91
25.55-	25.74	10.06-	10.13	2	6675	0.03	99.90
25.35-	25.54	9.98-	10.05	6	6673	0.09	99.87
25.15-	25.34	9.90-	9.97	3	6667	0.04	99.78
24.95-	25.14	9.82-	9.89	14	6664	0.21	99.73
24.75-	24.94	9.74-	9.81	10	6650	0.15	99.52
24.55-	24.74	9.67-	9.73	17	6640	0.25	99.37
24.35-	24.54	9.59-	9.66	20	6623	0.30	99.12
24.15-	24.34	9.51-	9.58	32	6603	0.48	98.82
23.95-	24.14	9.43-	9.50	66	6571	0.99	98.34
23.75-	23.94	9.35-	9.42	69	6505	1.03	97.35
23.55-	23.74	9.27-	9.34	102	6436	1.53	96.32
23.35-	23.54	9.19-	9.26	121	6334	1.81	94.79
23.15-	23.34	9.11-	9.18	132	6213	1.98	92.98
22.95-	23.14	9.04-	9.10	209	6081	3.13	91.01
22.75-	22.94	8.96-	9.03	232	5872	3.47	87.88
22.55-	22.74	8.88-	8.95	249	5640	3.73	84.41
22.35-	22.54	8.80-	8.87	324	5391	4.85	80.68
22.15-	22.34	8.72-	8.79	388	5067	5.81	75.83
21.95-	22.14	8.64-	8.71	495	4679	7.41	70.02
21.75-	21.94	8.56-	8.63	436	4184	6.52	62.62
21.55-	21.74	8.48-	8.55	411	3748	6.15	56.09
21.35-	21.54	8.41-	8.47	468	3337	7.00	49.94
21.15-	21.34	8.33-	8.40	487	2869	7.29	42.94
20.95-	21.14	8.25-	8.32	457	2382	6.84	35.65
20.75-	20.94	8.17-	8.24	412	1925	6.17	28.81
20.55-	20.74	8.09-	8.16	353	1513	5.28	22.64
20.35-	20.54	8.01-	8.08	265	1160	3.97	17.36
20.15-	20.34	7.93-	8.00	312	895	4.67	13.39
19.95-	20.14	7.85-	7.92	176	583	2.63	8.72
19.75-	19.94	7.78-	7.84	130	407	1.95	6.09
19.55-	19.74	7.70-	7.77	95	277	1.42	4.15
19.35-	19.54	7.62-	7.69	63	182	0.94	2.72
19.15-	19.34	7.54-	7.61	49	119	0.73	1.78
18.95-	19.14	7.46-	7.53	22	70	0.33	1.05
18.75-	18.94	7.38-	7.45	25	48	0.37	0.72
18.55-	18.74	7.30-	7.37	8	23	0.12	0.34
18.35-	18.54	7.22-	7.29	6	15	0.09	0.22
18.15-	18.34	7.15-	7.21	7	9	0.10	0.13
17.95-	18.14	7.07-	7.14	0	2	0.00	0.03
17.75-	17.94	6.99-	7.06	2	2	0.03	0.03

62 Hand Circumference

PERCENTILES

CENTIMETERS		INCHES	
24.47	99 TH	9.63	
24.10	98 TH	9.49	
23.87	97 TH	9.40	
23.56	95 TH	9.28	
23.09	90 TH	9.09	
22.78	85 TH	8.97	
22.54	80 TH	8.87	
22.34	75 TH	8.79	
22.16	70 TH	8.72	
22.00	65 TH	8.66	
21.84	60 TH	8.60	
21.70	55 TH	8.54	
21.56	50 TH	8.49	
21.42	45 TH	8.43	
21.28	40 TH	8.38	
21.13	35 TH	8.32	
20.98	30 TH	8.26	
20.83	25 TH	8.20	
20.65	20 TH	8.13	
20.45	15 TH	8.05	
20.20	10 TH	7.95	
19.83	5 TH	7.81	
19.59	3 RD	7.71	
19.41	2 ND	7.64	
19.12	1 ST	7.53	

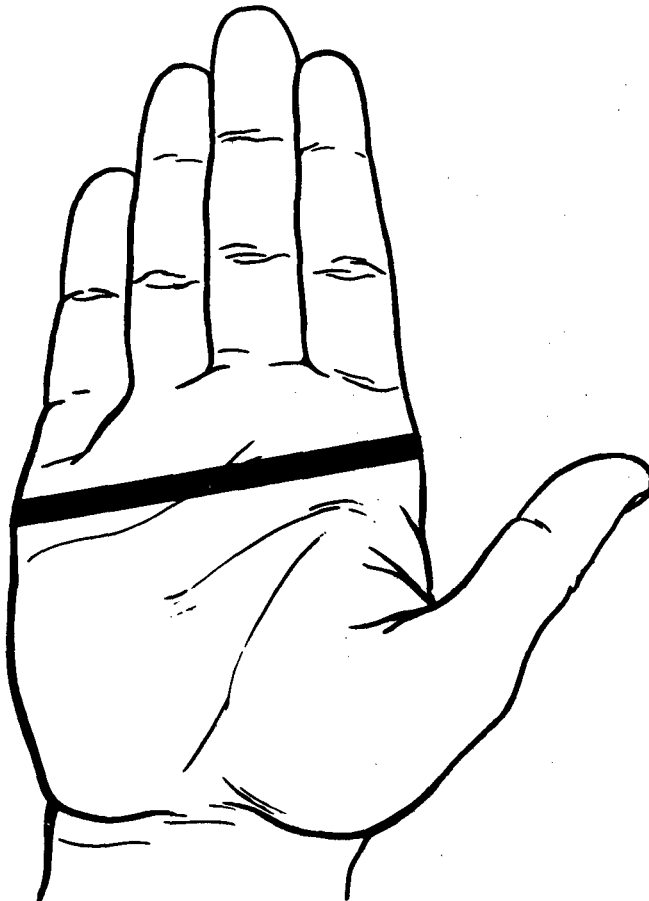

THE SUMMARY STATISTICS

....

Hand Circumference: Subject sits, with his right hand and fingers extended, palm up. The maximum circumference of the hand is measured at the level of the knuckles (distal ends of the metacarpal bones). A steel tape is used.

CENTIMETERS		INCHES	
21.61	MEAN	8.51	
0.01	SE(M)	0.01	
1.14	ST DEV	0.45	
0.01	SE(SD)	0.00	

....

SYMMETRY--BETA I = 0.25
 KURTOSIS--BETA II = 3.24
 COEFFICIENT OF VARIATION = 5.26

....

SAMPLE SIZE = 6682

63 Thumb Crotch Length

--INTERVALS--				--FREQUENCIES--			
CENTIMETERS		INCHES		ACTUAL FREQ	CUMULA TIVE-F	PERCEN T-FREQ	CUMUL- PCT-FG
7.45-	7.54	2.93-	2.96	1	6682	0.01	100.00
7.35-	7.44	2.89-	2.92	1	6681	0.01	99.99
7.25-	7.34	2.85-	2.88	0	6680	0.00	99.97
7.15-	7.24	2.82-	2.84	0	6680	0.00	99.97
7.05-	7.14	2.78-	2.81	0	6680	0.00	99.97
6.95-	7.04	2.74-	2.77	1	6680	0.01	99.97
6.85-	6.94	2.70-	2.73	4	6679	0.06	99.96
6.75-	6.84	2.66-	2.69	2	6675	0.03	99.90
6.65-	6.74	2.62-	2.65	4	6673	0.06	99.87
6.55-	6.64	2.58-	2.61	4	6669	0.06	99.81
6.45-	6.54	2.54-	2.57	7	6665	0.10	99.75
6.35-	6.44	2.50-	2.53	10	6658	0.15	99.64
6.25-	6.34	2.46-	2.49	28	6648	0.42	99.49
6.15-	6.24	2.42-	2.45	43	6620	0.64	99.07
6.05-	6.14	2.38-	2.41	56	6577	0.84	98.43
5.95-	6.04	2.34-	2.37	57	6521	0.85	97.59
5.85-	5.94	2.30-	2.33	76	6464	1.14	96.74
5.75-	5.84	2.26-	2.29	154	6388	2.30	95.60
5.65-	5.74	2.22-	2.25	229	6234	3.43	93.30
5.55-	5.64	2.19-	2.21	214	6005	3.20	89.87
5.45-	5.54	2.15-	2.18	208	5791	3.11	86.67
5.35-	5.44	2.11-	2.14	341	5583	5.10	83.55
5.25-	5.34	2.07-	2.10	460	5242	6.88	78.45
5.15-	5.24	2.03-	2.06	495	4782	7.41	71.57
5.05-	5.14	1.99-	2.02	517	4287	7.74	64.16
4.95-	5.04	1.95-	1.98	421	3770	6.30	56.42
4.85-	4.94	1.91-	1.94	491	3349	7.35	50.12
4.75-	4.84	1.87-	1.90	551	2858	8.25	42.77
4.65-	4.74	1.83-	1.86	521	2307	7.80	34.53
4.55-	4.64	1.79-	1.82	411	1786	6.15	26.73
4.45-	4.54	1.75-	1.78	295	1375	4.41	20.58
4.35-	4.44	1.71-	1.74	298	1080	4.46	16.16
4.25-	4.34	1.67-	1.70	247	782	3.70	11.70
4.15-	4.24	1.63-	1.66	186	535	2.78	8.01
4.05-	4.14	1.59-	1.62	134	349	2.01	5.22
3.95-	4.04	1.56-	1.58	72	215	1.08	3.22
3.85-	3.94	1.52-	1.55	58	143	0.87	2.14
3.75-	3.84	1.48-	1.51	41	85	0.61	1.27
3.65-	3.74	1.44-	1.47	22	44	0.33	0.66
3.55-	3.64	1.40-	1.43	11	22	0.16	0.33
3.45-	3.54	1.36-	1.39	5	11	0.07	0.16
3.35-	3.44	1.32-	1.35	4	6	0.06	0.09
3.25-	3.34	1.28-	1.31	2	2	0.03	0.03

63 Thumb Crotch Length

PERCENTILES

CENTIMETERS

INCHES

6.25	99 TH	2.46
6.08	98 TH	2.39
5.98	97 TH	2.35
5.84	95 TH	2.30
5.64	90 TH	2.22
5.50	85 TH	2.17
5.40	80 TH	2.12
5.31	75 TH	2.09
5.23	70 TH	2.06
5.15	65 TH	2.03
5.08	60 TH	2.00
5.02	55 TH	1.98
4.95	50 TH	1.95
4.89	45 TH	1.92
4.82	40 TH	1.90
4.76	35 TH	1.87
4.69	30 TH	1.85
4.61	25 TH	1.82
4.53	20 TH	1.78
4.43	15 TH	1.75
4.31	10 TH	1.70
4.14	5 TH	1.63
4.02	3 RD	1.58
3.94	2 ND	1.55
3.81	1 ST	1.50

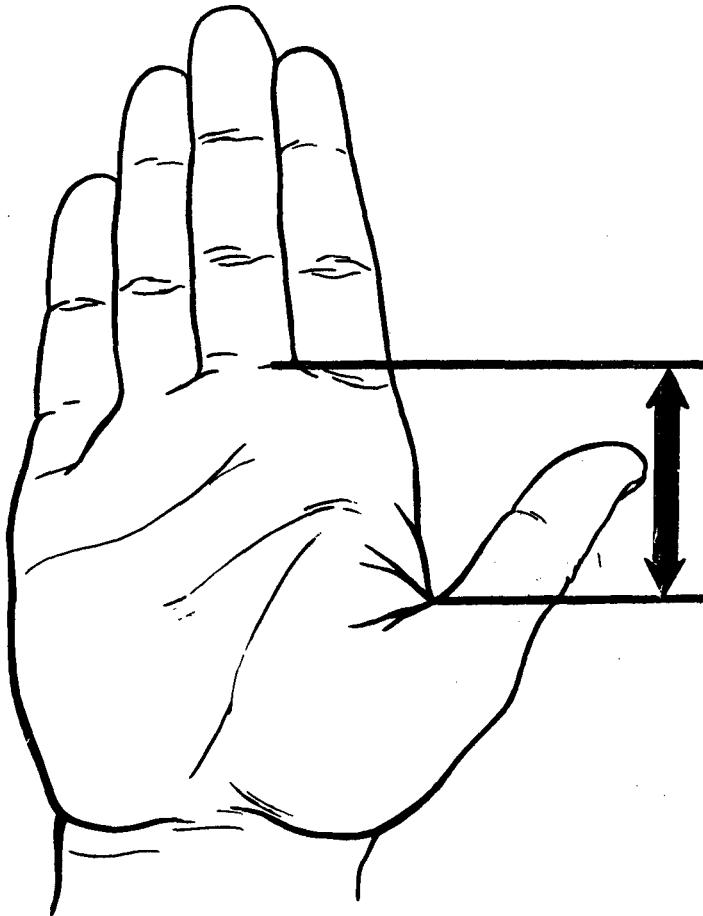

THE SUMMARY STATISTICS

....

CENTIMETERS

INCHES

4.97	MEAN	1.96
0.01	SE(M)	0.00
0.52	ST DEV	0.20
0.00	SE(SD)	0.00

....

SYMMETRY--BETA I =	0.18
KURTOSIS--BETA II =	3.19
COEFFICIENT OF VARIATION =	10.45

....

SAMPLE SIZE = 6682

Thumb Crotch Length: Subject sits, with his right hand and fingers extended, palm up, and with his thumb extended away from the hand. The length of the thumb crotch is measured from the skinfold at the base of the thumb to the notch between the first and second fingers. Sliding calipers are used.

64 Foot Length

--INTERVALS--				--FREQUENCIES--			
CENTIMETERS		INCHES		ACTUAL FREQ	CUMULA TIVE-F	PERCEN T-FREQ	CUMUL- PCT-FQ
32.15-	32.44	12.66-	12.77	1	6682	0.01	100.00
31.85-	32.14	12.54-	12.65	0	6681	0.00	99.99
31.55-	31.84	12.42-	12.53	1	6681	0.01	99.99
31.25-	31.54	12.30-	12.41	3	6680	0.04	99.97
30.95-	31.24	12.19-	12.29	5	6677	0.07	99.93
30.65-	30.94	12.07-	12.18	16	6672	0.24	99.85
30.35-	30.64	11.95-	12.06	18	6656	0.27	99.61
30.05-	30.34	11.83-	11.94	19	6638	0.28	99.34
29.75-	30.04	11.71-	11.82	44	6619	0.66	99.06
29.45-	29.74	11.59-	11.70	57	6575	0.85	98.40
29.15-	29.44	11.48-	11.58	84	6518	1.26	97.55
28.85-	29.14	11.36-	11.47	127	6434	1.90	96.29
28.55-	28.84	11.24-	11.35	224	6307	3.35	94.39
28.25-	28.54	11.12-	11.23	245	6083	3.67	91.04
27.95-	28.24	11.00-	11.11	352	5838	5.27	87.37
27.65-	27.94	10.89-	10.99	451	5486	6.75	82.10
27.35-	27.64	10.77-	10.88	464	5035	6.94	75.35
27.05-	27.34	10.65-	10.76	602	4571	9.01	68.41
26.75-	27.04	10.53-	10.64	610	3969	9.13	59.40
26.45-	26.74	10.41-	10.52	567	3359	8.49	50.27
26.15-	26.44	10.30-	10.40	695	2792	10.40	41.78
25.85-	26.14	10.18-	10.29	508	2097	7.60	31.38
25.55-	25.84	10.06-	10.17	470	1589	7.03	23.78
25.25-	25.54	9.94-	10.05	361	1119	5.40	16.75
24.95-	25.24	9.82-	9.93	268	758	4.01	11.34
24.65-	24.94	9.70-	9.81	163	490	2.44	7.33
24.35-	24.64	9.59-	9.69	133	327	1.99	4.89
24.05-	24.34	9.47-	9.58	87	194	1.30	2.90
23.75-	24.04	9.35-	9.46	50	107	0.75	1.60
23.45-	23.74	9.23-	9.34	33	57	0.49	0.85
23.15-	23.44	9.11-	9.22	19	24	0.28	0.36
22.85-	23.14	9.00-	9.10	2	5	0.03	0.07
22.55-	22.84	8.88-	8.99	0	3	0.00	0.04
22.25-	22.54	8.76-	8.87	1	3	0.01	0.04
21.95-	22.24	8.64-	8.75	1	2	0.01	0.03
21.65-	21.94	8.52-	8.63	0	1	0.00	0.01
21.35-	21.64	8.41-	8.51	1	1	0.01	0.01

64 Foot Length

PERCENTILES

CENTIMETERS		INCHES
30.03	99 TH	11.82
29.59	98 TH	11.65
29.33	97 TH	11.55
28.98	95 TH	11.41
28.45	90 TH	11.20
28.11	85 TH	11.07
27.85	80 TH	10.96
27.62	75 TH	10.87
27.42	70 TH	10.80
27.24	65 TH	10.72
27.07	60 TH	10.66
26.91	55 TH	10.59
26.74	50 TH	10.53
26.58	45 TH	10.47
26.42	40 TH	10.40
26.26	35 TH	10.34
26.08	30 TH	10.27
25.89	25 TH	10.19
25.68	20 TH	10.11
25.44	15 TH	10.02
25.13	10 TH	9.89
24.67	5 TH	9.71
24.37	3 RD	9.60
24.15	2 ND	9.51
23.80	1 ST	9.37

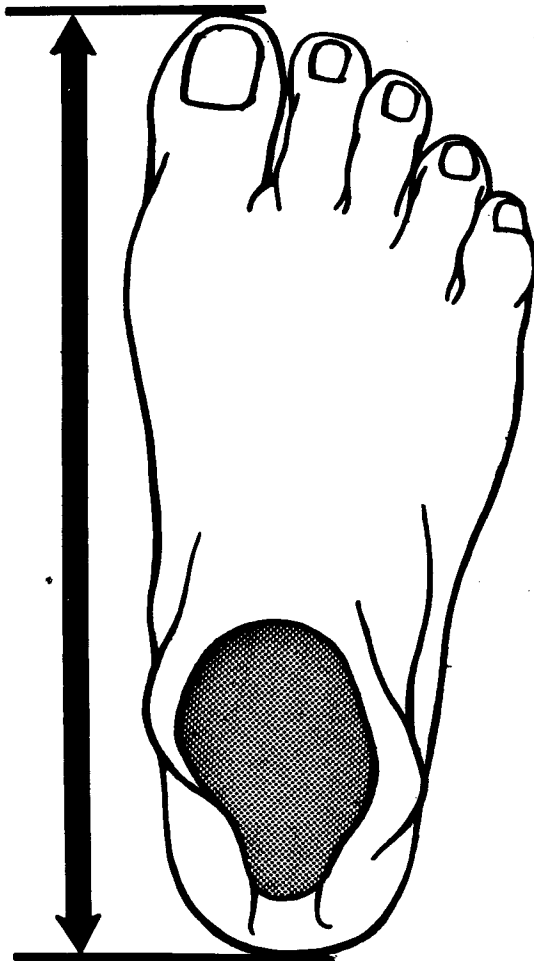

Foot Length: Subject stands erect, with his right foot in a foot measuring box, and with his weight evenly distributed on both feet. The maximum length of the right foot is measured from the back of the heel to the tip of the longest toe. A foot measuring box is used.

THE SUMMARY STATISTICS

••••

CENTIMETERS		INCHES
26.78	MEAN	10.54
0.02	SE(M)	0.01
1.30	ST DEV	0.51
0.01	SE(SD)	0.00

••••

SYMMETRY--BETA I = 0.16
 KURTOSIS--BETA II = 3.19

COEFFICIENT OF VARIATION = 4.86

••••

SAMPLE SIZE = 6682

65 Instep Length

--INTERVALS--				--FREQUENCIES--			
CENTIMETERS		INCHES		ACTUAL FREQ	CUMULA TIVE-F	PERCEN T-FREQ	CUMUL- PCT-FQ
24.35-	24.54	9.59-	9.66	1	6682	0.01	100.00
24.15-	24.34	9.51-	9.58	0	6681	0.00	99.99
23.95-	24.14	9.43-	9.50	1	6681	0.01	99.99
23.75-	23.94	9.35-	9.42	0	6680	0.00	99.97
23.55-	23.74	9.27-	9.34	1	6680	0.01	99.97
23.35-	23.54	9.19-	9.26	3	6679	0.04	99.96
23.15-	23.34	9.11-	9.18	2	6676	0.03	99.91
22.95-	23.14	9.04-	9.10	3	6674	0.04	99.88
22.75-	22.94	8.96-	9.03	10	6671	0.15	99.84
22.55-	22.74	8.88-	8.95	19	6661	0.28	99.69
22.35-	22.54	8.80-	8.87	13	6642	0.19	99.40
22.15-	22.34	8.72-	8.79	34	6629	0.51	99.21
21.95-	22.14	8.64-	8.71	24	6595	0.36	98.70
21.75-	21.94	8.56-	8.63	51	6571	0.76	98.34
21.55-	21.74	8.48-	8.55	92	6520	1.38	97.58
21.35-	21.54	8.41-	8.47	84	6428	1.26	96.20
21.15-	21.34	8.33-	8.40	210	6344	3.14	94.94
20.95-	21.14	8.25-	8.32	125	6134	1.87	91.80
20.75-	20.94	8.17-	8.24	247	6009	3.70	89.93
20.55-	20.74	8.09-	8.16	368	5762	5.51	86.23
20.35-	20.54	8.01-	8.08	268	5394	4.01	80.72
20.15-	20.34	7.93-	8.00	570	5126	8.53	76.71
19.95-	20.14	7.85-	7.92	312	4556	4.67	68.18
19.75-	19.94	7.78-	7.84	517	4244	7.74	63.51
19.55-	19.74	7.70-	7.77	617	3727	9.23	55.78
19.35-	19.54	7.62-	7.69	402	3110	6.02	46.54
19.15-	19.34	7.54-	7.61	727	2708	10.88	40.53
18.95-	19.14	7.46-	7.53	305	1981	4.56	29.65
18.75-	18.94	7.38-	7.45	336	1676	5.03	25.08
18.55-	18.74	7.30-	7.37	439	1340	6.57	20.05
18.35-	18.54	7.22-	7.29	185	901	2.77	13.48
18.15-	18.34	7.15-	7.21	262	716	3.92	10.72
17.95-	18.14	7.07-	7.14	111	454	1.66	6.79
17.75-	17.94	6.99-	7.06	95	343	1.42	5.13
17.55-	17.74	6.91-	6.98	96	248	1.44	3.71
17.35-	17.54	6.83-	6.90	46	152	0.69	2.27
17.15-	17.34	6.75-	6.82	66	106	0.99	1.59
16.95-	17.14	6.67-	6.74	17	40	0.25	0.60
16.75-	16.94	6.59-	6.66	7	23	0.10	0.34
16.55-	16.74	6.52-	6.58	13	16	0.19	0.24
16.35-	16.54	6.44-	6.51	2	3	0.03	0.04
16.15-	16.34	6.36-	6.43	1	1	0.01	0.01

65 Instep Length

PERCENTILES

CENTIMETERS		INCHES
22.26	99 TH	8.76
21.88	98 TH	8.61
21.66	97 TH	8.53
21.37	95 TH	8.41
20.96	90 TH	8.25
20.69	85 TH	8.15
20.49	80 TH	8.07
20.31	75 TH	8.00
20.16	70 TH	7.94
20.02	65 TH	7.88
19.89	60 TH	7.83
19.76	55 TH	7.78
19.63	50 TH	7.73
19.51	45 TH	7.68
19.38	40 TH	7.63
19.24	35 TH	7.58
19.10	30 TH	7.52
18.94	25 TH	7.46
18.77	20 TH	7.39
18.57	15 TH	7.31
18.31	10 TH	7.21
17.92	5 TH	7.06
17.67	3 RD	6.96
17.49	2 ND	6.89
17.21	1 ST	6.78

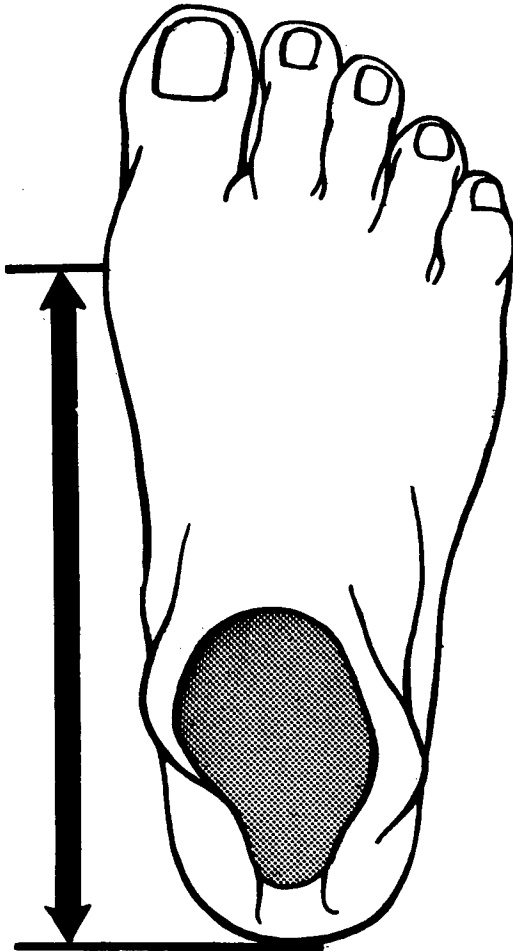

THE SUMMARY STATISTICS

.....

Instep Length: Subject stands erect, with his right foot in a foot measuring box, and with his weight evenly distributed on both feet. The length of the instep of the right foot is measured from the back of the heel to the center of the inner ball of the foot (first metatarsal-phalangeal joint). A foot measuring box is used.

CENTIMETERS		INCHES
19.64	MEAN	7.73
0.01	SE(M)	0.01
1.05	ST DEV	0.41
0.01	SE(SD)	0.00
.....		
	SYMMETRY--BETA I =	0.14
	KURTOSIS--BETA II =	3.26
	COEFFICIENT OF VARIATION =	5.32
.....		
	SAMPLE SIZE =	6682

66 Ball of Foot Breadth

--INTERVALS--

--FREQUENCIES--

CENTIMETERS		INCHES		ACTUAL FREQ	CUMULA TIVE-F	PERCEN T-FREQ	CUMUL- PCT-FQ
12.15-	12.24	4.78-	4.81	1	6682	0.01	100.00
12.05-	12.14	4.74-	4.77	0	6681	0.00	99.99
11.95-	12.04	4.70-	4.73	0	6681	0.00	99.99
11.85-	11.94	4.67-	4.69	2	6681	0.03	99.99
11.75-	11.84	4.63-	4.66	1	6679	0.01	99.96
11.65-	11.74	4.59-	4.62	4	6678	0.06	99.94
11.55-	11.64	4.55-	4.58	10	6674	0.15	99.88
11.45-	11.54	4.51-	4.54	5	6664	0.07	99.73
11.35-	11.44	4.47-	4.50	12	6659	0.18	99.66
11.25-	11.34	4.43-	4.46	24	6647	0.36	99.48
11.15-	11.24	4.39-	4.42	25	6623	0.37	99.12
11.05-	11.14	4.35-	4.38	31	6598	0.46	98.74
10.95-	11.04	4.31-	4.34	53	6567	0.79	98.28
10.85-	10.94	4.27-	4.30	79	6514	1.18	97.49
10.75-	10.84	4.23-	4.26	95	6435	1.42	96.30
10.65-	10.74	4.19-	4.22	141	6340	2.11	94.88
10.55-	10.64	4.15-	4.18	176	6199	2.63	92.77
10.45-	10.54	4.11-	4.14	222	6023	3.32	90.14
10.35-	10.44	4.07-	4.10	278	5801	4.16	86.82
10.25-	10.34	4.04-	4.06	296	5523	4.43	82.65
10.15-	10.24	4.00-	4.03	400	5227	5.99	78.23
10.05-	10.14	3.96-	3.99	402	4827	6.02	72.24
9.95-	10.04	3.92-	3.95	481	4425	7.20	66.22
9.85-	9.94	3.88-	3.91	457	3944	6.84	59.02
9.75-	9.84	3.84-	3.87	485	3487	7.26	52.18
9.65-	9.74	3.80-	3.83	536	3002	8.02	44.93
9.55-	9.64	3.76-	3.79	432	2466	6.47	36.91
9.45-	9.54	3.72-	3.75	407	2034	6.09	30.44
9.35-	9.44	3.68-	3.71	391	1627	5.85	24.35
9.25-	9.34	3.64-	3.67	329	1236	4.92	18.50
9.15-	9.24	3.60-	3.63	289	907	4.33	13.57
9.05-	9.14	3.56-	3.59	177	618	2.65	9.25
8.95-	9.04	3.52-	3.55	163	441	2.44	6.60
8.85-	8.94	3.48-	3.51	87	278	1.30	4.16
8.75-	8.84	3.45-	3.47	59	191	0.88	2.86
8.65-	8.74	3.41-	3.44	50	132	0.75	1.98
8.55-	8.64	3.37-	3.40	26	82	0.39	1.23
8.45-	8.54	3.33-	3.36	23	56	0.34	0.84
8.35-	8.44	3.29-	3.32	14	33	0.21	0.49
8.25-	8.34	3.25-	3.28	10	19	0.15	0.28
8.15-	8.24	3.21-	3.24	4	9	0.06	0.13
8.05-	8.14	3.17-	3.20	3	5	0.04	0.07
7.95-	8.04	3.13-	3.16	2	2	0.03	0.03

66 Ball of Foot Breadth

PERCENTILES

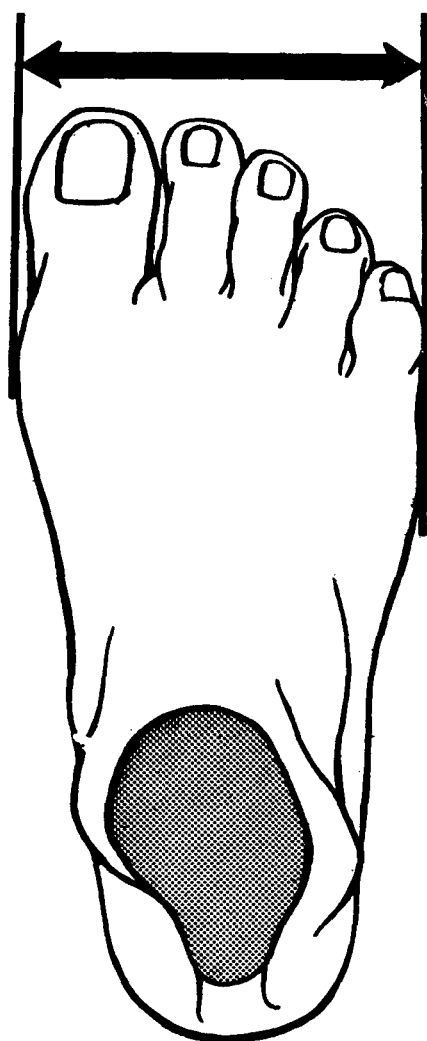

CENTIMETERS		INCHES
11.20	99 TH	4.41
11.03	98 TH	4.34
10.92	97 TH	4.30
10.77	95 TH	4.24
10.55	90 TH	4.15
10.40	85 TH	4.09
10.29	80 TH	4.05
10.19	75 TH	4.01
10.11	70 TH	3.98
10.03	65 TH	3.95
9.96	60 TH	3.92
9.89	55 TH	3.89
9.82	50 TH	3.87
9.76	45 TH	3.84
9.69	40 TH	3.81
9.62	35 TH	3.79
9.55	30 TH	3.76
9.47	25 TH	3.73
9.39	20 TH	3.70
9.29	15 TH	3.66
9.16	10 TH	3.61
8.97	5 TH	3.53
8.85	3 RD	3.48
8.75	2 ND	3.45
8.60	1 ST	3.39

THE SUMMARY STATISTICS

.....

Ball Of Foot Breadth: Subject stands erect, with his right foot in a foot measuring box, and with his weight evenly distributed on both feet. The breadth of the right foot is measured between the inner and outer balls of the foot (first and fifth metatarsal-phalangeal joints). A foot measuring box is used.

CENTIMETERS		INCHES
9.84	MEAN	3.87
0.01	SE(M)	0.00
0.55	ST DEV	0.22
0.00	SE(SD)	0.00

.....

SYMMETRY--BETA I = 0.17

KURTOSIS--BETA II = 3.18

COEFFICIENT OF VARIATION = 5.56

.....

SAMPLE SIZE = 6682

67 Heel Breadth

--INTERVALS--				--FREQUENCIES--			
CENTIMETERS		INCHES		ACTUAL FREQ	CUMULA TIVE-F	PERCEN T-FREQ	CUMUL- PCT-FQ
8.95-	9.04	3.52-	3.55	1	6682	0.01	100.00
8.85-	8.94	3.48-	3.51	2	6681	0.03	99.99
8.75-	8.84	3.45-	3.47	1	6679	0.01	99.96
8.65-	8.74	3.41-	3.44	1	6678	0.01	99.94
8.55-	8.64	3.37-	3.40	5	6677	0.07	99.93
8.45-	8.54	3.33-	3.36	6	6672	0.09	99.85
8.35-	8.44	3.29-	3.32	5	6666	0.07	99.76
8.25-	8.34	3.25-	3.28	12	6661	0.18	99.69
8.15-	8.24	3.21-	3.24	17	6649	0.25	99.51
8.05-	8.14	3.17-	3.20	38	6632	0.57	99.25
7.95-	8.04	3.13-	3.16	33	6594	0.49	98.68
7.85-	7.94	3.09-	3.12	45	6561	0.67	98.19
7.75-	7.84	3.05-	3.08	82	6516	1.23	97.52
7.65-	7.74	3.01-	3.04	116	6434	1.74	96.29
7.55-	7.64	2.97-	3.00	153	6318	2.29	94.55
7.45-	7.54	2.93-	2.96	213	6165	3.19	92.26
7.35-	7.44	2.89-	2.92	277	5952	4.15	89.08
7.25-	7.34	2.85-	2.88	295	5675	4.41	84.93
7.15-	7.24	2.82-	2.84	384	5380	5.75	80.51
7.05-	7.14	2.78-	2.81	497	4996	7.44	74.77
6.95-	7.04	2.74-	2.77	437	4499	6.54	67.33
6.85-	6.94	2.70-	2.73	570	4062	8.53	60.79
6.75-	6.84	2.66-	2.69	626	3492	9.37	52.26
6.65-	6.74	2.62-	2.65	614	2866	9.19	42.89
6.55-	6.64	2.58-	2.61	554	2252	8.29	33.70
6.45-	6.54	2.54-	2.57	392	1698	5.87	25.41
6.35-	6.44	2.50-	2.53	459	1306	6.87	19.55
6.25-	6.34	2.46-	2.49	300	847	4.49	12.68
6.15-	6.24	2.42-	2.45	238	547	3.56	8.19
6.05-	6.14	2.38-	2.41	127	309	1.90	4.62
5.95-	6.04	2.34-	2.37	72	182	1.08	2.72
5.85-	5.94	2.30-	2.33	49	110	0.73	1.65
5.75-	5.84	2.26-	2.29	29	61	0.43	0.91
5.65-	5.74	2.22-	2.25	15	32	0.22	0.48
5.55-	5.64	2.19-	2.21	9	17	0.13	0.25
5.45-	5.54	2.15-	2.18	5	8	0.07	0.12
5.35-	5.44	2.11-	2.14	1	3	0.01	0.04
5.25-	5.34	2.07-	2.10	0	2	0.00	0.03
5.15-	5.24	2.03-	2.06	1	2	0.01	0.03
5.05-	5.14	1.99-	2.02	1	1	0.01	0.01

67 Heel Breadth

PERCENTILES

CENTIMETERS		INCHES
8.10	99 TH	3.19
7.93	98 TH	3.12
7.82	97 TH	3.08
7.68	95 TH	3.02
7.47	90 TH	2.94
7.34	85 TH	2.89
7.24	80 TH	2.85
7.15	75 TH	2.82
7.08	70 TH	2.79
7.01	65 TH	2.76
6.95	60 TH	2.74
6.89	55 TH	2.71
6.83	50 TH	2.69
6.77	45 TH	2.67
6.72	40 TH	2.64
6.66	35 TH	2.62
6.60	30 TH	2.60
6.54	25 TH	2.57
6.47	20 TH	2.55
6.39	15 TH	2.52
6.29	10 TH	2.48
6.15	5 TH	2.42
6.05	3 RD	2.38
5.98	2 ND	2.36
5.87	1 ST	2.31

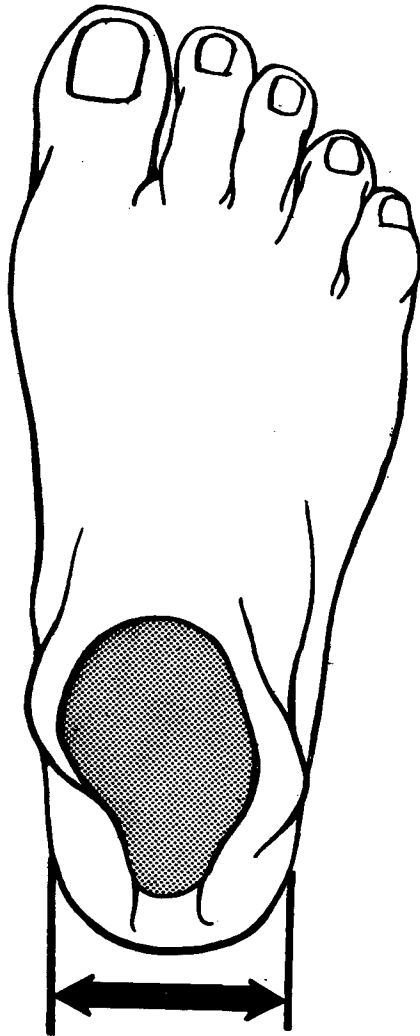

Heel Breadth: Subject stands erect, with his feet slightly apart, and with his weight evenly distributed on both feet. The breadth of the right heel is measured below and behind the projections of the ankle bones (malleoli). Sliding calipers are used.

THE SUMMARY STATISTICS

....

CENTIMETERS		INCHES
6.86	MEAN	2.70
0.01	SE(M)	0.00
0.47	ST DEV	0.18
0.00	SE(SD)	0.00

....

SYMMETRY--BETA I = 0.37
 KURTOSIS--BETA II = 3.39
 COEFFICIENT OF VARIATION = 6.84

....

SAMPLE SIZE = 6682

68 Ball of Foot Circumference

CENTIMETERS		INCHES		ACTUAL FREQ	CUMULA TIVE-F	PERCEN T-FREQ	CUMUL- PCT-FQ
31.15-	31.44	12.26-	12.37	1	6682	0.01	100.00
30.85-	31.14	12.15-	12.25	0	6681	0.00	99.99
30.55-	30.84	12.03-	12.14	0	6681	0.00	99.99
30.25-	30.54	11.91-	12.02	1	6681	0.01	99.99
29.95-	30.24	11.79-	11.90	3	6680	0.04	99.97
29.65-	29.94	11.67-	11.78	1	6677	0.01	99.93
29.35-	29.64	11.56-	11.66	8	6676	0.12	99.91
29.05-	29.34	11.44-	11.55	6	6668	0.09	99.79
28.75-	29.04	11.32-	11.43	14	6662	0.21	99.70
28.45-	28.74	11.20-	11.31	25	6648	0.37	99.49
28.15-	28.44	11.08-	11.19	37	6623	0.55	99.12
27.85-	28.14	10.96-	11.07	70	6586	1.05	98.56
27.55-	27.84	10.85-	10.95	94	6516	1.41	97.52
27.25-	27.54	10.73-	10.84	143	6422	2.14	96.11
26.95-	27.24	10.61-	10.72	214	6279	3.20	93.97
26.65-	26.94	10.49-	10.60	251	6065	3.76	90.77
26.35-	26.64	10.37-	10.48	349	5814	5.22	87.01
26.05-	26.34	10.26-	10.36	382	5465	5.72	81.79
25.75-	26.04	10.14-	10.25	481	5083	7.20	76.07
25.45-	25.74	10.02-	10.13	495	4602	7.41	68.87
25.15-	25.44	9.90-	10.01	599	4107	8.96	61.46
24.85-	25.14	9.78-	9.89	594	3508	8.89	52.50
24.55-	24.84	9.67-	9.77	531	2914	7.95	43.61
24.25-	24.54	9.55-	9.66	465	2383	6.96	35.66
23.95-	24.24	9.43-	9.54	487	1918	7.29	28.70
23.65-	23.94	9.31-	9.42	309	1431	4.62	21.42
23.35-	23.64	9.19-	9.30	279	1122	4.18	16.79
23.05-	23.34	9.07-	9.18	243	843	3.64	12.62
22.75-	23.04	8.96-	9.06	157	600	2.35	8.98
22.45-	22.74	8.84-	8.95	112	443	1.68	6.63
22.15-	22.44	8.72-	8.83	82	331	1.23	4.95
21.85-	22.14	8.60-	8.71	109	249	1.63	3.73
21.55-	21.84	8.48-	8.59	49	140	0.73	2.10
21.25-	21.54	8.37-	8.47	28	91	0.42	1.36
20.95-	21.24	8.25-	8.36	20	63	0.30	0.94
20.65-	20.94	8.13-	8.24	15	43	0.22	0.64
20.35-	20.64	8.01-	8.12	9	28	0.13	0.42
20.05-	20.34	7.89-	8.00	13	19	0.19	0.28
19.75-	20.04	7.78-	7.88	4	6	0.06	0.09
19.45-	19.74	7.66-	7.77	0	2	0.00	0.03
19.15-	19.44	7.54-	7.65	1	2	0.01	0.03
18.85-	19.14	7.42-	7.53	0	1	0.00	0.01
18.55-	18.84	7.30-	7.41	1	1	0.01	0.01

68 Ball of Foot Circumference

PERCENTILES

CENTIMETERS		INCHES	
28.40	99 TH	11.18	
27.99	98 TH	11.02	
27.73	97 TH	10.92	
27.39	95 TH	10.78	
26.87	90 TH	10.58	
26.52	85 TH	10.44	
26.25	80 TH	10.34	
26.02	75 TH	10.24	
25.81	70 TH	10.16	
25.62	65 TH	10.09	
25.43	60 TH	10.01	
25.25	55 TH	9.94	
25.07	50 TH	9.87	
24.89	45 TH	9.80	
24.70	40 TH	9.73	
24.51	35 TH	9.65	
24.30	30 TH	9.57	
24.08	25 TH	9.48	
23.82	20 TH	9.38	
23.51	15 TH	9.26	
23.11	10 TH	9.10	
22.50	5 TH	8.86	
22.09	3 RD	8.70	
21.78	2 ND	8.57	
21.27	1 ST	8.37	

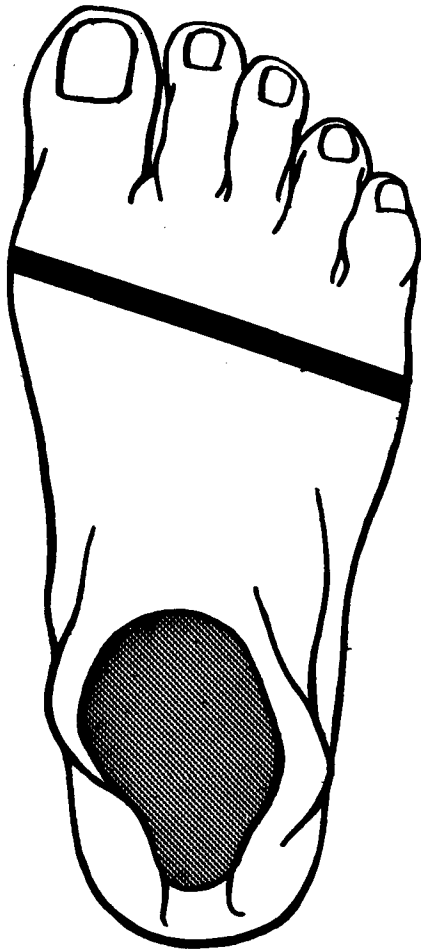

Ball Of Foot Circumference: Subject stands erect, with his feet slightly apart and with his weight evenly distributed on both feet. The circumference of the right foot is measured. A steel tape is used, with the tape passing over the inner and outer balls of the foot (first and fifth metatarsal- phalangeal joints).

THE SUMMARY STATISTICS

....

CENTIMETERS		INCHES	
25.02	MEAN	9.85	
0.02	SE(M)	0.01	
1.48	ST DEV	0.58	
0.01	SE(SD)	0.01	

....

SYMMETRY--BETA I = -0.17
 KURTOSIS--BETA II = 3.33
 COEFFICIENT OF VARIATION = 5.92

....

SAMPLE SIZE = 6682

69 Instep Circumference

--INTERVALS--

--FREQUENCIES--

CENTIMETERS		INCHES		ACTUAL FREQ	CUMULA TIVE-F	PERCEN T-FREQ	CUMUL- PCT-FQ
35.65-	36.04	14.04-	14.18	1	6682	0.01	100.00
35.25-	35.64	13.88-	14.03	0	6681	0.00	99.99
34.85-	35.24	13.72-	13.87	0	6681	0.00	99.99
34.45-	34.84	13.56-	13.71	0	6681	0.00	99.99
34.05-	34.44	13.41-	13.55	0	6681	0.00	99.99
33.65-	34.04	13.25-	13.40	0	6681	0.00	99.99
33.25-	33.64	13.09-	13.24	1	6681	0.01	99.99
32.85-	33.24	12.93-	13.08	0	6680	0.00	99.97
32.45-	32.84	12.78-	12.92	0	6680	0.00	99.97
32.05-	32.44	12.62-	12.77	5	6680	0.07	99.97
31.65-	32.04	12.46-	12.61	8	6675	0.12	99.90
31.25-	31.64	12.30-	12.45	14	6667	0.21	99.78
30.85-	31.24	12.15-	12.29	17	6653	0.25	99.57
30.45-	30.84	11.99-	12.14	29	6636	0.43	99.31
30.05-	30.44	11.83-	11.98	67	6607	1.00	98.88
29.65-	30.04	11.67-	11.82	100	6540	1.50	97.87
29.25-	29.64	11.52-	11.66	134	6440	2.01	96.38
28.85-	29.24	11.36-	11.51	191	6306	2.86	94.37
28.45-	28.84	11.20-	11.35	236	6115	3.53	91.51
28.05-	28.44	11.04-	11.19	427	5879	6.39	87.98
27.65-	28.04	10.89-	11.03	420	5452	6.29	81.59
27.25-	27.64	10.73-	10.88	537	5032	8.04	75.31
26.85-	27.24	10.57-	10.72	620	4495	9.28	67.27
26.45-	26.84	10.41-	10.56	610	3875	9.13	57.99
26.05-	26.44	10.26-	10.40	709	3265	10.61	48.86
25.65-	26.04	10.10-	10.25	581	2556	8.70	38.25
25.25-	25.64	9.94-	10.09	526	1975	7.87	29.56
24.85-	25.24	9.78-	9.93	484	1449	7.24	21.69
24.45-	24.84	9.63-	9.77	337	965	5.04	14.44
24.05-	24.44	9.47-	9.62	270	628	4.04	9.40
23.65-	24.04	9.31-	9.46	139	358	2.08	5.36
23.25-	23.64	9.15-	9.30	92	219	1.38	3.28
22.85-	23.24	9.00-	9.14	53	127	0.79	1.90
22.45-	22.84	8.84-	8.99	37	74	0.55	1.11
22.05-	22.44	8.68-	8.83	22	37	0.33	0.55
21.65-	22.04	8.52-	8.67	7	15	0.10	0.22
21.25-	21.64	8.37-	8.51	5	8	0.07	0.12
20.85-	21.24	8.21-	8.36	2	3	0.03	0.04
20.45-	20.84	8.05-	8.20	1	1	0.01	0.01

69 Instep Circumference

PERCENTILES

CENTIMETERS		INCHES	
30.57	99 TH	12.03	
30.10	98 TH	11.85	
29.79	97 TH	11.73	
29.37	95 TH	11.56	
28.72	90 TH	11.31	
28.28	85 TH	11.13	
27.93	80 TH	11.00	
27.64	75 TH	10.88	
27.38	70 TH	10.78	
27.14	65 TH	10.69	
26.92	60 TH	10.60	
26.71	55 TH	10.52	
26.50	50 TH	10.43	
26.30	45 TH	10.35	
26.10	40 TH	10.27	
25.89	35 TH	10.19	
25.67	30 TH	10.11	
25.44	25 TH	10.02	
25.18	20 TH	9.92	
24.89	15 TH	9.80	
24.51	10 TH	9.65	
23.95	5 TH	9.43	
23.56	3 RD	9.28	
23.27	2 ND	9.16	
22.79	1 ST	8.97	

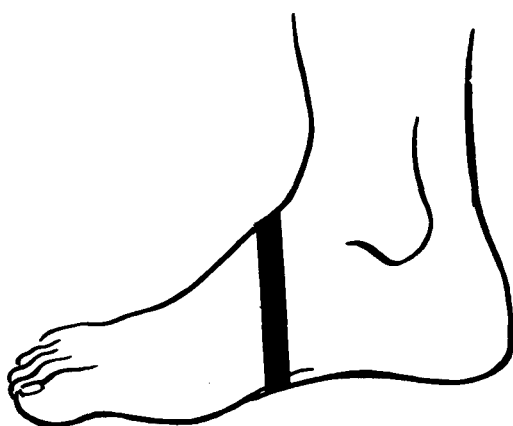

Instep Circumference: Subject stands erect, with his feet slightly apart, and with his weight evenly distributed on both feet. The vertical circumference of the instep of the right foot is measured. A steel tape is used, with the tape passing under the foot and over the junction of the leg and foot.

THE SUMMARY STATISTICS

••••

CENTIMETERS		INCHES	
26.56	MEAN	10.46	
0.02	SE(M)	0.01	
1.65	ST DEV	0.65	
0.01	SE(SD)	0.01	

••••

SYMMETRY--BETA I	=	0.17
KURTOSIS--BETA II	=	3.24
COEFFICIENT OF VARIATION	=	6.21

••••

SAMPLE SIZE = 6682

70 Heel-Ankle Circumference

--INTERVALS--			--FREQUENCIES--			
CENTIMETERS		INCHES	ACTUAL FREQ	CUMULA TIVE-F	PERCEN T-FREQ	CUMUL- PCT-FQ
40.45-	40.74	15.93- 16.03	1	6682	0.01	100.00
40.15-	40.44	15.81- 15.92	1	6681	0.01	99.99
39.85-	40.14	15.69- 15.80	5	6680	0.07	99.97
39.55-	39.84	15.57- 15.68	1	6675	0.01	99.90
39.25-	39.54	15.45- 15.56	4	6674	0.06	99.88
38.95-	39.24	15.33- 15.44	7	6670	0.10	99.82
38.65-	38.94	15.22- 15.32	13	6663	0.19	99.72
38.35-	38.64	15.10- 15.21	19	6650	0.28	99.52
38.05-	38.34	14.98- 15.09	27	6631	0.40	99.24
37.75-	38.04	14.86- 14.97	46	6604	0.69	98.83
37.45-	37.74	14.74- 14.85	50	6558	0.75	98.14
37.15-	37.44	14.63- 14.73	88	6508	1.32	97.40
36.85-	37.14	14.51- 14.62	86	6420	1.29	96.08
36.55-	36.84	14.39- 14.50	127	6334	1.90	94.79
36.25-	36.54	14.27- 14.38	170	6207	2.54	92.89
35.95-	36.24	14.15- 14.26	260	6037	3.89	90.35
35.65-	35.94	14.04- 14.14	271	5777	4.06	86.46
35.35-	35.64	13.92- 14.03	340	5506	5.09	82.40
35.05-	35.34	13.80- 13.91	378	5166	5.66	77.31
34.75-	35.04	13.68- 13.79	357	4788	5.34	71.66
34.45-	34.74	13.56- 13.67	485	4431	7.26	66.31
34.15-	34.44	13.45- 13.55	475	3946	7.11	59.05
33.85-	34.14	13.33- 13.44	486	3471	7.27	51.95
33.55-	33.84	13.21- 13.32	474	2985	7.09	44.67
33.25-	33.54	13.09- 13.20	471	2511	7.05	37.58
32.95-	33.24	12.97- 13.08	455	2040	6.81	30.53
32.65-	32.94	12.85- 12.96	323	1585	4.83	23.72
32.35-	32.64	12.74- 12.84	309	1262	4.62	18.89
32.05-	32.34	12.62- 12.73	285	953	4.27	14.26
31.75-	32.04	12.50- 12.61	192	668	2.87	10.00
31.45-	31.74	12.38- 12.49	141	476	2.11	7.12
31.15-	31.44	12.26- 12.37	106	335	1.59	5.01
30.85-	31.14	12.15- 12.25	81	229	1.21	3.43
30.55-	30.84	12.03- 12.14	53	148	0.79	2.21
30.25-	30.54	11.91- 12.02	42	95	0.63	1.42
29.95-	30.24	11.79- 11.90	27	53	0.40	0.79
29.65-	29.94	11.67- 11.78	11	26	0.16	0.39
29.35-	29.64	11.56- 11.66	6	15	0.09	0.22
29.05-	29.34	11.44- 11.55	3	9	0.04	0.13
28.75-	29.04	11.32- 11.43	4	6	0.06	0.09
28.45-	28.74	11.20- 11.31	0	2	0.00	0.03
28.15-	28.44	11.08- 11.19	2	2	0.03	0.03

70 Heel-Ankle Circumference

PERCENTILES

CENTIMETERS		INCHES
38.18	99 TH	15.03
37.67	98 TH	14.83
37.35	97 TH	14.70
36.92	95 TH	14.53
36.26	90 TH	14.28
35.83	85 TH	14.11
35.49	80 TH	13.97
35.20	75 TH	13.86
34.95	70 TH	13.76
34.71	65 TH	13.67
34.49	60 TH	13.58
34.28	55 TH	13.50
34.08	50 TH	13.42
33.87	45 TH	13.33
33.66	40 TH	13.25
33.45	35 TH	13.17
33.23	30 TH	13.08
32.99	25 TH	12.99
32.72	20 TH	12.88
32.41	15 TH	12.76
32.02	10 TH	12.61
31.44	5 TH	12.38
31.06	3 RD	12.23
30.78	2 ND	12.12
30.34	1 ST	11.94

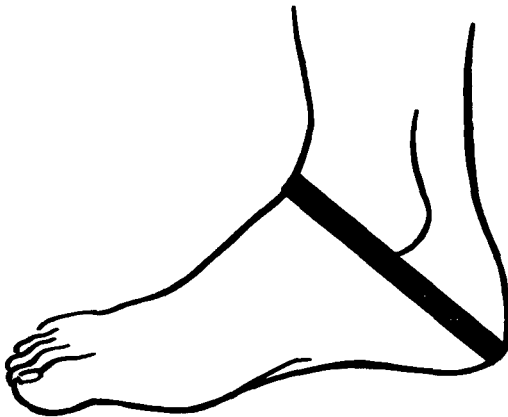

Heel-Ankle Circumference: Subject stands erect, with his feet slightly apart, and with his weight evenly distributed on both feet. The diagonal circumference of the right ankle is measured. A steel tape is used, with the tape passing under the tip of the heel and over the junction of the leg and the foot.

THE SUMMARY STATISTICS

.....

CENTIMETERS		INCHES
34.11	MEAN	13.43
0.02	SE(M)	0.01
1.66	ST DEV	0.65
0.01	SE(SD)	0.01

.....

SYMMETRY--BETA I = 0.14
 KURTOSIS--BETA II = 3.09
 COEFFICIENT OF VARIATION = 4.86

.....

SAMPLE SIZE = 6682

7. SUMMARY TABLES OF ANTHROPOMETRIC DATA

The detailed data for the seventy body measurements taken on the total Army series are presented in the previous section. However, to facilitate ready reference to values for groups of similar or related body measurements, the anthropometric data are summarized here in a series of ten tables. These tables show data for the total Army series, and for the four subseries. Two types of data are presented in the summary tables: percentile values and statistical values. Following the summary tables, selected bivariate tables are given to illustrate examples of correlation or relationship between body measurements.

In the summary tables, data are given first for the total Army series of 6682 men, followed by data for the four subseries drawn from the total Army series. These subseries consist of basic trainees (2639 men), infantry (3429 men), armored crewmen (489 men) and Army aviation personnel (125 men). Further discussion of these Army groups will be found in the following section (page 270).

The order of presentation of the seventy measurements in these ten tables is that indicated in the Visual Index (page 61), with the measurements grouped under the following headings: Weight, Standing Measurements, Sitting Measurements, Breadth Measurements, Circumferences and Surface Measurements, Head and Face Measurements, Hand Measurements, and Foot Measurements. The values shown in the tables are expressed in inches, with the exception of weight, which is given in pounds.

a. Tables of Percentile Values

The first set of five tables (Tables XVI to XX) shows selected percentile values for all of the seventy anthropometric measurements, from the 1st up to the 99th percentile. In addition, the range or spread from the 1st to the 99th percentile is indicated for each measurement. This is obtained by subtracting the 1st percentile value from the 99th percentile value. Due to the small sample size, only the 5th to 95th percentile values are shown for the Army aviator subseries.

TABLE XVI - PERCENTILE VALUES FOR TOTAL ARMY SERIES

Percentiles in Inches

No.	Measurements	1st	2nd	5th	10th	25th	50th	75th	90th	95th	98th	99th	Range (1st-99th)
1	Weight (pounds)	116	120	126	132	143	156	173	190	202	216	227	111
STANDING MEASUREMENTS													
2	Stature	62.6	63.4	64.5	65.4	67.0	68.7	70.4	72.1	73.1	74.2	74.9	12.3
3	Cervicale Height	52.9	53.7	54.8	55.8	57.2	58.8	60.6	62.1	63.0	64.0	64.6	11.7
4	Shoulder Height	50.9	51.6	52.6	53.5	54.9	56.6	58.2	59.8	60.7	61.7	62.4	11.5
5	Waist Height	36.8	37.4	38.4	39.2	40.5	41.9	43.4	44.5	45.3	46.3	46.9	10.1
6	Crotch Height	28.6	29.2	30.0	30.7	31.8	33.0	34.3	35.4	36.1	36.9	37.4	8.8
7	Kneecap Height	17.9	18.2	18.8	19.2	19.9	20.8	21.7	22.5	23.0	23.5	23.9	6.0
8	Calf Height	11.5	11.8	12.2	12.6	13.2	13.9	14.6	15.3	15.7	16.2	16.5	5.0
9	Functional Reach	28.3	28.8	29.5	30.1	31.2	32.5	33.8	35.0	35.8	36.7	37.2	8.9
SITTING MEASUREMENTS													
10	Vert. Arm Reach, Sitting	49.1	49.7	50.7	51.5	52.9	54.4	55.9	57.3	58.2	59.3	60.1	11.0
11	Sitting Height	32.3	32.7	33.3	33.8	34.7	35.7	36.7	37.6	38.1	38.6	39.0	6.7
12	Eye Height, Sitting	27.6	28.0	28.6	29.2	30.1	31.0	32.0	32.8	33.3	33.9	34.3	6.7
13	Mid-Shoulder Height	21.5	21.9	22.5	23.0	23.7	24.6	25.4	26.2	26.6	27.1	27.4	5.9
14	Shoulder-Elbow Length	12.8	13.0	13.3	13.6	14.0	14.5	15.0	15.5	15.7	16.1	16.3	3.5
15	Elbow-Fingertip Length	16.8	17.1	17.4	17.8	18.3	18.8	19.5	20.1	20.4	20.9	21.2	4.4
16	Knee Height, Sitting	18.8	19.1	19.6	20.0	20.6	21.3	22.0	22.7	23.1	23.6	23.9	5.1
17	Popliteal Height	15.3	15.6	16.0	16.3	16.9	17.5	18.2	18.8	19.2	19.6	19.9	4.6
18	Buttock-Knee Length	20.8	21.2	21.6	22.0	22.6	23.4	24.1	24.9	25.3	25.8	26.2	5.4
19	Buttock-Popliteal Length	17.3	17.6	18.0	18.4	19.0	19.6	20.3	20.9	21.3	21.7	22.0	4.7

TABLE XVI - PERCENTILE VALUES FOR TOTAL ARMY SERIES (Continued)

Percentiles in Inches

No.	Measurements	1st	2nd	5th	10th	25th	50th	75th	90th	95th	98th	99th	Range (1st-99th)
-----	--------------	-----	-----	-----	------	------	------	------	------	------	------	------	---------------------

BREADTH MEASUREMENTS

20	Chest Depth	7.6	7.7	8.0	8.2	8.6	9.1	9.6	10.1	10.5	11.0	11.4	3.8
21	Chest Breadth	10.3	10.5	10.8	11.0	11.4	12.0	12.6	13.1	13.5	14.0	14.3	4.0
22	Hip Breadth, Standing	11.4	11.6	11.9	12.1	12.5	13.0	13.6	14.1	14.5	14.9	15.2	3.8
23	Shoulder Breadth	15.7	16.0	16.3	16.6	17.2	17.8	18.5	19.2	19.6	20.1	20.5	4.8
24	Forearm-Forearm Breadth	14.9	15.2	15.7	16.1	16.9	18.0	19.1	20.3	21.1	22.0	22.7	7.8
25	Hip Breadth, Sitting	11.6	11.8	12.1	12.3	12.8	13.4	14.0	14.7	15.1	15.6	16.0	4.4

CIRCUMFERENCES AND SURFACE MEASUREMENTS

26	Neck Circumference	13.0	13.2	13.5	13.7	14.2	14.7	15.2	15.8	16.1	16.5	16.8	3.8
27	Shoulder Circumference	39.3	39.8	40.7	41.5	42.8	44.4	46.1	47.8	48.9	50.3	51.3	12.0
28	Chest Circumference	31.8	32.4	33.1	33.8	35.1	36.6	38.5	40.4	41.7	43.4	44.4	12.6
29	Waist Circumference	26.1	26.7	27.4	28.1	29.3	31.0	33.4	36.0	37.8	40.0	41.6	15.5
30	Hip Circumference	32.3	32.8	33.5	34.2	35.4	36.8	38.6	40.4	41.6	43.0	44.1	11.8
31	Upper Thigh Circum.	17.9	18.3	18.9	19.5	20.5	21.7	23.0	24.3	25.1	26.0	26.6	8.7
32	Lower Thigh Circum.	12.9	13.1	13.6	14.0	14.8	15.8	16.9	18.0	18.6	19.2	19.6	6.7
33	Calf Circumference	12.2	12.4	12.8	13.1	13.7	14.4	15.1	15.8	16.2	16.7	17.1	4.9
34	Ankle Circumference	7.8	7.9	8.1	8.2	8.5	8.9	9.3	9.7	9.9	10.2	10.4	2.6
35	Vertical Trunk Circum.	57.2	58.1	59.3	60.4	62.3	64.5	66.7	68.9	70.3	72.0	73.2	16.0
36	Arm Scye Circumference	14.8	15.1	15.6	16.0	16.7	17.4	18.3	19.2	19.8	20.6	21.2	6.4
37	Biceps Circum., Relaxed	9.4	9.6	10.0	10.3	10.8	11.5	12.3	13.0	13.5	14.0	14.4	5.0
38	Biceps Circum., Flexed	10.4	10.7	11.0	11.4	12.0	12.6	13.4	14.1	14.6	15.1	15.5	5.1
39	Forearm Circum., Flexed	9.8	10.0	10.3	10.5	11.0	11.6	12.1	12.7	13.0	13.5	13.8	4.0
40	Wrist Circumference	5.9	6.0	6.2	6.3	6.5	6.7	6.9	7.2	7.3	7.5	7.6	1.7
41	Shoulder Length	4.4	4.6	5.0	5.3	5.9	6.4	6.9	7.3	7.6	7.8	8.1	3.7
42	Interscye Breadth	12.6	12.9	13.4	13.8	14.6	15.4	16.2	17.0	17.4	18.0	18.4	5.8
43	Interscye, Maximum	17.2	17.6	18.3	18.8	19.7	20.7	21.7	22.6	23.1	23.8	24.3	7.1
44	Waist Back Length	14.8	15.1	15.6	16.0	16.8	17.7	18.6	19.5	20.0	20.5	20.9	6.1
45	Sleeve Inseam Length	16.7	17.0	17.4	17.8	18.4	19.1	19.8	20.5	20.9	21.4	21.7	5.0
46	Sleeve Length	30.2	30.6	31.3	31.8	32.7	33.8	34.8	35.8	36.4	37.1	37.5	7.3

TABLE XVI - PERCENTILE VALUES FOR TOTAL ARMY SERIES (Continued)

Percentiles in Inches

No.	Measurements	1st	2nd	5th	10th	25th	50th	75th	90th	95th	98th	99th	Range (1st-99th)
HEAD AND FACE MEASUREMENTS													
47	Head Circumference	20.63	20.81	21.07	21.30	21.66	22.08	22.51	22.91	23.16	23.43	23.61	2.98
48	Head Length	6.99	7.07	7.19	7.29	7.47	7.67	7.86	8.03	8.14	8.26	8.34	1.35
49	Occiput-Nasal Root	6.84	6.92	7.04	7.15	7.33	7.52	7.71	7.88	7.98	8.09	8.17	1.33
50	Occiput-Ext. Canthus	5.93	6.03	6.18	6.30	6.52	6.78	7.05	7.30	7.44	7.58	7.66	1.73
51	Occiput-Tragion	3.10	3.20	3.33	3.46	3.69	4.01	4.37	4.70	4.87	5.01	5.06	1.96
52	Occiput-Pronasale	7.94	8.04	8.18	8.31	8.52	8.74	8.96	9.15	9.27	9.40	9.48	1.54
53	Head Breadth	5.48	5.55	5.65	5.73	5.86	6.00	6.16	6.31	6.40	6.51	6.58	1.10
54	Bitragion Breadth	4.80	4.86	4.95	5.03	5.16	5.31	5.46	5.60	5.69	5.78	5.85	1.05
55	Head Height	4.46	4.56	4.69	4.81	5.00	5.21	5.42	5.61	5.72	5.83	5.90	1.44
56	Face Length	4.14	4.21	4.31	4.41	4.56	4.73	4.91	5.07	5.17	5.29	5.37	1.23
57	Face Breadth	5.01	5.07	5.15	5.23	5.36	5.51	5.66	5.79	5.88	5.98	6.05	1.04
58	Interpupillary Breadth	2.06	2.10	2.15	2.21	2.31	2.41	2.52	2.61	2.67	2.74	2.80	0.74
HAND MEASUREMENTS													
59	Hand Length	6.66	6.75	6.90	7.02	7.23	7.48	7.74	7.98	8.13	8.31	8.44	1.78
60	Palm Length	3.61	3.68	3.77	3.86	4.00	4.16	4.33	4.49	4.59	4.71	4.79	1.18
61	Hand Breadth	3.07	3.12	3.20	3.26	3.37	3.50	3.63	3.75	3.83	3.93	3.99	0.92
62	Hand Circumference	7.53	7.64	7.81	7.95	8.20	8.49	8.79	9.09	9.28	9.49	9.63	2.10
63	Thumb Crotch Length	1.50	1.55	1.63	1.70	1.82	1.95	2.09	2.22	2.30	2.39	2.46	0.90
FOOT MEASUREMENTS													
64	Foot Length	9.37	9.51	9.71	9.89	10.19	10.53	10.87	11.20	11.41	11.65	11.82	2.45
65	Instep Length	6.78	6.89	7.06	7.21	7.46	7.73	8.00	8.25	8.41	8.61	8.76	1.98
66	Ball of Foot Breadth	3.39	3.45	3.53	3.61	3.73	3.87	4.01	4.15	4.24	4.34	4.41	1.02
67	Heel Breadth	2.31	2.36	2.42	2.48	2.57	2.69	2.82	2.94	3.02	3.12	3.19	0.88
68	Ball of Foot Circum.	8.37	8.57	8.86	9.10	9.48	9.87	10.24	10.58	10.78	11.02	11.18	2.81
69	Instep Circumference	8.97	9.16	9.43	9.65	10.02	10.43	10.88	11.31	11.56	11.85	12.03	3.06
70	Heel-Ankle Circum.	11.94	12.12	12.38	12.61	12.99	13.42	13.86	14.28	14.53	14.83	15.03	3.09

Mean Age - 22.17 years

Number of men - 6682

TABLE XVII - PERCENTILE VALUES FOR BASIC TRAINEES

Percentiles in Inches

No.	Measurements	1st	2nd	5th	10th	25th	50th	75th	90th	95th	98th	99th	Range (1st-99th)
1	Weight (pounds)	112	117	124	129	139	153	170	188	199	212	202	108
STANDING MEASUREMENTS													
2	Stature	62.9	63.6	64.6	65.6	67.1	68.7	70.5	72.1	73.0	74.2	74.9	12.0
3	Cervicale Height	53.1	53.8	54.9	55.8	57.2	58.8	60.5	62.0	62.9	63.8	64.4	11.3
4	Shoulder Height	51.1	51.7	52.6	53.5	54.9	56.5	58.2	59.6	60.5	61.6	62.3	11.2
5	Waist Height	37.4	37.9	38.6	39.4	40.6	42.0	43.3	44.6	45.4	46.3	46.9	9.5
6	Crotch Height	29.0	29.5	30.3	31.0	32.0	33.2	34.4	35.6	36.2	37.0	37.5	8.5
7	Kneecap Height	18.1	18.4	18.8	19.3	20.0	20.8	21.7	22.5	22.9	23.5	23.8	5.7
8	Calf Height	11.8	12.0	12.4	12.7	13.3	13.9	14.6	15.3	15.7	16.1	16.4	4.6
9	Functional Reach	28.2	28.7	29.4	30.1	31.2	32.4	33.6	34.7	35.5	36.3	37.0	8.8

SITTING MEASUREMENTS

10	Vert. Arm Reach, Sitting	49.5	50.1	51.0	51.9	53.2	54.6	56.1	57.4	58.3	59.3	60.1	10.6
11	Sitting Height	32.6	33.0	33.6	34.2	35.0	35.9	36.8	37.6	38.2	38.7	39.1	6.5
12	Eye Height, Sitting	28.0	28.4	28.9	29.4	30.3	31.2	32.1	32.9	33.4	33.9	34.3	6.3
13	Mid-Shoulder Height	22.0	22.3	22.8	23.2	23.9	24.7	25.4	26.2	26.6	27.1	27.4	5.4
14	Shoulder-Elbow Length	12.9	13.0	13.3	13.6	14.0	14.5	15.0	15.4	15.6	16.0	16.2	3.3
15	Elbow-Fingertip Length	16.9	17.1	17.5	17.8	18.3	18.9	19.4	20.0	20.3	20.7	21.0	4.1
16	Knee Height, Sitting	18.9	19.2	19.6	20.0	20.6	21.2	22.0	22.6	23.1	23.5	23.8	4.9
17	Popliteal Height	15.4	15.7	16.0	16.4	16.9	17.6	18.3	18.9	19.3	19.7	19.9	4.5
18	Buttock-Knee Length	20.9	21.2	21.6	21.9	22.6	23.2	24.0	24.7	25.2	25.7	26.1	5.2
19	Buttock-Popliteal Length	17.2	17.5	17.9	18.2	18.8	19.5	20.2	20.8	21.2	21.6	21.9	4.7

TABLE XVII - PERCENTILE VALUES FOR BASIC TRAINEES (Continued)

No.	Measurements	Percentiles in Inches										Range (1st-99th)	
		1st	2nd	5th	10th	25th	50th	75th	90th	95th	98th		99th
BREADTH MEASUREMENTS													
20	Chest Depth	7.4	7.6	7.8	8.0	8.4	8.9	9.4	9.9	10.3	10.7	11.0	3.6
21	Chest Breadth	10.2	10.4	10.7	11.0	11.4	12.0	12.5	13.1	13.4	13.9	14.2	4.0
22	Hip Breadth, Standing	11.4	11.6	11.8	12.1	12.5	13.0	13.5	14.0	14.4	14.8	15.1	3.7
23	Shoulder Breadth	15.6	15.8	16.2	16.5	17.1	17.7	18.4	19.0	19.4	19.9	20.2	4.6
24	Forearm-Forearm Breadth	14.7	15.0	15.4	15.8	16.6	17.6	18.8	20.0	20.7	21.5	22.0	7.3
25	Hip Breadth, Sitting	11.5	11.7	12.0	12.2	12.7	13.3	13.9	14.6	15.0	15.5	15.8	4.3
CIRCUMFERENCES AND SURFACE MEASUREMENTS													
26	Neck Circumference	12.8	13.1	13.4	13.6	14.1	14.6	15.1	15.7	16.0	16.4	16.6	3.8
27	Shoulder Circumference	38.9	39.5	40.4	41.1	42.5	44.1	45.8	47.5	48.6	49.8	50.7	11.8
28	Chest Circumference	31.5	32.0	32.8	33.5	34.7	36.3	38.1	39.9	41.1	42.6	43.6	12.1
29	Waist Circumference	25.8	26.5	27.3	27.9	29.0	30.7	33.1	35.8	37.6	39.6	40.8	15.0
30	Hip Circumference	31.9	32.4	33.2	33.8	35.0	36.5	38.3	40.2	41.4	42.8	43.7	11.8
31	Upper Thigh Circum.	17.6	18.0	18.6	19.1	20.1	21.3	22.7	24.1	25.0	25.9	26.4	8.8
32	Lower Thigh Circum.	12.6	12.9	13.3	13.7	14.4	15.3	16.5	17.6	18.2	18.9	19.4	6.8
33	Calf Circumference	12.0	12.2	12.6	12.9	13.5	14.2	15.0	15.7	16.2	16.7	17.0	5.0
34	Ankle Circumference	7.8	7.9	8.1	8.2	8.6	8.9	9.3	9.7	9.9	10.2	10.4	2.6
35	Vertical Trunk Circum.	57.1	58.0	59.4	60.6	62.6	64.8	67.0	69.1	70.4	72.1	73.3	16.2
36	Arm Scye Circumference	15.0	15.2	15.6	16.0	16.6	17.4	18.2	19.1	19.6	20.3	20.8	5.8
37	Biceps Circum., Relaxed	9.2	9.5	9.8	10.1	10.6	11.3	12.1	12.9	13.4	13.9	14.2	5.0
38	Biceps Circum., Flexed	10.3	10.5	10.8	11.2	11.8	12.5	13.2	14.0	14.4	14.9	15.3	5.0
39	Forearm Circum., Flexed	9.8	9.9	10.2	10.5	10.9	11.5	12.0	12.6	12.9	13.2	13.5	3.7
40	Wrist Circumference	6.0	6.1	6.2	6.3	6.5	6.7	6.9	7.2	7.3	7.5	7.6	1.6
41	Shoulder Length	4.4	4.6	4.9	5.2	5.8	6.3	6.7	7.1	7.3	7.7	8.0	3.6
42	Interscye Breadth	12.6	12.8	13.3	13.7	14.5	15.3	16.2	16.9	17.3	17.8	18.2	5.6
43	Interscye, Maximum	17.5	17.9	18.4	18.9	19.7	20.6	21.5	22.4	23.0	23.6	24.0	6.5
44	Waist Back Length	14.8	15.0	15.5	15.9	16.7	17.6	18.5	19.3	19.8	20.2	20.6	5.8
45	Sleeve Inseam Length	16.9	17.1	17.4	17.8	18.4	19.1	19.8	20.4	20.8	21.3	21.7	4.8
46	Sleeve Length	30.4	30.8	31.3	31.8	32.7	33.7	34.8	35.7	36.2	36.9	37.3	6.9

TABLE XVII - PERCENTILE VALUES FOR BASIC TRAINEES (Continued)

Percentiles in Inches

No.	Measurements	1st	2nd	5th	10th	25th	50th	75th	90th	95th	98th	99th	Range (1st-99th)
HEAD AND FACE MEASUREMENTS													
47	Head Circumference	20.54	20.73	21.00	21.23	21.60	22.00	22.41	22.79	23.03	23.31	23.51	2.97
48	Head Length	6.96	7.05	7.17	7.28	7.45	7.64	7.83	8.00	8.11	8.23	8.32	1.36
49	Occiput-Nasal Root	6.84	6.91	7.03	7.14	7.31	7.51	7.69	7.86	7.96	8.09	8.18	1.34
50	Occiput-Ext. Canthus	5.91	6.01	6.15	6.27	6.46	6.69	6.93	7.17	7.31	7.47	7.57	1.66
51	Occiput-Tragion	3.07	3.17	3.31	3.43	3.65	3.95	4.29	4.62	4.80	4.97	5.04	1.97
52	Occiput-Pronasale	7.95	8.04	8.18	8.30	8.51	8.73	8.95	9.14	9.25	9.39	9.49	1.54
53	Head Breadth	5.51	5.57	5.65	5.73	5.86	6.01	6.16	6.29	6.38	6.49	6.56	1.05
54	Bitracion Breadth	4.79	4.85	4.94	5.02	5.15	5.30	5.44	5.58	5.66	5.76	5.82	1.03
55	Head Height	4.44	4.54	4.69	4.81	5.01	5.23	5.43	5.61	5.71	5.83	5.91	1.47
56	Face Length	4.12	4.20	4.31	4.40	4.54	4.71	4.88	5.06	5.16	5.28	5.35	1.23
57	Face Breadth	5.00	5.06	5.14	5.22	5.34	5.48	5.63	5.77	5.85	5.95	6.02	1.02
58	Interpupillary Breadth	2.05	2.08	2.13	2.19	2.29	2.41	2.51	2.60	2.66	2.73	2.79	0.74
HAND MEASUREMENTS													
59	Hand Length	6.71	6.79	6.92	7.04	7.25	7.49	7.74	7.97	8.11	8.27	8.38	1.67
60	Palm Length	3.63	3.70	3.79	3.88	4.02	4.18	4.34	4.50	4.59	4.70	4.78	1.15
61	Hand Breadth	3.10	3.14	3.21	3.27	3.37	3.49	3.61	3.73	3.81	3.89	3.95	0.85
62	Hand Circumference	7.57	7.67	7.82	7.96	8.20	8.48	8.79	9.09	9.27	9.47	9.60	2.03
63	Thumb Crotch Length	1.50	1.55	1.63	1.70	1.82	1.95	2.08	2.20	2.27	2.35	2.40	0.90
FOOT MEASUREMENTS													
64	Foot Length	9.43	9.57	9.77	9.94	10.24	11.20	10.89	11.20	11.41	11.66	11.84	2.41
65	Instep Length	6.81	6.92	7.09	7.24	7.48	7.74	7.99	8.24	8.40	8.59	8.73	1.92
66	Ball of Foot Breadth	3.44	3.49	3.57	3.64	3.76	3.90	4.04	4.19	4.27	4.38	4.45	1.01
67	Heel Breadth	2.32	2.36	2.42	2.48	2.57	2.68	2.81	2.93	3.00	3.09	3.15	0.83
68	Ball of Foot Circum.	8.51	8.71	8.98	9.20	9.55	9.92	10.29	10.63	10.83	11.05	11.19	2.68
69	Instep Circumference	9.11	9.26	9.50	9.72	10.11	10.55	11.00	11.40	11.64	11.91	12.09	2.98
70	Heel-Ankle Circum.	11.93	12.11	12.38	12.61	12.99	13.40	13.83	14.25	14.50	14.80	15.01	3.08

Mean Age - 20.18 years

Number of Men - 2,639

TABLE XVIII - PERCENTILE VALUES FOR INFANTRY

No.	Measurements	Percentiles in Inches										Range (1st-99th)	
		1st	2nd	5th	10th	25th	50th	75th	90th	95th	98th		99th
1	Weight (pounds)	102	123	129	134	144	158	173	190	202	218	230	110
STANDING MEASUREMENTS													
2	Stature	62.3	63.1	64.4	65.4	66.9	68.6	70.4	72.1	73.1	74.2	75.0	12.7
3	Cervicale Height	52.7	53.6	54.8	55.7	57.2	58.8	60.6	62.6	63.2	64.2	64.9	12.2
4	Shoulder Height	50.7	51.5	52.5	53.4	54.9	56.5	58.2	59.8	60.8	61.9	62.6	11.9
5	Waist Height	36.4	37.1	38.1	39.0	40.3	41.8	43.2	44.5	45.3	46.3	47.0	10.6
6	Crotch Height	28.4	29.1	29.9	30.6	31.7	32.9	34.2	35.3	36.0	36.8	37.3	8.9
7	Kneecap Height	17.8	18.2	18.7	19.1	19.9	20.7	21.6	22.5	23.0	23.6	23.9	6.1
8	Calf Height	11.4	11.7	12.2	12.5	13.2	13.9	14.7	15.4	15.8	16.3	16.6	5.2
9	Functional Reach	28.4	28.8	29.5	30.2	31.2	32.5	33.9	35.2	36.0	36.8	37.4	9.0
SITTING MEASUREMENTS													
10	Vert. Arm Reach, Sitting	48.9	49.5	50.4	51.3	52.7	54.2	55.7	57.1	58.1	59.2	60.2	11.3
11	Sitting Height	32.1	32.5	33.1	33.6	34.6	35.6	36.6	37.5	38.0	38.6	39.0	6.9
12	Eye Height, Sitting	27.4	27.9	28.5	29.0	29.9	30.9	31.9	32.8	33.3	33.9	34.2	6.8
13	Mid-Shoulder Height	21.3	21.7	22.3	22.8	23.6	24.5	25.3	26.1	26.6	27.1	27.4	6.1
14	Shoulder-Elbow Length	12.8	13.0	13.3	13.6	14.0	14.5	15.0	15.5	15.8	16.1	16.3	3.5
15	Elbow-Fingertip Length	16.8	17.1	17.4	17.7	18.2	18.8	19.5	20.1	20.5	21.0	21.3	4.5
16	Knee Height, Sitting	18.7	19.0	19.5	19.9	20.6	21.3	22.0	22.7	23.2	23.6	23.9	5.2
17	Popliteal Height	15.2	15.5	15.9	16.3	16.8	17.5	18.2	18.8	19.2	19.6	19.9	4.7
18	Buttock-Knee Length	20.8	21.1	21.6	22.0	22.7	23.4	24.2	24.9	25.4	25.9	26.2	5.4
19	Buttock-Popliteal Length	17.4	17.7	18.1	18.5	19.0	19.7	20.3	21.0	21.3	21.7	21.9	4.5

TABLE XVIII - PERCENTILE VALUES FOR INFANTRY (Continued)

Percentiles in Inches

No.	Measurements	Percentiles in Inches									Range (1st-99th)			
		1st	2nd	5th	10th	25th	50th	75th	90th	95th		98th	99th	
BREADTH MEASUREMENTS														
20	Chest Depth	7.7	7.8	8.0	8.2	8.6	9.1	9.6	10.2	10.6	11.1	11.4	11.4	3.7
21	Chest Breadth	10.3	10.5	10.8	11.0	11.4	12.0	12.5	13.1	13.5	14.0	14.4	14.4	4.1
22	Hip Breadth, Standing	11.5	11.6	11.9	12.1	12.5	13.0	13.6	14.1	14.5	14.9	15.2	15.2	3.7
23	Shoulder Breadth	15.9	16.0	16.4	16.7	17.2	17.8	18.5	19.2	19.6	20.2	20.6	20.6	4.7
24	Forearm-Forearm Breadth	15.1	15.4	15.9	16.3	17.1	18.1	19.2	20.4	21.2	22.2	22.8	22.8	7.7
25	Hip Breadth, Sitting	11.7	11.9	12.1	12.4	12.8	13.4	14.0	14.7	15.1	15.7	16.2	16.2	4.5

**CIRCUMFERENCES AND
SURFACE MEASUREMENTS**

26	Neck Circumference	13.0	13.2	13.5	13.8	14.2	14.7	15.2	15.8	16.2	16.6	16.8	16.8	3.8
27	Shoulder Circumference	39.6	40.1	40.9	41.7	43.0	44.5	46.1	47.8	48.9	50.4	51.6	51.6	12.0
28	Chest Circumference	32.1	32.6	33.3	34.0	35.2	36.7	38.5	40.4	41.8	43.5	44.8	44.8	12.7
29	Waist Circumference	26.3	26.8	27.5	28.2	29.4	31.1	33.2	35.7	37.5	40.0	41.9	41.9	15.6
30	Hip Circumference	32.8	33.1	33.8	34.4	35.6	37.0	38.5	40.2	41.4	43.0	44.3	44.3	11.5
31	Upper Thigh Circum.	18.2	18.7	19.3	19.8	20.8	21.8	23.1	24.3	25.1	26.1	26.7	26.7	8.5
32	Lower Thigh Circum.	13.1	13.4	13.8	14.3	15.1	16.1	17.1	18.1	18.7	19.4	19.8	19.8	6.7
33	Calf Circumference	12.3	12.5	12.8	13.2	13.8	14.4	15.1	15.8	16.2	16.7	17.1	17.1	4.8
34	Ankle Circumference	7.7	7.9	8.1	8.2	8.5	8.9	9.3	9.7	9.9	10.2	10.4	10.4	2.7
35	Vertical Trunk Circum.	57.2	58.0	59.2	60.2	62.0	64.2	66.4	68.7	70.0	71.6	72.7	72.7	15.5
36	Arm Scye Circumference	14.6	15.0	15.5	16.0	16.6	17.4	18.2	19.2	19.8	20.6	21.3	21.3	6.7
37	Biceps Circum., Relaxed	9.5	9.8	10.1	10.4	10.9	11.6	12.3	13.0	13.5	14.1	14.5	14.5	5.0
38	Biceps Circum., Flexed	10.6	10.8	11.2	11.5	12.1	12.7	13.4	14.1	14.6	15.2	15.6	15.6	5.0
39	Forearm Circum., Flexed	9.8	10.0	10.3	10.6	11.0	11.6	12.2	12.7	13.1	13.6	14.0	14.0	4.2
40	Wrist Circumference	5.9	6.0	6.1	6.3	6.5	6.7	6.9	7.1	7.3	7.4	7.6	7.6	1.7
41	Shoulder Length	4.4	4.7	5.1	5.4	6.0	6.6	7.0	7.4	7.7	8.0	8.1	8.1	3.7
42	Interscye Breadth	12.6	12.9	13.4	13.8	14.6	15.4	16.2	17.0	17.4	18.0	18.5	18.5	5.9
43	Interscye, Maximum	17.1	17.5	18.2	18.8	19.7	20.8	21.8	22.7	23.2	23.8	24.3	24.3	7.2
44	Waist Back Length	14.8	15.1	15.6	16.0	16.8	17.8	18.8	19.7	20.2	20.8	21.1	21.1	6.3
45	Sleeve Inseam Length	16.5	16.8	17.3	17.7	18.4	19.1	19.8	20.5	20.9	21.4	21.7	21.7	5.2
46	Sleeve Length	29.9	30.5	31.2	31.8	32.7	33.7	34.8	35.8	36.5	37.2	37.6	37.6	7.7

TABLE XVIII — PERCENTILE VALUES FOR INFANTRY (Concluded)

No.	Measurements	Percentiles in Inches										Range (1st-99th)	
		1st	2nd	5th	10th	25th	50th	75th	90th	95th	98th		99th
HEAD AND FACE MEASUREMENTS													
47	Head Circumference	20.70	20.87	21.11	21.32	21.69	22.11	22.54	22.95	23.19	23.47	23.65	2.95
48	Head Length	7.02	7.08	7.19	7.30	7.48	7.68	7.87	8.04	8.15	8.27	8.35	1.33
49	Occiput-Nasal Root	6.84	6.93	7.05	7.16	7.34	7.53	7.72	7.89	7.99	8.09	8.16	1.32
50	Occiput-Ext. Canthus	5.94	6.04	6.19	6.33	6.56	6.83	7.11	7.36	7.49	7.62	7.70	1.76
51	Occiput-Trigion	3.12	3.21	3.35	3.47	3.72	4.05	4.43	4.76	4.92	5.05	5.08	1.96
52	Occiput-Pronasale	7.94	8.04	8.18	8.31	8.51	8.73	8.96	9.15	9.27	9.40	9.48	1.54
53	Head Breadth	5.45	5.53	5.63	5.72	5.85	5.99	6.16	6.32	6.41	6.52	6.58	1.13
54	Bitrignon Breadth	4.81	4.87	4.95	5.03	5.16	5.31	5.46	5.61	5.69	5.79	5.86	1.05
55	Head Height	4.47	4.56	4.69	4.79	4.98	5.19	5.41	5.61	5.73	5.84	5.91	1.44
56	Face Length	4.15	4.22	4.32	4.42	4.57	4.75	4.92	5.08	5.17	5.29	5.38	1.23
57	Face Breadth	5.01	5.07	5.15	5.23	5.37	5.51	5.66	5.80	5.89	5.99	6.07	1.06
58	Interpupillary Breadth	2.07	2.11	2.16	2.21	2.31	2.41	2.51	2.60	2.66	2.73	2.78	0.71
HAND MEASUREMENTS													
59	Hand Length	6.61	6.73	6.88	7.01	7.22	7.46	7.73	7.99	8.16	8.35	8.48	1.87
60	Palm Length	3.60	3.67	3.76	3.85	3.99	4.15	4.32	4.49	4.60	4.72	4.81	1.21
61	Hand Breadth	3.06	3.11	3.19	3.25	3.37	3.50	3.64	3.77	3.86	3.95	4.01	0.95
62	Hand Circumference	7.48	7.60	7.78	7.93	8.19	8.48	8.78	9.08	9.27	9.50	9.67	2.19
63	Thumb Crotch Length	1.50	1.55	1.62	1.69	1.81	1.95	2.10	2.23	2.32	2.42	2.48	0.98
FOOT MEASUREMENTS													
64	Foot Length	9.35	9.48	9.68	9.86	10.16	10.50	10.85	11.19	11.40	11.64	11.81	2.46
65	Instep Length	6.77	6.88	7.04	7.19	7.45	7.72	8.00	8.26	8.42	8.62	8.77	2.00
66	Ball of Foot Breadth	3.36	3.42	3.51	3.59	3.71	3.84	3.99	4.13	4.21	4.31	4.37	1.01
67	Heel Breadth	2.30	2.35	2.42	2.47	2.57	2.69	2.82	2.95	3.03	3.13	3.19	0.89
68	Ball of Foot Circum.	8.30	8.48	8.76	9.01	9.42	9.83	10.21	10.53	10.73	10.99	11.18	2.88
69	Instep Circumference	8.87	9.08	9.35	9.58	9.95	10.36	10.79	11.21	11.47	11.78	11.98	3.11
70	Heel-Ankle Circum.	11.93	12.10	12.36	12.59	12.97	13.41	13.85	14.27	14.53	14.84	15.05	3.12

Mean Age — 22.79 years

Number of men — 3429

TABLE XIX - PERCENTILE VALUES FOR ARMORED CREWMEN

Percentiles in Inches

No.	Measurements	1st	2nd	5th	10th	25th	50th	75th	90th	95th	98th	99th	Range (1st-99th)
1	Weight (pounds)	119	123	128	134	146	162	181	202	215	232	244	125
STANDING MEASUREMENTS													
2	Stature	62.8	63.4	64.3	65.2	66.8	68.7	70.5	72.1	73.0	73.9	74.5	11.7
3	Cervicale Height	53.4	54.0	54.9	55.8	57.3	59.0	60.8	62.3	63.1	64.0	64.6	11.2
4	Shoulder Height	51.2	51.8	52.8	53.6	55.1	56.8	58.5	60.0	60.8	61.8	62.4	11.2
5	Waist Height	36.7	37.4	38.3	39.2	40.5	41.8	43.2	44.4	45.2	46.1	46.8	10.1
6	Crotch Height	28.3	28.9	29.8	30.5	31.7	32.9	34.1	35.3	36.1	37.0	37.8	9.5
7	Kneecap Height	18.1	18.3	18.8	19.2	20.0	20.8	21.8	22.6	23.1	23.7	24.1	6.0
8	Calf Height	11.5	11.7	12.1	12.4	13.1	13.9	14.8	15.5	15.8	16.2	16.4	4.9
9	Functional Reach	28.3	28.8	29.6	30.2	31.3	32.6	34.0	35.3	36.1	36.9	37.3	9.0
SITTING MEASUREMENTS													
10	Vert. Arm Reach, Sitting	49.4	49.8	50.7	51.5	53.0	54.5	55.9	57.3	58.2	59.5	60.6	11.2
11	Sitting Height	32.0	32.4	33.0	33.5	34.5	35.5	36.6	37.5	38.1	38.7	39.2	7.2
12	Eye Height, Sitting	27.4	27.7	28.3	28.9	29.8	30.8	31.8	32.6	33.2	33.9	34.4	7.0
13	Mid-Shoulder Height	21.2	21.7	22.3	22.8	23.7	24.6	25.5	26.3	26.8	27.4	27.9	6.7
14	Shoulder-Elbow Length	12.7	13.0	13.4	13.7	14.2	14.7	15.2	15.6	15.9	16.2	16.3	3.6
15	Elbow-Fingertip Length	16.6	16.9	17.4	17.7	18.3	18.9	19.6	20.2	20.6	21.1	21.4	4.8
16	Knee Height, Sitting	18.5	19.0	19.5	20.0	20.6	21.3	22.1	22.8	23.2	23.6	23.8	5.3
17	Popliteal Height	15.5	15.7	16.1	16.4	16.9	17.5	18.2	18.9	19.2	19.6	19.8	4.3
18	Buttock-Knee Length	20.9	21.2	21.7	22.1	22.7	23.5	24.3	25.1	25.6	26.2	26.6	5.7
19	Buttock-Popliteal Length	17.6	17.8	18.2	18.5	19.1	19.7	20.4	21.0	21.4	21.9	22.3	4.7

TABLE XIX - PERCENTILE VALUES FOR ARMORED CREWMEN (Continued)

No.	Measurements	Percentiles in Inches										Range (1st-99th)	
		1st	2nd	5th	10th	25th	50th	75th	90th	95th	98th		99th
BREADTH MEASUREMENTS													
20	Chest Depth	7.7	7.9	8.2	8.5	8.9	9.4	10.0	10.6	11.0	11.5	11.9	4.2
21	Chest Breadth	10.7	10.8	11.0	11.2	11.6	12.2	12.8	13.4	13.8	14.4	14.8	4.1
22	Hip Breadth, Standing	11.7	11.8	12.0	12.2	12.6	13.2	13.7	14.3	14.7	15.2	15.5	3.8
23	Shoulder Breadth	15.8	16.2	16.6	16.9	17.4	18.0	18.8	19.6	20.1	20.7	21.0	5.2
24	Forearm-Forearm Breadth	15.0	15.3	15.8	16.3	17.3	18.5	19.8	21.0	21.9	23.0	23.8	8.8
25	Hip Breadth, Sitting	11.8	12.0	12.2	12.4	12.9	13.5	14.3	15.0	15.5	15.9	16.2	4.4
CIRCUMFERENCES AND SURFACE MEASUREMENTS													
26	Neck Circumference	13.2	13.4	13.7	13.9	14.4	14.9	15.6	16.2	16.5	16.9	17.2	4.0
27	Shoulder Circumference	39.7	40.4	41.4	42.2	43.5	45.1	47.1	49.1	50.3	51.6	52.3	12.6
28	Chest Circumference	32.5	32.9	33.6	34.4	35.9	37.7	39.6	41.7	43.2	45.4	47.1	14.6
29	Waist Circumference	26.6	27.0	27.8	28.5	30.0	32.1	34.9	38.0	40.0	42.5	44.3	17.7
30	Hip Circumference	32.8	33.2	33.9	34.6	35.8	37.5	39.5	41.5	42.7	44.1	45.0	12.2
31	Upper Thigh Circum.	18.1	18.4	19.0	19.6	20.8	22.2	23.7	25.0	25.8	26.7	27.3	9.2
32	Lower Thigh Circum.	13.0	13.3	13.7	14.1	15.0	16.0	17.2	18.3	18.9	19.6	20.0	7.0
33	Calf Circumference	12.4	12.6	12.9	13.2	13.8	14.5	15.3	16.0	16.4	16.9	17.2	4.8
34	Ankle Circumference	7.8	7.9	8.1	8.2	8.5	8.9	9.3	9.8	10.0	10.3	10.4	2.6
35	Vertical Trunk Circum.	58.0	58.7	59.8	60.8	62.6	64.8	67.4	69.9	71.6	73.7	75.2	17.2
36	Arm Scye Circumference	15.3	15.6	16.0	16.5	17.2	18.0	18.9	19.9	20.5	21.3	21.9	6.6
37	Biceps Circum., Relaxed	9.6	9.8	10.1	10.4	11.1	11.9	12.7	13.4	13.9	14.5	14.9	5.3
38	Biceps Circum., Flexed	10.6	10.9	11.2	11.6	12.2	13.0	13.8	14.6	15.1	15.7	16.0	5.4
39	Forearm Circum., Flexed	9.9	10.1	10.4	10.7	11.2	11.8	12.4	13.0	13.4	13.8	14.2	4.3
40	Wrist Circumference	6.0	6.1	6.2	6.4	6.6	6.8	7.0	7.3	7.5	7.6	7.8	1.8
41	Shoulder Length	4.1	4.4	4.8	5.2	5.9	6.5	7.0	7.4	7.6	8.0	8.3	4.2
42	Interscye Breadth	12.8	13.1	13.6	14.0	14.8	15.6	16.4	17.2	17.8	18.5	19.1	6.3
43	Interscye, Maximum	17.6	17.9	18.5	19.0	19.8	20.9	22.0	23.0	23.7	24.3	24.7	7.1
44	Waist Back Length	14.7	15.1	15.6	16.1	16.9	17.9	18.8	19.7	20.1	20.6	20.9	6.2
45	Sleeve Inseam Length	16.7	17.0	17.5	17.9	18.5	19.2	19.9	20.6	21.0	21.5	21.9	5.2
46	Sleeve Length	30.0	30.5	31.3	31.9	33.0	34.0	35.0	36.0	36.7	37.5	38.1	8.1

TABLE XIX - PERCENTILE VALUES FOR ARMORED CREWMEN (Continued)

Percentiles in Inches

No.	Measurements	1st	2nd	5th	10th	25th	50th	75th	90th	95th	98th	99th	Range (1st-99th)
HEAD AND FACE MEASUREMENTS													
47	Head Circumference	20.88	21.00	21.21	21.41	7.50	22.22	22.68	23.09	23.33	23.57	23.72	2.84
48	Head Length	7.01	7.07	7.19	7.30	7.50	7.72	7.93	8.10	8.19	8.28	8.34	1.33
49	Occiput-Nasal Root	6.85	6.93	7.05	7.16	7.35	7.56	7.77	7.94	8.04	8.14	8.20	1.35
50	Occiput-Ext. Canthus	6.04	6.09	6.20	6.33	6.59	6.88	7.16	7.38	7.50	7.63	7.72	1.68
51	Occiput-Tragion	3.17	3.24	3.36	3.49	3.74	4.05	4.37	4.65	4.80	4.95	5.03	1.86
52	Occiput-Pronasale	7.88	8.01	8.18	8.32	8.54	8.77	8.99	9.18	9.29	9.41	9.48	1.60
53	Head Breadth	5.46	5.55	5.67	5.76	5.89	6.03	6.18	6.33	6.42	6.53	6.60	1.14
54	Bitragion Breadth	4.78	4.88	5.00	5.08	5.22	5.36	5.50	5.64	5.73	5.82	5.88	1.10
55	Head Height	4.55	4.63	4.74	4.84	5.01	5.21	5.40	5.58	5.68	5.80	5.87	1.32
56	Face Length	4.11	4.18	4.28	4.39	4.57	4.76	4.94	5.09	5.18	5.29	5.37	1.26
57	Face Breadth	5.05	5.12	5.22	5.30	5.43	5.58	5.72	5.85	5.93	6.01	6.06	1.01
58	Interpupillary Breadth	2.11	2.15	2.22	2.27	2.37	2.47	2.57	2.68	2.75	2.84	2.91	0.80
HAND MEASUREMENTS													
59	Hand Length	6.60	6.69	6.85	7.00	7.27	7.53	7.78	8.01	8.18	8.42	8.62	2.02
60	Palm Length	3.56	3.64	3.75	3.85	4.00	4.17	4.33	4.49	4.59	4.72	4.82	1.26
61	Hand Breadth	3.07	3.12	3.20	3.27	3.39	3.51	3.63	3.75	3.83	3.93	4.00	0.93
62	Hand Circumference	7.56	7.67	7.84	7.99	8.25	8.55	8.88	9.17	9.33	9.49	9.57	2.01
63	Thumb Crotch Length	1.52	1.56	1.64	1.70	1.82	1.96	2.09	2.20	2.27	2.36	2.42	0.90
FOOT MEASUREMENTS													
64	Foot Length	9.35	9.50	9.71	9.89	10.19	10.54	10.92	11.28	11.49	11.70	11.83	2.48
65	Instep Length	6.73	6.84	7.02	7.17	7.43	7.72	8.02	8.31	8.49	8.70	8.84	2.11
66	Ball of Foot Breadth	3.35	3.42	3.52	3.61	3.74	3.86	4.01	4.14	4.22	4.33	4.40	1.05
67	Heel Breadth	2.35	2.39	2.45	2.51	2.61	2.73	2.87	3.01	3.11	3.23	3.32	0.97
68	Ball of Foot Circum.	8.48	8.69	8.97	9.18	9.52	9.87	10.24	10.58	10.79	11.00	11.14	2.66
69	Instep Circumference	9.08	9.23	9.46	9.66	10.01	10.42	10.86	11.28	11.55	11.86	12.08	3.00
70	Heel-Ankle Circum.	12.05	12.19	12.43	12.66	13.07	13.54	14.01	14.43	14.69	14.98	15.18	3.13

Number of men - 489

Mean Age - 27.02 years

TABLE XX - PERCENTILE VALUES FOR AVIATORS

No.	Measurements	Percentiles in Inches										Range (1st-99th)	
		1st	2nd	5th	10th	25th	50th	75th	90th	95th	98th		99th
1	Weight (pounds)	129	140	154	166	179	193	203					
STANDING MEASUREMENTS													
2	Stature	65.5	66.3	67.5	69.0	70.7	72.1	72.7					
3	Cervicale Height	56.0	56.7	57.8	59.3	60.9	62.2	62.8					
4	Shoulder Height	53.4	54.1	55.4	57.0	58.6	59.7	60.2					
5	Waist Height	39.0	39.4	40.7	42.2	43.5	44.7	45.6					
6	Crotch Height	30.3	31.1	32.1	33.0	34.1	35.1	35.6					
7	Kneecap Height	18.6	19.1	19.8	20.6	21.5	22.4	22.8					
8	Calf Height	12.3	12.6	13.2	13.8	14.4	14.9	15.2					
9	Functional Reach	29.9	30.4	31.5	32.8	33.9	34.9	35.4					
SITTING MEASUREMENTS													
10	Vert. Arm Reach, Sitting	51.2	51.7	52.7	54.1	55.8	57.4	58.1					
11	Sitting Height	33.6	34.3	35.1	36.0	36.9	37.8	38.3					
12	Eye Height, Sitting	28.8	29.4	30.4	31.3	32.0	32.8	33.3					
13	Mid-Shoulder Height	23.2	23.4	24.0	24.7	25.6	26.4	26.8					
14	Shoulder-Elbow Length	13.6	13.9	14.2	14.6	15.1	15.6	15.8					
15	Elbow-Fingertip Length	17.7	17.9	18.3	18.8	19.4	19.9	20.2					
16	Knee Height, Sitting	19.8	20.1	20.7	21.4	22.1	22.8	23.1					
17	Popliteal Height	16.0	16.4	16.9	17.4	18.0	18.6	18.9					
18	Buttock-Knee Length	21.8	22.2	22.8	23.5	24.2	24.8	25.1					
19	Buttock-Popliteal Length	18.3	18.6	19.2	19.7	20.3	20.8	21.0					

TABLE XX -- PERCENTILE VALUES FOR AVIATORS (Continued)

No.	Measurements	Percentiles in Inches									Range 99th - (1st-99th)	
		1st	2nd	5th	10th	25th	50th	75th	90th	95th		98th
BREADTH MEASUREMENTS												
20	Chest Depth			8.2	8.6	9.0	9.5	10.0	10.5	10.8		
21	Chest Breadth			11.1	11.5	12.0	12.5	12.9	13.4	13.6		
22	Hip Breadth, Standing			12.2	12.4	12.9	13.4	13.8	14.2	14.5		
23	Shoulder Breadth			17.1	17.2	17.8	18.4	18.9	19.4	19.7		
24	Forearm-Forearm Breadth			16.4	17.2	18.0	18.8	19.8	20.8	21.4		
25	Hip Breadth, Sitting			12.4	12.7	13.2	13.9	14.4	14.8	15.2		
CIRCUMFERENCES AND SURFACE MEASUREMENTS												
26	Neck Circumference			13.9	14.2	14.6	15.1	15.6	16.0	16.2		
27	Shoulder Circumference			41.6	43.0	44.6	45.8	46.9	48.0	48.7		
28	Chest Circumference			34.0	35.6	37.3	38.5	39.8	41.4	42.5		
29	Waist Circumference			28.2	29.3	31.3	33.5	35.3	36.9	38.1		
30	Hip Circumference			34.0	35.0	36.7	38.2	39.5	40.6	41.4		
31	Upper Thigh Circum.			19.0	20.1	21.4	22.6	23.8	24.6	25.1		
32	Lower Thigh Circum.			14.0	14.7	15.5	16.3	17.2	17.9	18.0		
33	Calf Circumference			12.9	13.5	14.0	14.6	15.2	15.8	16.0		
34	Ankle Circumference			8.1	8.3	8.6	9.0	9.2	9.6	9.8		
35	Vertical Trunk Circum.			60.8	61.8	63.2	65.1	67.5	69.7	70.8		
36	Arm Scye Circumference			15.9	16.5	17.3	18.0	18.7	19.3	19.6		
37	Biceps Circum., Relaxed			10.2	10.6	11.3	12.1	12.7	13.1	13.4		
38	Biceps Circum., Flexed			11.2	11.7	12.4	13.0	13.6	14.1	14.2		
39	Forearm Circum., Flexed			10.7	10.9	11.3	11.7	12.2	12.6	12.7		
40	Wrist Circumference			6.2	6.3	6.5	6.7	6.9	7.2	7.4		
41	Shoulder Length			5.4	5.6	6.1	6.6	6.9	7.2	7.4		
42	Interscye Breadth			14.0	14.3	14.9	15.6	16.2	16.8	17.4		
43	Interscye, Maximum			18.8	19.3	20.1	21.0	21.8	22.6	23.1		
44	Waist Back Length			16.1	16.5	17.0	17.9	19.0	19.9	20.3		
45	Sleeve Inseam Length			17.6	18.0	18.5	19.1	19.7	20.3	20.7		
46	Sleeve Length			31.5	32.2	33.1	34.1	35.2	36.1	36.5		

TABLE XX - PERCENTILE VALUES FOR AVIATORS (Continued)

Percentiles in Inches

No. Measurements 1st 2nd 5th 10th 25th 50th 75th 90th 95th 98th 99th Range (1st-99th)

HEAD AND FACE MEASUREMENTS

47	Head Circumference	21.30	21.57	22.00	22.43	22.82	23.13	23.30				
48	Head Length	7.32	7.32	7.39	7.77	7.95	8.10	8.21				
49	Occiput-Nasal Root	7.19	7.25	7.42	7.63	7.81	7.95	8.04				
50	Occiput-Ext. Canthus	6.46	6.56	6.73	6.94	7.18	7.39	7.47				
51	Occiput-Tragion	3.50	3.64	3.86	4.12	4.43	4.69	4.80				
52	Occiput-Pronasale	8.35	8.47	8.64	8.83	9.03	9.24	9.34				
53	Head Breadth	5.72	5.80	5.91	6.04	6.19	6.34	6.41				
54	Bitragion Breadth	5.00	5.08	5.23	5.38	5.52	5.66	5.76				
55	Head Height	4.82	4.92	5.09	5.28	5.47	5.63	5.72				
56	Face Length	4.30	4.43	4.58	4.74	4.92	5.10	5.21				
57	Face Breadth	5.22	5.28	5.42	5.57	5.71	5.85	5.97				
58	Interpillary Breadth	2.19	2.25	2.33	2.42	2.53	2.61	2.64				

HAND MEASUREMENTS

59	Hand Length	6.96	7.07	7.23	7.43	7.67	7.85	7.92				
60	Palm Length	3.82	3.90	4.02	4.15	4.30	4.45	4.53				
61	Hand Breadth	3.23	3.28	3.36	3.47	3.60	3.72	3.78				
62	Hand Circumference	7.95	8.08	8.30	8.53	8.79	9.07	9.28				
63	Thumb Crotch Length	1.67	1.71	1.84	1.99	2.11	2.27	2.45				

FOOT MEASUREMENTS

64	Foot Length	9.67	9.86	10.23	10.59	10.89	11.14	11.32				
65	Instep Length	7.08	7.28	7.55	7.78	8.01	8.28	8.51				
66	Ball of Foot Breadth	3.49	3.58	3.71	3.84	3.98	4.12	4.20				
67	Heel Breadth	2.44	2.50	2.60	2.70	2.84	2.95	2.99				
68	Ball of Foot Circum.	9.01	9.19	9.54	9.91	10.24	10.55	10.78				
69	Instep Circumference	9.66	9.18	10.05	10.35	10.71	11.08	11.31				
70	Heel-Ankle Circum.	12.54	12.73	13.06	13.45	13.89	14.30	14.53				

Mean Age - 28.11 years

Number of men - 125

b. Tables of Statistical Values

The second set of five tables (Tables XXI to XXV) contains the statistical values for the seventy anthropometric measurements. These are: the number of men (N), the mean, the standard error of the mean (SE(M)), the standard deviation (S.D.), the standard error of the standard deviation (SE(SD)), the coefficient of variation (V(%)), and the range for each measurement. The range is indicated by the minimum value (Min.), the maximum value (Max.), and the total range, or the difference between the minimum and maximum values. The range or spread of each body measurement (from the lowest value on the smallest man to the highest value on the largest man) has been tabulated into intervals, as indicated in the data pages, Section 6,c. (p.69). The minimum value shown here represents the lower limit of the lowest such interval, while the maximum value is the upper limit of the highest interval.

TABLE XXI - STATISTICAL VALUES FOR TOTAL ARMY SERIES

Values in Inches

No. Measurements	N	Mean	SE(M)	S.D.	SE(SD)	V(%)	Min.	Range Max.	Total
1 Weight (pounds)	6677	159.10	0.29	23.35	0.20	14.68	99.5	283.5	184.0
STANDING MEASUREMENTS									
2 Stature	6682	68.71	0.03	2.60	0.02	3.79	59.7	78.6	18.9
3 Cervicale Height	6682	58.88	0.03	2.50	0.02	4.24	50.3	68.4	18.1
4 Shoulder Height	6682	56.58	0.03	2.45	0.02	4.33	48.5	65.8	17.3
5 Waist Height	6682	41.86	0.03	2.11	0.02	5.05	34.0	49.7	15.7
6 Crotch Height	6682	41.86	0.02	1.84	0.02	5.57	25.5	40.0	14.5
7 Kneecap Height	6682	20.81	0.02	1.28	0.01	6.14	16.8	25.3	8.5
8 Calf Height	6682	13.94	0.01	1.06	0.01	7.62	9.4	18.8	9.4
9 Functional Reach	6682	32.52	0.02	1.91	0.02	5.87	25.7	39.5	13.8
SITTING MEASUREMENTS									
10 Vertical Arm Reach, Sitting	6682	54.42	0.03	2.28	0.02	4.20	46.0	63.3	17.3
11 Sitting Height	6682	35.70	0.02	1.44	0.01	4.04	30.4	40.6	10.2
12 Eye Height, Sitting	6682	30.99	0.02	1.41	0.01	4.53	25.9	36.5	10.6
13 Mid-Shoulder Height	6682	24.56	0.02	1.25	0.01	5.09	20.0	28.8	8.8
14 Shoulder-Elbow Length	6682	14.52	0.01	0.73	0.01	5.05	11.7	17.2	5.5
15 Elbow-Fingertip Length	6682	18.88	0.01	0.91	0.01	4.81	15.4	22.7	7.3
16 Knee Height, Sitting	6682	21.28	0.01	1.08	0.01	5.05	17.4	25.5	8.1
17 Popliteal Height	6682	17.56	0.01	0.98	0.01	5.60	14.1	21.5	7.4
18 Buttock-Knee Length	6692	23.41	0.01	1.12	0.01	4.80	19.6	28.0	8.4
19 Buttock-Popliteal Length	6682	19.62	0.01	0.99	0.01	5.02	16.2	23.1	6.9

TABLE XXI - STATISTICAL VALUES FOR TOTAL ARMY SERIES (Continued)

Values in Inches

No.	Measurements	N	Mean	SE(M)	S.D.	SE(SD)	V(%)	Min.	Range Max.	Total
BREADTH MEASUREMENTS										
20	Chest Depth	6682	9.12	0.01	0.79	0.01	8.61	6.5	13.4	6.9
21	Chest Breadth	6682	12.04	0.01	0.84	0.01	7.02	9.6	16.4	6.8
22	Hip Breadth, Standing	6682	13.07	0.01	0.79	0.01	6.05	10.6	17.7	7.1
23	Shoulder Breadth	6682	17.86	0.01	1.00	0.01	5.59	14.3	23.1	8.8
24	Forearm-Forearm Breadth	6682	18.10	0.02	1.66	0.01	9.17	13.1	26.1	13.0
25	Hip Breadth, Sitting	6682	13.45	0.01	0.94	0.01	6.97	10.3	19.8	9.5
CIRCUMFERENCES AND SURFACE MEASUREMENTS										
26	Neck Circumference	6681	14.72	0.01	0.81	0.01	5.53	11.9	19.1	7.2
27	Shoulder Circumference	6682	44.55	0.03	2.51	0.02	5.64	36.5	57.2	20.7
28	Chest Circumference	6682	36.92	0.03	2.63	0.02	7.13	28.2	48.9	20.7
29	Waist Circumference	6682	31.61	0.04	3.22	0.03	10.19	23.1	50.3	27.2
30	Hip Circumference	6682	27.09	0.03	2.46	0.02	6.63	30.4	52.8	22.4
31	Upper Thigh Circumference	6682	21.82	0.02	1.89	0.02	8.66	15.3	30.6	15.3
32	Lower Thigh Circumference	6682	15.89	0.02	1.52	0.01	9.58	11.3	22.3	11.0
33	Calf Circumference	6682	14.41	0.01	1.05	0.01	7.29	11.1	20.0	8.9
34	Ankle Circumference	6682	8.93	0.01	0.57	0.00	6.34	7.1	12.1	5.0
35	Vert. Trunk Circum., Standing	6682	64.61	0.04	3.34	0.03	5.17	53.2	78.6	25.4
36	Arm Scye Circumference	6682	17.54	0.02	1.28	0.01	7.32	12.7	23.7	11.5
37	Biceps Circum., Relaxed	6682	11.59	0.01	1.08	0.01	9.29	8.2	17.4	9.2
38	Biceps Circum., Flexed	6682	12.70	0.01	1.08	0.01	8.52	9.0	17.8	8.8
39	Forearm Circum., Flexed	6682	11.59	0.01	0.85	0.01	7.31	8.9	16.3	7.4
40	Wrist Circumference	6682	6.72	0.00	0.34	0.00	5.13	5.4	8.5	3.1
41	Shoulder Length	6682	6.38	0.01	0.78	0.01	12.35	3.4	9.6	6.2
42	Interscye Breadth	6682	15.39	0.02	1.24	0.01	8.07	10.7	20.4	9.7
43	Interscye, Maximum	6682	20.72	0.02	1.46	0.01	7.03	15.8	26.5	10.7
44	Waist Back Length	6682	17.73	0.02	1.35	0.01	7.64	13.5	22.9	9.4
45	Sleeve Inseam Length	6682	19.13	0.01	1.05	0.01	5.51	15.4	23.5	8.1
46	Sleeve Length	6682	33.80	0.02	1.56	0.01	4.61	27.7	39.5	11.8

TABLE XXI - STATISTICAL VALUES FOR TOTAL ARMY SERIES (Concluded)

Values in Inches

No. Measurements	N	Mean	SE(M)	S.D.	SE(SD)	V(%)	Min.	Range Max.	Total
HEAD AND FACE MEASUREMENTS									
47 Head Circumference	6682	22.09	0.01	0.63	0.01	2.86	20.06	25.13	5.07
48 Head Length	6682	7.66	0.00	0.29	0.00	3.77	6.56	8.83	2.27
49 Occiput-Nasal Root	6682	7.52	0.00	0.28	0.00	3.77	6.48	8.67	2.19
50 Occiput-External Canthus	6682	6.79	0.00	0.38	0.00	5.67	5.45	8.20	2.75
51 Occiput-Triglion	6682	4.05	0.01	0.47	0.00	11.58	2.70	5.76	3.06
52 Occiput-Pronasale	6682	8.74	0.00	0.33	0.00	3.75	7.42	10.01	2.59
53 Head Breadth	6682	6.01	0.00	0.23	0.00	3.83	5.06	6.86	1.80
54 Bitrignon Breadth	6682	5.31	0.00	0.22	0.00	4.18	4.47	6.15	1.86
55 Head Height	6682	5.21	0.00	0.31	0.00	5.99	3.96	6.31	2.35
56 Face Length	6681	4.74	0.00	0.26	0.00	5.50	3.80	5.76	1.96
57 Face Breadth	6681	5.51	0.00	0.22	0.00	4.00	4.70	6.43	1.73
58 Interpupillary Breadth	6680	2.41	0.00	0.16	0.00	6.51	1.87	3.12	1.25
HAND MEASUREMENTS									
59 Hand Length	6682	7.49	0.00	0.38	0.00	5.06	6.08	9.30	3.22
60 Palm Length	6682	4.17	0.00	0.25	0.00	5.93	3.17	5.29	2.12
61 Hand Breadth	6681	3.50	0.00	0.19	0.00	5.52	2.78	4.22	1.44
62 Hand Circumference	6682	8.51	0.01	0.45	0.00	5.26	6.99	10.36	3.37
63 Thumb Crotch Length	6682	1.96	0.00	0.20	0.00	10.45	1.28	2.96	1.68
FOOT MEASUREMENTS									
64 Foot Length	6682	10.54	0.01	0.51	0.00	4.86	8.41	12.77	4.36
65 Instep Length	6682	7.73	0.01	0.41	0.00	5.21	6.36	9.66	3.30
66 Ball of Foot Breadth	6682	3.87	0.00	0.22	0.00	5.56	3.13	4.81	1.68
67 Heel Breadth	6682	2.70	0.00	0.18	0.00	6.84	1.99	3.55	1.56
68 Ball of Foot Circumference	6682	9.85	0.01	0.58	0.01	5.92	7.30	12.37	5.07
69 Instep Circumference	6682	10.46	0.01	0.65	0.01	6.21	8.05	14.18	6.13
70 Heel-Ankle Circumference	6682	13.43	0.01	0.65	0.01	4.86	11.08	16.03	4.95
Age (years)	6682	22.17	0.06	4.64	0.04	20.92	17.0	55.0	38.0

TABLE XII - STATISTICAL VALUES FOR BASIC TRAINEES

Values in Inches

No.	Measurements	N	Mean	SE(M)	S.D.	SE(SD)	V(%)	Min.	Range Max.	Total
1	Weight (pounds)	2638	155.97	0.45	23.09	0.32	14.81	99.5	255.5	156.0
STANDING MEASUREMENTS										
2	Stature	2639	68.78	0.05	2.54	0.03	3.69	60.1	77.4	17.3
3	Cervicale Height	2639	58.84	0.05	2.43	0.03	4.13	50.3	67.6	17.3
4	Shoulder Height	2639	56.56	0.05	2.39	0.03	4.22	48.9	64.3	15.4
5	Waist Height	2639	41.99	0.04	2.02	0.03	4.82	34.7	49.3	14.6
6	Crotch Height	2639	33.23	0.04	1.08	0.02	5.41	25.9	39.7	13.8
7	Kneecap Height	2639	20.87	0.02	1.24	0.02	5.93	16.8	25.3	8.5
8	Calf Height	2639	13.96	0.02	1.00	0.01	7.14	9.4	17.6	8.2
9	Functional Reach	2638	32.8	0.04	1.83	0.03	5.66	25.7	39.5	13.8
SITTING MEASUREMENTS										
10	Vertical Arm Reach, Sitting	2639	54.65	0.04	2.19	0.03	4.01	46.0	62.5	16.5
11	Sitting Height	2639	35.91	0.03	1.35	0.02	3.77	31.2	40.6	9.4
12	Eye Height, Sitting	2639	31.15	0.03	1.34	0.02	4.29	26.3	35.7	9.4
13	Mid-Shoulder Height	2639	24.68	0.02	1.16	0.02	4.68	20.6	28.8	8.2
14	Shoulder-Elbow Length	2639	14.48	0.01	0.71	0.01	4.92	12.2	17.1	4.9
15	Elbow-Fingertip Length	2639	18.87	0.02	0.86	0.01	4.57	15.9	22.2	6.3
16	Knee Height, Sitting	2639	21.27	0.02	1.04	0.01	4.87	18.2	25.3	7.1
17	Popliteal Height	2639	17.64	0.02	0.98	0.01	5.56	14.4	21.0	6.6
18	Buttock-Knee Length	2639	23.32	0.02	1.09	0.02	4.68	19.8	27.6	7.8
19	Buttock-Popliteal Length	2639	19.49	0.02	0.99	0.01	5.09	16.5	23.1	6.6

TABLE XXII - STATISTICAL VALUES FOR BASIC TRAINEES (Continued)

No.	Measurements	N	Mean	SE(M)	S.D.	SE(SD)	Values in Inches			Range Max.	Total
							V(%)	Min.	Max.		
BREADTH MEASUREMENTS											
20	Chest Depth	2639	8.96	0.01	0.74	0.01	8.24	6.6	11.8	5.2	
21	Chest Breadth	2639	11.99	0.02	0.83	0.01	6.95	9.6	15.4	5.8	
22	Hip Breadth, Standing	2639	13.01	0.02	0.78	0.01	6.00	10.7	17.6	6.9	
23	Shoulder Breadth	2639	17.75	0.02	0.97	0.01	5.48	14.3	21.4	7.1	
24	Forearm-Forearm Breadth	2639	17.78	0.03	1.61	0.02	9.03	13.1	25.3	12.2	
25	Hip Breadth, Sitting	2639	13.36	0.02	0.93	0.01	6.95	10.9	18.8	7.9	
CIRCUMFERENCES AND SURFACE MEASUREMENTS											
26	Neck Circumference	2639	14.62	0.02	0.80	0.01	5.46	11.9	19.1	7.2	
27	Shoulder Circumference	2639	44.21	0.05	2.50	0.03	5.66	36.5	54.8	18.3	
28	Chest Circumference	2639	36.53	0.05	2.54	0.04	6.97	28.2	48.3	20.1	
29	Waist Circumference	2639	31.33	0.06	3.18	0.04	10.15	23.1	46.2	23.1	
30	Hip Circumference	2639	36.79	0.05	2.51	0.03	6.81	30.4	49.3	18.9	
31	Upper Thigh Circumference	2639	21.48	0.04	1.95	0.03	9.06	16.0	29.8	13.8	
32	Lower Thigh Circumference	2639	15.50	0.03	1.49	0.02	9.61	11.3	20.8	9.5	
33	Calf Circumference	2639	14.28	0.02	1.08	0.01	9.56	11.1	18.0	6.9	
34	Ankle Circumference	2639	8.94	0.01	0.56	0.01	6.29	7.1	11.0	3.9	
35	Vert. Trunk Circum., Standing	2639	64.84	0.06	3.33	0.05	7.30	53.8	77.4	23.6	
36	Arm Scye Circumference	2639	17.48	0.02	1.22	0.02	7.00	13.5	22.9	9.4	
37	Biceps Circum., Relaxed	2639	11.42	0.02	1.09	0.01	9.53	8.2	15.2	7.0	
38	Biceps Circum., Flexed	2639	12.52	0.02	1.08	0.01	8.63	9.0	17.2	8.2	
39	Forearm Circum., Flexed	2639	11.51	0.02	0.80	0.01	6.99	8.9	14.7	5.8	
40	Wrist Circumference	2639	6.73	0.01	0.34	0.00	4.99	5.8	8.1	2.3	
41	Shoulder Length	2639	6.21	0.01	0.73	0.01	11.83	3.8	9.0	5.2	
42	Interscye Breadth	2639	15.33	0.02	1.23	0.02	8.00	10.9	20.0	9.1	
43	Interscye, Maximum	2639	20.63	0.03	1.36	0.02	6.61	16.0	25.9	9.9	
44	Waist Back Length	2639	17.59	0.02	1.28	0.02	7.30	13.3	22.7	9.4	
45	Sleeve Inseam Length	2639	19.14	0.02	1.01	0.01	5.30	15.8	23.5	7.7	
46	Sleeve Length	2639	33.76	0.03	1.48	0.02	4.38	28.4	39.5	11.1	

TABLE XXII - STATISTICAL VALUES FOR BASIC TRAINEES (Concluded)

Values in Inches

No.	Measurements	N	Mean	SE(M)	S.D.	SE(SD)	V(%)	Min.	Range Max.	Total
HEAD AND FACE MEASUREMENTS										
47	Head Circumference	2639	22.01	0.01	0.61	0.01	2.79	20.06	24.30	4.24
48	Head Length	2639	7.64	0.01	0.28	0.00	3.69	6.56	8.59	2.03
49	Occiput-Nasal Root	2639	7.50	0.01	0.28	0.00	3.73	6.56	8.44	1.88
50	Occiput-External Canthus	2639	6.70	0.01	0.35	0.00	5.26	5.45	7.96	2.51
51	Occiput-Triglion	2639	3.99	0.01	0.45	0.01	11.39	2.70	5.36	2.66
52	Occiput-Pronasale	2639	8.73	0.01	0.33	0.00	3.74	7.42	10.01	2.59
53	Head Breadth	2639	6.01	0.00	0.22	0.00	3.70	5.22	6.86	1.64
54	Bitrignon Breadth	2639	5.30	0.00	0.22	0.00	4.10	4.63	6.11	1.48
55	Head Height	2639	5.22	0.01	0.31	0.00	5.99	3.96	6.23	2.27
56	Face Length	2639	4.72	0.01	0.26	0.00	5.49	3.80	5.76	1.96
57	Face Breadth	2638	5.49	0.00	0.21	0.00	3.90	4.78	6.19	1.41
58	Interpupillary Breadth	2638	2.40	0.00	0.16	0.00	6.69	1.87	3.04	1.17
HAND MEASUREMENTS										
59	Hand Length	2639	7.50	0.01	0.36	0.00	4.79	6.44	9.26	2.82
60	Palm Length	2639	4.18	0.00	0.24	0.00	5.76	3.17	5.13	1.96
61	Hand Breadth	2639	3.50	0.00	0.18	0.00	5.18	2.85	4.22	1.37
62	Hand Circumference	2639	8.50	0.01	0.44	0.01	5.19	7.15	10.29	3.14
63	Thumb Crotch Length	2639	1.95	0.00	0.19	0.00	10.00	1.32	2.73	1.41
FOOT MEASUREMENTS										
64	Foot Length	2639	10.57	0.01	0.50	0.01	4.70	8.76	12.53	3.77
65	Instep Length	2639	7.74	0.01	0.40	0.01	5.11	6.44	9.26	2.82
66	Ball of Foot Breadth	2639	3.91	0.00	0.21	0.00	5.48	3.21	4.69	1.48
67	Heel Breadth	2639	2.69	0.00	0.18	0.00	6.56	2.03	3.55	1.52
68	Ball of Foot Circumference	2639	9.91	0.01	0.56	0.01	5.65	7.78	11.90	4.12
69	Instep Circumference	2639	10.56	0.01	0.65	0.01	6.13	8.21	12.77	4.56
70	Heel-Ankle Circumference	2639	13.42	0.01	0.64	0.01	4.78	11.32	15.92	4.60
	Age (years)	2639	20.18	0.03	1.48	0.02	7.35	17.0	31.0	24.0

TABLE XXIII - STATISTICAL VALUES FOR INFANTRY

No.	Measurements	N	Mean	SE(M)	S.D.	SE(SD)	V(%)	Values in Inches		
								Min.	Range Max.	Total
1	Weight (pounds)	3425	160.34	0.39	22.81	0.28	14.22	99.5	271.5	172.0
STANDING MEASUREMENTS										
2	Stature	3429	68.64	0.05	2.66	0.03	3.87	59.7	78.6	18.9
3	Cervicale Height	3429	58.89	0.04	2.56	0.03	4.34	50.3	68.4	18.1
4	Shoulder Height	3429	56.55	0.04	2.50	0.03	4.43	48.5	65.8	17.3
5	Waist Height	3429	41.76	0.04	2.18	0.03	5.23	34.0	49.7	15.7
6	Crotch Height	3429	32.93	0.03	1.86	0.02	5.66	25.5	40.0	14.5
7	Kneecap Height	3429	20.76	0.02	1.30	0.02	6.26	17.0	25.1	8.1
8	Calf Height	3429	13.94	0.02	1.10	0.01	7.92	9.9	18.8	8.9
9	Functional Reach	3429	32.59	0.03	1.95	0.02	5.99	26.9	39.5	12.6
SITTING MEASUREMENTS										
10	Vertical Arm Reach, Sitting	3429	54.25	0.04	2.34	0.03	4.31	46.0	63.3	17.3
11	Sitting Height	3429	35.56	0.03	1.48	0.02	4.15	30.4	40.6	10.2
12	Eye Height, Sitting	3429	30.89	0.02	1.44	0.02	4.67	25.9	36.5	10.6
13	Mid-Shoulder Height	3429	24.45	0.02	1.30	0.02	5.31	20.0	28.8	8.8
14	Shoulder-Elbow Length	3429	14.52	0.01	0.74	0.01	5.12	12.0	17.2	5.2
15	Elbow-Fingertip Length	3429	18.88	0.02	0.94	0.01	4.98	15.4	22.7	7.3
16	Knee Height, Sitting	3429	21.29	0.02	1.10	0.01	5.17	17.4	25.5	8.1
17	Popliteal Height	3429	17.51	0.02	0.99	0.01	5.64	14.1	21.5	7.4
18	Buttock-Knee Length	3429	23.46	0.02	1.13	0.01	4.84	19.6	28.0	8.4
19	Buttock-Popliteal Length	3429	19.68	0.02	0.97	0.01	4.96	16.2	23.0	6.8

TABLE XXIII - STATISTICAL VALUES FOR INFANTRY (Continued)

No.	Measurements	N	Mean	SE(M)	S.D.	SE(SD)	V(%)	Min.	Range		
									Max.	Total	
Values in Inches											
BREADTH MEASUREMENTS											
20	Chest Depth	3429	9.19	0.01	0.78	0.01	8.49	6.5	13.2	6.7	
21	Chest Breadth	3429	12.03	0.01	0.84	0.01	7.01	9.6	16.4	6.8	
22	Hip Breadth, Standing	3429	13.08	0.01	0.79	0.01	6.02	10.6	17.7	7.1	
23	Shoulder Breadth	3429	17.89	0.02	1.00	0.01	5.58	14.7	23.1	8.4	
24	Forearm-Forearm Breadth	3429	18.25	0.03	1.64	0.02	8.97	13.1	26.1	13.0	
25	Hip Breadth, Sitting	3429	13.48	0.02	0.92	0.01	6.84	10.3	18.6	8.3	
CIRCUMFERENCES AND SURFACE MEASUREMENTS											
26	Neck Circumference	3429	14.75	0.01	0.81	0.01	5.51	11.9	19.1	7.2	
27	Shoulder Circumference	3429	44.66	0.04	2.47	0.03	5.53	37.1	56.6	19.5	
28	Chest Circumference	3429	37.01	0.04	2.60	0.03	7.03	30.0	48.9	18.9	
29	Waist Circumference	3429	31.62	0.05	3.12	0.04	9.88	23.8	48.0	24.2	
30	Hip Circumference	3429	37.18	0.04	2.35	0.03	6.32	30.4	49.3	18.9	
31	Upper Thigh Circumference	3429	21.99	0.03	1.78	0.02	8.07	15.3	30.6	15.3	
32	Lower Thigh Circumference	3429	16.14	0.03	1.48	0.02	9.19	11.3	22.3	11.0	
33	Calf Circumference	3429	14.48	0.02	1.02	0.01	7.03	11.3	20.0	8.7	
34	Ankle Circumference	3429	8.93	0.01	0.57	0.01	6.36	7.1	12.1	5.0	
35	Vert. Trunk Circum., Standing	3429	64.32	0.06	3.30	0.04	5.13	53.2	78.6	25.4	
36	Arm Scye Circumference	3429	17.50	0.02	1.31	0.02	7.46	12.7	23.7	11.0	
37	Biceps Circum., Relaxed	3429	11.66	0.02	1.04	0.01	8.91	8.8	17.4	8.6	
38	Biceps Circum., Flexed	3429	12.78	0.02	1.05	0.01	8.22	9.2	17.8	8.6	
39	Forearm Circum., Flexed	3429	11.61	0.01	0.87	0.01	7.49	8.9	15.8	6.9	
40	Wrist Circumference	3429	6.69	0.01	0.35	0.00	5.16	5.4	8.5	3.1	
41	Shoulder Length	3429	6.50	0.01	0.78	0.01	12.07	3.4	9.6	6.2	
42	Interscye Breadth	3429	15.40	0.02	1.25	0.02	8.11	10.7	20.2	9.5	
43	Interscye, Maximum	3429	20.75	0.03	1.51	0.02	7.28	15.6	26.7	11.1	
44	Waist Back Length	3429	17.81	0.02	1.40	0.02	7.84	13.7	22.7	9.0	
45	Sleeve Inseam Length	3429	19.11	0.02	1.09	0.01	5.68	15.4	23.5	8.1	
46	Sleeve Length	3429	33.78	0.03	1.60	0.02	4.74	27.7	39.5	11.8	

TABLE XXIII -- STATISTICAL VALUES FOR INFANTRY (Concluded)

Values in Inches

No.	Measurements	N	Mean	SE(M)	S.D.	SE(SD)	V(%)	Min.	Range Max.	Total
HEAD AND FACE MEASUREMENTS										
47	Head Circumference	3429	22.13	0.01	0.64	0.01	2.87	20.06	25.13	5.07
48	Head Length	3429	7.67	0.00	0.29	0.00	3.78	6.56	8.83	2.27
49	Occiput-Nasal Root	3429	7.53	0.00	0.28	0.00	3.77	6.48	8.67	2.19
50	Occiput-External Canthus	3429	6.84	0.01	0.40	0.00	5.79	5.61	8.20	2.59
51	Occiput-Tragion	3429	4.08	0.01	0.48	0.01	11.79	2.70	5.76	3.06
52	Occiput-Pronasale	3429	8.73	0.01	0.33	0.00	3.77	7.58	9.93	2.35
53	Head Breadth	3429	6.00	0.00	0.24	0.00	3.94	5.06	6.82	1.76
54	Bitragion Breadth	3429	5.31	0.00	0.22	0.00	4.22	4.47	6.07	1.60
55	Head Height	3429	5.20	0.01	0.32	0.00	6.07	4.04	6.31	2.27
56	Face Length	3428	4.75	0.00	0.26	0.00	5.44	3.96	5.68	1.72
57	Face Breadth	3429	5.52	0.00	0.22	0.00	4.04	4.70	6.31	1.61
58	Interpillary Breadth	3429	2.41	0.00	0.15	0.00	6.32	1.87	3.12	1.25
HAND MEASUREMENTS										
59	Hand Length	3429	7.48	0.01	0.39	0.00	5.23	6.04	9.26	3.22
60	Palm Length	3429	4.16	0.00	0.25	0.00	6.06	3.25	5.29	2.04
61	Hand Breadth	3429	3.51	0.00	0.20	0.00	5.78	2.78	4.18	1.40
62	Hand Circumference	3429	8.50	0.01	0.45	0.01	5.33	6.99	10.36	3.37
63	Thumb Crotch Length	3428	1.96	0.00	0.21	0.00	10.83	1.28	2.92	1.64
FOOT MEASUREMENTS										
64	Foot Length	3429	10.52	0.01	0.52	0.01	4.93	8.41	12.77	4.36
65	Instep Length	3429	7.73	0.01	0.42	0.01	5.43	6.44	9.66	3.22
66	Ball of Foot Breadth	3429	3.85	0.00	0.21	0.00	5.55	3.13	4.81	1.68
67	Heel Breadth	3429	2.70	0.00	0.19	0.00	6.96	1.99	3.51	1.52
68	Ball of Foot Circumference	3429	9.80	0.01	0.60	0.01	6.14	7.30	12.37	5.07
69	Instep Circumference	3429	10.38	0.01	0.64	0.01	6.21	8.05	14.18	6.13
70	Heel-Ankle Circumference	3429	13.42	0.01	0.66	0.01	4.91	11.08	16.03	4.95
	Age (years)	3429	22.79	0.09	5.05	0.06	22.14	17.0	55.0	38.0

TABLE XXIV - STATISTICAL VALUES FOR ARMORED CREWMEN

No.	Measurements	Values in Inches							Range Max.	Total
		N	Mean	SE(M)	S.D.	SE(SD)	V(%)	Min.		
1	Weight (pounds)	489	165.42	1.20	26.55	0.85	16.05	107.5	283.5	176.0
STANDING MEASUREMENTS										
2	Stature	489	68.68	0.12	2.60	0.08	3.79	61.7	75.9	14.2
3	Cervicale Height	489	59.00	0.11	2.50	0.08	4.23	52.3	66.0	13.7
4	Shoulder Height	489	56.77	0.11	2.45	0.08	4.31	48.5	64.3	15.8
5	Waist Height	489	41.80	0.09	2.06	0.07	4.92	35.5	47.7	12.2
6	Crotch Height	489	32.91	0.09	1.89	0.06	5.75	26.7	38.5	11.8
7	Kneecap Height	489	20.88	0.06	1.33	0.04	6.38	17.2	25.1	7.9
8	Calf Height	489	13.95	0.05	1.14	0.04	8.20	11.1	17.6	6.5
9	Functional Reach	488	32.70	0.09	1.98	0.06	6.07	25.7	38.7	13.0
SITTING MEASUREMENTS										
10	Vertical Arm Reach, Sitting	489	54.45	0.10	2.31	0.07	4.24	46.8	62.1	15.3
11	Sitting Height	489	35.51	0.07	1.55	0.05	4.36	31.2	40.2	9.0
12	Eye Height, Sitting	489	30.80	0.07	1.45	0.05	4.71	26.7	35.3	8.6
13	Mid-Shoulder Height	489	24.56	0.06	1.37	0.04	5.56	20.8	28.6	7.8
14	Shoulder-Elbow Length	489	14.66	0.04	0.78	0.02	5.29	11.7	16.9	5.2
15	Elbow-Fingertip Length	489	18.94	0.04	0.96	0.03	5.07	16.4	21.7	5.3
16	Knee Height, Sitting	489	21.33	0.05	1.11	0.04	5.22	17.8	24.9	7.1
17	Popliteal Height	489	17.56	0.04	0.95	0.03	5.40	15.0	20.2	5.2
18	Buttock-Knee Length	489	23.54	0.05	1.20	0.04	5.10	20.2	27.8	7.6
19	Buttock-Popliteal Length	489	19.76	0.04	0.97	0.03	4.94	17.1	23.1	6.0

TABLE XXIV — STATISTICAL VALUES FOR ARMORED CREWMEN (Continued)

Values in Inches

No. Measurements	N	Mean	SE(M)	S.D.	SE(SD)	V(%)	Min.	Range	
								Max.	Total
BREADTH MEASUREMENTS									
20 Chest Depth	489	9.47	0.04	0.86	0.03	9.09	7.1	13.4	6.3
21 Chest Breadth	489	12.26	0.04	0.88	0.03	7.20	10.4	16.1	5.7
22 Hip Breadth, Standing	489	13.24	0.04	0.84	0.03	6.33	11.1	17.1	6.0
23 Shoulder Breadth	489	18.16	0.05	1.08	0.03	5.96	15.3	21.9	6.6
24 Forearm-Forearm Breadth	489	18.61	0.08	1.83	0.06	9.82	13.5	26.1	12.6
25 Hip Breadth, Sitting	489	13.63	0.05	1.04	0.03	7.60	10.7	19.8	9.1
CIRCUMFERENCES AND SURFACE MEASUREMENTS									
26 Neck Circumference	489	14.99	0.04	0.86	0.03	5.73	12.8	17.9	5.1
27 Shoulder Circumference	489	45.40	0.12	2.73	0.09	6.01	38.9	57.2	18.3
28 Chest Circumference	489	37.93	0.13	2.92	0.09	7.70	31.2	48.9	17.7
29 Waist Circumference	489	32.73	0.17	3.80	0.12	11.60	25.5	50.3	24.8
30 Hip Circumference	489	37.81	0.13	2.77	0.09	7.32	30.4	52.8	22.4
31 Upper Thigh Circumference	489	22.28	0.09	2.07	0.07	9.29	17.2	29.4	12.2
32 Lower Thigh Circumference	489	16.12	0.07	1.58	0.05	9.81	12.5	21.2	8.7
33 Calf Circumference	489	14.56	0.05	1.08	0.03	7.41	11.7	18.0	6.3
34 Ankle Circumference	489	8.93	0.03	0.59	0.02	6.56	7.6	10.8	3.2
35 Vert. Trunk Circum., Standing	489	65.15	0.16	3.59	0.11	5.52	55.0	76.9	21.9
36 Arm Scye Circumference	489	18.10	0.06	1.34	0.04	7.39	14.7	22.5	7.8
37 Biceps Circum., Relaxed	489	11.91	0.05	1.15	0.04	9.66	8.8	16.0	7.2
38 Biceps Circum., Flexed	489	13.07	0.05	1.18	0.04	9.01	9.7	17.0	7.3
39 Forearm Circum., Flexed	489	11.80	0.04	0.89	0.03	7.56	9.1	14.4	5.3
40 Wrist Circumference	489	6.80	0.02	0.37	0.01	5.50	5.4	8.0	2.6
41 Shoulder Length	489	6.39	0.04	0.87	0.03	13.59	3.4	9.4	6.0
42 Interscye Breadth	489	15.63	0.06	1.30	0.04	8.34	10.7	20.4	9.7
43 Interscye, Maximum	489	20.94	0.07	1.57	0.05	7.51	16.4	25.9	9.5
44 Waist Back Length	489	17.89	0.06	1.38	0.04	7.70	14.3	22.9	8.6
45 Sleeve Inseam Length	489	19.24	0.05	1.07	0.03	5.54	15.6	22.7	7.1
46 Sleeve Length	489	34.01	0.07	1.65	0.05	4.85	27.7	38.7	11.0

TABLE XXIV - STATISTICAL VALUES FOR ARMORED CREWMAN (Concluded)

No.	Measurements	N	Mean	SE(M)	S.D.	SE(SD)	V(%)	Min.	Range	Total
									Max.	
Values in Inches										
HEAD AND FACE MEASUREMENTS										
47	Head Circumference	489	22.24	0.03	0.65	0.02	2.92	20.41	24.42	4.01
48	Head Length	489	7.71	0.01	0.31	0.01	3.96	6.79	8.51	1.72
49	Occiput-Nasal Root	489	7.55	0.01	0.30	0.01	3.95	6.56	8.28	1.72
50	Occiput-External Canthus	489	6.87	0.02	0.40	0.01	5.77	5.69	7.96	2.27
51	Occiput-Tragion	489	4.06	0.02	0.43	0.01	10.66	3.01	5.36	2.35
52	Occiput-Pronasale	489	8.76	0.02	0.33	0.01	3.79	7.74	9.77	2.03
53	Head Breadth	489	6.04	0.01	0.23	0.01	3.74	5.33	6.78	1.45
54	Bitrignon Breadth	489	5.36	0.01	0.22	0.01	4.19	4.63	6.15	1.52
55	Head Height	489	5.21	0.01	0.29	0.01	5.48	4.19	6.07	1.88
56	Face Length	489	4.75	0.01	0.28	0.01	5.79	3.80	5.64	1.84
57	Face Breadth	489	5.58	0.01	0.22	0.01	3.89	4.98	6.43	1.45
58	Interpupillary Breadth	489	2.48	0.01	0.16	0.01	6.48	1.95	3.12	1.17
HAND MEASUREMENTS										
59	Hand Length	489	7.53	0.02	0.40	0.01	5.36	6.28	8.79	2.51
60	Palm Length	489	4.17	0.01	0.26	0.01	6.12	3.33	5.05	1.72
61	Hand Breadth	489	3.51	0.01	0.19	0.01	5.47	2.78	4.22	1.44
62	Hand Circumference	489	8.57	0.02	0.45	0.01	5.31	7.15	10.29	3.14
63	Thumb Crotch Length	489	1.96	0.01	0.19	0.01	9.93	1.28	2.73	1.45
FOOT MEASUREMENTS										
64	Foot Length	489	10.56	0.02	0.54	0.02	5.08	9.11	12.41	3.30
65	Instep Length	489	7.73	0.02	0.44	0.01	5.68	6.59	9.18	2.59
66	Ball of Foot Breadth	489	3.87	0.01	0.21	0.01	5.44	3.21	4.58	1.37
67	Heel Breadth	489	2.75	0.01	0.20	0.01	7.28	2.19	3.40	1.21
68	Ball of Foot Circumference	489	9.87	0.03	0.56	0.02	5.64	7.78	11.90	4.12
69	Instep Circumference	489	10.45	0.03	0.64	0.02	6.11	8.68	12.77	4.09
70	Heel-Ankle Circumference	489	13.55	0.03	0.68	0.02	5.01	11.79	15.56	3.77

TABLE XXV — STATISTICAL VALUES FOR AVIATORS

No.	Measurements	Values in Inches							Range Max.	Total
		N	Mean	SE(M)	S.D.	SE(SD)	V(%)	Min.		
1	Weight (pounds)	125	166.18	1.84	20.54	1.30	12.36	111.5	215.5	104.0
STANDING MEASUREMENTS										
2	Stature	125	69.05	0.21	2.29	0.15	3.32	61.3	74.3	13.0
3	Cervicale Height	125	59.36	0.19	2.13	0.13	3.59	53.4	64.8	11.4
4	Shoulder Height	125	56.93	0.20	2.18	0.14	3.83	50.1	61.9	11.8
5	Waist Height	125	42.13	0.18	2.01	0.13	4.77	36.3	46.9	10.6
6	Crotch Height	125	33.06	0.13	1.50	0.10	4.55	29.4	36.5	7.1
7	Kneecap Height	125	20.67	0.11	1.26	0.08	6.08	17.8	23.7	5.9
8	Calf Height	125	13.75	0.08	0.90	0.06	6.56	11.1	16.0	4.9
9	Functional Reach	125	32.74	0.16	1.78	0.11	5.44	28.0	38.7	10.7
SITTING MEASUREMENTS										
10	Vertical Arm Reach, Sitting	125	54.26	0.19	2.13	0.13	3.93	47.9	59.3	11.4
11	Sitting Height	125	36.02	0.12	1.34	0.08	3.73	31.6	39.1	7.5
12	Eye Height, Sitting	125	31.20	0.11	1.27	0.08	4.08	27.8	34.9	7.1
13	Mid-Shoulder Height	125	24.81	0.10	1.13	0.07	4.56	21.6	27.2	5.6
14	Shoulder-Elbow Length	125	14.69	0.06	0.67	0.04	4.58	12.8	16.6	3.8
15	Elbow-Fingertip Length	125	18.85	0.07	0.79	0.05	4.18	16.6	21.1	4.5
16	Knee-Height, Sitting	125	21.40	0.10	1.08	0.07	5.04	17.6	24.3	6.7
17	Popliteal Height	125	17.44	0.08	0.89	0.06	5.10	15.0	19.6	4.6
18	Buttock-Knee Length	125	23.51	0.09	1.01	0.06	4.28	20.4	26.1	5.7
19	Buttock-Popliteal Length	125	19.71	0.08	0.85	0.05	4.31	17.1	22.0	4.9

TABLE XXV - STATISTICAL VALUES FOR AVIATORS (Continued)

Values in Inches

No.	Measurements	N	Mean	SE(M)	S.D.	SE(SD)	V(%)	Min.	Range Max.	Total
BREADTH MEASUREMENTS										
20	Chest Depth	125	9.53	0.07	0.76	0.05	7.97	7.4	11.5	4.1
21	Chest Breadth	125	12.46	0.06	0.70	0.04	5.65	10.4	14.2	3.8
22	Hip Breadth, Standing	125	13.25	0.06	0.69	0.04	5.18	11.8	15.7	3.9
23	Shoulder Breadth	125	18.35	0.07	0.82	0.05	4.49	16.4	20.4	4.0
24	Forearm-Forearm Breadth	125	18.89	0.12	1.38	0.09	7.30	15.4	22.5	7.1
25	Hip Breadth, Sitting	125	13.82	0.07	0.84	0.05	6.07	11.9	16.2	4.3
CIRCUMFERENCES AND SURFACE MEASUREMENTS										
26	Neck Circumference	125	15.10	0.06	0.70	0.04	4.62	12.8	16.8	4.0
27	Shoulder Circumference	125	45.66	0.18	2.03	0.13	4.44	40.1	51.3	11.2
28	Chest Circumference	125	38.52	0.21	2.32	0.15	6.02	32.4	45.4	13.0
29	Waist Circumference	125	33.30	0.26	2.96	0.19	8.88	26.1	40.8	14.7
30	Hip Circumference	125	38.03	0.20	2.21	0.14	5.81	32.2	44.0	11.8
31	Upper Thigh Circumference	125	22.49	0.16	1.77	0.11	7.88	17.2	26.7	9.5
32	Lower Thigh Circumference	125	16.28	0.11	1.26	0.08	7.76	12.1	19.6	7.5
33	Calf Circumference	125	14.59	0.08	0.89	0.06	6.12	12.1	17.0	4.9
34	Ankle Circumference	125	8.98	0.05	0.54	0.03	5.98	7.5	10.9	3.4
35	Vert. Trunk Circum., Standing	125	65.42	0.27	3.00	0.19	4.59	57.4	73.9	16.5
36	Arm Scye Circumference	125	17.95	0.10	1.13	0.07	6.29	13.9	21.4	7.5
37	Biceps Circum., Relaxed	125	11.97	0.09	0.97	0.06	8.09	9.4	14.1	4.7
38	Biceps Circum., Flexed	125	12.96	0.08	0.92	0.06	7.08	9.7	14.7	5.0
39	Forearm Circum., Flexed	125	11.73	0.06	0.65	0.04	5.53	10.2	13.5	3.3
40	Wrist Circumference	125	6.75	0.03	0.32	0.02	4.68	5.8	7.5	1.7
41	Shoulder Length	125	6.48	0.06	0.62	0.04	9.64	4.4	8.0	3.6
42	Interscye Breadth	125	15.58	0.09	0.98	0.06	6.26	13.3	18.4	5.1
43	Interscye, Maximum	125	20.97	0.11	1.25	0.08	5.95	17.6	24.3	6.7
44	Waist Back Length	125	18.04	0.11	1.27	0.08	7.05	15.6	21.4	5.8
45	Sleeve Inseam Length	125	19.12	0.08	0.93	0.06	4.84	16.6	21.7	5.1
46	Sleeve Length	125	34.13	0.13	1.48	0.09	4.34	30.4	37.9	7.5

TABLE XXV - STATISTICAL VALUES FOR AVIATORS (Concluded)

Values in Inches

No.	Measurements	N	Mean	SE(M)	S.D.	SE(SD)	V(%)	Min.	Range Max.	Total
HEAD AND FACE MEASUREMENTS										
47	Head Circumference	125	22.39	0.06	0.62	0.04	2.75	20.41	23.83	3.42
48	Head Length	125	7.76	0.02	0.27	0.02	3.43	7.03	8.36	1.33
49	Occiput-Nasal Root	125	7.61	0.02	0.27	0.02	3.49	6.95	8.28	1.33
50	Occiput-External Canthus	125	6.95	0.03	0.32	0.02	4.56	6.16	7.81	1.65
51	Occiput-Tragion	125	4.14	0.04	0.39	0.02	9.51	3.25	5.13	1.88
52	Occiput-Pronasale	125	8.84	0.03	0.29	0.02	3.26	8.13	9.69	1.56
53	Head Breadth	125	6.05	0.02	0.22	0.01	3.68	5.14	6.62	1.48
54	Bitracion Breadth	125	5.38	0.02	0.23	0.01	4.19	4.82	5.99	1.17
55	Head Height	125	5.27	0.03	0.28	0.02	5.38	4.35	6.07	1.72
56	Face Length	125	4.76	0.02	0.26	0.02	5.52	4.15	5.52	1.37
57	Face Breadth	125	5.57	0.02	0.23	0.01	4.06	5.06	6.19	1.13
58	Interpupillary Breadth	125	2.43	0.01	0.14	0.01	5.63	2.11	2.81	0.70
HAND MEASUREMENTS										
59	Hand Length	125	7.44	0.03	0.31	0.02	4.17	6.52	8.24	1.72
60	Palm Length	125	4.16	0.02	0.21	0.01	5.03	3.56	4.66	1.10
61	Hand Breadth	125	3.48	0.01	0.17	0.01	4.77	3.09	3.91	0.82
62	Hand Circumference	125	8.56	0.03	0.39	0.02	4.53	7.70	9.89	2.19
63	Thumb Crotch Length	125	1.99	0.02	0.22	0.01	10.87	1.48	2.65	1.17
FOOT MEASUREMENTS										
64	Foot Length	125	10.56	0.04	0.50	0.03	4.75	9.23	11.94	2.71
65	Instep Length	125	7.77	0.04	0.41	0.03	5.27	6.36	8.79	2.43
66	Ball of Foot Breadth	125	3.84	0.02	0.21	0.01	5.40	3.33	4.34	1.01
67	Heel Breadth	125	2.71	0.02	0.17	0.01	6.23	2.30	3.16	0.86
68	Ball of Foot Circumference	125	9.90	0.05	0.53	0.03	5.31	8.72	11.43	2.71
69	Instep Circumference	125	10.41	0.05	0.51	0.03	4.94	8.68	11.98	3.30
70	Heel-Ankle Circumference	125	13.48	0.05	0.59	0.04	4.39	12.15	14.97	2.82
	Age (years)	125	28.11	0.54	6.04	0.38	21.47	18.0	48.0	30.0

c. Selected Bivariate Tables

The anthropometric data shown in the preceding tables, whether as percentile values or statistical values, represent values for individual body measurements. These are values for each independent measurement and as such give no indication of the interrelationships or correlations between or among the various body measurements.

In design work, human engineering, or any other application of anthropometric data, the use of data for only one body measurement alone is rare. Usually, information is required for two or more measurements considered together. Stature and chest circumference, as well as waist circumference, are utilized in the sizing of many items of clothing, while neck circumference and sleeve length are needed for shirts, and waist circumference and crotch height are required for trousers. Similarly, in human engineering applications, sitting height and functional reach, for example, are used in the design of vehicles and aircraft, while hip breadth, sitting and popliteal height are required for the design of seating.

It should be apparent that the relationships or correlations between body measurements are of basic importance in the use of anthropometric data, since the different parts of the body which are measured after all do go together and are related in some way. Some body measurements are closely related and have high correlations, some measurements have only moderate correlations, and some have only very low correlations.

The degree of correlation may be expressed by the coefficient of correlation or "r" value. The coefficients of correlation between body measurements may vary between .000, representing no correlation, and .999, representing an almost perfect correlation. Most correlations of this type are positive correlations, which means that as the value of one measurement increases, the value of the other measurement also increases. However, some correlations may be negative correlations; in this case, as the value of one measurement increases, the value of the other measurement decreases.

In general, height measurements (waist height, crotch height, sitting height) and the lengths of the arms or legs are highly correlated with stature. Circumference measurements or body girths are more highly correlated with weight. Breadth measurements tend to be more highly correlated with weight than with stature.

Some examples of the coefficients of correlation between a few selected body measurements are shown in Table XXVI. These Army data indicate only a moderate correlation (.482) between weight and stature. It may be noted that crotch height, sitting height, and functional reach have relatively low correlations with weight, but have much higher correlations with stature. On the other hand, shoulder and hip breadths and chest and waist circumference have relatively high correlations with weight, but have much lower correlations with stature. The extremely low correlation (.007) between crotch height and waist circumference is an outstanding example of two measurements which are virtually unrelated.

TABLE XXVI – COEFFICIENTS OF CORRELATION

No.	Measurements	1	2	3	4	5	6	7	8	9
1	Weight	—	.482	.232	.388	.365	.789	.837	.838	.842
2	Stature	.482	—	.804	.713	.566	.322	.381	.246	.227
3	Crotch Height	.232	.804	—						.007
4	Sitting Height	.388	.713		—	.289	.268	.393		
5	Functional Reach	.365	.566		.289	—				
6	Shoulder Breadth	.789	.322		.268		—			
7	Hip Breadth, Sitting	.837	.381		.393			—		
8	Chest Circumference	.838	.246						—	
9	Waist Circumference	.842	.227	.007						—

The variability of two body measurements and their interrelationship with each other may be shown graphically in a bivariate table. Several examples of this type of presentation are given in Tables XXVII to XXXVI. The bivariate table shows the ranges of two measurements, and the numbers or frequencies of men who have the various possible combinations of values of the two measurements. The values indicating the ranges of the two measurements represent the mid-points of the intervals in those ranges. The frequencies or numbers of men may be given as actual numbers or may be expressed as percentages of the sample. Table XXVII represents a bivariate table of stature and weight for the total Army sample in which the frequencies are given as numbers of men, while Table XXVIII shows the same bivariate with the frequencies expressed as percentages of the sample of 6682 men. Thus, Table XXVII shows that 229 men, of the total Army sample of 6682, were in the 68.50 inch interval (between 68.00 and 68.99 inches) of stature and also were in the 155.00 pound interval (between 150.00 and 159.99 pounds) of weight. Table XXVIII, however, indicates that the 229 men represent 3.4 percent of the sample of 6682 men. In the rest of the bivariate tables presented here, the frequencies are expressed as percentages of the total sample.

While the relationship between two measurements is indicated by the coefficient of correlation or "r" value, the extent or degree of correlation may be estimated from the appearance or general shape of the bivariate. Table XXIX, a bivariate of chest circumference and weight, shows a fairly well-defined band sloping from the lower left to the upper right, indicating that as the values for weight increase (from left to right), the values for chest circumference also increase (from bottom to top). The apparent correlation is further confirmed by the comparatively high coefficient of correlation of .838. Thus, heavier men generally have larger chest girths. On the other hand, there is no such trend shown in Table XXXI, the bivariate of crotch height and waist circumference; the distribution in this bivariate table is practically oval in shape. There is then virtually no correlation between these two measurements, as confirmed by the extremely low coefficient of correlation of .007. What this actually means is that almost any crotch height may be expected to occur with any waist circumference. The practical implication of this lack of correlation is that trousers of whatever waist girth must be made in virtually all inseam lengths in order to provide the trouser sizes and lengths necessary to fit the population; otherwise, trouser bottoms should be left unfinished and then tailored to fit the individual.

Each bivariate table reproduced here also shows the regression equations for the two related measurements. These equations, which are based upon the relationship between the two measurements in the bivariate, make it possible to calculate predicted values of one measurement from given values of the other measurement. In Table XXX, the regression equation for stature (Y) and chest circumference (X) is:

$$X = (0.248)Y + (19.870)$$

Thus, the average chest circumference of a man 72 inches tall would be expected to be:

$$(0.248) 72 + (19.870) = 37.73 \text{ inches}$$

This is based upon the relationship between stature and chest circumference as shown in this bivariate of Army data.

By way of comparison, two bivariate tables from the 1946 Army survey of approximately 24,500 men are shown here: Table XXXV — Stature and Weight, and Table XXXVI — Stature and Chest Circumference. The frequencies in these two bivariate tables are expressed as percentages of the total sample. Note that the stature scale runs from top to bottom in these two tables, and is thus the reverse of the stature scales in the 1966 bivariate tables. The intervals for stature and chest circumference in these two bivariate tables are .7 of an inch, which is the equivalent of two centimeters. The calculations for these two bivariate tables (as well as many others) were laboriously produced through the use of mechanical desk calculators 25 years ago; the 1966 bivariate tables, with scales conveniently in even inches, reflect the improvements and refinements made possible by modern computer programming.

In addition to illustrating the relationship between two measurements, the bivariate table serves a very important and practical function as the basis for the development of clothing tariffs. One of the ultimate objectives in the application of anthropometric data in the area of military logistics is the correlation of body sizes and clothing sizes in order to determine what quantities of which sizes of clothing are required to fit the bodies in the military population. The listing of quantities (or percentages) of clothing, by size, is called a clothing tariff, and it is from the bivariate table that such a tariff is generated or calculated.

A typical clothing size system might be composed of nine sizes: three girth sizes (small, medium, and large) combined with three lengths (short, regular, and long). The limits of fit in girth and length for each size may be represented by a square or rectangle. Thus, the system of nine sizes may be thought of as a grid of nine squares or boxes. This grid is superimposed upon the bivariate table. The frequencies or percentages in the bivariate which appear in each box of the grid are then added up; this number (or percentage) represents the number (or percentage) of men who require that size of clothing. Such a tally is made for each size in the size system. This then becomes a tariff, which is essentially a calculation of the quantities of clothing, tabulated by size, required for the military population.

TABLE XXVII - BIVARIATE TABLE OF STATURE AND WEIGHT (FREQUENCIES)

	HEIGHT																				C. TOTAL
	125	135	145	155	165	175	185	195	205	215	225	235	245	255	265	275	285				
78.50																					
77.50																					
76.50																					
75.50																					
74.50																					
73.50																					
72.50																					
71.50																					
70.50																					
69.50																					
68.50																					
67.50																					
66.50																					
65.50																					
64.50																					
63.50																					
62.50																					
61.50																					
60.50																					
59.50																					
2.	28.	106.	417.	928.	1137.	1284.	1019.	724.	459.	292.	185.	104.	39.	30.	15.	6.	5.	1.	0.	6682.	

SUMMARY STATISTICS

	MEAN	STD DEV	REGRESSION EQUATIONS	SE-EST
X-STATURE	68.71	2.60	(0.054)*Y + (60.039)	2.27
Y-WEIGHT	159.09	23.35	(4.388)*X + (-142.415)	20.37

CORRELATION COEFFICIENT	0.489	(BASED ON ORIGINAL DATA)	0.482	(BASED ON GROUPED DATA)

LINEARITY OF REGRESSION CHECK				
X AS A FUNCTION OF Y		0.500	8.841	18+6661
Y AS A FUNCTION OF X		0.487	2.282	18+6661

TABLE XXX -- BIVARIATE TABLE OF CHEST CIRCUMFERENCE AND STATURE

	STATURE																		TOTAL	
	59	60	61	62	63	64	65	66	67	68	69	70	71	72	73	74	75	76		77
C 48.50	0.0	0.0	0.0	0.0	0.0	0.0	0.0	0.0	0.0	0.0	0.0	0.0	0.0	0.0	0.0	0.0	0.0	0.0	0.0	0.0
H 47.50	0.0	0.0	0.0	0.0	0.0	0.0	0.0	0.0	0.0	0.0	0.0	0.0	0.0	0.0	0.0	0.0	0.0	0.0	0.0	0.0
E 46.50	0.0	0.0	0.0	0.0	0.0	0.0	0.0	0.0	0.0	0.0	0.0	0.0	0.0	0.0	0.0	0.0	0.0	0.0	0.0	0.0
S 45.50	0.0	0.0	0.0	0.0	0.0	0.0	0.0	0.0	0.0	0.0	0.0	0.0	0.0	0.0	0.0	0.0	0.0	0.0	0.0	0.0
T 44.50	0.0	0.0	0.0	0.0	0.0	0.0	0.0	0.0	0.0	0.0	0.0	0.0	0.0	0.0	0.0	0.0	0.0	0.0	0.0	0.0
C 43.50	0.0	0.0	0.0	0.0	0.0	0.0	0.0	0.0	0.0	0.0	0.0	0.0	0.0	0.0	0.0	0.0	0.0	0.0	0.0	0.0
C 42.50	0.0	0.0	0.0	0.0	0.0	0.0	0.0	0.0	0.0	0.0	0.0	0.0	0.0	0.0	0.0	0.0	0.0	0.0	0.0	0.0
J 41.50	0.0	0.0	0.0	0.0	0.0	0.0	0.0	0.0	0.0	0.0	0.0	0.0	0.0	0.0	0.0	0.0	0.0	0.0	0.0	0.0
R 40.50	0.0	0.0	0.0	0.0	0.0	0.0	0.0	0.0	0.0	0.0	0.0	0.0	0.0	0.0	0.0	0.0	0.0	0.0	0.0	0.0
C 39.50	0.0	0.0	0.0	0.0	0.0	0.0	0.0	0.0	0.0	0.0	0.0	0.0	0.0	0.0	0.0	0.0	0.0	0.0	0.0	0.0
U 38.50	0.0	0.0	0.0	0.0	0.0	0.0	0.0	0.0	0.0	0.0	0.0	0.0	0.0	0.0	0.0	0.0	0.0	0.0	0.0	0.0
M 37.50	0.0	0.0	0.0	0.0	0.0	0.0	0.0	0.0	0.0	0.0	0.0	0.0	0.0	0.0	0.0	0.0	0.0	0.0	0.0	0.0
F 36.50	0.0	0.0	0.0	0.0	0.0	0.0	0.0	0.0	0.0	0.0	0.0	0.0	0.0	0.0	0.0	0.0	0.0	0.0	0.0	0.0
E 35.50	0.0	0.0	0.0	0.0	0.0	0.0	0.0	0.0	0.0	0.0	0.0	0.0	0.0	0.0	0.0	0.0	0.0	0.0	0.0	0.0
R 34.50	0.0	0.0	0.0	0.0	0.0	0.0	0.0	0.0	0.0	0.0	0.0	0.0	0.0	0.0	0.0	0.0	0.0	0.0	0.0	0.0
E 33.50	0.0	0.0	0.0	0.0	0.0	0.0	0.0	0.0	0.0	0.0	0.0	0.0	0.0	0.0	0.0	0.0	0.0	0.0	0.0	0.0
N 32.50	0.0	0.0	0.0	0.0	0.0	0.0	0.0	0.0	0.0	0.0	0.0	0.0	0.0	0.0	0.0	0.0	0.0	0.0	0.0	0.0
C 31.50	0.0	0.0	0.0	0.0	0.0	0.0	0.0	0.0	0.0	0.0	0.0	0.0	0.0	0.0	0.0	0.0	0.0	0.0	0.0	0.0
E 30.50	0.0	0.0	0.0	0.0	0.0	0.0	0.0	0.0	0.0	0.0	0.0	0.0	0.0	0.0	0.0	0.0	0.0	0.0	0.0	0.0
29.50	0.0	0.0	0.0	0.0	0.0	0.0	0.0	0.0	0.0	0.0	0.0	0.0	0.0	0.0	0.0	0.0	0.0	0.0	0.0	0.0
28.50	0.0	0.0	0.0	0.0	0.0	0.0	0.0	0.0	0.0	0.0	0.0	0.0	0.0	0.0	0.0	0.0	0.0	0.0	0.0	0.0

VALUES IN THE TABLE ARE PERCENTAGES BASED ON A SAMPLE OF SIZE 6682.

SUMMARY STATISTICS

	MEAN	STD DEV	REGRESSION EQUATIONS	SE-EST
X-CHEST CIRCUMFERENCE	36.92	2.63	$(0.243)Y + (19.870)$	2.55
Y-STATURE	58.71	2.60	$(0.242)X + (59.760)$	2.52

CORRELATION COEFFICIENT 0.245 (BASED ON ORIGINAL DATA) 0.246 (BASED ON GROUPED DATA)

LINEARITY OF REGRESSION CHECK	ETA	F	D OF F	C.R.
X AS A FUNCTION OF Y	0.254	1.747	18+6661	1.95
Y AS A FUNCTION OF X	0.261	2.901	19+6660	4.04

TABLE XXXII - BIVARIATE TABLE OF SITTING HEIGHT AND FUNCTIONAL REACH

	FUNCTIONAL REACH																		
	25	26	27	28	29	30	31	32	33	34	35	36	37	38	39	TOTAL			
	.50	.50	.50	.50	.50	.50	.50	.50	.50	.50	.50	.50	.50	.50	.50	.50	.50	.50	.50
40.75						0.0	0.0	0.0	0.0	0.0	0.0	0.0	0.0	0.0	0.0	0.0	0.0	0.0	0.0
40.25						0.0	0.0	0.0	0.0	0.0	0.0	0.0	0.0	0.0	0.0	0.0	0.0	0.0	0.0
39.75						0.0	0.0	0.0	0.0	0.0	0.0	0.0	0.0	0.0	0.0	0.0	0.0	0.0	0.0
S 39.25					0.0	0.0	0.0	0.1	0.2	0.2	0.1	0.0	0.1	0.0	0.0	0.0	0.0	0.0	0.0
I 38.75					0.0	0.1	0.2	0.2	0.4	0.2	0.3	0.1	0.0	0.0	0.0	0.0	0.0	0.0	0.0
T 38.25				0.0	0.0	0.1	0.4	0.5	0.5	0.6	0.5	0.2	0.0	0.0	0.0	0.0	0.0	0.0	0.0
I 37.75				0.0	0.1	0.3	0.6	1.2	1.1	0.9	0.4	0.3	0.1	0.0	0.0	0.0	0.0	0.0	0.0
I 37.25	0.0			0.0	0.2	0.7	1.1	1.4	1.6	1.0	0.8	0.3	0.1	0.0	0.0	0.0	0.0	0.0	0.0
N 36.75				0.1	0.3	0.9	1.9	2.5	2.3	1.7	0.3	0.4	0.1	0.0	0.0	0.0	0.0	0.0	0.0
G 36.25				0.1	0.1	0.7	1.4	2.5	3.4	2.4	1.6	0.7	0.4	0.1	0.0	0.0	0.0	0.0	0.0
H 35.75				0.0	0.2	0.8	1.9	2.6	3.3	2.2	1.3	0.6	0.3	0.1	0.0	0.0	0.0	0.0	0.0
E 34.75				0.1	0.4	0.9	1.9	3.0	2.9	2.1	1.4	0.7	0.2	0.0	0.0	0.0	0.0	0.0	0.0
I 34.25	0.0			0.0	0.2	0.9	1.5	1.7	1.5	1.0	0.7	0.4	0.1	0.0	0.0	0.0	0.0	0.0	0.0
G 33.75				0.0	0.3	0.6	1.0	0.9	0.9	0.8	0.2	0.2	0.1	0.0	0.0	0.0	0.0	0.0	0.0
H 33.25				0.1	0.3	0.4	0.6	0.7	0.6	0.5	0.2	0.1	0.0	0.0	0.0	0.0	0.0	0.0	0.0
I 32.75				0.0	0.1	0.2	0.3	0.2	0.5	0.2	0.1	0.1	0.0	0.0	0.0	0.0	0.0	0.0	0.0
32.25				0.1	0.0	0.1	0.1	0.3	0.2	0.1	0.1	0.0	0.0	0.0	0.0	0.0	0.0	0.0	0.0
31.75				0.0	0.0	0.0	0.0	0.0	0.1	0.0	0.0	0.0	0.0	0.0	0.0	0.0	0.0	0.0	0.0
31.25				0.0	0.0	0.0	0.0	0.0	0.0	0.0	0.0	0.0	0.0	0.0	0.0	0.0	0.0	0.0	0.0
30.75				0.0	0.0	0.0	0.0	0.0	0.0	0.0	0.0	0.0	0.0	0.0	0.0	0.0	0.0	0.0	0.0
30.25				0.0	0.0	0.0	0.0	0.0	0.0	0.0	0.0	0.0	0.0	0.0	0.0	0.0	0.0	0.0	0.0
	0.0	0.0	0.5	2.1	6.3	12.6	18.2	21.7	17.2	11.0	6.2	2.8	0.9	0.3	0.1	100.0			

VALUES IN THE TABLE ARE PERCENTAGES BASED ON A SAMPLE OF SIZE 682.

SUMMARY STATISTICS

	MEAN	STD DEV	REGRESSION EQUATIONS	SE-EST
X-SITTING HEIGHT	35.70	1.44	(0.222)*Y + (28.471)	1.38
Y-FUNCTIONAL REACH	32.52	1.91	(0.399)*X + (18.627)	1.82

CORRELATION COEFFICIENT	0.294	(BASED ON ORIGINAL DATA)	0.239	(BASED ON GROUPED DATA)

LINEARITY OF REGRESSION CHECK EIA				
X AS A FUNCTION OF Y	0.294	F	D OF F	C.R.
Y AS A FUNCTION OF X	0.296	1.736	13+6666	1.57
		1.528	20+6659	1.54

TABLE XXXIII - BIVARIATE TABLE OF SITTING HEIGHT AND SHOULDER BREADTH

SHOULDER BREADTH

	14	14	15	15	16	16	17	17	18	18	19	19	20	20	21	21	22	22	23	
	.25	.75	.25	.75	.25	.75	.25	.75	.25	.75	.25	.75	.25	.75	.25	.75	.25	.75	.25	.75
40.75					0.0	0.0	0.0	0.0	0.0	0.0	0.0	0.0	0.0	0.0	0.0	0.0	0.0	0.0	0.0	0.0
40.25					0.0	0.0	0.0	0.0	0.0	0.0	0.0	0.0	0.0	0.0	0.0	0.0	0.0	0.0	0.0	0.0
39.75					0.0	0.0	0.0	0.0	0.0	0.0	0.0	0.0	0.0	0.0	0.0	0.0	0.0	0.0	0.0	0.0
S 39.25			0.0	0.0	0.1	0.1	0.1	0.2	0.1	0.1	0.1	0.1	0.0	0.0	0.0	0.0	0.0	0.0	0.0	0.0
I 38.75			0.0	0.0	0.1	0.3	0.3	0.3	0.4	0.2	0.1	0.0	0.0	0.0	0.0	0.0	0.0	0.0	0.0	0.0
T 38.25			0.0	0.0	0.2	0.6	0.7	0.7	0.7	0.2	0.2	0.2	0.1	0.0	0.0	0.0	0.0	0.0	0.0	0.0
Y 37.75			0.0	0.1	0.3	0.6	1.2	0.9	0.8	0.7	0.4	0.0	0.0	0.0	0.0	0.0	0.0	0.0	0.0	0.0
I 37.25			0.0	0.2	0.6	1.0	1.3	1.6	1.3	0.6	0.4	0.2	0.1	0.0	0.0	0.0	0.0	0.0	0.0	0.0
N 36.75			0.0	0.1	0.3	1.1	1.7	2.6	2.1	1.5	1.0	0.4	0.2	0.0	0.0	0.0	0.0	0.0	0.0	0.0
G 36.25			0.0	0.1	0.5	2.3	3.2	2.2	2.2	1.7	1.0	0.5	0.2	0.1	0.0	0.0	0.0	0.0	0.0	0.0
S 35.75			0.0	0.2	0.6	1.5	2.4	3.2	2.2	1.7	0.9	0.5	0.2	0.1	0.0	0.0	0.0	0.0	0.0	0.0
H 35.25			0.0	0.1	0.9	1.7	2.6	2.9	2.3	1.7	0.7	0.3	0.2	0.1	0.1	0.0	0.0	0.0	0.0	0.0
E 34.75			0.0	0.0	0.9	1.2	2.3	2.4	1.6	0.9	0.5	0.2	0.1	0.0	0.0	0.0	0.0	0.0	0.0	0.0
I 34.25			0.0	0.1	0.3	0.7	1.1	1.6	1.7	1.3	0.8	0.4	0.1	0.1	0.0	0.0	0.0	0.0	0.0	0.0
G 33.75	0.0	0.0	0.1	0.5	0.8	1.0	1.2	0.6	0.2	0.2	0.1	0.0	0.0	0.0	0.0	0.0	0.0	0.0	0.0	0.0
H 33.25			0.1	0.4	0.6	0.7	0.7	0.5	0.2	0.1	0.0	0.0	0.0	0.0	0.0	0.0	0.0	0.0	0.0	0.0
T 32.75			0.0	0.1	0.2	0.3	0.4	0.3	0.2	0.1	0.0	0.1	0.0	0.0	0.0	0.0	0.0	0.0	0.0	0.0
32.25			0.0	0.1	0.1	0.2	0.2	0.2	0.2	0.0	0.1	0.0	0.0	0.0	0.0	0.0	0.0	0.0	0.0	0.0
31.75			0.1	0.0	0.0	0.1	0.0	0.0	0.0	0.0	0.0	0.0	0.0	0.0	0.0	0.0	0.0	0.0	0.0	0.0
31.25			0.0	0.0	0.1	0.0	0.0	0.0	0.0	0.0	0.0	0.0	0.0	0.0	0.0	0.0	0.0	0.0	0.0	0.0
30.75			0.0	0.0	0.0	0.0	0.0	0.0	0.0	0.0	0.0	0.0	0.0	0.0	0.0	0.0	0.0	0.0	0.0	0.0
30.25			0.0	0.4	1.6	5.5	11.4	17.4	21.9	16.9	12.3	6.7	3.4	1.5	0.6	0.2	0.1	0.0	0.0	0.0

VALUES IN THE TABLE ARE PERCENTAGES BASED ON A SAMPLE OF SIZE 6682.

SUMMARY STATISTICS

	MEAN	STD DEV	REGRESSION EQUATIONS	SE-EST
X-SITTING HEIGHT	35.70	1.44	(0.392)*Y + (28.699)	1.39
Y-BIDELTIOID DIAMETER	17.86	1.00	(0.188)*X + (11.150)	0.96

CORRELATION COEFFICIENT	0.272	(BASED ON ORIGINAL DATA)	0.268	(BASED ON GROUPED DATA)

LINEARITY OF REGRESSION CHECK	EIA	F	D OF F	C.R.
X AS A FUNCTION OF Y	0.278	2.364	17+6662	3.01
Y AS A FUNCTION OF X	0.271	0.722	20+6659	-0.87

TABLE XXXV - BIVARIATE TABLE OF STATURE AND WEIGHT (1908 DATA)

U. S. Army Male Separates (White)

Weight

	100-109	110-119	120-129	130-139	140-149	150-159	160-169	170-179	180-189	190-199	200-209	210-219	220-229	230-239	240-249	250-259	260-269	270-279	Total
58.7-59.4				.004				.012	.004										.004
59.5-60.2	.004	.012	.004	.004	.004	.004		.008											.040
60.2-60.9		.016	.012	.004	.004	.004	.004	.004	.004	.004									.048
61.0-61.8	.016	.020	.061	.041	.012	.008	.004	.008	.008	.004	.004								.174
61.9-62.6	.020	.102	.167	.118	.049	.041	.045	.008	.008	.008	.004								.517
62.7-63.4	.033	.134	.253	.265	.163	.122	.124	.049	.020	.008	.004								1.043
63.5-64.2	.061	.261	.562	.611	.419	.289	.134	.049	.020	.008	.004	.004							2.414
64.3-65.0	.028	.277	.872	1.043	.888	.558	.187	.065	.033	.012	.012								3.975
65.0-65.7	.016	.208	.957	1.470	1.389	.819	.411	.204	.094	.028	.012								5.612
65.8-66.5	.037	.253	1.030	1.877	2.057	1.674	.798	.518	.183	.065	.028	.012							8.332
66.6-67.3	.016	.220	.990	2.179	2.639	1.996	1.340	.643	.261	.130	.065	.033	.012	.008	.004				10.552
67.4-68.1	.020	.138	.896	1.951	2.924	2.916	1.690	1.022	.444	.204	.094	.033	.008	.004	.004				12.352
68.1-68.8	.004	.053	.546	1.751	2.639	3.148	1.996	1.258	.700	.301	.090	.024	.004	.008	.004	.012			12.538
68.9-69.6	.008	.053	.517	1.507	2.346	2.659	2.330	1.181	.680	.310	.171	.094	.053	.041	.012				11.962
69.7-70.4		.057	.163	.908	1.886	2.248	2.101	1.258	.709	.395	.187	.077	.028	.004	.008	.004			10.013
70.5-71.2	.016	.008	.098	.493	1.120	1.829	1.531	1.246	.643	.391	.195	.110	.020	.028	.008	.004			7.744
71.3-72.0		.012	.053	.240	.688	1.124	1.177	.977	.696	.379	.110	.081	.033	.004	.012				5.586
72.1-72.8			.012	.106	.356	.570	.774	.684	.456	.220	.191	.086	.045	.020	.008	.004			3.506
72.9-73.6			.016	.057	.138	.310	.428	.301	.232	.102	.077	.033	.012	.016	.016	.004			1.722
73.7-74.4			.004	.041	.097	.122	.200	.151	.134	.081	.033	.024	.008	.008	.008	.004			.879
74.5-75.2			.004	.012	.020	.073	.081	.151	.086	.061	.033	.028	.012	.004					.569
75.3-76.0			.008	.016	.016	.016	.033	.024	.049	.049	.008								.215
76.1-76.8		.004	.004	.004	.004	.012	.016	.020	.012	.008	.008								.096
76.9-77.6				.004	.004	.004	.016	.008	.012	.012	.004	.008	.008	.004					.076
77.7-78.4				.008	.008	.004	.004	.004	.004	.004	.004								.024
78.4-79.1						.004					.004								.008
	.279	1.808	7.217	14.674	19.796	20.546	15.296	9.604	5.468	2.760	1.334	.647	.247	.157	.084	.036	.012	.016	99.981

Weight is in Pounds
 Stature is in Inches
 Stature: Mean = 65.434 S.D. = 2.484
 Weight: Mean = 154.757 S.D. = 20.492
 $r = .457$
 $x = 3.7707 - 103.239$
 $y = .055x + 59.860$

N = 24,554

TABLE XXXVI - BIVARIATE TABLE OF STATURE AND CHEST CIRCUMFERENCE (1946 DATA)

Stature	Chest Circumference																				Total																																																																																																																																																																																																																																																																																																																																																																																																																																																																																																																																																																																																																																																																																																																																					
	26.0-26.7	26.8-27.5	27.6-28.3	28.4-29.1	29.2-29.9	30.0-30.7	30.8-31.5	31.6-32.3	32.4-33.1	33.2-33.9	34.0-34.7	34.8-35.5	35.6-36.3	36.4-37.1	37.2-37.9	38.0-38.7	38.8-39.5	39.6-40.3	40.4-41.1	41.2-41.9		42.0-42.7	42.8-43.5	43.6-44.3	44.4-45.1	45.2-45.9	46.0-46.7	46.8-47.5	47.6-48.3	48.4-49.1	49.2-49.9	50.0-50.7	50.8-51.5	51.6-52.3	52.4-53.1	53.2-53.9	54.0-54.7	54.8-55.5	55.6-56.3	56.4-57.1	57.2-57.9	58.0-58.7	58.8-59.5	59.6-60.3	60.4-61.1	61.2-61.9	62.0-62.7	62.8-63.5	63.6-64.3	64.4-65.1	65.2-65.9	66.0-66.7	66.8-67.5	67.6-68.3	68.4-69.1	69.2-69.9	70.0-70.7	70.8-71.5	71.6-72.3	72.4-73.1	73.2-73.9	74.0-74.7	74.8-75.5	75.6-76.3	76.4-77.1	77.2-77.9	78.0-78.7	78.8-79.5	79.6-80.3	80.4-81.1	81.2-81.9	82.0-82.7	82.8-83.5	83.6-84.3	84.4-85.1	85.2-85.9	86.0-86.7	86.8-87.5	87.6-88.3	88.4-89.1	89.2-89.9	90.0-90.7	90.8-91.5	91.6-92.3	92.4-93.1	93.2-93.9	94.0-94.7	94.8-95.5	95.6-96.3	96.4-97.1	97.2-97.9	98.0-98.7	98.8-99.5	99.6-100.3	100.4-101.1	101.2-101.9	102.0-102.7	102.8-103.5	103.6-104.3	104.4-105.1	105.2-105.9	106.0-106.7	106.8-107.5	107.6-108.3	108.4-109.1	109.2-109.9	110.0-110.7	110.8-111.5	111.6-112.3	112.4-113.1	113.2-113.9	114.0-114.7	114.8-115.5	115.6-116.3	116.4-117.1	117.2-117.9	118.0-118.7	118.8-119.5	119.6-120.3	120.4-121.1	121.2-121.9	122.0-122.7	122.8-123.5	123.6-124.3	124.4-125.1	125.2-125.9	126.0-126.7	126.8-127.5	127.6-128.3	128.4-129.1	129.2-129.9	130.0-130.7	130.8-131.5	131.6-132.3	132.4-133.1	133.2-133.9	134.0-134.7	134.8-135.5	135.6-136.3	136.4-137.1	137.2-137.9	138.0-138.7	138.8-139.5	139.6-140.3	140.4-141.1	141.2-141.9	142.0-142.7	142.8-143.5	143.6-144.3	144.4-145.1	145.2-145.9	146.0-146.7	146.8-147.5	147.6-148.3	148.4-149.1	149.2-149.9	150.0-150.7	150.8-151.5	151.6-152.3	152.4-153.1	153.2-153.9	154.0-154.7	154.8-155.5	155.6-156.3	156.4-157.1	157.2-157.9	158.0-158.7	158.8-159.5	159.6-160.3	160.4-161.1	161.2-161.9	162.0-162.7	162.8-163.5	163.6-164.3	164.4-165.1	165.2-165.9	166.0-166.7	166.8-167.5	167.6-168.3	168.4-169.1	169.2-169.9	170.0-170.7	170.8-171.5	171.6-172.3	172.4-173.1	173.2-173.9	174.0-174.7	174.8-175.5	175.6-176.3	176.4-177.1	177.2-177.9	178.0-178.7	178.8-179.5	179.6-180.3	180.4-181.1	181.2-181.9	182.0-182.7	182.8-183.5	183.6-184.3	184.4-185.1	185.2-185.9	186.0-186.7	186.8-187.5	187.6-188.3	188.4-189.1	189.2-189.9	190.0-190.7	190.8-191.5	191.6-192.3	192.4-193.1	193.2-193.9	194.0-194.7	194.8-195.5	195.6-196.3	196.4-197.1	197.2-197.9	198.0-198.7	198.8-199.5	199.6-200.3	200.4-201.1	201.2-201.9	202.0-202.7	202.8-203.5	203.6-204.3	204.4-205.1	205.2-205.9	206.0-206.7	206.8-207.5	207.6-208.3	208.4-209.1	209.2-209.9	210.0-210.7	210.8-211.5	211.6-212.3	212.4-213.1	213.2-213.9	214.0-214.7	214.8-215.5	215.6-216.3	216.4-217.1	217.2-217.9	218.0-218.7	218.8-219.5	219.6-220.3	220.4-221.1	221.2-221.9	222.0-222.7	222.8-223.5	223.6-224.3	224.4-225.1	225.2-225.9	226.0-226.7	226.8-227.5	227.6-228.3	228.4-229.1	229.2-229.9	230.0-230.7	230.8-231.5	231.6-232.3	232.4-233.1	233.2-233.9	234.0-234.7	234.8-235.5	235.6-236.3	236.4-237.1	237.2-237.9	238.0-238.7	238.8-239.5	239.6-240.3	240.4-241.1	241.2-241.9	242.0-242.7	242.8-243.5	243.6-244.3	244.4-245.1	245.2-245.9	246.0-246.7	246.8-247.5	247.6-248.3	248.4-249.1	249.2-249.9	250.0-250.7	250.8-251.5	251.6-252.3	252.4-253.1	253.2-253.9	254.0-254.7	254.8-255.5	255.6-256.3	256.4-257.1	257.2-257.9	258.0-258.7	258.8-259.5	259.6-260.3	260.4-261.1	261.2-261.9	262.0-262.7	262.8-263.5	263.6-264.3	264.4-265.1	265.2-265.9	266.0-266.7	266.8-267.5	267.6-268.3	268.4-269.1	269.2-269.9	270.0-270.7	270.8-271.5	271.6-272.3	272.4-273.1	273.2-273.9	274.0-274.7	274.8-275.5	275.6-276.3	276.4-277.1	277.2-277.9	278.0-278.7	278.8-279.5	279.6-280.3	280.4-281.1	281.2-281.9	282.0-282.7	282.8-283.5	283.6-284.3	284.4-285.1	285.2-285.9	286.0-286.7	286.8-287.5	287.6-288.3	288.4-289.1	289.2-289.9	290.0-290.7	290.8-291.5	291.6-292.3	292.4-293.1	293.2-293.9	294.0-294.7	294.8-295.5	295.6-296.3	296.4-297.1	297.2-297.9	298.0-298.7	298.8-299.5	299.6-300.3	300.4-301.1	301.2-301.9	302.0-302.7	302.8-303.5	303.6-304.3	304.4-305.1	305.2-305.9	306.0-306.7	306.8-307.5	307.6-308.3	308.4-309.1	309.2-309.9	310.0-310.7	310.8-311.5	311.6-312.3	312.4-313.1	313.2-313.9	314.0-314.7	314.8-315.5	315.6-316.3	316.4-317.1	317.2-317.9	318.0-318.7	318.8-319.5	319.6-320.3	320.4-321.1	321.2-321.9	322.0-322.7	322.8-323.5	323.6-324.3	324.4-325.1	325.2-325.9	326.0-326.7	326.8-327.5	327.6-328.3	328.4-329.1	329.2-329.9	330.0-330.7	330.8-331.5	331.6-332.3	332.4-333.1	333.2-333.9	334.0-334.7	334.8-335.5	335.6-336.3	336.4-337.1	337.2-337.9	338.0-338.7	338.8-339.5	339.6-340.3	340.4-341.1	341.2-341.9	342.0-342.7	342.8-343.5	343.6-344.3	344.4-345.1	345.2-345.9	346.0-346.7	346.8-347.5	347.6-348.3	348.4-349.1	349.2-349.9	350.0-350.7	350.8-351.5	351.6-352.3	352.4-353.1	353.2-353.9	354.0-354.7	354.8-355.5	355.6-356.3	356.4-357.1	357.2-357.9	358.0-358.7	358.8-359.5	359.6-360.3	360.4-361.1	361.2-361.9	362.0-362.7	362.8-363.5	363.6-364.3	364.4-365.1	365.2-365.9	366.0-366.7	366.8-367.5	367.6-368.3	368.4-369.1	369.2-369.9	370.0-370.7	370.8-371.5	371.6-372.3	372.4-373.1	373.2-373.9	374.0-374.7	374.8-375.5	375.6-376.3	376.4-377.1	377.2-377.9	378.0-378.7	378.8-379.5	379.6-380.3	380.4-381.1	381.2-381.9	382.0-382.7	382.8-383.5	383.6-384.3	384.4-385.1	385.2-385.9	386.0-386.7	386.8-387.5	387.6-388.3	388.4-389.1	389.2-389.9	390.0-390.7	390.8-391.5	391.6-392.3	392.4-393.1	393.2-393.9	394.0-394.7	394.8-395.5	395.6-396.3	396.4-397.1	397.2-397.9	398.0-398.7	398.8-399.5	399.6-400.3	400.4-401.1	401.2-401.9	402.0-402.7	402.8-403.5	403.6-404.3	404.4-405.1	405.2-405.9	406.0-406.7	406.8-407.5	407.6-408.3	408.4-409.1	409.2-409.9	410.0-410.7	410.8-411.5	411.6-412.3	412.4-413.1	413.2-413.9	414.0-414.7	414.8-415.5	415.6-416.3	416.4-417.1	417.2-417.9	418.0-418.7	418.8-419.5	419.6-420.3	420.4-421.1	421.2-421.9	422.0-422.7	422.8-423.5	423.6-424.3	424.4-425.1	425.2-425.9	426.0-426.7	426.8-427.5	427.6-428.3	428.4-429.1	429.2-429.9	430.0-430.7	430.8-431.5	431.6-432.3	432.4-433.1	433.2-433.9	434.0-434.7	434.8-435.5	435.6-436.3	436.4-437.1	437.2-437.9	438.0-438.7	438.8-439.5	439.6-440.3	440.4-441.1	441.2-441.9	442.0-442.7	442.8-443.5	443.6-444.3	444.4-445.1	445.2-445.9	446.0-446.7	446.8-447.5	447.6-448.3	448.4-449.1	449.2-449.9	450.0-450.7	450.8-451.5	451.6-452.3	452.4-453.1	453.2-453.9	454.0-454.7	454.8-455.5	455.6-456.3	456.4-457.1	457.2-457.9	458.0-458.7	458.8-459.5	459.6-460.3	460.4-461.1	461.2-461.9	462.0-462.7	462.8-463.5	463.6-464.3	464.4-465.1	465.2-465.9	466.0-466.7	466.8-467.5	467.6-468.3	468.4-469.1	469.2-469.9	470.0-470.7	470.8-471.5	471.6-472.3	472.4-473.1	473.2-473.9	474.0-474.7	474.8-475.5	475.6-476.3	476.4-477.1	477.2-477.9	478.0-478.7	478.8-479.5	479.6-480.3	480.4-481.1	481.2-481.9	482.0-482.7	482.8-483.5	483.6-484.3	484.4-485.1	485.2-485.9	486.0-486.7	486.8-487.5	487.6-488.3	488.4-489.1	489.2-489.9	490.0-490.7	490.8-491.5	491.6-492.3	492.4-493.1	493.2-493.9	494.0-494.7	494.8-495.5	495.6-496.3	496.4-497.1	497.2-497.9	498.0-498.7	498.8-499.5	499.6-500.3	500.4-501.1	501.2-501.9	502.0-502.7	502.8-503.5	503.6-504.3	504.4-505.1	505.2-505.9	506.0-506.7	506.8-507.5	507.6-508.3	508.4-509.1	509.2-509.9	510.0-510.7	510.8-511.5	511.6-512.3	512.4-513.1	513.2-513.9	514.0-514.7	514.8-515.5	515.6-516.3	516.4-517.1	517.2-517.9	518.0-518.7	518.8-519.5	519.6-520.3	520.4-521.1	521.2-521.9	522.0-522.7	522.8-523.5	523.6-524.3	524.4-525.1	525.2-525.9	526.0-526.7	526.8-527.5	527.6-528.3	528.4-529.1	529.2-529.9	530.0-530.7	530.8-531.5	531.6-532.3	532.4-533.1	533.2-533.9	534.0-534.7	534.8-535.5	535.6-536.3	536.4-537.1	537.2-537.9	538.0-538.7	538.8-539.5	539.6-540.3	540.4-541.1	541.2-541.9	542.0-542.7	542.8-543.5	543.6-544.3	544.4-545.1	545.2-545.9	546.0-546.7	546.8-547.5	547.6-548.3	548.4-549.1	549.2-549.9	550.0-550.7	550.8-551.5	551.6-552.3	552.4-553.1	553.2-553.9	554.0-554.7	554.8-555.5	555.6-556.3	556.4-557.1	557.2-557.9	558.0-558.7	558.8-559.5	559.6-560.3	560.4-561.1	561.2-561.9	562.0-562.7	562.8-563.5	563.6-564.3	564.4-565.1	565.2-565.9	566.0-566.7	566.8-567.5	567.6-568.3	568.4-569.1	569.2-569.9	570.0-570.7	570.8-571.5	571.6-572.3	572.4-573.1	573.2-573.9	574.0-574.7	574.8-575.5	575.6-576.3	576.4-577.1	577.2-577.9	578.0-578.7	578.8-579.5	579.6-580.3	580.4-581.1	581.2-581.9	582.0-582.7	582.8-583.5	583.6-584.3	584.4-585.1	585.2-585.9	586.0-586.7	586.8-587.5	587.6-588.3	588.4-589.1	589.2-589.9	590.0-590.7	590.8-591.5	591.6-592.3	592.4-593.1	593.2-593.9	594.0-594.7	594.8-595.5	595.6-596.3	596.4-597.1	597.2-597.9	598.0-598.7	598.8-599.5	599.6-600.3	600.4-601.1	601.2-601.9	602.0-602.7	602.8-603.5	603.6-604.3	604.4-605.1	605.2-605.9	606.0-606.7	606.8-607.5	607.6-608.3	608.4-609.1

8. ANALYSES AND DISCUSSION OF THE ANTHROPOMETRIC DATA

a. U. S. Army Standards for Height and Weight

Physical standards of height, weight, and body build for military service are published in Army Regulations: Medical Services — Standards of Medical Fitness (AR 40 — 501). The standards in effect at the time of the Army anthropometric survey (1965-1966) may be summarized as follows. Height: men with heights above 66 inches and below 78 inches could be appointed in the Regular Army, and men with heights above 60 inches and below 78 inches were acceptable for enlistment or induction. Weight: minimum and maximum values were specified for appointment, enlistment, or induction. Acceptable minimum body weight, regardless of age, ranged from 100 pounds for a height of 60 inches, up to 153 pounds for a height of 78 inches. Acceptable maximum body weight was based not only on height but also on age, so that maximum acceptable weight ranged from 163 pounds for a height of 60 inches in the 16-20 year age bracket up to 254 pounds for a height of 78 inches for individuals 41 years of age or over. Maximum acceptable weight was 275 pounds for men 78 inches in height in the 21-24 year age group.

A revision of the above standards was published in 1968 in Change 22, AR 40 — 501 (19 June 1968). In this change, maximum acceptable height for appointment in the Army or for enlistment or induction in the Army and Air Force was raised from 78 inches to 80 inches. (Acceptable minimum and maximum heights for the Navy and Marine Corps, however, remained at 60 to 78 inches.) Minimum acceptable weight, regardless of age, was increased to 166 pounds for a height of 80 inches; maximum acceptable weight was increased to 267 pounds for a height of 80 inches for individuals 41 years of age or over; and maximum acceptable weight was set at 288 pounds for men 80 inches in height in the 21-24 year old age group. The table of militarily acceptable weight as related to age and height is shown as Table XXXVII. This table is adapted from: Table I. Table of Militarily Acceptable Weight (in pounds) as Related to Age and Height for Males — Initial Procurement, in Change 22, AR 40 — 501, Appendix III, dated 19 June 1968.

It may be noted here that physical standards for height and weight applicable for mobilization are the same as those discussed above. Thus, during general mobilization, acceptable height for the Army and Air Force is between 60 and 80 inches, and for the Navy and Marine Corps, between 60 and 78 inches. Minimum and maximum acceptable weights are as shown in Table XXXVII.

Analyses of the anthropometric data from the Army survey of 1966 on the basis of age groupings have not been completed as yet. However, the available data from the survey on weight and stature may be cited for comparison with the values shown in Table XXXVII. The first and 99th percentile values for weight in the total Army series were 116 and 227 pounds, respectively, while minimum and maximum values for weight were 100 pounds and 284 pounds, respectively. The maximum acceptable weight of 275 pounds (in 1966) was equivalent to the 99.9th percentile value for the Army series, so that only 0.1 percent of the men measured (about seven men out of 6682) exceeded this maximum in body weight.

The first and 99th percentile values for stature were 62.6 and 74.9 inches, respectively, for the total Army series, while the minimum and maximum values for stature were 59.7 and 78.6 inches, respectively. The change in the regulations which raised the acceptable height limit in the Army to 80 inches did not go into effect until after this anthropometric survey was completed; therefore, no Army men were measured in the survey who were 79 or 80 inches tall. It is estimated that only a very small percentage of the total population became eligible for Army induction as a result of this change in the maximum acceptable limit for stature.

In addition to the standards for height and weight, the Army regulation on standards of medical fitness also specifies various clinical conditions or symptoms which are causes for rejection for appointment, enlistment, or induction. Under the category of body build, causes for rejection are: a) congenital malformation of bones and joints; b) deficient muscular development which would interfere with the completion of required training; c) evidences of congenital asthenia; and d) obesity — even though the individual's weight is within the maximum shown in Table XXXVII, he will be reported as medically unacceptable when the medical examiner considers that the individual's weight in relation to the bony structure and musculature constitutes obesity of such a degree as to interfere with the satisfactory completion of prescribed training.

A slightly different set of physical standards apply to the selection of individuals for service in Army aviation. The new report on an anthropometric survey of Army aviators, conducted in 1970, should be consulted for information on the body size of Army aviators. However, the table of acceptable weight as related to age and height for Army aviation (as of 1969) is included here for comparison as Table XXXVIII. With a few minor exceptions, personnel being considered for selection for Army aviator training must not be below 64 inches or above 76 inches in height, and must not exceed the minimum and maximum limits of weight shown in Table XXXVIII. This table is adapted from: Table III. Table of Acceptable Weight (in pounds) as Related to Age and Height for Army Aviation, in Change 24, AR 40 — 501, Appendix III, dated 10 November 1969.

TABLE XXXVII – ARMY STANDARDS FOR HEIGHT AND WEIGHT
(as of 1968)

Height (inches)	Minimum (regardless of age)	Maximum Weight (pounds)					
		16-20 years	21-24 years	25-30 years	31-35 years	36-40 years	41 years and over
60	100	163	173	173	173	168	164
61	102	171	176	175	175	171	166
62	103	174	178	178	174	177	169
63	104	178	182	181	180	176	171
64	105	183	184	185	185	180	175
65	106	187	190	191	190	185	180
66	107	191	196	197	196	190	185
67	111	196	201	202	201	195	190
68	115	202	207	208	207	201	195
69	119	208	213	214	212	206	200
70	123	214	219	219	218	211	205
71	127	219	224	225	223	216	210
72	131	225	231	232	230	224	216
73	135	231	239	238	237	230	223
74	139	237	246	246	243	236	229
75	143	243	253	253	251	243	235
76	147	248	260	260	257	250	241
77	151	254	267	267	264	256	248
78	153	260	275	273	271	263	254
*79	159	266	281	279	277	269	260
*80	166	273	288	286	284	276	267

*Applies only to personnel enlisted, inducted or appointed in Army and enlisted or inducted into Air Force. Does not apply to Navy or Marine Corps enlistees or inductees.

TABLE XXXVIII – ARMY AVIATION STANDARDS FOR HEIGHT AND WEIGHT
(as of 1969)

Height (inches)	Minimum (regardless of age)	Maximum Weight (pounds)					
		16-20 years	21-24 years	25-30 years	31-35 years	36-40 years	41 years and over
60	100	137	143	146	148	151	152
61	102	142	148	151	153	155	156
62	103	147	153	156	158	160	161
63	104	151	157	160	162	164	165
64	105	156	162	165	167	169	170
65	106	160	166	169	171	173	174
66	107	165	171	173	175	177	178
67	111	169	175	178	180	182	183
68	115	173	179	182	184	186	187
69	119	177	183	185	187	189	190
70	123	180	186	189	191	193	194
71	127	184	190	193	195	197	198
72	131	187	193	196	198	200	201
73	135	190	196	199	201	203	204
74	139	193	199	202	204	206	207
75	143	196	202	205	207	209	210
76	147	198	204	207	209	211	212

b. Estimated and Measured Weight and Stature

Occasionally a comment is made to the effect that accurate measurements of height and weight really are not necessary and that since most men know their height and weight, these may be ascertained merely by asking the individual. During a physical or medical examination, a physician frequently will only ask the subject for his height and weight. The Army anthropometric survey afforded an opportunity to compare weight and height as estimated by Army men with the actual measurements of weight and height.

As a part of the background information obtained during the survey, each man was asked to give his weight (in pounds) and his height (in inches). Following these estimates by the individual, each man was weighed and his stature was measured.

The detailed data on estimated weight and stature for the total Army series are shown in Tables XXXIX and XL, respectively. The format for these tables is similar to that for the data on measured weight and stature given in Section 6. Statistical values for estimated and measured weight and stature for the total Army series and the four subseries are shown in Table XLI. The corresponding percentile values for estimated and measured weight are given in Table XLII, while percentile values for estimated and measured stature are shown in Table XLIII.

In all cases, the values for both estimated weight and stature are consistently higher than the values for measured weight and stature. In a comparison of the four Army subseries, the differences between means of estimated weight and measured weight and between means of estimated stature and measured stature are lowest in the basic trainee subseries. Possibly the younger basic trainees had a lesser tendency to overestimate their weight and height.

Mean estimated weight for the basic trainees was about three-quarters of a pound higher than measured weight. The difference between means of estimated and measured weight was 3.3 pounds for the infantrymen, 3.8 pounds for the armored personnel, and 2.4 pounds for the aviators. In the total Army series, mean estimated weight was 2.3 pounds above mean measured weight.

Mean estimated stature for the basic trainees was about one inch greater than mean measured stature. The difference in means between estimated and measured stature was 1.2 inches for the infantrymen, 1.3 inches for the armored personnel, and 1.1 inches for the aviators. In the total Army series, mean estimated stature was 1.1 inches higher than mean measured stature. The percentile values for estimated and measured weight and stature (Tables XLII and XLIII) indicate similar results.

The relationships between estimated and measured weight and stature also may be examined for the calculated coefficients of correlation. The coefficient of correlation ("r" value) between measured weight and measured stature for the total Army series was found to be .482, based upon grouped data (Table XXVII). The coefficient of correlation of .505 between estimated weight and estimated stature for the total Army series was slightly higher.

The coefficients of correlation between estimated weight and measured weight and between estimated stature and measured stature, nevertheless, indicated a relatively high degree of correlation. The coefficient of correlation between estimated weight and measured weight was .951 for the total Army series. In the subseries, the "r" value was .963 for basic trainees, .941 for infantrymen, .955 for armored personnel, and .948 for aviation personnel. Coefficients of correlation between estimated stature and measured stature were found to be slightly lower. The coefficient of correlation between estimated stature and measured stature was .935 for the total Army series. In the subseries, this "r" value was .932 for basic trainees, .939 for infantrymen, .932 for armored personnel, and .934 for aviation personnel.

It may be suggested that differences between estimated and measured weight and stature may be greater in small, short men and in heavy, tall men. This may be attributable to the supposition that both small, short men and heavy, tall men are somewhat more sensitive about their general body size. Perhaps small men may tend to overestimate or exaggerate their size, while large men may tend to underestimate or minimize their body size. The anthropometric data in their present form do not warrant firm conclusions on this subject; this should be investigated using the present data in the form of individually paired comparisons of estimated and measured weight and stature.

TABLE XXXIX - ESTIMATED WEIGHT FOR TOTAL ARMY SERIES

--INTERVALS--		--FREQUENCIES--				
POUNDS	KILOGRAMS	ACTUAL FREQ	CUMULA TIVE-F	PERCEN T-FREQ	CUMUL- PCT-FQ	
267.50-	271.49	121.45-123.25	3	6682	0.04	100.00
263.50-	267.49	119.63-121.44	2	6679	0.03	99.96
259.50-	263.49	117.81-119.62	2	6677	0.03	99.93
255.50-	259.49	116.00-117.80	0	6675	0.00	99.90
251.50-	255.49	114.18-115.99	2	6675	0.03	99.90
247.50-	251.49	112.37-114.17	3	6673	0.04	99.87
243.50-	247.49	110.55-112.36	11	6670	0.16	99.82
239.50-	243.49	108.73-110.54	8	6659	0.12	99.66
235.50-	239.49	106.92-108.72	6	6651	0.09	99.54
231.50-	235.49	105.10-106.91	13	6645	0.19	99.45
227.50-	231.49	103.29-105.09	18	6632	0.27	99.25
223.50-	227.49	101.47-103.28	15	6614	0.22	98.98
219.50-	223.49	99.65-101.46	37	6599	0.55	98.76
215.50-	219.49	97.84- 99.64	21	6562	0.31	98.20
211.50-	215.49	96.02- 97.83	43	6541	0.64	97.89
207.50-	211.49	94.21- 96.01	89	6498	1.33	97.25
203.50-	207.49	92.39- 94.20	76	6409	1.14	95.91
199.50-	203.49	90.57- 92.38	119	6333	1.78	94.78
195.50-	199.49	88.76- 90.56	49	6214	0.73	93.00
191.50-	195.49	86.94- 88.75	162	6165	2.42	92.26
187.50-	191.49	85.13- 86.93	167	6003	2.50	89.84
183.50-	187.49	83.31- 85.12	291	5836	4.35	87.34
179.50-	183.49	81.49- 83.30	323	5545	4.83	82.98
175.50-	179.49	79.68- 81.48	95	5222	1.42	78.15
171.50-	175.49	77.86- 79.67	359	5127	5.37	76.73
167.50-	171.49	76.05- 77.85	439	4768	6.57	71.36
163.50-	167.49	74.23- 76.04	465	4329	6.96	64.79
159.50-	163.49	72.41- 74.22	605	3864	9.05	57.83
155.50-	159.49	70.60- 72.40	176	3259	2.63	48.77
151.50-	155.49	68.78- 70.59	593	3083	8.87	46.14
147.50-	151.49	66.97- 68.77	592	2490	8.86	37.26
143.50-	147.49	65.15- 66.96	467	1898	6.99	28.40
139.50-	143.49	63.33- 65.14	420	1431	6.29	21.42
135.50-	139.49	61.52- 63.32	142	1011	2.13	15.13
131.50-	135.49	59.70- 61.51	307	869	4.59	13.01
127.50-	131.49	57.89- 59.69	237	562	3.55	8.41
123.50-	127.49	56.07- 57.88	154	325	2.30	4.86
119.50-	123.49	54.25- 56.06	84	171	1.26	2.56
115.50-	119.49	52.44- 54.24	29	87	0.43	1.30
111.50-	115.49	50.62- 52.43	31	58	0.46	0.87
107.50-	111.49	48.81- 50.61	17	27	0.25	0.40
103.50-	107.49	46.99- 48.80	5	10	0.07	0.15
99.50-	103.49	45.17- 46.98	5	5	0.07	0.07

TABLE XXXIX — ESTIMATED WEIGHT FOR TOTAL ARMY SERIES (Continued)

PERCENTILES

POUNDS		KILOGRAMS
227.36	99 TH	103.22
217.43	98 TH	98.71
211.38	97 TH	95.97
203.51	95 TH	92.39
192.15	90 TH	87.24
184.98	85 TH	83.98
179.60	80 TH	81.54
175.14	75 TH	79.51
171.31	70 TH	77.77
167.88	65 TH	76.22
164.73	60 TH	74.79
161.78	55 TH	73.45
158.95	50 TH	72.16
156.19	45 TH	70.91
153.49	40 TH	69.69
150.78	35 TH	68.45
148.00	30 TH	67.19
145.09	25 TH	65.87
141.93	20 TH	64.44
138.40	15 TH	62.83
134.10	10 TH	60.88
127.97	5 TH	58.10
124.12	3 RD	56.35
121.31	2 ND	55.07
116.90	1 ST	53.07

THE SUMMARY STATISTICS

••••

POUNDS		KILOGRAMS
161.38	MEAN	73.27
0.28	SE(M)	0.13
23.28	ST DEV	10.57
0.20	SE(SD)	0.09

••••

SYMMETRY--BETA I = 0.65
 KURTOSIS--BETA II = 3.75
 COEFFICIENT OF VARIATION = 14.43

••••

SAMPLE SIZE = 6682

TABLE XL - ESTIMATED STATURE FOR TOTAL ARMY SERIES

--INTERVALS--		--FREQUENCIES--				
INCHES	CENTIMETERS	ACTUAL FREQ	CUMULA TIVE-F	PERCEN T-FREQ	CUMUL- PCT-FG	
78.50-	79.49	199.39-201.92	1	6669	0.01	100.00
77.50-	78.49	196.85-199.38	12	6668	0.18	99.99
76.50-	77.49	194.31-196.84	24	6656	0.36	99.81
75.50-	76.49	191.77-194.30	64	6632	0.96	99.45
74.50-	75.49	189.23-191.76	151	6568	2.26	98.49
73.50-	74.49	186.69-189.22	330	6417	4.95	96.22
72.50-	73.49	184.15-186.68	473	6087	7.09	91.27
71.50-	72.49	181.61-184.14	724	5614	10.86	84.18
70.50-	71.49	179.07-181.60	964	4890	14.45	73.32
69.50-	70.49	176.53-179.06	892	3926	13.38	58.87
68.50-	69.49	173.99-176.52	887	3034	13.30	45.49
67.50-	68.49	171.45-173.98	839	2147	12.58	32.19
66.50-	67.49	168.91-171.44	594	1308	8.91	19.61
65.50-	66.49	166.37-168.90	370	714	5.55	10.71
64.50-	65.49	163.83-166.36	173	344	2.59	5.16
63.50-	64.49	161.29-163.82	90	171	1.35	2.56
62.50-	63.49	158.75-161.28	45	81	0.67	1.21
61.50-	62.49	156.21-158.74	27	36	0.40	0.54
60.50-	61.49	153.67-156.20	7	9	0.10	0.13
59.50-	60.49	151.13-153.66	2	2	0.03	0.03

TABLE XL - ESTIMATED STATURE FOR TOTAL ARMY SERIES (Continued)

PERCENTILES

INCHES		CENTIMETERS	
75.97	99 TH	192.97	
75.32	98 TH	191.33	
74.89	97 TH	190.22	
74.28	95 TH	188.68	
73.31	90 TH	186.21	
72.64	85 TH	184.51	
72.11	80 TH	183.16	
71.65	75 TH	181.99	
71.24	70 TH	180.95	
70.86	65 TH	179.98	
70.50	60 TH	179.07	
70.15	55 TH	178.19	
69.81	50 TH	177.32	
69.47	45 TH	176.46	
69.13	40 TH	175.59	
68.77	35 TH	174.69	
68.40	30 TH	173.74	
68.00	25 TH	172.71	
67.54	20 TH	171.56	
67.02	15 TH	170.23	
66.35	10 TH	168.52	
65.32	5 TH	165.91	
64.63	3 RD	164.16	
64.10	2 ND	162.82	
63.23	1 ST	160.60	

THE SUMMARY STATISTICS

••••

INCHES		CENTIMETERS	
69.81	MEAN	177.31	
0.03	SE(M)	0.08	
2.71	ST DEV	6.89	
0.02	SE(SD)	0.06	

••••

SYMMETRY--BETA I = -0.06
 KURTOSIS--BETA II = 2.98
 COEFFICIENT OF VARIATION = 3.88

••••

SAMPLE SIZE = 6669

TABLE XLI — STATISTICAL VALUES FOR WEIGHT AND STATURE

Values in Pounds and Inches

	N	Mean	SE(M)	S.D.	SE(SD)	V(%)	Min.	Range Max.	Total
Total Series:									
Age (years)	6682	22.17	0.06	4.64	0.04	20.92	17.0	55.0	38.0
Estimated Weight	6682	161.38	0.28	23.28	0.20	14.43	99.5	271.5	172.0
Measured Weight	6677	159.10	0.29	23.35	0.20	14.68	99.5	283.5	184.0
Estimated Stature	6669	69.81	0.03	2.71	0.02	3.88	59.5	79.5	20.0
Measured Stature	6682	68.71	0.03	3.60	0.60	3.79	59.7	78.6	18.9
Basic Trainees:									
Age (years)	2639	20.18	0.03	1.48	0.02	7.35	17.0	31.0	24.0
Estimated Weight	2639	156.71	0.45	23.29	0.32	14.86	97.5	252.5	155.0
Measured Weight	2638	155.97	0.45	23.09	0.32	14.81	99.5	255.5	156.0
Estimated Stature	2635	69.74	0.05	2.66	0.04	3.82	60.5	78.5	18.0
Measured Stature	2639	68.78	0.05	2.54	0.03	3.69	60.1	77.4	17.3
Infantry:									
Age (years)	3429	22.79	0.09	5.05	0.06	22.14	17.0	55.0	38.0
Estimated Weight	3429	163.60	0.38	22.35	0.27	13.66	102.5	271.5	169.0
Measured Weight	3425	160.34	0.39	22.81	0.28	14.22	99.5	271.5	172.0
Estimated Stature	3421	69.82	0.05	2.76	0.03	3.96	59.5	79.5	20.0
Measured Stature	3429	68.64	0.05	2.66	0.03	3.87	59.7	78.6	18.9

TABLE XLI - STATISTICAL VALUES FOR WEIGHT AND STATURE (Continued)

		Values in Pounds and Inches							Range	
		N	Mean	SE(M)	S.D.	SE(SD)	V(%)	Min.	Max.	Total
Armored:										
	Age (years)	489	27.02	0.28	6.14	0.20	22.71	17.0	51.0	34.0
	Estimated Weight	489	169.23	1.15	25.50	0.82	15.07	112.5	271.5	159.0
	Measured Weight	489	165.42	1.20	26.55	0.85	16.05	107.5	283.5	176.0
	Estimated Stature	488	69.97	0.12	2.71	0.09	3.87	61.5	77.5	16.0
	Measured Stature	489	68.68	0.12	2.60	0.08	3.79	61.7	75.9	14.2
Aviators:										
	Age (years)	125	28.11	0.54	6.04	0.38	21.47	18.0	48.0	30.0
	Estimated Weight	125	168.54	1.76	19.68	1.24	11.68	112.5	222.5	110.0
	Measured Weight	125	166.18	1.84	20.54	1.30	12.36	111.5	215.5	104.0
	Estimated Stature	125	70.17	0.20	2.21	0.14	3.15	63.5	74.5	11.0
	Measured Stature	125	69.05	0.21	2.29	0.15	3.32	61.3	74.3	13.0

TABLE XLII - PERCENTILE VALUES FOR WEIGHT

Weight	Percentiles in Inches										Range (1st-99th)	
	1st	2nd	5th	10th	25th	50th	75th	90th	95th	98th		99th
Total Series:												
Estimated Weight	117	121	128	134	145	159	175	192	204	217	227	110
Measured Weight	116	120	126	132	143	156	173	190	202	216	227	111
Basic Trainees:												
Estimated Weight	112	117	124	130	140	154	171	188	200	213	222	110
Measured Weight	112	117	124	130	140	154	171	188	199	212	220	108
Infantry:												
Estimated Weight	122	126	132	137	148	161	176	193	204	219	229	107
Measured Weight	120	123	129	134	144	158	173	190	202	218	230	110
Armored:												
Estimated Weight	122	126	133	139	151	166	185	204	216	230	240	118
Measured Weight	119	123	128	134	146	162	181	202	215	232	244	125
Aviators:												
Estimated Weight			136	145	156	168	182	195	202			
Measured Weight			129	140	154	166	179	193	203			

TABLE XLIII — PERCENTILE VALUES FOR STATURE

Stature	Percentiles in Inches										Range (1st-99th)	
	1st	2nd	5th	10th	25th	50th	75th	90th	95th	98th		99th
Total Series:												
Estimated Stature	63.2	64.1	65.3	66.4	68.0	69.8	71.6	73.3	74.3	75.3	76.0	12.8
Measured Stature	62.6	63.4	64.5	65.4	67.0	68.7	70.4	72.1	73.1	74.2	74.9	12.3
Basic Trainees:												
Estimated Stature	63.4	64.2	65.4	66.4	67.9	69.7	71.6	73.2	74.2	75.2	75.8	12.4
Measured Stature	62.9	63.6	64.6	65.6	67.1	68.7	70.5	73.0	73.0	74.2	74.9	12.0
Infantry:												
Estimated Stature	63.0	64.0	65.3	66.3	68.0	69.8	71.7	73.4	74.4	75.5	76.2	13.2
Measured Stature	62.3	63.1	64.4	65.4	66.9	68.6	70.4	72.1	73.1	74.2	75.0	12.7
Armored:												
Estimated Stature	63.4	64.1	65.3	66.3	68.1	70.1	72.0	73.5	74.3	75.0	75.5	12.1
Measured Stature	62.8	63.4	64.3	65.2	66.8	68.7	70.5	72.1	73.0	73.9	74.5	11.7
Aviators:												
Estimated Stature			66.4	67.2	68.7	70.2	71.7	73.1	73.9			
Measured Stature			65.5	66.3	67.5	69.0	70.7	72.1	72.7			

c. Comparisons of Army Subseries

A total Army series of 6682 men was measured during the anthropometric survey of 1966. For purposes of general analysis, the total Army series was separated into four subseries. The first subseries consisted of 2639 Army basic trainees; these were young men, measured at the beginning of their Army training. A second subseries of 3429 men was composed primarily of Army infantrymen. The third subseries consisted of 489 armored personnel, who represented tank crews or operators of other armored vehicles. Finally, the fourth subseries comprised a small sample of 125 Army aviators, including pilots and aircrewmembers. This very small sample is not considered to be representative of Army aviation personnel; data from the subsequent survey of Army aviators, in which a larger series of men was measured, should be consulted for information on this segment of the Army population.

Consideration of general differences in body size among these four groups from the Army population may be utilized in the development or sizing of specialized or protective clothing, or in the definition of specialized human engineering requirements.

Initially, the four Army subseries differed in their age distribution. The basic trainees were the youngest group, with a mean age of about 20 years, while the infantrymen were somewhat older, with a mean age of nearly 23 years. The Army armored personnel and aviators were still older, with mean ages of 27 and 28 years, respectively. The mean age of the total Army series was 22.2 years.

All of the basic anthropometric data on these four Army subseries are available in the summary tables of data presented in a previous section of this report. For purposes of a general comparison of body size, however, the discussion here will be limited to seven selected body measurements: weight; stature; sitting height; shoulder breadth; hip breadth, sitting; chest circumference; and waist circumference. Statistical values (means and standard deviations) of these seven measurements for the four subseries, as well as for the total Army series, are shown in Table XLIV. Selected percentile values for the four subseries and for the total Army series are presented in Table XLV. Due to the small sample size, only the 5th to 95th percentile values are shown for the Army aviator subseries.

As might be expected, body weight of the four Army groups showed a pattern similar to that of age. The young basic trainees had a mean weight of 156 pounds, while the mean weight of infantrymen was about 160 pounds. The older armored personnel and aviators also were somewhat heavier, with mean weights of about 165 and 166 pounds, respectively. The mean weight of the total Army series was 159.1 pounds.

There was relatively little variation in stature among the four Army subseries. Mean stature of the infantrymen was 68.6 inches, and that of armored personnel was 68.7 inches. The basic trainees had a mean stature of 68.8 inches, while that of the Army aviators was 69.0 inches. The mean stature of the total Army series was 68.7 inches.

The variations in sitting height among the subseries generally were similar to stature. Mean sitting height of armored personnel was 35.5 inches, while that of infantrymen was 35.6 inches. The basic trainees had a mean sitting height of 35.9 inches, and that of the aviators was 36.0 inches. The mean sitting height of the total Army series was 35.7 inches. It may be noted that although the basic trainees were the youngest in age and the lightest in weight of the four Army groups, their mean values for stature and sitting height were not significantly lower than the others.

Since body breadths and especially body circumferences are more highly correlated with weight, the mean values for shoulder breadth, hip breadth, chest circumference, and waist circumference reflect the mean body weights of the four Army subseries. Thus, the basic trainees showed the lowest mean values for the breadth and girth measurements, the infantrymen and armored personnel were intermediate, and the Army aviators had the highest mean values. For example, the mean chest circumference of basic trainees was 36.5 inches, while that of infantrymen was 37.0 inches. Armored personnel had a mean chest circumference of 37.9 inches, and the mean chest circumference of the aviators was 38.5 inches. The mean chest circumference for the total Army series was 36.9 inches. Mean values for the other body measurements may be found in Table XLIV.

The general distribution of percentile values for stature and sitting height showed relatively little variation among the four Army subseries. These two dimensions usually have a normal distribution pattern within the population, with very little deviation between the mean and the median or 50th percentile value.

The percentile values for weight show more variability among the four Army subseries, as do the percentile values for the breadth and circumference measurements, which are highly correlated with weight. In addition, the distribution of weight in the military population is markedly skewed; the 50th percentile values for weight are lower than the corresponding mean values in the respective Army subseries. Similarly, the percentile values for chest and waist circumference also indicate skewed distributions, with mean values somewhat lower than the 50th percentile values.

In this comparison of anthropometric data on four subseries within the total series of Army men, weight appears to be the primary factor contributing to differences in body size. Furthermore, differences in weight are attributable primarily to differences in age among the subseries.

TABLE XLIV — STATISTICAL VALUES FOR SELECTED MEASUREMENTS

No. Measurements	N	Mean	SE(M)	S.D.	Values in Inches			Range Max.	Total
					SE(SD)	V(%)	Min.		
Age (years)									
Total Series	6682	22.17	0.06	4.64	0.04	20.92	17.0	55.0	38.0
Basic Trainees	2639	20.18	0.03	1.48	0.02	7.35	17.0	31.0	24.0
Infantry	3429	22.79	0.09	5.05	0.06	22.14	17.0	55.0	38.0
Armored	489	27.02	0.28	6.14	0.20	22.71	17.0	51.0	34.0
Aviators	489	28.11	0.54	6.04	0.38	21.47	18.0	48.0	30.0
1 Weight (pounds)									
Total Series	6677	159.10	0.29	23.35	0.20	14.68	99.5	283.5	184.0
Basic Trainees	2638	155.97	0.45	23.09	0.32	14.81	99.5	255.5	156.0
Infantry	3425	160.34	0.39	22.81	0.28	14.22	99.5	271.5	172.0
Armored	489	165.42	1.20	26.55	0.85	16.05	107.5	283.5	176.0
Aviators	125	166.18	1.84	30.54	1.30	12.36	111.5	215.5	104.0
2 Stature									
Total Series	6682	68.71	0.03	2.60	0.02	3.79	59.7	78.6	18.9
Basic Trainees	2639	68.78	0.05	2.54	0.03	3.69	60.1	77.4	17.3
Infantry	3429	68.64	0.05	2.66	0.03	3.87	59.7	78.6	18.9
Armored	489	68.68	0.12	2.60	0.08	3.79	61.7	75.9	14.2
Aviators	125	69.05	0.21	2.29	0.15	3.32	61.3	74.3	13.0
3 Sitting Height									
Total Series	6682	35.70	0.02	1.44	0.01	4.04	30.4	40.6	10.2
Basic Trainees	2639	35.91	0.03	1.35	0.02	3.77	31.2	40.6	9.4
Infantry	3429	35.56	0.03	1.48	0.02	4.15	30.4	40.6	10.2
Armored	489	35.51	0.07	1.55	0.05	4.36	31.2	40.2	9.0
Aviators	125	36.02	0.12	1.34	0.08	3.73	31.6	39.1	7.5

TABLE XLIV - STATISTICAL VALUES FOR SELECTED MEASUREMENTS (Continued)

No. Measurements	N	Mean	SE(M)	S.D.	Values in Inches				Range Max.	Total
					SE(SD)	V(%)	Min.			
4 Shoulder Breadth										
Total Series	6682	17.86	0.01	1.00	0.01	5.59	14.3	23.1	8.8	
Basic Trainees	2639	17.75	0.02	0.97	0.01	5.48	14.3	21.4	7.1	
Infantry	3429	17.89	0.02	1.00	0.01	5.58	14.7	23.1	8.4	
Armored	489	18.16	0.05	1.08	0.03	5.96	15.3	21.9	6.6	
Aviators	125	18.35	0.07	0.82	0.05	4.49	16.4	20.4	4.0	
5 Hip Breadth, Sitting										
Total Series	6682	13.45	0.01	0.94	0.01	6.97	10.3	19.8	9.5	
Basic Trainees	2639	13.36	0.02	0.93	0.01	6.95	10.9	18.8	7.9	
Infantry	3429	13.48	0.02	0.92	0.01	6.84	10.3	18.6	8.3	
Armored	489	13.63	0.05	1.04	0.03	7.60	10.7	19.8	9.1	
Aviators	125	13.82	0.07	0.84	0.05	6.07	11.9	16.2	4.3	
6 Chest Circumference										
Total Series	6682	36.92	0.03	2.63	0.02	7.13	28.2	48.9	20.7	
Basic Trainees	2639	36.53	0.05	2.54	0.04	6.97	28.2	48.3	20.1	
Infantry	3429	37.01	0.04	2.60	0.03	7.03	30.0	48.9	18.9	
Armored	489	37.93	0.13	2.92	0.09	7.70	31.2	48.9	17.7	
Aviators	125	38.52	0.21	2.32	0.15	6.02	32.4	45.4	13.0	
7 Waist Circumference										
Total Series	6682	31.61	0.04	3.22	0.03	10.19	23.1	50.3	27.2	
Basic Trainees	2639	31.33	0.06	3.18	0.04	10.15	23.1	46.2	23.1	
Infantry	3429	31.62	0.05	3.12	0.04	9.88	23.8	48.0	24.2	
Armored	489	32.73	0.17	3.80	0.12	11.60	25.5	50.3	24.8	
Aviators	125	33.30	0.26	2.96	0.19	8.88	26.1	40.8	14.7	

TABLE XLV - PERCENTILE VALUES FOR SELECTED MEASUREMENTS

No.	Measurements	Percentiles in Inches										Range (1st-99th)	
		1st	2nd	5th	10th	25th	50th	75th	90th	95th	98th		99th
1 Weight (pounds)													
	Total Series	116	120	126	132	143	156	173	190	202	216	227	111
	Basic Trainees	112	117	124	129	139	153	170	188	199	212	220	108
	Infantry	120	123	129	134	144	158	173	190	202	218	230	110
	Armored	119	123	128	134	146	162	181	202	215	232	244	125
	Aviators		129	129	140	154	166	179	193	203			
2 Stature													
	Total Series	62.6	63.4	64.5	65.4	67.0	68.7	70.4	72.1	73.1	74.2	74.9	12.3
	Basic Trainees	62.9	63.6	64.6	65.6	67.1	68.7	70.5	72.1	73.0	74.2	74.9	12.0
	Infantry	62.3	63.1	64.4	65.4	66.9	68.6	70.4	72.1	73.1	74.2	75.0	12.7
	Armored	62.8	63.4	64.3	65.2	66.8	68.7	70.5	72.1	73.0	73.9	74.5	11.7
	Aviators		65.5	66.3	66.3	67.5	69.0	70.7	72.1	72.7			
3 Sitting Height													
	Total Series	32.3	32.7	33.3	33.8	34.7	35.7	36.7	37.6	38.1	38.6	39.0	6.7
	Basic Trainees	32.6	33.0	33.6	34.2	35.0	35.9	36.8	37.6	38.2	38.7	39.1	6.5
	Infantry	32.1	32.5	33.1	33.6	34.6	35.6	36.6	37.5	38.0	38.6	39.0	6.9
	Armored	32.0	32.4	33.0	33.5	34.5	35.5	36.6	37.5	38.1	38.7	39.2	7.2
	Aviators		33.6	34.3	34.3	35.1	36.0	36.9	37.8	38.3			

TABLE XLV - PERCENTILE VALUES FOR SELECTED MEASUREMENTS (continued)

No.	Measurements	Percentiles in Inches										Range (1st-99th)	
		1st	2nd	5th	10th	25th	50th	75th	90th	95th	98th		99th
4 Shoulder Breadth													
	Total Series	15.7	16.0	16.3	16.6	17.2	17.8	18.5	19.2	19.6	20.1	20.5	4.8
	Basic Trainees	15.6	15.8	16.2	16.5	17.1	17.7	18.4	19.0	19.4	19.9	20.2	4.6
	Infantry	15.9	16.0	16.4	16.7	17.2	17.8	18.5	19.2	19.6	20.2	20.6	4.7
	Armored	15.8	16.2	16.6	16.9	17.4	18.0	18.8	19.6	20.1	20.7	21.0	5.2
	Aviators		17.1	17.1	17.2	17.8	18.4	18.9	19.4	19.7			
5 Hip Breadth, Sitting													
	Total Series	11.6	11.8	12.1	12.3	12.8	13.4	14.0	14.7	15.1	15.6	16.0	4.4
	Basic Trainees	11.5	11.7	12.0	12.2	12.7	13.3	13.9	14.6	15.0	15.5	15.8	4.3
	Infantry	11.7	11.9	12.1	12.4	12.8	13.4	14.0	14.7	15.1	15.7	16.2	4.5
	Armored	11.8	12.0	12.2	12.4	12.9	13.5	14.3	15.0	15.5	15.9	16.2	4.4
	Aviators		12.4	12.4	12.7	13.2	13.9	14.4	14.8	15.2			
6 Chest Circumference													
	Total Series	31.8	32.4	33.1	33.8	35.1	36.6	38.5	40.4	41.7	43.3	44.4	12.6
	Basic Trainees	31.5	32.0	32.8	33.5	34.7	36.3	38.1	39.9	41.1	42.6	43.6	12.1
	Infantry	32.1	32.6	33.3	34.0	35.3	36.7	38.5	40.4	41.8	43.5	44.8	12.7
	Armored	32.5	32.9	33.6	34.4	35.9	37.7	39.6	41.7	43.2	45.4	47.1	14.6
	Aviators		34.0	34.0	35.6	37.3	38.5	39.8	41.4	42.5			
7 Waist Circumference													
	Total Series	26.1	26.7	27.4	28.1	29.3	31.0	33.4	36.0	37.8	40.0	41.6	15.5
	Basic Trainees	25.8	26.5	27.3	27.9	29.0	30.7	33.1	35.8	37.6	39.6	40.8	15.0
	Infantry	26.3	26.8	27.5	28.2	29.4	31.1	33.2	35.7	37.5	40.0	41.9	15.6
	Armored	26.6	27.0	27.8	28.5	30.0	32.1	34.9	38.0	40.0	42.5	44.3	17.7
	Aviators		28.2	28.2	29.3	31.3	33.5	35.3	36.9	38.1			

d. Comparisons with Other Services

The recent anthropometric surveys of the U. S. Armed Forces represent the first time that standard anthropometric data have been obtained on representative samples of men from all services in the same time frame. While separate reports will be published on the Marine Corps, Navy, and Air Force data, it is of interest here to examine the relationship of the Army data to that of the other series. Thus, Army men in 1966 may be compared in body size with men of the other services, not only on the basis of the recent data, but also with reference to data from previous anthropometric series.

This comparison is based on data from a total of 22 series, covering a period of 24 years (1946 to 1970). Seven body measurements have been selected to represent general body size for purposes of this comparison: weight; stature; sitting height; shoulder breadth; hip breadth; sitting; chest circumference; and waist circumference. Data on these seven measurements for the 22 anthropometric series are presented in the form of tables showing both statistical and percentile values. However, data on all seven selected measurements were not available for all of the 22 series.

(1) **Series.** Comparative anthropometric data are available on 22 series of men measured between 1946 and 1970, representing a combined population sampling of over 60,000 men. Ten of the series represent data obtained prior to 1966; the previously published reports should be consulted for details regarding these series. Nine of the series represent data collected during the U. S. Armed Forces surveys. The Army DRAGON study was conducted in 1967, and the final two series include data from the two recent surveys of Army aviators. The Army data of 1966 are contained in the present report, while preparation of the recent Marine Corps, Navy and Air Force data for publication is in progress.

The earliest series cited here is the large sample of U. S. Army separatees measured in 1946 at the end of World War II. Army aviators, as a specialized group, first were measured in 1959. Two earlier U. S. Air Force series are included: The widely-referenced series of USAF flying personnel of 1950, together with the USAF basic trainee series of 1952. Two series of U. S. Navy flyers are shown: a sample of Navy pilots measured in 1957-1958 (published in 1960), and the larger and more reliable series of Navy (and Marine Corps) aviators of 1964.

For comparison with the military data, the total series of civilian men, measured during the HEW National Health Survey of 1960-1962 is included, as well as two subseries from this total group, representing 18 to 24-year-old men and 25 to 34-year-old men, respectively. Another series of civilian men is that of the air traffic control trainees, measured by the Federal Aviation Agency in 1961.

The results of the U. S. Armed Forces anthropometric surveys include data for the total Army series of 1966, together with four subseries drawn from the total Army series: basic trainees, infantry armored crewmen, and Army aviators. The U. S. Marine Corps data of 1966 are listed, as well as the data on U. S. Navy recruits, also measured in 1966. The U. S. Air Force data on flying personnel, obtained in 1967, and the data on USAF basic trainees, measured in 1965, represent the most recent Air Force data, as yet unpublished. The U. S. Army DRAGON study represents anthropometric data collected on a sample of Army men by the McDonnell Company in 1967 during the development of the DRAGON XM-47 surface attack guided missile system. Two recent series of U. S. Army aviators are included; warrant officer candidate flight trainees, measured in 1968, and Army aviators, measured in 1970. A summary of these anthropometric series is given in Table XLVI, including the date, the number of men measured (N), the mean age of the series, the number of measurements taken, and references to published reports.

(2) **Anthropometric Measurements.** The seven body measurements discussed here have been selected to provide the basis for a general comparison of body size among the various anthropometric series. Weight and stature are two basic measurements of the body. Sitting height, shoulder breadth, and hip breadth, sitting are three measurements of the seated individual which are basic dimensions useful in human engineering. Finally, chest circumference and waist circumference are basic measurements of body girth, widely used in clothing sizing.

The values for weight given in the tables represent nude body weight. In the case of the series of civilian men, however, the weights shown are the recorded weights less two pounds for clothing, as suggested in the published report.

The values given for stature represent heights without shoes, taken with the subjects standing erect. The statures of the FAA air traffic control trainees were taken as wall-board measurements; the authors of the report point out that these values for stature tend to exceed those taken with an anthropometer by about 0.4 inch.

The values shown for sitting height represent a measurement between the seat surface and the top of the head, taken with the subject sitting erect. Normal or relaxed sitting height (as opposed to erect sitting height) also was measured during the survey of civilian men. The data show that relaxed sitting height is about 1.5 inches less than erect sitting height. Other references indicate differences of 0.8 inch (Jantz, Ellis, and Collins) or 1.75 inches (Morgan et al.) between erect and relaxed sitting heights.

TABLE XLVI - ANTHROPOMETRIC SERIES

No.	Series	Date	N	Mean Age	Measurements	Reference
1	US Army Separates	1946	24,500	24.3	66	Newman and White, 1951
2	US Army Aviators	1959	500	30.25	44	White, 1961
3	USAF Flying Personnel	1950	4063	27.9	132	Hertzberg et al, 1954
4	USAF Basic Trainees	1952	3332	18.9	60	Daniels et al, 1953
5	US Navy Pilots	1960	1190	-	25	Gifford, 1960
6	US Naval Aviators	1964	1549	29.6	96	Gifford et al, 1965
7	US Civilian Men (Total Series)	1960-62	3091	(44)	18	Stoudt et al, 1965;1970
8	US Civilian Men	1960-62	411	(21)	18	Stoudt et al, 1965;1970
9	US Civilian Men	1960-62	675	(30)	18	Stoudt et al, 1965;1970
10	FAA ATC Trainees	1961	684	27.9	64	Snow and Snyder, 1965
11	US Army (Total Series)	1966	6682	22.2	70	Present report
12	US Army Basic Trainees	1966	2639	20.2	70	Present report
13	US Army Infantry	1966	3429	22.8	70	Present report
14	US Army Armored	1966	489	27.0	70	Present report
15	US Army Aviators	1966	125	28.1	70	Present report
16	US Marine Corps	1966	2008	20.9	70	White and Churchill (in preparation)
17	US Navy Recruits	1966	4095	19.9	70	White and Churchill (in preparation)
18	USAF Flying Personnel	1967	2420	30.0	187	Clauser et al (in preparation)
19	USAF Basic Trainees	1965	2632	19.3	158	Clauser et al (in preparation)
20	US Army DRAGON Study	1967	254	23.3	15	Jantz et al, 1967
21	US Army Aviators	1968	1640	22.0	9	Schane et al, 1969
22	US Army Aviators	1970	1482	26.2	85	Churchill et al, 1971

The values given for shoulder breadth (bilateral breadth) represent a horizontal measurement across the shoulders at the level of the deltoid muscles in the upper arms. This measurement is usually taken with the subject in a seated position. The values shown for hip breadth, sitting represent the maximum width across the hips of the seated subject. Hip breadth, sitting is generally one-half to one inch greater than hip breadth, standing.

The values given for chest circumference represent the horizontal girth of the chest at the level of the nipples, taken during normal breathing. The values shown for waist circumference represent the horizontal girth of the waist at the level of the navel, taken with the abdomen relaxed.

It should be noted that all of the data discussed here are based upon measurements of subjects either without clothing or with only minimal clothing.

(3) Tables of Anthropometric Data. For comparative purposes, the anthropometric data are presented here in two sets of tables. In the first group of tables (Tables XLVII to LII), statistical values for the seven measurements are given, consisting of the mean age of the series (in years), the number of men (N) in the series, the mean and the standard error of the mean (SE(M)), the standard deviation (S.D.) and the standard error of the standard deviation (SE(SD)), the coefficient of variation (V(%)), and the range of the measurement, indicated by the minimum value (Min.), the maximum value (Max.), and the total range. In these tables, the series are ranked in decreasing order of the mean value for each measurement. Only the mean values for measurements of the civilian series were published; the standard deviations have been estimated, and the standard errors and coefficients of variation have been calculated. The minimum and maximum values for the civilian series also were not published and are not available.

Selected percentile values for the seven measurements, from the 1st up to the 99th percentile, are shown in the second group of tables (Tables LIV to LX), together with the range from the 1st to 99th percentile values. The mean age (in years) and the number of men also are given for each series. In these tables, the series have been arbitrarily ranked in decreasing order of the 50th percentile (median) value for each measurement. The 2nd, 25th, 75th, and 98th percentile values for measurements of the civilian men have been interpolated from the published data. In the FAA ATC series, the 1st, 2nd, 25th, 75th, 98th and 99th percentile values have been interpolated from the published data. The 2nd and 98th percentile values for the Army aviators of 1959 have been added to the percentiles previously published.

(4) Discussion. Anthropometric data presented in this way permit several types of comparisons to be made. The range or extent of variation for any one measurement may be assessed among the various military series, over a period of time, or among series with various mean ages. The data on civilian men may be compared with the military data. The most recent Army data of 1966 may be compared with earlier Army data or with data on men of the other military services.

There is a considerable variation in the distribution of age among the various series discussed here. Since general body size is affected by age, differences in body size should be considered with reference to age. Mean ages among the 22 series vary from about 19 to 30 years. No mean age was reported for the total series of civilian men, which had an age range of 18 to 79 years; it is estimated that mean age of this series was about 44 years. The 25 to 34-year-old group of civilian men presumably had a mean age of about 30 years. The two series of Army aviators (1959 and 1966), the two USAF flying personnel series (1950 and 1967), and the two series of Navy flyers (1960 and 1964), as well as the series of air traffic control trainees, all had mean ages of between 28 and 30 years. The military aviators are, therefore, a generally older group, composed almost entirely of officers. However, the Army warrant officer candidate flight trainees had a mean age of 22 years, and the most recent series of Army aviators had a mean age of 26.2 years. The Army series of 1946 and 1966 had mean ages in the 22 to 24-year-old bracket. The 18 to 24-year-old group of civilian men presumably had a mean age of about 21; the U. S. Marine Corps series also was about 21 years in mean age. The four youngest series are the Army basic trainees, the Navy recruits, and the two groups of USAF basic trainees (1952 and 1965), all of whom had mean ages between 19 and 20 years.

Among the series discussed here, mean weight (Table XLVII) varied from a high of 173.60 pounds for 1967 USAF flying personnel down to a low mean of 147.44 pounds for 1952 USAF basic trainees. Mean weights for most of the series were generally between 155 and 170 pounds. Mean weight for the 1966 Army series was about four pounds higher than for the 1946 Army series, but mean weight for Air Force flying personnel showed an increase of about ten pounds between 1950 and 1967. Mean weight for Army aviators measured in 1970 was 12 pounds heavier than the mean weight of 1966 Army personnel.

Mean values of stature (Table XLVIII) ranged between 70 and 68 inches for the various series. The Navy pilots of 1960 had a mean stature of 70.24 inches, while the total series of civilian men showed the lowest mean stature of 68.20 inches. With few exceptions, the range of stature found in the military series generally fell between minimum and maximum values of 60 and 78 inches. Mean stature for the Army series of 1946 was 68.47 inches; for the Army series of 1966, mean stature was 68.71 inches, indicating an increase of only one-quarter of an inch. Air Force flying personnel, however, showed an increase of about three-quarters of an inch in stature between 1950 and 1967.

Sitting height appears to be a generally consistent body measurement. The mean values for this measurement (Table XLIX) show a variation of about one inch, from a high mean of 36.69 inches to a low mean of 35.51 inches. A further indication of the consistency of sitting height may be seen in the relationship between sitting height and stature. If mean sitting height is expressed as a percentage of mean stature, the resulting ratio or index (sometimes called relative sitting height) was found to be about 52 percent for almost all of these series.

Mean values for shoulder breadth (or bideltoid breadth) varied between 19 and 17 3/4 inches (Table L). While shoulder breadth is more highly correlated with weight than with stature, mean shoulder breadth expressed as a percentage of mean stature showed ratios of 26 to 27 percent for these series.

Hip breadth, sitting (Table LI) showed more variation than shoulder breadth, with mean values ranging between about 15 to 13 inches. Hip breadth also is more highly correlated with weight than with stature; however, mean hip breadths were found to be between 19 and 21 percent of the corresponding mean stature values in these series.

Chest circumference is one of the basic girth measurements of the body, and is utilized as a primary controlling dimension in the sizing of clothing. Mean values for nude chest circumference (Table LII) vary in these series from about 39 1/4 inches down to 35 1/2 inches. The total series of civilian men showed the highest mean value for chest circumference, 39.20 inches. Mean chest circumference for the Army series of 1946 was 36.38 inches, while that of the 1966 Army series was 36.91 inches, indicating an increase of about one-half inch. The total range of chest circumference for all of these series varied from a minimum of 27 1/2 inches up to a maximum of 53 inches.

Waist circumference also is a basic clothing dimension, but it is an extremely variable measurement, highly correlated with weight and markedly influenced by age. Mean waist circumference (Table LIII) varied in these series from a high of 35 inches to a low value of about 30 1/3 inches. Again, the total series of civilian men showed the highest mean value at 35 inches. Mean waist circumference showed an increase of one inch in the Army series, from 30.60 in 1946 to 31.62 inches in 1966. The total range of waist circumference among all of these series varied from a minimum of 23 inches up to a maximum of over 50 inches.

The tables of percentile values for the seven selected measurements (Tables LIV to LX) make it possible to compare the distribution of percentile values for a measurement among the various series. With weight (Table LIV), it may be seen that the Army series of 1966 ranged from 116 pounds for the 1st percentile up to 227 pounds for the 99th percentile, giving a range of 111 pounds. The 1967 Air Force data indicate values of 128 pounds for the 1st percentile and 228 pounds for the 99th percentile, with a range of 100 pounds. The 99th percentile values are almost the same; one percent of the Army series was above 227 pounds in weight and one percent of the Air Force series was above 228 pounds in weight. The 1st percentile values differed in these two series; one percent of the Army men were below 116 pounds in weight, but one percent of USAF flying personnel were below 128 pounds in weight. Similar comparisons could be made, of course, at the 2nd and 98th percentile levels, at the 5th and 95th percentile levels, or at any other percentile levels.

Regarding the percentile values for stature (Table LV), the 50th percentile value (or median) of stature for the 1966 Army series is 68.7 inches, but that for the 1967 Air Force series is over one inch greater, 69.8 inches. One percent of the Army men are shorter than 62.6 inches, but one percent of the Air Force men are below 64.3 inches. At the other extreme of stature, it may be seen that one percent of the Army series are above the 99th percentile value of 74.9 inches, but two percent of the Air Force series are above the 98th percentile value of 74.9 inches.

Similar comparisons may be made for the remaining five body measurements by referring to the percentile values shown in Tables LVI to LX.

TABLE XLVII – STATISTICAL VALUES FOR WEIGHT

Rank	Series		Values in Pounds					Range		Total
			Mean	SE(M)	S.D.	SE(SD)	V(%)	Min.	Max.	
1	US Air Force	(1967)	173.60	0.44	21.44	0.31	12.35	118	264	146
	Age 30.0	N-2420								
2	US Naval Aviators	(1964)	171.40	0.48	19.09	0.34	11.14	110	245	135
	Age 29.6	N-1549								
3	US Army Aviators	(1970)	171.15	0.62	23.84	0.44	13.93	104	281	177
	Age 26.2	N-1482								
4	US Civilian Men	(1960-62)	169.00	1.08	28.12	0.77	16.64	—	—	—
	Age 25-34(30)	N-675								
5	US Navy Pilots	(1960)	167.44	0.53	18.25	0.38	10.90	118	228	110
	Age —	N-1190								
6	US Army Aviators	(1966)	166.18	1.84	20.54	1.30	12.36	112	216	104
	Age 28.1	N-125								
7	US Civilian Men	(1960-62)	166.00	0.50	27.73	0.35	16.70	—	—	—
	Age 18-79(44)	N-3091								
8	US Army Aviators	(1959)	165.77	0.85	18.90	0.60	11.40	110	229	119
	Age 30.25	N-500								
9	US Army Armored	(1966)	165.42	1.20	26.55	0.85	16.05	108	284	176
	Age 27.0	N-489								
10	US Army Aviators	(1968)	164.00	0.46	18.70	0.33	11.40	110	229	119
	Age 22.0	N-1640								
11	US Air Force	(1950)	163.66	0.33	20.86	0.23	12.74	104	265	161
	Age 27.9	N-4052								
12	US Army DRAGON	(1967)	162.24	1.55	24.65	1.09	15.19	109	253	144
	Age 23.3	N-254								
13	ATC Trainees	(1961)	161.81	0.85	22.09	0.60	13.65	105	239	134
	Age 27.9	N-678								
14	US Army Infantry	(1966)	160.34	0.39	22.81	0.28	14.22	100	272	172
	Age 22.8	N3425								
15	US Marine Corps	(1966)	160.16	0.44	19.67	0.31	12.28	110	248	138
	Age 20.9	N-2006								
16	US Army	(1966)	159.10	0.29	23.35	0.20	14.68	100	284	184
	Age 22.2	N-6677								
17	US Civilian Men	(1960-62)	158.00	1.19	24.22	0.84	15.33	—	—	—
	Age 18-24(21)	N-411								
18	US Navy Recruits	(1966)	157.75	0.36	23.28	0.26	14.76	104	272	168
	Age 19.9	N-4091								
19	US Army Trainees	(1966)	155.97	0.45	23.09	0.32	14.81	100	256	156
	Age 20.2	N-2638								
20	US Army	(1946)	154.81	0.13	20.56	0.09	13.28	95	305	210
	Age 24.3	N-24506								
21	USAF Trainees	(1965)	151.42	0.44	22.48	0.31	14.84	94	238	144
	Age 19.3	N-2632								
22	USAF Trainees	(1952)	147.44	0.36	20.97	0.26	14.22	100	295	195
	Age 18.9	N-3332								

TABLE XLVIII – STATISTICAL VALUES FOR STATURE

Values in Inches

Rank	Series		Mean	SE(M)	S.D.	SE(SD)	V(%)	Range		Total
								Min.	Max.	
1	US Navy Pilots Age – N-1190	(1960)	70.24	0.07	2.36	0.05	3.36	60.0	78.5	18.5
2	US Naval Aviators Age 29.6 N-1549	(1964)	69.94	0.06	2.33	0.04	3.33	63.5	77.2	13.7
3	US Air Force Age 30.0 N-2420	(1967)	69.82	0.05	2.44	0.04	3.49	62.2	77.6	15.4
4	US Army Aviators Age 22.0 N-1640	(1968)	69.70	0.06	2.40	0.04	3.44	61.5	77.0	15.5
5	ATC Trainees Age 27.9 N-678	(1961)	69.56	0.09	2.50	0.07	3.59	61.2	76.5	15.3
6	US Army Aviators Age 30.23 N-500	(1959)	69.50	0.10	2.25	0.07	3.24	62.7	76.0	13.3
7	US Air Force Age 27.9 N-4062	(1950)	69.11	0.04	2.44	0.03	3.53	59.4	77.6	18.2
8	US Civilian Men Age 25-34(30) N-675	(1960-62)	69.10	0.11	2.81	0.08	4.07	--	--	--
9	US Army Aviators Age 28.1 N-125	(1966)	69.05	0.21	2.29	0.15	3.32	61.3	74.3	13.0
10	US Navy Recruits Age 19.9 N-4095	(1966)	69.03	0.04	2.57	0.03	3.73	60.1	78.2	18.1
11	USAF Trainees Age 19.3 N-2632	(1965)	68.92	0.05	2.55	0.04	3.69	59.6	78.8	19.2
12	US Army Trainees Age 20.2 N-2639	(1966)	68.78	0.05	2.54	0.03	3.69	60.1	77.4	17.3
13	US Marine Corps Age 20.9 N-2008	(1966)	68.72	0.06	2.48	0.04	3.61	61.7	77.4	15.7
14	US Army Aviators Age 26.2 N-1482	(1970)	68.72	0.06	2.49	0.05	3.63	59.9	77.7	17.8
15	US Army Age 22.2 N-6682	(1966)	68.71	0.03	2.60	0.02	3.79	59.7	78.6	18.9
16	US Civilian Men Age 18-24(21) N-411	(1960-62)	68.70	0.13	2.73	0.10	3.97	--	--	--
17	US Army Armored Age 27.0 N-489	(1966)	68.68	0.12	2.60	0.08	3.79	61.7	75.9	14.2
18	US Army Infantry Age 22.8 N-3429	(1966)	68.64	0.05	2.61	0.03	3.81	61.0	76.4	15.4
19	USAF Trainees Age 18.9 N-3331	(1952)	69.54	0.05	2.61	0.03	3.81	61.0	76.4	15.4
20	US Army DRAGON Age 23.3 N-254	(1967)	68.51	0.17	2.65	0.12	3.86	61.8	76.0	14.2
21	US Army Age 24.3 N-24508	(1946)	68.47	0.02	2.52	0.01	3.68	59.1	78.7	19.6
22	US Civilian Men Age 18-79(44) N-3091	(1960-62)	68.20	0.05	2.85	0.04	4.18	--	--	--

TABLE XLIX – STATISTICAL VALUES FOR SITTING HEIGHT

Rank	Series		Values in Inches					Range		Total
			Mean	SE(M)	S.D.	SE(SD)	V(%)	Min.	Max.	
1	US Air Force	(1967)	36.69	0.03	1.25	0.02	3.41	31.8	41.4	9.6
	Age 30.0 N-2420									
2	US Naval Aviators	(1964)	36.28	0.03	1.25	0.02	3.43	32.2	41.6	9.4
	Age 29.6 N-1549									
3	ATC Trainees	(1961)	36.20	0.05	1.29	0.04	3.55	33.0	40.0	7.0
	Age 27.9 N-681									
4	US Army Aviators	(1968)	36.20	0.02	1.30	0.02	3.59	31.9	40.5	8.6
	Age 22.0 N-1640									
5	US Navy Recruits	(1966)	36.06	0.02	1.35	0.01	3.74	31.2	41.0	9.8
	Age 19.9 N-4095									
6	US Army Aviators	(1966)	36.02	0.12	1.34	0.08	3.73	31.6	39.1	7.5
	Age 28.1 N-125									
7	US Navy Pilots	(1960)	36.02	0.04	1.45	0.03	4.03	31.2	41.0	9.8
	Age — N-1190									
8	US Civilian Men	(1960-62)	36.00	0.05	1.41	0.04	3.92	—	—	—
	Age 25-34(30) N-675									
9	US Air Force	(1950)	35.94	0.02	1.29	0.02	3.58	29.9	40.2	10.3
	Age 27.9 N-4061									
10	US Army Trainees	(1966)	35.91	0.03	1.35	0.02	3.77	31.2	40.6	9.4
	Age 20.2 N-2639									
11	USAF Trainees	(1965)	35.87	0.03	1.37	0.02	3.81	31.0	40.4	9.4
	Age 19.3 N-2631									
12	US Marine Corps	(1966)	35.82	0.03	1.39	0.02	3.88	31.6	39.8	8.2
	Age 20.9 N-2008									
13	US Army Aviators	(1970)	35.80	0.03	1.27	0.02	3.56	31.0	40.1	9.1
	Age 26.2 N-1482									
14	US Civilian Men	(1960-62)	35.80	0.07	1.48	0.05	4.13	—	—	—
	Age 18-24(21) N-411									
15	US Army	(1946)	35.78	0.01	1.34	0.01	3.74	30.3	41.3	11.0
	Age 24.3 N-24352									
16	US Army	(1966)	35.70	0.02	1.44	0.01	4.04	30.4	40.6	10.2
	Age 22.2 N-6682									
17	US Army Aviators	(1959)	35.61	0.06	1.27	0.04	3.57	31.5	40.1	8.6
	Age 30.25 N-500									
18	US Civilian Men	(1960-62)	35.60	0.03	1.48	0.02	4.16	—	—	—
	Age 18-79(44) N-3091									
19	US Army DRAGON	(1967)	35.57	0.09	1.41	0.06	3.97	31.8	39.6	7.8
	Age 23.3 N-254									
20	US Army Infantry	(1966)	35.56	0.03	1.48	0.02	4.15	30.4	40.6	10.2
	Age 22.8 N-3429									
21	US Army Armored	(1966)	35.51	0.07	1.55	0.05	4.36	31.2	40.2	9.0
	Age 27.0 N-489									

TABLE L – STATISTICAL VALUES FOR SHOULDER BREADTH
Values in Inches

Rank	Series		Mean	SE(M)	S.D.	SE(SD)	V(%)	Min.	Range Max.	Total
1	US Air Force Age 30.0 N-2420	(1967)	18.99	0.02	1.01	0.01	5.31	15.6	22.3	6.7
2	US Naval Aviators Age 29.6 N-2549	(1964)	18.78	0.02	0.91	0.02	4.83	14.8	21.7	6.9
3	US Army Aviators Age 26.2 N-1482	(1970)	18.66	0.03	1.01	0.02	5.39	15.6	23.1	7.5
4	US Army Aviators Age 22.0 N-1640	(1968)	18.50	0.02	0.90	0.01	4.86	15.4	21.7	6.3
5	ATC Trainees Age 27.9 N-681	(1964)	18.44	0.04	1.15	0.03	6.23	13.5	22.5	9.0
6	US Army Aviators Age 28.1 N-125	(1966)	18.35	0.07	0.82	0.05	4.49	16.4	20.4	4.0
7	US Army Aviators Age 30.25 N-500	(1959)	18.27	0.04	0.88	0.03	4.82	15.0	22.0	7.0
8	US Army Armored Age 27.0 N-489	(1966)	18.16	0.05	1.08	0.03	5.96	15.3	21.9	6.6
9	USAF Trainees Age 19.3 N-2632	(1965)	18.02	0.02	0.98	0.01	5.42	15.0	21.4	6.4
10	US Army Age 24.3 N-24461	(1946)	17.95	0.01	0.99	0.00	5.52	13.8	23.2	9.4
11	US Marine Corps Age 20.9 N-2008	(1966)	17.91	0.02	0.91	0.01	5.09	15.4	22.8	7.4
12	US Army Infantry Age 22.8 N-3429	(1966)	17.89	0.02	1.00	0.01	5.58	14.7	23.1	8.4
13	US Air Force Age 27.9 N-4057	(1950)	17.88	0.02	0.91	0.01	5.06	14.6	22.8	8.2
14	US Army Age 22.2 N-6682	(1966)	17.86	0.01	1.00	0.01	5.59	14.3	23.1	8.8
15	US Army Trainees Age 20.2 N-2639	(1966)	17.75	0.02	0.97	0.01	5.48	14.3	21.4	7.1
16	US Navy Recruits Age 19.9 N-4095	(1966)	17.69	0.02	1.01	0.01	5.72	14.6	21.5	6.9

TABLE LI – STATISTICAL VALUES FOR HIP BREADTH, SITTING
Values in Inches

Rank	Series	Year	Mean	SE(M)	S.D.	SE(SD)	V(%)	Min.	Max.	Range	Total
1	US Air Force Age 30.0 N-2420	(1967)	14.88	0.02	0.91	0.01	6.09	12.1	19.0	6.9	
2	US Army Aviators Age 26.2 N-1482	(1970)	14.88	0.03	1.07	0.02	7.19	12.1	19.2	7.1	
3	US Naval Aviators Age 29.6 N-1549	(1964)	14.49	0.02	0.85	0.02	5.90	12.0	17.9	5.9	
4	US Army Aviators Age 30.25 N-500	(1959)	14.19	0.04	0.87	0.03	6.13	11.8	17.3	5.5	
5	ATC Trainees Age 27.9 N-681	(1961)	14.16	0.04	0.92	0.02	6.52	12.0	18.8	6.8	
6	US Civilian Men Age 18-79(44) N-3091	(1960-62)	14.00	0.02	1.10	0.01	7.86	—	—	—	
7	US Civilian Men Age 25-34(30) N-675	(1960-62)	14.00	0.04	1.10	0.03	7.86	—	—	—	
8	US Air Force Age 27.9 N-4058	(1950)	13.97	0.01	0.87	0.01	6.23	11.4	18.1	6.7	
9	US Army Age 24.3 N-24575	(1946)	13.95	0.01	0.90	0.00	6.45	11.2	19.9	8.7	
10	US Army Aviators Age 22.0 N-1640	(1968)	13.90	0.02	0.80	0.01	5.76	11.6	17.4	5.8	
11	USAF Trainees Age 19.3 N-2632	(1965)	13.88	0.02	0.99	0.01	5.76	11.6	17.4	5.8	
12	US Army Aviators Age 28.1 N-125	(1966)	13.82	0.07	0.84	0.05	6.07	11.9	16.2	4.3	
13	US Army Armored Age 27.0 N-489	(1966)	13.63	0.05	1.04	0.03	7.60	10.7	19.8	9.1	
14	US Civilian Men Age 18-24(21) N-411	(1960-62)	13.60	0.05	1.10	0.04	8.09	—	—	—	
15	US Army Infantry Age 22.8 N-3429	(1966)	13.48	0.02	0.92	0.01	6.84	10.3	18.6	8.3	
16	US Marine Corps Age 20.9 N-2008	(1966)	13.45	0.02	0.79	0.01	6.97	10.3	19.8	9.5	
17	US Army Age 22.2 N-6682	(1966)	13.45	0.01	0.94	0.01	6.97	10.3	19.8	9.5	
18	US Army Trainees Age 20.2 N-2639	(1966)	13.36	0.02	0.93	0.01	6.95	10.9	18.8	7.9	
19	US Navy Recruits Age 19.9 N-4094	(1966)	13.33	0.01	0.93	0.01	6.97	10.8	17.9	7.1	

TABLE LII – STATISTICAL VALUES FOR CHEST CIRCUMFERENCE
Values in Inches

Rank	Series	Mean	SE(ME)	S.D.	SE(SD)	V(%)	Min	Range		Total
								Max.		
1	US Civilian Men (1960-62) Age 18-79(44) N-3091	39.20	0.06	3.10	0.04	7.91	—	—	—	
2	US Civilian Men (1960-62) Age 25-34(30) N-675	39.10	0.12	3.20	0.09	8.18	—	—	—	
3	US Naval Aviators (1964) Age 29.6 N-1549	38.92	0.06	2.27	0.04	5.85	30.8	47.9	17.1	
4	US Air Force (1950) Age 27.9 N-4057	38.80	0.04	2.45	0.03	6.31	31.1	49.6	18.5	
5	US Air Force (1967) Age 30.0 N-2420	38.80	0.05	2.50	0.04	6.44	30.4	48.1	17.7	
6	US Army Aviators (1970) Age 26.2 N-1482	38.75	0.07	2.71	0.05	6.98	31.4	53.2	21.8	
7	US Army Aviators (1966) Age 28.1 N-125	38.52	0.21	2.32	0.15	6.02	32.4	45.4	13.0	
8	ATC Trainees (1961) Age 27.9 N-681	39.17	0.10	2.56	0.07	6.70	32.0	48.0	16.0	
9	US Army Armored (1966) Age 27.0 N-489	37.93	0.13	2.92	0.09	7.70	31.2	48.9	17.7	
10	US Civilian Men (1960-62) Age 18-24(21) N-411	37.80	0.15	3.00	0.10	7.94	—	—	—	
11	US Army Aviators (1959) Age 30.25 N-500	37.72	0.09	2.07	0.07	5.49	32.3	43.2	10.9	
12	US Navy Pilots (1960) Age — N-1190	37.59	0.06	2.19	0.05	5.83	29.2	46.8	17.6	
13	US Marine Corps (1966) Age 20.9 N-2008	37.11	0.05	2.30	0.04	6.19	31.6	49.3	17.7	
14	US Army Infantry (1966) Age 22.8 N-3429	37.01	0.04	2.60	0.03	7.03	30.0	48.9	18.9	
15	US Army (1966) Age 22.2 N-6682	36.92	0.03	2.63	0.02	7.14	28.2	48.9	20.7	
16	US Navy Recruits (1966) Age 19.9 N-4095	36.63	0.04	2.62	0.03	7.14	29.2	46.9	17.7	
17	US Army Trainees (1966) Age 20.2 N-2639	36.53	0.05	2.54	0.04	6.97	28.2	48.3	20.1	
18	US Army (1946) Age 24.3 N-24470	36.38	0.01	2.34	0.01	6.43	28.0	48.4	20.4	
19	USAF Trainees (1965) Age 19.3 N-2632	36.14	0.05	2.57	0.04	7.12	27.5	49.9	22.4	
20	USAF Trainees (1952) Age 18.9 N-3330	35.58	0.04	2.39	0.03	6.71	29.1	47.6	18.5	

TABLE LIII – STATISTICAL VALUES FOR WAIST CIRCUMFERENCE

Values in Inches

Rank	Series	Mean	SE(M)	S.D.	SE(SD)	V(%)	Min.	Range Max.	Total
1	US Civilian Men (1960-62) Age 18-79(44) N-3091	35.00	0.08	4.40	0.06	12.57	—	—	—
2	US Air Force (1967) Age 30.0 N-2420	34.49	0.06	2.91	0.04	8.43	26.7	49.1	22.4
3	US Army Aviators (1970) Age 26.2 N-1482	34.30	0.09	3.39	0.06	9.89	25.9	47.7	21.8
4	US Civilian Men (1960-62) Age 25-34(30) N-675	34.10	0.16	4.20	0.11	12.32	—	—	—
5	US Naval Aviators (1964) Age 29.6 N-1549	33.61	0.07	2.58	0.05	7.69	23.3	44.0	20.7
6	US Army Aviators (1966) Age 28.1 N-125	33.30	0.26	2.96	0.19	8.88	26.1	40.8	14.7
7	US Army Armored (1966) Age 27.0 N-489	32.73	0.17	3.80	0.12	11.60	25.5	50.3	24.8
8	US Army Aviators (1959) Age 30.25 N-500	32.70	0.11	2.49	0.08	7.61	26.0	40.1	14.1
9	ATC Trainees (1961) Age 27.9 N-681	32.41	0.11	2.97	0.08	9.15	25.0	45.0	20.0
10	US Navy Pilots (1960) Age — N-1190	32.37	0.07	2.48	0.05	7.66	26.0	42.0	16.0
11	US Air Force (1950) Age 27.9 N-4059	32.04	0.05	3.02	0.04	9.44	24.4	47.2	22.8
12	US Civilian Men (1960-62) Age 18-24(21) N-411	31.90	0.19	3.80	0.13	11.91	—	—	—
13	US Army Infantry (1966) Age 22.8 N-3429	31.62	0.05	3.12	0.04	9.88	23.8	48.0	24.2
14	US Army (1966) Age 22.2 N-6682	31.61	0.04	3.22	0.03	10.19	23.1	50.3	27.2
15	US Navy Recruits (1966) Age 19.9 N-4095	31.59	0.05	3.21	0.04	10.15	23.9	44.6	20.7
16	US Army Trainees (1966) Age 20.2 N-2639	31.33	0.06	3.18	0.04	10.15	23.1	46.2	23.1
17	US Marine Corps (1966) Age 20.9 N-2008	31.22	0.06	2.49	0.04	7.99	24.9	45.8	21.3
18	USAF Trainees (1965) Age 19.3 N-2632	30.68	0.06	2.94	0.04	9.58	24.5	45.8	21.3
19	US Army (1946) Age 24.3 N-24472	30.60	0.02	2.76	0.01	9.02	23.2	46.8	23.6
20	USAF Trainees (1952) Age 18.9 N-3325	30.32	0.05	2.73	0.03	8.99	23.2	46.9	23.7

TABLE LIV - PERCENTILE VALUES FOR WEIGHT

Rank	Series	Percentiles in Pounds										Range (1st-99th)		
		1st	2nd	5th	10th	25th	50th	75th	90th	95th	98th		99th	
1	US Air Force Age 30.0 N-2420	128	133	140	147	159	172	187	202	211	221	228	228	100
2	US Army Aviators Age 26.2 N-1482	122	126	133	140	154	171	187	202	212	223	230	230	107
3	US Naval Aviators Age 29.6 N-1549	129	133	140	147	158	171	184	196	204	214	221	221	92
4	US Civilian Men Age 25-34(30) N-675	112	118	127	134	148	167	187	206	221	236	246	246	134
5	US Navy Pilots Age - N-1190	128	131	138	144	155	167	180	192	199	208	214	214	86
6	US Army Aviators Age 28.1 N-125			129	140	154	166	179	193	203				
7	US Army Aviators Age 30.25 N-500	124	128	136	142	153	166	180	193	200	208	212	212	88
8	US Civilian Men Age 18-79(44) N-3091	110	115	124	132	147	164	183	203	215	229	239	239	129
9	US Army Armored Age 27.0 N-489	119	123	128	134	146	162	181	202	215	232	244	244	125
10	US Air Force Age 27.9 N-4063	123	126	132	138	149	162	177	193	201	212	216	216	93
11	US Army Aviators Age 22.0 N-1640	124	129	135	141	150	162	177	190	197	204	210	210	86

TABLE LIV -- PERCENTILE VALUES FOR WEIGHT (continued)

Rank	Series	Percentiles in Pounds										Range (1st-99th)		
		1st	2nd	5th	10th	25th	50th	75th	90th	95th	98th		99th	
12	ATC Trainees Age 27.9 N-684	116	120	128	134	145	159	173	190	199	213	223	223	107
13	US Army Infantry Age 22.8 N-3429	120	123	129	134	144	158	173	190	202	218	230	230	110
14	US Marine Corps Age 20.9 N-2008	122	126	131	136	146	158	172	186	195	206	213	213	91
15	US Army Age 22.2 N-6682	116	120	126	132	143	156	173	190	202	216	227	227	111
16	US Civilian Men Age 18-24(21) N-411	113	116	122	129	140	155	173	191	212	222	229	229	116
17	US Navy Recruits Age 19.9 N-4095	114	119	125	131	141	155	172	190	201	214	222	222	108
18	US Army DRAGON Age 23.3 N-254	113	118	122	130	137	154	174	191	201	220	232	232	119
19	US Army Trainees Age 20.2 N-2639	112	117	124	129	139	153	170	188	199	212	220	220	108
20	US Army Age 24.3 N-24500	114	118	124	130	141	153	167	181	192	205	215	215	101
21	USAF Trainees Age 19.3 N-2632	111	115	121	126	135	148	164	182	194	209	220	220	109
22	USAF Trainees Age 18.9 N-3351	109	112	118	124	133	145	160	174	186	199	208	208	99

TABLE LV - PERCENTILE VALUES FOR STATURE

Rank	Series	Percentiles in Inches										Range (1st-99th)	
		1st	2nd	5th	10th	25th	50th	75th	90th	95th	98th		99th
1	US Navy Pilots Age - N-1190 (1960)	64.9	66.0	66.5	67.3	68.6	70.3	71.8	73.4	74.3	75.0	75.8	10.9
2	US Naval Aviators Age 29.6 N-1549 (1967)	65.1	65.5	66.2	66.9	68.2	69.9	71.6	73.1	73.9	74.8	75.3	10.2
3	US Air Force Age 30.0 N-2420 (1968)	64.3	64.9	65.9	66.7	68.2	69.8	71.5	73.0	73.9	74.9	75.6	11.3
4	US Army Aviators Age 22.0 N-1640 (1961)	64.2	64.8	65.6	66.4	68.0	69.7	71.3	72.8	73.6	74.7	75.4	11.2
5	ATC Trainees Age 27.9 N-684 (1959)	63.8	64.5	65.5	66.5	67.9	69.5	71.2	72.6	73.6	74.5	75.2	11.4
6	US Army Aviators Age 30.35 N-500 (1950)	64.4	65.0	65.8	66.6	67.9	69.4	71.1	72.5	73.3	74.2	74.8	10.4
7	US Air Force Age 27.9 N-4063 (1960-62)	63.5	64.2	65.2	66.0	67.5	69.1	70.7	72.2	73.1	74.2	74.9	11.4
8	US Civilian Men Age 25-34(30) N-675 (1966)	62.6	63.3	64.4	65.5	67.2	69.0	70.9	72.7	73.8	75.1	76.0	13.4
9	US Navy Recruits Age 19.9 N-4095 (1966)	63.2	64.0	65.0	65.8	67.3	69.0	70.7	72.4	73.4	74.5	75.2	12.0
10	US Army Aviators Age 28.1 N-125 (1965)	65.5	66.3	67.5	69.0	70.7	72.1	72.7	73.1	73.1	74.2	74.8	11.8
11	USAF Trainees Age 19.3 N-2632	63.0	63.7	64.7	65.6	67.2	68.9	70.6	72.2	73.1	74.2	74.8	11.8

TABLE LV - PERCENTILE VALUES FOR STATURE (continued)

Rank	Series	Percentiles in Inches										Range (1st-99th)		
		1st	2nd	5th	10th	25th	50th	75th	90th	95th	98th		99th	
12	US Army Age 22.2 (1966) N-6682	62.6	63.4	64.5	65.4	67.0	68.7	70.4	72.1	73.1	74.2	74.9	74.9	12.3
13	US Army Trainees Age 20.2 (1966) N-2639	62.9	63.6	64.6	65.6	67.1	68.7	70.5	72.1	73.0	74.2	74.9	74.9	12.0
14	US Army Aviators Age 26.2 (1970) N-1482	63.2	63.7	64.6	65.5	67.0	68.7	70.4	71.9	72.8	74.0	74.9	74.9	11.7
15	US Marine Corps Age 20.9 (1966) N-2008	63.5	64.0	64.8	65.6	67.0	68.7	70.4	72.0	73.0	74.1	74.8	74.8	11.3
16	US Army Armored Age 27.0 (1966) N-489	62.8	63.4	64.3	65.2	66.8	68.7	70.5	72.1	73.0	73.9	74.5	74.5	11.7
17	US Army Infantry Age 22.8 (1966) N-3429	62.3	63.1	64.4	65.4	66.9	68.6	70.4	72.1	73.1	74.2	75.0	75.0	12.7
18	US Civilian Men Age 18-24(21) (1960-62) N-411	62.6	63.2	64.3	65.4	66.8	68.6	70.5	72.4	73.1	74.1	74.8	74.8	12.2
19	USAF Trainees Age 18.9 (1952) N-3351	62.5	63.2	64.2	65.1	66.8	68.6	70.3	71.9	72.7	74.0	74.7	74.7	12.2
20	US Army Age 24.3 (1946) N-24500	62.7	63.3	64.3	65.2	66.8	68.5	70.2	71.8	72.6	73.7	74.5	74.5	11.8
21	US Civilian Men Age 18-79(44) (1960-62) N-3091	61.7	62.5	63.6	64.5	66.4	68.3	70.1	71.8	72.8	74.0	74.6	74.6	12.9
22	US Army DRAGON Age 23.3 (1967) N-254	62.1	63.1	63.5	64.4	66.1	68.0	70.2	71.5	73.0	73.5	74.4	74.4	12.3

TABLE LVI - PERCENTILE VALUES FOR SITTING HEIGHT

Rank	Series	Percentiles in Inches										Range (1st-99th)	
		1st	2nd	5th	10th	25th	50th	75th	90th	95th	98th		99th
1	US Air Force Age 30.0 (1967) N-2420	33.9	34.2	34.7	35.1	35.8	36.6	37.5	38.3	38.8	39.3	39.6	5.7
2	US Naval Aviators Age 29.6 (1964) N-1549	33.5	33.8	34.2	34.7	35.4	36.3	37.1	37.9	38.4	39.0	39.4	5.9
3	US Army Aviators Age 22.0 (1968) N-1640	33.0	33.3	34.0	34.5	35.4	36.2	37.0	37.8	38.2	38.8	39.1	6.1
4	ATC Trainees Age 27.9 (1961) N-684	32.9	33.3	33.9	34.4	35.2	36.1	37.0	37.8	38.4	38.9	39.3	6.4
5	US Civilian Men Age 25-34(30) (1960-62) N-675	32.5	33.0	33.9	34.3	35.1	36.1	37.1	37.9	38.4	38.8	39.0	6.5
6	US Navy Pilots Age - (1960) N-1190	32.5	32.8	33.5	34.4	35.0	36.0	37.0	37.8	38.4	39.2	39.9	7.4
7	US Navy Recruits Age 19.9 (1966) N-4095	32.9	33.3	33.9	34.4	35.1	36.0	37.0	37.8	38.3	38.9	39.2	6.3
8	US Army Aviators Age 28.1 (1966) N-125	33.6	34.3	35.1	36.0	36.9	37.8	38.3					
9	US Air Force Age 27.9 (1950) N-4063	32.9	33.3	33.8	34.3	35.1	36.0	36.8	37.6	38.0	38.6	38.9	6.0
10	US Civilian Men Age 18-24(21) (1960-62) N-411	31.8	32.4	33.3	34.0	34.8	35.9	36.9	37.8	38.3	38.8	39.1	7.3
11	US Army Trainees Age 20.2 (1966) N-2639	32.6	33.0	33.6	34.2	35.0	35.9	36.8	37.6	38.2	38.7	39.1	6.5

TABLE LVI - PERCENTILE VALUES FOR SITTING HEIGHT (continued)

Rank	Series	Percentiles in Inches										Range (1st-99th)	
		1st	2nd	5th	10th	25th	50th	75th	90th	95th	98th		99th
12	USAF Trainees Age 19.3 (1965) N-2631	32.6	33.0	33.6	34.1	35.0	35.9	36.8	37.6	38.1	38.7	39.1	6.5
13	US Marine Corps Age 20.9 (1966) N-2008	32.7	33.0	33.6	34.0	34.9	35.8	36.8	37.6	38.2	38.8	39.2	6.5
14	US Army Age 24.3 (1946) N-24500	32.6	33.0	33.5	34.0	34.8	35.8	36.7	37.5	38.0	38.6	39.0	6.4
15	US Army Aviators Age 26.2 (1970) N-1482	32.8	33.2	33.7	34.2	35.0	35.8	36.6	37.4	37.9	38.5	38.8	6.0
16	US Army Age 22.2 (1966) N-6682	32.3	32.7	33.3	33.8	34.7	35.7	36.7	37.6	38.1	38.6	39.0	6.7
17	US Civilian Men Age 18-79(44) (1960-62) N-3091	31.9	32.4	33.2	33.8	34.7	35.7	36.7	37.6	38.0	38.6	38.9	7.0
18	US Army Infantry Age 22.8 (1966) N-3429	32.1	32.5	33.1	33.6	34.6	35.6	36.6	37.5	38.0	38.6	39.0	6.9
19	US Army Aviators Age 30.25 (1959) N-500	32.5	32.9	33.5	34.0	34.8	35.6	36.5	37.3	37.8	38.3	38.7	6.2
20	US Army Armored Age 27.0 (1966) N-489	32.0	32.4	33.0	33.5	34.5	35.5	36.6	37.5	38.1	38.7	39.2	7.2
21	US Army DRAGON Age 23.3 (1967) N-254	32.2	32.8	32.9	33.5	34.1	35.4	36.6	37.1	37.5	37.7	38.7	6.5

TABLE LVII - PERCENTILE VALUES FOR SHOULDER BREADTH

Rank	Series	Percentiles in Inches										Range (1st-99th)			
		1st	2nd	5th	10th	25th	50th	75th	90th	95th	98th		99th		
1	US Air Force Age 30.0 N-2420	16.7	17.0	17.4	17.7	18.3	19.0	19.7	20.3	20.7	20.7	20.7	21.2	21.2	4.7
2	US Naval Aviators Age 29.6 N-1549	16.6	16.9	17.3	17.6	18.2	18.8	19.4	19.9	20.3	20.3	20.6	20.9	20.9	4.3
3	US Army Aviators Age 26.2 N-1482	16.5	16.7	17.0	17.4	18.0	18.7	19.3	20.0	20.3	20.3	20.8	21.0	21.0	3.5
4	US Army Aviators Age 22.0 N-1640	16.3	16.7	17.0	17.3	17.9	18.5	19.1	19.8	20.1	20.1	20.6	20.8	20.8	4.5
5	US Army Aviators Age 28.1 N-125			17.1	17.2	17.8	18.4	18.9	19.4	19.7					
6	ATC Trainees Age 27.9 N-684	16.2	16.4	16.8	17.1	17.6	18.3	19.0	19.8	20.3	20.3	21.0	21.6	21.6	5.4
7	US Army Aviators Age 30.25 N-500	16.0	16.3	16.8	17.2	17.6	18.2	18.8	19.5	20.0	20.0	20.3	20.5	20.5	4.5
8	US Army Armored Age 27.0 N-489	15.8	16.2	16.6	16.9	17.4	18.0	18.8	19.6	20.1	20.1	20.7	21.0	21.0	5.2
9	USAF Trainees Age 19.3 N-2632	16.0	16.2	16.5	16.8	17.4	18.0	18.6	19.3	19.7	19.7	20.3	20.6	20.6	4.6
10	US Army Age 24.3 N-24500	15.8	16.0	16.4	16.7	17.2	17.9	18.5	19.2	19.6	19.6	20.2	20.6	20.6	4.8
11	US Marine Corps Age 20.4 N-2008	16.0	16.2	16.5	16.8	17.3	17.9	18.5	19.1	19.5	19.5	20.0	20.4	20.4	4.4

TABLE LVII -- PERCENTILE VALUES FOR SHOULDER BREADTH (continued)

Rank	Series	Percentiles in Inches										Range (1st-99th)	
		1st	2nd	5th	10th	25th	50th	75th	90th	95th	98th		99th
12	US Air Force Age 27.9 N-4063	15.9	16.1	16.5	16.8	17.3	17.9	18.5	19.1	19.4	19.8	20.1	4.2
13	US Army Infantry Age 22.8 N-3429	15.9	16.0	16.4	16.7	17.2	17.8	18.5	19.2	19.6	20.1	20.5	4.8
14	US Army Age 22.2 N-6682	15.7	16.0	16.3	16.6	17.2	17.8	18.5	19.2	19.6	20.1	20.5	4.8
15	US Army Trainees Age 20.2 N-2639	15.6	15.8	16.2	16.5	17.1	17.7	18.4	19.0	19.4	19.9	20.2	4.6
16	US Navy Recruits Age 19.9 N-4095	15.4	15.7	16.1	16.4	17.0	17.6	18.3	19.0	19.4	19.9	20.2	4.8

TABLE LVIII - PERCENTILE VALUES FOR HIP BREADTH, SITTING

Rank	Series	Percentiles in Inches										Range (1st-99th)		
		1st	2nd	5th	10th	25th	50th	75th	90th	95th	98th		99th	
1	US Army Aviators Age 26.2 N-1482	12.6	12.8	13.2	13.5	14.1	14.8	15.6	16.3	16.7	17.2	17.5	17.5	4.9
2	US Air Force Age 30.0 N-2420	12.9	13.1	13.5	13.8	14.3	14.8	15.4	16.0	16.4	16.9	17.2	17.2	4.3
3	US Naval Aviators Age 29.6 N-1549	12.7	12.8	13.1	13.4	13.9	14.5	15.0	15.6	15.9	16.3	16.6	16.6	3.9
4	US Army Aviators Age 30.25 N-500	12.4	12.5	12.8	13.1	13.5	14.2	14.8	15.4	15.7	16.1	16.3	16.3	3.9
5	US Civilian Men Age 25-34(30) N-675	11.7	11.9	12.2	12.5	13.2	14.0	14.8	15.6	16.0	16.8	17.4	17.4	5.7
6	US Civilian Men Age 18-79(44) N-3091	11.5	11.8	12.2	12.5	13.2	14.0	14.8	15.5	15.9	16.5	17.0	17.0	5.5
7	US Army Age 24.3 N-24500	12.2	12.4	12.7	12.9	13.4	13.9	14.4	15.1	15.5	16.2	16.7	16.7	4.5
8	ATC Trainees Age 27.9 N-684	12.1	12.3	12.8	12.9	13.4	13.9	14.5	15.2	15.6	16.2	16.6	16.6	4.5
9	US Air Force Age 27.9 N-4063	12.2	12.4	12.7	12.9	13.4	13.9	14.6	15.1	15.4	15.9	16.2	16.2	4.0
10	US Army Aviators Age 22.0 N-1640	12.0	12.4	12.6	12.9	13.3	13.9	14.4	15.0	15.4	15.7	15.9	15.9	3.9
11	US Army Aviators Age 28.1 N-125	12.4	12.7	13.2	13.9	14.4	14.8	15.2	15.6	16.0	16.4	16.8	17.2	4.8

TABLE LVIII - PERCENTILE VALUES FOR HIP BREADTH, SITTING (continued)

Rank	Series	Percentiles in Inches										Range (1st-99th)	
		1st	2nd	5th	10th	25th	50th	75th	90th	95th	98th		99th
12	USAF Trainees Age 19.3 (1965) N-2632	12.0	12.2	12.5	12.8	13.2	13.7	14.4	15.2	15.8	16.4	16.9	4.9
13	US Civilian Men Age 18-24(21) (1966-62) N-411	11.3	11.6	12.0	12.2	12.8	13.5	14.3	15.0	15.8	16.6	17.3	6.0
14	US Army Armored Age 27.0 (1966) N-489	11.8	12.0	12.2	12.4	12.9	13.5	14.3	15.0	15.5	15.9	16.2	4.4
15	US Army Infantry Age 22.8 (1966) N-3429	11.7	11.9	12.1	12.4	12.8	13.4	14.0	14.7	15.1	15.7	16.2	4.5
16	US Army Age 22.2 (1966) N-6682	11.6	11.8	12.1	12.3	12.8	13.4	14.0	14.7	15.1	15.6	16.0	4.4
17	US Marine Corps Age 20.9 (1966) N-2008	11.8	12.0	12.3	12.5	12.9	13.4	13.9	14.5	14.8	15.3	15.6	3.8
18	US Army Trainees Age 20.2 (1966) N-2639	11.5	11.7	12.0	12.2	12.7	13.3	13.9	14.6	15.0	15.5	15.8	4.3
19	US Navy Recruits Age 19.9 (1966) N-4095	11.6	11.8	12.0	12.2	12.7	13.2	13.9	14.6	15.0	15.5	15.9	4.3

TABLE LIX - PERCENTILE VALUES FOR CHEST CIRCUMFERENCE

Rank	Series	Percentiles in Inches										Range (1st-99th)	
		1st	2nd	5th	10th	25th	50th	75th	90th	95th	98th		99th
1	US Civilian Men Age 25-34(30) N-675	32.5	33.1	34.0	35.0	36.9	39.0	41.2	43.5	44.9	46.7	47.8	15.3
2	US Civilian Men Age 18-79(44) N-3091	32.5	33.2	34.3	35.2	37.0	39.0	41.2	43.5	44.9	46.6	47.7	15.2
3	US Naval Aviators Age 29.6 N-1549	33.7	34.3	35.2	36.0	37.4	38.9	40.3	41.8	42.7	44.0	45.0	11.3
4	US Army Aviators Age 26.2 N-1482	33.3	33.6	34.4	35.3	36.9	38.7	40.5	42.2	43.3	44.6	45.6	12.3
5	US Air Force Age 30.0 N-2420	33.4	34.0	34.9	35.7	37.1	38.7	40.4	42.1	43.1	44.2	45.0	11.6
6	US Air Force Age 27.9 N-4063	33.7	34.3	35.1	35.9	37.1	38.7	40.3	42.1	43.2	44.1	44.8	11.1
7	US Army Aviators Age 28.1 N-125	34.0	34.5	35.0	35.6	37.3	38.5	39.8	41.4	42.5			
8	ATC Trainees Age 27.9 N-684	33.3	33.8	34.5	35.0	36.3	37.8	39.5	41.3	42.9	45.1	47.4	14.1
9	US Army Armored Age 27.0 N-489	32.5	32.9	33.6	34.4	35.9	37.7	39.6	41.7	43.2	45.4	47.1	14.6
10	US Army Aviators Age 30.25 N-500	33.3	33.6	34.3	34.9	36.2	37.7	39.2	40.5	41.2	42.1	42.6	9.3
11	US Navy Pilots Age - N-1190	32.4	33.1	34.2	35.1	36.0	37.6	39.0	40.6	41.5	42.2	43.0	10.6

TABLE LIX - PERCENTILE VALUES FOR CHEST CIRCUMFERENCE (continued)

Rank	Series	Percentiles in Inches										Range (1st-99th)	
		1st	2nd	5th	10th	25th	50th	75th	90th	95th	98th		99th
12	US Civilian Men Age 18-24(21) N-411	31.9	32.6	33.5	34.1	35.7	37.5	39.7	42.2	44.2	46.6	48.1	16.2
13	US Marine Corps Age 20.9 N-2008	32.4	33.0	33.7	34.3	35.5	36.9	38.5	40.1	41.2	42.5	43.4	11.0
14	US Army Infantry Age 22.8 N-3429	32.1	32.6	33.3	34.0	35.2	36.7	38.5	40.4	41.8	43.5	44.8	12.7
15	US Army Age 22.2 N-6682	31.8	32.4	33.1	33.8	35.1	36.6	38.5	40.4	41.7	43.3	44.4	12.6
16	US Navy Recruits Age 19.9 N-4095	31.5	32.0	32.8	33.5	34.8	36.4	38.2	40.2	41.4	42.8	43.8	12.3
17	US Army Trainees Age 20.2 N-2639	31.5	32.0	32.8	33.5	34.7	36.3	38.1	39.9	41.1	42.6	43.6	12.1
18	US Army Age 24.3 N-24500	31.6	32.1	32.9	33.6	34.8	36.2	37.8	39.4	40.5	41.9	43.0	11.4
19	USAF Trainees Age 19.3 N-2632	31.1	31.7	32.4	33.1	34.3	35.9	37.7	39.6	40.8	42.4	43.5	12.4
20	USAF Trainees Age 18.9 N-3351	30.9	31.4	32.1	32.8	34.0	35.4	36.9	38.5	39.8	41.5	42.7	11.8

TABLE LX - PERCENTILE VALUES FOR WAIST CIRCUMFERENCE

Rank	Series	Percentiles in Inches										Range (1st-99th)	
		1st	2nd	5th	10th	25th	50th	75th	90th	95th	98th		99th
1	US Civilian Men (1960-62) Age 18-79(44) N-3091	26.8	27.4	28.4	29.5	31.8	34.8	38.0	40.8	42.9	45.0	46.6	19.8
2	US Air Force (1967) Age 30.0 N-2420	28.2	28.8	29.8	30.8	32.4	34.4	36.4	38.3	39.4	40.8	41.7	13.5
3	US Army Aviators (1970) Age 26.2 N-1482	27.9	28.1	28.9	29.9	31.8	34.2	36.6	38.7	40.0	41.7	42.9	15.0
4	US Civilian Men (1960-62) Age 25-34(30) N-675	26.6	27.4	28.6	29.3	31.0	33.7	36.7	39.6	41.6	44.0	45.8	19.2
5	US Naval Aviators (1964) Age 29.6 N-1549	27.6	28.3	29.3	30.3	31.9	33.6	35.3	36.8	37.8	39.1	40.1	12.5
6	US Army Aviators (1966) Age 28.1 N-125			28.2	29.3	31.3	33.5	35.3	36.9	38.1			
7	US Army Aviators (1959) Age 30.25 N-500	27.2	27.6	28.6	29.5	30.9	32.7	34.4	36.0	37.0	38.1	38.6	11.4
8	US Naval Pilots (1960) Age - N-1190	27.2	27.6	28.2	28.9	30.6	32.3	34.0	35.5	36.7	37.8	38.7	11.5
9	US Army Armored (1966) Age 27.0 N-489	26.6	27.0	27.8	28.5	30.0	32.1	34.9	38.0	40.0	42.5	44.3	17.7
10	ATC Trainees (1961) Age 27.9 N-684	26.4	27.0	27.9	28.7	30.2	32.0	34.0	36.2	38.0	40.6	44.0	17.6
11	US Air Force (1950) Age 27.9 N-4063	26.5	27.0	27.8	28.5	29.8	31.7	34.0	36.2	37.5	39.1	40.1	13.6

TABLE LX - PERCENTILE VALUES FOR WAIST CIRCUMFERENCE (continued)

Rank	Series	Percentiles in Inches										Range (1st-99th)	
		1st	2nd	5th	10th	25th	50th	75th	90th	95th	98th		99th
12	US Civilian Men Age 18-24(21) N-411	26.0	26.4	27.1	27.8	29.2	31.2	34.2	37.7	39.3	41.2	42.4	16.4
13	US Army Infantry Age 22.8 N-3429	26.3	26.8	27.5	28.2	29.4	31.1	33.2	35.7	37.5	40.0	41.9	15.6
14	US Army Age 22.2 N-6682	26.1	26.7	27.4	28.1	29.3	31.0	33.4	36.0	37.8	40.0	41.6	15.5
15	US Navy Recruits Age 19.9 N-4095	25.8	26.6	27.4	28.0	29.2	31.0	33.5	36.2	37.8	39.6	40.6	14.8
16	US Marine Corps Age 20.9 N-2008	26.5	26.9	27.6	28.3	29.5	31.0	32.6	34.4	35.7	37.5	38.8	12.3
17	US Army Trainees Age 20.2 N-2639	25.8	26.5	27.3	27.9	29.0	30.7	33.1	35.8	37.6	39.6	40.8	15.0
18	US Army Age 24.3 N-24500	25.6	26.1	26.8	27.4	28.6	30.2	32.1	34.3	35.8	37.6	39.1	13.5
19	USAF Trainees Age 19.3 N-2632	25.7	26.3	27.1	27.6	28.6	30.1	32.2	34.7	36.5	38.5	39.9	14.2
20	USAF Trainees Age 18.9 N-3351	25.7	26.1	26.9	27.5	28.6	29.9	31.5	33.6	35.5	38.0	39.8	14.1

e. Changes in Body Size, 1946 to 1966

The availability of body size information on men in today's Army suggests an investigation of changes in body size which may have taken place over a period of some years. In the Army anthropometric survey of 1966, seventy body measurements were taken on 6682 men, so that the body size of soldiers currently in service can be described in some detail. In the large-scale anthropometric survey of Army personnel carried out by the Quartermaster Corps in 1946 following the end of World War II, sixty-four body measurements are available on some 25,000 men. Thus, data are available for comparison as a basis for examining changes in body size in Army men over a twenty year period.

A large amount of background information also is available on the two series of Army men, such as age, birthplace, length of service, education, and so on. However, the 1946 series consisted primarily of Army separatees leaving the Army at the end of World War II. The age of this group varied between 15 and 57 years, with a mean age of 24.3 years. The 1966 series was composed of Army men still in service. The age of the 1966 group ranged between 17 and 55 years, with a mean age of 22.2 years. The 1966 Army series, then, was two years younger in average age.

There has been a considerable amount of speculation in recent years regarding large increases in human body size. The Army anthropometric data under discussion do not support these speculations. The changes in body dimensions of Army men between 1946 and 1966 actually are rather small, at least with respect to mean (or average) values. Some of these changes may be summarized here.

There has been an increase of four and one-quarter pounds in mean weight, and mean stature has increased one-quarter of an inch in Army men between 1946 and 1966. There have been increases of one-quarter of an inch in neck circumference, one-half inch in chest circumference, and one inch in waist circumference, on the average. These differences are based upon the mean values of the respective dimensions. There have been no appreciable changes in the general dimensions of the head and face, the hands, or the feet. Data on 41 measurements taken in both 1966 and 1946 given in Table LXI.

Of perhaps greater interest and importance, however, than the small increases in average body dimensions are the upward shifts in percentile values for body dimensions which have taken place between 1946 and 1966. These shifts are noticeable particularly in the higher percentile values at the upper end of the distribution of body dimensions in the Army population. This type of change is of significance in the consideration of larger sizes of clothing and of greater quantities of larger sizes in clothing required for the population. Even if general body size does not seem to have increased very much, it is apparent that there are now larger numbers of bigger men in the population.

Selected percentile values for 41 body measurements taken in both the 1966 and 1946 Army anthropometric surveys are shown in Table LXII. It will not be necessary here to discuss the percentile values for all of the body dimensions on which anthropometric data are available. However, some of these dimensions may be examined. The changes or shifts in the percentile values for these dimensions will reflect the changes in distribution of body sizes within the population.

The 95th percentile values for some dimensions may be considered as examples. Obviously, data may be examined or compared on the basis of any of the percentile values; the 95th percentile level represents values for all except the largest five percent of men in the population. It has become popular to utilize the 5th and 95th percentile values of various dimensions to indicate the minimum and maximum limits for design or sizing criteria. It should be emphasized, however, that this practice by definition virtually excludes ten percent of the user population from consideration.

In 1946, the 95th percentile value for stature was 72.6 inches; in 1966 this value had increased to 73.1 inches, a change of one-half inch. Thus, in 1946 five percent of the Army population were above 72.6 inches in height, and in 1966 five percent were above 73.1 inches; but in 1966 seven percent were above 72.6 inches in stature. The 95th percentile value for weight was 192 pounds in 1946, but was 202 pounds in 1966, a change of ten pounds. Therefore, five percent of Army men weighed above 192 pounds in 1946, and five percent were above 202 pounds in 1966; but in 1966, nine percent of Army men were heavier than 192 pounds, the 95th percentile level of weight in 1946.

Body circumferences or girth dimensions show some interesting changes when analyzed in this way. These data represent nude measurements, without clothing. In 1946, the 95th percentile value for neck circumference was 15.7 inches. In 1966, the 95th percentile value for neck circumference was 16.1 inches, an increase of 0.4 inches. While only five percent of Army men had neck girths greater than 15.7 inches in 1946, twelve percent had neck girths greater than 15.7 inches in 1966.

The 95th percentile value for chest girth was 40.5 inches in 1946; in 1966, this value had increased 1.2 inches, to 41.7 inches. While five percent of Army men had chests larger than 40.5 inches in 1946, nine and one-half percent had chest girths larger than 40.5 inches in 1966.

In 1946, the 95th percentile value of waist girth was 35.8 inches for Army men, and in 1966, the 95th percentile value was 37.8 inches, and increase of two inches. Thus, while only five percent of the population had waists larger than 35.8 inches in 1946, ten and one-half percent were above 35.8 inches in 1966. A similar shift in the 95th percentile values for hip circumference is shown in the data. At the 95th percentile level, hip girth was 40.5 inches in 1946, and 41.5 inches in 1966, an increase of one inch. Only five percent of the population had hip girths above 40.5 inches in 1946, as contrasted with eight percent in 1966.

This type of analysis would appear to indicate why there seems to be an increasing requirement for the larger sizes of military clothing. Changes in body size, as shown by an examination of Army anthropometric data, may or may not result in decisions to modify clothing patterns or to adjust the grading between clothing sizes. The anthropometric data do indicate, however, a requirement for larger quantities of the larger sizes of clothing in order to accommodate the shifts in the distribution of body sizes within the population.

As an example, if it may be assumed that 40.5 inches (the 95th percentile value for chest circumference in 1946) represents the upper limit of fit in the chest for a large-sized coat or jacket, then a larger size ("Extra-Large") would have been required for five percent of the population in 1946. If, furthermore, no changes are made in the pattern for that coat or jacket and the size remains the same, then the requirement or number needed for the larger size ("Extra-Large") has increased from five percent in 1946 up to nine and one-half percent for the Army population of 1966. This, then, would represent the necessity for a tariff adjustment, or an increase in the quantity of the clothing required for that size in response to the changes in body size in the Army population.

In summary, the sample of U. S. Army men measured in 1966, as compared with the 1946 sample, is on the average two years younger in age, but is about four pounds heavier and one-quarter of an inch taller. Most of the standing and sitting measurements are slightly higher for the 1966 Army series. As a reflection of the higher body weight, the 1966 Army men have greater body circumference or girths than those measured in 1946. Dimensions of the head and face, the hands and the feet do not show appreciable changes. Although the mean differences in body dimensions are not great, increases in the percentile values for body dimensions between 1946 and 1966 indicate changes in the distribution of body sizes in the Army population. Larger numbers of larger men in the present Army population may require adjustments in clothing tariffs in order to accommodate these changes in distribution.

TABLE LXI - STATISTICAL VALUES FOR 1966 and 1946 ARMY SERIES

No.	Measurements	N	Mean	Values in Inches				Range			
				SE(M)	S.D.	SE(SD)	V(%)	Min.	Max.	Total	
	Age (years)										
	U.S. Army (1966)	6682	22.17	0.06	4.64	0.04	20.92	17.0	55.0	38.0	
	U.S. Army (1946)	24,502	24.28	0.03	4.94	0.02	20.35	15.0	57.0	42.0	
1	Weight (pounds)										
	U.S. Army (1966)	6677	159.10	0.29	23.35	0.20	14.68	99.5	283.5	184.0	
	U.S. Army (1946)	24,506	154.81	0.13	20.56	0.09	13.28	95.0	305.0	210.0	
STANDING MEASUREMENTS											
2	Stature										
	U.S. Army (1966)	6682	68.71	0.03	2.60	0.02	3.79	59.7	78.6	18.9	
	U.S. Army (1946)	24,508	68.47	0.02	2.52	0.01	3.68	59.1	78.7	19.6	
3	Cervicale Height										
	U.S. Army (1966)	6682	58.88	0.03	2.50	0.02	4.24	50.3	68.4	18.1	
	U.S. Army (1946)	21,141	58.74	0.02	2.38	0.01	4.05	50.0	68.9	18.9	
4	Waist Height										
	U.S. Army (1966)	6682	41.86	0.03	2.11	0.02	5.05	34.0	49.7	15.7	
	U.S. Army (1946)	24,469	41.56	0.01	1.96	0.01	4.72	32.7	50.0	17.3	
5	Crotch Height										
	U.S. Army (1966)	6682	33.05	0.02	1.84	0.02	5.57	25.5	40.0	14.5	
	U.S. Army (1946)	24,497	32.84	0.01	1.75	0.01	5.33	25.6	39.8	14.2	

TABLE LXI — STATISTICAL VALUES FOR 1966 and 1946 ARMY SERIES (Continued)

No.	Measurements	N	Mean	Values in Inches				Range		
				SE(M)	S.D.	SE(SD)	V(%)	Min.	Max.	Total
SITTING MEASUREMENTS										
6	Sitting Height									
	U.S. Army (1966)	6682	35.70	0.02	1.44	0.01	4.04	30.4	40.6	10.2
	U.S. Army (1946)	24,352	35.78	0.01	1.34	0.01	3.74	30.3	41.3	11.0
7	Shoulder-Elbow Length									
	U.S. Army (1966)	6682	14.52	0.01	0.73	0.01	5.05	11.7	17.2	5.5
	U.S. Army (1946)	24,556	14.28	0.01	0.81	0.00	5.67	9.8	19.3	9.5
8	Elbow-Fingertip Length									
	U.S. Army (1966)	6682	18.88	0.01	0.91	0.01	4.81	15.4	22.7	7.3
	U.S. Army (1946)	24,354	18.73	0.01	0.88	0.00	4.70	14.8	23.4	8.6
9	Knee Height, Sitting									
	U.S. Army (1966)	6682	21.28	0.01	1.08	0.01	5.05	17.4	25.5	8.1
	U.S. Army (1946)	24,419	21.62	0.01	1.09	0.00	5.04	15.4	27.2	11.8
10	Buttock-Knee Length									
	U.S. Army (1966)	6682	23.41	0.01	1.12	0.01	4.80	19.6	28.0	8.4
	U.S. Army (1946)	24,244	23.40	0.01	1.12	0.01	4.79	19.3	28.0	8.7

TABLE LXI - STATISTICAL VALUES FOR 1966 and 1946 ARMY SERIES (Continued)

No.	Measurements	N	Mean	Values in Inches					Range Max.	Total
				SE(M)	S.D.	SE(SD)	V(%)	Min.		
BREADTH MEASUREMENTS										
11	Chest Depth									
	U.S. Army (1966)	6682	9.12	0.01	0.79	0.01	8.61	6.5	13.4	6.9
	U.S. Army (1946)	24,558	8.33	0.00	0.75	0.00	9.00	5.3	12.8	7.5
12	Chest Breadth									
	U.S. Army (1966)	6682	12.04	0.01	0.84	0.01	7.02	9.6	16.4	6.8
	U.S. Army (1946)	24,574	11.14	0.00	0.77	0.00	6.91	8.1	15.2	7.1
13	Shoulder Breadth									
	U.S. Army (1966)	6682	17.86	0.01	1.00	0.01	5.59	14.3	23.1	8.8
	U.S. Army (1946)	24,461	17.95	0.01	0.99	0.00	5.52	13.8	23.2	9.4
14	Forearm-Forearm Breadth									
	U.S. Army (1966)	6682	18.10	0.02	1.66	0.01	9.17	13.1	26.1	13.0
	U.S. Army (1946)	24,590	17.54	0.01	1.54	0.01	8.78	13.6	24.2	10.6
15	Hip Breadth, Sitting									
	U.S. Army (1966)	6682	13.45	0.01	0.94	0.01	6.97	10.3	19.8	9.5
	U.S. Army (1946)	24,575	13.95	0.01	0.90	0.00	6.45	11.2	19.9	8.7

TABLE LXI - STATISTICAL VALUES FOR 1966 and 1946 ARMY SERIES (Continued)

No.	Measurements	N	Mean	Values in Inches				V(%)	Min.	Range Max.	Total
				SE(M)	S.D.	SE(SD)					
CIRCUMFERENCES AND SURFACE MEASUREMENTS											
16	Neck Circumference										
	U.S. Army (1966)	6681	14.72	0.01	0.81	0.01	5.53	11.9	19.1	7.2	
	U.S. Army (1946)	24,423	14.46	0.00	0.73	0.00	5.05	11.6	19.1	7.5	
17	Chest Circumference										
	U.S. Army (1966)	6682	36.92	0.03	2.63	0.02	7.13	28.2	48.9	20.7	
	U.S. Army (1946)	24,470	36.38	0.01	2.34	0.01	6.43	28.0	48.4	20.4	
18	Waist Circumference										
	U.S. Army (1966)	6682	31.61	0.04	3.22	0.03	10.19	23.1	50.3	27.2	
	U.S. Army (1946)	24,472	30.60	0.02	2.76	0.01	9.02	23.2	46.8	23.6	
19	Hip Circumference										
	U.S. Army (1966)	6682	37.09	0.03	2.46	0.02	6.63	30.4	52.8	22.4	
	U.S. Army (1946)	24,500	36.67	0.01	2.24	0.01	6.11	26.4	50.0	23.6	
20	Upper Thigh Circum.										
	U.S. Army (1966)	6682	21.82	0.02	1.89	0.02	8.66	15.3	30.6	15.3	
	U.S. Army (1946)	24,832	21.44	0.01	1.70	0.01	7.93	16.2	27.7	11.5	
21	Lower Thigh Circum.										
	U.S. Army (1966)	6682	15.89	0.02	1.52	0.01	9.58	11.3	22.3	11.0	
	U.S. Army (1946)	24,711	14.72	0.01	1.05	0.00	7.13	11.5	19.8	8.3	
22	Calf Circumference										
	U.S. Army (1966)	6682	14.41	0.01	1.05	0.01	7.29	11.1	20.0	8.9	
	U.S. Army (1946)	24,686	14.08	0.01	0.94	0.00	6.68	10.7	18.6	7.9	

TABLE LXI - STATISTICAL VALUES FOR 1966 and 1946 ARMY SERIES (Continued)

No.	Measurements	N	Mean	Values in Inches				V(%)	Min.	Range Max.	Total
				SE(M)	S.D.	SE(SD)	V(%)				
CIRCUMFERENCES (continued)											
23	Arm Scye Circumference										
	U.S. Army (1966)	6682	17.54	0.02	1.28	0.01	7.32	12.7	23.7	11.0	
	U.S. Army (1946)	24,383	17.09	0.01	1.17	0.01	6.85	13.9	22.2	8.3	
24	Biceps Circum., Relaxed										
	U.S. Army (1966)	6682	11.59	0.01	1.08	0.01	9.29	8.2	17.4	9.2	
	U.S. Army (1946)	24,446	11.05	0.01	0.93	0.00	8.42	8.0	15.4	7.4	
25	Wrist Circumference										
	U.S. Army (1966)	6682	6.72	0.00	0.34	0.00	5.13	5.4	8.5	3.1	
	U.S. Army (1946)	24,391	6.70	0.00	0.40	0.00	5.97	5.3	8.3	3.0	
26	Shoulder Length										
	U.S. Army (1966)	6682	6.38	0.01	0.78	0.01	12.25	3.4	9.6	6.2	
	U.S. Army (1946)	24,453	6.05	0.00	0.67	0.00	11.07	4.0	8.4	4.4	
27	Interscye Breadth										
	U.S. Army (1966)	6682	15.39	0.02	1.24	0.01	8.07	10.7	20.4	9.7	
	U.S. Army (1946)	24,432	14.82	0.01	1.18	0.01	7.96	9.6	19.9	10.3	
28	Sleeve Length										
	U.S. Army (1966)	6682	33.80	0.02	1.56	0.01	4.61	27.7	39.5	11.8	
	U.S. Army (1946)	24,470	31.89	0.01	1.73	0.01	5.42	24.8	39.0	14.2	

TABLE LXI - STATISTICAL VALUES FOR 1966 and 1946 ARMY SERIES (Continued)

No.	Measurements	N	Mean	Values in Inches					Range Max.	Total
				SE(M)	S.D.	SE(SD)	V(%)	Min.		
HEAD AND FACE MEASUREMENTS										
29	Head Circumference	6682 24,466	22.09	0.01	0.63	0.01	2.86	20.06	25.13	5.07
	U.S. Army (1966)									
30	Head Length	6682 24,471	7.66	0.00	0.29	0.00	3.77	6.56	8.83	2.27
	U.S. Army (1966)									
31	Head Breadth	6682 24,447	6.01	0.00	0.23	0.00	3.83	5.06	6.86	1.80
	U.S. Army (1966)									
32	Head Height	6682 24,630	5.21	0.00	0.31	0.00	5.99	3.96	6.31	2.35
	U.S. Army (1966)									
33	Face Length	6681 24,494	4.74	0.00	0.26	0.00	5.50	3.80	5.76	1.96
	U.S. Army (1966)									
34	Face Breadth	6681 24,389	5.51	0.00	0.22	0.00	4.00	4.70	6.43	1.73
	U.S. Army (1966)									

TABLE LXI - STATISTICAL VALUES FOR 1966 and 1946 ARMY SERIES (Continued)

No.	Measurements	N	Mean	Values in Inches					Range Max.	Total
				SE(M)	S.D.	SE(SD)	V(%)	Min.		
HAND MEASUREMENTS										
35	Hand Length									
	U.S. Army (1966)	6682	7.49	0.00	0.38	0.00	5.06	6.08	9.30	3.22
	U.S. Army (1946)	24,487	7.58	0.00	0.36	0.00	4.75	5.91	9.06	3.15
36	Hand Breadth									
	U.S. Army (1966)	6681	.50	0.00	0.19	0.00	5.52	2.78	4.22	1.44
	U.S. Army (1946)	24,488	3.41	0.00	0.19	0.00	5.57	2.36	4.33	1.97
FOOT MEASUREMENTS										
37	Foot Length									
	U.S. Army (1966)	6682	10.50	0.01	0.51	0.00	4.86	8.41	12.77	4.36
	U.S. Army (1946)	24,372	10.44	0.00	0.48	0.00	4.60	8.27	12.01	3.74
38	Instep Length									
	U.S. Army (1966)	6682	7.73	0.01	0.41	0.00	5.32	6.36	9.66	3.30
	U.S. Army (1946)	24,475	7.61	0.00	0.44	0.00	5.78	5.51	9.65	4.14
39	Ball of Foot Breadth									
	U.S. Army (1966)	6682	3.87	0.00	0.22	5.56	3.13	4.81	1.68	
	U.S. Army (1946)	24,466	3.86	0.00	0.25	0.00	2.56	5.12	2.56	
40	Heel Breadth									
	U.S. Army (1966)	6682	2.70	0.00	0.18	0.00	6.84	1.99	3.55	1.56
	U.S. Army (1946)	24,341	2.64	0.00	0.21	0.00	7.95	1.58	3.94	2.36
41	Ball of Foot Circum.									
	U.S. Army (1966)	6682	9.85	0.01	0.58	0.01	5.92	7.30	12.37	5.07
	U.S. Army (1946)	24,468	9.70	0.00	0.50	0.00	5.15	7.87	11.81	3.94

TABLE LXII - PERCENTILE VALUES FOR 1966 AND 1946 ARMY SERIES

No.	Measurements	Percentiles in Inches										Range (1st-99th)					
		1st	2nd	5th	10th	25th	50th	75th	90th	95th	98th		99th				
1	Weight (pounds)																
	U.S. Army (1966)	116	120	126	132	143	156	173	190	202	216	227	227	211			
	U.S. Army (1946)	114	118	124	130	141	153	167	181	192	205	215	215	101			
STANDING MEASUREMENTS																	
2	Stature																
	U.S. Army (1966)	62.6	63.4	64.5	65.4	67.0	68.7	70.4	72.1	73.1	74.2	74.9	74.9	12.3			
	U.S. Army (1946)	62.7	63.3	64.3	65.2	66.8	68.5	70.2	71.8	72.6	73.7	74.5	74.5	11.8			
3	Cervicale Height																
	U.S. Army (1966)	52.9	53.7	54.8	55.8	57.2	58.8	60.6	62.1	63.0	64.0	64.6	64.6	11.7			
	U.S. Army (1946)	53.2	53.8	54.8	55.7	57.1	58.7	60.4	61.8	62.7	63.7	64.4	64.4	11.2			
4	Waist Height																
	U.S. Army (1966)	36.8	37.4	38.4	39.2	40.5	41.9	43.3	44.5	45.3	46.3	46.9	46.9	10.1			
	U.S. Army (1946)	37.1	37.5	38.3	39.0	40.2	41.5	42.9	44.0	44.8	45.6	46.3	46.3	9.2			
5	Crotch Height																
	U.S. Army (1966)	28.6	29.2	30.0	30.7	31.8	33.0	34.3	35.4	36.1	36.9	37.4	37.4	8.8			
	U.S. Army (1946)	28.8	29.2	30.0	30.6	31.7	32.8	34.0	35.1	35.8	36.5	37.2	37.2	8.4			

TABLE LXII - PERCENTILE VALUES FOR 1966 AND 1946 ARMY SERIES (continued)

No.	Measurements	Percentiles in Inches										Range (1st-99th)					
		1st	2nd	5th	10th	25th	50th	75th	90th	95th	98th		99th				
6	Sitting Height																
	U.S. Army (1966)	32.3	32.7	33.3	33.8	34.7	35.7	36.7	37.6	38.1	38.6	39.0					6.7
	U.S. Army (1946)	32.6	33.0	33.5	34.0	34.8	35.8	36.7	37.5	38.0	38.6	39.0					6.4
7	Shoulder-Elbow Length																
	U.S. Army (1966)	12.8	13.0	13.3	13.6	14.0	14.5	15.0	15.5	15.7	16.1	16.3					3.5
	U.S. Army (1946)	12.3	12.6	12.9	13.2	13.7	14.3	14.8	15.3	15.6	15.9	16.2					3.9
8	Elbow-Fingertip Length																
	U.S. Army (1966)	16.8	17.1	17.4	17.8	18.3	18.8	19.5	20.1	20.4	20.9	21.1					4.4
	U.S. Army (1946)	16.7	16.9	17.3	17.6	18.1	18.7	19.3	19.8	20.1	20.5	20.7					4.0
9	Knee Height, Sitting																
	U.S. Army (1966)	18.8	19.1	19.6	20.0	20.6	21.3	22.0	22.7	23.1	23.6	23.9					5.1
	U.S. Army (1946)	19.0	19.3	19.8	20.2	20.9	21.6	22.4	23.1	23.5	23.9	24.3					5.3
10	Buttock-Knee Length																
	U.S. Army (1966)	20.8	21.2	21.6	22.0	22.6	23.4	24.1	24.9	25.3	25.8	26.2					5.4
	U.S. Army (1946)	20.7	21.0	21.5	21.9	22.6	23.4	24.2	24.2	24.8	25.3	25.7					5.3

TABLE LXII - PERCENTILE VALUES FOR 1966 AND 1946 ARMY SERIES (continued)

No.	Measurements	Percentiles in Inches										Range (1st-99th)							
		1st	2nd	5th	10th	25th	50th	75th	90th	95th	98th		99th						
11	Chest Depth																		
	U.S. Army (1966)	7.6	7.7	8.0	8.2	8.6	9.1	9.6	10.1	10.5	11.0	11.4	11.4	11.4	11.4	11.4	11.4	11.4	3.8
	U.S. Army (1946)	6.8	7.0	7.2	7.4	7.8	8.3	8.8	9.3	9.6	10.1	10.5	10.5	10.5	10.5	10.5	10.5	10.5	3.7
12	Chest Breadth																		
	U.S. Army (1966)	10.3	10.5	10.8	11.0	11.4	12.0	12.6	13.1	13.5	14.0	14.3	14.3	14.3	14.3	14.3	14.3	14.3	4.0
	U.S. Army (1946)	9.4	9.6	9.9	10.1	10.6	11.1	11.6	12.1	12.4	12.8	13.2	13.2	13.2	13.2	13.2	13.2	13.2	3.8
13	Shoulder Breadth																		
	U.S. Army (1966)	15.7	16.0	16.3	16.6	17.2	17.8	18.5	19.2	19.6	20.1	20.5	20.5	20.5	20.5	20.5	20.5	20.5	4.8
	U.S. Army (1946)	15.8	16.0	16.4	16.7	17.2	17.9	18.5	19.2	19.6	20.2	20.6	20.6	20.6	20.6	20.6	20.6	20.6	4.8
14	Forearm-Forearm Breadth																		
	U.S. Army (1966)	14.9	15.2	15.7	16.1	16.9	18.0	19.1	20.3	21.1	22.0	22.7	22.7	22.7	22.7	22.7	22.7	22.7	7.8
	U.S. Army (1946)	14.4	14.7	15.2	15.7	16.5	17.4	18.5	19.5	20.3	21.1	21.8	21.8	21.8	21.8	21.8	21.8	21.8	7.4
15	Hip Breadth, Sitting																		
	U.S. Army (1966)	11.6	11.8	12.1	12.3	12.8	13.4	14.0	14.7	15.1	15.6	16.0	16.0	16.0	16.0	16.0	16.0	16.0	4.4
	U.S. Army (1946)	12.2	12.4	12.7	12.9	13.4	13.9	14.4	15.1	15.5	16.2	16.7	16.7	16.7	16.7	16.7	16.7	16.7	4.5

TABLE LXII - PERCENTILE VALUES FOR 1966 AND 1946 ARMY SERIES (continued)

No.	Measurements	Percentiles in Inches										Range (1st-99th)		
		1st	2nd	5th	10th	25th	50th	75th	90th	95th	98th		99th	
CIRCUMFERENCES AND SURFACE MEASUREMENTS														
16	Neck Circumference													
	U.S. Army (1966)	13.0	13.2	13.5	13.7	14.2	14.7	15.2	15.8	16.1	16.5	16.8	3.8	
	U.S. Army (1946)	12.6	13.0	13.3	13.5	13.9	14.4	14.9	15.4	15.7	16.1	16.4	3.6	
17	Chest Circumference													
	U.S. Army (1966)	31.8	32.4	33.1	33.8	35.1	36.6	38.5	40.4	41.7	43.3	44.4	12.6	
	U.S. Army (1946)	31.6	32.1	32.9	33.6	34.8	36.2	37.8	39.4	40.5	41.9	43.0	11.4	
18	Waist Circumference													
	U.S. Army (1966)	26.1	26.7	27.4	28.1	29.3	31.0	33.4	36.0	37.8	40.0	41.6	15.5	
	U.S. Army (1946)	25.6	26.1	26.8	27.4	28.6	30.2	32.1	34.3	35.8	37.6	39.1	13.5	
19	Hip Circumference													
	U.S. Army (1966)	32.3	32.8	33.5	34.2	35.4	36.8	38.6	40.4	41.6	43.0	44.1	11.8	
	U.S. Army (1946)	32.0	32.6	33.3	34.0	35.1	36.5	38.0	39.5	40.5	41.8	42.8	10.8	
20	Upper Thigh Circum.													
	U.S. Army (1966)	17.9	18.3	18.9	19.5	20.5	21.7	23.0	24.3	25.1	26.0	26.6	8.7	
	U.S. Army (1946)	17.9	18.2	18.8	19.4	20.2	21.3	22.5	23.7	24.5	25.4	26.0	8.1	
21	Lower Thigh Circum.													
	U.S. Army (1966)	12.9	13.1	13.6	14.0	14.8	15.8	16.9	18.0	18.6	19.2	19.6	6.7	
	U.S. Army (1946)	12.5	12.7	13.1	13.4	14.0	14.7	15.4	16.1	16.6	17.2	17.6	5.1	
22	Calf Circumference													
	U.S. Army (1966)	12.2	12.4	12.8	13.1	13.7	14.4	15.1	15.8	16.2	16.7	17.1	4.9	
	U.S. Army (1946)	12.0	12.2	12.6	12.9	13.4	14.0	14.6	15.3	15.7	16.2	16.5	4.5	

TABLE LXII - PERCENTILE VALUES FOR 1966 AND 1946 ARMY SERIES (continued)

No.	Measurements	Percentiles in Inches										Range (1st-99th)			
		1st	2nd	5th	10th	25th	50th	75th	90th	95th	98th		99th		
CIRCUMFERENCES (continued)															
23	Arm Scye Circumference														
	U.S. Army (1966)	14.8	15.1	15.6	16.0	16.7	17.4	18.3	19.2	19.8	20.6	21.2	6.4		
	U.S. Army (1946)	14.5	14.8	15.2	15.6	16.3	17.0	17.8	18.6	19.1	19.7	20.1	5.6		
24	Biceps Circum., Relaxed														
	U.S. Army (1966)	9.4	9.6	10.0	10.3	10.8	11.5	12.3	13.0	13.5	14.0	14.4	5.0		
	U.S. Army (1946)	9.1	9.3	9.6	9.9	10.4	11.0	11.7	12.3	12.7	13.2	13.5	4.4		
25	Wrist Circumference														
	U.S. Army (1966)	5.9	6.0	6.2	6.3	6.5	6.7	6.9	7.2	7.3	7.5	7.6	1.7		
	U.S. Army (1946)	5.8	5.9	6.0	6.2	6.4	6.7	7.0	7.2	7.4	7.6	7.7	1.9		
26	Shoulder Length														
	U.S. Army (1966)	4.4	4.6	5.0	5.3	5.9	6.4	6.9	7.3	7.6	7.8	8.1	3.7		
	U.S. Army (1946)	4.5	4.7	4.9	5.2	5.6	6.1	6.5	6.9	7.1	7.4	7.6	3.1		
27	Interscye Breadth														
	U.S. Army (1966)	12.6	12.9	13.4	13.8	14.6	15.4	16.2	17.0	17.4	18.0	18.4	5.8		
	U.S. Army (1946)	12.1	12.4	12.9	13.3	14.0	14.8	15.6	16.3	16.8	17.3	17.7	5.6		
28	Sleeve Length														
	U.S. Army (1966)	30.2	30.6	31.3	31.8	32.7	33.8	34.8	35.8	36.4	37.1	37.5	7.3		
	U.S. Army (1946)	27.9	28.3	29.0	29.7	30.8	31.9	33.1	34.1	34.8	35.4	36.0	8.1		

TABLE LXII - PERCENTILE VALUES FOR 1966 AND 1946 ARMY SERIES (continued)

No.	Measurements	Percentiles in Inches									Range (1st-99th)			
		1st	2nd	5th	10th	25th	50th	75th	90th	95th		98th	99th	
HEAD AND FACE MEASUREMENTS														
29	Head Circumference													
	U.S. Army (1966)	20.63	20.81	21.07	21.30	21.66	22.08	22.51	22.91	23.16	23.43	23.61	23.85	2.98
	U.S. Army (1946)	20.87	21.05	21.28	21.50	21.87	22.30	22.72	23.10	23.35	23.65	23.85	2.98	
30	Head Length													
	U.S. Army (1966)	6.99	7.07	7.19	7.29	7.47	7.67	7.86	8.03	8.14	8.26	8.34	1.35	
	U.S. Army (1946)	7.02	7.10	7.21	7.31	7.48	7.67	7.86	8.03	8.13	8.24	8.32	1.30	
31	Head Breadth													
	U.S. Army (1966)	5.48	5.55	5.65	5.73	5.86	6.00	6.16	6.31	6.40	6.51	6.58	1.10	
	U.S. Army (1946)	5.46	5.53	5.62	5.70	5.84	5.99	6.14	6.29	6.38	6.48	6.56	1.10	
32	Head Height													
	U.S. Army (1966)	4.46	4.56	4.69	4.81	5.00	5.21	5.42	5.61	5.72	5.83	5.90	1.44	
	U.S. Army (1946)	4.60	4.66	4.76	4.84	4.99	5.15	5.32	5.48	5.58	5.70	5.78	1.18	
33	Face Length													
	U.S. Army (1966)	4.14	4.21	4.31	4.41	4.56	4.73	4.91	5.07	5.17	5.29	5.37	1.23	
	U.S. Army (1946)	4.27	4.34	4.46	4.56	4.72	4.91	5.10	5.28	5.40	5.52	5.60	1.33	
34	Face Breadth													
	U.S. Army (1966)	5.01	5.07	5.15	5.23	5.36	5.51	5.66	5.79	5.88	5.98	6.05	1.04	
	U.S. Army (1946)	4.90	4.97	5.07	5.16	5.30	5.48	5.63	5.78	5.86	5.96	6.02	1.12	

TABLE LXII - PERCENTILE VALUES FOR 1966 AND 1946 ARMY SERIES (concluded)

No.	Measurements	Percentiles in Inches									Range (1st-99th)				
		1st	2nd	5th	10th	25th	50th	75th	90th	95th		98th	99th		
HAND MEASUREMENTS															
35	Hand Length														
	U.S. Army (1966)	6.66	6.75	6.90	7.02	7.23	7.48	7.74	7.98	8.13	8.31	8.44	1.78		
	U.S. Army (1946)	6.74	6.83	6.98	7.10	7.32	7.58	7.83	8.05	8.20	8.36	8.47	1.73		
36	Hand Breadth														
	U.S. Army (1966)	3.07	3.12	3.20	3.26	3.37	3.50	3.63	3.75	3.83	3.93	3.99	0.92		
	U.S. Army (1946)	2.95	3.00	3.09	3.16	3.28	3.41	3.55	3.67	3.75	3.82	3.88	0.93		
FOOT MEASUREMENTS															
37	Foot Length														
	U.S. Army (1966)	9.37	9.51	9.71	9.89	10.19	10.53	10.87	11.20	11.41	11.65	11.82	2.45		
	U.S. Army (1946)	9.31	9.45	9.65	9.83	10.11	10.44	10.75	11.05	11.24	11.44	11.55	2.24		
38	Instep Length														
	U.S. Army (1966)	6.78	6.89	7.06	7.21	7.46	7.73	8.00	8.25	8.41	8.61	8.76	1.98		
	U.S. Army (1946)	6.55	6.70	6.88	7.05	7.32	7.62	7.90	8.17	8.33	8.52	8.65	2.10		
39	Ball of Foot Breadth														
	U.S. Army (1966)	3.39	3.45	3.53	3.61	3.73	3.87	4.01	4.15	4.24	4.34	4.41	1.02		
	U.S. Army (1946)	3.28	3.36	3.46	3.54	3.70	3.86	4.03	4.18	4.27	4.37	4.44	1.16		
40	Heel Breadth														
	U.S. Army (1966)	2.31	2.36	2.42	2.48	2.57	2.69	2.82	2.94	3.02	3.12	3.19	0.88		
	U.S. Army (1946)	2.14	2.20	2.29	2.36	2.49	2.63	2.77	2.91	3.01	3.12	3.21	1.07		
41	Ball of Foot Circum.														
	U.S. Army (1966)	8.37	8.57	8.86	9.10	9.48	9.87	10.24	10.58	10.78	11.02	11.18	2.81		
	U.S. Army (1946)	8.55	8.68	8.88	9.05	9.35	9.70	10.03	10.35	10.55	10.76	10.93	2.38		

9. SUMMARY AND CONCLUSIONS

An anthropometric survey of U. S. Army personnel was conducted between November, 1965 and April, 1966. During the survey, seventy body measurements were made on a total sample of 6682 Army men, including 2639 basic trainees, 3429 infantrymen, 489 armored crewmen, and 125 Army aviators. The resulting anthropometric data are presented in detail in this report. The Army data are compared with data on men of other services, and a discussion of changes in body size in Army men between 1946 and 1966 is presented.

The U. S. Armed Forces anthropometric surveys of 1966, of which the Army survey was a part, represent the first major up-dating of anthropometric data on the U. S. military population in some twenty years. These surveys also provide, for the first time, standard anthropometric data for all of the Armed Forces.

Body size information, in the form of anthropometric data, is required as a basis for design criteria in the development of military equipment and materiel. Information on the range of variability in body size and proportions within the military population is necessary for the design, sizing, and tariffing of military clothing and individual equipment. Anthropometric data provide a basic input for the design and human engineering of military equipment and materiel. Due to the lack of adequate anthropometric data on the U. S. civilian population, the military data are widely used in civilian and industrial applications as well.

10. ACKNOWLEDGEMENTS

A large number of people aided in the conduct of the U. S. Army anthropometric survey through their active participation, cooperation, and assistance. Had it not been for the cooperation of the almost 7000 men who were measured, as well as their commanding officers and staffs, there would have been no anthropometric data to report.

The members of the measuring teams deserve full credit and acknowledgement for their long and tedious hours of measuring during the survey. The following men served on the measuring teams: SFC Emmett Headley, SSG Eli B. Oliver, SSG Theodore Stephens, SGT Howard E. Crockett, Sgt Robert J. Hayes, Sgt Thomas P. Skizenski, SP5 John D. Petraitis, SP5 Ira W. Clark, CPL Frank A. Mills, CPL Warren E. Stiles, CPL Andrew Taylor, SP4 Bobby L. Adams, SP4 Marvin J. Ingram, SP4 Harold D. Leonard, SP4 Don R. Montgomery, SP4 Robert A. Perrigo, SP4 Wilson E. Taylor, SP4 Otto E. Williammee, Jr., SP4 Frank D. Wood, PFC Daniel J. Arnold, PFC Ronald M. Davison, PFC Harlan G. Garbe, PFC Victor A. Kowalski, PFC Kris K. Snyder, and PFC Charles F. Troxell.

The active participation in the survey of the U. S. Army General Equipment Test Activity and the support of Dr. Howard W. Hembree, Technical Director, and his staff, is acknowledged. This activity provided the organization and personnel to make the survey a success. Major John E. Donaldson admirably performed all of the administrative and planning functions which were necessary to schedule and maintain the measuring team's visits to a dozen Army posts throughout the country. Able assistance was provided by Staff Sergeant Jackie W. Snyder as administrative coordinator. At different times during the survey, Captain Theodore A. Lide, Second Lieutenant James E. Gardner, and Second Lieutenant Lynn W. Kling, Jr. had the responsibility of leading and supervising the measuring teams; they performed this assignment very well.

The cooperation and assistance of Mr. Charles E. Clauser and other members of the Anthropology Branch, Aerospace Medical Research Laboratory, Wright-Patterson Air Force Base, is gratefully acknowledged with thanks. Through the cooperation of the U. S. Air Force, Mr. Edmund Churchill and the staff of the Anthropology Project carried out the exacting task of reducing and processing the data – it is largely their work which is presented in this report. Mr. Churchill also prepared the sections of this report on Data Processing and the Statistical Measures.

During his term as an assistant in the Anthropology Laboratory at Natick, Mr. Richard L. Burse was extremely helpful in planning the survey, in the training program for measurers, and in analyzing the results.

The illustrative sketches in this report are the work of Mrs. M. J. Kennedy, whose assistance is acknowledged with thanks.

11. REFERENCES

1. Baxter, J.H., Statistics, medical and anthropological, of the Provost Marshall General's Bureau, derived from records of the examination for military service in the Armies of the United States during the late War of the Rebellion, of over a million recruits, drafted men, substitutes and volunteers. Government Printing Office, Washington, D. C., 1875.
2. Churchill, E., J. T. McConville, L. L. Laubach, and R. M. White, Anthropometry of U. S. Army aviators — 1970. Technical Report 72-52-CE, U. S. Army Natick Laboratories, Natick, Mass., 1971.
3. Clauser, C.E., Pearl Tucker, J. T. McConville, E. Churchill, L. L. Laubach, and Joan Reardon, Anthropometric survey of Air Force women — 1968. AMRL Technical Report 70-5, Aerospace Medical Research Laboratory, Wright-Patterson Air Force Base, Ohio, 1971.
4. Damon, A., H. W. Stoudt, and R. A. McFarland, The human body in equipment design. Harvard University Press, Cambridge, Mass., 1966.
5. Daniels, G. S., H. C. Meyers, Jr., and E. Churchill, Anthropometry of male basic trainees. WADC Technical Report 53-49, Aero Medical Laboratory, Wright-Patterson Air Force Base, Ohio, 1953. (AD 20717)
6. Daniels, G. S., H. C. Meyers, Jr., and S. H. Worrall, Anthropometry of WAF basic trainees. WADC Technical Report 53-12, Aero Medical Laboratory, Wright-Patterson Air Force Base, Ohio, 1953. (AD 20542)
7. Davenport, C. B. and A. G. Love, The Medical Department of the United States Army in the World War, Volume XV, Statistics; Part I, Army anthropology. Government Printing Office, Washington, D. C., 1921.
8. Dobbins, D. A. and C. M. Kindick, Anthropometry of the Latin-American Armed Forces, Research Report No. 10 (Interim Report), U. S. Army Tropic Test Center, Fort Clayton, Canal Zone, 1967.
9. Garrett, J. W. and K. W. Kennedy, A collation of anthropometry. Aerospace Medical Research Laboratory, Wright-Patterson Air Force Base, Ohio, 1971. (2 volumes) (AD 723629)
10. Gifford, E. C., Compilation of anthropometric measures on U. S. Navy pilots. Report NAMC-ACEL-437, Air Crew Equipment Laboratory, U. S. Naval Air Material Center, Philadelphia, Pennsylvania, 1960.

REFERENCES (continued)

11. Gifford, E. C., J. R. Provost, and J. Lazo, Anthropometry of Naval aviators — 1964. Report NAEC-ACEL-533, Aerospace Crew Equipment Laboratory, U. S. Naval Air Engineering Center, Philadelphia, Pennsylvania, 1965.
12. Gould, B. A., Investigations in the military and anthropological statistics of American soldiers. For the U. S. Sanitary Commission. Hurd and Houghton, New York, New York, 1869.
13. Hansen, R. and D. Y. Cornog; H. T. E. Hertzberg (editor), Annotated bibliography of applied physical anthropology in human engineering. WADC Technical Report 56-30, Aero Medical Laboratory, Wright-Patterson Air Force Base, Ohio, 1958. (AD 155622)
14. Hart, G. L., G. E. Rowland, and R. Malina, Anthropometric survey of the Armed Forces of the Republic of Korea. Technical Report 68-8-PR (Contract Report, Rowland and Company, Haddonfield, New Jersey), U. S. Army Natick Laboratories, Natick, Mass., 1967. (AD 640891)
15. Hertzberg, H. T. E., E. Churchill, C. W. Dupertuis, R. M. White, and A. Damon, Anthropometric survey of Turkey, Greece, and Italy. AGARDograph 73, The McMillan Company, New York, New York, 1963. (AD 421428)
16. Hertzberg, H. T. E., G. S. Daniels, and E. Churchill, Anthropometry of flying personnel — 1950. WADC Technical Report 52-321, Aero Medical Laboratory, Wright-Patterson Air Force Base, Ohio, 1954. (AD 47953)
17. Jantz, R. L., W. S. Ellis, and L. R. Collins, Anthropometry for the Dragon (XM-47 surface attack guided missile system). Report F187, McDonnell Company, St. Louis, Missouri, 1967.
18. Kay, W. C., Anthropometry of Republic of Korea Air Force pilots. Republic of Korea Air Force Journal of Aviation Medicine, Volume 9, No. 1 (Seoul, Korea), 1961.
19. Military Standard: Human engineering design criteria for military systems, equipment and facilities. MIL-STD-1472A, U. S. Department of Defense, Washington, D. C., 1970.
20. Morgan, C. T., J. S. Cook, III, A. Chapanis, and M. W. Lund (editors), Human engineering guide to equipment design. McGraw-Hill Book Company, New York, New York, 1963.

REFERENCES (continued)

21. Newman, R. W. and R. M. White, Reference anthropometry of Army men. EPS Report No. 180, Quartermaster Climatic Research Laboratory, U. S. Army, Lawrence, Mass., 1951 (AD 149451)
22. Noorani, Lt. Col. Dr. Shoja-eddin and C. N. Dillard, Jr., Anthropometric survey of the Imperial Iranian Armed Forces. Technical Report of the Combat Research and Evaluation Center, Imperial Iranian Ground Forces, (Teheran, Iran), 1970. (Volume I – Data Collection and Analysis, Volume II – Statistical Data)
23. O'Brien, R. and W. C. Shelton, Women's measurements for garment and pattern construction. Miscellaneous Publication No. 454, U. S. Department of Agriculture, Washington, D. C., 1941.
24. Oshima, M., T. Fujimoto, T. Oguro, N. Tobimatsu, T. Mori, I. Tanaka, T. Watanabe, and M. Alexander (USAF), Anthropometry of Japanese pilots. Reports of the Aero Medical Laboratory, Volume 2, No. 2, (Tokyo, Japan), 1962.
25. Randall, F. E., A. Damon, R. S. Benton, and D. I. Patt, Human body size in military aircraft and personal equipment. Army Air Forces Technical Report 5501, Air Materiel Command, Wright Field, Ohio, 1946; reprinted 1963. (ATI 25419)
26. Randall, F. E. and E. H. Munro, Reference anthropometry of Army women. EPS Report No. 149, Quartermaster Climatic Research Laboratory, U. S. Army, Lawrence, Mass., 1949. (AD 209837)
27. Schane, W. P., D. E. Littell, and C. G. Moultrie, Selected anthropometric measurements of 1640 U. S. Army warrant officer candidate flight trainees. USAARL Report No. 69-2, U. S. Army Aeromedical Research Laboratory, Fort Rucker, Alabama, 1969.
28. Snow, C. C. and R. G. Snyder, Anthropometry of air traffic control trainees. Federal Aviation Agency, Office of Aviation Medicine, Civil Aeromedical Research Institute, Oklahoma City, Oklahoma, 1965.
29. Stoudt, H. W., A. Damon, R. A. McFarland, and J. Roberts, Weight, height, and selected body dimensions of adults – United States, 1960-62. Public Health Service Publication No. 1000 – Series 11 – No. 8, U. S. Department of Health, Education and Welfare, Washington, D. C., 1965.

REFERENCES (continued)

30. Stoudt, H.W., A Damon, R. A. McFarland, and J. Roberts, Skinfolds, body girths, biacromial diameter, and selected anthropometric indices of adults — United States, 1960-62. Public Health Service Publication No. 1000 — Series 11 — No. 35, U. S. Department of Health, Education and Welfare, Washington, D. C., 1970.
31. White, R. M., Anthropometry of Army aviators. EPRD Technical Report EP-150, Quartermaster Research and Engineering Center, U. S. Army, Natick, Mass., 1961. (AD 263357)
32. White, R. M., Anthropometric survey of the Royal Thai Armed Forces. U. S. Army Natick Laboratories, Natick, Mass., 1964. (AD 450836)
33. White, R. M., Anthropometric survey of the Armed Forces of the Republic of Vietnam. U. S. Army Natick Laboratories, Natick, Mass., 1964. (AD 458864)
34. White, R. M. and E. Churchill, U. S. Marine Corps anthropometry — 1966. Technical Report, U. S. Army Natick Laboratories, Natick, Mass. (in preparation)
35. White, R. M. and E. Churchill, Anthropometry of U. S. Navy recruits — 1966. Technical Report, U. S. Army Natick Laboratories, Natick, Mass. (in preparation)

APPENDIX - The Data Sheet (Front)

U. S. ARMY ANTHROPOMETRIC SURVEY - 1965

ANTHROPOMETRIC MEASUREMENTS

Location _____ Card 1: _____
 Subject No. 1 _____

Unit _____ Date _____

Name _____

Rank: Enlisted private or Specialist¹, NCO², WO³, Comm. Off. 4 7

Pay Grade: 1, 2, 3, 4, 5, 6, 7, 8, 9

Service No. _____

Branch of Service _____

Primary MOS _____ 13

Duty MOS _____ 18

Additional Specialty _____ 23

Present Job Assignment _____ 25

Length of Service: years completed _____ 28
 months, up to 12 _____ 30

Age: years, at last birthday _____ 32

Birthplace, Subject _____ 34

Birthplace, Father _____ 36

Birthplace, Mother _____ 38

Longest Residence _____ 40

Race _____ 42

National Extraction _____ 43

Education: years of schooling completed _____ 47

Marital Status: single¹, married², septd.³, divorced⁴, widower⁵ _____ 50

Nude Weight (nearest pound) _____ 53

Height, without shoes (nearest inch) _____ 55

Glasses: not worn¹, worn² _____ 56

Handedness: right-handed¹, left-handed², ambidexterous³ _____ 57

Combat Boots (size and width worn) _____

Station #1 - Scale _____ Card 2: 7

1 WEIGHT (to nearest pound) _____

Station #2 - Standing on floor; full anthropometer

2 STATURE _____ 10

3 CERVICAL HEIGHT _____ 14

4 SHOULDER HEIGHT (ACROMIALE) _____ 18

5 WAIST HEIGHT (ILIOCRISTALE) _____ 22

6 FUNCTIONAL REACH (from wall) _____ 26

Standing on box; half anthropometer

7 GROUCH HEIGHT _____ 30

8 PATELLA HEIGHT, TOP _____ 34

9 CALF HEIGHT _____ 37

Sitting, with foot box; half anthropometer

10 ARM REACH, UPWARD _____ 40

11 SITTING HEIGHT _____ 44

12 EYE HEIGHT, SITTING _____ 48

13 MID-SHOULDER HEIGHT, SITTING _____ 51

14 KNEE HEIGHT, SITTING _____ 54

15 POPLITEAL HEIGHT, SITTING _____ 57

Station #3 - Standing; large calipers

16 CHEST DEPTH _____ 60

17 CHEST BREADTH, SKIN _____ 63

18 HIP BREADTH, STANDING _____ 66

Sitting; large calipers

19 OCCIPUT - EXTERNAL CANTRUS _____ 69

20 OCCIPUT - FRAGION _____ 72

21 HEAD HEIGHT (VERTEX-TRAGION) _____ Card 3: 7

22 SHOULDER-ELBOW LENGTH _____ 10

APPENDIX - The Data Sheet (Back)

23 FOREARM-HAND LENGTH

24 BUTTOCK-KNEE LENGTH

25 BUTTOCK-POPLITEAL LENGTH

26 SHOULDER BREADTH (BIDELTOID)

27 MAXIMUM FOREARM-FOREARM BREADTH

28 HIP BREADTH, SITTING

Station #4 - Sitting; spreading calipers

29 FACE BREADTH (BIZYCOMATIC)

30 BITRACION DIAMETER

31 HEAD LENGTH

32 OCCIPUT - NASAL ROOT

33 OCCIPUT - PRONASALE

34 HEAD BREADTH

Sitting; sliding calipers

35 INTERPUPILLARY DISTANCE

36 FACE LENGTH (MENTON-NASAL ROOT)

37 HAND LENGTH

38 PALM LENGTH

39 THUMB CROTCH - 1ST FINGER BASE

40 HAND BREADTH (METACARPALS)

Standing on box; sliding calipers

41 HEEL BREADTH

Standing; foot board

Toe Length: 1st toe longer¹, 2nd toe longer²

42 FOOT LENGTH

43 BALL OF FOOT LENGTH (INSTEP)

44 BALL OF FOOT BREADTH

Station #5 - Standing; tape

45 HEAD CIRCUMFERENCE

46 NECK CIRCUMFERENCE

13			
16			
19			
22			
25			
28			

31			
34			
37			
40			
43			
46			

49			
51			
54			
57			
60			
62			

65		
----	--	--

68		
69		
72		
7		

10		
13		

16			
20			
24			
28			

32			
35			
38			
41			
44			
47			

50			
53			
56			
59			
62			
65			
68			

72			
7			
10			
13			
16			
19			
22			

31		
33		
35		

47 SHOULDER CIRCUMFERENCE

48 CHEST CIRCUMFERENCE

49 WAIST CIRCUMFERENCE

50 HIP (BUTTOCK) CIRCUMFERENCE

51 ARM SCYE CIRCUMFERENCE

52 BICEPS CIRCUMFERENCE, EXTENDED

53 WRIST CIRCUMFERENCE

54 HAND CIRCUMFERENCE (METACARPALS)

55 BICEPS CIRCUMFERENCE, FLEXED

56 FOREARM CIRCUMFERENCE, FLEXED

Station #6 - Standing on floor; tape

57 WAIST BACK LENGTH

58 SHOULDER LENGTH

59 INTERSCYE DISTANCE

60 INTERSCYE MAXIMUM

61 SLEEVE LENGTH

62 SLEEVE INSEAM

63 VERTICAL TRUNK CIRCUMFERENCE

Standing on box; tape

64 UPPER THIGH CIRCUMFERENCE

65 LOWER THIGH CIRCUMFERENCE

66 CALF CIRCUMFERENCE

67 ANGLE CIRCUMFERENCE

68 HEEL-ANKLE CIRCUMFERENCE

69 INSTEP CIRCUMFERENCE

70 BALL OF FOOT CIRCUMFERENCE

Station #7 - Skinfold calipers

71 DORSAL HAND 25

72 JUXTA-NIPPLE 27

73 TRICEPS 29

74 SUB-SCAPULAR 31

75 M-A-L XIPHOID 33

76 SUPRA-ILIAC 35

DISTRIBUTION

Number of Copies

DEPARTMENT OF DEFENSE ADDRESSEES

Director 1
Defense Supply Agency
Cameron Station
Alexandria, VA 22314

Director 1
Dept. of Defense Research & Eng.
ATTN: Advanced Research Projects Agency
The Pentagon
Arlington, VA 20301

Chief, Programs & Policy Office 1
Directorate of Tech. Operations
DPSC
2800 South 20th St.
Philadelphia, PA 19101

U. S. ARMY

Commanding Officer 1
US Army Aeromedical Research Laboratory
ATTN: Tech. Library
Fort Rucker, AL 36360

Library 1
US Army Airborne, Electronics &
Special Warfare Board
Fort Bragg, N.C. 28307

Commandant 1
US Army Armor School
ATTN: Chief, Pol & Tng Lit Div
Fort Knox, KY 40121

Commanding Officer 1
US Army Arctic Test Center
APO Seattle, WA 98733

President 1
HQ US Army Artillery Bd.
Fort Sill, OK 73504

US Army Aviation School Library 1
Bldg. 5313
Fort Rucker, AL 36360

Number of Copies

Commanding Officer, ARDC US Army Ballistics Research Labs ATTN: AMXRD-BVL (Dr. A. A. Woodward) Aberdeen Proving Ground, MD 21005	2
Commanding Officer, Eustis Directorate US Army Air Mobility R&D Laboratory ATTN: SAYFE-SS Ft. Eustis, VA 23604	1
Commanding General US Army Aviation Systems Command ATTN: AMSAV-R-F (Mr. Stephen Moreland) P. O. Box 209, St. Louis, MO 63166	2
Commanding General US Army Aviation Systems Command ATTN: AMSAV-MNA P. O. Box 209, St. Louis, MO 63166	1
Commanding General US Army Electronics Command ATTN: AMSEL-VL-3 Ft. Monmouth, NJ 07703	1
US Army Field Office Hq. Air Force Systems Command ATTN: SDOA (Mr. J. Proctor) Andrews Air Force Base Washington, D.C. 20331	2
Commanding General US Army Missile Command ATTN: AMSMI-RLH Redstone Arsenal, AL 35809	1
Commanding Officer US Army Tropic Test Center ATTN: Research Division Fort Clayton, Canal Zone	2
Commanding General US Army Materiel Command ATTN: AMCRD-J (Mr. C. Gardner) Washington, D.C. 20315	1

Number of Copies

Commanding General
US Army Materiel Command
Development & Engineering
ATTN: AMCRD-F (Air Mobility Ofc)
Washington, D.C. 20315

Commanding General
US Army Materiel Command
Dir. of Materiel Requirements
ATTN: AMCMR-BF (Fixed Wing Br)
Washington, D.C. 20315

Commanding General
US Army Materiel Command
Dir of Materiel Requirements
ATTN: AMCMR-BR (Rotary Wing Br)
Washington, D.C. 20315

Commanding General
US Army Materiel Command
Dir. of Materiel Requirements
ATTN: AMCMR-T (Troop Support Div.)
Washington, D.C. 20315

Commanding General
US Army Mobility Command
ATTN: AMSMO-RR
Warren, MI 48089

Director of Research Labs
US Army Personnel Research Office
ATTN: Tech. Library
2nd and T St., SW
Washington, DC 20315

Commandant
US Army Quartermaster School
ATTN: Quartermaster Library
Fort Lee, VA 23801

US Army Command & Gen. Staff College
Library Div.
Fort Leavenworth, KS 66027

Commanding Officer
US Army Mobility Equipment R&D Center
ATTN: Tech. Documents Center, Bldg. 315
Fort Belvoir, VA 22060

1

1

1

1

1

1

1

1

Number of Copies

Commanding Officer
US Army Research Office, Durham
ATTN: CRD-AA-IP
Box CM, Duke Station
Durham, NC 27706

Director
US Army Research Office
ATTN: Human Factors &
Operations Research Div.
3045 Columbia Pike
Arlington, VA 22202

Director
Army Tech Information
US Army Research Office
OCRD Room 209A
Arlington, VA 22200

Commanding Officer
US Army Aviation Materiel Command
ATTN: Tech. Library
P. O. Box 209
St. Louis, MO 63166

Commanding Officer
US Army Human Engineering Labs
ATTN: Tech. Library
Aberdeen Proving Grounds MD 21005

President
US Army Infantry Board
Fort Benning, GA 31905

Commandant
US Army Infantry School
ATTN: AJIIS-A
Fort Benning, GA 31905

The Army Library
ATTN: Procurement Section
Room 1A522, The Pentagon
Washington, D.C. 20301

Director
US Army Land Warfare Lab.
ATTN: Tech. Library
Aberdeen Proving Grounds, MD 21005

1

1

1

1

2

1

1

1

1

	<u>Number of Copies</u>
President US Army Aviation Test Board Fort Rucker, AL 36360	1
Commanding Officer US Army Board of Aviation Accident Research ATTN: Tech. Library Fort Rucker, AL 36360	1
Commanding General US Army Electronics Command ATTN: Tech. Library Fort Monmouth, NJ 07703	1
Commandant US Army Aviation School ATTN: ATSAV-DL-D Fort Rucker, AL 36360	1
Director US Army Board for Aviation Accident Research Fort Rucker, AL 36360	1
President US Army Aviation Test Board ATTN: SEBG-TD-V Fort Rucker, AL 36360	1
US Army Combat Developments Command Aviation Agency ATTN: O-41 Fort Rucker, AL 36360	1
Commanding Officer US Army Aeromedical Research Laboratory ATTN: Major John K. Crosley Box 577, Fort Rucker, AL 36360	1
Commanding Officer, ARDC Human Engineering Laboratory ATTN: AMXRD-HEL Aberdeen Proving Ground, MD 21005	3
Commanding Officer, ARDC US Army Ballistic Research Labs ATTN: AMXRD-BVL (Mr. J. B. Foulk) Aberdeen Proving Ground, MD 21005	1

Number of Copies

Commanding General US Army Aviation Command ATTN: AMSAV-EGGA 12th & Spruce St. St. Louis, MO 63102	1
Commanding General US Army Materiel Command ATTN: AMCPM-MO Washington, DC 20315	1
Commanding General US Army Materiel Command Project Manager - Iroquois ATTN: AMCPM-IR Washington, DC 20315	1
Commanding General US Army Materiel Command Project Manager - Cheyenne ATTN: AMCPM-AFS Washington, DC 20315	1
Commanding General US Army Aviation Command ATTN: AMC-PM 12th & Spruce St. St. Louis, MO 63102	1
Commanding General US Army Aviation Command ATTN: AMCPM-LOH (Light Observation Helicopter) 12th & Spruce St. St. Louis, MO 63102	1
Commanding General US Army Aviation Command ATTN: AMCPM (Heavy Lift Helicopter System) 12th & Spruce St. St. Louis, MO 63102	1
Commanding General US Army Aviation Command ATTN: AMCPM-HA (Utility Tactical Tspt Aircraft Systems) 12th & Spruce St. St. Louis, MO 63102	1

Number of Copies

Redstone Scientific Information Center 1
US Army Missile Command
ATTN: Ch, Documents Section
Redstone Arsenal, AL 35809

Commanding General 1
USA Test & Evaluation Command
ATTN: AMSTE-TAA
Aberdeen Proving Grounds, MD 21005

Director, Library 1
US Army War College
Carlisle Barracks, PA 17013

Commanding Officer 1
US Army Aviation Command
ATTN: AMSAV-D-L (Aircraft Systems
Life Supprt/Air Del Equip. Mgmt.)
12th & Spruce St.
St. Louis, MO 63102

U. S. AIR FORCE

Commander 1
Aeronautical Systems Division
ATTN: ENCCS (Mr. Harry Holder)
Wright-Patterson Air Force Base, OH 45433

Commander 4
6570th Aerospace Medical Res. Laboratory
ATTN: AMRL/HEA
Wright-Patterson Air Force Base, OH 45433

Commander 3
Anthropology Research Project
P. O. Box 308
Yellow Springs, OH 45387

Director 1
Air University Library
ATTN: AUL3T-7575
Maxwell Air Force Base, AL 36112

U. S. NAVY

Commander 2
Naval Air Development Center
ATTN: CSOS (Mr. John Lazo)
Warminster, PA 18974

	<u>Number of Copies</u>
Commander Naval Air Engineering Center ATTN: ESSD (Mr. C. Robert Osmanski) Philadelphia, PA 19112	1
Commander Naval Air Systems Command ATTN: AIR-5313 Washington, DC 20360	2
Commander Naval Air Test Center Patuxent River, MD 20670	1
Commander Naval Safety Center Naval Air Station ATTN: Code 81 Norfolk, VA 23511	1
Commander Naval Aerospace Medical Institute ATTN: Code 532 Naval Air Station Pensacola, FL 32512	1
Director Biological Sciences Division Office of Naval Research Department of the Navy Washington, DC 20360	1
Commanding Officer Naval Medical Field Research Laboratory Camp Lejeune, NC 28542	1
U. S. MARINE CORPS	
Commandant of the Marine Corps Headquarters, U. S. Marine Corps Washington, DC 20380	1
Director Development Center Marine Corps Development and Ed. Cmd. Quantico, VA 22134	1

Number of Copies

Marine Corps Supply Activity 1
1100 South Broad Street
Philadelphia, PA 19146

GOVERNMENT AGENCIES

Federal Aviation Agency 1
Aircraft Development Service (DS-30)
ATTN: Mr. Collin Simpson
Washington, DC 20552

Federal Aviation Agency 1
Civil Aeromedical Research Institute
Aeronautical Center, P.O. Box 1082
Oklahoma City, OK 73101

National Aeronautics and Space Administration 1
Ames Research Center N-239-3 (L.T.I.)
ATTN: Mr. Charles C. Kubokawa
Moffet Field, CA 94035

NASA Scientific and Technical Information Facility 1
ATTN: Acquisitions Branch (S-AK/DL)
P. O. Box 33
College Park, MD 20740

Exchange and Gift Division 1
Library of Congress
Washington, DC 20540

National Research Council 1
University of Rhode Island
Kingston, RI 02881

INTERNAL

Defense Documentation Center 12
Cameron Station
Alexandria, VA 23314

Technical Library, NLABS 2

Technical Editor, C&PLSEL 6

Airdrop Engineering Laboratory 2

General Equipment and Packaging Laboratory 2

U. S. Army Research Institute of Environmental Medicine 1

Number of Copies

Officer-in-Charge
Navy Clothing and Textile Research Unit, NLABS

1

USA NLABS Liaison Officer
Aeronautical Systems Division ASDL-8
Wright-Patterson Air Force Base, OH 45433

1

USA NLABS Liaison Officer
Defense Personnel Support Center
2800 South 20th Street
Philadelphia, PA 19101

1

Marine Corps Liaison Officer, NLABS

3

Senior Standardization Representative
U. S. Army Standardization Group, Canada
ATTN: U. S. Army Standardization Representative
c/o Directorate of Interservice Development
138 Queen Street
Ottawa, Ontario, Canada

2

Unclassified
Security Classification

DOCUMENT CONTROL DATA - R & D

(Security classification of title, body of abstract and indexing annotation must be entered when the overall report is classified)

1. ORIGINATING ACTIVITY (Corporate author) U. S. Army Natick Laboratories Natick, Mass.		2a. REPORT SECURITY CLASSIFICATION Unclassified	
		2b. GROUP	
3. REPORT TITLE THE BODY SIZE OF SOLDIERS: U. S. ARMY ANTHROPOMETRY - 1966			
4. DESCRIPTIVE NOTES (Type of report and inclusive dates) Final (1966 - 1971)			
5. AUTHOR(S) (First name, middle initial, last name) Robert M. White and Edmund Churchill			
6. REPORT DATE December 1971		7a. TOTAL NO. OF PAGES 329	7b. NO. OF REFS 35
8a. CONTRACT OR GRANT NO.		9a. ORIGINATOR'S REPORT NUMBER(S) 72-51-CE (CPLSEL-94)	
b. PROJECT NO. 1K024701A122-02			
c.		9b. OTHER REPORT NO(S) (Any other numbers that may be assigned this report)	
d.			
10. DISTRIBUTION STATEMENT Approved for public release; distribution unlimited.			
11. SUPPLEMENTARY NOTES		12. SPONSORING MILITARY ACTIVITY U. S. Army Natick Laboratories Natick, Mass. 01760	
13. ABSTRACT As a part of the U. S. Armed Forces anthropometric surveys of 1966, a sample of 6682 Army men was measured, including basic trainees, infantrymen, armored crewmen, and aviation personnel. Seventy body measurements were taken on each man. The anthropometric data from this survey are presented and discussed. These new data represent the first major updating of body size information on U. S. Army personnel since the Army anthropometric survey of 1946. Changes in the body size of Army men between 1946 and 1966 are discussed and the Army data are compared with anthropometric data from other services.			

14. KEY WORDS	LINK A		LINK B		LINK C	
	ROLE	WT	ROLE	WT	ROLE	WT
Anthropometry	8				9	
Body Size	8				9	
Surveys (Data Collection)	8					
Military Personnel	9		9		9	
Aviation Personnel	9		9		9	
Armed Forces (United States)	9		9		9	
Infantry	9		9		9	
Enlisted Personnel	9		9		9	
Evaluation			8			
Armed Forces Equipment			8, 9			
Comparisons					8	
Statistics					8	
United States			8, 9		9	