

AD 743143

FOREIGN TECHNOLOGY DIVISION

THIS IS AN UNEDITED ROUGH DRAFT TRANSLATION BY
JOINT PUBLICATIONS RESEARCH SERVICES



METHOD OF DETERMINING THE COEFFICIENT
OF VISCOUS FRICTION

by

S. Kornacki

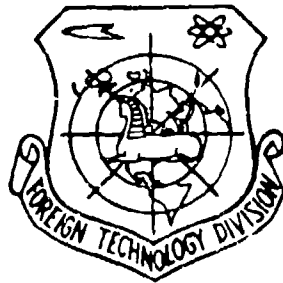

DDC
RECEIVED
JUN 14 1971
RECEIVED
B

Approved for public release;
Distribution unlimited.

Prescribed by
NATIONAL TECHNICAL
INFORMATION SERVICE
Springfield, Va. 22151

DOCUMENT CONTROL DATA - R & D		
<small>(Security classification of title, body of abstract and indexing annotation must be entered when the overall report is classified)</small>		
1. ORIGINATING ACTIVITY (Corporate author) Foreign Technology Division Air Force Systems Command U. S. Air Force		2a. REPORT SECURITY CLASSIFICATION UNCLASSIFIED
		2b. GROUP
3. REPORT TITLE METHOD OF DETERMINING THE COEFFICIENT OF VISCOUS FRICTION		
4. DESCRIPTIVE NOTES (Type of report and inclusive dates) Translation		
5. AUTHOR(S) (First name, middle initial, last name) Kornacki, S.		
6. REPORT DATE 1971	7a. TOTAL NO. OF PAGES 4	7b. NO. OF REFS 2
8a. CONTRACT OR GRANT NO.	8b. ORIGINATOR'S REPORT NUMBER(S) FTD-HC-23-1919-71	
8. PROJECT NO. 7343	8c. OTHER REPORT NO(S) (Any other numbers that may be assigned this report)	
9.		
d.		
10. DISTRIBUTION STATEMENT Approved for public release; distribution unlimited.		
11. SUPPLEMENTARY NOTES	12. SPONSORING MILITARY ACTIVITY Foreign Technology Division Wright-Patterson AFB, Ohio	
13. ABSTRACT The author gives a method of determining the coefficient of viscous friction in hydraulic elements, based on utilization of the properties of frequency phase diagram, the method permitting measurements in actual operating conditions of the element. A measuring system for the case of a control slide value is proposed. [AP1107874]		

Security Classification

14.

KEY WORD

Friction Coefficient
Valve
Hydraulics

LINK A

LINK B

LINK C

ROLE

WT

ROLE

WT

ROLE

WT

UNCLASSIFIED

Security Classification

UNEDITED ROUGH DRAFT TRANSLATION

by Joint Publications Research Services

METHOD OF DETERMINING THE COEFFICIENT OF VISCOUS FRICTION

By: S. KORNACKI

English pages: 4

Source: Pomiar Automatyka Kontrola (Measurements, Automation, Control) 1971, Vol.17, No. 4, pp. 182-183

Approved for public release;
distribution unlimited.

PO/0034-71-017-004

THIS TRANSLATION IS A RENDITION OF THE ORIGINAL FOREIGN TEXT WITHOUT ANY ANALYTICAL OR EDITORIAL COMMENT. STATEMENTS OR THEORIES ADVOCATED OR IMPLIED ARE THOSE OF THE SOURCE AND DO NOT NECESSARILY REFLECT THE POSITION OR OPINION OF THE FOREIGN TECHNOLOGY DIVISION.

PREPARED BY:
TRANSLATION DIVISION
FOREIGN TECHNOLOGY DIVISION
WP-AFB, OHIO.

METHOD OF DETERMINING THE COEFFICIENT OF
VISCOUS FRICTION

Author: S. Kornacki

Abstract: A method for determining the coefficient of viscous friction in hydraulic elements is described, based on utilization of the phase frequency characteristic. This enables measurements to be made under the actual working conditions of the element. A measurement system for distributor valve is proposed.

Aim of Measurement and Some Fundamental Relationships

In hydraulic control the need frequently arises for describing the properties of dynamic elements of the types shown in Fig. 1.

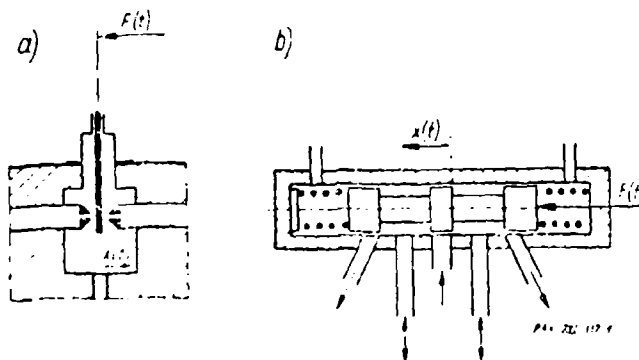

Fig. 1. Examples of elements discussed in the article.
a. Shutter; b. distributor valve.

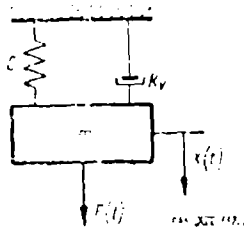

Fig. 2. Two-element model.

In addition to its resemblance to the actual object, a mathematical model should have simplicity in order to facilitate its use in the analysis of the whole system. For this reason, the elements represented above are treated as linear, while the differential equations which describe their operation are limited to the second order. This means that we consider the motion of a mass elastically suspended in a viscous medium (Fig. 2). The motion equation has the form

$$m \frac{d^2x}{dt^2} + k_v \frac{dx}{dt} + Cx = F(t) \quad (1)$$

where m is mass; k_v is substitute coefficient of viscous friction; C is rigidity of spring; $F(t)$ is external force; t is time.

Equation (1) describes a concrete object when the constants are assigned suitable values. Difficulties arise in determining the value of coefficient k_v . It can be determined on the basis of the phase frequency characteristic.

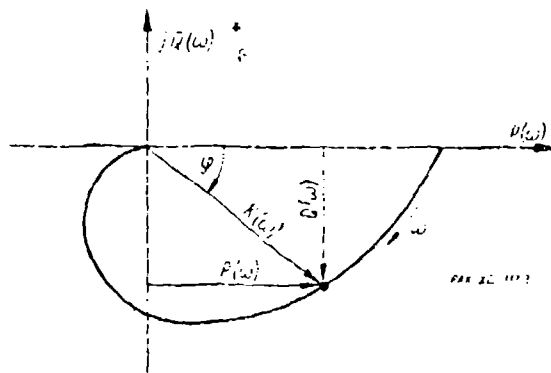

Fig. 3. Hodograph of a second-order element.

The hodograph of an element described by Equation (1) has the form shown in Fig. 3. The phase angle between the shift vector $x(t)$ and the force vector $F(t)$ is expressed by the relationship

$$\tan \phi = \frac{k_v \omega}{m\omega^2 - C} \quad (2)$$

where ϕ is the phase shift; ω is the pulse rate.

hence

$$k_v = \frac{m\omega^2 - C}{\omega} \tan \phi \quad (3)$$

If the phase angle ϕ corresponding to given pulse rate is known for known m and C , the value of k_v can be determined.

Sometimes the aim of measurement is to determine the changes in k_v under changing operating conditions of the element, i.e. changing temperature.

When consecutive measurements are made at the same pulse rate ($\omega_i = \omega_0$), we can use the formula

$$\frac{k_{v1} - k_{v2}}{k_{v0}} = \frac{tg \varphi_1 - tg \varphi_2}{tg \varphi_0} \quad (4)$$

Measuring System

The measurement of a moving mass and a fixed spring does not present any difficulties, and can be carried out with any desired accuracy. It is, however, considerably more difficult to determine the phase characteristic $\phi = \phi(\omega)$, since changes in force and translation must be recorded. The measurement method will be discussed below using the example of the motion of the valve slide of a hydraulic proportional distributor (Fig. 4). The force causing movement in this case is due to the pressure differential acting on surface A

$$F(t) = A \Delta p(t) = A \Delta p \sin(\omega t) \quad (5)$$

where Δp_0 is the pressure differential amplitude.

Pressure difference changes can be readily recorded using an electric sensor.

Direct recording of the slide translation is impossible in practice due to the fact that the movement takes place in an enclosed, oil-filled space. In the literature (2) it is suggested that this difficulty be overcome by assuming a proportional relationship between translation of the slide and the speed of the servomotor being controlled by the separator in question. Apart from rather special cases, this approach has a fundamental shortcoming due to large error caused by the phase delay between slide translation and the speed changes of the servometer. Better results are obtained by substituting the measurement of pressure drop at an opening made in the channel connecting the distributor intake ports for measurement of slide translation. There are two basic sources of error in determining the coefficient k_v : indirect measurement of slide translation, which introduces an additional phase shift, and errors in determining the quantities in equation (3). Furthermore, it follows from equation (3) that the total error depends on the pulse rate because of variable weight coefficients of the partial errors.

Determination of the optimum conditions through calculation is somewhat difficult. Good results are obtained by carrying out a series of measurements within a range of pulse rates for which the phase angle is contained within the limits

$$-60^\circ < \varphi < -30^\circ$$

and averaging out the values of k_v so obtained.

Reproduced from
best available copy.

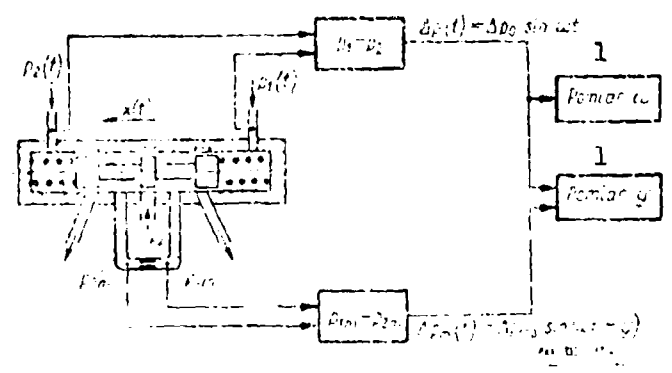

Fig. 4. Measurement system for a proportional distributor slide.
/Key:/ 1 - measurement of.

Bibliography

1. J.F. Blackburn, G. Reethof and J.L. Shearer: Fluid Power Control, New York 1960, the Technology Press of MIT and Wiley Sons, Inc.
2. S.C. Tsai and P.R. Ukrainetz: "Measuring coefficients of friction in servovalves", Hydraulics and Pneumatics, 1967, No 6.

END