

AD 738444

NUC TP 276



# PORTABLE UNDERWATER THERMAL POWER SYSTEM

by

Stephen K. Schultheis

Weapons and Countermeasures Department

January 1972



Reproduced by  
NATIONAL TECHNICAL  
INFORMATION SERVICE  
Springfield, Va. 22131

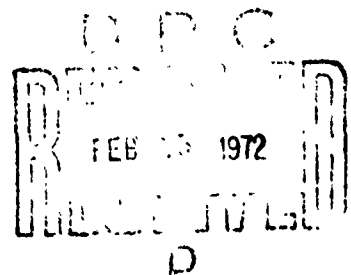

Approved for public release; distribution unlimited.



NAVAL UNDERSEA RESEARCH AND DEVELOPMENT CENTER, SAN DIEGO, CA. 92132

**AN ACTIVITY OF THE NAVAL MATERIAL COMMAND**

**CHARLES B. BISHOP, Capt., USN**  
Commander

**Wm. B. McLEAN, Ph.D.**  
Technical Director

**ADMINISTRATIVE STATEMENT**

This report documents the research and development of a portable underwater thermal power system. The work was funded by the Naval Undersea Research and Development Center's Independent Exploratory Development (IR/IED) program, and was conducted during the period 1968-1971.

This report has been reviewed for technical accuracy by H. E. Karig, R. K. Gottfredson, and R. W. Shaddock.

Released by  
D. D. AYERS, Head  
Torpedo and Countermeasures  
Division

Under authority of  
C. G. BEATTY, Head  
Weapons and Countermeasures  
Department

DISTRIBUTION BY	
CFSTI	WHITE SECTION <input checked="" type="checkbox"/>
DOC	BLUE SECTION <input type="checkbox"/>
MAN.	<input type="checkbox"/>
DATE	.....
BY	.....
DIST.	.....

**A**

UNCLASSIFIED

Security Classification

14 KEY WORDS	LINK A		LINK B		LINK C	
	ROLE	WT	ROLE	WT	ROLE	WT
Diesel engine Monopropellant fuel Diver tools Underwater power Combustion testing Power sources Portable underwater power						

UNCLASSIFIED

Security Classification

## **SUMMARY**

### **PROBLEM**

To design and test a portable thermal power system for underwater use.

### **RESULTS**

The system developed operates in a diesel cycle and uses the liquid monopropellant Otto Fuel, Composition II. It generates 1 hp. Use of combustion products as a recompression medium permits remote operation, completely independent of support from the surface. Thus the system is of potential use in many underwater applications, such as powering diver tools, submersibles, and weapons systems.

### **RECOMMENDATIONS**

Suggested improvements should be incorporated in a new prototype unit in order to allow the extended operation required to yield the data needed for more complete evaluation of performance parameters.

## **ACKNOWLEDGMENT**

During the development of the prototype "Portable Underwater Thermal Power System" many NUC personnel were asked for assistance in technical and support areas. Technical assistance from the Weapons and Countermeasures Department personnel, Code 35, was abundant and very helpful in determining basic parameters for the power system development. Outstanding facilities support was provided by Morris Dam Test Range personnel, Code 2532. In particular, the following people made significant contributions to this research: Robert Larson, Director, Morris Dam Range Section; Robert Evans, Project Technician; Roger Hubbell and Bernard Pennino, electronic support.

## CONTENTS

SUMMARY	iii
INTRODUCTION	1
THERMAL POWER CONCEPT	2
COMBUSTION TESTS	3
COMBUSTION TEST RESULTS	6
ENGINE DESIGN	9
ENGINE TESTS	12
ENGINE TEST RESULTS	13
CONCLUSIONS	14
REFERENCES	16

## INTRODUCTION

An investigation (initially focused upon the needs of divers) of power systems suitable for underwater use revealed that no truly portable system that can function without support from the surface is in existence. Currently available underwater power systems in the correct power range for use by divers are of the following type:

1. Electric motor with up to 200 ft of cable for surface-supplied power.\*
2. Pneumatic motor with direct cable to surface compressors.
3. Pneumatic-hydraulic motors operated by cable to a large, stationary ocean-floor power system (Ref. 1).

These three types of power satisfy most requirements for hand-held systems, but fail to satisfy one of the most important, portability. The general requirements for a diver-held power system are:

1. Safe to store, handle, operate, and maintain.
2. Self-contained and fully portable.
3. Capable of operating in seawater at depths to 300 ft.
4. Capable of initial starting and re-starting at full depth.
5. Capable of 4 hours of continuous operation without replacement of fuel.
6. Operable at least 100 hours intermittently without maintenance of power unit.
7. Deliver 1 hp at 1500-2500 rpm at tool attachment.

These requirements are based upon a diver's ability to do useful work during a 1-day operation. A power source capable of delivering at the rate of 1 hp for 4 hours should not require any fuel addition during a 1-day operation.

The requirements of power and torque for a useful diver tool system vary greatly with specific job applications. Drilling holes up to 1/2-in. diameter does not require over 10 ft-lb, whereas tightening a 1/2-in. bolt may take up to 150 ft-lb (Ref. 2). Whether the application involves a steady 10 ft-lb or an impact loading of 150 ft-lb, the power source/tool combination must be torque balanced, leaving the diver free to aim the system and apply axial loading.

Since no existing power system meets all of these requirements, research was conducted in an effort to develop a suitable design. The successful use of liquid monopropellants in torpedo engine applications suggested that this power source might be adapted to meet the listed requirements. A compelling advantage offered by the liquid monopropellant

\* The "Seapower Unit," produced by Oceanautic Manufacturing Company, 110-V, 60-cycle electric unit

in actual use (Otto fuel) is safety. Many years of Fleet experience with this fuel have proven that it is exceptionally safe to store and use.

Table 1 compares three candidate energy sources for underwater use: compressed air, batteries, and liquid monopropellant. The data given are the most recent. An optimum storage configuration (optimum tankage, etc.) is assumed. The weights shown in Table 1 are for the fuel only, and do not include actual motor or engine weight.

Table 1. Portable Energy Sources (4 hp-hr Available).

Available Form	Weight in Air, lb	Volume, ft <sup>3</sup>	Weight in Seawater, lb	Volume in Seawater To Be Buoyant, ft <sup>3</sup>
1. Compressed air in cylinder	682	8.0	170	10.7
2. Lead-acid battery (75% efficient motor)	200	1.5	104	3.1
3. Silver-zinc battery (65% efficient motor)	85	0.6	47	1.3
4. Liquid monopropellant Otto fuel (internal combustion engine 15% efficient)	73	0.9	15	1.1

The compressed air cylinder is only marginally "portable," since it would require a 1/2-ton hoist to put it into the water. Once in the water, it could be directed to a given location by a single diver, although its excessive bulk would make a very awkward system (Ref. 3).

The lead-acid battery is considerably lighter and smaller than the compressed air cylinder, but still not portable in the hand-held sense.

For the energy requirements previously mentioned, the silver-zinc battery system (Ref. 4) and the liquid monopropellant system are nearly identical in weight and volume. However, the cost of replacing or recharging the battery system is much greater than the cost of refueling the monopropellant system.

The results of this preliminary power source investigation show the thermal power unit operating on liquid monopropellant is an excellent contender for use in underwater portable power applications.

## THERMAL POWER CONCEPT

Combustion of a liquid monopropellant in an underwater environment poses certain problems as well as providing certain advantages over other power sources. Since



a monopropellant contains its own oxidizer, it is not necessary to introduce an external oxidizer to promote combustion. Regardless of the thermodynamic cycle, the ideal monopropellant combustion can occur in the presence of its own exhaust products.

Assuming non-condensable products of combustion, it is necessary to expel these gaseous products to the surroundings. Since underwater use involves operation at high pressures, the expulsion of combustion products underwater requires increasingly higher exhaust pressures as depth increases. This affects the operating thermodynamic cycle and must be considered when studying the use of thermal power underwater.

Otto Fuel (Composition II) is a nitrate ester liquid monopropellant with a specific gravity of 1.23 and a freezing point of  $-25^{\circ}\text{F}$ . Otto Fuel II is thermally stable up to  $250^{\circ}\text{F}$ , above which self-decomposition occurs. The minimum safe storage life ranges from 24 days at  $195^{\circ}\text{F}$  to 100 years at  $122^{\circ}\text{F}$  (Ref. 5).

At the start of the program to develop a small thermal power system, the main question was whether to pursue development of an internal or external combustion engine. Existing experience with Otto Fuel II combustion was entirely related to the continuous combustion phenomena of external combustion engines. Although these external combustion/expansion engines have demonstrated high overall efficiency (20-27%), they would present many problems in a low-horsepower configuration. Among these problems is that of start-up and re-starts while underwater. This would require an igniter, and therefore pose safety and operational problems. Finally, the extremely low fuel flow rates involved in a 1-hp engine could give rise to flow instability and difficult fuel metering to the combustion chamber.

Before the feasibility of using Otto Fuel II in an internal combustion engine could be established, the following information was required:

1. Minimum temperature and pressure for complete combustion.
2. Ignition lag time at various temperatures and pressures.
3. Effect of air and inert atmosphere on start-up conditions.
4. Residue buildup at achievable operating temperatures.

Some information was available regarding the decomposition and combustion of Otto fuel, but the characteristics of the fuel which relate to its potential use in an internal combustion engine were generally unknown. The information that was available regarding temperature and pressure required for combustion was based upon either continual-flow external combustion or upon single-droplet combustion studies.

## COMBUSTION TESTS

With the need for additional combustion information established, a test program was initiated. The goal was to design a combustion chamber that could be used with air or nitrogen, and a fuel injector of variable displacement that could inject any liquid fuel into

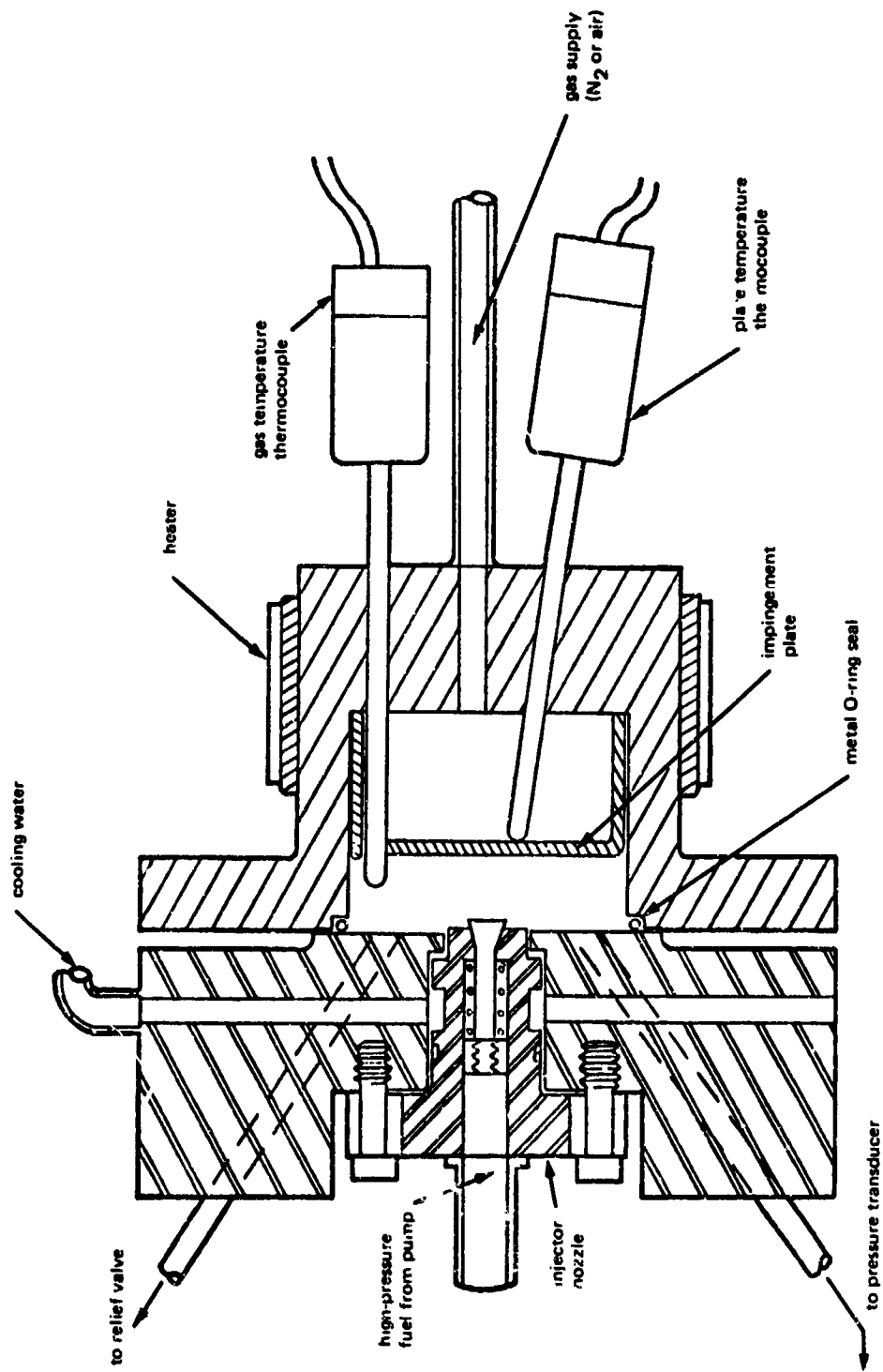

Figure 1. Combustion chamber cross section.

a high-temperature, high-pressure environment. Ignition delay time could be expressed as a function of pressure rise in the chamber, and post-run inspection would yield information about residue buildup.

The final chamber configuration is shown in Fig. 1. The chamber has a volume of 4 cu in. and an impingement plate 1/2 in. from the injector nozzle. During a typical combustion test, the chamber is heated with an 800-W cylindrical heater and pressurized with nitrogen or air. Fuel is then injected through the injector nozzle onto the impingement plate, whose surface temperature is known. Injection pressure, chamber pressure, and chamber temperature are recorded on a high-speed strip chart, from which ignition lag time is determined.

Combustion tests have been conducted using both single- and multiple-pulse injection. The single-pulse tests were used primarily to establish ignition lag times and determine the feasibility of operating an internal combustion engine on Otto Fuel II. The multiple-pulse ignition tests followed the single-pulse tests and provided qualitative information about residue buildup. These tests used a prototype fuel injector nozzle and fuel pump, which were later a part of the prototype engine system.

Figure 2 shows the test stand and equipment used for multiple-pulse combustion tests. An electric motor was used to power the fuel injection pump. The injection rate was variable with motor speed, and therefore the total number of fuel injections into the combustion chamber was controlled.

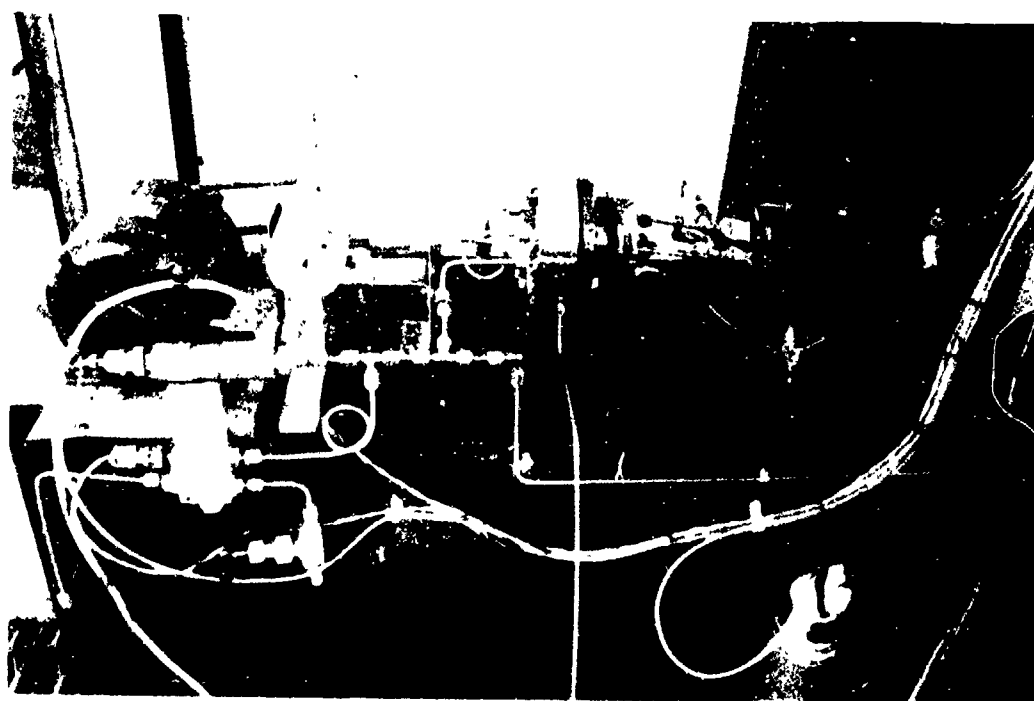

Figure 2. Combustion test apparatus.

## COMBUSTION TEST RESULTS

Single-pulse combustion tests were conducted over a wide temperature and pressure range. The temperatures ranged from 500 to 850°F and pressure ranged from 700 to 3000 psig. Both temperature and pressure ranges were tested using air, nitrogen, and mixtures of air and nitrogen.

Initial testing indicated the ignition lag time does not vary with pressure in the range tested. Thus, all succeeding tests were conducted at the same pressure (2000 psig) in order to simulate the probable top-dead-center (TDC) conditions encountered in an engine. This allowed study of temperature effects alone.

Figure 3 shows the results of single-pulse combustion tests using air and nitrogen at 2000 psi. The minimum ignition lag time recorded by the strip chart system was 0.015 sec. This appears to be the limit of the recorder's response rate, and thus makes all ignition lag times relative to this 0.015-sec line.

A Bosch-type fuel injector nozzle was used during initial tests, and the ignition lag times were found to be insensitive to the injection pressure differential. A conical-seat injector nozzle with variable injection pressures was used in later tests, and it was determined that injection pressure differentials as low as 300 psi gave results identical to those of the 2000-psi Bosch-type injector. The small pressure differential is favorable since the power required to operate the fuel pump is reduced.

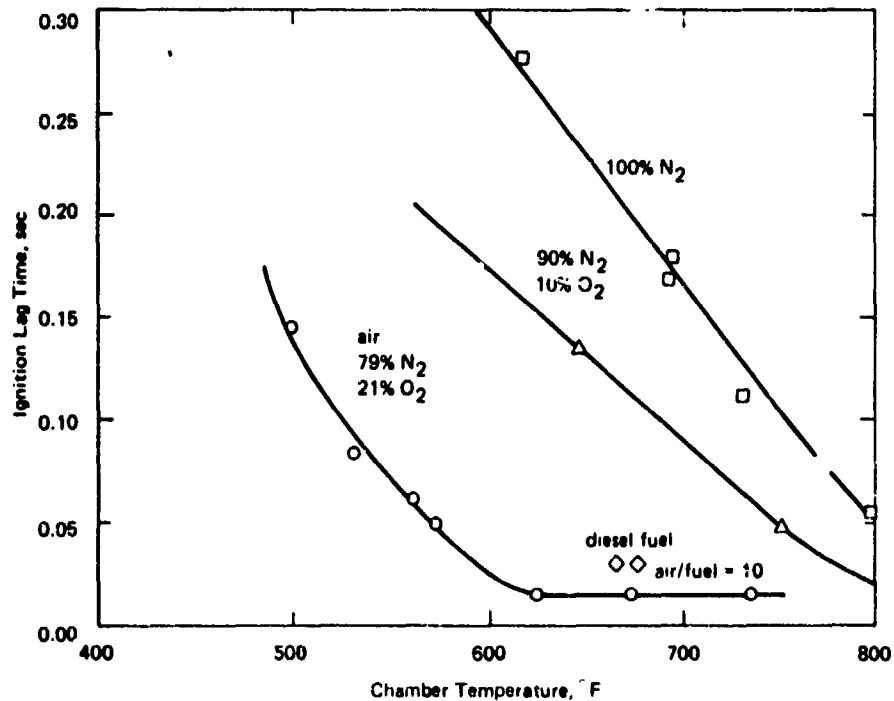

Figure 3 Ignition characteristics of Otto fuel II.

In order to establish a known reference point in Fig. 3, some combustion tests were conducted using diesel fuel and air. The air/fuel ratio was 10, and results indicated an ignition lag time slightly higher than the one obtained with Otto Fuel II at optimum conditions. Thus, under conditions which yield an indicated combustion lag time of 0.015 sec, it is quite feasible that an engine could be operated. Figure 3 shows that the minimum ignition lag time occurs at 620°F in air, and at about 850°F in an inert atmosphere (N<sub>2</sub>).

Considering the operation of an internal combustion engine underwater, the important ignition lag time is that of fuel burning in purely inert gas (this assumes that exhaust products are used as a re-compression medium). However, it is possible that an engine start-up sequence could utilize an air or oxygen charge to achieve proper operating temperatures.

The peak operating temperature of a diesel engine is about 600–700°F at TDC (Ref. 6). Thus, according to Fig. 3, any existing diesel engine should be able to operate using Otto Fuel II and air. To demonstrate this, a small diesel engine was modified to operate on Otto fuel. The engine was a 4-stroke-cycle Yanmar marine diesel with a power output of 3–5 hp. The exhaust passages were closed to form a re-circulating loop with the intake manifold, and air was supplied to the intake valve in variable amounts.

The Yanmar diesel was started on diesel fuel to achieve steady-state operating temperature, then switched to an Otto fuel supply while running. Transition to Otto fuel operation was consistently smooth, and operation with air supplied to the intake manifold was excellent. However, as the amount of air was decreased and the quantity of combustion by-products increased, operation became unstable and the engine stopped.

The engine tests supported combustion test data and indicated that peak operating temperature of the diesel engine was less than the 800°F needed to support rapid Otto fuel combustion in an inert atmosphere.

Another important consideration is residue buildup. Figure 4 shows the residue after a single-pulse combustion test at 675°F with an air/nitrogen mixture (5% O<sub>2</sub>). The light-gray residue is typical of high-temperature tests, but above 800°F it is almost undetectable.

The multiple-pulse combustion tests were designed to evaluate injector nozzle and fuel pump performance and to investigate residue buildup in the combustion chamber. The fuel pump is a single-stage piston pump driven by a quick-rise cam (Fig. 2 shows pump and test stand). The injector nozzle is a check-valve type with circumferential cooling passages, as shown in Fig. 1. A high-pressure pulse from the fuel pump causes the injector nozzle to open and atomized fuel to spray past the conical poppet in the end of the nozzle.

The fuel pump and injector nozzle performed as expected during the multiple-pulse combustion tests. Fuel injection was consistent, and the nozzle response was adequate to prevent hot gases from igniting fuel within the annulus of the nozzle. Thus, the prototype pump and nozzle was ready for engine use.



Figure 4. Residue after single-pulse burn.



Figure 5. Residue after multiple-pulse combustion test.

The residue buildup information obtained from multiple-pulse combustion tests was generally qualitative. Figure 5 shows typical results of a low-temperature multiple-pulse combustion test. The residue is a sticky black buildup caused by 120 injections (Fig. 3 shows the residue from a single injection). The temperature of the impingement plate (see Fig. 1) was 600°F at the start of the test and was over 800°F at the end of the 120 injections. As the initial impingement-plate temperature was increased, residues became light gray and dry, subject to flaking into powder form.

## ENGINE DESIGN

Many of the necessary engine design parameters were established by the combustion tests described. In order to successfully operate an engine on Otto fuel in an underwater environment, the following conditions must be met.

1. Initial compression temperature must reach 600°F minimum (using air-charge start).
2. Temperature at piston TDC must be at least 820°F for continuous operation on combustion products.
3. Exhaust pressure must be allowed to vary according to depth below water surface, or remain fixed at some value greater than maximum operating depth pressure.
4. Residue buildup must be minimized by maintaining high operating temperatures.

With the need for high temperature and pressure established, several feasible diesel cycles were investigated. Computer studies indicated a specific fuel consumption of 10 to 13 lb/hp-hr was achievable. A pressure-volume diagram showing the cycle selected for engine prototype design is shown in Fig. 6. The shaded area indicates the portion of the expansion cycle not used during 200-ft-depth operation. This "wasted" area reduces the cycle efficiency by about 10%, but is necessary to avoid excessive compression pressures.

A cross section of the prototype engine is shown in Fig. 7. This prototype was designed for test stand use and contains some features that a hand-held configuration would not have. Among these features is an externally mounted, clamp-on heater used to pre-heat the cylinder head prior to start-up, thereby allowing investigation of the effects of running temperature on residue buildup.

The prototype engine relies on an external water pump (or pressurized water supply) for circulating cooling water and an external throttle control system, which may be remotely operated. A portable version of the engine would have to have these features built in.

Some of the pertinent engine data follows:

Type: Single cylinder, diesel cycle  
Bore: 1.0 in.  
Stroke: 1.37 in.  
Net displacement: 1.0 cu in.

Clearance volume: 0.050 cu in.  
Compression ratio: 20:1  
Design power: 1.0 hp at 4000 rpm  
Cycle: 2-stroke, open exhaust port

The piston of the prototype engine was designed to retain heat in the upper section. Heat conduction was minimized by leaving an air space between the piston head and the piston rod support area. Also, the piston ring groove was located very near the top of the piston to minimize heat transfer to the cylinder walls.

The fuel injector nozzle was designed to allow tests with various injection pressures. It consists of a spring-loaded pintle inside a nozzle body (see Fig. 7). The nozzle body is cooled during the heat-up period to prevent pre-ignition of any fuel in the vicinity of the pintle. At the same time, the fuel stored so near the cylinder head pre-heats slightly before injection (this aids combustion efficiency).

During operation of the prototype engine, fuel was injected directly into the cylinder, impinging on the piston head. The disadvantage of direct injection is the large surface area for heat loss. With the small clearance volume, surface area at TDC in the prototype engine is about 1.6 in<sup>2</sup>, while the minimum possible surface area would be 0.78 in<sup>2</sup> (hemispherical). However, as mentioned, the piston head is well insulated to prevent excessive heat conduction. The overriding advantages of simplicity and size dictated the use of direct injection in the prototype engine.

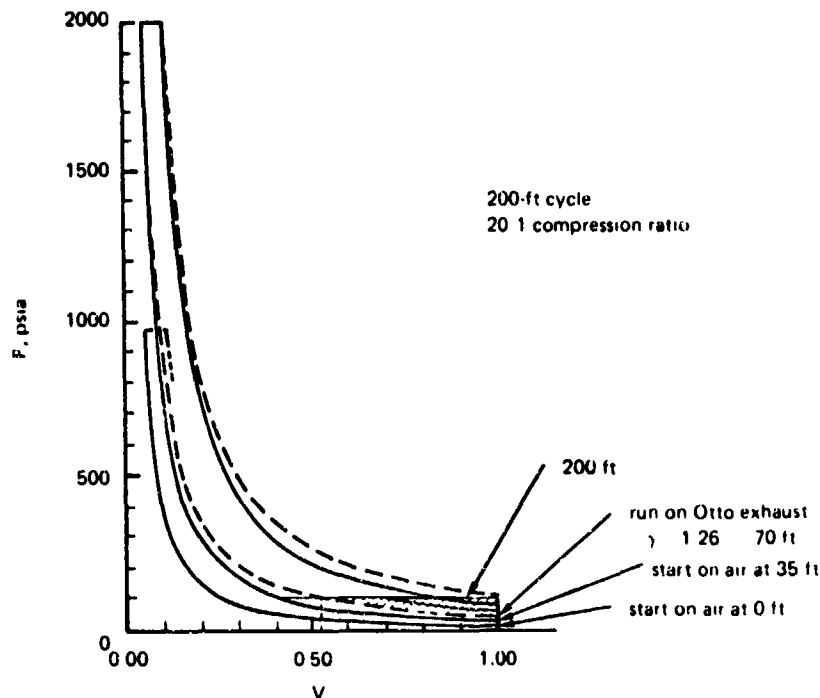

Figure 6 P-V diagram



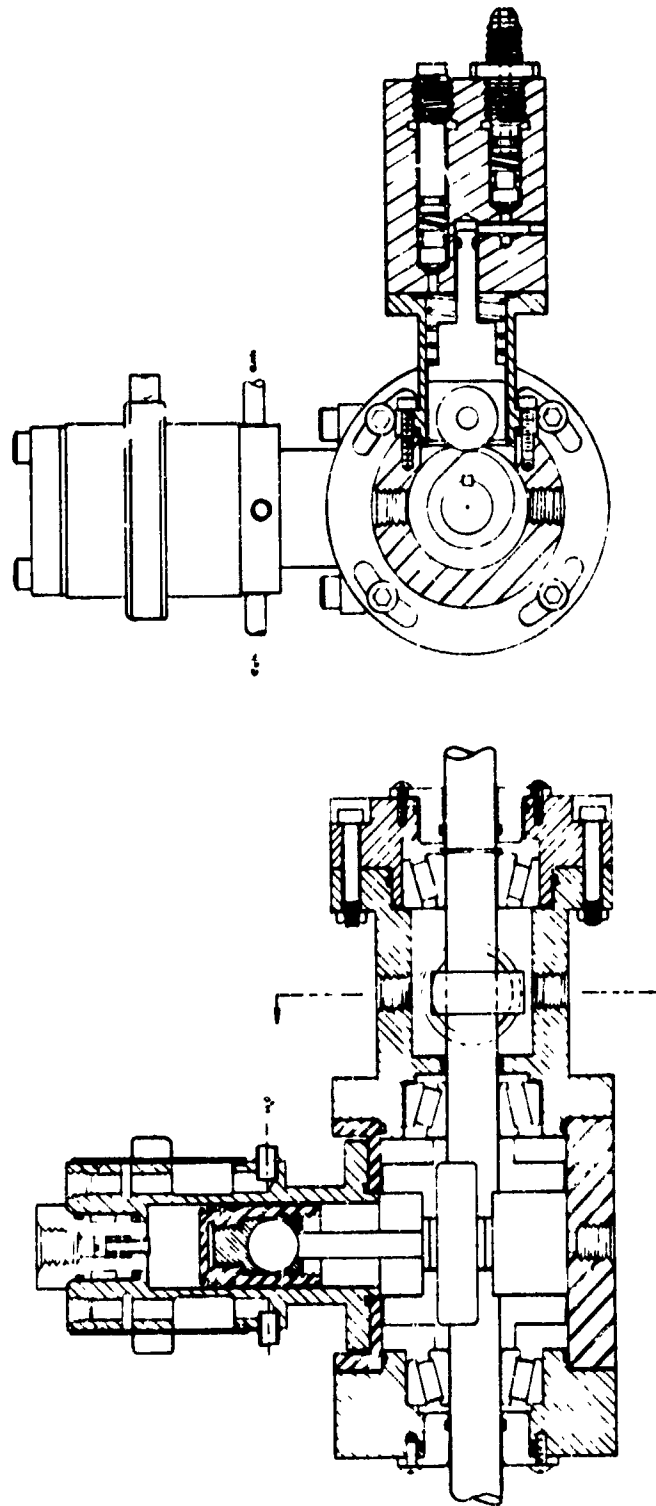

Figure 7. Prototype engine cross section.

## ENGINE TESTS

The hardware used for testing the prototype engine is shown in Fig. 8. The output shaft of the engine was connected in series to a torque cell and a hydraulic motor. During a typical engine test, the following sequence was used:

1. Heat-up period
2. Engine start with hydraulic motor
3. Steady-state running with hydraulic motor on
4. Engine loaded by gradually turning the hydraulic motor into a hydraulic pump (pressurizing the output)
5. Continued running with load to make performance measurements.

Throughout the engine tests, a high-speed strip chart recorder monitored the following parameters:

1. Rpm
2. Torque
3. Hydraulic fluid pressures
4. Cylinder temperature
5. Fuel tank pressure
6. Exhaust pressure

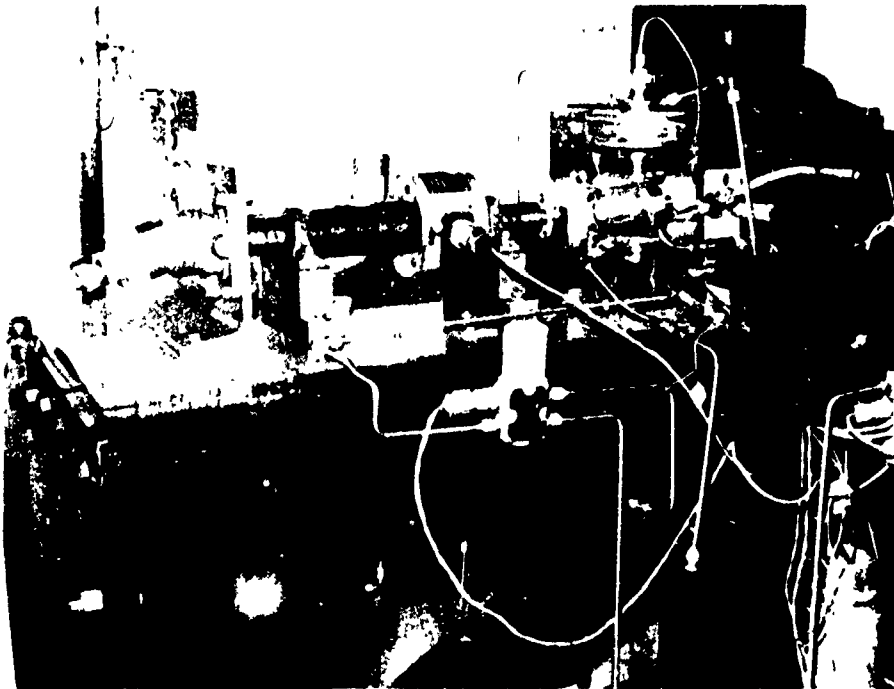

Figure 8. Engine test stand.

Also, the total amount of fuel used during an engine run was measured, and visual parameters of cylinder temperature and rpm were noted for comparison with recorded data.

With the data collected from each run, the engine performance was determined, and the effects of speed, injection timing, injection pressure, and start-up temperature were studied.

For safety purposes, all engine tests were conducted remotely, thus requiring some elaborate plumbing and wiring that otherwise would not have been necessary.

### ENGINE TEST RESULTS

A total of 25 engine tests were made between July and October 1971. During the series of tests, the following range of start-up and running conditions was investigated:

Cylinder head temperature (start-up): 510–770°F

Injection timing: 0–15 deg after TDC

Injection pressure: 100–1050 psid†

Rpm: 3800–4700

Power: up to 1.5 hp

At an early stage in testing, some of the variable engine parameters were eliminated. To insure combustion of the first fuel injected into the engine, cylinder head temperature had to be at least 600°F or higher. Injection timing of 15 deg after TDC was established as an adequate setting after studying the torque tracing from the strip chart recorder. At this setting, actual fuel injection begins near TDC and reaches a peak at about 15 deg after TDC.

With timing and temperature fairly well established, the remaining engine tests concentrated on studying the effects of engine speed and fuel injector setting. The best engine test results were obtained with the fuel injector opening pressure differential set at 1050 psi and with the engine speed near 4000 rpm.

Engine run time was limited by several factors during this initial series of tests. Most important was the lack of adequate cooling near the piston head because of the required heater location. Another major factor limiting engine run time was the use of hydraulic fluid reservoirs to load the engine. Though the hydraulic pump gave accurate engine control, once the hydraulic fluid was transferred to a second reservoir, no load was transmitted through the torque cell.

Table 2 lists data from the last 25 engine tests. The run times ranged from 0.6 to 35.7 sec, with an average of about 8 sec. All of the engine tests listed had steady-state conditions, which allowed analysis of power produced, etc. In runs which had variable loads applied (longer runs), the maximum power achieved is listed. Since fuel flow rates are extremely small (about 1 ml/sec), the total fuel consumed during a test was the only parameter measured relating to thermal efficiency, specified fuel consumption, etc.

† Psid = differential pressure, lb/in<sup>2</sup>.

Table 2. Engine Test Data Sheet.

1971 Test Data	Test No.	$\Delta P$ (Injector)	$T_{start}$ °F	Timing, deg (ATDC)	Shaft Speed, rpm	Run Time, sec	Fuel Consumed, ml	Maximum Power, hp
26 July	...	100	570	10	3830	1.2	...	...
27	...	100	570	10	4200	0.6	...	0.24
28	1	100	560	10	4600	4.5	...	0.26
	2	100	510	10	4900	2.5	...	0.00
29	1	110	600	10	4200	2.5	...	0.30
	2	110	600	10	4100	2.6	...	0.12
30	1	650	650	10	4700	2.7	...	0.40
	2	650	645	10	4500	7.6	...	0.37
2 Aug	1	650	650	10	...	...	...	...
	2	650	630	10	4000	0.8	...	1.47
3	...	650	625	10	...	...	...	...
6	...	650	640	10	4600	0.7	...	0.38
9	1	650	610	15	4000	0.7	...	1.51
	2	...	...	...	...	2.5	...	0.00
10	...	600	...	15	4070	2.1	...	0.00
1 Sept	...	1000	660	15	4650	2.6	...	0.42
	8	1050	630	15	4150	8.3	...	0.40
9	...	...	...	...	...	3.5	...	...
	...	...	...	...	...	...	...	...
16	...	...	720	15	...	12.8	...	...
4 Oct	...	1050	670	15	3980	35.7	40	0.24
	6	...	690	15	4120	5.8	6	0.20
8	...	1050	620	15	3980	25.5	35	0.11
	...	1050	770	15	4200	5.8	...	0.23
12	...	1050	675	15	4200	10.9	...	0.33

Test results indicated the specific fuel consumption to be on the order of 40 to 50 lb/hp-hr. This figure varied greatly, and is difficult to establish unless a given test is conducted at one power level only. The test of October 4 (Table 2) gave a specific fuel consumption of 46.7 lb/hp-hr, but due to the conservative method of determining horsepower produced, the actual value may be nearer 30 lb/hp-hr. More accurate test equipment must be employed in order to establish reliable fuel consumption data.

Inspection of the engine after the longer tests indicated no problems ascribable to residue buildup or incomplete combustion. The piston head was always free of deposits, except for a very thin, black scale that formed near the center of the head. This scale flaked off easily, and would not present any problem during an extended engine run.

### CONCLUSIONS

The preliminary analysis and gathering of related data through tests has led to the design and successful operation of a small thermal power system.

Test results have shown that a system consisting of a self-contained, Otto fuel-powered diesel engine can be successfully operated with only inert combustion products used as a recompression medium.

A number of improvements to the prototype design would allow extended operation and give data needed to better evaluate performance parameters. Some of these improvements are listed below:

1. Forced-circulation cylinder cooling
2. Electromagnetic clutch dynamometer in place of a hydraulic system for loading the engine
3. Re-designed fuel injector for greater atomization
4. Re-designed cylinder head for rapid heat-up prior to engine start
5. Increased accuracy in fuel flow measurements.

With these improvements, the Portable Underwater Thermal Power System could be further developed for actual underwater testing and specific application potential could be evaluated.

## REFERENCES

1. "NCEL Adapts Off-the-Shelf Tools for Undersea Use," *Undersea Technology*, October 1967.
2. Hackman, D. J., *Power Tools for Divers*, Battelle Memorial Institute (undated report).
3. Taggart, R., "Auxiliary Power for Man in the Sea," *Journal of Hydronautics*, Vol. 1, No. 1, July 1967.
4. Jasinski, R., *An Analysis of All Potentially Useful High-Energy Battery Systems*, TYCO Laboratories, Massachusetts, 1965.
5. "Safety and Handling Instructions, Otto Fuel II," NAVORD OP 3368.
6. Heldt, P. M., *High-Speed Diesel Engines*, Nyack, N. Y., 1944.

## BIBLIOGRAPHY

- Faeth, G. M., *Monopropellant Droplet Decomposition Studies (U)*, Ordnance Research Laboratory, Pennsylvania State University, 1968 (CONFIDENTIAL). ✓
- Karhan, B. L., *The Ignition and Combustion of a Liquid Monopropellant*, TM 705.9161-01, Ordnance Research Laboratory, Pennsylvania State University, 1967.