

72-26 CE

Washington Electric Corporation
10150 1st Ave. N.E.

Contract No. DAAG17-75-C-0044

November 1971

Reproduced by
**NATIONAL TECHNICAL
INFORMATION SERVICE**
Springfield, Va. 22151

Training & Personal Life Support
Equipment Custody

203-321-31

UNCLASSIFIED

Security Classification

DOCUMENT CONTROL DATA - R & D

(Security classification of title, body of abstract and indexing annotation must be entered when the overall report is classified)

1. ORIGINATING ACTIVITY (Corporate author) Westinghouse Electric Corporation Pittsburgh, Pennsylvania		2a. REPORT SECURITY CLASSIFICATION UNCLASSIFIED	
		2b. GROUP	
3. REPORT TITLE Thermoelectric Heating and Ventilating System			
4. DESCRIPTIVE NOTES (Type of report and inclusive dates) Final- October 1969-August 1971			
5. AUTHOR(S) (First name, middle initial, last name) A. M. Bernard			
6. REPORT DATE November 1971		7a. TOTAL NO. OF PAGES 36	7b. NO. OF REFS
8a. CONTRACT OR GRANT NO. DAAG17-70-C-0044		8b. ORIGINATOR'S REPORT NUMBER(S) 72-26-CE(C&PLSEL-91)	
8c. PROJECT NO. 1J062110AJ33		8d. OTHER REPORT NO(S) (Any other numbers that may be assigned this report)	
10. DISTRIBUTION STATEMENT Approved for public release; distribution unlimited			
11. SUPPLEMENTARY NOTES		12. SPONSORING MILITARY ACTIVITY U.S. Army Natick Laboratories Natick, Massachusetts 01760	
13. ABSTRACT Modifications and improvements incorporated into a thermoelectric heating and ventilating system are described. Improvements were incorporated into the fuel supply, fuel pressure regulation, fuel metering, burner and start-up and operation systems. In addition, functional considerations were included into the system packaging to account for system operation under all environmental considerations including anticipation of shock and vibration. The thermoelectric heating and ventilating system is designed to provide a flow of temperature regulated air for use in heating or ventilating a specially designed military clothing ensemble. The system weighs ten pounds unfueled and required 0.26 pounds of fuel for each hour of operation. Eighteen c.f.m. of air (S.T.P. conditions) at four inches water column pressure is delivered for use in keeping an individual in thermal balance when operating in extreme environments (-40°F to +110°F) or when exposed to hazards. The electrical power required to obtain the flow of air is supplied by a thermoelectric generator which converts thermal energy directly into electrical energy. The thermal energy is derived from the combustion of liquid military fuels; leaded gasoline, kerosene, JP-4 and diesel fuels.			

DD FORM 1473

REPLACES DD FORM 1473, 1 JAN 64, WHICH IS OBSOLETE FOR ARMY USE.

UNCLASSIFIED

Security Classification

UNCLASSIFIED

Security Classification

14. KEY WORDS	LINK A		LINK B		LINK C	
	ROLE	WT	ROLE	WT	ROLE	WT
Modification	8				8	
Improvement	8				8	
Thermoelectricity	9		7,10		4	
Heating	9		7,8		4	
Ventilation	9		7,8		4	
Systems	9		7		4	
Military Clothing	4		1		4	
Shock			6			
Vibration			6			
Environments			6			
Fuel Systems					9	

UNCLASSIFIED

Security Classification

Approved for Public Release;
Distribution unlimited

AD _____

TECHNICAL REPORT
72-26-CE

THERMOELECTRIC HEATING AND VENTILATING SYSTEM

by

A. M. Bernard

Westinghouse Electric Corporation
Pittsburgh, Pennsylvania

Contract No. DAAG 17-70-C-0044

Project Reference:
1J062110A533

Series: C&PLSEL- 91

November 1971

Clothing and Personal Life Support Equipment Laboratory
U.S. ARMY NATICK LABORATORIES
Natick, Massachusetts 01760

MAR 2 1972

FOREWORD

This final report was prepared by the Astranuclear Laboratory of the Westinghouse Electric Corporation. The work described was performed under U. S. Army Contract DAAG 17-70-C-0044 with the technical direction of Mr. Leo A. Spano of the U. S. Army Natick Laboratories, Natick, Massachusetts. The work presented began in October of 1969 and was completed in August 1971. The Project Number was 1J062110A533.

The modified system, which provides a flow of temperature regulated air for heating or ventilating a clothing ensemble, weighs approximately 10 pounds unfueled and uses 0.26 pounds of liquid hydrocarbon fuel for each hour of operation. The 18 cfm of temperature regulated air is used to keep the individual in thermal balance while operating in extreme environments (-40°F to 110°F) or toxic atmospheres. The regulated electric power required to obtain the air flow is supplied by a thermoelectric generator which converts the thermal energy of the combustion of liquid hydrocarbon fuels directly into electrical energy.

TABLE OF CONTENTS

	<u>Page</u>
LIST OF FIGURES	v
LIST OF TABLES	v
ABSTRACT	vi
INTRODUCTION	1
IMPROVEMENT AREAS	1
FUEL TANK IMPROVEMENTS	5
FUEL PRESSURE REGULATION IMPROVEMENTS	7
FUEL METERING IMPROVEMENTS	10
BURNER IMPROVEMENTS	14
IGNITION SYSTEM IMPROVEMENTS	18
SYSTEM RUGGEDIZATION IMPROVEMENTS	23
SYSTEM PACKAGING IMPROVEMENTS	26

LIST OF FIGURES

<u>Figure</u>		<u>Page</u>
1	Fuel Tank Assembly	6
2	Fuel System	8
3	Typical High Pressure and Low Pressure Adjustable Regulator	9
4	Electrically Heated - Thermostat Controlled Fuel Regulator	12
5	Fuel Metering Components	13
6	Schematic Representation of ^(W) Developed Burner	17
7	Air Inlet Side of Multifuel Burner	20
8	Combustion End of Multifuel Burner	21
9	Electrical Schematic Diagram of T/E Heating & Ventilating System	23
10	Layout of Thermoelectric Heating and Ventilating System	27

LIST OF TABLES

<u>Table</u>		<u>Page</u>
I	Thermoelectric Heating and Ventilating System Improvement Program	4
II	Fuel Pressure Regulation and Metering System Characteristics	15
III	Measured Performance of ^(W) Developed Burner	19

ABSTRACT

Modifications and improvements incorporated into a thermoelectric heating and ventilating system are described. Improvements were incorporated into the fuel supply, fuel pressure regulation, fuel metering, burner and start-up and operation systems. In addition, functional considerations were included into the system packaging to account for system operation under all environmental considerations including anticipation of shock and vibration.

The thermoelectric heating and ventilating system is designed to provide a flow of temperature regulated air for use in heating or ventilating a specially designed military clothing ensemble. The system weighs ten pounds unfueled and requires 0.26 pounds of fuel for each hour of operation. Eighteen c. f. m. of air (S. T. P. conditions) at four inches water column pressure is delivered for use in keeping an individual in thermal balance when operating in extreme environments (-40°F to $+110^{\circ}\text{F}$) or when exposed to hazards. The electrical power required to obtain the flow of air is supplied by a thermoelectric generator which converts thermal energy directly into electrical energy. The thermal energy is derived from the combustion of liquid military fuels; leaded gasoline, kerosene, JP-4 and diesel fuels.

THERMOELECTRIC HEATING AND VENTILATING SYSTEM IMPROVEMENT PROGRAM

INTRODUCTION

The Thermoelectric Heating and Ventilating System previously developed for Natick Laboratories had a number of areas which could be improved to make the system more adaptable to field operation. The areas requiring attention were beyond the previous developments which essentially made the system capable of integration into a field package for any one of a number of systems including casualty evacuation, explosive ordnance demolition or the thermalibrium* concept. The system improvements performed enhance the system performance of all potential field uses for the defined concepts.

The areas of improvement involve; problems associated with military fuels as typically affecting the fuel regulation and metering system, environmental considerations, simplification of the start-up procedure, packaging improvements which make the unit more rugged for field handling and less expensive to manufacture. A description of these improvement areas is given in the following paragraphs.

IMPROVEMENT AREAS

Fuel Regulation and Metering System

The use of some military fuels under certain conditions results in the formation of waxes or gums which can accumulate in the fuel system. The conditions are associated with the environment as well as the materials themselves. The thermoelectric heating and ventilating system, because of its miniaturization and the lightweight materials used, is susceptible to the formation of deposits within the fuel pressure regulation and metering system and has its performance reduced by these formations. Examination of the effects of the materials and the effects of fuels on the materials were performed to reduce the formations of deposits and minimize the effect of deposit formation on system performance. Of particular importance are the fuel pressure regulator diaphragm, fuel tank bladder, active metals in the fuel system and the fuel metering orifice.

* A multiprotective, ventilated suit of unique design.

Environmental Effects

Besides the precipitation of deposits which are affected by environmental changes, particularly temperature, the next biggest performance affecting factor is the change of fuel properties with temperature. A large variation of fuel viscosity can be expected over the anticipated temperature of operation. Because the present system is essentially a constant pressure fuel system, a large change in fuel flow to the burner can be expected without manual manipulation. Temperature compensation to reduce the effects of fuel property variation have been provided.

Fuel Descriptions

A definition of operating fuels and alternate fuels was necessary to determine the fuel metering, modifications, and start-up requirements for the system. Besides leaded gasoline, operation is expected with kerosene, JP-4 and diesel fuels. Gaseous hydrocarbons, particularly propane, methane and natural gas, can also be accommodated with the present system, but modifications are necessary.

Altitude Variations

The variation of altitude expected during operation produces a noticeable change of air flow for combustion due to the change of density of the air. The previous burner-combustion system was adequate at low altitude operation but tended to run fuel rich and noisy at elevated altitudes. Modifications and improvements to the combustion system were made for a greater amount of excess air to eliminate possible atmosphere contaminants, reduce operating noise and provide uniform operation at all expected altitudes.

System Start-up and Operation

The manual functions of the previous system developed needed to be reduced to minimize the dependency of the operator whose primary function is not expected to be total attention to the thermoelectric heating and ventilating system. During start-up and warm-up

the operator function should be reduced to simple casual observation rather than total attention. The possibility of inclusion of automatic ignition and warm-up was investigated. Also, the fuel manual pressurization system was improved so that less operator effort is required before start-up can proceed.

System Package and Weight

The void volume of the present system was reduced by more efficient packaging. However, means of manufacturing must yet be selected to produce the system components more economically. The combination of the two appropriately applied can produce a lighter weight system than the present system.

Ruggedization

The previous system was designed to specifications which do not include field handling conditions. The following specifications were defined as design objectives:

Shock, Method 516 - Drop Test - Procedure III,
Shock, Method 516 - High Intensity Test - Procedure V,
Shock, Method 516 - Bench Handling Test - Procedure VI, and
Vibration, Method 514.1 for equipment classes 6 and 7 of MIL-STD-810A are used as the design objectives for the mechanical environment to which a field unit might be exposed.

All of the tasks undertaken as a part of this program, the associated problems, and solutions considered are described in the following Table I.

TABLE I
THERMOELECTRIC HEATING AND VENTILATING SYSTEM
IMPROVEMENT PROGRAM

TASK	PROBLEMS	SOLUTIONS
1. Fuel Pressure Regulation	"O"-Ring and diaphragm material attack Non-Repeatability	Material coatings, material substitution Filters
2. Fuel Metering	Physical property change of fuel with ambient property variation for different fuels. Fuel starvation and bubble accumulation. Orifice clogging	Locate orifice in area with small temperature variation. Use temperature-compensating variable orifice. Add winterizing/conversion kit. Reduce diameter of fuel line from orifice to burner. Filters Install cleaning mechanism.
3. Fuels	Wax, gum and tar formulations. Reactions with active materials and storage. Water precipitation and ice crystal formation at low temperature. Property variations due to ambient changes and different fuels.	Additives, material coating and substitution. Filters, drying materials, additives. See 2 above.
4. Burner	Reduced operator manipulation. Noise, air flow changes with altitude variations and smcking.	Automate start-up/ignition cycle. Use electrical automatic ignition or spring energy or hand crank-generator. Improve air delivery to fuel, improve air mixing with fuel, streamline burner/combustion chamber.
5. Automatic Start	Operator attention and participation. Requires external fuel ignition. Energy source availability.	Automate ignition/start cycle. Examine mechanical sources. Use auxiliary power.
6. Fuel Tank	Bladder attack, pressurizing Air permeation into fuel. Tank capacity. Tank pressurization.	Material coatings/substitution Increase size of tank. Increase manual pump capacity
7. System Packaging	Large void areas. Expensive manufacturing procedure. Expensive parts. Expensive materials Maintenance. Parts protection. Functional location Interface with system-backpack mounting/ Filter. Aesthetic appearance.	Relation of components. Material substitution. Examination of alternate fabrication techniques. Combination of component functions. Complete mission/system examination.
8. System Ruggedization	Shock. Vibration. Vulnerability of critical parts.	Spring suspensions. Dampers/isolators. Protective cover. Specification identification.

FUEL TANK IMPROVEMENTS

Modifications were made to the fuel tank of the system. To reduce the amount of manual effort necessary for the pressurization of the fuel, the pump plunger area was increased by 70 percent by increasing the diameter to .92 inches. This means that the maximum force which would have to be exerted by the operator would be about 37 lbs. when the tank is pressurized to the maximum starting operating pressure of 55 psi. Also, the orientation of the pump was changed so that the direction of the force stroke is now parallel to the packboard rather than away from the packboard as previously done when it was necessary to restrain the entire system from movement while also pumping. A drawing of the improved tank configuration is shown in the accompanying sketch, Figure 1. A four leg mounting was also incorporated to mount the tank to the packboard. Each mounting bracket is held in place by neoprene isolators. The actual isolators have their axis of mounting oriented at a 45° angle to the packboard so that two perpendicular axes of isolation are provided as resistance to mechanical loads rather than the single axis previously used for mounting.

To assure that sufficient fuel is available for eight hours continuous system operation, the tank capacity was increased slightly to approximately 2.3 pounds of gasoline (approximately 2/3 of an hour additional capacity).

Because of weight, the fuel tank is 6061 aluminum and a coating is applied to all surfaces which come in contact with the fuel. A Kynar coating (Reg. T. M. of Pennsalt Chemicals Corporation), a vinylidene fluoride resistant to most chemicals, was chosen because of the relatively low temperature of application. Since the fuel tank is a pressure vessel and its strength is determined by the heat treatment, the final heat treatment to achieve the T4 to T6 condition was the curing application of the coating.

The diaphragm accumulators were procured from the Bellofram Corporation. In response to the fuel system performance specifications a solid polyurethane with no fabric net support reinforcement was recommended. With a fabric net reinforcement additional thickness of material would be required to prevent diffusion of air into the fuel since the

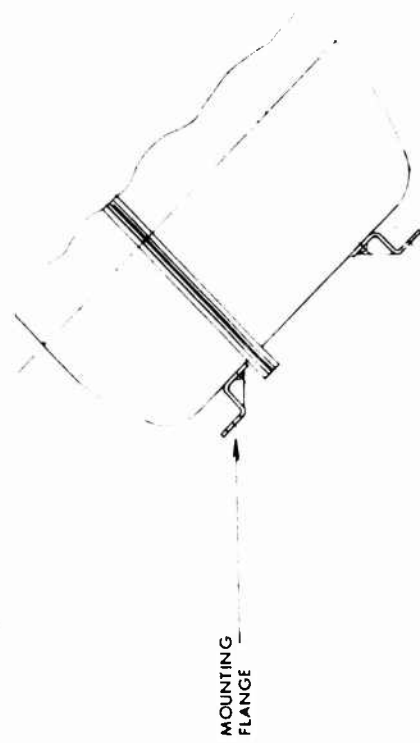
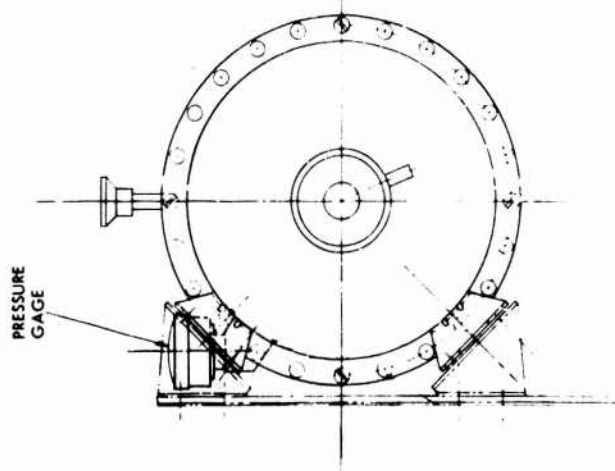
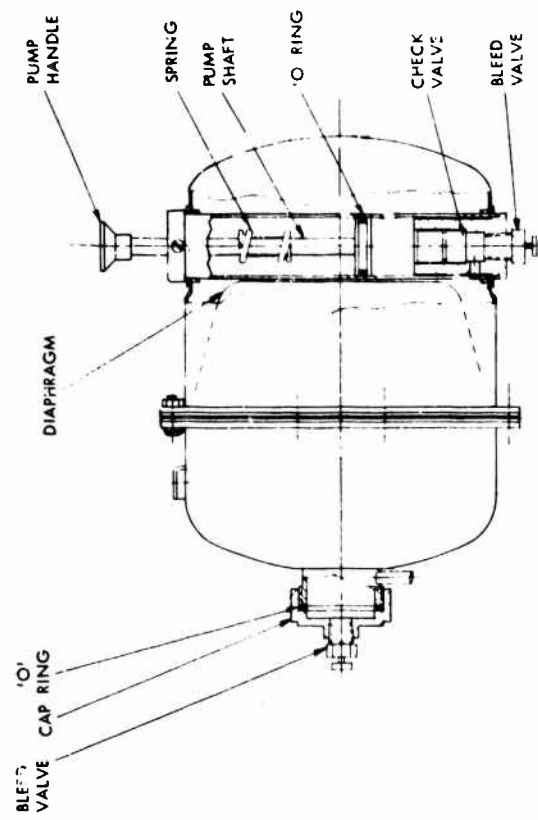

Figure 1. Fuel Tank Assembly

net reinforcement can act as a wick. At the system operating conditions no wick reinforcement was necessary and diffusion would not occur with a solid material diaphragm. This was suspected as being a problem with previous systems but no evidence was found during the tests performed on the modified system.

FUEL PRESSURE REGULATION IMPROVEMENTS

The fuel system is shown in Figure 2. Major changes from the prior system are the location of the shut-off valve and the incorporation of the temperature controlled multiple orifice. The shut-off valve is now located before the pressure regulators rather than after. This prevents the low pressure regulator from approaching the tank pressure and possibly damaging the diaphragms when the fuel flow is shut off. Fuel lines and fittings are made of Teflon; this material was selected so that the elements of the fuel system will be as chemically inert as possible. All metallic elements in contact with the fuel up to the metering orifice are stainless steel. The only exception is the fuel tank cap which is anodized aluminum and was retained from the previous system.

Generant Inc., the manufacturer of the present system regulators was contacted regarding the performance specifications of the fuel regulation system for this application, especially for materials compatibility and inertness to fuels. The fuel regulators and a detailed description of the operation and specifications for the system were sent to Generant for examination and recommendations for improvements in the operation of the system. The portion removed included the high and low pressure regulators, shut-off valve, hypodermic needle capillary tube and associated tubing. Since the pressure regulators were manufactured by Generant, they were concerned about the non-repeatable performance and desired to examine the regulation configuration. In response to this investigation, Generant supplied modified adjustable high pressure and low pressure regulators for system tests. A typical regulator is shown in Figure 3. Pressure and flow tests indicated that the improved regulators would meet the required performance objectives in the simulated fuel system. Table II shows the performance obtained over the nominal operating conditions.

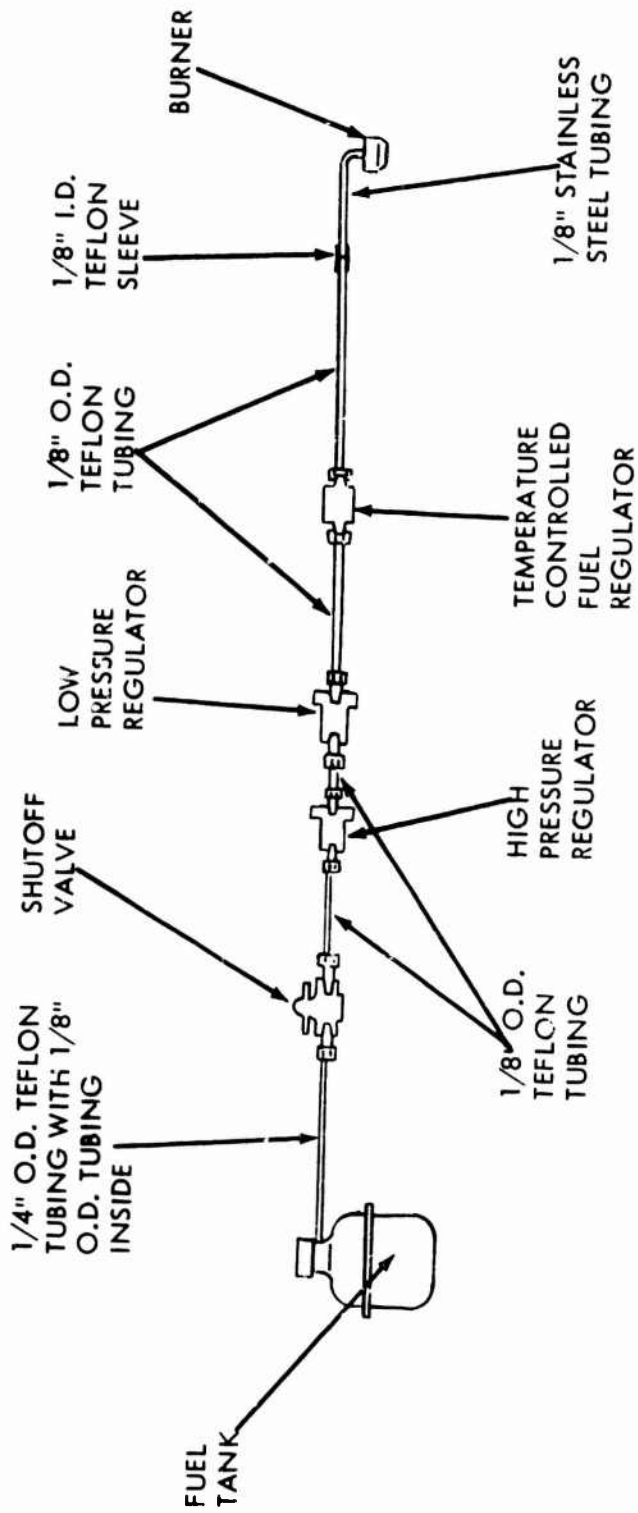

Figure 2. Fuel System



Figure 3. Typical High Pressure and Low Pressure Adjustable Regulator

FUEL METERING IMPROVEMENTS

The system is expected to operate over a wide ambient temperature (-40°F to $+110^{\circ}\text{F}$). Military fuels have a large variation of properties, particularly density and viscosity, over this temperature range. The present system is essentially a constant pressure system and so would experience a large variation in fuel flow to the burner unless manual manipulation or automatic control were provided. Rather than depending upon operator control, a thermostatically controlled, electrically heated orifice was utilized to keep the fuel metering system at a tolerable temperature range.

This concept is most attractive since the parasitic power requirement during startup is small and judicious choice of location within the system can be utilized to maintain the proper temperature during steady-state operation.

The Lee Company of Westbrook, Conn., was contacted regarding the application of their multiple orifices arranged in series to provide a calibrated flow restriction for metering of the fuel. Based on a nominal operating condition where 0.25 lbs/hr of gasoline (MIL-G-3056B) is required at 70°F , the Lee Corporation recommended a configuration which has a minimum passage diameter of 0.010 inches. A comparable conventional orifice would be 0.004 inches diameter and have the same pressure drop (50 inches w.c.) as the multiple orifice Lee "Visco Jet" * and the present 0.008 inches diameter 0.75 inches long capillary tube. The "Visco Jet" is also screened on the inlet and exit to prevent passage clogging.

Because of the unique configuration and method of operation, the "Visco Jet" has a number of distinct advantages over conventional orifices. The use of larger screen holes and larger passageways means that a greater level of contamination can be tolerated without clogging the fuel system. Also, there is a built-in compensation for viscosity variation so a broader temperature range of operation can be expected with a relatively constant fuel input. The large passages result in lower velocities in the throat of the orifice and helps reduce or prevent cavitation.

* Trade Name of the Lee Company.

The recommended Lee "Visco Jet" provides a variation of 2% in fluid resistance at the nominal flow rate of gasoline over a temperature range of 70° to 110°F. This, of course, means that precise temperature control of the metering orifice is not necessary for fuel control. Below 70°F external ambient temperature, the metering orifice is heated electrically until the temperature of the orifice reaches or exceeds 70°F. The power input to the electrical heater is controlled by a bimetallic thermostat which senses the orifice temperature. This arrangement is shown in Figure 4. Figure 5 shows the actual components. Under the most extreme ambient conditions, less than 4 watts of electrical power is required to heat the orifice to the operating temperature and to heat the fuel and maintain the temperature level of operation until the system reaches thermal equilibrium. Under steady state conditions, the fuel is maintained at the expected temperature level by locating the metering orifice in the air mixing chamber at the entrance to the suit blower since the air temperature will be fairly constant in this region.

The electrical heaters are supplied by Hotwatt, Inc., of Danvers, Mass. These miniature heaters 1/8 inch diameter by 1 inch length supply a nominal 5.7 watts at normal battery start-up voltage of 10.8 volts dc.

Miniature bimetallic thermostats weighing less than 0.1 ounce were obtained from Chatham Controls. These hermetically sealed thermostats, suitable for shock and vibration environment, have an operating temperature differential of less than 4°F from the temperature at which the contacts open until they close on sensing a temperature decrease.

Prior to ignition of the burner, the metering components (Lee "Visco Jet", heater, thermostat, and support housing) can be brought up to operating temperature (approximately 70°F) from the most extreme ambient condition (-40°F) in less than five minutes with less than 5 watts. Approximately 3 to 4 watts are required to heat the fuel and maintain the temperature level of operation at rated fuel flow until the system reaches thermal equilibrium. Under steady-state conditions, the fuel is maintained at the proper temperature level by locating the metering orifice in the air mixing chamber at the entrance to the suit blower since the air will be adjusted to the comfort level of the operator which is a narrow

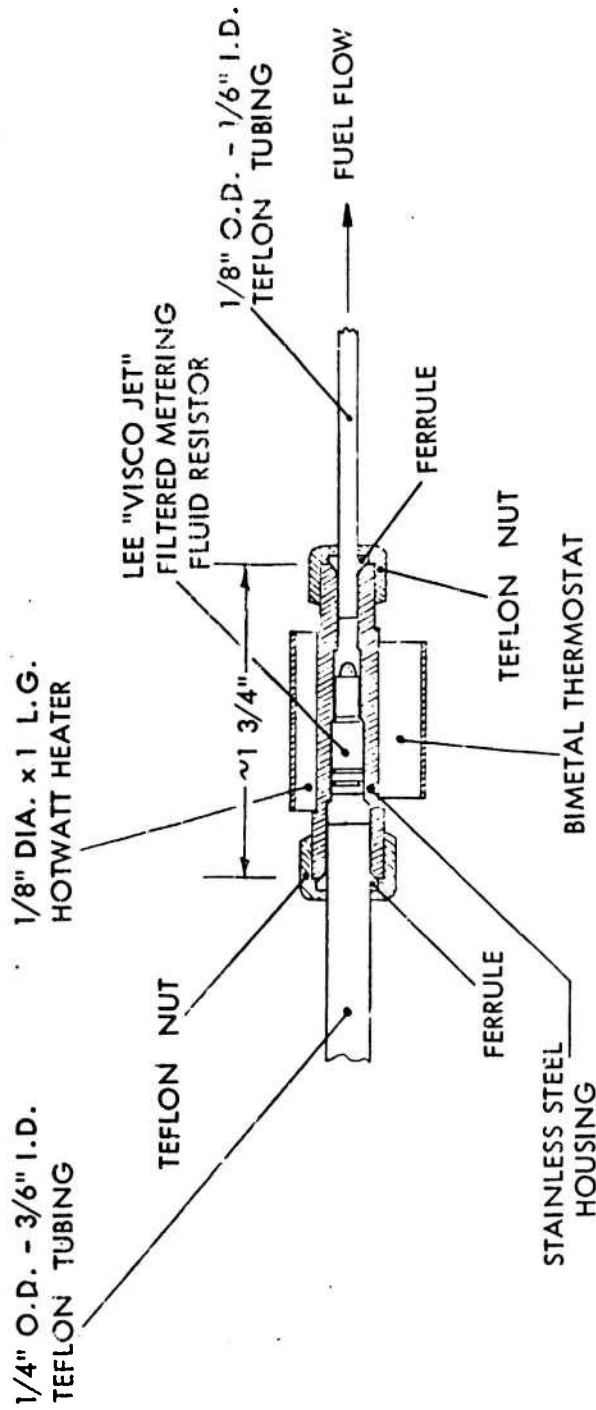

Figure 4. Electrically Heated Thermostat Controlled Fuel Regulator

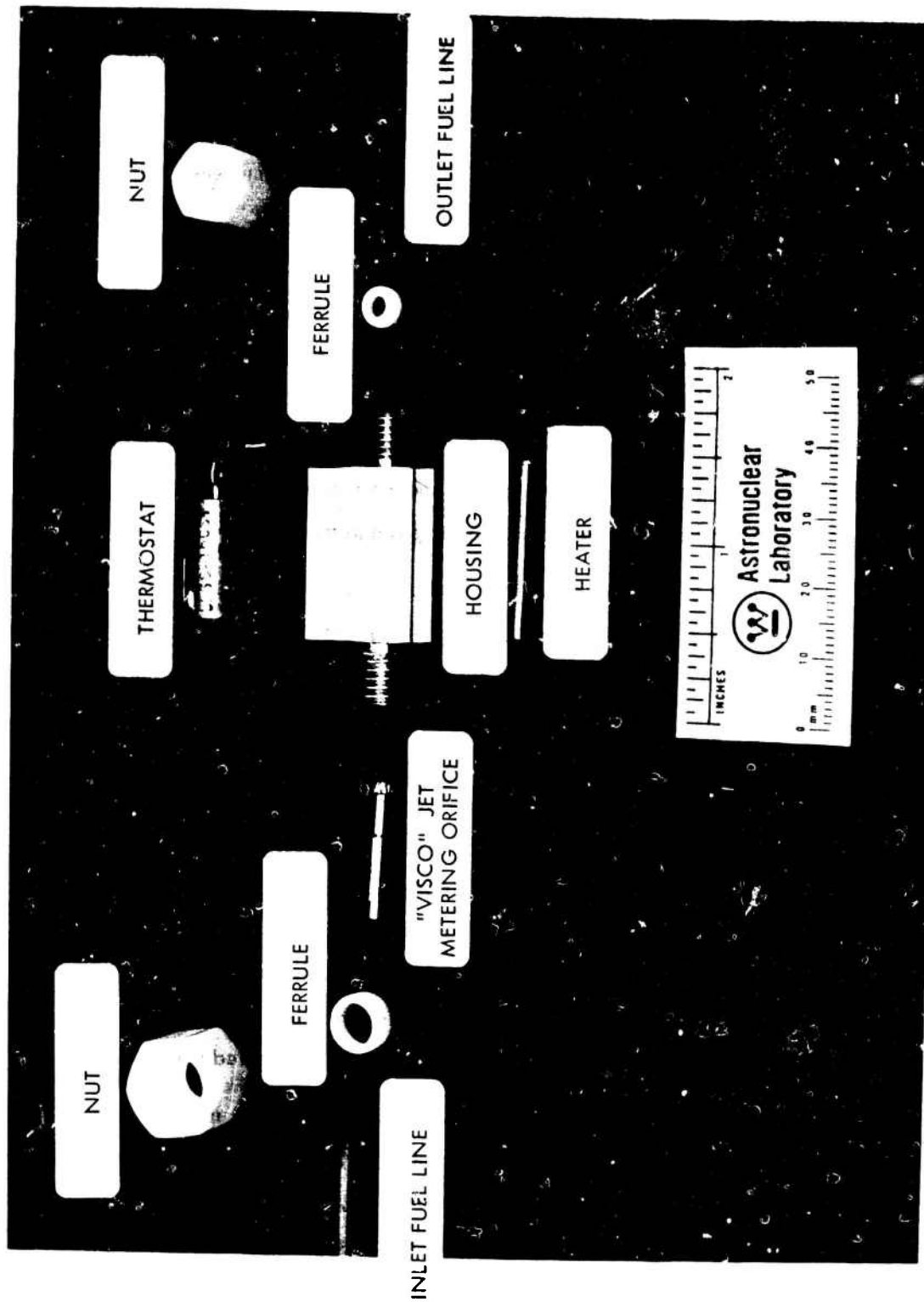

Figure 5. Fuel Metering Components

temperature band in itself. In the case of hot environment operation when temperatures as high as $+110^{\circ}\text{F}$ can be experienced, the viscosity compensating feature of the Lee "Visco Jet" is utilized to maintain a relatively constant fuel flow to the burner.

Table II lists the metering characteristics of the fuel supply system when tested with the Generant pressure regulators at operating conditions.

BURNER IMPROVEMENTS

The work associated with the improvements to the combustion system was performed at the Westinghouse Research Laboratories to take advantage of the facilities available and to perform the sophisticated studies necessary and to utilize the consultation from expert personnel. While conducting this investigation, performance characteristics of the overall system operation were identified for investigation on this program.

When the system is operating in a mode where heated air is being delivered to the suit and there is free discharge from the suit blower, smoking and acoustical noise from the burner-combustion chamber could occur and was observed. The suit blower is a high-pressure medium-flow device, whereas the generator-burner blower is a low-pressure medium-flow device. Because the two are coupled, when any amount of heated air is being delivered by the system, it is possible for the suit blower to overpower the generator-burner blower, reducing the air pressure and hence, air flow to the burner head causing the burner to run rich, smoke and produce noise. This condition can be improved by assuring that a flow resistance equivalent to the filter and suit is present on the suit blower discharge when operating the system for investigation or demonstration. A cap with an orifice hole of the proper dimensions placed on the suit blower outlet to provide the required flow resistance is sufficient for demonstration purposes when the system is run in the heated mode.

The burner assembly of this system is a light-weight, low-pressure, multifuel type. The original work on this burner concept, prior to this contract, was performed as part of Westinghouse independent development. Patent Number 3,324,921 has been granted to Westinghouse covering this burner concept. The burner work performed as part of previous

TABLE II
 PRESSURE REGULATION AND FUEL METERING SYSTEM
 CHARACTERISTICS

<u>Fuel Tank Pressure (psig)</u>	<u>Intermediate Pressure (psig)</u>	<u>Orifice Pressure</u>	<u>Fuel Flow (grams/min)</u>
50	10.3	Not measured	2.13
45	10.3	Not measured	2.13
40	10.3	Not measured	2.10
35	10.6	Not measured	2.09
30	10.8	Not measured	2.06
25	10.8	Not measured	2.07
20	11.0	Not measured	2.07
15	11.2	Not measured	2.05
10	10.2	Not measured	2.09

contracts for Natick was to modify the burner to accommodate the reduced fuel rates and to fit the smaller combustion chamber. Westinghouse established an independent research and development program to improve burner concepts of this type. Under this Westinghouse sponsored program, the burner of the thermoelectric heating and ventilating system was thoroughly examined and modifications for performance improvements of this concept were made. This contract related work was limited to following investigations and incorporation of the improvements into the T/E heating and ventilating system.

The results of the investigations of the operation of the burner of the thermoelectric heating and ventilating system both as a separate component and as part of the overall system indicated:

1. More than 65% excess air was required to insure complete combustion of fuel.
2. The volume of space in the vicinity of the burner head was not being utilized for mixing of the combustion products.

Since the burner is a low-pressure device which is dependent upon the generator blower to develop the required pressure head, it was not possible to increase the turbulence at the burner head region and thus promote better air/fuel mixing and a reduction of excess air in the present configuration.

Configurations utilizing a porous ceramic wick which allow a complete utilization of space around the burner head and also increase turbulence at the burner promoting better fuel air mixing with a reduction of excess air were examined. The approach taken is to disperse the fuel, vaporize and mix the fuel with air by passing a portion of the air necessary for combustion through a porous wick and burn the fuel in a turbulent region at the hot burner surface.

Using this approach, a configuration was developed and tested at performance levels approximating those necessary for operation in this system. With leaded gasoline rates of about 0.25 lbs/hr, the configuration shown schematically in Figure 6 was tested at static air pressure drops of 0.1 to 0.3 inches of water column across the burner, operating on excess

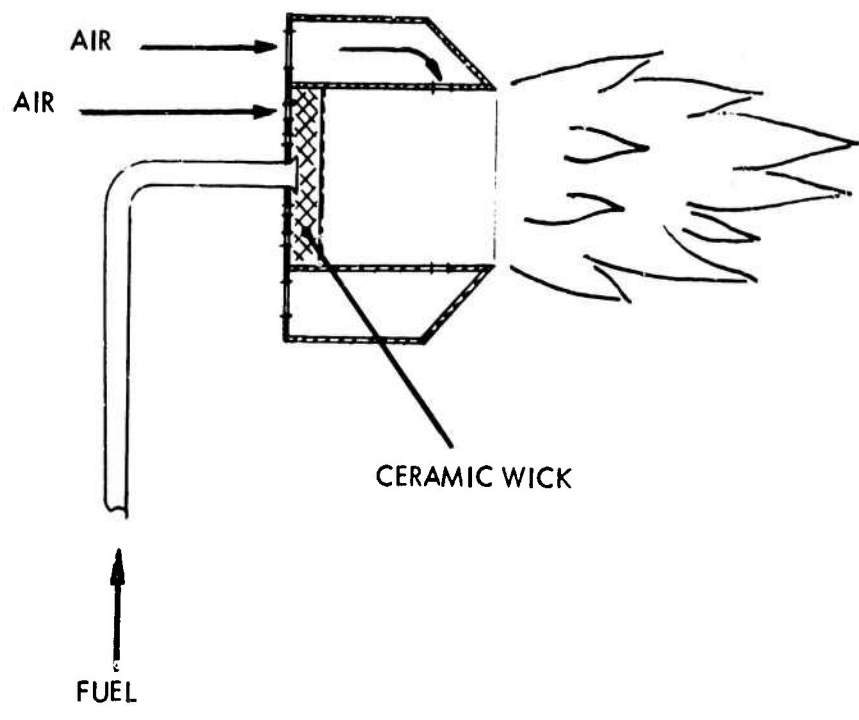

Figure 6. Schematic Representation of Westinghouse Developed Burner

air requirements of about 10%. This new configuration exhibits satisfactory performance capabilities at operating levels from slightly fuel rich to excess air levels greater than 50%. The developed configuration was adapted to the system and operates at the greater excess air levels at sea level and satisfactory operation can be expected at elevated altitudes.

The burner operates at excess air levels at sea level elevation so that when elevated altitude operation is encountered, the volume air flow rate delivered to the burner will remain the same but the mass flow rate will be reduced due to the decreased density and the burner would operate near the minimum air requirement. Also, the problem of intermittent smoking from the burner and related noise is virtually eliminated. The basic burner housing is made from Type 321 Stainless Steel 0.020 inch thick which is very stable at elevated temperatures in combustion atmospheres.

The measured performance of the Westinghouse developed burner is given in Table III. The air inlet side and combustion end of the multifuel burner are shown in Figures 7 and 8.

IGNITION SYSTEM IMPROVEMENTS

To reduce the operator function during the startup of the system, automatic ignition systems were investigated. Of particular interest were high voltage spark ignition devices. The types considered were high voltage coil-capacitance discharge and piezoelectric spark ignition. These proved to be unsatisfactory.

With the improved burner and fuel distribution system, tests indicated that it is unnecessary to provide a reduced air flow/air pressure delivery to the burner during the warm-up period as had been done previously. One step in the startup/warm-up procedure is eliminated as well as the associated operator surveillance. Figure 9 is an electrical diagram of the heating and ventilating system. The operational procedures are described as follows:

Startup Procedure

1. Fill tank with fuel (diaphragm fully depressed and pump bleed valve open).

TABLE III
MEASURED PERFORMANCE
OF WESTINGHOUSE DEVELOPED BURNER

Fuel Flow Rate (gasoline)	2.4 cc/min
CO ₂	6.5%
CO	75 ppm
O ₂	11.5%
Bacharach Smoke	0-1



Figure 7. Air Inlet Side of Multifuel Burner

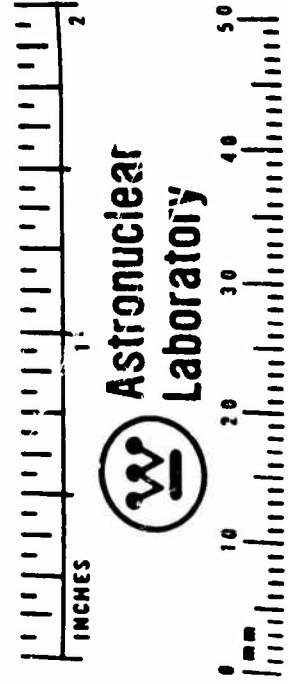

Figure 8. Combustion End of Multifuel Burner

SWITCH SEQUENCE	
POSITION	OPERATION
1	Off
2	Ignite-Warm Up
3	Self Powered
4	Suit Blower
5	External Load

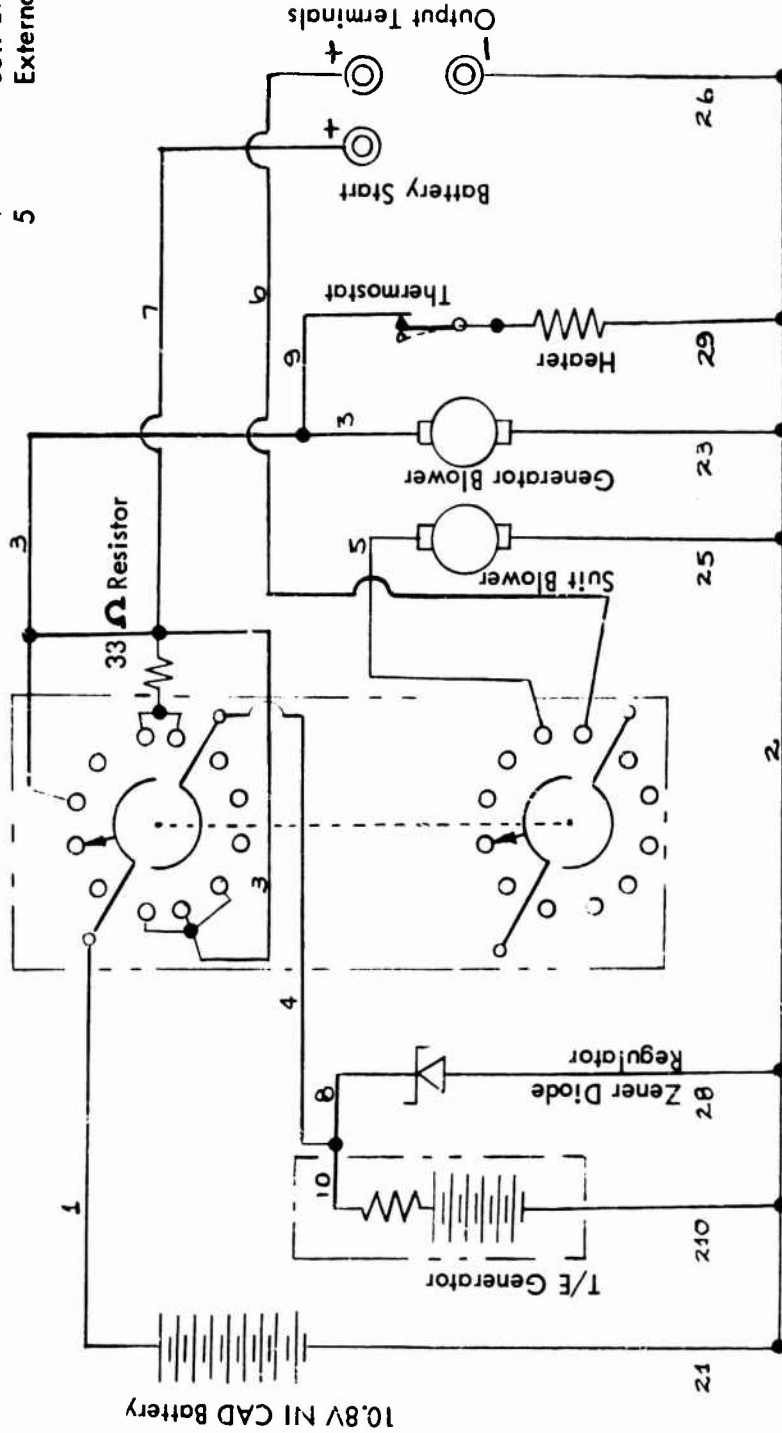

Figure 9. Electrical Diagram of T/E Heating & Ventilating System

2. Pressurize tank slightly and bleed air from fuel tank cap.
3. Pressurize tank.
4. Open burner.
5. Turn fuel shut-off valve to open and ignite burner.
6. Turn selector switch to warmup position (2) and close burner.
7. When burner noise subsides, turn selector switch to run position (3) (unit is now self-powered).
8. After 3-5 minutes, system may be operated with the selector switch in the suit blower (4), or external load (5), position. Some burner noise may be noticeable until steady-state conditions are achieved.

Shutdown Procedure

1. Turn fuel shut-off valve to off position.
2. Turn selector switch to off position (1).

Startup from External Power Source. (Any 6 to 12 volt D.C. source can be used)

1. Connect external source to external battery and ground terminals with the proper polarity.
2. Start as above.

SYSTEM RUGGEDIZATION IMPROVEMENTS

The components of the system most susceptible to shock and vibration loads are: the blowers (motors and fans), fuel pressure regulators, fuel tank, burner-blower assembly and air temperature adjustment.

The motors used to power the blowers are designed to missile and aircraft standards. Normal shock and vibration levels greater than those anticipated in field use of the system are standard operating conditions for the motors. The impellers of the blowers, which are mounted to the shaft of the motor, are light-weight nylon in the case of the suit centrifugal blower and aluminum in the case of the vane-axial burner-blower, and are not expected to impose a severe load on the motors during shock and vibration loads. The covers of the motors are anodized aluminum for protection against dust, moisture, fungus and salt spray.

The pressure regulators are of concern, because of possible deflection of the regulating spring-diaphragm during shock or vibration conditions. In such a case a fuel surge might be possible to the burner. Constant surging of fuel could cause quenching and eventual outage of the burner leading to a flooding of the burner combustion cavity unless quickly detected. However, the spring force on the diaphragm, the regulating mechanism, is much greater than any load which might occur as a result of exposure to mechanical loads as defined by MIL-STD-810A. Therefore, the mechanical loads would have a negligible effect on the performance of the fuel pressure regulators. Also, as an added precaution, a mounting configuration suspending the regulators was selected to dampen out high shock loads. Some additional dampening is expected from the flexible fuel lines. Also, the housing to which the regulator mountings are attached are fastened to the packboard with neoprene inserts to further help isolate the fuel system from mechanical loads. The performance of the regulators is not expected to be affected by shock or vibration loads.

The fuel tank is described in a previous section. The tank design has a safety factor of 3 to 4 so that pressures of 150 to 200 psi can be tolerated. A preliminary design was tested to 150% of the design pressure without failure.* The check valve on the manual pumping system has a burst pressure of 270 psi. Normal operation of the fuel tank is nominal pressurization to 50 to 60 psig at startup and decreasing pressure to about 10 psig when the fuel is exhausted. The most severe conditions would be encountered at startup when the tank pressure is a maximum and the fuel capacity is a maximum (2.3 to 2.4 lbs). Under the most severe conditions, the mechanical loads as a result of exposure to conditions of MIL-STD-810A are not expected to produce loadings which could compromise the tank design or jeopardize the system performance. The mounting configuration, as previously described was selected to reduce the mechanical effects. Also, the supports which hold the neoprene inserts of the mountings were attached to the packboard with neoprene inserts to further reduce the effects of mechanical loads.

* Development of a Heating & Ventilating System, S. F. Bauer, L. J. Fox, Report WAED 67.36E, Westinghouse Electric Corp., Aerospace Electrical Division, Lima, Ohio.

The blower for the generator burner is attached to a housing to properly direct the air for burner combustion and thermoelectric generator cooling. The housing also supports the burner and is hinge-mounted for burner ignition. The entire assembly swings upward and outward from the packboard for ignition and is rigidly held against the thermoelectric generator-combustion chamber during operation. During operation all separating flanges seal to prevent air leaks which could reduce the burner pressure and cause noisy operation and intermittent smoking from the burner exhaust. In the normal operating mode, the burner-blower assembly is held in the closed position by two extension springs having a total holding force of from 7 to 20 lbs. The total assembly weighs approximately 1 lb. Under severe mechanical load it is conceivable that some movement of the burner assembly with respect to the fixed generator-combustion core can occur but the movement would be slight. To allow for such movement and to improve the sealing features at the outer periphery, a more resilient seal of foam polyurethane was incorporated which can allow as much as 0.125 inch movement and still retain the seal. Although little or no movement would be expected, and only under the most severe conditions, no performance changes would be expected. As for the generator itself, the device is constructed so that a compressive loading through the heat exchangers on the thermoelectric modules is maintained and no performance changes are anticipated over exposure to mechanical loads as described by MIL-STD-810A.

The exit air temperature adjustment is performed by positioning a butterfly valve to proportion the ambient air mixed with the heated air from the thermoelectric generator to obtain the desired temperature. The set position is maintained by the frictional resistance of the lever system. To prevent undesired movement, resistance was built into the leverage system by incorporating a spring washer into the pivot of the system lever. A resistance level was selected so as not to present excessive operator exertion in adjustment and is maintained by a lock unit. In the event that movement should occur during mechanical loads, the operator can readjust the system to the desired level. Maintaining the selected level was not considered critical since the exit air temperature of the suit blower will not affect the performance of the system.

The remaining components of the system are not considered to be affected by mechanical loads and in turn do not have an effect on the performance of the system. For the overall system, consideration was given to the enclosure of the overall package to prevent penetration into the package. An overall cover was fabricated from 2024 aluminum 0.020 inches thick and mounted to the packboard. Care was taken to allow sufficient clearance of all components and no components were attached to the cover. A hinged panel was provided at one corner to allow burner access for ignition and shut down.

SYSTEM PACKAGING IMPROVEMENTS

The system was packaged as shown in Figure 10. The location of components was determined on the basis of functional operation. Although the location is as shown, the package is not considered to be an optimum configuration since the program was performed by incorporating modifications and improvements into one of the two thermoelectric heating and ventilating systems developed under a previous project.

The system was packaged in the configuration shown as:

1. Locate the fuel metering components in a relatively low temperature variation area.
2. Reduce the static pressure drop between the heated air exit from the thermoelectric generator and entrance to the mixing chamber below the suit blower.
3. Reduce the complexity of the air temperature control mechanism.
4. Provide multiple functions wherever possible.
5. Utilize as many existing components from the previous contract as possible.
6. Incorporate all modifications and improvements into the existing system to demonstrate feasibility of concept and be representative of a total system designed specifically for field use.

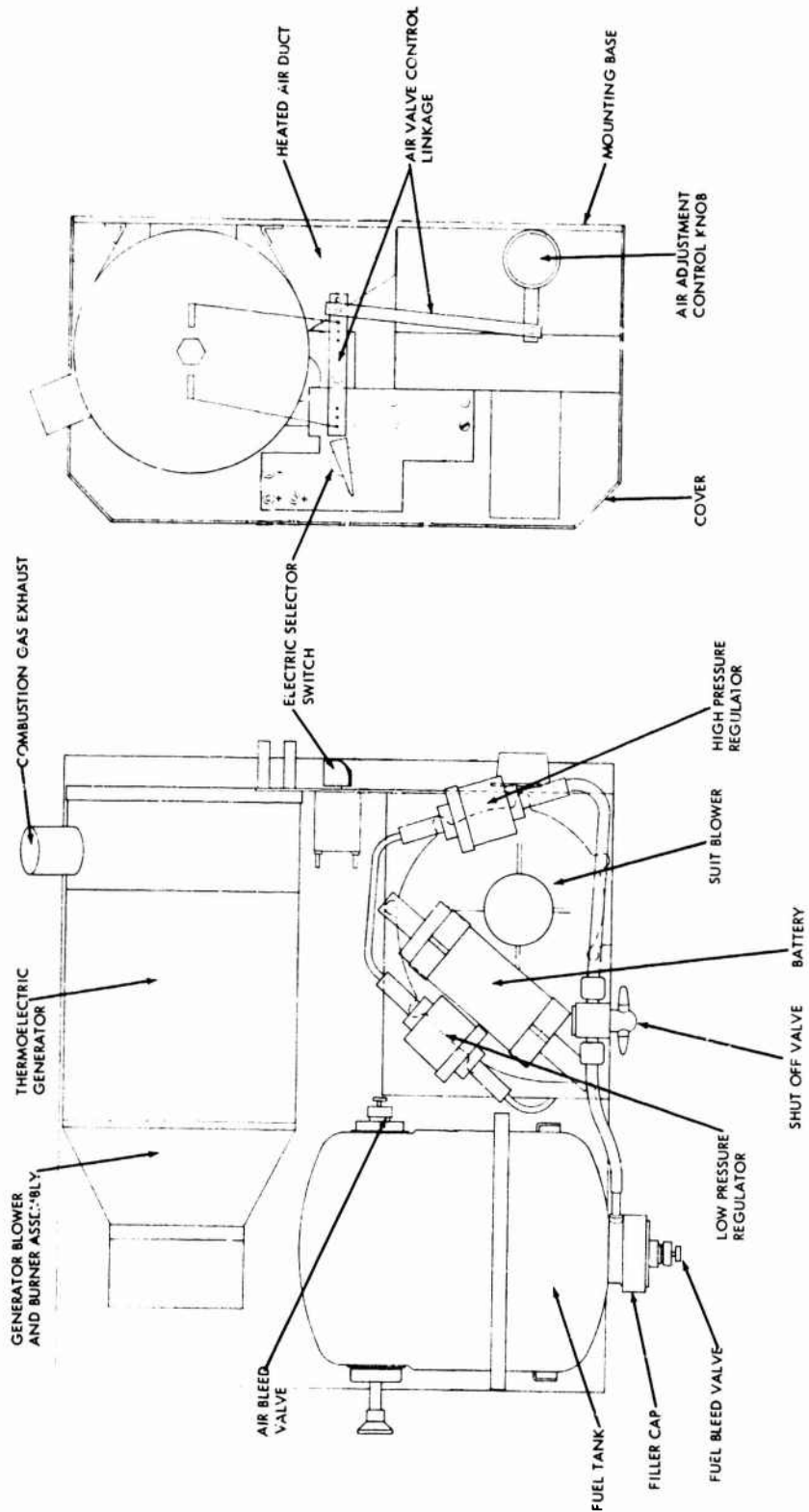

Figure 10. Layout of Thermolectric Heating and Ventilating System