



STANFORD RESEARCH INSTITUTE
Menlo Park, California 94025 · U.S.A.

AD 781417

September 24, 1971

Semiannual Technical Report No. 1
Covering the Period February 12 through August 31, 1971

DYNAMIC TENSILE FAILURE IN ROCKS

By: Carl F. Petersen and Donald A. Shockey

Prepared for: Bureau of Mines
Twin Cities Mining Research Center
Twin Cities, Minnesota 55111

Attn: Dr. D. E. Siskind

SRI Project PYU-1087

ARPA Order Number: 1579, Amendment 2
Program Code Number: 1F10
Name of Contractor: Stanford Research Institute
Date of Contract: February 12, 1971
Contract Expiration Date: February 11, 1972
Amount of Contract: \$73,151
Contract Number: H0210018
Principal Investigator: Dr. Donald R. Curran
Phone Number: (415) 326-6200, Ext. 4560
Project Scientist: Dr. Carl F. Petersen
Phone Number: (415) 326-6200, Ext. 4614
Short Title of Work: Dynamic Tensile Failure in Rocks



Sponsored by Advanced Research Projects Agency

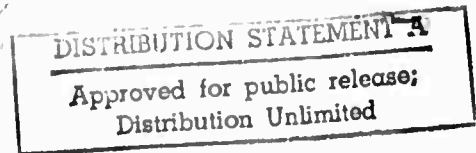

Approved:

DR Curran for
George R. Abrahamson, Director
Poulter Laboratory
Physical Sciences Division

The views and conclusions contained in this document are those of the authors and should not be interpreted as necessarily representing the official policies, either expressed or implied, of the Advanced Research Projects Agency of the U. S. Government.

Reproduced by
**NATIONAL TECHNICAL
INFORMATION SERVICE**
Springfield, Va. 22151

28

DOCUMENT CONTROL DATA - R&D

(Security classification of title, body of abstract and indexing annotation must be entered when the overall report is classified)

1 ORIGINATING ACTIVITY (Corporate author) Stanford Research Institute 333 Ravenswood Avenue Menlo Park, California 94025		2a REPORT SECURITY CLASSIFICATION Unclassified	
		2b GROUP Poulter Laboratory	
3 REPORT TITLE DYNAMIC TENSILE FAILURE IN ROCKS			
4 DESCRIPTIVE NOTES (Type of report and inclusive dates) Semiannual Technical Report No. 1. February 12 through August 31, 1971			
5 AUTHOR(S) (Last name, first name, initial) Carl F. Petersen and Donald A. Shockey			
6. REPORT DATE September 24, 1971		7a. TOTAL NO OF PAGES 28	7b. NO OF REFS 9
8a. CONTRACT OR GRANT NO. H0310018		9a. ORIGINATOR'S REPORT NUMBER(S) PYU-1087	
b. PROJECT NO. ARPA Order No. 1579, Amend. 2			
c. Program Code No. 1F10		9b. OTHER REPORT NO(S) (Any other numbers that may be assigned this report)	
d.			
10. AVAILABILITY/LIMITATION NOTICES			
11. SUPPLEMENTARY NOTES		12. SPONSORING MILITARY ACTIVITY Advanced Research Projects Agency Military Geophysics Program Washington, D.C. 20301	
13. ABSTRACT <p>In this program dynamic tensile failure in rocks is being studied through flatplate impact experiments using a gas gun and ytterbium stress gages. Six gas gun experiments have been performed on novaculite with successful specimen recovery. The stress history at the specimen-plexiglass interface has been recorded with an ytterbium stress gage. The record is in agreement with a computer-predicted profile.</p> <p>The virgin novaculite and the recovered specimens have been examined by optical microscopy. Spall cracks tend to be large and few in number. Fracture proceeds intergranularly.</p> <p>The tensile strength of 27 specimens of novaculite was measured in the expanded ring test (hoop-stress loading) to be 6,400 ± 440 psi.</p>			

14. KEY WORDS	LINK A		LINK B		LINK C
	ROLE	WT	ROLE	WT	ROLE
Tensile strength Fracture Novaculite Ytterbium stress gage Gas gun					

INSTRUCTIONS

1. **ORIGINATING ACTIVITY:** Enter the name and address of the contractor, subcontractor, grantee, Department of Defense activity or other organization (*corporate author*) issuing the report.

2a. **REPORT SECURITY CLASSIFICATION:** Enter the overall security classification of the report. Indicate whether "Restricted Data" is included. Marking is to be in accordance with appropriate security regulations.

2b. **GROUP:** Automatic downgrading is specified in DoD Directive 5200.10 and Armed Forces Industrial Manual. Enter the group number. Also, when applicable, show that optional markings have been used for Group 3 and Group 4 as authorized.

3. **REPORT TITLE:** Enter the complete report title in all capital letters. Titles in all cases should be unclassified. If a meaningful title cannot be selected without classification, show title classification in all capitals in parenthesis immediately following the title.

4. **DESCRIPTIVE NOTES:** If appropriate, enter the type of report, e.g., interim, progress, summary, annual, or final. Give the inclusive dates when a specific reporting period is covered.

5. **AUTHOR(S):** Enter the name(s) of author(s) as shown on or in the report. Enter last name, first name, middle initial. If military, show rank and branch of service. The name of the principal author is an absolute minimum requirement.

6. **REPORT DATE:** Enter the date of the report as day, month, year; or month, year. If more than one date appears on the report, use date of publication.

7a. **TOTAL NUMBER OF PAGES:** The total page count should follow normal pagination procedures, i.e., enter the number of pages containing information.

7b. **NUMBER OF REFERENCES:** Enter the total number of references cited in the report.

8a. **CONTRACT OR GRANT NUMBER:** If appropriate, enter the applicable number of the contract or grant under which the report was written.

8b, 8c, & 8d. **PROJECT NUMBER:** Enter the appropriate military department identification, such as project number, subproject number, system numbers, task number, etc.

9a. **ORIGINATOR'S REPORT NUMBER(S):** Enter the official report number by which the document will be identified and controlled by the originating activity. This number must be unique to this report.

9b. **OTHER REPORT NUMBER(S):** If the report has been assigned any other report numbers (*either by the originator or by the sponsor*), also enter this number(s).

10. **AVAILABILITY/LIMITATION NOTICES:** Enter any limitations on further dissemination of the report, other than those

imposed by security classification, using standard statements such as:

- (1) "Qualified requesters may obtain copies of this report from DDC."
- (2) "Foreign announcement and dissemination of this report by DDC is not authorized."
- (3) "U. S. Government agencies may obtain copies of this report directly from DDC. Other qualified DDC users shall request through _____."
- (4) "U. S. military agencies may obtain copies of this report directly from DDC. Other qualified users shall request through _____."
- (5) "All distribution of this report is controlled. Qualified DDC users shall request through _____."

If the report has been furnished to the Office of Technical Services, Department of Commerce for sale to the public, indicate this fact and enter the price, if known.

11. **SUPPLEMENTARY NOTES:** Use for additional explanatory notes.

12. **SPONSORING MILITARY ACTIVITY:** Enter the name of the departmental project office or laboratory sponsoring (paying for) the research and development. Include address.

13. **ABSTRACT:** Enter an abstract giving a brief and factual summary of the document indicative of the report, even though it may also appear elsewhere in the body of the technical report. If additional space is required, a continuation sheet shall be attached.

It is highly desirable that the abstract of classified reports be unclassified. Each paragraph of the abstract shall end with an indication of the military security classification of the information in the paragraph, represented as (TS), (S), (C), or (U).

There is no limitation on the length of the abstract. However, the suggested length is from 150 to 225 words.

14. **KEY WORDS:** Key words are technically meaningful terms or short phrases that characterize a report and may be used as index entries for cataloging the report. Key words must be selected so that no security classification is required. Identifiers, such as equipment model designation, trade name, military project code name, geographic location, may be used as key words but will be followed by an indication of technical context. The assignment of links, roles, and weights is optional.

CONTENTS

LIST OF ILLUSTRATIONS	111
LIST OF TABLES	111
I SUMMARY	1
II DESCRIPTION OF SPECIMENS	3
A. Microstructure	3
B. Defect Structure	3
III QUASI-STATIC TENSILE TESTS	7
IV FLAT PLATE IMPACT STUDIES	8
A. Recovery Experiments	8
B. Stress Gage Measurements	8
V DESCRIPTION OF FRACTURED SPECIMENS	15
VI FRACTURE MECHANISM OF NOVACULITE UNDER A SHORT-TIME TENSILE PULSE	19
VII FUTURE PLANS	22
REFERENCES	23

ILLUSTRATIONS

1. Microstructure of Arkansas Novaculite showing the equiaxed quartz grains (etched 2 minutes in HF at room temperature).	4
2. a) Micrograph focused on a plane about 100 μ beneath the polished surface of an Arkansas novaculite specimen showing the two basic types of internal flaws; b) Schematic drawing of the rodlike and platelike defects shown in (a).	5
3. Recovery system for gas gun experiments.	9
4. Recording system for ytterbium gage measurement.	12
5. Experimental ytterbium gage record for Shot No. 6	13
6. a) Computer prediction for Shot No. 6 with no spall. b) Computer prediction for Shot No. 4 with spall.	14
7. Low magnification view of Specimen No. 3 showing several cracks on the main spall planes and several transverse cracks extending from the impact surface to about the midplane.	17
8. Low magnification view of the impact surface of Specimen No. 5 showing the radial pattern of cracks transverse to the main spall planes.	18

TABLES

I Summary of Experiments Performed	10
------------------------------------	----

I SUMMARY

The failure mechanisms in rock, despite a long history of study, are still only poorly understood. In this program we are studying dynamic tensile failure in rocks through flatplate impact experiments using a gas gun and ytterbium stress gages.

The research program is divided into three phases:

- I. Stress-Time Measurements: Determination of stress histories of rock specimens during tensile failure.
- II. Damage Measurements: Use of optical and scanning electron microscope techniques to describe damage to impacted rock specimens that have failed in tension.
- III. Model Development: Development and substantiation of a model for dynamic tensile failure in rocks.

During the first year, the main emphasis will be on Phases I and II. The initial experiments are on Arkansas novaculite; the second material to be studied will be Sioux quartzite.

Six dynamic experiments have been performed on novaculite with successful specimen recovery. A small ytterbium stress gage has been designed and used to record the stress history at the specimen-plexiglass interface. The record obtained is in fair agreement with the profile predicted by a computer run.

The virgin novaculite and the recovered specimens have been examined by optical microscopy. Spall cracks normal to the impact direction and other cracks whose planes roughly contain the impact direction are the main cracks formed. The spall cracks tend to be large and few in number. The other set of cracks is thought to be caused by bending, but a detailed analysis has not been performed. Examination of the fracture surfaces has shown that fracture proceeds intergranularly. Segments of

several fracture surfaces are being prepared for more detailed examination by scanning electron microscopy.

The expanded ring test (hoop-stress loading) has been used to obtain the quasi-static tensile strength of novaculite. Results for 27 specimens gave a tensile strength of $6,400 \pm 440$ psi. No significant difference was found between tests conducted in air and under vacuum.

At present it appears that novaculite fails by the following fracture mechanism:

- (1) Simultaneous activation of a number of preexisting structural defects
- (2) Growth of the activated flaws radially outward
- (3) Coalescence of the expanding cracks
- (4) Complete separation of the specimen into two or more parts.

II DESCRIPTION OF SPECIMENS PRIOR TO TESTING

A. Microstructure

Arkansas novaculite--a natural-occurring, polycrystalline quartz-- is a mineralogically simple rock, consisting of a chemically simple mineral, and is therefore a suitable material with which to begin these studies. Metallographic examination of polished and etched surfaces at 1000X shows that novaculite consists of equisized, equiaxed, and randomly oriented quartz grains having an average diameter of about 10 μ .

Figure 1 shows a polished surface which has been etched for 2 minutes in 40% HF at room temperature to reveal the grain structure. Black areas are holes where natural flaws intersect the surface or where grains have been pulled out during the polishing process. Bright areas are caused by reflected light from internal surfaces.

B. Defect Structure

From casual observation of polished surface with the unaided eye, it is apparent that natural novaculite has a defect structure. Moreover the defects are strongly oriented. Closer examination with a microscope shows that defects are present on essentially two distinguishable size levels; namely, larger defects having dimensions of a few hundred microns, and smaller ones on the order of the grain size.

By exploiting the translucency of novaculite and focusing into the material to a depth of about 100 μ , the larger flaws are found to exist in two dominant shapes--plates and rods. Figure 2 shows a rodlike and a platelike flaw slightly below the surface of polish and inclined at an angle to it, so that only a section of each is in focus. The planes of the rather homogeneously distributed platelike flaws are roughly parallel with respect to one another, and the rodlike defects are inclined at about $\pm 45^\circ$ to these planes. (Rodlike flaws possibly originate from tiny bubbles of water rejected during crystallization

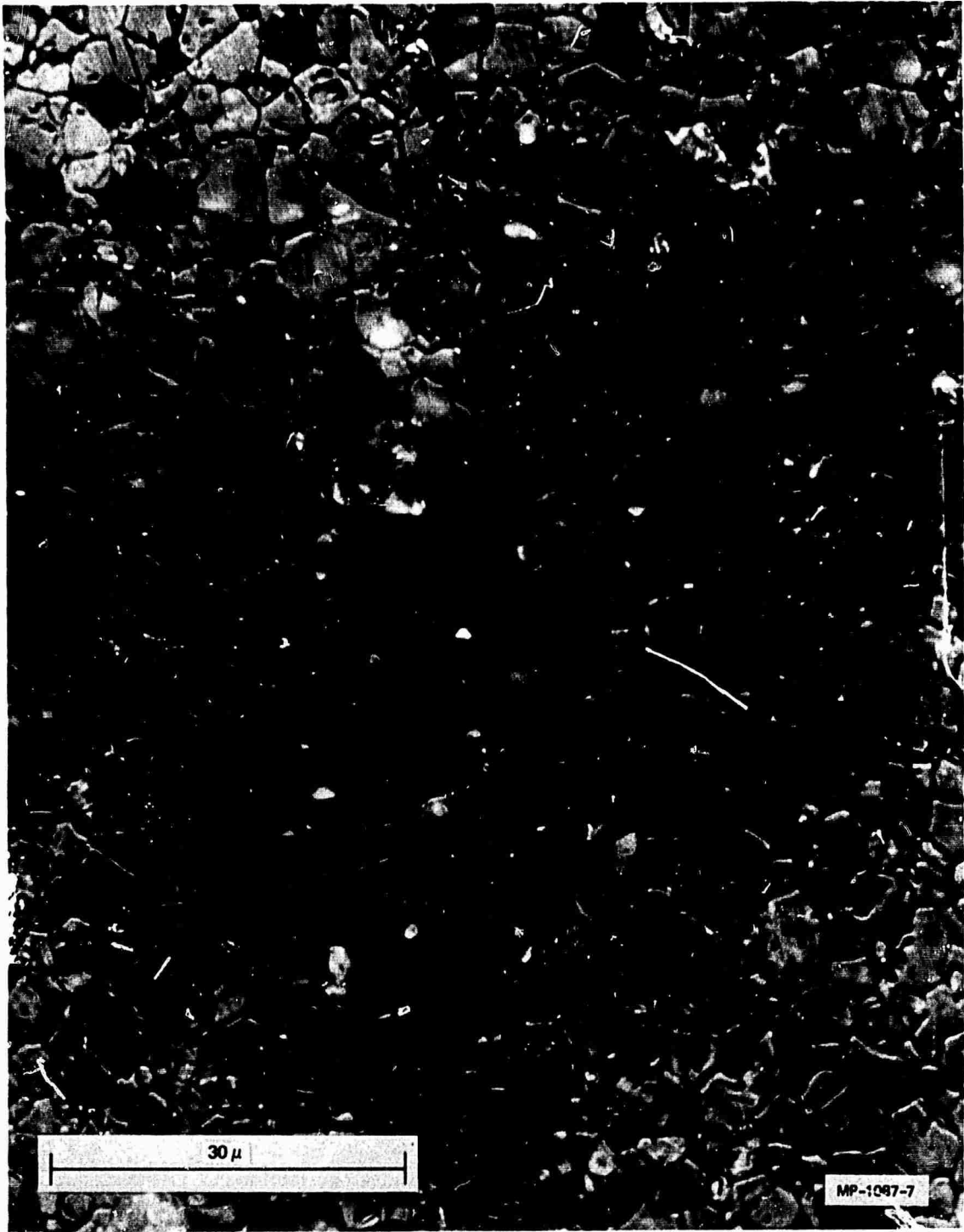
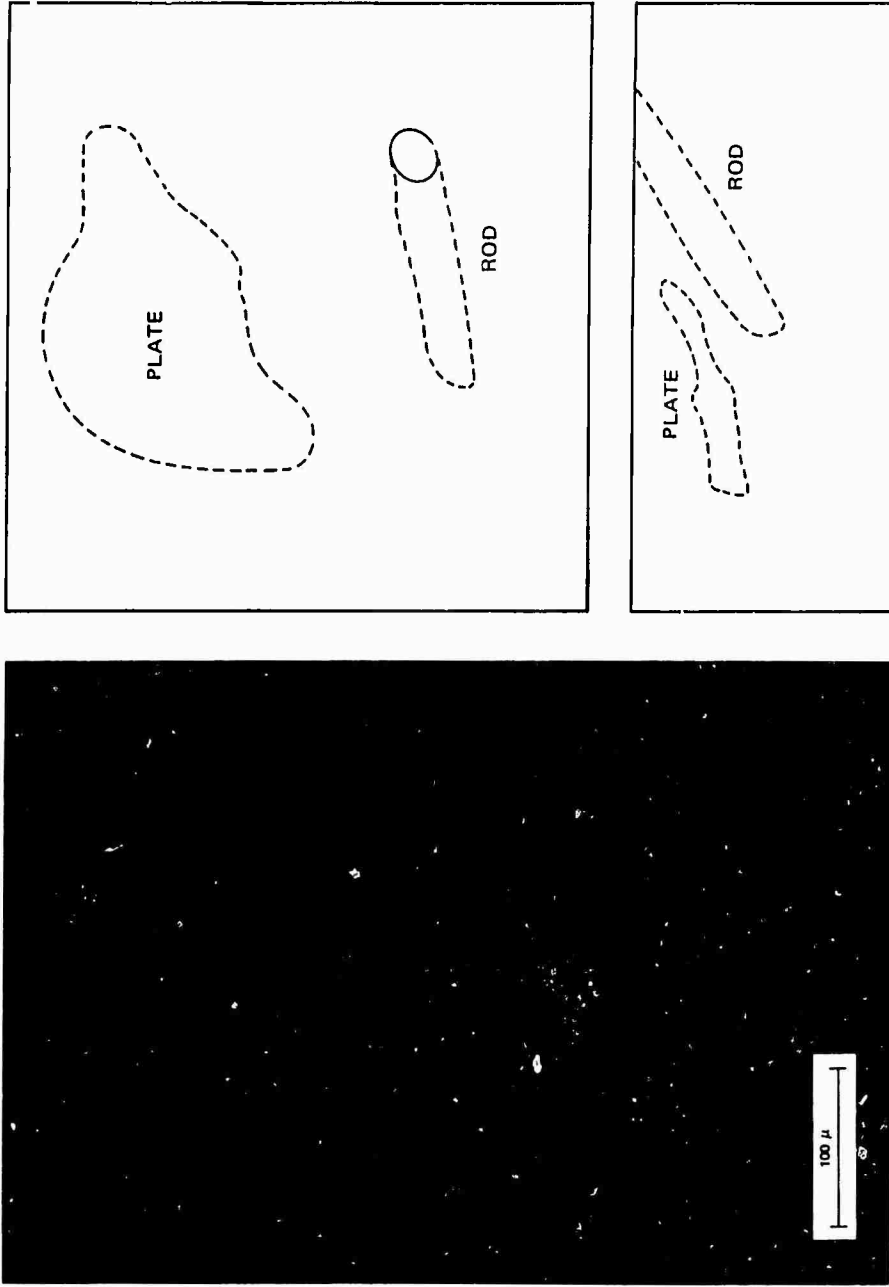

FIGURE 1 MICROSTRUCTURE OF ARKANSAS NOVACULITE SHOWING THE EQUIAXED QUARTZ GRAINS (etched 2 minutes in HF at room temperature)



MP-1987-9

FIGURE 2 (a) MICROGRAPH FOCUSED ON A PLANE ABOUT 100 μ BENEATH THE POLISHED SURFACE OF AN ARKANSAS NOVACULITE SPECIMEN SHOWING THE TWO BASIC TYPES OF INTERNAL FLAWS, (b) SCHEMATIC DRAWING OF THE RODLIKE AND PLATELIKE DEFECTS SHOWN IN (a)

of the rock, which coalesce to form capillary tubes [Khvorova and Dmitrik, 1969].) The size distribution of these flaws was not determined, but the mean plate diameter or rod length was of the order of 200 μ . (The largest flaw observed was ~ 2 mm.) The plates would appear to be particularly effective crack starters, and their strong preferred orientation is expected to result in highly anisotropic fracture properties.

Metallographic examination at higher magnification (500X - 1000X) reveals the presence of a population of smaller flaws on the order of 10 μ . Evidence can be seen for example, in Figure 1, where the bright spots on the micrograph can only be explained as reflection of light from internal surfaces. Since the sizes of these surfaces compare well with the grain size, it is likely that these cracks are at grain boundaries where imperfect adhesion of two grains occurs. The presence of microcracks at grain boundaries indicates that fracture in novaculite will be mainly intergranular.

III QUASI-STATIC TENSILE TESTS

The tensile strength of novaculite was determined using the SRI expanded ring test [Sedlacek, 1968; Sedlacek and Halden, 1962]. In this test hydrostatic pressure acts radially against the internal wall of a cylindrical specimen to create a uniform tangential tensile stress in the specimen wall. Nonaxial stresses caused by misalignment and localized stress concentrations, which normally arise from gripping or supporting the test specimens, are eliminated in this method.

Specimens were diamond ground from oversized blanks to the following dimensions:

I.D.	2.00 ± 0.0005 in.
O.D.	2.300 ± 0.0005 in.
Height	0.300 ± 0.0005 in.

All strength measurements were made at a stress rate of 3000 psi/sec.

Measurements were taken both in air and under a vacuum of 10^{-5} torr. Some materials show higher strengths under vacuum, even at these high stress rates [Sedlacek, 1970], indicating that stress corrosion is an important factor. No significant difference was seen for novaculite. Results of 15 tests in air gave a tensile strength of $6,400 \pm 440$ psi, and 12 tests under vacuum gave $6,500 \pm 480$ psi. The extremes measured were 7500 and 5400 psi. These strengths are considerably higher than those reported by Hardy and Jayaraman [1971] for a variety of rocks, such as Barre granite 1280 psi; Crab Orchard sandstone, 1030 psi; and Leuders limestone, 680 psi.

IV FLAT PLATE IMPACT STUDIES

A. Recovery Experiments

The main objective in the recovery experiments is to apply a known stress wave of one-dimensional compression and tension to the specimen and to recover it without further damage from boundary release waves, reverberations, or secondary impacts. Flat plate impact was attained in SRI's gas gun. Specimens were kept relatively thin (diameter: thickness ratio of 5:1 or greater) to reduce boundary effects. The specimens were mounted in 1145 aluminum rings set in an aluminum target plate (Fig. 3). The rings were machined with an 8° taper and press-fit so that the ring and specimen would easily pop free from the plate. As the specimen flies from the target plate, it passes through a hole in a rigid steel plate and falls into a container lined with soft rags. The projectile and the rest of the assembly are stopped by the steel plate. This recovery method was found to be quite satisfactory for these experiments.

Tension was introduced into the specimens by designing impact experiments such that release waves originating at the back of the thin projectile head meet release waves coming from the free surface at the center of the specimen. Six such experiments have been performed and are described in Table I. It should be noted that the calculated peak tensile stress is higher than the actual tensile stress produced in the specimen because the calculation assumes that spall does not occur. Spall damage was observed in all specimens except No. 6.

B. Stress Gage Measurements

Piezoresistant stress gages made of ytterbium have recently been developed at SRI for use in the sub- and low-kilobar stress range [Keough, 1970; Ginsberg, 1971]. For this project we designed a small gage covering a square area 0.2 inch on a side and 0.002 inch thick.

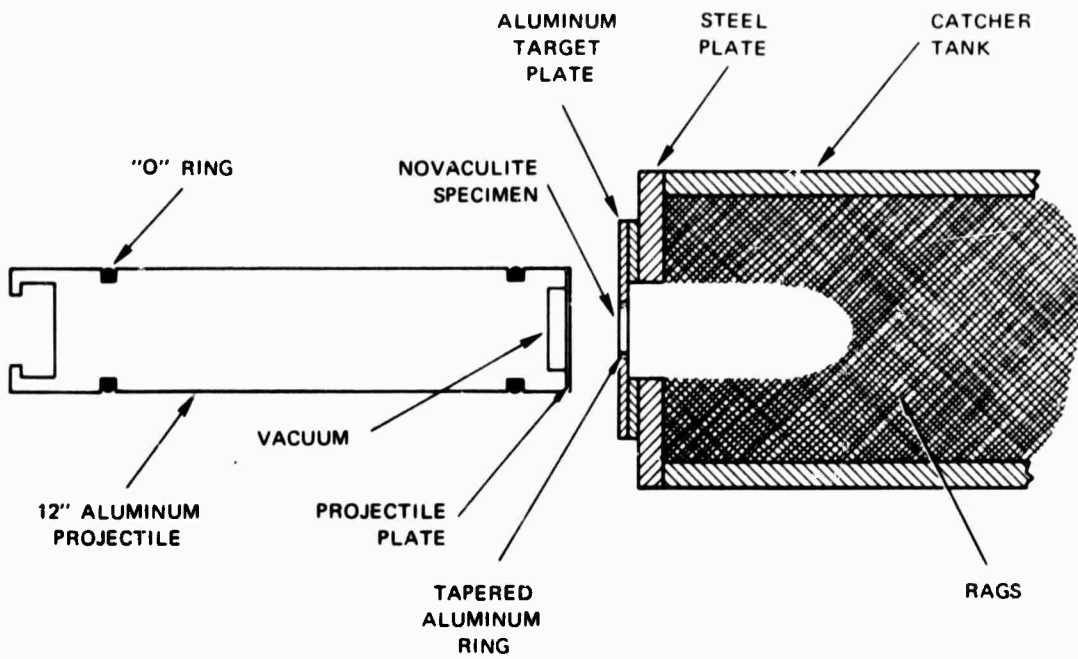

MA-1087-3

FIGURE 3 RECOVERY SYSTEM FOR GAS GUN EXPERIMENTS

Table I

SUMMARY OF EXPERIMENTS PERFORMED

Shot No.	Novaculite Thickness (inches)	Projectile Head (inches)	Backing Material (inches)	Calculated Peak Compressive Stress (kbar)	Calculated Peak Tensile Stress (kbar)	Projectile Velocity (ft/sec)
1	0.239	0.33 polyethylene	--	0.43	0.43	102
2	0.247	0.062 plexiglass	--	0.72	0.72	83
3	0.243	0.125Al 0.25 Mg ⁺	--	2.38	0.61	94
4	0.188	0.025 polyethylene	Yb gage + 0.090 plexiglass	0.64	0.42	151
5	0.188	0.025 polyethylene	Yb gage + 0.215 plexiglass	0.39	0.25	94
6	0.188	0.025 polyethylene	0.010 plexiglass + Yb gage + 0.215 plexiglass	0.41	0.27	100

It is in a grid pattern with a resistance of about one ohm. So far, the gage has been used as a back-surface gage at the interface between the novaculite specimen and a plexiglass plate. In future experiments the gage may also be used between two novaculite disks.

Triggering and noise problems, respectively, ruined the first two attempts at dynamic measurements (Shots 4 and 5); specimen recovery, however, was successful. The noise problems, presumably piezoelectric in origin, were overcome by using a differential recording scheme (Fig. 4) and by separating the gage from the rock by a thin (0.010 inch) plexiglass layer. With these improvements a good record was obtained for Shot 6 (Fig. 5).

The main features of this record are the three peaks that precede the large stretching signal. This record indicates that no spall occurred, and sectioning of the specimen showed no spall cracks. Figure 6a shows a computer run similar to Shot 6 in which spall does not occur. The stress-time profile is very similar to the experimental record. The slopes and rounding of the experimental record are caused by tilt, whereby one part of the gage sees the peak stress before another part. The peaks on the record correspond to 0.08, 0.10, and 0.08 kbar, according to our present calibration (Ginsberg, 1971). (It should be noted that the measurements are of the stresses in the plexiglass backing material, not the novaculite.) No correction has been made for tilt. The corresponding peaks in the computer run are 0.14, 0.09, and 0.06 kbar. The experimental peaks are separated by 1.5 μ sec, and the computed peaks are separated by 1.6 μ sec.

Figure 6b shows a similar computer profile for which spall occurs. In this case, a gage in the position we used would see the compressive stress pulse followed by a lower compressive pulse, the spall signal. In future experiments we expect to record this type of signal.

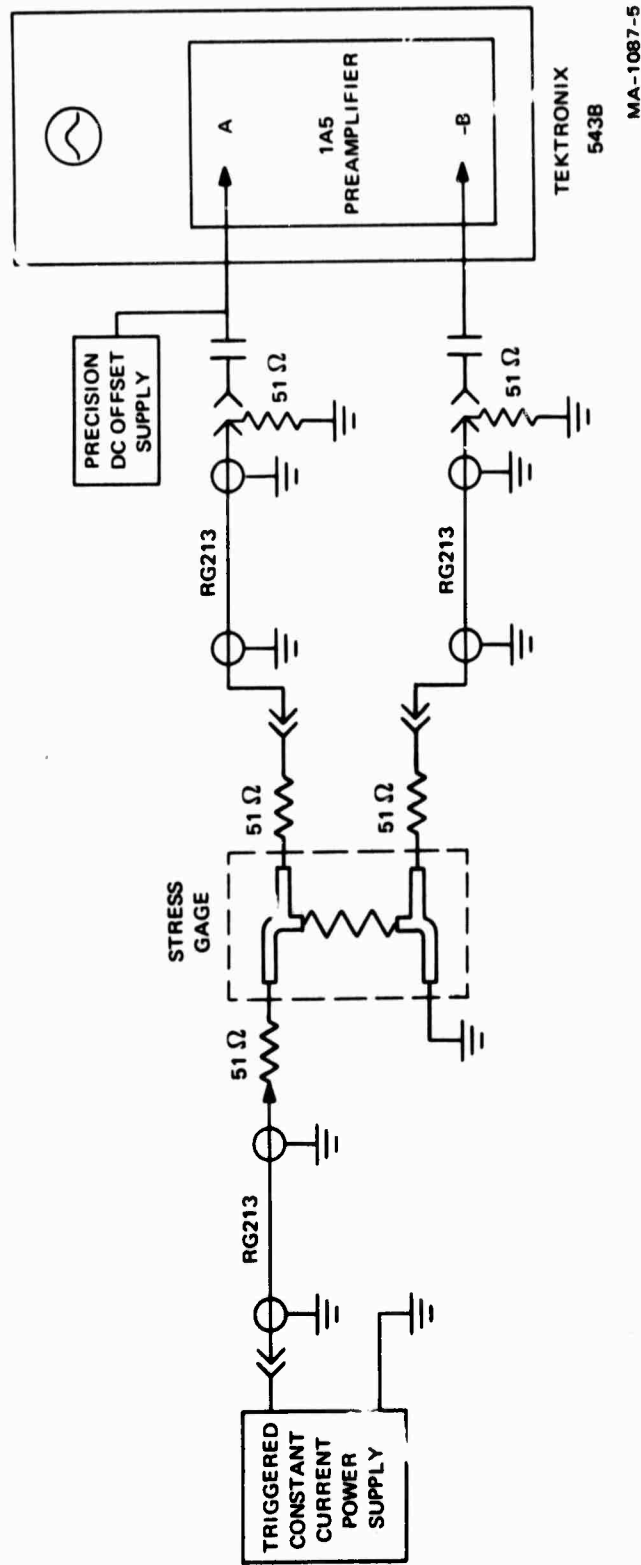

FIGURE 4 RECORDING SYSTEM FOR YTTERBIUM GAGE MEASUREMENT

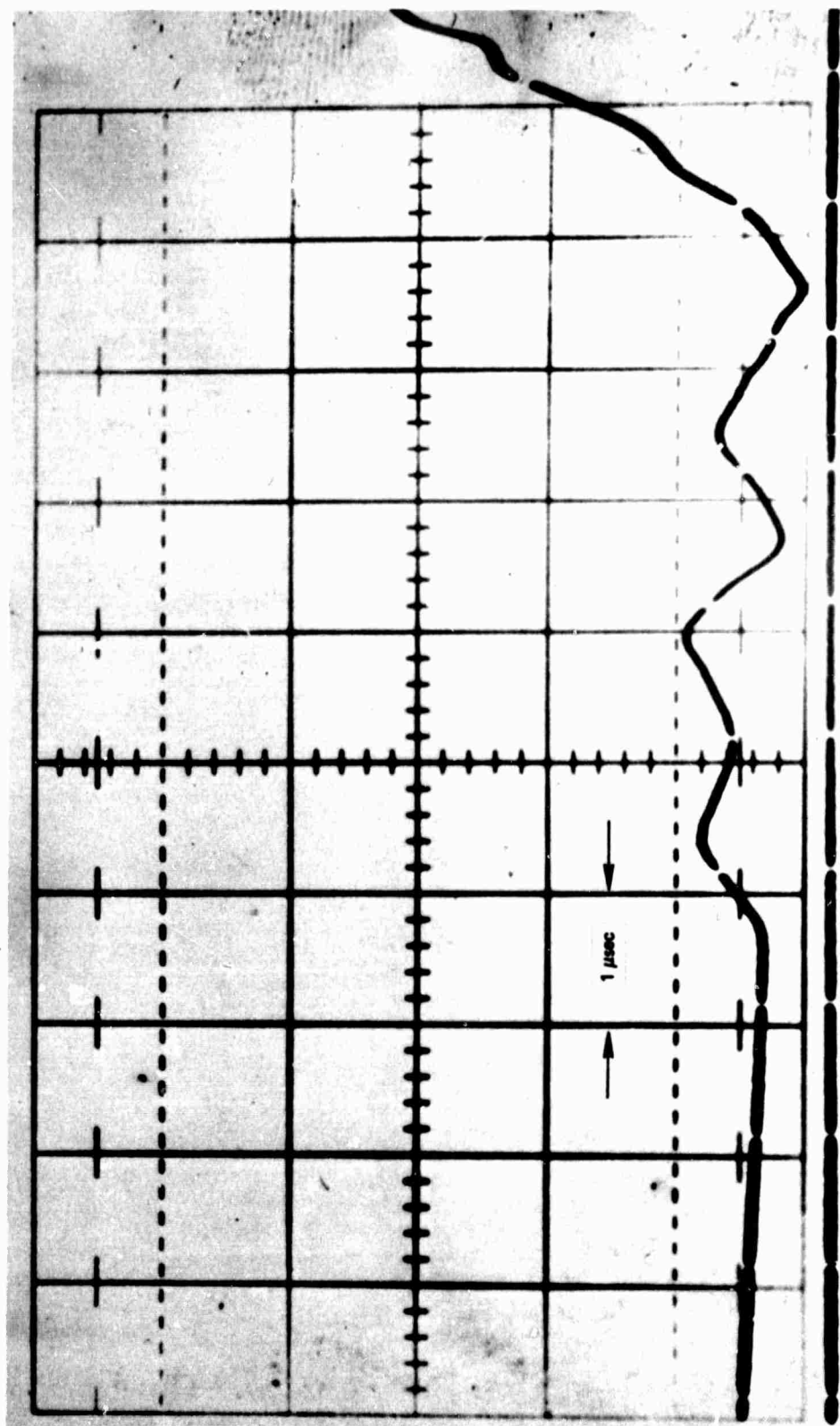

FIGURE 5 EXPERIMENTAL YTTERBIUM GAGE RECORD FOR SHOT NO. 6

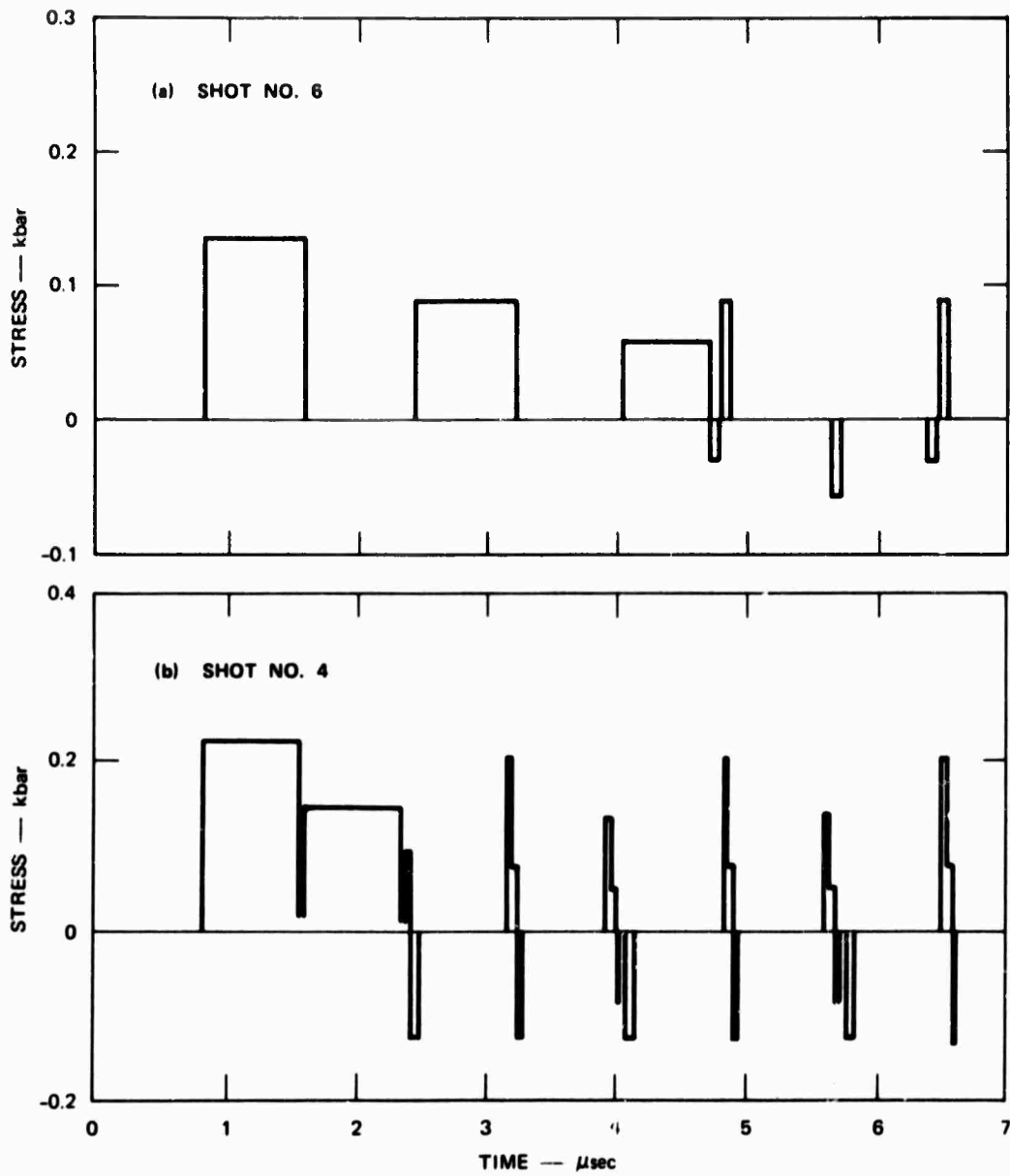

FIGURE 6 COMPUTER PREDICTION FOR SHOT NO. 6 WITH NO SPALL AND SHOT NO. 4 WITH SPALL

V DESCRIPTION OF FRACTURED SPECIMENS

The fracture damage produced during the impact experiments consisted of a number of cracks in essentially two main orientations; namely, cracks lying perpendicular to the impact direction which we will call spall cracks, and those whose plane roughly contains this direction.

The first three specimens were oriented so that the large preexisting platelike flaws lay perpendicular to the impact direction; in the remaining three the flaws lay parallel. It is not yet possible to say which orientation is the weaker. In either case, only a small number of spall cracks were activated (the maximum was eight) and, in two specimens, complete spall separation was apparently achieved by the propagation of spall cracks. These spalled specimens were unusual in that the midplane, where spalling was expected to be heaviest, was rather free of cracks, the main spalling cracks lying close to the specimen surfaces. It could be that these cracks initiated at the specimen periphery.

Spall cracks are expected to see the higher tensile force and, moreover, experience tension somewhat earlier than the latter type. Therefore, spall type fracture is expected to occur first and also to predominate. This is indeed the case for more ductile materials such as Armco iron [Barbee et al., 1970] and Lexan [Curran and Shockey, 1971]. However, significant cracking on planes containing the impact direction has been observed in novaculite in this work, (one specimen, in fact, showed this crack-type exclusively) as well as in polymide, a more brittle polymer [Curran and Shockey, 1971]. The origin of these cracks is currently being investigated, but it appears to be dependent on the ductility of the specimen and the specimen geometry. Their formation merits closer investigation, since these cracks greatly increase the connectivity of spall cracks and thereby heavily influence particle size and general comminution characteristics.

Damage is often in the form of a two-dimensional network whose density decreases with increasing radial distance from the center (Fig. 7). Usually this type of cracking can only be observed on one side of the specimen; the cracks do not propagate through to the free surface. This can be seen more directly by sectioning a specimen on a chord as in Fig. 8, which shows that the cracks extend from the impact surface into about the midplane, where branching sometimes occurs. Since crack propagation generally occurs under tension and crack arrest occurs in compression, we assume that the specimen half near the impact face saw lateral tension and the other half saw lateral compression. A similar stress state arises in bending tests, except in this present case it is the hoop stresses which apparently change sign at some sort of neutral axis. Thus, specimen geometry probably plays a role in producing the cracks which form normal to the spall plane.

Examination of the fracture surfaces with the light microscope has shown that fracture proceeds intergranularly in novaculite. The broken surface consists of countless, well-defined, equisized polygonal blocks-- quartz grains exposed by the passage of a crack along the grain boundaries. Thus the measured fracture strength is really the strength of the "cement" holding individual grains together, and not of the quartz itself.

The light microscope, however, proved unfruitful in yielding further information about the fracture mechanism. It is difficult, for example, to identify any crack initiation sites, propagation markings, or arrest lines. Such features are, of course, valuable clues in understanding the fracture process. Scanning electron microscopy could be helpful here, and several fracture surface segments are currently being prepared for examination.

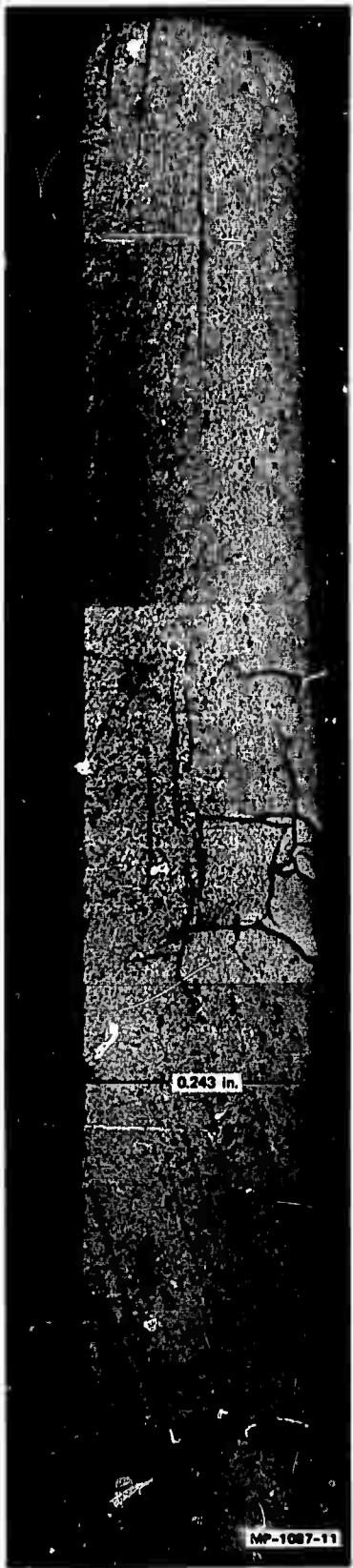

FIGURE 7

LOW MAGNIFICATION VIEW OF SPECIMEN NO. 3 SHOWING SEVERAL CRACKS ON THE MAIN SPALL PLANES AND SEVERAL TRANSVERSE CRACKS EXTENDING FROM THE IMPACT SURFACE TO ABOUT THE MIDPLANE

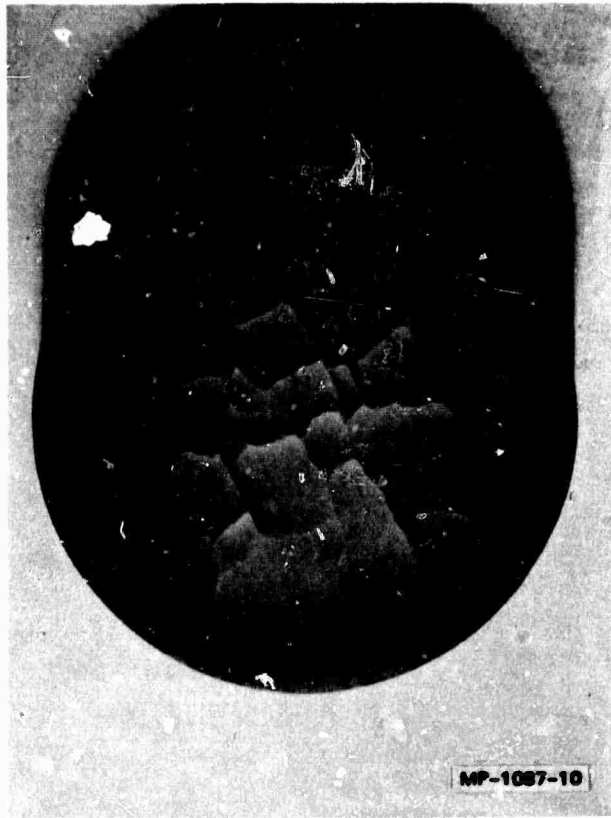

FIGURE 8 LOW MAGNIFICATION VIEW OF THE
IMPACT SURFACE OF SPECIMEN NO. 5
SHOWING THE RADIAL PATTERN OF
CRACKS TRANSVERSE TO THE MAIN
SPALL PLANES

VI FRACTURE MECHANISM OF NOVACULITE UNDER A SHORT-TIME TENSILE PULSE

On the basis of metallographic examination of the first six novaculite specimens impacted with the gas gun and of similar experiments carried out on a transparent polymer, it is likely that novaculite fails by the following fracture mechanism:

1. Simultaneous activation of a number of preexisting structural defects--These include channel-like pores, large voids and planar fissures, and grain boundary seams (see Section II.B). Since the stress required to activate a flaw decreases with increasing flaw size and decreasing root radius of the crack periphery, the largest and sharpest flaws are expected to be the most influential in instigating the fracture process. Thus, in the case of novaculite, the distribution of irregular plate-like flaws about 200μ in diameter by 10μ thick probably control internal spall initiation. Fractographic examination with the SEM will be helpful in checking this.

2. Growth of the activated flaws radially outward--Similar impact experiments on a transparent plastic where individual cracks could be directly observed revealed that damage was in the form of penny-shaped cracks which grew by radial expansion [Curran and Shockey, 1971]. The path of the fracture is determined by two factors; namely, the direction of the maximum tensile stress and the local structural discontinuities in the vicinity of the crack periphery. Strain energy release per unit crack advancement is greatest for crack extension normal to the direction of maximum tension. This tends to maintain crack growth on a level plane since the stress pulse in these experiments is constant in direction. The fact that smooth planar cracks are not observed in novaculite is a result of the micro and defect structure. Since the strength of the quartz grains is greater than the strength of the bonding between them, the microstructure determines the small scale roughness of the fracture

path, because the advancing crack must pass around the grains rather than through them. In a similar manner the defect structure causes both small and large scale deviation from the planar fracture path favored by the maximum tensile stress. The crack intersects inherent pores, fissures, and voids as it grows, and incorporates these into the crack. Such flaws do not generally lie in the tensile plane, however, and thus result in larger scale irregularity of the fracture surface. Moreover, since the crack prefers to follow a least-resistance path, it is not even necessary that structural discontinuities intersect the plane of preferred propagation; rather it is often sufficient when a large flaw lies somewhat out of the preferred plane, for an interaction of the stress fields can cause the crack to turn into the flaw. Considerable roughness also results from a splitting-up of the main crack into two or more branches as a consequence of the defect structure or of high fracture speeds. Secondary branches may run a distance and stop, or they may join up with other cracks, which sometimes produces free chips of material. Crack branching is responsible for the shattering phenomenon in brittle materials.

The fracture path then is not simply determined by the direction of the maximum tensile stress σ_{max} , but rather by the ratio of σ_{max} to the local strength of the material S_{loc} . Fracture propagation occurs on those planes which are normal to the direction in which $\frac{\sigma_{max}}{S_{loc}}$ is a maximum. Notice that since S_{loc} varies strongly with position in the material, the fracture path will not be constant but will wander haphazardly through the specimen along the course of least resistance.

3. Coalescence of the expanding cracks--Two radially expanding cracks on nearby planes will eventually approach each other to the point where the concentrated stress fields associated with the crack tips overlap. The material between the two cracks is subjected to magnified

stresses, and due to the proximity of two free surfaces (in which the stress has fallen to zero) the maximum stress direction is altered. Accordingly, the direction of crack extension is altered, usually causing one or both cracks to turn in to one another. This process, carried to completion so that the two cracks join up, is called crack coalescence, and is an important stage in the fracture process. Inability of cracks to coalesce, would be manifested by a significant increase in the toughness of rocks. Coalescence accelerates fracture since crack size discontinuously increases, resulting in a sudden reduction in the available load-supporting area and a corresponding reduction in the material strength by about 30%. The cross-sectional area capable of bearing load diminishes at an ever-accelerating rate, and leads to the final stage of fracture.

4. Complete separation of the specimen into two or more parts--

The connectivity of individual cracks on at least one fracture path is complete and the cracks have run to the outer surfaces. Cracks on other planes stop growing because the stress is relieved.

VII FUTURE PLANS

Further impact experiments will be performed on novaculite with the aim of recording spall signals and obtaining accurate measurements of tensile strengths and associated times of fracture. In these experiments specimens will also be recovered and examined. We plan to use the scanning electron microscope for more detailed study of fracture surfaces, including comparison of specimens from gas gun experiments with ones from the expanded ring experiments.

We have recently received a shipment of Sioux quartzite. An experimental program similar to that for the novaculite will be followed except that specimen sizes will probably have to be increased because of the larger grain size. SRI's 4-inch-diameter gas gun will be used instead of the 2½-inch gun being used for the present program.

REFERENCES

1. Barbee, T. W., L. Seaman, and R. C. Crewdson, "Dynamic Fracture Criteria in Homogeneous Materials," Final Report, Stanford Research Institute, prepared for Air Force Weapons Laboratory, Technical Report No. AFWL-TR-70-99, November 1970.
2. Curran, D. R. and D. A. Shockey, "Dynamic Fracture of Polymers," Work in progress for Ballistics Research Laboratory, Aberdeen Proving Grounds, Aberdeen, Md., Stanford Research Institute Contract FYU-1033, (1971).
3. Ginsberg, M. J., "Calibration and Characterization of Ytterbium Stress Transducers," Draft Final Report, Stanford Research Institute, prepared for Defense Atomic Support Agency, May 1971.
4. Hardy, R. H. and N. I. Jayaraman, "Hoop-Stress Loading--A New Method of Determining the Tensile Strength of Rock," Am. Inst. of Mining, Metallurgical and Petroleum Engineers (1971).
5. Keough, D. D., "Development of a High-Sensitivity Piezoresistive Shock Transducer for the Low Kilobar Range," Final Report, Stanford Research Institute, prepared for Defense Atomic Support Agency, DASA-2508, March 1970.
6. Khvorova, I. V. and A. L. Dmitrik, "An Electron Microscope Study of Siliceous Rocks and Problems of their Post-Sedimentational Formation," Lithology and Mineral Resources, 1, 1-14 (1969).
7. Sedlacek, R., "Tensile Fatigue Strength of Brittle Materials," Air Force Materials Laboratory, Wright-Patterson Air Force Base, Ohio, Technical Report AFWL-TR-66-245, March 1968.
8. Sedlacek, R., "Processing of Ceramics--Surface Finishing Studies," Final Technical Report, Stanford Research Institute, prepared for Naval Air Systems Command, Contract No. N00019-69-C-0229, April 1970.
9. Sedlacek, R. and F. A. Halden, "Method of Tensile Testing of Brittle Materials," Rev. Sci. Instr. 33, 298-300 (1962).