

AD 729 903

HIGH-GAIN, LONG-PERIOD SEISMOGRAPH STATION  
INSTRUMENTATION

VOLUME II

LAMONT-DOHERTY GEOLOGICAL OBSERVATORY  
of  
COLUMBIA UNIVERSITY

31 MARCH 1971

Details of instructions for  
**this document may be better  
studied on microfiche**

SPONSORED BY  
ADVANCED RESEARCH PROJECTS AGENCY  
ARPA Order No. 1513

# DISCLAIMER NOTICE

THIS DOCUMENT IS THE BEST  
QUALITY AVAILABLE.

COPY FURNISHED CONTAINED  
A SIGNIFICANT NUMBER OF  
PAGES WHICH DO NOT  
REPRODUCE LEGIBLY.

## DOCUMENT CONTROL DATA - R &amp; D

*(Security classification of title, body of abstract and indexing annotation must be entered when the overall report is classified)*

1. SPONSORING ACTIVITY (Corporate author) Lamont-Doherty Geological Observatory Columbia University Palisades, NY 10964		2a. REPORT SECURITY CLASSIFICATION <b>UNCLASSIFIED</b>	
		2b. GROUP	
3. REPORT TITLE High-Gain, Long-Period Seismograph Station Instrumentation, Volume II			
4. DESCRIPTIVE NOTES (Type of report and inclusive dates) Scientific.....Interim			
5. AUTHOR(S) (First name, middle initial, last name) Dr. Lynn Sykes			
6. REPORT DATE 31 March 1971	7a. TOTAL NO. OF PAGES 58 + 4 Appendices	7b. NO. OF REFS 13	
8. CONTRACT OR GRANT NO. F44620-70-C-0038	9a. ORIGINATOR'S REPORT NUMBER(S)		
9. PROJECT NO. AO 1513 62701D	9b. OTHER REPORT NO(S) (Any other numbers that may be assigned this report) <b>AFOSR - TR - 71 - 2373</b>		
10. DISTRIBUTION STATEMENT Approved for public release; distribution unlimited.			
11. SUPPLEMENTARY NOTES TECH, OTHER		12. SPONSORING MILITARY ACTIVITY AF Office of Scientific Research(NPG) 1400 Wilson Boulevard Arlington, VA 22209	

Five high-gain, long period seismograph stations are being installed, operated, and evaluated at sites in Alaska, Australia, Israel, Spain, and Thailand. Details of these installations are given in a series of five Technical Reports each entitled "High-Gain, Long-Period Seismograph Systems Installation Report." These instruments are capable of operating at magnifications greater than 500,000 at periods of 35 to 45 seconds. The purpose of this report is to describe the instruments in detail, present a parts list, and present technical drawings and operation manuals for the major components.

Details of illustrations in  
this document may be better  
studied on microfiche

14 KEY WORDS	LINK A		LINK B		LINK C	
	ROLE	WT	ROLE	WT	ROLE	WT
Long-period seismograph design High-gain Seismograph vault Pressure tank design and installation Velocity transducers Displacement transducers Phototube amplifiers Digital data acquisition system Photographic recorders 100 sec galvanometers 30 sec seismometers Maintenance procedures System response characteristics						
<del>207</del>						



**BLANK PAGE**

3100-1

GENERAL DESCRIPTION OF THE DIGITAL DATA LOGGER

I. MAIN CHARACTERISTICS

Electrical and environmental characteristics for the Data Logger are provided in Table 3100-1. In addition to the overall system characteristics given in Table 3100-1, response and step characteristics for the type A and type B input filters are shown in figures 3100-1 through 3100-6. Characteristics for the equipment listed in Table 1-1 are contained in the respective equipment manuals provided with the system.

Table 3100-1. Data Logger Equipment Characteristics

Characteristic	Specification
Primary Input Power	115 or 230 VAC, $\pm$ 10%, 47 HZ to 63 Hz, with typical power consumption of <u>6.8 amps</u> and maximum surge power consumption of <u>15.0 amps at 115 VAC</u> . Individual equipment current consumption is as follows:

Table 3100-1. Data Logger Equipment Characteristics (Cont'd)

Characteristic	Specification	
Primary Input Power (Cont'd)	<u>Assembly</u>	<u>Current Consumption (Amps @ 115 VAC)</u>
	Time Display	0.2
	Model 3000 ADC	0.5
	Cipher Tape Transport	2.6
	+24 volt power supply	1.3
	+5 volt power supply	1.0
	+18 volt power supply	0.1
	-18 volt power supply	0.1
	Fans (7)	1.0
	Operating Temperature	0°C to +50°C
Relative Humidity	0% to 95%	
Dust Environment	High level	
Logic Levels (ADC output)	Logic 1 = zero volts Logic 0 = -6 volts	
Logic Levels (remainder of system)	Logic 1 = +2.5 volts to Vcc Logic 0 = zero volts	
Type A Input Signals (channels 1 through 9)	Bipolar, 30V pp, with valid data accepted from 0.01 Hz to 0.10 Hz.	

Table 3100-1 Data Logger Equipment Characteristics (Cont'd)

Characteristic	Specification
Type A Input Signal Filtering (Cont'd)	<p>Noise level <math>\leq 0.001\%</math>.</p> <p>Gain accuracy, <math>\leq 0.006\%</math></p> <p>Linearity, <math>\leq 0.010\%</math></p> <p>DC off-set drift/weak, <math>\leq 0.005\%</math></p> <p>Filter corner frequency accuracy, <math>\leq \pm 5\%</math></p> <p>Temperature coefficient, <math>\leq 15\mu\text{v}/\text{C}</math></p> <p>Output of each signal conditioner is available at test points reached by opening the front door. Test jacks are on end of plug-in circuit cards. Test switch is provided on card to bypass high pass portion of filter to allow DC testing. When switch is in test position, a lamp on filter is lit.</p>
Type B Input Signal Filtering	<p>3 db from DC to 0.01 Hz; at least 60 db down from passband response at 0.05 Hz. (4-pole filter with corner frequency at 0.01 Hz.)</p> <p>Temp coefficient = <math>60 \mu\text{v}/^\circ\text{C}</math>.</p> <p>Other characteristics the same as Type A.</p>

Table 3100-1. Data Logger Equipment Characteristics (Cont'd)

Characteristic	Specification
Test Input Signal (channel 10)	Ground or zero volts to $\pm 10.24$ volts
Type B Input Signals (channels 11 through 16)	Bipolar, 20.48V pp, with valid data accepted from dc to 0.01 Hz.
Type A Input Signal Filtering	<p>3 db from 0.01 to 0.1 Hz; at least 60 db down from mid-band response at 0.5 Hz. (4-pole Chebychev type filter with a rolloff of approximately 24 db/octave and a corner frequency of 0.1 Hz.)</p> <p>Input impedance, 10,000 ohms balanced to ground, center tap not grounded.</p> <p>Maximum input, 30 volts peak-to-peak.</p> <p>End-to-end gain, <math>\approx 0.6667</math>.</p> <p>Input is protected from an over-voltage of <math>\pm 35</math> volts and from near but not direct strikes of lightning by Gas discharge tubes.</p>

Table 3100-1. Data Logger Equipment Characteristics (Cont'd)

Characteristic	Specification
<b>Multiplexer Signals (16 Channel)</b>	Inputs and output are analog, bi-level, $\pm 10.24$ volts. Switching rate is 8.192 kHz.
<b>Sample Rate</b>	Switch-selectable; 0.5, 1.0, 2.0 or 4.0 samples of all 16 channels per second.
<b>Record Format</b>	A four word (18 bits per word) header, followed by 2000 + data words (number of data words is at least 2000 in all cases; however, the actual number is determined by number of channels used and the selected sample rate.) Each data word contains a 1 bit channel ID flag, 16 bits of data, and 1 bit for odd parity.
<b>Data Averaging Method</b>	Digital integration.
<b>Relay Closure Output</b>	Closes each minute for 1 second, each hour for 10 seconds, and each 12 hours for 30 seconds. Permits generation of pulses for insertion into Sprengnether Model R-6007 photographic recorders.  Contact capacity $\geq 450$ mA.

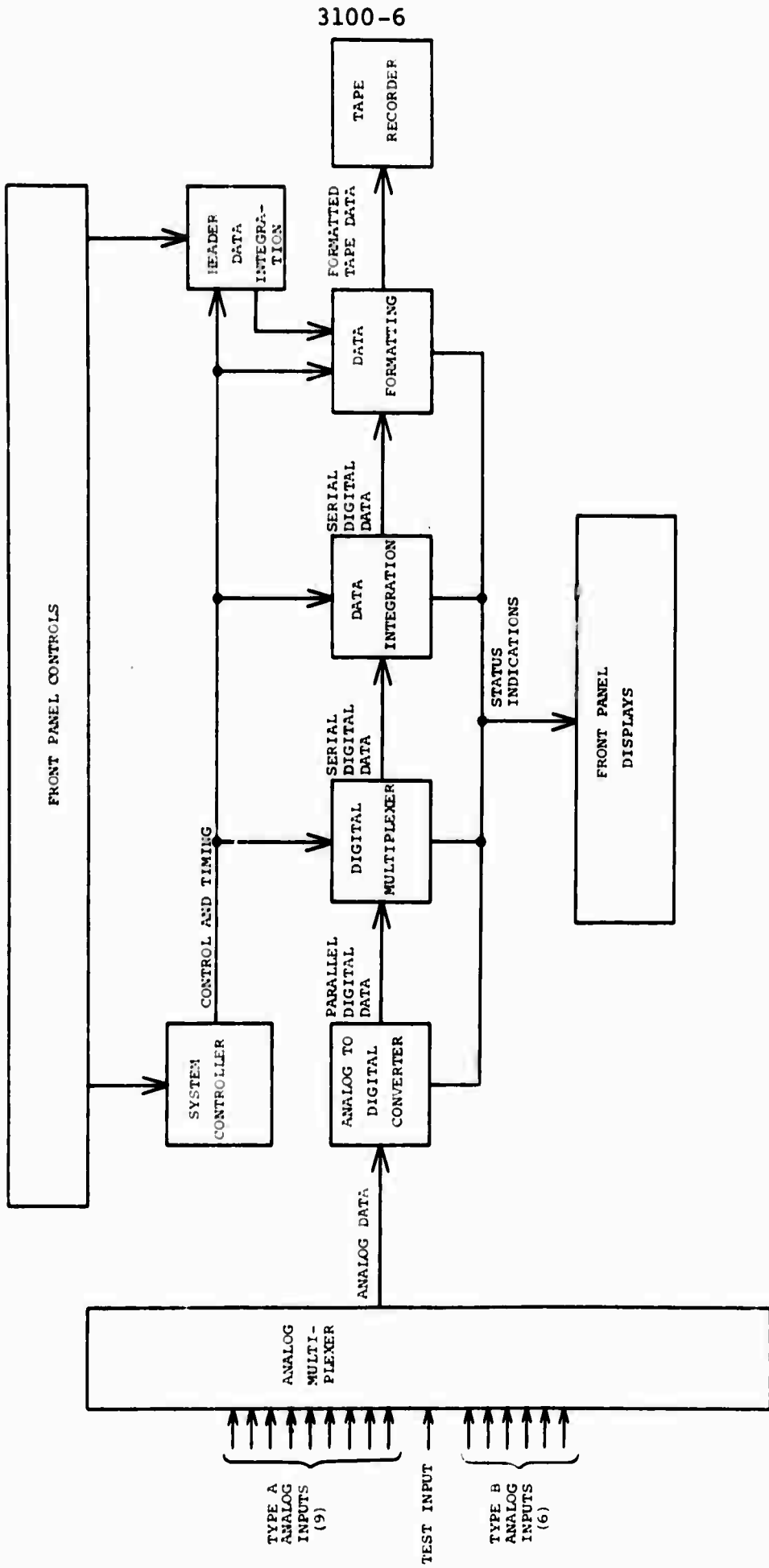

70548

Figure 3100. Data Logger, Simplified Block Diagram





## II. GENERAL THEORY OF OPERATION

A block diagram of the Data Logger system is shown on drawing 3100. This block diagram illustrates the primary functions of the system and is used as a basis for the general description contained in the following paragraphs. The functional flow of data is shown from left-to-right wherever possible.

### SIGNAL INPUTS

The inputs to the Data Logger are shown on the left hand side of the drawing. These inputs consist of 9 channels of analog velocity data (channels 1-9), 1 analog test channel supplied from a DAC (digital to analog converter) or ground (channel 10), and 6 channels of analog displacement data (channels 11-16). Channels 1 through 9 are designated type A inputs, channels 11 through 16 are designated type B inputs, and channel 10 is designated as a test input. These inputs, with the exception of the test channel, are routed through signal conditioning filters to an analog multiplexer. Electrical characteristics for the input signals and conditioning filters are given in Table 3100-1.

Channel 10 (test input) receives inputs from a 15 bit DAC when local tests are conducted on the system. Fifteen DAC input switches on the control panel are used to set the analog output of this DAC. A switch is also

provided on the control panel to set the channel 10 input to ground when DAC tests are not being conducted.

The system, as supplied by the manufacturer, only contains enough signal conditioning filters to accept three type A inputs (channels 1, 2, and 3) and three type B inputs (channels 11, 12, and 13). However, the system is prewired to accept all fifteen input channels if expansion is desired.

#### SIGNAL MULTIPLEXING

The conditioned signals from the input filters are applied to a 16-input analog multiplexer that sequentially selects each of the 16 channels at an 8192 Hz rate. Since there are 16 input channels, each channel is selected 512 times per second or 1024 times every two seconds. Channel selection is always in order, with channel 1 being selected first and channel 16 being selected last. The multiplexer selects channels 1 through 16 repeatedly on a continuous basis.

The outputs of the multiplexer are fed into an Astrodata Model 3000 Analog-to-Digital Converter (ADC) where they are converted into a parallel, 14 bits plus sign bit, digital output. The ADC digitizes the multiplexer outputs at an 8192 Hz rate so that each channel is digitized as it is selected by the multiplexer. Theory of operation information for the ADC is contained

in the Model 3000 Analog-to Digital Converter manual supplied with the Data Logger equipment.

#### LEVEL SHIFTING

The Logic levels for the digital outputs of the ADC are zero volts for a logic 1 and -6 volts for a logic 0. Since these logic levels are incompatible with the integrated circuit (IC) logic levels that are used throughout the remainder of the Data Logger logic, these outputs are routed through level shifter circuits that convert the levels to +5 volts for a logic 0 and zero volts for a logic 1. The 15 bit parallel outputs from these level shifters are supplied to a 15 bit indicator display on the control panel and inverted and supplied to a digital multiplexer for data integration.

#### DATA INTEGRATION

The data integration logic, as shown on the block diagram, consists of the adder, the carry flip-flop, and the 400 bit serial storage register or summing register. This logic performs the function of arranging the digital inputs from the level shifters into 16 channels of information containing 25 bits of summed data per channel. When the sum is completed, this 25 bits of data represents processed average data for a

given channel.

The averaging process is accomplished by summing each of the channel inputs a selected number of times up to a maximum of 1024 summations. Since 1024 summations is equal to  $2^{10}$ , 25 bits are required and allotted to each channel to prevent overflow. In other words 15 bits of data that has been summed 1024 times is left shifted by 10 bits. Therefore the 15 most significant bits of data in the 25 bit word represent the processed average data for that channel (although 16 rather than 15 bits are saved in order to reduce round-off error). Since 25 bits are required for each channel, and there are 16 channels of data, a 400 bit summing register is provided to store the data for all of the channels.

As data for a given channel is serially fed into the adder by the 16 bit multiplexer, the previous value of that channel is also being serially routed into the adder from the summing register. The two values are then summed together and the new data is routed back into the summing register where it is stored until the next summation is performed for that channel. A given channel of 25 bits that is stored in the summing register can also be selected for display on the front panel indicators.

Although data from all 16 channels is routed into

the multiplexer in order, the B type channels are only summed on every 5th cycle. Timing and control circuits in the system generate a disable term that is applied to the multiplexer four out of every five cycles when the B type channels are multiplexed. When this term is applied, the output of the multiplexer is inhibited and a string of logic 0's are routed into the adder for that particular channel. The B channel sum will, therefore, remain unchanged four out of five times.

After the selected number of summations are completed for a given channel, the resulting sum is divided by the number of summations to obtain an average data value. The averaged value is then shifted into the tape data register. The division is done by shifting the binary point since the divisions are binary multiples. This division is done as the number is being shifted into the tape register by selecting the appropriate 16 bits out of the 25 bit sum.

During the summation cycle which completes the sum for 1 or more channels, the 16 appropriate bits out of the 25 for each channel are routed into a 256 bit serial storage register, or tape data register as it is labeled on the front panel. At the same time, the 400 bit summing register is reset to zero (for those channels whose sum is complete) in order to initialize it for the next cycle. When the 256 bit

serial storage register is completely filled it contains 16 bits of information for 16 channels. Of course, in 4 out of every 5 cycles only the A channel register positions contain significant information since the B channel sums were not completed.

The number of shift cycles per second from the summing register into the serial storage register is controlled by the SAMPLE RATE switch located on the power supply support assembly. This switch also controls the number of summations that will be performed in a given cycle by the adder. When a sample rate of 0.5 is selected each channel will be summed 1024 times and will be shifted into the serial storage register once every 2 seconds. When a sample rate of 1.0 is selected, each channel is summed 512 times and shifted into the serial storage register once every second. In this case the most significant bit of the 25 data bits in the summing register is bypassed and the next most significant 16 bits are shifted into the serial storage register. When a sample rate of 2.0 is selected, each channel is summed 256 times, the first two most significant bits are bypassed and the remaining 16 most significant bits are shifted into the serial storage register once every 0.5 seconds. When a sample rate of 4.0 is selected, each channel is summed 128 times, the first three most significant bits

are bypassed, and the remaining 16 most significant bits are shifted into the serial storage register once every 0.25 seconds.

#### DATA FORMATTING

When the 256 bit serial storage register is completely loaded, data averaging is complete and the data formatting process is begun. Data formatting is accomplished by the 18 bit serial register or tape character register as it is labeled on the front panel.

The 16 channels of 16 bit data are loaded serially into the tape character register from the tape data register one at a time. Each of these 16 bit words occupies in turn the middle 16 positions in the 18 bit tape character register. The most significant bit position is occupied by a channel 1 flag bit that is true only when channel 1 data is loaded. The least significant bit position is occupied by a parity bit that represents odd parity on the 16 data bits only.

In addition to channel data from the tape data register, tape record information (header data) is also loaded into the tape character register in parallel from the header data multiplexer. This information consists of four 18 bit words that are loaded into the tape character register and written on tape prior to loading and writing channel data. The contents and

generation of header data words will be described later in this chapter. The emphasis here is that header data is loaded and written first followed by channel data to complete a tape record. The 18 bit header data words do not contain a channel 1 flag bit or a parity bit.

The header data and channel data words are transmitted to the tape, 6 bits at a time until the entire 18 bit word is written. To accomplish this, the 6 most significant bits of the tape character register are transmitted to the tape, the register is then right shifted 12 bit positions and looped back into itself, the next 6 most significant bits are transmitted out, the register is again right shifted 12 times and looped, and finally the last group of 6 bits is transmitted out. The 6 bit group of output data is available to a front panel display.

#### TAPE CONTROL

The tape control logic is provided to control the tape transport functions such as step/write, busy, ready, stop, and forward. In addition to these functions a divide by 6000 counter is provided to control the generation of a 0.75 inch gap on the tape after the record has ended. The divide by 6000 counter is used to count tape characters. Since each tape character contains 6 bits and there are 3 tape characters required



for each 18 bit word, the counter actually functions as a divide by 2000 word counter. The reason for this divide by 2000 function is that a tape record is specified to consist of at least 2000 18 bit words, including the four header data words. After the record has been completed, the counter causes a gap command to be sent to the tape transport, which then generates a 0.75 inch gap on the tape. However, since the record is specified to consist of multiples of the 16 possible channels, the divide by 2000 counter output is gated with an "end of the last B channel" signal which delays the gap command until multiples of the 16 channels are contained in the tape record.

The "number of channels to be written" and "step/write" functions of the tape control logic provide the means to select the actual number of A type channels and B type channels that will be written on the tape. All 16 channels are processed up to this point regardless of how many are actually implemented. The test channel and those channels for which there is no hardware implementation are prevented from being written on tape by these circuits. In other words if only three A channels are selected, the 6 remaining A channels in a given cycle, starting with channel 4, will not be written on tape because the step/write command is inhibited. Any number of A channels and B channels can be

selected with the exception that there must always be at least one A channel.

#### HEADER DATA

The header data is generated by the logic shown at the top of the block diagram. This logic consists of the 1.024 MHz oscillator, the clock divider counter, time tick filter, time of day counters, header data multiplexer, and front panel switches.

The oscillator and clock divider counters generate a 0.1 sec timing signal (10 Hz) that is applied to a time of day counter. The time of day counter supplies time of day information to the header data multiplexer.

In addition to the timing input from the clock divider counter, a timing input can also be supplied to the time of day counter from the external time tick filter. This filter receives a modulated carrier wave in the form of sine-wave bursts. This signal is transformed into a digital time tick that is supplied to the time of day counter in place of the internally generated timing signal if desired. The time-of-day count is available on a display panel located on the front of the cabinet.

In addition to time-of-day information, the header data words also include record type, station identification, year identification, number of channels selected,

and sample rate information. All of this information is generated by manually set switches located primarily on the Data Logger front panel. All of this information is routed to the multiplexer in parallel and multiplexed into the tape character register as 18 bit parallel digital words. A sample of four words of header data is shown in Table 3100-2 and 3100-3.

#### ERROR INDICATION

When the system is being operated, an error indication is provided on the front panel display to verify the accuracy of test channel information that is being processed in the system. This error indication counts the number of errors processed and displays this count as a 4 bit BCD code.

Front panel displays can be used in conjunction with the DAC to test the system. In the test mode, any channel of the analog multiplexer can be addressed and the system can be stepped through one cycle of the ADC, integrator, or tape word.

Table 3100-2. Typical switch settings

	<u>Position</u>	<u>Location</u>
1. System Power	ON	AC Panel
2. Tape Unit Power	ON	Tape Unit
3. Fast Forward	OFF	Front Panel
4. DAC Inputs	All Switches Off (Down)	Front Panel
5. Test Channel	DAC	Front Panel
6. Year Units	5	Front Panel
7. Time Control		
START	Press	Front Panel
STOP	Press	Front Panel
RESET	Press	Front Panel
Note: Arm light is	OFF	Front Panel
8. ADC/Sum/Tape	ADC	Front Panel
9. Echo Check	Reset	Front Panel
10. Test Error	Reset	Front Panel
11. Master Clear	Press	Front Panel
12. Start	Off	Front Panel
13. Operate/Test	Test	Front Panel
14. A Channel	3	P/S Panel
15. B Channel	3	P/S Panel
16. Sample Rate	1	P/S Panel
17. Record Type	1	P/S Panel
18. Station ID	99	P/S Panel
19. Clock		
Day	295	Front Panel
Hours	23	Display
Minutes	54	
Seconds	54	

Table 3100-3. Header Data for Switch Settings in Table 3100-2.

<u>BIT</u>		<u>WORD 1</u>	<u>Bit Display</u>	<u>WORD 2</u>	<u>Bit Display</u>	<u>WORD 3</u>	<u>Bit Display</u>	<u>WORD 4</u>	<u>Bit Display</u>
MSB	1	TYPE	1	100Day2	1	10Min4	1	-	0
MSB	2	-	0	100Day1	0	10Min2	0	-	0
MSB	3	10ID8	1	10Day8	1	10Min1	1	ACHAN8	0
MSB	4	10ID4	0	10Day4	0	1Min8	0	ACHAN4	0
MSB	5	10ID2	0	10Day2	0	1Min4	1	ACHAN2	1
MSB	6	10ID1	1	10Day1	1	1Min2	0	ACHAN1	1
MSB	7	GND	0	1Day8	0	1Min1	0	GND	0
MSB	8	GND	0	1Day4	1	10Sec4	1	GND	0
MSB	9	1ID8	1	1Day2	0	10Sec2	0	GND	0
MSB	10	1ID4	0	1Day1	1	10Sec1	1	BCHAN4	0
MSB	11	1ID2	0	GND	0	1Sec8	0	BCHAN2	1
MSB	12	1ID1	1	GND	0	1Sec4	1	BCHAN1	1
MSB	13	GND	0	10HR2	1	1Sec2	0	SR0.5	0
MSB	14	GND	0	10HR1	0	1Sec1	0	SR1	1
MSB	15	1YR8	0	1HR8	0	.1Sec8	0	SR2	0
MSB	16	1YR4	1	1HR4	0	.1Sec4	0	SR4	0
MSB	17	1YR2	0	1HR2	1	.1Sec2	0	GND	0
LSB	17	1YR1	1	1HR1	1	.1Sec1	0	GND	0

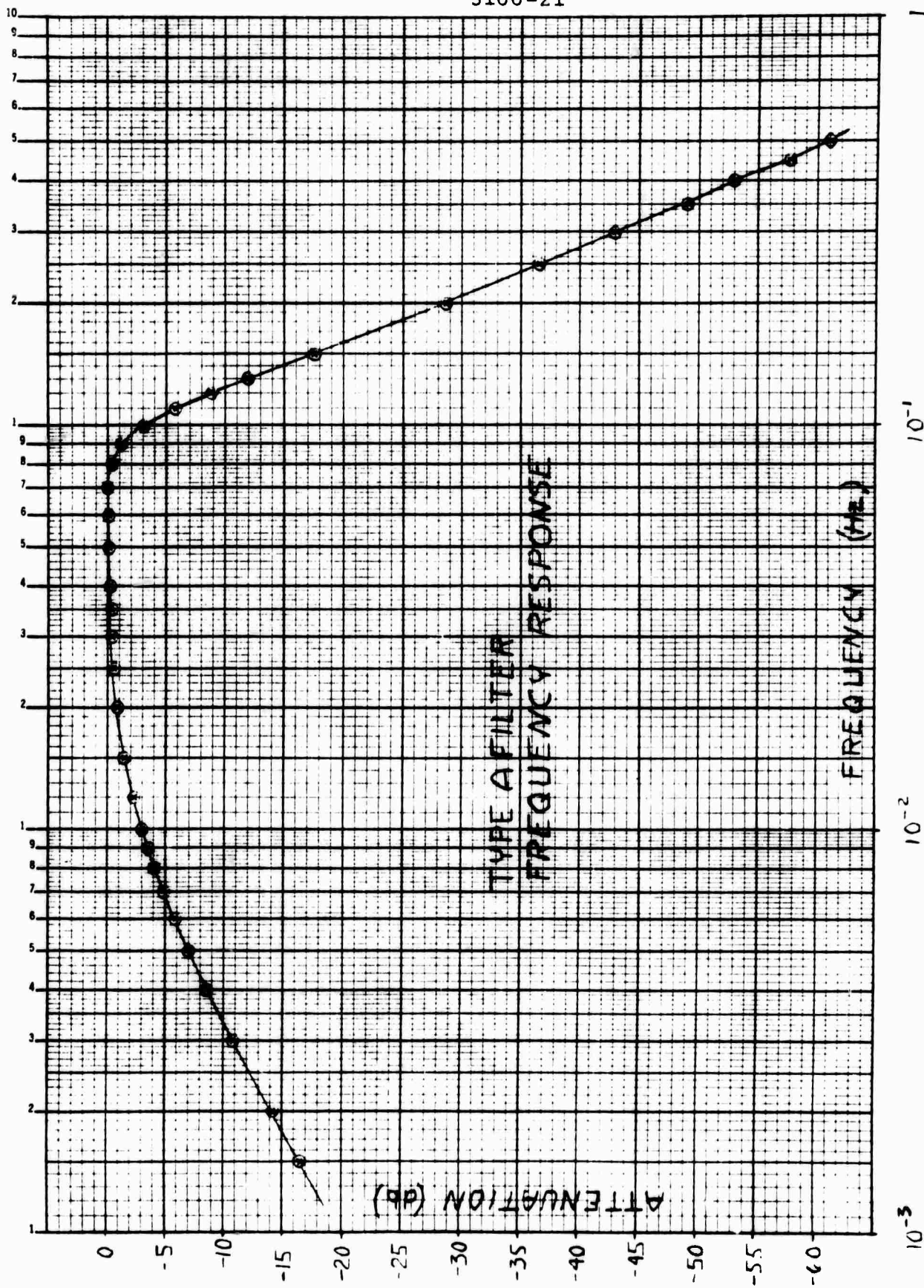

Figure 3100-2 - Type A Input Filter, Frequency Response Characteristics

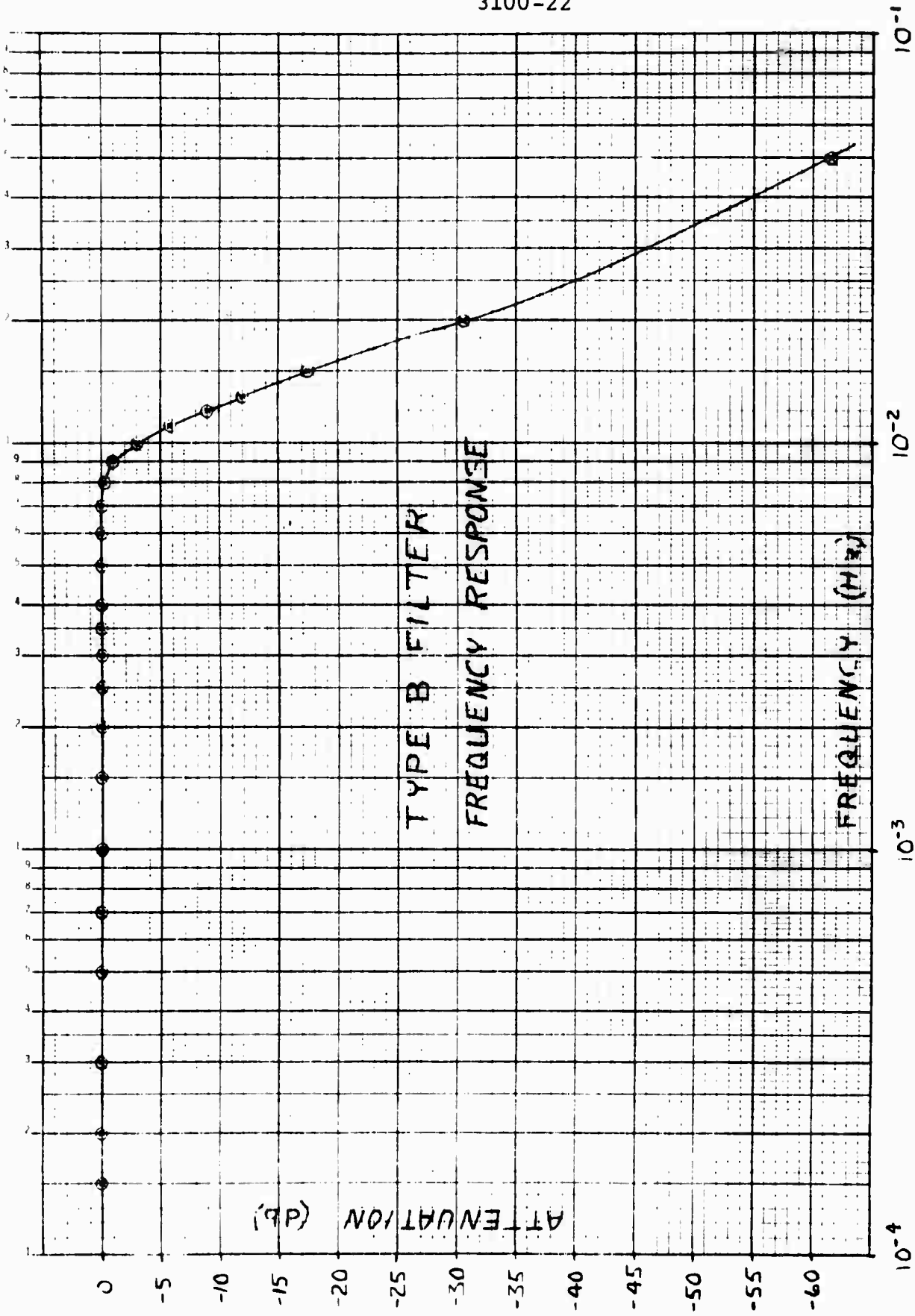

Figure 3100-3. Type B Input Filter, Frequency Response Characteristics

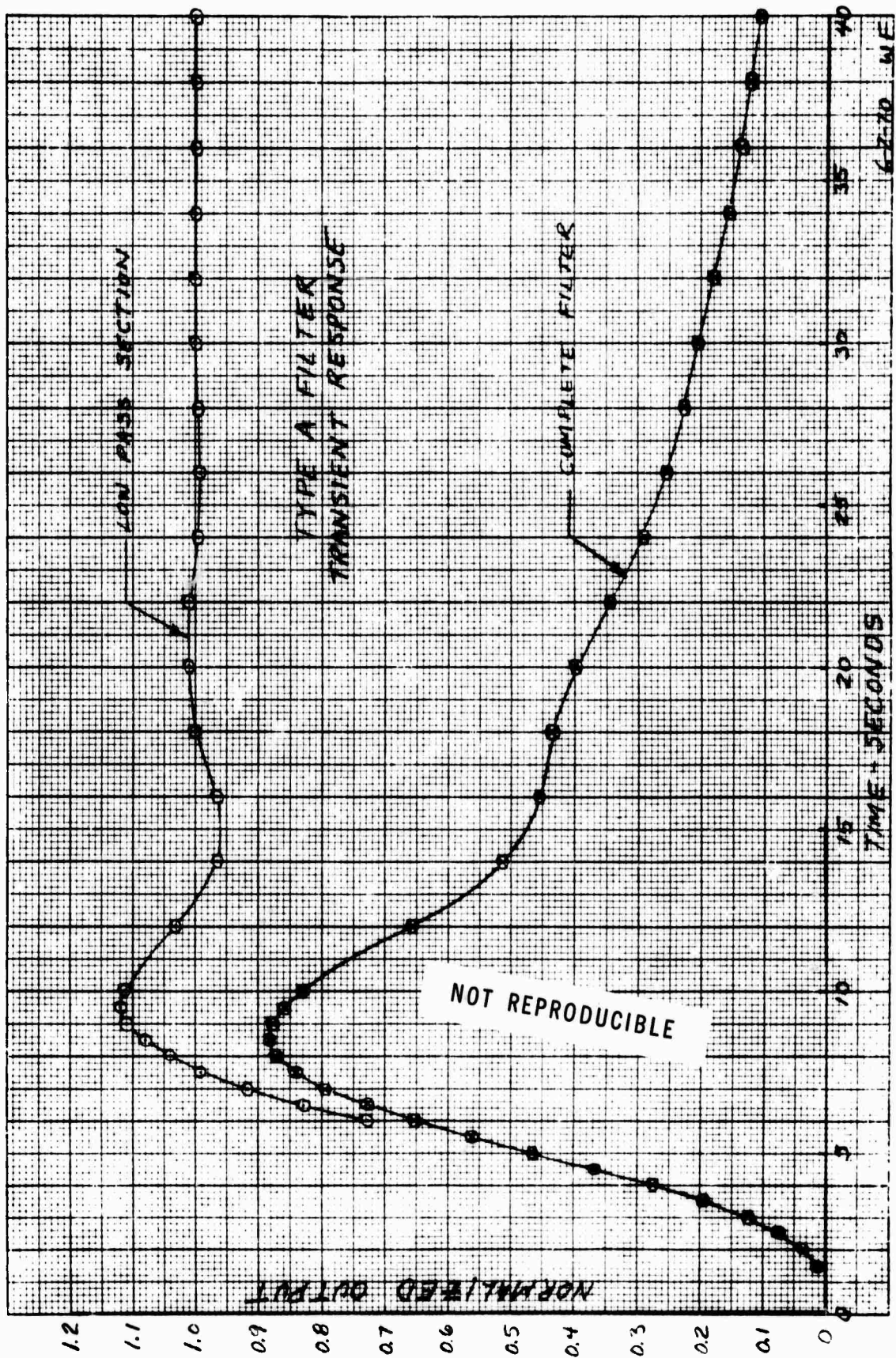
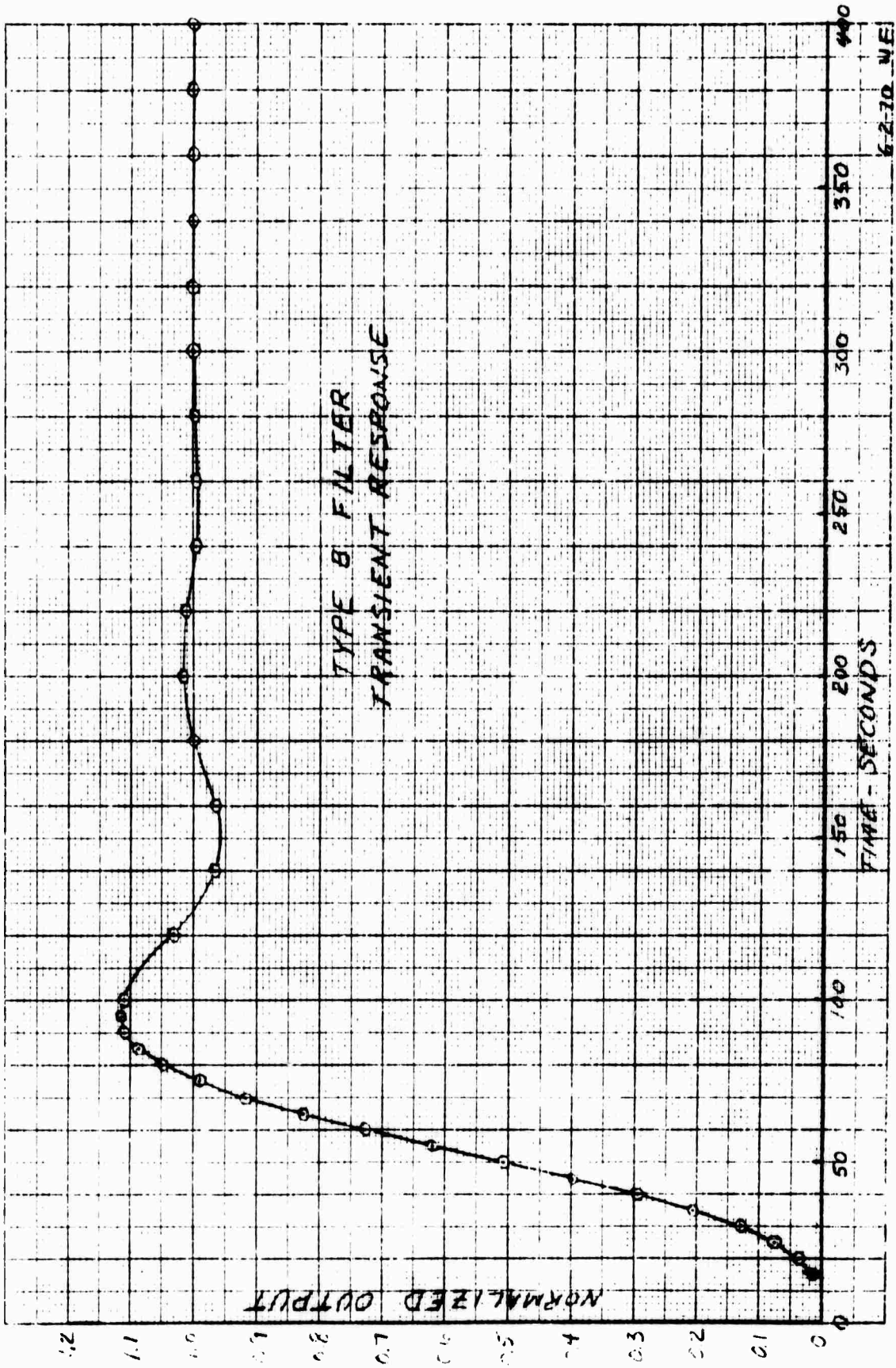

Figure 3100-4. Type A Input Filter, Transient Response Characteristics





NOT REPRODUCIBLE

Figure 3100-5. Type B Input Filter, Transient Response Characteristics

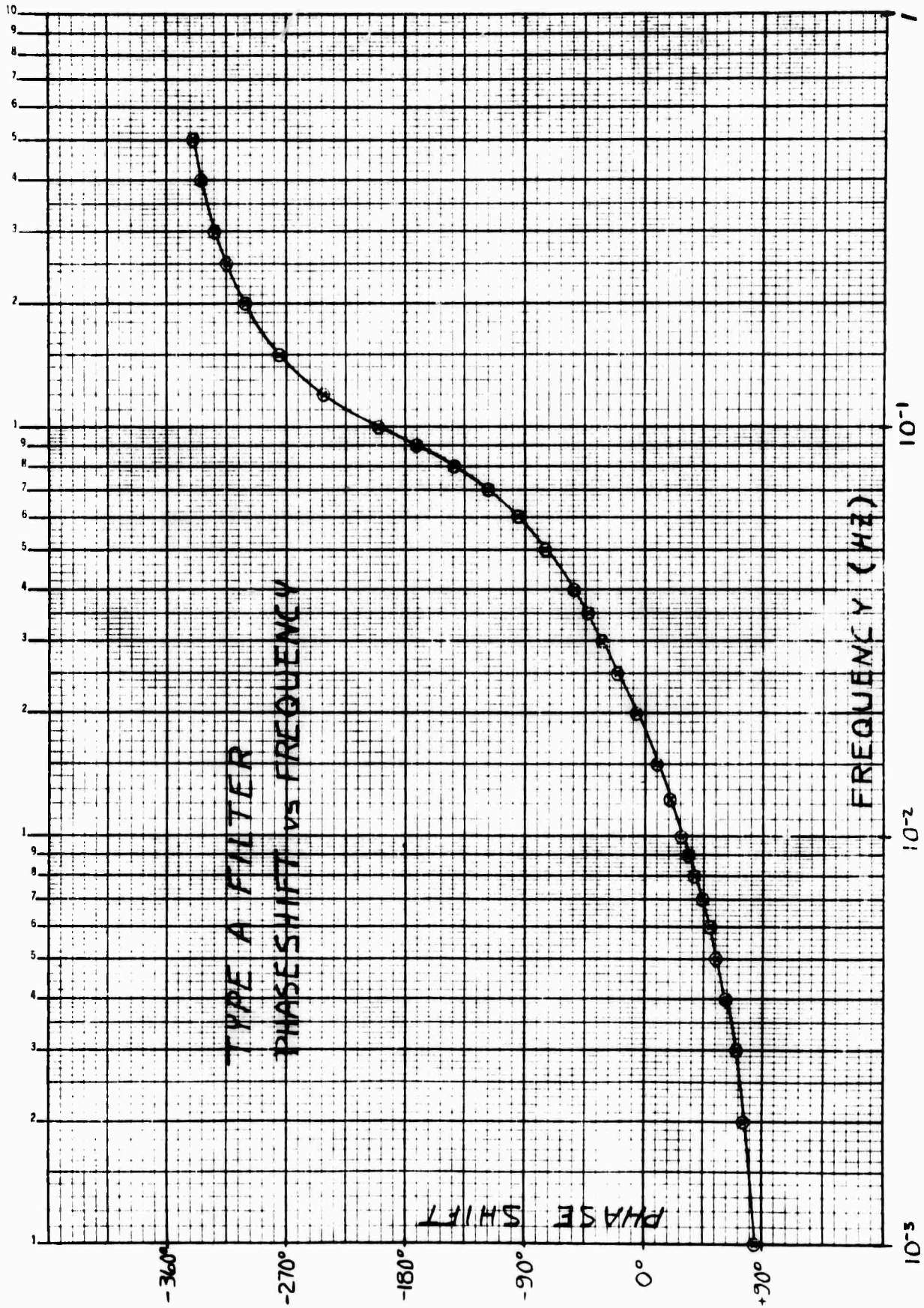

Figure 3100-6. Type A Input Filter Phase Shift Characteristics

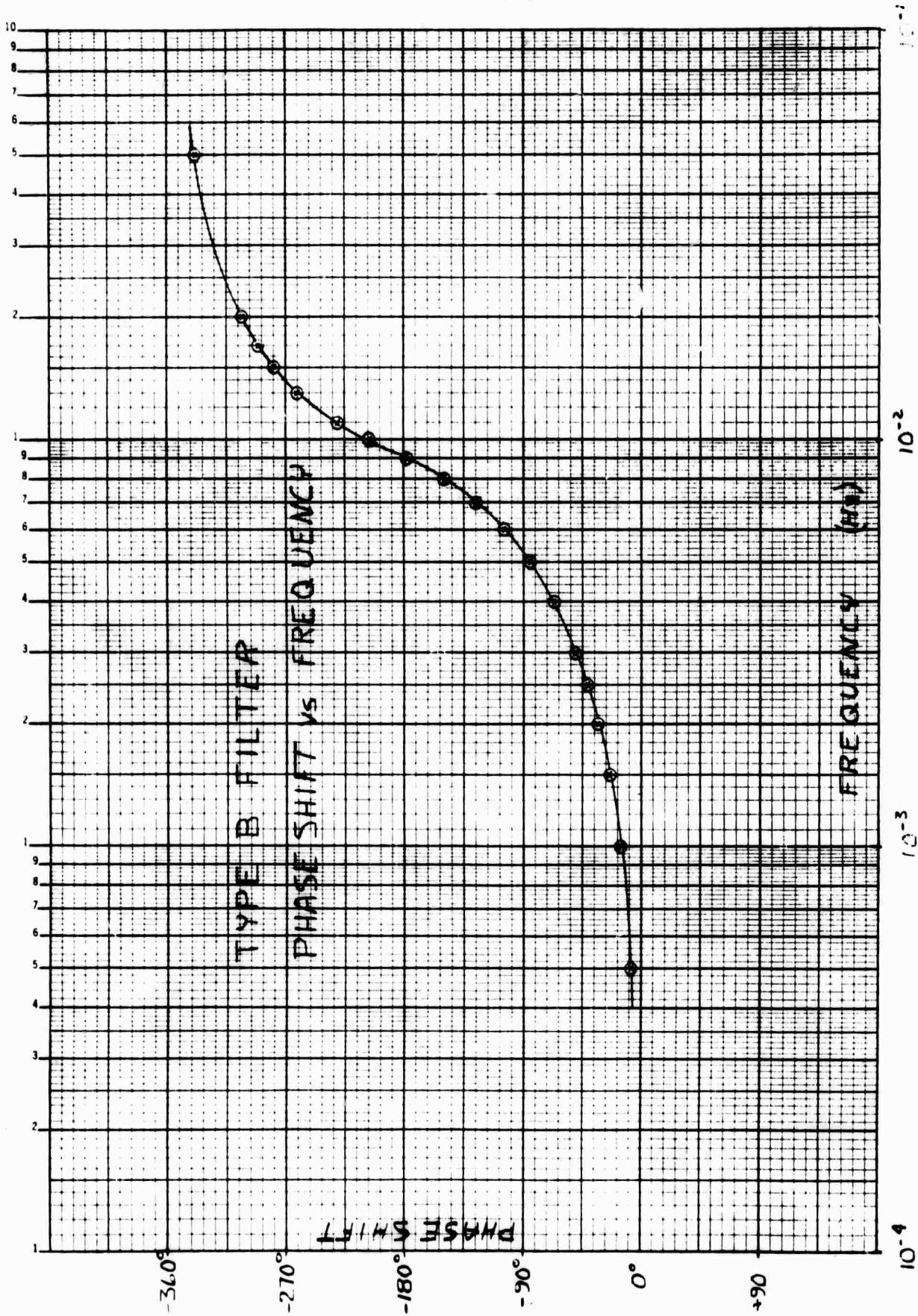

Figure 3100-7. Type B Input Filter Phase Shift Characteristics

3100-27

ASTRODATA WIRING CHANGE

To Institute Automatic ADC Stepping in Test Mode

Lift two white wires from ADC stepping test switch. Place them upon the center terminals (common) of a new toggle switch, one on each terminal. This switch may be bracket mounted on the back of the panel door containing the test lamps and switches or it may be soldered directly terminal to terminal onto the ADC push button switch. Add white wires to the two connections now open on the ADC push button switch connecting the free ends to the end terminals of the new switch. Carefully solder flat pins to the end of 2 wires to run from the new switch to A23 3 and 8. Insert the pins in the appropriate holes of A23. Route the 2 wires up to the new switch.

Turn switch "on", test lamp on, start clock. Activating new switch should cause ADC to step at 1 sec. rate. If not, reverse leads to switch from A23-3 and 8.

Selector in ADC position, mux button to test channel. DAC on, flipping various DAC switches should cause corresponding lamps to illuminate.

PURPOSE

The purpose of this change is to enable the technician to see the voltage rise and fall of a long-period test signal as it is applied to the input of a channel of

the Astrodata. The ADC is simply a digital voltmeter and by stepping it regularly it will indicate voltage. One need only apply a test signal, select that channel with the manual MUX stepper and watch the ADC display lamps. From these lamps he can see the rise and fall and change of polarity of the applied sine wave and also its amplitude.

#### CIRCUIT DESCRIPTION

Reference schematic 13, JK flip-flop B8-041. Normally the ADC step switch causes the FF to reset by pulsing C. It is flipped by releasing the button. This pulses or steps the ADC once. By lifting the leads from the ADC switch and inserting 0.1 sec-B from A23-3 and 0.1 sec from A23-8 to set and reset the FF (sheet 9), the ADC is then operated at 1 sec intervals. The clock must be running to supply these pulses.

#### CHANGES TO ASTRODATA WIRING FOR INSTALLATION OF SLAVE TIME RELAY

Remove red and black leads from the rear of the red and black time mark terminals on the lower skirt of the tape recorder. Splice the red lead from the slave time relay chassis to the red lead just removed from the General Radio terminal. Perform the same operation for the black leads - connect the remaining leads from the

3100-29

slave relay terminal strip to the General Radio terminals.

Locate the time relay card in position 16 of the "C" section. Remove black lead from position 48 and insert it into any terminal of the CB strip. This grounds this lead. Add orange jumper from yellow on position 16 - #43 to 48. #47 should be red lead to slave relay. Add .1 MFD 200 volt capacitor between red wire terminal 47 and CB ground strip.

Purpose of this slave relay is to insure that small relay on board C16 is not damaged by overloading the contacts.

REVISIONS		
LETTER	DESCRIPTION	DATE

AUXILIARY TIME RELAY MOUNTED ON A BRACKET

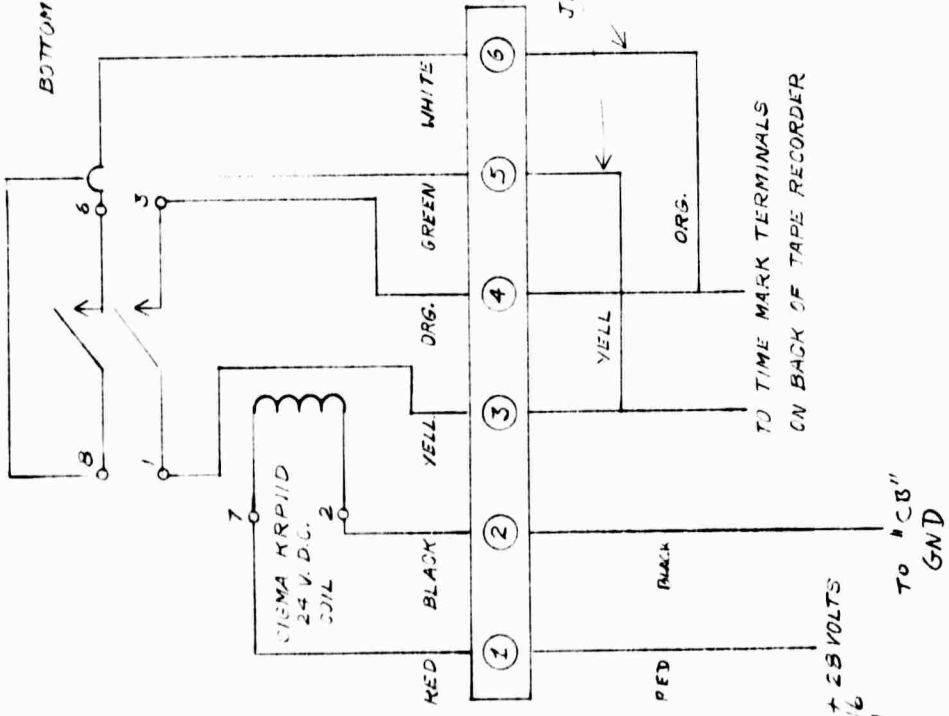

BOTTOM RIGHT OF TAPE RECORDER

SEPARATE TIME SYSTEMS MAY BE ACTIVATED BY REMOVING THE YELLOW AND ORANGE JUMPERS BETWEEN 3 TO 5 AND 4 TO 5.

CONTRACT	
DRAWN BY	
CHECK BY	
PROJ ENGR	

  
**LAMONT GEOLOGICAL OBSERVATORY**  
**OF COLUMBIA UNIVERSITY**

AUXILIARY "SLAVE" TIME  
 RELAY - Digital Recorder

DWG NO	3102	REV	
SCALE		WEIGHT	
		SHEET	1 OF 1

TOLERANCES  
 UNLESS OTHERWISE SPECIFIED  
 DIMENSIONS ARE IN INCHES  
 DECIMAL ±  
 .005 ±  
 .010 ±  
 .015 ±  
 .020 ±  
 ANGLES ±

BREAK SHARP EDGES



ASTRODATA DIGITAL SYSTEM

Basic Start and Test Procedure

1. Apply power by lifting the left bottom circuit breaker switch on lower front of unit.
2. Fans will run; some lamps will light.
3. Press master clear.
4. Set the clock either by radio or manually.
5. Push "operate test" button to illuminate "test".
6. Set ADC-tape-sum switch to ADC.
7. Press mux button until lamps 8 and 1 light.
8. Set test channel switch to DAC.
9. Press ADC button several times. Lamps 14 and 15 may light or all 15 lamps, this is normal.
10. Set DAC input switch 7 up. Press ADC button, lamp 7 should light and lamps 12, 13, 14 and 15 may flash as the button is pressed. Setting any one DAC input switch and pressing the ADC button should illuminate that lamp. Lamps 8 thru 15 may light instead of 7.
11. Set all DAC switches down, test channel switch to ground, ADC-tape-sum knob to tape.
12. Press "start" button to illuminate word "start", press tape button. Tape character lamps should flicker on approximately 5 times and stop. Press tape button one more. Should be no change.
13. Press adder button - after several flashes



tape character lamps shall extinguish. Each press of the adder button will cause several flashes.

14. Press master clear.

15. On tape deck press "power" button to illuminate the word power if not already "on". Install a tape reel and thread it. Press "Load" button. This will cause the tape to advance to the reflective marker and the ready lamp will illuminate. In the event a tape is already loaded and past the load marker, take up tape slack by manually turning the takeup reel and simply press "ready" and "load", holding ready in while pressing load. This should tension the tape.

16. Press "operate-test" button to illuminate word "operate".

17. Press start button to illuminate the word "start".

18. Lights will flash, tape will move incrementally and the numbered lamps alongside the tape control buttons will flash. At this point, data is being recorded on the tape.

#### Restart after power failure

1. Reset clock.
2. Wind bottom tape reel by hand to remove slack tape.
3. Press "master clear".
4. Press "ready" button on tape unit and hold

button in while pressing "load".

5. Press "start".

#### Stopping and unloading tape

1. Press "end of file" switch - red end of tape light will illuminate.
2. After approximately 10 minutes tape will stop.
3. Press rewind. Tape will rewind to reflective marker and stop.
4. Press rewind again. Tape will wind off reel and stop.
5. Clean record head with cotton swab and freon.

#### Astrodata First Aid - in the event of failure

##### A. General procedures

1. Never remove or install a circuit card with the power "on".
2. When the system fails or develops trouble, before doing anything, determine that the station mains are supplying approximately 115 Volts  $\pm$  10% AC, 45 to 65 cps.
3. Open the rear door and check all major power supply voltages, i.e., +18 volts, -18 volts, etc. These voltages appear on distribution blocks on the left side.
4. When checking voltages on card test points,

be extremely careful not to short two points together with the clip lead. A short circuit here can destroy a good card.

5. Try to troubleshoot slowly and methodically. Refer to the Datalogger block diagram and other diagrams as necessary.

6. A good oscilloscope and a digital voltmeter are necessary.

7. Spare cards of all types necessary for maintenance are supplied to each station. Because of the great cost of these cards, please keep them dry and protected from mechanical damage. If a card is found to be defective, return it to LDGO, addressed to Fred England. Include a description of the trouble caused by the card in as much detail as possible. It will be repaired and returned to you.

8. At times the instructions may seem unnecessarily simplified. This is done so that technicians of all levels of competence may, hopefully, troubleshoot this complex piece of equipment. If difficulties arise, do not hesitate to cable LDGO for assistance or advice.

#### B. Specific troubleshooting procedure

1. In the event of erratic or no action of the lights and after determining that all major voltages are correct, inspect the clock numerals. If the timing indications are correct, then in all probability the

master oscillator is okay. If not, it may indicate a malfunctioning master oscillator. Remove the right side panel of the recorder. Using an oscilloscope set at 1 micro sec and gain at 2 volts/cm, there should appear a pattern as in Figure 1a. on pin 1 of the oscillator socket. Scope ground on pin 3. If this does not appear, install a new oscillator.

2. The master oscillator is divided down from 1.024 MHZ through A22-184 TP13 to 1024 KHZ. See logic diagram 8. Then to logic diagram 13 through A14-112 to TP 17 which develops the 1.024 MHZ. Then through B9-112 to TP16 to 1.024 MHZ. Also through A9112-TP17 for 8192HZ through B9-112 to TP 17 for 8192HZ. Thence to sheet 10. This diagram plainly shows how the 8192HZ signal is further divided down to the lowest frequency signal used (0.5HZ from A24-TP23).

These dividers operate in such a manner that if a failure occurs in one section, there will be no output from that unit or any lower frequency sections, i.e., if 4HZ is missing and all higher frequencies are correct, 8HZ-16HZ, etc. then 2 HZ, 1HZ and .5 HZ will be missing.

3. All timing signals must be present and correct. Without these conditions the system cannot function.

4. If all timing signals are present and the system does not step or flash, then the ADC is suspect. Systematically replace ADC cards until the defective

unit is located. Make sure all original cards that work are kept in the ADC after operation is resumed. Note cards 17101 and 17124 must be kept together as matched sets. Thus replace both cards at the same time.

### Signal Tracing

To trace a specific signal through this system from input to tape head requires a specialized technique. Conventional troubleshooting procedures are only useful in a limited area of the data logger. The following procedure allows you to check out specific channels from input connector, through the signal conditioner and through the analog mux. Refer to the ADC instruction manual to check it out.

1. Select a signal of the proper frequency to be accepted in the pass band of the signal conditioner used in the channel that is to be tested (20 to 100 sec for A channels, 100 sec to DC for B channels).

2. If a function or signal generator is not available, the DAC cable may be used. Upon inserting this cable into any of the input plugs on the bottom rear panel of the data logger, the DAC test light on the front panel will illuminate. The DAC test channel switch only inserts DAC into channel 10. It is not used when the DAC cable is used.

3. Normally "A" channels 1, 2, and 3 are used.

Channels J4, 5, 6, 7, 8 and 9-14-15-16 should have a shorting jumper between pins A and B. J1, 2 and 3, and J11, 12 and 13 are shorted by jumpering A and D. Also, a jumper wire should be in place on each unused signal conditioner socket between pins 7 and 22.

4. To simplify reading the oscilloscope pattern, remove all signal cables except the test signal - short all unused jacks.

5. Use an extender on card C2. Connect oscilloscope trigger on pin 70, ground is 16, signal probe to 5, sweep set at 12 m sec. This should indicate a display as in photo 1B.

6. If a signal generator is not available, plug the DAC cable into the channel to be tested. Photo 3B shows switches 7 and 8 "on" in the DAC test channel. Photo 2B shows DAC cable in J1 a few seconds after DAC switches 7 and 8 were switched "on". DAC test switch "off". Photo 5B shows signal distorted because of mis-adjusted probe on oscilloscope. Photo 6A shows a negative signal applied by utilizing DAC switches 1-2-3-4-5--7 and 8. Channel 1 has been driven off scale at the bottom because of the impulse applied to the signal conditioner filter.

Applying a DAC signal to a B channel filter effects no immediate indication of a signal because of the very long filter time constant.

Refer to schematics 18 and 15 in the data logger manual for the complete circuit tested. The output of the analog mux with no signals should appear as in Photo 1B. Depending upon the exact oscilloscope triggering, Channel 1 will appear at the extreme left. Use the DAC channel 10 as in Photo 3B as an index or reference to count channels.

if in the preceding test procedure you have located a channel malfunctioning, then simply trace back substituting the proper cards toward the input signal until the defect is found. Always remember the delay in signals on the output of the analog mux card C2 caused by the filters in the signal conditioner.

On the back of each unused signal conditioner socket, i.e., channels 4, 5, 6, 7, 8, 9, 14, 15, and 16 a jumper has been added from 7 to 22. This connects the input to the output of each signal conditioner card slot - except those in use. See Diagram 2. These jumper wires should be removed before signal conditioners are put into these sockets.

If at any time it is desired to apply a signal to a previously unused channel, simply insert the signal between A and B of the selected channel. Be sure and set the channel selector switch inside the rear door. If it is desired to add a signal to the existing 6 channels, then the next consecutive channel must be used.

For example, channels 1-2 and 3 are now used. If you desire to add an A type channel, then channel 4 must be used. Therefore, J104 is the input connector to be used. Do not add a signal to the displacement group unless it is fully understood that the sample rate is less frequent than a velocity channel. Change A channel selector switch to 4.

#### Some Typical Troubles and Solutions

1. Symptom - Normal operation causes echo check error.  
 Conditions - test position - manual stepping of "tape" leads to occasional echo check lamps - header data reads okay on tape character lamps - lamps on tape deck do not correspond to tape character lamps.  
 Trouble - found head connector reversed at jack on main board.
2. Symptom - Immediately upon setting test channel switch to DAC and with no DAC input switches used, test channel errors appeared. Also immediately upon plugging DAC test cable into any data logger input and also with no DAC input switches used errors appeared.  
 Trouble - found DAC card 27103 was defective having a constant output. Replaced card and trouble disappeared.



3100-40

3. Symptom - Continuous test channel errors.

Trouble - Card A15 intermittently defective caused loss of TB1T14.

4. Symptom - Lamp selector switch in tape position no lights - also lamps on tape deck dead.

Trouble - Found B13 12-bit shift register feeding lamp selector switch inoperative - B9 2-way band feeding it was locked 5 volts true with small pulses riding on it. This was Data 16 on pin 5 but pin 54 was high - same as B9-112-5 GO signal fixed high schematic 17-2 B10-9 is origin of Go signal. F 5/2 Hz signal was missing on B12-74 at which terminal B10-10 received it, to make a GO signal. Found intermittent open lead between A16-6 and B12-74, see sheet 10 - replaced lead - poorly crimped in flat pin.

### FILTER FAN INSTALLATION

1. Drill or punch four .144" dia. holes. Use drawing on front of this sheet as a template if desired, or note dimensions.
2. Cut rectangular opening in panel as shown on front of this sheet.
3. Attach spring steel Mounting Clips with #6 flat head screws of type and length to suit panel.
4. Insert block between clips so that the formed guide rails on the clips enter the slots in the block. For air movement in the direction shown, slide the block in until the lugs in the clips snap into the recesses in the block, shown as recess #3. It is necessary to bend the clips slightly away from the block while inserting it so that recess #1 and the outer wall of recess #3 will not engage the clips prematurely.
5. Insert Filter box and frame assembly between the clips. It is held in place by retaining fingers on the clips.

If block must be removed, spring tabs carrying lugs can be pried away from block with a knife or screw driver inserted along inside edge of clip. Block should then be drawn out, not pushed in.

Leads should be soldered to terminals or use Plug and Cord Assembly, Part No. 16415.

### OILING THE MARK 4 MUFFIN FAN

The Mark 4 Muffin Fan has been oiled at the factory to provide ten years of operation at room temperatures. If you intend to use your Mark 4 Muffin in ambient temperatures that exceed room temperatures, it is recommended to plan a re-oiling schedule for at least one oiling per year. Special oil and applicators are available as accessory items in the Rotron Oiler Kit No. 19263, available at \$2.50 each. Oiler refill bottles, No. 19263-4, may be purchased at \$1.25 each.

### OILING INSTRUCTIONS

To inject oil into the bearing:

1. Position the needle at an angle of 45° to the rubber dust cap located at the center of the motor spider.
2. Pierce the rubber dust cap.
3. Depress plunger firmly until oil has gone down one calibration line. **NOTE:** The dust cap will remain on the needle if you should withdraw the needle too quickly. Instead
4. Hold the dust cap in position and withdraw needle and wipe off excess oil. Oil may be left in the syringe for future use. Be



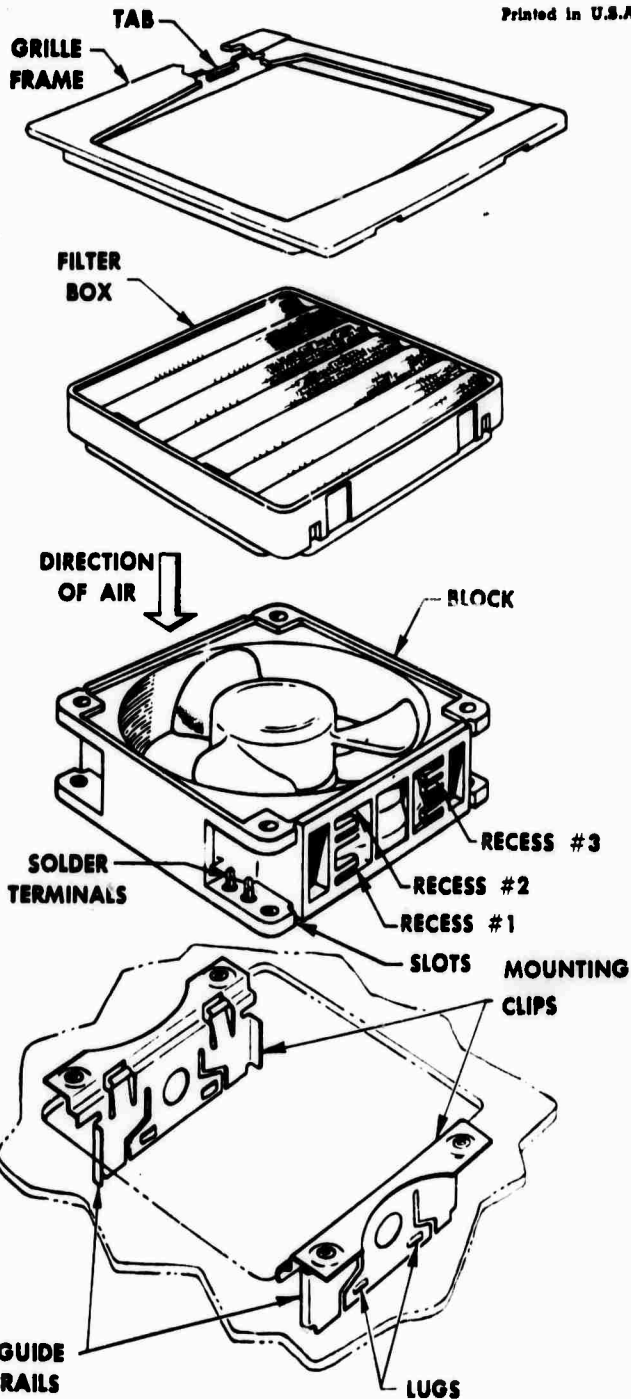





sure that the rubber dust cap remains in place after oiling.



**NOTE:** 1. Mounting Clips are supplied only with the Grille Fan and Filter Fan, but are available as an accessory item.

2. Screws are not supplied.

### ACCESSORY ITEMS

MOUNTING CLIPS	SPIRAL GRILLE	FILTER ASSEMBLY	ROTRON FILTERCOAT	FINGER GUARD	PLUG AND CORD ASSEMBLY	ROTRON OILER KIT	OILER KIT REFILL BOTTLES
							
Rotron Part No. 13996 (Set) \$ .20	Rotron Part No. 16238 \$ .80	Rotron Part No. 15449 \$2.30 (includes Mounting Clips)	Rotron Part No. 18440 \$1.00	Rotron Part No. 14099 \$1.00	Rotron Part No. 16415 \$ .60	Rotron Part No. 19263 \$2.50	Rotron Part No. 19263-4 \$1.25

3100-42

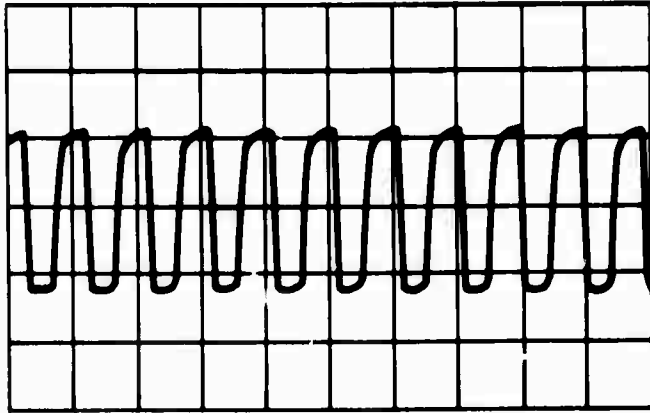

Figure 1A - Output of the 1.024 MHz oscillator. Oscilloscope gain 2 volts/cm. Sweep 1 microsec.

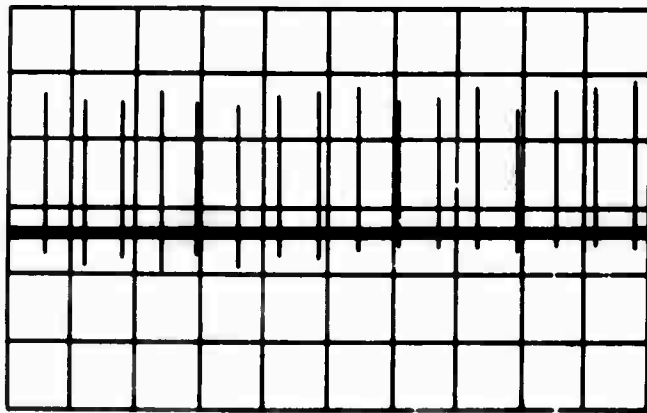

Figure 1B - Output of analog mux card C2. No input to any channel. Oscilloscope set .2 volts/cm, sweep .2 msec. Trigger on C2-70, ground C2-16, signal C2-5.

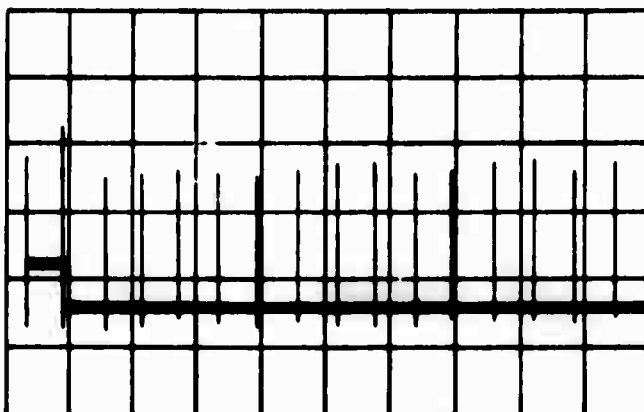

Figure 2B - Output of analog mux card C2 with DAC signal on channel 1. DAC switches 7 and 8 on. Oscilloscope set as 1B.

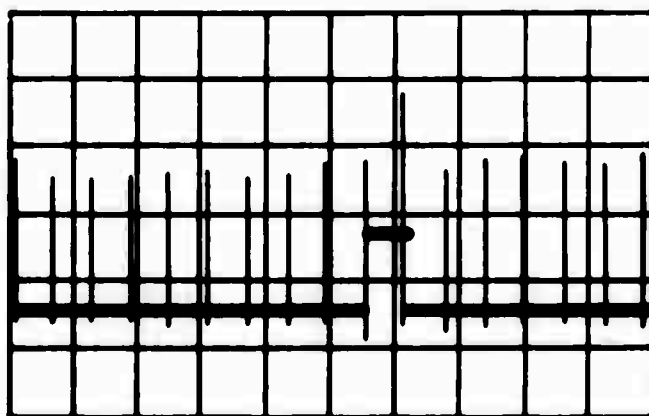

Figure 3B - Output of analog mux card C2 with DAC signal applied to channel 10. DAC switches 7 and 8 on. Oscilloscope set as 1B.

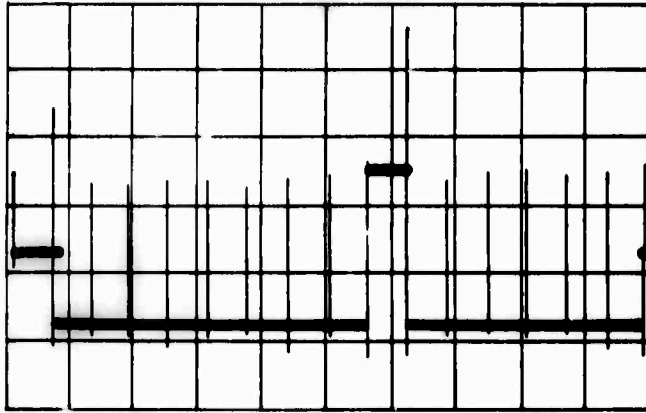

Figure 4B - Output of analog mux card C2 with DAC signal applied to channels 1 and 10. DAC switches 6 and 7 on. Oscilloscope set as 1B.

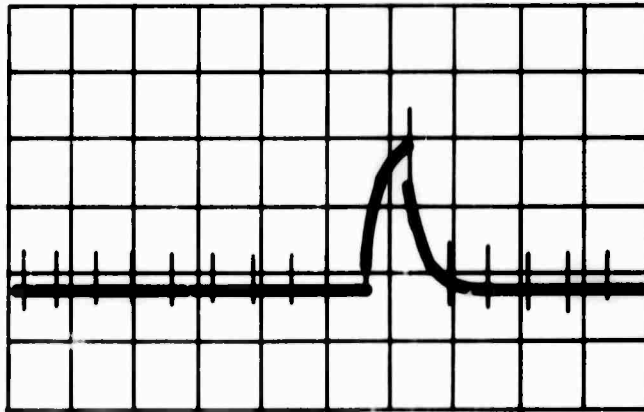

Figure 5B - Output of analog mux card C2 with DAC signal on channel 10 oscilloscope probe improperly adjusted.

3100-45

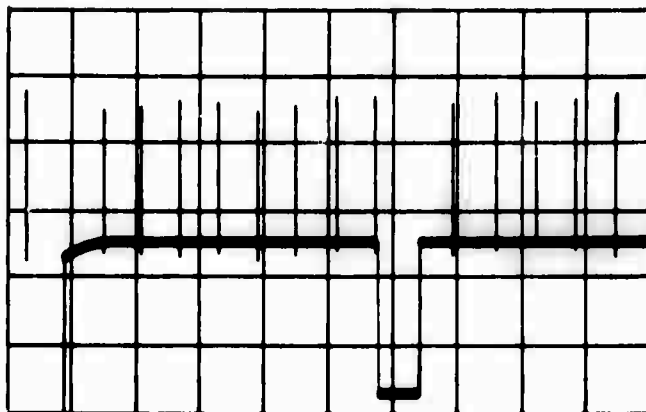

Figure 6A - Output of analog mux card C2 with DAC signal on channels 1 and 10. Negative signal applied with DAC switches 1, 2, 3, 4, 5, 7, and 8 on. Oscilloscope set as 1B.

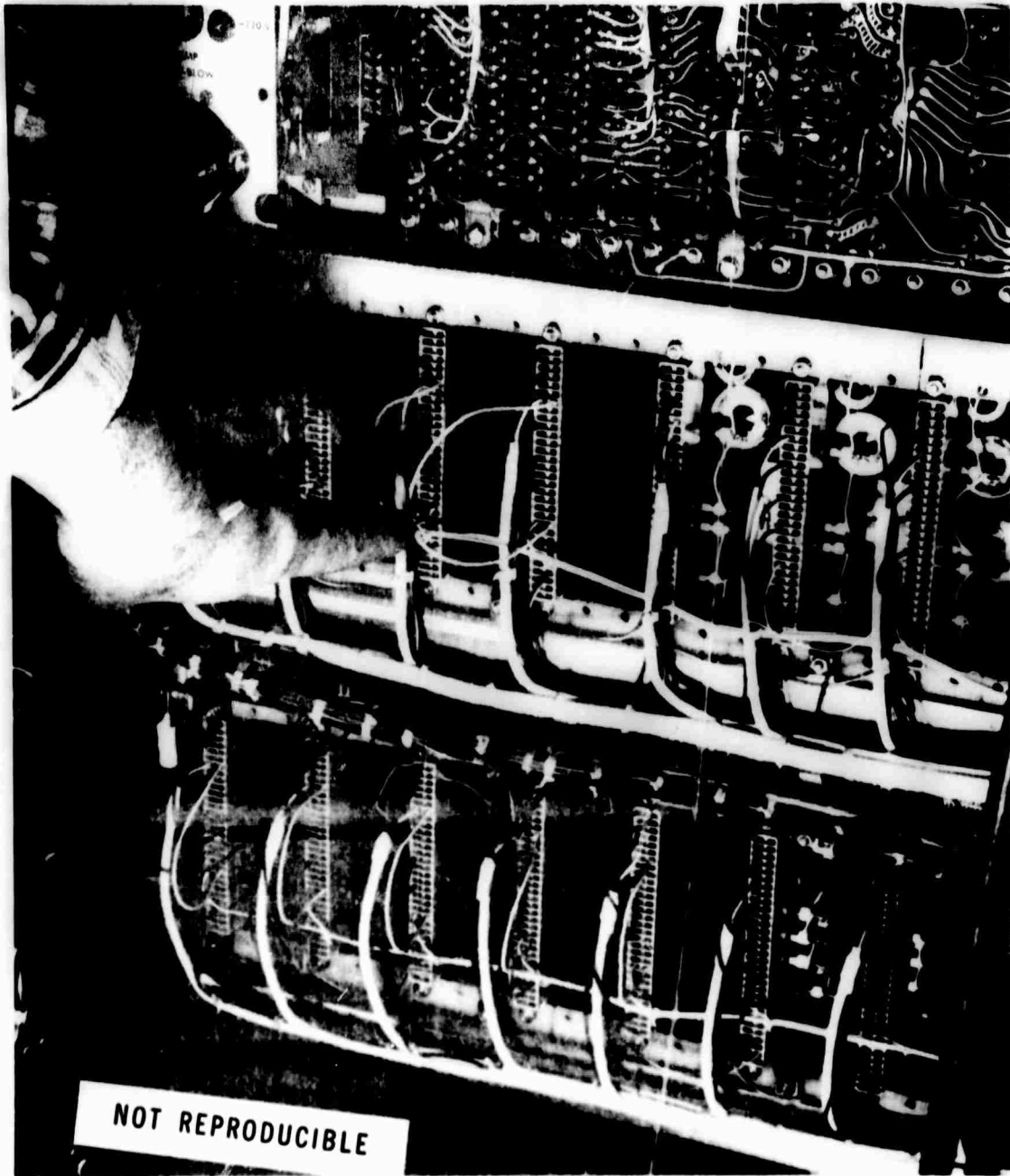
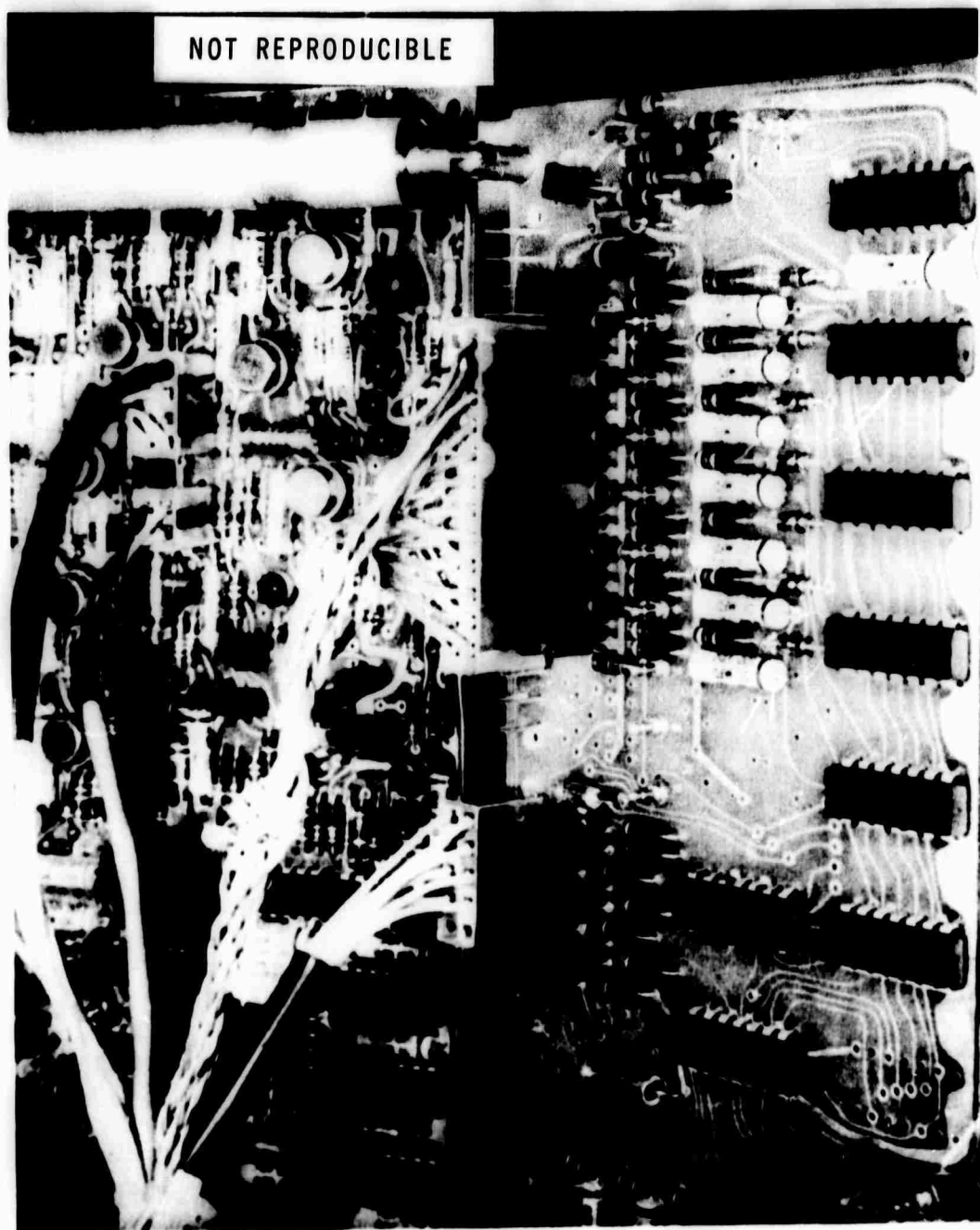

Plate 3100-1: Location of Jumper cables in the Digital Data Acquisition system inserted to connect input to output of channels with no signal conditioners.

3100-47



NOT REPRODUCIBLE

Plate 3100-2: Close-up view of the Cipher tape deck main board showing location of connectors. Be sure that these connectors are placed on pins as shown.



3100-48

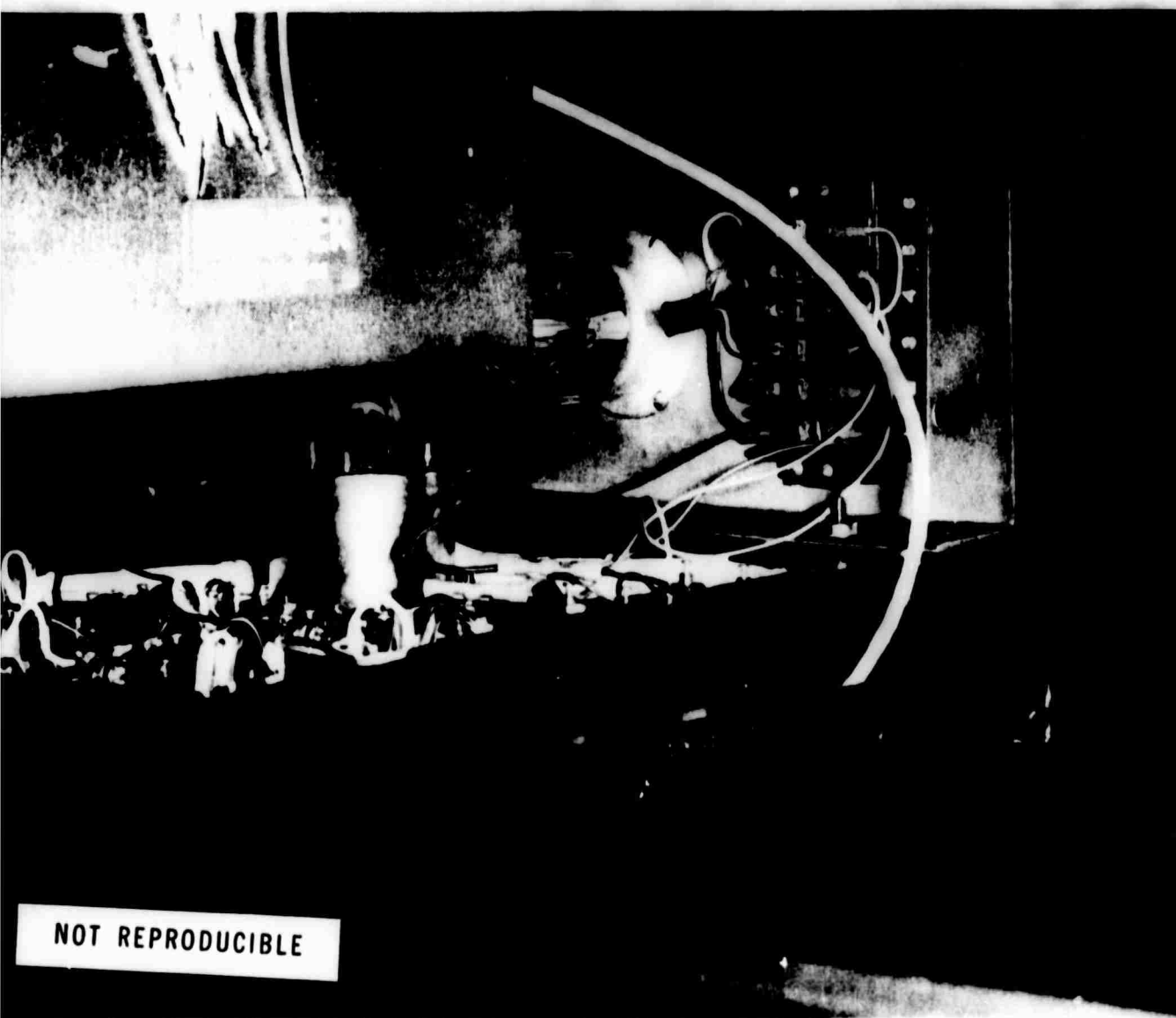
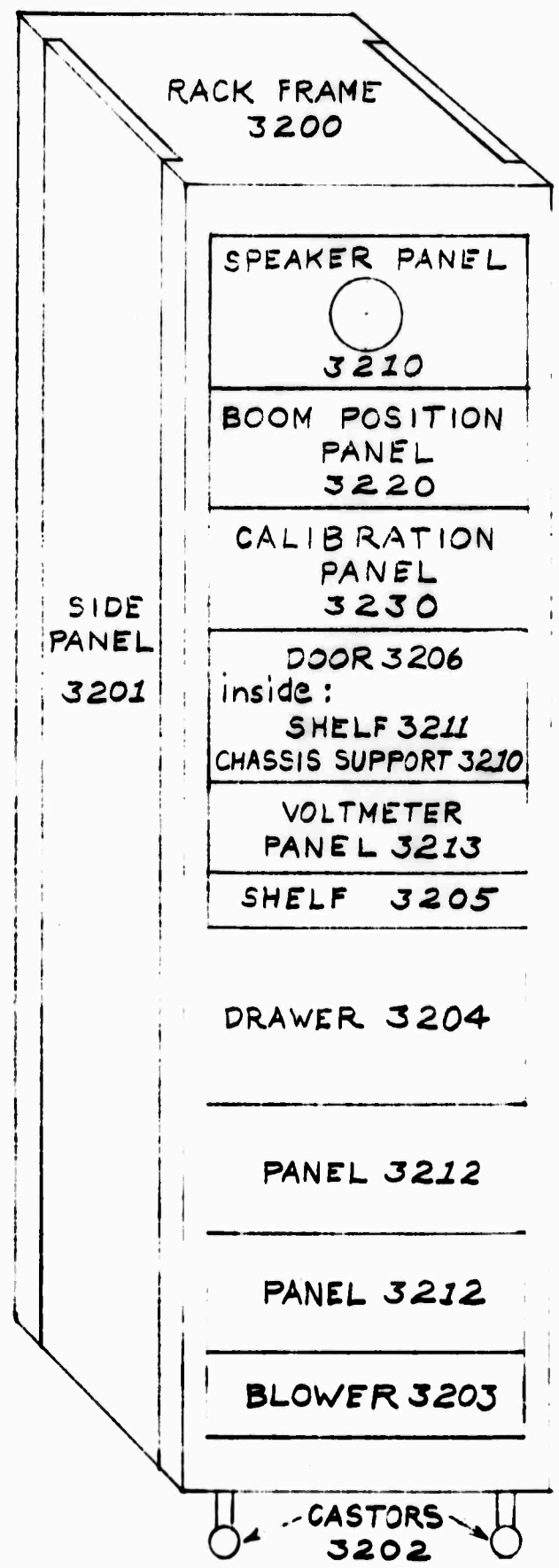

Plate 3100-3: Time relay installed behind the main connector panel of the Digital Data Acquisition System.

# CONTROL PANEL 3200

FRONT VIEW



BACK VIEW

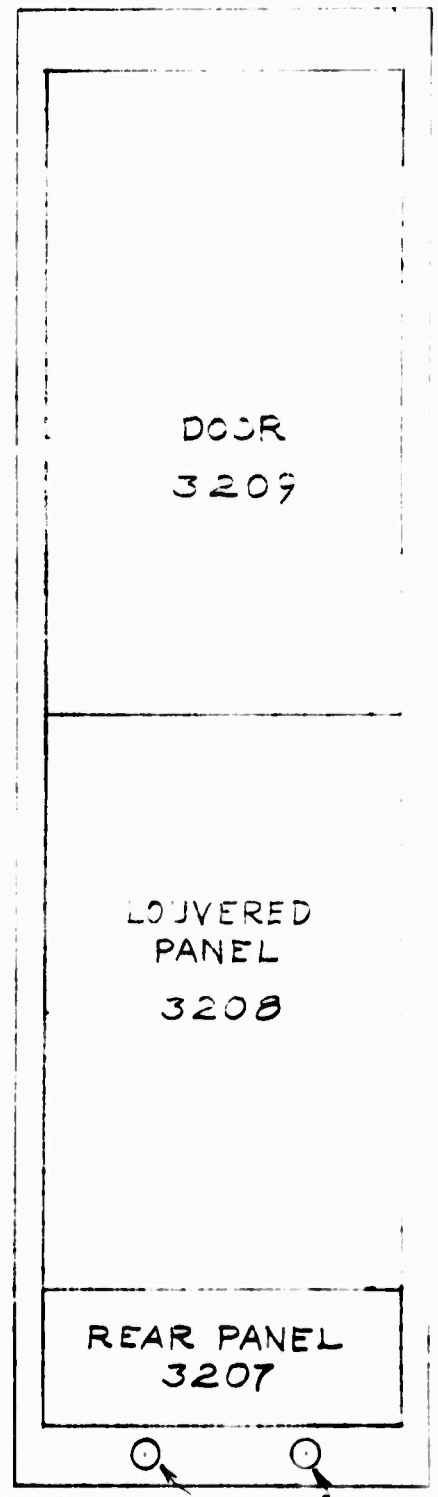

4" SIGNAL IN AND OUT — POWER IN

115V WIRING DIAGRAM FOR ELECTRONIC RACK

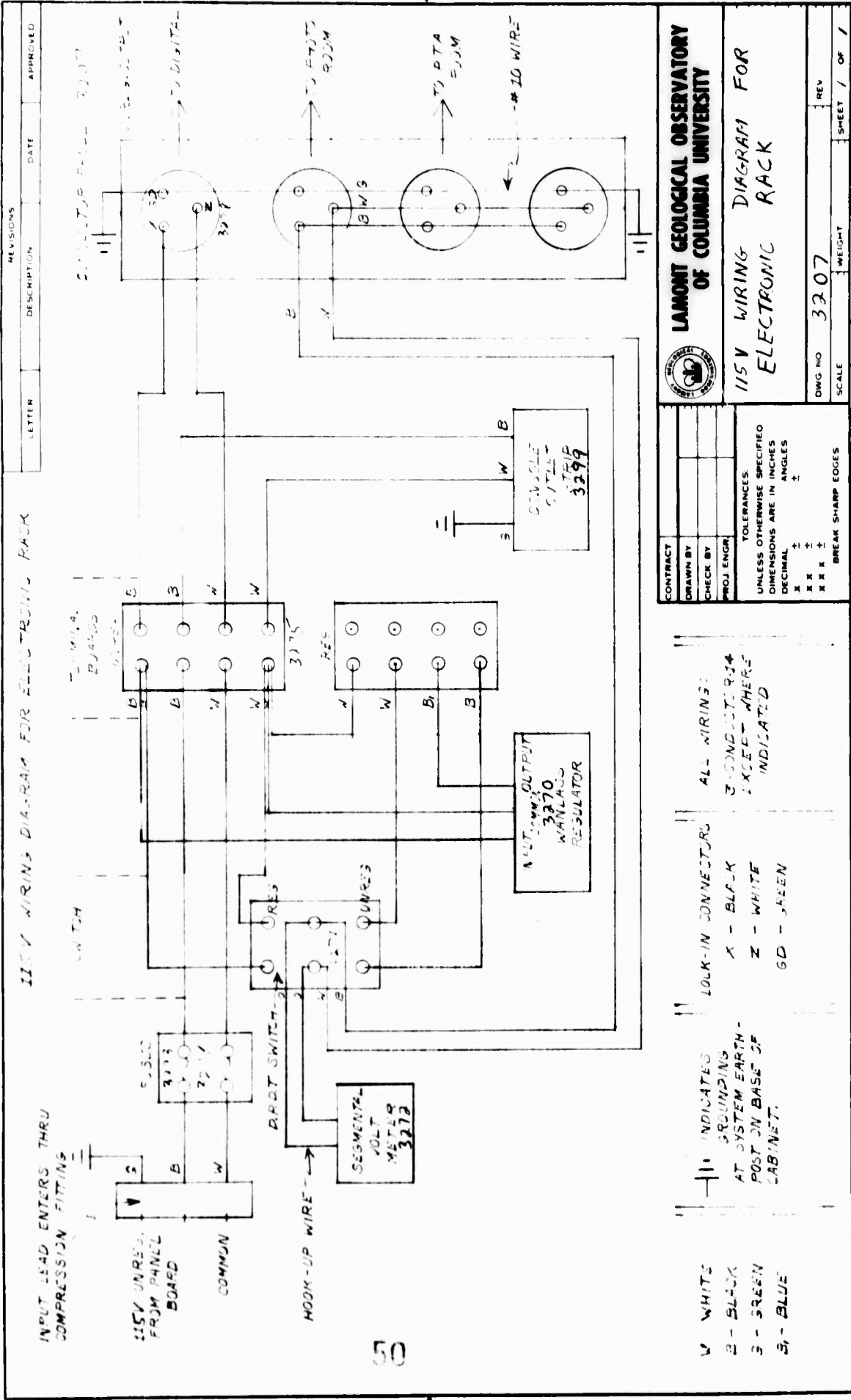

REVISIONS	LETTER	DESCRIPTION	DATE	APPROVED

LAMONT GEOLOGICAL OBSERVATORY  
OF COLUMBIA UNIVERSITY

115V WIRING DIAGRAM FOR  
ELECTRONIC RACK

DWG NO	3207	REV	
SCALE		WEIGHT	
		SHEET	
		OF	

CONTRACT	
DRAWN BY	
CHECK BY	
PROJ ENGR	

TOLERANCES  
UNLESS OTHERWISE SPECIFIED  
DIMENSIONS ARE IN INCHES  
DECIMAL  
X ±  
X X ±  
X X X ±  
BREAK SHARP EDGES

ALL WIRING:  
3 CONDUCTOR 3/4"  
EXCEPT WHERE  
INDICATED

LOCK-IN CONNECTORS  
X - BLACK  
Z - WHITE  
GD - GREEN

INDICATES  
GROUNDING  
AT SYSTEM EARTH -  
POST ON BASE OF  
CABINET.

W - WHITE  
B - BLACK  
S - GREEN  
B - BLUE

LETTER	DESCRIPTION	DATE	APPROVED
		0 1 2 3	

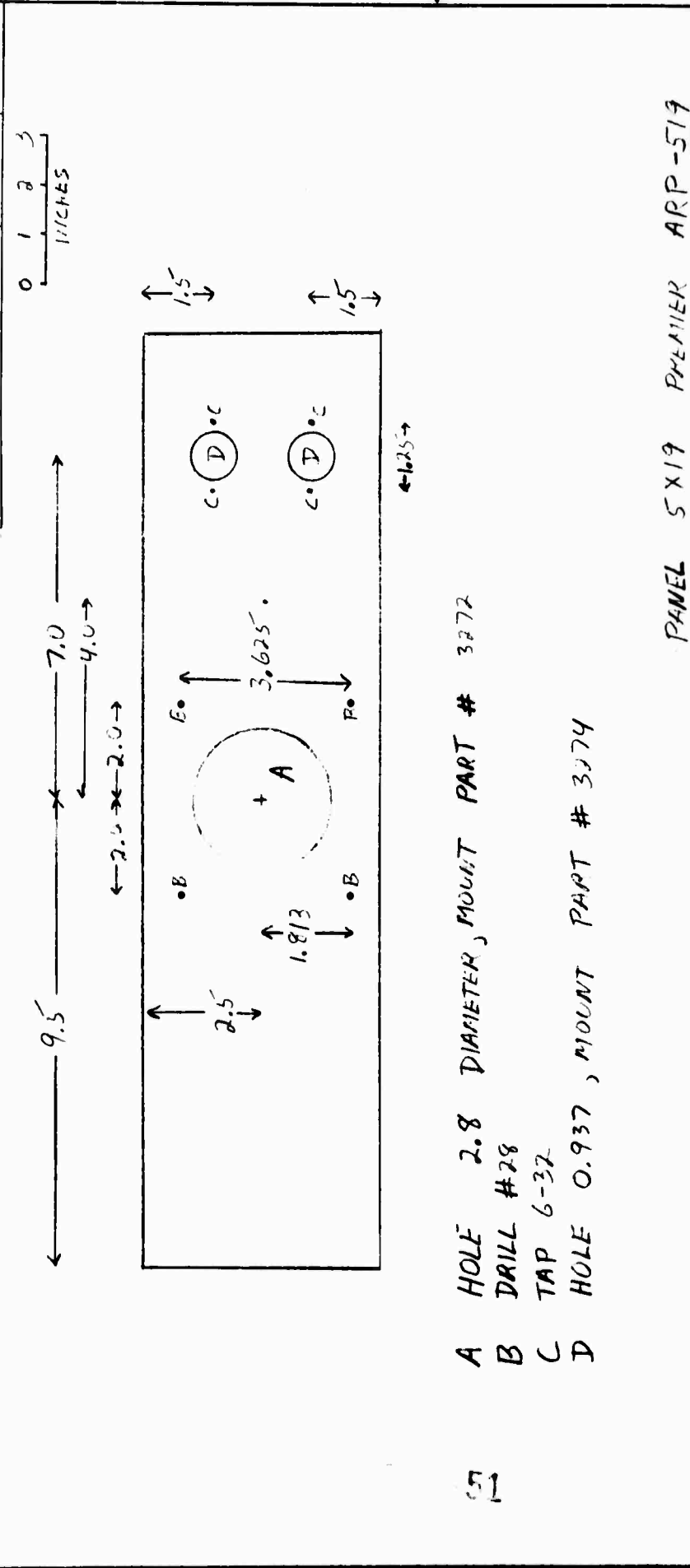

1/16 INCHES

- A HOLE 2.8 DIAMETER, MOUNT PART # 3272
- B DRILL #28
- C TAP 6-32
- D HOLE 0.937, MOUNT PART # 3274

PANEL 5 X 19 PREMIER ARP-519

CONTRACT	PROJ ENGR		<b>LAMONT GEOLOGICAL OBSERVATORY OF COLUMBIA UNIVERSITY</b>
DRAWN BY	CHECK BY		
TOLERANCES UNLESS OTHERWISE SPECIFIED DIMENSIONS ARE IN INCHES DECIMAL                    ± XXX                         ± XXXX                       ± BREAK SHARP EDGES			
DWG NO	SCALE	WEIGHT	REV
3213	2/1		1

VOLTMETER PANEL

REVISIONS		
LETTER	DESCRIPTION	DATE

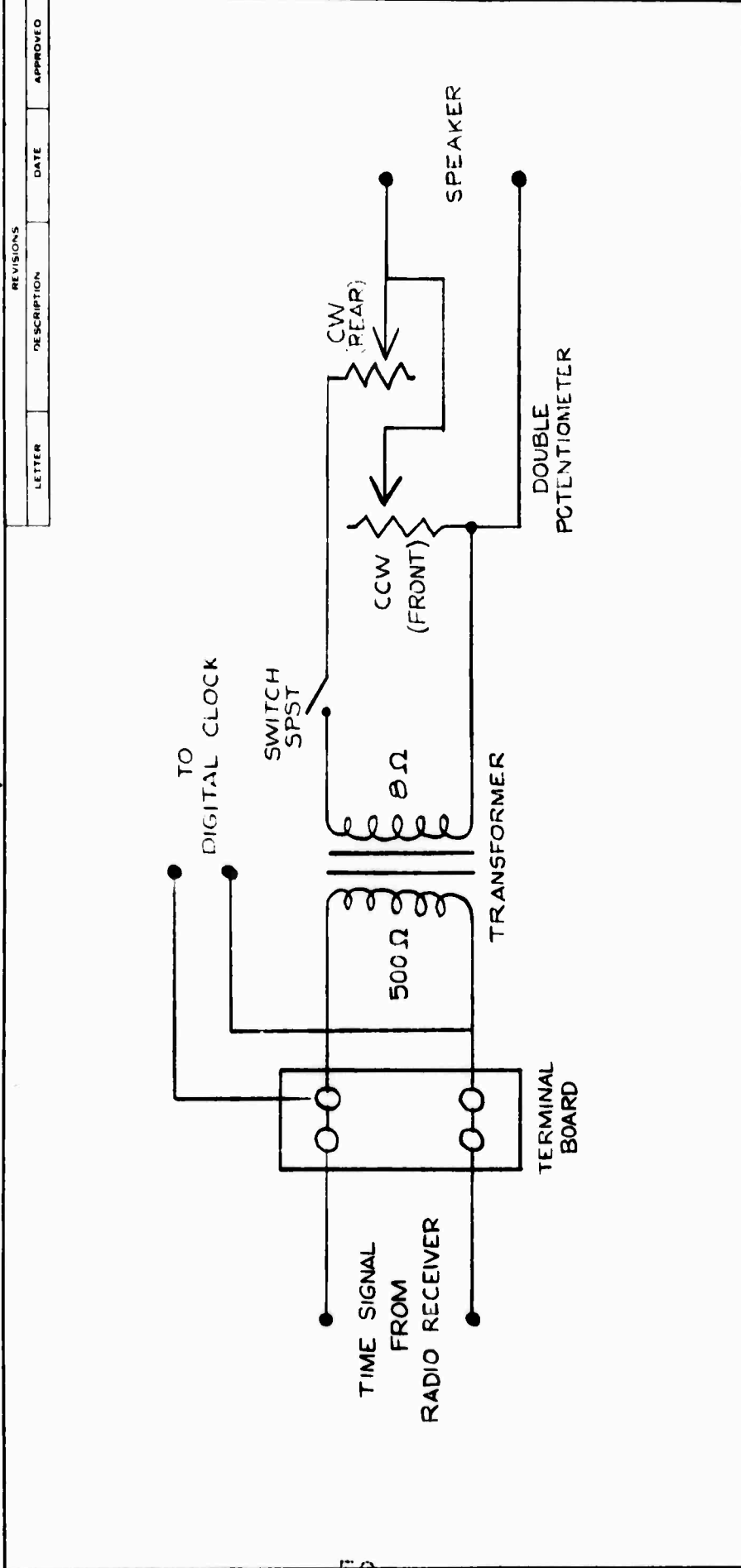

CONTRACT	
DRAWN BY	
CHECK BY	
PROJ. ENGR.	

TOLERANCES:  
UNLESS OTHERWISE SPECIFIED  
DIMENSIONS ARE IN INCHES  
DECIMAL     ±  
X             ±  
X X         ±  
X X X      ±  
X X X X   ±  
BREAK SHARP EDGES

LAMONT GEOLOGICAL OBSERVATORY  
OF COLUMBIA UNIVERSITY

SPEAKER PANEL

DWG NO. 3215     REV.     SHEET 1 OF 1

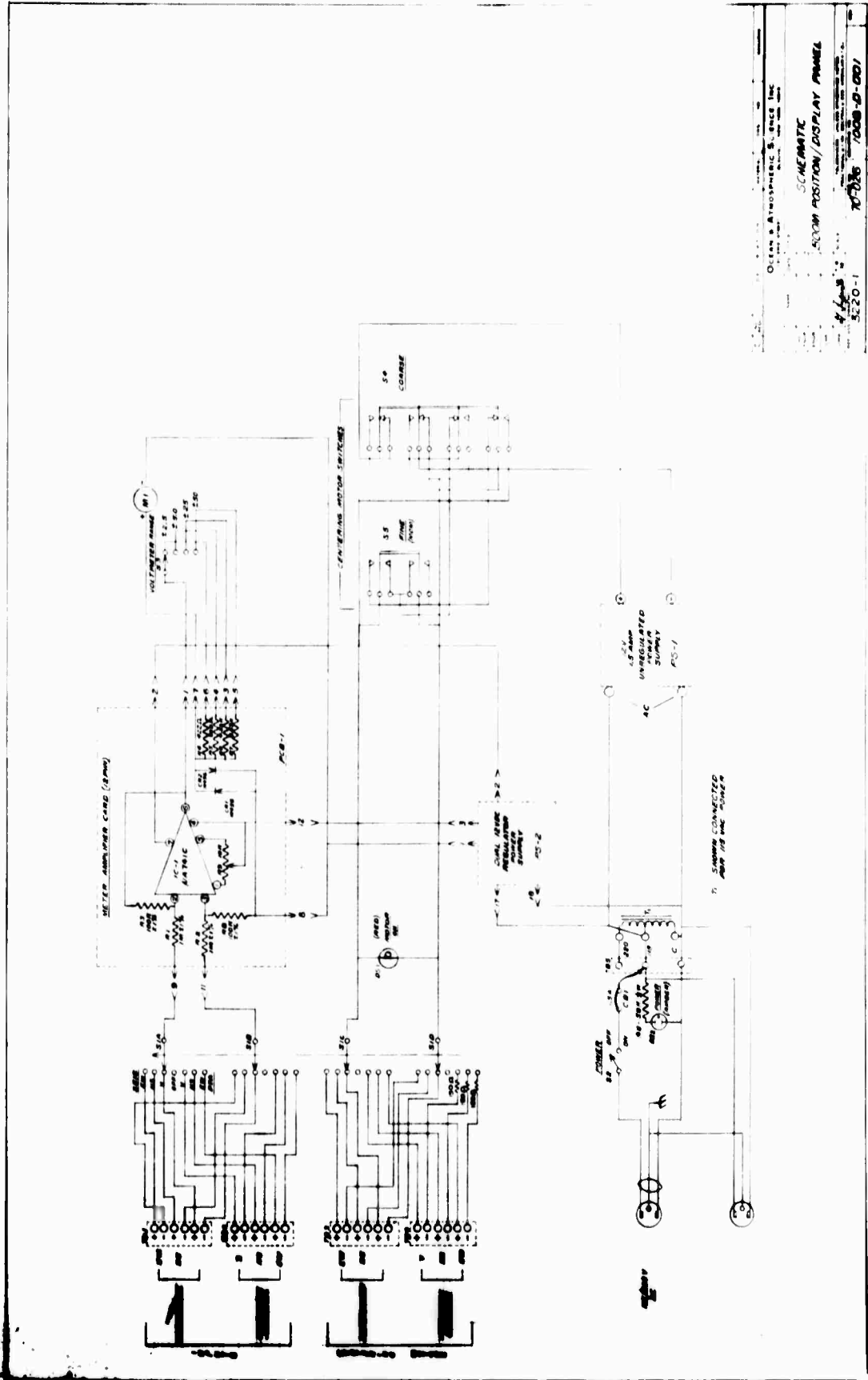

Ocean & Atmospheric S. Space Inc.  
 SCHEMATIC  
 SYSTEM POSITION/DISPLAY PANEL  
 10736 1008-B-001  
 520-1

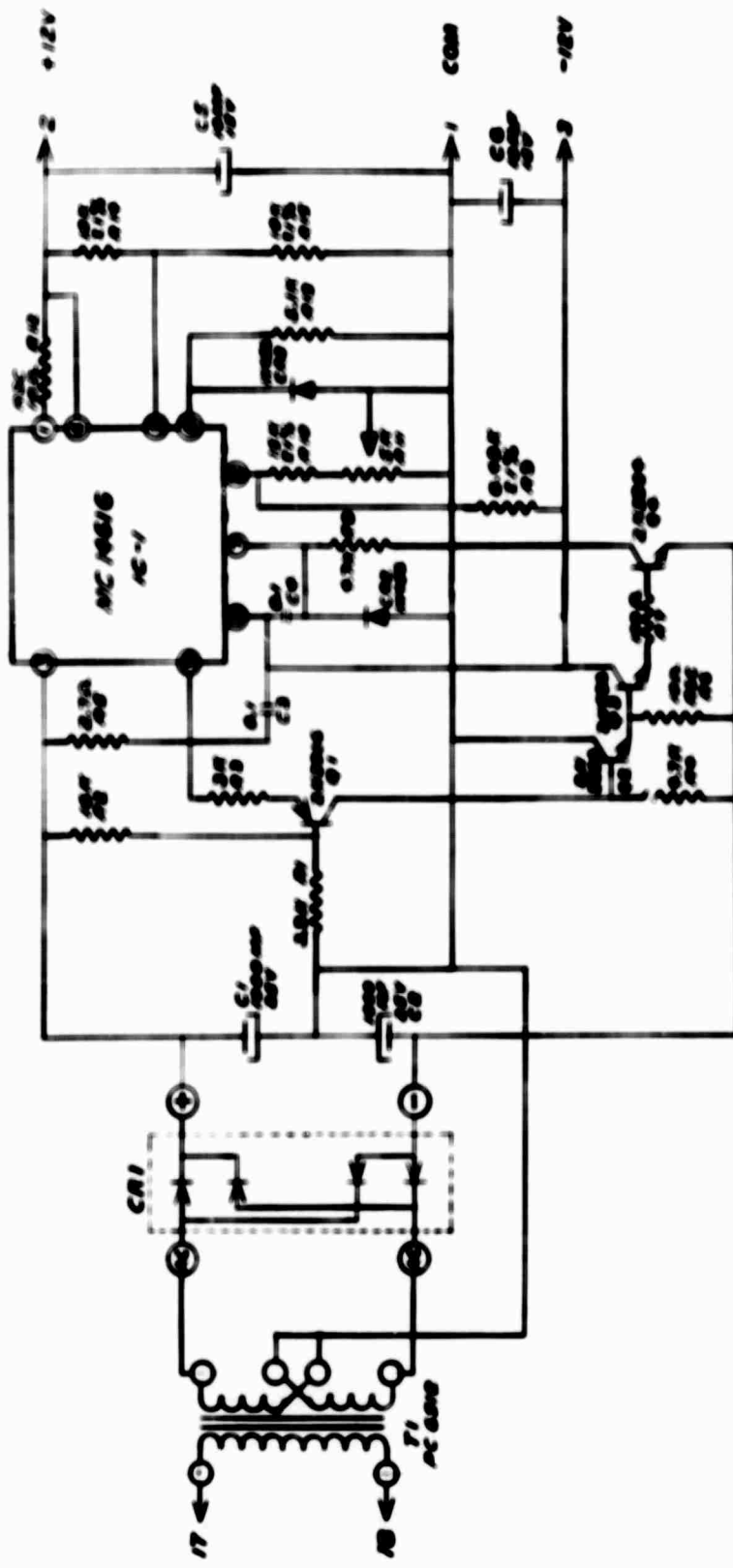

54

REV	NO	DESCRIPTION
REVISIONS		DATE
OCEAN & ATMOSPHERIC SCIENCE, INC.		
100 ALBUQUERQUE BLVD., SUITE 1000		
ALBUQUERQUE, NEW MEXICO 87105		
NAME	DATE	SCALE
JOB NO. 1007-B-00		

**SCHEMATIC**  
**POWER SUPPLY (DUAL REGULATED)**

REVISIONS: 0.1  
 0.1 - REVISED FOR IMPROVED REGULATION  
 0.2 - REVISED FOR IMPROVED REGULATION

NO. 5220-2

FORM NO. 1007-B-00

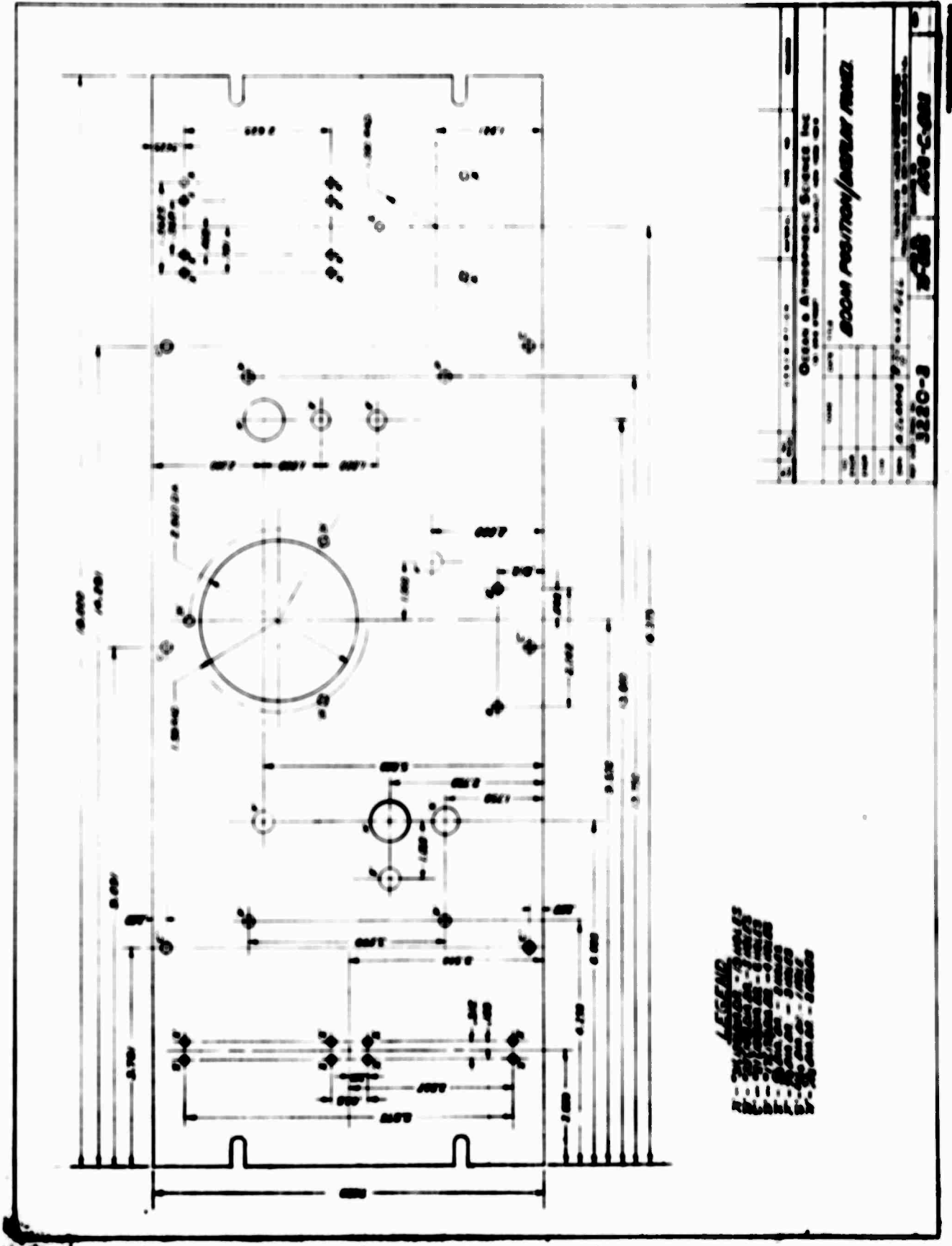

**LEGEND**  
 [Symbol] - 3" DIA. VENT  
 [Symbol] - 4" DIA. VENT  
 [Symbol] - 6" DIA. VENT  
 [Symbol] - 8" DIA. VENT  
 [Symbol] - 10" DIA. VENT  
 [Symbol] - 12" DIA. VENT  
 [Symbol] - 14" DIA. VENT  
 [Symbol] - 16" DIA. VENT  
 [Symbol] - 18" DIA. VENT  
 [Symbol] - 20" DIA. VENT

*ROOM POSITION/NUMBER AREA*

0-073  
 3220-2  
 000-C-000



4-0001 0001 2.0 2.0 0-0001  
 5-0001 0001 2.0 2.0 0-0001

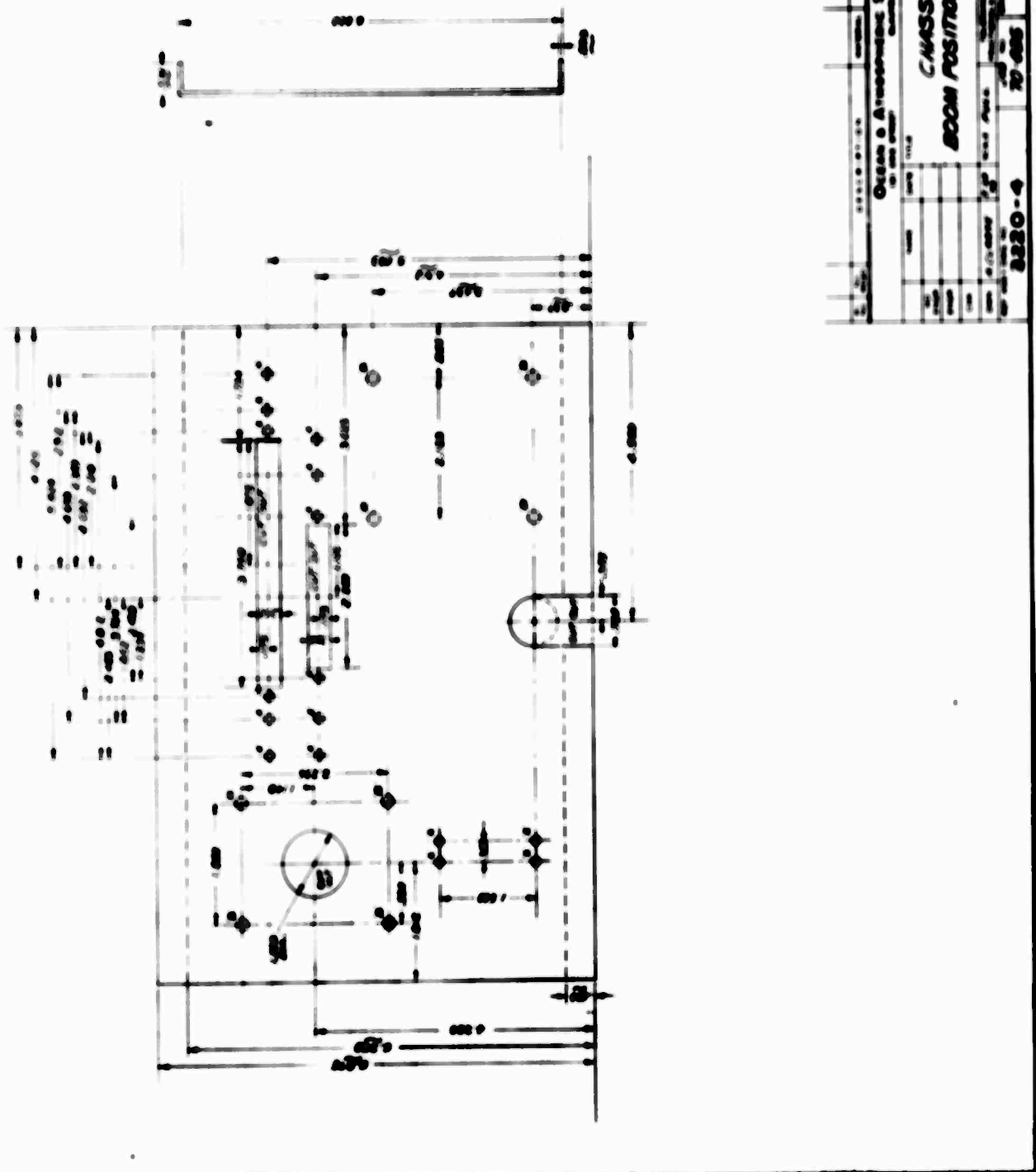

Ocean & Atmosphere Sciences Inc.	
CHASSIS	
BOOM POSITION/DISPLAY PANEL	
2220-4	10-005 1009-C-004

3220-1

Dwg. #1008-D-001

PARTS LIST FOR PCB-1

<u>Symbol</u>	<u>Description</u>	<u>Mfg. Number</u>
CR 1	Diode, silicon	1N 456
CR 2	same as CR 1	
IC 1	Integrated Circuit All fixed resistors are metal film type, RN60D, $\pm$ 1%.	NA 741 C
R 1	1 megohm	
R 2	same as R 1	
R 3	100 K ohms	
R 4	422 ohms	
R 5	909 ohms	
R 6	4.53 K ohms	
R 7	9.53 K ohms	
R 8	same as R 3	
R 9	Resistor, adjustable, Cermet type 10 K ohms.	Bourns 3069P- 1-103

PARTS LIST FOR PS-2

C 1	Capacitor, Electrolytic, 1000 MFD @ 25 VDC.	Sprague TL-1218
C 2	same as C 1	
C 3	Capacitor, Ceramic, .1 MFD at 50 VDC	Centralab CK-104
C 4	same as C 3	

3220-2

Dwg. #1008-D-001

## BOOM POSITION DISPLAY PANEL

<u>Symbol</u>	<u>Description</u>	<u>Mfg. Number</u>
CB 1	Circuit Breaker, 1.5 A	Mallory CBB-150
DS 1	Bulb, incandescent, Miniature bayonet 14.4 Volts at 100 milliamperes	GE #1892
DS 2	Bulb, neon type, Miniature bayonet, without resistor	GE NE-51
M 1	Meter, Panel type, zero center, 500-0-500 micro-amperes, with special scale 2.5-0-2.5 & 5-0-5. Scale accuracy 2%, Taut band construction.	Honeywell Type M S 3T
PCB 1	Meter Amplifier Card - see separate parts list	
PS-1	Power Supply, modular, 12 VDC @ 1.5 amperes output regulated.	Ferrotran Model SU-12A
PS-2	Power Supply, Plug-in, dual regulated, tracking +12 VDC @ 100 MA and -12 VDC @ 100 MA. See separate parts list.	OAS Type Mod 12-0.1 Dwg. #1007- B-001
R 11	Resistor, Composition, 1/4 watt, 56K ohms, ± 10%.	
S 1	Switch, Rotary, 4 poles, 7 position non-shorting type contacts.	CTS #T235
S 2	Switch, toggle, 1 PST	C-H
S 3	Switch, Rotary, 1 pole, 4 position non-shorting contacts.	CTS #T205
S 4	Switch, lever type, 4 poles 3 position latching, 3 amp contacts.	Switchcraft #29312L

3220-3

Dwg. #1008-D-001

**BOOM POSITION DISPLAY PANEL  
(Cont.)**

<u>Symbol</u>	<u>Description</u>	<u>Mfg. Number</u>
S 5	Switch, lever type, 2 poles 3 position non locking, center off, 3 amp contacts.	Switchcraft # 29307
T 1	Transformer, Autoformer voltage changing, 115/230 VAC @ 60 cycles. 100 VA rating.	Signal # SDO-100
TB 1	Terminal board, Barrier type screw connection, 6 termi- nals.	Cinch-Jones # 6-140
TB 2	same as TB 1	
TB 3	same as TB 1	
TB 4	same as TB 1	
TB 5	Terminal board, Barrier type screw connection, 3 terminals.	Cinch-Jones # 3-140

## PARTS LIST FOR PS-2 (Cont.)

<u>Symbol</u>	<u>Description</u>	<u>Mfg. Number</u>
C 5	Capacitor, tantalum, 10 MFD @ 15 VDC	Sprague 196D106X0015EB
C6	same as C 5	
CR 1	Rectifier Bridge, 1 amp @ 100 V RMS	International Rectifier # 10BD1P
Cr 2	Diode, silicon	1N 456
CR 3	same as CR 2	
IC 1	Integrated Circuit module	Motorola MC1461G
Q 1	Transistor, PNP, silicon	Motorola 2N 3906
Q 2	Transistor, NPN, silicon	Motorola 2N 3904
Q 3	Transistor, NPN, silicon	Motorola 2N 696
Q 4	same as Q 2	
R 1	Resistor, fixed composition, $\frac{1}{4}$ w, $\pm 1\%$ , 3.9 K	
R 2	Ditto - 16 K	
R 3	Ditto - 3 K	
R 4	Ditto - 4.7 K	
R 5	Ditto - 2.7 ohms	
R 6	Resistor, fixed wirewound, $\frac{1}{4}$ w, $\pm 1\%$ , 10 ohms	
R 7	Resistor, fixed composition, $\frac{1}{4}$ w, $\pm 1\%$ , 100 ohms	
R 8	same as R 4	

3220-5

Dwg. #1007-B-001

PARTS LIST FOR PS-2 (Cont.)

<u>Symbol</u>	<u>Description</u>	<u>Mfg. Number</u>
R 9	Resistor, fixed metal film, RN60D, + 1%, 6.49 K	
R 10	Ditto - 15.0 K	
R 11	Resistor, adjustable, Cermet type, 5000 ohms	Bourns 3069P-1-502
R 12	Resistor, fixed wirewound, 1/4 w, + 1%, 10 ohms	
R 13	Resistor, fixed composition, 1/4 w, + 10%, 5.1 K	
R 14	Resistor, fixed metal film, RN60D, + 1%, 10 k ohms	
R 15	same as R 14	

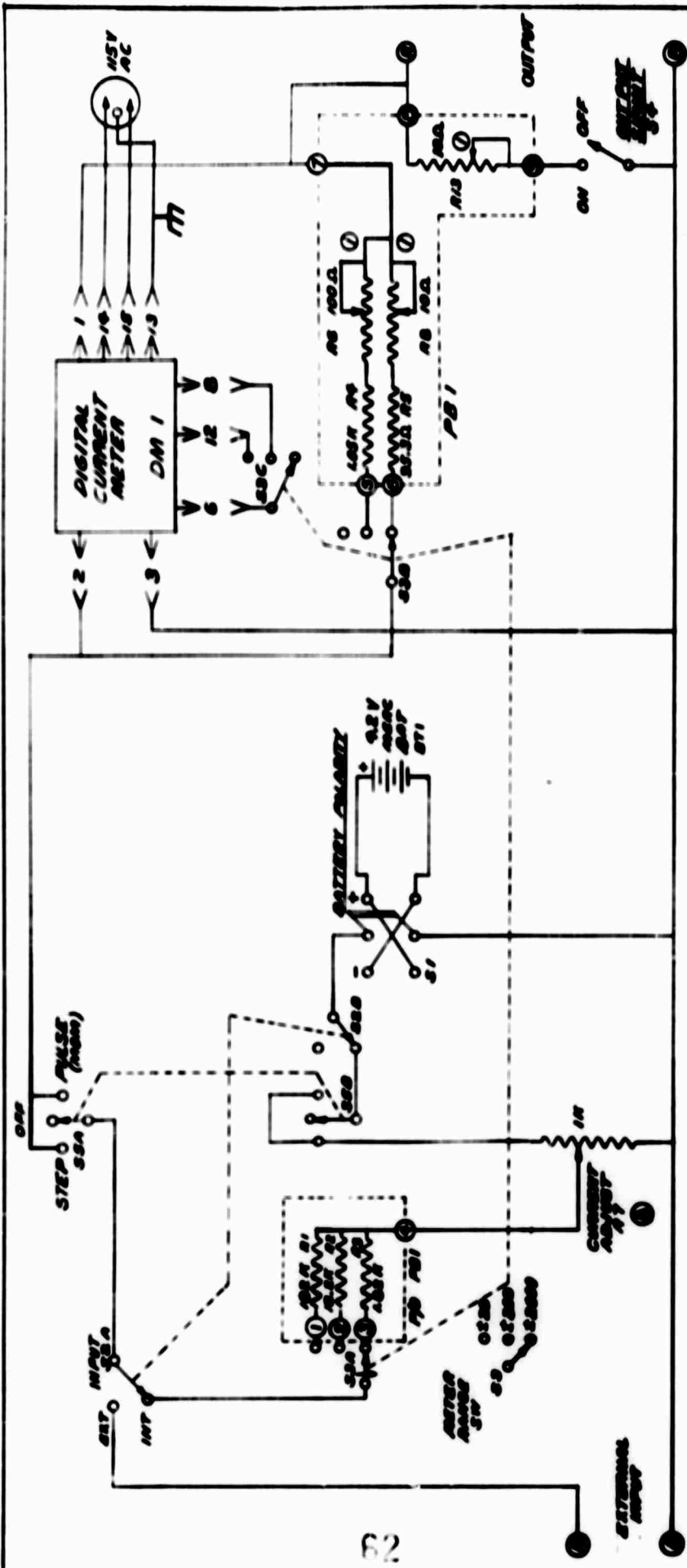

62

Be sure that the meter chassis is well grounded directly to the green power inlet ground wire. Be careful wires are not caught between front panel and rear cover when screwing on rear cover.

REV	DATE	DESCRIPTION	MATERIAL	QTY	NO	REMARKS
1		OCEAN & ATMOSPHERIC SCIENCE, INC. 101 ONE STREET BLAUVELT, NEW YORK 10013				
NAME		TITLE				
NO	DATE					
ENGR						
CHE						
DRW	5-1-70	SCALE				
REF ASSY QTY NO	3230-1	JOB NO	70-026	DRAWING NO	1008-B-008	REV

**SCHEMATIC  
CALIBRATION PANEL**

REV

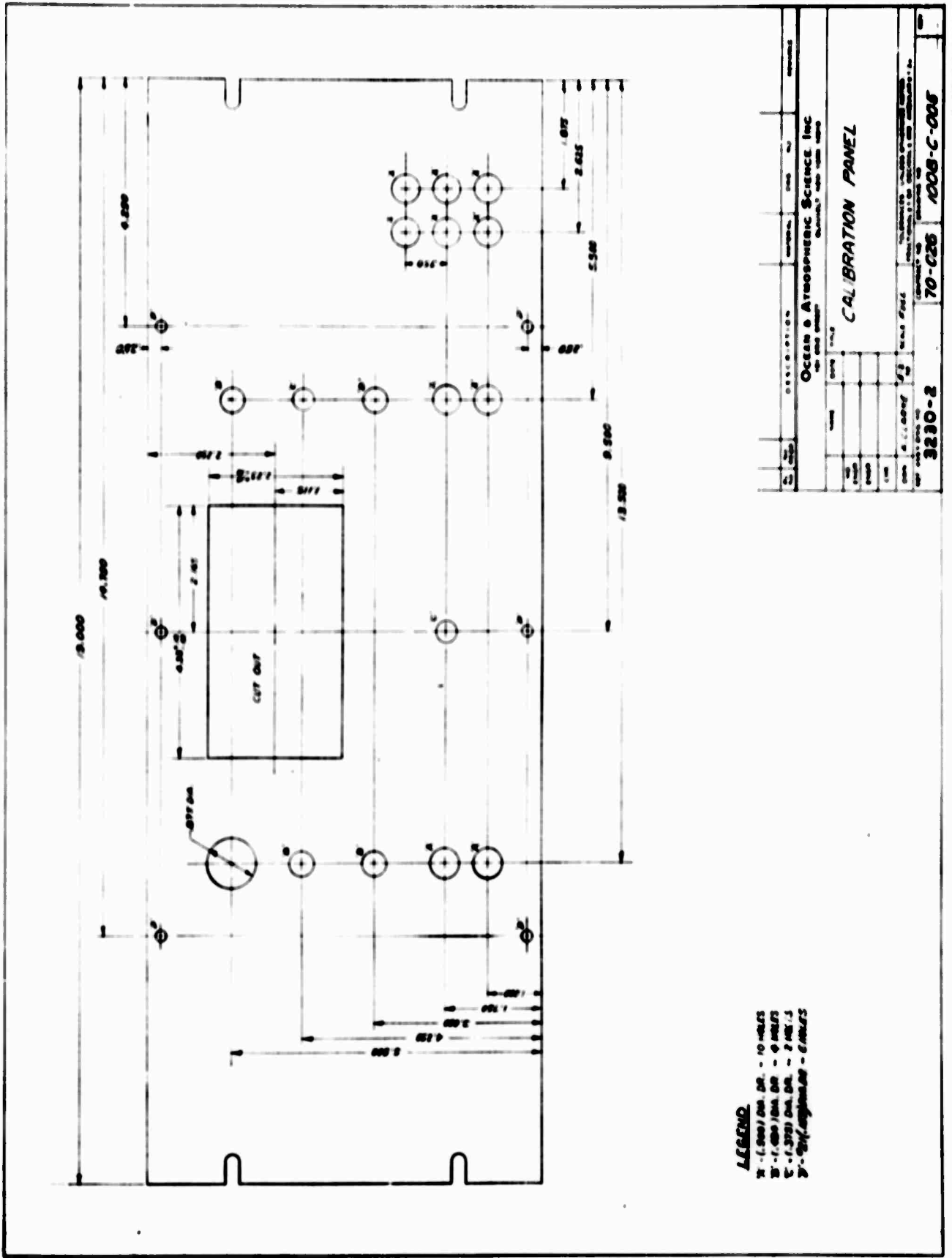



3230-1

Dwg. #1008-B-002

## CALIBRATION PANEL

<u>Symbol</u>	<u>Description</u>	<u>Mfg. Number</u>
BT 1	Mercury Battery 4.2 VDC	Mallory #TR-133
DM 1	Digital Panel Meter, Bipolar, 19.99 microamperes full scale.	Newport 210-2, Option E 2
R 1	Resistor, fixed, metal film type, RN60D, 182 K, $\pm$ 1% ohms	
R 2	Ditto R 1 - 18.2 K	
R 3	Ditto R 1 - 1.82 K	
R 4	Ditto R 1 - 1.05 K	
R 5	Ditto R 1 - 95.3 K	
R 6	Resistor, adjustable, Cermet type, 100 ohms	Bourns 3069-P-1-101
R 7	Potentiometer, Precision, conductive plastic type, 10 turns, bushing mount 1000 ohms	Bourns 3051-S-1-102
R 8	Resistor, adjustable, Cermet type, 10 ohms	Bourns 3069-P-1-100
R 9	Not used	
R 10	Not used	
R 11	Not used	
R 12	Not used	
R 13	same as R 8	
S 1	Switch, Toggle, DPDT	Cutter-Hammer # 8376K2
S 2	same as S 1	
S 3	Switch, Rotary type, 3 poles 3 position, non-shorting contacts.	CTS #T207

## CALIBRATION PANEL (Cont.)

<u>Symbol</u>	<u>Description</u>	<u>Mfg. Number</u>
S 4	Switch, toggle, DPST	Cutter-Hammer # 8376K1
S 5	Switch, toggle, DPDT, center off, one side momentary	Cutter-Hammer # 8833K3

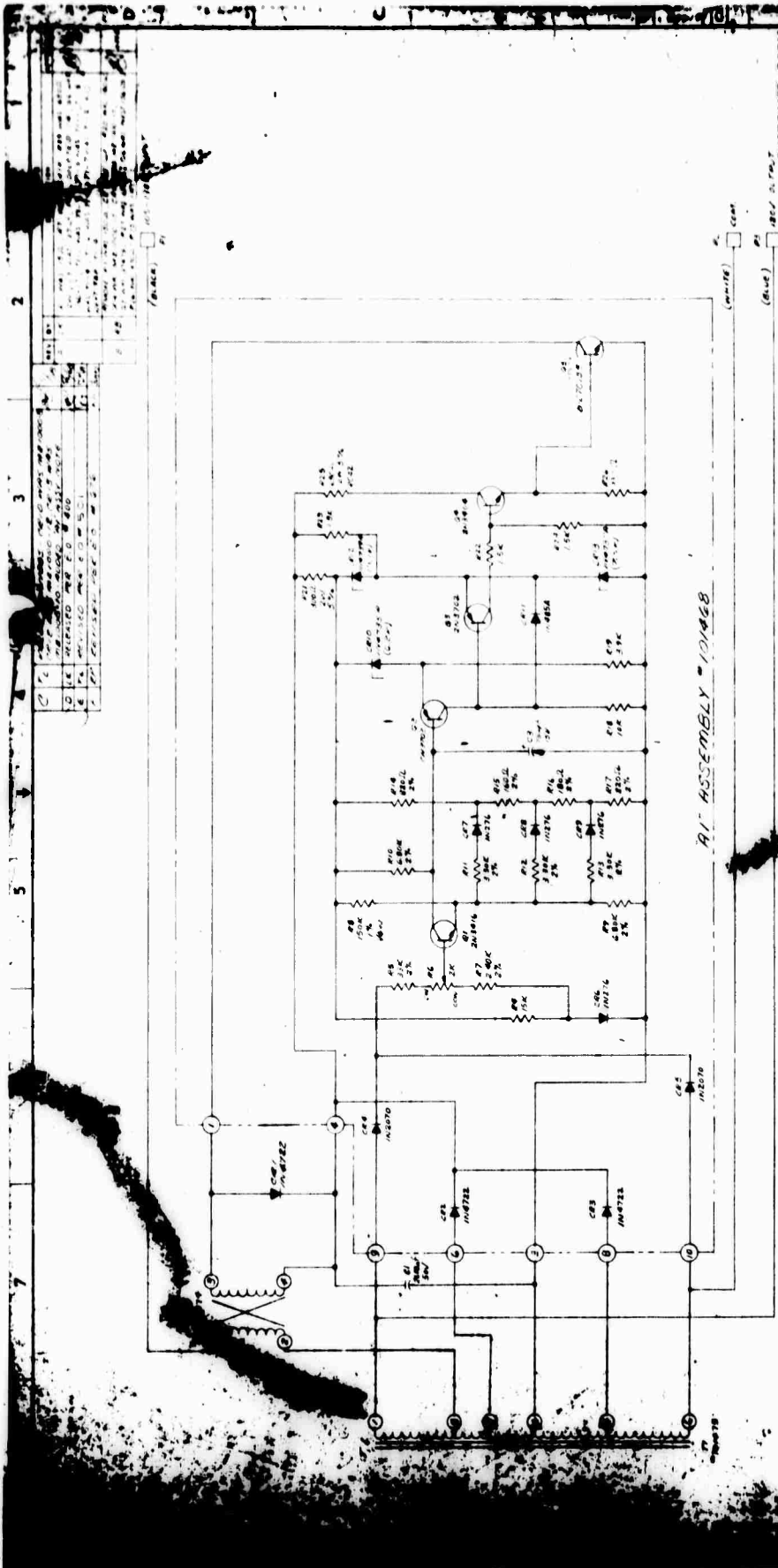

91 ASSEMBLY - 101468

REV	DESCRIPTION	DATE
1	INITIAL DESIGN	10/15/58
2	REVISED PER P.O. #100	10/15/58
3	REVISED PER P.O. #100	10/15/58
4	REVISED PER P.O. #100	10/15/58
5	REVISED PER P.O. #100	10/15/58
6	REVISED PER P.O. #100	10/15/58
7	REVISED PER P.O. #100	10/15/58

NOT REPRODUCIBLE

RESISTORS AND ALL P.C. BOARD COMPONENTS  
 CAPACITORS AND ALL P.C. BOARD SOURCE  
 RESISTORS AND ALL P.C. BOARD TYPE

CUSTOMER COPY

DESCRIPTION	REV	DATE	BY	QTY
SCHEMATIC				
10002 AC REGULATOR				
MODEL - 5117				
3270 D				
101465				

3410-1

**TOPAZ ULTRA-ISOLATORS**

**INSTRUCTION MANUAL**

**NO. 82267**

**TOPAZ INC.**

**ELECTRONICS**

**MAGNETICS**

**3802 HOUSTON ST., SAN DIEGO, CALIFORNIA • 92110 (714) 297-4815**

3410-2

INSTRUCTIONS FOR USING TOPAZ ULTRA-ISOLATORS

GENERAL

THE TOPAZ ULTRA-ISOLATOR IS GENERALLY CONSIDERED THE MOST SOPHISTICATED ISOLATION TRANSFORMER MADE. THIS IS TRUE FOR THESE REASONS:

1. COMMON MODE NOISE REJECTION IS ONE TO TWO ORDERS OF MAGNITUDE BETTER THAN THAT OF COMPETITIVE TRANSFORMERS.
2. TRANSVERSE NOISE GENERATED BY THE COMMON MODE NOISE IS REDUCED MORE THAN TWO ORDERS OF MAGNITUDE.
3. ELECTROMAGNETIC NOISE FIELDS FROM THE ISOLATOR ARE KEPT TO A MINIMUM.
4. THE ISOLATOR MAY BE USED UNDER CLASS B (MILITARY CLASS S) TEMPERATURE CONDITIONS. THAT IS, FULL LOAD CONDITION TEMPERATURE RISE PRINTED ON THE ISOLATOR ADDED TO THE AMBIENT ENVIRONMENTAL TEMPERATURE CAN BE AS MUCH AS 130° C.
5. TERMINALS AND RECEPTACLES ARE UTILIZED RATHER THAN SHIELDED LEADS WHICH ARE USUALLY NECESSARY TO OBTAIN A HIGH DEGREE OF SHIELDING. THIS PERMITS EASY CONNECTIONS TO LINE AND LOAD.

THE ISOLATOR CONTAINS THREE COMPLETE ELECTROSTATIC SHIELDS. TWO OF THESE ARE SPECIFICALLY FOR THE PURPOSE OF SUPPRESSING TRANSVERSE NOISE RESULTING FROM INJECTED COMMON MODE NOISE. THESE TWO BOX SHIELDS COMPLETELY ENCLOSE BOTH THE INPUT AND OUTPUT COILS, ONE ON EACH. THEIR CONNECTIONS ARE WITHIN THE ISOLATOR UNIT AND SHOULD NOT BE CHANGED. (UNITS CAN BE SUPPLIED ON SPECIAL ORDER WHEREBY THESE SHIELDS ARE LEFT FLOATING AND CONNECTED TO TERMINALS ON BOTH THE INPUT AND OUTPUT SIDES OF THE ISOLATOR.)

THE BARRIER ULTRA-SHIELD LIES BETWEEN THE TWO TRANSVERSE NOISE SUPPRESSOR SHIELDS. IT IS CONNECTED TO THE ISOLATOR METAL CASE AND TO BOTH THE POWER LINE INPUT GROUND TERMINAL AND THE OUTPUT SHIELD TERMINAL. WHEN THE GROUND TERMINAL IS CONNECTED TO A GOOD EARTH-GROUND THE EFFECTIVE CAPACITANCE OF THE INPUT

POWER LINE TO THE OUTPUT TERMINALS DROPS TO THE GUARANTEED MAXIMUM FOR THE MODEL ISOLATOR USED (.005 PICO FARADS, .001 PICO FARADS OR .0005 PICO FARADS, WHERE 1 PICO FARAD IS  $10^{-12}$  FARADS).

THE USER WILL GENERALLY WISH TO PREVENT THE CAPACITIVE COUPLING OF POWER LINE NOISE INTO HIS SECONDARY (LOAD) CIRCUITS BY UTILIZING A 2-CONDUCTOR SHIELDED CABLE FROM THE ISOLATOR TO THE LOAD. TYING THE SHIELD OF THIS CABLE TO THE SHIELD TERMINAL GROUNDS THIS SHIELD AND GUARDS THE SECONDARY LINES. FURTHER CONNECTING OF THE OTHER END OF THE SHIELD TO A METAL CABINET, SCREEN ROOM, CHASSIS, RELAY RACK, ETC., GUARDS THE LOAD CIRCUITS FROM ELECTROSTATIC NOISE PICK-UP.

IF THE USER EXERCISES CARE IN HIS CHOICE OF SHIELDED CABLE AND METAL CABINET CONTAINING HIS INSTRUMENTS, COMMON MODE NOISE PROBLEMS CAN BE REDUCED TO A MINIMUM.

#### PHASING

ALL ISOLATORS ARE PHASED AS DEPICTED IN SCHEMATIC DIAGRAMS BY PHASING DOTS. BECAUSE OF THIS, THEIR WINDINGS CAN BE READILY CONNECTED IN SERIES OR PARALLEL.

IN PARALLELING TWO OR MORE ISOLATORS IT IS ESSENTIAL THAT THE FOLLOWING PRE-CAUTIONS BE ABSOLUTELY OBSERVED:

PARALLEL ONLY UNITS OF THE SAME MODEL NUMBER AND THEN PARALLEL ONLY INPUT WITH INPUT, OR OUTPUT WITH OUTPUT WINDINGS. DO NOT PARALLEL DIFFERENT POWER UNITS, DIFFERENT STYLE UNITS (SPACE SAVERS WITH STANDARDS), OR INPUT WITH OUTPUT WINDINGS EVEN ON SAME STYLE UNITS.

3410-4

WHEN PARALLELING CONNECT SAME NUMBERED TERMINALS TOGETHER. EXAMPLE:

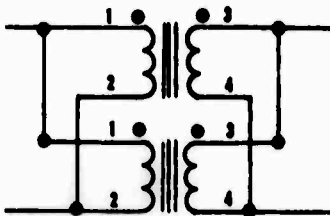

IN SERIES CONNECTIONS IT IS BEST TO USE UNITS OF THE SAME MODEL NUMBERS WHOSE INPUT AND OUTPUT WINDINGS ARE SET FOR THE SAME VOLTAGE INPUTS OR OUTPUTS. EXAMPLE:

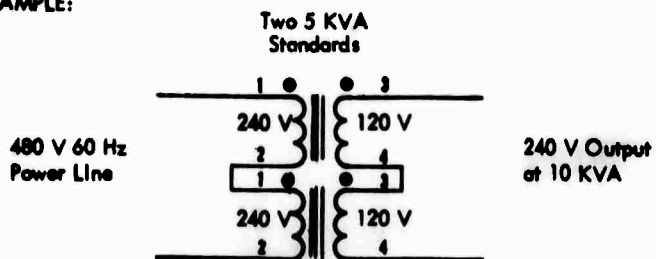

HYBRID CONNECTION SERIES & PARALLEL

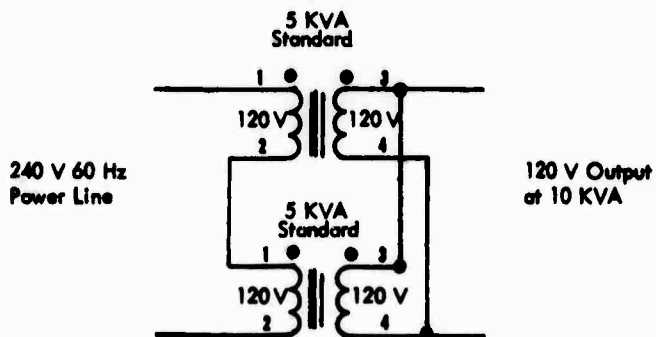

**3-PHASE CONNECTIONS OF SINGLE PHASE ISOLATORS**

(USER MAY SKIP THIS SECTION IF HE USES ISOLATOR ONLY AS SINGLE PHASE UNIT)

USE ONLY UNITS OF THE SAME MODEL NUMBERS WHEN CONNECTING SINGLE PHASE ISOLATORS IN 3-PHASE CONFIGURATIONS. IT IS RECOMMENDED THAT ONLY ISOLATORS OF 5 KVA AND LARGER BE USED FOR 3-PHASE APPLICATIONS. BE SURE THAT THE 3-PHASE POWER SUPPLIED BY THE POWER COMPANY RESULTS FROM A TRUE  $\Delta$  OR  $Y$  CONFIGURATION AT THE POLE PIGS (POWER COMPANY TRANSFORMERS). COMMONLY, THE POWER COMPANY SUPPLIES SO-CALLED 3-PHASE POWER WHICH COMES FROM A  $\Delta$  WITH ONLY 2 SIDES. SEE FIGURE BELOW:

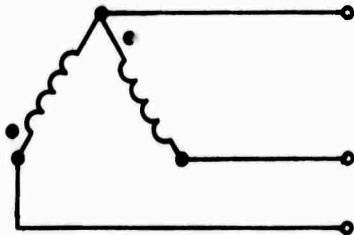

**UNSATISFACTORY SET-UP**

COILS SHOWN ARE SECONDARY COILS OF TWO POLE PIGS CONNECTED IN AN OPEN  $\Delta$

THIS CONFIGURATION CAN BE USED FOR RUNNING MOTORS BUT IS NOT USUALLY SATISFACTORY FOR ELECTRONIC USE. THE PROPER CONNECTIONS WILL BE TO THE SECONDARIES OF 3 SINGLE PHASE POLE TRANSFORMERS, ONE OR MORE OF WHICH MAY ALSO BE SUPPLYING SINGLE PHASE POWER.

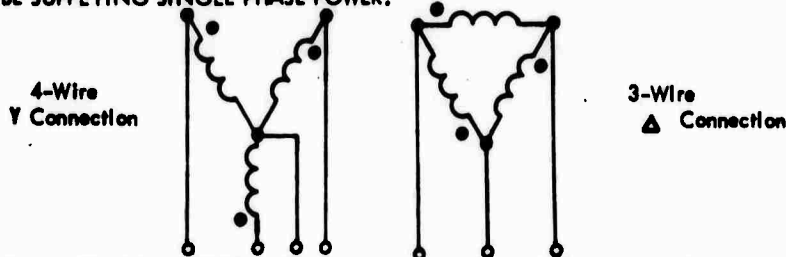

**TWO STYLES OF SATISFACTORY SET-UPS** - COILS SHOWN ARE SECONDARY COILS OF THREE POWER COMPANY TRANSFORMERS. PRIMARIES ARE NOT SHOWN.



SCHEMATICS FOR 3 SINGLE PHASE ISOLATORS CONNECTED IN  $\Delta$  TO  $\Delta$  ,  $\Delta$  TO  $Y$  , AND  $Y$  TO  $\Delta$  ARE GIVEN IN THIS BOOKLET. IT SHOULD BE NOTED THAT  $Y$  TO  $Y$  CONNECTIONS ARE NOT SHOWN SINCE THEY ARE GENERALLY NOT SATISFACTORY.

$Y$  TO  $Y$  CONNECTIONS WITH ISOLATED NEUTRALS, WHICH IS THE WAY THE ISOLATORS WOULD GENERALLY BE USED, MAY TEND TO GENERATE UNBALANCED AND LARGE THIRD HARMONIC VOLTAGES BETWEEN PHASE AND NEUTRAL. THIS CAN BE FURTHER AGGRAVATED BY RESONANCE WITH THE LINE. FOR THESE REASONS THE  $Y - Y$  CONNECTIONS OF SINGLE PHASE TRANSFORMERS SHOULD BE USED WITH CAUTION.

#### ELECTRICAL CONNECTIONS

THERE ARE THREE STYLES OF ISOLATORS, AS SHOWN BELOW, AND EACH HAS DIFFERENT TERMINATIONS.

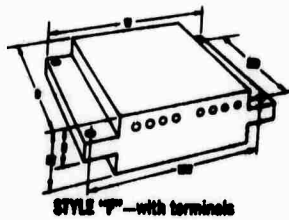
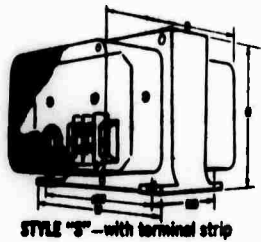
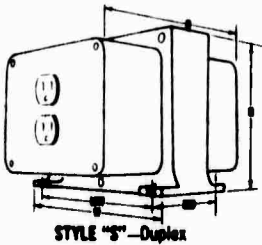

DETERMINE THE STYLE OF THE ISOLATOR WHICH YOU HAVE AND CONSULT THE APPROPRIATE SECTION BELOW FOR THE CONNECTION DIAGRAM OF THAT STYLE AND MODEL NUMBER UNIT.

STYLE "S" - DUPLEX OUTLET UNITS

With Input 120 Volts, 60 Hz; Output 120 Volts		With Input 240 Volts, 60 Hz; Output 120 Volts	
Model Numbers	Power	Model Numbers	Power
1/811T25S	125 VA	0131T25S	1 KVA
1/211T25S	500 VA	0231T25S	2.5 KVA
0111T25S	1 KVA	0131T21S	1 KVA
0211T25S	2.5 KVA	0231T21S	2.5 KVA

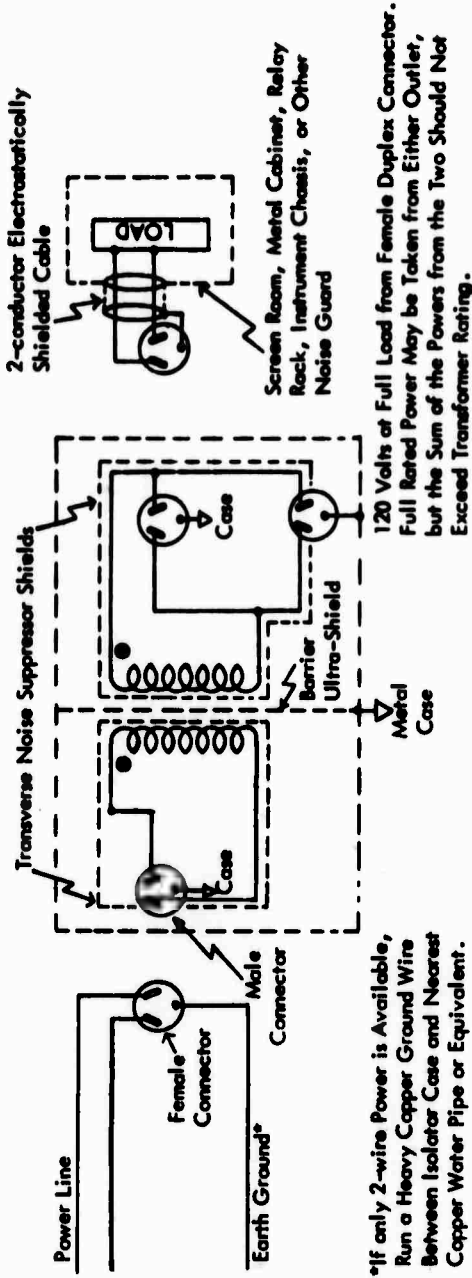

\*If only 2-wire Power is Available, Run a Heavy Copper Ground Wire Between Isolator Case and Nearest Copper Water Pipe or Equivalent.

STYLE "F" 5 KVA UNITS WITH TERMINAL STRIP CONFIGURATIONS

Input 120 Volts, 60 Hz, Output 120 Volts

Model Numbers
0511T25F 0511T21F 0511T35F

STYLE "S" 5 KVA UNITS WITH TERMINAL STRIP CONFIGURATIONS

Output Under Full Load 120 Volts

Model Numbers	Input
0511T25S 0511T21S 0511T35S	120 Volts, 60 Hz
0531T25S 0531T21S 0531T35S	240 Volts, 60 Hz
0541T25S 0541T21S 0541T35S	480 Volts, 60 Hz

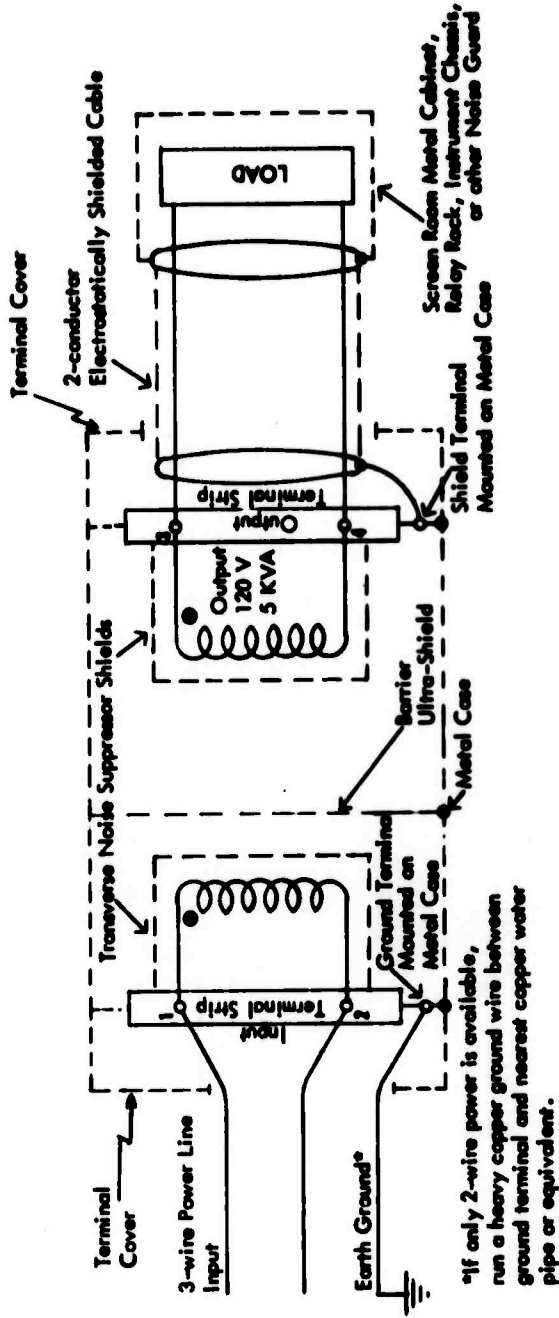

**STYLE "S" 10 AND 20 KVA UNITS  
WITH TERMINAL STRIP CONFIGURATIONS**

**240/480 VOLT, 60 HZ INPUTS; 120/240 VOLT (UNDER FULL LOAD) OUTPUTS**

Power  
10 KVA  
20 KVA

Model Numbers  
10A5T25S, 10A5T21S, 10A5T3SS  
20A5T25S, 20A5T21S, 20A5T3SS

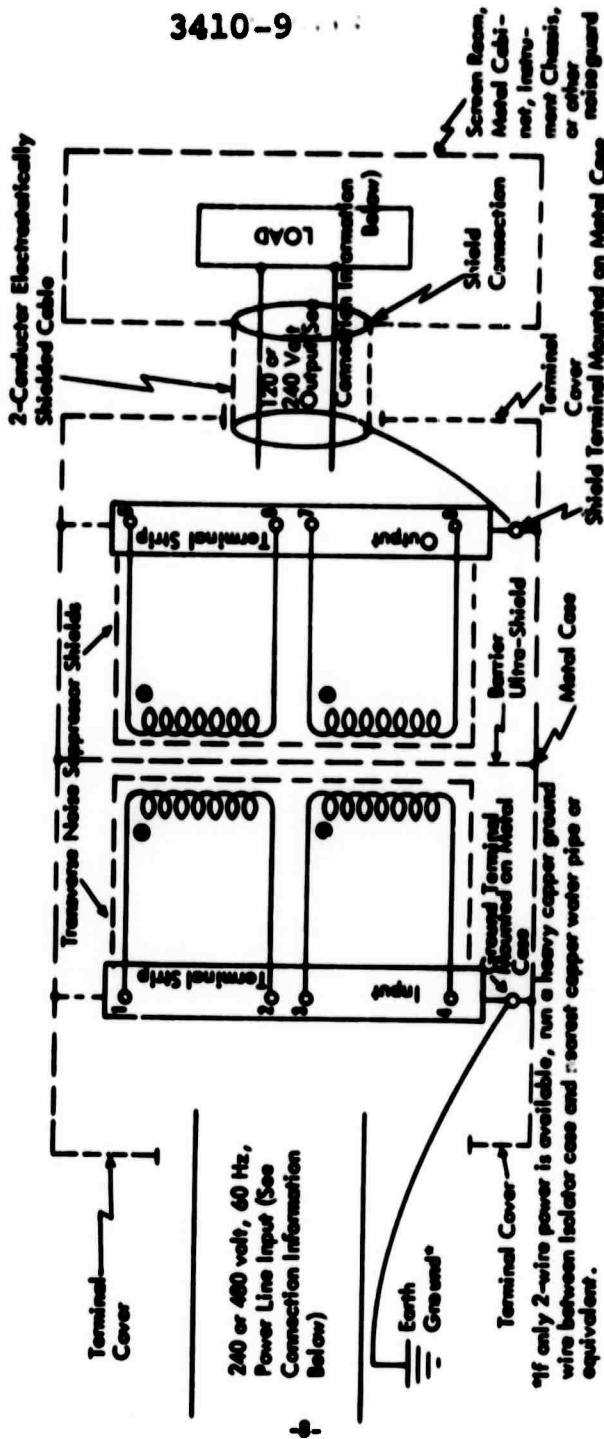

\*If only 2-wire power is available, run a heavy copper ground wire between isolator case and nearest copper water pipe or equivalent.

**INPUT CONNECTIONS**

Power Line Voltage	Jumper Wire From	Another Jumper Wire From	Connect Power Line "Hot" Wires To
240	1 to 3	2 to 4	1 & 4
480	2 to 3	None	1 & 4

Connect ground line to ground terminal on isolator case.

**OUTPUT CONNECTIONS**

Voltage Desired	Jumper Wire From	Another Jumper Wire From	Connect Lead Via 2-Conductor Shielded Cable To
120	5 to 7	6 to 8	5 & 8
240	6 to 7	None	5 & 8

Connect shield of shielded cable to shield terminal on isolator case.

3410-10

**STYLE "F" 1 KVA UNITS WITH TERMINAL CONFIGURATIONS  
INPUTS FROM 102 TO 250 VOLTS, 60 HZ; OUTPUTS 115 OR 230 VOLTS, FULL LOAD**  
Model Numbers: 0155T25F, 0155T21F, 0155T35F

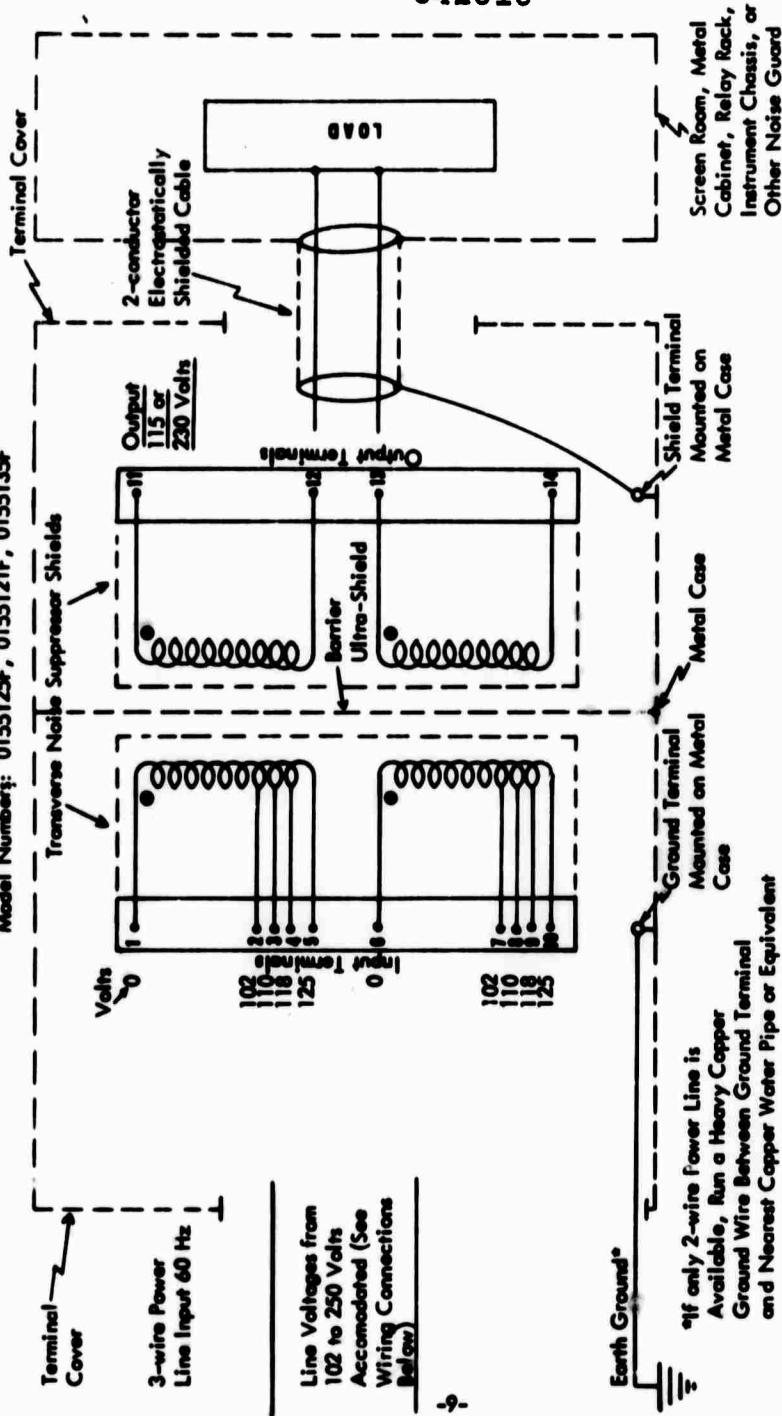

Due to the many possible combinations of terminal connections this Isolator is a very versatile device. However, there are shielding qualities built into the unit which can be markedly degraded by improper series and parallel connections of the primary coils (connections incidentally, which would be permissible on ordinary transformers). The connections which are preferred and which will not degrade shielding performance are given below. In addition, some connections are included which give the same degree of shielding but degrade the power handling capability of the unit. When these latter are used, it would be wise to label the transformer as to maximum power it can now deliver, lest one should forget in the future that the unit is not a 1 KVA transformer as used.

**PREFERRED INPUT CONNECTIONS WHICH PRESERVE SHIELDING EFFECTIVENESS AND ALLOW ISOLATOR TO DELIVER FULL 1 KVA**

Power Line Voltage	Jumper Wire* From	Another Jumper* Wire From	Connect Power Line "Hot" Wires To
102	1 to 6	2 to 7	1 & 7
110	1 to 6	3 to 8	1 & 8
118	1 to 6	4 to 9	1 & 9
125	1 to 6	5 to 10	1 & 10
204	2 to 6	None	1 & 7
212	2 to 6	None	1 & 8
220	3 to 6	None	1 & 8
228	4 to 6	None	1 & 8
235	5 to 6	None	1 & 8
243	5 to 6	None	1 & 9
250	5 to 6	None	1 & 10

Connect ground line to ground terminal on Isolator case in all instances.

**POSSIBLE INPUT CONNECTIONS WHICH PRESERVE SHIELDING EFFECTIVENESS BUT DEGRADE MAXIMUM POWER CAPABILITY**

Power Line Voltage	Jumper Wire* From	Connect Power Line "Hot" Wires To	Maximum VA Delivery
94	2 to 8	1 & 7	450
133	5 to 7	1 & 8	650
141	5 to 7	1 & 9	700
148	5 to 7	1 & 10	750

Connect ground line to ground terminal on Isolator case in all instances.

**OUTPUT CONNECTIONS**

Voltage Desired	Jumper Wire* From	Another Jumper* Wire From	Connect Load Via 2-Conductor Shielded Cable To
115	11 to 13	12 to 14	11 & 14
230	12 to 13	None	11 & 14

Connect shield of shielded cable to shield terminal on Isolator case.

\*Jumper wire should be copper and #13 or larger diameter. (Note: #12 is larger, #14 is smaller)

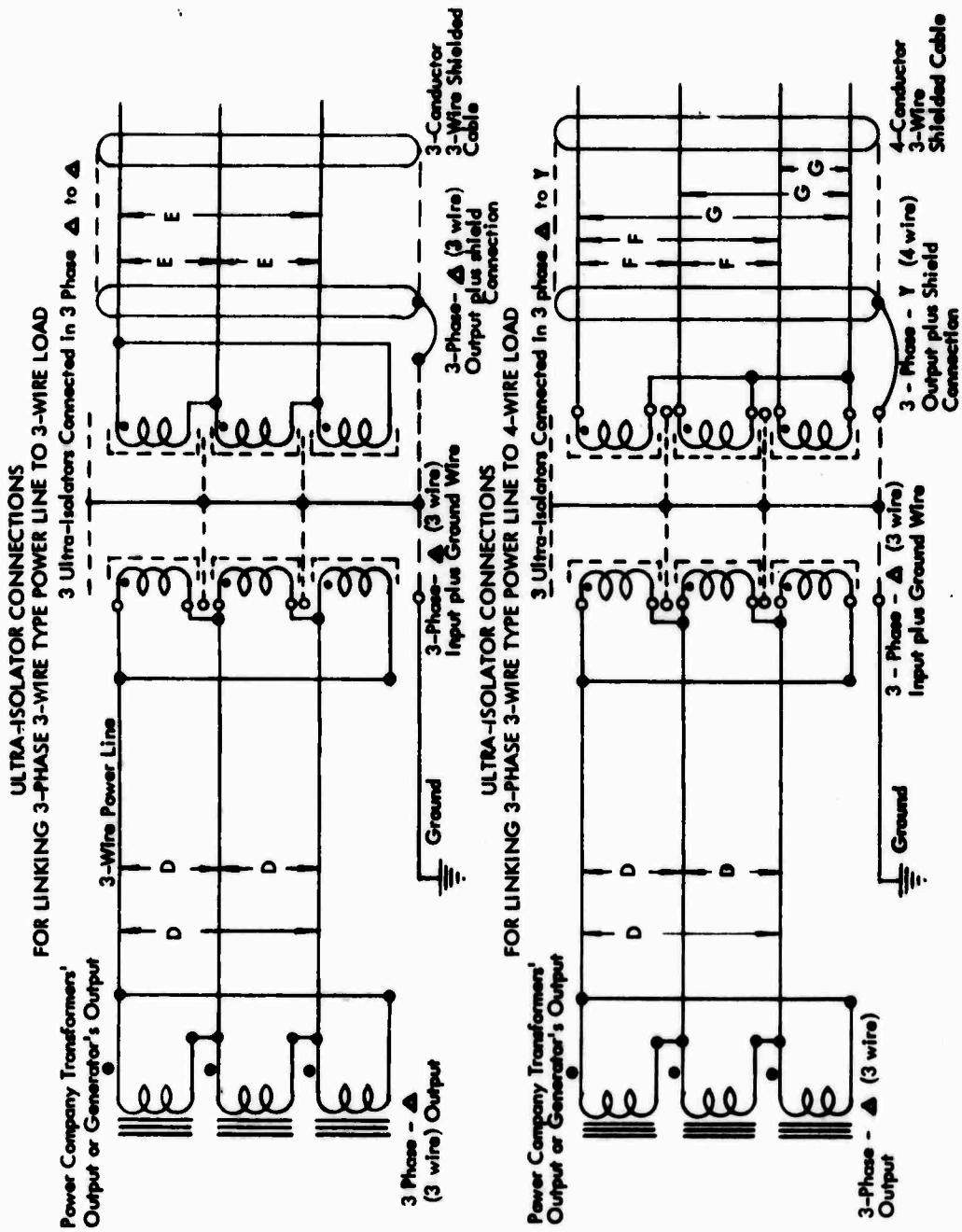

3410-13

The following table applies to both drawings above.

D (Phase to Phase)	VOLTS AT 60 Hz			KVA PER PHASE	3 PHASE TOTAL KVA DELIVERED	MODEL NUMBERS
	E (Phase to Phase)	F (Phase to Phase)	G (Phase to Neutral)			
120	120	208	120	5	15	0511T25S, 0511T21S, 0511T35S
240	120	208	120	5	15	0531T25S, 0531T21S, 0531T35S
480	120	208	120	5	15	0541T25S, 0541T21S, 0541T35S
240	120	208	120	10	30	1065T25S, 1065T21S, 1065T35S
240	240	416	240	10	30	1065T25S, 1065T21S, 1065T35S
480	120	208	120	10	30	1065T25S, 1065T21S, 1065T35S
480	240	416	240	10	30	1065T25S, 1065T21S, 1065T35S
240	120	208	120	20	60	2065T25S, 2065T21S, 2065T35S
240	240	416	240	20	60	2065T25S, 2065T21S, 2065T35S
480	120	208	120	20	60	2065T25S, 2065T21S, 2065T35S
480	240	416	240	20	60	2065T25S, 2065T21S, 2065T35S



**ULTRA-ISOLATOR CONNECTIONS  
FOR LINKING 3-PHASE 4-WIRE TYPE POWER LINE TO 3-WIRE LOAD**

Power Company Transformers' Output or Generator's Output

3 Ultra-Isolator's Connected In

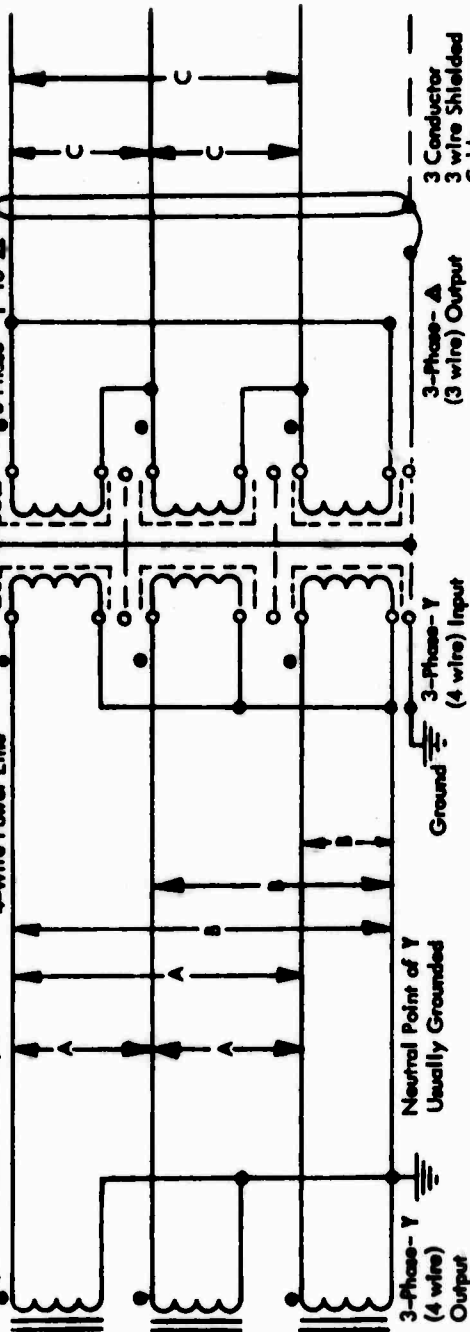

VOLTS AT 60 Hz

MODEL NUMBERS

A (Phase to Phase)	B (Phase to Neutral)	C (Phase to Phase)	KVA Per Phase	Total KVA Delivered	MODEL NUMBERS
208	120	120	5	15	0511T25S, 0511T21S, 0511T35S, 0511T25F, 0511T21F, 0511T35F
416	240	120	5	15	0531T25S, 0531T21S, 0531T35S
832	480	120	5	15	0541T25S, 0541T21S, 0541T35S
416	240	240	10	30	1065T25S, 1065T21S, 1065T35S
416	240	240	10	30	1065T25S, 1065T21S, 1065T35S
832	480	240	10	30	1065T25S, 1065T21S, 1065T35S
832	480	240	10	30	1065T25S, 1065T21S, 1065T35S
416	240	240	20	60	2065T25S, 2065T21S, 2065T35S
416	240	240	20	60	2065T25S, 2065T21S, 2065T35S
832	480	240	20	60	2065T25S, 2065T21S, 2065T35S
832	480	240	20	60	2065T25S, 2065T21S, 2065T35S

3410-15

TOPAZ ALSO MANUFACTURES  
THIS SOLID STATE POWER CONVERSION EQUIPMENT

1. DC TO AC INVERTERS - BOTH SINE WAVE AND SQUARE WAVE OUTPUTS.
2. DC TO DC CONVERTERS
3. AC TO AC FREQUENCY CHANGERS
4. AC TO AC UNINTERRUPTIBLE POWER SYSTEMS

SEND FOR FREE CATALOG TITLED "SOLID STATE POWER CONVERSION EQUIPMENT"

IN ADDITION, TOPAZ BUILDS SMALLER VERSIONS OF ULTRA-SHIELDED TRANSFORMERS TO THE CUSTOMER'S SPECIFICATIONS. TYPES THAT ARE AVAILABLE:

1. POWER - DOWN TO SMALL UNITS THE SIZE OF A THIMBLE
2. INPUT - AVAILABLE WITH ELECTROMAGNETIC SHIELDING, AS WELL AS ELECTROSTATIC SHIELDING
3. PULSE - THE SAME ELECTROSTATIC SHIELDING SPECS NOW APPLY TO TINY PULSE TRANSFORMERS

CALL OR WRITE US FOR DETAILS.

TOPAZ INCORPORATED  
3802 HOUSTON STREET  
SAN DIEGO, CALIFORNIA 92110  
PHONE (714) 297-4815

-14-

LETTER	DESCRIPTION	DATE	APPROVED

- NOTES:
- 1 CIRCUIT BREAKER BOX (3420)
  - 2 TOPAZ TRANSFORMER (3410)
  - 3 LINE FILTERS (3411)
  - 4 CONNECTOR, FEMALE (3422)
  - 5 CONNECTOR, MALE (3423)
  - 6 CONNECTOR, ROMEX (3282)
  - 7 A.C. MAINS - 110V 60 HZ OR 240V 50 HZ
  - 8 OUTPUT 110V TO CONSOLE THRU TWISTLOCK CONNECTORS (3278, 3279)
  - 9 GROUND ON CHASSIS
  - 10 SYSTEM GROUND ON CONSOLE
  - 11 CABLE, #10 3 CONDUCTOR (5180)
  - 12 COMPRESSION FITTING (3280)
- G GREEN  
 R RED  
 B BLACK  
 W WHITE

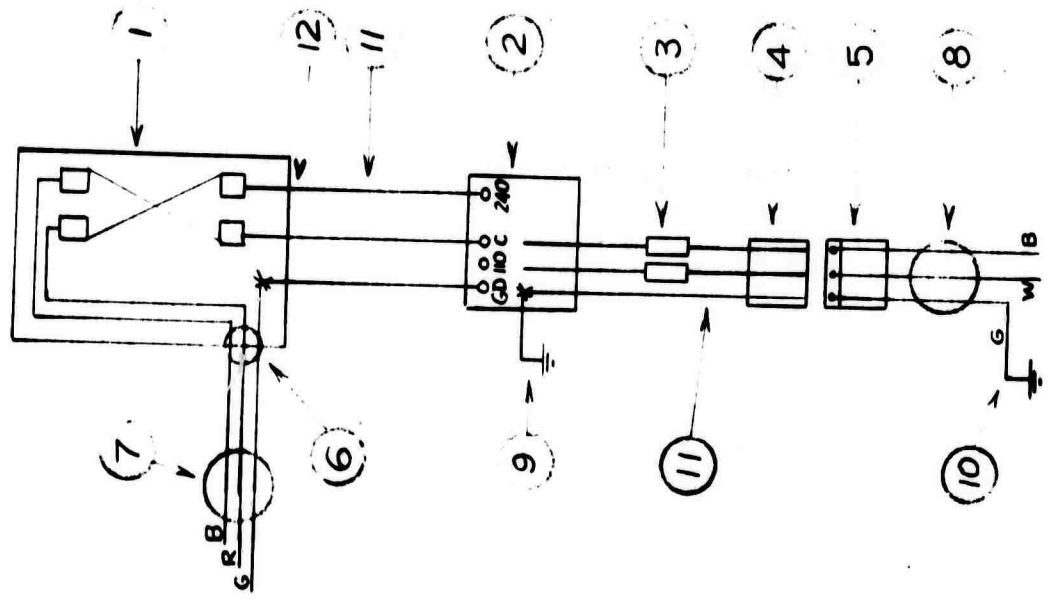

82

CONTRACT	
DRAWN BY	
CHECK BY	
PROJ. ENGR.	
TOLERANCES: UNLESS OTHERWISE SPECIFIED DIMENSIONS ARE IN INCHES DECIMAL     ± "       "     ± "       "     ± "       "     ±	
BREAK SHARP EDGES	

**LAMONT GEOLOGICAL OBSERVATORY  
OF COLUMBIA UNIVERSITY**

**POWER DISTRIBUTION PANEL**

DWG. NO.	<b>3424</b>	REV.	
SCALE		WEIGHT	
		SHEET	1 OF 1

## TO OPERATE ALL MODELS:

### ● PLUG IN:

Just plug the electrical cord into any 115 volt A.C. outlet. Turn the humidity control knob clockwise until unit starts. Immediately, the fan starts pulling moisture-laden air from the room across cold, refrigerated coils which condense or "draw off" the moisture. The air flows out the front Grille into the room as dry, clean air.

### ● AUTOMATIC OPERATION:

A Humidstat, built into these Dehumidifiers, assures you of efficient, economical operation. This humidity control automatically starts the Dehumidifier when humidity rises; shuts it off after the excess moisture has been removed from the air. Control has "Off" position plus a choice of three "Dryness Degree" settings— "Dry," "Extra Dry" and "Maximum Dry" where lower humidity conditions are required.

### ● HOW TO USE:

For best operation of your Dehumidifier, we recommend that you turn the humidity control knob completely clockwise. At this setting the unit will operate continuously at maximum capacity. Allow the Dehumidifier to operate at this setting for three to four weeks. After this period of time, careful consideration should be given to the dampness in the area being dried. If the sweating has discontinued and if the dampness odors are gone, we would recommend that the control be turned counterclockwise one quarter turn.

At this setting, more economical operation is obtained but the relative humidity probably will be higher than at the completely clockwise position. After three or four weeks operation at the one quarter turn counterclockwise position, if the moisture condition in the area being dried is still satisfactory, we would recommend that the operation of the Dehumidifier be continued with the control set in this position. However, if at this setting the dampness condition is not completely corrected, we recommend that the control be returned toward the completely clockwise setting.

This will require minor adjustments from time to time. But it should be remembered that the control must be set near enough to the completely clockwise position to correct the dampness condition for which you bought the Dehumidifier. Also, it is important to set the control as far counterclockwise as possible to obtain the most economical operation. During particularly humid periods, the Dehumidifier will run continuously due to the seepage of humid air into the room through the walls, around doors and windows and through the use of clothes dryers and similar equipment that add moisture to the air. The continuous operation of the Dehumidifier during such humid periods is entirely normal and necessary to maintain the desired conditions.

The Dehumidifier should be kept in operation as long as excess moisture is present in the room air. However, when the temperature of the room is relatively cool or the humidity conditions do not require use of the dehumidifier, it is perfectly normal for frost to form on the coil. The Dehumidifier should be turned off instead of operating under these conditions, since it will not perform when frost builds up.

A light coating of frost on the coil is normal when the Dehumidifier is first turned "ON". Under normal conditions, it will disappear within 30 to 45 minutes unless temperature or humidity conditions are as described above.

When the Dehumidifier is first put into operation, it will remove relatively large amounts of moisture. This will continue until the relative humidity in the area is reduced to the value where moisture damage will not occur. As time goes by, the amount of water collected day by day will be reduced, and will vary due to changes in humidity.

3600-2

## ASSEMBLY AND INSTALLATION

### FOR ALL MODELS: *Deluxe, Custom and Heavy Duty*

For easy portability, lift from top rear and roll on two front rollers provided on the base. When locating the Dehumidifier, be sure that it is placed so there is no restriction to air flowing from the front Grille or to air flowing into rear opening. Close all doors and windows and other outside openings to the room, since the size of space in which the Dehumidifier will operate effectively is greatly influenced by the rate at which new moisture-laden air enters the room. Other factors which may influence the effectiveness of the unit are: the presence of moisture on or in the walls and floors, the number of people in the room, the ambient room temperature and the completeness of air circulation. Best performance in odd-shaped rooms where air circulation is impaired may be obtained by using more than one Dehumidifier.

## REMOVING COLLECTED WATER

- All Models are supplied with a sturdy high impact styrene 10-quart Bucket which hangs conveniently on the back of the unit to accumulate the water removed from the air. They are also equipped with an Automatic Water Overflow Control which stops the unit before the Bucket fills to overflowing in the event that you forget to empty it. The Custom Supreme and Heavy Duty models are equipped with a signal light which indicates that the automatic water overflow control has stopped the unit. When the Bucket is emptied, the control will again turn the unit on and the drying action will be resumed. This convenient device is activated by the weight of the water in the Bucket and will give you long, trouble-free service.

The Water Overflow Control Switch on the bottom rear of your unit is adjusted at the factory for a water level of approximately  $\frac{1}{2}$  bucket. If higher water level is desired turn the adjusting screw in the center of the stainless steel spring clockwise in  $\frac{1}{2}$  turn steps until the desired level is reached.

If you prefer, you may connect any standard garden hose to the threaded nozzle on the rear of the receptacle (after removing membrane from center section) to carry the water directly to a basement drain. If after using with a garden hose it is necessary to again use as a receptacle, the opening should be capped with a standard hose cap and washer.

## NORMAL CARE OF YOUR DEHUMIDIFIER

Occasionally it may be necessary to clean the front Grille or evaporator. Use a vacuum cleaner attachment, or brush, to clean the front Grille and the circular tube evaporator at the rear.

### ● FAN AND FAN MOTOR

The fan motor used on all Westinghouse Dehumidifiers is oiled at the Factory. Under ordinary circumstances, the fan will not require servicing or oiling during the life of the Dehumidifier.



These Dehumidifiers perform in accordance with AHAM Capacity Standard DH-1. Pints of water removed per 24 hours based on 80° ambient, 60% relative humidity.

# YOUR ELECTRIC DEHUMIDIFIER

3600-3

## What It Will Do For You, And How It Works

By removing moisture vapor from the air, the Electric Dehumidifier protects your home from the dangers of excess humidity. The mildewing of stored valuables, the rusting of tools and all metal objects, the swelling of floors, panel walls, drawers and doors is easily and economically prevented through the use of the Electric Dehumidifier.

### AREA MUST BE TOTALLY ENCLOSED

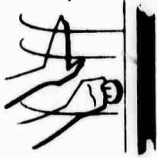

Be sure all doors and windows of the area in which you place the Dehumidifier are closed. This eliminates the entrance of moisture-laden air from the outside.

### HOW DOES IT WORK?

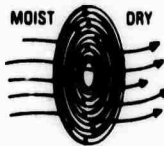

The Electric Dehumidifier removes moisture from the air by passing the air over a cold coil where the moisture condenses out of the air and runs off the coil into the collecting tray where it is directed either to a bucket or a hose. This Dehumidifier then reduces the relative humidity of the surrounding air by two methods. The removal of moisture from the air reduces its relative humidity. The relative humidity of the air is further reduced by heating the dry air that is discharged over the condenser and out the front of the Dehumidifier. The air is actually heated several degrees in this process. It is important to remember that the surrounding air will always increase in temperature as the Dehumidifier operates. NOTE: As indicated above, the moisture droplets will drip from the coil into the water reservoir, this is normal operation.

### WHY WILL THE DEHUMIDIFIER NOT COOL MY ROOM?

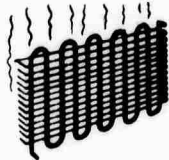

The Dehumidifier will not cool your room. The air dried in passing over the air drying coil picks up heat from the condenser. This heat is then added to the heat of compression which raises the temperature of the surrounding air, which further reduces its relative humidity.

### WILL THE DEHUMIDIFIER DRY MY HOUSE IF I RUN IT IN THE BASEMENT AND CIRCULATE THE AIR WITH THE FURNACE BLOWER?

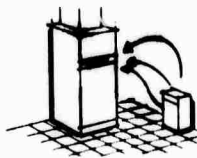

The Dehumidifier must be operated in an enclosed area in order to be effective. It is effective when the home is closed; which generally is not true when there are a number of people using the living quarters going in and out of the doors regularly. The Dehumidifier is most effective in the basement. Here, too, the windows and doors must be kept closed and the most effective dehumidification occurs when the air from the basement is not drawn by the blower into other parts of the home.

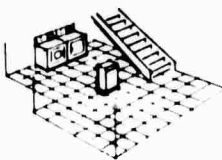
**WHERE SHOULD I LOCATE THE DEHUMIDIFIER?**

For best results, the Dehumidifier should be located near the center of the area being dehumidified. However, when it is desirable to locate the Dehumidifier elsewhere so as to utilize a hose connection from the collecting tray to a drain, the Dehumidifier may be located some distance from the center of the area. It should be remembered that good circulation of the air is essential for any part of an enclosed area requiring dehumidification.

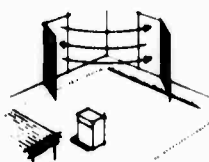
**CAN I LOCATE MY DEHUMIDIFIER IN THE LIVING ROOM SO AS TO OBTAIN MORE COMFORTABLE CONDITIONS HERE?**

Since the doors and windows must be kept closed at all times, the Dehumidifier will substantially raise the temperature of the air in the living room where it is operated. For these reasons, it may not produce more comfortable conditions and may not be too effective.

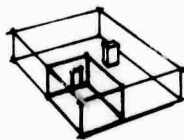
**WILL THE DEHUMIDIFIER DRY AN ENCLOSED STORAGE AREA IN A BASEMENT?**

A Dehumidifier operating in a basement will have little or no effect in drying a storage area unless there be adequate circulation of air in and out of the enclosed area. It may be found necessary to install a second Dehumidifier inside the enclosed storage area for satisfactory drying action.

**WHAT IS THE FUNGUS GROWTH THAT COLLECTS ON THE EVAPORATOR COIL AND HOW DO I REMOVE IT AND CLEAN THE EVAPORATOR?**

In some cases, there will be a collection of fungus attached to the bottom of the dehumidifying coil after an extended period of operation. The fungus is an air-borne spore that collects on the evaporator coil and, since it is air-borne and peculiar to the particular location involved, there is nothing we can do about it. This condition is worse in some areas than in others.

Where the fungus is present, it tends to collect the air-borne dust and aggravate the situation. The best way to clean this material from the evaporator coil is by the use of a soft brush and an adequate amount of clean water. As the material is loosened from the evaporator coil with a soft brush such as a corn buttering brush, it should be flushed away with clean water. It may be necessary to use a test tube brush or a pipe cleaner to clean out the drain of the collecting tray.

**HOW CAN I OPERATE THE DEHUMIDIFIER IN AN UNHEATED ROOM (OR THE HOLD OF A SHIP) THAT MAY BE AS COLD AS 50°F?**

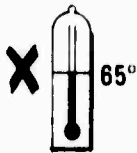

A mechanical Dehumidifier ordinarily will not operate satisfactorily below 65°F or at humidity conditions that do not require use of the Dehumidifier. At this temperature the evaporator coil operates below freezing temperatures in order to reduce the relative humidity to a reasonable value. Although the Dehumidifier can be operated with ice forming on the evaporator coil, it becomes necessary to defrost this coil at least once an hour to obtain satisfactory performance. This would require the use of an auxiliary timer (which can be purchased at an electrical supply store) to provide the defrosting cycle. Generally, we do not recommend the operation of a mechanical Dehumidifier at an ambient temperature below 65°F.

**WHEN I FIRST INSTALLED MY DEHUMIDIFIER IT REMOVED LARGE QUANTITIES OF WATER, BUT NOW IT REMOVES ONLY SIX OR EIGHT PINTS A DAY. WHAT IS WRONG WITH MY DEHUMIDIFIER?**

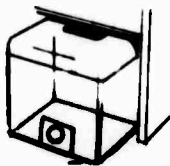

When the Dehumidifier is first put into operation, it will remove relatively large amounts of moisture until the relative humidity in the area being dried is reduced to the value where moisture damage will not occur. After this, the amount of moisture removed from the air will be considerably less than that removed when the Dehumidifier is put into operation. This reduction in the amount of moisture being removed indicates that the Dehumidifier is doing its job and that it has reduced the relative humidity to a safe value. Our literature states that the Dehumidifier will remove a stated amount of moisture under conditions of normal use at 80° ambient and 60% relative humidity. These conditions have been established as industry standards for normal operation. The performance of the Dehumidifier should be judged by the elimination of the dampness and dampness odors rather than by the amount of moisture being removed and deposited in the bucket.

**AT WHAT SETTING SHOULD I LOCATE THE AUTOMATIC CONTROL ON MY DEHUMIDIFIER?**

For best operation of your Dehumidifier, we recommend that you turn the humidity control knob completely clockwise. At this setting the unit will operate continuously at maximum capacity. Allow the Dehumidifier to operate at this setting for three to four weeks. After this period of time, careful consideration should be given to the dampness in the area being dried. If the sweating has discontinued and if the dampness odors are gone, we would recommend that the control be turned counter-clockwise one quarter turn.



## 3600-6

At this setting, more economical operation is obtained but the relative humidity probably will be higher than at the completely clockwise position. After three or four weeks if the moisture condition in the area being dried is still satisfactory, we would recommend that the operation of the Dehumidifier be continued with the control set in this position. However, if at this setting dampness condition is not completely corrected, we recommend that the control be returned toward the completely clockwise setting.

This will require minor adjustments from time to time. But it should be remembered that the control must be set near enough to the completely clockwise position to correct the dampness condition for which you bought the Dehumidifier. Also, it is important to set the control as far counter-clockwise as possible to obtain the most economical operation. During particularly humid periods, the Dehumidifier will run continuously due to the seepage of humid air into the room through the walls, around doors and window and through the use of clothes dryers and similar equipment that add moisture to the air. The continuous operation of the Dehumidifier during such humid periods is entirely normal and necessary to maintain the desired conditions.

The Dehumidifier should be kept in operation as long as excess moisture is present in the room air. However, when the temperature of the room is relatively cool, or the relative humidity is low, it is perfectly normal for frost to form on the coil. The Dehumidifier should be turned off instead of operating under these conditions, since it will not perform properly when frost builds up. Should your dehumidifier fail to operate, remember the humidity may be below the control setting. This is normal, as the dehumidifier has removed sufficient moisture. Remember also, that should the unit operate continuously, the room moisture level will decrease enough to activate the control cutoff.

### WHY DOES MY DEHUMIDIFIER COIL FROST WHEN IT IS FIRST TURNED ON?



A light coating of frost on the coil is normal when the Dehumidifier is first turned "On". Under normal conditions it will disappear within 30 to 45 minutes.

### WILL A DEHUMIDIFIER ELIMINATE THE FROSTING OF WINDOWS IN THE WINTER TIME?



The answer is no. The reason -- a dehumidifier air drying coil normally operates above a freezing temperature -- and for that reason cannot take enough moisture out of the air to prevent it condensing on the inside surface of a window pane that is below 32°F. It will be found helpful to use a dehumidifier in an area such as a kitchen or laundry that is a source of high humidity. In reducing the humidity condition in these special areas, the frosting on windows in other parts of the home can be reduced.

# SERVICE MANUAL

## EXIDE Constant Voltage Float Charger—Model US Single Phase, 60 Cycle AC

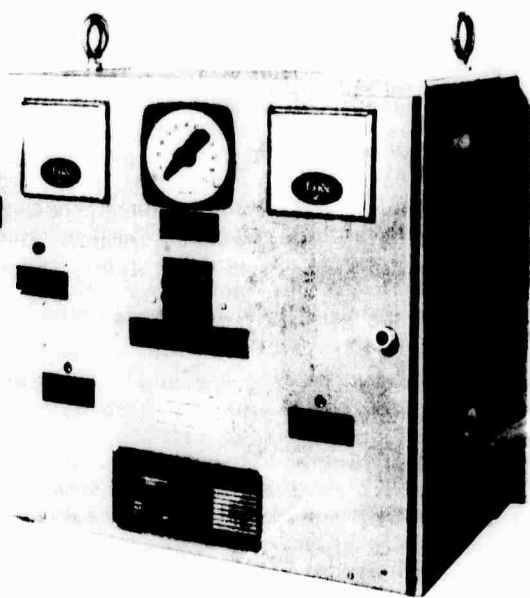

NOT REPRODUCIBLE

Model US-50-1-6 Charger,  
door closed.

Model US-50-1-6 Charger,  
door open.

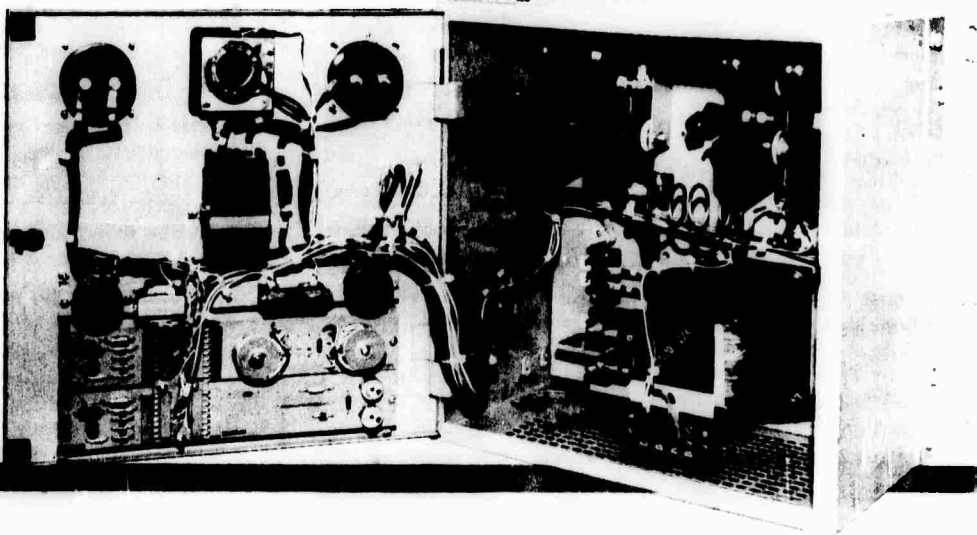

### 1. Introduction

a. Wiring diagrams and schematic diagrams for all standard Model US chargers are shown in the Installing and Operating Instructions, Form No. 6777 (Section 58.20). Parts listing is given by Form No. 6779 (Section 130.00). Operating ratings, model numbers and capacities, specifications and dimensions, together with a description of standard equipment, accessory equipment, and a brief discussion of operation theory with performance data can be found in Form No. 6778 (Section 56.50).

b. The instructions which follow pertain only to the servicing and trouble-shooting (or repair) of Model US chargers. For other information see the appropriate information listed in paragraph 1a. above.

c. As an aid to easy servicing and repair, all Model US chargers are designed so the parts are easily accessible for testing or repair when the front panel is opened. No special tools are required in servicing this

equipment. Ordinary electricians' hand tools such as pliers, screwdrivers, and wrenches are adequate. Since accuracy of measurement is important when setting float and equalizing voltages, precision portable volt-ammeters such as the one-percent accuracy type similar to Weston Model 280 or 281 are recommended for these d-c measurements. A conventional voltohmmeter or analyzer such as the Simpson Model 260 is also satisfactory, but is not as accurate. However, it will also check a-c voltage, d-c resistance, and current. An oscilloscope is also helpful in checking the firing waveforms. The waveforms shown in these instructions were taken with a Waterman Model OCA-11A with Shielded Multiple Plug, AC-1, however, any similar oscilloscope will do. A commercial diode and controlled rectifier checker will be helpful in checking the diode rectifiers and controlled rectifiers. Use a Solitron controlled rectifier checker model R107, or similar, or one can substitute known good semiconductors in place of the suspected ones.

*continued on next page*

d. Two basic circuits are used in the Model US chargers: either a full-wave rectifier using a center-tapped transformer, or a full wave-bridge rectifier using an untapped transformer. In addition, the primary circuits are either 115 volt nominal, or 230 volt nominal (or other voltages), single phase, 60 cycle AC. The primaries contain taps for voltage adjustment and differ slightly schematically depending upon whether or not a manual or automatic equalizing charge timer (ECT) is included. The automatic timer arrangement also includes a time delay relay (TDR). Typical schematics are shown in figures 1 and 2. Figure 1 shows the basic full-wave circuit with manual reset timer, while figure 2 shows the basic full wave-bridge circuit with automatic reset timer.

**2. Normal Performance**

a. Before servicing or trouble-shooting is attempted it is necessary to determine whether or not the charger is operating within performance limits. One indication of normal charger performance is to maintain the set float voltage and the set equalizing voltage within 1/2 percent without exceeding the rated current output (in amperes). It must do this with a-c supply voltage variations as great as 10 percent above (or below) the voltage for which the primary of the power transformer (PVT) is connected, and for frequency fluctuations of the supply from 57 to 63 cycles per second. To determine this performance three items are needed, namely, a variable a-c supply, a variable load, and a fully charged battery. Refer to the specifications listed by model number in Form No. 6778 (Section 56.60) for the type of battery and number of cells, calculate the operating limits, and check if operation conforms; a sample tabulation follows for US-32-1 chargers.

Note: Where the charger is known to be operating satisfactorily this check need not be made.

**NOTE**

Refer to Installing and Operating Instructions Form No. 6777 (Section 58.20) for the correct schematic for the model of equipment in use.

**Fig. 1. Schematic Diagram, Full-Wave Center-Tap Circuit with Manual Set Equalizing Charge Timer**

- BCB = Bottery Circuit Breaker
- BVM = Bottery Voltmeter
- CAM = Charger Ammeter
- CSR = Current Sensing Resistor
- CVT = Control Voltage Transformer
- EAR = Equolizing Adj. Rheostat
- ECT = Equolizing Charge Timer
- FAR = Float Adj. Rheostat
- PCB = Power Circuit Breaker, AC
- PLL = Pilot Light, AC
- PRD = Power Reguloting Device (SCR)
- PVT = Power Voltage Transformer
- R6 = Resistor (if used)
- SVS = Surge Voltage Supsessor
- Module A = Firing Module
- Module B = Firing Module
- Module C = Phase Shift-Logic Module
- Module D = Sensing Module
- Module M = Moster Control Board

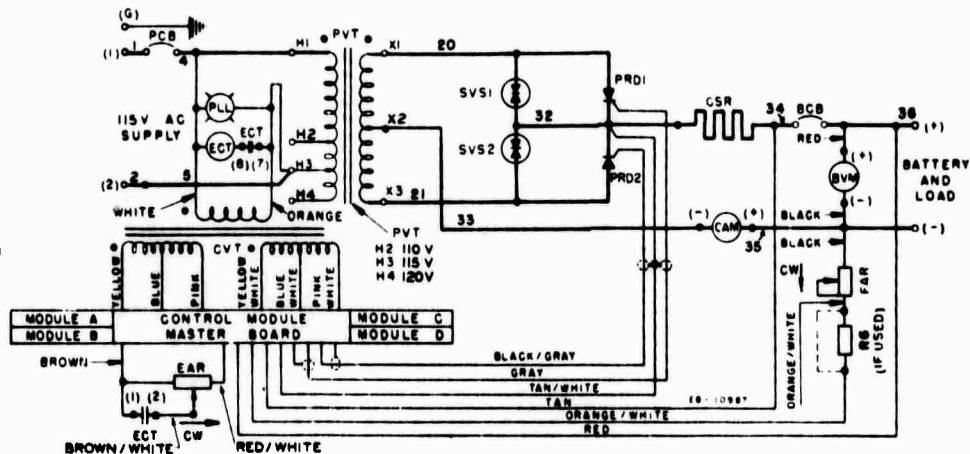

**Fig. 2. Schematic Diagram, Full-Wave Bridge Circuit with Automatic Set Equalizing Charge Timer**

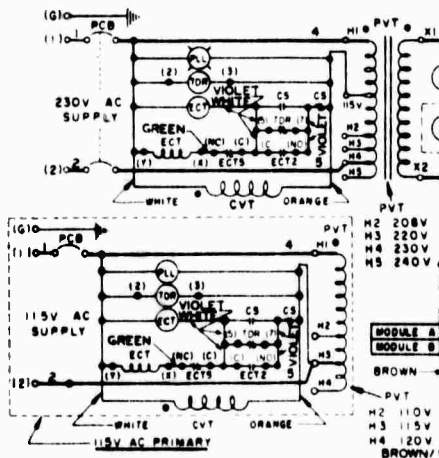

- BCB = Bottery Circuit Breaker
- BVM = Bottery Voltmeter
- CAM = Charger Ammeter
- CS = Charge Switch
- CSR = Current Sensing Resistor
- CVT = Control Voltage Transformer
- EAR = Equolizing Adj. Rheostat
- ECT = Equolizing Charge Timer
- FAR = Float Adj. Rheostat
- PCB = Power Circuit Breaker, AC
- PLL = Pilot Light, AC
- PRD = Power Reguloting Device (SCR)
- PRX = Power Rectifier (Diode)
- PVT = Power Voltage Transformer
- R6 = Resistor (if used)
- SVS = Surge Voltage Supsessor
- TDR = Time Delay Relay
- Module A = Firing Module
- Module B = Firing Module
- Module C = Phose Shift-Logic Module
- Module D = Sensing Module
- Module M = Moster Control Board

Type of Battery	Float Voltage	Float Tolerance	Voltage Per Cell	
Lead-Acid	.14 cell	30.1	0.15	2.15
Nickel-Cadmium	.22 cell	31.48	0.157	1.43
Nickel-Iron	.21 cell	31.50	0.158	1.50

Type of Battery	Equalizing Voltage	Tolerance	Voltage Per Cell	
Lead-Acid	.14 cell	32.6	0.163	2.33
Nickel-Cadmium	.22 cell	34.1	0.17	1.55
Nickel-Iron	.21 cell	33.6	0.168	1.6

b. Assuming that the charger has been operating in the float voltage position, another indication of normal performance can be obtained by placing it in the equalize position (turn manual timer off zero to say, one hour or more; or with an automatic reset timer, move CS switch to EQUALIZE position). Observe that maximum charge current shows on charger ammeter until the battery reaches the equalizing voltage, after which the current should slowly decrease (this check will be governed by the time required to reach the equalizing voltage level).

c. On the other hand, if the charger has been operating in the equalizing voltage position, after the timer is returned manually or automatically to zero, the charger will operate with zero or little output current until the float voltage is reached; after which the current should increase slowly to the system load value (the battery is now "floating" across the line with approximately equal input and output currents).

d. When operating normally, the current limit control will limit the maximum charger output current to approximately 110 percent of the rated charge current. In case of a high d-c current demand, the current control must keep the charger output within safe values and without tripping the a-c or d-c circuit breakers, even down to a short circuit. Thus, tripping of the circuit breakers indicates an unserviceable component or circuitry.

e. Normally, in event of a high current demand, the charger will safely deliver up to 110 percent of its current rating, at slightly lower output voltages than it was initially adjusted for, without tripping the breakers. This action is shown in the performance curves of figures 3 and 4. These curves show the recharging of a 100 A.H. antimony-alloy, lead-acid battery which was completely

discharged before being recharged by a Model US-50-1-6 charger. Observe that the higher current output (in amperes) occurs during the early hours of the charge, and that the battery voltage rises as the battery charges. When the battery voltage reaches the float voltage of 2.15 volts per cell (Fig. 3), or the equalizing voltage of 2.33 volts per cell (Fig. 4), the current is well within the charger rating, and thereafter the current gradually diminishes as the charge progresses. These curves were made with no load on the charger other than the completely discharged battery. Any other load on the system would reduce the charge current into the battery by a like amount, and the time to reach either 100 or 110 percent charge limits (as shown on the graph) would be increased accordingly.

f. Normal performance is also predicated upon proper location and installation of the charger. Ventilation should be adequate, rated ambient temperature should not be exceeded, and the size and length of the connecting leads must be adequate. It is also important that proper choice of the primary voltage tap be made, as explained in Section 58.20, Form No. 6777, Installing and Operating Instructions. Make certain that no loose, dirty, or corroded connections exist.

### 3. Trouble Shooting

a. Generally speaking, there are four major components or functional parts which form the bulk of the unit as follows:

1. Power voltage transformer (PVT).
2. Power regulating devices (PRD1, PRD2, or SCR).
3. Power rectifiers (PRX1, PRX2) or silicon diodes (omitted on 12-volt chargers).
4. Control unit and modules.

b. The major components are not checked in the order they are listed above, since a charger may exhibit a number of difficulties, each with different symptoms. In many cases, failure of one component may cause another component or part to fail. Therefore, the following paragraphs treat major components, functional circuits and parts individually (or by symptom) together with serviceability measurements and tests

Fig. 3. Recharge characteristic of 6-ampere charger with a float setting of 2.15 volts per cell (100 A.H. battery discharged at 8-hour rate to 100 A.H.)

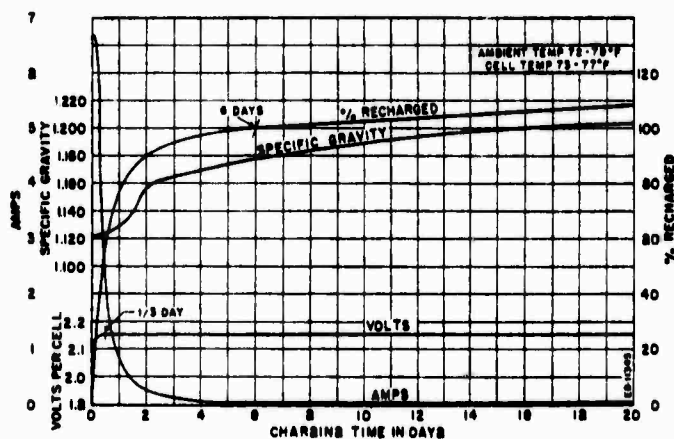
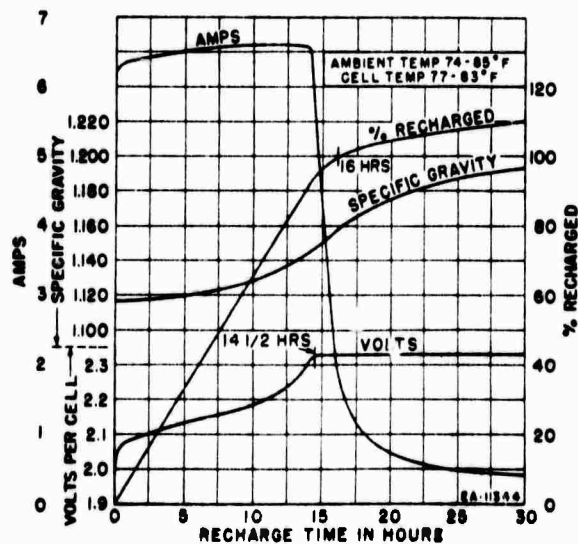

Fig. 4. Recharge characteristic of 6-ampere charger with an equalize setting of 2.33 volts per cell (100 A.H. battery discharged at 8-hour rate to 100 A.H.)



which should isolate the part at fault. See the trouble-shooting tabulation in Table A below. When using the table for trouble shooting, first locate the fault symptom observed in the left hand column of Table A, then follow the sequence for checking components in the numerical order listed (1, 2, 3, etc.) for that particular symptom. Follow this check sequence until the trouble is located. After correcting the trouble, check the charger for normal performance following the procedure outlined in paragraph 2.

e. A log should be kept showing the dates the charger was checked and adjusted, and the cause of the trouble, noting if the part was replaced or repaired. This will serve as a guide to the stocking of spare parts, and as a guide in trouble shooting.

d. When communicating with the nearest Exide Industrial Marketing Division Office (see addresses on rear cover), give full model number of charger, serial number, date new, and related information.

**CAUTION**

Always isolate and deenergize the charger by opening the AC power circuit breaker (PCB), and the battery circuit breaker (BCB), when attaching or removing leads or parts, and when working within the unit (this avoids possibility of heavy short circuit currents damaging your tools or the equipment).

**A. Power Voltage Transformer (PVT)**

a. With PCB and BCB breakers OFF, open the cabinet and carefully check the line voltage (with an a-c voltmeter of proper range) as measured across line terminals 1 and 2 on the lower left side of the cabinet. Refer to par. 3B if no AC voltage. Check the wiring connections (leads 4 and 5) to ascertain that unit has proper primary tap connected for the line voltage indicated. Check that the voltage at the primary is the same as that of the line when PCB is turned ON. (If not, PCB or wiring between it and PVT is open.) Pilot light (PLL) should be illuminated at this time; if not, replace pilot lamp. If lamp still does not light, check wiring to lamp socket and socket.

h. Check a-c secondary voltage on PVT (leads X1 and X2, also X3 when used). Secondary voltage should be approximately 10 percent higher than the rated equalizing voltage for the charger (see nameplate) on open circuit (battery disconnected). If secondary voltage is less than rated equalizing voltage, and correct primary tap is used and proper primary voltage exists, PVT is at fault or power regulating device PRD1, PRD2, or surge voltage suppressors SVS1 or SVS2 are out of order. See paragraphs 3E, F, for checks of these parts before replacing power transformer.

**B. External Circuit Wiring**

a. When no line voltage exists between terminals 1 and 2 check the a-c line back to source.

h. With no output, or a low output, the external d-c wiring may be at fault. Check the wiring between charger and battery to see that it is properly installed (refer to paragraph 2, Installing Instructions, Form No. 6777, Section 58.20). Make certain that terminals are tight and clean, and that the d-c wiring is free of grounds. The total operating voltage drop in the loop or leads between the charger and battery terminals should never exceed 0.5 volt (at rated charge current) as a maximum limit, and preferably should be kept considerably below this limit by using a sufficiently large wire size.

**C. Circuit Breakers**

a. When a-c voltmeter of suitable range is connected between leads 1 and 2 and indicates line voltage, but does not indicate when connected between leads 4 and 5 when PCB is closed, the PCB breaker is probably inoperative. Deenergize the a-c supply to the charger and remove the circuit breaker. Use a volt ohmmeter to check for continuity between the circuit breaker terminals with breaker on. Zero resistance should be indicated if the unit is operative. If unit is operative, check performance by connecting it in series with a lamp and suitable voltage supply. Select a lamp with a capacity slightly less than operating current. If the lamp flickers and then goes out the circuit breaker cannot carry suffi-

Table A. Order of Checking Components (see para. 3.A. through 3.O. for procedures)

	Aa.	Ab.	B	Ca.	Cb.	D	E	F	Ga.	Gb.	Gcd.	Gf.	H	I	J	K	L	M	N	O
	AC Supply & Pilot Light	AC Supply & PVT	Ext. Ckt.	AC Bkr.	DC Bkr.	Rect. Diodes	Surge Volt. Suppressor (SVS)	SCR'S	Scope Adjust	CVT	Module AB & C	Module B	Volt Adj	Curr Adj	Timer	TDR	Int. Wiring	CSR	DC V.M.	DC Ammeter
Pilot Light Off, Bkr. On	1	...	...	2	...	...	...	...	...	...	...	...	...	...	...	...	3	...	...	...
No Output Current	...	1	2	3	4	11	...	12	7	8	9	10	6	...	...	...	13	...	...	5
Low Output Volt. and/or Current	...	1	2	...	...	12	...	13	8	9	10	11	3	4	...	...	...	7	5	6
High Output Voltage	...	1	2	...	...	...	...	9	5	6	7	8	3	...	...	...	...	...	4	...
High Output Current	...	...	...	...	...	...	...	8	4	5	6	7	...	1	...	...	9	3	...	2
AC Bkr. Tripping	...	1	...	2	...	5	12	8	6	9	10	11	...	3	...	...	7	4	...	...
DC Bkr. Tripping	...	...	...	...	1	9	12	10	5	6	7	8	...	2	...	...	11	4	...	3
Volt. Adj. Ineffective	...	...	...	...	...	...	...	5	1	2	3	4	...	...	6	7	...	...	...	...
Timer Failure	...	...	...	...	...	...	...	...	...	...	...	...	...	...	2	3	1	...	...	...
Rect. Diode and/or SCR Failure	...	1	...	...	...	...	2	...	...	...	...	...	...	...	...	...	3	...	...	...



cient current and is not usable. If the lamp stays on, replace it with a larger lamp and check that the breaker operates. Make these tests a number of times to determine if the breaker is erratic in its operation. Replace the faulty breaker with a good one of the proper rating.

b. When the battery circuit breaker is suspected of being inoperative or at fault, a similar test to that made for the PCB breaker (using a d-c supply instead of an a-c supply) will determine the operating condition of the breaker.

c. If the rectifier diodes become shorted the battery will try to discharge through BCB in the reverse direction, will actuate it, and disconnect the charger from the battery. In this case the breaker is operating normally to protect the charger and is not out of order. Such a condition may be indicated by the charger ammeter (CAM) showing a reverse current flow, off-scale to the left, before the breaker operates.

**D. Rectifier Diodes (PRX).** (Note: Not used in Model US-12 units.)

a. Use a volt-ohmmeter such as the Simpson Model 260 (or an ohmmeter of any type with less than 30 volts internal supply and a pair of clip test leads). Solitron controlled rectifier checker Model R107, if available, may be used instead of the volt-ohmmeter. Follow the procedure given in paragraph g. below, instead of paragraphs b. and c.

b. Deenergize charger by setting PCB and BCB at OFF. Set the ohmmeter on the direct-reading scale (R x 1), and open the cabinet door. Do not disconnect any wires or leads from the diodes. Connect one lead to heat sink (scrape off paint) and one lead to insulated tip of the diode, Fig. 5. Note the ohmmeter indica-

tion; if the diode is operative and battery polarity is correct it should read from 5 to 15 ohms (when connected in the forward direction). This tests the forward conduction resistance, since the heat sink is connected both electrically and mechanically to the cathode, which is always negative in the forward condition. The insulated tip of the diode (connected to the pigtail) is the anode, and is of positive polarity.

c. Reverse the connections to the diode (see figure 6) and read the reverse (back or blocking) resistance which should be considerably more than the forward resistance. Set the ohmmeter scale switch to RX100 or RX10,000 to obtain a more precise reading. If the diode is at fault, it will read the same in both directions, or the reverse resistance will be low, indicating incipient failure and reduced performance.

Note that the insulated tip of the diode is always the anode while the heat sink or stud end is the cathode for negative polarity type diodes (positive types are oppositely polarized). While the diodes are marked with an arrow to indicate forward current direction this is sometimes difficult to see inside the cabinet. Also, since some ohmmeters are not polarized as marked on the meter (for example, the test lead marked plus, or colored red, goes to the negative battery terminal) it is easier to perform the forward and reverse current tests by connecting the leads and observing the indication without regard to polarity markings. The low resistance will always be in the forward direction, and the higher resistance in the reverse direction. A shorted diode will usually read the same in both directions.

d. If more than one shorted diode is located, remove the connections from the diodes and check each one again, separately. It is sometimes found that only one of the diodes is shorted when the leads are disconnected

Fig. 5. Normal test result, low resistance of rectifier diode when connected in forward direction.

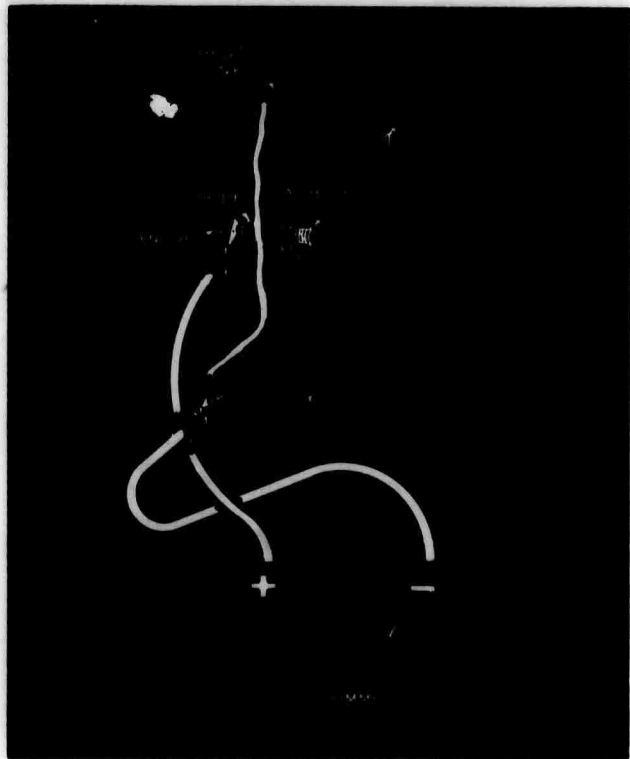

NOT REPRODUCIBLE

Fig. 6. Normal test result, high resistance of rectifier diode when connected in the blocking direction.

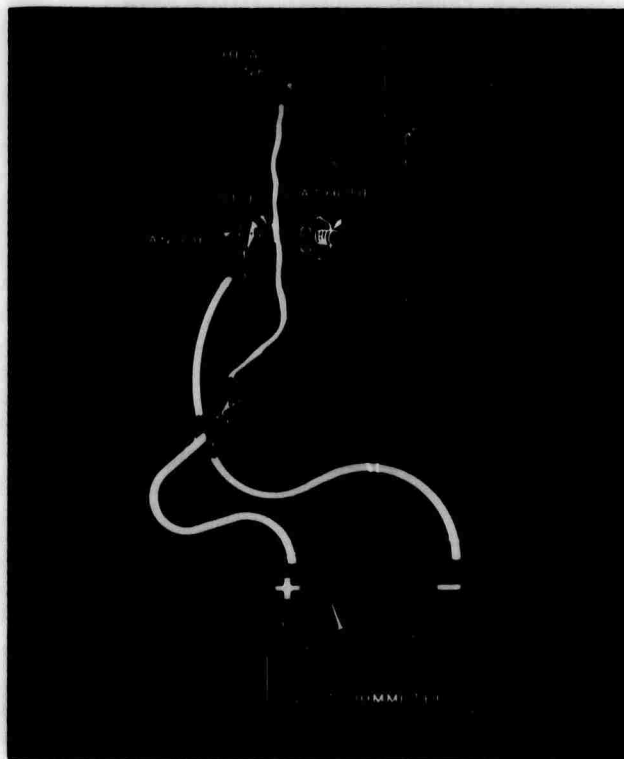

93

and the diodes are isolated. Replace any shorted diode with a good one of the same rating; install the new diode in the same physical position as the defective one and make the same connections.

e. To prevent damage to the diode, do not tighten the nut more than on the faulty one. A limit of 15 in. lbs. for 10-32 studs is generally used,  $\frac{1}{4}$  inch studs are torqued to 30 in. lbs., and  $\frac{1}{2}$  inch studs to 150. A torque wrench, if available, should be used to avoid damaging the diode. It is also good practice to make the ohmmeter forward and reverse resistance checks, as described in paragraphs b. and c. above, on the replacement diode to make certain that it is in good condition.

f. Note that diodes usually short in pairs in bridge circuits, seldom as single units, and it is rare that all four diodes in a bridge are found defective. When diodes fail it usually is because of surge voltages, therefore, surge voltage suppressors SVS1 and SVS2 (also SVS3 and SVS4, when used) should also be checked to determine that they are operative (refer to paragraph 3E.).

g. To check diodes with the Solitron SCR checker, connect the red and the yellow test leads to their respective colored jacks, place the selector switch to LEAKAGE OHMS X 10,000 position, and short the red and yellow leads by clipping them together. Plug the a-c cord in a 115 volt a-c outlet, turn ZERO OHMS knob clockwise until tester power supply is turned on, and then set the knob for full scale indication (zero on the lower (leakage) scale of the meter). Unclip the test leads and connect the yellow lead to the diode anode, and the red lead to the diode cathode. Multiply the meter indication by 10,000 to obtain the leakage resistance in ohms. Transpose the yellow and red lead connections so that the yellow lead connects to the cathode and the red lead to the anode. The meter indication will now indicate approximately zero (a low forward resistance). If both indications are high the diode is open; if both are low the diode is shorted. A normal diode will show a high leakage resistance and a low forward resistance, as explained in paragraph c. above.

#### E. Surge Voltage Suppressor (SVS)

a. Make a visual check to see if the suppressor appears normal or shows signs of throwing lead.

b. If any signs of lead-throwing appear, replace the suppressor with one known to be in good condition.

c. If the suppressor is shorted, an ohmmeter check will indicate continuity. When the suppressor shows a high resistance measured with it disconnected from the charger, and has a normal appearance with no signs of lead-throwing, it can be presumed to be in good operating condition.

#### F. Power Regulating Device (SCR)

a. Power regulating devices PRD1 and PRD2 are silicon controlled rectifiers, which cannot be checked similarly to the rectifier diodes by forward and reverse resistance checks, since the SCR will always show a high resistance until triggered. Use a Solitron model R107 SCR checker and connect the yellow test lead to the stud, which is the anode, and connect the red test lead to the heavy insulated lead, which is the cathode (SCR's are constructed oppositely to conventional diodes). The other small insulated lead is the gate connection to which the green test lead is connected.

h. Check the silicon controlled rectifier for oper-

ation at rated gate voltage and gate current, and for shorts and leakage current as outlined in the following paragraphs, against the manufacturer's specification for the type used. Remove and replace any shorted units or SCR's not within ratings.

c. Check the gate firing voltage with Model R107 tester as follows:

1. Zero the leakage scale as described in paragraph 3.D.g. for diode checking, set the GATE LEVEL control fully counterclockwise, and connect the test leads as outlined in paragraph a. above.
2. Set the selector switch to GATE VOLTS position.
3. Slowly adjust the GATE LEVEL control clockwise until the SCR CONDUCTING indicator begins to light. Read the upper meter scale to determine the voltage necessary to fire the SCR. A firing voltage of from 0.2 to 3.0 volts is satisfactory.

d. Check the gate firing current with Model R107 tester as follows:

1. Make the preliminary adjustments and connections as in step 1, paragraph c. above, for voltage check.
2. Set the selector switch to MA X 10 or other suitable range. (Single-phase chargers require a range of 1 to 70 milliamperes, and three-phase chargers require a range of 1 to 170 milliamperes.)
3. Slowly adjust the GATE LEVEL control clockwise until the SCR CONDUCTING indicator just begins to light. Read the upper meter scale to determine the firing current (multiply scale value by 10, or other appropriate multiplier, to determine current value in milliamperes).

e. A short-circuit check is made by observing the SCR CONDUCTING indicator. When it glows regardless of the position of the GATE LEVEL control, while performing the tests in paragraphs c. and d. above, the SCR is shorted.

f. The leakage resistance is determined by zeroing the leakage scale as described in paragraph 3.D.g. for the diode check, and connecting the leads as described in paragraph 3.F.a. above (the gate lead need not be connected). Multiply the value indicated on the lower meter scale by 10,000 to get the leakage resistance value in ohms. Keep GATE LEVEL control in extreme clockwise position. A good SCR will usually have 1-to-4 meg-ohms leakage resistance, but is still serviceable with 100,000 ohms.

g. In a bridge rectifier, shorting of one arm will place the adjacent arm diode in full conduction and produce a heavy shunting current around the rectifier as shown in figure 7. If sufficient, this current will damage the associated diode causing it to fail with a consequent complete short circuit. Failure of the SCR, therefore, is usually associated with operation of circuit breaker PCB. If PCB operates immediately after being reset (and paragraphs 3.A. through 3.E. checks have been made), check the SCR performance first as described in paragraphs 3.F.b. through f. above.

h. After making the SCR test, if abnormal output current still occurs, or if circuit breaker tripping occurs, or both occur, even though the SCR checked satisfactory on the tester, check the output current waveform

Fig. 7. Shunt path offered by shorted diode.

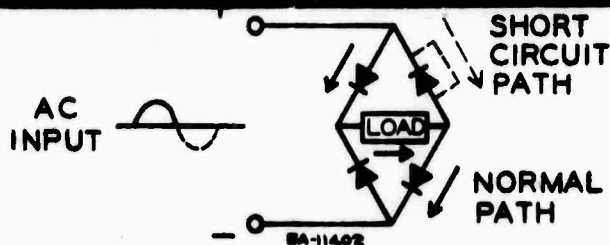
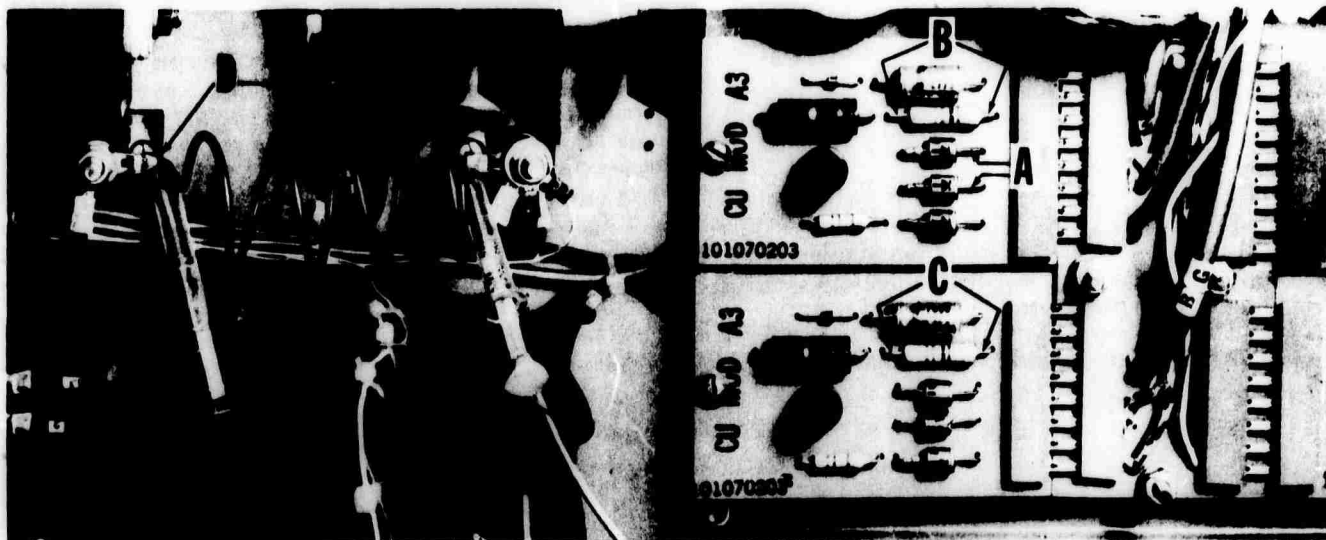

Fig. 8. Oscilloscope connection (Test) points in US Charger.



NOT REPRODUCIBLE

with an oscilloscope as described in paragraph 3.G.g. The SCR may sometimes fire by itself instead of being controlled by the module because of a change of internal gating characteristics, which changes the level at which the SCR operates. Thus, the tester may show the SCR as being within specifications when it is not suitable for operation with the equipment. Normally, this condition will be most easily located by observing an output pulse on the oscilloscope which is not accompanied by a firing pulse (see figures 13 and 14). A similar and opposite condition will sometimes occur, where the output pulse from one module is observed but not that of the other pulse and, in both instances, a firing pulse is available from modules A and B. With the SCR's previously checked on the tester, the obvious trouble is not a defective SCR, but defective wiring in the circuit preventing an output from appearing on the oscilloscope.

#### G. Control Unit, Modules A-B, C, and D, also Control Transformer (CVT)

a. Use an oscilloscope such as the Waterman Model OCA-11A, with shielded multiple plug, AC-1, to check the module and firing waveforms. First set the controls as tabulated in Table B below, and then make the preliminary adjustments in the order listed.

Table B. Oscilloscope Control Settings

Control	Setting	Control	Setting
FOCUS	Center of Rotation	H. POSITION	Center of Rotation
V. POSITION	Center of Rotation	H. MULTIPLIER	50V. position
FREQUENCY	Center of Rotation	SYNCHRONIZER	LINE position
V. MULTIPLIER	10V. position	STABILITY	REP position
CPS	30 - 300 position	V. INPUT	AC switch position
BEAM	OFF (fully CCW)	H. INPUT	AC switch position

1. Connect oscilloscope primary power plug to a 115 volt a-c receptacle, and turn BEAM control clockwise sufficiently to turn on the power. Allow 30 seconds for the oscilloscope to warm up before proceeding (the scope filament may be seen to glow inside the cabinet through the ventilating orifices indicating it is ON).
2. After warm up, rotate BEAM control further in a clockwise direction until a horizontal line (trace) appears on the face of the oscilloscope. (It may be necessary to rotate the V. POSITION and H. POSITION controls to make the line appear.)
3. When the trace line appears, adjust the FOCUS control for maximum sharpness, and center the trace horizontally and vertically with the H. POSITION and V. POSITION controls. (If trace line cannot be made to appear, the oscilloscope is in need of repair.)
4. When the oscilloscope is operating properly, connect the test lead screw-connector to the vertical-input, microphone connector on the shielded plug (AC-1). The oscilloscope is now ready for testing the US Charger.
  - a. To display the Control Voltage Transformer (CVT) waveform, make the following connections and adjustments.
    1. Make certain charger is deenergized (PCB and BCB at OFF), open the charger front panel door to expose the control unit components, and connect the oscilloscope to the top and center diodes of Module A. Connect the vertical input test lead to the cathode of the top diode, and the grounding plug test lead to the cathode of the center diode, see figure 8, points A.



2. Energize charger (PCB and BCB to ON), a single moving sine-wave trace should appear on the oscilloscope. Adjust FREQUENCY control slowly until the signal trace is stationary (turn control clockwise if waveform is moving to the left, and counterclockwise if waveform appears to move to the right). When stabilized, the waveform should appear similar to figure 10. If the signal trace appears reversed or inverted 180 degrees, reverse the oscilloscope power plug in the a-c receptacle. The signal trace shown in the figure is used to determine the CVT waveform, and to establish a time basis for the other displays which will be obtained later.

#### NOTE

It may be necessary to adjust the FREQUENCY control slightly, from time to time, to keep the waveform stationary.

3. If a distorted waveform which is not similar to figure 10 is obtained, remove both Module A and Module B from the Master Board, and connect the oscilloscope vertical input test lead to pin 5 from the top of the master board, and connect

the ground plug test lead to pin 6.

4. Observe the signal trace on the oscilloscope, noting if the distorted waveform is now improved. If improved, either Module A, or Module B, or both, are unserviceable and should be replaced.

#### CAUTION

When making connections or working inside the charger always be certain to deenergize the AC and DC supplies by opening circuit breakers PCB and BCB.

e. To display the firing pulse from Module A (top module on left side), turn V. MULTIPLIER control on oscilloscope from position 10 to position 1. Leave the remaining controls set as in Table B, deenergize the charger (PCB and BCB at OFF), and make the following connections and adjustments.

1. Connect the oscilloscope to the 200 ohm resistor of Model A (second item from top of Module), see Fig. 8, "B." The vertical input test lead connects to the left side of the resistor, and the grounding plug lead to the right side of the resistor.
2. Energize charger (PCB and BCB to ON) and observe the waveform on the oscilloscope.

Fig. 9. Oscilloscope connections to test points A.

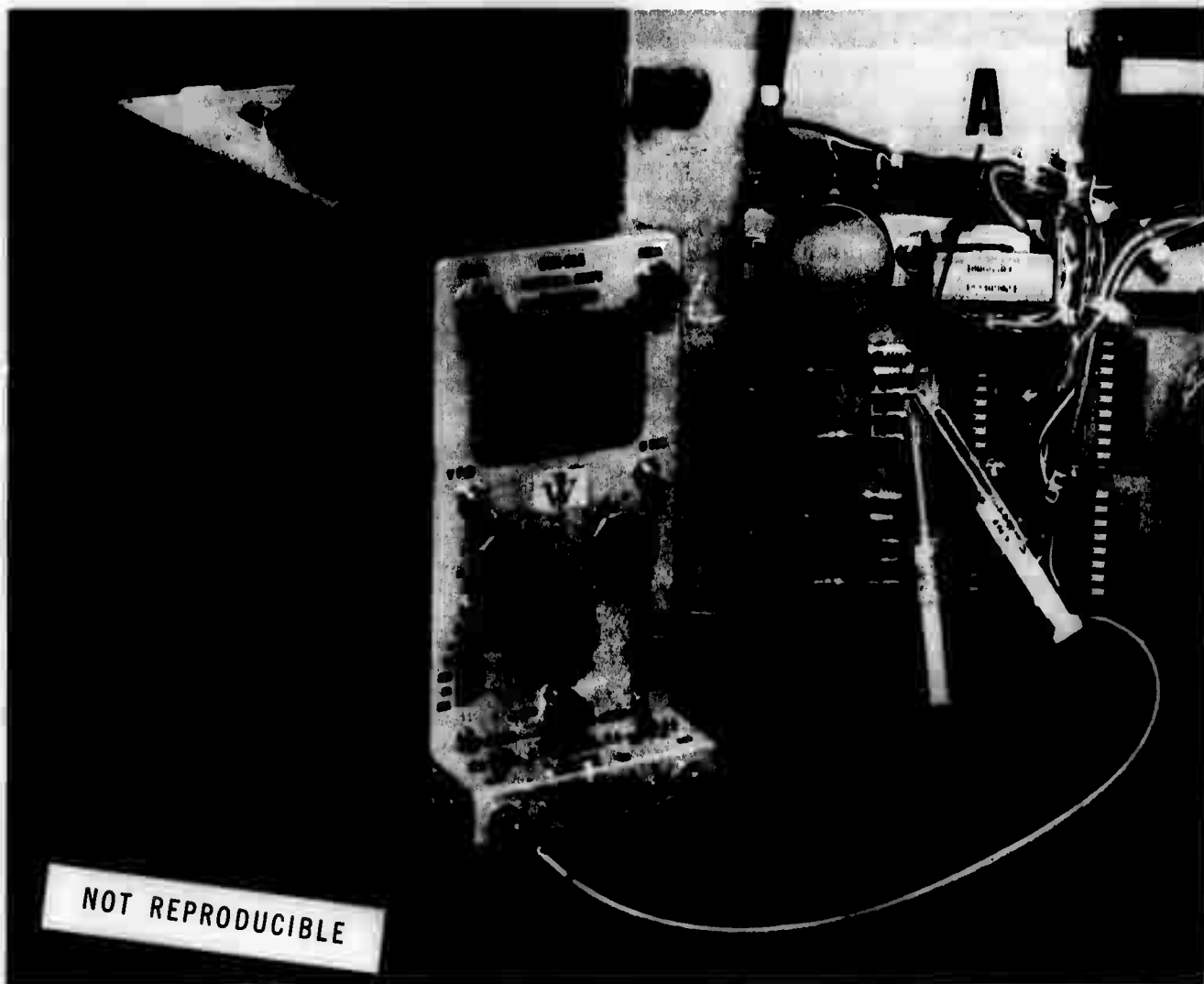

Typical signal traces for various modes of operation together with explanations of their meaning are shown in figures 11 and 12. If the observed waveform is reversed, then reverse the test leads at the resistor. Adjust the FREQUENCY control as required to keep the waveform stationary during observations.

d. To display the firing pulse from Module B (bottom module on left hand side), set the oscilloscope controls as in paragraph 3.G.c., deenergize the charger (PCB and BCB at OFF) and make the following connections and adjustments.

1. Connect the oscilloscope to the 200 ohm resistor of Module B (the second item from the top of the Module), see Fig. 8, "C." Connect the vertical input test lead to the left side of the resistor, and the grounding plug lead to the right side of the resistor.
2. Energize charger (PCB and BCB to ON) and observe the waveform on the oscilloscope. Typical signal traces for various modes of operation together with explanations of their meanings are shown in figures 11 and 12. If the observed waveform is reversed, then reverse the test leads at the resistor. Adjust the FREQUENCY control as required to keep the waveform stationary during observations.

**NOTE**

While the waveforms in the figures are placed side by side for comparison, each of these signal traces are taken separately from either Module A or Module B as marked on the drawing.

e. Trouble shooting Modules A, B, and C following the systematic procedure given in Table A requires that the proper sequence be followed. First make the oscilloscope display check to see if the waveforms of figure 11 can be obtained. If so, proceed with the remaining checks outlined in Table A for the particular symptom. If not, make the following checks in the order outlined below to locate the fault.

1. If no firing pulses are obtained as indicated by traces B and C of figure 12, replace both Modules A and B. If no firing pulses appear after replac-

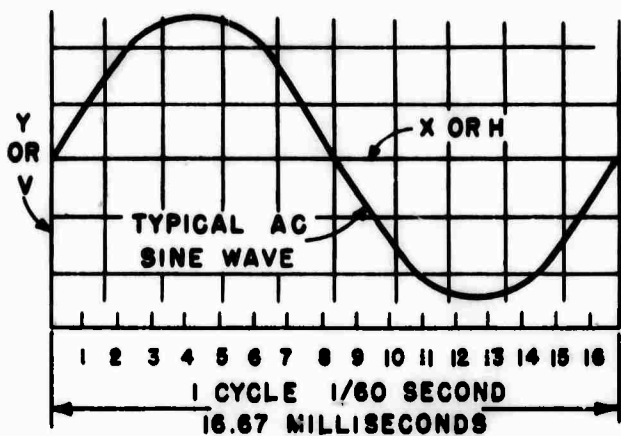
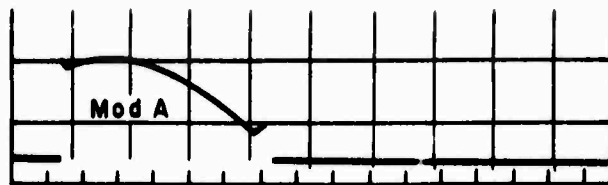
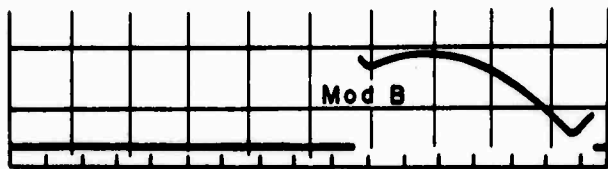

Fig. 10. CVT waveform.



(A)



(B)

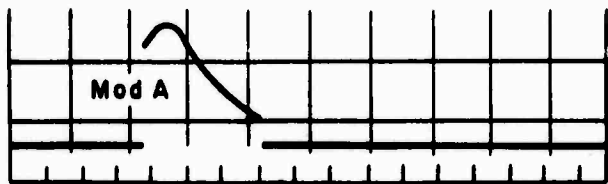

(C)

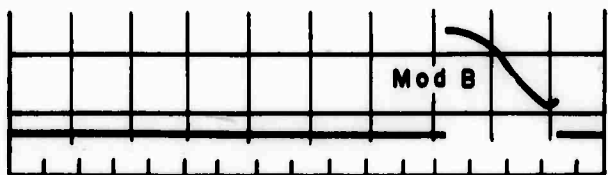

(D)

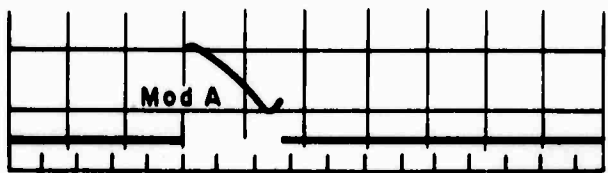

(E)

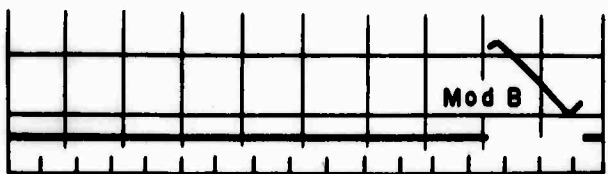

(F)

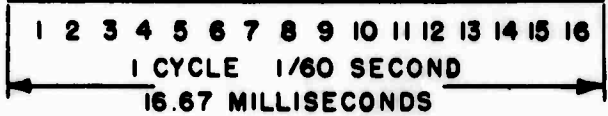

Fig. 11. Typical good traces showing firing pulses as provided for the SCR gates by Modules A and B. (Traces A and B represent the maximum firing pulse period with BCB open. Traces C and D represent the full output of charger. Traces E and F represent about 10% of rated charger output.)

ing A and B, replace Module C. If still no firing pulses appear, proceed further with the check sequences of Table A.

2. If firing pulses are obtained similar to traces A and B, and C and D, replace the module from which no firing pulse is obtained. If this replacement does not clear the trouble, proceed with the check sequence in Table A.
3. If firing pulses similar to traces F and G, or G and H of figure 12 appear, replace the module which shows a shape similar to trace F. After replacing the suspected module, if the firing pulses do not become normal as shown in figure 11, replace Module C. If this still does not clear the fault, proceed with the sequence of Table A.
- f. The above checks in paragraph e. will reveal if modules A, B, and C are at fault. To clear the control unit, a check of Module D and associated parts is necessary, proceed as outlined below:
  1. When an abnormal output exists, or the voltage and current controls appear ineffective, either

control Module D, the externally connected adjustment potentiometers, or the associated wiring may be at fault.

2. With a voltmeter of suitable range, check the voltage between the black wire on FAR rheostat and the red/white wire on the EAR rheostat. The indicated voltage should be equal to the charger output voltage (battery voltage). If the voltage indicated is much lower than the battery voltage, or if it is zero, check for open circuits in the associated wiring.
3. If the correct battery voltage is indicated in step 2, connect the voltmeter between the red/white wire on EAR and the orange/white wire on FAR. If no voltage is now indicated, replace the FAR rheostat. If substantially the battery voltage is indicated, but it is slightly lower than the previous battery voltage indicated, replace Module D.
4. After the fault is located and firing pulses are obtained as in figure 11, the output pulse wave-

**Fig. 12. Typical faulty traces showing deformed or missing pulses with explanation of causes.**

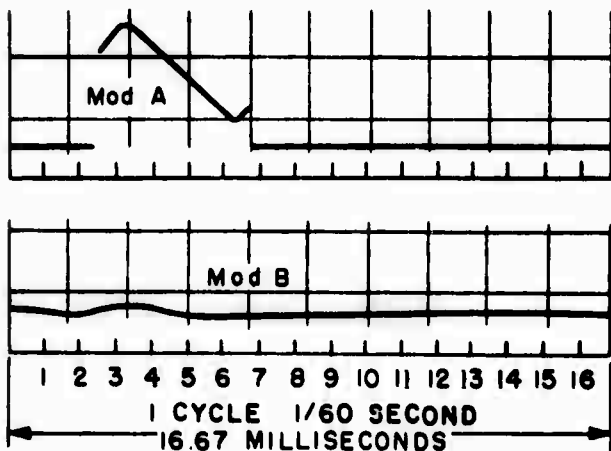

TRACES A and B: These traces show satisfactory firing pulse from Module A, but none at all for Module B. The fault may be in Module B, in PRD2 (SCR), or in connecting wiring.

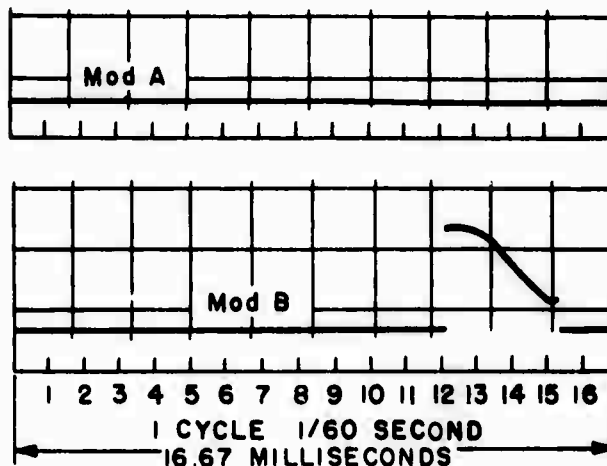

TRACES C and D: These traces show a satisfactory firing pulse for Module B, but none at all for Module A. The fault may be in Module A, in PRD1 (SCR), or in connecting wiring.

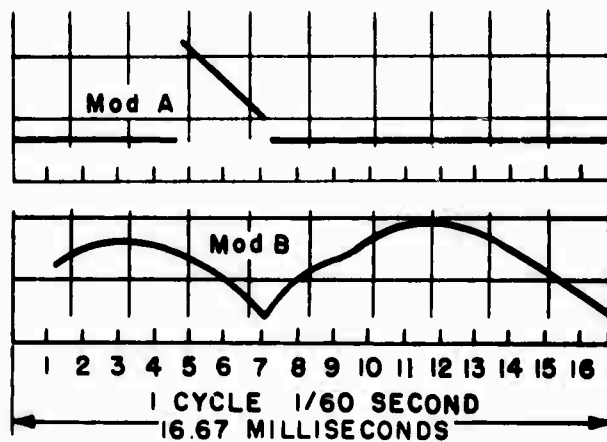

TRACES E and F: These traces show a satisfactory firing pulse from Module A, but an unsatisfactory pulse from Module B. Replace Module B, it is at fault.

form should be checked as described in paragraph g. below. If traces similar to those of A and B of figure 13 are obtained, the output is satisfactory, and the charger should respond properly to voltage and current adjustment. Adjust the voltage as described in paragraph 3.H.b., and the current as described in paragraph 3.I.b.

g. To display the charger output current waveform, set the V. MULTIPLIER control on the oscilloscope to 1 and leave the remaining controls set as in Table B. Then make the following connections and adjustments.

1. Deenergize charger (PCB and ECB at OFF). Connect the oscilloscope vertical input lead to the side of current sensing resistor CSR, that connects to PRD1 and PRD2 (lead 32), and connect the grounding plug lead to the other side of the CSR (lead 34) which connects to BCB. See Fig. 8.
2. Energize the charger (PCB and BCB at ON) and adjust the V. MULTIPLIER control clockwise until the signal trace height is approximately

two scope chart divisions. If necessary, adjust FREQUENCY control to keep trace stationary. The signal trace is illustrated and the conditions are explained in figures 13 and 14.

#### H. Voltage Adjustment and Response

a. When abnormal output voltage exists (or no output current is present) and the previous checks in Table A sequence have been made without locating the fault, turn BCB to OFF to disconnect the battery and proceed as follows:

1. Check the battery voltage with a portable voltmeter of one-percent accuracy, such as the Weston model 45, 280, or 281 and compare it against the float voltage adjustment range on the charger nameplate to make certain that the battery voltage is *not higher* than this range. For proper operation, the open circuit voltage of the battery must be lower than the rated float voltage.
2. If the battery voltage is higher than the float voltage range, check the number and type of cells

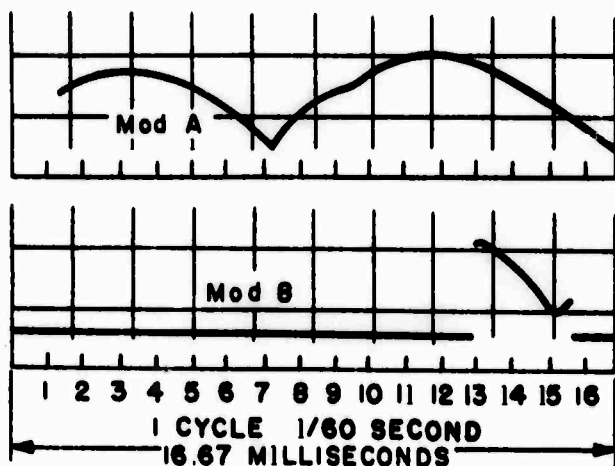

TRACES G and H: These traces show a satisfactory firing pulse from Module B, but an unsatisfactory pulse from Module A. Replace Module A, it is at fault.

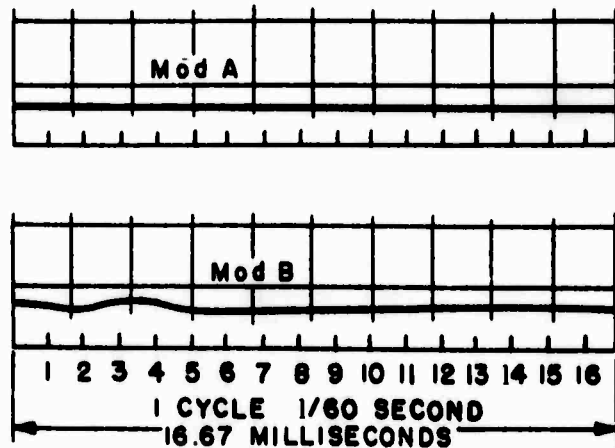

TRACES I and J: These traces show no firing pulse from Module A as well as Module B. This type of trace is associated with a series of tests of other components, see paragraphs 3.G.e., and f.

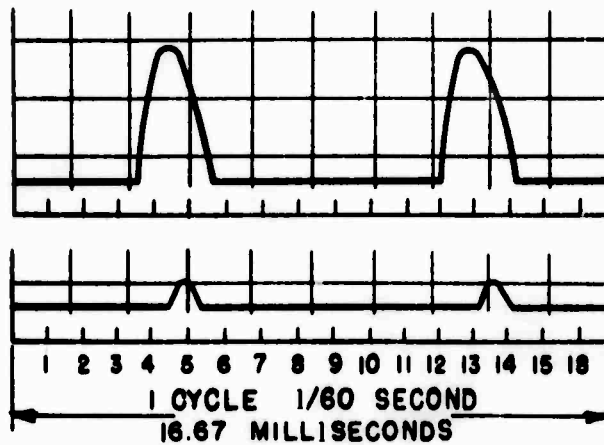

Fig. 13. Traces showing normal condition of charger output current. (Trace A is for rated charger current. Trace B is for about 10% rated charger current.)

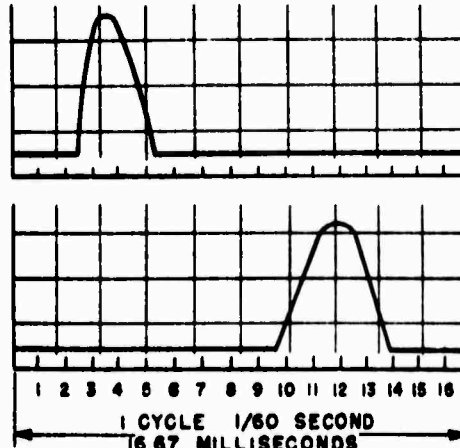

Fig. 14. Traces showing abnormal charger output condition. (Trace A shows PRD1 only providing current, but under controlled conditions. Trace B shows PRD2 only providing current, but out of control in an overloaded condition.)

- ing A and B, replace Module C. If still no firing pulses appear, proceed further with the check sequences of Table A.
2. If firing pulses are obtained similar to traces A and B, and C and D, replace the module from which no firing pulse is obtained. If this replacement does not clear the trouble, proceed with the check sequence in Table A.
  3. If firing pulses similar to traces F and G, or G and H of figure 12 appear, replace the module which shows a shape similar to trace F. After replacing the suspected module, if the firing pulses do not become normal as shown in figure 11, replace Module C. If this still does not clear the fault, proceed with the sequence of Table A.
- f. The above checks in paragraph e. will reveal if modules A, B, and C are at fault. To clear the control unit, a check of Module D and associated parts is necessary, proceed as outlined below:
1. When an abnormal output exists, or the voltage and current controls appear ineffective, either

control Module D, the externally connected adjustment potentiometers, or the associated wiring may be at fault.

2. With a voltmeter of suitable range, check the voltage between the black wire on FAR rheostat and the red/white wire on the EAR rheostat. The indicated voltage should be equal to the charger output voltage (battery voltage). If the voltage indicated is much lower than the battery voltage, or if it is zero, check for open circuits in the associated wiring.
3. If the correct battery voltage is indicated in step 2, connect the voltmeter between the red/white wire on EAR and the orange/white wire on FAR. If no voltage is now indicated, replace the FAR rheostat. If substantially the battery voltage is indicated, but it is slightly lower than the previous battery voltage indicated, replace Module D.
4. After the fault is located and firing pulses are obtained as in figure 11, the output pulse wave-

**Fig. 12. Typical faulty traces showing deformed or missing pulses with explanation of causes.**

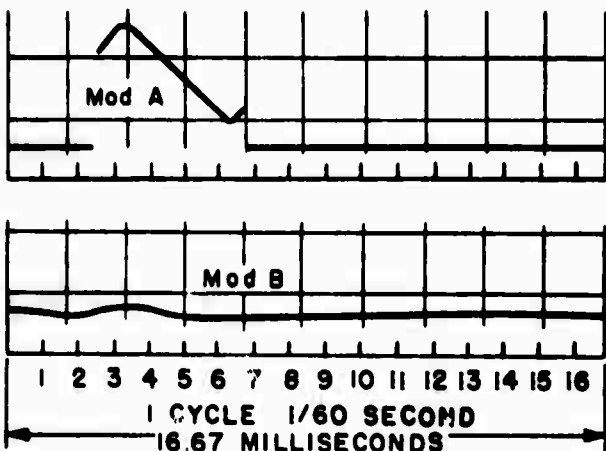

**TRACES A and B:** These traces show satisfactory firing pulse from Module A, but none at all for Module B. The fault may be in Module B, in PRD2 (SCR), or in connecting wiring.

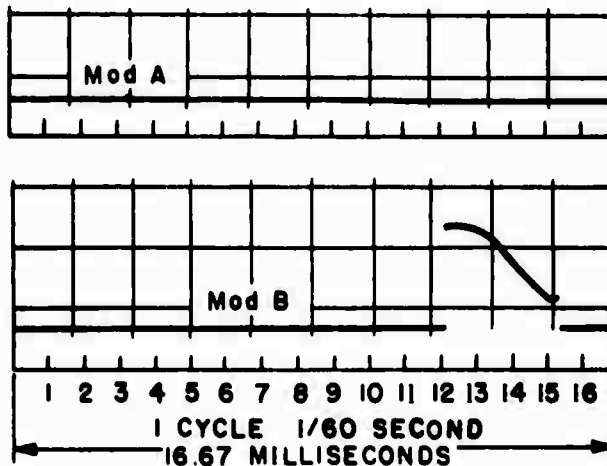

**TRACES C and D:** These traces show a satisfactory firing pulse for Module B, but none at all for Module A. The fault may be in Module A, in PRD1 (SCR), or in connecting wiring.

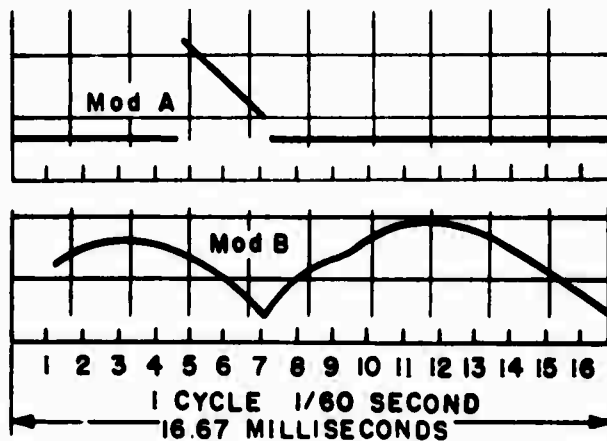

**TRACES E and F:** These traces show a satisfactory firing pulse from Module A, but an unsatisfactory pulse from Module B. Replace Module B, it is at fault.

form should be checked as described in paragraph g. below. If traces similar to those of A and B of figure 13 are obtained, the output is satisfactory, and the charger should respond properly to voltage and current adjustment. Adjust the voltage as described in paragraph 3.H.b., and the current as described in paragraph 3.I.b.

g. To display the charger output current waveform, set the V. MULTIPLIER control on the oscilloscope to 1 and leave the remaining controls set as in Table B. Then make the following connections and adjustments.

1. Deenergize charger (PCB and BCB at OFF). Connect the oscilloscope vertical input lead to the side of current sensing resistor CSR, that connects to PRD1 and PRD2 (lead 32), and connect the grounding plug lead to the other side of the CSR (lead 34) which connects to BCB. See Fig. 8.
2. Energize the charger (PCB and BCB at ON) and adjust the V. MULTIPLIER control clockwise until the signal trace height is approximately

two scope chart divisions. If necessary, adjust FREQUENCY control to keep trace stationary. The signal trace is illustrated and the conditions are explained in figures 13 and 14.

#### H. Voltage Adjustment and Response

a. When abnormal output voltage exists (or no output current is present) and the previous checks in Table A sequence have been made without locating the fault, turn BCB to OFF to disconnect the battery and proceed as follows:

1. Check the battery voltage with a portable voltmeter of one-percent accuracy, such as the Weston model 45, 280, or 281 and compare it against the float voltage adjustment range on the charger nameplate to make certain that the battery voltage is *not higher* than this range. For proper operation, the open circuit voltage of the battery must be lower than the rated float voltage.
2. If the battery voltage is higher than the float voltage range, check the number and type of cells

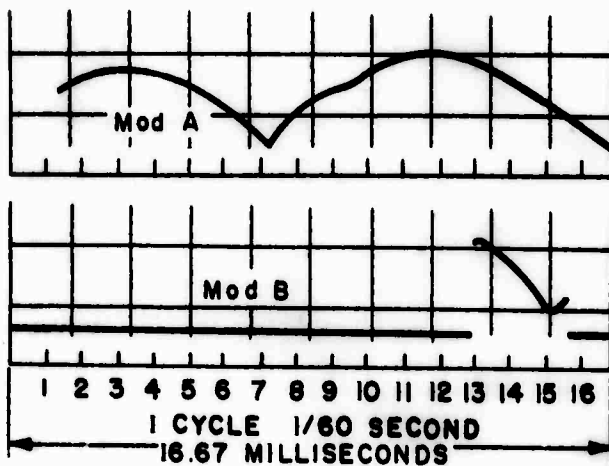

TRACES G and H: These traces show a satisfactory firing pulse from Module B, but an unsatisfactory pulse from Module A. Replace Module A, it is at fault.

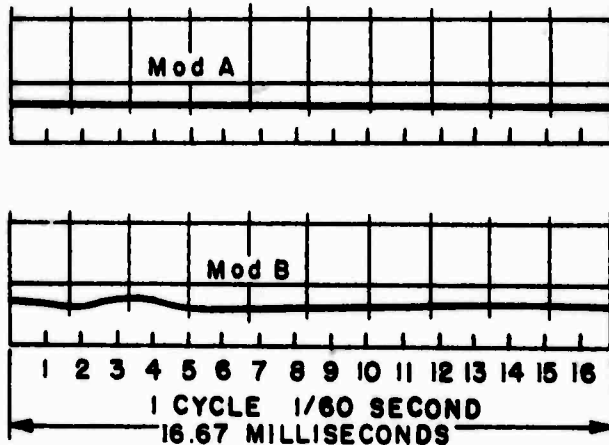

TRACES I and J: These traces show no firing pulse from Module A as well as Module B. This type of trace is associated with a series of tests of other components, see paragraphs 3.G.c., and f.

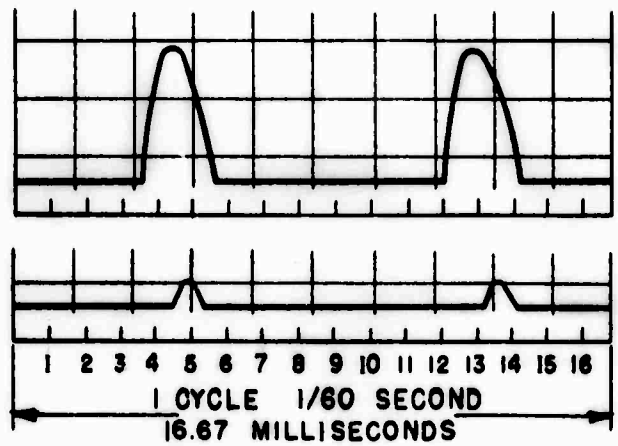

Fig. 13. Traces showing normal condition of charger output current. (Trace A is for rated charger current. Trace B is for about 10% rated charger current.)

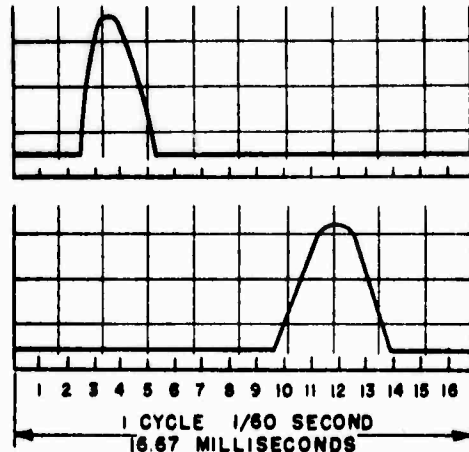

Fig. 14. Traces showing abnormal charger output condition. (Trace A shows PRD1 only providing current, but under controlled conditions. Trace B shows PRD2 only providing current, but out of control in an overloaded condition.)



connected to the charger making certain the proper number and type of cells are not exceeded.

3. Close BCB breaker to connect charger to battery. If battery voltage is now within the float voltage range, or is slightly lower, proceed with step 4. However, if the battery voltage rises too high with BCB closed, but is within range when BCB is open, make certain that the equalizing charge timer is at zero (or turn charge switch CS to FLOAT, and also turn FAR control counterclockwise). If still no reduction in voltage is obtained, proceed with the check sequence in Table A trouble-shooting chart.
4. If the battery voltage is slightly lower or within the float voltage range, turn the equalizing timer or charge switch CS to EQUALIZE. If still no output appears, or the voltage does not rise from the previous value, turn float charge control FAR fully clockwise, and if still no voltage rise is obtained or no output appears, proceed with the remaining check sequences in Table A trouble-shooting chart.
5. If the voltage increased or output was obtained when charge switch CS was turned to EQUALIZE in step 4, proceed with the voltage adjustment as described in paragraph 3.H.b. below.

**b. Float Adjustment (FAR).**

1. Since the charger must be operable for this adjustment, preceding checks in Table A, paragraph 3 above must indicate a serviceable charger. Use a portable voltmeter of one-percent accuracy such as Weston Model 45, 280, or 281. Connect the battery supply leads to the battery and energize d-c (battery) breaker BCB. Set a-c circuit breaker PCB to ON.
2. Since the equalizing voltage is higher than the float voltage, the float voltage is reached first. And, since the float voltage adjustment will affect the equalizing adjustment, it should always be made first.
3. Note and mark the position of the float control (FAR) so that it can be reset to the same position. Turn the control fully clockwise, watching the response on the portable voltmeter. Clockwise rotation should cause the charger output current to increase rapidly, while the voltage should rise slowly, depending upon whether the battery is fully charged, the size of any connected load, and the size of the charger versus the size of the battery. After getting several volts response in battery voltage rise, turn the float control counterclockwise, which should result in a rapid drop in charger output current to about half rated value, and eventually in a slow decrease in battery voltage.
4. Return float control to its initial setting, or leave it at the desired float voltage setting.

**c. Equalize Adjustment (EAR)**

1. Since the equalize adjustment will not affect the float voltage adjustment and requires a higher voltage, it should always be made after the float voltage is determined as in paragraph 3.H.h. above. Use a portable voltmeter of one-percent accuracy as in the float adjustment. Connect battery supply leads to the battery and energize d-c

(battery) breaker at BCB. Set a-c circuit breaker PCB to ON.

2. Note position and mark it, so that equalizing voltage control EAR can be reset to the same position. On chargers equipped with a timer, set manual timer off zero to close its contacts, or if there is an automatic timer, set charge switch CS to EQUALIZE. Then turn equalizing control EAR clockwise. The current output indicated on the charger ammeter should increase sharply, while the voltage slowly rises, depending on whether the battery is fully charged, the size of any connected load, and the size of the charger versus the size of the battery. Use the most convenient of the following two methods of adjustment of the EAR control.
3. Turn equalizing control fully clockwise to maximum voltage position. Charger will deliver full output (110 percent of rated charger current). When the desired equalizing voltage is reached, or is slightly exceeded, turn EAR control counterclockwise until charger output decreases to below the rated charger current. Observe the portable voltmeter, and when the battery voltage reaches the desired equalizing voltage, the current output of the charger should be about one-half the charging rating. Leave the control set at this point.
4. When the battery is in a discharged condition, it will take several hours of charging to reach the equalizing voltage. An alternate adjustment procedure for this case is as follows. Turn the EAR control clockwise a little at a time to raise the battery voltage. Each time, wait until the current (ampere) output from the charger drops from the current limit (110 percent of charger rating) to below the maximum current rating, before turning the control a little more to raise the battery voltage. When the desired equalizing voltage is reached, stop turning the EAR control and allow the charger current to decrease to about one-half rated charger current. Turn the EAR control slightly in either direction, if necessary, to obtain this half-current indication.

**I. Current Limit Adjustment and Response**

**a.** When high output current exists, control Module D, current sensing resistor CSR, or the interconnecting wiring may be at fault. Make the following checks to isolate the fault.

1. Turn potentiometer P4 on Module D counterclockwise. If the high output current now decreases, make the current adjustment described in paragraphs b. or c. below, as applicable.
2. If the output current does not decrease when P4 is turned, replace Module D.
3. After replacing Module D, if the output current shows no response to the adjustment of P4 and remains high, check the wiring between current sensing resistor CSR and the Module. If the wiring is satisfactory, proceed with the check sequence listed in Table A trouble-shooting chart.

**b. Manual Reset Timer (ECT).**

1. Make certain charger leads are connected to the battery and that panel voltmeter indicates the proper polarity. Place battery circuit breaker

- BCB to ON and a-c line circuit breaker PCB to ON. Pilot light should illuminate indicating power is applied.
2. With timer knob at zero (off position), a float voltage charge should be indicated on the panel voltmeter and the ammeter should show either a low charge current, or practically none at all, depending on the state of the battery charge.
  3. Turn reset control knob to maximum (72 hours) position, and check that output voltage increases and that the charge current on ammeter rises sharply to 110% of rated charge current. As the equalizing charge continues, the timer control knob should revolve counterclockwise towards zero, and the voltmeter indication should rise above the initially observed value and slowly increase. The time to note a definite increase of voltage will depend upon the state of charge of the battery, but the test should be continued long enough to determine that the voltage is increasing.
  4. Now turn PCB breaker OFF to simulate line voltage failure. Timer control knob should stop (this will require close observation to determine), charging current should return to zero (panel ammeter), and voltage should reduce slightly. Place a load on the battery and discharge it heavily for a short period of time until the voltmeter drops to float value or slightly lower.
  5. Return PCB breaker to ON and observe that charge ammeter again reads 110% of charge rate and voltage increases to equalizing level. If current is greater than, or less than 110-percent of rated charge, open cabinet door and break seal on lower potentiometer on Module D. Adjust this control (P4) for 110-percent charge rate. Close door and repeat step 4, then step 5. If charge rate resumes the value for which it was set, reseal P4 and close door. Turn timer knob to zero or leave it equalize, as desired.
- c. Automatic Reset Timer (ECT).**
1. Make certain charger leads are connected to the battery, and that panel voltmeter indicates the proper polarity. Place CHARGE switch (CS) to FLOAT position, set battery breaker BCB to ON, and line breaker PCB to ON. Pilot light should illuminate indicating a-c power is applied.
  2. A float-voltage charge should now be indicated on the panel voltmeter and the ammeter should show either a low charge current, or practically none at all, depending on the state of battery charge.
  3. Set CHARGE switch (CS) to EQUALIZE, and check that the output voltage increases (panel meter), and that the charge current on the ammeter rises sharply to 110% of rated charge current. As the equalizing charge continues, the progress pointer inside the timer dial will revolve slowly counterclockwise towards zero and the output voltage as indicated on the panel meter should slowly increase. The time to note a definite increase of voltage will depend upon the state of charge of the battery, but the test should be continued long enough to determine that the voltage is increasing.
  4. Turn PCB breaker OFF to simulate a line voltage failure. Timer progress pointer should stop and reset to initial time setting, charging current should return to zero (panel ammeter), and output voltage should reduce slightly. Place a load on the battery and discharge it for a short period of time until the voltmeter drops to float value or lower.
  5. Return circuit breaker PCB to ON and observe that charger ammeter again reads 110% of charge rate, and that voltage increases again to equalizing level. The timer progress pointer will travel towards zero. (Pointer resets on deenergization.) If charge current is now greater than, or less than 110 percent of rated charge current, open cabinet door, break seal on lower potentiometer of Module D. Adjust this control (P4) for 110 percent charge rate. Close door and repeat step 4, then step 5. If charge rate resumes value for which it was set, reseal P4 and close door (otherwise readjust charge rate and repeat until stabilized). Leave CHARGE switch in either FLOAT or EQUALIZE position, as desired.
- J. Timer (ECT)**
- a. Manual Set Equalizing Charge Timer**
1. Energize charger as in paragraph 3.H.b.1. above.
  2. Turn timer knob off zero (slightly clockwise) and observe that charger current increases to maximum value and battery voltage starts to rise. Meanwhile, timer motor is operating and timer knob is revolving slowly counterclockwise towards zero. When the timer knob reaches zero, the output voltage should drop to float-voltage value and output current should drop to zero, temporarily, until the float voltage is reached.
  3. If operation does not occur as in step 2 above, check timer contacts to determine if they opened; if they did not, replace the timer. If the timer motor stopped running before reaching zero and dropping the charger output, try changing connections between timer motor and voltage sensing contacts. Interchange leads 1 and 2 with leads 7 and 8 (terminals are numbered on fibre plate on back of timer). If interchanging leads does not prevent motor stopping before opening contacts, replace the timer.
- b. Automatic Set Equalizing Charge Timer**
1. The automatic set circuit involves three parts, namely: Equalizing Charge Timer (ECT), Charge Switch (CS), and Time Delay Relay (TDR). Energize charger and follow steps 1 through 4 of paragraph 3.H.c. above.
  2. Set PCB breaker to ON and observe that equalizing voltage and charge rates are produced.
  3. Set CHARGE switch (CS) to FLOAT position (the progress pointer should reset to full preset time), observe that float voltage and that a low or no-charge rate is indicated. Then turn PCB to OFF and immediately back to ON, observe that float charge condition still prevails. Now turn PCB to OFF for about 10 seconds (not less than 5 seconds) and then to ON. Charge should increase to full rate and to equalizing voltage for preset period to which timer knob is set, the



progress pointer should return slowly toward zero as it charges. When the progress pointer reaches zero, charger will automatically return to float condition. The progress pointer should also reset to full preset time.

4. If timer does not automatically switch to equalize operation when PCB is turned off for more than 5 seconds, check operation of the time delay relay TDR (paragraph 3.K.). If timer does not return to float condition automatically at end of equalizing charge, check timer operation and contacts to determine if they opened.

#### K. Time Delay Relay (TDR)

a. The time delay relay (TDR) is of the plug-in type and is mounted inside the cabinet. It is set for a 5-second time delay.

b. When energized across terminals 2 and 3 by 115 VAC, the contact between terminals 5 and 7 is normally closed. After being deenergized for 5 seconds or more these contacts open.

c. Remove the time delay relay and connect terminals 2 and 3 to a 115 VAC supply. Connect an ohmmeter (or a lamp in series with an adequate voltage supply) in series with the TDR contact terminals 5 and 7, then remove supply voltage from terminals 2 and 3. The ohmmeter will indicate zero, or the lamp will operate, as long as the contacts are closed. They should open after 5 seconds in the deenergized position, if not, replace TDR.

#### L. Internal Wiring

a. Check internal wiring for obvious mechanical faults or wear. Follow the correct wiring diagram in Form No. 6777, Section 58.20, for the charger model used, and check continuity with an ohmmeter to determine open connections. Check wiring against ground also, and remove any grounds.

#### M. Current Sensing Resistor (CSR)

a. Use a portable precision voltmeter of the type listed in paragraph 1.c., and measure the voltage drop across current sensing resistor CSR. With rated current output indicated on the panel ammeter, a nominal voltage drop of 0.3 volts or less (in proportion to rated current) should be observed.

b. If voltage drop is higher or lower than the nominal indication, replace the CSR with the spare unit and recheck the voltage drop.

#### N. Battery Voltmeter (BVM)

a. The battery voltmeter is of the 2-percent accuracy type. It is connected across the charger output to the battery and should indicate regardless of whether or not the charger is operating, or BCB switch is ON. If it does not, use a precision voltmeter of the 1-percent type (such as Weston model 280 or 281) shunted across the meter terminals. An indication on the test meter will show that panel meter BVM is open, or not connected. Check the wiring for an open circuit, and replace meter if circuit wiring is complete.

b. A shorted voltmeter will also show no indication but will actuate the battery circuit breaker and disconnect the charger. Meanwhile, the heavy discharge battery current through the meter will cause a visible indication such as smoke from burning wire insulation. Disconnect the charger from the battery and replace the meter.

c. If the meter calibration is in doubt, checking against the precision meter will determine if the panel voltmeter is off calibration more than two percent.

#### O. Charger Ammeter (CAM)

a. The charger ammeter is connected in series between the charger output and battery. If open (or no charge occurs) it will indicate zero, or if shorted, it will also indicate zero. First be certain the connections are tight. If still no indication, turn PCB or BCB switches to OFF position, disconnect the charger ammeter, and substitute a precision ammeter of suitable range (Model 280 or 281 Weston, or similar). Be certain to make solid connections; clip contacts may not carry sufficient current, or may make poor contact and cause the reading to be inaccurate.

b. A reverse-scale indication of the meter indicates the charger is inoperative or internally shorted, and that the battery is discharging through rectifier, or that the meter leads have been reversed. Turn BCB and PCB to OFF and check wiring and meter connections. Then check meter operation, using a 1½ volt D-Cell as the power source.

# Exide

## CONSTANT VOLTAGE BATTERY CHARGERS

### SINGLE-PHASE

### MODEL US & USF — WITH SILICON-CONTROLLED RECTIFIERS

#### SECTION 57.01

For float service on single-phase, 60 Hz AC power supply. Charges lead-acid, nickel-cadmium and nickel-iron alkaline batteries.

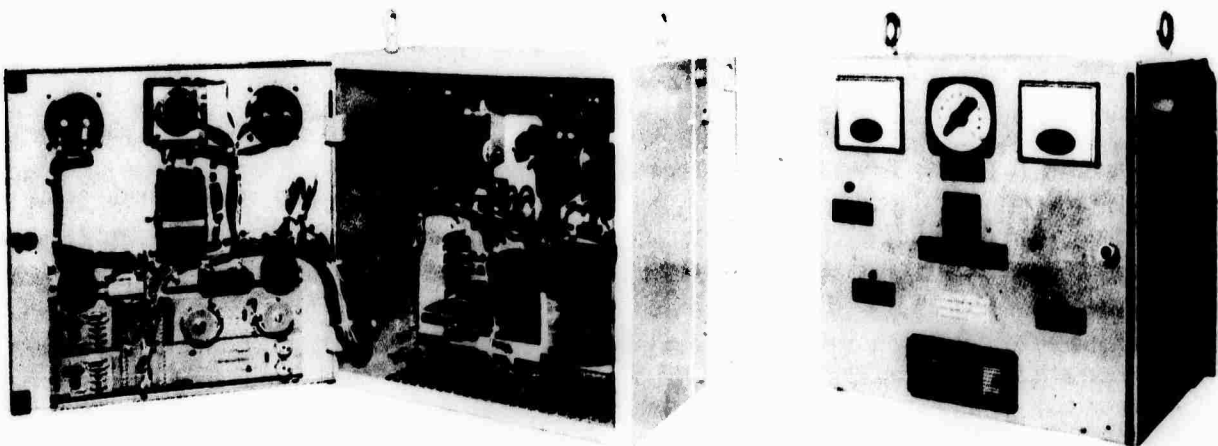

Model US-50-1-6 Charger

- Latest solid-state circuitry.
- Filtered and unfiltered models available.
- Completely self-protected—no input or output fuses required.
- Truly short-circuit proof—will not open breakers.
- Will recharge completely discharged batteries without overloading or opening breakers.
- Standard units equipped with manually-set equalize charge timer.
- Can be supplied with automatically-set equalize charge timer to reduce maintenance time.
- Uses economical, non-encapsulated plug-in control units.
- Permits paralleling to other constant voltage chargers.
- Maintains 1/2% float voltage regulation 0 to 100% capacity, with  $\pm 10\%$  line voltage variation at 60 Hz  $\pm 5\%$ .
- Meets NEC, NEMA, and ASA standards.

## How The Exide US Single-Phase Charger Works

Exide US single-phase chargers are completely self-protected. Power is fed through AC breakers to a power-voltage transformer. The AC breakers provide isolation of the charger from the AC source and protect the charger against damage from internal faults. The transformer provides isolation between the AC source and the battery—and converts AC supply voltage to the voltage needed in the AC/DC converter.

Conversion to DC occurs in a full wave, silicon controlled rectifier (SCR) section. The SCR's provide rectification and also serve as phase controlled power elements. They are protected against transient surge voltages both on the AC and the DC side.

Voltage regulation and current limit are provided by a feedback loop. Specifically, DC voltage from the charger is fed into a voltage sensing network containing a float and equalizing control potentiometer and a voltage control reference. Concurrently, a current-limit signal is fed from a current sensing resistor into a current sensing network. A control circuit then selects either voltage- or current-limit operation, monitoring the phase shifter to give firing impulses precisely when needed to control the SCR's for proper charger output. Power for firing control comes from the control-voltage transformers.

These sensitive circuits assure close voltage control and overload protection — right down to short circuit of the output terminals. Furthermore, when the AC current returns to recharge a completely discharged battery, the charger will not overload itself and open the circuit breakers thus saving the expense of a costly field trip to close them. The circuit breakers will operate only to protect the system in case of internal charger failure.

Filtering\* in the USF models, is accomplished by a properly designed filter section installed at the output of the rectifier section of the charger.

The DC output breakers function mainly to isolate the charger from the battery, protecting both from possible faults in the charger.

To provide a fully automatic fast recharge after an AC outage these chargers can be furnished with an automatically-set, equalize charge timer. This timer, which can be set for any time period between 0 and 75 hours, boosts the charging voltage to the set equalizing voltage after every AC outage. After the preset time period has elapsed the charger automatically returns to the normal float voltage. This assures a fully charged, healthy battery immediately after every AC failure without any additional maintenance expenditure.

\* Ripple content of the charger output voltage wave form will be less than 0.03 Volts (30 MV.) RMS under steady state conditions with charger connected to a battery having an 8 hour rating of at least 4 times the full load current rating of the charger.

### HOW TO SIZE CHARGER FOR STATIONARY BATTERY APPLICATIONS

To select a charger to recharge a battery in the minimum time and recharging it at the equalizing voltage (2.33 v.p.c. for lead-acid, 1.55 v.p.c. for nickel-cadmium and 1.6 v.p.c. for nickel-iron) use the following formula:

$$A = \frac{AH \times 1.10}{T} + L$$

where A = ampere capacity of charger, but not less than 20% of 8-hr. discharge rate of battery.

AH = ampere hours discharged from battery.

1.10 = minimum charging efficiency factor for lead-acid. Use 1.40 for nickel-cadmium and nickel-iron.

T = No. of hours for recharging.

L = continuous load on battery.

Example: Assume you have a 240 A.H. battery, discharged 50% and you want it recharged in 12 hours and charger is to also supply a continuous load of 5 amperes.

$$A = \frac{(240 \times .50) \times 1.10}{12} + 5 = 11 + 5 = 16 \text{ ampere charger.}$$

## Equipment for Exide US & USF Single-Phase Chargers

### STANDARD

1. Input AC magnetic circuit breaker.
2. Output 1 pole DC magnetic circuit breaker.
3. Output DC voltmeter, 3½ inch scale, 2% accuracy.
4. Output DC ammeter, 3½ inch scale, 2% accuracy.
5. Float voltage potentiometer.
6. Equalizing voltage potentiometer.
7. Current limit set at 110% capacity.
8. 0-72 hour manually-set, equalize charge timer.
9. 230 volt AC chargers have 208v, 220v, 230v, 240v taps.
10. 115 volt AC chargers have 110v, 115v, 120v taps.
11. AC power "ON" pilot light.
12. Cabinets are NEMA Type I painted with ASA 61 dull gray paint. S1 thru S4, S21, S31 & S41 are #14 gauge steel. S5 thru S10 cabinets are #11 gauge.
13. Convection cooled for up to 104 F (40 C) ambient temperature operation.
14. USF models have output ripple suppressed to 30 MV.

### OPTIONAL

This equipment is available at a slight increase in cost in lieu of standard parts.

1. Output DC voltmeter, 3½ inch scale, 1% accuracy.
2. Output DC ammeter, 3½ inch scale, 1% accuracy.
3. 0-75 hour automatically-set, equalize charge timer which operates automatically after an AC voltage failure longer than 5 seconds.
4. Toggle switch in lieu of equalizing timer.

### ACCESSORY

The following can be added at installation. If delivery time permits, it may be added at factory (exception, items 6 and 7):

Item No.	Name	Cat. Sect.	Form No.
1	AC failure alarm relay (PLR)	57.41	6771
2	Ground detection lamp with switch (GDL)	57.42	6772
3	Ground detection using charger, voltmeter and switch (GDS)	57.44	6773
4	Ground detection relay (GDR)	57.43	6774
5	DC low or high voltage alarm relay (LVR) (HVR)	57.45	6775
6	Drip-proof shield for above chargers	—	—
7	23" Rack mounting bracket (applied after discarding the std. brackets for 19" mtg.)	—	—

\* When any accessory equipment items 1 to 5 are added, or the automatic reset timer, a self-adhering sticker appears at charger nameplate.

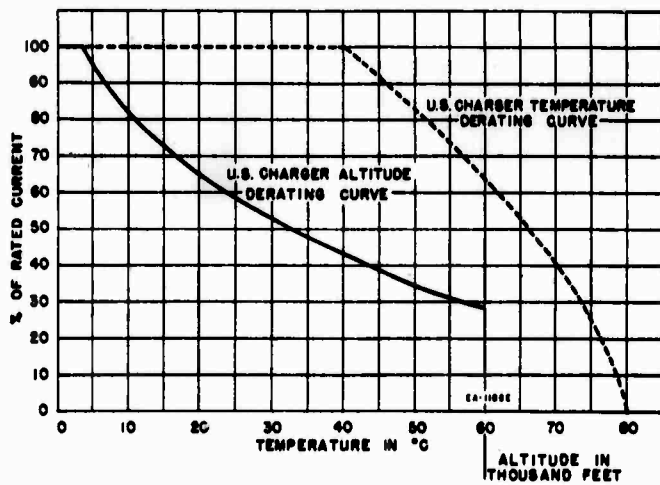
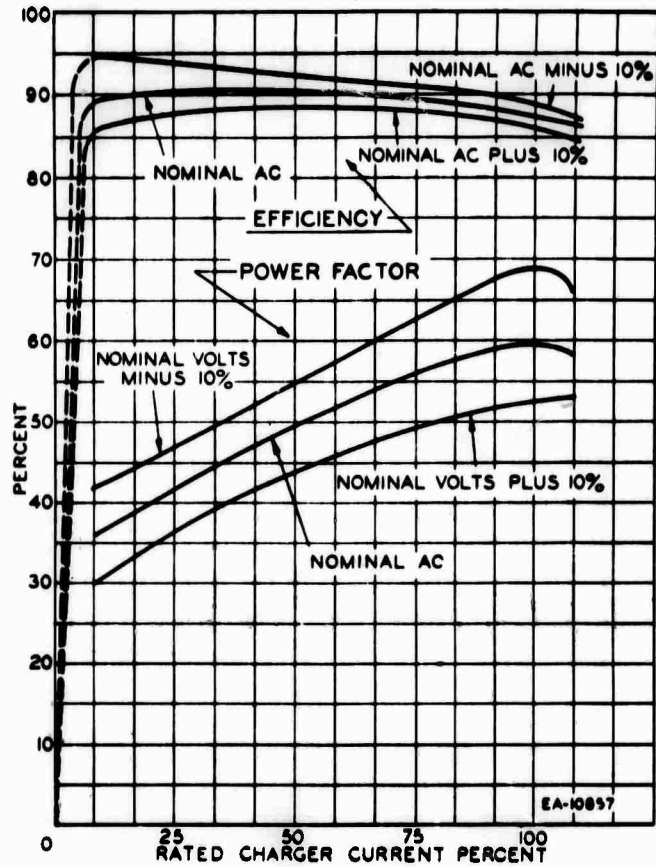
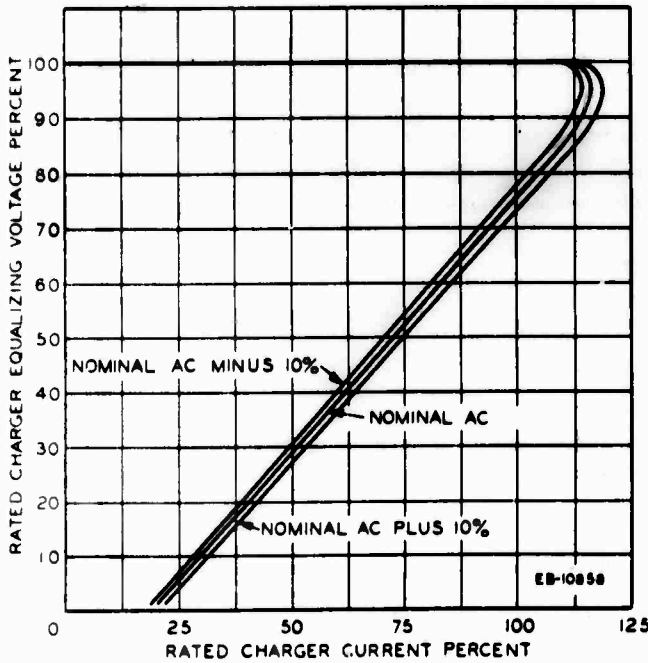
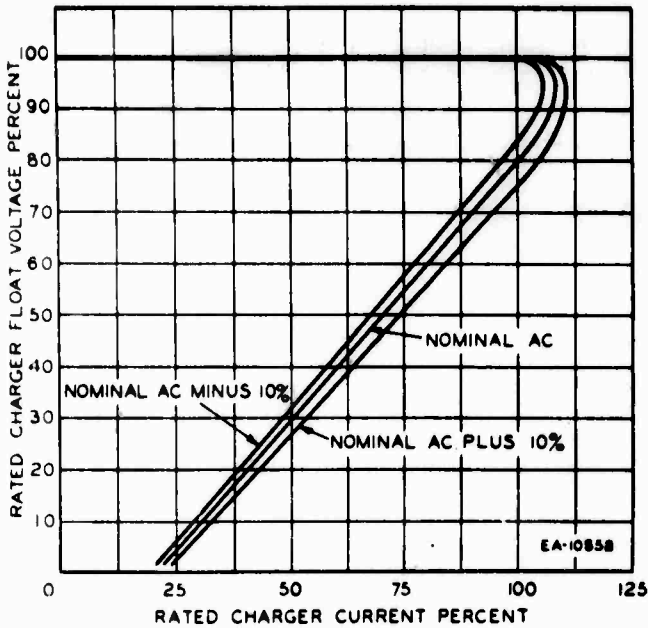

**ADDITIONAL CATALOG SECTIONS FOR EXIDE SINGLE-PHASE CHARGERS**

Item No.	Title	Cat. Sect.	Form No.
1.	Unfiltered Model US Data—electrical ratings, weights and cabinet sizes .....	57.03	7157
2.	Filtered Model USF Data—electrical ratings, weights and cabinet sizes .....	57.04	7158
3.	Accessories for use with all single- and three-phase Model US and USF Chargers..	57.40	7159
4.	Schematic diagrams—Unfiltered Model US, nominal 12-volt DC output .....	57.05	7160
5.	Schematic diagrams—Unfiltered Model US, from 25 to 260-volts DC output .....	57.06	7161
6.	Schematic diagrams—Filtered Model USF, nominal 12-volts DC output .....	57.07	7162
7.	Schematic diagrams—Filtered Model USF, from 25 to 260-volts DC output .....	57.08	7163
8.	S1 and S2 Cabinet Outline Drawings .....	57.10	7071
9.	S3 and S4 Cabinet Outline Drawings .....	57.11	7072

**INSTRUCTIONS FOR EXIDE SINGLE-PHASE CHARGERS**

Item No.	Name	Cat. Sect.	Form No.
1.	Installing and Operating Instructions including schematic and wiring diagrams....	58.20	6777
2.	Parts List .....	103.00	6779
3.	Service Manual .....	58.25	6780



# PARTS LIST

## EXIDE Constant Voltage Float Charger— Model US, Single Phase, 60 Cycle AC Supply

**NOTE 1.** When ordering parts, also give the full description of the charger as shown on its nameplate, particularly the serial number as well as the catalog number.

**NOTE 2.** This parts list is for the standard charger, with the Manual Timer, cat. no. 147 108 001, being the same in all models shown. For a charger with the Automatic Reset Timer (AECT) the manual timer is omitted, and, in all the models shown, these four parts are used to accomplish the timer automatic resetting feature—

Symbol	Part Name	Part Cat. No.
CS	Charger Switch	145 901 013
ECT	Automatic Timer	147 108 002
TDR	Time Delay Relay	140 302 001
	Socket for TDR	154 103 005

### OTHER PUBLISHED US CHARGER INFORMATION IS—

	Section No.	Form No.
Data or Catalog information	56.50	6778
Installing & Operating information, plus diagrams	58.20	6777
Service Manual (Trouble Shooting)	58.25	6780

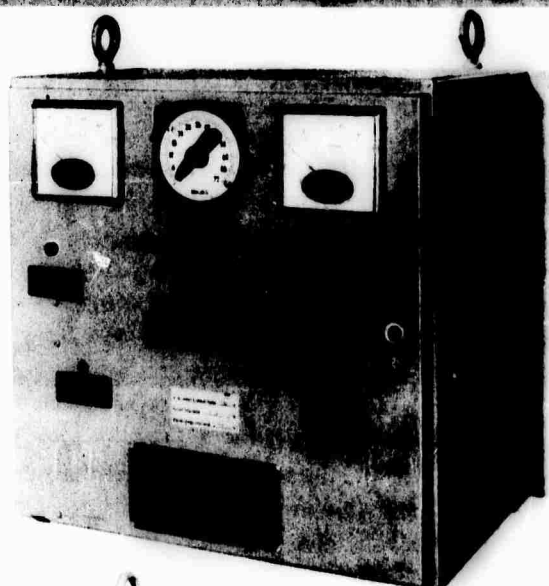

Model US-50-1-6 Charger,  
door closed

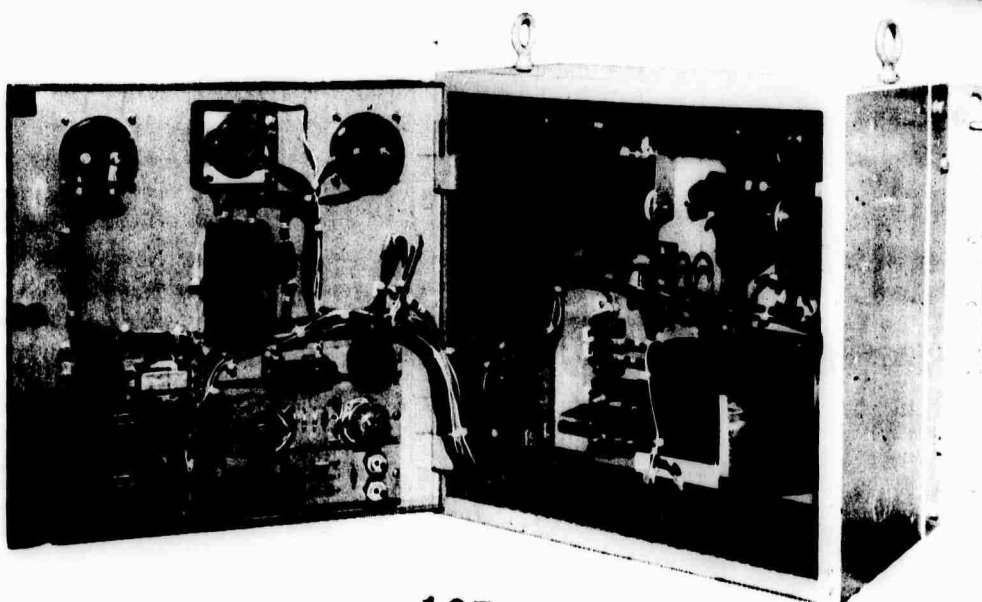

Model US-50-1-6 Charger,  
door open

Form 6779



PARTS LIST

Item No.	Charger Model Cat. No.	US-12-1-1 101 100 101	US-12-1-3 101 100 201	US-12-1-6 101 100 301	US-12-1-9 101 100 401	US-12-1-12 101 100 501	US-12-1-16 101 100 601	US-12-1-20 101 100 701	US-12-1-25 101 100 801	US-25-1-1 101 101 001	US-25-1-3 101 101 011	US-25-1-6 101 101 061
1	Charger D-C Ammeter (CAM)	136 401 066	136 401 067	136 401 068	136 401 069	136 401 071	136 401 071	(S)136 402 198	(S)136 402 198	136 401 066	136 401 067	136 401 068
2	Battery Circuit Breaker (BCB)	122 111 003	122 111 010	122 111 011	122 111 013	122 111 014	122 111 016	122 111 018	122 111 018	122 111 003	122 111 010	122 111 011
3	Voltmeter D-C (BVM)	136 301 083	136 301 083	136 301 083	136 301 083	136 010 083	136 301 083	136 301 083	136 301 083	136 301 084	136 301 084	136 301 084
4	Current Sensing Resistor (CSR)	141 121 008	141 121 001	141 121 002	141 121 003	141 121 004	141 121 005	141 121 006	141 121 006	141 121 008	141 121 001	141 121 002
5†	Control Module A (Mod. A)	101 070 201	101 070 201	101 070 201	101 070 201	101 070 203	101 070 203	101 070 203	101 070 203	101 070 203	101 070 201	101 070 203
6†	Control Module B (Mod. B)	101 070 201	101 070 201	101 070 201	101 070 201	101 070 203	101 070 203	101 070 203	101 070 203	101 070 201	101 070 201	101 070 203
7†	Control Module C (Mod. C)	101 070 301	101 070 301	101 070 301	101 070 301	101 070 301	101 070 301	101 070 301	101 070 301	101 070 301	101 070 301	101 070 301
8†	Control Module O (Mod. O)	101 070 401	101 070 401	101 070 401	101 070 401	101 070 401	101 070 401	101 070 401	101 070 401	101 070 402	101 070 402	101 070 402
9	Master Control Board (m) (Mod. M)	101 070 101	101 070 101	101 070 101	101 070 101	101 070 101	101 070 101	101 070 101	101 070 101	101 070 101	101 070 101	101 070 101
10†	Control Transformer (CVT)	149 308 021	149 308 021	149 308 021	149 308 021	149 308 021	149 308 021	149 308 021	149 308 021	149 308 021	149 308 021	149 308 021
11†	Equal. Adjust. Rheostat (EAR)	141 509 005	141 509 005	141 509 005	141 509 005	141 509 005	141 509 005	141 509 005	141 509 005	141 509 006	141 509 006	141 509 006
12†	Equal. Chg. Manual Timer (ECT)	147 108 001	147 108 001	147 108 001	147 108 001	147 108 001	147 108 001	147 108 001	147 108 001	147 108 001	147 108 001	147 108 001
13	Equal. Chg. Timer Knob (EQT)	133 101 004	133 101 004	133 101 004	133 101 004	133 101 004	133 101 004	133 101 004	133 101 004	133 101 004	133 101 004	133 101 004
14†	Float Adjust. Rheostat (FAR)	141 509 008	141 509 008	141 509 008	141 509 008	141 509 008	141 509 008	141 509 008	141 509 008	141 509 011	141 509 011	141 509 011
15	Power Circuit Breaker A-C (PCB)	122 111 001	122 111 002	122 111 003	122 111 005	122 111 005	122 111 007	122 111 010	122 111 010	122 111 001	122 111 003	122 111 005
16	Pilot Light A-C (PLL)	139 304 001	139 304 001	139 304 001	139 304 001	139 304 001	139 304 001	139 304 001	139 304 001	139 304 001	139 304 001	139 304 001
*17†	Power Regulating Device, SCR (PRD)	143 312 004	143 312 004	143 312 001	143 312 001	143 312 001	143 312 001	143 312 001	143 312 001	143 312 004	143 312 001	143 312 001
18	Heat Sink Assembly for PRD	131 102 054	131 102 051	131 102 051	131 102 051	131 102 051	131 304 004	131 304 004	131 304 004	131 102 052	131 102 050	131 102 051
*19†	Power Diode (PRX)	None	None	None	None	None	None	None	None	None	None	None
20	Heat Sink Assembly for PRX	None	None	None	None	None	None	None	None	None	None	None
21†	Resistor (RS)	None	None	None	None	None	None	None	None	None	None	None
22†	Surge Voltage Suppressor (SVS)	2	2	2	2	2	2	2	2	2	2	2
23†	Power Transformer (PVT)	141 923 006	141 923 006	141 923 006	141 923 006	141 923 006	141 923 006	141 923 006	141 923 006	141 923 006	141 923 006	141 923 006

Recommended Spare Parts: \* For domestic shipment; † For export shipment. Notes: (m) = Master Control Board has CVT mounted on it as standard (s) = Ammeter on 20 and 25 amp. sizes employs external shunt 136 403 056.

Item No.	Charger Model Cat. No.	US-25-1-1 101 101 201	US-25-1-12 101 101 301	US-25-1-16 101 101 401	US-25-1-25 101 101 501	US-32-1-1 101 101 701	US-32-1-3 101 101 801	US-32-1-4 101 101 901	US-32-1-9 101 102 001	US-32-1-12 101 102 101
1	Charger O-C Ammeter (CAM)	136 401 069	136 401 071	136 401 071	(S)136 402 198	136 401 066	136 401 067	136 401 068	136 401 069	136 401 071
2	Battery Circuit Breaker (BCB)	122 111 013	122 111 014	122 111 016	122 111 018	122 111 018	122 111 018	122 111 018	122 111 018	122 111 014
3	Voltmeter D-C (BVM)	136 301 084	136 301 084	136 301 084	136 301 084	136 301 084	136 301 084	136 301 084	136 301 084	136 301 084
4	Current Sensing Resistor (CSR)	141 121 003	141 121 004	141 121 005	141 121 006	141 121 007	141 121 008	141 121 008	141 121 003	141 121 004
*5†	Control Module A (Mod. A)	101 070 203	101 070 203	101 070 203	101 070 203	101 070 203	101 070 203	101 070 203	101 070 203	101 070 203
6†	Control Module B (Mod. B)	101 070 203	101 070 203	101 070 203	101 070 203	101 070 203	101 070 203	101 070 203	101 070 203	101 070 203
7†	Control Module C (Mod. C)	101 070 301	101 070 301	101 070 301	101 070 301	101 070 301	101 070 301	101 070 301	101 070 301	101 070 301
8†	Control Module O (Mod. O)	101 070 402	101 070 402	101 070 402	101 070 402	101 070 402	101 070 402	101 070 402	101 070 403	101 070 403
9	Master Control Board (m) (Mod. M)	101 070 101	101 070 101	101 070 101	101 070 101	101 070 101	101 070 101	101 070 101	101 070 101	101 070 101
10†	Control Transformer (CVT)	149 308 021	149 308 021	149 308 021	149 308 021	149 308 021	149 308 021	149 308 021	149 308 021	149 308 021
11†	Equal. Adjust. Rheostat (EAR)	141 509 006	141 509 006	141 509 006	141 509 006	141 509 006	141 509 006	141 509 006	141 509 004	141 509 004
12†	Equal. Chg. Manual Timer (ECT)	147 108 001	147 108 001	147 108 001	147 108 001	147 108 001	147 108 001	147 108 001	147 108 001	147 108 001
13	Equal. Chg. Timer Knob (EQT)	133 101 004	133 101 004	133 101 004	133 101 004	133 101 004	133 101 004	133 101 004	133 101 004	133 101 004
14†	Float Adjust. Rheostat (FAR)	141 509 011	141 509 011	141 509 011	141 509 011	141 509 011	141 509 011	141 509 011	141 509 011	141 509 011
15	Power Circuit Breaker A-C (PCB)	122 111 007	122 111 010	122 111 011	122 111 012	122 111 012	122 111 012	122 111 012	122 111 010	122 111 010
16	Pilot Light A-C (PLL)	139 304 001	139 304 001	139 304 001	139 304 001	139 304 001	139 304 001	139 304 001	139 304 001	139 304 001
*17†	Power Regulating Device, SCR (PRD)	143 315 001	143 315 001	143 315 001	143 315 001	143 315 001	143 315 001	143 315 001	143 315 001	143 315 001
18	Heat Sink Assembly for PRD	131 102 051	131 102 051	131 304 004	131 304 004	131 102 052	131 102 050	131 102 051	131 102 051	131 102 051
*19†	Power Diode (PRX)	None	None	None	None	None	None	None	None	None
20	Heat Sink Assembly for PRX	None	None	None	None	None	None	None	None	None
21†	Resistor (RS)	None	None	None	None	None	None	None	None	None
22†	Surge Voltage Suppressor (SVS)	2	2	2	2	2	2	2	2	2
23†	Power Transformer (PVT)	141 923 006	141 923 006	141 923 006	141 923 006	141 923 006	141 923 006	141 923 006	141 923 006	141 923 006

Recommended Spare Parts: \* For domestic shipment; † For export shipment. Notes: (m) = Master Control Board has CVT mounted on it as standard (s) = Ammeter on 20 and 25 amp. sizes employs external shunt 136 403 056.

Item No.	Charger Model Cat. No.	US-32-1-16 101 102 201	US-32-1-20 101 102 301	US-32-1-25 101 102 401	US-50-1-1 101 102 501	US-50-1-3 101 102 801	US-50-1-4 101 102 701	US-50-1-9 101 102 901	US-50-1-12 101 102 901	US-50-1-16 101 103 001	US-50-1-20 101 103 101	US-50-1-25 101 103 201
1	Charger D-C Ammeter (CAM)	136 401 071	(S)136 402 198	136 401 066	136 401 066	136 401 067	136 401 068	136 401 069	136 401 071	136 401 071	(S)136 402 198	(S)136 402 198
2	Battery Circuit Breaker (BCB)	122 111 016	122 111 018	122 111 020	122 111 003	122 111 010	122 111 011	122 111 012	122 111 014	122 111 016	122 111 018	122 111 020
3	Voltmeter D-C (BVM)	136 301 084	136 301 084	136 301 084	136 301 085	136 301 085	136 301 085	136 301 085	136 301 085	136 301 085	136 301 085	136 301 085
4	Current Sensing Resistor (CSR)	141 121 005	141 121 006	141 121 007	141 121 008	141 121 001	141 121 002	141 121 003	141 121 004	141 121 005	141 121 006	141 121 007
*5†	Control Module A (Mod. A)	101 070 203	101 070 203	101 070 203	101 070 201	101 070 201	101 070 201	101 070 203	101 070 203	101 070 203	101 070 203	101 070 203
6†	Control Module B (Mod. B)	101 070 201	101 070 203	101 070 203	101 070 201	101 070 201	101 070 201	101 070 203	101 070 203	101 070 203	101 070 203	101 070 203
7†	Control Module C (Mod. C)	101 070 301	101 070 301	101 070 301	101 070 301	101 070 301	101 070 301	101 070 301	101 070 301	101 070 301	101 070 301	101 070 301
8†	Control Module D (Mod. D)	101 070 403	101 070 403	101 070 403	101 070 404	101 070 404	101 070 404	101 070 404	101 070 404	101 070 404	101 070 404	101 070 404
9	Master Control Board (m)	101 070 101	101 070 101	101 070 101	101 070 101	101 070 101	101 070 101	101 070 101	101 070 101	101 070 101	101 070 101	101 070 101
10†	Control Transformer (CVT)	149 308 021	149 308 021	149 308 021	149 308 021	149 308 021	149 308 021	149 308 021	149 308 021	149 308 021	149 308 021	149 308 021
11†	Equal Adjust. Rheostat (EAR)	141 509 004	141 509 004	141 509 004	141 509 004	141 509 004	141 509 004	141 509 004	141 509 004	141 509 004	141 509 004	141 509 004
12†	Equal. Chg. Manual Timer (ECT)	147 108 001	147 108 001	147 108 001	147 108 001	147 108 001	147 108 001	147 108 001	147 108 001	147 108 001	147 108 001	147 108 001
13	Equal. Chg. Timer Knob	133 101 004	133 101 004	133 101 004	133 101 004	133 101 004	133 101 004	133 101 004	133 101 004	133 101 004	133 101 004	133 101 004
14†	Float Adjust. Rheostat (FAR)	141 509 011	141 509 011	141 509 011	141 509 013	141 509 013	141 509 013	141 509 013	141 509 013	141 509 013	141 509 013	141 509 013
15	Power Circuit Breaker A-C (PCB)	122 111 011	122 101 032	122 101 033	122 111 002	122 111 005	122 111 010	122 111 011	122 111 012	122 101 033	122 101 034	122 101 034
16	Pilot Light A-C (PLL)	139 304 001	139 304 001	139 304 001	139 304 001	139 304 001	139 304 001	139 304 001	139 304 001	139 304 001	139 304 001	139 304 001
*17†	Power Regulating Device, SCR (PRD)	143 315 001	143 317 001	143 317 001	143 312 002	143 312 002	143 315 002	143 315 002	143 315 002	143 315 002	143 317 002	143 317 002
18	Heat Sink Assembly for PRD	131 304 004	131 304 004	131 304 004	131 102 050	131 102 050	131 102 051	131 102 051	131 102 051	131 304 004	131 304 004	131 304 004
*19†	Power Diode (PRX)	143 117 002	143 117 014	143 117 014	143 108 003	143 108 003	143 115 003	143 115 003	143 117 003	143 117 003	143 117 015	143 117 015
20	Heat Sink Assembly for PRX	131 102 051	131 102 051	131 102 051	131 102 051	131 102 051	131 102 051	131 102 051	131 102 051	131 102 051	131 102 051	131 102 051
21†	Resistor (RS)	None	None	None	None	None	141 114 032	141 114 032	141 114 032	141 114 032	141 114 032	141 114 032
22†	Surge Voltage Suppressor (SVS)	141 923 006	141 923 006	141 923 006	141 923 007	141 923 007	141 923 007	141 923 007	141 923 007	141 923 007	141 923 007	141 923 007
23†	Power Transformer (PVT)	149 107 022	149 107 023	149 107 024	149 107 025	149 107 026	149 107 027	149 107 028	149 107 029	149 107 030	149 107 031	149 107 032

Recommended Spare Parts—\* For domestic shipment; † For export shipment. Notes: (m) = Master Control Board has CVT mounted on it as standard. (s) = Ammeter on 20 and 25 amp. sizes employs external shunt 136 403 056.

Item No.	Charger Model Cat. No.	US-130-1-3 101 103 301	US-130-1-6 101 103 401	US-130-1-9 101 103 601	US-130-1-12 101 103 701	US-130-1-15 101 104 001	US-130-1-20 101 104 101	US-130-1-25 101 104 201
1	Charger D-C Ammeter (CAM)	136 401 067	136 401 068	136 401 069	136 401 071	136 401 071	(S)136 402 198	(S)136 402 198
2	Battery Circuit Breaker (BCB)	122 111 011	122 111 011	122 111 013	122 111 014	122 111 014	122 111 018	122 111 020
3	Voltmeter D-C (BVM)	136 301 087	136 301 087	136 301 087	136 301 087	136 301 087	136 301 087	136 301 087
4	Current Sensing Resistor (CSR)	141 121 001	141 121 002	141 121 003	141 121 003	141 121 004	141 121 005	141 121 006
*5†	Control Module A (Mod. A)	101 070 201	101 070 203	101 070 203	101 070 203	101 070 203	101 070 203	101 070 203
6†	Control Module B (Mod. B)	101 070 201	101 070 203	101 070 203	101 070 203	101 070 203	101 070 203	101 070 203
7†	Control Module C (Mod. C)	101 070 301	101 070 301	101 070 301	101 070 301	101 070 301	101 070 301	101 070 301
8†	Control Module D (Mod. D)	101 070 406	101 070 406	101 070 406	101 070 406	101 070 406	101 070 406	101 070 406
9	Master Control Board (m)	101 070 101	101 070 101	101 070 101	101 070 101	101 070 101	101 070 101	101 070 101
10†	Control Transformer (CVT)	149 308 021	149 308 021	149 308 021	149 308 021	149 308 021	149 308 021	149 308 021
11†	Equal Adjust. Rheostat (EAR)	141 509 007	141 509 007	141 509 007	141 509 007	141 509 007	141 509 007	141 509 007
12†	Equal. Chg. Manual Timer (ECT)	147 108 001	147 108 001	147 108 001	147 108 001	147 108 001	147 108 001	147 108 001
13	Equal. Chg. Timer Knob	133 101 004	133 101 004	133 101 004	133 101 004	133 101 004	133 101 004	133 101 004
14†	Float Adjust. Rheostat (FAR)	141 509 015	141 509 015	141 509 015	141 509 015	141 509 015	141 509 015	141 509 015
15	Power Circuit Breaker A-C (PCB)	122 111 010	122 111 012	122 111 014	122 111 016	122 101 036	122 101 037	122 101 037
16	Pilot Light A-C (PLL)	139 304 001	139 304 001	139 304 001	139 304 001	139 304 001	139 304 001	139 304 001
*17†	Power Regulating Device, SCR (PRD)	143 312 003	143 315 003	143 315 003	143 315 003	143 315 003	143 317 003	143 317 003
18	Heat Sink Assembly for PRD	131 102 050	131 102 051	131 102 051	131 102 051	131 102 051	131 304 004	131 304 004
*19†	Power Diode (PRX)	143 108 005	143 115 006	143 115 006	143 117 005	143 117 005	143 117 018	143 117 018
20	Heat Sink Assembly for PRX	131 102 051	131 102 051	131 102 051	131 102 051	131 102 051	131 102 051	131 102 051
21†	Resistor (RS)	None	None	None	None	None	141 114 034	141 114 034
22†	Surge Voltage Suppressor (SVS)	141 923 010	141 923 010	141 923 010	141 923 010	141 923 010	141 923 010	141 923 010
23†	Power Transformer (PVT)	149 107 033	149 107 034	149 107 035	149 107 037	149 107 038	149 107 041	149 107 042

Recommended Spare Parts—\* For domestic shipment; † For export shipment. Notes: (m) = Master Control Board has CVT mounted on it as standard. (s) = Ammeter on 20 and 25 amp. sizes employs external shunt 136 403 056.

(Continued)



(Continued)

Item No.	Charge Model	85-265-1.3	85-265-1.4	85-265-1.5	85-265-1.6	85-265-1.7	85-265-1.8	85-265-1.9	85-265-1.10	85-265-1.11	85-265-1.12	85-265-1.13	85-265-1.14	85-265-1.15
Item No.	Charge Model	101 100 201	101 100 401	101 100 601	101 100 801	101 100 001	101 100 201	101 100 401	101 100 601	101 100 801	101 100 001	101 100 201	101 100 401	101 100 601
Item No.	Name	136 401 001	136 401 001	136 401 001	136 401 001	136 401 001	136 401 001	136 401 001	136 401 001	136 401 001	136 401 001	136 401 001	136 401 001	136 401 001
1	Charger D-C Ammeter	(CAB) 136 401 001	136 401 001	136 401 001	136 401 001	136 401 001	136 401 001	136 401 001	136 401 001	136 401 001	136 401 001	136 401 001	136 401 001	136 401 001
2	Battery Circuit Breaker	(BCB) 122 111 010	122 111 011	122 111 011	122 111 011	122 111 011	122 111 011	122 111 011	122 111 011	122 111 011	122 111 011	122 111 011	122 111 011	122 111 011
3	Voltmeter D-C	(VDB) 136 301 000	136 301 000	136 301 000	136 301 000	136 301 000	136 301 000	136 301 000	136 301 000	136 301 000	136 301 000	136 301 000	136 301 000	136 301 000
4	Current Sensing Resistor	(CSB) 141 121 001	141 121 002	141 121 003	141 121 004	141 121 005	141 121 006	141 121 007	141 121 008	141 121 009	141 121 010	141 121 011	141 121 012	141 121 013
5*	Control Module A	(Mod. A) 101 070 201	101 070 202	101 070 203	101 070 204	101 070 205	101 070 206	101 070 207	101 070 208	101 070 209	101 070 210	101 070 211	101 070 212	101 070 213
6*	Control Module B	(Mod. B) 101 070 201	101 070 202	101 070 203	101 070 204	101 070 205	101 070 206	101 070 207	101 070 208	101 070 209	101 070 210	101 070 211	101 070 212	101 070 213
7*	Control Module C	(Mod. C) 101 070 301	101 070 301	101 070 301	101 070 301	101 070 301	101 070 301	101 070 301	101 070 301	101 070 301	101 070 301	101 070 301	101 070 301	101 070 301
8*	Control Module D	(Mod. D) 101 070 401	101 070 401	101 070 401	101 070 401	101 070 401	101 070 401	101 070 401	101 070 401	101 070 401	101 070 401	101 070 401	101 070 401	101 070 401
9	Master Control Board (M)	(Mod. M) 101 070 101	101 070 101	101 070 101	101 070 101	101 070 101	101 070 101	101 070 101	101 070 101	101 070 101	101 070 101	101 070 101	101 070 101	101 070 101
10*	Control Transformer	(CVT) 149 308 021	149 308 021	149 308 021	149 308 021	149 308 021	149 308 021	149 308 021	149 308 021	149 308 021	149 308 021	149 308 021	149 308 021	149 308 021
11*	Equal Adjust Rheostat	(EAB) 141 509 010	141 509 010	141 509 010	141 509 010	141 509 010	141 509 010	141 509 010	141 509 010	141 509 010	141 509 010	141 509 010	141 509 010	141 509 010
12*	Equal Chg. Manual Timer	(ECT) 147 108 001	147 108 001	147 108 001	147 108 001	147 108 001	147 108 001	147 108 001	147 108 001	147 108 001	147 108 001	147 108 001	147 108 001	147 108 001
13	Equal Chg. Timer Knob	133 101 004	133 101 004	133 101 004	133 101 004	133 101 004	133 101 004	133 101 004	133 101 004	133 101 004	133 101 004	133 101 004	133 101 004	133 101 004
14*	Fault Alarm, Sheet*AD	(FAB) 141 512 001	141 512 001	141 512 001	141 512 001	141 512 001	141 512 001	141 512 001	141 512 001	141 512 001	141 512 001	141 512 001	141 512 001	141 512 001
15	Power Circuit Breaker A-C	(PCB) 122 111 012	122 101 034	122 101 035	122 101 036	122 101 037	122 101 038	122 101 039	122 101 040	122 101 041	122 101 042	122 101 043	122 101 044	122 101 045
16	Pilot Light A-C	(PLL) 139 304 001	139 304 001	139 304 001	139 304 001	139 304 001	139 304 001	139 304 001	139 304 001	139 304 001	139 304 001	139 304 001	139 304 001	139 304 001
*17*	Power Regulating Device, SCR (PRD)	143 312 004	143 315 004	143 315 004	143 315 004	143 315 004	143 315 004	143 315 004	143 315 004	143 315 004	143 315 004	143 315 004	143 315 004	143 315 004
18	Head Sub-Assembly	131 102 050	131 102 051	131 102 051	131 102 051	131 102 051	131 102 051	131 102 051	131 102 051	131 102 051	131 102 051	131 102 051	131 102 051	131 102 051
*19*	Power Switch (PS)	143 108 008	143 115 010	143 115 010	143 117 008	143 117 008	143 117 008	143 117 008	143 117 008	143 117 008	143 117 008	143 117 008	143 117 008	143 117 008
20	Head Sub-Assembly	(Mounted on PRD Head Sub.)	131 102 051	131 102 051	131 102 051	131 102 051	131 102 051	131 102 051	131 102 051	131 102 051	131 102 051	131 102 051	131 102 051	131 102 051
21*	Resistor (R)	141 114 045	141 114 045	141 114 045	141 114 045	141 114 045	141 114 045	141 114 045	141 114 045	141 114 045	141 114 045	141 114 045	141 114 045	141 114 045
22*	Surge Voltage Suppressor (SVS)	141 923 010	141 923 010	141 923 010	141 923 010	141 923 010	141 923 010	141 923 010	141 923 010	141 923 010	141 923 010	141 923 010	141 923 010	141 923 010
23*	Power Transformer (PT)	149 107 043	149 107 044	149 107 044	149 107 045	149 107 045	149 107 046	149 107 047	149 107 048	149 107 049	149 107 050	149 107 051	149 107 052	149 107 053

Recommended Spare Parts... \*For domestic shipment, \*\*For export shipment. Notes: (M) = Master Control Board Not CVT mounted on it as standard (R) = Resistor on 20 and 25 amp. sizes employs external about 135 003 054.

Other US Charge Single Phase AC publications are--	Section No.	Form No.
Data or Catalog information	56.50	6776
Installing & Operating information, plus diagrams	58.20	6777
Service Manual (Trouble Shooting)	58.25	6780



# Exide

## INDUSTRIAL GROUP

ESB INCORPORATED



# CONSTANT VOLTAGE BATTERY CHARGERS

SINGLE-PHASE UNFILTERED

MODEL US — WITH SILICON-CONTROLLED RECTIFIERS

**SECTION 57.03**  
 For float service on single-phase, 60 Hz AC power supply. Charges lead-acid, nickel-cadmium and nickel-iron alkaline batteries.

CHARGER FOR NUMBER OF CELLS						ADJUSTMENT RANGE		
LEAD-ACID 5-R	NICKEL-CADMIUM 6-9	NICKEL-IRON R	FLOAT VOLTAGE					
			EQUALIZE VOLTAGE		10.7—13.5 VOLTS 11.0—14.0 VOLTS			
CHARGER MODEL NO.	CATALOG NO.	DC OUTPUT AMPERES	AC INPUT VOLTS	AC INPUT AMPERES	TYPE MOUNTING	CABINET SIZE SEE SEC. 57.10	SHIPPING WEIGHT LBS.	SCHEMATIC DIAGRAM SEE SEC. 57.05
US 12-1-1	101 100 101	1	115	0.4	Wall or Rack	S1	44	Fig. 1 Standard Fig. 2 Applies if optional automatic-set equalize charge timer is specified
US 12-1-3	101 100 201	3	115	1.0		S1	48	
US 12-1-6	101 100 301	6	115	2.0		S1	51	
US 12-1-9	101 100 401	9	115	2.5		S1	54	
US 12-1-12	101 100 501	12	115	3.5		S1	60	
US 12-1-16	101 100 601	16	115	4.5		S1	65	
US 12-1-20	101 100 701	20	115	5.5		S1	70	
US 12-1-25	101 100 801	25	115	7.		S1	75	

CHARGER FOR NUMBER OF CELLS						ADJUSTMENT RANGE		
LEAD-ACID 11-13	NICKEL-CADMIUM 17-18	NICKEL-IRON 18-18	FLOAT VOLTAGE					
			EQUALIZE VOLTAGE		23.6—27.3 VOLTS 25.0—30.3 VOLTS			
CHARGER MODEL NO.	CATALOG NO.	DC OUTPUT AMPERES	AC INPUT VOLTS	AC INPUT AMPERES	TYPE MOUNTING	CABINET SIZE SEE SEC. 57.10	SHIPPING WEIGHT LBS.	SCHEMATIC DIAGRAM SEE SEC. 57.05
US 25-1-1	101 100 901	1	115	0.55	Wall or Rack	S1	46	Fig. 1 Standard Fig. 2 Applies if optional automatic-set equalize charge timer is specified
US 25-1-3	101 101 001	3	115	1.75		S1	55	
US 25-1-6	101 101 101	6	115	3.5		S1	62	
US 25-1-9	101 101 201	9	115	5.5		S1	70	
US 25-1-12	101 101 301	12	115	7.0		S1	78	
US 25-1-16	101 101 401	16	115	10.0		S1	85	
US 25-1-20	101 101 501	20	115	12.5		S1	92	
US 25-1-25	101 101 601	25	115	17.5		S2	105	

CHARGER FOR NUMBER OF CELLS						ADJUSTMENT RANGE		
LEAD-ACID 14-16	NICKEL-CADMIUM 22-24	NICKEL-IRON 26-22	FLOAT VOLTAGE					
			EQUALIZE VOLTAGE		30.1—36.8 VOLTS 32.8—37.3 VOLTS			
CHARGER MODEL NO.	CATALOG NO.	DC OUTPUT AMPERES	AC INPUT VOLTS	AC INPUT AMPERES	TYPE MOUNTING	CABINET SIZE SEE SEC. 57.10	SHIPPING WEIGHT LBS.	SCHEMATIC DIAGRAM SEE SEC. 57.05
US 32-1-1	101 101 701	1	115	0.7	Wall or Rack	S1	48	Fig. 1 Standard Fig. 2 Applies if optional automatic-set equalize charge timer is specified
US 32-1-3	101 101 801	3	115	2.0		S1	60	
US 32-1-6	101 101 901	6	115	4.0		S1	70	
US 32-1-9	101 102 001	9	115	6.5		S1	80	
US 32-1-12	101 102 101	12	115	9.0		S1	90	
US 32-1-16	101 102 201	16	115	12.0		S1	100	
US 32-1-20	101 102 301	20	230	8.5		S1	110	
US 32-1-25	101 102 401	25	230	10.5		S2	140	

SECTION 57.03

CHARGER FOR NUMBER OF CELLS			FLOAT VOLTAGE		ADJUSTMENT RANGE		SCHEMATIC DIAGRAM SEE SEC. 57.06
LEAD-ACID 20-25	NICKEL-CADMIUM 34-37	NICKEL-IRON 32-35	EQUALIZE VOLTAGE		47.3—58.3 VOLTS	51.3—58.3 VOLTS	
CHARGER MODEL NO.	CATALOG NO.	DC OUTPUT AMPERES	AC* INPUT VOLTS	AC INPUT AMPERES	TYPE MOUNTING	CABINET SIZE SEE SEC. 57.10/11	SHIPPING WEIGHT LBS.
US 50-1-1	101 102 501	1	115	1.1	Wall or Rack	S1	57
US 50-1-3	101 102 601	3	115	3.5		S1	66
US 50-1-6	101 102 701	6	115	6.5		S1	80
US 50-1-9	101 102 801	9	115	10.0		S1	95
US 50-1-12	101 102 901	12	115	13.0		S2	105
US 50-1-16	101 103 001	16	230	9.0		S2	130
US 50-1-20	101 103 101	20	230	11.5		S3	145
US 50-1-25	101 103 201	25	230	14.5		S3	185

Fig. 1 Standard  
Fig. 2 Applies if optional automatic-set equalize charge timer is specified.

CHARGER FOR NUMBER OF CELLS			FLOAT VOLTAGE		ADJUSTMENT RANGE		SCHEMATIC DIAGRAM SEE SEC. 57.06
LEAD-ACID 35-62	NICKEL-CADMIUM 84-93	NICKEL-IRON 79-87	EQUALIZE VOLTAGE		118.2—139.5 VOLTS	128.1—144.5 VOLTS	
CHARGER MODEL NO.	CATALOG NO.	DC OUTPUT AMPERES	AC* INPUT VOLTS	AC INPUT AMPERES	TYPE MOUNTING	CABINET SIZE SEE SEC. 57.10/11	SHIPPING WEIGHT LBS.
US 130-1-3	101 103 301	3	115	8.0	Wall or Rack  Floor	S1	85
US 130-1-6	101 103 401	6	115	16.0		S2	100
US 130-1-6	101 103 501	6	230	8.0		S2	100
US 130-1-9	101 103 601	9	115	24.0		S2	135
US 130-1-9	101 103 701	9	230	12.0		S2	135
US 130-1-12	101 103 801	12	115	32.0		S3	210
US 130-1-12	101 103 901	12	230	16.0		S3	210
US 130-1-16	101 104 001	16	230	21.5		S4	250
US 130-1-20	101 104 101	20	230	27.0		S4	325
US 130-1-25	101 104 201	25	230	35.0	S4	400	

Fig. 1 Standard  
Fig. 2 Applies if optional automatic-set equalize charge timer is specified.

CHARGER FOR NUMBER OF CELLS			FLOAT VOLTAGE		ADJUSTMENT RANGE		SCHEMATIC DIAGRAM SEE SEC. 57.06
LEAD-ACID 118-124	NICKEL-CADMIUM 167-186	NICKEL-IRON 158-175	EQUALIZE VOLTAGE		236.5—279.3 VOLTS	256.3—288.9 VOLTS	
CHARGER MODEL NO.	CATALOG NO.	DC OUTPUT AMPERES	AC* INPUT VOLTS	AC INPUT AMPERES	TYPE MOUNTING	CABINET SIZE SEE SEC. 57.10/11	SHIPPING WEIGHT LBS.
US 260-1-3	101 104 301	3	115	15.5	Wall or Rack	S2	140
US 260-1-6	101 104 401	6	230	15.5		S3	220
US 260-1-9	101 104 501	9	230	24.0		S3	290
US 260-1-12	101 104 601	12	230	32.0	Floor	S4	380
US 260-1-16	101 104 701	16	230	43.0		S4	460
US 260-1-20	101 104 801	20	230	54.0		S4	560
US 260-1-25	101 104 901	25	230	68.0		S4	680

Fig. 1 Standard  
Fig. 2 Applies if optional automatic-set equalize charge timer is specified.

\*115 v AC chargers have 110, 115, 120 v taps  
230 v AC chargers have 208, 220, 230, 240 v taps

Recommended float voltage and equalizing voltages:

TYPE	VOLTAGE PER CELL FLOAT	PER CELL EQUALIZE
Lead-Antimony	2.15	2.33
Lead-Calcium	2.17	2.33
Nickel-Cadmium	1.43	1.55
Nickel-Iron	1.5-1.55	1.6-1.65

See Section 57.40, Form 7159, for available accessories.

INDUSTRIAL GROUP  
ESB INCORPORATED  
P O Box 5723, Philadelphia, Pa. 19120



**INSTRUCTION MANUAL**

**Installation - Operation - Servicing**

**Exide Static Inverter Power Supplies**

**Model: 120/2F1 -CV**

<b>CUSTOMER</b> COLUMBIA UNIVERSITY
<b>CUST. ORDER NO.</b> 43900-232590
<b>PROJECT</b> LAMONT GEOLOGICAL OBSERVATORY
CF COLUMBIA UNIVERSITY
<b>EQUIPMENT MODEL</b> 120/2F1-CV
<b>ESB ORDER NO.</b> PH-49979
<input type="checkbox"/> FOR CUSTOMER APPROVAL
<input checked="" type="checkbox"/> CERTIFIED <input type="checkbox"/> PRELIMINARY
<b>DATE</b> 3-10-71 <b>BY</b> T. Southerland
<b>EXIDE POWER SYSTEMS DIVISION</b>
<b>ESB INCORPORATED</b> P. O. BOX 11506 RALEIGH, N. C. 27604

113

Instruction 2674  
120/2F1-CV  
2/70

CCS UNIT NO.  
**31795**

**EXIDE POWER SYSTEMS DIVISION**  
ESB INCORPORATED  
RALEIGH, N. C. 27604



**INSTALLATION****1. Preliminary**

- a. Check the electrical ratings on the nameplate of the power supply to see that the intended use is appropriate. Check for mechanical damage or loose electrical connections due to damage in shipment.
- b. The power supply should be placed in a dry location and upright position with no obstructions to allow free air flow through the top and bottom ventilation openings. To allow for ventilation and access into the power supply, leave 24 inches clearance above, 12 inches in rear and 24 inches in front.

**2. Connections**

- a. Check the DC power. It should be off and the power supply DC circuit breaker should be open.
- b. Knockouts are provided in the cabinet for entrance of power cables. The wiring diagram shows the location of the AC load and DC input power connections. For frequency synchronization if provided, a 120 VAC, 60 cps reference source is required which is connected to Terminals TB5-3 and 4.

**PLACING INTO OPERATION**

1. Be sure that the unit is properly connected as detailed in Installation instructions and wiring diagrams.
2. The power supply may be started with or without an AC output load.
  - a. To start the power supply: Apply DC power and close the DC circuit breaker.



**INVERTER ADJUSTMENTS****1. Voltage Level**

The voltage level is that of the Sola transformer output and is not adjustable.

**2. Frequency Check and Adjustment**

An oscilloscope with a 60 cps line sync. may be used for this adjustment if it is known that the power line frequency is sufficiently accurate. Connect the oscilloscope's vertical input terminals to the power supply output terminals. Synchronize the oscilloscope to LINE and set the sweep speed and gain controls to display one or two complete cycles of the power supply output waveform. The waveform should be stationary on the oscilloscope and one complete cycle should be about 17 milliseconds long. If not, adjust the trimming potentiometer (R24) at the bottom of the inverter control logic module until this is obtained. Several turns of the adjustment may be needed as this is a 25 turn Trimpot.

(Note: If frequency synchronization is provided, the synchronization must be disabled by turning off the AC source or removing Fuse F1 from the sync. logic card. Fuse F1 is the upper fuse on the card).

**3. Phase Check and Adjustment**

If a static transfer switch is provided, the inverter should be in phase with the AC source. To check, connect an AC voltmeter (at least 240 V full scale) between terminals 6 and 8 on the sync. logic card and turn on inverter and AC source. Adjust the single turn potentiometer adjustment on the sync. logic card (R63) for minimum voltmeter indication.

**SERVICING**

The power supply contains no moving parts which would require periodic maintenance. It is desirable to occasionally (such as once a month) check the output frequency as detailed under "Adjustments". Any accumulated dust should be blown out by air when the unit is disconnected.

In the event of faulty operation, the following trouble-shooting procedure may make it possible to isolate the problem.

20/2P1-CV  
2/70

CORE UNIT NO.  
**31795**

**EXIDE POWER SYSTEMS DIVISION**  
EED INCORPORATED  
MILB. & C. 2148



115

## 120V/2KVA TROUBLE SHOOTING PROCEDURE - INVERTER POWER STAGE

The following are required for trouble shooting:

- 1) Volt-ohmmeter similar to Tripplet 630
- 2) One dual-channel oscilloscope whose cabinet is isolated from the power line.

If the inverter should malfunction, the input circuit breaker CBI and/or the fuses F1 and F2 will clear the fault. Assuming that either of these things has happened, the inverter output voltage will fall to zero. If the inverter is the preferred source in a static transfer system, the critical load will be switched to the alternate source.

If the inverter voltage should fall to zero, open circuit breaker CBI if it is not already tripped. Remove the DC power from TB4. After removal of the DC power, remove Amptrap fuses F1 and F2. These fuses are located directly below the 12" heat sinks. Check these fuses with an ohmmeter. If either or both are open, obtain good replacements of the same type but do not replace the fuses yet.

Also, check the fuse on the printed circuit logic board with an ohmmeter. This is F3, which is a 1/2-amp fuse. Obtain a similar replacement if necessary, but do not insert.

Check the Capacitor C1 by removing lead 169 from one of its terminals. (Note: Before removing anything, short the terminals of this capacitor with a metal bar). Set the ohmmeter on X1000 and check the capacitor resistance. The ohmmeter needle should start at zero ohms and quickly go to very high (> 100,000) ohms. Now reverse the ohmmeter leads. The ohmmeter should peg below zero ohms for a short time then move up to very high ohms again. If this behavior is not observed, remove the capacitor and replace with an equivalent good unit. Even if the capacitor passes these tests, observe the sides of the capacitor. If any oil or bulges are present, remove the capacitor and replace with an equivalent good unit. Do not reconnect wire 169 until the semiconductor checks are made.

After checking capacitor C1, check input capacitor C20 in the same manner as capacitor C1. Replace with an equivalent good one if found defective.

110



The next series of tests is an ohmmeter test of the power semi-conductors. Use the Rx1000 scale or equivalent. SCR's Q1 and Q2 are located on the upper portion of heat sinks HS-1 and HS-2. A cathode to anode check (large terminal to case) should indicate in excess of 100,000 ohms regardless of polarity of ohmmeter probes. Reverse the probes to get a measurement in both directions. Rectifiers CR1 and CR2 are located on the lower portion of the same heat sinks; check them in a similar manner but look for a typical rectifier characteristic, i.e., high in one direction but low in the other.

Replace any components which do not measure as specified above. (Be sure to double-check a suspected component after it has been removed from the circuit).

Also check the rectifiers on the smaller heat sink HS-3. They should first be isolated from the rest of the circuit by disconnecting wire #150 at the fuse block of F1 and wire #151 at the fuse block of F2. Typical rectifier characteristics should again be measured.

This completes the check of the power semiconductors with the exception of the transient suppression thyrectors CR40 and CR41. These components are mounted on the cards which are attached to Heat Sinks 1 and 2. They can be ohmmeter checked with one lead off and will act just as SCR's because they should read high ohms in both directions. However, a simpler check is to observe (with sight and smell), the condition of the devices.

After checking the power semiconductors and the capacitors (and replacing any that were defective), the next step is to check the logic. This is done by replacing the DC power leads to TB4 with the input circuit breaker OFF, and leaving fuses F1 and F2 out. Make sure the fuse on the logic board is O.K. Place the oscilloscope ground on terminal 2 of TB1, the strip on the logic card. Place the input to the scope on terminal 3 of TB1, this is the gate of SCR Q2. (Note that the terminals are numbered right to left, 1-10). Turn on the DC input breaker. The scope picture should show a square wave similar to that shown below.

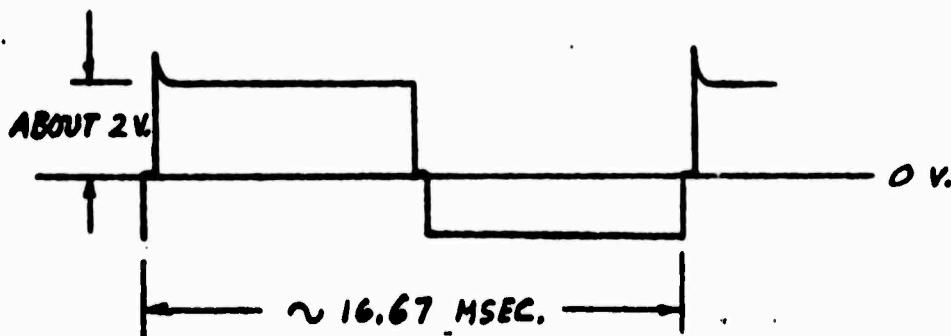

117



Repeat this test with the scope probe on terminal 4 of the TB1. The picture should be similar. If the picture is not the same on either terminals 3 or 4, the logic card is defective. Replace the entire card with a similar part.

After the checks have been made on the semiconductors and the logic card and no defective parts remain, check that the DC input breaker is OFF and replace fuses F1 and F2. Reconnect wire 169 to C1, also any other wires that may have been disconnected. Apply the DC power by putting the input breaker in the "ON" position. If the circuit breaker trips, or fuses F1 and F2 blow, disconnect the load at terminal TB5-1; or in the case where a static switch is installed, disconnect the inverter output at terminal TB5-5. Replace fuses as necessary and try to operate the inverter again.

If trouble still exists, then the probable fault lies in the magnetic components of the inverter. However, faults of this type can only be checked at the factory or by phone conversation with factory service personnel. If this situation exists, call Area Code 919-834-3400.

Recommended Spare Parts List For Static Inverters/ <del>Switches</del> Model <b>120/2F1-CV</b>		To: <b>USER</b>	
Applicable Spec:		Date: <b>8-1-70</b>	
Approved By: <b>M. P. Cooke</b>		Effective: <b>8-1-70</b> Supersedes:	

<u>Recom'd Qty.</u>	<u>Description</u>	<u>Circuit Symbol</u>	<u>Part No.</u>
1	Inverter Control Assembly	-----	308032-03
3	Fuse, Busmann AGC-.5A	F3	622019-04
4	Fuses, Chase Shawmut A25X40	F1-F2	622019-21
2	Silicon Controlled Rectifiers	Q1-Q2	305486-00
2	Diode (Rectifiers)	CR1,CR2	621806-33
2	Diode (Rectifiers)	CR3,CR4	621806-34
1	Capacitor	C1	305475-00
1	Capacitor	C20	304885-02
1	Thyrector	D40-D41	621810-09

**CUSTOMER COLUMBIA UNIVERSITY**  
**CUST. ORDER NO. 43900-232590**  
**PROJECT LAMONT GEOLOGICAL OBSERVATORY**  
**OF COLUMBIA UNIVERSITY**  
**EQUIPMENT MODEL 120/2F1-CV**  
**ESB ORDER NO. PH-49979**

FOR CUSTOMER APPROVAL  
 **CERTIFIED**       PRELIMINARY  
 DATE 3-10-71 BY T. Southerland

**EXIDE POWER SYSTEMS DIVISION**  
**ESB INCORPORATED** P. O. BOX 11506  
 RALEIGH, N. C. 27604

FURN W-341



PS 7102 23

BATTERY CHARGER

MODEL 15/30-1-25 ENCLOSURE 54

AMP 36.6  
VOLTS 280  
PHASE 1  
60 HZ

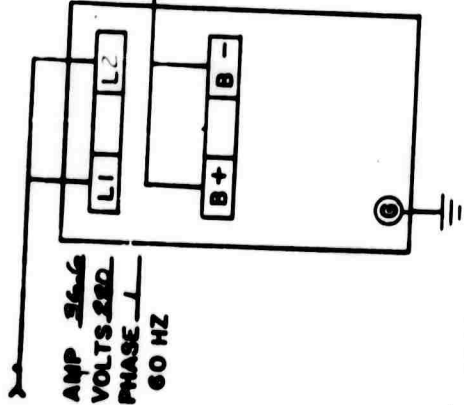

\* AMP 55

60 CELL  
TYPE PLX-13  
LEAD ANTIMONY

\* AMP 40

STORAGE BATTERY

INVERTER

MODEL 120/2 F1-CV ENCLOSURE W4

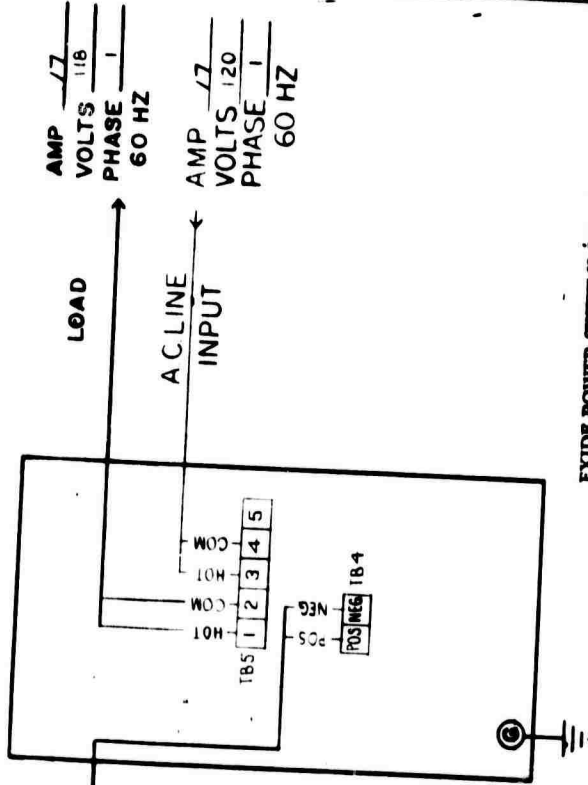

AMP 17  
VOLTS 118  
PHASE 1  
60 HZ

AMP 17  
VOLTS 120  
PHASE 1  
60 HZ

**SYSTEM INTERCONNECTION NOTES:**

1. TYPE OF SYSTEM: TRANSFER  REVERSE TRANSFER   
CONTINUOUS
2. USE PROPER WIRE SIZE FOR INSTALLATION CONDITIONS AND ABOVE POWER REQUIREMENTS.
3. WIRE THE INVERTER DIRECTLY TO THE BATTERY ROUTE + AND - WIRES TOGETHER IN THE SAME CONDUIT OR BUNDLE. AVOID EXCESSIVE WIRE LENGTH.
4. \*CURRENT LISTED IS MAX. RMS FOR WIRE SIZING ONLY.

EXIDE POWER SYSTEMS DIVISION  
E.S.B. INCORPORATED  
MILWAUKEE, WIS. U.S.A.



**EXIDE STATIC STANDBY POWER SYSTEM INTERCONNECTION**

USER COLUMBIA UNIVERSITY  
PROJECT LA MOUNT GEOLOGICAL OBSERVATORY  
ENGINEERS OF COLUMBIA UNIVERSITY  
CUSTOMER ORDER NO. 43900-232590

3801-1

EXIDE PM-49979  
ORDERS EX-200-1578  
RELEASE NO.

7

FORM W368

PS 7102 23

DON JONES 2-24-71  
J. SOUTHWORTH 3-3-71

Model 120/2FI-CV

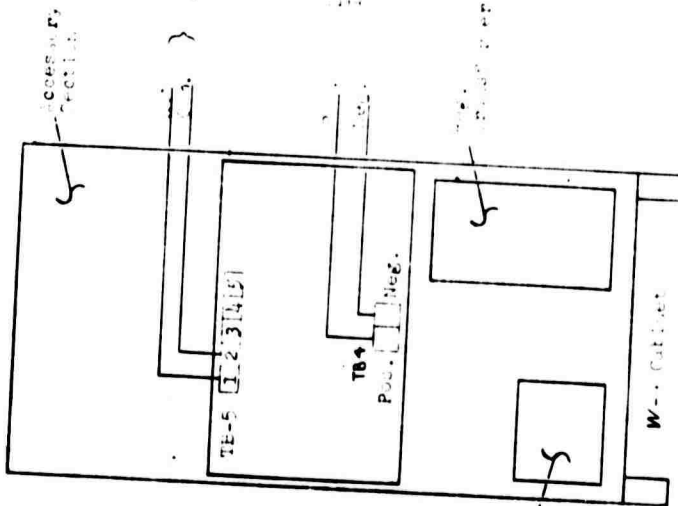

NOT REPRODUCIBLE

121

NEXT ASSY (REP)	
SYN	REVISIONS
DESCRIPTION	DATE APPROVED

DWG. NO.  
D-306252-02  
C-305746

DESCRIPTION  
SCHEMATIC DIAGRAM, MODEL 120/2FI-CV  
INVERTER WITH AUTO SYNC & CURRENT LIMIT.  
OUTLINE & MOUNTING DIMENSIONS

CUSTOMER  
COLUMBIA UNIVERSITY  
OFFICE OF THE CONTROLLER  
BOX 6 - CENTRAL HALL ROOM  
NEW YORK, NEW YORK '0027

PROJECT  
LA MOUNT GEOLOGICAL OBSERVATORY  
OF COLUMBIA UNIVERSITY

CUSTOMER ORDER 43900-232 590  
ESB ORDER PH-49979

DFTM	ZONJONES	2-24-71	
CHKD			
APPD			EXIDE INVER SYSTEMS DIVISION ESB INCORPORATED NEW YORK, N.Y.
ENG APPD			TITLE INTERCONNECTION DIAGRAM, MODEL 120/2FI-CV INVERTER
ENG APPD			
MATL APPD			DWG STATUS
MFG			CODE IDENT NO <b>31795</b>
APPROVAL			DWG SIZE 30690
			MFG CODE 3801-2
APPROVAL			DRAWING NO 30690-49979
			SCALE
			SHEET

SPECIAL INSTRUCTIONS

- DO
1. Read the 1<sup>st</sup> traction manual
  2. Check power supply wire size tables
  3. Check for loose connections
  4. Allow for good ventilation
- DONT
1. Don't connect input power wires unless DC power is off and DC circuit breaker is off.
  2. Don't operate power supply until input voltage is checked and checked.
  3. Don't attempt any adjustments without first consulting the instruction manual.

7

REV	DESCRIPTION	DATE	APPROVED
A	RELEASED	5/1/68	PC
B			
C	REVISION	5/14/68	PC
D	REVISED PER EQ 93505	5/19/68	PC

NOT REPRODUCIBLE

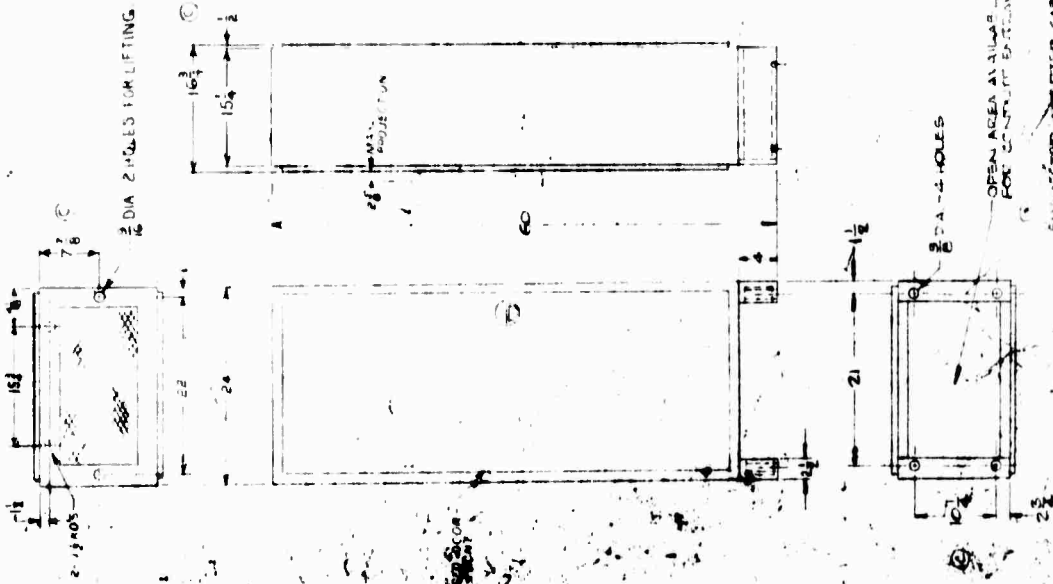

CUSTOMER: COLUMBIA UNIVERSITY  
 CUST. ORDER NO. U-3900-232590  
 PROJECT: LABORATORY TECHNICAL OBS. EVALUATOR  
 OF COLUMBIA UNIVERSITY  
 EQUIPMENT MODEL NO. 2721-01  
 ES ORDER NO. 24-95975  
 DATE: 5-10-68 BY: J. SULLIVAN  
 FOR CUSTOMER APPROVAL  
 CERTIFIED  PRELIMINARY  
 ESSE POWER SYSTEMS DIVISION  
 P. O. BOX 18008  
 RALEIGH, N. C. 27604



OVERHEAD CLEARANCE	HEIGHT
24	24

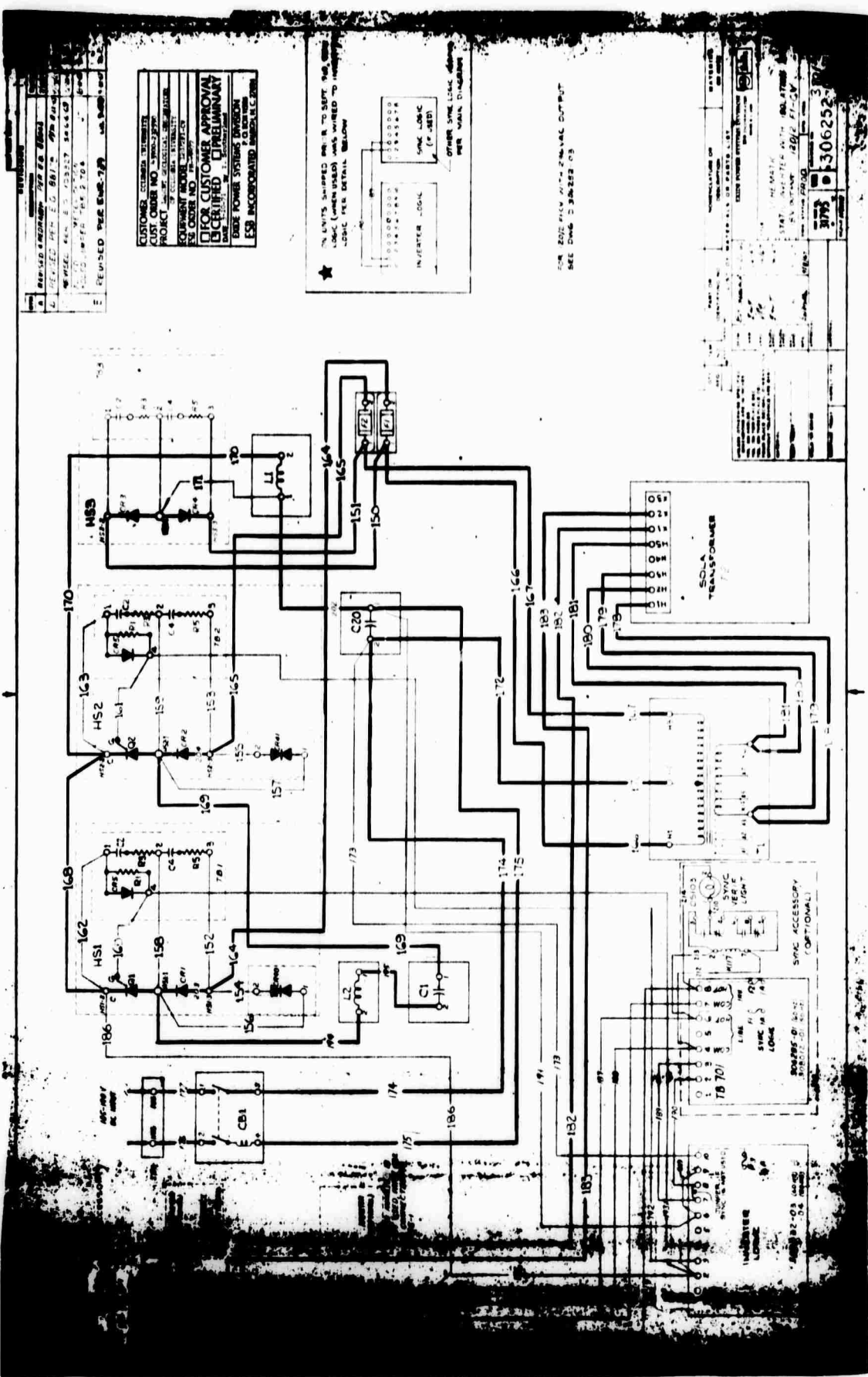

REVISED DRAWING	7/27/58	27
REVISED BY	E. D. BENT	27
REVISED DATE	7/27/58	27
REVISED BY	E. D. BENT	27
REVISED DATE	7/27/58	27
REVISED BY	E. D. BENT	27
REVISED DATE	7/27/58	27
REVISED BY	E. D. BENT	27
REVISED DATE	7/27/58	27

CUSTOMER ORDER NUMBER  
 PROJECT  
 DRAWING NUMBER  
 REV. ORDER NO.  
 DATE  
 FOR CUSTOMER APPROVAL  
 DISCREPANCY  
 ESB POWER SYSTEMS DIVISION  
 ESB INCORPORATED, INDIANAPOLIS, IN.

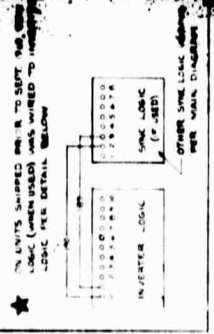

FOR SOLA TRANSFORMER OUTPUT  
 SEE DRAW. 3-306252-03

REVISED DRAWING	7/27/58	27
REVISED BY	E. D. BENT	27
REVISED DATE	7/27/58	27
REVISED BY	E. D. BENT	27
REVISED DATE	7/27/58	27
REVISED BY	E. D. BENT	27
REVISED DATE	7/27/58	27
REVISED BY	E. D. BENT	27
REVISED DATE	7/27/58	27

**BLANK PAGE**

# INSTRUCTIONS

*Installing and Operating*

# Exide BATTERIES

Types PLX, PWA  
In Plastic Containers

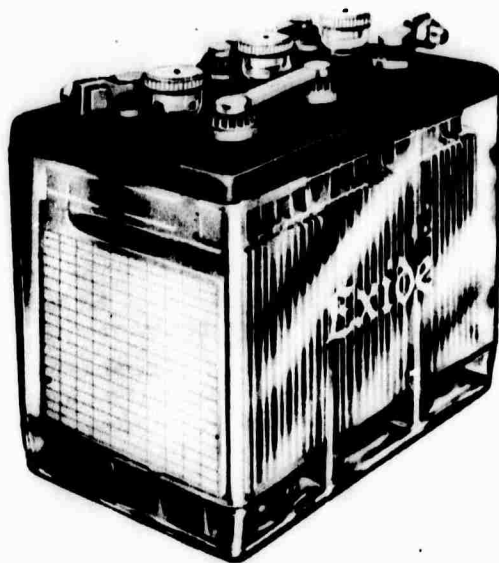

**Exide Battery, Type 3-PLX-13**



## RATINGS

### 1. Rating

Based on electrolyte temperature of 77°F. at beginning of discharge and on full charge specific gravity of 1.210, see Par. 7a.

Type of Cell	Plates Per Cell	Charge Rate (Par. 8) Amperes	W. E. Co. KS-5361 List	DISCHARGE CAPACITY		Max. Water (Par. 6c) For Floated Battery Pints per Cell per Month
				8-Hour		
				Ampere Hours	Approx. Points in Gravity	
PLX	7	5		50	105	.05
	13	9		100	115	.10
PWA	7	5	140A, 141A	50	100	.05
	13	9	150A, 151A	100	110	.10

Limiting Voltage per Cell (Approx.) ..... 1.75

## INSTALLATION

### 2. Handling — Unpacking

a. These cells are shipped "charged and wet," meaning assembled, charged, and filled with electrolyte\* to the upper line on the container. Upon delivery from carrier, examine electrolyte level or height to see that none is spilled. If electrolyte has been lost in transit and level is less than 1/2 inch below top of plates, add water or preferably electrolyte of 1.210 specific gravity, then give a thorough charge. If the level is more than 1/2 inch below top of plates, claim should be made against carrier for a new cell, as the "spilled" cell is more than likely to have been permanently damaged.

b. Clean covers by wiping off with damp rag to remove electrolyte in case any was spilled.

c. PLX and PWA batteries are available for use, with or without vent cylinders, which are mounted by the installer in each cell. As shipped, all have a plastic vent cap in the cover hole, and, if the vent cylinders are not to be used, the vent caps are left in the cover. When the vent cylinder is used, the vent cap is temporarily removed, and the smaller end of the vent cylinder engaged in the hole in the baffle cover (directly under the cover hole). The vent cap is then fitted on top of the vent cylinder, and the combination becomes an explosion control feature. With the vent cylinder in place, hydrometer readings are obtained by removing the cap and inserting stem of hydrometer syringe down through the vent cylinder.

If shipped without electrolyte for special reasons, See Par. 9 for Filling and Charging instructions.

### b. Location of Battery

a. Battery room or compartment must be ventilated, but in such a way as to keep out water, oil, dirt, etc. It should also be dry, and, if practicable, moderate in temperature. Locate and install the battery so that all cells are readily accessible for adding the water necessary to restore level lowered by charging and evaporation.

b. For cells connected in one series, arrange so that all cells will be at about the same temperature. For example, do not have several alongside a radiator or in sunshine.

### 4. Connecting Units Together and to System

a. Arrange the units on the racks or stands so that the positive terminal of one will be connected to the negative terminal of the next throughout the battery. A clear space of 1/2 inch should be provided between adjoining units. The positive terminals are painted red on top or are marked POS. or +. The negatives are painted black or marked NEG. or —. Set units so that any pilot balls (Par. 6e) face the observer.

b. Interunit connection is made by bolting connectors or jumpers to the respective terminal posts. Scrape the posts bright and clean. Then apply a thin film of No-Ox-Id grease (or vaseline), which should also be put on the threads of the bolts. Wipe the connector clean and apply a film of No-Ox-Id grease for about 1/2 inch around the bolt hole. Tighten connections. Wipe off surplus grease that squeezed out. Check connections to see that polarity is correct. Retighten connections.

c. Arrange terminal connections so that positive of charging source will connect with positive of battery, and negative of charging source with negative of battery. Test charging wires for positive and negative with a voltmeter, or dip the ends of the wires in a glass of water to which a few grains of salt have been added, but do not allow ends of wires to touch each other and do not use a strong solution of salt. In the water, fine bubbles will be given off from the negative wire.

d. See that any exposed metal in the connectors, other than lead, is thoroughly protected by a film of vaseline or No-Ox-Id grease.

## 5. Freshening Charge

a. During transit the battery may have lost some of its charge. If specific gravity of electrolyte is below 1.200, give a freshening charge by charging (Par. 8) as long as the specific gravity (Par. 7) of the lowest gravity cell shows any increase, and continuing for three hours after the last increase is shown. If the charge rate used is considerably

below the rate on page 2, this three hour period should be lengthened in proportion. The specific gravity at the end of this charge should be as shown in Par. 7.

b. When the Freshening Charge is complete, make a written record of the specific gravity of each cell and note the temperature and level of electrolyte in two or three cells for future comparison.

## CONDENSED OPERATING RULES

### 6. General Care

a. Keep the outside of the battery *clean and dry* by wiping with a dry cloth. Keep vent plugs in place.

b. Add regularly *only approved water* (distilled, if necessary). Do not add higher than the upper or top line on the container. Add before the level lowers to the bottom line on the container.

c. The amount of water necessary to add bears a definite relation to the amount of overcharge and may be used as a rough check against excessive charging. Under these conditions, if the amounts shown on Page 2 are exceeded for a floated (Par. 8a) battery, the overcharging is harmful. For example, a 60-cell PLX-13 battery should not require more than  $60 \times .10 = 6.0$  or 6 pints of water per month. A hard worked battery (manually-cycled, Par. 8c) will require three to four times the amount shown on Page 2.

d. Except in emergency, *stop discharge* before the voltage becomes too low for satisfactory service. The drop in specific gravity should not exceed the number of points shown in the table in Par. 1. A point is considered equal to .001 specific gravity. For example, the difference between 1.200 and 1.150 specific gravity is 50 points.

e. The red, white and blue *pilot balls* of batteries so equipped, give a rough check on the state of charge when the level of electrolyte is at the upper line; the battery being discharged approximately two-thirds or more when all three balls are down and fully charged when all are up. The blue ball sinks when the battery is slightly discharged and the white when approximately one-third discharged.

f. Always charge at rate low enough to keep the electrolyte temperature below 110 degrees Fahrenheit and while the cells are gassing never charge at rates higher than shown in table in Par. 1.

g. CAUTION. In the operation of the battery, gases are formed which may be explosive if ignited. Never bring burning material, such as lighted matches, cigarettes, and the like, or sparks of any kind near the battery. Ventilate the battery compartment when charging, in order to dispose of gas generated by battery.

b. Never allow metals, special solutions, powders, jellies or *impurities* of any kind to get into the cells.

i. Ammonia or soda solution will neutralize the effects of *spilled acid* or electrolyte if applied promptly.

j. If the battery is to *stand idle* for some time, give it a charge until *all* the cells gas and add enough water during this charge to raise the level of electrolyte to the

upper line. Give a freshening charge every six months and before putting into service again. During the idle period, be sure all battery circuits are open to prevent the possibility of any current leaking away.

k. At yearly intervals tighten the connector bolts.

### 7. Specific Gravity of Electrolyte

a. The specific gravity of the electrolyte with the cells fully charged, and the electrolyte level at the upper line on the container should be as shown in the following table for the temperature indicated.

Temperature	107°F.	77°F.	47°F.
Electrolyte Level at	1.190	1.200	1.210
Upper line . . . . .	1.210	1.220	1.230

b. It is adjusted within these limits at the factory and will not require adjusting during the life of the battery unless electrolyte is actually lost out of the battery. If, however, electrolyte is lost it should be replaced with electrolyte of about the same specific gravity as in the surrounding cells.

c. A lowering in level (between additions of water) increases the full charge gravity about 8 points for each 1/4 inch decrease in level. Addition of water will lower the full charge gravity similarly.

d. The table (Par. 7a) shows the effect on gravity of changes in electrolyte temperatures. For example, a change of 30°F. changes the gravity 10 points (.010 sp. gr.).

e. The full charge specific gravity will decrease in value as the battery ages. No definite value can be given but this decrease is very small, not over a few points per year at the most. This change is mentioned so that it will be understood.

### 8. Charging Methods

#### Floated Batteries

a. By "floated" batteries, are meant those which are permanently connected to the electrical system with which they are used in such a manner that they are normally kept fully or nearly fully charged (except for momentary or emergency discharge) by being constantly maintained at a voltage that will result in a small net charge. The "floating rate" is the sum of the very low current (generally termed "trickle rate") required to counteract the small internal

battery losses plus the average current requirements for the remainder of the circuit. If the latter is zero, the floating rate required becomes the trickle rate for the battery. The required floating or trickle current is automatically provided when the proper voltage is maintained across the battery.

b. The voltage *directly at the battery terminals* should average 2.15 volts per cell continuously. Some variations from this value may occur in daily use and to insure the battery being fully charged, give an Equalizing Charge once a month. This can be given either as in Par. 8d, or by raising the battery voltage to 2.33 volts per cell (140 volts for 60 cells) for a period of 8 to 24 hours, resuming normal floating at the end of this period.

### **Manually-Cycled Batteries**

c. By "manually-cycled" batteries are meant those which are normally allowed to reach a certain state of dis-

charge before being placed on charge, the charge being started manually.

d. If the battery requires *charging only once a week* or less frequently, charge until *all the cells gas freely* and until half-hourly readings of the specific gravity of any certain cell and of the voltage for the battery *both* show no further increase over a period of one hour. This is termed an *Equalizing Charge*.

e. If the battery requires *charging more often than once a week*, charge until the cells are gassing and until the specific gravity of a certain cell is within 5 points of the highest obtained on that cell during the Equalizing Charge last given, allowance being made for change in level (Par. 7c). *Then stop the charge*. Every sixth or seventh charge should be continued into an Equalizing Charge.

## **9. Filling and Charging if Shipped Without Electrolyte in Cells, Called "Dry-Charged"**

a. When ready to prepare for service, proceed as follows:

b. Remove vent cap and fill each cell with dilute sulphuric acid electrolyte of between 1.200 and 1.205 specific gravity, and with its temperature below 90°F. fill to the upper line on the container. Replace vent cap.

c. Allow battery to stand one to four hours after filling before charging at rates in Par. 1. Charge until four consecutive hourly readings show no rise in both specific gravity and voltage of the lowest cell. The length of the charging time may be up to 12 hours at the rates in Par. 1.

d. If temperature exceeds 110°F., reduce the charging rate and lengthen the time proportionately.

e. Make certain of the polarity of all connections as described in Par. 4.

f. At completion of charge, the specific gravity should be as shown in Par. 7a. If specific gravity is higher, remove some and replace with water. If lower, remove some and add electrolyte. Charge for an hour to mix solution before reading gravity again.

**EXIDE POWER SYSTEMS DIVISION**

**ESB INCORPORATED**

PHILADELPHIA, PA. 19120



**EXPORT SALES:** ESB Incorporated, International Group, 12 South 12th Street, Philadelphia, Pa. 19107

**IN CANADA:** ESB (Canada) Ltd., 2301 Dixie Road, P. O. Box 907, Postal Station "U," Toronto 18, Ontario, Canada

117

OPERATING INSTRUCTIONS  
SPRENGNETHER PHOTOGRAPHIC RECORDERS  
SERIES H AND D-H

The Sprengnether Series H and D-H are translating drum type Recorders using photographic registration. They are intended for use in Seismological Observatories where the continuous accumulation of analogue data in a high density format is required.

The Series H is a fully enclosed unit with both front and rear panel controls.

The Series D-H is identical in operation except for a lighter, open construction and simplified control circuit.

I. SPECIFICATIONS:

- |                                   |   |  |
|-----------------------------------|---|--|
| a) Recording Speeds               | = | <u>7 1/2</u> mm/Min                      |
|                                   | = | <u>15</u> mm/Min                         |
| b) Drum Translation Rate          | = | <u>5-10</u> mm/Revolution                |
| c) Recording Time                 | = | 24 Hours                                 |
| d) Record Dimensions              | = | 11-1/2 x 36 Inches                       |
|                                   | = | 28 x 91 cm                               |
| e) Recommended Photographic Paper | = | Kodak Linagraph 490 or Equivalent Papers |
| f) Time Marks                     |   |  |
| Source                            | = | External Contact Closure                 |
| Current                           | = | 40 MA Maximum, Inductive                 |
| g) Power                          | = | 110V 50/60 Hz<br>20 Watts Maximum        |
| h) Weight                         | = | <u>180</u> lbs                           |
| i) Dimensions                     | = | <u>30</u> x 16 x 16 Inches               |

## II. RECORDER INSTALLATION

### I. UNPACKING:

Carefully unpack the recorder by first removing the top of the packing case. Next remove all boxes and packing material in the partitioned end of the case being sure no small packages are discarded with the packing.

Remove sides of shipping box and unbolt the wooden recorder mounting blocks from the base of the shipping box.

Place the recorder across boxes or chairs to raise it well above the floor and unbolt the mounting boards. Save these screws as they are also used as leveling screws.

Remove the screws from the mounting boards and clean the threads to remove wood chips and dirt. Apply a drop of oil on each screw, put on lock nut to within 1/2" from head of the screw. Replace screw and lock nut in the recorder with the pointed end downward. Screw them in until only about one-half inch of thread is exposed below the recorder base.

Place the recorder on the pier with the leveling cups placed under the recorder leveling screws and level the recorder in both planes using a carpenter's level.

### 2. PREPARE RECORDING DRUM FOR OPERATION:

Remove packing material which held the drum in place during shipment and wipe all dirt from drum drive shaft. Remove the soft wire wrapped around the plunger which engages the lead screw. Raise the plunger and rotate one quarter turn so that the index pin rests on the indent on the upper face of the plunger housing. Move the drum to the extreme left-hand position until it stops. On drums having two translation rates, be sure only one plunger at a time is engaged in the lead screw, or the gear box and motor can be damaged.

Reverse the pinion gear on its shaft so that the teeth will engage the large shaft gear. This pinion gear was reversed in shipment to avoid possible damage.

The knurled nut which holds this gear also serves as a clutch and allows the drum to be rotated freely while removing and replacing recording paper. Loosen the nut about one turn with a counter-clockwise rotation to disengage the recorder drum. When tightening, use only enough pressure to assure positive drive.

A spring loaded friction anti-backlash brake is provided to assure smooth even rotation of the drum. A cork pad at the end of the flat spring serves as a friction pad against the side of the large shaft gear.

Pressure on the spring is pre-set at the factory and should not require adjustment for several years. Friction can be adjusted by loosening the lock nut on the screw in the center of the spring strip and tightening the screw about one turn. With the clutch knob loosened so the drum is free to rotate, the friction brake should be adjusted until the drum will stop after a slight rotation without rolling back. This should be tried in several steps through a complete rotation of the drum.

### 3. LIGHT SOURCE INSTALLATION:

Unpack the light source units and fasten to the mounting posts on the back panel of the recorder. (FIG 2 & 3) The banana jacks connect to color coded receptacles for deflector and lamp power. All lamp connectors are red and deflector connectors black. The lamp intensity balance potentiometers and time mark amplitude controls are located at the rear of this assembly. When it is necessary to replace lamps, rotate the bulb socket until the filament is aligned for the best focus (that is, when the filament image at the aperture strip is vertical and sharp).

The cylindrical lens is carried in a clip type holder between the drum and the recorder back panel. Place the cylindrical lens in the holder with the convex side away from drum. Be sure the lens is clean. Handle the lens with care when processing it down into the mounting clips. Assist the downward motion by moving the lens clip outward with the fingers. An adjusting screw on the back of the recorder just below the aperture strip is for positioning the cylindrical lens to obtain the sharpest focus in the vertical dimension of the recording spot.

## III. RECORDER OPERATION

### I. SERIES II RECORDERS:

The recorder controls (FIG 1) are located on the left front panel and on the light and time mark control unit at the rear.

#### a) Front Panel:

The "Motor" switch controls 110V 60 Hz power to the drum drive motor.

The "Rectifier" switch activates the power supply. This provides 6 volt 60 Hz for the lamp circuits and 12 volt DC for the time mark deflectors.

The "Test" switch shunts the clock contacts and provides a manually controlled time mark. There are three sets of front panel lamp controls. Each set includes a lamp power switch, a fine light intensity control rheostat, and a lamp current meter. The upper set controls the right hand recording channel, the center corresponds to the center drum channel and the bottom to the left hand channel.

b) Back Panel:

There are two controls on the light and time mark unit at the back of the recorder. The "Lamp" control is used to regulate the approximate light density during initial setup.

The "Deflector" control adjusts the time mark amplitude as observed on the drum.

2 SERIES D-II RECORDERS:

The controls for the Series D-II Recorders are located on the top and rear panels (FIG I).

a) Top Panel

The "Motor" switch controls 110V 60 Hz power to the drum drive motor.

The "P.S." switch activates the lamp and deflector power supply with 6 volt 60 Hz and 12VDC outputs respectively.

b) Back Panel

The "Test" switch actuates manual time marks.

The "Meter" select switch transfers the lamp current meter to each channel during trace light intensity adjustment.

Switch positions one, two and three connect the meter to the lamp control unit for the left, center and right recording channels respectively. The "meter" switch may be left at any position during recording. The lamp power switches activate the recording lamp circuits.

The "Lamp" and "Deflector" controls are identical to those in the Series II Recorder.

#### IV. RECORDING SYSTEM; INSTALLATION AND ADJUSTMENT

##### 1. GALVANOMETER INSTALLATION:

Place galvanometer at the rear of the Recorder (FIG 3 & 4) at a distance equal to the specified galvanometer focal length. Pencil type galvanometers are mounted on a special bracket secured to the recorder frame.

Locate galvanometer on a line that is perpendicular to the back of the recorder and projected from the center of the recorder aperture strip (FIG 3).

Activate the lamps and adjust lamp current until a high level of intensity is obtained. This will aid in making the "preliminary" adjustment.

Set the galvanometer so that the height of the mirror is midway between the center of the light source and the slot between the recorder aperture strips (FIG 3).

Adjust the galvanometer leveling screws until the base is level using a small spirit level. Unclamp the suspension very slowly until the clamp reaches its stop. The galvanometer suspension should now be completely free and oscillate at its natural period. If the suspension sticks or does not oscillate at its correct period, it indicates that more precise leveling is required. This can be accomplished more easily by using a flashlight to illuminate the galvanometer coil and gap so that the correct centering can be observed. Rotating a galvanometer leveling screw clockwise will cause the coil to move away from that leveling screw. With long period galvanometers this adjustment will be rather small. After the coil is correctly centered and operating at its correct period, rotate the galvanometer lens until the image at the recorder is vertical.

##### 2. LIGHT SPOT ADJUSTMENT:

The light spot should now be adjusted by means of the galvanometer zero adjustment until the light image rests on the center of the horizontal plane of the recorder aperture. (Short the galvanometer terminals to make this adjustment.)

If the light image does not fall on the aperture, it can be raised or lowered by adjusting the recorder light source up or down until the image is centered over the slot. The width of this slot was pre-set at the factory, but should it be necessary to make a change, the aperture strips can be adjusted within a limited range to provide



a means of adjusting the slot size to allow more light to fall on the cylindrical lens. This slot should be kept at a minimum to prevent fogging of the recording paper, about 1/16" being the proper gap.

Raise the sliding door and observe the light spot on a piece of white paper taped to the drum. Bring spot to best focus by adjusting the position of the cylindrical lens. The lens position control is located below the aperture slot. Clockwise rotation of the knurled knob increases lens to drum distance.

### 3. TIME MARK:

The "Deflection" Control regulates time mark amplitude. Obtain time mark signals by momentary closure of the "time test" switch on the recorder panel. Adjust the "Deflection" Control until the light spot is deflected by approximately 1 or 2 mm as viewed on the surface of the drum.

Connect the time mark clock to the "timer" terminals on the recorder. The clock only furnishes circuit closing contacts since the power for the relays is furnished by the power supply in the recorder.

After all the above adjustments are complete, reduce the light intensity to about half of the full brilliance and make a test recording to determine if the trace is sharp and clear and that time marks have correct amplitude. After correct adjustment of light intensity is made, the reading on the meter should be noted so that it can be easily re-set, should the light intensity be increased for other adjustments. On the Series DH 2 and 3 component recorders these readings are made for each lamp by means of the switch located below the meter, the switch being changed to read the current for each lamp.

### V. MAINTENANCE:

The recorder will require a minimum of maintenance, normal care such as occasional oiling of the gear box and drum plunger and feed screw. Occasionally the drum shaft should be wiped with a clean rag to remove dust and dirt so the drum translates freely.

The main point of wear is the drum plunger tip which engages the feed screw. This plunger tip is made of brass so that the major wear occurs on this tip rather than the screw thread. The tips are replaceable and spare tips can be ordered from the factory at nominal cost.

To replace the tip, remove the four screws fastening the plunger housing to the drum end and remove the complete assembly. Pull the replaceable tip out of the plunger shaft and replace with new tip. Rotate the tip while installing so that the engaging grooves align with the threads when the plunger housing is held flat against the drum end.

**Motor:**

Lubricate the motor every three months using the oil provided with the recorder.

Apply 10 drops to each of the two red oil holes (motor bearings).

Apply 20 drops to the yellow oil hole (gear reducer).

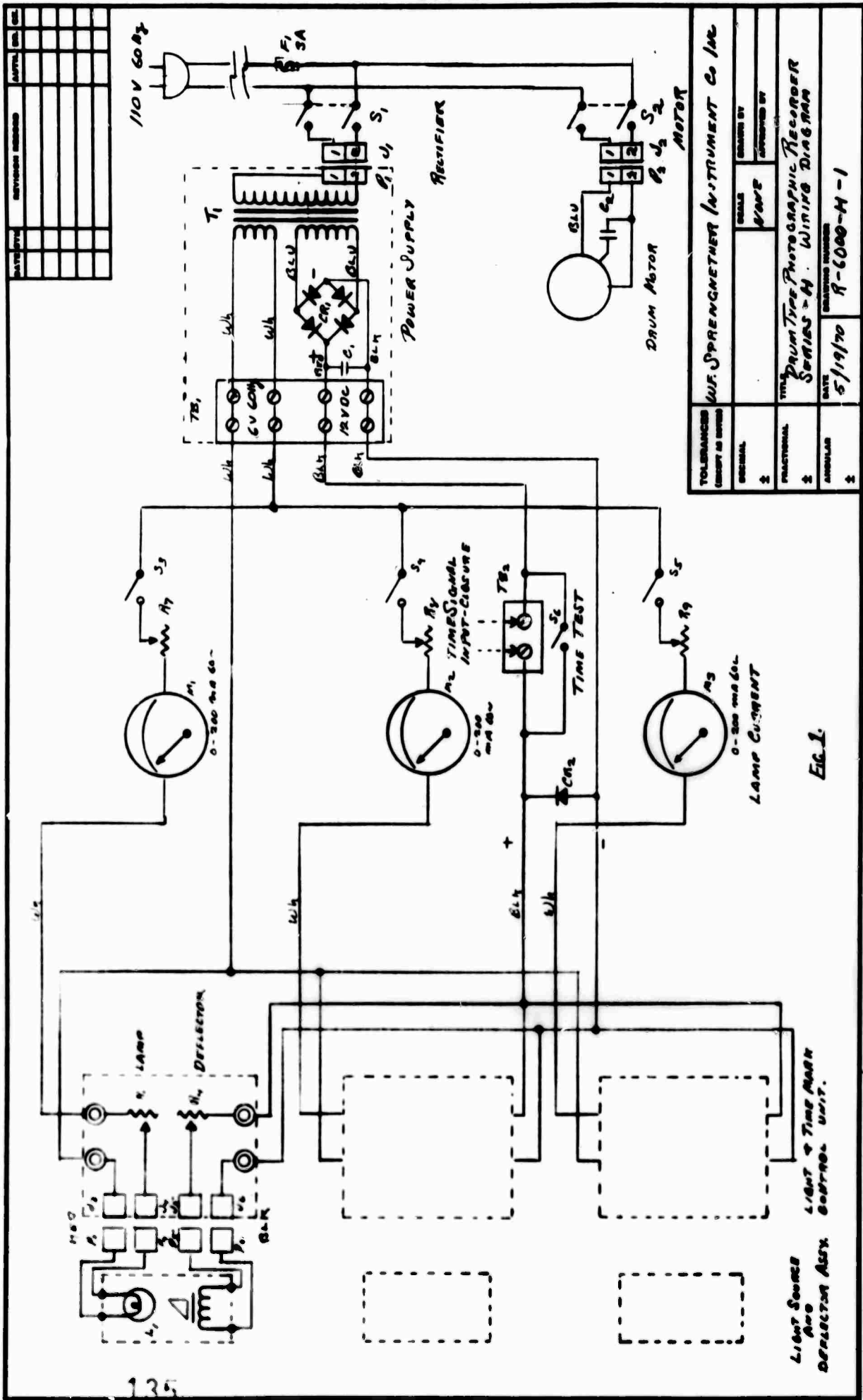

FIG. 1

LIGHT SOURCE  
DEFLECTOR ASSY.  
DRUM

LAMP CURRENT

TIME TEST

0-300 mA DC

0-300 mA AC

0-300 mA DC

TOLEANCES (UNLESS AS NOTED)	DECIMAL	FRAC.	ANGULAR
	±	±	±
W. F. SPRENGNETHER INSTRUMENT CO. INC.			
DESIGNED BY	DATE	REVISED BY	DATE
	5/19/70		
DRUM TYPE PHOTOGRAPHIC RECORDER SERIES - H - WINDING DIAGRAM			
DRAWING NUMBER R-6000-H-1			

REV.	DATE	BY	CHK.

REVISIONS			
LETTER	DESCRIPTION	DATE	APPROVED

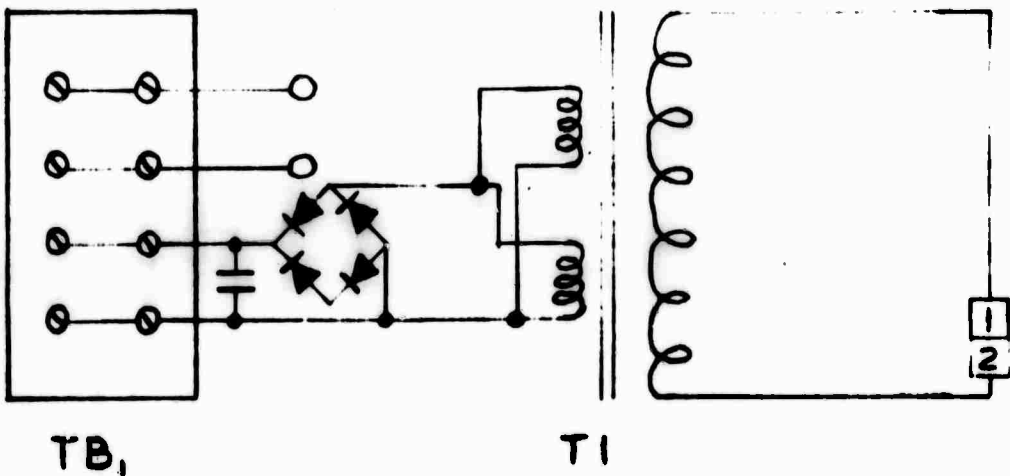

POWER SUPPLY

CONTRACT		 <p><b>LAMONT GEOLOGICAL OBSERVATORY OF COLUMBIA UNIVERSITY</b></p>								
DRAWN BY										
CHECK. BY										
PROJ. ENGR.										
<p><b>TOLERANCES:</b> UNLESS OTHERWISE SPECIFIED DIMENSIONS ARE IN INCHES</p> <table> <tr> <td>DECIMAL</td> <td>ANGLES</td> </tr> <tr> <td>.X ±</td> <td>±</td> </tr> <tr> <td>.XX ±</td> <td></td> </tr> <tr> <td>.XXX ±</td> <td></td> </tr> </table> <p><b>BREAK SHARP EDGES</b></p>		DECIMAL	ANGLES	.X ±	±	.XX ±		.XXX ±		<p><b>AMENDMENT TO FIGURE 1 OF MANUAL FOR 4100</b></p>
DECIMAL	ANGLES									
.X ±	±									
.XX ±										
.XXX ±										
DWG. NO. <b>FIG. 1-1</b>		REV								
SCALE	WEIGHT	SHEET 1 OF 1								

DATE SYM	REVISION RECORD	AUTH.	DR.	CK.

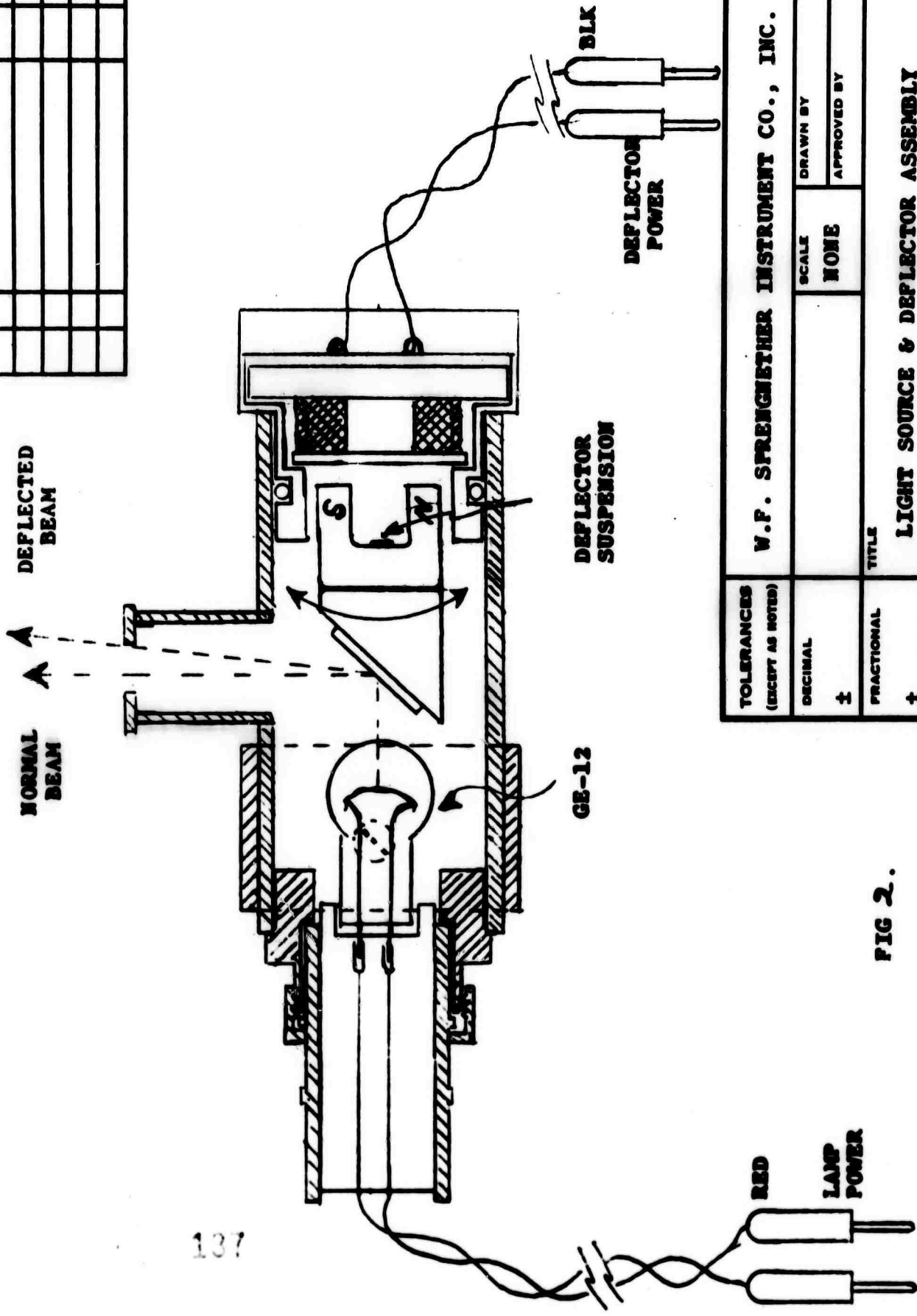

137

TOLERANCES (EXCEPT AS NOTED)		W.F. SPRENGMETHER INSTRUMENT CO., INC.	
DECIMAL	±	SCALE	NONE
FRACTIONAL	±	DRAWN BY	APPROVED BY
ANGULAR	±	TITLE LIGHT SOURCE & DEFLECTOR ASSEMBLY	
		DATE	DRAWING NUMBER
		5/19/70	

FIG 2.

MADE IN U.S.A.  
87947

McE ALUMINUM © 10 0400  
MILITARY STANDARD FORM

# ADJUSTMENT OF LIGHT SPOT

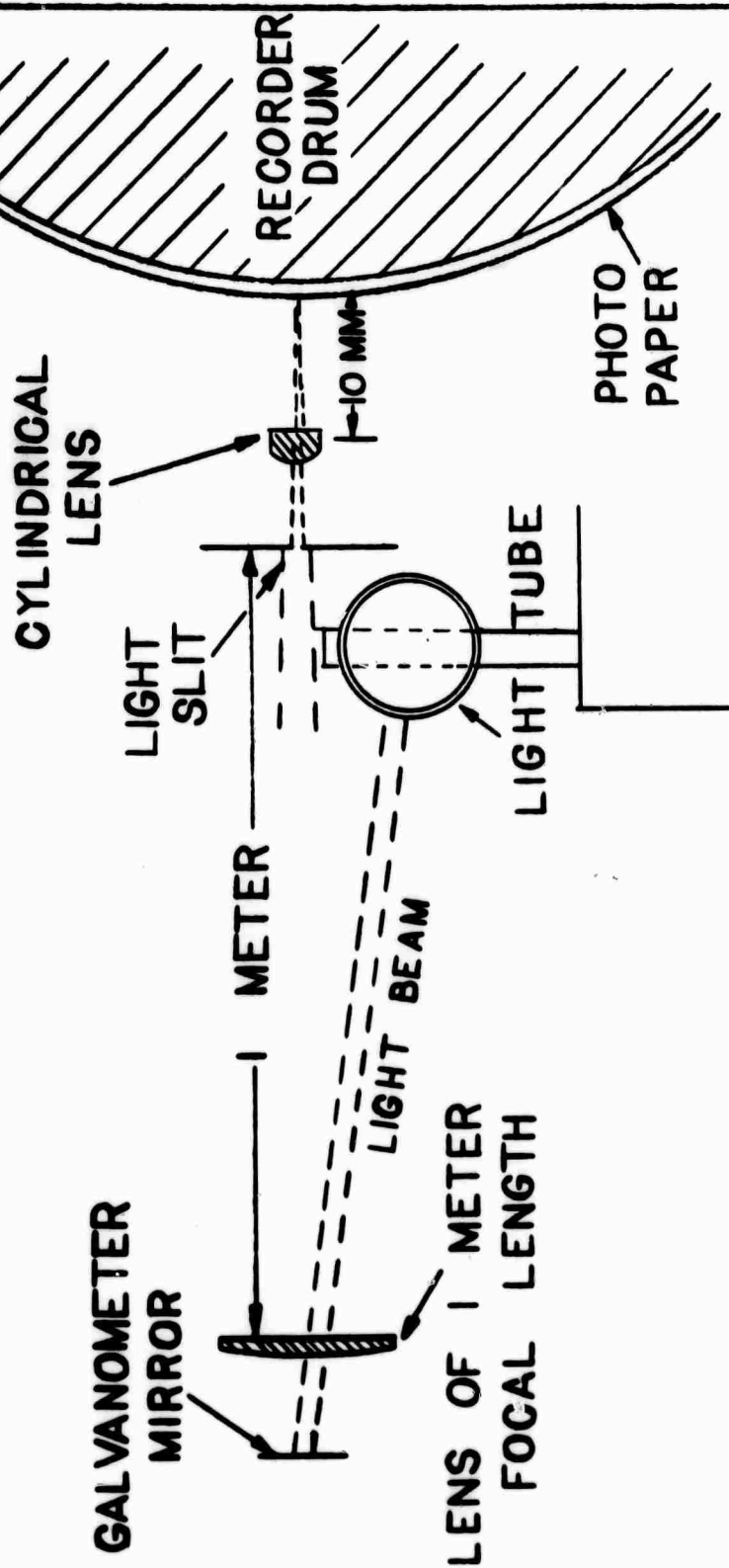
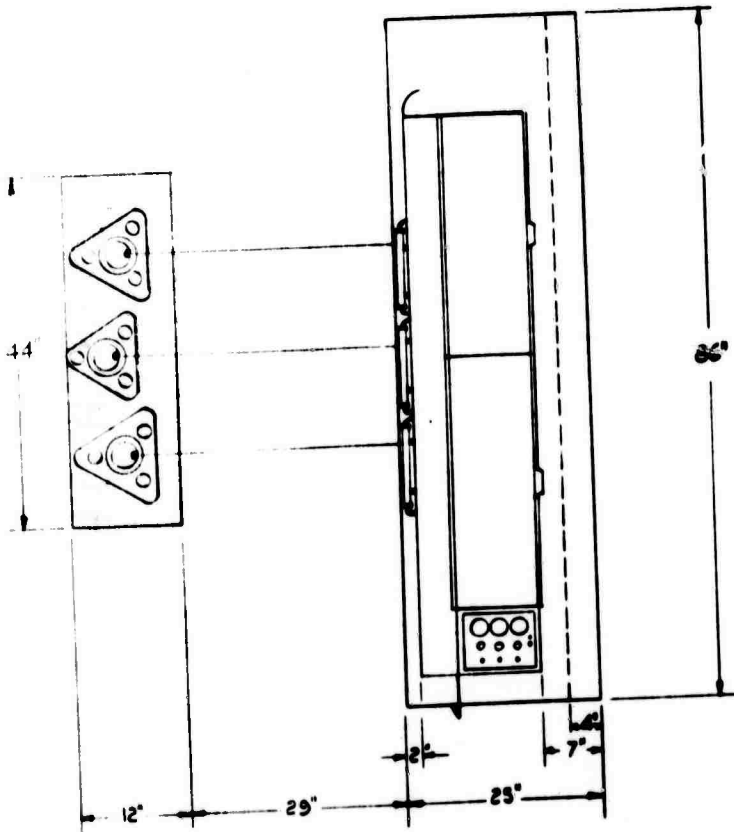

FIG. 3

4100-12



PIER ARRANGEMENT  
FOR  
SPRENGNETHER  
THREE COMPONENT RECORDER

SCALE: 0 12"

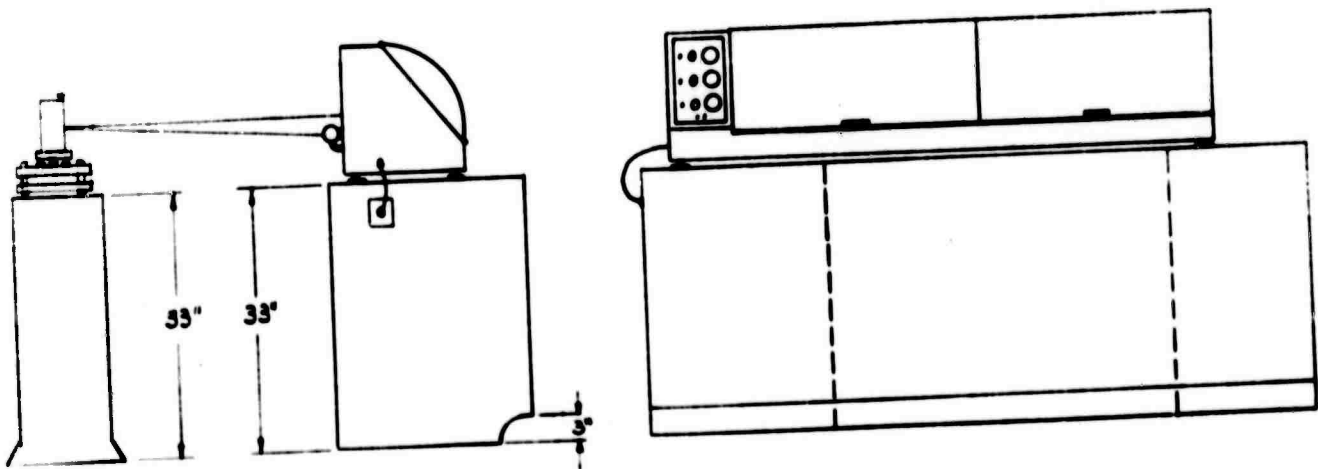

FIG. 4  
W.F. SPRENGNETHER INSTRUMENT CO.  
ST. LOUIS, MO.  
U.S.A.

GEARBOX  
COVER

CONNECTED  
TO MOTOR

CLUTCH KNOBS  
TIGHTEN TO  
ENGAGE DRUM

GEAR BOX DETAIL

ROTATE KNOB TO  
SELECT SPEED

FIG 5

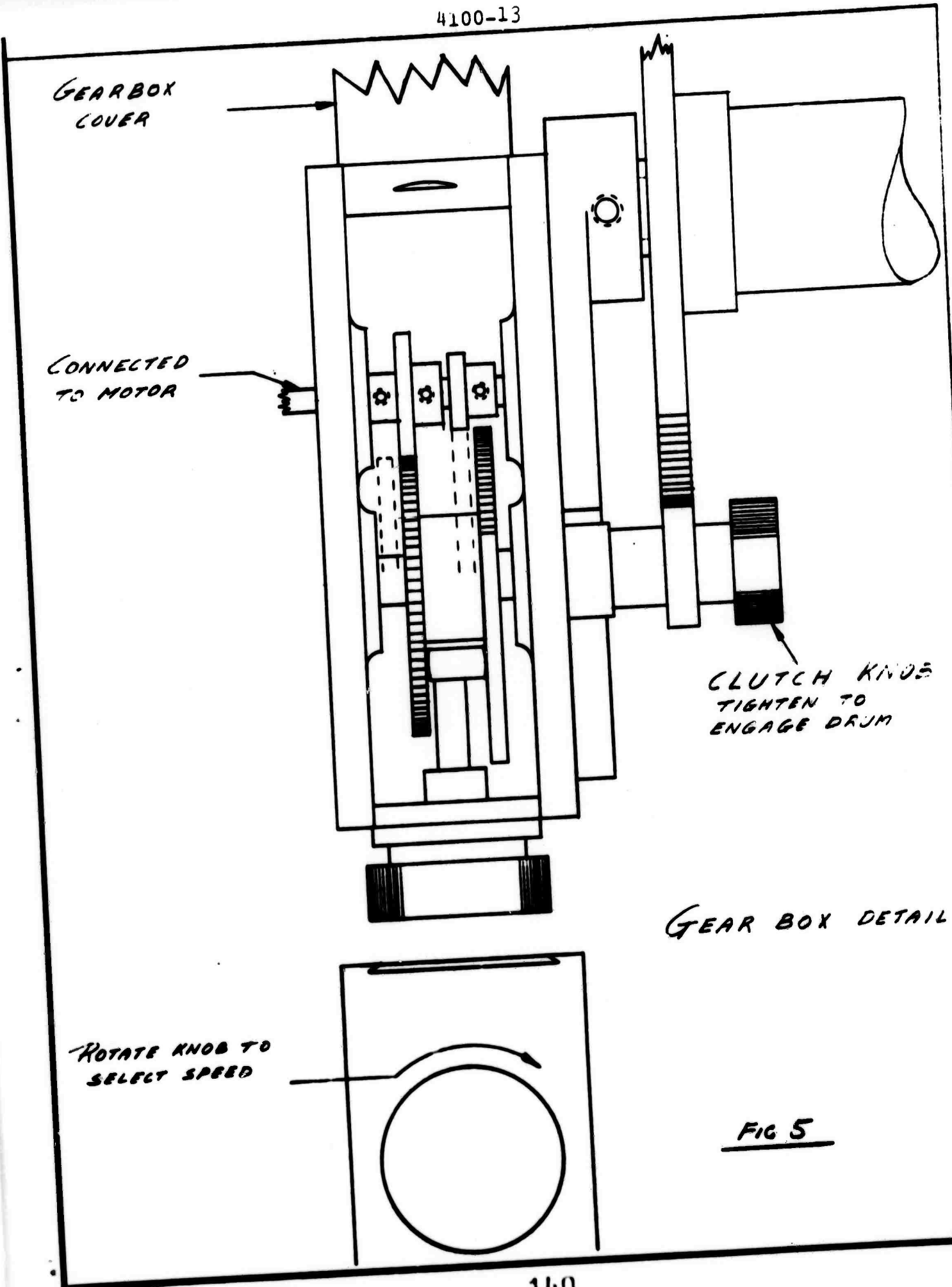



SERIES H  
PHOTOGRAPHIC RECORDER  
PARTS LIST

<u>Symbol</u>	<u>Identification</u>	<u>Source</u>
C <sub>1</sub>	Capacitor 100 mfd 50W VDC, TL-1309	Sprague
C <sub>2</sub>	Motor Capacitor 0.85 mfd	
CR <sub>1</sub>	Rectifier Bridge 200 PIV, 125V 3A DC #3ORB2AL	I.R.
CR <sub>2</sub>	Diode IN2069	
M <sub>1</sub> , M <sub>2</sub> , M <sub>3</sub>	Lamp Current Meter 0-200 MA 60 Hz #M382	W.F.S.
L <sub>1</sub> , L <sub>2</sub> , L <sub>3</sub>	Lamp - GE-12	G.E.
P <sub>1</sub> , P <sub>2</sub>	Connector P-302-AB	Cinch Jones
J <sub>1</sub> , J <sub>2</sub>	Connector S-302-CCT	Cinch Jones
P <sub>3</sub> to P <sub>15</sub>	Banana Plug #108303	E.F. Johnson
J <sub>3</sub> to J <sub>15</sub>	Banana Jack #221	H.H. Smith
R <sub>1</sub> , R <sub>2</sub> , R <sub>3</sub>	Potentiometer 50 ohms 12-1/2 watt #0110	Ohmite
R <sub>4</sub> , R <sub>5</sub> , R <sub>6</sub>	Potentiometer 5000 ohms 12-1/2 watt #0123	Ohmite
R <sub>7</sub> , R <sub>8</sub> , R <sub>9</sub>	Potentiometer 50 ohms 25 watt #0149	Ohmite
S <sub>1</sub> , S <sub>2</sub>	Power Switch Microswitch #12TS-115-2	Honeywell
S <sub>3</sub> , S <sub>3</sub> , S <sub>5</sub>	Lamp Power Switch, Microswitch #IITS-115-2	Honeywell
S <sub>6</sub>	Time Test Switch Microswitch IITS-95-3	Honeywell
T <sub>1</sub>	Transformer #AMA-980	W.F.S.
TB <sub>1</sub>	Terminal Block #4-140-Y	Cinch
TB <sub>2</sub>	Terminal Block #2-140	Cinch
	Light Source and Deflector Assembly #R-6000-DF	W.F.S.

4100-15

**SERIES H  
PHOTOGRAPHIC RECORDER  
PARTS LIST**

<u>Symbol</u>	<u>Identification</u>	<u>Source</u>
	Light and Time Mark Control Unit #R-6000-LD	W.F.S.
	Power Supply #R-6000-PS	W.F.S.
	Drum Motor #KYC-22T5	Bodine

REVISIONS	DATE	APPROVED
LETTER	DESCRIPTION	

**BENCH CONSTRUCTION:**  
 LEGS AND BRACES - TUBULAR STEEL  
 1 1/2" SQUARE BOX-SECTION  
 TOP - 3 6" x 1/2" DRESSED HARDWOOD  
 PLANKS WITH 6' x 1/6" x 1/2" SHEET OF  
 MARINE PLYWOOD GLUED TO PLANKS  
 AND EDGES FINISHED WITH 2" x 1/2"  
 DRESSED PINE  
 EACH LEG HAS AN ADJUSTABLE FOOT

**DETAIL:**  
 1 TUBULAR STEEL FRAME  
 2 SCREW  
 3 ADJUSTABLE FOOT

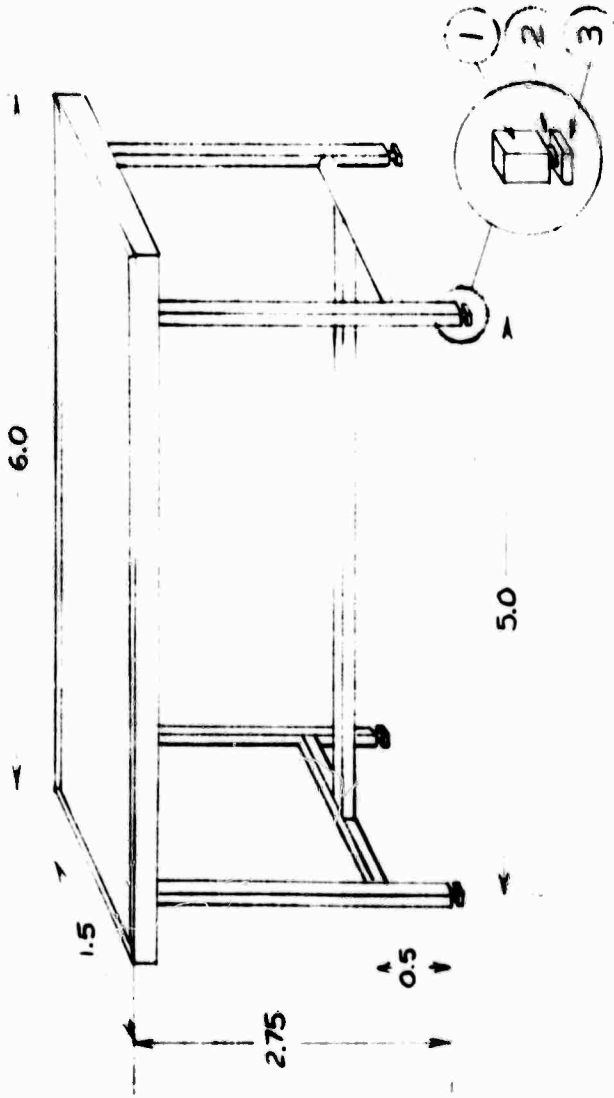

0 1 2  
 FEET

CONTRACT			<b>LAMONT GEOLOGICAL OBSERVATORY          OF COLUMBIA UNIVERSITY</b>
DRAWN BY			
CHECK BY			
PROJ ENGR			
TOLERANCES: UNLESS OTHERWISE SPECIFIED DIMENSIONS ARE IN INCHES DECIMAL     1 R             2 R R         2 R R R      2 BREAK SHARP EDGES		DWG NO <b>4103</b>	SHEET <b>1</b> OF <b>1</b>
		<b>RECORDER BENCH</b>	REV

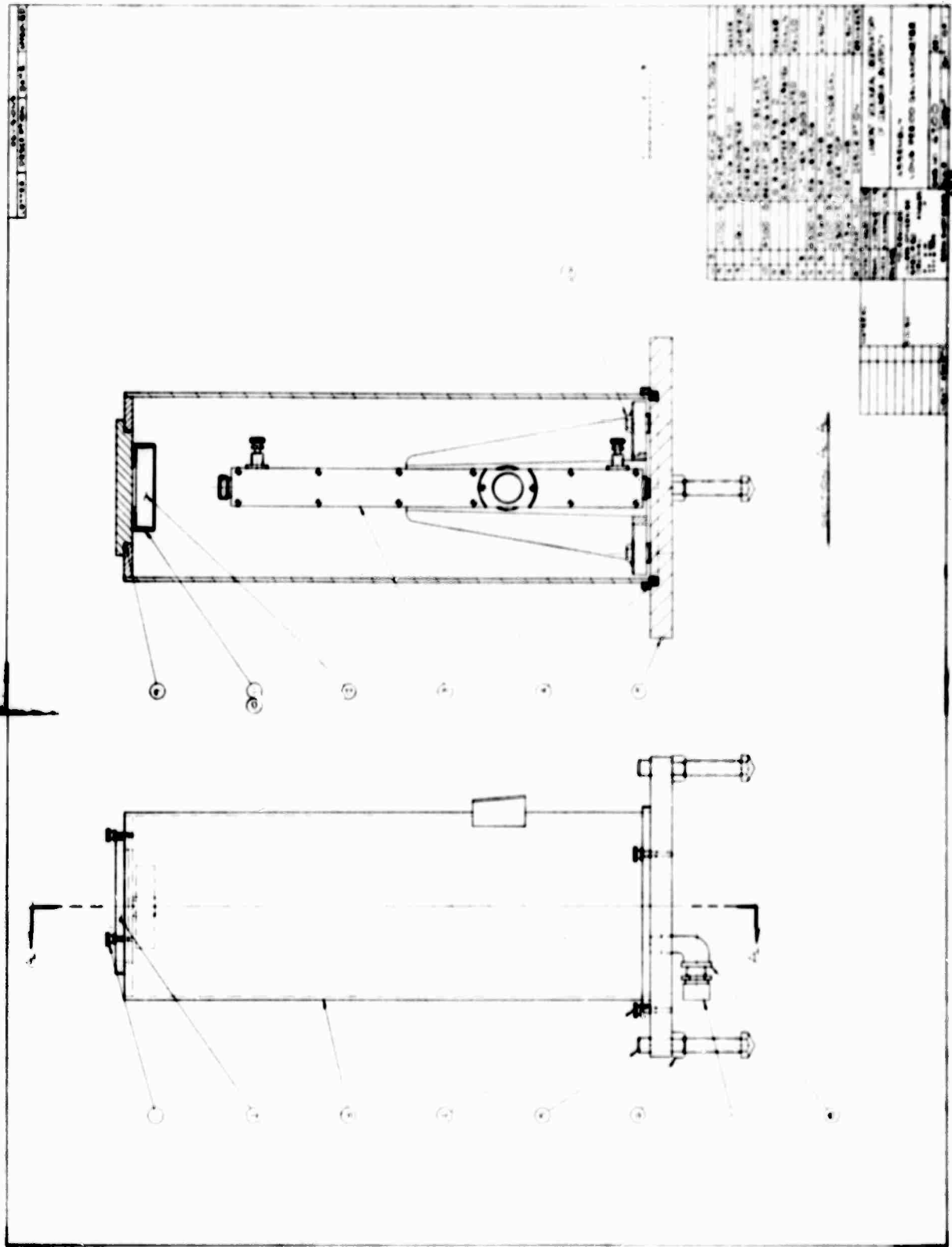

DATE	DESCRIPTION	BY

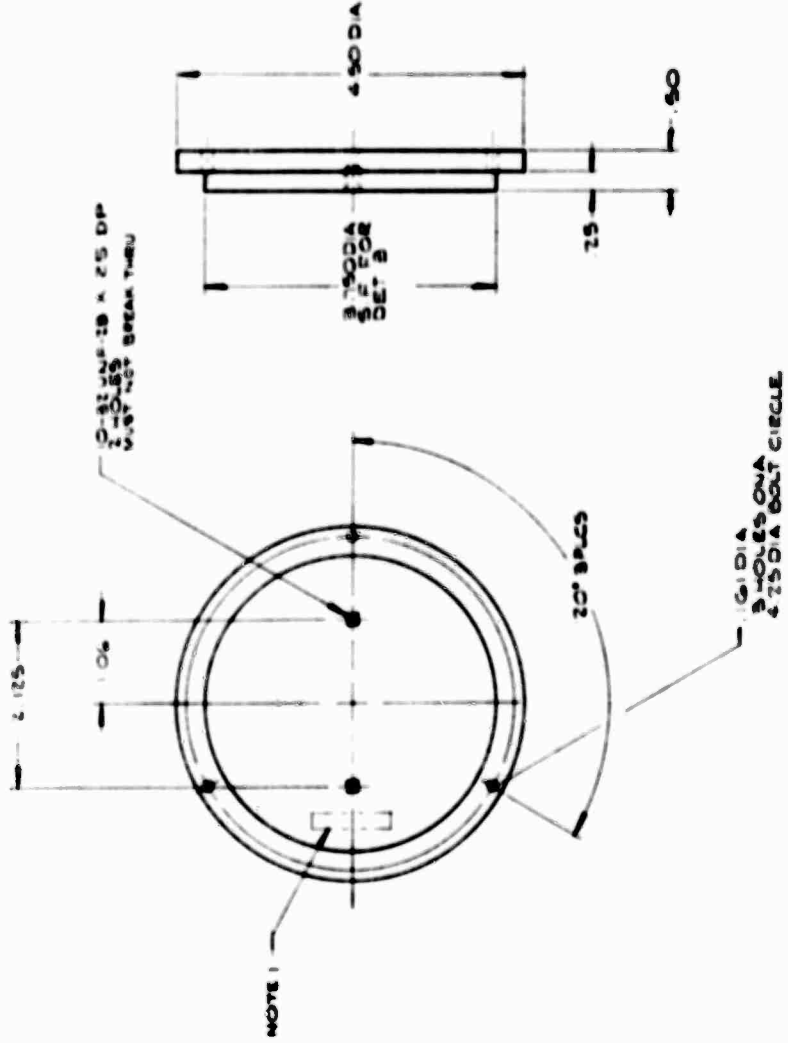

NOTES  
 1 STAMP OR STENCIL PART WHERE INDICATED  
 2 SURFACE FINISH ALL OVER EXCEPT WHERE NOTED



<b>LAMONT GEOLOGICAL OBSERVATORY        OF COLUMBIA UNIVERSITY</b>	
COVER, TOP - LONG PERIOD GALVANOMETER	
DRAWING NO. 4200-2	
SCALE 1/1	DATE 1957
MATERIAL: BRASS 35-45-20-5-000 QUANTITY: 1 MADE BY: COSTELLO CHECKED BY: B. H. STUBBS DATE: 1957	
FINISH: ENGLISH CHEMICAL: ACID DIP	
TOLERANCES: UNLESS OTHERWISE SPECIFIED DIMENSIONS ARE IN INCHES DECIMALS: .001 FRACTIONS: 1/16 ANGLES: .001 HOLE DIA: .001 HOLE POSITION: .001	
4200 1 NEXT ASSEMBLY	

ASD

146

NOTE: DIMENSIONS ARE IN INCHES UNLESS OTHERWISE SPECIFIED

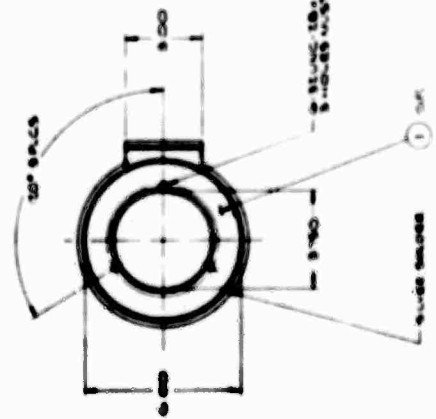
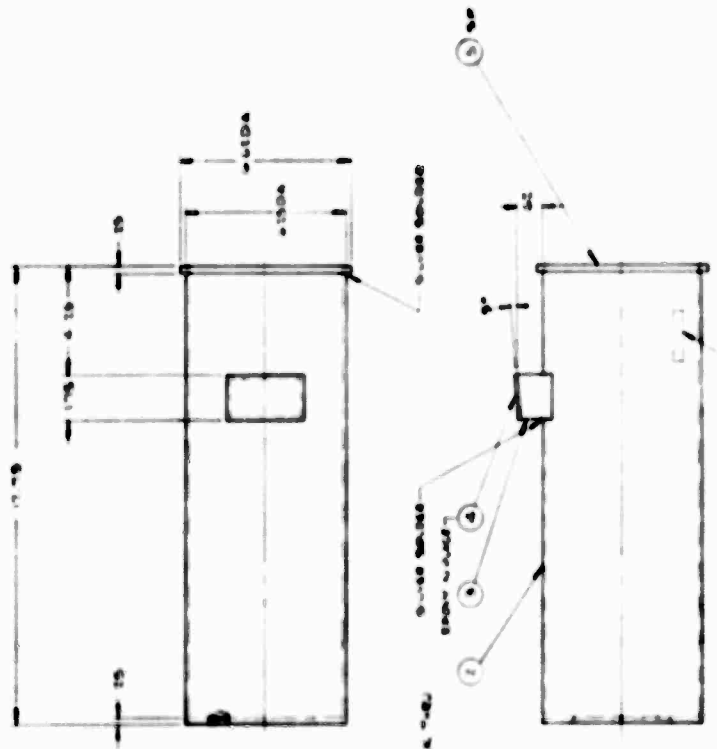

NOTE: DIMENSIONS ARE IN INCHES UNLESS OTHERWISE SPECIFIED

1 1/2

REV	DATE	BY	CHKD	DESCRIPTION
1	10/10/50	J. J. ...	J. J. ...	...
2	...	...	...	...
3	...	...	...	...
4	...	...	...	...
5	...	...	...	...
6	...	...	...	...
7	...	...	...	...
8	...	...	...	...
9	...	...	...	...
10	...	...	...	...
11	...	...	...	...
12	...	...	...	...
13	...	...	...	...
14	...	...	...	...
15	...	...	...	...
16	...	...	...	...
17	...	...	...	...
18	...	...	...	...
19	...	...	...	...
20	...	...	...	...
21	...	...	...	...
22	...	...	...	...
23	...	...	...	...
24	...	...	...	...
25	...	...	...	...
26	...	...	...	...
27	...	...	...	...
28	...	...	...	...
29	...	...	...	...
30	...	...	...	...
31	...	...	...	...
32	...	...	...	...
33	...	...	...	...
34	...	...	...	...
35	...	...	...	...
36	...	...	...	...
37	...	...	...	...
38	...	...	...	...
39	...	...	...	...
40	...	...	...	...
41	...	...	...	...
42	...	...	...	...
43	...	...	...	...
44	...	...	...	...
45	...	...	...	...
46	...	...	...	...
47	...	...	...	...
48	...	...	...	...
49	...	...	...	...
50	...	...	...	...

ASD

DATE	DESCRIPTION	DATE	APPROVED

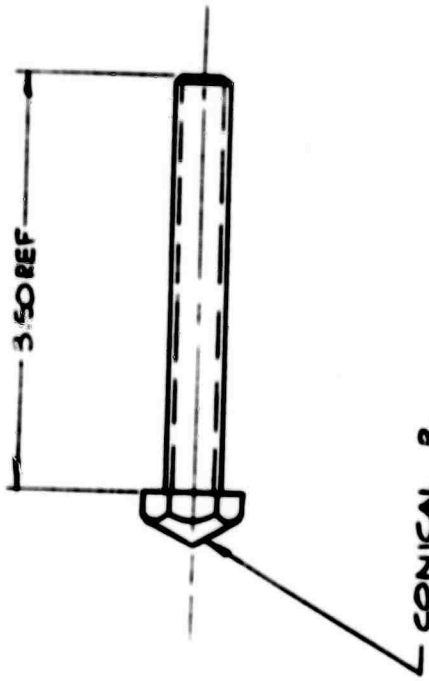

147



CONTRACT # 4200-5 DESIGN BY H. COLEMAN 7/7/70 CHECK BY W. LINDEN 7/15/70 PROJ. ENG.		TOLERANCES UNLESS OTHERWISE SPECIFIED DIMENSIONS ARE IN INCHES DECIMAL .005 ANGLES ± 1° FINISH: CHROMIC ACID DIP BREAK SHARP EDGES	
MATERIAL: MAKE FROM BRASS HET HD SCR .500-20x3.50		FINISH: CHROMIC ACID DIP	
4200	3	NEXT ASM	QTY

**LAMONT GEOLOGICAL OBSERVATORY  
OF COLUMBIA UNIVERSITY**  
 LEG, LEVELING  
 LONG PERIOD GALVANOMETER  
 DES NO 4200-5  
 SCALE 1/1 WEIGHT SHEET OF 1

ASD

LETTER	REVISIONS	DESCRIPTION	DATE	APPROVED

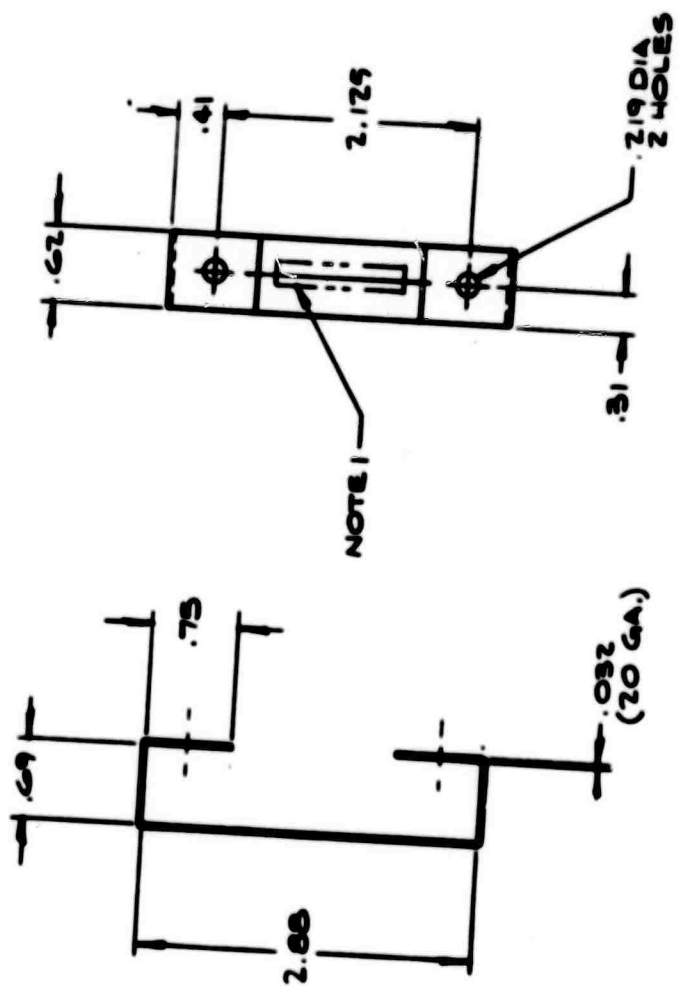

NOTES  
 1 STAMP OR STENCIL PART  
 NO WHERE INDICATED



148

<b>MATERIAL:</b> BRASS 1/2 HARD		CONTRACT: ARMO-10-C-001 DRAWN BY: H. COFFMAN/7/70 CHECK BY: M. HARRISON/3/15/70 TOOL USED:	
<b>FINISH:</b> CHEMIC ACID DIP		TOLERANCES UNLESS OTHERWISE SPECIFIED DIMENSIONS ARE IN INCHES DECIMALS ANGLES .1 .04 .01 .005 .01 .005 GREAT BRASS BRONZE	
4200	1	NEXT ASSEMBLY	
LAMONT GEOLOGICAL OBSERVATORY OF COLUMBIA UNIVERSITY		BRACKET, DEHYDING AGENT - LONG PERIOD GALVANOMETER	
DRAW NO 4200-10		SCALE 1/1 ORIGIN	
SHEET 1 OF 1		ASD	



1. ALL DIMENSIONS ARE IN INCHES  
 2. ALL DIMENSIONS ARE TO CENTER UNLESS OTHERWISE SPECIFIED  
 3. ALL DIMENSIONS ARE TO CENTER UNLESS OTHERWISE SPECIFIED

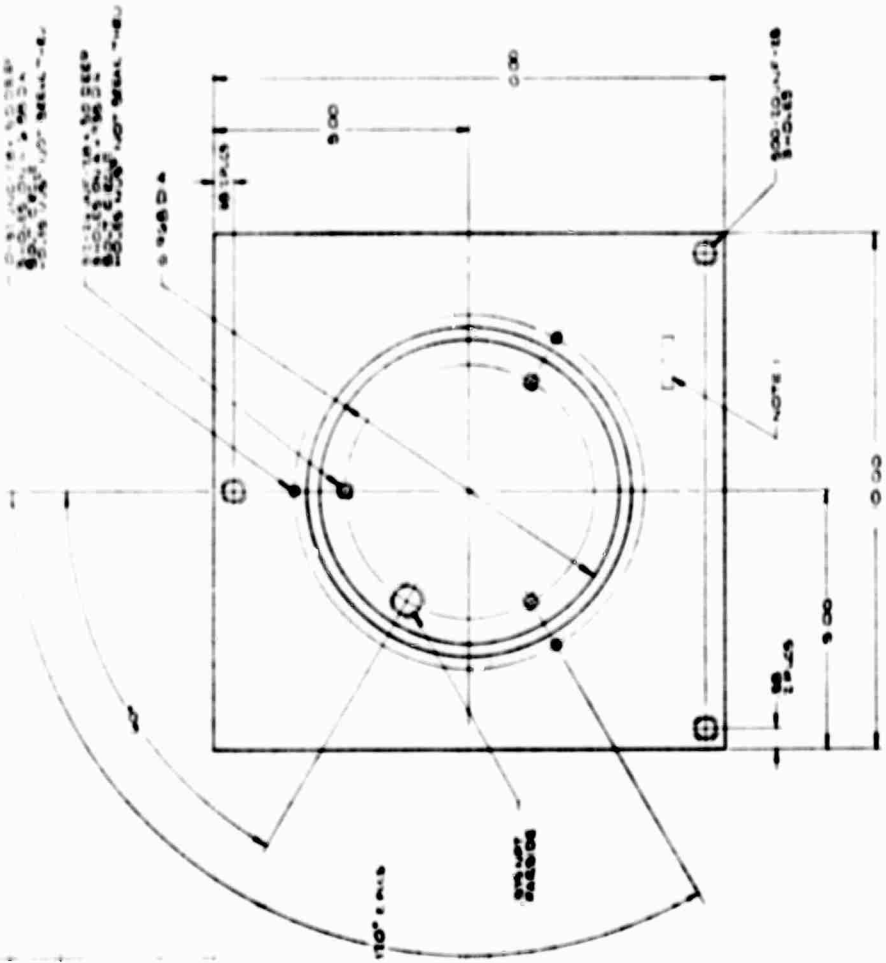

NOTES:  
 1. ALL DIMENSIONS ARE TO CENTER UNLESS OTHERWISE SPECIFIED  
 2. ALL DIMENSIONS ARE TO CENTER UNLESS OTHERWISE SPECIFIED

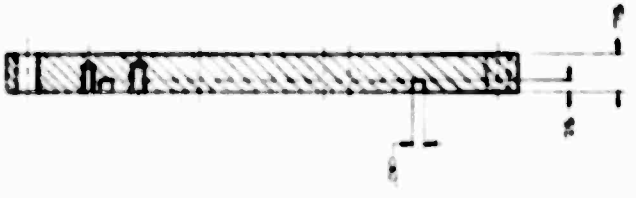

<b>PLATE BASE</b> 10.00 DIA. 0.125 THICK	
DATE: 4/10/13 DRAWN BY: [Name] CHECKED BY: [Name]	435

LETTER	DESCRIPTION	DATE	APPROVED

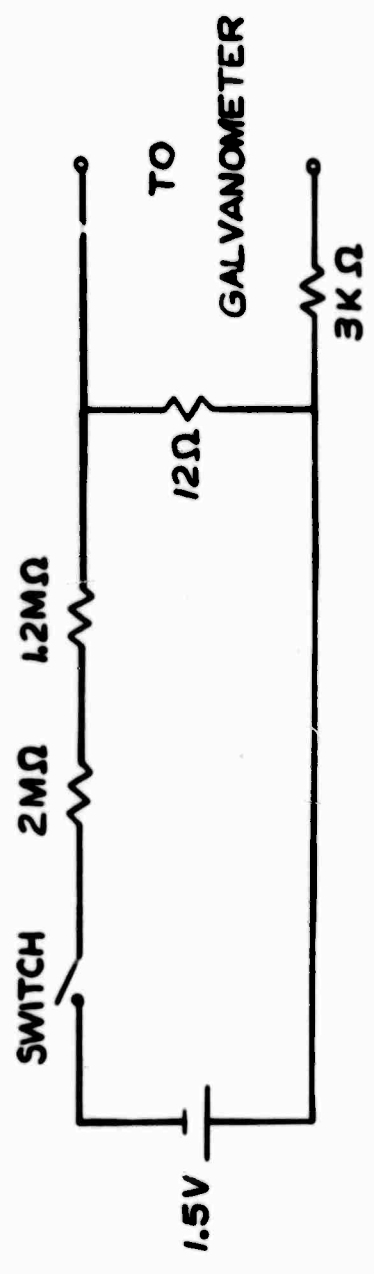

150

<b>LONG PERIOD GALVANOMETER RESISTIVE NETWORK</b>	
DRAW NO <b>4202</b>	SHEET 1 OF 1
TOLERANCES UNLESS OTHERWISE SPECIFIED DIMENSIONS ARE IN INCHES DECIMALS                      FRACTIONS	
.1                                  1/16 .05                                1/32 .02                                1/64 .01                                1/128	BREAK SQUARE EDGES

LETTER	DESCRIPTION	DATE	APPROVED
--------	-------------	------	----------

- NOTES: 1 LONG PERIOD GALVANOMETER  
 2 BINDING POSTS  
 3 SPRAGUE 6K OHM RESISTORS  
 4 WELDED CONNECTION  
 5 COPPER WIRE

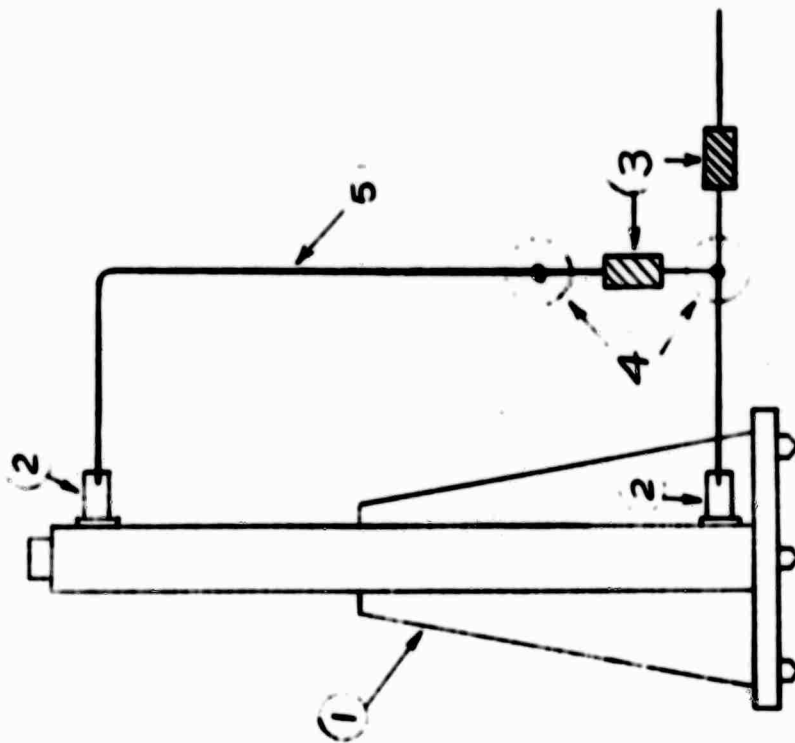

151

 <b>LAMONT GEOLOGICAL OBSERVATORY OF COLUMBIA UNIVERSITY</b>		<b>LONG PERIOD GALVANOMETER L-PAD ATTENUATOR</b>	
CONTRACT	DESIGNED BY	ENG. NO.	REV.
DRAWN BY	CHECKED BY	4203	
SCALE	DATE	SCALE	SHEET 1 OF 1
TOLERANCES UNLESS OTHERWISE SPECIFIED DIMENSIONS ARE IN INCHES DECIMALS .1 .2 .3 .4 .5 .6 .7 .8 .9 .0 ANGLES 1/2 1/4 1/8 1/16 3/32 1/8 1/4 1/2 3/4 1			
BREAK SHARP EDGES			

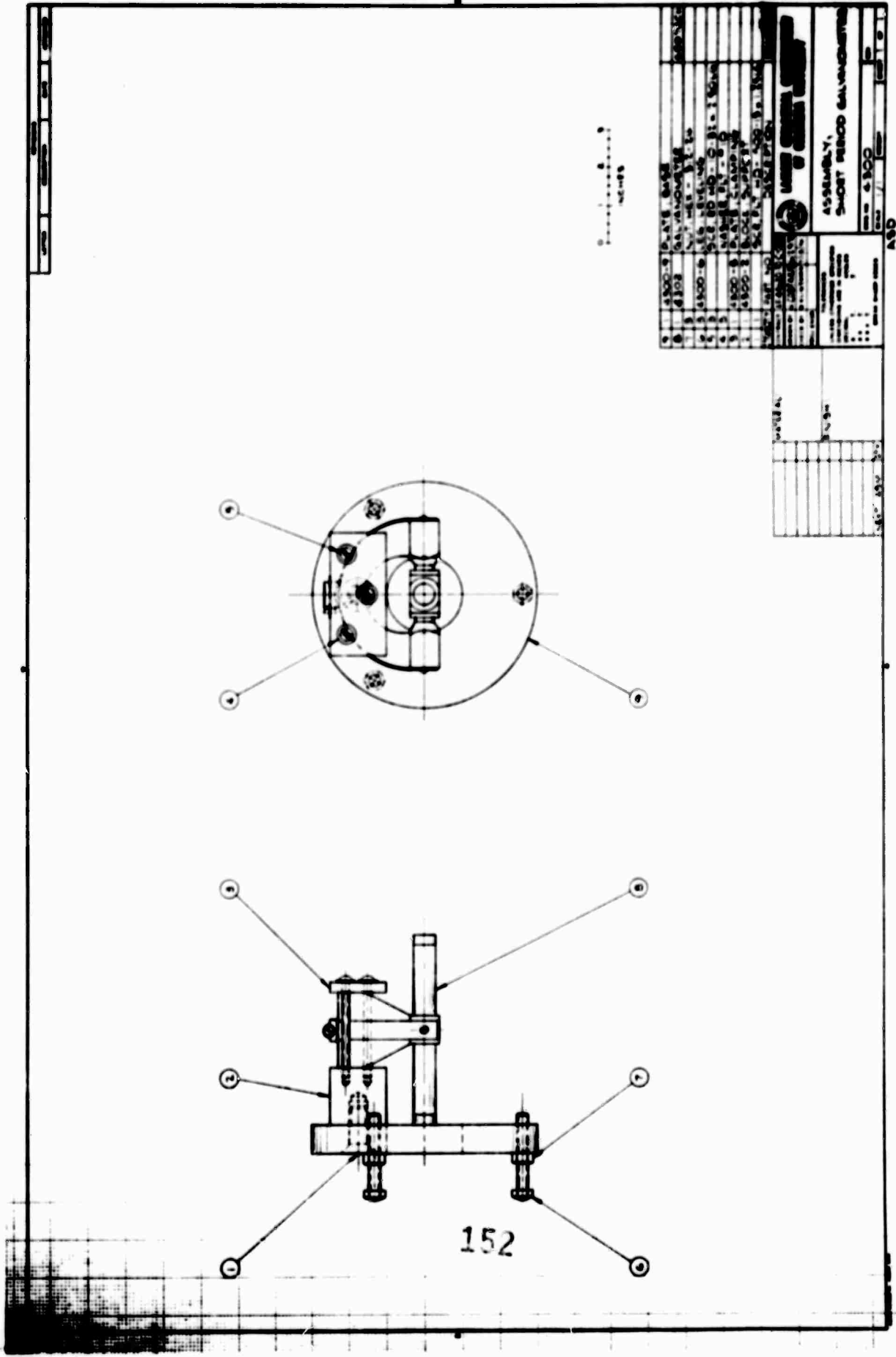

1	1500-8 PLATE BASE	
2	1500-9 GALVANIZED	
3	1500-6 WASHER	
4	1500-5 BUSHING	
5	1500-4 BUSHING	
6	1500-3 WASHER	
7	1500-2 WASHER	
8	1500-1 WASHER	
UNIT NO. 1500-1 1500-2 1500-3 1500-4 1500-5 1500-6 1500-7 1500-8 1500-9		
ASSEMBLY, SHORT PERIOD GALVANIZING		
1500-1 1500-2 1500-3 1500-4 1500-5 1500-6 1500-7 1500-8 1500-9		

152

REVISED	DESCRIPTION	DATE	APPROVED
---------	-------------	------	----------

NOTES:  
 1. STAMP OR STENCIL PART NO. WHERE INDICATED  
 2.  $2 \frac{1}{2}$  SURFACE FINISH ALL OVER EXCEPT WHERE NOTED.

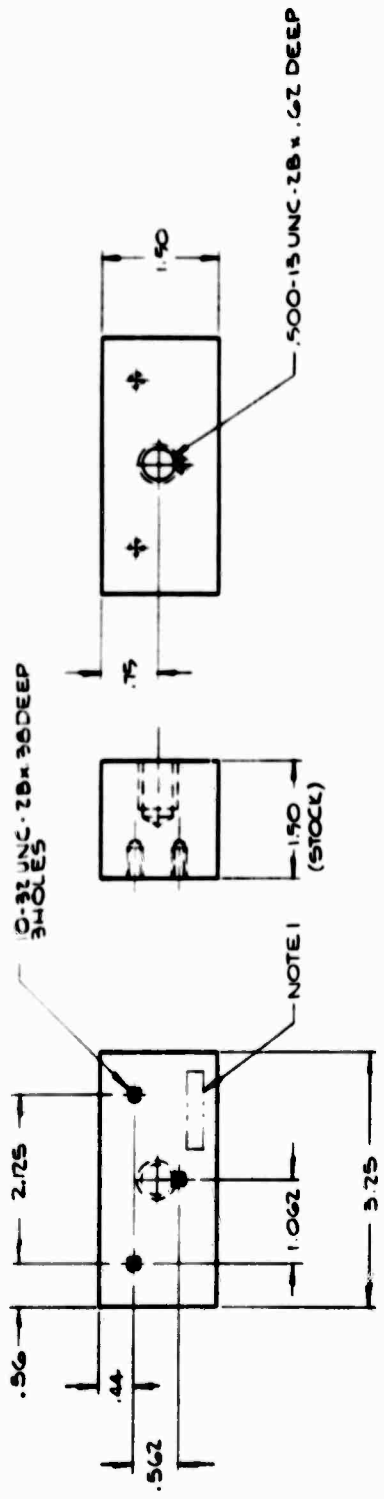

CONTRACT NO. 4420-70-C-0056			BLOCK, SUPPORT -	
DRAWN BY H. OSTASZCZAK			SHORT PERIOD GALVANOMETER	
CHECKED BY M. K. HANNA		DATE NO. 4300-2		REV.
TOLERANCES UNLESS OTHERWISE SPECIFIED DIMENSIONS ARE IN INCHES DECIMALS .125 ± .01 .062 ± .005 .031 ± .002 .015 ± .001 BREAK SHARP EDGES		SCALE 1/1		SHEET 1 OF 1
MATERIAL:	BRASS 1/2 HARD	ASD		
FINISH:	CHROMIC ACID DIP.			
4300	1			
NEXT ASM	QTY			

REVISIONS		DATE	APPROVED
LETTER	DESCRIPTION		

- NOTES:
- 1 STAMP OR STENCIL PART NO. WHERE INDICATED.
  - 2  $\sqrt{.25}$  SURFACE FINISH OVER EXCEPT WHERE NOTED.

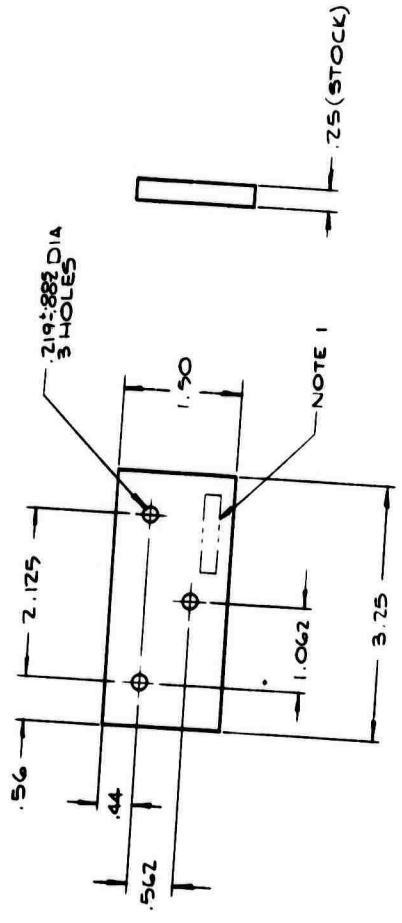

<b>LAMONT GEOLOGICAL OBSERVATORY OF COLUMBIA UNIVERSITY</b>	
PLATE, CLAMPING - SHORT PERIOD GALVANOMETER	
DWG NO 4300-3	
SCALE 1/1	WEIGHT
REV	SHEET 1 OF 1
<b>ASD</b>	
CONTRACT JE 442270-C-0036 DRAWN BY H. COSTAKIS/7/17/70 CHECK BY W. KLINZMAN 7/11/70 PROJ ENGR	TOLERANCES UNLESS OTHERWISE SPECIFIED DIMENSIONS ARE IN INCHES DECIMAL ± .02 ANGLES ± 1° XXX ± .005 BREAK SHARP EDGES
MATERIAL: BRASS 1/2 HARD	FINISH: CHROMIC ACID DIP.
4300 NEXT ASM QTY 1	

REVISIONS		
LETTER	DESCRIPTION	DATE

APPROVED

DATE

DESCRIPTION

LETTER

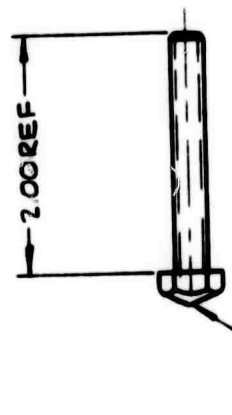

CONICAL RADIUS



155

<p>LAMONT GEOLOGICAL OBSERVATORY OF COLUMBIA UNIVERSITY</p>		<p>LEG. LEVELING SHORT PERIOD GALVANOMETER</p>	
<p>CONTRACT # 44-20-70-6028 DRAWN BY A. COSIALS 6/27/70 CHECK BY S. KLINTSMAN 7/13/70 PROJ. ENGR.</p>		<p>DWG. NO. 4300-6 SCALE 1/1 WEIGHT SHEET 1 OF 1</p>	
<p>MATERIAL: MAKE FROM 3/2-24 x 2.00 BRASS HEX HD BOLT</p>		<p>TOLERANCES UNLESS OTHERWISE SPECIFIED DIMENSIONS ARE IN INCHES DECIMAL ANGLES ± .01 ± 15 ± .005 ± .005 BREAK SHARP EDGES</p>	
<p>FINISH: CHROMIC ACID DIP.</p>		<p>4300 NEXT ASSEMBLY</p>	

ASD





LETTER	DESCRIPTION	DATE	APPROVED

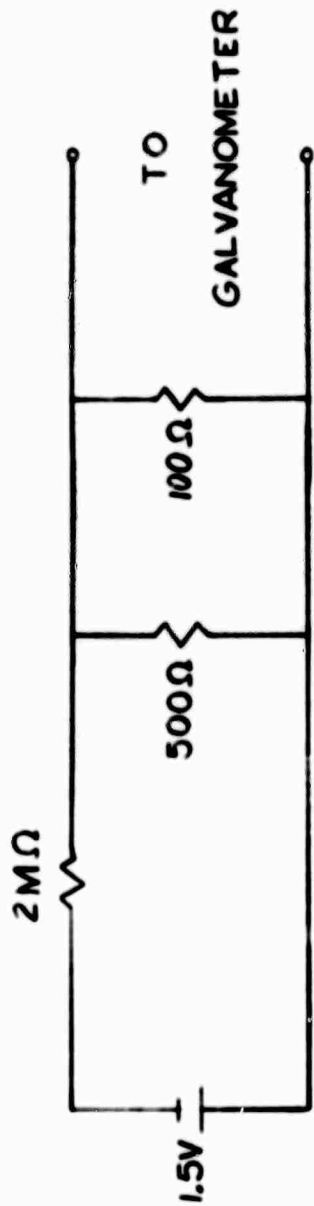

157



LAMONT GEOLOGICAL OBSERVATORY  
OF COLUMBIA UNIVERSITY

SHORT PERIOD GALVANOMETER  
RESISTIVE NETWORK

SCALE: 100V  
SERIAL NO. 4303  
SHEET 1 OF 1

CONTRACT  
ISSUED BY  
CHECKED BY  
APPROVED BY

TOLERANCES  
UNLESS OTHERWISE SPECIFIED  
RESISTORS ARE TO MIL-STD-203  
R 1%  
R 1/2%  
R 1/4%  
R 1/10%  
GREEN GRAB-BAG RESISTORS

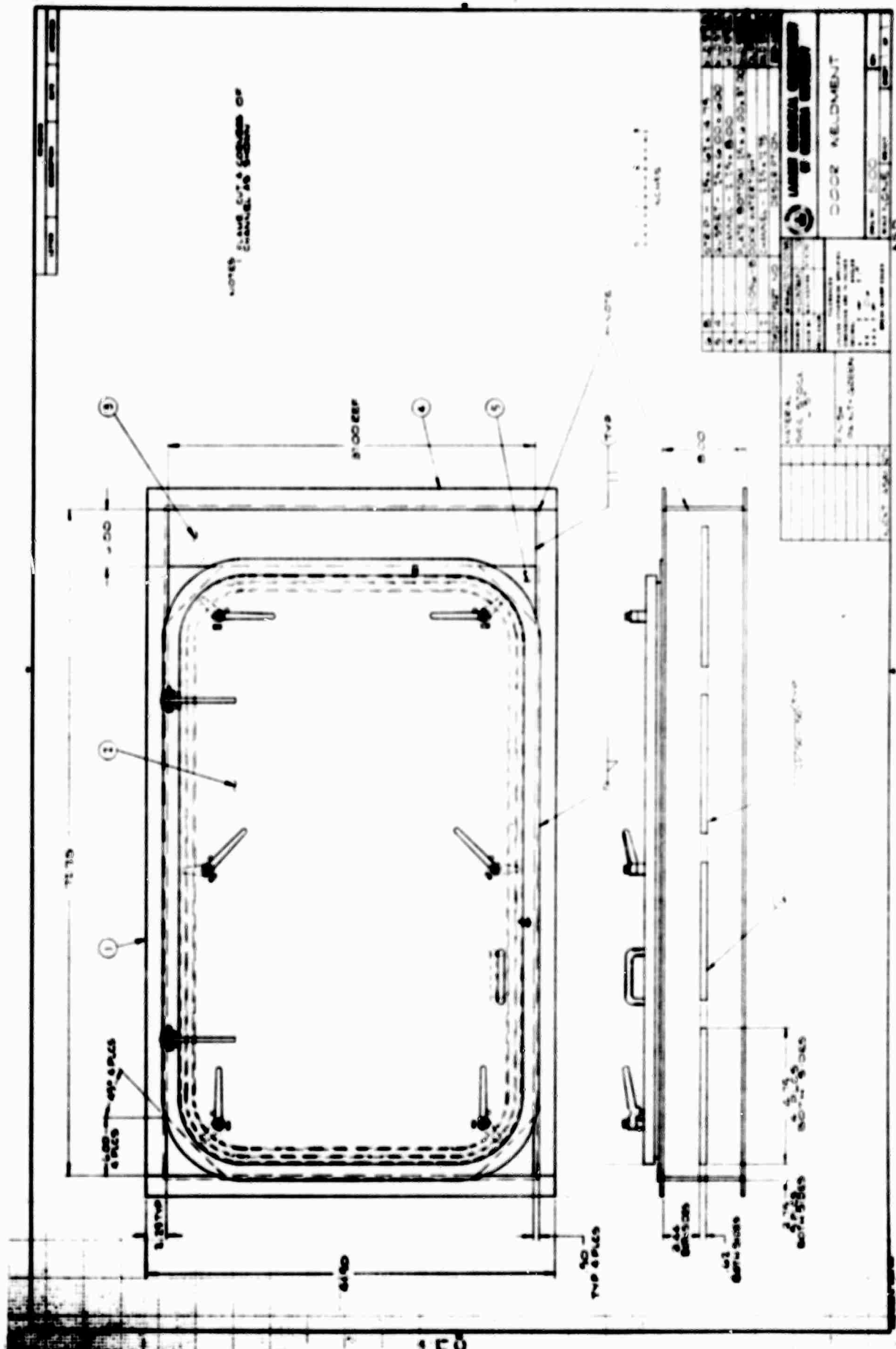

REVISED	DESCRIPTION	DATE	APPROVED

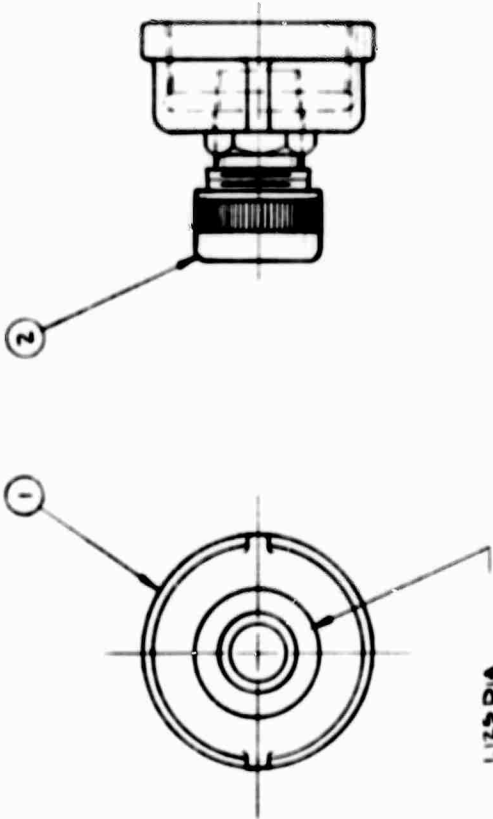

FRONT VIEW  
INCHES

ITEM NO.	2	ITEMS COMPRISION	3 TO
DATE		CAP B BE - 1.000 PT	REMARKS
CONTRACT NO.		DESCRIPTION	
ORDER BY			
DATE OF ORDER			
QUANTITY			
UNIT PRICE			
TOTAL			
 <b>LAMONT GEOLOGICAL OBSERVATORY OF COLUMBIA UNIVERSITY</b>			
<b>BUSHING, ADAPTER</b>		DRAW NO. <b>5103</b>	SHEET 1 OF 1
UNLESS OTHERWISE SPECIFIED DIMENSIONS ARE IN INCHES FRACTIONS 1/16" UP 11.11.11.11.11 11.11.11.11.11 11.11.11.11.11			
MAT'L: SEE LIST OF MAT'L		FINISH:	

100

REVISIONS			
LETTER	DESCRIPTION	DATE	APPROVED

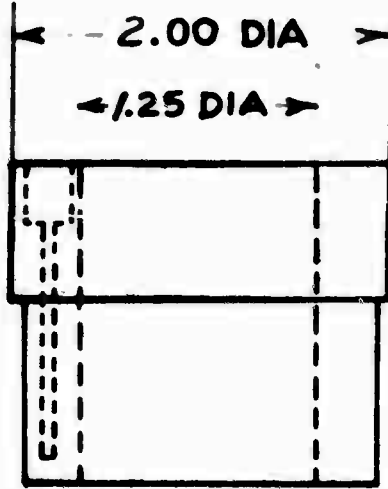

← - 1.875 - →

0.25 DIA →  
0.062 DIA →

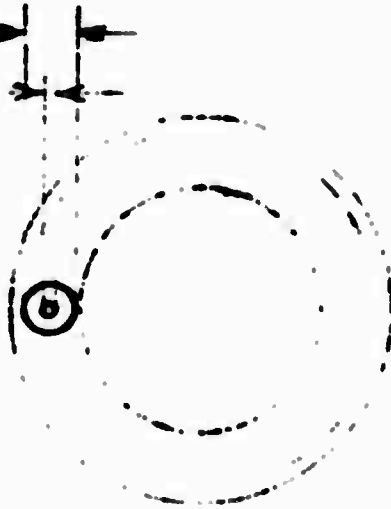

INCHES

CONTRACT	
DRAWN BY	
CHECK BY	
PROJ. ENGR.	
<b>TOLERANCES:</b> UNLESS OTHERWISE SPECIFIED DIMENSIONS ARE IN INCHES DECIMAL                      ANGLES .X                      ±                      ± .XX                      ± .XXX                      ± <b>BREAK SHARP EDGES</b>	



**LAMONT GEOLOGICAL OBSERVATORY  
OF COLUMBIA UNIVERSITY**

**GAUSSMETER HOLDER  
(PLEXIGLASS)**

DWG. NO.	<b>8002</b>	REV.	
SCALE		WEIGHT	SHEET / OF /

11-11-54

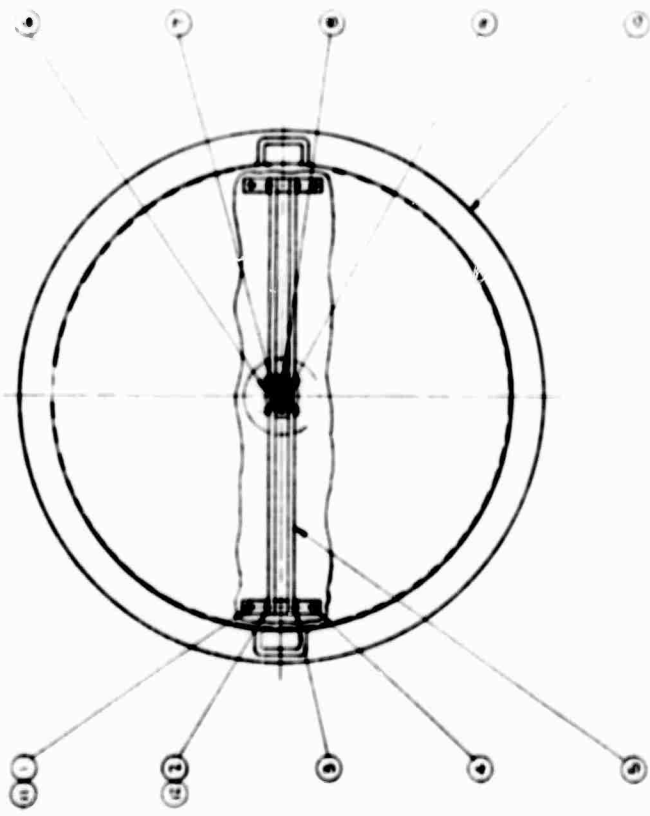

1  
2  
3  
4  
5  
6  
7  
8  
9  
10

11	WHEEL	STEEL
12	WHEEL	STEEL
13	WHEEL	STEEL
14	WHEEL	STEEL
15	WHEEL	STEEL
16	WHEEL	STEEL
17	WHEEL	STEEL
18	WHEEL	STEEL
19	WHEEL	STEEL
20	WHEEL	STEEL
21	WHEEL	STEEL
22	WHEEL	STEEL
23	WHEEL	STEEL
24	WHEEL	STEEL
25	WHEEL	STEEL
26	WHEEL	STEEL
27	WHEEL	STEEL
28	WHEEL	STEEL
29	WHEEL	STEEL
30	WHEEL	STEEL
31	WHEEL	STEEL
32	WHEEL	STEEL
33	WHEEL	STEEL
34	WHEEL	STEEL
35	WHEEL	STEEL
36	WHEEL	STEEL
37	WHEEL	STEEL
38	WHEEL	STEEL
39	WHEEL	STEEL
40	WHEEL	STEEL
41	WHEEL	STEEL
42	WHEEL	STEEL
43	WHEEL	STEEL
44	WHEEL	STEEL
45	WHEEL	STEEL
46	WHEEL	STEEL
47	WHEEL	STEEL
48	WHEEL	STEEL
49	WHEEL	STEEL
50	WHEEL	STEEL

ASSEMBLY  
SEPARATOR ENCLOSE  
PREPARED

111

LETTER	REVISION	DATE	APPROVED

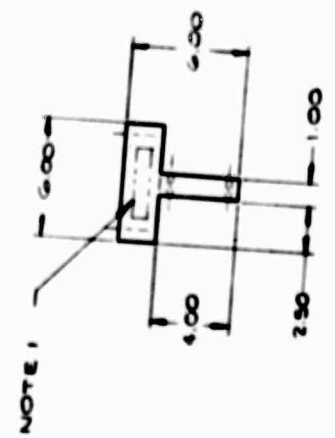
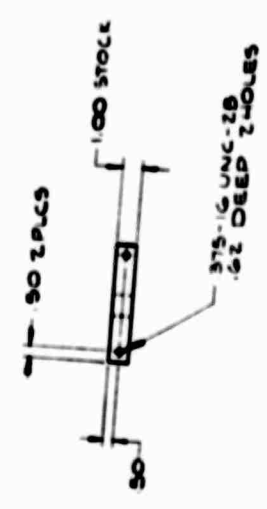

- NOTES
- 1 STAMP OR STENCIL PART NO WHERE INDICATED
  - 2 15% SURFACE FINISH ALL OVER EXCEPT WHERE NOTED



<b>LAMONT GEOLOGICAL OBSERVATORY OF COLUMBIA UNIVERSITY</b>	
<b>SUPPORT SEISMOMETER ENCLOSURE PRESSURE</b>	
DWG NO <b>B201-1</b>	
SCALE 1/4"	HEIGHT
SHEET 1	OF 1
CONTRACT <b>AMASO-2-COM</b> DRAWN BY <b>COSTAKIS-T-20</b> CHECK BY <b>W.F. B. S-70</b> TITLE <b>ENCLOSURE</b>	UNLESS OTHERWISE SPECIFIED DIMENSIONS ARE IN INCHES DECIMALS .00 .01 .05 .10 .15 .20 .25 .30 .35 .40 .45 .50 .55 .60 .65 .70 .75 .80 .85 .90 .95 .000 .001 .005 .010 .015 .020 .025 .030 .035 .040 .045 .050 .055 .060 .065 .070 .075 .080 .085 .090 .095 .0000 .0001 .0005 .0010 .0015 .0020 .0025 .0030 .0035 .0040 .0045 .0050 .0055 .0060 .0065 .0070 .0075 .0080 .0085 .0090 .0095 .00000 .00001 .00005 .00010 .00015 .00020 .00025 .00030 .00035 .00040 .00045 .00050 .00055 .00060 .00065 .00070 .00075 .00080 .00085 .00090 .00095 .000000 .000001 .000005 .000010 .000015 .000020 .000025 .000030 .000035 .000040 .000045 .000050 .000055 .000060 .000065 .000070 .000075 .000080 .000085 .000090 .000095 .0000000 .0000001 .0000005 .0000010 .0000015 .0000020 .0000025 .0000030 .0000035 .0000040 .0000045 .0000050 .0000055 .0000060 .0000065 .0000070 .0000075 .0000080 .0000085 .0000090 .0000095
MATERIAL: <b>ALUMINUM 2024-T4</b>	FINISH:
1103 2 NEXT ASSY DIV	GREAT SHARP EDGES

REV	DESCRIPTION	DATE	APPROVED

- NOTES
- 1 STAMP OR STENCIL PART NO WHERE INDICATED
  - 2 15/32 SURFACE FINISH ALL OVER EXCEPT WHERE NOTED

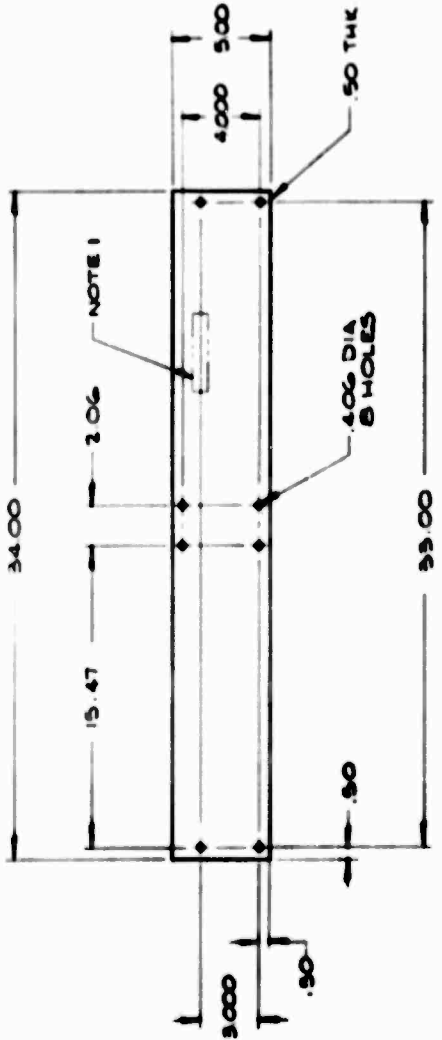

		<b>LAMONT GEOLOGICAL OBSERVATORY OF COLUMBIA UNIVERSITY</b>	
<b>MATERIAL</b> MILD STEEL		CONTRACT #AM3D-30-C-008 ORDERED BY COSTA/HT-253 CHECK BY W. E. B. P. 70	
<b>FINISH</b>		TOLERANCES UNLESS OTHERWISE SPECIFIED DIMENSIONS ARE IN INCHES DECIMALS: 1/16 FRACTIONS: 1/32 ANGLES: 1/16 HOLE DIA: .005 BREAK SHARP EDGES	
1103	2	DATE	REV
NET ASM QTY		SCALE 1/4"	SHEET 1 OF 1
		PLATE - SEISMOMETER ENCLOSURE PRESTRESSER	
		DRAWING NO. B201-2	

LETTER	DESCRIPTION	DATE	APPROVED

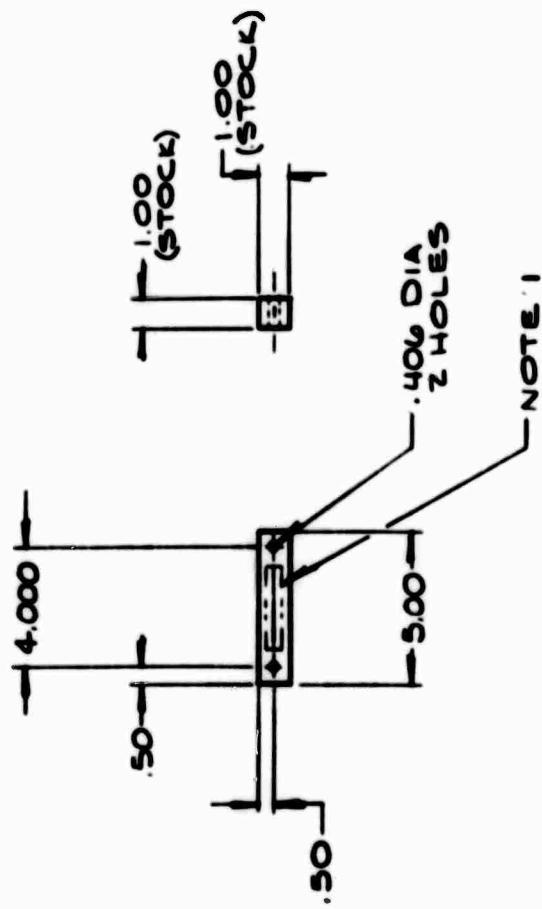

- NOTES
- 1 STAMP OR STENCIL PART NO. WHERE INDICATED
  - 2  $1\frac{1}{2}$  SURFACE FINISH ALL OVER EXCEPT WHERE NOTED



164

		<b>CONTRACT AF4420-70-C02</b> <b>DRAWN BY COSTAKE T-24-70</b> <b>CHECK BY W.K. 8-3-70</b> <b>PROJ. ENGR.</b>	
<b>MATERIAL:</b> ALUMINUM 2024-T4		<b>FINISH</b>	
1103 7 NEXT ASMGTY		TOLERANCES UNLESS OTHERWISE SPECIFIED DIMENSIONS ARE IN INCHES DECIMAL     ± .01 .             ± .02 .             ± .005 BREAK SHARP EDGES	
<b>BLOCK, SPACER</b> <b>SEISMOMETER ENCLOSURE</b> <b>PRESTRESSER</b>		DWG NO <b>8201-3</b> REV.	
SCALE <b>1/4</b>		SHEET <b>1</b> OF <b>1</b>	



REVISIONS		
LETTER	DESCRIPTION	DATE

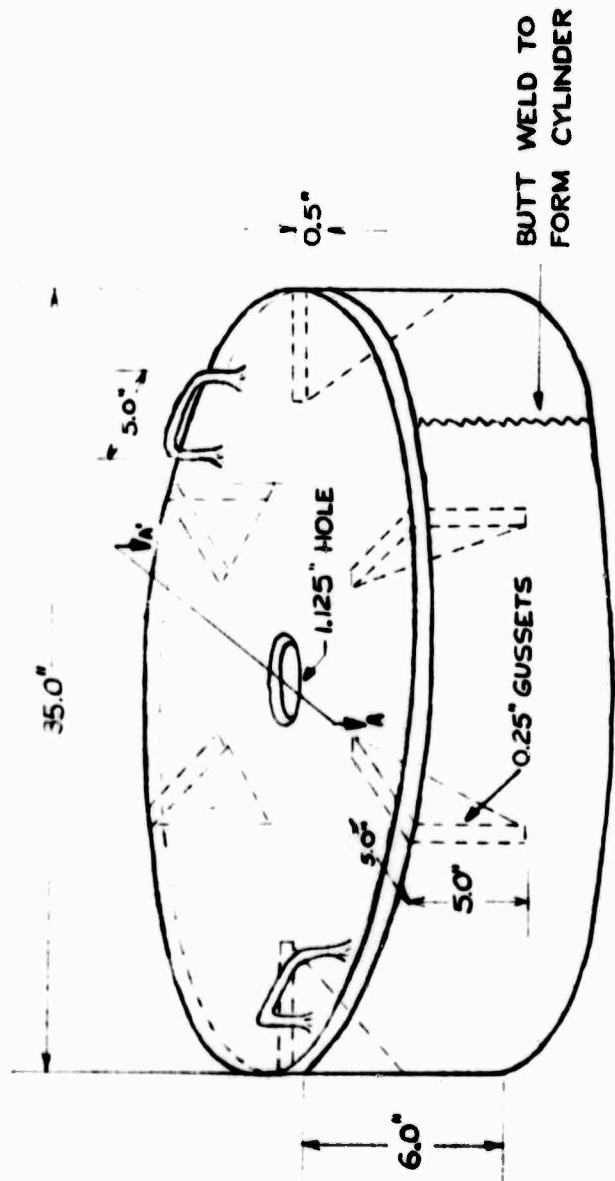

BUTT WELD TO  
FORM CYLINDER

SECTION AA'

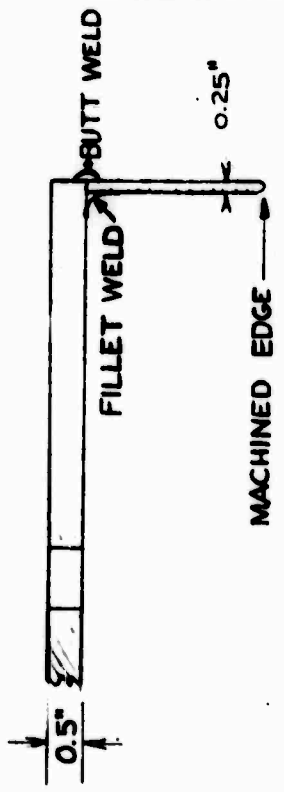

		<b>LAMONT GEOLOGICAL OBSERVATORY OF COLUMBIA UNIVERSITY</b>	
<b>PRESTRESSER - MODIFIED</b>		Dwg. No. <b>8201 - MOD</b>	
CONTRACT DRAWN BY CHECK BY PROJ. ENGR.		SCALE WEIGHT REV SHEET 1 OF 1	
TOLERANCES: UNLESS OTHERWISE SPECIFIED DIMENSIONS ARE IN INCHES DECIMAL                    ± ANGLES                      ± BREAK SHARP EDGES			

REVISIONS		
LETTER	DESCRIPTION	DATE

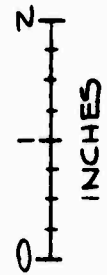
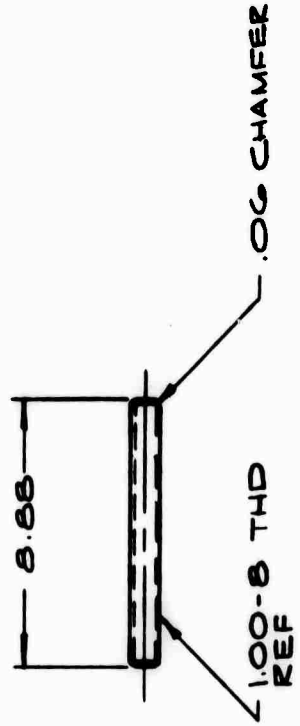

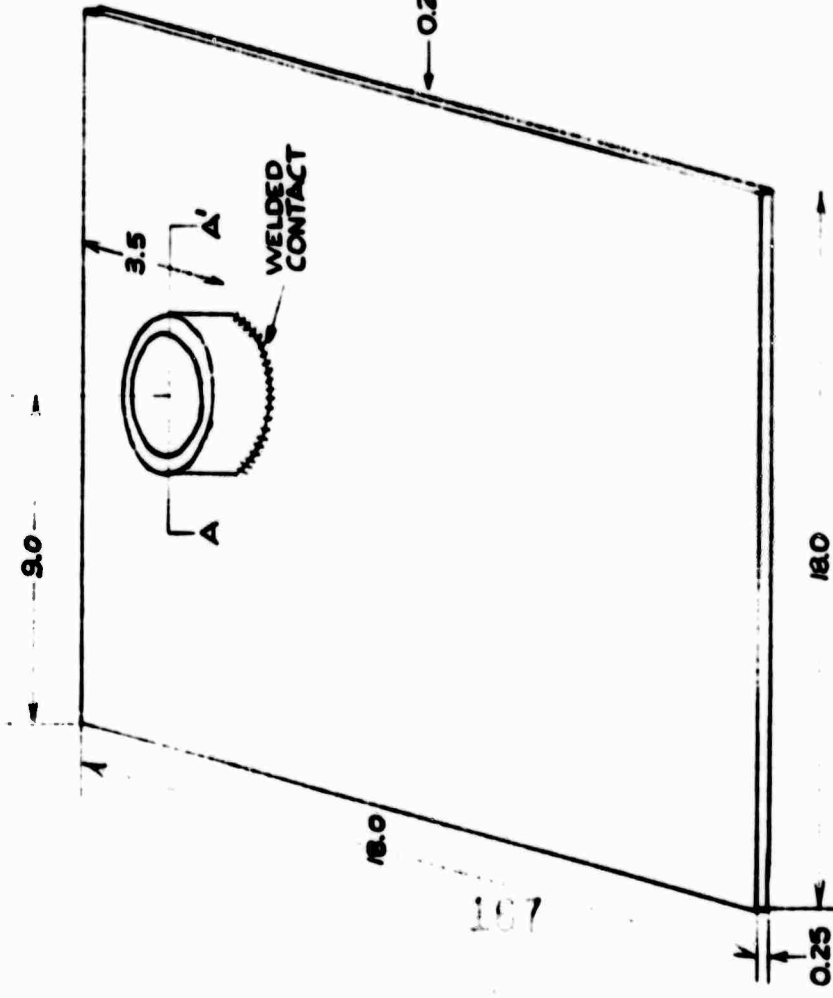

		<b>LAMONT GEOLOGICAL OBSERVATORY OF COLUMBIA UNIVERSITY</b>	
<b>ROD, THREADED - SEISMOMETER ENCLOSURE PRESTRESSOR</b>		DWG NO <b>8201-4</b> REV	
CONTRACT <b>AF-4620-D-C-088</b> DRAWN BY <b>LDSTADT-79-TD</b> CHECK BY <b>W.K.</b> 8-3-70 PROJ ENGR		TOLERANCES: UNLESS OTHERWISE SPECIFIED DIMENSIONS ARE IN INCHES DECIMAL ± .01 ANGLES ± 10° XXX ± .005 BREAK SHARP EDGES	
<b>MATERIAL: MAKE FROM 1.00-8 THD ROD-STEEL</b>		<b>FINISH:</b>	
1103 NEXT ASSEMBLY		SCALE <b>1/4</b> WEIGHT SHEET <b>1</b> OF <b>1</b>	

LETTER	REVISIONS	DATE	APPROVED
	DESCRIPTION		

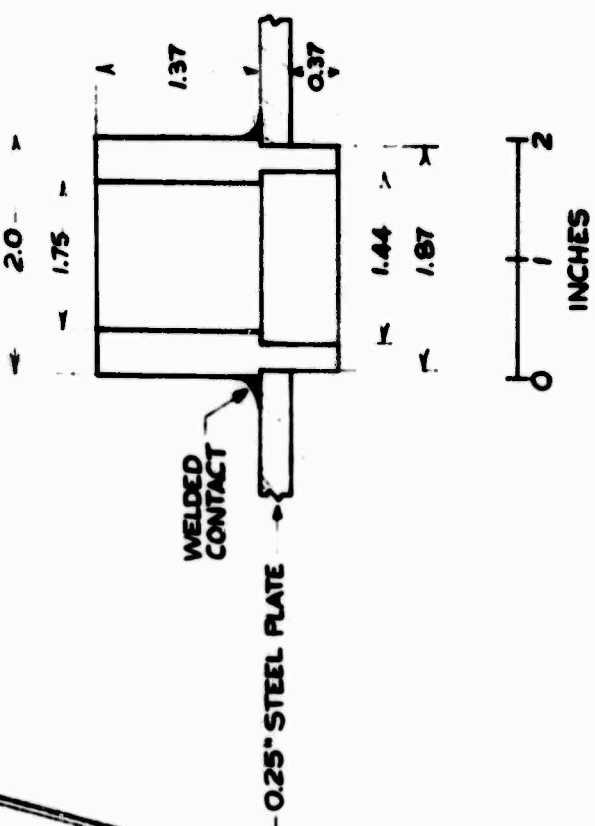

**SECTION AA'**



CONTRACT		<p>LAGOMT GEOLOGICAL OBSERVATORY OF COLUMBIA UNIVERSITY</p> 	<p>DRILL GUIDE</p>
DRAWN BY			
CHECK BY			
PROJ. ENGR.			
<p>TOLERANCES UNLESS OTHERWISE SPECIFIED DIMENSIONS ARE IN INCHES DECIMAL</p>		<p>DRWS NO <b>E202</b></p>	<p>REV</p>
<p>1 ± .005 2 ± .002 3 ± .001 4 ± .0005 5 ± .0002 6 ± .0001</p>		<p>SCALE</p>	<p>SHEET 1 OF 1</p>
<p>BREAK SHARP EDGES</p>			



LETTER	DESCRIPTION	DATE	APPROVED
--------	-------------	------	----------

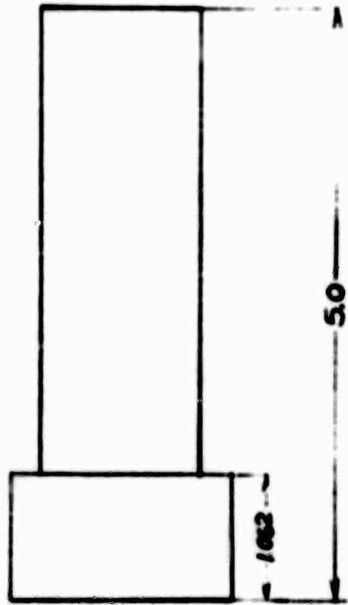
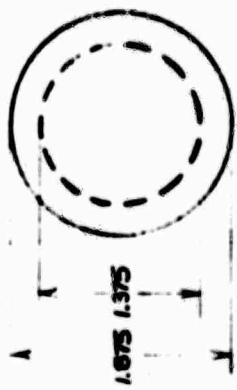

MACHINED 2" DIAM  
ALUMINIUM ROD

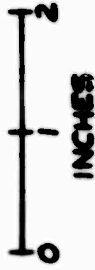

169



LAMONT GEOLOGICAL OBSERVATORY  
OF COLUMBIA UNIVERSITY

GUIDE PIN

WORK NO. **0204** DATE

SCALE

SHEET 1 OF 1

UNLESS OTHERWISE SPECIFIED  
DIMENSIONS ARE IN INCHES  
DECIMALS

1  
2  
3  
4  
5

OTHER SHOWN DIMENSIONS

DESIGNED	DATE	APPROVED

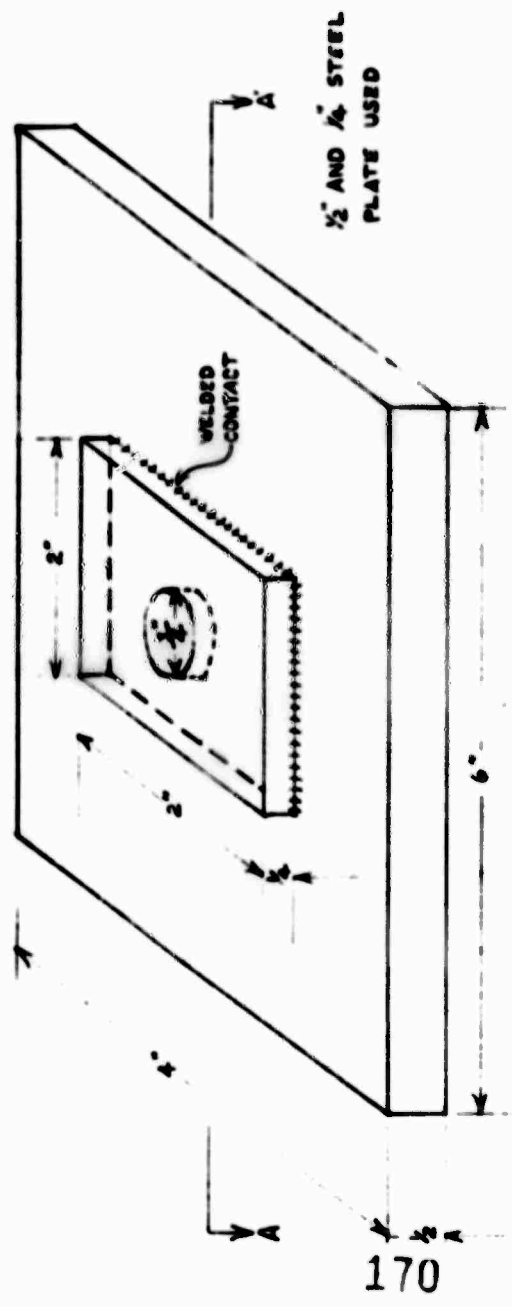

1/4" AND 1/8" STEEL  
PLATE USED

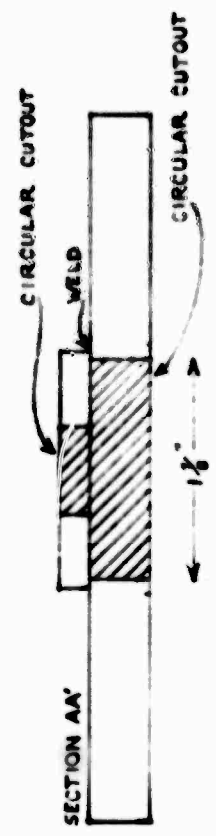

		<b>SETTING FIXTURE</b>	
DRAW NO. <b>B 205</b>	DATE	SCALE FULL SIZE	SHEET <b>OF</b>
CONTRACTOR	DRAWN BY	CHECKED BY	APPROVED BY
TOLERANCES UNLESS OTHERWISE SPECIFIED DIMENSIONS ARE IN INCHES DECIMALS: .125, .250, .375, .500, .625, .750, .875, 1.000 ANGLES: 15°, 30°, 45°, 60°, 75°, 90°, 105°, 120°, 135°, 150° BEVELS: SHARP EDGES			

REVISED      REVISIONS      DATE      APPROVED

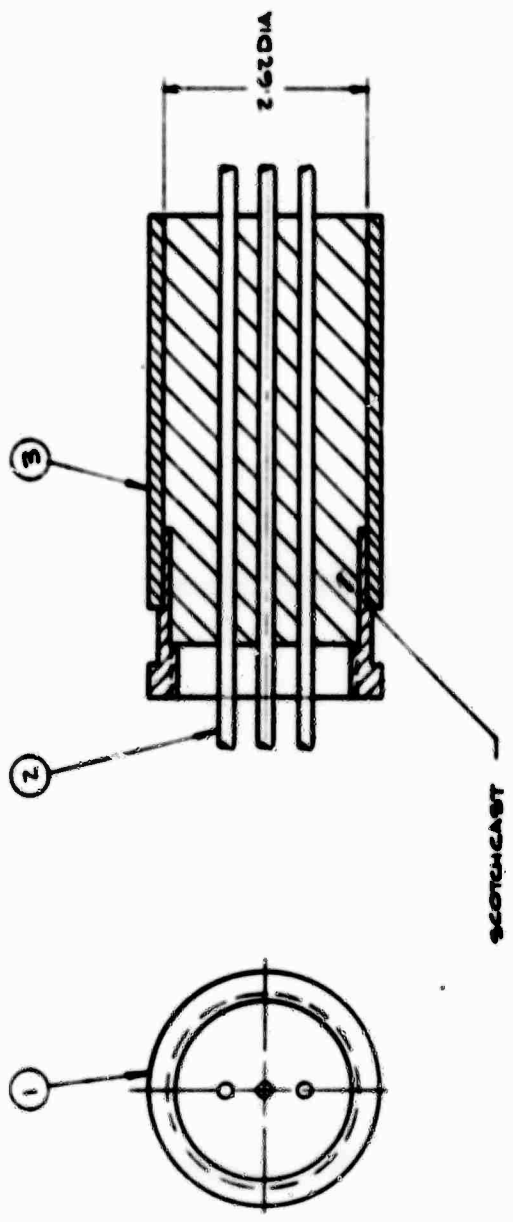

INCHES

DATE	BY	CHKD	APP'D
10/1/54	W. J. ...	...	...
<b>AMERICAN WIRE AND CABLE COMPANY</b>			
<b>LAUREL GROUNDS WIRE INSULATOR</b>			
<b>ASSEMBLY, WIRE INSULATOR</b>			
PART NO. 0206		REV. 1 OF 1	
SHEET 1 OF 1		REV.	
MATERIAL: UNFINISHED FINISH: ... QUANTITY: ... UNIT PRICE: ... TOTAL PRICE: ... ORDER GROUP CODES: ...			

ASD

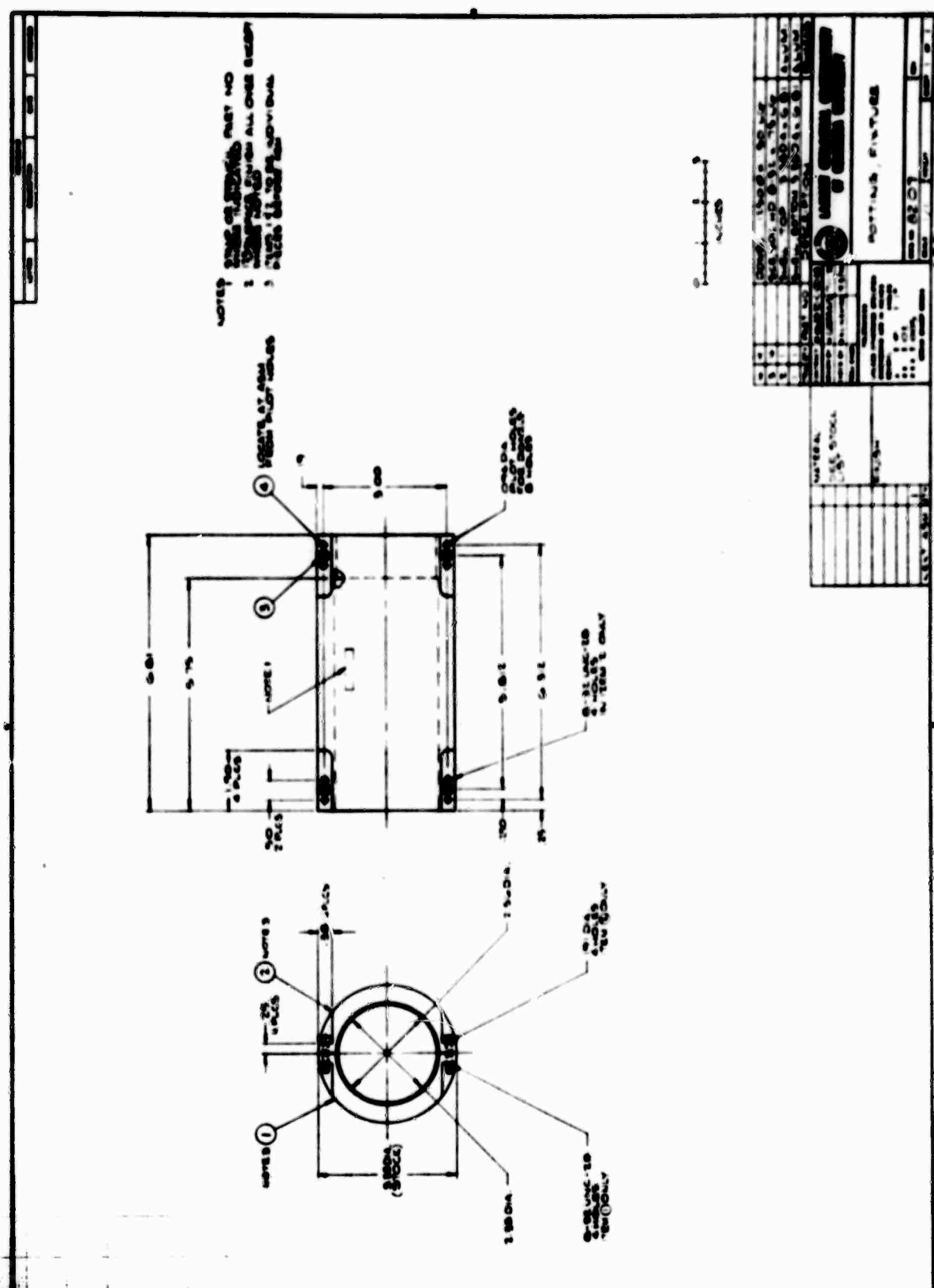



LETTER	DESCRIPTION	DATE	APPROVED
--------	-------------	------	----------

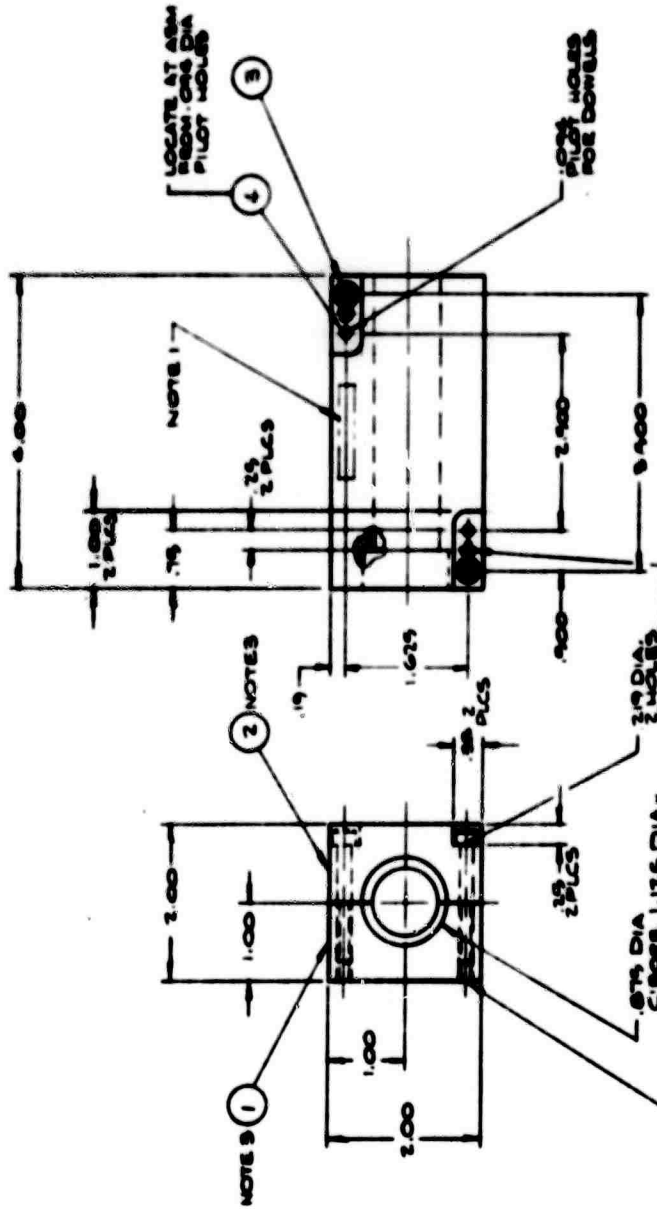

- NOTES
- 1 STAMP OR STENCIL PART NO WHERE INDICATED
  - 2 UNLESS FINISH ALL OVER EXCEPT WHERE NOTED
  - 3 ITEMS ON 2 TO BE INDIVIDUAL PIECES BEFORE ASM.



ITEM NO	PART NO	DESCRIPTION	QTY
4	DOWEL	.1250 DIA x 1.50 LG	
3	SCS, SOC NO	10-32 x 1.50 LG	
2	BLOCK, TOP	1.00 x 1.00 x 6.00 ALUM.	
1	BLOCK, BOTTOM	1.00 x 1.00 x 6.00 ALUM.	

**LABORATORY OBSERVATORY OF COLUMBIA UNIVERSITY**

POTTING FIXTURE SUB ASM

DES NO: **B208**

SCALE: 1/1

ASD

MATERIAL:	SEE STOCK LIST
FINISH:	
NET ASSEMBLY	

0-32 UNC-2B  
2 HOLES  
ITEM 2 ONLY

0.75 DIA  
2 HOLES  
ITEM 1 ONLY

10-32 UNC-2B  
2 HOLES  
ITEM 3 ONLY

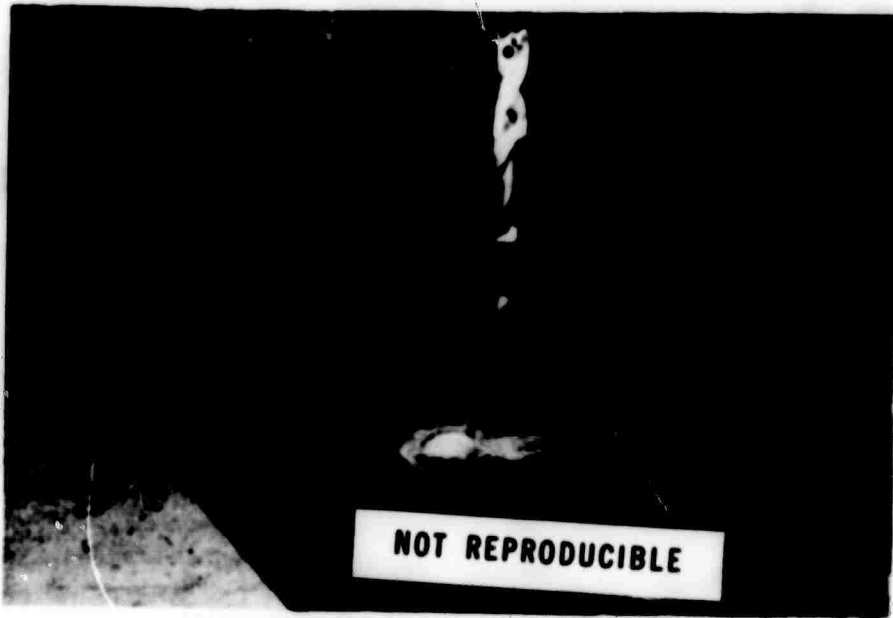

Plate 1: Drill guide (#8202) and drilling template.

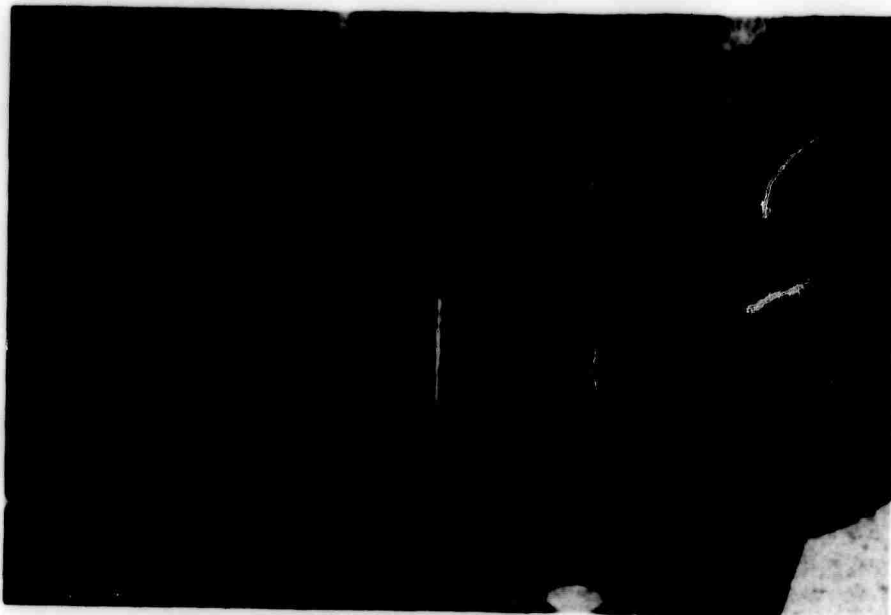

Plate 2: Guide pin (#8204) and drilling template.

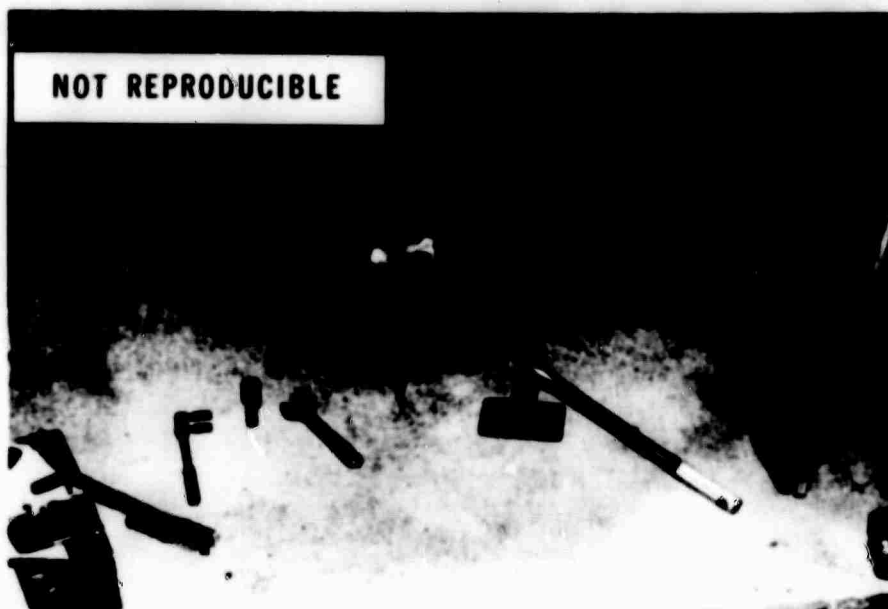

Plate 3: Five tank hold-down bolts (#1106) in place and one roof-bolt anchor (#1105) being set.



Plate 4: Pressure tank base (#1100) attached to seismometer pier with prestresser (#8201) in place. Note "Sakrete" squeezed from under base during release of prestresser.

III-3

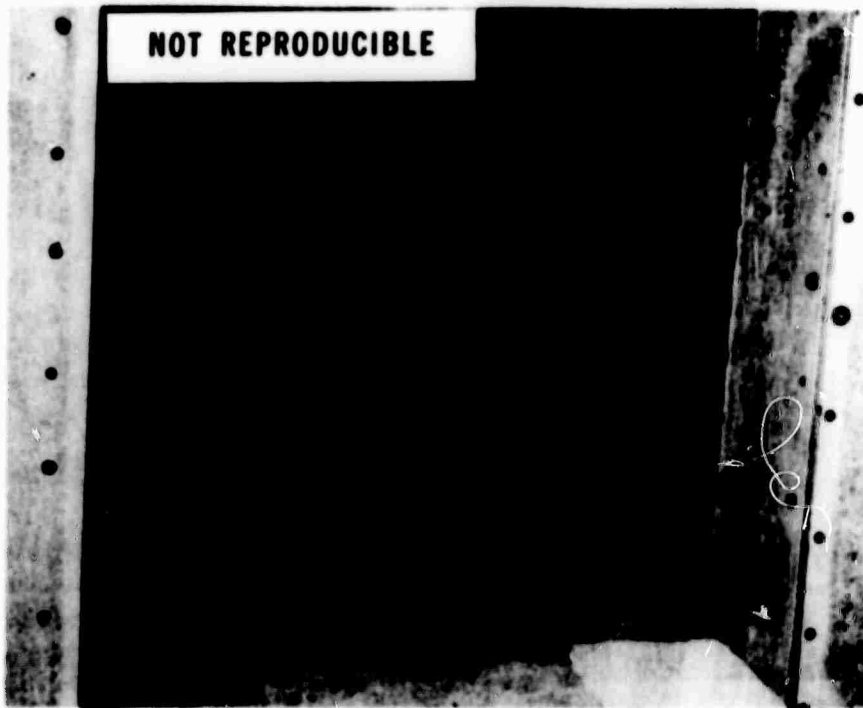

Plate 5: Bottom view of new prestresser (#8201 MOD).



Plate 6: New prestresser (#8201 MOD) in place in the seismometer pressure tank bottom (#1100)

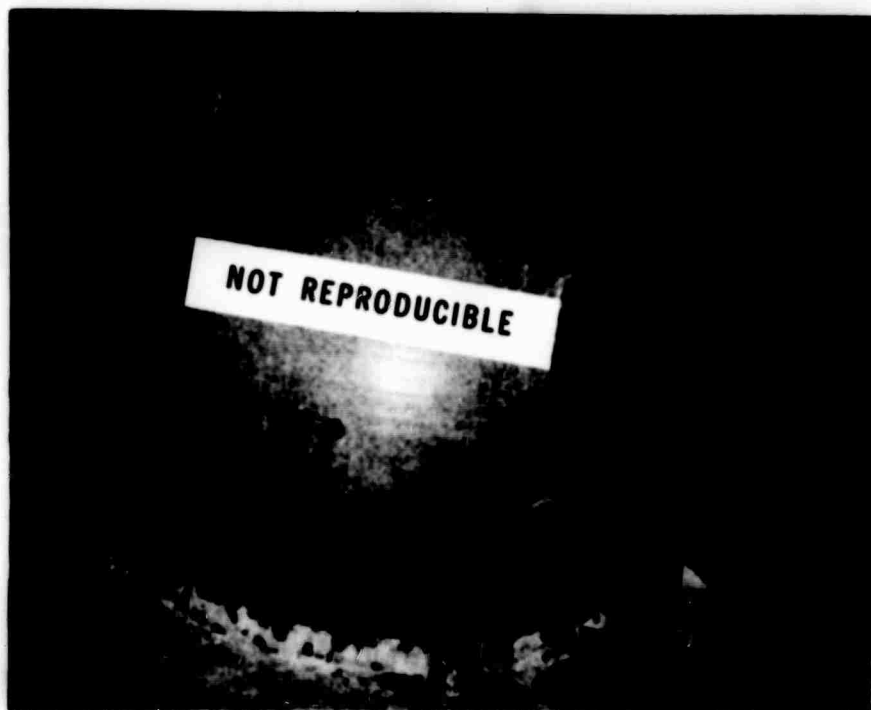

Plate 7: Pressure tank (#1100) with "C" clamps (#1109) and steel clamping plates (#1110).

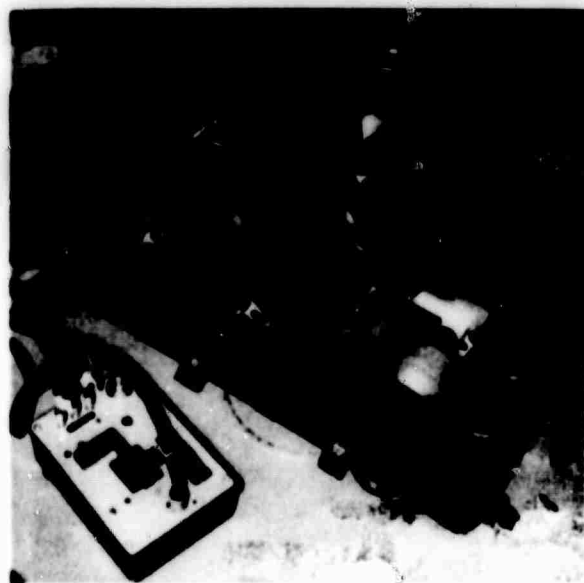

Plate 8: Vertical seismometer (#1200) in pressure tank (#1100) with displacement transducer oscillator - discriminator (#1206).

III-5

NOT REPRODUCIBLE

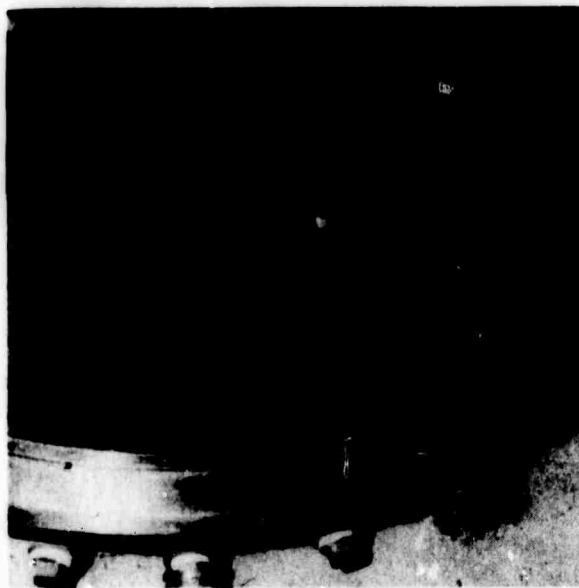

Plate 9: Vertical seismometer installed and completely wired showing remote centering assembly (#1201) and motor (#1203), terminal blocks (#1207) and cable holders (#1208).



Plate 10: Vertical seismometer showing displacement transducer (#1204), mounting plate (#1205), wire clamps (#1205-1), remote centering assembly (#1201) and motor holders (#1208) and ends of coil assembly leaders (#1202).

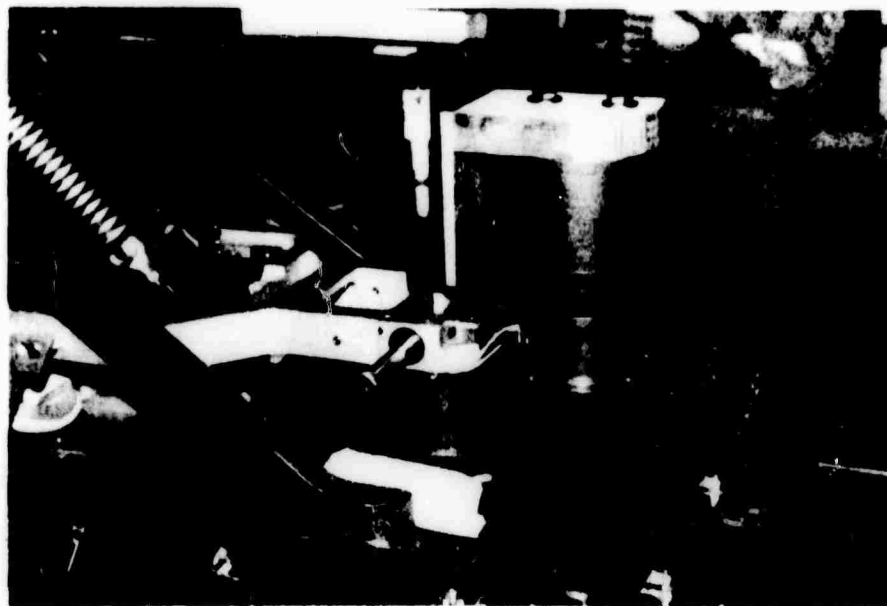

Plate 11: Vertical seismometer showing micro-meter mount assembly (#1211) for displacement transducer calibration.

NOT REPRODUCIBLE

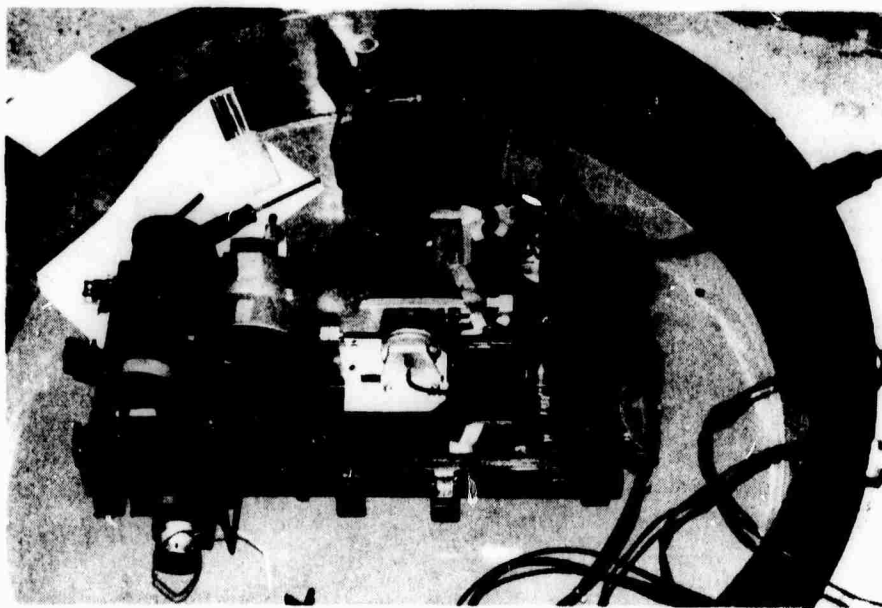

Plate 12: Horizontal seismometer (#1300) showing calibration equipment (Catenary suspension) (#1212), displacement transducer (#1303), displacement transducer oscillator discriminator (#1206), terminal block (#1207), terminal base-plate (#1306), cable holder (#1208-1) and remote centering assembly (#1302).

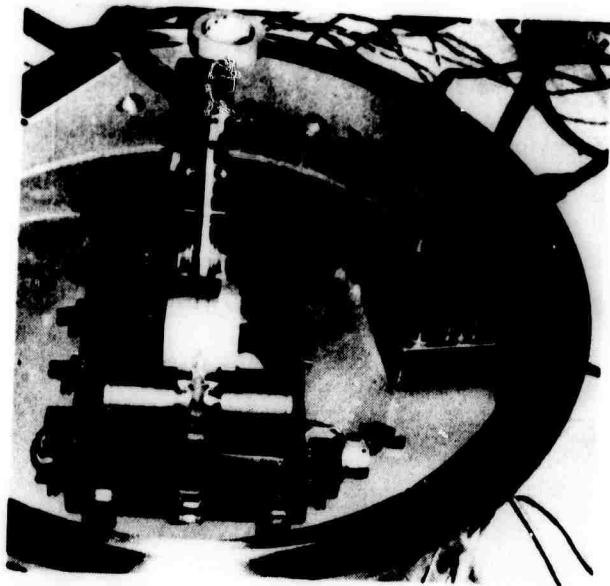

Plate 13: Top view of horizontal seismometer (#1300)

NOT REPRODUCIBLE



Plate 14: Side view of horizontal seismometer showing micrometer mount assembly (#1211) for displacement transducer calibration. All signal, calibration and displacement transducer cables are attached.



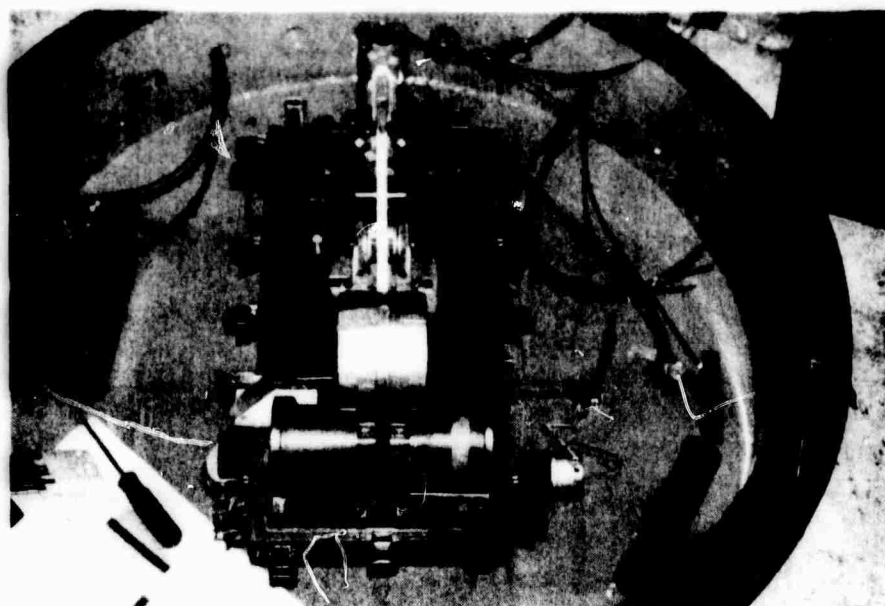

Plate 15: Top view of horizontal seismometer with catenary suspension (#1212) attached at the center of oscillation and the micrometer mount assembly (#1211).

**NOT REPRODUCIBLE**

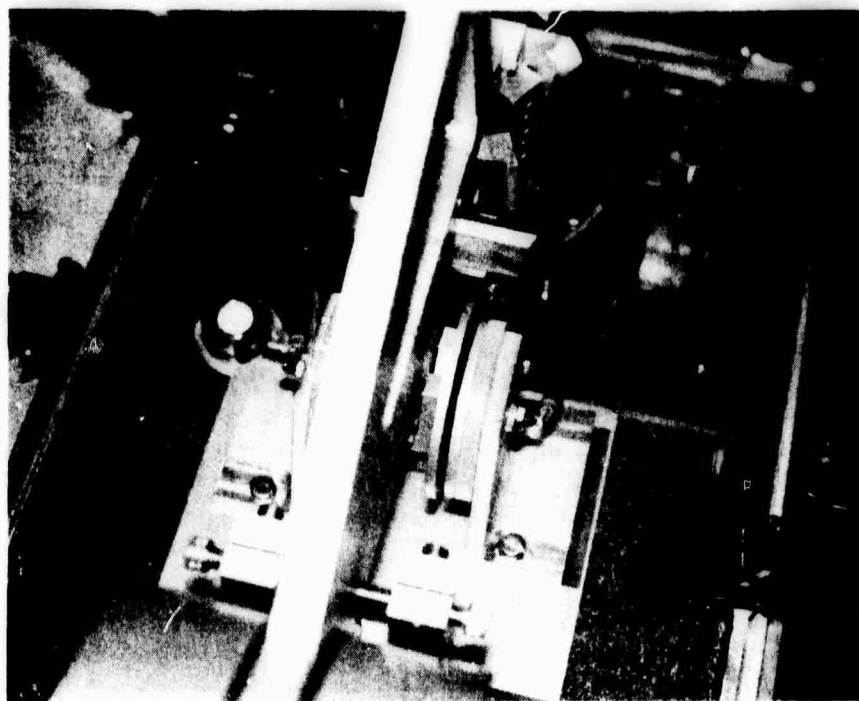

Plate 16: Horizontal seismometer displacement transducer #1303) showing maximum capacitance gap for one plate and copper shim for aligning capacitance plate.



Plate 17: Side view of horizontal seismometer showing displacement transducer assembly (#1303), terminal blocks (#1305), terminal base plate (#1306), cable holder (#1208-1) and attachment of ends of coil assembly leaders (#1202).

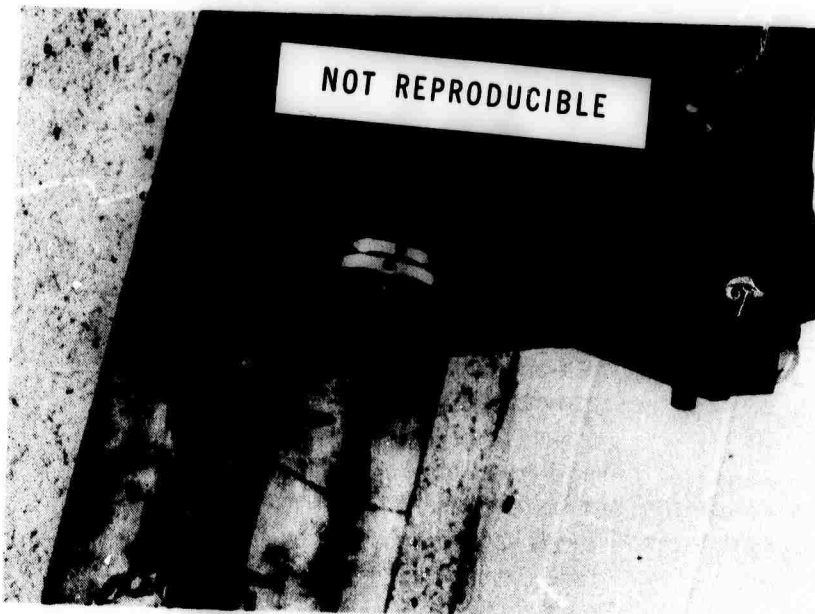

Plate 18: Bottom view of horizontal seismometer (# 1300) showing remote centering assembly (#1302) and modified period adjustment leg (#1308).



Plate 19: Phototube amplifiers (#2100) and power supplier (#2200) installed.

III-11

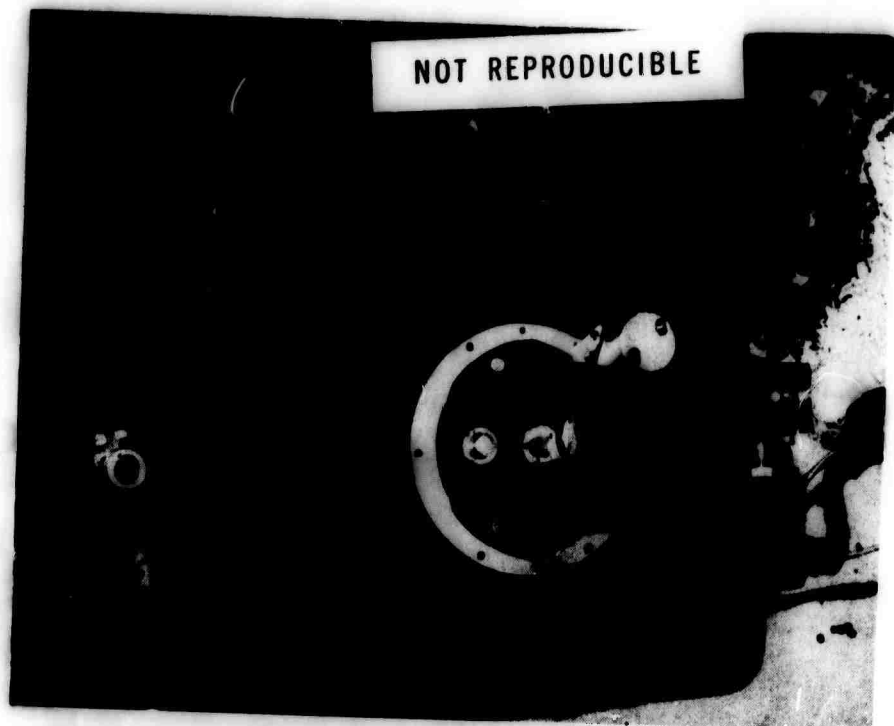

Plate 20: Vertical view of the phototube amplifier (#2100).



Plate 21: Displacement transducer power supply (#2300).

III-12

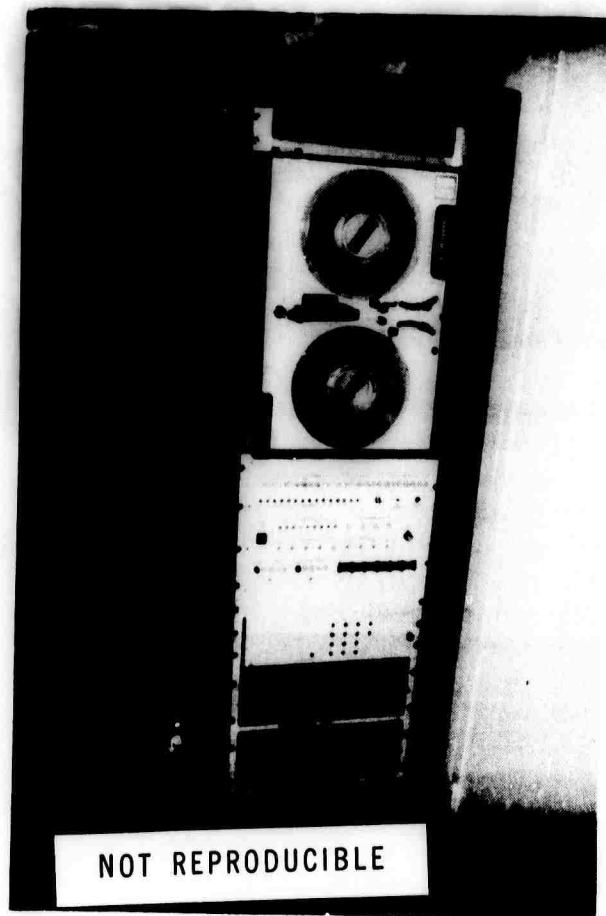

Plate 22: Digital data acquisition system  
(#3100).

III-13

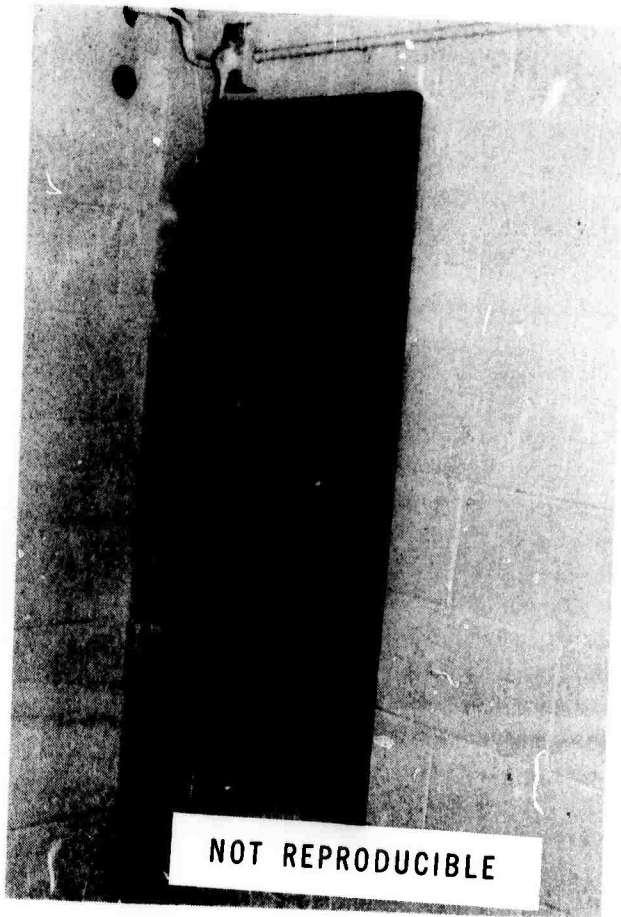

Plate 23: Power distribution panel (#3424).

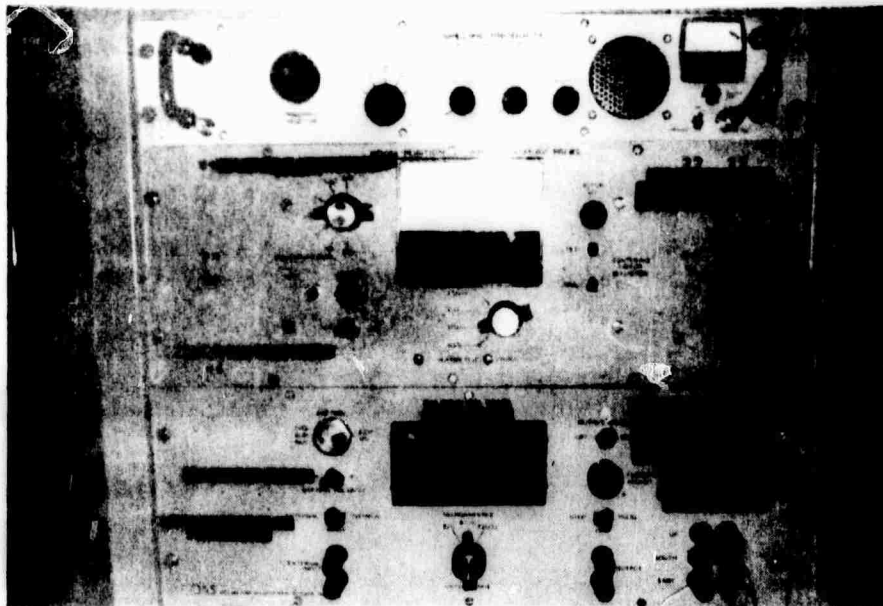

Plate 24: Radio receiver (#3218), boom and galvanometer position and control panel (#3220) and calibration panel (#3230).

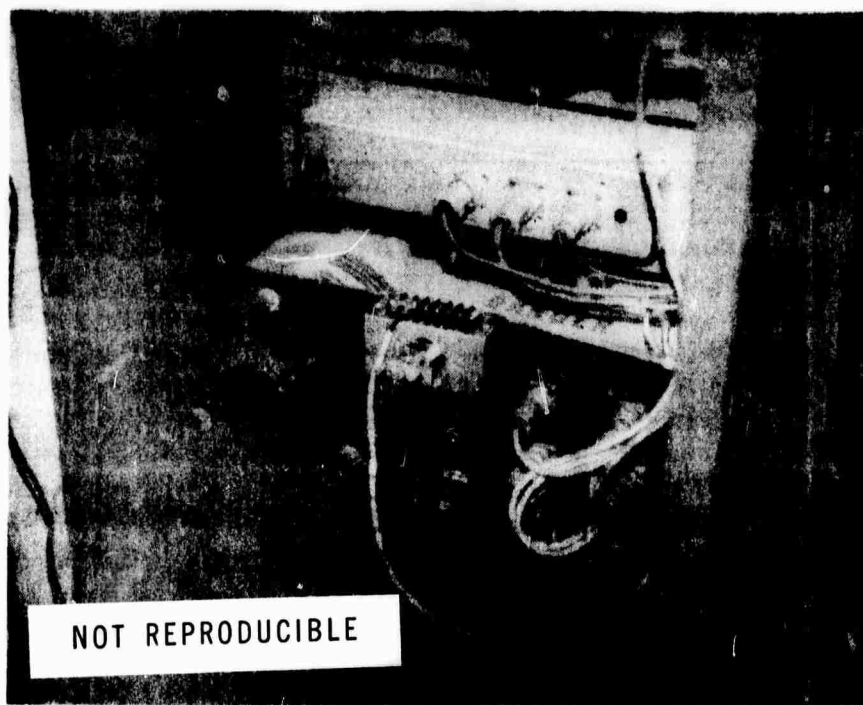

Plate 25: Time relay mounted on WSSN console (see Figures 8 and 9).



Plate 26: Photographic recording room.



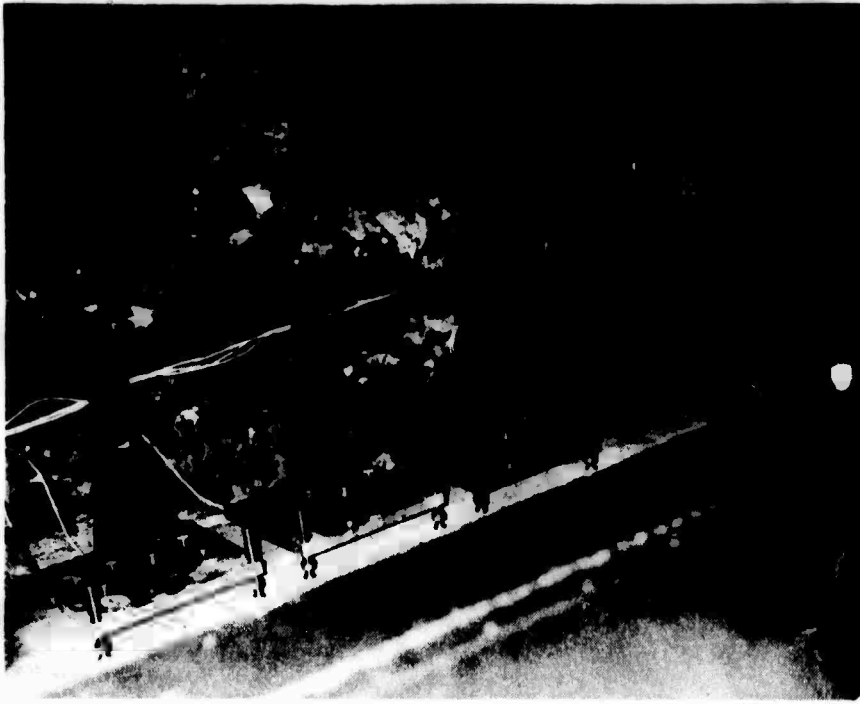

Plate 27: Standard low gain recording galvanometers (#4201), galvanometer bases (#4200), and filter galvanometers (#4350).

NOT REPRODUCIBLE

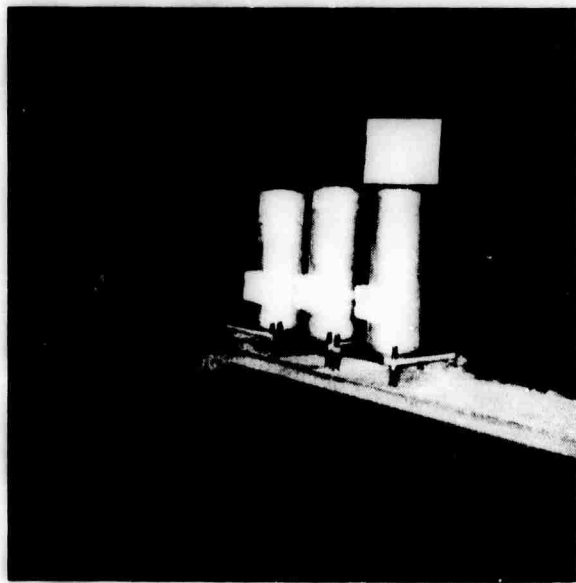

Plate 28: Standard low gain galvanometer bases and enclosures (#4200) with styro-foam protective lens covers for shipment.

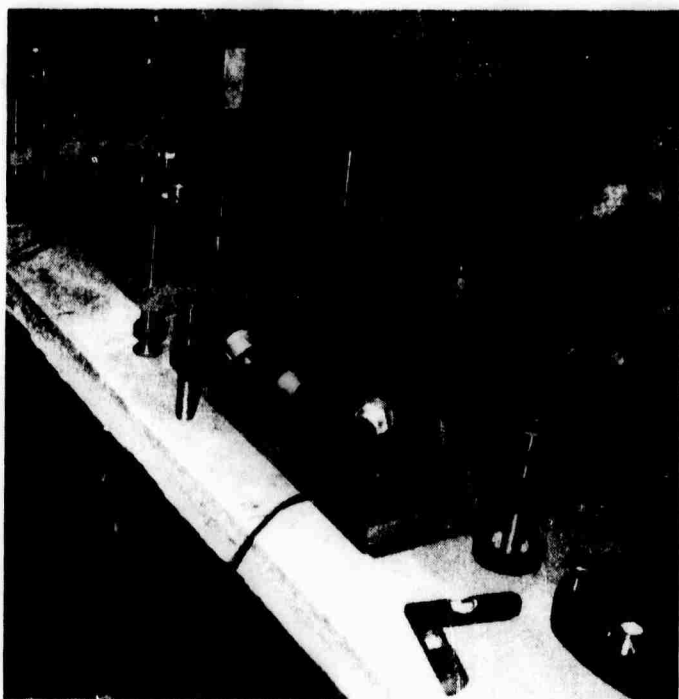

Plate 29: Standard low gain galvanometer base (#4200) inverted, showing street - L and wiring.

**NOT REPRODUCIBLE**

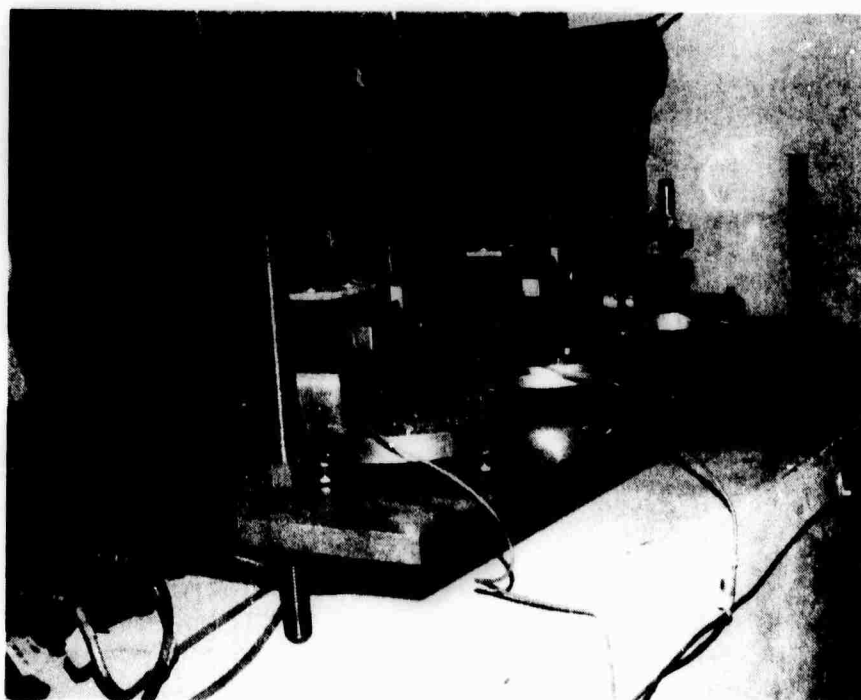

Plate 30: High-gain photographic recording galvanometers (#4302), bases (#4300, 4304), and resistive network (#4303).

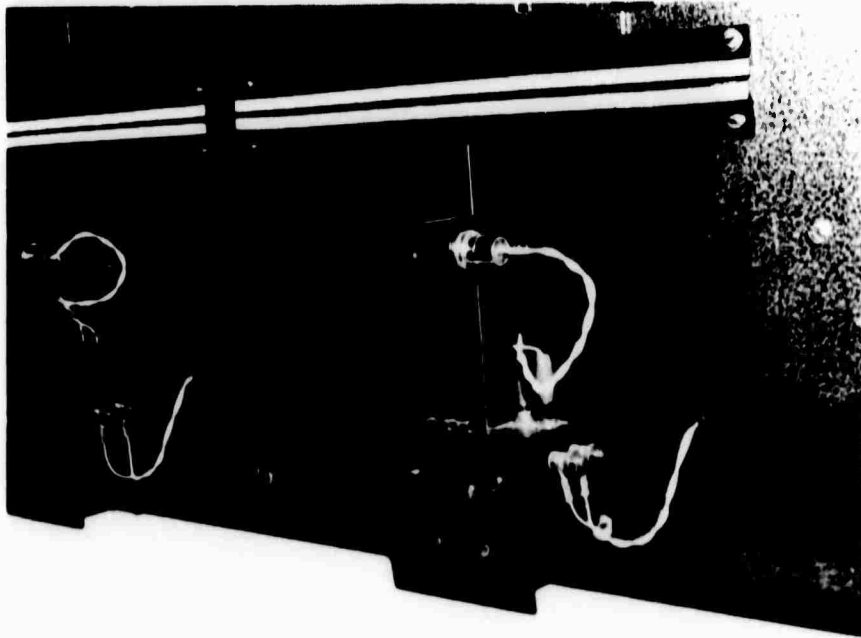

Plate 31: Rear view of photographic recorder (#4100) showing one light source.

NOT REPRODUCIBLE



Plate 32: Cables sealed with glyptal (#7009) and placed in wire potting mold (#8207).



**Plate 33:** Installation of wire potting mold (#8207).

**NOT REPRODUCIBLE**



**Plate 34:** Wire potting mold (#8207) after Scotch cast (#7002) was poured into mold.

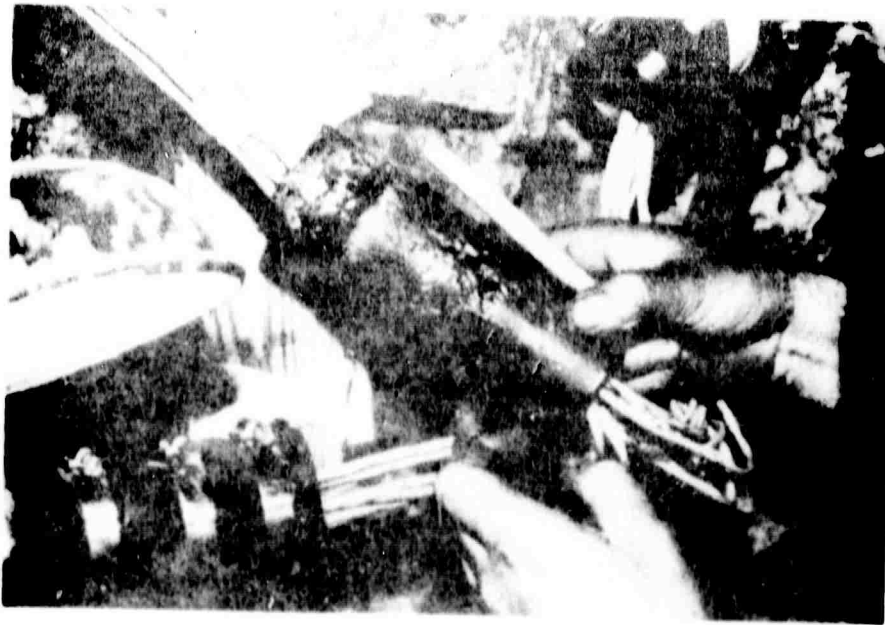

Plate 35: Potted wires after mold (#8207) was removed.

**NOT REPRODUCIBLE**

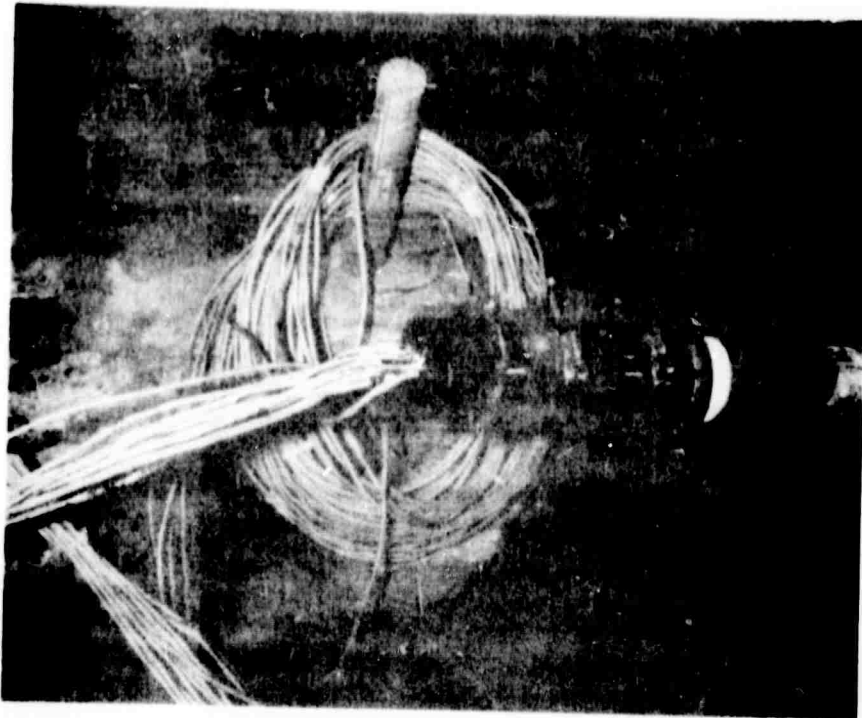

Plate 36: Potted wire assembly (#5105, 5106, 5107).



Plate 37: Pressure valve (#1102) and potted cable (#1112, #8208) input to pressure tank (#1100).

NOT REPRODUCIBLE



Plate 38: Marsh marine connectors (#1101, 1103) installed on pressure tank (#1100).

**BLANK PAGE**

IV-1

Daily Routine Check List

Observe and enter into log items 1 thru 5.

1. Meteorological conditions and forecast.
2. Radio time and station time.
3. Console AC voltage.
4. Seismometer boom positions (do not center unless completely sagged).
5. PTA galvanometer positions.
6. Check position of all recording gals. Adjust only as needed.
7. Calibrate system with step function. Current used should alternate daily from 4.0 to 40 microamps.
8. In dark room check to see if all systems responded to calibration step.
9. Six minutes after start of step #7 records can be removed.
10. Put new records on drum.
11. Return to console and remove step function calibration current.
12. Center seismometers and PTA's only as needed.
13. Disconnect all connectors and cables from the calibration coil inputs on the calibration panel.
14. Every few days check astrodata system to be sure air filters on tape deck and top and bottom of the main rack are clean and that all fans are operating smoothly.



## Daily Routine, Expanded Description

Since <sup>this</sup> is to be a seven day per week operation, a convenient time schedule should be adopted. In areas where 00:00 GCT occurs during working hours, records should be removed just previous to 24:00 GCT and the new records put on just after 00:00. In locations where this schedule is not possible, the station operators should try for the same format at 06:00, 12:00 or 18:00 GCT. This will facilitate interpretation of records. In addition, continuity of records can be determined at a glance.

In the event that none of the above schedules can be incorporated, the station operators must start and stop records at any hour mark.

In positioning the drums for record start assure that the hour marks will be vertically aligned under the component designation, (i.e. at mid record directly under ELO, NHI, etc.).

Assuming that a schedule has been determined, the station operator should perform the following operations daily and in the order outlined.

Observe and enter into the proper section of the station log:

1. Meteorological conditions and forecast at time of log entry; example: clear, gusty- rain predicted.

If thermometers are available, log their data.

2. Clock correction(s). Tune radio - assure that clock(s) have no gross errors such as hours and minutes. Do not argue with readings, log them as they read or sound.

3. Station voltage as indicated on console panel.  
Note. It will be assumed that the time of the clock correction entry in the log also will indicate the presence of the observer in the area, thus no separate entry for this data will be needed. If extensive time is consumed for repairs or tests, the operator should use a separate sheet to detail all test, repairs, or other operations he performed and when and how long he worked at them.

4. Position of the seismometer booms. (+ 5 Volts).  
Use the most sensitive meter range possible.

5. Position of the P.T.A. galvanometer. (+ 12 Volts).  
Use the most sensitive meter range possible.  
If these checks are in the acceptable ranges given above in parentheses, proceed to daily calibration.

6. Remove jumper wires from calibration coil plugs on the calibration panel. Set calibrate panel meter range select to + 200, place output shunt switch in ON position, and the switch directly below it to STEP position. Internal-external switch must be in internal position. Digital current meter should now register

numbers. Adjust the vernier potentiometer knob to make the digital display read 40 micro amps. Switch meter range select to  $\pm 20$  - at this point the digital display should read 4 micro amps.

Return shunt and step switches to OFF positions. Console is now ready for calibration. Replace jumper wires connecting calibrate output to calibration coils.

7. Enter dark recording room and check the positions of all the galvanometer spots on the aperture of the recorders - adjust zeros only as needed. Be sure spots are on zero after adjustments.

8. Back at the console, put step/pulse switch in STEP position. A 4 micro amp reading will appear on the digital current meter and this amount of current will be flowing in the calibrate coil circuits.

9. Re-enter dark room and observe if the calibration step was effective. The HI gain galvanometers should respond with a substantial deflection.

10. If at least six minutes have passed since the step function was put on, the records can now be removed.

Record should look like the following:

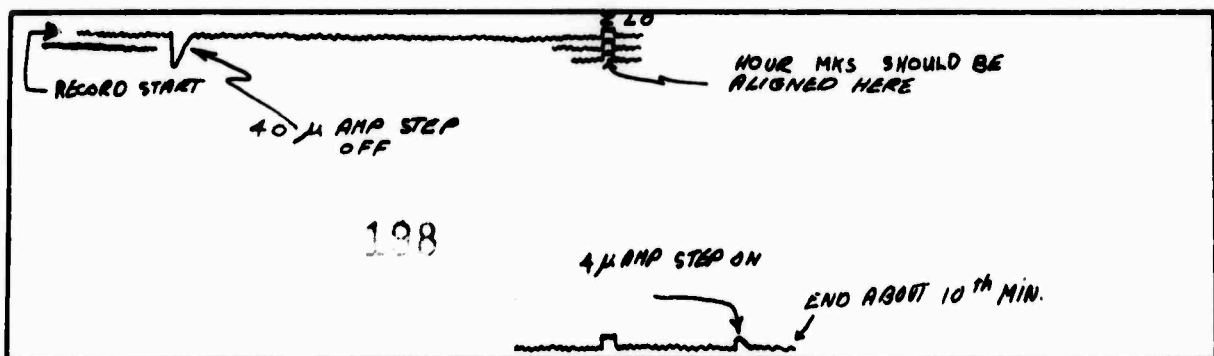

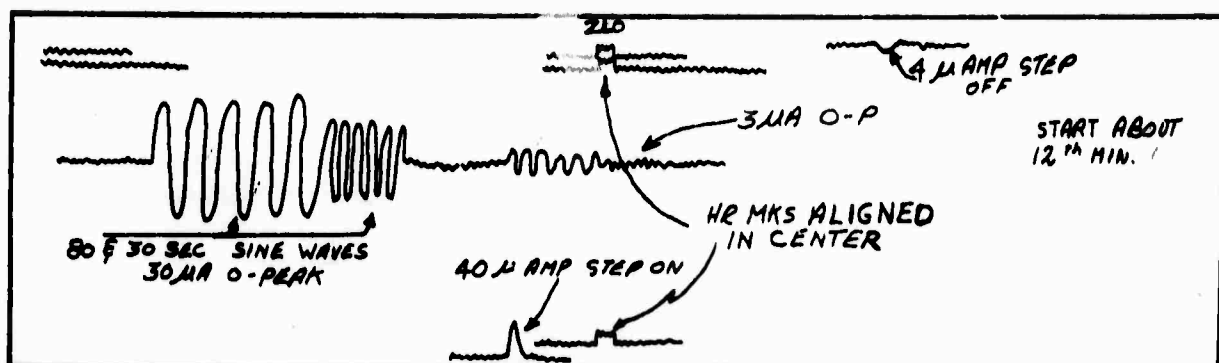

The above record clearly went on during the 33rd minute of some hour and off during the 10th minute of some hour. Please note cal currents and location of hour marks.

Carefully look at the record format shown. You will note:

- a. Hour marks centrally located on records.
- b. At the beginning of each alternate daily record, turning off the calibration step switch will produce a 40 micro amp calibration pulse in the proper direction. Since this amount of current is too large to make a readable signal on the HI (P.T.A.) records, the next calibrate pulse (the one just before removal of the records) should be only 4 micro amps. To facilitate this switching and to eliminate daily dialing of currents just change the meter range switch from  $\pm 200$  to  $\pm 20$  and the proper 4 micro amps will be presented to the

calibrate coils. We now have an ideal situation, where for each 24 hours of recording, we have a meaningful "Lo and Hi" calibration pulse.

c. The records drawn show arbitrary start and stop time. It is preferred to have start and stop overlapping an hour mark if possible and in so doing the chance of having cal pulses occurring on the record lap are eliminated.

11. Put new records on drums - indexed properly.

12. Return to console - place step switch in OFF position: this will appear as a downward pulse on all records.

Note: It is imperative that system sensitivity vs boom or P.T.A. galvanometer position is known - therefore, if booms or PTA galvanometers needed adjustment, now is the time to perform this operation.

Center the booms to within  $\pm 1$  volt of zero

Center the P.T.A. to within  $\pm 2$  volts of zero

(Boom positions in excess of  $\pm 5$  volts and P.T.A. position in excess of  $\pm 12$  volts warrant centering of only the unit exceeding these limits).

Centering of either boom or P.T.A., no matter how carefully done induces extremely violent boom or P.T.A. galvanometer motions, the result of which could be stuck galvanometers. Six minutes after any centering operation check (and free if needed) all galvanometers.

IV-7

The result of centering could change the sensitivity or response of the system, therefore repeat the step calibration using both 4 and 40 micro amp steps.

Once weekly the Station Operator should, in addition to his daily routine, drive the seismometers with an 80 and 30 second sine wave generated by the Wavetek signal generator. Inject this sine wave into the calibration console at External input and put selector switch in External position. Peak to peak current should be about 60 micro amps (30-0 30). After 6 cycles each of 80 and 30 second sine input, switch the meter range to  $\pm 20$  and the peak to peak current should now be 6ma (3-0-3). Record 6 cycles of 80 and 30 seconds again.

Please use care to record these data toward the center of the record so the peaks are not lost (look at format record).

13. Be sure to disconnect all plugs and connectors from the input to the calibration coils in order to prevent any stray currents from traveling between seismometers through the calibration coils.

#### IV-8

#### Quarter or tri-annual procedure

This check should coincide with the normal weekly check. After the daily routine has been completed to the point of record removal, proceed as follows:

1. Perform any centering operations necessary to the booms, P.T.A., and recording gals.
2. Put new records (test) on drum. Position drum 2" from left index.
3. Record galvo free period and current sensitivity.
4. Re-index drum to center position.
5. In a manner similar to performing the weekly sinusoidal calibration, perform the system frequency response, detailed below.

#### Frequency Response

1. Set Wavetek Signal Generator to  $1.25 \times 0.1$  which equals an 80 second period (OFF switch set to X1).
2. Select sine wave output
3. Adjust attenuator to full CCW position. Set frequency vernier knob to calibrated position.
4. With cables provided, connect the Wavetek output into the calibration panel at External input.
5. External/internal switch to external.
6. Output shunt switch to ON.
7. Step/pulse switch to STEP.

IV-9

8. Adjust attenuator (step 3) until the digital current meter reads about  $\pm 40$  micro amps.

9. Output shunt switch to OFF. Attach seismometer coils in series to calibration panel output.

10. Enter dark recording room and measure the amplitude of the spot motion on the aperture of the "Lo" recorder. It should be close to 200 mm peak to peak. Adjust attenuator (step 8) to obtain the amplitude.

11. Start frequency response with a 250 second sine wave.

Example: the lowest value division on the wavetek dial is .4. Therefore,  $.4 \times .01 = .004$  frequency

$$\text{period} = \frac{1}{\text{frequency}} \quad \text{or} \quad T = \frac{1}{f}$$

$$\text{and } T = \frac{1}{.004} = 250 \text{ seconds}$$

12. Continue the response using the periods listed for the duration (in minutes) shown

Dial Setting	Period	Duration
.4	250 seconds	18 minutes
.6	166	12
.8	125	12
1.0	100	10
1.2	84	10



## IV-10

Dial Setting	Period	Duration
1.4	71 sec.	10 min.
1.6	62	8
1.8	55	8
2.0	50	8
2.2	45	7
2.5	40	7
2.7	37	6
2.8	35	6
3.0	33	6
3.3	30	5
3.7	27	5
4.0	25	5
4.5	22	5
5.0	20	5
5.5	18	5
6.6	15	5
9.0	11	5
10.0	10	5

Periodically during the frequency response note the peak to peak amplitude (in micro amperes) of the current going to the calibrate coils. Variations should be carefully logged.

Remove all records, using extreme care in their handling and processing. Data pertinent to this response should be marked in pencil directly on the dried photo-

IV-11

graphic records. A complete log sheet listing peak to peak currents and the time when frequencies were changed should be included with the records.

Before returning the systems to their normal "record" conditions, open circuit signal coils # 1 and 2 for all three seismometers and pulse the seismometer with a 2000 micro amp pulse. The coils are open circuited at the long period recording galvanometer and the PTA galvanometer ( $T_g = 100$ ) . As a result of the pulse, the booms of the seismometer should swing at their natural period. This motion can be viewed and timed on the boom position display meter.

Log these data on the frequency response log sheet.

Security Classification

**DOCUMENT CONTROL DATA - R & D**

*Security classification of title, body of abstract and indexing annotation must be entered when the overall report is classified*

1. ORIGINATING ACTIVITY (Corporate author) <b>Lamont-Doherty Geological Observatory of Columbia University</b>		2a. REPORT SECURITY CLASSIFICATION <b>UNCLASSIFIED</b>	
2b. GROUP			
3. REPORT TITLE <b>High-Gain, Long-Period, Seismograph Station Instrumentation</b>			
4. DESCRIPTIVE NOTES (Type of report and inclusive dates) <b>Technical Report</b>			
5. AUTHOR(S) (First name, middle initial, last name) <b>Group effort</b>			
6. REPORT DATE <b>31 March 1971</b>		7a. TOTAL NO. OF PAGES <b>58 + 4 Appendices</b>	7b. NO. OF REFS <b>13</b>
8a. CONTRACT OR GRANT NO. <b>F 44620-70-C-0038</b>		9a. ORIGINATOR'S REPORT NUMBER(S) <b>None</b>	
b. PROJECT NO. <b>OF 10</b>		9b. OTHER REPORT NO(S) (Any other numbers that may be assigned this report)	
c. <b>ARPA Order 1513</b>		d.	
10. DISTRIBUTION STATEMENT <b>Distribution of this document is unlimited</b>			
11. SUPPLEMENTARY NOTES		12. SPONSORING MILITARY ACTIVITY <b>Air Force Office of Scientific Research</b>	
13. ABSTRACT Five high-gain, long-period seismograph stations are being installed, operated, and evaluated at sites in Alaska, Australia, Israel, Spain, and Thailand. Details of these installations are given in a series of five Technical Reports each entitled "High-Gain, Long-Period Seismograph Systems Installation Report". These instruments are capable of operating at magnifications greater than 500,000 at periods of 35 to 45 seconds. The purpose of this report is to describe the instruments in detail, present a parts list, and present technical drawings and operation manuals for the major components.			

208

**BLANK PAGE**

# SEISMOMETER VAULT

# P.T.A. ROOM

# RECORDER ROOM

BULKHEAD  
DOOR " 3  
5100  
OR  
ROCK FACE

BULKHEAD  
DOOR " 2  
5100

BULKHEAD  
DOOR " 1  
5100

CASEMENT  
DOOR  
3700

DEHUMIDIFIER  
4400

DEHUMIDIFIER  
3600

QUAD  
BOX  
2400

CABLES POTTED  
IN 2" PIPE  
5101

DISPLACEMENT  
TRANSDUCER  
POWER SUPPLY  
2300

CABLES POTTED  
IN 2" PIPE  
5101

TIME  
RELAY  
CLOSURES

DIGITAL  
RECORDER  
AND  
CLOCK  
3100

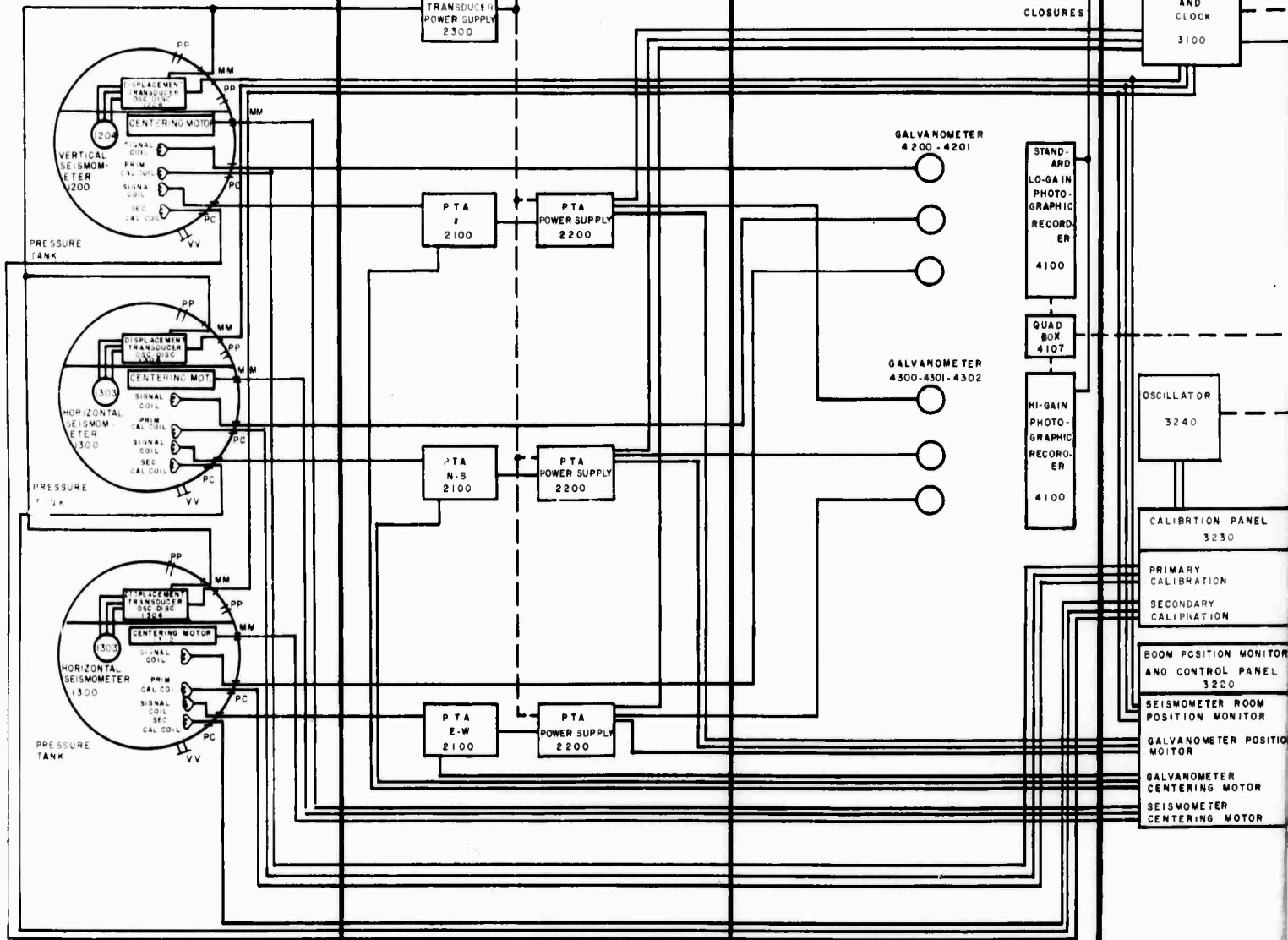

SPARE  
CABLES

*Handwritten mark*

# CONTROL ROOM

CASEMENT  
DOOR  
3700

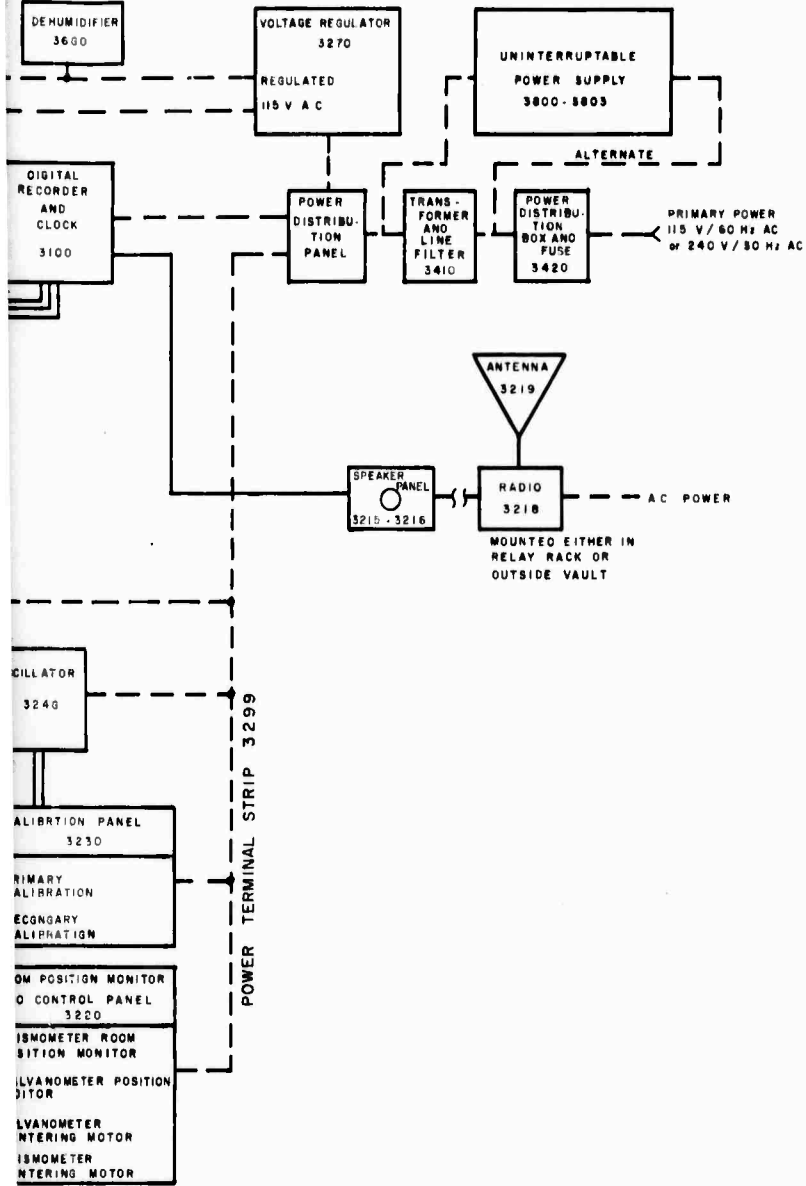

SYMBOLS USED ON PRESSURE TANK		
VV	PRESSURE TANK VENT VALVE	1102
PC	POTTED CABLES	8208
MM	MARSH - MARINE CONNECTORS	1101 1103
PP	PIPE PLUG	1104

LAMONT - DOHERTY GEOLOGICAL  
OBSERVATORY OF COLUMBIA UNIVERSITY

HIGH - GAIN BROAD - BAND  
LONG - PERIOD  
SEISMIC SYSTEM

208a B