

NYSTAGMUS AND VISUAL PERFORMANCE DURING SINUSOIDAL STIMULATION

OF THE VERTICAL SEMICIRCULAR CANALS

Fred E. Guedry, Jr., and Alan J. Benson

AD-726173



U. S. ARMY AEROMEDICAL RESEARCH LABORATORY
NAVAL AEROSPACE MEDICAL RESEARCH LABCRATORY

March 1971

Approved for public release; distribution unlimited.

90 06 11 172

Approved for public release; distribution unlimited.

**NYSTAGMUS AND VISUAL PERFORMANCE DURING SINUSOIDAL STIMULATION
OF THE VERTICAL SEMICIRCULAR CANALS**

Fred E. Guedry, Jr., and Alan J. Benson

**Bureau of Medicine and Surgery
MF12.524.004-5001BX5G**

U. S. Army Aeromedical Research Laboratory

Approved by

**Ashton Graybiel, M.D.
Assistant for Scientific Programs**

Released by

**Captain N. W. Allebach, MC, USN
Officer in Charge**

10 March 1971

**NAVAL AEROSPACE MEDICAL RESEARCH LABORATORY
NAVAL AEROSPACE MEDICAL INSTITUTE
NAVAL AEROSPACE MEDICAL CENTER
PENSACOLA, FLORIDA 32512**

SUMMARY PAGE

THE PROBLEM

Legibility of cockpit instruments can be degraded by strong vestibular stimulation. The purposes of this experiment were to clarify the mechanisms involved in the differential visual suppression of nystagmus during pitch-forward and pitch-backward stimulation, to ascertain the influence of luminance level on visual performance, and to ascertain habituation effects induced by the experimental conditions.

FINDINGS

Subjects positioned on their sides were oscillated sinusoidally (0.04 Hz, peak velocity ± 90 deg/sec) about an Earth-vertical axis. Initially, nystagmus slow phase velocity was about equal during the forward- and backward-pitch halves of the stimulus cycle in darkness; but when subjects tracked a dimly illuminated aircraft instrument, nystagmus slow phase velocity during forward pitch was about ten times that during backward pitch. Consequently, tracking errors were much greater during forward pitch. Change in luminance level from 0.01 ft-L to 1.0 ft-L produced small, statistically significant decrements in nystagmus slow phase velocity and substantial improvements in tracking performance. Following this part of the experiment, nystagmus was again recorded in darkness. There was a differential decline in slow phase velocity, the slow-phase-down response showing significantly greater decline. Stimulus-response phase relations were also altered for the slow-phase-down response, but were unaltered for the slow-phase-up response. It is proposed that interactions between eyelid and eyeball movements caused different frequencies of upbeating and downbeating nystagmus which, in turn, produced different visual suppression of nystagmus slow phase velocity in the two halves of the stimulus cycle. The asymmetric visual suppression may have contributed to the asymmetric habituation of the two reactions.

ACKNOWLEDGMENTS

The authors wish to express their appreciation to G. T. Turnipseed, D. J. Gripka, and J. W. Norman for their assistance with experimental equipment and in collecting and analyzing experimental data. Thanks are also due to LCDR R. S. Kennedy for comments on interdependence of eyelid and eyeball movement.

The findings in this report are not to be construed as an official Department of the Army position, unless so designated by other authorized documents.

INTRODUCTION

It is well known that vestibular nystagmus is suppressed by the introduction of visual stimuli that are fixed relative to the head. Recently, however, it has been indicated that different directions of vestibular nystagmus, e.g., horizontal nystagmus (z-axis), vertical nystagmus (y-axis), and rotary nystagmus (x-axis), are not necessarily all visually suppressed to the same degree (6,9). In particular, suppression of vertical nystagmus of opposite directions differed and this was accompanied by reported differences in visual acuity. Although the difference in nystagmus reactions might be partially attributable to artifacts in electro-oculography (1), the corresponding difference in visual acuity indicated that something more was involved.

The purpose of the present experiment was to compare the two directions of vertical nystagmus produced by vestibular stimuli of equivalent magnitude under several conditions of illumination and to obtain a continuous evaluation of corresponding changes in vision. To accomplish the latter, a manual compensatory tracking task that was dependent upon the legibility of an instrument dial was used. Another purpose of the experiment was to determine any response declines that might occur in nystagmus recorded in darkness over the course of the experimental session.

The intensity of the vestibular stimulus used in the present experiment was selected following an earlier experiment (2) that had indicated these stimulus intensities would yield electro-oculographic recordings of vertical nystagmus in both directions which were usually scorable. Moreover, it was important that the intensity and duration of the vestibular stimulus would be such that most subjects would be able to complete the sequence without incapacitating nausea or sickness.

PROCEDURE

SUBJECTS

Nine young men were subjects in this experiment. All were in normal health without significant otoneurological defects. Of the nine, two yielded records of nystagmus that were considered unscorable, and another was unable to complete the experiment due to sickness; therefore, the data described in this report were obtained from six subjects.

APPARATUS

Subjects were rotated about an Earth-vertical axis in the Human Disorientation Device (HDD) which is described in detail elsewhere (8). The subject was positioned with his head at the center of rotation and his left ear down so that a line between the two ears was colinear with the axis of rotation. Angular acceleration of the HDD thus stimulated the subject's vertical canals about the y-axis* of the skull.

*The nomenclature system proposed by Hixson et al. (10) is used here.

A diagram illustrating subject position, the rotation device, and recording channels is shown in Figure 1. Eye movements were recorded by a conventional electro-oculographic technique from electrodes placed above and below the right eye. The other variable studied was the psychomotor performance required by compensatory tracking of a visual display. The visual display was an aircraft flight instrument (localizer/glide-slope indicator) that has a vertical and a horizontal needle. The diameter of the instrument face was 40 mm and it was positioned in the center of a dull black panel 0.8 m in front of the subject. In this experiment only one needle was energized, and when in null position, it was at right angles to the plane of the expected vestibular nystagmus. Localized illumination of the instrument was provided by a small projector which was fitted with neutral density filters to give needle and instrument markings a luminance of either 0.01 ft-L or 1.0 ft-L (0.034 cd/m², 3.4 cd/m², respectively). The needles and other detail on the instrument face were the only visible visual detail available to the subjects during the psychomotor tracking task.

The energized needle of the instrument was driven by a quasi-random forcing function and by a control stick. By appropriate movement of the control stick, the subject could override any offset of the needle by the forcing function and thus maintain the needle in null position. Deflections of the needle were proportional to the voltage difference, $\theta_i - \theta_0$, which constituted instantaneous tracking errors. The absolute value of this voltage was integrated over 1-second intervals and the integral error displayed in numerical form by means of a digital voltmeter and printer.

METHOD

Subjects were given four periods of exposure to sinusoidal oscillatory motion, each exposure (trial) lasting about 215 seconds. Rest periods of no less than 5 minutes intervened between trials. A dark adaptation period of 10 minutes preceded the first trial. In each trial after steady-state oscillation was achieved, peak angular velocities were ± 90 deg/sec and the frequency of oscillation was 0.04 Hz.

During the first and fourth trials, the HDD capsule was in complete darkness. The purpose of these trials was to record the vertical nystagmus produced by the vestibular stimulus without the presence of visual suppression.

During the second and third trials, the psychomotor tracking task was performed under two luminance levels, 0.01 ft-L and 1.0 ft-L. Three of the subjects had the higher luminance level first and the other three subjects had the lower luminance level first. Prior to each of these trials there was a 4-minute tracking period without any imposed vestibular stimulation; performance during the last minute of this period was used as a measure of "static" tracking proficiency. Motion of the HDD was then started and oscillation was maintained until at least eight cycles were completed. Tracking performance and nystagmus were scored during the last five complete cycles.

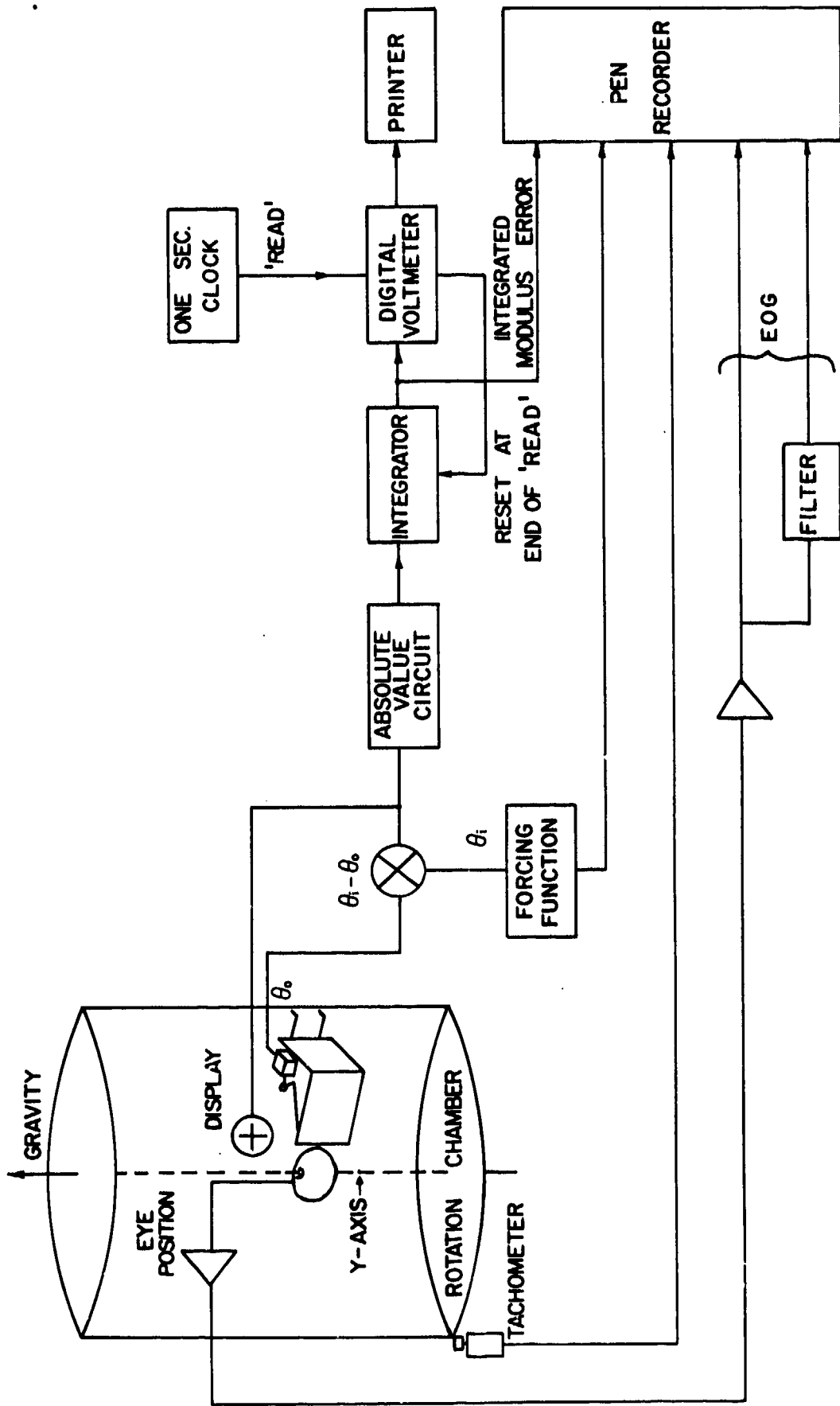

Figure 1

Diagrammatic representation of the subject position and of the apparatus used to measure tracking performance ($\theta_t - \theta_o$) and eye movements (electro-oculograph, EOG).

RESULTS

Although the axis of the rotation stimulus was vertical relative to the Earth, the subject was positioned on his left side so that the clockwise half of the rotation cycle produced a stimulus to the vertical semicircular canals comparable to "forward pitch," which is accompanied by "vertical" nystagmus with slow phase directed upward (toward the top of the head). The counterclockwise half of the cycle produced "backward pitch" accompanied by nystagmus with slow phase directed downward (toward the feet).

Mean velocity of nystagmus slow phase throughout the course of a stimulus cycle is illustrated in Figure 2. The mean response curves were derived from measures taken at 1-second intervals throughout each of the last five complete stimulus cycles for each subject for each of the four conditions. Thus, each plotted point is an average of five measures obtained from each of six subjects.

VELOCITY OF NYSTAGMUS SLOW PHASE IN THE DARK

In Figure 2 it can be seen that during Trial 1, nystagmus slow phase speed was about the same during each half of the stimulus cycle. The mean difference in favor of forward pitch was not statistically significant. In Trial 4 the nystagmus slow phase speed was reduced during both halves of the stimulus cycle, as compared with the response in Trial 1; the over-all decline from Trial 1 to Trial 4 was statistically significant ($P < .01$). Also in Trial 4, eye speed in the two halves of the stimulus cycle differed significantly ($P < .05$); slow-phase-up nystagmus was greater than slow-phase-down nystagmus. Thus, there was a differential reduction from Trial 1 to Trial 4 for the two directions of nystagmus, the slow-phase-down response decline being significantly greater than the slow-phase-up response decline ($P < .01$). These findings are illustrated in Figure 3 by recordings from a single subject during Trials 1 and 4.

VELOCITY OF NYSTAGMUS SLOW PHASE DURING ILLUMINATION

During Trials 2 and 3, the presence of the illuminated dial suppressed nystagmus slow phase velocity in both halves of the stimulus cycle. The brighter of the two luminance levels produced the greater suppression of nystagmus ($P < .01$), an effect that was proportionately greater ($P < .05$) during the backward pitch (slow phase down) part of the cycle.

The most striking feature of the data was the significant ($P < .001$) differential visual suppression of the nystagmus during the two halves of the stimulus cycle. During backward pitch with the 1.0 ft-L luminance level, mean slow phase velocity was only 3 per cent of the mean nystagmus velocity recorded in darkness during Trial 1. During forward pitch the mean nystagmus slow phase velocity was 37 per cent of the mean velocity recorded in darkness during Trial 1. An even greater differential visual suppression for the two directions of nystagmus was evident with the 0.01 ft-L luminance level. Records obtained during performance of the tracking task with the 0.01 ft-L luminance are shown in Figure 4.

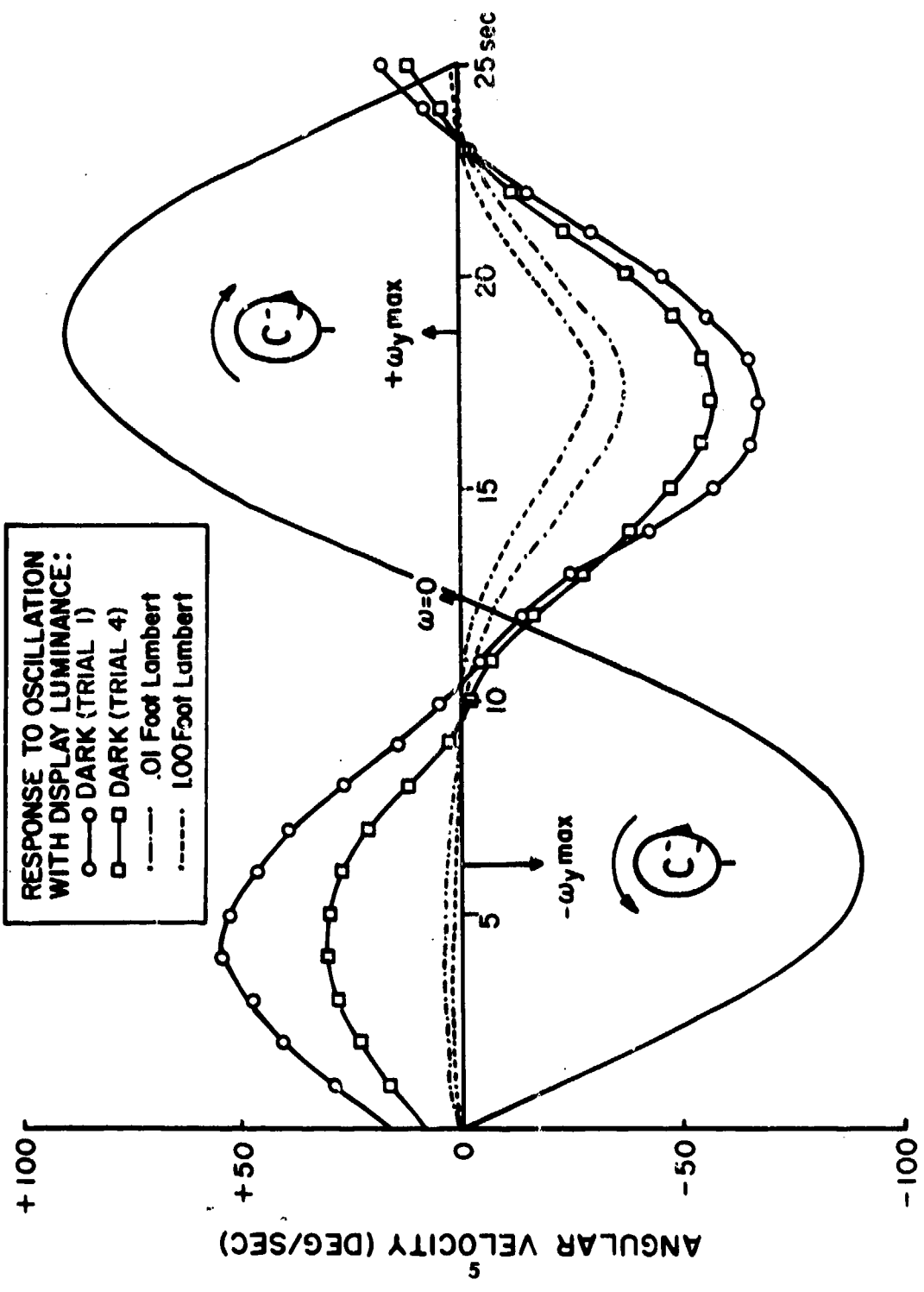

Figure 2

Showing the effect of display luminance on mystagmus slow phase velocity and the differential habituation (Trial 1 - Trial 4 dark comparison) of responses in the backward-pitch ($-\omega_y$) and forward pitch ($+\omega_y$) halves of the stimulus cycle. Smooth sinusoid represents stimulus velocity.

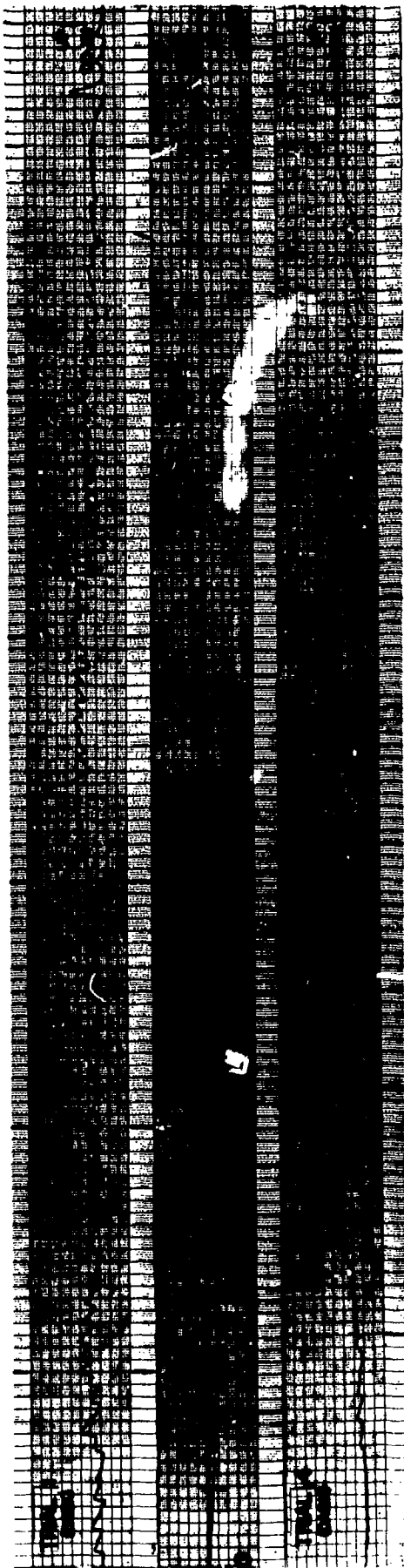

Figure 3

Nystagmus recorded from a single subject in darkness at the beginning (Trial 1) and end (Trial 4) of the experiment.

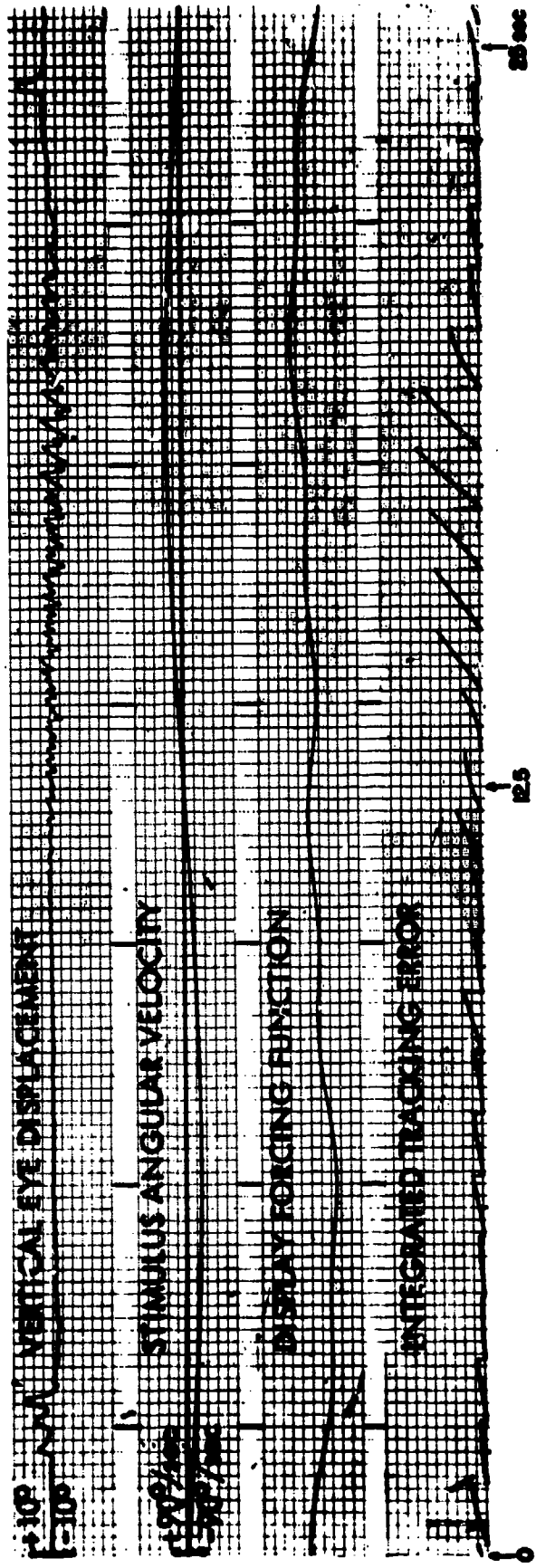

Figure 4

Nystagmus and tracking performance when display luminance was 0.01 ft-L. Note the absence of discernible nystagmus during the negative stimulus velocity (backward pitch) and the strong nystagmus and greater tracking error during the positive stimulus velocity (forward pitch).

NYSTAGMUS BEAT FREQUENCY

Changes in the beat frequency of nystagmus do not necessarily correspond with changes in nystagmus slow phase velocity. Figure 5 shows the mean beat frequency of nystagmus for each 1-second interval throughout a typical stimulus cycle during Trials 1 and 4. Measures from the last five cycles of Trials 1 and 4 were averaged to obtain the curves in Figure 5. These curves show that nystagmus beat frequency rises and declines twice during each cycle, more or less like eye velocity. But in contrast to the eye velocity, which in Trial 1 was of approximately equal magnitude in the two halves of the cycle, the frequency of the nystagmus beat was substantially higher during forward pitch than backward pitch. Furthermore, there was no evidence of a significant alteration in beat frequency between Trials 1 and 4, comparable to the response decline exhibited by the measures of nystagmus slow phase velocity.

Figure 6 shows the mean beat frequency during a 3-second interval selected to encompass symmetrically the peak slow phase velocity for each response direction for each luminance condition. The frequency of nystagmus during backward pitch was consistently less than the frequency of nystagmus during forward pitch in the dark ($P < .01$). This difference was increased by the introduction of the illuminated dial because the beat frequency of slow-phase-down nystagmus was reduced by illumination, whereas the frequency of slow-phase-up nystagmus was unaltered.

PERFORMANCE ON PSYCHOMOTOR TRACKING TASK

Comparison of performance-error measures when the subjects were stationary with measures obtained during angular oscillation revealed (Figure 7) substantial performance decrements related to vestibular stimulation. Mean error scores were averaged over the last five cycles of each of the two luminance conditions (Trials 2 and 3) for each subject. Each peak of the biphasic performance decrement corresponded closely with peak velocities within a stimulus cycle. Tracking performance was significantly ($P < .01$) worse with the 0.01 ft-L luminance level than with the brighter 1.0 ft-L luminance level. At each luminance level, tracking performance was significantly ($P < .01$) worse during the forward-pitch than during the backward-pitch half of the stimulus cycle. These various differences in tracking performances were consistent with subjective impressions of visual blurring. However, some subjects believed that they achieved equivalent performance at the two luminance levels, but this subjective assessment was rarely supported by the objective measures of tracking task error.

PHASE RELATIONS BETWEEN STIMULUS AND RESPONSE

During sinusoidal oscillation, the phase relations between stimulus and response have been considered of significance in estimating some basic properties of the vestibulo-ocular response system (13). As shown in Figure 2, the zero crossing of nystagmus slow phase velocity preceded that of the stimulus velocity. During Trial 1, the zero crossing of nystagmus preceded the stimulus transition from backward to forward pitch (b-f transition) by 2.2 seconds, while the zero crossing of nystagmus preceded the transition from forward pitch to backward pitch (f-b transition) by 1.9 seconds. The difference was not

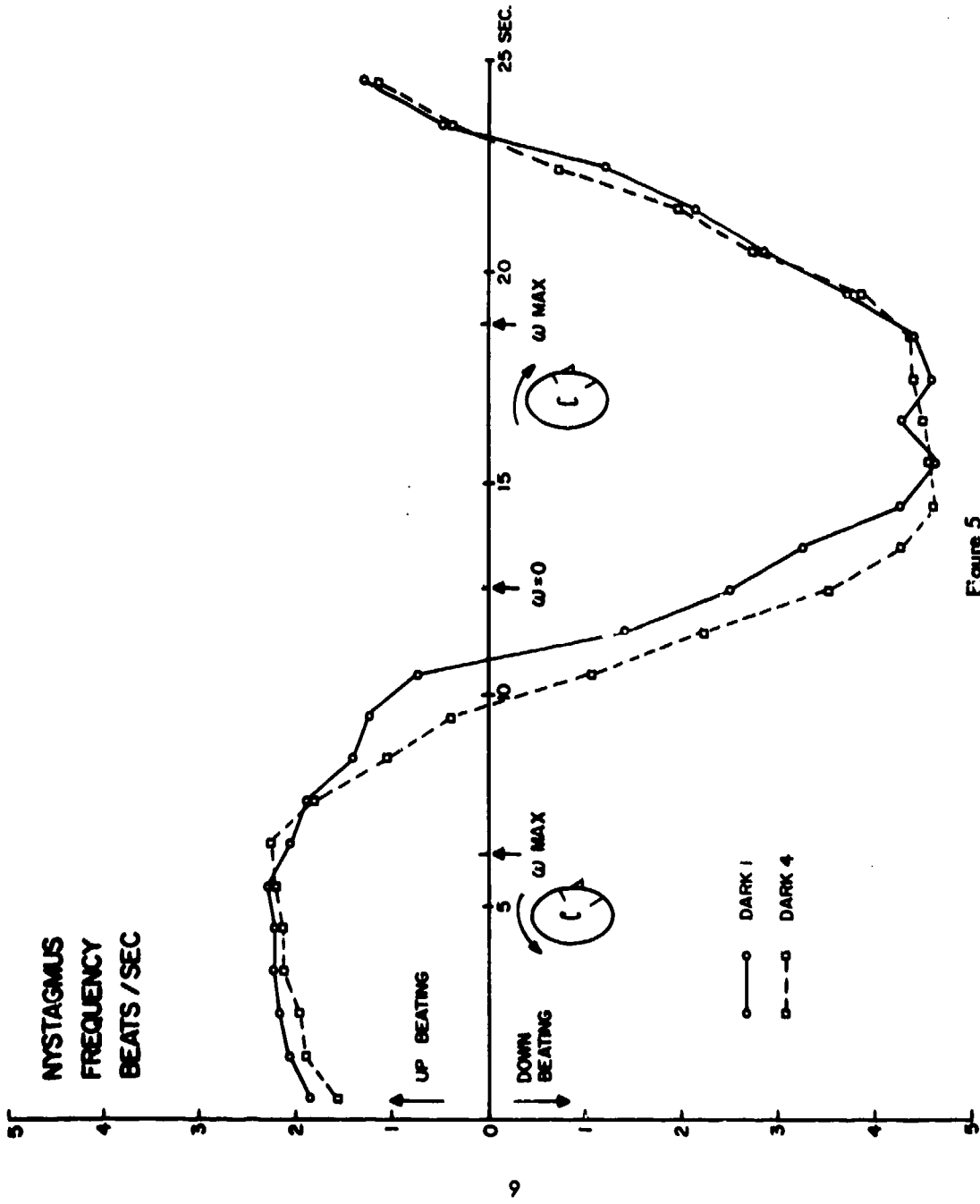

Figure 5

Mean nystagmus beat frequency for each 1-second interval of the stimulus cycle averaged over the last five cycles of Trial 1 and of Trial 4. Downbeating nystagmus frequency is arbitrarily plotted below the axis of ordinates.

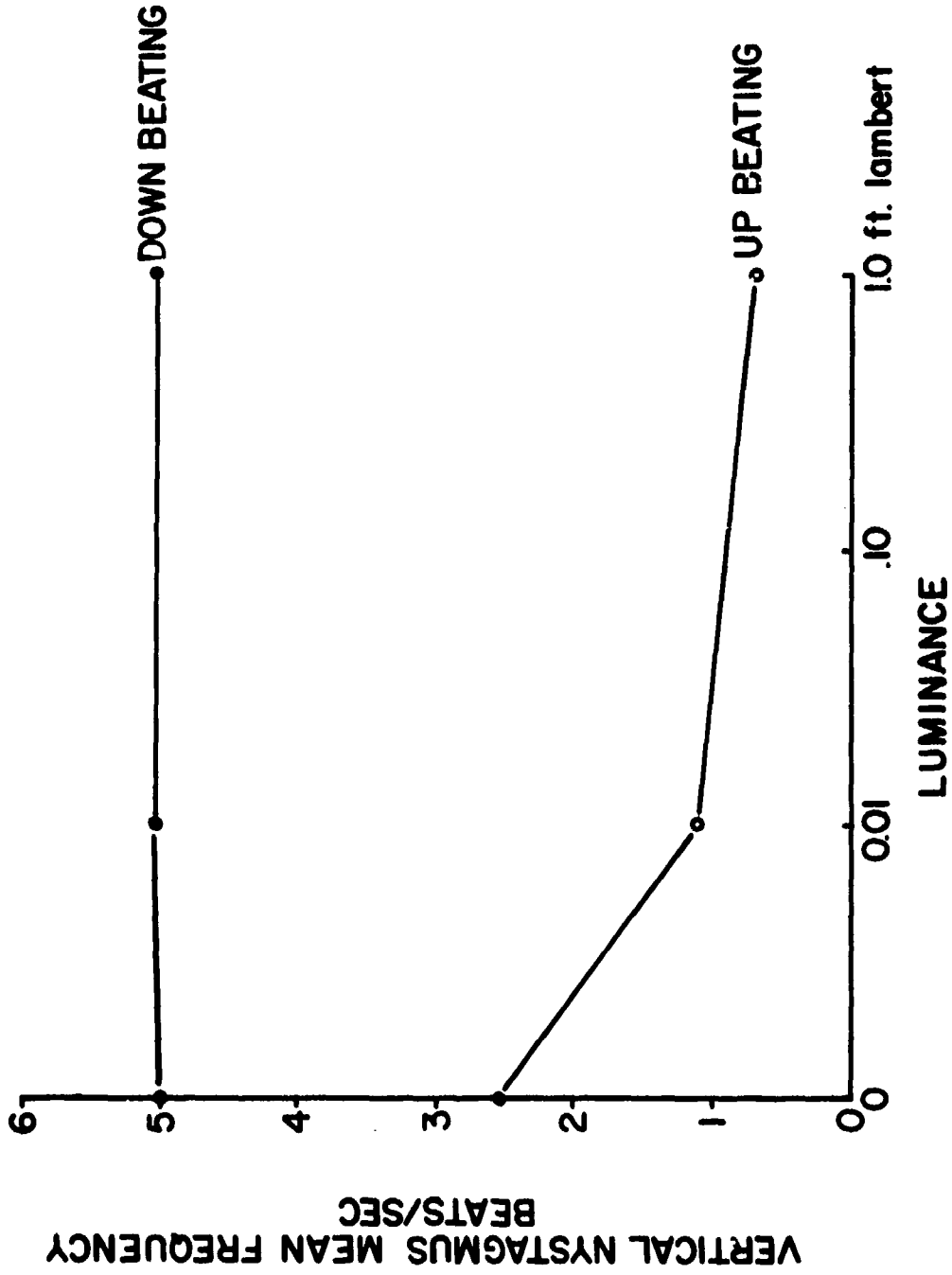

Figure 6

A comparison of mean peak nystagmus frequency in the dark condition and in the 0.01 ft-L and 1.0 ft-L luminance conditions. The means were calculated from the interval encompassing the peak slow phase velocity ± 1.5 seconds. Slight discrepancies between 0 luminance frequencies in this figure and mean peak frequencies in Figure 5 are due to different counting methods used.

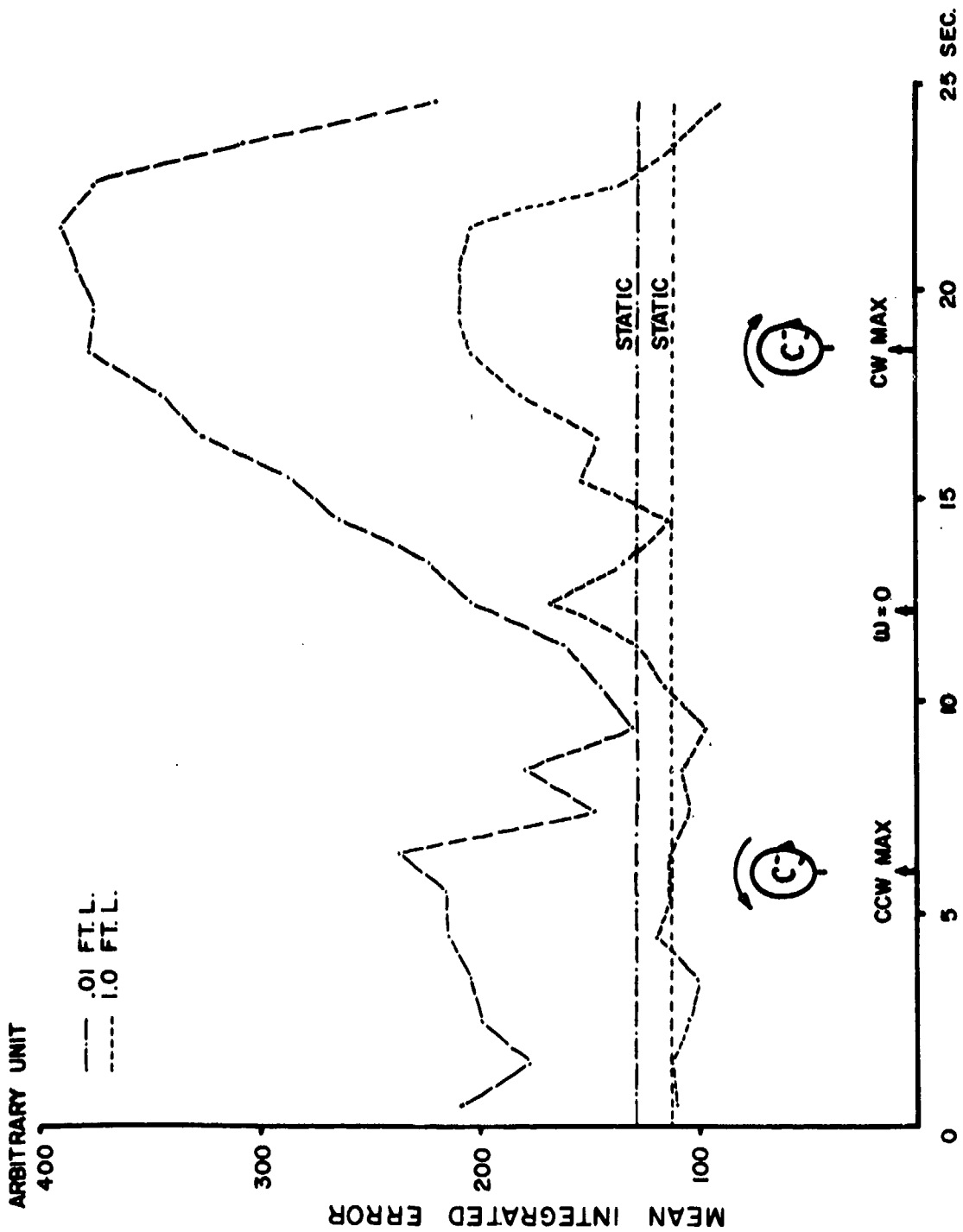

Figure 7

Effect of display luminance on tracking-task performance. Straight horizontal lines show mean level of tracking performance while stationary. Irregular curves represent tracking performance during oscillation at 0.04 Hz and peak velocity of ± 90 deg/sec. Each point in the curves is a mean 1-second integrated error score averaged over five cycles for six subjects.

statistically significant. However, on Trial 4, the nystagmus zero crossing preceded the b-f transition by 3.0 seconds, whereas the nystagmus zero crossing again preceded the f-b transition by 1.9 seconds. The difference in phase advance of these two mean-crossing times during Trial 4 was statistically significant ($P < .01$). In the b-f transition, the increase in the phase advance from 2.2 seconds in Trial 1 to 3.1 seconds in Trial 4 was also statistically significant ($P < .01$). In all of these phase-relation comparisons, although mean data from the last five complete stimulus cycles of Trials 1 and 4 for each subject were used, inspection of individual results in each cycle revealed remarkable consistency in the differential phase advance for the two transitions.

These temporal differences in times of zero crossings can also be expressed in terms of phase angle. The phase advances in Trial 1 for the b-f and f-b zero crossing were 31.7 deg and 27.2 deg, respectively. Assuming a simple second-order system as exemplified by the torsion pendulum model of van Egmond et al. (3), the phase angles obtained with a stimulus frequency of 0.04 Hz correspond to time constants (i.e., the Π/Δ values of van Egmond et al.) of 6.5 seconds and 7.8 seconds, respectively. These values are very close to those obtained in other studies in which the vertical semicircular canals were stimulated by angular accelerations in the y-axis. In Trial 4 the b-f and f-b zero crossings correspond to mean phase advances of 44.2 deg and 27.2 deg, respectively. Thus, between Trial 1 and 4 there was an asymmetric change in phase advance for the two response transitions in each stimulus cycle.

DISCUSSION

DIFFERENCES IN PITCH-BACKWARD AND PITCH-FORWARD NYSTAGMUS

Differences in nystagmus reactions produced by pitch-forward and pitch-backward stimuli of equal magnitude have been noted previously (2,6,7,9) and they were apparent in the present experiment. These differences were much more prominent in the illuminated conditions than in darkness, apparently due to differential visual suppression of the two reactions.

However, there were also differences in the two nystagmus reactions in the dark trials. In both Trials 1 and 4, the beat frequency of the pitch-forward nystagmus (slow phase up) was considerably higher than that of the pitch-backward nystagmus. In regard to slow phase velocity, a slight difference in the two reactions was not statistically significant in Trial 1, but this difference became prominent in Trial 4 and was then statistically significant. On Trial 4 nystagmus slow-phase-up velocity was greater than nystagmus slow-phase-down velocity. One might conclude that slow-phase-up nystagmus is simply stronger, harder to suppress by vision, and less subject to response decline over a series of trials. But this is an over-simplification which does not explain why the up- and the down-beating nystagmus should differ in the manner described. Accordingly, a hypothesis has been developed which proposes that the observed directional difference in the vertical nystagmus is a consequence of the higher frequency of slow-phase-up nystagmus, which in turn is attributed to neurological and anatomical features that govern vertical as opposed to lateral eye movements.

Consider the position of the eyelids when a man, with head vertical, looks straight ahead. The margin of the upper lid covers about half the width of the iris, but the margin of the lower lid is at the level of the inferior border of the iris. Thus, on looking downward, no movement of the lower lid is required to prevent obstruction of the pupil by the lower lid, until the gaze is directed 20 degrees to 30 degrees below the horizontal. However, on looking upward, the upper lid must move upward with the eye (as indeed it does) to prevent reduction of the pupillary aperture. During upward movement of the eye, not only is the synergistic contraction of Levator palpebrae superioris required, but for large movements the frontal bellies of Occipitofrontalis also contract to retract the eyebrows (11). Although Levator palpebrae superioris and Rectus superior share a common innervation and fascial sheath, during rapid elevation of the eye the movement of the upper lid lags the upward movement of the eye (1), perhaps because of the presence of smooth muscle in Levator palpebrae superioris or other anatomical features that impair its dynamic response. Thus, when rapid vertical eye movements occur, and in particular the compensatory eye movements of vestibular origin, there is a functional advantage in restriction of the amplitude of upward eye movements so that vision is not degraded by occultation of the pupil by the upper lid. If the eye tends to return approximately to level gaze position at the end of the nystagmus fast phase, the amplitude of vertical nystagmus with slow phase up may be limited in comparison with the amplitude of nystagmus of opposite direction. The reduced amplitude and an equivalent slow phase velocity can only be accomplished with a higher beat frequency.

Now, with a higher beat frequency and comparable slow phase velocity, the ability to see visual detail might also be impaired. During the fast phase of nystagmus, visual acuity is presumably nil. A high beat frequency would yield many interruptions of vision per unit time and also short "view periods" during the slow phase of eye movement. If the vision were so impaired, this would cause the slow phase velocity to increase, much as the introduction of a blurring lens does, and the increased slow phase velocity would further degrade vision during the view periods. Thus, neuroanatomical characteristics may tend to limit amplitude of slow-phase-up nystagmus and increase beat frequency which in turn may cause a minor degradation of vision. This would cause a higher slow phase velocity which would further degrade vision, et cetera.

The differential reduction of nystagmus in the dark from Trial 1 to Trial 4 might be explained on the basis of a differential visual suppression of the backward- and forward-pitch reactions during the two intervening illumination trials. There have been previous indications that a series of canal stimuli alternating in direction yields an asymmetrical response decline when only one direction of nystagmus has been suppressed by voluntary efforts to see visual detail during the series (5). These declines were demonstrated by responses recorded from subjects tested in darkness* before and after fairly lengthy habituation series. However, recently a direction specific decline in slow phase velocity of

*Alertness of subjects before and after such series must be artificially maintained by assigned mental tasks to demonstrate these effects.

horizontal nystagmus has been reported following two sessions of sinusoidal oscillation in which visual suppression was introduced during only one half cycle (14). Each of the two habituation sessions was slightly longer than the illumination sessions in the present experiment (13 cycles compared with 8 or 9 cycles), but these findings at least support the hypothesis that the differential decrement in slow phase velocity observed between Trials 1 and 4 was due to the suppression of up- and down-beating nystagmus during Trials 2 and 3 when the subject attempted to fixate on the instrument display.

The change in the nystagmic response from Trial 1 to Trial 4 also included an alteration of the stimulus-response phase relations. The phase advance associated with the backward-to-forward pitch transition increased significantly, whereas that associated with the forward-to-backward pitch transition was unaltered. A shift in the zero reference of the central nervous system (that range of differential inputs from the anterior and posterior canals which are processed centrally as zero stimulation) could account for the increased phase advance with the b-f transition, but there should also be a decreased phase advance with the f-b transition. This latter effect did not occur; the f-b zero crossing was unaltered. It would appear that a conditioned suppression, more or less proportional to the visual suppression of nystagmus, with only a little change in the zero reference might account for an increased phase advance in the b-f transition and little or no change in the f-b transition.

Thus it may be argued that a beat frequency difference in the two directions of vertical nystagmus caused a difference in visual suppression which, in turn, caused a difference in response decline during the course of the experiment. The nature of the habituation process may include both a differential conditioned suppression of vestibular signals to the oculomotor system and a slight shift in the zero reference.

Interplay between eyelid reflexes and vertical eye movements may be only one aspect of a functional organization that predisposes a bias in upward versus downward eye movements. In man, head carriage, eyebrows, eyelashes, and upper eyelid appear structured to emphasize the lower half of the visual field. During forward locomotion, fixation of any object in the intended path of motion, from eye level and below, requires suppression of optokinetic stimuli arising from all other objects in the path of intended motion because these would drive the eyes downward, but at inappropriate speeds. Laterally displaced objects would similarly require selective suppression. Thus, selective ability to suppress downward (and lateral), as opposed to upward, eye tracking movements may be a product of natural training and evolution.

EFFECTS OF LUMINANCE ON NYSTAGMUS AND PSYCHOMOTOR TRACKING

In the present experiment both manual tracking performance and slow phase velocity of nystagmus were altered significantly by a change in display luminance from 0.01 ft-L to 1.0 ft-L. In a previous study dealing with horizontal nystagmus produced by rotation about the z-axis (4), display luminance within the range 0.01 ft-L to 10.0 ft-L influenced manual tracking performance, but a similar mean trend for nystagmus was not regarded as statistically significant. Considering both experiments, it appears that

nystagmus intensity is inversely related to luminance of an instrument face in an otherwise dark environment, but the differential effects on nystagmus are very slight when the luminance level is varied within a range of comfortable photopic vision.

RECORDING OF VERTICAL NYSTAGMUS

Electro-oculographic recording of vertical nystagmus is made difficult by artifacts from movement of the eyeball relative to the eyelid (1) and from eyeblinks. In the present experiment the mean slow-phase-up velocities of nystagmus in darkness were greater than the mean slow-phase-down velocities, and the mean difference was significant in Trial 4. In one earlier study (6) it was reported that these two reactions were equal in darkness and in another (9) it was found that the slow-phase-down nystagmus was slightly greater than slow-phase-up nystagmus. Although these discrepancies might be dismissed as sampling errors, it appears more likely that they are attributable to changes in recording artifacts as a result of stimulus level or more precisely, response level. In still another study (2), involving very high stimulus levels, EOG records revealed little clearly discernible slow-phase-up nystagmus of good quality at a time in the stimulus cycle when visual degradation was greatest, as indicated both by manual tracking performance and verbal report; slow-phase-down nystagmus was still discernible during the other half of the stimulus cycle and hence could have been adjudged the stronger reaction. The lower stimulus levels used in the present experiment revealed a strong slow-phase-up nystagmus during illumination. These results considered together suggest that when stimulus levels exceed some limit, slow-phase-up nystagmus may not be discernible in EOG records due to artifacts associated with nystagmus of very high slow phase velocity, low amplitude, and high beat frequency.

However, this question must remain open until some suitable method of faithfully recording such vertical nystagmus is available. Lorente de No (12) has indicated that in rabbits, nystagmus amplitude and beat frequency increase together to some limit, but beyond that limit, a further increase in beat frequency is accompanied by amplitude reductions which may reach the point where some of the extraocular muscles show only steady contraction or relaxation. Something very much like this may have happened in the earlier study (2) during strong stimulation in a direction to produce slow-phase-up nystagmus. Because of inadequacies in EOG, we cannot be sure that a very high frequency low amplitude nystagmus was not present, but if it was not, then the visual degradation during this period must be explained. The dysrhythmic eye movements may have been sufficient to degrade vision, but there were some periods of apparent ocular quiescence in which vision was apparently still degraded. Perhaps a mismatch between vestibular commands for ocular motion and incoming retinal data may account for visual degradation when ocular immobility is attributable to vestibular "overdriving."

REFERENCES

1. Barry, W., and Melvill Jones, G., The influence of eye lid movement upon electro-oculograph recording of vertical eye movements. Aerospace Med., 36: 855-858, 1965.
2. Benson, A. J., and Guedry, F. E., Comparison of tracking task performance and nystagmus during sinusoidal oscillation in yaw and pitch. NAMRL-1123. USAARL Serial No. 71-17. Pensacola, Fla.: Naval Aerospace Medical Research Laboratory, 1970.
3. van Egmond, A. A. J., Groen, J. J., and Jongkees, L. B. W., The mechanics of the semicircular canals. J. Physiol., 110:1-17, 1949.
4. Gilson, R. D., Benson, A. J., and Guedry, F. E., Influence of vestibular stimulation and display luminance on the performance of a compensatory tracking task. NAMI-1097. USAARL Serial No. 70-10. Pensacola, Fla.: Naval Aerospace Medical Institute, 1970.
5. Guedry, F. E., Psychophysiological studies of vestibular function. In: Neff, W. D. (Ed.), Contributions to Sensory Physiology. New York: Academic Press, 1965. Pp 63-135.
6. Guedry, F. E., Vision during angular acceleration considered in relation to space operations. In: Stahle, J. (Ed.), Vestibular Function on Earth and in Space. Oxford: Pergamon Press, 1970. Pp 27-34.
7. Guedry, F. E., and Benson, A. J., Tracking performance during sinusoidal stimulation of the vertical and horizontal semicircular canals. In: Busby, D. E. (Ed.), Recent Advances in Aerospace Medicine. Dordrecht, The Netherlands: D. Reidel Publishing Co., 1970. Pp 276-286.
8. Hixson, W. C., and Niven, J. I., A bioinstrumentation control center for the Human Disorientation Device. NSAM-848. Pensacola, Fla.: Naval School of Aviation Medicine, 1963.
9. Hixson, W. C., and Niven, J. I., Directional differences in visual acuity during vertical nystagmus. NAMI-1079. Pensacola, Fla.: Naval Aerospace Medical Institute, 1969.
10. Hixson, W. C., Niven, J. I., and Correia, M. J., Kinematics nomenclature for physiological accelerations. Monograph 14. Pensacola, Fla.: Naval Aerospace Medical Institute, 1966.
11. Johnston, T. B., and Whillis, J. (Eds.), Gray's Anatomy; Descriptive and Applied. 29th Edition. London: Longman, Green and Co., 1946. Pp 1233-1234.

12. Lorente de Nó, R., Interaction of corneal reflex and vestibular nystagmus. Amer. J. Physiol., 103:704-711, 1933.
13. Niven, J. I., and Hixson, W. C., Frequency response of the human semicircular canals: I. Steady-state ocular nystagmus response to high-level sinusoidal angular rotations. NSAM-459. Pensacola, Fla.: Naval School of Aviation Medicine, 1961.
14. Ramsey, H. R., The effects of visual information on vestibular nystagmus habituation. Doctoral Dissertation, The University of Oklahoma Graduate College, Norman, Oklahoma, 1970.

Unclassified

Security Classification

DOCUMENT CONTROL DATA - R & D

(Security classification of title, body of abstract and indexing annotation must be entered when the overall report is classified)

1. ORIGINATING ACTIVITY (Corporate author) Naval Aerospace Medical Research Laboratory Naval Aerospace Medical Center Pensacola, Florida 32512		2a. REPORT SECURITY CLASSIFICATION Unclassified	
		2b. GROUP N/A	
3. REPORT TITLE NYSTAGMUS AND VISUAL PERFORMANCE DURING SINUSOIDAL STIMULATION OF THE VERTICAL SEMICIRCULAR CANALS			
4. DESCRIPTIVE NOTES (Type of report and inclusive dates)			
5. AUTHOR(S) (First name, middle initial, last name) Fred E. Guedry, Jr., and Alan J. Benson			
6. REPORT DATE 10 March 1971		7a. TOTAL NO. OF PAGES 18	7b. NO. OF REFS 14
8a. CONTRACT OR GRANT NO.		8b. ORIGINATOR'S REPORT NUMBER(S) NAMRL-1131	
b. PROJECT NO. MF12.524.004-5001BX5G		8c. OTHER REPORT NO(S) (Any other numbers that may be assigned this report) USAARL Serial 71-16	
10. DISTRIBUTION STATEMENT Approved for public release; distribution unlimited.			
11. SUPPLEMENTARY NOTES Joint report with U. S. Army Aeromedical Research Laboratory, Fort Rucker, Alabama		12. SPONSORING MILITARY ACTIVITY	
13. ABSTRACT Men were positioned on their sides and oscillated sinusoidally (0.04 Hz, peak velocity ± 90 deg/sec) about an Earth-vertical axis. Initially, nystagmus slow phase velocity was about equal during the forward- and backward-pitch halves of the stimulus cycle in darkness; but when subjects tracked a dimly illuminated aircraft instrument, slow phase velocity during forward pitch was about ten times that during backward pitch. Consequently, tracking errors were much greater during forward pitch. Change in luminance level from 0.01 ft-L to 1.0 ft-L produced small, statistically significant decrements in slow phase velocity and substantial improvements in tracking performance. Following this part of the experiment, nystagmus was again recorded in darkness. There was a differential decline in slow phase velocity, the slow-phase-down response showing significantly greater decline. Stimulus-response phase relations were also altered for the slow-phase-down response, but were unaltered for the slow-phase-up response. It is proposed that interactions between eyelid and eyeball movements caused different frequencies of upbeatting and downbeating nystagmus which, in turn, produced different visual suppression of slow phase velocity in the two halves of the stimulus cycle. The asymmetric visual suppression may have contributed to the asymmetric habituation of the two reactions.			

14. KEY WORDS	LINK A		LINK B		LINK C	
	ROLE	WT	ROLE	WT	ROLE	WT
Vestibular stimulation						
Compensatory tracking						
Human factors						
Aviation						
Vision						
Habituation						